

HOBBY  
ELECTRONICS

# Hands-on Electronics

NOVEMBER  
1988

THE MAGAZINE FOR THE ELECTRONICS ACTIVIST!

## Build Your Own Printer Spooler/Buffer

Make your computer available for more important tasks!

COMBINED WITH  
**Popular  
Electronics**

## Hands-Off Intercom

Our convenient two-way communications system  
frees you from the tyranny of switches!A  
GERNSBACK  
PUBLICATION

## RGB Blue Box

It will turn your black screens blue!

## Beginners Guide to Vintage Radios

Is your find a treasure, or just junk!

## The TV Amp

Crank up the volume  
without disturbing others!

## Capacitance Adapter

Put your DMM to a new use!

**And much more!**\$2.50 U.S.  
\$2.95 CANADA3 New  
FactCards  
This Issue





## CONSTRUCTION

- 29 **Print Buffer/Spooler**—ties two computers to one printer
- 39 **Hands-Off Intercom**—a switchless intercom that offers all the convenience of face-to-face conversation
- 41 **The TV AMP**—tailors TV volume to the needs of the viewer
- 43 **RGB Blue Box**—a circuit that turns your black computer display to blue
- 44 **Capacitance Adapter**—use your DMM to measure capacitance

## FEATURES

- 59 **Beginner's Guide to Vintage Radio**—find out just how old that "collector's" item really is
- 64 **DC-Network Analysis Program**—use your computer to do complex math in moments
- 68 **Understanding Ohms Law**—take that important first step on the way to electronics proficiency
- 70 **Using Thermocouples**—use them to measure heat, cold, pressure, and more
- 74 **E-Z Math**—hone your network-analysis skills

## HANDS-ON REPORTS

- 24 **Brown's PC Pedal**—put your foot to work
- 26 **Jetset Airdaptor System**—provides quality sound for in-flight entertainment systems

## SPECIAL COLUMNS

- 82 **Carr on Ham Radio**—DX'ing the smart way
- 84 **Friedman on Computers**—let your computer help you pick your new car
- 86 **Circuit Circus**—junkbox circuits that can make life a bit easier
- 88 **Ellis on Antique Radio**—replacing drive belts in old radios
- 93 **Jensen on DX'ing**—this one's for you...our readers
- 94 **Saxon on Scanners**—the sum is greater than its individual parts

## DEPARTMENTS

- 2 **Editorial**—Popular Electronics comes home
- 4 **Letters**—here's what your fellow readers are thinking
- 6 **Electronics Library**—an information avalanche
- 14 **New Products**—here's what the market has in store
- 37 **FactCards**—squirrel 'em away for a rainy day
- 47 **GIZMO Special Section**—just when you thought you'd seen it all
- 71 **Free Information Card**—ask the manufacturer



Jetset Airdaptor—page 26



Print Buffer/Spooler—page 29



RGB Blue Box—page 43



Hands-Off Intercom—page 39



Vintage Radios—page 59



Saxon on Scanners—page 94



# Hands-on Electronics®

NOVEMBER  
1988

THE MAGAZINE FOR THE ELECTRONICS ACTIVIST!

COMBINED WITH  
**Popular  
Electronics**

## Popular Electronics comes home!

In September, 1958 I had the good fortune to join the staff of **Popular Electronics** as Managing Editor. It was my first magazine position; my previous experience had been in writing and editing equipment manuals and hard-cover books. For an electronics buff and novice experimenter like me, that new position was the chance of a lifetime. The thrill of the very first moment I entered the editorial office has stayed with me till this very day.

**Popular Electronics** was first published in February, 1943 as a section of **Radio Craft** magazine, a Gernsback publication. The section was discontinued some five years later, and the **Popular Electronics** title was sold to the Ziff-Davis Publications group in 1954. The rest, as they say, is history.

Almost everyone involved in electronics knows of **Popular Electronics'** dramatic rise in popularity and circulation during the period between 1959 and 1961. That popularity continued, and grew, until the early 1980's when the magazine changed its editorial direction, and its name to *Computers and Electronics*.

Long before the magazine's demise, in 1963 to be precise, I left to join the Davis Publications group. There I served as Editor-in-Chief of *Radio-TV Experimenter*, *Elementary Electronics*, *Whites Radio Log*, *Hi-Fi Stereo Buyers Guide*, and a host of annual and semi-annual electronics publications. I left Davis in 1981 and joined Gernsback Publications, Inc., the publisher of **Hands-on Electronics** magazine.

Sometimes the paths and fortunes of the publishing industry take some strange and surprising turns. The original title of **Hands-on Electronics** was **Special Projects**. And now **Hands-on Electronics** will change its name once again—to **Popular Electronics**. The transition has already begun, as is evident by the two logo titles on this month's cover.

The name change sits well with me because I always had a strong feeling for the **Popular Electronics** title. In its heyday, the scope and content of that magazine truly addressed and served the needs of the electronics experimenter. The new **Popular Electronics** will revive that tradition; it will strive to serve the electronics hobbyist in the future as well as it did in the past.



Julian S. Martin, KA2GUN  
Editor

# STAFF

Volume 5, No. 11

November 1988

Larry Steckler, EHF, CET  
Editor-In-Chief & Publisher  
Art Kleiman, editorial director  
Julian S. Martin, KA2GUN, editor  
Carl Laron, WB2SLR, managing editor  
Robert A. Young, associate editor  
Herb Friedman, W2ZLF, associate editor  
John J. Yacono, associate editor  
Brian C. Fenton, associate editor  
Byron G. Wels, K2AVB, associate editor  
Teri Scaduto, assistant editor  
Kathryn Campbell, editorial assistant  
Ruby M. Yee, production director  
Karen S. Tucker, production manager  
Robert A. W. Lowndes, editorial associate  
Marcella Amoroso, production assistant  
Andre Duzant, technical illustrator  
Injae Lee, assistant illustrator  
Jacqueline P. Cheeseboro, circulation director  
Nancy Estrada, manager, HOE Bookstore

### BUSINESS AND EDITORIAL OFFICES

Gernsback Publications, Inc.  
500-B Bi-County Boulevard  
Farmingdale, NY 11735.  
516/293-3000  
President: Larry Steckler  
Vice-president: Cathy Steckler

Cover photography by  
Herb Friedman

Composition by  
Mates Graphics

Advertising Sales Offices listed on page 105.



**Hands-on Electronics** including **Popular Electronics**, (ISSN 0743-2958) Published monthly by Gernsback Publications, Inc., 500-B Bi-County Boulevard, Farmingdale, NY 11735. Second-Class postage paid at Farmingdale, NY and at additional mailing offices. One-year, twelve issues, subscription rate U.S. and possessions \$21.95, Canada \$26.95, all other countries \$29.45. Subscription orders payable in U.S. funds only. International Postal Money Order or check drawn on a U.S. bank. U.S. single copy price \$2.50 © 1988 by Gernsback Publications, Inc. All rights reserved. **Hands-on Electronics** trademark is registered in U.S. and Canada by Gernsback Publications, Inc. **Popular Electronics** trademark is registered in U.S. and Canada by Electronics Technology Today and is licensed to Gernsback Publications. Printed in U.S.A.

Postmaster: Please send address changes to **Hands-On Electronics**, including **Popular Electronics**, Subscription Dept., P.O. Box 338, Mount Morris, IL 61054-9932

A stamped self-addressed envelope must accompany all submitted manuscripts and/or artwork or photographs if their return is desired should they be rejected. We disclaim any responsibility for the loss or damage of manuscripts and/or artwork or photographs while in our possession or otherwise.

As a service to readers, **Hands-on Electronics** including **Popular Electronics** publishes available plans or information relating to newsworthy products, techniques and scientific and technological developments. Because of possible variances in the quality and condition of materials and workmanship used by readers, **Hands-on Electronics**, including **Popular Electronics** disclaims any responsibility for the safe and proper functioning of reader-built projects based upon or from plans or information published in this magazine.

# SELECT 5 BOOKS

## for only \$3.95

(values to \$133.70)  
and get a Free Gift!

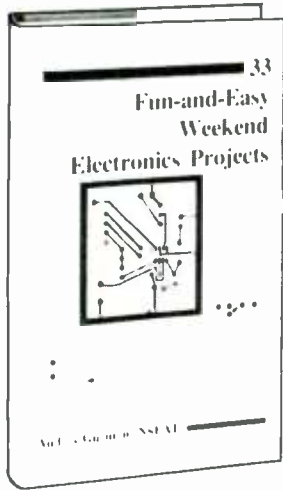

2861 \$14.95

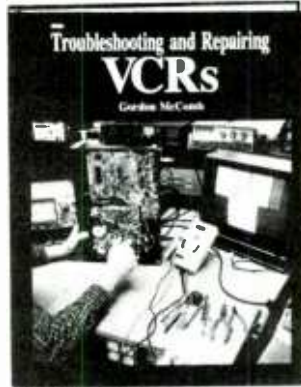

2960 \$24.95



2705P \$14.95



1897P \$13.95



2880 \$20.95

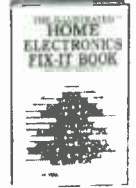

2883 \$25.95



1599P \$17.95

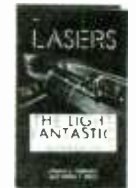

2905 \$19.95

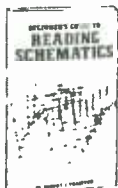

1536P \$8.95



1775P \$18.95



1667P \$14.95



2925 \$15.95



2882 \$24.95



2809 \$26.95  
Counts as 2



1493P \$15.95



2985 \$24.95



2800 \$23.95



2790 \$18.95



2735P \$13.95

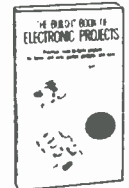

1498P \$11.95

Electronics projects . . . ideas . . . the latest technology  
all at up to 50% off publishers' prices

**Membership Benefits • Big Savings.** In addition to this introductory offer, you keep saving substantially with members' prices of up to 50% off the publishers' prices. • **Bonus Books.** Starting immediately, you will be eligible for our Bonus Book Plan, with savings of up to 80% off publishers' prices. • **Club News Bulletins.** 14 times per year you will receive the Book Club News, describing all the current selections—mains, alternates, extras—plus bonus offers and special sales, with hundreds of titles to choose from. • **Automatic Order.** If you want the Main Selection, do nothing and it will be sent to you automatically. If you prefer another selection, or no book at all, simply indicate your choice on the reply form provided. As a member, you agree to purchase at least 3 books within the next 12 months and may resign at any time thereafter. • **Ironclad No-Risk Guarantee.** If not satisfied with your books, return them within 10 days without obligation! • **Exceptional Quality.** All books are quality publishers' editions especially selected by our Editorial Board.

All books are hardcover unless numbers are followed by a "P" for paperback. (Publishers' Prices Shown)  
© 1988 ELECTRONICS BOOK CLUB®, Blue Ridge Summit, PA 17294-0810

**FREE when you join!**

Here's 15 Best Electronic Projects From Delton T. Horn  
Projects you can build—some unique, some old favorites—from the author's vast treasury of electronics know-how.

(a \$7.95 value!)

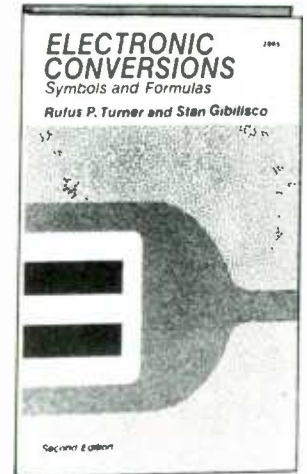

2865 \$21.95



1199P \$18.95



728P \$11.95



2724 \$24.95



1367P \$17.95



2941 \$21.95



1421P \$16.50

**ELECTRONICS BOOK CLUB**  
Blue Ridge Summit, PA 17294-0810

Please accept my membership in the Electronics Book Club® and send the 5 volumes listed below, plus my FREE copy of Delton T. Horn's All-Time Favorite Electronic Projects (3105P), billing me \$3.95 plus shipping and handling charges. If not satisfied, I may return the books within ten days without obligation and have my membership canceled. I agree to purchase at least 3 books at regular Club prices (plus shipping and handling) during the next 12 months and may resign any time thereafter.

Name \_\_\_\_\_  
Address \_\_\_\_\_  
City \_\_\_\_\_  
State/Zip \_\_\_\_\_ Phone \_\_\_\_\_  
Signature \_\_\_\_\_

Valid for new members only. Foreign applicants will receive special ordering instructions. Canada must remit in U.S. currency. This order subject to acceptance by the Electronics Book Club®. RESP-1188





## Letters

### AUTHOR! AUTHOR!

I was glad to see my story, "Mini Marque" in the September issue. But I was understandably perturbed to see it credited to someone named Donald P. Ray. My name is Daniel; always has been, too. Please be sure to credit any of my future articles to the right person. Unmistakably Yours—

Daniel P. Ray

### ANTENNA ADDENDUM

It is always a pleasure to see my work in your magazine, and my article "5 Classic Antennas," which appeared in your September issue, was no exception. However, it appears that some information was inadvertently left out of Fig. 2. Far from optional, that information dealt with how one can determine the proper dipole length for a particular frequency. In essence, that is done by dividing 468 by the intended operating frequency (in MHz), or length (in feet) =  $468/\text{Freq. (in MHz)}$ . As an example, for an operating frequency of 10 MHz, the length would be  $468/10 = 46.8$  feet.

W. Clem Small

### SMOOTH SAILING

I hope you can help me with a problem. I sail on merchant ships, and the newer ships have windows that don't open, the way the old port-holes did. A random long-wire antenna gives me the best reception, but on the new ships there is no way to make a direct connection to the outside. Because the ship is metal, a receiver is completely shielded without an outside antenna.

I've seen ads recently for small antennas that mount on the rear windows of cars. I assume that the antenna and the feed wire are capacitively coupled to allow the transfer of RF through the glass.

Would that same principle—if I am correct—work on shortwave frequencies? If so, what would be the critical parameters in terms of the size and composition of plates and the thickness of glass?

C.W.H. Jr.  
Hayward, CA

You're right, antennas like the one you've seen advertised use capacitive coupling. However, those are designed primarily for UHF and VHF radio work. Assuming normal-thick-

ness auto glass as the dielectric, at HF shortwave frequencies the reactance (essentially AC resistance) of the link will attenuate the signals to the point where they are useless.

That's not to say that the technique can not be used for your situation. Capacitive reactance decreases as frequency or capacitance increases. The relationship is  $X_C = -1/(2\pi fC)$ . If, as we assume, your marine glass is thicker than auto glass, you are ahead of the game already. Further, you are not constrained to the small plate size that must be used by automotive-antenna manufacturers (for obvious safety reasons). We can't give you precise parameters, but we encourage you to do a little experimentation; you might be able to find a combination that works at least on the higher shortwave bands.

### KEEP IT SIMPLE

I am 12 years old, and I'm starting a hobby in electronics. I would appreciate it if you would include some simpler—but interesting—projects in your magazine.

S.H.  
Akron, OH

We try to give hobbyists of all levels, interests, and ages, something to look forward to in each issue. Beginners can find simple but useful circuits nearly every month in our Circuit Circus column. Be sure to check it out.

### CURRENCY CONVERSION

I read C.A.'s letter in the June 1988 issue of *Hands-on Electronics*, and I may have the answer to his U.S.-to-British currency problem. As a U.S.A.F. serviceman, stationed in the United Kingdom, I've had some experience with that problem.

Credit cards issued in the U.S. are accepted by major and minor companies world wide—I know they are here. My stateside card works just as well in Great Britain as it does back in the States. I feel confident that a letter with a signature and a major credit card number sent to the company with the Denco coils will turn the trick. Let the credit-card company do the currency conversion.

J.R.S.  
MSgt, USAFAD  
APO New York

Our experience has been that credit-card acceptance by electronics firms, especially smaller ones, is far from universal. However, enough do accept them to make it worth a shot.

By the way, perhaps the easiest solution of all would be to buy an international postal money order. Those money orders are available in most major currencies, including British Pounds, and are sold by nearly all U.S. Post Offices. The conversion is done by the Postal clerk and you pay for the money order in U.S. Dollars.

### ELECTRONIC FENCE CHARGER

I would like to build an electronic fence charger for a small city garden, to discourage small animals such as squirrels, rabbits, raccoons, and rats. However, it must be harmless if children or pets come in contact with it. If it could selectively kill rats, that would add frosting to the cake.

I suspect that, even operated at 1½ volts, the fence charger described in your May issue would have an output that is far too high. Can you suggest modifications to make it suitable? Because the load would be greatly reduced, is it possible to use a more-readily available transistor for Q3? What value for R2 would give me a frequency of 1 Hz?

I've been out of electronics for over 15 years, and have forgotten most of what I once knew. I have very little experience with solid-state devices, and the only test instrument I own is a VOM.

I was considering using a 555 timer and a 6.3 filament transformer, but hesitated because I was unsure if that would be safe. It would be simpler and draw far less current; if I could be assured of the safety factor, I believe it would be quite satisfactory.

A.M.S.  
Baltimore, MD

For many reasons, most of them obvious, we can not assure you of the suitability or safety of any circuit or project not presented in *Popular Electronics*. Further, as a rule we can not recommend modifications to any circuit published in these pages. While we've had a chance to examine the circuits as described, there's no way for us to reliably predict the way a circuit will work when changed, except to wire it up and try it out. That's simply not practical.

However, there's nothing to stop you from trying things out for yourself. Experimentation is a large part of the fun of the electronics hobby—try it, you might like it.

### HAVES AND NEEDS

I'm a subscriber to your fine magazine; I'm writing to see if anyone has a schematic that could be used in building a welding device for welding broken band-saw blades. Thanks for your help.

Glen Montross  
1110 Orem Road  
Baltimore, MD 21220

I have a chandelier that uses sixteen 60-watt light bulbs, for a total of 960 watts. I'm using a conventional light dimmer that is intended to handle 600 watts. It gets so hot that I think it may pose a fire hazard.

Do you know where I could obtain a dimmer that can handle that wattage? If not, perhaps you could suggest a suitable circuit. Thanks.

Bill Brahmananda  
72 Commonwealth Ave.  
Boston, MA 02116





## NEW FROM ETT



□ **RATCHET — ELEVEN-PIECE RATCHET TOOL KIT....\$10.00.** Includes reversible ratchet handle, extension bar, six bits, two precision screwdrivers, and a cutter. Comes in fitted case. Get one for your shop, another for your car, another for your tool kit.

□ **TOOL KIT—NINE-PIECE TOOL KIT....\$9.50.** Includes saw, bubble level, three screwdrivers, torque multiplier, callipers for inside and outside measurements, nippers, and a tape measure.



□ **BP233—ELECTRONIC HOBBYISTS HANDBOOK .... \$9.95.** Provides an inexpensive single source of easily located data that the electronics enthusiast is likely to need in his day-to-day hobby activities. 8 x 10 inches.

□ **BP232—CONCISE INTRODUCTION TO MS-DOS....\$5.95.** If you are a PC user and want to get the most out of your computer, you must learn its MS/PC-DOS operating system. That's what this book shows you.



□ **BP194—MODERN OPTO DEVICE PROJECTS....\$6.25.** Provides a number of practical designs that use opto-electronic devices such as fiber optics, LEDs, and passive IR detectors.

□ **BP234—TRANSISTOR SELECTOR GUIDE....\$10.00.** Prepared from a vast database of specifications. Unique guide offers a wide range of selection tables. More than 1400 devices are listed along with specs.



MAIL TO: Electronic Technology Today Inc.  
P.O. Box 240  
Massapequa Park, NY 11762-0240

## SHIPPING CHARGES IN USA AND CANADA

\$0.01 to \$5.00	... \$1.25	\$30.01 to \$40.00	\$5.00
\$5.01 to 10.00	... \$2.00	\$40.01 to \$50.00	\$6.00
\$10.01 to \$20.00	\$3.00	\$50.01 and above	\$7.50
\$20.01 to \$30.00	\$4.00		

**SORRY, No orders accepted outside of USA and Canada**

Total price of merchandise \$ \_\_\_\_\_  
Shipping (see chart) \$ \_\_\_\_\_  
Subtotal \$ \_\_\_\_\_  
Sales Tax (NYS only) \$ \_\_\_\_\_  
Total Enclosed \$ \_\_\_\_\_

Name \_\_\_\_\_

Address \_\_\_\_\_

City \_\_\_\_\_ State \_\_\_\_\_ Zip \_\_\_\_\_

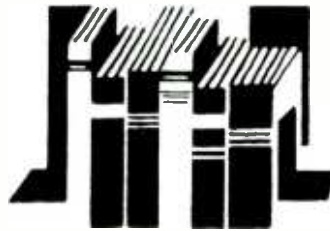

## Electronics Library

## WORDSTAR 200 HANDBOOK

by Greg M. Perry

This book, organized by feature and command, provides thorough descriptions and brief examples of features to help beginning and intermediate users get the most out of MicroPro's WordStar 2000 Release 3. For newcomers to computers, the book also offers basic descriptions of computer hardware and software, and word processing; and useful appendices on disk-operating systems and installing WordStar 2000. Readers who are familiar with earlier WordStar releases will gain valuable insight into the different commands, new features, and increased power of Release 3.

The *WordStar 2000 Handbook* covers the fundamentals of creating and editing documents, block editing, search and replace functions, and spell checking. Advanced formatting and printing techniques are discussed, as well as macros and function keys, indexing, and creating charts and columns. Readers will learn how to use WordStar's page-preview mode, Speed Write feature, background formatting, line and box drawing, and improved file-conversion utilities.

Published by Osborne McGraw-Hill, 2600 Tenth Street, Berkeley, CA 94710. 364 pages. \$21.95, paperback.

CIRCLE 88 ON FREE INFORMATION CARD

## RADIO-ELECTRONICS' GUIDE TO COMPUTER CIRCUITS

by The Editors of Radio-Electronics

Filled with articles drawn from Robert Grossblatt's popular *Radio-Electronics* columns, "Drawing Board" and "Designer's Notebook," this book presents a comprehensive survey of microprocessors and their numerous applications. Aimed at electronics hobbyists and experimenters, each topic and project is described concisely, without a hint of "computer-ese."

All topics are completely explained, with plenty of introductory theory. Each of *Radio-Electronics' Guide to Computer Circuits'* eight sections—logic; designing considera-



tions; power considerations; memory considerations; sequencing, display circuits, and special-purpose ICs; using the 4017 and 4018 microprocessors; using the 4089 and 5101 microprocessors; and using the Z80 microprocessor—discusses a different situation, purpose, or microprocessor group.

Several projects allow hobbyists to experiment with microprocessor circuits. Those include a seven-digit display that shows the complete hexadecimal-number set, a simple logic probe, and a battery back-up for CMOS circuits. *Radio-Electronics' Guide to Computer Circuits* also contains selections from the popular "New Ideas" column, in which readers contribute original circuit designs.

Published by Tab Books Inc., Blue Ridge Summit, PA 17294-0850; Tel. 1-800-233-1128. 150 pages. \$9.70, paperback. \$14.95, hardcover.

CIRCLE 98 ON FREE INFORMATION CARD

## THE CELLULAR TELEPHONE DIRECTORY

by Steven Scott Brown

This unique guide shows cellular-telephone users how to place and receive calls in more than 100 U.S. and Canadian cities. A postcard, provided with the book, is to be filled in by the reader with the name and address of his home cellular company, and mailed to the publisher. The publisher then mails a list, customized according to the home cellular company, that allows the reader to determine for each city whether he may dial immediately and have the charges appear on his home bill, or if he must provide the local cellular-telephone company with a credit-card number for billing. Updated bulletins are provided when necessary.

The listing for each city includes a Triple-A map of the area, indicating where a traveler can use a cellular phone. The names, addresses, and phone numbers of local cellular-telephone companies are provided, along with complete rate information—including free calls. Instructions detail how to receive calls when traveling.

Other features that are particularly useful for travelers include an area-code direc-



tory, and lists of toll-free numbers for airlines, hotels, and rental cars.

Published by Communications Publishing Service, 3790 El Camino, Suite 300, Palo Alto, CA 94306. 232 pages. \$14.00, paperback.

**CIRCLE 86 ON FREE INFORMATION CARD**

### ELECTRONICS BUILD AND LEARN (Second Edition)

by R.A. Penfold

The purpose of this book is to help the complete beginner to understand what basic electronic components do, and how they are used in practical circuits. Theory and practice are combined, so the reader can learn by doing.

The first chapter contains full details on how to build a "circuit-demonstrator unit" that is used in subsequent chapters to introduce common electronic components. *Electronics Build and Learn* goes on to describe how those components are built up into useful circuits—including oscillator, radio, multivibrator, bistable, pulse, and logic circuits.

Practical tests and experiments, to help the reader investigate and understand the theory involved, are presented at every stage of the book. This second edition has been

revised to include a chapter on logic circuitry, a new circuit-demonstrator board using IC holders, and several new illustrations and photographs.

Published by Electronics Technology Today, P.O. Box 240, Massapequa, NY 11762. Order No. PCP104. 111 pages. \$11.95 (including shipping), paperback.

**CIRCLE 97 ON FREE INFORMATION CARD**

### UNDERSTANDING & REPAIRING CB RADIOS

by Lou Franklin

This comprehensive reference is designed to help professional technicians and serious radio hobbyists to quickly solve any type of CB-radio problem. All types of CB radios are covered: 23- and 40-channel, crystal, PLL-synthesized, tube, transistor, AM, FM, SSB, CW, American, British, and export models.

Beginning with a thorough discussion of technical specifications and measuring equipment, the book presents basic electronic-troubleshooting techniques as they relate to CB radios. Shortcuts are described whenever applicable. A detailed analysis of virtually every type of circuit found in CB radios—from the classic 23-channel tube transceiver

#### UNDERSTANDING & REPAIRING

### CB RADIOS

For the Professional Technician

Lou Franklin

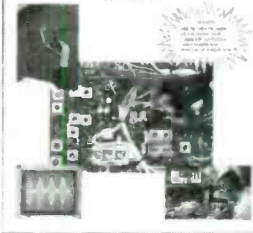

ers to modern, multimode, solid-state models—is included, with each circuit explained in the simplest possible way. There is no complicated math or electronic theory in *Understanding & Repairing CB Radios*.

A separate chapter on mobile and base-CB antennas—including problems and installation—is featured. Throughout the text are pointers on where to find specific parts, accessories, test equipment, and further information. Appendices give tips on solving RFI, TVI, and ignition-noise problems, and list FCC frequencies.

Published by C.B. City International, P.O. Box 31500, Phoenix, AZ 85046. 366 pages. \$32.45, including shipping; paperback.

**CIRCLE 87 ON FREE INFORMATION CARD**

## HOLD IT ANYWHERE YOU WANT IT!

PanaVise electronic work holding systems allow you to position, tilt and rotate your projects without removing them from their holding devices! With over 30 years experience and made-in-USA quality, PanaVise ensures reliable, long-lasting service.



**MULTI-PURPOSE WORK CENTER:** Self-Centering Extra Wide Opening Head (opens to 9"), famous "split ball" Standard Base (moves in three planes), and convenient Tray Base Mount (with parts wells) handle difficult to hold items with ease! Model #350. \$52.95.



**STANDARD PANAVISE:** Our most popular vise, the Standard PanaVise is an extremely versatile, useful workbench tool. Jaws open a full 2.25" and the patented "split ball" base tilts, turns and rotates through three planes. One convenient control knob locks work into any position! This durable, all-purpose mini-vise stands about 6" tall and will deliver years of rugged service. Model #301. \$33.95.



**ELECTRONIC WORK CENTER:** A complete combination to make work areas more efficient and manageable! Circuit Board Holder gently, but firmly, holds PCB's up to 12" wide. Add our Standard Base (moves in three planes), Tray Base Mount (with parts wells), and Solder Station (self-centers wire and holds iron at perfect angle) for a great combo! Model #324. \$54.95.

# PANAVISE

See your local electronics supplier or contact PanaVise for the source nearest you:  
PanaVise Products, Inc. 2850 E. 29th Street.  
Long Beach, CA 90806. (213) 595-7621

**CIRCLE 16 ON FREE INFORMATION CARD**

## ELECTRONICS LIBRARY

### BASIC ELECTRICITY

by Gene McWhorter

Written for budding scientists and curious hobbyists, from junior-high age up, this book presents the basic concepts of electricity. In a highly illustrated, colorful format, such basic questions as "What is electricity?" and "How can it be controlled?" are answered.

The reader discovers fundamental principles by studying real-life examples, presented in carefully coupled text and illustrations. Each chapter ends with a multiple-choice quiz to reinforce the learning process, and a list of hands-on experiments from Radio Shack's *Science Fair* project kits. Kit builders will learn about the underlying principles that make their kit experiments work.



The easy-to-read book covers electric charge, electrons, atoms, current, voltage, resistance, series and parallel circuits, magnetism, meters, motors, and generators. It explains what electricity is, how it flows through wires, how it works in circuits, how it is measured, and how it is obtained from generators and used in motors. *Basic Electricity, JE-101*, builds a foundation that will set the stage for later understanding of more-complicated subjects.

Published by Master Publishing, Inc., P.O. Box 834158, Richardson, TX 75083-4158. 128 pages. Available at Radio Shack stores for \$7.95, softcover.

CIRCLE 90 ON FREE INFORMATION CARD

### DOS PROGRAMMER'S REFERENCE

by Terry R. Dettmann

Whether they program in assembly language, C, Pascal, or BASIC, this book will help intermediate and advanced programmers make the most of their DOS-based applications. Readers who are just beginning to program at DOS-level will learn how using DOS and BIOS functions can help their programming. A combination of tutorial and reference material, the book contains numerous sample programs.

*DOS Programmer's Reference* explores the structure and innermost working of DOS. It explains how readers can use DOS to

extend their control of personal-computer systems. In-depth coverage is included on DOS and BIOS functions, including some that were previously undocumented; disk organization and structure; device drivers; input/output control, including video display, keyboard, and mouse; expanded memory; Terminate and Stay Resident programs; and interrupt handlers.

The reference section features a detailed, function-by-function listing of all DOS and BIOS functions. Mouse functions and expanded memory functions are also included in the book.

Published by Que Corporation, P.O. Box 90, Carmel, IN 46032; Tel. 1-800-428-5331. 821 pages. \$22.95, paperback.

CIRCLE 94 ON FREE INFORMATION CARD

### MAINTENANCE AND REPAIR OF VIDEO CASSETTE RECORDERS

by Matthew Mandl

The opening chapters of this book describe the basic technical aspects of video-cassette recorder circuits and systems so that the reader can understand how the picture and sound are recorded. With that background information, even beginners in electronics will be able to put this book to good use.

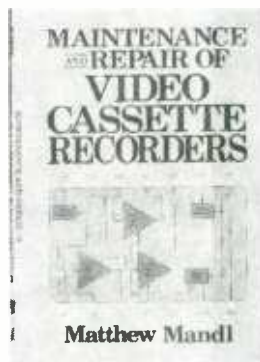

Basic signals and systems are discussed, with a description of the most-common problems found in both VHS and Beta formats. The essential differences between those two formats are also explained.

*Maintenance and Repair of Video Cassette Recorders* covers basic power-supply systems, and all the tools and test equipment that might be needed. Signal-tracing procedures and parts-isolation and replacement techniques are identified. Safety precautions—to minimize damage to VCR circuitry and components—are emphasized. Proper linkage to cable-TV lines, audio accessories, monitors, and switching units is also described.

The book includes a master index to common VCR troubles, and appendices listing television-station allocations, cable-TV frequencies, television standards in broadcast-

ing, color-television reference standards, and component-color codes.

Published by Prentice-Hall Inc., Englewood Cliffs, NJ 07632. 245 pages. \$24.95, hardcover.

CIRCLE 99 ON FREE INFORMATION CARD

### HOW TO DESIGN SOLID-STATE CIRCUITS (Second Edition)

by Mannie Horowitz and Delton T. Horn

Aimed at circuit designers, engineers, technicians, and students, this book provides information on semiconductors—how they perform in various applications, and how to ensure their reliable operation. A basic knowledge of electronics is required to obtain maximum benefit from this book.



The text begins with a discussion of devices made of individual semiconductors, leading into a description of the semiconductor diode and its many functions in modern circuits. The four major categories of semiconductors—diodes, transistors, integrated circuits, and thyristors—are examined.

(Continued on page 12)



"I made it almost human . . . Unfortunately."





## ELECTRONICS LIBRARY

(Continued from page 8)

*How to Design Solid-State Circuits* presents the DC-bias and stabilization conditions for bipolar and field-effect transistor devices. The use of semiconductors in audio and RF amplifiers using a varying input are discussed, as well as silicon-controlled rectifiers and other, lesser-known, thyristors.

Throughout the book, emphasis is placed on digital-circuit design and its many variations. Designs using both integrated circuits and discrete components are described.

Ranging from simple temperature-sensitive resistors to integrated circuit units composed of multiple microcircuits, a wide array of the latest in solid-state devices is described. New materials in this revised edition cover zener diodes, light-sensitive diodes, unijunction transistors, phototransistors, and microwave transistors.

Published by Tab Books Inc., Blue Ridge Summit, PA 17294-0850; Tel. 1-800-233-1128. 369 pages. \$16.95, paperback.

CIRCLE 98 ON FREE INFORMATION CARD

## MICROSOFT WORD TIPS, TRICKS, AND TRAPS

by Bryan Pfaffenberger and Steve Lambert

Microsoft Word is a powerful program that offers sophisticated word-processing capabilities to those who know how to use it properly. Unfortunately, its level of sophistication prohibits many users from tapping more than a fraction of its power. *Microsoft Word Tips, Tricks, and Traps* puts even the most advanced Word features at the user's fingertips.

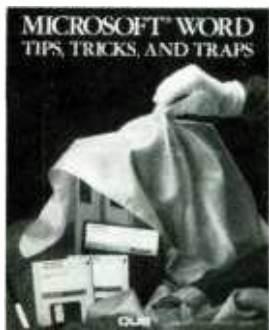

Although it is aimed at those who have had some experience with Word and are looking to move beyond its basic features, even beginners will be able to benefit from this book. Starting at the most elementary levels—where experienced Word users might be surprised to find simple tricks that are new to them—the book continues to the most advanced applications.

Hundreds of practical suggestions to improve efficiency and make better use of Word's basic functions and advanced features are presented. The book shows readers how to do things with Word that they didn't think were possible. It demonstrates strategies for effective editing and for avoiding the program's common pitfalls. The new features of IBM-compatible Word 4.0 are highlighted—even many undocumented features are included.

Published by Que Corporation, P.O. Box 90, Carmel, IN 46032; Tel. 1-800-428-5331. 378 pages. \$19.95, paperback.

CIRCLE 94 ON FREE INFORMATION CARD

## LOUDSPEAKER AND HEADPHONE HANDBOOK

edited by John Borwick

Written by an international team of experts, this comprehensive technical reference book covers the theoretical and practical aspects of loudspeaker and headphone performance, design, and operation in domestic, public, and professional applications. Every aspect of loudspeaker and headphone theory, construction, operation, measurement, and application is covered in sufficient depth to equip students and practitioners with a solid working knowledge of the subject.

The latest techniques for computer-aided design of drive units, crossover networks, and enclosures are described, as well as recent developments in digital-audio technology. Other subjects covered include the principles of sound radiation, transducer-drive mechanisms, international standards, and electrostatic loudspeakers. Tables, graphs, and diagrams provide convenient reference material for students and engineers.

Published by Butterworths, 80 Montvale Avenue, Stoneham, MA 02180. 573 pages. \$29.95, hardcover.

CIRCLE 89 ON FREE INFORMATION CARD

## INTERNATIONAL RADIO STATIONS GUIDE

by Peter Shore

Turn on a short-wave radio, and you can tune in the world. For casual listeners, amateur DXers, and professional-radio monitors, this newly revised book provides an up-to-date guide to the increasingly complex radio bands.

The information presented in the *International Radio Stations Guide* was compiled from frequency registrations that were made by broadcasters with the International Telecommunication Union's Frequency Registration Board. It includes worldwide short-

wave stations; European, Middle Eastern, and North African long-wave and medium-wave radio stations; and U.S. and Canadian medium-wave stations. Also listed are English-language broadcasts, programs for DXers and shortwave listeners, and United Kingdom FM-radio stations.

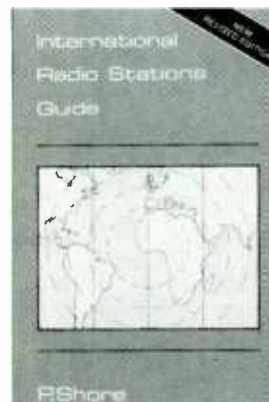

The book's language-translation table, wavelength/frequency conversion chart, time differences from Greenwich Mean Time, and list of abbreviations all are helpful tools for those interested in getting the maximum entertainment value and enjoyment from their sets.

Published by Electronics Technology Today, P.O. Box 240, Massapequa, NY 11762. Order No. BP255. 311 pages. \$11.95 (including shipping), cloth.

CIRCLE 97 ON FREE INFORMATION CARD

## USING WORDPERFECT FOR THE MACINTOSH

by Daniel J. Rosenbaum

Spanning beginning to intermediate techniques, this book is full of short examples and applications that provide the reader with a clear understanding of WordPerfect concepts.

After a brief overview of the program, the book describes the basics of entering, editing, and formatting text in WordPerfect. More sophisticated procedures, such as printing





options, graphics, macros, and file merges, are then covered.

Using *WordPerfect for the Macintosh* details how to use the speller and the thesaurus, and such special features as footnoting, searching, file management, and creating lists and tables. A list of codes and a tear-out command card are also included.

Published by McGraw-Hill Book Company, 1221 Avenue of the Americas, New York, NY 10020. 326 pages. \$21.95, paperback.

CIRCLE 96 ON FREE INFORMATION CARD

### HANDBOOK OF ELECTRONICS CALCULATIONS FOR ENGINEERS AND TECHNICIANS (Second Edition)

by Milton Kaufman and Arthur H. Seidman

This extensively revised and updated edition—containing over 150 pages of new material—provides hundreds of detailed, worked-out solutions to practical, everyday problems encountered by electronics engineers, technicians, instructors, and students. With a practical, rather than theoretical, approach it is intended as a "cookbook" for solving on-the-job problems.

Virtually every important discipline in electronics is covered. Some of the topics included are fiber optics, microprocessors, semiconductor devices, digital logic, video amplifiers, microwaves, communications systems, analog-to-digital conversions, computer-aided design, op-amps, power supplies, and antennas.

Throughout this handbook, information is presented in a clear, straightforward manner. All math has been kept as simple as possible. Each problem is stated, then followed with a concise review of applicable theory and a detailed solution. The book also suggests the proper components to use for particular applications.

Published by McGraw-Hill Book Company, 1221 Avenue of the Americas, New York, NY 10020. 848 pages. \$49.50, hardcover.

CIRCLE 96 ON FREE INFORMATION CARD

### TRANSISTOR SELECTOR GUIDE

by J.C.J. Van de Ven

Prepared using computerized techniques, from a vast database of electronic-component specifications, this guide offers a variety of transistor-selection tables. Compiled to be of maximum use to electronics engi-

neers, designers, and hobbyists, the book can be used in two ways. Devices can be selected by alpha-numeric classification, or by case type.

The *Transistor Selector Guide* begins with a detailed introduction, covering component markings, codings, and standards. It also explains the symbols used and how the tables are arranged.

Alpha-numeric tables sequence the comprehensive specifications of over 1400 devices. In a similar fashion, in other tables the devices are tabulated by case type. Still other tables are sub-divided by electronic specifications. There are sections on Darlington transistors, devices that can handle over 300 volts, devices that can handle currents over 5 amps, devices that can handle more than 5 watts of power, RF devices that operate upwards of 30 MHz, and FETs. Also included in this reference work are illustrations of package outlines and leadouts, and a surface-mount device markings-conversion list.

Published by Electronics Technology Today, P.O. Box 240, Massapequa, NY 11762. Order No. BP234. 187 pages. \$12.00 (including shipping), cloth.

CIRCLE 97 ON FREE INFORMATION CARD

The writing's on the wall ...

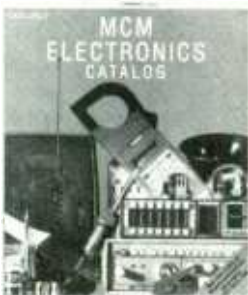
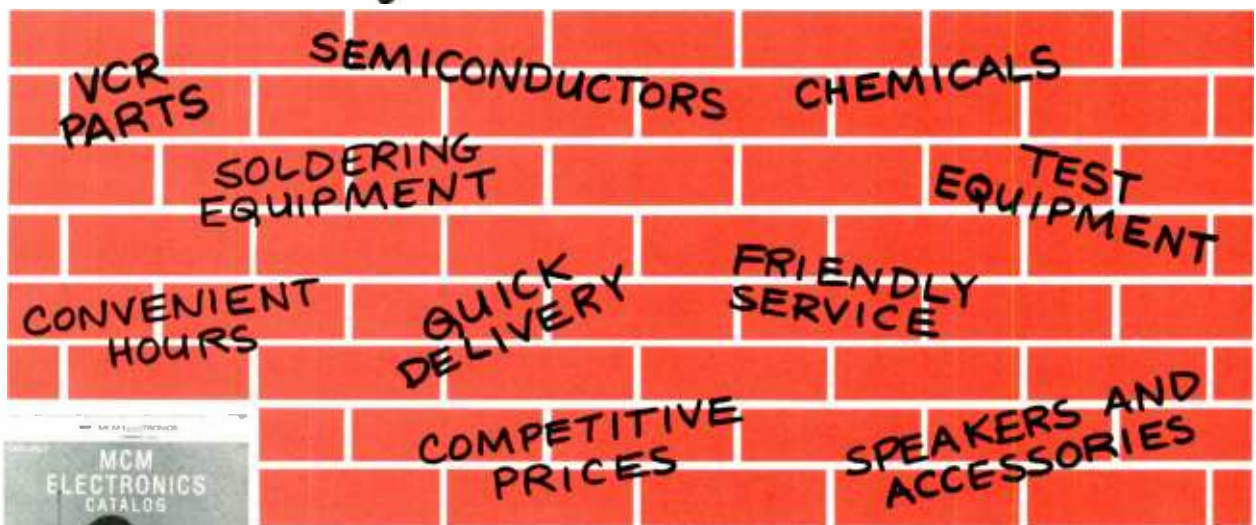

MCM has all your electronic part needs!

For your FREE copy,  
call TOLL-FREE! 1-800-543-4330  
In Ohio, call 1-800-762-4315  
In Alaska or Hawaii, call 1-800-858-1849



MCM ELECTRONICS  
858 E. CONGRESS PARK DR.  
CENTERVILLE, OH 45459-4072  
A PREMIER Company

HO-20

CIRCLE 12 ON FREE INFORMATION CARD

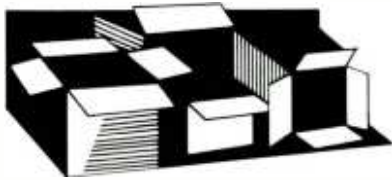

## New Products

To obtain additional information on new products covered in this section from the manufacturer, please circle the item's code number on the Free Information Card.

### OSCILLOSCOPE CALIBRATOR

B&K Precision's Model 1400 offers companies an alternative to expensive annual service calls to calibrate oscilloscopes. Easily set up, it can be used to calibrate any oscilloscope, and as a signal source for testing other frequency-, time-, or voltage-measuring instruments.



The Model 1400 generates voltage- and time-calibration signals, and an uncalibrated sine-wave-output signal for convenience. The voltage range, in a 1-2-5 sequence, is from 1 millivolt to 100 volts peak square waves. Its accuracy into a standard, 1-megohm oscilloscope input is 0.5 percent. The time output, also in a 1-2-5 sequence, ranges from 0.5 seconds to 10 nanoseconds, with 0.015 percent accuracy. That configuration matches that of the input level and time-base selectors on most oscilloscopes, greatly simplifying the calibration process. Rise time is less than 1 nanosecond, and the sine-wave output is fixed at 1 kHz.

The oscilloscope calibrator has a suggested price of \$499.00. For additional information, contact B&K Precision, Division of Maxtec International Corp., 6470 W. Cortland St., Chicago, IL 60635.

CIRCLE 70 ON FREE INFORMATION CARD

### LOGIC COMPARATOR

American Reliance's AR-90LMC logic comparator is based on a proprietary custom IC that allows use of a single model with both TTL and CMOS logic. It features two modes of comparison—normal or latch. Direct viewing of logic states is possible with the built-in monitor mode.

The unit's unique design allows it to operate at 20 MHz and to detect a single timing error as short as 50 ns. Those speeds are two and three times faster, respectively, than those of its nearest competitor. The AR-90LMC also tests ICs of up to 28 pins.



The logic comparator, including both 16-pin and 28-pin test clips, an interconnect cable, carrying case, and operator's manual, is priced at \$379.00. For further information, contact American Reliance, 9241 E. Valley Blvd., Rosemead, CA 91770.

CIRCLE 85 ON FREE INFORMATION CARD

### TINY MOBILE CB TRANSCEIVER

Measuring just 4 $\frac{1}{4}$  by 1 $\frac{1}{4}$  inches, Midland International's Model 77-099 is the world's smallest 40-channel mobile citizens-band transceiver. The high-tech, miniature CB can be mounted virtually anywhere—even on motorcycles, snowmobiles, and other recreational vehicles.



The Model 77-099 features ETR-frequency control for pinpoint channel-tuning accuracy with separate scan-up and -down controls. A dual-conversion superheterodyne receiver provides efficient signal amplification and stability. Full-time ANL eliminates reception-background noise, and a ceramic filter improves selectivity. Other features include enhanced modulation, separate LED systems for transmitting and receiving, a condenser-electro microphone with front-panel locking mount, and a large, high-intensity LED channel readout.

The radio is enclosed in a rugged, black-

metal cabinet. A double-layered RF heat sink provides maximum heat dissipation and longer life.

The suggested retail price for Model 77-099 is \$89.95. For more information, contact Midland International, Consumer Communications Division, 1690 North Topping, Kansas City, MO 64120.

CIRCLE 84 ON FREE INFORMATION CARD

### MACINTOSH MODEM PACKAGE

The Macintosh Communications Package from Practical Peripherals is a complete modem setup designed specifically for Macintosh computers. The package includes a PM2400SA stand-alone modem, two custom cables that plug between any old or new Macintosh computer, and the Microphone communications package from Software Ventures. Free access time to CompuServe and Official Airline Guide is also included.



The PM2400SA is a 2400-, 1200-, and 300-baud, fully Hayes-compatible modem. It features adaptive equalization for error-free data transmissions in even the most difficult situations.

The complete Macintosh Communications Package, with a five-year factory-repair/replacement warranty, retails for \$239.00. For further information, contact Practical Peripherals, Inc., 31245 La Baya Drive, Westlake Village, CA 91362.

CIRCLE 83 ON FREE INFORMATION CARD

### PRO-LOGIC SURROUND-SOUND DECODER

NEC's Dolby Pro-Logic Surround-Sound Decoder, Model PLD-310 provides consumers with several ways to obtain dynamic audio quality from their VCRs. By selecting the normal, phantom, wide, or by-pass mode settings, users can tailor the surround-sound audio effects to their individual sound systems.

The normal mode uses the Dolby Pro-



Logic Surround active-decoding system to steer the audio signal to the left, center, right, and surround channels. That technique creates a more dynamic listening experience for the listener through the improved localization of sounds.



The phantom setting—for audio systems without a center speaker—directs signals to the left and right channels; in effect, it creates a center channel where one does not actually exist. The wide setting generates a full-frequency response in all speakers, regardless of their location. The bypass mode allows conventional stereo use without the addition of surround-sound processing.

The PLD-310, with wireless remote, has a suggested retail price of \$449.00. For more information, contact NEC Home Electronics (U.S.A.) Inc., 1255 Michael Drive, Wood Dale, IL 60191.

**CIRCLE 82 ON FREE INFORMATION CARD**

### SELF-IGNITING PYROPEN

CopperTool's Weller WPA-2 Pyropen features an instant push-button ignition. The versatile cordless, butane-gas powered tool can be used either as a soldering iron or as a hot-air gun.

Especially useful for single-handed operation outdoors or in the field—any place where electricity or battery charging is not available—the Pyropen burns for about three hours before requiring a fill-up. Gas is stored



"Is the line voltage in this country 110 or 220?"

in the tool's handle, which has a window to permit the user to see how much fuel remains.

Temperature is controlled by varying the gas flow. When the Pyropen is used as a heat gun, a gas-catalyst reaction system converts the flame to hot air, at a temperature of 650°C (1202°F). As a soldering gun, the WPA-2 is ready for use in 30 seconds, with a temperature range of 250°-500°C (482°-932°F).



A wide variety of interchangeable hot-blow and soldering tips are available, including a high-powered chisel, tapered needle or pyramid, and a micro spade.

The 4.4-ounce WPA-2 Pyropen costs \$79.40. For more information, write CopperTools, Pyropen WPA-2, P.O. Box 728, Apex, NC 27502.

**CIRCLE 81 ON FREE INFORMATION CARD**

### COMPACT AT-COMPATIBLE PC

Zenith's Z-286 LP is one of the smallest, yet most powerful, 80286 systems available today. Despite its compact size—about 60% smaller than a standard-size 80286 system—the Z-286 LP offers 8-MHz, zero wait-state performance, and includes two open expansion slots.

By operating without wait states, the Z-286 LP performs as though its clock speed was 11.5 MHz. Fast 1:1 and 1:2 disk interleave allows information to be read quickly, without the additional disk rotations associated with standard 1:3 interleave disks.

The system's "slushware" feature copies the ROM-BIOS at system bootup from slow 8-bit, read-only memory to fast 16-bit RAM. That technology increases system performance by up to 15 percent.

The Z-286 LP has one megabyte of RAM, including 256K of EMS (expanded memory specification) capability for addressing memory beyond 640K. Memory expansion to 6 megabytes is accomplished through the manufacturer's use of 1-megabyte single in-line memory modules (SIMMs), that plug into sockets on the system board. Other features include a real-time clock, two serial ports, a parallel port, a 101-key keyboard,

*(Continued on page 18)*

# FREE Heathkit<sup>®</sup> CATALOG



Featuring superior quality electronic products in kit and assembled form. Innovative home products, test instruments, self-study electronics courses. Challenging and educational kits for first-time as well as seasoned builders. Quality ready-to-use electronic products for homeowners, sports enthusiasts and professionals. All from Heath Company, a leader in the changing electronics market.

Send NOW for your **FREE** Heathkit Catalog.

Send to:  
Heath Company, Dept. 107-712  
Benton Harbor, Michigan 49022

108 full-color pages packed with the latest in high quality electronic products

Name \_\_\_\_\_

Address \_\_\_\_\_

City \_\_\_\_\_

State \_\_\_\_\_ Zip \_\_\_\_\_

**Heathkit<sup>®</sup>**  
Heath  
Company

A subsidiary of Zenith Electronics Corporation

CL-792

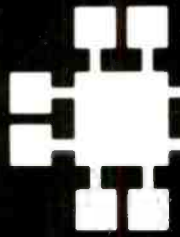

# JDR Microdevices®

Complete customer satisfaction... superior service... friendly, knowledgeable personnel  
quality merchandise... providing the best values in leading edge technology.

## STATIC RAMS

2112	256x4	(450ns)	2.99
2114	1024x4	(450ns)	.99
2114L-2	1024x4	(200ns)(LOW POWER)	1.49
TMM2016-100	2048x8	(100ns)	1.95
HM6116-4	2048x8	(200ns)(CMOS)	3.29
HM6116-3	2048x8	(150ns)(CMOS)	3.95
HM6116LP-4	2048x8	(200ns)(CMOS)(LP)	4.29
HM6116LP-3	2048x8	(150ns)(CMOS)(LP)	4.95
HM6116LP-2	2048x8	(120ns)(CMOS)(LP)	5.49
HM6264LP-15	8192x8	(150ns)(CMOS)(LP)	6.49
HM6264LP-12	8192x8	(120ns)(CMOS)(LP)	6.99
HM43256LP-15	32768x8	(150ns)(CMOS)(LP)	12.95
HM43256LP-12	32768x8	(120ns)(CMOS)(LP)	14.95
HM43256LP-10	32768x8	(100ns)(CMOS)(LP)	19.95

## DYNAMIC RAMS

4116-250	16384x1	(250ns)	.49
4116-200	16384x1	(200ns)	.89
4116-150	16384x1	(150ns)	.99
4116-120	16384x1	(120ns)	1.49
MK4332	32768x1	(200ns)	6.95
4164-150	65536x1	(150ns)	2.89
4164-120	65536x1	(120ns)	3.19
MCM6665	65536x1	(200ns)	1.95
TMS4164	65536x1	(150ns)	1.95
4164-REFRESH	65536x1	(150ns)(PIN 1 REFRESH)	2.95
TMS4416	16384x4	(150ns)	3.75
47128-150	131072x1	(150ns)	5.95
TMS4464-15	65536x4	(150ns)	7.95
41256-150	262144x1	(150ns)	12.45
41256-120	262144x1	(120ns)	12.95
41256-100	262144x1	(100ns)	13.45
HMS1258-100	262144x1	(100ns)(CMOS)	6.95
1MB-120	1048576x1	(120ns)	34.95
1MB-100	1048576x1	(100ns)	37.95

## EPROMS

2708	1024x8	(450ns)(25V)	4.95
2716	2048x8	(450ns)(25V)	3.49
2716-1	2048x8	(350ns)(25V)	3.95
TMS2532	4096x8	(450ns)(25V)	5.95
2732	4096x8	(450ns)(25V)	3.95
2732A	4096x8	(250ns)(21V)	3.95
2732A-2	4096x8	(200ns)(21V)	4.25
27C64	8192x8	(250ns)(12.5V CMOS)	4.95
2764	8192x8	(450ns)(12.5V)	3.49
2764-250	8192x8	(250ns)(12.5V)	3.69
2764-200	8192x8	(200ns)(12.5V)	4.25
MCM68766	8192x8	(350ns)(21V)(24 PIN)	15.95
27128	16384x8	(250ns)(12.5V)	4.25
27C256	32768x8	(250ns)(12.5V CMOS)	5.95
27256	32768x8	(250ns)(12.5V)	5.95
27512	65536x8	(250ns)(12.5V)	11.95
27C512	65536x8	(250ns)(12.5V CMOS)	12.95

MEMORY PRICES SUBJECT TO CHANGE DUE TO MARKET CONDITIONS. PLEASE CALL TO CONFIRM PRICES.

## HIGH-TECH SPOTLIGHT 1 MB EPROMS

■ 128K x 8 ORGANIZATION ■ 200 NS  
■ CMOS DESIGN FOR LOW POWER  
**\$34.95**



## 8000

8031	3.95
8035	1.49
8039	1.95
8052AH BASIC	34.95
8080	2.49
8085	1.95
8086	6.49
8088-2	5.99
8088-2	7.95
8155-2	2.49
8155-2	3.95
8741	9.95
8748	7.95
8749	9.95
8755	14.95

## 8200

8203	14.95	8255-5	1.59
8205	2.99	8255-1	1.95
8212	1.49	8259-5	2.29
8216	1.49	8257	2.29
8224	2.25	8272	4.35
8228	2.25	8274	4.95
8237	3.95	8275	16.95
8237-5	4.75	8279	2.49
8243	1.95	8279-5	2.95
8250	6.95	8282	3.95
8251	1.29	8283	3.95
8251A	1.69	8284	2.25
8251B	1.59	8286	3.95
8253-5	1.95	8287	3.95
8255	1.49	8288	4.95

## MATH COPROCESSORS



8087	5 MHz	\$99.95
8087-2	8 MHz	\$159.95
8087-1	10 MHz	\$229.95
80287	6 MHz	\$179.95
80287-8	8 MHz	\$249.95
80287-10	10 MHz	\$309.95
80387-16	16 MHz	\$499.95
80387-20	20 MHz	\$799.95



## 74LS00

74LS00	16	74LS112	29	74LS241	69
74LS01	18	74LS122	45	74LS242	69
74LS02	17	74LS123	49	74LS243	69
74LS03	18	74LS124	2.75	74LS244	69
74LS04	16	74LS125	39	74LS245	79
74LS05	18	74LS126	39	74LS251	49
74LS08	18	74LS132	39	74LS253	49
74LS09	18	74LS133	49	74LS257	39
74LS10	16	74LS136	39	74LS258	49
74LS11	22	74LS138	39	74LS259	1.29
74LS12	22	74LS139	39	74LS260	49
74LS13	26	74LS14	49	74LS266	39
74LS14	39	74LS147	99	74LS273	79
74LS15	26	74LS148	99	74LS279	39
74LS20	17	74LS151	39	74LS280	1.98
74LS21	22	74LS153	39	74LS283	59
74LS22	22	74LS154	1.49	74LS290	.89
74LS27	23	74LS155	59	74LS293	.89
74LS28	26	74LS156	49	74LS299	1.49
74LS29	17	74LS157	35	74LS323	3.95
74LS32	18	74LS158	29	74LS323	2.49
74LS33	28	74LS160	29	74LS365	39
74LS37	26	74LS161	39	74LS367	39
74LS38	26	74LS162	49	74LS368	39
74LS42	39	74LS163	39	74LS373	79
74LS47	75	74LS164	49	74LS374	79
74LS48	85	74LS165	65	74LS375	95
74LS51	17	74LS166	95	74LS377	79
74LS73	29	74LS169	95	74LS390	1.19
74LS74	24	74LS173	49	74LS393	79
74LS75	29	74LS174	39	74LS541	1.49
74LS76	29	74LS175	39	74LS624	1.95
74LS83	49	74LS191	49	74LS640	99
74LS85	49	74LS192	69	74LS645	99
74LS86	22	74LS193	69	74LS672	89
74LS90	39	74LS194	69	74LS682	3.20
74LS92	49	74LS195	69	74LS688	2.40
74LS93	39	74LS196	59	74LS783	22.95
74LS95	49	74LS197	59	25LS2521	2.80
74LS107	34	74LS221	59	26LS31	1.95
74LS109	36	74LS240	69	26LS32	1.95

## 7400

7400	19
7402	19
7404	19
7406	29
7407	29
7408	24
7410	19
7411	25
7414	49
7415	25
7417	25
7420	19
7430	19
7432	29
7438	29
7442	49
7447	89
7473	34
7474	34
7475	45
7476	35
7483	50
7485	59
7486	35
7489	2.15
7490	39
7493	35
74121	29
74123	49
74125	45
74150	1.35
74151	35
74153	55
74154	1.49
74157	1.65
74161	69
74164	85
74166	100
74175	89
74367	65

## LINEAR

TL071	69	LM567	79
TL072	1.09	NE570	2.95
TL074	1.95	NE592	98
TL082	1.49	LM723	49
TL084	1.95	LM733	98
LM107	1.29	LM741	29
LM309K	1.25	LM747	69
LM311	59	MC1330	1.69
LM311H	89	MC1350	1.19
LM317K	3.49	LM1408	35
LM317Y	65	LM1488	49
LM318	1.49	LM1489	49
LM319	1.25	LM1496	85
LM320	see 7900	ULN2003	.79
LM323K	3.45	XR705	3.95
LM324	34	KR221	1.25
LM331	3.95	LM2917	1.95
LM334	1.19	CA3046	89
LM335	1.79	CA3146	1.29
LM336	1.75	MC3373	1.29
LM338K	4.49	MC3470	1.95
LM339	59	MC3480	8.95
LM340	see 7900	MC3487	2.95
LF353	59	LM3900	49
LF356	99	LM3901	2.95
LF357	99	LM3909	98
LM358	59	LM3914	1.89
LM380	89	MC4024	3.49
LM383	1.95	MC4046	1.29
LM386	1.75	RC4136	1.25
LM393	4.95	RC4558	69
LM394M	5.95	LM13600	1.49
TL494	4.20	75107	1.49
TL497	3.25	75110	1.95
NE555	49	75150	1.95
NE556	49	75154	95
NE558	79	75188	1.25
NE564	1.95	75189	1.25
LM565	45	75451	39
LM566	1.49	75452	39
NE590	2.50	75477	1.29

H TO 5 CAN. K TO 3 T TO 220

## 6500

6502	2.25
65C02 (CMOS)	7.95
6520	1.65
6522	2.95
6526	13.95
6532	5.95
6545	2.95
6551	2.95

## Z-80

Z80-CPU	1.25
4.0 MHz	
Z80A CPU	1.29
Z80A CTC	1.69
Z80A DART	5.95
Z80A DMA	5.95
Z80A PIO	1.89
Z80A SIO 0	5.95
Z80A SIO 1	5.95
Z80A SIO 2	5.95

## 6.0 MHz

Z80B CPU	2.75
Z80B CTC	4.25
Z80B PIO	4.25
Z80B DART	6.95
Z80B SIO 0	12.95
Z80B SIO 2	12.95
Z8671 ZLOG	9.95

## 6800

6800	1.95
6802	2.95
6803	3.95
6809	3.95
6809E	2.95
6810	1.95
6820	2.95
6821	1.25
6840	3.95
6843	3.95
6844	6.95
6845	2.75
6847	4.75
6850	1.95
6883	22.95

## CLOCK CIRCUITS

MM58167	9.95
MM58174	9.95
MSM5832	2.95

## BIT RATE GENERATORS

MC14411	9.95
BR1941	4.95
4702	9.95
COM8116	8.95

## INTERSIL

ICL7106	9.95
ICL7107	10.95
ICL7660	1.99
ICL8038	3.95
ICM7207A	5.95
ICM7208	15.95

## DISK CONTROLLERS

1771	4.95
1791	9.95
1793	9.95
1795	12.95
1797	12.95
2791	19.95
2793	19.95
2797	29.95
8272	4.39
UPD765	4.39
MB8876	12.95
MB8877	12.95
1691	6.95
2143	6.95
9216	6.29

## UARTS

AV5 1013	3.95
AV3 1015	4.95
TR1602	3.95
2651	4.95



### CAPACITORS TANTALUM

1.0µ	15V	12	1.0µ	35V	45
6.8	15V	42	2.2	35V	19
12	15V	45	4.7	35V	39
22	15V	99	10	35V	69

### DISC

10.11	50V	05	001µ	50V	05
22	50V	05	005	50V	05
33	50V	05	01	50V	07
47	50V	05	05	50V	07
100	50V	05	1	12V	10
220	50V	05	1	50V	12

### MONOLITHIC

01µ	50V	14	1µ	50V	18
047µ	50V	15	47µ	50V	25

### ELECTROLYTIC

RADIAL		AXIAL			
1µ	25V	14	1µ	50V	14
4.7	50V	11	10	50V	16
10	50V	11	22	16V	14
47	35V	13	47	50V	19
100	16V	15	100	35V	19
220	35V	20	470	50V	29
470	25V	30	1000	16V	29
2200	16V	70	2200	16V	70
4700	25V	1.45	4700	16V	1.25

### VOLTAGE REGULATORS

7805T	49	7812K	1.39
7808T	49	7905K	1.69
7812T	49	7912K	1.49
7815T	49	78L05	49
7905T	59	78L12	49
7908T	59	79L05	69
7912T	59	79L12	1.49
7915T	59	LM323K	4.79
7805K	1.59	LM338K	6.95

### DISCRETE

1N751	.15	4N28	69
1N414825	1µ	4N33	89
1N400410	1µ	4N37	1.19
1N532	.25	MCT.2	59
KBPO2	.55	MCT.6	1.29
2N2222	25	TIL-111	99
PN2222	10	2N3906	10
2N2937	25	2N4401	25
2N3055	79	2N4402	25
2N3934	10	2N4403	25
4N26	69	2N6045	1.75
4N27	69	TIP31	49

### SOLDER STATION

- ADJUSTABLE HEAT SETTING WITH TIP TEMPERATURE READOUT
- REPLACEMENT TIPS AVAILABLE \$2.95

**\$49.95**



### WIREWRAP PROTOTYPE CARDS

FR-4 EPOXY GLASS LAMINATE WITH GOLD PLATED EDGE-CARD FINGERS  
SILK SCREENED LEGENDS. MOUNTING BRACKETS INCLUDED



### FOR PS/2

JDR-PR32	32 BIT PROTOTYPE CARD	69.95
JDR-PR16	16 BIT CARD WITH I/O DECODING LAYOUT	49.95
JDR-PR16PK	FARTS KIT FOR JDR-PR16 ABOVE	15.95
JDR-PR16V	15 BIT CARD FOR VIDEO APPLICATIONS	39.95

### FOR AT

JDR-PR10	15 BIT CARD WITH I/O DECODING LAYOUT	34.95
JDR-PR10PK	FARTS KIT FOR JDR-PR10 ABOVE	12.95

### FOR XT

IBM-PR1	WITH +5V AND GROUND PLANE	27.95
IBM-PR2	AS ABOVE WITH I/O DECODING LAYOUT	29.95

### BYPASS CAPACITORS

0.1µ	CERAMIC DISC	100	\$5.00
0.1µ	MONOLITHIC	100	\$10.00
1µ	CERAMIC DISC	100	\$6.50
1µ	MONOLITHIC	100	\$12.50

### RESISTOR NETWORKS

SIP	1C PIN	9 RESISTOR	69
SIP	E PIN	7 RESISTOR	59
OIP	16 PIN	8 RESISTOR	1.09
OIP	16 PIN	15 RESISTOR	1.09
DIP	1C PIN	7 RESISTOR	95
OIP	14 PIN	13 RESISTOR	99

**SHORTING  
BLOCKS**  
5/\$1.00



### EXTENDER CARDS

FOR PROTOTYPE DEBUGGING AND TROUBLESHOOTING



EXT-8088	FOR XT SYSTEM	29.95
EXT-80286	FOR AT SYSTEM	39.95
EXT-16	MICROCHANNEL 16-BIT	69.95
EXT-32	MICROCHANNEL 32-BIT	99.95

### "SNAPABLE" HEADERS

CAN BE SNAPPED APART TO  
MAKE ANY SIZE HEADER.  
ALL WITH 1" CENTERS

1x40	STRAIGHT LEAD	99
1x40	RIGHT ANGLE LEAD	49
2x40	2 STRAIGHT LEADS	2.49
2x40	2 RIGHT ANGLE LEADS	2.99

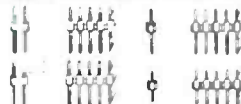

## WHY THOUSANDS CHOOSE JDR

- QUALITY MERCHANDISE
- COMPETITIVE PRICES
- MOST ORDERS SHIPPED IN 24 HOURS
- FRIENDLY, KNOWLEDGEABLE STAFF
- 30-DAY MONEY BACK GUARANTEE
- TOLL FREE TECHNICAL SUPPORT
- EXCELLENT CUSTOMER SERVICE

CALL FOR VOLUME QUOTES

### SOLDERLESS BREADBOARDS

WBU-D	100 TIE PTS.	2.95	WBU-204	1660 TIE PTS.	24.95
WBU-T	630 TIE PTS.	6.95	WBU-206	2390 TIE PTS.	29.95
WBU-204-3	1360 TIE PTS.	17.95	WBU-208	3220 TIE PTS.	39.95

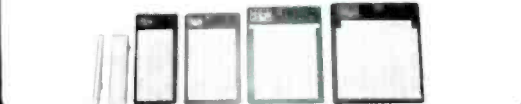

### IDC CONNECTORS/RIBBON CABLE

DESCRIPTION	ORDER BY	CONTACTS					
		10	20	26	34	40	50
SOLDER HEADER	IDHxxS	.82	1.29	1.68	2.20	2.58	3.24
RIGHT ANGLE SOLDER HEADER	IDHxxSR	.85	1.35	1.76	2.31	2.72	3.39
WIREWRAP HEADER	IDHxxW	1.86	2.98	3.84	4.50	5.28	6.63
RIGHT ANGLE WIREWRAP HEADER	IDHxxWR	2.05	3.28	4.22	4.45	4.80	7.30
RIBBON HEADER SOCKET	IDSxx	.63	.89	.95	1.29	1.49	1.69
RIBBON HEADER	IDMxx	...	5.50	6.25	7.00	7.50	8.50
RIBBON EDGE CARD	IDExx	.85	1.25	1.35	1.75	2.05	2.45
10' GREY RIBBON CABLE	RCxx	1.60	3.20	4.10	5.40	6.40	7.50

FOR ORDERING INSTRUCTIONS, SEE D-SUBMINIATURE CONNECTORS BELOW

### 3 VOLT LITHIUM BATTERY

**\$1.95**

HOLDER **\$1.49**



### SPECTRONICS CORPORATION EPROM ERASERS

Model	Turner	Chip Capacity	Intensity (µW Cm <sup>2</sup> )	Unit Cost
PE 140	NO	9	8,000	\$89
PE 140T	YES	9	8,000	\$139
PE 240T	YES	12	9,600	\$189



### D-SUBMINIATURE CONNECTORS

DESCRIPTION	ORDER BY	CONTACTS						
		9	15	19	25	37	50	
SOLDER CUP	MALE	DBxxP	45	59	69	69	1.35	1.85
	FEMALE	DBxxS	49	69	75	75	1.39	2.29
RIGHT ANGLE PC SOLDER	MALE	DBxxPR	49	69	...	79	2.27	...
	FEMALE	DBxxSR	55	75	...	85	2.49	...
WIREWRAP	MALE	DBxxPWV	1.69	2.56	...	3.89	5.60	...
	FEMALE	DBxxSWV	2.76	4.27	...	6.84	9.95	...
IDC RIBBON CABLE	MALE	IDBxxP	1.39	1.99	...	2.25	4.25	...
	FEMALE	IDBxxS	1.45	2.05	...	2.35	4.49	...
HOODS	METAL	MHODDxx	1.05	1.15	1.25	1.25	...	...
	GREY	HOODxx	39	39	...	39	69	75

ORDERING INSTRUCTIONS:  
INSERT THE NUMBER OF CONTACTS IN THE POSITION MARKED xx OF THE ORDER BY PART NUMBER LISTED  
EXAMPLE: A 15 PIN RIGHT ANGLE MALE PC SOLDER WOULD BE DB15PR

**MOUNTING HARDWARE 59¢**

### IC SOCKETS/DIP CONNECTORS

DESCRIPTION	ORDER BY	CONTACTS									
		8	14	16	18	20	22	24	28	40	30
SOLDERTAIL SOCKETS	xxST	.11	1	.12	15	18	15	20	22	30	
WIREWRAP SOCKETS	xxWV	.59	.69	.69	.99	1.09	1.39	1.49	1.69	1.99	
ZIF SOCKETS	ZIFxx	...	4.95	4.95	5.95	5.95	5.95	6.95	9.95	9.95	
TOOLED SOCKETS	AUGATxxST	.82	.79	.89	1.09	1.29	1.39	1.49	1.69	2.49	
TOOLED Ww SOCKETS	AUGATxxWV	1.30	1.80	2.10	2.40	2.50	2.90	3.15	3.70	5.40	
COMPONENT CARRIERS	ICCKR	.49	.59	.69	.99	.99	.99	.99	1.09	1.49	
DIP PLUGS (IDC)	IDPxx	.95	.49	.59	1.29	1.49	...	.85	1.49	1.59	

FOR ORDERING INSTRUCTIONS, SEE D-SUBMINIATURE CONNECTORS ABOVE

### RS-232 BREAKOUT BOX

FOR TROUBLESHOOTING  
SERIAL COMMUNICATIONS

- OPEN CLOSE INDIVIDUAL CIRCUITS
- 20 JUMPERS CROSS-CONNECT ANY TWO CIRCUITS
- 10 LEDS SHOW CIRCUIT ACTIVITY
- GENDER-BO \$34.95



### GENDER CHANGERS

FOR 25 PIN D-SUBMINIATURE  
CONNECTORS

GENDER-FF	FEMALE-MALE	7.95
GENDER-MM	MALE-MALE	7.95
GENDER-MF	MALE-FEMALE	7.95
GENDER-NM	NULL MODEM	8.95
GENDER-JB	JUMPER BOX	8.95
GENDER-MT	MINIESTER	14.95

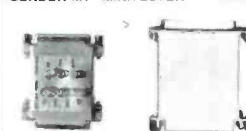

### DATARASE

- ERASES 2 EPROMS IN 10 MINUTES
- VERY COMPACT, NO DRAWER
- THIN METAL SHUTTER PREVENTS UV LIGHT FROM ESCAPING

**\$34.95**



### JOYSTICK

- SET X-Y AXIS FOR AUTO CENTER OR FREE MOVEMENT
- FIRE BUTTON FOR USE WITH GAME SOFTWARE
- ADAPTOR CABLE FOR IBM, APPLE II

**\$19.95**



JDR MICRODEVICES, 110 KNOWLES DRIVE, LOS GATOS, CA 95030  
LOCAL (408) 866-6200 FAX (408) 378-9927 TELEX 171-110



RETAIL STORE: 1256 SOUTH BASCOM AVE., SAN JOSE, CA (408) 947-8881  
HOURS: M-F 10-7 SAT. 9-5 SUN. 12-4



**ORDER TOLL FREE 800-538-5000**

COPYRIGHT 1988 JDR MICRODEVICES

CONTINENTAL U.S. AND CANADA

CIRCLE 14 ON FREE INFORMATION CARD



## Did You Get Your Free Catalog?

IF YOU HAVEN'T SEEN THE FREE MARK V ELECTRONICS CATALOG, HURRY UP! YOU'LL FIND EVERYTHING SUITABLE AND ESSENTIAL FOR FACTORIES, SCHOOLS, PROFESSIONALS AND ENTHUSIASTIC AMATEURS. OVER 60'S OF ASSEMBLES AND KITS WITH DIFFERENT LEVEL OF DIFFICULTY FOR KIT ASSEMBLY

**BEGINNERS:** 6WX2 STEREO MINI AMP, LIGHT CONTROLLER, BATTERY FLUORESCENT LIGHT DRIVER, AND MORE.

**INTERMEDIATE:** 4% D. P. M., 0-50V 3A POWER SUPPLY, 120W MOSFET POWER AMP, AND MORE.

**PROFESSIONALS:** 1.2GHZ FREQ. COUNTER, 300W HQ AMP., 4680W 4 CHANNEL PRO. COLOR LIGHT CONTROLLER, AND MORE.

ANYWAY, THE SELECTION IS INCREDIBLE, THE VALUES ARE EVEN BETTER. AFTER ALL, ASK FOR YOUR OWN COPY TODAY AND YOU'LL HAVE MORE THAN A CATALOG, MORE THAN A REFERENCE.

YES, PLS SEND ME A COPY OF THE ALL-NEW FREE MARK V CATALOG.

NAME \_\_\_\_\_  
 ADDRESS \_\_\_\_\_  
 CITY \_\_\_\_\_ STATE \_\_\_\_\_ ZIP \_\_\_\_\_

**MARK V ELECTRONICS, INC.**  
 8019 E. SLAUSON AVE., MONTEBELLO, CA 90640.  
 FAX: (213) 888-1029

OFFICE HOURS (PACIFIC TIME)  
 MON. - FRI. 9:30 TO 5:00 SAT. 10:00 TO 5:00

**INFORMATION: (213) 888-8988**

CIRCLE 15 ON FREE INFORMATION CARD

## NEW PRODUCTS

(Continued from page 15)

MS-DOS 3.21 (with disk caching), and Microsoft Windows software. It is equipped with a high-resolution color video card for 640-by-480 VGA-level video and compatibility with software written for EGA, MDA, CGA, and Hercules graphics.



The 17-pound Z-286 LP measures only 3.9 x 14 x 15 inches. It is available with a fast 40-megabyte hard-disk drive and a high-density, "media-sensing" 1.44-megabyte floppy drive.

The suggested retail price for the Z-286 LP system is \$3,999.00. For further information, contact Zenith Data Systems, 1000 Milwaukee Avenue, Glenview, IL 60025; 800-842-9000, ext. 1.

CIRCLE 80 ON FREE INFORMATION CARD

## SURGE PROTECTOR

Voltage spikes—originating from appliances, fluorescent lights, weather, or the power company—can shorten the useful lifetime of electronic equipment. Spi-Ro Manufacturing's SP-6-CB surge protector is designed to protect communications, computer, scientific, and satellite equipment from voltage surges and spikes on the incoming-power line.

The unit has an EMI/RFI filter and a UL-listed surge suppressor. It is rated at 15 amps, 125 volts, and 60 Hz. The SP-6-CB provides nanosecond switching response. The maximum spike current is 4,500 amps.



It provides six protected outlets, with a resettable circuit breaker. An indicator light lets the user know that the internal filter network is operating.

The SP-6-CB costs \$29.95. For additional information, contact Spi-Ro Manufacturing, Inc., P.O. Box 1538, Dept. 16, Hendersonville, NC 28793.

CIRCLE 79 ON FREE INFORMATION CARD  
 (Continued on page 22)

## Employers

Willing workers available now at as little as 1/2 your usual cost.

This is your chance to get help you've needed, but thought you couldn't afford.

No business too large or too small. Call your private industry council or write National Alliance of Business, P.O. Box 7207, Washington, D.C. 20044



"I suggest you either switch arms more often or try carrying two radios."

# HSC Halted specialties co.

**IBM / APPLE SOFTWARE BLOWOUT!**

IBM TITLES	APPLE TITLES
Vis: On Graph	Vis:Tutor for Vis:Word
Vis: On Calc	Applications Manager
Vis: On Word	Desktop/Plan
Vis:Calc	Vis:File
Vis:Word	FlashCalc
Vis:Spell	Vis:Answer
Vis:Schedule	Vis:Trend/Plot
StretchCalc	
Vis:Corp	Closeouts

Priced from \$6.95 to \$12.95  
 \* Mouse and Basic required for some programs

**COMPUTER CHASSIS with POWER SUPPLY**

- \* Heavy Duty Plastic Case
- \* 17" x 17" x 8" O.D.
- \* Hinged Drive Mounting Assembly for 2 Half Height Floppy Drives and 1 Internal Hard Drive
- \* +5 -12 12 Power Supply
- \* IEC Receptacle, Power Switch
- \* Fan

**\$69.00**

**HALF HEIGHT EXTERNAL DRIVE ENCLOSURE**

- \* Attractive Low Profile Case
- \* 19" x 15" x 3" O.D.
- \* Fits directly under PC
- \* Standard IBM Colors
- \* Bezel fits One 5 1/4" and One 3 1/2" Drive

**\$29.95**

**DISPLAY PAGING RECEIVER**

- \* Dual Conversion Superhet
- \* 450 Mhz Crystal Controlled Receiver Module
- \* Twenty Char. Alpha-Numeric LED Display (ASCII Encoded)
- \* RCA GDP 1802 Processor Based Display/Mode Controller
- Untested - "As-Is" **\$19.95**

**AT / XT 3-SLOT MOTHERBOARD EXTENDER**

- \* Fused Extender Card
- \* One 16 Bit Slot
- \* Two 8 Bit Slots
- \* Test Points for All Bus Points
- \* Power Connector
- \* Cable Included

**\$89.95**

**Great for the Experimenters!**

**Pioneer Laser Disc Player**

- \* 1-2 mW He-Ne Laser
- \* Laser Power Supply
- \* 2 Front Surface Mirrors
- \* Two 1/2" Voice Coil Actuated Oscillating Mirrors
- \* One Beam Splitter
- \* Two Optical Lenses
- \* One Optical Detector
- \* Mini Gear Reduction Motor
- \* All Controlling Electronics
- \* Assorted Switches, Fan, Solenoid

THESE UNITS ARE OEM MODELS AND REQUIRE A COMPUTER CONTROLLER (NOT AVAILABLE FROM HALTED). THEY CANNOT BE MANUALLY CONTROLLED!

"As-Is" **\$99.00**

**CHECK OUT THESE DEALS!**

**TEAC FD-55B DISK DRIVE**

- \* 5 1/4"
- \* IBM Compatible
- \* 360K
- \* 90 Day Warranty

**\$89.95**

**DELTEC AC LINE CONDITIONER 400 WATT**

- \* Eliminates AC line noise and regulates to a constant 120 VAC
- \* Reliable Ferroresonant Trans.
- \* Attractive Case with Power Cord, Outlets, and Switch Circuit Breaker

**\$149.00**

**RS-232 BREAKOUT BOX**

- \* Switchable Lines
- \* LED Indicators
- \* Patch Terminals & Jumpers
- \* Compact Size

**\$31.95**

MINIMUM \$10 ORDER QUANTITIES LIMITED. CA RES. ADD SALES TAX.

MAIL ORDERS WE SHIP C.O.D.  
 3500 RYDER STREET  
 SANTA CLARA, CA 95051

Call NOW! 408-732-1573 800-4-HALTED

CA Residents & Info Toll Free Order Line

HANDS-ON ELECTRONICS/POPULAR ELECTRONICS

CIRCLE 8 ON FREE INFORMATION CARD



# Train with NRI for a high paying career servicing computers.

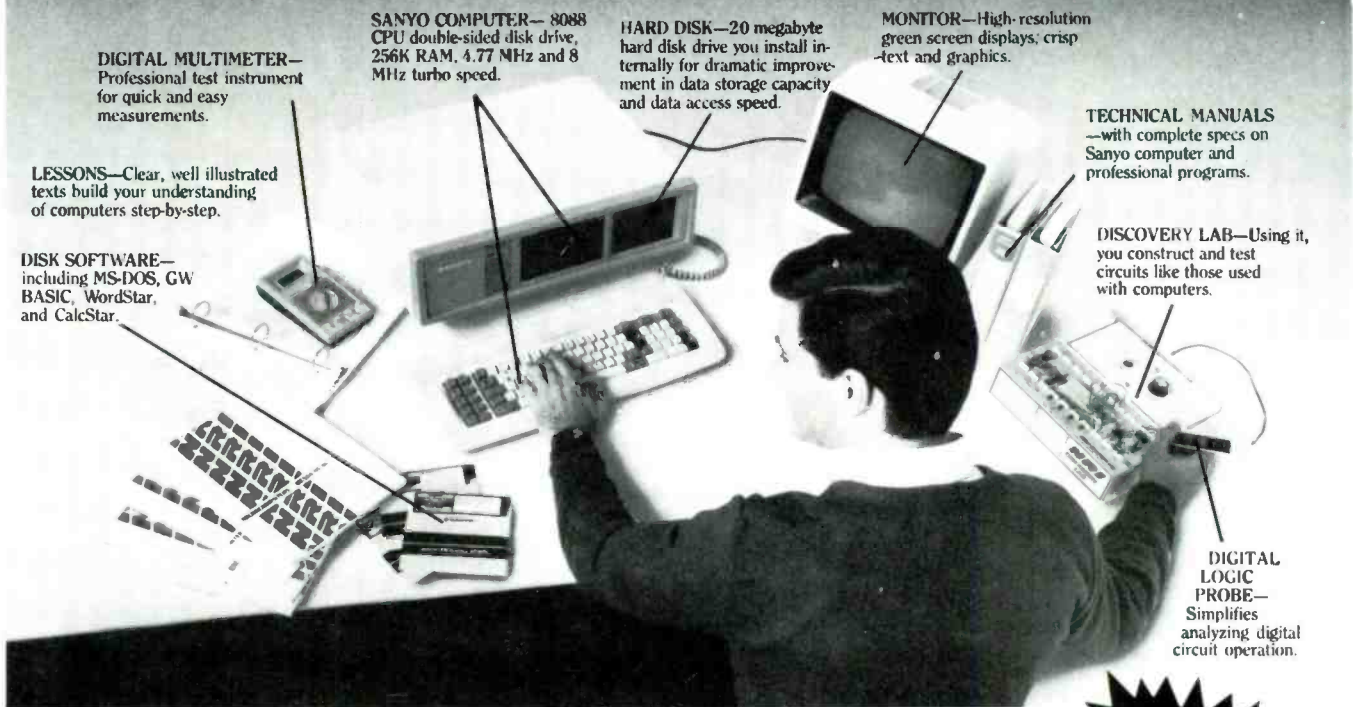

**DIGITAL MULTIMETER**—Professional test instrument for quick and easy measurements.

**LESSONS**—Clear, well illustrated texts build your understanding of computers step-by-step.

**DISK SOFTWARE**—including MS-DOS, GW BASIC, WordStar, and CalcStar.

**SANYO COMPUTER**—8088 CPU double-sided disk drive, 256K RAM, 4.77 MHz and 8 MHz turbo speed.

**HARD DISK**—20 megabyte hard disk drive you install internally for dramatic improvement in data storage capacity and data access speed.

**MONITOR**—High-resolution green screen displays; crisp text and graphics.

**TECHNICAL MANUALS**—with complete specs on Sanyo computer and professional programs.

**DISCOVERY LAB**—Using it, you construct and test circuits like those used with computers.

**DIGITAL LOGIC PROBE**—Simplifies analyzing digital circuit operation.

## Get started now by building this fully PC-compatible computer



Now you get it all . . . training for one of America's fastest-growing career opportunities . . . training to service all computers . . . training on a total computer system. Only NRI can give you the well-rounded training you need, because only NRI gives you a complete computer system . . . computer, monitor, floppy disk drive, hard disk drive, software, even test instruments like a DMM and logic probe to work with and keep. It all adds up to training that builds the knowledge and ability you need to succeed as a computer service specialist.

### Get inside the newest Sanyo Computer—fully compatible with the IBM PC\*

As an NRI student, you'll get total hands-on training as you actually build your own latest model Sanyo 880 Series computer from the keyboard up. It's fully compatible with the IBM PC and, best of all, it runs programs almost twice as fast as the PC. As you assemble the Sanyo 880, you'll perform demonstrations and experiments that will give

you a total mastery of computer operation and servicing techniques. You'll do programming in BASIC language—even run and interpret essential diagnostic software.

### Understanding you get only through experience

You need no previous knowledge to succeed with NRI. You start with the basics, rapidly building on the fundamentals of electronics with bite-size lessons. You perform hands-on experiments with your NRI Discovery Lab and then move on to master advanced concepts like digital logic, microprocessors, and computer memories.

### Learn at home in your spare time

You train in your own home at your own convenience, backed at all times by your own NRI instructor and the entire NRI staff of educators and student service support people. They're always ready to give you guidance, follow your progress, and help you over

the rough spots to keep you moving toward your goal.

### Free 100—page catalog tells more . . . send today

Send the postage-paid reply card today for NRI's 100-page catalog that gives all the facts about computer training plus career training in robotics, data communications, TV/audio/video servicing, and many other fields. If the card is missing, write to NRI at the address below.

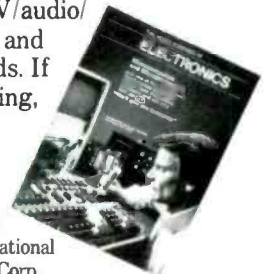

\*IBM is a registered trademark of International Business Machines Corp.

## **NRI** SCHOOLS

McGraw-Hill Continuing Education Center  
3939 Wisconsin Avenue  
Washington, DC 20016



We'll give you tomorrow

VARIOUS CLOCK KITS

- HAL-5314 (Most Famous Clock Kit) \$12.95  
6-DIGIT ELECTRONIC CLOCK KIT 12 OR 24 HOUR  
FORMAT COMPLETE KIT LESS POWER SUPPLY  
ADAPTOR AND CASE RUNS OFF ANY 12 VOLT A.C.  
SOURCE REQUIRES 250 MA
- HAL-5375 (Alarm Clock Kit) \$16.95  
6-DIGIT ELECTRONIC CLOCK KIT 12 HOUR FORMAT  
ONLY OPERATE ON 12 VOLTS A.C. OR D.C. HAS TIME  
BASE ONBOARD COMES COMPLETE LESS POWER  
ADAPTOR AND CASE
- HAL-79 (Student Class Kit) \$7.95  
4-DIGIT BASIC ELECTRONIC KIT WITH OPTIONS AND  
PROVISIONS TO MAKE IT AN ALARM CLOCK AND A  
D.C. OPERATED CLOCK COMPLETE LESS OPTIONS  
POWER SUPPLY ADAPTOR AND CASE
- OPTION #1 - TO MAKE IT AN ALARM CLOCK \$2.95
- OPTION #2 - TO MAKE IT A D.C. 12V CLOCK \$4.95
- CLOCK CASE - Reg. \$6.50 Clock Case - When Bought with  
Clock Kit (ONLY) \$4.50
- 12 VOLT A.C. ADAPTOR - Reg. \$4.95 - When Bought with  
Clock Kit (ONLY) \$2.95
- 60HZ TIME BASE Complete - \$4.95
- CRYSTAL TIME BASE KIT USING MM5369
- HAL NTSC RF MOD \$19.95  
BUILD YOUR OWN VIDEO RF MODULATOR A MINI TV  
TRANSMITTER FOR CHANNELS 3 OR 4 USING A SAW  
OUTPUT FILTER KEEPING CO CHANNEL INTERFER-  
ENCE AT A MINIMUM COMES COMPLETE LESS CASE  
POWER SUPPLY AND HARDWARE
- NOTE: CASE POWER SUPPLY AND HARDWARE  
ENCLOSE \$12.95 Extra

HAL FG 100 \$69.95  
FUNCTION GENERATOR KIT 1 HZ TO 100 KHZ IN FIVE  
BANDS AMPLITUDE AND OFFSET ADJUSTABLE OUT-  
PUT IMP. 500 OHMS WAVE FORMS SINE SQUARE  
AND TRIANGULAR AND TTL CLOCK 0 TO 5V LEVEL 200  
NS RISE AND FALL TIME COMPLETE WITH CASE AND  
POWER SUPPLY AND ALL ELECTRONIC PARTS INCLUD-  
ING MANUAL

SHIPPING INFORMATION: PLEASE INCLUDE 10% OF  
ORDER FOR SHIPPING AND HANDLING CHARGES  
(MINIMUM \$2.50 MAXIMUM \$10). CANADIAN ORDERS  
ADD \$7.50 IN US FUNDS. MICHIGAN RESIDENTS ADD  
4% SALES TAX FOR FREE FLYER SEND 22c STAMP  
OR CASE

HAL-TRONIX, INC.

12671 Dix-Toledo Hwy.  
P.O. Box 1101, Dept C.  
Southgate, MI 48195  
(313) 281-7773

Hours: 12:00 - 6:00 EST Mon.-Sat



NOW A DEALER FOR  
TEN-TEC AND M F J



CIRCLE 23 ON FREE INFORMATION CARD

NEW PRODUCTS

(Continued from page 18)

STEREO SPEAKER SYSTEM

Bose's 10.2 Series II Stereo Everywhere loudspeaker system delivers consistent stereo soundstage, stable center image, and powerful bass—even if the listener is not equidistant from the two speakers.

By shaping the speakers' radiation pattern asymmetrically toward the middle of the room, the loudness of the closer speaker actually decreases relative to that of the other. The farther speaker's radiation pat-

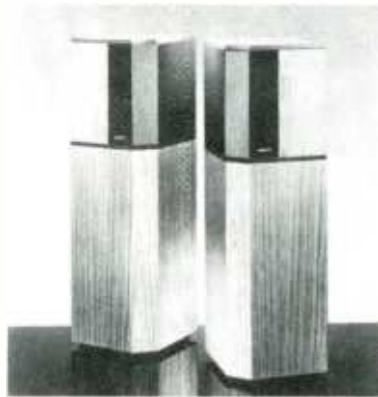

tern compensates for the later arrival of its sound, so the listener continues to hear stereo as he moves about the room.

The three-drive Stereo Targeting Array feature precisely angles an 8-inch mid-range driver and two 2-inch tweeters. The array is matched with a new interactive crossover, specifically designed to provide flat response and a stable stereo image.

Bass performance is improved with Bose's patented Acoustimass technology. A high-performance, 8-inch low-frequency driver that fires into two internal chambers is mounted inside the 10.2. That technology produces low-frequency energy by launching sound into the room via a mass of air contained in each chamber's port, rather than from the driver's cone, as with conventional speakers. The result is reduced cone motion and reduced harmonic distortion at the lower octaves.

The 10.2 Series II, comprising two 40-inch high floor-standing speakers covered in genuine-wood veneer, costs \$1,299.00. For more information, contact Bose Corporation, The Mountain, Framingham, MA 01701.

CIRCLE 78 ON FREE INFORMATION CARD

PORTABLE CD PLAYER

Technic's SL-XP6 portable CD player offers three play modes—normal, resume, and random—and the ability to operate from three power sources—batteries, AC, and car battery.

In resume mode, the unit will continue playback from the beginning of the track that was playing when the power was turned off. The random-play mode, which is controlled by an internal microcomputer, shuffles the play sequence. With the auto-repeat feature, the first track on the disc follows the last.



The skip keys and memory key allow for 18-step random access programming. The play, stop, and skip-forward functions can be accessed from a wired remote control on the headphone cord, as well as from the unit itself.

The SL-XP6 can run on the supplied NiCd-rechargeable batteries, or with two AA batteries (not included.) An AC adaptor is pro-

THIS SPACE CONTRIBUTED AS A PUBLIC SERVICE

A defense against cancer can be cooked up in your kitchen.

- There is evidence that diet and cancer are related. Follow these modifications in your daily diet to reduce chances of getting cancer:
1. Eat more high fiber foods such as fruits and vegetables and whole grain cereals.
  2. Include dark green and deep yellow fruits and vegetables rich in vitamins A and C.
  3. Include cabbage, broccoli, Brussels sprouts, kohlrabi and cauliflower.
  4. Be moderate in consumption of salt-cured, smoked, and nitrate-cured foods.
  5. Cut down on total fat intake from animal sources and fats and oils.
  6. Avoid obesity.
  7. Be moderate in consumption of alcoholic beverages.
- FOR MORE FACTS, WRITE OR CALL:  
AMERICAN CANCER SOCIETY

THE FUTURE IS NOW!

National Superconductor is dedicated to bringing the new high temperature superconducting materials and technology to the marketplace as fast as possible. We will supply you with the electromagnetic materials of tomorrow, today!

Meissner Levitation Kit



A coated, water-resistant YBCO disk with a cubical samarium-cobalt magnet.

\$25.00

Resistivity Measurement Kit

Comes with low temperature thermocouple and complete instructions for graphing the zero resistance transition of the superconducting sample.



\$59.00

Other products include: bars, rings, low-temp. thermocouples, and economical liquid nitrogen transfer vessels.

For more information, call or write:



NATIONAL SUPERCONDUCTOR, INC.  
13968 Van Ness Ave., Gardena, CA 90249  
(213) 323-3923

CIRCLE 24 ON FREE INFORMATION CARD



vided to recharge the NiCd batteries while they remain in the player. To conserve batteries, power is shut off automatically after five minutes in the stop mode.

A quadruple-oversampling 176.4-kHz digital filter helps provide realistic sound and superb stereo imaging. An LCD display shows total number of tracks, total playing time of the disc, elapsed playing time, repeat, program, play mode, and battery level.

The compact SL-XP6, constructed of die-cast aluminum and weighing just 13.4 ounces without batteries, costs \$349.00. For more information, contact Technics, One Panasonic Way, Secaucus, NJ 07094.

CIRCLE 77 ON FREE INFORMATION CARD

### HAND-HELD DIGITAL MULTIMETER

The Fluke 83 3<sup>3</sup>/<sub>4</sub>-digit sealed multimeter offers a powerful combination of measurement functions, including frequency, capacitance, duty cycle, MIN MAX Alert, and Input Alert. The minimum/maximum/average recording mode makes the Fluke 83 ideally suited for finding intermittent failures and interference.

Along with standard DMM functions, the Fluke 83 measures frequency, duty cycle, and capacitance. The Input Alert safety feature warns when the leads are connected to the current jack while the meter is selected for voltage or resistance. Intermittent failures are pinpointed by the MIN MAX Alert, which beeps when a new minimum or maximum value is recorded.

The Touch Hold capability senses a stable reading and locks it on the display for convenient viewing after the test leads have been removed. A relative (zero) mode is also featured. The Fluke 83 has a 5-kHz AC-voltage response, and DC-voltage accuracy within 0.3 percent. It is overload-protected to 1000 volts in ohms and diode test.

The EMI-shielded unit, packed in a splash-proof and dust-proof case that includes a flexible-rubber stand, costs \$189.00. For



more information, contact John Fluke Mfg. Co., Inc., P.O. Box C9090, Everett, WA 98206; 800-443-5853, ext. 33.

CIRCLE 76 ON FREE INFORMATION CARD

### CAR-STEREO AMPLIFIER

Blaupunkt's BQA 208 car-stereo power amplifier delivers high-quality sound in a 4 x 55-watts or a 2 x 110-watts (maximum RMS) format. It is designed to provide installation flexibility in a wide variety of configurations.

The amplifier is also rated for 4 x 50-watts or 2 x 100-watts RMS with less than 0.2% total harmonic distortion. It has a broad-band-frequency response ranging from 5



Hz to 100 kHz. Channel separation is 60 dB, and the signal-to-noise ratio is less than 96 dB. It has preamp and speaker-level inputs, and adjustable input sensitivity of 300 millivolts to 2 volts.

The BQA 208 car stereo amplifier has a suggested retail price of \$439.95. For further information, contact Robert Bosch Corp., Blaupunkt Division, P.O. Box 4601, North Suburban, IL 60198.

CIRCLE 75 ON FREE INFORMATION CARD

### DIGITAL VIDEO STABILIZER ELIMINATES ALL VIDEO COPYGUARDS



While watching rental movies, you will notice annoying periodic color darkening, color shift, unwanted lines, flashing or jagged edges. This is caused by the copy protection jamming signals embedded in the video tape, such as Macrovision copy protection. The DIGITAL VIDEO STABILIZER: RXII completely eliminates all copy protections and jamming signals and brings you crystal clear pictures.

### WARNING

The Digital Video Stabilizer: RXII is intended for private home use only. It is not intended to copy rental movies or copyrighted video tapes that may constitute copyright infringement.

### FEATURES

- The best and the most exciting Video Stabilizer in the market
  - Easy to use and a snap to install
  - State-of-the-art micro-chip technology
  - 100% automatic - no need for any troublesome adjustments
  - Works on all types of VCRs, TVs, and Monitors
  - Light weight (8 ounces) and Compact (1x3.5x5")
  - Beautiful deluxe gift box
  - Uses a standard 9 Volt battery which will last 1-2 years.
  - Similar units sold elsewhere for \$99 or more!
  - UNCONDITIONAL 30 DAYS MONEY BACK GUARANTEE
  - 1 YEAR WARRANTY
  - FAST UPS DELIVERY
- Air Shipping available

To Order: 1-800-445-9285 or 516-694-1240

\$49 ea + \$3 for p&h

Visa, M/C, COD M-F: 9-6 (battery not included)  
SCO Electronics Inc.  
Dept. C10 62 Marine St. Farmingdale NY 11735

CIRCLE 19 ON FREE INFORMATION CARD

# ATTENTION! ELECTRONICS TECHNICIANS

EARN YOUR  
**B.S.E.E.  
DEGREE**

THROUGH HOME STUDY

Our New and Highly Effective Advanced-Placement Program for experienced Electronic Technicians grants credit for previous Schooling and Professional Experience, and can greatly reduce the time required to complete Program and reach graduation. No residence schooling required for qualified Electronic Technicians. Through this Special Program you can pull all of the loose ends of your electronics background together and earn your B.S.E.E. Degree. Upgrade your status and pay to the Engineering Level. Advance Rapidly! Many finish in 12 months or less. Students and graduates in all 50 States and throughout the World. Established Over 40 Years! Write for free Descriptive Literature.

**COOK'S INSTITUTE**  
OF ELECTRONICS ENGINEERING

**CIE** 4251 CYPRESS DRIVE  
JACKSON, MISSISSIPPI 39212

CIRCLE 9 ON FREE INFORMATION CARD



# HANDS-ON REPORT

## BROWN'S PC-PEDAL



*If ten fingers are not enough for speedy keyboarding, try putting your big toe to work!*

**T**he faster you type, the more your computer's keyboard slows you down. The culprits are the very keys that make your computer so powerful. Every time you press the *Control* <Ctrl>, the *Alternate* <Alt>, the *Shift*, the *Delete* <Del>, the *Backspace*, the *Caps Lock*, or the *Number Lock* <Num Lock> keys, your hands have to leave the *home row*. The result? Delays, added stress on your already overworked weakest fingers (the pinkies), and disruption of your smooth typing rhythm. In fact, those interruptions can cut the average computer typist's speed by half or more.

Now, thanks to *PC-Pedal*, you can eliminate keyboard problems by putting them on the floor. Whatever your shoe size, *PC-Pedal* is a perfect fit. And if the notion of typing with your feet sounds strange, consider sewing machines, organs, pianos, airplanes, automobiles, and dictation equipment. All use convenient foot pedals; why shouldn't your computer?

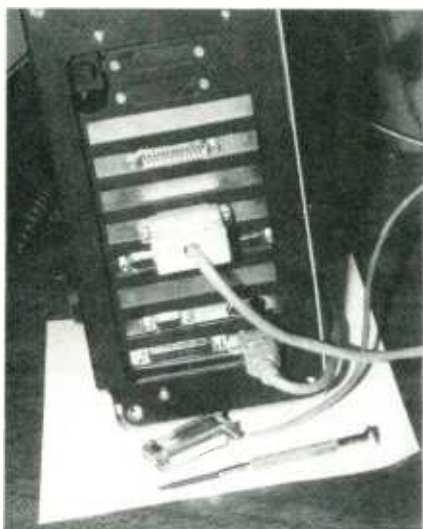

*The PC-Pedal attaches to your computer's parallel printer port via a through connector. That allows you to use that port for both your printer and the pedal.*

*PC-Pedal* is a unique combination of hardware and software. The hardware consists of the foot pedal itself, a rubber-topped, skid-proof switch that clicks on when you press and off when you release, plus a six-foot cord that attaches to your computer. *PC-Pedal*'s software is an assortment of easy-to-use programs on disk; the commands you enter define the pedal's behavior.

*PC-Pedal* is compatible with nearly every word processing, spreadsheet, and applications program on the market. You'll find that, as with driving a car, playing the piano, or sewing, the use of your foot will become so instinctive and natural, you'll use the pedal automatically with almost any software. It's easy to learn, because *PC-Pedal* doesn't change the behavior of the keys it redefines. You should save typing time and effort the very first time you use it.

**Stepping Up Your Speed.** With *PC-Pedal* you can define the foot switch as the <Ctrl> Key, a timesaving convenience for someone using *WordStar* or any program that makes extensive use of the <Ctrl> key. The command for that option couldn't be simpler: you type PEDCTRL and press the <Enter> key. Throughout your edit session, *PC-Pedal* replaces the <Ctrl> key. Not only is the *PC-Pedal* faster than using the <Ctrl> key, it's often faster than pressing a pre-defined function key, such as the <F1> or <F2> keys.

Someone using a word-processing program that makes little use of the <Ctrl> key, such as *Microsoft Word* or *MultiMate*, can save time and increase typing speed by using *PC-Pedal* as the <Shift> key. If your project includes many words, phrases, or titles in capital letters, *PC-Pedal* bypasses the irritating <Caps Lock> key. And if you're using *Lotus 1-2-3*, you can switch between Cursor control and numeric

input on the numeric keypad without touching the <Num Lock> key. That feature will bring a tear to an accountant's eye.

**Additional Features.** In addition to defining *PC-Pedal* as the <Ctrl>, <Alt>, or <Shift> key, you can simplify the Backspace-and-<Del> function. In *WordStar* (like several other word-processing programs), you press the <Del> key to erase a character to the left. In other programs, you press the <Backspace> key to perform the same function. Neither key is conveniently positioned, but the <Space> Bar is so easy that you'll choose the alternative *PC-Pedal* command, pedal plus <Space> bar for the <Backspace>-and-<Delete>, function every time.

What if you want to use more than one *PC-Pedal* definition in a single editing session? No problem. Type the appropriate multiple key command; then tell *PC-Pedal* what you want it to represent by depressing the pedal and desired key simultaneously. For example, pedal plus <Shift> defines the pedal as the <Shift> key until you press another combination, such as pedal plus <Ctrl>, which defines it as the <Ctrl> key.

**How Easy Is It?** The host computer that you wish to use *PC-Pedal* must be an IBM PC, or be 100% IBM compatible, and must be equipped with 100% IBM-compatible parallel-printer port. For instance, the *QuadBoard* parallel port will not support the *PC-Pedal*, but most others will. *PC-Pedal* operates on IBM PC, IBM XT, IBM AT, AT&T Personal Computer, Compaq, Zenith 150, Canon, and other true IBM-compatibles. As a sample of how easy it is to get the big toe functioning, here are the instructions you must follow to get *PC-Pedal* working:



1. Attach the through-connector to a parallel printer port and plug your printer back through the same connector. Do this with the power off. When the connection is complete, power-up the computer.

2. Use the DOS DISKCOPY command to make a working backup copy of the original program disk. Put the original program disk in a safe place and use the backup to install PC-Pedal.

3. Insert the backup copy of the PC-Pedal disk in Drive A: and enter the installation command, SETUP. Press the <Enter> key.

4. Use the DOS COPY command to copy the PC-Pedal programs you want to use onto your word processing, spreadsheet, or applications programs and DOS disks.

5. To use PC-Pedal, load the desired program(s) into memory by typing the appropriate command(s). Load PC-Pedal after any program that changes the keyboard and before all other programs.

**Operating The PC-Pedal.** The foot pedal is made of formed steel and is

housed in a black-steel case. A rubber-top tread on the unit mates with the sole of the footwear you use; slippage is nil. A six-foot length of stranded two-conductor cable has foil shielding and drain wire in accordance with FCC requirements. A 25-pin subminiature "D" through-connector is configured for attachment of both printer and the PC-Pedal to the same parallel port on the computer. Through screws assure secure connection to the mating "D" connector on the second device.

To operate PC-Pedal, run the key-

board program that produces the effect you want and then step on the pedal each time you want that effect to occur. At first, try the simplest combinations; that is, try defining PC-Pedal as a single state key (the <Shift> key by itself, the <Alt> key by itself, or the <Ctrl> key by itself). As you become more confident, try PC-Pedal's multi-key programs.

PC-Pedal works in combination with most word-processing, spreadsheet, and applications packages. In most cases, the best time to run PC-Pedal is  
(Continued on page 103)

**TABLE 1  
Single-Key Programs**

Command	Defines Pedal As	Program File
PEDSHIFT	Shift Key	PEDSHIFT.COM
PEDALT	Alternate Key	PEDALT.COM
PEDCTRL	Control Key	PEDCTRL.COM

**TABLE 2  
Double-Key Programs**

Command	Defines Pedal As	Program File
SHIFTCTL	<Shift> or <Ctrl> Key	SHIFTCTL.COM
SHIFTALT	<Shift> or <Alt> Key	SHIFTALT.COM
CTRLALT	<Ctrl> or <Alt> Key	CTRLALT.COM

# ALL ELECTRONICS CORP.

SEND FOR  
**FREE**  
CATALOG



**ITT PUSH  
BUTTON**

ITT MDPL series. 3/4" X 1/2" gray rectangular key cap. S.P.S.T.N.O. Push to close.  
Rated: 0.1 amp switching,  
0.25 amp carry current. P.C. mount.  
CAT# PB-8 65¢ each  
10 for \$6.00



**PIEZO WARNING  
DEVICE**

Murata Erie # PKB8-4A0  
High pitched audible alarm.  
Operates on  
3 - 20 Vdc @ 20 ma  
1" high x 7/8" dia.  
P.C. board mount.  
CAT# PBZ-84 \$1.75 each



**24 VOLT D.C.SOLENOID**

Intermittent duty cycle. 240 ohm coil. Mounting flange is 1 1/8" wide. Solenoid body 1 1/2" X 1/2" X 1/2".  
CAT# SOL-34 \$1.00 each  
10 for \$8.50 - 100 for \$75.00  
**Large Quantity Available**



**10 AMP SOLID STATE  
RELAY**

ELECTROL #S2161  
CONTROL: 5.5 - 10 Vdc  
(will operate 3-32Vdc)  
LOAD: 10 Amp @ 240 Vac  
2 1/4" X 1 3/4" X 7/8"  
CAT# SSRLY-10B \$9.50 each  
10 for \$85.00 - 25 for \$175.00  
50 for \$300.00 - 100 for \$500.00



**XENON TUBE**

1" long flashtube prepped with 3 1/2" red and black leads. Ideal for electronic flash or strobe projects.  
CAT# FLT-3 2 for \$1.00



**N-CHANNEL  
MOSFET**

IRF-511 TO-220 case  
CAT# IRF 511  
\$1.00 each  
10 for \$9.00  
**LARGE QUANTITY  
AVAILABLE**



MAIL ORDERS TO:  
**ALL ELECTRONICS**  
P.O. BOX 567  
VAN NUYS, CA 91408

TWX-5101010163(ALL ELECTRONIC)

OUTSIDE THE U.S.A.  
SEND \$1.50 POSTAGE  
FOR A CATALOG!!

ORDER TOLL FREE  
**800-826-5432**

INFO: (818)904-0524

FAX: (818)781-2653

MINIMUM ORDER \$10.00

QUANTITIES LIMITED  
CALIF. ADD SALES TAX  
USA: \$3.00 SHIPPING  
FOREIGN ORDERS  
INCLUDE SUFFICIENT  
SHIPPING. NO C.O.D.



# THE ULTIMATE COMPUTER PROJECT KIT

Introducing the **CDK-52, Controller Design Kit**. Now you can build advance home-brew projects with unbelievable ease and economy.

The **CDK-52** is a unique circuit bread-boarding tool, that combines a powerful control-oriented micro-processor; and a simple open bus structure for interfacing to your own circuit designs. It also contains a high-end BASIC interpreter, EPROM Programmer, 8K RAM, Serial Port, 24 Bit I/O Port, and much more. The **CDK-52** comes in kit form, and includes two comprehensive Users Manuals.

The **CDK-52** gives you the ability to learn software/hardware integrating techniques, create BASIC language programs, perform I/O experiments, or even build a complete process control system. So whether your interests are Home Energy Management, Speech Synthesis, or Robotics, the **CDK-52** is the "Right Stuff" for building today's hi-tech home-brew projects.

As a limited introductory offer, the versatile **CDK-52** can be yours for only \$249.00. And, for an added plus, we'll even pay your shipping charges. To get your **CDK-52** call:

**CLAYTRONICS, INC at**  
**(707) 554-9903 or write**  
**P.O. Box 7293 Vallejo, CA 94590**



## JETSET AIRDAPTOR SYSTEM



*Go first class all the way when you fly with this electronic audio system that connects to the plane's armrest jack!*

**A**lmost nothing irks this air traveler more than to spend over \$500 for coach seats on a coast-to-coast round-trip ticket only to find that he has to kick in an extra \$3 for the in-flight movie. And what do you get for that \$3? An ill-fitting, poor audio quality, uncomfortable plastic headband and air-pipes arrangement that the airline euphemistically calls a headset. When I complained, the attendant smiled and said: "If you can read lips, the movie is free, sir."

That magic word—free—started my search for a better way. Rejoice fellow air travelers, I found one!

Air travelers can now enjoy music, movies, and other in-flight entertainment with premium-quality stereo sound using the *Jetset System*. The heart of the system is their *Airdaptor* portable stereo-amplifier module. That lightweight, 3 × 2 $\frac{3}{8}$  ×  $\frac{1}{2}$ -inch module converts the "piped" sound supplied to the armrest jack on your passenger seat to electronic signals. Also included are a set of lightweight, high-quality stereo headphones for listening. The headphones that come with the unit can also be used with Walkman-style tape players.

**Hook Up Way Up.** To use *Jetset System*, simply unfurl the *Airdaptor* cord

and plug into the airliner armrest's audio jack. Then, plug the headphones into the *Airdaptor*, and enjoy the full capabilities of the in-flight entertainment system. At the end of the flight, the cord stows neatly in place around the *Airdaptor*.

The *Airdaptor* is small enough to fit in a shirt or blouse pocket. It can be used on-board aircraft fitted with the standard air-pipe audio connector (on flights with in-flight entertainment) in any seating class. The *Airdaptor's* rugged matte-black enclosure has the



*The Airdaptor amplifier module is compact and lightweight. The plug that seats in the air-pipe jack in the aircraft is designed to equalize the air-pulsed sounds so that the twin stereo microphones detect a balanced sound in keeping with high-fidelity standards. Two "AAA" batteries, which can be reached by removing an access panel on the rear of the unit, power the module. The stereo headset plug connects the earpieces to the amplifier and turns on the power.*



look and feel of an expensive high-tech instrument.

The Airdaptor module is powered by two inexpensive "AAA" batteries. For convenience and longest battery life, power is automatically switched off when the headset is disconnected for storage.

**How It Works.** Unlike the headphone jack on a home stereo system, the jack on most commercial airliners carries piped-in sound, not electrical signals. That design allows airlines to use very inexpensive headsets, consisting of little more than two flexible plastic tubes, a rubber connector, and a hard plastic frame. While that is economical for airlines, it restricts sound quality at the earphones and listener comfort. To improve both, the Jetset System applies up-to-the-moment electronic technology and some clever engineering to the task.

The secret of the Airdaptor module is the patented sound pickup that plugs into the airliner's seat jack. That pickup features a pair of sensitive, condenser microphones, mounted in a specially designed seat connector, and acoustic *correction baffles* to equalize excess hiss and sibilance from the sound source. The microphones convert the piped sounds to stereo electronic signals, which are fed to the Airdaptor module. Those signals are amplified by a class AB high-fidelity stereo amplifier. The amplifier output signal is reconverted to sound by the stereo headphones. Amplifier response is rated at 30-20,000 Hz. For hazard reliability, the amplifier is short-circuit and reverse-polarity protected.

Testing the product was an easy task. On a short two-hour flight and the three-hour return flight (congested air traffic was to blame) the Jetset System performed flawlessly. The audio quality was superior to the air-pipe headset I rented for \$3. What's more, the comfort of the earpiece and improved audio fidelity made listening to the in-flight programs delightful, without any listening fatigue. On the ground, a battery test was performed using the same batteries that saw five hours of service. The Jetset System was turned on and the earpiece was taped to the exit port of a room-ventilation system. The rushing air produced a loud sound at the ear pieces, thus confirming that the batteries were working in excess of a normal load. After 17 continuous hours of testing, the quality of sound repro-

duction delivered by the unit was completely unaltered.

The Jetset System is manufactured by Lotus Developments, Ltd. in the United Kingdom, and is available for immediate delivery to U.S. air travelers from: Executive Travelware, P.O. Box 59387, Dept. PE, Chicago, IL 60659. It is priced at \$19.95, plus \$3.00 shipping and handling. Illinois residents add 8% sales tax. Treat yourself to a Jetset System or give it as a gift to a frequent flyer you know. ■

First-aid kits are fine for some emergencies. But what if you were choking? Having a heart attack? Or a stroke? This kit would be useless. Call the Red Cross. We'll teach you and your employees how to save a life. From work safety to CPR, you can count on the Red Cross. We'll help. Will you?

 American Red Cross

 AOL  
COUNCIL A Public Service of This Publication



## CABLE TV SPECIALS



### CONVERTERS

	JRX-3 DIC—36 Channel Corded Remote	\$129.95
	RCA 58-3 58 channel set top with Jerrold Decode	\$99.95
	SB-3 — 'The Real Thing'	\$109.95
	SB-3-Taiwan Copy	\$89.95
	DRZ-3D1C—68 Channel Wireless with Decoder	\$199.95
ZENITH:	Z-TAC Cable Add-On	\$169.95
VIEW STAR:	MXC 2001—65 Channel Wireless— with Parental Lockout	\$89.95
	MXC 2001 A-B—Same as above with A-B Switch	\$109.95
	MXC 2501—65 Channel Wireless with Volume	\$119.95
	Universal V7472—72 Channel Wireless Remote MTS Stereo Converter-Full Feature Decoder Compatible	\$129.95

### MISCELLANEOUS

OAK:	ECONO-3V Mini-Code	\$89.95
	ECONO-3V Mini-Code Vari-Sync	\$89.95
	ECONO-3V Mini-Code Vari-Sync Plus Auto On-Off	\$119.95
OAK:	Sine-wave Anti-Jammer Kit	\$39.95
JERROLD:	400 & 450 Handheld Transmitters	\$29.95
HAMLIN:	MLD-1200 Channels 2 or 3	\$99.95
NEW ITEMS:	Scientific Atlanta SA-3	\$129.95
GENERAL		
INSTRUMENTS:	VCU Amplified Video Switch Signal Amplifier	\$59.95

ALL UNITS GUARANTEED. QUANTITY PRICES AVAILABLE.

## UNITED ELECTRONIC SUPPLY

P.O. BOX 1206H • ELGIN, ILLINOIS 60121 • 312-697-0600

# “Where can I turn for help?”



There is a way to get help when you need it. The American Home Satellite Association. An organization created exclusively to protect and enhance your enjoyment of your satellite TV system.

Take our toll free “Helpline,” for example. From locating satellite signals to locating a reputable dealer, help is just a phone call away. AHSA provides educational videotapes and informative books, too. At very special member prices.

Plus, 10 times a year, AHSA’s official newsletter, *Sky Report*, will bring you the latest word on products, legislation, programming, and more. Not to mention reviews of new products and services. And that’s not all AHSA has in store for you.

## Programming shouldn’t cost a fortune.

With AHSA’s group buying power, you can save on premium services, superstations and basic programming services. Enjoy savings on accessories, equipment, and programming guides, too.

## You’re not alone anymore!

With your voice behind us, AHSA is promoting legislation to guarantee fair access at reasonable prices. Addressing zoning and piracy issues. Even sending expert witnesses to Congressional hearings. Join other dish owners around the nation, and become a force to be reckoned with.

---

### Rush my free information kit.

Name \_\_\_\_\_

Address \_\_\_\_\_

City \_\_\_\_\_ State \_\_\_\_\_ Zip \_\_\_\_\_

### Sign me up right away and send my complete membership kit.

Check enclosed for \$36 (made out to AHSA)

Bill my  VISA  MasterCard

Card # \_\_\_\_\_

Exp. Date \_\_\_\_\_

Authorized Signature \_\_\_\_\_

X \_\_\_\_\_

30-day Money Back Guarantee



**American Home  
Satellite Association**

CA

Return completed coupon to:  
American Home  
Satellite Association, Inc.,  
Suite 800, 500 108th Ave. NE,  
Bellevue, WA 98004-5560  
Or call Toll Free  
1-800-321-AHSA (2472).



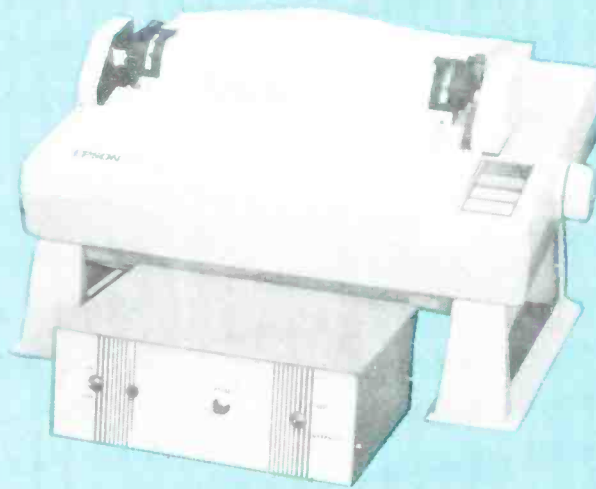

## PRINTER SPOOLER/BUFFER

*Free up your computer and avoid switching cables between machines with this combination print buffer and automatic T-switch*

BY JOHN EMERSON

I got my start in computing several years ago, with a home-brew 8085-based computer running the CP/M operating system. When fairly sophisticated CAD packages started showing up for MS-DOS, I purchased an XT clone. However, with a large investment in CP/M software, I wasn't ready to relegate my old 8085 system to the dust heap. And therein began my dilemma—two computers and only one printer.

It seemed that no matter which computer I was using, the printer was hooked up to the other. And although my printer is extremely fast, outputting 400 lines per minute, waiting for the printout of a long listing was tiresome. I had spooler programs, but they use memory, disk space, and bus cycles. The spooler programs also assumed a much slower printer, which caused the print speed to be cut to less than 100 lines per minute. The *Print Buffer/Spooler* (PSB) described in this article—which combines the functions of an automatic T-switch and a 64K spooler—solved both my problems.

**System Overview.** The PSB circuit (see Fig. 1) has a relatively low parts count, and handshakes with Centronics-compatible parallel printers and ports. It is built around an 8031 microcontroller, which is supported by readily available parts. The PSB has two major modes of operation: graphics and text. In the graphics mode, what goes in, comes out. A form-feed character is inserted after each computer releases the buffer. Characters cannot be swapped, inserted, or deleted because most control codes are also valid pin-patterns for dot-matrix printers in the graphics mode.

The main difference between the graphics and text modes lies in the way that form feeds are handled. The text mode eats them. That is, the input routine inserts a form-feed between computers (as in the graphics mode), but the output routine keeps track of the last character printed. If the last character printed was a form-feed, the PSB deletes any additional, consecutive form-feeds. In other words, there's always one form-feed between

computers, but there's never more than one form feed.

In the text mode, additional switches allow the unit to expand tabs and form feeds, although they are fixed at 8-spaces per tab and 66-lines per page. While my printer is very fast, it doesn't understand a tab code. I've also had even dumber printers that didn't understand form feeds. The PSB can compensate for those shortcomings.

In the graphics mode, those switches are disabled because the circuit can't tell the difference between a tab or form-feed and the graphics bit-patterns 09H and 0CH.

**The 8031 Microcontroller.** Like the popular Z80, the 8031 has built-in clock-generation circuits, eliminating the cost of external clock hardware and allowing it to operate directly from a crystal. And as we all know, any reduction in parts count, reduces the final cost.

Unlike the Z80, the 8031 uses a modified *Harvard* architecture, with separate address spaces for programs and

FROM COMPUTER 1

FROM COMPUTER 2

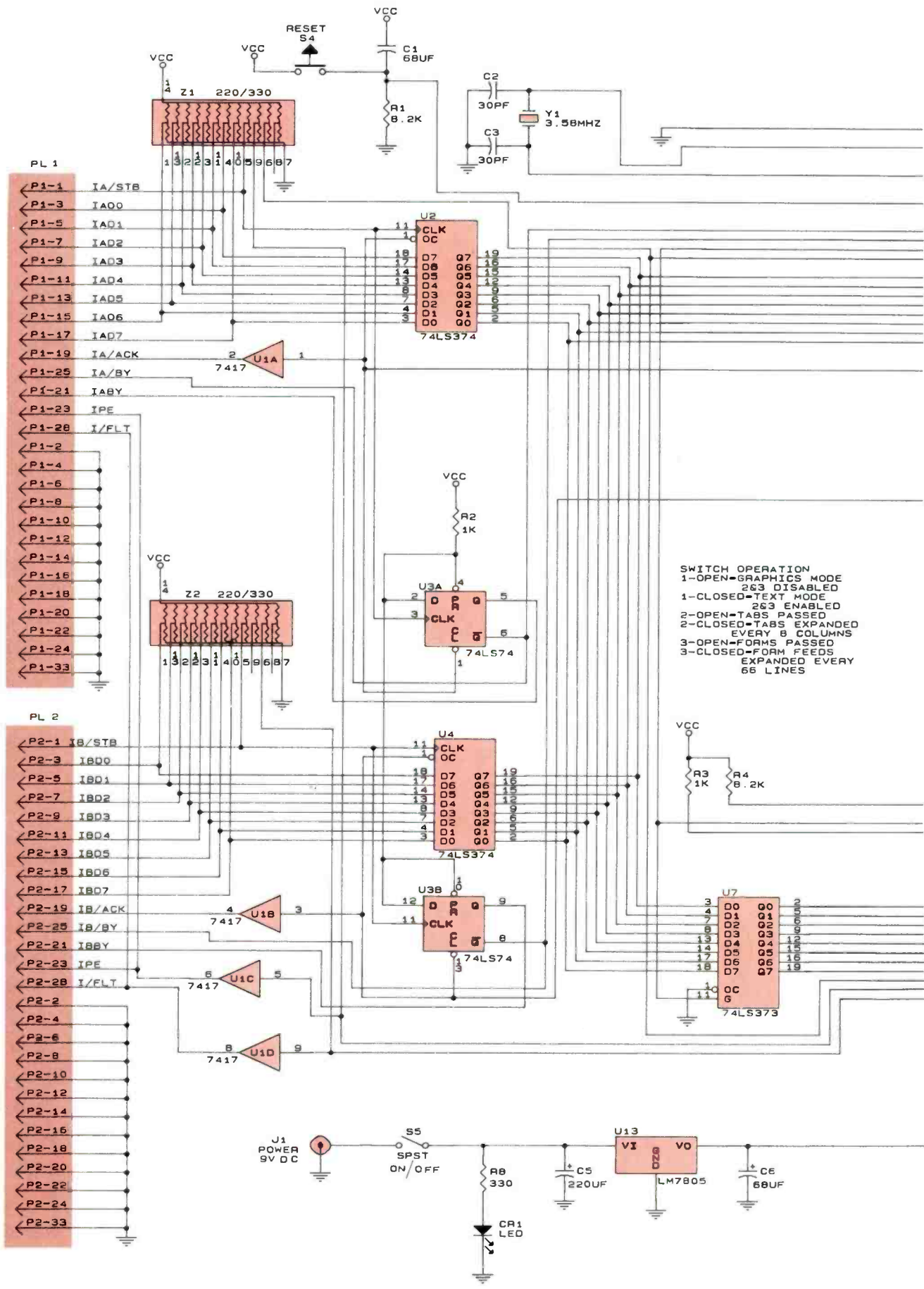





data. A true Harvard architecture has separate address and data buses, allowing that type of computer to read or write data for the current instruction while it simultaneously reads the next instruction, making it a very fast computer.

The 8031 has common address and data buses, but separate read lines for program (/PSEN) and data (/RD). That doesn't increase speed over a common address space, but it does effectively double the amount of memory that the 8031 can address. It can address up to 64K of program and up to 64K of data, for a maximum of 128K, compared to the Z80's 64K total (without external bank-switching hardware). That permits the use of a full 64K buffer, plus 8K of program, without the bank-switching hardware that the Z80 would have needed.

The 8031 has two on-board, 16-bit timer/counter circuits, allowing one computer to time-out when it is done with the buffer, something that could be done entirely in software (with a speed penalty) in a Z80 system. That scheme avoids some additional programming or external counter hardware.

The 8031 has a good interrupt structure, allowing the timer and two computer-interface ports to be interrupt driven without incurring a hardware penalty. With the Z80, some sort of decoding hardware would be required to handle three sources. The 8031 has 128 bytes of onboard RAM, 32 of which are organized into four banks of work-

ing registers. Because 32K static RAMs are fairly expensive, I wrote the software to test for the presence of external RAM, and generate a small (104-byte) buffer in that internal memory.

Although not used in the printer-sharer circuit, the 8031 has a full duplex, interrupt-driven serial port (UART) onboard. It is available in versions with onboard ROM (8051) and even EPROM (8751). If external memory is not required, the data, address, and handshake pins may be configured as up to four 8-bit parallel ports. For control functions, each I/O port bit can be addressed individually.

The 8031 instruction set includes the ability to set or clear individual bits in the accumulator, several registers, and the I/O ports, and to test those same bits and perform a jump on bit set or cleared. Arithmetic functions include multiply and divide instructions, each of which is executed in just four cycles. The rest of the instructions are executed in one or two cycles.

**Circuit Analysis.** Assume that computer A places a byte of data on the IAD0-IAD7 terminals of PL1, then pulses PL1's IA/STB terminals low. On the rising (trailing) edge of the pulse, the data from PL1's IAD0-IAD7 terminals is clocked into U2. The same rising edge clocks U3-a. Flip-flop U3-a's  $\bar{Q}$  output goes high, sending an active-high busy signal (IABY) back to computer A—which is interpreted by the computer to mean "Don't send me any more, I'm processing."

Flip-flop U3-a's  $Q$  output goes low, giving computer A an active-low busy signal (IA/BY) and sending an interrupt to U5 (the 8031 microprocessor). An interrupt (or interrupt service routine) tells the processor to stop its current task, save its place, and do something else for a while. On completion of the interrupt service routine, the processor returns to the original task.

During the interrupt service routine, pin 10 of U5 is brought low. That signal enables the three-state outputs of U2 to send the buffered byte to U5 pins 1 to 8 (P1.0–P1.7). The interrupt routine then reads the data through P1.0–P1.7 (U5 pins 1–8) and brings pin 10 high again. The high-to-low transition clears U3-a, removing the busy signals being returned to the computer. The low-to-high transition returns U2 to its three-state mode. The output of U5 at pin 10 is buffered by U3-a and returned to the computer as an acknowledge signal (IA/ACK).

The interrupt-service routine, having accepted the first byte from computer A, places that byte into the 64K buffer. That disables responses to computer B's interrupt lead and sets one of the internal timer/counters for 15 seconds. Once the timer/counter starts running, it returns to the main program.

The sequence is repeated for each character sent by computer A. With each character, the timer is reset to count out 15 seconds. As long as computer A delays no more than 15 seconds between characters, the counter never reaches zero, and computer B's interrupt remains disabled.

Assume computer A has the buffer, and that less than 15 seconds have elapsed since it sent the last character. Computer B sends one character. When its IB/STB signal sets U3-b, that flip-flop sends busy and not-busy signals back. Meanwhile, the character is latched into U4. Since U5 is prevented from acknowledging computer B's interrupt, the character is not read into the buffer. Computer B gets a continuous busy signal, and cannot send any more characters.

Meanwhile, U5 continues to accept characters from computer A at over 2000 characters-per-second (cps), assuming that computer A can send that fast. Fifteen seconds after computer A has sent its last character, the timer (no longer being reset) arrives at zero, and generates its own interrupt.

At that point, the timer-interrupt service routine stops the timer and inserts

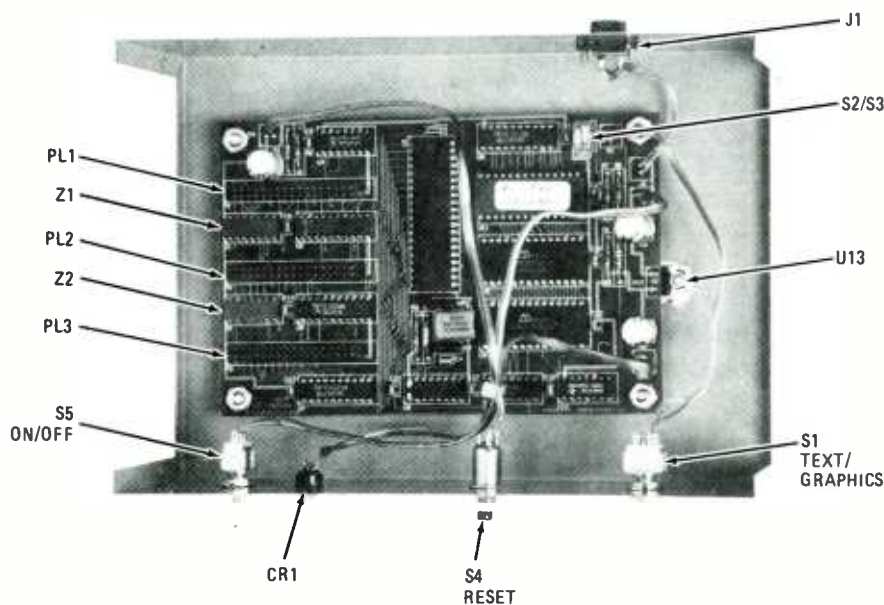

Shown here is a top-side view of the Print Buffer/Spooler's fully-populated printed-circuit board prior to the sealing of its metal enclosure.



a form-feed character into the buffer after the last character received from computer A. It then enables the interrupt signals from both computers. Computer A's interrupt is already enabled, but computer B has been waiting for that signal.

On return from the timer interrupt, the processor recognizes the pending computer-B interrupt, originating at the  $\bar{s}$  output of U3-b, present at U5 pin 13. The computer-B interrupt service routine accepts the character from U4, placing it into the buffer immediately after the timer's form-feed. That clears U3-b (removing the busy for computer B), disables the computer-A interrupt, sets the timer (again for 15 seconds), and then returns to the main loop.

As long as computer B continues to send characters at intervals of less than 15 seconds, the interrupt for computer A remains disabled. The circuit can accept characters from computer B, while continuing to print computer A's file from the buffer. Should the buffer become full (temporarily stopping the timer), the active computer interrupt is disabled until the main loop has taken one character from the buffer and sent it on to the printer. The interrupt is then re-enabled.

The main-loop software takes characters from the buffer and sends them to the printer. Because it uses the same I/O bus for sending that the interrupts use for receiving, it must temporarily disable the active computer's interrupt for the duration of the transfer, then remember which computer was active, and re-enable its interrupt when the job is complete.

The main loop polls T1 (U5 pin 15), an input connected to the printer's busy signal. If the printer is busy processing the last character sent, U5 sits in a tight loop, testing and re-testing pin 15. When the busy signal is cleared, the loop is expanded to test for a character in the buffer.

If the printer is not busy and there is at least one character in the buffer, the processor disables the active computer interrupt, takes the next character from the buffer, places it on U5's P1.0–P1.7 terminals, and uses the port as an output. The processor then brings its pin 14 high, allowing data to be fed to U7. When pin 14 of U5 is brought low again, the data is latched into U7, and U6-a (which is set to produce the 1.5- $\mu$ s pulse that the printer expects) is triggered.

Once the data has been latched

into U7, the processor clears the P1.0–P1.7 terminals and returns the port to the input mode. It then re-enables the active computer's interrupt and goes back to polling the printer's busy signal.

In text mode, however, the previous character is saved in one of the registers. The current character is tested, to see if it is a form feed. If it is not, the character is sent normally. If it is a form feed, the character is then compared to the previous character. If that was also a form feed, it returns to the main loop without sending the character. The result is that multiple, consecutive form-feeds are disallowed.

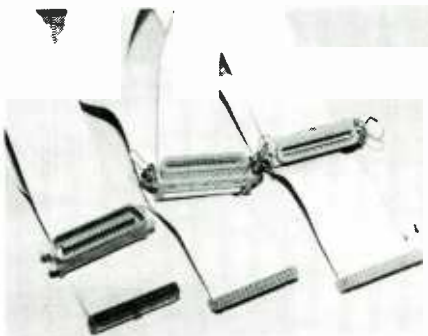

*Three ribbon cables are needed to connect the PSB between your two computers and the printer. One end of each cable is terminated in a 34-pin header connector. The other ends of the cables terminate in connectors selected to mate with the computer or printer ports to which they are to be attached.*

The disallowance of consecutive form feeds is a very useful feature. For example, consider that my text editor inserts a form feed at the end of each file, my 8080 assembler inserts a form feed at the beginning of each file, and the sharer program inserts a form feed between files. If a text file were printed, followed by a program listing, I could end up with three consecutive form-feeds between the two documents—a waste of paper—if that feature were missing.

The tab-expansion feature uses a register and software to count characters (modulo 8). Non-printing characters, such as a line-feed or bell, do not count. A carriage return resets the counter. When a tab character is encountered, the program branches to a loop, printing space characters and bumping the counter until it rolls over, and then returns to the main loop.

Similarly, the form-feed expansion counts line-feeds (modulo 66). When a form feed is encountered, it prints line



*A wall-mounted power supply capable of providing between 8 and 24-volts DC at 1 amp can be used to power the Print Buffer/Spooler. The author chose a 9-volt unit as his power source.*

feeds and bumps the counter, returning to the main loop when the form-feed counter rolls over. Note that that routine is placed after the multiple form-feed test.

Switches are used to set the upper addresses of the program memory. That approach may seem a bit strange, but there is a good reason. In designing the basic unit, all available signal pins on the 8031 (U5) were used. I had no way to add features by testing a switch and doing a conditional branch because I had no place left to attach the switches. Instead, I wrote five different versions of the program.

Each version has its logical origin at address 0000H, even though they are physically loaded into ROM at address 0 (text mode, expand forms and tabs), 400H (text mode, expand only forms), 800H (text mode, expand only tabs), 0C00H (basic text mode, no expansions), and 1C00H (graphics mode). The switches then select which of the five physical addresses are presented to the processor as address zero.

Because the five programs are not identical, changing any mode switch while operating could easily send the 8031 (U5) branching off to *never-never land*. The switches should only be changed with the power off.

In hardware, the paper empty (POPE) and fault (PO/FLT) signals from the printer are buffered by U1-c and U1-d, and sent directly to both computers. The 8031 doesn't need to know the type of error; it simply sees a busy signal from the printer and can't send.

**Construction.** The authors prototype of the circuit was fabricated on a double-sided printed-circuit board, the foil patterns for that board are shown in Fig. 2. You can, if you wish, wire-wrap the Print/Buffer Spooler, but bear in

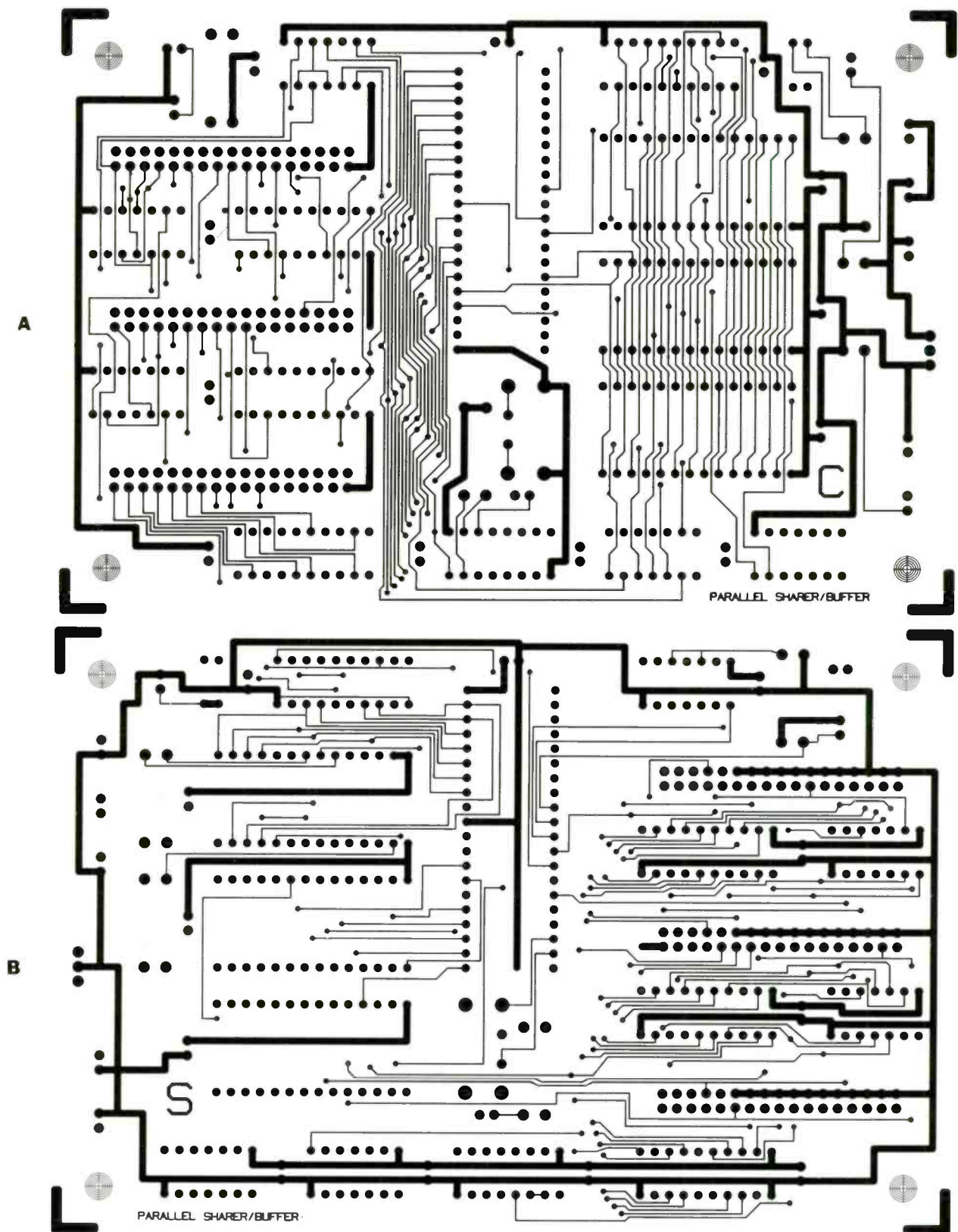

Fig. 2—The full-scale foil pattern for the double-sided printed-circuit board. The component side is shown in A; the solder side is shown in B.

mind that there are some fairly-high frequencies running through the circuit. So, if you go the wire-wrap route, it's important that lead lengths be kept as short as possible, especially in the paths running from U5 pins 18 and 19 to

Y1, Y1 to C2 and C3, and C2 and C3 to ground. In the area of U6, the paths from U6 to C4 and R3, and from R3 to  $V_{CC}$ , should also be kept fairly short.

Note that the 32K static RAMs are CMOS devices and as such, anti-static

precautions are an absolute necessity. The RAMs are not necessary to the sharing operation. The program tests for their presence and sets itself up according to the amount of RAM found. The circuit can be built and will work without them. They can be added later, as your budget permits.



## PARTS LIST FOR THE PRINT SPOOLER/BUFFER

### SEMICONDUCTORS

U1—7417 hex buffer/driver, integrated circuit  
 U2, U4—74LS374 octal D-type flip-flop, integrated circuit  
 U3—74LS74 dual D-type flip-flop, integrated circuit  
 U5—8031 microprocessor (CPU w/128 X 8 RAM I/O), integrated circuit  
 U6—74LS123 dual monostable multivibrator, integrated circuit  
 U7, U8—74LS373 octal D-type transparent latch, integrated circuit  
 U9, U10—43256-15L RAM, integrated circuit  
 U11—2764 8 X 8 EPROM, integrated circuit  
 U12—74LS04 hex inverter, integrated circuit  
 U13—7805 5-volt, 1-amp regulator, integrated circuit  
 CR1—T1-3/4 or similar light-emitting diode

### RESISTORS

(All resistors are 1/4-watt, 5% units, unless otherwise noted.)

R1, R4—8200-ohm  
 R2, R3, R5-R7—1000-ohm  
 R8—330-ohm  
 Z1, Z2—220/330-ohm terminating network (14 pin DIP)

### CAPACITORS

C1, C6—68- $\mu$ F, 16-WVDC, electrolytic (vertical mount)  
 C2, C3—30-pF ceramic disc or mica

C4—0.001- $\mu$ F, ceramic disc  
 C5—220 $\mu$ F, 35-WVDC, electrolytic (vertical mount)  
 C7-C18—0.1- $\mu$ F, ceramic disc

### ADDITIONAL PARTS AND MATERIALS

J1—Selected to match power-supply connector (see text)  
 PL1-PL3—34-pin header (Digi-Key R230-ND)  
 S1, S5—Single-pole, single-throw toggle switch  
 S2, S3—2-place DIP switch (Digi-Key CT2062)  
 S4—Single-pole, single-throw normally-open, pushbutton switch  
 Y1—3.58-MHz color-burst crystal  
 Printed circuit or perfboard materials, 34-pin header connectors (Digi-Key R8305-ND mates with PL1-PL3), 34-conductor ribbon cable, 8- to 24-volt wall-mounted DC power supply, enclosure, IC sockets, wire, solder, hardware, etc.

Note: All resistors, capacitors, switches and connectors, and most ICs are available from Digi-Key Corporation, PO box 677, Thief River Falls, MN 56701-9988. The 8031 and 43256-15L 32K X 8 static RAMs are available from Jameco Electronics, 1355 Shoreway Road, Belmont, CA 94002. The terminating networks Z1 and Z2 are available from Ohm Electronics, Inc., 746 Vermont St., PO Box 368, Palatine, IL 60067; Tel. 312/359-5500.

The following items are available from the author: pre-programmed EPROM, \$8.95 (containing the algorithms for all five modes of operation); double-sided glass-epoxy printed-circuit board, UL FR-4 rated (with solder mask and silk-screened component-placement legend) \$15.95; source code (MS-DOS 3.2 format 5/4-inch floppy disk containing the original source files for all five modes of operation) \$19.95; Deluxe hacker-pak, \$39.95 (includes all of the above, plus a full-size print of the schematic). Make check or money order payable to John Emerson, PO Box 43, Elgin, IL 60121. Please specify item(s) and quantity desired. All orders subject to \$2.00 postage and handling. Illinois residents please include 6% sales tax.

Popular Electronics will send a print out of the program listing at no cost until January 31, 1989, provided the sender submits a self-addressed envelope with sufficient postage for two ounces of first class mail (currently \$.45). Mail your request to Buffer/Spooler, Popular Electronics, 500-B Bi-county Boulevard, Farmingdale, New York 11735). Mail post marked after January 31, 1989 will not be honored unless a handling charge of \$2.00 in check (no cash, coin, or stamps please) is included with the request.

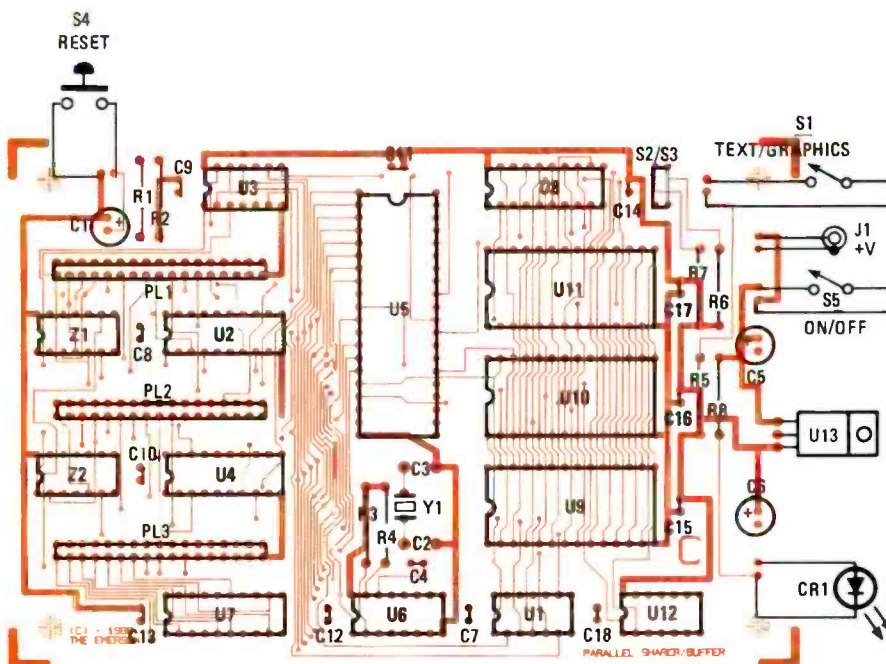

Fig. 3—Using this layout diagram as a guide, install the circuit elements, being mindful of component orientation and positioning—particularly the ICs, electrolytic capacitors, the power connector, and the LED.

If only one RAM is used in the circuit, it should be installed in the U9 location. In fact, because the RAM integrated circuits are the most costly circuit elements in the project, it is recommended that the circuit be assembled and tested without them in place to avoid the chance of damaging \$24 worth of silicon. If the circuit works without the RAM installed, it should work when they are installed.

Unless you are a real wizard with a soldering iron, it's a good idea to invest in sockets for all the ICs, especially if you are getting some of them from your junkbox. Even if you are the definitive expert on soldering and desoldering, socket the EPROM.

If you buy the EPROM from the supplier given in the Parts List, there is still a possibility of a bug being found later. Fear not, for if that should occur, you'll be informed and a replacement EPROM will be made available on an exchange basis.

Assuming that you've purchased the printed-circuit board from the supplier

(or etched your own from the foil pattern provided), install the components using Fig. 3 as a guide. Be careful of the orientation of all ICs, electrolytic capacitors, the power connector, and the LED. If you've purchased the circuit board from the supplier mentioned in the Parts List, the marked corner of the IC outlines and connectors is pin 1; a plus sign (+) indicates the positive lead of electrolytic capacitors, and the cathode of the power indicator LED.

The connectors specified for PL1, PL2, and PL3 are inexpensive headers that mate with T&B Ansley P/N 609-3430 ribbon-cable connectors. For wire-wrap construction, substitute T&B Ansley P/N 609-3457 for PL1-PL3. Similar connectors are available from other sources, including AMP, 3M, and Molex. The pinout for the ribbon cables directly match the 34-pin card-edge connectors used by Radio Shack on TRS-80 models I-IV. The cable pinout also matches the first 34 pins of the standard 36-pin, parallel printer connector (pins 18 and 36 are not used).

For the 25-pin D connector used on PCs and clones, use a 25-conductor ribbon cable connected to the first 25 pins of the 34-pin connector on the unit. Carefully cut the number 2, 4, and 6 conductors of the ribbon cable. The rest of the ribbon-cable's conductors match correctly and will provide all of the necessary signals.

Power for the circuit is provided by a Radio Shack, part No. 277-1026, AC-to-DC adaptor, but any unit capable of supplying between 8 and 24-volts of filtered DC at 650 milliamps will do. Power input jack J1 is then selected to mate with the plug of the power supply. The 7805, properly heat sunked, does an excellent job of regulating with inputs in that range. For heat sinking, the regulator was bolted directly to the cabinet. The mounting tab of its TO-220 package is connected to ground. Mounting the regulator that way provides two benefits; no insulator is required and, by connecting the metal cabinet directly to logic ground at the regulator, the unit's immunity to noise and ESD (electrostatic discharge) is increased.

The circuit was housed in a Radio Shack 270-274A cabinet, but any metal enclosure of ample size will do. A metal cabinet is specified primarily for heat sinking the 7805, but the extra noise and ESD immunity that such a cabinet provides can't hurt.

**Software.** The software required to make the buffer work is fairly clever. However, it is also fairly complex. Because of that, and due to space reasons, we will not be able to go into its details in this article.

Of course, you still need the software if the buffer is going to do anything useful. There are three ways to obtain it: The easiest way is to purchase the pre-programmed EPROM from the source mentioned in the Parts List. Plug it into the the U11 socket on the board and you are ready to go. If you are into burning your own EPROMs, or would like to make some modifications to the code, you can purchase an MS-DOS format, 5¼-inch floppy disk with the complete source code from that same supplier.

that the actual printing begins on a clean sheet of paper.

**Troubleshooting.** The most likely source of trouble is the ribbon cables used to connect the Print Spooler/Buffer to the printer and computers. If the PSB doesn't sign on, check that there is power to the ICs (a bad or mis-installed U13 would allow the power LED come on, but the ICs would be dead). Then check the printer cable for continuity and shorts. If the unit signs on, but doesn't pass data from one or the other computer, check the computer cable for continuity and shorts. Be sure to observe the proper polarity when building and connecting all of the cables used by the unit.

Find out what's working and what's

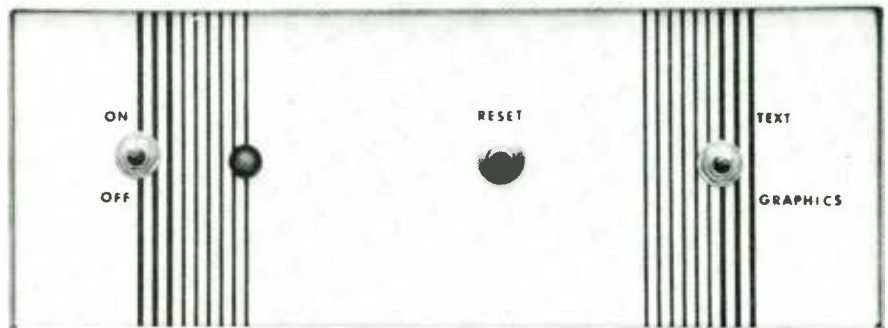

Here's the finished prototype. If desired, dry-transfer lettering can be used to label the front-panel controls and provide a more professional look.

Finally, for those true hackers (masochists) who have the time, typing ability, and desire to key in the hex data required for the buffer/spooler program, you can request a copy of the complete source code, in Intel hex format, from the address given in the Parts List.

**Operation.** When the unit is connected to a printer (both are powered up) and the printer is placed on line, it should immediately print the message: TESTING RAM. Less than 6 seconds later (immediately if no RAM is installed), it should print a status message similar to:  
 PRINTER SHARER/32K BUFFER  
 COPYRIGHT 1988 - JOHN EMERSON  
 IN TAB EXPAND MODE

Note: The buffer size displayed varies with the amount of RAM installed, and the mode displayed depends on the settings of S1, S2, and S3, which are set according to the instructions given in Fig. 1. After the message is output, the printer should then form feed to the top of the next page, so

not. If the sign-on message prints, the problem is in an input section. If nothing prints, check the processor. A logic probe or scope should see pulses on U5 pin 30. If the printer is ready for data, U5 pin 15 should be a steady low. Probe U5 pin 15 and press the reset button. When you release the button, if the processor is working, you should see a series of pulses as the processor sends the sign-on message. Probe U6 pin 1 and repeat the procedure. If there are no pulses, chances are that U6 is the culprit.

If an input problem is indicated, U1 and U3 will probably affect both inputs, while U2 will only affect input A and U4 will affect input B, probably with scrambled characters. Scrambled characters at sign-on point to U7. Total failure with an indication that the processor is running can probably be traced to U8 or U11. An indication, at sign on, that less memory is available than is installed, could be caused by a bad RAM or a bad U12.

Good luck, and may the data flow be with you. ■



# Here are your free FactCards!

Introducing Hands-On Electronics® FactCards. Each issue, Hands-On Electronics® will present 3 new FactCards, each dealing with one of a variety of electronics topics. Some will deal with electronics basics, some will deal with discrete components, some will deal with IC's, and some will deal with circuits and applications.

All will contain the type of information electronics hobbyists need, but sometimes must search to find. With FactCards, you can find that information in a hurry.

# Clip your cards, save them, and start building your FactCards library today!

## Hands-on Electronics.

### 88 Hands-on Electronics FactCard

### MM74C946: 4 1/2-Digit Counter/Decoder/LCD Display Driver

1	V <sub>CC</sub>	D1	40
2	E1	C1	39
3	G1	B1	38
4	F1	A1	37
5	BACKPLANE	OSCILLATOR	36
6	A2	GND	35
7	B2	STORE	34
8	C2	RESET	33
9	D2	CLOCK	32
10	E2	ENABLE	31
11	G2	LZ0	30
12	F2	LZ1	29
13	A3	CARRY	28
14	B3	1/2-DIGIT	27
15	C3	F4	26
16	D3	G4	25
17	E3	E4	24
18	G3	O4	23
19	F3	C4	22
20	A4	B4	21

**FEATURES**

- Low power operation—less than 100 μW quiescent
- Direct 4 1/2-digit 7-segment display drive for higher contrast and long display life
- Pin compatible to Intersil's ICM7224
- Store and Reset inputs permit operation as frequency or period counter
- True count inhibit disables first counter stage
- Carry output for cascading 4-digit blocks
- Schmitt trigger on the clock input allows operation in noisy environments or with slowly changing inputs
- Leading zero blanking input and output for correct leading zero blanking with cascaded devices
- On-chip backplane oscillator/driver which can be disabled to permit slaving of multiple devices to an external backplane signal

**ABSOLUTE MAXIMUM RATINGS (Note 1)**

Voltage at Any Pin	-0.3V to V <sub>CC</sub> + 0.3V
Operating Temperature Range	-40°C to +85°C
Storage Temperature Range	-65°C to +150°C
Package Dissipation	500 mW
Operating V <sub>CC</sub> Range	3.0V to 6.0V
Absolute Maximum V <sub>CC</sub>	6.5V
Lead Temperature (Soldering, 10 seconds)	300°C

### 89 Hands-on Electronics FactCard

### 555 Circuits

**WIDE RANGE, TUNABLE FUNCTION GENERATOR**

TRIANGLE WAVE: -10V to +5V

SQUARE WAVE: TIMING DIAGRAM

TRIANGLE WAVE OUTPUT

SQUARE WAVE OUTPUT 1

SQUARE WAVE OUTPUT 2

$f = \frac{1}{T} \approx \frac{0.1}{R_{ABC} C_1}$   
(AS SHOWN, f IS VARIABLE FROM 10 Hz TO 50 kHz.)

$*t_1 = t_2 \approx 5R_{ABC} C_1$   
 $T = t_1 + t_2 \approx 10R_{ABC} C_1$

### 90 Hands-on Electronics FactCard

### 4073: Triple 3-Input AND Gate 4075: Triple 3-Input OR Gate

**FEATURES**

- Wide supply voltage range: 3.0V to 15V
- High noise immunity: 0.45 V<sub>DD</sub> typ.
- Low power TTL compatibility: fan out of 2 driving 74L or 1 driving 74LS
- 5V - 10V - 15V parametric ratings
- Symmetric output characteristics
- Maximum input leakage 1 μA at 15V over full temperature range

**ABSOLUTE MAXIMUM RATINGS**

V <sub>DD</sub> DC Supply Voltage	-0.5V <sub>DD</sub> to +0.5V <sub>DD</sub>
V <sub>IN</sub> Input Voltage	-0.5V <sub>DD</sub> to V <sub>DD</sub> + 0.5V <sub>DD</sub>
T <sub>S</sub> Storage Temperature Range	-65°C to +150°C
P <sub>D</sub> Package Dissipation	500mW
T <sub>L</sub> Lead Temperature (soldering, 10 seconds)	260°C

**RECOMMENDED OPERATING CONDITIONS**

V <sub>DD</sub> DC Supply Voltage	+5V <sub>DD</sub> to +15V <sub>DD</sub>
V <sub>IN</sub> Input Voltage	0V <sub>DD</sub> to V <sub>DD</sub>
T <sub>A</sub> Operating Temperature Range	-55°C to +125°C
CD4073BM/CD4075BM	-55°C to +125°C
CD4073BC/CD4075BC	-40°C to +85°C



DC ELECTRICAL CHARACTERISTICS

Parameter	Conditions	Typ	Units
<b>CMOS TO CMOS</b>			
V <sub>T+</sub> Positive Going Threshold Voltage	V <sub>CC</sub> = 5V, V <sub>IN</sub> (0-5) V	2.9	V
V <sub>T-</sub> Negative Going Threshold Voltage	V <sub>CC</sub> = 5V, V <sub>IN</sub> (5-0) V	2.2	V
Hysteresis (V <sub>T+</sub> - V <sub>T-</sub> )	V <sub>CC</sub> = 5V	0.7	V
Logical "1" (V <sub>IN(1)</sub> )	V <sub>CC</sub> = 5V		V
Logical "0" (V <sub>IN(0)</sub> )	V <sub>CC</sub> = 5V		V
Logical "1" (V <sub>OUT(1)</sub> )	V <sub>CC</sub> = 5V, I <sub>O</sub> = -10 μA		V
Logical "0" (V <sub>OUT(0)</sub> )	V <sub>CC</sub> = 5V, I <sub>O</sub> = +10 μA		V
Clock Input Current (I <sub>IN</sub> )	V <sub>CC</sub> = 5V, V <sub>IN</sub> = 5V/0V	0.005	μA
Input Current @ Pins 29, 31, 33 and 34	V <sub>CC</sub> = 5V, V <sub>IN</sub> = 0V	-12.0	μA

Parameter	Conditions	Typ	Units
<b>CMOS TO CMOS</b>			
Oscillator Input Current (I <sub>OSI</sub> )	V <sub>CC</sub> = 5V, V <sub>IN</sub> = 0V/5V	±1.0	μA
Supply Current (I <sub>CC</sub> )	V <sub>CC</sub> = 5V, V <sub>IN</sub> = 0V/5V	10	μA
Oscillator Input Voltage	When Driving Oscillator Pin with External Signal		V
V <sub>H</sub> (OSC)			V
V <sub>L</sub> (OSC)			V
<b>CMOS/LPTTL INTERFACE</b>			
Logical "1" (V <sub>IN(1)</sub> )	V <sub>CC</sub> = 4.75V		V
Logical "0" (V <sub>IN(0)</sub> )	V <sub>CC</sub> = 4.75V		V
Logical "1" (V <sub>OUT(1)</sub> )	V <sub>CC</sub> = 4.75, I <sub>O</sub> = -360 μA		V
Logical "0" (V <sub>OUT(0)</sub> )	V <sub>CC</sub> = 4.75V, I <sub>O</sub> = 360 μA		V

WIDE-RANGE SQUARE-WAVE/TRIANGLE-WAVE GENERATOR

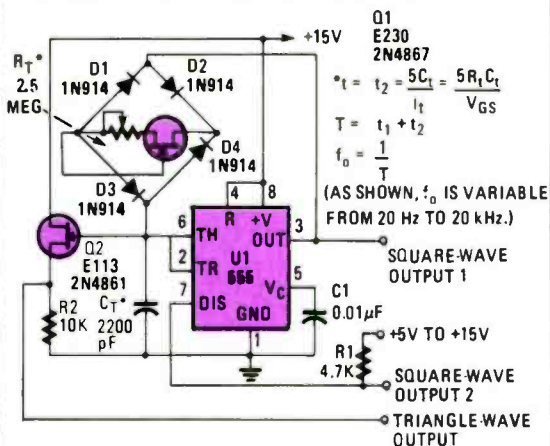

INVERTING BISTABLE BUFFER

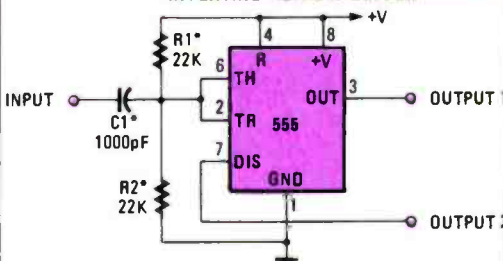

TIMING DIAGRAM

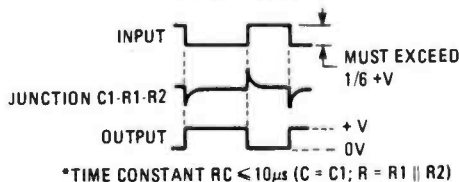

For new ideas in electronics read Radio-Electronics®

During the next 12 months

- Radio-Electronics® will carry up-to-the minute articles on:
- hobby computers
  - solid-state technology
  - TV games • Video
  - color TV • stereo
  - test equipment
  - radio
  - radar detectors
  - industrial electronics
  - servicing
  - TV-radio-stereo
  - experimenter circuits
  - exceptional construction projects

Don't take a chance on missing even one issue. Subscribe now and save!

STATIC ELECTRICAL CHARACTERISTICS

CHARACTERISTIC	CONDITIONS			LIMITS at 25°C (Typ.)	UNITS
	V <sub>O</sub> (V)	V <sub>IN</sub> (V)	V <sub>DD</sub> (V)		
Quiescent Device Current, I <sub>DD</sub> Max.	—	0.5	5	0.01	μA
	—	0.10	10	0.01	
	—	0.15	15	0.01	
Output Low (Sink) Current, I <sub>OH</sub> Min.	0.4	0.5	5	1	mA
	0.5	0.10	10	2.6	
	1.5	0.15	15	6.8	
Output Voltage: Low-Level, V <sub>OL</sub> Max.	4.6	0.5	5	-1	V
	2.5	0.5	5	-3.2	
	9.5	0.10	10	-2.6	
	13.5	0.15	15	-6.8	
Input Current I <sub>IN</sub> Max.	—	0.18	18	±10 <sup>-6</sup>	μA

CHARACTERISTIC	CONDITIONS			LIMITS at 25°C (Typ.)	UNITS
	V <sub>O</sub> (V)	V <sub>IN</sub> (V)	V <sub>DD</sub> (V)		
Output High (Source) Current, I <sub>OH</sub> Min.	—	0.5	5	0	V
	—	0.10	10	0	
	—	0.15	15	0	
Output Voltage: High-Level, V <sub>OH</sub> Min.	—	0.5	5	5	V
	—	0.10	10	10	
Input Low Voltage, V <sub>IL</sub> Max.	0.5	—	5	—	V
	1	—	10	—	
	1.5	—	15	—	
Input High Voltage, V <sub>IH</sub> Min.	0.5, 4.5	—	5	—	V
	1.9	—	10	—	
	1.5, 13.5	—	15	—	



NEW IDEAS AND INNOVATIONS IN ELECTRONICS

The newest ideas and innovations in electronics appear in Radio-Electronics®, Keep up-to-date!

Subscribe Today!



# HANDS-OFF



# INTERCOM

*Here's an easy-to-build, easier-to-use switchless intercom that offers all the convenience of a face-to-face conversation*

BY CHARLES D. RAKES

**W**e all like to travel interstate road systems that allow traffic to travel in both directions without having to slow down to pass or exit. Our telephone system offers a similar benefit by allowing two-way conversations. So why should we be limited to using an intercom system that requires flipping levers and switches to go from the talk to the listen mode? You'll have no need for them if you build our two-way switchless intercom system.

Our *Bidirectional Intercom* system requires only a two-wire interconnecting cable. The power can be turned off on either unit without killing the operation, and when either unit is powered on, both are operational.

**Operation Basics.** Take a look at the block diagram shown in Fig. 1 and you'll see two inverting op-amps connected in tandem. Amplifier A increases the microphone's output to a usable level. That amp's output signal is fed to op-amp B, which inverts the signal 180°.

A balance-control potentiometer connects across the outputs of amplifiers A and B. Under ideal conditions, the signal waveform at output A is the same as the signal waveform at output B, but 180° out of phase. If an audio tone is fed into the microphone and

the balance potentiometer's wiper is all the way over to the A output position, the tone will be heard at a high level. As the wiper is rotated toward the B output, the audio level will decrease until it just about disappears near the center of the potentiometer's range. As you continue to rotate the wiper, the signal will begin to increase once again.

With the balance control set for a minimal output, the intercom's tendency to go into self oscillation due to acoustical feedback between the microphone and speaker is kept to a minimum. The microphone's amplified signal at A's output is fed to the other intercom through the audio in/out cable.

ble. Since both intercom units are alike, the audio information coming from one unit feeds the other at the input of op-amp B. The incoming audio is amplified slightly by op-amp B and the output signal is sufficiently increased by the power-amp to drive the speaker.

**Only Two Wires?** The secret that allows the intercom to use a single wire pair to carry both DC power and audio is in the use of an audio transformer, T1 (see the schematic diagram in Fig. 2). The DC resistance of the transformer winding is about 30 ohms, which allows DC power to pass from one intercom to the other with very little loss.

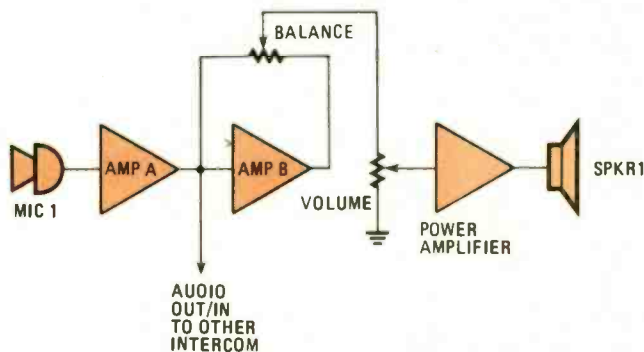

*Fig. 1—The microphone's output is amplified and sent right out to the other intercom. Some of its output is shifted by 180° and mixed with the original signal to cut down feedback that would occur locally before being amplified.*

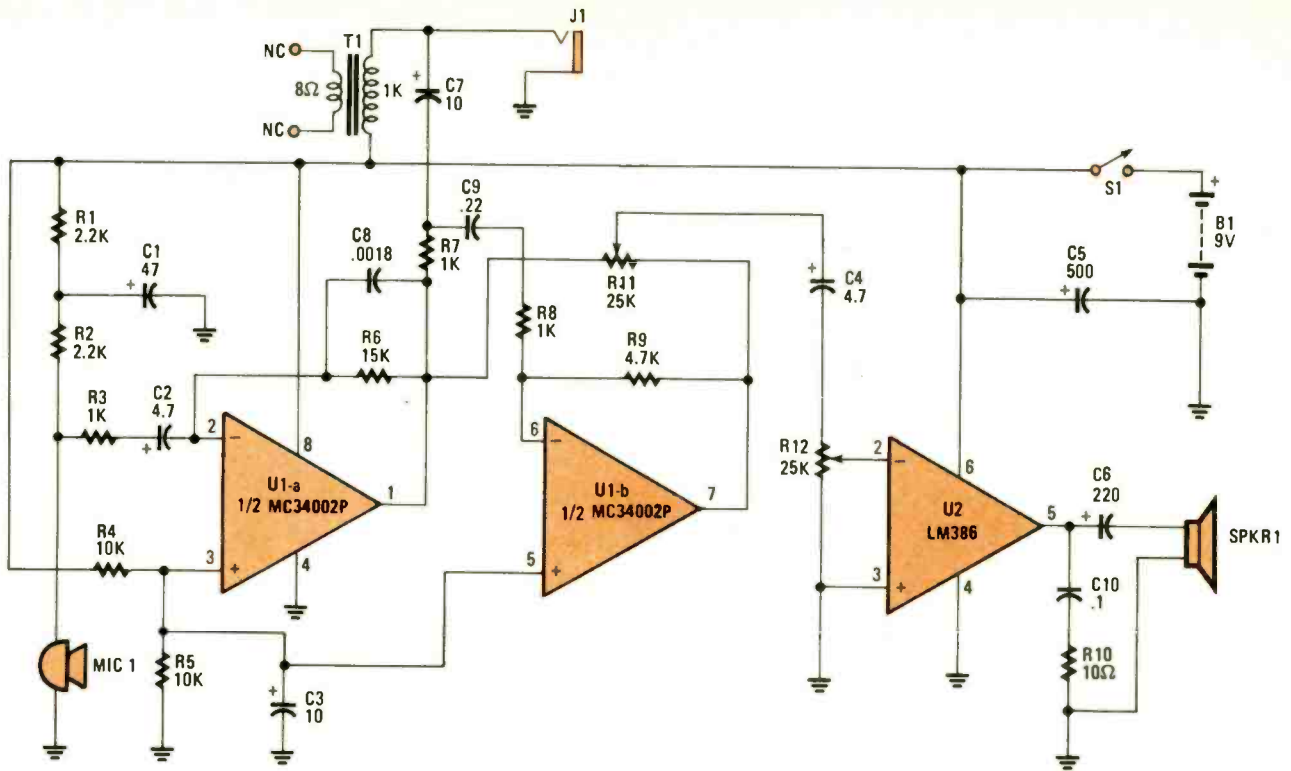

Fig. 2—Op-amps U1-a and U1-b perform the amplifying and inverting functions while the power amp, U2, boosts the signal to listening level.

Actually the battery current must pass through two 30-ohm windings in series when operating power is supplied by a single unit. Now, the audio signal would be reduced to zilch if it had to look into a 15-ohm load, and that's what it would see because the transformers are essentially two 30-ohm loads connected in parallel to an audio signal. But here's where the impedance characteristic of the transformer comes into play. True, the DC resistance of the transformer is very low but the impedance (resistance to AC) is much higher, over 1000-ohms, giving the audio a free ride through the coupling capacitor C7 from one unit to the other.

**Building the Twins.** Follow the schematic diagram and photos if you want to duplicate the author's prototype, or go free-lance and follow your own scheme, as neither the layout or enclosure is critical.

In the prototype, most of the circuitry mounts on a 3 x 4-inch section of perfboard. The exceptions are the two potentiometers, microphone, and power switch, which mount on the cabinet's front panel, and the 1/4-inch phone jack, J1, which mounts on the back panel.

To mount the microphone, drill or punch a 1/2-inch hole in the front panel.

### PARTS LIST FOR THE BIDIRECTIONAL INTERCOM

<p><b>CAPACITORS</b>  C1—47-<math>\mu</math>F, 16-WVDC, electrolytic  C2, C4—4.7-<math>\mu</math>F, 16-WVDC, electrolytic  C3, C7—10-<math>\mu</math>F, 25-WVDC, electrolytic  C5—500-<math>\mu</math>F, 25-WVDC, electrolytic  C6—220-<math>\mu</math>F, 16-WVDC, electrolytic  C8—.0018-<math>\mu</math>F, 100-WVDC, mylar  C9—0.22-<math>\mu</math>F, 100-WVDC, mylar  C10—0.1-<math>\mu</math>F, 100-WVDC, disc</p> <p><b>RESISTORS</b>  (All fixed resistors are 1/4-watt, 5% units.)  R1, R2—2200-ohm  R3, R7, R8—1000-ohm  R4, R5—10,000-ohm  R6—15,000-ohm  R9—4700-ohm  R10—10-ohm  R11, R12—25,000-ohm potentiometer</p>	<p><b>ADDITIONAL PARTS AND MATERIALS</b>  B1—9-volt battery (see text)  J1—1/4-inch phone jack  MIC1—Electret mike element, Radio Shack 270-092 or equivalent  S1—SPST mini toggle switch  T1—1000-ohm to 8-ohm, miniature output transformer  U1—MC34002P or TL082CP dual op-amp, integrated circuit  U2—LM386 audio power-amplifier, integrated circuit  SPKR1—8-ohm, 3-inch round speaker</p> <p>Perfboard, 2 7/8 x 5 3/8 x 5-in. instrument case, knobs, IC sockets, battery snaps, battery holder (see text), rubber grommet, two-wire cable, solder, 1/4-inch phone plugs, etc.</p>
--	---

A rubber grommet is fitted in the hole, and the microphone is pressed in place so its face is flush with the front edge of the grommet. Be sure to observe the plus and minus connections on the electret microphone when wiring to the balance of the circuit.

No matter what construction scheme you follow, it's always a good idea to use IC sockets, and double-check the polarity of the electrolytic capacitors before soldering them in place. If you follow a good common-

sense approach in building this or any project, you can save hours of head scratching, not to mention damaged parts. Don't forget that when you've finished one intercom, you are only half-way there, so double up on parts.

**Checking It Out.** If the intercoms are to be used sparingly—remaining off except when in actual use—then a standard 9-volt transistor-radio battery will do. But if heavy use is expected, we

*(Continued on page 101)*



# THE TV AMP

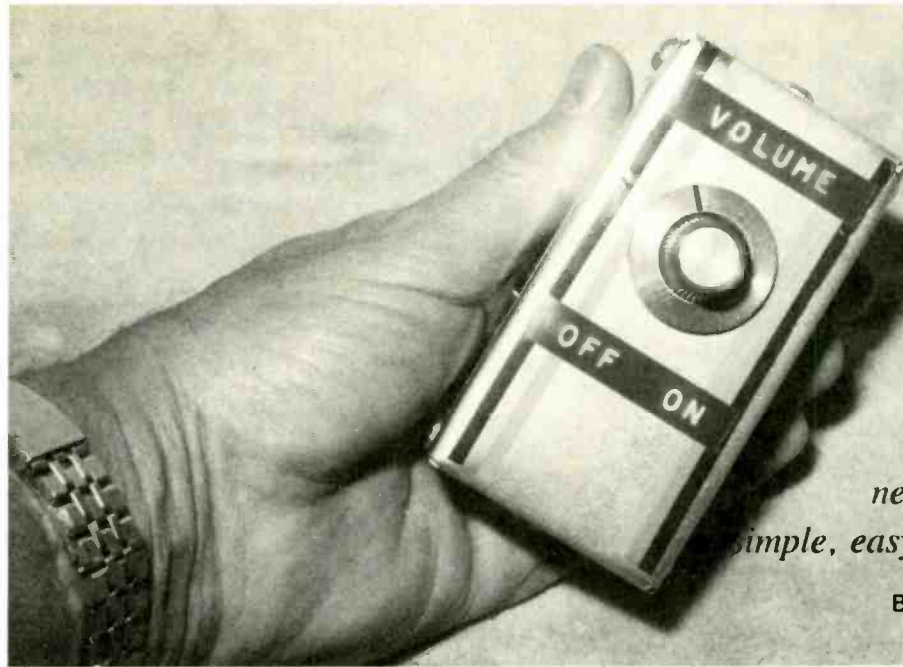

*Tailor TV sound to the needs of the viewer with this simple, easy-to-build, audio amplifier*

BY HOMER L. DAVIDSON

Just about everyone has a relative or friend that suffers from a hearing impairment that makes it difficult to watch TV without cranking up the volume. If the volume is set to a level that is comfortable for others, the hearing impaired person is left out of the fun.

But with the *TV Audio Amplifier* (see photo) described in this article, you can let everyone get the full enjoyment offered by TV without subjecting anyone to a sonic blast. The TV Audio Amplifier picks up the TV's audio output signal and amplifies it enough to drive a set of earphones for private listening.

**Circuit Operation** Figure 1 shows a schematic diagram of the TV Audio Amplifier. The circuit is built around an LM324 low-power quad op-amp and an LM386 low-voltage audio power amplifier. One op-amp in the LM324 package (U1) is configured as a pre-amp, which is used to amplify the signal input from an electret microphone element (not shown) that plugs into J1. A bias voltage of around 4.17 volts is supplied to pin 3 of U1 through a resistor/capacitor network consisting of R6, R7, and C3. The microphone picks up the TV audio and produces an electrical signal that is fed through C1 and R4 to the inverting input of U1 at pin 2.

Op-amp U1 amplifies the signal to a level determined by input resistor R4 and feedback resistor R5. With the values given, the gain of that stage is equal to  $R5/R4 = 100K/1K = 100$ . The

amplified signal is output at pin 1 and fed through volume control R8 and coupling capacitor C4 to the non-inverting input of U2 at pin 3. As configured, U2 has a gain of about 200, which is more than enough gain to drive a set of earphones.

The earphones are connected to the circuit through a normally open phono jack (J2) and coupling capacitor C8. Regular stereo earphones (with an impedance in the range of 8- to 38-ohms) may be used for listening. A 32-ohm unit, like those supplied with radio and cassette players, is ideal.

A 9-volt transistor-radio battery is used for power. Because the circuit draws only 9.3 mA of current during normal operation, the battery should last a long time (as long as the circuit is not left on accidentally).

Aside from the circuit's intended use, it can also come in handy for late-night TV viewing. For instance, ardent sports fans might use it to watch their favorite team's late-night battles. Another application for the circuit might be when one family member wants to watch TV while another is reading.

**Assembly** There is nothing critical about the physical layout of the circuit, other than keeping the input and output stages as far apart as possible (preferably at opposite ends of the board). The author's prototype was built on perfboard using point-to-point wiring (see photos). It's recommended that the ICs be socketed to avoid damaging them during soldering.

Begin the assembly by first mounting the IC sockets, and marking the loca-

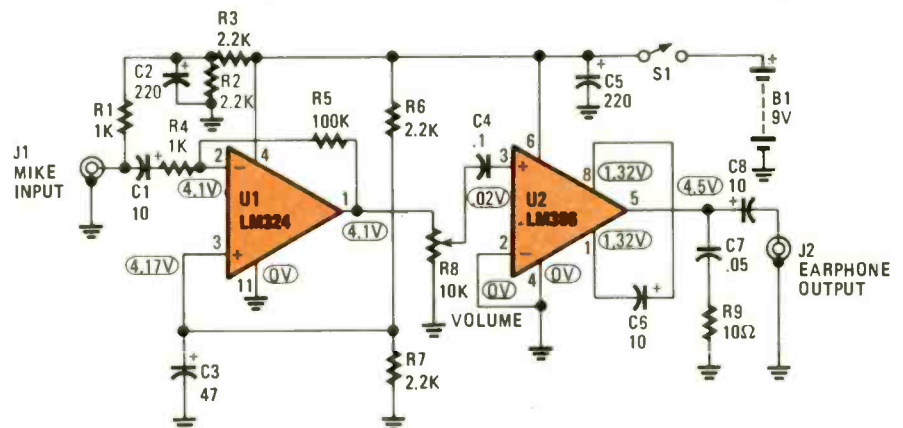
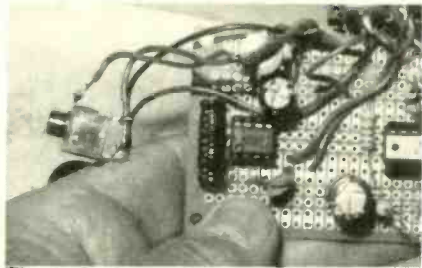

Fig. 1—The TV Audio Amplifier is built around an LM324 quad op-amp and an LM386 low-power audio amplifier. The circuit uses an inexpensive electret microphone element as the pick-up and a set of earphones as the output device.



The author's prototype was built on perf-board using point-to-point wiring. Note that U1 and U2 are located at opposite ends of the board to prevent distortion.

tion of pin 1 for each IC on the top and bottom of the board. That helps to prevent costly errors and hours of frustrating troubleshooting later.

When soldering, use a small point-ed-tip soldering iron to avoid bridging the socket pins. Once the sockets are in place, use a pocket knife to etch between each row of terminals to eliminate any shorts and to remove any excess solder or flux.

Mount the support components (resistors, capacitors, etc.) on the board, making sure that capacitor C5 (a 220- $\mu$ F unit) is placed as close as possible to pin 6 of U2 to prevent the circuit from breaking into self-oscillation. Next, solder a piece of #22 bare-copper wire around the outside edges on the underside of the board, in a "U" shape, to serve as a ground bus. Solder another piece of bare wire down the remaining side to serve as the +V bus. Left-over component leads can then be used to tie the parts together, and to connect the circuit to the power-supply and ground buses.

Solder two wires to both the input and output of the circuit. They will be used to connect the microphone and earphone jacks (J1 and J2) to the circuit. It's a good idea to use color-coded wire to make the connections between the board and the chassis-

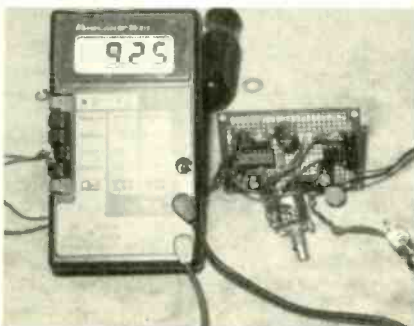

A working current check may point to the probable cause of the circuit's malfunction. The circuit's current drain on the battery should be about 9.3 mA.

mounted components—preferably, black for the ground connection and red for the signal line.

The author used stereo jacks for J1 and J2, bridging the two signal contacts (see Fig. 2) for monophonic oper-

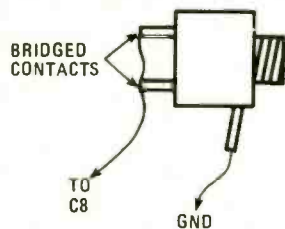

Fig. 2—Connect both stereo jack terminals together to convert the stereo jack for monophonic operation.

ation. The bridged-signal contacts of J1 and J2 should be connected to C1 and C8, respectively. The jacks should be placed at opposite ends of the enclosure. Leave enough slack in the wires so that the cover can be easily removed to change the battery.

Finally, double check the orientation of each component, and the wiring connections between them, against the schematic diagram to make sure that the project is properly wired before applying power to the circuit. There is nothing more disappointing than to fire up a project and find that it doesn't work.

Figure 3 shows the pinout connections for the microphone element. Solder two leads to the microphone element, red for +V and black for

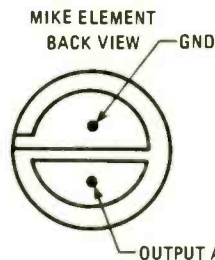

Fig. 3—Shown here is a bottom view of the electret microphone element. Be careful when soldering the terminals, they are small and extremely fragile.

ground. The leads of the microphone element are then threaded through a  $\frac{1}{8}$ -inch plastic headphone-plug housing, and the microphone element is glued to the end (see photos). Connect the microphone element to one end of the smallest flexible microphone cable available, and connect a plug to the other end to form an assembly like that shown in Fig. 4.

Prepare the enclosure by drilling two  $\frac{7}{32}$ -inch holes, one at each end, for the

## PARTS LIST FOR THE TV AUDIO AMPLIFIER

### SEMICONDUCTORS

U1—LM324 quad low-power op-amp, integrated circuit

U2—LM386 low-voltage audio power amplifier, integrated circuit

### RESISTORS

(All resistors are  $\frac{1}{4}$ -watt, 5% units, unless otherwise noted.)

R1, R4—1000-ohm

R2, R3, R6, R7—2200-ohm

R5—100,000-ohm

R8—10,000-ohm audio potentiometer with SPST switch (see text)

R9—10-ohm

### CAPACITORS

C1, C6, C8—10- $\mu$ F, 35-WVDC electrolytic

C2, C5—220- $\mu$ F, 35-WVDC electrolytic

C3—47- $\mu$ F, 35-WVDC electrolytic

C4—0.1- $\mu$ F, ceramic disc

C7—0.05- $\mu$ F ceramic disc

### ADDITIONAL PARTS AND MATERIALS

B1—9-volt transistor-radio battery

J1, J2—Miniature open-circuit stereo phono jack

PL1—Miniature plug (mates with J1, see text)

Printed circuit or perfboard materials, earphones, electret microphone element (Radio Shack 270-090 or equivalent), microphone cable, metal enclosure, IC sockets (optional), battery and battery holder, wire, solder, hardware, etc.

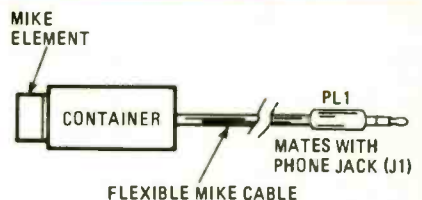

Fig. 4—The microphone element is glued to the end of the plug housing and its leads are soldered to the plug contacts.

input and output jacks, and a  $\frac{3}{8}$ -inch hole on the top for the volume control. (See photos.) Make sure that jacks will clear the perfboard assembly when the enclosure is sealed.

Mount the circuit-board assembly inside the metal enclosure. The board should be insulated from the metal cabinet with  $\frac{1}{8}$ -inch plastic washers.

**Troubleshooting** The first step in troubleshooting the circuit is to take voltage and current readings. Remove one terminal of the battery and rotate the battery 180°. Insert an ammeter in

(Continued on page 101)



# RGB BLUE BOX

Build the RGB Blue Box  
and turn your black screens blue

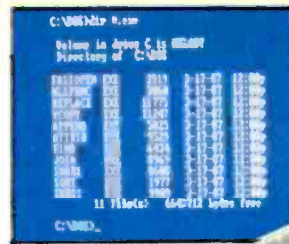

BY MICHAEL A. COVINGTON

**B**ack in the good old days, a "blue box" was a tone generator that tricked the telephone company's circuits into giving you free calls. The RGB "Blue" Box described in this article does something that's more legal, and much simpler—it turns your PC's RGB-monitor screen blue at the flip of a switch. That is, it makes your computer display bright white text on a blue background, instead of the usual low-intensity white on black.

That color change is a real eye-saver. By brightening the background as well as the text, it overcomes any glare that may be falling on the screen. Some color monitors have a "text mode" in which the display becomes green on black, like a green-phosphor monochrome screen. But that approach misses the point. The best way to conquer glare is to increase the total light output of the screen, not reduce it, so that's what the Blue Box does.

**How it Works.** The RGB Blue Box connects between your IBM PC Color Graphics Adapter (CGA), or equivalent, and your RGB color monitor. By flipping a switch, you choose between two modes. One mode passes the signal from the PC to the monitor unaltered; the other transforms it to make text more readable.

The monitor has four TTL-level inputs—red, green, blue, and Intensity—and it interprets disconnected wires as high ("on"). That's why the screen turns white if you disconnect the monitor

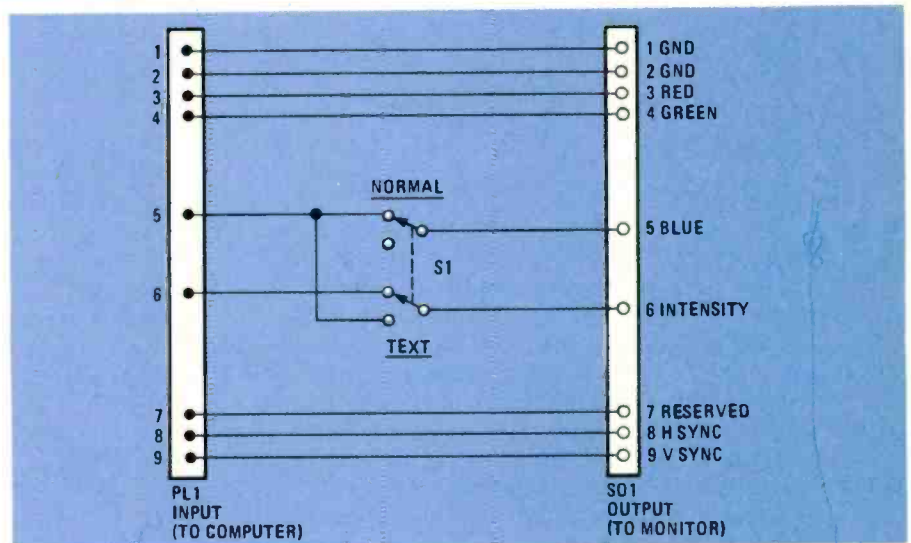

Fig. 1—Here's the schematic diagram for the RGB Blue Box. The circuit is simplicity itself. Thanks to that, it should cost no more than \$10 to build.

## PARTS LIST FOR THE RGB BLUE BOX

- PL1—9-pin D-connector, male, solder type, without hood
- SO1—9-pin D-connector, female, solder type, without hood
- S1—DPDT toggle switch, miniature, panel mount
- 2 hardware kits for mounting D-connectors, or four 4-40 × 1/2-inch machine screws with nuts; metal enclosure; monitor extension cable, 9-pin female to 9-pin male; etc.

from the computer. And—you guessed it—the screen turns blue if you disconnect only the blue line.

That is exactly what the Blue Box does; but wait, there is more. Instead of just discarding the blue signal, the Blue Box reroutes it to the intensity input. As a result, most of the text colors come out intensified.

There are software utilities that perform a similar color change, but the Blue Box is more reliable. With the Blue Box, the border is always blue, and when the screen goes blank during scrolling, you see blue rather than black. More importantly, unlike software screen drivers, the Blue Box cannot affect your programs: it intercepts the signals after they've left the PC, so

(Continued on page 102)

# CAPACITANCE ADAPTER FOR YOUR DMM



**Here's a simple adapter circuit that lets your DMM measure capacitance up to 2.2 microfarads**

BY JOHN CLARKE AND GREG SWAIN

**W**HEN WAS THE LAST TIME YOU HAD TROUBLE deciphering a capacitor label? The fact is that it's easy to misinterpret capacitor markings. And that's something that no one can afford when building projects.

A capacitance meter easily solves that problem by allowing you to simply plug the unknown capacitor into the test terminals and read the value in picofarads (pF) or microfarads ( $\mu\text{F}$ ) directly from the digital display. You can also use a capacitance meter to check suspected bad or unmarked capacitors, as well as select critical capacitor values.

If you are one of the fortunate few hobbyists who have purchased one of the modern digital multimeters, you may already have a capacitance meter. Many of them now come with built-in capacitance ranges that are typically capable of measuring up to about  $20\mu\text{F}$ .

On the other hand, if you are like most of us who use digital multimeters that don't have capacitance-reading capabilities, then perhaps this simple *Capacitance Adapter\** is for you.

The Adapter is designed to plug directly into the test terminals of a DMM, and allow you to measure capacitance values of up to  $2.2\mu\text{F}$  in two ranges:  $0\text{--}2200\text{pF}$  ( $.0022\mu\text{F}$ ) and  $0\text{--}2.2\mu\text{F}$ . Don't be put off by the rather low upper limit of the circuit—capacitors with values greater than  $2.2\mu\text{F}$  are usually clearly marked and seldom require testing.

On the down side, the Adapter is only suitable for use with digital multimeters, which usually have fixed input impedances of 10 megohms, because analog meters (with their comparatively low input impedances) would load down the circuit, causing inaccurate readings.

## About the Circuit

Figure 1 shows the schematic diagram of the Capacitance Adapter, which is basically a capacitance-to-voltage converter. The circuit consists of only two active devices: a 74HC132 quad, two-input NAND Schmitt trigger (U1) and 7805 5-volt regulator (U2). One gate in the U1 package (U1-a) forms a free-running oscillator, while R1 allows for frequency adjustments. The squarewave output of the oscillator is fed to two inverters, U1-b and U1-c.

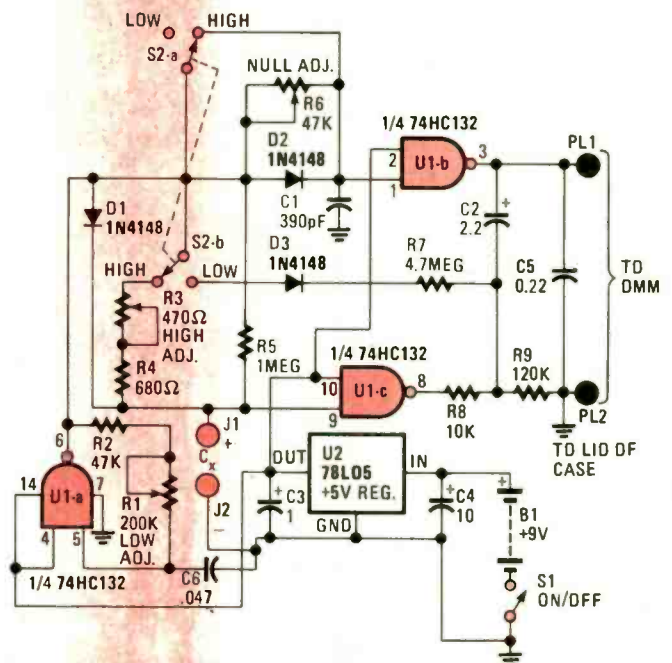

**Fig. 1—The circuit is built around a single 74HC132 quad NAND Schmitt trigger. It produces a voltage that is directly proportional to the unknown capacitance,  $C_x$ .**

\*This story first appeared in *Silicon Chip*, Australia (November, 1987); reprinted with permission.



When the capacitor in question (which we'll refer to as  $C_x$ ) is connected to the J1/J2 input terminals, the circuit produces a voltage—one millivolt per picofarad on the lower range and one volt per microfarad on the upper range—that is directly proportional to the capacitance. And it is that voltage that's shown on the DMM display and interpreted as a capacitance value.

Capacitor  $C_x$  (when connected across J1/J2) charges via D1 during the positive half-cycle of the oscillator output and discharges on negative half-cycle via resistor R5 (in the LOW range) or via the series-parallel network formed by R3/R4 and R5 (in the HIGH range).

When the circuit is set to the HIGH range, the output of U1-a is fed directly to the pin 1 input of U1-b. So the output of U1-b is simply an inverted reproduction of its input signal. And with no capacitor connected across the J1/J2 input terminals, the output of U1-c is virtually identical to that of U1-b. If we were to measure the voltage difference between the U1-b/U1-c outputs, the result would be zero.

Now consider what happens when a capacitor is connected across the J1/J2 terminals. Capacitor  $C_x$  charges quickly via D1 and discharges slowly via R3/R4 and R5. That causes pin 9 of U1-c to stay high for longer than it stays low (the time duration on the size of the capacitor). So the output waveform from  $C_x$  is a series of pulses at the same frequency as U1-a, but with the pulse length being inversely proportional to the size of  $C_x$ .

Refer to Fig. 2. Waveforms A, B, and C correspond to the outputs of the three gates, respectively. If  $C_x$  is relatively large, the positive pulses fed to pin 8 of U1-c will be very short (as shown in waveform C). If the averaged voltage difference between the waveforms B and C is measured, it would be proportional to the capacitance of  $C_x$ .

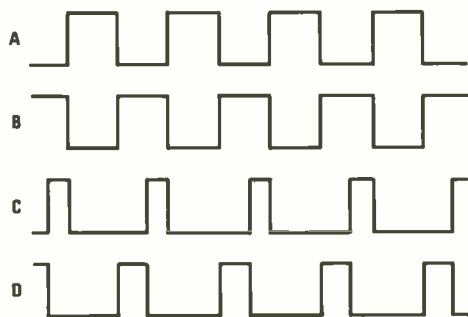

Fig. 2—This collection of waveforms shows the relationship between the three NAND Schmitt triggers when the circuit is set to the HIGH range.

The pulses are filtered by a dual RC filter (consisting of R8/C2 and R9/C5) to give a smooth DC voltage. That voltage is then measured by the DMM to give a direct readout of the capacitor value.

Sadly, things become more complicated when the circuit is switched to the LOW range due to stray capacitance across the J1/J2 terminals. Without some correction for stray capacitance, reading low-value capacitors would result in serious errors. That's where the null circuit comes into play.

When S2 is set to the LOW range, the output of U1-a is fed to pin 1 of U1-b via diode D2, charging the 390-pF capacitor, C1. Capacitor C1 charges quickly via D2 and discharges

slowly via R6. So the input to pin 1 stays high for a short period, each time pin 6 of U1-a switches low. The result is that the positive pulses output by U1-b are slightly shorter than they otherwise would be; compare the waveforms shown in A and B of Fig 3. Look closely, as the difference may not be apparent at first glance.

The C waveform in Fig. 3 shows the output of U1-c with only stray capacitance at the J1/J2 input (in other words, no test capacitor is connected). The stray capacitance is charged via D1 and discharges via R8, so the positive output pulses of U1-c are also slightly shorter than they otherwise would be (if there was no stray capacitance).

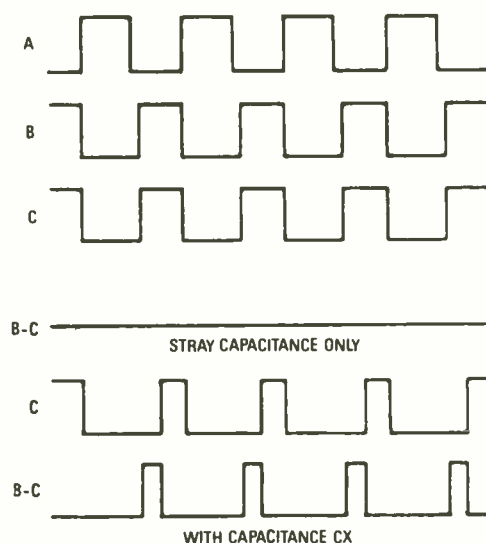

Fig. 3—Shown here are the waveform timing diagrams for the LOW range. Note that the positive pulses at B and C are shorter than those at A, due to capacitor C1 and the stray capacitance at the J1/J2 input.

Potentiometer R6 is the null adjustment, which should be set so that the positive-going edge of the B waveform in Fig. 3 coincides with the positive-going edge of waveform C (making the delay times equal). If measured, the voltage difference between waveform B and C would be zero, because the two waveforms are identical. In other words, the effects of stray capacitance are canceled out.

### Offset Voltage

When the circuit is set to the LOW range, D3 and R7 are switched into the circuit. Diode D3 feeds the squarewave output of U1-c to a voltage divider consisting of R7 and R8 (which is tied to pin 8 of U1-c). Actually, D3 is forward biased only when the output of U1-b exceeds 3.1 volts, and is reverse biased when the output drops below that value.

As a result, a fixed 5-mV offset appears on the negative output terminal (jacking up the negative terminal by 5 mV). To null the circuit, the voltage on the positive terminal must also be increased by 5 mV. That's achieved by adjusting R6 so that U1-b goes high before U1-c triggers.

The offset voltage overcomes a tendency for U1-b and U1-c to lock together when their respective trigger points are close. By adding the 5-mV offset, the circuit is nulled with U1-b set to trigger well before U1-c, eliminating the locking problem.

On the HIGH range, stray capacitance is insignificant compared to the value of  $C_x$ , so the nulling circuit is disabled (via S2). Similarly, the offset-voltage circuit is no longer required and D3 is also disconnected via S2.

Power for the circuit is derived from a 9-volt transistor-radio battery. A 78L05 3-terminal regulator provides a regulated 5-volt source so that the oscillator and nulling circuits remain in calibration over the life of the battery.

The circuit demands that U1 be a high-speed CMOS NAND gate (74HC132) because that type of IC has shorter propagation times than do standard CMOS. And that's particularly important when measuring low-capacitance values on each range.

### Construction

The Capacitance Adapter was built on a small printed-circuit board, and housed in a small plastic enclosure, measuring about  $3\frac{1}{2} \times 2\frac{1}{4} \times 1\frac{1}{4}$  inches—although any suitably-sized enclosure will do. The project (with banana plugs PL1 and PL2 protruding through the rear of the enclosure) is designed to be plugged directly into the DMM test terminals. The two banana jacks, J1 and J2, are mounted on the front panel of the enclosure, along with the range and power switches.

Begin construction by first etching a printed-circuit board, using the full-size foil pattern shown in Fig. 4 as a template.

### PARTS LIST FOR THE CAPACITANCE ADAPTER

#### SEMICONDUCTORS

U1—74HC132 quad two-input NAND Schmitt trigger, integrated circuit

U2—78L05 low-power 5-volt regulator, integrated circuit

D1—D3—1N914 or 1N4148 small signal diode

#### RESISTORS

(All resistors are  $\frac{1}{4}$ -watt, 5% units, unless otherwise noted.)

R1—200,000-ohm miniature, vertical PC-mount trimmer potentiometer

R2—47,000-ohm

R3—470-ohm miniature vertical, PC-mount trimmer potentiometer

R4—680-ohm

R5—1-megohm

R6—47,000-ohm miniature vertical, PC-mount trimmer potentiometer

R7—4.7-megohm

R8—10,000-ohm

R9—120,000-ohm

#### CAPACITORS

C1—390-pF polystyrene

C2—2.2- $\mu$ F 16-WVDC electrolytic

C3—1- $\mu$ F 16-WVDC electrolytic

C4—10- $\mu$ F 16-WVDC electrolytic

C5—0.22- $\mu$ F metalized polyester

C6—0.047- $\mu$ F metalized polyester

#### ADDITIONAL PARTS AND MATERIALS

B1—9-volt transistor-radio battery

J1, J2—banana panel jacks (1 red, 1 black)

PL1, PL2—banana plugs

S2—Double-pole, double-throw toggle switch

S1—Single-pole, double-throw toggle switch

Printed circuit or perboard materials, enclosure, IC sockets, battery connector, alligator clips, wire, solder, hardware, etc.

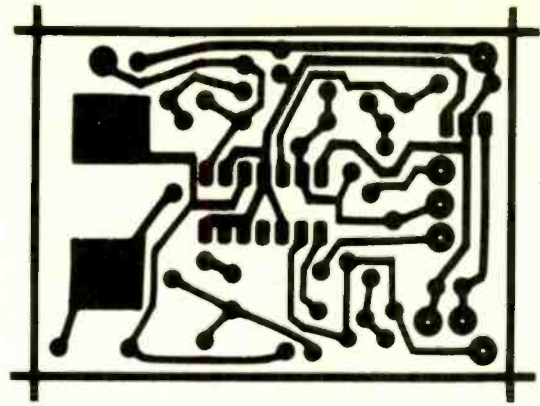

Fig. 4—Shown here is a full-scale template of the Capacitance Adapter's printed-circuit artwork.

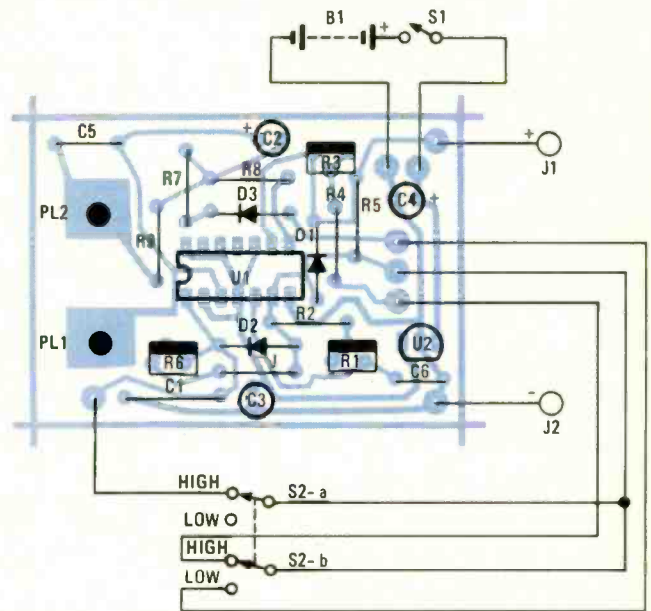

Fig. 5—This parts-placement diagram of the Adapter shows both location and orientation of the board-mounted components, as well as indicating the off-board wiring connections.

Once etched, begin installing the components given in the Parts List using Fig. 5 as a guide. Install the resistors, capacitors, and trimmer potentiometers; followed by U1 and U2. And don't forget to install the jumper (marked with a J). Make sure that all polarized parts (ICs, diodes, and electrolytic capacitors) are correctly oriented.

The banana plugs are soldered to the foil side of the board (see photos) and further secured using the screw-on insulated moldings. It will be necessary to cut the moldings down to about  $\frac{1}{4}$ -inch, so that the battery fits into the case. The switch and input-terminal positions can then be labeled using dry-transfer (rub-on) lettering, and the finished panel sprayed with a clear lacquer to keep the lettering from rubbing off.

Next mount the switches and test terminals to the finished front panel of the enclosure, and connect the off-board components to the circuit board as shown in Fig. 5.

The case can now be drilled to accept the printed-circuit board assembly. Two 0.32-inch holes are drilled in the rear panel to provide clearance for the banana plugs, while another three holes are drilled in the sides of the case to allow screwdriver access to the trimmer potentiometers.

The assembly goes together with the battery sandwiched

(Continued on page 106)



# GIZMO

NOVEMBER 1988

A CHRONICLE OF CONSUMER ELECTRONICS

VOLUME 1, NUMBER 9

Canon Personal Copier . . . . .	pg. 1
Welbilt Microwave Oven . . . . .	pg. 2
Vistacom Videophone . . . . .	pg. 3
Bushnell Star Machine . . . . .	pg. 4
Ricoh Auto-Focus 35-mm Camera . . . . .	pg. 5
CES Notes . . . . .	pg. 6
Remington Lektro Razor . . . . .	pg. 6
Ten-Hour Humidifier . . . . .	pg. 7
Diver's G-Shock Watch . . . . .	pg. 8
Portable Personal Word Processor . . . . .	pg. 8
Studio Monitor Speakerphone . . . . .	pg. 8
Talking Security System . . . . .	pg. 8
AM/FM Stereo A/V Receiver . . . . .	pg. 9
Conductor Battery . . . . .	pg. 9
Databank/Phonebook/ Calculator . . . . .	pg. 9
Telephone Light . . . . .	pg. 9
Tetris Game software . . . . .	pg. 9
Digital Stereo Monitor/ Receiver . . . . .	pg. 10
Electronic Speller/Calculator . . . . .	pg. 10
Integrated Answering System . . . . .	pg. 10
Portable Smoke Alarm . . . . .	pg. 10
Remote Control CD Player . . . . .	pg. 10
Transportable 8mm VCR . . . . .	pg. 10
TV/Stereo System . . . . .	pg. 10
Color Viewfinder Camcorder . . . . .	pg. 11
"Digital Compatible" Headphone . . . . .	pg. 11
Environmental Sound Machine . . . . .	pg. 11
FM-Pager/Vehicle-Alarm System . . . . .	pg. 12
Hands-Free Personal Headlights . . . . .	pg. 12
Intelligent A/V Remote Control . . . . .	pg. 12
Three-Way Speaker System . . . . .	pg. 12
Video Game Organizer . . . . .	pg. 12



CIRCLE 31 ON FREE INFORMATION CARD

## Dupe-It-Yourself

**CANON PERSONAL COPIER (PC-3). Manufactured by: Canon U.S.A., Inc., One Canon Plaza, Lake Success, NY 11042. Price: \$745.**

Not so long ago, people were inclined to wonder how civilization ever got along without photocopy machines. Nowadays, some observers are beginning to ponder how we'll survive those instant-duplication systems. When in doubt, photocopy appears to be a byword in business, education, and government today. The resulting mountain of copies would seem to represent deforestation on a scale not seen since the Ice Age.

As if institutional copy mania wasn't enough, a few years ago *Canon U.S.A., Inc.* began a high-powered marketing campaign on behalf of a new category of photocopy machines dubbed "personal copiers." The first and most low-priced of the Canon products was the *PC-3*, and although this year the company added new models to its personal-copier line, the *PC-3* remains at the center of this market effort.

Although anything but unfamiliar with copy machines, we wondered how well a

portable, budget-priced unit was likely to perform. After using the *PC-3* for a couple of weeks, we can report that in its copy functions, it performs impressively indeed. Although limitations are inherent in its price and size, anyone who has experience with earlier attempts at bringing copy systems down in price and size will be surprised by the *PC-3*'s performance.

Described as ideal for "the home, small business, CEO's desk, or college dorm," the 25-pound copier has a built-in tote handle (although at 25 pounds, users who plan to transport it on a regular basis might want to acquire Canon's optional \$99.95 suitcase-style carry case). As with some other "portable" electronic products, the *PC-3* is better described as "luggable."

Once lugged, the machine must be set up in space sufficient to accommodate its moving "copyboard." The back-and-forth motion takes the board about five-and-a-half inches beyond each end of the 13 $\frac{3}{4}$ -inch long unit (the *PC-3* is 16 inches wide and 5 $\frac{1}{2}$  inches high). Additional space is required by an optional 9 $\frac{1}{2}$ -inch long copy tray into which duplicates fall. Another necessity is a three-prong wall outlet or adaptor. The instructions also warn not to plug anything else into the outlet occupied by the *PC-3*. Power requirements are listed as 220/240 volts. All of which makes us wonder just how ideal this would be for the typical college dorm room.

NOVEMBER 1988

Controls are simple in the extreme. A wheel mounted on the machine's left side controls contrast and copy darkness, indicated by a gray strip on the wheel that displays increasing exposure. The power switch is located to the right of the paper feed. Copying is activated by manually sliding a single sheet into the paper feed. A pair of mounted plastic guides makes it possible to copy onto sheets smaller than the standard 8½ × 11 piece of paper, which is the largest size the PC-3 can accommodate.

Above the exposure wheel are three indicators: "power on," a blinking "paper jam" signal, and a small window that tells the user what color toner cartridge is installed. A second window alerts the user when it's necessary to install a fresh toner cartridge. If the controls were any simpler, there wouldn't be any controls on the unit at all.

The Canon cartridge system is one of the most ingenious aspects of the PC-3 and its companion models. The mini-cartridge is designed to "contain everything that can run or wear out." Depending on the sorts of originals being copied (type or image), cartridges are good for about 1,500 duplicates. The black color cartridge, however, will do 3,000 copies. Other colors offered are brown, green, red, and blue. Prices

range from \$89.95, for black, to \$94.95 for the other hues.

When the PC-3 first appeared on the market, durability was one of our initial concerns. However the cartridge system seems to make that an unjustified worry. We were told that the demonstrator unit loaned to **GIZMO** by Canon's public relations firm has been making the rounds for a number of years, including a 20-city promotional tour. To us that sounds like a torture test even *Consumer Reports* would have a hard time bettering.

The PC-3 will accept a variety of paper types. The manual lists "plain paper, post cards, business cards, labels, [and] OHP transparencies." From feed to fresh copy takes about 18 seconds.

Perhaps the most impressive aspect of the PC-3's performance is the crisp and legible copies it produces, particularly in duplicating color photos in a single hue. To our eyes, the resulting copy was beyond the capability of even full-size photo copiers of just a few years ago. With careful adjustment of the exposure control, even the most elusive photographic detail was clear in the final product. In its duplication of black-and-white type, the PC-3 was equally adept.

Paper jams are also more easily resolved with that small unit than with large, multi-

feed machines. It was usually enough to slide the copyboard to the side, lift up the top cover, and turn the blinking signal lamp off.

So what didn't we like about the PC-3? Its manual—or at least parts of it—struck us as badly organized. Terminology isn't spelled out up front and in setting the unit up we spent too much time trying to figure out which was the machine's left side in order to check the "fixing roller" that was concealed behind a door. The illustrations of that component weren't much help, a criticism we'd also make of the section showing how to install a cartridge. On the other hand, the troubleshooting and copy tips sections were very clear.

The most important question facing a potential buyer of a PC-3, or its higher priced companion models, is whether he or she needs one. It certainly came in handy in the **GIZMO** office, and it's hard to see how a small business or busy home office couldn't benefit from having one on-hand. But, although lower priced than good copy machines of the past, the price tag on the PC-3 still represents a hefty chunk of money. Most college students, particularly given what high education already costs today, would probably be better served by their neighborhood copy shop. ■

## New Wave

**WELBILT MICROWAVE OVEN (MR73T).** Manufactured by: Welbilt Appliance, Inc., P.O. Box 3618, New Hyde Park, New York 11042. Price: \$210.

When we first took the microwave plunge, we thought it would be the dawn of a new, faster, and more modern lifestyle: Meals cooked in minutes and food that was fresh, attractive, and full of nutrients that didn't have time to escape. That was the theory, or was it a dream? In reality, we use our microwave like most families do, as a supremely convenient warmer and popcorn maker, indispensable now that we live with one, but no more universal or lifestyle-altering than a conventional toaster would be.

We broke into the world of "naked foods" (as initiates sometimes tag microwaved comestibles) with a *Welbilt MR37T Microwave Oven*. Carrying a comparatively low price tag, the unit has features that include cook and quick-defrost settings, and keypad heat and time controls with power settings expressed as a percentage of the unit's full-power capability (rated by Welbilt at 500 watts). The oven is small enough to fit on top of a refrigerator (the location of microwaves in



CIRCLE 32 ON FREE INFORMATION CARD

a surprising number of homes), a big plus in smaller kitchens or ones with limited counter space.

Given its status as a household's first microwave, the Welbilt has served well, if not perfectly. Its first night, we kept stoking carrots and potatoes into the unit to determine how long cooking takes and how well the job is done. At three minutes,

those dense vegetables were barely affected by their time in the oven; in 15 minutes they had withered and dried to an unsightly (but surprisingly) still edible mess. Besides our first lesson in microwave time and timing, that basic training made us conclude that the more items in the oven, the longer it takes to cook them. We knew then that we were in for another



lifetime of learning to cook; so much for the magic and ease of modern microwave living.

Within a week, our household had narrowed down the microwave's uses to making popcorn, warming baby bottles, heating already-prepared coffee, and cooking hot dogs. That may sound modest, or even ridiculously limited, but the convenience factor in bottle-warming and coffee-reheating alone are worth the price of admission to microwave cookery. Prospective parents should consider adding a microwave to their list of pre-birth purchases. Getting up in the middle of the night to warm baby's bottle will make anyone appreciate a device that cuts warming time to 45 seconds.

For coffee drinkers, automatic brewers often turn fresh coffee to swill if a fresh pot is kept on warm for more than 30 minutes. With a microwave, coffee drinkers can turn the coffee maker off as soon as it's filled and reheat individual cups, as desired, via the oven. Hot dogs, for some reason, brown as well as heat to a sizzle, coming out better than when barbecued.

Our experience with frozen dinner-entrees made us realize that for people who

live alone, especially the elderly, a microwave can make cooking a lot easier and less time-consuming. As time went on, we snickered at our conventional stove as it stood spotless from disuse.

It took a growing popcorn habit to teach us the limits of our Welbilt. Heating popcorn directly on the rotating glass plate inside the unit is not a good idea (as the manual warns): ours cracked with a large pop during one heavy day of popcorn making about a month after the unit's purchase. After contacting area dealers listed in the manual (one was disconnected and the second told us to contact the firm in a week), we called the Welbilt company, which was able to furnish a replacement plate within a few days.

Because we know somebody who's handy, we also replaced the oven's no-longer-functioning light (it had worked loose), but it was not a simple procedure. In order to replace the bulb, it was necessary to remove a panel from the oven interior. Our friend the handyman suggested it wasn't a maintenance procedure the ordinary householder would find easy to do, which is why authorized dealer and service center lists exist.

The handyman also remarked that the oven was easy to use and that its controls for time and heat settings were well organized. We were less sensitive to the architecture of the model, but noted that it didn't take us long to master the unit's functions and controls.

For the short period in which we did without the supplied rotating oven plate, we learned that the model performed irregularly (at best) without its turntable. Using an ordinary plate atop the oven floor rotator provided a makeshift solution. But the standard plates had a tendency to crack if used improperly (i.e. popcorn again), just as the Welbilt-supplied glass plate had.

We realize that in terms of the microwave market, we're driving an economy model of a product available in all kinds of luxurious configurations and upgraded high-tech versions. But the Welbilt has won our household's confidence, despite the rocky road to learning its capabilities, and limits. We would no more live without a microwave than we would chuck our conventional stove. Neither has made us a better cook, but even the miracles of technology have their limitations. ■

## TV Telephone

**VISTACOM VIDEOPHONE.** Distributed by: **Eyetele Communications, Inc., 522-7th St., Suite 320, New Westminster, B.C. V3M 5T5, Canada. Price: \$16,500.**

Last Month, **GIZMO** reported on the Mitsubishi Visitel Visual Telephone Display, a device that transmits and receives still black-and-white images over standard telephone lines. Now comes word of a device developed by *Vistacom* of Finland, "designed for transmission of both sound and moving color pictures over a single telephone network."

Introduced to the European market last spring, in North America the *Vistacom Videophone* is being distributed by a Canadian firm, *Eyetele Communications, Inc.* At press time, the device's introduction was so recent that *Eyetele* had only one demonstration unit for the entire continent. Actual availability of the product is scheduled for the fall.

Besides selling at a per-unit price, \$16,500, that would buy 40 of the Visitel units, the *Vistacom Videophone* uses a totally different technology from that used by the Mitsubishi product and similar telephone video displays developed by Panasonic and Sony. The *Vistacom* can transmit and receive 30 color moving-images per second.

The unit combines telephone, TV



CIRCLE 33 ON FREE INFORMATION CARD

monitor/camera, and a 56K or 64K computer into a desktop package that's not much larger than a VCR. In fact, *Vistacom* rates its reduction in the size of the necessary coding-decoding computer as the product's outstanding breakthrough. Earlier videophone technology required a separate video "codec," often about the size of a small refrigerator. Although the moving picture on the *Videocom* screen appears "natural," it's actually a computer simulation of full motion.

The compact codec encodes individual images or frames, scanning the image being received by the unit's camera every 30 seconds and responding to "new movement," that is motion detected since the last 30-second scan, by adding it to memory. Then those frames are transmitted to the second Video Telephone, which reassembles the still pictures (or frames) in such a way as to give the impression of full motion.

(Continued on page 7)





CIRCLE 34 ON FREE INFORMATION CARD

## Star Struck

**STAR MACHINE (18-3330). Manufactured by: Bushnell Division, Bausch & Lomb, 300 N. Lone Hill Ave., San Dimas, CA 91773. Price: \$34.95**

Planetariums around the United States have undergone something of a popularity boom in recent years. After decades of approaching astronomy in a classroom-like spirit, those institutions have discovered show business. Maybe it was a spin-off of the popular "light shows" of the psychedelic 1960's, but with the addition of music, in particular, artificial star gazing has become a popular diversion for thousands who otherwise would never consider educating themselves about the constellations visible in the night sky.

The Bushnell Division of Bausch & Lomb has developed a budget-priced *Star Machine* that brings at least a little of this popular twinkle into the home. It may not be as spectacular as the presentation at New York's Hayden Planetarium, or programs at other facilities around the country, but on a small scale it has some of the same visual appeal. And if you're careful not to let on that it's educational, youngsters who use the device might even learn something.

Looking something like a two-layer cake, and about the same size, the *Star Machine's* directions call it "a direct cousin of the great projectors in star theaters throughout the world." And in fact, it works much like a planetarium system. A flashlight bulb is mounted inside the de-

vice beneath a lens, with power provided by two "C" batteries. The unit's perforated top (or "master star disc") allows the lensed light to project 31 constellations and some 312 stars onto a flat surface, either wall or ceiling. A wire fold-up stand allows the *Star Machine* to be angled for wall projection. In aiming for the ceiling, Bushnell suggests a distance of four to six feet between the projection surface and this mini-planetarium.

In addition to the perforated disc, which rotates, the *Star Machine's* top is ringed by an outer rim divided into 12 segments, each representing a month, with the four compass points also indicated. Four plastic discs, which fit over the "master star disc," mask some sky area and project the stars and constellations appropriate for each season. A fifth slip-on disc shows the northern constellations.

When used vertically, the star projector shows the sky as it would appear from the North Pole. Tilting it will "show the approximate position of the North Star" from the user's own latitude instead of the polar view. The four seasonal discs, positioned using the segmented outer ring, project "those stars visible in the sky at about 9:00 p.m." during each month. A flashlight-like "red star selector beam" (which uses two "AA" batteries) projects a red arrow, allowing users to pick out particular constellations. Bushnell also includes a narrative audio tape.

In use, the *Star Machine* projects an appealing celestial glow, its hundreds of stars appearing as pinpoints of light. It also reminded us that the **GIZMO** "prov-

ing-grounds" ceiling is long overdue for a paint job. Or as the instructions say, "the whiter and smoother the ceiling, the clearer the stars appear." The projected night sky also covers a fairly large area, so finding a ceiling or wall without obstructions can take a little thought, especially in cramped quarters. Even for someone completely unknowledgeable in astronomy, constellations are easy to spot and identify. For such a simple piece of equipment, its flashlight bulb projection is surprisingly clear and distinct.

Care is minimal, although the directions caution against touching the lens that covers the *Star Machine's* internal light bulb. It should be cleaned using lens tissue. The master disc's perforations "will become plugged with dirt and dust if left out for long periods of time." An occasional dusting or, if necessary the application of a damp towel will keep the tiny holes clean and open.

Although the designation can be the kiss of death, the Bushnell *Star Machine* is undeniably an educational toy. Aside from consumer purchases, we're sure many of the economical units have found their way into classrooms around the country. Bushnell, clearly interested in expanding astronomy's popularity, goes to some length to back up the product's educational dimension.

The instruction booklet invites the user to send in two questions to "Bushnell's science expert" who will answer them for the cost of two self-addressed, stamped envelopes. In addition, the company has organized a "Blast Off Club" for budding junior scientists. The booklet says "Blast Off" stands for "Bausch & Lomb's Amateur Scientist Tell-Net Offered for Free." The free membership entitles kids to a newsletter designed to foster interest in Bushnell's line of educational products, dubbed "Spectacu-learn." Besides the *Star Machine*, those include microscope kits, an astro/terrestrial telescope, and a number of other kits and instruments.

Although we know how kids usually react to "educational toys," the *Star Machine* seems to us to be something with a real potential for fostering interest in astronomy. Or it may merely introduce a youngster to the spectacle that is the night sky before joining other educational playthings gathering dust in some closet. But we have an idea that more than a few parents may find themselves enjoying this home planetarium on their own. ■

Gizmo is published by Gernsback Publications, Inc., 500-B Bi-County Blvd., Farmingdale, NY 11735. Senior Writer: George Arthur. Contributors to this issue: Cathy Burke, Marilyn Ciaphone, Alan Ginsberg, Ingrid Johanson, Ross Skoggard. Copyright 1988 by Gernsback Publications. All rights reserved.



## Snap Smart

**RICOH COMPACT AUTO-FOCUS 35-mm CAMERA (FF-7). Manufactured by: Ricoh Corp., 5 Dedrick Place, West Caldwell, NJ 07006. Price: \$250.**

"Serious" photographers may still turn up their noses at the point-and-shoot school of automatic photography. But for thousands of consumers, the 35-mm auto-focus camera has moved picture-taking beyond the snapshot stage. We may still be taking vacation pictures, but with the current crop of electronic cameras the resulting photos have only their subject in common with earlier generations of family snapshots.

After all, if the point of a vacation is relaxation, who wants to take an intensive course in photography to prepare for the rigors of snapping your spouse and offspring at the beach? But the camera industry also recognizes that a bit of an artist lurks within many of its customers. Cameras currently on the market offer features such as multiple exposure and continuous shooting, plus an array of optional accessories and add-ons. But ultimately what the amateur user is interested in is a clear photograph with proper light and dark contrast.

Ricoh Corp. has introduced a camera that gets results while still leaving some room for photographic individualism. The FF-7 Compact Auto-Focus Camera offers much of the sophistication and creative capabilities of a single-lens reflex camera to the casual photographer. Or so Ricoh claims, and after using the FF-7 for a couple of weeks, we're inclined to agree.

We took the FF-7 through its paces in a wide variety of lighting situations, including some of the most difficult. The camera's automatic back-light control and fill-in flash handled just about every problem we created, giving us a near-perfect picture even under the most trying of situations.

Back-lit subjects, as many poor pictures taken in the past have taught us, can be a difficult photographic situation. The FF-7's back-light function automatically increases the camera's exposure if the subject is illuminated from behind and is more than 10 feet away, creating fully detailed light and shadow. If the subject is within 10 feet of the lens, the flash pops up, exposure is calculated and, in the resulting exposure, black shadows or washed-out highlights are eliminated. Auto exposure provides programmed shutter speeds ranging from  $\frac{1}{4}$  to  $\frac{1}{4000}$  of a second with film speeds from ISO 100 to 1600.

Another picture-taking problem appears when the subject is in front of a distant scene, making it necessary for the



CIRCLE 35 ON FREE INFORMATION CARD

photographer to decide between blurry background or foreground. In those situations, the FF-7 allows the photographer to have his or her cake and eat it too. By depressing the electronic shutter's button half way, automatic focus adjusts to the background. The camera can then be aimed at the foreground subject and, with the shutter button still partly engaged, the control is fully depressed. The result is a sharp, in-focus picture of both background and foreground subject. The FF-7 focus system allows sharp pictures at distances from two-and-a-half feet to, theoretically, as far as the human eye can see.

If in taking a picture, the user is too close, the camera's viewfinder eyepiece blinks to alert the photographer. An LCD display located on the top of the camera indicates all basic operations, including battery condition, automatic film advance, exposure count, automatic rewind, and film indicator, as well as the FF-7's six user-selectable operational modes.

Modes are selected by simply pushing a control button on the side of the unit, with each mode indicated by simple graphics, which are displayed on a corner of the LCD panel window. Mountains indicate the panorama mode. "M.E." means multiple exposure, night photography is symbolized by mountains against a night sky, while "TV" indicates the FF-7's mode used for taking pictures off a television screen. The letter "C" indicates one-frame-per-second continuous shooting, while the number "60" tells the user the camera is set to make an exposure every minute ("interval timer" mode), ideal for those nature shoots when the photographer gets tired of sitting in the bush waiting for the perfect picture.

We were intrigued by the television mode, which allows photographs of scenes and subjects on the TV screen, sans those horizontal blue lines that usually

show up in such snapshots. According to Ricoh, the mode "automatically synchronizes the shutter speed of the FF-7 with the scan rate of any television screen." Some of our TV pictures had a fuzzy quality, especially when there was any quick movement on the screen. But in its ability to take a good picture from TV, this Ricoh compared most favorably with other cameras we've used.

The TV mode coupled with the FF-7's multiple-exposure capability made for some interesting pictures, superimposing one exposure on top of another by simply imprinting the two separate shots on the same frame. The image was surprisingly bright and clear. In the TV mode, multiple exposure allows the photographer to, for example, place stars of different programs in the same picture. Or how about putting a cartoon character on the set of a network news program? A little silly, but also fun; more serious shutterbugs will undoubtedly come up with different uses for the FF-7's multiple exposure function.

The Panorama mode also yielded some striking, and effortless, pictures. In this mode, the camera won't focus on nearby subjects. The night photography mode permits available light shots by setting a slow shutter speed and defeating the flash.

As is apparent, we enjoyed using the auto-focus camera, and found it well-designed, right down to its sleek and easy-to-handle size and shape. Of course, to really understand the FF-7's capabilities will require some careful reading of the manual. But it's not an intensive course in photography; rather it is only something that's more substantial than those little four-page booklets normally supplied with simple, snapshot cameras. Hands-on experience, and a willingness to "waste" a few rolls of film, will give the novice a working understanding of the camera's functions, and its potential. ■



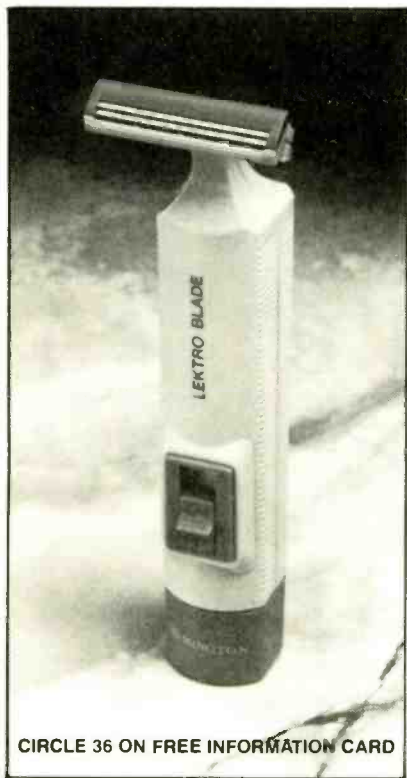

CIRCLE 36 ON FREE INFORMATION CARD

## Hand Glider

**LEKTRO BLADE RAZOR (MVB-1, LVB-1).** Manufactured by: Remington Products, Inc., 60 Main St., Bridgeport, CT 066602. Price: \$14.95

In years past, selling razors in the United States was a simple enough proposition. Manufacturers could buy some ad time on sports broadcasts, run print ads showing an attractive woman admiring a man's clean shave, and it was considered a marketing job well-done. But that was back when some men still went to barber shops for their shaves. Today, razor and electric shaver marketers have lots more to contend with, including a female market that previously was unacknowledged.

All of which helps explain why Remington Products, Inc. heralded its new *Lektro Blade Razor* as nothing less than "a revolution in blade shaving." Launched in May with an enormous advertising campaign, according to the company the Lektro Blade was some two years in development and represents Remington's first entry into the "wet shaver market."

In order to get a full picture of this tonsorial revolution, GIZMO decided to test the razor in both its male and female (MVB-1 and LVB-1, respectively) product forms. Similar to the popular "Freedom Blade" razor in its use of a standard twin-blade cartridge and a vibrating action, the Lektro is both smaller and lighter than the

Freedom Blade, a competing predecessor product. Instead of a rechargeable battery, the Remington uses a standard "AA" battery as its power source. With the battery inserted into the handle compartment, the Lektro weighs only 2.5 ounces.

Its 9,000-rpm motor activates "two vibrating blades for a smooth massage-like shave with less pull, drag, and irritation," although visually it's impossible to detect movement by the razor's head. Our male tester is a long-time electric shaver user, preferring the mindless skin safety of the electric to the close but attention-demanding shave of a blade. Light bearded, his use of the Lektro confirmed at least two of Remington's claims to his satisfaction. In shaving, the operational word was "glide." Less drag, pull, and irritation were all noticeable in using the razor, even compared to a standard electric shaver. What wasn't so easy to accept were claims of shave closeness, although our tester admitted that his skepticism was as much a matter of shaving as ritual as one of practical consideration.

An electric razor, he reasoned, allows the user to mindlessly mow down his beard without fear of nicks or cuts, even as the user reads the paper, day dreams, or whatever. For that reason alone, the Lektro doesn't equal the ease of a standard electric dry shave.

In wielding this vibrating, electric wet razor, the user has to pay attention, as with an old-fashioned safety razor. For our tester, that is a little like having the worst of both shaving worlds. While the buzz of the Lektro lulled him into his accustomed state of electric razor relaxation, the reality of two blades gliding across his face kept him alert and attentive.

In pre-shave preparation, our tester used both a shaving cream and lathered up with ordinary bar soap. Not surprisingly, the hand-soap lathered shave was just okay. As with practically any razor, the Lektro performed best with shaving cream. In our own use of the new Remington shaver, we were most impressed by its light weight and handling ease. Using it for the first time, we didn't cut ourselves, a common outcome of trying a razor for the first time.

Our female tester has used disposable twin-blade razors in the past and has always found shaving her legs an infinitely delayable task. Fear of cutting and nicking is enough to get her to put this grooming chore off. The Remington's status as an electric razor also made her wonder if she was adding the danger of electrical shock to the possibility of cutting her skin.

According to a Remington press release, the Lektro is "safe and immersible" and can be used in "shower or tub." The instructions, on the other hand, warn not to "submerge [sic] entire unit." Although we had previously never heard that word,

we assume the caution means not to "submerge" or "immerse" the Lektro Blade under water, which would appear to be in contradiction to the reassuring statement in the product release.

The first time she used the LVB-1, cuts appeared, but that was because she shaved without applying soap or shaving lather first (as the instructions say to). Once she followed directions, she found the Lektro Blade comfortable, smooth, and safe. So much so that she intends to use the razor from now on.

Which is exactly the kind of "shaving revolution" Remington most likely hopes to ignite. However, our male user has decided that this is one revolution they can start without him. ■

## CES Notes

June's Chicago Consumer Electronics Show, the biggest consumer electronics trade show in the world, seemed dedicated to going beyond the old saw that "a man's home is his castle." How about a man's home is his concert hall, his movie theater, his office, his audio-recording studio, his TV-production facility, and his publishing house? Electronic-age man may never have to leave home again, unless he owns a dog.

Since the next generation of home-entertainment equipment is hanging in limbo while the courts and Congress sort out litigation and legislation involving digital audio tape (DAT), and while the electronics industry tries to develop a worldwide standard for high-definition television, the big noise at CES was in home-office products. Personal Fax (facsimile) machines, printers that receive and send coded information for producing text and images over the phone were featured by numerous exhibitors. A Fax machine can replace the functions of a copier, a computer modem, and various express and overnight delivery services. They sell for around \$1,000, and nearly all the major electronic manufacturers and brands feature one. GIZMO plans to review some



CIRCLE 37 ON FREE INFORMATION CARD

Toshiba IDTV



of these hot new products in a future section.

Other gadgets aimed at the up-to-date home-office include electronic spellers that function as a dictionary, thesaurus, etc. (see *Gizmo Bytes* elsewhere in this section), fit in the hand, and start at around \$100; "lifestyle-compatible" computers; hand-held computers combining calculator, clock, and "Fil-o-Fax"-style personal organizers; integrated word processors with built-in display screens, printers, and software and which are designed to be simpler to use than computers but with more functions and capabilities than electronic typewriters; video phones that send a black-and-white still image over the phone lines to similar units in five seconds (see October's **GIZMO** for coverage of one such unit, the Visitel); and the "personalization" of 8mm video equipment (also reported on in October).

Home entertainment did offer some remarkable innovations at CES. *Yamaha Electronics Corp. USA* (6660 Orangethorpe Ave., Buena Park, CA 90620) showcased its top-of-the-line sound system featuring the company's second generation *Digital Sound Field Processor (DSP-3000)*, which recreates the sound fields of specific and sampled music environments.

To recreate the acoustic ambience of some 35 concert halls, movie theaters, sta-

diums, and jazz clubs, Yamaha engineers sampled sound field patterns of the various rooms and halls and programmed them into the memory of the DSP units, which in turn controlled the response of six speakers and a woofer to reproduce those patterns. The effect was remarkable as the unit switched through six European and American concert halls and opera houses while playing a video laser disc of *Rigoletto* on the linked TV monitor. Some halls "felt" intimate and ancient, others vast and modern. A laser disc of John Cougar Mellencamp reproduced the rock performance as it would sound in a nightclub or a stadium. The DSP-3000, which should be available by the time you read this, will sell for \$1899.00. The first-generation DSP-1, which recreates 17 sound environments, is currently available at a price of \$999.00.

*Toshiba America, Inc.* (82 Totowa Rd., Wayne NJ 07470) had an exhibition room set aside for its *IDTV*, Improved Definition Television, with a Carver Sonic Holography system designed to create the audio illusion of sound coming from various spots in the room outside the speakers. Available in the fall, a suggested retail price has not been announced, although it's expected to be in the \$2,000 plus range.

Moving from the electronically sublime to the ridiculous, novelty phones occupied

numerous booths and the attention of many CES participants. Duck shaped phones quacked instead of ringing, fish shaped phones made splashing sounds, while Bozo the Clown instruments joined such established favorites as Mickey Mouse and Garfield the Cat.

All-in-all, though, it appears that doubts about the economy and the launch date of new audio and video technologies have made manufacturers cautious. As a result, the Summer Consumer Electronics Show imparted a strong sense of *deja vu*. Most manufacturers seemed content to add additional capabilities to existing products rather than to roll out truly new product designs. Soon consumers will be able to buy nearly anything with a radio built-in, from a camera, to a jacket, to a telephone, to a beer cooler.

We have to run along now, our phone is quacking. ■

## VIDEOPHONE

(Continued from page 3)

One question that occurred to us immediately (or at least immediately after "how does it work?") is who was going to buy such a unit, at least at that price?

In an interview with a West Coast newspaper, Eyetel's president, Rob Calis, said initially business and government will be the units' primary market. "We have had a secret order for more than a thousand of them by one major corporation." And he fully expects gizmo fanatics with deep pockets to buy pairs of Vistacom Videophones. Eventually, Eyetel's president says the price will come down and, as with computer technology, use will become more widespread.

But if you've got an insatiable hankering for moving telephone conversations in living color, minus a bank account to match, Eyetel Communications, Inc. has good news for you. The Vistacom can be leased for around \$400 per month, per desktop unit. ■



CIRCLE 38 ON FREE INFORMATION CARD

Yamaha DSP-3000

## Ten-Hour Humidifier

A Japanese source tells us that after the initial popularity of humidifiers in his homeland, sales dropped off dramatically. Apparently the American market hasn't reached that stage yet, as *Goldstar Electronics International, Inc.* (1050 Wall St. W., Lyndhurst, NJ 07071) has just introduced a restyled *Ten-Hour Humidifier (GH-522UA)*. The unit's one-gallon tank makes ten hours of operation possible, while a "convenient large opening" makes for easy refilling. The unit also features a 360-degree directional nozzle and an adjustable humidistat, mist volume/humidity control, removable air filter, and automatic shut-off. Its case is finished in dark gray and the entire assembly weighs eight pounds. Price: \$59.95.

CIRCLE 39 ON FREE INFORMATION CARD



Ten-Hour Humidifier

# Gizmo/Bytes



Portable Personal Word Processor

## Portable Personal Word Processor

"Personal electronics" can encompass a variety of products, including a newly introduced *Personal Word Processor (PWP 80)* from *Smith Corona* (65 Locust Ave., New Canaan, CT 06840). Described as ideal for "small professional offices," the unit features an eighty-character, sixteen-line flip-up display, 50,000 characters of internal, editable memory, and a disk drive. Menu-driven, the unit's features include a "Spell-Right" electronic dictionary (featuring 75,000 words), which is part of an "Enhanced Grammar-Right System." That dictionary's capabilities also include a thesaurus, a punctuation checker, and something called "phrase alert," which "identifies wordy, vague, misused, and overly used phrases, automatically replacing the original phrase with a new one." The PWP 80 can also copy an entire disk, and includes a header/footer function, as well as "graphic page view," which allows the user to see an image of the document on the flip-up screen before it's printed. Available since August, Smith Corona also offers a companion model, the PWP 40, with fewer capabilities and a lower price. Price: \$749.

CIRCLE 40 ON FREE INFORMATION CARD



Studio Monitor Speakerphone

## Studio Monitor Speakerphone

Even though in-the-ear headphones dominate the consumer market, older style "earmuff" headsets still have their partisans, including the *Koss Corp.* (4129 N. Port Washington Ave., Milwaukee, WI 53212). That company has introduced a new *Studio Monitor Stereophone, the Pro 450*, which it says is a "reference-quality unit that combines ultra-wide frequency response with a wide, dynamic range in a sturdy, yet comfortable design." That much we understand, but when the company goes on to describe the product as using a "hybrid dual element" (for increased bass performance and extended dynamic range) along with a "neodymium magnetic motor structure," and a "multi-pivoting spider design that frees the element plate to float on the listener's head," we're willing to admit we'll have to take Koss's word for it. Less esoteric features include 25- and 8-foot cables and a microphone mount, as well as a one-year warranty. Price: \$174.95.

CIRCLE 41 ON FREE INFORMATION CARD



Diver's G-Shock Watch

## Diver's G-Shock Watch

Some people just can't stand not knowing what time it is. Although aimed at the sports market, the *Diver's G-Shock Watch (DW5600C-9)* from *Casio, Inc.* (570 Mt. Pleasant Ave., P.O. Box 7000, Dover, NJ 07801) undoubtedly has great appeal for time-keeping fanatics. Housed in a bright yellow case with matching yellow-resin band, the watch is shock resistant and water resistant to 200 meters. It features an alarm, calendar, chronograph, and a countdown timer. The watch face is backlit for viewing in the dark (or the watery depths) and has a battery that's good for 7 years. Price: \$64.95.

CIRCLE 42 ON FREE INFORMATION CARD



Talking Security System

## Talking Home Security System

Wireless home security systems by their nature can make a lot of noise, but a new one from *Dicon Systems, Inc.* (631 Executive Dr., Willowbrook, IL 60521) lowers the decibel level in order to "talk" with the user. The *9000 Security System* not only instructs the user how to use and test the system, but reports when a sensor triggers an alarm and voices a variety of other commands, requests, and messages. The 9000 integrates security, fire, medical, and other emergency monitoring, and features a central console that's roughly the size of a telephone answering machine. A console-installed automatic telephone dialer is capable of calling eight local or long-distance numbers and relaying an emergency message in the user's own voice. The message relayed is appropriate for each situation. Software based, the system uses codes (rather than conventional keys) to arm or disarm sensors and alarms. Up to four separate security zones can be created, allowing for selective monitoring. "Authorized visitors" can be provided with a "visitor code" allowing them to enter or leave protected premises. The 9000 also features remote control. Dicon also offers a number of optional accessories as well as a two-year warranty on the basic system and a 24-hour monitoring service on a subscription basis. Price: \$494.

CIRCLE 43 ON FREE INFORMATION CARD



## Tetris Game Software

We knew it had to happen, but we're a little surprised it happened so quickly. We're talking about what's called "the first entertainment software from the Soviet Union to be available in the West," a game called *Tetris* being marketed here by *Spectrum HoloByte* (2061 Challenger Dr., Alameda, CA 94501). Developed by two Soviet computer programmers, Tetris has been enhanced with "beautiful graphic art background scenes from the Soviet Union" and is available in versions for IBM, Commodore 64, and Macintosh computers. Based on the arrangement of four squares into various configurations, it has been described as both "a puzzle in motion" and the "Rubik's Cube of software." According to Spectrum HoloByte, it's a game that's extremely easy to learn but challenging and difficult to master. We guess this is an example of software *glasnost*. Price: \$34.95-\$39.95. **CIRCLE 44 ON FREE INFORMATION CARD**



Tetris Game Software

## AM/FM Stereo A/V Receiver

The product release issued by *Sansui Electronics Corp.* (1250 Valley Brook Ave., Lyndhurst, NJ 07071) on behalf of its new *AM/FM Stereo A/V Receiver (RZ-1000)* is a refreshing contrast to the usual hyperbole of these sorts of announcements. The company says the receiver, which features 32 watts per channel, 30 broadcast-signal presets, frequency direct tuning, and "station call memory," is "just right for any application where high power and ultimate sophistication are not required." Such plain speaking is nearly unheard of, although Sansui does claim the RZ-1000 is capable of "flawless performance." Capabilities include dubbing from VCR to cassette or from one cassette deck to another and the unit can drive 4-ohm speakers. Inputs for CD, record player, two tape decks, and a VCR/VDP are all provided. Price: \$280. **CIRCLE 45 ON FREE INFORMATION CARD**



AM/FM Stereo A/V Receiver

## Conductor Alkaline Battery

The age of specialization is indeed upon us when even batteries are keyed to specific products, as is the case with the new *Conductor Alkaline Battery* from the *Eveready Battery Co., Inc.* (Checkerboard Sq., St. Louis, MO 63164). Designed for use with portable audio equipment (which is where 40 percent of batteries purchased in this country are used), the Conductor Alkaline Battery is described as a "high-output power source" that "maximizes audio-device performance and provides the steady power required in today's portable audio equipment." At the Summer Consumer Electronics Show, the conductor was included in the exhibition of the "most innovative consumer electronics products" of the year. Conductor batteries are available in "AA," "AAA," "C," and "D" sizes, and in a variety of multi-packs. Price: \$2.75-\$4.71. **CIRCLE 46 ON FREE INFORMATION CARD**



Conductor Battery

## Databank/Phonebook/Calculator

Combination is the name of at least one of the important games in consumer electronics, witness the *Citizen Databank/Phonebook/Calculator (MB-150)* from *CBM America Corp.* (2999 Overland Ave., Los Angeles, CA 90064). Offered in a slim, vertical black wallet case, the CB-150 contains a 125 name and phone-number capacity and incorporates a 10-digit calculator. Data is stored alphabetically and is protected with a "security lock system." Price: \$29.99. **CIRCLE 47 ON FREE INFORMATION CARD**

## Automatic Telephone Light

Think of an electronic communications update of a night light and you'll have a pretty fair idea of how the *Telite-II Automatic Telephone Light* works. Developed by *Effective Solutions* (14902 Preston Rd., suite 212-310, Dallas, TX 75240), the Telite connects with the telephone much as a telephone answering machine does. The lamp lights whenever the phone is used, turning on when the receiver is picked up or when the instrument rings. A 30-second delay provides illumination after the call is completed. Although it can be plugged in to a standard AC outlet, there's also a battery back-up feature (using four "AA" batteries). Telite-II is equipped with an eighteen inch cord and is available in white, ivory, orange, yellow, and charcoal. If you've ever stumbled through the dark in pursuit of a ringing telephone, you'll understand the utility of this device. Price: \$39. **CIRCLE 48 ON FREE INFORMATION CARD**

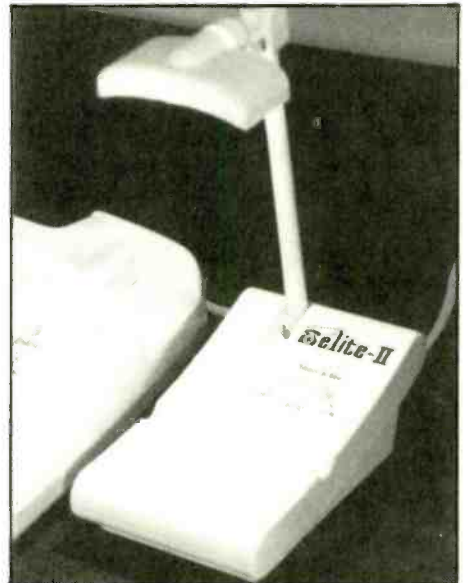

Telephone Light

# Gizmo/Bytes



Transportable 8mm VCR



TV/Stereo System

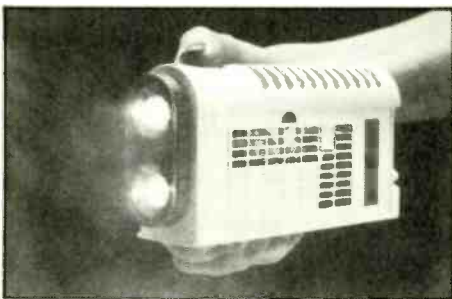

Portable Smoke Alarm



Electronic Speller/Calculator



Integrated Answering System

## Transportable 8mm VCR

Portability seems to be increasingly an important part of home video, as illustrated by the new *Transportable 8mm VCR (ES-100)* recently introduced by *Canon U.S.A., Inc.* (1 Canon Plaza, Lake Success, NY 11042). A tabletop 8mm video recorder, it weighs only 5.7 pounds and features a detachable handle. Among its technical attributes are pulse-code modulation processing for recording digital stereo audio, a "theater-sound" mode, built-in MTS decoder, wireless remote control, a flying erase head, and noise-free slow motion. The ES-100 offers up to 4 hours of recording and playback in the long-play mode, and in playback offers freeze frame, single-frame advance, and slow motion at two speeds. The deck also features forward and reverse picture search and double-speed playback with sound. The unit includes a 152-channel, cable-compatible TV tuner. Timer functions permit the recording of up to 3 events over a two week period. Price: \$1,000.

CIRCLE 49 ON FREE INFORMATION CARD

## TV/Stereo System

A new brand of audio/video products appeared on the market this summer. And that brand, *Monitor Audio-Video Products* (1950 E. Orangethorpe Ave., Fullerton, CA 92631), took the plunge in a big way, introducing no fewer than fourteen systems, including a nineteen-inch *TV/Stereo System (AV-3500)* equipped with an amplifier/equalizer, tuner, double cassette recorder, turntable, and two three-way speakers housed in an all-walnut cabinet. The audio components in each Monitor system are interchangeable, so consumers can step up from the AV-3500's 20-watt system to a 30 or 40-watt ensemble. Price: \$689.

CIRCLE 50 ON FREE INFORMATION CARD

## Portable Smoke Alarm

Here's another product for the sometimes nervous traveler, although the *Lite A Life Portable Smoke Alarm* would also be useful to have around the house. The 13-ounce hand-held unit uses a "dual ionization chamber" for early detection. When smoke is discovered in the environment, an alarm sounds and the unit's dual-beam light automatically turns on. Other features include a low-battery indicator, a test button, and a hanger that attaches to (and detaches from) a doorknob in seconds. The Lite A Life is one of a number of travel-oriented products from the *Ronde* division of *Advanced Products & Technologies* (P.O. Box 2014, Redmond, WA 98073). Price: \$49.95.

CIRCLE 51 ON FREE INFORMATION CARD

## Electronic Speller with Built-in Calculator

Since **GIZMO** covered Franklin's line of electronic spelling dictionaries (see the April issue), the company has added a new feature to its 80,000-word *Spellmaster*, a built-in four-function calculator. *Franklin Computer* (Rt. 73, Haddonfield Rd., Pennsauken, NJ 08110) calls the updated product the *Pocket Spellmaster Plus*, combining a calculator with advanced phonetic-spelling technology and word-game capabilities. The calculator includes a replay feature for "review of even the most complicated calculations (including individual sub-totals)" and up to 99 displays. In addition, it can check the "values of both memory and constant without disturbing the calculations" and can indicate why any calculation can't be performed. Price: \$129.95.

CIRCLE 52 ON FREE INFORMATION CARD

## Integrated Telephone Answering System

Simplicity doesn't seem to be a highly regarded quality in the contemporary consumer-electronics market, however *GTE Consumer Communications Products Corp.* (30 Buxton Farms Rd., Stamford, CT 06905) has introduced an *Integrated Telephone Answering System (6010)* that, at least as described, seems impressively straightforward. The system uses a single micro-cassette for both outgoing and incoming messages, and offers features that include beeperless remote operation, call monitor, memo record, and a toll-saver function. A privacy feature "enables the user to record the outgoing message or listen to incoming messages" via the system's handset. Price: \$109.95.

CIRCLE 53 ON FREE INFORMATION CARD



## "Digital Compatible" Stereo Headphone

Some portable stereo equipment is high priced enough that consumers might hesitate to lug it around for fear of losing it. A new *Digital Compatible Stereo Headphone* (485) from *Jasco Products Co., Inc.* (P.O. Box 466, Oklahoma City, OK 73101) is economical enough that consumers might want to purchase several sets. Described as a "versatile, mid-size headphone" for use with a personal radio, cassette player, or home-stereo unit with use of the stereo adaptor included with the headphone. Beyond that, Jasco is rather mum on the product's technical specifications. Price: \$17.89.

CIRCLE 54 ON FREE INFORMATION CARD



"Digital Compatible" Headphone

## Travel Environmental Sound Machine

Some travelers never adjust to life on the road, with a good night's sleep particularly hard to come by in a strange location. *Hammacher Schlemmer* (147 E. 57th St., New York, NY 10022) offers a product custom-made for the uneasy traveler, the *Travel Environmental Sound Machine*. Small enough to fit into a suitcase or overnight bag, that "electronic relaxation device" synthesizes four soothing, natural sounds to block out disturbing noises. Sound selections include rain fall, water fall, and surf in two different styles. Each sound plays for 30 minutes before shutting off and each adjusts for rhythm intensity, volume, bass, and treble. In addition, "multi-frequency white noise" masks unwanted sounds. There's also a built-in alarm clock with digital display. Power is supplied via an AC adapter or by four "AA" batteries. The entire sleep-inducing appliance weighs a mere one pound. Price: \$154.95.

CIRCLE 55 ON FREE INFORMATION CARD



Environmental Sound Machine

## Color Viewfinder VHS Camcorder

Are camcorder owners ever annoyed by the black-and-white picture provided by most viewfinders? *Chinon America, Inc.* (43 Fadem Rd., Springfield NJ 07081-0639) figures they must be, which is why the company has introduced its *Movie/Color View VHS Camcorder (CV-T65)*. The unit's viewfinder is said to give the user "a totally true, lifelike preview of the scene, permitting far more accurate and pleasing compositions." The CV-T65 also uses a miniature built-in speaker for an instant audio "playback," analogous to video playback and incorporates a built-in character generator for adding titles or other information to a scene. The camcorder's CCD has 250,000 pixels of resolution. Other features include simplified fade in/fade out and a back-light switch. Price: \$1,999.95.

CIRCLE 56 ON FREE INFORMATION CARD



Color Viewfinder Camcorder

## Remote Control CD Player

We don't know about the unit's "elegant Eurostyling," but the price seems right. From *Audio Dynamics Corp.* (851 Traeger Ave., San Bruno CA 94066), this *Remote Control Compact Disc Player (CD-1000E)* features triple-beam pickup, advanced error processing, and sixteen-track random-access programming along with "full-function display and controls." The CD-1000E comes equipped with a dedicated remote and can also be operated with Audio Dynamics's unified system remote control that comes with the company's CA-2000E integrated amplifier. Price: \$249.

CIRCLE 57 ON FREE INFORMATION CARD

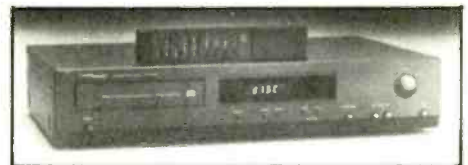

Remote Control CD Player

## Digital Stereo Console Monitor/Receiver

Consider yourself a big television fan, a *really* big TV fan? Then you might want to have a look at a really big TV, a new 35-inch screen, direct-view, *Digital Stereo Console Monitor/Receiver (CK-3514R)* from *Mitsubishi Electric Sales America, Inc.* (5757 Plaza Dr., P.O. Box 6007, Cypress, CA 90030-0007). The unit features a "full square, high contrast" screen with Mitsubishi's "Diamond Vision II" picture tube as well as an integrated, illuminated wireless remote control. In its audio aspects, the CK-3514R offers a four-speaker system, cable-compatible MTS stereo, and a ten-watt per channel amplifier. There are also multiple audio and video inputs and outputs to "facilitate system expansion," which might also entail renting a second house for what's already a hefty home entertainment colossus. Price: \$2,899.

CIRCLE 58 ON FREE INFORMATION CARD

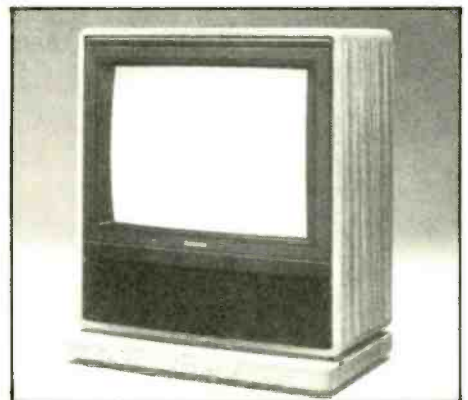

Digital Stereo Monitor/Receiver

# Gizmo/Bytes

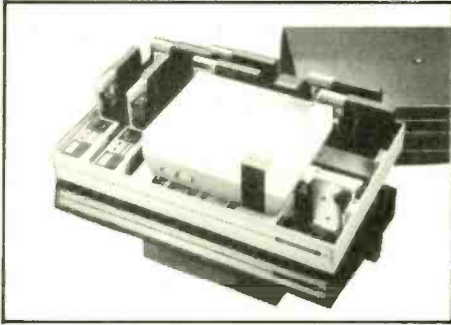

Video Game Organizer



Intelligent A/V Remote Control

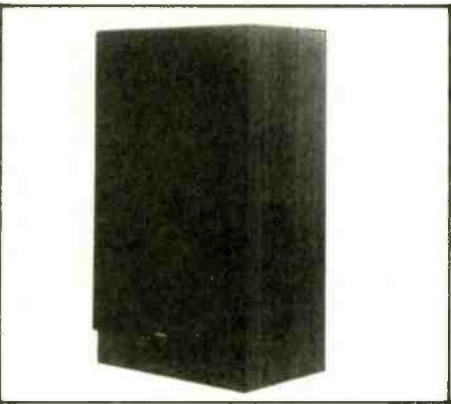

Three-Way Speaker System



Hands-Free Personal Headlights

## Video Game Organizer

Tired of telling the kids to pick up their video-game cartridges? Maybe your household needs a *Video Game Organizer (42000)*. From *Hartzell Manufacturing, Inc.* (2516 Wabash Ave., St. Paul, MN 55114), the organizer will accommodate Nintendo, Sega, and Atari 2600 and 7800 game systems. Designed to fit on top of or under a TV, with the translucent cover removed, games can be played without removing them from the Organizer base. "Full color packaging shows how all systems can be stored," which, if you've ever struggled to put something back into its case, is a small feature worth noting. Price: \$29.95.

CIRCLE 59 ON FREE INFORMATION CARD

## Intelligent A/V Remote Control

*Technics* (1 Panasonic Way, Secaucus, NJ 07094) deserves points for at least one aspect of its introduction of an *Intelligent A/V Remote Control (SH-R700)*, namely that the product isn't called a "universal remote." Offering a total of 144 commands, 46 are dedicated for use with Technics audio equipment while the other 98 are capable of learning the major commands of most infrared remotes for a CD player, TV, VCR, or unspecified "optional unit," such as a second tape deck. Commands are accessed via a touch-sensitive LCD showing five different display faces, which change to match the component in operation. The SH-R700 operates on four "AA" batteries and will preserve the commands in memory for about a week after the power source has become too low to operate the unit. Price: \$200.

CIRCLE 60 ON FREE INFORMATION CARD

## Three-Way Home Speaker System

According to the folks at *International Jensen* (4138 N. United Pkwy., Schiller Park, IL 60176), compact-disc players generate "wide power swings," leading many consumers to search out speaker systems with "greater power-handling capabilities." Which is where the firm's new *Three-Way Speaker System (3150)* comes in. Part of the "CD-ready concert line" of loudspeakers, the 3150's continuous power handling is rated at 80 watts, while mid-range frequencies are handled by a 5-inch cone driver with high frequencies generated by a 3-inch cone tweeter. Sensitivity of the 3150 is 94 db, and frequency response is rated at 33 Hz to 21 kHz. Price: \$129.95.

CIRCLE 61 ON FREE INFORMATION CARD

## Commander FM Pager Vehicle Alarm System

Here's a new combination device sure to appeal to people who practically live in their cars or trucks. From *Crimestopper Security Products, Inc.* (1770 S. Tapo St., Simi Valley, CA 93063), the *Commander (HP-8850PR)* combines the functions of an FM pager and a remote-control vehicle-alarm system. The pager/remote signals if an intrusion is attempted on the vehicle it protects, and can also be connected with a cellular phone so that when a call comes in, the hand set also rings. It can also be used "to alert somebody to a car or notify them that a ride has arrived." In its security functions, the system allows its user to control all functions of alarms on two cars from the pager unit. The Commander also signals if a driver has left the key in the ignition or the parking lights on, and allows the user to program vehicle security functions via remote control. Price: \$799.95.

CIRCLE 62 ON FREE INFORMATION CARD

## Hands-Free Personal Headlights

Maybe this is merely a novelty item, but the description in the catalog from *Hammacher Schlemmer* (147 E. 57th St., New York, NY 10022) makes it sound as if *Hands-Free Personal Headlights* might actually come in handy. Powered by four "AAA" batteries, the plastic headset will fit over eyeglasses and illuminate a three-foot wide area at arms length to a claimed brightness of 1,000 candlepower. The two lights are said to have greater intensity than ordinary flashlights. Hands-Free Personal Headlights are sold in sets of two, one normal and one high power, and include a carrying case. Each set weighs 3.2 ounces. Price: \$29.95.

CIRCLE 63 ON FREE INFORMATION CARD



# BEGINNERS GUIDE TO VINTAGE RADIO

*Is your latest find a gem from radio's "golden age," or just a flea-market special? Once you know what to look for, you'll be able to tell at a glance.*

BY MARC ELLIS

Maybe you already have a couple of vintage radios in your possession; a set or two that caught your eye at a rummage sale or in a relative's attic. Or maybe you don't own anything right now, but know that you have an affinity for the look and feel of decades-old electronic equipment. No matter how you developed your interest, if you're new to the radio-collecting hobby, this guide will give you the background you need to evaluate your "finds" with a knowledgeable eye.

**When the Classics Were Made.** The radios of greatest interest to most of today's collectors span the years from the beginning of serious broadcast radio (early 1920's) to the onset of World War II (early 1940's). Of course, there are collectors who are interested in the relics of the earliest days of radio. Unfortunately, however, Fleming Valves, DeForest Audions, or other very early pieces of point-to-point communications gear are museum-quality items. They don't often show up at flea markets, house sales, or the other channels normally available to the average collector.

Conversely, the sets made after World War II may be the collectables of tomorrow—but I don't sense much interest in collecting that period today. I'm sure that there are readers who will disagree, but those later sets just don't seem to have the classic appearance or romantic associations that the earlier ones do.

The "classic-radio" period spans less than twenty years. But within that small

slice of time, sets were manufactured by the millions in a bewildering variety of types and styles. Technological advances came so rapidly that new designs were rendered obsolete almost as soon as they came on the market. The sociological and economic changes that occurred as an era of national prosperity was replaced, in turn, by the Great Depression and the gathering storm clouds of World War II, also had profound effects on the radio industry.

Let's take a trip, now, through that fascinating period and look at some typical sets manufactured at various times within it. In the process, you'll learn the sign-posts that will help you relate the radios that you find to the years in which they were made.

**The Earliest Broadcast Sets.** If I were to ask you to identify the first type of radio in general use during the early

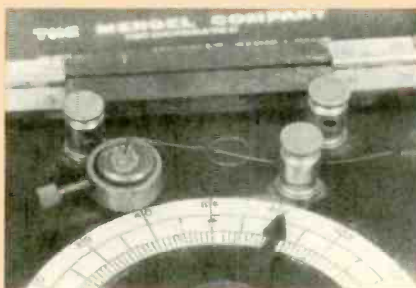

*A crystal detector consisted of a fine wire (the "cat's whisker") in contact with a fragment of galena (lead ore). The version shown does not have the usual swivel-arm mount for the wire.*

days of broadcasting, you'd probably answer "the crystal set," and you would certainly be right. The wonderful thing about the crystal set was that it required no external power. The detection properties of the "crystal" (a small piece of lead ore, or *galena*) extracted the sound portion of the signal from the radio frequency "carrier" and made it audible in the headphones. The only energy used was the energy of the radio signal itself.

Regrettably, crystal sets aren't easy to find. By the time the broadcasting industry became big enough to create a mass market for radio receivers, the vacuum tube was becoming generally available. And even a small one-tube radio could easily outperform the most elaborately made crystal set. By 1925, crystal sets were largely relegated to the status of kid's toys. A survey of mid-1920's advertising in two prestigious radio magazines did not show one serious crystal set for sale. If you do find a vintage crystal set, you'll have no trouble identifying it. It won't have any tubes, of course, and the bit of rock-like galena—mounted in a small metal cup—will be in plain sight. You'll also find a short length of springy wire (the "cat's whisker"), typically attached to one end of a pivoted metal arm. The arm is arranged so that the wire tip can be placed in contact with various locations on the surface of the crystal. In practice, the listener tried various spots until he or she found one that provided the loudest volume.

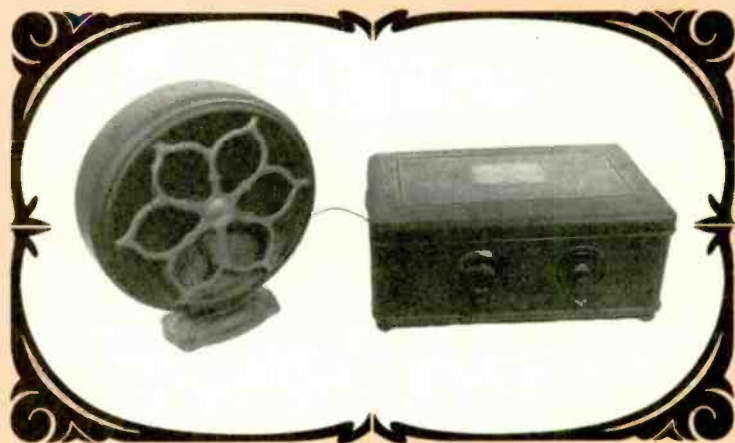

However, watch out! Not every set having a crystal is a 1920's model. Crystal sets were made as toys, educational kits, and novelty items at least into the 1950's. Look at your find with a critical eye before you make a purchase. Should you have your heart set on adding a good example of an early twenties crystal set to your collection, your best bet would be to attend the swap meet at an antique-radio convention. You'll have a good chance of locating one there. But, of course, it's not likely to be cheap.

### Battery Radios of the 1920's.

During most of the 1920's, the radio most likely to be found in the family living room was a vacuum-tube set powered by batteries. The development of practical technology for plug-in AC operation did not occur until near the end of the decade, and, like all new technologies, it was high-priced when introduced and therefore not widely adopted at first.

Battery radios were made in many sizes and styles. And if you're new to collecting, it would be natural for you to assume that a simple-looking one- or two-tube receiver might be an older design than, say, a five-tube set with multiple controls. Don't make that mistake, though.

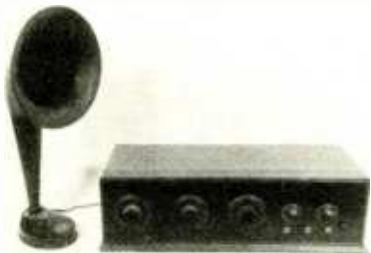

The three-dial battery-operated TRF was common in the 1920's. The one shown in this photo is a Neutrodyne and was originally built from a kit.

There were three major storage-battery-operated tube-receiver designs in use throughout the 1920's: the regenerative, the TRF (tuned radio frequency), and the superheterodyne. The first and last of those were the brainchilds of the legendary radio inventor, Howard Armstrong. A searching technical discussion of the designs is beyond the scope of this article, but the regenerative circuit was by far the most efficient.

**Inside the Regenerative Radio.** A tube that was set up for regenerative service was basically an amplifier. But,



The RCA Radiola III is good example of a typical regenerative receiver. Its two-tube circuit made loudspeaker operation possible, especially on strong local signals.

using an adjustable-feedback arrangement, part of the output was coupled back into the input. Because of that set up, received signals could be amplified over and over again, resulting in tremendous gain.

If too much of the output were to be fed back to the input, however, the tube would begin to oscillate like a radio transmitter, causing an unearthly howl in the headphones and sending out a signal that would interfere with reception throughout the neighborhood. To obtain maximum amplification, then, the trick was to stay just below the point of oscillation.

Not only did the single tube act as an RF amplifier—boosting the signals from the antenna—it performed another function as well. While going about its job as an amplifier, it could also serve as a detector—separating the audio signals from the radio “carrier wave” so that they could be heard in the headphones.

Though there are certainly exceptions, the typical regenerative receiver of the period had one tube functioning as described. Sometimes an extra tube was included, as an audio amplifier, for louder headphone volume. Occasionally, a couple of added tubes (either built into the set or available as an “add-on” amplifier) were used to drive a loudspeaker.

To determine if your flea-market find is regenerative, first look at the controls and tubes. If it has a limited number of tubes, a control marked “regeneration” or “amplification” and only one “tuning” or “station selection” control, there isn't much doubt. The “regeneration” or “amplification” control typically operates a mechanical arrangement that changes the physical relationship between two coils; one in the tube's output circuit, the other in the input circuit.

The tubes used in those sets were

quite often of the variety designed to be lit by dry cells (look for types 11, 12 or 99). However, storage-battery types (most often the 01-A) are also found. Though regenerative sets were made by many manufacturers, you're most likely to find sets made by Crosley—a company that saturated the market with inexpensive sets—and RCA, which used regeneration in most of its low-end line.

**The TRF Scene.** During the early 1920's radio manufacturers could secure a license to use regenerative circuits directly from Armstrong, their inventor. The license could be obtained fairly easily, and on reasonable terms. Towards the middle of the decade, after Westinghouse bought the patent rights, regenerative licenses were difficult—or impossible—to get.

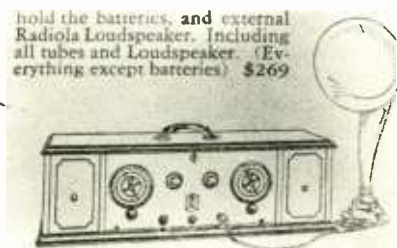

A typical mid-1920's RCA superheterodyne used six tubes. A set like the one shown here was considered to be a “semi-portable.”

Manufacturers who couldn't (or chose not to) secure a regenerative license had to use more tubes. Generally speaking, it required two RF amplifier tubes and a separate detector tube to get approximately the same results obtained from a single tube operating as a regenerative amplifier-detector. Three tuned circuits (coil and variable-condenser—condensers are now called capacitors—combinations) were required for efficient operation of the two RF stages. Radios of that design were called TRF (tuned radio-frequency) sets.

Most TRF sets of that era also had the two additional audio-amplifier tubes, which were needed to operate a horn-type loudspeaker. The theory apparently was that anyone willing to purchase (and buy batteries for) a three-tube radio, would just as soon invest in the two additional tubes and have a more versatile set.

You might think that the cumbersome and expensive TRFs wouldn't be able to compete with the more efficient little regenerative radios. But the



"regen" sets were more difficult to tune and adjust. And the multiple tuned-circuits of the TRFs made them a little more selective (able to separate closely-spaced stations). That proved to be an important factor as the number of stations broadcasting at once began to increase.

The five-tube (generally all type 01-A's), three-dial basic TRF set eventually became an industry standard. It was made by scores of manufacturers, but a couple of the better-known ones were Atwater Kent and Freed-Eisemann. The *Neutrodyne* circuit, made famous by Freed-Eisemann, was a method for preventing un-

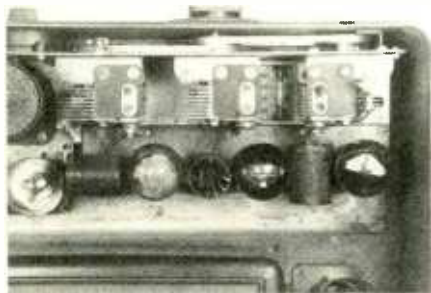

A "straight-down" view of an open Model 42 cabinet shows belts and pulleys linking the tuning condensers for single-control operation. The corner of the separate power-supply box is seen at the lower left of the photo.

wanted oscillation in RF amplifiers. (A common problem with triode RF-amplifier tubes whose inputs and outputs were tuned to the same frequency.) The three-dial TRF set fell into disuse only when the first plug-in sets appeared on the market.

### Armstrong's Other Masterpiece.

The superheterodyne, Howard Armstrong's other masterpiece of radio circuitry, wasn't in widespread use during the 1920's battery-set era. In later decades it was to become the dominant radio design. However at this time, RCA—the patent owner—retained exclusive manufacturing rights.

The superheterodyne circuit represents yet another approach to amplifying radio frequencies. Signals coming in from the antenna are converted to a much lower frequency by mixing (heterodyning) them with a signal generated by an internal oscillator.

The lower frequency, typically between 150 and 450 kHz, is called the IF, or the *intermediate frequency*. The IF signal is amplified and detected much as it would be in a TRF receiver. But by amplifying at a lower frequen-



The Cathedral-style Gloritone screen-grid set represents the transitional period of radio-receiver development. Note that the tuning dial is viewed through a tiny window.

cy, greater gain can be obtained without danger of oscillation, and greater selectivity can also be achieved.

Identifying a superheterodyne set of the 1920's by its physical appearance requires a fairly sophisticated knowledge of radio circuitry. However if the set is a pre-1930 battery model, has six tubes or more (usually type 99's), and was made by RCA, it's probably a superhet.

### Enter the "Socket-Power" Radio.

Broadcast-radio listening entered a brand-new era when the first practical plug-in, or "socket-power" radios appeared on the market. Though many prior schemes had been tried for powering battery sets from the AC power line, the necessary "battery-eliminator" units tended to be heavy, bulky, and expensive.

The true breakthrough came in the late 1920's, when amplifying tubes especially designed for alternating-current service became available. Clumsy external batteries or battery eliminators could now be replaced by a compact power supply unit (usually using a type-80 rectifier tube) built right into the receiver cabinet. The power lead coming out of the radio now terminated in a simple AC plug rather than a tangle of individual wires intended for connection to various DC voltage sources.

These first AC radios were generally TRF sets (except for RCA's, which were generally superheterodynes). But the familiar array of three tuning knobs had all but disappeared. The three tuning condensers formerly operated by those knobs were still in the radios. But, in most models, their shafts were ganged by belt-and-pulley arrangements that permitted tuning all three with a single control. The rheostats for-

merly required for controlling current flow from the batteries through the tube filaments also disappeared—leaving the front panel of the late-1920's AC radio with just three controls: power (typically a separate toggle switch), volume, and tuning.

For some reason, the preferred material for the cabinets of those sleek new radios was now metal rather than wood, or wood and Bakelite. And the hinged top of the older-style sets was replaced by a friction-fitting metal lid that could be lifted off for tube replacement. External loudspeakers were still the rule, housed in matching metal cases. But a more compact paper-cone style had replaced the earlier horn design. Late 1920's AC-powered sets by Crosley and Atwater-Kent are good examples of this "new look" in radio. RCA, however, opted for furniture-style cabinets with rich wood-grain finishes.

### Transition-Period Radios.

From the final years of the 1920's through the early years of the 1930's, the evolution of radio receivers passed through what I think of as the "transitional period." All of the basic receiver circuits had been invented, and further advances in circuitry would be refinements of design. Those were paralleled by refinements being made on the mechanical aspects of the radio chassis.



This view of the Gloritone's chassis shows the 24-A screen-grid tubes wired to the three-section tuning condenser. The power transformer, with its ventilating cover, is seen just to the left of the tuning condenser.

For example, the three tuning condensers so typical of the TRF radio were no longer ganged by belts and pulleys. Instead, they were combined in one frame and tuned by a common shaft. This broke up the familiar "row-style" arrangement of the RF amplifier stages. Now the RF amplifier tubes and coils tended to be grouped around the common variable capacitor so that they could be arranged for max-



The rear view of this depression-era AC-DC radio shows its tall glass tubes. This set uses a line-cord resistor.

imum compactness and minimum lead length.

The power-supply circuitry, formerly housed on a separate chassis within the radio cabinet, moved onto the radio chassis itself—achieving still greater compactness and design integration. The functional groups of the receiver were no longer separate “building blocks” but blended together as a unified whole.

Finally the loudspeaker, stripped of its decorative case and reduced in diameter, was placed inside the radio cabinet. The design of the speaker also changed. Formerly nothing more than a scaled-up earphone movement incorporating relatively weak permanent magnets, the new unit (called a *dynamic* speaker) contained a powerful electromagnet operated from the receiver’s power supply.

The new speaker required four leads (one pair for electromagnet power) compared with the original two. Though smaller in size than the old-style separate speaker, the built-in speaker delivered much more sound—particularly since the audio tube that drove it, no longer having to rely on a limited battery supply, was delivering more power.

The presence of the speaker inside the cabinet caused another major change in the radio’s physical appearance. Previously, the hinged-lid, coffin-shaped, wooden box of the mid-1920’s battery TRF had been replaced by the more rectangular box of the late 1920’s socket-power radio with its built-in power supply. Now, because of its more compact chassis, the cabinet of the “transitional” radio took up less table space, but required more vertical space to accommodate the speaker.

One of the resulting cabinet styles, the familiar *cathedral*, curved upward to form a dome around the speaker. Another common style, the

*tombstone*, took the shape of a vertically oriented rectangular slab. But however they were shaped, cabinets were now made of hardwood veneers, metal having virtually disappeared as a material for radio enclosures.

It’s worth noting, too, that the late-1920’s release of screen-grid tubes (which were highly efficient RF amplifiers) gave the TRF design a last breath of life before the superhet became king. And the screen-grid TRF, with its distinctive group of three top-capped 24-A tubes is a common relic of that era.

By now, radio broadcasting had become such an important feature of American family life that it was natural for a radio receiver to become the focal point of the living room. Thus, the “transitional period” was also the period of the magnificent living-room console. The speakers of those big consoles were mounted below the chassis, and the cabinets were made tall enough so that the knobs and dial could be elevated for easy visibility. Cabinets were as massive and elegantly crafted as the family could afford.

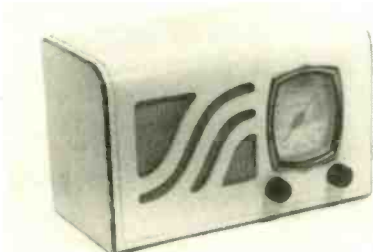

The 1939 Philco set shown here was one of the last wood-cabinet table models in the line. Note the large tuning dial with rotating pointer.

But whether it was a table model or a console, the typical “transitional period” set had moved into the modern era of vacuum-tube radio design. Inside, the radio no longer looked like a hand-assembled laboratory prototype, but more like the mass-produced home appliance it had become. Outside, the “apparatus” look was gone. The multi-knobbed Bakelite front panel or neutral metal enclosure was replaced by a cabinet made of fine wood in a furniture style and finish.

**Impact of the Depression.** As you might imagine, the financial crash of 1929 and the deepening depression of the 1930’s had quite an impact on the

burgeoning radio industry. But, if anything, the number of radio listeners was increasing. Broadcasting was in its Golden Age, when some of the most popular radio series of all time had their beginnings. The programs were a blessing to the cash-starved depression family; they were free, and could be enjoyed without leaving the home.

However, if the manufacturers wanted to continue to sell radio sets, they’d have to develop economy versions. The market for the elaborate consoles and table models of the late 1920’s was definitely dwindling. Luckily, radio stations were increasing in number and power—so the new sets didn’t have to be supersensitive. And the improvements in the efficiency of vacuum tubes and components made it possible to downsize receivers and still maintain reasonable performance.

In creating the “depression radio” two bulky and expensive power-supply components—the filter choke and the power transformer—were eliminated completely. By wiring the field coil (electromagnet) of the dynamic speaker in place of the filter choke, the field coil could replace the choke and still receive the DC power it needed to function. The transformer was eliminated by devising a new method for lighting the tube heaters.

Formerly connected in parallel and operated from a low-voltage winding on the transformer, the heaters were now wired in series to build up as large a voltage-drop as possible. That series string of heaters was connected, in turn, with a series resistor to increase the voltage drop still further. The combined voltage drops of the tubes and series resistor totaled \$15 or so, and the entire “shooting match” could be operated directly from the AC (or, as we shall see, DC) line without benefit of a power transformer.

### Recognizing Depression AC-DC’s.

The elimination of the power transformer resulted in an interesting fringe benefit; a radio without a power trans-



A 1940’s Emerson, like the one shown here, is a typical “second-generation” AC-DC set.



former could be operated from DC as well as AC current. During the 1930's, the downtown sections of many large cities were supplied *only* with DC power. Conventional radios having power transformers could be operated downtown only by using a costly power inverter. Here was a ready-made market for the new "bare-bones" radios, which quickly became known in the trade as "AC-DC sets."

The first AC-DC "depression radios" make interesting collectibles. Cabinets were generally made of wood in a variety of fanciful styles. They look nice on a bookshelf, and are much easier to store and display than the full-size models.

Besides the distinctive cabinet, you can also recognize the first-generation AC-DC set by its series resistor and the types of tubes used. The tubes were a mixture of 6-volt types originally developed for auto use (6A7, 6D6, 6Q7—to name a few) and higher-voltage types designed especially to help build up the voltage drop in the series string (typical were the 25Z5 and 25L6). You'll also often see the 43, a 6-volt type designed especially for use in AC-DC sets.

Series resistors were sometimes included in the set's line cord as an asbestos-covered third wire; sometimes housed in metal plug-in tube-like enclosures mounted on the set's chassis. The former type were commonly called *line-cord resistors*; the latter were known as *ballasts*.

Those little radios were made both as TRFs and as superheterodynes. But construction practices were such that it isn't always easy to tell the difference without a knowledgeable eye or a circuit diagram!

### The Second Generation of AC-DC sets.

The design of the AC-DC set slowly evolved through the 1930's, and by the early 1940's it had quite a different look. The cabinet was now generally made of Bakelite, often in a dark-brown color. That plastic material could be formed much more easily into the soft curves of the streamlined, or "moderne" look then in vogue.

The old tall-glass ("G" style) tubes had been replaced by the shorter metal, or "GT"-style glass versions—resulting in a more compact cabinet. By the way, don't confuse the "GT"-type glass tubes with the even smaller miniature glass tubes of a later era. The former have a separate metal or plas-

tic base equipped with an octal (8-prong) plug. The latter are one-piece glass types having no separate base; the connecting pins (usually 7) pass directly out through the tube's glass bottom.

The speaker of that second-generation AC-DC set was frequently a *permanent-magnet* type rather than the older style dynamic version. Through the development of better magnetic materials, permanent magnets could now be made much more powerful than before, making obsolete the need for a speaker field coil. And improvements in power-supply components over the years had done away with the necessity of having a field coil to play the part of a filter choke. One easy way to identify a permanent-magnet speaker is to check the number of leads going to it; there are only two of them, compared with the four wires required for a dynamic speaker.



*The Zenith 1940 portable had an "airplane luggage" case and a removable loop antenna with suction cups for mounting on car windows.*

Second-generation AC-DC sets were usually superheterodynes rather than TRFs. And the superheterodyne sets of that period were easily recognizable by the pair of tall, square-topped aluminum enclosures housing the IF transformers. The top of each transformer normally contained a pair of access holes used for reaching the tuning adjustments.

**Enter the Portables!** Lightweight, battery-powered radios that could be carried anywhere appeared in the late 1930's. Like most earlier innovations in radio receivers, that one was made possible through development of a new variety of vacuum tube. The new battery-radio tubes required much less power (especially to light their filaments) than "normal" types. That meant that the portable could be operated for a long time by a compact battery pack housed within the case.

The battery portables of that era have a romance all of their own. Most came in suitcase-style cases, often

covered with "airplane-luggage" fabric. Some had shortwave bands as well as standard broadcast. And a few had special arrangements to remove and orient the antenna for best reception.

The little battery portables were often marvels of mechanical ingenuity and organization of interior space. It was quite a trick to find places for a full set of batteries without coming up with a cabinet size appreciably larger than the standard AC-DC table model. And since those sets were generally designed for plug-in operation as well, designers also had to provide a spot to store the line cord when not in use.

As you might imagine, the "3-way" portables (so named because they would operate from the AC line, DC line, or internal battery power) were enormously popular with teenagers,—who lugged them to beaches, parks, or other recreational areas to add a little extra romance and excitement to the proceedings.

You can identify the first-generation 3-way portable not only by its case style and battery compartments, but also by its tube complement. The tubes will be in the octal-based "GT" style described previously, and you'll see types such as 1A5, 1A6, 1A7, 1B7, 1H5, 1N5, etc. The "1" at the beginning of the type number indicates that the tube operates from a 1.4-volt DC source.

**Other Trends in Radio.** So far we've covered the evolution of broadcast radio receivers during the 1920's. Then we skipped rather abruptly from the early to the late 1930's as we discussed the AC-DC sets and 3-way portables—types that were quite dominant during that era.

But it should be stressed that—throughout this period—plenty of full-size, full-featured, wood-cabinet table models and consoles were also being made. So I'd like to finish this beginner's guide to vintage radio by discussing some of the other developments that took place during the 1930's and early 1940's. Developments that apply generally to the full-sized radios and, in many cases, to the scaled-down models as well.

You already know that, during this period, the tall glass "G"-type tubes were replaced by the much shorter and more compact, octal-based, GT-type (glass) and metal tubes. You know, too, that the dynamic speaker

*(Continued on page 99)*

# THE DC NETWORK

Let your computer solve for DC-network node voltages and avoid brain strain

By James E. Tarchinski

IN THE OCTOBER 1987 ISSUE OF **Hands-on Electronics**, we published *ACNAP*, a program written in BASIC that enables a personal computer to calculate the node voltages of alternating-current (AC) networks. Due to the number of requests we've received for a direct-current version of that program, we would now like to introduce *DCNAP*: The Direct-Current Network Analysis Program.

## A Little Background

DCNAP (also written in BASIC) solves for the node voltages in DC circuits using a technique called *nodal analysis*. The circuits entered can have anywhere from 1 to 25 nodes and contain resistors, conductors, independent current sources, voltage-controlled current sources, and independent voltage sources.

The DCNAP program listing is given in Table 1, and a flow chart of the program is shown in Fig. 1. Note that the numbers in brackets on the flow chart correspond to the line numbers in the program listing shown in Table 1.

Those of you with sharp eyes and good memories may notice the resemblance between DCNAP and its AC cousin, ACNAP. The reason for that is, as you may already suspect, that DCNAP was created by optimizing the original ACNAP program to handle DC circuits. As mentioned in the ACNAP article, that program is capable of analyzing DC circuits by setting the frequency of operation to zero hertz and being certain not to enter any inductive elements in the circuit description when analyzing DC networks. However, ACNAP would be somewhat inconvenient for a large number of DC circuits; hence the need for DCNAP.

While creating DCNAP, care was taken not to modify any line numbers from the original (ACNAP) program listing. To use DCNAP, enter the pro-

TABLE 1

```

1000 'DC NETWORK ANALYSIS PROGRAM (DCNAP)
1010 '
1020 CLEAR : DIM A(25,26)
1030 SCREEN 0,0,0,0 : COLOR 10,0,0 : WIDTH 80 : CLS
1060 '
1070 PRINT "*****"
1080 PRINT "*"
1090 PRINT "*"
1100 PRINT "*"
1110 PRINT "*"
1120 PRINT "*"
1130 PRINT "*****"
1140 COLOR 11
1150 PRINT
1160 PRINT " This program uses Nodal Analysis to determine the node voltages"
1170 PRINT "of linear D.C. networks. These networks may range in size from"
1180 PRINT "1 to 25 nodes, not counting the ground, or datum, node."
1190 PRINT
1200 PRINT " Models for five types of devices are incorporated in this"
1210 PRINT "program:"
1220 PRINT " 1. Resistors"
1230 PRINT " 2. Conductors"
1250 PRINT " 3. Independent current sources (ICS)"
1260 PRINT " 4. Voltage-controlled current sources (VCCS)"
1270 PRINT " 5. Independent voltage sources (IVS)"
1280 PRINT
1290 LOCATE 23,1 : COLOR 7 : PRINT "Press any key ...";
1300 '
1310 INS=INKEYS:IF INS<>" " THEN GOTO 1310
1320 INS=INKEYS:IF INS=" " THEN GOTO 1320
1330 CLS : COLOR 10
1340 PRINT "For all circuits, these conventions must be followed:"
1350 COLOR 11
1360 PRINT
1370 PRINT "1. All nodes of the circuit must be labeled with consecutive"
1380 PRINT " integers (1, 2, 3, etc.)."
1390 PRINT
1400 PRINT "2. The ground node must be Node 0."
1410 PRINT
1420 PRINT "3. The ground node is not counted when determining the number"
1430 PRINT " of nodes in a circuit."
1440 PRINT
1450 PRINT "4. No two voltage sources (IVS) may be connected to the same node,"
1460 PRINT " not counting the ground node (Node 0)."
1470 PRINT
1480 LOCATE 23,1 : COLOR 7 : PRINT "Press any key ..."; : COLOR 10
1490 '
1500 INS=INKEYS:IF INS<>" " THEN GOTO 1580
1510 INS=INKEYS:IF INS=" " THEN GOTO 1590
1520 CLS
1530 PRINT "Enter the number of nodes in the circuit."
1540 INPUT "not counting the ground node (1-25): ",N
1550 IF N > 25 OR N < 1 THEN PRINT "PLEASE ENTER A VALID NUMBER!": GOTO 1610
1560 N1 = N + 1
1570 '
1580 PRINT
1590 PRINT
1600 CLS
1610 PRINT "***** RESISTOR SECTION *****"
1620 CLS : INPUT "Enter number of resistors: ",NC
1630 IF NC < 1 THEN GOTO 1950
1640 POS = "RESISTOR"
1650 P1S = "INITIAL NODE: "
1660 P2S = "FINAL NODE: "
1670 P3S = "VALUE (Ohms): "
1680 FOR I = 1 TO NC
1690 GOSUB 3740
1700 VL = 1 / VL
1710 A(IN,IN) = A(IN,IN) + VL : A(IN,EN) = A(IN,EN) - VL
1720 A(EN,EN) = A(EN,EN) + VL : A(EN,IN) = A(EN,IN) - VL
1730 NEXT I
1740 '
1750 PRINT
1760 '
1770 '***** CONDUCTOR SECTION *****"
1780 '
1790 CLS : INPUT "Enter number of conductors: ",NC
1800 IF NC < 1 THEN GOTO 2400
1810 POS = "CONDUCTOR"
1820 P1S = "INITIAL NODE: "
1830 P2S = "FINAL NODE: "
1840 P3S = "VALUE (Mhos): "
1850 FOR I = 1 TO NC
1860 GOSUB 3740
1870 A(IN,IN) = A(IN,IN) + VL : A(IN,EN) = A(IN,EN) - VL
1880 A(EN,EN) = A(EN,EN) + VL : A(EN,IN) = A(EN,IN) - VL
1890 NEXT I
1900 '
1910 '
1920 '
1930 '***** INDEPENDENT CURRENT SOURCE SECTION *****"
1940 '
1950 CLS : INPUT "Enter number of ICSS: ",NC
1960 IF NC < 1 THEN GOTO 2560
1970 POS = "INDEPENDENT CURRENT SOURCE"
1980 P1S = "INITIAL NODE: "
1990 P2S = "FINAL NODE: "
2000 P3S = "VALUE (Amps): "
2010 FOR I = 1 TO NC
2020 GOSUB 3740
2030 A(IN,IN) = A(IN,IN) + VL : A(IN,EN) = A(IN,EN) - VL
2040 A(EN,EN) = A(EN,EN) + VL : A(EN,IN) = A(EN,IN) - VL
2050 NEXT I
2060 '
2070 '
2080 '
2090 '***** INDEPENDENT VOLTAGE SOURCE SECTION *****"
2100 '
2110 CLS : INPUT "Enter number of IVSS: ",NC
2120 IF NC < 1 THEN GOTO 2560
2130 POS = "INDEPENDENT VOLTAGE SOURCE"
2140 P1S = "INITIAL NODE: "
2150 P2S = "FINAL NODE: "
2160 P3S = "VALUE (Volts): "
2170 FOR I = 1 TO NC
2180 GOSUB 3740
2190 A(IN,IN) = A(IN,IN) + VL : A(IN,EN) = A(IN,EN) - VL
2200 A(EN,EN) = A(EN,EN) + VL : A(EN,IN) = A(EN,IN) - VL
2210 NEXT I
2220 '
2230 '
2240 '
2250 '***** END OF PROGRAM *****"
2260 '
2270 CLS : PRINT "*****"
2280 PRINT "*"
2290 PRINT "*"
2300 PRINT "*"
2310 PRINT "*"
2320 PRINT "*"
2330 PRINT "*****"
2340 '
2350 '
2360 '
2370 '
2380 '
2390 '
2400 '
2410 '
2420 CLS : INPUT "Enter number of ICSS: ",NC
2430 IF NC < 1 THEN GOTO 2560

```



# ANALYSIS PROGRAM

TABLE 1 (continued)

```

2440 POS = "ICS"
2450 P1S = "INITIAL NODE (The tail): "
2460 P2S = "FINAL NODE (The point): "
2470 P3S = "MAGNITUDE (Amps): "
2490 FOR I = 1 TO NC
2500   GOSUB 3740
2510   A(IN,N1) = A(IN,N1) - VL
2520   A(EN,N1) = A(EN,N1) + VL
2530 NEXT I
2540 '
2550 '
2560 '***** VOLTAGE CONTROLLED CURRENT SOURCE SECTION *****
2570 '
2580 CLS : INPUT "Enter number of VCCSs: ",NC
2590 IF NC < 1 THEN GOTO 2740
2600 POS = "VCCS"
2610 P1S = "INITIAL NODE (The tail): "
2620 P2S = "FINAL NODE (The point): "
2630 P3S = "MAGNITUDE (Amps/volt): "
2640 FOR I = 1 TO NC
2650   GOSUB 3740
2660   PRINT
2670   INPUT "CONTROLLING NODE (Positive): ",CP: IF CP > N OR CP < 0 THEN BEEP:
GOTO 2660
2680   INPUT "CONTROLLING NODE (Negative): ",CN: IF CN > N OR CN < 0 OR CN = CP
THEN BEEP: GOTO 2680
2690   A(IN,CP) = A(IN,CP) + VL : A(IN,CN) = A(IN,CN) - VL
2700   A(EN,CP) = A(EN,CP) - VL : A(EN,CN) = A(EN,CN) + VL
2710 NEXT I
2720 '
2730 '
2740 '***** INDEPENDENT VOLTAGE SOURCE SECTION *****
2750 '
2760 CLS : INPUT "Enter number of IVSs: ",NC
2770 IF NC < 1 THEN GOTO 2960
2780 POS = "IVS"
2790 P1S = "NEGATIVE NODE: "
2800 P2S = "POSITIVE NODE: "
2810 P3S = "MAGNITUDE (Volts): "
2830 FOR I = 1 TO NC
2840   GOSUB 3740
2850   IF IN > EN THEN VL=-VL : T0=IN : IN=EN : EN=T0
2860   FOR J = 1 TO N1
2870     A(IN,J) = A(IN,J) + A(EN,J)
2890     A(EN,J) = 0
2900   NEXT J
2910   A(EN,EN) = 1 : A(EN,IN) = -1 : A(EN,N1) = VL
2930 NEXT I
2940 '
2950 '
2960 '***** GAUSSIAN ELIMINATION SECTION *****
2970 CLS
2980 PRINT "CALCULATING, PLEASE WAIT..."
2990 FOR I = 1 TO N
3000   HF = I
3010   B = ABS(A(I,I))
3020   FOR K = I+1 TO N
3030     T = ABS(A(K,I)): IF T > B THEN B = T : HF = K
3040   NEXT K
3050   IF I = HF THEN GOTO 3110
3060   FOR K = 1 TO N1
3070     T = A(I,K)
3080     A(I,K) = A(HF,K)
3090     A(HF,K) = T
3100   NEXT K
3110   IF B < 9.999999E-21 THEN CLS : PRINT "ERROR! - The circuit entered is no
t valid.": GOTO 3590
3120 '
3130   T = A(I,I)
3140   FOR K = I TO N1
3150     A(I,K) = A(I,K) / T
3180   NEXT K
3190 '
3200   FOR K = 1 TO N
3210     IF K = I THEN 3280
3220     T = - A(K,I)
3230     A(K,I) = 0
3240     FOR L = I+1 TO N1
3250       A(K,L) = A(K,L) + T*A(I,L)
3270     NEXT L
3280   NEXT K
3290 NEXT I
3300 '
3310 CLS
3320 PRINT "THE NODE VOLTAGES ARE:": PRINT
3330 FOR I = 1 TO N
3340   IF I=20 THEN INS="":LOCATE 23,1:PRINT "Press any key ...":WHILE INS=""
:INS=INKEYS:WEND:CLS
3410   PRINT "V(:";I;") = ";A(I,N1):" volts"
3570 NEXT I
3580 '
3590 LOCATE 23,1
3600 PRINT "Press any key to continue...";

```

gram given in Table 1 into your computer, taking special care to enter the program line numbers exactly as shown. Because of the program's origin, DCNAP does not always have line numbers that are perfect increments of ten, as is customary in magazine listings. Once the program is entered, you must run BASIC in order to use DCNAP.

## Program Description

DCNAP is initialized by the first three lines of code (1000-1030). The variables are cleared, the "A" array is given dimension, and the screen is cleared, and set up in the 80-column text mode.

The next section of the program, lines 1070-1590, displays two screens of introductory information. The first screen contains general comments about the program (as shown in Fig. 2), while the second screen notes the four major rules that must be followed when using DCNAP. Basically, those rules state that each node in the circuit to be analyzed must be given a *unique* integer node number, and that the ground (or datum) node *must* be called Node 0.

No integer value may be skipped and the ground node is not counted when determining the number of nodes in a network. Also, no two independent voltage sources may be connected to the same node, with the single exception of the ground node (Node 0). After the instruction screens are displayed, the computer prompts you to enter the number of nodes in the circuit. If the number of nodes is less than one or greater than 25, an error message is displayed and the user is given another opportunity to input a valid number.

When the number of nodes is correctly entered, the program then prompts you to enter the circuit's description, which is done one element at a time. Resistors are entered first, followed by conductors, Independent Current Sources (ICS), Voltage-Controlled Current Sources (VCCS), and finally Independent Voltage Sources (IVS). Because each type of element is entered using the same format, a common subroutine (which begins on line 3740) is used to enter component data.

For resistors and conductors, it doesn't matter which node you consider

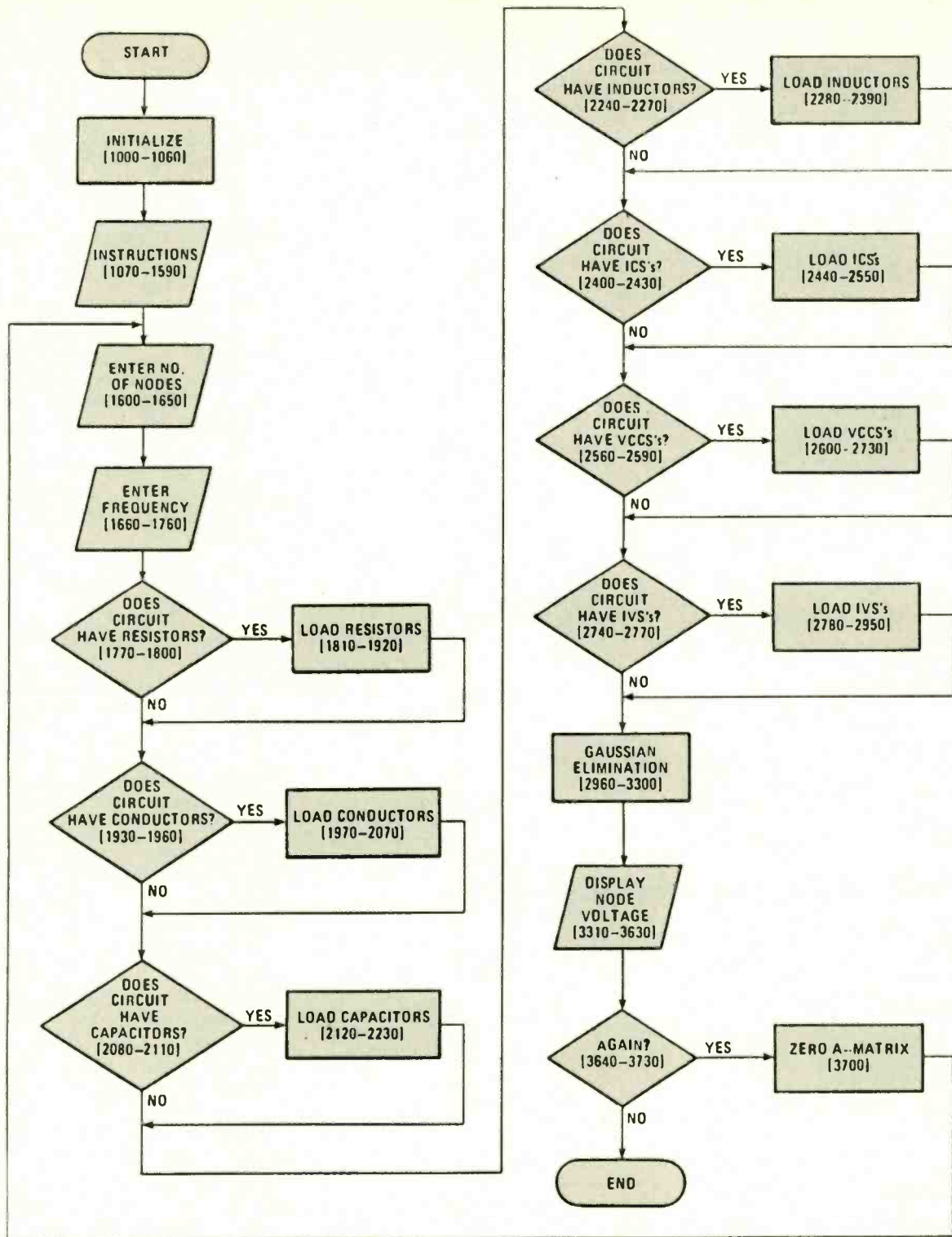

Fig. 1—Because DCNAP was derived from the original ACNAP program, the line numbers are not always in perfect increments of ten. Take care when entering the program not to miss a line number transition.

to be the "Initial Node," and which you consider to be the "Final Node," as long as there is one of each. For the other three element types however, the node names must not be confused or DCNAP will yield incorrect results. For those elements, the input prompts specify what names are associated with

which terminal of the circuit. For example, the "Initial Node" of an independent current source (ICS) is the tail of the arrow, while the "Final Node" is the arrow's point.

When all the component values are entered, lines 2960-3290 of the program solve for the circuit's node volt-

ages, using a Gaussian elimination algorithm. If the numeric values in the equations become too small for the computer to deal with, or if the circuit description entered is not valid, the error message of line 3110 is displayed.

The circuit's node voltages, with respect to the ground node (Node-0), are printed to the screen by lines 3310-3620. To make certain that the



**TABLE 1 (continued)**

```

3610 INS = INKEYS : IF INS <> "" THEN GOTO 3610
3620 INS = INKEYS : IF INS = "" THEN GOTO 3620
3630 '
3640 CLS : PRINT "would you like to analyze another circuit?"
3650 PRINT " 1. Yes, or"
3660 PRINT " 2. No"
3670 INPUT "Your choice: ",A
3680 IF A = 2 THEN END 'exit program
3690 IF A <> 1 THEN BEEP: GOTO 3640 'improper entry
3700 FOR I=1 TO N : FOR J=1 TO N1 : A(I,J)=0 : NEXT : NEXT
3710 GOTO 1600
3720 '
3730 '
3740 '***** INPUT SUBROUTINE *****
3750 PRINT : PRINT
3760 PRINT "===== ";POS;" #";I;" ====="
3770 PRINT
3780 PRINT P1S;
3790 INPUT "",IN : IF IN > N OR IN < 0 THEN BEEP : GOTO 3780
3800 PRINT P2S;
3810 INPUT "",EN : IF EN > N OR EN < 0 OR IN = EN THEN BEEP : GOTO 3800
3820 PRINT P3S;
3830 INPUT "",VL
3840 RETURN

```

```

*****
*
*          DCNAP - D.C. Network Analysis Program
*
*          (c) 1988 by James E. Tarchinski
*
*****

```

This program uses Nodal Analysis to determine the node voltages" of linear D.C. networks. These networks may range in size from" 1 to 25 nodes, not counting the ground, or datum, node."

Models for five types of devices are incorporated in this" program:"

1. Resistors"
2. Conductors"
3. Independent current sources (ICS)"
4. Voltage-controlled current sources (VCCS)"
5. Independent voltage sources (IVS)"

Press any key ...

**Fig. 2—The first screen contains general comments about the program.**

top lines do not scroll off the screen before you have an opportunity to write the node voltages down, line 3340 pauses for a key press when the variable "I" is equal to 20 (assuming that there are at least 20 nodes in the circuit).

**Example Circuits**

After you enter DCNAP and save it to disk, you'll probably want to run some test data to verify that the program is functioning properly. Let's go through a few sample solutions. As previously mentioned, you must first call up BASIC; load and run DCNAP.

In addition to verifying that you've entered the program correctly, the solutions also demonstrate exactly how to

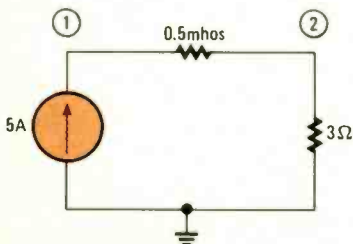

**Fig. 3—This simple two-node circuit is used for the first example.**

use the DC Network Analysis Program. The circuit for our first example is the two-node network shown in Fig. 3. The DCNAP solution for that circuit would be as follows (assuming that you've gotten past the *press any key* prompt:

```

Enter the number of nodes in the circuit,
not counting the ground node (1-25): 2

Enter the number of resistors: 1
===== RESISTORS # 1 =====
INITIAL NODE: 2
FINAL NODE: 0
VALUE (Ohms): 3

Enter the number of conductors: 1
===== CONDUCTOR # 1 =====
INITIAL NODE: 1
FINAL NODE: 2
VALUE (Mhos): 0.5

Enter the number of ICSs: 1
===== ICS # 1 =====
INITIAL NODE (The Tail): 0
FINAL NODE (The Point): 1
VALUE (Amps): 5

Enter the number of DCSSs: 0
Enter the number of IVSs: 0

THE NODE VOLTAGES ARE:
V(1) = 25 volts
V(2) = 15 volts

would you like to analyze another circuit?
1. Yes, or
2. No
Your choice: 1

```

The next example that we'll analyze is the three-node circuit shown in Fig.

4. That circuit contains a voltage-controlled current source whose output current is dependent on  $V_x$ , the voltage from Node-1 to Node-2. A solution for

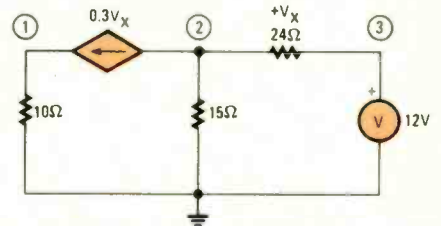

**Fig. 4—The three-node circuit is a bit more complicated than the first, but is still child's play for DCNAP.**

that circuit can readily be obtained as follows:

```

Enter the number of nodes in the circuit,
not counting the ground node (1-25): 3

Enter the number of resistors: 3
===== RESISTOR # 1 =====
INITIAL NODE: 1
FINAL NODE: 0
VALUE (Ohms): 10

===== RESISTOR # 2 =====
INITIAL NODE: 2
FINAL NODE: 0
VALUE (Ohms): 15

===== RESISTOR # 3 =====
INITIAL NODE: 2
FINAL NODE: 3
VALUE (Ohms): 24

Enter the number of conductors: 0
Enter the number of ICSs: 0
Enter the number of VCCSs: 1
===== VCCS # 1 =====
INITIAL NODE (The Tail): 2
FINAL NODE (The Point): 1
VALUE (Amps): 0.3
CONTROLLING NODE (Positive): 2
CONTROLLING NODE (Negative): 3

Enter the number of IVSs: 1
===== IVS # 1 =====
NEGATIVE NODE: 0
POSITIVE NODE: 3
MAGNITUDE (Volts): 12

CALCULATING, PLEASE WAIT...
THE NODE VOLTAGES ARE:

V(1) = -5.877554 volts
V(2) = 12.04082 volts
V(3) = 12 volts

```

The two test circuits that have been analyzed contain all of the circuit elements that DCNAP can handle. So if the version of DCNAP that you enter into your computer correctly solves both networks, you can be somewhat confident that you have entered the program correctly. If your solutions do not agree with the ones above, double check your work.

It may take a bit of work to enter DCNAP and then eliminate any typographical errors. But when you are done you'll have a powerful program capable of solving even the most complex DC circuits in just seconds. ■

# UNDERSTANDING OHM'S LAW

**At one time, some scientists considered Ohm's Law not to be worth the paper it was written on. But those scientists never put it to the test. When was the last time you did?**

BY STAN CZARNIK

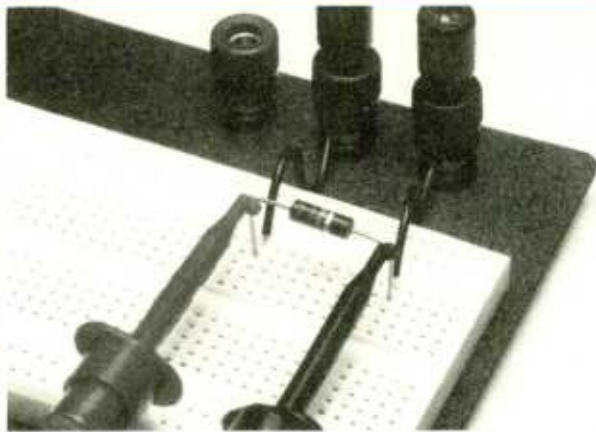

To begin your study of Ohm's Law you'll need to measure the voltage across a resistor. Using a high impedance digital meter will prevent you from loading down the circuit.

IT IS DIFFICULT, IF NOT IMPOSSIBLE, TO THINK ABOUT electrical resistance without also thinking about some form of mathematical representation. A digital readout, a moving needle, or even a color-coded resistor, it all comes down to numbers. That was not always the case.

Some of the first experiments in conductivity were those of the solitary English scientist, Henry Cavendish (1731–1810). Without access to batteries, Cavendish used primitive capacitors, called Leyden jars, as a source of current. Cavendish studied the effect known in modern electronics as voltage drop by directing static discharges through glass tubes of different sizes containing solutions of salt in water. But Cavendish had no measuring instruments. So he completed the test circuits with his own body and figured the various degrees of conductivity by the kind of shock he received: The first voltmeter was the human nervous system!

There were other studies of electrical conductivity. The French physicist Andre Marie Ampere (1775–1836) noted that conductors possess certain "imperfections." He called those imperfections resistance. But the precise relation of resistance to other electrical forces remained unclear.

## A Web of Naked Fancies

What was needed was a way of representing those forces in an exact, unambiguous, quantitative fashion. That is the great historical contribution of Georg Simon Ohm (1787–1854).

Ohm's first formal investigations dealt with the length of a current-carrying wire and the attenuation of electromagnetic intensity due to its length. He also studied wire's made of different materials: gold, brass, platinum, lead, and so on. Ohm found that all conductors are not created equal, and that conductivity varied according to both a wire's length and cross-sectional area. Those conclusions were made public in 1825.

Ohm's experiments did not impress his contemporaries very much, but Ohm continued his work anyway. He went on to confront the elementary forces and principles that make an electrical circuit what it is. He sought to define the interaction of three key variables. Those are: the electrical potential of a voltaic cell (later known as a thermocouple), the electromagnetic intensity, and the length of a connecting wire, or voltage, current, and resistance.

Those studies were followed by a comprehensive volume entitled *The Galvanic Circuit Mathematically Worked Out*

published in 1827. Ohm's book was not greeted with a lot of enthusiasm. In fact, some of the comments were just plain hostile. One critic called it a "web of naked fancies." In other words: Crazy! The web of naked fancies contained Ohm's Law.

Many people have trouble with math, even fairly simple math. I am one of those people. But, Ohm's Law is fundamental to all electrical science, and understanding it can provide the confidence necessary to master more complicated formulas. And there are plenty of those both in and out of electronics.

## Current

The fundamental form of Ohm's Law tells us that the level of current in a simple linear series circuit varies directly with the voltage and inversely with the resistance. In other words, current (in amps) equals potential difference (in volts) divided by resistance (in ohms). Algebraically, with  $I$  representing current,  $E$  standing for voltage, and  $R$  for resistance:

$$I = E/R$$

So let's see how that works out. Say you select a resistor and determine its value to be 218 ohms with a multimeter. If you connect the resistor to a couple of 1.5-volt batteries in series, and measure the voltage across the resistor, it should be about 3.00 volts. The current in the circuit can now be predicted by dividing 3.00 by 218. According to my pocket calculator, that equals .013, or 13 milliamps. Check that figure by opening the circuit and measuring the actual current. You will find that predicated value and the actual value are very close.

Repeat the exercise with a few other resistors until you are comfortable with the results. Remember, the numbers you obtain are important, but not nearly as important as your understanding of the relationships involved.

## Resistance

The second form of Ohm's Law tells us that resistance equals voltage divided by current. Expressed mathematically, that is:

$$R = E/I$$

Choose another resistor, connect it to your battery pack, and determine the current moving through the circuit. For the



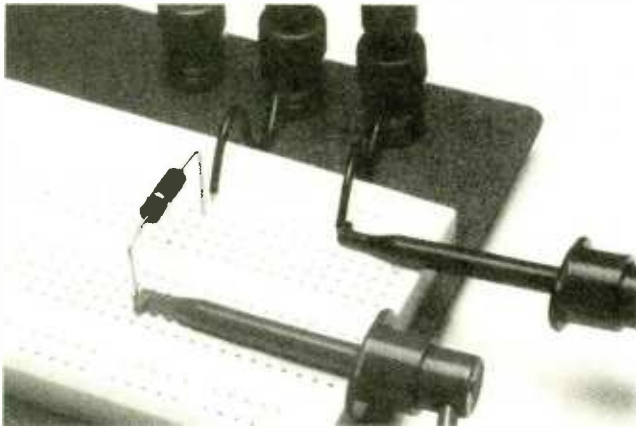

Measuring current requires that you open the circuit and place the meter into it as a part of the circuit.

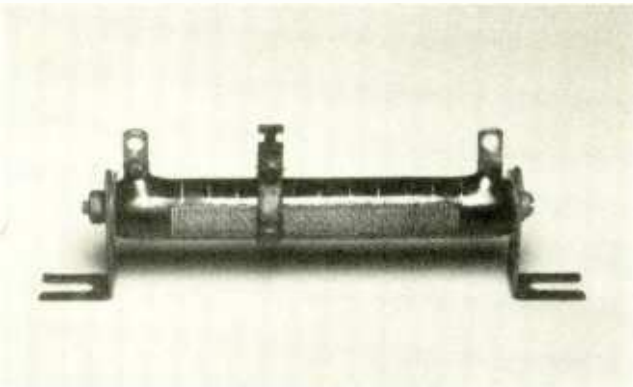

If you dig down to the bottom of your junk box, you may find one of these old-fashioned wire-wound variable resistors. They are interesting devices to experiment with. This one provides from 0 to 10 ohms of resistance.

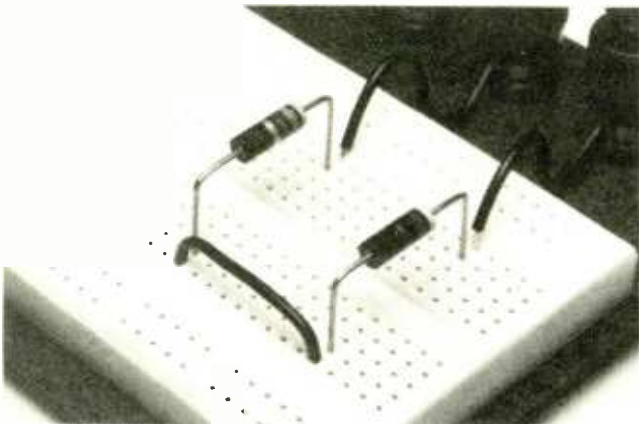

A simple voltage divider is perhaps one of the most useful circuits you can create. By using a potentiometer in place of one of the resistors, you can perform the experiment with many different values of resistance but fewer parts.

#### MATERIALS LIST FOR THE OHM'S LAW LAB

1.5-volt "D" or "C" cells (2)  
 Battery holder  
 Hook-up wire  
 Multimeter  
 Resistors, Assorted  
 Solderless breadboard  
 Test cables and clips

sake of our example, we'll say the current is 8.5 milliamps, or .0085 amp. Now measure the voltage. Determine the value of R by dividing E by I, or in our case we divide 3.00 by .0085. That comes out to about 353 ohms. The calculated value of resistance in the circuit is likely to be a bit higher than the value of the resistor, but the two numbers will be quite close. Once again, repeat the exercise a few times with a few different resistors. Potentiometers, rheostats, and other sources of resistance may, of course, be used as well.

With the exception of superconductors, all conductors have resistance. Resistance is a distinctive feature of a given conductor. Given a constant temperature, the voltage and current can vary, but the resistance will remain the same. According to some interpretations, that is the real essence of Ohm's Law.

To demonstrate that, remove one battery from your battery pack. That will give you about 1.50 volts. Now repeat the experiment described previously. With the same resistor, the current flowing through the circuit will be about one-half of what it was originally. One-half the original voltage divided by one-half the original current, will give you a value of R that is very close to one you obtained the first time you performed the experiment.

#### Voltage and Voltage Dividers

The third and final form of Ohm's Law states that voltage equals the current multiplied by the resistance. Or, expressed as an equation:

$$E = I \times R$$

Start by determining the value of a resistor. Suppose the value is 449 ohms. Now connect that same resistor to the power pack and measure the current moving through the circuit. Suppose the value is about 6.7 milliamps, or .0067 amp. The value of R, 449, multiplied by the value of I, .0067, equals just over 3.00, the value of E. The calculated value of E will be close to actual voltage across the resistor.

This ought to be getting pretty easy, so let's complicate things a bit. Choose a second resistor. Now patch together a series circuit consisting of the two resistors and the battery pack. You have built a simple voltage divider that resembles the one shown in the photographs.

Suppose the value of the second resistor, R<sub>2</sub>, is 95 ohms. We already know the value of R<sub>1</sub>. The question becomes: What are the new voltages across R<sub>1</sub> and R<sub>2</sub>?

First, we need to measure the new current. Since there is no "load" on the output, you can open the circuit anywhere and hook up your multimeter. My instrument tells me there are 5.5 milliamps, or .0055 amp, moving through the circuit. To calculate the voltage across R<sub>1</sub>, just multiply the value of R<sub>1</sub> (449 ohms in our case) by the value of I (.0055 amps in our example). Calculate the voltage across R<sub>2</sub> in the same way. Your predictions will be very close to the actual voltages across R<sub>1</sub> and R<sub>2</sub>.

Turn off your pocket calculator, disconnect the batteries, put away the voltmeter, and congratulate yourself because you've taken the first steps toward understanding electronics: You know the three fundamental forms of Ohm's Law.

For a brief biography of Georg Simon Ohm, see S.P. Bordeau, *Volts to Hertz; The Rise of Electricity* (1982, Burgess Publishing Company, Minneapolis MN). For more on basic circuit laws, we recommend P. Horowitz and W. Hill, *The Art of Electronics* (1980, Cambridge University Press, Cambridge, MA).

# USING THERMOCOUPLES

**This simple device generates voltage that is used to measure heat, cold, pressure, flow, and directly creates cold from electricity!**

By Walter W. Schopp

Simply twist the ends of one copper and one steel wire together and you have created an amazing device called a *thermocouple*. If you apply heat to the twisted junction, a voltage is produced across the open wire ends. Reverse the situation and run current through the junction and the temperature of the junction will go up or down depending on the direction of the current.

That *thermoelectric* effect of direct temperature-to-electricity or electricity-to-temperature conversion was discovered over a century ago. Simple thermocouple devices that directly convert heat to electricity, are extensively used for measurements of temperature, flow, and pressure. Thermoelectric cooling devices are found in applications that make use of the electricity-to-temperature conversion abilities of the thermocouple.

## Actual Thermocouples

The simple copper and steel thermocouple leaves a lot to be desired because the output voltage from that configuration is very low. Years of research have produced a variety of metals and alloys that produce more output.

A common material used for thermocouples is *copper constantan*. Copper constantan is an alloy of 60% copper and 40% nickel. A thermocouple junction made from that material combined with another alloy can produce about one and a half millivolts at 100°F.

Other combinations of materials used in thermocouples are iron and iron constantan, chromel and alumel, and various alloys of platinum and rhodium. The last two materials are quite expensive and are used mostly for extending the temperature range above 3000°F. That is usually of little interest to the home experimenter.

The output of the thermocouple is rated in millivolts per degree and is always *non-linear*. That means that as the temperature changes, the millivolts per degree will not always be the same. By plotting the output against the temperature, tables for various materials have been compiled. The tables are available from many sources. One of the prime sources for them, and all the materials needed to experiment with is Omega Engineering Inc., Box 4047, Stamford, CT 06907.

## Series Connections

The output from a single thermocouple junction can directly drive a pivot-and-jewel type millivolt meter. By using

an op-amp, a thermocouple's output can be amplified and unloaded. That is useful if the thermocouple is to be used as a sensing and control device.

The thermocouple junction can be compared to a small battery whose voltage increases or decreases with temperature changes. But unlike batteries, since each material in the junction assumes a fixed polarity, the connections that are made between the thermocouples produce voltage equal and opposite to that of the thermocouples themselves. That effectively cancels out any voltage produced by the thermocouples (see Fig. 1). It is comparable to connecting batteries in series with every other battery connected backwards. Series connections of thermocouple joints can be accomplished by making certain that only every-other joint sees heat, while the reverse connected joints are not heated (see Fig. 2.)

A circuit showing how a lot of thermocouples can be connected together to produce a usable voltage with every other junction kept cool is shown in Fig. 3. One ring of junctions is shown, but many rings can be made around a heat source. Enough thermocouples can be arranged in a circular pattern to power a small radio. The ring of thermocouples can be heated with a candle in the center, or slipped over the chimney glass of a lantern.

## Hook Up

You can connect thermocouples in parallel, or use larger wire size to increase their current generating capability. The size of the wire has little to do with the output voltage from the junction. Small-diameter wires heat and cool quicker,

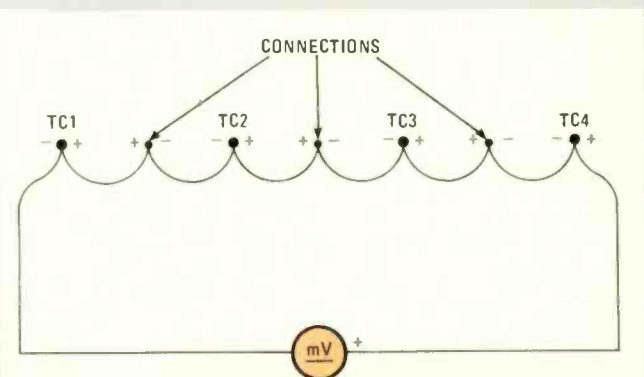

Fig. 1—Connections between thermocouples are themselves thermocouples of opposing polarity and equal magnitude.



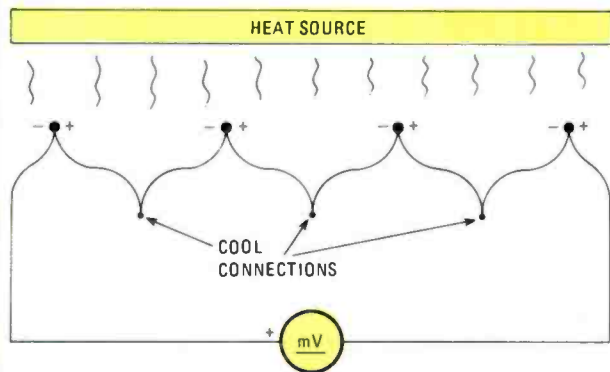

Fig. 2—Since connections between thermocouples are thermocouples of opposing polarity, to connect thermocouples in series requires that we keep the connections between the thermocouples cool.

and so respond to changes in temperature faster. The size of wire that is chosen will entirely depend on the intended use. In a series configuration, the distance between joints is limited only by the ability to keep every-other joint away from the direct heat.

Long runs between the output device (a readout or op-amp stage) and the junction are limited by the IR drop of the wire, but since the voltage and current are quite low, wire resistance in fairly long runs is not usually a problem. The voltage drop in a long wire will reduce the rated output of the junction, but that can be remedied by recalibration. The connecting wire between the junction and the output device can be common hook-up wire as long as you remember that the joints you have made for the extension are also junctions and will also change your calibration. If an equal amount of junctions are made in each leg, they will cancel each other's voltage output.

### Variations in Connection

Thermocouples are often used for sensing temperature in harsh environments that preclude ordinary methods of measurement. Selected materials can be used to make junctions that can measure temperatures inside furnaces or the temperature at different points in a flame.

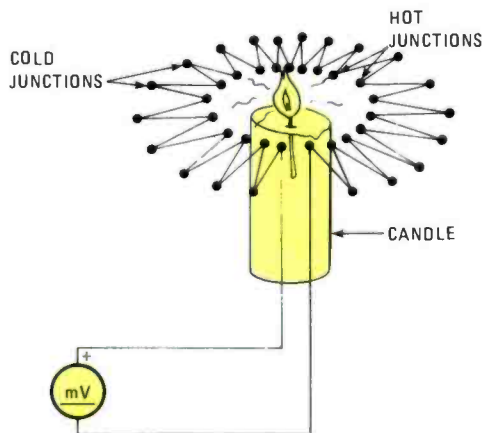

Fig. 3—Here's a circuit showing how a lot of thermocouples can be connected together to produce usable voltage with every other junction kept cool.

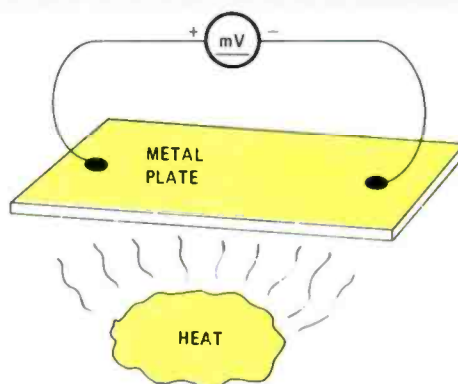

Fig. 4—Average temperature measurements can be obtained by connecting to more than one point on the surface of a metal plate. Here the two connections act as a single junction.

An interesting variation of the standard junction is to make two junctions by spot welding the wires at different points on a metal panel (see Fig. 4). Each of the junctions will put out a portion of the total output. The outputs of the two junctions will output the same voltage as one junction of the selected thermocouple material. The output produced from that configuration will be determined by the average temperature between the two junctions.

The cost of monitoring a number of separate junctions can also be kept to a minimum by using a common-leg switching circuit as shown in Fig. 5. To avoid confusion remember that the meter is common to all junctions. To get meter readings that make sense, the junctions should be made from the same materials. The same rules apply if accuracy is required: calibrate the final circuit to compensate for all the extra junctions.

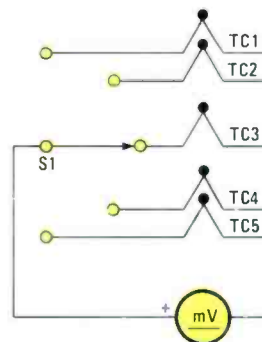

Fig. 5—Reduced lead length can be achieved by switching between various thermocouples at the reading station.

### Air Flow Measurements

Thermocouples are often used in applications other than temperature sensing. One such application is air-flow sensing. Since the junction produces no heat when used as a temperature sensor, it would have the same temperature as that of the air flowing around it, and so flow conditions could not be detected. That is remedied by pre-heating the junction.

The junction can be heated by twisting four wires together instead of two. Two of the wires are used for the thermocouple while the other two wires are connected to a variable

(Continued on page 98)

# NETWORK ANALYSIS: SUPERPOSITION THEOREM

By Louis E. Frenzel

**If you can understand addition, then understanding superposition will be a snap!**

**T**HIS MONTH WE'LL CONTINUE OUR DISCUSSION OF techniques for network analysis. Last month, we introduced Thevenin's theorem which is widely used to reduce a circuit to an equivalent voltage source. In this installment, we present the superposition theorem, which allows you to analyze circuits with two or more voltage sources.

Today many electronic circuits derive their power from two or more voltage sources. Analyzing such circuits is tricky using conventional techniques, but when you use the superposition theorem, the process is fast and nearly painless. Combined with Thevenin's theorem, the superposition techniques will give you an extra-powerful tool for simplifying and analyzing more complex circuits. Everything that you need is contained within this lesson including a brief review of Thevenin's theorem in case you missed it last month. So, let's begin.

## The Superposition Theorem

Basically, what the superposition theorem says is that the current through a component or a voltage across it is a combination of the effects produced by the multiple voltage sources. More specifically, that current or voltage is the algebraic sum of the individual currents or voltages produced by the voltage sources acting independently on the component. That leads to a conclusion about how we might be able to implement the theorem on practical circuits. If we simply disable all but one voltage source, then compute the various currents and voltage drops, then repeat the process with the other voltage sources, the total voltage or current associated with a component is obtained by just adding the individual currents or voltages.

The process of the superposition theorem is as follows:

1. Disable all but one voltage source in the circuit. You do that by replacing it with a short circuit. Any internal impedance associated with the voltage source should be retained in the circuit.
2. Calculate the total-circuit resistance and the various currents through, and voltages across, each component using Ohm's and Kirchhoff's laws.
3. Repeat Steps 1 and 2 for each voltage source in the circuit.
4. Combine the currents or voltages for the desired compo-

nent algebraically by adding them together. The result will be the desired current or voltage.

To see how that works, let's start with a simple example. Take a look at the circuit in Fig. 1A. It consists of two voltage sources, one of 5 volts and one of 12 volts. Those sources are connected to a pair of resistors that form a voltage divider. We wish to determine the output voltage at point A, the center of the resistors, with respect to ground. Using the superposition theorem, we first calculate the output voltage at point A first with the 5-volt source,  $V_1$ , connected. Then we make the same calculation with the 12-volt source,  $V_2$ , connected. The true output voltage is then simply the algebraic sum of the two voltages we calculated independently.

To begin the analysis of the circuit in Fig. 1A, first replace the 12-volt source with a short. The resulting circuit is shown in Fig. 1B. The result is simply a voltage divider across the 5-volt source. The output voltage at A with respect to ground is simply the voltage across the resistor R2. We can use the familiar voltage-divider formula to calculate that voltage. It is:

$$V_A = V_1 R_2 / (R_1 + R_2) = 5(3.3K) / (1K + 3.3K) \\ = 5(3.3K / 4.3K) = 5(0.767) = 3.84 \text{ volts}$$

The output voltage at A with respect to B then with  $V_2$  shorted is simply +3.84 volts. See Fig. 1B.

The next step is to replace  $V_2$  and remove  $V_1$ . The equivalent circuit for that is illustrated in Fig. 1C. The 5-volt source is replaced with a short. That leaves the 12-volt source  $V_2$  driving the voltage divider made up of R1 and R2. In that case, the output voltage at A is the voltage across R1 rather than R2. We can still use the voltage-divider formula to find the output voltage, but the formula has to be rearranged. The output voltage then is:

$$V_A = V_2 R_1 / (R_1 + R_2) \\ = -12(1K) / (1K + 3.3K) = -12(1K) / (4.3K) \\ = -12(.233) = -2.79 \text{ volts}$$

To complete the problem, we simply combine the two voltages we calculated independently. We do that by adding them algebraically:

$$3.84 + (-2.79) = 1.05 \text{ volts.}$$

As you can see, the output is a positive 1.05 volts.



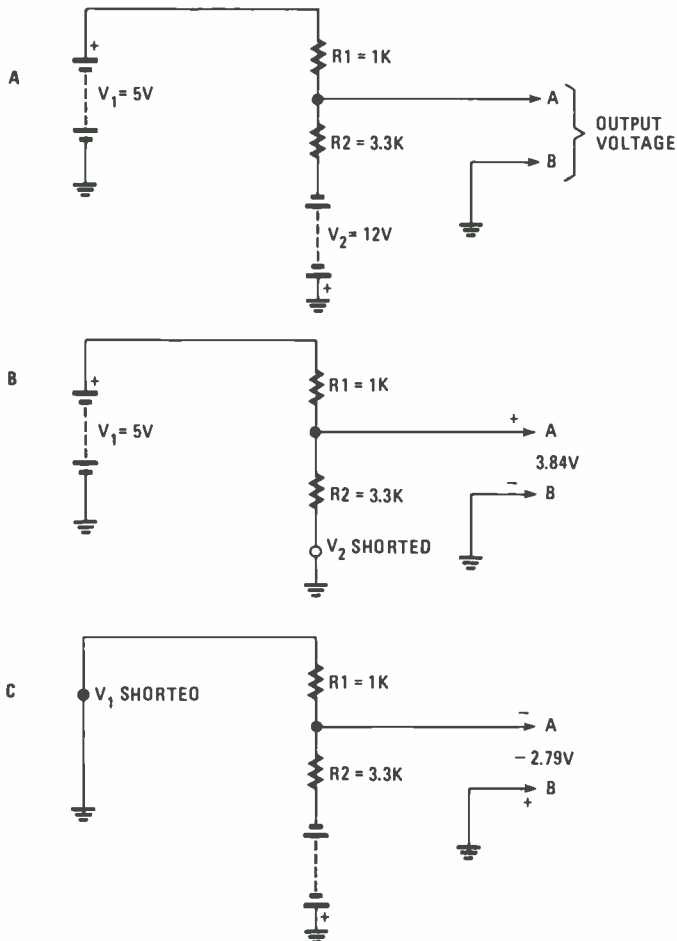

Fig. 1—The analysis of a circuit with more than one voltage source must be performed by examining the effects of each source independently with the others shorted.

Let's take another more complex example. Refer to the circuit in Fig. 2A. Again we have two voltage sources involved, therefore, the superposition theorem is needed. Our objective is to determine what the current is in resistor R2. One way to look at the circuit is as a voltage divider made up of R1 and R3 connected to two voltage sources. Resistor R2 is the load.

We can start by replacing V<sub>1</sub> with a short. That produces the equivalent circuit shown in Fig. 2B. Effectively R1 and R2 are in parallel and that combination is in series with R3 across the 9-volt source V<sub>2</sub>.

For starters, we need to compute the total circuit resistance. That is done by first finding the parallel equivalent of R1 and R2. We use the familiar parallel resistor formula. Where the total resistance of R1 and R2 in parallel is designated R<sub>1,2</sub>:

$$\begin{aligned} R_{1,2} &= R_1 R_2 / (R_1 + R_2) \\ &= 1500(1000) / (1500 + 1000) \\ &= 1500000 / 2500 = 600 \text{ ohms} \end{aligned}$$

The total resistance of the circuit R<sub>T</sub> then is simply R<sub>1,2</sub> in series with R3 or:

$$R_T = R_{1,2} + R_3 = 600 + 250 = 850 \text{ ohms}$$

We can now calculate the total-circuit current I<sub>T</sub> using Ohm's law:

$$I_T = V_2 / R_T = 9 / 850 = .016 \text{ amperes}$$

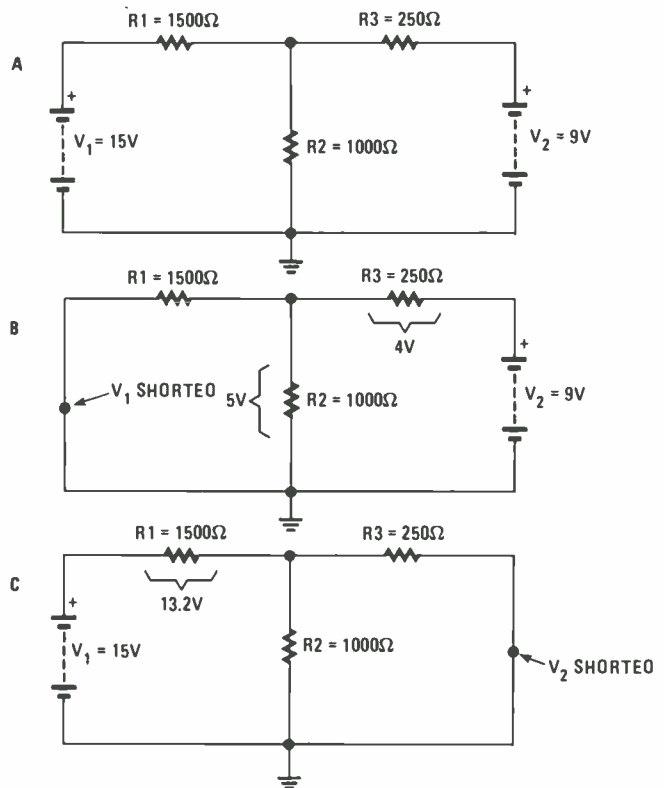

Fig. 2—Using the voltage divider relationship is common practice when analyzing circuits containing more than one voltage source since each source is shorted at some point.

Our objective is still to find the current through R2. We first find the current through R2 with V<sub>2</sub> applied and V<sub>1</sub> disabled. We can do that with standard Ohm's and Kirchhoff's law calculations. For example, knowing the total-circuit current, we can compute the voltage drop across R3:

$$V_{R3} = I_T R_3 = .016(250) = 4 \text{ volts}$$

With 4 volts across R3, then by Kirchhoff's law we know that there must be 5 volts across R1 and R2. Remember Kirchhoff's law says that the sum of the voltage drops around the circuit is equal to the source voltage. In this case, the 5 volts across R1 and R2 adds to the 4 volts across R3 to give us 9 volts, the value of V<sub>1</sub>.

Finally, we can calculate the current in R2 because we know the voltage across it and its resistance value:

$$I_{R2} = V_{R2} / R_2 = 5 / 1000 = .005 \text{ ampere}$$

We now need to repeat the procedure, but with V<sub>2</sub> disabled. We replace V<sub>2</sub> with a short to produce the equivalent circuit shown in Fig. 2C. Now R3 is in parallel with R2. We again compute the total-circuit resistance. We do this by finding the parallel combination of R2 and R3 in parallel which we designate R<sub>2,3</sub>:

$$\begin{aligned} R_{2,3} &= R_2 R_3 / (R_2 + R_3) \\ &= 1000(250) / (1000 + 250) \\ &= 250000 / 1250 = 200 \text{ ohms} \end{aligned}$$

The 200-ohm equivalent resistance is in series with R1, producing a total-circuit resistance of:

$$R_T = R_{2,3} + R_1 = 200 + 1500 = 1700 \text{ ohms}$$

The total-circuit current can be found by using Ohm's law:

$$I_T = V_1 / R_T = 15 / 1700 = .0088 \text{ ampere}$$

That current is flowing through R1, therefore, we can find the voltage drop across it:

$$V_{R1} = I_T R1 = .0088(1500) = 13.2 \text{ volts}$$

The voltage across R2 can be found by simply subtracting the voltage across R1 from V<sub>1</sub> giving us 1.8 volts. Kirchhoff's voltage law says that the sum of the voltages around a circuit is equal to the source voltage. In this example we know the source voltage V<sub>2</sub> = 15 volts and one voltage drop that makes it up. To find the unknown drop, we subtract the known drop from the source voltage:

$$\begin{aligned} V_{R2,3} &= V_2 - V_{R1} \\ &= 15 - 13.2 = 1.8 \text{ volts} \end{aligned}$$

With 1.8 volts across R2, we can now find its current, again by Ohm's law:

$$I_{R2} = V_{R2} / R2 = 1.8 / 1000 = .0018$$

Now we know the current in R2 produced by both sources independently. To find the total current in R2 then, we simply add the two currents algebraically. In the example circuit, both currents are flowing in the same direction, therefore, they will add rather than oppose one another. The total current in R2 then is:

$$I_{R2} = .005 + .0018 = .0068 \text{ amperes}$$

### Example Problem

Now check your own understanding of this process. The problem below will give you a handle on the procedure. Don't look at the answer at the end of the article until you work the complete problem.

1. Refer to Figure 3. Calculate the current through R2.

### Thevenin's Theorem Review

Thevenin's theorem is widely used to simplify electronic circuits for the purpose of analyzing their operation or designing them. Thevenin's theorem says that an entire network containing a voltage source plus various circuit elements (resistors, capacitors, and inductors) can be replaced by a single voltage source in series with an impedance called the Thevenin's equivalent voltage V<sub>Th</sub> and resistance R<sub>Th</sub>.

Figure 3A shows a complex network containing an AC voltage source, various resistive elements, and the load. That circuit can be replaced by the Thevenin's equivalent voltage and resistance as illustrated in Fig. 3B. With the Thevenin's equivalent in place, the same voltage appears across load terminals A and B as with the original circuit. Because the Thevenin's equivalent is much simpler, analysis of the load voltage and current is faster and easier to determine.

To translate a circuit into its Thevenin's equivalent is known as "Theveninizing" the circuit. The process of determining the Thevenin's equivalent is as follows:

1. Remove the load from the output terminals A and B in the original circuit of Figure 3A.
2. Calculate the voltage between terminals A and B without the load using standard Ohm's law and Kirchhoff's law techniques. That is the Thevenin's equivalent voltage V<sub>Th</sub>.
3. Replace the voltage source V<sub>S</sub> with a short. Then com-

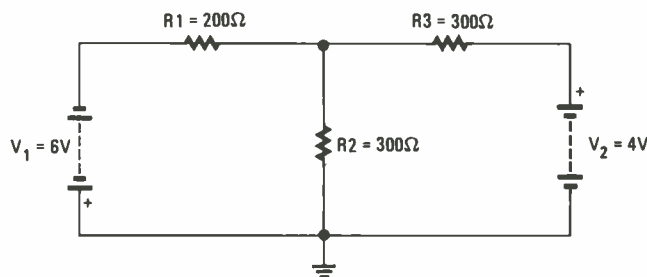

Fig. 3—Remember to follow the steps outlined when analyzing this practice example. Refer to the text as necessary but don't refer to the answer until you are done.

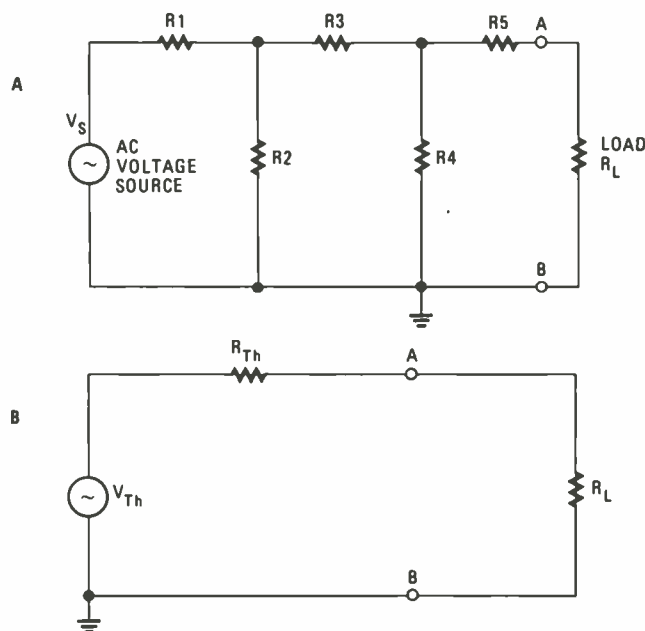

Fig. 4—No matter how complex a linear circuit is, the Thevenin's equivalent will simplify analysis.

pute the total resistance between terminals A and B. That is the Thevenin's equivalent resistance R<sub>Th</sub>.

4. Redraw the circuit consisting of the Thevenin's equivalent voltage source V<sub>Th</sub> in series with the Thevenin's equivalent resistance R<sub>Th</sub>. See Fig. 3B.

See last month's installment for further details.

### Superposition with Thevenin

You have seen how the superposition theorem helps you to find the voltage or current in a circuit with two or more voltage sources. While the superposition method permits you to analyze those complex circuits, the calculations are still messy and time consuming. One way to simplify them further is to employ Thevenin's theorem along with the superposition method. By doing that, you can reduce your two voltage-source circuit down into an equivalent single voltage source with a series resistance. When analyzing the operation of the circuit with different values of load resistance, the process is helpful. An example will show what we mean.

Take a look at the circuit in Fig. 5A. It has voltage sources of 12 and 5 volts. The load resistor is R2, 500 ohms. Let's see how we can use the superposition method to produce the Thevenin's equivalent of this circuit.

First, we remove the load resistance from between termi-



nals A and B. The remaining circuit shown in Fig. 5B is the one we will Theveninize. We begin by applying the superposition method of replacing one of the voltage sources with a short and calculating the load voltage. Replacing  $V_2$  with a short produces the circuit in Fig. 5C. That is simply a voltage divider made up of  $R_1$  and  $R_3$  connected across the 12-volt source,  $V_1$ . The voltage between A and B ( $V_{AB}$ ) is the voltage across  $R_3$ . Using the voltage-divider formula:

$$\begin{aligned} V_{AB} &= V_1(R_3)/(R_1 + R_3) \\ &= 12(180)/(120 + 180) \\ &= 12(180)/300 = +7.2 \text{ volts} \end{aligned}$$

Note the voltage is positive because  $V_1$  is positive with respect to ground.

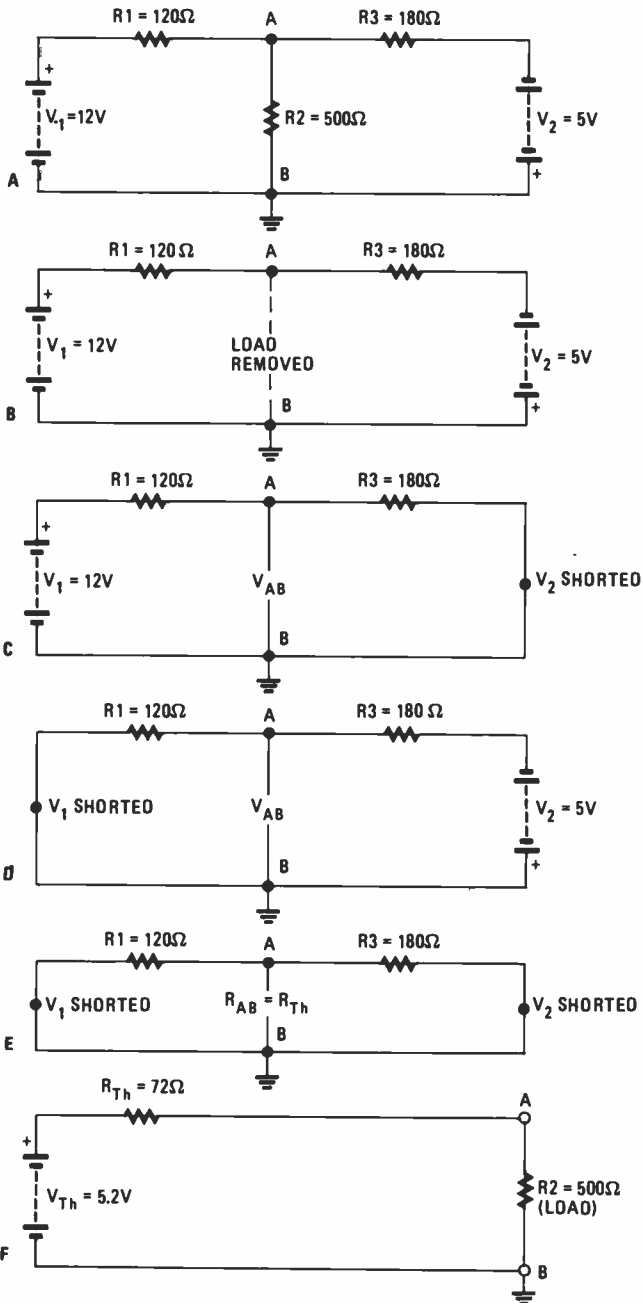

Fig. 5—Superposition can be used to help Theveninize a circuit like A by allowing you to determine the Thevenin voltage by shorting the power supplies and summing their effects before determining the Thevenin resistance.

Next we want to find the equivalent voltage across the output terminals produced by  $V_2$  with  $V_1$  shorted. Shorting  $V_1$  produces the equivalent circuit shown in Fig. 5D. That is just a voltage divider made up of  $R_1$  and  $R_3$  connected across  $V_2$ . The output across terminals A and B is the voltage across  $R_1$ . Again, the conventional voltage-divider formula can be used. In that case, the polarity of  $V_2$  with respect to ground is negative, therefore, we label  $V_2$  as being negative:

$$\begin{aligned} V_{AB} &= V_2(R_1)/(R_1 + R_3) \\ &= -5(120)/(120 + 180) \\ &= -5(120)/300 = -2 \text{ volts} \end{aligned}$$

Here the voltage is negative because  $V_2$  is negative with respect to ground.

The composite output voltage across terminals A and B is simply the sum of the two voltages we just calculated. In that case,  $V_{AB}$  equals:

$$V_{AB} = +7.2 + (-2) = +5.2 \text{ volts}$$

That is the Thevenin's equivalent voltage  $V_{Th}$ .

Now we can find the Thevenin's equivalent resistance. To do that, both voltage sources are replaced with shorts producing the circuit shown in Fig. 5E. Resistors  $R_1$  and  $R_3$  are connected in parallel across terminals A and B. The resistance between A and B is  $R_{AB}$  and is the Thevenin's equivalent resistance:

$$\begin{aligned} R_{AB} &= R_{Th} = R_1 R_3 / (R_1 + R_3) \\ &= 120(180)/(120 + 180) \\ &= 21600/300 = 72 \text{ ohms} \end{aligned}$$

Now we can draw the complete Thevenin's equivalent for the original circuit in Fig. 5A. It is shown in Fig. 5F. A 5.2-volt source is in series with a 72-ohm resistance with the load connected to terminals A and B. The equivalent circuit will, of course, produce exactly the same output voltage with varying loads as the original circuit.

### Exercise Problem

Check your knowledge of the superposition process by working the following problem.

2. Theveninize the circuit given in Fig. 1. Determine  $V_{Th}$  and  $R_{Th}$ .

### Practical Voltage Sources

In order to use the superposition method and Thevenin's theorem in circuit analysis, the power sources in the circuit must be voltage sources. As we indicated in the previous article on Thevenin's theorem, a perfect voltage source is one that has a zero internal resistance. In other words, the output impedance of the source is zero. That means that when it supplies current to a load, there will be no internal voltage drop. And, therefore, the output voltage that is available will be equal to the full value capable of being supplied by the voltage source.

In reality, there are no perfect voltage sources. Very few voltage sources even approach perfection. Probably the closest is a battery. While its internal resistance is not zero, it is very small, so little voltage is dropped across it. However, as a battery is used, it deteriorates chemically. As it does, its internal impedance rises. When current is drawn from the battery in its weakened condition, some voltage will be lost across the higher internal resistance. That's why a battery's output voltage declines with use.

Not all voltage sources, of course, are batteries. Therefore, we must take a look at some practical electronic circuits and see how they are used as voltage sources. To do that, we must develop a working definition of voltage sources so that we can see if a particular circuit qualifies as a voltage source or not.

For our discussion here, we will define a voltage source as one whose internal resistance, or output impedance, is much less than the load resistance. To be more specific, we will assume that a good voltage source is one whose internal resistance is less than one-tenth of the load resistance. For example, if our load is 100 ohms, then a good voltage source for driving the load would have an internal resistance of less than one-tenth that, or less than 10 ohms. A better voltage source is one whose internal resistance is less than 1% of the load resistance, but such superior voltage sources are not usually necessary in electronic circuits.

## Power Supplies

Power supplies are usually good voltage sources. Their internal resistance is low so that their output voltage remains essentially constant with load variations. Just keep in mind that all power supplies do have a finite value of internal resistance. That internal resistance in turn determines the regulation of the power supply. Regulation, of course, is a figure that indicates the percentage of output voltage change between no load and full load conditions of a power supply. It is calculated with the expression:

$$\% \text{ reg} = (V_{NL} - V_{FL} / V_{FL}) \times 100$$

Here  $V_{NL}$  is the output voltage of the power supply with no load and  $V_{FL}$  is the output voltage with a full (maximum) load. For example, if  $V_{NL} = 6$  volts and  $V_{FL} = 5$  volts, the regulation is:

$$\% \text{ reg} = ((6 - 5) / 5) \times 100 = (1/5) \times 100 = 20\%$$

The lower the percentage of regulation, the lower the change in output voltage for no load to full load conditions. What that means essentially is that the lower the percent regulation, the lower the internal resistance of the power supply and the better the voltage source it is. A perfect voltage source has a percent regulation of zero. In a practical power supply, its internal resistance is responsible for the output-voltage variation from no load to full load.

What makes up the internal resistance of a power supply? Actually, a lot of factors contribute to it. Take a look at the simple power supply shown in Fig. 6. It uses a transformer T1 to step down the AC-line voltage to a lower AC voltage. A bridge rectifier converts the lower AC into pulsating DC. A large capacitor C1 smoothes out the pulsations to create a nearly-pure DC.

Just looking at the circuit, it is not obvious where the internal resistance lies. There are several sources of internal resistance in the power supply. Those are the winding resistances of the primary and secondary windings of the transformer, the voltage drop across the rectifier diodes, and the effectiveness of the filter capacitor. When a load is connected to a power supply, current is drawn from it and voltage drops appear across the transformer windings and the diodes. The load also causes the filter capacitor to discharge more between half cycles and, therefore, the output voltage will drop producing an effect similar to an internal resistance. By proper design, all of those factors can be minimized. Nevertheless, the power supply ends up with a rather large equiv-

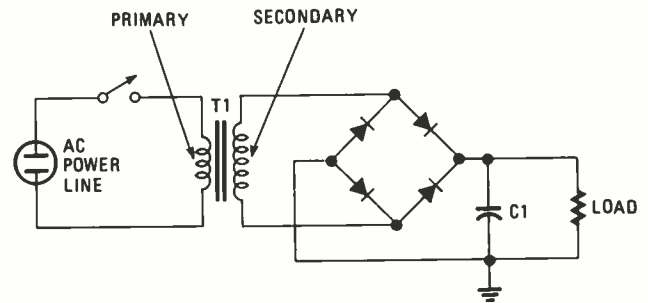

Fig. 6—A common power supply has an internal impedance that is a composite of the transformer-winding resistance, diode voltage drops, and capacitor impedance.

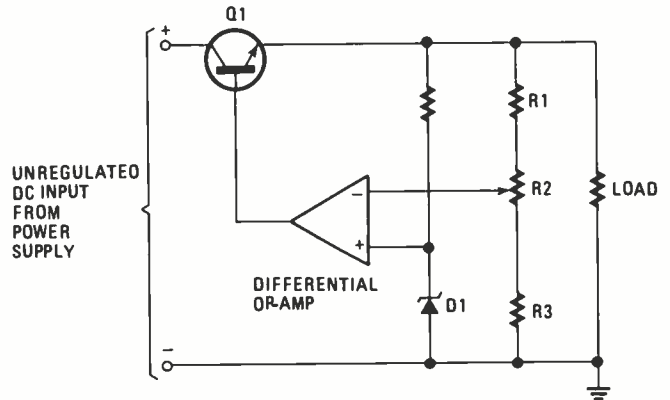

Fig. 7—A feedback voltage regulator greatly reduces a power-supply's output impedance by responding to the load.

alent internal resistance which may be detrimental in those applications where the load voltage must remain constant with load-resistance variations.

The way to compensate for or offset the effect of high internal impedance in a power supply is simply to add a regulator circuit to it. A regulator circuit is a sophisticated electronic circuit with feedback that senses changes in the output voltage and thereby adjusts the output voltage automatically to maintain it at a fixed level. A typical regulator is shown in Fig. 7. Its input comes from the output of the power supply in Fig. 6. Most regulators use a variable series impedance between the power-supply output and the load. That is usually a bipolar transistor such as Q1 whose conduction is varied to change its resistance, and thereby vary the output voltage. Changes in the power-supply output voltage caused by changing load current or varying power-line voltage are sensed by the regulator.

In Fig. 7, the voltage divider made up of R1, R2, and R3 taps off a part of the output and applies it to one input of an op-amp. The other input to the op-amp comes from Zener diode D1 which is used as a voltage standard or reference. The voltage across D1 remains constant because of Zener action. The op-amp compares the output voltage sample to the reference voltage and amplifies the difference to create base drive for Q1. The regulator circuit then adjusts the base drive to the transistor causing it to conduct more or less as required to maintain a constant load voltage.

If the output voltage goes down due to a load increase, the circuit causes Q1 to conduct more. Its resistance decreases, therefore, less voltage is dropped across it and more appears at the output. Thus the original decrease is compensated for.



Such electronic regulators work very rapidly and maintain a very constant output voltage. Such electronic regulators work very rapidly and maintain a very constant output voltage. The effect is as if the internal resistance has been reduced to an extremely low value. When power-supply output voltage variations are a problem, adding a regulator effectively decreases the internal resistance. Regulated power supplies, like batteries, are extremely good, but not perfect voltage sources.

### Transistor Circuits

Many transistor circuits also serve as voltage sources of varying degrees of quality. Transistor amplifiers, for example, all have an internal resistance which to a load appears as an output impedance. Take the simple common-emitter amplifier circuit shown in Fig. 8A. Its output impedance is just slightly less than the value of the collector resistor  $R_c$ . In the circuit shown, the output impedance or internal resistance of the circuit as seen by the load is 1000 ohms. Its equivalent circuit is shown in Fig. 8B.

In general, an amplifier would not be considered a good voltage source, but remember that that can only be determined by considering the load resistance in comparison to the output impedance. If the load resistance is 10K ohms or greater, then the circuit is a good voltage source by our previous definition. For values less than 10K ohms, the circuit is not a good voltage source.

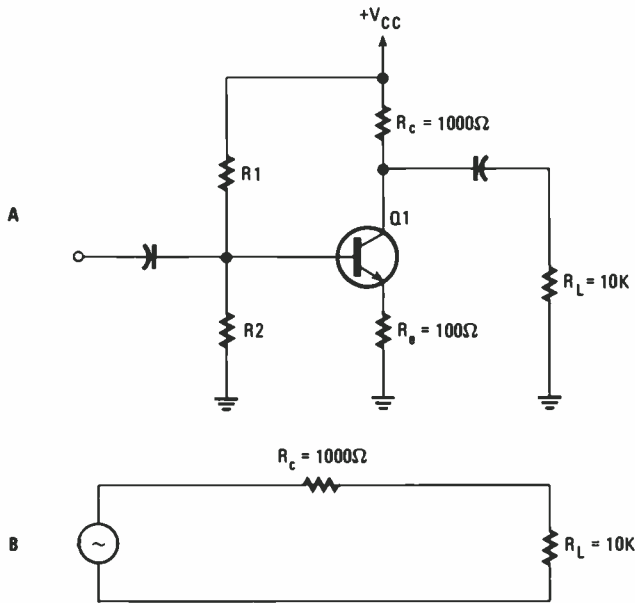

Fig. 8—The output impedance of a common-emitter amplifier is approximately equal to the value of the collector resistor's.

When the output of one amplifier is connected to the input of another as in Fig. 9A, the output resistance  $R_c$  forms a voltage divider with the input resistance of the next stage  $R_i$  as the equivalent circuit in Fig. 9B shows. The resulting voltage-divider action causes the input voltage to the second stage (Q2) to be lower than the actual voltage delivered by the previous amplifier (Q1). Such voltage-divider action can offset a considerable amount of the gain produced by the amplifier if the effect is not taken into consideration.

One way to overcome the loss due to voltage-divider action when cascading stages is simply to make the output impedance of the driving amplifier lower compared to the input resistance of the driven amplifier. In the amplifier of Figure

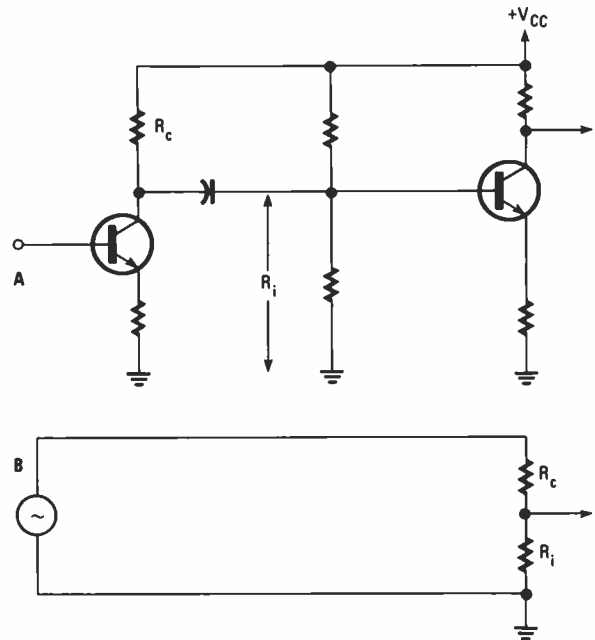

Fig. 9—Cascading amplifier stages causes each stage to load the previous stage. The loads must be taken into account when designing the overall circuit.

9A, that means making the value of collector resistor  $R_c$  smaller.

While that can be done, it has several detrimental effects. For example, lowering the value of  $R_c$  decreases the gain of Q2 and increases the power consumption of the circuit. Both of those are undesirable characteristics although the output impedance is reduced. Such trade-offs are common in electronic-circuit design. Usually the choice of a collector resistor is some optimum value that is a balance between low output impedance, high gain and minimum current consumption. An alternative or additional technique is to work on making the input resistance  $R_i$  equal to Q2's or higher.

### Lowering Amplifier Impedance

One way to lower the output impedance of the amplifier is simply to use an emitter follower circuit between the amplifier and the load. A typical emitter-follower circuit (Q2) is shown in Fig. 10A. That is a common-collector amplifier circuit whose primary characteristics are a high input impedance, low output impedance, and unity gain. The high input impedance minimizes the voltage-divider loss between Q1 and Q2. While the emitter follower does not provide voltage amplification, it does produce the same voltage at its output that appears at its input. A lower output impedance for the same voltage level allows much lower load resistances to be driven.

In most amplifier designs, the biasing resistors R1 and R2 in Fig. 10A are usually eliminated and the emitter follower is connected directly to the collector of the driving amplifier, which provides not only the signal input, but also the correct DC bias level. That is illustrated in Fig. 10B. The output is taken from across the emitter resistor. Such a circuit usually results in an output impedance of several-hundred ohms, whereas the output impedance of the driving amplifier, Q1 may be several thousand ohms. While the emitter follower itself does not provide any voltage gain, its low output impedance minimizes the overall gain lost to voltage-divider action in the cascaded stages.

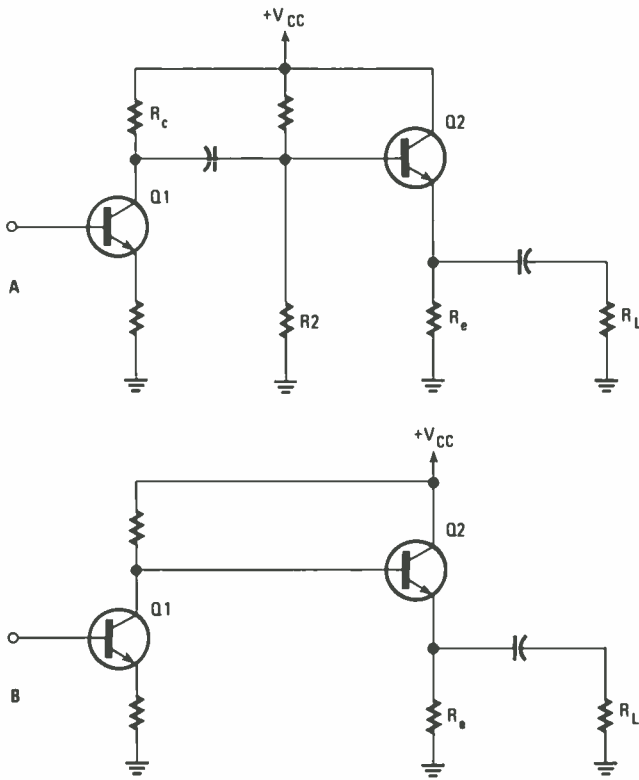

Fig. 10—Using an emitter-follower stage is an excellent way to lower the output impedance, and allow the amplifier to amplify a signal without having to drive the output.

### Additional Stages

If even lower output impedance is needed, several emitter-follower stages may be cascaded as shown in Fig. 11A. One stage, Q1, will get the output impedance down to several hundred ohms. The next stage, Q2, will reduce that even farther to some value less than 100 ohms. A popular combination is to use a field-effect transistor as a source follower, and follow it with an emitter follower for further output-impedance reduction. See Figure 11B. The FET stage Q2 minimizes loading on the amplifier circuit while providing some decrease in output impedance. The bipolar stage Q3 reduces the output impedance even more.

One technique that is similar in effect to cascading emitter followers is to use the popular Darlington connection shown in Fig. 12. There two bipolar transistors, Q2 and Q3, are connected in such a way that they appear as a single very high gain transistor called a Darlington pair. With very high gain, the Darlington connected device, when used in an emitter-follower circuit, produces very high input impedance and extremely low output impedance.

Another way to reduce the output impedance of a circuit is to add a power amplifier to it. A widely used power amplifier is the popular complementary-symmetry circuit shown in Fig. 13. It is a class-B amplifier where each transistor supplies one-half of the signal to the load. Transistor Q2 supplies the positive half-cycles, and Q3 supplies the negative half-cycles. Such power amplifiers have extremely low output impedance.

Complementary-symmetry amplifiers like the one in Fig. 13 are commonly used in audio power amplifiers that must drive speakers. Speakers have inherently very low impedances of 4, 8, or 16 ohms. In order to drive a speaker properly, the driving amplifier must have a very low output impedance.

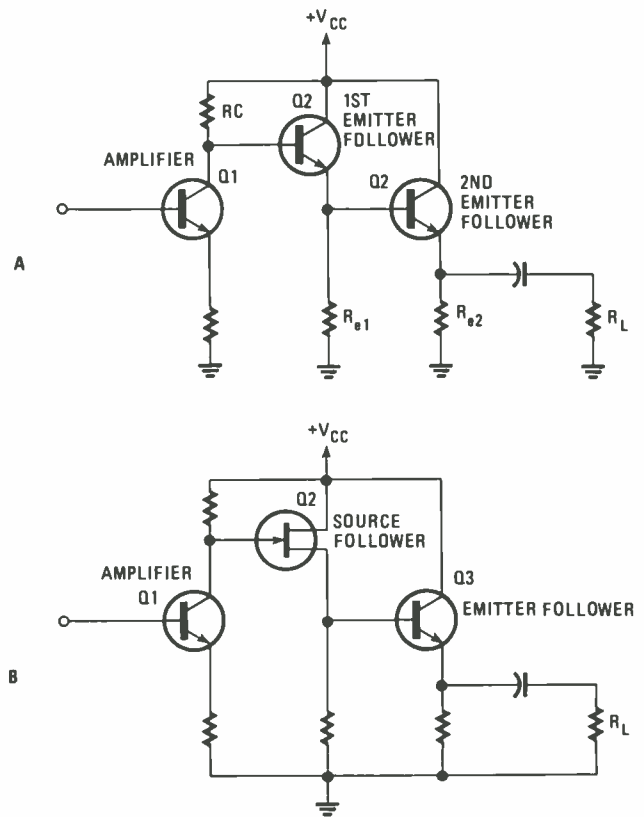

Fig. 11—Emitter followers can themselves be cascaded to produce a circuit with lowered output impedance.

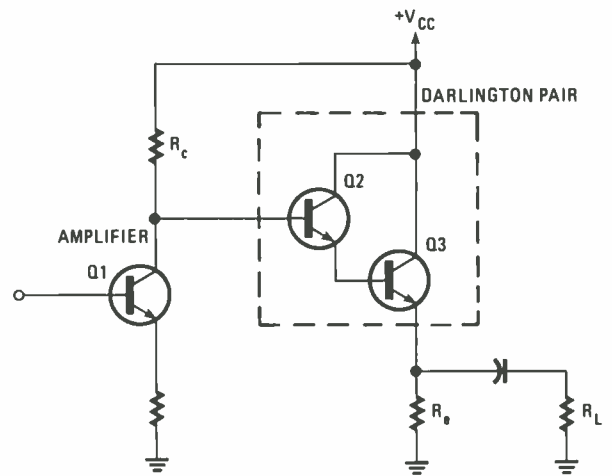

Fig. 12—Here we show the use of a Darlington pair to lower the output impedance of an emitter-follower amplifier.

Such low impedances are easily accomplished with power-amplifier circuits such as that shown. Such amplifiers are excellent voltage sources.

### Transformers

Another technique for lowering the output impedance of an amplifier is simply to use a transformer. Recall that a transformer, because of its turns ratio, can be used to match impedances. The windings can be chosen so that the output impedance is much less than the input impedance. The relationship between the impedance ratio and turns ratio is expressed in the formula:



$$Z_p/Z_s = (N_p)^2/(N_s)^2$$

Where  $Z_p$  is the primary impedance,  $Z_s$  is the secondary or load impedance,  $N_p$  is the number of turns on the primary, and  $N_s$  is the number of turns on the secondary.

Rearranging the formula to solve for the turns ratio in terms of the impedance ratio, we get:

$$N_p/N_s = Z_p/Z_s$$

For example, assume we have an 8-ohm speaker load but the output impedance of our amplifier is 800 ohms. We can match the two with a transformer. The turns ratio needed is:

$$N_p/N_s = 800/8 = 100 = 10 \text{ or } 10\text{-to-}1$$

The transformer needs a turns ratio of 10-to-1 or 10 times as many primary turns as secondary turns. The transformer makes the amplifier appear to have lower output impedance than it really does.

At one time, transformers were widely used in power amplifiers to achieve low output impedance. A typical class-A audio amplifier is shown in Fig. 14. While such amplifiers are still used in some small radios and audio amplifier circuits, today most of those circuits have been replaced by transformerless power amplifiers such as the complementary-symmetry circuit described previously.

## Op-Amps

Op-amps are very popular for implementing a variety of amplifier, signal-processing, and signal-generating circuits. The op-amp, as you recall, is a very-high gain differential amplifier that is normally used with input and feedback circuits of various types to set the characteristics of the circuit.

Most op-amps are designed with power-amplifier output stages for low output impedance. Typical open-loop output impedance is usually less than 100 ohms. However, when negative feedback is used (as in most applications), the output impedance is decreased considerably. The actual amount of output impedance depends on the feedback circuit and the amount of overall circuit gain. For example, in the typical inverting-amplifier stage of Figure 15, the output impedance may only be 10 ohms.

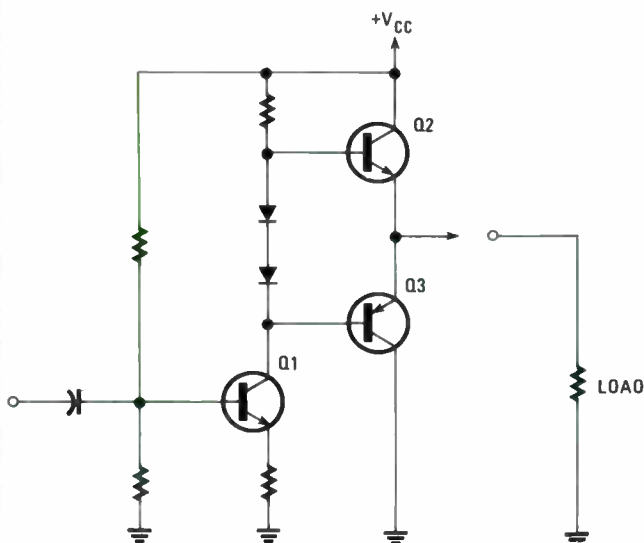

Fig. 13—A Basic complementary-symmetry power amplifier has a very low output impedance. It makes a good last stage.

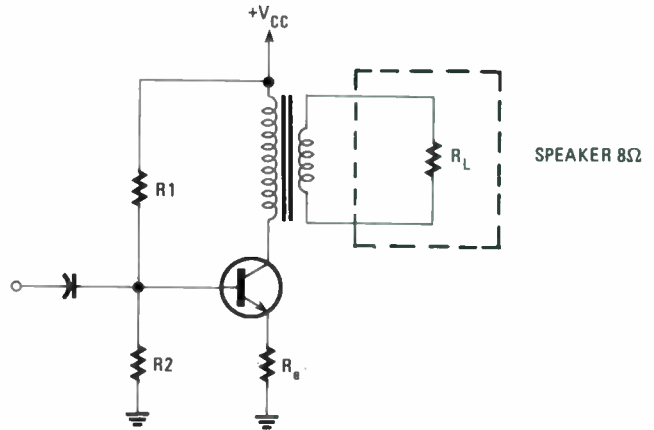

Fig. 14—Using impedance-matching transformers is another way of reducing the output impedance of a driving stage.

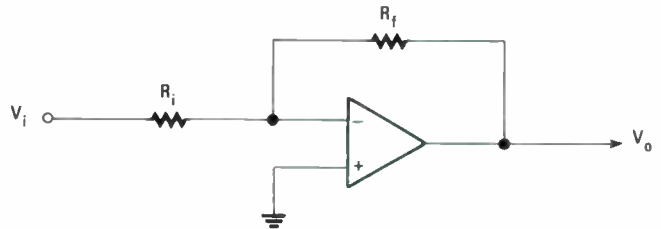

Fig. 15—Op-amp inverters not only have an inherently low output impedance, but they also have high input impedance.

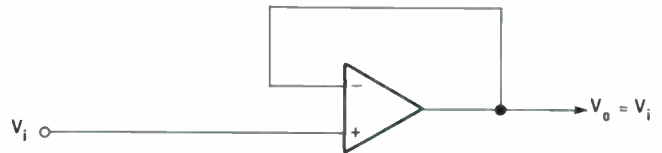

Fig. 16—Op-amp followers typically have an output impedance of less than 1 ohm. But their input impedance is extremely high so as not to load the preceding stage.

For even lower values of output impedance, an op-amp follower can be used. The op-amp follower, as shown in Fig. 16, has 100% feedback from the output to the inverting (−) input. That produces a circuit similar in performance to the simple emitter or source follower. The input impedance is extremely high while the output impedance is extremely low. The amplifier gain is unity. With such a configuration, the output impedance is usually decreased to much less than 1 ohm. For applications requiring a very-high quality voltage source, use op-amp circuits, particularly the follower.

## Voltage-Source Calculations

The most important thing to remember is that practical electronic circuits have output impedance. Most circuits have a finite value of internal resistance and, therefore, are not perfect voltage sources. However, if they meet the criterion stated earlier for a good voltage source, regardless of their output impedance, then the circuits will work well. Just keep in mind that the internal resistance must be taken into consideration when forming superposition and Thevenin's calculations.

Earlier in the discussion we indicated that to perform the analysis, the voltage source is usually replaced by a short circuit. When practical voltage sources are involved, that is

(Continued on page 106)



By Joseph J. Carr, K4IPV

# GARR ON HAM RADIO

## DXing the smart way

□ SOME READERS OF THIS COLUMN complain that their amateur-radio hobby has been hampered by too little space, restrictive antenna covenants on their property deed (one of the most serious anti-amateur problems in decades!), the cost of equipment, and neighbors who take a dim view of high-power RF signals zapping their TV reception. Those amateurs are forced to use low-power and less-than-the-best antennas. So what do they do about DXing?

In a word: tactics. The key to DX performance for the low-power, low-budget operator is learning to work the system. Smart DXing leads you to lots of QSL wallpaper, plus the much sought after WAC, DXCC, WAZ and other operating awards. During my own amateur career (beginning in 1959), I used less than 180-watts (and often only 50-watts), except for the past few years when my budget could afford a 2000-watt PEP linear amplifier. Even today, I run my Kenwood TS-430 transceiver "barefoot" (without the linear) more often than not.

### DXing in Three Words

Three words describe the route to DXing success: listen, listen, and listen. Hey! Wait a darn minute...ya gotta transmit to work 'em don't you? Yes, you will eventually have to transmit—when it makes good sense to do so. But first listen to that juicy DX station under the 50-deep pile-up to figure out how he or she is answering the thundering herd.

DX operators frequently answer stations a few kilohertz above or below their own transmitting frequency. Sometimes that's due to the frequency offset that is inherent in CW transceivers. More often, however, it is an intentional strategy on the part of the DX operator to herd the pile-up away from his own transmitting frequency so that he or she can be heard by everyone. I have even heard some stations an-

nounce "answering 10-kHz upband" (or "10U" on CW) to force the issue.

It is also common practice for DX operators to use the narrowest bandwidth setting on their receiver when working the pile-up (usually 1.8-kHz for SSB and either 250 or 500-Hz for CW), along with a 5 or 10-kHz offset between transmit and receive frequencies (with modern dual-VFO transceivers that trick is easily handled). They then permit the successful state-side stations to "fall in the slot" created by the filter. That's where tactics on your part really pay off. Identify the pattern of operations, discover where all the stations are being answered, and then place your signal at that point. You'll then be the one to fall in the slot.

The advantage of figuring out who is being answered makes you competitive with the high-power operators who are outside the DX operator's receiver pass-band. That "two-gallon" linear amplifier serves only to heat up the shack. On

the other hand, if you DX the dumb way, calling more than listening and calling at random, then you have the same problem as the mouse in an elephant-stomping contest.

Also listen for the geographical pattern of answers. Many DX operators answer by USA and Canadian call zones. They work "all W1" for awhile, and then "all W2" or some other zone, all the way across the continent. It does a K4 no good to call when the rare DX is working only K0 or some other zone.

### Odd Hours

I normally get up around 0500 to be at my office by 0715. One restless night I arose about 0430 and listened to 40 meters. Nothing but hiss. On a bored bet, I sent out a standard "CQ" call, and got an immediate answer from a station I took to be a K2. On the second go around, I correctly identified the other guy as VK2 from Australia! If you DX the wee hours of the morning be-

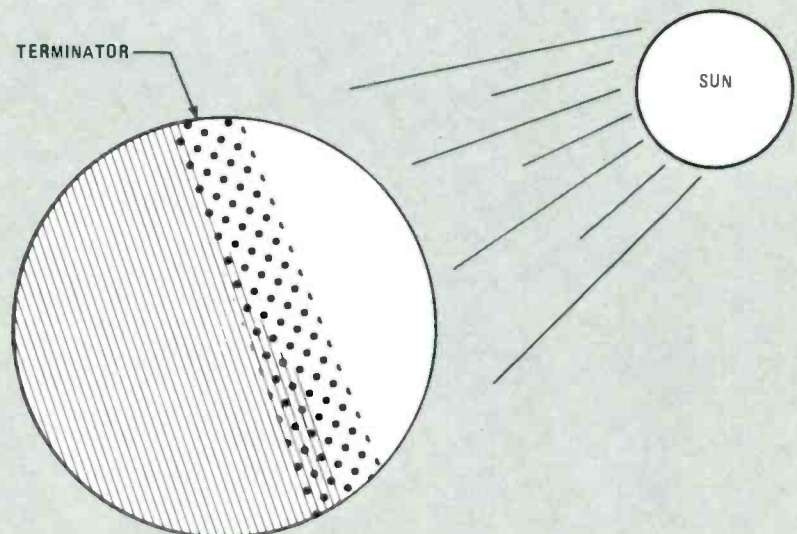

Fig. 1—The "terminator" is the global dawn/dusk line—also called the "gray line" in popular terminology—between the part of our planet that is in darkness and the part that is in daylight.



tween midnight and sun-up, then you know that the world is alive with very-DX stations from all over.

The 40-meter band is a mess between dinner time and midnight or 0100 because of the megawatt international broadcasters who share the band with us. But the reason why they use 40 meters is that it is good for long-distance, propagation after sundown—even though 40 meters during daylight hours is useful only as a short-distance band.

If you wait until the broadcasters go to bed, then you can take advantage of that propagation before the sun ruins it again at sunup. The 75/80-meter band is also good for DX, especially in the wee hours of the morning during the winter months. "All 80-meter DXCC" has been worked numerous times, and it is no longer a rare thing. Although normally thought of as a short-range (few hundred miles) groundwave band during daytime, and ripped to shreds during prime time by TV and VCR 3.58-MHz color oscillators and 15.734-kHz horizontal oscillators in video equipment (the real TVI), after midnight

there is often a lot of DX to be heard on 3500–4000 kHz.

Last year I visited Ireland and an old friend (EI2CN) in County Louth. He told me that 20 meters often opens up paradoxically in the post-midnight hours, often about 0100–0200 local time. Believing him only because of his long standing reputation for integrity and truthfulness, I did some listening over several months last summer, fall, and winter. Guess what? The 20-meter band does, in fact, open sometimes in those odd hours of the morning when the standard wisdom indicates that it should be deader than Schrodinger's cat. And the openings observed from my east coast QTH were to Southeast Asia.

East-coast amateur operators have a slight advantage over those in the rest of the country. If they get up early, then they can easily work Europe, the European USSR, Central-Asian USSR, and the Middle East for a couple hours before the rest of the USA wakes up. On Saturday mornings I have noticed a lot of DX to the east of us loud and clear, with only small QRM from other USA

amateurs. But as the sun "walked" across the continent, the rest of the amateurs started coming on the air, and the crescendo commenced...and the DX faded under the groans of a thousand dancing pachyderms. But from sunup to about 0930 or 1000, the east-coast amateur finds it "easy pickins."

### DXing the Gray Line

Most HF propagation (as illustrated in Fig. 1) is due to the ionosphere and its interaction with solar radiation. That's why some DX bands (10–30 MHz) are good only during daylight hours, and others (1.8–10 MHz, for instance) are only good for DX during darkness hours. There is a class of DXing, however, that is best around sunset and sunrise. We'll cover other aspects of radio-wave propagation in future installments of this column.

Alas, we've come to the end of the space allotted to us for this month's column. But, in the meantime, if you have any comments and suggestions for future columns, write to Joe Carr, K4IPV, PO Box 1099, Falls Church, VA 22041. ■

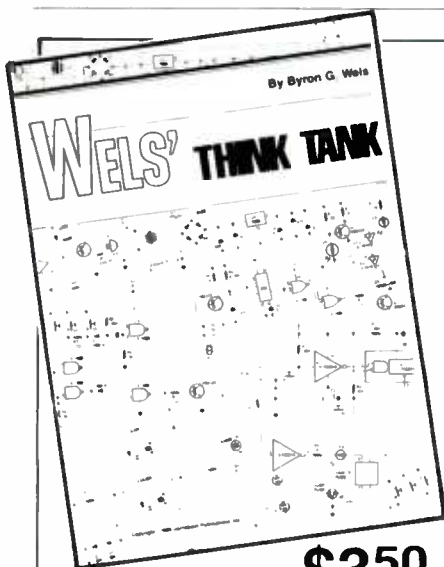

**\$3<sup>50</sup>**

## THINK TANK

**53 PAGES, OVER 130  
PROJECTS!**

**SIMPLE, EASY-TO-BUILD AND  
USEFUL IDEAS FOR YOUR  
HOME, HOBBY, CAR.**

■ **HERE'S THE ANSWER** to that eternal question among electronics hobbyists—"What will I do?" In WELS' THINK TANK you'll find over 53 pages jam-packed with over 130 one-evening projects that will keep you absorbed. These are tantalizing devices that you can quickly put together and then use immediately. There are projects for your car, your home, your work bench, other hobbies, such as photography, music, and stereo. Telephone projects, light controls, and a vast assortment of miscellaneous do-it-yourself items. Flipping through the pages of this book, the question becomes "Which one will I start with!"

■ **THE THINK TANK** originally appeared in

Hands-On Electronics Magazine, and immediately won a good deal of reader acceptance. The mail poured in as readers offered their own circuits or asked for assistance with electronics projects they worked on.

■ **WHAT KIND OF PROJECTS** will you find in the WELS' THINK TANK BOOK? The index, which occupies the entire back page, lists them. Choose from nearly a dozen amplifiers, an assortment of automotive projects from automatic parking lights to electronic air horns, battery chargers to battery monitors. You'll find fuzz boxes for your guitar to a tremolo unit. A darkroom timer for you photo buffs. And at a price of only \$3.50, you can't go wrong!

## THINK TANK—Circuits for Experimenters and Project Builders!

169—Please send one copy of THINK TANK at \$3.50. Shipping \$1.25 (U.S. and Canada only).

169—Please send \_\_\_\_\_ copies of THINK TANK. Total cost is sum of copy price and shipping cost multiplied by number of copies ordered.

Allow 6-8 weeks for the material to arrive.

Please print

\_\_\_\_\_  
(Name)

\_\_\_\_\_  
(Street Address)

\_\_\_\_\_  
(City)

\_\_\_\_\_  
(State)

\_\_\_\_\_  
(Zip)

Detach and mail today:  
**HANDS-ON BOOKSTORE**  
P.O. Box 4079  
Farmingdale, NY 11735

All Payment must be in U.S.  
Funds!

**H11-88**



# FRIEDMAN ON COMPUTERS

## Use your computer to research a car, its options, and work out the financing

□MUCH AS THEY MIGHT BE DESPISED, ridiculed, and vilified, when it comes to consumer items the truth of the matter is that marketing experts know more about our buying habits than we know. They are in business to make a buck—*big bucks*, so that they don't waste their resources on penny-ante stuff; every dollar spent on advertising must reach thousands of consumers.

How the mass-merchandisers spend their advertising money tells us a lot about what's in, what's out, what's hot, and what's cool. Right now, the Ford Motor Company is telling us that there are so many IBM-compatibles in homes and offices that personal-computer software is a convenient and inexpensive way to get the attention of millions of potential customers. More important, as I'll show, a computerized advertising program in the home can be a lot more effective than a lot of "feel good" TV advertising.

### Shop At Home

How do we know all this? Because Ford now makes available to potential customers a software package called *The Ford Simulator*, which lets you compare the specs and prices on 29 best-selling Ford models and their optional accessories. (As far as I know, the software is only available on 5¼-inch disk for IBM-compatibles.)

The idea behind the software is that you can select the car you want, review and select the optional equipment, print out a sticker that contains everything except the transportation and dealer prep charges, and even work out a spreadsheet showing the financing all in the comfort of your own home—without a salesperson breathing down your neck.

The financing feature is especially terrific. If you want to calculate the monthly finance payments by juggling the old heap's trade-in value, the down payment, or the length of the loan,

you'll come up with a new monthly payment as fast as you can change the data. You can even print out the spreadsheet so that you can compare the figures at your leisure.



Fig. 1—The opening menu of the Buyer's Guide lets the user select one of 29 best-selling Ford vehicles.



Fig. 2—After the car is selected the screen displays its specifications.



Fig. 3—Then the screen displays the standard features.

### Three In One

The Ford Simulator's opening menu provides three options. The first option is a *Driving Simulator*—a game, that is supposed to give you the feel and sense of handling for various Ford models. If you believe for one second that pushing some keys will give you the feel of a car, I have a really nice bridge in Brooklyn, New York that I think you'd like to buy.

The *third* option is a *Customer Response* letter to Ford that tells them how you like the program, and more important, lets you ask for specific auto information. It's a cute idea; we will probably see a lot more of it in the future.

I saved the second option for last because that's the real biggie, and the real purpose of the software. The second option is a *Buyer's Guide* for 29 best-selling Ford cars, listing their specifications, as well as the price of each model, each option, and each option package. The program lets you select the car and its optional accessories, and then totals your purchase.

Finally, as described earlier, it will work out your financing on a spreadsheet, print the spreadsheet, and even print a sticker showing your specific selections.

### Screen Displays

The screen photographs show how I priced out a Crown Victoria LX—a real, existing honest-to-goodness six-passenger vehicle.

Figure 1 shows the opening menu for the Buyer's Guide. Notice that I have selected the Crown Victoria LX, which brings up the screen displays shown in Fig. 2 and Fig. 3: a list of the specifications and the standard features, respectively. Figure 4 is the first option package. It has what I want, so I select the package. The second option package is several hundred dollars of mostly dress-up gadgets, so I skip over that screen and come to the screen shown in Fig. 5:



a list of individual options. Some of the items, such as the tilt wheel, are in the selected option package, so I ignore them and select only the cassette radio and front-vent windows. The screen shows the total cost of the options.

Figure 6 is the spreadsheet screen display. Notice that the last entry was for a 48-month loan. I can go back and juggle the entries to come up with financing that's affordable.



**Fig. 4—**A series of screen displays shows all the available option packages and their price, and the savings they represent are compared to the prices of individual options. You select only the packages you want.



**Fig. 5—**Finally, you get a chance to select individual options; those not included in the option packages you selected.



**Fig. 6—**A spreadsheet lets you juggle all the financial parameters, so that you can come up with a book-of-the-month-club figure that your budget can handle.

#### Ford Simulator Sticker

FORD Winning the world over.	1988 Ford LTD Crown Victoria LX 4-door sedan 5.0L EFI V-8 engine Automatic overdrive transmission
<b>STANDARD EQUIPMENT</b>	<b>PRICE INFORMATION</b>
The features listed below are INCLUDED AT NO EXTRA CHARGE in the MSRP shown at right:	Manufacturers Suggested Retail Price*
5.0L EFI V-8 engine Automatic overdrive transmission Rear-wheel drive Power assisted steering Power front disc/rear drum brakes Maintenance-free battery Coil springs/gas shocks suspension Deluxe wheel covers Dual electric remote control mirrors Split bench, dual recliner front seats Full bench, center armrest rear seats Elect. AM/FM stereo search radio Air conditioning	STANDARD VEHICLE PRICE \$16,157  OPTION PACKAGE 111A 699  OPTION PACKAGE TOTAL \$ 699 ADDITIONAL OPTIONS Electronic AM/FM/cassette 137 Front vent windows 79  TOTAL VEHICLE AND OPTIONS \$17,072
	TOTAL \$17,072
1988 Ford LTD Crown Victoria LX 5.0L EFI V-8 engine Automatic overdrive transmission	===== 17mpg City ===== * ===== ** == GAS MILEAGE == ** == INFORMATION == *** ===== ***** ===== 0 0 ===== 0 0 ===== 0 0 ===== 0 0 ===== 0 0 ===== 00 24mpg Hwy
ACTUAL MILEAGE will vary with options, driving habits and vehicle's condition. Results reported to the EPA indicate that the majority of vehicles with these estimates will achieve the MPG shown at the right.	
*Prices and equipment were as accurate as possible as of 12/27/87	

**Fig. 7—**The software will also print out a sticker that lists everything except the transportation and dealer-prep charges.

Any screen display up through the spreadsheet can be individually printed. A sticker, such as shown in Fig. 7, can also be printed, although there is no screen display for a sticker.

### They Goofed

I have seen attempts at computerized data books for electronic techs; some were good, some were bad, some were abysmal. But the Ford Simulator is the first consumer Buyer's Guide that I have seen, and it would be great if only Ford hadn't decided to hedge their bets. Either someone in their development group believed that the average consumer isn't intelligent enough to purchase a \$10,000-\$20,000 vehicle without playing games, or they thought games would attract more users.

The problem with the Ford software is those games. Although the games are superbly executed in graphics and color, they require a color card and a color monitor. Unfortunately, it can not be used with a monochrome system. Even if the computer has a Hercules card and is running the SIMCGA.COM program, the display is buried under layers of graphics.

Ford's concept is great; it's the execution that got sloppy. If others don't get scared off by poor consumer reaction to Ford's color and graphics error, you'll probably see many more high-cost items advertised via computer software. Being able to think at one's leisure—and to have the ability to spreadsheet the purchase and financing, sure beats a lot of TV and newspaper advertising. ■



By Charles D. Rakes

# CIRCUIT CIRCUS

## Junkbox circuits that can make life a bit easier

□ HOBBYISTS AND TECHNICIANS ALIKE often find themselves in need of a "quicky" circuit to aid in the testing or repair of some type of electronics gadget. At other times, the need is for an inexpensive add-on circuit to improve or protect some previous project. With that in mind, this month's Circus presents a mixture of circuits that, hopefully, will be of use to you in testing your experimental circuits, or in modifying an existing circuit.

### Tunable Audio Frequency Meter

Our first circuit, see Fig. 1, is a *Tunable Audio-Frequency Meter* that can also double as a variable audio-frequency tone decoder. The operation of the circuit is simple. A single transistor, Q1, amplifies the input signal and squares up the waveform. The output of Q1 is then used to drive U1, a 555 oscillator/timer configured as a Schmidt trigger. The squarewave output of U1 at pin 3 is fed to a simple diode-limiter circuit (D4) to provide a maximum positive swing through R7 of about 0.6 volt.

The signal at the wiper of R7 is fed to the input of U2 (a 567 phase-locked loop) at pin 3. If the input frequency is in range, R10 can be adjusted to tune in the signal and lock up U2, causing LED1 to light. A simple hand-drawn dial plate can be calibrated in hertz and placed over the shaft of R10.

With a capacitor value of 0.1- $\mu$ F for C6, the tuning range of the circuit is between 400 Hz and 5 kHz. That range can be raised or lowered by changing the value of C6. Increasing the value of C6 lowers the frequency, and the opposite holds true when C6's value is decreased.

Resistor R7 should be set to pass the minimum signal level that still allows a good response from U2. Too great a signal level at the input of U2 causes the frequency-detection bandwidth to broaden. That reduces the accuracy of

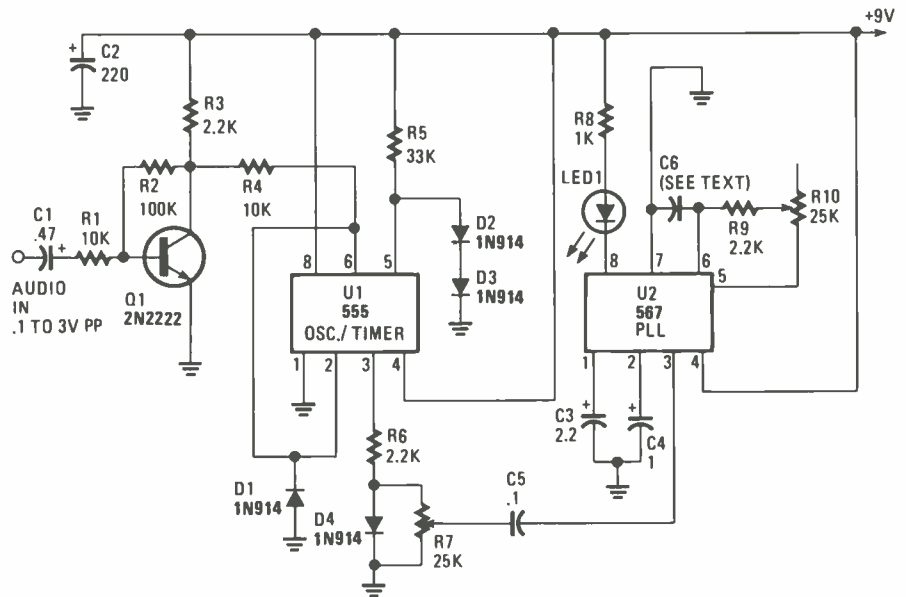

Fig. 1—The Tunable Audio Frequency meter can also double as a variable audio-frequency tone decoder.

the circuit in determining the actual input frequency from the dial.

A sensitive relay can be connected between pin 8 of U2 and the +V bus to power some other device when the de-

sired frequency is reached, or a transistor can be added to activate an external circuit or function. A number of 567 PLL circuits can be duplicated and their inputs paralleled to operate

### PARTS LIST FOR THE TUNABLE AUDIO FREQUENCY METER

- |  |   |
|--|---|
| U1—555 oscillator/timer, integrated circuit      | R8—1000-ohm, 1/4-watt, 5% resistor                        |
| U2—567 phase-locked loop, integrated circuit     | C1—0.47- $\mu$ F ceramic disc capacitor                   |
| Q1—2N2222 general-purpose NPN silicon transistor | C2—220- $\mu$ F, 25-WVDC, electrolytic capacitor          |
| D1—D4—1N914 small signal silicon diode           | C3—2.2- $\mu$ F, 25-WVDC, electrolytic capacitor          |
| LED1—Light-emitting diode (any color)            | C4—1- $\mu$ F, 25-WVDC, electrolytic capacitor            |
| R1, R4—10,000-ohm, 1/4-watt, 5% resistor         | C5—0.1- $\mu$ F, 100-WVDC mylar or ceramic disc capacitor |
| R2—100,000-ohm, 1/4-watt, 5% resistor            | C6—See text   |
| R3, R6, R9—2200-ohm, 1/4-watt, 5% resistor       |   |
| R5—33,000-ohm, 1/4-watt, 5% resistor             |   |
| R7, R10—25,000 potentiometer                     |   |

Printed circuit or perfboard materials, enclosure, IC sockets, 9-volt power source, audio generator, wire, solder, hardware, etc.



individually and respond only to their own pre-set frequency.

### Solid-State Night Light

If you still have little tykes living at home that don't like to sleep without having a light on, take a gander at the unusual *Solid-State Night Light* circuit shown in Fig. 2. The Solid-State Night Light doesn't put out a blinding beam, but it does emit enough light to chase away the "boogy-man."

To keep the kids interested and to add that special touch, the LEDs can be of different colors and arranged in some special design. Also additional LED strings can be added in parallel with the one shown, as indicated by the second string of LEDs connected to the circuit by a dashed line, to form circles, spirals, stars, etc.

The circuit's operation is very simple. Power for the circuit is provided by a 12-volt transformer, T1. The AC output of the transformer is rectified by D1 and the SCR to supply DC to the LEDs and the control circuitry. A light-dependent resistor, R5, in conjunction with transistor Q1 (which is in series with the gate of SCR1) is used to control the operation of the circuit. Resistor R1 sets the turn on/off sensitivity to the ambient-light level.

Ambient light striking R5 causes its resistance to be low, allowing current to pass through D1 and R5 to the base of Q1, biasing it on. With Q1 conducting, current through R2 is shunted (away from the gate of SCR1) to ground. That keeps SCR1 turned off. But as the ambient light decreases below the sensitivity setting, R5's resistance increases, delivering less and less base bias to Q1, until that transistor eventually turns off. With Q1 turned off, current through R2 biases SCR1 on, supplying power to the LEDs. The Night Light remains on until the sun comes up, or another light is turned on.

### AC Circuit Breaker

Our next circuit is presented in response to a reader's request for an *AC Circuit Breaker* to go along with the DC breaker circuit presented a few months ago. The circuit in Fig. 3 just might be the answer to your AC fuse-blowing blues. With the component values given, the Breaker can be set to open at current levels of from 0.25-amps to 5-amps. Resistive or inductive loads can be connected to the circuit.

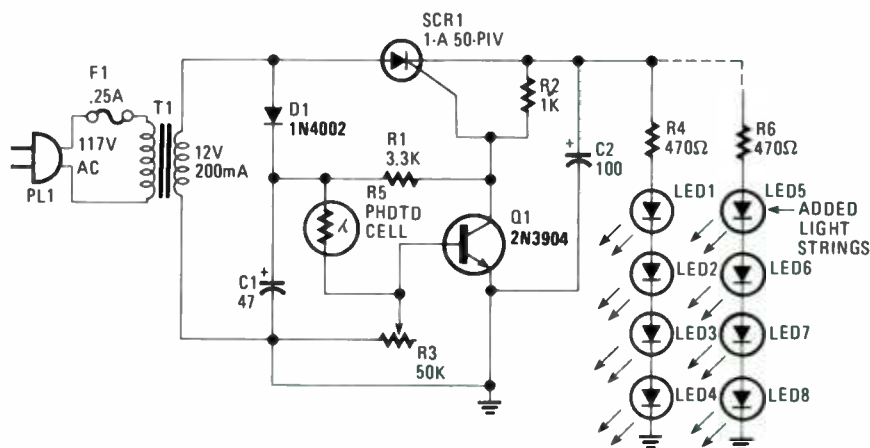

Fig. 2—Power for the Solid-State Night Light circuit is derived from a 12-volt transformer, with its output rectified by D1 and SCR1.

### PARTS LIST FOR THE SOLID-STATE NIGHT LIGHT

- Q1—2N3904 general-purpose NPN transistor
- D1—1N4002 100-PIV, 1-A silicon rectifier diode
- LED1-LED4—Light-emitting diode
- R1—33,000-ohm, ¼-watt, 5% resistor
- R2—1000-ohm, ¼-watt, 5% resistor
- R3—50,000-ohm potentiometer
- R4—470-ohm, ¼-watt, 5% resistor
- R5—Light-dependent resistor
- C1—47-µF, 25-WVDC electrolytic capacitor
- C2—100-µF, 25-WVDC electrolytic capacitor
- T1—117-volt primary, 12-volt, 200-mA secondary step-down transformer
- F1—0.25-A 3AG fuse
- PL1—117-VAC molded plug and line cord

Printed circuit or perfboard materials, enclosure, IC sockets, wire, solder, hardware, etc.

The AC neutral line (white wire) connects directly between the line and the operating load. The hot line (black wire) connects through a special current transformer and a triac control circuit. As the load current fluctuates, so does the voltage at the secondary of T1. The secondary voltage of T1 is rectified by D1. Capacitor C1 is then used to filter out some of the ripple content of the resulting DC voltage. Resistor R1 provides a constant 1000-ohm load to the output and also offers a fast discharge path for C1.

The desired trip current is set by R12, which has its wiper connected to the base of Q1. As long as the voltage at the wiper of R12 remains below 1.2 volts, Q1 and Q2 remain off, and the load is unaffected by the Circuit Breaker. Resistors R7 and R8 supply current to the internal LED of U1 (an MOC3010 optoisolator/coupler). As long as the LED is activated, the U1 gate current to TR1, maintaining the normal operation of the connected load.

When an overload condition occurs, the voltage at the base of Q1 rises above the 1.2-volt trigger level, turning it on. That, in turn, causes transistor Q2 to turn on, supplying a positive bias to the gate of SCR1, triggering it into conduction. That pulls SCR1's anode voltage to near ground potential, robbing the optoisolator/coupler's LED drive. That opens the optoisolator/coupler's output circuit, which turns off the bias to the triac and opens the Circuit Breaker. When conditions are back to normal, S1 can be pressed to re-set the circuit.

The Circuit Breaker contains only one item that's not common: the current transformer. The current transformer is easily fabricated from a 12-24-volt, 1-2-amp power transformer. The selected transformer must be of the kind that has the secondary as the outermost winding. Carefully remove the secondary winding and replace it with 7 or 8 turns of #16 solid or stranded wire. The new winding is connected in series with the AC load; see Fig. 3. The 117-volt primary winding now becomes the secondary that connects to D1.

The remaining circuitry can be meshed together on a small perfboard. It's a

(Continued on page 96)



By Marc Ellis

# ELLIS ON ANTIQUE RADIO

## Replacement drive belts made easy

□ FOR THOSE OF YOU WHO MAY HAVE just joined us, we've devoted the last three issues of *Ellis on Antique Radio* to the ongoing restoration of a very interesting receiver: a Zenith Model 7S232 "Shutter-Dial" set. Zenith's beautiful and ingenious shutter-dial mechanism was used on many of its broadcast/shortwave models, beginning in the late 1930's. On that type of dial, calibrations for individual bands were printed on sets of movable, semicircular shutters linked to the band-change switch. The dial arrangement was such that only the calibration for the selected band was visible behind a strategically-placed window.

In the three previous columns, we took stock of the set's major electronic and mechanical problems, corrected some of the more obvious ones, and powered up the set to try it out. At that time, using a short test antenna, I determined that the broadcast band and one of the two shortwave bands were definitely operational. But I wasn't able to observe any movement in the tuning-eye tube. The broken belt connecting the flywheel-shaft pulley and the tuning-condenser drive pulley had not yet been replaced and the shutter-dial assembly (previously removed for repair) was still off the radio.

### Tired Fingertip!

At the start of this month's restoration session, I considered reinstalling the dial assembly, but decided to delay that operation a little longer. I still need a replacement dial-glass and hope to find something suitable at a clock-supply shop. The fitting process will obviously go a lot smoother if I can carry the assembly along with me from dealer to dealer.

It was definitely time to replace the drive belt. I'd been pushing the tuning-condenser drive pulley by hand while testing for reception on the different

bands. But the mechanism is geared for vernier action, and my pushing finger was getting pretty tired! I wanted to have the help of the tuning knob and flywheel before searching for any more stations.

If the Zenith tuning drive had been equipped with the more-usual dial cord system, there would have been no problem. Dial cord is a generic item that is still available and can be used in almost any radio, modern or old. But dial belts are seamless loops having very specific diameters, and are made for individual sets. They're not used in modern radios and are no longer manufactured.

### Strategies That Failed

After reading the first column in this series, one reader wrote me that he had replaced the drive belt in a similar radio with an "O" ring. For those of you not familiar with "O" rings, they are rings made of a rubber-like material having a circular cross-section. The rings are used for various sealing and retaining purposes. Hardware stores carry assortments of them.

I thought using an "O" ring would be a terrific idea until I tried to get one in the required size (about three and a half inches in diameter). The hardware

clerk just looked at me, smiled and shook his head. The biggest one he had was about half that diameter. To get a bigger one, I'd have to go to a more specialized supplier—and those aren't usually open on week-ends when I'm free to shop.

Then I had what I thought was a truly inspired notion. Before leaving the store, I picked up some vacuum-cleaner drive belts. It was hard to judge their size through the bubble packs, so I spent about six bucks and purchased several. The belts were about a half-inch wide—but I figured I could slit them to the one-eighth-inch width I needed.

After about an hour of playing with a matte knife, a metal straight-edge, and some clamps, I managed to carve out some pretty creditable-looking eighth-inch belts. But none of them fit correctly! Although the full-width belts had fit snugly enough, the slit versions had lost so much of their resilience that they were too loose. So it was back to ground zero.

### Success at Last

What finally worked for me was an adaptation of a belt supplied to me by the old gentlemen who sold me the set—and who had started to restore it himself. He'd made his belt from many strands of fine monofilament fishing line, forming it around a jig made of nails hammered into a board (see photos). His belt was a little too tight, so that the flywheel didn't run smoothly. It also had a tendency to slip, and was a little messy looking because the strands wouldn't lie smooth as the pulleys turned.

To determine the correct size, I made up several one-turn test loops using dial cord joined with an ordinary square knot. After finding the loop that fit correctly on the radio, I used it as a pattern to set up my own nail-and-board jig. I then used the jig to make up a "belt"

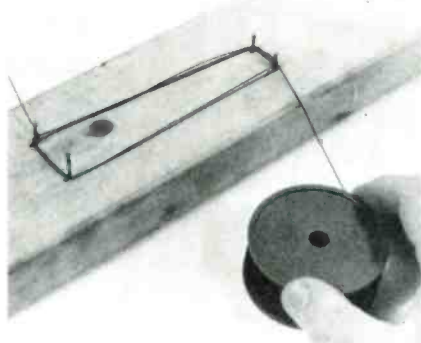

After much experimenting, a replacement drive belt was successfully made on a crude jig, consisting of four nails hammered into a board.



MASTER THE NEW ELECTRONICS WITH MCGRAW-HILL'S

# Contemporary Electronics Series

The fast, easy and low cost way to meet the challenges of today's electronic innovations. A unique learning series that's as innovative as the circuitry it explains, as fascinating as the experiments you build and explore.

From digital logic to the latest 32-bit microprocessor, the McGraw-Hill Contemporary Electronics Series puts you into the electronic picture one easy step at a time. Fifteen unique Concept Modules, sent to you one every 4-6 weeks, give you a handle on subjects like optoelectronics, robotics, integrated circuits, lasers, fiber optics and more.

Each Concept Module goes right to the heart of the matter. You waste no time on extraneous material or outdated history. It's a fast, efficient, and lively learning experience...a non-traditional approach to the most modern of subject matter.

## Unique Interactive Instruction

With each module, you receive a McGraw-Hill Action Audio Cassette. Each tape is a dynamic discussion that drives home the key facts about the subject. Your learning

With your first module, you get this solderless breadboarding system. You'll use it throughout the series to build electronic circuits and bring concepts to life.



experience is reinforced through interaction with vividly illustrated text, audio cassettes, and actual electronic experiments. Indexed binders preserve backup material, notes, and tapes for convenient referral.



## Perform Experiments in Contemporary Electronics

Throughout your series, laboratory experiments reinforce every significant point. This essential experience...dynamic, hands-on demonstrations of theory in practice... will help you master principles that apply all the way up to tomorrow's latest VLSI (Very Large Scale Integrated) circuitry.

In your very first module, you'll use integrated circuits to build a digital oscillator, verifying its operation with a light emitting diode (LED). You'll learn to identify passive and active components, understand concepts common to all electronic circuits.

## For Anyone Interested in Electronics

The Contemporary Electronics Series is designed for anyone from hobbyist to professional. It's for you if you're looking for new fields of interest...if you're a teacher who

wants an update in contemporary circuits...a manager or supervisor in an electronics plant...a doctor, an engineer, a chemist who finds electronics playing an increasingly important role in your work. It's even for electronics engineers or technicians who feel their training needs freshening up. It's the quickest, most convenient, probably least expensive way to do it. And the only one that gives you hands-on experience.

## 15-Day No-Risk Trial

To order your first module without risk, send the card today. Examine it for 15 days under the terms of the order form and see how the Contemporary Electronics Series gets you into today's electronics. If card has been used, write us for ordering information.



McGraw-Hill  
Continuing Education Center  
3939 Wisconsin Ave.  
Washington, D.C. 20016

## ELLIS ON ANTIQUE RADIO

consisting of four turns of dial cord (ends tied, as before, with a square knot). The result was not only neat-looking, but it also worked perfectly. The tuning-condenser drive now runs smoothly with no slippage, and the flywheel action is excellent.

Here's the conclusion I've come to about belt substitution. Using a material with "stretch" is not nearly as important as obtaining the correct diameter. The tuning condenser on the Zenith is mounted on a springy "L" bracket in such a way that the end of the condenser carrying the drive pulley has about a quarter-inch of "give" in the direction of the flywheel pulley. When the drive belt is the correct length to take up about half of that "give," everything runs right. If it's slightly looser than needed, there's slippage; get it tighter than needed and there's binding.

### Voltage-Checks

Now that I could tune the set easily, I connected it to a good outside antenna and fired it up once more. This time, I heard signals on all three bands and observed movement in the tuning eye. But, to me, the set's performance still isn't quite convincing. It isn't lively enough and the tuning-eye's movement seems sluggish.

I feel that my next major move is likely to be a realignment, but before moving into that phase, I wanted to convince myself that there was nothing functionally wrong with the radio. So to get a quick picture of the set's general health, I decided to do a voltage check.

Such a check involves measuring the voltage at each tube-socket connection under actual operating conditions and comparing the results with the voltages published by the set manufacturer. That's an excellent "scattergun" method for checking a radio because most component failures have some effect on tube operating voltage(s).

The results I obtained are probably within the acceptable range for a normally operating set. The plate and screen voltages do seem a little low—possibly a result of the aging electrolytic capacitors. The capacitors show no signs of leakage and the set runs without hum, so I'm on the fence about replacing them. I also want to investigate some irregularities in a few of the bias readings. More on that next month.

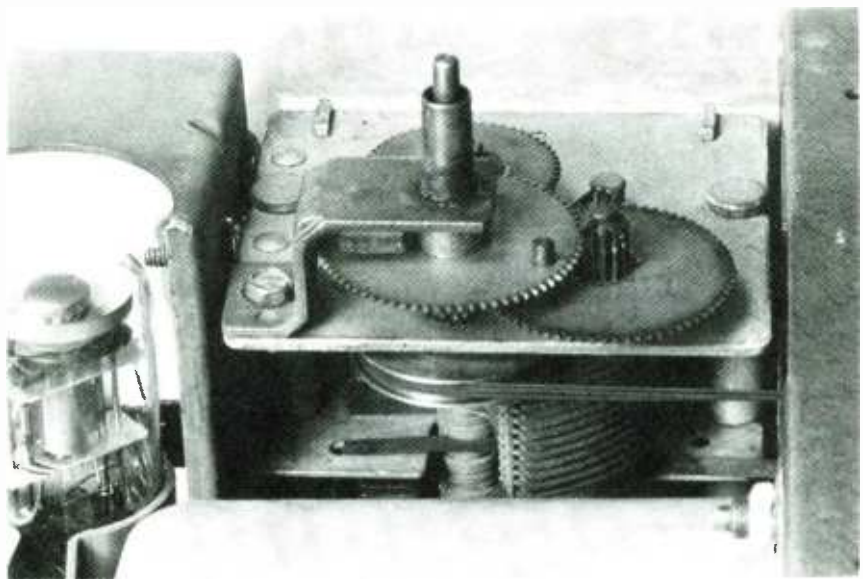

Here's the drive belt in place on the radio. It looks neat and works well.

PAGE 830 ZENITH

MODELS 7S204, 7S232, 7S240 7S242, 7S258, 7S260 7S261		ZENITH RADIO CORP.								
Chassis 5709		SOCKET VOLTAGES								
Tube	Position	1	2	3	4	5	6	7	8	9
6A8	Converter Osc.	0	6.4	255	89	-10	182	0	0	-2
6K7	I.F.	0	6.4	243	89	0	—	0	0	-2
6H6	2nd Det. A.V.C.	0	0	2	-2	2	—	6.4	2	—
6F5	1st Audio	0	0	—	117	—	—	6.4	-1.5	1.5
6F6	Power	0	0	243	255	-2	—	6.4	2	—
5Y4	Rect.	0	—	AC	—	AC	—	32A	32B	—
6T5	Target	H	Ep	Eg	Et	Ek	H	—	—	—
		0	16	2	255	2	6.4	—	—	—

All voltages measured from point indicated to ground (antenna terminal, 1000 Ohm per Volt meter, antenna and ground disconnected).  
Line voltage 117V Consumption 1.5 W. Power supply 117V

Shown here is the manufacturer's voltage chart for the Zenith Model 7S232. The values measured during voltage checks differed a bit, but not seriously.

### The Mysterious Philco Thing

Last month I received a letter and some interesting pictures from Larry Lovell, 2732 King St., Endwell, NY 13760. (Unfortunately the photos that we received could not be reproduced for this column.) While cleaning out the attic, he came across a mysterious gadget in a small wooden cabinet bearing the Philco logo.

Mounted on the front panel is a telephone-like dial mechanism which, when activated, rotates a metallic vane inside a large coil. A type 30 tube is also part of the assembly. Larry would like some help identifying the device.

At first, I wondered if it was some kind of a Rube Goldberg gadget built

inside a case salvaged from a small Philco radio. However, studying Larry's pictures with a magnifying glass soon dispelled that notion. The back of the dial assembly is clearly marked Philco Part No. 38-9704, and the tube definitely bears the Philco house brand. All-in-all, it appears that the unit was built in the Philco plant and not pieced together by an old-time experimenter.

As it happens, I was recently browsing through the latest copy of *Antique Radio Classified* magazine when I noticed that someone was trying to locate a wireless remote control for a Philco 39-116 console. Could Larry's unit be a wireless remote? The dial defi-

(Continued on page 96)





By Don Jensen

# JENSEN ON DX'ING

## The mailbag is jammed to capacity

□ ONE OF THE BEST PARTS OF DOING this column is reading the mail from you. The letters just keep coming. As a result, I've got a stack of your letters with questions about SWLing and reports of shortwave loggings. So, this month's column is dedicated to you—our most-important asset.

### Vanishing Act

The first letter is from Ray B. Fuller, Raleigh, NC, who has a question about *United Nations Radio*. "I used to hear UN Radio all the time, but I haven't tuned across it for a long while," writes Ray. "What happened to the UN station?"

UN Radio used to be a common shortwave logging, as Ray remembers, back when its programming was broadcast on the *Voice of America* (VOA) transmitters. But in 1985, the United Nations, faced with a hike in charges levied by the VOA, decided it couldn't afford to continue leasing air time from the Voice of America.

But the international organization didn't abandon broadcasting altogether. In September 1986, it began furnishing weekly news and current affairs programs in English and various other languages to other shortwave stations around the world.

Robert Ross, writing in the "DX Ontario" bulletin, noted that UN English-language programming can be heard now from four different stations on shortwave. UN Radio broadcasts can be heard via the *Voice of Nigeria* (VON) on Saturdays at 0600 UTC on 15,185 kHz; at 0700 on 17,800 kHz, and at 1900 on 7,255 kHz. The last transmission is directed to listeners in North America.



2 11.87 - 2 5.88

Most international shortwave broadcasters, including Radio Prague—*Praha*, in Czechoslovakian—send regular schedules of their programs in various languages to SWLs who request them.

ROZVRH PROGRAMU – OBLASTI PŘIJMU  
BROADCAST SCHEDULE – ZONES OF RECEPTION  
HORAIRE – RÉGIONS DE RÉCEPTION  
HORARIOS – ZONAS DE ESCUCHA  
PROGRAMMPLAN – EMPFANGSBEREICHE  
ORARI – ZONE DI RICEZIONE  
HORARIÓS – ZONAS DE RECEPÇÃO

جدول البرامج ومناطق البت الازاعي

Transmitting on Saturdays at 1200 UTC, *Radio Beijing's* UN broadcasts can be heard on 11,600 kHz, 11,755, and 15,280 kHz.

*Radio Cairo's* UN programming can be heard on Sundays at 1945 UTC on 9,700 and 11,665 kHz, and at 2135 UTC on 15,375 kHz.

And via the Congo, the *Voice of the Revolution's* UN broadcasts can heard on Tuesdays at 2015 UTC on 7,105 and 9,710 kHz; Saturdays at 2300 on 15,190 kHz.

Reception reports on any of those broadcasts can be sent to United Nations Radio, Room S:805, United Nations, NY 10017.

### News For the Home Folks

Mrs. Robert Schmitt, Lincoln, NE, says in her letter that she particularly enjoys listening to shortwave programming to learn more about what's going on in the countries whose stations she hears.

"I find it interesting to hear the news that doesn't make it to our nightly TV-news broadcasts," she says. "Any program suggestions along that line?"

If I'm reading you right, Mrs. Schmitt, what you're really talking about is news that's intended for domestic audiences.

If that is indeed what you're looking for, *Radio New Zealand* (RNZ), which relays its home-service programs on shortwave; the Australian Broadcasting Commission's domestic shortwave outlets, and the *South African Broadcasting Corporation's* "Radio 5" programming fit the bill, as do quite a number of other similar broadcasts.

But a few international broadcasters offer a sampling of the news home audiences are hearing.

Let me pass along one that you can easily find and tune into, recommended by program reviewer Alex Batman, whose "Easy Listening" column is a regular feature in the North American SW Association's "Frendx" bulletin.

Alex suggests "Coast to Coast," a *Radio Canada International* (RCI) program that's aired Sundays from 2135 to 2200 UTC on 7,345, 11,880, and 17,820 kHz. "Each week," he says, "that program interviews a journalist in a different region of Canada: the Atlantic provinces, Quebec, Ontario, British Columbia, etc. The main news stories from the region are explored."

### All For One

Michael Rains, Louisville, KY, writes to ask "Would you please pub-  
(Continued on page 97)

CREDITS: John Topoleski, PA; John Tuchscherer, WI; Raymond Bauernhuber, NY; Sheryl Paszkiewicz, WI; Rufus Jordan, PA; Alan Laves, TX; Richard Eckman, CA; Paul Bauer, FL; Wally Rhyne, NC; Andy Rugg, QUE; North American SW Association, 45 Wildflower Road, Levittown, PA 19057)

By Marc Saxon



# SAXON ON SCANNERS

## The sum is greater than its individual components

□EVERY NOW AND THEN SOMEONE comes up with the bright idea of merging two good products to produce something better than either product alone. That's what we thought when we found out about the *ICOM IC-228A* (25 watt) and *IC-228H* (45 watt) scanners. You're probably wondering why scanners have wattage ratings; thought you'd never ask!

Both units are scanners covering the VHF high-band (138 to 174 MHz). Both also contain built-in transmitters that can operate throughout the 140- to 150-MHz range. The transmitter coverage includes the 2-meter ham band, plus all sorts of MARS, CAP, and other emergency service channels that lie in the 148- to 150-MHz range.

The IC-228A and IC-228H may be programmed for twenty memory channels, and if the units are programmed for semi-duplex transceiving, then the same memory channel can be operated with offset frequencies.

The units have a priority channel, lock-outs, and search/scan, and an optional tone-squelch module. With the tone-squelch option installed, when the frequency of a received tone equals the tone frequency that you've set, a thirty-second alert tone is sounded. It's like a beeper/pager.

Although the units have a lot to offer, there are only thirteen front panel controls to run this mobile unit. And it's rather easy on the eyes. Operating information is highlighted via orange, red, and green LCD's. And it's compact, too!—measuring only 5½ inches wide, 2 inches high, and roughly 6 inches deep.

Clever, no? As you can see, manufacturers have come to the conclusion that overlapping user interests call for new types of products having features drawn from several areas. Because these scanners are so new, we don't have information on whether or not it's possible to user-modify either version to transmit

over the entire 138- to 174-MHz receiving range.

The sets come from ICOM America, Inc. (PO Box C-90029, Bellevue, WA 98009-9029) and carry a suggested retail of \$509 for the 25-watt version, \$539 for the 45-watt job. For more information on these and other products, contact ICOM America directly.

### They Back Their Products

A note from Norman Monroe, K4FRY, of Gadsden, AL, mentions that about ten years ago he purchased a Bearcat 100 handheld programmable scanner. It worked well for five years then stopped.

He sent it back to Bearcat for repairs, but they returned it untouched, explaining that they didn't repair equipment that was more than five years old. But they offered to sell him a Bearcat 20/20 at an extremely low price to replace the dead scanner. Norm took them up on their offer. The new unit worked just fine for four years, but was unable to survive several generous squirts of all purpose cleaner applied by the housekeeper. That caused the 20/20 to be sent back for repairs. Bearcat said that the

unit had been damaged beyond repair. To replace the 20/20, Bearcat generously sent Norm a brand new 210XLT scanner for only the normal cost of a repair, plus shipping (a total of around \$34).

Norm wonders if we've heard any other instances of manufacturers concern for their customers to equal his story. Well, we have been told of several other offers by Bearcat to replace defunct equipment, but this is the first instance that we know of where it was a two-stage deal extending over a ten year span.

### Movin' On

Speaking of equipment, when you're shopping around for a new scanner, don't overlook the fact that many new radio systems are making a bee-line for the 800-MHz band. That includes business as well as public-safety agencies. Cities from Sanford, FL to Denver, CO have moved their public-safety agencies to that new frontier, and there are many more to follow. You may want to consider that fact as you shop around, and select a scanner that offers coverage of 800-MHz frequencies.



ICOM's IC-228A (25 watt) and IC-228H (45 watt) scanners may be programmed for twenty memory channels, and features a priority channel, lock-outs, search/scan, and an optional tone-squelch module. Unit transmits on 2-meter band.



It's hard to believe that this year marks the twentieth birthday of the scanner. Yes, it was developed in 1968 by James A. Lovell when he founded Electra/Bearcat. Before the invention of the scanner, tunable receivers were used. In 1971, Lovell sold the company to Masco Corp., and in 1984 the company was purchased by Uniden Corp. Lovell retired in 1974.

### Where to Look

Mike Bertrand, Stony Point, NY asks for a rundown on the frequencies to monitor U.S. Coast Guard communications. The best bets include 156.80, 157.05, 157.075, 157.10, and 157.15 MHz on the VHF band. The USCG Auxiliary is most often monitored on 157.175 MHz and there is some helicopter activity taking place on 164.30 MHz.

If you have the UHF aeronautical band in your scanner, listen on 237.9, 240.6, 275.2, 277.8, 282.8, 285.0, 342.2, 381.7, 381.8, and 383.9 MHz. We have found that 381.7 and 381.8 are quite active at times.

### Mysterious VHF Signals

Morrie Schaefer, Escalon, CA, reports that while exploring new frequency territory, with his unit in the search/scan mode, he suddenly found himself listening to someone speaking Russian! The frequency was 143.625 MHz. That frequency will do it every time because it's popularly used by Soviet-manned space vehicles.

Soviet-manned space frequencies in this part of the spectrum fall between 142.40 and 143.625 MHz, so it's worth a shot to sift through the entire range to see what it has to offer. The Soviets have a busy manned space-flight schedule, and their cosmonauts can often be heard "live, from outer space" on your home scanner. Of course, unless you can understand Russian, it isn't going to give you many insights into things like flying saucers, little green men, and bug-eyed monsters.

One reader, who does speak Russian, advises that the transmissions that he has monitored here seem to mostly fall into the realm of: "We are going to have a meal now," "My left boot is very uncomfortable," "Boris says his ears are ringing," and similar.

Satellites in the American ATS series have downlinks on 137.10, 137.11, 139.056, 140.056, and 141.056 MHz.

You might take a listen there, as well. In fact, satellites may turn up just about anywhere between 136 and 144 MHz, although you can expect to hear mostly non-voice transmissions and no call-signs or other ID's.

Also, remember that specific satellites can be heard only when they are located (generally) above your geographic area, and many transmissions take place only upon command from the ground station, except for those with continuous beacons. It's sort of a grab bag; you must be very patient and you must happily accept whatever you manage to hear.

### Political Stuff

With the national political campaigns going full blast these days, being a scanner buff can help you to tune in on the behind-the-scenes activities. Those activities are often more interesting than the campaign appearance itself.

Air Force 1 and 2 can be heard placing air/ground telephone calls on 415.70 MHz. The ground-station paired frequency is 407.85 MHz, and you may well be within the range of one of the many transmitters to be found on that frequency.

When the candidates come to your local area, you might want to check out certain frequencies that will probably be in use. The Secret-Service agents with the sunglasses, funny lapel pins, and what look like hearing aids, are often seen talking into their wrist-watches. They are actually wearing body transceivers, although they are short-range. They have been monitored on 407.825 and 407.875 MHz. Also listen on 165.2125, 165.375, 165.7875, and 166.5125 MHz for communications during and after the candidates are in your area.

Should the President come to town to stump for a candidate, listen on 169.925, 166.2125, 167.825, 168.7875, 167.025, 164.8875, 166.70, 164.65, and 167.025 MHz for communications activities during the visit. As many scanner owners have learned, election time usually is very special. Don't miss out, it won't happen again until 1992!

Keep us posted, gang. Send in any questions, brainstorm, frequencies, clippings, photos, or whatever to Marc Saxon, *Saxon on Scanners*, Popular Electronics, 500-B Bi-County Blvd., Farmingdale, NY 11735. ■

# FREE

## precision tool folder

small  
precision  
tools

for micro-electronics  
and miniature applications



minitool, inc.

Informative folder shows Minitool's line of precision miniature hand tools for laboratory and production tasks, fine assembly work, delicate deburring jobs, precise scribing and measurement, printed circuit artwork and repair.

- Hardened steel and carbide tool sets
- Technician tool sets
- Fine line diamond scribes
- Audible micro-electronic test equipment
- Electrical micro test probes with inter-changeable tips
- Unique precision pin vises
- Sapphire burnishing tools
- Micro surgical knives
- Zirconium ceramic scissors
- Ceramic tipped tweezers
- Direct-reading micro rulers

**Send NOW for your FREE folder.**

**Minitool, Inc.**

**1334/F DELL AVENUE.**

**CAMPBELL, CA 95008**

**or call 408-374-1585**

**CIRCLE 21 ON FREE INFORMATION CARD**

# AMAZING SCIENTIFIC & ELECTRONIC PRODUCTS

**PLANS—Build Yourself—All Parts Available in Stock**

- LC7—BURNING CUTTING CO<sub>2</sub> LASER \$ 20.00
- RUB4—PORTABLE LASER RAY PISTOL 20.00
- TCC1—3 SEPARATE TESLA COIL 20.00
- PLANS TO 1.5 MEV 20.00
- IOG1—ION RAY GUN 10.00
- GRA1—GRAVITY GENERATOR 10.00
- EML1—ELECTRO MAGNET COIL GUN/LAUNCHER 6.00

### KITS

- MFT3K—FM VOICE TRANSMITTER 3 MI RANGE 49.50
- VVPM7K—TELEPHONE TRANSMITTER 3 MI RANGE 39.50
- BTC3K—250.00 VOLT 10-14" SPARK TESLA COIL 199.50
- LHC2K—SIMULATED MULTICOLOR LASER 39.50
- BL51K—100.000 WATT BLASTER DEFENSE DEVICE 69.50
- ITM1K—100.000 VOLT 20' EFFECTIVE RANGE INTIMIDATOR 69.50
- PSP4K—TIME VARIANT SHOCK WAVE PISTOL 59.50
- PTG1K—SPECTACULAR PLASMA TORNAO GENERATOR 149.50
- MVPIK SEE IN DARK KIT 199.50

### ASSEMBLED

- PTW1K—SPECIAL EFFECT VISUAL PLASMA GENERATOR FOR GLOBES/NEON TUBING ETC 659.50
- BTC10—50,000 VOLT—WORLD'S SMALLEST TESLA COIL 49.50
- LGU40—1MW HeNe VISIBLE RED LASER GUN 249.50
- TAT30 AUTO TELEPHONE RECORDING DEVICE 24.50
- GPV10—SEE IN TOTAL DARKNESS IR VIEWER 349.50
- LIST10—SNOOPER PHONE INFINITY TRANSMITTER 169.50
- IPG70—INVISIBLE PAIN FIELD GENERATOR—MULTI MODE 74.50

• CATALOG CONTAINING DESCRIPTIONS OF ABOVE PLUS HUNDREDS MORE AVAILABLE FOR \$1.00 OR USE OUR PHONE FOR "ORDERS ONLY" 603-673-4730

PLEASE INCLUDE \$3.00 PH ON ALL KITS AND PRODUCTS PLANS ARE POSTAGE PAID. SEND CHECK, MO, VISA, MC IN US FUNDS

**INFORMATION UNLIMITED**  
**P.O. BOX 716 DEPT. HO AMHERST, NH 03031**

## ELLIS ON ANTIQUE RADIO

(Continued from page 92)

nately suggests some kind of a control function. The coil, with the trimmer capacitor that I notice associated with it, could easily be a tuned circuit for a small radio transmitter. And the presence of a couple of standard battery connectors indicates that the unit was intended to be portable.

The first two digits of a Philco part number generally indicate the year of manufacture, so Larry's unit seems to be a year older than the radio in the classified ad. However, I'm sending Larry the name and address of the advertiser and maybe they can get together. In the meantime, if any reader has any idea as to what that gadget is and can tell us how it works, I'd certainly like to hear from you!

## One-Stop Tube Shopping

Some months ago, Marvin Tocherman of International Components Corp. (105 Maxess Rd., Melville, NY 11747) wrote me to say that his company stocked over 2,000 receiving and industrial tubes—including many older types—and would be happy to be of service to readers of **Popular Electronics**. In looking over the enclosed catalogue, I was struck by the fact that many types from the 1920's and 30's were listed and the prices quoted were quite reasonable.

However, I also noticed that the catalogue was geared to the needs of radio/TV servicemen buying in bulk, and that a \$50.00 minimum order was required. So I wrote Marv and asked if he would consider lowering the minimum-order requirement for **Popular Electronics** readers. The result is that he will now accept a \$25.00 minimum from those who mention this column. Let me hasten to say that this is not a personal endorsement or recommendation since I've never had occasion to order anything from International Components. But I'd certainly encourage you to send for a catalogue and draw your own conclusions.

Well that about does it for this month, but be sure to come back next month when we'll have more antique-radio tips, techniques, and information for you. In the meantime, be sure to send your comments, suggestions, and questions to Marc Ellis, C/O **Popular Electronics**, 500-B Bi-County Blvd., Farmingdale, NY 11735. ■

## CIRCUIT CIRCUS

(Continued from page 87)

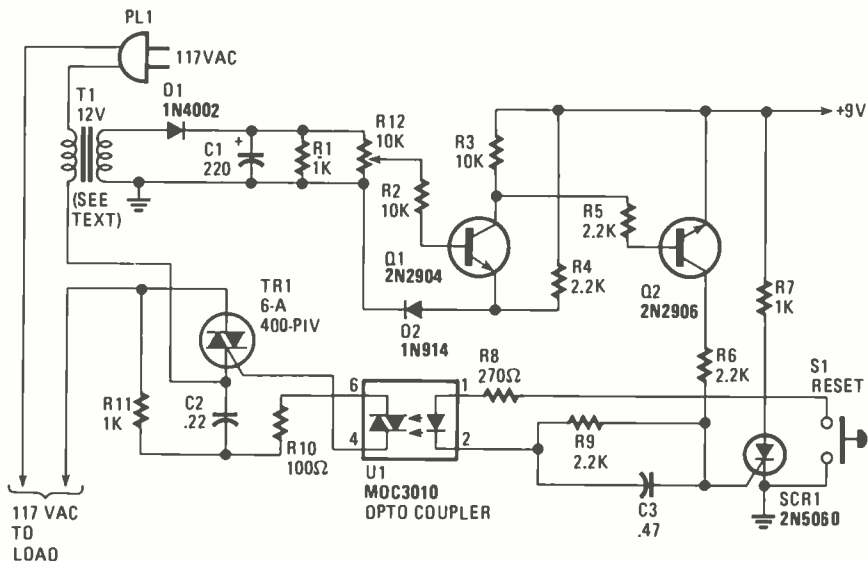

Fig. 3—The AC Circuit Breaker, with the component values shown, can be set to open at current levels of between .25 and 5A.

### PARTS LIST FOR THE AC CIRCUIT BREAKER

U1—MOC3010 optoisolator/coupler, integrated circuit	R10—100-ohm, ¼-watt, 5% resistor
TR1—6-A, 200-PIV triac	R12—10,000-ohm potentiometer
SCR1—2N5060 low-power, silicon-controlled rectifier	C1—220-µF, 25-WVDC mylar capacitor
Q1—2N2904 general-purpose NPN silicon transistor	C2—0.22-µF, 400-WVDC mylar capacitor
Q2—2N2906 general-purpose PNP silicon transistor	C3—0.47-µF, 100-WVDC mylar capacitor
D1—1N4002 100-PIV, 1-A rectifier diode	T1—117-volt primary, 12-volt secondary transformer (modified, see text)
D2—1N914 small signal silicon diode	S1—Normally-open pushbutton switch
R1, R7, R11—1000-ohm, ¼-watt, 5% resistor	PL1—117-VAC molded plug and line cord
R2, R3—10,000-ohm, ¼-watt, 5% resistor	Printed circuit or perboard materials, enclosure, IC socket, 117-VAC socket, 9-volt power source, wire, solder, hardware, etc.
R4—R6, R9—2200-ohm, ¼-watt, 5% resistor	
R8—270-ohm, ¼-watt, 5% resistor	

good idea to use an IC socket for the optoisolator/coupler. For long-term service, a small aluminum heat sink for TR1 wouldn't hurt. Either a 9-volt battery or a simple AC-derived power supply can be used to power the circuit.

To use the Circuit Breaker, turn the wiper of R12 to ground, connect the load, and apply AC power. Operate the load at its maximum current and slowly back off R12 to the point where the circuit trips off. From that setting, turn R12 up an additional eighth of a turn for resistive loads, and a quarter turn or more for inductive loads.

Resistor R12's trip setting can be

roughly calibrated by connecting a 100-watt light bulb for the load and marking the trip point for slightly less than one amp, a 200-watt lamp for about 2 amps, a 300-watt lamp for 3 amps, and so on up to 5 amps. For a greater operating range, increase the wire size on T1 and use a triac with higher current rating for TR1.

Well that's about all the space allotted to us for this month. But be sure to join us next month when we'll have another set of circuits that, hopefully, will entertain you and train you in the ways of electronics. So until then, good luck and may the flow be with you. ■



## JENSEN ON DX'ING

(Continued from page 93)

lish information on shortwave radio clubs?"

Okay, Mike. There are a number of U.S. and Canadian clubs for radio listening fans. Some focus exclusively on shortwave radio, others concentrate on medium wave, long wave, or other specialized aspects of DXing. There are also some combination clubs, which cover several radio interests. Each publishes a regular bulletin with news and information for their members.

The Association of North American Radio Clubs (ANARC), while not a club itself, is the umbrella organization that links those separate clubs. And ANARC will send you a list of its affiliated clubs, which includes their mailing addresses, their areas of specialization, information about their bulletins, membership fees, and the cost of a sample bulletin, so you can see for yourself if your interests and the club's mesh.

The Club List can be obtained free from ANARC, but you must include a stamped, self-addressed business-size envelope. If you live in Canada, send 50 cents in Canadian stamps, not affixed to your self-addressed envelope. Overseas, send two International Reply Coupons.

The address is ANARC Publications Manager, PO Box 462, Northfield, MN 55057.

### Time Out

Here's a question from several readers, including Barry Ossman, Brooklyn, NY; Chuck Phillips, Spokane, WA, and our previously mentioned Kentuckian, Michael Rains.

"Would you explain what UTC is and how to convert it?"

UTC is the abbreviated form of the French words meaning *coordinated universal time*, or the common time standard used throughout the world by international broadcasting stations and SWLs.

It is, essentially, the equivalent of the older term, Greenwich Mean Time, or GMT. Converting to and from UTC and your local time is simple enough. It is just a matter of adding or subtracting the appropriate number of hours.

The UTC equivalents are: Eastern Daylight Time, plus 4 hours; Eastern Standard and Central Daylight Time, plus 5 hours; Central Standard and

Mountain Daylight Time, plus 6 hours; Mountain Standard and Pacific Daylight Time, plus 7 hours; and Pacific Standard Time, plus 8 hours.

SWLs and stations normally use the 24-hour clock system, which considers the hours from 1 AM to noon to be 0100 to 1200 hours, and from 1 PM to midnight as 1300 to 2400 hours.

Thus, 4 AM EST is the same as 0900 UTC; 11 AM CST is 1700 UTC; 3 PM MST is 2200 UTC, and 8 PM PST is 0400 UTC—tomorrow, since the conversion takes us past midnight UTC into the next day.

With a little practice, you'll be making those time conversions with little difficulty.

### ABBREVIATIONS

<b>ANARC</b>	Association of North American Radio Clubs
<b>DXing</b>	listening to shortwave broadcasts
<b>EST kHz</b>	Eastern Standard Time kilohertz (1000 hertz or cycles)
<b>MST</b>	UTC + 7 hours
<b>PST</b>	UTC + 8 hours
<b>RCI</b>	Radio Canada International
<b>RNZ</b>	Radio New Zealand
<b>SW</b>	Shortwave
<b>SWL(s)</b>	shortwave listener('s)
<b>US</b>	United States
<b>USSR</b>	Russia (Union of Soviet Socialist Republics)
<b>UTC/GMT</b>	Universal Time Code/ Greenwich Mean Time
<b>VOA</b>	Voice of America
<b>VON</b>	Voice of Nigeria

### Down The Dial

Send your letters, with your own loggings, comments or questions on shortwave and SWLing to *Jensen on DXing*, **Popular Electronics**, 500-B Bi-County Blvd., Farmingdale, NY 11735.

Now here are some of the stations being reported by listeners in the U.S. and Canada:

**Antarctica**—15,474 kHz. *Radio Nacional Arcangel San Gabriel*, despite its Spanish language programming, is located in Antarctica, territory claimed by Argentina. Tune it in at around 2230-2300 UTC.

**Asia**—5,005 kHz. *Radio Nepal* has been heard lately at about 1300 UTC with flute music followed by the news.

**Australia**—6,080 kHz. *Radio Australia* can be heard with English programming between 1300 and 1400 UTC.

**East Germany**—15,240 kHz. *Radio Berlin International's* English service can be heard from 1530 to sign off at 1557 UTC.

**Fiji Islands**—7,259 kHz. *Radio Vanuatu* is an exotic Pacific island broadcaster that puts decent signals into North America at around 0630 UTC.

**Guatemala**—3,370 kHz. A programming highlight from *Radio Tezulutan's* Spanish language station is the excellent marimba music. Tune in at around 0130 UTC.

**Mexico**—11,769 kHz. *Radio Mexico International (XERMX)* is heard here with talks in Spanish and songs during the 1430 to 1500 UTC time period.

**USA**—9,755 kHz. *KUSW* in Salt Lake City, Utah, is the latest U.S. entry into the field of commercial SW broadcasting. Tune it in at around 0430 UTC.

**USSR**—13,645 kHz. *Radio Vilnius'* English program, although produced in the Vilnius studios in the Soviet Union's Lithuanian S.S.R., is aired by transmitters throughout the USSR. Listen for the program at 2300 UTC.

**West Africa**—3,366 kHz. The *Ghana Broadcasting Corp.* has been noted at around 0600 UTC with news, then English language lessons. ■



## CHEMICAL SOLUTIONS

### FREE CHEMTRONICS CATALOG!

Comprehensive new source for over 200 products used in electronic manufacturing and field service. Precision cleaning agents, flux removers, bulk solvents, circuit refrigerants, precision dusters, non-residual wipers, foam swabs, premoistened pads/swabs, antistatic compounds, conformal coatings, lubricants, adhesives, desoldering braids, rosin core solder and solder masking agents. Complete with technical specifications and application guide.



**Chemtronics Inc.**  
681 Old Willets Path  
Hauppauge, N.Y. 11788  
516-582-3322

## THERMOCOUPLES

(Continued from page 73)

voltage source and used for heating the junction, (see Fig. 6). The two circuits are completely independent and will not interfere with each other. The heating voltage is increased until the desired output from the thermocouple is obtained. The pre-heated junction is placed directly in the air flow (as shown in Fig. 7). As more air flows by the junction and cools it, less output voltage is read on the meter.

A small-gauge wire junction will respond quite rapidly to minute changes of air flowing around it.

Remember that different gases have different cooling abilities, so if you are measuring the flow rate of a gas other than air, and accuracy is required, the thermocouple unit will have to be calibrated for the gas used. The output of the junction can be directly calibrated in air-flow units.

Junctions can be pre-heated without making a special junction by using an oscillator and a power amplifier generating a radio frequency as shown in Figs. 7 and 8. The RF is induced across the joint on the same two lines as the DC output. The radio frequency is high enough so that the meter will not respond to it, but it will still provide heating to the junction. That method is used in many commercial units.

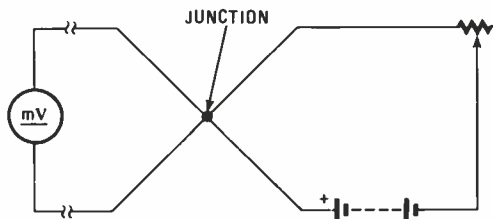

Fig. 6—Thermocouples can be better used to detect certain changing conditions if they are heated while in operation. Ganging two of them together allows one of them to act as a sensor and the other as the needed heating element.

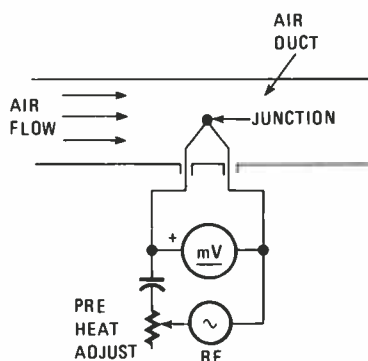

Fig. 7—A thermocouple can be used to detect gas flow if it is heated. Sending it RF signals that the meter cannot respond to is one way to heat a thermocouple.

### Vacuum and Cold Measurements

Another use of the pre-heated thermocouple sensor is to measure vacuum, or rather the absence of air. Placing the thermocouple junction in a vacuum inhibits its ability to cool itself with surrounding air. That makes the output of the junction produce a voltage that is proportional to the available air inside the chamber. The output voltage will increase as the air left in the chamber is exhausted. By calibrating the pressure against the output produced by the ther-

mocouple, pressure in the hundredths of an atmosphere can be measured. See Fig. 8.

Another interesting fact about thermocouples is that they also work in reverse. That is to say, that they are able to measure cold as well as heat. When the thermocouple junction is cooled beyond the point where it produces a positive voltage, the thermocouple junction crosses zero volts and starts producing a reverse or negative voltage that can be calibrated to hundreds of degrees below zero.

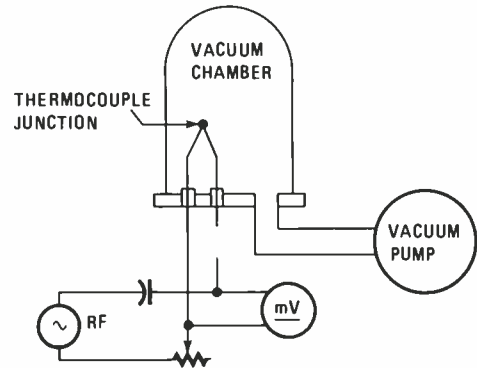

Fig. 8—Thermocouples heated with RF signals can be used to detect the presence/absence of air which would cool it.

That makes them useful in cryogenic measurements. When used to measure the temperature of cryogenic liquids like nitrogen or helium, pre-heating the junction is necessary to keep it warm in its super-cold environment. When the liquid is surrounding the junction, it is kept cold and produces a

(Continued on page 100)

## Justice Is Blind. I Can See Her Point Of View.

This honors graduate from Wharton and Harvard Law couldn't get a job. He was legally blind. But times change. A Louis Harris poll now proves how valuable workers with disabilities can be to employers like you.

A  
Disability  
Can Be  
An Asset.

The President's Committee on  
Employment of the Handicapped,  
Washington, D.C. 20036  
For more information, call  
1-800-526-7234  
In West Virginia, call  
1-800-526-4698

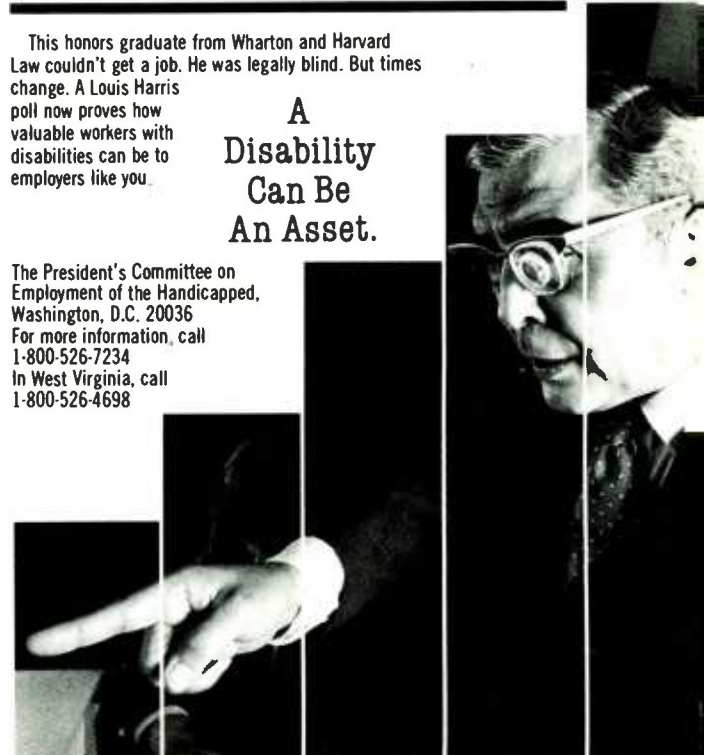



## VINTAGE RADIO

(Continued from page 63)

with its 4-wire connection gave way to the 2-wire permanent magnet speaker. It's also important to note that the superheterodyne circuit became dominant as RCA finally began licensing other manufacturers to use it, and the TRF design finally faded slowly into oblivion.

Once the superheterodyne was well-established, the 1930's would see no further basic changes in radio receiver circuits. There were, however, many developments that made radios easier and more pleasurable to use. One of them was the improvement of the tuning dial.

**Better Dials and More Bands.** The tuning dial entered the 1930's as a small window just big enough to show the frequency being received and a couple of divisions to either side. As the set was tuned, the scale moved by under a fixed indicator line in the window.

By the middle of the decade, that window (usually in the form of a semi-circular arc) was becoming much larger, so more of the scale was visible at once. A little later on, the functions of the scale and pointer became interchanged, with the scale becoming fixed—printed on a large oval, square or circular dial—and the indicator becoming a movable pointer. That meant that the entire tuning scale of the set was visible at once.

Also during the 1930's, radios began to sprout extra bands. Some sets had one labeled "police" beginning just a little higher in frequency than the standard broadcast band. Tuning around that band, patient listeners could eavesdrop on some of the first police car-dispatcher communications.

Still later in the decade, as European countries began to be drawn into the conflict that was to become World War II, there was heightened interest in a higher frequency band sometimes labeled "Shortwave," and sometimes labeled "Foreign Broadcast." There, the international broadcasters could be heard—country after country reporting on world events, each with its own unique point of view.

Multiband sets now had several concentric scales representing the different frequency ranges. It wasn't uncommon for the broadcast scales to have the call letters of major-market

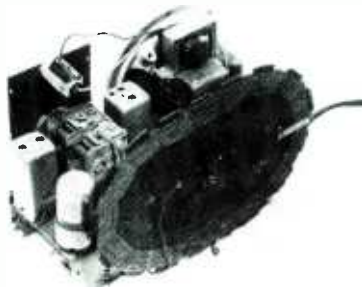

*This view of the Emerson's chassis shows the loop antenna, the "GT"-type tubes, and its square-topped IF-transformer cans.*

radio stations printed near their operating frequencies. Likewise—on the shortwave scale—the names of different countries would often be shown near frequencies typically used by them. Generic markings (such as "Police," "Aircraft," "Amateur," and "Ships") were also sometimes used.

By the end of the 1930's, many manufacturers had "straightened out" their dial scales, turning them into horizontal lines. Multiband sets had two or more straight lines arranged parallel to each other—each with its appropriate range of markings. The pointers of those easier-to-read *slide rule* dials moved horizontally, of course, instead of describing a circular arc as did the earlier "clock-type" pointers.

Pushbuttons that could be set to select frequently-tuned-in local stations were also common as the decade ended. These supplemented the main tuning dial, but did not replace it. One type was entirely mechanical and worked by physically moving the tuning condenser to the proper position. Another was electronic and worked by switching individual fixed capacitances in and out of the tuning circuit. The craze for pushbuttons affected other controls on the set as well. Some sets bristled with buttons to control station selection, bandswitching, tone, and even the "on-off" function.

**Other Developments.** No discussion of dials would be complete without mentioning the *tuning eye*. That innovative tuning aid of the mid-1930's was a specialized vacuum tube known as an *electron ray tube*. It was mounted horizontally; you looked into its top end through a circular opening in—or above—the tuning dial. With the set tuned on, the end of the tube lit up with a phosphorescent green glow and a pair of shadows became visible on a circular *target*. The stronger the

station, the closer together the shadows moved—looking vaguely like the closing of the pupil of an eye.

The tuning eye was actually a fringe benefit of the automatic volume-control circuitry that was coming into use during that era. The AVC, as it was called, automatically reduced set sensitivity when strong stations were tuned in—preventing overloading—and increased sensitivity as weak stations were tuned in. The control voltage generated during that AVC action, applied to the grid of the tuning-eye tube, was responsible for the opening and closing effect.

Let's complete our coverage of events during the 1930's and early 1940's with a word or two about the all-important topic of antennas. Throughout the 1920's, an elaborate outside antenna system had generally been required for adequate reception. But because of the superior sensitivity of the early 1930's radios, and the more powerful and more numerous broadcast stations on the air then, a less elaborate antenna would now do the job quite well.



*This RCA table model from about 1940 boasted a slide-rule dial and pushbuttons for station selection.*

By the late 1930's, there was no need even for that wire. A multiple-turn loop antenna mounted inside the set cabinet pulled in all the local stations with no trouble at all. External antennas were used only for more distant stations or to enhance shortwave reception for the really serious listener.

**Wrapping it Up.** Those of you who are new collectors should now have a solid orientation to the types of sets that might fall into your hands and the era of radio development to which each of those radios belongs. That information will help you make intelligent acquisitions and give you a knowledge base that you can expand on yourself as you dig deeper into this fascinating hobby. Happy collecting! ■

## THERMOCOUPLES

(Continued from page 98)

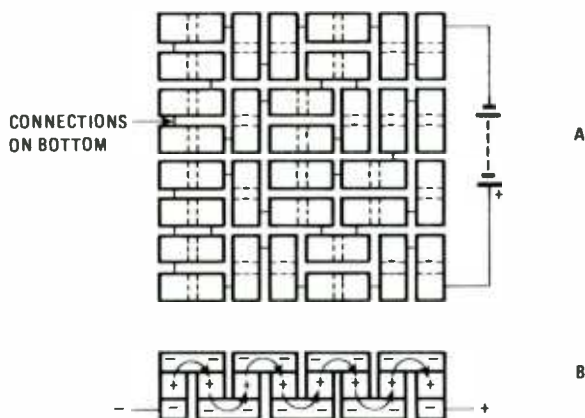

Fig. 9—Thermocouples can be joined in mass to either provide or extract heat. This is an example of one such unit with the polarities marked for clarity. The top view of the unit is shown in A; a side view is shown in B.

reverse voltage. As the junction is brought out of the liquid, the current quickly heats the junction and the reverse voltage drops to the crossover point and moves in the positive direction. By controlling the small heating current, any crossover temperatures may be selected.

### Temperature Control

The other aspect of the thermocouple is its ability to directly convert electricity into heat or cold. As was mentioned earlier, inducing current into the thermocouple junction will cause the junction to get hot or cold depending on the direction of the current flowing through the junction.

That means that thermocouples have applications in heating and cooling. Let's look a little more closely at that.

Thermoelectric cooling panels are composed of small cubes of the two thermocouple materials. The junctions are made by bridging the cubes with small rectangular conducting plates. Since the actual materials are not in direct contact with each other, that type of junction can be compared to the junction shown in Fig. 4. As can be seen in Fig. 9B, on the bottom side the current flow is from the plus material to the minus material, while on top side it is minus to plus. That means that with that configuration, all the heat-producing junctions are on one side of the plate, while the cold producing junctions are on the other. The cubes are arranged and bridged on the top and bottom so that they form a large number of junctions connected in series (see Figs. 9A and 9B). The panels are made in a variety of sizes by changing the number of junctions. The junctions are large and a lot of current is required to operate the units. As current flows in the device, one side of the device gets hot while the other side of the device gets cold.

### Try it Yourself

When making a thermocouple junction, make certain that the junction is twisted together very tightly. Variations in output voltages from two identical thermocouples can result from bad junctions caused by oxide formations between the materials. The best method for making a junction is to twist the two wires together and fuse the wire tips with a flame. Thermocouple wires from any common metals can be fused over an open flame from the kitchen stove. Once the junction is made, you have a small energy producer that will work virtually forever.

Thermocouples are easy to make and inexpensive to experiment with. All that is needed to get started is a length of thermocouple wire and a voltmeter capable of reading millivolts. Get some wire and build yourself a micro-power supply. Who knows? You could be the one to solve the energy crisis by discovering a new thermoelectric material or technique. ■

## FACTCARDS

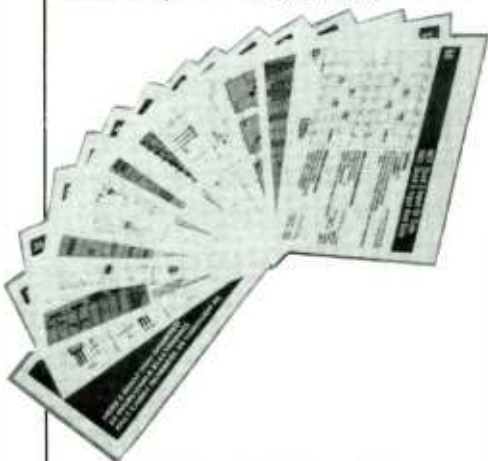

Jampacked with information at your fingertips

■ ALL YOU NEED to know about electronics from transistor packaging to substitution and replacement guides. FACTCARDS numbers 34 through 66 are now available. These beautifully-printed cards measure a full three-by-five inches and are printed in two colors. They cover a wide range of subjects from Triac circuit/replacement guides to flip-flops, Schmitt triggers, Thyristor circuits, Opto-Isolator/Coupler selection and replacement. All are clearly explained with typical circuit applications.

■ WANT TO EXPAND your knowledge of

electronics? Do it the easy way by studying the Electronics Fact Cards. Do you travel to and from your job each day? Drop a handful of cards in your pocket before you leave, and the bus becomes a schoolroom! At home, you can build some of the projects and not only have fun building and using them, but learn how they work at the same time.

■ YOU'LL BE AMAZED both at how rapidly you learn with these cards, and how easy it is to understand. These new cards are available right now. Don't miss out. Send your check or money order today.

### FACTCARDS—Facts at your fingertips for Experimenters and Project Builders!

H11-88

Please send one copy of FACTCARDS at \$3.50. Shipping \$1.00 (U.S. and Canada only).

Please send \_\_\_\_\_ copies of FACTCARDS. Total cost is sum of copy price and First Class postage and handling cost multiplied by number of card sets ordered.

Please Print

Allow 6-8 weeks for the material to arrive

(Name) \_\_\_\_\_

(Street Address) \_\_\_\_\_

(City) \_\_\_\_\_

(State) \_\_\_\_\_

(Zip) \_\_\_\_\_

Detach and mail today  
HANDS-ON BOOKSTORE  
P.O. Box 4079  
Farmingdale, NY 11735

All Payment must be in U.S. Funds!



## TV AUDIO AMPLIFIER

(Continued from page 42)



Shown here is the completed microphone assembly. The microphone is mounted to the plastic housing of a stereo headphone plug, with the microphone leads connected to the metal contacts of the plug.



The TV audio Amplifier allows you to listen to your favorite TV program without cranking up the volume.

series with the two disconnected terminals (see photo). Under normal working conditions, the circuit pulls about 9.3 mA of current.

Suspect a leaky IC or improperly wired connection if the current is higher than 10 mA. With a heavy current measurement, the battery voltage will drop below 7 volts. Take voltage measurements on each IC pin and compare those readings with the schematic diagram. If a low-voltage measurement is noted, suspect a leaky IC or an incorrectly connected component.

Check C5 and the capacitor connections when hum can be heard all the time with the volume turned down. Assuming everything checks out, you are ready to put the TV Amp to work. Now hearing-impaired individuals can enjoy TV programming without subjecting others to uncomfortable sound levels. ■

## INTERCOM

(Continued from page 40)

suggest using 6 "AA" cells and a matching holder.

Check the intercoms out individually. Start by setting all the potentiometers to their mid-range position. Put in the batteries and turn the power on. If all is okay, no feedback should be heard. Rotate the balance potentiometer left and right of center and the speaker should sing out as the circuit goes into acoustical oscillation. The circuit should balance allowing a gain setting of near 80% of maximum.

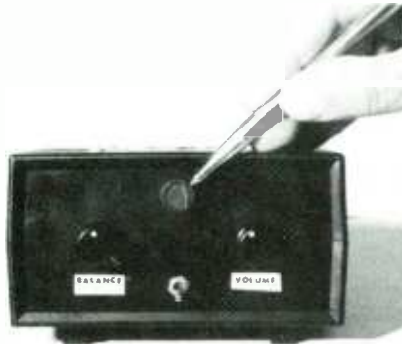

The microphone fits right on the faceplate of the unit, but you don't have to worry about feedback as it is canceled out by an active feedback loop.

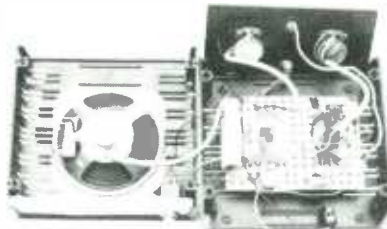

Perf-boarding this project is the way to go. Note that shielded cable and a metal cabinet are not necessary to protect the audio from inductive noise.

If both units pass, connect them together with a length of two-wire cable and phone plugs. Connect the cable tip-to-tip and ring-to-ring or you'll reverse the polarity and fry something. Separate the units by 25 feet or more and check them out.

If the intercoms tend to go into oscillation, the gain may be set too high, or the balance potentiometer may be out of adjustment. For best results get within a foot of the intercom and talk toward the microphone. It's a good idea to stay close to the unit at the listening end, too. ■

For 25 years,  
our people have  
endured long hours  
and tough  
working conditions  
for no pay.



And 9 out of 10 would  
do it again.

TO FIND OUT WHY

call

(316) 263-2100

or write

REACT INTERNATIONAL, INC.

242 Cleveland

Wichita, KS 67214

## ELECTRONIC COMPONENTS CATALOG

... yours FREE  
by dialing

1-800-992-9943

Call Today for your FREE  
subscription to the latest  
Mouser Electronics Catalog.  
Contains 192 pages featuring  
over 17,000 in-stock, quality  
electronic components.  
..PLUS..Mouser's proven  
service and prompt delivery.

Outside U.S.A., Send \$2.



**MOUSER  
ELECTRONICS**

2401 Hwy 287 North  
Mansfield, Texas 76063

**DISTRIBUTION  
CENTERS  
COAST-TO-COAST**

CIRCLE 11 ON FREE INFORMATION CARD

## RGB BLUE BOX

(Continued from page 43)

the computer doesn't even know it's there. If you don't like what you see, you can return to normal color at the flip of a switch.

**Construction.** The schematic diagram for the circuit is shown in Fig. 1. All you need are two 9-pin connectors, an SPDT switch, and a metal enclosure. The metal enclosure is man-

datory for RFI shielding if you don't want to disrupt your neighbors' TV reception and face a fine from the FCC.

As shown in the photos, I used a small aluminum Minibox as an enclosure. The D-connectors were mounted in roughly rectangular holes that were cut with a "nibbler" tool. By mounting the connectors on the outside, I concealed the fact that the holes weren't exactly the right shape.

Wiring is simple. Keep all wires short and direct because this is a high-fre-

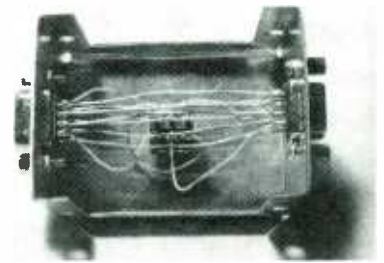

Keep all wire runs short and direct—the RGB Blue Box will pass frequencies to 18 MHz. The actual layout you use, however, is not critical.



Follow the numbers embossed on the D-connectors. Don't count pins or guess—the male and female connectors are mirror images, so it's easy to get confused.

quency circuit—to keep the screen image sharp, the Blue Box must pass signals as high as 18 MHz.

Identify pins by the numbers on the D-connectors, remembering that the male and female connectors are mirror images of each other. Remember, too, that the two ends of the Blue Box are not interchangeable—the computer must connect to the input and the monitor must connect to the output.

For shielding, the metal enclosure must make contact with the metal housing of both D-connectors; those in turn are connected to the cable shields.

**Testing.** Connect a monitor extension cable from your computer to the input of the Blue Box, then connect the monitor to the output of the Blue Box. Boot up the computer. The initial messages from DOS should appear in blue and white with one setting of the switch and in black and white with the other setting. Label those switch positions "text" and "normal" respectively.

For a thorough checkout, run the following BASIC program:

```
10 FOR I=1 TO 15
20 COLOR I, 0
30 PRINT "THIS IS COLOR", I
40 NEXT
```

If all is okay, all colors except color 8 should be visible with the switch in both positions, although in the "text" setting, some of them will look the same as others.

## Hands-on Electronics

## REPRINT BOOKSTORE

- |   |  |
|---|--|
| <input type="checkbox"/> SP1 Special Projects #1 (Winter 1980) . . . \$6.00 | <input type="checkbox"/> 106 Radio-Electronics back issues (1986) . . \$3.75 |
| <input type="checkbox"/> SP4 Special Projects #4 (Summer 1982) . . . \$6.00 | Write in issues desired _____  |
| <input type="checkbox"/> SP5 Special Projects #5 (Winter 1983) . . . \$6.00 | <input type="checkbox"/> 105 Radio-Electronics back issues (1985) . . \$4.25 |
| <input type="checkbox"/> SP6 Special Projects #6 (Spring 1983) . . . \$6.00 | (Jan. 85 not available)  |
| <input type="checkbox"/> SP7 Special Projects #7 (Summer 1983) . . . \$6.00 | Write in issues desired _____  |
| <input type="checkbox"/> SP8 Special Projects #8 (Fall 1983) . . . \$6.00   | <input type="checkbox"/> 104 Radio-Electronics back issues (1984) . . \$5.25 |
| <input type="checkbox"/> SP9 Special Projects #9 (Winter 1984) . . . \$6.00 | (December 1984 issue is not available)                                       |
| <input type="checkbox"/> SP10 Special Projects #10 (Spring 1984) . . \$6.00 | Write in issues desired _____  |
| <input type="checkbox"/> 111 Hands-On Electronics #1 . . . \$5.00           | <input type="checkbox"/> 103 Radio-Electronics back issues (1983) . . \$5.50 |
| <input type="checkbox"/> 112 Hands-On Electronics #2 . . . \$5.00           | (Jan., Feb., May are not available)  |
| <input type="checkbox"/> 113 Hands-On Electronics #3 . . . \$5.00           | Write in issues desired _____  |
| <input type="checkbox"/> 114 Hands-On Electronics #4 . . . \$5.00           | <input type="checkbox"/> 102 Radio-Electronics back issues (1982) . . \$5.75 |
| <input type="checkbox"/> 115 Hands-On Electronics #5 . . . \$5.00           | (Jan., Feb.) is not available)   |
| <input type="checkbox"/> 115A Hands-On Electronics #6 . . . \$4.50          | Write in issues desired _____  |
| <input type="checkbox"/> 116A Hands-On Electronics (Jan-Feb '86) . . \$4.50 | <input type="checkbox"/> 153 Etch your own PC boards . . . \$3.00            |
| <input type="checkbox"/> 116B Hands-On Electronics (Mar/Apr '86) \$4.50     | <input type="checkbox"/> 154 How to Repair VCR's . . . \$3.50                |
| <input type="checkbox"/> 116C Hands-On Electronics (May/Jun '86) \$4.50     | <input type="checkbox"/> 155 IBM Typewriter to Computer . . . \$3.00         |
| <input type="checkbox"/> 116D Hands-On Electronics (Jul/Aug '86) . . \$4.50 | <input type="checkbox"/> 125 Radio-Electronics Annual 1985 . . . \$5.95      |
| <input type="checkbox"/> 116E Hands-On Electronics (Sep/Oct '86) . . \$4.50 | <input type="checkbox"/> 126 Radio-Electronics Annual 1986 . . . \$4.95      |
| <input type="checkbox"/> 116K Hands-On Electronics (Nov '86) . . . \$4.00   | <input type="checkbox"/> 156 How to Make PC Boards . . . \$2.00              |
| <input type="checkbox"/> 116L Hands-On Electronics (Dec '86) . . . \$4.00   | <input type="checkbox"/> 157 All About Kits . . . \$2.00                     |
| <input type="checkbox"/> 117 Hands-On Electronics                           | <input type="checkbox"/> 158 Electro Importing Co. Catalog (1918) . . \$5.95 |
| (1987 back issues) . . . \$3.75   | <input type="checkbox"/> 159 Low Frequency Receiving Techniques              |
| Write in issues desired _____   | Building and using VLF Antennas . . . \$6.00                                 |
| <input type="checkbox"/> 118 Hands-On Electronics                           | <input type="checkbox"/> 160 New Ideas - 42 Circuits . . . \$3.50            |
| (1988 back issues) . . . \$3.50   | <input type="checkbox"/> 161 Descrambling (Feb., 1984) . . . \$3.00          |
| Write in issues desired _____   | <input type="checkbox"/> 162 Build Your Own Satellite TV Receiver \$7.00     |
| <input type="checkbox"/> 150 TV Descrambler . . . \$3.00                    | <input type="checkbox"/> 163 Receiving Satellite TV . . . \$7.00             |
| <input type="checkbox"/> EH87 Experimenters Handbook . . . \$3.95           | <input type="checkbox"/> 164 Modern Electrics (April, 1908) . . . \$3.00     |
| <input type="checkbox"/> 152 8-Ball Satellite TV Antenna . . . \$5.00       | <input type="checkbox"/> 165 How to Repair CD Disc Players . . . \$5.00      |
| <input type="checkbox"/> 108 Radio-Electronics (1988 back issues) . \$3.00  | <input type="checkbox"/> 166 Collected Works of Mohammed Ulysses Fips        |
| Write in issues desired _____   | (62 pages, April Fools Collection) . . . \$7.50                              |
| <input type="checkbox"/> 107 Radio-Electronics back issues (1987) \$3.25    | <input type="checkbox"/> 167 Designing With IC's . . . \$4.00                |

To order any of the items indicated above, check off the ones you want. Complete the order form below, include your payment, check or money order (DO NOT SEND CASH), and mail to Hands-on-Electronics, Reprint Department, P.O. Box 4079, Farmingdale, NY 11735. Please allow 4-6 weeks for delivery.

If you need a copy of an article that is in an issue we indicate is unavailable you can order it directly from us. We charge 50¢ per page. Indicate the issue (month & year), pages and article desired. Include payment in full, plus shipping and handling charge. Make checks payable to Gernsback Publications, Inc.

ARTICLE \_\_\_\_\_

PAGES \_\_\_\_\_

MONTH \_\_\_\_\_

YEAR \_\_\_\_\_

TOTAL PAGES \_\_\_\_\_

@50¢ each

TOTAL PRICE \_\_\_\_\_

MAIL TO: Hands-on-Electronics

Reprint Bookstore, P.O. Box 4079, Farmingdale NY 11735

All payments must be in U.S. funds

SHIPPING CHARGES IN USA & CANADA

\$0.01 to \$5.00 . . . \$1.25    \$30.01 to \$40.00 . . . \$5.00

SORRY — We only ship to

\$5.01 to 10.00 . . . \$2.00    \$40.01 to \$50.00 . . . \$6.00

USA & Canada

\$10.01 to \$20.00 . . . \$3.00    \$50.01 and above . . . \$7.50

\$20.01 to \$30.00 . . . \$4.00

Total price of merchandise . . . \$ \_\_\_\_\_

Sales Tax (New York State Residents only) . . . \$ \_\_\_\_\_

Shipping Charge (see chart) . . . \$ \_\_\_\_\_

Name \_\_\_\_\_ Total Enclosed . . . \$ \_\_\_\_\_

Address \_\_\_\_\_

City \_\_\_\_\_ State \_\_\_\_\_ Zip \_\_\_\_\_

H11-88



## BROWN'S PC-PEDAL

(Continued from page 25)

before you load other programs. After becoming familiar with PC-Pedal and its various operations, you may want to create an AUTOEXEC.BAT file that will load PC-Pedal automatically when you start an edit session. Refer to the Batch File section of your DOS manual for instructions.

**PC-Pedal's Options.** Do not try to use more than one keyboard or *state* key command at a time. To cancel one program and replace it with another, you must use the REMOVE.COM command. Single key programs in this group make the pedal act like one of the *state* (<Ctrl>, <Alt>, or <Shift>) keys. If you want to alternate keys, use one of the single-key programs listed in Table 1. For any command to work, its program file must be on the logged disk when you enter the command.

The three programs in the double-key program group, shown in Table 2, allow you to define the pedal as either of two state keys, depending on which you activate. PC-Pedal can duplicate only one key at a time, so you must tell it which you want to use; do that by pressing the state key and the pedal simultaneously. For example, after entering the SHIFTCTL command, you can define PC-Pedal as the <Shift> key by pressing the pedal and the <Shift> key together. This definition stays in effect until you press the <Ctrl> key and pedal simultaneously, which defines the pedal as the <Ctrl> key. When you use a multi-key program, you can change definitions at any time.

In addition to the programs in Tables 1 and 2, there's a triple-key program that lets you use all three state keys interchangeably. That program is called PCPEDAL.COM and its associated command is PCPEDAL.

**Using Other Software.** If you use WordStar, you will probably want to use these PC-Pedal commands: PED-CTRL, AND WSERASE (or BACKWORD).

The first defines the PC-Pedal as the <Ctrl> key; the second loads the Backspace and Delete function, which you activate by pressing the Space Bar and the PC-Pedal simultaneously. An alternative command, BACKWORD, removes the entire word to the left of the Cursor when you press the Space Bar and the pedal. As you

become more experienced, you may want to try: SHIFTCTL. That program allows you to bypass the cumbersome <Caps Lock> key altogether. After loading SHIFTCTL, define the PC-Pedal as the <Ctrl> key by pressing the pedal and <Ctrl> key simultaneously. This definition remains in effect until you change it. When you have to type something in capital letters, redefine the pedal as the <Shift> key by pressing <Shift> and the pedal simultaneously. WSERASE replaces WordStar's inconvenient <Del> (Delete) key, so remember to lift the pedal as you type spaces between words in a capitalized phrase or heading.

With most other word processing programs, you may want to use the commands PEDSHIFT and PEDERASE. The first defines the pedal as the <Shift> key; the second activates the Backspace-and-Delete function. After you become more familiar with PC-Pedal, you may want to alternate between the <Shift> and <Alt> keys.

Multimate users should note that the PEDERASE command will not delete the character at left unless you first define the <Backspace> key as a <Del> key.

If you're using Lotus 1-2-3 or another spreadsheet program, typing the command PEDSHIFT will eliminate the unwieldy <Num Lock> key as you alternate between numerical input and Cursor commands on the numeric pad.

By far, the greatest savings in time and effort with spreadsheet and database users comes with the ability to selectively duplicate the Cursor keys with the pedal. To use as Cursor-Arrow key, set the numeric keypad in number mode by hitting <Num Lock> once and set the pedal to the Cursor Arrow that you desire by using the "SetKey Routine:" <Alt> key down, pedal down and then up, <Alt> key up. Hold down <Shift> Key (to toggle Num Lock) and hit the desired Cursor key.

XyWrite III word-processing system users may find they have a problem with PC-Pedal, as they do with other memory-resident programs. PC-Pedal can be made workable with XyWrite by making a keyboard file change as specified in the XyWrite manual.

You can get your copy of PC-Pedal from Brown and Co., Inc., P.O. Box 2443, So. Hamilton, MA 01982, or call (credit-card orders only) 617/468-7464. PC-Pedal sells for \$59.95, plus \$1.50 for postage and handling. ■

## NEW SUPER LONG PLAY TAPE RECORDERS

12 Hour Model — \$105.00\*  
USES D-120 TAPE

Modified Panasonic Slimline, high quality, AC/DC Recorders provide 6 continuous hours of quality recording & playback on each side of cassette for a total of 12 hours.  
Built-in features include:  
• Voice level control • Digital counter, etc. TDK DC 120 Cassette Furnished.



### PHONE RECORDING ADAPTER

Records calls automatically. All Solid state connects to your telephone jack and tape recorder. Starts recording when phone is lifted. Stops when you hang up.

\$24.50\*

FCC APPROVED

VOX VOICE ACTIVATED CONTROL SWITCH

Solid state. Self contained. Adjustable sensitivity. Voices or other sounds automatically activate and control recorder. Uses either recorder or remote mike.

\$24.95\*

\*Add for ship & hdg. Phone Adapter & Vox \$1.50 ea. Recorders \$4.00 ea. Cal. Res. add tax. Mail order, VISA, MIC, COD's OK. Money Back Guarantee. Qty. disc. avail. Dealer inquiries invited. Free data.  
AMC SALES INC. Dept. 9335 Lubec St., Box 928, Downey, CA 90241 Phone (213) 869-8519

CIRCLE 6 ON FREE INFORMATION CARD

## Be an FCC LICENSED ELECTRONIC TECHNICIAN!



No costly School. No commuting to class. The Original Home-Study course prepares you for the "FCC Commercial Radiotelephone License". This valuable license is your "ticket" to thousands of exciting jobs in Communications, Radio-TV, Microwave, Computers, Radar, Avionics and more! You don't need a college degree to qualify, but you do need an FCC License.

**No Need to Quit Your Job or Go To School**

This proven course is easy, fast and low cost! **GUARANTEED PASS** — You get your FCC License or money refunded. **Send for FREE facts now. MAIL COUPON TODAY!**

### COMMAND PRODUCTIONS

FCC LICENSE TRAINING, Dept. 203  
P.O. Box 2824, San Francisco, CA 94126  
Please rush FREE details immediately!

NAME \_\_\_\_\_  
ADDRESS \_\_\_\_\_  
CITY \_\_\_\_\_ STATE \_\_\_\_\_ ZIP \_\_\_\_\_

# HANDS-ON MARKETPLACE

## FOR SALE

**TRANSISTORS-tubes:** MRF421 \$24.00, MRF454 \$14.50, MRF455-MRF477 \$11.75, MRF492 \$16.00, SRF2072 \$12.75, SRF3800 \$17.50, 2SC2290 \$16.75, 2SC2879 \$22.00, 6LF6, 6LQ6, 6JS6, 8950, etc-call. New **RANGER AR3500** all mode 10 meter transceiver \$319. Quantity discounts! Best prices on hard-to-find parts, antennas, mics, power supplies, & equipment! Catalog \$1.00 (refundable), or free with order. **RFPC**, Box 700, San Marcos, CA 92069. For information or same day shipment—call (619) 744-0728. Visa/MC/C.O.D.

**CABLE TV converters, remotes, Accessories—**Free Catalog. **ARIZONA VIDEO**, 3661 N. Campbell, #310B, Tucson, AZ 85719. (602) 323-3330.

**THE invention of television.** Fascinating story of how radio, motion pictures, and television were invented. 144 pages. 45 rare photos. Send \$10.00 ck: **MO. BELLTOWNE PUBLISHING**, 10011 Belltowne, Sugarland, TX 77478.

**TUBES 59¢.** Year guarantee. Free catalog. Tube tester \$8.95. **CORNELL**, 4219 University, San Diego, CA 92105.

**CABLE TV equipment S.A., Jerrold, Zenith, Hamlin, Oak, Eagle filters remotes and more.** Best prices C.O.D.'s accepted dealers needed. Ours work where others failed and we guarantee it! **TRANS-WORLD CABLE, CO.**, 1-(800) 442-9333.

**CABLE TV descramblers Jerrold, Scientific Atlanta, Zenith, most major brands dealer inquiries welcome.** Visa—M/C accepted. **E & O VIDEO**, 9691 E. 265th Street, Elko, MN 55020 1-(800) 638-6898.



## TUBES - 2000 TYPES DISCOUNT PRICES!

Early, hard-to-find, and modern tubes. Also transformers, capacitors and parts for tube equipment. Send \$2.00 for 20 page wholesale catalog.

**ANTIQUE ELECTRONIC SUPPLY**  
688 W. First St. • Tempe, AZ 85281 • 602/894-9503

**CABLE descrambler liquidation.** Major makes and models available. Industry pricing! (Example: Hamlin combos, \$44 each...minimum 10 orders). **Dealers only!** Call **WEST COAST ELECTRONICS**, (818) 989-0890.

**DESCRAMBLERS.** All brands. Special: combo Jerrold 400 and SB3 \$165. Complete cable descrambler kit \$39. Complete satellite descrambler kit \$45.00. Free catalog. **MJH INDUSTRY**, Box 531, Bronx, NY 1046-0531

**EXPERIMENTERS...** Crystal set and one-tube radio. Free catalog. **BOB RYAN**, P. O. Box 3039, Anaheim, CA 92803.

**FAIR PRICES SB3, SX3, SA3, Tri-Bi, MLD-1200-3** some Oak, any notch filters. Small dealer only. No Michigan sales. (313) 979-8356.

**SUPER power electronic TV antenna.** Brings clear channels, \$6.00. **AMERICAN ASSOCIATES** Dep't. NEH, P. O. Box 18A182, Los Angeles, CA. 90018.

## PLANS/KITS

**BUILD** this five-digit panel meter and square wave generator including an ohms, capacitance and frequency meter. Detailed instructions \$2.50. **BAGNALL ELECTRONICS**, 179 May, Fairfield, CT 06430.

**VOICE disguisers! FM bugs! Telephone transmitters! Phone snoops! More!** Catalog \$1.00 (refundable). **XANDI ELECTRONICS**, Box 25647, 32T, Tempe, AZ 85282.

**PC boards made to order.** Details—SASE. Eprom programmer plans. \$3.50 includes semiconductor bonus! **GALLIUM JUNCTION**, 540-C N.E. Northgate Way, Suite 542, Seattle, WA 98125.

**CATALOG: hobby/broadcasting/HAM/CB: Cable TV, transmitters, amplifiers, bugging devices, computers, more!** **PANAXIS**, Box 130-F(11), Paradise, CA 95967.

**COMPUTER REPAIR DEPOT IBM Compaq, Apple, AT&T & many others.** Call **BI-TRONIX, INC.** (408) 236-3385 or (209) 952-7116. P. O. Box 23069, San Jose, CA 95153.

## CLASSIFIED AD ORDER FORM

To run your own classified ad, put one word on each of the lines below and send this form along with your check to:

**Hands-on-Electronics Classified Ads, 500-B Bi-County Boulevard, Farmingdale, N.Y. 11735**

**PLEASE INDICATE** in which category of classified advertising you wish your ad to appear. For special headings, there is a surcharge of \$10.00.

( ) Plans/Kits ( ) Business Opportunities ( ) For Sale  
( ) Education/Instruction ( ) Wanted ( ) Satellite Television  
( ) \_\_\_\_\_

Special Category: \$10.00

### PLEASE PRINT EACH WORD SEPARATELY, IN BLOCK LETTERS.

(No refunds or credits for typesetting errors can be made unless you clearly print or type your copy.) Rates indicated are for standard style classified ads only. See below for additional charges for special ads. **Minimum: 15 words.**

1	2	3	4	5
6	7	8	9	10
11	12	13	14	15 (\$21.00)
16 (\$22.40)	17 (\$23.80)	18 (\$25.20)	19 (\$26.60)	20 (\$28.00)
21 (\$29.40)	22 (\$20.80)	23 (\$32.20)	24 (\$33.60)	25 (\$35.00)
26 (\$36.40)	27 (\$37.80)	28 (\$39.20)	29 (\$40.60)	30 (\$42.00)
31 (\$43.40)	32 (\$44.80)	33 (\$46.20)	34 (\$47.60)	35 (\$49.00)

We accept MasterCard and Visa for payment of orders. If you wish to use your credit card to pay for your ad fill in the following additional information (Sorry, no telephone orders can be accepted.):

Card Number \_\_\_\_\_

Expiration Date \_\_\_\_\_

PRINT NAME \_\_\_\_\_

SIGNATURE \_\_\_\_\_

**IF YOU USE A BOX NUMBER YOU MUST INCLUDE YOUR PERMANENT ADDRESS AND PHONE NUMBER FOR OUR FILES. ADS SUBMITTED WITHOUT THIS INFORMATION WILL NOT BE ACCEPTED.**

**CLASSIFIED COMMERCIAL RATE:** (for firms or individuals offering commercial products or services) \$1.40 per word prepaid (no charge for ZIP code)...**MINIMUM 15 WORDS.** 5% discount for same ad in 6 issues within one year; 10% discount for 12 issues within one year if prepaid. **NON-COMMERCIAL RATE:** (for individuals who want to buy or sell a personal item) \$1.15 per word, prepaid...no minimum. **ONLY FIRST WORD AND NAME** set in bold caps at no extra charge. Additional bold face (not available as all caps) 25¢ per word additional. Entire ad in boldface, \$1.70 per word. **TINT SCREEN BEHIND ENTIRE AD:** \$1.75 per word. **TINT SCREEN BEHIND ENTIRE AD PLUS ALL BOLD FACE AD:** \$2.05 per word. **EXPANDED TYPE AD:** \$1.85 per word prepaid. Entire ad in boldface, \$2.20 per word. **TINT SCREEN BEHIND ENTIRE EXPANDED TYPE AD:** \$2.30 per word. **TINT SCREEN BEHIND ENTIRE EXPANDED TYPE AD PLUS ALL BOLD FACE AD:** \$2.70 per word. **DISPLAY ADS:** 1" x 2 1/4"—\$175.00; 2" x 2 1/4"—\$350.00; 3" x 2 1/4"—\$525.00 **General Information:** Frequency rates and prepayment discounts are available. **ALL COPY SUBJECT TO PUBLISHERS APPROVAL. ADVERTISEMENTS USING P.O. BOX ADDRESS WILL NOT BE ACCEPTED UNTIL ADVERTISER SUPPLIES PUBLISHER WITH PERMANENT ADDRESS AND PHONE NUMBER.** Copy to be in our hands on the 18th of the third month preceding the date of issue (i.e.; Aug. issue copy must be received by May 18th). When normal closing date falls on Saturday, Sunday or Holiday, issue closes on preceding work day. Send for the classified brochure. Circle Number 49 on the Free Information Card.



150W x 2 pre-main amplifier, kit or assembled, dynamic sound, 3 section tone control, class A-DC, \$78, discount if wholesale, send check, M.O. KATLI ELECTRIC, P.O. Box 5565, Hacienda, CA 91745, details send self-addressed envelope.

**PROJECTION TV...** Convert your TV to project 7 foot picture. Easy! Results comparable to \$2,500 projectors. Plans and 8" lens \$24.95... Professional systems available... Illustrated catalog FREE. **MACROCOMA** 15HB Main Street, Washington Crossing, PA 18977. Creditcard orders 24HRS. (215) 736-3979.

**FM TRANSMITTER** fits in matchbox with "N" cell battery or phoneline powered. Tuneable 60-95MHZ. Super sound, sensitive, powerful. Board, parts, instructions \$19.95. **PTS**, Box 1951, Fort Worth, TX 76101.

**RADAR** Detector kit \$39.95. Dazer weapon kit \$45.00. **QUANTUM RESEARCH**, 17917-77 Avenue, Edmonton, Alberta, T5T-2S1.

**CRYSTAL** radio sets, plans, parts, kits. Catalog \$1.00. **MIDCO**, 660 North Dixie Highway, Hollywood, FL 33020.

**KITS\*parts\*plans\***. We have hard to find parts! Variable tuning capacitors, tuning coils, crystal headphones, germanium diodes, shortwave, crystal, CB radio kits (no soldering). Very inexpensive. Send large SASE for catalog. **YEARY COMMUNICATIONS**, 12922 Harbor #800H, Garden Grove, CA 92640.

"007" Type electronics. Super surveillance. Amazing prices. Catalog \$2.00. **JD's Electronics**, Dept. Q Box 9042, Wichita, KS 67277

**PRINTED** circuit boards drilled and etched. Free delivery. **K&F ELECTRONICS, INC.** 33041 Groesbeck, Fraser, MI 48026. (313) 294-8720.

## COMPUTERS

**COMMODORE**/Amiga chips, factory fresh and guaranteed. Lowest prices in the country, including impossible to obtain spare parts and diagnostics. "The Commodore Diagnostician", (7,000 sold—\$6.95 plus \$1.00 postage). **KASARA MICRO-SYSTEMS INC.**, 31 Murray Hill Drive, Spring Valley, NY 10977. 1-(800) 248-2983 or (914) 356-3131.

## EDUCATION & INSTRUCTION

**ENGINEERING** software for IBM-PC. CompDes—circuit design, CompMath—mathematics, CompView—waveform viewer. \$49 each. (614) 491-0832. **BSOFT SOFTWARE**, 444 Colton Road, Columbus, OH 43207.

**LEARN** new skills fast through our short specialized home study courses. Condensed and highly effective! Passport to success! 50 choices. Diploma awarded. **CIEE-13**, Box 20345, Jackson, MS 39209.

**MAGIC!** Four illustrated lessons plus inside information shows you how. We provide almost 50 tricks including equipment for four professional effects. You get a binder to keep the materials in, and a one-year membership in the International Society of Performing Magicians with a plastic membership card that has your name gold-embossed. You get a one-year subscription to our quarterly newsletter, "IT'S MAGIC!" Order now! \$29.95 for each course + \$3.50 postage and handling. (New York residents add applicable state and local sales tax.) **The Magic Course**, 500-B BiCounty Boulevard, Farmingdale, NY, 11735, or telephone (516) 293-3751 and ask for Nancy Estrada.

## CABLE TV CONVERTERS

**CABLE TV converters.** Scientific Atlanta, Jerrold, Oak, Zenith, Hamlin. Many others. "New" Video Hopper "The Copy Killer." Visa, M/C & Amex. 1-(800) 826-7623. **B & B INC.**, 10517 Upton Circle, Bloomington, MN 55431.

## CB RADIO - 10 METERS

**CB RADIO OWNERS!** We specialize in technical information, parts and services for CBs. Repair/modification books, plans, kits, 10-meter and FM conversions, high-performance accessories. Catalog \$2.00 **CBCI**, Box 31500H, Phoenix, AZ 85046.

## CABLE-TV BOXES

Descramblers • Converters

FREE CATALOG

**TRANS-WORLD CABLE CO.**  
12062 Southwest 117th Ct., Suite 126  
Miami, Florida 33186  
800-442-9333

## SATELLITE TV

**FREE CATALOG** Systems, Upgrades Houston, Uniden, Chapparal, etc. **SAVE \$\$\$\$\$.** **SKYVISION** 2008 Collegeway, Fergus Falls, MN 56537. (218) 739-5231.

## BUSINESS OPPORTUNITIES

**YOUR own radio station!** AM, FM, TV, cable. Licensed/unlicensed. **BROADCASTING**, Box 130-F(11), Paradise, CA 95967.

**MAKE \$250,000** yearly in IBM's computer color monitor repairs, details \$1.00. **RANDALL**, Data Display Products, Box 2168 H, Van Nuys, CA 91404.

**WIN sweepstakes.** Proven instruction packet, send \$7.00 (refundable) **USA Mailing**, Box 457, Excelsior, MN 55331.

## Cable TV Converters

Why Pay A High Monthly Fee?

Jerrold Products include "New Jerrold Tri-Mode," SB-3, Hamlin, Oak VN-12, M-35-B, Zenith, Magnavox, Scientific Atlanta, and more. (Quantity discounts) 60 day warranty. For fast service C.O.D. orders accepted. Send SASE (60 cents postage) or call for info (312) 658-5320. **MIDWEST ELECTRONICS, INC.**, 5143-H W. Diversey, Chicago, IL 60639. MC/Visa orders accepted. No Illinois orders accepted. Mon.-Fri. 8 A.M.-5 P.M. CST

## CABLE EQUIPMENT

**CABLE TV SECRETS** - the outlaw publication the cable companies tried to ban. HBO, Movie Channel, Showtime, descramblers, converters, etc. Suppliers list included. \$8.95. **CABLE FACTS** Box 711-H, Pataskala, OH 43062.

## HIGH TECH ELECTRONICS

**SCRAMBLER** phones! Phone bug detectors! Electronic countermeasures equipment! Executive and personal protection products! Much more! Catalog \$3.00 (refundable with first order). **DIVERSIFIED WHOLESALE PRODUCTS** P.O. Box 1275, Redondo Beach, CA 90278.

## SOFTWARE

"**SOFTWARE Maniacs**" Humdinger shareware /PD for IBM PC. No minimum order! Low as \$2.75 a disk. Send \$1.00 for: Catalog/free programs on 5.25 disk to: **TRIBAL ENTERPRISES INC.**, 5722 South Flamingo Road, Department H, Suite 231, Cooper City, FL 33330

## PROGRAMMABLE CONTROLLERS

**POCKET CONTROLLER:** Versatile, low cost, programmable digital controller. Designed for technician, experimenter, student, anyone that deals with electronics. Battery operated. Only \$69.95. For literature, call (800) 533-7159, in CT 791-8220 or write **POCKET CONTROLLER COMPANY**, Box 232, Seymour, CT 06483.

## ADVERTISING INDEX

HANDS-ON ELECTRONICS magazine does not assume any responsibility for errors that may appear in the index below.

Free Information No.	Page
6	AMC Sales . . . . . 103
5	All Electronics . . . . . 25
—	Amazing Devices . . . . . 95
—	American Satellite Home Assoc. 28
—	Antique Electronic Supply . . . . 104
7	CIE . . . . . 11
18	Chemtronics . . . . . 97
20	Claytronics . . . . . 25
—	Command Productions . . . . . 103
9	Cook's Institute . . . . . 23
10	Digi-Key . . . . . CV2
—	Elec. Industry Association . . . . CV4
—	Electronic Tech. Today . . . . . 6, CV3
—	Electronics Book Club . . . . . 3
23	Hal-Tronix . . . . . 22
8	Halted Specialties . . . . . 18
—	Heath . . . . . 15
13, 14	JDR Microdevices . . . . . 16
12	MCM Electronics . . . . . 13
15	Mark V. Electronics . . . . . 18
—	McGraw Hill (C.E.D.) . . . . . 91
—	Midwest Electronics . . . . . 105
21	Mini Tools . . . . . 95
—	Mouser . . . . . 101
—	NRI . . . . . 21
24	National Super Conductor . . . . 22
—	Pacific Cable . . . . . 5
16	PanaVise . . . . . 7
19	SCO Electronics . . . . . 23
—	Trans World . . . . . 105
22	United Electronic Supply . . . . . 27

## ADVERTISING SALES OFFICE

**Gernsback Publications, Inc.**  
500-B Bi-County Blvd.  
Farmingdale, NY 11735  
(516) 293-3000  
President: Larry Steckler  
Vice President: Cathy Steckler

### For Advertising ONLY

**516-293-3000**  
**Larry Steckler**  
publisher  
**Arline Fishman**  
advertising director  
**Christina Estrada**  
advertising assistant  
**Shelli Weinman**  
advertising associate  
**Lisa Strassman**  
credit manager

## SALES OFFICES

**EAST/SOUTHEAST**  
**Becky Akers**  
Pattis/3M  
310 Madison Ave., Suite 1804  
New York, NY 10017  
**212-953-2121**

**MIDWEST/PACIFIC**  
**Joe Shere**  
1507 Bonnie Doone Terrace  
Corona Del Mar, CA 92625  
**714-760-8697**

## CAPACITANCE ADAPTER

(Continued from page 46)

between the board and the front panel of the enclosure (see photo). A strip of electrical tape can be used to prevent shorts between the battery case and the trimmer potentiometers.

### Calibration

Calibrating the circuit involves first setting the NULL adjustment (R6), then adjusting R1 and R3 so that the DMM displays the correct reading for a capacitor of known value on the LOW and HIGH ranges, respectively.

To set the NULL control, set the DMM to the millivolt

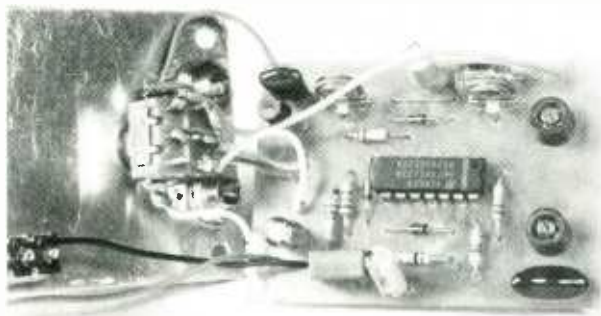

The Capacitance Adapter is designed to be plugged directly into the jacks of your DMM. Banana plugs PL1 and PL2 are soldered directly to the underside of board, and protrude the enclosure of the project.

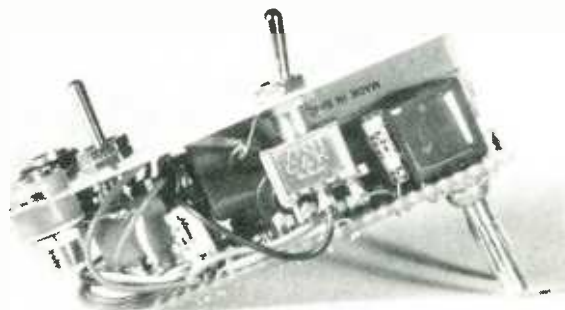

Shown here is the Adapter's printed-circuit board prior to being sealed in its enclosure. Note that the battery is sandwiched between the printed-circuit board and the front panel of the enclosure.

range, S2 to LOW, and adjust R6 for a reading of 0 mV. In practice, it is difficult to set R6 so that the meter reads exactly zero, so a reading that is slightly negative is considered satisfactory.

Now connect a capacitor of known value, say between 1000 and 2200-pF, across J1 and J2. Adjust R1 so that the meter displays 1 mV per picofarad. In other words, if the capacitor value is 1000 pF, adjust the meter to read 1 volt).

Finally, set the Adapter to the HIGH range and connect a 0.1 to 1- $\mu$ F capacitor across J1 and J2. Adjust R3 so that the meter displays 1-volt per microfarad (or 0.1 volt for a 0.1- $\mu$ F capacitor and 1 volt for a 1- $\mu$ F capacitor). ■

## E-Z MATH

(Continued from page 81)

not the case. Instead of replacing the voltage source with a short, it must be replaced with a resistance whose value is equal to the internal resistance of that voltage source. For example, in analyzing a circuit with an emitter follower whose output impedance is 50 ohms, the voltage source would be replaced with a 50-ohm resistor in performing superposition or Thevenin's calculations. ■

### Answers

1. Short  $V_1$ . Calculate the current in R2:

a. Find the parallel resistance of R1 and R2.  $R_{1,2} = R_1 R_2 / (R_1 + R_2) = 200(300) / (200 + 300) = 60000/500 = 120$  ohms b. Find the total-circuit resistance  $R_T$ .  $R_T = R_{1,2} + R_3 = 120 + 300 = 420$  ohms c. Find the total-circuit current  $I_T$ .  $I_T = V_2 / R_T = 4.5/420 = .0107$  A d. Find the voltage across R3.  $V_{R3} = I_T R_3 = .0107(300) = 3.21$  V. e. Find the voltage across R1 and R2.  $V_{R1,2} = V_2 - V_{R3} = 4.5 - 3.21 = 1.29$  V. f. Find current in R2.  $I_{R2} = V_{R1,2} / R_2 = 1.29/300 = .0043$  A. In this case, the current through R2 flows from bottom to top because of the polarity of  $V_2$ . Let's call this a positive current or + .0043 A.

2. Short  $V_2$ . Calculate current in R2. a. Find the parallel resistance of R2 and R3. Since  $R_2 = R_3$ :  $R_{2,3} = R_2/2 = 300/2 = 150$  ohms b. Find the total-circuit resistance.  $R_T = R_{2,3} + R_1 = 150 + 200 = 350$  ohms c. Find the total-circuit current.  $I_T = V_1 / R_T = 6/350 = .0171$  A. d. Find the voltage across R1.  $V_{R1} = I_T R_1 = .0171(200) = 3.42$  volts e. Find the voltage across R2 and R3.

$V_{R2,3} = V_1 - V_{R1} = 6 - 3.42 = 2.58$  volts f. Find the current in R2.  $I_{R2} = V_{R2,3} / R_2 = 2.58/300 = .0086$  A.

This current flows in R2 from top to bottom because of the polarity of  $V_1$ . Let's call this a negative current to distinguish it from the other current, or - .0086. The total current in R2 is the algebraic sum of the two previously calculated currents:

$$I_{R2} = + .0043 + (- .0086) = - .0043$$

The total current is the difference between the two currents and it is negative because the negative current is greater. The total net current in R2 flows from top to bottom.

2. Since the circuit in Fig. 1 has no load, the output voltage calculated earlier, 1.05 volts, is the Thevenin's equivalent voltage:

$$V_{Th} = +1.05$$

The Thevenin's equivalent resistance is the parallel combination of R1 and R2 or:

$$R_{Th} = R_1 R_2 / (R_1 + R_2) = 1000(3300) / (1000 + 3300) = 3300000/4300 = 767.4$$
 ohms

# BUY BONDS



# Electronics Paperback Books

GREAT PAPERBACKS AT SPECIAL PRICES



**BP173—COMPUTER MUSIC PROJECTS** ..... \$6.95. Shows how to use your home computer to produce electronic music. Many circuits. Mostly jargon-free.



**BP176—TV DXING FOR THE ENTHUSIAST**... \$7.95. Practical authoritative intro to this unusual aspect of electronics. 812 x 11 in. 144 pp.



**PCP103—PRACTICAL MIDI HANDBOOK** \$9.95. Explains what MIDI (the Musical Digital Interface) can do and how you can put it to work. Covers Keyboards, drum machines, sequencers, computers, guitars and computer music.



**RF10—RADIO'S FIRST TWO DECADES** ..... \$3.50. This story of radio's early days makes for fascinating reading. Spark-gap transmitters, KDKA's beginnings, and much more.



**PCP102—INTRODUCING DIGITAL AUDIO** ..... \$9.95. CD, DAT, and Sampling. What is involved in the digital part of audio signals? Principles and practices of digital audio techniques.



**BP195—INTRODUCTION TO SATELLITE TV**..... \$9.95. A definitive introduction to the subject written for the professional engineer, electronics enthusiast, or others who want to know more before they buy. 8 x 10 in.



**BP146—THE PRE-BASIC BOOK** ..... \$6.95. A book on the BASIC programming for those who have not yet bought a computer as well as those who have trouble learning how to program.



**BP239—GETTING THE MOST FROM YOUR MULTIMETER**..... \$5.95. Covers basics of analog and digital meters. Methods of component testing (includes transistors, thyristors, resistors, capacitors and other active and passive devices).



**BP135—SECRETS OF THE COMMODORE 64** ..... \$5.75. Masses of useful info and programming tips not found in any user's manual.



**BP143—INTRO TO PROGRAMMING THE ATARI 800/800 XL** ..... \$5.95. Perfect complement to the Atari user's manual. Even shows how to use animated graphics.



**BP148—COMPUTER TECHNOLOGY EXPLAINED** ..... \$5.50. Explanations for computer terms often encountered. A dictionary for computer lingo.



**BP152—INTRO TO Z-80 MACHINE CODE** ..... \$5.95. Speed up your programs. They may be harder to write, but it's worth learning how. Some demo programs are included.



**BP105—ANTENNA PROJECTS** ..... \$5.50. Practical radio antenna designs that deliver good performance and are relatively simple and inexpensive to build.



**BP198—AN INTRODUCTION TO ANTENNA THEORY** \$6.95. Basic concepts relevant to receiving and transmitting antennas.



**BP144—FURTHER PRACTICAL ELECTRONICS CALCULATIONS AND FORMULAE**..... \$9.00. Companion volume to BP53. Book carries on with new data not found in earlier edition. 450 pages.



**BP125—25 SIMPLE AMATEUR BAND ANTENNAS**..... \$5.50. All kinds of antennas for all kinds of amateur radio reception.



**BP178—ELECTRONIC CIRCUITS FOR THE COMPUTER CONTROL OF ROBOTS** ..... \$7.50. Data and circuits for interfacing the computer to the robot's motors and sensors.

## Quality Paperbacks



**BP183—AN INTRODUCTION TO CP/M**..... \$6.95. To run and use programs operations under CP/M you need this book.



**BP104—ELECTRONIC SCIENCE PROJECTS** ..... \$5.75. Simple to complex, a group of projects with a strongly scientific flavor.



**BP92—CRYSTAL SET CONSTRUCTION** ..... \$5.50. A variety of crystal radio receivers for the experimenter and hobbyist.



**BP110—HOW TO GET YOUR ELECTRONIC PROJECTS WORKING** ..... \$5.75. How to find the faults in your projects, repair them and get them working.



**BP121—DESIGN & MAKE YOUR OWN PC BOARDS** ..... \$5.75. Everything you need to know before you make printed-circuit boards for your projects.



**BP56—ELECTRONIC SECURITY DEVICES** ..... \$5.50. Three basic sections. Switch activated alarms, infrared & ultrasonic systems, smoke, gas, water detection.



**BP85—INTERNATIONAL TRANSISTOR EQUIVALENTS** ..... \$7.50. Locates possible substitutes for a popular user-oriented selection of modern transistors. Japanese, European and American types.



**BP117—PRACTICAL ELECTRONIC BUILDING BLOCKS, Book 1** ..... \$5.75. Build the blocks and then combine them to form almost any custom project of your choice.



**BP118—PRACTICAL ELECTRONIC BUILDING BLOCKS, Book 2** ..... \$5.75. Amplifiers for all kinds to add to the circuits from Book 1 of this series.

## Affordable Prices



**BP128—20 PROGRAMS FOR THE ZX SPECTRUM & 16K ZX81** ..... \$5.75. All programs run on both machines. Include flow charts and info on how to modify to run on other computers.



**BP106—MODERN OP-AMP PROJECTS** ..... \$5.00. Includes a Slide Timer, AF Sign & Gen. Mic'd Pre-amp, Scratch Filter, and much more.



**BP59—SECOND BOOK FOR CMOS IC PROJECTS** ..... \$5.50. Multivibrators, amplifiers, triggers & gates, special devices including reaction timer, simple electronic organ, and more.



**BP182—MIDI PROJECTS** ..... \$6.95. Details of how to interface many popular home computers with MIDI music systems.



**BP45—SINGLE IC PROJECTS** ..... \$5.75. All projects in this book are based on one IC and are simple to construct. Great way to get started with IC's.



**BP49—POPULAR ELECTRONIC PROJECTS** ..... \$5.95. A collection of a wide range of electronic projects and circuits for the experimenter.



**BP97—IC PROJECTS FOR BEGINNERS** ..... \$5.50. Written especially for the less experienced experimenter. Complete parts layouts and wiring diagrams.



**BP115—INTO THE QL ARCHIVE**..... \$4.95. Presents the powerful database for the Sinclair QL. Step-by-step approach includes practical examples.



**BP80—POPULAR ELECTRONIC CIRCUITS, Book 1** ..... \$5.95. More circuits for hobbyists. Audio, radio, test music, household and more.

CHECK OFF THE BOOKS YOU WANT

**ELECTRONIC TECHNOLOGY TODAY INC.**  
P.O. Box 240, Massapequa Park, NY 11762-0240

Name \_\_\_\_\_  
Address \_\_\_\_\_  
City \_\_\_\_\_ State \_\_\_\_\_ Zip \_\_\_\_\_

SHIPPING CHARGES IN USA AND CANADA

\$0.01 to \$5.00	... \$1.25
\$5.01 to 10.00	... \$2.00
\$10.01 to \$20.00	... \$3.00
\$20.01 to \$30.00	... \$4.00
\$30.01 to \$40.00	... \$5.00
\$40.01 to \$50.00	... \$6.00
\$50.01 and above	... \$7.50

SORRY, No orders accepted outside of USA and Canada

Total price of merchandise ..... \$ \_\_\_\_\_  
Sales Tax (New York State Residents only) ..... \$ \_\_\_\_\_  
Shipping (see chart) ..... \$ \_\_\_\_\_

All payments must be in U.S. funds Total Enclosed .. \$ \_\_\_\_\_

H-1188

