

PRICE FIFTY CENTS



# AND TELEVISION

SEPT. 1947

★ ★ Edited by Milton B. Sleeper ★ ★

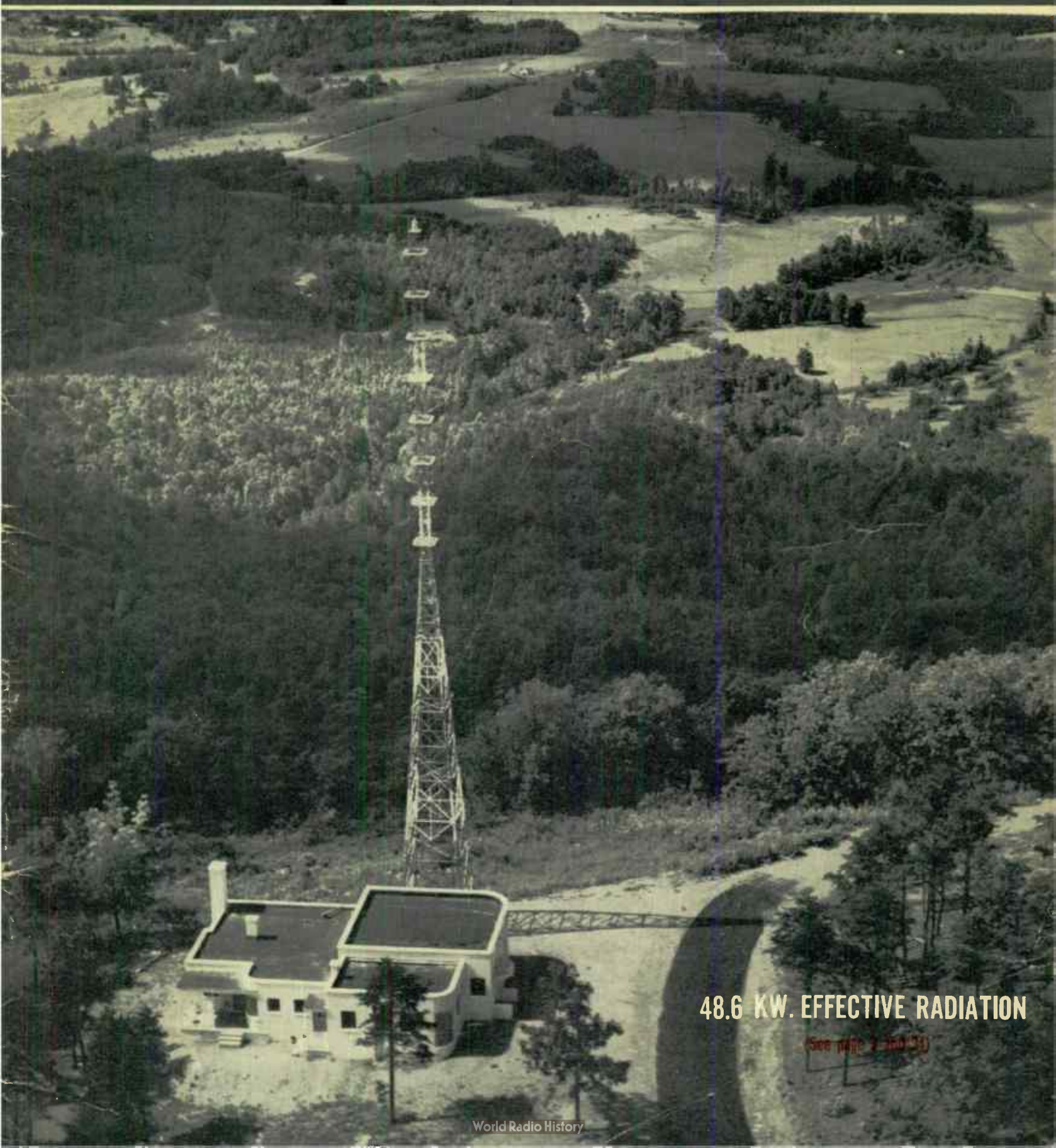

48.6 KW. EFFECTIVE RADIATION

(See page 2 and 3)



# Why the *Lock-In* tube is at home **ON THE ROAD!**

#### **STAYS PUT IN SOCKET...THROUGH LOCK-IN FEATURE**

No matter how rough the road, the tubes in an automobile's radio will stay in their sockets—if those tubes are Sylvania *Lock-Ins*. Specially designed "lock-in" locating lug on each tube keeps them in place—assuring firm socket contact.

#### **COMPACT...MADE TO FIT SMALL SPACES**

This famous Sylvania product is ideal for use in space-seeking modern vehicles—it's so compact . . . has reduced overall height and weight. Further, it has no top cap connection . . . overhead wires are eliminated!

#### **MECHANICALLY RUGGED...ELECTRICALLY SUPERIOR**

Improved tube mount keeps elements ruggedly supported on all sides. There are few welded joints and *no* soldered joints—the elements can't warp or weave. Electrical features include: short, direct connections . . . less loss; getter located on top . . . shorts eliminated by separation of getter material from leads. See *Sylvania Distributors* or write *Radio Division, Emporium, Pa.*



**SYLVANIA'S LOCK-IN TUBE . . .**  
... the radio tube whose electrical and mechanical superiority makes it the ideal choice for equipment on the road, in the air, marine radar, FM and Television.

# SYLVANIA ELECTRIC

MAKERS OF RADIO TUBES; CATHODE RAY TUBES; ELECTRONIC DEVICES; FLUORESCENT LAMPS, FIXTURES; WIRING DEVICES; ELECTRIC LIGHT BULBS

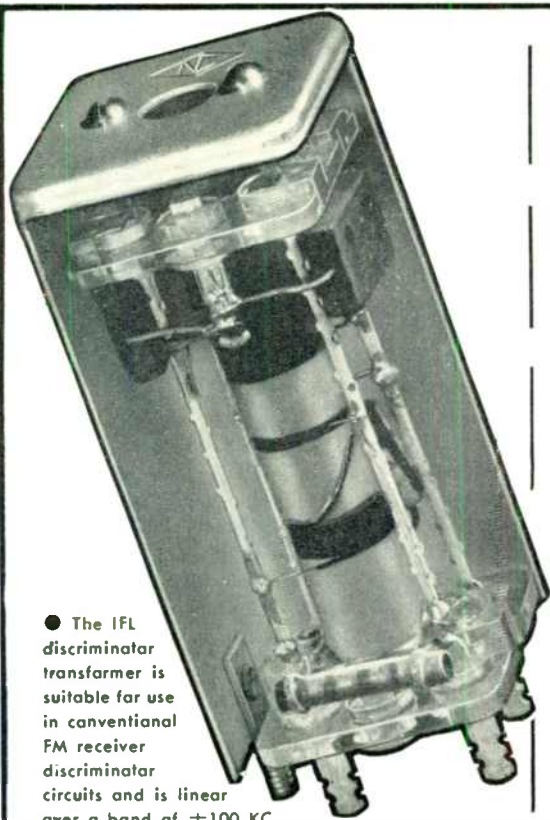

● The IFL discriminator transformer is suitable for use in conventional FM receiver discriminator circuits and is linear over a band of  $\pm 100$  KC.



● The IFM is an IF transformer with a 150 KC bandwidth at 1.5 db attenuation. Approximate stage gain of 30 is obtained when used with 6SG7 tube.

● The IFL, IFM, IFN and IFO transformers all operate at 10.7 mc and are designed for use in FM superheterodyne receivers. The transformer cans are  $1\frac{3}{8}$ " square and stand  $3\frac{1}{8}$ " above the chassis.



● The IFN is an IF transformer with a 100 KC bandwidth at 1.5 db attenuation. Approximate stage gain of 30 is obtained when used with 6SG7 tube.

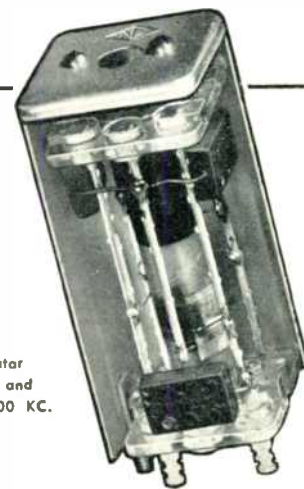

● The IFO is an FM discriminator transformer of the ratio type and is linear over a band of  $\pm 100$  KC.

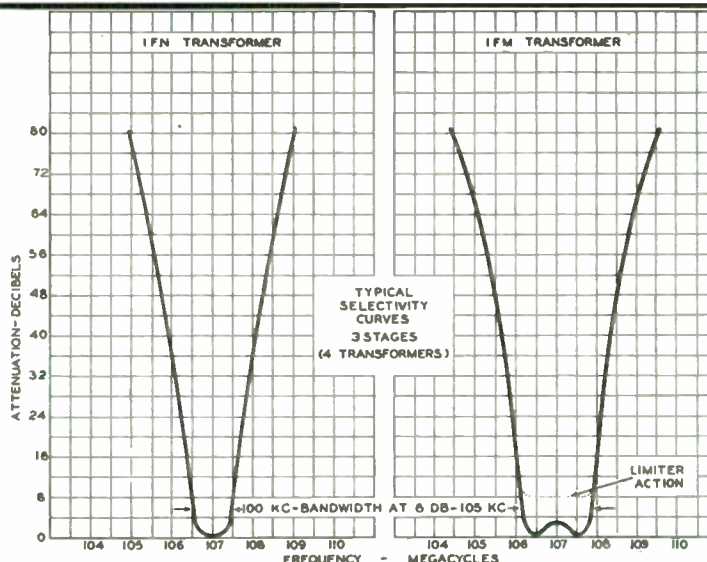

it's the **ENGINEERING** that counts

- National parts are engineered and designed by men who believe in quality. That's why these permeability-tuned IF transformers can be depended upon to deliver fine performance.
- Intended specifically for FM usage they have the proper selectivity for FM application. In addition, these transformers are of the currently popular low-impedance type and thus make it much easier to stabilize your IF amplifier.
- If you're planning to build or order FM equipment in the near future, send for your copy of the 1947 National catalog today — containing a complete list of transformers and some 600 other precision-made radio parts.

**National Company, Inc.**

Dept. No. 11  
Malden, Mass.



**MAKERS OF LIFETIME RADIO EQUIPMENT**

# All controlled by 1 STUDIO CONSOLE

1 Announcer's Booth...



2 Studios...



2 Turntables...



9 Remote Lines...



2 Network Lines...



RAYTHEON

## NO OTHER CONSOLE offers all these outstanding features...

**Seven built-in pre-amplifiers** — put 5 microphones and 2 turntables, or 7 microphones, on the air simultaneously.

**Nine mixer positions** — lead to 5 microphones, two turntables, one remote line and one network line.

**Nine remote and two network lines** — may be wired in permanently.

**Most dependable, trouble-free switches used throughout.**

**Frequency Response 2 DB** from 30 to 15,000 cycles. Ideal speech-input system for either AM or FM.

**Distortion less than 1%**, from 50 to 10,000 cycles.

**Noise Level minus 65 DB's** or better. Air-plane-type four-way rubber shock mounting eliminates outside noise and operational "clicks."

**Meets all FCC Requirements** for FM transmission.

**Dual Power Supply** provides standby circuit instantly available for emergency use.

**Instant Access** to all wiring and components. Top hinged panel opens at a touch. Entire cabinet tilts back on sturdy full-length rear hinge.

Providing *complete* high-fidelity speech-input facilities for the modern station... with all control, amplifying and monitoring equipment in a *single compact cabinet*... the Raytheon RC-11 Studio Console handles any desired combination of studios, remote lines or turntables, broadcasting and auditioning simultaneously through two high quality main amplifier channels.

Telephone-type, lever action 3-position key switches reduce operational errors to a minimum; while efficient, functional appearance and smart two-tone metallic tan blend well with other studio equipment.

*Priced remarkably low... write for details!*

*Devoted to Research and Manufacturing for the Broadcasting Industry*

RAYTHEON

*Excellence in Electronics*

**RAYTHEON MANUFACTURING COMPANY**

COMMERCIAL PRODUCTS DIVISION

WALTHAM 54, MASSACHUSETTS

Industrial and Commercial Electronic Equipment, Broadcast Equipment, Tubes and Accessories

Sales offices: Boston, Chattanooga, Chicago, Dallas, Los Angeles, New York, Seattle



# AND TELEVISION

FORMERLY, FM MAGAZINE and FM RADIO-ELECTRONICS

VOL. 7

SEPTEMBER, 1947

NO. 9

COPYRIGHT 1947, Milton B. Sleeper

## CONTENTS

<b>WHAT'S NEW THIS MONTH</b>	
By-Products of FM.....	4
<b>FM FOR TROPICAL &amp; MOUNTAINOUS COUNTRIES</b>	
C. M. Jansky, Jr.....	21
<b>FM AND TELEVISION PROBLEMS</b>	
Milton B. Sleeper.....	24
<b>THE KLIPSCH REPRODUCER</b>	
Paul W. Klipsch.....	25
<b>FMI RAILROAD RADIO</b>	
F. A. Mesch and Lew H. Morse.....	30
<b>48.6-KW. INSTALLATION AT WMRC-FM, Part 2</b>	
W. Ennis Bray.....	34
<b>PILOT FM TUNER</b>	
Official Service Data.....	37
<b>FM COMMUNICATIONS FOR LOGGING CAMPS</b>	
Robert L. Wasley.....	38
<b>TELEVISION HANDBOOK, 8th Installment</b>	
Madison Cawein.....	41
<b>SPECIAL DEPARTMENTS</b>	
Products & Literature.....	6
Engineering Sales.....	8
Spot News Notes.....	28
News Picture.....	29
Advertisers' Index.....	63

THE COVER DESIGN AND CONTENTS OF FM AND TELEVISION MAGAZINE ARE FULLY PROTECTED BY U. S. COPYRIGHTS, AND MUST NOT BE REPRODUCED IN ANY MANNER OR IN ANY FORM WITHOUT WRITTEN PERMISSION

\*\*\*\*\*

**MILTON B. SLEEPER, Editor and Publisher**

STELLA DUGGAN, Production Manager  
LILLIAN BENDROSS, Circulation Manager  
Published by: FM COMPANY

Publication Office: 264 Main St., Great Barrington, Mass. Tel. Great Barrington 500  
New York: 511 Fifth Avenue, New York 17, Tel. VA 6-2483  
Chicago: MARIAN FLEISCHMAN, 360 N. Michigan Ave., Tel. STAt 4822  
Pasadena: MILO D. PUGH, 35 S. Raymond Ave., Pasadena 1, Calif. Tel. MADison 6272  
FM Magazine is issued on the 20th of each month.

Single copies 50¢ — Yearly subscription in the U. S. A. \$5.00; foreign \$6.00. Subscriptions should be sent to FM Company, Great Barrington, Mass., or 511 Fifth Avenue, New York 17, N. Y.

Contributions will be neither acknowledged nor returned unless accompanied by adequate postage, packing, and directions, nor will FM Magazine be responsible for their safe handling in its office or in transit. Payments are made upon acceptance of final manuscripts.



### THIS MONTH'S COVER

Photographer Coxe, of Greenville, S. C., flying his own plane, took this picture of the WMRC-FM installation on Paris Mountain. This is probably the most powerful commercial FM broadcast station now on the air, and its wide service area confirms the urgency of getting all FM transmitters up to their full rated power. General manager E. Ennis Bray gives the details in his second and concluding article on page 31.

Entered as second-class matter, August 22, 1945, at the Post Office, Great Barrington, Mass., under the Act of March 3, 1879. Additional entry at the Post Office, Concord, N. H. Printed in the U. S. A.

MEMBER,  
AUDIT  
BUREAU OF  
CIRCULATIONS



World Radio History



## RMC TRANSCRIPTION PLAYER MODEL TP-16C

(Patents Applied For)

**TWO-SPEED—16-INCH, COMPACT,  
FULLY PORTABLE, LIGHTWEIGHT,  
EASY TO CARRY, LOW PRICE**

Designed and built to meet the quantity production demand for a fine tone, dependable, and very low price transcription player. Advanced design, expertly engineered, and sturdily-built for trouble-free performance. Meets the demands of radio stations, transcription services, advertising agencies, and schools for realistic reproduction of transcription records up to 16 inches, 78 or 33 1/3 r.p.m. Free of wow and rumble. Switch output impedance: 30, 250, and 500/600 ohms. In Carrying Position: 23" w., 17 1/2" h., 8" d. Constant speed heavy duty motor, silent, smooth operation. 16" TURNTABLE embodies special re-enforced construction (patent pending).

Supplied with or without professional broadcast station Para-Flux Reproducers.

AVAILABLE THROUGH AUTHORIZED JOBBERS

Bulletin TP1, yours for the asking

# RADIO-MUSIC CORPORATION

EAST PORT CHESTER • CONN.

# PRODUCTS & LITERATURE

So many new instruments, components, and materials are being brought out that space does not permit us to publish illustrated descriptions of them all. Accordingly, rather than selecting a few each month, we have established this new department of Products & Literature so that a great number of brief descriptions can be published. From these, you can select items which interest you, and send for catalogs or bulletins. We'll appreciate it if you will mention FM and TELEVISION in your requests.

**Audio Frequency Meter** has 6 ranges, covering 0 to 30,000 cycles for use in checking audio oscillators and tone generators. Minimum sensitivity, .5 volt input. Operates from 110 volts, 60 cycles, with self-contained power supply. Circuits include an input voltage-gain amplifier followed by two limiting amplifiers. — Model 300, Barker & Williamson, Upper Darby 1, Pa.

**Mobile Power Supplies** operating from storage batteries, for radio installations on cars, trucks, and busses, and railroad service. Models cover a wide range of special types and ratings. — Bulletin 447-JF, Carter Motor Co., 2644 N. Maplewood Ave., Chicago 47

**Selenium Rectifier** for relays and low-current controls. Contained in Bakelite case  $\frac{3}{8}$  in. in diameter by  $1\frac{1}{2}$  ins. long. — Bradley Laboratories, Inc., 82-M Meadow St., New Haven, Conn.

**Resistor-Fuse** unit  $\frac{1}{2}$  in. long by  $\frac{3}{32}$  in. in diameter. Available in values from 15 to 150 ohms, 1 watt. Resistor also serves as smokeless, non-flaming fuse. — International Resistance Corp., 401-A N. Broad St., Philadelphia 8

**DC Dry Electrolytics** of all types and sizes, in metal cans and impregnated cardboard tubes, rated from 5 to 2,000 mfd. and 6 to 600 working volts. — Bulletin J-4, Pyramid Electric Co., 155 Oxford St., Paterson, N. J.

**Instrument Case** for Simpson model 260 volt-ohm-milliammeter has protective roll-top front of Bakelite strips with cloth backing. — Simpson Electric Co., 5200-5218 W. Kinzie St., Chicago 44

**Rotary Switch** for circuits requiring up to 32 positions, and as many as 10 decks. Contacts rated at 5 amperes, 120 volts. Break-down between terminals or terminals to ground 2,500 volts. — U. S. Instrument Corp., 409 M Broad St., Summit, N. J.

**Terminal Blocks** for 1 to 14 connections. Can be built up, as required, from a kit containing individual molded sections, threaded tie-rods, and end brackets. —

Bulletin FM-118, Curtis Development & Mfg. Co., 1 N. Crawford Ave., Chicago 24

**Pocket Stethoscope** is the name of a new signal tracer, light in weight,  $4\frac{1}{8}$  ins. wide,  $2\frac{3}{8}$  ins. deep,  $8\frac{3}{4}$  ins. high. Has PM speaker and jacks for plugging in a volt-ohm-milliammeter to make the instrument an effective RF VT voltmeter. — Models TS-3 and -5, Feiler Engineering Co., 422 S. Dearborn St., Chicago 5

**Television Transmitter**, described as the Acorn Package, designed to enable telecasters to get on the air with a minimum investment. Video output 500 watts, audio 250 watts, on channel No. 1 to 13. Includes dual image-orthicon pickup chain, antenna, 16 mm. film projector, audio pickup gear, and test equipment. — DuMont Labs., 38 Inc., 2F Main Ave., Passaic, N. J.

**Tube Checker** employing differential frequency system. Tests all standard receiver tubes, and also voltage regulators and low-power Thyratrons. Four different potentials can be used in combination with various screen potentials to eliminate possible overloading of diodes and battery tubes. — Model 798-MF, Weston Elect. Inst. Co., Newark 5, N. J.

**Miniature Resistors** of  $\frac{1}{2}$ -watt capacity  $9/64$  in. diameter by  $\frac{3}{8}$  in. long, and 1-watt capacity  $7/32$  in. diameter by  $9/16$  in. long. Values  $\pm 5\%$  from 10 ohms to 22 megohms. Designed to meet JAN-R-11 specs, including salt water cycling and humidity tests. — Bulletin LD, Ohmite Mfg. Co., 4980 W. Flourney St., Chicago 44

**65-Watt Tetrode** for mobile applications up to 200 mc. Has instant-heating 6-volt thoriated tungsten filament, non-emitting grids, fits standard sockets. Can be stepped up to 200 watts output with 2,000 volts plate potential. — Type 4-65A, Eitel-McCullough, Inc., 178-F San Mateo Ave., San Bruno, Calif.

**Sound-Powered Telephone** handset for use in adjusting FM and television antennas. Separate line or the transmission line can be used from roof to set. — Type FMT U. S. Instrument Corp., Summit, N. J.

**Pickup Adapter** to adapt the Western Electric arm to take G.E. variable reluctance or Pickering 120M cartridges. — Type M-M, Technical Products International, 453 W. 47 St., New York

**Packaging** for tubes and delicate assemblies, called "Vibra-Safe". Part to be packed is first wrapped in several thicknesses of Kimpac wadding and inserted in Fiberpak container. This package is wrapped in

single-faced corrugated, and put in a second Fiberpak container, with a roll of corrugated at the top and bottom. Packing is intended to withstand crushing loads and vibration. — Continental Can Co., 100 E. 42 St., New York 17

**Antenna Fittings** for aircraft and special mobile uses. Units developed by Air Materiel Command, include strain insulators, corona shield, and tension takeup. — Dayton Aircraft Products Co., A-342 Xenia Ave., Dayton 10, Ohio

**Transformer Laminations** of 18 different types and sizes for RF, AF, and power devices. Mechanical and electrical design data is presented in very complete tables which also show most suitable applications. — Bulletin 47, Thomas & Skinner Steel Products Co., 1164 E. 23 St., Indianapolis, Ind.

**7-in. Oscilloscope** in portable case 17 ins. high,  $11\frac{3}{8}$  ins. wide, and  $17\frac{1}{4}$  ins. deep, weighing 37 lbs. Push-pull amplifier with four 7C7 tubes used to provide extra gain with reduced distortion and increased clarity of images. Provision is made for Z-axis input with impedance to ground of approximately  $\frac{1}{2}$  megohm with 30 mmf. shunt capacitance. — Sylvania Electric Products, Inc., 5th Ave. & 42nd St., New York 18

**Midget Electrolytics** in cans with waxed-paper jackets spun over at the ends. New types are available with DC working-voltage ratings of 500, 600, and 700 volts. — Aerovox Corporation, New Bedford, Mass.

**Tube Puller** for extracting such miniature tubes as the 6AG5 and 50B5 from hard-to-reach parts of receiver chassis. — Salescrafters, Inc., F510 N. Dearborn St., Chicago 10

**Television Receiver Kit** with 7- or 10-in. tube has FM sound reception, pretuned coils. \$77.50 or \$124.50 without tubes. Electro-technical Industries, 121-F North Broad St., Philadelphia

**Labels** of the removable, self-adhesive type are described in a bulletin illustrating typical designs used for inspection, instructions, and warnings. — Avery Adhesive Label Corp., 36 W. Union St., Pasadena 1, Calif.

**Auditorium Speaker** developed for halls and theatres seating up to 1,000. Employs separate bass speaker and multi-cellular high-frequency horn with dividing network crossing over at 800 cycles. Power rating 20 watts, 67 ins. high, 50 ins. wide, 23 ins. deep. — Altec Lansing Corp., 250 W. 57 St., New York 19.

*Catalogs and bulletins on new products listed here are available without charge unless a price is shown.*

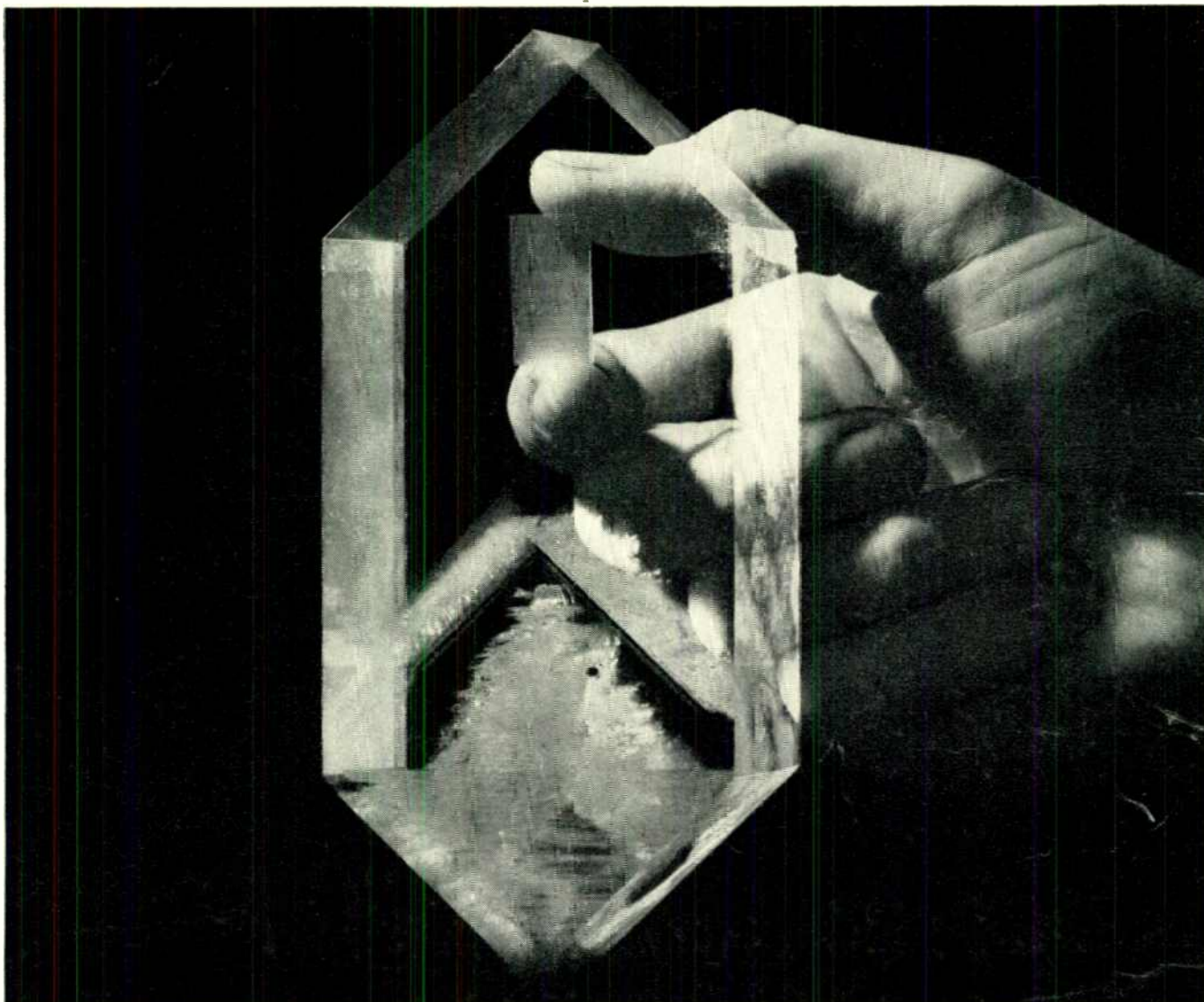

A CRYSTAL THAT GREW FROM A SEED . . . *The large crystal in the foreground is an EDT (Ethylene Diamine Tartrate) crystal. It started from a seed (a piece of mother crystal) and in three months grew in a slowly cooling solution to the size shown. The small plate is cut from a large crystal, then gold-plated for electrical connection and mounted in vacuum. Cultivated EDT crystals can do the same job as quartz in separating the nearly 500 conversations carried by a coaxial circuit.*

## Crystals for Conversations

AT WAR'S END, the Bell System began to build many more Long Distance coaxial circuits. Hundreds of telephone calls can be carried by each of these because of electric wave filters, which guide each conversation along its assigned frequency channel. Key to these filters was their frequency-sensitive plates of quartz.

But there was not enough suitable quartz available to build all the filters needed. Bell Telephone Laboratories scientists met the emergency with cul-

tivated crystals. Years of research enabled them to write the prescription at once—a crystal which is grown in a laboratory, and which replaces quartz in these channel filters.

Now Western Electric, manufacturing unit of the Bell System, is growing crystals by the thousands. Many more Long Distance telephone circuits, in urgent demand, can be built, because the scientists of Bell Telephone Laboratories had studied the physics and chemistry of artificial crystals.



**BELL TELEPHONE LABORATORIES**

Bell Telephone Laboratories pioneered in the research of FM radio and television, and are active in developing improvements in both fields today.

September 1947 — formerly *FM*, and *FM RADIO-ELECTRONICS*

7



# FM · AM · Audio Equipment to Meet YOUR Specs

## BROADCAST STUDIOS

Collins custom-built FM-AM tuners, amplifiers, and speakers are of such flexible design as to meet individual studio requirements without the high cost usually associated with custom-built equipment. Collins engineers are long-experienced in the requirements of high-fidelity installations.

## PRIVATE HOMES

For fine FM, AM, phonograph installations in private homes, Collins custom-built FM-AM tuners, amplifiers, and speakers add up to performance that is winning the hearty approval of the most critical listeners. Flexible designs keep costs surprisingly low.

## HALLS and SCHOOLS

Collins custom-built units can be furnished in any combination to suit the needs of radio and sound systems for public auditoriums and schools. Specifications for turntables, microphones, and speakers can be met with equipment so rugged in design that maintenance is cut to the irreducible minimum.

### Ask for Information

Quotations on Collins custom-built equipment show net prices on orders placed with the factory. Standard Collins receivers and amplifiers, however, are available through parts jobbers. For details, address:

# COLLINS

## AUDIO PRODUCTS, Inc.

118-A Park Street, Westfield, N. J.

TeL: WESTFIELD 2-4390

# ENGINEERING SALES

**Pilot:** Lineup of representatives for Pilot Radio now includes Anderson Sales Co., Boston; Bader & Fox Distributing Co., Portland, Ore.; Glenn Burdick, Buffalo; Sol Chain, New Haven, Conn.; Golbus Sales Co., San Francisco and Los Angeles; Mayray Co., New Orleans; Allen D. McGehee, Worthington, O.; James H. Podolny, Pittsburgh; Arthur Rixon & Son, Greenville, S. C.; Ross Associates, Inc., Detroit; Salescrafters, Inc., Chicago; Texport Co., Austin, Tex.; James C. Wilson, Bristol, Tenn.

**Bendix:** Paul J. Reed, after 4 years at Bendix Radio headquarters in Baltimore, has been made district manager for New England and upper New York. He will make his headquarters in Boston.

**Amperex:** Sam Norris, Amperex sales manager since 1942, has been appointed executive vice president of the Corporation.

**Zenith:** New general sales manager of Zenith Radio Distributing Corp., Zenith subsidiary, is William W. Bayne, former Zenith district sales manager.

**Stewart-Warner:** Additional Stewart-Warner television service stations are: Missouri Research Labs., St. Louis; National Radio & Television Service, Washington, D. C.; Arlington Television Labs., Arlington, Va.; Television Sales & Service, Inc., Newark, N. J.; Short Hills Radio & Appliance Co., Short Hills, N. J.; Pioneer Television Co., Philadelphia; Minor's Radio & Television Co., Baltimore.

**Sylvania:** William M. Maguire has been transferred from Sylvania's Salem plant to the distributor sales department of the radio tube division. He will work with sales division managers and distributors east of the Mississippi.

**National:** After 21 years on the editorial staff of QST, with war time out to direct Raytheon's field engineering, Clark C. Rodimon has joined the National Company, Malden, Mass. His work will be on the development and marketing of amateur and commercial products.

**Merit:** New representatives for Merit Coil & Transformer Corp. are Herb Becker, 1466 S. Grand Avenue, Los Angeles 16, for southern California and Arizona, and Bullock-Cobb Co., 233 E. Market Street, Louisville 2, for Indiana, Tennessee, and Kentucky.

# Here's News!

## ABOUT OUR AM-FM TUNER

It's the finest quality that money can buy. Latest design features are all included—uses all miniature tubes. Ideal for use in a custom radio installation or may be installed in any cabinet.



## 8 TUBE MODEL TU 6 AM-FM TUNER

### Controls:

Off-On — Phono — Television  
Band Switch (AM-FM)  
Tuning Control

## SPECIAL FEATURES

- Automatic Frequency Control — First time used on any tuner. Makes this tuner free from the usual drift. Eliminates the need of a tuning indicator. On FM this tuner tunes like a standard broadcast receiver. Only one response point.
- Large slide rule type dial, calibrated in Megacycles on FM and in Kilocycles on AM. Edgelighted for maximum beauty and brilliance.
- Tuned RF stage for FM
- RF Amplifier for AM.
- 5 Gang Tuning Condenser.
- Frequency Range:  
FM — 88 — 108 MC  
AM — 550 — 1600 KC
- Polished chrome chassis for the ultimate in long-lasting beauty.
- Top Quality Performance. Extreme sensitivity and selectivity. Highest quality reception of any AM-FM tuner.
- 105-125 Volt AC operation.
- Built-in loop antenna on AM. Built-in dipole antenna for FM reception.
- Separate IF transformers for both AM and FM to insure maximum performance.
- Band switch is ultra new "Flat" type permitting extremely short leads for best performance.
- Phonograph input provided on tuner chassis for playing records. Phonograph switch included.
- Television tuner input also provided on this model with switch. The 2 above features provide great versatility in application for this tuner.

The TU 6 tuner represents the absolute ultimate in AM-FM tuner design. All of the very latest, most modern features are included.

THIS TUNER MAY BE USED WITH  
OUR AK 20—HIGH FIDELITY  
AMPLIFIER

USE THE COUPON BELOW for free information on one or both of these products.

The RADIO CRAFTSMEN, Inc.  
Makers of craftsmen built Products  
1341 SOUTH MICHIGAN AVENUE  
CHICAGO 5, ILLINOIS  
Cable address: "Radercraft"

THE RADIO CRAFTSMEN, INC.  
1341 South Michigan Avenue  
Dept. N, Chicago 5, Ill.  
Gentlemen: I am interested in:

Send complete information without obligation.  
Name \_\_\_\_\_  
Address \_\_\_\_\_  
City \_\_\_\_\_ Zone \_\_\_\_\_ State \_\_\_\_\_

FM AND TELEVISION



# Nielsen Audimeter Uses **CLARE SEALED TYPE "K" RELAY** for Radio Audience Research

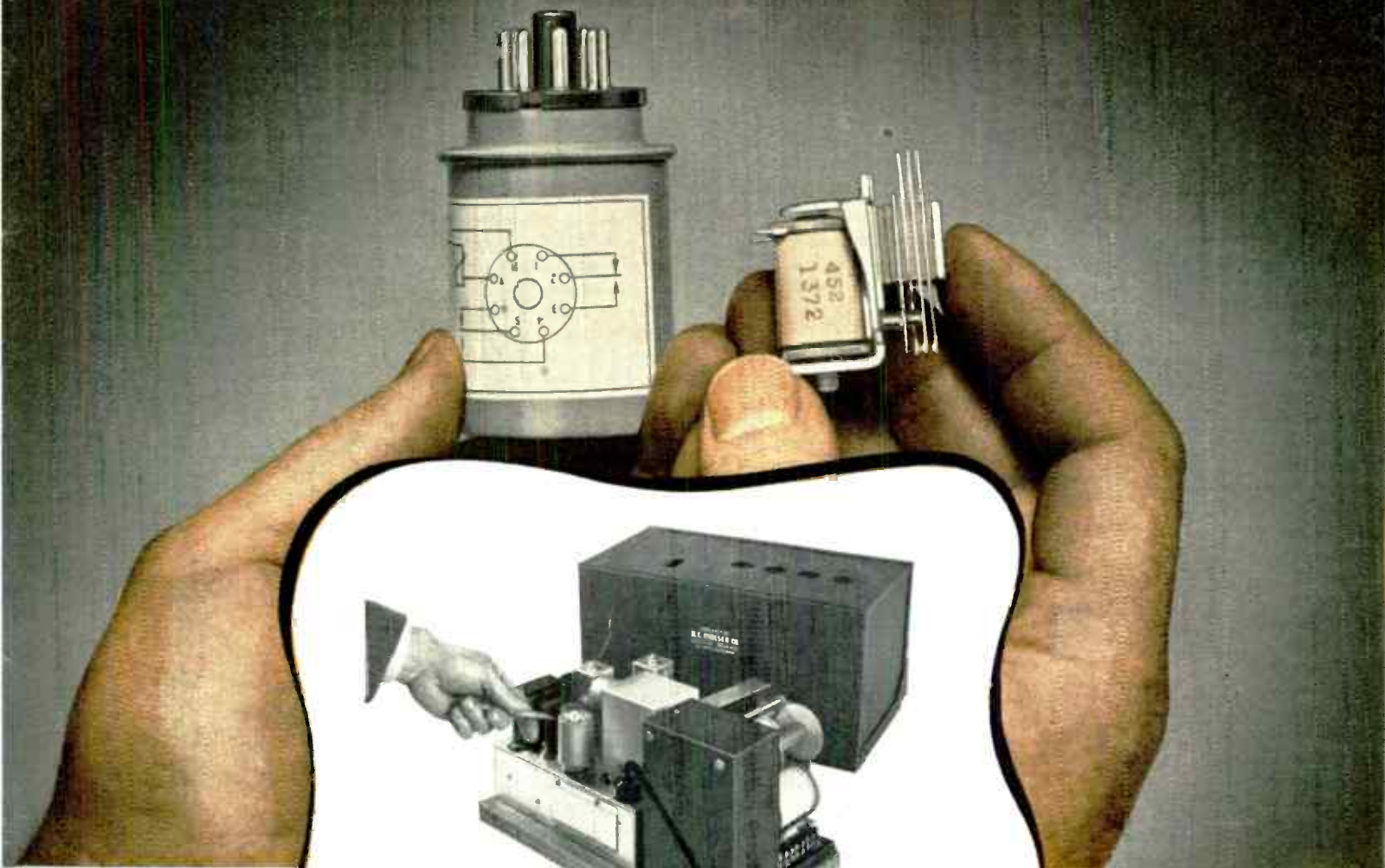

Pencil points to Clare "SK"  
Relay in Nielsen Audimeter

● One of the most interesting developments in radio listening research is the Audimeter, designed by A. C. Nielsen Company, Chicago marketing research organization, to provide information hitherto unobtainable. Attached to home radio receivers, scientifically selected on a nation-wide basis, this device keeps an accurate 24 hour a day record of when each receiver is operated and the stations to which it is tuned.

Clare Sealed Type "K" Relays were chosen for use in the Audimeter because of their extreme reliability, capacity for precise, sensitive adjustment, and the fact that they are sealed so that dirt and handling cannot affect their operation.

In the Audimeter, the unusually sensitive Clare Sealed Type "K" Relay operates under the control of a vacuum tube to stop the recording stylus at the correct spot to identify station choice on the calibrated record tape.

Clare Sealed Type "K" Relays, sealed in nitrogen in a metal cover, are immune to conditions imposed by high altitudes, dust, moisture or combustible gases. They function at maximum precision under extreme conditions. Like all Clare "Custom-Built" Relays they are available in a wide range of contact ratings and contact forms, flat or hemispherical contacts of rare metals or special alloys and with coil windings to match the circuit and application.

Clare "custom-building" makes it possible... with the utmost economy... to secure a relay exactly suited to specific requirements. Clare sales engineers are located in principal cities to help you secure just the relay you need. Write to C. P. Clare & Co., 4719 West Sunnyside Avenue, Chicago 30, Illinois. In Canada: Canadian Line Materials Ltd., Toronto 13, Ontario, Canada.

## CLARE RELAYS

"Custom-Built" Multiple Contact Relays for Electrical and Industrial Use

# For Versatility of Application

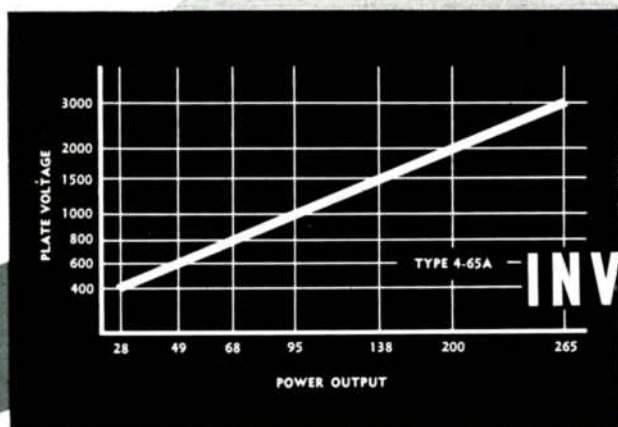

WITHIN THIS POWER RANGE

INVESTIGATE THE NEW

## EIMAC 4-65A

### MORE FOR YOUR VACUUM TUBE DOLLAR

Conservatively rated at 65 watts plate-dissipation, the 4-65A is physically small and radiation cooled.

Instant heating thoriated tungsten 6.0 volt filament makes the 4-65A ideally suited for mobile application.

Self-supported internal elements. No troublesome insulators.

Direct electron beaming without the use of deflecting hardware.

Low interelectrode capacitances. (Average) Grid-Plate  $.08 \mu\mu\text{f}$ , Input  $8.0 \mu\mu\text{f}$ , Output  $2.1 \mu\mu\text{f}$ .

Unique design shields input output circuits, simplifies neutralization.

Non-emitting processed grid provides stability familiar to all Eimac tetrodes.



ACTUAL SIZE

Versatile operation . . . the 4-65A has excellent power characteristics over a plate voltage range from 400 to 3000 volts, as indicated in the above chart.

Base pins fit available commercial sockets.

Low inductance and short direct leads enable operation above 200 mc.

Processed metal plate assures long tube life and can really "take it" during momentary overloads.

Hard glass envelope provides resistance to thermal shock and permits high temperature operation.

Proven design, the 4-65A is a physically smaller version of the 4-125A.

In the 4-65A you get truly "more for your vacuum tube dollar"

**PRICE \$14.50**

**EITEL-McCULLOUGH, Inc.**  
179 San Mateo Ave.,  
San Bruno, California

Follow the Leaders to

**Eimac**  
TUBES

The Power for R-F

EXPORT AGENTS: FRAZAR & HANSEN, 301 CLAY ST., SAN FRANCISCO 11, CALIFORNIA, U.S.A.

Write today for additional data.

# WARD sets the stage

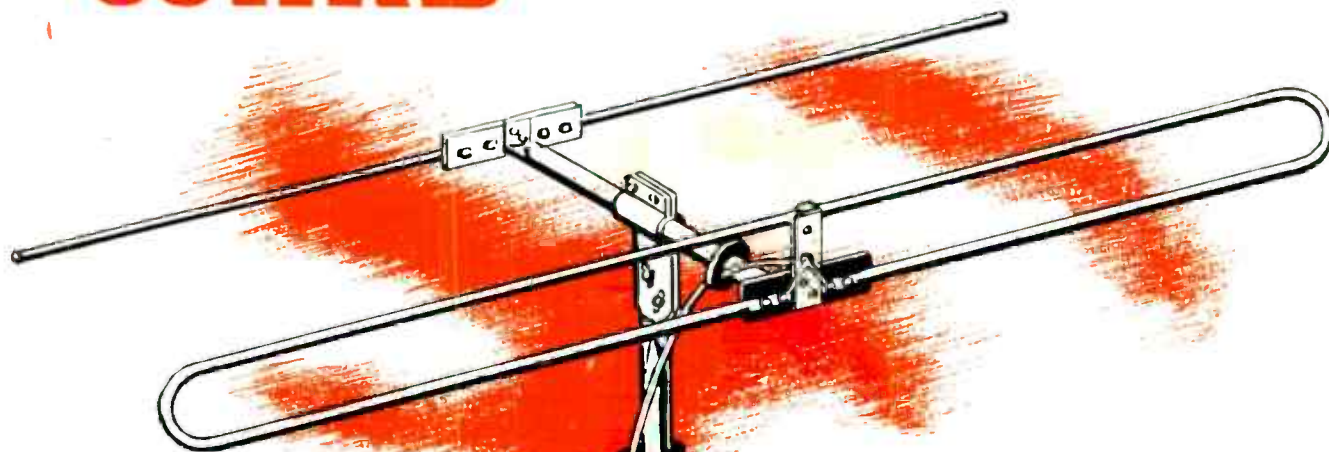

**-for a "boom" in FM and Television aerial sales**

An intensive consumer advertising campaign in the Saturday Evening Post and leading newspapers is convincing millions of present and prospective FM and Television set owners that:

- (1) *Quality reception is difficult, if not impossible, without a good outside dipole antenna.*
- (2) *Ward "Magic Wand" FM and Television Aerials offer the finest FM and Television reception at modest cost.*

Alert radio dealers are finding this campaign exceedingly helpful in creating extra sales and profitable installation jobs. In addition these dealers are winning satisfied customers who can now enjoy the true beauty of FM or television reception.

Available in straight or folded dipoles for both FM and television bands (reflector kits available), Ward "Magic Wand" Aerials are products of the world's largest makers of aerials for car and home.

Listing at only \$9.00 to \$12.00 (reflector kit \$5.25) they are priced to encourage volume sales and an adequate profit margin.

Phone or see your nearest Ward distributor today for full details on how to capitalize on this hard-hitting consumer advertising for Ward "Magic Wand" FM and Television Aerials; or write direct to:

## THE WARD PRODUCTS CORPORATION

1523 East 45th Street, Cleveland 3, Ohio

DIVISION OF THE GABRIEL COMPANY

EXPORT DEPT.: C. W. Brandes, Mgr., 4900 Euclid Ave., Cleveland 3, Ohio.

IN CANADA: Atlas Radio Corp., 560 King St., W., Toronto, Ont., Canada.

As Advertised in the Saturday Evening POST

WORLD'S LARGEST MAKER OF AERIALS FOR CAR AND HOME

**WARD**  
*Magic Wand*  
FM AND TELEVISION AERIALS

### FM-TELEVISION AERIAL OPPORTUNITY!

WARD PRODUCTS CORP.  
1523 East 45th St., Cleveland 3

Please advise how I can profit from your national advertising for "Magic Wand" FM and Television Aerials.

NAME \_\_\_\_\_  
COMPANY NAME \_\_\_\_\_  
ADDRESS \_\_\_\_\_  
STATE \_\_\_\_\_ CITY AND ZONE \_\_\_\_\_  
MY JOBBER IS \_\_\_\_\_



**RIGHT ON  
"MAIN STREET"**

**W**HEN the most desirable FM location happens to lie in a congested area, tower design is of prime importance.

It is therefore necessary that such a structure be designed to have an adequate margin of safety, and be of pleasing appearance.

This installation has back of it the experience and engineering ability acquired in building thousands of Towers and Vertical Radiators, both here and abroad . . . This obvious advantage adds nothing to the cost of a Blaw-Knox job.

**BLAW-KNOX DIVISION  
OF BLAW-KNOX COMPANY**

2046 Farmers Bank Building, Pittsburgh 22, Pa.

**BLAW-KNOX ANTENNA  
TOWERS**

# Put This Formula To Work For You

$$I = \frac{E}{IRC}$$

The formula  $I = \frac{E}{IRC}$  is a favorite and easily-remembered solution to resistance problems. Radio and electronic Engineers know that IRC offers the most complete line of resistance products in the industry . . . a fixed or variable resistor for most every requirement . . . with uniform dependability proved by years of rigorous laboratory and field tests. Purchasing Agents and material control executives like IRC's service . . . "on-time" deliveries . . . factory stock-piles of the most popular types and ranges from which they can draw in emergency . . . IRC's distributor network, providing speedy, 'round-the-corner service for small order requirements.

Put this formula to work for you . . . check below the catalog bulletins in which you are interested—tear out this page, and mail it to us today with your letterhead, giving your name and title. International Resistance Company, 401 N. Broad Street, Philadelphia 8, Pennsylvania. In Canada: International Resistance Company, Ltd., Toronto, Licensee.



INSULATED COMPOSITION INSULATED WIRE WOUND RESISTORS IRC types BT & BW



FINGER-TIP CONTROLS AND SWITCHES IRC types H & SH



WIRE WOUND RESISTORS IRC type MW



MATCHED PAIR RESISTORS



POWER RESISTORS



FLAT POWER RESISTORS IRC type FRW



VOLUME CONTROLS IRC type DS



WIRE WOUND POTENTIOMETERS IRC type W



VOLTMETER MULTIPLIERS IRC types MFA & MFB



POWER RHEOSTATS IRC types PR & PRT



WATER-COOLED RESISTORS IRC type LP



PRECISION RESISTORS



HIGH VOLTAGE RESISTORS IRC type MV



HIGH POWER RESISTORS IRC type MP

## INTERNATIONAL RESISTANCE COMPANY

Wherever the circuit says  $\sim$

Power Resistors • Precisions • Insulated Composition Resistors • Low Wattage Wire Wounds • Rheostats • Controls • Voltmeter Multipliers • Voltage Dividers • HF and High Voltage Resistors

# Western Electric

1304 TYPE REPRODUCER SETS

HIT A NEW HIGH IN

*Quality!*



## *Here's Why!*

1. *Wide Response* . . . Famous 9 Type Reproducers bring out the full quality of today's finest recordings—vertical or lateral.
2. *Constant Speed* . . . Entirely new drive mechanism provides constant speed operation at  $33\frac{1}{3}$  and 78 rpm—eliminates trouble from "wows" and rumble.
3. *Rapid Acceleration* . . . Goes from standstill to stable operating speed of  $33\frac{1}{3}$  rpm in one-half revolution.
4. *Vibration-free* . . . Mechanical filters isolate turntable from vibration in motor, driving mechanism and cabinet.
5. *Electrical Speed Change* . . . New electrical method of changing speed eliminates clash-gears or planetary ball devices—permits quick speed change while turntable is running.

The 1304 Type Reproducer Sets will be in production during this year. For full details, call your local Graybar Broadcast Representative or write Graybar Electric Co., 420 Lexington Ave., New York 17, N. Y.

— QUALITY COUNTS —



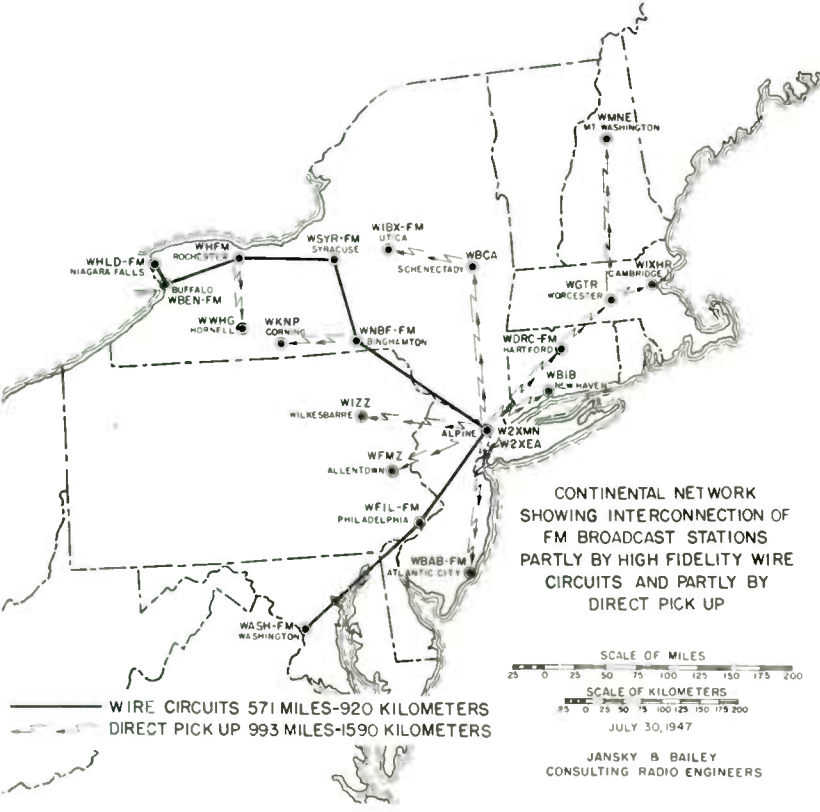

FIG. 1. WIRE AND RADIO DISTRIBUTION OF THE CONTINENTAL FM NETWORK PROGRAMS ORIGINATING AT WASHINGTON, D. C.

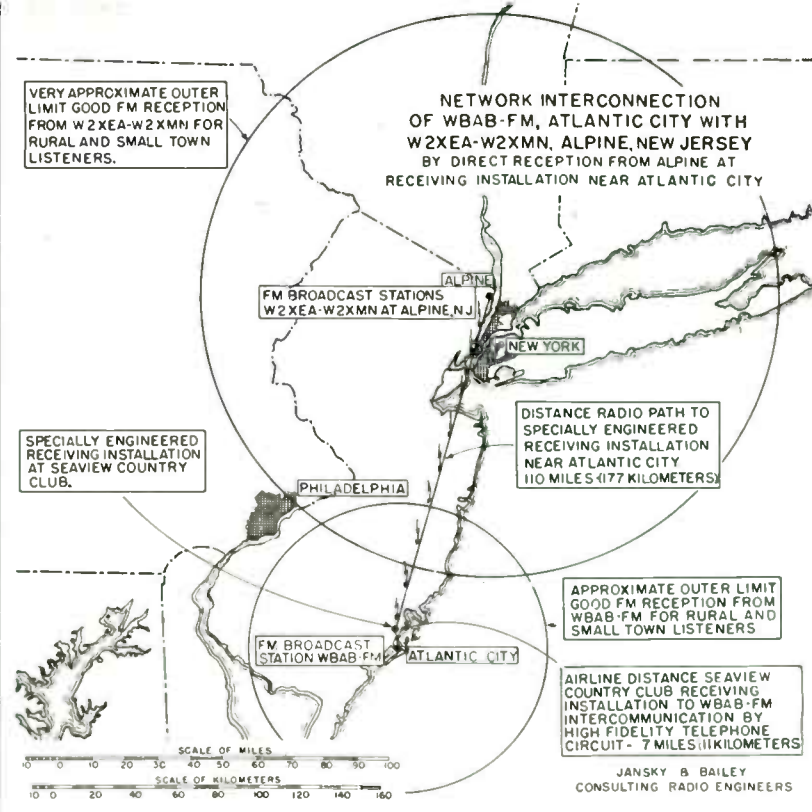

FIG. 2. ALPINE PROGRAMS COULD BE PICKED UP DIRECTLY AT THE AMBASSADOR, ATLANTIC CITY, OR THROUGH WBAB-FM

# FM FOR TROPICAL AND MOUNTAINOUS COUNTRIES

An Address Delivered at the FCC's Demonstration of FM for the Delegates to the International Telecommunications Conference, Atlantic City, August 6, 1947

BY C. M. JANSKY, JR. \*

THE development of the radio art has reached a point where the United States Delegation feels that those attending the International Telecommunications Conference at Atlantic City should have an opportunity to hear Frequency Modulation broadcast programs, and to secure first-hand information regarding methods

\*Jansky & Bailey, National Press Bldg., Washington, D.C.

by which very high frequencies (VHF) can be used to deliver high-grade, static-free and interference-free broadcast service over very large areas.

On July 27, 1947, there were in operation in the United States 253 FM broadcast stations in the band between 88 and 108 mc. In addition, on that date there were outstanding Government authorizations for the construction of 699 such

stations not yet in operation, and applications for the right to construct and operate 172 more. The combined total of stations in operation, under construction, and applied for on that date was 1,124. This number is increasing steadily. These figures show the great interest in FM broadcasting in the United States, and the faith and confidence which the industry here has in this new medium.

AT THE DEMONSTRATION, ONE RECEIVER WAS TUNED TO W2XMN, THE OTHER TO WBAB-FM. NOTE KLIPSCH SPEAKER AT RIGHT



# FM & TELEVISION PROBLEMS

## Proposed Cut in Television Channels—FM Networks—AT&T's Strange Attitude—FMA Needs the Needle

BY MILTON B. SLEEPER

**WE HAVEN'T** any actuary's figures to prove it, but it must be true that the men of the radio business are rugged, sturdy individuals. If it weren't so, they wouldn't stand up long under the continued pressure of new problems created by technical progress, expanding services, and the competition between conflicting interests.

**Proposed Allocations Changes** ★ On August 14, the FCC served up a hot potato in the form of a proposal which, in the face of television's need to increase the number of channels, deletes channel No. 1, 44 to 50 mc.

As if in compensation, the FCC proposes to eliminate the sharing of television channels by communications services, ex-

cept Nos. 7 and 8, 174 to 180 and 180 to 186 mc. This is of no present significance, however, because no communications systems have been assigned to share television frequencies. Thus the change stands as a net loss to television.

To be sure, the worth of channel No. 1 for television is open to question. No one wants it, and the one station to which it has been assigned is not under construction.

The Television Broadcasters Association is preparing to renew its request for 3 additional channels between 108 and 174 mc. Our Government has the following blocks in that part of the spectrum:

108 to 118 mc.  
132 to 144 mc.  
(144-148 mc. ham band)

148 to 152 mc.  
162 to 174 mc.

It is doubtful if the Government can justify its position in holding all these bands. If it cannot, it certainly should release them for television service.

Television has another problem. Channel No. 2, 54 to 60 mc., is seriously troubled with harmonic interference from amateurs on 14 mc. Also, it is adjacent to the amateur's 50- to 54-mc. band. In many cases, amateur stations are near and in line with antennas directed at television stations. Space should be found above 108 mc. for another channel to take the place of the present No. 2.

The truth is that we are approaching a show-down on the matter of television frequencies. The prospect of losing No. 1 channel may be only the beginning, as we pointed out two months ago. The plan to assign communications systems to television's channel No. 1 is only the first raid that will be made into that territory on behalf of the safety services.

The FCC knows this. TBA should recognize it. This is the time to be frank and open, not only for the benefit of television broadcasters and set manufacturers, but in the public interest.

(CONCLUDED ON PAGE 45)

### STATUS OF U.S. TELEVISION STATIONS

As of September 1, 1947

#### ON THE AIR

CHICAGO	Balaban & Katz	DISTRICT OF COLUMBIA	Evening Star Bestg. Co. Bamberger Bestg. Svc.	MICHIGAN	Detroit: King-Trendle Bestg. Corp. Fort Industry Co.	Pittsburgh:	DuMont Laboratories, Inc.
LOS ANGELES	Television Productions, Inc.	FLORIDA	Miami: Southern Radio & Teleg. Equipment Co.	MINNESOTA	Minneapolis: Minnesota Bestg. Corp. St. Paul: KSTP, Inc.	RHODE ISLAND	Providence: The Outlet Co.
DETROIT	Evening News	ILLINOIS	Chicago: American Bestg. Co. National Bestg. Co. WGN, Inc.	NEW JERSEY	Newark: Bremer Bestg. Corp.	TEXAS	Dallas: Carter Publications, Inc. KRLD Radio Corp.
NEW YORK	Columbia Bestg. System DuMont Laboratories, Inc. National Bestg. Co.	INDIANA	Bloomington: Sarkes Tarzian Indianapolis: Wm. H. Block Co.	NEW YORK	Buffalo: WBEN, Inc. New York City: Bamberger Bestg. Co. American Bestg. Co. News Syndicate, Inc.	UTAH	Salt Lake City: Intermountain Bestg. Corp.
PHILADELPHIA	Phileo Corp.	IOWA	Ames: Iowa State College	OHIO	Cincinnati: Crosley Bestg. Corp. Cleveland: National Bestg. Co. Scripps-Howard Radio, Inc. Columbus: Crosley Bestg. Corp. Dayton: Crosley Bestg. Corp. Toledo: Fort Industry Co.	VIRGINIA	Richmond: Havens & Martin, Inc.
ST. LOUIS	Pulitzer Pub. Co.	KENTUCKY	Louisville: WHAS, Inc.	WASHINGTON	Seattle: Radio Sales Corp.	WASHINGTON	Seattle: Radio Sales Corp.
SCHENECTADY	General Electric Co.	LOUISIANA	New Orleans: Maison Blanche Co.	WISCONSIN	Milwaukee: The Journal Co.	TELEVISION APPLICATIONS	
WASHINGTON	National Bestg. Co. DuMont Laboratories, Inc.	MARYLAND	Baltimore: A. S. Abell Co. Hearst Radio, Inc. Radio Tele. of Balt. Inc.	BOSTON	New England Theatres, Inc.	BOSTON	New England Theatres, Inc.
TELEVISION C.P.'s		MASSACHUSETTS	Boston: West'lyse Radio Sta., Inc. Raytheon Mfg. Co.	CINCINNATI	DuMont Laboratories, Inc.	CINCINNATI	DuMont Laboratories, Inc.
CALIFORNIA	Los Angeles: National Bestg. Co. American Bestg. Co. Times-Mirror Co. Dorothy S. Thackrey Earl C. Anthony, Inc. Riverside: Bestg. Corp. of Amer. San Francisco: American Bestg. Co. Chronicle Pub. Co. Assoc. Broadcasters, Inc. Stockton:			CLEVELAND	DuMont Laboratories, Inc.	CLEVELAND	DuMont Laboratories, Inc.
				DALLAS	Interstate Circuit, Inc.	DALLAS	Interstate Circuit, Inc.
				DETROIT	United Detroit Theatres Corp.	DETROIT	United Detroit Theatres Corp.
				LOS ANGELES	Don Lee Bestg. System	LOS ANGELES	Don Lee Bestg. System
				PHILADELPHIA	Daily News Television Co.	PHILADELPHIA	Daily News Television Co.
				SAN FRANCISCO	Don Lee Bestg. System	SAN FRANCISCO	Don Lee Bestg. System



# THE KLIPSCH SOUND REPRODUCER

A Corner-Type Speaker Which Uses the Walls as Part of the Acoustical System

BY PAUL W. KLIPSCH \*

**R**ESULTING largely from a desire to hear symphonic music reproduction with some semblance to a live rendition, armchair philosophy led to experimenta-

tion with corner speaker enclosures. Examples of this design are shown in this issue of *FM AND TELEVISION*, page 21, and page 20 of the August, 1947 issue.

the horn has come to be recognized as the most effective means of achieving high efficiency and, incident to this high efficiency, low distortion. The earlier work has been reported elsewhere.<sup>1, 2, 3</sup> The general design selected as offering the most performance per cubic foot is depicted in Figs. 1 through 4. These figures show oblique, top, side, and front views of the third experimental model designated as model X-3. The efficiency of this horn, based on voice coil impedance measure-

to 30 cycles, whereas the X-3 fundamental radiation was good down to only about 38 or 40.

This idea, together with some mechanical simplifications including flat side members and simplified access door construction, was standardized as the K-3, and a pilot lot was put into production.

**Recent Woofer Development \*** As a result of a demand on the part of individuals who wanted to apply this speaker system to

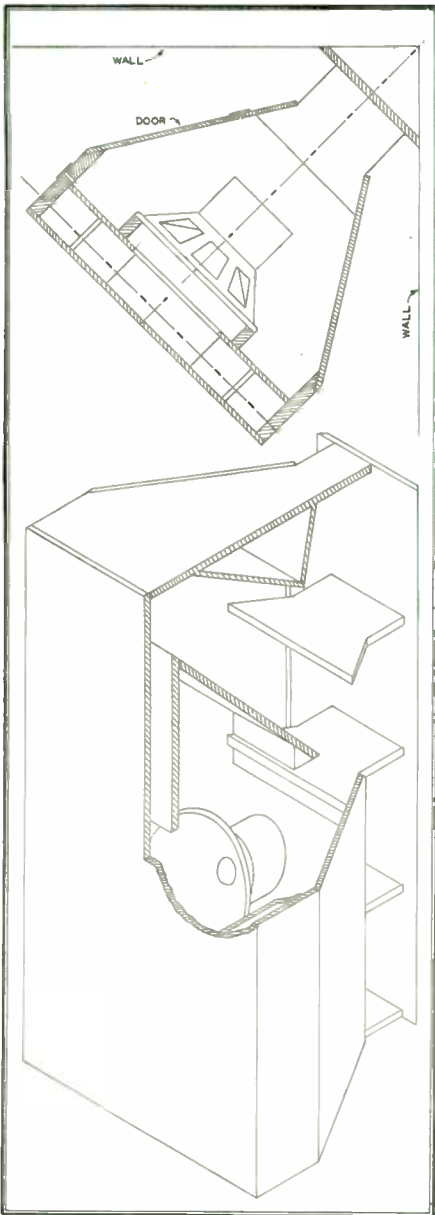

FIGS. 1 AND 2. TOP AND ISOMETRIC VIEWS OF THE BASS REPRODUCER

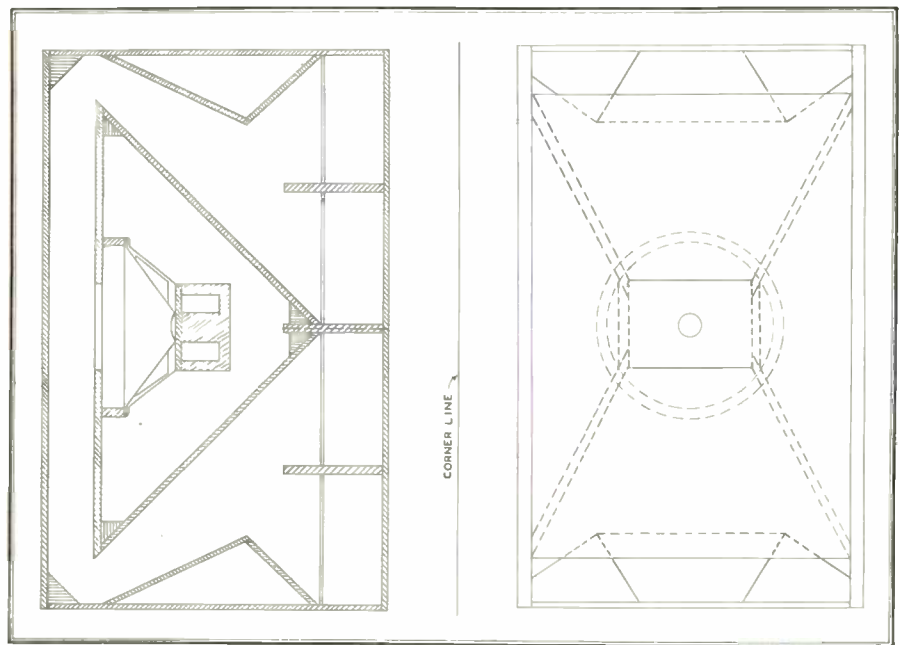

FIGS. 3 AND 4. SIDE AND FRONT VIEWS, SHOWING CAVITIES OF THE CORNER SPEAKER

ments, was better than 20% in the range from 45 to 400 cycles.<sup>2</sup>

The war interrupted development, but late in 1945 some serious thinking was brought to bear on several aspects of the X-3 design; the multiple taper came in for close scrutiny, and it was decided that a taper more closely approximating the simple exponential would be worth trying. Accordingly, using a unit built by Mr. Sherman Fairchild as a guinea pig, the initial taper was altered to eliminate the multiple-taper idea and at the same time to make the average taper rate somewhat lower than the original 47 cycles per second. The result was that the unit would produce a clean fundamental down

electric organs, an effort was made to improve the efficiency in the extreme low end. One successful attack was made by Mr. R. W. Brickenkamp, who scaled the writer's K-3 drawings up by a factor of 4/3, using an 18-in. driver. It was, and still is, this writer's opinion that the limit of performance has been closely approached in the design, and that material improvement in low-end cutoff must be at the cost of larger structures. That is to say, the performance per cubic foot has approached the limit. However, it was recognized that the 15-cubic-foot K-3 has about 1,400 cubic inches of waste space in the form of "sinuses" which occurred in folding the horn around the air chamber. Thus, it can be reasoned that if the horn can radiate below its nominal cutoff,<sup>4</sup> and if the air chamber had been designed "tight," as indicated in the original paper,<sup>1</sup> would it not be possible to increase the maximum wavelength to

**Early Development \*** More by luck than deliberate cerebration, the horn was chosen as a basis, which was fortuitous as

\* Klipsch and Associates, Hope, Arkansas.

<sup>1</sup> P. W. Klipsch "A Low Frequency Horn of Small Dimensions," *J. Acous. Soc. Am.* 13, 137-144 (October 1941).

<sup>2</sup> P. W. Klipsch "Improved Low Frequency Horn," *J. Acous. Soc. Am.* 14, 171-182 (January 1943).

<sup>3</sup> P. W. Klipsch "Design of Compact Two-Horn Loudspeaker," *Electronics* 19, 156-159 (February 1946).

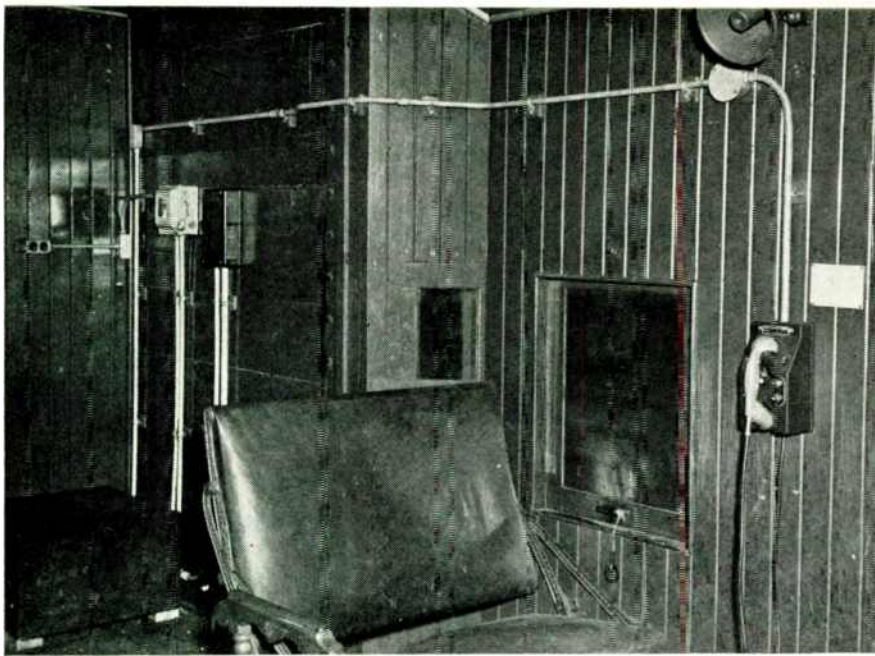

FIG. 1. SPEAKER, HANDSET, AND CONTROL CIRCUITS INSTALLED IN A CABOOSE

# FMI RAILWAY RADIO

Frequency Modulation Is Employed for an Inductive System  
Operating on 50 to 250 kc.

BY F. A. MESCH AND LEW H. MORSE\*

THE FMI (Frequency-Modulated Inductive) equipment described in this article is the result of over four years of continuous, practical experience in the application and design of radio communication equipment to the stringent needs of railroads. As is well known by this time, there have been two main avenues of approach to the solution of this problem: low-frequency FM carrier propagated along the wayside wires, and conventional FM communications on 152 to 162 mc. through space in the usual manner. The purpose of this article is not to argue the relative merits of the two, but rather to treat at some length the low-frequency inductive system developed by the Aircon Radiotelephone Manufacturing Company. It should be noted, however, that the inductive equipment,

\* Railway Radiotelephone and Signals, Inc., 1407 Central Street, Kansas City 6, Mo.

operating on 50 to 250 kc., is so designed as to be readily integrated with a VHF system wherever the use of the latter is indicated, or connected into a regular PBX board to serve as an auxiliary telephone circuit.

**General Description** \* Briefly, an inductive communication link between a wayside station and a moving train consists of the following: — 1) an office unit transmitter and receiver operating on 115-volt AC, and capacitively coupled to the trackside wires, 2) the wayside wires themselves which serve as a transmission path for the carrier, and 3) specially-designed mobile equipment and a power supply operating from the particular voltage available in the engine or caboose. Signal voltage is picked up by a large single-turn loop placed on the engine or caboose, in a plane parallel to the wayside wires. With well-

designed equipment of this sort, very satisfactory communication can be realized between wayside stations installed approximately every 50 miles along the right of way, or between moving trains and the nearer of any two wayside stations. The advantage of having such a communication system now seems beyond argument and, at this writing, all of the major railroads in the country have witnessed demonstrations of one type of radio link or another. Many have made extensive installations, while others are now in the planning stage.

Historically, the equipment described below was developed with the cooperation of the Kansas City Southern Railway, and an extensive inductive system was installed on the Kansas City-Shreveport run of this line. While the figures given above represent the maximum that are quoted for reliable day-to-day communication, there were cases, during experimental runs, when communication was maintained over an inductive link for distances up to 135 miles. Such a phenomenal range as this, with a 5-watt wayside transmitter and a 50-watt mobile transmitter, presupposes unusual terrain conditions, low line-to-ground leakage, and low line noise. A typical installation of present day equipment is shown in Fig. 1.

**Mobile Equipment** \* A typical mobile installation consists of 1) the mobile transmitter-receiver unit and a separate power supply adapted to the available power source, 2) a single-conductor loop antenna which is mounted on either caboose or locomotive, 3) loop tuning unit, 4) remote control unit and handset, 5) call-type loudspeaker, and 6) suitable mounting equipment and a steel, weatherproof box to house the transmitter-receiver and its power supply.

Actual operation of the equipment is quite simple. It is only necessary to turn on the equipment at the start of the run, and calls can be made at any time merely by lifting the handset from the hook and depressing the push-to-talk button on the handset. The receiver itself is always in a stand-by condition during the run, and incoming calls are heard over the loudspeaker. When the handset is lifted, communication over the speaker is interrupted and continued over the handset. The two controls on the handset box, volume and squelch, are seldom reset once they are adjusted to suit the individual operator. A pair of lights on the handset box indicate when the equipment is on "transmit" and when the station is being called.

Fig. 2 shows the mounted power supply and transmitter-receiver. The box is made in two weights, since a heavier covering is necessary when the equipment is to be mounted externally on a tender than for use inside a caboose. Rubber gaskets make this box impervious to moisture.

FIG. 2. FM INDUCTIVE TRANSMITTER-RECEIVER UNIT AND POWER SUPPLY IN STEEL CASE

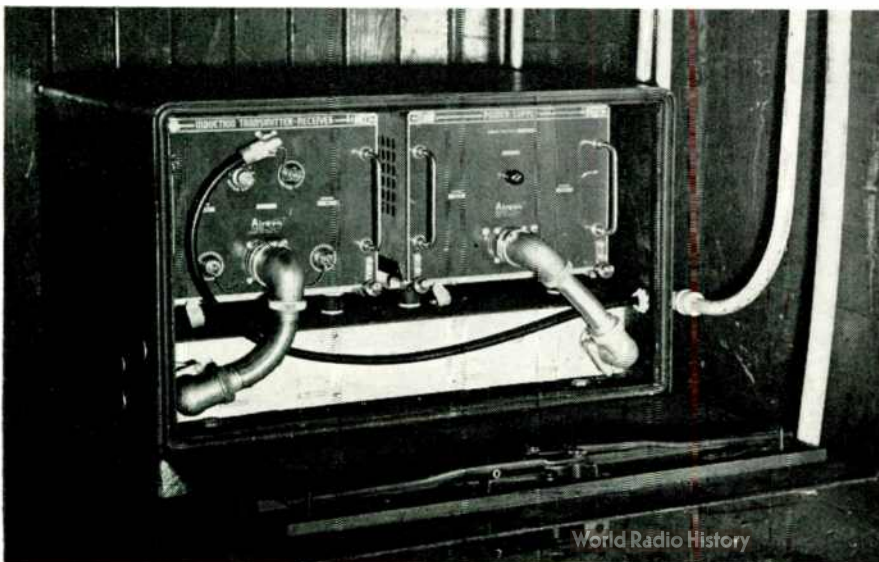



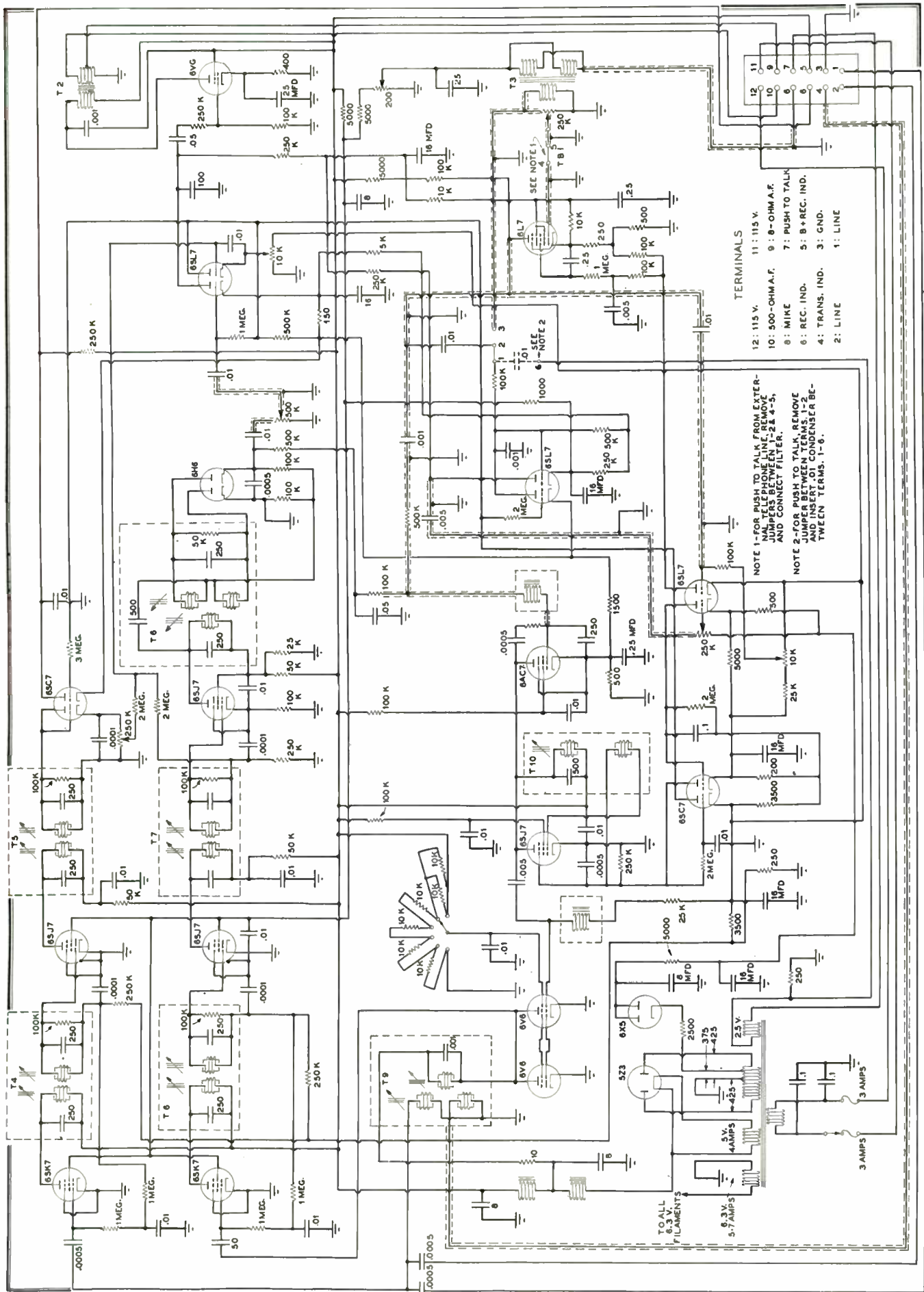

FIG. 5. THERE ARE SEVERAL NOVEL CONTROL FEATURES BUILT INTO THE CIRCUIT OF THE WAYSIDE TRANSMITTER-RECEIVER



FIG. 6. THE LOOP ANTENNA FOR TRANSMITTING AND RECEIVING, MOUNTED ON THE ROOF OF A DIESEL LOCOMOTIVE

phone used is a differential type which has proved very successful in noisy locations.

Two type 1625 tubes serve as Class C power output for the mobile induction transmitter. These are driven by a single 6V6, reactance-modulated by a 6AC7 which is fed directly by the microphone.

Like the receiver RF tubes, the transmitter oscillator is also slug tuned. Deviation is limited to 4 kc., and this is controlled by the amount of modulator stage gain.

Three different power supplies are available, each supplying an output of more than 300 watts, the level required by the mobile induction equipment when on the TRANSMIT position. The 32- and 64-volt DC types each employs tandem dynamotors. Relay action connects both in series to supply high voltage for operation of the transmitter. For trains that have 117 volts, 60 cycles available, a conventional rectifier-type power supply is employed which uses two type 5U4 rectifiers, each with its own filter system.

Dimensionally, power supply and transmitter-receiver are identical. Each is 20 in. deep, with front panels 8 by 10 ins.

While this is a somewhat simplified description of the mobile inductive equipment, it will be seen that the equipment is straightforward in design, though extremely rugged, and very easy to service.

**Wayside Station** ★ A typical wayside station consists of 1) a transmitter-receiver unit, 2) separate remote-control unit which also mounts a speaker, and 3) a handset and hook-switch. As with the mobile equipment, the only controls which need be touched by the operator are squelch and volume control. The crackle-finished, grey steel cabinet seen in Fig. 4 can be mounted in any out-of-the-way spot in the station and forgotten. Dimensions of the office unit are: 20½ ins. long, 20½ ins. wide, 9 ins. deep. The remote control box, customarily mounted on the operator's desk, measures 9½ by 7½ by 4½ ins.

TRANSMIT and RECEIVE lights, squelch and volume controls, and a permanent-magnet speaker are mounted in this remote control box. Fig. 5 shows the circuit of the wayside unit.

The transmitter-receiver and power components of the wayside unit are mounted on a single, vertical chassis which is hinged inside the dust-cover. Thus access to top or bottom chassis components is greatly simplified.

**Wayside Receiver** ★ TRF receiver for the wayside station consists of a 6SK7 RF tube followed by two 6SJ7 limiters. The second limiter is followed by a balanced discriminator, which feeds its audio output to one half of a 6SL7. (The other half of the first audio tube serves as the squelch tube.) The power output tube is a 6V6. Both the regular signal channel and the separate noise channel to be described are slug-tuned.

Perhaps the most interesting feature of the receiver is this separate noise channel, an innovation which was found to be of great assistance in cutting down the high level of electrical noise frequently found on wayside telegraph lines. Essentially, the noise channel consists of a separate

RF channel, identical to the regular signal channel. Line noise is picked up on the receiver side of the line blocking condenser, and applied to the grid of the 6SK7 noise channel RF amplifier. (The normal frequency of this channel is fixed at 190 kilocycles, since the noise envelope will not differ essentially anywhere over the 50- to 200-ke. range of the receiver.) The RF noise amplifier stage is followed by a 6SJ7 noise limiter, identical to the signal channel limiter, and then one-half of a dual triode rectifies the noise current. The DC voltage thus derived is proportional to noise voltage and is used in a differential manner to buck out the equal and opposite DC voltage produced by noise in the signal channel. The bandwidth of both channels is identical, so that each provides, at a given instant, two noise voltages of equal but opposite voltage. With a sequence such as the one given above, line noises cancel out before the squelch tube is reached and, therefore, noise alone can never open the audio end and be heard over the speaker.

**Transmit-Receive Interlocks** ★ Since it is desirable to operate the wayside station  
(CONTINUED ON PAGE 50)

FIG. 4. STEEL-ENCLOSED WAYSIDE TRANSMITTER-RECEIVER OPERATES ON 117 VOLTS AC

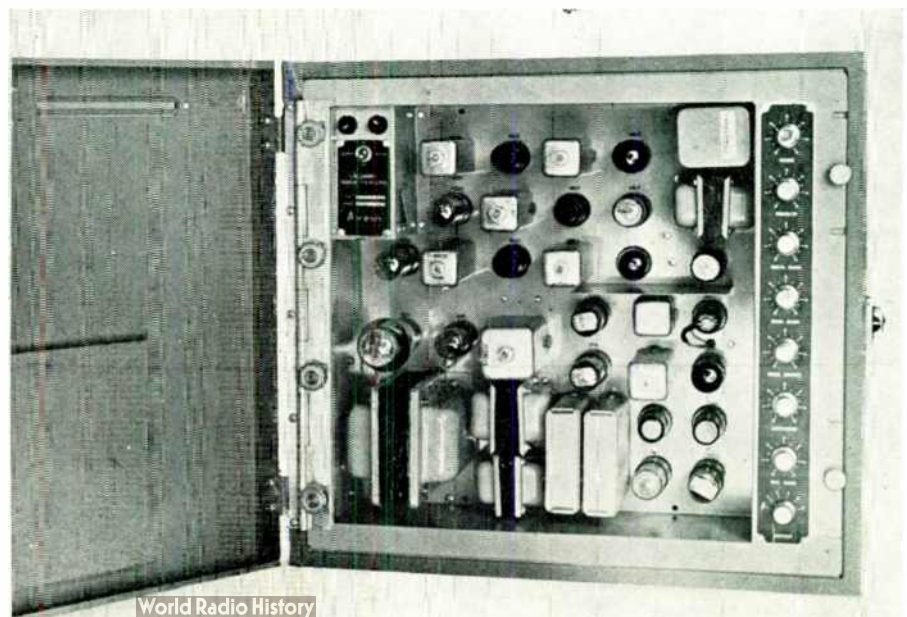

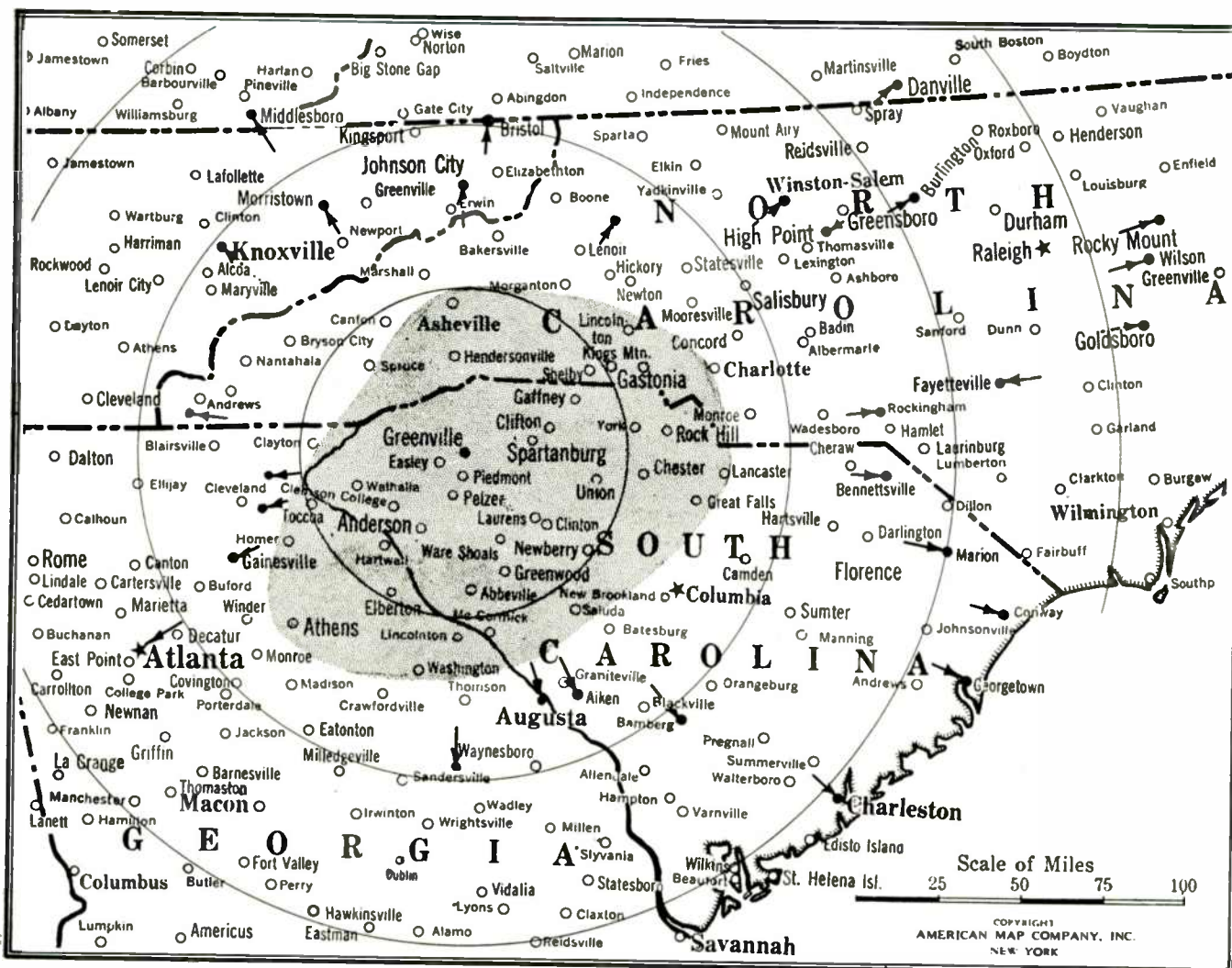

FIG. 9. SHADED AREA SHOWS CALCULATED SERVICE AREA OF WMRC-FM. CIRCLES ARE AT INCREMENTS OF 50 MILES

# THE 48.6-KW. INSTALLATION AT WMRC-FM

An Account of the Planning, Installation, and Operation of a High-Power FM Station—Part 2

BY W. ENNIS BRAY

**Studio-Transmitter Link** ★ We had another problem on the Mountain. Our studios, in the business section of Greenville, were 6¼ miles airline from the FM transmitter. It seemed as if we could get a 15,000-cycle line over that distance without too much trouble or any prohibitive expense. However, we couldn't sell that idea to the Telephone Company.

They allowed that it might be done at a cost of \$20,000 to \$30,000, but they were definite only in their indifference to doing the job at all. At that point, our chief engineer went into action. It wasn't long before we had a 70-mc. relay transmitter in operation at the studio, and a suitable receiver on the Mountain. The total cost was \$500!

Fig. 10 shows the antenna for the transmitter. It was some kind of a radar tower,

bought from Government surplus, light enough in weight that we put it up on the roof of the studio building without any difficulty.

The transmitter cabinet, with a row of four meters across the top, can be seen through the control room window in Fig. 11. This is a convenient spot for it, because the operator can keep his eye on the meters.

Fig. 11 shows the link receiver, set into the wall of the engineer's office at the transmitter. It is a Hallcrafters model, somewhat revised to meet the needs of this special purpose. The system has proved entirely satisfactory, and not only eliminated the initial expense of a telephone line and the monthly charges, but also the possibility of failure in case of a bad sleet storm on the Mountain.

**Coverage** ★ The shaded area on the map in Fig. 9 indicates the calculated coverage area of WMRC-FM, with a radiated output of 48.6 kw. Circles on the map are 50 miles apart. Some of the points where consistent reception has been reported are marked by arrows. Those reports came in while we were operating on 36 kw. effective radiation.

We believe they indicate that we shall deliver solid coverage, day and night throughout the year, somewhat beyond the calculated contour. More will be known about that when the station has been on the air a year. Then the records of listener reports will show up any seasonal changes. Meanwhile, we have been pleased indeed to find that the installation is more than meeting our expectations.

Certainly the performance disproves the

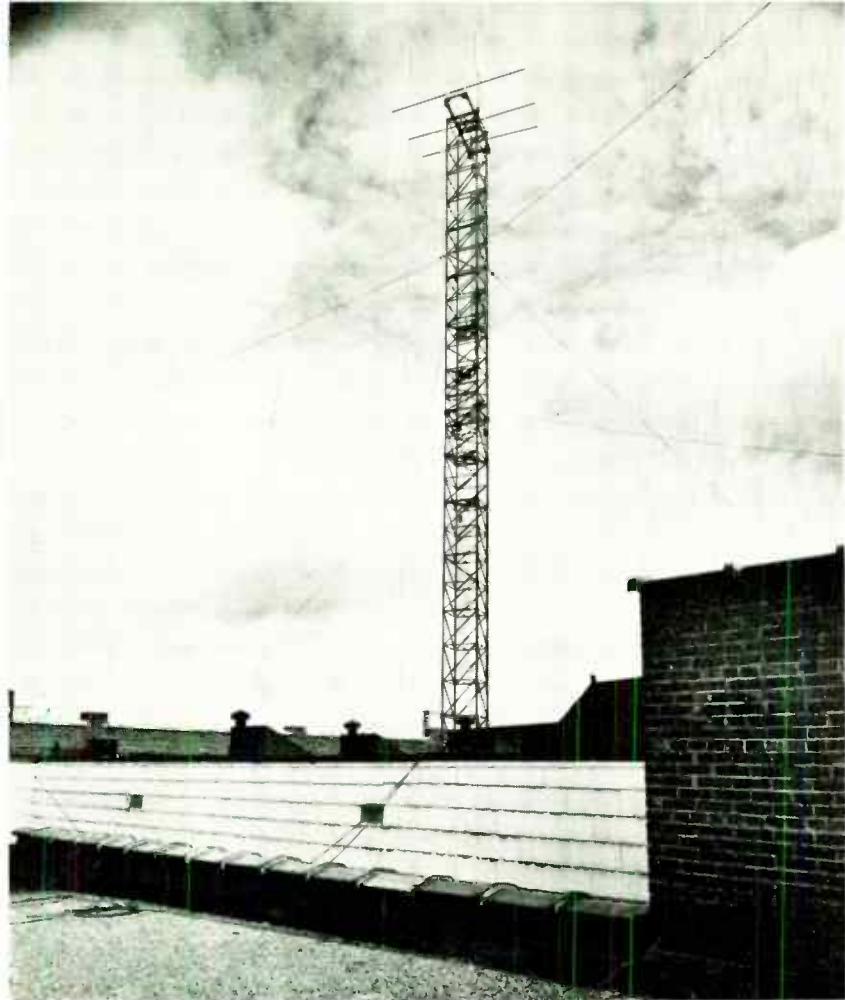

FIG. 10. WMRC-FM RELAY, BUILT BY CHIEF ENGINEER, USES SURPLUS RADAR TOWER. FIG. 11. CONTROL ROOM IS BETWEEN STUDIOS

line-of-sight theory. As any one knows who has flown over this section, there is hardly a level area. In contrast to the straight lines of the plowed fields in the middle-west, in our country all the furrows show the curved lines of contour plowing. So far, we have not found any locations within reasonable distance of the station where our signals cannot be picked up.

We find, for example, that WMRC-FM is being heard at Danville, Va., nearly 175 miles away. That is direct line with Mt. Mitchell, over 6,000 ft. high. This is one of the most distant reports we have received.

One of the most significant reports of long-distance reception has come to us from WRAL-FM, in Raleigh, N. C., at a distance of nearly 200 miles. They have been receiving us so consistently that they asked us to put on a special program from WMRC-FM for their inaugural ceremony. They plan to rebroadcast our transmission as a part of their first official broadcasting. We shall, of course, cooperate with them. This will be our first experience in what, we hope, will eventually become regular participation in FM network operation for this area. The relative location of WRAL-FM can be seen on the map in Fig. 9.

**Programs** ★ Until the official inauguration of WMRC-FM, we operated the station from 3:00 p.m. to 9:00 p.m. Now we start at noon, 7 days a week.

Programming is, for the most part, independent of WMRC, an ABC affiliate. We do carry such ABC features as Drew

Pearson, the Paul Whiteman Club, Elmer Davis, Christian Science Monitor, and America's Town Meeting on FM. One of the most popular FM features is the reporting of local baseball games. Evening games start at 8:15, and we keep the station on the air until they are over. Radio dealers tell us that this has helped them to make many FM set sales, since the games are not broadcast over any other station.

A considerable part of our FM programs are made up of World transcriptions. The quality is excellent, to the point where many of our listeners report that sometime they cannot distinguish them from live talent. Local news is transmitted three times a day from our studios.

In the meantime, as the completion of the FM installation has given us more time to devote to program problems, we are testing out new live-talent ideas to take full advantage of FM quality. We have sampled local talent with a hill-billy band, for example. Galen Harvey has experimented with the Hammond organ on a series of musical programs combined with guest interviews.

Now we are setting up a plan of developing special FM shows, based on our initial experience, and we are beginning to learn much from our first sponsored programs. This has taken us to the point where we expect to gain rapidly from practical experience.

As a part of our preparation for establishing FM rates and selling time, we

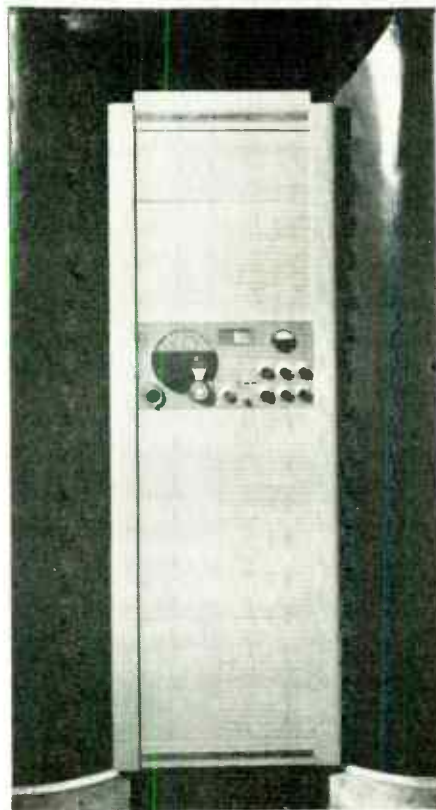

FIG. 12. RELAY RECEIVER USED AT THE TRANSMITTER ON PARIS MOUNTAIN

have been making a very thorough survey of our audience.

At the end of August, our figures showed 15,000 FM sets in use within our service area. But here is what astonished us: Of that total, there are about 4,000 Pilot FM tuners. We find that their performance is consistently satisfactory. However, most of them are being used with outside antennas. This is due in part to the intelligent sales promotion by the local distributor. Credit must also be given to *FM AND TELEVISION Magazine* and its effort to educate the dealers and servicemen in the matter of assuring satisfactory reception by the use of adequate antenna installations. For this we, in turn, are very grateful.

**Organization** ★ An outline of our organization may be of interest to newcomers. Since our staff handles both the FM and AM stations, we are organized for 18 hours of AM operation. This requires extra transmitter and control-room operators, and announcers.

Under the General Manager, acting as coordinator of all station activities, there are the:

- Commercial Manager
- Chief Engineer
- Program Director
- Production Manager
- Traffic Manager
- 3 Transmitter Operators
- 5 Announcers



FIG. 13. TESTS WITH A HILL-BILLY BAND ON FM HAVE PRODUCED INTERESTING RESULTS

- 3 Control Operators
- 2 Bookkeepers
- 2 Salesmen

FIG. 14. GALEN HARVEY USES THE HAMMOND ORGAN FOR SEPARATE FM PROGRAMS



While titles and duties vary at different stations, this is a typical organization for a station in such an area as ours.

**Conclusion** ★ If this account of WMRC-FM were written at the end of 1947, rather than in July, there would be much more factual information to include. So far, we have gone through the period of initial enthusiasm, the discouragements of erecting an FM station under unfavorable conditions, hoping against hope that enough receivers would be sold to justify our putting programs on the air, and wondering if we would ever reach the point of selling time.

Now, all that is behind us. The station is giving an excellent account of itself in point of coverage, we have a larger audience already than we dared to expect, and we are selling time. There are still some problems ahead, but there is every reason to expect we shall lick them, as we have already met others which, in prospect, seemed more formidable.

We are asked: "Do you think you are better off for having pushed ahead in FM, or do you wish now that you had waited six months or a year?"

There is no doubt that we gained many competitive advantages by taking the lead in our area. We are set up to make the most of being first, and we intend to maintain this position. There is so much about FM that can be learned only by first-hand experience. The sooner that experience is gained, the sooner it can be applied to profitable FM operation.



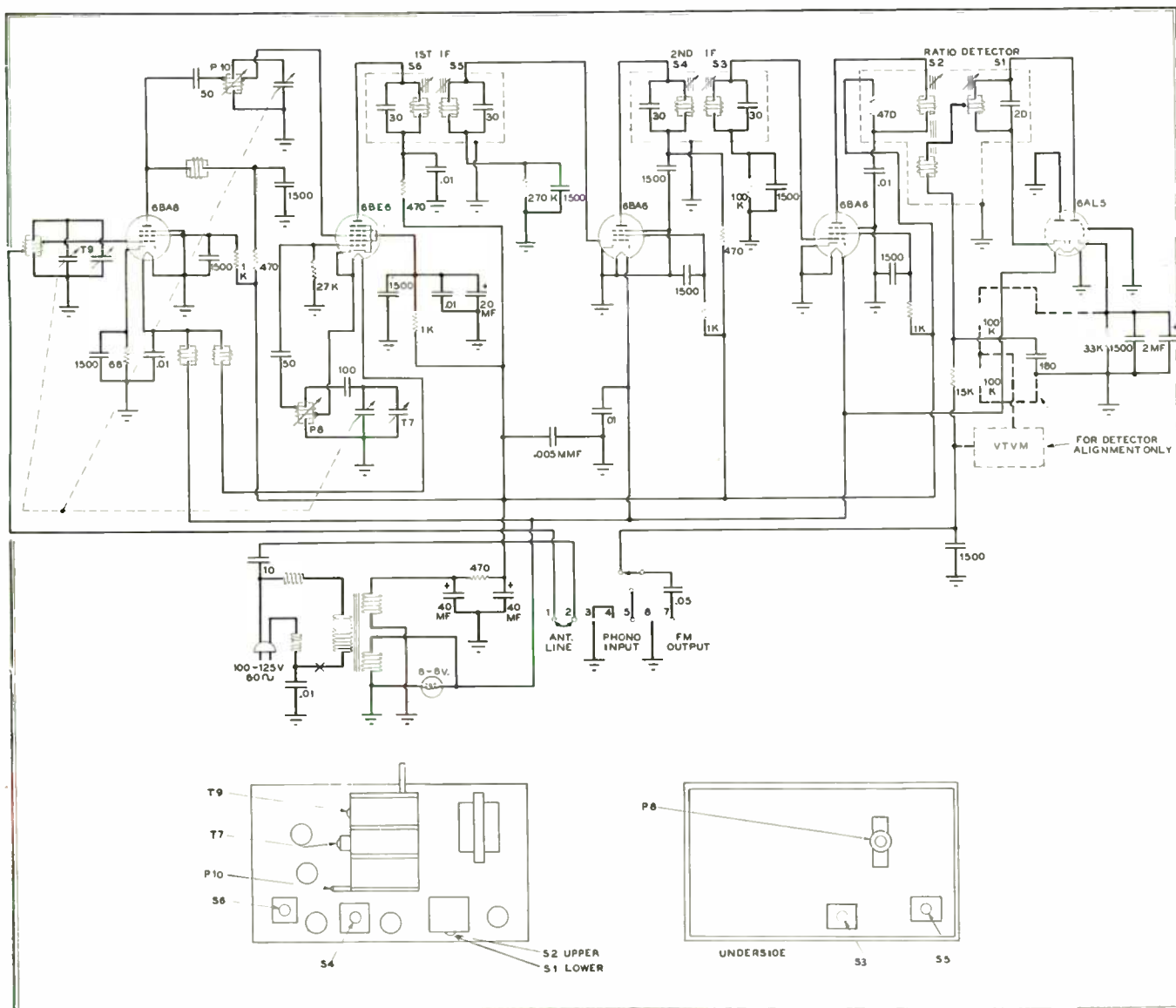

PILOTUNER CIRCUIT EMPLOYS RATIO DETECTOR. ALIGNMENT POINTS ARE INDICATED ON TOP AND BOTTOM CHASSIS DRAWINGS

# DATA ON THE FM PILOTUNER

Circuit and Service Information Show Ease of Use with AM Sets

THE FM Pilotuner was designed as a head end for use with an audio amplifier and speaker, or the audio end of any AM set. It is a complete FM tuning system, covering 88 to 108 mc.

**Antenna** ★ Because of the many different conditions under which the tuner may be required to operate, provisions are made for 3 types of antennas:

1. **BUILT-IN ANTENNA:** When the Pilotuner is shipped from the factory, it is connected for line-cord operation. This is connected internally by the wire link between terminals No. 1 and 2, as shown in the accompanying diagram.

2. **SINGLE-WIRE ANTENNA:** Increased receiving range can be obtained in some areas by removing the link between ter-

minals 1 and 2, and connecting a 4-ft. length of wire to terminal 1.

3. **OUTSIDE ANTENNA:** Maximum range and noise reduction are obtained by using an outside dipole with a 300-ohm line for a leadin. The link between terminals 1 and 2 should be removed, and the 300-ohm line connected across terminals 1 and 3.

**Connections to Am Sets** ★ A 5-ft. cord is furnished with the tuner for connecting it to an AM set, audio amplifier, or record player. The outside shield of the cable must be connected to terminal 6 on the tuner, and the inner wire to terminal 7.

At the other end of the cable, the inner lead goes to the "high" side of the phono connections and the shield to the low

side. To determine which is the high side, turn on the set and switch it to the phono position. Touch one phono terminal and then the other. On the high side, you will hear a hum in the speaker. A little ingenuity may be needed to connect the cable to the special sockets and terminals used on some sets, but if the instructions as to polarity are followed, proper results will be obtained.

**Connections to Phono Combinations** ★ In the case of a radio-phonograph combination, disconnect shielded lead coming from pickup and connect tuner in its stead as indicated in previous paragraph. Then attach center wire of disconnected lead to terminal 4 and shield to terminal 5. Then having located (*Concluded on page 40*)

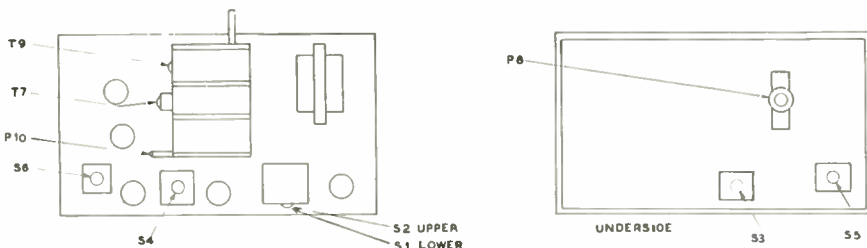

# FM COMMUNICATIONS FOR LOGGING CAMPS

How the Ontario-Minnesota Pulp & Paper Company Uses FM in the Canadian Woods

BY ROBERT L. WASLEY\*

**A**SSOCIATED with the production of paper and pulp products such as insulation and building board is the procurement of the industry's most important raw material, pulpwood. The yearly weight and volume of this commodity is staggering, and the transportation from the forests to the mills poses major problems.

The Ontario-Minnesota Pulp and Paper Company, Ltd., a Canadian subsidiary of the Minnesota and Ontario Paper Company in the United States, gets its supply of pulpwood from the vast and rugged timberlands of northwestern Ontario. This area is still largely an uninhabited wilderness, dotted with thousands of lakes and rivers. The winters are extremely long and cold. There are few roads and fewer telephone lines. Much of the terrain is irregular and rocky. It is from this isolated area that millions of logs must be moved to the mills.

**Problem in Logistics** ★ Many individual logging camps are built each season for cutting timber in the surrounding area. Most of the pulpwood is cut during the winter months, and skidded either to logging roads for transportation by rail or truck to the mill, or onto ice of nearby rivers and lakes to await the spring thaw when it can be towed in booms through connecting lakes, and driven down rivers to the mill.

Logging operations require the services of hundreds of men and much heavy

\*Radio Engineer, Minnesota & Ontario Paper Company, 500 Baker Arcade, Minneapolis, Minn.

machines such as tractors and bulldozers. Marine craft are also used, including tugboats, barges, amphibious crafts called Alligators, which are capable of pulling themselves across portages, and numerous smaller boats.

Logging might be closely compared to a military expedition, since the problems of logistics are so similar. A steady stream of food and stores must be kept moving to the camps. Personnel must be transferred from camp to camp where unforeseen circumstances call for more men in a hurry. Machines break down and repair parts must be supplied. Immediate medical attention or advice is necessary when accidents happen. Weather forecasts from the outside world are needed for efficient operations. Forest fires in remote sections are a constant danger. These are just a few of the many factors that affect woods operations, and demonstrate the need for communications.

In the past, logging operations have been characterized by the complete lack of communications or, at best, inadequate communications. Some telephone lines have been built, but these are costly due to the fact that they must be moved each year to follow the movements of the camps. Also, maintenance on these lines is unusually high.

The Ontario-Minnesota Pulp and Paper Company has found the answer to their communication problem in FM. The Company operates two mills in Canada, one at Fort Frances on the International Border, and another 93 air-miles to the north in Kenora, at the head of sprawling Lake-of-

the-Woods. Each of the mills has been equipped with a 250-watt General Electric FM transmitter for operation in the 30- to 40-Mc. band. Since no direct wire telephone lines run between Fort Frances and Kenora, it was decided that a network should be designed to provide radio communications between the mills. A 300 ft. steel tower, Fig. 1, was built at Kenora, and another at Fort Frances.

**Fort Frances Station** ★ The immediate area surrounding Fort Frances is flat and boggy, the remnant of an old glacial lake bed. Since there was no advantageous high ground within reasonable distance on which to erect a tower and transmitter house, it was necessary to choose a site 3 miles from the mill on a flat composed of muskeg. The tower base, of reinforced concrete, extends 6½ ft. below the ground line to a level of loose sand. This base is supported on 5 concrete piles cast in place and extending down through 7½ ft. of sand and into 1 ft. of clay.

The 4 guy wire anchors, 175 ft. from the tower base, were cast into reinforced concrete blocks, 8 by 8 by 1½ ft. resting on sand. A machined bolt is imbedded on the upper surface of the tower base and of each anchor, for the purpose of making yearly surveys to detect settling or shifting.

The transmitter is housed in a structure 8 by 10 ft. The house is constructed with 13-in. brick walls and a concrete roof and floor. The foundation consists of 9 concrete piles which extend down through 6 ft. of muskeg, and rest on a reinforced concrete slab 13½ x 12½ x 1½ ft. The house is equipped with a steel-plated door, as a precaution against stray bullets from the guns of hunters.

A 5-kva. electric wall heater and thermostat control keep the house at a constant temperature, even in 40-below weather. At one end of the room is a service bench with a series of outlets for plugging in test equipment. The transmitter, outlets, and tower lighting control equipment are supplied from a 2-kva. G.E. voltage stabilizer because the line voltage fluctuates considerably. Tower lighting is controlled by a G.E. photo-electric unit, arranged in parallel with a Sangamo sidereal time clock, to assure that the lights will be turned on in event either device should fail.

The transmitter, power line, tower, and the guy anchors all have separate grounding networks, and are tied together by a copper bus located behind a plate in the wall. In this fashion, a very low resistance to ground was obtained.

FM AND TELEVISION

FIG. 2. FORT FRANCES MILL CAN TALK DIRECTLY TO FLANDERS CAMP, 60 MILES AWAY

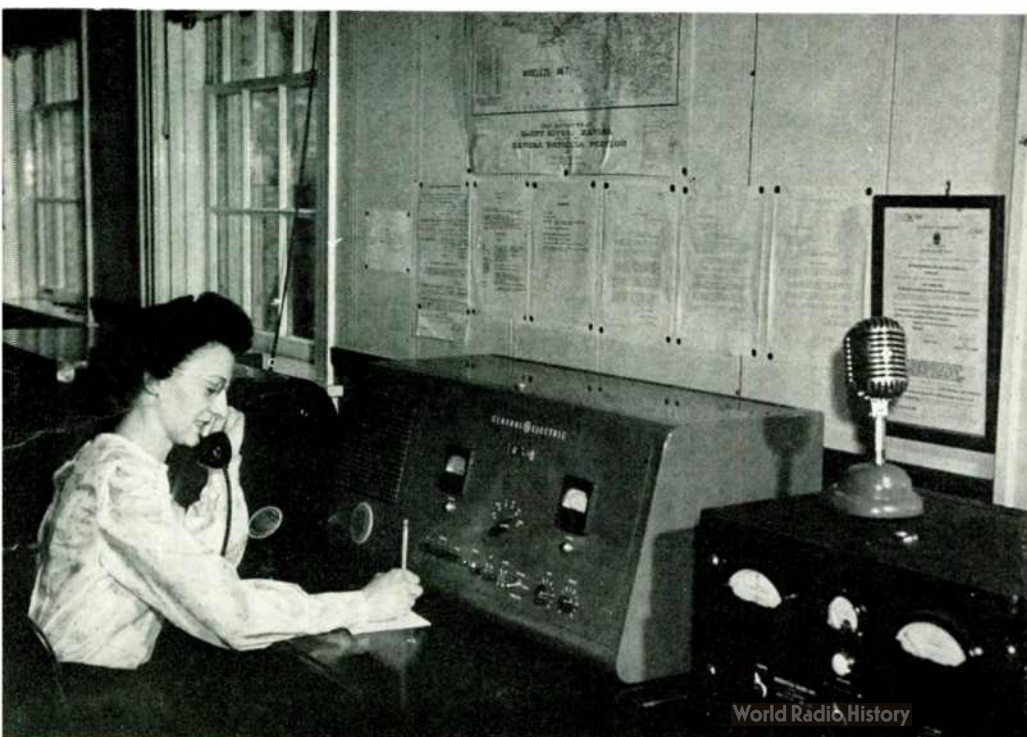

The receiver is on the same rack with the transmitter. Both units can be controlled at the transmitter house, or from a remote control unit in the mill office. A Doolittle FM frequency monitor with an RF adaptor-amplifier, located alongside the remote control unit, is used to monitor the frequency and modulation continuously. This can be seen in Fig. 2. Another remote control is provided at the logging office, several blocks away.

**Kenora Station** ★ The transmitter at Kenora is located on a rocky hill about ½ mile north of the mill. The tower base and guy anchors were secured by drilling into solid rock. A 200-ft. swath was cut through the trees to run in the necessary power and telephone lines. The transmitter house is an insulated wooden structure, containing essentially the same equipment as the Fort Frances installation.

A separate, sound-proof operating room was constructed in the office building across the street from the Kenora mill.

**Headquarters Camp Installations** ★ Most of the logging camps are established to the northeast and west of the two mills, and at distances up to 100 miles. To make complete coverage possible, it was decided to install relay stations at two previously-established headquarters camps, which are more or less permanent in nature. One is located about 60 miles west and slightly north of Kenora, and the other about 60 miles west of Fort Frances. A 60-watt transmitter was installed at each camp office, and coaxial dipole antennas were mounted on 90-ft. guyed wooden masts. Thus, 4 key stations made it possible for 9 radio-equipped camps, scattered throughout the surrounding area, to send and receive messages, either by direct communications or by relay, to any of the other stations in the network.

FIG. 3. KENORA OPERATOR AND ENGINEER LEYDIER CHECK 60-WATT PORTABLE

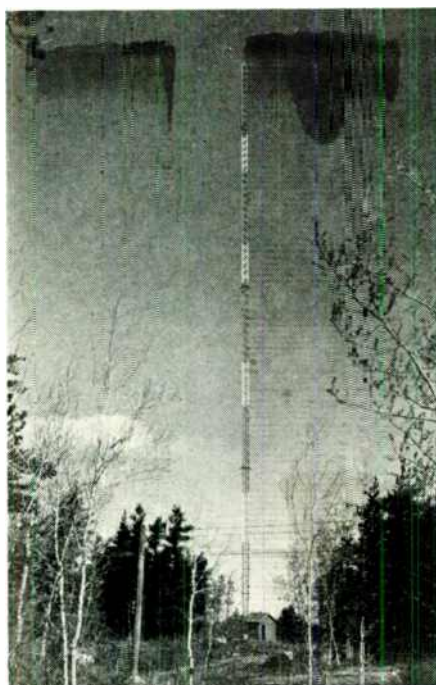

FIG. 1. THE 300-FT. TOWER AT KENORA

**Portable Stations** ★ The portable stations for individual camps as well as those used at the headquarter camps are 60-watt G.E. units, with the transmitter and receiver shock-mounted in a small, taxi-size wardrobe trunk. These equipments are shown in Figs. 4, 5, and 6. When the trunk lid is open, a panel is exposed which carries a loud speaker, the necessary controls, and a wall bracket to mount and hold the telephone handset. In the upper right hand corner of the trunk is an antenna mounting bracket. A telescoping quarter-wave, whip-type antenna, carried in the lid of the trunk, can be quickly removed, extended, and screwed into the antenna mounting bracket. The lower compartment contains the power cord, a length of ground wire with an alligator clamp, 60 ft. of coaxial cable with terminating connectors used if the antenna is mounted remotely, and a large C clamp to fasten the removable antenna bracket if it is desired to mount the antenna in a more advantageous location. The upper compartment consists of a drawer containing a complete set of spare tubes, a kit of small tools, spare fuses, a multimeter and test leads, and a space for storing the telephone handset. The complete station can be assembled and put on the air in less than 5 minutes.

At Camp Mando, the trunk unit was set up in the camp clerk's office with the antenna at the top of a 30-ft. pole. The equipment draws 325 watts maximum from the camp's 115-volt, 60-cycle, gasoline-driven power system.

**Tugboat Installations** ★ Similar 60-watt stations are being installed aboard two of the Company's lake tugboats. These units are of the standard mobile type. The radiating system consists of an Andrews Unipole with a quadrature counterpoise.

The mast can be lowered to allow the tugboat to pass beneath low bridges and power lines.

**Radio Maintenance** ★ A policy of preventive maintenance has been established to insure continuous satisfactory service. Before the equipment was put into operation, selected personnel from the electrical department were given a 10-day course covering the theory, circuits, operation, maintenance, and test equipment.

Each mill was furnished with radio service equipment comprising an oscilloscope, RF signal generator, a multimeter, tube tester, a set of wave meters, and other small equipment necessary to make complete over-all alignments and major repairs. A complete stock of spare parts and tubes is kept on hand at all times.

**Advantages of FM** ★ Camps operated from O. & M. headquarters are as much as 100 miles into the virgin timberlands. Roads are rough logging trails, or mere paths cleared by bulldozers. During the spring and fall, rains stop or slow down traffic to the camps. Before the radio system was put into operation, all communications were frequently cut off for days at a time. Winter snowfalls are even more effective in isolating the camps.

The log books of the main stations are filled with records of unusual events. A camp on Trail Lake, for example, reported that one of its men had suffered serious injury. While a doctor at Kenora gave first aid instructions by radio, arrangements were made to stop a Canadian Pacific train at Vermillion Bay, where the injured man was taken by a camp truck. Within a few hours, he was at the Kenora hospital.

At John Lake, an equally isolated spot, a woodsman was taken with appendicitis. All roads were closed, but a doctor was dispatched in a plane equipped with pon-

FIG. 4. PORTABLE UNITS ARE USED IN WOODS FOR SUMMER LOGGING DRIVE

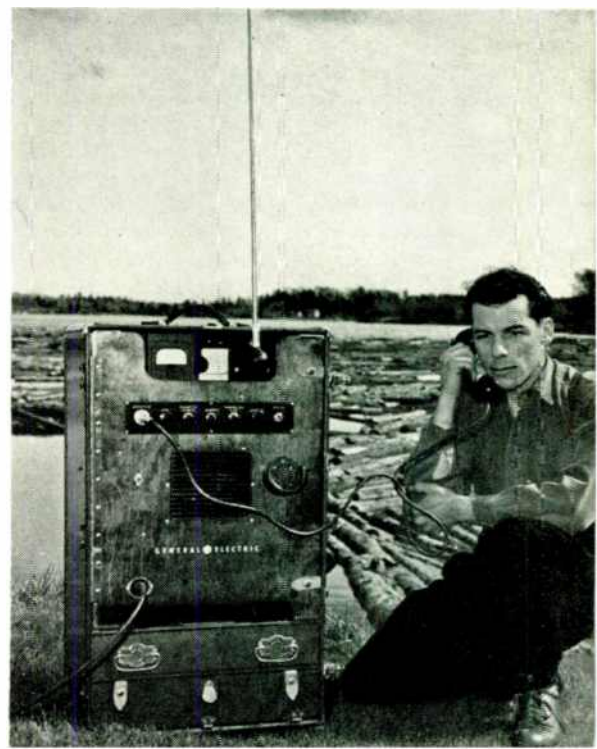



FIG. 5. ENGINEER SНИЕZEK USES TRUCK DURING CAMP CONSTRUCTION. FIG. 6. BOSS WHITE'S OPERATING SHACK AT CEDAR LAKE

toons. Arriving at the camp, the doctor found the man's condition so serious that he called the Kenora hospital to say that he was flying the patient back, and to prepare for an emergency operation.

So the log goes on with its record of services to the men and the Company.

This summer, the Company will use FM in a new way. For the first time, it will attempt to coordinate and expedite a major log drive by radio. Thousands of cords of pulpwood must be rounded up from many lakes and herded through a labyrinth of rivers, lakes and dams, to arrive eventually at the mills. This harvest of pulpwood begins with the spring thaw and ends with the winter freeze. It is a battle against time, water levels, and head winds. Personnel associated with the drive are scattered over many miles. Five 60-watt portable stations in trunk-units, powered by gasoline-driven generators, are to be used at strategic points in an effort to conserve head waters and increase the total yield by coordinating the drive.

Construction is now under way for another Company system to be installed throughout Northern Minnesota. A 250-watt station is to be located in Big Falls, Minnesota to serve some 19 logging camps in the surrounding area. There is to be another station at the mill in International Falls, for the purpose of controlling the water level of Rainy River at International Falls. Several 60-watt mobile installations are planned for the powerline service trucks.

J. A. Ryan, logging supervisor at Kenora, summed up the value of FM recently when he reported to Mando executives: "You can take anything away from me in the way of equipment just so I retain the new FM radio. I've logged for years, but I wonder now how we ever did it effectively before without radio."

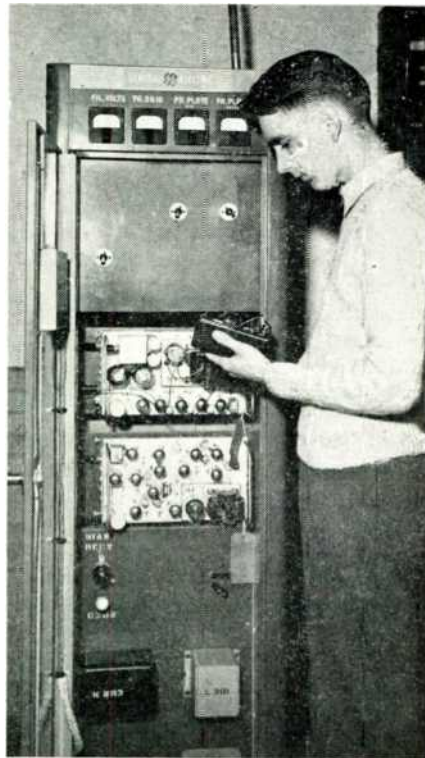

FIG. 7. 250-WATT MAIN STATION TRANSMITTER. EQUIPMENT IS SERVICED ON PREVENTATIVE MAINTENANCE SCHEDULE

## DATA ON THE PILOTUNER

(CONTINUED FROM PAGE 37)

the leads from the phonograph to the radio set, leave them connected, but attach the shielded wire of the cable to the "high" side, and the center wire to the "low" side. If the connections are made correctly, the phonograph will operate normally when the Pilotuner is switched off.

**AC Hum** ★ If there is an excessive hum on FM, reverse the line cord plug on the receiver, or tuner, or both. If it continues, the connecting cable from the tuner may not have been wired correctly.

**Alignment** ★ Allow at least 30 minutes for the tuner to warm up before making adjustments. **STEP 1, IF ALIGNMENT:** Set the tuner at 88 mc. Connect a signal generator to the grid of the 6BE6 through a capacity of .01 mfd. Set the generator at 10.7 mc., and adjust S2, S1, S4, S3, S6, and S5 for maximum output. Use a VTVM connected across two 100,000-ohm resistors, as shown in the diagram.

**STEP 2:** Repeat Step 1.

**STEP 3, RATIO DETECTOR:** With the tuner at 88 mc. and the generator still connected and set at 10.7 mc., adjust the VTVM to zero setting and then connect it from the junction of the two 100,000-ohm resistors to the audio output of the ratio detector, as the diagram shows. Adjust S1 until the meter reads zero. The meter should register reversed polarity when S1 is rotated through zero output.

**STEP 4, OSCILLATOR:** Adjust the tuner to 90 mc. Set the generator at 90 mc., and connect it to the antenna terminal through a 300-ohm carbon resistor. Connect the VTVM as in Step 1, and adjust P8 for maximum output.

**STEP 5:** Without changing the connections, adjust the tuner and generator to 106 mc., and adjust T7 for maximum output.

**STEP 6:** Repeat Steps 4 and 5.

**STEP 7:** Repeat Step 4, but adjust P10 for maximum output.

**STEP 8, RF:** With the tuner and generator at 106 mc., repeat Step 4, but adjust T9 for maximum output.

# TELEVISION HANDBOOK

## CHAPTER 3—Primary Components of Equipment

### Part 2: Image Dissector Tube and Its Associated Circuits

BY MADISON CAWEIN

**3. The Image Dissector** ★ (3.1) *Description:* This section describes the image dissector and its associated circuits in some detail for the information of those television engineers who are not familiar with this type of photo-electric pickup device. It will be the purpose to present simplified circuit arrangements for the dissector, whereby those skilled in the art may arrive at an understanding of dissector performance as a television pickup device.

The dissector is recommended primarily as a motion-picture pickup, rather than as a direct-pickup camera-tube. There are two reasons for this: the first is concerned with the sensitivity of the dissector, which is admittedly less than that of storage types of television pickup tubes; and the second is concerned with linearity of photo-response and freedom from electronic shading. In the reproduction of motion pictures by television systems, the sensitivity to light is not of prime importance, whereas linearity of response and freedom from shading are of prime importance.

There are three types of standard dissectors: the standard diameter is  $4.5 \pm \frac{3}{16}$  in.; overall lengths are  $9.5 \pm \frac{1}{4}$  in. or  $13 \pm \frac{1}{4}$  in.; multiplier apertures are supplied on-center or approximately 1.5 ins. off-center (to remove the multiplier structure from the light path of a projector); and spectral response curves, either of the *daylight* variety which peaks in the green, or of the *infrared* variety which peaks around 8,000 Angstroms, can be supplied. Fig. 49 shows typical spectral response curves for the two types of dissectors.

A photograph of the standard image dissector, type D12LD, is shown in Fig. 50 while Fig. 51 gives a suitable circuit diagram for this tube. This tube comprises a photo-sensitive cathode of the caesium-oxide-silver type, arranged in an evacuated envelope opposite an optical window. An 11-stage electron multiplier is placed directly inside of the optical window. This multiplier contains an aperture, usually square and approximately 0.012 in. on a side, for high-definition television pickup. The size and shape of the aperture may vary from tube to tube, the size depending upon the magnification of the electron image between cathode and aperture, and the resolution desired. This electron image extends outward from the cathode like bristles in a brush, usually diverging from

the cathode. It is possible to obtain a blow-up in image-size up to 2.5 times, depending upon the type of magnetic focussing-field utilized. The extended electron image is focussed in the plane of the aperture by means of a longitudinal field parallel to the axis of the dissector. This image is deflected across the aperture, either horizontally or vertically, or both, by means of rectilinear, saw-toothed magnetic fields, arranged at right angles to one another. The tube is relatively non-microphonic.

A second type is called the *gooseneck* dissector, Fig. 52. The type number of

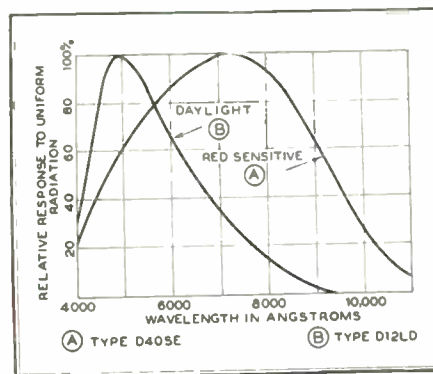

FIG. 49. SPECTRAL RESPONSE OF TWO TYPES OF IMAGE DISSECTOR TUBES

this tube is D15LF. A third type of tube, D40SE, is shown in Fig. 53. This tube is shorter than the standard tube, and is used for direct pickup in industrial applications. The short tube is more difficult to scan than the long tube, but has a shorter focal length and requires a less expensive lens for direct pickup applications. The long tubes are for use in-telescope channels, usually with continuous motion projectors. The numbers in the type designation refer to size of aperture D15LF, for example, refers to a long dissector with a 15-mil, square aperture.

As the extended image is scanned across the aperture, the portion of the extended space current entering the multiplier is proportional at every instant of time to that part of the extended-image current-density at which the aperture is looking.

The aperture current is proportional to the area (or square of the linear dimensions) of the aperture, to the illumination of the cathode, and to the photo-sensitivity of the cathode. The photo-sensitivity is approximately 20 microamperes per

lumen (for the portion of radiant energy in the visible spectrum). There are approximately  $10^{-10}$  amperes entering the 40-mil aperture at any instant of time, when the cathode illumination is 40 f-c. The subject of the sensitivity of the dissector will be discussed later.

The recommended operating voltage of the electron multiplier is between 100 and 200 volts per stage. The gain per stage is of the order of 3.4 at the higher potential, and the overall gain is approximately 1,000,000, so that the output current is of the order of 0.1 milliamperes for those regions of the optical surface having 40 f-c illumination. Calculations for other illuminations and sizes of apertures can be made as indicated in the discussion on sensitivity in the next section. The gain per stage of the multiplier is proportional approximately to the square root of the intra-stage potential.

The image dissector can be used for direct pickup, providing that a high-quality projection lens is used; but only in cases where the studio illumination is relatively high; that is, of the order of 5,000 foot-candles or greater. The lens should be  $f/2.5$ , having a back focal length of 9.25 ins. (in the case of a 10-in. dissector) and an aperture approximately 4 ins. in diameter. Due to the wide angle of this lens, reflected images from the wall coating can produce an *optical shading* which is bothersome. For this reason, the dissector walls are sandblasted to reduce reflections.

The recommended application for the dissector, however, is with a still projector or a motion picture projector, in which case an image approximately 1.2 by 1.6 ins. is projected onto the cathode directly. The average illumination level should be approximately 1,200 foot-candles, to obtain a signal relatively free from noise, with a 15-mil aperture. If infrared filters are not used, the average illumination necessary, with a 2,870° K source, is in the neighborhood of 120 foot-candles to obtain good pictures with the 40-mil tube, using a red-sensitive surface.

(3.2) *Sensitivity of Dissector:* In Fig. 54, assume that there is a uniform distribution of light on the cathode of a dissector, so that the illumination is

$$f(t) = L \text{ (lumens/ft}^2\text{)} \quad (7)$$

Let  $M$  be the linear magnification between the extended electron-image ar-

# NOW!

## TELEVISION

## AT TWICE

## THE PRESENT

## RANGE



# VEE-D-X LONG DISTANCE TELEVISION ANTENNA

Men of vision choose . . . THE VEE-D-X!  
MEASURE THESE IMPORTANT FEATURES  
with your TELEVISION YARDSTICK!

1. RECEPTION AT TWICE THE PRESENT RANGE  
High front-to-back ratio, designed for maximum attenuation of all signals in other than the desired directions.
2. LOW IMPEDENCE —  
Gives you minimum transmission-line losses. Where man-made static interference calls for co-axial cable — proper impedance-matching is easy with the VEE-D-X antenna.
3. "Q" OR MATCHING SECTION —  
gives you convenient method of matching impedences of transmission lines to antenna.
4. RESONATES FOR HIGHER GAIN —  
at any given frequency with only slightest reduction of band-width.



### FM FOR TROPICS & MOUNTAINS

(CONTINUED FROM PAGE 56)

**FM Network Operation** ★ The map presented in Fig. 2 shows in graphic form the method by which Atlantic City FM station WBAB-FM receives and rebroadcasts programs from W2XMN-W2XEA, at Alpine, New Jersey.

W2XEA operates on a frequency of 92.1 mc. with a power of approximately 20 kw. W2XMN operates simultaneously on a frequency of 44.1 mc. with a power of approximately 30 kw. In each case, an antenna array with several units is used to increase the radiation in the horizontal plane. The approximate range of the stations at rural or small town receiving locations, using outside antennas, is about 90 miles (145 kilometers). Although the coverage area is shown as circular, there are minor differences in range in different directions, due to several factors.

At the Seaview Country Club, 7 miles (11 kilometers) distant from Atlantic City, a special receiving antenna has been installed on a tower 120 ft. (37 meters) high. As the ground elevation is 40 ft. (12 meters), the antenna is approximately 160 ft. (49 meters) above sea level. A receiver which takes full advantage of the ability of FM to suppress noise and interference is used. It is capable of operating on low signal strengths, if necessary. The output of the receiving set is connected to a wire circuit which carries the program to the WBAB-FM transmitter. This wire circuit, which is capable of carrying audio frequencies up to 16,000 cycles, is connected to the input of the FM transmitter, thereby making it possible to rebroadcast programs as received from Alpine. WBAB-FM uses a 1-kw. transmitter, with an antenna height of approximately 200 ft. (61 meters). The range of this station is about 45 miles (72 kilometers) for normal receiving sets. This range is the same day and night.

The airline distance from Alpine to Atlantic City is 116 miles (186 kilometers). The distance from Alpine to the special receiving installation is 110 miles (177 kilometers). The balance of the distance to WBAB-FM's transmitter is covered by the short wire circuit.

An additional FM radio link, not shown on the map, is employed for the special demonstration over the route shown in Fig. 2. The program originates at Yonkers, N. Y., across the Hudson River from Alpine. The program is carried over a low-power FM radio circuit from the Yonkers station W2XCR to Alpine on a frequency of 158 mc.

**Alpine-to-Atlantic City Profile** ★ Fig. 3 shows the extent of radio transmission beyond true line-of-sight utilized in direct reception of W2XEA-W2XMN at Atlantic City. The center of the transmitting array at Alpine is 350 ft. (107 meters) above

(CONCLUDED ON PAGE 61)



Distributors' Territories Still Open—Write to

**LA POINTE-PLASCOMOLD CORP.**

Unionville, Conn.

# The WORKSHOP FM "TOWER" A New Type of FM TRANSMITTING ANTENNA

Incorporates design and structural features  
unique in the field of broadcasting

The new Workshop FM "Tower" Antenna is the ultimate in clean-cut design and performance. Complicated feed systems coupled with elaborate mechanical structures — costly, inefficient, troublesome — have been eliminated.

## FEATURES

### THE SINGLE SELF-SUPPORTING TOWER STRUCTURE IS THE ANTENNA!

No protruding elements to increase wind and ice load.

### INSTALLATION PROBLEMS CUT TO A MINIMUM.

Complete section easily handled by two men.

### TOTAL WEIGHT — 183 lbs.

This allows use of lighter and less expensive supporting structures.

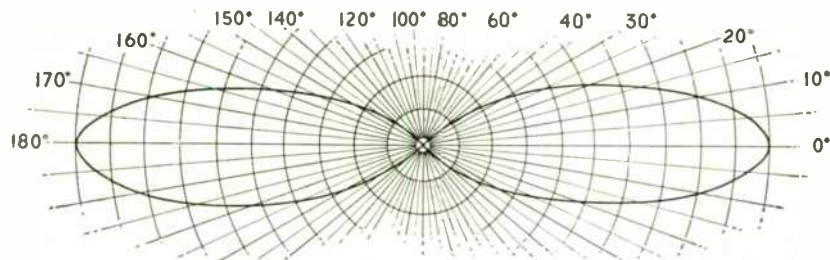

Vertical Pattern of Workshop "Tower" Antenna — single section.  
Actual measurements in power at 101 mc.

### HIGHEST GAIN PER ANTENNA HEIGHT.

Equal or superior in gain to a 3-bay  $\frac{1}{2}$  wave spaced array of conventional types.

### MECHANICALLY STRONG.

Four strong aluminum alloy channels rigidly mounted to reinforced circular end castings.

### SECTIONS CAN BE STACKED FOR ADDITIONAL GAIN.

For higher gain Model FMT1 can be stacked on heavier lower sections—available soon.

### NO DE-ICING EQUIPMENT NECESSARY.

High voltage points separated by a 15" gap. Icing effects negligible.

### LESS WINDLOAD AND WEIGHT THAN ANY OTHER ANTENNA OF COMPARABLE GAIN.

### LOW MAINTENANCE COST.

Simplicity of construction assures a minimum of maintenance.

### HORIZONTALLY POLARIZED.

Uses a new "wave-guide" principle of radiation (patent pending). Two short wave-guide sections arranged and fed at 90 degrees.

### ABSOLUTELY NON-DIRECTIONAL.

The azimuth pattern is circular to better than a ratio of 1.1 to 1 in power.

### LOW STANDING WAVE RATIO AT YOUR FREQUENCY.

Antennas are pretuned at the factory. Accurate standing wave ratio carefully measured on each antenna before shipping. Complete data supplied.

### EYE APPEAL.

The neat streamlined appearance of the new Workshop "Tower" Antenna adds to the beauty of any building or tower rather than detracting from it.

### PROVIDES A MOUNTING FOR A STANDARD 300mm BEACON.

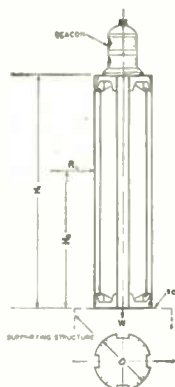

ANTENNA LOAD DATA		
LOAD $R_1$ , includes 300 mm beacon		409 <sup>0</sup>
	30" sq ft	
HEIGHT $H_1$		11' 8"
HEIGHT $H_2$		6' 11"
DIAMETER $D$		18 1/2"
BENDING MOMENT AT TOP OF SUPPORTING STRUCTURE moments include 300 mm beacon		
	30" sq ft	2,840 ft lbs
WEIGHT $W$ exclusive of beacon		183 lbs

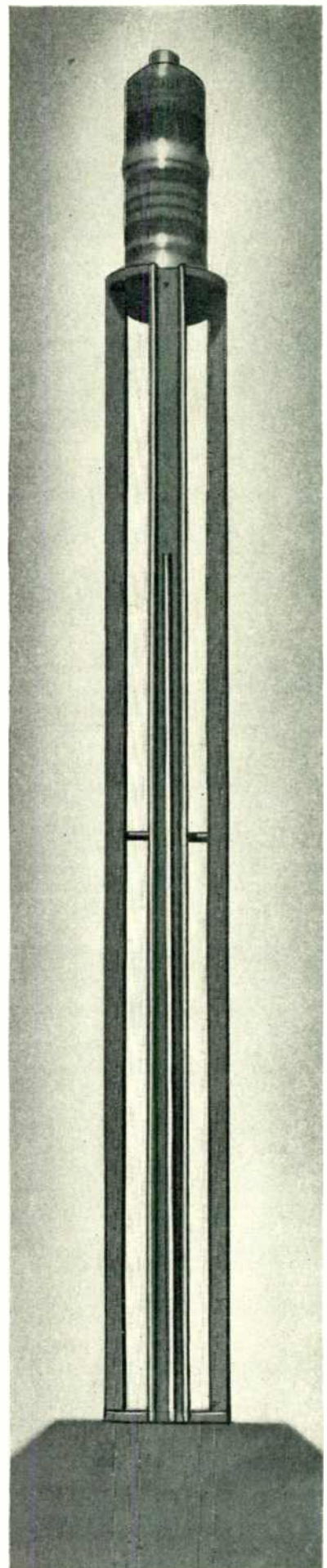

## THE WORKSHOP ASSOCIATES INCORPORATED

Specialists in High-Frequency Antennas

66 NEEDHAM STREET, NEWTON HIGHLANDS 61, MASSACHUSETTS





## Have you ordered your Alden Four Inch Facsimile Recorder?

**Now \$100.00**

The Alden Four Inch Recorder is jigged and fixtured for its preproduction runs — orders are being accepted for production. Broadcasters who are not content with just theory are using this recorder for home use tests.

Here are some of the things you can do with  
the Alden Four Inch Facsimile Recorder —

You can use this recorder with the inexpensive sets even when operating under marginal reception conditions. Such sets connect to amplifier supplied in our complete home recording package with the recorder housed in either a chairside cabinet or night table.

Again, "Alden Four" recorder with its built-in rectifier may be operated directly from sets having a 3 watt output.

The low frequency requirements of this four inch recorder make possible experimental multiple operation of facsimile and sound simultaneously with more than 10,000 cycles of the frequency spectrum left for sound. Note this gives higher frequencies on the spectrum for sound than used for simultaneous television and sound broadcasting.

The same low frequency requirements make possible the simultaneous transmission and reception of broadcasts to bulletin size or four inch recorders by phone line and radio separately or in combination.

Manufacturers indorse the Alden Four Inch Recorder because of small cubic space, and its low power consumption makes it particularly adaptable to mobile use and operation from rural lighting units.

Free descriptive literature sent on request — or send one dollar to be placed on our SPECIAL MAILING LIST to receive timely facsimile releases. This includes a 20-page booklet just off the press discussing dual operation, multiplexing, hook-ups to existing sets, standards, how facsimile broadcasting operates, and answering many other pertinent questions.

# ALDEN PRODUCTS COMPANY

117 North Main Street

Brockton 64, Mass.

60

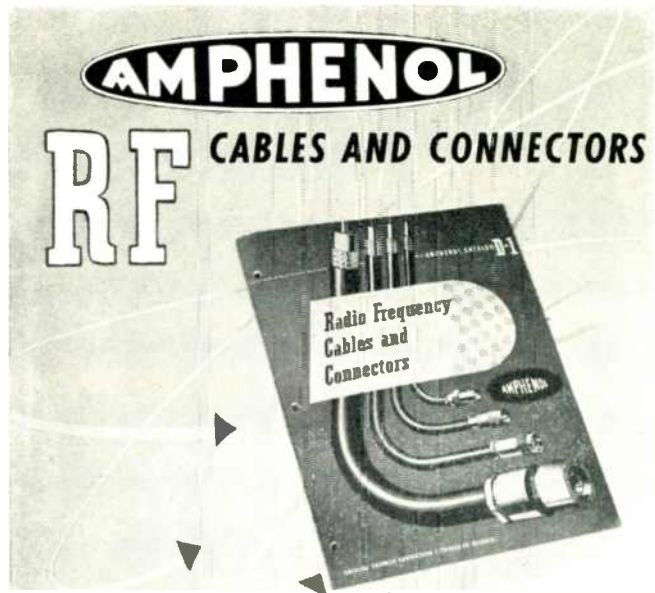

## Efficient Connecting Links for Electrons at Work...

Write today on your business letterhead for your free copy of the new D-1 catalog. Amphenol will serve you well as a dependable source of supply. Catalog D-1 is today's guide for the engineer and purchasing agent in the selection of highest quality cables and connectors.

Amphenol radio frequency cables, connectors and cable assemblies assure lasting, low-loss continuity on highly critical circuits.

Available—from stock—to makers of electronic equipment and to amateurs, they are produced in several types. Each is designed to meet the requirements in a specific field of application.

To simplify your selection, the new Amphenol D-1 Catalog of radio frequency cables, connectors and cable assemblies includes decibel loss and power rating data of all cables. Functional illustrations and tabular matter quickly show which connector is needed for each cable. Installation dimensions are shown, as are instructions for the proper assembly of cables to connectors. Included is a cross-index of army-navy and Amphenol type designation numbers.

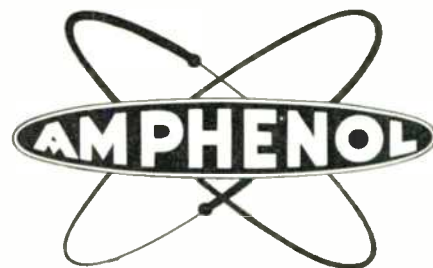

AMERICAN PHENOLIC CORPORATION

1830 South 54th Avenue, Chicago 50, Ill. U.S.A.

COAXIAL CABLES AND CONNECTORS • INDUSTRIAL CONNECTORS, FITTINGS AND CONDUIT • ANTENNAS • RADIO COMPONENTS • PLASTICS FOR ELECTRONICS

FM AND TELEVISION



## FOR HIGH FIDELITY AT LOW COST! -the UNIVERSITY TWEETER

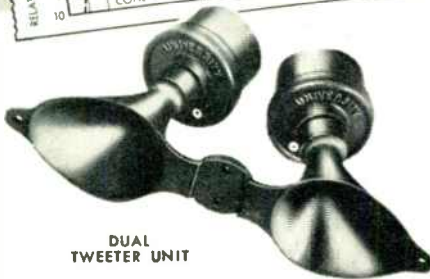

DUAL  
TWEETER UNIT

The reproduction of music and voice with breath-taking realism, is now possible with the new UNIVERSITY Dual Tweeter. Used in conjunction with any standard 12" cone speaker in FM and AM radio equipment and wide range phonograph amplifiers, it adds the brilliant "highs" so frequently carried through all stages of amplification, only to be lost in the bottleneck of a single unit reproducer. Frequency response is 2,000 to 15,000 cycles. The die-cast dual horn design offers wider dispersion angle than the conventional single cellular horn—horizontal distribution is 100°, vertical distribution 50°. A high pass filter with auxiliary high frequency volume control, permits easy connection by merely attaching two wires to the existing speaker. Compact dimensions require a mounting space only 2 3/4" high x 9 1/2" wide. Power handling capacity of the dual unit is 16 watts. For complete information write today to UNIVERSITY LOUDSPEAKERS, INC. 225 Varick St., New York 14, N. Y.

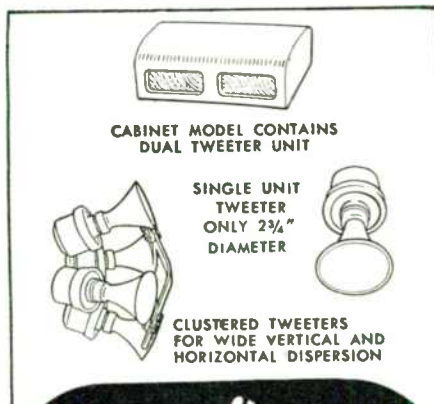

University  
Loudspeakers

## FM FOR TROPICS & MOUNTAINS

(CONTINUED FROM PAGE 58)

ground level, or 850 ft. (259 meters) above sea level. The receiving antenna at the Seaview Country Club is 120 ft. (37 meters) above ground level, or 160 ft. (49 meters) above sea level. The distance between the two points is 110 miles (177 kilometers).

The distance to the horizon from Alpine is only 37 miles (59 kilometers). Therefore, the distance from Alpine to the Atlantic City receiving location is 3 times line-of-sight. A projection of the line-of-sight from the Alpine transmitting antenna shows that the receiving antenna at the Seaview Country Club is actually 7,400 ft. (2,260 meters) below line-of-sight.

The extent to which reception is possible at distances considerably beyond line-of-sight over comparatively level terrain is indicated in Fig. 3. Field intensity measurements show the same to be true in hilly and mountainous country. FM signals can be received behind hills and mountains. This is proved by measurements made on a 1-kw. FM transmitter in Washington, D. C. The antenna is 400 ft. (122 meters) above ground and 800 ft. (244 meters) above sea level. Approximately 72 miles (116 kilometers) to the west, the ground elevation rises to a height of 3,800 ft. (1,160 meters). At 5 miles (8 kilometers) beyond this point, the elevation drops to 1,700 ft. (519 meters). There, 5 miles (8 kilometers) beyond the mountain and 77 miles (124 kilometers) from Washington, the signal intensity is such as to give good reception in rural and small town receiving locations without outside antennas.

## WHAT'S NEW THIS MONTH

(CONTINUED FROM PAGE 4)

sounded better tonight," or "Perhaps the microphone was set differently. I thought he sounded better last week." The Donkey Serenade and Pop Goes the Weasel elicited gleeful praise. Complaints that the announcer shouts at the microphone have been consistent. In the beginning of the series, it was possible to hear occasional coughs from the audience. Rather than being objectionable, they sounded so real that they seemed natural. The microphone over the audience must have been moved, because we haven't heard any coughing lately.

No AM program can hold the undivided attention of its listeners for an hour. Nor can it inspire the critical attitude of a concert goer, as FM does. This brings us back to the opening remark about a new demand for high-fidelity transmission and reproduction. The more accurately the reception reproduces the original studio program, the more keen the listeners' critical faculties become.

(CONCLUDED ON PAGE 62)

## A BASIC Improvement in Sound Reproduction

# KLIPSCH SPEAKER SYSTEM

The ideal speaker for FM Reception and Station Monitoring, with

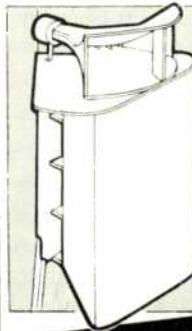

FREQUENCY RANGE

**30** to 15,000 cycles

PERFORMANCE equivalent to conventionally designed speakers 8 to 16 times as bulky

### INDISPENSABLE FOR

- Broadcast Station Monitoring
- High Fidelity Radio-Phonographs
- Electronic Musical Instruments (Organs etc.)
- High Quality Sound Reinforcement Systems
- Wired Music Installations
- Research, Test Work, Demonstrations of Wide Range Reproduction

The KLIPSCH Speaker System design utilizes the corner of a room as an integral part of the acoustic system, the walls and floor being in effect an extension of the low frequency horn.

- **FUNDAMENTAL TONES** down to 30 cycles per second.
- **CLEAN RESPONSE** throughout the range of hearing.
- **LOW DISTORTION** and intermodulation at all frequencies.
- **PERFECT DISPERSION** of middle and high frequencies throughout the entire room.
- **HIGH EFFICIENCY:** Because of the horn loading, acoustic output for a given input power is several times that of conventional speakers.
- **NON-RESONANT: BASS TONES ARE REPRODUCED** — not generated by the speaker. Instruments of low pitch are clearly recognized; one hears the original tone — not one created by the loudspeaker.

WRITE FOR FULL PARTICULARS TO

**BROCINER** ELECTRONICS  
LABORATORY

1546 SECOND AVENUE, NEW YORK 28, N. Y. • REgent 7-6794

# Kiver has done it again! F-M SIMPLIFIED

by Milton S. Kiver

Registered Professional Engineer

An Amazingly Simple Approach that Lifts Frequency Modulation Radio out of the Fog!

With the same clarity of explanation and interest-provoking style that won high places for his other works — "U.H.F. Simplified" and "Television Simplified" — Mr. Kiver takes F-M apart, puts it back together again, and makes it work in your mind. He throws light in the dark corners of doubt concerning principle, apparatus and characteristics. You get complete procedures for aligning receivers — full accounts of tuners — and all the other information needed for installation, operation and servicing. You'll welcome the wealth of information — the absence of mathematical detail.

## Hundreds of Illustrations

### Simplified Diagrams — Charts and Tables of Data!

Graphic examples of every step and phase that lead to complete mastery of this increasingly important subject are included. Nothing is omitted that would help the reader apply his knowledge in practical work without further study.

Readers treasure this book, because it is quick to grasp — easy to understand and remember. There are no loose ends that leave you dangling — it is wrapped up in one 352-page package — concise, compact, complete, and crystal clear!

No Radio Library  
Is Up-To-Date Without

# F-M SIMPLIFIED

For Free Examination of this Great New Book Mail the Coupon Below

### MAIL THIS COUPON

D. VAN NOSTRAND COMPANY, Inc.  
280 Fourth Avenue, N. Y. 3, N. Y.

Please send me a copy of "F-M SIMPLIFIED." After 10 days I will either return the book or send you \$6.00 plus few cents postage. (If you send \$6.00 with this coupon we will pay the postage, same return privilege guaranteed.)

Name .....

Address .....

City.....Zone.....State.....

FM-Sept. 1947

## WHAT'S NEW THIS MONTH

(CONTINUED FROM PAGE 61)

Apparently, people have developed a mental defense against the limited and distorted quality of AM. That must have the effect of closing an auditory gate part way, just as they squint to protect their eyes against the sun. If that is so, it would explain why people talk, or play cards, or read while they listen to AM, or even during the reception of low-fidelity recordings on FM. But live talent coming through on FM demands undivided attention. And gets it!

That's not all there is to this aspect of FM. Next, we shall hear listeners say: "I don't like station — — — — as well as — — — —. Their programs lack something. They seem to be dull and lifeless."

The difference will be due to the audio systems, or to the skill of the program directors and their staffs, or both.

We have heard broadcasters say: "What's the use of using live talent and 15,000-cycle quality at the station when so many of the receivers won't reproduce more than 8,000 or 10,000 cycles, at the outside?"

Well, we shan't attempt a technical reply to that question, but here is an answer from actual listening experience:

While we were at the FCC's demonstration of FM for the International Telecommunications conference, several friends were listening at our home in Great Barrington. Our FM receiver is a very good model, but the audio response probably cuts off around 10,000 cycles.

The first part of the transmission came over the Continental Network's 8,000-cycle line. The second part was a live talent program originating at Yonkers and beamed to Alpine on a 15,000-cycle relay transmitter.

You might expect that there would have been very little difference in the tone quality on such a receiver. But you'd be wrong! On our return to Great Barrington, we checked with our friends. "What was the difference," they wanted to know, "between the first and second parts of that program?"

Being cautious, we asked: "Was there much difference?"

They said there was a decided difference. In fact, "We could distinguish so much more clearly between the different instruments. And the sound effects! Why, they were amazing!"

There you have the difference between 8,000 cycles and 15,000 cycles reproduced on a 10,000-cycle receiver. The *technical reasons* aren't important. What counts is the *effect* of the difference on the radio audience. Certainly, everyone will agree that broadcasting that commands the listeners' undivided attention is worth more to sponsors than programs that are heard as a background for conversation, playing cards, reading, or just getting off to sleep.

— Milton B. Sleeper

## COIL KITS for FM and TELEVISION



COMPLETE KITS CONSIST OF FM DISCRIMINATOR AND 3 FM I.F. COILS

Discriminators in Standard Sizes (1 3/4" square by 3" long) and Midget Sizes (3/4" square by 1 3/8" long) — wound on precision ground Steatite — coil winding shunted with silver micas — iron core tuned with newly developed high frequency powdered iron, providing excellent stability and wave shape. Standard Sizes for high quality consoles. Midget Sizes for exceptionally small FM outfits and inexpensive designs.

Send for latest Catalog of Stanwyck High Quality Components

STANWYCK WINDING CO.  
102-106 South Lander St., Newburgh, N. Y.

## ZOPHAR



## WAXES COMPOUNDS and EMULSIONS

FOR  
INSULATING and WATERPROOFING  
of ELECTRICAL and  
RADIO COMPONENTS

Also for  
CONTAINERS and PAPER  
IMPREGNATION

FUNGUS RESISTANT WAXES

ZOPHAR WAXES and COMPOUNDS

Meet all army and navy  
specifications if required

Inquiries Invited

ZOPHAR MILLS, INC.  
FOUNDED 1846  
122-26th ST., BROOKLYN, N. Y.

# ADVERTISERS INDEX

Adair, George P. ....	19
Alden Products Co. ....	60
American Phenolic Corporation ....	60
Anderson & Merryman. ....	18
Andrew Company. ....	4, 18
Approved Electronic Inst. Corp. ....	56
Barone, S. A., Company. ....	19
Bell Telephone Labs. ....	7
Blaw-Knox Company. ....	12
Boonton Radio Corp. ....	63
Brociner Electronics Lab. ....	61
Browning Laboratories, Inc. ....	
<i>Inside Back Cover</i>	
Clare, C. P., & Company. ....	9
Collins Audio Products Co. ....	8
Commercial Radio Equip. Co. ....	18
Eitel-McCullough, Inc. ....	10
Engineering Research Assoc., Inc. ....	18
Finch Telecommunications, Inc. ....	51
FM Company. ....	55
General Electric Co. ....	5
Graybar Electric Co. ....	20
Hallicrafters Co. ....	17
Help Wanted. ....	63
International Resistance Corp. ....	13
James Knights Company, The. ....	63
Jansky & Bailey. ....	14, 18
Karp Metal Products Co., Inc. ....	15
Kaufman, Robert L. ....	18
Kear and Kennedy. ....	19
KERA-FM. ....	52
La Pointe Plascomold Corp. ....	58
Littlefuse, Inc. ....	19
May, Russell P. ....	18
McCachren, Winfield Scott. ....	19
McIntosh, Frank H. ....	18
McKey, Dixie B. & Assoc. ....	18
McNary and Wrathall. ....	19
National Company, Inc. ....	1
Pickering & Company. ....	56
Pilot Radio. ....	47
Pollack, Dale. ....	19
Pyramid Electric Co. ....	57
Radio Consultants, Inc. ....	18
Radio Craftsmen. ....	8
Radio Engineering Labs. Inc. <i>Back Cover</i>	
Radio Music Corp. ....	3
Ray, Garo W. ....	18
Raytheon Mfg. Co. ....	2
RCA Communications, Inc. ....	18
Sangamo Electric Co. ....	53
Simpson Electric Co. ....	16
Standard Measuring & Equip. Co. ....	19
Stanwyck Winding Co. ....	62
Sylvania Electric Products, Inc. ....	
<i>Inside Front Cover</i>	
U. S. Recording Co. ....	18
University Loudspeakers, Inc. ....	61
Van Nostrand, D. ....	62
War Assets Admin. ....	64
Ward Products Co. ....	11
WASH-FM. ....	54
WBEN-FM. ....	52
WCFC. ....	48
WELD. ....	50
Western Electric Co. ....	20
WGHF. ....	50
Williams, Nathan. ....	19
Willette, Raymond M. ....	18, 19
Wilson, Herbert L. ....	18
WMRC-FM. ....	54
Workshop Associates, The. ....	18, 59
Zenith Radio Corp. ....	49
Zophar Mills, Inc. ....	62

# MANY FEATURES IN ONE INSTRUMENT

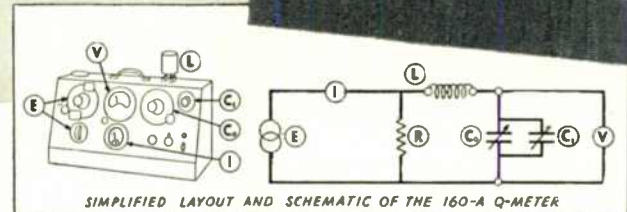
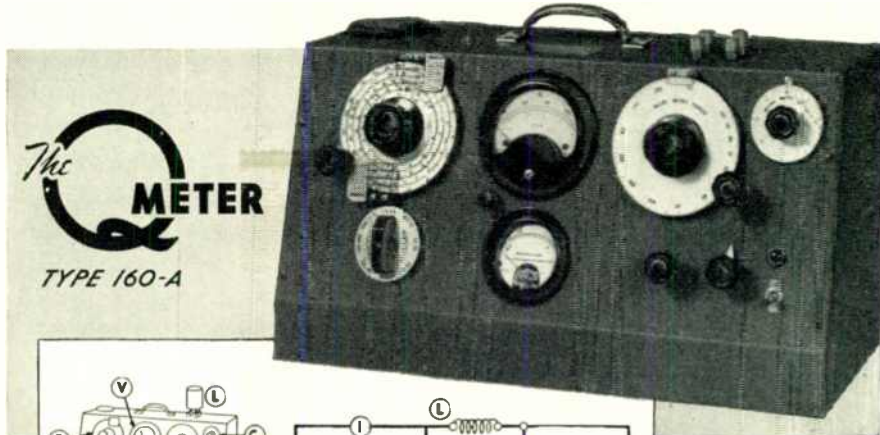

**THE BASIC METHOD OF MEASUREMENT EMPLOYED IN THE 160-A Q-METER**  
 An R.F. oscillator (E) supplies a heavy current (I) to a low resistance load (R), which is accurately known. The calibrated voltage across the load resistance (R) is coupled to a series circuit consisting of the inductance under test (L) and a calibrated variable air capacitor (C<sub>0</sub>+C<sub>1</sub>) having a vernier section (C<sub>1</sub>). When this series circuit is tuned to resonance by means of capacitor (C<sub>0</sub>+C<sub>1</sub>), the "Q" of (L) is indicated directly by the V.T. Voltmeter (V). Variations of this method are used to measure inductance, capacitance and resistance.  
**Oscillator Frequency Range:** 50 kc. to 75 mc. in 8 ranges. **Oscillator Frequency Accuracy:** ± 1%. 50 kc.—50 mc. **Q-Measurement Range:** Directly calibrated in Q, 20-250. Multiplier extends Q range to 625. **Capacitance Range:** Main section (C<sub>0</sub>) 30-450 mmf. Vernier section (C<sub>1</sub>) +3 mmf, zero, —3 mmf.

DESIGNERS AND MANUFACTURERS OF  
 THE Q METER  
 QX CHECKER  
 FREQUENCY MODULATED SIGNAL GENERATOR  
 BEAT FREQUENCY GENERATOR  
 AND OTHER DIRECT READING TEST INSTRUMENTS

**BOONTON RADIO Corporation**  
 BOONTON · N · J · U · S · A



## WANTED

ONE of the leading manufacturers of mobile equipment and FM broadcast transmitters seeks representatives to handle sales, installation, and maintenance in certain territories now open.

Consideration will be given to outstanding parts jobbers or service organizations experienced in handling transmitting equipment. This is a once-in-a-lifetime opportunity to establish a permanent and profitable connection in the fastest-growing section of the radio industry.

For information on available territory and commissions, write at once, giving details of qualifications and area now covered.

**BOX 11**  
**FM AND TELEVISION**  
**Great Barrington, Mass.**

*Crystals for the Critical*

**"STABILIZED"**

### H17 CRYSTAL FOR AIRLINES AND VHF EQUIPMENT

Especially designed for all types of airline and VHF equipment, the H17 "Stabilized" Crystal is rendering outstanding performance in this equipment. Pin spacing permits two units to be mounted in loctal socket.

When developing new equipment, write JK for pre-production samples. Just address the Specification Department.

*Write For Illustrated Folder*

**The JAMES KNIGHTS CO.**  
 SANDWICH, ILLINOIS

**ELECTRONIC**

**EQUIPMENT**

**BARGAINS**

**JOBBERS**

**WHOLESALEERS**

**MANUFACTURERS**

Large inventories of valuable electronic tubes, devices and equipment are being offered by the WAA Approved Distributors listed herewith for your convenience. Alert commercial buyers are taking advantage of this big bargain opportunity. Why not fill *your* present and future requirements from these available stocks. Act now—while inventories still permit wide selection.

Purchase of this surplus equipment has been greatly simplified. The Approved Distributors appointed by WAA were selected on a basis of their technical background and their ability to serve you intelligently and efficiently. Write, phone or visit your nearest Approved Distributor for information concerning inventories, prices and delivery arrangements. You'll find you can "Save with Surplus."

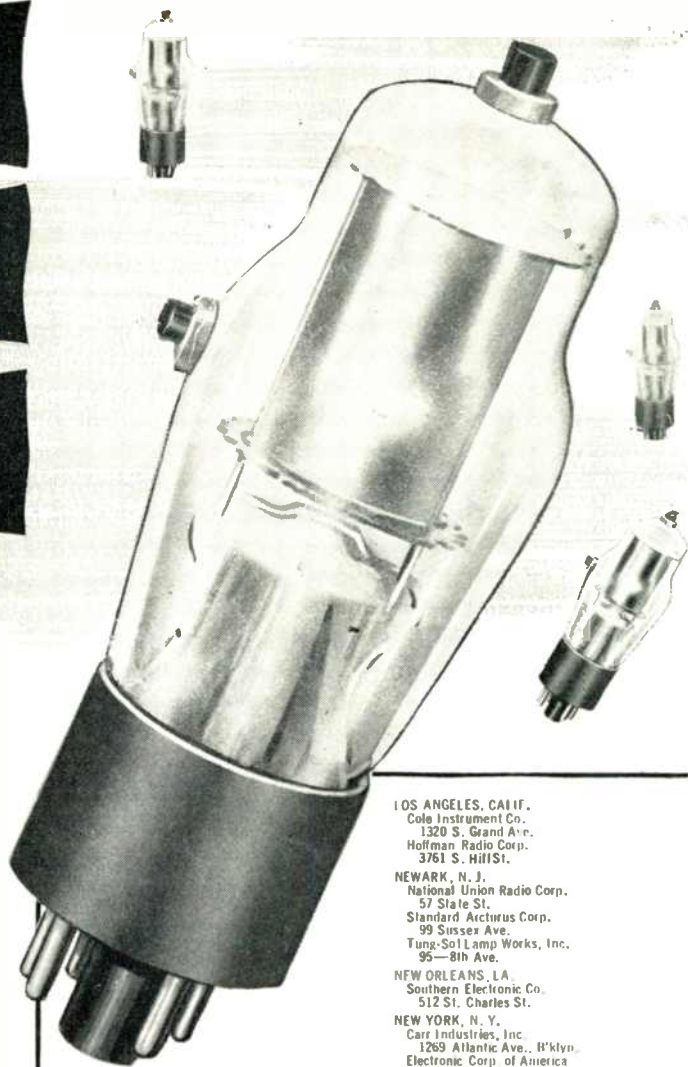

LOS ANGELES, CALIF.  
Cole Instrument Co.,  
1320 S. Grand Ave.  
Hoffman Radio Corp.  
3761 S. Hill St.

NEWARK, N. J.  
National Union Radio Corp.  
57 State St.  
Standard Acturus Corp.  
99 Sussex Ave.  
Tung-Sol Lamp Works, Inc.  
95—8th Ave.

NEW ORLEANS, LA.  
Southern Electronic Co.  
512 St. Charles St.

NEW YORK, N. Y.  
Carr Industries, Inc.  
1269 Atlantic Ave., B'klyn.  
Electronic Corp. of America  
353 W. 48th St.  
Emerson Radio & Phonograph Corp.  
76—9th Ave.  
General Electronics, Inc.  
1819 Broadway  
Hammarlund Mfg. Co., Inc.  
460 W. 34th St.  
Johanns & Keegan Co., Inc.  
62 Pearl St.  
Newark Electric Co., Inc.  
242 W. 55th St.  
Smith-Meeker Engineering Co.  
125 Barclay St.

NORFOLK, VA.  
Radio Parts Distributing Co.  
128 W. Olney Road

ROCHESTER, N. Y.  
W. & H. Aviation Corp.  
Municipal Airport

SALEM, MASS.  
Hylton Radio & Electronics Corp.  
76 LaFayette St.

SCHENECTADY, N. Y.  
General Electric Co.  
Bldg. 267, 1 River Road

WASECA, MINN.  
E. F. Johnson Co.  
206 2nd Ave., S. W.

HOUSTON, MASS.  
Automatic Radio Mfg. Co., Inc.  
122 Brookline Ave.  
Technical Apparatus Co.  
165 Washington St.

BUCHANAN, MICH.  
Electro-Voice, Inc.  
Carroll & Cecil Sts.

CANTON, MASS.  
Tobe Deutschmann Corp.  
863 Washington St.

CHICAGO, ILL.  
American Condenser Co.  
4410 N. Ravenswood Ave.  
Belmont Radio Corp.  
3633 S. Racine Ave.

EMPORIUM, PENNA.  
Sylvania Electric Products, Inc.

GORT WAYNE, IND.  
Essex Wire Corp.  
1601 Wall St.

HOUSTON, TEXAS  
Navigation Instrument Co., Inc.  
P. O. Box 7001, Heights Station

OFFICE OF AIRCRAFT AND ELECTRONICS DISPOSAL

**WAR ASSETS ADMINISTRATION**



1284

Offices located at: Atlanta • Birmingham • Boston • Charlotte • Chicago • Cincinnati • Cleveland  
Dallas • Denver • Detroit • Fort Worth • Helena • Houston • Jacksonville • Kansas City, Mo. • Little Rock  
Los Angeles • Louisville • Minneapolis • Nashville • New Orleans • New York • Omaha • Philadelphia  
Portland, Ore. • Richmond • St. Louis • Salt Lake City • San Antonio • San Francisco • Seattle • Spokane • Tulsa

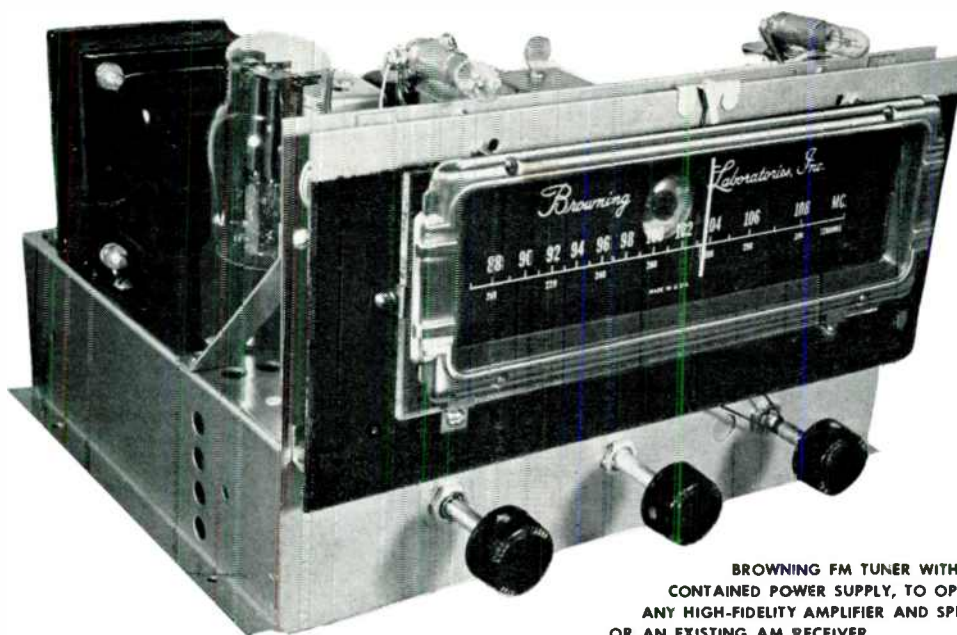

BROWNING FM TUNER WITH SELF-CONTAINED POWER SUPPLY, TO OPERATE ANY HIGH-FIDELITY AMPLIFIER AND SPEAKER OR AN EXISTING AM RECEIVER

Amazing Performance—Low Cost—Highest P/C Ratio\* in this

## BROWNING Model RV-10 FM Tuner

\* **P/C** REPRESENTS the Performance-to-Cost ratio, the factor of merit which counts with Particular Customers. Spelled backwards, it stands for Critical People.

Either way, they want the extra value built into the BROWNING RV-10 Tuner, the tuner that delivers genuine FM reception—the high-quality kind, free of interference, static, and fading.

The BROWNING RV-10 is extremely sensitive on long-distance FM reception. It has a 2-stage cascade limiter and discriminator to assure 1) the effective suppression of static and fading, and 2) the capture-effect protection against co-channel interference that will become increasingly necessary as more FM stations come on the air.

Yes, we could reduce the price by eliminating those features, but such a tuner would not give what the public expects of FM reception, and it couldn't be sold as a genuine Armstrong type of circuit.

When you are selling custom FM installations or tuners to operate with existing AM sets, Critical People and Particular Customers will prefer the greater value (the higher P/C ratio) of the BROWNING RA-10 as

compared to any other tuner on the market. Here are the condensed specifications:

**TUNING:** Full FM broadcast band, 88 to 108 mc.

**TUBES:** Three type 6AU6, one 7F8, two 6SJ7, one 6H6, plus one type 80 rectifier and 6U5 or 6E5 tuning eye.

**SENSITIVITY:** Tuned RF stage gives extra sensitivity and reduces image interference, with full limiting action on signals of less than 10 microvolts. This is a conservative rating.

**IF AMPLIFIER:** A two-stage IF amplifier is provided.

**NOISE LIMITING:** Two-stage cascade noise limiter.

**PHONO-FM SWITCH:** Front panel switch permits input transfer from FM to phonograph.

**POWER SUPPLY:** Self-contained power supply for all tubes in the tuner.

**OUTPUT:** High-impedance output for any type of high-fidelity amplifier.

Before you buy any FM tuner, check the P/C ratio of the BROWNING RV-10. For additional technical details, price, and delivery, see your parts jobber or write:

# BROWNING LABORATORIES, Inc.

750 Main Street, Winchester, Massachusetts

In Canada: Measurement Engineering, Ltd., 61 Duke Street, Toronto, Ontario



LONG AGO, it became apparent that the mastery of any given radio problem is not necessarily an end in itself. This is sharply pointed up by a brief review of the evolution of the REL Dual-Channel FM Modulator.

The early FM Modulators built by REL, according to the principles set forth by Dr. E. H. Armstrong, showed a very marked improvement over any other known method of radio signalling. Even then, it was evident that the quieting of the radio frequency path and the potential increase in the useful audio range and fidelity would obsolete existing audio terminal apparatus, both originating and reproducing.

That was twelve years ago. Through the intervening years, while the improvement of our Modulator has gone ahead steadily, in many cases audio techniques have lagged sadly behind. What was once merely evident has now assumed the proportions of a very serious problem, for it is almost universally a fact that the wide-band system of FM broadcasting is far ahead of audio techniques and apparatus which are needed to utilize its capabilities fully.

REL has gone to great lengths to help alleviate this need. We have engineered and are producing terminal equipments which make possible the full realization of the advantages of FM broadcast service.

Now we look to new horizons: Some time ago, we launched a program which we have called FM Network Systems Engineering. This project led to the design and manufacture of an entirely new line of REL FM Relay equipment. By the use of this apparatus, it is now possible for FM broadcasters to select programs from many sources, and make them available to their own audiences.

For the finest in FM engineering, continue to look to REL for Reliable Engineering Leadership.