

PRICE—TWENTY-FIVE CENTS

F M

JANUARY 1942

I. R. E. PRESIDENT
1942



**RADIO BROADCAST, COMMUNICATIONS & TELEVISION ENGINEERING
AND DESIGN PRACTICE** ★ ★ *Edited by M. B. SLEEPER*
REG. U. S. PAT. OFF. www.americanradiohistory.com

FM STATION MONITORING IS EASY with this G-E *multi-purpose** Unit

Distortion is prevented by careful adjustments on a G-E wide-band oscilloscope.

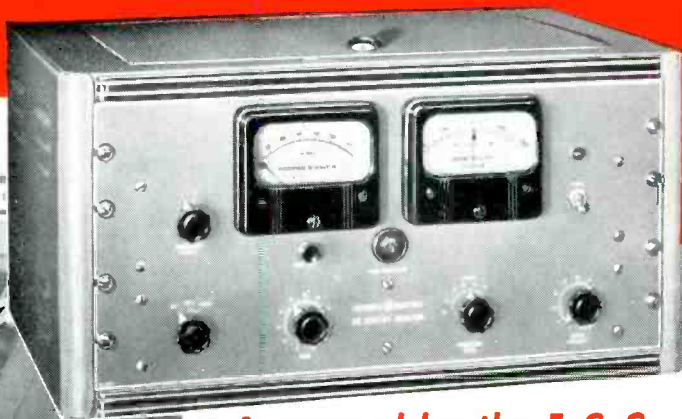
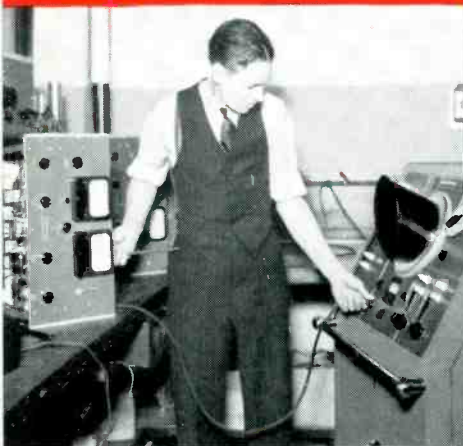

Approved by the F. C. C.

With this new monitor, General Electric has removed one more hurdle from your path to FM. You will find this self-contained, multi-purpose* instrument one of the most valuable units in your FM station. It provides:

- ★ Direct reading of center-frequency deviation (with or without modulation) †
- ★ Direct reading of modulation percentage †
- ★ Instant calibration against a precision crystal standard
- ★ Adjustable modulation-limit flasher †
- ★ High fidelity output for audio monitor †

All tubes and crystal units can be reached easily through the top of the cabinet. Removing chassis assembly from cabinet allows complete access to all panels and wiring.

In FM, more precise measuring techniques are a necessity. This instrument is custom-built for your requirements. Order your monitor now through the nearest G-E office, or direct from General Electric, Radio and Television Department, Schenectady, N. Y.

†Provision has been made for remote console operation.

Some of the FM Pioneers Who Have Already Bought G-E Monitors

John L. Booth Broadcasting Co., Detroit, Mich.
 Capitol Broadcasting Co., Inc., Schenectady, N. Y.
 Columbia Broadcasting System, New York, N. Y.,
 and Chicago, Ill.
 (Five units; three of these for "S-T" service)
 Don Lee Broadcasting System, Los Angeles, Cal.
 FM Radio Broadcasting Co., Inc., New York, N. Y.
 General Electric Co., Schenectady, N. Y.
 (Three units; one of these for "S-T" service,
 and one for television sound)
 Gordon Gray, Winston-Salem, N. C.
 The Journal Co., Milwaukee, Wis.
 Johan Lagercrantz, Stockholm, Sweden
 Royal Miller, Sacramento, Cal.
 Midland Broadcasting Co., Kansas City, Mo.
 Moody Bible Institute, Chicago, Ill.
 News Syndicate Co., New York, N. Y.
 Radio Engineering Laboratories, Long Island City,
 N. Y.
 San Diego City Schools, San Diego, Cal.
 Standard Broadcasting Co., Los Angeles, Cal.
 (Two units; one of these for "S-T" service)
 University of Illinois, Urbana, Ill.
 Walker-Downing Radio Corporation, Pittsburgh,
 Pa.
 WFIL Broadcasting Corporation, Philadelphia, Pa.
 WGN, Inc., Chicago, Ill.
 Yankee Network, Paxton, Mass., and Mt. Wash-
 ington, N. H.



FM Broadcast Transmitters
250 to 50,000 Watts



Relay Transmitters



Receivers for Home
and "S-T" Service

FM



FM Police and Emergency
Transmitters and Receivers

NEEDS



Tubes

GENERAL ELECTRIC

160-18-6914

\$1,000,000,000 IN PRIORITY ORDERS

Will Be Filled by *FM* Readers in 1942



8 ■ *FM* Magazine, as a clearing house for the exchange of technical information and data, is saving radio engineers countless hours of time which would be required to duplicate work already done by others.

That is why files of *FM* Magazine are being thumbed over and over in every laboratory and drafting room in the Country where radio equipment is being designed and manufactured to meet our billion-dollar needs in 1942.

This is true whether engineers are working on AM or FM equipment, for the name "*FM*" Magazine represents the Forward March of radio progress in both fields, since the editorial contents covers both.

Thus, under war conditions, the most interesting radio publication has become the most useful.

It follows naturally the magazine which performs the greatest service to radio engineers and executives is the most effective medium for reaching them with advertising.

M. B. SLEEPER, *Editor and Publisher*

Partial List of Police Departments, Public Utilities, and other purchasers of Browning Monitors

Police Departments

- Arlington, Mass.
- Atchison, Kansas
- Big Spring, Texas
- Bloomington, Indiana
- Bremerton, Washington
- Centralia, Washington
- Coffeyville, Kansas
- Columbia, Missouri
- Crawfordsville, Indiana
- Emporia, Kansas
- Fitchburg, Mass.
- Fond du Lac County, Wisconsin
- Great Bend, Kansas
- Klamath Falls, Oregon
- Leominster, Mass.
- Marathon County, Wisconsin
- Milton, Pa.
- Nampa, Idaho
- Sharon, Mass.
- Shelby County, Indiana
- Sidney, Ohio
- St. Charles, Missouri
- Twin Falls, Idaho
- General Electric Company
- Graybar Electric Company
- Burdick Corp., Milton, Wis.
- Cleveland Railway Company
Cleveland, Ohio
- Water Supply Commission
Belchertown, Mass.
- Hygrade Sylvania Corp.
Salem, Mass.
- San Antonio Public Service
San Antonio, Texas
- San Diego Gas & Electric
San Diego, California
- Southern California Edison
Los Angeles, California
- Toledo Edison Company
Toledo, Ohio
- Transmitter Mfg. Company, Inc.
New York City
- United Electric Light Company
Springfield, Mass.
- United Illuminating Company
New Haven, Connecticut
- University of Maryland
College Park, Md.

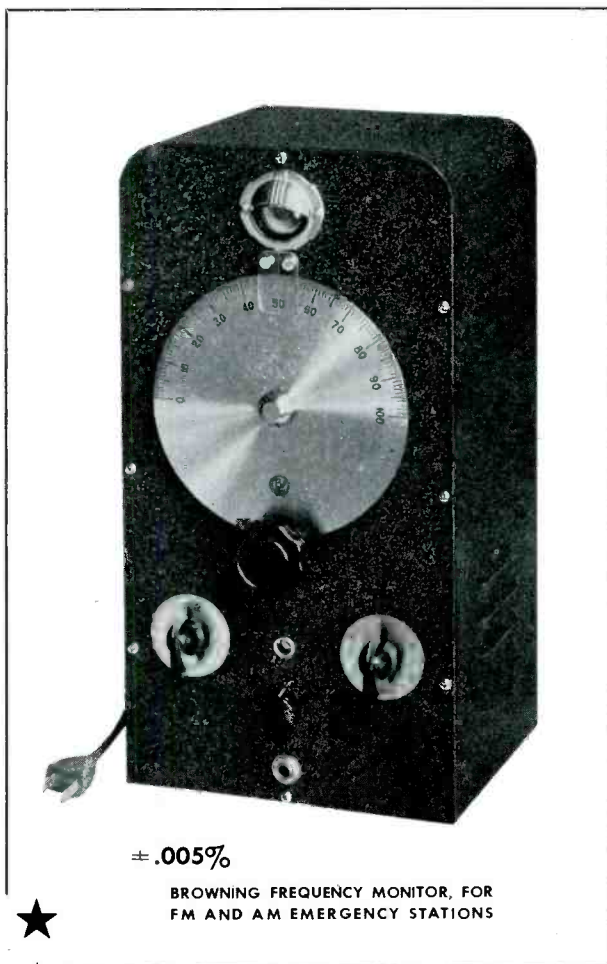

$\pm .005\%$

BROWNING FREQUENCY MONITOR, FOR FM AND AM EMERGENCY STATIONS



Increased Accuracy to Meet New

FCC REQUIREMENTS

For All Emergency Transmitters

The new Type S-2 Browning Frequency Monitor provides the greater precision now required by the FCC for all emergency transmitters. Suitable for both FM and AM, the Browning Monitor is built with one to four bands, for any frequencies between 1.5 and 60 mc. Prices:

1 Band **\$125.00** 3 Bands **\$165.00**
 2 Bands **145.00** 4 Bands **185.00**

BROWNING LABORATORIES, INC.

755 MAIN STREET

WINCHESTER, MASSACHUSETTS



I.R.E. PRESIDENT, 1942

ARTHUR F. VAN DYCK is the first president of the Institute of Radio Engineers to take office under conditions created by our participation in World War 2.

Thus his office is made more important because of the grave responsibilities carried by members of the Institute, and it is made more difficult because the exchange of information, a primary function of the I.R.E., is limited by the secrecy under which so much of the new radio work is being done, and the pressure put upon radio engineers which leaves them very little time to prepare papers.

Whatever the responsibilities and difficulties, Arthur Van Dyck has been well trained to meet them by his years of experience as manager of the RCA License Laboratory, in New York City.

One of his current activities has to do with the development of the Alert Receiver, and its application to the defense of centers of population and industry. Two types of Alert Receivers are shown on this month's cover. A muted speaker can be turned on, or signal lights and a bell cut in by tuned-reed relays energized by frequencies below the response of ordinary broadcast receivers. The purpose is to warn defense workers in advance of enemy attack, without disturbing citizens who are listening to regular programs.

A very interesting communication on this subject from Mr. Van Dyck appears on page 36 of this issue. An article giving the details of the equipment is scheduled for our February number.



THE RADIO ENGINEERING NEWS JOURNAL OF BROADCASTING, COMMUNICATIONS & TELEVISION

VOL. 2 JANUARY, 1942 NO. 3

COPYRIGHT 1942 M. B. SLEEPER

CONTENTS

FM RECEIVER PERFORMANCE	5
<i>by John V. L. Hogan</i>	
COMPACT SINGLE-CHANNEL RECEIVER	7
<i>by Dana H. Bacon</i>	
EMPLOYEE TRAINING METHODS	12
<i>by George Daniel</i>	
THE MANUFACTURERS SAY:	17
<i>A Statement by Earnest Searing</i>	
DYNAMIC SYMMETRY IN RADIO DESIGN	18
<i>by Arthur F. Van Dyck</i>	
FEDERAL MARINE RADIO UNIT	22
SPOT NEWS	26
NEWS PICTURE	27
<i>Walter Damm's FM Car Radio</i>	
MAKING A START IN TELEVISION, Part 2	28
<i>by Austin C. Lescaboura</i>	
WHAT THE BROADCASTERS HAVE TO SAY	34
<i>A Statement by E. K. Cohen</i>	
RADIO DESIGN PRACTICE	35
COMMENTS	36

THE COVER DESIGN AND CONTENTS OF FM MAGAZINE ARE FULLY PROTECTED BY U. S. COPYRIGHTS, AND MUST NOT BE REPRODUCED IN ANY MANNER OR IN ANY FORM WITHOUT WRITTEN PERMISSION

★ ★ ★ ★ ★

M. B. SLEEPER, *Editor and Publisher*

S. R. Cowan, *Advertising Manager*

Published by: FM COMPANY

Editorial and Advertising Office:

112 East 36th Street, New York City, Tel. LE 2-8070

FM Magazine is issued on the 20th of each month. Single copies 25¢ — Yearly subscription in the U.S.A. \$3.00; foreign \$4.00. Subscriptions should be sent to FM Company, 112 East 36th St., New York City. A charge of 25¢ each will be made for duplicating copies returned because of subscriber's failure to give change of address.

The publishers will be pleased to receive articles, particularly those well illustrated with photos and drawings, concerning all phases of FM developments. Manuscripts should be sent to the publication office, at New York City. Contributions will be neither acknowledged nor returned unless accompanied by adequate postage, packing, and directions, nor will FM Magazine be responsible for their safe handling in its office or in transit.

Advertising correspondence, copy, and cuts should be addressed to the advertising office at New York City.

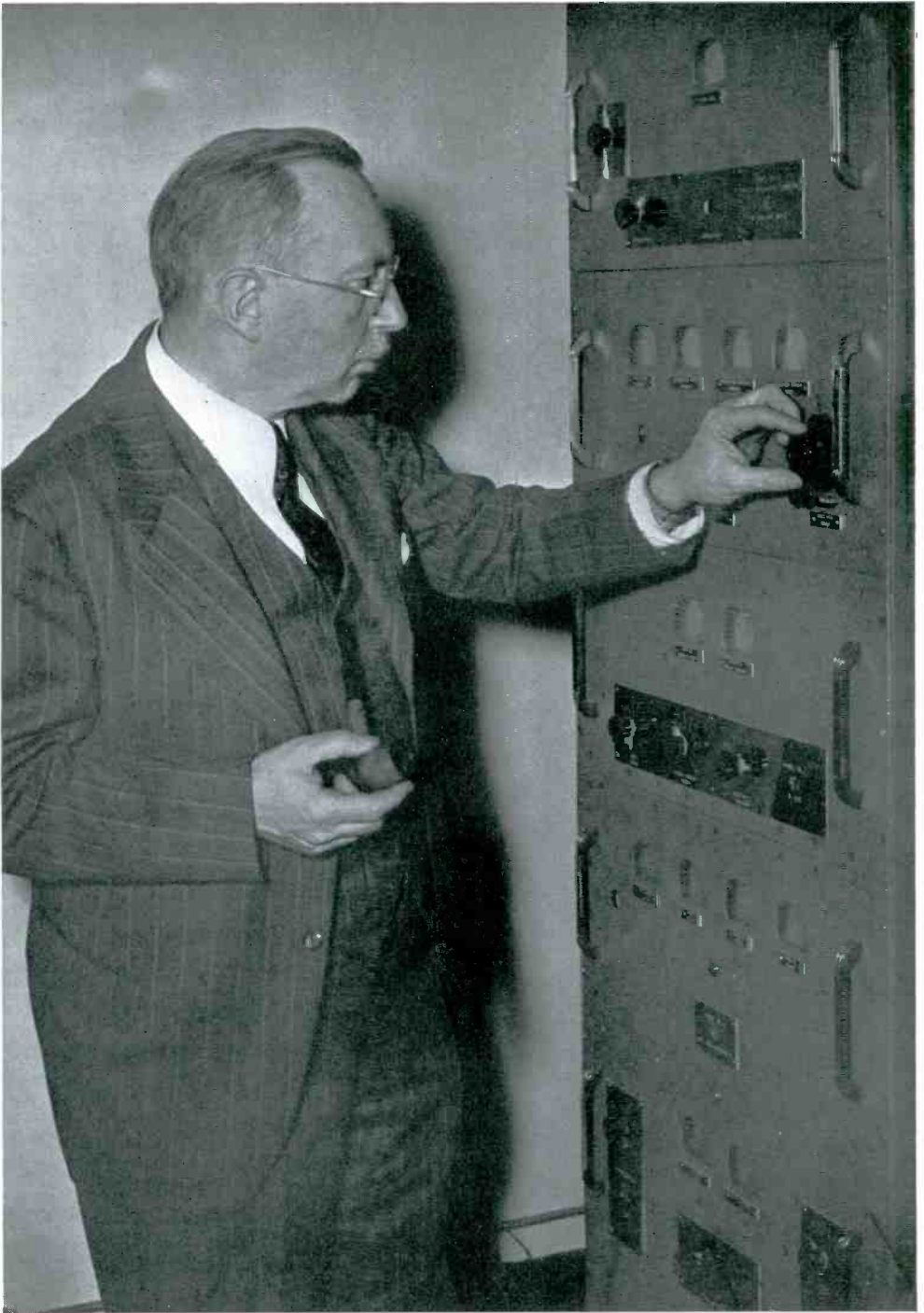

JOHN V. L. HOGAN, PRESIDENT OF THE INSTITUTE OF RADIO ENGINEERS IN 1920, HAS HAD A FINGER IN ALL ANGLES OF THE RADIO PIE, FROM THE PRE-WAR DAYS OF RADIO TELEGRAPHY TO TODAY'S FM BROADCASTING. AN EARLY ASSOCIATE OF FESSENDEN, MENTION OF HIS NAME RECALLS HIGH FREQUENCY ALTERNATORS, THE BUSH TERMINAL STATION, INTERNATIONAL RADIO COMPANY, WITH ALL OF WHICH HE HAD AN ACTIVE PART

A Broadcaster Discusses

FM RECEIVER PERFORMANCE

FM Introduces New Concepts of Broadcasting to Which Radio Set Designs Must Be Adjusted

BY JOHN V. L. HOGAN *

ONCE it started, AM radio broadcasting grew and developed at such a rapid rate that it was impossible to guide into any planned, coordinated pattern. It had spread across the country and into our forty-eight states before we had any definite concept of its social, economic and political significance.

Nor was there, at least in the early years, any engineering relationship established between broadcasters and radio receiver manufacturers. Each one was so busy keeping up with progress in his own field and with his own competitors that he had no time to think of the other end of the radio circuit.

With the advent of commercial broadcasting came the technique of audience surveys and the establishment of listener coverage as a salable commodity. More audience meant higher time rates, thus relating revenue to antenna power.

Those AM stations which made money first and fastest expanded their facilities by increasing their power. Those with less capital or smaller profits had to do the best they could with what they could afford.

Thus, when the time came to take stock of what broadcasting had become, a review of the national setup revealed a total lack of correlation in geographical distribution of stations and their power, and their relation to population and trading centers.

FM Planning ★ The FCC undertook to improve this condition in AM broadcasting and they accomplished much. However, there were the same elements of resistance to a complete reorganization of broadcasting as there would be to replanning and straightening the crooked streets and alleys of an overgrown country town.

When the FCC gave official approval to FM broadcasting, the Commissioners were

able, in the light of past AM experience, to lay out a pattern for FM to grow into. They determined:

1. To prevent the development of such inequalities in competition as exist between high-power and low-power AM stations.

2. To do this, they discarded, for FM, the old practice of licensing stations according to power and, instead, required each FM station to cover a specified area.

3. Further, all stations located in a given area must give complete coverage of that area, using whatever power is required to do it.

4. Thus, with respect to the potential radio audience, all stations within a given area are on an equal competitive footing, so far as plant is concerned.

5. Moreover, the FM coverage areas¹ are planned in relation to the distribution of population and the location of retail trading centers.

6. To assure listeners of adequate signals from the FM stations serving them, the FCC specified that every FM transmitter must deliver a signal of 1 millivolt per meter in the urban sections, and 50 microvolts per meter in the rural sections. Proof of performance,² as shown by field strength surveys, must be filed with the FCC within one year after a station starts regular operation.

Standards of FM Performances ★ This new concept of broadcasting must be understood by the engineers who design circuits for FM reception, by the manufacturers who produce them and by the dealers who sell them. Why? Because, as the general public comes to understand FM, listeners will, for the first time,

* Licensee of W2QXR and President, Interstate Broadcasting Company, Inc. WQXR, 730 Fifth Avenue, New York City.

¹ This is explained in FM Engineering Considerations, by E. S. Winlund, *FM Magazine*, July, 1941.

² See Rules Governing High Frequency Broadcasting Stations, *FM Magazine*, November, 1940.

have a definite basis for judging the performance of FM circuits in radio receivers of various price ranges.

First, the engineers and manufacturers have a definite minimum signal standard. They know that their FM circuits must give satisfactory performance on 50 microvolts per meter in the country and 1 millivolt per meter in business areas, since these values have been established by the commission. In other words, the broadcast station does its job when it delivers the required signal strength throughout its service area. It is then up to the manufacturers and their engineers to produce sets capable of satisfactory performance from those specified signals.

Next, the dealers must have the assurance that the sets they sell are capable of receiving any FM station from any point within its service area. If I were a radio dealer, I would require such a guarantee from the manufacturers of sets I sold. If I felt it necessary to handle sets so cheapened in design that they would not deliver such performance, I would at least require the manufacturer to set forth the limitations of the set frankly and honestly, and I would protect myself against the appearance of misrepresentation by being equally frank in my sales talk.

Finally, the action of the FCC in requiring FM stations to deliver signals of specified minimum strength throughout their service areas should serve as a protection to purchasers of FM receivers, so they would know that an FM set would be capable of receiving any given station if it is used within the station's service area — unless limitations of performance were stated definitely in the manufacturer's advertising and literature.

Protection to the Public ★ This protection should be given the public on FM reception, and purchasers of sets can rightfully demand it. This is an entirely new concept of radio performance which is not yet generally understood because no such standards have been, nor can be, applied to AM reception.

One factor of performance remains to be standardized. That relates to the noise-limiting capability of receivers. There should be an agreement reached as to the minimum strength of interference that a set is capable of stopping when supplied by a signal of 50 microvolts and of 1 millivolt.

If, then, interference of more than the established value is encountered, the dealer and the manufacturer would be justified in saying: "You must improve your antenna so as to deliver a stronger signal to the receiver." Only on that basis is it fair to ask the owner to spend extra money on his antenna to meet special local interference conditions, or to buy

a more expensive set with greater noise-limiting capabilities.

I have not mentioned tone quality, important as I feel it to be. That, however, is related to the investment the purchaser chooses to make in the amplifier and reproducer system and to his aural response and personal judgment.

However, by using the FCC requirements as a sensitivity standard, by setting at least a minimum standard for rating limiters, and by requiring the publication of sub-standard characteristics, the public would be protected against misrepresentation. Thus the continuation of the present high standards of performance, established by ethical radio manufacturers, would be reasonably assured, to the everlasting benefit of radio listeners.

NAVY OFFERS RATINGS TO RADIO LOCATOR MAINTENANCE MEN

THE Navy offers an exceptional chance to "get in on the ground floor" of a new radio development — the radio locator, used for detecting planes and other craft. Enlistment of radio technicians for specialized training and duty in connection with this new device is now under way.

In order to secure men who have had practical radio experience, first enlistments are being made in the rating of Radioman Second Class, Naval Reserve. This rating pays \$72 per month, plus complete clothing, food, lodging, medical and dental care, and all other Naval benefits. Married men receive an additional \$1.15 per day dependency allowance.

Applicants must (a) be male citizens between the ages of 17 and 50, (b) be a high school graduate, (c) hold or have held an Amateur Class A or B license, or, if no amateur experience, be actively engaged in radio repair or service work or have had experience with transmitting or receiving equipment.

Men selected will be sent to a Naval Training School for an intensive eight months' course in mathematics and radio theory and its application to the locator devices. Pending completion of the Navy's new Radio Material School on Treasure Island in San Francisco Bay, students will attend the Radio Training School at Noroton Heights, Conn. (if enlisted east of the Mississippi River) or Los Angeles, Calif. (if enlisted west of the Mississippi River). When the Treasure Island School is ready to receive students, it is expected transfers will be made to that point.

(CONCLUDED ON PAGE 46)

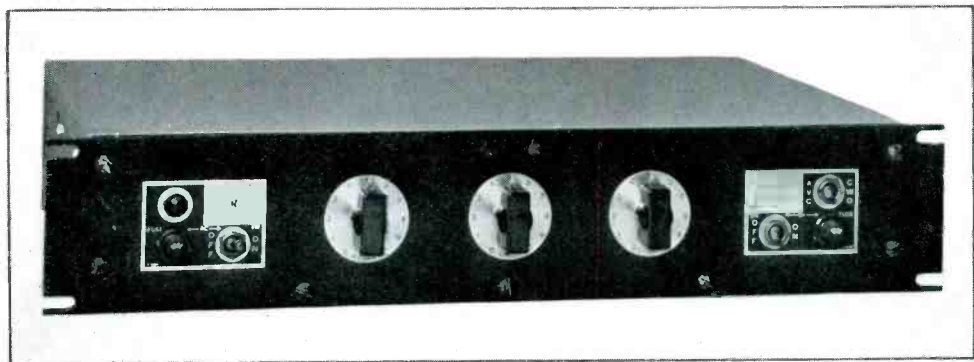

FIG. 1. THE SINGLE-CHANNEL RECEIVER, WITH ITS POWER SUPPLY, IS CARRIED ON A PANEL $3\frac{1}{2}$ BY 19 INS. DEPTH BEHIND THE PANEL IS 13 INS. CIRCUITS ARE CRYSTAL CONTROLLED

COMPACT SINGLE-CHANNEL RECEIVER

Special-Purpose Receiver Presents Interesting Design Features by Which High-Efficiency Circuits Are Fitted on a Narrow Rack Panel

BY DANA H. BACON*

THE National SCR-2 receiver is designed primarily for commercial service on fixed frequency channels. Typical applications are found in airways communication and commercial point-to-point systems. Compact diversity installations can be made simple and reliable by using two or three SCR-2 receivers with considerable saving in first investment and maintenance costs.

As shown in the various photographs, the SCR-2 is built for rack mounting, all components being supported by a standard $3\frac{1}{2}$ ins. by 19 ins. panel. The use of such a narrow panel is made possible by employing two separate chassis for the built-in power unit and for the receiver proper. The chassis are mounted parallel to the panel, arranged with interconnecting cables and plugs to provide for easy removal, thus making all components readily accessible. Overall depth from back of panel is 13 ins. The net weight is approximately 24 pounds.

Even though the SCR-2 has been built to require a minimum of rack panel space, its performance has been made fully equal to, if not better than, that of general coverage receivers employing the same number of equivalent circuits. The saving in space which results from omission of the multi-gang tuning condenser, the band switching system, and the high power audio output stage with its associated power

requirements permits generous design of RF and IF tuned circuits and shielding. It is interesting to note that some of these points offer the same advantages in a receiver utilizing plug-in coil assemblies. All RF and IF circuits are tuned with air dielectric condensers of the self-locking type, assuring the permanence of adjustment essential in equipment of this type.

The following technical information covers performance characteristics, installation, alignment and operation.

Circuit ★ The SCR-2 has two stages of tuned RF amplification, a dual purpose converter with crystal controlled oscillator, two stages of IF amplification, a detector, and one audio stage. The auxiliary circuits are AVC, CW oscillator, noise peak limiter, and power supply. Nine tubes are employed. In Fig. 2, looking from right to left, they are:

First RF	V-1	6K7
Second RF	V-2	6K7
Converter	V-3	6K8
First IF	V-4	6K7
Second IF	V-5	6K7
Detector-Limiter	V-6	6SN7-GT
BFO	V-7	6SJ7
AVC-Audio	V-8	6SN7-GT
Rectifier	V-9	6X5-GT
Pilot Lamp	I-1	(Mazda) 47

Sensitivity ★ Overall sensitivity is sufficient to give 6 milliwatts output with a signal of 1

*Chief Electrical Engineer, National Company, Inc., Malden, Mass.

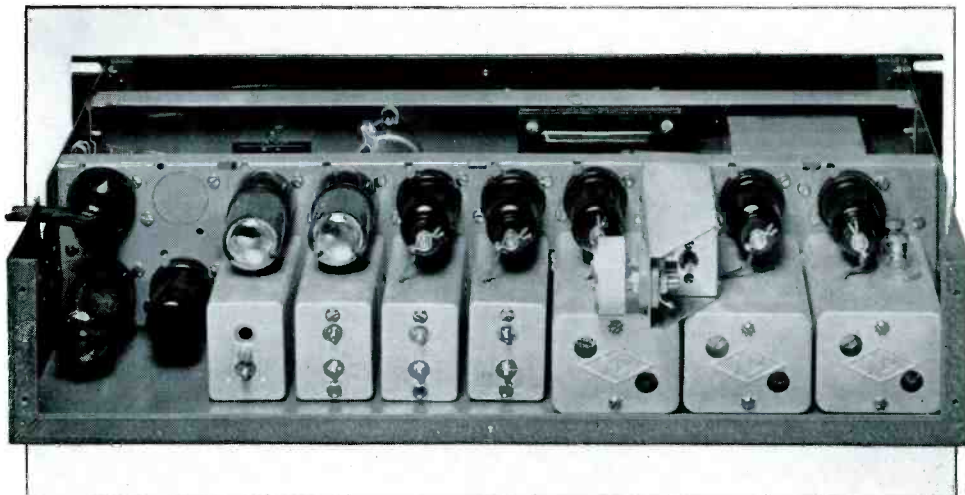

FIG. 2. ALL ALIGNING ADJUSTMENTS ARE ACCESSIBLE FROM THE REAR. CRYSTAL IS MOUNTED AT THE RIGHT, BETWEEN THE SECOND AND THIRD TUBES

microvolt or less. At a signal input of only 2.5 microvolts, the signal-to-noise ratio is 10db, average.

Selectivity ★ In order to minimize the need for receiver readjustment, and to eliminate, as far as practicable, detuning arising from transmitter drift and other effects, the selectivity characteristic of the SCR-2 has a broad "nose" with steep sides. Band width at 2 times down is 4 kc., while at 1,000 times down, the band width is 19 kc.

Audio Fidelity ★ Overall audio response has been made adequate for commercial service, where wide range reproduction is not desirable. The audio characteristic is essentially flat from 100 to 1,500 cycles, with increasing attenuation of higher frequencies, thus providing for good intelligibility in the speech band, with maximum reduction of unwanted signals and noise.

Automatic Volume Control ★ The AVC system is unusually effective. When receiving modulated signals, the audio output remains constant within 4 db. with input signal changes from 1 microvolt to well over 1 volt. The AVC system is inoperative when receiving CW signals. The adjustable noise peak limiter will, however, hold the output level of CW signals constant within 6 db. with signal input changes from 1 microvolt to 1 volt.

Audio Output ★ Normal output impedance of the SCR-2 is 500 to 600 ohms. Neither side of the output circuit is grounded. The maximum undistorted audio power is approximately 15 milliwatts.

Antenna Input ★ Either single or two-wire antenna feeder systems can be used with the input circuit provided. Standard input impedance is approximately 500 ohms. Two insulated binding posts shown at the extreme right in Fig. 2, are provided for feeder connections.

Doublet feeders can be connected directly to the terminals E-1, Fig. 4, since neither terminal is grounded. It is recommended that the receiver chassis be permanently grounded either by means of the rack mounting or by a direct ground lead.

In an installation having a single wire feeder system, the single wire should be connected to either one of the terminals E-1 and the other terminal to the ground.

It is recommended that in installations where several SCR-2 receivers are used, each be connected to a separate antenna. Where such an arrangement is not possible, it is usually best to connect input terminals of two or more receivers in series rather than in parallel. It is sometimes necessary, for best efficiency, to employ individual shielded series resonant tuned circuits between a common single-wire antenna lead-in and the input terminals of the individual receivers. In such an installation each series resonant circuit is tuned to the operating frequency of the receiver to which it is connected.

Alignment ★ Inasmuch as the receiver is aligned and tested before shipment for proper operation on a specified frequency, only minor readjustments need be made at the time of installation. The rear view photograph, Fig. 2, shows the locations of all tuning adjustments. It will be noted that all are accessible from the

rear with the receiver rack-mounted in operating position.

To check receiver alignment, proceed as follows: Feed a steady test signal, preferably one having tone modulation, into the input terminals E-1. Turn the AVC-CWO switch to the CWO position and disable the CW oscillator by removing the BFO tube V-7. With the limiter control fully retarded, advance the RF gain and AF gain controls sufficiently to provide adequate signal output. Never align any circuit unless the AVC circuits are inoperative and the limiter control is fully retarded.

1. Check the crystal oscillator tuned circuit trimmer C-4 to make sure that the setting is such that the crystal oscillates strongly at the proper frequency.

2. Check the adjustment of the six IF transformer inductance trimmers L-1 to L-6 inclusively to make sure that their adjustment is correct to provide maximum sensitivity at the correct frequency. These adjustments permit tuning the IF amplifier, as a whole, over a range of approximately 450 to 460 kc., and thus provide a means of compensating for minor discrepancies between transmitter frequency and the frequency of the receiver crystal.

3. After the IF amplifier is properly adjusted, check the settings of trimmer capacitors C-1, C-2, and C-3. Some types of RF transformers have two trimmer capacitors connected in parallel; when aligning such types, either trimmer capacitor of a pair can be used for alignment purposes.

4. Replace the CW oscillator tube V-7 and check the adjustment of inductance trimmer L-7, preferably with modulation removed from the test signal, to provide a CW beat note of the desired pitch.

Modulated Signals ★ For the reception of MCW signals, the controls are set as follows: AC switch on, B+ switch on, RF gain at 10, and the AVC-CWO switch at AVC. The AF gain control should be set to provide the desired audio output level and the limiter control may be advanced to the point where the limiter circuits just start to cut off modulation peaks. If the static background is high, it is permissible to advance the limiter control so that static peaks are reduced as much as possible without impairing the intelligibility of the signal. It is recommended that the RF gain control always be advanced as far as receiving conditions permit. If, however, fully advancing the RF gain

FIG. 3. TOP VIEW, SHOWING THE POWER SUPPLY SECTION LOCATED BETWEEN THE FRONT PANEL AND THE RECEIVER CIRCUITS. THUS POWER PACK TEMPERATURE RISE DOES NOT AFFECT RECEIVER

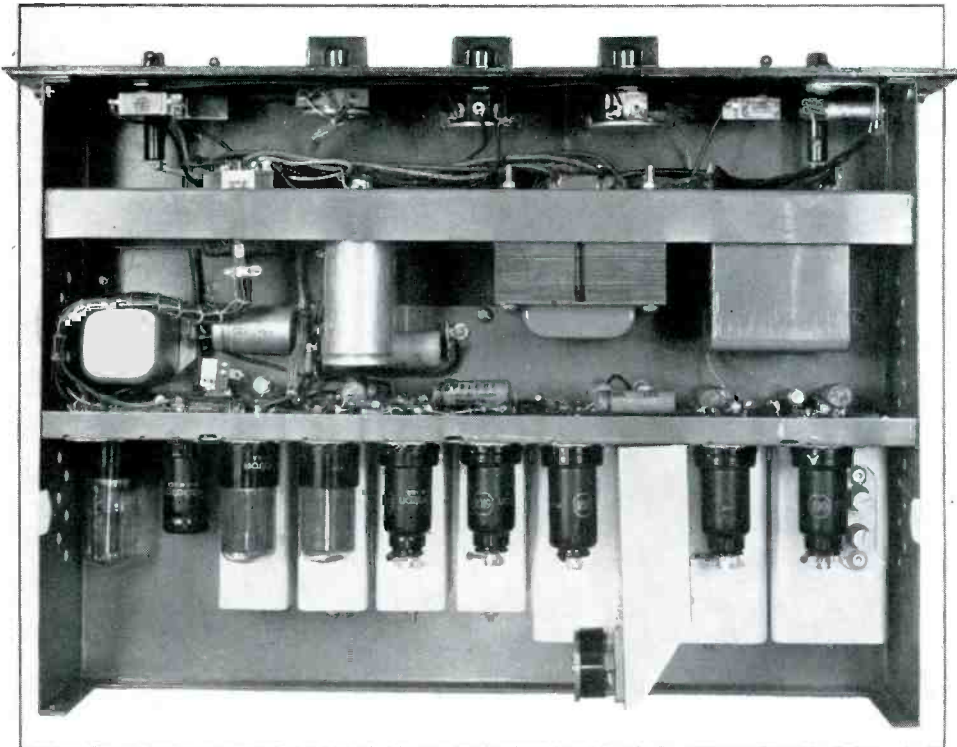

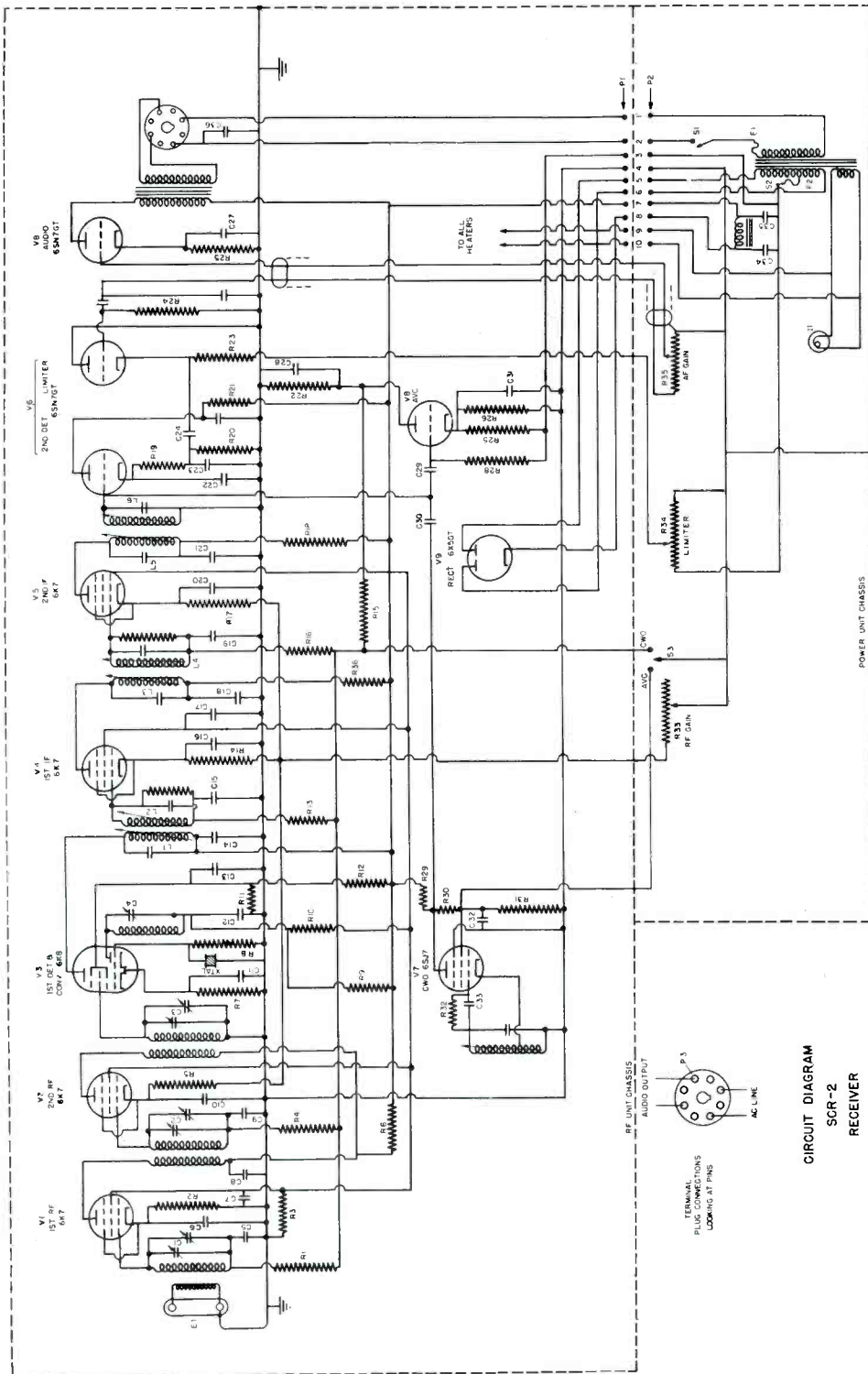

CIRCUIT DIAGRAM
SCR-2
RECEIVER

FIG. 4. ALL CIRCUIT ELEMENTS ARE INCLUDED IN THE UNIT, EXCEPT THE LOUSPEAKER OR SUBSEQUENT POWER AMPLIFIER, IF IT IS REQUIRED

Capacitors			Resistors (Cont'd)						
C-5	.01	mfd	600	Volt	R-6	20,000	ohm	2	Watt
C-6	.1	mfd	400	Volt	R-7	250	ohm	1/2	Watt
C-7	.1	mfd	400	Volt	R-8	.25	meg	1/2	Watt
C-8	.1	mfd	400	Volt	R-9	15,000	ohm	2	Watt
C-9	.01	mfd	400	Volt	R-10	5,000	ohm	1/2	Watt
C-10	.1	mfd	400	Volt	R-11	.1	meg	1/2	Watt
C-11	.1	mfd	400	Volt	R-12	50,000	ohm	1/2	Watt
C-12	.1	mfd	400	Volt	R-13	.5	meg	1/2	Watt
C-13	.1	mfd	400	Volt	R-14	.5-2m	ohm	1/2	Watt
C-14	.1	mfd	400	Volt	R-15	.5	meg	1/2	Watt
C-15	.01	mfd	400	Volt	R-16	.5	meg	1/2	Watt
C-16	.1	mfd	400	Volt	R-17	500	ohm	1/2	Watt
C-17	.1	mfd	400	Volt	R-18	2,000	ohm	1/2	Watt
C-18	.1	mfd	400	Volt	R-19	5,000	ohm	1/2	Watt
C-19	.01	mfd	400	Volt	R-20	25,000	ohm	1/2	Watt
C-20	.1	mfd	400	Volt	R-21	2,000	ohm	1/2	Watt
C-21	.1	mfd	400	Volt	R-22	.5	meg	1/2	Watt
C-22	250	mmf	500	Volt	R-23	.1	meg	1/2	Watt
C-23	.001	mfd	500	Volt	R-24	.25	meg	1/2	Watt
C-24	1.	mfd	200	Volt	R-25	1,500	ohm	1/2	Watt
C-25	.01	mfd	400	Volt	R-26	1,500	ohm	2	Watt
C-26	.006	mfd	300	Volt	R-27	500	ohm	1/2	Watt
C-27	25	mfd	50	Volt	R-28	5	meg	1/2	Watt
C-28	.1	mfd	400	Volt	R-29	.25	meg	1/2	Watt
C-29	50	mmf	500	Volt	R-30	.1	meg	1/2	Watt
C-30	1	mmf	400	Volt	R-31	.1	meg	1/2	Watt
C-31	.1	mfd	400	Volt	R-32	50,000	ohm	1/2	Watt
C-32	.1	mfd	400	Volt	R-33	10,000	ohm	Variable	
C-33	.001	mfd	500	Volt	R-34	10,000	ohm	Variable	
C-34	8	mfd	450	Volt	R-35	.5	meg	Variable	
C-35	8	mfd	450	Volt	R-36	2000	ohm	1/2	Watt
C-36	.01	mfd	600	Volt					
Resistors			Plugs and Fuses						
R-1	.5	meg	1/2	Watt	P-1	Jones	P-310-CCT		
R-2	500	ohm	1/2	Watt	P-2	Jones	S-310-AB		
R-3	20,000	ohm	2	Watt	P-3	Alden	Type 988		
R-4	.5	meg	1/2	Watt	F-1	Type	3AG 1 Amp.		
R-5	500	ohm	1/2	Watt	F-2	Type	3AG 125 MA.		
					X-1	Littelfuse	1075A		
					X-2	Littelfuse	1075A		

VALUES OF COMPONENT PARTS SHOWN IN THE SCHEMATIC WIRING DIAGRAM, FIG. 4

control results in objectionable background noise at times when no signal is being received, it may be retarded somewhat. Receiver sensitivity and AVC action will be limited with the RF gain control retarded.

CW Signals ★ For the reception of CW signals, the controls are set as follows: AC switch on, B+ switch on, AVC-CWO switch at CWO, and the AF gain at 5. The RF gain control should be advanced to the point where adequate signal output is obtained even when the signal fades to the minimum usable level. The limiter control should be advanced to the point where the limiter circuit definitely reduces audio output even with weak signal input. Readjustment of the AF gain and limiter controls may be required in order to obtain the most desirable leveling action.

Stand-by ★ Where the receiver is used intermittently as, for instance, only at certain hours each day, the AC switch is left on at all times, and the receiver temporarily turned off by the B+ switch. This plan lengthens the life of the tubes and other circuit components since it

tends to maintain constant temperature in all circuit elements. In addition, the receiver is, of course, at all times ready for instant operation.

Fuses ★ Two fuses are housed in extractor posts and mounted on the receiver panel. Fuse F-1 on the left-hand side is connected in one side of the AC line and has a rating of 1 amp. Fuse F-2, on the right-hand side, is connected in the B-negative return circuit and has a rating of 125 milliamperes.

Changing Frequency ★ It is possible to operate the receiver at a different fixed frequency by substituting the proper crystal, provided the fixed frequency is within the tuning range of the RF and crystal oscillator tuned circuits. The frequency range of these tuned circuits is indicated on the shield cans. The crystal frequency may be either 455 kc. higher or lower than the signal frequency, depending on the tuning range of the crystal oscillator circuits. The crystal can be either of the fundamental or harmonic type, the latter being recommended for operation at frequencies above 10 mc.

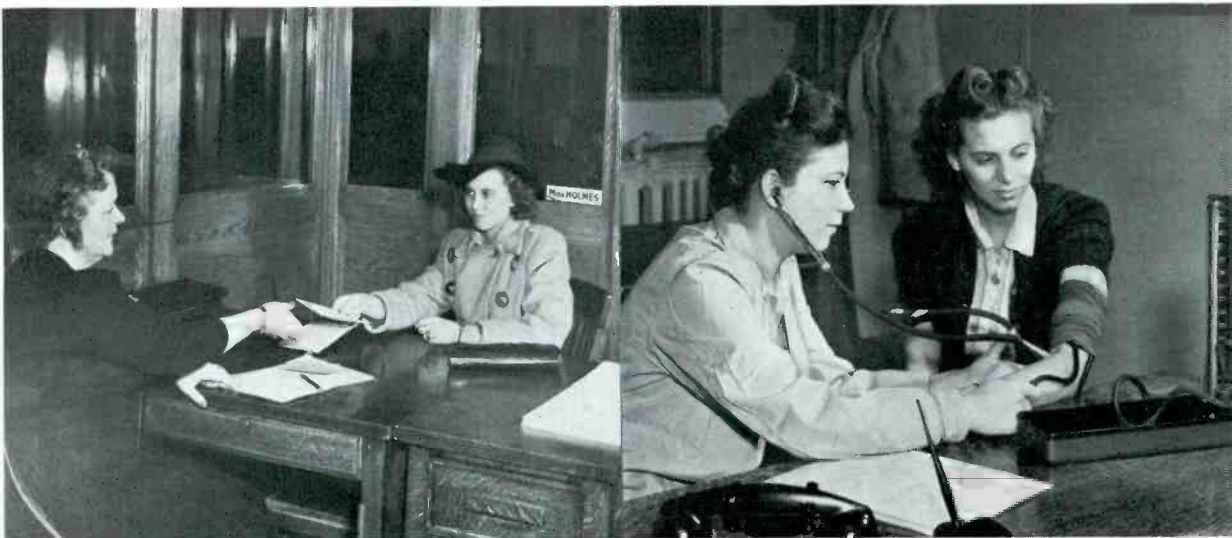

GERALDINE PAHLER, ONE OF THE HUNDREDS OF GIRLS EMPLOYED BY WESTERN ELECTRIC ON GOVERNMENT RADIO CONTRACTS, APPLIES TO MISS MARY HOLMES, EMPLOYMENT INTERVIEWER. NEXT, SHE IS SENT TO DR. CORNELIA GASKILL FOR CHECKUP TO DETERMINE PHYSICAL FITNESS FOR FACTORY EMPLOYMENT

EMPLOYEE TRAINING METHODS

Western Electric Company Classifies, Trains, and Grades Unskilled Workers in Newly Established "Vestibule School"

BY GEORGE DANIEL*

IN OCTOBER of 1939, the 625 workers in the Western Electric Company's Specialty Products Division at Kearny, New Jersey, were employed in their normal pursuits of producing broadcast transmitters and associated equipment, radio units for aviation, marine, and police services, hearing aids, and other by-products of telephone research.

But changing world conditions have made the Specialty Products Division of today the source of loudspeaker systems for the Navy, of radio "command sets" for America's new squadrons of training and combat planes, and of higher powered radio units for ground use. To meet Division orders, Company plants in other locations are producing such essential material for the Signal Corps as field telephone sets, throat microphones and "bomber mikes" used by Air Corps pilots, together with thousands of miles of rubber-covered field wire. Totalling nearly \$150,000,000, these Government orders on Specialty Products' books supplement the Company's production schedules

on telephone apparatus, already vastly increased to meet defense communications needs.

In meeting this short-time multiplication of demand, not only has the Specialty Division's plant capacity at Kearny been increased greatly, but other newly-leased plants also are taking their places in the expanding picture of War production. Today, the Specialty Products shop at Kearny alone employs about 4,000 men and women, an increase of 640 per cent within little more than two years.

A great number of these new Western Electric employees are young people finding their first jobs in industry. Many come directly from high school. Yet, today, for all their inexperience, they are doing their jobs with deftness and precision on equipment which must pass the most rigid inspections.

To the manufacturer of war materials, there are two methods of introducing the new employee to his job and surroundings. With production pressure constantly calling for more manpower, the novice may be called directly to his work. On the other hand, he may be given preliminary training in his new duties. Western

* Western Electric Company, 195 Broadway, N. Y. C.

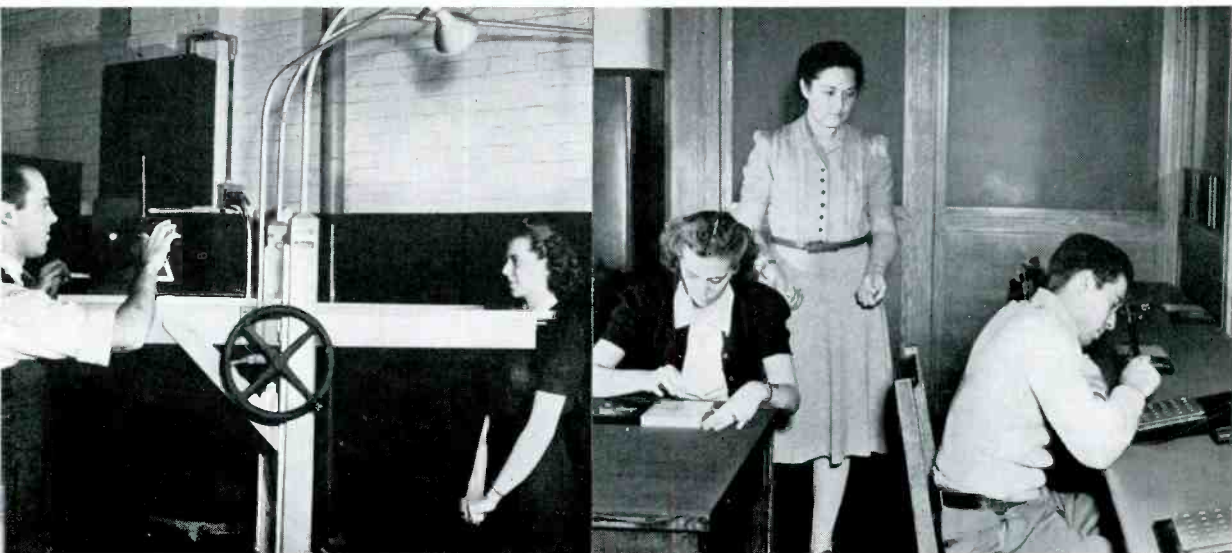

JAMES M. ORCHARD TAKES GERALDINE'S BADGE PHOTO. SHE THEN TAKES FINGER DEXTERITY TEST, PUTTING SMALL PINS INTO HOLES VERY CLOSE TOGETHER, WHILE IRWIN LEVY HAS 10-MINUTE MONOTONY TEST. HE MUST POKE STYLUS THROUGH HOLES WITHOUT TOUCHING METAL PLATE, TIMER COUNTS MISSES

Electric has found that this latter method of induction enables new employees to attain their required efficiency more rapidly.

Apprenticeship and other long-run types of training have long been a standard practice of the Western Electric Company. When the huge increases in employment due to defense needs were first foreseen, it was decided that something more than customary methods of instruction was needed; that brief, concise training would in many cases be essential. To meet this problem, there was instituted at Kearny on October 21, 1940, a Vestibule School, named to depict the passageway of training leading from the outside world into industry.

Naturally, it was seen that the success of such a movement would depend to a great extent upon the quality and ability of the instructors. Out of the previous experience of the Kearny Works of the Western Electric Company in other types of training, a procedure of developing skilled instructors was evolved. First, of course, a curriculum was planned, and the men were selected who knew thoroughly the topics they were to teach, and who were considered to have potential teaching ability.

A series of conferences presented to the new instructors the lessons of experience gained in other training projects. Several operations were searchingly analyzed, that the new teachers might understand completely the fundamentals of work which was to them second nature. Preparation of the school's faculty included a period devoted to supervised practise instruction.

Now, the Vestibule School operates in this manner: After an acceptable applicant for

work is selected by interview and physical examination, and has been fingerprinted and photographed, the work of proper placement and training begins immediately. To aid in assuring his being placed to best advantage, the new employee is given qualifying tests illustrated in the accompanying pictures. An opportunity to demonstrate manual and finger dexterity is extended to both men and women, as shown on pages 13 and 14. Occasionally, if the future job requires it, a test of general mental ability may also be given. Female employees are tested for speed and accuracy in winding wire over a series of pins, page 15.

The trainees in the Specialty Products Division are generally separated into four groups, according to the work to be performed. These are wiring, cable forming, bench work, and inspection. The subjects each student must learn depends partly upon the group in which he is placed.

Any of the subjects comprising the present curriculum can be taught within a period ranging from a half day to two days. First comes the "Induction" course, to acquaint the new employee with Company procedure. Half-day subjects are the reading of blue prints for wiring work and for assembly jobs, the identification of machine screws and nuts, micrometer reading, and cable forming.

A one-day period is allotted to each of these two subjects: the use of rubber stamps for indicating designations, and drilling and tapping. The longest course, given to those whose work will require it, is that in soldering and connecting. It lasts for two days.

Let's follow a typical new Specialty Products



BOTH APPLICANTS TAKE MANUAL DEXTERITY TEST, PUTTING METAL CYLINDERS IN HOLES. ALL ARE THE SAME SIZE AND SHAPE. TIMER'S SCORING SHOWS SKILL IN REPEATING ONE OPERATION. IRWIN GOES ON TO INSTRUCTOR EDWARD RICHARDSON, TO LEARN CABLE FORMING

employee — man or woman — from the beginning of his Vestibule School training until he is ready to begin work. At the time of his first reporting for work, the personnel department, guided by the results of the qualifying tests which were given him a few days before, has already decided to what work the new employee should be best suited. This information is sent on to his supervisor-to-be, who checks against the school's curriculum the subjects which the novice should learn to qualify for his new position. On the basis of this selection, depending upon how many and which subjects he is to be taught, the student will spend from two days to two weeks in the school.

In this case, the employee has been designated as a solderer, and his future supervisor has indicated his course of study. The first course, which is prescribed in all cases, acquaints him with factory routine, presents such general information to him as safety rules, fire drills, and Company services and their locations. With this "Induction" course, preliminary formalities end and more specific instruction begins.

Since this new employee will be given the soldering and connecting course, to avoid wasting time, his instructor first asks if he has any previous knowledge of the subject. If the answer is affirmative, the student is requested to demonstrate his ability, and depending on the caliber of this demonstration, the instructor may cut certain parts of the course as he sees fit. Of course, if the student has no previous knowledge, the entire course is given.

The instructor begins the lesson by familiarizing the student with the tools he will use and

their proper care. First, the information is carefully explained to him, after which he is asked comprehensive questions designed to show whether or not this new knowledge has been clearly grasped. This done, the instruction in actual manual operations begins.

The first operation which must be learned is the cutting of connecting wires to the correct length. The instructor demonstrates the procedure, explaining carefully the reasons for the procedure as he goes. Then the student is asked to perform the same operation. Whether he does it correctly or not the instructor constantly asks him *why* he does it in that manner. If his method is incorrect, his inability to give the right answer affords his instructor the opportunity to correct the faulty impression. Only when he has thoroughly demonstrated his grasp of the operation is the next part of the course considered.

Throughout the period of training, it is constantly borne in mind that the student is not actively learning while his instructor is demonstrating. Only while and when he actually *performs* the operation will he really learn it.

The next part of the course covers skinning the wires. This is done by a machine which burns the insulation to the point that the wire can be pulled free. Once again, when the student is shown what is expected, he is immediately given opportunity to try it himself. The instructor supervises him carefully, constantly asking him "Why?" By this stressing of the reasons behind the operations, as well as the simple mechanics involved, the student is prepared to perform his eventual job more intelligently.



MISS DOROTHY MITCHELL TESTS GERALDINE'S SKILL AT WINDING WIRE OVER PINS. THEN, AFTER LEARNING HOW TO BURN INSULATION FROM WIRES, SHE TACKLES THE JOB OF SOLDERING WIRES TO TERMINAL BLOCKS. USUALLY, SIX BLOCKS ARE WIRED BEFORE ADEQUATE SKILL IS ATTAINED

The final phases of the subject to be covered, connecting the wires to the terminals and then actually soldering them, are presented and explained in a similar manner. This first part of the course can be fully covered in something less than one day.

At this point the student is given actual practise in the operations he has just learned. He receives a terminal block to which well over a hundred wires are to be connected and soldered, and with the instructor's occasional guidance, he is expected to complete the entire block. Depending upon his progress, between one and five of these blocks may be given to him for practise.

The instructor determines the time at which further practise would be of relatively little value, and then gives the student a final block on which he is to be graded. These ratings, made by the instructor in each of the subjects which he teaches, not only continue to assist the student after he actually begins his new job, but give his supervisor some idea of what may be expected from him. The grades, which consist of average, and above or below average, are based on ratings of the school's former students.

When the student finishes the course in soldering, he will go to whatever other courses his future supervisor may have designated. He may well be expected to know something of the reading of blue prints for wiring jobs, in which case he will not be expected to understand a complicated drawing after only a half-day's instruction, but he will be shown where to look for the scale key on each print and how to interpret the various symbols.

Beyond this, the supervisor may designate that special additional instruction, other than covered in the school's curriculum, will be necessary, such as the understanding of small tools and their uses. In such cases, a study is made of these requests, and if facilities for teaching are available or can be provided, arrangements will be made for the instruction.

His studies finally completed, the new employee goes directly to his job, but preceding him is his school record and his instructor's comments about him. After starting work, his progress will be subject to four regular reviews, at the end of his 2nd, 4th, 8th, and 12th weeks. From these reviews comes his supervisor's recommendation that he should be retained, transferred, or dropped.

The success of the Vestibule School seems now to be established. Production is scarcely delayed by taking time out for teaching, for not only does the trained employee develop speed in his operation more quickly than his untrained co-worker, but work which is taken from the production line during the course of the training to provide carefully supervised practice for the fledgling workers usually produces output with an even lower percentage of spoilage than would occur in the shop under similar circumstances. Then, too, his supervisor loses no important time from his own work while instructing the beginners.

The U.S. Government's wartime radio contracts will exceed one billion dollars in 1942, more than double the volume of the manufacturers' sales of sets and tubes in 1929, when sales reached an all-time high.

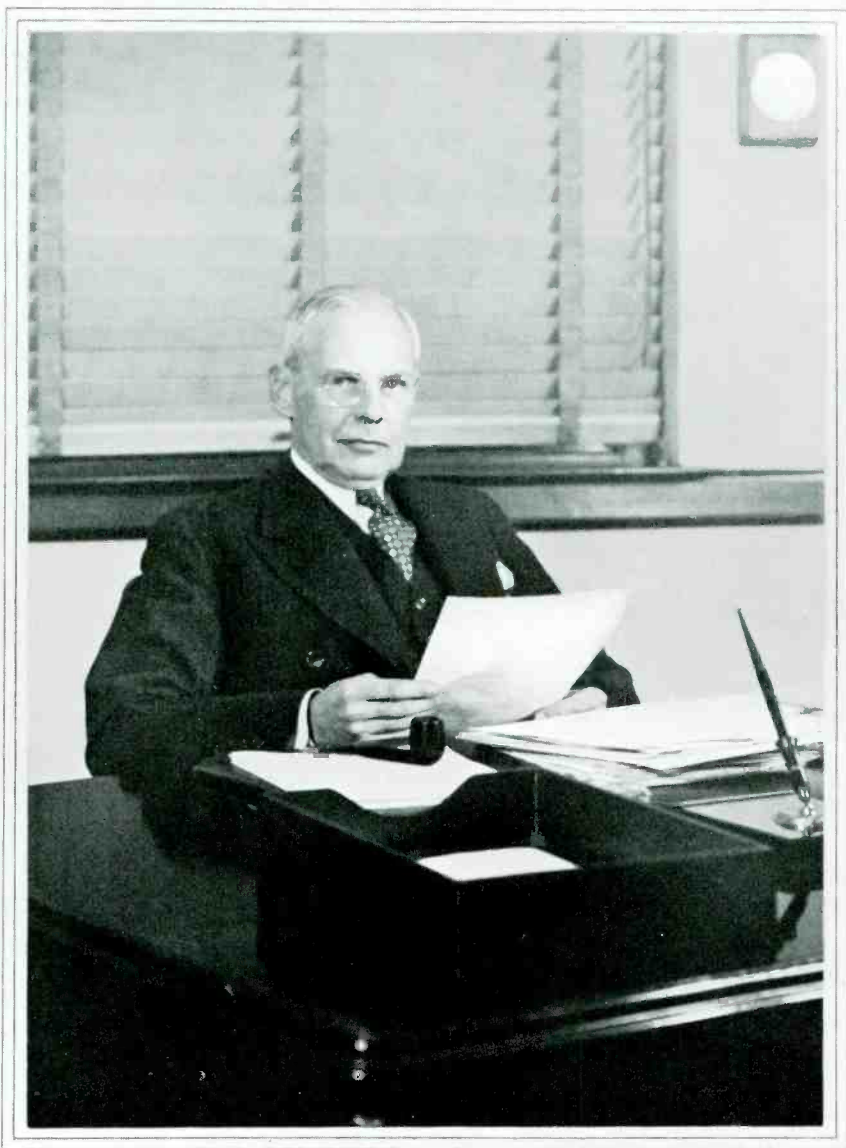

ERNEST SEARING

HE HAS WATCHED RADIO CIRCUIT DESIGNS CHANGE FROM THOSE WHICH HAD NO RESISTANCES EXCEPT GRID LEAKS TO THOSE WHICH CALL FOR RESISTORS BY THE HANDFUL. NEW CIRCUITS HAVE BROUGHT NEW PROBLEMS TO HIS INTERNATIONAL RESISTANCE COMPANY WHICH, BY FINDING WAYS TO SOLVE THEM, HAS CONTRIBUTED TO RADIO PROGRESS

THE MANUFACTURERS SAY:

A Statement by Ernest Searing, President, International Resistance Company, Philadelphia

DURING the many years that we at IRC have devoted our entire attention and effort to the development and production of fixed and variable resistance devices of many types to meet the constantly changing requirements of the industry, we have learned by watching the changes in the demands made upon us to foretell with a fair degree of accuracy the future trends of the radio business.

Normally, the character of incoming orders we receive forms a pretty accurate barometer of approaching changes in the radio receiving set business. Usually this barometer forecasts fair weather ahead when we begin to receive calls for special types of resistors and volume controls from the laboratories of the set manufacturers for use in new experimental models. The pointer moves up a little further when transmitter manufacturers begin to call for rheostats and attenuators for improved broadcasting equipment to match improved receiving sets.

When the orders for production requirements for the new model receivers start to come in, which, generally, is some time ahead of the announcement of the new models to the trade, the barometer moves upward again.

We have watched this barometer of ours move upward a number of times during the past years. Sometimes the upswing was due to one new development, sometimes to another. In the old days, the cat's whiskers and ear-phones were quickly supplanted by battery sets, and this advance proved to be only the foundation for an even greater upswing in our resistor production, which accompanied the advent of the AC tube.

Since then, year by year, new developments have followed thick and fast. Often, major improvements have come along and boosted the industry's business to new high levels, just when the outlook seemed darkest and when the pessimists were reviving the old bugaboo of a saturated market or were prophesying a black future for the industry because of some other fear complex.

However, the industry never has stood still because there is no limit to the resourcefulness and ingenuity of the great army of radio research engineers, who, never satisfied with past accomplishments, are always seeking new worlds to explore and conquer. They have al-

ways come to the rescue with new ideas which have been developed and commercialized by courageous manufacturers and distributors. Thus, in spite of difficulties, the progress of radio has been rapid and continuous, even through years of general business depression.

Last June the future looked black indeed. It appeared that the industry would starve to death in two months but, as sometimes happens, the pessimistic doctors underestimated the vitality of the patient. It was robust then and it kept right on getting huskier in spite of occasional lack of nourishment.

Of course, there are serious problems ahead now in the shape of the scarcity of raw materials, priorities, price ceilings, scarcity of labor, and what not, but there are, I think, four factors which combine to prevent any alarming downward swing of the radio barometer.

First, is the fact that the great importance of radio to disseminate information in every town and hamlet and in every home throughout the country must be recognized as a very necessary part of our war effort. Provision must be made in the allocation of raw materials for the manufacture of the parts necessary for servicing these sets.

Second, the tremendous aggregation of engineering ability in our industry can safely be trusted to find ways and means for conserving critical raw materials sufficiently to permit a reasonable volume of home set production without interfering with our country's needs for war.

Third, an enormous volume of radio equipment of many kinds must be produced for actively carrying on the war. This will provide new business for the set manufacturers, jobbers and dealers who go after it.

Last and not least, the advent of FM opens an enormous new field and creates a new demand for higher-priced, higher-quality sets. If the number of home sets produced during the coming year is curtailed, the dollar value per set made and sold will be greatly increased — thanks to the timely introduction of FM.

Now, because our country is at war and all of our efforts must be concentrated upon winning it, our methods of doing business must be revised, old plans will have to be altered and new problems will have to be solved — but our old reliable barometer is still pointing upward.

DYNAMIC SYMMETRY IN RADIO DESIGN

Part 1. Simple Geometric Relations Can Replace Guesswork in Planning Arrangement of Radio Apparatus Designs

BY ARTHUR VAN DYCK *

UNTIL the time when radio entered the home in broadcast service, radio design requirements were almost entirely utilitarian in nature. Now, however, an important part of the design problem in apparatus for the home is that of appearance, or the artistic aspect. Cabinets or other housings, panels, knobs, dials, escutcheons, and all those parts which present in any degree a freedom of choice in form, size, and position, give opportunity for design decisions whose correctness determines the artistic merit of the product. The design of useful cabinets has always presented some difficulty in artistic aspects, and radio cabinets are particularly difficult because of the numerous and strict technical requirements which are involved. Therefore it has seemed to the writer that any new "tools" for such design, which may be found, will be useful to those engineers dealing with such radio design, including both preliminary layouts and final detailing.

It is realized that the nature of this subject is very different from the usual discussions of mechanical design, but the writer feels that it may be useful because of the ever closer relationship between art and engineering, particularly apparent in radio at this time.

A powerful new "tool" is available in dynamic symmetry, a theory of art which was discovered, or rediscovered, only a few years ago. The subject has a strong fascination to engineers because it affords an interesting and useful tie between art and engineering. This paper is intended to give only an outline of the subject and to point out its principles, methods, and applications. It is largely a review of publications on

the subject, particularly those of Jay Hambidge, published by the Yale University Press, New Haven, Connecticut.

For centuries past, artists have admired the classic perfection of all forms of ancient Greek and Egyptian art, — have marvelled at the apparent ease with which it was obtained, and have wondered over the fact that so little was recorded of the designers who accomplished it. It has been admitted that but little of modern art approached the ancient perfection, and the secret of the ancients has been sought assiduously. About twenty-five years ago, Jay Hambidge, a professor of art at Yale University, made the astonishing discovery that the beauty of ancient art, in sculpture, architecture, ceramics, jewelry, etc., was due not merely to artistic inspiration, but to the use of exact geometrical formulas. Hambidge found, furthermore, that the geometrical relations used were very simple, as in fact they had to be, because the ancients had no knowledge of geometry as we know it today, or even of higher arithmetic. Geometry was developed later by the Greeks. Hambidge was able to prove his theory conclusively, and it is accepted generally today.

Artists, sculptors, and architects who were trained without aid of this revolutionary idea, have naturally been somewhat slow in applying it in their work. However, it is spreading rapidly among the new generation, and many authorities on art believe that the rebirth of dynamic symmetry will bring about a renaissance of art of vast possibilities eventually far surpassing the ancient art, because of the present better understanding of geometrical and arithmetical relations and elaborations.

Of importance to the engineer is the fact that knowl-

THE original text of Arthur Van Dyck's article appeared in the Proceedings of the Institute of Radio Engineers for September 1932. The ideas he presented at that time were so far ahead of radio design practice ten years ago, that the paper did not receive the attention it so highly merited.

Subsequent work by industrial designers has made radio engineers conscious of the practical value of clean-cut appearance, both in the production and the sale of equipment. As the author points out, beauty of form and detail is not the product of inspired ability, but can be achieved by the application of simple geometrical and arithmetical relations.

* RCA License Laboratory, 711 Fifth Avenue, New York City.

edge of these principles makes it possible for him to enrich his designs with true art, with a resultant beauty of form and detail which previously he has been educated to believe could be supplied only by the "inspired" artist. We have been long accustomed to the fact that civil engineers designed beautiful bridges without the aid of artists, but now we know that this is because the bridge designer is guided by exact geometrical rules having fundamental beauty as well as fundamental structural correctness. Now we hope that other branches of engineering may be enriched, and the writer's intention in these notes is to assist, in a small beginning way, the work of the radio engineer in its artistic aspects.

The science of preferred numbers is receiving

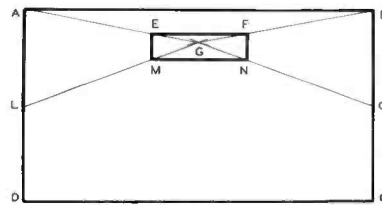
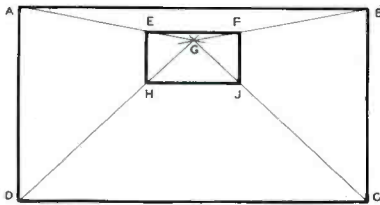

FIG. 1, LEFT. ELEMENTARY METHOD OF DETERMINING SIZE AND LOCATION FOR A NAME PLATE ON A PANEL.
FIG. 2, RIGHT. SIMILAR METHOD APPLIED TO A SMALLER NAME PLATE

increasing attention among engineers, particularly in connection with standardization work of various kinds. Preferred numbers bear distinct relation to dynamic symmetry, and a study of the latter will help greatly in any application of the former. This connection is separate from the primary object of these notes and is mentioned here only to call attention to the relation.

Dynamic Symmetry ★ Dynamic symmetry is the science of *relations of areas*. Static symmetry involves the relations of *lengths*. If the various *areas* of any design are properly related to each other, the impression or "feeling" which the beholder obtains, is that of life and growth — the design seems vital, pleasing, and "right". In nature, dynamic symmetry is universal and controls the orderly arrangement of members of organisms — shells, plant leaves and seeds, even the human body.

Before examining some of the rules and methods of Hambidge, it may be well to see how they are to be used, in one or two simple applications. For example, in the design of a radio panel with various devices located thereon, locations for these devices may be chosen at random, as well as the panel proportions, or they may be chosen with exact regard for the panel proportions. Also correct

panel proportions may be chosen which will provide better-looking locations.

In a specific example, it is desired to locate a name plate on a panel in the middle near the top. What should be the shape of the name plate if it must be 4 inches long?

Fig. 1 shows one possibility, whose construction is:

Given $ABCD$ and EF
Draw AE and BF , thus giving G
Draw GD and GC
Draw EH and FJ perpendicular to EF
 $EFJH$ is the desired shape.

If the shape obtained is higher than desired, construct as in Fig. 2, using other vital points of the panel rectangle.

Still other proportions can be obtained, as will be shown later, but these suffice for this example.

Important Rectangle Shapes ★ Let us now examine some of the relations of areas and lengths. Squares and rectangles are of course the most useful and most powerful areas. To be truly vital, that is, capable of systematic pleasing subdivision or extension, they must have certain fundamental relations. These *area* relations are the basis of all work on the subject. The most simple relations of area are, of course, 1, 2, 3, 4, 5, etc.

Consider the construction of Fig. 3:

Given square $ABCD$
Swing arc DB to F
Draw FE
Swing arc DE to H
Draw HC
etc.

If $ABCD$ has one unit of area, and a side of unit length,

then a square with AE as side has 2 units of area
and a square with AG as side has 3 units of area
and a square with AJ as side has 4 units of area

and a square with *AL* as side has 5 units of area.

Another condition of fundamental importance is the ratio of the *sides* of these areas because the laying out of designs must utilize linear dimensions rather than areas, although proportional areas are being sought.

It is found in Fig. 3 that:

If $AB = 1 = \sqrt{1}$, then,
 $AE = \sqrt{2}$
 $AG = \sqrt{3}$

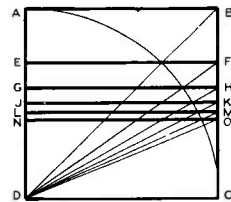
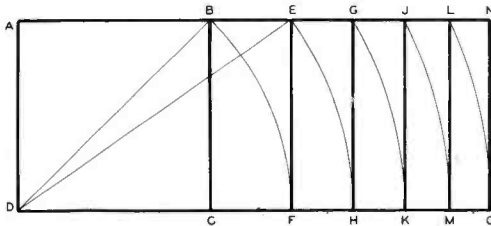

FIG. 3, LEFT, AND FIG. 4, RIGHT. MEANS FOR OBTAINING VITAL EXTENSIONS OR SUBDIVISIONS OF AREAS WHICH ARE PLEASING TO THE EYE BECAUSE OF THEIR SYSTEMATIC RELATIONSHIP

$AJ = \sqrt{4}$
 $AL = \sqrt{5}$

Then,

- ABCD* is a square, or root-one rectangle (ratio of sides = $\sqrt{1/1}$)
- Aefd* is a root-two rectangle (ratio of sides = $\sqrt{2/1} = 1.414/1$)
- AGhd* is a root-three rectangle (ratio = $\sqrt{3/1} = 1.732/1$)
- AJKd* is a root-four rectangle (ratio = $\sqrt{4/1} = 2/1$)
- ALMd* is a root-five rectangle (ratio = $\sqrt{5/1} = 2.236/1$).

Each one of these rectangles is a "powerful" shape, that is, each contains geometrical relations which can be used in various ways to produce proportional areas and other pleasing related shapes. They can also be constructed *inside* a square as shown in Fig. 4.

- Given square *ABCD*
- Swing arc *DA* to *C*
- Draw *DB*
- Where *DB* cuts arc, draw horizontal *EF*
- Draw *DF*
- Where *DF* cuts arc, draw horizontal *GH*
- etc.

Then,

- ABCD* is a square
- EFCD* is a root-two rectangle
- GHCD* is a root-three rectangle
- JKCD* is a root-four rectangle
- LMCD* is a root-five rectangle.

An interesting extension of the above square inscribing is shown in Fig. 5, and the inscribing is done by another method than that used in Fig. 4:

- Inscribe a semicircle on *CD*
- Bisect *CD* at *P*
- Erect perpendicular
- With *CP* as radius, draw *PF*
- Draw *EF* parallel to *AB*
- EFCD* is the root-two rectangle
- Also *QFCO* is a root-two rectangle, the reciprocal of *EFCD*
- Draw *DF*

- Draw arc *CR* to *CH*
- Draw *HG* parallel to *AB*
- etc., forming root-two, -three, -four, and -five rectangles.

There is one more useful, and very powerful fundamental shape, perhaps the most powerful one of all. This one is called the rectangle of the "whirling squares," for reason explained later. It is formed from a square as shown in Fig. 6. The ratio of the sides is readily calculable and is found to be $1.618/1$.

- Draw square *ABDC*
- Bisect *CD* at *E*
- With radius *EB*, swing arc *BG*
- Draw perpendicular *GF*
- Draw *BF*
- Then *ABDC* is a square
- BFGD* is a whirling-square rectangle
- AFCG* is a whirling-square rectangle.

Euclid demonstrated (see Fig. 7) that if a whirling-square rectangle is constructed on the radius of a circle, then

- the side of the rectangle is the side of a hexagon,
- the end of the rectangle is the side of a decagon,
- the diagonal of the rectangle is the side of a pentagon, all inscribed in the circle.

The inherent quality of growth of dynamic shapes is well exemplified by this theorem.

Therefore, we have the following "parent" rectangles (expressed as ratio of long side to short side).

1.0 (square)	1.4045	2.764
1.414 (root-two)	1.414	2.809
1.618 (whirling-squares)	1.4472	2.8944
1.732 (root-three)	1.528	3.236
2.0 (root-four)	1.618	3.427
2.236 (root-five)		3.618

Some of the above are not as powerful as combinations of them are, and from the above ratios, an indefinitely large number of others

Root-two and root-three ratios are not found in nature or in Greek statuary, and do not combine well with root-five or whirling-square ratios. They are, therefore, much less important.

The most important ratios in the above list are shown in Fig. 8 with the manner of their generation, which is in effect simple division of them. Also, to the right of each rectangle, is shown the reciprocal of that rectangle, which is

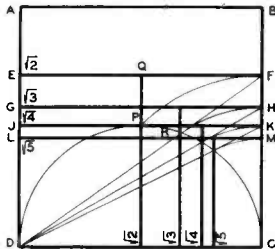

FIG. 5. AN EXTENSION OF THE METHOD OF INSCRIBING ILLUSTRATED IN FIG. 4

can be derived. For example, adding a square (or 1.0) to each gives:

- 2.0
- 2.414
- 2.618
- 2.732
- 3.0
- 3.236

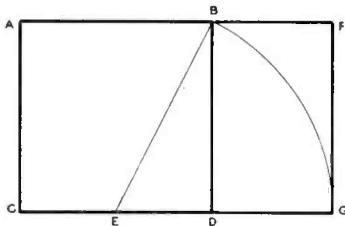

FIG. 6. BASIC CONSTRUCTION OF A "WHIRLING SQUARE" RECTANGLE, ANOTHER VITAL SHAPE

Similarly, the reciprocals and the half values are related and useful. Therefore, the available ratios are many, far too many to be worthwhile listing completely. The following list gives the principal ratios, and the most important ones are in bold type:

1.0	1.7135
1.118	1.809
1.1545	1.854
1.191	2.236
1.2236	2.309
1.236	2.4472
1.309	2.472
1.382	2.618

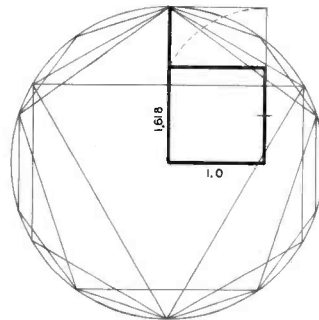

FIG. 7. THIS SHOWS A WHIRLING SQUARE CONSTRUCTED AS A RADIUS OF A CIRCLE

that rectangle which is proportional to the larger one, and has its long side equal to the short side of the larger one. Some possible divisions of these are also shown. These figures are reproduced in this paper for illustration and reference. They are, of course, only certain ones of the many different subdivisions possible in each dynamic rectangle.

Examples of Dynamic Relations ★ Before proceeding to practical applications, let us examine a few of the countless fascinating relations which are hidden in dynamic ratios and shapes. These are informative, interesting, and useful.

The square and its diagonal furnish the series of root rectangles. The square and the diagonal of half the square furnish the remarkable shapes upon which nature bases the architectural plans of plants and the human figure.

The root-five rectangle and its main divisions are the shapes most used in nature. It should be noted especially that *the three shapes of square, root-five rectangle, and whirling-square rectangle are very closely related.* (See Fig. 9.)

Construction and relation of square, root-
(CONTINUED ON PAGE 41)

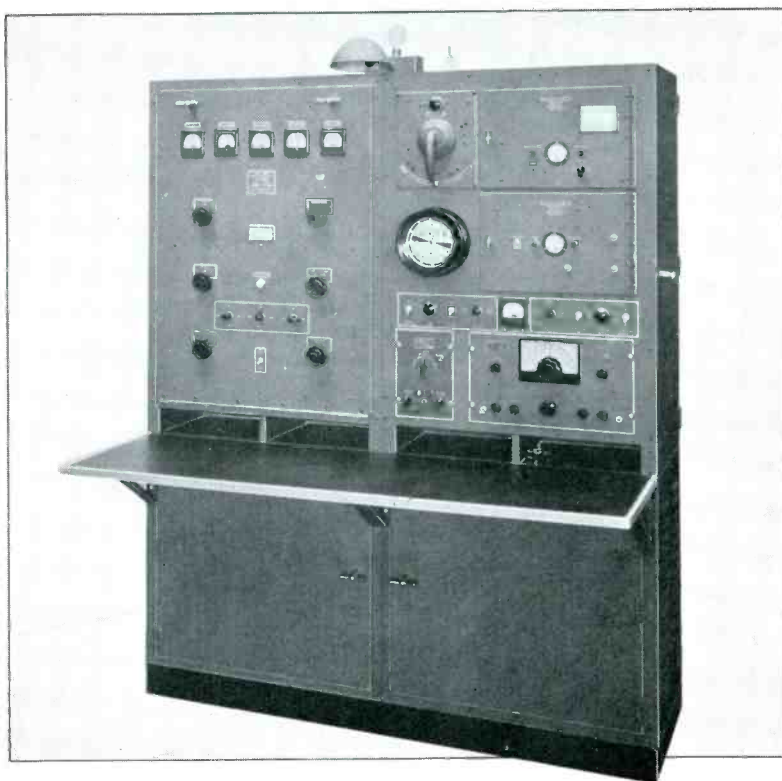

FIG. 1. THIS UNIT CONTAINS ALL ELEMENTS OF SHIP'S RADIO COMMUNICATIONS EQUIPMENT, INCLUDING MOTOR-GENERATORS, READY FOR CONNECTION TO DC SUPPLY AND ANTENNA

FEDERAL MARINE RADIO UNIT

More Efficiency, Quicker Installation Are Achieved by Single-Unit Design*

UP TO the present time the installation of radio equipment on shipboard has followed no fixed plan. The principal demand for ship radio facilities has been in the main for replacement of obsolete equipment on old vessels, or the installation of selected units of equipment in the case of new ships. In either case, the equipment was placed where space and convenience dictated, and tables or benches were constructed to support the apparatus. As regulations with respect to equipment details and installation methods became more stringent the time required to perform the installation of a complete shipboard equipment has increased to a matter of weeks.

With the plans for building a large number of new cargo vessels came the incentive to standardize radio room installations, and unify the equipment to the point where the majority

of the labor could be accomplished prior to placement of the apparatus on board a vessel. To this end, and in keeping with the trend toward speedier production of quality equipment, the Federal Telegraph Division of International Telephone and Radio Mfg. Corp., at Newark, N. J., which is an I. T. & T. associate, has developed a single unit of equipment in which is housed all of the apparatus required for a modern, efficient, and completely reliable radio installation for cargo vessels.

This Marine Radio Unit is furnished completely cabled, adjusted, and ready for installation. The assembly includes an operating shelf, message racks, and all necessary appurtenances for complete and efficient operation. The Marine Radio Unit, shown in the accompanying illustrations, possesses all of the features required by the Federal Communications Commission, the Bureau of Marine Inspection, and the U. S. Maritime Commission, plus many additional features which are included to im-

* Data furnished by Federal Telegraph Division of I. T. & T., Newark, N. J.

prove operation, increase operating efficiency, and permit ready maintenance.

The equipment includes main and emergency radio transmitters, providing a power output of 300 watts MCW (A-2) emission, or 240 watts CW (A-1) emission when powered from the ship's DC lines. In addition, the transmitter will deliver 50 watts MCW or 40 watts CW when operated from a 24-volt storage battery. Two motor generators are provided, one operating from the ship's power, and the other from the battery power. Selection of one or the other sources of power is provided by panel switches.

This transmitter, which is shown on the left hand side of the unit, provides operation on any five predetermined frequencies in the range 350 to 500 kc. (835 to 600 meters).

The transmitter circuit combines simplicity with ruggedness. The frequency-determining oscillator, which utilizes a 210 tube, employs ceramic coil forms of low temperature coefficient, and aged condensers to insure a minimum frequency deviation from any cause. A buffer amplifier, consisting of a Federal Telegraph F-123-A tube in a band pass circuit, is used to drive a pair of similar tubes in parallel in the final amplifier. This stage is coupled to the antenna circuit by means of a radio frequency transformer, adjusted at installation to the antenna resistance. The antenna circuit comprises a high Q loading inductance and variometer. Only two controls are necessary to change frequencies, the oscillator frequency switch and the antenna resonating variometer. Plate modulation of the amplifier is employed to obtain MCW. Protective devices such as fuses and a resetting circuit breaker associated with the power amplifier plate circuit reduce the possibility of failure to a minimum. In addition, the circuits employed are those in which the amplifier power is reduced to a low value if the frequency is changed, or the antenna detuned, opened or grounded.

The production of a transmitter of dimensions and characteristics adaptable for use in a compact unit of this type has been a matter of progressive development. Outstanding in this connection is the use of a high frequency power source. The generators, which are powered from the ship's DC line, develop power at 720 cycles for operating the full wave mercury vapor rectifier and filter system in the transmitter. The use of AC supply provides safety to operating personnel, inasmuch as no high voltage exists outside of the transmitter panel. The physical dimensions of the power units for operating at this frequency are so reduced over that necessary at lower frequencies, that they fit conveniently into the transmitter frame. The motor generators, shown in Fig. 3, mounted in the lower section of the Marine

Unit, although rated at 750 watts, are small enough to be carried by one man. Both machines are mounted on rubber cushions, and arranged on separate beds which permit the machines to be slid outward for servicing without disconnecting any wiring. The transmitter fuses and power components are accessible from the left side door, or the transmitter can be swung outward to a 45- or 90-degree angle for service or replacement of parts.

Two receivers are also incorporated in the marine radio unit. The regular receiver, designated Radio Receiver 128AX, covers the frequency range of 15 to 650 kc. in four bands. It is battery operated, thereby providing reliability in case of failure of the ship's power. The receiver uses a tuned radio frequency circuit, into which has been built all of the desirable features required for marine use, such as absence of images, smooth regeneration, sharpness of tuning, and freedom from vibrational or microphonic noises. The dial is directly calibrated in frequency, and illuminated. The receiver chassis is completely removable from the front, cable length permitting servicing of the receiver on the operating table. The chassis can be detached completely for replacement by removing two plugs attached to the power cables. The second receiver, known as Radio Receiver 123-BX, is a simple affair using a crystal detector. This receiver, use of which is mandatory on all ocean going vessels, provides means for reception should all other devices fail. Though outmoded, and only dimly recalled by many in connection with the infancy of radio, the crystal receiver in its modern form with etched panel and double circuit tuning, is quite an effective and reliable device when used with a ship's main antenna.

A complete Auto Alarm equipment is provided in the marine radio unit. The alarm, composed of two separately mounted chassis hinged to the front panel, is used to monitor the calling and distress band (500 kc.) whenever the operator is not on watch, or when he is engaged in reception on other than this band. The upper section of the auto alarm houses a sensitive receiver, receptive to modulated signals in a band approximately 12 kc. above and below the 500-kc. band. The output of this receiver is rectified, and employed to operate a selector device, which is mounted in the lower chassis. This selector, which is motor driven, segregates the incoming signals, discriminating between distress signals and those of other origin, such as atmospherics and routine ship business. When the international distress call, consisting of 12 four-second dashes spaced one second apart, is received, bells in the radio room, the operators quarters and on the ship's bridge are operated, and can

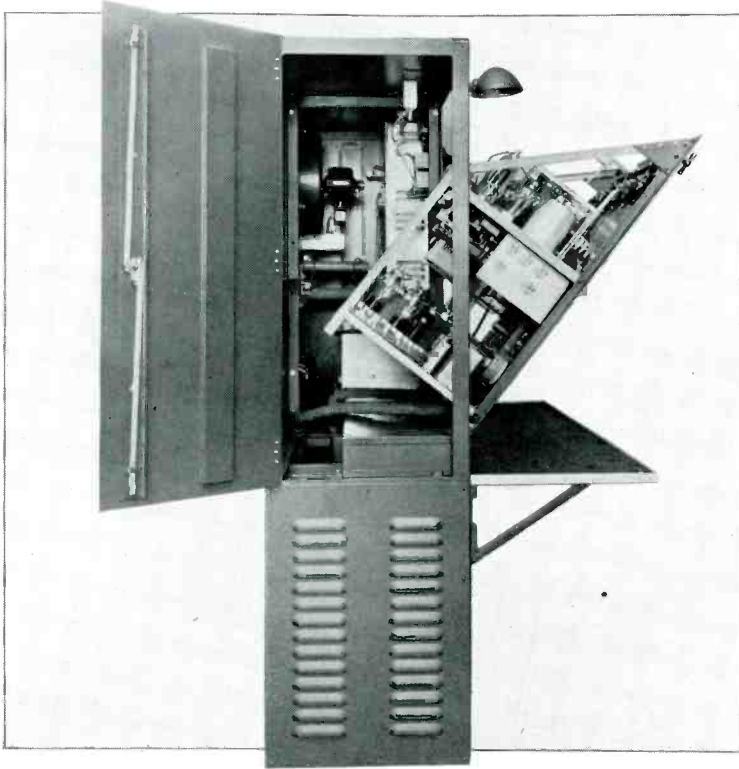

FIG. 2, LEFT. REMOVABLE PANELS AND DOORS PROVIDE ACCESS TO ALL PARTS OF THE EQUIPMENT, EVEN UNDER THE CROWDED CONDITIONS ON BOARD SHIP

FIG. 3, RIGHT. THIS MARINE UNIT, WITH EVERY PART PLANNED FOR EASE OF OPERATION AND MAINTENANCE, REPRESENTS A TREMENDOUS ADVANCE OVER THE AWKWARD, SPREAD-OUT SHIP INSTALLATIONS USED IN WORLD WAR I. SPECIAL CONSIDERATION HAS BEEN GIVEN TO EMERGENCY OPERATING FEATURES

only be silenced from the operating position. The device is extremely foolproof. It possesses such features as automatic transfer to battery power upon failure of the ship's power, operation of an alarm bell should a tube fail, the motor speed vary, or the voltage of the battery supply drop abnormally. Signal lights on the bridge and on the operating panel also indicate misadjustment or the need for adjustment due to increasing atmospherics or noise level. Both sections are hinged to the front panel of the main unit, and all of the apparatus which comprises the circuits is immediately accessible from the front of the unit.

An antenna transfer switch is mounted near the top of the unit to effect the transfer of antennas and circuits associated with the auto alarm and receivers for any desired functions. When in normal operating position, the main transmitting equipment is connected to the main antenna, and the receivers arranged to operate through a break-in relay from the main antenna. When placed in auto alarm position, the main antenna is connected to the auto alarm receiver, and an auxiliary receiving antenna is connected to the receivers to permit reception of press and weather reports on other bands without leaving the distress band

unmonitored. By simply placing the switch in this position, the power circuits for the auto alarm are closed. The auto alarm is thus put in service by this single simple operation. Another switch position, labelled Direction Finder, closes through the circuits to the Radio Direction Finder on the bridge, permitting its operation. Antenna grounding facilities are also provided. The design of this switch is such that only the grounded handle is exposed to the operation, all high voltage connections being back-panel.

A radio clock is placed directly in front of the operator, in line with his eyes. The clock has special indications for silent periods, and the four second intervals are marked in red on the second hand scale to aid the operator in transmitting the international distress signal, should this be necessary. A keying device, associated with the auto alarm, may be put in operation by throwing a single switch on the auto alarm panel, whereupon the international distress signal is transmitted automatically, using either the main or emergency power supplies.

Battery charging and control circuits are located on a panel directly above the receivers. Two sets of batteries are provided for both

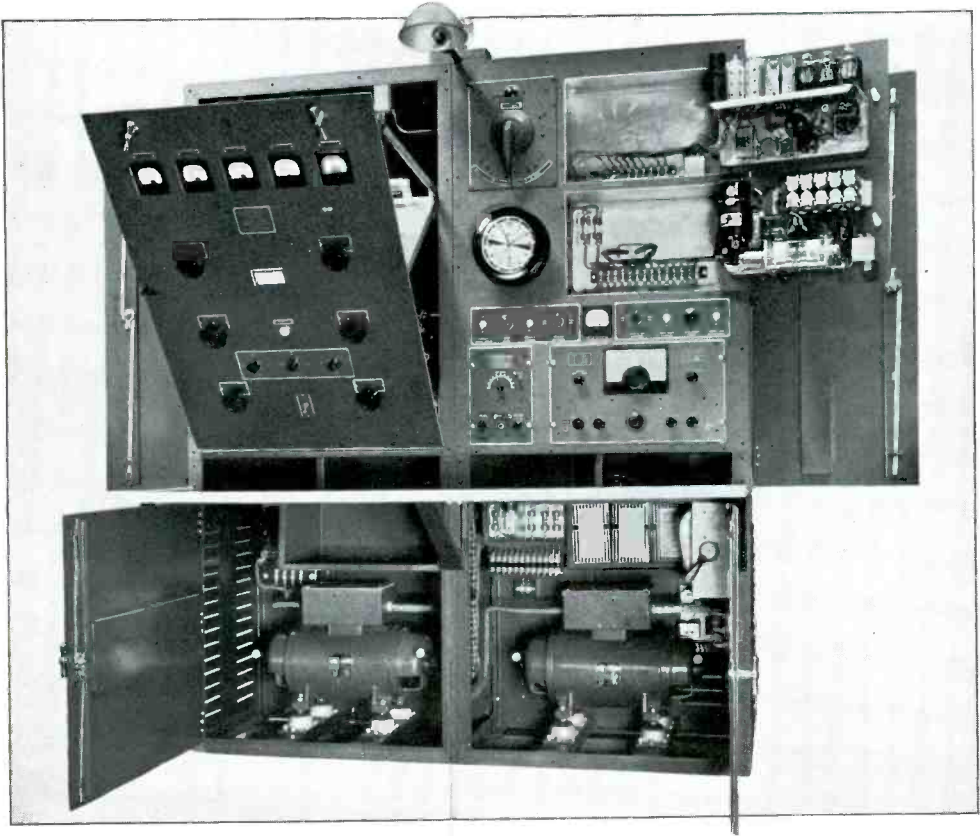

the auto alarm and the main receiver, and the switching facilities permit charging of one set of batteries while the other is in use. The charging switches associated with the transmitter emergency battery are mounted on the front of the transmitter panel. All charging resistors are placed within the cabinet, a ventilating fan serving to exhaust the heat generated. This fan, which also serves to cool the transmitter components, goes on automatically when any of the charging or transmitter switches are thrown, its speed being proportioned to the heat generated. When the batteries are being trickle charged, the fan rotates slowly. When one or more chargers are in full operation, the fan operates at high speed, exhausting quite completely the heat generated. Although the placement of charger components and the discreet use of baffle plates provides natural ventilation, absolute safety in case of failure of the fan is insured by a thermostat which functions should the generated heat become excessive, turning off the supply power. The resistors are mounted in clip holders, to enable their ready replacement.

Emergency illumination of the equipment controls and motor generator units is provided

to permit efficient operation in case of failure of the ship's power.

Accessibility of the internal parts has been extended to a point not previously approached in marine equipment. All panels, with the exception of the antenna switch, are removable from the front. Two side doors permit additional access to the interior for routine inspection. The equipment, with doors and panels open, is shown in Fig. 3.

The marine radio unit has been constructed mechanically for severe use under conditions of unusual vibration which might possibly occur in marine service. All panels are heavily copper plated before painting to prevent rust, should the paint become chipped. Equipment labels and designation plates are finished in a soft grey tone, adding considerably to the finished appearance of the unit. All doors are reinforced to avoid annoying rattles, and three-point door latches are employed. To facilitate handling, and to enable the equipment to be transported through narrow passage ways and doors, the equipment can be divided into two equal sections, which are bolted together after they are mounted in place. Special terminal

(CONCLUDED ON PAGE 47)

SPOT NEWS

Notes and Comments, personal and otherwise, about broadcast, communications, and television activities

240,000 Sets: Estimated number of sets providing FM reception now in use is almost at the quarter-million mark. Final check will probably show from 50,000 to 60,000 sets sold during the pre-Christmas weeks. At an average retail price of \$200, this represents over \$10,000,000. In 1940, with the average retail sale estimated at \$30, this number of sets would have amounted to only \$1,500,000!

Lieut. Paul A. de Mars: No. 1 FM broadcast station engineer reported for duty on January 3rd at the Radio and Electrical Section of the Bureau of Aeronautics, Washington. We are glad we got his story about the new Mt. Washington station, to be published next month, before the Navy got him.

REL Expansion: New equipment is being installed in an additional plant to give REL greatly increased production facilities.

Safety Record: 800 Philco employees in 3 departments have worked 3,000,000 man-hours in 2 years without a lost-time accident. Operations included riveting, assembling, soldering, testing, trouble-shooting, quality control, and production in one machine shop group.

W2QXR: John V. L. Hogan's FM affiliate of WQXR has been moved to the Chanin Building, East 42nd Street, New York City. W2QXR, now with greatly increased signal strength, will continue to operate as an experimental station, but will maintain a daily program schedule from 5:00 P.M. to 10:00 P.M., on 43.2 mc.

Terminal Radio: New quarters, occupying 12,000 square feet at 85 Cortlandt Street, New York

BEN GROSS MAKES A RECORDING WITH STROMBERG-CARLSON'S NEW PHONOGRAPH ATTACHMENT



City, will handle Terminal Radio's business in radio parts, sound equipment and electronic apparatus, under the supervision of Adolph L. Gross. Uptown store at 70 West 45th Street will be devoted to the sale of radio receivers, combinations, and records, in charge of Jack Haizen.

Philadelphia: W53PH (WFIL) is offering its listeners a 28-page monthly program booklet which gives a complete list of all music numbers to be played and the names of the composers. Distribution will probably total 2,500 copies. No charge is made to listeners.

No More: WOR has stopped playing request numbers on their all-night "Moonlight Saving Time" show. Reason: enemy agents could use requested recordings for coded information with great effectiveness.

Howard M. Paul: The Milwaukee Journal's W55M has lost a publicity writer and the Naval Aviation Training School has gained an ensign. Paul is a graduate of Marquette University.

52 FM Applications: For construction permits now await action by the FCC. Most of these will not be acted upon until the conclusion of the newspaper-radio investigation.

N. E. Coverage: Superior coverage provided by FM is spotlighted by Yankee Network's check on Paxton and Mt. Washington. One or both of these FM stations can be heard by 51 out of the 52 AM stations in New England. Tests were made to determine the usefulness of these two stations to the Interceptor Command, for giving instructions quickly to all AM stations in case of aerial attack. Single outpost station that could not be reached is WAGM at Presque Isle, Maine.

Dividends: Christmas present to Stromberg-Carlson stockholders was a dividend of fifty cents per share on common stock, the first since 12½ cents were paid in 1937. Lee McCanne, secretary and assistant general manager, says this improvement was due in a large measure to sweeping progress of FM.

New Year's Present: Sturges Dick Dorrance, 3rd weighed in at 8 lbs., 2 oz. on January 1st, in New York City. He is the first heir of FMB's general manager, who will now have less spare time to write stories for Collier's and This Week.

(CONCLUDED ON PAGE 45)



NEWS PICTURE FM Car Radio installed in Walter J. Damm's automobile is probably the first to be designed for this specific purpose. Built by REL, this receiver has a sensitivity control and signal strength indicator, shown above, calibrated in microvolts per meter. With the set crystal-controlled on W55M, Walter Damm can check the Milwaukee Journal's FM station, of which he is general manager, by the direct-reading meter. Speaker, mounted at the top of the luggage compartment, talks into the car





DU MONT TELEVISION TRANSMITTER W2XWV, AT 515 MADISON AVENUE, NEW YORK CITY

Essential Facilities for

MAKING A START IN TELEVISION . . .

Part 2. Suggestions for Equipment and Personnel, Based on Capital Available and Immediate Telecasting Ambitions

BY AUSTIN C. LESCARBOURA *

SO YOU are definitely interested in providing a telecasting service for the community, following a survey of its cultural, economic and advertising aspects? Such must be the starting point in any serious discussion of telecasting equipment, quarters, personnel, and cost, both initial and continuing, and eventually leading up to a self-sustaining and profitable business just as the radiophone experiments of a quarter-century ago paved the way for the highly lucrative broadcasting of today.

Let's be brutally frank so as to eliminate any false concepts from the very start of this discussion. Please note that telecasting is no piker's game. It takes real money to go into telecasting. Also, it will take a lot more to keep going. Certainly it calls for patience and grit, courage and even a gambling instinct, while fitting together those jig-saw puzzle factors of a video broadcasting service to an adequate number of television receivers, and finally fitting in that most

* In charge of television information service for Allen B. Du Mont Labs., Inc., Passaic, N. J. Author, "This Thing Called Broadcasting," "Radio for Everybody," "The Cinema Handbook," "Behind the Motion Picture Screen," etc.

elusive bit that completes the pretty picture, Santa Claus, who, minus beard and make-up, is none other than the commercial sponsor you are counting on to foot the telecasting bill.

This is a real pioneering proposition. It calls for the pioneer who is ever ready to answer the unmistakable challenge of uncertainties, thrills and potential rewards that go with trail-blazing in any virgin field.

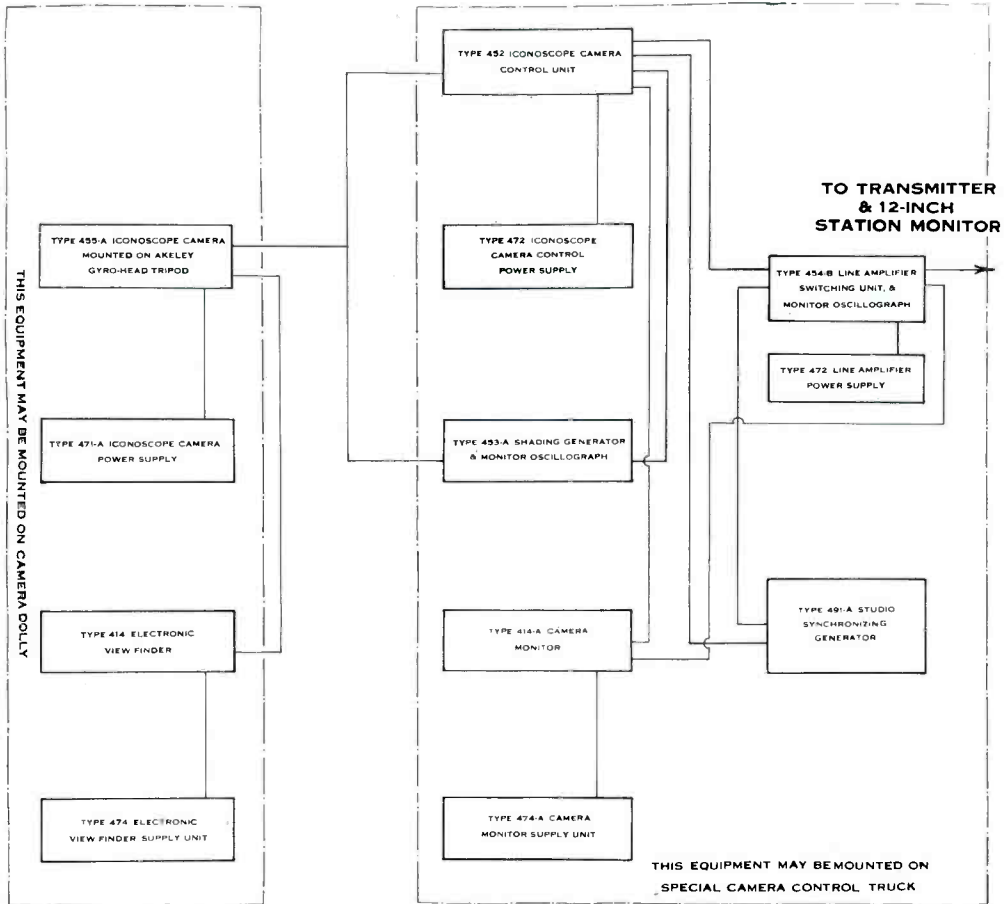

FIG. 1. ELEMENTS OF A SINGLE ICONOSCOPE CAMERA CHAIN FOR TELEVISION TRANSMISSION

Basic Considerations ★ The problem and cost of equipping a television station are governed by two major considerations: (1) The cost of the equipment, which must be determined by the available capital or funds, and (2) the flexibility of operation desired, which also means program ambitions. To operate a station and hold down a license may perhaps be achieved with a minimum of equipment and facilities, true, but the commercial value of the station will be determined by its program output. While there is adequate justification for entering the telecasting field on a purely experimental basis at this time, with a minimum investment, it must be plain that equipment and facilities and program efforts should be expanded as rapidly as possible if the venture is to develop into a profitable business.

Fortunately, the new unit-and-chain television technique recently developed by Du Mont engineers greatly facilitates fitting the television equipment to the available funds and flexibility desired. Instead of having to consider the telecasting station as a single item, at a set cost and adequate to handle the anticipated future requirements when the transmitter may be on a full commercial basis, Du Mont engineers have broken down the pickup facilities into functional

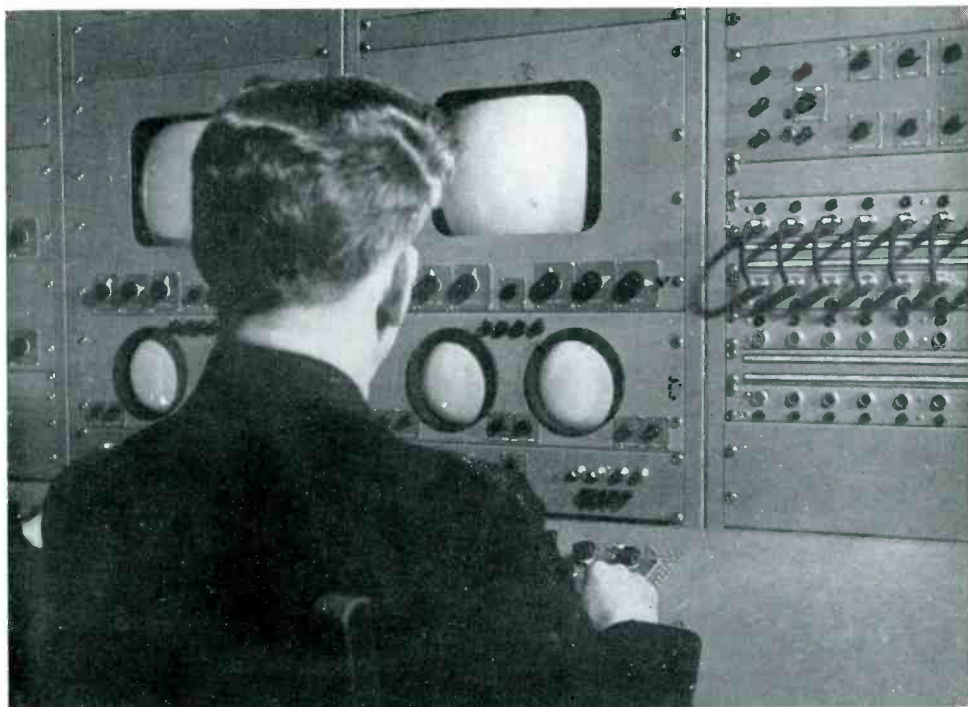

FIG. 2. MONITOR OPERATOR AT THE CONTROLS OF A DUAL FILM PICKUP CAMERA CHAIN. UNITS OF THIS SYSTEM ARE MOUNTED PERMANENTLY ON STEEL RACKS. LARGER TUBES SHOW PICTURES TRANSMITTED. SMALLER TUBES MONITOR THE SIGNAL DETAILS

units which in turn are grouped into chains for the immediate program requirements. Subsequently, they can be regrouped and added to for other and future program needs. These units can be used either in the studio, mounted on a suitable dolly or shelving, or can be readily transported in truck or automobile for outside pickups or demonstration purposes. Since the units are basic in their respective functions, there is a minimum of obsolescence and junking of equipment as the station grows in power and flexibility. It is very much the sectional bookcase idea, with the bookcase at any moment complete and serving immediate needs, yet always ready to be expanded or rearranged to cover future requirements.

With the advent of this Du Mont unit system, it is believed that a start can be made in television on almost any capital and program basis. Operation can begin under an experimental license. Experimental signals can be put on the air. Demonstrations can be given in making the community television conscious. The attendant publicity of such a new service, plus the spotting of television receivers throughout the territory particularly in taverns and clubs and other public places, can pave the way for television receiver sales. Then, when commercial operation is justified, the necessary additional units and greater power can be put to work.

In nine cases out of ten, this unit-and-chain technique will make possible a start in telecasting, as compared with the complete-station take-it-or-leave-it basis of other equipment. This technique has been developed to meet the admittedly experimental and pioneering character of telecasting at this time, yet with firm faith in its rapid advancement towards a full commercial status in the community that has been made television conscious.

Single Iconoscope Camera Chain ★ The basic equipment for any telecasting activities comprises an iconoscope camera and associated equipment to deliver a suitable video signal to the transmitter. The chain of units provides for the scanning and synchronizing system, the video system, the monitoring system, and the power supply. Here Du Mont engineers have split each functional group into several units according to their immediate electrical functions, resulting in compact and fully portable units that serve equally well in the studio or in outside pickup work. Inasmuch as a detailed description of the Du Mont television camera equip-

ment appeared in the November, 1941, issue of *FM*, no technical details need be dealt with here.

One application of this equipment is in connection with the existing broadcast studio. Obviously, the economic factors involved in equipping a studio solely for television operation are likely to be out of proportion to the anticipated return on the investment at this early date. However, using the Du Mont units as an iconoscope camera chain, the camera, together with the associated equipment mounted on a dolly, can be wheeled into the studio, in conjunction with adequate lighting, and the show is on. Meanwhile, the same equipment, because of extreme portability, can be carried to remote locations for outside pickups or demonstrations.

The camera and corresponding control equipment is arranged to operate in single or dual chains. In the case of a single chain, Fig. 1, this equipment is divided into units as follows:

1. Frequency Divider Unit
2. Blanking Sweep and Power Unit
3. Camera
4. Camera Power Supply
5. Electronic View Finder
6. View Finder Supply
7. Camera Control
8. Shading Generator
9. Camera Monitor
10. Camera Monitor Supply
11. Camera Control Power Supply
12. Line Amplifier
13. Line Amplifier Power Supply
14. Line Monitor
15. Line Monitor Supply.

In the case of two cameras or a dual chain, which will be necessary for more ambitious program requirements since one camera can work for long shots and the other for close-ups, or the cameras can be arranged for different angles or again for switching from one scene or feature to another without loss of time, two units instead of one are required for the Camera, Camera Power Supply, Electronic View Finder, View Finder Supply, Camera Control, Shading Generator, Camera Monitor, Camera Monitor Supply, and Camera Control Power Supply. The other single units serve in either the single or dual iconoscope camera chain.

Inasmuch as the electronic view finder constitutes an outstanding development in television camera technique, we may be pardoned for delving briefly into this detail. This unit, attached directly to the Du Mont camera, is simply a television that reproduces the video images exactly as they are being picked up by the camera lens. Thus the cameraman knows precisely what he is passing on to his video audience. He can check on the focusing, the lighting, the field of view and other details right at the camera itself. Also, in changing from one lens to another, the electronic view finder requires no readjustment, eliminating the cost of matched lenses or the uncertainties of ordinary optical view finders. In the Du Mont electronic view finder, the television cameraman for the first time has definite means for checking on his pickup in television terms, which is essential for good television images.

With a single iconoscope camera chain, you are all set for studio or outside pickups, on the simplest and most economical basis. However, to provide more convenient operation in picking up live talent studio programs, two iconoscope cameras, with the dual camera chain, are recommended. A wide range of program material can be covered with one or two such cameras, including the flashing of facsimile news bulletins such as teletype tape and actual typing, still pictures, animated diagrams of baseball and football games, home economics demonstrations, illustrated lectures, etc. Furthermore, a modest start can be made in film programs by using a 16 mm. movie projector specially converted for the purpose, in conjunction with the Du Mont camera, merely by projecting the movie images into the end of the television camera with lens

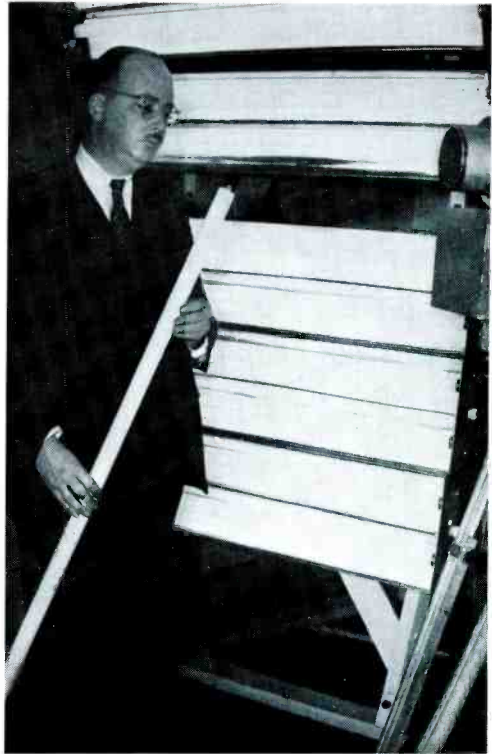

FIG. 3. FLUORESCENT LAMPS ARRANGED FOR USE IN TELEVISION. LIGHT IS WELL DIFFUSED, AND DOES NOT RAISE STUDIO TEMPERATURE

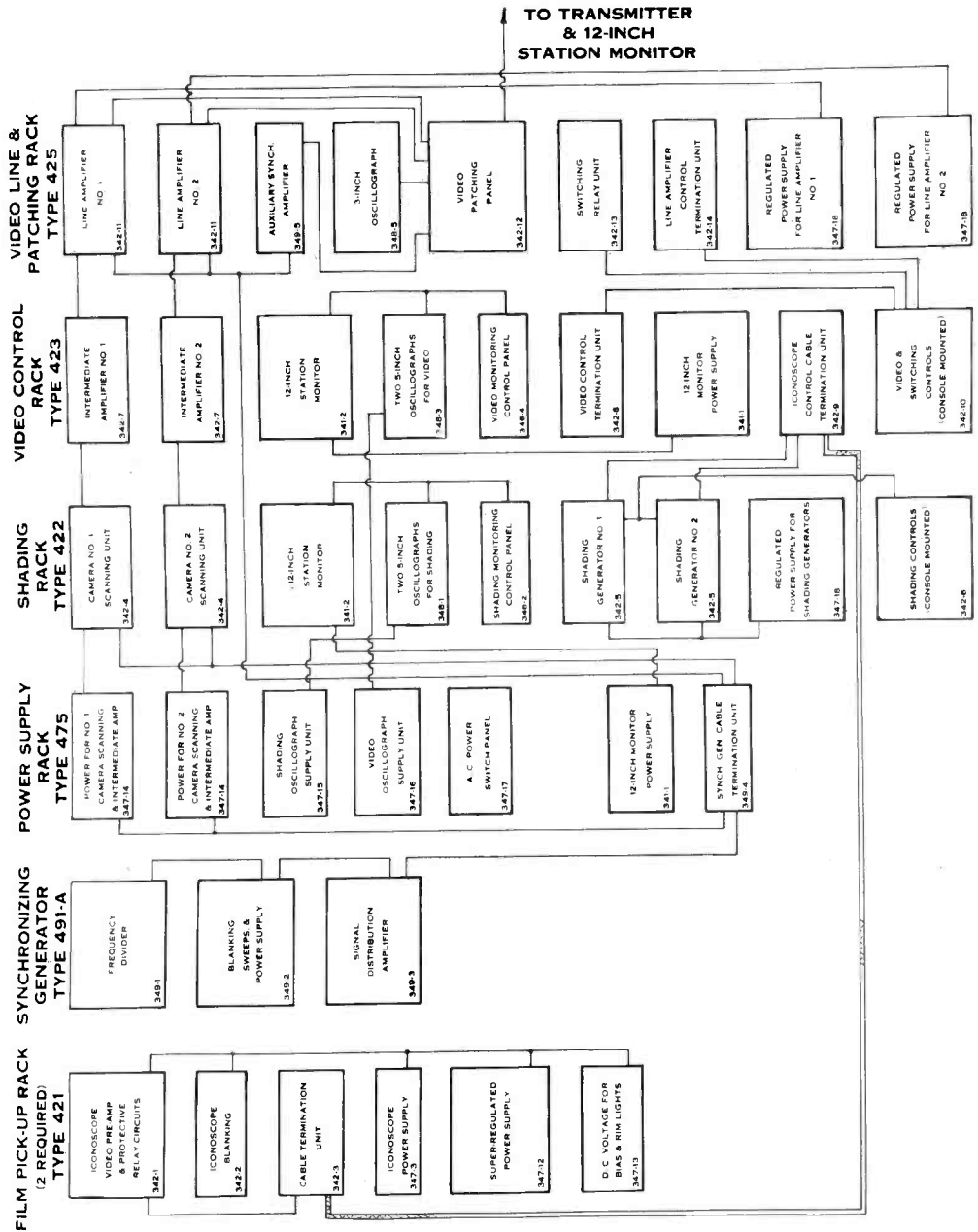

FIG. 4. DUAL FILM PICKUP CAMERA CHAIN, FOR TELEVISION MOTION PICTURE FILM

removed. However, for good quality film programs, the Du Mont Dual Film Pickup Camera Chain is essential.

Dual Orthicon Camera Chain ★ For the best portable field work, it is advisable to use Orthicon Cameras, which are more sensitive to light. The Du Mont Dual Orthicon Camera Chain is especially designed for this service. The Orthicon control equipment is similar in appearance to the Iconoscope cameras and control apparatus.

Illuminating Equipment ★ Inasmuch as there are many variables encountered in the illumination of the television studio, such as magnitude of the stage, lens equipment of the camera, nature of the pickup, kind of pictorial lighting desired, and so on, this phase can be dealt with only in the broadest terms.

Studio illumination is not a major item of cost, since modern photography has given rise to several economical means. Photo-flood bulbs in suitable reflectors, or better still the reflector-type photo-flood bulbs, are generally used because of their low cost combined with intense localized lighting for small studios or sets. Such illumination, however, is quite glaring and also very warm, to the discomfort of the performers.

Seeking a more satisfactory type illumination, Du Mont engineers have been experimenting with fluorescent-lamp lighting in the studios of Du Mont Station W2XWV in New York City. The basic installation comprises 24 standard fluorescent lamp bulbs totaling 960 watts shown in Fig. 3. The tubes are mounted in horizontal rows on heavy framework with suitable reflectors, forming two banks placed on either side of the television camera facing the performers. Operating on three-phase current, these fluorescent lamps indicate a high power factor. The total effect is virtually that of six-phase operation. Meanwhile, otherwise objectionable flicker of individual fluorescent lamps is canceled out and a perfectly smooth, steady, ideal flat lighting of virtual daylight quality, is obtained. For dramatic or modeling effects, one or more baby spots are added.

Dual Film Pickup Camera Chain ★ Inasmuch as films are bound to play a large part in television programs, corresponding to the rôle of electrical transcriptions in sound broadcasting, the dual film pickup camera chain is to be considered sooner or later in building up telecasting facilities. It is expensive equipment, and for this reason may be left for later consideration in planning the telecasting station.

The Du Mont Dual Film Pickup Camera Chain, unlike the iconoscope camera chain, is a single, massive, and obviously non-portable piece of costly equipment for studio use. The various units, Fig. 2, are rack mounted and serve not only the film pickup cameras, but provide a complete central studio control console. This provides for patching in programs originating in any one of several studios, and monitoring each program before it goes to the transmitter, as well as monitoring outside pickups in the same manner. The components for the Dual Film Pickup Camera Chain are given in Fig. 4.

Television Film Projectors ★ In addition to the two Iconoscope Film Pickup Cameras and the control equipment, two special television film projectors are required. Film projectors for this purpose are not commercially available. In order to properly synchronize the operation of the film projector with the scanning sequence of the camera and its control operation, a special conversion design is required. The cost of converting of one of few standard projectors adaptable, is necessarily added to the price of the original equipment. Two projectors, as well as two cameras, are required if continuous transmission of film is desired, and it is recommended that two be used to avoid interruption of the program.

Either 35 mm. or 16 mm. film projectors can be adapted to television pickup, although the former is preferred. However, as stated previously when dealing with program possibilities, the 16 mm. film may be more extensively used in conjunction with local events, since the camera equipment is inexpensive and simple to operate, and the films can be readily processed and ready for projection in an hour or two if necessary.

Depending on film program requirements, one of the better makes of projectors is altered for film pickup purposes. For 30-frame transmission, regardless of the number of scanning lines, intermittent operation is used. A shutter is employed



FIG. 5. TYPICAL CONSTRUCTION OF PORTABLE CAMERA CHAIN UNITS. THIS INSTRUMENT IS A SHADING GENERATOR

(CONTINUED ON PAGE 42)

WHAT THE FM BROADCASTERS HAVE TO SAY:

A Statement by E. K. Cohan,
Director of Engineering,
Columbia Broadcasting
System, New
York City

THE Columbia Broadcasting System now has in operation two FM stations, W67NY and W67C, the former atop 500 Fifth Avenue in New York, and the latter atop 1 North LaSalle Street, Chicago. In addition, construction permits have been granted to Columbia for FM stations in St. Louis and Los Angeles.

Ordinarily, the construction of such stations would offer no serious problems to an engineering department experienced in the design, construction, and installation of some of the country's foremost standard broadcast stations. In this case, however, the engineering had to be coordinated with the building of a new 50-kw. AM key station in New York, the construction of a new three-transmitter, thirteen-direction-antenna short-wave transmitting station on Long Island, and against a background of matériel scarcity and national defense priorities.

That six diversified types of transmitters have gone into operation in 1941 is a tribute to the engineers in charge of construction at each project.

In building FM transmitters, construction difficulties not usually associated with AM stations are frequently encountered. For example, the desirability of a site considerably elevated above surrounding terrain generally results in the selection of a skyscraper roof or a mountaintop. If the former, the building construction must be studied to determine if it can carry the dead weight and wind load of an antenna. But to do this, it is first necessary to know the structural design required to conform to rigidly enforced building codes.

In the northern part of the U. S. A., another factor enters the problem, that of sleet. Because of the location of such antenna structures atop skyscrapers adjoining streets where traffic



is heaviest, falling ice can become a serious hazard. Thus, some means of preventing or remedying the formation of ice must be incorporated in the design of the structure.

Assuming, however, that the site selected presents no serious problems thus far, there are still the questions of available space and power supply.

Many skyscrapers are spired or so set back that the available roof space is distinctly limited, and ingenuity must be employed to design a structurally strong and electrically efficient radiating system.

Power supply in a skyscraper is rarely available in sufficient capacity above the lower floors, and in one case of record more than \$25,000 was expended to bring necessary power to the floors where it was needed.

A volume could be written about transportation of equipment. Did you ever try trucking large steel poles through New York and Chicago streets, or hoisting transmitters 60 floors through skylights and fire wells?

Mountaintop transmitter sites present their own special problems. Accessibility, power and water supply, and wind velocity are among them. And did you ever try to get a 330-mc. STL to operate without temperament 18 hours a day, 7 days a week?

These and other problems are an interesting

(CONCLUDED ON PAGE 46)

RADIO DESIGN PRACTICE

Items about New Designs
and News about Designers

UHF Power Tube: A new radio transmitting tube, especially suitable for operation as an ultra-high-frequency power amplifier, has been announced by the General Electric Company. This is the GL 8010-R, illustrated on this page. It has a coated cathode, heated by electron bombardment from an auxiliary filament. Anode and cathode are fitted with radiators for forced-air cooling.

The parallel plane electrodes are closely spaced to facilitate neutralization. Grid-plate capacitance is 1.5 mmfd.; grid cathode capacitance is 2.3 mmfd.; and plate cathode capacitance is 0.07 mmfd. Low lead inductance is provided by the disk-type terminals.

When used as a class C radio-frequency amplifier, the tube has a maximum DC plate voltage

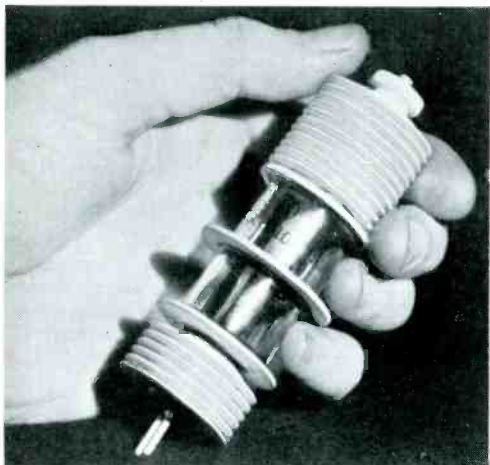

GENERAL ELECTRIC TYPE GL 8010-R POWER TUBE FOR UHF TRANSMITTERS

of 1350. Maximum plate current is 150 milliamps; maximum plate input, 100 watts; and maximum plate dissipation, 50 watts. The tube has an amplification factor of 30.

Cellulose Acetate Tubing: Tubing of cellulose acetate, in round, oval and square shapes is now offered under the trade name Lumarith Protectoid. It is wound in continuous lengths, varying from $\frac{1}{8}$ to 3 ins. inside diameter, in clear transparent material, as illustrated on this page, or it can be furnished with an inner base of paper or fibre. Wall thickness of clear tubing of $\frac{1}{16}$ to $\frac{1}{4}$ in. inside diameter is .002 or .003 in.; $\frac{1}{4}$ to $\frac{1}{2}$ in. inside diameter is up to .02 in.; $\frac{1}{2}$ to 3 ins. inside diameter is up to $\frac{1}{32}$ in. Lumarith Protectoid is a product of the Celluloid Corporation, 180 Madison Avenue, New York City.

Stepping Switch: A new stepping switch for automatic, remote-controlled, or manual operation has been brought out by The Autocall Company of Shelby, Ohio. Circular in design, contact pile-ups of 2 to 50 are mounted around the circumference. They can be of any make, break or break-make, bridging or non-bridging combinations, up to 12 springs. Magnetically actuated mechanism actuates a spider with 1 to 8 arms through Bakelite rollers. The mechanism and springs can be removed for inspection without disturbing the wiring. Contacts can be furnished to break 5 amps. at 48 v., DC; 1 amp. at 125 v., DC; and 5 amps. at 115 v. DC, with non-inductive loads. Actuating coils are available for operation on 48 to 230 v., DC. Operation is at 10 steps per second. These switches are made in either homing or magnetic-release types.

Dielectric Strength of Glass: A study of glass as a dielectric, by E. B. Shand, of Corning Glass Works, Corning, N. Y., is now available to engineers. Three main headings cover dielectric failure of glass, factors governing failure, and curve data. There are tables on disruptive strength, breakdown characteristics, selected break-down data, oil puncture tests on power insulators, and characteristics data on Pyrex glass and porcelain.

Terminal Bushings: New miniature terminal bushings, intended for small components such as transformers and condensers, have been brought out by Isolantite, Inc., 233 Broadway, New York City. Terminals are tinned hard copper. Mounting flanges can be spun or eyeleted into metal panels up to $\frac{1}{16}$ in. thick. Insulation is of glazed Isolantite. Two terminal lengths with two sizes of bushings can be supplied.

(CONCLUDED ON PAGE 46)

CELLULOSE ACETATE TUBING FOR COIL FORMS IS AVAILABLE IN ROUND, OVAL, AND SQUARE SHAPES

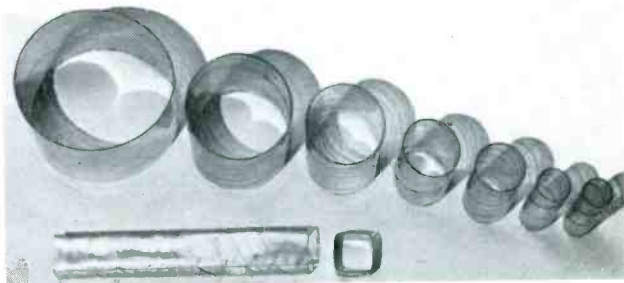

COMMENTS

of Interest to Readers of *FM Magazine*. As Expressed in Letters Written to the Editor

E. K. Cohan: May I call your attention to pages 20 and 41 of the December issue of *FM*, in which reference to the opening of our FM station W67NY speaks of our temporary antenna and low power?

It is possible that you refer to the 3 kilowatts we are using at W67NY as low power compared with some of the other metropolitan New York stations, but to avoid misunderstanding I would like to point out that our present power of 3 kilowatts is the regularly licensed power for this station.

We are, as the article indicates, using a temporary antenna, but when the permanent antenna is finally installed our service area with 3 kilowatts of power will be as great as those stations which, because of their location and antenna, will require higher power to cover the same area.

Sincerely yours,

E. K. COHAN,

Director of Engineering, CBS

John Shepard, 3rd: On page 37 of the last issue of *FM Magazine* I noticed the statement, "At this time the Capitol Broadcasting Company is installing the first ST link."

How come, when as you know, we have had an ST link in operation over a distance of forty-five miles for a couple of years?

Very sincerely yours,

JOHN SHEPARD, 3RD,

President, The Yankee Network

Arthur Van Dyck: An editorial article in your December issue, entitled "Use of Fugitive Signals," poses the question—"Is it possible that an emergency use for our broadcasting stations has been overlooked?" I would like to give you my view that the answer is "yes."

There seems to be general apathy about the use of broadcasting for defense purposes. I think I have found the reason for this, and it is very interesting.

For the first twenty years of radio, there were no amplifiers, and communication could be had only between operators with headsets. It was not possible to call a station unless an operator was on duty. And so radio communication grew up to be used only where operators could be maintained on watch. Finally we got into this groove so deeply that when amplifiers, loudspeakers and calling systems became possibilities, we never even thought of using radio in applications where operators could not be maintained. Then along came broadcasting

and, still in the groove, we did not try to utilize calling possibilities.

But now the urgency of war compels us to use every facility we have to maximum degree. One of the things we have which we are not yet using to maximum degree is the broadcasting system, as is pointed out in your editorial. We have not realized what a great war instrument broadcasting can be!

We have heretofore looked at broadcasting as an entertainment system. In its technical setup, it is really a communication system, and an excellent one. Just think of it—one microphone at any place in the country can deliver strong reliable signals to every home, office, factory, school, airport, etc., in the country, or in any desired portion of the country. The only limitations are that it is one-way communication, insofar as the millions of homes and offices are concerned, and a calling system has not been provided.

So what? Just this—we are in a new kind of war, which is new in two basic respects. First, nearly every citizen may be at a fighting front at any time. Therefore he needs rapid communication as much as only soldiers needed it in previous wars. Second, the aircraft, tank and mobile radio have speeded up operations. Enemy attacks can now occur on extremely short warning. At Pearl Harbor the time was zero, but even with maximum alertness, the time available to prepare defenses will be measured by *minutes*, not hours.

There is no way to communicate quickly to all citizens, or even to hundreds of organized defense workers, except by radio broadcasting. The system is all there, ready and waiting to be used, except for one detail. That is the prevention of use of the stations as radio beacons. There is much exaggeration of the seriousness of this situation, however. It is true that a broadcasting station can be very useful to a flyer who is lost and has no other navigational aid available. But military aviators starting on a mission are not lost, and have facilities which make them independent of need to use the stations for beam purposes. They can use the station to advantage when right over it, to determine exact position of its antenna and therefore of other things whose relative positions they know. So stations *should* go off the air when enemy planes are within a few miles. To prevent use of the stations at greater distances, for beam purposes, it is necessary only to operate a group in each area on the same frequency. This method is that now used in England where broadcasting stations, on the same frequency, stay on the air until enemy planes are

(CONTINUED ON PAGE 47)



Vacuum Tube PERFORMANCE begins on Eimac's own MACHINES

Eimac tubes are different. Different in their outstandingly superior performance capabilities... the shapes of the bulbs... the rugged design and the materials used. They are the only tubes on the market which are unconditionally guaranteed against premature failures which result from gas released internally.

So exacting are the production requirements for Eimac tubes that the tools are specially made in the Eimac factory. The glass lathes... the vacuum pumps... there's many a "gadget" so unusual that procurement from a conventional tool maker is impossible.

Follow the leaders to

Eimac
TUBES

Eitel-McCullough, Inc.
San Bruno, Calif.

EIMAC REPRESENTATIVES

California, Nevada
HERB BECKER, 1330 W.
104th St., Los Angeles, Cal.
N. Y., N. J., Penn., Md., Del.,
Dist. of Col., Maine, N. H.,
R. I., Conn., Mass.
ADOLPH SCHWARTZ, 262
Grayson Place, Teaneck, New
Jersey.

Wash., Ore., Idaho, Mont.
GENERAL SALES CO.,
Venez O. Jensen, 2605-07
3500th Ave., Seattle, Wash.
Colo., Wyo., New Mexico,
Arizna, Utah
RICHARD A. HYDE, 4253
Cutman St., Denver, Colo.

Chicago, Illinois, Wisconsin
G. G. RYAN, 549 W.
Washington Blvd., Chicago,
Ill.
N. Caro., S. Caro., Georgia,
Tenn., Fla., Ala., Miss.
JAMES MILLAR, 316 Ninth
St. N. E., Atlanta, Georgia.

Texas, La., Okla., Ark.
J. EARL SMITH, 2821 Live
Oak St., Dallas, Texas.
Ohio, Mich., Ky., Ind., Minn.,
Mo., Kan., Neb., Iowa
PEEL SALES ENGINEER-
ING CO., E. R. Peel, 154
E. Erie St., Chicago, Ill.

Expert Agents: Frazar & Co., Ltd., 301 Clay Street, San Francisco

HOW GENERAL ELECTRIC'S

Dramatic FM Promotion Can *Become the FM Leaders*



In the Radio Department of Barker Brothers, the G-E movie, "Listen, It's FM" was shown to over 1800 customers during the special G-E FM Promotion Week.

A SOUND-MOVIE IN FULL COLOR

In simple, easily understood, everyday language, this talking picture answers the very common question—"What is radio?"

It also describes, by means of familiar analogies and colorful animation, the difference between conventional AM radio and the new FM system.

The four advantages of the Armstrong System of FM:

- (1) Static reduced to the vanishing point
- (2) Life-like reproduction
- (3) Elimination of station interference
- (4) Elimination of fading

are all convincingly explained and demonstrated.

GENERAL ELECTRIC has two FM promotion attractions—(1) a sound-movie in full color and (2) a miniature-station FM demonstrator. Both these promotions are available to G-E radio dealers. They are ideally suitable for showings in department stores—utility showrooms—dealer showrooms—fairs—meetings of luncheon clubs such as Rotary and Kiwanis—musical societies, literary clubs and church groups—wherever people congregate.

The beauty of this show is that you can cash in on it even if you don't have FM broadcasting in your community at present. You can use this show to begin to develop the market and to establish yourself as the leader in FM in your community. FM will be in your area sooner or later and radio owners will want it.

Active promotion of FM is first-class business insurance for the present and the future. FM is one of those business opportunities that every live-wire dealer will want to grasp.

General Electric's field representatives and G-E radio distributors are eager to help you get into the FM business on a sound and profitable basis. Ask them for help and assistance in organizing your own FM show.

Here's How This FM Promotion Succeeded at Barker Brothers in Los Angeles

November 28, 1941

"The outstanding success of the General Electric FM demonstration week in Barker Bros. caught us napping.

"We, of course, expected a good response to our promotion, having used the combined pulling power of radio, complete metropolitan Los Angeles newspaper coverage, and store promotion, but we certainly did not expect

the crowds of people that thronged into our department.

"The sales force are most enthusiastic over the results. It is unusual to stage an educational demonstration of this kind with such a large volume of direct and immediate sales."

O. R. Coblentz, *Manager*
Radio Department
BARKER BROS.



Help Broadcasters and Dealers in their Communities

MINIATURE-STATION FM DEMONSTRATOR

This portable demonstration unit consists of two miniature radio stations which actually broadcast the same program—a high fidelity musical recording. One station broadcasts the program over ordinary radio, AM, and the other over FM.

The program can be picked up by any modern FM receiver. By switching back and forth from the AM to the FM band, your customers can hear for themselves the amazing superiority of FM over AM.

In addition, a violet-ray noise-maker, an electric razor, and a house door bell are each used to demonstrate how FM rejects static while interference from these devices ruins the reception of conventional radio.



The G-E Miniature Station FM Demonstrator was in use continuously during store hours at Barker Brothers in Los Angeles.

THESE G-E RADIO FIELD MEN WILL HELP YOU PUT THE JOB ACROSS

G. S. PETERSON

General Electric Company, Box 5970-A, Van Buren S. Post Office, Chicago, Ill. Regional Radio Sales Manager for Midwest and Southwest States.

H. A. CROSSLAND

General Electric Company, 235 Montgomery St., San Francisco, Calif. Regional Radio Sales Manager for Pacific Coast and Rocky Mountain States.

D. W. MAY

Metropolitan Distributing Branch, General Electric Company, 570 Lexington Ave., New York, N. Y. Metropolitan New York and Northern New Jersey.

L. W. YULE

General Electric Company,

140 Federal Street, Boston, Mass. New England States.

T. P. BEGY

115 Frontenac Avenue, Buffalo, New York. New York (excluding Metropolitan District) Western Vermont, Northern New Jersey.

R. J. MEIGS

General Electric Company, 1405 Locust S., Philadelphia, Pa. Southern New Jersey, Eastern Pennsylvania, Delaware, Maryland, Virginia, North Carolina.

R. P. VAN ZILE

General Electric Company, 609 Red Rock Bldg., Atlanta, Ga. South Carolina, Georgia, Florida, Alabama, Mississippi, Louisiana, Tennessee.

R. A. BUESCHER

General Electric Company, 4966 Woodland Avenue, Cleveland, Ohio. Western Pennsylvania, West Virginia, Kentucky, Ohio, Michigan, Indiana.

H. J. MANDERNACH

General Electric Company, Box 5970-A, Van Buren St. Post Office Chicago, Ill. Indiana, Illinois, Eastern Missouri, Eastern Wisconsin, Arkansas.

E. P. TOAL

General Electric Company, 12 South 6th St., Minneapolis, Minn. Western Wisconsin, Minnesota, North and South Dakota, Nebraska, Iowa.

C. T. WANDRES

General Electric Company, 1801 North Lamar St., Dallas, Texas. Western Missouri, Kansas, Oklahoma, Texas, Southern New Mexico.

T. F. HALL

General Electric Company, 212 No. Vignes St., Los Angeles, Cal. California, Arizona, Western Nevada.

B. S. WELLS

General Electric Company, 200 South Main St., Salt Lake City, Utah. Eastern Nevada, Utah, Colorado, Northern New Mexico, Wyoming, Southern Idaho, Montana.

JOHN KLENKE

3871 50th Ave., N.E., Seattle, Washington. Washington, Oregon, Northern Idaho.

GENERAL ELECTRIC

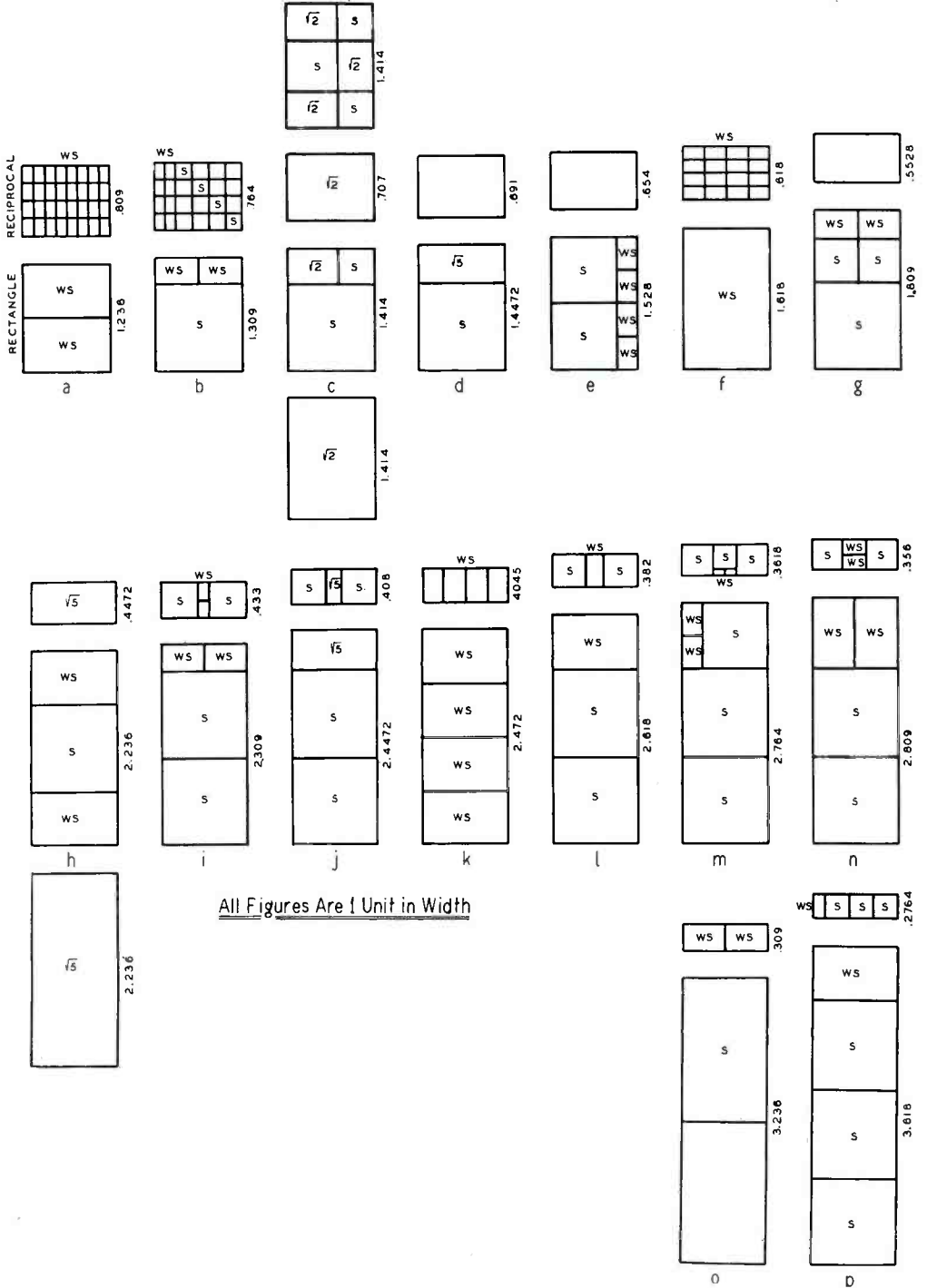

All Figures Are 1 Unit in Width

FIG. 8. THE POSSIBILITIES OF APPLYING DYNAMIC SYMMETRY TO RADIO EQUIPMENT ARE CLEAR FROM THESE RELATIONSHIPS OF AREAS REPRESENTING VARIOUS RATIOS. NUMERALS AT THE LEFT OF THE RECTANGLES ARE THE RATIOS OF HEIGHT TO WIDTH

DYNAMIC SYMMETRY IN RADIO DESIGN

(CONTINUED FROM PAGE 21)

five, and whirling-squares, are shown in Fig. 9.

$ABCD$ is a square
 $EGHF$ is a root-five rectangle
 $BGHC$, $EADF$, $AGHD$, and $EBCF$ are whirling-square rectangles.

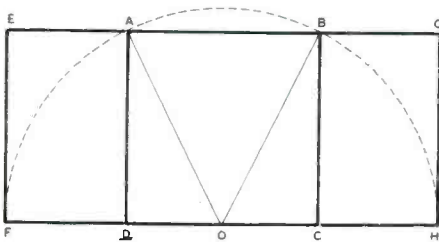

FIG. 9. CONSTRUCTION OF SQUARE, ROOT-FIVE, AND WHIRLING SQUARE RECTANGLES

Derivation of whirling squares and spirals are shown in Fig. 10.

Draw a whirling-square rectangle $ACFD$
 Draw one diagonal and the perpendicular to it

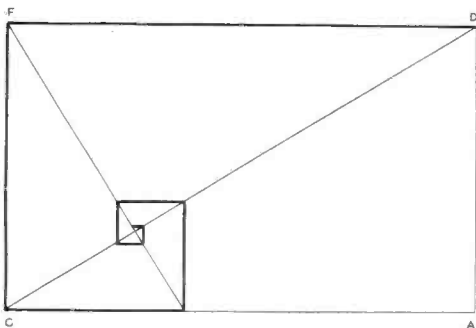
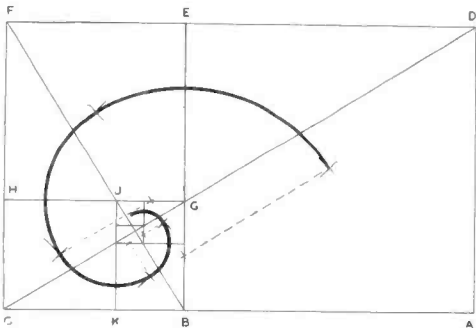

FIG. 10. SPIRAL AND WHIRLING SQUARE DESIGNS

Then draw BE
 $ABED$ is a square
 $BCFE$ is a whirling-square rectangle
 Repeat by drawing GH (the same diagonals serve as for the first rectangle)

(CONTINUED ON PAGE 43)



The latest in TELEVISION

- ★ The electronic view finder is the outstanding development in recent television progress. Enables cameraman to see his pickups in television terms, exactly as the images appear on the televisions of his audience.
- ★ Other outstanding DuMont television features are the DuMont functional units in portable form, plugged together to form chains meeting any capital or program needs; the stable DuMont synchronizing signal generators that remain in sync, regardless; and the DuMont television transmitters with side band filtered off before amplification, for reduced size and cost.
- ★ These features spell the dawn of commercialized television.
- ★ Interested? Write for details.

DU MONT

ALLEN B. DU MONT
 LABORATORIES, Inc.

Passaic ★ New Jersey

Cable Address: Wespexlin, New York

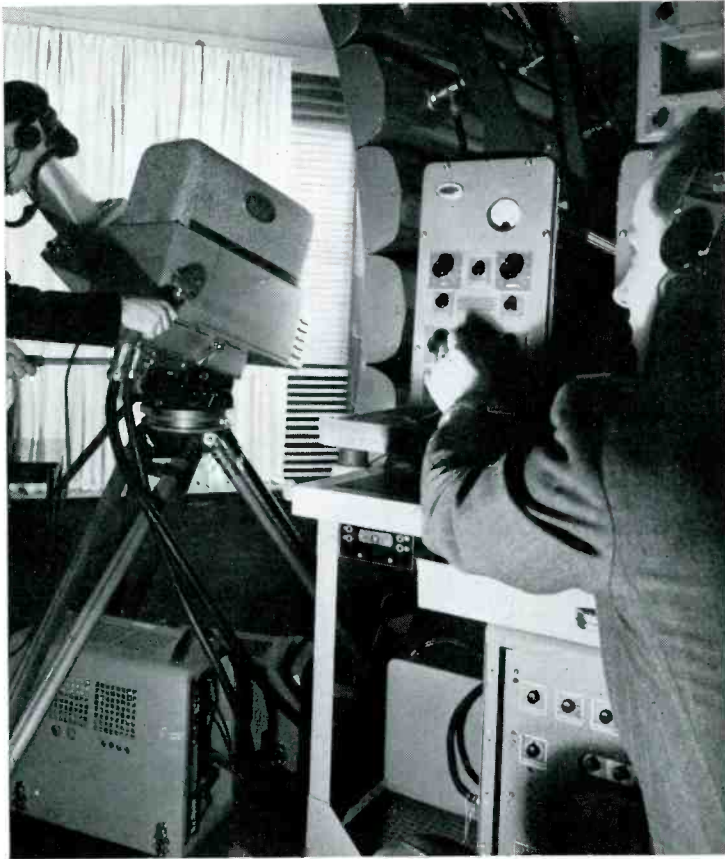

FIG. 6. CAMERAMAN SEES THE SCENE SCANNED BY THE CAMERA IN THE ELECTRONIC VIEW FINDER

(CONTINUED FROM PAGE 33) in conjunction with 30-frame transmission which flashes the picture once each scanning field during the vertical blanking time. Means are provided on the projector for automatically interlocking the shutter with the synchronizing generator.

12-in. Station Monitor ★ While 5-in. monitors are provided at the portable camera control equipment and a 12-in. monitor at the central studio control panel, it is recommended that an additional 12-in. station monitor be installed at the main transmitter location for the convenience of the transmitter operator and as an additional check on the program being fed to the transmitter. This monitor is not essential but should be used when more than two cameras can be fed to the transmitter, involving complicated switching.

The foregoing just about covers the television pickup equipment. Of course there are certain other requirements, such as backgrounds and studio furnishings. Also, no mention is made here of the necessary microphones, amplifiers, transcription turntables, and other audio equipment, because such requirements are pretty well established today, and since some of the earlier telecasting may be in conjunction with existing broadcasting facilities, that equipment may already be available to the telecaster.

From the pickup facilities we now go on to the actual transmitting equipment, both for primary transmission to the video audience, and for relay transmission from remote pickup points to the main studio and station.

Capital Investment ★ Up to the present, no comprehensive analysis of capital investment required for a television transmitter has been available. That is probably because the television transmitters already on the air are not suitable as a basis of comparison. The (CONTINUED ON PAGE 44)

DYNAMIC SYMMETRY IN RADIO DESIGN

(CONTINUED FROM PAGE 41)

GHFE is a square
Repeat by drawing JK
KCHJ is a square
etc.

This construction reveals a series of squares arranged in a spiral whirling to infinity around points formed by drawing a curve through the

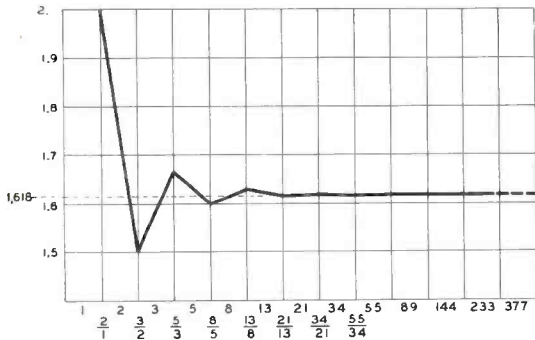

FIG. 11. PLOT OF THE FIBONACCI SERIES

centers of the squares. This curve is widely used in nature.

Nature uses not only the whirling-square rectangle ratio (1.618), but a number series involving it. Note the following summation series (known as the Fibonacci series): 1, 2, 3,

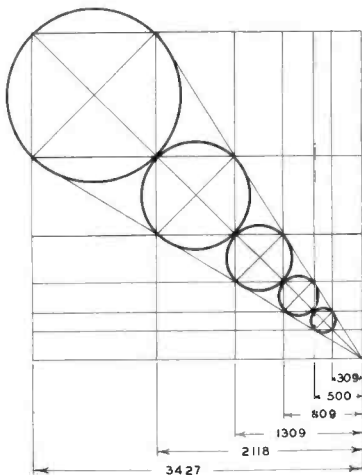

FIG. 12. ANOTHER APPLICATION OF POWERFUL RELATIONSHIPS BETWEEN AREAS

5, 8, 13, 21, 34, 55, 89, 144, etc. (each term is the sum of the two preceding terms).

Fig. 11 plots the ratio of each number to the one preceding it against the terms, and it will be noticed that the geometrical progression ap-
(CONCLUDED ON PAGE 46)

LOOK TO LINGO

for proven

FM

Antenna Efficiency

The Lingo Turnstile Antenna has a definite, important place in your FM plans. This company pioneered in the development of FM broadcasting and since then Lingo Turnstile Radiators have achieved a proven record of efficiency from an imposing list of actual installations. Although today our plant is engaged wholly in national defense production, we will continue our efforts to provide even greater efficiency in design and performance to meet the requirements of a greater FM industry tomorrow!

JOHN E. LINGO & SON
Licensed Manufacturers of Patented Turnstile Antennas
CAMDEN, NEW JERSEY

Frequency Modulation First in Michigan

Michigan's pioneer F.M. station is now on the air. Independent programming 18 hours daily. Owned and operated by The Detroit News, associate station WWJ.

Rate Card on Request

W 4 5 D

4500 Penobscot Bldg.
DETROIT, MICHIGAN

CHECK YOUR FILE OF **FM** MAGAZINES FOR MISSING ISSUES. SEE SPECIAL OFFER ON PAGE 45.

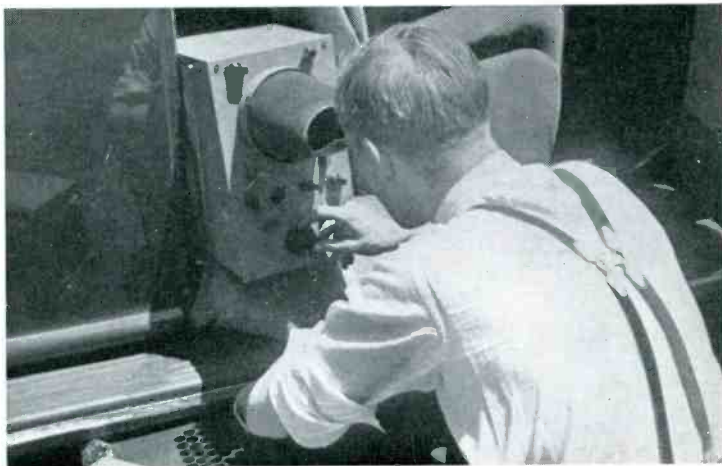

FIG. 7. OPERATOR AT THE SHADING GENERATOR, DURING THE PICKUP OF AN OUTDOOR EVENT

(CONTINUED FROM PAGE 42) operators of these stations, drawing on their own experience, would probably say: "You can spend as much money as you have, and more if you aren't careful!" The reason for such answers is that the stations are operated largely for the purpose of further experimentation, research, and development of television apparatus and technique.

However, an analysis of what is being done gives the framework into which a strictly operating plan can be fitted, concerned only with organizing for future commercial broadcasting, and disregarding the extremely expensive aspect of research.

Accordingly, in Part 3, which will appear in the February issue of *FM Magazine*, we shall break down the cost of specific installations and discuss the operating personnel required to program the station and maintain and operate the equipment.

The Milwaukee Journal's new Radio City building is nearing completion. This unique structure will house the most modern studio facilities for WTMS and W55M and the television transmitter, as well as a music and transcription library and offices for the sales and engineering staffs. The Journal has been most active in giving public demonstrations of FM reception, by means of which listeners in W55M's service area have learned what to expect of FM receivers. As a result, the FM audience is growing rapidly.



JACK MULHOLLAND DEMONSTRATED THE RECEPTION QUALITY OF TRUE FM PERFORMANCE TO 18,000 VISITORS AT THE WISCONSIN HOBBY SHOW. THE AUDIO OSCILLATOR, AT THE RIGHT, WAS USED TO DEMONSTRATE THE RESPONSE TO SOUNDS ABOVE AND BELOW THE RANGE OF AM RECEPTION. NOTE THE SPARK GAP ON THE CONSOLE, INTERFERENCE FROM WHICH WAS ELIMINATED ON FM

SPOT NEWS

(CONTINUED FROM PAGE 26)

American Network: Has now filed its application for 47.9 mc. Transmitter will be erected on the Lincoln Building, East 42nd Street, New York City, and will cover 8,840 square miles with a population of 12,000,000.

A. L. Champigny: Uncle Sam's priority orders have taken another man from General Electric's radio and television department at Schenectady.

Interceptor Command Offices: 1st Interceptor Command Headquarters are at Mitchel Field, Long Island, New York; 2nd I.C.H. are at City-County Building, Seattle; 3rd I.C.H. are at Drew Field, Tampa; 4th I.C.H. are at Riverside, California. Field inspectors have been assigned to these offices by the FCC, to perform liaison duties between the Interceptor Command and the broadcast stations.

FM Schedules Extended: Yankee Network stations W43B and W39B are now on the air from 6 A.M. to 2 A.M., except Sundays, when they start at 8 A.M.

FM for Education: In a communication to the National Committee on Education by Radio, John W. Studebaker, U. S. Commissioner of Education recommended highly the use of FM transmitters by public school systems and Universities. He stated: "... an average school station can now be installed at the price of one classroom. . . . We should have at least 100 cities and counties in the United States using the five educational channels." These are 42.1 to 42.9 mc.

Latin American Radio: John Haber, vice-president of American Steel Export Company, Philco agents, has returned from fourteen weeks in Central and South America. He reports: "The boom is particularly evident in the larger cities of Brazil and Argentina. Home construction, business construction, such civic improvements as paving and widening streets, installation of modern sewage systems are progressing at an unprecedented pace. It's the first thing you notice. Interest in radio programs in general and short wave broadcasts from the United States in particular is at an all time high in our sister republics to the south."

John F. Rider: Has gathered and cross-indexed 744 pages of data on changers and recorders. The volume, under the title "Automatic Record Changers and Recorders," will be published this month by John F. Rider, Publisher, Inc., 404 Fourth Avenue, New York.

Complete YOUR FILE OF Back Numbers

Check your file of back copies against the list below, and order those you are missing while we can still supply them. There are only a few copies of some issues.

- | | |
|---|--------------------------------------|
| <input type="checkbox"/> November, 1940 | <input type="checkbox"/> April, 1941 |
| <input type="checkbox"/> December | <input type="checkbox"/> May |
| <input type="checkbox"/> January, 1941 | <input type="checkbox"/> June |
| <input type="checkbox"/> February | <input type="checkbox"/> July |
| <input type="checkbox"/> March | <input type="checkbox"/> August |
| | <input type="checkbox"/> September |
| | <input type="checkbox"/> October |
| | <input type="checkbox"/> November |
| | <input type="checkbox"/> December |

Back issues of "FM" are a source of important reference material and engineering data, available from no other source. As time goes on, these issues are proving to be of increasing value. Complete your file of back numbers while you have the chance.

\$1.00 for SIX ISSUES

Any six issues, from March to December, 1941, will be sent postpaid for \$1.00, provided the copies you want are still available when your order is received.

FM COMPANY

112 EAST 36th STREET
NEW YORK CITY

RADIO DESIGN PRACTICE

(CONCLUDED FROM PAGE 35)

Panel Meters: During World War I, huge quantities of small panel meters were used on radio equipment and various electrical apparatus. Most popular of these was the Weston type 301, for front-of-panel or rear-of-panel mounting. Since then, the number of companies manufacturing such instruments has increased greatly. Many new ranges have been added and new works for special purposes have been fitted into the same cases. Different cases have been brought out, too, so that there is an al-

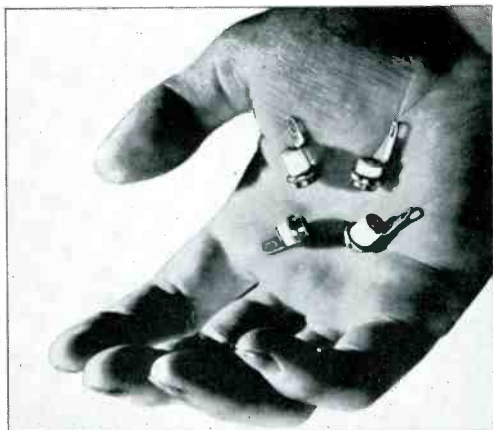

MINIATURE ISOLANTITE TERMINAL BUSHINGS

most endless list of types made up of various ranges in combination with case designs which are essentially interchangeable.

Manufacturers are snowed under with orders for small meters and this condition will prevail indefinitely. Is it not likely that useful results would come from the publication of a list of preferred ranges and cases, just as RCA has done with tubes, in order to get relief from a top-heavy list of types? While it might not be possible or practical to shift quickly to concentration on a limited number of meter types, there is no question but what such concentration would aid the manufacturers, over a period of time, to dig out from under accumulated orders.

Coil Forms: One of the important specialties produced in the enlarged plant of Henry L. Crowley & Company, Inc., at West Orange, N. J., is a wide range of threaded coil forms, varying in diameter from a fraction of an inch to several inches. These are made from ceramic Crolite, extruded, machined, and then fired in kilns to permanent forms of great hardness and low electrical losses at high frequencies.

WHAT THE FM BROADCASTERS SAY:

(CONCLUDED FROM PAGE 34)

challenge to the radio engineers entering upon their apprenticeships in FM construction. Many of them are factors with which they have not had to concern themselves in the past. But given time—and material—FM, AM, UHF or SW are all in the day's work.

DYNAMIC SYMMETRY IN RADIO DESIGN

(CONCLUDED FROM PAGE 43)

proaches the ratio 1.618. The above series does not represent the true series exactly, but is fairly close. A closer series is 118, 191, 309, 500, 809, 1309, 2118, 3427, 5545, etc., which are the values previously associated with the fundamental rectangle shapes. Note that—Any two terms added equal the next term.

Every term divided into its successor equals 1.618

Every term divided into a third term equals $(1.618)_2 = 2.618$

Every term divided into a fourth term equals $(1.618)_3 = 4.236$

Every term divided into a fifth term equals $(1.618)_4 = 6.854$

etc.

Powers of 1.618 divided by 2 produce the series of numbers.

Many other dynamic numerical relations are also present.

The above series has long had interest to mathematicians and records of work on it go back hundreds of years. An illustration of its application in geometrical figures is given in Fig. 12.

Part 2 of this article will appear in the February issue of the FM Magazine.

RADIO LOCATOR MAINTENANCE MEN

(CONCLUDED FROM PAGE 6)

Students who successfully complete the course of instruction may be recommended by the Officer-in-Charge of the School for advancement in rating up to and including Chief Radioman (at \$99 monthly, plus allowances).

This training and duty in connection with the new and secret radio locators will prove especially attractive to the man who wishes to make radio his profession, since it embraces a branch of the radio science which will have many commercial applications when the emergency is over.

All Navy Recruiting Stations are prepared to provide any additional details that interested, qualified radiomen may desire.

FEDERAL MARINE RADIO UNIT

(CONTINUED FROM PAGE 25)

facilities are provided to simplify this procedure. A compartment is provided in the base section for spare parts.

The advantages of the new design are evidenced by the fact that the marine radio unit is being placed on all of the 312 "Liberty" (EC-2) vessels now under construction by the U. S. Maritime Commission. It is estimated that the time required to install the marine radio unit is but one fifth that required to install the twelve equivalent pieces of apparatus which this unit replaces. The standardization of parts and placement is also being hailed by those responsible for operator instruction, as it is now possible to place an operator familiar with this equipment on any vessel in the "Liberty" fleet, with the assurance that he will be enabled to operate efficiently without additional instruction, inasmuch as each knob and control is in exactly the same place on every vessel. This represents a decided step forward in marine design.

COMMENTS

(CONTINUED FROM PAGE 36)

within sight of the transmitting antennas.

Such operation has other advantages which are important. Each area has a single frequency which becomes the official one. The public then has a definite frequency to tune to for official pronouncements, instead of searching all over the many stations ordinarily audible. If one station goes off the air, for any reason whatever, nothing is disrupted and service is not lessened. The possibility of subversive use of stations is lessened because all stations while on the same frequency have the same program from official protected source.

Official workers can be notified to report by signals sent on the official frequency, in various ways. I think that the best way by far is the sub-audible modulation method, recently publicized under the name of "Alert Receiver System," because this permits the loud speaker to be silent until an alarm is given, various code signals can be given, and this can be done without interruption of the regular program.

There is nothing difficult, or objectionable, about using the vast broadcasting system of the country for civilian protection communication purposes, provided it is organized under certain easily arranged conditions.

We have the slogan "Keep them flying." We need another—"Keep them radiating." Our public is now too intimately and emotionally dependent upon news through broadcasting to silence stations unnecessarily without causing more trouble than silence will prevent.

Your Opportunity
to Own Two Important

REFERENCE VOLUMES

If You Act Promptly!

**1ST BOUND VOLUME
OF FM MAGAZINE**

NOVEMBER 1940 TO APRIL 1941

**2ND BOUND VOLUME
OF FM MAGAZINE**

MAY 1941 TO OCTOBER 1941

These two bound volumes of **FM** Magazine comprise a 600-page record of the most important developments in modern radio progress, invaluable as a reference source to engineers, patent attorneys and radio executives.

When the remaining volumes have been sold, there will be no way to get complete files of **FM** Magazine.

The binding, of three-quarter pigskin, was done by Eggeling, and is of the finest workmanship, designed to last a lifetime.

The cost is less than you would pay to have a single set of copies bound.—
Send your order at once!

\$5.00

EACH, POSTPAID, IN THE U. S. A.

FM COMPANY

**112 EAST 36th STREET
NEW YORK CITY**

ENGINEERS IN SHIRTSLEEVES ★ ★ men on the fighting front of applied radio engineering ★ ★ designing, supervising, installing, and maintaining radio equipment for military use abroad, for protection at home, and for essential broadcasting and communications services ★ ★ to them, FM MAGAZINE is the most useful of all radio engineering papers ★ ★ ★ ★

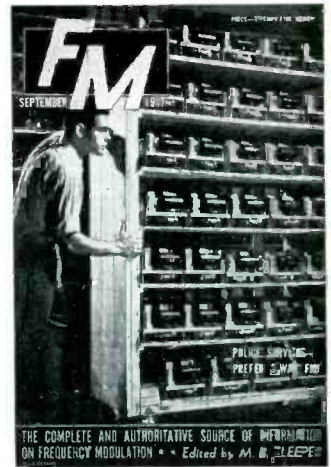
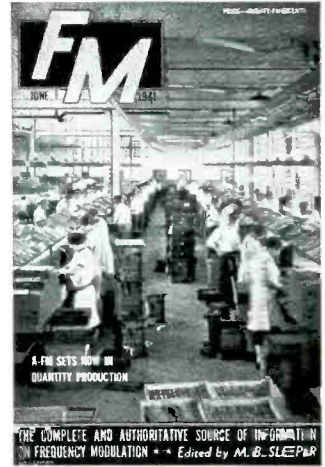



Cat. No. 565-A

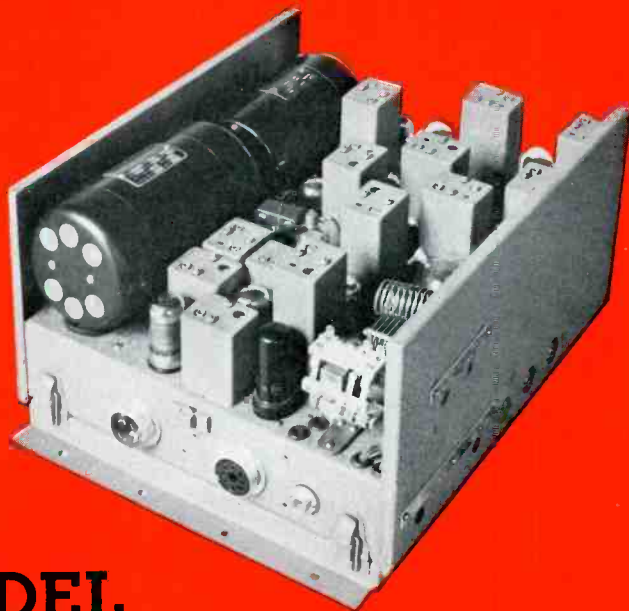

VICTORY MODEL

FM 2-Way Radio for All Emergency Services

A Completely New Development by the PIONEERS of 2-way Mobile Radio

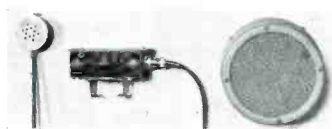

AS A PART of REL's all-out engineering plans to conserve materials and speed deliveries, the REL Victory Model 2-way FM emergency equipment is now in full production. This is the first FM emergency equipment with the receiver and transmitter combined on a single chassis — an arrangement which affords many mechanical and electrical improvements which increase efficiency and simplify installation and service. These improvements cannot be found in the older multi-chassis construction.

Greater range, higher quality, and better signal-to-noise ratio and squelch action result from increased efficiency obtained by simplified circuits of compact design. The 807 tube, source of troublesome parasitics, has been replaced by the new 815 power

tube, designed specifically for ultra-frequencies.

Simplified construction, based on 10 years of field experience with mobile equipment, makes the REL Victory Model the last word in ruggedness and dependability. Loose connections in inter-chassis cables are eliminated. Test jacks are protected from dust by the snap-on cover. Hours are saved in installation and servicing.

Low-voltage receiver dynamotor supplies power to all transmitting tubes except power amplifier, thus avoiding plate voltage dropping-resistor loss and its resulting storage battery drain.

Finally, the improvements in the REL Victory Model are geared to new production methods which assure fast deliveries for all emergency service needs.

565-A SPECIFICATIONS

Frequency: Any frequency in the 30-40 mc. band. **Drain:** 14 amps. receiving, 31 amps. transmitting from 6v. battery. **Size:** 17 $\frac{1}{4}$ " long, 14 $\frac{3}{4}$ "

deep, 9" high. **Weight:** 50 lbs. **Accessories:** Supplied complete with all cables, antenna and support, control unit, speaker, choice of hand-grip microphone or French type hand set.

Receiver: 11 tubes, double IF super-heterodyne, single-crystal control, limiter acts on signals of less than 1 microvolt, with squelch action on less than .5 microvolt.*

Transmitter: 6 tubes, output in excess of 25 watts, crystal-control phase shift, new single-tube modulator in newest FM circuit development.

* Measurements made on production receiver with General Radio 804-B signal generator. Still greater sensitivity is indicated by other types of measuring instruments.



RADIO ENGINEERING LABS., Inc.
Long Island City New York

Sales Offices:

5334 Hollywood Blvd., Hollywood, Calif.
420 Market Street, San Francisco, Calif.
2040 Grand River Ave. W., Detroit, Mich.
310 Fifteenth St., Denver, Colo.

On THE INDUSTRIAL FRONT



KEEP 'EM FRYING

© FRED M. LINK

REMEMBER PEARL HARBOR

JOSEPH A. HOFFMANN

ENGINEERS and MANUFACTURERS of FM and AM EQUIPMENT for GOVERNMENT, PUBLIC UTILITY, POLICE and FIRE



Fred M. Link 125 WEST 17th ST., NEW YORK, N.Y.
Engineer • Manufacturer Telephone: CHELSEA 2-3838