

PRICE—TWENTY-FIVE CENTS

FMM

DECEMBER 1941

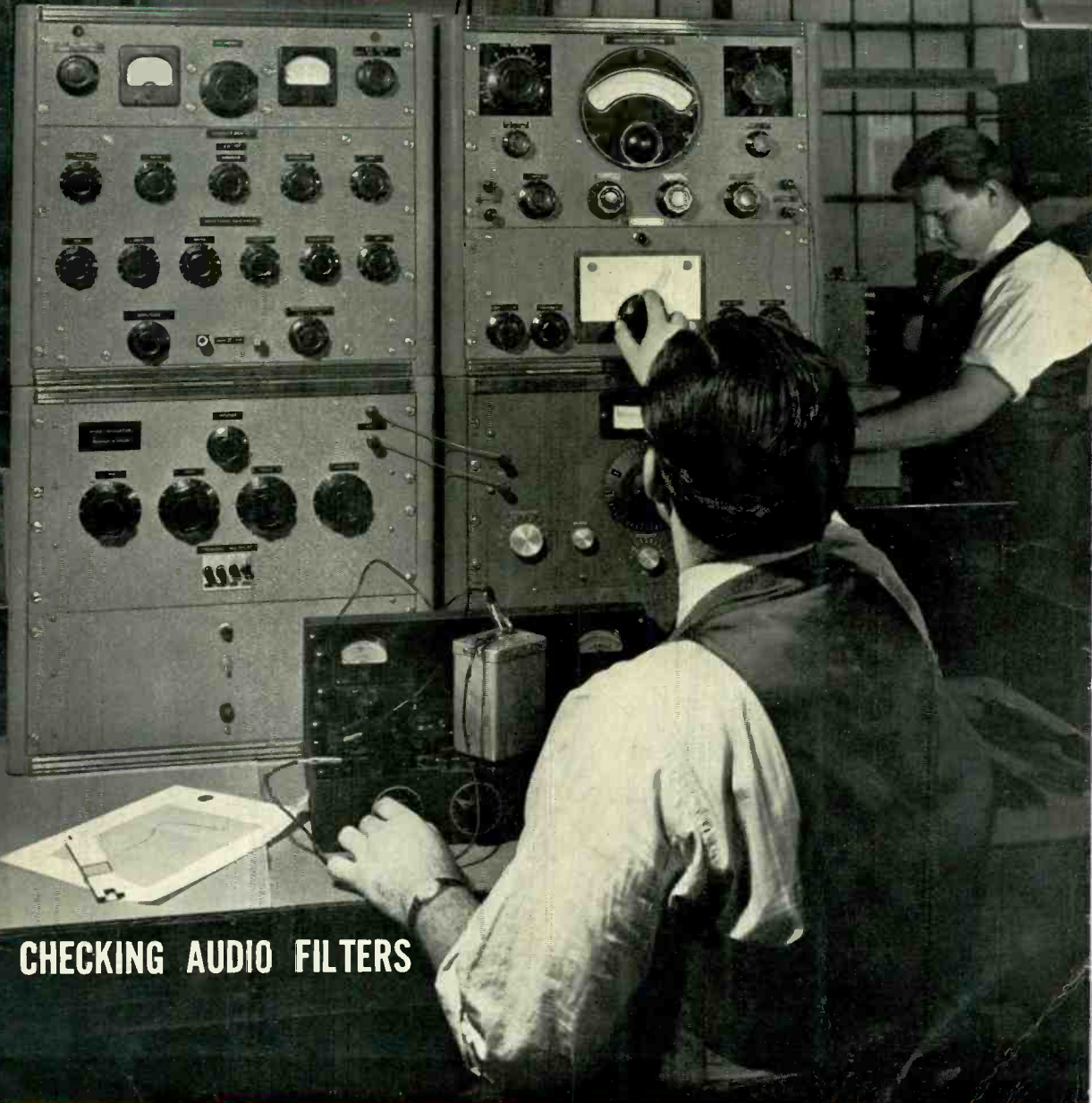

CHECKING AUDIO FILTERS

**RADIO BROADCAST, COMMUNICATIONS & TELEVISION ENGINEERING
AND DESIGN PRACTICE ★ ★ Edited by M. B. SLEEPER**

REG. J. S. PAT. OFF.

More
PROFITS
 from **BETTER**
REMOTES

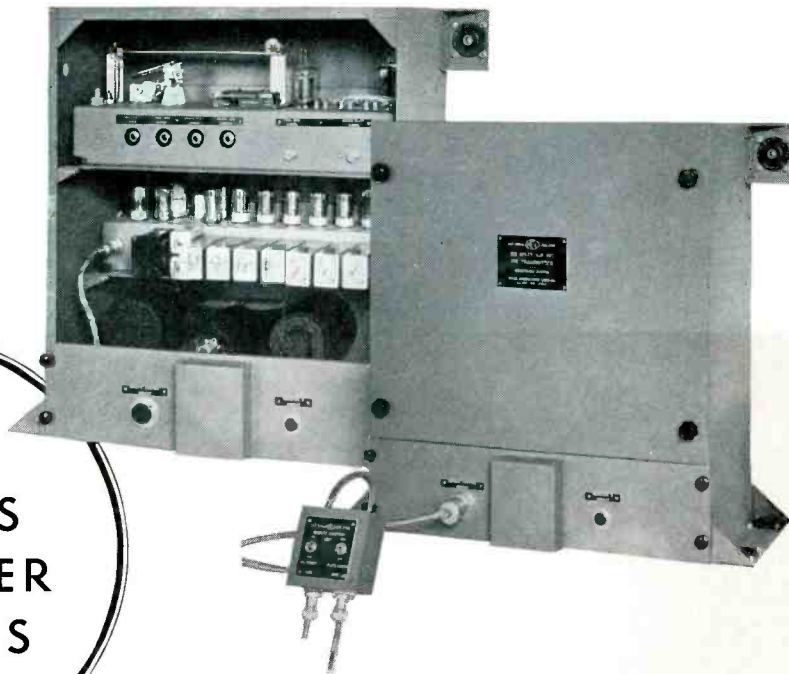

REL

SPECIFICATIONS

For use on any one of the four channels assigned to FM Relay-Broadcast pick-up service. Meets all FCC requirements.

Stability: — 500 cycles at 161 mc. Direct crystal control.

Fidelity: — 1 db at 30-16,000 cycles.

Distortion: Below 100 cycles 1%, above 100 cycles less than 1%.

Noise: 76 db below 100% modulation, hum included.

Swing: 100 kc. maximum for 100% modulation.

Cat. No. 545: One-cabinet type (illustrated) operates on 115 v., 60 cycles, 23" wide, 33" high, 11" deep. Shock mounted. 142 lbs.

Cat. No. 532: Has separate power supply, operating on either 115 v., 60 cycles, or 12 V., DC, 23" wide, 22" high, 11" deep. 64 lbs. Power supply, 23" wide, 11" high, 11" deep. AC type, 78 lbs., DC type, 71 lbs. *Note:* One power supply is furnished with transmitter. Alternate type furnished extra.

Cat. No. 538R: Receiver, triple IF, crystal controlled superheterodyne, for 115 v., 60 cycles. Audio output 0 level, 500 ohms. Additional output for monitor speaker.

FM Remote Pick-up Equipment

GIVE your sponsors greater value from remote pick-ups by using REL portable FM equipment to deliver clear signals, free of interference, to your studios or transmitter.

FCC regulations permit AM or FM broadcast stations to use FM transmission for remotes on four channels — 156.75, 158.4, 159.3 and 161.1 mc.

New REL equipment for this service gives higher signal-to-noise ratio, distortion-free, high-fidelity audio, and freedom from interference usually encountered on AM pick-up

transmission. Opens new possibilities for selling more effective on-the-spot events, interviews and unusual features where lines are not available.

Equipment is adaptable to all conditions, rugged, easy to set up and use, and moderate in cost. Prices on request.

REL

RADIO ENGINEERING LABS., Inc.
 Long Island City New York

Sales Offices:

5334 Hollywood Blvd., Hollywood, Calif.
 420 Market Street, San Francisco, Calif.
 2040 Grand River Ave W., Detroit, Mich.
 310 Fifteenth St., Denver, Colo.

PUBLIC UTILITIES: An Important Group of *FM* Readers



7 Public utilities are spending thousands of dollars right now for two-way *FM* communications equipment to provide constant contact between headquarters and maintenance trucks.

When the FCC set aside frequencies for this service, the purpose was to speed up emergency repairs.

Now, the use of these systems is being extended to sabotage patrols.

Since power plants and substations are important military targets, the installation of two-way *FM* systems for public utilities is being made a vital part of protection for National Defense.

Our records show that *FM* Magazine goes to the chief engineer or manager of distribution at every public utility in the U. S. A. which has 20,000 electric meters or more, as well as to some of the smaller companies.

FM carries more information and data on the subject of emergency equipment than all other radio publications combined. Thus, it has become the most effective medium for advertising radio equipment, instruments, accessories, and associated apparatus to this great, new market, whose orders carry priority ratings.

M. B. SLEEPER, *Editor and Publisher*

**Partial List of Police
Departments, Public
Utilities, and other
purchasers of
Browning Monitors**

Police Departments

- Arlington, Mass.
- Atchison, Kansas
- Big Spring, Texas
- Bloomington, Indiana
- Bremerton, Washington
- Centralis, Washington
- Coffeyville, Kansas
- Columbia, Missouri
- Crawfordsville, Indiana
- Emporia, Kansas
- Fitchburg, Mass.
- Fond du Lac County, Wisconsin
- Great Bend, Kansas
- Klamath Falls, Oregon
- Leominster, Mass.
- Marathon County, Wisconsin
- Milton, Pa.
- Nampa, Idaho
- Sharon, Mass.
- Shelby County, Indiana
- Sidney, Ohio
- St. Charles, Missouri
- Twin Falls, Idaho
- General Electric Company
- Graybar Electric Company
- Burdick Corp., Milton, Wis.
- Cleveland Railway Company
Cleveland, Ohio
- Water Supply Commission
Belchertown, Mass.
- Hygrade Sylvania Corp.
Salem, Mass.
- San Antonio Public Service
San Antonio, Texas
- San Diego Gas & Electric
San Diego, California
- Southern California Edison
Los Angeles, California
- Toledo Edison Company
Toledo, Ohio
- Transmitter Mfg. Company, Inc.
New York City
- United Electric Light Company
Springfield, Mass.
- United Illuminating Company
New Haven, Connecticut
- University of Maryland
College Park, Md.

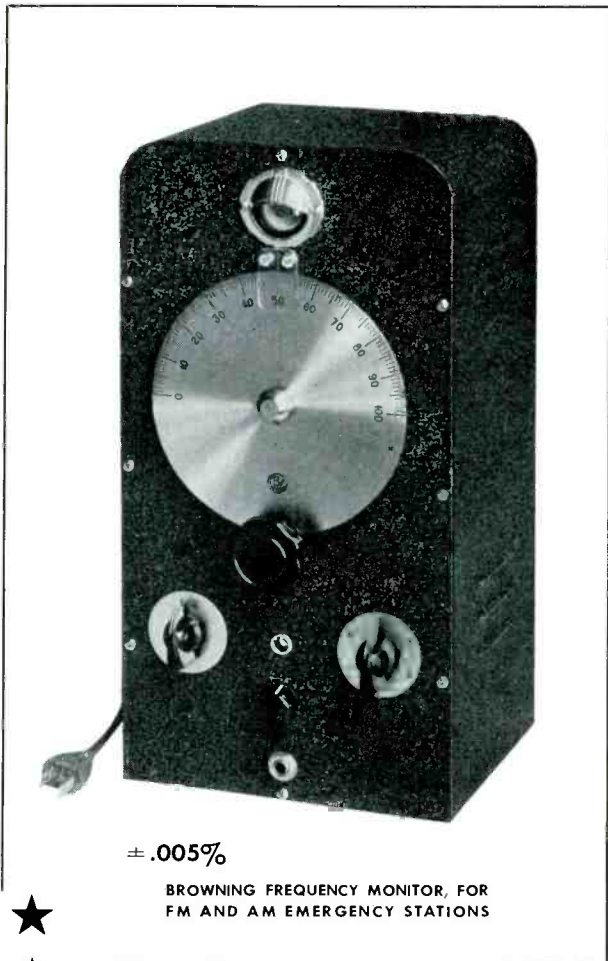

± .005%

BROWNING FREQUENCY MONITOR, FOR
FM AND AM EMERGENCY STATIONS



Increased Accuracy to Meet New

FCC REQUIREMENTS

For All Emergency Transmitters

The new Type S-2 Browning Frequency Monitor provides the greater precision now required by the FCC for all emergency transmitters. Suitable for both FM and AM, the Browning Monitor is built with one to four bands, for any frequencies between 1.5 and 60 mc. Prices:

1 Band.....\$125.00 3 Bands.....\$165.00
2 Bands..... 145.00 4 Bands..... 185.00

BROWNING LABORATORIES, Inc.

755 MAIN STREET

WINCHESTER, MASSACHUSETTS



AUDIO FILTERS

THE development of audio-range filters and equalizers is a complex art, and the equipment required is equally complicated. The apparatus used in this work is shown in this month's cover photograph, taken in the United Transformer Corporation's laboratory.

Mounted at the top of the left hand rack is a modified Owens inductance bridge, for the adjustment of inductance to four significant figures. Below, is a direct-reading precision oscillator for generating frequencies of 10 to 100,000 cycles, with a calibration also accurate to four significant figures.

The right hand rack carries, above, a direct-reading audio Q meter capable of measuring the Q of coils over a wide range of voltages and the entire range of audio frequencies. Beneath it is a harmonic wave analyzer, for the precise measurement of filter curves.

Actual circuits in which a filter will be used can be duplicated by the apparatus on the bench.

A great deal of special equipment, of which this is a typical example, is being built by engineers in order to meet emergency needs quickly, or to suit purposes for which no standard apparatus has been produced in the past.



THE RADIO ENGINEERING NEWS JOURNAL OF BROADCASTING, COMMUNICATIONS & TELEVISION

VOL. 2 DECEMBER, 1941 NO. 2

COPYRIGHT 1911 M. B. SLEEPER

CONTENTS

FM FIGHTS ABROAD, SERVES AT HOME	5
<i>by M. B. Sleeper</i>	
LOW-COST A-FM RECEIVER	6
<i>by Edward Jous</i>	
MAKING A START IN TELEVISION	8
<i>by Austin C. Lescaboura</i>	
THE MANUFACTURERS SAY:	14
<i>A Statement by William J. Halligan</i>	
WHY IS MODEL INSTALLATION	16
SPOT NEWS	20
NEWS PICTURE	21
<i>First licensed A-FM set in \$60 bracket</i>	
DATA ON MOROTOLA EMERGENCY FM	22
<i>by Norman E. Wunderlich</i>	
1-KW. BROADCAST TRANSMITTER	27
<i>by Frank A. Gunther</i>	
STROMBERG MODEL 535 SERIES	31
<i>from official manual</i>	
RADIO DESIGN PRACTICE	36
FM BROADCAST STATIONS	38

THE COVER DESIGN AND CONTENTS OF FM MAGAZINE ARE FULLY PROTECTED BY U. S. COPYRIGHTS, AND MUST NOT BE REPRODUCED IN ANY MANNER OR IN ANY FORM WITHOUT WRITTEN PERMISSION

★ ★ ★ ★ ★

M. B. SLEEPER, *Editor and Publisher*

Published by: FM COMPANY

Editorial and Advertising Office:
112 East 36th Street, New York City, Tel. LE 2-8070

FM Magazine is issued on the 20th of each month. Single copies 25¢ — Yearly subscription in the U.S.A. \$3.00; foreign \$4.00. Subscriptions should be sent to FM Company, 112 East 36th St., New York City.

The publishers will be pleased to receive articles, particularly those well illustrated with photos and drawings, concerning all phases of FM developments. Manuscripts should be sent to the publication office, at New York City. Contributions will be neither acknowledged nor returned unless accompanied by adequate postage, packing, and directions, nor will FM Magazine be responsible for their safe handling in its office or in transit.

Advertising correspondence, copy, and cuts should be addressed to the advertising office at New York City.

PLEASE NOTE FM MAGAZINE'S NEW ADDRESS: FM COMPANY
112 E. 36 ST., NEW YORK CITY

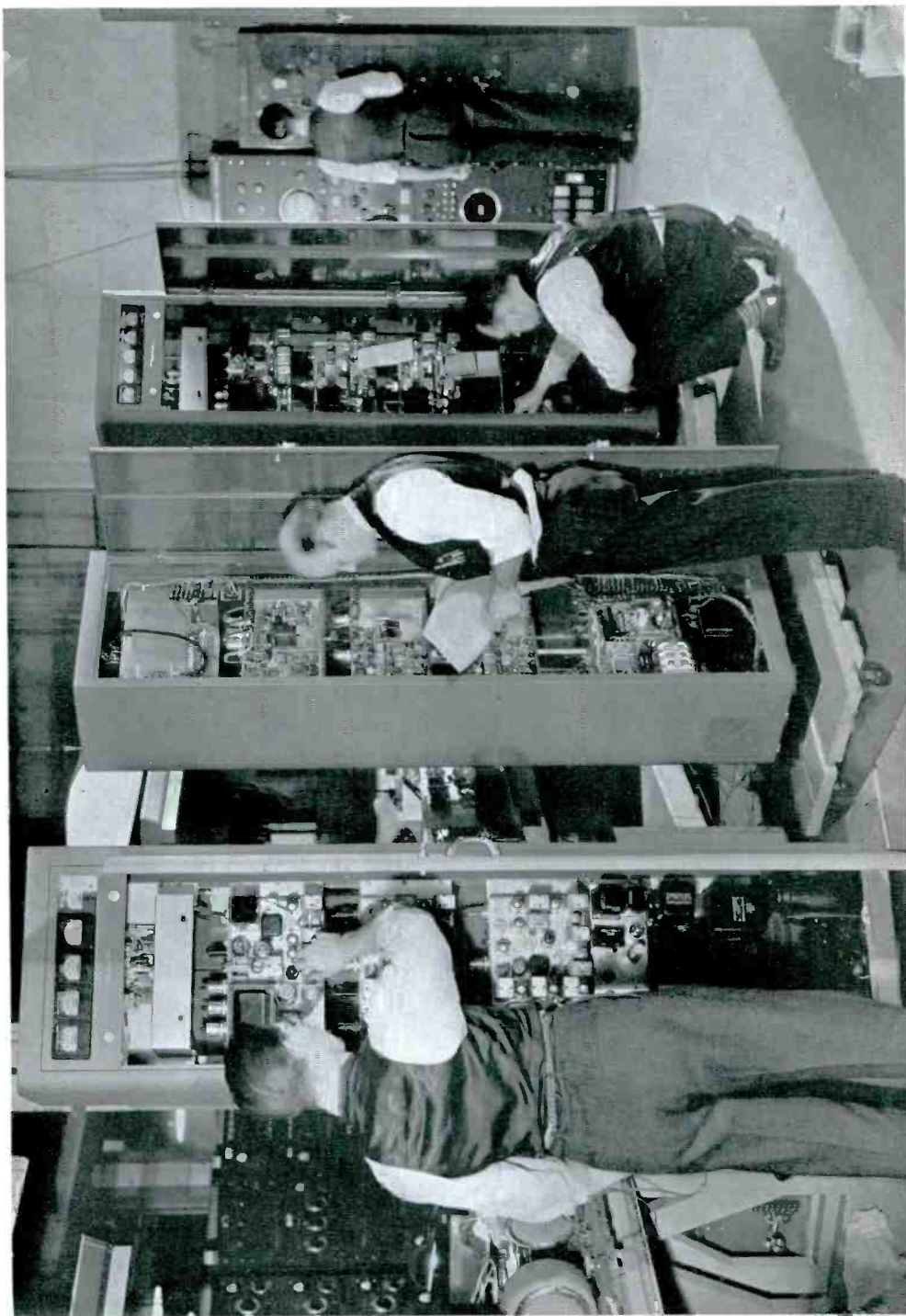

MICHIGAN STATE POLICE ARE REPLACING II-WAY AM SYSTEM WITH MOTOROLA FM TALK-BACK. HERE ARE SOME OF THE SEVEN 400-WATT TRANSMITTERS IN PROCESS OF COMPLETION. MAIN STATIONS WILL TRANSMIT ON 37.5 MC., CARS ON 37.38 MC. FRANK WALKER IS CHIEF ENGINEER OF THIS STATE-WIDE SYSTEM

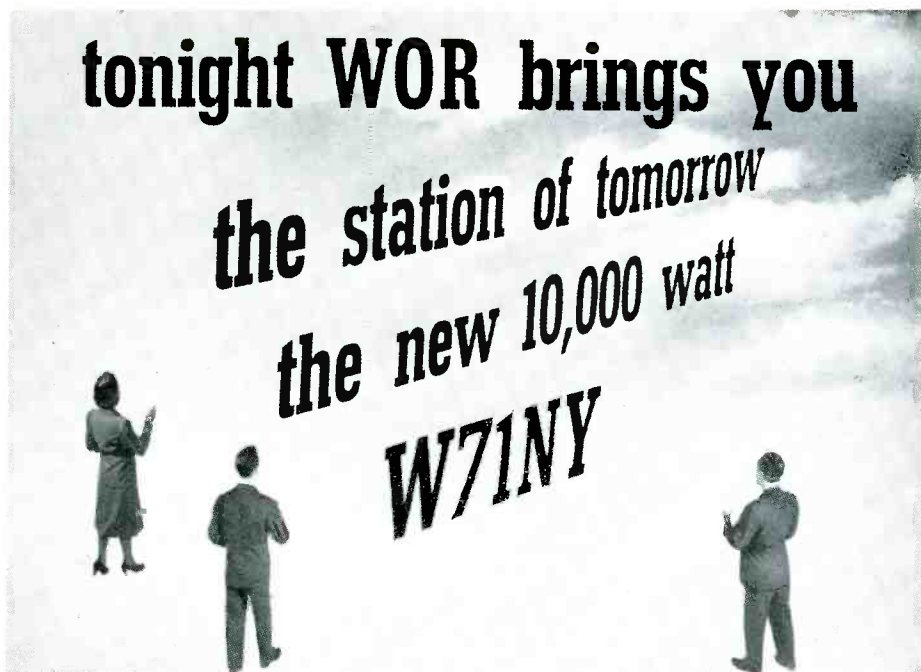

HEADING OF A FULL-PAGE ANNOUNCEMENT IN NEW YORK HERALD-TRIBUNE OF W71NY'S INAUGURAL, USING FULL OUTPUT POWER, ON NOVEMBER 30TH

FM FIGHTS ABROAD, SERVES AT HOME

War Brings FM into Wide Use for Military, Emergency, and Communications Services, While New Broadcast Stations Open and FM Network Starts

BY M. B. SLEEPER

FREQUENCY Modulation, gauged by the number of transmitters and receivers in use, is forging ahead at a rate unprecedented in an industry whose history is a series of records successively broken by new records.

This, be it noted, is due to National Defense which while creating the priorities that hold back the production of A-FM home receivers, is demanding more and still more FM apparatus for our fighting forces abroad and our defense organizations at home.

Many engineers and executives in the radio and associated manufacturing organizations do not realize the extent to which FM systems are being used in other than broadcasting applications. We, at *FM Magazine* see this clearly through the increasing number of subscriptions and correspondence from Govern-

ment departments, municipal and state police officials, engineers of the public utilities, and from officials of foreign governments and purchasing agencies.

FM is today meeting all kinds of communications needs to an extent that Major Armstrong himself could not have anticipated when, in March, 1940, he and the FMBI, with the support of FCC Chairman Fly, won official recognition for Frequency Modulation as an improved method of radio signalling!

Just last month, *FM Magazine* recorded the Major's remark that only three superheterodyne sets were in use during World War I. Now, at this time of writing, radio receivers in every army are designed around the Major's superheterodyne, and our own fighting forces

(CONTINUED ON PAGE 37)

LOW-COST A-FM RECEIVER

New Factors Enter into Design of Low Cost Set for True FM Reception

BY EDWARD JONS*

THE development of the Pilot T-301 table model receiver, for the standard broadcast and FM bands, was not undertaken for the purpose of breaking down the price structure which exists for A-FM sets, but to make FM programs available to those whose means make the ownership of expensive models out of the question.

In designing this new model, therefore, the engineering effort was directed toward eliminating what might be considered the "extras" in the higher-bracket types, while maintaining the basic advantages of the Armstrong FM circuits. That is, we undertook to assure adequate reduction of static and sharpness of tuning when this model is used within the service contours of FM stations, as specified by the FCC. Its ability to do so has been demonstrated to representatives of the National Better Business Bureau.

Since the receiver was designed to meet predetermined specifications of performance rather than a maximum selling price, it is a matter of good fortune, plus much time and effort spent in careful planning, rather than deliberate intention, that it comes within the sixty-dollar bracket. Low as this price is, it is still more than twice the average retail unit of radio set sales in 1940! This engineering policy, we believe, is the surest safeguard to protect the public from a new crop of sets

emulating the series of AM sets that finally wound up at \$6.95.

It is easy to design a set that goes all out for high-quality performance, but there are some new and tricky factors introduced when price becomes a consideration. First, there is the matter of assuring true FM performance which is self-apparent when compared with AM reception. This allows honest sales promotion, and fair dealing with people not yet sufficiently familiar with the comparative performance of FM circuits to weigh claims and then to stand by their own decisions.

This calls for relating engineering and promotion so that the sales department will not mislead the dealers and the public into expecting \$200 console performance from a moderately-priced table model yet, at the same time, making full use of the capabilities that the set actually possesses.

FM circuit design has brought up another factor that has not confronted engineers before. Many people are buying A-FM sets today against the time when there will be FM broadcasting where they live. That may be six months, a year, or two years from now.

These might be considered as contingent sales, for the customer's satisfaction with his purchase is contingent upon the FM reception when the programs are available to him. The catch is that some people who buy sets now will not judge the FM performance for a year or more, and then they will compare their sets with models which are current at that time.

It is impossible to know how sets built today will be rated in 1943, or 1944. On that account, we have built into the T-301 not only a factor of safety to provide against adverse receiving conditions which may be encountered in parts of any FM station contour, but a further margin to protect the good will of the Company and its dealers against possible dissatisfaction in the future among those who will not use the FM band for some time to come.

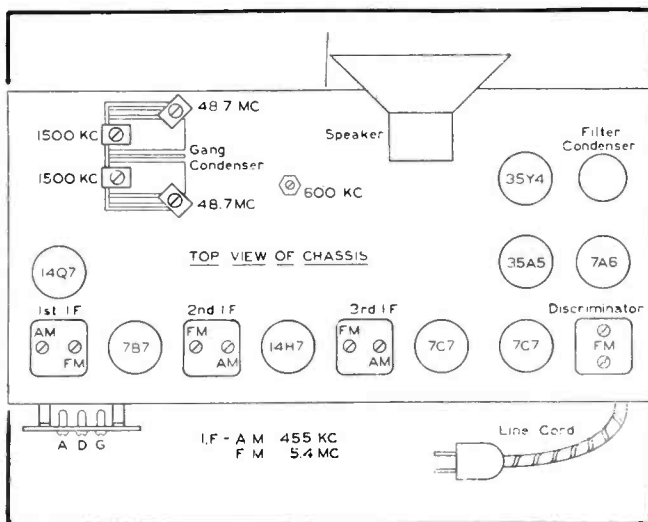

CHASSIS LAYOUT OF PILOT T-301

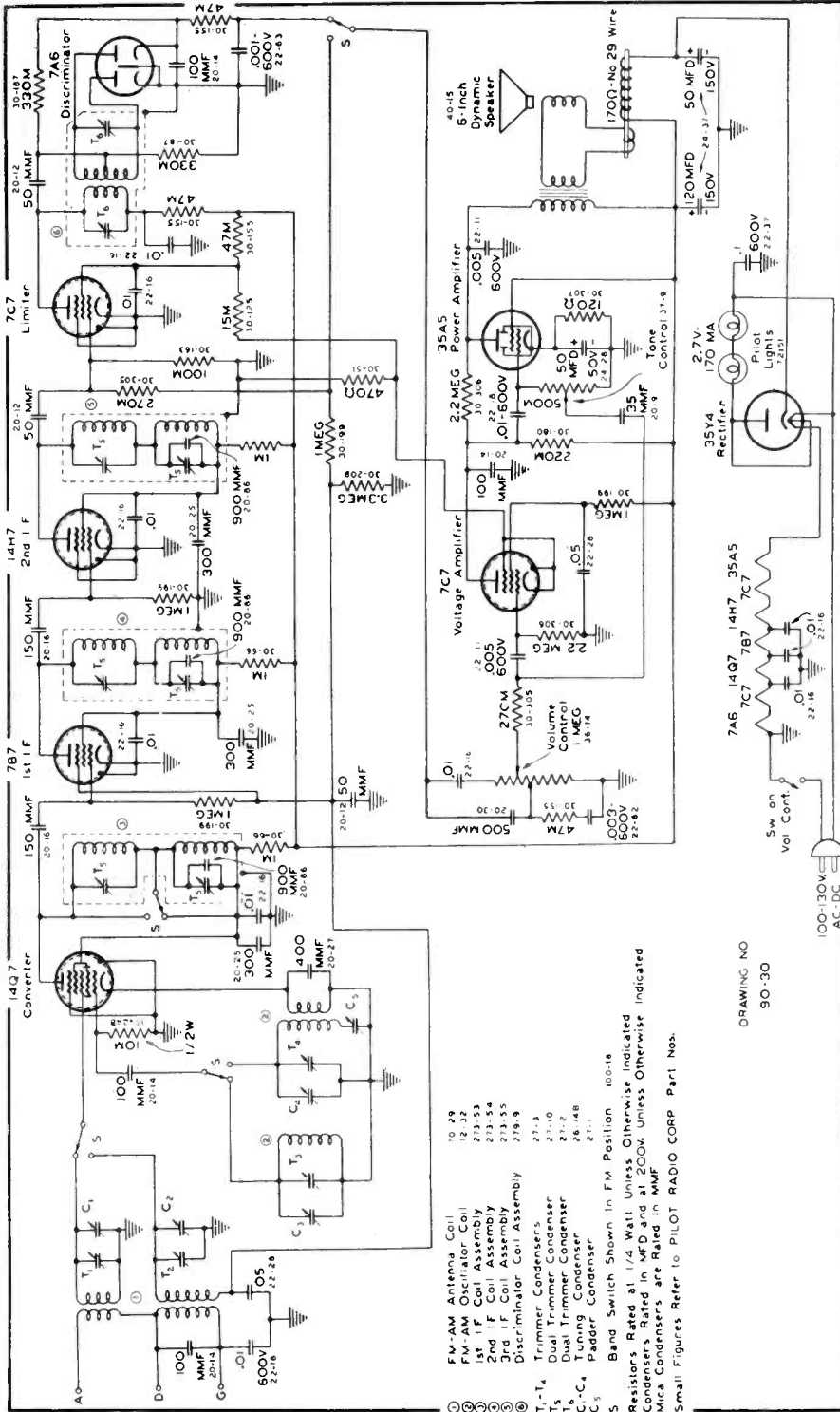

SCHEMATIC DIAGRAM OF THE PILOT T-301 TABLE MODEL. THIS RECEIVER, DESIGNED TO FILL THE DEMAND FOR A-FM PERFORMANCE AT MODERATE COST, AFFORDS THE BASIC ADVANTAGES OF ARMSTRONG FM RECEPTION, BOTH AS TO REDUCTION OF INTERFERENCE AND PROTECTION AGAINST INTERFERENCE BETWEEN STATIONS TRANSMITTING ON NEARBY CHANNELS

A Practical Survey for

MAKING A START IN TELEVISION

Part 1. Survey of the Position of the Local-Service Television Station, and Availability of Low-Cost Program Material

BY AUSTIN C. LESCABOURA *

The preparation of this article was undertaken by Mr. Lescaboura at the request of *FM Magazine*. The plan outlined, representing the attitude of the Du Mont Laboratories, is a practical approach to setting the "static cycle of interlocking factors" in motion. We shall be pleased to publish letters expressing the views of our readers on this subject in the "Comments" department. Part 2 of this survey, giving specifications of equipment and actual figures from which cost estimates can be made up, will appear in the January issue.

MUCH talk and little action characterizes television thus far. Wishful thinking is abundant. Daring enterprise is conspicuous by its absence. Indeed, aside from a mere handful of regularly scheduled programs handled by outstanding leaders in the fields of radio-set production, broadcasting, and motion pictures, television has been confined mainly to promises, gestures, and hopes, sprinkled with construction permits and experimental licenses, while waiting for the other fellow to spin the otherwise static cycle of video broadcasting obviously dependent on available television sets, which set sales in turn stall for a greater choice of programs delayed for want of commercial sponsorship, which sponsorship awaits something more for its money. And there you are.

But once that static cycle of interlocking factors starts spinning, and the early players begin cashing in on their pioneering efforts or bold bets, hundreds will rush in and try to place sure bets so as to make some of that supposedly easy television money. The late-comers will probably be too late. At least that is the lesson we gain from a review of radio broadcasting history.

The time to make a start in television is here and now. Tomorrow may be too late. A thousand dollars invested now may be worth ten thousand later on, for the studio and transmitting facilities, the operating personnel and the programs, can now be realized on a relatively modest basis as contrasted with the highly refined and commercialized television of the future.

The limited number of channels being licensed for television broadcasting are bound to be taken up one by one throughout the country. Commercial licenses are certain to be assigned to and retained by those making a sincere attempt at regularly scheduled programs of genuine interest to the public. The situation is strikingly parallel with that of radio broadcasting two decades ago, making due allowance, of course, for the far greater intricacies of television. In 1921 various interests, notably newspapers, department stores, radio manufacturers, insurance companies, colleges and schools, fraternal organizations, and others, entered the broadcasting field because of the tremendous publicity they might gain. It was primarily their own publicity, since outside sponsorship for revenue purposes was yet to be worked out.

The broadcasting start was usually made on a very modest basis. Many a 5-watt and 10-watt home-made transmitter of that day has since become the 5-kw. and even the 50-kw. key station of 1941. Amateur talent was the rule rather than the exception. There were so many hours a day to be plugged with phonograph recordings, newspaper clippings, weather reports, retransmitted time signals, and occasional amateur talent, with once in a very great while some professional artist virtually shanghai'd into the studio. But the main thing—and that is the point here to be stressed and developed in what follows—a *start was made in actual broadcasting*. The rest has been a matter of simple, natural evolution.

It is with the thought of making a molehill out of the mountain of television problems that the

* In charge of television information service for Allen B. Du Mont Labs., Inc., Passaic, N. J. Author, "This Thing Called Broadcasting," "Radio for Everybody," "The Cinema Handbook," "Behind the Motion Picture Screen," etc.

following facts and figures and conclusions are presented, not so much for the more powerful interests whose ample finances and resources belittle the problems, and therefore qualify those organizations for the stewardship of television services in the great metropolitan areas, but rather for those of limited means but colossal ambition who seek to exploit, on a modest scale, the purely local television possibilities which will grow into valuable telecasting rights.

The Program ★ First and foremost, ahead of any financial, technical, locale and licensing considerations, we must consider the television program. What do you propose to offer your potential television audiences? What facilities have you for carrying out such a program? What sort of an audience can you count on for such a program? And most important of all, can you provide that kind of a program hour after hour, day in and day out, month after month, for be it definitely understood that in television, as in all other forms of "show business," *the show must go on*, regardless.

It may seem trite to insist that the program is the first consideration, but to one who has had wide experience with both movies and broadcasting, there is the recurring thought of having had all the necessary technical facilities at hand, yet being at a loss for good program material. The movie lens, radio microphone, and television camera have insatiable appetites for talent. And remember, too, that their diet must be varied continuously—something different, new, fresh, day after day. That means a colossal flow of program material and talent if the television station is to be worth its keep.

Therefore, before you get down to the financial and technical details of video broadcasting, the very first step is to consider your territory from the program standpoint, for your programs must not only be forthcoming in a steady stream but must fit the people as would a suit of clothes—in scope, taste, variety.

Having determined what seems the best compromise program plan—features that will interest and please a substantial percentage of the audience—the next step is to survey the program material available, locally and otherwise. The program you plan is essentially a blueprint or a working policy. You must line up features that will fill out and give final substance to that blueprint or policy. Lastly, you must appraise your available showmanship, for no matter how good and how numerous program features may be, their presentation in proper sequence and balance must determine the acceptance of your video broadcasting service. In the final analysis, it is this acceptance, as reflected by many television receivers tuned in on your programs, which will bring commercial sponsorship into the picture and makes your television enterprise a going business.

The program, then, is your primary concern. Television is essentially *entertainment*. Appraise just what you are capable of offering the potential local audience. Can you provide them with a worth while video broadcasting service? Will it be worth the while of local taverns and other public places first and, later, the better families, to invest several hundred dollars in television receivers? Can you maintain a flow of good programs, so that the interest will be sustained over the years? Formidable questions, these, but absolutely basic. *The program must be considered first*, for upon your program policy depends your right to become a telecaster in your community. Other considerations are mere details.

The Local Touch ★ At this point we start debunking the formidable proportions which video broadcasting has assumed in most quarters. Based on present standards of television stations in the New York, Los Angeles, Chicago and other leading metropolitan areas, there would hardly seem to be room for a modest start in video broadcasting. We might well subscribe to the prevalent idea of limiting television to densely populated areas, with perhaps some sort of network linked together by relay transmitters, and later on by coaxial lines, for the coverage of outlying districts. Yet in so thinking we get away from certain parallel cases which have already proved there is ample room for the modest but purely local service in the small community, and video broadcasting is no exception. For instance:

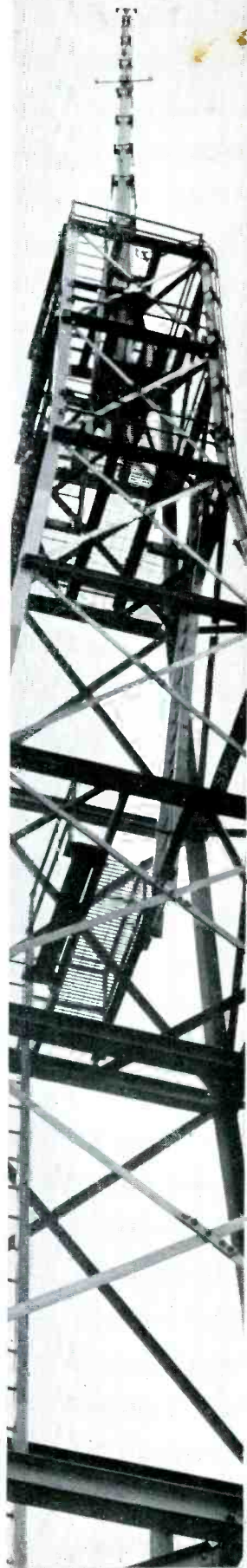

The local newspaper, even the insignificant country weekly, thrives regardless of the sheer bulk, prestige, news coverage, and top-notch features of big metropolitan dailies. Hundreds of purely local broadcasting stations continue to thrive despite a world of top-flight talent reaching local receivers from network stations. The fundamental reason for this seemingly fantastic situation is *local interest*. The local newspaper and the local broadcaster supply news in local terms. The local high school football game may well overshadow the country's annual Rose Bowl contest on the same day. The local pageant may mean far more than the Inaugural ceremonies in Washington. It is by providing *such* news, catering to *such* interest that the local newspaper, local broadcaster and now the local telecaster, justify their existence. There is a definite, non-competitive, profitable place for this local enterprise.

Thus by reducing this whole telecasting proposition to these terms, and picking a locality in keeping with your own financial size and capabilities, you immediately withdraw from a hopelessly competitive struggle with the giants in the field. Cut television down to your own size, and your problems correspondingly shrink.

Handling the Program ★ Program material, for purposes of technical and operative considerations, can be classified in four main groups:

1. **STUDIO PICK-UPS:** Here you have those features brought to or produced in the studio, and over which, therefore, you have the greatest control as regards lighting, timing, arrangement and other details. Studio programs can consist of speakers facing the television camera as well as the microphone, for a sight-and-sound broadcast; demonstrations, such as home economics, first aid, scouting, national defense; animated sports news, with a diagrammatic baseball diamond or football gridiron; election returns including the facsimile showing of teletype tape hot off the wire; musical concerts, including closeups of pianists, violinists and others; and simple plays especially selected and arranged for the limitations of the television stage. Much of this material can be simply and inexpensively handled with local amateur talent and invited guests. The plays can be amateur affairs put on by local schools or dramatic groups. By emphasizing the local interest feature, these studio pickups can be kept non-competitive with network programs.

Just as early sound broadcasters depended mainly on amateur or gratis talent, so can the pioneer telecaster count on such available material locally obtained. The writer, in collaboration with Allen B. Du Mont, handled the first regularly scheduled television programs over Station W2XCD at Passaic, N. J., during 1931-32, with not only amateur talent but legitimate stage performers as well, coaxed over to the television studio either through sheer curiosity or the promise of a new thrill and the attendant publicity. At no time was any difficulty experienced in getting good talent.

As a matter of fact, in the average community talent will usually seek the television studio. Just as those who gladly filled in the blank spaces of early broadcast schedules have in many instances become big names on today's programs, through such early training and the building up of audience acceptance, so there is much latent talent now seeking an opportunity of getting into television and of growing up with it.

All in all, television studio programs present no particular difficulty. Any sizable community can provide ample talent for amateur theatricals, fashion shows, speeches and lectures, instruction, and other possibilities. Meanwhile, at this early stage, when there is still a great element of novelty involved, there need be no particular concern about a thoroughly rehearsed or polished performance. You are not faced with the high standards obtaining in radio broadcasting, often requiring forty hours of rehearsing and revising in order to provide a full hour of flawless entertainment. Almost anything, within reason, will get across in television if those participating are known, personally or by reputation, to the audience.

2. **FILM PICK-UPS:** Here we have the most prolific, simple, and inexpensive source of program material. Just as recordings and transcriptions are used widely in radio broadcasting, so films can be used extensively and effectively in telecasting. The superior quality of television images secured with proper film pick-up makes this an entertainment means of great importance.

The standard film pick-up equipment, with special projectors and dual film pick-up chain, is costly. It may cost more than the equipment required for outside pick-ups, including the truck. However, a modest start may be made by using a 16-millimeter movie projector specially converted for the purpose, in conjunction with the Dual Ieonoscope or Orthicon Camera chains. This is accomplished by merely projecting the movie images into the end of the television camera, with lens removed.

Film pick-up of outside features is feasible. By making movies of the outside event and then flashing the film over the air, the outside pick-up can be achieved at relatively low cost. The filming can be done silently, while the running comment can be supplied at the studio as the film is being monitored during actual transmission, just as many newsreel features are made "silent" with sound dubbed in during laboratory processing. The 16-mm. film can be processed with simple, inexpensive equipment, and films televised within an hour if necessary. The films need not be reversed, since either a negative or positive image can be used.

In this manner, events which occur during the day can be telecast to evening audiences. Thus the television station can establish itself as the local newsreel theatre of the air.

There is still another important angle to film pick-up, and that is the network idea. It is now generally agreed that if scattered television transmitters are to be grouped together into some sort of network, the earliest attempts will be by means of sound films especially made for the purpose, following in the footsteps of

the electrical transcriptions now widely employed for establishing program networks among independent and scattered broadcasters.

Thus far, telecasters have experienced no particular difficulty in securing a constant flow of suitable films. There are industrial films, educational films, travel films, and others which never get to the theatre screens, yet are of tremendous interest to the general public. Such films are available through non-theatrical exchanges or film libraries, in many instances without cost except for transportation charges. As telecasting develops, there is every indication of an increasing supply of these non-theatre films for the television audiences.

Although standard theatre movies are being utilized at this early stage of television entertainment, it must be made clear that television will soon have its own exclusive films, for television entertainment need not in any way overlap or conflict with local movies. Both have their own distinct fields. Already special television films are available, with the action, lighting, timing and photography definitely slanted towards television.

3. REMOTE PICK-UPS: Here you have the climax of television entertainment, for with remote pick-up technique you can bring actual news events directly to your television audience. Eventually, a good third or more of the day's television offerings will comprise remote or outside pick-ups.

Remote pick-up calls not only for cameras, microphones and associated equipment, including complete monitoring facilities as in the case of studio work, but also the link with the main transmitter. This link can be a coaxial cable for very short distances, but prohibitive cost will rule it out in practically every instance. Therefore, it becomes necessary to utilize an ultra-short-wave relay transmitter for the video signals, and another relay transmitter for the audio signals. Suitable receiving equipment and monitors must be provided at the main transmitter to handle the relayed signals.

The usual practice so far has been to utilize one or more trucks to carry the pick-up equipment and transmitters. However, in this as in other respects the equipment has been simplified by subdividing it into handy, fully portable units that can be loaded into automobiles. In fact these same units can be used in the studio and out in the field. This dual usage slashes the necessary investment.

Direct remote pick-up is the climax of the television program. Relay transmitters can be had, and in local work the distances are such that low-power equipment will serve the purpose, thereby keeping the invest-

CAMERAMAN WATCHES ACTION IN THE VIEW-FINDER ATTACHED TO THE TELEVISION CAMERA, WHILE THE MONITOR OPERATOR CORRECTS THE IMAGES TRANSMITTED

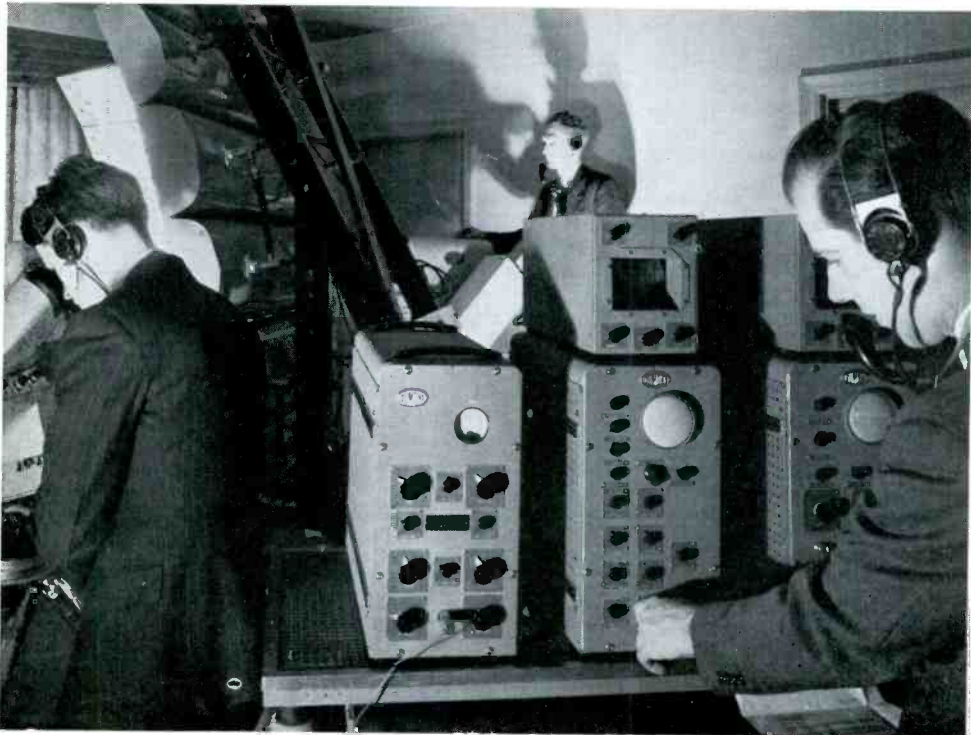

ment down to a minimum. Likewise, the use of standard automobiles instead of huge trucks. The telecaster should go on to remote pick-ups at the earliest possible time, but film pick-up may be utilized as an improvisation in the meantime.

4. ELECTRICAL TRANSCRIPTIONS: Since telecasting provides sound as well as images, the sound channel must be utilized all the while the television transmitter is on the air. Even when the pattern is being shown for test purposes, or to tide over from one program to the next, the sound channel should be operating. In this connection, electrical transcriptions are of utmost importance. The initial telecasting setup might well include the turntables, amplifiers and controls, along with microphones and other sound equipment.

Established libraries and services insure adequate electrical transcriptions for the telecaster, but here again, as in the television programs themselves, repetition is positively fatal.

Appraising the Community ★ Having settled upon a program policy — the justification for seeking a place in the telecasting field — the next step preliminary to applying for a license is a survey of the community to be served.

Because of the quasi-optical nature of its transmission, television necessarily treats with limited areas. Whereas a broadcasting station might count on a service area of say 100 miles' radius, a modest television transmitter is more limited. In addition to power limitations, there is the factor of the effective height of the television transmitting aerial. As a rough rule — subject to many disconcerting exceptions in practice — the transmitting range with adequate power is approximately the horizon as viewed from the transmitting aerial. Thus, in the average metropolitan area where tall buildings or lofty hills are available for the transmitting antenna, a service range of approximately 40 miles can be counted upon.

Within the effective service area contemplated, it is well to survey the potential audience. Factors of vital interest in this connection are:

- (a) Population in the proposed service area, including vital statistics such as whites, native born, married, single, children, etc.
- (b) The annual wholesale and retail trade of the area.
- (c) The total and the average purchasing power of the population, with a breakdown of different groups according to annual earnings.
- (d) Number of families; how many own their homes; how many have cars; how many have radio sets.
- (e) Cultural status of the community — college graduates, high school graduates, present students, local cultural activities.
- (f) Number of radio sets now in use. Number of sets purchased over the past five years, by years. Proportion of better grade radio sets and phonograph contributions.
- (g) Advertising revenue realized by local newspapers and existing local broadcasting stations.

A survey of this sort can best be undertaken by organizations specializing in such work, particularly those with past experience in gathering such data as the basis for new broadcasting and particularly television stations. Much of the information can be compiled from available sources, such as census data published by the Department of Commerce, advertising data issued by local newspapers and broadcasters, and marketing guides issued by newspaper and trade associations.

A convincing picture will have to be presented along with the application for a television license. In fact, the requirements are such that it may be best to ascertain what information is required by the FCC, and then set out to get such information through the proper survey or compilation of existing data.

License ★ Television licenses are being granted by the FCC to parties presenting convincing evidence that they can and will provide a satisfactory telecasting service in given localities. A construction permit is first granted, whereby the television equipment can be contracted for and installed. At this stage in television progress, an experimental license is usually obtained. Such a license precludes the handling of commercial or sponsored programs, but inasmuch as sponsors are mighty scarce in any new television area, this basis of operation is best since it does not pin down the telecaster to hard and fast program schedules. Certainly it is wiser to operate under an experimental license until program policy and practice have been fully worked out, a sizable audience built up, and commercial sponsorship is justified, whereupon the telecaster is ready to commit himself to regularly scheduled programs, on a limited or unlimited commercial license basis.

Revenue ★ Again you must understand that television is quite unlike radio broadcasting in the matter of immediate prospects or, to put it another way, television is just twenty years behind radio broadcasting. The fifty-million odd radio sets already in use provide a flying start for the new broadcaster in practically any locality. The potential audience already exists. Sets are ready

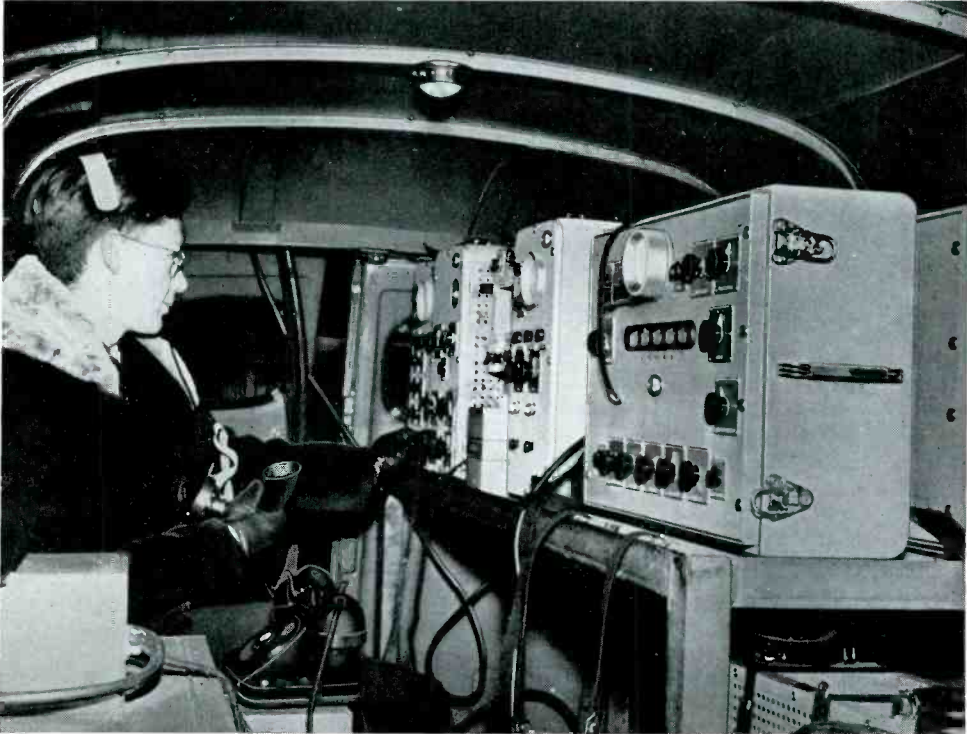

THESE TELEVISION UNITS CAN BE USED IN THE STUDIO, OR SENT OUT ON LOCATION FOR REMOTE PICK-UPS AS SHOWN HERE. THIS SAVES THE COST OF DUPLICATE EQUIPMENT

to be tuned in on the new station. If its programs are attractive, it has a made-to-order audience almost from the beginning. Commercial sponsorship is just a matter of salesmanship.

But with television, the telecaster starts in a new territory without an existing audience. Television receivers are not yet installed. Television programs at first are played largely to an empty house. Provisions must be made to get television receivers installed, and this may mean close cooperation with manufacturers of such receivers, at the start.

Television broadcasting is strictly a pioneering matter. Make no mistake about that. There are rich rewards ahead, when television will have become firmly established. But at present it is a long pull over several years, mainly for the purpose of gaining practical experience, establishing a following in the community, building up a worth while audience and, finally, cashing in on a growing commercial sponsorship.

Too many variables enter into the situation to permit of hard and fast deductions and conclusions. It is safe to assume, however, that a telecasting station should operate experimentally for a reasonable period of time, in order to establish itself on a commercial or revenue-producing basis. Unless you are prepared to go through this period of evolution, just as others are already doing, you will find no place in the commercialized television of the future. Bets are being placed now. No bets can be accepted after the wheel has been spun and winning numbers are about to be called.

Equipment ★ Just as we have endeavored to reduce program considerations to simple, local proportions so, too, has the necessary equipment been reduced to elementary terms by Du Mont engineers. So-called "chains" or combinations of units can be made up to meet any studio or remote pick-up situation, and obsolescence has been reduced to a minimum. In Part 2 we shall deal with Du Mont television studio and transmitting equipment, as well as remote pick-up facilities, arranged according to purse and purpose. Specifications and prices of various pieces of equipment will be presented. From such data it should be easy to estimate the approximate cost of a television setup to cover any local requirements.



WILLIAM J. HALLIGAN

BOSTON BOY AND WEST POINTER, AMATEUR AND WARTIME NAVY OPERATOR, WHO MADE GOOD IN CHICAGO BY PUTTING UP COMMUNICATIONS RECEPTION IN METAL CABINETS. AMATEURS PREFERRED HIS PACKAGED GOODS TO HOMEMADE RIGS AND, AS THE IDEA TOOK HOLD, HE SET UP TO DO PRECISION ASSEMBLY ON PRODUCTION BASIS. HALLIGAN'S HALLICRAFTERS IS NOW RATED AS LARGEST PRODUCER OF COMMUNICATIONS RECEIVERS

THE MANUFACTURERS SAY:

A Statement by William J. Halligan, President, the Hallicrafters Company, Chicago

THE twin sciences of frequency modulation and ultra-high frequencies have a great future. There is no question that FM is a superior form for broadcasting entertainment and information to the general public. As such, it is without question "here to stay." But we, at the Hallicrafters, believe that its communications possibilities are even more extensive. Eight years of UHF research and development so convinced us of this future that we became one of Major Armstrong's first licensees. Of course, when we say ultra high frequency, we mean 300 to 3,000 megacycles—not 100 megacycles.

The whole world has marveled at the progress of the radio art but we feel sure that the surface has scarcely been scratched because so many new applications are becoming a daily occurrence. One of the world's largest gold mines has installed their own radio communications equipment. Huge Cuban sugar plantations now have our marine radiotelephone for convenient field to office communications. The internationally famous Burma Road is covered with radio communications stations to facilitate traffic and to serve in defense emergencies.

The future of radio communications holds endless opportunities for improvement in our daily industrial life. It is not difficult to visualize interstate trucking companies equipped so that their drivers are in constant communications with the home office dispatcher, or the business man on our modern trains keeping in communication with his office via radio. No, the surface has hardly been scratched. Engineers in laboratories are constantly discovering newer and more amazing possibilities, particularly in the application of Frequency Modulation and ultra high frequency transmission and reception.

This emergency is developing more and more improvements in direction finders, radio locators, radio altimeters, panoramic receivers, single side band receivers, extremely compact portable transmitters and receivers, and television equipment. Many of these and their uses we visualized vaguely now, but when this emergency has passed they will become industrial necessities.

For the eight years that we, at Hallicrafters, have been in the radio communications field,

we have been responsible for the development of transmitters and receivers that were characteristically our own. Our designs have been found of great value in national defense, and we are greatly pleased that we were fortunate enough to be serving both the amateur and commercial fields, thus enabling us to attain a growth sufficient to quickly supply Hallicrafters radio communications equipment to satisfy the urgent needs of our army, navy and other governmental agencies.

I believe that the future of radio communications, with the addition of Frequency Modulation, presents a bright picture to the manufacturer whose laboratory and engineering staff can keep ahead of swiftly changing advances in the art. When peace comes again, radio will be found to have contributed greatly to our victory. Then all will enjoy the use of many new inventions that are now reserved for military purposes.

FM MAGAZINE WILL SERVE WARTIME NEEDS

The effect of our entry into the war upon *FM Magazine* will be to increase its service to radio engineers and executives in manufacturing plants, government departments, public utilities, broadcasting stations, and state and municipal police organizations.

All these groups are concerned with the development and production of radio equipment or its application and use. There will be no limitations on their activities, since their orders carry priorities.

Editorially, *FM* will continue to present engineering data and information on new equipment, featuring design practice and the practical application of technical developments. Its position as the complete and authoritative source of information on Frequency Modulation will be maintained, because of the increasing application of this system to military and home defense communications.

As a former radio operator in the U. S. Navy and, during World War I, a pilot in the British Royal Air Force, your Editor is fortunate in having an intimate understanding of radio communication and equipment as applied to military needs.



FIG. 1. W71NY HAS THE FIRST WESTERN ELECTRIC 10-KW. FM TRANSMITTER TO BE DELIVERED

W71NY IS MODEL INSTALLATION

First Commercial FM Station in New York City Sets High Standards of Engineering Practice and Operating Efficiency

NO ONE can doubt that the WOR organization is going to do a serious job of FM broadcasting. The whole layout of W71NY, at 444 Madison Avenue, makes this clear, as will be seen from the accompanying illustrations.

The transmitter room, on the 42nd floor, occupies 1,800 square feet. It is in the form of an L, the long leg of which appears in Fig. 2. In the shorter angle, space is provided for the comfort of the staff, including folding beds, refrigerator, and a neat and tidy kitchen.

Such office building locations, ideal as they are, call for much original technique in raising heavy pieces of awkward dimensions from the street level. In this case, the work was made particularly difficult because the elevators

run only to the 40th floor. The equipment was broken down into sections that passed through the elevator doors, but they could not be carried up the stairway to the 42nd floor. The problem was solved by cutting trap doors in the floors, and raising the apparatus with a block and tackle. The 30-ft. coaxial antenna, mast sections, and copper tubing for coaxial transmission lines were raised on the tops of the elevator cars. These methods made it possible to bring everything up inside the building.

Transmitting Equipment ★ Fig. 1 is a close-up of the Western Electric model 506 A-1 transmitter, rated at 10 kw. The modulator unit is at the right, with the power amplifier at the left. The P.A. uses the newly developed 389AA

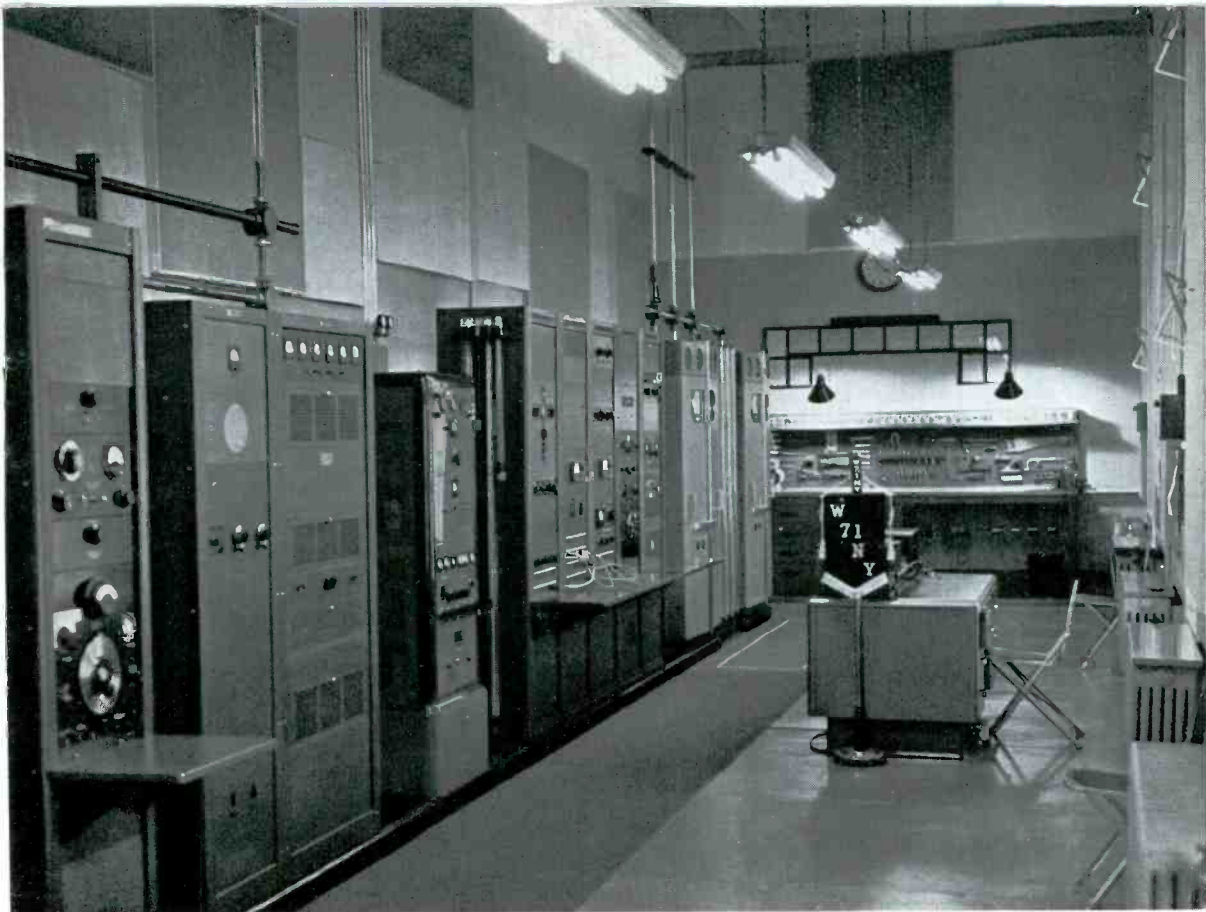

FIG. 2. COMPLETE STATION EQUIPMENT IN A SINGLE ROW, WITH CONTROL DESK OPPOSITE

single amplifier tube, short and squat in appearance, and weighing 55 pounds. Tuning is accomplished by changing inductance, with motor-driven controls. There is no tuning condenser in the circuit.

Fig. 2 shows the complete line-up, with the 10-kw. transmitter at the far end. Reading from left to right, the first rack carries the frequency monitoring equipment. Beyond it is the original 1-kw. Western Electric transmitter. This is connected to a separate coaxial antenna, and the filaments of the tubes are lighted at all times during FM program hours, so that it can be substituted for the other transmitter in a matter of seconds. It is controlled from a duplicate speech input and monitoring board.

Next in line is a 100-watt transmitter for communication with mobile pick-up units when they are out on remotes.

Following is the speech input equipment for the two FM transmitters, and other apparatus used in operating the station. This includes a G.E. converter for picking up FM programs from other stations, and a Hammarlund receiver tuned to WOR. This would be used to pick up WOR programs in case of a failure in the high-fidelity line which joins this station

with the studios at 1440 Broadway, less than a mile distant.

Routine checking of the transmitter is done with instruments mounted permanently on the two racks at the right, adjacent to the transmitter. These are General Radio types, and include:

- 775-A frequency limit monitor
- 608-A oscillator
- 620-A frequency meter
- 636-A wave analyzer
- 733-A oscillator
- 732-B distortion and noise meter
- 732-P1 filter

In addition, low-level Daven volume indicators are provided. A built-in 3-in. oscillograph completes the complement of instruments.

Thus, in equipment and arrangement, the station has been planned with great care and thoroughness from the start, rather than being allowed to grow like Topsy, as was the case in the early AM installations.

Test Equipment ★ W71NY is unusually well equipped to handle all the work of checking the performance of the station, as will be seen from Fig. 3. For the benefit of other station operators, the equipment is listed below:



FIG. 4. EQUALLY COMPLETE, AND TYPICALLY TIDY, IS THE WORK-BENCH AT W71NY. PRACTICALLY ANY JOB CAN BE HANDLED BY THE STAFF, WITHOUT HAVING TO GO OUTSIDE FOR SHOP FACILITIES



FIG. 3. W71NY HAS ITS OWN COMPLEMENT OF TEST EQUIPMENT, MAKING IT ENTIRELY INDEPENDENT OF THE AM STATION AT CARTERET, N. J. THE BENCH IS MOUNTED ON HEAVY CASTERS, SO THAT IT CAN BE MOVED TO ANY PART OF THE STATION

From left to right, on the top of the bench—

- Ryder Volt Ohmyst
- Esterline-Angus recording milliammeter
- General Radio direct current amplifier
- RCA cathode ray oscillograph
- Du Mont cathode ray oscillograph
- General Radio 605-B signal generator
- RCA high frequency field intensity meter
- RCA low frequency field intensity meter

On the upper shelf are:

- Industrial Instruments megabridge
- General Radio vacuum tube voltmeter
- Hickock AC-DC voltmeter
- Weston wattmeter
- Weston tube checker
- General Radio portable AC voltmeter
- General Radio DC supply for signal generator

The instruments on the lower shelf are:

- RCA beat frequency oscillator
- Link FM oscillator
- Boonton Radio Q meter
- Cornell-Dubilier capacitor analyzer
- Weston ohmmeter
- RCA power supplies for field intensity meters

With this apparatus available, W71NY engineers can make practically any tests or measurements required in a broadcast station.

Spare Tubes ★ Two ordinary steel cabinets, not shown, have been fitted with wooden racks to carry an adequate number of spares for all types of tubes used in the transmitter and speech equipment. The racks are sloping, so that any tube can be located quickly and accurately in case of emergency.

Even a 389AA power output tube is included. It has a compartment all its own, and a special mounting so that, while it is held firmly, it can be removed easily, and with the minimum danger of fumbling.

Antenna ★ The vertical coaxial antenna for the 10-kw. transmitter is 25 ft. in length, mounted on a steel pole. The height is approximately 630 ft. above seal level, sufficient to give a calculated service range of about 52 miles. However, that is by no means the limit distance from which reception is being reported.

Programming ★ The operating schedule runs from 8:00 A.M. to 11:30 P.M. daily. Programs originate from the WOR studios, and are carried to W71NY by high-fidelity telephone lines. The FM station has duplicate turntables for recordings, should the need arise. In fact, the walls of the transmitter room have been given acoustic treatment, and microphones are available so that live programs can be put on

right there, in case of emergency. There is space to accommodate a large orchestra.

An analysis of W71NY programming shows that 30% of the time is given to Mutual network programs not heard over WOR, 5% are WOR programs, 10% are W71NY originations and special features, 45% are high-fidelity transcriptions, and 5% are recordings.

There will, undoubtedly, be a revision of this schedule now that W71NY is transmitting sponsored programs.

USE OF "FUGITIVE SIGNALS"

It is common practice to shut down broadcast stations at the first warning of approaching enemy planes, so that the stations cannot be used as radio beacons. This is necessary, of course, but it eliminates the simplest means of conveying information and instructions to a great number of people.

To telephone orders to air raid wardens and other service groups is slow and complicated. Signalling by sirens is of limited usefulness, because they are not under a single command, and even powerful sirens cover a relatively small area.

On the other hand, if commands could be transmitted by the local broadcasting stations,

the majority of the people could be reached instantly.

The trouble is that even the unmodulated carrier of any station can be used by enemy planes as a radio beacon. However, if the broadcast stations were equipped so that the carrier, modulated by a steady note, could be put on and off to transmit brief code signals, much information could be conveyed to listeners without having the stations on the air long enough for such "fugitive signals" to be used for compass bearings.

Perhaps six or eight short, easily distinguishable combinations of long and short notes from an audio howler would be enough to give much useful emergency information. There is nothing complicated about the arrangements needed for broadcast stations to perform this service. Instructions could be given from military headquarters quickly, and with the use of a minimum number of telephone lines. An audio howler would produce a signal in radio receivers that would attract immediate attention.

Is it possible that an emergency use for our broadcasting stations has been overlooked? Certainly the possibilities of this idea are worth exploring.

FM Magazine will be pleased to publish any comments on this subject from its readers.

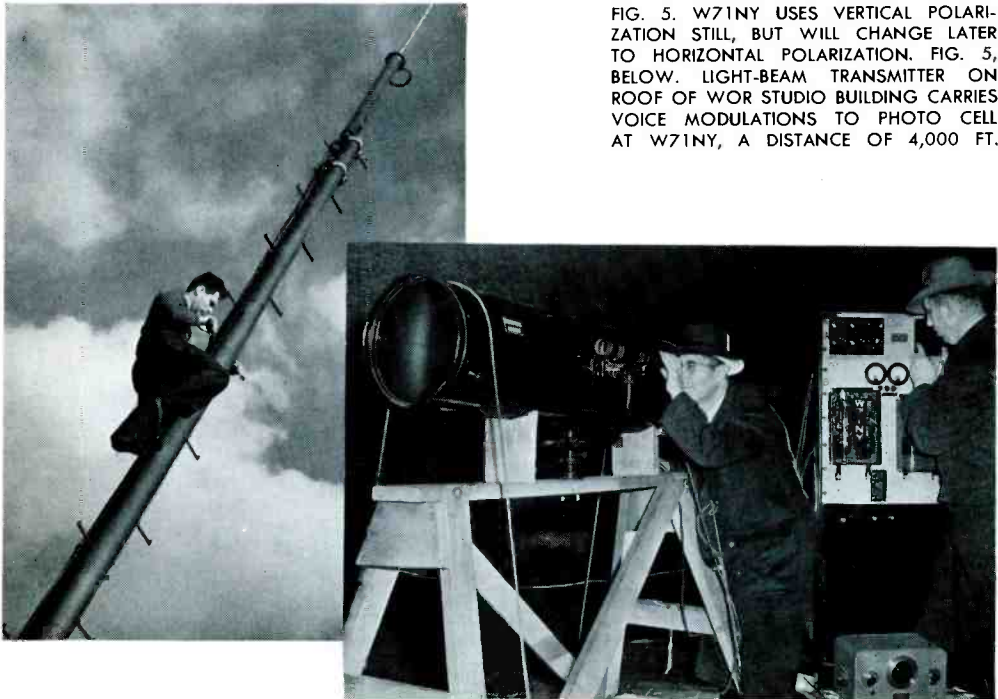

FIG. 5. W71NY USES VERTICAL POLARIZATION STILL, BUT WILL CHANGE LATER TO HORIZONTAL POLARIZATION. FIG. 5, BELOW. LIGHT-BEAM TRANSMITTER ON ROOF OF WOR STUDIO BUILDING CARRIES VOICE MODULATIONS TO PHOTO CELL AT W71NY, A DISTANCE OF 4,000 FT.

SPOT NEWS

Notes and Comments, personal and otherwise, about broadcast, communications, and television activities

180,000: Rate of A-FM set production continues to increase. Total in use at the end of November is approximately 180,000, of which, 35,000 are being used in New York City, 19,000 in Chicago, 18,000 in New England, 10,000 in Detroit and in Los Angeles, 9,000 in Philadelphia, 5,800 in Milwaukee, and 5,500 in Pittsburgh.

Purge: W65H Hartford will use no hot music on its FM programs.

CBS: W67NY, using low power, started regular programs on December 1st. Hours are 3:00 to 6:00 and 7:00 to 10:00 P.M. High fidelity lines carry programs from 485 Madison Avenue studio to FM transmitter atop 500 Fifth Avenue.

W. G. H. Finch: Called to military service. Fate of his W55NY Construction Permit is not known at this time.

Reading, Pa.: Hawley Broadcasting Company is latest FM applicant in Pennsylvania. They ask for 46.5 mc. to cover 4,275 square miles.

W2XQR: John V. L. Hogan's FM transmitter, operating on low power with a small antenna at Long Island City, will put on commercial long pants. After signing off on December 7th, W2XQR will be moved to the Chanin Building, West 42nd Street, New York City, where it will be operated as W59NY.

70%: That is the proportion which A-FM receivers bear to total radio set sales at Bloomingdale's, New York's second largest department store.

Zenith: A 32-page program book gives the month's schedule from W5IC, from 8:30 A.M. to midnight. Selections on "Evening Music", 6:00 to 10:00 P.M. nightly, are listed separately, with composers' names. Listeners are asked to send ten cents for the monthly issue.

Los Angeles: Hughes Tool Company has been granted a C.P. for K49LA. Installation of transmitter is expected to go forward without delay.

Objection: FMBI bulletins and some FCC releases concerning FM stations give the areas covered, but not the population. Inasmuch as radio audiences are measured by people and not square miles, the current practice lacks the really vital information.

Chicago: Highly organized technique gives W59C audience magnificent reproduction of Chicago Opera performances. Four mikes are located in the footlights, two at conductor's podium, and one above the orchestra. WGN staff producer Jacobson cues engineer Gause in handling the mixer, while announcer Venables supplies comments and program notes. High-fidelity line connects Opera House to studio.

Worcester: WTAG's FM outlet, WIXTG, has been giving public demonstrations of FM reception, in cooperation with G.E., Stromberg-Carlson, and Zenith. Special FM Studio was set up at Barnard Department Store, and G.E.'s movie explanation of staticless radio was shown to over 50,000 people.

American Network: Stockholders at December 3rd meeting reelected John Shepard, 3rd, as president, Jack Latham executive vice-president, Walter J. Damm vice-president, and named Gordon Gray secretary and treasurer.

Linus Travers: Vice-president of Yankee-Colonial Network was featured speaker in discussion of "Problems of FM Broadcasting" at fifth annual School Broadcast Conference, Chicago.

Schenectady: G.E. has applied for permission to change W57A C.P. to 48.5 mc., with new coverage of 6,600 square miles with population of 502,200.



JOHN L. BOOTH'S W49D IS GIVING DEMONSTRATIONS WHICH DRAMATIZE THE DIFFERENCE BETWEEN FM AND AM RECEPTION. EXHIBIT IS AT EATON TOWER, WHERE THE W49D STUDIOS AND TRANSMITTER ARE LOCATED. LATEST A-FM RECEIVERS ARE ON DISPLAY



NEWS PICTURE

"Here it is!" First licensed A-FM model in \$60 bracket, providing all elements of Armstrong FM circuits, is now being delivered by Pilot Radio. I. Goldberg, Pilot president, and Edward Jons, Pilot engineer, spot-check samples from first production release. Laboratory model of this set was demonstrated to dealers during Music Trades Show, where it effectively eliminated heavy static encountered at Hotel New Yorker.

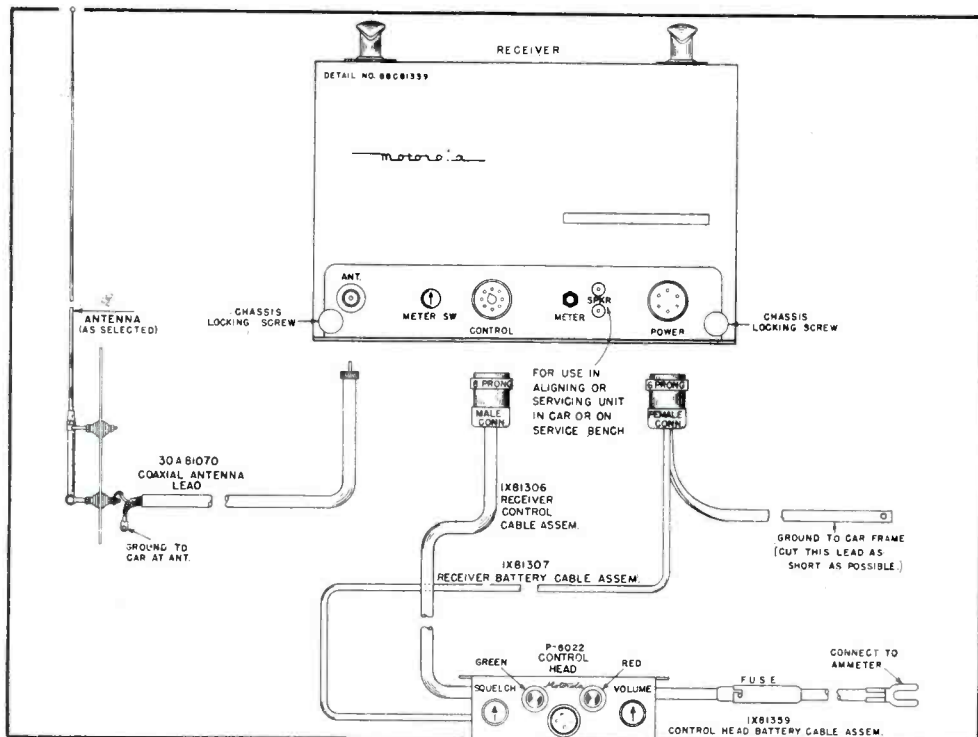

FIG. 1. UNITS COMPRISING THE CAR RECEIVER INSTALLATION. THE SAME RECEIVING SET, WITH AN AC POWER SUPPLY, IS USED FOR HEADQUARTERS EQUIPMENT

DATA ON MOTOROLA EMERGENCY FM

Part 1—FMR-13 and FSR-13 Receivers for Mobile and Headquarters Installations

BY NORMAN E. WUNDERLICH*

THE Motorola¹ type FMR-13 and FSR-13 receivers are designed to receive frequency modulated signals in the band from 30-40 megacycles, and are adjusted at the factory for operation at a specified frequency. If at any time it becomes necessary to change the operating frequency, a new crystal can be substituted for the one supplied, and the receiver retuned in accordance with the procedure outlined here.

The received signal is to be frequency modulated by a plus or minus 15 kc. deviation. The receiver uses a double superheterodyne circuit with crystal-controlled oscillators. The intermediate frequency channels are 4.3 mc.

* Galvin Manufacturing Corporation, 4545 Augusta Boulevard, Chicago, Ill.

¹For photographs and other specifications, see *FM Magazine*, April, 1941.

and 455 kc. A unique type of squelch is used which gives exceptional control at low signal input levels. Squelch, volume control, and speaker leads are brought out into a cable for control from a remote control box. A meter jack and switch on the receiver make available various circuits for measurements. Speaker jacks are provided on the chassis to facilitate testing.

Two power supplies are available. P-8030 is for a 6-volt battery and P-8034 for 117 volts AC. Either can be attached to the receiver and connections made by plugs. Either supply will deliver 250 volts at 80 MA. The 6-volt vibrator supply uses an improved heavy duty vibrator and two 6X5GT tubes in parallel as rectifiers. The 117-volt AC supply uses an 80 tube as rectifier.

When the receiver is operated on 6 volts

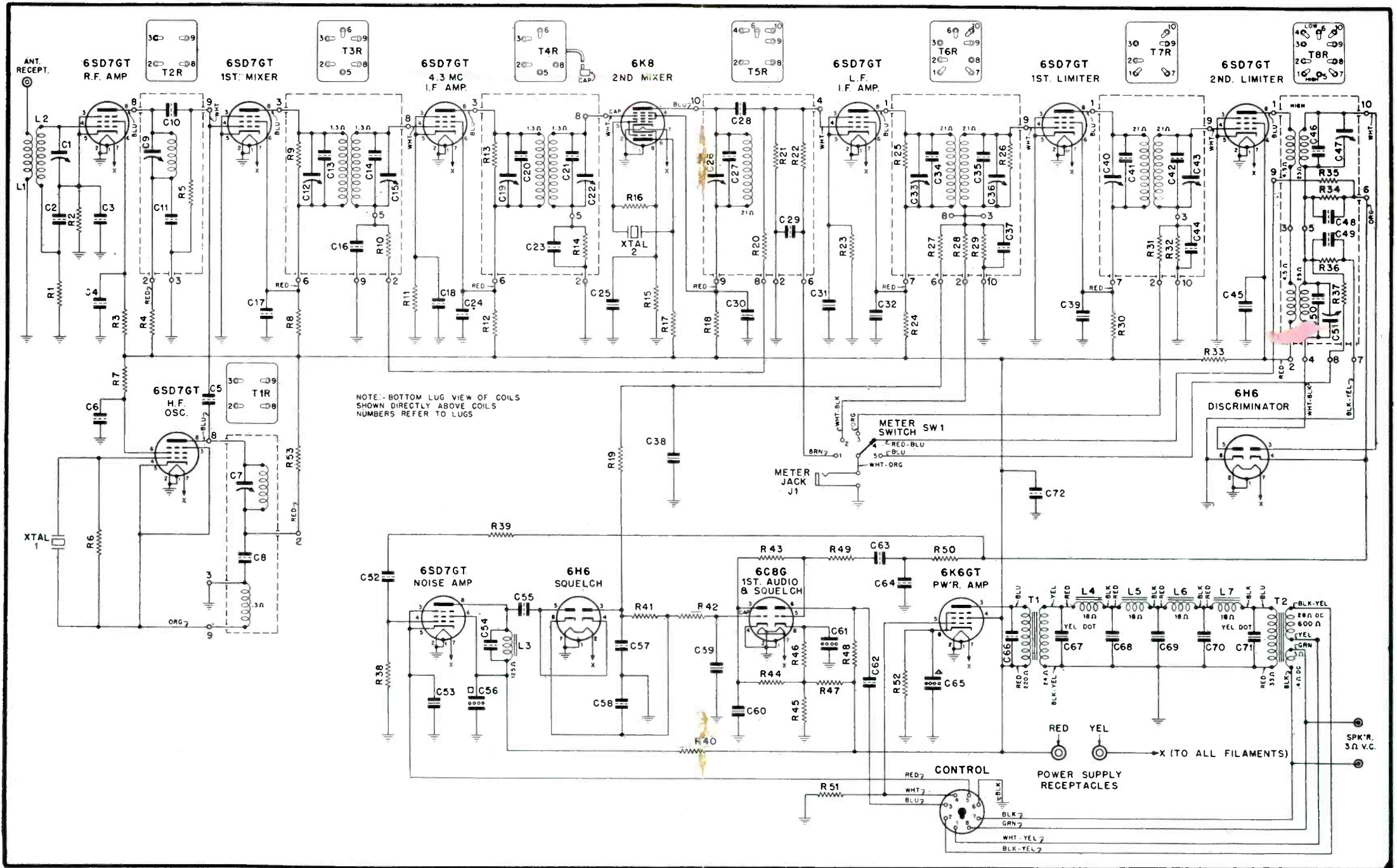

FIG. 2. SCHEMATIC DIAGRAM OF MOTOROLA FM RECEIVER FOR EMERGENCY SERVICE

THIS DIAGRAM IS COMPLETE, EXCEPT FOR THE B POWER SUPPLY, SHOWN IN FIG. 3

either side of the control head. Two slots are supplied at both ends, in order that the head may be mounted out front or behind the panel.

The large Amphenol cable connector plug ends should be at the rear of the trunk. Remove the rear seat and fish the cable through

the trunk. Dress the cable down to the floor and route it under the floor mat, along the left-hand side of the car, up over the steering col-

umn to the control head. Do this carefully. The cable should be protected from damage by rubber grommets or friction tape at points

DC, the DC supply is fed into the control box, goes through the switch, and then to the receiver by a heavy A lead. The plug used must carry a jumper between pins 3 and 4 to complete the +B, Fig. 3.

When the receiver is operated on AC, the 117-volt supply is brought directly into the power plug. Pins 3 and 4 must be jumpered to provide +B to the receiver. There is a blank pin 5 to which one side of the supply may be connected and then brought out to a switch. Also the 6-volt filament supply is brought out to terminal 2 which may be extended to operate a pilot light.

When operating this receiver in conjunction with a Motorola FM Transmitter, the +B circuits, Pins 3 and 4 in power plug, are controlled by a relay in the transmitter and are opened when transmitting, which effectively mutes the receiver.

Tubes ★ Tubes used and their functions are as follows:

- 6SD7GT—R.F. Amplifier
- 6SD7GT—1st Mixer
- 6SD7GT—High Frequency Oscillator and Multiplier
- 6SD7GT—4.3 mc. IF Amplifier
- 6K8 —Low Frequency Oscillator and 2nd Mixer
- 6SD7GT—455 kc. Amplifier
- 6SD7GT—455 kc. First Limiter
- 6SD7GT—455 kc. Second Limiter
- 6H6 —Discriminator
- 6C8G —Squelch and 1st Audio
- 6SD7GT—Noise Amplifier
- 6H6 —Squelch
- 6K6G —Power Amplifier

Equipment ★ A complete installation includes the following equipment:

1. Complete Receiver Unit
2. Control Head
3. Cables and Connectors
4. Speaker
5. Antenna
6. Installation and Operating Instruction

To simplify the installation procedure, all units are assembled at the factory as completely as possible, leaving a minimum number of operations for the installation man. Therefore, the actual installation in the car does not require any unusual skill or knowledge, but can be accomplished by any good mechanic who will follow the instructions carefully.

Installation ★ Before proceeding with the actual installation, it is desirable to start by laying out a definite plan wherein the exact locations for the various components will be definitely selected. This position should be such that the

antenna lead will be no longer than that supplied.

The control head should be mounted on the instrument panel within easy reach of the front seat passenger.

Set the receiver in the position which will allow the antenna lead to reach the antenna connection without any sharp bends or undue stress being applied to either end connectors.

Unscrew the chassis plate unlocking screws about three-quarters of an inch and push the chassis back on base about $\frac{1}{2}$ in. This will unlock the rear edge of the chassis from the base plate. Then it can be lifted up and off of the base plate.

CAUTION: Care must be used when replacing chassis on base mounting plate. The base locking screws must be unscrewed about $\frac{3}{4}$ in. and the chassis must be placed squarely over base plate and about $\frac{1}{2}$ in. to the rear before it is lowered on the base plate. The base plate locking screws are then screwed up snug, pulling the chassis forward and locking it to base plate.

To unlock cover, turn the carrying handles $\frac{1}{4}$ turn; i.e., turn the left-hand handle clockwise and the right-hand handle counterclockwise, and lift off cover. To replace cover, have handles lined up lengthwise with inside locking tongue pointing back. Place cover completely down over chassis and turn handles rear side out, i.e., the right hand-handle clockwise and the left-hand handle counterclockwise.

The chassis end plates form chassis supports for convenience and speed in servicing, and to prevent damaging chassis parts while being serviced.

Place the chassis base mounting plate in the position previously selected for the receiver and use the base as a template to drill six holes with a No. 22 drill ($\frac{5}{32}$ -in. hole). If the floor of the trunk compartment is metal *be careful not to drill too deep and pierce gas line or tank. Be sure to check space between the floor and gas line or tank and check to see that mounting screws will not pierce gas line or tank.*

For shock mountings, use the rubber step washer assembly, and discard six of the large flat washers.

In cases where above mountings are not required or desired, the step washers can be discarded and the thinner flat washers placed under the chassis, using shorter mounting screws, if necessary, to prevent puncturing gas tank.

In some cars the receiver unit may be mounted on the shelf which separates the spare tire space from the luggage compartment.

The control head is to be mounted below the face of the instrument panel, using the two mounting brackets which are fastened to

DIAG. NO.	PART NO.	DESCRIPTION	DIAG. NO.	PART NO.	DESCRIPTION
C1	19A81260	VARIABLE CONDENSER (3.5-50 MFD)	R4	686080	CARBON RESISTOR (4,700-1/2-10) INS.
C2	21B6569	MOLDED MICA CONDENSER (500 MFD) 10%	R5	686046	CARBON RESISTOR (4.7 MEG-1/2-10) INS.
C3	21B6567	MOLDED MICA CONDENSER (5000 MFD) 10%	R6	686048	CARBON RESISTOR (47,000-1/2-10) INS.
C4	21B6567	MOLDED MICA CONDENSER (5000 MFD) 10%	R7	686048	CARBON RESISTOR (47,000-1/2-10) INS.
C5	21A81338	CERAMIC CONDENSER (2 MFD)	R8	686227	CARBON RESISTOR (27,000-1/2-10) INS.
C6	21B6568	MOLDED MICA CONDENSER (2000 MFD) 10%	R9	686377	CARBON RESISTOR (470,000-1/2-10) INS.
C7	19A80873	AIR TRIMMER CONDENSER (RANGE 5-4 1/2 MFD)	R10	686031	CARBON RESISTOR (100,000-1/2-10) INS.
C8	21B6567	MOLDED MICA CONDENSER (5000 MFD) 10%	R11	686022	CARBON RESISTOR (330-1/2-10) INS.
C9	19A80873	AIR TRIMMER CONDENSER (RANGE 5-4 1/2 MFD)	R12	686231	CARBON RESISTOR (15,000-1/2-10) INS.
C10	21B6571	MOLDED MICA CONDENSER (50 MFD) 10%	R13	686377	CARBON RESISTOR (470,000-1/2-10) INS.
C11	21B6567	MOLDED MICA CONDENSER (5000 MFD) 10%	R14	686234	CARBON RESISTOR (27,000-1/2-10) INS.
C12	PART OF 19A80869	AIR TRIMMER CONDENSER (RANGE 5-4 1/2 MFD)	R15	686022	CARBON RESISTOR (330-1/2-10) INS.
C13	21K81357	CERAMIC CONDENSER (10 MFD) 10%	R16	686048	CARBON RESISTOR (47,000-1/2-10) INS.
C14	21K81357	CERAMIC CONDENSER (10 MFD) 10%	R17	686398	CARBON RESISTOR (150,000-1/2-10) INS.
C15	PART OF 19A80869	AIR TRIMMER CONDENSER (RANGE 5-4 1/2 MFD)	R18	686230	CARBON RESISTOR (10,000-1/2-10) INS.
C16	21B6569	MOLDED MICA CONDENSER (500 MFD) 10%	R19	686046	CARBON RESISTOR (1 MEG-1/2-10) INS.
C17	21B6567	MOLDED MICA CONDENSER (5000 MFD) 10%	R20	686048	CARBON RESISTOR (47,000-1/2-10) INS.
C18	21B6567	MOLDED MICA CONDENSER (5000 MFD) 10%	R21	686048	CARBON RESISTOR (47,000-1/2-10) INS.
C19	PART OF 19A80869	AIR TRIMMER CONDENSER (RANGE 5-4 1/2 MFD)	R22	686046	CARBON RESISTOR (1 MEG-1/2-10) INS.
C20	21K81357	CERAMIC CONDENSER (10 MFD) 10%	R. 3	686491	CARBON RESISTOR (560-1/2-10) INS.
C21	21K81357	CERAMIC CONDENSER (10 MFD) 10%	R24	686227	CARBON RESISTOR (27,000-1/2-10) INS.
C22	PART OF 19A80869	AIR TRIMMER CONDENSER (RANGE 5-4 1/2 MFD)	R25	686031	CARBON RESISTOR (100,000-1/2-10) INS.
C23	21B6569	MOLDED MICA CONDENSER (500 MFD) 10%	R26	686048	CARBON RESISTOR (47,000-1/2-10) INS.
C24	21B6567	MOLDED MICA CONDENSER (5000 MFD) 10%	R27	686046	CARBON RESISTOR (1 MEG-1/2-10) INS.
C25	8A81123	TUBULAR CONDENSER & BRACKET (.05-600V)	R28	686260	CARBON RESISTOR (1.5 MEG-1/2-10) INS.
C26	19A80873	AIR TRIMMER CONDENSER (RANGE 5-4 1/2 MFD)	R29	686031	CARBON RESISTOR (100,000-1/2-10) INS.
C27	21B6572	SILVER MICA CONDENSER (50 MFD) 5%	R30	686227	CARBON RESISTOR (27,000-1/2-10) INS.
C28	21B6571	MOLDED MICA CONDENSER (50 MFD) 10%	R31	686260	CARBON RESISTOR (1.5 MEG-1/2-10) INS.
C29	21B6569	MOLDED MICA CONDENSER (500 MFD) 10%	R32	686031	CARBON RESISTOR (100,000-1/2-10) INS.
C30	8A81123	TUBULAR CONDENSER & BRACKET (.05-600V)	R33	686227	CARBON RESISTOR (27,000-1/2-10) INS.
C31	8A81123	TUBULAR CONDENSER & BRACKET (.05-600V)	R34	* 686031	CARBON RESISTOR (100,000-1/2-10) INS.
C32	8A81123	TUBULAR CONDENSER & BRACKET (.05-600V)	R35	686377	CARBON RESISTOR (470,000-1/2-10) INS.
C33	PART OF 19A80869	AIR TRIMMER CONDENSER (RANGE 5-4 1/2 MFD)	R36	* 686031	CARBON RESISTOR (100,000-1/2-10) INS.
C34	21B6572	SILVER MICA CONDENSER (50 MFD) 5%			
C35	21B6572	SILVER MICA CONDENSER (50 MFD) 5%			
C36	PART OF 19A80869	AIR TRIMMER CONDENSER (RANGE 5-4 1/2 MFD)			
C37	21B6574	MOLDED MICA CONDENSER (100 MFD) 10%			
C38	8A81123	TUBULAR CONDENSER & STRAP (.05-600V)			
C39	8A81255	TUBULAR CONDENSER & BRACKET (.05-600V)			
C40	PART OF 19A80869	AIR TRIMMER CONDENSER (RANGE 5-4 1/2 MFD)			
C41	21B6572	SILVER MICA CONDENSER (50 MFD) 5%			
C42	21B6572	SILVER MICA CONDENSER (50 MFD) 5%			
C43	PART OF 19A80869	AIR TRIMMER CONDENSER (RANGE 5-4 1/2 MFD)			
C44	21B6574	MOLDED MICA CONDENSER (100 MFD) 10%			
C45	8A81255	TUBULAR CONDENSER & BRACKET (.05-600V)			
C46	21B6573	SILVER MICA CONDENSER (40 MFD) 5%			
C47	PART OF 19A80869	AIR TRIMMER CONDENSER (RANGE 5-4 1/2 MFD)			
C48	21B6569	MOLDED MICA CONDENSER (500 MFD) 10%			
C49	21B6569	MOLDED MICA CONDENSER (500 MFD) 10%			
C50	21B6573	SILVER MICA CONDENSER (40 MFD) 5%			
C51	PART OF 19A80869	AIR TRIMMER CONDENSER (RANGE 5-4 1/2 MFD)			
C52	21B6568	MOLDED MICA CONDENSER (2000 MFD) 10%			
C53	8A81255	TUBULAR CONDENSER & BRACKET (.05-600V)			
C54	21B6568	MOLDED MICA CONDENSER (2000 MFD) 10%			
C55	21B6567	MOLDED MICA CONDENSER (5000 MFD) 10%			
C56	PART OF 23A81256	ELECTROLYTIC CONDENSER (15/250V)			
C57	21B6567	MOLDED MICA CONDENSER (5000 MFD) 10%			
C58	21B6567	MOLDED MICA CONDENSER (5000 MFD) 10%			
C59	8A81255	TUBULAR CONDENSER & BRACKET (.05-600V)			
C60	8A81255	TUBULAR CONDENSER & BRACKET (.05-600V)			
C61	PART OF 23A81256	ELECTROLYTIC CONDENSER (15/250V)			
C62	21B6567	MOLDED MICA CONDENSER (5000 MFD) 10%			
C63	21B6567	MOLDED MICA CONDENSER (5000 MFD) 10%			
C64	21B6569	MOLDED MICA CONDENSER (500 MFD) 10%			
C65	PART OF 23A81256	ELECTROLYTIC CONDENSER (20/25V)			
C66	21B6567	MOLDED MICA CONDENSER (5000 MFD) 10%			
C67					
C68					
C69					
C70					
C71					
C72	21B6568	MOLDED MICA CONDENSER (2000 MFD) 10%			
R1	686031	CARBON RESISTOR (100,000-1/2-10) INS.	XTAL1	48XB1487	M.F. CRYSTAL (FREQ. DEPENDS ON CHANNEL ASSIGNED)
R2	686432	CARBON RESISTOR (270-1/2-10) INS.	XTAL2	48XB1488	L.F. CRYSTAL (4755 KC)
R3	686074	CARBON RESISTOR (68,000-1/2-10) INS.	SW1	40A81254	METER SWITCH (SPST)

* NOTE: R34 & R36 MUST BE MATCHED RESISTORS

R37 686046 CARBON RESISTOR (1 MEG-1/2-10) INS.
R38 686046 CARBON RESISTOR (1 MEG-1/2-10) INS.
R39 686377 CARBON RESISTOR (470,000-1/2-10) INS.
R40 686231 CARBON RESISTOR (15,000-1/2-10) INS.
R41 686046 CARBON RESISTOR (1 MEG-1/2-10) INS.
R42 686046 CARBON RESISTOR (1 MEG-1/2-10) INS.
R43 686046 CARBON RESISTOR (1 MEG-1/2-10) INS.
R44 686046 CARBON RESISTOR (1 MEG-1/2-10) INS.
R45 686260 CARBON RESISTOR (1.5 MEG-1/2-10) INS.
R46 686000 CARBON RESISTOR (47,000-1/2-10) INS.
R47 686462 CARBON RESISTOR (47,000-1/2-10) INS.
R48 686414 CARBON RESISTOR (270,000-1/2-10) INS.
R49 686429 CARBON RESISTOR (820,000-1/2-10) INS.
R50 686407 CARBON RESISTOR (220,000-1/2-10) INS.
R51 686433 CARBON RESISTOR (2.2 MEG-1/2-10) INS.
R52 686327 CARBON RESISTOR (1,000-1/2-10) INS.
R53 686000 CARBON RESISTOR (47,000-1/2-10) INS.

L1 21A81270 ANTENNA PRIMARY COIL
L2 21A81272 ANTENNA SECONDARY COIL
L3 21A81278 NOISE AMPLIFIER COIL & CONDENSER
L4 25B81258 AUDIO CHOKE
L5 25B81258 AUDIO CHOKE
L6 25B81258 AUDIO CHOKE
L7 25B81258 AUDIO CHOKE

T1R 1X81311 OSC. COIL & SHIELD ASSEMBLY
T2R 1X81312 R.F. COIL & SHIELD ASSEMBLY
T3R 1X81313 I.F. COIL & SHIELD ASSEMBLY
T4R 1X81314 I.F. COIL & SHIELD ASSEMBLY
T5R 1X81315 I.F. COIL & SHIELD ASSEMBLY
T6R 1X81316 I.F. COIL & SHIELD ASSEMBLY
T7R 1X81317 I.F. COIL & SHIELD ASSEMBLY
T8R 1X81318 DISCRIMINATOR COIL & SHIELD ASSEMBLY

T1 25B81259 OUTPUT TRANSFORMER
T2 25B81263 LINE MATCHING TRANSFORMER

J1 9A20261 SINGLE CIRCUIT OPEN JACK

SW1 40A81254 METER SWITCH (SPST)

COMPLETE LIST OF PARTS, GIVING VALUES, SPECIFIED IN THE WIRING DIAGRAM, FIG. 2

where it runs through holes in the car frame or over seat guides.

Insert the cable plugs. The control cable plug pins are color coded and are to be plugged into the back of the control head.

The A battery power lead should be dressed up to the control head and plugged in. The

ground lead of the receiver end should be short and direct to car frame.

The antenna lead is a piece of co-axial line, insulated with Polystyrene beads, and should be connected so that no sharp bends occur. The ground should be firm at both ends. A

(CONTINUED ON PAGE 42)

1-KW. BROADCAST TRANSMITTER

REL Unit for Use at a 250- to 1,000-Watt FM Station, or as a Driver for a 10-kw. Power Amplifier

BY FRANK A. GUNTHER*

THE subject of transmitter failures is one which is generally shunned by engineers who operate radio equipment and those who design it, for they are an anathema to both. As such, while they are known to occur, they are rarely mentioned.

Actually, though, a failure is only as serious as the time required to correct it. Considered in those terms, the responsibility is passed from the operating force back to the manufacturer, where it really belongs.

In designing the new series of units which comprise the REL line of FM transmitters we have, therefore, made the matter of maintenance a prime factor of mechanical design.

In the days when transmitters first graduated from spread-out assemblies to rack-and-panel units, accessibility was sacrificed for compactness of design, because appearance had become a sales factor. During those years, rapid strides were being made and new models were replaced with newer ones. Thus, obsolescence relieved station operators of some of the more serious errors in earlier mechanical designs.

Still, it was not unusual, when a minor part gave way, to have a transmitter off the air for whatever length of time was required to remove major components and wiring before the repair or replacement could be made.

Now, components have been improved to the extent that a failure is rare indeed. Circuits have been stabilized to the point where modern transmitters are expected to serve for an indefinite number of years. It would almost seem, then, that accessibility for purposes of maintenance is less important than in previous designs. And therein lies a point of danger.

Parts do break down, still, sometimes from fatigue over long periods of use, sometimes because of inherent weaknesses which could not be detected in the initial inspection before they were put into service.

* Vice president in charge of engineering, Radio Engineering Laboratories, Inc., Long Island City, N. Y.

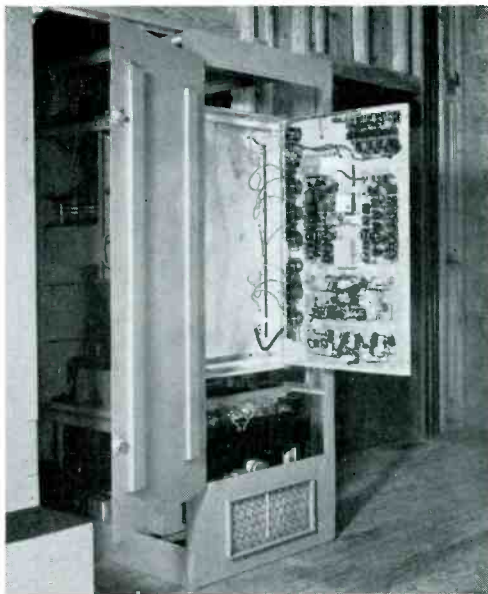

FIG. 1. FM MODULATOR UNITY SWUNG OUT OF THE CABINET TO GIVE ACCESS TO THE COMPONENTS

Because transmitters are in service for a greater number of hours a day, and because they will not be replaced for many years to come, allowance must be made for such failures and their quick correction. The very unexpectedness of trouble makes ease of correction doubly important.

An examination of the accompanying illustrations will show how this policy of design was applied to the REL type 518-DL FM transmitter of 250 to 1,000 watts output.

The front of the transmitter is protected by a main front door. This has been removed in Fig. 2, giving access to the control knobs, yet affording complete protection to the operator. With the inner door open, Fig. 3, parts at the front can be reached which are not accessible from either side.

The side views, Figs. 4 and 5, show the method of construction more clearly. The components are grouped in small, removable sub-assemblies, mounted on welded angle supports. These sub-assemblies are so arranged that there is ample space around each one for reaching all parts of the adjacent ones. Furthermore, the grouping of components on these separate units has been planned so that there is no waste of space. Neither is mechanical advantage gained at the sacrifice of electrical efficiency.

Great structural strength has been achieved, too, since welding has replaced bolts and screws entirely in the assembly of all the framework.

The new Armstrong phase-shift modulator is built into the transmitter as a completely separate group of sub-assemblies. This is

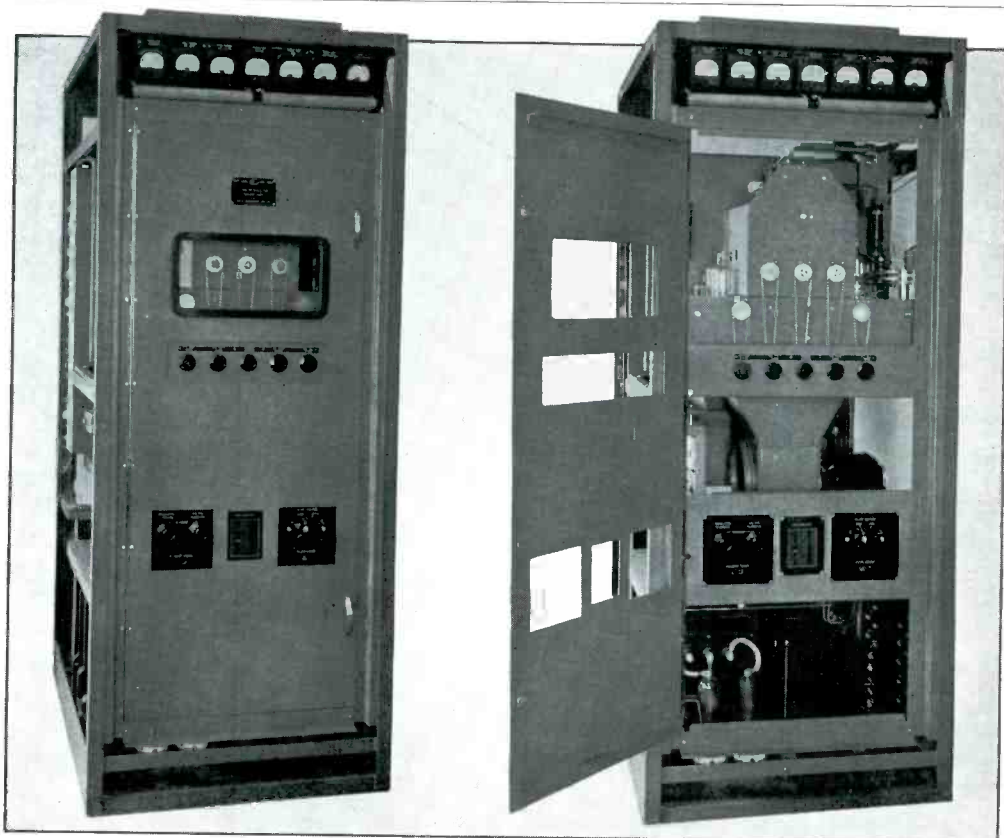

FIG. 2, LEFT. FRONT STEEL DOOR AND SIDE PLATE REMOVED. FIG. 3, RIGHT. AN INNER PROTECTIVE DOOR PROVIDES QUICK ACCESS TO COMPONENTS AT THE FRONT

shown in Figs. 1 and 6. In the latter illustration, the rear plate of the transmitter has been removed as well as the protective door of the modulator cabinet. In Fig. 1, the panel which carries all the modulator unit components has been swung out, exposing all the parts and wiring behind the panel. This particular photograph was taken at W45CM, Columbus, when their 10-kw. transmitter was being set up. Here, again, every part has been arranged so that it can be removed without disturbing any other circuit element.

In this manner, provision has been made for the quickest possible correction of any fault which may occur over a period of many years of service on the air.

The audio input enters the lower portion of the modulator at zero level, 500 ohms for program type of modulation. Every tube employed in the modulator unit, except those in the last two stages, is a standard receiving type, operated at normal voltages. No counter-bias arrangements are used. The last two stages employ Heintz-Kaufman type 24

triodes, one as a doubler and the second as the final output tripler stage. The output circuit of this is tuned to the operating frequency.

The complete description of the No. 558 phase-shift modulator unit will be given in detail in a separate story at a later date.

Every precaution dictated by long experience is used to assure noise-free operation. Critical circuits make use of automatically regulated plate supply voltage and a Selenium rectifier for DC operation of the heaters. The modulator output power, of between 20 and 30 Watts, is coupled to the intermediate power amplifier by means of two $\frac{3}{8}$ -in. concentric lines.

The I.P.A. consists of two Heintz-Kaufman No. 257 pentode amplifiers in push-pull. The plate supply of the power amplifier also supplies the I.P.A. Reference to Fig. 4 will show how the grid and plate circuits of this high gain amplifier are isolated by shielding from each other.

Link coupling transfers the I.P.A. output over to the P.A. grid circuit. Fig. 5 shows the

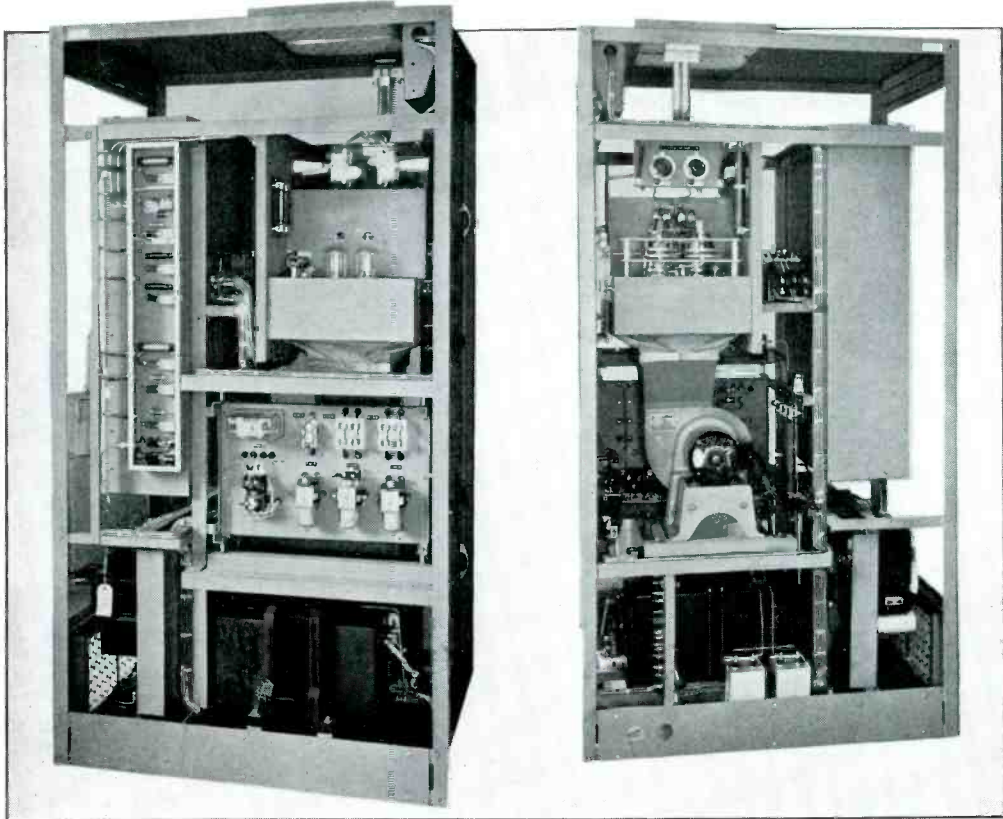

FIG. 4, LEFT. VERTICAL BOX CONTAINS FILTER TO KEEP EXTRANEOUS VOLTAGES FROM MODULATOR CIRCUITS. FIG. 5, RIGHT. SHOWING ARRANGEMENT OF BLOWER AND MODULATOR

details of the power amplifier. Again the grid circuits are completely shielded. This stage uses two of the phenomenally efficient Eimac 304TL's in push-pull. This final tank and output link are shown right at the top of the tubes. Above these are the line-tuning condensers and finally the two $\frac{7}{8}$ -in. output coupling lines. These are employed whether the output is fed directly into an antenna or used to drive the grids of a 10-kw. amplifier.

Directly in front of the 304TL's are the neutralizing condensers. The circuit is so stable that once these are adjusted and locked during the factory tests, they need never be adjusted. Their position remains unchanged even when the tubes are replaced.

The bottom of Fig. 4 shows the I.P.A. and P.A. plate transformer. Two No. 827A rectifiers are used in a full wave circuit. The bottom of Fig. 5 shows the rectifier sockets and the two-section filter consisting of the large chokes and the two condensers in the foreground.

The transmitter is regularly supplied to operate from 220 volts, 60-cycle single phase

mains. The large plate transformer is primary-tapped so that it will deliver 1250/1375/1500 DC at 1.7 amps. at the output of the filter. A switch is shown on the lower right of Fig. 1. This permits changes of the plate voltage instantly, without any perceptible interruption in service to the listener. In this manner, power can be reduced, if necessary, to take care of ice formations on the antenna, trouble in the power tubes, or any such emergency. The I.P.A. operates on whatever voltage is selected for the P.A. Thus, if 1,250 volts are selected to assure sufficient output from the P.A., then the I.P.A. will deliver more than sufficient excitation when operating with this same 1,250 volts on its plate.

The power amplifier operates at approximately 65% efficiency in the FM broadcast band of 40 to 50 mc. Here, for the first time, is a transmitter for this service that delivers 1 kw. output with only 1,375 volts on the plates. This is the highest voltage in the entire transmitter, adding greatly to the safety of personnel, condensers, resistors, rectifier and transformers.

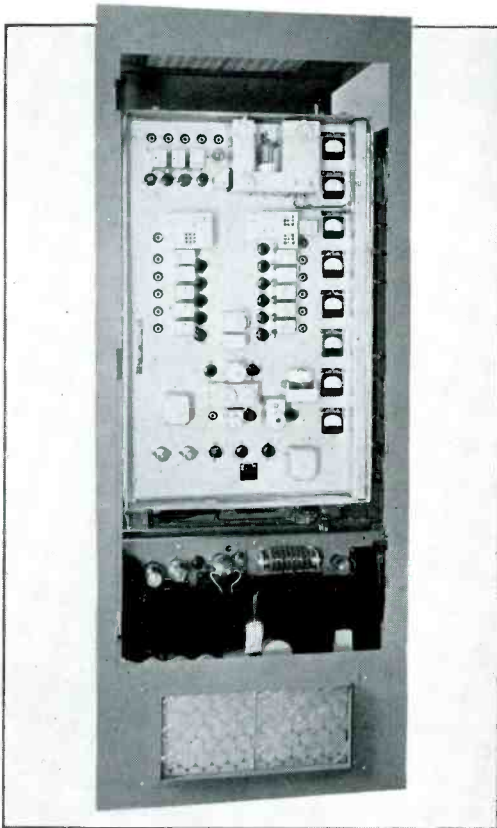

FIG. 6. HK-24'S ARE IN RECESS AT TOP. DOOR OF MODULATOR UNIT HAS BEEN REMOVED. NOTE SPUN GLASS FILTER FOR AIR INTAKE

The entire transmitter is enclosed by steel plates except for the intake and exhaust ducts which are protected by removable spun glass filters. Overall air circulation and cooling for the large tubes is furnished by a Sturdevant 1/20-H.P. motor blower. This is shown clearly in Fig. 5. This is shock mounted on four Lord-type units, in a similar manner to the relay panel mounting. Cool air from this blower flows through the canvas duct, shown above it, directly to the tube bases. This canvas coupling protects the tubes from any mechanical vibration in the blower. Bypass holes permit some of the air to reach the glass sides of the tubes as well. Further bypass holes permit part of this air to act as a cooling medium to both I.P.A. and P.A. grid and plate tank circuits.

The main power switch is shown in the center of Fig. 2. This is a two-pole, 25-amp. Westinghouse air circuit-breaker. Separate filament and plate switches are also visible in Fig. 2 as well as the two voltage controls, one

for all the tubes in the modulator unit, and the other for the I.P.A. and P.A. filaments.

Complete time-delay starting control is supplied so that the entire transmitter may be started and stopped from a remote position such as a control desk. When the time-delay relay is energized, it first applies filament current to all the tubes, and plate voltage to the tubes in the modulator unit. Then, when it finally closes, plate voltage is applied to the I.P.A. and P.A. tubes and the station is on the air.

The I.P.A. and P.A. circuits have individual plate overload relays. If either relay opens, the power is cut off both sections because the main magnetic switch is opened. Then, after 1 to 2 seconds, the recycling relay closes the main power switch and plate voltage is reapplied to the I.P.A. and P.A. tubes.

The recycling relay can be adjusted for a sequence of 1 to 30 seconds. It is a Westinghouse motor-driven unit, mounted in a glass case. In Fig. 4 it can be seen at the lower left hand corner of the relay panel.

The measured RMS harmonic distortion in this transmitter is less than 1% for all signal frequencies between 50 and 15,000 cycles at 75 kc. deviation. The signal-to-noise ratio is better than 70 db, measured at the output of a monitor receiver. This is an unweighted measurement, with 150-ke. total swing, and includes hum. Overall audio response is within 1 db from 30 to 15,000 cycles.

The outside dimensions¹ of the transmitter cabinet are: 31½ ins. wide, 76 ins. high and 38¼ ins. deep.

¹ Dimension drawings of this unit and of the 10- and 50-kw. amplifiers were shown in *FM Magazine*, June, 1941.

A CORRECTION OF SR&D

"Standard Rate & Data" recently carried a notice to the effect that mail addressed to *FM Magazine* at Newton, Mass., had been returned. That, of course, was the correct address until last August, when *FM* moved to its present location at 112 East 36th Street, New York City.

Such a notice implies that a magazine has suspended publication. It is hard to understand how an organization upon which advertisers and agencies depend for accurate information could publish a notice of this sort without investigation. The Newton post office may have made a mistake on a single letter, but mail is forwarded daily to the New York office from readers who take the address from back issues.

At least, SR&D was prompt in correcting this error when it was brought to their attention.

STROMBERG MODEL 535 A-FM SERIES

535 Series Combines the 530 Chassis with Separate FM Tuner*

THE No. 535 receivers are fifteen tube receivers providing reception of both AM and FM stations. The "Armstrong Wide-Swing Frequency Modulation System" is used.

Six button automatic tuning is provided.

Separate continuously variable bass and treble controls are provided in these chassis.

The No. 535-PG, PL and PS receivers are equipped with record players using a one-ounce sapphire pickup in conjunction with specially equalized circuits. The record player shifts and plays the standard 10-in. or 12-in. records. The records may be intermixed on the No. 535-PG and PS Receivers.

Voltage:

105-125 volts, 60 cycles

NOTE: 25-cycle models also available

Input Power Rating:

130 to 155 watts

Tuning Range:

Broadcast, 540 to 1,600 kc.

Medium wave, 1.6 to 3.6 mc.

Short wave, 5.7 to 18 mc.

FM, 42 to 50 mc.

Intermediate frequency:

AM, 455 kc.

FM, 4.3 mc.

Speaker field: 610 ohms

Voice Coil: 11 ohms

FM Alignment ★ All alignment adjustments are made at the factory. Alignment should not be attempted in the field unless absolutely necessary. In that case, the following instruments will be required:

1. Standard signal generator with sweep circuit.
2. Wide band sweep signal generator.
3. Oscillograph.
4. Microammeter, 0-200 microamps.
5. Center 0 microammeter, 100 microamps.

INTERMEDIATE FREQUENCY ADJUSTMENTS

NOTE: All IF adjustments are made using a wide band sweep signal generator with a sweep circuit of plus or minus 300 kilocycles.

1. Push in the FM button.
2. Tune the set to the extreme high frequency end of the dial (50 megacycles).
3. Connect the 0-200 microammeter across the R-17 4700-ohm resistor. (This resistor is mounted on the terminal strip located on the side of the base.)
4. Connect the oscillograph between ground and the junction of C-43 .01-mf. capacitor and R-26 100,000-ohm resistor located on the

same terminal strip with the R-17 resistor.

5. Connect the ground terminal of the wide band sweep signal generator to the ground terminal of the 6AC7 second IF tube socket.

6. Introduce a signal of 4.3 megacycles to the grid of the 6AC7 second IF tube socket (terminal No. 4), using a 0.1 capacitor in series with the output lead of the signal generator. Keep the 0 to 200 microammeter at approximately 100 microamps.

7. Adjust the secondary and primary of the third IF transformer for maximum reading on the 0 to 200 microammeter.

8. Connect the output lead of the wide band sweep signal generator and the 0.1 microfarad capacitor in series with it to the grid of the 6AB7 first IF tube socket (terminal No. 4).

9. Connect the ground lead of the signal generator to the ground terminal of the 6AB7 first IF tube socket.

10. Adjust the second IF transformer in the same manner.

11. Connect the output lead of the wide band sweep signal generator with the 0.1 microfarad capacitor in series with it to the grid of the 6SA7 Modulator and Oscillator tube (terminal No. 8).

12. Connect the ground terminal of the signal generator to the ground terminal of the 6SA7 tube socket.

13. Adjust the first IF transformer in the same manner.

DISCRIMINATOR ADJUSTMENT

1. Connect the ground terminal of the standard unmodulated signal generator to the ground terminal of the 6AB7 first IF tube socket.

2. Connect the output lead of the unmodulated standard signal generator to the grid of the 6AB7 first IF tube (terminal No. 4), using a 0.1 microfarad capacitor in series with the output lead of the standard signal generator, leaving the wide band sweep signal generator connected to the grid of the 6SA7 Modulator and Oscillator tube socket.

3. Adjust the attenuator of the wide band sweep signal generator for a curve on the oscillograph.

4. Set the frequency of the unmodulated standard signal generator to approximately 4.3 megacycles and adjust the attenuator for interference patterns on the oscillograph. Adjust the unmodulated standard signal generator frequency until interference patterns on each trace come together. (This is done in order to assure that the frequency of the

*Data presented is from the official Stromberg-Carlson Manual.

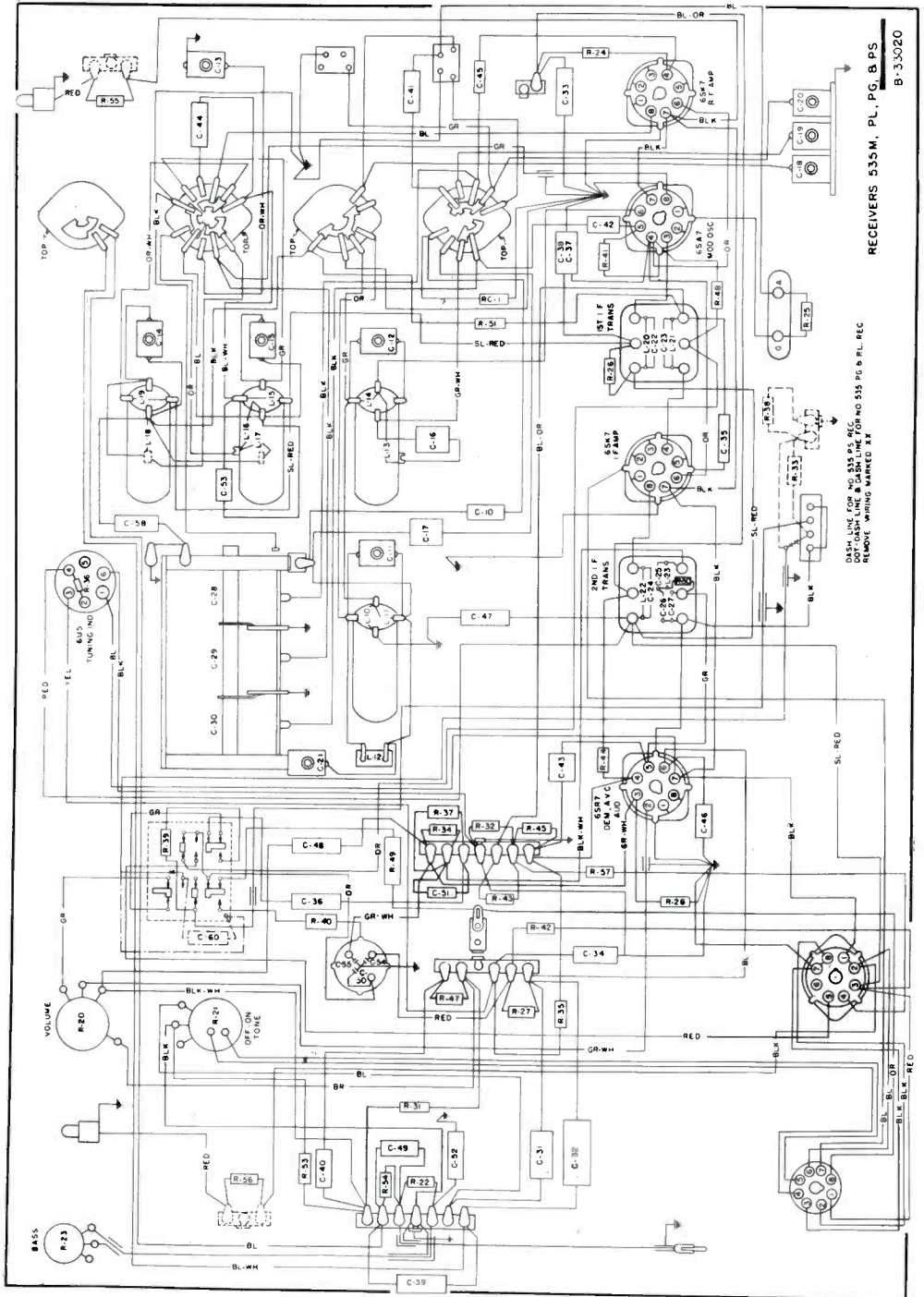

RECEIVERS 535M, PL. PG. 8 P.S. B-33020

PICTURE DIAGRAM OF THE 535 STROMBERG AM CHASSIS USED WITH THE FM TUNING UNIT. THE POWER SUPPLY IS A SEPARATE ASSEMBLY, AS INDICATED IN THE DIAGRAM OPPOSITE

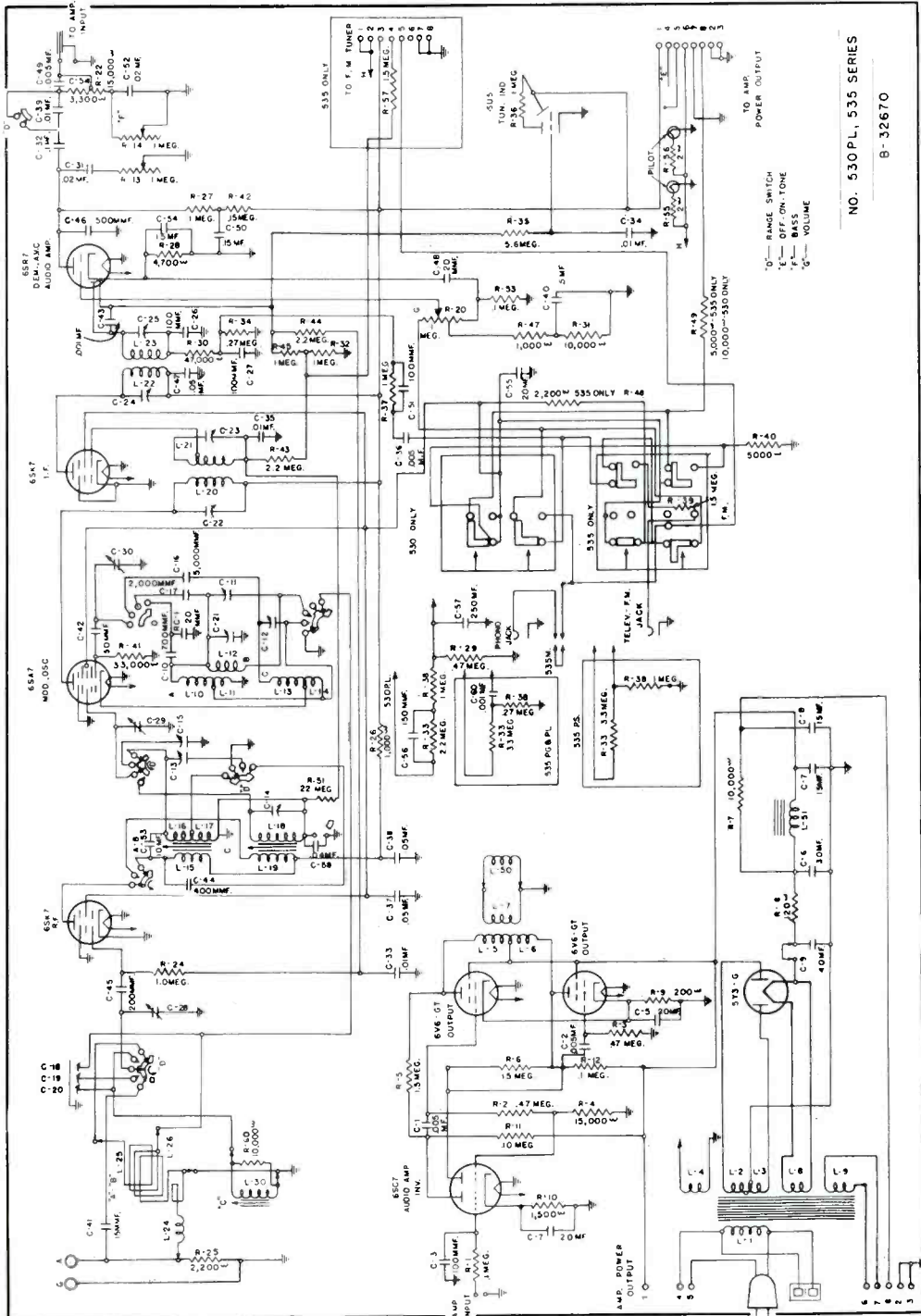

NO. 530 PL. 535 SERIES
B-32670

10- RANGE SWITCH
 11- TUNING TONE
 12- BASS
 13- VOLUME

SCHEMATIC WIRING DIAGRAM OF THE AM SECTION AND POWER SUPPLY. CONNECTIONS TO FM TUNING UNIT ARE AT THE RIGHT OF THE DIAGRAM

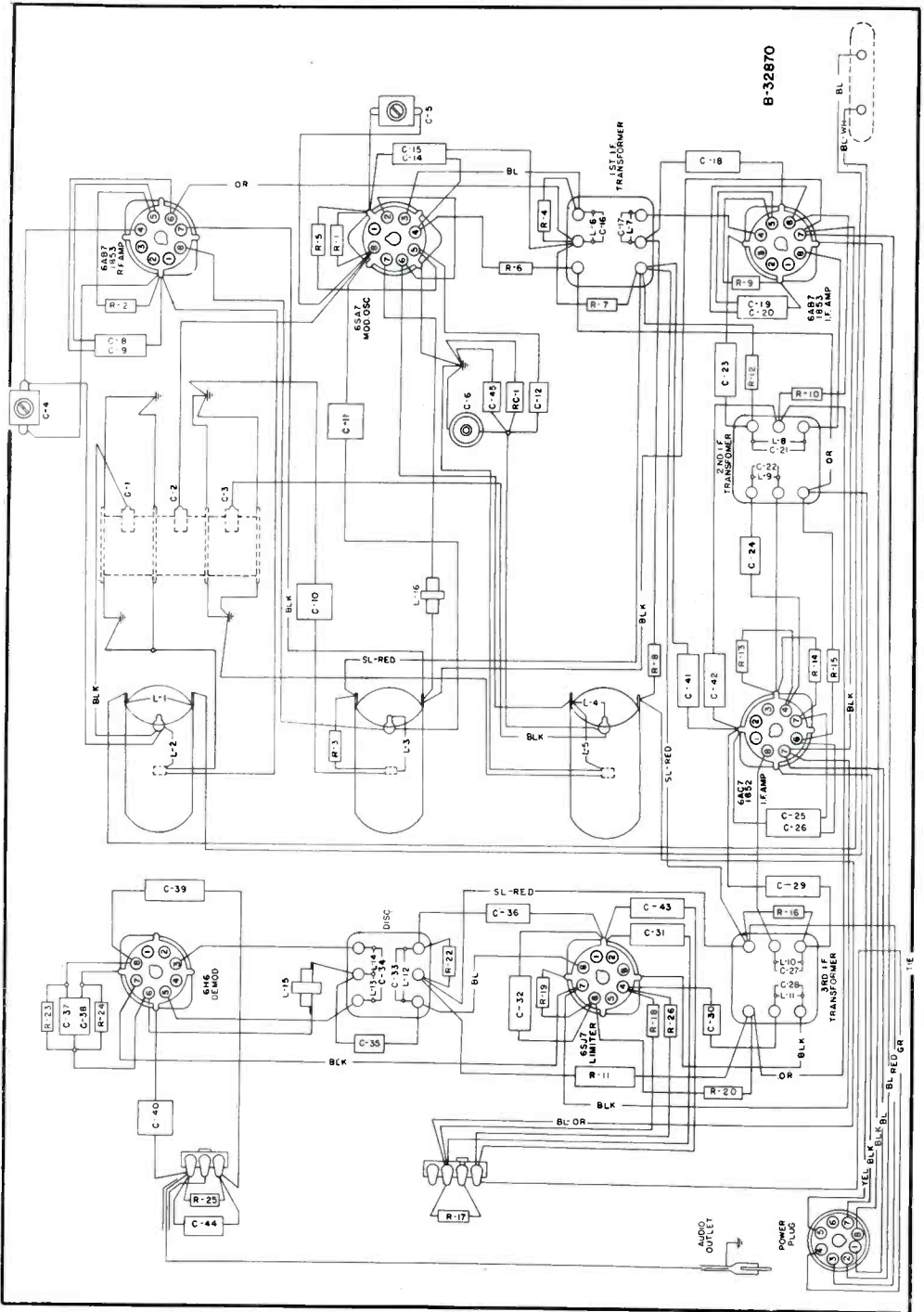

PICTURE DIAGRAM OF THE FM TUNING UNIT. PLUG CONNECTOR GOES TO AM CHASSIS FOR CONNECTION TO THE AUDIO OUTPUT AMPLIFIER. SCHEMATIC DIAGRAM IS ON OPPOSITE PAGE

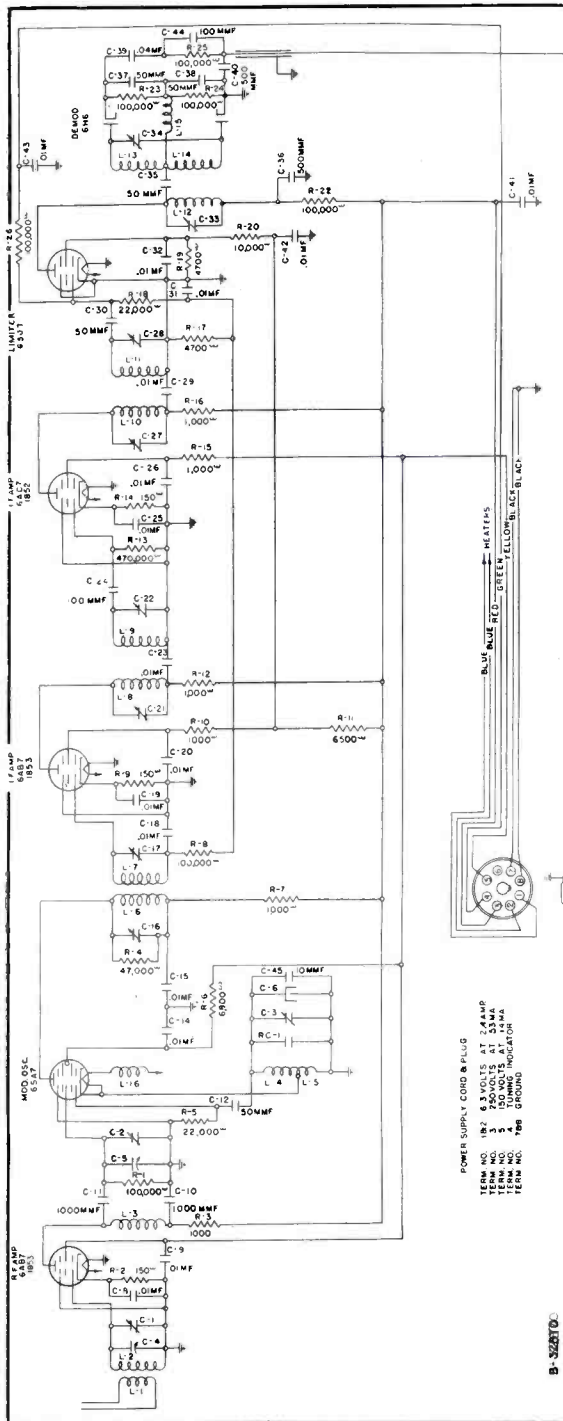

SCHEMATIC WIRING DIAGRAM OF THE FM TUNING UNIT IN THE STROMBERG MODEL 535

standard signal generator which is used to align the discriminator coincides with the mean frequency of the wide band sweep generator.)

5. Remove the wide band sweep signal generator.

6. Connect the center "0" microammeter with a .5 megohm resistor in series across one-half of the discriminator load. (From ground to the junction of the two .1 megohm resistors R-23 and R-24.)

7. Set the attenuator of the standard signal generator for maximum output.

8. Adjust the primary of the discriminator transformer for maximum reading on the center "0" microammeter.

9. Connect the center "0" microammeter and the .5 megohm resistor in series with it across the whole discriminator load. (From ground to the junction of R-23 .1 megohm resistor and C-29 .04 mf. capacitor.)

10. Adjust the secondary of the discriminator transformer for center "0" reading of the microammeter.

11. Vary the frequency of the standard signal generator, making sure that the voltage peaks, which should be of the same magnitude, are the same number of kilocycles off on either side of resonance. Any departure from these conditions may be corrected by a slight readjustment of the primary.

NOTE: Connect the wide band sweep signal generator to the grid of the 6SA7 Modulator and Oscillator tube socket and make slight readjustments of the IF transformers for proper curve, since there is some interaction between these stages and the discriminator.

RADIO FREQUENCY ADJUSTMENTS

1. Set the signal generator frequency and the receiver tuning dial to 48.5 megacycles.

2. Replace the 0.1 microfarad capacitor in series with the output lead from the signal generator with a 100-ohm resistor and connect it to one of the FM terminals on the back of the chassis.

3. Connect the ground lead of the signal generator to the other FM terminal.

4. Adjust the oscillator aligner (air trimmer) for maximum signal.

5. Adjust the R.F. and antenna aligners for maximum signal on the 0 to 200 microammeter, maintaining the center "0" microammeter at "0" at all times by rotating the receiver dial slightly back and forth.

RADIO DESIGN PRACTICE

Items about New Designs
and News about Designers

Cabinet Materials: According to Paul B. Leverette of GE's plastics department at Pittsfield, Mass.: "Cabinet and decorative uses account for by far the larger volume of plastics materials. Phenolic and urea plastics are principally used for this application and national defense has created a shortage of both for this purpose. At present, there is no alternative in plastics which is not just as short in supply and therefore the only answer for cabinets and control knobs during the shortage seems to be a return to wood."

Canadian Air Force: Specified range of ambient temperature from -50° to $+160^{\circ}$ F. for operation of REL type mobile FM emergency equipment. Data on this apparatus was published in the last issue of *FM Magazine*.

FM Stamina: According to Jim Millen of James Millen Manufacturing Corp.: "One of two . . . cars, on the trail of speeding suspects, crashed into a telegraph pole and was completely demolished. The officers were hurt, but able to use their 2-way FM equipment, which was still working, to communicate with their companion car. That's just one example of the punishment that FM apparatus is taking in service ranging from police cars to Army tanks. Experience shows that AM equipment does not stand up as well under comparable circumstances. This is in spite of the fact that FM mechanical design has not been refined to the extent that it will be as soon as production of present models begins to catch up with orders."

Condensers: Aerovox is producing compensating capacitors of predetermined temperature coefficients, from $-.005\%$ to $+.005\%$ per degree C. Known as type K capacitors, they are supplied only in low-loss, yellow XM Bakelite.

They are available in a limited range of capacities and voltage ratings. Specifications for these units are available on request, in accordance with capacity, voltage and temperature coefficient requirements for individual applications. They are suited for use in circuits which must be held to very close limits in equipment exposed to wide variations of ambient temperatures.

Multipliers: A new series of sealed precision voltmeter multipliers has been brought out by International Resistance Company. Hermetically sealed in glazed ceramic tubes, they are unaffected by immersion in salt water. Dimensions meet existing government specifications. Terminals are Monel metal ferrules. Smaller type is $4\frac{5}{16}$ ins. long, of 1, 1.5, 2, 2.5 and 3 megohms, for 1, 1.5, 2, 2.5 and 3 kilovolts respectively. Larger type is $8\frac{1}{16}$ ins. long, of 3.5, 4, 4.5 and 5 megohms, for 3.5, 4, 4.5 and 5 kilovolts respectively.

A-FM Set Ratings: November issue of Consumers Union Reports gives their ideas of ratings of current A-FM radio receivers.

Meters: Shortage of Al-ni-co steel has not affected manufacturers of electrical measuring instruments who considered its use but did not adopt it. Instead, they kept to tungsten and cobalt steels for permanent magnets, a fortunate decision, since there is a sufficient supply of these, even under present peak demands.

Disc Resistors: In a variety of sizes and resistance values are now produced by International Resistance Company. They are designed for use in loading low-power concentric transmission lines, for high frequency measuring

(CONTINUED ON PAGE 47)



THE STAFF AT W65H HARTFORD, RESPONSIBLE FOR THE PLANNING AND DESIGN OF THIS VERY SUCCESSFUL FM STATION. MUCH OF THE EXPERIMENTAL DEVELOPMENT OF FM RELAY CIRCUITS HAS BEEN CARRIED ON BETWEEN W2XMN ALPINE AND STATION W65H

FM FIGHTS ABROAD, SERVES AT HOME

(CONTINUED FROM PAGE 5)

have the further advantage of using his FM inventions.

Defense at home is giving great impetus to the use of FM. Michigan has been added to the list of states using networks of FM main station transmitters operating with patrol cars equipped to talk back to headquarters

fixed FM communications systems that are being set up, because of their military nature, but an account of this application will make an engineering romance when it can be written.

Of paramount military importance are the various uses to which FM is being put by the tanks and the field service of the Signal Corps.

Meanwhile, FM progresses on other fronts. At this time of writing, Capitol Broadcasting Company is installing the first ST link. It will

TWO INTERESTING WINDOW DISPLAYS WHICH FEATURE A-FM RECEIVERS. THE ONE AT THE RIGHT IS PARTICULARLY APROPOS AT THIS TIME WHEN THE UNITED STATES HAS BEEN DRAWN INTO THE WAR

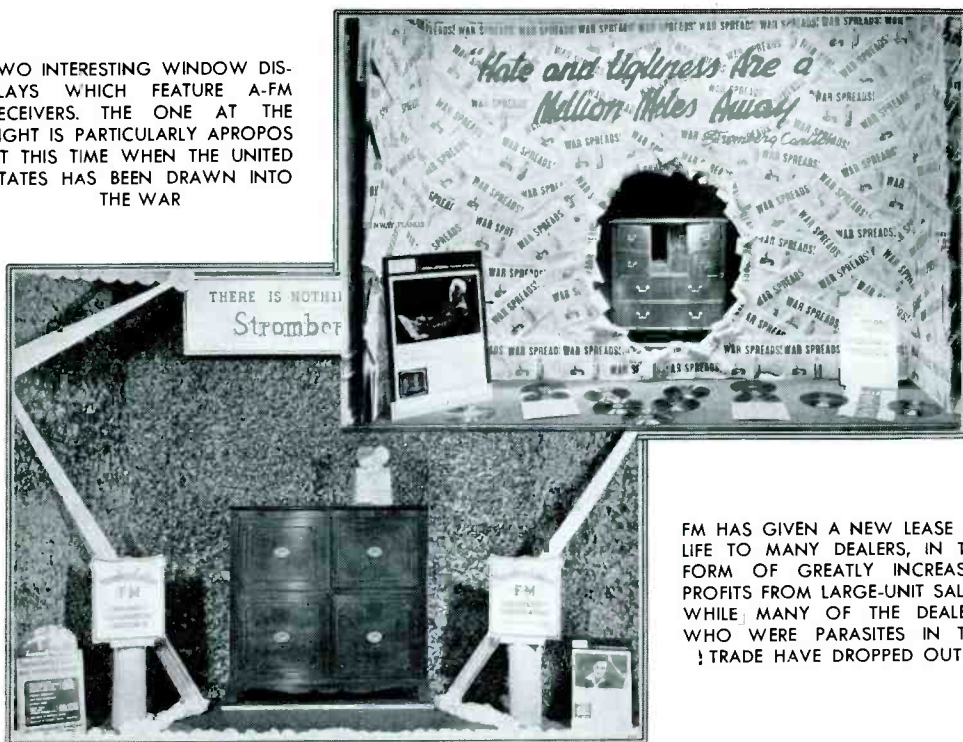

FM HAS GIVEN A NEW LEASE OF LIFE TO MANY DEALERS, IN THE FORM OF GREATLY INCREASED PROFITS FROM LARGE-UNIT SALES, WHILE MANY OF THE DEALERS WHO WERE PARASITES IN THE ! TRADE HAVE DROPPED OUT

and to each other. New Jersey will have awarded a contract for state-wide FM coverage by the time this issue of *FM* is distributed.

Practically all new municipal police installations use FM talk-back equipment, and the complete conversion of present AM systems is only a matter of amortizing the cost of the original apparatus, so that new funds can be obtained.

This is but one of the services, however, on the channels assigned to FM emergency use. A great number of arsenals and vital defense plants are being patrolled by cars equipped with 2-way FM.

The two-car technique used by various law-enforcement agencies owes its effectiveness to the long range and dependability of the new car transmitters and receivers.

Very little can be said about some of the

beam programs by FM from the Schenectady studio to the W47A transmitter, high up in the Hilderberg Mountains.

FM is moving into another field: that of remote pick-up transmission from the scene of action to the broadcast studio or transmitter. FCC regulations require the use of wires wherever they are available. However, some remotes which make the best program material do not allow time for making wire connections, and others must be handled on the move by portable equipment. Remotes handled by AM transmission generally suffer from disadvantageous conditions which often destroy their value to listeners.

The use of FM eliminates disturbing noise and interference, and conveys all the sound color and atmosphere of the action and locale.

(CONTINUED ON PAGE 41)

FM STATIONS

List of Stations for Which C.P. Applications Have Been Filed, and Those Granted up to Nov. 17th

EDITOR'S NOTE: *This FM Station Listing, revised from month to month, is a regular feature of FM Magazine. We ask the cooperation of the Station Managers in correcting any errors or omissions which may appear, due to changes in the status of the stations, modifications, or confusion in the source of information.*

★ Indicates that station is maintaining full program schedule. E Indicates experimental operation. X Indicates that the FCC is withholding action, pending the outcome of the Newspaper-Radio investigation. C Indicates that construction is under way, and station will be on the air shortly.

CALIFORNIA		Los Angeles		IOWA		Cedar Rapids				
K31LA	Columbia B'c'st'g System	47 X	The Gazette Co.							
K37LA	Earle C. Anthony, Inc.					Ashland				
K45LA ★	Don Lee B'c'st'g System 2,600,000					61 X	Ashland Broadcasting Co.			
K49LA	Hughes Tool Company					Lexington				
K53LA	Standard Broadcasting Co.	W51SL	American B'c'st'g Corp. of Ky.							
K61LA	Metro-Goldwyn-Mayer Studios, Inc.					Louisville				
		65 X	Tribune Building Co.	57 X	Lexington Courier-Journal & Times					
		Oakland								
		41 X	The Sun Co. of San Bernardino	LOUISIANA						
		San Francisco		Alexandria						
35	Don Lee Broadcasting System					47 X	Alexandria Broadcasting Co.			
K45SF	Hughes Productions, Inc.					Baton Rouge				
CONNECTICUT		Hartford		W45BR ★	Baton Rouge B'c'st'g Co.	361,400				
W53H E	The Travelers Broadcasting Serv., Inc.					MAINE				
W65H ★	WDRC, Inc.	1,119,000					Falmouth			
DISTRICT OF COLUMBIA								71 X	Portland Broadcasting System	
71	M.A. Leese Radio Corp.							MARYLAND		
ILLINOIS		Chicago		Baltimore						
W47C	WJJD, Inc.					59	Baltimore Radio Show, Inc.			
W51C ★	Zenith Radio Corp.	4,500,000					63 X	The A. S. Abell Co.		
W59C ★	WGN, Inc.	4,500,000					MASSACHUSETTS			
W63C C	National B'c'st'g Co.					Boston				
W67C ★	Columbia B'c'st'g System	4,500,000					35	Columbia Broadcasting System		
W75C ★	Moody Bible Institute	4,500,000					W43B ★	The Yankee Network 6,635,751		
W79C	Oak Park Realty & Amus. Co.					47	Boston Edison Co.			
79	Chicago Federation of Labor					W67B E	Westinghouse Radio Stations, Inc.			
		Cicero						New Bedford		
83	WHFC, Inc.					57 X	E. Anthony & Sons, Inc.			
		Rockford						Springfield		
W71RF X	Rockford Broadcasters, Inc.					W81SP E	Westinghouse Radio Stations, Inc.			
INDIANA		Evansville						Worcester		
W45V ★	Evansville on the Air	465,000					61 X	Worcester Telegram Publishing Co.		
		Fort Wayne						MICHIGAN		
W49FW	Westinghouse Radio Stations, Inc.					Battle Creek				
		Indianapolis						81 X	Federated Publications, Inc.	
53 X	Indianapolis B'c'st'g Co., Inc.									
		South Bend						Detroit		
W71SB X	South Bend Tribune					W45D ★	The Evening News Ass'n	2,498,000		
								W49D ★	John Lord Booth	2,900,000
								W53D	WJR, The Goodwill Station	
								65	James F. Hopkins, Inc.	
								W73D	King Trendle Broadcasting Co.	
								Grand Rapids		
								55	King Trendle Broadcasting Corp.	
								61 X	Federated Publications, Inc.	
								Lansing		
								71 X	Federated Publications, Inc.	
								W77XL	WJIM, Inc.	

I n the considered judgment of leading engineers...

When important decisions are made about vacuum tubes it is not uncommon for an Eimac tube to win the honors. *Reason:* the designers of Eimac tubes have consistently held as their objective the anticipation of the future requirements of the radio industry. Efforts have not been confined to the production of a tube for yesterday's requirements.

This policy has kept Eimac tubes ahead of the industry... a factor that is logical because the efficiency and progress of radio depends almost entirely upon the development of new ideas... new improvements in vacuum tube performance. Take the Eimac 250T, for example, which now possesses the most recently developed refinements. Check these features illustrated below and then check the performance of Eimac tubes in your transmitter. You'll see then why Eimac tubes are to be found in most of the important new developments in radio.

Follow the leaders to **Eimac**
TUBES

Eitel McCullough Inc.
San Bruno, Calif.

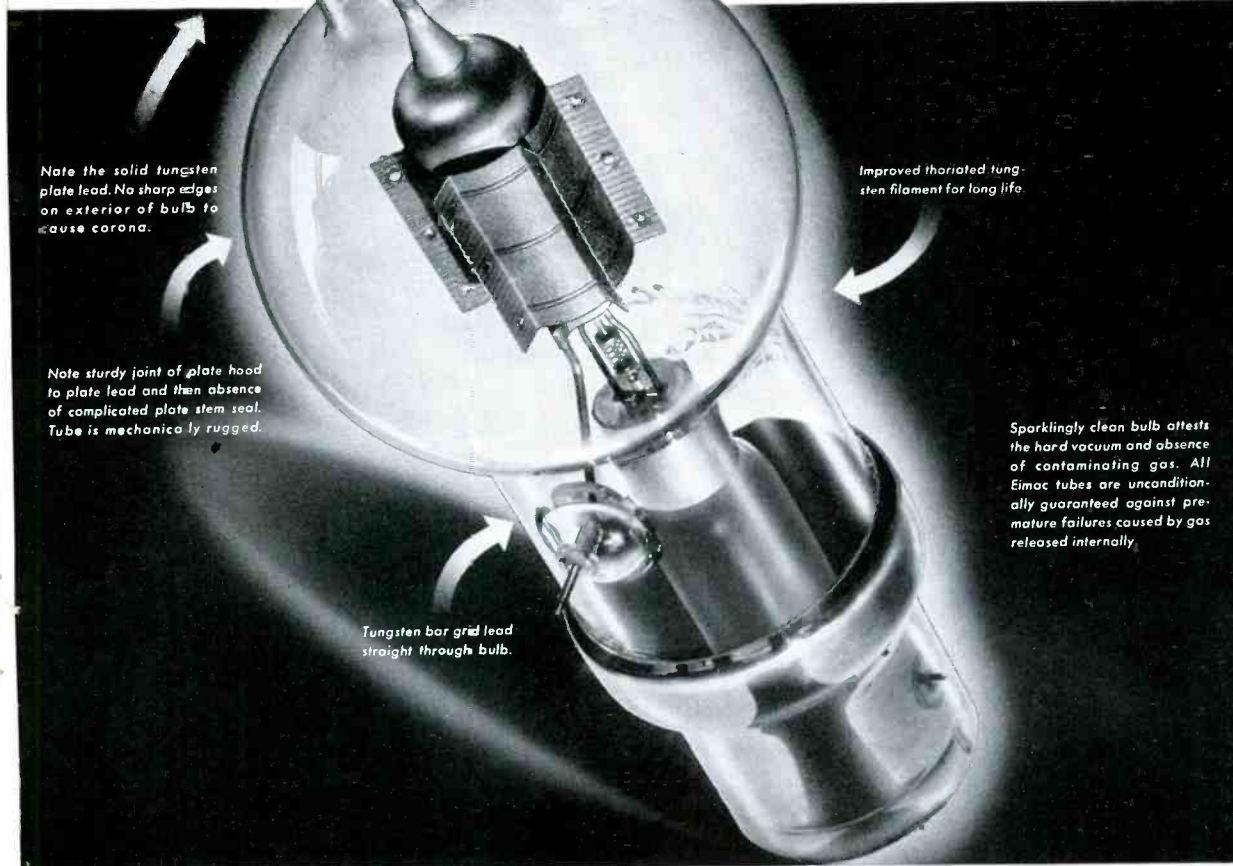

Note the solid tungsten plate lead. No sharp edges on exterior of bulb to cause corona.

Note sturdy joint of plate hood to plate lead and then absence of complicated plate stem seal. Tube is mechanically rugged.

Tungsten bar grid lead straight through bulb.

Improved thoriated tungsten filament for long life.

Sparklingly clean bulb attests the hard vacuum and absence of contaminating gas. All Eimac tubes are unconditionally guaranteed against premature failures caused by gas released internally.

EIMAC REPRESENTATIVES

California, Nevada
HERB BECKER, 1530 W.
104th St., Los Angeles, Cal.
N. Y., N. J., Penn., Md., Del.,
Dist. of Col., Maine, N. H.,
R. I., Conn., Mass.
ADOLPH SCHWARTZ, 262
Grayson Place, Teaneck, New
Jersey.

Wash., Ore., Idaho, Mont.
GENERAL SALES CO.,
Verner O. Jensen, 2605-07
Second Ave., Seattle, Wash.
Colo., Wyo., New Mexico,
Arizona, Utah
RICHARD A. HYDE, 4253
Quitman St., Denver, Colo.

Chicago, Illinois, Wisconsin
G. G. RYAN, 549 W.
Washington Blvd., Chicago,
Ill.
N. Caro., S. Caro., Georgia,
Tenn., Flor., Ala., Miss.
JAMES MILLAR, 316 Ninth
St. N. E., Atlanta, Georgia.

Texas, La., Okla., Ark.
J. EARL SMITH, 2821 Live
Oak St., Dallas, Texas.
Ohio, Mich., Ky., Ind., Minn.,
Mo., Kan., Neb., Iowa
PEEL SALES ENGINEER-
ING CO., E. R. Peel, 154
E. Erie St., Chicago, Ill.

Export Agents: Frazar & Co., Ltd., 301 Clay Street, San Francisco

MISSOURI	Kansas City			Syracuse
K49KC	Commercial Radio Equipment Co.		W63SY	Central N. Y. Broadcasting Co.
	St. Louis			NORTH CAROLINA Winston-Salem
47 X	Star-Times Publishing Co.		W41MM C	Gordon Gray
47 X	Globe-Democrat Publishing Co.		67 X	Piedmont Publishing Co.
K51L	St. Louis University			OHIO
55	The Pulitzer Publishing Co.		85 X	Cleveland
K59L	Columbia Broadcasting System			United Broadcasting Co.
	NEW HAMPSHIRE Mount Washington			Columbus
W39B ★	The Yankee Network	2,000,000	W45CM ★	WBNS, Inc.
				1,100,000
	Manchester			Youngstown
35	The Radio Voice of New Hampshire		35	William F. Maag, Jr.
	NEW JERSEY Ewing Township			PENNSYLVANIA Philadelphia
47 X	Mercer Broadcasting Co.		W49PH C	Pennsylvania Broadcasting Co.
	Newark		W53PH ★	WFIL Broadcasting Corp.
91	N. J. Broadcasting Corp.		W57PH	Westinghouse Radio Stations, Inc.
	NEW YORK Albany		61 X	Gibraltar Service Corp.
51 X	WOKO, Inc.		W69PH ★	WCAU Broadcasting Co.
	New York City		73	Wm. Penn B'c's't'g Co.
W31NY E	Mj. Edwin H. Armstrong	12,200,000	W81PH	Seaboard Radio Broadcasting Corp.
W35NY	Municipal B'c's't'g System			Pittsburgh
W47NY C	Muzak Corporation		W47P ★	Walker-Downing Corp.
W51NY E	National Broadcasting Co.		65	Pittsburgh Radio Supply House
W55NY	William G. H. Finch		W75P	Westinghouse Radio Stations, Inc.
W59NY E	Interstate Broadcasting Co.			Reading
59	Frequency B'c's't'g Corp.		65	Hawley B'c's't'g Co.
W63NY C	Marcus Loew Booking Agency			RHODE ISLAND Providence
W67NY ★	Columbia B'c's't'g System	12,000,000	75	Cherry & Webb Broadcasting Co.
67	Wodaam Corporation		85	The Outlet Company
71	Bremer Broadcasting Corp.			TENNESSEE Nashville
W71NY ★	Bamberger B'c's't'g Service	12,000,000	W47NV ★	National Life & Acc. Ins. Co.
W75NY	Metropolitan Television, Inc.			819,000
79 X	News Syndicate Co., Inc.			TEXAS Amarillo
83	FM Radio Broadcasting Co., Inc.		51 X	Amarillo Broadcasting Corp.
83	Knickerbocker Broadcasting Co.			UTAH Salt Lake City
83	WBXX Broadcasting Co.		K47SL X	Radio Service Corp. of Utah
87	The Debs Memorial Radio Fund, Inc.			WISCONSIN La Crosse
87	Greater N. Y. B'c's't'g Corp.		65 X	La Crosse Tribune Co.
	Frequency Broadcasting Corp.			Milwaukee
	Rochester		W55M ★	The Journal Co.
47 X	WHEC, Inc.			1,522,000
W51R ★	Stromberg-Carlson Tel. Mfg. Co.	585,000		Superior
	Schenectady		45 X	Head of the Lakes Broadcasting Co.
W47A ★	Capitol Broadcasting Co.	967,000		
W57A E	General Electric Co.			

EXPERIMENTAL FM STATIONS CURRENTLY OPERATING

W1XX	Westinghouse Radio Stations, Inc., Hull, Mass.	42	6 mc. 100 w.
W1XSN	Westinghouse Radio Stations, Inc., West Springfield, Mass.	44	6 mc. 1 kw.
W1XSO	The Travelers Broadcasting Service, Hartford, Conn.	43	7 mc. 1 kw.
W1XTG	Worcester Telegram Pub. Co., Inc., Worcester, Mass.	43	4 mc. 1 kw.
W2XMN	Edwin H. Armstrong, Alpine, N. J.	42	8 mc. 40 kw.
W2XOY	General Electric Co., Schenectady, N. Y.	43	2 mc. 2½ kw.
W2XQR	John V. L. Hogan, New York City	43	2 mc. 1 kw.
W2XWG	National Broadcasting Co., New York City	45	1 mc. 1 kw.
W3XMC	McNary & Chambers, Washington, D. C.	42	6 mc. 100 kw.
W3XO	Jansky & Bailey, Washington, D. C.	43	2 mc. 1 kw.
W8XAD	W H E C, Inc., Rochester, N. Y.	42	6 mc. 1 kw.
W9XYH	Head of the Lakes Broadcasting Co., Superior Wisconsin	43	0 mc. 1 kw.
W9XER	Midland Broadcasting Co., Kansas City	46	5 mc. 1½ kw.
W8XFM	Crosley Corporation, Chicago	43	2 mc. 1 kw.

FM FIGHTS ABROAD, SERVES AT HOME

(CONTINUED FROM PAGE 37)

AM broadcasting stations will find many uses for the FM remote pick-up equipment.

Among the new FM stations going on the air, W71NY, the WOR affiliate, has attracted much attention from both listeners and other broadcasters. This station has been on the air with FM since their first 1-kw. transmitter was installed at Carteret, N. J., in August, 1939, operating with the call W2XWI and, later, W2XOR. The transmitter was moved to its present site, 444 Madison Avenue, New York City, in June, 1940. The station shifted to full power, using a 10-kw. Western Electric transmitter, on November 30, 1941.

The day following, CBS, using a temporary antenna and low power, started a regular 6-day schedule on their W67NY. Meanwhile, steel workers have been pushing up the permanent antenna which is making the Salmon Tower Building, at 42nd Street, a Fifth Avenue landmark. The antenna will use radiators designed and built by Federal Telegraph. The transmitter is a G. E. installation.

Coincident with the W71NY inaugural, American delivered its first group of sponsors to a network of seven stations comprising W2XMN and W71NY New York, W65H Hartford, W43B Boston, W39B Mt. Washington, W47A Schenectady, and W53PH Philadelphia. Sponsors were Hat Style Council, Hecker Products, Socony-Vacuum, Swan Soap, and Zenith Radio.

This 7-station network also carried special, live programs originated in New York, Hartford, and Boston. The smooth coordination of the participating stations was a convincing demonstration of the practicability of FM chain operations without wires and their attendant expense. Such a network also has military importance, since it is independent of the wire lines required to join AM stations.

Radio amateurs, evidencing their first interest in the use of FM, must now postpone their plans "for the duration." The order from the FCC, taking all amateurs off the air, will not, we hope, affect the publication of our esteemed contemporary, *QST*. There is much work for amateurs to do in connection with civilian defense, and *QST* should be highly useful in such activities.

In the months to come, our Country will reap the benefits of a government and a social economy that has given encouragement and opportunity to our engineers, inventors, and scientists, and for the commercial development and application of the products of their work. In no other country in the world could Frequency Modulation have attained its present status within the brief time that has elapsed since Major Armstrong's first disclosure of this new means of radio signalling.

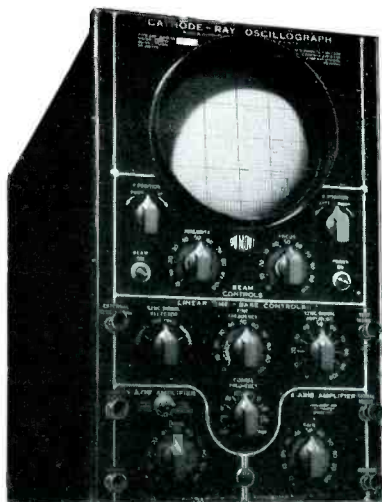

The product of **CATHODE-RAY HEADQUARTERS**

- ★ Replete with features that make your work easier and more pleasant, DuMont Type 208 Cathode-Ray Oscilloscope will extend your investigations into studies not previously feasible without much labor and expense. That is why it has already won the highest endorsements of users.

This oscilloscope is but one of a large line of instruments, cathode-ray tubes and associated equipment developed, produced and marketed by the DuMont organization in a decade of intensive specialization.



- ★ Write for descriptive literature on this and other DuMont products. Submit your cathode-ray problem for engineering aid, recommendations, specifications, quotations.

DUMONT

**ALLEN B. DU MONT
LABORATORIES, Inc.**

Passaic ★ New Jersey

Cable Address: *Wespexlin*, New York

(CONTINUED FROM PAGE 26)

good ground is very essential at each end of the co-axial line to the antenna. It is important that the inner conductor be very securely fastened to the antenna proper.

Insert the cable plugs into chassis as shown in Fig. 1.

Alignment ★ The usual practice of using a voltmeter on the voice coil of an AM receiver to indicate gains and resonance will not be of value in aligning an FM receiver. The output at the speaker depends on frequency swing and

This measurement is important, in that it indicates, in one measurement, that there is sufficient gain, that excessive regeneration is absent, and that amplifier tubes are working normally. In short, it is an overall figure of merit for the receiver.

The actual measurement is made by observing the noise voltage at the speaker without any carrier at the antenna. Then sufficient carrier is introduced at the antenna to reduce the output voltage to 1/10 its former value. The input is then the quieting signal.

Each receiver is tuned and adjusted for its

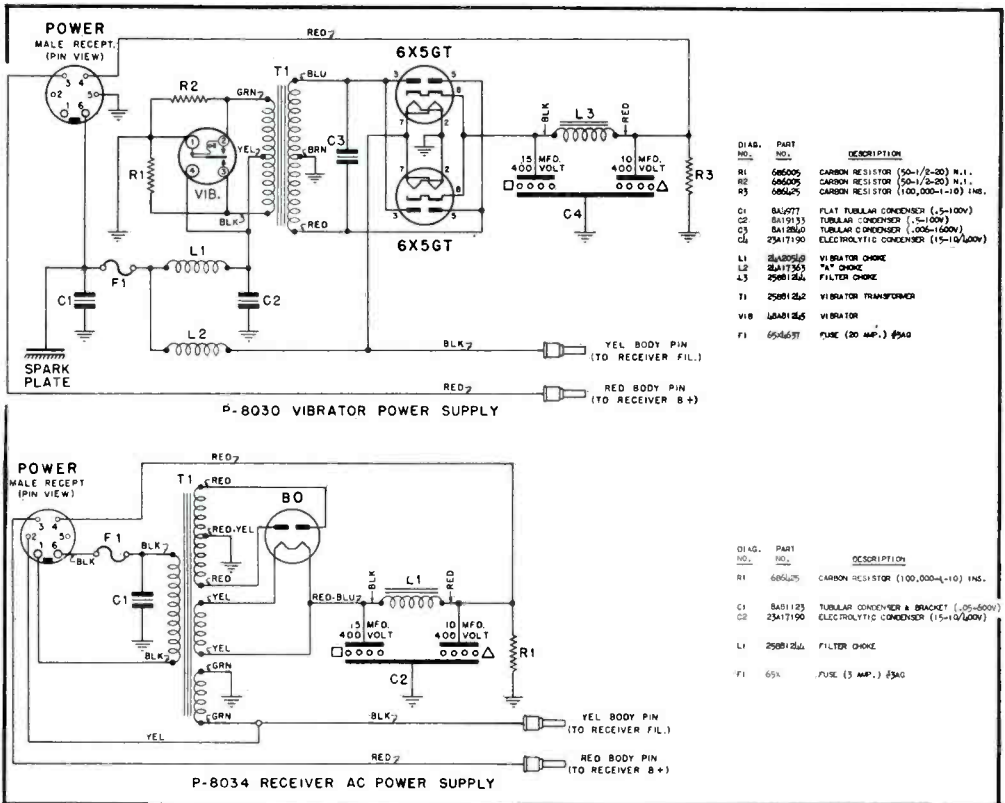

FIG. 3. WIRING DIAGRAMS OF THE BATTERY AND AC-OPERATED POWER SUPPLIES

not on amplification of the carrier. Alignment and gain measurements are carried out in FM work by observing, with a high resistance voltmeter or series microammeter, the voltage, or current, developed by grid rectification in the limiters. Alignment is made to bring this reading to a maximum value, and stage gains can be made by choosing a reference level and applying to the stage under measurement the inputs to develop this reference level.

Quieting signal, by R.M.A. definition, is that input signal necessary to reduce the output noise, at the speaker, 20 decibels, the measurement to be made in a well-shielded room in the absence of extraneous noises.

exact operating frequency prior to shipment from the factory. Unless it has been handled roughly while in transit, or otherwise abused or tampered with, it should require no further adjustment before putting it in service, except to align the antenna circuit to the antenna.

The antenna trimmer C-1 should be aligned to produce maximum indication of first limiter (Switch Position No. 2) due to rectification of noise without carrier. Use a 0-50 microammeter.

Approximate alignment positions of the original frequency are indicated by red dots on the shield cans.

Get a signal from the transmitter which the receiver is normally intended to receive.

Check discriminator balance against this frequency. (Switch Position No. 4.) If balance is within \pm or $-$ 4 microamperes, alignment can be considered satisfactory.

If balance is more than 4 microamperes, then proceed to realign as outlined hereafter.

Alignment Procedure ★ If, at any time, due to replacement of parts, change in operating frequency, or for other reasons complete realignment becomes necessary, proceed as follows:

First, the equipment listed below is needed:

1. Low frequency signal generator—General Radio No. 605-B or equivalent.
2. High frequency signal generator—Ferris 18-C or equivalent.
3. 0-50 microammeter with reversing switch or 50-0-50 microammeter.
4. Control head.
5. A lead.
6. Control head cable.
7. 3-ohm speaker.
8. High resistance voltmeter, at least 20,000 ohms per volt.
9. Audio oscillator.
10. Output meter.

It is preferable to check with a 6-volt power supply, in order to observe any condition which might produce hash or ripple.

In setting up the receiver on the bench for test, plug in the power supply cable and the control cable. The speaker can be plugged into either the control box or chassis directly. Plug the meter into the meter jack.

Turn the squelch control completely to the left and the volume control to the right.

Calculation of Crystal Frequencies ★ The low frequency mixer uses a crystal which is the sum of the two IF frequencies: 4.3 mc. + 455 kc. = 4,755 kc. This crystal is located adjacent to the 6K8 tube. The oscillator for the high frequency mixer is a multiple of the crystal frequency. For channel frequencies from 30-37 mc. the fourth harmonic is used, and from 37-40 mc. the fifth harmonic is used.

If the channel frequency is between 30-37 mc. subtract 4.3 mc. from the channel frequency and divide by 4, to find the crystal frequency. If the channel frequency is between 37-40 mc., subtract 4.3 mc. from the channel frequency and divide by 5, to find the crystal frequency. The high frequency oscillator crystal is adjacent the antenna adjustment.

AF Amplifier ★ Check the audio amplifier by applying an audio voltage across the discriminator (6H6 cathode to ground). To make this check, the squelch must be rendered inoperative by shorting the 270,000-ohm plate resistor which is the 9th resistor on the ter-



- Those extra-heavy-duty transmitting capacitors such as stack-mounting micas, heretofore made to order, are now standard Aerovox items available to FM broadcasting stations and others, at substantial savings in cost. You can order them through local Aerovox jobbers. Or you can submit your more special requirements to us for engineering collaboration, specifications, quotations.

- **Write for DATA . . .**

If you are engaged in professional radio work, write on business stationery for the Aerovox Transmitting Capacitor Catalog. Consult the local Aerovox jobber about our transmitting capacitor line not listed in our general catalog.



minimal strip, counting from the end near the center of the receiver. 1 volt of 400 cycles should produce 1.2 watts in the speaker voice coil. Varying the audio frequency should show a sharp cut-off at 3,000 cycles.

Low Frequency IF Amplifier ★ Apply 455 kc. from the generator to the grid of the 6K8. Set the meter switch on position No. 2 (1st limiter). Align T5 and T6 for maximum reading, reducing the input as the maximum is reached. No modulation is necessary. When alignment is attained, approximately 13,000 microvolts should produce a reading of 15 microamperes.

Set the switch on position No. 3 (2nd limiter) and align T7 for maximum reading.

capacity (clockwise rotation, in direction of arrow on can) until the reading is 2/3 of its observed maximum value. Set switch to position No. 4 and, starting with high trimmer at minimum (counterclockwise position) increase by clockwise rotation until the meter reads zero.

Alignment is now complete. Check alignment by moving the generator dial + 15 kc. (470 kc.) and then - 15 kc. (440 kc.). The meter readings should be equal and opposite and approximately 25 microamperes.

High Frequency IF Amplifier ★ Set the meter on position No. 2 (1st limiter). Apply 4.3 mc. to the grid of the first mixer. The generator should be adjusted for maximum reading, which may

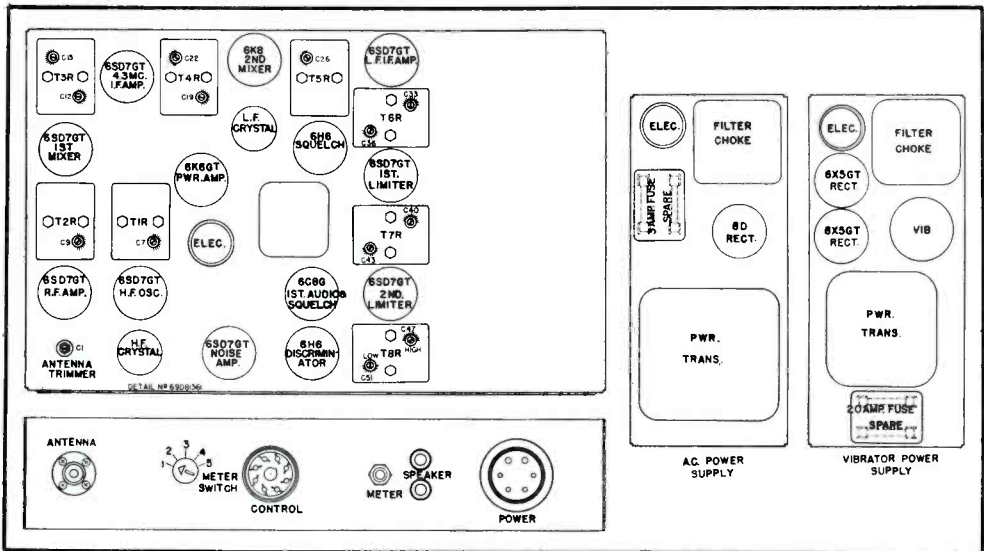

FIG. 4. CHASSIS LAYOUTS OF THE RECEIVER AND THE TWO POWER SUPPLY UNITS

Approximately 300 microvolts should produce a reading of 15 microamperes. This completes the low frequency amplifier.

Discriminator ★ The discriminator used in this receiver is of the back-to-back type. It consists of two resonant circuits, each feeding an individual diode. The diode loads are so connected that the voltages developed in each one are added to obtain the output. One of the resonant circuits is tuned approximately 25 kc. above 455 kc., and the other an equal amount below. The output is zero when the center carrier frequency is applied, and shifts positive or negative as the center carrier is increased or decreased in frequency.

The method of alignment for this receiver is as follows: Apply 10,000 microvolts to the 6K8 grid at 455 kc. Set the meter switch at position No. 5. Tune the low frequency adjustment for a maximum reading. Observe this reading and then detune by increasing

depart as much as ± 5 kc. from 4.3 mc. because of crystal tolerances. Align T3 and T4 for maximum reading on the meter. Approximately 3.5 microvolts should produce 15 microamperes

Alignment of RF Circuits ★ Apply a signal from the high frequency generator by connecting the attenuator box directly into the antenna connection and to the frame of the receiver.

Set the trimmer of T-1 approximately, that is, open if the desired carrier is near the high frequency end of the range, or closed, if near the low frequency end of the range, and mid-position for intermediate frequencies.

Set the meter switch on position No. 2 and adjust the frequency of generator in the vicinity of desired frequency until deflection is noted on meter. Then adjust T-1, T-2, and antenna for maximum reading of meter. Approximately 1.5 microvolts should produce a reading of 35 microamperes.

The fluctuation noise in the receiver should produce, in absence of carrier, a reading of approximately 10 microamperes.

NOTE: It is possible to obtain false alignment of the antenna and R.F. stage by tuning to harmonics of the oscillators. This will be evidenced by a steady reading of the meter which does not decrease to a normal noise reading as the carrier is decreased.

Quieting Signal ★ Use an output meter across the 600-ohm line. This can be clipped across the output of the filter. Reduce the signal input to the receiver to 0 by setting the attenuator between taps. Set the volume control to read a convenient level on the output meter. Apply a signal to the antenna sufficient to reduce this output reading to 1/10 its former value. This corresponds to 20 db. This signal input is the quieting signal and should be approximately 0.4 microvolts.

If the quieting signal is high, it indicates that the alignment is not perfect. Recheck all alignments using the input at the antenna and as low an input as will give a reading on the meter (switch on position No. 2). Unbalance of the discriminator will result in higher quieting signal also.

If it is noted that increase in signal input results in an *increase* of noise at very low inputs, it indicates regeneration is present, which is contributing noise. High quieting signal may also be due to a high local interference such as fluorescent lights, vibrator power supplies and other electrical disturbances. Hash from its own power supply will be observable when a low input signal is applied.

Noise Amplifier and Rectifier ★ Clip a high resistance voltmeter across the 1-megohm load resistance which is on the noise rectifier socket. Remove the grid clip from the 6C8G tube. With zero input level (attenuator between taps) read the voltage developed across this load resistor. With the squelch control minimum (counterclockwise) the reading should be approximately 5 volts. With the squelch control maximum clockwise the reading should be approximately 80 volts.

Squelch Action ★ With no carrier applied to antenna, set the squelch control so it just "closes." The input signal to "open" the squelch should be .1 microvolt or less. With the squelch full on (clockwise) it should require about .6 microvolt or less to open.

Transmitter Test ★ This alignment is accomplished as follows: Apply signal from transmitter to receiver. Adjust the discriminator circuit for balance. Remove the transmitter and reconnect the signal generator to the receiver. Adjust the frequency of the generator to that which will produce balance in the dis-



LOOK TO LINGO

for proven **FM** Antenna Efficiency

The Lingo Turnstile Antenna has a definite, important place in your FM plans. This company pioneered in the development of FM broadcasting and since then Lingo Turnstile Radiators have achieved a proven record of efficiency from an imposing list of actual installations. Although today our plant is engaged wholly in national defense production, we will continue our efforts to provide even greater efficiency in design and performance to meet the requirements of a greater FM industry tomorrow!

JOHN E. LINGO & SON
Licensed Manufacturers of Patented Turnstile Antennas
CAMDEN, NEW JERSEY

A *New* VOICE IN DETROIT.



W45D

First F. M. station in Michigan, owned and operated by The Detroit News, associate station WWJ. Independent programming 18 hours a day. Rate card upon request.

4500 PENOBSCOT BLDG.

CHECK YOUR FILE OF **FM** MAGAZINES FOR MISSING ISSUES. SEE SPECIAL OFFER ON PAGE 46.

Complete

YOUR FILE OF

Back Numbers

Check your file of back copies against the list below, and order those you are missing while we can still supply them. There are only a few copies of some issues.

- | | |
|-----------------------------------------|--------------------------------------|
| <input type="checkbox"/> November, 1940 | <input type="checkbox"/> April, 1941 |
| <input type="checkbox"/> Out of Print | <input type="checkbox"/> May |
| <input type="checkbox"/> December | <input type="checkbox"/> June |
| <input type="checkbox"/> Out of Print | <input type="checkbox"/> July |
| <input type="checkbox"/> January, 1941 | <input type="checkbox"/> August |
| <input type="checkbox"/> February | <input type="checkbox"/> September |
| <input type="checkbox"/> Out of Print | <input type="checkbox"/> October |
| <input type="checkbox"/> March | <input type="checkbox"/> November |

Back issues of "FM" are a source of important reference material and engineering data, available from no other source. As time goes on, these issues are proving to be of increasing value. Complete your file of back numbers while you have the chance.

\$1.00 for SIX ISSUES

Any six issues, from March to November, 1941, will be sent postpaid for \$1.00, provided the copies you want are still available when your order is received.

FM COMPANY

112 EAST 36th STREET

NEW YORK CITY

criminator. The generator will then be at the exact frequency of the transmitter and overall touch-up alignment should be made, reducing the generator output to as low a value as possible and still get a meter reading (position No. 2). All stages can be aligned for this setting except T-7 which must be aligned from switch position No. 3.

If a signal generator is not available, this alignment may be made by selecting a location where the received signal from the transmitter is very weak.

CAUTION: It is necessary to have a weak signal to obtain proper alignment, and it is preferable to use an unmodulated signal from the generator or transmitter.

It is to be noted that the discriminator balance can be used as a means of comparing the frequencies of several transmitters intended to operate at the same frequency. A variation of 2 microamperes represents a deviation of approximately 1 kc.

Noise ★ One of the inherent characteristics of Frequency Modulation reception is its ability to reduce noise in the presence of a received carrier. To obtain this noise reduction, it is necessary that the receiver be exactly tuned to the received carrier and it is assumed that this tuning operation has been completed and so the procedure is not considered in this discussion.

In a well-shielded room, the fluctuation noise in the receiver, in absence of carrier, will produce approximately 10-15 microamperes reading for meter switch position No. 2 (1st limiter). When an antenna is connected to the receiver, this reading will increase, due to pick-up of extraneous noises, to 15-20 microamperes. In cases of bad interfering noises the reading will be much higher and will require higher signal inputs to quiet the noise.

These interfering noises may be of a local nature produced by sparking motors, fluorescent lights, and other electrical devices, and such disturbances may be eliminated by the use of filters or shields. Interference may also be produced by diathermy apparatus. This apparatus generates radio frequency interference and radiates energy over great distances. The source of such interference may be difficult to locate. It may be possible to shift the operating frequency of a known interfering unit slightly to take it out of the frequency range of the receiver. Thorough shielding and filtering will also cut down radiation from diathermy apparatus.

Electric fences will sometimes radiate interference three or four miles. This type of interference is characterized by an intermittent buzzing noise. Noises created by electrical fences may sometimes be cured by paralleling the interrupter points with a filter consisting of a 1.0 mfd. condenser connected in series with a 500-ohm resistor.

Passing automobiles will also radiate interference but this is usually of a temporary nature and not serious.

In the case of a mobile installation, work will be necessary on the car electrical system, to limit the production of electrical interference. The level of interference created by the car in which the mobile equipment is installed will be the limiting level for satisfactory reception. FM as well as AM systems are affected by electrical noise and in all cases care should be taken to reduce the noise produced by the car to the lowest possible level.

Generator noise can be detected by coasting the car in gear, with ignition shut off. The installation of a generator filter (part M-346) will usually stop the generator noise. Installation instructions are packed with the filter unit.

Installation of spark plug suppressors (part 6X16621) at the spark plugs, will usually reduce the ignition interference to an acceptable degree.

By-pass condensers which are totally shielded (Part 8K19266) can be tried at various points on the battery system such as at the distributor, ignition switch, gauges, etc. Caution: Do not connect condenser across generator field.

Installation of hood-grounding wipers (part 1X81618) will usual help. Instructions for installing wipers are included in the hood wiper envelope.

Adding extra bonding strips from the motor block to the frame of the car sometimes will help. It may also help to bond the exhaust pipe and muffler to the car frame.

There is no "sure cure" for ignition interferences, and it will be found necessary to try various things until the offending radiation is located and stopped. A successful method used on one car may not work on the next.

RADIO DESIGN PRACTICE

(CONTINUED FROM PAGE 36)

instruments, signal generators, and other devices where resistance is required with a minimum of capacity and inductance.

Railroad Radio: Efforts to use radio for communicating with locomotive engineers go back a number of years, but the General Railway Signalling Company has obtained the first results of practical usefulness by employing FM transmission. An experimental installation at the Proviso, Illinois, yards of the Chicago and Northwestern has shown that transit time can be cut, overall economies effected, and more efficient utilization of existing facilities obtained by radio communication for controlling the movements of locomotives and cars in the terminal area. At the Elwood Ordinance Plant, Joliet, Mich., trainloads of high explosives are moved day and night, by radio control, without the use of signal blocks and lights.

Your Opportunity
to Own Two Important

REFERENCE VOLUMES

If You Act Promptly!

**1ST BOUND VOLUME
OF FM MAGAZINE**

NOVEMBER 1940 TO APRIL 1941

**2ND BOUND VOLUME
OF FM MAGAZINE**

MAY 1941 TO OCTOBER 1941

These two bound volumes of **FM** Magazine comprise a 600-page record of the most important developments in modern radio progress, invaluable as a reference source to engineers, patent attorneys and radio executives.

We have been able to make up an additional 15 copies of the First Volume, and 85 copies are available of the Second Volume.

The binding, of three-quarter pigskin, was done by Eggeling, and is of the finest workmanship, designed to last a lifetime.

The cost is less than you would pay to have a single set of copies bound.—
Send your order at once!

\$5.00

EACH, POSTPAID, IN THE U. S. A.

FM COMPANY

**112 EAST 36th STREET
NEW YORK CITY**



800 CHIEF ENGINEERS OF AM BROADCAST STATIONS READ FM MAGAZINE EVERY MONTH. AT SOME AM STATIONS, AS MANY AS TEN OR TWELVE ENGINEERS AND EXECUTIVES ARE PAID SUBSCRIBERS

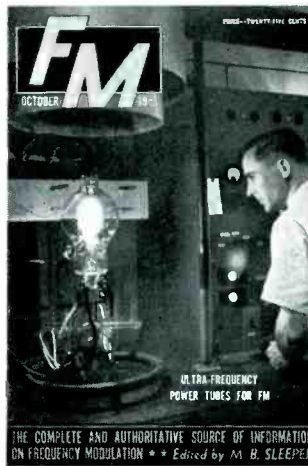

WANTED

Manufacturer of electrical testing equipment can handle sub-contract order up to \$50,000 for radio or electrical instruments. Workers highly skilled in complicated wiring and assembly of small parts. Well-equipped tool room and punch-press department. Prepared to purchase additional machinery if required. Details of production facilities will be sent upon request. Address:

Box 22, Station F, New York City

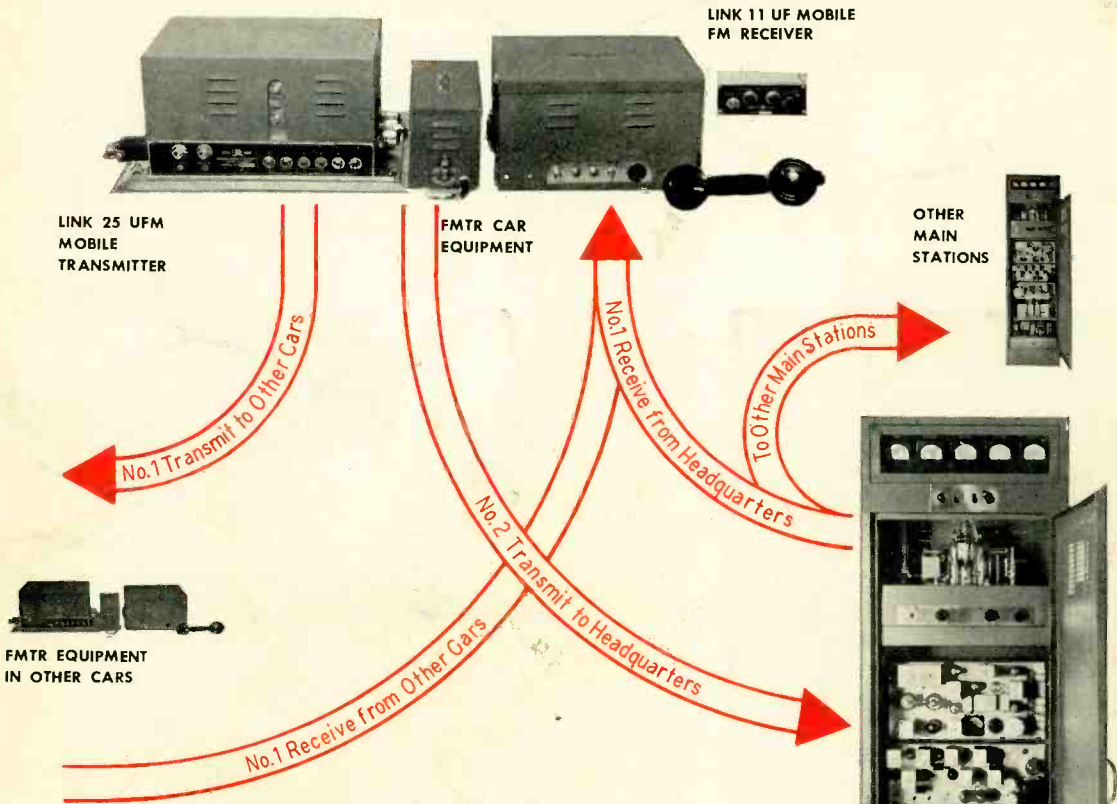

LINK "3-WAY" FM COMMUNICATIONS SYSTEM

USED BY STATE POLICE AND LARGE PUBLIC UTILITY GROUPS

LINK "3-way" FM uses two frequencies. Main stations talk to cars and other main stations on No. 1 frequency. Car transmitters are equipped to operate on two frequencies. They use No. 2 frequency to talk back to the main stations, and No. 1 to talk to other cars and, in emergencies, to main stations when No. 2 frequency is in use. This speeds up service, protects a main station, while listening to a car, against interference from another main station operating on No. 1 frequency, and makes it possible to use any car as a temporary main station at the scene of a disaster.

RADIO OPERATOR'S CONTROL UNIT CAN BE UP TO 20 MILES FROM TRANSMITTER



WIRE LINES FROM BARRACKS TO REMOTE FM HEADQUARTERS TRANSMITTER & RECEIVERS

LINK 250 UFS FM HEADQUARTERS TRANSMITTER & RECEIVERS

ONLY TWO METALLIC CONDUCTORS REQUIRED



ENGINEERS and MANUFACTURERS of FM and AM EQUIPMENT for GOVERNMENT, PUBLIC UTILITY, POLICE and FIRE

Fred M. Link 125 WEST 17th ST., NEW YORK, N. Y.

Engineer • Manufacturer

Telephone: CHELSEA 2-3838