

# FM

APRIL 1941

5-30

FM CONQUERS HIGH-  
ALTITUDE WEATHER



THE COMPLETE AND AUTHORITATIVE SOURCE OF INFORMATION  
ON FREQUENCY MODULATION ★ ★ Edited by M. B. SLEEPER

REG. U.S. PAT. OFF.

[www.americanradiohistory.com](http://www.americanradiohistory.com)

For Checking Center-Frequency of FM Emergency Transmitters, as Well as AM Types

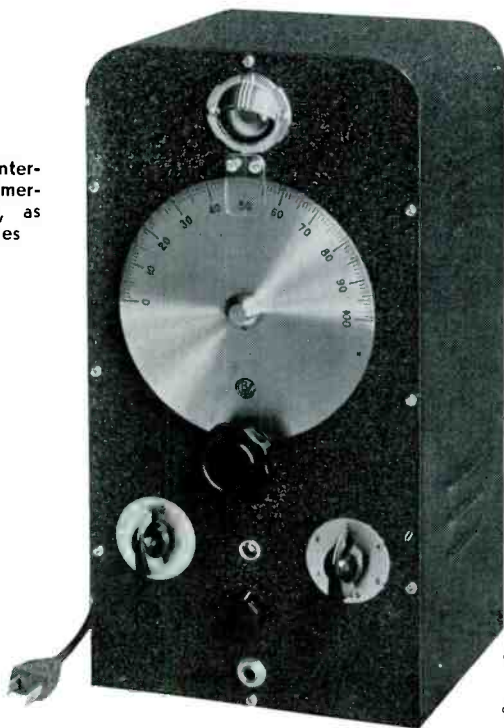

Complete,  
any two bands  
**\$97.95**  
any three bands  
**\$122.50**

## *More Accurate—because it is Easier to Read* **BROWNING FREQUENCY METER**

MEETS FCC REQUIREMENTS FOR ALL FM AND AM EMERGENCY TRANSMITTERS

1. Scale can be read with precision because of wide spread of the dial calibrations.
2. Designed for use by operators of police, fire and emergency radio transmitters.
3. Checks frequencies within any two or three bands specified at time of purchase. Each band is 50 to 1000 kc. wide, depending upon position in the 1.5 to 60 mc. spectrum.
4. Complete stability of standard crystal oscillator and electron-coupled oscillator.
5. Cathode ray indicator for accurate visual check against crystal standard as well as against transmitter.
6. 100-kc. crystal oscillator provides at least two check-points within each band.
7. Fast operation. Less than one minute required to check transmitter frequency exactly.
8. Light in weight — easy to carry — plugs into any 115-volt AC or DC supply.
9. Each instrument precision-built on order, hand-calibrated to better than .01% for each band.

*Complete technical data on this popular instrument will be sent on request*

Note: A 5-band Frequency Meter for frequencies between 30 and 40 mc. now available at \$172.50

**BROWNING LABORATORIES, Inc.**  
755 MAIN STREET  
WINCHESTER, MASSACHUSETTS

Only **ZENITH** has this



**MICROSTATIC FREQUENCY MODULATION**  
*plus* **RADIORGAN TONE COLOR CONTROL**

**FOUR STYLINGS AVAILABLE**

*Zenith FM Receivers are available in Chairside, Console, Spinet and Radio-phonograph combination stylings—all in fine hand-rubbed finish—all designed for FM-AM reception.*



**ASK YOUR  
ZENITH DISTRIBUTOR**

*Phone—write or wire your Zenith distributor today for complete information on all the Zenith Microstatic Frequency Modulation Receivers.*

Modern radio listening demands receivers designed for FM-AM reception. New FM stations are going on the air all over the country—many more are planned. Public interest and, more important, public buying are growing with amazing rapidity... And Zenith is ready now with a wide selection of FM-AM receivers incorporating fourteen points of definite superiority. You need these Zenith FM-AM models on your sales floor—otherwise you are not selling modern radio.

Model illustrated is 12-H-678 permitting four band reception. Also plays and automatically changes phonograph records. Available in mahogany or walnut finish.



**AMERICA'S OLDEST  
MANUFACTURER  
OF FINE RADIOS FOR  
THE HOME**



# How To Make Money With The G-E FM Translator



Dear Mr. Jones:

You're probably wondering whether Frequency Modulation (FM) is going to obsolete that set I sold you a short time ago!

I've got good news for you! General Electric has brought out a marvelous FM Translator which *protects your investment* by bringing your present radio up-to-date!

It is low in cost—attaches easily to your set—and gives you the marvel of FM true high-fidelity tone as well as freedom from static that is absolutely amazing!

Can you drop in to see this Translator? I'd like to demonstrate it for you!

Cordially yours,

P.S. Will you kindly ask for me?



**1. SEND THIS INVITATION ON A PENNY POSTAL** to a list of the customers who bought AM consoles and radio-phonograph combinations from you during the last year. It's a *proven* prospect getter!

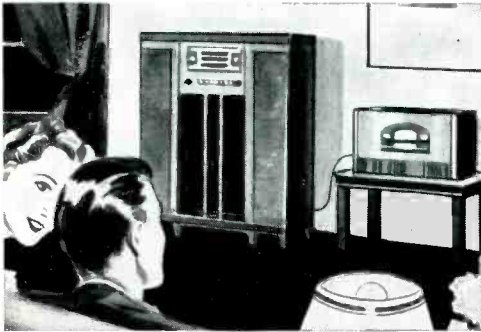
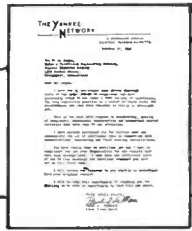

"I have had my assistants make pretty thorough tests of the model JFM-90 FM Translator and have personally tried it out under a wide variety of conditions . . . this receiver is really an excellent job . . . the best with respect to sensitivity, quality of components, mechanical construction and electrical characteristics that has come to our attention."

Paul A. deMars  
Vice President,  
Yankee Network

**2. EXPLAIN AND DEMONSTRATE** FM's freedom from static (electric razor stunt) and its "full-color" musical reception. Show how easy it is to apply the G-E FM Translator to their present sets—one simple connection!

**3. THEN POINT WITH PRIDE** to this assurance of a prominent FM broadcaster that the G-E Translator will give them *top quality* FM reception—and at the lowest cost—only \$49.95.

## IT'S GOOD BUSINESS

YOUR CUSTOMERS GET GOOD FM RECEPTION AT LOWEST COST  
YOU GET A GOOD PROFIT—NO TRADE-IN PROBLEM

# GENERAL ELECTRIC



**W**HAT effect will weather have upon FM transmitter located at great height on mountain tops? This is an important question, for the answer determines the practicability of using such elevations for stations intended to cover large areas.

In this issue, A. F. Sise, chief engineer in charge of FM for the Yankee Network and ranking authority on this subject, gives the answer in terms of practical experience.

The Yankee Network station W39B (WIXER), atop Mt. Washington, N. H., is an ideal test installation, for it is subject to what meteorologists describe as the worst weather in the world.

Although all programs originate in Boston, where they are beamed 43 miles by FM to Paxton, and rebroadcast 140 miles to Mt. Washington, this system is operating without interference from atmospheric disturbances.

Transmission with 1-kw. output is reported free from fading or day-night variation at points beyond the estimated range of 100 miles, regardless of temperature changes at the transmitter, and of ice accumulations which at times enshroud the antenna to a thickness of a foot or more. Not only has W39B met every specification of expected performance, but it is reported as furnishing better entertainment to listeners 300 miles away than they can get from their local AM stations.



**THE COMPLETE AND AUTHORITATIVE SOURCE OF INFORMATION ON FREQUENCY MODULATION**

VOL. 1 APRIL, 1941 NO. 6

COPYRIGHT 1941 M. B. SLEEPER

**CONTENTS**

FM FOR CLEVELAND SCHOOLS . . . . .	5
<i>by William E. Levenson</i>	
MORE FM SERVICE IN NEW ENGLAND . . . . .	9
<i>by A. F. Sise</i>	
WHAT THE FM BROADCASTERS HAVE TO SAY . . . . .	15
<i>A statement by Frank R. Smith, Jr.</i>	
REVIEW OF THE STATUS OF FM BROADCASTING . . . . .	16
<i>by M. B. Sleeper</i>	
HERTZ TO FM . . . . .	26
<i>by George H. Clark</i>	
THE MANUFACTURERS SAY . . . . .	28
<i>A statement by I. Goldberg</i>	
IMPROVED SPEAKER SYSTEM FOR FM . . . . .	30
<i>by Benjamin Olney</i>	
400 ENGINEERS HEAR FM SESSIONS . . . . .	34
<i>by Dick Dorrance</i>	
FM SPOT NEWS . . . . .	36
NEW EMERGENCY FM EQUIPMENT READY . . . . .	38
<i>by Norman E. Wunderlich</i>	
G.E. PERFECTS FM STATION MONITOR . . . . .	43
<i>by W. R. David</i>	

THE COVER DESIGN AND CONTENTS OF FM MAGAZINE ARE FULLY PROTECTED BY U. S. COPYRIGHTS, AND MUST NOT BE REPRODUCED IN ANY MANNER OR IN ANY FORM WITHOUT WRITTEN PERMISSION

★ ★ ★ ★ ★

M. B. SLEEPER, *Editor and Publisher*

*Published by:* FM COMPANY

*Editorial and Advertising Office:*

41 Washington Street, Newton, Mass. Tel. Lasell 0808

FM Magazine is issued on the 20th of each month. Single copies 25¢ — Yearly subscription in the U.S.A. and foreign countries \$3.00. Subscriptions should be sent to FM Company, 41 Washington St., Newton, Mass.

The publishers will be pleased to receive articles, particularly those well illustrated with photos and drawings, concerning all phases of FM developments. Manuscripts should be sent to the publication office, at Newton, Mass. Contributions will be neither acknowledged nor returned unless accompanied by adequate postage, packing, and directions, nor will FM Magazine be responsible for their safe handling in its office or in transit.

Advertising correspondence, copy, and cuts should be addressed to the advertising office at Newton, Mass.



## FM by NATIONAL

National Receivers give superb FM reception. Although designed primarily as communication receivers, their high standards of performance make them outstanding for entertainment purposes. The model illustrated above has dual high fidelity output circuits, excellent signal to noise ratio and extreme sensitivity. It was described in detail in the December issue of FM.

*Correspondence is invited*

**NATIONAL COMPANY, INC., MALDEN, MASS.**



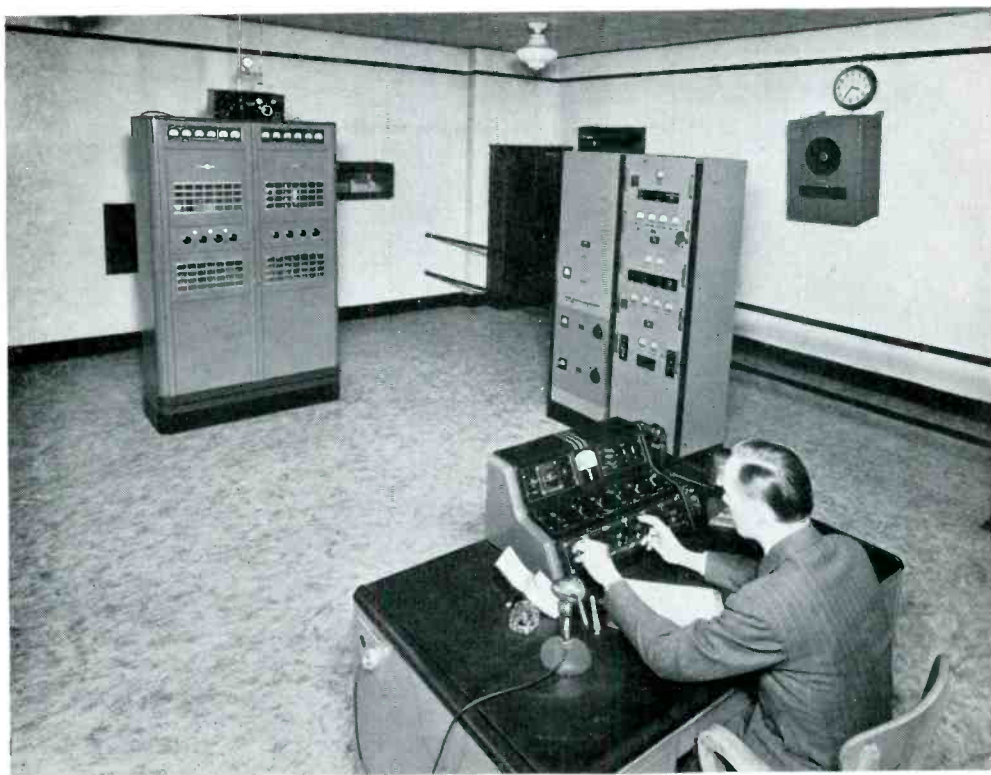

MASTER CONTROL ROOM OF THE FM STATION OPERATED BY THE BOARD OF EDUCATION

# FM FOR CLEVELAND SCHOOL SYSTEM

How Cleveland's WBOE, Now Changed to FM, Serves as Educational Auxiliary

BY WILLIAM B. LEVENSON\*

**T**HE establishment of new FM radio stations, many of which will provide ample time for programs of a cultural nature, is of real significance to the educator. Whereas most of current programs are concerned with mass appeal, it is quite likely that, with more local radio services and possible additional networks, increased attention will be given to a class appeal. It is common knowledge that, for purposes of circulation, there is no one public but rather many "publics."

Frequently overlooked but of potential importance is the frequency band set aside for non-commercial, educational broadcasting. Judging by the interest of educators in the operation of the Cleveland School Station WBOE, it is quite probable that there will be a

\*Supervisor of Radio Activities, Board of Education, Cleveland, O.

steady, if not rapid, growth of such FM transmitters throughout the country.

The use of radio as the teacher's assistant has come to have a definite place in the schools of Cleveland. More than 15 years of experimentation with radio as a new tool of instruction have demonstrated that this medium of communication, if used wisely, constitutes a tremendous educational force.

The history of Cleveland's use of radio began when the local commercial stations donated time to the schools for this purpose. However, in 1937 with a financial grant from the General Education Board of the Rockefeller Foundation, the schools were enabled to establish their own station. The frequency used was 41.5 mc., and the license granted was the official No. 1 for a non-commercial, educational broadcasting station. It will be recalled



ABOVE, ONE OF THE SPACIOUS, WELL-EQUIPPED STUDIOS IN THE SCHOOL ADMINISTRATION BUILDING. AT THE RIGHT IS CONTROL ROOM WINDOW. RIGHT, WILLIAM B. LEVENSON, CLEVELAND SUPERVISOR OF RADIO ACTIVITIES

that at that time the FCC had set aside 25 channels between 41,000 and 42,000 kilocycles for specific assignment to such non-commercial use.

With the coming of frequency modulation and the reallocation of a separate band for educational use, between 42 and 43 megacycles, the WBOE frequency was shifted. This change involved quite an expenditure, since it meant not only modifying the transmitter, but in view of the fact that the Cleveland Schools had been provided with custom-built, crystal-tuned AM receivers, these, too, had to be either converted or replaced.

Fortunately, aid in the modification of the transmitter equipment was forthcoming when Major Edwin H. Armstrong, because of his interest in educational broadcasting, generously provided an exciter unit for the transmitter.

FM sets purchased from various manufacturers have been installed in each of the public schools and the station is now on the air 7 hours each school day, 8:30 A.M. to 4:30 P.M.

The studios of WBOE are located on the 6th floor of the School Administration Building, generally considered one of the finest in the country. The following have been installed: 3 studios, a demonstration classroom studio, a master control room, a transcription room, engineer's office, workshop, reception lobby, and office and storage space.

The smallest studio, "C", is 11 by 16 ft.; studio "B" is 19 by 27 ft.; studio "A" is 21 by 43 ft.; and the demonstration studio is 30 by 44 ft. The ceiling height of all studios is 12 ft.

Each studio has been designed to meet a particular requirement. Studio C is used only for speakers or radio lesson teachers who require no sound effects, piano, or groups to assist them. The next in size will accommodate small musical or dramatic groups. Studio A serves the requirements for large dramatic groups, orchestral combinations such as high school bands, and lessons or programs in which the use of a piano is necessary. All three studios are equipped with a proportionate number of folding chairs for spectators and visitors.

The Demonstration Studio is equipped as a typical classroom at one end, having a loud-speaker, blackboard, slide projector and screen, and work tables for classes. This room also contains approximately 150 folding chairs for visitors so that reactions to the radio lesson may be observed.

The 1 kw. transmitter is located at a school 6 1/2 miles distance, where the height above sea level is 900 ft. and 240 ft. above any available location in the downtown area. A tower has been erected which is 250 ft. in height, supporting a pipe mast which terminates in an antenna unit approximately 302 ft. above ground.

**Types of Programs** ★ The programs presented by the school station range from illustrated stories for the kindergarten through dramatizations planned for high schools as well as discussions developed for teachers and parents. With the cooperation of the local commercial stations, private lines have been installed which make possible selective program service



from all the major networks: NBC Blue and Red, CBS, and Mutual. The following is a list of programs which were carried by WBOE during the year 1939-1940:

### Elementary Schools

Geography  
Rhythmic Activities  
Art  
Safety  
Science  
Music for Young Listeners  
Handwriting  
Science  
Song Study  
History  
French  
Arithmetic  
Kindergarten Stories  
Rote Songs  
Handcrafts

### Junior High Schools

Art  
French  
German  
Current Issues  
Pioneers of Health

Answer Me This  
Safety  
Clevelanders at Work

### Senior High Schools

Current Issues  
Home Economics  
Art  
French  
German

### To Teachers

Kindergarten Talks  
Elementary Physical Education

### To the Public

Your Schools  
This Living World

### To Parents

Your Child and His School  
Pre-School Children

CBS—Frontiers of Democracy—Junior High School

NBC—Gallant American Women—Senior High School

CBS—New Horizons—Junior High School

NBC—Echoes of History—Secondary Grades

CBS—Tales from Far and Near—Elementary Grades

CBS—This Living World—Secondary Grades

NBC—Adventures in Reading—Secondary Grades

NBC—Between the Bookends—After School

CBS—Men Behind the Stars—After School

MBS—Intercollegiate Debates—After School

CBS—Adventures in Science—After School

MBS—Good Health and Training—After School

CBS—Young People's Concert—After School

All chains—international broadcasts and daily news

All local stations—Local programs of educational interest

In preparing the radio programs four methods are in use at the Cleveland Schools:

**Elementary Schools** ★ In the elementary schools, the radio lessons are prepared at a "curriculum center" or laboratory school. Twelve

(CONTINUED ON PAGE 45)

### ELEMENTARY SCHOOL CLASS ROOM USES RADIO RECEPTION FOR SPECIAL INSTRUCTION



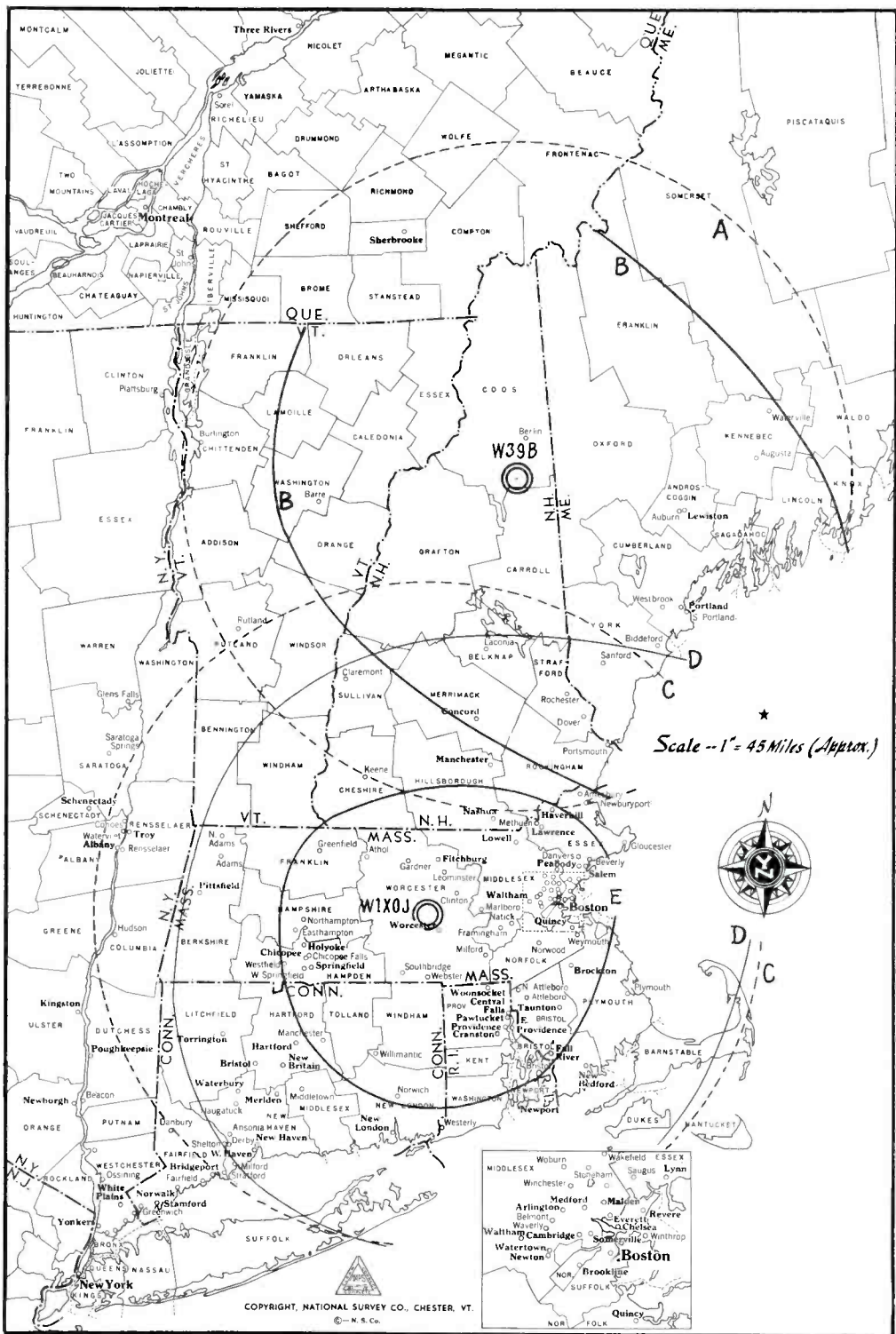

A & C, 100-MILE RADIUS—B, MEASURED SERVICE AREA OF PRESENT W39B, MT. WASHINGTON STATION—D, CALCULATED 50-MICROVOLT AND, E, 1-MILLIVOLT CONTOURS OF W1XOJ, AT PAXTON  
 ACTUAL RANGE OF BOTH STATIONS IS MUCH GREATER, AS SHOWN BY LISTENERS' REPORTS

# MORE FM SERVICE IN NEW ENGLAND

## FM Overcomes World's Worst Weather to Provide Improved Programs in Rural Area

BY A. F. SISE \*

**T**HE Yankee Network, in the spring of 1937, embarked upon a program designed to carry FM to practically all of the rural districts of New England, as well as the more thickly populated urban centers. The first step in this program, the erection of the Paxton station W1XOJ,<sup>1</sup> has been described in *FM Magazine*.

The following is an account of the first phase of the second step, marked by the completion of W1XER, Yankee's FM station on Mt. Washington, N. H., highest point of land in the northeastern United States and home of "The worst weather in the world."

When W1XER went on the air December 18, 1940, it marked the inception of an interference-free radio service to some million and a half potential listeners living in Northern New England. Most of these people could never have been provided with a really satisfactory radio service in any other manner, as this is mostly a rural population spread over a large area. Once again, John Shepard, 3rd, has pioneered a new frontier.

Back in 1937, when Shepard became one of the prime moving spirits in Radio's Revolution, Yankee engineers under Paul A. de Mars, Technical Director, evolved a plan to provide 90% of New England with FM programs.

This complete plan involved the building of a 50-kw. FM station on a mountain top at Paxton, Massachusetts, a 5-kw. station on Mt. Washington in New Hampshire, and a 5-kw. station on Mt. Mansfield, in Vermont. It was estimated at the outset that the 5-kw. station on Mt. Washington, with its great height above sea level, 6,288 ft., would serve an area similar to the 50-kw. station at Paxton, although the Northern New England terrain is extremely rough and mountainous.

Performance measurements have just been

\* Chief Engineer in charge of FM, Yankee Network, 21 Brookline Ave., Boston, Mass.

<sup>1</sup> W1XOJ Exceeds Expectations, by Paul A. de Mars, *FM Magazine*, March, 1941.

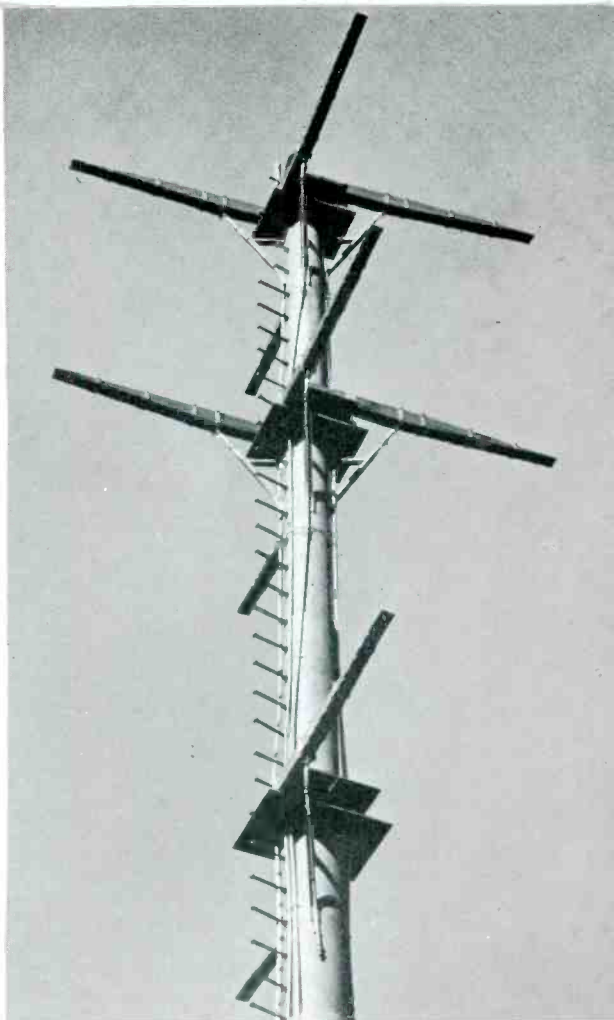

TRUCK-SPRING DI-POLE ELEMENTS ARE USED TO WITHSTAND STRAINS OF ICE COATINGS AND HIGH WINDS ON MT. WASHINGTON

completed on the 1-kw. and temporary antenna now being used, indicate that when W1XER goes to full power, it will have a service range of at least 75 to 100 miles, and, in some directions, notably the flat country of southeastern New Hampshire and southern Maine, the range will be considerably greater.

One of the most difficult problems Yankee had to overcome in order to build a station on the exposed peak of Mt. Washington was the weather. Dr. Charles Brooks, Director of Harvard's Blue Hill Observatory, recently published an article summarizing his studies of weather on Mount Washington and described that climate as "perhaps the worst weather in the world."

Mt. Washington has the most severe climatic conditions of any mountain, regardless of altitude, that has been visited by humans often enough to provide any sort of weather records. Mt. Washington has more severe





AN AIRPLANE VIEW OF THE MT. WASHINGTON SUMMIT, LOOKING NORTHEAST. THIS SHOWS THE RUGGEDNESS OF THE COUNTRY WHICH SURROUNDS STATION W39B. MT. WASHINGTON RISES 6,288 FT. ABOVE SEA LEVEL, AND IS THE HIGHEST POINT IN NORTHEASTERN U. S. A.

weather than mountains in arctic Spitzbergen, other higher mountains in the Alps, or Byrd's Little America in the Antarctic. Snow falls in every month of the year. During the winter

months, the wind exceeds hurricane velocity (75 miles per hour) on an average of from 16 to 20 days each month. The world's maximum wind velocity was recorded on Mt. Washington during April, 1934, officially clocked at 231 miles per hour. The writer has seen ice and rime formations (hoar frost) build out from exposed objects to a length of 4 to 6 ft., giving all structures on the Summit a most weird appearance. The front cover picture shows the Yankee tower with a moderate rime deposit.

It was at this bleak and inhospitable arctic outpost that John Shepard, 3rd, dared to gamble \$35,000 in 1937. His engineers had told him that they frankly did not know just how an antenna system would radiate when loaded with tons of ice and rime. They were not sure of the best way to design and operate an FM broadcasting station under such unusual and severe conditions. Accordingly, an experimental program was adopted. In 1937 a high frequency broadcasting station was put in operation on Mt. Washington. Permission was secured from the Federal Communications Commission to set up a communication channel between the mountain and Boston. These fa-



L. TO R. — LAFAYETTE GOSSELIN, Y. N., PAUL GERHARD, OF THE OBSERVATORY, JOHAN BROWN, U. S. GOVT., RICHARD B. LEARNARD, Y. N., AND PATRICK J. HARNEY, U. S. GOVT.

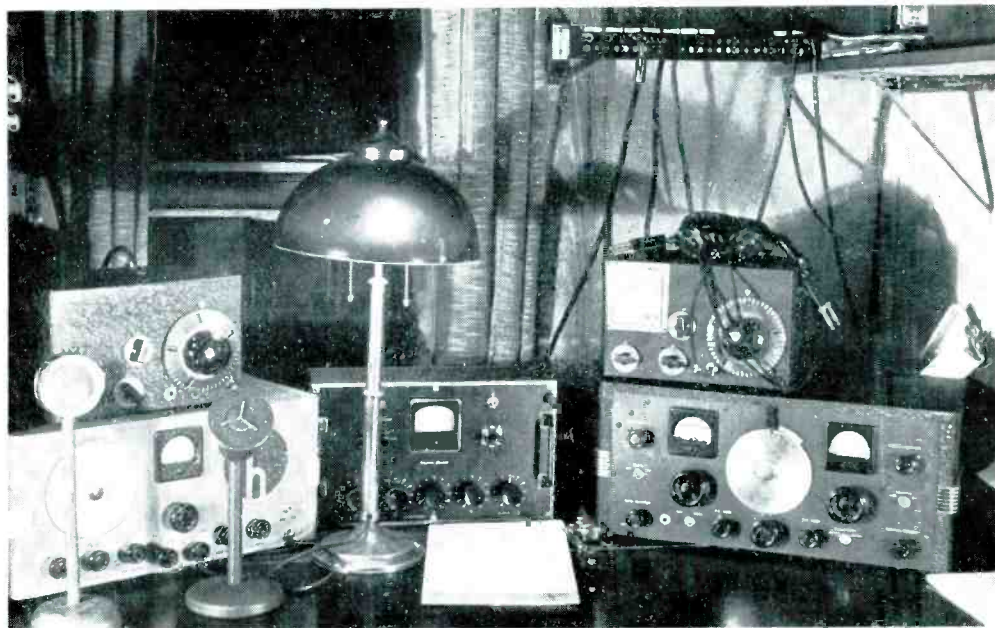

OPERATING DESK HAS, LEFT, 1/4 M. RECEIVER FOR EXETER, N. H. AND GENERAL-PURPOSE ALL-WAVE RECEIVER; CENTER, W.E. SPEECH AMPLIFIER AND MIXER; RIGHT, COMMUNICATIONS RECEIVER FOR PINKHAM NOTCH WEATHER REPORTS, AND ONE FOR SQUANTUM TRANSMITTER

cilities operated on a wavelength close to the present FM broadcasting wavelengths. An antenna was designed and constructed which, it was believed, would operate under the most severe conditions. An AM transmitter of 500 watts was installed in space rented from the Mount Washington Observatory in their new building. Storage tanks for 10,000 gallons of gasoline were buried on the side of the mountain below the Summit. A power generating plant was installed, and WIXER came into being.

The hardships encountered in the construction of this experimental station are almost undescribable. At one time, heavy rains washed out a good portion of the 8-mile mountain road, making it necessary to rebuild large sections of this road in order to transport necessary supplies and materials to the Summit. On another occasion, the tower foundation holes, 8 ft. square and 8 ft. deep, blasted from the immense pile of huge boulders that forms the Summit, filled with water after an exceptionally heavy overnight rain. Before they could be pumped out, the water froze. It was necessary to use live steam to thaw this mass of ice in order to empty the holes.

OBSERVATORY BUILDING WHICH NOW HOUSES THE FM TRANSMITTER. LEFT, TERMINUS OF THE FAMOUS COG-WHEEL RAILROAD WHICH BRINGS UP TOURISTS IN THE SUMMER

Each morning, the ice and rime had to be melted from the structural steel by means of steam to enable the erection crew to start their work. Water for this steam, as well as for





concrete mixing and living supplies, had to be trucked up the Mountain, 8 miles from the base. The steel crew was able to work only six days out of 18 spent on the mountain, and then under exceedingly stormy conditions.

Construction finally had to be halted in November, 1937, because of the severity of the weather. The 50-ft. fabricated steel section of the antenna tower was nearly completed and a single di-pole antenna was mounted on the top. This was the radiating system used by WIXER during the winter of 1937-1938.

During the summer of 1938, the tower was completed and an open-wire, 2-bay turnstile antenna was used during the next winter. Even though designed in the most rugged manner, this open-wire feeder system was unable to stand up under the constant battering of the elements, although it did provide a reasonably good communication circuit during that winter.

With three years of experience on Mt. Washington as a necessary prerequisite to the design and maintenance of any commercial venture, Yankee began construction of its FM broadcasting station in the summer of 1940. The following features were incorporated in the antenna design —

1. Ability to withstand 300 miles per hour wind velocity, as well as several feet of ice and rime deposits.
2. Radiating elements heavy enough to withstand the shock of hundreds of pounds of falling ice.
3. A system that would radiate efficiently when completely encased in ice and rime many feet thick, without materially changing the circular radiating pattern.

4. Flexibility to operate over a comparatively wide range of frequencies.

The supporting structure consists of 50 ft. of fabricated steel tower, made of exceptionally heavy steel. Above this rises a 44-ft. self-supporting steel pole 24 ins. in diameter at the base and 14 ins. diameter at the top. On this pole are mounted the heaviest of steel truck springs, each with a top leaf of ¼-in. copper bar, cut approximately to ¼ wavelength. These ¼-wave elements, complete, weigh 360 pounds each, and are capable of withstanding almost any amount of shock from falling ice. Details of the antenna are given in the accompanying illustrations.

Each element is fed by a coaxial transmission line, terminating in an end seal directly under the spring, where it is protected from falling ice. A clamp makes contact with the spring at a convenient point about 18 ins. from the pole. The mechanical construction of the collars about the pole supporting the elements is so rugged and the collars necessarily so large, that they protrude some distance from the pole. However, by placing heavy copper over the collars and electrically bonding both halves together, the whole collar unit remains at ground RF potential as does the pole. The net effect is that the radiating portion of each element is that portion which protrudes beyond the collar. Accordingly, this portion is made approximately ¼-wavelength long.

The lines feeding each element are brought down the tower separately, and all enter the transmitter building together, so that the power in each element can be controlled

LEFT, COUPLINGS TO THE EIGHT ELEMENTS OF THE FM ANTENNA. CONCENTRIC CABLES ARE FILLED WITH NITROGEN, 1 TO 5 LBS. PRESSURE, TO PREVENT MOISTURE CONDENSATION. RIGHT, 40- AND 10-KW. DIESEL GENERATORS, WITH CONTROLS AND VENTILATOR FAN REGULATOR

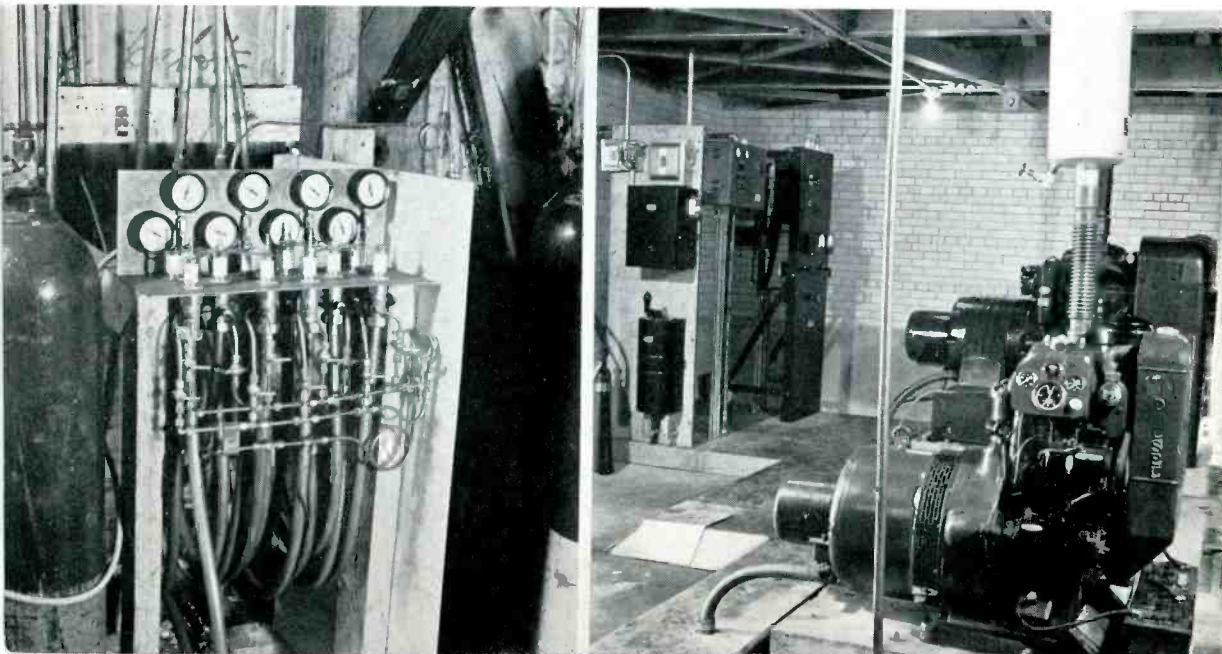



readily. This design is similar to the one so successfully used at Yankee's Paxton station.

The transmitter building is temporarily the Mt. Washington Observatory building. Space is still rented in their building for transmitting equipment and living quarters. The close cooperation between this organization and Yankee has greatly simplified the many living problems arising at so isolated a location. A separate building to house the power generating equipment was constructed under the most severe weather conditions.

The writer awoke on the morning of August 24, 1940, to find that 4 inches of snow had fallen during the night. A 90-mile hurricane had blown this into drifts a foot or more deep about the foundation forms of the generator building under construction, and rime formations over a foot long were observed on the antenna tower. He has seen workmen struggle with boards and shingles on the roof of this building during 85-mile-per-hour hurricane winds, at temperatures not many degrees above zero, in a desperate effort to close in the building before real winter set in.

Some of the materials for this building and its associated power equipment had to be taken by truck part way up the mountain and then by tractor and sled over snow drifted up to 4 feet deep the remainder of the way. The building is ventilated in a most unusual manner. There are no windows, but air is sucked in through 600 3-in. holes made in the concrete foundation. Any conventional system of ventilation would soon become plugged with rime in the winter time.

The power equipment housed in this building consists of two General Motors diesel engine generators, one of 40- and one of 10-kw. capacity. Additional space is provided for another 40- and another 10-kw. machine to be added next summer.

Storage space is now provided for 25,000 gallons of fuel oil and 10,000 gallons of gasoline, in buried tanks located on the side of the mountain a short distance from the Summit. Remotely operated electric pumps convey the fuel to smaller tanks located in the power building.

Programs are supplied to WIXER from Paxton, Massachusetts, 140 miles distant. A standard FM receiver, with some additional RF discrimination, receives WIXOJ on 44.3 mc. The output of this receiver is fed into the WIXER transmitter to be rebroadcast on 43.9 mc.

If, at any time in the future, it should become advisable to program WIXER separately, it is believed that this could easily be done by means of an FM relay transmitter operating in the vicinity of 150 mc.

During the last two months of the construction and testing period at WIXER, it was necessary for the Yankee engineers and operating personnel to either ski or walk the 8 miles of mountain road to the Summit, because the snow made the road impassable even to a tractor. Some of the equipment late in arriving was taken half way up the mountain by ski-mobile, a contrivance with skis on front and tractor tread in the rear. It was back-packed by men the remainder of the way. A small

LEFT, FM PROGRAM RECEIVER AND SPARE, AND TONE-OPERATED RELAY TO CUT IN AUTOMATIC ANNOUNCEMENTS. RIGHT, 39.46-MC. PHONE.—LEFT TO RIGHT, FM RECEIVERS, 50- AND 25-W. TRANSMITTERS, SPEECH EQUIPMENT FOR FM MODULATOR AND 1-KW. AMPLIFIER

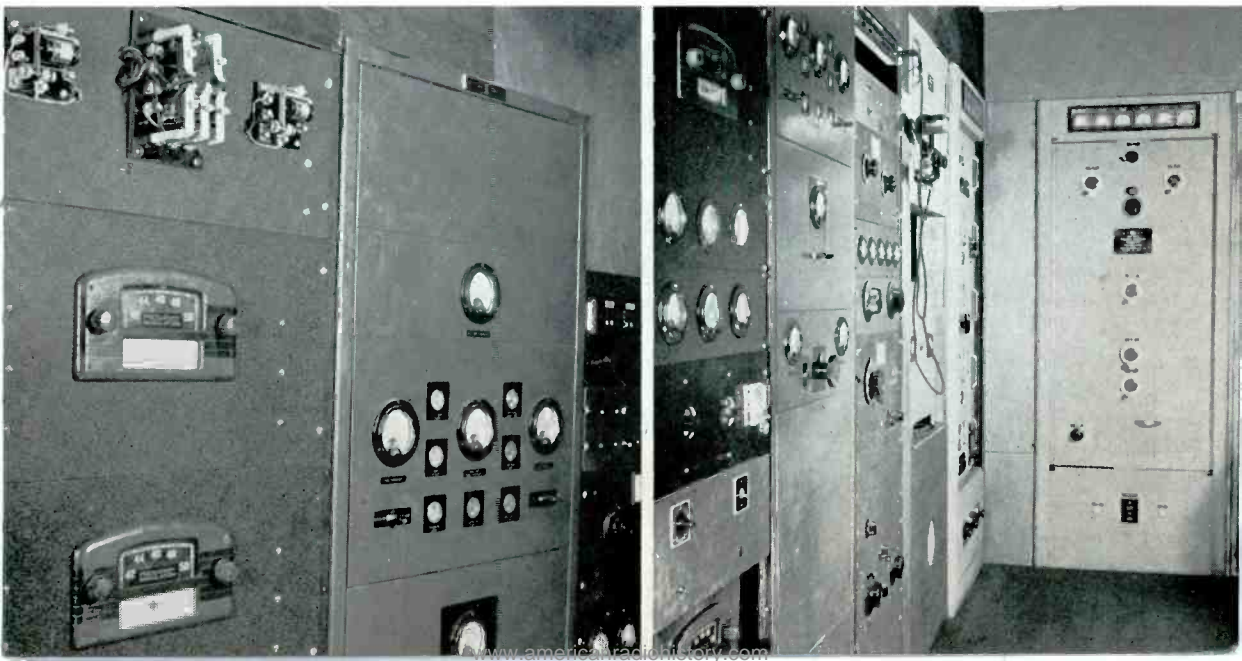

amount of odds and ends were actually back-packed the entire 8 miles.

During the winter months the operating personnel is isolated on the Summit for 4-week periods at a time. Each man of the staff plans to go down the mountain for one week, every four weeks. He cannot always leave on schedule, but makes the arduous journey down and back as weather conditions permit. It is necessary to transport, during the summer, all food and supplies required for the seven winter months, as usually the road is impassable from middle October until late May or June. Yankee's crew of two share occupancy of Observatory building with one Mt. Washington Observatory man and two United States Government Weather Bureau men.

At present, WIXER is operating with a power of 1 kw. Next spring, when the mountain road becomes passable once more, Yankee plans to begin construction of its own radio building. This will be large enough to provide living quarters for ten men, as well as to house the new transmitting equipment. With a power step up to the 5 kw. authorized by the FCC, and improvements in the antenna by the addition of more elements, WIXER should have an equivalent power gain of 16 by

next fall, when this work will be completed.

The first two months of WIXER's operation have been very gratifying. Continuous re-broadcasting of Paxton's FM programs, from a distance of 140 miles, has become an accomplished fact. Enthusiastic letters have been received from listeners throughout northern New England, some from surprisingly distant points. Yankee engineers have listened in at most of the cities and towns within the estimated service area. Reception has been as good as or better than expected, even in many unfavorably located areas.

A preliminary survey of coverage using a specially equipped field car has just been completed. By means of an automatic recorder geared to the drive shaft of this car and a receiver equipped for recording, an ink trace of signal intensities along twelve radials has been obtained.

The results of this survey are shown on the accompanying map. It is believed that all points within this area, excepting a few extremely unfavorable locations, are enjoying excellent service at the present time, and with the present low power.

There is no doubt but that this second step of FM pioneering in New England is destined to be an outstanding success.

## FCC CUTS RED TAPE TO SPEED COMMERCIAL FM BROADCASTING

The Commission has revised its policy concerning the existing high frequency broadcast stations operating experimentally by means of frequency modulation as follows:

I. A person having (1) an experimental FM station and (2) a commercial FM construction permit may be authorized, upon appropriate request, to operate his existing station commercially on the frequency designated in the commercial construction permit with commercial call letters, provided the applicant demonstrates that he has made a bona fide effort to comply with the construction permit. Such showing must include photostatic copy of acknowledgment of order for transmitter and promised delivery date.

II. A person having (1) an experimental FM station and (2) an application pending for a commercial FM construction permit may be granted one or more extensions of his present special temporary experimental authorization, on condition that operations thereunder shall be experimental only, on the experimental frequency, and with experimental call letters.

III. A person having an experimental FM station but no commercial construction permit or application pending therefor may be granted one or more extensions of his present special temporary experimental authorization, so long

as no commercial FM broadcast service is actually rendered in the area served by such experimental station. When such commercial FM service is placed in operation the special temporary experimental authorization will be discontinued.

No authorization for any class of high frequency broadcast station (whether AM or FM) which expired January 1, 1941, by Order No. 69 and which has not heretofore been extended, may be reinstated.

A subsequent order by the FCC will speed up the inauguration of service by new stations now under construction, for which commercial C. P.'s have been issued. If, for example, a station must use 20 kw. to cover its assigned area, it may go on the air at once with low power perhaps 1- to 3-kw., pending delivery of the power amplifier stages.

The reason is that an FM transmitter is made up of an exciter unit and power amplifier of 1-kw. output, followed by a succession of power amplifiers sufficient to deliver the required output to the antenna. FM transmitters of 1- to 3-kw. are available from several manufacturers, but deliveries on the additional amplifier stages cannot be made promptly. Thus, for example, the Detroit News station W45D may go on the air at once, using the 4-kw. basic unit already installed, and operate on this power pending delivery of their 50-kw. amplifier.

## WHAT THE FM BROADCASTERS HAVE TO SAY:

A Statement Concerning W47P,  
by Frank R. Smith, Jr., the  
General Manager of WWSW,  
at Pittsburgh, Pa.

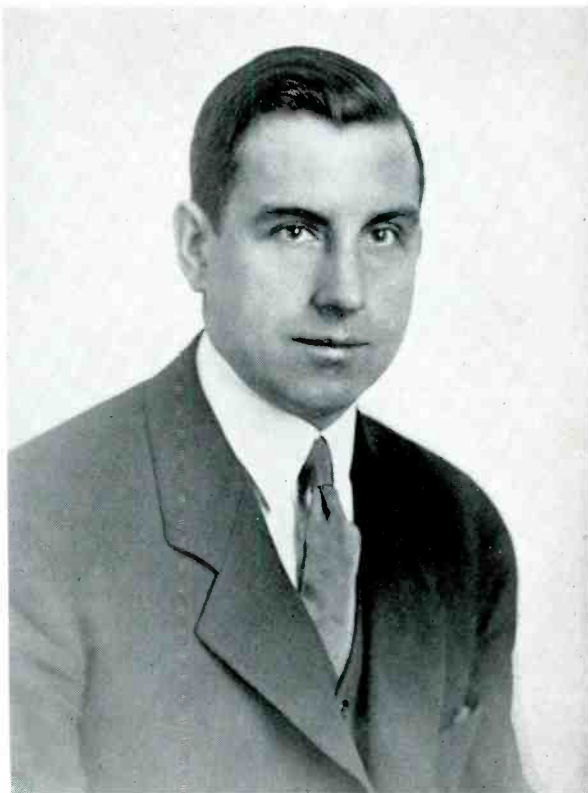

**A**S WE approach the inauguration of FM broadcasting in the Pittsburgh area, the primary question, as we see it, is simply: "What will be the reaction of the listening audience?"

In using the term "listening audience" we are not indulging in wishful thinking. On or about April first, when Station W47P begins serving the Pittsburgh trading area of some 8,400 square miles, more than 200 FM receivers will be spotted throughout the territory. This is a conservative estimate, and does not include the potential listeners indicated by increasing inquiries about FM receivers directed toward local radio set dealers, or those concerning FM reception which are arriving daily at our offices from such points as Uniontown, Mercer, New Castle, Butler, Greensburg, and scores of other towns beyond the Pittsburgh district.

One of our most immediate concerns, therefore, is establishing the very highest type of performance and entertainment for FM listeners from the very first. In our AM operations, we have consistently stressed "showmanship" in all programs, and this same principle will be carried into our FM operation. To a considerable degree, our FM station will be programmed by Station WWSW, with in-

dependent features added carefully and only after thorough testing.

One program promotion of major importance is the broadcasting of all Pittsburgh Pirates Baseball Games, at home and abroad. Programs of civic interest, such as forums, debates, discussions and lectures, and features of musical interest, including organ recitals, symphony, string ensemble, and choral presentations, all promise entertainment of variety and quality for FM listeners. It is on these factors that we place our hope of favorable response to that important question, "What will be the reaction of the listening audience?"

We approach FM with no false hope about immediate revenue from this service. Our first interest is to build audience acceptance for what we feel is an important advancement in radio, and to continue our established policy of keeping pace with the newest and best methods of the industry. Therefore, we regard the considerable outlay of time and money involved in entering the FM broadcasting field as an investment in experimentation and progress.



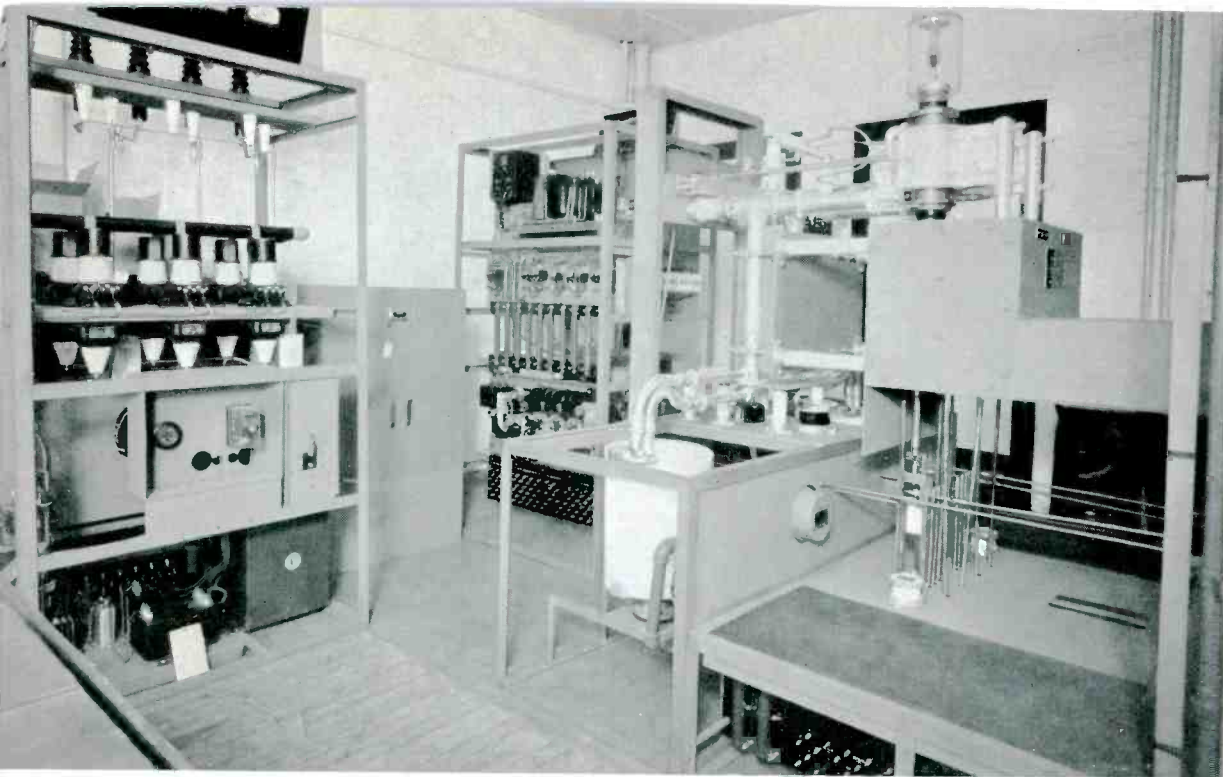

50-KW. FM TRANSMITTER UNDERGOING FINAL TEST AT R. E. L. FACTORY BEFORE SHIPMENT TO DETROIT, WHERE IT WILL BE INSTALLED AT THE EVENING NEWS ASSOCIATION STATION W45D

## *A Review of the* **STATUS OF FM BROADCASTING**

BY M. B. SLEEPER

**S**O RAPID has been the progress of FM broadcasting that radio executives and engineers are now pausing to analyze the reasons for what has happened already, in order to schedule the readjustments which will be required in both the manufacturing and broadcasting branches for the immediate future and for the period of long range planning.

These questions are being asked repeatedly: (1) What does FM contribute to public interest, convenience, and necessity to account for a rate of development unprecedented not only in the radio art but in any other field of applied science? And (2) Why has an established industry been so ready to accept a new idea so revolutionary as to affect and alter every precedent established in the design of technical equipment and in program production and distribution?

The answers are simple: FM supplies urgent needs which are well recognized. Further, it provides improvements which are logical steps in the advancement of the art.

First and foremost, FM offers the only solution to the increasing aggravation due to overcrowding on the AM band. This is evidenced by squeals, chatter, and cross-talk, particularly after sun-down. While some relief will come from the reallocation of frequencies, the fact remains that the degree of relief needed can only come from taking probably one-half the AM stations off the air.

Now, the way is open to do this, and at the same time to increase the total number of stations available to listeners, by a wholesale shift from AM to FM operation.

Static interference, representing loss of enjoyment to listeners and loss of revenue to broadcasters, has become accepted as a necessary evil, particularly in the summer months. This condition aggravated by the fact that so many people go to the country, where broadcast programs would be more important to them except for the fact that reception is weaker and, therefore, more seriously affected by static. This handicap is largely overcome by frequency modulation.

Observations over a cycle of twelve months show that FM is not afflicted with the fading that plagues so many AM listeners, and in contrast to the great loss of AM transmitting range during daylight hours, FM signals carry just as far in the daytime as at night.

To the much-needed improvements in broadcast service, FM adds the "presence-effect", due to its tone realism, which brings the personalities of the speakers and artists into listeners' homes. The enthusiastic public response to this advance in quality of reproduction shows a greater degree of critical discrimination on the part of the radio audience than was generally anticipated.

Signposts which indicate the extent of FM progress in its various aspects are clear to those who are interested in reading them. They are:

**BROADCASTING** ★ The following pages present a bird's-eye view of progress to March 1st. Data presented shows that construction permits have been granted to 42 stations. There are 51 applications pending. Among them are those of the Yankee Network for Paxton, Mass., CBS for Boston, and Outlet Store for Providence, R. I., which will be issued as soon as coverage problems are settled by FCC hearings to be held shortly.

The first commercial FM broadcasting license was issued on March 1st to W47NV, Nashville, affiliate of WSM. This station, with sponsors already on contract, is on the air weekdays from 1:00 to 11:00 P.M., and on Sundays from 11:00 A.M. to 9:00 P.M., with no duplication of any other local program service.

Other new stations are expected to be in commercial operation during April, in addition to some of the eleven stations already on the air under experimental licenses, which have already received their commercial C.P.'s.

In the tabulation of stations, details are given as far as they were available. In some cases, final decisions as to plans and equipment cannot be made until pending questions have been settled by the FCC.

**COVERAGE** ★ Over 50,000,000 people are within the service range of the stations for which C.P.'s have been issued already. This is 40% of the population of the entire Country, and represents a much larger percentage of the national purchasing power, since these stations are centered in the greatest trading areas. It is safe to estimate that 60% of our population will be within range of FM stations before the end of 1941.

**AUDIENCE** ★ The foregoing figures show that the broadcasters are confident that FM receivers will be bought as soon as programs are made available. This judgment is confirmed by past experience with the introduction of short-wave tuning, when one-band receivers became obsolete in a single season. During 1941, a similar fate will overtake plain AM receivers, because the new FM broadcasting offers far more usefulness and entertainment value than was added by short-wave tuning. Further, the curiosity factor is a powerful influence toward impelling the American people to replace sets which cannot tune in what their friends can hear!

During the experimental stages of FM broadcasting, the total audience has grown to about 100,000 listeners. By the end of 1941, it is certain that it will cut deeply into the audience of AM stations. Also, FM will regain for radio some of the listeners lost to phonographs since, to the noise-free entertainment of recorded music, FM adds greatly superior tonal qualities.

**PROGRAMMING** ★ The realism and presence-effect of FM reception gives new impact and conviction to broadcasting. As FM technique is developed by program directors and script writers, the value of broadcasting as a medium of entertainment and advertising will be enhanced greatly. On such a high-quality AM station as WOR, reception of studio programs sounds dull compared to the brilliance of the affiliated FM transmitter W2XOR, even though the production follows standard AM technique. As stations are licensed for commercial operation, the full advantages of FM broadcasting will be made available to the radio audience.

**PROGRESS** ★ The nation-wide spread of FM broadcasting, as shown by the information tabulated on the pages following, is striking evidence of the sincere efforts being made by the broadcasting stations to serve the interest, convenience, and necessity of American listeners.

FM ANTENNA AT W47NV, NASHVILLE, FIRST STATION LICENSED FOR COMMERCIAL OPERATION

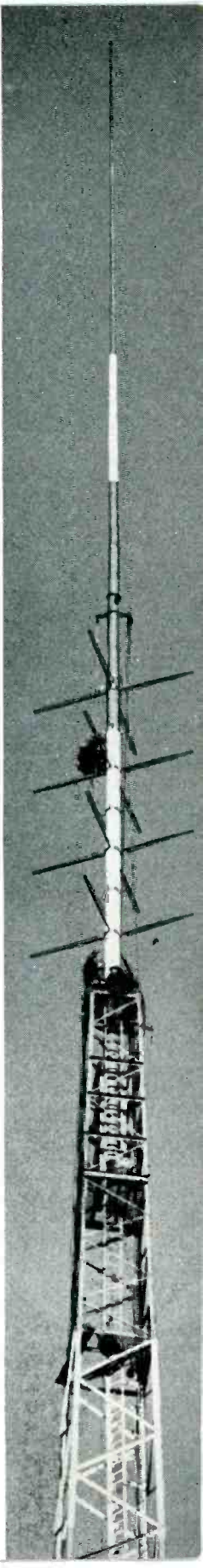

# STATUS OF FM BROADCASTING STATIONS AS OF MARCH 1, 1941

City	Freq.	FM Call AM Affil.	Operating Company Address Location of F.M. Transmitter	Chief Executive General Manager Chief Engineer	Coverage, Sq. M. Population	Transmitter	Studio to Transmitter Link	Antenna	Present Status of Operating Plans	Programs
<b>CALIFORNIA</b>										
Los Angeles	44.5	K45LA KHJ	Don Lee Broadcasting System 5515 Melrose Ave., Hollywood Not given	Thomas S. Lee Lewis Allen Weiss Frank Kennedy	6,944 2,600,000	Will use 50 kw. Have re- quested FCC permis- sion to use 1 kw. tem- porarily			Awaiting FCC permis- sion to use 1 kw. pending installation of permanent trans. C. P. not yet issued	
Los Angeles	44.9	KFI	Earle C. Anthony, Inc. 141 N. Vermont Ave. Not given	Earle C. Anthony Harrison Holloway { Curtis W. Mason { H. L. Blattnerman	1,370 2,259,392					
Los Angeles	45.1	KFVD	Standard Broadcasting Co. 338 S. Western Ave. Not given	J. Frank Burke J. Frank Burke, Jr. John A. Smithson	5,707 3,084,185				C. P. not yet issued	
Los Angeles	45.5	KFSG	Echo Park Evangelistic Assn. 1100 Glendale Blvd.	Aimee Simple McPherson Dr. Giles N. Knight Myron E. Kluge	6,972 2,489,174	Will use 25 kw. G. E. transmitter, RCA speech equipment	Radiolink	Turnstile, hori- zontal po- larization	Application recently modified to meet FCC area require- ments	
Los Angeles	45.5		Metro-Goldwyn-Mayer Studios, Inc.		7,060 2,467,178				Application was filed on Feb. 13	
San Francisco	43.5	KFRG	Don Lee Broadcasting System 100 Van Ness Ave. Not given	Thomas S. Lee W. D. Pabst E. Underwood	3,080 1,428,331				C. P. not yet granted	
<b>CONNECTICUT</b>										
Hartford	4.53	W53H (WJXS) WTIC	The Travelers Best. Service 26 Grove St. Talcott Mountain, Avon, Conn.	Owned by Travelers Ins. Co. Paul W. Morency J. Clayton Randall	6,100 1,118,000	Now using 1 kw. com- posite. Will add 6 kw. G. E. amplifier, RCA speech equipment	Wire, 8 1/2 mi.	Permanent an- tenna, 5-bay turnstile, hori- zontal po- larization	Operating on regular schedule since Mar. 1, 1940. Now await- ing delivery of per- manent equipment	Daily, 4:00 P.M. to mid- night
Hartford	46.5	W65H (WJXPW) WDRG	WDRG, Inc. 750 Main St. Meriden Mountain, Conn.	Franklin M. Doolittle Franklin M. Doolittle I. A. Martino	6,100 1,118,000	Now using 1 kw. com- posite. Output re- quired for permanent installation to be de- termined. RCA speech equipment	Wire, 17 mi.	Turnstile an- tenna, hori- zontal polar- ization	Operating on regular schedule since Dec. 1940. Exp. license is- sued Aug. 1939	Daily, 2:00 P.M. to 10 P.M. Now transmit- ting 5.6 hours of programs weekly not heard on AM.
<b>FLORIDA</b>										
Ft. Lauderdale	44.5	WFTL	Tom M. Bryan 2700 S. Andrews Ave. Not given	Tom M. Bryan R. M. Tigert Francis G. Carroll	2,150 306,000				C. P. not yet issued	
<b>ILLINOIS</b>										
Chicago	44.7	W47C WJJD	WJJD, Inc. 230 N. Michigan Ave. 75 E. Wacker Drive	Ralph L. Atlas Ralph L. Atlas Walter Myers	10,800 4,500,000				C. P. has been issued. Station under con- struction	



Chicago	45.1	W51C (W9XX/R) None	Zenith Radio Corp. 6001 Dickens Ave. 135 S. LaSalle St.	.....	10,760 4,500,204	Now using 5 kw. composite. Will be increased to 50 kw.	Radio and wire, 20 mi.	Vertical polarization	C. P. issued Oct. 31, 1940. Permanent transmitter now under construction	Daily, 7-30 A.M. to midnight.
Chicago	45.9	W30C WGN	WGN, Inc. 441 N. Michigan Ave. Tribune Tower Bldg.	Col. R. R. McCormick Frank P. Schreiber Carl J. Meyers	10,800 4,865,448	Installing G. E. transmitter, modified RCA speech equipment. Will use 30 kw.	Wire, 600 ft.	3-bay turnstile, horizontal polarization	C. P. issued Dec. 6, 1940. Permanent transmitter now under construction	Commercial operation expected by Sept. 1
Chicago	46.3	W63C WMAQ WENR	National Broadcasting Co. 222 N. Bank Dr.	Harry C. Kopf Harry C. Kopf Howard C. Lutgens	10,800 4,500,000	.....	.....	.....	C. P. has been issued	.....
Chicago	46.7	W67C WBBM	Columbia Bcastg. System, Inc. 410 Michigan Ave. 1 N. La Salle St.	H. Leslie Atlas H. Leslie Atlas Frank B. Falknor	10,800 4,500,000	Construction under way. No details available	.....	.....	C. P. was issued Jan. 15, 1941	.....
Chicago	47.5	W45— WNB1	Moody Bible Inst. of Chicago 153 Institute Place Not given	Moody Bible Inst. Henry C. Crowell A. P. Frye	10,800 4,500,000	.....	.....	.....	C. P. was issued Mar. 5, 1941	.....
Cicero	46.7	WHFC	WHFC, Inc. 6138 Cermak Rd. Not given	R. W. Hoffman M. E. Clifford E. P. Hayes	2,885 3,835,000	.....	.....	.....	C. P. modified Feb. 14, 1941	.....
Rockford	47.1	W71— WROK	Rockford Broadcasters, Inc. 109 S. Water St. Probably atop A.M. tower	Ruth Hanna Simms Walter M. Koessler Thomas C. Cameron	3,900 270,000	Transmitter will probably be 5 kw.	Wire, 6 mi.	.....	C. P. granted Feb. 19, 1941	.....

### INDIANA

Evansville	44.5	W45W WGBF WEOA	Evansville on the Air, Inc. 519 Vine St. 203 NW 5th St.	Alvin Eades Clarence Leitch John B. Caraway, Jr.	8,397 495,000	10 kw. composite transmitter. RCA speech equipment	Wire, 200 ft.	Lingo turnstile	C. P. granted Oct. 24, 1940	Commercial operation expected by May 1, 1941
Fort Wayne	44.9	W49— WOWO WGL	Westinghouse Radio Stations, Inc. 925 S. Harrison St. Atop WGL antenna	Westinghouse E. & M. I. L. H. Wailes R. G. Duffield	6,100 420,000	.....	Wire, 190 ft.	.....	C. P. granted Feb. 19, 1941	.....
South Bend	47.1	W71— WSBT	South Bend Tribune South Bend Tribune Bldg. At WSBT site	F. A. Miller F. D. Schurz H. G. Cole	4,300 148,000	RCA transmitter, using 5 kw. RCA speech equipment. Ordered but not yet delivered	Wire, if available	Turnstile, horizontal polarization	C. P. granted Feb. 5, 1941	Commercial operation planned Aug. 1, 1941. Will transmit all special FM programs

### IOWA

Cedar Rapids	44.7	None	Gazette Co.	No information supplied	7,400 282,000	.....	.....	.....	C. P. not yet granted	.....
--------------	------	------	-------------	-------------------------	------------------	-------	-------	-------	-----------------------	-------

### KENTUCKY

Ashland	43.3	WCMI	Ashland Broadcasting Co. 20th & Front Sts. Not given	Gilmore N. Nunn R. MacKensie Harry J. Harris	5,119 421,990	1 kw. Western Electric transmitter, complete speech equipment	Wire, 2 mi.	Turnstile, horizontal polarization	C. P. application amended Feb. 14, 1941	.....
Lexington	44.1	WLAP	American Bcastg. Corp. of Ky. Radio Bldg. Off Mason Headley Rd.	Gilmore N. Nunn Ted Grizzard Sanford Helt	7,290 415,501	1 kw. Western Electric transmitter and speech equipment	Wire, 2 mi.	Turnstile, horizontal polarization	C. P. application amended Feb. 14, 1941	.....

Louisville	45.7	WHAS	Courier-Journal & L'ville Times 300 W. Liberty St. Not given	Barry Bingham W. L. Coulson Orritt W. Towner	13,200 1,004,320		C. P. not yet granted
Alexandria	44.7	KALB	Alexandria Broadcasting Co. 3rd & Jackson Sts. Not given	Walter H. Allen C. Edly Rogers Jesse R. Sexton	3,025 116,119		C. P. not yet granted
Baton Rouge	44.5	W45RG WJBO	Baton Rouge Broadcasting Co. 352 Florida St. Not given	Charles P. Mauship, Sr. H. Vernon Anderson Wilbur T. Galsion	8,100 361,400		C. P. granted. No further information supplied
Baltimore	46.3	None	A. S. Abell Co.	No information supplied	6,040 1,810,159		C. P. not yet granted
<b>MARYLAND</b>							
<b>MASSACHUSETTS</b>							
Boston	44.1	WEEI	Columbia Bcastg. System, Inc. 182 Tremont St. Not given	Harold E. Fellows Harold E. Fellows Philip K. Baldwin	16,230 5,972,246	Design work in process	C. P. application designated for hearing by FCC.
Boston	44.3	WIXOJ WNAC WAAB	The Yankee Network 21 Brookline Ave. Paxton, Mass.	John Shepard, 3rd Linus Travers Paul A. deMars	19,230 6,635,751	50 kw. R.E.L. transmitter in operation since Jan. 15.	Operating under experimental license. FCC hearing Apr. 7
Boston	46.7	WB7— (W1XK) WBZ	Westinghouse Radio Stations, Inc. 275 Tremont St. Atop WBZ antenna	Westinghouse E. & M. Co. L. B. Wadles F. M. Sloan	6,700 3,400,000	Have been using 1 kw. Westinghouse. No data supplied on permanent installation	Horizontal polarization. Has been operating under experimental license. C. P. issued Feb. 19, 1941
Springfield	48.1	WB1— (W1XSN) WBZA	Westinghouse Radio Stations, Inc. 140 Chestnut St. Atop WBZA antenna	Westinghouse E. & M. Co. L. B. Wadles H. E. Randol	2,500 500,000	Have been using 1 kw. Westinghouse. No data supplied on permanent installation	Horizontal polarization. Has been operating under experimental license. C. P. issued Feb. 19, 1941
Worcester	43.1	W1XTG WTAG	Worcester Telegram Pub. Co. 20 Franklin St. Not given	George F. Booth E. F. Hill H. H. Newell	20,437 6,606,882	Have been using 1 kw. No data supplied on permanent installation	Horizontal polarization. Has been operating under experimental license since July 16, 1940. C. P. not issued. Application set for hearing
Week days 6:30 a.m. to midnight. Sundays 7:30 a.m. to midnight. About 24 hrs. special FM programs weekly							
Battle Creek	48.1	WELL	Federated Publications, Inc. 1 West Michigan Ave. Not given	A. L. Miller D. E. Jayne Raymond Roof	4,100 278,739		C. P. not yet issued
Detroit	43.7	WJR	WJR, The Goodwill Station 2103 Fisher Bldg. Not given	G. A. Richards Leo Fitzpatrick (M. R. Mitchell { Andrew Friedenthal	14,144 3,636,615		Amendment to C. P. application filed

Detroit	44.5	W45D WWJ	Evening News Assn. 615 Lafayette St. Atop Penobscot Bldg.	W. E. Scripps W. J. Scripps Carl Wesser	6,820 4 kw basic R. E. L. trans- mitter unit now in- stalled. 50 kw. R. E. L. amplifier is being set up. Will use 13.3 kw. output. W. E. speech equipment	Studio adja- cent to FM transmitter	2-bay turn- stile, hori- zontal polar- ization	C. P. issued Feb. 13, 1941. Have requested permission to oper- ate temporarily on 4 kw. output	Will have al- most entirely special pro- grams for FM	
Detroit	44.9	W49D WMBC	John L. Booth Bessig, Inc. 7310 Woodward Ave. Not given	John L. Booth John L. Booth Edward Clark	6,800 2,900,000			C. P. issued Feb. 11, 1941		
Detroit	46.5	W3BK	James F. Hopkins, Inc. 6559 Hamilton Ave. Not given	James F. Hopkins James F. Hopkins Paul Frincke	6,820 2,900,000			C. P. not yet issued		
Grand Rapids	45.5	WOOD	King-Trendle Bessig, Corp. Grand Rapids Natl. Bank Bldg. Not given	George W. Trendle H. Allen Campbell Roy Gardner	4,340 428,384			C. P. application filed Feb. 24, 1941		
Grand Rapids	46.1	None	Federated Publications, Inc. Grand Rapids Not given		5,300 518,766			C. P. not yet issued		
Lansing	45.1	WJIM	WJIM, Inc. City National Bldg. Olds Tower Bldg.	Harold F. Gross Harold F. Gross Charles L. Beady	5,341 421,000	Wire, 1414 ft.	Turnstile, hori- zontal polar- ization	C. P. not yet issued. Only awaiting FCC action	Plan 10 hrs. daily, start- ing with 15 hrs. of spe- cial FM programs weekly.	
Lansing	47.1	None	Federated Publications, Inc. Lansing Not given		3,820 278,162			C. P. not yet issued		
<b>MISSOURI</b>										
Kansas City	44.9	W9XA None	Commercial Equipment Co. 7134-36 Main St. Medical Arts Bldg.	Evere H. L. Dillard	4,100 790,000	Operating since Mar. 1940 with 1 kw. trans- mitter	Vertical coax- ial antenna	C. P. not yet granted. Station wants to op- erate on low power temporarily		
St. Louis	43.1	KNOK	Star-Times Pub. Co. 12th & Delmay Sts. Not given	Elzey Roberts John C. Roberts, Jr. A. F. Rekart	9,900 1,640,000			C. P. not yet granted		
St. Louis	43.5	KSD	Pulitzer Publishing Co. Post Dispatch Bldg. Not given	Joseph Pulitzer George M. Burbach Robert L. Coc	6,564 1,531,182			C. P. not yet granted		
St. Louis	44.3	WEW	St. Louis University 3612 Lindell Blvd. Same address	Rev. W. A. Burk, S.J. Nicholas Pachara George E. Rueppel	13,500 1,682,500	Plan to use 10 kw. RCA transmitter and speech equipment	3-bay turnstile, horizontal polarization	C. P. not yet granted. Details of service area not yet settled		
<b>NEW HAMPSHIRE</b>										
Mt. Washington	43.9	W39B (W1XER) WNAC	The Yankee Network 21 Brookline Ave., Boston Atop Mt. Washington	John Shepard, 3rd Linus Travels Paul A. de Mars	31,000 2,000,000	Now using 1 kw. A. 5 kw. R. E. L. transmitter is under construction for permanent installation	2-bay turnstile, horizontal polarization	Rebroadcasts Paxton permission to operate commercially now, as new transmitter cannot be carried up until late spring	Started Dec. 17, 1940 to transmit daily 8:00 a.m. to mid- night.	



## NEW JERSEY

3,700  
910,000

C. P. not yet issued

## NEW YORK

Albany	45.1	WOKO	WOKO, Inc. Radio Center Bldg. Helderberg Mts., New Scotland O. A. Sardi	Harold E. Smith Harold E. Smith O. A. Sardi	7,164 922,163	G. E. transmitter on order. Expect to use 1/2 kw.	Radio link	Turnstile, horizontal polarization	C. P. not yet granted
Binghamton	44.9	W49BN WNBF	Wylie B. Jones Advt. Agency Capitol Theatre Bldg. 5 mi. SE of Binghamton	John C. Clark Cecil P. Mastin Louver Stanz	6,660 516,388	Will use 2 kw. R. E. L. transmitter	Wire, 9 mi.	3-bay turnstile, horizontal polarization	C. P. issued Oct. 31, 1940. Application for modification awaiting FCC action
New York City	42.1	WNYE WNYC	City of N. Y. Mun. Bstg. Sys. 2500 Municipal Bldg. Municipal Bldg.	City of New York M. S. Novik I. Brinberg	3,889 11,550,274	Same building			C. P. not yet issued. Designated for hearing
New York City	43.1	W31- (W2XMN) None	Edwin H. Armstrong Alpine, N. J.	Edwin H. Armstrong	15,610 12,237,173	40 kw. RCA composite transmitter	Wire, and experimental radio link	Turnstile, horizontal polarization	C. P. was issued Mar. 5, 1941. 11 A.M. to 11 P.M. daily
New York City	44.5	None	Muzak Corp. 229 Fourth Ave. Not given	Waddill Catchings	4,490 10,546,481				C. P. not yet issued
New York City	44.7	WNAZ WAAB	The Yankee Network 21 Brookline Ave., Boston Palisades Park, Cliffside, N. J.	John Shepard, 3rd Linus Travers Paul A. de Mars	8,500 11,208,250			Turnstile, horizontal polarization	C. P. not yet issued
New York City	44.7	None	News Syndicate, Inc. 202 E. 42 St. Same address		8,500 11,212,416			Will be mounted atop present mast. Horizontal polarization	C. P. application filed Feb. 13, 1941
New York City	45.1	W51NY (W2XW(3)) WEAF WJZ	National Broadcasting Co., Inc. 30 Rockefeller Plaza Atop Empire State Bldg.	Niles Trammell William S. Hedges O. B. Hanson	8,500 11,896,500	Now using 1 kw. RCA transmitter and speech equipment. Permanent transmitter will be 5.5 kw.	1.7 mi.	Turnstile, horizontal polarization	C. P. granted Jan. 24, 1941. Now awaiting delivery of new equipment.
New York City	45.5	W55NY None	William G. H. Finch 1819 Broadway Not given	William G. H. Finch	8,500 12,000,000	No information supplied			Now transmitting 3 P.M. to 11 P.M. Wednesday through Sunday. C. P. has been granted
New York City	45.9	W59NY None	Frequency Broadcasting Co. 1250 Atlantic Ave., Bklyn. Not given	Thomas E. Murray	8,500 11,000,000	10 kw. W. E. transmitter			C. P. has been granted
New York City	46.3	W63NY WHN	Marcus Loew Booking Agency 1540 Broadway Not given	Herbert L. Pettley Frank Roehrenbeck Paul Fueling	8,500 12,074,192			Turnstile, horizontal polarization	C. P. has been granted
New York City	46.7	W67NY WABC	Columbia Bstg. System, Inc. 485 Madison Ave. Atop 500 Fifth Ave.	William S. Paley Arthur Hull Hayes Henry Crossman	8,500 12,000,000	Design work is in process		Turnstile, horizontal polarization	C. P. granted Jan. 7, 1941
New York City	46.7	WNEW	Wodiam Corp. 501 Madison Ave. Not given	Arde Bulova Bernice Judis M. J. Weiner	8,500 11,431,600				C. P. not yet issued

New York City	47.1	W71NY (W2XOR) WOR	Bamberger Bestg. System, Inc. 1440 Broadway Atop 441 Madison Ave.	Alfred J. McCosker Theodore C. Streibert J. R. Poppele	8,500 12,000,000	Now using 1 kw. W.E. transmitter and speech amplifier. Permanent 10 kw. W.E. transmitter on order	Wire, 3 mi.	Permanent antenna will be turnstile, horizontal polarization	C. P. issued. Limited commercial operation scheduled for Mar. 1, 1941	Daily, 9:00 a.m. to midnight. About 112 hours weekly are special FM programs
New York City	47.1	WAAT	Bremer Broadcasting Corp. 1819 Broadway Not given	Paul H. La Stayo Paul H. La Stayo Anthony Castellani	8,500 11,325,000				C. P. not yet issued. Designated for hearing	
New York City	47.5	W75NY None	Metropolitan Television c/o Bloomingdale Bros., Inc. Hotel Piere	Ira Hirschman	8,500 12,000,000				C. P. has been issued	
New York City	47.5	WBXX	WBXX Bestg. Co., Inc. 260 E. 161 St. Cliffside Park, N. J.	Amory L. Haskell W. C. Alcorn H. L. Wilson	8,730 11,328,713		Wire, 15 mi.	9-bay turnstile horizontal polarization	C. P. not yet issued. Designated for hearing	
New York City	47.9	WHOM	New Jersey Bestg. Corp. 29 W. 57 St. Not given	Paul F. Hutton Joseph Lang Alison Burnham	8,500 11,500,000				C. P. not yet issued	
New York City	48.3	WMCA	Knickerbocker Bestg. Co., Inc. 1657 Broadway Atop Chamlin Bldg., E. 42 St.	Edward J. Noble Donald S. Shaw Frank Marks	8,500 10,817,455	Application filed to obtain information			C. P. not yet issued. Amendment to application filed Feb. 13, 1941	
New York City	48.3	None	FM Radio Bestg. Co., Inc. 70 Pine St. Same address		8,600 9,800,000				C. P. not yet issued	
Rochester	45.1	W5J— (W8XOY) WHAM	Stromberg-Carlson Tel. Mfg. Co. 100 Carlson Rd. Atop Rochester Gas & Elec. Bldg.	Wesley M. Angle William Fay Kenneth J. Gardner	3,200 584,800	Present transmitter 1 kw. R.E.L., and W.E. speech equipment. Will use 3 kw. R.E.L. for permanent transmitter	Wire, 1/4 mi.	2-bay turnstile horizontal polarization	Experimental license granted Nov., 1939. C. P. for commercial installation granted Mar. 5, 1941	Monday through Friday, 10 a.m. to midnight. Sat. & Sun., 2
Schenectady	44.7	W47A	Capitol Broadcasting Co.		6,589 367,000				P.M. to 10 P.M. Has been on the air since Nov. 1939. C. P. has been issued	
Schenectady	45.7	W57A (W2XOY) WGY	General Electric Co. 1 River Road Helderberg Mts., New Scotland	General Electric Co.	6,600 805,060	General Electric transmitter	Radio, 12 mi.	Turnstile horizontal polarization	C. P. granted Nov. 1940. Licensed for experimental operation Aug. 1938	Scheduled programs started Nov. 20, 1940. Daily
Syracuse	46.3	W63SY WSYR	Central N. Y. Bestg. Corp. Starrett-Syracuse Bldg. 12 mi. south of Syracuse	Harry C. Wilder F. R. Ripley Armand Belle Isle	6,800 600,000		Radio	Not decided	C. P. has been granted	Expect to operate on commercial basis about July 1st, 1941
<b>NORTH CAROLINA</b>										
Winston-Salem	44.1	W41— None	Gordon Gray Clingman's Peak	Gordon Gray	69,400 4,125,000	Will install 50-kw. transmitter	Radio link		Commercial C. P. issued Mar. 12	
Winston-Salem	46.7	WSJS	Piedmont Publishing Co. 416 N. Marshall St. Not given	Gordon Gray N. L. O'Neil Phil Hedrick	4,600 500,684				C. P. not issued	

**OHIO**

Cleveland	41.5	WBOE None	Cleveland Board of Education Board of Education Bldg. Not given	City of Cleveland William B. Levenson	FM transmitter donated by Major Armstrong	Wire, 6 1/2 mi.	License granted	8:30 A.M. to 4:30 P.M. on each school day
Columbus	44.5	W45CM (W8XYH) WBNS	WBNS, Inc. 33 N. High St. 1035 Barnett Rd.	Robert H. Wolf Richard A. Boyel Lester H. Natzer	12,400 Now using 1/4 kw. G.E. 1,500,000 Will use 60 kw. G.E. transmitter with RCA speech equipment	10-bay turnstile, horizontal polarization.	Experimental license granted Dec. 1939. Commercial C. P. is- sued Nov. 1940	Scheduled broadcasting started Apr. 1940. Now transmitting programs wkly.
Youngstown	43.5	WFMJ	WFMJ Broadcasting Co. 101 W. Boardman St. Not given	William F. Maag, Jr. William F. Maag, Jr. Frank A. Diermper	2,304 1,445,498	noon to midnight, 48 hrs. special Commercial operation expected July, 1941	C. P. not yet issued	

**OREGON**

Portland	44.5	KOIN	KOIN, Inc New Heathman Hotel Not given	C. W. Myers C. Roy Hunt Louis S. Bookwalter	8,175 608,611		C. P. not yet issued	
----------	------	------	--	---	------------------	--	----------------------	--

**PENNSYLVANIA**

Philadelphia	44.7	W47PH WIP	Penn. Broadcasting Co. 35 S. 9th St. Atop Gimbel Bldg., 9th & Chestnut Sts.	Benedict Gimbel, Jr. Benedict Gimbel, Jr. Clifford C. Hartis	9,300 Will use 10 kw. trans- mitter with W. E. 4,500,000 speech equipment	4-bay turnstile, horizontal polarization	C. P. issued Feb. 11, 1941	
Philadelphia	45.3	W53- WFIL	WFIL Broadcasting Co. Widener Bldg. Atop Widener Bldg.	Samuel R. Rosenbaum Roger W. Clipp Arnold N. Green	9,300 3,850,000	Wire same building	C. P. issued, and con- struction of perma- nent transmitter scheduled for com- pletion May 1, 1941	FM programs will not du- PLICATE WFIL pro- grams
Philadelphia	45.7	W57- KYW	Westinghouse Radio Stations, Inc. 1619 Walnut St. Not given	Westinghouse E. & M. Co. L. B. Wables Ernest H. Gager	9,300 Now using 1 kw. West- inghouse transmitter. 4,500,000 Will probably use 10 kw. with RCA speech equipment	6-bay turnstile, Horizontal polarization	C. P. issued Feb. 19, 1941	
Philadelphia	46.1	None	Gibraltar Service Co. Philadelphia Not given	Phila. Evening Bulletin	9,318 3,998,402		C. P. not yet issued. Application filed Feb. 20, 1941	
Philadelphia	46.7	W67PH WCAU	WCAU Broadcasting Co. 1622 Chestnut St. Not given	Dr. Leon Levy Dr. Leon Levy John G. Leicht	9,300 RCA transmitter and 4,142,132 speech equipment. Will use 9.6 kw.	6-bay turnstile, Horizontal polarization	C. P. issued Nov. 26, 1940. Commercial transmission sched- uled to start Apr. 15	
Philadelphia	48.3	WQBG	Seaboard Radio Bstg. Co. Mt. Carmel Ave. & Easton Rd. Not given	Paul F. Harron Edward D. Clerly John H. Henninger	9,400 3,900,000		C. P. not yet issued	
Pittsburgh	43.9	WJAS	Pittsburgh Radio Supply House Chamber of Commerce Bldg.	H. J. Brennen C. S. Wasser Walter McCoy	16,100 3,175,432		C. P. not yet issued	



Pittsburgh	44.7	W47P WWSW	Walker & Downing Radio Corp. 212 Wood St. 341 Rising Main St.	Paul Block Frank R. Smith, Jr. Henry R. Kaiser	8,400 3 kw. G. E. transmitter. Will use 1.9 kw. out- put. RCA speech equipment	Wire, 1 1/4 mi. Horizontal polarization	6-bay turnstile. Horizontal polarization	C. P. granted Dec. 6, 1940. Commercial transmission sched- uled to start Apr. 1	Plan to be on the air 24 hrs. daily
Pittsburgh	47.5	W75P KDKA	Westinghouse Radio Stations, Inc. Grant Bldg. Allison Park	Westinghouse E. & M. Co. L. B. Wailes Dwight A. Myer	8,400 Westinghouse transmit- ter, probably 1 kw. output, under con- struction	Wire, 10 mi. Horizontal polarization	6-bay turnstile. Horizontal polarization	C. P. granted Jan. 14, 1941	Plan at least 20 hrs. weekly of special FM programs
<b>RHODE ISLAND</b>									
Providence	44.3	WJAR	Outlet Co. 176 Weybosset St. Not given	Mortimer L. Burbank John J. Boyle Thomas C. J. Prior	16,370 6,263.346			C. P. not yet issued. Designated for FCC hearing	
Providence	47.5	WPRO	Cherry & Webb Bestg. Co. 15 Chestnut St. Near E. Providence	William S. Cherry, Jr. William T. Bush Howard W. Thornley	6,207 4,230.838			C. P. not yet issued	
<b>TENNESSEE</b>									
★ Nashville	44.7	W47NV WSM	Natl. Life & Accident Ins. Co. National Bldg. Atop AM radiator	Edwin W. Craig Harry Stone J. H. deWitt, Jr.	16,000 20 kw. composite trans- mitter 819,000			Com'l license granted March 1, 1941	At least 10 hrs. daily. Programs will be independent of WSM
<b>TEXAS</b>									
Amarillo	45.1	KFDA	Amarillo Broadcasting Corp. Nunn Bldg. Not given	Gilmore N. Nunn Earl R. Strandberg Howard Blaker	6,503 80,024			C. P. not yet issued. Modification has been filed	
<b>UTAH</b>									
Salt Lake City	44.7	K47SL KSL	Radio Service Corp. of Utah Union Pacific Bldg. Not given	J. Reuben Clark, Jr. Ivor Sharp Eugene C. Pack	623 194,000			C. P. has been issued. Expect to be on the air before fall	
<b>WISCONSIN</b>									
Milwaukee	45.5	W55M (W9XAO) WTMJ	The Journal Co. 333 W. State St. Richfield, Wis.	W. J. Damm L. W. Herzog D. W. Gellerup	8,540 1,522,944	Now using 1 kw. R. E. L. transmitter under con- struction. Will use 30 to 40 kw. output	2-bay turnstile, horizontal polarization	Exp. license issued Feb. 23, 1940. Com- mercial C. P. issued Oct. 31, 1940. Com- mercial operation scheduled to start July 1, 1941	Now trans- mitting daily 1:00 to 10:15 p.m. 56 1/2 hrs. of special FM programs weekly
Superior	44.5	(W9XYH) WEBC	Head of the Lakes Bestg. Co. Superior 40th & Tower Sts.	Morgan Murphy Walter C. Bridges Charles Persons	2,754 168,193	Now using 1 kw. G. E. Will use 3 kw. Com- posite speech equip- ment	Turnstile, hori- zontal polar- ization	Exp. license issued Feb. 1940. Commer- cial C. P. not yet issued	Started Mar. 14, 1940 to transmit 4 hrs. daily special FM programs

# HERTZ TO FM As Seen by George H. Clark,\* During an Extraordinary Career Which Goes Back to the Days When—

## 1881 and Its Rural 'Phone

When I became what was to be,  
Our daily words of mystery  
Came to us through an iron wire  
Thrilled by a dim electric fire.  
The ether lay in lazy ease,  
Save for the lightning's pleasantries.

## 1888; the Hertz Oscillator; 1.4 Meters

My mileposts from initial heaven  
Had added up to total seven  
When Hertz, our wireless first "than  
whom,"  
Received his blitz-spark, room to room.  
Thus in this humble laboratory  
Wireless first lisped its little story.

## 1895; Marconi's Bamboo Mast; 40 Meters

A lad of mere fourteen was I  
When 'neath the fair Italian sky  
The ether's virgin vast domain  
Was harnessed to commercial gain.  
With almost childish ceremony  
Was this achieved by young Marconi.<sup>2</sup>

<sup>1</sup> It was then!

<sup>2</sup> The same lad was the first to cross the Atlantic by wireless, using a kite to support his receiving antenna in Newfoundland.

## 1901; Marconi's Kite Aerial; <sup>3</sup> 800 Meters

Life's escalator bore me on  
Till I attained my wireless dawn,  
Basing my puny amateur story<sup>4</sup>  
Upon my hero's greater glory.  
It seemed 't was almost I who won  
The Atlantic's conquest, just begun.<sup>5</sup>

<sup>3</sup> The same lad was the first to cross the Atlantic by wireless, using a kite to support his receiving antenna in Newfoundland.

<sup>4</sup> That same year, I built my first amateur station, in Everett, Mass.

<sup>5</sup> G. Marconi worked 1800 miles; G. Clark, 200 feet.

## 1902; Ships' Masts; Back to 300 Meters

First voter was I, on the morn  
That Navy radio was born.<sup>6</sup>  
Ships' masts took eager place on shore;  
The spark gap spoke, with deafening roar;  
The tortured ether felt the blow  
Of wireless hammers housed below.

<sup>6</sup> See the forthcoming "History of Radio in the U. S. Navy," by Hooper and Clark.

## 1911 Brings Wooden Towers and 2000 Meters

The arc transmitter found our shores,  
And Elwell's latticed two by fours  
Upode the California air

\* The mention of George Clark's name brings back many happy recollections to countless members of the radio fraternity. The original lines appeared on his Christmas card.

With some revisions, they are reprinted here, by permission, for the enjoyment of FM readers. George Clark, who started his radio career with Stone Telegraph and Telephone Company in 1903, is now Historian for R.C.A., 30 Rockefeller Plaza, New York City.

To free a new emission there.  
Six hundred feet o'er golden ground  
The messages poured their silent sound.

## 1912; the Navy's Self-supporting Towers; 3800 Meters

Then came the pride of Navy's way—  
Three towers topping NAA,  
And here the spark, its span outrun,  
Resigned to an imprisoned sun.<sup>7</sup>  
Poulsen to Elwell passed to Clark  
The final burial of the spark.<sup>8</sup>

<sup>7</sup> I.e., the arc in its iron prison.

<sup>8</sup> Its tombstone was my report on the "Salem-Arlington" tests.

## 1915; the Grid Grows Greater

A tiny lamp of flashlight size  
Lay hidden from commercial eyes  
For many years. But now its might  
Grew to a giant's, overnight.  
DeForest's audion<sup>9</sup> became  
Radio's first and greatest name.

<sup>9</sup> "Vacuum tube," as if you needed to be told!

## 1918; Tubular Masts; 13,600 Meters

But for the moment, in its span  
From child's estate to sturdiest man,  
It yielded to a giant disc  
At maximum speed, with minimum risk.  
Alexander's alternator  
Bowed, in its day, to nothing greater.<sup>10</sup>

<sup>10</sup> The New Brunswick station won fame, with this alternator, during World War, Serial No. 1.

## 1920; Broadcasting; Back to 300 Meters

Came Conrad, by deForest led  
To complete the word by Fessenden said.<sup>11</sup>  
McCarthy's intellect was ours  
From countless wire-connected towers.  
Mae West antennas<sup>12</sup> sought the sun,  
And Mae once gave us Eden's fun!

<sup>11</sup> The first "broadcast," tho to a limited audience, of commercial operators, was given on Christmas Eve of 1906, by the late Professor R. A. Fessenden, America's greatest scientist-inventor in radio fields.

<sup>12</sup> Diamond-shaped, if a diamond can be 300 feet high and only fifteen feet wide in the middle.

## 1940; My Oscillations Are Getting Feeble!

Today I'm old, and weak, and deaf;  
I can't hear WEAF!<sup>13</sup>  
My Heavyside Layer, (to be blunt),  
Is mostly noticed out in front.  
This screed contains full many a wheeze,  
But I have other types than these.

<sup>13</sup> That's some DEAF!

This Veteran of Wireless views  
The daily kinescopic news;  
He hears the words from nations sent,  
As sponsors' blurbs seem almost meant;  
And diathermy cures his ills

By serving megacyelic pills.<sup>11</sup>

<sup>11</sup> At least, he has *tried* this!

### Today; Loops; Dipoles; 3 Meters

Radio turns a different page,  
For U.H.F. is all the rage.  
*My* frequency is nearly nix;  
*Radio's*, ten to power six.  
Dipoles arise. FM confuses,  
And Television slowly oozes.

(Nor by "FM" am I to mean  
This young and clever Magazine;  
I speak of AM's utter lack,  
Where trains swing sideways on their track.  
Let Howard Armstrong shout with glee  
To know FM confuses *me!*)

### Peering into the Invisible Future

What further will the future bring?  
I join with you in wondering.  
My granddad did not even know  
That ever would be radio,  
And my young grandson<sup>15</sup> well may see  
The birth of some new mystery.

<sup>15</sup> Peter.

Perhaps, ten generations hence,  
May come the end of consequence,  
And man, existing, may refuse  
New life to form, nor his to lose.  
But, as I scan my life—and metre!—  
I gladly pass the torch to Peter.<sup>16</sup>

<sup>16</sup> My grandson.

DR. SERGE KOUSSEVITZKY, CONDUCTOR, BOSTON SYMPHONY, AT DEMONSTRATION OF WESTINGHOUSE FM BROADCAST, CHATTING WITH W. C. SWARTLEY, RIGHT, WBZ AND WBZA MANAGER, AND F. M. SLOAN, WBZ CHIEF ENGINEER. DR. KOUSSEVITZKY'S COMMENTS ON FM REPRODUCTION ARE PARTICULARLY INTERESTING BECAUSE HE WAS LISTENING TO A PERFORMANCE BY HIS OWN ORCHESTRA!



### WESTINGHOUSE DEMONSTRATES FM FROM BOSTON STATION

**T**HE famous Boston Symphony Orchestra and Dr. Serge Koussevitzky, its noted conductor, were the principal participants in the first Westinghouse demonstration of FM from their station at Hull, Mass., near Boston, on February 26th.

The demonstration, broadcast from WIXK, originated at Boston Symphony Hall, where Richard Burgin, assistant conductor, was directing.

"Astonishing," remarked Dr. Koussevitzky repeatedly, as he listened to the crystal clear reception of his orchestra, as it came in at the WBZ studios. "Never before in a broadcast have I been able to pick out each instrument individually," he said. "Every instrument sounds so clear—so beautiful—so natural.

Each instrument keeps just the right color and timbre, particularly the clarinet, which has always been so bad on the air. It is now so clear, and has the whole beauty of the instrument.

"My congratulations," continued Dr. Koussevitzky, "first to the engineers who made the broadcast possible, and secondly to my musicians, who played. Through FM they will now be sure that the public hears what they give them by their instruments."

Mr. W. C. Swartley, general manager of WBZ and WBZA, greeted the fifty guests at the Hotel Bradford studios. The musical portion of the broadcast included "Capriccio Espagnol" by Rimsky-Korsakov, Schubert's "Unfinished Symphony," and an excerpt from "The Enchanted Lake," by Liadov. After the demonstration, F. M. Sloan, chief engineer of WBZ and WBZA, answered questions.





## I. GOLDBERG

RADIO MANUFACTURER SINCE 1908. OLD-TIMERS IN PRACTICALLY EVERY COUNTRY OF THE WORLD CUT THEIR EYE TEETH ON HIS PILOT PARTS. HIS FAMOUS AIRPLANE LABORATORY MADE FIRST NEW YORK-BERMUDA FLIGHT, SET SKY-TO-EARTH CONVERSATION RECORD FROM BUENOS AIRES TO AUSTRALIA. FIRST ALL-WAVE PRODUCTION MODEL WAS HIS PILOT DRAGON. HIS NEW YORK PLANT HUMS IN PEACE, WHILE LONDON FACTORY DUCKS BOMBS

# THE MANUFACTURERS SAY:

A Statement by I. Goldberg, President of the Pilot Radio Corporation, Long Island City, N. Y.

**T**HE advent of frequency modulation reminds me of the days when Pilot Radio pioneered the first all-wave receiver. I recall that we made what seemed then to be a daring announcement in the trade papers: "If it isn't an all-wave set, it isn't a modern radio!"

At that time, there were those who scoffed at the idea, saying: "Why should anyone pay extra for short-wave reception? There's nothing on short waves worth hearing."

Well, when the public began to realize that there were stations on the air that couldn't be heard by the standard one-band sets, the all-wave idea caught on so rapidly that, within a year, every U. S. radio manufacturer was forced to switch over to all-wave tuning.

I do not hesitate to predict that, by the end of 1941, the same sort of thing will happen again. Nashville, Tenn., is already operating as a commercial FM station, and many others will now follow in rapid succession. Listeners will learn quickly that the finest quality of radio entertainment cannot be heard on their present sets, and they will suddenly come to the realization that, "If it doesn't tune FM, it isn't a modern radio!"

The public response to FM in areas where broadcasting is on the air is due to the fact that FM does not offer merely one advantage over AM. It has three distinct points of superiority, any one of which is an ample reason for purchasing one of the new receivers.

These are: (1) elimination of noise, (2) improved tone quality and full, natural volume range, (3) elimination of inter-station interference.

As dealers learn to sound out each customer as to which point is of greatest interest to him, and then concentrate sales effort on that particular feature of FM, sales volume and profits increase accordingly. In the automobile business, it is established practice to find out if the prospect is more concerned about appearance, economy, or safety. Radio dealers are finding that the same system can be applied with equal effectiveness to the three special advantages of FM reception.

It's no use to sell tone quality to the city dweller who is tone-deaf, but who is bothered by noise from elevator motors and electrical equipment. If the man who wants FM's tone-realism lives where there is no interference problem, he only wants to know about the quality of reproduction. Or if the prospect lives in a rural section where, at night, stations from all over the country come jamming in, so

that he logs squeals and chattering at every point on the dial, what he wants, and what he'll buy, is a radio that will give him clear, clean-cut programs free from fading, and that is the feature of FM to sell him.

Even now, while most of the FM stations are still under construction, and those on the air are operating under temporary licenses, thousands of listeners are getting greater entertainment value from the FM programs than from AM stations. Giving one or more of the reasons enumerated above, we at Pilot Radio Corporation, as well as the broadcasters, are receiving reports which express the modern listening habit: "We keep our set on the FM side most of the time."

I want to take this opportunity to answer one question that must be in the minds of dealers who have not yet started to sell FM-AM receivers. The question is: "How will my regular AM set sales be affected if I take on a line of FM-AM models?"

As a manufacturer of both types of receivers I can reply to that from the experiences of Pilot dealers. The answer, very definitely, and without exception, is this:

Our dealers have, in every case, increased their total sales by taking on FM-AM models, without any reduction in volume on AM set sales. Our dealers are selling FM-AM models to people who are not prospects for AM sets. This accounts for greater total volume. On the other hand, people who have only a limited amount to spend won't go up to the price of the new sets. So there has been no decline in AM sales.

Most of our dealers, however, have one or two salesmen who have become known as FM specialists. They are generally those experienced in going after business outside the stores. These men are making commissions such as they have never earned before.

The progress of FM will undoubtedly increase the dollar-volume of radio set sales substantially this year. If the United States stays out of war, our people will have more money to spend. If we go into war, the demand for sets will certainly increase here just as it did in England. Over there, the importance of disseminating information by radio has been recognized, and radio factories have been allotted an adequate supply of raw material. Undoubtedly, that would be done here, too. With FM broadcasting launched on nationwide expansion, and with trade conditions so favorable, 1941 should be radio's greatest year of progress and profit.

# IMPROVED SPEAKER SYSTEM FOR FM

## Details of Stromberg-Carlson Concentric Speaker, Developed for FM Receivers

BY BENJ. OLNEY \*

**L**OUND speakers having an extended high frequency range have been available for several years, but their use in radio receivers has been retarded by factors inherent in the established AM broadcast structure. Except for occasional opportunities to reproduce locally originated programs carried to high fidelity transmitters over suitable studio lines, the full possibilities of the wide range speaker could not be realized generally. Frequency modulation, however, has now removed the audio band-width limitation and, in addition, offers two other advantages which further make feasible the employment of a wide range loud speaker: low noise level and low distortion. It is the purpose of this article to describe a loud speaker system capable of doing justice to FM transmissions.

**Two-Way or Dual System** ★ It is an unfortunate fact that the requirements of a loud speaker for most efficiently reproducing the high frequency range are opposed to those of an efficient low-frequency speaker. The low-frequency unit requires a comparatively large diaphragm or else one of moderate size coupled to some auxiliary device for increasing its ef-

fectiveness at low frequencies, and the entire moving system must be sufficiently sturdy to withstand the large forces and amplitudes associated with the reproduction of low frequency sounds. The result is a comparatively massive diaphragm and driving coil system. On the other hand, a light coil and cone system is essential for efficient high-frequency reproduction, while the amplitudes and forces encountered are comparatively small. It follows that single wide-range speakers embody design compromises varying in severity with the width of the frequency band it is attempted to cover. The system described here employs separate high- and low-frequency speakers, each specially designed for the range it is to cover. The electrical input is fed through a network which divides the energy at 1,500 cycles. An exploded view of the system is shown in Fig. 1.

**Low Frequency Speaker** ★ The low-frequency unit has a molded fibre cone, 8 ins. in diameter, which is relatively shallow and whose periphery is supported by soft, carpinchoe leather. This construction provides a relatively uniform acoustic response up to 1,500 cycles, beyond which it falls off. It is difficult to secure uniform response much above this frequency

\* Acoustical Engineer, Stromberg-Carlson Telephone Mfg. Co., Rochester, N. Y.

FIG. 1. THE 3 ELEMENTS, COMPRISING HIGH- AND LOW-FREQUENCY SPEAKERS, AND LABYRINTH

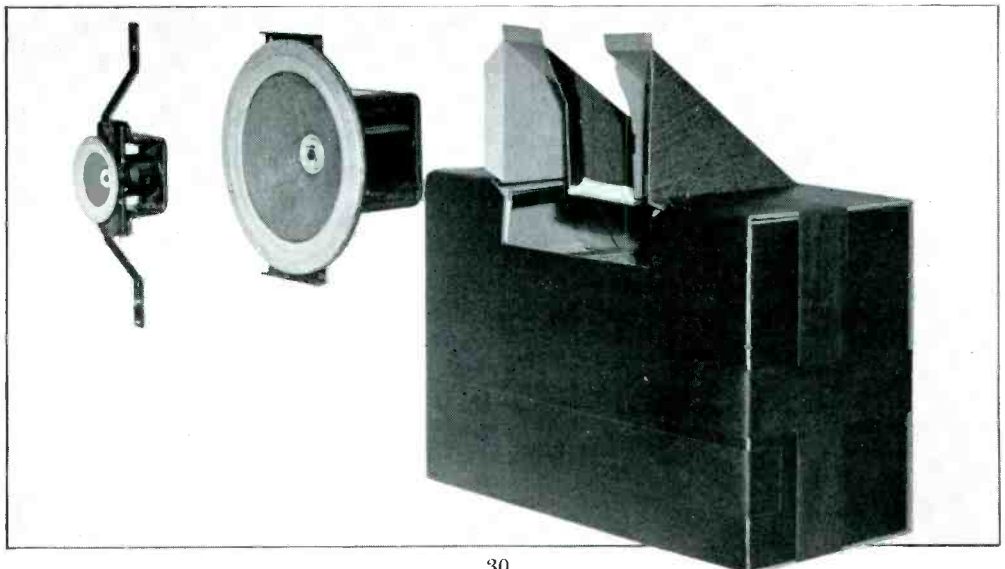





FIG. 2. THE STROMBERG-CARLSON CONCENTRIC SPEAKER MOUNTED ON A BAFFLE BOARD

from a single cone which meets the low-frequency requirements.

The provision of adequate low-frequency response without objectionable resonances in a radio cabinet of moderate size is a difficult matter. The open-backed cabinet of usual dimensions fails as a baffle for very low frequencies because of the relatively short circulation path between the two sides of the cone, and has the further disadvantage of a pronounced air resonance in the box-like cavity behind the loud speaker. This results in "boomy" reproduction. The speaker under discussion employs an acoustical labyrinth to overcome these difficulties. As the labyrinth has been described several times already in acoustical literature, its action will be but briefly touched upon here. It consists of a folded, sound-absorbent duct, coupled to the back of the speaker diaphragm and discharging usually through the floor of the cabinet. It eliminates the troublesome cavity resonance by abolishing the cavity from the acoustical system, while the low frequency response is extended by sound radiated from the open end of the duct in phase with that from the front of the cone.

In addition, a high acoustic resistance is presented to the cone near the low-frequency cut-off, which reduces overshooting and "hang-over" vibrations.

**High Frequency Speaker** ★ The high-frequency speaker has a molded fibre cone only  $2\frac{1}{2}$  ins. in diameter, terminated in a carpinchoe leather edge support and driven by a small, light coil. The small size of the cone was dictated by two considerations. First, smoother response at high frequencies can be obtained with a small cone, particularly when a vibration-absorbing edge support is used. Second, more uniform spacial distribution of the high frequencies is obtained, as wide angular coverage is secured when the diameter of the cone becomes small compared with the wave length of the sound being radiated.

A disadvantage of such a small cone is that its radiation resistance falls off rapidly below about 2,500 cycles per second, even in an infinite baffle. This phenomenon also is connected with the ratio of the diaphragm diameter to the wave length of sound. As the acoustic power generated is equal to the radiation resistance times the diaphragm velocity squared, it is evident that compensation for the decreasing radiation efficiency may be obtained by suitably increasing the diaphragm velocity as the frequency becomes lower. This is done in the present instance by employing the air confined between the back of the high-frequency cone and a closed housing as the principal elastic element of a resonant system whose mass element is the diaphragm and

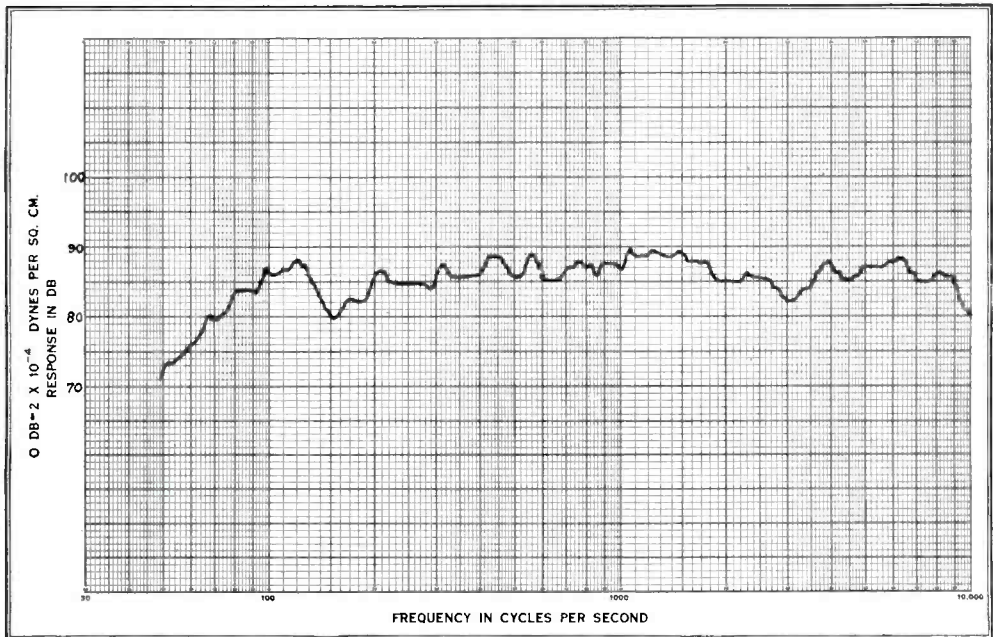

FIG. 3. RESPONSE CURVE OF THE CONCENTRIC SPEAKER, MOUNTED IN A RADIO CABINET

driving coil combination. The resonance is broad, due to mechanical and acoustic resistance in the system, and results in the maintenance of essentially uniform response down to 1,500 cycles. A further advantage of the closed back construction lies in the distributed stiffness of the confined air which serves to protect the high-frequency cone from possible damage due to acoustic driving at low frequencies by the large diaphragm, closely adjacent.

**Coaxial Mounting of Speakers** ★ A feature of this system is the mounting of the high-frequency unit coaxially with the low-frequency unit and partially within the hollow of its cone as shown in Fig. 2. This arrangement was adopted after much experimenting with speakers arranged in the usual side by side relation, and was found to be essential for most natural reproduction, especially of speech, percussion instruments and other sounds rich in transients. The inferior results obtained with the side-by-side speakers appear to be connected with the ability of the hearing sense to distinguish between laterally spaced sound sources, even when they are closely adjacent. In the case of speech, one is accustomed to the sound coming from a single, small source, and is disconcerted by a division of the high- and low-frequency components between two sources, perceptibly separated in space. The ear also can perceive changes in transient

sounds due to phase differences among their components. It appears possible for phase shift to arise from the side-by-side speaker relationship, and to be variable with the position of the listener.

The location of the high-frequency unit directly in front of the low-frequency cone raises the question of possible obstructive effects upon the radiation from the latter. Acoustic theory predicts that an 8-in. cone should begin to exhibit appreciable beam radiation effects around 1,000 cycles, and that a spherical object roughly equivalent to the high frequency speaker volume should begin to act effectively as an obstacle at about the same frequency. As the dividing network attenuates the electrical input to the low-frequency speaker above 1,500 cycles, it follows that any resulting modification of the low-frequency speaker's radiation must occur in the approximate range 1,000 to 1,500 cycles. As a matter of fact, measurements have shown that the high frequency unit actually serves as a spreader for the radiation from the low-frequency cone in the 1,000 to 1,500-cycle region, and offsets the slight axial concentration that otherwise might occur. It is doubtful if the above phenomenon has much practical significance, even in the absence of the obstruction, on account of the limited frequency range over which it can operate. The question is here discussed because it has been raised by many upon first seeing the system.

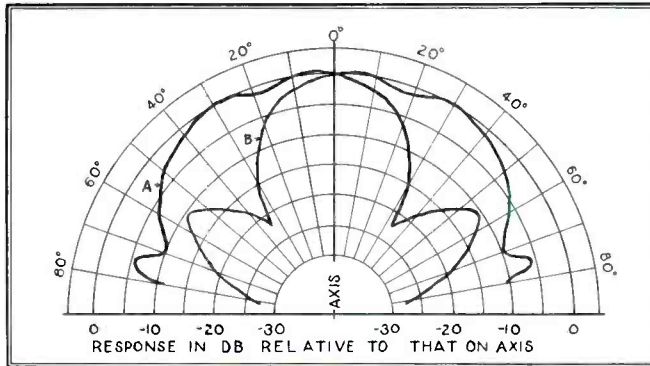

FIG. 4. DIRECTIONAL EFFECTS COMPARED BETWEEN (A) 2½-IN. HIGH-FREQUENCY UNIT OF CONCENTRIC SPEAKER, (B) 8-IN. CONE SPEAKER. MEASUREMENTS WERE MADE AT 6,000 CYCLES

**Performance** ★ A response curve<sup>1</sup> of the complete loud speaker system mounted in a radio cabinet is shown in Fig. 3. The measurement was made in a damped room with a rotating microphone, and the curve was drawn by an automatic recorder arranged to register the average response as the microphone swept around its 8 ft. diameter circular path. In spite of the averaging, a certain amount of the irregularity at the lower frequencies remains chargeable to room effects, as has been determined by past comparisons with outdoor measurements. Supplementary measurements beyond 10,000 cycles indicate that the response recovers at about 13,000 cycles and then cuts off sharply at 17,000 cycles.

Fig. 4 shows a comparison between the measured directional radiation characteristics of an 8-in. cone speaker and the 2½ in. high-frequency speaker described in this article. The frequency was 6,000 cycles in both cases and the conditions of measurement were alike. The difference shown is similar for other high frequencies. It will be seen that the radiation pattern of the smaller speaker is essentially uniform over 50 degrees either side of the axis.

This wide angle response over an extended frequency range is unusual in a loud speaker for home use, and is a very desirable characteristic which has had much less attention than it

<sup>1</sup> Loud speaker response curves are released for publication with a certain amount of reluctance because of the considerable difficulty in interpreting them without long familiarity with the attendant measuring conditions. With the exception of those taken out of doors under certain conditions, almost all such measurements either include effects due to peculiarities of the measuring room and apparatus, or else the artifices employed to reduce the room effects introduce other, and often as serious, inaccuracies. To the experienced engineer familiar with the conditions, acoustic response measurements serve as useful tools, not only to gauge the progress of development work, but always in conjunction with listening tests, to appraise the final result. The dangers attending their too rigorous interpretation by others deserve more appreciation than has generally been exhibited.

deserves. It is believed to be an important factor in lending the property of "presence" to the reproduction from the speaker here described. Not only is anyone in a reasonable listening position able to hear the high frequencies unattenuated, but the wide-angle distribution causes more of these waves to strike the walls and ceiling and, by virtue of repeated reflection, produce a beneficial amount of high-frequency reverberation. It is interesting to note that this desirable property is obtained merely by the very simple expedient of making the diaphragm small. It is difficult to produce as uniform a directional pattern by the use of deflectors or diffusing vanes. These also, in any commercial applications that have come to our attention, affect only the radiation in the horizontal plane, whereas the distribution by the small cone is the same in all planes passing through the axis.

### FIRST FM COMMERCIAL ISSUED

Frequency modulation's first paid broadcast by a full-fledged commercial FM station took place at Nashville, Tenn., when W47NV became the initial FM transmitter in the country to secure full commercial status from the FCC.

W47NV is owned and operated by WSM of the National Life & Accident Insurance Company. It began commercial operation on a regular schedule Saturday, March 1. FM's first commercial program was aired Sunday at 5 P.M., sponsored by the Standard Candy Company of Nashville — a concern that was WSM's first advertiser 16 years ago when the Tennessee station started operation on the regular broadcast band.

The Federal Communications Commission has reported W47NV as the first FM station receiving its final consent to proceed with commercial schedules. Nucleus of the new FM station's staff comprises Tom Stewart, Bill Terry, Jr., and Herbert Oglesby.



# 400 ENGINEERS HEAR FM SESSIONS

## Broadcast Station Engineers Devote Week to FM Papers and Discussions

BY DICK DORRANCE\*

IF THERE existed any doubts in the minds of broadcast engineers that FM commands a front-rank place in the plans and worries of today's broadcast industry, they were sweepingly dispelled by the fanfare lavished over frequency modulation at this year's edition of the annual Broadcast Engineering Conference at Columbus, Ohio.

Conducted under the auspices of Ohio State University and, organized by the initiative of Dr. William L. Everitt of that institution's Department of Electrical Engineering, the Conference devoted its entire second week, February 17 to 21, to frequency modulation and its attendant problems, advantages and peculiarities.

FM's week opened, properly enough, with a talk on the present state of the new art by Major Edwin H. Armstrong, who told some 400 engineers congregated from every section of the country that a surge of frequency modulation into American homes "within the next three or four years" is practically inevitable.

"Barring some dislocation of the economic system as a result of war," prophesied the Major, "I believe that inside of the next three or four years there will be more FM listeners than there are AM listeners."

He traced the progress of FM from a laboratory curiosity in the late months of 1939, through its spectacular career of 1940 that held such high points as the FCC hearing in March, the decision to give FM a commercial go-ahead, the deluge of applications filed with Washington, and the growing boom of public favor.

Of particular interest were the Major's remarks concerning the price range of future FM receivers. "If the public wants it," he declared, referring to frequency-modulation broadcasting, "ways will be found to meet every man's pocket-book." He recalled with a smile that he had once made the rash statement that a superheterodyne could not be manufactured for under \$100.

Of particular interest were a succession of letters received by both The Yankee Network and the Alpine station from listeners who voiced both pleasure and amazement over the entertainment afforded by FM programs. They indicated convincingly that with high power it is possible for FM transmitters to service reliably a surprisingly large amount of territory, in excess of 100 miles from the station.

\* FM Broadcasters, Inc., 52 Vanderbilt Ave., New York City.

By the straightforward method of reading many of these letters, Major Armstrong showed clearly that public interest in FM is rising steadily. But even more important, they refuted any notion that the public does not want full-fidelity, freedom from interference, and the thorough realism that FM offers its listeners.

To spike a few of the fallacious statements that have been made about frequency modulation, the Major dubbed as an "imaginary bugaboo" the idea that FM is limited in range to less than 50 miles.

During the five days in which FM held the stage, all of its phases from microphone to turnstile received clinical attention. Stuart Bailey, of Jansky & Bailey, Washington firm of consulting engineers who operate FM station W3XO, outlined the Commission's regulations and the problems which they imposed upon FM allocation, particularly in instances where geographical distribution of population is not in step with the technical coverage capabilities of FM signals. This situation often creates difficulty in meeting the FCC's rules for types of station classification.

An interesting sidelight of the discussion on allocation problems was the spontaneous coining of the term "scared rabbits" by C. M. Jansky, Jr., to designate AM station owners who fear FM's possibilities to such an extent that they have rushed into filing an FM application as a form of investment insurance. The term apparently struck close to home among a number of engineers present, and recurred frequently in subsequent talks during the course of the conference.

The afternoon of FM's first day provided a highlight of the meeting when Harvey Fletcher, audio expert of the Bell Laboratories, drew a large crowd to hear his discourse on "Hearing, the Determining Factor for High-Fidelity." Testimony to Mr. Fletcher's reputation as an expert was reflected in the presence, during his talk, of several outstanding members of Ohio State's faculty. An interesting yardstick for establishing the limits of most normal hearing were hearing tests conducted with some 2,000,000 persons at both the New York and San Francisco Fairs during the past two summers. His demonstration showed how a high-fidelity service may be rendered the listener despite a compromise with practical limitations met under actual conditions.

Other interesting sessions on succeeding days

included those led by M. L. Levy, of Stromberg-Carlson, on receiver design problems and production, and a two-installment, exhaustive outline of FM antenna problems by Andrew Alford of Mackay Radio. Covering all phases of UHF radiators, Mr. Alford displayed a startling familiarity with his subject that extended from transmission lines to various types of stacked arrays, including his own horizontal ring antenna as well as customary turnstiles.

Probably the only dissenting views in the five days of FM arose during a talk on "FM Field Tests" delivered by Raymond F. Guy of NBC. Accompanied by recordings of NBC tests made at various points on Long Island, backed up by projected slides depicting the results of such tests in chart form, Mr. Guy's discourse brought out the following anti-FM points:—our modern AM broadcasting is very good indeed; the public's radio taste, in caliber of transmission, is conditioned by its pocket-book, and thus primarily in tune with 4,000-cycle reproduction; clear channel AM stations using 500 kilowatts should be given more

serious thought; the scarcity of AM channels might well be remedied if the FCC really wanted to find more room "as it did for FM."

"NBC is interested in FM," declared Mr. Guy, but added, "if television hadn't been knocked on the head about a year ago, it would probably be going full blast today."

The series of recordings made by NBC engineers during field tests were played to show comparisons of 75 kc. and 15 kc. swing in FM transmission, stacked up against reputedly comparable transmission, also by a 1-kw. transmitter, with AM on the same frequency. They tended to show 75-kc. FM at a disadvantage when pitted against varying noise levels.

The demonstration did not seem to precipitate any great degree of sympathy from those present, and the most immediate reaction at the conclusion of Mr. Guy's discussion came from Major Armstrong, who rose slowly to his feet.

"Mr. Guy," said the Major, his head cocked characteristically to one side, "I thought I

(CONTINUED ON PAGE 48)

AT THE BROADCAST CONFERENCE, L. TO R., HARVEY GLATSTEIN OF WCKY, PAUL G. FRITSCHEL (SEATED) OF GENERAL ELECTRIC, C. H. TOPMILLER WCKY CHIEF ENGINEER, EUGENE G. PACK KSL CHIEF ENGINEER, AND J. E. TAPP KGER CHIEF ENGINEER, EXAMINE G. E. FM MONITOR



# FM SPOT NEWS

Notes and comments, personal and otherwise, that have to do with FM activities

**WSM:** Associated FM transmitter W47NV, owned by the National Life & Accident Insurance Company, Nashville, takes the place at the top of the honor roll with the first commercial FM license, granted March 1st.

**Major Armstrong:** Granted a commercial C.P. for W2XMN, Alpine, N. J., on March 5th. With tower upped 80 ft. to 480 ft. height, his station will reach Springfield, Mass.; Albany, N. Y.; Wilkes-Barre and Philadelphia, Pa.

**Howard Cervantes:** Called for active duty in Naval Reserve, he will be missed by many friends and customers at Haynes-Griffin, in the Hotel Roosevelt, New York City.

**Gordon Gray:** Has been issued a C.P. for a 50 kw. FM transmitter which he will erect on the summit of Clingman's Peak, near Winston-Salem, N. C. Area of 69,400 square miles is the largest coverage of any station so far projected, and will furnish high-quality reception to thousands of listeners who have never had adequate AM service.

**FMBI:** Has issued an FM sound effects demonstration record for use by FM transmitters. Quality is excellent in comparison with AM, but lacks full brilliance of original production.

**W.E.:** Description of remarkable new 1126A speech amplifier, with automatic level control developed for FM studios, will appear in May issue of *FM Magazine*.

**Paul Prichard:** High-voltage manager of radio department at John B. Varick, Manchester, N. H., distributors for Zenith, staged a most successful FM meeting for New Hampshire dealers. Paul deMars, as guest speaker, provided a special demonstration program from Paxton. Sales of Zenith FM-AM sets are running ahead of the \$69.50 AM consoles in this territory, Paul reports.

**CBS:** Will erect FM transmitter at Hollywood. Application for C.P. was filed March 5th. CBS has been granted C.P.'s. for New York City and Chicago. Boston application has been designated for hearing.

**F.M. Link:** Signal Corps has ordered 240 standard model FMTR Link mobile FM transmitter-receiver assemblies. Army designates these as SCR-298. It is a tribute to the design of these units that they are accepted as a Signal Corps standard.

**T. R. Kennedy, Jr.:** Radio editor of *The New York Times* records in a most interesting article on FM: "FM has driven the price factor out of



MALBON JENNINGS AND MAJOR ARMSTRONG COSTUMED FOR REMOVING ICE FROM FM ANTENNA AT W2XMN, ALPINE, N. J.

the mind of the average buyer." "I find more people interested in FM; our percentage of FM sales is increasing rapidly," said the manager of another music store.

**Frank Gunther:** Chief engineer of R.E.L. is on the move steadily, bringing several FM stations to completion. Quote: We can deliver a 50 kw. transmitter in about four months now.

**Federated Publications, Inc.:** Their FM applications for Grand Rapids, Battle Creek, and Lansing have been designated for a consolidated hearing before the FCC.

**WBNS:** Their affiliated FM transmitter, W45CM, has a new FM studio of special acoustic design with floating walls, ceiling, and floor, engineered by Johns-Manville.

**WWSW:** Walker & Downing, Pittsburgh, plan to operate their FM station W47P on a 24-hour a day schedule.

**A. F. Sise:** Yankee's chief engineer in charge of FM, and Mrs. Sise, are spending two weeks at Sun Valley, where they have been invited to show the tyros what to do on skis, and how.

**Arthur Freed:** Has joined the Freed-Eisemann organization as general sales manager, according to an announcement from Joseph D. R. Freed, president of Freed Radio Corporation, N. Y. C. This brings together again the two-man team of the old days, and presages fast-moving expansion of FM set sales bearing the Freed Eisemann name.



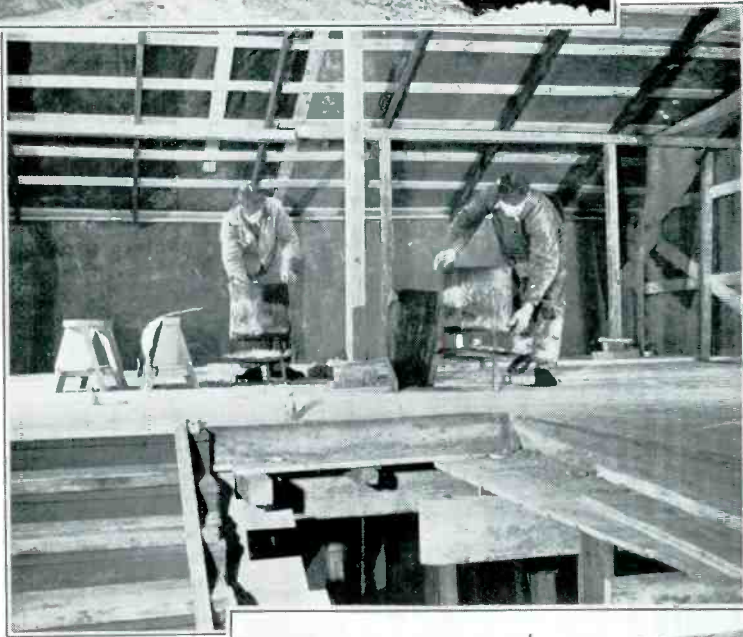

## NEWS PICTURE

**Milwaukee Journal** speeds construction on its permanent FM station, W55M. Without waiting for spring weather, concrete has been poured and dried under canvas, aided by heaters inside. Every effort is being made to rush completion of this transmitter building which will house an R.E.L. installation rated at 30 to 40 kw. W9XAO, the FM affiliate of WTMJ, began scheduled broadcasting on February 24, 1940, using 1 kw. under experimental license. Walter J. Damm, general manager of the AM and FM stations, expects the new W55M to be ready for commercial operation on July 1st. Meanwhile, the special programming of W9XAO is gaining enthusiastic response, and is building a large FM audience in the Milwaukee area.

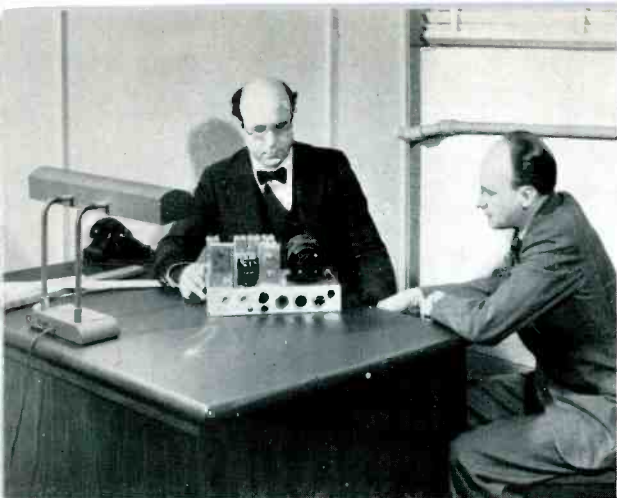

PROF. DANIEL E. NOBLE, EXPERT ON EMERGENCY FM EQUIPMENT, LEFT, AND THE WRITER

**I**N ADDITION to its standard AM emergency equipment, Motorola is now producing a complete line of FM transmitters, receivers, and auxiliary apparatus for police, fire, public utility, and similar services.

The new FM line has been designed by Prof. Daniel E. Noble, now Director of Research for Motorola, and formerly of the faculty of the University of Connecticut. He is widely known in FM engineering circles for his work on the design of station WXPW, and as a consultant to the Connecticut State Police, and the State Forestry Service. It was as a result of his survey and tests that the Connecticut State Police set up the most complete and extensive 2-way FM system now in use.

With this background of experience, Prof. Noble has contributed many original features in the design of the Motorola FM equipment. Perhaps most important of these is the increased sensitivity of the receiver, by means of which greater range is obtained and noise interference is reduced. Measurements show that, in the model shown in Fig. 2, the limiter tubes are substantially saturated by a signal of only .1 microvolt.

Fig. 5 shows the noise reduction ability of this new receiver, and Fig. 4 gives the block diagram. It will be seen that the circuit is designed around the use of crystal-controlled intermediate circuits of high and low frequency.

The total gain of the receiver exceeds 300,000,000 and signals of .1 microvolt are actually usable because of the inherent reduction of both internal and external noise when even the weakest carrier is present. As shown in Fig. 3, input signals of less than .25 microvolt create a 20 db reduction in the noise output from the receiver. As these weak signals actually saturate the limiter, it can be seen how great an improvement is obtained in

## NEW EMERGENCY FM EQUIPMENT READY

Complete Line of Car and Station  
Units Has Been Engineered  
by Prof. Noble

BY NORMAN E. WUNDERLICH \*

the maintenance of reliable communication over great distances, and under conditions of extreme interference.

Another important development and a patented feature of the emergency receiver is the new type of carrier-off squelch or noise-suppressor, which automatically cuts off the receiver output when no carrier is coming in. This squelch works on a new principle, utilizing the inherent noise reduction of the FM system in the presence of a carrier. Even though the carrier be only .1 microvolt, it will trip the squelch, and no amount of noise will open it.

A variable squelch control knob is provided on the operator's control panel, to afford adjustment to prevailing noise levels of .1 to 3 microvolts. This panel can be seen in the lower illustration in Fig. 1.

This is in sharp contrast to the performance of AM receivers which require the squelch to be set so tightly to keep them quiet in noisy locations that a signal of 2 to 5 microvolts is required to open it. Thus the range of reception is limited substantially.

Further details of the receiver and the transmitter are given in the following specifications:

### SPECIFICATIONS OF FSR-13 AND FMR-13 RECEIVERS

**Standard Equipment** ★ Frequency modulation receiver unit; speaker; tubes; control unit; connecting cables; operating and service manual.

**Frequency Range** ★ 30 to 40 megacycles.

**Audio Output** ★ Output—1 watt, with either DC or AC power supply.

**Carrier-Off Noise Suppression** ★ Greatly improved type of adjustable squelch on control unit. From .1 microvolt to 3 microvolts; will open on smallest input signal but not on noise.

**Radio-Frequency Sensitivity** ★ .25 microvolt signals are usable because total gain exceeds 300 million times. The receiver limiter tubes are substantially saturated with .25 microvolt signal.

\* Galvin Mfg. Corp., 4545 Augusta Blvd., Chicago, Ill.

**Audio Frequency Response** ★ Audio characteristics are matched to transmitter for optimum voice transmission for emergency communication. Special filter cut-off below 500 and above 3,000 cycles improves signal-to-noise ratio.

**Power Supply** ★ The mobile receiver type FMR-13 uses a vibrator B supply mounted on the set chassis. Normal operating receiver drain is 8 amperes.

Central Station Receiver Type FSR-13 is supplied with a 115 volt 50/60 cycles AC rectifier unit, drawing approximately 65 watts.

**Circuit Design** ★ Double-conversion superheterodyne with two crystal controlled oscillators are employed for maximum stability. Has a total of 13 tubes, less power supply, performing the following functions:

First RF amplifier—6SD7  
 HF oscillator-multiplier—6SD7  
 First converter—6SD7  
 First IF (4.3 mc.)—6SD7  
 Second converter—6K8  
 Second IF (455 kc.)—6SD7  
 Carrier-off noise suppressor—6SD7  
 Carrier-off noise suppressor rectifier—6H6  
 Discriminator—6H6  
 First audio—6C8

Audio output—6K6

DC power supply—6X5 or OZ4

AC power supply—80

Metering switch is provided for making adjustments

**Control Units** ★ The mobile receiver is connected directly into transmitter which carries all circuits and switching relays. Volume, squelch, and "on-off" switch are controlled from instrument panel. Same control is furnished when receiver only is installed. Central station installation has desk console control unit.

**Mechanical Design** ★ Overall size, including cover, is  $9\frac{5}{16}$  ins. wide;  $14\frac{3}{4}$  ins. long;  $9\frac{1}{2}$  ins. high. Variety of speakers for mobile units are available. Central station speaker is mounted in control console.

#### SPECIFICATIONS OF FMT-30 TRANSMITTER

**Standard Equipment** ★ One 30-watt transmitter unit; crystal; tubes; microphone, cord and plug; one mobile control unit; interconnecting cables and plugs; vertical antenna and mountings with mobile units; operating and service manual.

**Power Output** ★ 30 watts.

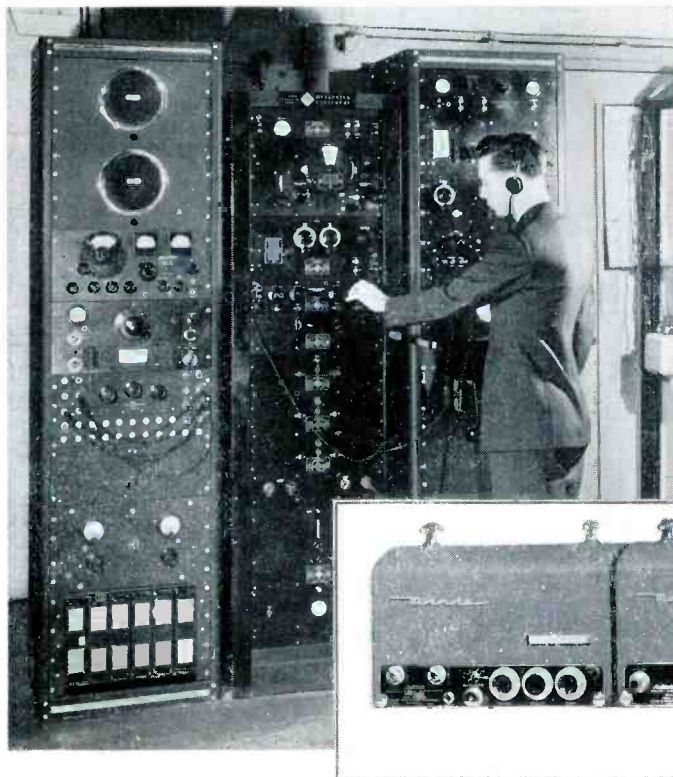

FIG. 1. DESIGN FOR ACCURACY. LEFT, FREQUENCY CONTROL EQUIPMENT USED AT GALVIN MFG. CORP., MANUFACTURERS OF MOTOROLA EQUIPMENT. BELOW, COMPLETE 2-WAY CAR INSTALLATION, COMPRISING TRANSMITTER, RECEIVER, CONTROL BOX AND HANDSET



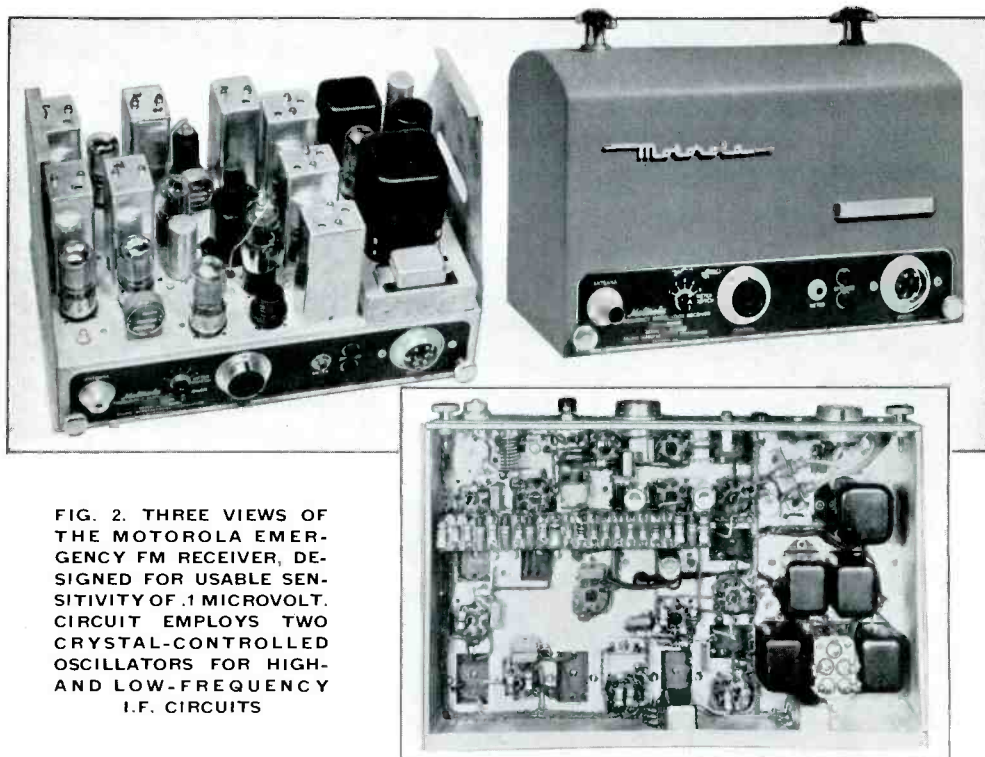

FIG. 2. THREE VIEWS OF THE MOTOROLA EMERGENCY FM RECEIVER, DESIGNED FOR USABLE SENSITIVITY OF .1 MICROVOLT. CIRCUIT EMPLOYS TWO CRYSTAL-CONTROLLED OSCILLATORS FOR HIGH- AND LOW-FREQUENCY I.F. CIRCUITS

**Frequency Range** ★ 30 to 40 megacycles—Tolerance .01% crystal controlled.

**Frequency Modulation** ★ Deviation 15 kc. each side of carrier.

**Audio Input Level** ★ 10 db at 500 cycles for 15 kc. deviation.

**Power Supplies** ★ The type FMT-30 mobile transmitter for 6-volt battery employs a 600-volt DC dynamotor. Stand-by, 2.8 amperes; transmitting, 30 amperes at 6 volts.

**Circuit Design** ★ Direct crystal controlled, phase modulated, with multiplication of 32 times to obtain desired carrier and deviation of frequency modulated output.

**Tubes** ★ A 7C7 crystal oscillator drives two type 7A8 modulators which provide the radio frequency voltage phase shift and are modulated direct from the microphone or line transformer. Modulator output is multiplied 32 times by means of two type 7C7 frequency quadrupler stages and one type 6V6 frequency doubler, to arrive at carrier frequency, driving one 807 power amplifier.

Switch is provided so that all current readings necessary to adjust the transmitter can be obtained in a single meter.

**Control Units** ★ Remote instrument panel type with "on-off" switches, pilot lights, volume and squelch controls, and jack for microphone. Military hand microphone standard. French handset optional. May be plugged in at transmitter if required. Service microphone outlet on transmitter chassis.

**Mechanical Design** ★ Overall size is  $9\frac{5}{16}$  ins. wide,  $14\frac{3}{4}$  ins. long, 11 ins. high, including handles and mounting. A heavy base plate serves as a substantial mounting and is designed for quick and easy detachment of chassis. The cover is locked in place by a quarter turn of the two handles.

Headquarters transmitters for FM systems are available with ratings from 50 to 500 watts output. The basic unit is a desk console containing a 50-watt transmitter, a receiver and speaker, controls, meters, and electric clock.

When higher power is required, the 50-watt unit is used as an exciter for an amplifier of 250 or 500 watts. Thus, with this simple com-

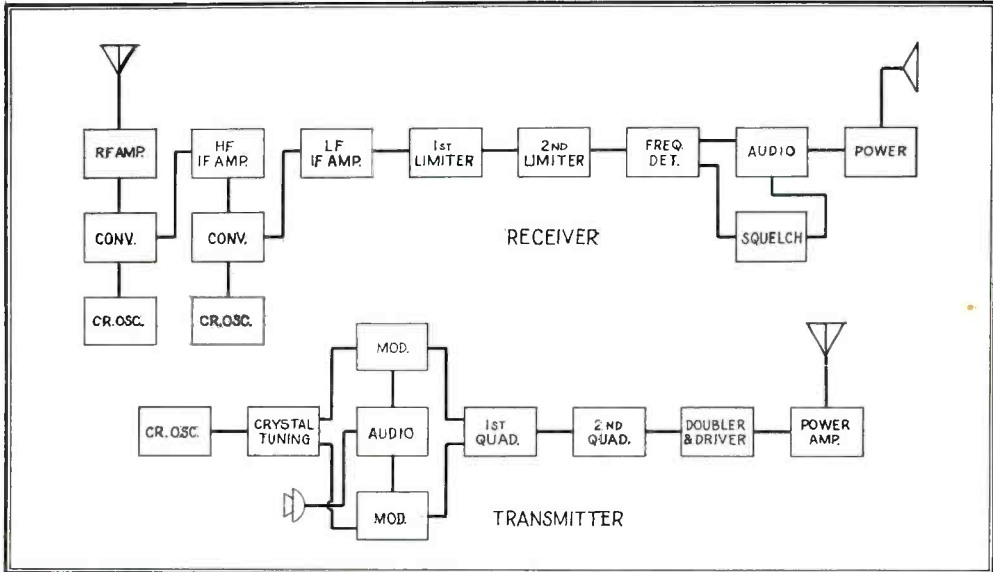

FIG. 4. BLOCK DIAGRAMS OF THE MOTOROLA FM EMERGENCY RECEIVER AND TRANSMITTER

bination of standard units, sufficient flexibility is obtained to meet the needs of practically any system.

Motorola is now installing a group of sixteen receivers and 250-watt FM transmitters for one of the large oil companies, to give them

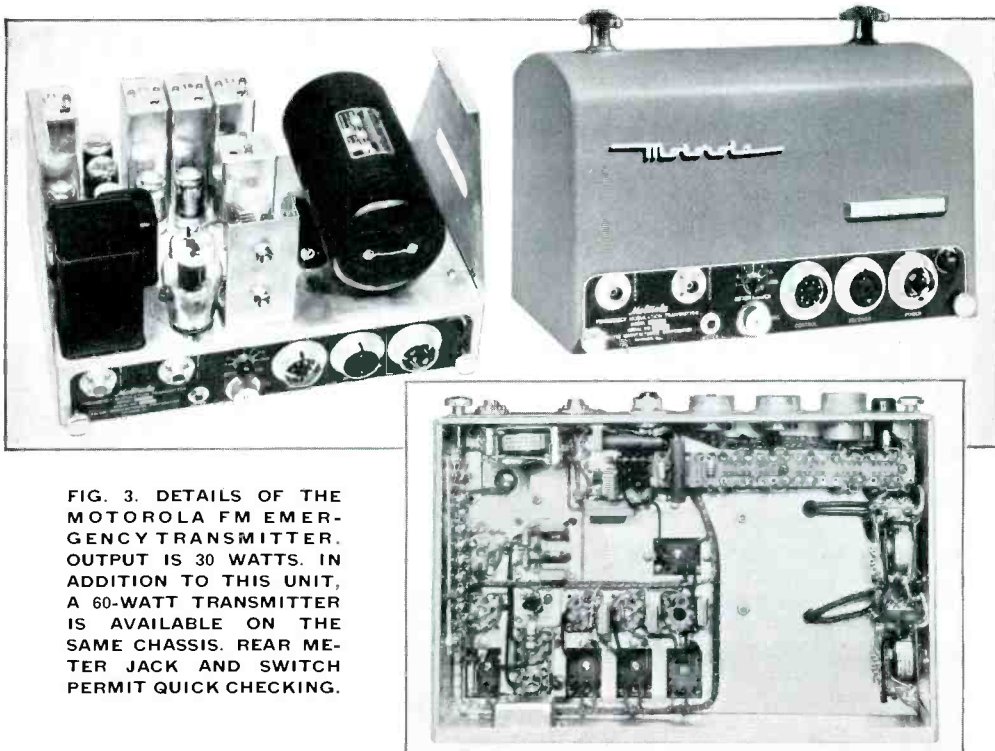

FIG. 3. DETAILS OF THE MOTOROLA FM EMERGENCY TRANSMITTER. OUTPUT IS 30 WATTS. IN ADDITION TO THIS UNIT, A 60-WATT TRANSMITTER IS AVAILABLE ON THE SAME CHASSIS. REAR METER JACK AND SWITCH PERMIT QUICK CHECKING.

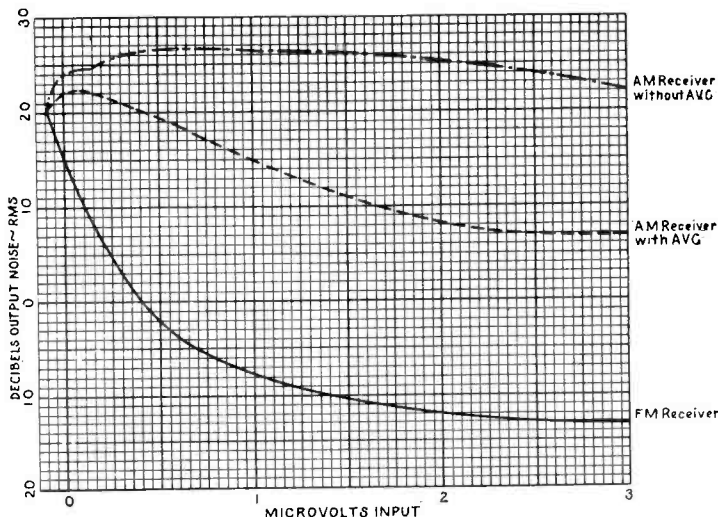

FIG. 5. NOISE REDUCTION IN MOTOROLA FM RECEIVER IN PRESENCE OF LABORATORY NOISE WITH VARYING SIGNAL INPUT, COMPARED TO AM TYPE RECEIVERS

point-to-point communication throughout their fields in the bayou section of Louisiana.

Details of this unusual installation will be given in a forthcoming issue of *FM Magazine*.

### A-FM RECEIVING SETS

Effective with the May issue, receiving sets designed for the reception of both AM and FM signals will be referred to as A-FM receivers. Up to the present time, such sets have been described by the initials FM-AM. This is awkward to pronounce, and does not appear as descriptive in print as A-FM.

Considerable discussion has led to the conclusion that A-FM is less confusing to broadcast listeners, also, and is easier to explain since people generally know that an FM radio is for receiving FM broadcasting. Thus, A-FM indicates more clearly that standard reception is added.

Further comments on this subject will be welcomed by the Editor, and letters of special interest will be published in *FM Magazine*.

### MAY ISSUE WILL REVIEW ALL CURRENT RECEIVER MODELS

In the May issue of *FM Magazine* there will be a complete review of all receiving sets designed for both FM and AM reception, as well as FM tuners, which are now available for delivery. With the illustrations of the various models there will be the essential specifications.

The number of such sets now in production has reached an imposing total, and includes a wide range of styles and prices. This review

will be of particular value to dealers in areas where FM broadcasting is just starting, as it will facilitate the selection of lines and models suited to the requirements of the individual store.

### SPECIAL FM MEETING

A special open meeting will be held at the Hotel Roosevelt in New York City on Wednesday, April 2, for the discussion of various developmental problems currently confronting FM.

The session, starting at 10 A.M., is to be open to all recipients of FCC construction permits, applicants for permits, and others who are interested in the development of FM, regardless of whether or not they are members of FM Broadcasters, Inc.

Among topics to be discussed, with intent to secure the opinion of the entire industry, will be the newly-authorized studio-transmitter lines (STL), the recent FCC Order No. 79, and other pertinent matters.

Also, the annual meeting of FM Broadcasters, Inc., will be held at 2 P.M. on the same day, Wednesday, April 2, to consider certain additions and changes in the organization's by-laws — namely, the establishment of associate and contributory memberships in FM Broadcasters, Inc., the election of three directors whose terms are expiring, and other subjects.



# G.E. PERFECTS FM STATION MONITOR

## One Instrument Performs Five Functions Essential to Monitoring FM Station

BY W. R. DAVID\*

**M**UCH interest was exhibited by broadcast engineers, during the laboratory sessions of the Broadcast Engineering Conference, in the operation and performance of General Electric's new FM station monitor. It was set up, at the Conference, with a standard 250-watt FM broadcast transmitter, square wave generator, and a television oscilloscope, all arranged for operation representing actual practice.

**Functions** ★ The monitor, shown in Fig. 1, is a self-contained, multi-purpose instrument providing:

1. Direct reading of center frequency deviation, with or without modulation
2. Direct reading of modulation percentage
3. Instant calibration against a precision crystal standard
4. Adjustable modulation limit flasher
5. High-fidelity output for audio monitor

As can be seen from the illustration, this unit can be mounted in the cabinet, or on a standard speech input rack. The panel of the production units will be a photo-etching with polished metal finish for lettering and trim, and a smooth gray background, harmonizing with the gray wrinkle finish of the cabinet. The two panel instruments are standard VU instrument size, with illuminated dials. All controls are conveniently arranged and plainly marked. A standard cord is employed to connect the unit to a source of power. Input, output and ground terminals are provided on the rear of the chassis, and are accessible through an opening in the cabinet. Crystals and tubes are accessible through the top door of the cabinet.

**Required by FCC** ★ FCC rules governing high frequency (FM) broadcast stations specify:

Section 3,243, Frequency Monitor: The licensee of each high frequency broadcast station shall have in operation at the transmitter a frequency monitor independent of the frequency control of the transmitter. It shall have a stability of 20 parts per million. For detailed requirements thereof see Standards of Good Engineering Practice for High Frequency Broadcast Stations.

Section 3,244 Modulation Monitor: The licensee of each high frequency broadcast station shall have in operation at the transmitter an approved modulation monitor. For detailed requirements thereof see Standards of Good Engineering Practice for High Frequency Broadcast Stations.

**Use of the Monitor** ★ Center-frequency deviation of the transmitter, either with or without modulation, is indicated directly in cycles on the right hand panel instrument. The scale reads from minus 2,000 cycles through zero to plus 2,000 cycles, the deviation range permitted on FM broadcast transmitters by the FCC. Some FM stations are now using monitors of the ordinary type, which indicate carrier frequency deviation only when the transmitter is not modulated. Obviously, continuous monitoring, with or without modulation, is a decided advantage.

Percentage of modulation from 0 to 120% is indicated accurately on the left hand panel instrument. The instrument reads either positive or negative modulation, depending on the position of a front-of-panel switch. The modulation percentage is calibrated on the basis of 100% modulation for a frequency swing of plus or minus 75 kc. A modulation limit flasher is mounted on the front panel, together with a control which permits setting the "flashing" point at any value between 50% and 120% modulation. The flasher indicates peaks of modulation of too short duration to register on the panel instrument.

Means for monitoring are included. An FM detector within the monitor provides a source of high fidelity audio output. A standard (100 micro-second) de-emphasis filter is incorporated, and a single audio stage acts as both a buffer and amplifier. The audio output circuit is designed to feed into the new General Electric high-fidelity monitoring amplifier and loudspeaker. Both of the latter units are designed especially for FM.

A monitor of this type is the most important instrument in an FM broadcast station. Any irregularities in the transmitter are indicated instantly. Furthermore, with suitable additional instruments, the monitor can be used to take the measurements of overall performance as required by the FCC under proof of performance, namely, audio frequency response, audio distortion, and noise level.

\* Radio and Television Department, General Electric Company, Schenectady, N. Y.

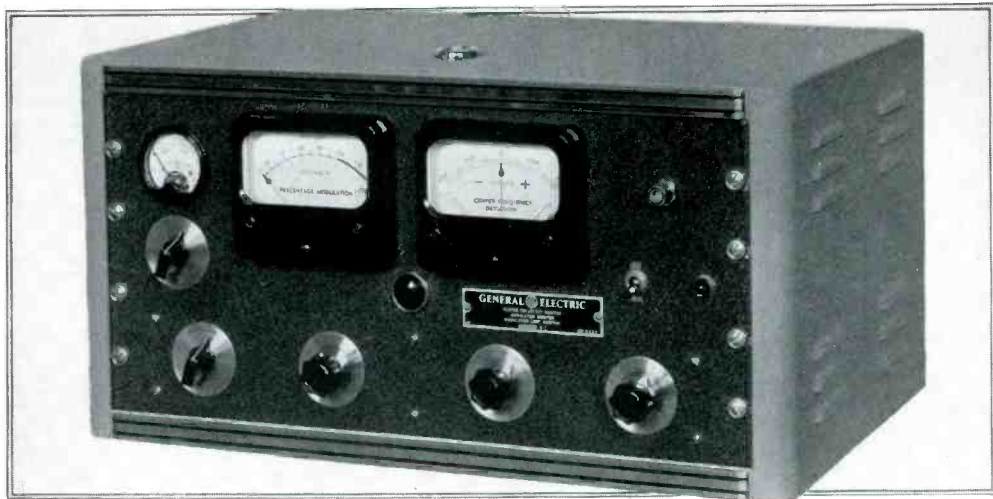

FIG. 1. SPECIAL MONITORING INSTRUMENT IS REQUIRED BY FCC RULES FOR FM TRANSMITTERS

**Characteristics** ★ The electrical characteristics are as follows:

Power input: 115 volts, 60 cycles, single phase AC

Radio-frequency range: 42 to 50 megacycles  
Radio-frequency input: approximately 2.5 volts, rms.

Audio-frequency response: within  $\frac{1}{2}$  db. of standard de-emphasis curve from 30 to 15,000 cycles<sup>1</sup>

Audio-frequency output: approximately .3 volt rms into a 500-ohm load

Stability: .002% (1,000 cycles at 50 megacycles) as required by FCC

To minimize the effects of line voltage changes, an automatic voltage-regulated power supply is built into the monitor.

Both crystals provided are of the finest quartz stock, with temperature co-efficients of less than one part per million per degree centigrade. They are mounted in hermetically-sealed, Type G-31 thermocells, along with thermostats and heater coils which hold the crystal temperature constant within plus or minus one degree centigrade. The G-31 cells are similar in appearance to the metal type receiving tubes.

In the event that the station frequency is changed, it is necessary to replace only one of the crystals, and to make minor adjustments. The essential monitoring circuits are aligned precisely during factory tests, and they are not affected by the crystal change to accommodate a new transmitter frequency.

<sup>1</sup> When used with a standard FM broadcast transmitter, this characteristic produces an overall response that is virtually flat from 30 to 15,000 cycles.

**Calibration** ★ Instant calibration is afforded by means of a second crystal. During normal operation, one crystal in a high precision G-31 thermocell is in use. The second crystal, also the high precision G-31 type, becomes a part of the circuit when the switch in the lower left hand corner is thrown to "Calibrate." If the monitor circuits are out of adjustment, as may happen over a period of time, a simple front-of-panel control (right hand lower dial) brings the center-frequency deviation instrument back to the zero position. This calibration is very precise, since no frequency multiplication is employed for the calibrating crystal. Therefore, complete advantage is taken of the extreme accuracy of the crystal as its fundamental frequency.

Another calibration is accomplished when the switch is in the "Calibrate" position, namely, the modulation instrument on the left, which reads signal level in the monitor. Adjustment of the signal level is provided by the second dial from the left. Because of the inherent limiting characteristics of the monitor circuit, this level adjustment is not critical with respect to the overall accuracy of the monitor.

Since all essential monitoring functions are performed in one unit, it has been possible to simplify calibration processes so that complete calibration is only a matter of a few seconds. The inherent stability of the device makes frequent calibration unnecessary.

**Installation** ★ Installation of the instrument is not at all intricate. Aside from the power cord which can be plugged into any convenient outlet, connections include RF input, audio

output and ground. The panel instruments are easy to read and the controls are self-evident from the panel designations.

While the monitor is suitable for use only at the transmitter, because of the signal input level required, the actual RF power required is very small. General Electric's FM transmitters of all ratings have a built-in pick-up coil which is matched to the input characteristics of the monitor. A small pick-up coil is all that is needed to adapt the monitor for other makes of FM transmitters.

Provision is made for the extension of certain of the indicators and controls of the monitor to other points, such as the operating console of a 50-kw. FM broadcast transmitter. These include the center frequency and modulation percentage instruments and the modulation limit flasher with its control. Thus the design has been made highly flexible.

### A CORRECTION

The statement by E. W. Craig, Executive Vice President of the National Life & Accident Insurance Company, operating W47NV, Nashville, Tennessee, which appeared in the March issue of *FM Magazine* was inadvertently altered editorially in a manner which destroyed its true meaning.

The last sentence in the third paragraph of the statement appeared as follows: "Used as a service for local and regional broadcasting, FM should serve a dual purpose: to provide extra service for listeners within the primary area of AM stations, and to allow a greater expansion of facilities for service to the millions of rural listeners who have not been getting satisfactory AM programs."

The sentence as Mr. Craig originally wrote it was as follows: "Used as a service for local and regional broadcasting, FM should serve a dual purpose — provide excellent service for the listener within its coverage area, and allow a greater expansion of facilities for service to the millions of rural listeners."

We offer our apologies to Mr. Craig for having given a portion of his statement an apparently distorted meaning.

### FM FOR CLEVELAND SCHOOL SYSTEM

(CONTINUED FROM PAGE 7)

such schools have been established in Cleveland, and at each of these schools experimentation takes place in the development of improved methods for the teaching of any given subject, such as safety, health, arithmetic, science, etc. To these schools there have been brought those teachers who appear to be especially

**Description for FCC** ★ Many applicants for FM construction permits have specified this monitor in their applications. The reference "General Electric FM Station Monitor, Catalog 6933906" can be used for Question 18 (g) and 19 (f) of FCC Form 319 (revised December, 1940). If further explanation is desired, the reference may be enlarged to "General Electric FM Station Monitor, Catalog 6933906, indicating percentage of modulation, center frequency (with or without modulation), overmodulation by flashing light, and with output connections for high-quality audio monitoring."

As far as the writer knows, this is the first monitor designed especially for FM use. It has been discussed informally with engineers of the FCC and formal approval is anticipated as soon as it is possible to submit certain required test data.

interested and capable in teaching these special subjects. As a reservoir of techniques and procedures is developed at the school, and as thought then is given to their distribution to other elementary schools, various agencies of distribution are employed. The radio station generally is regarded as one of these. Thus, each elementary school receives from time to time so-called "demonstration lessons" which have been prepared at the various laboratory schools. The basic purpose is to provide in-service teacher training, as well as to vitalize instruction.

It should be understood that the message from the loud speaker is but one aspect of this type of presentation. Accompanying each radio series there is generally a quite voluminous "Classroom Teacher's Radio Lesson Guide." Comprehensive instructions are assembled for activities to be performed by the teacher in preparation for the lesson, as well as during it, and very often following the radio visit. In some lessons no follow-up is essential, and in other lessons no pupil activity is desirable. Also, in most of the elementary school lessons, as the radio teacher discusses a certain phase of work, selected lantern slides are shown and synchronized with the discussion. Occasionally, instead of the lantern slides, other visual aids are employed such as maps or worksheets.

**Junior High Schools** ★ In the Cleveland junior high schools, rather than the demonstration lesson approach, the radio programs are nearly all of the supplementary enrichment type. The scripts are prepared and selected from various sources by the junior high production head, who then utilizes the services of the WBOE Radio Players, and these scripts are



then dramatized. The following is an excerpt from the Junior High Handbook:

*Each program is being presented at two different periods in order that scheduling will be facilitated. If a recording of any broadcast is desired, a copy can be made for the school provided a record blank is furnished. In order to coordinate better these broadcasts with classroom work, this radio manual has been prepared.*

The purpose is not necessarily to provide in-service teacher training but largely to bring to the schools, in a pleasurable way, authentic and stimulating experiences. In the series "Clevelanders at Work", for example, the occupational duties of various leading Cleveland workers are dramatized. Following each dramatization, there is an interview with a Clevelander who is actually doing that type of work. Thus, the junior high school boy and girl become acquainted more or less directly with the working conditions, labor supply, and type of training needed in the various Cleveland industries.

**High Schools** ★ In the high schools, six curriculum centers have been established which, in many ways, resemble the elementary laboratory schools and where, likewise, scripts are prepared.

At the high school curriculum centers, the script is generally prepared along dramatic lines, and for production the services of the high school radio workshop are utilized. The direction of the program is then largely a school project. The script, prepared by expert teachers of the curriculum center, is then dramatized by talented pupils under the guidance of the school radio director. It is significant that, since the establishment of the Cleveland school station, all but two of the Cleveland high schools are now equipped with public address systems and studios, and in

most of these schools a radio workshop has been established.

**Special Programs** ★ Another form of program development is that which is done directly by the station staff with little or no school responsibility. Since the WBOE program director receives a daily listing from each of the networks, it is a simple matter to select and schedule those programs which have a particular interest for the school population. For instance, if an important talk is to be given by a European leader and one of the American networks is to carry it, WBOE may then relay it directly to the schools. If a program is regularly scheduled for that period, the network program is recorded and later repeated by transcription. The use of recordings or transcriptions is an extremely important aspect of school station operation.

Aside from the relaying and recording of network programs, the station staff also prepares programs of its own. Some of these are to celebrate national holidays or special weeks, while other programs are developed as the city is visited by celebrities whose messages are considered to have educational value. Visual materials, such as maps, to accompany these special programs, have been prepared occasionally with the cooperation of the local newspapers.

It should be clear from this discussion that the educational non-commercial station is in no way a competitor with the local commercial stations. As a matter of fact, Cleveland schools are particularly fortunate in having the splendid cooperation of Cleveland stations WTAM, WHK, WGAR, WCLE. It is only under the American scheme of broadcasting that such mutual aid can exist with its resulting benefits for the listeners, both young and old.

## BOOK REVIEW

**VACUUM TUBE VOLTMETERS.** By John F. Rider. 179 pages. 113 illustrations. Published by John F. Rider Publishing Co., 404 Fourth Avenue, N. Y. C. \$1.50

The vacuum tube voltmeter, now available in several specialized and perfected designs is one of the most useful tools of the engineers and servicemen. John Rider, in his usual thorough-going and practical manner, covers all the aspects of this convenient and versatile meter, and uses a generous number of clean and well-drawn illustrations to accompany the text. Many new uses for the vacuum tube voltmeter will, undoubtedly, be suggested to the

readers of this book.

Following a general discussion of the subject, there are chapters devoted to diode, triode, slide-back, rectifier-amplifier, tuned, audio-frequency, and logarithmic types of vacuum tube voltmeter, with explanations of the designs and application of each. There are also complete data on constructing and calibrating these instruments and a bibliography of 145 references. These references cover the findings of workers in the United States as well as of those in foreign countries.

This is a thoroughly practical and useful book. At the same time the exhaustive treatment of the subject makes it valuable for reference purposes. — M. B. S.

## FM HANDBOOK SERIES

G. H. Browning's monthly contribution, entitled "FM Handbook," was omitted from this issue because editorial space was lacking. However, Chapter 5 will appear in the May number.

This series, supplemented by additional data, will be published later in book form by *FM Magazine*. Judging from the number of favorable comments which have been received, this series has been most useful in clearing up, in the minds of many readers, the mysteries of FM circuits.

## YANKEE NETWORK GOES TO 8,000 CYCLES ON NEW YORK TO BOSTON LINE

**Y**ANKEE NETWORK has become the first customer of the AT & T for 8,000-cycle intercity program network service under its recently filed tariffs. The new service will be used between New York and Boston on the eastbound leg of Yankee Network's round robin between these two cities carrying New York programs to Boston with new standards of fidelity. For the present, cities which are served by the westbound leg will continue to receive programs over the regular grade of facilities between Boston and New York.

The new circuit, about 233 miles long, is routed in underground cable throughout its entire length. Special light-weight loading coils of 22 millhenries inductance are placed at 3,000-ft. intervals to permit transmission over a wide frequency band. For this length of circuit, transmission is uniform within  $\pm 1$  db between 40 and 8,000 cycles. By virtue of design and operating levels, the effects of delay distortion and harmonic distortion are kept to negligible proportions. The average signal to noise ratio for this circuit is over 60 db. Those who wish to get a more detailed description of this type of program facility may refer to a paper by A. B. Clark and C. W. Green, subject "Long Distance Cable Circuit for Program Transmission," published in the July, 1930, issue of the *Bell System Technical Journal*.

The 5,000-cycle circuit is the type now in general use in intercity program transmission network. Thus, there is great interest being evidenced in the 8,000-cycle circuit of the type now being furnished the Yankee Network for its new high fidelity New York to Boston service.

By virtue of careful planning years ago, the Bell System is able to furnish 8,000-cycle service without drastic reaction on the telephone plant, the major features being the release of additional frequency space now occupied by other telephone services in much of the plant, and a general readjustment of the present program-circuit characteristics.

## A Few Back Numbers of FM MAGAZINE

ARE AVAILABLE TO THOSE WHO  
SEND THEIR ORDERS AT ONCE

January, 1941, featuring:

Connecticut Police FM System  
Tests of W2XOR Reception on Long Island  
G.E. Police Radio Equipment  
Service Data on Zenith and Scott Sets  
G. H. Browning's FM Handbook, Chap. 3.

February, 1941, featuring:

Practical Ideas for FM Antennas  
Planning an FM Station  
W.E. Speech Input Equipment  
Data on Stromberg-Carlson & Meissner Sets  
G. H. Browning's FM Handbook, Chap. 4

March, 1941, featuring:

List and Map of FM Stations  
RCA 1 and 10 Kw. Transmitters  
Details of Paxton FM Station  
Police FM Success in Nebraska  
Data on Stromberg-Carlson & G.E. Sets  
G. H. Browning's FM Handbook, Chap. 4

PRICE, 25¢ PER COPY, SUBJECT  
TO PRIOR SALE. ADDRESS:

FM COMPANY, NEWTON, MASS.

\*\*\*

## Amateur Radio Defense

● The radio amateur is the backbone of our industry. His interests are protected and preserved by Amateur Radio Defense Association. Technical data on radio defense equipment for amateur and commercial application is found in the pages of a new monthly magazine, "Amateur Radio Defense." Can we send a copy for your inspection?

Write  
for  
specimen  
copy  
today



\$2.00  
per  
year  
by  
subscription

Pacific Radio Pub. Co.

Established 1917

Monadnock Bldg.

San Francisco

# HIGHEST QUALITY

## *F-M Reception*

# AT LOWEST COST



## With this New Meissner

# F-M RECEPTOR

Commercial F-M Broadcasting is now an actuality — stations now operating or soon to begin will cover many of the most populous areas throughout the country — thousands of buyers in these areas are now ready and anxious to purchase F-M receivers!

### AND HERE'S THE ANSWER —

The New Meissner F-M Receptor — a complete, compact 8-tube receiver, less audio — ready to be connected to the input of the audio system in any regular radio receiver! "Phono" or "Television" terminals may be used on sets so equipped. Quality of reproduction is limited only by the capabilities of the audio amplifier and speaker in the regular receiver.

The size of this remarkable unit is an important feature — in its attractive walnut cabinet it measures only 13" wide, 7" high and 6 $\frac{3}{8}$ " deep! Many present console receivers will have extra space for installation of the Receptor chassis, which is only 9 $\frac{1}{2}$ " wide, 5 $\frac{1}{2}$ " high and 6" deep.

Entirely self-powered, simple to install, this unit is complete and ready for operation. Tuned R-F amplification provides superior range and noise rejection. Indicator tube shows exact resonance for most perfect reception. Five-inch linear scale covers full F-M band from 41.5 to 50.5 mc. Designed for maximum performance — dimensioned to fit any installation — priced to fit the "average" purse!

Sold as complete Receptor described above or as chassis only, less tubes and cabinet. Prices on request.

**Write for Free General Catalog Today!**

ADDRESS DEPT. F-4



## 400 ENGINEERS HEAR FM SESSIONS

(CONTINUED FROM PAGE 35)

understood FM, but I guess I was just all bawled up."

An exchange of queries and answers then took place, with the resultant clarification of several points that had not seemed, at least to FM proponents, particularly valid or correct.

The incident ended amicably enough — on the tolerant note that every man is entitled to his own opinion.

Other highpoints of FM's week were a two-part talk on the properties of UHF transmission by Kenneth A. Norton of the FCC, explaining how atmosphere and ground conditions affect UHF signals; a roundtable on FM operating problems by Paul A. deMars of The Yankee Network, assisted by Edward J. Content of WOR and D. W. Gellerup of WTMJ. A feature of the roundtable was the description of Paxton's (WIXOJ) new ten-bay turnstile array, and the many problems met by The Yankee Network in constructing its new station atop Mount Washington, N. H., given by Mr. deMars. General questions on FM procedure, submitted in advance by letter and proffered from the audience, consumed much of the four hours devoted to this part of the conference.

Other speakers were I. R. Weir of General Electric, discoursing on FM transmitters, as did John Morrison of Western Electric. E. D. McArthur of G-E described new UHF vacuum tubes and hinted at latent possibilities in cavity resonators.

A troublesome day for the wireline people occurred Thursday when, during the course of Mr. Weir's remarks on transmitters and the experiences of General Electric with the Helderberg station W2XOY, a representative of AT & T advanced the information that a number of full-fidelity wireline links between FM studios and transmitters are operating quite satisfactorily.

Major Armstrong thereupon volunteered, from his experience, that the circuit between New York and Alpine had frequently been so noisy that, on occasions, he found it necessary to cut the program service coming over it.

General Electric parried with an account of similar difficulties in its wireline at Schenectady, where atmospheric conditions have apparently created high frequency noises in program transmission.

The lively interest of so many engineers attending the conference, a number of whom came solely for the week devoted to FM, is a gratifying indication of frequency modulation progress. The subjects discussed covered a wide scope and, reflecting as it did a year's swift technical progress, the entire conference served much to make FM chests swell.





# LOOK TO *Motorola*

FOR THE LATEST DEVELOPMENTS IN F-M



A complete Motorola F-M Mobile Transmitter and Receiver for patrol car. Installs in trunk compartment, working with rear whip antenna. Control box and handset mount on dash.

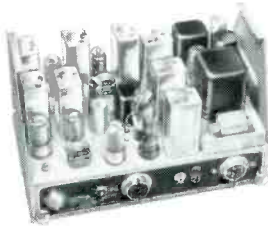

(Left) Motorola F-M Mobile Receiver (cover removed). Triple detection with two crystal controlled oscillators, tuning range 30-40 mc., high gain perfected squech. Same unit for central station, but with 110 volt A.C. power supply.

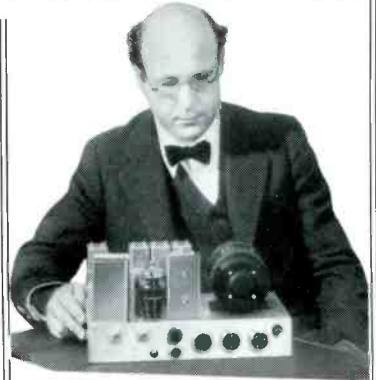
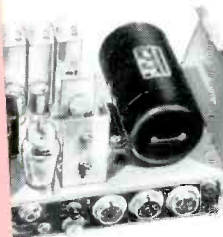

## DANIEL E. NOBLE

Directing Research and Advanced Development for Motorola

Formerly of the University of Connecticut and famous for his work in Frequency Modulation, Prof. Daniel E. Noble is now Director of Research for Motorola.

Among Prof. Noble's achievements is the State of Connecticut 2-Way F-M Police Radio Communication Network installation, comprising 225 patrol cars and 10 central stations with a 2-way coverage of 4,965 square miles.

With his background, Prof. Noble brings to Motorola a vast store of knowledge and experience which are reflected in Motorola F-M Designs.

Look to **MOTOROLA** for the latest in F-M.

A Subscription to FM Magazine  
WILL GIVE YOU  
INFORMATION ON  
FREQUENCY MODULATION  
ACTIVITIES WHICH YOU WILL NOT FIND  
IN ANY OTHER PUBLICATION  
FM Is Sold By Subscription Only

DESCRIPTIVE LITERATURE AND TECHNICAL DATA  
**MOTOROLA CORPORATION** ★ CHICAGO, ILL.  
VARIOUS MOTOROLA AUTO AND HOME RADIOS



Pilot FM-AM prices start at \$139.50. The two distinguished Pilot FM-AM phonographs shown here are, above, the Continental model at \$279.50 and, left, the Hepplewhite, \$239.50

*Triple the Profit, Half the Effort . . .*  
**WHEN YOU SELL PILOT FM-AM**

**L**ET your customers HEAR the difference between FM and AM. They'll sell themselves! If you want to give them facts, show them what stations are on the air and are being built to serve them. Remind them that over 100 more stations are being planned. Tell them how police radio is being shifted to FM's greater range, how the Army is changing to FM for the Tanks, and how the FCC is encouraging the nation-wide expansion of FM broadcasting.

But above all, let them enjoy the two-speaker tone quality and noise-freedom of Pilot FM reception!

Is regular broadcast reception provided, too? Certainly, better than they can get from straight AM sets. Is there a phono-combination? Absolutely, with the finest record changer.

What about distance? These sets have Pilot's famous super-sensitive, long-distance tuned RF circuits with 3-gang condensers on both FM and AM.

Prices? Pilot FM-AM instruments are the greatest value in radio and recorded entertainment ever offered to the public.

TRIPLE YOUR PROFITS BY LETTING PILOT FM-AM DEMONSTRATIONS DO YOUR SELLING FOR YOU. FOR FURTHER DETAILS WRITE:

**PILOT RADIO CORPORATION, Long Island City, New York**

"The Standard

**Pilot**  
**RADIO**

of Excellence"