

# Everyday Mechanics

TRADE MARK REGISTRATION APPLIED FOR  
"It Tells You How to Make and How to Do Things"

Vol. 1

JULY, 1916

No. 5

## WHAT DO YOU THINK ABOUT IT?

**A** FEW days before the forms for this issue closed we received the following letter, and so aptly does it cover the points at issue with our esteemed Chicago contemporary that we cannot resist the temptation to publish it herewith. We have withheld the name of the writer for obvious reasons.

"I chanced to purchase a copy of your May issue from a newsstand a few days ago. My interest was aroused by the positively unique appearance and the low price of the magazine.

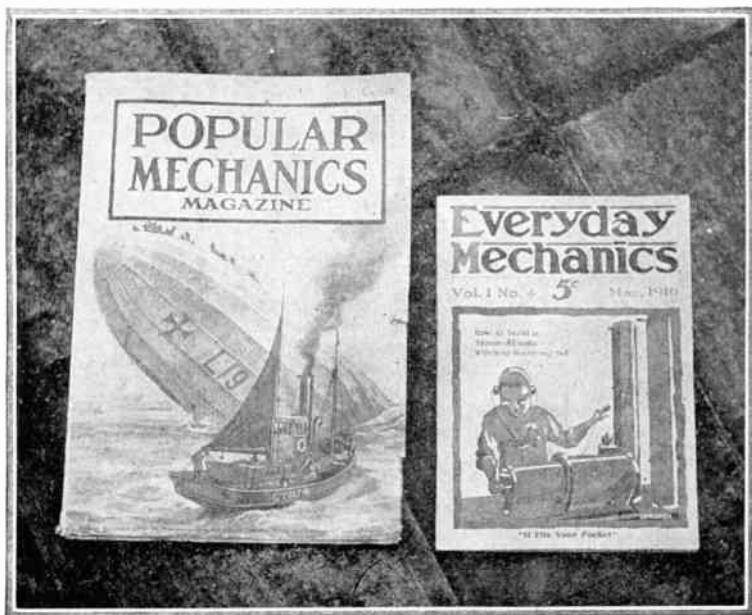

"Upon looking through the magazine, which I have read from cover to cover, I was astounded to learn that you are being persecuted by the great *Popular Mechanics*.

"Now, I have read *Popular Mechanics* since the days when it was a five-cent weekly and its present publisher was struggling to make ends meet; I have followed its growth with great interest for thirteen years; I have contributed to Mr. Windsor's magazine from time to time and in short have grown to think of it as one of my most treasured possessions.

"However, when I read of the malicious injustice tendered you at the hands of *Popular*, my first impulse was in the nature of 'seeing red' for a time. Then, on cooler thought, I thought perhaps my own vision or sense of perspective and proportion was failing.

"Being something of a camera fiend, I thought to test my vision by photographing *Popular* and *EVERYDAY* side by side. The camera, it is said, does not lie. The result of my hike to the roof with the camera is enclosed herewith. Use it and me any way you wish. If there is the remotest resemblance between those two magazines, then not only I, but my camera as well, have gone batty.

"In my humble estimation, the publisher of *Popular* sees in you the possibility of his first real rival—a rival not with a poor imitation of his own great magazine, but one with an idea infinitely greater and better. Furthermore, he evidently believes you have the ability to put it across.

"Go to it. You are not using unfair competition—you are producing a better article. I believe you'll win and to prove that I believe it, I enclose a check for a ten-years' subscription."

Our correspondent's photograph is reproduced herewith just to prove, as he says, that either the camera lies or else we all must be batty in the eyesight!

#### WOULD YOU PAY 10c FOR "EVERYDAY"?

In the May issue, I stated frankly just what we are having to contend with in publishing your little magazine. Perhaps you have noted that other publishers have had either to cut down the size or increase the price of their magazines.

"EVERYDAY" was started just before the raw materials entering into its manufacture increased so inordinately in cost. We could not foresee this contingency, to say nothing of the expenses of defending the action brought against us by *Popular Mechanics*.

In the May editorial, I asked the opinion of my readers. Hundreds have responded saying that they would willingly pay ten cents; not a single one has said that he would not pay it. What do YOU say? Shall we raise the price to ten cents?

If you subscribe now at 50 cents, you will receive every number for a year without the payment of anything more, even though we do have to raise the price. Isn't it a pretty good idea to take from one to five years at this rate?

YOUR EDITOR.

## EXPERIMENTAL HIGH FREQUENCY APPARATUS

BY THE EDITOR

I WANT to tell you, in this article, about that fascinating, elusive, and altogether puzzling form of electrical energy known as an alternating current of high potential and high frequency. The study of high frequency phenomena has afforded me many an hour of the keenest pleasure and interest, to say nothing of profitable employment, and I feel that a discussion of the startling characteristics of this current, together with a description of the apparatus necessary for its generation, cannot be without a certain degree of value to readers of EVERYDAY.

A review of my correspondence of three years past convinces me that in treating of high frequency apparatus in various articles, I have fallen into the common error of assuming a certain breadth of knowledge on the part of my readers that they do not possess. And, strangely enough, this dearth of knowledge appears to be due, not to the complexity, but to the utter simplicity of the apparatus in its experimental form.

Accordingly, it is my intention to tell, not of the theory and mathematics of the high frequency current, but what the current is, how it is used, what it

will do, and how to produce it. The apparatus required is not expensive and neither is it difficult to make in the amateur's workshop. Hence, when once he has learned what wonderful results he can obtain and what

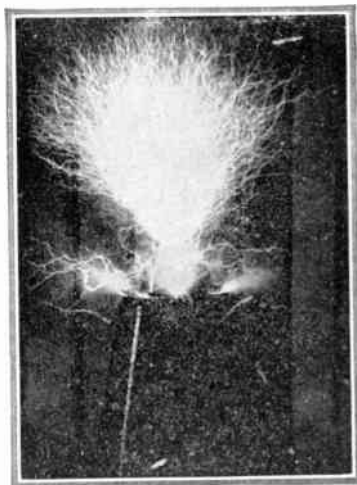

Fig. 1. Great streamers of fire reach out from the terminal

startling experiments he can perform with the crudest instruments imaginable, I believe my reader will agree with me that there is no more interesting or entertaining branch of electrical science than this which deals with alternating currents that oscil-



Fig. 2. The high frequency current is harmless to the human organism

late with a frequency of perhaps a million cycles per second.

It is safe to assume that a goodly portion of my readers will

understand what is meant by an alternating current of electricity. For the benefit of those who do not, however, it may be de-

fixed briefly as a current which periodically changes its direction of flow a certain number of times per second. Commercial currents, which light our homes and offices, run our fans, etc., if alternating, may change their direction of flow from 120 to 250 times per second; these currents would be described as 60 or 125-cycle currents, because, in the case of the 60-cycle current, for instance, the current would alternate 120 times or make 60 complete cycles or reversals from positive to negative and from negative to positive, in the space of one second.

Such a current possesses certain well-known characteristics which make it dangerous when applied to the body at pressures exceeding 110 or, at the most, 220 volts. The passage of the current is accompanied by a disagreeable sensation of "shock" or contraction of the muscles; if the voltage is sufficiently high to force even a tenth of an ampere through the body, the shock is frequently fatal. The physiological result is a paralysis of the muscles of the heart, and the injury which follows is caused literally by suffocation. In addition, the point of contact with the current-carrying wire is seared and burned if the contact is sufficiently long and the current strong enough.

Now, if we take that 60-cycle

current with its dangerous and painful characteristics, and, by means of certain simple apparatus, make it increase in frequency or number of reversals per second until the periodicity reaches ten or fifteen thousand cycles per second, we change its characteristics as if by magic:

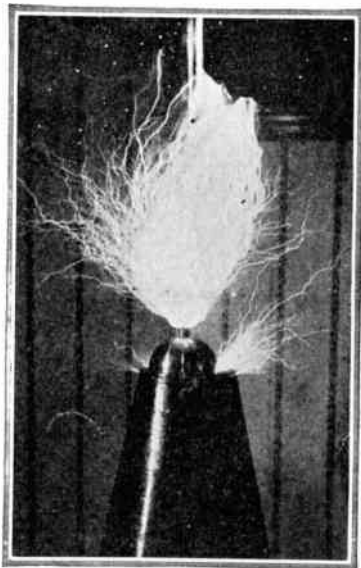

Fig. 3. The discharge leaps through 2 ft. of air to a "grounded" wire

No longer is it painful when applied to the human body and no longer is it dangerous. We can increase the voltage of the current until it will leap across a gap of several inches or even feet in length with a crashing blue-

white flame, and still this stupendous exhibition of the discharge of seemingly stored-up energy is as harmless as the bite of the proverbial barking dog.



Fig. 4. Homemade lighting. Three instantaneous discharges of the coil

Instead of the death-dealing shock and paralysis when applied to the body, we have a sensation of the gentlest warmth, with a constructive effect upon the human organism instead of a destructive one.

If we were to apply the ordinary 60-cycle current to the ends of a helix composed of four or five turns of heavy wire, the result would be a dead short circuit; let us apply the high frequency current, and we find not a short circuit but a difference of potential of perhaps thousands of volts between the terminals of the helix. Let us hold a single turn or ring of wire over that helix while the high frequency current is passing and we find that a current of perhaps a hundred volts is induced *in that single turn of wire*; to prove it, we may light a 110-volt incandescent lamp by touching the ends of the ring of wire to the terminals of the lamp. Think of it—a lamp lighted by the current induced in a single turn of wire totally devoid of any connection with the main circuit, but merely held over the helix through which the high frequency current is passing.

If the high frequency transformer is permitted to discharge through the air, or, indeed, *into* the air, the discharge takes the form of a myriad of snapping, snarling sparks and tongues of flame. In the pictures reproduced herewith, we used but 300 watts of electrical energy. This same quantity of electricity at commercial frequencies would not begin to produce this spectacular display but it might be

infinitely more dangerous in its quiet flame-like discharge at high voltage.

If one terminal of the high frequency coil is connected with a piece of bare wire suspended from the ceiling with thread or cord and the coil set in operation, the wire will glow with a weird, purplish light and tiny forks of flame will dart from every angle. A most interesting experiment, for which I am indebted to Dr. Frederick Finch Strong, is that of connecting the terminal of the coil to the steel rod of an umbrella and hanging the umbrella from the cord in an inverted position. Every rib stands out in purple fire while the little tongues of flame dart from the tip of each rib.

The experiments are not confined to such applications. The high frequency current, when taken through the body by means of suitable electrodes and appliances, acts as a tonic, building up the system and improving general nutrition. Applied to the body as a condenser, the current serves to reduce blood pressure and its use in cases of arteriosclerosis or hardening of the arteries has proven a boon to suffering humanity. The current produces admirable X-ray pictures and in this connection it is said to be less dangerous by far than the usual procedure with an X-ray tube excited with a direct current. Applied to the scalp

through the medium of a vacuum electrode, the current stimulates the growth of hair by increasing nutrition and by massaging every tiny coil.

Passing from the physiological or therapeutic side of the current, it is capable of cultivating plants and vegetables, stimulating their growth to such an ex-

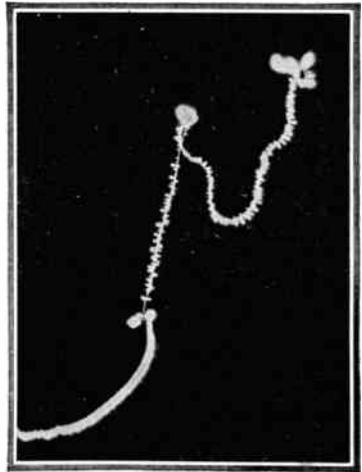

Fig. 5. A real "live" wire. How a wire charged with high frequency current looks in the dark

tent that they mature in half the normal time. Discharged through the air, the current liberates great quantities of ozone. Discharged into an antenna or aerial of overhead wires, the current sets up vibrations of the ether which extend into almost infinite space and give us what you have

all heard of and what most of you play with—radio telegraphy.

Now, with that prodigious list of accomplishments to its credit,

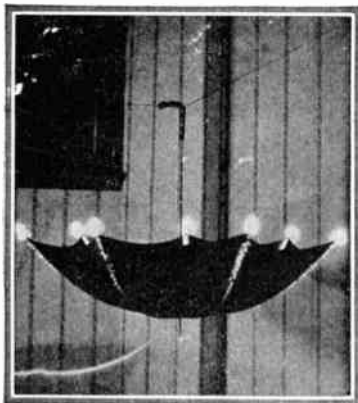

Fig. 6. Frame of umbrella charged with high frequency current

do you not agree that the experimental study of this current and the apparatus that generates it is fully worth while?

*How the Current is Generated.*

—For all practical purposes of the experimenter and student, there is but one generator of high frequency currents available. This is the form most commonly used by wireless amateurs throughout the country. The generator consists merely of some instrument of producing a high potential such as an induction coil or a transformer, a condenser in which to store this current at high voltage, a spark gap across

which the condenser may discharge, and a suitable oscillation transformer or high frequency coil to raise the voltage of the high frequency current set up by the discharge of the condenser across the spark gap. That, in a nutshell, gives you the salient features of an experimental high frequency generator.

In view of the fact that the average radio amateur is very likely to have in his possession the exciting portion of the apparatus comprising the transformer or induction coil, condenser, and spark gap, I will pass over the description of these instruments in this article and confine my description to the oscillation transformer which is the one part of the apparatus that seems to trouble the experimenter; in reality it is the very acme of simplicity, both in principle and construction.

Fig. 7 shows a little resonator or oscillation transformer of the Oudin type, so-called because of its originator. This transformer consists merely of a primary coil of brass ribbon wound into a spiral, and a secondary coil of a single layer of cotton-covered magnet wire wound upon a cardboard cylinder. The lower end of the secondary winding is joined with the inside turn of the primary spiral. That is all there is to the coil so far as the basic principle is concerned. The refinements to be described are



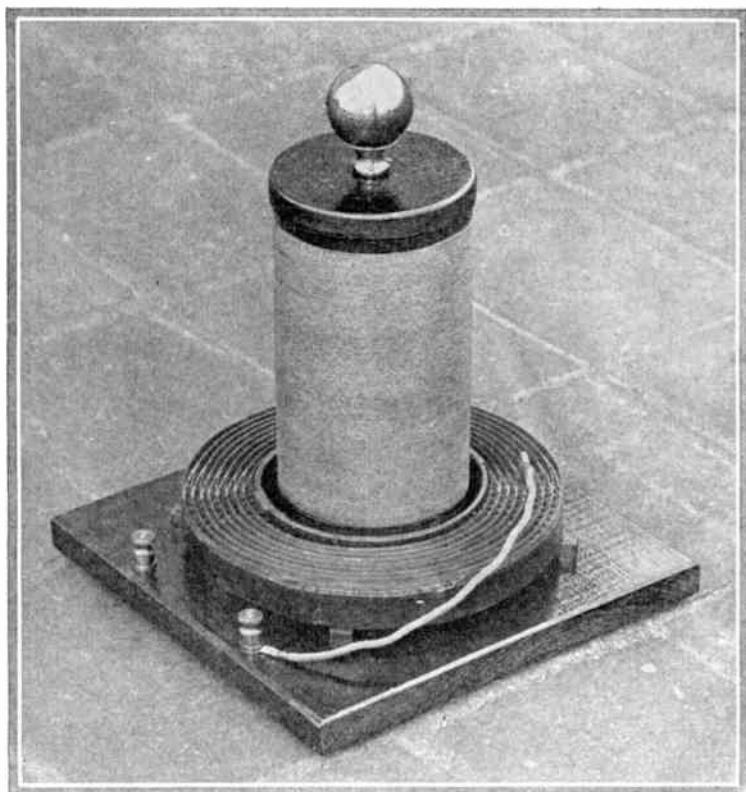

Fig. 7. A small coil suitable for use of amateur, lecturer or class-room instructor  
It will throw a 12-in. discharge

in the nature of conveniences which make the outfit more efficient, better adapted to demonstration work, and of a more workmanlike appearance.

This transformer will throw a spark 12 in. in length when used with a standard  $\frac{1}{4}$  K. W. wire-

less transformer. The spray discharge reaches out to a greater distance if the coil is carefully "tuned." By tuning is meant the moving of the clip connector from one turn of the primary coil to another until the point of "resonance" is found.

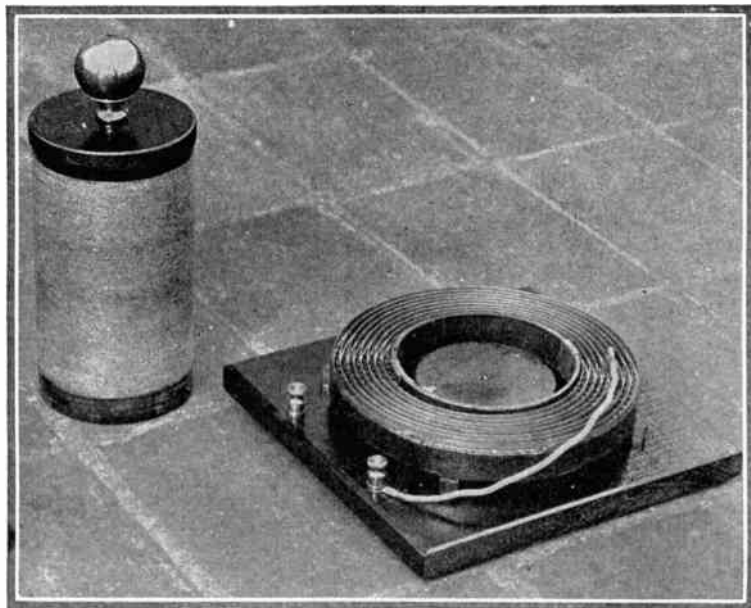

Fig. 8. The secondary may be removed for induction experiments

Perhaps the most novel feature of the little coil is the fact that the secondary lifts out of the primary, leaving the latter free for use in connection with experiments showing the principle of induction or how a current is induced in a coil of wire held over the primary.

Figs. 9 and 10 show clearly the details of construction of the oscillation transformer. The reader will see that the construction is very simple. The wooden heads for the cardboard cylinder may either be turned up on

the lathe or else cut with a jig saw. The latter does not make as nice a job but it is perfectly satisfactory for all that.

The cardboard cylinder is a stock article that may be procured from advertisers in *EVERYDAY MECHANICS* or else through our Service Department. It is perfectly smooth and ready to be wound. I suggest this because it is difficult to get anything in the open market that will answer the purpose of the paper cylinder; wood will not do as it changes its size so materially with changes

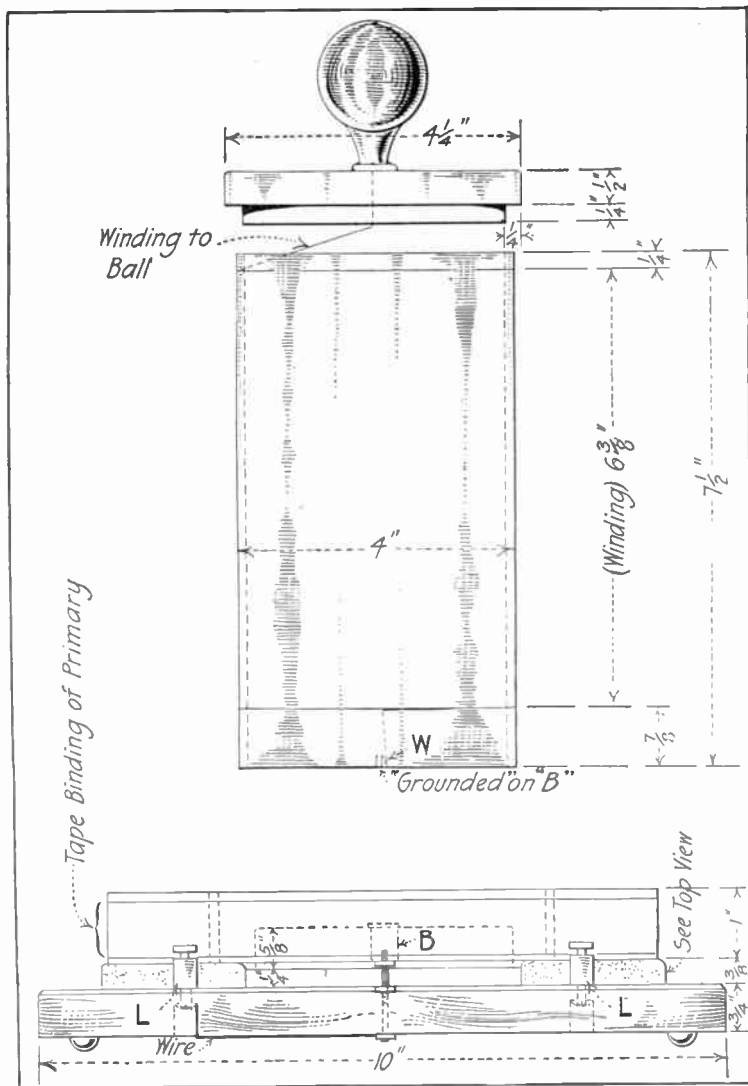

Fig. 9. Details of construction

of atmosphere that the winding becomes loose.

The cylinder, fitted with its wooden heads, is put in the lathe, or, if no lathe is available, it may be mounted between centers in a simple winding rig of home construction. The wire is No. 28 D. C. C. copper magnet wire wound in a single, perfectly smooth layer. When the layer is finished, it must be soaked with shellac, or, preferably, armalac compound. This treatment is absolutely necessary as the current will jump right through the cotton insulation between turns otherwise when the coil is in operation. In order to get the greatest spark length from this coil, the turns should be slightly separated, and the simplest way to do this, if no lathe is available is to wind the wire with a cotton thread beside it, removing the thread when the winding is complete. I have not specified the number of turns as it is unimportant in an experimental coil of this kind. The best working range I have found to be between four hundred and eight hundred turns for the secondary and from five to ten turns in the primary.

The brass ball that surmounts the coil may be surreptitiously removed from the nearest bed post when the family is not looking; or, if you hesitate to borrow in this manner, go to the nearest five and ten-cent store, and

you may find something that will answer. The top turn of the winding is connected with the ball.

The primary is quite as simply constructed as the secondary—only more so. Copper ribbon would be better, but it is so high in price and so difficult to get that I have discarded it temporarily in favor of brass. The inside turn of 1-in. brass ribbon is started by taping the ribbon to a ring of cardboard 5 in. in diameter. Placing the coil of ribbon and the ring flat upon the floor, the builder may proceed to wind up the spiral as shown in the photograph, Fig. 8, with a length of corrugated paper packing between turns to separate them. When nine turns have been taken, pull the spiral to make it tight and run a band of friction tape around the outside. You will be surprised to find how firm and workmanlike the primary is when finished.

The "ground" connection shown in the drawings is a convenience, pure and simple. It is simply a means whereby the secondary winding is connected with the primary by the mere act of setting the cylinder on the lower head. The drawings show the scheme so clearly that I do not need to add much more.

Two binding posts are used on the base. One connects with the ground point, while the other connects with a length of flexible

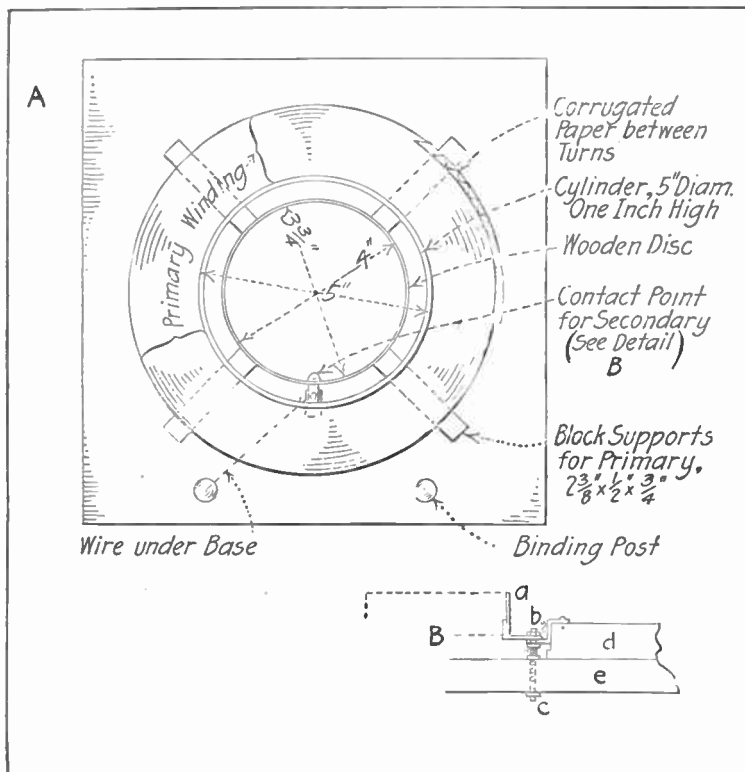

Fig. 10. Detail of primary and "ground" connection

conductor that terminates in a clip to slip over the proper primary turn. The circuit is the usual one with the primary of the oscillation transformer inserted in place of the wireless helix.

This oscillation transformer is large enough for all practical purposes of the average experimenter. It will produce long

sparks of good quality, generate a sufficiently high potential for X-ray work, excite vacuum tubes for electro-therapeutic or demonstration purposes, furnish current for experiments in electro-horticulture, etc. Altogether it is a most practical and useful, though inexpensive, piece of apparatus.

The photographs of the spark

pictures reproduced herewith were taken of the discharge of a somewhat larger oscillation transformer having a cone-shaped secondary. This cone has a base of about 12 in., while it is some 18 in. high. The winding is a single layer of No. 24 D. C. C. magnet wire wound double and then one wire removed to afford separation of turns. The winding is coated with armalac. The cone is of cardboard, built up.

The primary is composed of eight turns of brass ribbon, 1 in. wide, and wound into a large spiral in a manner similar to that employed in the case of the small coil.

The output of the cone-coil with 300 watts in the low-frequency circuit is a spark from 18 ins. to 2 ft. long. This is obtained with a rotary gap, standard wireless transformer, and a condenser of .01 mfd. capacity. I wish that space would permit of a discussion of the exciting apparatus herewith, but that will have to be deferred until the following issue.

#### TO FLATTEN WARPED BOARD

The amateur craftsman is sometimes in doubt how he can flatten a board that has warped. One way is to lay a thick mass of wet sawdust, or a thickly folded wet cloth on the concave side, and ex-

pose the convex side to gentle heat or very dry air. The moisture enters the fibers of the wood of the concave side of the board

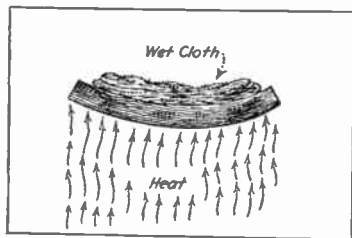

Put the wet cloth on the concave side

and causes them to swell. Heat, on the other hand, removes the moisture from the convex side, and causes the fibers to shrink. In consequence, the board gradually flattens.

Contributed by H. P. THORNTON.

*In Tinning Lugs*, if proper methods are not used smooth surfaces will not be obtained. The following has proven a successful method: The lug should be thoroughly cleaned of oil and dirt, dipped in flux and held in molten solder until it is hot. When hot it should be taken and wiped of all excess solder with a rag, not waste, as lint from waste sticks in solder.—H. L. BAER.

## SEA ANCHORS FOR THE MOTORBOAT

BY GEORGE E. WALSH

THE average motorboat carries an anchor that is suitable enough for ordinary occasions, but not at all adaptable to heavy weather when forced to ride out a storm off shore. Yet every boat is liable, at some time, to meet just such conditions when the life of the craft and its occupants will depend upon the anchor equipments. For inland lakes and rivers the small folding anchors of light weight will answer all purposes, but for the ocean or Great

anchors for ocean work should be 3-16-in., and the others larger, in proportion to the weight.

Folding anchors are most commonly used for the motorboat because of the convenience of stowing them away. All the common forms of anchors are made for folding up in sizes as small as 4 pounds. A boat equipped with two or three of the small folding anchors can often ride out a storm without dragging better than one having only a single anchor twice the size. This is obtained by attaching two or more anchors on a single cable, so that the lifting power of the waves will not raise the stocks of all at the same time. On separate cables each swell might lift the stock of two or three anchors at once, and thus permit the boat to drift. A small 10-pound anchor attached to a cable 20 or 30 feet from the main anchor will often prevent the latter from being lifted, and as a consequence it will hold on like grim death.

The amount of cable is also important. A short cable suitable for fishing in quiet waters would be useless in a storm. The more perpendicular the cable, the less is its holding power. Fifty or 60 feet of chain on the bottom may hold a sharp boat in a wind, but a blunt bow or heavier boat may

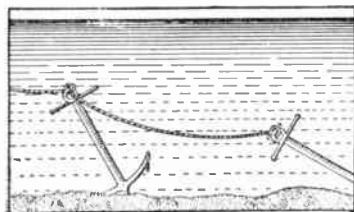

Two anchors on one cable

Lakes the estimated minimum weight of an anchor should be 20 pounds for a boat from 1 to 1½ tons; 30 pounds for a 2-ton craft; 50 pounds for a 4-ton boat, and so on up. A 30-ft. motorboat, regardless of its tonnage, should carry a 30-pound anchor for inland waters, and a 50-pounder for ocean or the Great Lakes. The chains for the smallest size

call from 100 to 150 feet on the ground. In a heavy storm off shore 500 or 600 feet may be necessary even with two anchors attached to it. In such cases only the part on the bottom need be of chain, a strong hemp rope being used as the real cable.

But there are times when it is impossible to anchor, and, likewise, impractical to keep on running. The sea may be too rough, and the engine must be shut off entirely. It is a case of "laying to" or being swamped. It is at such times that a sea anchor or drag is of vital necessity. If you have the proper materials on board, a sea anchor can be improvised in an emergency, but it is much better to make one at home and have it stored away for just such an emergency. It can be stored away in a locker ready for immediate use. Take an iron ring with a diameter of 30 to 36 inches, and lace a conical bag made of sail cloth to it. Any old sail cloth will answer the purpose, but it should be at least  $1\frac{1}{2}$  to 2 times the diameter of the iron ring from the mouth to the end of the cone. A tripping rope should be attached to the cone for hauling in the drag when no longer needed.

Another sea anchor is made with a hinged iron frame so that it can be folded up in a smaller space. One is about as good as the other, however, and when thrown overboard in a storm either will hold the bow of the boat be-

fore tide and wind so the waves will break clean against the nose. With the engine shut down, you can "ride out" a pretty stiff storm at sea with one or two sea drags of this kind thrown overboard. The boat will drift slowly, but if there is plenty of sea room that will cause no disadvantage. The sea drag may save the boat from

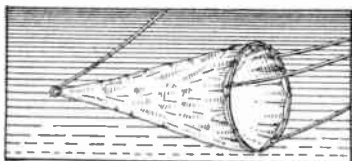

A homemade sea anchor

wreck when caught in a storm where the depth of the water precludes the use of ordinary anchors.

Finally, as a last resort in an emergency, one should be provided with oil bags, or have the material aboard for improvising them. When the crests of the waves break so high over the bow that there is danger of being swamped, the oil bags are absolutely necessary. An ordinary canvas bag or roll 2 ft. long and 6 in. in diameter will do the trick, but it is better to have this prepared in advance. Lace the bag to an iron ring, and stuff it as tight as you can with old pieces of canvas or waste. Two of these should be carried, one for either side of the bow. Fill them with cylinder oil.



and attach them to the cables of the sea anchors about 15 to 20 ft. from the boat. The oil will gradually soak through the canvas bag and spread out on the water, reducing the fury of each wave until comparative calm follows. By refilling the bags with oil every few hours, one may thus ride out a storm safely as long as the supply of cylinder oil lasts. Motorboats caught in heavy storms off our coast have been saved time and again by means of the sea anchor and oil bags, riding the waves for forty-eight hours at a stretch.

#### A SWING CHURN

A great saving in time and back-breaking labor is a swing churn that any amateur can make at small cost. The one I have in mind was made from an 18 by 24-in. piece of tin of good heavy quality, and its capacity is about four gallons. It has 2-in. legs upon which to stand when desired, a handle at each end to operate it by, and a 6-in. opening in the top through which to pour the milk and cream.

The top is made like a milk bucket lid to go down inside so as to keep the milk from flying out. A heavy metal band with a ring in the center is soldered at each end of the churn. A cord

is passed through the ring and the churn suspended from the ceiling.

The churn can be adjusted to any convenient height, but the

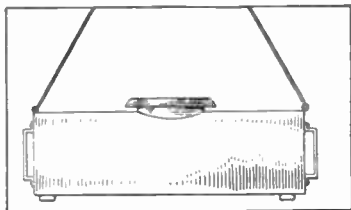

The churn can be adjusted to any convenient height

work is usually done sitting, and the smallest child can operate it. You grasp one of the end handles and shove from you, then draw it back smartly, the impact of the milk against the ends of the churn furnishing the necessary friction to make the butter. This takes about half as long as the old ordinary lid and dash method and is work in no sense of the word. The churn will last an indefinite time—the one described has been in constant use for twenty years. It is not a patented or proprietary invention, and so far as the writer knows cannot be purchased, there being only two churns of this make in existence—mine and one other.

Contributed by L. DORMAN.

## CONSTRUCTION OF A MODEL SUBMARINE WITH WIRELESS CONTROL\*

### PART IV. THE TORPEDO TUBE AND AIR TANK

BY THE LABORATORY STAFF

THE torpedo tube consists of a  $9\frac{1}{4}$ -in. length of  $\frac{7}{8}$  in. diameter brass tubing, fitted with a hinged gate at the muzzle and a cover, also hinged, at the breech. At the latter end there is also an inlet tube through which the compressed air is admitted to discharge the torpedo.

Fig. 1 shows well the general appearance of the tube with breech cover open in the upper view and closed in the lower. (Glancing next at the drawings below, Fig. 2, we note the construction in detail. The brass tube is selected from a length of perfectly smooth stock, free from dents and imperfections. After filing or turning both ends true, the 3-16 in. hole may be drilled for the air inlet as is shown in the drawing. This, the reader will note, is  $\frac{3}{4}$  in. from the breech end of the tube. The inlet tube is forced into the main tube with rather a snug fit and then the joint is most carefully soldered, care being taken to see that the solder sweats well into the union. This process will be aided through

the use of a hot, well-tinned copper, and a bit of good soldering paste as a flux. The use of acid should be avoided. The solder should be plentifully banked up and floated around the joint on the outside to strengthen the union. When the job is cold, a fine, round file may be used inside the torpedo tube to clear away the piece of inlet that enters the main tube. Care should be taken to avoid scratching the inner surface any more than is necessary.

The breech-covering device commands attention now. This consists of two pieces of 1-16 in. thick brass sheeting cut into rectangles as shown in the drawing. In one piece is cut the large hole to take the end of the torpedo tube. This job is one for the jeweller's saw, unless the builder can place the piece on a wooden face-plate in the lathe and cut away the stock in this manner. The two pieces of brass are then clamped together and the tap and clearance holes drilled for the No. 2-56 screws that provide the means for clamping the cover shut when the torpedo is to be fired.

The next operation will be to drill a tap hole for a No. 2-56

\*This series will be concluded with two more instalments. Part V will describe the diving mechanism and the wiring of the model, while Part VI will cover the torpedo and deck fittings. The model is on exhibition in the magazine offices on Saturday afternoons between the hours of three and four.

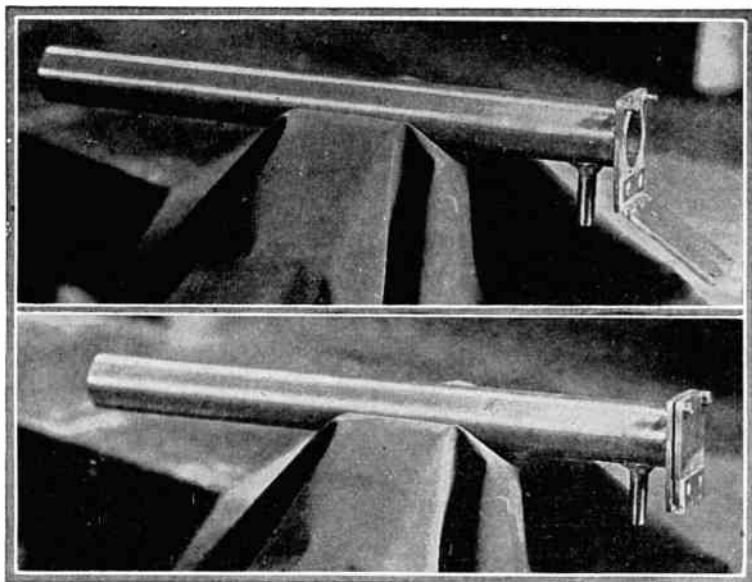

Fig. 1. Torpedo tube. Breech end opened and closed

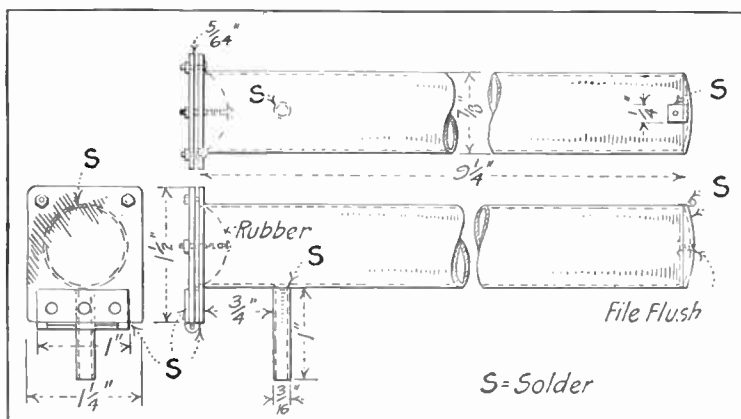

Fig. 2. Detail for construction of torpedo tube

screw clear through the two pieces at the bottom with the small standard brass hinge in place. The tap is run through and the pieces separated. Very short lengths of brass rod, threaded 2-56 are then used to assemble the two pieces of the cover with

ber that is attached to the breech cover. This piece of rubber was cut from one of the flat stoppers used to close the drain of a wash basin. The stopper can be purchased in any five and ten cent store as can the hinge also.

The muzzle end of the tube is

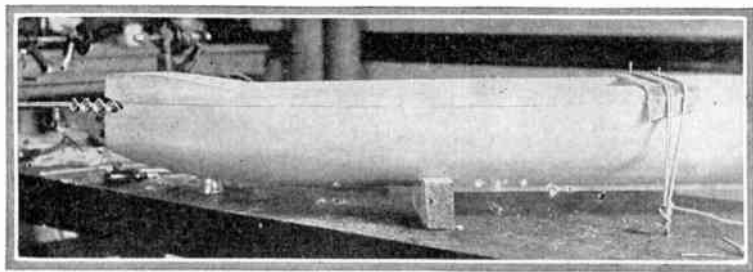

Fig. 3. How the hole for the tube is bored

the hinge that joins them. This scheme will enable the worker to true up the assembly and hold the parts in place while soldering the pieces to the hinge. It also stiffens the entire job when finished. The builder will note that the hinge occupies a position that separates the swinging part of the cover from the stationary part by about 1-32 in., or the thickness of one leg of the hinge. The reason for this separation will be seen if the reader will refer to Fig. 7 which shows the torpedo tube complete with both muzzle gate and breech cover. The method of sealing the breech is seen in the half-sphere of rub-

ber that is attached to the breech cover. This piece of rubber was cut from one of the flat stoppers used to close the drain of a wash basin. The stopper can be purchased in any five and ten cent store as can the hinge also. The muzzle end of the tube is closed with a gate made up of two pieces of sheet brass held together with a screw and soldered. The cover closes by means of its weight and no attempt is made to make it watertight. This little gate is given a rounded face by pounding a piece of soft sheet brass with the ball peen of a machinist's hammer. This piece is then joined with a flat piece, the upper part of which is projected to form part of the tiny hinge. The main part of the hinge is a piece cut from a stock brass hinge. This portion is soldered carefully to the muzzle of the tube after having been held with a length of brass rod

threaded in as in the case of the breech.

After finishing the work on the tube, we shall see how it is inserted in the hull of the model. For this, refer to Fig. 3. The top piece, No. 7, of the hull is nailed temporarily and two screws inserted at points 1 in. to either side of the center line at the bow. Then, holding the hull down to the bench with some sort of clamping device such as that shown in Fig. 3, start the hole for the torpedo tube with a sharp  $\frac{7}{8}$ -in. bit, as shown in the illustration. This work must be most cautiously done to avoid splitting and inaccurate cutting. When turning the brace, sight constantly along the center line of the deck and have an assistant with a good eye sight in the horizontal direction. The tube should be given an incline slightly downward as it leaves the bow of the boat; this will insure the torpedo being discharged well into the water in the event that the model is running in the awash condition.

When the hole is through, the tube may be carefully inserted, removing the No. 7 plank, and inserting the tube from the inside. Fig. 4 shows the tube in place and also how the deck or No. 7 plank fits over it. In these pictures the tube is shown without the muzzle gate in place. Fig. 8 shows the tube in place and also how a cut is taken in the wood to permit

the tube to be inserted with muzzle gate in position.

The pneumatic system which discharges the torpedo is shown in Fig. 7 and in detail in Figs. 5 and 6. The tank consists of a length of standard wrought iron pipe of the 2-in. size, fitted with a cap at either end. The construction is simple and easily understood from a study of the drawings and photographs. The first operation is to drill the  $\frac{3}{8}$ -in. hole in the center of the pipe to take a standard valve of the bicycle tire variety. This valve is inserted in the usual way with a piece of thick rubber packing on the inside. Next, the one cap may be screwed on with plenty of white lead in the threads. The cap should be well set up as it is not to be removed again.

In the face of the cap, near the edge, is drilled a hole to take the stem of a standard  $\frac{1}{8}$ -in. pet cock. If you do not happen to have a pipe tap of this size, let the plumber from whom you buy the pipe do the tapping for you while you wait. The pet cock is to have its handle cut off and a long arm of brass strip set in its place. A spiral spring, coiled a few times around, will serve to keep the valve closed normally. The outer end of the valve arm is connected with the plunger of a solenoid. The details with dimensions are given in Fig. 6.

The solenoid consists of a

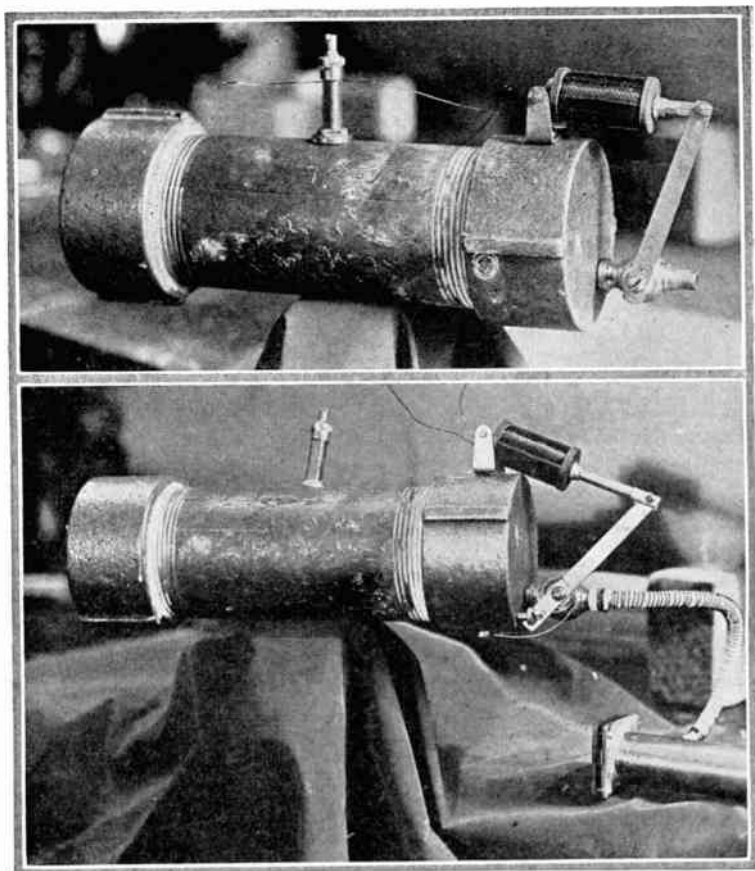

Fig. 5. Two views of the compressed air tank. Above: Valve open. Below: Valve closed

length of brass tubing fitted with fibre heads and wound with No. 24 enameled wire. The fibre heads are  $\frac{3}{4}$  in. in diameter and the

bobbin thus formed is wound full of the wire in even layers.

The method of pivoting the solenoid is detailed at *A* and *B*

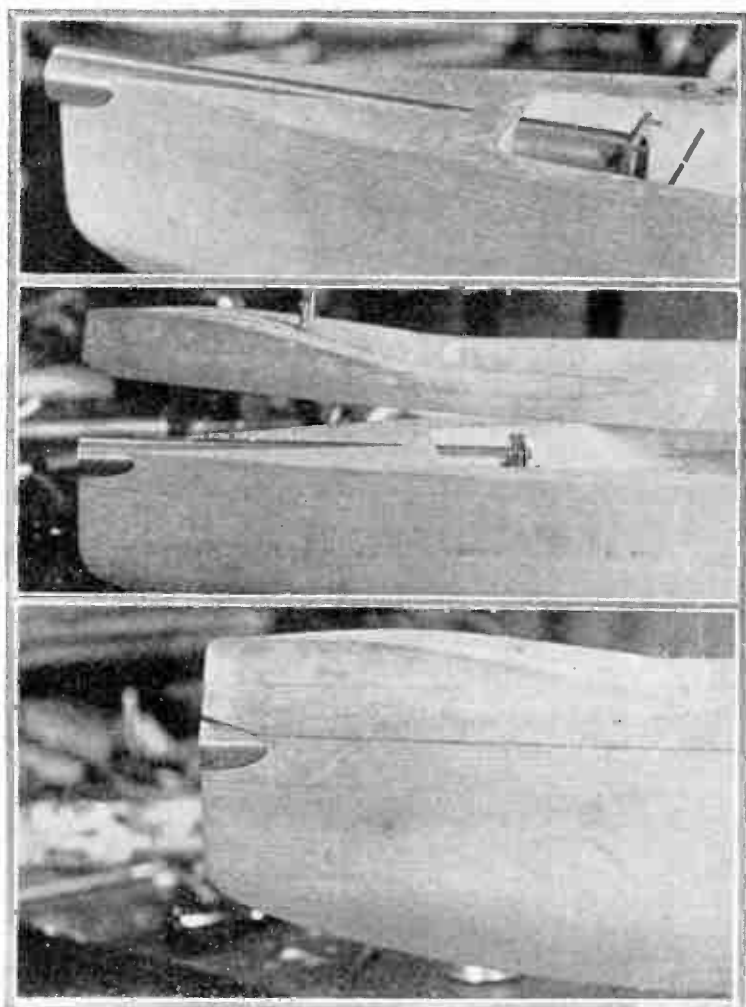

Fig. 4. How the tube is inserted

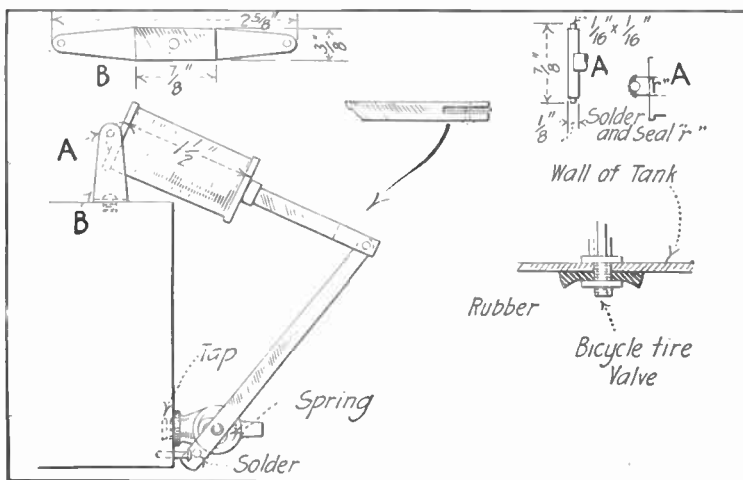

Fig. 6. Detail for construction of air tank and valve

in the drawing. The end of the tube is fitted with a cross-piece of brass rod which is soldered in place as shown at A. This cross-piece is held in a simple bearing made of a single length of brass strip drilled and bent up to suit. A single screw holds the bearing to the cap on the tank.

With reference to Fig. 7, the tank is seen to be connected with the torpedo tube by means of a length of rubber tubing. The latter must be wound with wire to prevent bursting under the pressure. Fig. 8 shows how the tank is secured to the hull. Two cradle pieces of wood are nailed

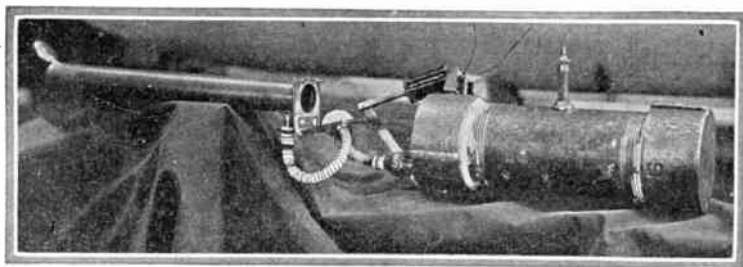

Fig. 7. Rubber tubing connected to air tank and torpedo tube. The pneumatic system complete



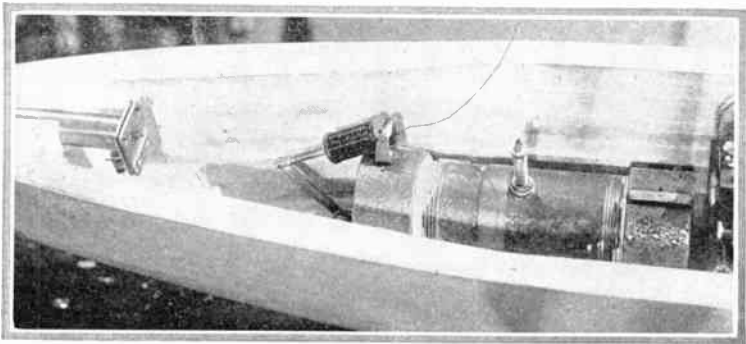

Fig. 8. The tank fastened in place

to the bottom plank and the tank held with a single strap of brass. In this view, the reader will note that the valve in the top of the tank and the solenoid are not in line. This off-setting of the solenoid is necessary to permit the torpedo to be inserted in the tube.

Before clamping the tank permanently in the hull and after fitting the second cap to the pipe, the pet cock valve should be adjusted so that it opens when current is applied to the solenoid and closes through the agency of the spring when the current is turned off. The position of the valve can best be determined by pumping up the tank with a small bicycle pump. The sound of the air escaping gives the cue. This is also the right time to test the tank for possible leaks. To this end, place it bodily under water after pumping to a mod-

erate pressure. No pressure gauge is necessary as the exact amount of pressure is of little consequence. The sole object of the pneumatic system is to discharge the torpedo from the tube; once it is in the water, the torpedo is self-propelling through the agency of a spring motor contained within the cylinder.

---

*To Make Gully in Cement.*—When the cement floor is being laid a gully around the edge of same is usually made to drain off water. An iron pipe laid in the cement while still soft and gradually sloped to the drain, makes a gully which would drain off water much better and faster than one dug out with trowel or cut out with a chisel when cement is hard.—H. L. BAER.

## AN ELECTRIC SHAVING MUG

BY WM. WERNECKE, JR.

THE following suggestion may be used in the construction of various heating or cooking utensils. The device described, an electric shaving mug, will, besides proving an appropriate gift to any man, bring delight to the user.

A mug that will stand heat is the first thing required, and an aluminum cup of standard shape and design, which can be purchased in almost any town, will do perfectly well. These cups are spun from a flat sheet and have no seams to open or leak. It is necessary that no holes be drilled in the cup, as it will be practically impossible afterwards to render such holes watertight. The heating element must be fastened to the mug with a suitable clamp, which will also allow the removal of the coil without injury to the cup. The bases or bottoms of such mugs have a recessed part, made by a flange and in this the coil is placed. The legs of the mug are made of sheet brass, as shown in Fig. 1, one of the three having an enlargement near its center with a hole for an insulating button (see Fig. 2) of "transite" or some other material to hold the supply cord, so as not to be an annoyance to the user. The clamp for holding the heating coil in place is shown in Fig. 3. This

clamp has a screw in its center in order to hold it in place. The brass legs, and the clamp may be nickelplated, if so desired. The heating coil (Fig. 4) consists of a coil of flat "nichrome" wire or "ribbon," as it is called, 12 ft. long, 1-16 in. in width, and .003 in. thick. This is equal in cross section to a No. 26 gauge wire. To wind the coil procure a block of wood  $\frac{7}{8}$  in. thick and about 4 in. square, with a  $\frac{1}{2}$  in. hole in the center for its axis or pivot. Clamp a  $\frac{1}{2}$  in. rod in a vise so that the block can be rotated about it. Begin at the center and fasten one end of the ribbon to the block, leaving about 2 inches projecting for a connection; then wind the ribbon in a spiral coil, separating each turn from the preceding one with an asbestos cord. A part of the coil is shown in Fig. 5 as it would appear highly magnified, in which *A* represents the asbestos insulation between the layers of ribbon and *B* the nichrome ribbon. The insulation may be obtained by "untwisting" some  $\frac{1}{8}$  in. round asbestos packing and using one of the strands. This cord insulates the turns of the ribbon, as the current must not be short-circuited. At the same time, however, it must be wound very closely to fit in the limited space

under the bottom of the cup. Before taking the coil from the block, rub into its surface a little asbestos retort cement, or a cement composed of a mixture of silicate of soda and silica or glass sand. This mixture when dry will tend to hold the coil together and the electric current may be passed through the coil to test it as well as to bake it in its coiled shape. The support for the heating coil is made of a piece of 5-16 in. asbestos-wood or transite. Cut it to fit exactly into the recessed bottom of the mug, then with a chisel remove the material in the top to form a depression 1-16 in. deep to receive the coil with its top flush. The leads of the coil are run through the disc. The surface of the coil is then plastered evenly with retort cement. The legs are fastened to a second piece of insulating material, with round head brass machine screws  $\frac{1}{2}$  in. long with nuts. The heads of these screws are shown in Fig. 6, the nuts being above the brass and between the two insulating pieces. The ends of the heating ribbon are brought through the lower insulating disc, and attached to the binding posts as shown. The leads may be covered with tape to prevent the possibility of short-circuiting.

This shaving mug uses  $3\frac{1}{2}$  amp. on a 110-volt circuit, either direct or alternating, or about 3 cents' worth of electricity per hour.

Care should be taken to use a separable attachment for connecting, as an ordinary lamp socket may be burned out by turning off the current, it being only adapted

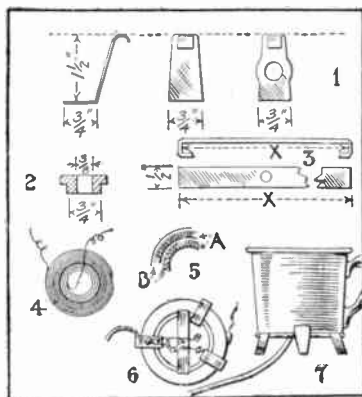

Various parts of the shaving mug

to a small capacity. Do not allow the coil to become extremely hot nor should current pass through it if no water is in the cup, as such occurrences mean the winding of a new coil.

*The white spots on the dining table may be avoided by cutting out round pieces of pasteboard and sewing thick white buttons on one side. Place the hot dishes on the button side, and allow a current of air to get under the dish.—*  
MARY F. SCOTT.

## CONSTRUCTION OF A TRANSATLANTIC RECEIVING SET

PART III. THE CONDENSERS, CIRCUIT DIAGRAMS, OPERATION, AND LIST OF STATIONS THAT MAY BE HEARD WITH THE SET

BY LOUIS GERARD PACENT

**I**N the first and second instalments of this series we have seen how the receiving transformer, audion cabinet, and inductances or loading coils, are constructed. In this, the concluding chapter, the specifications for the variable condensers and the diagrams of connections will be presented. Following this, operating instructions will be found and then, as a fitting close for the series, a list of the large international stations with their call letters, wavelength, time of operation, system used, and description of system, is given.

*Condensers.*—The construction of a business-like variable condenser of the rotary plate type is somewhat of a poser for the average amateur. The job involves some very careful lathe work and close filing and the plates should really be stamped on a punch press. In view of this, it is believed that the amateur will find it cheaper and far more satisfactory to purchase the standard variable condensers now on the market for amateur radio work. They are not expensive, and the consensus of opinion seems to be that, by the time the parts have been worked up in

the home shop, it would have been less expensive to buy the complete instrument outright.

The condensers used in series with the grid and across both wing and grid inductances are of the standard amateur type\* having 16 stationary and 15 movable, semi-circular plates. The capacity is 0.0005 mfd. Across the secondary of the receiving transformer is connected a condenser of 0.001 mfd. capacity and having 23 stationary and 22 rotary standard amateur plates. The condenser across the telephones is a similar one but in this case the container is filled with castor oil which serves to increase the capacity about five times.

With reference to the diagram of connections, the 2 mfd. condenser shown connected across the "B" battery is one of the standard telephone type that may be purchased from any well-stocked supply house for a small sum. It is so cheap that its construction by the amateur is not justified.

\*For prices, names of manufacturers, catalogs, etc., write to Service Department, EVERYDAY MECHANICS, Aeolian Hall, New York.

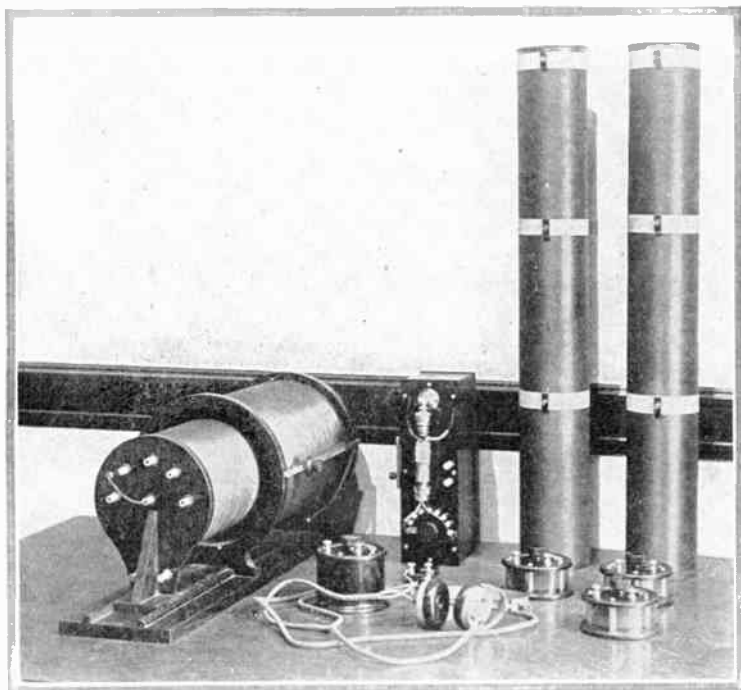

Fig. 1. The receiving set complete

*Telephone Receivers.*—It is not within the province of the author to pass upon the relative merits of the various makes of amateur and professional receivers on the market. Suffice it to say that the highest priced receiver is justified if the pocketbook is not too depleted. In the latter event, the amateur is advised to purchase a good pair of receivers of the low-priced amateur type from a reliable house with a reputation

back of it. Such receivers can usually be sold at a slight discount to a fellow amateur when the original owner feels he can spend the money necessary for a better pair of instruments.\*\*

*Operation of Instruments.*—The circuit diagram shows clearly how the various instruments are connected. The operating room will naturally rest with the in-

\*\*Consult your dealer, or write our Service Department if there is no dealer in your city.

dividual and to offer suggestions, in view of the diversity of conditions and surroundings, would be futile. The specifications for the aerial were given in the opening chapter of the series; hence, we have only to learn how the instruments are actually operated in order to obtain the greatest efficiency.

The first operation, after making sure that connections are correct, and that the filament of the audion bulb lights up well in response to the current from the 6-volt battery, is to tune the primary and secondary to a trial wavelength, and then at a certain value of inductance in the grid circuit, vary the capacity of the condenser shunted across it very slowly until you hear an incoming signal, the pitch or note of which you can vary with changes in the capacity of the condenser.

When this point has been reached vary the constants in the wing circuit until a louder response in the telephones is obtained. Once the incoming signal is heard, it is an easy matter to vary the coupling between primary and secondary of the receiving transformer and other constants of the circuit until the highest efficiency is obtained.

The audion is a voltage-operated instrument and as a result the operator will find that maximum results are obtained with high values of inductance and

low capacities of condenser for a given wavelength. For a lengthy and very comprehensive explanation of the Armstrong regenerative circuits, the reader is referred to Proceedings of the Institute of Radio Engineers, Vol. 3, No. 3, September, 1915.

*Stations to be Heard.*—The list of stations which follows has been prepared with great care and with due attention to accuracy. The owner of one of these receiving sets is advised to cut out the list and paste it up before his instruments or else make a copy of the list. By following the operating directions carefully, the operator will be able to hear practically all of these stations with the instruments described, providing, of course, that everything has been made to specification and that the antenna is properly insulated and of the necessary length.

#### DESCRIPTIONS OF SYSTEMS

*Poulsen or Federal* (Undamped Waves).—The Federal-Poulsen arc-generator, as used for producing undamped high frequency oscillations suitable for radio telegraphic work consists of an electric arc formed between water-cooled copper and carbon electrodes, surrounded by some gas containing hydrogen and situated in a strong transverse magnetic field.

*Goldschmidt* (Undamped Waves).—The Tuckerton Radio Station is equipped with a Fed-

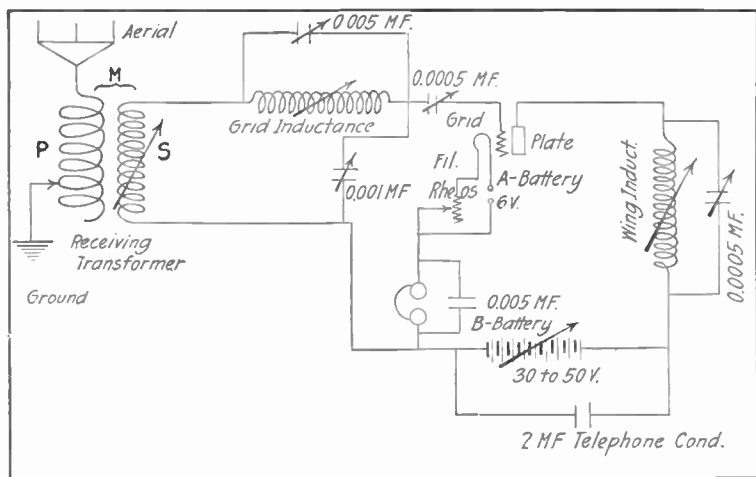

Fig. 2. Wiring diagram of receiving set

eral-Poulsen arc-generator and a Goldschmidt radio frequency alternator.

The Goldschmidt alternator generates undamped oscillations through the multiplication of a relatively low initial frequency by means of a series of "reflections" between stator and rotor of the machine. For example, an alternating current of say 10,000 cycles is put through the stator, and the rotor is tuned to the frequency of the stator. The resultant frequency will be twice the initial frequency. The latter current is put through another oscillating circuit tuned to its frequency and the result is again multiplied. This frequency is then connected to a proper load-

ing coil connected to antenna and ground.

*Sayrille and Nauch Stations (Undamped Waves).*—These stations use a series of transformers in each of which the initial frequency is multiplied by two. Current is generated by an alternator at a relatively low frequency (10,000 cycles per second or less), after which the frequency is increased to from 30,000 to 40,000 cycles by two groups of transformers.

*Marconi (Damped Waves).*—The Marconi Company uses a rotary spark disc discharger, consisting of a wheel with studs mounted near the periphery and rotating at a certain speed. The spark jumps from these studs to

two stationary electrodes. The discharger is mounted on the generator shaft. The disc has as many studs as there are generator poles so that one spark takes place at every alternation. The speed is kept at a value where the note emitted is musical to the ear of the receiving operator and not easily mistaken for atmospheric (static).

*Fessenden* (Damped Waves).—The National Electric Signalling

Company, the owner of the Fessenden patents, uses a system similar to Marconi with the exception that a 500 cycle alternator is employed. The note emitted is therefore high and piercing, approaching a whistle.

*Telefunken*.—The Telefunken Company makes use of a 500 cycle generator, using a "quenched" spark gap. This system is noiseless and it represents the latest achievement in the art.

<i>Call.</i>	<i>Station.</i>	KIE	Kahuka, Hawaii.
CX	Clifden, Ireland.	KSS	South San Francisco, Cal.
CWA	Cerrito, Uruguay.	NAA	Arlington, U. S. A.
EAC	Cadiz, Spain.	NBA	Darien, Panama.
EAL	Palmas (Las).	OUI	Eilvese, Germany.
EAT	Teneriffe, Spain.	PCH	Scheveningen, Holland.
EGC	Madrid, Spain.	POZ	Nauen, Germany.
FAO	Hanoi, French Indo-China	VIS	Sydney, Radio, Australia.
GB	Glace Bay, Canada.	WBV	Hoboken, N. J.
ICX	Massana, Erythra.	WBW	Burrwood, La.
ISG	Mogadiscio, Ital. Somali- land.	WCC	South Wellfleet, Mass.
KAV	Norddeich, Germany.	WCG	Brooklyn, N. Y.
KET	Bolinas, Cal.	WCH	Boston, Mass.
KFS	San Francisco, Cal.	WGG	Tuckerton, N. J.
KIJ	Koko Head, Hawaii.	WNU	New Orleans, La.
KIX	Heeia Point.	WSL	Sayville, N. Y.
		WXN	Fort Mills, Phil. Islands.

STATION	CALL	WAVELENGTHS	HOURS	SYSTEM USED
Arlington, U. S.	NAA	1200, 6000, 7500	Continuous	Composite, Fessenden, Poulsen
Bolinas, Cal.	KET	6000	Not Fixed	Marconi, Rotary
Boston, Mass.	WCH	300, 600, 1610, 2000, 2400, 2800	Not Fixed	Federal



STATION	CALL	WAVE LENGTHS	HOURS	SYSTEM USED
Brooklyn, N. Y.	WCG	1800, 2600, 3600 300, 600, 1650	{ 1 9 P.M. 1 12 A.M. 7-7.05	Fessenden
Burrwood, Ia.	WBW	300, 600, 1650 1800	{ 9 9.05, etc., until 7 05 P.M.	Composite
Cadiz, Spain	EAC	300, 600, 2540	Continuous	Marconi
Cerrito, Uruguay	CWA	600, 1000, 1250	Continuous	Telefunken
Clifden, Ireland	5CN	4000, 6000, 7500 10000	Continuous	Marconi
Darien, Panama	NBA	10000, 8000	Not Fixed	Poulsen
Eilvese, Germany	OUI	9000	Continuous	Goldschmidt
Fort Mills, Phil. Is.	WVN	600, 1200	Not Fixed	U. S. Army
Glace Bay, Canada	GB	4000, 6000, 8000 10000	Continuous	Marconi
Hanoi, French Indo-China	FAO	600, 3400, 3000	{ 7-11 A.M. 2-5 P.M.	French Govt.
Heeia Point, Hawaii	KHX	300, 600, 3000 3500, 5500, 8000	Continuous	Poulsen
Hoboken, N. J.	WBV	2250	Not Fixed	Marconi
Koko Head, Hawaii	KuJ	11000	Not Fixed	Marconi
Kahuka, Hawaii	KIE	6500	Not Fixed	Marconi
Madrid, Spain	EGC	600, 900, 1600 2000, 2500	Continuous	Telefunken
Massana, Erythra	ICX	1600	Not Fixed	Marconi
Mogadiscio, Ital.	ISG	4000	Not Fixed	Marconi
Somaliland	POZ	6300, 9400, 12600	Continuous	Telef. (Trans-atlantic)
Nauen, Germany	KAV	300, 600, 1800	Continuous	Telefunken
Norddeich, Germany	WNU	300, 600, 1800, 1850	Continuous	Composite
New Orleans, La.		2000	Not Fixed	U. S. Army
Nulato, Alaska	EAL	300, 600, 2540	Continuous	Marconi
Palmas (Las)	WSL	2740, 8000, 9400	Continuous	Telef. (Trans-atlantic)
Sayville, N. Y.				
Seheveningen, Holland	PCII	300, 500, 600, 1800	Continuous	Mixed
San Francisco, Cal.	KFS	300, 600, 3000, 3500, 3700	Continuous	Poulsen
South S. Frisco, Cal.	KSS	10000	Continuous	Poulsen
South Wellfleet, Mass.	WCC	300, 600, 2100	Continuous	Marconi
Sydney, Radio, Australia	VIS	300, 600, 2500	Continuous	Telefunken
Teneriffe, Spain	EAT	300, 600, 2500 7500	Continuous	Marconi
Tuckerton, N. J.	WGG	7500, 8400	Continuous	Goldschmidt-Poulsen

## SHOCK ABSORBER FOR DETECTOR

For his detector, one "wireless bug" made a very attractive shock absorber by using a block of white pine  $\frac{1}{2}$  in. in thickness, and  $\frac{1}{4}$  in. larger than the detector base all the way around. On top of this block are laid two or three sheets of felt the same size; on the sides and ends of the block

are fastened thin strips of cigar-box wood, being high enough to clear the felt by about  $\frac{1}{8}$  in., thus making a shallow box with a padded felt bottom. The upper edge of the strips are neatly rounded off and the whole given a coat of mahogany stain and varnished, making a very attractive shock absorber.

Contributed by C. H. BIRON.

## SOME IMPORTANT DETAILS OF KITCHEN CONSTRUCTION

By F. H. SWEET

**D**ETAILS of kitchen construction, such as the location of the ice-box, the kind of kitchen floor to use, the location of the pantry and others are of great importance, but many times overlooked.

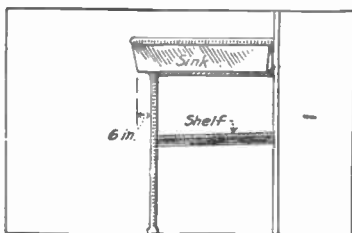

The legs should be set 6 in. back

The best sink is the enamel or porcelain one; that of soapstone is a close second. Although the galvanized iron is supposed to be superior to the plain iron, there seems to be considerable doubt on that point. The iron sink, if attended to and oiled occasionally, can be kept in very good order. Some who have used both declare in favor of the plain iron, claiming that the galvanized involves constant care, owing to its great tendency to spot; nor is it entirely rust-proof. In the setting of the sink, the point where the legs set on the floor should be at least 6 inches back of the front line of

the sink. This rule applies to cases where the cupboard is used underneath as well as all "table" shelves. The reason for this is obvious. The foot projecting beyond the line of the leg would interfere were these two members made on the same line. "Table" shelves, sinks and the like should be of a convenient height for those using them. It is perhaps well that all "table" shelves should be zinc-covered; particularly those adjacent to the sink. Tile is even better than zinc for this purpose. A marble slab raised above the shelf level is often a convenience not to be underestimated. Oftentimes the swinging shelf is of advantage; but this should only be used where space will not permit the use of a fixed shelf. Its great objection lies in the fact that as an emergency, it is usually down when it is much wanted.

The location of the ice-box is frequently overlooked in the general arrangement. It should not be in the kitchen; yet handy to it. Often it can be placed in the pantry. In that case it should not stand with its back against the chimney or any other hot place, and if it can be filled from the outside, or at least without going through the kitchen, it is a decided advantage.

The relation of the cold-closet to the kitchen is also important. The best place for it is at the foot of the cellar stairs, where it will save as many steps as possible. Oftentimes much can be saved in the way of steps, and the size of the refrigerator (which will not hold everything, anyway), by the use of a cold-box. This is not advisable as a window ornamentation. On the contrary, its best form is in the shape of a lift provided with shelves, lined with zinc and screened to keep out the

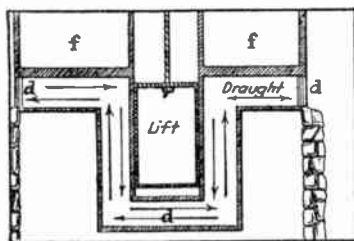

This system affords a circulation of air around the lift

roving elements. This lift is preferably located in the pantry and lowered from thence to the cold-closet, or some other specially built contrivance. If it seems desirable to connect it with a draught-box, it is best that this should come below it, *D*, so that the lift will not catch the dust.

All the standing finish and hardware of the kitchen should be as simple as possible, that it may be

cleaned with ease. The woodwork is best in the natural finish, and not too light. The walls, if of plaster, are easier to take care of if painted; they would have to be painted anyway in the end, as the kitchen accumulates dirt rapidly. The walls should be of a medium tone, and the ceiling, while lighter, should not be pure white.

The ordinary kitchen floor is laid in narrow strips of matched Southern pine; this or some hard wood makes a good flooring. Better than this, however, is the tile floor. Its non-yielding qualities are easily remedied by the use of several rubber mats, which can be taken up separately and cleaned. The interlocked rubber flooring is not bad, either, although inferior to the tile from the standpoint of durability. The tile has one advantage above all others which should recommend it for kitchen use, that of extreme cleanliness. In fact, where the question of expense is not too pressing, it should be used. For floor, walls, and even ceiling, there is nothing better.

The kitchen or pantry dresser, as commonly built, comprises a table shelf, with a number of enclosed shelves above with glazed doors. Below the wide shelf is a cupboard for flour-bins, drawers, etc. The accompanying diagram shows one form of construction. The upper case of shelves is supported at the ends by wooden brackets or a prolongation of the

sides of the case. If the width be considerable, iron brackets (*g*) are used in the interval. The front, or nose (*h*) of the table shelf (*st*) projects beyond the cupboard door. The bin is made to

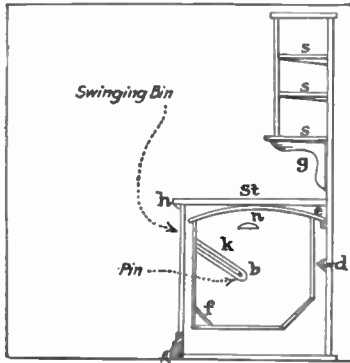

Swinging bin for pantry

swing on two metal pins (*b*), one on either side, from metal cups in the irons (*k*). This allows it to be readily tipped over forward for use and also admits of its withdrawal by aid of tracks in the irons (*k*), so that it can be cleaned. The handle in front (*c*) is to control the swing; the handles at the side (*n*) to remove it by. The pins (*b*) are set a little to the front of the center, so that the bin shall have a tendency to retain a normal upright position. The cleat at back (*d*) prevents the bin from swinging too far forward. The strip at the front bot-

tom angle (*f*) avoids an awkward corner from which to remove the flour. The cover at the top (*e*) prevents rodents from entering, should they succeed in gnawing through from the cellar. To complete this precaution the underside of the top and the outside of the bin should be covered with zinc.

Kitchen chairs should be strong and simple, as they are subjected to all sorts of hard usage. The combination of chair and ladder will be found very useful in more ways than one.

#### DIRECT OR ALTERNATING?

To determine whether the current in an arc-lamp is direct or alternating, hold a shiny object, such as a knife-blade, nicked pencil tip, or a bit of mirror—so as to get a "high-light" or reflection from the arc-lamp on it. If the source of light is a direct current arc, the reflection will merely blur. If it is an alternating arc light, the astonishing result will be a sort of picket fence of light strips, or a row of brilliant dots. That is because such an arc really glows its brightest intermittently. It seems perfectly steady, but in reality it becomes dim many times in a second.

Contributed by E. P. THORNTON.

## A COPPER PLATING OUTFIT

BY CHESTER KEENE

HERE is a simple and inexpensive copper plating outfit which should interest every amateur. It consists of a glass jar, *A*, about 8 in. in diameter and 12 in. high, in which is a porous cup, *B*, which may be purchased from any supply house. The support *G* is made of two

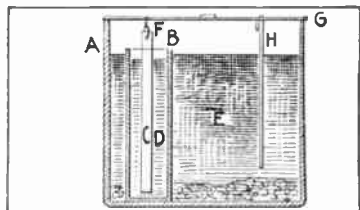

A simple copper plating outfit

copper strips, crossed and riveted or bolted together. From this frame is hung by a loop of copper wire a common battery zinc, *C*. Fill the porous cup to within 1 in. of the top with a solution of one part sulphuric acid to ten parts of water. Into the large jar drop about a pound of copper sulphate crystals and then pour hot water on them until it is filled to the level of the solution in the porous cup. Hang a length of copper wire, *H*, from the frame and set aside for two hours. Cleanse the article to be plated and hang in the large jar with

a length of copper wire. Use only copper wire for this purpose. In a short time the article will be covered with a thin film of copper and may be removed.

This device will last indefinitely and the only thing necessary to keep it in perfect condition is to occasionally add copper sulphate crystals and to draw off part of the solution *D* and add clear water.

## A MACHINE SHOP KINK.

Before going to work in the shop or garage try the following: Wash your hands thoroughly. Take the cake of soap, which should be of fair quality, from the water. Wipe your hands reasonably dry and then take the soap and work up as much lather as you can without using more water. Without wiping the hands, rub the soap in. Be sure and get some under the nails. When you come back with your hands all covered with grease and dirt you will be surprised to see how easily it will wash off.

I have found the same plan good for chapped hands. When used for this purpose use good soap.

Contributed by G. W. GREENE.

## HOW TO USE A SIMPLE WAVEMETER

BY THE STAFF ENGINEER

**I**N the last number of *EVERYDAY MECHANICS* appeared an article entitled "Construction of a Simple Wavemeter." The purpose of this article is to show how to use the instrument described in tuning a transmitting set, ascertaining the wave-length of an incoming signal, etc., within the limits of the wavemeter.

### TUNING A TRANSMITTER

*Closed Oscillating Circuit.*—Disconnect aerial and ground from the secondary of the oscillation transformer and make coupling very loose so that no inductive effect takes place between primary and secondary windings. The upper part of Fig. 1 shows the connections of a standard transmitting set with secondary of oscillation transformer not shown, but disconnected from the closed oscillatory circuit as explained above.

The wavemeter is shown at the lower part of Fig 1, showing a small tungsten filament flashlight bulb connected in series with the condenser and inductance. This lamp will light to incandescence when the resonance point between the transmitter closed circuit in operation and the wavemeter circuit is reached. Care should be taken that the wavemeter inductance coil is not placed too near

the oscillation transformer, otherwise the induced currents will burn out the lamp.

For tuning the transmitter to a definite wavelength, set the clip at some point on the oscillation transformer primary. Place the wavemeter inductance about 3 ft. from the oscillation transformer and, with the key closed, adjust the variable condenser until the lamp lights brilliantly. If the lamp does not light place the inductance nearer until the desired results are obtained. By taking note of the variable condenser reading, which is graduated in degrees from 0 to 180, and referring to the curve, the wavelength at that particular point is known.

If the wavelength is too high, decrease the number of turns in the oscillation transformer, and if too low increase the number of turns until the definite wavelength is found. If this wavelength is found to be with less than three turns of the primary, it is better to leave the clip at three turns and decrease the capacity of the high tension condenser until the desired wave is found. It has been found that not less than three turns are needed to transfer the energy efficiently from the primary to the secondary circuit.

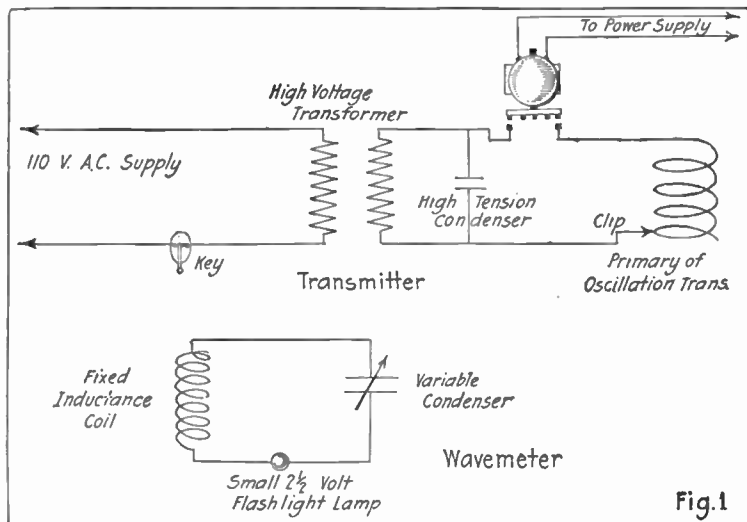

Fig.1

Diagram of connections for tuning the closed oscillating circuit of transmitter

*Open Oscillating Circuit.*—To tune the open oscillating circuit to the wavelength of closed circuit, excite this circuit with a small induction coil or transformer as shown in Fig. 2. Make sure that the spark length used is very small, otherwise the wave emitted will be too broad to read correctly on the wavemeter. The wavelength will be found by noting the point on the condenser scale, when the lamp lights to incandescence, as was the case in finding the wavelength of the closed circuit.

If the wavelength is too long, due to the natural period of the

aerial itself, insert a high tension condenser in series with the aerial. If the aerial is not too long and the proper condenser is used, the wavelength will be found without any difficulty.

Now that you have both the open and closed circuit tuned to one wavelength, you will find that two wavelengths will be found on the wavemeter when the distance between the primary and secondary windings is too small. This is due to a reaction which takes place in both oscillating circuits. By varying the coupling or distance you will find that *one* wave will be the result at a cer-

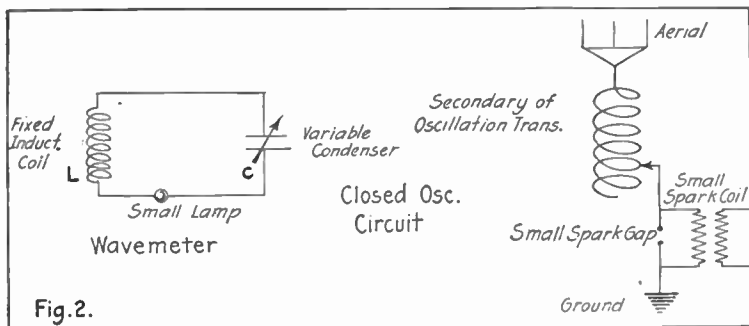

Fig. 2. Tuning the open oscillating circuit of a transmitter

tain coupling. This is the point of sharpest tuning and highest efficiency.

#### DETERMINING THE LENGTH OF AN INCOMING WAVE

For determining the wavelength of an incoming signal, tune the

receiving until the signal is at its highest point, then place the wavemeter inductance coil about 3 in. from the receiving transformer primary as shown in Fig. 3.

You will note that an ordinary crystal detector and telephones

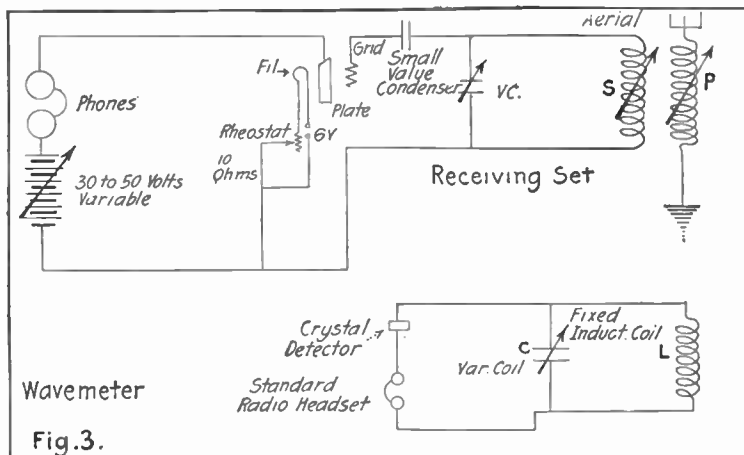
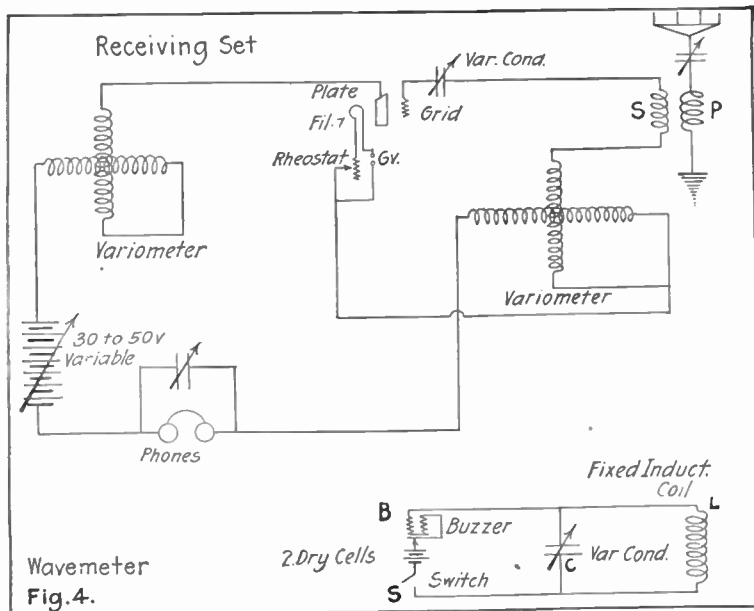

Fig. 3. To determine the wavelength of an incoming signal





To find the wavelength of a receiving set or any oscillating circuit

are used in place of the small flashlight lamp, because the incoming energy is too small to light the lamp. By varying the condenser capacity, the incoming signal will be heard at some definite condenser reading and by referring to the curve the wavelength of the incoming signal will be found.

*Be advised that if the wavelength of the signal is longer than the range of the wavemeter no result will be obtained.*

#### FINDING THE WAVELENGTH OF A RECEIVING SET OR ANY OSCILLATORY CIRCUIT

For finding a certain wavelength in a receiving set, excite the wavemeter with a high note buzzer as shown in Fig. 4, and adjust the variable condenser so that the wavemeter sends out a certain wavelength, acting as a small transmitting set. By manipulating the receiving set in the ordinary manner as if re-

ceiving from a definite station, the buzzer signal will be heard at a certain setting and this shows that the resonance point has been reached. The same method can be used for finding the wavelength of any oscillatory circuit consisting of one or more inductances or capacities.

The wavemeter is useful for almost countless experiments and the interested reader will find a further and very excellent discussion of these instruments and their uses in the 1916 Year Book of the Radio Clubs of America.

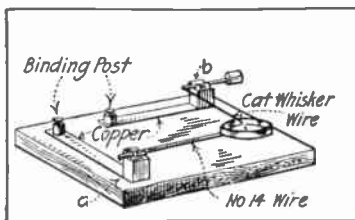

This detector may easily be adjusted

ing the connectors so as to swivel, the mineral may be reached regardless of the length of the "cat-whisker" wire.

Contributed by KIMBALL STARK.

#### AN EFFICIENT DETECTOR

Here is a home-made detector which is easily and cheaply constructed, has a very fine contact, and is easily adjusted. Upon a 4-inch square of fibre or wood, about 3-4 inch from diagonally opposite corners, mount two spring connectors which may be found on discarded dry cells. A. Through the loop of one connector, B, pass a small rod on the end of which is fastened a fibre knob. Through the loop of the other connector is placed a wire on the end of which is fastened a small cup to hold the mineral. This is made by a short length of No. 14 copper wire and a cup taken from the end of a dry battery carbon. By fasten-

#### THREE-WAY SWITCHES

As three-way switches cost more than most people care to invest, a pull-chain socket may replace them in many instances. Where stair lights are over the bottom landing, it merely means dropping a string to the lower landing. If they are not over the bottom landing, a screw eye or pulley fastened to the ceiling will lead the string to a convenient place. Silk fishing line is best suited to such purposes. The person starting up pulls the string which turns on the current and upon "landing" breaks the circuit by pulling the same string.—  
A. WAKELAND.

## A KITE CAMERA FOR AERIAL PHOTOGRAPHY

BY CHARLES I. REID

COMPARATIVELY few of us can have the experience at the present time of going up in an aeroplane, but it is quite possible to see how our surroundings look from a high viewpoint, by taking aerial photographs from a kite. It would take a very large kite, indeed, to carry some styles of cameras, but the making of a camera light enough for the purpose is not a difficult undertaking. For making aerial pictures from a kite, a camera taking pictures two inches square is large enough. If larger pictures are desired, they can be subsequently enlarged. The construction of the camera box and shutter is explained by the diagrams. The box of the camera is made pyramid shaped, in order to keep weight and air resistance to the minimum. The sides of the box are made of light, but stiff, cardboard, fastened together by means of lantern slide binding strips of cloth glued along the edges. The back of the camera is made in the form of a tight fitting cover, also made of cardboard, the inside measurements of which are the same as the size of picture to be taken. The lens is probably the most important part of the camera, and for a kite camera nothing would serve the purpose better than a single achromatic lens, such as is

fitted to small box cameras. Such a lens is light in weight, and capable of making very good pictures. The lens can be procured at almost any camera store, or one can be taken from some other camera. The lens should be obtained first of all, before starting to construct the camera box, as the dimensions must be in proportion to the focal length of the lens. A lens of 2 or 3 in. equivalent focus is quite suitable. The equivalent focus of the lens can be determined by focusing the sun on a piece of white paper, measuring the distance from the paper to the lens, which is the distance the lens should be placed in front of the film. The lens is fitted to a partition of heavy cardboard fitted inside the cone. By sliding the lens back and forth slightly in its tube, while holding a ground glass against the back of the camera cone, the lens can be focused on a distant object, and then permanently glued into place. The front of the camera, also of cardboard, is provided with a circular opening which must be large enough so as not to obstruct the view of the lens. On the front is fitted the shutter, which consists of a sheet of cardboard, blackened on the inner side, and cut into the shape of a triangle. Into the shutter near the

center is cut a slit, which serves to make the exposure by admitting light through the lens for a fraction of a second, as it passes

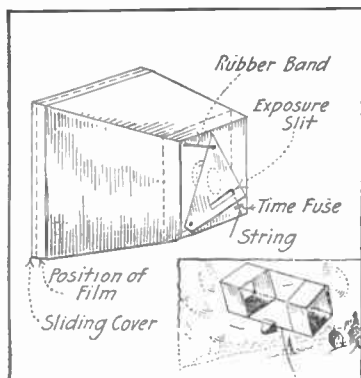

Detail of shutter for kite camera

across the aperture. The size, or width, of the slit regulates the exposure, and a few trials should be made to ascertain the most suitable width to give a slow instantaneous exposure of about 1-25 second duration. In general, the slit can be as large as it is possible to make it without admitting light while the shutter is closed. The shutter is pivoted at the narrow end, and the motive power is supplied by a rubber band which draws the shutter to the left when it is released to make the exposure. The shutter is released at the proper time by means of a time fuse attached to a string which holds the shutter

closed, against the pull of the rubber band until the burning fuse reaches the string, severing it and releasing the shutter. At that moment the picture is made. The shutter must fit snugly against the front of the camera, and admit no light, except when making the exposure.

When the camera has been completed, it should be covered on the outside with opaque black paper, and blackened on the inside with india ink. The kite used for carrying the camera into the air should be of a fairly large type and of good construction. The box form is very suitable for the purpose, and many other forms will also prove suitable. The camera may be attached by tying onto one of the wooden struts of the kite, the best position being determined by shifting the position of the camera and the tail string of the kite until a good balance is obtained. When taking pictures from a kite it is usually desired to make the exposure after the kite has reached the maximum height. The length of the time fuse regulates the time of making the exposure, and by making a trial flight or two, timing with a measured length of burning fuse, one can soon determine the correct length of fuse to use to release the shutter at the right time. The camera is loaded in the darkroom by the light of the ruby lamp by placing a sheet

of cut film, taken from a film pack or a roll film cut up into sheets of the proper size, into the back of the camera, or the sliding cover, with the dull or emulsion side facing the lens. The cover is then placed into position, and after making sure that the shutter is properly closed, the camera is taken into the daylight and attached to the kite. Besides the great novelty and the amount of pleasure to be derived by making pictures of our surroundings from above, a kite camera also has many practical uses, permitting the making of pictures of many otherwise inaccessible subjects.

see how this would fit over and slip along the rail. Even though the piazza rail is not perfectly flat on top this would work just the same.

It requires a piece of wood just the width of the top of the piazza railing, *A*. The length may be what you please to make it, only let it be at least 1-3 greater than the width. It looks a little better not to have it perfectly square. The side pieces should be the same length as the top piece. Use  $\frac{1}{4}$ -in. wood for this work; too heavy wood will give an effect of clumsiness, which is far from pleasing.

The side pieces, *B*, may be joined to the top with screws or

#### A PIAZZA CONTRIVANCE

Each spring and summer the owner of the small piazza wishes he had a larger one, for there is only room on it for a few piazza chairs and perhaps a table. We, of the small piazza brigade, sigh because we have no place for our potted plants, for work baskets or for the serving of afternoon tea.

Here is a contrivance which increases the piazza capacity. You may call it a rail slide if you like. It is made of wood to fit right over the piazza rail, and resembles a box cover with the two ends left out. Now you

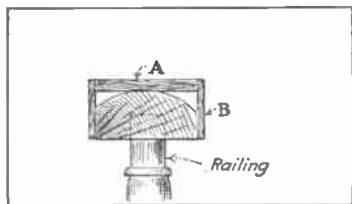

A piazza slide shelf

brads. In fastening these, do not fit the side pieces underneath the top piece, for this would make it too small to fit over the top of the rail. The inside measurement must be right. Finally, shellac, varnish or stain the slide, and it is ready for piazza use.

Contributed by F. H. SWEET.

## THE CONSTRUCTION OF A PRIVATE LIGHTING PLANT

By THE LABORATORY STAFF

### PART III. CONSTRUCTION OF THE GENERATOR (Continued)

---

*Editor's Note: The aim of this series will be to describe in detail the construction of a complete electric lighting plant suitable for a country house, a small hotel, or for the workshop and laboratory. The present instalment describes the direct current generator and the instructions are given in the words of the designer, A. E. Watson, E. E., Ph.D., who is Professor of Electrical Engineering in Brown University. Later articles will cover the storage battery, gasoline engine, control devices, etc.*

---

**W**INDINGS. Having completed the general mechanical parts of the machine, the builder will be ready for the more purely electrical. Preliminary to the placing of the wire, there must be the uninteresting work of suitably insulating the core. An amateur is liable to slight this part of the work.

The winding easily divides itself into two separate portions—armature and field. Just what sizes of wire to use will depend upon the voltage and current desired. In the first instalment of this series the plan announced was to confine the description to the 25-volt winding; subsequently, however, so many requests have been made for other voltages that the specific directions in this article will cover a 50-volt winding, while the data and general instructions for 7, 25 and 110-volt windings are given as well.

First, insulate the core: sharp corners are to be filed off, and a

thin coat of shellac put on, extending along the shaft also for  $1\frac{1}{2}$  in. Wind several turns of thin, tough brown paper around the shaft, and gash the paper a little so that it will lap up on the heads for  $\frac{1}{8}$  in. Cut a number of discs of paper  $3\frac{1}{4}$  in. in diameter with  $\frac{5}{8}$ -in. hole, and some strips  $2\frac{1}{2}$  in. wide of indefinite length. Slip on a disc over each head and shellac it on. When dry make a single radial cut between the teeth with a pair of scissors and turn the edges of the paper over the corners into the grooves. Start the strip of paper in the bottom of a groove, and pass it over a tooth into the next groove; press it well into the corners with a thin strip of wood, and then press it down into the next groove, and so on around the core to the starting place; cut the paper, but do not lap the ends. Slit the overhanging edges and bend them so as to cover any exposed iron. Put another disc

on the heads, slit and bend over the edges as before; put another strip all the way around the core, in the grooves, but be careful to have the joints always in different places in successive layers. Four layers everywhere will be a sufficient amount. The paper should occupy only so much space that a 3-16 in. strip can be forced down into the insulated grooves. Use thin shellac freely as an adhesive and do not allow the paper to "pucker" anywhere.

Provide a continuous coil of about 1¾ lb. No. 22 (25-1000 in. in diameter) double cotton covered magnet wire. Rest the armature between lathe centers or on other convenient support, so as to be turned back and forth as the winding progresses. Lay the starting end of the wire through one of the grooves toward the commutator end. For the moment it may be twisted around the end of the shaft. Carry the continuation of the wire across the head at the pulley end, giving the core a half turn so as to bring the opposite groove on top; lay the wire in this groove but leave enough room in passing the shaft to allow for five more turns. Cross the head at the commutator end, at the same distance from the shaft back to the starting point, rotating the core back to its original position. Lay a second turn beside the first, then a third, and

so on until six turns are on. This should make just one layer in the grooves. The wires may be smoothed down and firmly pressed into position with the aid of a chisel-shaped piece of soft wood. If the wires bulge a little in the grooves, pull them further away from the shaft, thus drawing them tight in other places. If sufficient room has not been allowed to get all the turns in past the shaft, a little stretching of this kind may provide space. Shellac these six turns and let them dry. *A*, Fig. 11, shows this first layer. Continue the winding in a second layer, and place six turns on the other side of the shaft. *B*, Fig. 11, shows this stage. Shellac again and when dry, wind on a third layer of six turns, passing the shaft on the same side as the first layer, only further out. See *C*, Fig. 11. A fourth layer goes on the other side, as shown in *D*, and also a half layer of three turns—*E*. Make a loop in the wire about 3 in. long, twist the two together and lay the continuation in the groove next to the starting point. There will now be two slots a little less than half full of wire, and the twenty-seven turns will be so spread over the ends of the armature as to be but one layer deep where they pass the shaft. Wind twenty-seven turns in the next slot and its opposite. These wires will cross the first

wire at a slight angle; bring out a second loop and wind twenty-seven turns in the third slot and its opposite, and so on around until each of the slots have twenty-seven wires in them and eight loops are made for con-

necting the entire winding up to this point. Trim off all superfluous insulation on the shaft and slip the commutator into position. Remove the cotton covering from the portions of the loops next to the screws in the segments. In-

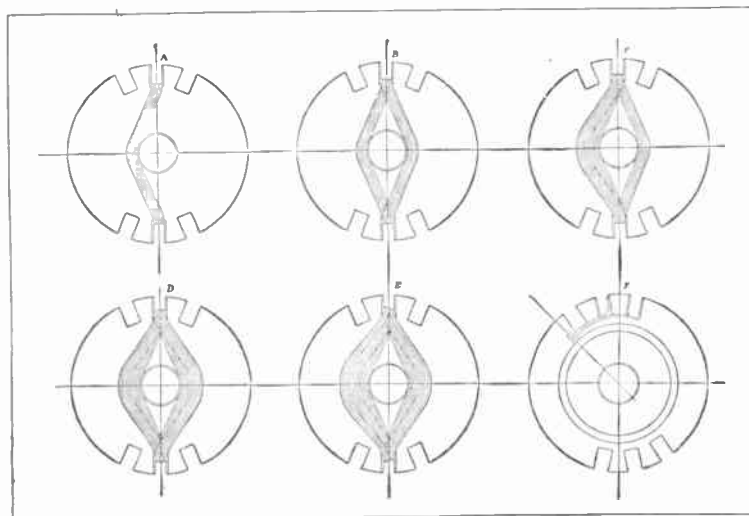

Fig. 11. Stages in winding of the armature

necting to the commutator. Continue a ninth coil of twenty-seven turns on top the first coil; bring out a ninth loop, and wind a tenth coil of twenty-seven turns on top the second coil, and so on until the sixteen grooves have fifty-four wires each and fifteen loops are protruding. Cut the wire and twist it to the starting end. This will give a sixteenth loop. No cut is to be made dur-

ing the entire winding up to this point. Trim off all superfluous insulation on the shaft and slip the commutator into position. Remove the cotton covering from the portions of the loops next to the screws in the segments. In-

sert both wires of one of the loops in the slot in one of the screws; this connection should not be in a direct axial line, but carried to the second segment beyond, in the direction of rotation. See *F*, Fig. 11. Solder the wires in position. Bring the second loop to the next segment, and so on until all have been connected. The appearance will then be as if the commutator



had been given one-eighth of a turn after the wires had been connected. The object of this advance, or "lead," is to bring the brushes in a more convenient position. Shellac the connecting wires to prevent unraveling of the insulation. Remove the paper from the surface of core so that the ends of the sheet iron teeth will be exposed. If the winding has been carefully done and tightly pressed in place, no binding wires will be needed; but if desired, a place about  $\frac{1}{2}$  in. wide may previously have been turned in the center of the core to a diameter of 2.15-16 in.; strips of thin mica may be laid over the copper wires for extra insulation, and this space tightly wound with fine brass wire. Solder the wires together before loosening the tension.

It is common practice among manufacturers of dynamos and motors to cover the exposed ends of the armature with conical "dressings" of canvas. The amateur may not feel inclined to bother with this.

Other windings may be:—  
Seven volts, suitable for plating, can be obtained by using No. 13 (72-1,000 in. diameter) wire. Two turns will make one layer, and two layers put in each slot for each half winding, and loops brought out as usual and four turns wound in the next slot. This wire will allow an output

of thirty amperes, and copper brushes of extra thickness should be used.

Twenty-five volts. This is a suitable potential for a motor using batteries for a source of current. Use No. 17 wire (45-1,000 in. diameter). Put four turns per layer, three layers deep for each half-winding. See Fig. 12. It may be necessary to use slightly thinner insulation in the slots in order to get the wire in, but the potential is so low that there would be no danger of "ground" or "short circuit." In crossing the heads, let four wires be on one side of the shaft, and two on the other, in regular order. The halves of the winding will then balance the inequality. This winding will allow a current of eight amperes.

One hundred and ten volts. It is practicable to wind an armature for this potential, but special care and considerable patience will be required. No. 26 wire (16-1,000 in. diameter) is wanted. Wind six and one-half layers, eight turns per layer for each half-winding. There will be 52 turns per segment. The current capacity will be two amperes.

Higher voltage should not be attempted in so small a machine, as the excessive number of turns of wire introduces the insulation so many times as to reduce the amount of copper below its safe current-carrying capacity. An

armature would last so short a time as scarcely to repay the builder for his trouble.

*Field Winding.* In consequence of the round core of the field magnet, this winding can be quickly done in a lathe. Fig. 13 shows a detail of a spool. It consists of

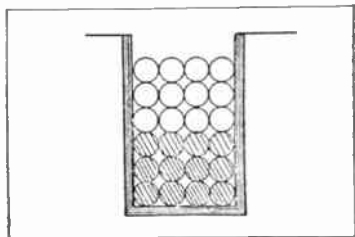

Fig. 12. One slot of armature with winding in place

three leatheroid or fiber discs 4 in. outside diameter, the two outer ones having a hole 2 1/16 in. diameter, the inner one 2 1/8 in. A tin or other thin sheet metal tube, soldered along its lapped edge, and rolled with a small flange at the ends, holds the discs in position. For winding, the spool may be slipped on a wooden arbor with check-pieces or flanges to keep the discs from spreading by the crowding action of the wire.

Wind four or five layers of paper around the tin tube, duly shellacked. The edges of the paper can be pressed under the loose disc and lapped on to the others. Put the starting end of

the wire through the notch, and draw through a considerable length depending on the size used. Wind one turn of this end length backwards around the spool and coil the rest around the arbor. Press the loose disc against this one turn, and wind two or three layers in the main part of the spool. By hand, wind two or three turns backwards, from the wire on the arbor. Put a piece of thin paper on the main coil and wind several more layers; give the end wire a few more turns and so on until the requisite number is in place. It will be seen that the object of the extra disc and the long protruding end at the start was to keep the wire leading to the first layer well insulated from the successive ones, and also to leave the inside end so that if accidentally broken off, a turn or two can be unwound without disturbing the main part of the spool.

If fine wire is used the ends may finally be led through holes drilled near the edges of the discs, but large wires can be tied to the discs by string taken through a number of small holes. Leave the ends protruding about 6 in. As usual with electrical apparatus, shellac the outside layer.

About 1,500-amp. turns are required for field excitation; the particular sizes of wire will depend on the voltage of the armature.

Fifty volts. Shunt: 3 lbs. of No. 25 wire (18-1,000 in. diameter), wind thirty-three layers deep. For a compound field use first  $2\frac{1}{4}$  lbs. of No. 26 wire (16-1,000 in. in diameter) twenty-nine layers deep; wrap on a few turns of thin paper, shellac discs of paper over the leading ends of

fifteen layers deep, and in the series  $1\frac{1}{2}$  lbs. of No. 6 wire (162-1,000 in. in diameter) one layer deep.

Twenty-five volts. Series\*:  $4\frac{1}{2}$  lbs. of No. 10 wire (102-1,000 in. in diameter) seven layers deep. Shunt: 3 lbs. of No. 22 wire (25-1,000 in. in diameter) twenty-

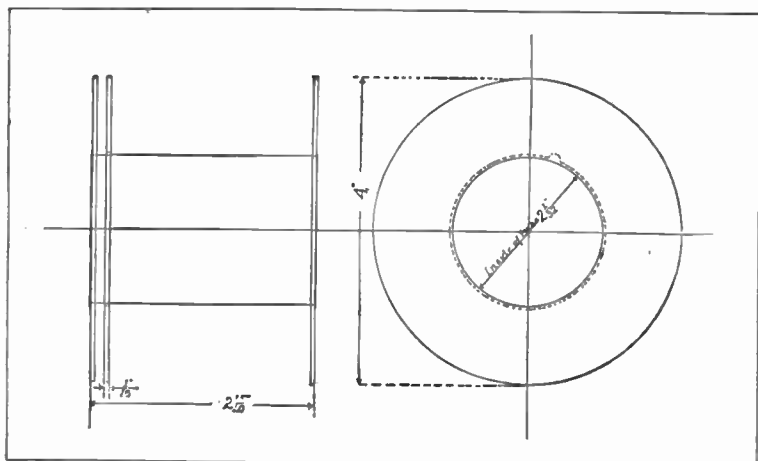

Fig. 13. Detail of the spool

the wires to protect their insulation, and wind, in the same direction,  $1\frac{1}{2}$  lbs. of No. 14 wire (64-1,000 in. in diameter) three layers deep.

Seven volts. For shunt use  $4\frac{1}{2}$  lbs. of No. 17 wire (45-1,000 in. in diameter) seventeen layers deep. A compound winding may have in the shunt, 3 lbs. of No. 18 wire (4-100 in. in diameter)

three layers deep. Probably the builder would have no occasion for a compound field for this potential.

One hundred and ten volts. Shunt: 3 lbs. of No. 27 wire (14-1,000 in. in diameter) forty-one layers deep.

In each case an odd number of

\*Suitable for use as motor operated by battery current. Gives strong starting torque.

layers has been stated in order to bring the terminals of the coils at opposite ends of the spool.

*Connections.* Any kind of seasoned hard wood is suitable for the connection board. Finish it in varnish or shellac and drill

Use no shellac on the surface of the brass as electrical contact would thereby be destroyed. Connections are made by soldering sheet copper clips to the wires and clamping them to the blocks. Incandescent lamp cord is suit-

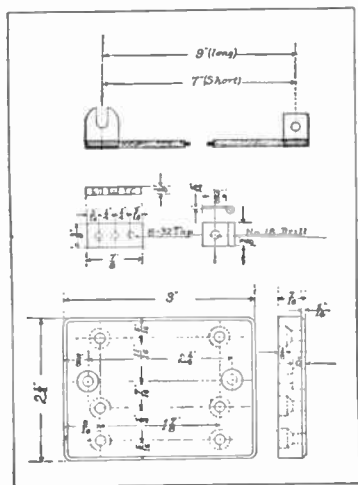

Fig. 14. The connection board

as shown in Fig. 14. Rectangular brass strips are to be drilled and tapped 8-32 and attached to the board by screws *f* (Fig. 4), inserted through from the back and entering the center holes. The two end screws for each strip *g* (Fig. 4) enter the board  $\frac{1}{8}$  in. to prevent "skewing." These holes may be made with a No. 18 drill, after their location has been marked from the strips.

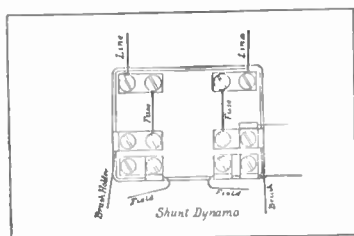

Fig. 15. Showing connections for shunt dynamo

able for flexible cables to connect the brushes with the terminals. One strand will be sufficient for the current of a 50 or 110-volt armature, but two strands for the 25-volt, and four for the 7-volt winding should be used, all soldered into a sufficiently large clip.

*To remove paint* which is often carelessly left on the window pane by the painter, wet the spots with hot vinegar and then rub with a penny. If the spots are old, soak them with turpentine and use the same method.—  
MARY F. SCOTT.

## CEMENT ON THE FARM

By F. H. SWEET

WITH the wonderful development of the Portland cement industry during the past fifteen years, comes the most ideal building material ever produced. It may well be called the "cement age."

The price of lumber is advancing to almost prohibitive figures; therefore, it is natural that a substitute material with the advantages of moderate cost, durability, and beauty should be developed and looked upon with favor.

To-day cement can be successfully used on the farm in the place of wood in the construction of floors, troughs, gutters, tanks, ditches, dams, walks, posts, building blocks, and dozens of other things that will readily come to mind.

Use nothing but the best cement that can be obtained. It should be in a fine, powdery condition and contain no lumps. Cement should be stored in a dry place, as dampness is an element of great danger.

The sand used should be clean, sharp, and not too fine. It should be free from loam or clay, as these will tend to destroy the adhesive quality and to retard the setting of the cement. Clay mixed with the sand may be removed by washing.

By sharp sand we mean that the edges of the grains must be

sharp and not round and worn off, as will often be the case with sand found in the bed of a stream. Coarse sand is better than fine sand. Fine sand, even if clean, makes a poorer mortar or concrete, and requires more cement to thoroughly coat the grains. A large proportion of the grains should measure from 1-32 to 1-16 of an inch in diameter. Some fine sand is necessary to fill the spaces between the larger grains, thus saving cement.

The water should be clean and free from acids or alkalis. For making the best concrete add just enough water so that, when all the concrete is in the form and well tamped, moisture will show on the surface. The tamping is a very important operation, and the quality of the work is dependent upon how well this is done. Unless this is thoroughly accomplished, the concrete is likely to be honeycombed and imperfect, especially near the forms.

For the ordinary farm construction, as the making of floors, walls, walks, gutters, etc., the following proportion is to be recommended: 1 part cement, 2½ parts clean, loose sand, and 5 parts of loose gravel or broken stone. For floors this should be tamped to a depth of from 5 to 8 in. This should be finished with a surface

coat of 1 to  $1\frac{1}{2}$  in. in thickness, composed of 1 part cement and  $1\frac{1}{2}$  to 2 parts of clean, coarse sand, mixed. Nearly all constructions which come in contact with water should be covered with a mortar at least as rich as the proportion last named. For engine foundation, 1 part cement, 2 parts sand and 4 parts broken stone is best.

In estimating the amount of material necessary for a certain construction, do not make the mistake of thinking that a mixture of 1 barrel of cement,  $2\frac{1}{2}$  barrels of loose sand and 5 barrels of gravel or broken stone will make  $8\frac{1}{2}$  barrels of concrete. The cement will fill the voids between the grains of sand. The total amount of concrete will be but slightly more than the amount of gravel or broken stone used.

To make 1 cubic yard of concrete of the following proportions—1 part cement,  $2\frac{1}{2}$  parts sand and 5 parts gravel—requires about  $1\frac{1}{4}$  barrels of cement (5 sacks),  $3\frac{1}{4}$  barrels of sand, and  $6\frac{1}{2}$  barrels of gravel.

Be very careful in measuring the proportion. Mix the concrete as near the place it is to be used as possible. Use as soon as mixed. Do not mix too much.

Measure the sand first and spread it in an even layer in a mixing-box, place the cement on top and turn it with a shovel at least three times. Then add the broken stone or gravel which has

previously been wet, and turn the whole at least three times. Begin to add the water on the second turning, not too much at once. A sprinkling-pot is better than a hose for adding the water, as it does not wash away the cement.

Concrete work should be avoided in freezing weather, as frost damages it. Where it is absolutely necessary to do work at this time, a small amount of salt added to the water will prevent freezing; this does not damage the concrete where used in small quantities.

An objection is sometimes raised that concrete floors and walls are too smooth and become slippery when wet. This fault is largely due to the fact that the finishing surface was completed with a steel smoothing trowel instead of a wood trowel, or smoothing board, which would have left the surface rough. This fault is also overcome in a great measure by dividing the wearing surface into snail squares about 4 inches on each side, by means of triangular grooves  $\frac{3}{8}$  in. in depth. This not only makes a neat appearance, but furnishes a good foothold for stock.

---

*To clean mother-of-pearl use pure olive oil and rub with a nail brush, then rub with a piece of chamois.*—MARY F. SCOTT.

## HOW TO MAKE A FRESH AIR WINDOW TENT

BY KATHERINE LOUISE SMITH

SO many persons desire fresh air at night and it is so disagreeable to dress in a cold room in the morning, that the inside window tents are becoming more and more popular. The value of these tents lies in the fact that the user gets the fresh air while the room is barely chilled. The patented tents of this description are expensive, but a good one can be made at home at small cost if the following directions are carried out.

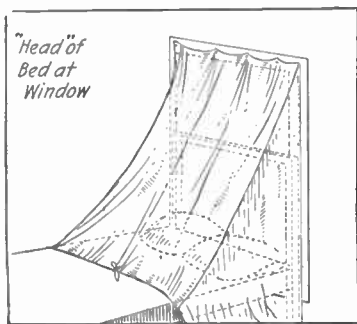

One form of the window tent

Take two pieces of denim, cretonne or sail cloth; cotton sheets will do, but they do not confine the air well and admit more light to the room. Sew the strips together along the edges and bind both ends. The length of the strips must depend on the height

of the window and width of the bed, as the cloth must be able to extend from top of the window casing over the bed when the bed is drawn up to the window with the side next to the casing. It is advisable that these home tents be attached to the top of the window casing instead of the top of the lower sash, as are the manufactured tents, because, by extending the full length of the window, they do not prevent opening and closing the sash. The center or seam of the two pieces of cloth must be tacked exactly in the center of the top of the window casing.

After the bed is moved so that the side of the top is next to the window, drop the end of the cloth over so that it falls toward the room. Fasten this end by tapes sewed to the cloth and tied to the bed frame under the mattress. As the two widths of cloth will probably be wider than the casing at the top of the window, there will be enough cloth hanging free to form the sides of the tent, and if desired it can be made secure by tacking it along the sides of the window.

Another way to make a window tent is to tack one width of sail cloth to the top of the window frame, allowing the cloth to fall over the bed and to fasten to the

bed frame. The openings left at the sides are filled in with denim cut to fit and sewed securely. All the seams must be bound, and the edges of the side pieces should be tacked to the side window frames.

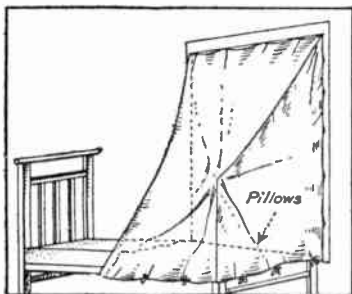

The bed may also be turned around

It is desirable to use a single instead of a double bed. Of course the patented tents possess the advantage of a frame that can be raised or lowered, but these home-made tents are a good substitute.

In using an inside window tent it is possible to dress and undress in a warm room and after crawling under the tent the bed clothes can be securely pulled up. The lower half of the window which the occupant of the bed faces can be left open and the sleeper's face can be close to the window or back several inches. Home experimenters have tried rattan for a frame, but though it bends easily after being soaked in water, it is difficult to devise a method to attach it to the window frame.

Any stout and heavy cloth will make these tents, as the main idea is to get fresh air without cooling the room and to allow the sleeper to keep the lower half of his body warm.

A knitted hood can be drawn over the head and part of the face so that only the nostrils and mouth are exposed. Some persons sleep this way when the thermometer is at zero and experience no discomfort. If it is desired, a square flap can be cut in the tent toward the room and this can be fastened by buttons and loops. This allows the occupant to look into the room when he desires and medicine can be passed through.

---

#### WHERE TO PLACE YOUR MIRRORS

Over a fireplace to reflect the room. Between the windows at the end of a long, narrow room to emphasize the light there. Where it will reflect a glimpse of the garden. Place one on a dark wall where it will catch the light. One in the hall opposite the entrance into the drawing or living-room will give a sense of spaciousness. In a bedroom where it will reflect the mirror of the dressing-table. Remember that flowers in front of a mirror are twice as attractive as flowers placed in front of a wall.

(Contributed by F. H. SWEET.)



# Everyday Chemistry

## HOW TO DISTINGUISH AMBER FROM ITS SUBSTITUTES

By W. C. DUMAS

A GUM known as Zanzibar copal is often used as a substitute for amber in the manufacture of amber articles and in jewelry. The copal gum is hardened by a special process, and finished articles made of it are so nearly like amber that they cannot be distinguished by a casual examination.

However by a few simple tests it is easy to tell if the article is genuine amber or simply one of its substitutes. Zanzibar copal gives a different solubility in many liquids, and a different set of chemical reactions than amber.

If a fragment of real amber is carefully heated in a glass tube, an ill-smelling gas called hydrogen sulphide is given off. This has a very disagreeable odor, the same as that of rotten eggs. A scrap of paper moistened with a lead acetate solution and held in the mouth of the tube will turn black. If a piece of copal is heated in the same manner, no hydrogen sulphide is obtained.

Another test which can easily be made to confirm the above test is to treat some of the powdered substance for ten minutes with an oil known as cajuput oil. This

operation is best carried out in a closed flask having a condenser inserted into the top, so that the liquid evaporated will condense and be returned to the flask. After the substance has been extracted for ten minutes, the liquid is cooled and filtered. This gives a clear solution. Now add to this solution three times its volume of heavy benzine and mix well. If the substance was copal, used as a substitute, a precipitate will appear at once, but if it is real amber, there will be only a slight cloudiness in the solution.

In the manufacture of amber articles there is considerable waste. These wastes are in the form of scraps and shavings. As a matter of economy, this waste is made into "pressed amber" articles. This is done by pressing the fragments into a compact mass in a press at 45,000 lbs. pressure per square inch. Although these built-up pieces are excellent for some purposes, they are not as good or desirable as amber cut from solid pieces. They show flaws and minute air bubbles, and have a slightly different coloring. By these differences, and from their irregular structure, they can

be identified as pressed amber by a microscopical examination.

If it is important or desirable to have a further confirmatory test as to the genuineness of an amber article, this can be carried out in a more exact manner by

measuring how much will dissolve in a given volume of equal parts of benzine and absolute alcohol. This mixture will dissolve 72.4% of Zanzibar copal, while only 33.1% of amber is taken up by it.

---

## TO REMOVE TARNISH FROM GOLD AND SILVERWARE

By L. G. HASKELL

**P**ROCURÉ a plate of either zinc or aluminum about 3 in. by 5 in. at the hardware store. Aluminum is the best and may be bought for a few cents. Then make a solution of sodium carbonate (washing soda) with hot water. Put this in an enameled dish or glazed crock or washbowl not granite or tinware, and place the silverware in the solution so that all pieces are touching either the plate or some piece which is in contact with it. The tarnish will almost immediately vanish, and this is much easier than the old-fashioned method of using silver polish, which is an abrasive, and requires plenty of elbow-grease for extended periods of time. Gold and gold plate, silver and silver plate, copper and copper plate and even iron will be cleaned by the above method.

This method of cleaning the family jewelry, etc., is based upon the chemical fact that silver and

gold, when in solution, are extremely easily displaced by aluminum and zinc. The aluminum and zinc change from the metallic state to the ionic form in solution very much easier than the silver or gold do; hence, the silver and gold will give up their charges to the aluminum or zinc, leaving metallic gold and silver. Thus the gold and silver is not used up or destroyed.

Any electrolyte would do for the solution, but sodium carbonate is the best because it will also dissolve off any grease on the silverware.

If the aluminum plate does not seem to work very well, this will probably be due to the strong coating of oxide on the plate. This should be cleaned off, leaving a clean surface of pure aluminum and not aluminum oxide, and then the plate should do the work in a few seconds if the directions have been carefully followed.

## A SIMPLE "SHOCKING" COIL

By HAROLD HYMANS

OBTAIN a carriage bolt 3 in. long and  $\frac{1}{4}$  in. in diameter and file away the square shoulder below the head so that part of the bolt will be round, like the lower part. From stout cardboard cut two washers 1 in. in diameter and slip them on the bolt. Then screw the nut on the lower end so it will appear as shown in Fig. 1.

Cover the bolt between washers with two thicknesses of heavy waxed paper to insulate the bolt. It is best to give the paper a thin coat of shellac to keep it in place. Make two small holes in each washer for the ends of the wires to come out of and then begin to wind the inside or primary coil by using No. 20 cotton insulated copper wire. Wind this on in three layers the same as thread around a spool. Over the last layer put two thicknesses of waxed paper and cover with a thin coat of shellac. The ends of the wires will project from the washers at opposite ends of the bolt, and they should be about six inches long. A current of electricity from a battery sent through these wires will magnetize the bolt.

For the outside or secondary coil obtain some No. 30 double insulated copper wire and wind eleven layers over the first coil,

taking care to get the wire on evenly and smooth. Cover the last layer with a thickness of waxed paper shellaced to keep it in place. This covering protects the wire from chafing. Care must be taken in winding the wire to see that the insulation is not scraped off, as this will short circuit the coil and the shocking current will not be as strong.

From wood  $\frac{3}{4}$  in. thick cut a base block  $3\frac{1}{2}$  in. wide by 5 in. long and with straps a quarter of an inch wide, as shown in Fig. 2, screw the coil fast to the middle of the base block as shown in the drawing of the induction coil.

From heavy tin cut and shape an armature as shown in Fig. 3 and provide it with holes so it may be screwed to the base board. The armature is  $1\frac{3}{4}$  in. long and at its loose end several wraps of tin are made and beaten flat and the tip end of the arm can be bent around to prevent the lug from flying off.

A small piece of wood in which a screw eye is placed (Fig. 5) should be made fast to the base block to occupy the position shown at A and to this one end of the heavy wire is attached by passing it through a small hole so that the screw eye will bear on it to make the contact, for the cur-

rent must pass through the wire into the screw eye and to the armature *B*, and out at *C*.

Three binding posts are made from small pieces of sheet brass or copper  $\frac{3}{8}$  in. wide and  $\frac{3}{4}$  in. long and provided with two holes, to receive a brass screw and screw eye and washer, as shown in Fig. 4.

The binding posts are fastened at each corner of the base block and to *D* one end of the No. 30 wire is caught under the screw head. Another end is caught at *E*, and the remaining No. 20 wire is fastened at *C*.

When this apparatus is properly mounted, the armature should vibrate between the bolt head and the screw eye end against which it rests when not in action.

The wires from a dry cell are attached at *F* and *C*, and the current passing into the coil through *B* and *A* and out at *C* magnetizes the bolt and draws the lug *H* to the bolt head. As quick as this happens, however, the current is interrupted, for *B* is pulled away from *A* and opens the circuit. The bolt becomes demagnetized, the lug *H* is released, and the circuit is again closed through *A*. This is repeated many times in each second, producing an interrupted current in the primary coil. This induces a current in the secondary coil of higher voltage, due to the increased number of turns.

The handles shown in Fig. 6 are made from tin and are 3 in. long and  $\frac{3}{4}$  in. in diameter. These are attached to *D* and *E* by flexible copper wire.

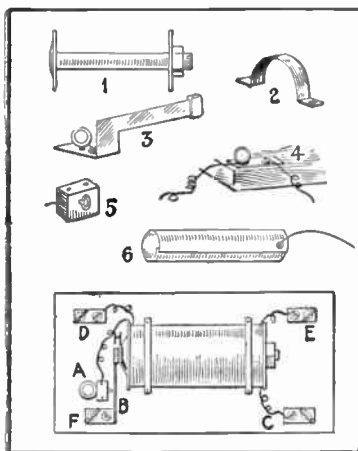

The shocking coil and its various parts

The intensity of the shocking current may be varied somewhat by turning the screw eye at *A*.

#### TO DRIVE A NAIL IN PLASTER

If a nail is heated either in boiling water or over a flame it can be driven into plaster without chipping the plaster. If you use a flame, be careful not to heat the nail too much.

Contributed by G. W. GREENE.

## AN ELECTRICAL FLASHLIGHT POWDER IGNITER

BY CHESTER KEENE

**F**LASHLIGHT powder may be ignited by the heavy spark which accompanies the breaking of a circuit containing an inductance. The apparatus consists primarily of an inductance coil shown in the illustration. The core consists of a bundle of iron wire, 4 in. long and  $1\frac{1}{2}$  in. in diameter, insulated with tape, and wound full of No. 18 S. C. wire. By using such a comparatively thick and short core, a heavier spark is produced at the breaking points. A quarter-inch strip, 4 in. long and  $2\frac{1}{2}$  wide, is mounted on top of the coil. To the center of this is screwed the top of a small baking powder can. For details of the automatic breaker see the illustration. It consists of a bent strip of brass pivoted on the small insulating block, *B*. At one end is an armature, *A*, and the other end touches the bottom of the can when the armature is  $\frac{1}{4}$  in. from the core. A spring, *C*, is used to keep the strip and box normally in contact. To make connections, one end of the inductance coil is connected to a binding post, the other to the pivoted strip either by flexible cord or by making contact at the pivot. The can is connected to the other binding post. The operation is as follows.

The flashlight powder is heaped around the end of the brass strip where it touches the can. Closing the circuit will cause the apparatus to operate like a buzzer

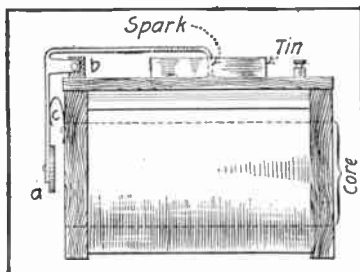

The short thick coil produces a heavy spark

and the continual flood of sparks will ignite the powder. It is surprising the small amount of power this apparatus will work on, due to the stumpy kickback coil used.

---

*Save all your grape-basket tops. Split into strips, they make excellent markers for potted bulbs, for flower and vegetable seeds started in the house. They are just the right length, and the smooth surface can be used to write names and dates of planting.—F. H. SWEET.*

# PRACTICAL MECHANICS FOR EVERYDAY MEN

## TO WIPE MOISTURE FROM WIND- SHIELD

A piece of wood, a strip of rubber and a few other pickings from the scrap heap were used by one motorist to make a device enabling him to wipe the moisture off the front of the wind-

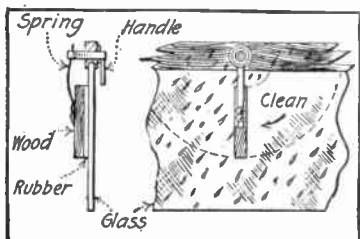

The handle is in back of the windshield

shield from the driver's seat. The arrangement consisted of a strip of rubber wedged in a block of wood which was fastened to a short length of rod passing through the frame of the windshield. By moving the handle on the other side back and forth, enough of the surface was cleaned to give the driver a clear view of the road.

Contributed by W. P. LANG-REICH.

## LOCKING A FIREARM

A most practical and safe way of securely locking a firearm is by snapping a padlock just behind the trigger, rendering it impossible to draw the trigger back.

Contributed by WM WERNECKE, JR.

## DON'TS FOR HOMEBUILDERS

Don't use red paper in the dining-room if you have mahogany furniture there; it detracts from the rich color of the wood. Use a soft green or a buff.

Don't be content with the ordinary chandelier hanging over the dining-table; save up for a canopy lamp which hangs low over the board. A silk shade, in a color harmonious with your hangings and wall covering, is effective.

Don't throw away or give away remnants and rags of silk. A rag-carpet style rug can be made from them which will be just the thing for a bare corner.

Don't keep the candles for your dining-table in the hot kitchen. If they are kept in the refrigerator for two or three days before being used, they will burn longer.

Don't use the ordinary metal

hooks in the bathroom, kitchen or pantry; if dipped in enamel paint they will not rust when wet cloths are hung upon them.

Don't use sand soap or any gritty substance to clean the enamel bathtub; nothing is better for this purpose than kerosene. Go over the tub with a cloth dipped in the kerosene, airing the room for a few minutes afterward, to get rid of the odor.

Don't whitewash your cellar walls without first dissolving a handful of salt in a pint of water and adding this to about 8 quarts of whitewash. This will cure the latter of its one bad habit—rubbing off.

Don't wash painted walls or floors with a rag; buy a long-handled rubber brush, such as is used for cleaning plate-glass store windows.

(Contributed by F. H. SWEET.

---

#### AN INEXPENSIVE CAMP LIGHT

A good camp light can be easily made from a candle, a quart screw-cap fruit jar, a block of wood and a few nails.

To make this, nail the cap of the fruit jar to a block about 4 in. square and 3 in. thick. Drive four headless nails a short way in, around the center of the cap to form a holder for the candle. A large wire nail put

through a hole near the edge of the block, and bent in proper shape makes a good handle.

Tie a piece of twine, well satu-

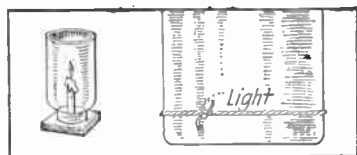

The jar may easily be removed

rated with kerosene, around the jar close to the bottom; light the twine and the fire will cut the bottom off as clean as a whistle. Screw the jar tightly onto the cap, so it may be removed as easily as a lamp chimney. When long, the candle may be lighted from the top without removing the jar. This arrangement gives a clear flickerless light sufficient to read by.

(Contributed by T. H. LINTHICUM.

---

#### A SAFE KEY LOCK

The ordinary householder who thinks he is safe behind locked doors when he leaves the key in the hole over night should have his mind disabused. A professional thief carries with him a small pair of nippers by which he can turn a key in the lock from the outside, and drop it on the floor out of his way. Then, with ordinary skeleton keys he can

throw back the lock without trouble, and without waking the owner. But there is a simple method of balking the thief, and if applied at night time one may rest assured that no one can unlock the door from the outside. It makes the ordinary lock as safe as the most ingenious patent locks.

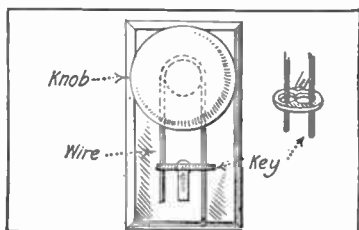

How the thief is foiled

The device consists simply of a piece of stiff wire twisted into a hook that will slip easily over the shaft of the door knob. When the door is locked, the key is left in the hole. The wire is dropped down over the shaft of the door knob, and the two ends inserted through the hole or holes of the flat end of the key. The wire should be long enough so that the ends will be at least two or more inches below the key. No amount of twisting or pushing from the outside can dislodge the key. It will resist all efforts to twist it around so that it can be pushed inward. The sense of security obtained in this way more

than pays for the slight trouble of adjusting the wire in the key each night before retiring.

Contributed by GEORGE E. WALSH.

#### ANTI-HUM CONTRIVANCE

The unpleasant and undesirable humming of telephone as well as of telegraph wires can be quickly and cheaply remedied by observing the little hint presented below.

An ordinary porcelain cleat, such as is commonly and generously used in wiring for insulating purposes, is inserted in the circuit as shown. Then, a wire a trifle longer than the porcelain cleat is bridged over, thus putting the line in electrical circuit again. If possible, the connections should

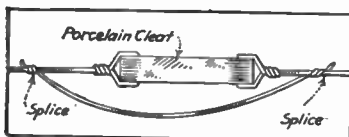

An ordinary porcelain cleat is used

be soldered. This will remedy the humming and buzzing created by overhead wires.

Contributed by WM. WERNECKE, JR.

#### A DUST MOP

A good dust mop for the polished floor can be made by the



amateur mechanic after the following instructions. The handle and end piece are of wood, round and about 1 in. in diameter. A heavy wire is bent, as shown in the illustration, and driven into each end of the crosspiece. The handle end of wire is driven into

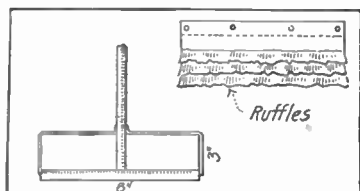

Slip the bag over the frame

the handle or flattened and fastened to the handle with screws.

The bag, which is made of heavy material, slips over the end-piece and it should fit very closely. On this are sewed,  $\frac{1}{2}$  in. apart, several ruffles of canton flannel, which should be 2 or 3 in. wide and quite full. The bag may be fastened to the mop by sewing through the hem, or eyelets may be made in the hem and laced or tied together with tape.

Cut the bag 5x10 in.; begin in the center and sew the ruffles  $\frac{1}{2}$  in. apart; sew up the sides of the bag and hem.

Several bags may be made and used for different purposes, such as, washing windows, removing dust from walls and polishing floors.

Contributed by A. J. Wood.

### STEAM HEATING IN AN EMERGENCY

The school board of an independent school in Texas solved the problem of heating the high school building in a novel way. During the cold weather the janitor fired up the furnaces in the basement of the building while all water pipes were frozen, with the result that the steam heating plant blew up and could not be used until repairs could be made, which would have required about ten days. The teachers and school board did not want to dismiss school, so they set about to find a way to heat the building temporarily. The building was equipped with steam radiators and pipes, but not for stoves.

The problem was finally solved by the trustees securing an ordinary traction steam engine, such as is used in that section to run threshing machines and to pull large gang plows. This engine they backed up to the south side of the building and connected the steam pipes leading to the radiators in the building to the boiler of the engine, so that the steam generated would pass into the radiators in the school building. The connection was made by leading the pipe from its connection with the boiler in the basement of the school through a basement win-

dow to the blow-off valve of the engine. With all pipes connected, the janitor fired the engine and the building was heated even better than with the heating apparatus in the basement.

Contributed by J. E. KING.

#### DANGER SIGNAL FLAGS

Red flags lose their value as danger signals during and for some time after a shower, as the material gets wet and heavy and does not "fly." By fastening a piece of wire to the stick and

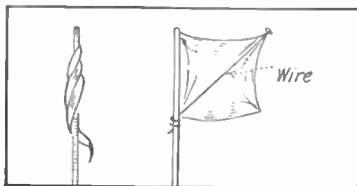

The wire keeps the flag spread out

tying the corner of the flag to it, as shown in the illustration, the signal may be seen in wet weather as well as on a clear day.

Contributed by Wm. P. LANGREICH.

#### NEW WRINKLE FOR AN EYE-SHADE

Home-made eye-shades are usually constructed of a piece of cardboard with a string tied to each

end, which is intended to pass around the back of the head, thus holding the shade in place. This string is invariably too tight or too loose, and consequently it is a problem to keep the shade in position.

A simple remedy is this: Cut out a piece of the string about two inches long and insert in its place a common rubber band, somewhat shorter than the piece of string which was removed. This will always be at a tension while the shade is being worn and hold the shade where intended.

Contributed by L. B. ROBBINS.

#### DRILLING GLASS

Holes can be drilled in plate glass without the aid of diamond point tools in the following manner:

Break about 1 inch off the end of a small three-cornered file, and, using a sharp corner, scratch a small hole where drilling is to be done, by holding the file at an angle and working the hand in a circular motion. If the glass is on an even, level surface, this will make a location for the drill, which may be a small round, or rat-tail file, chucked handle end in a breast drill.

Place the drill on the table or work-bench point up, locate the file in the hole previously scratched and, with slow, even

pressure on the glass and plenty of turpentine for a lubricant, a clean, round hole will be cut through the glass. This can be enlarged by the use of a file. Be sure, however, to use the turpentine lubricant freely and feed the drill slowly.

Contributed by C. H. BIRON.

#### A MULTIPLICATION AND DIVISION TABLE IN A SINGLE LINE

By means of this "logarithmic line" and a pair of dividers, any number can be multiplied by another number with the accuracy obtainable by using an ordinary slide rule. In fact, this is based upon the principle of the slide rule.

First, set one point of the dividers on the point "one," as shown in the "First Setting," and bring the other point down on one of the numbers to be multiplied. Let us choose 17.

Second, let us assume that 17 is to be multiplied by 25. Pick up the dividers and place one of the points on 25, as shown in the sketch, and the other point will show the answer—425.

Where a larger number is to be multiplied.  $9 \times 9$ , for instance, the "First Setting" is made from the number 10 instead of from the top. Try it! The answer, of course, is 81. Try several examples and in a short time you

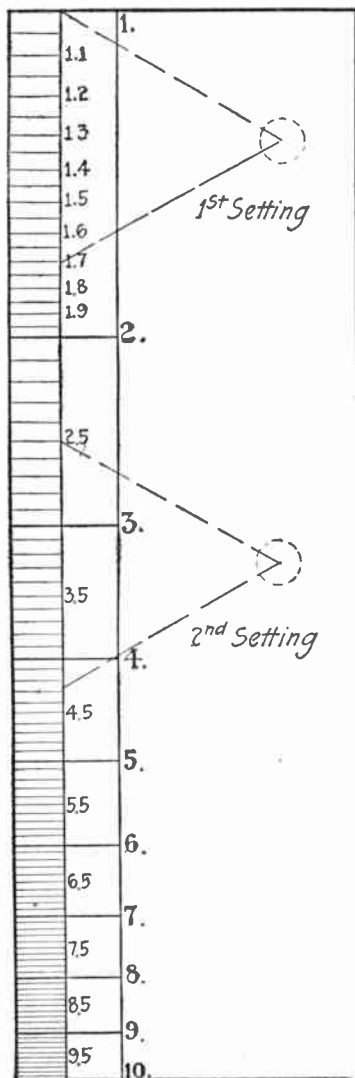

will be an expert user of this "multiplication line."

If you have no dividers just use a slip of paper and with lead pencil marks you can space off the distances for the first setting just as accurately as with a pair of dividers.

It might be explained that the point marked 1.7 may be used as 17, as 170, 1,700, 17,000, etc., or even for 0.0017. It makes no difference. In the same way 2.5 may be used as 0.00000025 or 25,000,000,000. All you have to do is to be careful about placing the decimal point in the proper place in the answer. There is an accurate method of doing this by use of this line, but it would take considerable space to explain it here. Almost any book on the slide rule will tell how, or, better, you can learn through experiment by solving a few miscellaneous problems "on your own hook."

To divide any number by any number, just reverse the process.

Contributed by N. G. NEAR.

#### A FISH SNAGGER

Many kinds of fish which inhabit still waters, both fresh and salt, are seemingly attracted more by sight than by smell; nearly all have a marked curiosity for bright strange things. An excellent way to catch these fish is by snagging them.

Mould two lumps of lead about the size of an egg. Imbed the lead with the shanks of small, but strong, fish-hooks. Arrange the snaggers about 20 in. apart on a line. The fish escaping the top snagger will be caught by the

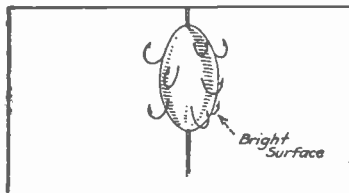

Keep the lead bright by scraping

lower one if the line is manipulated right. The lead is kept bright by scraping with a knife.

The best results from this method of fishing can be obtained in water shallow enough that the movements of the game can be watched.

Contributed by LAWRENCE W. PEDROSE.

#### A GOOD INVISIBLE INK

There are very many uses for a good invisible ink, such as making drawings, writing personal letters, etc. Most of these inks run and give a very watery appearance. The formula for a practical ink is as follows: Take 1 part flseed oil; 20 parts of aqua ammonia, and 100 parts of pure water. Mix this for

about five minutes, then let it stand for another five minutes, after which stir thoroughly. Write with it as you would with ordinary ink. To make the writing visible dip it in water. The writing will fade and become invisible as the paper dries. The letter will go through this process as many times as you wish.

Contributed by ANDREW W. GALLAGHER.

#### A TILTING TOP FOR THE CAMERA TRIPOD

Tilting a camera either up or down, as in photographing a tall building, or an object on the ground, with the ordinary camera tripod is a very awkward proposition. The tripod in its tilted condition also is a very unstable support for the camera. To overcome this I made a tilting top for my tripod, as shown in the illustration. The extra top consists of two boards about 4 in. square joined at one end by a hinge. One of the boards has a tripod socket for fastening to the tripod, and the other has a tripod screw for fastening the camera. Two side arms are provided, being pivoted to the top board, and having slots through which pass two binding nuts, one on each side. This allows the camera to be tilted to any angle, or reversed for vertical pictures, without removing from the tripod. In the

drawing, the camera is shown pointed downward, as in photographing an object on the ground. By turning it half way around the camera can likewise be tilted upward to any degree. By swinging it around a quarter turn it is in position to make vertical pictures of any object, still having facilities for up and down tilting at the same time. This attachment enables one to make



This device allows the camera to be tilted at any angle

pictures of many objects otherwise inaccessible to a camera.

Contributed by CHARLES I. REID.

#### FOR THE DRAFTSMAN

It is important for draftsmen to save space as well as time. This is done in one way by having as few tools as possible without "skimping." A pile of "junk" in the drawer is undesirable. One way to save space and time is to use the eraser instead of a cork to hold thumb tacks.

Contributed by N. G. NEAR.

## FOR FOUNTAIN PEN USERS

When you fill your pen next time, apply a little vaseline to the threads and then when you want to fill it again, the point will unscrew easily. This will also make the pen less likely to leak.

If you have a self-filling pen, remember that it will give better service if you clean it thoroughly with water once a week. Water can't hurt it.

Contributed by G. W. GREENE.

## HOW TO MAKE AN ANVIL

The illustration shows how an anvil can be made from an ordinary railroad rail about 8 inches long. Plane off the top, drill holes through the web, and chisel and chip away the remainder along the lines indicated.

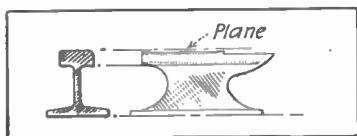

An anvil made from a length of rail

The top surface is then case-hardened by heating to a cherry red, applying yellow prussiate of potash in the usual way, and quenching in water.

The flange at the bottom makes the anvil convenient for spiking down to a block or onto a bench. If desired, holes may be

bored into the lower flange for holding.

It is not absolutely necessary to case-harden the surface, nor is it necessary to do all the work outlined above. However, if done along these lines the maker will then own a small anvil of excellent quality and shape, of which he can well be proud.

Contributed by N. G. NEAR.

AN ELECTRICALLY OPERATED  
CAMERA SHUTTER

It is often very desirable to operate the shutter of a camera from the distance, especially in photographing birds, animals and

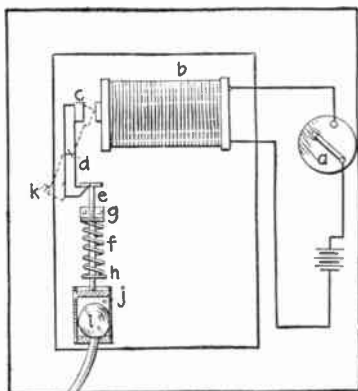

Detail of the snapping device

reptiles. The device and arrangement depicted in the illustration serves the purpose very nicely.

and its construction and operation are exceedingly simple and reliable. In brief the operation is as follows:

The switch *A* is fastened to the limb of a tree and connected in series with the electro-magnet *B* and the battery. When a current passes through *B*, *C* is attracted, thereby releasing *E*. The spring, *F*, which is compressed when *E* is raised, expands, thereby compressing the bulb *L*. The switch may well be displaced by a push button.

Contributed by WM. WERNECKE, JR.

#### TO STOP TYPEWRITER CYLINDER SLIP

The practice of using a piece of emery cloth to roughen the typewriter platen so that the paper will not slip is not a good one. It makes the platen rough, but emery loosens the cloth and gets into the vital working parts of the machine.

A much better method is the use of common wood or grain alcohol and a piece of cloth. Just keep the platen cleaned with alcohol.

Sometimes typewriter repairmen are called out to "cure slip," and they do nothing more than wipe the platen with a little alcohol.

Contributed by N. G. NEAR.

#### NOVEL PUMP JACK

This device enables the worker to convert the rotary movement of a motor or engine into a reciprocating motion suitable for operating a hand pump.

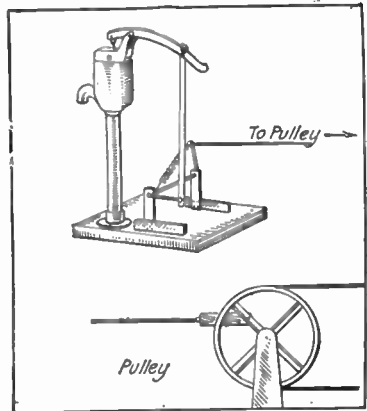

The pulley may be located indoors

The principal advantages are ease of construction and the fact that the pump may be located out-of-doors and at some distance from the engine without having to carry a belt through the exposure incident to changes of weather. The illustration shows the scheme clearly and the reader will note that the reciprocating movement is imparted to the pump mechanism through the medium of a heavy, bare wire. Obviously, the engine or motor may be located in a shed or barn.

the wire passing through a small hole in the wall.

The length of movement given the pump handle may be varied as occasion requires by changing the location of the coupling between the wooden strip and the iron handle.

Contributed by ODIS REYNOLDS.

#### FUN WITH A VACUUM

A great deal of entertainment can be derived from a burnt out incandescent light bulb. The spur of glass on the big end is hollow. While you hold that part under the hottest water that you can keep your hands in, carefully file off the point of the bulb. As soon as the water reaches the hollow part it will enter and immediately begin to boil because the extremely rarefied atmosphere inside lowers the boiling point to the temperature of the water. As soon as the space is filled with steam the boiling will cease.

Still keeping the opening under water, or closing it with a moistened finger, hold the bulb under a stream of cold water. The boiling will immediately begin again. Why? Because the cold water condenses the steam and so leaves a partial vacuum.

If you securely close the opening with sealing wax when the bulb is about one-fifth full of water, you will have a very novel

toy. When the water has cooled, inverting the bulb will send it to the other end with a sharp click. In physics, a similar apparatus is called a water hammer. You will be able to make the water boil at will by heating it gradually in a vessel of warm water, and you will always be able to show how water can be made to boil by cooling.

Contributed by E. M. SULLIVAN.

#### SUBSTITUTE FOR DESK

The illustration shows a very convenient substitute for a writing desk, which may be easily made from the front part of a drawer of a bureau or chiffonier.

Select a drawer the desired height from the floor. About 5 in. from the front place a partition across the length of the drawer. Disconnect the front of the

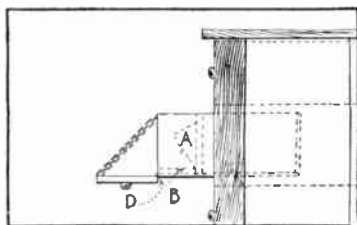

The drawer is a convenient substitute for a desk

drawer from the ends and bottom. Fasten to the partition racks for stationery, as *A* in the figure. Then reinforce the bottom of



drawer with a strip about 6 in. wide and of sufficient thickness to bring it flush with the lower edges of ends, *B*. Now, the front may be hinged to the bottom, *D*.

Two pieces of dog chain support this front as a writing shelf. When not in use the front is fastened up by means of a hook at each end of the drawer.

From the outside this drawer is not unlike the others and the space behind the partition is used the same as the other drawers.

Contributed by T. H. LINTHICUM.

#### TO MAKE COINS LEGIBLE

Not every possessor of old coins from which part of the inscription is obliterated, knows how to make the inscriptions temporarily legible, so as to ascertain the date and value. You can do it by placing the coin on a red-hot iron—an ordinary fire-shovel, for example. The parts where the letters of the inscriptions once existed oxidize at a different rate from the surrounding parts. The film of oxid that covers them has a different thickness, and, therefore, reflects a different color from that of the adjacent parts. In consequence, the obliterated letters take shape and become legible. The inscription, which is of a greenish hue when the coin is hot, disappears as it cools.

Contributed by E. P. THORSTON.

#### A CHEESEBOX WORKBASKET

The amateur carpenter in search of a novelty on which to try his skill might care to try the "cheesebox workbasket."

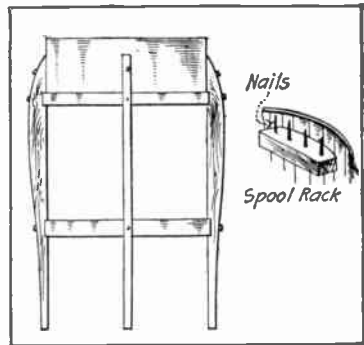

A cheesebox is the feature of this workbasket

Ask the grocer to save you a good cheesebox and cover. Sandpaper the sides of both to a fairly smooth finish. The legs are made as shown. For assembling use brads driven from the inside. Stain or enamel it the desired color and add round-head brass screws for looks. The spool rack comes next and when this is tacked or screwed into place the interior of box and cover should be finished off with cretonne edged with guimp.

If you are a little hazy on the two last named articles, ask the lady for whom you are making it, who may have ideas of her own as to how the finishing touches should be made.

Contributed by J. B. HUNTER.

---

# THE TECHNICAL ADVISER

---

The object of this department is to answer the questions of readers who may experience difficulty in the construction or use of apparatus described in the magazine. The columns are free to all readers whether they are subscribers or not, and questions pertaining to matters electrical or mechanical will be answered in the order in which they are received. If the reader cannot wait for an answer to be published he may secure an immediate answer by mail at a cost of 25 cents for each question.

In order to insure prompt attention, readers should adhere closely to the following rules which have been formulated with a view to expediting the handling of the mass of correspondence. Questions should be written on one side of the paper, enclosed in an envelope addressed to The Technical Adviser, care of Everyday Mechanics, Eolian Hall, New York City. The letter should state plainly whether answer is to be published or sent by mail; in the latter case the fee of 25 cents per question should be enclosed in coin, one-cent stamps, check or money-order. The envelope enclosing questions should not contain matter intended for any other department of the magazine.

---

17. **W. J. B., Jr.**, (Residence not stated) asks for wiring diagram of an audion amplifier, and (2) whether the radio telephone described in our December number can be used on an alternating current circuit. **Ans.**—(1) See article entitled "Construction of an Audion Amplifying Transformer" on Page 208 of the March, 1916, issue. (2) The telephone cannot be used successfully in this form owing to the buzzing created by the alternations of the current. It is better to use a straight transmitting outfit similar to that used for radio telegraphy, incorporating a transformer, condenser, oscillation transformer, and a spark gap having carbon electrodes and an exceedingly short gap. The separation should be scarcely more than the thickness of a piece of paper. Grind or file the two carbon electrodes so that their ends are perfectly flat and true and arrange them in a holder that will permit of a micrometer adjustment. Place

the microphone transmitter in the aerial circuit. Use standard condenser, transformer and oscillation transformer, and tune just as you would for telegraphy. There will be a distinct hissing in the receiver but you can talk a few miles without difficulty and once the ear is accustomed to the hissing, the conversation will be distinguished through it.

18. **L. C. B., Revere, Mass.**, asks a question similar to the second one of No. 17 above. **Ans.**—Refer to the preceding question and follow instructions given there.

19. **I. C., Brooklyn, N. Y.**, writes that he is building the transatlantic receiving set and wants to know if we mean that the aerial must be 500 feet long, in one wire, or whether he may use an aerial containing 500 ft. in all as, for example, could he use an antenna having six wires, each 85 ft. long? **Ans.**—In order to make the set respond to the wavelength specified, you must have an antenna with a

capacity of about .00087 mfd. For simplicity and convenience, the specification of the 500-ft. single wire was given. You might use four wires 200 ft. long instead. Or if you are content with a wavelength of some 8,500 meters, you may use the 85-ft. aerial you specify. Still again, if you use a variable condenser in shunt across the primary of the receiving transformer, you will be able to get the longer waves even with your 85-ft. aerial.

20. **H. S., Bronx, N. Y.**, asks for plans for a variable condenser. While we cannot take the space in this department to give you this set of plans, we shall present, in an early issue, a complete article on an amateur condenser, the plates of which may be purchased in the open market. Please refer to conditions printed at the heading of this department.

21. **C. G. B., Astoria, L. I., N. Y.**, wants to know if it is permissible to use a switch system for variation of the inductance in the instruments of the transatlantic receiving set instead of the plug contact devices. Ans.—Yes, there is certainly no objection to such a system with the possible exception of the leads or "dead ends" it introduces in the case of the loading inductances. You could employ a switch on the receiving transformer and a series of binding posts on the loading coils.

22. **L. F., Fort Stanton, N. M.**, asks questions as follows: (1) The only available supply of current here is 110-volt D. C. A motor generator set is out of the question due to its cost. What arrangement and apparatus would you advise for a radio set capable of sending 500 miles at night and having a rating up to

2 K. W.? (2) Is it advisable to use a liquid interrupter for breaking the 2 K. W. circuit? (Could the interrupter sold by a New York firm for \$2.25 be so altered as to handle this current with safety in connection with a 2 K. W. transformer of the open core type? How would the efficiency of a set of that kind compare with that of a closed core set of similar rating? (3) Give dimensions and data for a 2 K. W. transformer. (4) What alterations would have to be made in the interrupter sold by the Electro Importing Company in order to make it pass 2 K. W.? I understand this electrolytic interrupter will not handle over 1 K. W. with safety. Ans.—Our friend has asked a mouthful, and we might not be blamed if we were to state simply "It can't be did." However, that answer would not help our correspondent. Without attempting to answer each and every question as it is asked, let us briefly state a few facts and let our correspondent analyze the answer. In the first place, a transmitter to send 500 miles is some transmitter, notwithstanding the joyous claim of having done half that distance with a flashlight battery and a buzzer. To make ourselves clear, friend L. F., suppose we were to ask you whether you would expect to light forty standard 50-watt tungsten lamps using primary batteries as a source of power? You would say no. Neither can you expect to operate a fairly high-powered radio station that would cost several hundred dollars for the average man using apparatus that can scarcely be raised above the level of toys. Do you suppose that if an electrolytic interrupter costing \$2.25 could be made to

displace a motor-generator set costing \$200.00, the rest of us would keep right on using the generator? That is not compatible with the law of economics.

Now, if you were to ask whether you could use a modified form of electrolytic interrupter for a 2 K. W. radio station, we might answer yes; but when you put the 500-mile radius specification in there it makes a difference. If you were to ask us the probable range of the station, we would tell you that your guess is as good as ours.

If you want an experimental station for study, education and amusement, we can give you specifications. But we would not attempt to guarantee what results you would obtain. Electrolytic interrupters, in our experience, are an unmitigated nuisance, although you can have a lot of fun with them while they are working. The trouble is, they do not keep working very long.

If, after this "wet blanket," you still feel that you want to play with apparatus of this sort, we shall be glad to work out plans for a suitable set.

23. **C. L., Altoona, Pa.**, states that he has taken the 12 H. P. engine from an old automobile and wants to run it on natural gas. He wishes to know whether the same carburetor will answer. *Ans.*—You will require a simple mixing valve instead of the carburetor. The function of the valve in this case is not to render gaseous a volatile liquid such as gasoline, but to mix one gas with another; that is, to mix natural gas with air. Look up a few gas engines in your city and observe the simplicity of the mixing valve. After

this, we believe you will have no difficulty in adapting a home-made one to your purpose.

24. **P. G., New York City**, asks the resistance of the relay used in our model submarine. *Ans.*—We are using a polarized relay of 20 ohms resistance and this appears to be quite sufficient for the purpose.

25. **R. W. G., Orwigsburg, Pa.**, asks whether a vibrator can be used on a spark coil rated at 2 in., with current supplied by a dynamo giving 25 volts and having a capacity up to 10 amp., and (2) if the 5-16 in. silver rod used for the 100-watt radio spark coil would be suitable for contacts. He also asks where the silver rod can be obtained. *Ans.*—Yes, the vibrator will work nicely on voltages up to 25 with currents up to 7 or 8 amp. The points will require frequent cleaning, but if your condenser capacity is right, the spark will not pit the surface very much. (2) The silver rod is quite satisfactory. It can be obtained through our Service Department, which will refer your inquiry to the manufacturer.

26. **J. P. C., Whitestone, L. I., N. Y.**, asks: Whether a small radio transmitting set can be made on the principle of the kicking coil high frequency outfit described in the March number of this magazine. He wants a very small and compact set for work in the field and in camp. *Ans.*—Yes, you have all of the elements of a radio transmitter and a very efficient one at that. The objection is found in the fact that to obtain any great results from the set, a very large condenser must be used. This means a long wave, and as 200 meters is the limit for the ama-

teur under ordinary conditions, the restriction is prohibitive. This is to be regretted, for the outfit would be ideal in many re-

spects; but the obstacle is seemingly insurmountable and we therefore have not recommended kicking coils for the purpose.

---

We print below just a few excerpts from letters received from readers in answer to the editorials in the May issue of EVERYDAY. Lack of space in this number prevents our printing the complete letters. Let us have YOUR opinion.

## What Our Readers Think

---

In my mind, if they keep up this selfish, unjust claim which they are making against your magazine there is no doubt that in a short time *Popular Mechanics Magazine* will become one of the most unpopular mechanical magazines in the country.—*Alfred C. Talles.*

---

I have been getting ideas about your trouble and of twenty-five men everyone says that you are right and that *Popular Mechanics* has no more hold over you than it has over *Popular Electricity* or *Popular Science* or *Modern Mechanics*. They cannot class their magazine as a total mechanical one—as only a small part. They're sore because you left and started your own magazine; they all said you were ideal, and that *Popular Mechanics* is all war pictures. One said it was a lot of "bull" just to scare you out. They have no hold on you; all they have is money. I stopped *Popular Mechanics* subscription last year. I got tired of it. When EVERYDAY came out I thought it just the thing. All I want is the mechanical department. All they want is to put you out of the way. They think they own the magazine traffic. They have no patent on your name or articles. I am with you—let me know how it turns out.—*J. P. Stearns.*

---

The men who started the action against your little magazine are very short-sighted, inasmuch as they did not foresee the reaction which would follow such unjust tactics.

Although never a subscriber to *Popular Mechanics*, I can show a pile of "Populars" about two feet high, which I have purchased at news-stands. I have, however, bought the last "Popular" I shall ever buy, for I shall lend neither my moral nor financial support to men who follow such methods.

When I read the first copy of EVERYDAY MECHANICS, I immediately claimed it for my own, as it is a gem, in a class by itself, and when you state it was an idea you have long cherished, I can readily understand why it had the class which distinguished it above others, for I then realized you had put your whole being into its making.—*Harry Little.*

---

How is that? Where the deuce is that color-blinded, dimension-blinded, weight-blinded, brain-blinded fellow who is apt to confound one magazine with the other? I want at once the picture of that queer creature. I have at home a large album of fools' pictures; his will be a conspicuous one among the others. No, I would never confuse the two magazines. I would never buy EVERYDAY, thinking it was *Popular*, because *P. M.* is twice as large as *E. M.*, *P. M.* costs three times as much as *E. M.*, *P. M.* weighs eight times *E. M.*, *P. M.* doesn't fit my pocket, and *E. M.* fits it and suits my taste.—*M. L. Schiaffino.*

I consider it the finest and most interesting practical collection of articles I have ever had the pleasure of reading, and I sincerely hope the publication will not in any way be interfered with by the malicious prosecution of your large but petty contemporary.

Please arrange that my subscription commences with the first issue, as I cannot afford to forego such useful material.—*W. A. Brooke.*

Whatever you do, don't sell out to publishers who would "improve" our little friend along the same lines that *Popular Electricity*, *Modern Electrics*, et al., were improved—into a "picture album," as some of your correspondents very strikingly call it.—*Chas. J. Huppert, Jr.*

If you lose out, then the Merriam people could stop the Century people using the word "dictionary," and so on others, ad infinitum. Probably EVERYDAY MECHANICS is not mechanics, but a song book or Holy Bible.—*T. E. Phillip.*

I dropped *Popular Mechanics* two or three years ago, because it was running all to advertisements, and because it was more of an exploitation of goods for sale than information on making them. I think I will take the trouble to tell Mr. Windsor a few things. He isn't the whole show, by any means, and while his magazine is probably interesting to the people who buy it, I don't grant him any right of censorship over anything I read—its title, or its purposes.

This suit is decidedly small potatoes, and I haven't any doubt you will beat them to a frazzle. Even if they compel a change of name—which I don't think they can—remember, "A rose by any other name would smell as sweet," and keep up the good work you have begun. The little magazine is splendid, and I shall not miss a copy.—*Chas. E. Pearce.*

Your little magazine is a thing I and every educator of boys have long wanted. I have been disgusted times without number with mechanical publications which tell of the great things done or being done, and no matter how much I might want to try a few experiments, never a word to tell me how to go at it nor even what principle the thing is based on. It certainly does seem to me that in every manual training department, Y. M. C. A., civic club room and in every school where there are boys, this little magazine, EVERYDAY MECHANICS, ought to be hailed as a valuable find. It is my experience that a boy seldom goes wrong when once he becomes interested in any branch of nature study, biological or physical. And interesting them is not a difficult thing if only they can find some place to begin experimenting.—*Edwin A. Lewis.*

I have been a reader of *Popular Mechanics* for the past five years, and there is more practical information in one copy of your magazine than there is in a whole year's of *Popular Mechanics*.—*I. L. Mackenzie.*

I am very sorry to note the attitude shown by *Popular Mechanics*. Let me say that I would never confuse your excellent publication for such a combination of uninteresting and worthless matter as I find in their magazine. There was a time when I bought it because it was good, but those days are over. Their attempts to be "modern" took all the value away from their magazine.—*Everett P. Gordon.*

I am afraid *Popular Mechanics* cannot be "popular" after all, and in the future it may be unpopular. To cope with your expenses I say, "Increase the price of EVERYDAY. I am willing to forward my share if you do."

After I hear from you I am going out after ten more subscriptions for your EVERYDAY, and I am going to get them and as many more as I can, so now, how much do I like EVERYDAY? Use this and anything I can do for you in the future. Just mention it, and leave the rest to your Uncle Dudley. With all my heart I wish you and your EVERYDAY MECHANICS the greatest success ever known.—*Jas. M. Johnston.*

I think it a very interesting and instructive little magazine. Hoping that you will win the verdict from the senseless picture book and catalog, *Popular Mechanics*.—*Richard Ayres*.

I would like you to start my subscription from the beginning, Vol. 1, No. 1, as I cannot afford to miss even one issue of your very valuable little magazine. It is just the kind of how-to-make-it magazine that I have waited for this long, and now that it is in existence, I would not like to see it be "put out of commission" by a big "own-all" hog, grappling with everything that even seems to be a competitor.

EVERYDAY MECHANICS is not to be considered, or even spoken of, or even included in the class with *Popular Mechanics*, because EVERYDAY MECHANICS is an "ideal made real," and not a "picture gallery." Wishing you success in this fight, so that you may continue your work as planned, I remain—*Harry Hay*.

Inclosed please find fifty cents for one year's subscription to your wonderful little magazine. I am an engineering student and have been buying the magazine from the newsstand. The reason I am subscribing is that I wish to help you this way in overcoming the nerve of *Popular Mechanics* in bringing such a ridiculous suit. It's a simple case of the big "bully" pushing the little fellow off the street. Keep up the good work, Curtis.

Wishing you continued success, I am—*Louis R. Rohrecker*.

## Would YOU Pay 10c for "Everyday"?

¶ In the May issue, I stated frankly just what we are having to contend with in publishing your little magazine. Perhaps you have noted that other publishers have had either to cut down the size or increase the price of their magazines.

¶ "EVERYDAY" was started just before the raw materials entering into its manufacture increased so inordinately in cost. We could not foresee this contingency, to say nothing of the expenses of defending the action brought against us by *Popular Mechanics*.

¶ In the May editorial, I asked the opinion of my readers. Hundreds have responded saying that they would willingly pay ten cents; not a single one has said that he would not pay it. What do YOU say? Shall we raise the price to ten cents?

Sincerely,

Thomas Stanley Curtis, *Your Editor*

P. S. If you subscribe now at 50 cents, you will receive every number for a year without the payment of anything more, even though we do have to raise the price. Isn't it a pretty good idea to take from one to five years at this rate?

T. S. C.

## Protective Patents procured promptly.

Strictly professional service. No fee refund, no certificate guarantee, no so-called prize or free search schemes used in our business. Inventor's 104 page Blue Book on Patents sent on request.

**TRADE MARKS A SPECIALTY**

**ROEB & ROBB**

304-308 Southern Building, - - - Washington, D. C.

## BUILD YOUR OWN GRANDFATHER'S CLOCK WITH OUR HELP

We furnish blue prints, finishing material and instructions. Buy the works, dial, weights and pendulum from us at surprisingly low prices. You make a fine profit building artistic clocks for your friends.

**Complete Works, \$5.00**

Others with chimes at all prices Ask for Attractive Free Offer

**CLOCK COMPANY**

1659 RUFFNER ST.

PHILADELPHIA, PA.

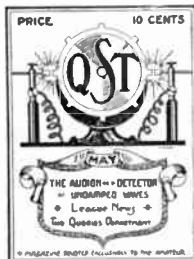

## WIRELESS

QST is the only magazine devoted entirely to Amateur Wireless Telegraphy. Along with all the radio news, QST contains the most up-to-date articles on wireless apparatus. A Queries Department answers your questions free. The Apparatus Exchange is for your use—Gratis. QST is the magazine

written for and by the amateurs. It is just what you want. Everything in it will interest you.

Send 10c for a Sample Copy. **Subscribe Without Delay**

Three months 25c. \$1. per year

**AMERICAN RADIO RELAY LEAGUE**

Subscription Department, Hartford, Conn.