

Everyday Engineering

"It Tells You How to Make and How to Do Things"

VOL. 3

JULY, 1917

No. 4

THE WIRELESS AMATEUR—HIS PART

So many conflicting statements have been made by the technical and lay press relative to the status of the radio amateur under the recent war order that it has been deemed wise to obtain the facts direct from headquarters. To this end, the Editor of *EVERYDAY ENGINEERING* made a trip to Washington and from the office of the Radio Headquarters of the United States Government, obtained the facts embodied in the following letter. This statement has been approved by the proper authorities and it may be taken as absolutely dependable in connection with the present situation.

WASHINGTON, D. C., June 2, 1917.—May I suggest that the letter which follows be taken as an open answer to the hundreds of communications addressed to *EVERYDAY ENGINEERING* relative to the status of the wireless amateurs throughout the country? So many letters have been received that it may prove impossible to answer them individually in time to make the reply of service.

When the editorial in the May issue was written, the Executive Order closing all amateur and private stations was but two days old. Despite the most energetic efforts of the editorial staff to procure an authoritative statement from some official, the information given was not altogether correct, although it must be admitted that no official appealed to could pick the flaws in the statement at that early date.

What I shall say here has been approved by the proper authorities, and it may be taken as a true statement of the facts as they are understood by the authorities whose business it is to enforce the order.

Attitude of the Authorities. Despite the hysterical raving of many prominent amateurs, manufacturers, dealers, and others interested in the perpetuation of amateur radio, my conversation with the government officials has convinced me that the United States Government from the highest official down, has no desire to

hinder, belittle, deride, or discourage the American Wireless Amateur. On the other hand, the Government is keenly appreciative of the great work done by the amateur as a class, and the Officials fully appreciate the important place he holds in this hour of the country's need.

I am told that no legislation has been or will be enacted to stamp out this peculiarly American institution and that, on the other hand, the really serious amateurs who show their patriotism and the true love of their art by enlisting in some branch of the service at this time will be given every opportunity for advancement. As evidence that the more advanced amateurs recognize this fact, a most gratifying percentage of the better class have already enlisted or else have made known their desire to be of service in the future pursuit of their hobby.

It is inconceivable that any sane man, with the best interests of the industry at heart, could criticize the attitude of the authorities once he has been placed in possession of the facts. The country is at war and war is a business so serious that it overshadows everything else in its importance. Every individual of the ninety-million souls inhabiting this land of ours will be called upon to make some sacrifice; for some, the sacrifice will be great, for others small; but let us clearly understand that none can escape in some measure the burden cast upon us by the struggle of democracy over autocracy.

For the wireless amateur, the sacrifice is just this: He must submit to a temporary discontinuance of the promiscuous and unguarded pursuit of a hobby which means nothing more than pleasure and perhaps some education for him. That is the sum total of his sacrifice and when we come right down to it, it is not quite so bad as it seems. Wireless amateurs have always boasted of what they could and would do in time of war and their country's need. The time has come now when they can make good their boast and in doing so, continue their investigations with infinitely greater benefit to themselves than heretofore.

The Manufacturers' Side. Perhaps the manufacturer has a greater "kick coming" than the amateur. His stock is worthless, his daily mail penniless, his machinery idle. That is to say, this is the condition the *unprepared* manufacturer finds himself up against. All I can say for him is that it serves him right, for how any sane business man could go along blindly for months with a sword hanging over his head and make no provision to ward off

the blow when it falls, is more than I can understand. Yet I know a round half-dozen of them who have done just this.

The manufacturer who has the right to call himself one, has prepared for the inevitable during all this time when the handwriting has appeared so plainly on the wall. He has arranged to get his share of the billions of dollars' worth of business distributed impartially in this country. There is no reason why any shop, large or small, should be without profitable work in abundance in this day of unprecedented prosperity. The manufacturer who cannot get his share of the contracts for screw machine parts, turret-lathe parts, etc., is lacking in business acumen. Looking at the worst side of it, he can take a job in the shop of a wiser business man and earn as an ordinary machinist probably more than he made out of his own mismanaged business. The loss of his own "business" is the *sacrifice he is called upon to make*.

The Magazines' Side. With the first intimation of a closure of the amateur radio stations, most magazines in this field *lost practically every dollar's worth* of wireless advertising. That is their sacrifice. They are not whining under the burden of having 75 per cent. or more of their revenue cut off in a day; they are struggling along as best they can and lending every possible hand to the country by the dissemination of knowledge and information to the men it most vitally affects. The magazines which survive this blow will operate at an actual loss greater *per month* in some cases than their net profits *per year* were formerly. Still they must continue if possible. They are the go-between for the authorities and the general public.

Dismantle All Apparatus. Now that we have discussed the little sacrifices of each class affected, and assuming that the discussion has been read carefully and thoughtfully, must we not agree that *the amateur, after all has the best of it?*

What he is called upon to do is this: Dismantle, which means take down and pack away, all radio apparatus which can readily be connected with an antenna and used for either sending or receiving. This means that no complete receiver may be kept standing for experiments with wavemeters, etc. It means that no complete transmitter may be kept assembled for tests with dummy antenna. It means, in short, that there are to be no radio experiments performed whatsoever during the tenure of the war, except in such special cases as those of scientific investigators and laboratories

devoted to serious research work, in which cases special permits may be granted for specific experimental work.

Briefly, it means that the radio amateur is to discontinue his experiments in the entirety insofar as radio is concerned. If he is a good operator, he may enlist and get the kind of work he likes. If he is solely an experimenter, and has advanced to that point which makes his work of serious interest, he may enlist and have the backing and co-operation of the Government in his research. If he must do radio work, the amateur will do it under the auspices of Uncle Sam—that's all there is to it. When you come down to it, boys, it's a small sacrifice we are called upon to make.

Permissible Experiments. Parts of radio apparatus so arranged that they cannot be used for the radiation of energy or the reception of radiated energy, may be used for certain experiments which are in no way related to radio work. For instance, the transformer may be used for high voltage tests and experiments; the complete apparatus comprising transformer, spark gap, and condenser may be used for Tesla coil and high frequency experiments *providing* the oscillation transformer used be connected permanently into the circuit and be so wound (with a large number of turns in the secondary), that it may not be used for the transmission or radiation of signals.

Plant culture and X-Ray experiments may be performed only under the conditions outlined above, *i.e.*, in such manner that the apparatus could not, by means of quick conversion, be used for radio work.

All manner of scientific experiments, shop work, and laboratory work in general, which may be productive of some discovery or invention of industrial, mercantile, or military value are encouraged.

In the case of readers of this magazine and Members of the American Society of Experimental Engineers, the results of such experiments should be reported to the Society. A committee has been appointed to investigate such reports and to weed out the possible suggestions from the impracticable ones. Ideas and inventions of undoubted importance will be referred by the Society to the Naval Consulting Board, of which the Society is now an auxiliary.

Police Department Supervision. It is suggested that the experimenters in each locality who are unable to enlist and who feel justified in carrying on their research in such an independent manner, communicate with the local police headquarters, stating

the nature of their experiments, and denoting their willingness to submit to police supervision should the nature of their work render this advisable. This plan, it is believed, will do much to obviate the annoyance and interruption to legitimate experimental activities in all parts of the country.

In this connection, let me reiterate that the officials impressed upon me the fact that the authorities do not wish to discourage such legitimate and useful activity. The object is solely to reduce to a minimum the likelihood of a misuse of such scientific apparatus under the guise of research work. A frank co-operation between the police authorities and the workers will do much to minimize the dangers and to place the work upon a valuable and productive footing.

Magazine Articles, Good and Bad. I am given to understand that all authoritative and dependable articles that deal with technical subjects from a textbook standpoint will be looked upon with favor by the authorities. Articles which will tend to educate the reader into the uses of apparatus, the repair of break-downs, the handling of tools and machinery, measures of safety and of first aid in case of accident, all come under the desirable class. Articles showing new and important uses for parts of the forbidden radio apparatus, and especially uses which have some commercial or industrial importance, are encouraged.

Articles which depend for their value, upon the actual use and construction of radio apparatus, are in disfavor. If, however, the operation or construction or principle can be shown by photographs or drawings without the necessity for the actual experimentation with the instruments, such an article is permissible.

EVERYDAY ENGINEERING MAGAZINE will adhere closely to the line thus drawn and every effort will be made to confine the published material to this class. All important articles will be submitted to the authorities for approval before they are published.

Summary of the Situation. To sum it up, boys, it is up to us, each one of us, to do his bit and make his share of the sacrifice. Some of us can enlist, all of us can help in some way or another.

Let us bear in mind that Uncle Sam is our best friend. He needs us, and *we cannot get along without him.* Don't forget that. He will help us or those who come after us far more than we can help him. Let's go to it, and in doing so, bear in mind that we are at last making good our long-vaunted bluff that in time of need, the American Experimental Engineer would not be found wanting.

(Signed). THOMAS STANLEY CURTIS.

BUILDING A MODEL SUBMARINE CHASER

THE latest product of the Laboratory Staff is the model of an approved type of submarine chaser or patrol boat. The little craft is 34 inches long, 5½ inches beam, and it draws approximately an inch of water when loaded with driving mechanism and battery.

In popularity the model bids fair to overshadow the submarines EM1 and EM2. Its speedy lines and the finish of the craft have brought forth expressions of enthusiastic admiration among the visitors to the laboratory in the past few weeks.

No attempt has been made to make the craft radiodynamic in

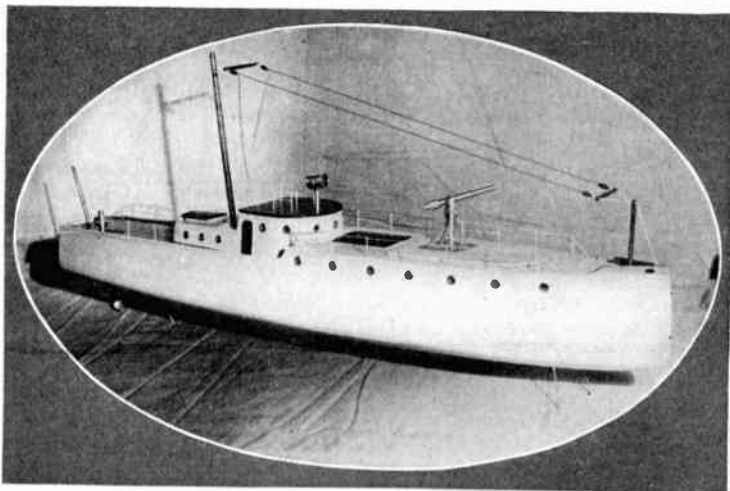

The completed model, ready for launching.

its control, owing to the restrictions placed upon wireless experiments during the war. There is room enough, however, to introduce a control device operated by clockwork to make the craft perform a certain set of evolutions. The displacement is sufficiently great to permit of an extra pound of weight.

The drive is by means of a single screw connected with a well-constructed battery motor placed well forward. The original intention was to use the small storage battery employed in EM1 as the source of current supply. The manufacturer has had so

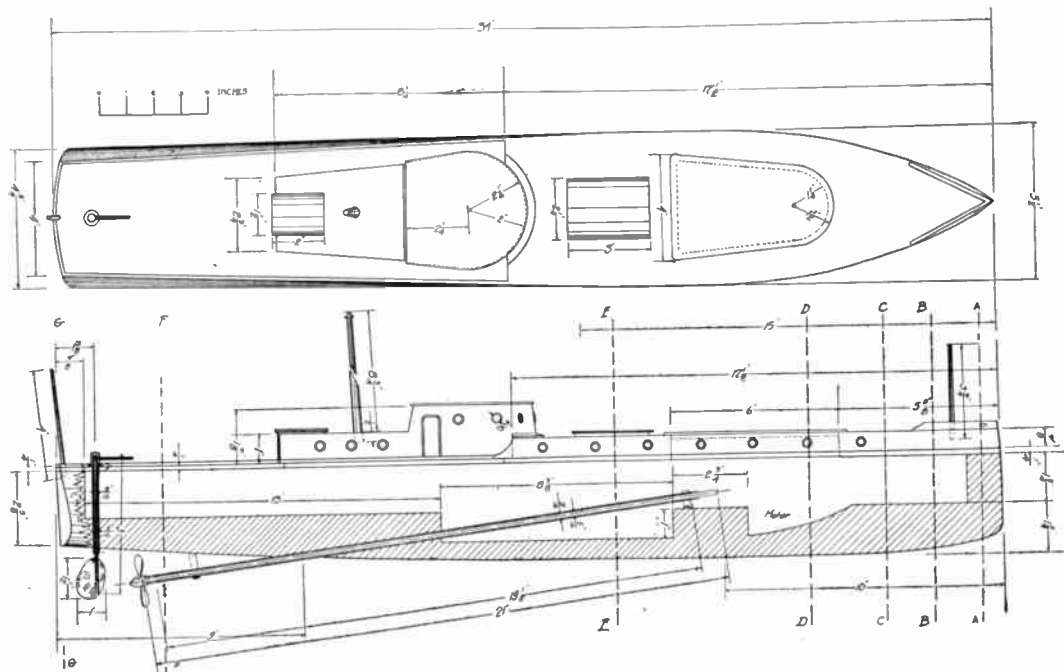

Plan and sectional view of the hull.

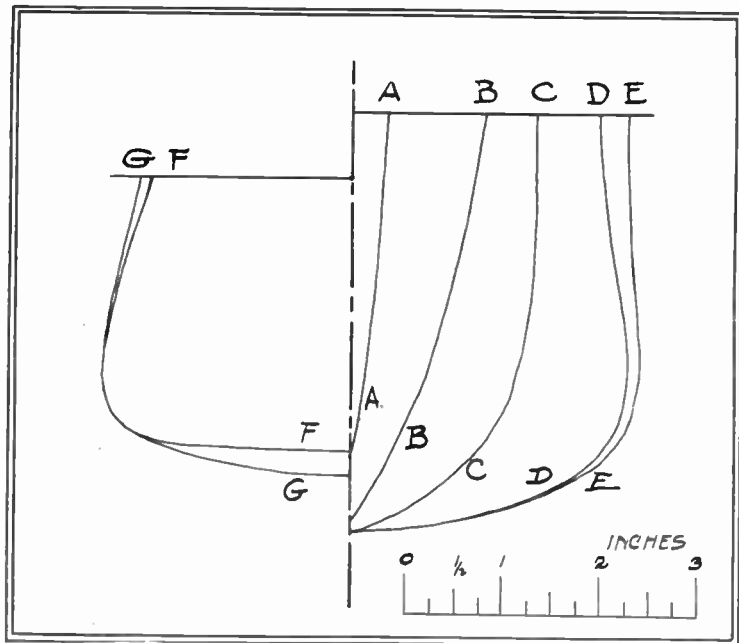

Half sections of hull. Letters refer to cut on page 199.

much difficulty, however, in filling not only our orders but those of readers who endeavored to purchase these little cells as the result of our endorsement, that we have decided to give them up in despair.

The construction of a small storage battery of suitable capacity and proportions is not a difficult matter and we hope to have an article from the pen of W. C. Houghton on this subject in the near future. Prof. Houghton's manual training class has constructed a fleet of models in which his home-made storage cells are very successfully used.

In the meantime, we have resorted to the rather unsatisfactory expedient of using flashlight cells connected in series—parallel. They operate the motor with considerable "pep" but they are short-lived and, consequently, expensive.

FEATURES OF DRIVE.

The propeller shaft housing is securely held in its proper rela-

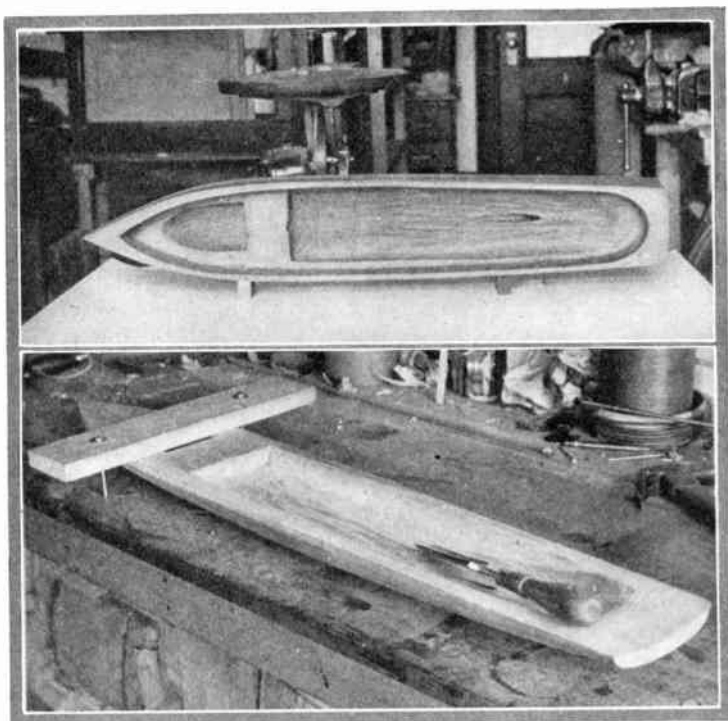

Above: The hull, gouged out. Below: Method of holding down.

tion to the hull by means of brackets formed by bending annealed brass strip to the proper shape and afterward filing it thin and smooth. One bracket, the inside one, is soldered to the shaft tube in order that a firm bearing may be secured at the point where the power is transmitted from motor to propeller shaft. The coupling is the simple type comprising a short length of coiled brass spring. The outside bracket must, obviously, be left unsoldered in order that the shaft tube may be inserted through the hull. No necessity for soldering has made itself apparent, as the fit is a snug one.

The motor was removed from its cast iron base and supported between angles of brass bar as shown very clearly in one of the illustrations. This method of mounting makes possible the alignment of the motor shaft with reasonable accuracy. The flexible

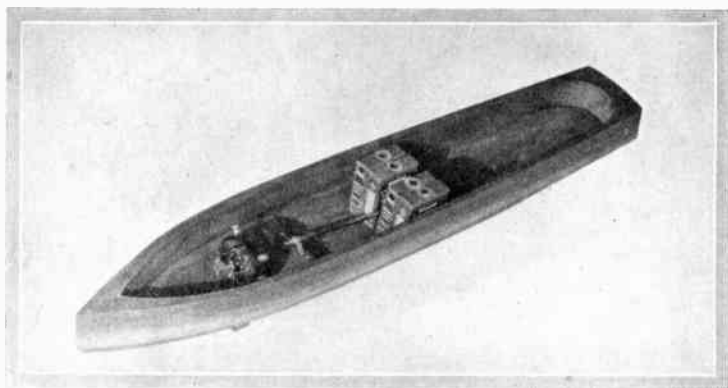

The motor in place, coupled to the propeller shaft.

coupling takes care of whatever inaccuracy exists between the motor and propeller shafts.

The rudder is of the balanced type and of very simple construction. The profile is traced upon a sheet of brass and the blade cut roughly with snips and finished with grinder or file. The rudder post is a length of brass rod split with the hacksaw sufficiently to take the rudder blade. A hole is drilled and an escutcheon pin inserted near the end. This pin is then headed over to draw up the halves of the split rod in order that the job may be neatly soldered. After this important operation has been performed, the heads of the rivet may be ground or filed off and the job smoothed up with emery cloth.

The rudder post passes through a tube of brass fitted with a suitable flange at the top to provide a nice finish. The tiller is a short length of smaller brass rod inserted as shown in the illustrations. No particular provision has been made in our model to hold the tiller in any desired position. This might readily have been done by forming a segment of a circle of brass sheeting with depressions at the desired points to engage the tiller.

HULL CONSTRUCTION

The hull, proper, is constructed after the method used in the case of our submarines. Two pieces of $1\frac{3}{4}$ inches thick sugar pine form the body of the hull. They were worked out roughly to finished shape on the jig saw, formed up with the drawknife and finished with spoke shave and sandpaper.

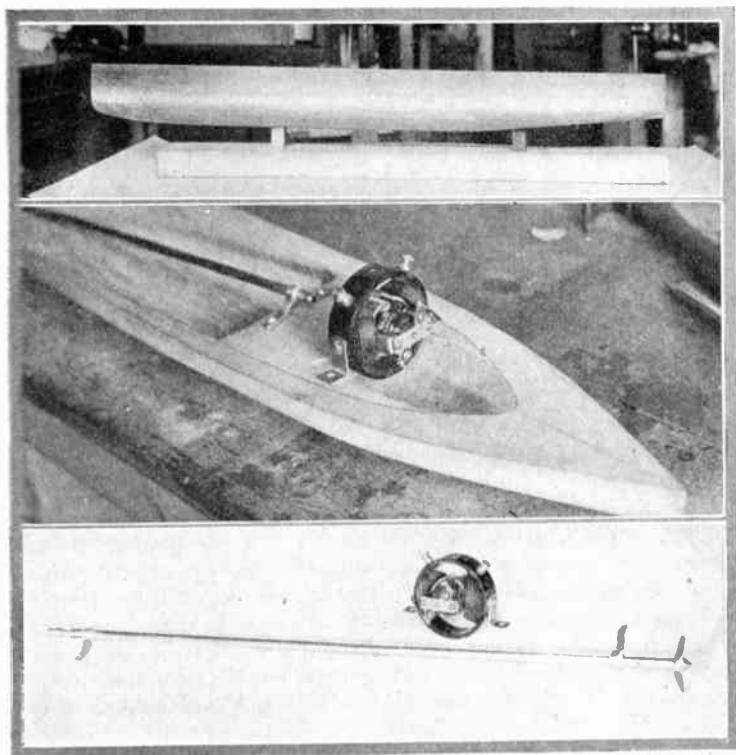

Profile of hull, method of mounting motor and the propeller shaft and tube.

The inside of the hull was hollowed out before the two pieces of pine were permanently cemented together. In the case of the upper piece, the jig saw did the work readily. The lower piece was bored and gouged out. One of the photographs shows the method employed to hold the stock to the bench while the gouge was being used. The bit of stock supporting the motor and the propeller shaft bearing was left in position, the gouge being worked around it.

The two pieces were then cemented together with our old favorite, the mixture of white lead, whiting, bath tub enamel and japan drier. The paste is smeared liberally on *both* faces to be joined; they are then subjected to pressure by means of furniture

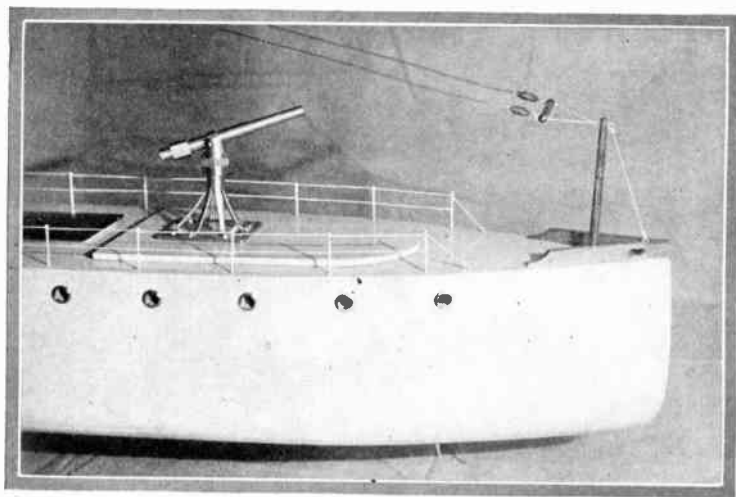

Bow of completed model.

clamps or any other convenient method. The cement will harden in three days. It is well to use a few very slender brads in joining the hull planks to assist in making the structure rigid. If the walls are brought down as thin as they should be, this task of placing brads will be a delicate one. The expedient we employed was to drill down through from the gunwale with a No. 55 drill to insure a straight path for each brad.

The deck and forward superstructure, if such it may be called, are integral. A piece of $\frac{1}{4}$ in. stock runs over the entire hull while the rise forward is formed by the addition of a piece of $\frac{3}{8}$ in. stock to this thin decking forward. The deck and its companion piece are secured after being finished closely to shape in the vise. The superstructure should be hollowed out a bit if possible to decrease the weight at this critical height.

Right here, let us indicate a good, old rule that will save endless trouble. Use every expedient your ingenuity will devise to keep weight low in the hold of the model. Never let an ounce of dead weight remain above the water line if you can find a way to remove it. A close adherence to this suggestion will produce a craft of superior stability that will behave well in fairly rough as well as calm water.

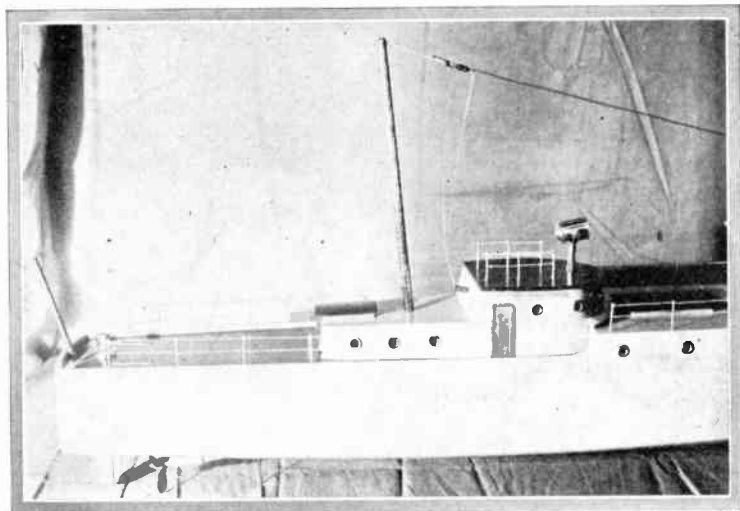

Stern end of the completed model.

The gunwale is a length of $\frac{3}{16}$ in. square stock running the circuit of the deck. The gunwale is painted grey while the deck is stained and varnished after the "plank lines" have been laid in it. These lines are merely score marks made with a scribe to imitate the lines of the usual deck planks.

The "conning tower" is of wood, hollowed out to the thinnest possible degree and decked over with cigar box wood. The structure is made removable so that access may be had to the storage battery amidships.

The port holes are finished with short pieces of brass pipe cut off in the lathe with a parting tool so ground as to produce the desired finish on the face of each port. A bit of celluloid placed in each hole in back of the brass collar gives the desired semblance of glass. The holes in the hull and conning tower are $\frac{3}{8}$ in. in diameter to make a snug fit for the brass collars which are forced into position after the hull has been painted.

The wireless aerial rigging and the spars are turned up from clean dowel rod. The little insulators are bits of $\frac{1}{8}$ in. dowel rotated at very high speed in a drill chuck in the lathe and turned to the desired shape with a very sharp tool. The chief difficulty will be met and overcome if these two precautions are exercised.

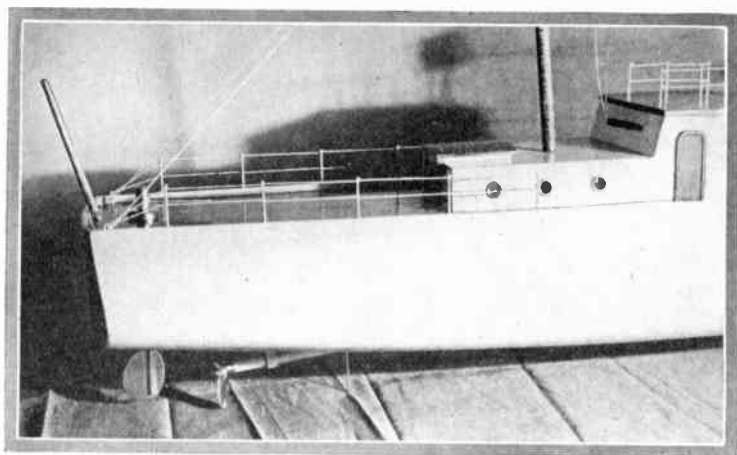

Close up of stern, showing fittings.

The railings and stanchions are respectively of hard, smooth linen thread and slender steel brads. The brads are inserted into holes drilled at the proper places. Care should be taken in driving the brads to make all of the same height. In our case the latter is $\frac{7}{8}$ in. from gunwale to tip of stanchion. The thread is taken over each stanchion in a half hitch which enables the constructor to draw up the lines tightly, making the appearance neat and trim. Both railings and stanchions are painted grey.

The little doors in the conning tower are of cigar box wood, carved to resemble the door and casing and secured to the tower by means of the marine cement and a few brads made from cut-off pins.

PAINTING AND FINISHING

The reader is referred to the May, 1917, issue for a most comprehensive and valuable article on the painting of a model boat. We have followed the suggestions of the author, Mr. Hobbs, with entire success in the case of the little submarine chaser and his instructions are therefore commended to the attention of other workers.

Space will not permit of a detailed description of the gun and searchlight in this issue. They will be covered in a later number as separate articles.

EVERYDAY AERONAUTICS



BY LIEUT. VICTOR W. PAGE
Instructor in Aviation, U. S. A.

EDITOR'S NOTE: This is to be an instructive series of articles dealing with the elementary principles of aerial navigation and while each article will be complete in itself, the various instalments will supplement each other in a logical manner. It is intended to make this a regular feature of the magazine.

PART I. AIRCRAFT TYPES

THE navigation of the air, which has been the dream of mankind for ages, has only been realized in recent years. Practical aircraft have been built in definite forms that can easily be classified, and also in several experimental types that are little known and which have been discarded in favor of the types known to be practical.

The air is a gas that surrounds the earth and which is said to extend above the earth's surface for about 40 miles, though the density becomes less and the air becomes rarer as the distance above the earth's surface increases. Above a certain height, about four or five miles from sea level, it is very difficult for human beings to breathe because of the rarity of the air. We are so used to moving about in the air that many consider it an almost intangible substance and do not realize that 16 cubic feet of air will weigh about a pound and that it exerts a pressure of about 15 pounds per square inch surface on everything. We are so constituted that this load is not appreciable to us any more than the force of gravity.

Air in motion may exert considerable force. A gentle breeze creates very slight pressure but a cyclone or hurricane, which means air travelling at a rate of from 75 to 100 miles per hour can do considerable damage. Much destruction is caused by tornadoes due to the great pressure of air travelling at a high speed,

and which has sufficient velocity to uproot large trees and tear buildings apart. Winds are caused by the conflict between rising air currents due to the lesser weight of heated air which rises from the earth's surface and the down currents of cold and therefore heavier air which rushes down to take its place. The physical contour of the earth and variations of temperature as well as seasons of the year all have their influence on air movements termed winds.

The ascensional power of warm air was well known to the ancients and the first craft to navigate, or rather be supported by

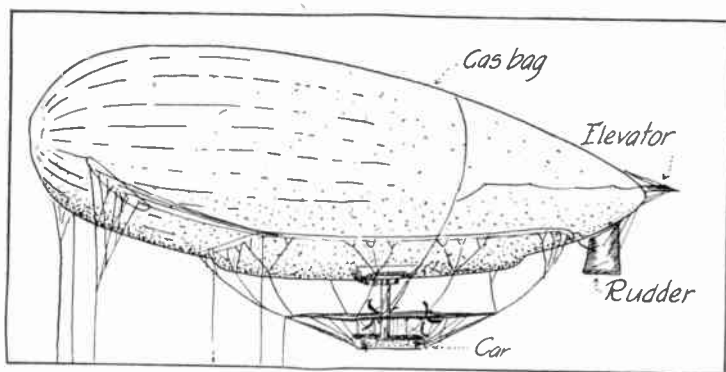

Fig. 1. Non-rigid type dirigible balloon.

the air were very large globular or pear-shaped bags of paper or parchment filled with hot air and smoke from a fire burning beneath the opening in the bottom of the bag. A cork or piece of wood floats on water because it is lighter than the supporting medium, a stone sinks because it is heavier than water. A bag filled with hot air, smoke and gases resulting from combustion is lighter than the surrounding cold air, it displaces and will rise because it is of lesser weight than the supporting medium. The first airships were of the lighter than air type and are called balloons. This type is made in two forms, aerostats or spherical balloons free to rise in the air and blown hither and yon at will of the elements, and dirigible balloons, which are driven by power and which may be steered by special directional members or rudders. The free balloon is of little value except for exhibition purposes. The kite balloon, however, which is held captive is a splendid type for military observation purposes.

Practical balloons are made up of various textile fabrics, such as silk or linen which are very closely woven and which are impregnated with rubber compound to lessen the porosity in order that they may retain gas. This cloth is cut into strips of the proper size and shape which are sewed together to form the envelope or gas bag. The seams are covered with strips of rubberized tape to insure a gas-retaining joint. The bag is filled with hydrogen gas, the lightest known element. One cubic foot of this gas is capable of lifting one ounce weight, therefore a bag with a capacity of 32,000 cubic feet would be able to lift one ton or 2,000

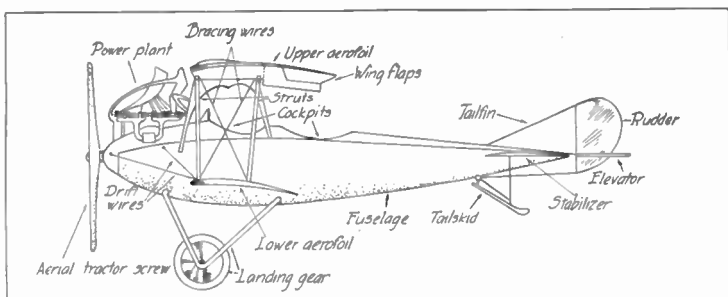

Fig. 2. Side view of typical biplane, showing important parts.

pounds, this weight including the gas, bag and basket and objects raised from the ground. The kite balloons are shaped like a big sausage instead of a pear or globe and are allowed to rise to the desired height by unwinding a cable from a power driven winch.

Dirigibles are made in two types, called non-rigid and rigid. The former class includes approximately cigar-shaped bags carrying a basket or body member suspended from the bag by a series of slings, these being attached either to a netting or to special fabric anchorage pieces sewed to the bag. The bag holds its shape because it is distended by the internal gas pressure. The rigid type, of which the well known Zeppelin airship is an example, has a metallic framework that divides the main gas container into sections, the only function of the gas bags being to hold the gas. The framework shapes the bag and permits of easy attachment of the "gondolas" or cars carrying the power plants close to the body of the ship. These types will be considered more in detail in proper sequence.

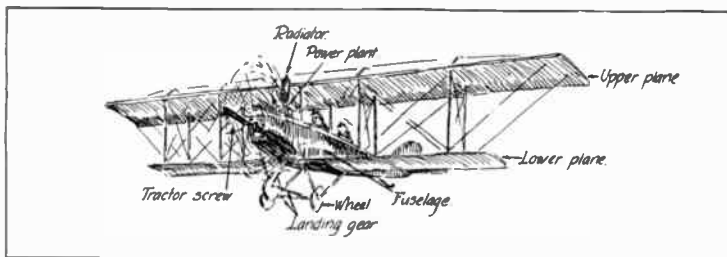

Fig. 3. Tractor biplane in flight.

Heavier-than-air machines may be divided into three types: airplanes, helicopters and ornithopters. The first named is made in three different patterns designated by the number of supporting surfaces or wings it has. A monoplane has one wing; a biplane, two; and a triplane, three. The helicopter is a machine that depends on lifting screws for sustentation and propellers for securing movement in a horizontal plane. The ornithopter is a type devised to imitate bird flight and sustentation is supposed to be derived by the flapping of wings. Neither of the two latter forms is practical or seems to have any future.

The airplane in its simplest or monoplane form consists of a body to carry the pilot, power plant and controlling members, supported by wings, one at each side of the body. The engine turns an aerial propeller which pulls the machine through the air because the air pressure under the wing and the suction effect on top of the wing exerts a lift greater than the weight of the machine if it is drawn through the air with sufficient speed. The airplane in its various forms will also be discussed in succeeding instalments. The airplane is the most practical type of machine to navigate the air and thousands are in daily use. Its principle of operation is easily understood. If wind moving at high velocity exerts pressure, drawing an object through the air at high speed will produce pressure against it. If this is a plane section, such as a kite, it will rise because of the wind beneath it. Airplane wings may be compared to a kite, the propeller thrust or tractor screw pull can be likened to the tension of the kite string when one runs along the ground to raise the kite.

To polish furniture, use a piece of velveteen instead of chamois. The former is just as good and is cheaper.—A. E. BRUCE.

A CABINET FOR SCREWS, NUTS AND BOLTS BUILT FOR THE KITCHEN BUT HANDY IN THE SHOP

THE next time you go to a large department store, browse around among the pots and pans, bread boards and kitchen cabinets. It's a gold mine for the experimental engineer who needs shop furniture and who may have the ever-ready flat pocketbook.

We chanced to see the little cabinet shown in the photograph in the basement of a big New York store the other day. We picked it up gingerly looking for the price mark and shutting our eyes momentarily to the legends "Salt, Ginger, Mustard, Pepper, Spice, Nutmeg" on its six little drawers. Under the usual hieroglyphics we found the mark "65." Inquiry revealed that this was actually the price, 65 cents. More questions showed us that there were other dinky little cabinets, some at 40 cents and others as high as a dollar.

We promptly annexed the first selection because its drawers fitted decently and it had less ginger-bread on it than the dollar specimen.

Extending the ramble we picked up a knife tray that is the handiest thing ever for carrying small tools on the job from one part of the shop to the other. It has three compartments and a handle in the center. It reduced our currency to the extent of 35 cents and it has saved us five dollars' worth of time and temper already.

We have found that there are birch and maple boards in all sorts of mysterious shapes and forms in piles in this basement. Nobody seems to know what they are used for in the culinary art, but who cares? We have used them for the bases of instruments, have made odd cabinets of the rectangular ones, and fibre-board cylinders of the round ones, and have come to the conclusion that we cannot turn out and finish a disc or oval of this size for the 10 to 25 cents these nameless kitchen tools command.

Bread boards are fine for instrument panels, switchboards, tops and bases of cabinets, etc., and they are made in such a profusion of sizes that one is almost sure to find something that will do. Finished with good black insulating paint, rubbed down, and



Adopted by the Laboratory Staff. Of course, we changed its name.

painted again, they present a splendid appearance. They are battened at both ends and never seem to warp.

Rolling pins cost 10 cents. We cannot set up and turn a hardwood cylinder of this size for the same money. We have made, among other things, cheap wooden pulleys of rolling pins cut to the desired length and turned to finished shape and bore. It is infinitely easier than to rough out the pulley from a big chunk of hardwood. This makes up for the slightly higher cost of the actual raw material.

We have heard experimental engineers say that they did not count their time. That is a bad admission to make even though made innocently and honestly. Every hour and every ten minutes a man can save from needless waste means that just so much time can be more profitably employed. Our time is worth just as much at play as it is at work and we feel that we are cheating ourselves if we waste time by doing unnecessary labor that could be saved by the application of a little ingenuity, even though we do love our work.

NOTES ON SELENIUM CELLS.

BY J. H. HENNEQUIN

The issue of EVERYDAY ENGINEERING for April, 1915, had a Technical Adviser question asked by V. O. of Naugatuck, Conn. He inquired for the name of a dealer from whom he could purchase a selenium cell.

The writer has made several cells in the past few months. At least four of these were built before he made one that was a success. The process of winding two wires close enough around a porcelain tube, but not having them touch was the most difficult step in their construction.

To overcome these difficulties, a block of plaster of paris was cast. This was $2\frac{1}{2} \times \frac{3}{4} \times \frac{1}{4}$ in. When dry, a thin coat of plaster of paris was rubbed over the block and the winding of the wires (30 enameled copper) immediately started so that they would sink into the wet plaster of paris. After the winding was completed, the block was dipped into a thin plaster of paris paste until the wires were held firm. Then one side was sandpapered until the wires were scraped clean. Then selenium was melted and smeared in a thin coating over the wires. This was annealed for three hours. The writer used a bunsen flame and kept the heat just below the melting point. Cells of various conductivities were made in a similar manner with good results.

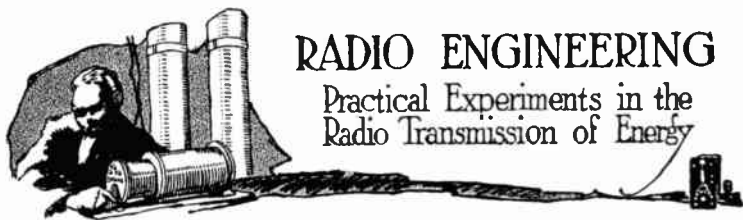

RADIO ENGINEERING

Practical Experiments in the
Radio Transmission of Energy

THE USE OF DUMMY AERIALS

PART II

BY M. B. SLEEPER

With Drawings by the Author

VERY few experimenters have hot-wire ammeters, although they are not expensive to buy or difficult to make, and absolutely essential in accurate work. Fig. 3 shows the working parts of a hot-wire ammeter. The pointer is mounted on the balance wheel of an old alarm clock. Two drops of sealing wax are sufficient to hold it in place. A split shot is pinched on the lower end of the pointer to act as a counterbalance. Just enough of the clock frame is kept to hold the wheel. The leads are brought through the wooden bottom of the case in hard rubber bushings. One end of the wire is fastened to a brass rod; the other is soldered to a piece of No. 30 spring brass strip, fitted into a slot in the lead screw. Fig. 4 shows a screw put through the case to adjust the tension of the wire. After the parts are mounted on the base, a silk thread is put twice around the pointer shaft and tied to the wire. The other end goes to a thin spring which keeps the string tight. It will be noticed that a second wire is connected across the terminals. This acts as a shunt to carry a part of the current and to prevent the heavy current from burning out the No. 36 wire. The shunt should be about No. 24 wire.

Fig. 4 shows the meter enclosed. A round tobacco can makes an excellent case. It is only necessary to cut out the bottom, leaving a rim to hold the glass cover. Two or three drops of solder inside will keep the glass in place. Finally, the case is put over the round base, and fastened with wood screws.

To calibrate the meter, it is connected in series with an ammeter, Fig. 5, and a variable resistance. Then the resistance is varied. As the pointer of the calibrated meter moves, the hot-wire ammeter

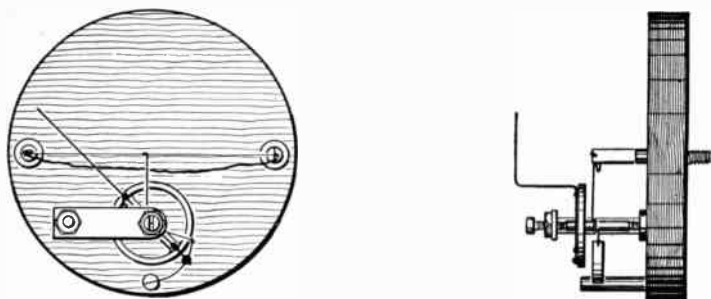

Fig. 3. Working parts of a hot-wire ammeter.

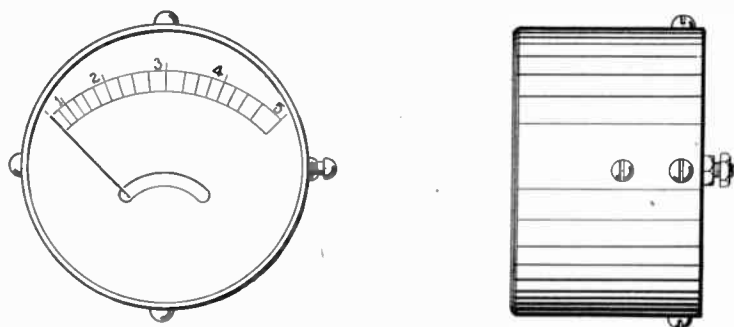

Fig. 4. Ammeter enclosed in case.

gives corresponding current readings. It is a simple matter, therefore, to calibrate an ammeter to give an indication in amperes, instead of comparative readings which are of little value in practical work.

The inductance has been described already as 15 or 20 turns of rubber-covered wire on an 8-in. cylinder or frame. A pin, soldered to a flexible lead, is used as a slider, by sticking it through the insulation onto the wire.

Air condensers are generally used for dummy circuits, but they are difficult to build and expensive to buy. However, small mica condensers can be used. A new type of mica condenser has been brought out recently, which is exactly suited for dummy aerials on sets up to one-half kilowatt, or even higher power. The drawing in Fig. 6 shows five of these *units* mounted in slots in a hard

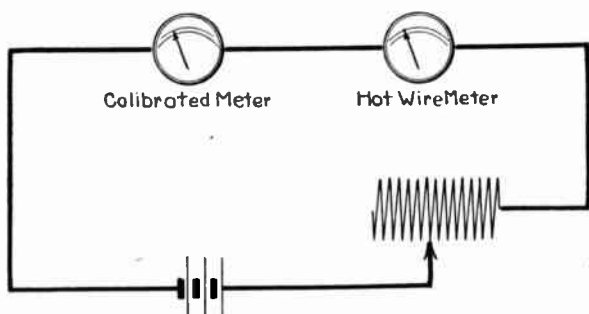

Fig. 5. How the meter is calibrated.

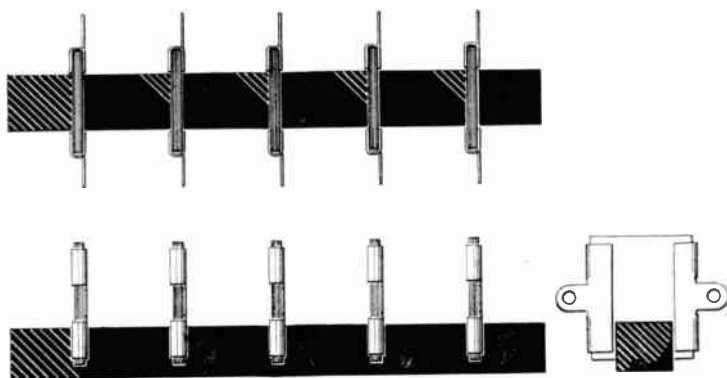

Fig. 6. Five condenser units mounted in slots in a hard rubber rod.

rubber or Bakelite rod. The condenser plates are $1\frac{1}{4}$ by 1 in., and $\frac{1}{8}$ in. thick; each condenser has a capacity of 0.001 mfd., and can stand 3,000 volts.* The strain on each condenser unit is reduced by connecting several in series, for

$$V_c = \frac{V}{N_c} \quad 9.$$

where

V_c = strain on each condenser, in volts,

V = voltage of circuit,

and N = number of units of equal capacity and breakdown strength in series.

Connecting the units in series reduces the total capacity, since

* Since these condensers cannot be purchased in small quantities from the manufacturer, they will be supplied by the Service Department at 50 cents each.

$$C = \frac{C_c}{N_c} \quad 10.$$

where

C = total capacity, in mfd.,

C_c = capacity of each condenser, in mfd.,

and N_c = number of units of equal capacity.

If it is necessary to connect so many units in series to prevent a high voltage break-down that the capacity is made too low, two

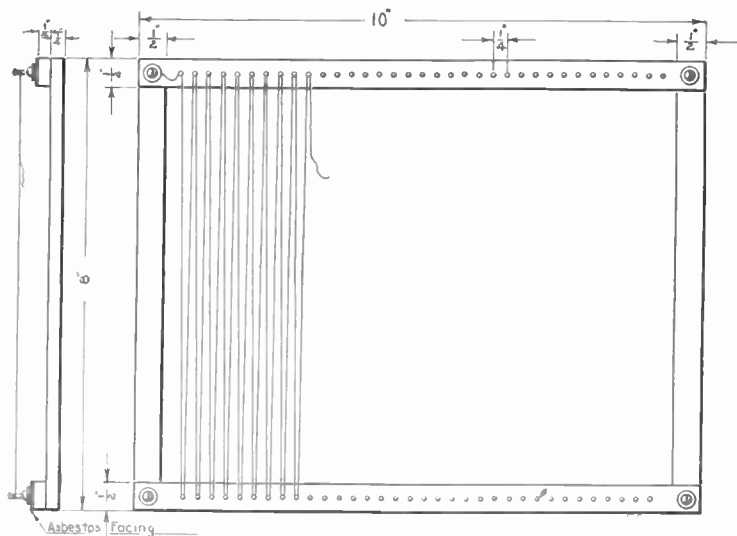

Fig. 7. Non-inductive resistance unit.

or three series sets may be joined in parallel to bring up the capacity.

$$C = C_c \times N_c \quad 11.$$

C = total capacity, in mfd.,

where C_c = capacity of each condenser, or series set in mfd.,

and N = number of equal units or series sets in parallel.

To reduce the possibility of condenser trouble, the units, mounted on the hard rubber strip, should be placed in a tin box, filled with castor oil. The case should be grounded, so that it will not affect the circuit. When necessary, several rows can be placed in one box, and fastened in place by screws through the bottom into the strips.

These condensers are also useful in measuring other capacities or inductances.

Advance resistance wire is one of the best alloys for the resistance element. No. 22 Advance wire will carry an intermittent load of over 10 amperes. It is seldom that more than 20 ohms are required. This means 43.5 ft. of Advance wire. If this cannot be obtained, German silver wire may be substituted. In this case, 66.25 ft. of No. 22, 18% German silver wire will be required. This wire is wound over brass escutcheon pins in a hard rubber



Fig. 8. Pressing the spring opens the clip to take the wire.

frame faced with sheet asbestos. It is necessary to protect the hard rubber from the heat of the wires when they are carrying more than their rated current capacity. Fig. 7 gives the dimensions of the frame and shows how the wire is wound back and forth to make the unit non-inductive.

It is impossible, of course, to use a slider to vary the resistance. A clip is necessary, therefore. The details of a clip contact which will not injure the wire are given in Fig. 8.

By means of this apparatus all kinds of transmitters, whether for damped or undamped waves, run from alternating or direct current can be tested for efficiency and output.

CORRECTION

In the article on dummy aerials in the June issue, page 176, equation 5 should have read:

$$W = I^2 R.$$

Equation 7 should have been:

$$W = I_1^2 (R_R + R_{RC})$$

where $R_R + R_{RC}$ = the total resistance of the unit,
and I_1 = new reading of the ammeter.

These formulas, although correct in the original manuscript, were set incorrectly by the printer, even after the proofs were revised.

POLISHING HARD RUBBER AND BAKELITE

Almost all home-made knobs and panels are left with a dull finish, because few people understand the method of polishing hard rubber and bakelite. It is possible, however, as commercial apparatus shows, to give these materials a mirror-like polish.

Fine emery paper and lard oil, or better linseed oil, will take out all the scratches and tool marks. The first rubbing should be with a circular motion, and finally with a straight movement, in the case of panels or flat pieces. Round parts, of course, can be run in a lathe.

The next step is to apply rotten stone and linseed oil on a piece of cotton waste. When this is wiped off, the material should have a dull, but clear appearance, free from scratches. Then polishing rouge is applied, to give a glossy finish. It is important, particularly on parts run in a lathe, not to heat the piece by too heavy pressure.

A final high polish can be obtained with vienna lime powder on a piece of felt or leather. If the preceding steps have been taken carefully, the lime powder will give the gloss found on commercial instruments.

All of the materials required are sold by hardware stores.

CONNECTORS FOR COPPER TUBING

Copper tubing is used extensively for connections in radio or high frequency apparatus. Since the high frequency currents flow

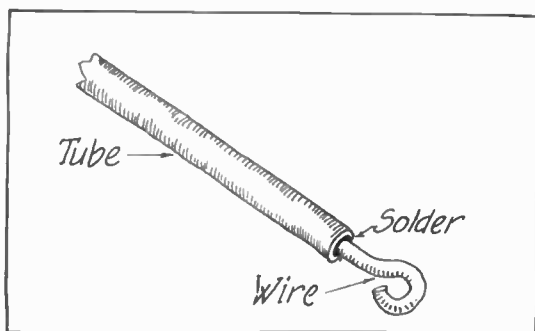

Insert the wire in the tube and sweat it in place.

on the surface without permeating the wires it is necessary to have as large a surface as possible, and at the same time, to keep down the weight and size of the conductor. Hence the use of copper tubing.

Practically the only difficulty in the use of tubing is in forming the connections. The drawing with this article gives a method of overcoming the trouble. A short length of copper wire is formed into an eye. The wire should be just large enough to put into the tube when it has been flattened slightly. Solder is applied at the end of the tubing, and the wire sweated in place.

DETECTING HYPO IN PHOTO PRINTS.

BY T. LANSING

PREPARE an iodo-starch solution as follows: Stir about a thimbleful of cornstarch in about an ounce of water. The exact proportions are unimportant. Cook this on the stove until it boils and the starch thickens. Stir into a thin, homogeneous paste, diluting slightly if necessary. Strain through a cloth, into a bottle. Now add about half a teaspoonful of tincture of iodine and stir until the whole solution has a deep blue color.

Pour a portion into another bottle for use and dilute until you can barely see through it. Put away the bottle of concentrated solution until the second bottle needs replenishing.

To use, pour a quarter of an inch or less of the dilute solution into a clean test tube. Remove your plate or print, or string of film from the washwater and let the water still clinging to it drain into the test tube. If a very small addition of washwater causes the color to immediately vanish, there is plenty of hypo still left on the film. If you can dilute halfway up the tube before the color vanishes, cheer up, for the washing is nearly done. When the hypo is completely gone, the color will gradually become lighter as the tube is filled with water and there will be no sudden vanishing of the blue color. To make sure you know the results and their meaning make a few trials with clean water first and then with water into which you have introduced a trace of hypo, gradually reducing this with clean water until you are using clean water again. The advantages of this test are the quickness with which you can learn to tell just how much hypo remains to be washed away, and also the convenience of having your means of testing always ready on the shelf.

THE AMATEUR ELECTRICIAN'S SWITCHBOARD

BY RALPH R. WEDDELL

EVERY electrical experimenter should have an experimental switchboard from which he may obtain various voltages of alternating or direct current. The installation described is designed for 110 volt alternating current, although various features may be incorporated in it for some other source of current.

By consulting the plan, Fig. 1, it will be seen that there are four different sources of current available, namely, 3 to 26 volts A.C., 0-110 Volts A.C., through a water rheostat, 110 volts A.C., and direct current from storage or dry cells. Separate knife switches are on each of these circuits. The same type of knife switches, as well as other apparatus such as fuse blocks and plug receptacles should be used, as the uniformity of these gives the switchboard a very neat appearance. Fifteen ampere, 125 volt, double pole knife switches are suitable.

Each of the 110 volt circuits is protected with a separate fuse block before the knife switch as shown. The type of fuse block known as the double pole, main, should be used. The writer recommends using renewable fuse plugs instead of the regular type which, when blown once, have to be renewed with a new plug. By paying a few cents more for the renewable plugs and buying a pound of fuse wire, say six ampere, hundreds of fuses may be blown at a small cost. The experimenter should have a larger fuse in his service box, that is the fuses before the meter, than on his switchboard. If these two are the same, and there is an overload on the experimenting circuit from the board, the service fuses will blow first, as there is also the outside load such as is being used for lights, etc., plus the experimenting load on these service fuses while the experimenting load only is on the switchboard fuses.

To make the various experimental circuits readily accessible plug receptacles are used at the bottom of the wiring on the board. By means of these, current that is being used to run an instrument may be changed by removing the plug from one receptacle and inserting it in another.

The board itself is made of wood so as to form a back or wall above the experimenting table. This wall should project from the back of the table about three inches to allow sufficient space for "fishing" the low voltage wires which should run in back of the board. The switchboard should be covered with sheet asbestos.

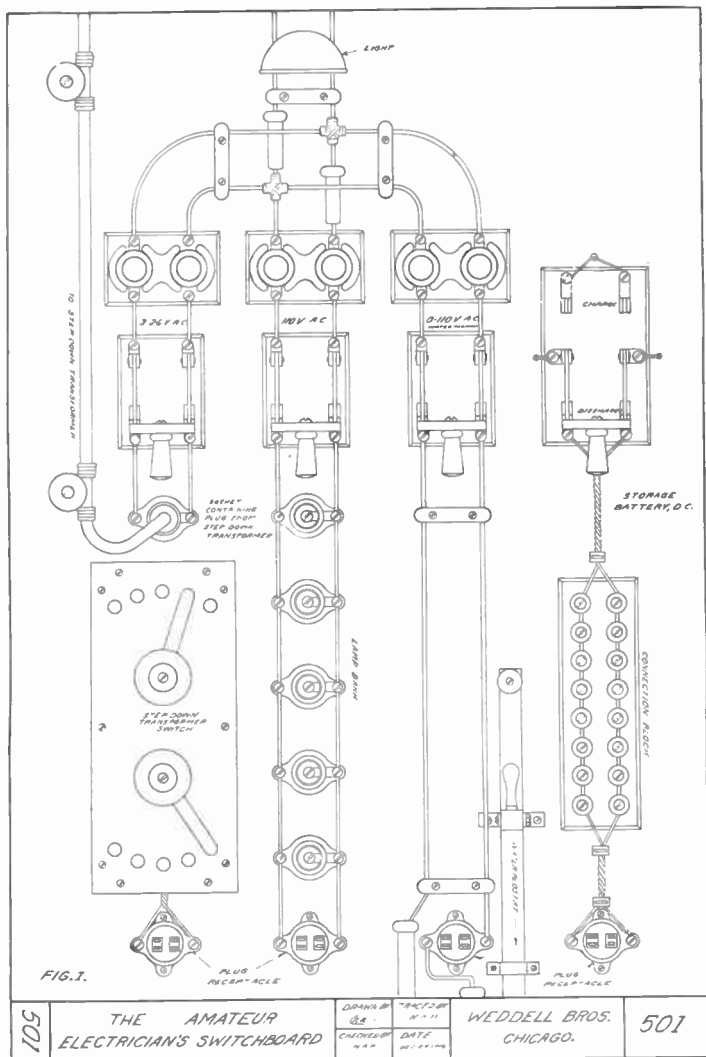

In installing the switches, do not fasten them as shown in the cut, but reverse so that should they fall, the circuit break would not be accidentally closed.

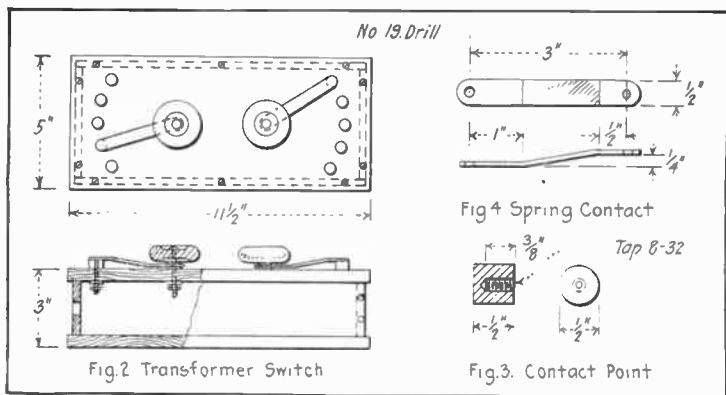

Details of transformer switch.

An electric light with a shade is placed at the top of the board as shown in Fig. 1.

The 3 to 26 volts A.C. is obtained from a small step-down transformer* from which ten different voltages are obtainable. A special transformer switch is designed so as to obtain these different voltages direct from the board. Fig. 2 shows an assembly of this switch. Details are shown in the following views. Radiator wheels, which may be bought from any hardware store, are used for switch handles. This switch may, of course, be modified to suit any other type of transformer than the one here described.

The regular 110-volt service is run through the lamp-bank to the plug receptacle. The lamp-bank, which consists of five lamps, is in multiple connection with the circuit, which permits quite a bit of current to be taken from the mains.

Another convenient source of current is the 110-volt line connected in series with a water rheostat, which may be used as resistance for running arc lights, etc. Detailed assembly view of a water rheostat is shown in Fig. 8. It consists of a glass jar *A*, which is filled with a solution of salt water. A one-quart fruit jar is ideal for this purpose. Two electrodes *B* of round sheet brass are brought nearer together or farther apart, as the case may be, by means of the shifting rod *C*, which is a stick of wood about $\frac{3}{4}$ in. square. The rod can be held in any position by means

* See article by Mr. Miller in this issue.

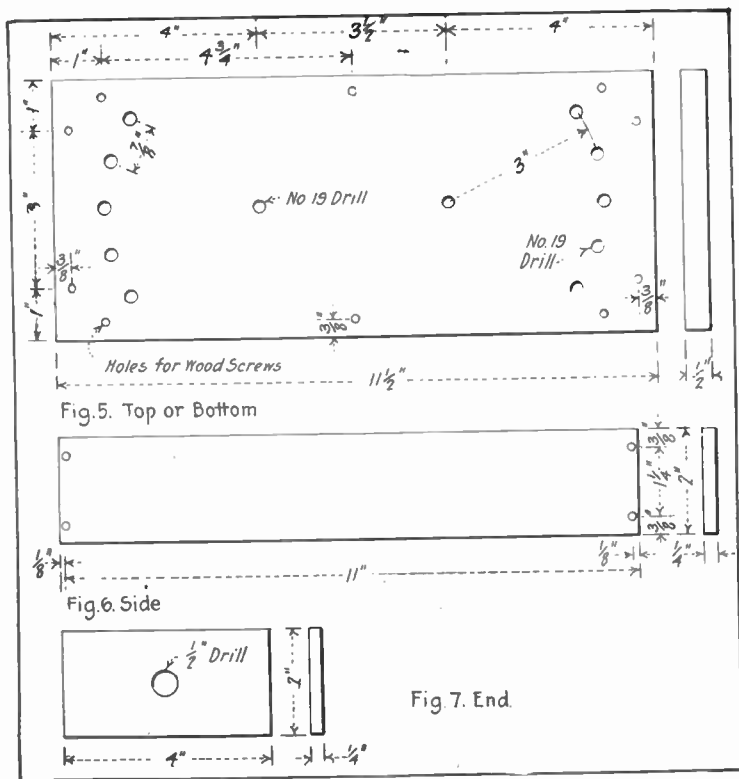

Case for transformer switch.

of a cam lifting arrangement *E*, which is merely a wooden spool whittled down on one side slightly. When the spool is turned by means of a handle the larger side of the spool presses up against the shifting rod and holds it in place. The shifting rod has a handle fitted to it and is held by means of a guide *F*, which is a strap made of brass. The glass jar is directly underneath the table as shown.

For direct current a storage battery should be used but if not obtainable, dry cells will do. The direct current knife switch in the plan, Fig. 1, is of the double-pole, double-throw type. One side of the switch is used for charging the battery, which in the writer's

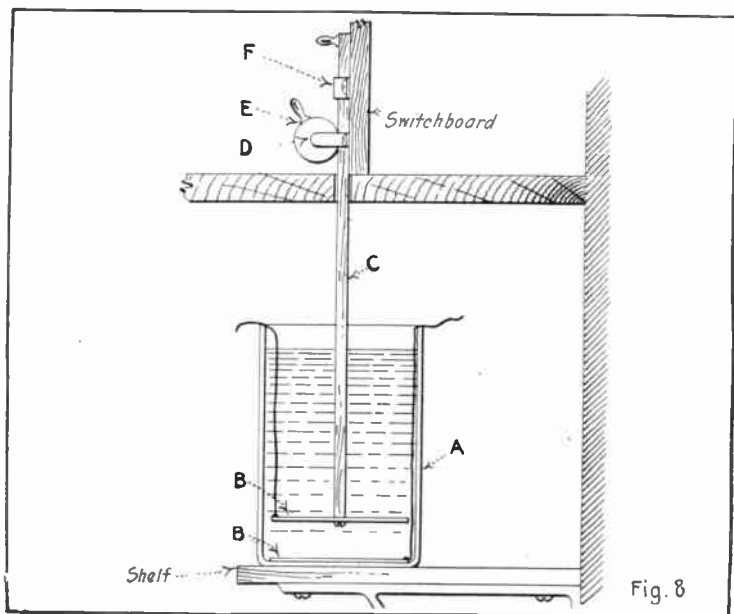

Details of water rheostat.

case is from a small chemical rectifier run from the step-down transformer. The other side of the switch throws the direct current into the experimental circuit. A connection block is shown in multiple or parallel between the switch and plug receptacle. The connection block consists of several pair of binding posts, in this case, screws with washers, on a base. This is convenient for tapping the direct current to run apparatus at various places, such as telegraph instruments, signal bells, etc.

This type of switchboard has been in use in the writer's laboratory for the past two years and has well served its purpose.

Smoothing irons will retain their heat much longer if a brick is used as a stand instead of the usual iron affair. Where convenient, obtain a white brick.—A. E. BRUCE.

To keep the polish on brass, coat the metal with clear varnish after it has been polished in the usual way.—A. E. BRUCE.

THE EVERYDAY MOTORIST



AUTOMOBILE POWER PLANT FAULTS

PART 1

CAUSES OF LOST POWER

Editorial Note:—This is the first of a series of articles to appear in the new automobile department, the others to follow in succeeding issues. The series will give easily understood instructions for making repairs to engines, give hints for locating troubles in all parts of the mechanism and will also include maintenance and operation advice.

AS a guide to those not familiar with gasoline engine construction, a sectional view of a typical four cylinder truck engine of standard design is presented in the accompanying illustration. All parts are indicated and while the design shown is not the only possible arrangement of parts, it is not likely that the reader will be called upon to repair or operate a four-cycle engine that will differ materially from that shown in the design.

The symptom denoting faulty action that is most easily recognized is loss of power. This condition will be apparent because frequent use of the lowest speed ratios of the gear-set will be necessary and the speed, carrying capacity and hill-climbing ability of the automobile will be reduced in proportion as the engine loses power. The first thing to test in such a condition is the amount of compression in the cylinders prior to ignition of the charge. This is done by rocking the fly wheel or starting crank as the piston nears its top center, to feel if there is a definite resistance or cushion to retard the movement of the piston when it nears the closed end of the cylinder. If the piston moves freely and encounters but little resistance it is apparent that there is some opportunity for the compressed gases to escape. These may work by the piston or leak through various openings in the cylinder head. If the cylinder head is of the detachable type, a defective packing between that member and the cylinder will permit the compressed gas to escape.

Sometimes the loss of power is accompanied by overheating and in event of the engine running hot and the fault not being attributed to the cooling, lubrication, or carburetion system, it is evident that the defect must exist in the engine itself. Many of the conditions that result in loss of power also produce overheating.

There are a number of points where the gas may escape from the top of the cylinder beside a leaky cylinder head packing. The compression relief cock may leak where it is screwed into the cylinder though this will never be serious enough to produce a marked diminution in engine power. It is only when other opportunities for leakage are present that this component need be examined. The commonest cause of faulty compression is defective valve action. The valve head may be warped, scored or pitted, carbonized or covered with scale. The valve seat is subject to the same trouble as the valve head with the additional possibility of foreign matter becoming wedged between the seat and the valve head. A crack or blow hole sometimes is found in the combustion chamber, though this defect is a rare one. Carbon deposits, sharp edges or corners in combustion chamber will produce preignition and overheating. Preignition results in loss of power because the gas in the interior of the cylinder is exploded before the piston reaches the proper explosion point. The valve stem may be carbonized or bent, which will cause it to stick open, or it may be binding in its guide, which will also prevent it from seating properly. If the valve stem guide is carbonized it will cause the valve to stick. Where the valves are carried in removable cages there is often an opportunity for escape of gas due to imperfect retention of the valve cage.

If the valves are functioning properly and the valve heads do not seem unduly scored or pitted the compression leak may be looked for around the piston rings. These packing members may have lost their elasticity and may have worn loose in the grooves. The rings may be stuck, due to gummed oil or carbon deposits which will result in their binding in the grooves. If the surfaces are scored or otherwise worn, or if the slots in the rings are in line the gas may leak by. Piston rings sometimes break, this also permitting loss of gas. The cylinder wall may have become scored owing to defective lubrication or the piston may be too tight a fit in the cylinder, which results in overheating and loss of power because of excessive friction. After the engine has been used for a time the piston will undoubtedly be found small or worn out of

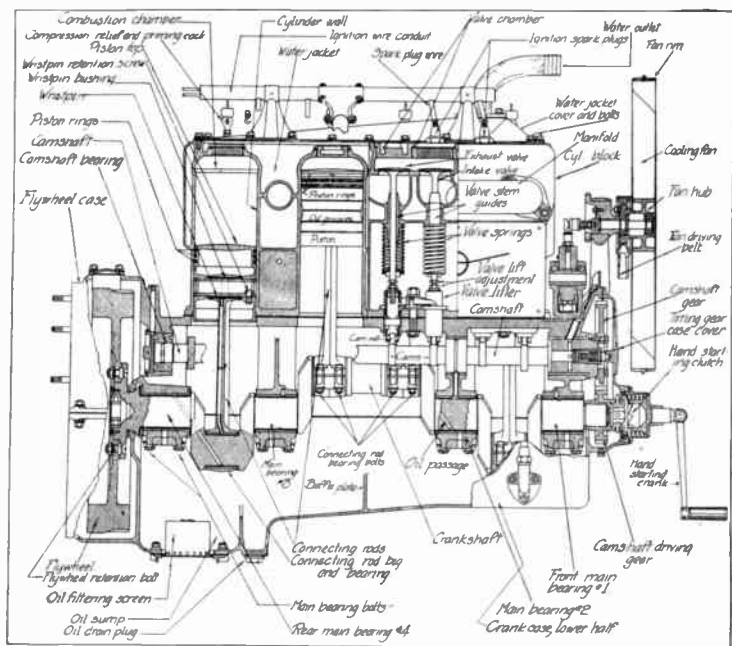

Cross section of typical four-cylinder engine.

round instead of being too tight a fit. Cylinder walls are sometimes scored by a wrist pin coming loose in the piston bosses and working out against the cylinder walls. Any depreciation of cam shaft bearings will alter the valve timing as will a sprung cam shaft or worm cam contours. If the bearings are adjusted too tightly or if lubrication is defective, loss of power and overheating will certainly ensue. Depreciation at various points in the valve-operating mechanism which will reduce the lift of the valves will also produce loss of power.

Lost power frequently results from misfiring or irregular operation which may be due to mechanical depreciation in the engine itself or to faulty action of some of the auxiliary groups. Considering the various points in the motor mechanism that would result in irregularity of power delivery, we must add to the troubles already enumerated, poor valve timing and depreciation or in the

valve operating systems. If the inlet valve closes too late or opens too early, this will result in back-firing through the vaporizer. If the valves do not seat properly, ignition will not be positive, and even if the gas is exploded it will not have full power. The valve spring may have weakened or may be broken. This will prevent the valve from closing properly and will result in irregular valve action. Among the points to be looked at in the valve-operating system are the small pins on which the cam rollers revolve and the various bearing points where the cam riders are supported and where the valve-operating tappet rods join the cam rider. The pins supporting the inlet valve-operating rocker arms sometimes wear loose on overhead valve engines. This lost motion, in combination with that in other parts of the valve system will result in the valves not opening as wide as they should. In the case of the inlet valve a full charge of fresh gas will not be inspired into the cylinder, whereas if the exhaust valve does not open fully a portion of the burnt gas may be retained in the cylinder, thus diluting the next fresh charge and preventing prompt ignition.

GRINDING CYLINDERS IN THE LATHE

AS a rule, the average automobile repairman cannot invest in special machine tools such as cylinder grinders because he would not have work enough of that nature to do to justify the investment. A very efficient grinding attachment that can be used in connection with any engine lathe of sufficient capacity is now offered at a very moderate price. This enables any garage machinist to grind cylinder bores in a satisfactory manner. Boring cylinders is not always necessary; if the scratches in the bore are not too deep, they may be ground out without removing much of the cylinder metal. Grinding makes a smoother job and does not require as much "running in" as boring does.

The attachment consists of a supporting shaft attached to a base casting intended to be bolted to a lathe face plate. This spindle carries bearings on which a tube revolves, the tube being driven by an integral pulley and carrying the abrasive wheel at the end.

A graduated adjustment screw is provided to set the attachment off-center sufficiently to let the wheel follow the circle of the cylinder wall. The device is rotated by the lathe spindle at the required speed, the emery wheel running inside the cylinder as a planetary gear runs inside an internal gear. The wheel is

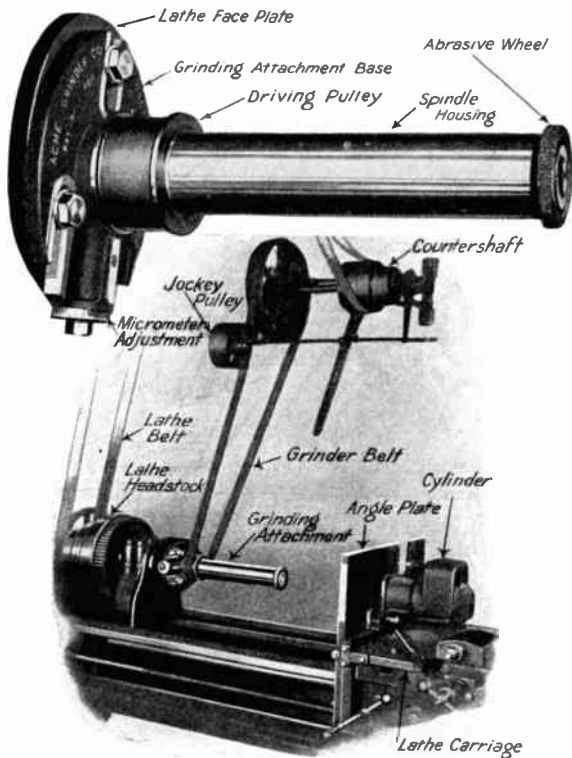

With this device, the cylinders may be ground in the lathe.

rotated at the proper peripheral speed by an independent counter shaft that drives only the grinding attachment. The grinder drive belt is kept tight by an idler or jockey pulley so that the drive is positive regardless of the change in position of the attachment as it revolves. The cylinder to be ground is bolted or clamped to an angle plate attached to the tool post carriage and the cylinder may be fed toward the lathe head by the lead screw so the cut will extend the full length of the bore. A micrometer adjustment regulates the amount of stock removed by the wheel. As the tube which carries the abrasive wheel is hollow for the greater part of

its length, this space may be filled with lubricating oil to insure adequate lubricity of the ball bearings on which the tube revolves.

ICE CHEST FOR CAMP OR SUMMER RESORT

BY J. J. TERRY

AN excellent storage chest for keeping ice in camp, or at a summer resort, may be easily and cheaply made by using two old packing boxes. Those made of boards about an inch thick, are best. Strong dry-goods boxes will answer. They may be strengthened by nailing pieces of 2 x 4s in their corners. The 2 x 4 corner pieces may project through the bottom of the larger box for about six in., to form legs for the box to stand on. The smaller box should be small enough to fit inside the larger one and leave a vacant space of four inches or more between each of its sides and the sides of the outer box. A similar space should also be left between the bottoms of the two boxes. The top edge of the inside box should be about an inch below the level of the top edge of the larger one. Strips of 2 x 4, or other lumber, may be nailed in the bottom of the larger box for the smaller one to rest on. They may be built up sufficiently to bring the top of the smaller box up to the required height. The bottom of the inner box should also be nailed to these strips to keep it in place. A hole about an inch in diameter should be bored through the bottom of the two boxes, and a piece of lead pipe or gas pipe fitted into them for a drain pipe. Before the inner box is nailed to the cross pieces in the bottom of the larger one, the space should be packed full of well-dried sawdust, which should be well pounded down to make it lie as solid as possible. After the inner box is nailed in place, the vacant space between it and the larger box, on all sides, should be filled with the dry sawdust. It should be well rammed down with an old broom handle to make it compact. After all the spaces have been filled, caps, made of strips of boards, may be fitted over them. Their inner edges may be nailed to the top edges of the inner box, and their outer edges may be butted up against the inside of the larger box, flush with its top edge, and nails driven through from the outside to hold them in position. A lid may be made from the covers of the two boxes, the cover of the smaller one being nailed to the under side of the larger one in such a position that it fits into its own box. It will have to be reduced a few inches in length and breadth to make it do this. Sheets of tough paper, or other insu-

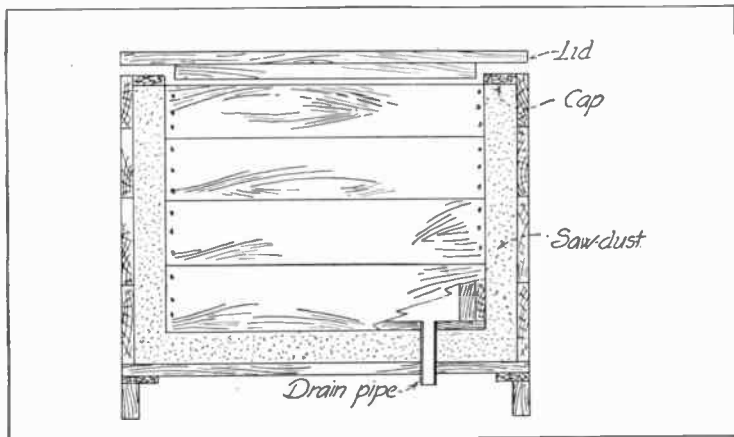

Sawdust is packed between the boxes.

lating material may be inserted between these covers before they are nailed together. All cracks in the boxes should be covered and made tight. The inside of the inner box should be lined with sheet zinc or thin galvanized sheet iron. If no metal lining is used, all cracks should be carefully stopped and two coats of some good wood filler applied. Then the box should be lined with heavy oil-cloth. It will be necessary, of course, to punch a hole through it, over the drain pipe, to let the water drain off. A box having a measurement, inside, of 24 x 24 x 34 will hold over 600 pounds of ice.

THE CARE OF RUGS

Valuable rugs should not be cleaned at home, but during the winter months some cleaning must be done. Try this way: Turn them right side down, and tap gently with a light, flexible stick or piece of rubber, on the wrong side, and then sweep them with a dampened broom. Do not use a vacuum cleaner on

a rare rug, as it loosens the nap when drawing out the dust. Rugs packed away for summer should have monthly inspection. Never fold a handsome rug when putting it away. Roll it in sheets of newspaper and camphor between, and then wrap it in newspapers and sew it tightly up in an enveloping sheet or non-wool covering.

Contributed by MARY F. SCOTT.

METALS USED BY THE EXPERIMENTAL ENGINEER

IT is desirable that every experimental engineer should know something of the characteristic properties of the various metals upon which he intends to exercise his craft. In an elementary article such as this pretends to be I need only consider the metals in common workshop use, and I shall therefore limit my remarks to the following: Cast iron, wrought iron, mild steel, cast steel, copper, tin, zinc, lead, gunmetal, and brass.

Cast Iron: This is obtained by smelting iron ore in a blast furnace. The molten metal collects at the bottom of the furnace and is then allowed to run into moulds formed in a bed of sand. The moulds are in the shape of short bars called "pigs," and the iron thus cast is known as pig-iron. Cast iron is not pure iron, but has a certain proportion of carbon—usually from 3 to 5 per cent.—mixed with it. For the making of iron castings the pig-iron is again melted in another furnace and the metal is poured into properly prepared moulds of the required shapes. Pig-iron is made in varying grades or qualities, and by suitably proportioning the mixture of these grades in the foundry melting furnace, castings of various degrees of hardness and closeness of grain may be produced at will. For some purposes, such as engine cylinders and liners, where the metal is to be subjected to considerable wear, a hard, close-grained mixture is used; but for many other purposes a softer mixture is equally suitable, and has the advantage of being more easily tooled. Owing to its very short grain cast iron is comparatively brittle and will not stretch or bend to any very great extent. It is only about one-third as strong under tension as it is under compression, and for this reason is not used for piston or connecting rods, bolts, and other machine details which have to stand considerable pulls. Its cheapness and the great facility with which it can be cast into almost any desired shape cause it to be the metal which is most used in the building of engines and machinery. It is also largely used for bridges, columns, railings, gates, stoves, and other architectural and domestic fittings. Where iron castings are required to be specially tough they are sometimes reheated for long periods in a furnace, surrounded by powdered red hematite, or oxide of iron. The iron thus treated is known as malleable cast iron.

Wrought Iron: This is practically pure iron, containing only a very small portion of carbon. It is produced by putting broken

pig-iron into a "puddling furnace," and burning out the carbon. The iron, when melted, is worked into soft, pasty, ball-shaped masses, by the aid of a long rod inserted by the man in charge of the furnace, and these balls are then placed under the steam hammer and hammered into slabs or blooms. These blooms are subsequently rolled out into bars or sheets as required. Wrought iron is more ductile than cast iron, and has a long fibrous grain. It bends readily when cold, and when hot may be forged into various shapes and may also be welded. It is used for making parts of engines and machinery, bolts, nuts, shafting, spindles, cranks, tie-rods, and other purposes where tensile strength is required. It is also largely used for steam boilers and for bridges, girders, tanks and other constructional work. Of late years, however, it has in many cases been replaced by mild steel.

Mild Steel: This is sometimes called Bessemer steel after the inventor of the process by which most of it is produced. Molten pig-iron is placed into a vessel known as a "converter," and subjected to a powerful blast. This causes all the carbon to be burned out and when this has taken place the blast is shut off, and a known quantity of carbon, in the form of spiegeleisen, is introduced. The metal is then run off into a large casting ladle, from which it is afterwards poured into ingot moulds. The steel ingots thus formed are then taken to the rolling mills where they are rolled out into bars or sheets as required. The proportion of carbon contained by mild steel varies from about 15 to 4 per cent. Mild steel is harder and tougher than wrought iron. Its uses correspond to those mentioned for wrought iron.

Cast Steel: This differs from mild steel in being much harder and more brittle. It has another distinguishing characteristic, in its capability of being hardened and tempered. It contains a high percentage of carbon, ranging from .5 to about 1.6 per cent. It is made by heating bars of wrought iron in contact with layers of charcoal until a sufficient quantity of carbon has been absorbed by the iron. The bars so treated are subsequently broken up and melted in a crucible, the molten metal being then cast into ingots, which are afterwards hammered into bars. One of the chief uses of cast steel is the manufacture of tools of every description, its adaptability to tempering being of the greatest value in this respect. The use of steel for castings for parts of machinery requiring great strength is extending very rapidly.

Copper: This is a metal of a red color, which is, doubtless,

very familiar to the reader. It is extremely ductile and can be readily hammered, drawn, or bent into various shapes while cold without injury. It is not so strong as wrought iron or steel, and is softer. It is rather higher in price. When copper is hammered or drawn it becomes hard and must then be annealed. This is done by heating it and then quenching it in water. It is very largely used for locomotive fire-boxes, for pipes in which there are difficult bends, and sometimes for bolts and other machine details which are likely to be subjected to corrosive action. It is an excellent conductor of both heat and electricity, and is used almost exclusively for electric cables and wires, and for certain parts of electrical machinery. Copper is also very largely used for model steam boilers.

Tin: This is a white, soft metal, which melts at a low temperature. It is not much used in its pure state but is frequently used in combination with other metals to form alloys. For instance, it occurs in bronze or gunmetal, pewter, and white metal for bearings. "Tin-plate" is really sheet-iron coated with tin.

Zinc: This is a greyish-white metal, usually sold in the form of sheets. It is easily bent into various shapes and does not rust. It is not much used by engineers, except for making of small trays, tanks, and similar utensils, and for electric batteries of certain types. Its most general use is in connection with buildings, where it is to be found in gutters, pipes, sprouts, etc.

Lead: This is also a well-known metal bluish-gray in color, and comparatively heavy. It melts at a very low temperature, and can be readily cast into almost any desired shape. It is too soft, however, to be of much value in machine construction. It can be easily hammered or bent when cold and, like zinc, is used more by the builder than by the engineer.

Gunmetal: This is a deep yellow metal, and is an alloy of tin and copper, the proportions of the two constituents varying according to the required hardness of the mixture. Soft gunmetal contains about 8 per cent. of tin and 80 per cent. of copper. Sometimes a little zinc is added, but this is done mainly to cause the mixture to run more easily when casting. Gunmetal is largely used for bearings, steam fittings for boilers and other details of engines and machinery.

Brass: This is also a yellow metal, but is lighter in color than gunmetal. It is an alloy of copper and zinc, in the proportion of about two of copper to one of zinc. It is cheaper than gunmetal

and is softer. It is used for much the same purposes, but is distinctly inferior for parts which are subjected to bad wear. It is easily worked and is sold in sheets, wire, and rods, as well as in the form of castings. Sheet brass and brass wire may be readily bent into various shapes, but cast brass is more brittle in character. Brass and gunmetal are much used for small castings for model and instrument making.

FOLDING DRAWING BOARD HOLDER

BY T. H. LINTHICUM

TO have a drafting outfit in the workshop, where space and light are usually very limited, brings one face to face with two difficulties: One is to locate the drawing board when in use, in a position to obtain the proper light, and the other is to get the board holder out of the way when not in use. In an effort to easily and cheaply overcome these difficulties, I fixed up the rough though efficient arrangement shown.

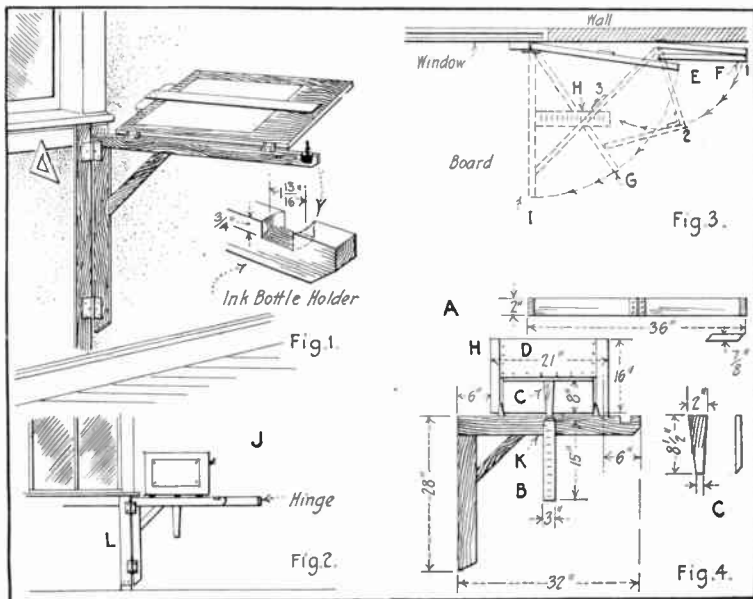

The position of the board affords lots of light from the right direction.

The drawing board *H* is hinged to a bracket *K*, Fig. 4. The bracket is hinged to the side rail *L*, Fig. 2—under the window sill about 6 in. from the end. When the board is in use the bracket is held at right angles to the wall by a folding arm which is broken and hinged in two equal lengths—see detail *A*, Fig. 4. This arm also forms a rest for the adjusting base *B*, Fig. 4, which has one end hinged to the bracket. The adjusting strut *C*, Fig. 4, is hinged to a strip on the back of the board. Above the strut a pocket *D* is made of heavy cardboard for the drawing instruments. On the upper edge, near the end of the bracket, a 1 13/16-in. hole is made to hold the ink bottle—see detail Fig. 1.

The plan view, Fig. 3, shows how the arrangement works. *E* shows position of the bracket when folded against the wall, *F* the folding arm. Now when the board is needed, the bracket is swung out to position *G*; the adjusting base *B* raised; the strut on back of board set in a notch and then the bracket is swung into position *I*, and the adjusting attachment let down upon the arm. When not in use, the board is fastened back against the wall by the hook *J*, Fig. 2.

The following materials are required for the holder:

- One 1 ¼ in. x 2 in. x 29 in. side rail.
- One 1 ¼ in. x 2 in. x 28 in. bracket upright.
- One 1 ¼ in. x 2 in. x 32 in. bracket top rail.
- One 1 ¼ in. x 2 in. x 18 in. bracket support.
- Two 7/8 in. x 2 in. x 18 in. folding brace arms.
- One 7/8 in. x 3 in. x 15 in. adjusting strut base.
- One 7/8 in. x 2 in. x 8 ½ in. adjusting strut.
- One pair 2 in. steel butt hinges for bracket.
- Three 2 in. butt hinges for brace arm.
- One 2 in. steel butt hinge for adjusting strut.
- One 2 in. steel butt hinge for adjusting base.
- One pair 3 in. "T" hinges for drawing board.

Frame up the bracket with mortise and tenon joints and hinge it to the side rail; then hinge one end of the arm to the top rail of bracket 6 in. from end, sawing the bracket at right angles to the wall, and hinge the other end of the arm to the wall. Prepare the drawing board and attach it to the bracket with the strap part of the hinges on the board cleats, and the butts on the top edge of rail. Then hinge the adjusting base to the rail so that the strut engages the notches.

A MERCURY INTERRUPTER FOR LARGE COILS

BY J. W. BACON, E.E.

THE following is a description of a mercury interrupter, built on the turbine principle, which is suitable for use with induction coils of one kilowatt capacity, or less. The interrupter will operate satisfactorily at a speed of 600 revolutions per minute, at which speed it makes and breaks the circuit 600 times per minute. For higher frequencies it is only necessary to drive the interrupter at a higher speed. The limit to frequency is determined by the time constant of the induction coil with which it is used, and the simplest method of obtaining the proper speed is by trial with the given coil. The advantages of this interrupter over one of the mechanical break type are: Quickness of break, which increases the size of spark for the given coil; absolute quietness, which is of especial importance in x-ray work; reliability, due to the fact that there are no contact points to burn unevenly or to stick, as is the case with mechanical breaks. The materials used in construction are cheap and easy to acquire.

The following description refers to Fig. 1, which is a vertical section of Fig. 2, taken through the center.

The base *A* is of soft wood, $1\frac{1}{2}$ in. thick, turned to a 9-in. diameter at the bottom and $6\frac{1}{2}$ -in. diameter at the top. A circular hole, just large enough to take a 5-in. pipe (about $5\frac{1}{4}$ in.), is then countersunk to a depth of $\frac{1}{4}$ in. in the top face. This hole should be centered.

Obtain a piece of 5-in. pipe 4 in. long, threaded on one end (a 4-in. nipple will do) and a 5-in. pipe cap. Screw this nipple as far as possible into the cap *D*, mount in a lathe, and face off outside end of nipple parallel to outside face of cap. The total height from outside end of nipple to outside face of cap should now be $5\frac{1}{4}$ in. Find and mark center of outside face of cap, and draw with this center three circles of 3-in., 2-in. and $1\frac{1}{2}$ -in. radius, respectively. Divide the 3-in. radius circle into six equal parts spacing the dividing points opposite the outside lugs on the cap, which are made for a wrench grip. (See Fig. 2.) At these points drill $\frac{1}{4}$ -in. holes to take the bolts *K*. Take two diametrically opposite points on 2-in. radius circle and drill and tap holes at these points to take two short pieces of $\frac{1}{8}$ -in. gas pipe *O*. One of these gas pipes is plugged at its outer end with a metal plug *P*, which has a small hole (about $\frac{1}{16}$ in.) drilled through it, longitudinally. *P* had best be threaded

into *O*. On the $1\frac{1}{2}$ -in. circle choose two points $2\frac{1}{4}$ in. apart so that a line through these points will be parallel to a line through the centers of the two holes made for *O*. Drill and tap a hole at one of these points for a $\frac{1}{4}$ -in. threaded binding post *M*. The binding posts *M* and *N* (to be mentioned later) are made from $\frac{1}{4}$ -in. iron or steel stock, and supplied with necessary $\frac{1}{4}$ -in. washers and nuts. Either a wing nut or a knurled head nut can be used for the movable part. At the other point a $\frac{1}{2}$ -in. hole should be drilled. Now place cap and nipple in countersunk recess in base *A* and mark and drill $\frac{1}{4}$ -in. holes in base for bolts *K*. The lower ends of these holes should be countersunk 1-in. diameter for about $\frac{1}{4}$ -in. depth, to take nut and washer of bolts *K*, as shown in Fig. 1. The bolts *K* are made from $\frac{1}{4}$ -in. iron stock and threaded on each end. Drill and ream to $\frac{5}{8}$ in. a hole at the center point of cap *D* to admit shaft *G* of revolving part.

The shaft *G* is of $\frac{5}{8}$ -in. cold-rolled steel 7 in. long, and is turned to a point at lower end, on a 60-degree bevel. Obtain a piece of close-grained hard wood 2 in. square, and $2\frac{3}{4}$ in. long, with the grain running lengthwise. Center one end and drill a $\frac{5}{8}$ -in. longitudinal hole through it. Slide this block of wood on shaft, and pin it to same by means of a small wire nail *O*, being sure to have lower end near point of shaft. Place shaft in a lathe and turn down this block of wood to shape *C*. The top diameter is $1\frac{1}{2}$ in. and the bottom diameter, before beveling, is $\frac{5}{8}$ in. The lower end is then beveled at a 45-degree angle. Drill and tap radial hole $2\frac{3}{4}$ in., from point of shaft, for *Q*. This is a piece of $\frac{1}{8}$ -in. steel stock $\frac{3}{8}$ in. long, threaded, and having a longitudinal $\frac{1}{8}$ -in. hole drilled through it with a $\frac{1}{8}$ -in. hole drilled in its side, $\frac{1}{8}$ in. from the end, to meet said longitudinal hole. A $\frac{1}{4}$ -in. hole is now drilled in *C*, starting at the bottom adjacent to shaft, and intersecting hole already drilled and tapped for *Q*. This hole must be parallel to face of *C*, or in other words, must be in the same plane as the axis of the shaft *G*. This is the correct design, since centrifugal force alone is relied on to shoot stream of mercury out of *Q*. The latter is now screwed into *C* until the hole in its side comes opposite the $\frac{1}{4}$ -in. hole in *C*, and in this position the outer end of *Q* should be about $1\frac{1}{8}$ in. from the center of shaft *G*. A collar *F*, with set screw, is next made for shaft *G*, out of $\frac{3}{4}$ -in. steel stock $1\frac{1}{4}$ in. long. This large size is used in order to counteract the buoyant force of the mercury in the well, on *C*, and thus reduce friction between *F* and *D*.

A piece of $\frac{1}{4}$ -in. iron or steel plate *E*, 2 in. by $\frac{3}{4}$ in., has a 60-degree conical hole drilled in its center, to be used to seat the lower end of shaft *G*. *E* also has two holes drilled into it for screws to fasten it to base *A*. The piece *E* is centered for fastening to base *A* by passing shaft *G* through its bearing in *D*, and placing same on base *A*. If *E* has already been placed near the center of *A* it can now easily be centered, by moving *G* up and down until it seats squarely. *E* is now screwed to base *A*, after first removing *G* and *D*. The collar *F* should now be adjusted, by trial, for free running of shaft *G*.

The contact piece *H* is cut from $\frac{1}{8}$ -in. sheet iron in the form of

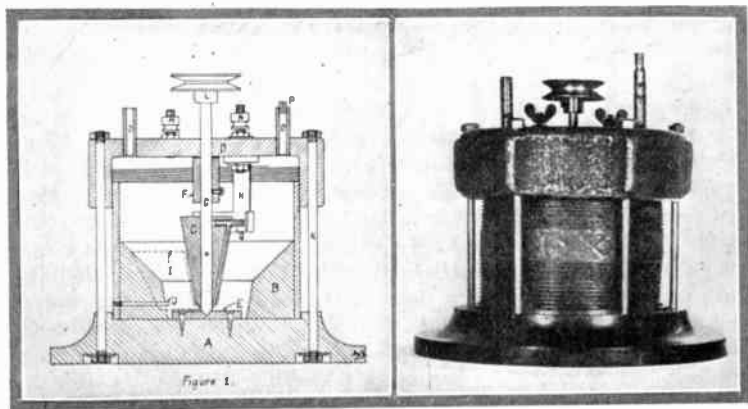

The mercury interrupter in section and photo of the completed device.

a letter "T." The cross part should be $3\frac{1}{2}$ in. long and $\frac{3}{4}$ in. wide, and the stem part $2\frac{1}{8}$ in. long and 1 in. wide. This makes the total height of the "T" $2\frac{5}{8}$ in. and the total width $3\frac{1}{2}$ in. Hold this "T" vertically, with the cross down, and bend the cross until its lower edge lies along a horizontal circle of $1\frac{3}{8}$ -in. radius. It is with this cross part of *H* that the stream of mercury from *Q* makes contact, and it is bent in an arc in order to be at a constant distance from the end of *Q*, as the shaft *G* revolves. The stem part of the "T" is now bent at a right angle along a line 2 in. from the farther edge of the cross part, and in the same direction as the ends of the cross part, curve. The bent end of the stem is now drilled and tapped $\frac{1}{4}$ in. at such a point that, when *H* is mounted

on binding post *N*, the inside face of the cross part of *H* will be just $\frac{1}{4}$ in. from the outer end of *Q*. The binding post *N* is electrically insulated from cap *D* by means of a fibre bushing, having a shoulder 1 in. outside diameter and $\frac{1}{4}$ in. thick, on one end. The body of this bushing is of $\frac{1}{2}$ in. outside diameter to fit hole in *D* and of sufficient length to pass clear through the cap *D*. This bushing should be drilled and tapped $\frac{1}{4}$ in. to fit binding post *N*. *H* and *N* are now assembled as shown in Fig. 1, and fastened to cap *D*, with the shoulder of the fibre bushing on the bottom next to *H*, and a flat fibre washer on the top of *D*, under the fastening nut *Q*, in revolving should now come opposite or slightly above the center of the cross part of *H*. Care must be taken in making the fibre bushing, as the mercury has a tendency, in splashing, to short circuit *N* and the cap *D*. The above dimensions give ample insurance against this.

In order to reduce the amount of mercury for the operation of the interrupter, a block of wood *B* is used to diminish the size of the mercury well. *B* is a block of wood, hard or soft, $2\frac{1}{4}$ in. thick, turned in a lathe to such an outside diameter (about 5 in.) that it can just be driven into the lower end of the 5-in. pipe nipple. The inside diameter is $2\frac{1}{4}$ in. at the bottom, $2\frac{5}{8}$ in. at the center and $4\frac{7}{8}$ in. at the top. After driving block *B* into the pipe nipple until flush with bottom of same, a piece of $\frac{1}{8}$ -in. iron stock *J* is threaded, and screwed through the block *B* into a threaded hole previously made for it in the nipple. *J* is used to insure good contact between binding post *M* and the mercury in the well. In order to keep the mercury in the well from revolving with *C* a baffle plate *I*, made of sheet iron, is wedged into a saw cut in block *B*. This plate *I* does not come in the section shown in Fig. 1 and for that reason is represented dotted. The baffle may be inserted at any point on inside circumference of block *B*.

The interrupter is now complete and should be assembled and the bolts *K* drawn tight. The mercury may now be poured in through pipe *O*. For the dimensions given $4\frac{1}{2}$ lbs. of mercury should be used. All metal parts of the interrupter which come into contact with the mercury must be made of iron or steel, as the mercury will alloy with and dissolve any other metal.

In the illustrations shown, a pulley *L* is mounted on the shaft *G* to permit belt drive. A direct drive by electric motor or otherwise is more satisfactory, and for this use the pulley *L* is necessary. A good flexible coupling for the interrupter can be made of a short

length of thick-walled rubber tubing. With a coupling of this type, the motor need not be run with its shaft vertical, since the tubing will allow a right angle bend. In operating, illuminating or other gas is allowed to pass through the interrupter, entering at *O* and being ignited at *P*. This supply of gas is essential, as it prevents the burning or oxidizing of the mercury and contact piece *H*. If trouble is had in maintaining an even flame at *P*, the pipe *O* into which *P* is screwed may be stuffed with cotton, which should steady the flame.

SOME WORKSHOP TIPS FOR HOME MECHANICS

TIDINESS in the workshop goes a long way toward producing good work; and what is more, if things are always kept in one definite place so that everything, both tools and materials, can be found *easily*, just when they are wanted, many a little job is done at once, which would otherwise be put off until "to-morrow" and, as the domestic authorities will tell you, "to-morrow" will never arrive, says a writer in *Junior Mechanics*.

TO SECURE RECOGNITION

Now, many a budding mechanic has had his career cut short through nobody's fault but his own. If he is unfortunate enough to be the only member of the household with a natural leaning toward things mechanical—or electrical, for that matter—he should be prepared to render his services to the above-mentioned authorities the moment the first opportunity arrives.

A GAS LEAK

It may be a smell of gas is reported. If after a good look around with a few matches or a taper, the leaky joint is revealed, don't put the job off because there is no red or white lead in the house, but apply a little soap as you would putty when on a woodwork job. This will prove quite effective for a length of time, and is better than paint. The latter is really not much use unless it is applied to the screw thread of the piping or fitting before it is screwed up. It is too thin to use as "putty" for, by the time it has dried, the gas will certainly have forced its way out again, and we are but little better off than we were at the start.

It should be understood, however, that the foregoing hints only refer to very minor leakages such as may occur on gas brackets, burners, or fittings. If there is the slightest possibility of the es-

cape being a big one, no light of any description should be used to search for the leak, and under no circumstances whatever should a naked light be used in such a quest under the floor boards in a room or passage. In the case of a large escape due to accidental breakage the gas supply should be shut off at the main, *i. e.*, at the meter, and the plumber summoned to attend to the matter at once. Remember, it is possible for a large amount of gas to accumulate in a room without its being detected at once, because illuminating gas, being lighter than air, rises, and may therefore be above the level of one's nose when the room is entered. On more than one occasion has a nasty accident come about under such circumstances. If the gas even has to be shut off suddenly at the main, make a point of going the rounds afterwards to see that every burner in the place has also been turned off, *before the supply is resumed.*

STARTING OBSTINATE SCREWS

Many methods have been given from time to time as to the best way to "start" screws, and, of them all, the writer has come to the conclusion that the use of a good solid punch with a flat head of the same size as the screw's, and a good heavy hammer, is the best means to adopt. Suppose, for instance, we have to take an ordinary house door off its hinges so as to get at its bottom edge to "ease" it (*i. e.*, plane off a bit), in order that it can clear the carpet or door mat, and thus swing easily: Take the punch in one hand, and place it fair and square against the head of the screw, and then give it a good blow with the hammer. This is more easily said than done, if one is not at home with a hammer; for there is an instinctive fear of one's own fingers suffering! Therefore, in such circumstances, instead of an ordinary punch, procure, say an old $\frac{1}{4}$ -in. bolt, and place it so that while you hold its threaded end, the head of the bolt rests upon the screw's head, as shown in the sketch above. Then your fingers being well out of the way, a good blow may safely be delivered, and most probably will be, simply because knowing that no harm will occur to your fingers, there will be no hesitation in striking, and a true blow will result. The shock of such a blow has the effect of bending down the rust joint which is causing the screw to adhere so firmly to the wood. Once this joint is broken, or "started," as the mechanic would say, the rest becomes comparatively easy. It must be remembered, however, that a heavy hammer is necessary—light blows are no use and only tend to disfigure the screw head.

BAD CASES

There are exceptionally bad cases, however; and the writer remembers one case quite well, which resulted in his long screwdriver becoming twisted a whole quarter of a turn before the obstinate screw could be persuaded to shift. The screwdriver lies on his bench to this day, and could tell of many a strenuous struggle were it able to speak. Door-hinges are, however, not such tough jobs as they appear, for to begin with, one is able to arrange matters with box or step ladder so that one's back is supported by the opposite door-post (or jamb, as it is termed), and thus a most effective thrust can be put upon the screwdriver to prevent it slipping out of the screw slot. Assuming that the available thrust is great enough, but the turning effort is not sufficient to budge the screw, then put an ordinary G-clamp on the flat part of the screw-

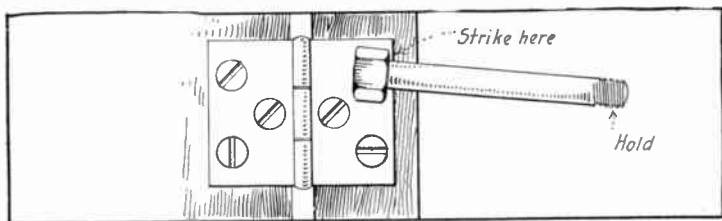

The obstinate screw may be started by hitting the head of the bolt.

driver, and then get some one else to give you a hand while you put on the pressure, and keep the blade in the slot. In this way it is possible to bring such forces to bear on the screw, that a big screwdriver of $\frac{3}{8}$ -in. diameter will be twisted—it was, in fact, under such circumstances as these that the writer's screwdriver above referred to attained its permanent deformity.

INEXPENSIVE TIDINESS

Coming back to tidiness. Some years ago, when the writer had a fit of wood-carving, he bought a couple of nests of drawers and arranged his tools in regular order, a strip of $\frac{1}{2}$ -in. wood at front and back of each drawer being cut out to receive ten handles and blades, respectively, of the five dozen odd carving tools. Two drawers, however, still remaining unused, a fair member of the household, who was never more happy than when tittivating-up the workshop, proceeded one night to sort and classify the contents of the old screw box, which contained many more "classes" than com-

partments. It was found that at least 20 different compartments would be essential; and so the "assistant" commandeered some picture backing and proceeded to business. Now, fitting small divisions of this size is no easy matter, and yet neither is a simple way out of the difficulty easy to find. Pondering the matter for a while, an idea (an unusually bright one for the writer he was told) occurred: The glue pot was on; and quite a number of match-boxes were floating around in the well of the bench; so it was suggested that instead of attempting cabinet-maker's work, the "assistant" should lay a mosaic work made up of the insides of as many match-boxes as could be found. No sooner said than done. It was found that the drawer would take eight boxes in a row, and exactly four rows, thus giving 32 compartments. These have all been in use now for some time, and the arrangement, though simple, is still and ever will be an inexpressibly convenient one. The writer never buys screws except by the gross, and although one compartment will not hold more than a dozen or so of anything near 1 in. size, it is an easy matter to keep the stock in their packets as bought, and transfer to the small compartments ever so often. Therefore, readers, don't despise the humble match-box.

MAKING A COMBINED CAMPING TENT, HAMMOCK AND TABLE

By T. S. ZERBE

A COMBINED tent, hammock and table, which may be packed to form a bundle 6 inches in diameter and 48 inches long, the whole weighing less than 16 pounds, is described in this article. Every part of the device can be made by any boy possessing the ordinary ingenuity, at a ridiculously low cost. The tent material is the only thing that requires the expenditure of money, to any great extent, and this can be gaged by the size of the pocket book, as canvas is cheap and obtainable everywhere. A very good material for this use will cost less than six dollars, and the whole outfit should not exceed an expenditure of eight dollars.

The tent cloth is made in one piece, the dimensions being 14 by 16 ft. This has a slit 6 feet long running in from each end, as at *AA*, midway between the side margins, the flaps *B* thus formed being designed for the ends of the tent. Five loops *C* should be sewn on the side margins along a 7-foot measurement, as indicated in the drawing, so as to provide for holding

down the ends of the tent by means of stakes driven into the earth through the loops.

The preparations to be considered first are the devices necessary to hold the tent cloth in place. For this purpose a wire should be selected, 18 feet long, preferably soft steel, either tinned

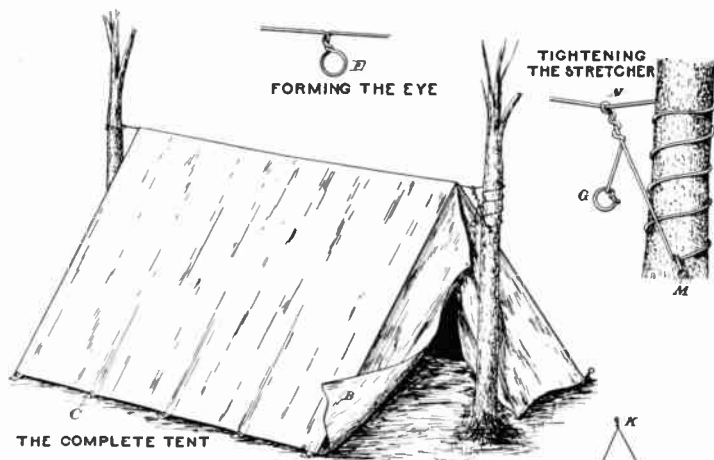

THE COMPLETE TENT
THE COMPLETE ROLL



END OF THE HAMMOCK

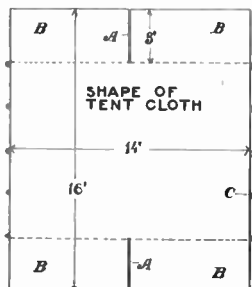
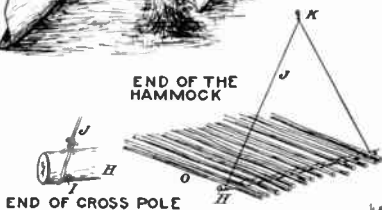

END OF CROSS POLE

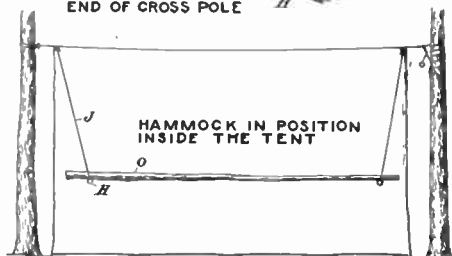

HAMMOCK IN POSITION INSIDE THE TENT



HOW THE STRETCHER IS MADE

The complete tent may be rolled up and carried under your arm.

or coppered, $\frac{1}{8}$ in. thick. This is prepared in the following manner: A strong hook, *D*, should be attained at one end. Three feet from the hook the wire is bent and a loop *E* formed, using in the making a $\frac{3}{4}$ -in. rod or a branch of hard wood about that diameter.

Seven feet distant another loop of like character should be twisted, at the extreme end, 6 ft. distant from the last loop *F*, a ring *G*, or a cross bar, should be twisted on, to serve as a means for handling the end of the wire and stretching it.

For the hammock and table two poles *H* are used, each $3\frac{1}{2}$ ft. long and 2 in. in diameter. Strong curtain poles are the most serviceable. At each end bore an $\frac{1}{8}$ -in. hole, into which is then driven a heavy wire *I*, so that the ends project a half inch. Two pieces of wire *J* are then cut, each 7 ft. long, and the ends attached by wrapping and twisting the projecting ends of the wires through the pole, this being used to prevent the wire hanger from slipping off. At the fold of the hanger is attached a hook *K*. The best material for the hanger *J* is stranded wire, such as is now generally used in aeroplanes.

In the final stage of the preparation two sheets of thin tar boards are selected, each 24 in. by 30 in. This can be rolled up and not get out of shape. In assembling, the tar boards are wrapped around the two poles *HH*, and bound by the hanger wires. The tent material is then folded up and rolled around the poles, so that it makes a package about 6 in. in diameter, and around this the long stretcher wires are wound, as shown at *L*.

In putting up the tent select two trees which are not less than 8 ft. apart. The hooked end of the stretcher wire is wrapped around the tree twice, at a height of 6 ft. from the ground, the hook being fixed to the stretcher, as shown. The other end of the wire is carried across and wrapped around the other tree, at a point $6\frac{1}{2}$ ft. above the ground. If the tree is a small one, the wire can be carried around the trunk four or five times spirally. A twenty-penny nail may then be driven into the tree, as at *M*, and after bending the wire around this nail the end is carried up, thrown over the stretcher, and, with the hand in the ring *G*, pulled down, so as to make the stretcher taut. A final turn of the wire around the return member serves to hold the stretcher firmly, and also permits a still further stretching operation, should it sag too much.

It is now ready to receive the hammock, the hooks *KK* being affixed to the loops *EF*, ready to receive the poles *O*, which are

laid from one hanger pole *H* to the other, and on which the moss beds and straw are distributed ready to receive the blankets.

Finally, the tent material is thrown over the stretcher and the ends brought down to the ground on opposite sides. Stakes *O*, either prepared of wire, or wood cut on the ground, then driven through the loops and into the ground, serve to hold the sides of the tent material taut.

The surplus material, represented by the flaps *B*, encloses the ends of the tent. Each morning, after the bedding is removed from the poles, the tar board is laid on to form a table for use during the daytime. As thus constructed the table, or the hammock, is nearly two feet from the ground, and there is ample room in the tent around the table for the use of the occupants.

HOW TO MAKE INSIDE WALLS SANITARY

BY F. H. SWEET

THE cause of insanitary walls is dirt, which comes from dust outside, and from the grime and soot of heating apparatus on the inside of the house, as well as from outside smoke sifting through doors and windows. In addition, the marring of the walls by furniture, the dropping on it of grease, or the splashing of water adds to the dirty and discordant effects, as well as the presence of bacilli, or germs, from unsuspected sources.

A great problem is how to keep a wall clean. Every house-keeper is willing to admit that the present condition is dirty, unsanitary and undesirable. The use of wall papers where grease and dirt is prevalent has been thoroughly unsatisfactory. Whether it is a cheap wall paper or an expensive one, it must be stuck on with paste. It is inclined to become loose at the lap or seam, making a lodging place to receive dirt and dust which is unsightly, and which mars the continuity of the wall surface.

If the paper is cheap the coloring is frequently an aniline dye which fades, or if it is a permanent coloring, it is sometimes secured with the use of arsenic, either condition being unsatisfactory and the latter dangerous.

The common custom of pasting one coat of wall paper over another does not secure cleanliness. It simply covers up dirt, leaving the old deposit on the paper in its original dirtiness.

The use of common clay kalsomine or mud washes is very

objectionable because they are made from a base frequently of glue, which is confessedly unclean and unwholesome.

The important thing, however, is how to make a wall clean. Where to begin, what to do, what to use. That is our problem. First of all, take off the old wall coating. If it is wall paper soak it off by generously brushing the paper over with warm water. This will soften up the paste, and as a rule make it an easy matter to pull the paper off the wall. Be sure, however, that the paper is thoroughly soaked, for if it isn't, a quick jerk may loosen the plaster from the lath. Particles of paper that remain on the wall can be scraped off with a putty knife. Then wash the bare wall thoroughly so as to remove every trace of paste.

If the wall has been kalsomined take a sponge and plenty of warm water, and go over the wall surface carefully; this will take off the kalsomine easily. Use the water as warm as possible, for the warmer it is the more quickly it dissolves the glue, which is the base of common kalsomine.

After all the wall is thoroughly cleansed and the old material removed, wipe it over with a dry cloth so that all particles of dust or other extraneous matter may be removed.

It is time now to choose a new material. In everything there is a best, and in wall coatings the best material is a natural cement which will adhere to the wall through its own adhesive power. It will not require, and will not contain, any glue or casein or any foreign matter to make it adhere to the wall. It always mixes best in clear cold water because it is a natural cement.

A natural wall cement means a sulphate of lime coating, and this is also a perfect germicide as well as being thoroughly anti-septic. No germ life can live after being coated over with a natural cement coating. The best wall coating which fills all of these requisites is a calcic sulphate—almost pure sulphate of lime.

Never permit any decorator to put a material on the wall that requires hot water in the mixture. Hot water as a solvent means glue, and glue on your wall is unwholesome as well as filthy, being made from the refuse animal life.

The tinted wall is the ideal wall because of its softness in color, the ease with which the tint is applied, its antiseptic qualities, and the ease also of recoating, provided the tinting material is correct. But the tinted wall must be tinted with a natural cement, otherwise it will be a failure. It will fade, it will crack, chip and peel. The color will stay on about long enough for the decorator to collect

his bill, but not much longer, and the result will be wholly disappointing.

The natural cement tint can be put on the wall at an expense of about eight cents a square yard, or to put it another way, a room 15 x 20 feet can be coated with two coats of natural cement at an expense for material of \$1.50, not including the labor. This varies in different localities, some men charging twenty-five cents an hour, other men thirty-five.

As soon as the wall is cleaned and the material selected the wall should be sized, for then there will be a certainty that no discoloration of the plaster or wall will show through the tint.

If the wall is a rough wall—what is commonly called sand-coated, a soap and water size will serve admirably to stop suction of the wall. This is made by dissolving one bar of laundry soap in an eight-quart bucket of water and brushing the solution on the wall. Before it is quite dry brush on the tint. If the plaster is smooth plaster, or what is commonly called putty-coat, use a hard-size made by thinning hard oil down with turpentine, adding japan drier. This will effectually prevent any lime spots or any color from coming through the tint. Another very good size which is somewhat cheaper is made from linseed oil, thinned down with benzine, with japan added. This is much less expensive than the former and frequently serves as well.

It is time now to tint the wall. Do not make the mistake of overlooking the directions on the package. They are put there to give the very best results. Use an ordinary 7-inch flat wall brush; fill it about half full and make a stroke of about two feet, never more, working the material thoroughly on to the wall and into the preceding lap of the brush. Go slow and work the material thoroughly into the wall; then the tint will be permanent and even.

The question at once arises, can such a wall be washed? It cannot if there is any color in the natural cement coating, unless the pigments which color the cement are covered with oil or varnish. It is the colors that do not bear washing, not the cement. It is easier and more advisable to recoat a wall than to wash it. Few people really wash a wall; they simply add dirt to dirt, for if they used water hot enough to take off the grease they would scald their hands; and if the water is not hot enough the grease stays on.

Very artistic effects can be secured by stenciling a wall. It makes a break in the plain surface, and very harmonious contrasts and dainty color schemes can be worked out by the use of stencils.

To use the stencil successfully, start at one corner of the room, press the stencil firmly against the wall, have the material that you are going to stencil with mixed up ready to use, dip the ends of your brush in this, and simply rub it across the face of the stencil, being careful not to get too much stuff on the brush so that it will run in back of the stencil and blur or blot. When you finish one section remove the stencil from the wall and carefully match it on the next.

An ordinary round paint brush is as good a stencil brush as any. Tie the bristles about half way down so that they will not spread, and in using just dip the tips of the bristles into the tinting material.

A REFRIGERATOR KINK

BY N. G. NEAR

HOUSEWIVES will find this method handy for cooling bottles of milk or other things quickly, and for *keeping them cold* and in continual contact with the ice.

Place a piece of sheet metal in the refrigerator so as to slant

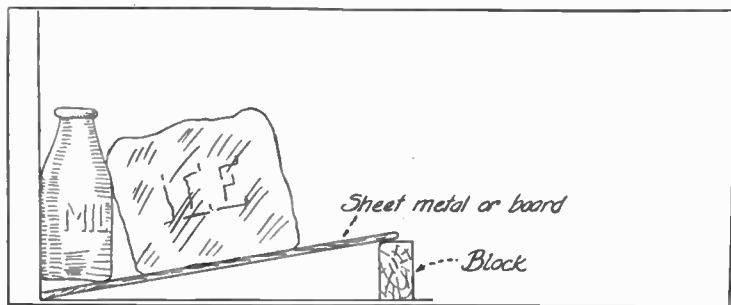

Gravity aids in keeping the milk cool.

as indicated. It is shown exaggerated in the cut for the purpose of illustration.

Put the bottle up against the wall of the refrigerator as shown and let the ice slide against it. Gravity will hold the ice in continual contact with the bottle.

This is better than placing the bottle on top of the ice because the bottle can't fall and break after the ice has slightly melted.

Pressure of the ice against the bottle can be increased by placing weights on top of the ice. Bottles cool much more quickly under high pressure than when placed only lightly against the ice.

TO HANG A SHELF ON A HARD-FINISHED WALL

By F. E. TUCK

IT is frequently desirable to hang a shelf on a hard-finished wall, but one hesitates to do so on account of the damage done to the plaster. The illustration shows how to suspend a shelf without marring the wall in the slightest. It is easily put up, can be adjusted at any height or taken down at a moment's notice.

On the under side of the shelf attach two ornamental brass



The shelf is suspended from the molding.

shelf brackets. At each corner of the upper surface screw in brass cup hooks and suspend the shelf from the picture molding by heavy gilt or brass chain. A single chain from the molding to within about 6 in. of the hooks is sufficient. At this point two branches are necessary, one running to each of the hooks. In order to hold the shelf level the branch fastened to the rear hook should be one or two links shorter than the other. The chain bears the weight of the shelf and contents, while the brackets steady the shelf.

Vinegar may be used in place of water when mixing plaster of paris, resulting in a paste which, when used, will not set nor harden as quickly.—A. E. BRUCE.

APPLICATION FOR MEMBERSHIP

The American Society of Experimental Engineers.
 Aeolian Building, New York, N. Y.

Gentlemen:

I hereby make application for the degree of Associate Membership in the American Society of Experimental Engineers in which, upon acceptance of my application, I am to share all of its rights and privileges.

I enclose (check, money order, draft) for Two Dollars (\$2.00), one-half of which sum is to enter or extend my subscription to EVERYDAY ENGINEERING MAGAZINE, for a period of one year, and the remaining half to pay my annual dues in the Society, for one year from date.

It is understood that, upon acceptance of my application, I am to be supplied with the regulation certificates of membership and the Official Publications of the Society during the tenure of my membership.

In making application for membership, I do hereby solemnly pledge myself to abide by the By-laws of the Society and to do my best in the advancement of practical scientific knowledge and the development of the characteristic of resourcefulness in my fellow men; furthermore, I do pledge myself never willfully to be guilty of an act unbecoming an American citizen. Failing in these pledges, by word or deed, I shall be deemed unworthy of membership in the American Society of Experimental Engineers, and shall thereby forfeit said Membership with all of its rights and privileges.

Signed

City or Town

Street Address

State

My age is Nationality
 If naturalized, say so.

My Education
 Grammar or High School, College, Correspondence, etc.

Am employed as
 If still at school, say so.

Am particularly interested in
 Branch of Science or Craftsmanship.

Why I want to join the A. S. E. E.

I suggest the name of Address

..... as a worthy member of the A. S. E. E.

WILL YOU JOIN THE American Society of Experimental Engineers

AND—Gain recognition for the Experimenter as a class?

Encourage resourcefulness and the ability to do things as American citizens?

Promote the study of Experimental Science with a definite object in view?

Assist in the Industrial and Scientific Preparedness of your Country?

Encourage practical Model Making?

Receive definite, authoritative, understandable information about the fascinating hobby, Experimental Engineering, in all its branches, including Electricity, Radio-Telegraphy, Chemistry and Electro-Chemistry, Mechanics, etc.?

Receive specific reports monthly giving data not found in available text-books, such as the winding to use on a magnet or solenoid to give a certain pull at a certain distance, and the hundred and one questions of this kind that beset every practical worker in this field?



PUT your name to the blank opposite if you know of the A. S. E. E. and its objects. If you do not, send for a copy of the March issue of this magazine in which the organization of the Society was given its first public announcement.

HOUSEHOLD ENGINEERING

Practical Mechanics
for Everyday Men

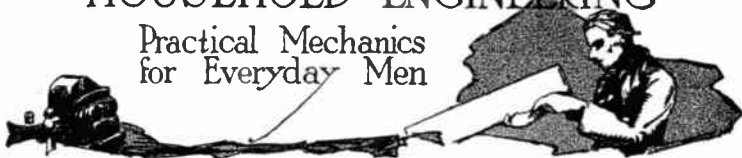

A DRAWING BOARD HOLDER

When no support for the drawing board is available, utilize the finger-pulls on the window sash in the manner shown. Lock the window to prevent its opening when pressure is put on the edge of the board.

This position will afford plenty of light and a convenient

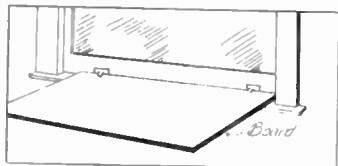

By locking the window, the board is held rigid.

working angle, not to be had when a flat top table is used.

Contributed by L. B. ROBBINS.

ARCHITECTS TACK HAMMER AND PULLER

In architectural offices any appliance to minimize labor is welcomed. The following thumb-tack hammer and puller was devised by an ingenious draughtsman for just such a purpose and has won a permanent place in his office.

An old screw-driver was bent

as shown and the blade slotted, the better to pry stubborn tacks. The handle was bored out and a hardened steel core driven in so about $\frac{1}{8}$ in. projected beyond the end of the handle. The steel was previously magnetized at a nearby electrical shop.



This makes a handy tool for the draughtsman.

Thus a tack can be picked up by means of the magnet; driven in the required position upon the drawing board and later removed; all by means of the same tool.

TO PURIFY ZINC

Melt the metal over a fire and then add a small quantity of ammonium chloride, (sal ammoniac) stirring continually with an old iron spoon.

Collect the impurities that come to the surface and you will have zinc pure enough for all technical uses.

You can use the same process for tin, lead or babbitt metal.

ELIMINATING THE NOISE OF A BELT-JOINT

A belt-joint made in a careless manner is very destructive to the bearings of the machine and the clicking noise made by the steel hooks passing over the iron pulleys is very annoying to the workmen. Both of these faults can be eliminated by the

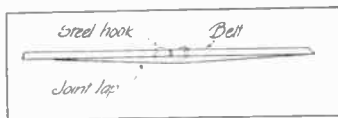

The joint lap is glued in place.

use of a "joint-lap." This is a piece of leather $\frac{1}{8}$ in. thick at the thickest part and about 6 in. long. Clean the surface of the belt around the joint and glue the lap in place. Then clamp the two to a board. Remember to place the patch against the board. When dry, the joint will pass over the pulley without the usual noise, the life of the belt joint will be doubled and the bearings of the machine will give better service.

Contributed by M. E. DUGGAN.

FASTENING AN ANGLE TO SHEATHING

The following method was employed to fasten an angle to a No. 26 gauge sheathing:

The steel being too thin for tapping, and the sheathing not accessible from the back, two $\frac{1}{4}$ in. holes were drilled $\frac{3}{4}$ in. apart. Then a short length of

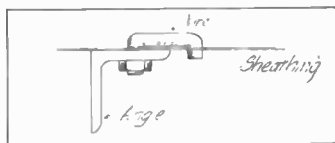

The sheathing was too thin.

No. 7 wire was threaded to take a 10/24 nut. The wire was bent into a U shape and passed through the holes as shown. Then the angle was fastened in place by tightening the nut.

Contributed by HARRY MAURTON.

RULING PEN CLEANER

A discarded tooth brush may be used by the draughtsman in place of the usual cloth pen-wiper. Merely cut or break the

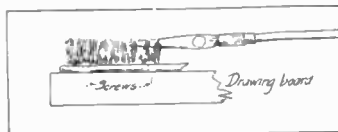

Screw the brush to your drawing-board handle off and screw the remaining portion to the drawing table. The pen may be cleaned in the manner shown.

Contributed by F. VASQUEZ SCHIAFFINO.

FIRE EXTINGUISHER

This will put out a blaze if used at once. Put three pounds of salt in a gallon of water, and to this add $1\frac{1}{2}$ pounds of sal ammoniac. This liquid should be bottled and when the fire is discovered, should be poured on it.

BOTTLE WATERING FOUNTAIN

An automatic watering fountain, especially attractive for the pen of little chicks in the spring may be made in the simple manner illustrated. The bottle is of the half-gallon or quart size, held against the

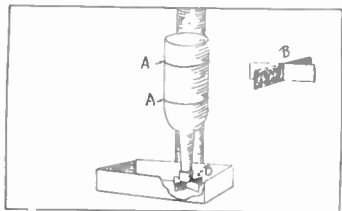

The pan is always supplied with water. The pan is always supplied with water. post by the wire loops *A*. Two small tin strips (*B*) support it over a shallow pan. This pan should be about an inch higher than the width of the strips.

Contributed by D. R. VAN HORN.

AN EXPERIMENT IN COHESION

The secret of cohesion between different substances is more or less a disputed fact. The following peculiar experiment is interesting and practical as well.

Rub a meerschaum pipe with a silver dollar, and if it is the genuine article the pipe will not be marked. However, if the pipe is an imitation of meerschaum a mark similar to that of a hard lead pencil will be left. This is a handy method of detecting pipes that are called

meerschaum but which really are nothing more than specially prepared clay.

Contributed by H. G. FRANK.

HOW TO OPEN SHOE POLISH TINS

The ordinary shoe polish tin may be opened with ease by placing it against the wall and rolling it back and forth as shown and applying a slight pressure. This method does not require the patience of the one given in the printed directions.

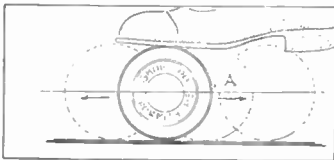

This will open the tin without trouble. To prevent scratching of the wall, place a board against it before rolling the tin.

Contributed by HENRY HOLTZER.

PROTECTION FOR POCKET

Because the frequent removal of his fountain pen wore the inside of his coat pocket badly,

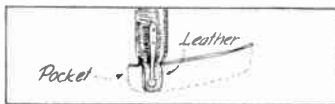

How the wear was prevented.

one man cut a small piece of leather and sewed it over the edge as shown. This holds the pen more securely and saves the wear.