

TRANSFORMERS—world's most perfect machines?

© elementary  
SEPTEMBER-OCTOBER 75¢  
Electronics

BASIC COURSE  
Understanding  
Television Receivers

**Blast That Team!!**

Build our  
Touchdown  
TwinHailer

- portable
- powerful
- only one IC

*plus*

- OpAmp Privafone
- CB 10-6 Skipverter
- Junk-Box Q-Tester
- 5-in-1 Tracer/Gainer



**DXer's Guide to the Kalahari**

# Now! Space Age Science for Everyone AMAZING KIT-A-MONTH CLUB

You Get ALL the following in nine monthly kits!



**No Experience Necessary**  
Everyone will enjoy the easy-to-use equipment and exciting, learn-by-doing courses. It's easy — it's fun!

**Developed By Top Scientists**  
The ABSClub program is a real science course developed with world famous Southwest Research Institute — a non-profit, publicly-owned organization, nationally recognized as the center of scientific research in the Southwest.

**Equipment Is Good Quality**  
These kits are not toys. They consist of standard components by Centralab, General Electric, Strobelite, Tachyon Precision Tube, Clinch-Jones, Amplicon, Lancaster Lens, General Instruments, Teim, RCA, Stackpole, Eastman Kodak and other reliable manufacturers.

**No Special Tools Required**  
All you need are a screwdriver and pliers. Also included: hardware, solder, wire, etc.

**Fun For The Whole Family**  
This program offers such a variety of activities that every member of the family finds a field of interest. In many homes, working with the kits is a family affair enjoyed by all.

**Invaluable For Students**  
Makes school science fascinating and easy. Gives students a real head start. The kits are a valuable source of ideas and equipment for school projects.

**Monthly Club Bulletin**  
The \$1 membership fee covers a year's subscription to the ABSClub Bulletin which carries news of interest to members, plus ideas submitted by members for additional projects with the kits.

**MEMBERS ARE ENTHUSIASTIC**  
Over 50,000 members have successfully used and enjoyed these kits. All the projects are proven and practical.

"Every kit is very complete in explanation, illustrations, materials, hardware and extras. This is what I like!"  
F. Betorich, Marshall, Pa.

"I have enjoyed every kit. I wish I could give them to all my students!"  
Allen T. Ayers, Physics Dept., James Town High School, Jamestown, New York.

"Hard-to-get equipment at a great price. Thanks to your kits I am enjoying new fields of science."  
J. Alwomg, White Springs, Illinois.

"I have immensely enjoyed every minute with the kits, and eagerly await the postman every month."  
Fred Carter, Sanford, Florida.

"The ABSClub kits are very practical, interesting and educational... and the projects always work."  
Larry Schurts, Eden, New York.

"A wealth of information presented in an easy-to-learn manner."  
Tom Webster, Vidor, Texas.

"It is incredible that we can obtain so much material for such a price. The manuals alone are of great value."  
Sister M. Marie, P.H.C., St. Augustine High School, Chicago, Illinois.

"I am an electronics student in the Air Force. We have not covered anything in school that your kits have not covered."  
John Q. Dill, Keesler Air Force Base, Biloxi, Miss.

"When I started your program I knew little about any of the topics that you presented. I now am repairing radios and photography is my main hobby."  
Bruce Russell, Denver, Colo.

**ELECTRICAL LAB**  
All the equipment for basic electrical experiments with Wheatstone Bridge (measures resistance), Rheostat and De-magnetizer, Thermocouple, Mystery Switch Box, Continuity Tester, Lenaxon Voltmeter, Schematic Code Tester, Electro-magnet, Relay, Magn. Lamp, Electro-magnet, Inductive Coil, Batteries, Ohm coils and Electrodes for Plating and Electrolysis. **FOR SAFETY!** a step-down transformer. Transformer provides required current.

**STROBE LIGHT**  
A Neon Lamp that flashes at intervals you can synchronize with the speed of rotating or vibrating objects in order to freeze their motion to permit close study and accurate checking frequencies and RPM. Flashes are timed by a variable frequency oscillator with a range of 20 to 600 cycles per second.

**PHOTOELECTRIC RELAY**  
Crystal Photocell, Servomotor, Relay, Large Condensing Lens in Cabinet Mount. Features automatic on-off or holding (cut-off) operation. Sensitivity Control. Plug-in Outlets for controlled circuit. Use for relays, counters, etc. Operates on 115V AC. A basic unit for many existing experiments.

**ANALOG COMPUTER**  
Electronic Computer multiplies, divides, calculates powers, sums, set up the problem on the scales of two potentiometers and find the answer on the scale of third potentiometer as indicated by a sensitive meter. Instruction Manual covers computer theory and practical use. Over 150 sample problems and answers demonstrate use with fractions, trigonometry, logarithms, physics formulas, ballistics, etc.

**LIGHT AND OPTICS LAB**  
Creating optical projects for the study of light. Includes: Millimeter Lens, Precision Lens, Prism, Polarizing Filter, Diffraction Grating, Mirror, Telescoping Tubing, Lens Mounts, Two Mirrors and Brackets. All the parts and instructions to build a Camera Obscura, Camera Lucida, Pinholescope, and many other optical devices.

**PHOTOGRAPHY LAB**  
A PRECISION 35mm SLR CAMERA — National type 35mm film (loading lenses and 3 1/2" f/11 projection lens. Produces quality enlargements up to 8 1/2" x 10". Contact Print Frame takes negatives up to 3 1/2" x 4 1/2". 3 Plastic Developing Trays, News Selflight, Trip, Thermometer, Film Clips, Developing Chemicals, Printing and Enlarging Paper and Darkroom Handbook. Most quality enlargements and 100 prints for only \$15. Full instructions included.

**RADIO LAB AND COURSE**  
YOU BUILD A SHORTWAVE AND BROADCAST RADIO. 2 Tube regenerative circuit (115V AC). CASE ON MICROPHONE with AUDIO AMPLIFIER. RADIO TRANSMITTER for code or voice. RIPPLE FINE WAVE GENERATOR with variable frequency. Indispensable in the understanding of other theory. CODE PRACTICE OSCILLATOR with manual. "Steps to a Ham License." All you need to pass the FCC Ham License Exam.

**RADIO SERVICING TOOLS**  
Signal Tester, Inductance Variable Shooting Tool which permits you to "listen in" as you probe through a faulty circuit until you find the trouble spot. CONTINUITY TESTER. Pro-pumps open circuits and test voltages. The use of both is greatly facilitated in accompanying manual. "Simplified Radio and TV Servicing."

**DC POWER SUPPLY**  
Designs regular 110-120V AC to the direct current is used for electronic projects and experimenting. Consists of a Power Transformer, Vacuum Tube Rectifier, 20-70 mA DC Capacitor Filter Circuit, and a precision Voltage Selector. A Safe Isolated Input: Supply eliminates the need of expensive Multi-watt batteries.

**MICROCRAFT LAB**  
Microprojector (prints microscope subjects on 1 1/2" x 3" with brilliant detail) on wall or screen, has sturdy steel Cabinet, large Condensing Lenses for extra brightness, and a 20" Projection Lens. Microscope features: Binocular Eye piece for wide field viewing, Substage Light and Polarizing Filter. Magnifies up to 270X. Includes Slide, Cover Glasses and Microscope Manual.

**PHOTOMICROGRAPHY CAMERA**  
Photographic subjects mounted on microslide slides. Enlarges up to 100X. Takes clear sharp pictures of specimens too small to be seen with the naked eye. A fully-reflex camera with no-magnifying required lens. Standard roll film, either 120 or 350, black and white or color. Has a photographic record of your projects with microscope subjects.

**LIGHT TRANSMITTER-RECEIVER**  
TRANSMITTER consists of a Light Beam, a Modulating Battery, Diaphragm and an Optical Projection System. THE RECEIVER is a Two-Stage Audio Amplifier, controlled by a Photoelectric Cell that catches the projected light beam and causes the original sound waves to be reproduced in the headphones.

**ATOMIC ENERGY LAB**  
ATOMIC CLOUD CHAMBER WITH PROJECTOR ILLUMINATION. See the trajectories of alpha and beta particles, and of cosmic rays. PHOTOMICROSCOPE. Shows exploding atoms. ELECTROSCOPE — metal housed with Selsol and Magnifying Viewer. Measures background radiation and tests sample sources. SAFE RADIOACTIVE MATERIAL. Alpha Source in handy container and Uranium Dioxide. Full instructions and explanations given up the fascinating field of nuclear physics.

**SPECTROSCOPE**  
Analyzes spectra of glowing gases. See and identify the Fraunhofer Lines. A quality instrument featuring an easy-to-use built-in base and a powerful readout system for a bright spectrum. Equipment includes: Alkali Halide and a 2 Watt Neon Spectral Lamp. Full instructions and explanations given up the fascinating field of nuclear physics.

**ULTRAVIOLET LAMP**  
140 watt line free UV Lamp. Heavy metal cabinet. A Foot Cord. Rotary Switch. Produces dazzling red effects with invisible black light. Has many uses in the fields of Microbiology, Plant Detection and Science. Accessories include: Insectable Ink, Tissue Paper, Fluorescent Crystals.

**SURVEYOR'S TRANSIT**  
A precision Transit. 6X erect image telescope with Range Finder. Built for measuring accurate distances and heights. Vertical leveling for both horizontal and vertical scales. Loading Head with Thumb Screw Adjustment and Spirit Level. Claims under head hold wooden legs of tripod. Legs not included. Includes cover elementary surveying, range-finding.

**TELESCOPE AND MOUNT**  
30X erect image. Extends to 30" length. Five ground and polished lenses. Beautifully engraved. Steady Reinforced Mount makes it easy to follow the movements of heavenly bodies. Mount has fittings for wooden legs that complete the tripod. Legs are separate 1 1/2 meter non-included.

**WEATHER STATION**  
A REMOTE READING AMBARIOMETER AND WIND-VANE — Flashing Moon Light on indoor indicator-board shows wind speed and direction. Operates on less than 1 cent per month. Safety Power Cord makes all connections easy. 100 Ft. of lead on Wire Plus — Air Trawl Barometer with a 5" indicator dial. Slugs. Pressure measures recorded hourly. Rain Gauge measures rainfall to 1/100 inch. ALSO Cloud Chart, Weather Map and Forecasting Manual — a complete set-up for amateur meteorology.

You get ALL the equipment for ALL the above in nine monthly kits!

SEND \$100 ONLY TO ENROLL PAY \$4.95 ONLY FOR EACH KIT THAT YOU RECEIVE

Take as few as you wish — or get all nine... it's up to you!

**SOME QUESTIONS ANSWERED**

- Q. How is it possible? It seems incredible to be able to get all the equipment shown above in just nine kits — at only \$4.95 per kit!
- A. The direct-to-you "no middleman" club plan is just part of the answer. The other key is ABSClub's especially designed multi-use equipment. For example: the Microprojector quickly and easily converts into the Spectroscope, Photo Enlarger and Cloud Chamber Illuminator. Similarly, the Transit doubles as a Telescope Mount. Such multi-purpose design — plus club plan economy — makes possible this all-science program at a price everyone can afford.
- Q. May members choose the order in which they receive their kits?
- A. Yes. With the first kit members receive a list of the equipment and projects contained in each of the remaining eight kits. With this information they are able to choose the kit sequence that best suits their particular interest.
- Q. Can members get their kits all at once instead of one-a-month?
- A. Yes. At any time members can have the balance of their kits sent in one shipment. We recommend that you start on the kit-a-month plan because the monthly spacing will give you time to get the full measure of knowledge and enjoyment that each kit has to offer.

**NO OBLIGATION — NO RISK!**

- ★ You take only as many kits as you wish. No minimum — you may cancel anytime.
- ★ Two weeks approval on each kit you take. You may return any kit for full refund.

Send coupon today — get your first kit on its way!

TRIAL MEMBERSHIP COUPON

AMERICAN BASIC SCIENCE CLUB, Inc.,  
104 Heiman, San Antonio, Texas 78205

I wish to try the Kit-A-Month Program:

I enclose \$1.00 to enroll and \$4.95 for the first kit postpaid.

I enclose \$1.00 to enroll. Send first kit COD. I'll pay COD fee.

I understand if I am not satisfied with the first kit I may return it for a complete refund including the \$1.00 membership fee.

NAME \_\_\_\_\_

ADDRESS \_\_\_\_\_

CITY AND STATE \_\_\_\_\_ (PLEASE PRINT) ZIP CODE \_\_\_\_\_

**AMERICAN BASIC SCIENCE CLUB, INC.**

NO EXPERIENCE NECESSARY — IT'S FUN! IT'S EASY!

# You can pay \$600 and still not get professionally approved TV training.

## Get it now for \$99.

Before you put out money for a home study course in TV Servicing and Repair, take a look at what's new.

National Electronic Associations did. They checked out the new TV training package being offered by ICS. Inspected the six self-teaching texts. Followed the step-by-step diagrams and instructions. Evaluated the material's practicality, its fitness for learning modern troubleshooting (including UHF and Color).

Then they approved the new course for use in their own national apprenticeship program.

They went even further and endorsed this new training as an important step for anyone working toward recognition as a Certified Electronic Technician (CET).

This is the first time a self-taught training program has been approved by NEA.

The surprising thing is that this is not a course that costs hundreds of dollars and takes several years to complete. It includes no kits or gimmicks. Requires no experience, no elaborate shop setup.

All you need is normal intelligence and a willingness to learn. Plus an old TV set to work

on and some tools and equipment (you'll find helpful what-to-buy and where-to-buy-it information in the texts).

Learning by doing, you should be able to complete your basic training in six months. You then take a final examination to win your ICS diploma and membership in the ICS Servicing Academy.

Actually, when you complete the first two texts, you'll be able to locate and repair 70% of common TV troubles. You can begin taking servicing jobs for money or start working in any of a number of electronic service businesses as a sought-after apprentice technician.

Which leads to the fact that this new course is far below the cost you would expect to pay for a complete training course. Comparable courses with their Color TV kits cost as much as six times more than the \$99 you'll pay for this one.

But don't stop here. Compare its up-to-dateness and thoroughness. Find out about the bonus features—a dictionary of TV terms and a portfolio of 24 late-model schematics.

Get all the facts. Free. Fast. Mail the reply card or coupon below.

**ICS**<sup>®</sup> Dept. M5589G  
Scranton, Penna. 18515

Yes, I'd like all the details about your new TV Servicing/Repair basic training package. I understand there's no obligation. (Canadian residents, send coupon to Scranton, Pa. Further service handled by ICS Canadian, Ltd.)

Name \_\_\_\_\_

Street \_\_\_\_\_

City \_\_\_\_\_ State \_\_\_\_\_ Zip \_\_\_\_\_

Prices slightly higher outside U. S. and Canada.

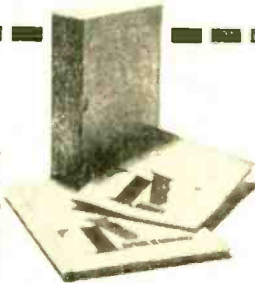



# elementary Electronics

Dedicated to America's Electronics Hobbyists

☆

- SPECIAL AUTUMN CONSTRUCTION**
- 31 Touchdown TwinHailer—*build it, and you've got a portable PA system that really socks it home*

### THEORY FOR EVERYONE

☆

- 37 Dirty Decibels—*we look at noise pollution*
- 69 Transformers—*power and paradox—the inner workings uncoiled!*
- 81 Meter Scales You Can Count On
- 89 Basic Course, Part X—*Understanding Television Receivers*

☆

### CONSTRUCTION ROUNDUP

☆

- 41 Sun Spot Special—*build now for SW skip*
- 49 Stereofone—*the amp designed for your hi-fi headset*
- 59 Junk Box Q Tester—*get the best of transistor sales*
- 62 Handy-Dandy Radio—*for Junior, if Daddy will keep his paws off*

☆

### ELECTRONIC FEATURETTES

☆

- 30 Electronics Through the Ages—*cartoon special*
- 46 Omar Mung—*his head is pointy and his bottom bulgy, but does he get around!*
- 56 Holographic! What a Memory!
- 78 They Play the Numbers Without Nixies

☆

### AS OUR LAB SEES IT

- 67 Heathkit AD-27 Compact Stereo Center
- 79 Bose Model 901 Direct/Reflecting Speaker System

### SWL AND DX FEATURES

- 18 DX Central Reporting—*light ships and light towers*
- 45 How I Got Started in Shortwave Radio—*a reader tells it like it was*
- 57 From TV's Tender Years—*looking back at the giant's infancy*
- 64 DXer's Guide to the Kalahari—*Africa's hot spot*

☆

### THE REGULARS

- 10 Random Noise—*editorial chit-chat*
- 11 Hey, Look Me Over—*it's new, it's here!*
- 14 NewScan—*misfit news that's fit to print*
- 23 e/e Etymology—*words, words, words!*
- 24 Literature Library—*info for the asking*
- 85 En Passant—*it's your move*

☆

Cover Highlights

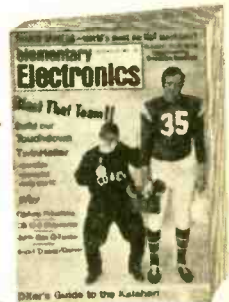

### AUTHORS IN THIS ISSUE

Stephen Daniels—WB2GIF, Herb Friedman—W2ZLF/KBI9457, Webb Garrison, Charles Green—W6FFQ, Jorma Hyypia, Jim Kyle—K5JKX, Don Jensen, Lars Jorgensen, Thomas K. Sear, Edward Shaw, C.M. Stanbury II, Art Trauffer, and the ELEMENTARY ELECTRONICS' Editorial Staff.

Cover photo by Leonard Heicklen

**SEE YOUR MUSIC IN DAZZLING ACTION with**



**Dramatic New Breakthrough  
In Audio-Visual Enjoyment**

Now you can have a thrilling psychedelic "see-in" right in your own home, club, school or business—in fact—anywhere you want to add sensational "mod" effects. Colored light beams dance and prance, whirl and swirl in perfect time with the music—each individual note creating its own unique twisting, radiating shape. Adds a spectacularly wild, new dimension to a world of music and entertainment. Combines electronics, science and art with dramatic results. Attaches in seconds to your radio, tape recorder, hi-fi, or stereo with two alligator clips. Can be used on small screens, large walls, stages and whole auditoriums. Build your own MusicVision™ with low-cost Do-It-Yourself Kit. Loads of fun! Fast! Easy!

All you need is a light source. If you don't have one, the versatile Edmund 35mm 500 Watt Projector is a terrific bargain. All kinds of other uses too—set up to accept motorized accessories. Also available in 15"x15"x27" Walnut Cabinet Model, Tube Unit, or 8" and 12" Sets which include encased 8" or 12" Motordrizer. Color Wheel and set of apertures for use with your own 35mm projector. Large 12" set provides fabulous effects for commercial applications. Order by stock number listed below. Money-back guarantee. Complete information in new catalog. If you want additional details now, send 25¢ in coin for fully illustrated, 16-page Booklet No. 9096EK. "Introduction to MusicVision™." \* Patent pending.

- BOY'S STARTER KIT ..... Stock No. 71,095EK \$ 6.00 Postpaid
- 8" DO-IT-YOURSELF KIT ..... Stock No. 71,099EK \$22.50 Postpaid
- 8" SET (Motordrizer, color wheel, apertures) ..... Stock No. 71,030EK \$45.00 Postpaid
- 12" SET (Same as above w/larger Motordrizer) ..... Stock No. 71,032EK \$57.50 Postpaid
- WALNUT VENEERED CABINET MODEL ..... Stock No. 85,181EK \$99.50 F.O.B.
- EDMUND 500 Watt 35mm PROJECTOR ..... Stock No. 71,057EK \$24.50 Postpaid



**NEW! LOW-COST COLOR ORGAN**

Accompany music with colored lighting that changes in hue and intensity. Create tremendous variety of unusual and beautiful effects. Simply plug in 3 diff. sets of colored lights and place near audio source. Notes picked up by interior "mike" determine which colored lights go on—loudness determines intensity. Surprising number of commercial, display and home uses—control lighting in pools and fountains, window and holiday decorations, great for parties. Tough, compact unit with light intensity control. 4-9/16"x2 3/4"x4 3/4" 1 lb. 6 oz.

- Stock No. 1900EK ..... \$39.95 Ppd.
- 4 CHANNEL DE LUXE 2,000 WATT
- Stock No. 71,103EK ..... \$195.00 Ppd.

**KEEP PACE WITH THE SPACE AGE!**

# AMAZING BARGAINS

for Fun • Study • Profit  
from  
**EDMUND SCIENTIFIC CO.**  
300 Edscorp Building  
Barrington, N. J. 08007

**'BRIGHT IDEAS' in UNIQUE LIGHTING**  
Big, new 100-page handbook packed with facts, hints and illustrations. All latest developments, applications, equipment. 8 1/2" x 11" looseleaf paper punched to fit 3 ring binder.  
Stock No. 9100EK ..... \$3.00 Ppd.



**CATCH THAT STROBE ACTION!**  
It's wild, spectacular stop-action lighting effects will make a party, create a light show, turn the "sawingers" into psychedelic performers. Top quality, low-cost, solid state electronic strobe. Adjustable flash rate from 2 to 16 flashes per second. Clear lucite lens projects long life Xenon lamp—up to 10,000,000 flashes. 60° high lustre reflector covers 2,000 sq. ft. area—even in dark of night. Rugged but compact 16" sq. & lightweight (3 1/2 lb.). Wrinkle-finished metal case. 110-120 V. AC. UL approved.  
Stock No. 71,174EK ..... \$89.95 Ppd.

**TUNE IN AND TURN ON OUR OWN  
Psychedelic Light Show**

Take one breakthrough sized conservative looking allied sound finished light box—with its built-in color organ. Activate by attaching to hi-fi or stereo speaker. Plug in and switch on! Music fills the room and the prismatic screen leaps into pulsating life. Patterns are wild and wonderful, or soft and soothing in music. Perfect home entertainment, little theater or club. Humane current. (180Wx12 1/2x9 1/2")  
Stock No. 80,126EK ..... \$49.95 Ppd.



**NEW! PROJECTION KALEIDOSCOPE**  
At last—a low-cost unit complete with interchangeable 9" diam. liquid wheel. Projects infinite variety of brilliant color patterns which do not repeat. Specially designed wheel, 3" projection lens and Edmund Visual Special Erects Projector make it all possible. Easily operated. Large screen image at short projection distance perfect for photo backgrounds, light shows, parties, dances, etc. Front or rear projection. Incl.: 1 RPM 115V Motor, motor bracket, instructions.  
Stock No. 71,121EK ..... \$94.50 Postpaid  
**SOLID Multi-Colored Glass Accessory Wheel (9" Diameter)**  
Stock No. 71,122EK ..... \$15.00 Ppd.



**SUPER 6" SPACE CONQUEROR**  
Superb Astronomical Reflector—Up to 576X. Capable of revealing faint stars of nearly 1<sup>st</sup> magnitude, split doubles stars separated by less than 1 sec. of arc. Features aluminized & overcoated 6" f/8 ground and polished pyrex parabolic mirror accurate to 1/4 wave. 48 F.L. BX achromatic finder scope, 4 eyepieces—48X Kellner, 147 00X & 147 192X Ramsdens. Barlow to double or triple power—rack & pinion focusing mount, 4734" aluminum tube. Electric clock drive w/manual slow-motion control. Setting circles. Heavy-duty equatorial mount. Peistaltic base. Compares to \$295-\$370 models.  
Stock No. 85,086EK ..... \$199.50 F.O.B.  
**3" REFLECTOR TELESCOPE**  
Stock No. 85,050EK ..... \$29.95 Ppd.  
**4 1/4" REFLECTOR TELESCOPE**  
Stock No. 85,105EK ..... \$84.50 F.O.B.



**NEW SURPLUS Ni-Cd CELLS**  
Save over 50%! Long life—accept 300 charge and discharge cycles. 1.2v. Volts per cell. 700 ma-hr. capacity; sub-"C" size. Excellent charge retention. Multiple cells, welded in series from 1v. to 12v. 1/2" dia. x 1 1/2" high. Easily convert to "C" size with sleeves below for use in tape recorders, cameras, toys, radios, flashlights, alarms, experiments, etc.  
Order # Cells DC Volt. Price Ppd.  
60,534EK 4 5.00 \$4.80  
**70,812EK—Trickle Charger**  
(1-10 cells) ..... \$11.50  
**PKG. OF 4 "C" SIZE SLEEVES**  
Stock No. 41,217EK ..... \$1.00 Ppd.

**MONEY-BACK GUARANTEE**

Order by Stock No.—Send Check or M.O.

**GIANT FREE CATALOG**

148 Pages! More than 4,000



**UNUSUAL BARGAINS!**

Packed with nearly 4000 unusual bargains. Dozens of electrical and electromagnetic parts, accessories. Enormous selection of Astronomical Telescopes.

EDMUND SCIENTIFIC CO., 300 Edscorp Building, Barrington, N. J. 08007. Mail coupon for FREE Catalog "EK"

Name \_\_\_\_\_  
Address \_\_\_\_\_  
City \_\_\_\_\_ State \_\_\_\_\_ Zip \_\_\_\_\_

SCIENCE & MECHANICS—INSTRUMENTS DIV.  
229 Park Ave., S., New York, N.Y. 10003

Enclosed is \$\_\_\_\_\_ Please send me the new S&M  
Supersensitive Photo Meter. If I am not satisfied, I will  
return the meter within 10 days for a complete refund.

(Prices subject to change without notice)

**Model 102 Photo Meter**

- |  |  |
|--|--|
| <input type="checkbox"/> \$57.50 with standard<br>probe, computer + carry-<br>ing case | <input type="checkbox"/> Add'l. Standard Probe<br>\$7.50 |
| <input type="checkbox"/> Microscope Adapter \$5.00                                     | <input type="checkbox"/> \$2.00 carrying case            |
| <input type="checkbox"/> Add'l. Computer \$2.00  | <input type="checkbox"/> 3/8" mini Probe \$7.50          |
|  | <input type="checkbox"/> Easel Probe \$7.50              |

Add 10% for Canadian and foreign order. New York City  
residents add 6% sales tax. (No Stamps)

Name \_\_\_\_\_ (please print)

Address \_\_\_\_\_

City \_\_\_\_\_ State \_\_\_\_\_ Zip \_\_\_\_\_

## the new and improved S&M Supersensitive Photo Meter

Here is a precision instrument that meets the highest standards of any meter available. It offers consistently accurate readings at very low light levels, which, if required, can be converted to ft.-candles from a graph supplied. Researchers, scientists, and educators have confirmed that this meter can read light levels as low as 0.000245 ft.-candles.

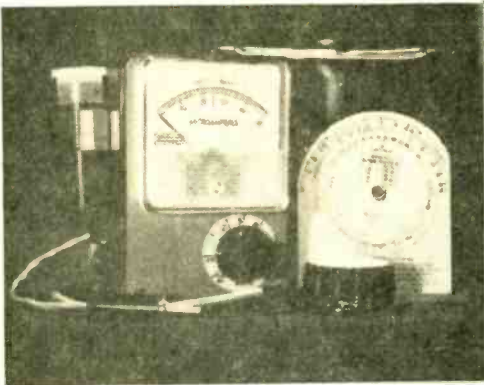

The S&M Supersensitive Photo Meter uses the newest Clairex Corp. CL-505L Cadmium Sulfide Light Cell to measure light levels from twilight to bright sunlight at ASA speeds of 3 to 25,000. A new 3/8" high easel type probe and also a miniature probe are now available as accessories. The Computer included gives F stops from .7 to 90; lists exposure time from 1/15,000 sec. to 8 hrs.; 4 range selection; EV-EVS-LV settings. Used extensively in Photo Labs, Physics and Research Labs, Hospitals, High Schools, Universities and numerous industries. Also used with movie or still cameras, microscopes and telescopes and IS A MUST FOR PHOTOMICROGRAPHY.

Use COUPON at top . . . and get a Booklet on  
Photomicrography FREE!

# elementary Electronics

Sept./Oct. 1969

Vol. 9/No. 1

Dedicated to America's Electronics Hobbyists

*Editor-in-Chief*

JULIAN M. SIENKIEWICZ  
WA2CQL, KMD4313

*Managing Editor*

RICHARD A. FLANAGAN  
KQD2566

*Technical Editor*

CHARLES S. HARRIS

*Art Editor*

JIM MEDLER

*News Editor*

HELEN PARKER  
KQD7967

*Art Director*

ANTHONY MACCARRONE

*Cover Art Director*

IRVING BERNSTEIN

*Associate Art Director*

JOHN YUSKO

*Art Associate*

MARGARET R. GOTTLIEB

*Advertising Director*

JIM CAPPELLO

*Production Director*

CARL BARTEE

*Assistant Production Manager*

MARILYN VARGAS

*Instruments Division Manager*

WILFRED M. BROWN

*Chairman of the Board*

B. G. DAVIS

*President and Publisher*

JOEL DAVIS

*Vice-President and General Manager*

LEONARD F. PINTO

*Vice-President and Treasurer*

VICTOR C. STABILE, KBP0681

ELEMENTARY ELECTRONICS is published bi-monthly by Science & Mechanics Publishing Co., a subsidiary of Davis Publications, Inc. Editorial, Business and Subscription offices: 229 Park Avenue South, New York, N.Y. 10003. One-year subscription (six issues)—\$4.00; two-year subscription (12 issues)—\$7.00; and three-year subscription (18 issues)—\$10.00. Add \$1.00 per year for postage outside the U.S.A. and Canada. Advertising offices: New York, 229 Park Avenue South, 212-OR 3-1300; Chicago, 520 N. Michigan Ave., 312-527-0330; Los Angeles, J. E. Publishers' Rep. Co., 8380 Melrose Ave., 213-653-5841; Atlanta, Pirnie & Brown, 3108 Piedmont Rd., N.E.; 404-233-6729; Long Island, Len. Osten, 9 Garden Street, Great Neck, N.Y., 516-487-3305; Southwestern advertising representative: Jim Wright, 4 N. 8th. St., St. Louis, 314-CH-1-1965.

Second-class postage paid at New York, New York and at additional mailing office. Copyright 1969 by Science and Mechanics Publishing Co.

# The New 1969 Improved Model 257 **A REVOLUTIONARY NEW TUBE TESTING OUTFIT**

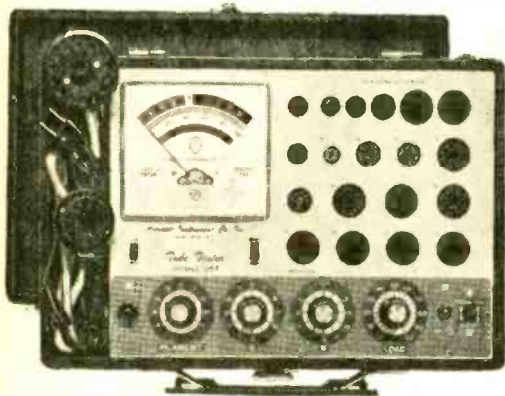

**COMPLETE WITH ALL ADAPTERS AND ACCESSORIES, NO "EXTRAS"**

#### STANDARD TUBES:

- ✓ Tests the new Novars, Nuvisitors, 10 Pins, Magnovals, Compactrons and Decals.
- ✓ More than 2,500 tube listings.
- ✓ Tests each section of multi-section tubes individually for shorts, leakage and Cathode emission.
- ✓ Ultra sensitive circuit will indicate leakage up to 5 Megohms.
- ✓ Employs new improved 4½" dual scale meter with a unique sealed damping chamber to assure accurate, vibration-less readings.
- ✓ Complete set of tube straighteners mounted on front panel.

The Model 257 is housed in a handsome, sturdy, portable case. Comes complete with all adapters and accessories, ready to plug in and use. No "extras" to buy. Only . . . . .

#### BLACK AND WHITE PICTURE TUBES:

- ✓ Single cable used for testing all Black and White Picture Tubes with deflection angles 50 to 114 degrees.
- ✓ The Model 257 tests all Black and White Picture Tubes for emission, inter-element shorts and leakage.

#### COLOR PICTURE TUBES:

- ✓ The Red, Green and Blue Color guns are tested individually for cathode emission quality, and each gun is tested separately for shorts or leakage between control grid, cathode and heater. Employment of a newly perfected dual socket cable enables accomplishments of all tests in the shortest possible time.

**\$47<sup>50</sup>**

### NOTICE

We have been producing radio, TV and electronic test equipment since 1935, which means we were making Tube Testers at a time when there were relatively few tubes on the market, way before the advent of TV. The model 257 employs every design improvement and every technique we have learned over an uninterrupted production period of 32 years.

Accurate Instrument Co., Inc.

## SEND NO MONEY WITH ORDER PAY POSTMAN NOTHING ON DELIVERY

Try it for 10 days before you buy. If completely satisfied you may remit \$47.50 plus postage and handling charge. (If you prefer you may use our Easy Payment Plan.) If not completely satisfied, return to us, no explanation necessary.

#### ACCURATE INSTRUMENT CO., INC.

Dept. 668 2435 White Plains Road, Bronx, N. Y. 10467

Please rush me one Model 257. If satisfactory I agree to remit \$47.50 plus postage and handling charge. (If you prefer you may use our Easy Payment Plan.) If not satisfactory, I may return for cancellation of account.

Name \_\_\_\_\_

Address \_\_\_\_\_

City \_\_\_\_\_ Zone \_\_\_\_\_ State \_\_\_\_\_

**Save Money!** Check here and enclose \$47.50 with this coupon and we will pay all shipping and charges. You still retain the privilege of returning after 10 day trial for full refund.

# 10 Exciting New Kits



NEW  
Kit ID-29  
\$29.95\*



NEW  
Kit GD-48  
\$59.95\*



NEW  
Kit TD-17  
\$12.95\*



NEW  
Kit GR-88  
\$49.95\*  
each

NEW  
Kit GR-98



NEW  
Kit GD-69  
\$19.95\*

NEW  
Kit IP-28  
\$47.50\*

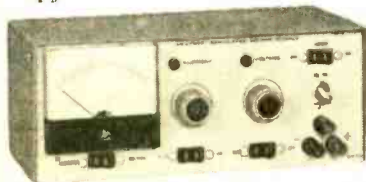

## NEW Heathkit Solid-State Auto Tune-Up Meter . . . Measures Dwell, RPM And DC Voltage

The new Heathkit ID-29 is most versatile . . . really three automotive test instruments in one . . . and its low price makes it even a better value. Measures Dwell on all 4-cycle 3, 4, 6, or 8 cylinder engines . . . measures RPM in two ranges 0-1500 and 0-4500 . . . measures DC voltage from 0 to 15 volts. And no batteries are needed . . . running engine provides both signal and power. Easy to use . . . on both 6 and 12 volt system without changing leads. It's lightweight, easy to carry . . . comes equipped with black polypropylene case that has a built-in lead storage compartment and is resistant to virtually everything. Fast, simple assembly . . . takes just one evening. The perfect accessory for the handyman who wants to do his own car tune-up, emergency road service personnel, or shop mechanics . . . order your ID-29 now. 4 lbs.

## NEW Heathkit GD-48 Solid-State Metal Locator

A low cost, versatile, professional metal detector at one-third the cost of comparable detectors. Packed with features for long life, rugged reliability, and dozens of uses. Completely portable, battery operated and weighs only 3 lbs. The GD-48 is highly sensitive, probes to 7 feet, and has an adjustable sensitivity control. Its built-in speaker signals presence of metal; front panel meter gives visual indication. Other features include built-in headphone jack, telescoping shaft for height adjustment, smartly styled and smartly designed for easy in-hand use and easy assembly. Whether you're an amateur weekend hobbyist or a professional treasure hunter the GD-48 is for you . . . also a great help to contractors, surveyors, Gas, Electric, Telephone and other public Utility Companies. 4 lbs. GDA-48-1, 9 Volt Battery \$1.30\*; GD-396, Headphones, 2000 ohm (Suprex) \$3.50\*

## NEW Heathkit Electronic Metronome

The new Heathkit TD-17 is a low cost, precise performing electronic Metronome . . . a handy helper for any music student. Battery operated . . . no springs to wind . . . accurate, steady calibration is always maintained . . . from 40 to 210 beats per minute. Instruction label on bottom gives conversion from time signature and tempo to beats per minute. Stylish fruit wood finished cabinet. Easy solid state circuit board construction . . . assembles and calibrates in only 2-3 hours. The new Heathkit TD-17 Electronic Metronome is so low in cost every music student can afford one . . . order yours now. 1 lb.

## NEW Heathkit GR-88 Solid-State Portable VHF-FM Monitor Receiver

Tunes both narrow and wide band signals between 154-174 MHz . . . for police, fire, most any emergency service. Exceptional sensitivity and selectivity, will outperform other portable receivers. Features smart compact styling . . . with durable brown leatherette case, fixed station capability with accessory AC power supply, variable tuning or single channel crystal control, collapsible whip antenna, adjustable squelch control and easy circuit board construction. The new GR-88 receiver is an added safety precaution every family should have . . . order yours today. 5 lbs.

## NEW Heathkit GR-98 Solid-State Portable Aircraft Monitor Receiver

Tunes 108 through 136 MHz for monitoring commercial and private aircraft broadcasts, airport control towers, and many other aircraft related signals. Has all the same exceptional, high performance features as the GR-88 above. The perfect receiver for aviation enthusiast . . . or anyone who wants to hear the whole exciting panorama of America in flight. 5 lbs. GRA-88-1, AC Power Supply \$7.95

## NEW Heathkit GD-69 "Thumb Tach" . . . An Accurate, Low Cost Tachometer To Measure RPM's On Any Model Engine

The new Heathkit GD-69 "Thumb Tach" Tachometer is an accessory every R/C modeler should have. An accurate, inexpensive and easy way to make sure your model engine is giving maximum performance (also suitable for measuring RPM's of any rotating shaft). Features all solid-state design and battery operation for long life reliability. Simple to use . . . set the slide switch to the meter scale you want to use, aim the lens at the propeller or flywheel. The meter reads directly in RPM from reflected light for precise, accurate measurements . . . doesn't load engine. Easy 2 or 3 hour assembly. Raise your engine performance standards now . . . with the new Heathkit GD-69. 1 lb.

## NEW Heathkit 1-30 VDC Solid-State Regulated Power Supply

The new modestly priced IP-28 is an excellent power supply for anyone working with transistors whether it be in a laboratory or in a home workshop . . . and its low price makes it the ideal power supply for classroom use. Compact brown and beige. Heathkit instrument styling with large easy-to-read meter . . . with two voltage ranges 10 v. and 30 v. . . and two current ranges 100 mA, 1 A. External sensing permits regulation of load voltage rather than terminal voltage. Adjustable current limiting prevents supply overloads and excessive load current. Convenient standby switch. Fast, easy assembly with one circuit board and wiring harness. Order yours today. 9 lbs.



# From The Leader



## NEW Heathkit Ultra-Deluxe "681" Color TV With AFT ... Power Channel Selection & Built-In Cable-Type Remote Control

The new Heathkit GR-681 is the world's most advanced Color TV with more built-in features than any other set on the market. Automatic Fine Tuning on all 83 channels ... eliminates touchy fine tuning forever, power push button VHF channel selection, built-in cable-type remote control ... or you can add the optional GRA-681-6 Wireless Remote Control any time you wish ... plus the built-in self-servicing aids that are standard on all Heathkit color TV's but can't be bought on any other set at any price. Other features include a bridge-type low voltage power supply for superior regulation; high & low AC taps to insure that the picture transmitted exactly fits the "681" screen. Automatic degaussing, 2-speed transistor UHF tuner, hi-fi sound output, two VHF antenna inputs, top quality American brand color tube with 2-year warranty.

**GRA-295-4, Mediterranean Cabinet shown ..... \$119.50\***

### Heathkit "295" Color TV

Big, Bold, Beautiful ... with the same high performance features and built-in servicing facilities as the GR-681 above ... but less the Automatic Fine Tuning, push button VHF power tuning and built-in cable-type remote control. You can add the optional GRA-295-6 Wireless Remote Control at any time.

**GRA-295-1, Contemporary Walnut Cabinet shown ..... \$62.95\***

Both the GR-681 and GR-295 fit into the same Heath factory assembled cabinets; not shown, Early American style at \$99.95.\*

### NEW Deluxe Heathkit "581" Color TV With AFT

The new Heathkit GR-581 will add a new dimension to your TV viewing. Brings you color pictures so beautiful, so natural, so real ... puts professional motion picture quality right into your living room. Has the same high performance features and exclusive self-servicing facilities as the GR-681, except with 227 sq. inch viewing area, and without power VHF tuning or built-in cable-type remote control. The optional GRA-227-6 Wireless Remote Control can be added any time you wish. And like all Heathkit Color TV's you have a choice of different installations ... mount it in a wall, your own custom cabinet, your favorite B&W TV cabinet, or any one of the Heath factory assembled cabinets. **GRA-227-2, Mediterranean Oak Cabinet shown ..... \$99.50\***

### Heathkit "227" Color TV

Same as the GR-581 above, but without Automatic Fine Tuning ... same superlative performance, same remarkable color picture quality, same built-in servicing aids. Like all Heathkit Color TV's you can add optional Wireless Remote Control at any time (GRA-227-6). And the new Table Model TV Cabinet and roll around Cart is an economical way to house your "227" ... just roll it anywhere, its rich appearance will enhance any room decor.

**GRS-227-6, New Cart and Cabinet combo shown ..... \$49.95\***

Both the GR-581 and GR-227 fit into the same Heath factory assembled cabinets; not shown, Contemporary cabinet \$59.95.\*

### NEW Heathkit Deluxe "481" Color TV With AFT

The new Heathkit GR-481 has all the same high performance features and exclusive self-servicing aids as the new GR-581, but with a smaller tube size ... 180 sq. inches. And like all Heathkit Color TV's it's easy to assemble ... no experience needed. The famous Heathkit Color TV Manual guides you every step of the way with simple to understand instructions, giant fold-out pictorials ... even lets you do your own servicing for savings of over \$200 throughout the life of your set. If you want a deluxe color TV at a budget price the new Heathkit GR-481 is for you.

**GRA-180-1, Contemporary Walnut Cabinet shown ..... \$49.95\***

### Heathkit "180" Color TV

Feature for feature the Heathkit "180" is your best buy in color TV viewing ... has all the superlative performance characteristics of the GR-481, but less Automatic Fine Tuning. For extra savings, extra beauty and convenience, add the table model cabinet and mobile cart. Get the value-packed GR-180 today.

**GRS-180-5, Table Model Cabinet & Cart combo ..... \$39.95\***

Both the GR-481 and GR-180 fit the same Heath factory assembled cabinets; GRA-180-2, Early American Cabinet \$75.00.\*

Add the Comfort And Convenience Of Full Color Wireless Remote Control To Any Rectangular Tube Heathkit Color TV ... New Or Old!

**Kit GRA-681-6, for Heathkit GR-681 Color TV's ..... \$59.95\***

**Kit GRA-295-6, for Heathkit GR-295 & GR-25 TV's ..... \$69.95\***

**Kit GRA-227-6, for Heathkit GR-581, GR-481 & GR-180**

**Color TV's ..... \$69.95\***

## Now There Are 6 Heathkit Color TV's To Choose From

### 2 Models In 295 Sq. Inch Size

NEW  
Kit GR-681  
With AFT

**\$499.95\***

(less cabinet)



Kit GR-295

**\$449.95\***

(less cabinet)

### 2 Models In 227 Sq. Inch Size

NEW  
Kit GR-581  
with AFT

**\$419.95\***

(less cabinet)



Kit GR-227

**NOW ONLY \$379.95\***

(less cabinet & cart)

### 2 Models In 180 Sq. Inch Size

NEW  
Kit GR-481  
with AFT

**\$359.95\***

(less cabinet)



Kit GR-180

**NOW ONLY \$329.95\***

(less cabinet & cart)

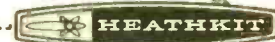

## NEW

### FREE 1969 CATALOG!

Now with more kits, more color. Fully describes these along with over 300 kits for stereo/hifi, color TV, electronic organs, electric guitar & amplifier, amateur radio, marine, educational, CB, home & hobby. Mail coupon or write Heath Company, Benton Harbor, Michigan 49022.

HEATH COMPANY, Dept. 139-19  
Benton Harbor, Michigan 49022

Enclosed is \$ \_\_\_\_\_, plus shipping. \*Schlumberger company

Please send model (s)  
 Please send FREE Heathkit Catalog.  Please send Credit Application.

Name \_\_\_\_\_

Address \_\_\_\_\_

City \_\_\_\_\_ State \_\_\_\_\_ Zip \_\_\_\_\_

\*Mail order prices; F.O.B. factory. Prices & specifications subject to change without notice. CL-358

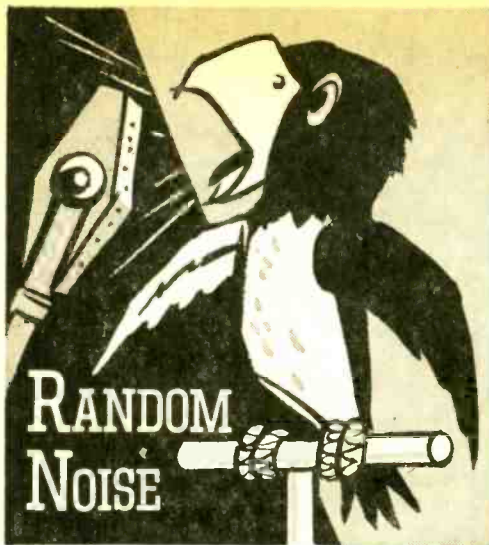

By JULIAN M. SIENKIEWICZ, Editor

**H**ere comes the IC, so expect to see more and more projects in ELEMENTARY ELECTRONICS using integrated circuits (that's what an IC is, folks!). This may sound like the Editor of *e/e* is catching up with the field, but there's more to new components than sticking them into projects. When the IC first came on the scene, it appeared with several attending headaches.

First off was the IC's price. Twenty bananas was typical and by no means high. Can you visualize a project in *e/e* such as our Touch-down TwinHailer (page 31) that could be built for half the price using transistors instead of an IC? Neither could this Editor. Price was a big reason for keeping ICs out of projects.

Another good reason ICs weren't used in projects was because our authors couldn't buy them. Electronics parts houses simply wouldn't supply them to single-unit purchasers. Sure, if you were a big manufacturing corporation and wanted 1000 units you could get them after waiting six to eight weeks. Imagine what would happen to the poor reader who wanted to purchase an IC for his project. He didn't stand a chance.

But the biggest reason why ICs took so long in coming to the pages of *e/e* was lack of technology—that's right, our authors didn't have enough experience with ICs to design units that could be constructed by our readers and work as intended. With gains of 5000 and 10,000, IC amps would break into oscillation and destroy themselves in milliseconds if the reader changed the circuit's wiring configuration by even as little as an eighth of an inch. The situation was very much like the early days of transistors when two or three transistors would go up in smoke before a project could be made operative.

We demanded that our authors study and

build projects with ICs until they became *expert*. Then, we called on our authors to design meaningful projects using ICs to take advantage of their high gain, compactness, and today's new prices (under five dollars). After all, who needs an IC to wire up a code practice oscillator when one transistor can do the job cheaply and efficiently.

One thing we shied away from was circuits appearing in manufacturers' spec sheets. Somehow, these circuits are great performers on exotic test benches and fully-equipped laboratories, but they fail miserably on our experimenters' work benches.

Yes, ICs have come to *e/e* now that their price is right, they're readily available, and circuits using ICs in hobby-type projects can be made to operate. But don't throw away your transistors. The oldest one you own can't be over 21 years old and that's still the prime of life!

**One More Time!** We had planned to end our *Basic Course in Electricity and Electronics* with this issue of ELEMENTARY ELECTRONICS, but you won't let us! That's right, our readers thought so much of the course that we've decided to put a new one in the works. This one will be a programmed learning course on how AC and DC circuits work. Starting with simple DC and AC circuits, the course will progress to series circuits, parallel circuits, combined series and parallel circuits, impedance, RL circuits, RC circuits, and tuned LC circuits. So watch for our new course—it'll be a boon to newcomers and oldtimers alike!

**Who's Omar Mung?** You'll enjoy our story on the new personality on the electronics scene. What's more, you'll have fun doodling pics of Mr. Mung and possibly winning a shortwave receiver. Want the complete facts? Then turn to page 46 and pull out your ballpoint. ■

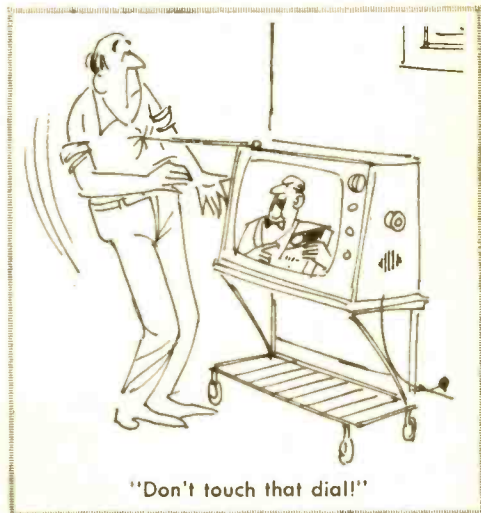



New Products  
that caught  
the Editor's eye

### Talk Your Masterpiece on the Road

Ampex has a new stereo cassette system, the Micro 42, which is a recorder/player. The unit comes complete with a remote control microphone and a slide-out accessory tray. Mounted on the underside of the unit, the tray holds the microphone and extra cassettes. Other features



Ampex Micro 42 Recorder/Player Cassette

include fast forward, rewind, stop, play, eject, and record. The Micro 42 also has a tone control and two separate volume controls, as well as a pilot light, record light and jacks for an earphone and microphone. Mounting bracket, hardware and demonstration tape are included with the Micro 42. Frequency response is 100 to 10,000 Hz; peak power output is 10 watts per channel, and it operates on 12 VDC. You can get companion stereo speakers as an accessory, if you wish. Price of Micro 42 is \$119.95. For further information write to Ampex Corp., 2201 Estes Avenue, Elk Grove Village, Ill. 60007. (Continued on next page)

# TWO NEW "plastic view" screwdriver kits

## EASY TO USE, CARRY & STORE

These neat, extremely compact kits fit hip pocket, tool box, boat kit, glove compartment . . . can also be hung on a wall. Durable "Plastic View" zipper case permits instant identification of tools.

Amber plastic (UL) Service Master handles are shock-proof, breakproof, have patented spring holding device that accepts all Xcelite Series 99 blades — lets you add tools as needed at minimum cost.

Space saving, single-ended interchangeable blades . . . can be used with Xcelite extensions for extra reach.

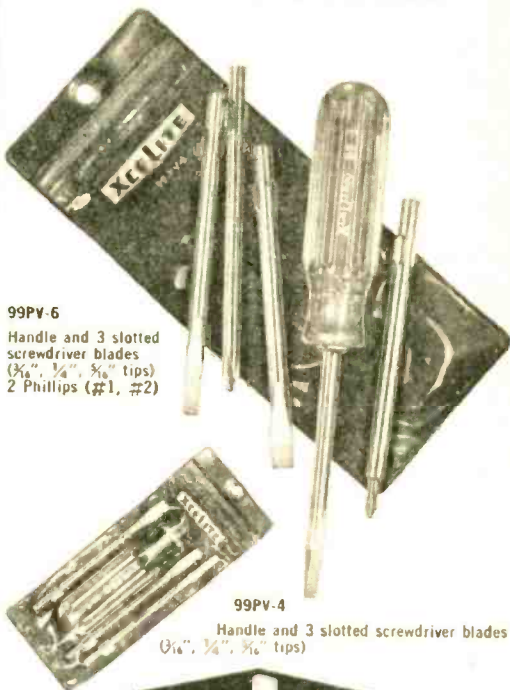

99PV-6

Handle and 3 slotted  
screwdriver blades  
( $\frac{3}{16}$ ",  $\frac{1}{4}$ ",  $\frac{5}{16}$ " tips)  
2 Phillips (#1, #2)

99PV-4

Handle and 3 slotted screwdriver blades  
( $\frac{3}{16}$ ",  $\frac{1}{4}$ ",  $\frac{5}{16}$ " tips)

# XCELITE

XCELITE INC. • 80 BANK ST., ORCHARD PARK, N. Y. 14127  
Send Catalog 166 with information on "Plastic View"  
Screwdriver Kits.

name \_\_\_\_\_

address \_\_\_\_\_

city \_\_\_\_\_

state & zone \_\_\_\_\_





IF strip. The 382C includes Perfectune, a light that automatically goes on when stations are perfectly tuned in. Not a meter, Perfectune is



Scott 382C AM/FM Stereo Receiver

actually a miniature computer. The FM IF section contains a quartz crystal lattice filter, aligned once at the factory, and said never to need aligning again. The IC multiplex incorporates 40 transistors and 27 resistors, and gives stereo separation of 40 dB. Solder joints are eliminated with Scott's wire-wrap technique—a wire is wrapped around a terminal under great tension, effecting a permanent bond. There's also a muting circuit which cuts out noise between FM stations, a 3-dimensional back-lit dial, and plug-in speaker connectors which get rid of phasing problems. Controls are: dual bass and treble; stereo balance; input selector; tape monitor; speakers *on/off*; power *on/off*; volume; volume compensation; muting; noise filter; precision signal strength meter; front panel stereo headphone output; tuning; stereo/mono mode switch. Frequency response, 20-20,000 Hz -1 dB. Size is 15¾x5x11½ in., price \$299.95. For more details write to H. H. Scott Inc., 111 Powder Mill Rd., Maynard, Mass. 01754. ■



*Live Better Electronically With*

# LAFAYETTE RADIO ELECTRONICS

## 1970 Catalog 700 **FREE!**

**Now OFF PRESS  
BETTER THAN EVER  
496 Pages**

Stereo Hi-Fi • Citizens Band • Ham Gear • Tape Recorders • Test Equipment • TV and Radio Tubes and Parts • Cameras • Auto Accessories • Musical Instruments • Tools • Books

Featuring Everything in Electronics for  
• HOME • INDUSTRY • LABORATORY  
from the "World's Hi-Fi & Electronics Center"

LAFAYETTE Radio Electronics  
Dept. 25099 P.O. Box 10  
Syosset, L.I., N.Y. 11791

---

Please Send the FREE 1970 CATALOG 700 25099

Name

Address

City

State  Zip

**TUBES!** **CORNELL** **TUBES!**

Send For **FREE** **CORNELL'S** **NEW 1969** **CATALOG** **Many New Items**

**30¢** per tube

**33¢** per tube **WE SELL PICTURE TUBES**

IN LOTS OF 100

4219 E UNIVERSITY AVE., SAN DIEGO, CALIF. 92105

WRITE NOW FOR **1970** **SENT FREE** **MCGEE'S** **CATALOG**

**1001 BARGAINS IN**

SPEAKERS—PARTS—TUBES—HIGH FIDELITY  
COMPONENTS—RECORD CHANGERS—  
Tape Recorders—Kits—Everything in Electronics

1901 McGee Street, Kansas City, Missouri 64108

**CLASSIFIED  
SECTION  
ON PAGE 111**

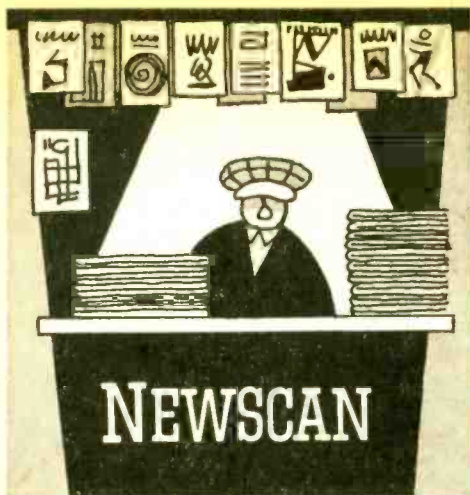

## Solid State Solid

Transistors are back in the electronic industry's spotlight, about to do again what they do best—replace vacuum tubes. This time, they seem ready to crack the vacuum tube's last bastion: the huge, virtually untouched U. S. television set market.

TV set makers should be a \$55 million per year semi-conductor customer by 1971, compared to \$16 million in 1967. The reason: Transistor costs have finally dropped so far below those of vacuum tubes that the wholesale redesign of TV circuitry is now justified.

For set manufacturers, the switch to transistors means a chance to revolutionize styling and design. And for set owners, the coming of



Engineer examines tiny, low-cost transistors Texas Instruments believes will push most vacuum tubes out of US television sets by 1971. New breeds of transistors, encapsulated in plastic instead of more expensive metal enclosures, often cost as little as 15 cents apiece in production quantities.



transistorized TV means lower maintenance costs, since about five out of six service calls result from vacuum tube failure or color misalignment due to tube aging.

Last year 10,900,000 color and black-and-white TV sets came off U.S. assembly lines. But less than *five percent* of their circuits used transistors. The reason: skilled TV set designers have had years of experience in milking the most performance at the lowest cost from vacuum tube circuits. During those years, transistors were causing a revolution in the radio industry. The tiny specks of silicon pushed tubes out of radios because they were 20 or more times smaller, less power-hungry, and longer-lived. But TV designers couldn't justify a shift to transistors on these grounds because most of a TV set's size, weight and power consumption is tied to the picture tube—which even transistorized sets must use.

Howard Bonner, director of TI's Application Group and former chief engineer of Philco-Ford's TV set facility, now believes that due to reduced manufacturing costs, transistors will now push vacuum tubes out of the last industry they dominate. By 1971, when U. S. set manufacturers anticipate producing 12 million sets, Mr. Bonner sees the percentage of transistorization increasing from the present five percent to approximately *70 percent*.

According to Mr. Bonner, the first areas of the TV sets to be transistorized are the tuners and intermediate frequency circuits, where transistors have performance, as well as price advantages over tubes. Next, he believes, transistors will push tubes out of the signal processing circuit: synch separation, automatic gain control, color synchronization and other areas.

## A Hop, Skip and a Jump

The forces that make one athlete jump farther than another are being measured electronically by a scientist/long-jumper at the University of California. He's Dr. Melvin Ramey, a 30-year-old assistant professor of Civil Engineering who's still fit enough to better 45 feet in the triple jump.

His studies to date have shown that a long jumper—himself included—exerts a force of from 600 to 900 pounds in the 0.1 to 0.2 second his leg drives for take-off. Making possible Dr. Ramey's studies in human ballistics is a new type of recording instrument called a Status electrographic recorder which was developed by Varian Associates. The electrostatic device instantly produces a permanent graph of the lift-off thrust.

In Dr. Ramey's words, "We rarely have any precise data on athletics other than finishing times or distances." What specifically makes one athlete able to jump 26 feet or more while another apparently as strong and quick cannot reach 22 feet?



Under the close observation of Dr. Melvin Ramey, University of California sophomore trackman Keith Williams takes off from instrumented platform as recorder plots his thrust during long jump test. Grid lines on wall serve to locate his center of gravity during trajectory to a landing on gym mats.

"I think," continued Dr. Ramey, who lettered in the triple and long jump at Penn State, "we may be able to aid the physical educator and coach help each man reach his unknown potential. Precise measurements of each component of an event will indicate levels of strength which should be attained by weight training or other means recommended by the trainer.



"For example, the electrographic chart of a 22-foot jumper may show adequate speed on the runway but a deficiency in vertical thrust at takeoff. Because the Varian electrographic chart is shown in pounds it can be compared with the chart of a 26-footer so the athlete and his coach can see exactly how much stronger his takeoff leg must become.

"By the same token, we may not encourage some boys to train for certain events," he said.

"The same measurement techniques are applicable to many sports and events in which running and jumping play a key role," Dr. Ramey observed, adding that with research program sponsorship he could instrument an entire running track.

### Electronic Yo-Yo

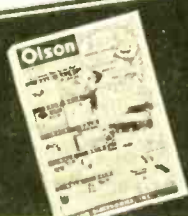
A formidable weapon in man's age-old struggle against the unknown was brought into service this past April when the University of Maryland dedicated a new \$7.8-million cyclotron facility at its College Park campus. Built jointly by the university, Raytheon Company of Lexington, Mass., and Compagnie de Telegraphie Sans Fil (now Thomson-CSF) of Versailles and Paris, the new atom smasher is the world's largest sector-focused isochronous cy-

**Fill in coupon for a FREE One Year Subscription to OLSON ELECTRONICS' Fantastic Value Packed Catalog—Unheard of LOW, LOW PRICES on Brand Name Speakers, Changers, Tubes, Tools, Stereo Amps, Tuners, CB, and other Values. Credit plan available.**

NAME \_\_\_\_\_  
 ADDRESS \_\_\_\_\_  
 CITY \_\_\_\_\_ STATE \_\_\_\_\_  
 GIVE ZIP CODE \_\_\_\_\_

If you have a friend interested in electronics send his name and address for a FREE subscription also.

**OLSON ELECTRONICS**

463 S. Forge Street Akron, Ohio 44308

A sensible way to protect  
(and preserve) your copies of  
**Elementary  
Electronics**



A durable, custom-designed Library Case will protect your copies of ELEMENTARY ELECTRONICS from dust and wear. At the same time, it will help you conserve valuable space and reduce library clutter.

Each Library Case has a muscular 9 $\frac{3}{4}$ "x6 $\frac{3}{4}$ "x4 $\frac{1}{2}$ " frame that can hold 24 issues of ELEMENTARY ELECTRONICS.

In elegant washable Blue simulated leather, its spine is embossed with 16-k gold lettering for maximum legibility. (Each Library Case also includes gold transfer so you can print the volume and year each case contains.) To order, merely fill in and return the form below.

To: JESSE JONES BOX CORP.  
 P. O. Box 5120, Dept. D, Philadelphia, Pa. 19141

Please send me \_\_\_\_\_ ELEMENTARY ELECTRONICS Library Cases at \$3.50 each.\* I understand this price includes postage, packing and handling. (\*3 Library Cases for \$10.00. 6 for \$19.00.) My check (or money order) for \_\_\_\_\_ is enclosed.

NAME \_\_\_\_\_  
 ADDRESS \_\_\_\_\_ (PLEASE PRINT)  
 CITY \_\_\_\_\_ STATE \_\_\_\_\_ ZIP \_\_\_\_\_

Note: Satisfaction guaranteed or money refunded.  
 Allow 3 weeks for delivery

clotron. It will hurt hydrogen nuclei at half the speed of light at a variety of targets selected by the staff of the school's department of physics and astronomy.

The experimenters will use the machine to try to unravel the still mysterious forces underlying both the atomic nucleus and certain cosmological and astro-physical problems. The unraveling of this structure is one of the most difficult and challenging problems confronting modern science. Although the machine will be used mainly for nuclear research, other studies are planned in space physics, medicine and biology, radio-chemistry and solid state physics.

The cyclotron, which took three years to construct, is housed in an underground pit behind eight-foot walls used as shielding from the intense radiation that the cyclotron generates. The machine itself is a variable energy accelerator that will be used to produce high intensity beams of protons (hydrogen nuclei), and other particles. The protons will have an energy of 10 to 140 million electron volts (MeV). Deuteron energies will vary from 10 to 95 MeV, alpha particle energies from 20 to 190 MeV.

The particles will spiral outward from the center of the machine under the control of an

electromagnet with a 400-ton steel core. The main coils for the magnet carry 2,500 amperes of current at 200 volts.

The acceleration electrodes are two 90-degree dees separately driven by two independent power amplifiers for push-pull or push-push operation from 9.8 to 22 MHz. The power for each dee is obtained from a Machlett 8786 tube capable of delivering 260 kilowatts of RF power.

The accelerating particles reach their peak velocity at the perimeter of the circular machine. Here they are extracted through a special port and are directed to the various target areas in the building by the electro-magnets of the beam handling system. The extraction radius of the machine is 45 inches. During operation, the interior of the cyclotron is maintained at a pressure nearly a billion times smaller than atmospheric pressure. Pumpdown time to achieve a vacuum of  $10^{-6}$  Torr is three hours.

The cyclotron complex is built on six levels and measures 145 feet from top to bottom. The cyclotron itself is 25 feet underground in a room known as the cyclotron cave. A lower level, the pit, contains ion generating equipment, special power supplies for the magnets, and various parts of the cooling system. ■

# Learn more about electronics this easy way by mailing the coupon below

EVERY ISSUE of **ELEMENTARY ELECTRONICS** brings you easy-to-follow aids for better understanding of theory and applications of electricity and electronics... in word and picture with diagrams that are easy to follow... a source of up-to-the-minute information for everyone interested in electronics who wants to increase his knowledge... followed every issue by thousands of CBers, Hams, SWLs, Experimenters.

Save  
up to  
\$3.50

**MAIL THE COUPON** below today and you can save up to \$3.50 over the cost of buying copies on the newsstand... and be sure you don't miss a single information-packed issue... because the mailman will bring your copy to your door just as soon as each issue is off the press.



Elementary Electronics, 229 Park Avenue South, New York, N. Y. 10003

I don't want to miss a single issue. Enter my subscription for:

- 3 years—18 issues—\$10.00  
SAVING ME \$3.50 over the newsstand price
- 2 years—12 issues—\$7.00  
SAVING ME \$2.00 over the newsstand price
- 1 year—6 issues—\$4.00  
SAVING ME 50¢ over the newsstand price

- I enclose \$\_\_\_\_\_
- Please bill me

NAME \_\_\_\_\_

STREET ADDRESS \_\_\_\_\_

CITY \_\_\_\_\_

STATE \_\_\_\_\_ ZIP CODE \_\_\_\_\_

Outside U.S. and Canada: Add \$1.00 per year

EE-969





## NEW NEWSFRONT

This is the moon. Some of the most important headlines in the history of man are now originating here!

Get to know it now. Get to know it well. Get the new Hammond Moon Globe.

A triumph of graphics, cartography and research, the Hammond Moon Globe pinpoints Archimedes . . . the Sea of Serenity . . . Copernicus . . . the Ocean of Sorrows . . . Herodotus . . . scores of names that will very shortly be as commonplace as New York or Chicago. It will help you follow all future moon probes step by step. Localize landing sites. Check exploration areas. Spot mountain ranges, waterless seas and craters. Easily locate every major physical feature of the entire lunar surface with the aid of the globe's longitudinal and latitudinal grid.

The inflatable Hammond Moon Globe is a generous 13 inches in diameter; constructed of tough, lifetime plastic; is expertly lithographed by Hammond's own craftsmen.

Available in illuminated model, \$16.95, or standard model, \$12.50.

**HAMMOND**<sup>®</sup>  
INCORPORATED

Dept. H-1EE9  
515 Valley Street  
Maplewood, N. J. 07040

Please send . . . . . Hammond Moon Globe(s), as checked below. I enclose check or money order plus 75¢ for postage & handling:

..... Illuminated Model(s) @ \$16.95 ea.

..... Standard Model(s) @ \$12.50 ea.

Name .....

Address .....

City/State/Zip .....

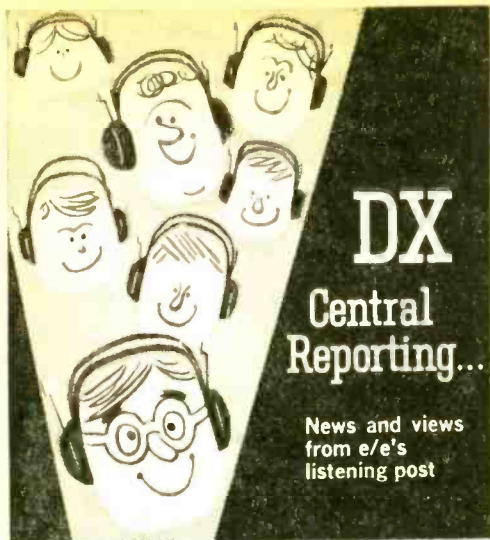

by Don Jensen

### ● DON'T GIVE UP THE SHIP

This is the off season for many SWLs. Low powered, long distance catches on the short-wave bands are few and far between now, it's true, but that's no reason to pull the big switch until colder weather arrives. This is the time for *DXperimentation*, tuning lesser known stations closer to home that you didn't have time for, or maybe never even thought about, during last winter's peak DX period.

There are many little-trod paths your off season DXing can take. For example, for some really unusual domestic SWLing, how about the lightship and off-shore light tower stations operated by the U.S. Coast Guard? They are naturals for dog days DXing when millions of Americans head, lemming-like, for the nearest body of water big enough to float a boat. And, if you're a boater yourself, with a marine band receiver aboard your "Neversink II," you can try your hand at some maritime mobile DXing!

With their mast-mounted beacons, these



*The Scotland lightship days are numbered. The U.S. Coast Guard is replacing lightships with manned and unmanned light towers.*

Coast Guard vessels have been guiding shipping past coastal shoals and Great Lakes reefs since 1820. Until a few years ago, there were some 19 lightships on duty stations, mostly along the Atlantic seaboard.

Since 1961, the government gradually has been replacing them with permanent tower platforms, perched, spider-like, on legs 80 feet above the waves. By the early 1970s, all will have disappeared from the sea.

Besides their powerful lights, foghorns and underwater warning bells, the Coast Guard's light vessels (L/Vs) carry shortwave transmitters for communicating with shore-based sta-



*The Ambrose light tower rides high above the waves of the Atlantic just outside of New York City. It looks like a baby flattop.*

tions and passing ships. Several marine band frequencies are used for daily weather transmissions and other voice traffic.

DXers have reported hearing the Delaware lightship, anchored in the mouth of Delaware Bay off New Jersey's southern tip, contacting Coast Guard stations NMK, Cape May, N.J., and NMY, New York, on 2,662 kHz. The Delaware and Barnegat, N.J., lightships soon will be replaced by giant, unmanned towers.

Off New England, the Boston and Portland L/V's are heard on 2,182 kHz, while the Nantucket Light has been noted on 2,694 kHz at times.

Other floating beacons? Well, Pollock Rip L/V has been logged on 2,694 kHz, and the Diamond Shoal L/V has been heard with traffic for the Oregon Inlet Coast Guard station in North Carolina on both 2,182 and 2,702 kHz. Presumably the lightships also use a number of other frequencies. The Ambrose tower regularly communicates with NMY, New York, on 2,256 and 2,670 kHz.



# This valuable Personalized Confidential Guide to 379 Super Money-Making Opportunities is yours FREE

...with a 100% NO RISK CHARTER TRIAL SUBSCRIPTION to the  
INCOME OPPORTUNITIES NEWSLETTER Reporting Service

IF you would like to own your own business... if you want to start on the way to BIG MONEY while keeping your present job... IF you prefer to work from your own home... IF you want to take advantage of the amazing new opportunities now open to ambitious men and women... YOU should read this ad and clip the coupon below.

YOU CAN get out of your rut and start earning big money right now with the 379 money-making opportunities in a new confidential report entitled: AMERICA'S BEST MONEY-MAKING OPPORTUNITIES.

IT'S YOURS FREE, too, when you accept this no risk offer.

LEARN how thousands of ambitious people like yourself are opening the door to really big income and security in their own business in this exclusive report personalized for you.

It tells you about:  
**55 BUSINESSES YOU CAN START FOR UNDER \$500!**

Proven profit makers which offer independence and financial security...many can be started on a part time basis...opportunities to start your own business with a next-to-nothing investment...with addresses for obtaining detailed information.

### 200 HIGH-PROFIT FRANCHISES!

Selected franchise profit-making opportunities with initial investment of under \$3,000...covers all major areas such as: services...products...schools...sports and recreation...stores...vending machines...cosmetics...health aids and much more.

### SUCCESS SECRETS OF 23 TOP MAIL ORDER PROS

The inside success stories behind the big mail order money makers...with a checklist of 23 best sellers...and full details you can use to get into the big mail order field.

### RED HOT NOVELTIES FOR SALESMEN

How to get your share of the multi-billion dollar advertising specialties industry which offers unlimited opportunities to salesmen. Commissions on matchbooks alone run to more than \$7,000,000...sources for profit making in major areas.

## Extra Valuable Bonus

These Special MONEY MAKING REPORTS are included with your NO RISK subscription:

### 25 HOME-BASED, SPARE-TIME MONEY-MAKERS

For anyone who would want additional income—laminating, specialty mail order, secretarial services. Full details on how to get customers and how to price your product for profit!

### DIRECT SELLING DIRECTORY

Leaders in the direct selling field—Salad-master, Tupperware, Stanley, and many others help put you on the path to financial independence selling nationally known products...and earning commissions of up to \$1,000 monthly!

### 20 FASTEST GROWING RETAIL BUSINESSES!

Survey and report of independent businesses which are currently booming—coin-op car wash, beauty/wig salons, poodle grooming parlors... economic indicators to help you to make the

wisest choice for a profitable business!

### 22 MONEY-MAKING HOBBIES!

Hobbies are not only for fun, but can be profitable as well! Here's how to turn your coin/stamp collecting, your tropical fish or even your own art and craft items into a substantial secondary source of income!

### 33 PART-TIME, FULL-TIME VENDING MACHINE OPPORTUNITIES

Learn the secrets to big steady income with your own vending machine operation. Get the inside information on types of machines, kinds of products, investment needed, potential income, how to select locations—and much, much more!

### 22 LOW-COST, HIGH PROFIT FAST FOOD FRANCHISES

How you can cash in on the great fast food restaurant boom. Details on types of opportunities such as: Barbecue, burgers, franks, Cantonese, donuts, etc. with information you need on investment and how to project profits.

## WHY we want to send you this Valuable Personalized Confidential Report FREE

TO HELP YOU TO DISCOVER a new service that brings you hundreds of golden money making opportunities—the new INCOME OPPORTUNITIES NEWSLETTER Confidential Reporting Service...we will send you this valuable report FREE.

ALL YOU NEED DO is to accept our 100%



NO RISK OFFER to agree to try INCOME OPPORTUNITIES NEWSLETTER entirely at our risk. If after reading two issues you do not agree that this confidential opportunities reporting service will help you to learn about super money-making opportunities YOU can take advantage of to earn greater income and financial independence, you simply tell us and we cancel your subscription and YOU KEEP the Special Report. You have absolutely nothing to lose when you send in the NO RISK coupon below.

## Here's all you need do to get started on the way to BIG MONEY OPPORTUNITIES

JUST CLIP the coupon below and mail it with \$1.00 for 2 issues of INCOME OPPORTUNITIES NEWSLETTER—a \$3.00 value so you can see for yourself how valuable this reporting service will be to YOU. Then you decide if you want to receive each golden opportunity-packed issue.

## MAIL THIS NO RISK COUPON TODAY

INCOME OPPORTUNITIES NEWSLETTER 229 Park Avenue South, New York, N. Y. 10003

Here's my dollar. Send me 2 issues of INCOME OPPORTUNITIES NEWSLETTER (a \$3.00 value) and enter my 100% NO RISK CHARTER TRIAL SUBSCRIPTION to the complete INCOME OPPORTUNITIES NEWSLETTER Service at the low rate of \$1.50 per month for one year. After reading my 2 issues I will send you payment for my subscription or cancel my subscription and you will refund my dollar. When you receive my payment you will send me my personalized copy of the Confidential Report: AMERICA'S BEST MONEY MAKING OPPORTUNITIES. I will also receive the 6 VALUABLE BONUS REPORTS as part of my subscription. I may cancel my subscription at any time and receive a FULL REFUND for all issues still due me.

I'm already sold. Here's my \$18.00 for a full year's service. RUSH the Personalized Confidential Report AMERICA'S BEST MONEY MAKING OPPORTUNITIES right away...and add 2 extra months' service (value \$3.00) FREE. Same money-back guarantee of course.

NAME \_\_\_\_\_  
PLEASE PRINT—It prevents errors  
STREET ADDRESS \_\_\_\_\_  
CITY \_\_\_\_\_  
STATE \_\_\_\_\_ ZIP CODE \_\_\_\_\_

EE-969

To get started on the way to big income mail this coupon with only \$1.00 now.

INCOME OPPORTUNITIES NEWSLETTER

229 Park Avenue South,  
New York, N. Y. 10003

The most famous light vessel of them all, however, is no more! The Ambrose weighed anchor for the last time August 23, 1967, when she was replaced by a permanent tower structure at the entrance to New York's lower bay.

The Ambrose tower's three man crew lives a life of lonely luxury in the middle of the bay, half way between Sandy Hook and the Rockaways. In addition to its six-million candlepower light and other navigational aids, the Ambrose is outfitted with color TV, hi-fi, a well-stocked modern galley . . . even air conditioning. At night, though, the Coast Guardsmen can see the lights of Manhattan, so near, yet so far away.

These stations aren't great DX, though their irregular transmissions add some challenge, and they can provide some interesting listening opportunities during the off season.

## ● TIP TOPPER

King Mahendra, what took you so long? Since the pudgy, progressive monarch of the remote Kingdom of Nepal announced a four-year communications development plan back in 1962, DXers have waited anxiously to hear the new, improved Radio Nepal.

First stage, reportedly, was to install a second hand, 20-kW shortwave transmitter, purchased in Brazil, at Katmandu, capital of the isolated Himalayan country. Next, British engineers, London sources said, were busily at work building a completely new station with a 100-kW shortwave transmitter.

When the powerful Radio Nepal transmitter finally became operational, most SWLs were disappointed. Though widely heard in Asia, the new station was only rarely logged by Stateside listeners.

Now, however, thanks to a relatively new frequency and schedule, a growing number of DXers have been hearing this rare station. Operating on 11,970 kHz., Radio Nepal signs on at the unusual time of 0220 GMT. A haunting oriental signature tune precedes sign on. After a few resounding clangs of a great gong, Nepali language programming begins.

Even midwest SWLs have heard Radio Nepal until after 0300 GMT. Characteristically, the modulation is weak, causing what one listener has termed "strain level readability." No "armchair copy," but a good bet for the persistent SWL on some nights. Radio Nepal qualifies as our *Tip Topper* this issue.

## ● BANDSWEEP

810 kHz—HJGY, Radio Sutatenza, Colombia is regularly heard until sign off at 0403 GMT. This potent transmitter was personally dedicated last year by Pope Paul VI . . . . 1500 kHz—National Radio Club has a scoop here. New marine band transmitter on Anguilla

has provisions for medium wave broadcasting. Not heard yet, but worth a try if trouble re-occurs on this Caribbean isle . . . . 4,810 kHz—YVMG, Maricao, Venezuela with a surprise. English announcements, heard on Monday morning at 0105 GMT—That's Sunday night here, mate . . . . 4,845 kHz—Radio Botswana has moved from 4,836 to 0358 GMT sign on. This channel formerly was used by the BBC's Central African relay . . . . 6,050 kHz—Radio Australia's Darwin relay base uses this frequency, and several others, for its new 250 kW transmitters. These powerhouses have been running at reduced strength lately—just 100 kW . . . . 6,100 kHz—Been wondering about the time ticks heard late nights after the German signs off? It's the Portuguese Naval Observatory station with voice announcements each five minutes in Portuguese, natch . . . . 7,205 kHz—A pox on you if you don't try for Mozambique's "other" station, Radio Pax, which opens here at 0357 GMT . . . . 14,460 kHz—The psych-warfare boys are busy early mornings here with programs directed to North Korea. The Voice of the United Nations Command transmits from Okinawa . . . . 15,100 kHz—Windward Islands Broadcasting Service, at St. George's, Granada, plays request numbers and offers birthday greetings at 2045 GMT. OK, now all together. "Happy Birthday to you . . . . (Credits: Sheldon Miller, Florida; Bill Sparks, California; A. R. Niblack, Indiana; Grady Ferguson, North Carolina; National Radio Club; Newark News Radio Club; Japanese Short Wave Club)

## ● MISTAKEN IDENTITY

The slim, sharp-featured pilot leveled his P-47 Thunderbolt high above the Nicaraguan jungle and pointed the nose of the aging World War II fighter northeast toward Guatemala City.

For Jerry Fred DeLarm, a flying soldier of fortune from San Francisco, the flight that day, June 24, 1954, was a "milkrun" compared with

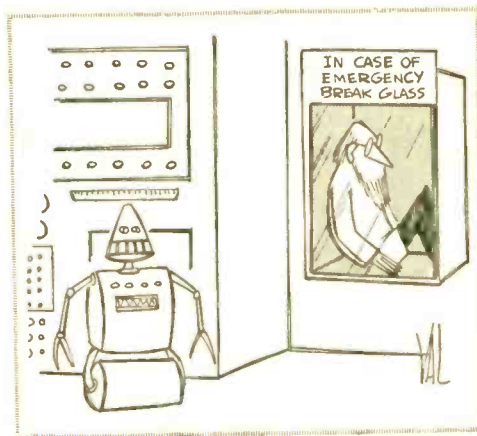

# THINK FUN! THINK BOAT-CAMPING . . .

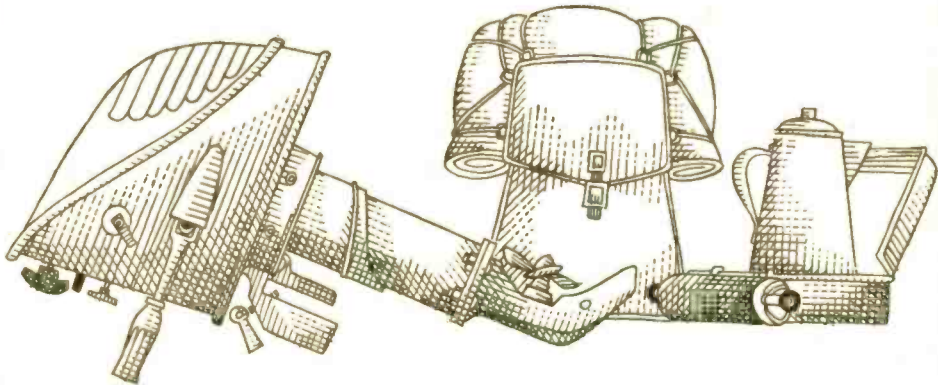

. . . And let Camping Journal, the world's largest camping magazine, show you how to get the most honest-to-goodness fun out of it

Boat-camping, with its soaring popularity, is featured each and every month in CAMPING JOURNAL, bible of the great outdoors. Outstanding authorities tell you how to rig, equip and maintain your boat for maximum economy, safety and enjoyment. They spot the launching ramps in your own neck of the woods, report on the lunker hot-spots . . . ideal cruises . . . dream skiing waters. And if you trailer your boat, as most of us do, CJ regularly features outstanding trips, what to see, gear to take along. There are construction projects for the build-it buff and expertise on the expanding recreational-vehicle world—a natural

boating companion. Doesn't it seem likely that CAMPING JOURNAL can add to your appreciation of boating and kindred outdoor recreation? Use the coupon below and—Welcome Aboard!

CAMPING JOURNAL, Subscription Dept. EE-969  
229 Park Ave. S., New York, N.Y. 10003  
Begin my 1-year subscription to CAMPING JOURNAL with the next issue.  
 Enclosed is \$6.00 for 12 issues  Bill me later  
(Outside USA and Canada, add \$1.00)  
NO STAMPS PLEASE!

Name .....

Address .....

City .....

State ..... Zip.....

# You miss plenty...

when you miss a single issue of



NEW DEVELOPMENTS in the world of electronics come so fast these days that there's hardly a field where there aren't new application breakthroughs.

THAT'S WHERE the bigger and better coverage you find in every issue of **SCIENCE AND ELECTRONICS** comes in. It keeps you posted on the really important developments in language you don't have to be an engineer to understand... with diagrams you can easily follow.

DON'T RISK missing the kind of reading that has made **SCIENCE AND ELECTRONICS** (formerly Radio-TV Experimenter) must reading every issue for practicing electronics hobbyists—amateurs, SWLs, CBers, experimenters, project builders.

You can **SAVE PLENTY** when you use the coupon below

BE SURE of every issue by subscribing now... and you'll be saving over the cost of buying your copies on the newsstand... and you'll never miss an issue because the postman will bring it right to your door. Clip and mail the coupon today.

## Science and Electronics

229 Park Avenue South New York, N. Y. 10003 EE-969

I don't want to miss a single issue. Enter my subscription for:

- 3 years — 18 Issues — \$10  
SAVING ME \$3.50 over the newsstand price
- 2 years — 12 issues — \$7  
SAVING ME \$2.00 over the newsstand price
- 1 year — 6 Issues — \$4  
SAVING ME 50¢ over the newsstand price
- I enclose \$\_\_\_\_\_  Please bill me

NAME \_\_\_\_\_

STREET ADDRESS \_\_\_\_\_

CITY \_\_\_\_\_

STATE \_\_\_\_\_

ZIP CODE \_\_\_\_\_

Outside U.S. and Canada: Add \$1.00 per year

## DX CENTRAL

his wartime missions over Saipan.

His target? The transmitters of La Voz de Guatemala, TGWA, the official government station of the Red-tinged regime of Jacobo Arbenz Guzman. DeLarm was practically the entire air force of a rag-tag Army of Liberation poised near the Guatamalan frontier. Supposedly, the anti-communist rebels had the backing of the U.S. Central Intelligence Agency.

The fighter banked steeply over the capital of the "Land of Eternal Spring." Below, a 166-foot radio tower stabbed skyward. The pilot pushed his Thunderbolt into a bomb run.

The bombs found their mark, but DeLarm had goofed. It wasn't the government station he'd knocked out. It was TGNA, the religious, non-political Radio Cultural, owned by the Dallas-based Central American Mission and run by the Rev. Harold Van Broekhoven, an evangelist from Passaic, N.J.

Van Broekhoven, together with Canadian radio technician, H. Leslie Garrison and a tiny missionary staff, had put the station together on a shoestring budget some four years earlier. Its dual four kilowatt transmitter aired religious and cultural programs on medium and short-wave.

But, because of a quirk of banana republic politics, the station had been blasted off the air. Though it wasn't much consolation to Van Broekhoven, DeLarm returned four days later to bomb the right station.

The Guatemalan regime quickly folded and Arbenz went into exile in Cuba. But TGNA came back, and by the way, so did La Voz de Guatemala, though under "new management." Today, both stations can still be heard during the evening hours. TGNA on 5,955 kHz; TGWA on 6,180 kHz. ■





# ELEMENTARY ELECTRONICS ETYMOLOGY

By Webb Garrison



## Piezoelectricity

▲ Late in the last century, magnetic and electric properties of crystals came under intensive scrutiny. Working with tourmaline, a complex borosilicate that occurs in 3-, 6-, and 9-sided prisms, European scientists discovered an unexpected effect. When tourmaline crystals are heated, faces linked with one end of their uniterminal (or polar) axes develop positive electrical charges. Opposite faces develop negative charges. When such crystals are cooled, the charges are reversed. From a classical term for "fire," *pyroelectricity* was coined to name the heat-linked flow of electrons.

Pyroelectric effects, it was found, are associated not only with tourmaline but also with such diverse substances as quartz, tartaric acid, and cane sugar. Then it was found that when subjected to mechanical stress, a pyroelectric crystal develops a potential difference across some of its faces. Conversely, such substances produce a mechanical force when voltage is applied in a suitable way. From Greek for "to press," the author of an 1895 volume on crystallography called stress-induced current *piezoelectricity*.

Electricity produced by pressure seemed only a laboratory curiosity. But later it was found that an assembly of piezoelectric crystal elements, adjusted to resonate to a desired frequency, can be used to control and measure frequency with great accuracy. Interconversion of electric and elastic waves, accomplished by means of the piezoelectric effect, may prove important in long-range exploration of space.

## Avalanche

▲ Wherever there are mountains plus snow, the frozen stuff poses special dangers. Sometimes it forms thick drifts that choke valleys for days. Melting may create flood conditions.

In rugged terrain, there is yet another danger. Accumulated snow may begin sliding down a steep grade. Momentum of the moving mass

causes it to dislodge and then pick up new quantities of snow, so that through a self-feeding cycle the power of the slide increases very rapidly. From an early word for "descent," natives of the French Alps called a rapidly-descending mass of snow an *avalanche*. Adopted into English, until recent times the technical word was reserved as a label for mountain catastrophes.

Now it is applied to a group of electronic phenomena, all of which involve some type of breakdown process. Especially in semiconductors, gas-discharge tubes, and Geiger counters, collisions between high-energy ions can lead to production of more ions; these, in turn, accelerate the process of collision. Even though no descending snow is involved, no other label is quite so appropriate as "avalanche" for such a self-multiplying process.

## Lead

▲ From classical times, craftsmen have made wide use of a heavy metal that fuses at a low temperature. Dull pale bluish-gray in color, it is so malleable that it can be made into objects of any desired shape.

Linguistic evidence suggests that it was known in Britain very early. A rare codex (handwritten volume) that dates from the 10th century mentions a variety of ores and metals, including what the author terms "leades."

Precisely where the name originated, no one knows. It has north-European roots, however. For in Anglo-Saxon it was called *lǣad*, a name equivalent to German *löd* and Dutch *lood*. A plausible guess links all these terms with an Old Norse label that indicated a primitive kind of draw-plate for manufacture of wire.

Whatever its ultimate source, the name of the metal that could easily be drawn was gradually altered so that it emerged into English as *lead*. Scholars preferred Latin *plumbum*, from which the title of the modern *plumber* (originally an expert in the use of lead) stems.

Artisans who spoke no Latin used lead in making pots, cauldrons, seals, coffins, stained glass windows, metal roofing plates, bullets, and many other common artifacts.

Very late in the history of its use by man, electric properties of lead were discovered. An early "accumulator" or lead-acid cell, forerunner of the modern storage battery, used sponge lead for the negative plates and lead dioxide for the positive plates—with dilute sulphuric acid serving as the electrolyte.

In today's sophisticated electronic systems, lead's importance is decreasing except in solders. But lacking an abundant supply of the stuff that ancients drew into wire, it would have been difficult or impossible to produce inexpensive storage batteries which were vital to development of self-starting automobiles. ■

# LITERATURE



## ELECTRONIC PARTS

- ★2. Now, get the all-new 512-page, fully illustrated *Lafayette Radio 1969* catalog. Discover the latest in CB gear, test equipment, ham gear, tools, books, hi-fi components and gifts. Do it now!
- ★5. *Edmund Scientific's* new catalog contains over 4000 products that embrace many interests and fields. It's a 148-page buyers' guide for Science Fair fans.
- ★4. *Olson's* catalog is a multi-colored newspaper that's packed with more bargains than a phone book has names. Don't believe us? Get a copy.
- ★1. *Allied's* catalog is so widely used as a reference book, that it's regarded as a standard by people in the electronics industry. Don't you have the 1969 *Allied Radio* catalog? The surprising thing is that it's free!
7. Before you build from scratch, check the *Fair Radio Sales* latest catalog for electronic gear that can be modified to your needs. *Fair* way to save cash.
8. Get it now! *John Meshna, Jr.'s* new 46-page catalog is jam packed with surplus buys—surplus radios, new parts, computer parts, etc.
23. No electronics bargain hunter should be caught without the 1969 copy of *Radio Shack's* catalog. Some equipment and kit offers are so low, they look like misprints. Buying is believing.
- ★140. How cheap is cheap? Well, take a gander at *Cornell Electronics's* latest catalog. It's packed with bargains like 6W4, 12AX7, 5U4, etc., tubes for only 33¢. You've got to see this one to believe it!
135. Get with ICs! *RCA's* new integrated Circuit Experimenter's Kit KD2112 is the first of its kind and should be a part of your next project. Get all the facts direct from *RCA*. Circle 135.

106. With 70 million TV and 240 million radios somebody somewhere will need a vacuum tube replacement at the rate of one a second! Get *Universal Tube Co.'s* Troubleshooting Chart and facts on their \$1.50 flat rate per tube.

10. *Burstein-Applebee* offers a new giant catalog containing 100s of big pages crammed with savings including hundreds of bargains on hi-fi kits, power tools, tubes, and parts.

11. Now available from *EDI (Electronic Distributors, Inc.)*: a catalog containing hundreds of electronic items. *EDI* will be happy to place you on their mailing list.

6. Bargains galore, that's what's in store! *Poly-Paks Co.* will send you their latest eight-page flyer listing the latest in available merchandise, including a giant \$1 special sale.

## CB—AMATEUR RADIO SHORTWAVE RADIO

102. No never mind what brand your CB set is. *Sentry* has the crystal you need. Same goes for ham rigs. Seeing is believing, so get *Sentry's* catalog today. Circle 102.

146. It may be the first—*Giljer's* speciality catalog catering to the SWL. Books, rigs, what-nots—everything you need for your listening post. Go *Giljer*, circle 146!

100. You can get increased CB range and clarity using the "Cobra-23" transceiver with speech compressor—receiver sensitivity is excellent. Catalog sheet will be mailed by *B&K Division of Dynascan Corporation*.

141. Newly-designed CB antenna catalog by *Antenna Specialists* has been sectionalized to facilitate the picking of an antenna or accessory from a handy index system. Man, *Antenna Specialists* makes the pickin' easy.

130. Bone up on the CB with the latest *Sams* books. Titles range from "ABC's of CB Radio" to "99 Ways to Improve your CB Radio." So Circle 130 and get the facts from *Sams*.

107. Want a deluxe CB base station? Then get the specs on *Tram's* all new Titan 11—it's the SSB/AM rig you've been waiting for!

96. Get your copy of *E. F. Johnson's* new booklet, "Can Johnson 2-Way Radio Help Me?" Aimed for business use, the booklet is useful to everyone.

129. Boy, oh boy—If you want to read about a flock of CB winners, get your hands on *Lafayette's* new 1969 catalog. *Lafayette* has CB sets for all pocketbooks.

46. Pick up *Hallcrafters's* new four-page illustrated brochure describing *Hallcrafters's* line of monitor receivers—police, fire, ambulance, emergency, weather, business radio, all yours at the flip of a dial.

116. Pep-up your CB rig's performance with *Turner's* M+2 mobile microphone. Get complete spec sheets and data on other *Turner* mikes.

48. *Hy-Gain's* new CB antenna catalog is packed full of useful information and product data that every CBER should know. Get a copy.

111. Get the scoop on *Versa-Tronics's* Versa-Tenna with instant magnetic mounting. Antenna models available for CBERs, hams and mobile units from 27 MHz to 1000 MHz.

45. CBERs, Hams, SWLs—get your copy of *World Radio Labs's* 1969 catalog. If you're a wireless nut or experimenter, you'll take to this catalog.

101. If it's a CB product, chances are *International Crystal* has it listed in their colorful catalog. Whether kit or wired, accessory or test gear, this CB-oriented company can be relied on to fill the bill.

103. *Squires-Sanders* would like you to know about their CB transceivers, the "23'er" and the new "55S." Also, CB accessories that add versatility to their 5-wattors.

## TOOLS

★78. Need a compact screwdriver kit? *Xcelite's* 99PV-4 and 99PV-6 kits consist of handle, 3 and 5 blades, respectively, in a see-thru zipper case. Get *Xcelite's* catalog 166!

118. Secure coax cables, speaker wires, phone wires, etc., with *Arrow* staple gun tackers. 3 models for wires and cables from 3/16" to 1/2" dia. Get fact-full *Arrow* literature.

## ELECTRONIC PRODUCTS

143. Bring new life to your hobby. Exciting plans for new projects—let *Electronics Hobby Shop* give you the dope. Circle 143, now.

44. Kit builder? Like wired products? *EICO's* 1969 catalog takes care of both breeds of buyers. 32 pages full of hi-fi, test, CB, ham, SWL, automotive and hobby kits and products—do you have a copy?

144. Hear today the organ with the "Sound-of-Tomorrow," the *Melo-Sonic* by *Whippany Electronics*. It's portable—take it anywhere. Send for pics and descriptive literature.

42. Here's colorful 116 page catalog containing a wide assortment of electronic kits. You'll find something for any interest, any budget. And *Heath Co.* will happily send you a copy.

128. If you can hammer a nail and miss your thumb, you can assemble *Schober* organ. To prove the point, *Schober* will send you their catalog and a 7-in. disc recording.

12. *C. B. Hanson* new Automatic Control records both sides of a telephone call automatically—turns off automatically, too! Get all the details—today!



# LIBRARY

★ Starred items indicate advertisers in this issue. Consult their ads for additional information and specifications.

126. Did you dig *Delta's* new literature package chucked full of pics and specs on such goodies as an FET-VOM, SCR ignition system, computerized auto tach, hi-voltage analyzer, etc.? Man, then let *Delta* know you're alive! Circle 126 now!

109. *Seco* offers a line of specialized and standard test equipment that's ideal for the home experimenter and pro. Get specs and prices today.

9. Troubleshooting without test gear? Get with it—let Accurate Instrument clue you in on some great buys. Why do without?

145. *Alco Electronic Products* has 28 circuit ideas using their remote control relay. Get 100-and-one odd jobs done at home without calling an electrician. Get all the facts today!

## SCHOOLS AND EDUCATIONAL

★74. Get two free books—"How to Get a Commercial FCC License" and "How to Succeed in Electronics"—from *Cleveland Institute of Electronics*. Begin your future today!

★3. Get all the facts on *Progressive Edu-Kits Home Radio Course*. Build 20 radios and electronic circuits; parts, tools and instructions come with course.

142. *Radio-Television Training of America* prepares you for a career—not a job. 16 big kits help you learn as you build. 120 lessons. Get all the facts today!

114. Prepare for tomorrow by studying at home with *Technical*

*Training International*. Get the facts today on how you can step up in your present job.

136. *International Correspondence Schools* has a 384-page manual explaining the function, operation, and objectives of *ICS*. Get the facts on 266 courses of study currently available. Sorry, offer may expire soon.

137. For success in communications, broadcasting and electronics get your *First Class FCC license* and *Grantham School of Electronics* will show you how. Interesting booklets are yours for the asking.

## HI-FI/AUDIO

104. You can't hear FM stereo unless your FM antenna can pull 'em in. Learn more and discover what's available from *Finco's* 6-pages "Third Dimensional Sound."

119. *Kenwood* puts it right on the line. The all-new *Kenwood FM-stereo* receivers are described in a colorful 16-page booklet complete with easy-to-read-and-compare spec data. Get your copy today!

30. *Shure's* business is hi-fi—cartridges, tone arms, and headphone amps. Make it your business to know *Shure!*

17. Mikes, speakers, amps, receivers—you name it, *Electro-Voice* makes it and makes it good. Get the straight poop from *E-V* today.

99. Get the inside info on why *Koss/Acoustech's* solid-state amplifiers are the rage of the experts. Colorful brochure answers all your questions.

26. The all new, lavishly-illustrated, full-color brochure, "At Home With Stereo" clues you in on *H.H. Scott's*

1969 stereo consoles. Discover how to pick a hi-fi console for your living room.

## TAPE RECORDERS AND TAPE

14. You just gotta get *Craig's* new pocket-size, full-color folder illustrating what's new in home tape recorders—reel-to-reel, cartridge and cassette, you name it! It looks like a who's who for the tape industry.

123. Yours for the asking—*Elpa's* new "The Tape Recording Omnibook." 16 jam-packed pages on facts and tips you should know about before you buy a tape recorder.

31. All the facts about *Concord Electronics Corp.* tape recorders are yours for the asking in a free booklet. Portable, battery operated to four-track, fully transistorized stereos cover every recording need.

34. "All the Best from *Sony*" is an 8-page booklet describing *Sony-Super-scope* products—tape recorders, microphones, tape and accessories. Get a copy today before you buy!

35. If you are a serious tape audiophile, you will be interested in the all new *Viking/Telex* line of quality tape recorders.

## TELEVISION

70. Need a new TV set? Then assemble a *Heath* TV kit. *Heath* has all sizes. B&W and color, portable and fixed. Why not build the next TV you watch?

127. *National Schools* will help you learn all about color TV as you assemble their 25-in. color TV kit. Just one of *National's* many exciting and rewarding courses.

## ELEMENTARY ELECTRONICS

Department 1069

229 Park Avenue South

New York, N.Y. 10003

Please arrange to have the literature whose numbers I have circled at right sent to me as soon as possible. I am enclosing 25¢ to cover handling. (No stamps, please.)

Sorry, only 20 circled items maximum.



Indicate total number of booklets requested

1	2	3	4	5	6	7	8	9	10
11	12	14	17	23	26	30	31	34	35
42	44	45	46	48	70	74	78	96	99
100	101	102	103	104	106	107	109	111	114
116	118	119	123	126	127	128	129	130	135
136	137	140	141	142	143	144	145	146	

NAME \_\_\_\_\_

ADDRESS \_\_\_\_\_

CITY \_\_\_\_\_

STATE \_\_\_\_\_ ZIP \_\_\_\_\_

# Electronics comes alive with NRI Training Kits

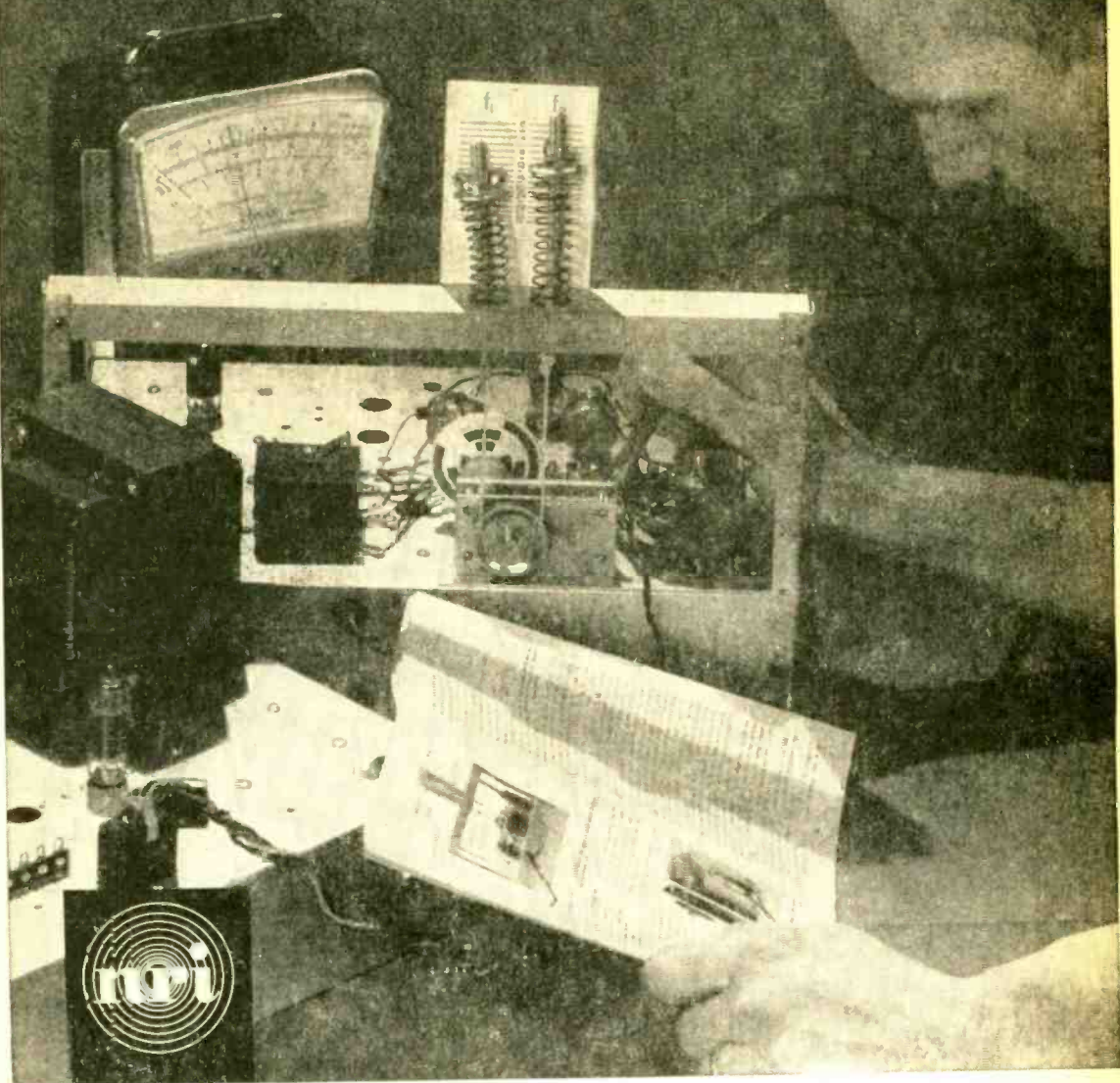

# DISCOVER THE EASE AND EXCITEMENT OF TRAINING AT HOME THE NRI WAY

## New Achievement Kit—Custom Training Kits—"Bite Size" Texts

Only NRI offers you this pioneering method of simplified "3 Dimensional" home-study training in Electronics, TV/Radio and Broadcasting/Communications. It's a remarkable teaching idea unlike anything you have ever encountered, the result of more than half a century of simplifying, organizing and dramatizing learning-at-home techniques. If you are an ambitious man—regardless of your education—you can effectively learn the Electronics field of your choice the NRI way.

NRI has *simplified* Electronics by producing "bite size" lesson texts averaging only 40 pages each. Dozens of illustrations open wide a picture window through which you'll see and understand practical uses of Electronics. You start out with NRI's exclusive Achievement Kit, containing everything you need to get started fast. (Illustrated at right.)

NRI has *organized* Electronics training to take you step-by-step from the first stages into more intriguing areas. Once you know the fundamentals thoroughly, it's easy to grasp more advanced theory and techniques. You move with confidence and enthusiasm into a new adventure filled with the excitement of discovery.

NRI has *dramatized* Electronics through the careful development of special training equipment that is programmed into your training systematically... beginning with your first group of lessons. Things you read about come alive in your hands as you build, experiment, purposely cause "problems" in circuits—and solve them. You learn to use test equipment, to build radios and TV sets, transmitter, or computer circuits. It's the priceless "third dimension" in NRI training... practical experience.



## YOU GET MORE FOR YOUR MONEY FROM NRI

Mail postage-free card now for your free NRI catalog. Then, compare. You'll find—as have thousands of others—NRI training can't be beat. Read about the new Achievement Kit sent the day you enroll; about "bite-size," texts and custom designed training equipment. See why NRI gives you more value. Whatever your reason for wanting more knowledge of Electronics, NRI has an instruction plan for you. Choose from major programs in TV/Radio Servicing, Industrial Electronics and Complete Communications. Or select from special courses to meet specific needs. Check the course of interest to you on postage-free card and mail today for free NRI catalog. Nosalesman will call. NATIONAL RADIO INSTITUTE, Electronics Div., Washington, D.C. 20016.

### Available Under NEW GI BILL

If you served since January 31, 1955, or are in service, check GI line in postage-free card.

More than 50 years of leadership  
in Electronics Training



## Career? Part-Time Earnings? Hobby? Choose From 12 Training Plans

- 1. TELEVISION-RADIO SERVICING** — Learn to fix all TV sets, including Color. Includes your choice of NRI Color Kit or 19" black-white TV Kit. Also covers radios, stereo hi-fi, etc. Profitable field spare or full-time.
- 2. INDUSTRIAL-MILITARY ELECTRONICS** — Basics to computers. Starts with fundamentals, covers servos, telemetry, multiplexing, phase circuitry, other subjects.
- 3. COMPLETE COMMUNICATIONS\*** — Operation, service, maintenance of AM, FM and TV broadcasting stations. Also covers marine, aviation, mobile radio, facsimile, radar, microwave.
- 4. FCC LICENSE\*** — Prepares you for 1st Class FCC License exams. Begin with fundamentals, advance to required subjects in equipment and procedures.
- 5. MATH FOR ELECTRONICS** — Brief course for engineers, technicians seeking quick review of essential math: basic arithmetic, short-cut formulas, digital systems, etc.
- 6. BASIC ELECTRONICS** — For anyone wanting a basic understanding of Radio-TV Electronics terminology and components, and a better understanding of the field.
- 7. ELECTRONICS FOR AUTOMATION** — Not for beginners. Covers process control, ultrasonics, telemetry and remote control, electromechanical measurements, other subjects.
- 8. AVIATION COMMUNICATIONS\*** — Prepares you to install, maintain, service aircraft in-flight and landing systems. Earn your FCC License with Radar Endorsement.
- 9. MARINE COMMUNICATIONS\*** — Covers electronic equipment used on commercial ships, pleasure boats. Prepares for FCC License with Radar Endorsement.
- 10. MOBILE COMMUNICATIONS\*** — Learn to install, maintain mobile transmitters and receivers. Prepares for FCC License exams.
- 11. ELECTRICAL APPLIANCE REPAIR** — Learn to repair all appliances, including air conditioning, refrigeration, small gas engines. Leads to profitable part or full-time business.
- 12. ELECTRONICS FOR PRINTERS** — Operation and maintenance of Electronic equipment used in graphic arts industry. From basics to computer circuits. Approved by major manufacturers.

\* You must pass your FCC License exams (any Communications course) or NRI refunds in full the tuition you have paid.

# ELECTRONICS

By Jack Schmidt

## THRU THE AGES

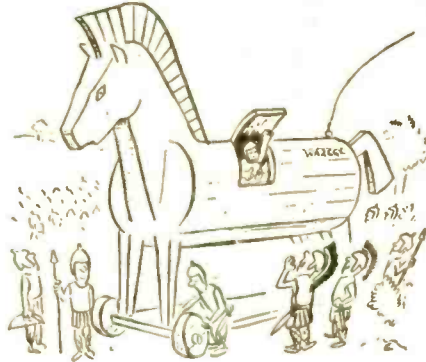
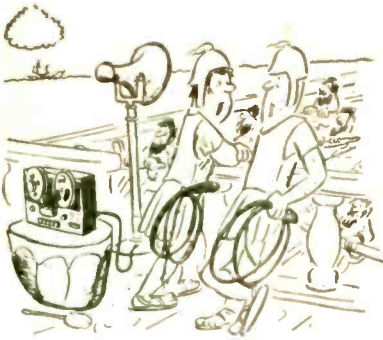
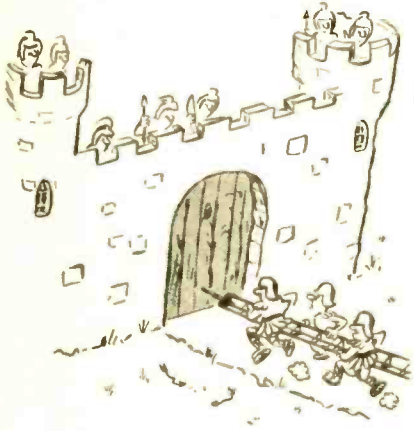

"...and to increase speed, you switch to seven inches-per-second."

"Don't try to DX Athens, it'll be all work tonight and no play!"



"Great Scott, the battery's run-down."

"Beep, Beep, Beep, Beep..."

ELEMENTARY ELECTRONICS

# T ouchdown winHailer

by Lars Jorgensen

Hey coach, how would you like, during practice, to be able to instruct your stars (?), every man jack of them if necessary—and still get home after a hard day's training session without having lost your voice or without having to suck cough drops because of a raw throat? The answer to your problem is our

Touchdown TwinHailer, a high-powered loud hailer that's almost guaranteed to drown out the grunts, groans, and general noise of a practice session. Of course, you can always use the Touchdown TwinHailer for other, more mundane matters: CB/CD crowd control, voluntary police or fire auxiliary work, or boat hailing. But none will be as much fun as shouting down a noisy bunch of players who think they are perfect and can do no wrong.

One IC = 5 Watts Output. The Touchdown TwinHailer uses a single IC (integrated circuit) to produce a solid 5 watts of clean audio to drive a pair of high-efficiency public-address (PA) re-entrant horns. And 5 watts input to these horns produces an awful lot of volume—particularly when the frequency response is tailored to deliver almost total power in the intelligence-carrying mid-range frequencies. The self-contained 30-V power supply, consisting of 20 standard D cells connected in series, operates the amplifier at full output power. (Continued Overleaf)



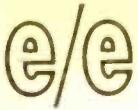

## TD TWINHAILER

Circuit design allows the TwinHailer to deliver sufficient power output if the battery voltage drops to 18 V. Therefore, you can expect long-term service from a set of batteries. Alkaline batteries will provide months of service since the standby drain of the TwinHailer is only 14 to 20 mA. As a further advantage, alkaline batteries may be recharged many times from an inexpensive charger, available from many electronic parts and hobby suppliers.

Heart of the TwinHailer is a GE type PA-246 integrated circuit. This small component packs a mike preamp, an amplifier/driver, and a 5-watt output stage in a single small unit. As a result, the TwinHailer is simple to build and unique in design, employing one of the latest electronic developments.

**Making the Board.** Because the IC is small and has closely spaced leads, the com-

plete amplifier circuit can be assembled on a simple printed circuit board (see our photo and drawing). You should have no difficulty in making the PC board, since broad copper foil areas are used. We've included an exact size drawing of this board which you can use as a pattern.

The first step is to thoroughly clean the copper foil of a 3 x 4½-in. piece of copper clad epoxy board. Next, place carbon paper on top of the copper foil, slip the board and carbon paper under the pattern, and trace the outline of the circuit foil areas with a ballpoint pen. Incidentally, the circles on the pattern indicate where holes are to be drilled in the board; they're not used to indicate clear areas in the foil. Since the resist (protective coating used in producing the etched circuit) covered circles would overlap at the IC terminals, mark the centers of all of the holes including the four corner mounting holes for the board, by pressing a very sharp ice pick through the center of the holes in the pattern to produce an indent in the foil. This will assist you in locating the drilling

centers after the etching process has been completed. After making certain that all outlines and holes have been traced and marked, remove the pattern and the carbon paper. You will now have a light tracing outlining the pattern on the copper foil. Those areas that are solid black on the pattern should be covered with resist to protect that foil area from the etchant. Use a resist pen (available from Lafayette Radio) to first outline the foil areas to be covered, then fill in these areas completely with resist.

When applying resist to areas to be protected from the etchant, try to leave free of etchant a very small area where the centers have been marked by the ice pick. If at all possible, keep the area the same diameter (or slightly less) as a #58 drill. This will help locate drilling centers after etching and removal of the resist. Those holes that are

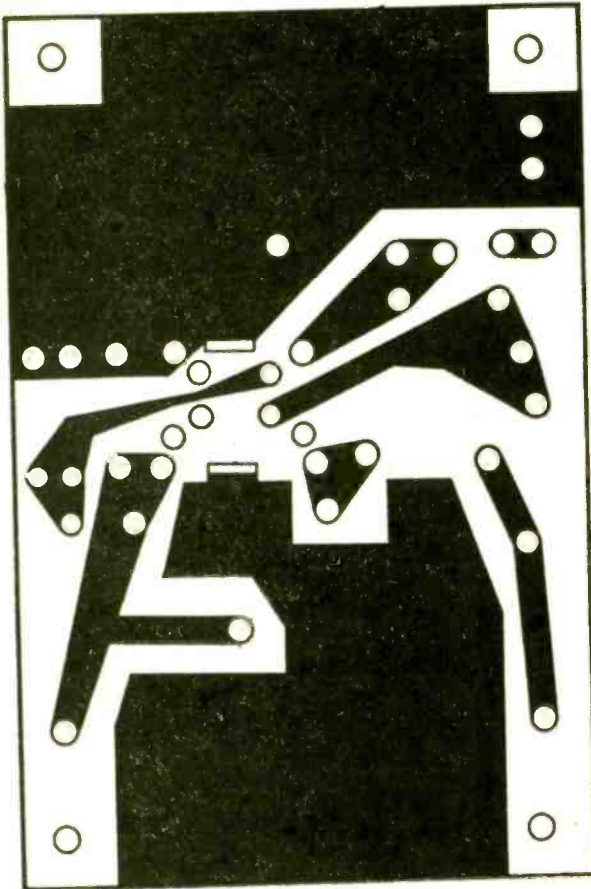

*Full size amplifier PC board pattern—Apply resist over all black areas where foil is to remain when board is etched, white areas will then be clear. Touch circle centers with resist pen to mark drilling centers for parts mounting holes.*

to be drilled where no connections to the copper foil are to be made (e.g., the two unused IC terminals and the corner board mounting holes) should be completely covered with resist the full diameter of the hole on the pattern. Make certain there are no pinholes in the resist before starting the etching process.

**Etching.** After all foil areas making up the circuit are protected with resist, place the board in a pan containing etchant (also available from Lafayette Radio). Be sure the entire board is completely immersed in the etchant. After 20 minutes lift the board out of the etchant with tweezers. If all unprotected foil has been removed from the board, rinse it thoroughly under running water for at least two minutes to remove all traces of the etchant. Should there be the slightest trace of unprotected foil remaining, re-immers the board in the etchant for periods of 2 minutes until all of the excess copper has been removed. Don't allow the board to remain in the etchant any longer than necessary or the etchant may start to undercut the resist and thus remove some of the desired copper foil.

Strip off the resist by rolling it with your fingertips. That resist which can't be removed by rolling can be stripped off either with nail polish remover or a Brillo pad. Finally, scrub the board with a Brillo pad and household cleanser to be certain the

*Speakers atop cabinet housing point 60° either side of center. When used with "close-talking" microphone unit produces widely dispersed, highly penetrating sound. And it's all done with one IC.*

foil is absolutely clean. Drill all the holes with a #58 bit, using the center marks previously indented or marked (all component leads will fit into holes of this diameter).

**Making the Amplifier.** You are now ready to mount the components and solder them to the foil of the circuit board. The two tabs at the center of the IC are heat sinks and must be soldered to the large copper foil areas that fan out from the IC. Using your #58 bit, first drill four closely

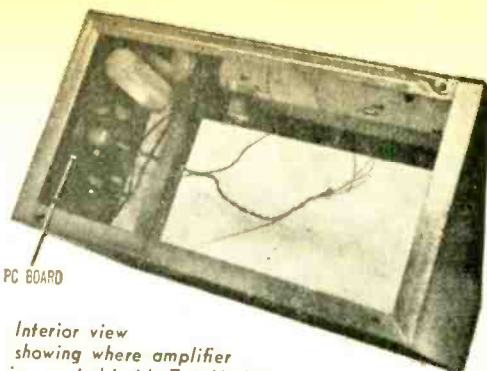

PC BOARD

*Interior view showing where amplifier is mounted inside TwinHailer.*

spaced holes adjacent to the heat-sink foils directly under the heat-sink tabs (these locations are the  $\frac{1}{4} \times \frac{1}{16}$ -in. rectangles on the pattern).

Next, using the sides of the bit as a router, break through the holes to form a slot. Insert the IC very carefully into the board, making certain that the tabs pass through the board to the foil side. The IC should be positioned so that the notch in its case will be near the



center of the board. Using a 50-watt iron having a small fine tip, solder the IC's leads and the heat sink tabs to their respective connections on the copper foil. (Remember, you get only one chance with the IC—one mistake, and the IC's had it).

Once the IC has been mounted and soldered in position, insert the balance of the components into the holes in the board at the locations indicated on our drawing and solder them to the foil. Note that capacitor



## TD TWINHAILER

C6 isn't mounted on the board. Reasons are that this would require a bigger board (more difficult to handle and more expensive) and that C6 may not be needed (it, too, is expensive).

Try the amplifier without C6. If it motor-boats, add the capacitor (it can be placed just off the edge of the board and its leads will hold it in position). See our photo for the position of C6's mounting holes.

**Speakers and Output Load.** For maximum efficiency the GE PA-246 IC requires a 16-ohm load. We have provided for this by connecting two 8-ohm speakers (SP1 and SP2) in series. Because these PA horns are highly directional, it's best not to point both straight ahead, since the sound would then be directed in a narrow beam. Instead, mount the speakers on the top of the 6 x 9 x 5-in. aluminum cabinet housing the Twin-Hailer so they form an approximately 120° angle. This way, they'll make a wide angle of sound dispersion.

For optimum performance the speakers

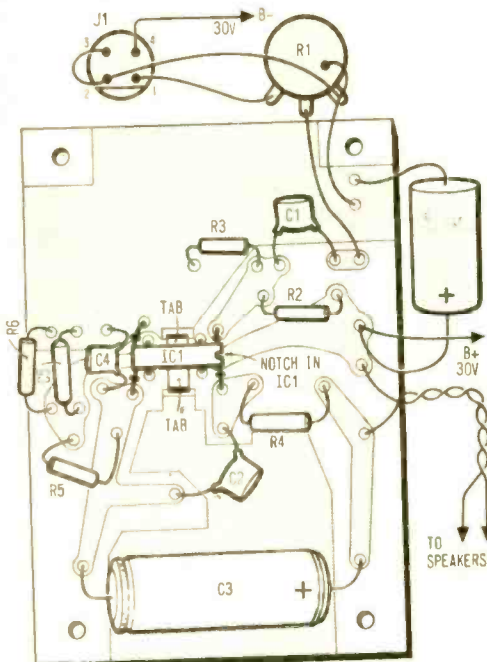

*For clarity in locating actual positions, parts are shown as though mounted on foil side of PC board, however, they should be inserted from non-foil side.*

must be properly phased. On the assumption that these speakers are all manufactured so that the polarity of a given terminal on every speaker is the same, we can arbitrarily assign a (+) to the left-hand terminal and a (-) to the right-hand terminal. By looking into the front of the speaker you can observe the terminals referred to at the bottom of the bell to which the manufacturer has soldered 2-conductor zip cord.

To determine which of the two leads is connected to the (+) terminal and which is connected to the (-) terminal of the speaker, use your ohmmeter. Touch one of its test leads to one of the two conductors of the zip cord connected to the speaker and place the other test lead on the (+) terminal of the speaker. If the meter reads a short, you have identified the conductor soldered to this terminal. If, on the other hand, you read 6 to 8 ohms, and hear a click each time you touch the (+) terminal, you've obviously identified the conductor connected to the speaker's (-) terminal. Mark the plus lead for identification when connecting the speaker.

Repeat this test on the other speaker, again marking the lead connected to the (+) terminal. You should have no problem in phasing the speakers now when wiring them in a series connection for the Twin-Hailer. Another way to determine the polarity is to listen to the output of the Twin-Hailer at a fair distance from the speakers. Having judged its volume, reverse the connections to *one* of the speakers. If the polarity was correct to start with, the volume will be less than originally. Conversely, if the original connection was incorrect, the volume will increase. In either case, you want the connection that gives the greatest output volume.

**Completing Your TwinHailer.** Mount both the jack (J1) for the microphone/power switch, and also the volume control (R1), at the top left-hand corner of the cabinet. Two battery holders, each holding 10 D cells, are mounted one on the front and one on the rear panels of the cabinet. Since 10 D cells are heavier than you might think, use four mounting screws to fasten each holder to its respective panel, taking care that the mounting screws don't contact any of the battery terminals. To be on the safe side, you might want to insulate the holder from the panel with either a sheet of plastic or plastic insulating tape.

Note that each holder has a solid-colored



wire as well as one with a green tracer connected permanently to the ends of the series connections for the 10 cells. Connect the solid color of one holder to the wire with the green tracer of the other holder. The remaining solid-colored wire should be connected to the (+) battery connection of the amplifier and remaining wire with the green tracer should be connected to the #4 termi-

assembly from the metal of the cabinet; this is necessary to prevent possible contact between the foil of the PC board and the side of the cabinet. Next, mount the volume control (R1) in the top of the cabinet adjacent to J1.

Now run a jumper from terminal #3 of J1 to terminal #2 of J1 and then to the ground side of the volume control (R1).

*Schematic diagram for TwinHailer amplifier. Note pin numbers and their relation to notch in IC type PA-246. Notch must be near center of board. Be sure everything's okay before soldering as repeated application of heat can destroy the IC.*

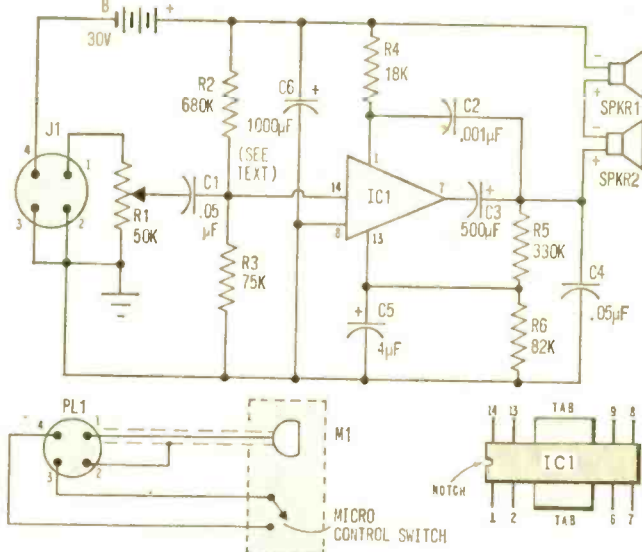

#### PARTS LIST FOR TWINHAILER

- B1—30-V battery (consists of 20 D cells in series or 20 1½-V alkaline cells in series)  
 C1—0.05-µF, 75-V ceramic capacitor  
 C2—0.001-µF, 75-V ceramic capacitor  
 C3—500-µF, 50-V electrolytic capacitor (Lafayette 34T5531 or equiv.)  
 C4—0.005-µF, 75-V ceramic capacitor  
 C5—4.0-µF, 6-V electrolytic capacitor (Lafayette 99T6004 or equiv.)  
 C6—1000-µF, 50-V electrolytic capacitor (Lafayette 34T5627 or equiv.)  
 \*IC1—Integrated circuit amplifier (General Electric PA-246)  
 J1—4-contact panel mounting microphone jack (Lafayette 99T6264 or equiv.)  
 \*M1—Dynamic microphone with separate switch mounted in case (Piezo DX-109 or equiv.)  
 PL1—4-contact microphone plug (Lafayette 99T6263 or equiv.)  
 R1—50,000-ohm miniature potentiometer (La-

- fayette 32T7359 or equiv.)  
 R2—680,000-ohm, ½-watt resistor  
 R3—75,000-ohm, ½-watt resistor  
 R4—18,000-ohm, ½-watt resistor  
 R5—330,000-ohm, ½-watt resistor  
 R6—82,000-ohm, ½-watt resistor  
 SP1, SP2—8-ohm, 5-watt miniature re-entrant horn speaker (Lafayette 99T4508 or equiv.)  
 1—6 x 9 x 5-in. aluminum cabinet with removable front and rear panels (Lafayette 12T8532 or equiv.)  
 Misc.—Printed circuit board, etchant, resist, resist ballpoint pen, wire, solder, hardware, etc.  
 \*DX-109 microphone (\$4.95) and PA-246 integrated circuit amplifier (\$3.84) available from Custom Components, Box 352, Alden Manor, Elmont, N.Y. 11003. Add 65¢ postage and handling charges per order \$1.00 on orders to Canada. New York State residents add sales tax.

nal of J1. (These connections should not be made until all of the other components of the system have been hooked up and you are ready to test your TwinHailer.)

Mount the amplifier board inside the cabinet on the left-hand 6 x 5-in. side of the cabinet, using ¼ in. spacers to raise the

Ground this terminal to the rear cover of the control and also to the large foils on the PC board that are soldered to the heat sink of the IC. Connect the speaker wires to the amplifier output with leads as short as possible. Also, make certain that the speaker leads are well insulated, since the IC



## TD TWINHAILER

would be destroyed instantly if they should short to the cabinet.

To conserve battery power, a convenient, handy switch built into the microphone is used to turn the amplifier *on* or *off* as needed. We suggest you use the microphone specified in the Parts List since it has high output (enough to drive the IC to full power output), it's designed for close talking (necessary to achieve high volume without feedback), and has a rising response characteristic in the mid-frequency range for greatest intelligibility. You virtually can shout into the mike without overloading it, and its plastic diaphragm is immune to corrosion. The built-in switch has two separate leads to be used for switching power *on* and *off* to the amplifier.



Here's one bank of batteries that makes up one half of the battery supply to power the Touchdown TwinHailer. Ten D cells (five in top row are visible, bottom five are not) series up to 15 volts DC. An identical bank of unit's other side plate makes up the additional 15 volts DC for the required 30 volts needed for grandstand shouting.

**Checkout.** Connect the microphone and set volume control (R1) to about one-quarter of its full *on* position. Slide S1 to turn the TwinHailer *on*. If you hear a slight hiss from the speakers, you've passed the first hurdle. Should you hear motorboating as soon as the power is switched *on*, shut everything down and install capacitor C6. Now for the acid test: does it work? Talk into the microphone in a fairly loud voice. If you hear nothing from the speakers, in all prob-



Once the Touchdown TwinHailer is made, any cutie in the cheer leader group can operate it with one hand. Volume control is set to desired loudness. Let's be honest, at games set the control maximum clockwise. The mike on-off switch is flipped on only when something needs shouting, otherwise the unit is kept off to conserve batteries. There is enough soup in the banks of batteries to work any exciting football game.

ability you goofed in wiring in the mike plug, or possibly in J1. Check both out and correct any errors. If you do hear the voice, but it's modulated with motorboating, you will, of course, have to install C6.

Don't be misled by what appears to be a lack in power output when you talk into the microphone. From your position behind the speakers the volume is considerably less than when looking into them, so to speak. If this weren't the case, you wouldn't be able to raise the power output without immediately getting a feedback howl.

To get a true picture of the TwinHailer's capabilities, have a friend talk into the mike while you listen in front of the speakers. Chances are you'll be most pleasantly surprised. In fact, the TwinHailer will out-shout just about any portable bullhorn, and with considerably less distortion.

The Touchdown TwinHailer need not be a portable unit. It'll make a good PA system for office, store, or warehouse. If use is constant, you may want to build a 30-volt power supply to eliminate the dry cells. It's a good idea to keep the battery supply handy just in case there is a line power shortage or blown fuse. ■

*We all know air pollution ruins our lungs.  
But how about that air pollutant that ruins our ears?  
We mean, of course, those . . .*

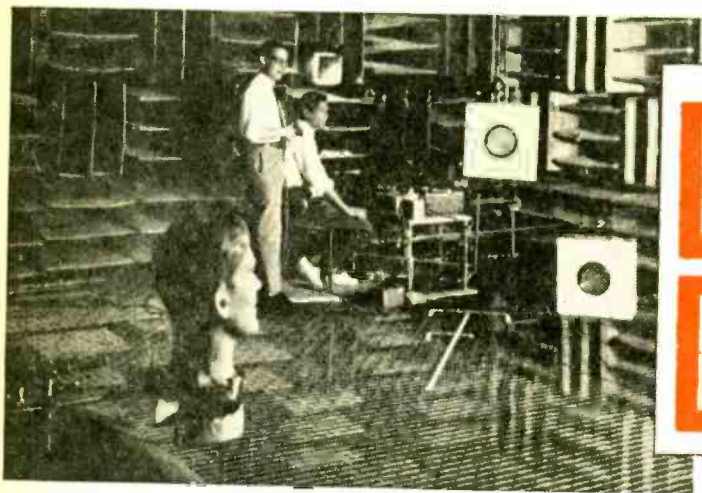

## DIRTY DECIBELS

by Jorma Hyypia

**O**nce upon a time there were three little monkeys—see no evil, speak no evil, and hear no evil. Like the third monkey, we all have good reason to cover our ears because the air around us is being increasingly polluted with evil sounds. The trouble is, we like some dirty decibels so much that we won't give them up. And yet, if this sonic self-immolation continues, we may eventually have to pay the ultimate penalty. Our ears will drop off!

Sound pollution—like air and water pollution—has been creeping up on us so gradually that only scientific experts have been fully cognizant of the dangers it imposes on us all. Everyone is at one time or another annoyed by unwanted sounds; but annoyance is a minor hazard compared to the very real physical damage that is being done to the hearing organs of millions of people. To grasp the true significance of sound pollution, we must find answers to two questions. How loud is too loud? And just how fragile are our ears?

First, note that we keep referring to sound pollution rather than to noise pollution since it is the larger problem. Noise can be defined as any kind of sound that is unwanted. However, there are many kinds of sounds that are wanted, at least by some individuals, and therefore cannot be considered noise within this definition; yet these sounds are

among the most damaging, and insidiously so, because those who are hurt most by them have no desire to eliminate the pleasantly offending sounds.

Take Rock 'n Roll music for example. The artistic merits of such music are not in question here; we are concerned only with the loudness with which this type of music is often played in discotheques, or at home by record collectors. Scientists have discovered that an alarming number of teenage Rock addicts have hearing deficiencies that would be expected normally only in 65-year-old people!

To make matters worse, Rock addicts are precisely the people who lean toward other very noisy activities—for example, driving of noisy sports cars or hot-rods, participating in school bands, and, more recently, racing ear-shattering snowmobiles. What is this generation coming to? Quite possibly a massive group of early-age candidates for electronic ear trumpets!

**How Intense Is Loud?** Everyone knows that the sound of a jet plane at take-off is much louder than normal human conversation. But how much louder? To say that the loudness of conversation is about 60 decibels, and that the loudness of a jet engine is 150 decibels means very little to most people. Frequently there is a gross misconception about the relative sound intensities involved

## e/e DIRTY DECIBELS

because decibel ratings are so easily misunderstood.

Loudness, as measured in decibels, is not synonymous with sound intensity. Loudness is the subjective sensory effect that results when our hearing organs are stimulated by sound waves. Loudness is not even directly proportional to sound intensity; it varies logarithmically.

What exactly does that mean? No need to ponder the perhaps long-forgotten mysteries of logarithms. Just look at Table 1 that relates decibels to relative sound intensities. Zero decibels represents the threshold audibility, which is generally taken as  $10^{-16}$  watts per square centimeter when using a standard sound frequency of 1000 Hz per second as a reference frequency (the audibility of sound varies with the frequency). The relative sound intensity is one unit at zero decibels loudness.

When loudness reaches 10 decibels, the relative intensity is also 10—ten times greater than at the threshold of audibility. At this point it would seem that decibel loudness and relative intensity increase at the same rate and that the changes are proportional. This is simply a coincidence for the 10 dB level. For each subsequent increase of ten decibels, the intensity increases by a factor of ten, not merely by ten units. Note that while the decibel scale extends from zero to 150 dB, the relative intensities go from one to one million billion units!

Thus the loudness of a jet at take-off is 90 decibels louder than normal conversation, but the intensity of the jet noise is one billion times greater than the intensity of conversational sound!

Those who are adept at logarithmic calculations can easily convert decibel units of loudness into sound intensity equivalents, and vice versa, by using the following simple equation:

$$dB = 10 \log \frac{I}{I_0}$$

$I$  is the energy of the sound source in watts per square centimeter.  $I_0$  is the energy at the threshold of audibility ( $10^{-16}$  watts/sq. cm.)

Assume that you wish to calculate the intensity of sound produced by a jet at take-off (150 dB). By substituting 150 for dB in

the equation, and solving for  $I$ , you arrive at the answer: 0.1 watt/sq. cm.

A similar calculation reveals that 60 dB conversation is equivalent to a sound intensity of  $10^{-10}$  watts/sq. cm. By dividing the intensity of the jet's sound by the intensity of the sound of conversation we find that the jet noise is a billion times more intense than the sound of conversation between two people. If the jet noise doesn't actually seem to be that much louder, it may be because the automatic volume control (AVC) system in your ear is working well. But we will get to that later.

Note that in these calculations the sound intensities must be expressed in watts per unit area, not as total watts of energy created by the sound source. Thus the wattage data given in Table 2 cannot be directly applied to these relationships.

The threshold of pain is about 130 decibels; sounds louder than this are not heard clearly because of the effect of superimposed pain. This obviously is the danger point since the body's nervous system is protesting. However, sounds well below the 130 dB level can also be very harmful if they stimulate the ear continuously for too long a time. In terms of sound intensity, the zero to 130 decibel range of clear sound extends from  $10^{-16}$  watts per square centimeter (10 millionths of a billionth watt/sq. cm.) to  $10^{-3}$  watts per sq. cm. (one thousandth watt/sq. cm.).

**Drummers Beware!** Table 2 shows the total sound energies created by various sound sources. The relationships are often startling. Bell Telephone scientists who made the measurements discovered that a 75-piece

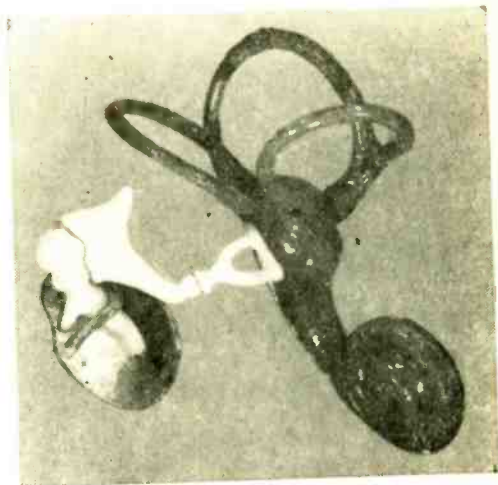

**TABLE 1—dBs vs. Intensities**

Loudness In Decibels	Typical Reference	Relative Sound Intensities
0	Threshold of audibility	1
1		1.26
2		1.58
3		2
6		4
9		8
10		10
20		100
30		1,000
40		10,000
50		100,000
60	Conversation	1,000,000
70	Electric dishwasher	10,000,000
80	Vacuum cleaner	100,000,000
90	Times Square, N.Y.C.	1,000,000,000
100	Subway train	10,000,000,000
110	Motorcycle	100,000,000,000
120	Propellor driven plane	1,000,000,000,000
130	Threshold of pain in ears	10,000,000,000,000
140		100,000,000,000,000
150	Jet plane at takeoff	1,000,000,000,000,000

**TABLE 2—Total Sound Energies**

Sound Sources	Energy (Watts)
75 piece orchestra at its loudest	70
Bass drum	25
Trombone at its loudest	6
Piano at its loudest	0.4
75 piece orchestra, average loudness	0.09
Average speaking voice	0.000024
Violin at softest concert playing	0.0000038

These figures represent total measured sound energy radiated by various sound sources; they cannot be directly compared with decibel scales of loudness. Sound intensities must be expressed in terms of unit area, usually as watts per square centimeter, for comparison with the decibel scale.

orchestra playing at its loudest develops about 70 watts of sound energy. That is about 777 times greater than the energy generated when the orchestra plays at average loudness, and 18 million times greater than the energy generated by a single violin playing its softest passages. Another amazing discovery is that the bass drum in the orchestra contributes more than a third of the total sound energy of a 75-piece orchestra playing at its loudest! The drum generates four times as much energy as the next loudest instrument, the trombone.

These figures indicate that drummers may be particularly prone to ear damage. So drummers beware! Use ear-plugs—at least during practice sessions.

Incidentally, what happens if a couple of drummers get together for a joint practice session? If the loudness of the sound produced by one bass drum (neglecting snare and other drums) is 100 dB, what will be the loudness when both drums are played simultaneously? If you guess 200 dB you are wrong. The answer is 103 dB! Why? Because doubling the intensity in- (Continued overleaf)

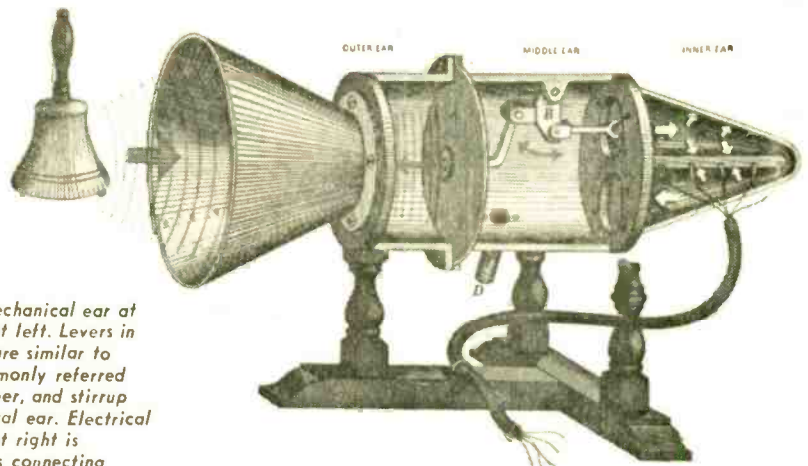

Note similarity of mechanical ear at right to ear replica at left. Levers in middle ear at right are similar to the three levers commonly referred to as the anvil, hammer, and stirrup or stapes in the natural ear. Electrical harness in inner ear at right is comparable to nerves connecting sensors in cochlea to brain.

# e/e DIRTY DECIBELS

creases the level of loudness by only 3 dB, as Table 1 clearly shows. See what we mean about dB ratings being misleading? It's not the dBs that erode your hearing; it is the intensity of a sound that is important.

**Amazing Sensitivity.** You need study the ear structure only as far as the eardrum to begin to appreciate the fantastic sensitivity of this remarkable organ.

Alexander Wood, in *The Physics of Music*, makes some revealing comments about the sensitivity of the human eardrum. The ear is most sensitive to sounds having frequencies in the order of 3500 Hz; at this frequency the threshold of audible intensity is  $1.55 \times 10^{-17}$  watt. This intensity would be

ble sound at 1000 Hz is produced by a pressure of 0.0002 microbar on the eardrum; this pressure is only about 5 billionths as much as standard atmospheric pressure!

Incidentally, it is in the 3500 to 4000 Hz range of hearing that teenage Rock fans seem to suffer the most serious losses. This frequency loss causes an inability to hear so-called fricative speech sounds such as f, s, sh, ch, and th. It's no joke. Rock addicts who are unaware that they have suffered ear damage may be giving the wrong answers in classrooms because they may not always hear clearly and correctly what their teachers are saying. This same hearing deficiency may materially reduce their employment opportunities in later years.

**Impedance Matching.** The minute vibrations of the eardrums must be transmitted to a liquid contained in the cochlea of the

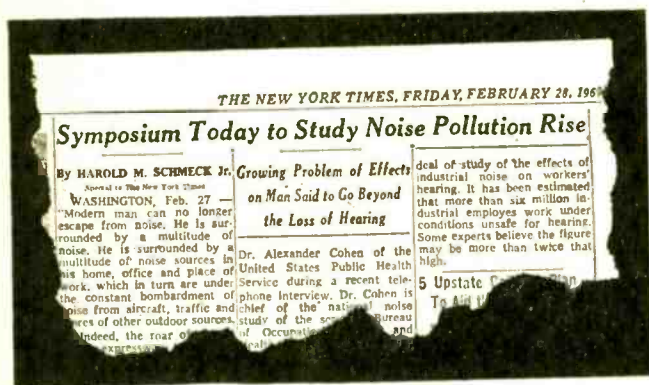

*Our ears are constantly bombarded by traffic, aircraft, shouting children and irate adults, and rock and roll, observed the National Council on Noise Abatement at a symposium held in Washington, D.C. earlier this year. A plan to study important potential effects other than hearing loss was initiated.*

equivalent to the radiant energy received from a 50-watt electric lamp placed 3000 miles away (assuming that the heat and light are not interrupted by passing through an absorbing atmosphere).

Wood states that the pressure amplitude of audible sound at 3500 Hz would be about  $1.1 \times 10^{-4}$  dyne per square centimeter. He concludes that since the eardrum is about one square centimeter in area, audible sound would be heard if a hypothetical insect weighing only one ten-thousandth as much as a mosquito were to stomp on the eardrum at a frequency of 3500 Hz.

The displacement amplitude (distance of back and forth movement) of the eardrum would be about  $1.25 \times 10^{-10}$  centimeters. This displacement, says Wood, would be equivalent to only about one hundredth of the diameter of a nitrogen molecule. And that's not much!

Others have pointed out that a barely audi-

ear—a curled, multi-passage organ that looks like a small snail shell. In the cochlea are the nerve sensors that detect the liquid movement and produce the signals that are sent to the brain for interpretation.

Long before man ran into impedance matching problems—like matching a loudspeaker to an associated amplifier system—nature had to contend with an even trickier impedance matching problem. Remember that it is the vibration of air that makes the eardrum move; these vibrations would be far too weak to move the liquid in the cochlea. Some sort of amplifying system is needed to increase the initial intensity of these vibrations.

Three tiny bones in the middle ear—popularly called the hammer, anvil and stirrup—do just that. Their action as levers magnify the intensity of the vibrations imparted to the eardrum before passing them

*(Continued on page 109)*

# Build the Sun Spot Special



**A self-powered converter, it tunes the  
6- and 10-Meter ham bands,  
plus 11-meter CB**

**by Charles Green, W6FFQ**

**N**ow is the time for all good men to take advantage of "skip" —making it possible to communicate over greater distances than normally considered feasible. Every eleven years the sun develops a severe case of "freckles," commonly referred to as sun spots, which disturbs the earth's ionosphere. This affects the propagation of high frequency radio signals that normally travel in straight paths (called line of sight transmission, e.g. TV signals). High frequency signals will, therefore, be reflected differently by the ionosphere than they would be if no sun spots disturbed it. The end result is transmission and reception over distances much further away than planned.

As this sun spot activity increases towards its eleven year cycle peak, communications in the CB band and the 10- and 6-Meter ham bands evince "skips" of hundreds, or even thousands of miles.

Our Sun Spot Special is a single tube, 3-band converter unit that, when used in con-

junction with a standard broadcast band receiver, permits you to get in on the fun of listening to DX skip signals by tuning in on the CB band, the 10 Meter ham band, and the most popular portion of the 6 Meter ham band (from 50 to 52 MHz). The converter unit, containing a built in power supply, covers these bands with three pairs of plug-in coils.

**How It Works.** Antenna signals are fed to the antenna plug-in coil assembly through J1, and are tuned by variable capacitor section C5A, and mixed with the RF output of the oscillator V1B circuit, in V1A. The oscillator circuit plug-in coil assembly is tuned by variable capacitor section C5B, so that it is 1550 kHz above the frequency of the incoming signals. The IF transformer T1, in the plate circuit of V1A, is tuned to 1550 kHz. By this signal conversion the RF output of V1A is coupled to your broadcast receiver (which must be tuned to 1550 kHz) through J2.

*(Continued overleaf)*

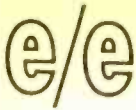

## SUNSPOT SPECIAL

There are three sets of pairs of plug-in coil assemblies. The CB band set of coils covers 26.965 MHz to 27.255 MHz (channels 1 to 23). The 10-Meter ham band set of coils covers 28 MHz to 29 MHz and the 6-Meter ham band set of coils covers 50 to 52 MHz. (the most popular portion of the band).

The built-in power supply for the converter consists of transformer T2, the half-wave rectifier D1 and RC filter R7-C12A, C12B.

**Construction.** The converter is built on a 7 x 7 x 2-in. aluminum chassis. Best way to start your construction project is to study the photos and note the locations of the various components. The vernier dial is fastened front and center along the front edge of the chassis. If you are using the same type of vernier drive that we used, it must first be mounted on a heavy aluminum sheet, approximately 5½ x 3¾ -in., which, in turn, is fastened to a piece of ½-in. aluminum angle stock, and finally mounted on the chassis as shown in the photographs. In order to locate the mounting holes for the variable tuning capacitor (C5A, C5B) fasten the capacitor's shaft, temporarily, to the flexible coupling and to the vernier dial shaft, and mark the mounting hole centers on the chassis. Now remove the capacitor from the coupling, drill the holes and then fasten it permanently to the chassis. The trimmer condensers attached to the variable capacitor are not used, so dispense with them by carefully unscrewing and removing the adjusting screws as

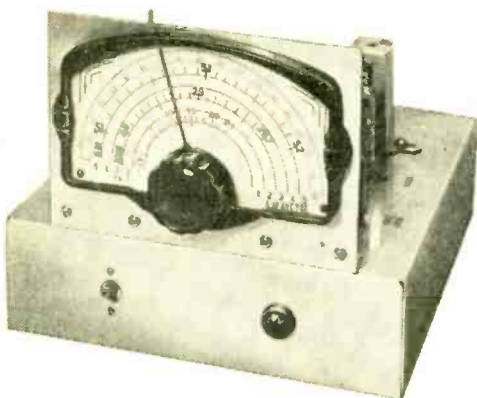

Completed Sunspot Special, ready for use with any broadcast set. Pilot lamp is at right front; switch S1 at left. You yourself calibrate dial.

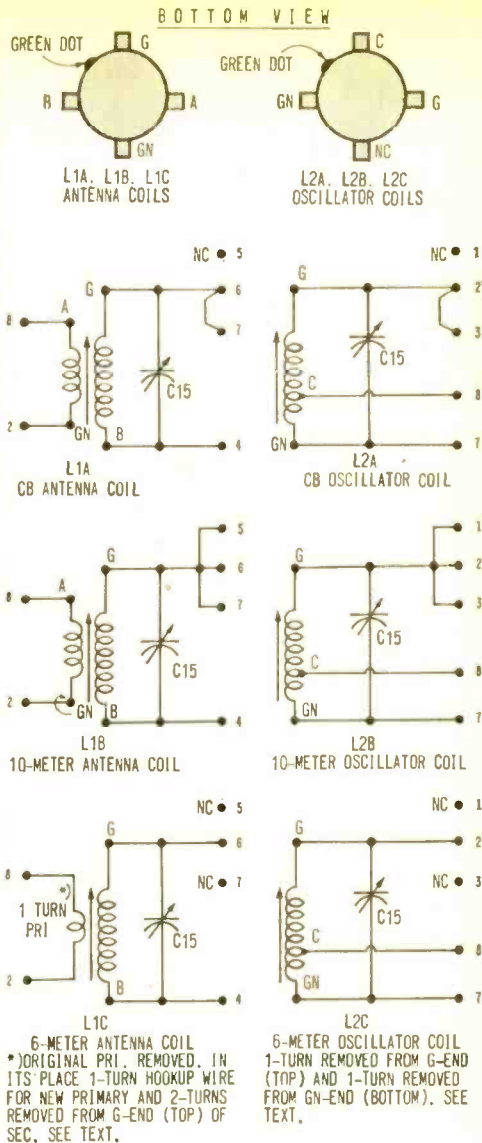

Though coils are J. W. Miller standard types, many must be modified slightly for optimum results. Numbers on drawings above correspond to pins in old octal tube bases or standard octal male plugs.

well as the copper strip that, along with insulated back plates that are permanently fastened to the stator plates, makes up the trimmer.

Locate the mounting holes for the remainder of the components, keeping the same spacing relationship to the tuning capacitors C5A and C5B as shown in the photographs. Because this converter operates at high fre-



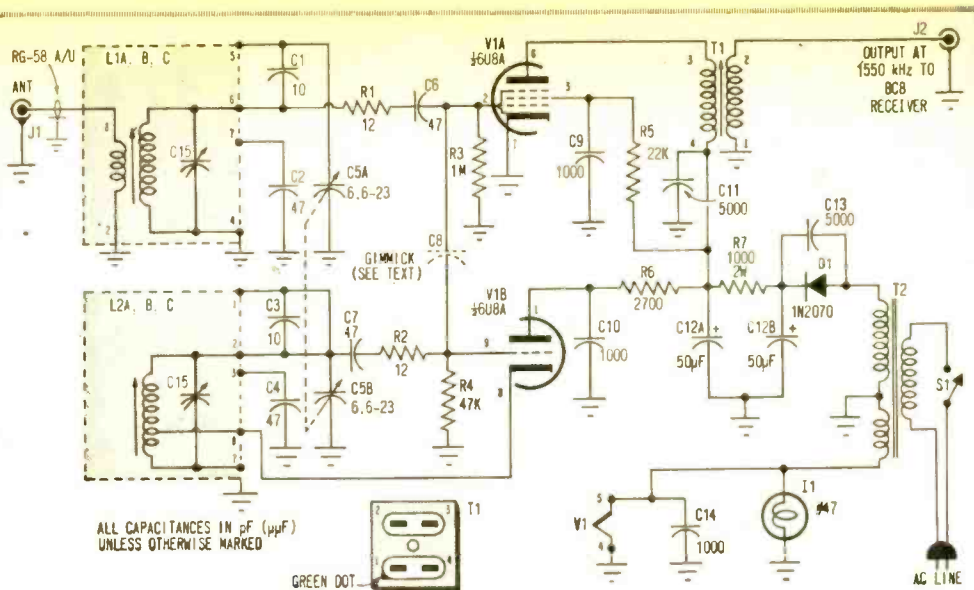

### PARTS LIST FOR SUNSPOT SPECIAL

- C1, C3—10pF, NPO, 500V min. ceramic disc capacitor  
 C2, C4, C6, C7—47 pF, NPO, 500V min. ceramic disc capacitor  
 C5—6.6 to 23 pF dual-gang variable capacitor (J. W. Miller 1461-2 or equiv.)  
 C8—"Gimmick" capacitor—3 turns of hookup wire twisted together (see text)  
 C9, C10, C14—1000 pF, 500V min. ceramic disc capacitor  
 C11, C13—5000 pF, 500V min. ceramic disc capacitor  
 C12—Dual 50 uF, 150 V electrolytic capacitor  
 C15—2 to 25 pF mica trimmer capacitor (Allied Radio 43F7078 or equiv.)  
 D1—1N2070 silicon rectifier, 400 PIV, 750 mA (or equiv.)  
 I1—Pilot lamp assembly, with #47 bulb (Lafayette 33T3264 or equiv.)  
 J1, J2—Phono jack, single hole mount (Lafayette 99T6234 or equiv.)  
 L1A, L1B, L1C—Antenna coils (J. W. Miller D-5495-A) (see text)  
 L2A, L2B, L2C—Oscillator coils (J. W. Miller D-5496-C) (see text)

- R1, R2—12 ohms, 1/2 watt, 10% resistor  
 R3—1 megohm 1/2 watt, 10% resistor  
 R4—47,000 ohms, 1/2 watt, 10% resistor  
 R5—22,000 ohms, 1/2 watt, 10% resistor  
 R6—2700 ohms, 1/2 watt, 10% resistor  
 R7—1000 ohms, 2 watt, 10% resistor  
 S1—Spst switch (slide or toggle), 125V-3A rating  
 T1—IF output transformer, 1400 to 1600 kHz (J. W. Miller 13-W2)  
 T2—Power transformer, 6.3V-0.6A, 125V-15 mA sec. (Stancor PS-8415 or equiv.)  
 V1—6U8A vacuum tube  
 1—7 x 7 x 2-in. aluminum chassis (Allied Radio 42E7849 or equiv.)  
 I—Vernier dial (Lafayette 99T2566 or equiv.)  
 Misc.—Insulated flexible coupling (Allied 47C2403), six octal tube bases (see text), two octal tube sockets for coils (Allied 47E-3370), one 9 pin miniature tube socket (Allied 47E1128), one AC line cord, #22 solid plastic jacketed hookup wire, #18 and #22 bus wire, aluminum sheet to mount dial (see text), perf board and push-in clips, tie strips, RG-58A/U coaxial cable, hardware, solder, etc.

quencies, the location of components is critical. Mount the rest of the components following our layout. Drill 3/8-in. holes in the chassis directly below the stator lugs of the tuning capacitors to permit running the connecting leads below chassis.

Wire the components in accordance with the schematic, keeping the leads as short and direct as possible when wiring the RF por-

tion. The power supply wiring should be kept close to the chassis and as far away from the RF wiring as possible.

D1, R7, and C13 are mounted to a 1 1/4 x 1 3/4-in. piece of perf board with push-in terminals. The AC line cord and T2 primary winding tie point terminals are also fastened to this perf board.

Make the C8 ("gimmick") capacitor by



soldering two 1 to 1 1/4-in. lengths of plastic covered hook-up wire (solid conductor) to pins 2 and 9 of the socket for the 6U8 tube. Twist the leads together three turns and cut off the excess wire.

**Making The Coils.** We made our coil assemblies by mounting the coils into old octal tube bases. If you do not have any available you can use standard Amphenol type octal male plugs. The various basic coils and their associated trimmer capacitors are listed on the drawing detailing the coil assemblies. Use short lengths of stiff bus wire to keep the components rigid in their bases.

Before mounting the 6-Meter coils (L1C and L2C) they must be modified to cover the frequency range. Remove 2 turns from the G end (top) of the secondary winding of L1C. Clip off the leads and remove the primary winding of L1C and replace it with a 1-turn loop of hook-up wire placed around the secondary and solder the two ends of the loop to the terminals on the coil where the original primary terminated. Remove 1-turn from the G end (top) of coil L2C and one turn from the bottom (GN end) of the coil winding.

The CB coil assemblies and the 10-Meter coil assemblies must have jumpers connecting the base pins as detailed in the drawing. Keep these jumpers as short as possible, mak-

ing sure that they do not short out to the other coil connections.

**Alignment.** Plug the CB band coils into their respective sockets, connect the AC cord into the power line and turn S1 on, allowing the unit to warm up for a few minutes. Connect J2 to your broadcast band receiver antenna and ground terminals with coaxial cable and tune the receiver to 1550 kHz or a clear channel as close to 1550 kHz as possible. If your receiver does not have antenna and ground terminals, but uses a ferrite loopstick antenna, wrap a few turns of hook-up wire around this loopstick and terminate the ends in the coaxial cable connected to J2. If your broadcast receiver should be an AC-DC type, make sure there is no connection between the chassis, or common B- of a "hot chassis" and the converter in order to prevent possible electrical shock.

Connect a signal generator to the stator of C5A and set the generator controls to produce a modulated output signal at 1550 kHz, or, if a clear channel was not available at 1550 kHz, to the specific frequency to which the receiver has been tuned. Adjust the tuning slugs of IF transformer T1 to produce maximum output signal from the broadcast receiver. Disconnect the signal generator from C5A and connect it to J1. Set tuning capacitor C5A/C5B to not quite maximum capacity (almost fully closed), retune the signal generator to produce a modulated signal at 26.965 MHz and then turn the slug adjusting screw of both coils L1A and L2A,

first one then the other, to produce maximum signal output. Retune the signal generator to 27.255, adjust C5A/C5B to approximately 1/4 its maximum capacity (almost fully open) and adjust C15 on each coil for maximum signal output. Repeat the preceding adjustments to assure the accuracy of calibration for both the highest and lowest frequencies. Then calibrate the entire CB band, using the signal generator set at each of the frequencies in accordance with channel allocations tabulated in the chart accompanying this article. If

*(Continued on page 106)*

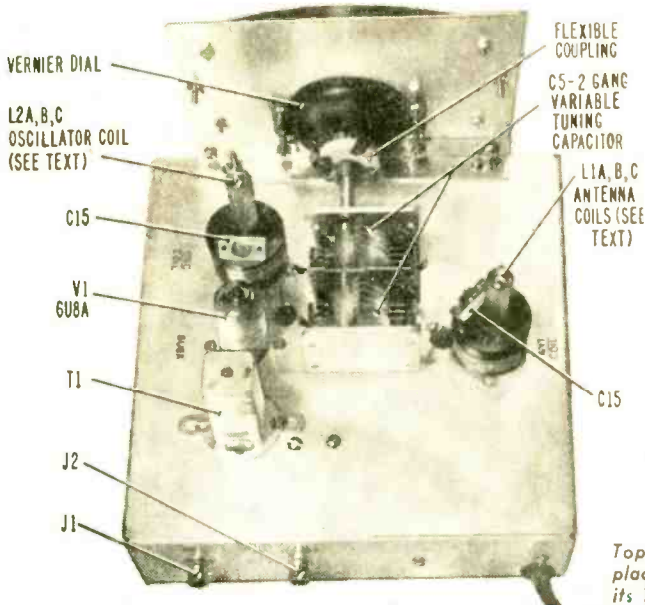

Top of Sunspot Special, showing placement of all major components on its 7 x 7 x 2-in. aluminum chassis.

# how I got started in SHORTWAVE RADIO

**T**he majority of people think of "short-wave" as the squawk and squeal of Grandpaw's old radio up in the attic or the *dit-dah-dah-dit* they hear in the movies. Well, there is all that, but there's more, too. Did you know that there are really story-type soap operas still on the air? Did you ever go to Japan or Egypt to be interviewed on the street? Ever wonder what the other countries *really* think of us? Or, do you just want to know the correct time?

My introduction to shortwave listening



came some years ago when a friend of mine got one of those multi-band portable radios. It had a dozen or more transistors and cost a small fortune at the time. We were tuning around when we heard a female voice apparently giving the news of the day. Boy! This news was *nothing* like I ever heard before! Imperialist rebels! American aggression! Who in the world could be talking treason like this?

Then came the station break: "This is Radio Peking." It answered my question and sold me at once on the idea of shortwave. I didn't waste a week getting my own receiver.

**How much** for all this? Well, you *could* buy a big job for hundreds, or a large portable such as my friend's for less than \$100.00. But I bought a kit from a catalog

for around \$40.00 and assembled my own in about 18 hours. I had only the barest knowledge of electronics at the time, but I didn't let that stop me. You can even find cheaper, ready-made sets, too, but selectivity would limit reception to the more powerful transmitters.

Oh, sometimes you might pick up a smaller country—it all depends on propagation. This phenomenon includes a number of factors, but the right combination of these would enable you to hear anything from any place in the world on even the cheapest of receivers.

For dependable service, though, it takes a better set. The more expensive ones can put you down inside such little places as Togoland in Africa, which is just 32 miles wide on the ocean front; or Nepal, whose history is largely unknown, and which lies far away in the Himalayan Mountains.

What a world this turned out to be! My small, homebuilt receiver was a marvel! Ecuador, broadcasting the gospel 24 hours a day; Moscow with

their vignettes of Soviet life on a collective farm; symphonies from Deutsche Welle in Germany; popular music and letter request programs from Holland, Switzerland, and South Africa; time signals every minute from Canada and Colorado. And *all* without one commercial!

**Every major** country has its schedule of English-language broadcasts. Of course, every country also has its programs of life in that particular country. Foreign-language programs are a boon for America's immigrated citizens and other visitors who would love to hear programs in their own tongues with news of their homelands.

I've had my "skywire" up for years now, and I find there's almost unlimited enjoyment to be had by the shortwave listener

*(Continued on page 110)*

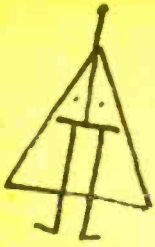

Uni-Mungtion  
Mungistor



Sawtooth Mung



Ho Chi Mung



Mungconi



Peace Mung



Munger



Multigrig Mung



Flying Mung



Mungtini



Dipsey  
Mungster

Thunder Mung



# Omar Mung's

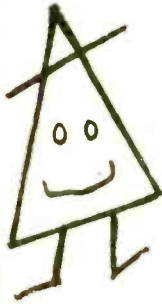

O M Omar  
Himself

**B**atten down the hatches—there's a Mung among us! In fact, truth be known, there are probably thousands of the strange little critters prowling about. For the Mung Dynasty knows no geographic boundaries. Mungs have been spotted from the North Pole to the South Pole, from the Greenwich Meridian to the longitude 180 line, and heaven only knows how many points between. Prolific as all get out, Mungs are also multiplying like crazy!

But the real hotbed of Mungism is the U.S. Navy's Electronic Technician School at Great Lakes Naval Training Center in Illinois.

The Mungs, headed by clan patriarch Omar Mung, are triangular, cartoon-like characters who have quickly become the mascots of the Navy's electronics technicians. A Mung, it is said, is as unpredictable as a gremlin; as ubiquitous as World War II's Kilroy. The ET trainees at Great Lakes have discovered that Omar and his kin are friendly and helpful—at times. But like a pair of hot leads, they're dangerous when crossed.

**Omar Mung**, known as Ming to sailors stationed on the West Coast, turned up alive and well at the Naval Base near Chicago several months ago. At first the Mung sightings were only occasional. But it wasn't long before Omar's brothers and sisters, cousins and uncles, began popping up throughout the A-2 Branch of the electronics school.

Initially, it was the electronics branch of the Mung family tree—Multigrig Mung, Electromungnet, and



Uni-Mung



Tunable Mung  
(Inductive)



Charles  
de Mung



Metramung

# Dubious Dynasty

Tunable Mung (Inductive)—who turned up at Great Lakes to make their home with Omar. Then came their non-technical relatives—Batmung, Mickey Mung, Humpty Mung, and all the rest. Now, Mungs can be found everywhere and anywhere. After the noon lunch break, they appear mysteriously, chalked on classroom blackboards. They regularly crop up between columns in the base newspaper.

Electronics Technician First Class Timothy Gough, an instructor at the Navy school, says the most extraordinary thing about Mungs is their habit of appearing in the most unexpected places.

"You'll find them inside equipment chassis, under gear that hasn't been moved for years . . . everywhere. Remove 38 tight-fitting screws on a receiver's base plate. Inside, in the heavy layer of dust, a Mung has been drawn!"

At any given time, there are about 2000 sailors attending the electronics school. Each week, some of these technicians graduate and go on to ships and shore stations around the world. And with them go the Mungs.

The history of the family, not surprisingly, is obscure. Chief Electronics Technician David Penney, another instructor at ET school, believes the pointy-headed characters evolved from the schematic symbol for the Zener diode. He vaguely recalls seeing a forerunner of the Mungs, doodled by an unknown sailor, about six years ago when he entered the Navy. But according to Penney, Mungism in its present form really caught hold in, of all places, Antarctica during the Navy's Operation Deepfreeze early in 1968.

*(Continued overleaf)*



Antenna Mung



Mickey Mung



Atomic Mung



Munguide



English  
Bar Mung

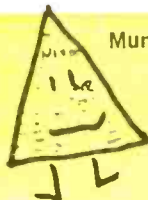

Mung Paper



Mungey

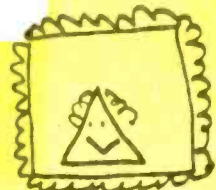

Munga Lisa

After months of duty at an isolated field electronics base, the Navy men were getting restless prior to their departure for home. In an attempt to control this restlessness and keep the men busy, a certain division officer split the sailors into work crews, issued them brushes and various colors of paint, and sent them out to decorate the rocks cluttering the station's antenna farm.

The paint details were followed up by crews instructed to collect all rocks of a particular hue. Bugged by the senseless chore, members of the red-rock-gathering detail retaliated. In doing so they gave Omar Mung his rebirth.

One morning, to his surprise, the division officer spotted Omar's likeness painted on a pole right outside his window. He ordered the seamen to paint over the cartoon character, but the next day Omar had again appeared on the pole. Again and again the drawing was daubed over with black paint, only to mysteriously reappear the following morning.

Then, Mung began to show up all over the polar station—in desk drawers, between pages of instruction manuals, even on the metal flagpole that marks the southernmost spot on the globe.

According to Penney, there are two Mungs painted on the steel post erected at the South Pole, a quarter mile from the Navy station. It seems that a couple of electronics men, after a few beers, decided that Omar should have a permanent place on the polar continent.

But in March of this year, following a year in cold storage, Omar and his Mung

family set out for pleasanter climes. In addition to their invasion of Great Lakes, the triangular tribe has turned up in Vietnam (would you believe Mao Tse Mung and Ho Chi Mung?) And it is reliably reported that at least one Mung family member has been seen on each new piece of electronic gear taken aboard the USS *Tacoma* during her last stay in the shipyards.

All Mungs, of course, bear a certain basic family resemblance, notably their geometric shape. But sophisticated Mung creators at Great Lakes insist on specific physical characteristics.

For one thing, they will not accept a Mung who does not have an upward twist to the left corner of his mouth. And, the purists contend, Omar himself must have his pointed hat cocked rakishly to the left, its brim line forming what the ETs term a "positive slope." When his brim tilts down on the right, watch out! It means he is in an exceedingly unfriendly mood. However, when Omar's hat is at a "negative slope," he supposedly becomes invisible to human eyes. As a result the ET students find it convenient to blame any misfortune, from a failing test grade to a burned out resistor, on an ill-tempered but unseen Mung.

Penney claims to have heard rumbles of Thursday prayer meetings, at which harried sailors plead for Omar's help with the weekly proficiency tests given the following day.

The inventiveness of the trainees doesn't surprise Master Chief Electronics Technician M.H. Neiss, supervisor of the school's A-2 Branch, who noted that the young sailors in his outfit rank among the Navy's top 20 percent in intelligence.

"They're sharp! Many of them go on to become electronics officers," says Neiss. The 27-year Navy veteran, dubbed the Chief Mung by the school's commandant, is amused by the growth of Mungism.

"I wish I were a cartoonist," he says. "The Mungs should be in a comic strip!"

But Neiss is considering signing an Omar and his crew as technical instructors, using them to illustrate Navy electronics teaching manuals.

Whether the Mungs would instruct or intimidate the ET students isn't clear. Already, ET/1 Gough cautions his classes to "treat Omar right or he'll get you!"

One thing is clear. In just a few months the Mung Dynasty has pretty well taken over one major Navy installation. What's next—the world? —Don Jensen ■

### May the Best Mung Win!

The Editors of e/e are looking for the most original, most unusual Mung (they already have some pretty cool creations of their own). All entries must be accompanied by this coupon, with no more than one Mung per entry. The decision of the Editors will be final; winning entry and winner will be announced in a forthcoming issue of e/e. First prize will be a shortwave receiver; other prizes to be announced. All entries become the property of e/e and cannot be returned.

Mail your Mung to Mung Editor, ELEMENTARY ELECTRONICS, 229 Park Ave. South, New York, N.Y. 10003.

May the best Mung win! ■

for privacy.  
for pleasure.  
try...



# the STEREOFONE

by Herb Friedman

The next time you want to bend an ear with your hi-fi system, but competition from the kids who want to grind out rock while your darling wife fights with Aunt Jane over what channel is to be watched on the big eye, be a hero and give in. Let them fight it out while you enjoy the latest sparkling concert via the Stereophone. Connect your turntable and stereo headphones to the Stereophone and you've got your own private, intimate hi-fi. You can even use this combination for wee-hours listening to a thundering *1812 Overture* and the only person who will ever hear the cannon is you.

The Stereophone is a dual, IC (integrated circuit) amplifier designed specifically with input equalization for a magnetic cartridge and output to feed stereo headphones. Measuring just  $6\frac{1}{4} \times 3\frac{3}{4} \times 2$  in., it can be tucked away into the night table drawer along with a turntable, ready to serve as your personal

hi-fi system for those times when you just can't fall asleep. Or you can place it next to your favorite chair and tune out the Dullsville TV shows and settle down for a pleasurable few hours. Use tight-fitting headphones and you'll hear nothing but sweet sounds.

**Latest Design Employed ICs.** The Stereophone uses a single IC to provide a separate equalized preamplifier for each channel. With a 3-millivolt cartridge connected to the inputs, the IC preamp will develop approximately 4 volts output, which is fed to Q1 and Q2, the headphone driver amplifiers. Circuitry associated with transistors Q1 and Q2 is designed to match any headphone having an impedance of 75 to 1000 ohms, which is the impedance range, usually, of quality stereo headphones. Those in the 75 to 1000-ohm range can provide a high output almost to the threshold of

# e/e STEREOFONE

pain, without distortion. So-called "budget" hi-fi phones, which really incorporate miniature 8-ohm speakers for the transducers, present a serious mismatch to the amplifier. Therefore, only moderate distortion-free audio level can be obtained.

**How It Works.** The major component of the Stereophone is an IC Dual Stereo Pre-amplifier (circuit is shown in Fig. 1). This IC consists of two independent, high gain, differential input amplifiers. Consider the section with input terminals 8 and 9 and output terminal 13: if terminal 8 were to be grounded for AC signal, an input signal applied to terminal 9 would be amplified and appear at output terminal 13. Any signal applied to terminal 8 would cancel the input signal applied to terminal 9 in the input transistors' emitter circuit.

In our Stereophone, all that's required to provide the equalization is to introduce feedback from output terminal 13 to input terminal 8. We apply feedback through R3, R4, C4 and C5. As the frequency increases, capacitors C4 and C5 feed back proportionately more signal to the input terminal 8. Therefore, the higher the frequency the lower will be the gain through terminal 9. The equalization effected by R3, R4, C4 and C5 in combination with C2, which is connected across the input differential amplifier, provides the IC with equalization for magnetic cartridges.

The same method of compensation for magnetic pickups is provided in the other amplifier section of the IC by R12, R13, C12 and C13 in combination with C10.

As a general note, just the IC circuit alone

can be used as a preamp when converting record players that now use ceramic cartridges to use magnetic cartridges. Substitute a 0.2- $\mu$ F capacitor for C6 and C14 and connect the C6 output to the stereo phono amplifier.

The IC amplifier less transistor Q1 and Q2 is powered by 14 to 15 VDC (15 V maximum) at approximately 1 mA. Transistors Q1 and Q2 require approximately 15 to 17 mA each at 15 VDC. Note that Q1 and Q2 are "stacked" across the DC supply voltage. This is to equalize the load on both sides of the power supply to avoid a voltage unbalance, which can affect operation of the IC. Both positive and negative power supply terminals are above ground. Circuitry within the IC provides an AC center tap (or ground) connection. Resistors R19 and R20 center tap (see Fig. 4) the DC supply to prevent any unbalance caused by a mismatch of Q1 and Q2 characteristics. Also, using an ungrounded power supply simplifies biasing of the IC.

Capacitors C17 and C18 should be 1000 to 2000  $\mu$ F each to provide ample filtering in the power supply. Two capacitors were used to ensure that sufficient filtering could be fitted inside the cabinet. A single capacitor of at least 2000  $\mu$ F may be substituted for both C17 and C18 if one small enough to fit in the space is available. Capacitor Cx (100  $\mu$ F) is needed only if the amplifier breaks into high frequency oscillation, which could be caused by crossed IC input-output wiring. Initially, build the amplifier without Cx. If needed, then install it as close to the IC as possible (its capacity is too small to provide any degree of hum filtering). In the photographs we have shown Cx mounted only to give you an idea of its proper location. We did not need it in our amplifier.

C19 and C20 are used to place both sides of the power supply at the AC ground. They must be used, or else the common impedance of the IC, as well as R19 and R20, will feed either the left or right input to both channels.

One note of caution

CIRCUIT SCHEMATIC

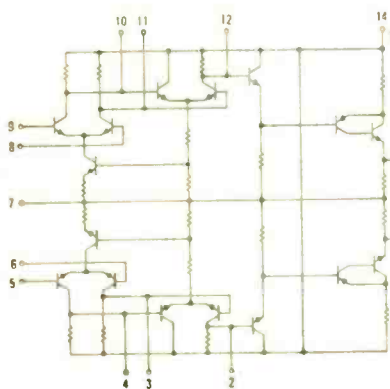

EQUIVALENT CIRCUIT

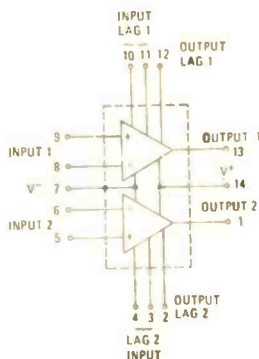

*Schematic diagram and equivalent circuit of Motorola IC, heart of Stereophone.*





Above, view of front panel showing locations of various controls and input/output jacks. Right, schematic of complete Stereofone amplifier (less power supply), including pin locations for IC and transistors Q1 and Q2. Power-supply schematic appears on page 52.

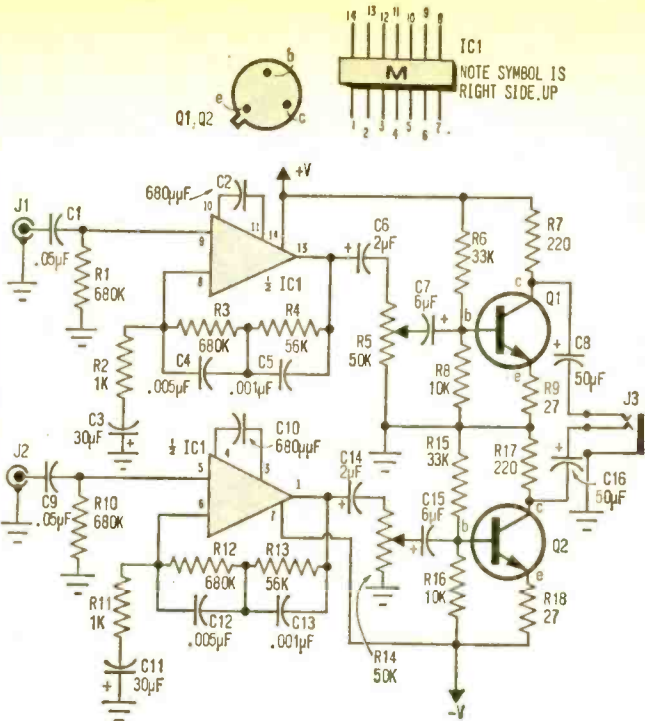

#### PARTS LIST FOR STEREOFONE

- C1, C9—0.05- $\mu$ F, ceramic disc capacitor  
 C2, C10—680-pF, ceramic disc capacitor  
 C3, C11—30- $\mu$ F, 12-VDC electrolytic capacitor (Lafayette 99T6084 or equiv.)  
 C4, C12—0.005- $\mu$ F, ceramic capacitor (Lafayette 99T6062 or equiv.)  
 C5, C13—0.001- $\mu$ F, ceramic capacitor (Lafayette 99T6060 or equiv.)  
 C6, C14—2- $\mu$ F, 6-VDC electrolytic capacitor (Lafayette 99T6020 or equiv.)  
 C7, C15—6- $\mu$ F, 6-VDC electrolytic capacitor (Lafayette 99T6072 or equiv.)  
 C8, C16, C19, C20—50- $\mu$ F, 12-VDC electrolytic capacitor (Lafayette 99T6085 or equiv.)  
 C17, C18—1000- $\mu$ F, 15-VDC electrolytic capacitor (DCE Blue Beaver-BR1000-15 or equiv.—see text)  
 Cx—100- $\mu$ F, 15-VDC electrolytic capacitor (Sprague TE-1162 or equiv.)  
 D1, D2—750-mA, 200-PIV silicon diode (Lafayette 19T4210)  
 J1, J2—Phono jack (Lafayette 99T6234 or equiv.)  
 J3—3-conductor, open circuit phone jack (Lafayette 99T6118 or equiv.)  
 IC1—Integrated circuit stereo amplifier (Motorola MC1303L)  
 Q1, Q2—NPN silicon transistor (RCA 2N3242A or 2N4074 or equiv.)

- R1, R3, R10, R12—680,000-ohm,  $\frac{1}{4}$  or  $\frac{1}{2}$ -watt, 10% resistor  
 R2, R11—1000-ohm,  $\frac{1}{4}$  or  $\frac{1}{2}$ -watt, 10% resistor  
 R4, R13—56,000-ohm,  $\frac{1}{4}$  or  $\frac{1}{2}$ -watt, 10% resistor  
 R5—50,000-ohm audio taper miniature potentiometer with spst switch (Lafayette 32T-6367 or equiv.)  
 R6, R15—33,000-ohm,  $\frac{1}{4}$  or  $\frac{1}{2}$ -watt, 10% resistor  
 R7, R17—220-ohm,  $\frac{1}{4}$  or  $\frac{1}{2}$ -watt, 10% resistor  
 R8, R16—10,000-ohm,  $\frac{1}{4}$  or  $\frac{1}{2}$ -watt, 10% resistor  
 R9, R18—27-ohm,  $\frac{1}{4}$  or  $\frac{1}{2}$ -watt, 10% resistor  
 R14—50,000-ohm, audio taper miniature potentiometer (Lafayette 32T7359 or equiv.)  
 R19, R20—1500-ohm,  $\frac{1}{4}$  or  $\frac{1}{2}$ -watt, 10% resistor  
 S1—Part of R5  
 T1—10/20 ct/40 ct VAC, 0.035 amp low voltage power transformer (Allied 54E4731 or equiv.)

Misc.—Hook-up wire, hardware, perfboard, push-in terminals, AC cord, solder, etc.

when purchasing the capacitors: most American-made high capacity ones are large physically and are expensive. Low cost, fairly good quality imported brands, such as

Ducati (available through IRC dealers), are perfectly satisfactory for this circuit, as are the "house" brands of Lafayette, Olson, and Radio Shack. (Continued overleaf)

# e/e STEREOFONE

**Construction.** Our Stereofone was built in a Radio Shack Mini-utility case, using the aluminum cover as a front panel. Do not use a Bakelite panel. If you are not skilled at close-quarter wiring use a larger cabinet as wiring may be somewhat difficult due to the small space in the one we used. If you use a larger cabinet follow the same general layout with additional clearance between the components.

The amplifier perfboard sub-assembly and the power supply, as well as the balance of components complementing the Stereofone are fastened to the aluminum panel which normally serves as a cover for the plastic box.

The amplifier is built on a  $3\frac{1}{2} \times 1\frac{7}{8}$ -in. section of G-pattern perfboard. We suggest the G-pattern board as the extra "fill-in" holes exactly match the terminal spacing of the IC and it also makes for easier parts layout. Push-in terminals are used to mount the IC and for tie points. Make certain the board is not oversized so as to prevent the cover panel from fitting in place.

**Mounting the IC.** Insert into holes in the perfboard, two rows of terminals, one on each side of the IC, leaving two rows of holes blank in between the rows of terminals to provide space for the body of the IC. By bending down IC terminals 2, 4, and 6 and 9, 11 and 13 the IC will drop into position in the push-in terminals. However, to avoid heat damage from soldering, do not install the IC until all the components have been connected and soldered on the back of the perfboard. The remaining terminals of the IC may be connected to their respective push-in terminals by short pieces of solid hook-up wire. Though we used  $\frac{1}{2}$ -watt resistors for better photographic detail, we suggest you use  $\frac{1}{4}$ -watt

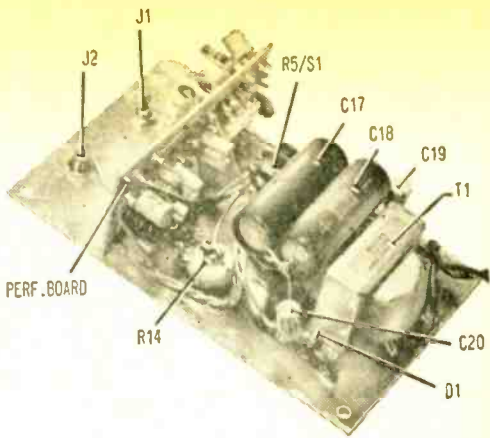

Rear view of front panel showing location of amplifier perfboard, panel-mounted controls, and dual-polarity-output power supply.

resistors and miniature capacitors as space is at a premium and it gets difficult to hook up the amplifier sub-assembly when using  $\frac{1}{2}$ -watt resistors.

The components for the Q1 and Q2 amplifiers are mounted on the IC side of the perfboard.

The perfboard assembly is secured to the panel with a small L bracket. However, before securing it to the panel, double-check polarization of the electrolytic capacitors. They must be polarized as indicated in the schematic.

**Final Assembly.** Since there is not sufficient room on the panel for standard-size volume controls use the miniature type; as an added bonus they're almost half the price of standard controls. Jack J3 must be a three-circuit (stereo) type.

Silicon rectifiers D1 and D2, and R19, R20, C19 and C20 are mounted on terminal tie strips held in place by the power transformer's (T1) mounting screws. T1 is a multi-voltage transformer. For the Stereofone use only the color-coded leads indicated in the schematic and cut off the remaining leads as close as possible to the transformer body and tape them to ensure that they won't short to the panel.

When connecting the power supply output leads to the perfboard assembly, extra  
(Continued on page 56)

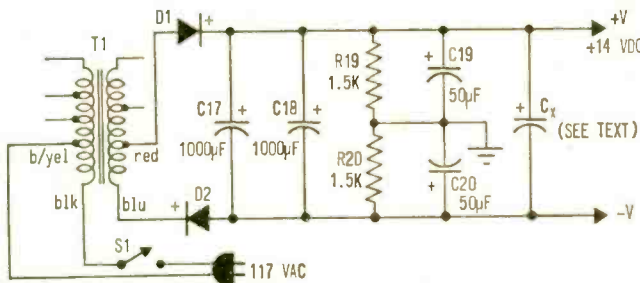

Power supply schematic, detailing positive and negative DC output and reference AC ground.

# 10 Reasons why RCA Home Training is

# your best investment for a rewarding career in electronics:

Transistor experiments  
on programmed breadboard—  
using oscilloscope.



## 1 LEADER IN ELECTRONICS TRAINING

RCA stands for dependability, integrity and pioneering scientific advances. For over a half century, RCA Institutes, Inc., has been a leader in technical training.

## 2 RCA AUTOTEXT TEACHES ELECTRONICS FASTER, EASIER

Beginner or refresher — AUTOTEXT, RCA Institutes' own method of Home Training will help you learn electronics faster, easier, almost automatically.

## 3 THOUSANDS OF WELL PAID JOBS ARE OPEN NOW

RCA Institutes can help you qualify for a rewarding career if you have an interest in electronics. Every year, thousands of well paid electronics jobs go unfilled just because not enough men take the opportunity to train themselves for these openings.

## 4 WIDE CHOICE OF CAREER PROGRAMS

Select from a wide choice of courses and career programs ranging from basic Electronics Fundamentals to advanced training including Computer Programming and Electronics Drafting. Each

Career Program begins with the amazing AUTOTEXT method.

## 5 SPECIALIZED ADVANCED TRAINING

For those working in electronics or with previous training, RCA Institutes offers advanced courses. Start on a higher level. No wasted time on material you already know.

## 6 PERSONAL SUPERVISION THROUGHOUT

All during your program of home study, your training is supervised by RCA Institutes experts who become personally involved in your efforts and help you over any "rough spots" that may develop.

## 7 VARIETY OF KITS, YOURS TO KEEP

At no extra cost, a variety of valuable specially engineered kits come with your program—yours to keep and use on the job.

## 8 TRANSISTORIZED TV KIT AND VALUABLE OSCILLOSCOPE

You will receive in most career programs a valuable oscilloscope. Those enrolled in the TV Program or courses receive the all-new Transistorized TV Receiver—exclusive with RCA. (Picture tube available at additional cost.)

## 9 CONVENIENT PAYMENT PLANS

You can take advantage of RCA's convenient monthly payment plans. There is one to suit your budget.

## 10 RCA GRADUATES GET TOP RECOGNITION

Thousands of graduates of RCA Institutes are now working for leaders in the electronics field; many others have their own profitable businesses... proof of the high quality of RCA Institutes training.

**RCA INSTITUTES, INC.** Dept. EA-99  
320 West 31st St., N.Y., N.Y. 10001

Canadians: These same RCA courses are available to you in Canada. No postage. No customs. No delay. Your inquiry will be referred to our school in Canada.

All courses and programs approved for veterans under new G.I. Bill.

**CLASSROOM TRAINING ALSO AVAILABLE. FREE CATALOG ON REQUEST.**

### ACCREDITED MEMBER National Home Study Council

Construction of Oscilloscope.

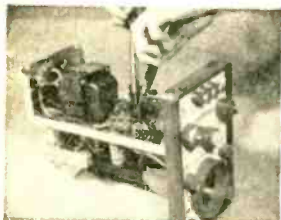

Construction of Multimeter.

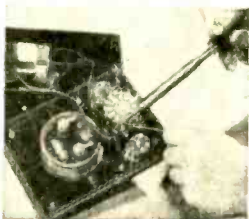

# RCA

If Reply Card Is Detached—Send This Coupon Today

## RCA INSTITUTES, INC.

Home Study Dept. EA-99  
320 West 31st Street  
New York, N.Y. 10001

Name \_\_\_\_\_

Address \_\_\_\_\_

City \_\_\_\_\_

State \_\_\_\_\_

Zip \_\_\_\_\_

Check here if interested in Classroom Training



## STEREOFONE

care must be taken to get them correctly wired the first time. You might not get a second chance if voltage having reversed polarity is fed to the IC, which would damage it.

**Using the Stereofone.** In terms of low distortion, the IC works best into approximately 10,000 ohms, so try not to run the volume controls wide open; leave a little resistance in the circuit to provide the proper

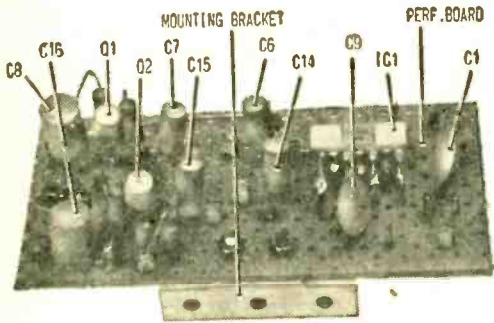

Top view of Stereofone amplifier perf board assembly, showing location of all major components on upper side of board.

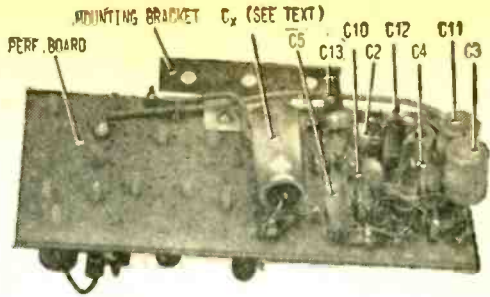

Bottom view of amplifier perf board assembly, showing placement of components. Cx is needed only if amplifier oscillates.

IC load as the input impedance of Q1 and Q2 is low. Isolation resistors were not installed because they would reduce the sound to an unacceptable level if using 8-ohm phones. Normally, wide open volume controls would produce deafening volume, but this will not be the case as the total output level has been reduced somewhat so that, even though it is preferable to use high quality phones, we could provide for the 8-ohm variety. While the sound level when using 8-ohm phones will be moderate, for those willing to put up with a little extra distortion (approximately 10%) go ahead and run the volume to the top if you must have thundering volume. ■

# Holographic! What A Memory!

Would you believe 150,000 English words stored on a surface smaller than a half dollar? Well, that's what IBM scientists are saying is possible with their new memory device which uses holographic encoding techniques. An electron beam is employed to write computer-generated binary Fourier holograms on strips of photographic film. Each hologram contains one byte of data, made up of one clock bit and eight data bits. The holograms are organized into 256

tracks on each film strip, and the strips are placed on the inside surface of a transparent drum for readout by a laser beam.

Set up in a lab at IBM (below, left), a laser beam is reading out information from the memory storage drum. Diagram (below, right) details system's operation. Laser beam must be positioned to within 0.0025-in. accuracy for system to operate. Man, that's *holog-riffic!*

—Chris Crumm

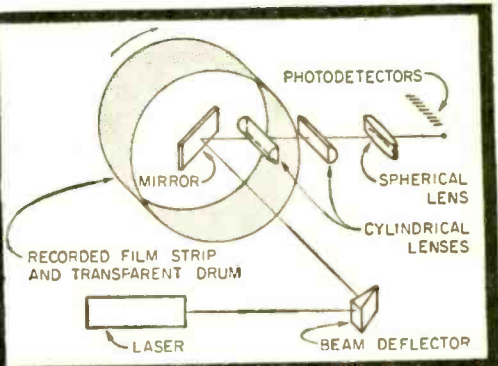
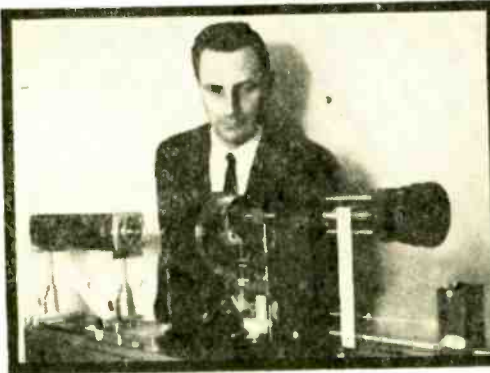



Jenkins 102 "Radiovisor" of 1929 contrasted with 1952 DuMont Royal Sovereign. DuMont had 30-in. screen.

## FROM TV'S TENDER YEARS

**M**ost people today think of television as a post-World War II phenomenon. Truth is that the U.S. industry's basic engineering standards were adopted in 1941. Limited programming was available as early as the late 1920s from Washington, D.C.;

the next few years saw more than two dozen stations scattered across the country.

Since the first broadcasts were made with mechanical scanning systems, definition was on the crude side (45-60 lines) by today's standards (525 lines). Even so, receivers

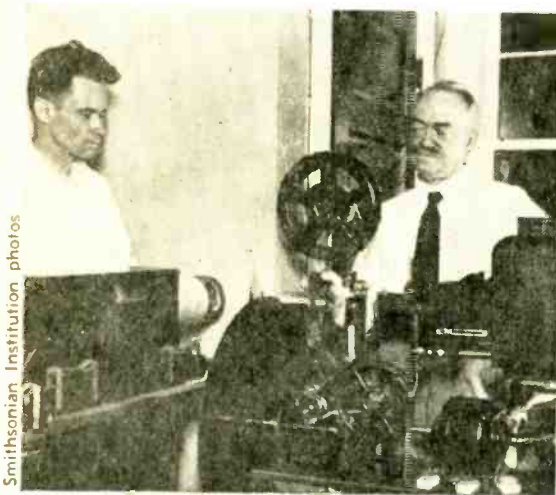

Smithsonian Institution photos



Radiovision, as early TV was often called, relied on motion pictures for much of its programming. 1929 photo at left shows telecasting from Jenkins' lab; at right is early scanner operating in 1800-2100 kHz range.



# TV'S TENDER YEARS

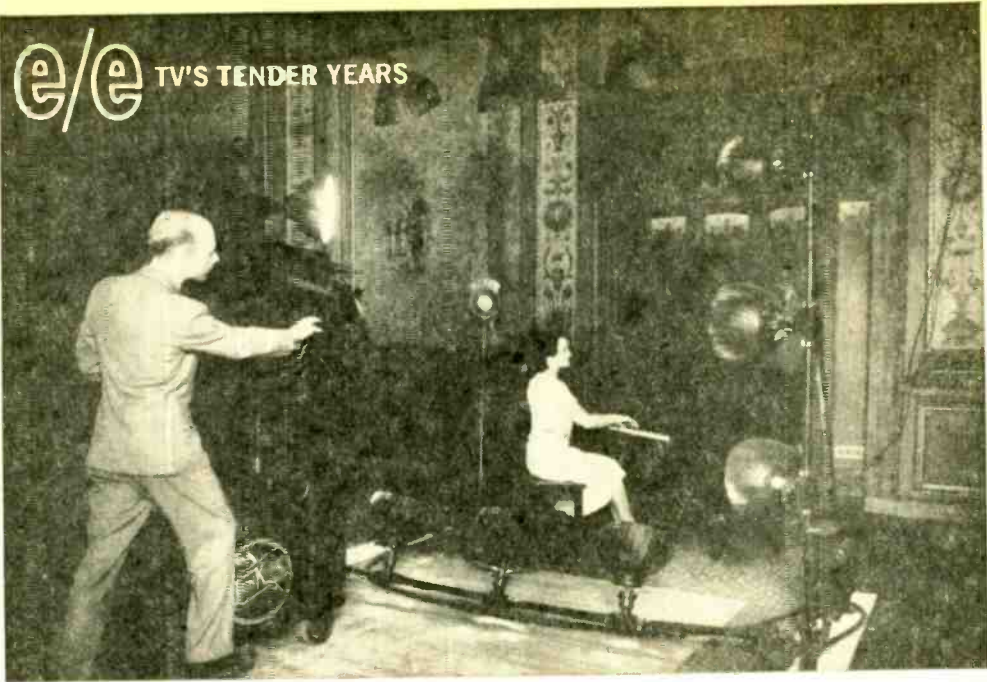

Pianist Ruth Rowe performs before TV cameras in 1931 telecast. The station: W2XCD of Passaic, N.J.

were marketed in commercially finished cabinets. And, by 1931, at least one company, the Jenkins Television Corp., could boast that it was selling enough receivers to the public to meet expenses.

Mechanical scan gave way to the versatile

electron beam in the early 30s with successive improvements in the cathode ray tube. And by 1939, the industry's standards were remarkably close to today's versions (even color TV depends on specs stemming from those early monochrome days).

## Television Stations on the Air June 1, 1931

Call	Company, Location	(Power in watts, lines per frame)	Call	Company, Location	(Power in watts, lines per frame)
<b>2000-2100 kHz</b>					
W3XK	Jenkins Laboratories, Wheaton, Md.	(5000, 60)	W1XAV	Shortwave & Television Lab. Inc., Boston, Mass.	(500, 60)
W2XCR	Jenkins Television Corp., New York, N.Y.	(5000, 60)	W9XR	Great Lakes Broadcasting Co., Downer's Grove, Ill.	(5000, 60)
W2XAP	Jenkins Television Corp., portable	(250, 60)	W2XR	Radio Pictures, Inc., Long Island City, N.Y.	(500, 60)
W2XCD	DeForest Radio Co., Passaic, N.J.	(5000, 60)	<b>43000-46000 kHz</b>		
W2XBU	Harold E. Smith, Near Beacon, N.Y.	(100, 48)	W3XAD	RCA Victor Co., Inc., Camden, N.J.	(50, 60)
W9XAO	Western Television Corp., Chicago, Ill.	(500, 45)	W2XBT	National Broadcasting Corp. portable	(750, 60)
<b>2100-2200 kHz</b>					
W1XAD	RCA Victor Co., Camden, N.J.	(500, 60)	W1XG	Shortwave & Television Lab. Inc. portable	(30, 45)
W2XBS	National Broadcasting Co., New York, N.Y.	(5000, 60)	<b>43000-44000 kHz</b>		
W2XCW	General Electric Co., S. Schenectady, N.Y.	(20000, 7)	W9XD	The Journal Company, Milwaukee, Wis.	(500, 7)
W2XAV	Westinghouse Elec. & Mfg. Co., E. Pittsburgh, Pa.	(20000, 60)	<b>48500-50300 kHz</b>		
W2XR	Radio Pictures, Inc., Long Island City, N.Y.	(500, 60)	W3XAD	RCA Victor Co., Inc., Camden, N.J.	(50, 60)
W9XAP	Chicago Daily News, Chicago, Ill.	(1000, 45)	W2XBT	National Broadcasting Corp. portable	(750, 60)
W3XAK	National Broadcasting Co., portable	(5000, 60)	W1XG	Shortwave & Television lab. inc., portable	(30, 60)
<b>2750-2850 kHz</b>					
W2XAB	Atlantic Broadcasting Corp., New York City	(500, 7)	<b>60000-60000 kHz</b>		
W9XG	Purdue University, W. Lafayette, Ind.	(1500, 7)	W3XAD	RCA Victor Co., Inc., Camden, N.J.	(50, 60)
W2XBO	United Research Corp., Long Island City, N.Y.	(500, 7)	W2XBT	National Broadcasting Corp. portable	(750, 60)
			W1XG	Shortwave & Television Lab. Inc., portable	(30, 60)

# JUNK BOX

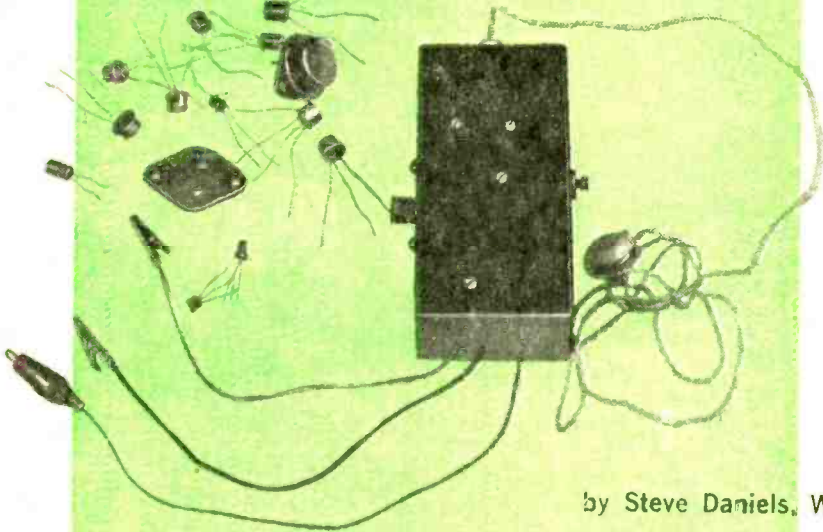

by Steve Daniels, WB2GIF

## TRANSISTOR TESTER

*Get the best out of bargain transistors with our low-cost Transistor Tester*

Like most experimenters you undoubtedly have been tempted by ads (some appearing in *Science and Electronics*) that read: "HUGE BARGAIN—ASSORTMENT OF 25 TRANSISTORS—PNP AND NPN, \$1.00." After reading further you usually find a statement, in small type, to the effect that these are not tested. With our Junk-Box Transistor Tester you will be able to grade them as to type (npn or pnp), open, leaky, beta (DC current drain), and applications (voltage or power). So with the expenditure of a little of your precious time and a few bucks (in case your junk box is shy of some components), you will have a device that will reduce the cost of these bargain transistors to something like 5¢ each, or less, by helping you to identify and classify those unknown transistors.

Of course, some will be absolutely NG, and most will have had all identifying marks as to type number and manufacturer obliterated. Naturally, you

# e/e TRANSISTOR TESTER

cannot guess whether they are pnp or npn just by looking at them. No—the situation is not hopeless and you did not throw away the dollar you invested for the bag of transistors.

**What JBTT Can Do.** The first things you must know about an unmarked transistor are: a) is it an npn or a pnp, and b) is it good or bad. Our basic test unit is, essentially, a Hartley Oscillator when a transistor is connected to it. (See Fig. 1.) The resistor connected to the base of the transistor under test serves as a protector by limiting the current and it also provides base bias. The circuit in this unit is not critical as to transistor gain, and will tell you if the transistor under test is basically good or bad.

In order for the circuit to oscillate, battery polarity must be correctly oriented for the type of transistor (whether a pnp or an npn) being used. Dpdt switch S1 reverses the battery polarity. If no oscillation is generated with the switch in *npn* position, slide it to *pnp*, which reverses the polarity, and then, if the transistor is functional, regardless of how good, you should get oscillation.

You do have to know which lead is the base, which the emitter, and which the collector. Typical base connections are illustrated in Fig. 2. You may have to refer to a transistor handbook or cross reference book (a good one is Datadex, M. W. Lads Publishing Co., 11401 Roosevelt Blvd., Philadelphia, Pa. 19154) for those weird types not covered in the diagrams in Fig. 2.

**How Simple Is It?** Connect the transistor to the test clips and depress S3. If no tone is heard in the carpiece, reverse the po-

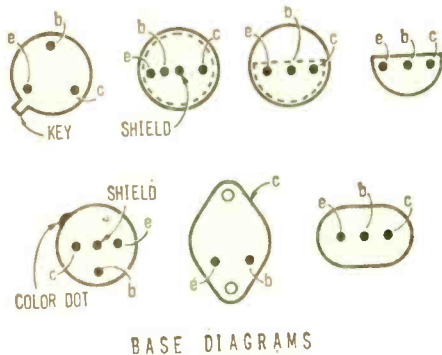

Fig. 2. Typical base diagrams for the most popular transistors usually found in packages offered in bargain sales by majority of supply houses.

larity switch S1. If after trying both of these you still get no tone, in all probability, the transistor under test really is NG. (However, don't toss it in the wastebasket yet. If you conduct basic tests that we will describe further on, you may be able to discern more data to classify it as OK.) When you do hear a tone, indicating the transistor under test is

## PARTS LISTS FOR JUNK BOX

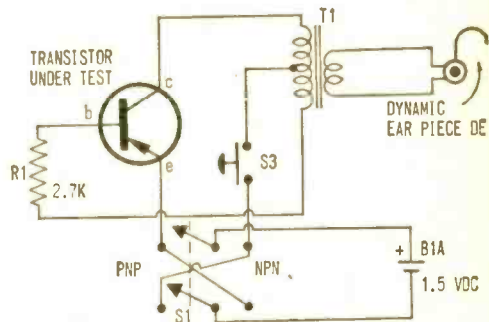
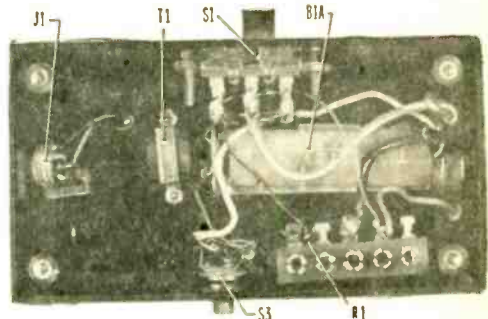

Fig. 1. Schematic for basic Hartley oscillator, heart of our tester. It determines whether transistor will work and whether type is npn or pnp.



### Oscillation Tester (see fig. 1.)

- 1—Battery holder for one type AA cell (Lafayette 34T5005 or equiv.)
- 1—1.5 V. Type AA penlight cell (Lafayette 99T6258 or equiv.)
- 3—Alligator clips (Lafayette 32T3500 or equiv.)
- DE—Dynamic earpiece (Lafayette 99T2548 or equiv.)
- J1—Miniature phone jack (Lafayette 99T6211 or equiv.)
- 1—Miniature phone jack (Lafayette 99T6211 or equiv.)
- 1—4 x 2 1/8 x 1 1/8-in. plastic box with metal panel (Lafayette 99T8078 or equiv.)
- R1—2700 ohm, 1/2 watt, 10% resistor
- S1—Dpdt slide switch (Lafayette 34T3912 or equiv.)
- S3—Spdt normally open momentary push button switch (Lafayette 99T6218 or equiv.)
- T1—Transformer, pri. 500 ohm c.t., sec. 3.2 ohms (Lafayette 99T6127 or equiv.)



oscillating in the circuit, you will have ascertained if the transistor is pnp or npn from the position of S1. Isn't that easy? Now try the rest of the transistors in the bargain bag and you'll wind up with 2, 3, or 4 piles representing good, bad, npn and pnp transistors.

**Ready To Delve Deeper?** Search through that junk box again for a 0 to 10 mA. milli-

ammeter. With the meter, a few resistors and a slide switch breadboarded as shown in Fig. 3 you will be able to further classify the transistors under test. You will be able to make fairly accurate measurements of DC current gain (beta). If you do not want to manually reverse the meter wiring when (Continued on page 107)

## TRANSISTOR TESTERS

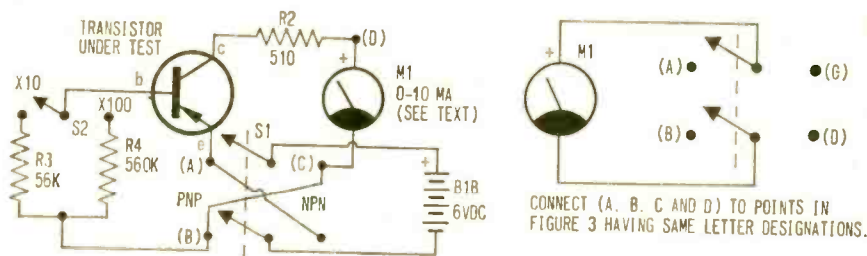

Fig. 3. Left, schematic for Beta test. If no 10-0-10 mA meter is available, wire a second dpdt switch as shown in Fig. 3a (right) to reverse meter readings when required.

### Beta Tester (see figs. 3 & 3a.)

- 1—Battery holder for four type AA cells (Lafayette 34T5009 or equiv.)
- 4—1.5 V. Type AA penlight cells (Lafayette 99T6258 or equiv.)
- 1—0-10 mA. milliammeter (Lafayette 38T6085 or equiv.)
- \*1—6¼ x 3¾ x 2-in. plastic box (Lafayette 19T2001 or equiv.)

- \*1—plastic panel for box (Lafayette 19T3701 or equiv.)
- R2—510 ohm, ½ watt, 10% resistor
- R3—56,000 ohm, ½ watt, 10% resistor
- R4—560,000 ohm, ½ watt, 10% resistor
- S1—Dpdt slide switch (Lafayette 34T3912 or equiv.)
- S2—Spdt slide switch (Lafayette 34T3704 or equiv.)

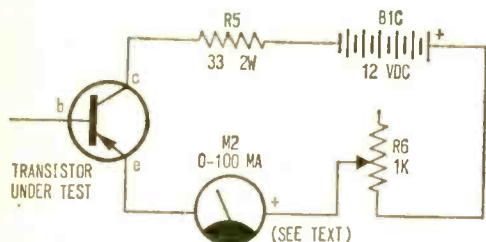
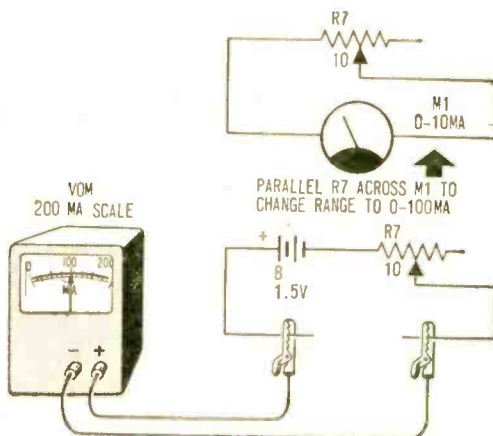

Fig. 4. Left, schematic for leakage and shorts test. Fig. 4a, Right, schematic showing how meter shunt is calibrated and connected to M1.

### Leakage and Shorts Tester (see figs. 4 & 4a.)

- 1—Battery holder for 8 type AA cells (Lafayette 99T6323 or equiv.)
- 8—1.5 V. Type AA penlight cells (Lafayette 99T6258 or equiv.)
- #1—0-100 mA. milliammeter (Lafayette 38T6089 or equiv.)
- \*1—6¼ x 3¾ x 2-in. plastic box (Lafayette 19T2001 or equiv.)

- \*—good size box if meter is panel mounted, holds all parts for test unit.
- #—required unless experimenter desires to convert 0-10 mA. meter, see text.



- \*1—plastic panel for box (Lafayette 19T3701 or equiv.)
- R5—33 ohm, 2 watt, 10% resistor
- R6—1000 ohms, 5 watt wirewound potentiometer (Lafayette 33T1349 or equiv.)
- #R7—10 ohm, 5 watt wirewound potentiometer (Lafayette 33T1332 or equiv.)
- ##—required for shunt if converting 0-10 mA. meter to higher range.
- Misc. hardware, hookup wire, Fahnestock clips (Lafayette 32T6459 or equiv.)

# The Handy-Dandy Transistor Radio



It's normal for us humanoids to want our purchases to be versatile and to present us with many services. For those who have to stretch our dollars, and that is nearly all of us, and especially electronics experimenters, students and hobbyists, we are forever searching for things that serve many uses. With this thought in mind we dreamed up many applications for our Handy-Dandy Transistor Radio. Not only can we use it to entertain us, brief us on the latest news and weather, etc., we can use it as an AM tuner for our hi-fi amplifier and speaker combo, for private listening with our good headphones (either magnetic or crystal), as a low-level general purpose audio amplifier, as a phono-amplifier for crystal or ceramic phono pickups or as a RF-AF signal tracer.

We used a packaged transistor radio

called "Build-In" radio, available from Radio Shack. It is a conventional six transistor broadcast receiver mounted in a clear plastic case that serves to protect the receiver yet take up very little space, with a separate speaker and switch/volume control. It has been packaged to facilitate building it into any type of cabinet or interesting housing (e.g. a combination lamp, desk pen and desk radio assembly; in toys; in odd-shaped enclosures, etc.).

**Multi-use Package.** We mounted the plastic case containing the receiver, less the speaker and switch/volume control, centered on a wooden base  $8\frac{1}{2} \times 4 \times \frac{3}{4}$ -in. so that the shaft of the tuning capacitor could extend beyond a fiber board front panel  $8\frac{1}{2} \times 3\frac{1}{4} \times \frac{1}{8}$ -in. The speaker was mounted to the left of the receiver and a closed circuit jack between the speaker and the receiver. The switch/volume control was mounted to the right of the receiver to balance the panel layout. Calibrated knobs were substituted for the plain knobs because they facilitate tuning and audio level settings. Fahnestock clips were fastened behind the panel to the base board so that various patch cords could be connected to use the various functions mentioned

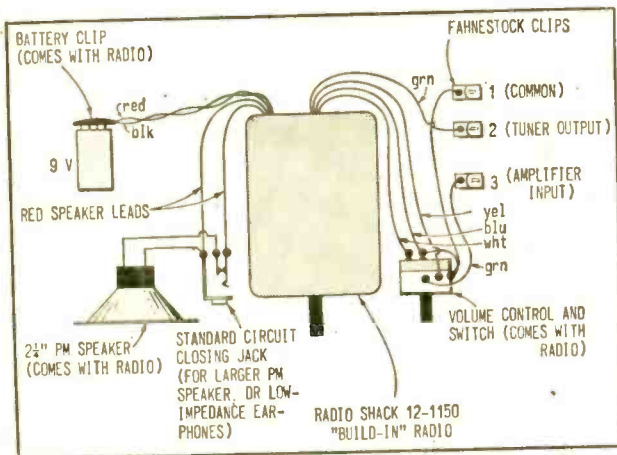

External wiring for "Build-In" kit as phono or mike amp, AF or RF signal tracer, and BCB tuner.

## Making a transistor set into a many-splendored thing

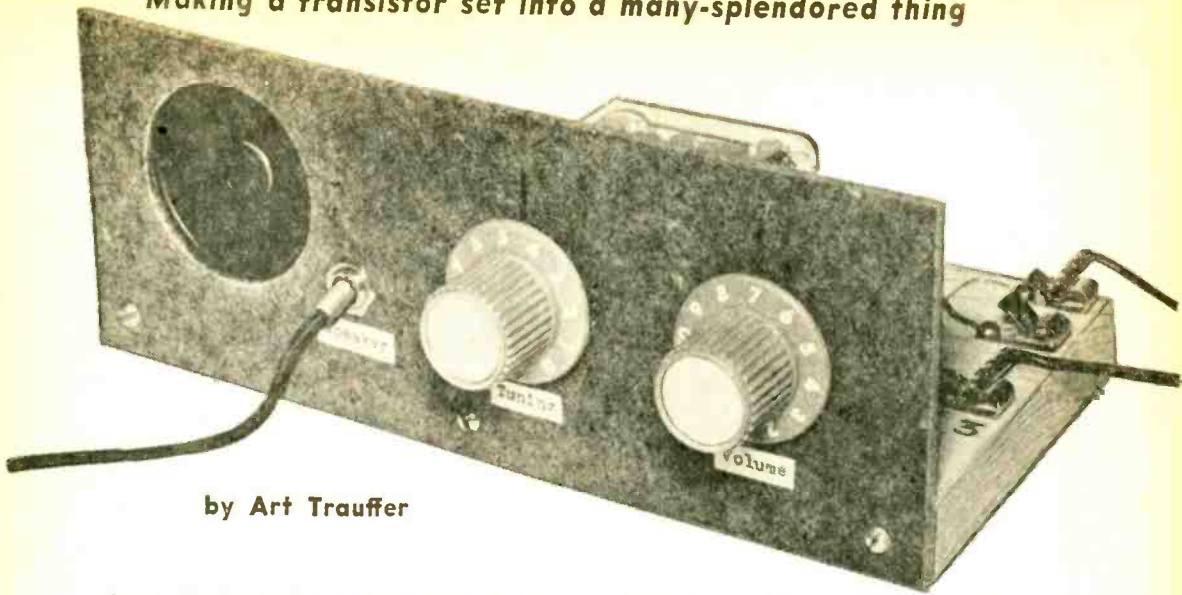

by Art Trauffer

above. The block diagram details the various output/input combinations available as well as the general hook-up of the complete assembly.

The battery which powers the radio is mounted to the base board behind the speaker with a metal strap. There are two holes drilled into the plastic case of the radio that may be used to hold it in position on the panel. They are undersized for clearance of 6-32 machine screws, which would, if carefully started, cut their own thread in the soft plastic when screwed in. Use screws about  $\frac{3}{8}$ -in. long, being careful not to damage the printed circuit board of the receiver, which could happen if the screws are too long. The leads from the receiver to the speaker, switch/volume control and battery are color coded and the receiver is supplied with full inter-connecting instructions. The variations we have added are indicated in the block diagram. The photos clearly show the mounting details and layout.

**The Dividends.** Now that you have assembled your Handy-Dandy combo how can you apply it to reap the dividends from its multiple uses?

If you want to use it as a tuner for your hi-fi amplifier all you have to do is connect a shielded cable, the shield to clip #1 (Common) the hot lead to clip #2 (Tuner Output) on the Handy Dandy. The shield is

connected to the ground side and the hot lead to the center of the input of your amplifier. Run a jumper from #2 clip to #3 clip. If you do not want the speaker on your Handy-Dandy to operate and the full output signal from the detector will not overload the input of your amplifier, omit the jumper.

You just want to listen to the game or a special musical program and the rest of the family want the TV. Get out your high quality headphones and plug them into the jack on the front panel. The local speaker will be disconnected and you will be able to listen in comfort and privacy.

You need a low level general purpose amplifier for a project; all you have to do is

*(Continued on page 105)*

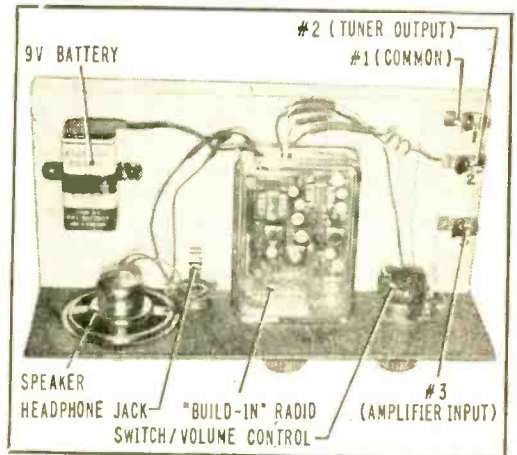

Top view of completed assembly, showing locations of components comprising Handy-Dandy transistor lash-up. Note similarity to diagram at left.

**A**ccording to an ancient Bantu legend, Tilo, the sky god, is responsible for all mysteries. It is therefore appropriate that three air-portable radio stations are responsible for much of the DX interest in lower Africa. That interest in countries surrounding the Kalahari desert, from Zambia on the north to the Republic of South Africa on the south, has been growing steadily for the past four years. Today, this area has become one of the hottest on anybody's dial.

Kicking off all the action, before any Tilo-type capers, was the emergence early in 1965 of ultra-rightist Radio RSA—the propaganda arm of the state-owned South African Broadcasting Corp. RSA's powerful transmitters now beam programs all over the world, including a four-hour session to North America. While RSA's approach is a very cleverly done soft sell, many SWLs have not been fooled. One listener, in fact, recently suggested that burning RSA's QSL card just might be a more meaningful protest than burning one's draft card.

Later in 1965, Rhodesia, ruled by a white minority, declared its independence from Britain. The British hurriedly set up a relay station (then known as Bechuanaland). They were able to put this station on the air rapidly because of secret help from the U.S. government and the use of highly sophisticated American air-transportable equipment. So long as their Francistown station was on the air, the BBC consistently refused to answer questions about either of these aspects of their Botswana operation (but also scrupulously avoided denying them), and it was this secrecy which really made the station controversial.

Much to everyone's surprise, now that the station is closed, the controversy has suddenly become even hotter. Why? Because a little official information has now been released in hopes of glossing over the above-mentioned secrecy. While U.S. Government involvement is still not admitted, it has now been acknowledged that American gear was used. And while the equipment, Continental Electronics air-transportable antenna and transmission system, is definitely not the original American portable used at Francistown, the Continental is indeed a very advanced unit with capabilities almost matching those of the widely pub-



# DXing the Kalahari





What's that? You never heard of the Kalahari? Why man, it's second only to the Sahara as deserts go in Africa and it's inhabited by Hottentots and Bushmen. DX them you can't, but wait til you get a load of those rare catches right next door!

by C. M. Stanbury II

licized VOA portables. To be precise, it can be put on the air in just 18 days.

**A Piece of the Action.** Even a novice SWL will have no trouble logging RSA's broadcasts to North America. These are aired at 1830-2220 EST on 9705, 11876, and 15220 kHz. However, if it happens you don't want to give RSA the satisfaction of knowing you've listened (and assuming you don't plan to use their QSL card merely for incendiary purposes), South Africa can be logged via a far longer DX route. For example, in the evening you might try for SABC's commercial service, Springbok Radio, intended for domestic consumption on 4945, 3250, or even 3020 kHz. The latter channel is of course 75-meter ham territory on this continent.

At the opposite extreme is R. Botswana, which DXers will find a very difficult station to log. R. Botswana operates on 4834 and 7295 kHz, supposedly with a morning transmission beginning at 2300 EST. However, to the best of our knowledge, no reliable SWL has ever reported reception at this hour. But NA DXers do definitely have a chance, albeit a slim one, of hearing R. Botswana on 7295 at 1400 EST S/Off.

**More DX.** Between these two extremes lie the other four countries of lower Africa which can be heard in North America with varying degrees of effort. They are Rhodesia and Zambia along with the two Portuguese

#### ABBREVIATIONS

BBC	British Broadcasting Corporation
BCB	broadcast band
DXer	radio listener interested in long-distance reception
kHz	kilohertz (kilocycles)
NA	North American
QRM	noise and signals interfering with desired signal
QSL	a decorated postcard or letter used to acknowledge a reception report
R	Radio (as in Radio South Africa)
RBC	Rhodesian Broadcasting Corp.
SABC	South African Broadcasting Corp.
S/Off	sign off
SW	shortwave
SWL	shortwave listener
VOA	Voice of America
ZBC	Zambia Broadcasting Corp.

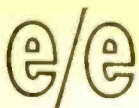

## DXING KALAHARI

colonies of Angola and Mozambique. The only station still carrying on an active anti-Rhodesian campaign is the Zambian Broadcasting Corp. at Lusaka. SWLs on this continent should watch for both stations around 2300 EST. ZBC transmits on 3346 and 4911 kHz; RBC on 3396 and 5975 kHz.

In related conflicts, rebel bands are active in both Angola and Mozambique. True, Portugal has a new government, at least on paper, but its hard-line colonial policies are unlikely to change markedly. The stations to watch for from these areas are R. Clube de Mocambique, technically a privately owned station at Lourenco Marques; R. Angola, a government operation at Luanda; and R. Commercial at Sa da Baneira, Angola.

**On the Broadcast Band.** Lower Africa is extremely difficult to log on the BCB in North America, especially with those 50-kHzers now removed from the Botswana scene. Outside the Chicago area (where WBBM holds down 780) your best bet is the R. Springbok outlet on 782 kHz at Bloomfontein. Unlike its SW counterpart, 782 does not operate all night but instead signs on at 2156 EST. In Chicagoland you might try at the same time on 1286 kHz but sideband QRM will be intense.

However, the real BCB action will come



Africa's Kalahari Desert is some 120,000 sq mi big, located in one of its hottest areas.

when DXers try to track down the present whereabouts of those three 50,000-watt portables formerly at Francistown. The first is so wrapped in intrigue that locating it will be extremely difficult (would you believe dangerous?). But either Washington or London, depending on who officially owns them, will eventually be forced to reveal the current locations of their two Continental air-portables. If they don't, there's good chance that Tilo, the sky god, may let the cat out of the bag beforehand.

### e/e's Shortwave Guide to the Kalahari

kHz	Station	Location	Time (EST)
3218	R. Clube de Mocambique	Lourenco Marques, Mozambique	Evenings
3250	Springbok Radio <sup>1</sup>	Paradys, South Africa	Evenings
3346	Zambia Broadcasting Services	Lusaka, Zambia	2300
3396	Rhodesia Broadcasting Corp. <sup>2</sup>	Gwelo, Rhodesia	2300
3920	Springbok Radio <sup>1</sup>	Paradys, South Africa	Evenings
4795	R. Commercial	Sa da Bandeira, Angola	1700-1800, 0000-0100
4820	R. Angola	Luanda, Angola	1700-1800, 0000-0100
4834	R. Botswana	Gaberones, Botswana	2300
4911	Zambia Broadcasting Services	Lusaka, Zambia	2300
4925	R. Clube de Mocambique	Lourenco Marques, Mozambique	Evenings
4945	Springbok Radio <sup>1</sup>	Paradys, South Africa	Evenings
5975	Rhodesia Broadcasting Corp. <sup>2</sup>	Gwelo, Rhodesia	2300
6175	R. Angola	Luanda, Angola	0000-0100
7295	R. Botswana	Gaberones, Botswana	1400
9660	R. Angola	Luanda, Angola	0000-0100
9705	R. RSA <sup>1</sup>	Bloemendal, South Africa	1830-2220
11780	R. Clube de Mocambique	Lourenco Marques, Mozambique	2300
11875	R. RSA <sup>2</sup>	Bloemendal, South Africa	1830-2220
15220	R. RSA <sup>1</sup>	Bloemendal, South Africa	1830-2220

<sup>1</sup> Reports to Johannesburg. <sup>2</sup> Reports to Salisbury.



**HEATHKIT AD-27**  
**Solid-State FM Stereo**  
**30-Watt Compact Kit**

**T**he Heath AD-27 Compact Stereo Center is tailor-made for those who want a quality stereo system that can blend right in with the general decorating scheme. That's hi-fi showroom talk meaning the stereo gear doesn't stick out like a sore thumb.

♪ The AD-27 consists of an FM/FM stereo receiver and a record changer housed in a walnut-finish, roll-top cabinet. When the roll-top is down the cabinet appears to be the top of a roll-top desk or bar. In fact, if the cabinet is placed on a small table or record storage unit, the entire assembly looks just like an updated version of Grandpa's roll-top desk or an executive-suite bar.

♪ Both bass and treble tone controls are

provided in the AD-27 as well as separate volume and balance controls. The tone controls are ganged together so that both channels are adjusted simultaneously. For this reason, both the left and right speakers must be identical. (Since mono is long since dead, mismatched speakers are found only in ancient systems.) The selector switch selects either FM, phono, or an auxiliary input. Three panel switches control the power, speakers, and the stereo-mono modes. A recessed panel contains the auxiliary input jacks, tape outputs, headphone jack, and speaker terminals.

♪ The amplifier output is so wired that the headphone jack provides full-time monitoring, whether the speakers are *on* or *off*. The headphone outputs are provided with 100-ohm series resistors to prevent burn-out or overload of sensitive headphones. They also prevent amplifier overload if one of the newer 3.2-ohm headphones is used.

♪ The record changer is the popular BSR McDonald 500 complete with a calibrated stylus force adjustment, counterweight, calibrated anti-skate, and a cueing lever. It is supplied with a Shure M44MB cartridge. Interchangeable spindles are provided so that the changer can be used for full automatic or full manual operation. The cabinet is large enough to allow the cover to be closed with a record on the platter, thereby not only protecting the record from dust but also eliminating all vestiges of "needle chatter."

♪ Typical of simplified kits, the AD-27 is supplied with all critical components—the FM front end and MPX assembly—completely preassembled and pre-aligned. In ad-

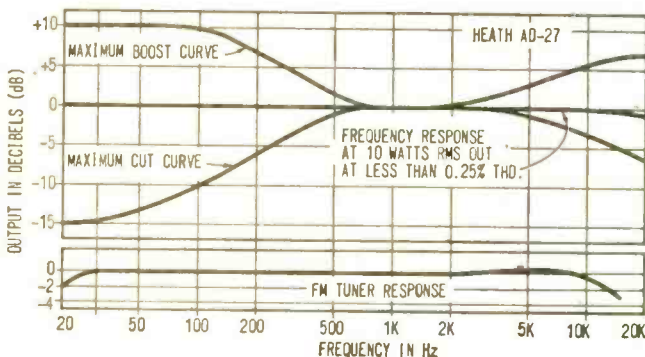

*Since it was tough to believe performance curves shown at left, our honest Injun approach to test reports prompted us to recheck the AD-27. (We came up with identical curves.) Incidentally, though Heath recommends their AS-37, AS-16, and AS-10 speaker systems for use with the AD-27, its boost and cut capabilities are such that most quality speakers will serve.*

# e/e HEATHKIT AD-27

dition, because the power supply, MPX, and amplifier assemblies are spread out on the underside of the cabinet, a pre-formed wire harness has been provided for interconnection of the assemblies. This greatly simplifies final wiring.

♪ The changer assembly isn't a kit, so you face no mechanical assembly problems. You simply install a few items such as the pickup and counterweight, just as you would with any other changer or turntable purchased ready-made. To simplify accurate stylus pressure, the stylus force adjustment has click-stops at the  $\frac{1}{3}$  and  $\frac{2}{3}$  gram positions between the indicated gram markings (1 gram, 2 grams, etc.)

♪ The amplifier, which is rated at 10 rms watts per channel (sustained sine waveform), 15 watts music power, is an example of what can be obtained using the latest solid-state design techniques. As shown in the accompanying chart, the measured frequency response at a sustained 10-watt output is essentially ruler flat from 20 to 20,000 Hz, extending from below 10 to above 50,000 Hz at lower, normal volume levels. At full 10 watts output, the measured total harmonic distortion (THD) was 0.1% from 20 to 10,000 Hz, rising to but 0.25% at 20 kHz. This performance level was undreamed of at the AD-27's price just a year or so ago.

♪ The measured tone-control range shown in the chart, though adequate, was consider-

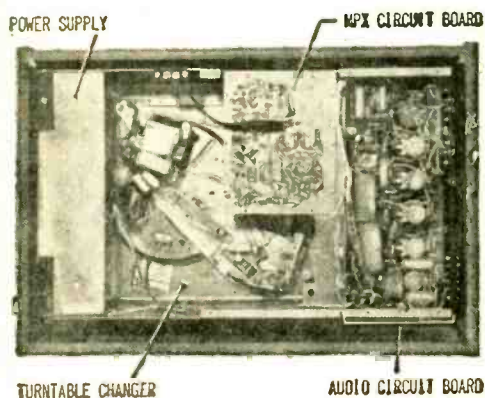

AD-27's electronics is divided into three sections: power supply, tuner-MPX and AF amplifier, all of which are mounted in cabinet's base. Pre-formed wiring harness is provided for interconnection of all assemblies and record changer.

ably different from that specified by the manufacturer. But as we said, the measured performance is adequate, and not untypical of solid-state amplifiers. The measured noise level of  $-60$  dB was right on specs. That's almost *dead* quiet—very good!

♪ The FM sensitivity checked out at  $4.5$   $\mu$ V (IHF) for 30 db attenuation of hum, noise and distortion. Full noise limiting was obtained with a 30- $\mu$ V input. Mono FM distortion was 0.8%; stereo, 1.1%. An instrument alignment, as opposed to the few "builder adjustments," made no significant improvement in performance other than separation, which (at 1 kHz) was 20 dB user-

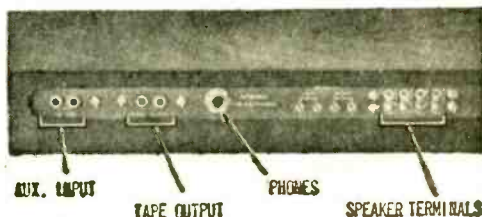

Auxiliary inputs, tape outputs, phone and speaker outputs are available through slit on side of cabinet. Narrow slit makes it somewhat difficult to connect to speaker terminals, so use of soldering lugs is suggested. Check connections carefully.

adjusted and 27 dB instrument-aligned. A front panel *phase control* allows the user to adjust for optimum separation by simply setting the control for maximum sound level.

♪ The Heath AD-27 is supplied without speakers. Since the system is capable of hi-fi performance, we suggest that good quality speakers be selected as opposed to run-of-the-mill speakers usually used with low-cost stereo systems. However, 10 watts per channel is not going to produce outstandingly loud volume levels with low-efficiency speakers and we suggest extra care be taken to avoid speakers that are specifically recommended for higher power levels. Also, the 10 watts is available only with 4- and 8-ohm loads; a 16-ohm load resulted in clipping at 7 watts, so we suggest your choice of speakers be restricted to 4- and 8-ohm models. Heath recommends their AS-37, AS-16, and AS-10 speakers.

♪ Priced at only \$169.95 (including the cabinet), the Heath AD-27 delivers hi-fi performance at a cost that'll establish new low-price levels in the hi-fi marketplace. For additional information on the Heath AD-27, write to the Heath Co., Dept. EE, Benton Harbor, Mich. 49022. ■



# TRANSFORMERS

## -POWER AND PARADOX

Can Mike Faraday's law of induction fully explain the inner workings of the world's most perfect machine?

by Jim Kyle, K5JKX

**I**t has been described as the world's most perfect machine. Yet 50 years elapsed between its discovery and the first attempts to put it to practical use.

Without it, the nationwide electrical-power networks we take for granted could not exist. Yet the first U.S. patent was not taken out until nine years after Edison's incandescent lamp was a success.

The bigger it is, the better it works. Yet many are no larger than an ordinary pencil eraser.

What is this strange paradox of electricity and electronics? It's our old friend of toy-train days, the reliable servant on the power pole, the heart of our power-supply circuits and transistorized inverters, and the bane of hi-fi addicts—the transformer.

To be such a vital component of the entire electrical industry, the transformer is a strange device indeed. Most of us tend to take it for granted—except when something goes wrong in one, and then we merely replace it.

Experimenters aren't the only persons who take the transformer for granted. Two of the three leading encyclopedias fail to mention either its inventor or the date of its invention. One makes no mention at all of its history; the other reports that it was "perfected" in the years 1885-1886 but omits mention of earlier events.

**Faraday's Folly.** Actually, the first transformer was constructed in the year 1831 by the famed Michael Faraday. Ten years earlier, at the age of 30, Faraday had discovered the principle of electrical induction. In the decade that followed, he had formulated his laws of induction which laid much of the groundwork for today's entire science of physics.

Faraday's first transformer was strikingly similar to those we use today. It featured an iron ring for a core (the toroidal core is claimed to be one of the latest advances!) and was wound with two coils, as shown in Fig. 1. The primary contained about 72 feet of wire and the secondary about 60 feet. Both

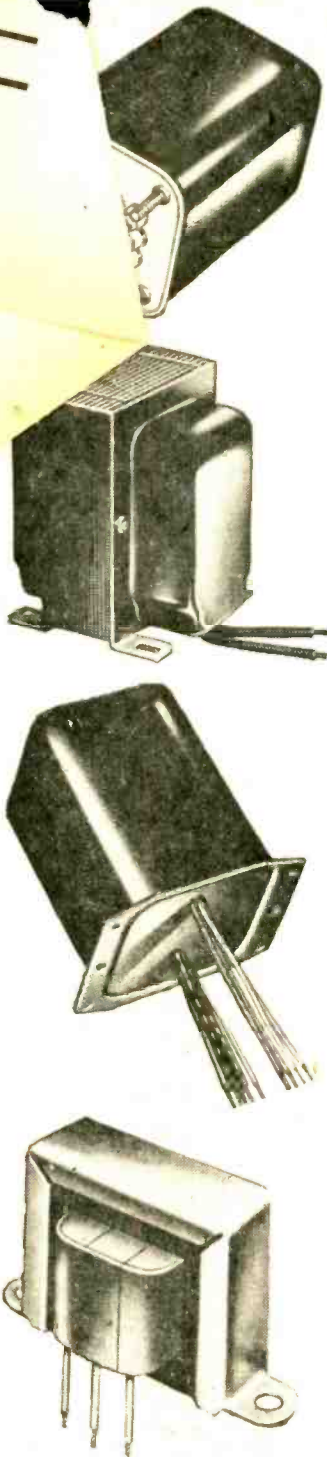

# e/e TRANSFORMERS

windings were made of bare wire (insulated wire wasn't as available in 1831), but the turns were separated by twine and the layers by calico, so that no turns shorted together.

Faraday tested his apparatus with direct current from a battery. He connected the ends of the secondary winding to a loop of wire which passed around a magnetized needle; this formed a crude but sensitive milliammeter. He then connected the primary winding to the battery, as shown in Fig. 2.

At the instant of connection, the needle deflected to one side; when he broke the circuit, the needle swung an equal distance to the other side. When he reversed the battery, the same thing happened but the direction of swing reversed. Thus he proved that the energy was transformed from electric current into magnetism, and back to electricity.

The record shows no additional experimenting with transformers until 1881. In that 50 years, the telegraph and the telephone came into being. Joseph Henry, who, independently discovered induction at about the same time as Faraday, had extended his discovery far enough to invent the electric bell, the relay, and the first telegraph receiver. Samuel F. B. Morse contributed a key, a code, and a driving force, to establish a working telegraph system.

By 1879, Edison in this country and Swan in Great Britain had both developed electric light bulbs. The world was looking for a means of making use of the power inherent in electricity.

But one major drawback acted as an effective block to progress. All electric power at that time was *direct* current, which could

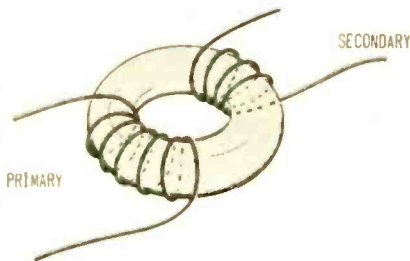

Fig. 1. Faraday's original transformer was wound something like this. Core was iron ring, with two windings of wire. Since insulated wire wasn't available, each turn was separated from its neighbors by twine and layers were separated by cloth.

be neither raised nor lowered in any practical means. Most positions require high current and low voltage, but long-distance power transmission needs low current and high voltage. The result was that electricity you happened to be within a mile of the generating plant, but it wasn't use otherwise.

**Enter AC.** In this atmosphere, the experimenters named Lucien Gaulard and John Gibbs developed a "series power system" using alternating current. It included transformers to step the power up to high voltage for transmission, and back down to low voltage for ultimate use. The two were awarded an English patent on their system in 1881.

Four years later, George Westinghouse purchased the patent rights of Gaulard and Gibbs, and assigned William Stanley to develop the system further. In 1886 Stanley and Westinghouse demonstrated the complete system. The next year Westinghouse was awarded U.S. patent No. 366,362, specifically covering the transformer developed.

By 1888, the use of alternating current and the Westinghouse system was common throughout the U.S. and to a lesser degree in Europe. That same year, Nikola Tesla announced his discovery of the "rotating field principle" for electric motors and began an association with Westinghouse which continued for several years.

During those years, Tesla added greatly to the store of knowledge about transformers, their principles, and their practical design. He also set the standard frequency for alternating current in this country at 60 Hz and chose the voltage levels which are still standard for AC power—110, 220, 440, and integral multiples of these figures.

Since that time, the detailed knowledge which has accumulated about transformers has become a cumbersome mass similar in many ways to the specialization trends in medical science. Let's stay out of that morass and look at the bigger picture—what is a transformer, how does it work, what kinds of transformers do we commonly meet, and how do they differ from each other? Then we can get into a little more detail and examine methods of repairing a defective transformer, and even designing your own for some special purpose.

**What Is A Transformer?** As the name implies, a transformer is a device which transforms something from one form to an-

in voltage by  
over applica-  
relatively low  
er transmits  
high voltage.  
has from

other. The electrical transformer changes *impedance* from its original value to any new value desired.

If a transformer is used in a signal-carrying circuit, the change of impedance is usually the main reason for using the transformer. If, however, it's in a power circuit rather than handling a signal, the *effect* of the impedance change is of more importance.

Impedance is simply the ratio of voltage to current in any circuit. For a constant amount of current flow, the greater the voltage, then the higher the impedance (and vice versa). If the voltage is held constant, reducing impedance permits more current to flow.

With a constant amount of power—the *product* of voltage and current held constant, rather than either of their individual values—an impedance change amounts to a change in both voltage and current levels.

If impedance is reduced, voltage comes down and current goes up by the same ratio to retain constant power. Similarly, if impedance is increased, the voltage goes up and the current comes down.

The designer of a power transmission system has the option of transmitting the power at either high voltage and low current, or low voltage and high current. Normally, the high voltage route is chosen, since the amount of power lost in wire resistance increases as the *square* of the current. When current flow is doubled, line losses increase by four times!

Soldering guns take advantage of this; they contain transformers which step the 117-VAC line voltage down to less than a volt. At this voltage, a 100-watt gun is driving about 100 amperes through its tip. And though the tip is 10-gauge copper or iron, it frequently gets red hot with the power that is converted to heat.

But while production of heat is the main purpose of a soldering gun, it's an unwanted action in power transmission. By keeping line impedance high, the designer can minimize the current and cut to the lowest possible amount the power lost in the line.

Keep in mind that the impedance we're speaking of here has almost no relation to the "characteristic impedance" of RF transmission lines, which depends upon other factors. The lines we're discussing are *power* lines carrying AC power from the generating station to the users.

**Up And Down.** Since the transformation of impedance also changes both the voltage

and the current present in the line, such transformers are most frequently known as "step up" or "step down" transformers. The change "up" or "down" invariably refers to the change in voltage. A generating station may produce power at 13,200 volts. A step-up transformer may then boost this voltage to 222,000 volts and at the same time reduce the current level by the same ratio that voltage is increased (16 $\frac{2}{3}$  times).

After a trip of several hundred miles, the voltage may then meet a series of step-down transformers and be distributed around a residential neighborhood at 7200 volts. Just before leaving the power pole to come down to an individual home, a final step-down reduces voltage to 110 or 220 volts (or both) for use by lamps and appliances. Fig. 3 shows the entire arrangement, though in much-simplified form.

Physically, a transformer (regardless of type) consists of a core with two or more windings of wire around it. The core may be made of any of a number of types of material; the choice depends largely upon the intended use for the transformer.

Power transformers commonly use a laminated core composed of a number of layers of thin silicon steel; some of recent design use Hypersil, a special steel alloy. Audio transformers may employ either silicon steel, Hypersil, Mumetal (another special alloy), or permalloy. Radio-frequency transformers normally use a ferrite core; some use only air as their cores.

The shape of the core may also vary. The most efficient core shape is a toroid, which looks like a doughnut; this shape makes maximum use of the magnetic fields. However, it is also the most difficult type of core to wind wire on, so many transformers use alternated "E" and "I" core laminations. A special ratio of width to height allows the pieces punched out when forming the "E" to be used as the "I" parts; such a core is known as a "scrapless" core. Fig. 4 shows some of the various types of cores you may run across.

The windings are almost invariably of copper wire, but the size of wire, number of turns, and insulation used are all determined by the specific transformer design. Wire must be large enough to carry the required current and yet small enough to fit into available space. The number of turns is determined by the magnetic properties of the core material, and the transformer application. The insulation depends upon

# E/E TRANSFORMERS

the voltage levels which will be present; frequently, these are far higher within the transformer than they ever will be outside its shell.

Both core and windings are often encased in a metal shell, for physical protection as well as for partial shielding. Many transformers, though, are of so-called "open-frame" design; in these the windings are protected only by a wrapping of paper soaked in wax.

Some medium-power transformers include a copper strap around the core to minimize external magnetic fields. High-power transformers are almost always encased in heavy shells filled with insulating oil; this beats the paper used in smaller units by providing both better insulation and increased cooling of the windings.

**How Does It Work?** The transformer is unusual among machines in that it has no moving parts. It operates by converting electrical energy to magnetic energy, and back again. Power applied to one winding magnetizes the core at the instant of application. The magnetization of the core induces electrical energy in the other winding so long as the magnetism is changing.

If both windings have the same number of turns, the energy developed in the second (secondary) winding will be at the same impedance level as that applied to the first (primary) winding—except for a slight loss in the magnetization process.

If the secondary winding has twice as many turns as the first, the power of the magnetic field must be spread over twice as many turns and so can develop only half the current. With constant power, this doubles the voltage, and the simultaneous halving of current and doubling of voltage increases the impedance level to four times that of the primary.

In general, the voltage step-up ratio is equal to the ratio of the number of turns on the secondary to those on the primary; the impedance ratio is equal to the *square* of the ratio of turns.

The energy lost between windings is generally called core loss; in large, well-designed transformers this lost energy can be as little as 0.5 percent of that transferred. No other machine approaches this 99.5 percent efficiency; by contrast, an automobile wastes

nearly  $\frac{3}{4}$  of the power available in its fuel.

The transformer operates only when the current flow through its windings is changing. As soon as the current through the primary becomes steady, the core's magnetism is also steady. And when the core's magnetism stops changing, no energy is induced in the secondary windings.

Thus, at the instant direct current is applied to a transformer, a single surge of current will appear in the secondary windings. Another will appear when power is removed. But in between, no energy will be transferred.

For this reason the transformer is useful only with alternating current or rapidly pul-

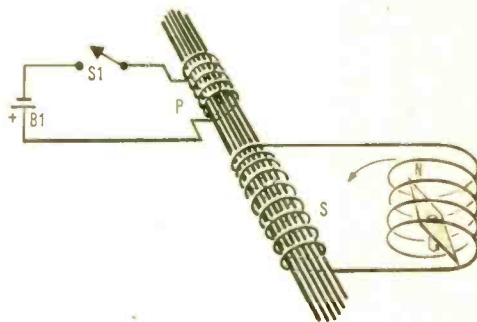

Fig. 2. Equivalent circuit of Faraday's experimental setup. Closing switch S1 caused magnetized needle to deflect, proving that electrical energy had passed through transformer.

sating DC (such as produced by a vibrator). AC continually changes its intensity, reversing direction some 60 times per second in the case of normal power lines.

The whole basis of the transformer's operation is Faraday's law of induction, which is also the basis of all electric generating apparatus. This states that an electric current is induced in any conductor which is in motion relative to a magnetic field.

In most generators, the conductor itself is in motion while the magnetic field remains stationary. In the transformer, the conductors remain stationary and the field moves. The motion of the field is provided by the reversal of current flow in the primary winding during each cycle of alternating current. When current flows in one direction, the field has one "sense" (it is oriented in one direction); when current direction reverses, so does the sense or direction of the field. This change of direction is, effectively, motion.

This motion of the field is the only mo-

tion connected with the transformer. And the fact is that the phenomenal efficiency of the transformer is due primarily to its lack of moving parts.

A transformer isn't limited to a single pair of windings, though in practice only one winding is used as the primary and all other windings upon the core are used as secondaries. An ordinary TV power transformer may contain three or four secondaries in addition to its primary. One of these secondaries usually has a large number of turns (compared to the primary) so that it provides high voltage. The rest have fewer turns and thus supply low voltage for filament and heater use.

Some transformers have been made with "dual primaries" so that primary current could be supplied from either 117-VAC or interrupted 6- or 12-VDC sources; these, however, are not exceptions to the one-primary rule, since only one of the two or three primary windings is used at any given time.

**What Kinds Exist?** Almost any device which couples two circuits by magnetic means may legitimately be called a transformer. Generally, however, transformers are divided into three categories: two handle signals, the other deals with power. The classes are power transformers, audio-frequency transformers, and high-frequency transformers.

Power transformers include all those designed particularly for the supply or conversion of power. They range from the ordinary doorbell transformer up to huge oil-filled units capable of handling  $\frac{1}{2}$  million volt-amperes. The characteristic they all share in common is that they are designed for maximum conversion efficiency at a single frequency, and for minimum power losses.

Audio-frequency transformers are used to match impedances, and to transmit audio-frequency signals from one circuit to another. They include input transformers, interstage transformers, driver transformers, output transformers, and modulation transformers, among other types. Their common characteristic is that they are designed to handle a relatively wide frequency range and to reject pickup of stray signals. Complexity may be anything from the simple 59¢ "universal" output transformer; through multi-kilowatt broadcast modulation transformers; to multiple-shielded, carefully balanced, wide-range microphone transformers

used to carry the entire band of audible frequencies without distortion.

An important sub-class of audio-frequency transformers is that known as *geoformers*; these are similar to ordinary audio units except that they are designed for frequencies in the subsonic range, from 1/10 to 10 Hz. Such frequencies are most often encountered in geological exploration, which explains the name. Geoformers normally have much more massive cores and higher-inductance windings than do ordinary audio units. Frequently, they are also shielded against stray pickup of power-line frequencies.

High-frequency transformers include all types which match impedances or transmit a band of frequencies above the audio range, from approximately 50 kHz on up. The most common example is the intermediate-frequency (IF) transformer used in radio receivers. Another is the RF coil assembly of a receiver, though it is frequently not considered as a transformer. Other high-frequency transformers include pulse transformers, used to either generate or transmit extremely brief pulse signals, and wide-band units which transmit both AF and RF signals without significant distortion.

The three major classes of transformers all follow the same basic operating principles. Even so, the design objectives for each class differ so greatly that almost all the design details are also different. This is not always so, however; 400-Hz power transformers have frequently been used as AF transformers by enterprising experimenters, with notable results. And in an emergency, an audio transformer can often be used to replace a power transformer if the transformation ratio is sufficiently close and the power-handling capacity is adequate.

**Power Transformers.** The design of a power transformer starts with a knowledge of the primary voltage available for it, and the voltages and currents required from the secondaries. For each secondary, the designer multiplies the voltage desired by the current requirement from that winding to determine that secondary's volt-ampere rating of the transformer.

The actual AC voltage and current which the transformer must supply depend largely upon the type of circuit it will be connected to. AC rating may vary from 71 percent of the DC load up to 2.2 times the DC load; voltage may vary from half to one and a half times the desired DC level. When the AC values are determined, their total is

## TRANSFORMERS

multiplied by a factor which ranges from 1.1 up to 1.5 (depending upon the safety factors and loss values expected) to determine the actual volt-ampere ratings.

From the volt-ampere ratings thus determined for each winding, the designer must calculate the size of wire to be used for each. This way, he can ensure that the wire will be able to carry the current without overheating or losing too much inside the transformer. He then chooses a set of dimensions for the core, guided by the frequency and the power level the transformer is to operate on. He also determines from the core data the number of turns required in the transformer primary.

The number of turns in the primary, together with the primary voltage, gives him the number of turns per volt required for each secondary winding. He then calculates the number of turns needed for each, from the number of turns per volt and the voltage required. In the process, he must see that the selected core provides enough room for all necessary windings.

If not, he must choose a larger core size and repeat the turns calculations until he finds one set of figures which can be used. He then has a prototype built, to that set of figures, and tests it.

Only rarely does the first attempt turn out right. Turns can be added to or subtracted from windings as necessary to adjust the voltages. If the transformer overheats, then a complete redesign is required.

Only after all the original specifications have been met, and repeated tests prove the design practical, is the transformer actually put into production.

This extensive design and testing effort is one reason why transformers are expensive. Other reasons include the high cost of core material and wire, and the numerous safety features (which we have ignored) which are often included in the design.

The result of all this is a transformer which meets all its design specifications. This transformer, however, has *not* been tested for such factors as ability to handle a wide range of frequencies. Neither has it been severely tested for performance at loads much greater than its voltage or current ratings. It may perform successfully in many applications which were not considered in

the original design. It may not. Only experimentation can tell, and the manufacturers offer no assurance of success.

In particular, a power transformer rated to supply a given amount of current into a power supply using a choke-input filter may fail completely if the filter is changed to a capacitor-input design. Reason is that capacitor-input filters take from 30 to 40 percent more current from the transformer. Most small transformers, though, are either designed for capacitor-input filters, or are rated for both types.

Use of a power transformer with power at a frequency other than that for which it was designed is also a source of possible damage to the transformer. (This is especially so if the new frequency is lower than the design frequency.) Normally, no harm results from using low-frequency power transformers at higher frequencies, though transformer efficiency may suffer.

**Audio Transformers.** The design of an audio-frequency transformer depends primarily upon a different set of factors. The audio-transformer designer is interested in the impedance levels of the signal source and the load which his unit must couple together. He also is concerned with the frequency band to be coupled, the amount of distortion permissible, the operating voltages, and (in the case of output or modulation transformers) the efficiency required.

Impedance transformation depends upon the ratio of the squares of the turns ratio, rather than upon the turns ratio directly. And since transformers present different electrical characteristics to signals of low, mid-range, and high frequencies, audio transformer design is much more complex than is the power case with transformers.

Response at low frequencies is determined largely by the inductance of the windings. At high frequencies, response is affected by both the inductance and unavoidable stray capacitances. High inductance is necessary for low-frequency response, but it prevents high-frequency response by increasing the capacitance. The result is a fall-off of signal transfer at both high and low frequencies, together with a phase shift at each end.

At the low end of the range, load voltage may lead source voltage in phase by 80 degrees or more; at the high end, it may lag behind by the same amount.

This phase distortion normally isn't audible. Still, it may easily create extreme problems in high-quality audio amplifiers when

feedback is added to reduce total distortion. Phase shift introduced by the transformer may change phase of the feedback by enough, at some frequency, to turn the amplifier into a power oscillator. (See Fig. 5). This usually happens at a supersonic frequency; you can't hear the result, but output is distorted and the speakers may be destroyed.

To overcome this problem, high-quality audio transformers are usually designed to pass a much wider band of frequencies than

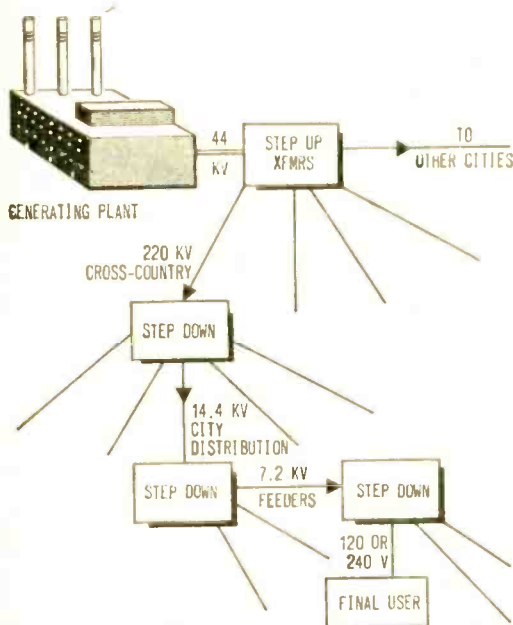

Fig. 3. Simplified version of typical power-transmission network. Note use of 220-kV level for most effective cross-country transmission.

they are actually intended to handle. This maintains phase distortion within the actual signal band inside acceptable limits.

All transformers introduce harmonic distortion into signals passing through them because of the hysteresis effect in the core material. The designer must take this problem into account and choose core materials and sizes to keep this distortion within his design limits. This is a serious problem with inexpensive transformers; if 4-percent silicon steel is used for the core (a common material for cheap designs), as much as 30 percent third-harmonic distortion, and up to 5 percent of fifth-harmonic on top of this, may be added to strong signals.

The greater the inductance of the windings, the lower the harmonic distortion. In

many designs, distortion level rather than low-frequency response requirements sets the minimum permissible inductance. The end result is heavy, large, and bulky transformers.

**High-Frequency Transformers.** The design problem in high-frequency transformers is similar to that for audio units, except that in many cases no magnetic core is used. The magnetic field naturally surrounding the windings provides ample coupling between primary and secondary. In such cases, the ratio of turns between primary and secondary loses its meaning since the coupling between windings may vary over a wide range. In metallic-core units, the coupling is almost perfect and turns ratio determines the transformation ratio.

For pulse and wide-band applications, special core materials and shapes are often used. One such special shape now finding wide use is the ferrite toroid, a doughnut-shaped core made of a magnetic ceramic. The toroid shape holds all the magnetic field essentially within the transformer itself, where it does maximum good and causes the least interference problems. The ferrite material also reduces core losses.

Such transformers have been built to operate over the frequency range from 3 to 30 MHz, providing a constant impedance ratio over the entire band, and handling 2000 watts of power.

**How Do You Fix One?** The normal reaction when a transformer develops a fault is simply to purchase and install a replacement. This may prove to be neither convenient or practical—and in any case you can probably save money by repairing the defective unit rather than replacing it.

A few words of caution are in order, however. If the unit handles extremely high voltages (anything above 1000 volts, for example), don't try to repair it unless you have some experience at repair of smaller transformers. Even then, extreme care is necessary. Internal voltages of a transformer may exceed the expected levels by up to 100 times under failure conditions. This means that if your repair job fails, you may have 100,000 volts looking for a place to go!

Since transformers are such extremely simple machines, they can have only two possible faults. One or more windings may have an open or short circuit. The first step of repair is to determine which type of fault exists, and in which winding.

(Continued overleaf)

# e/e TRANSFORMERS

Short circuits are characterized by overheating of the transformer. If power is applied for any appreciable length of time to a transformer with a shorted turn or turns, the overheating will literally burn out the affected part of the winding (together with the insulation and adjacent layers of wire, usually) and thus convert the short into an open circuit.

It's not too unusual, though, for a winding to short out to the core or the shell of the unit without shorting to any other winding. This can give you a shock when you touch the transformer with power applied.

Open circuits, as well as shorts to the core or shell, can be located with an ohm-

shellac which binds each lamination to its neighbors. Application of alcohol or lacquer thinner can soften this enough to allow I-layers to be removed a few at a time. Take care not to let the solvent get into the windings where it may damage the wire insulation, and don't break any connections.

When enough of the I-laminations are removed, the corresponding E-laminations can be driven out by using a thin wooden block and tapping it with a mallet. After a few of the E-laminations are out, the rest of the core stack usually comes out rather easily. Remember how it was assembled, so you can reassemble it.

With the windings (which are in one wrapped mass of wire) removed from the core, recheck to determine exactly where in the mass of wire the fault is located. If it's near the inner layers, file the removed core layers neatly in your junkbox against the time you next need some sheet steel. (Fixing the unit without special winding lathes simply isn't practical.)

If, however, it's near the outside, then you stand a chance of making a successful repair. Carefully remove the outer wrap of insulating paper and save it. Then, still working carefully, unwind each layer of wire from the outside in. Spool the wire as it is unwound, to prevent kinks and snarls, and, if possible, keep a record of how many turns were on each layer.

When the start of the winding which contains the fault is reached, turns-counting becomes necessary. It isn't necessary to save this wire, if you can obtain a fresh supply of the same size wire with the same type of insulation. Simply unwind and discard each layer. When the fault is passed, continue on until you reach the end of the winding. No more unwinding is necessary.

Using fresh wire, replace the winding. Insulate between layers as it was before, and be sure to put the same number of turns back on each layer, as tightly as they were wound originally. Then replace each winding above the repaired one, until the outer layer of insulation is back in place.

From here, work in reverse. Put the core stack back into the winding form a few laminations at a time. The final few will probably have to be tapped into place with wood-block and mallet. Apply fresh shellac to bind the plates together and prevent humming, and replace the shell.

Most problems met by inexperienced transformer-repairers are in one of two gen-

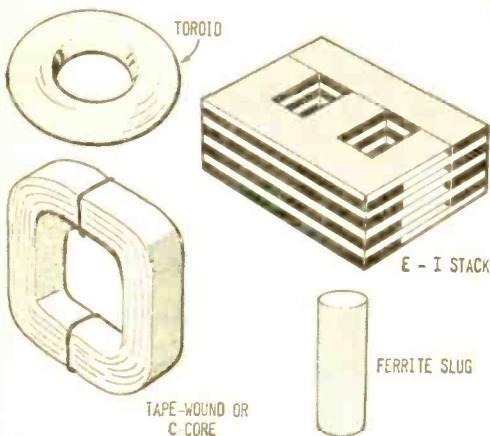

Fig. 4. Common types of transformer cores. Most power transformers use E-I stack; tape-wound or C-core appears in high-quality audio units. Slugs and toroids are generally restricted to RF work.

meter, by checking for continuity.

When the type of fault is determined, and the affected winding, the procedure becomes one of patience and physical care rather than one of troubleshooting. The next step is to disassemble the transformer. Just how to do this depends upon the construction of the individual unit. Most low-voltage power transformers are held together by long screws which run through the core stack and the shell. When these are removed, the shell can be taken off and the core and winding are exposed.

To fix the affected winding, it must be removed from the core. The conventional E-I core is, however, usually soaked in



eral classes. Either the repaired windings won't fit into the available space in the core stack, or a shorted turn or winding develops during the process of disassembly or reassembly.

If the windings won't fit, you didn't wind them tightly enough. The only cure is to strip them back down and try again, winding more tightly. However, if only a few layers of core material won't fit, you may get by with simply leaving them out. The unit won't have as much safety factor as it did originally, but it may perform satisfactorily.

If a short develops, you can attempt another repair. Usually, though, the damage is so severe that it's better to abandon the effort. This is not so catastrophic as it may sound—after all, the transformer was ruined in the normal way of things before you even began the repair job!

**Designing Your Own.** According to almost all the textbooks on the subject, transformer design is an exotic and complicated art. It requires hundreds of la-

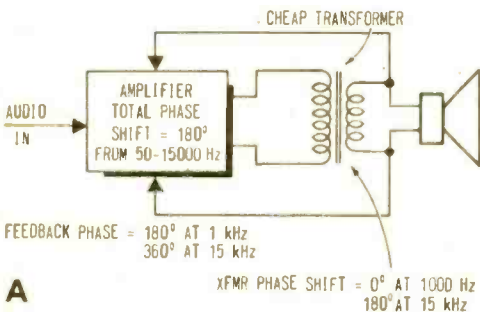

**Fig. 5A.** With cheap output transformer, phase shift at 15 kHz is such that feedback is positive and amplifier actually functions as oscillator.

borious calculations involving dozens of independent variable elements.

And for an engineer assigned the job of designing a new unit for production, it is. However, from an experimenter's point of view, most special-purpose transformer designs are far less difficult.

Most of the variables, in fact, can be eliminated by letting a transformer engineer do most of the work for you. That is, for your special-purpose design, start with an existing transformer which was designed for a similar purpose. If you need a low-voltage power transformer, say to supply a special voltage for some transistor project, start with a filament transformer rated to supply ap-

proximately the same amount of power you'll need. If your need is for an audio transformer, start with an audio unit as close to your needs as available, and modify it as required.

This approach turns your design job into something more like a custom modification. At the same time, it solves most of the total-design problems for you.

Most of the special-purpose units needed by experimenters fall into the power-transformer class, so we'll go through the steps for one of these. The same general principles apply to modification of audio transformers, however.

The transformer you start with need not be in perfect condition. But the better the shape of the unit, the easier will be your modification task. We'll assume that the primary (117-VAC) winding is in good shape; condition of the secondaries is immaterial.

Begin by taking the transformer to your bench and removing all the secondary windings so that only the primary remains. Then

**Fig. 5B.** With quality transformer, identical amplifier circuitry now exhibits only minor phase shifts. Amplifier therefore works as intended.

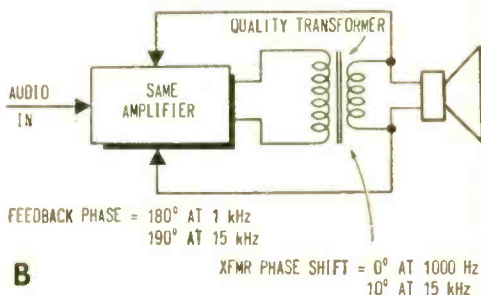

wind a temporary secondary of exactly 10 turns, and reassemble the windings and core stack. Connect the primary to its rated voltage and measure the voltage produced by the temporary secondary.

In a power transformer, the output voltage is determined by the primary voltage and the turns ratio. This means that output voltage is a definite number of volts for each turn in the secondary, when the primary is receiving rated voltage. All you need do is measure the voltage produced by the 10-turn secondary and divide by 10 to determine the number of volts produced by each secondary turn. From there it's only one step to decide how many turns

## e/e TRANSFORMERS

you'll need to produce any desired voltage.

For instance, if you measure 7.53 volts across the 10-turn secondary, this means that each turn is producing 0.753 volts. If you want 35 volts from your finished transformer, then you will need  $35/0.753$  turns on the secondary. This divides out to be just a fraction greater than  $46\frac{1}{2}$  turns. Either 46 or 47 turns will probably give you the desired results, since the chances are your voltmeter wasn't closer than about 3 percent to the exact reading in the first place.

With the number of turns determined, the second step is to choose a wire size. The wire *must* be large enough to carry your desired output current without over-

heating. Most copper wire tables include a listing for circular mil wire size; the normal figure for wire capacity employed in professional transformer designs is 1000 circular mils per ampere of current. If you need 5 amps from your secondary, this means you would want wire at least 5000 circular mils in diameter. The safest choice, though, is to use the largest size of wire which will fit into available space.

With wire size and number of turns determined, the job from here on becomes the same as a transformer repair. Simply wind on the new secondary, being sure to insulate each layer properly, then reassemble the unit permanently.

For the audio units, the design factor is usually impedance level rather than voltage ratio; impedance depends upon the square of the turns ratio. With this difference, a similar approach works. ■



## They Play The Numbers Without Nixies

*Precise control of more than 1.4 million phosphor dots is required to meet quality standards for Sylvania's color TV tubes.*

*And therein lies reason why the lady in our photo is playing her own kind of numbers by individually screening each phosphor—red, green, and blue—to form a triangular dot pattern. And why the happy faces at right? Easy! They're holding the 150 millionth Compactron to roll off GE production lines since the tube's birth back in 1950.*



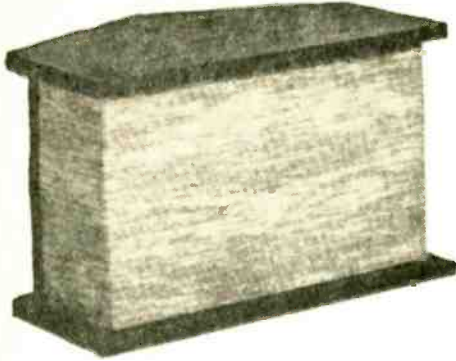

BOSE Model 901  
Direct/Reflecting  
Speaker System



**A**udio engineers generally acknowledge that speaker systems are the weak link in the chain of components encompassing hi-fi reproducing systems. Amplifiers, pre-amps, recordings, have all benefited from state-of-the-art developments employing solid-state devices, but speaker design has followed the same basic concept since the introduction of the dynamic reproducer.

Many design engineers have attempted to overcome the inherent weaknesses of the moving coil reproducer. By novel applications of mechanical, electrical, and acoustical principles in combination they attempt to produce a speaker system that sounds like the original vocal, solo instrument, or orchestral rendition.

Hi-fi enthusiasts spend hours, even weeks or months in selecting a speaker system that pleases them. As a result, they are convinced that there really is little possibility that a new system will be developed that can provide cleaner, more realistic reproduction of sound. To correct for the deficiencies in

speaker systems, amplifiers have been provided with unique compensating circuits that provide boost and/or cut at both high and low ends and sometimes in the mid-range of the audio spectrum. All of these circuits add to the cost of the amplifier.

**Design Considerations.** The recently introduced Bose 901 speaker system appears to have met the challenge. The Bose 901 is a product resulting from extensive research that disclosed many basic considerations to be taken in designing a speaker system. Among them are: a) correct balance between reflected and direct sound radiation; b) a means to overcome conflicts created by inherent resonances of speaker mechanisms and speaker housings; c) a new technique in the measurement of speakers, resulting in new standards for design, taking into account environmental conditions in which the speaker system will be operated; d) a new approach to the equalization of the signal driving the speaker to correct for deviations in frequency response created by

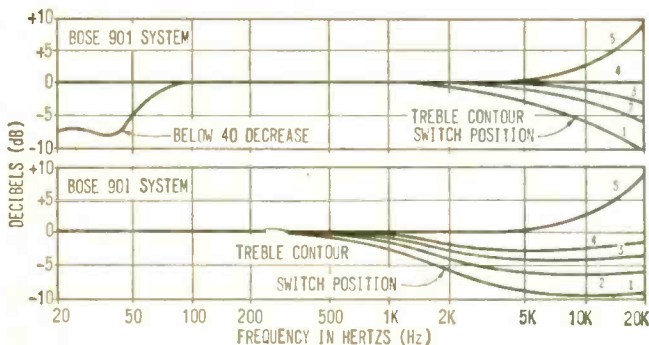

Curves supplied by manufacturer show various treble contours possible with Bose 901 speaker system and its equalizer. In upper graph, treble level switch is in normal position; in lower graph, switch is in decrease position.

## BOSE 901 SPEAKERS

mechanical design limitations; e) elimination of cross-over networks because of their inherent inability to effectively control amplitude and phase of the acoustic output in the crossover region, be they active or passive; f) a means to provide smooth, continuous acoustical blending of stereo channels without the necessity for a center speaker; and g) a means of eliminating standing waves that can affect frequency response.

**Adapting Design Research.** The Bose 901 system is comprised of two speaker enclosures, each pentagonal in shape,  $12\frac{3}{4} \times 20 \frac{9}{16} \times 12\frac{7}{8}$ -in. (HWD), and each containing nine 4-in. speakers. In addition, the system is furnished with an active equalizer that is inserted between the preamp and the power amp.

The form of the housing was developed for reasons other than to make a speaker having a different shape than those which are now popular. Two rear baffles are joined at an angle of  $120^\circ$  to establish a proper reflective angle off the wall of the room in which the speakers are operating. Because of this angular placement and the large ratio (8 to 1) of radiated sound, achieved by employing eight speakers on the rear angled baffles and one facing forward on the front baffle, there is uniform dispersion throughout the room without a "hole" in the center.

For listeners, this creates the illusion of being in a concert hall with a full orchestra spread across a stage. It removes completely the necessity of having the listener located directly on the axis of the speakers in order to enjoy the full high frequency response of the system. To create the concert hall illusion, the speaker housings must be placed 8 to 20-in. from the wall (12-in. is ideal average) to take advantage of the reflective wall

surface that was calculated in the overall system design.

Also, the enclosures are shaped in pentagons to ensure that there are no surfaces parallel to the speakers, thus avoiding standing waves.

By placing eight speakers closely spaced on the rear baffles, acoustic coupling creates a resonant frequency for each speaker that will be different from that of every other speaker. The end result will be that each resonance becomes inaudible because it changes the output of just one of many speakers in the system. Thus, the distortion of sound that is caused by resonances in conventional systems is eliminated by using many speakers, each being driven by the same signal. This, in fact, is the principal reason for the improved clarity and definition of reproduction from the Bose 901, as compared to other speaker systems.

**Excellent Bass Response.** To solve the problem of wide response with good bass reproduction, designers have always used as large a speaker as possible for reproducing lows, along with smaller speakers to reproduce mid range and highs. In addition, they have employed a passive crossover network to route the appropriate frequency segment to a specific speaker. At best, these networks contribute appreciably to the overall distortion of the complete system. Despite the distortion effects of this combination on the response curve of such a speaker system, it appeared to be the only feasible method of covering the full audio range with dynamic speakers.

Bose, however, developed special techniques, requiring many hours of precision measurements of room characteristics along with computer analysis of taped performances, to prove that multiple small speakers can reproduce the same range as with single large speakers with no resonances or distortion. Bose employs a total of nine 4-in.

*(Continued on page 104)*

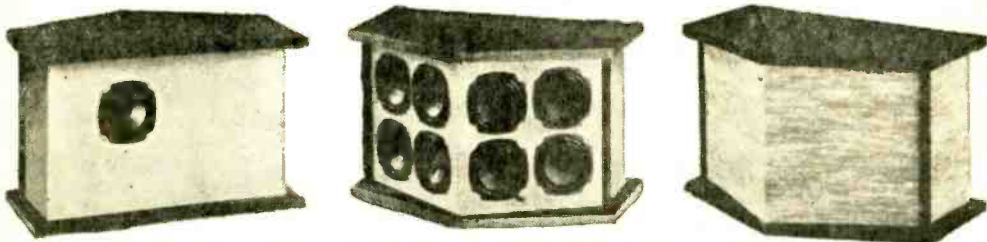

Left, view of front and (center) view of back of Bose 901 with grille cloth removed (note that unit has eight speakers in rear, only one in front). Right, view of rear of unit with grille cloth in place.

# METER SCALES

## you can count on

**E**ither because nothing suitable was available, or, because of economic limitations, have you ever had to use a meter that had a scale not calibrated in the proper units for the particular application? For example, your power supply output is 65 volts, but your meter indicates 100 volts full-scale. To gain resolution you "juggle" the multiplier so that 65 volts is now the full-scale indication, but then you have to convert the reading on the meter scale by a factor which you are always forgetting. Or, the meter should

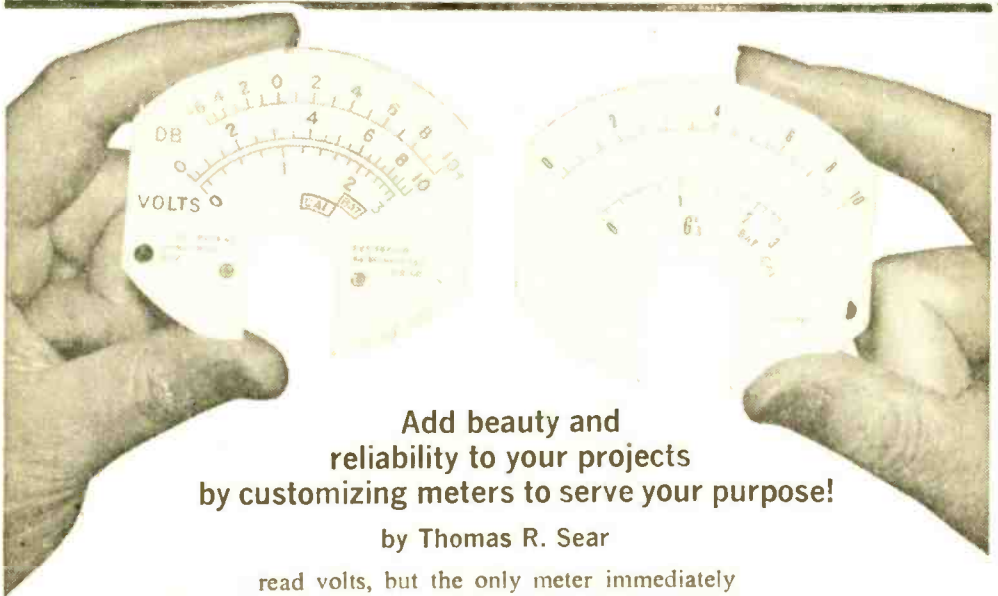

**Add beauty and  
reliability to your projects  
by customizing meters to serve your purpose!**

by Thomas R. Sear

read volts, but the only meter immediately available has a milli-ammeter scale. Sound familiar?

**How You Do It.** If so, here is a method that will enable you to customize your meters to utilize maximum scale deflection, and yet you will always know just what units you're reading. In addition, you will have a meter scale that doesn't look home-made and makes you look like a real professional.

All you need is a ruler, a compass, some dry transfer numerals, and a protractor.

If you draw the required scale several times larger than the actual size of the exist-

# e/e CUSTOM SCALES

ing meter scale and then photographically reduce this drawing to the original size, the slight inaccuracies that inadvertently creep into your drawing will be minimized by the reduction in size. The resulting scale will look professional and will enhance the overall appearance of the project as well as making it easier to use the equipment.

**Preliminary Steps.** First remove the meter movement and scale from the meter case and very carefully remove the meter scale from the meter movement. You must determine the length of the original meter scale arc in degrees before making a new scale. To do this tape the original meter scale to the center line in the lower half of a piece of paper at least 8½ x 11 in. Then place the compass point near the center of the scale (point A in Fig. 1) and draw two curved, dotted lines. Now place the compass point at each end of the scale (points B, Fig. 1) and draw the solid curved lines that are shown. Make certain that the pencil lead is kept sharp, and that the compass point is placed exactly where specified. Do not draw the lines too heavy so that they may be easily erased in the event you may require the original scale for a future application. Draw the two straight lines between point O and the crossing of the curved lines. Point O is the center of the circle, a portion of which is the meter scale arc.

**Drawing the New Arc.** Next, draw two lines from point O exactly through the ends of the meter scale, extending them so that they are 3 to 4 times the length of the radius of the scale, as shown in Fig. 2. Using a protractor accurately measure the angular distance between the two straight lines, and record it for later use. Using point O as a

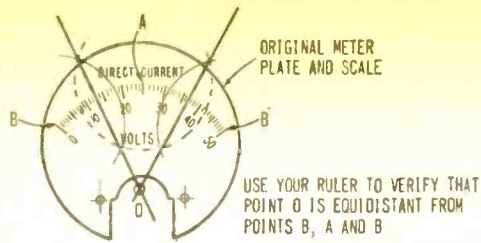

Fig. 1. To determine length of original scale you must know where center of original scale arc is located. Reason is that you use it as your starting point when you draw your new scale.

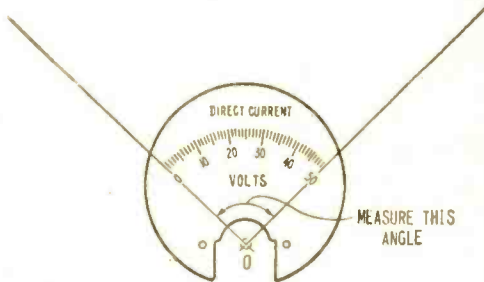

Fig. 2. Carefully measure angle of arc by placing protractor between radii and centered at O. Record reading for use later when calculating new scale.

center draw an arc using a radius about 3 times the length of the original radius (OA in Fig. 3). An enlargement of 2 to 3 times produces an effective new scale size. Dry transfer letters are available in many sizes, therefore you can readily select a suitable ratio of arc enlargement to lettering size. The enlargement factor is determined by dividing the radius of the enlarged arc by the radius of the original arc.

You now remove the original scale from the paper and work directly with the newly drawn lines.

**Enlarge the Scale.** Draw an outline of the original scale that is enlarged by the same ratio as the radius of the arc. Make certain that cutouts are enlarged, and mounting holes are spaced in the same increased proportion as the increase in arc radius (see Fig. 4). It is advisable, also, to draw the new scale arc and its divisions proportionately thicker so that when the enlarged scale drawing is reduced photographically to the original scale size, they will not be lost in the reduction.

**Dividing the Scale.** Dividing the scale requires a little thought. If the new scale is an even multiple of the original scale the graduations on the original scale will be

## What You Will Need

**Drafting Equipment:** Compass, ruler, protractor, pencils, pens, india ink (select professional quality tools and supplies) from your local art supplier. Some items are available from electronics mail order houses such as Allied Radio and Lafayette Electronics.

**Dry Transfer Letters:** Sometimes called "Press-Type," or "wax lettering." Datak offers several letter, words and numeral kits in combination or singly. Datak products are available at Allied Radio and Lafayette Electronics. Art supply stores may carry Datak as well as other products equally as good.

right where you want them, and you can just extend them as shown in Fig. 5. (Note: it may be easier to extend these markings before removing the original scale.) It's more likely though, that you will be changing the markings radically. For example, you may be using a 10-volt full-scale meter for a 17-volt full-scale reading. In this case you first rough out a meter scale, deciding just how you want it to be divided to match the read-out that you need (e.g. whether to have graduations every  $\frac{1}{2}$  volt, or every 10 volts).

Once you know how you are going to divide your scale, count how many divisions will be required on the scale. In Fig. 6 there are 20 divisions on the scale. Then divide the arc length in degrees (measured earlier), by the number of new scale divisions. For example, if the arc length of the scale in Fig. 6 was measured as 103 degrees we divide 103 by 20. The answer is 5.15 degrees per division. This tells us that the divisions on our meter will be drawn every 5.15 degrees.

To ensure that your scale graduations are uniform in length, draw four dotted lines lightly as shown in Fig. 6 (these will be erased later). For best contrast the lines of the scale should be drawn with ink; however, any dark pencil will do if you make the lines uniform in thickness. As far as the weight of the lines is concerned, they can be made as dark as you wish during the reproduction process.

**Marking the Scale.** Carefully apply the correct dry-transfer lettering and numbering to the scale drawing. Clean up the drawing

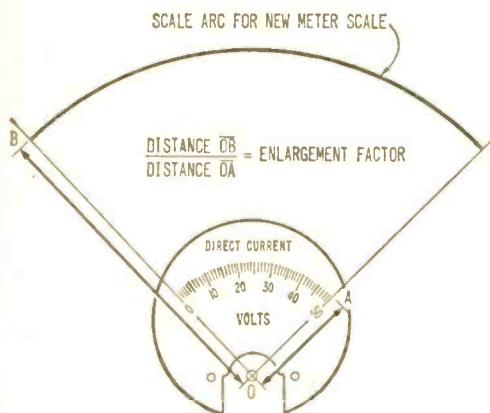

Fig. 3. To enlarge scale, extend radii OA 3-4 times to OB. Select size of transfer letters to complement scale expansion, and draw new scale arc from point O as center. Bold lines ordinarily reduce best.

OUTLINE OF METER SCALE PLATE

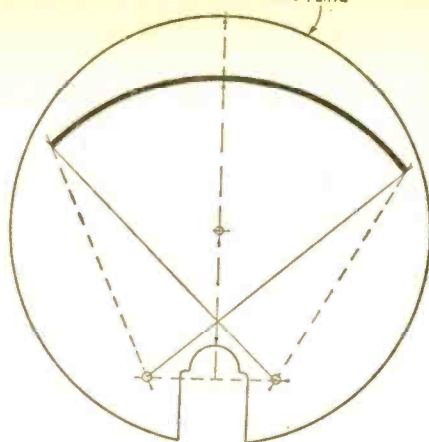

Fig. 4. Draw new meter face outline, increasing old meter face diameter by scale enlargement factor. Enlarge original cut-outs and space between old mounting holes, using same enlargement factor.

with an eraser, and spray it with a coat of clear plastic to ensure that it remains clean and that the lettering is not accidentally scraped off in handling.

**Photographing the Scale.** Once the scale is drawn, accurately measure the distance between the meter scale mounting holes as shown in Fig. 7. Mark this dimension on your drawing for use in the reduction process. When the scale is being photographically reduced, the photographer will actually measure this dimension on the print with an accurate ruler.

If you have photographic equipment, proceed as follows; if not, give your drawing and these instructions to a photo lab and

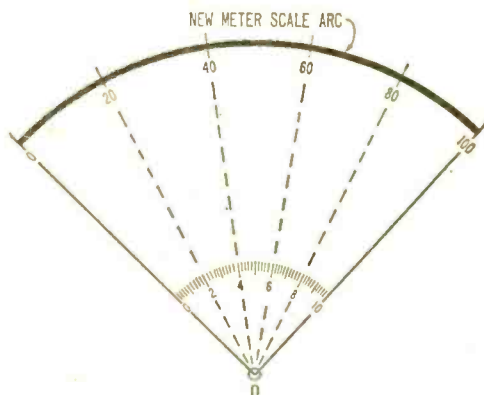

Fig. 5. When new scale divisions are even multiples of original ones, extend them to new scale arc. Use ruler, carefully centering it on point O and each division marker on old scale.

they will do the remaining work for you.

Take a closeup picture of the completed drawing so as to obtain a full-sized good quality negative. Next, make contact prints of the drawing on double-weight eggshell paper. It is during this phase of the work that the dimension determined in Fig. 7 is so important. While the film is in the enlarger or projector, and prior to making the print, measure the mounting hole spacing of the projected image and verify that it is correct. It is a good idea to make more than one copy at this time just in case your first mounting effort is not successful.

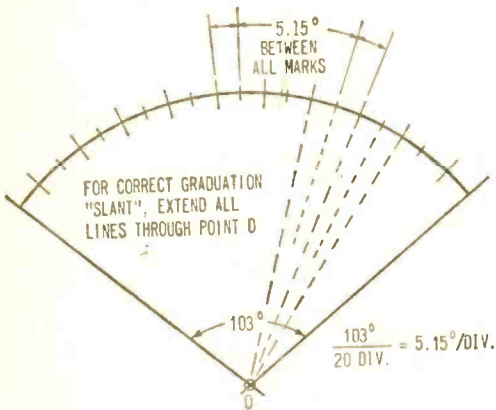

Fig. 6. When new scale divisions are not even multiples of original scale, divide arc length measured earlier (refer to Fig. 2) by number of new scale divisions desired. Extend all graduations through point O to assure correct slant of markers.

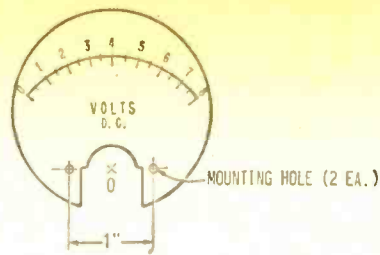

Fig. 7. When photographically printing new scale, final print must be exactly same size as original scale. To be sure, before actually exposing the sensitized paper, project negative onto easel and measure distance between mounting holes. They must exactly match original holes.

**Finally.** Trim the new scale to slightly larger than necessary by cutting out the scale 1/16th in. larger than the outline. Mount the new scale on the back of the old meter scale plate using a good quality cement. Alignment is very important, so line up the mounting holes and use backlighting to ensure that the scale outlines match.

Trim the excess paper off, using either a very sharp razor blade or, preferably, a very fine jeweler's file. Always work away from the viewing side of the scale.

Mount the new customized scale on the meter movement and replace the meter case.

**Applications.** While this article has described the process as applied to the changing of one linear scale to another linear scale, it is possible to make scales for watts, decibels, etc. The only limiting factor is your own ingenuity. The process was developed while converting a meter that was graduated in decibels and volts to one that would read out in Gs (gravity) as shown in the lead picture.



## Two for the Fish Flicks

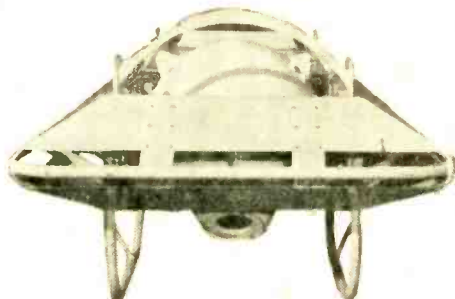

Two, 250-watt tungsten-halogen lamps on this underwater sea sled will help put fish on film. Developed by Sylvania, lamps will illuminate deep to probe fishes' fickle ways.



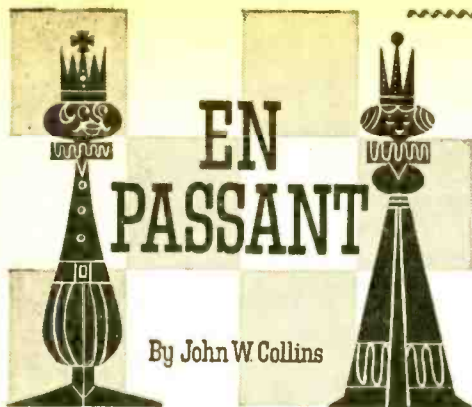

“A good game of chess is decided in the Middle Game” says Tarrasch. And it is true that most of the decisive battles are fought in that part of the game. It is there that the tactical motifs I have shown in previous columns (double attack, pin, skewer, vulnerable first rank, etc.) come into their own. There that hidden combinations are found. There that one must avoid mistakes and exploit the mistakes of one's opponent. And it is there too that one must attack certain squares, down files, on diagonals, and across ranks. Here are some of these typical attacks.

**Attack On QN7.** Legend has it that a certain impoverished but solicitous chess-playing father's only legacy to his chess-playing son was the advice: “Never take the Queen Knight's Pawn!” Be that as it may, when the Queen penetrates as far as QN7 into the enemy camp she may be attacked from all sides and lost.

Black

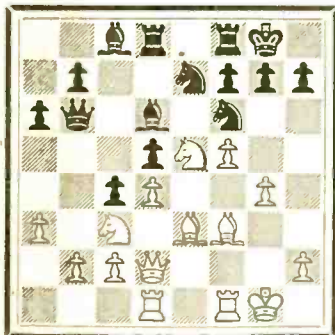

White

Black moves. White has just played 1 QR-Q1, setting a trap. 1 . . . QxNP?? (taking the bait) 2 R-N1, QxRP 3 R-R1, Q-N5 4 KR-N1 and the Black Queen is caught.

**Forcible Exposure Of The King.** A frequent way of getting at the King is by sacrificing a Bishop or a Knight at KN6 or KR6 for two Pawns. After that it is a matter of bringing up

the Queen and some additional pieces to effect a mate.

Black

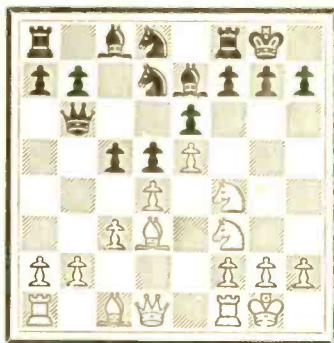

White

An initial attack on the KRP sets it up. 1 Q-B2, P-B4? 2 PxP e.p., NxP 3 N-N5, P-N3 4 BxP! (on target) PxP 5 QxP# K-R1 6 Q-R6# K-N1 7 N-N6 (threatening mate by either 8 Q-R8 or 8 NxB) N-B2 8 NxB mate.

**Attack with the King Bishop's Pawn.** A Pawn at KB6 can be crushing, catastrophic for the opponent, as all kinds of mating attacks may revolve around it.

Black

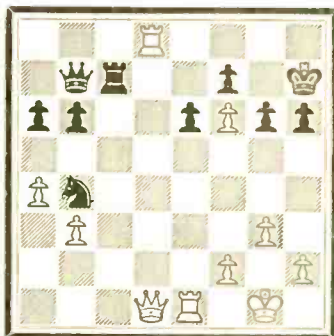

White

1 R-R8#! KxR 2 Q-Q8# K-R2 3 Q-KB8 and 4 Q-N7 mate can be postponed for only one move with the “spite check” 3 . . . Q-N7#.

**Game of the Issue.** Dr. Reuben Fine, a New York psychologist, has had one of the most brilliant chess careers of our time. It has been distinguished in chess play and in chess writing. This has been true of only a small number of grandmasters.

Fine, born in 1914, learned the moves from an uncle when he was about 8 years old. He played in high school and began to frequent the Manhattan and Marshall Chess Clubs in the spring of 1929. It was then that his great pas-

# e/e EN PASSANT

sion for the game began—a passion which lasted for some eight years. During those eight years, he became tops in rapid-transit tournaments, devoted himself to the study of the books and games of Tarrasch, Reti, Nimzovitch, Lasker, Capablanca, Alekhine, and Steinitz, started writing his own books, played on three U.S. World Championship Teams, won the U.S. Speed Championship four times, gave simultaneous exhibitions (some blindfold), and competed in tournaments (home and abroad) and matches. But by 1938 his passion for chess had subsided. This was due to several things—his eagerness to get back to professional work, his dislike of how the chess world was organized, his belief that the Russians played politics with the world championship, and his disappointment at being unable to get a crack at the title by playing matches with Alekhine, Botvinnik, or Smyslov, all World Champions.

Fine played in thirty-six master tournaments and finished first, or tied for first and second, in twenty-one of them. In matches, he defeated H. Steiner, 5½-4½, A. Dake, 6-4, I. Horowitz, 6-3, G. Stahlberg, 5-3, H. Steiner (again), 3½-½, and drew with M. Najdorf, 4-4.

But it may well be that the psychologist-chess-player has made his most indelible mark on chess history with his books. The list is impressive—CHESS THE EASY WAY, an introductory textbook for beginners and one of the all-time best sellers, THE IDEAS BEHIND THE OPENINGS, an explanatory review of each opening, PRACTICAL CHESS OPENINGS, a compilation of 10,000 opening variations, THE MIDDLE GAME IN CHESS, one of the few worthwhile books on a part of the game which is comparatively neglected, BASIC CHESS ENDINGS, a 573 page definitive work which is hailed as a masterpiece, and several other books.

Former World Champion Max Euwe wrote that Fine likes "sharp positions," that he goes in for chancey situations, that he never takes risks, that he confronts his opponents with tricky problems from the very first move, but that above all his play is logical. Fine himself says he is an eclectic and that he stresses accuracy more than everything else. He considers the game below to be the best one of his career. It is a French Defense, was against Salo Flohr (Black), and was played in the AVRO Tournament, 1938. AVRO was Fine's greatest tournament victory: he scored 8½ points, which included two wins from Alekhine and a win and a draw with Botvinnik, and tied for first and second places with Paul Keres. Game at top of next column.

Why did Black resign? Because he will be mated, lose his Queen, or be a piece and a Pawn behind. Here is the analysis:

- |           |       |          |         |
|-----------|-------|----------|---------|
| 1 P-K4    | P-K3  | 15 RxP   | Q-Q1    |
| 2 P-Q4    | P-Q4  | 16 Q-R5! | N-K2    |
| 3 N-QB3   | B-N5  | 17 R-Q4! | P-KN3   |
| 4 P-K5    | P-QB4 | 18 Q-B3  | Q-B2    |
| 5 B-Q2    | N-K2  | 19 N-B3  | N-B4    |
| 6 N-B3    | N-B4? | 20 N-N5  | Q-N3    |
| 7 PxP!    | BxP   | 21 RxB!  | KxR     |
| 8 B-Q3    | N-R5  | 22 P-KN4 | N-R5    |
| 9 O-O     | N-B3  | 23 QxBP# | B-K2    |
| 10 R-K1   | P-KR3 | 24 B-N4  | QR-K1   |
| 11 N-R4!  | B-B1  | 25 BxB   | RxB     |
| 12 R-QB1! | B-Q2  | 26 Q-B6  | P-R3    |
| 13 NxN    | QxN   | 27 R-Q1! | PxN     |
| 14 P-QB4! | PxP   | 28 B-K4# | Resigns |

Position after 28 BxK4 #

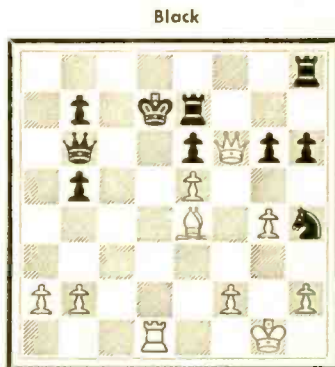

White

Solution to Problem 19: 1 K-B7

**Stranger Than Fiction.** Here is the shortest master game of all time. It is a Queen's Pawn Opening, was played in Paris, 1924, and the contestants were Gibaud, White, and Lazard.

- |        |       |                  |
|--------|-------|------------------|
| 1 P-Q4 | N-KB3 | 4 P-KR3?? N-K6!! |
| 2 N-Q2 | P-K4  | Resigns          |
| 3 PxP  | N-N5  |                  |

Black

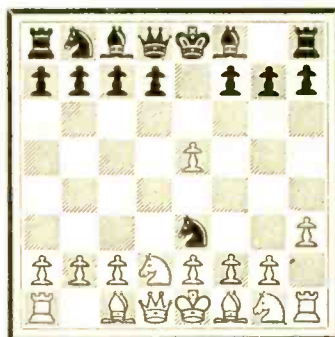

White

Black mates or wins the Queen. If 5 PxN, Q-R5# 6 P-N3, QxNP mate.

(Continued on page 105)

# E/E's BASIC COURSE IN ELECTRICITY & ELECTRONICS.\*

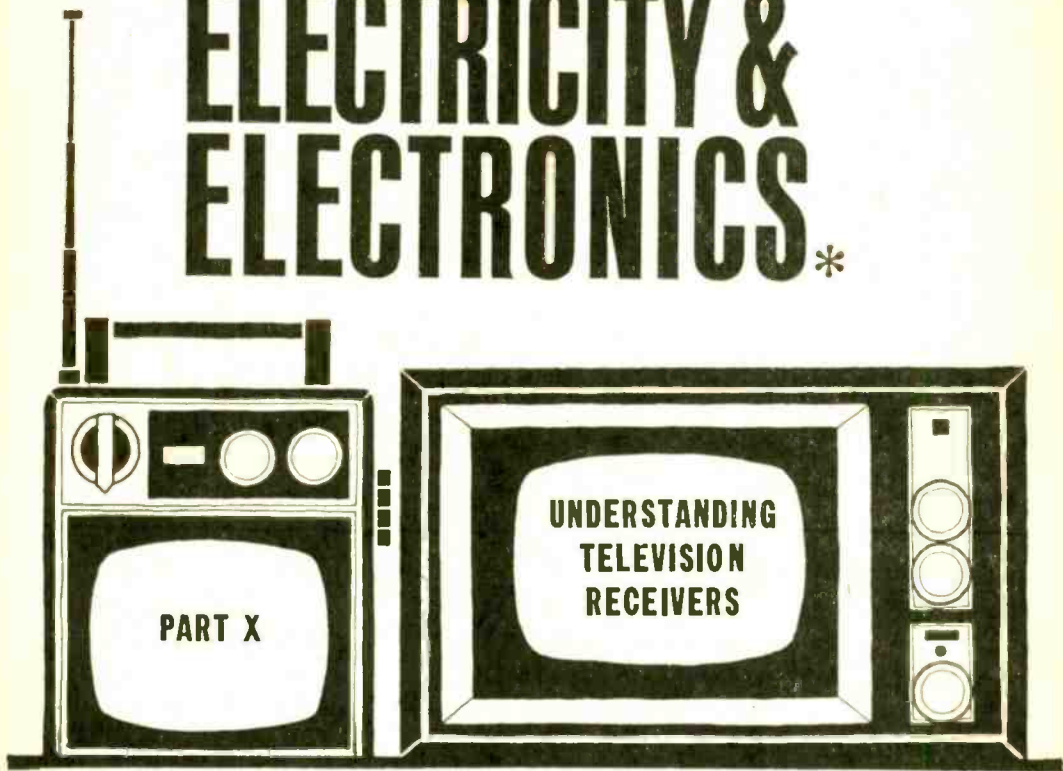

**W**HAT YOU WILL LEARN. In this chapter you will learn how a television receiver converts electronic signals into picture and sound reproductions. Learning the basic principles of television receivers is no more difficult than learning the principles of radio. The basic electronic principles are the same for both. You will find this to be true for any electronic equipment, regardless of how complicated it may seem. We suggest you review the Basic Course on television transmitters in the preceding issue of **ELEMENTARY ELECTRONICS**.

\* This series is based on *Basic Electricity/Electronics*, Vol. 1, published by Howard W. Sams & Co., Inc.

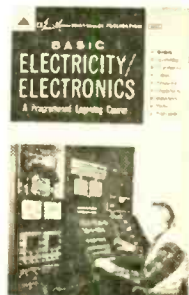

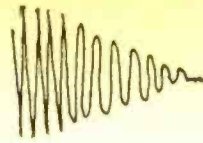
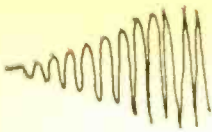

## THE TELEVISION RECEIVER

There are, of course, as many varieties of TV receivers as there are bats in the belfry. Thing is, since they all must process the same signals from a TV transmitter, the function of their circuits must be identical.

Block Diagram of a TV Receiver

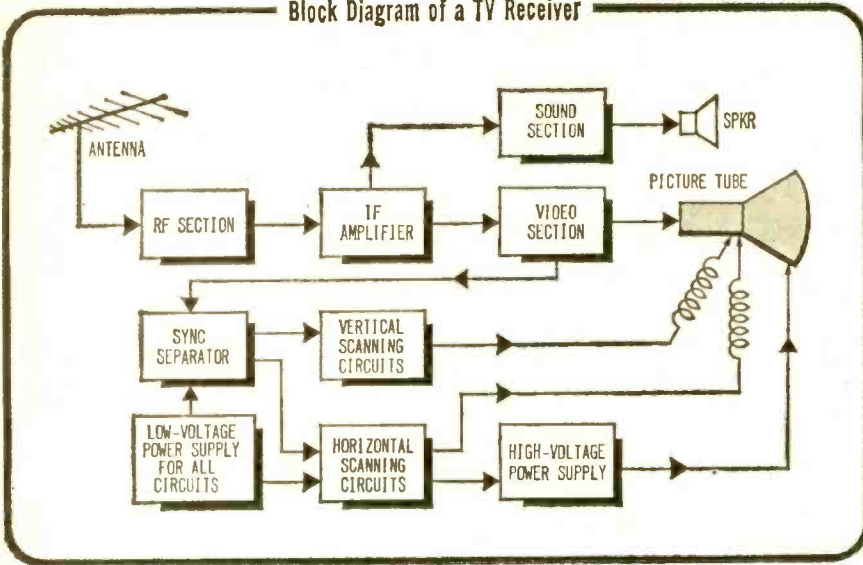

The illustration above shows a single antenna bringing both the *FM* sound carrier and the *AM* video carrier to the RF (radio-frequency) circuits. This is satisfactory, since the sound- and video-carrier frequencies are fairly close together (though the sound carrier is 4.5 MHz higher).

Both carriers are amplified and converted into an intermediate frequency (*IF*). The *IF* signals are amplified and then separated, each being sent to its proper section. In the sound section, the audio component of the frequency-modulated wave is extracted and sent to the speaker. In the video section, the picture signals and blanking pulses are taken from the amplitude-modulated wave and sent to the cathode-ray (picture) tube.

Synchronizing (*sync*) pulses time the controlling voltages of the vertical and horizontal circuits. Outputs of these stages cause the image to be placed on the screen of the cathode-ray tube.

### RF Section

In most TV sets the RF section (sometimes called the *front end* or *tuner*) normally consists of an RF amplifier, a mixer, and an oscillator. Refer to illustration on next page. Dashed lines to two or more circuits in a diagram indicate that a single control has an effect on each circuit or part indicated.

Q1. ----- and ----- carriers are received by a single antenna.

- Q2. The two frequencies differ by -- MHz.
- Q3. The carrier containing the synchronizing pulses is at a (lower, higher) frequency than the audio carrier.
- Q4. Outputs from the RF section are fed to the ----- and ----- sections.
- Q5. What stages are tuned by the receiver channel selector switch?
- Q6. What section delivers the picture image to the picture tube?

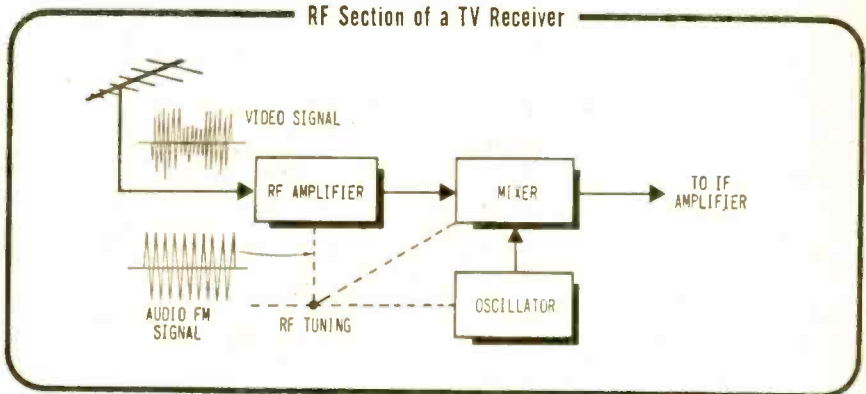

**Your Answers Should Be:**

- A1. *Sound and video carriers* are received by a single antenna.
- A2. The two frequencies differ by 4.5 MHz.
- A3. The carrier containing the synchronizing pulses is at a *lower* frequency than the audio carrier.
- A4. Outputs from the RF section are fed to the *sound and video* sections.
- A5. *RF amplifier, mixer, and oscillator stages* are tuned by the selector switch.
- A6. The *video section* delivers the picture image to the picture (cathode-ray) tube.

**RF Amplifier.** All the TV station carriers reaching your receiver appear at the input of the RF amplifier. In selecting a channel, the tuner provides the right combination of inductance and capacitance in this circuit so that only the video- and sound-carrier frequencies of that channel are amplified. All other channel frequencies are rejected.

**Mixer and Oscillator.** The mixer is tuned to the same frequency as the RF amplifier. Its purpose is to develop the intermediate frequency for the IF amplifiers located in the sound and video sections. The mixer (converter) does this in the same manner as the mixer in the AM radio receiver. The oscillator develops a frequency that is the desired IF above the video- and sound-carrier frequencies. The oscillator and carrier frequencies are mixed to produce the IF difference frequency at the output of the mixer. This frequency is then fed to

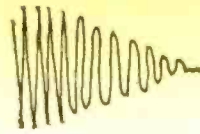
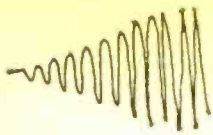

the IF amplifiers with the appropriate video and sound modulations still existing.

**Fine-Tuning Control.** Most sets have a *fine-tuning control* in addition to the channel selector. The fine-tuning control adjusts the value of a component (usually a capacitor) in the oscillator circuit. The change in value of this component causes an appropriate change in the frequency of the oscillator, allowing the IF for sound and video to be tuned more precisely.

### Sound Section

You may have noticed the similarity between the mixer and oscillator of a radio receiver and the corresponding circuits in a TV receiver. In fact, most of the circuits of the sound section are similar in operation to those found in an FM radio.

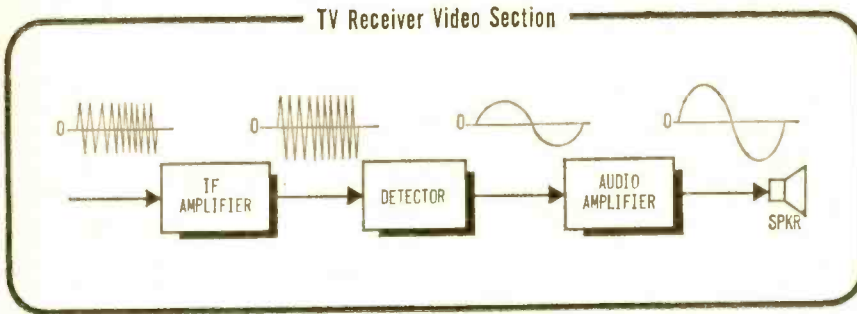

**IF Amplifiers.** The IF signal contains both frequency and amplitude modulation. The IF frequency is usually near 45 MHz, which is a much higher frequency than the 455-kHz IF usually found in an AM radio. This higher IF frequency modulated by both the audio and video signals is more difficult to amplify. Thus, the gain (amount of amplitude increase between circuit input and output) is low, and more than one stage of IF amplification is necessary. Depending on the quality of the receiver, the IF section will have two, three, or four IF amplifiers, one after the other. This row of amplifying circuits is sometimes called the *IF strip*.

- Q7. Front end is another name for the -----.
- Q8. What are the two carriers that enter the RF amplifier from the antenna?
- Q9. What are the frequencies that become inputs to the mixer?
- Q10. The selector switch tunes the mixer to the same input frequency as the -----.
- Q11. The oscillator is tuned to a (higher, lower) frequency than the video carrier.
- Q12. IF amplifiers are circuits in both the ----- and ----- sections.



**Q13.** There are (more, fewer) circuits in a TV IF strip than in the similar section of a home radio.

**Your Answers Should Be:**

- A 7.** Front end is another name for the *RF* section.
- A 8.** *Sound and video carriers* enter the RF amplifier from the antenna.
- A 9.** *Sound, video, and oscillator frequencies* are inputs to the mixer.
- A10.** The selector switch tunes the mixer to the same input frequency as the *RF* amplifier.
- A11.** The oscillator is tuned to a *higher* frequency than the video carrier.
- A12.** IF amplifiers are circuits in both the *sound* and *video* sections.
- A13.** There are *more* circuits in a TV IF strip than in the similar section of a home radio.

### Sound Detection and Amplification

Because the TV sound is contained in the form of frequency modulation, the method for removing the audio component is different from that for AM.

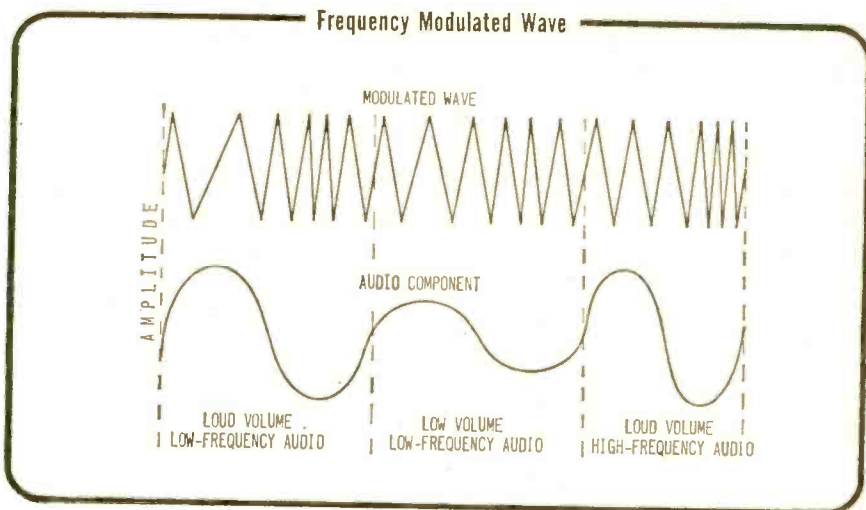

**The Detector.** FM and AM detectors have the same purpose—to remove the audio component from the modulated intermediate frequency. For FM, the variations in frequency are changed into voltage variations by the detector. The output of the detector (quite frequently called a *discriminator* because it discriminates between AF and IF), is an audio frequency representing the tone and amplitude of the sound originating at the studio.

The difference in volume, as shown in the illustration, is determined by the distance between cycles of the carrier (or IF). For a given carrier, its frequency is the same for each cycle of audio. Carrier frequency decreases

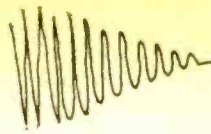
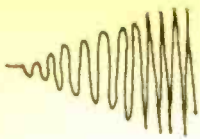

(cycles farther apart) during the positive portion of an audio wave and increases (cycles closer together) during the negative portion. The greater the volume of the audio, the greater is the difference in carrier frequency between the positive and negative half cycles of the audio. A weaker volume shows less difference (carrier frequency will be more uniform throughout the audio cycle) between positive and negative half cycles of the audio.

High and low tones are determined by the number of times the periodic carrier-frequency variations repeat themselves. For low audio tones, repetition of cycles (audio frequency) is less often. For high tones, repetition of cycles occurs a greater number of times per second.

**The Audio Amplifier.** The purpose and method of amplifying audio are identical in AM and FM receivers. The amplifier in either system raises the amplitude of the pure audio signal to the level required for operating the speaker. The volume control and tone control (if the TV set has one) are normally separate variable resistances in the first of two audio-amplifier stages.

- Q14. Detectors are designed to remove ----- modulation from the ----- frequency.
- Q15. The audio component of an FM signal is removed by a (an) ----- circuit.
- Q16. In frequency modulation, the distance between cycles of the carrier frequency determines the (volume, tone) of the sound.
- Q17. A high tone requires (more, less) repetition of the IF variations than a low tone.
- Q18. A discriminator separates the modulation frequency from the -----.

**Your Answers Should Be:**

- A14. Detectors are designed to remove *amplitude* modulation from the intermediate frequency.
- A15. The audio component of an FM signal is removed by a *discriminator* circuit.
- A16. In frequency modulation, the distance between cycles of the carrier frequency determines the *volume* of the sound.
- A17. A high tone requires *more* repetition of the IF variations than a low tone.
- A18. A discriminator separates the modulation frequency from the *intermediate frequency*.

**Video Section**

The purpose of the video section is to amplify the modulated picture signal and distribute its signal components to the correct stages of the set.



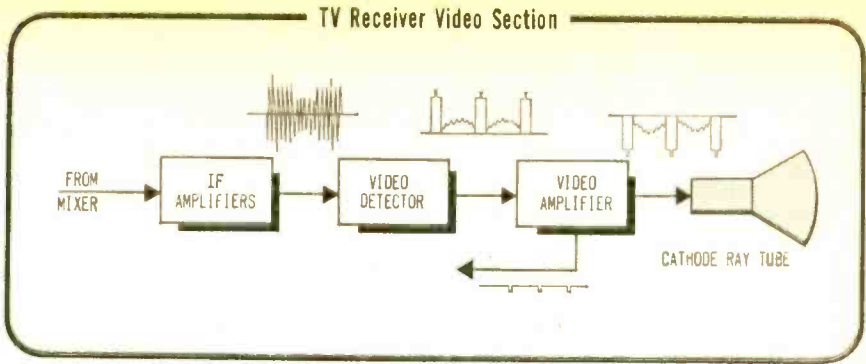

**IF Amplifiers.** The output of the IF amplifiers contains the video signal and is fed to the video detector, as shown in the diagram.

**Contrast Control.** The contrast control is actually a variable resistance in one of the video-amplifier stages. Its purpose is to vary the amount of output from the amplifier with which it is associated. This increases or decreases the amplitude difference between the voltages representing the white and black portions of the image. If the amplifier output is increased, the difference between the two voltages becomes greater and the contrast is increased.

**Video Detector.** Like the detector used in an AM radio, a TV video detector is usually a diode. As we have already learned, a diode conducts current in one direction only. When the modulated signal is applied, the detector conducts only during the time the waveform is going positive. The varying frequency representing the sound, and the negative portion of the video signal cannot pass through the detector stage. Therefore, the output of the detector is identical to the picture signal as it left the camera and before it was placed on the carrier.

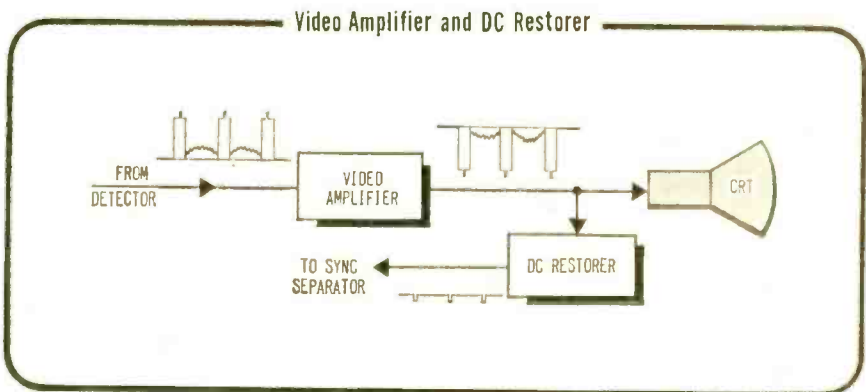

**Video Amplifiers.** The output of the detector is a relatively weak signal, not strong enough to cause a reproduction of the picture. Video amplifiers are therefore required to achieve the necessary signal amplitude. These must be wide-band amplifiers because the frequency content of the picture signal covers a wide frequency range.

The output from the video-amplifier section is the reverse (upside-down) of the waveform that entered its input. This is the condition of the waveform that is desired. If the image and blanking pulses were positive-going instead of negative-going, the blacks of the image would appear as whites, and the whites as blacks.

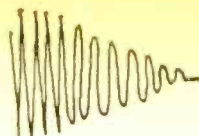
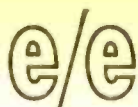
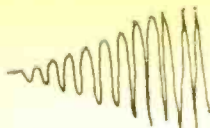

- Q19. The contrast control changes the amount of ----- of a video amplifier.
- Q20. The video detector selects the (positive, negative) portion of the picture signal and rejects the ----- frequency.
- Q21. In the output of the video-amplifier section the sync pulse has a voltage (more, less) negative than the image.

**Your Answers Should Be:**

- A19. The contrast control changes the amount of *output* of a video amplifier.
- A20. The video detector selects the *positive* portion of the picture signal and rejects the *intermediate* frequency.
- A21. In the output of the video-amplifier section the sync pulse has a voltage *more negative* than the image.

### Image Display

In the illustration below, zero voltage is shown on the reference line. Any portion of the signal below this line is negative. As you may recall, the camera image produces a signal in which whites are more positive than blacks and grays, and grays more positive than the blacks. The cathode-ray tube places the image on the screen with an electron beam similar to that used for scanning in

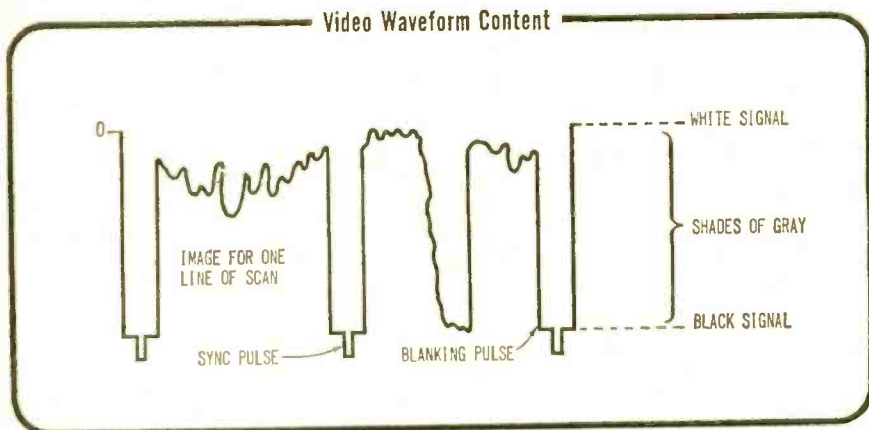

the camera. Video signals fed to the cathode-ray tube control the number of electrons striking the fluorescent screen. The fluorescent material on the screen gives off light in proportion to the number of electrons that strike it.

To reproduce blacks, the beam must be shut off. Whites require a maximum number of electrons. The video signal controls the number of electrons by the value of its negative voltage. Negative voltage repels electrons. A highly negative portion of the image signal (black) stops electron flow completely.

**DC Restorer.** To achieve proper values of the image and blanking voltages that control the number of electrons in the beam, a definite voltage reference level must be established and maintained. In other words, zero voltage is the reference shown in the illustration, and must be at the top of the waveform. If the waveform varies above or below this zero reference, the video and blanking will not appear on the screen properly. The circuit in most TV sets that maintains this level is called a *DC restorer*.

**Brightness Control.** Another front-panel adjustment, the *brightness control*, is a variable resistor in the picture-tube circuit. The purpose of this control is to adjust the position of the waveform on the zero reference level to a point that provides the best screen brightness for viewing purposes. If the control is adjusted so that the near-white amplitudes in the image are brought closer to the zero reference, more electrons strike the screen, making it brighter. When the control is turned in the other direction, so that even the white amplitudes are below the zero reference, fewer electrons strike the screen and the entire picture is darker.

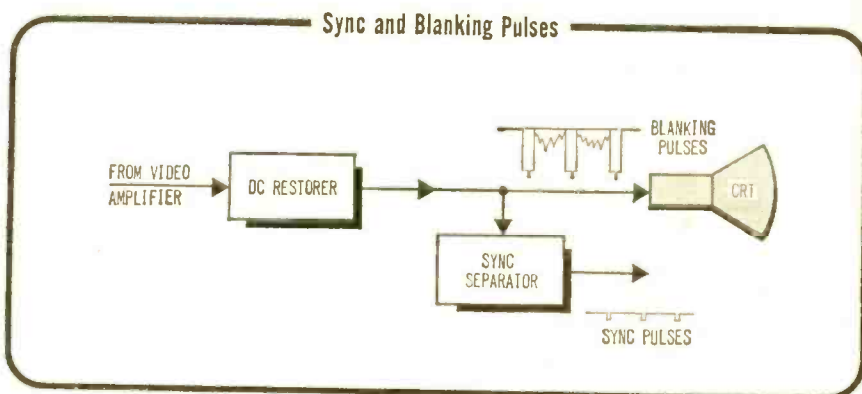

- Q22. The screen of a cathode-ray tube glows brighter if (more, fewer) electrons strike it.
- Q23. To put "black" on the picture tube, the voltage representing black in the video waveform must be as (negative, positive) as the ----- pulse.
- Q24. A zero reference level of the video waveform is established by the -----.
- Q25. The ----- adjust the zero reference level for the desired brightness of the screen.

**Your Answers Should Be:**

- A22. The screen of a cathode-ray tube glows brighter if *more* electrons strike it.
- A23. To put "black" on the television screen, the voltage representing black in the video waveform must be as *negative* as the *blanking* pulse.
- A24. A zero reference level of the video waveform is established by the *DC restorer*.
- A25. The *brightness control* adjusts the zero reference for the desired brightness of the screen.

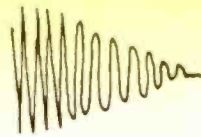
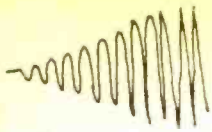

### Scanning

In the discussion thus far, video and blanking pulses have been fed to the cathode-ray tube for each scanned line of the picture waveform entering the set. The picture portion of the waveform controls the intensity of the electron beam,

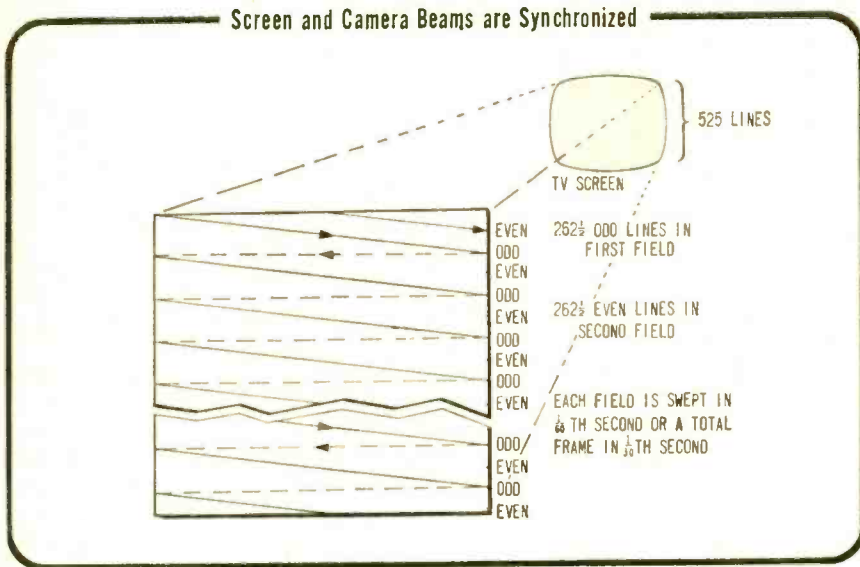

while the periodically appearing blanking pulses shut the beam off at the proper intervals.

Some method is needed to move the beam on the receiver screen from side to side and top to bottom in synchronization (in step) with the action that takes place in the camera. Each of the video waveforms represents one particular scan line among the 525 lines that should appear on the screen for a complete picture. Up to this point all of the video waveform has been used except the small *sync pulses* that are on top of the blanking pulses.

There are 525 horizontal lines in a complete picture on a TV screen. Each line represents an image line scanned by the TV camera and a screen line to be swept (reverse of scan) by the electron beam in the TV tube. The entire 525 lines are called a *frame*.

The camera sweeps every other line (interlaced scanning) for ease in electronic control and viewing (this technique effectively eliminates flicker). The receiver beam must do likewise, sweeping every other line precisely in sequence with the camera. In the first pass, called a *field*, the beam must start in the upper left-hand corner and trace every odd line, ending at the middle of the bottom line for a total of 262½ lines (½ of 525). The beam must then return to the top center of the screen and sweep each even line in sequence, completing 262½ lines of the field at the end of the bottom line.

In the process, the beam must excite the fluorescent screen with the correct intensity indicated by the corresponding portions of the video waveform. At the end of each line, the beam is blanked and must be rapidly returned to the

left to start the next line of the picture. When the beam reaches the bottom of the screen, it must be blanked again and rapidly returned to the correct position (left or middle) at the top to sweep the next field. It must complete a *field* ( $262\frac{1}{2}$  lines) in precisely  $1/60$  of a second and a full *frame* (complete picture) in  $1/30$  of a second.

- Q26. There are \_\_\_\_\_ lines to a field and --- fields to a frame.
- Q27. The sweep of the receiver beam must be \_\_\_\_\_ with the ---- of the camera beam.
- Q28. The start and the position of each scan line on the CRT screen are controlled by the \_\_\_\_\_.

**Your Answers Should Be:**

- A26. There are  $262\frac{1}{2}$  lines to a field and *two* fields to a frame.
- A27. The sweep of the receiver beam must be *synchronized* with the *scan* of the camera beam.
- A28. The start and the position of each scan line on the CRT screen are controlled by the *synchronizing pulses*.

**Moving the Electron Beam**

You know that a negative voltage repels and a positive voltage attracts electrons. The cathode-ray tube (CRT) uses this effect to send an electron beam to the screen and control its movement.

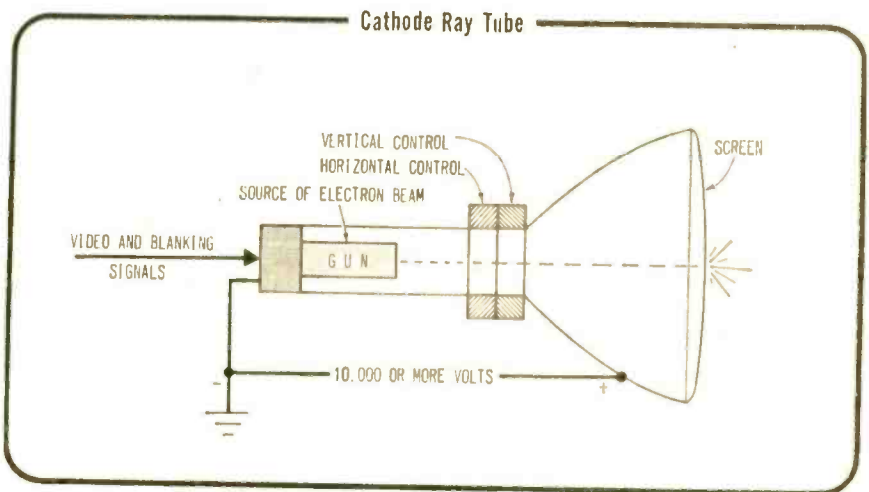

The basic construction and connections of a CRT are illustrated above. At the left end is shown an electron gun which shoots a narrow stream of electrons toward the screen. To speed the electrons on their way, the inner surface of the flared portion of the tube has a conductive coating energized with a voltage that is several thousand volts positive with respect to the electron source.

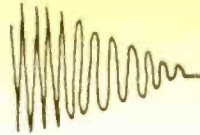
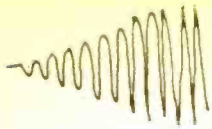

The CRT is connected to the output of the last video amplifier from which is received the video and blanking signals. The CRT element which controls the number of electrons responds to the varying amplitude of the video and releases the quantity required. This element also stops the flow of electrons when the blanking pulse appears.

During the time a video signal is present, the beam must be moved from left to right across the screen. When the beam reaches the right side, the blanking pulse shuts off the electrons and the beam moves back to start the next line.

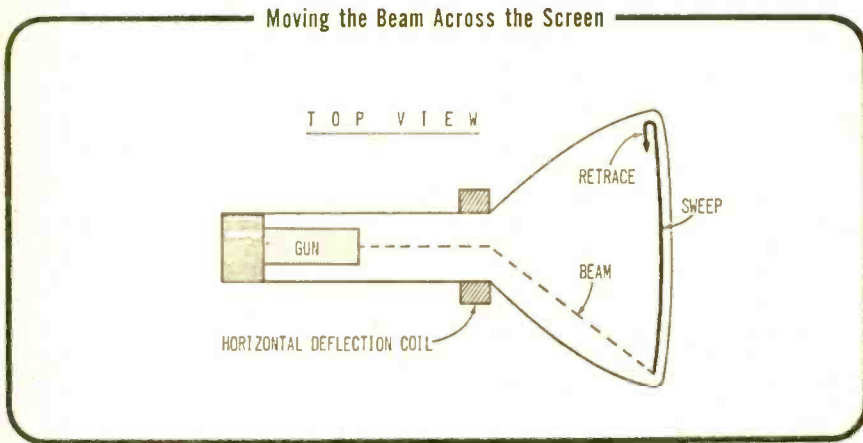

A horizontal-deflection coil wrapped around the neck of the tube moves the beam from side to side. Current moving through the coil sets up a magnetic field which has an attracting and a repelling effect on electrons similar to positive and negative voltages. The stronger the field, the greater its effect on the beam. To increase the strength of the field requires an increase in current through the coil. The illustration shows the beam deflected to the left.

The change in strength of the magnetic field during a sweep must coincide with the time duration of the scanned line. A gradual rise of current within the coil during this time period accomplishes this. The starting time is triggered rapidly at the end of each line (during the blanking pulse), the sudden drop in by the sync pulses that ride on the blanking pulses. If the current decreases magnetic field strength returns the beam to the left very quickly.

A similar magnetic field is set up by a second coil (the vertical-deflection coil) which controls the movement of the beam line by line from the top of the screen to the bottom. On completion of a field, the beam quickly retraces to the top.

Q29. The electron beam in the CRT is generated by a (an)

-----.

Q30. Electrons are drawn to the screen of the CRT by a (an)

-----.

Q31. ----- move the CRT beam.

Q32. An increase in current through a deflection coil (increases, decreases) the magnetic field.

**Your Answers Should Be:**

- A29.** The electron beam in the CRT is generated by an *electron gun*.
- A30.** Electrons are drawn to the screen of the CRT by a *positive voltage*.
- A31.** *Magnetic fields* move the CRT beam.
- A32.** An increase in current through a deflection coil *increases* the magnetic field.

**Sync Control Circuits**

The beam movement is accomplished by steadily increasing the current flow in each of the deflection coils during precise time intervals. The starting times for these intervals are controlled by the sync pulses.

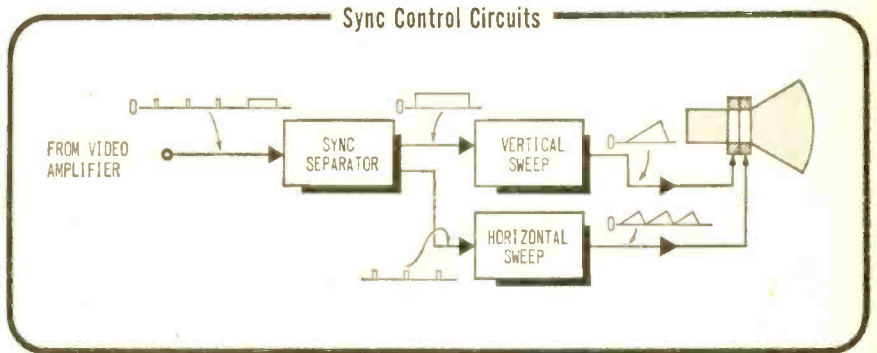

**Sync Separator.** Sync pulses arrive at the sync separator from the video amplifier. There is one narrow sync pulse for each line of scan. This pulse is intended to control the starting time of each horizontal sweep across the screen. When one field of  $262\frac{1}{2}$  lines has been completed, the video waveforms are followed by a sync pulse many times wider than the horizontal sync pulses.

This wide pulse is the trigger that develops a vertical sweep to move the beam from line to line down the face of the screen. Every other vertical sync pulse

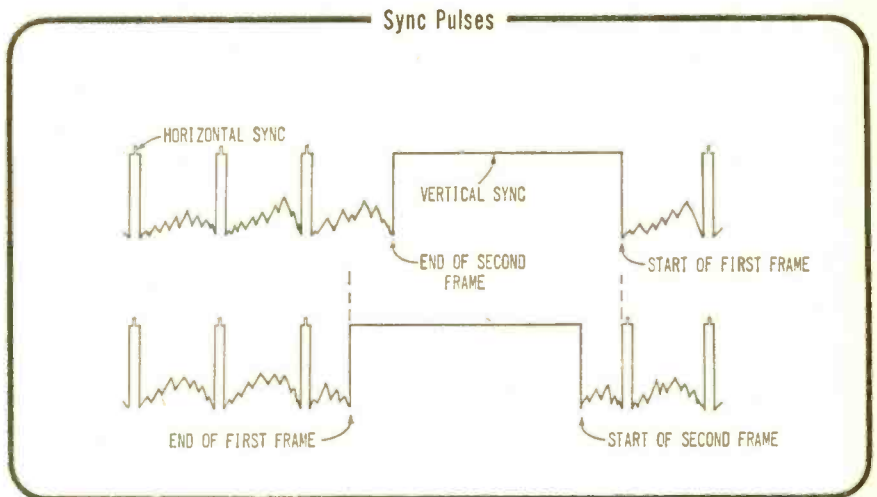

starts in the middle of a video waveform, accounting for  $262\frac{1}{2}$  lines in each frame of interlace scanning.

The illustration on the previous page shows the comparative widths of the horizontal and vertical sync pulses and the relative starting times of the first and second frames. The sync pulses are removed from the complete video waveform and sent to the sync separator.

The narrow and wide pulses are distributed to the appropriate sweep circuits (horizontal and vertical) by the sync separator. This is accomplished by capacitor and resistor combinations which can distinguish between voltage waveforms with short time durations and those with long durations. The short sync pulses are sent to the *horizontal-sweep circuit* and the long pulses to the *vertical-sweep circuit*.

### Sweep Circuits

The two sweep circuits (horizontal and vertical) generate a linear rising voltage each time they receive a sync pulse. The *horizontal-sweep circuit* is triggered 525 times during the same time the *vertical-sweep circuit* is triggered twice.

**Horizontal-Sweep Circuit.** Horizontal sweep is produced by an oscillator which generates a slowly rising and rapidly decaying sawtooth waveform, whether or not the set is tuned to a transmitting station. This accounts for the *raster* (lines on the screen) when the TV receiver is on but no signal is being received.

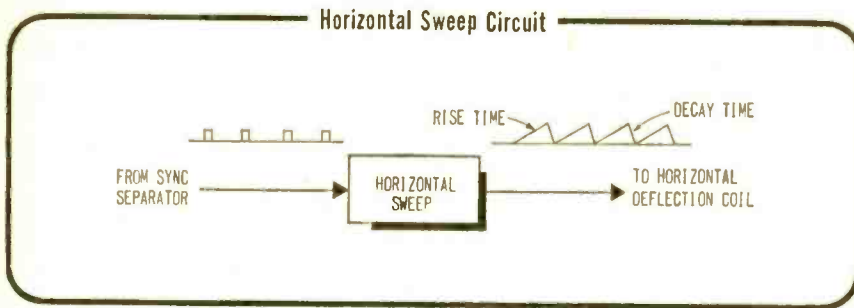

The purpose of the sync pulse is to trigger the oscillator so that oscillations start at the same time as the line scan in the camera. Capacitor and resistor combinations convert the oscillations to the sawtooth waveshapes shown in the diagram above. Rise time of the sawtooth causes the current in the horizontal-deflection coil to increase gradually, moving the beam across the screen in step with the line scan in the camera. At the end of the line, coil current decreases rapidly, returning the beam (which is now blanked) to the left side of the screen. There are  $262\frac{1}{2}$  lines to each frame, so the frequency of the horizontal oscillator must be 15,750 cycles per second.

**Vertical-Sweep Circuit.** The vertical-sweep oscillator and amplifier are almost identical to those in the horizontal-sweep section. The main difference is that the frequency of oscillation is much lower—60 times a second, to match the



frequency at which each field is swept. The rise time (plus a short decay time) of the vertical sawtooth lasts for 1/60 of a second before another vertical-sync pulse arrives to start the next waveform. Gradual increase in current in the vertical-deflection coil moves the beam from the top to the bottom of the screen. The decay of the vertical sawtooth waveform brings the beam back to the top in time for the next sync pulse.

**Height Control.** In most TV receivers a *height* control varies the setting of a variable resistor in the vertical-sweep stage. Adjustment of the control moves the starting position of the sweep up or down. The resistor controls the amount of initial current that flows through the coil.

## High-Voltage Power Supply

The several thousand volts required for the CRT are developed in the high-voltage power supply, a group of circuits usually contained in a metal cage inside the set. A diode discharging a capacitor through a transformer produces the high voltage for the CRT. Even after the set has been turned *off*, the capacitor can retain its charge for some time. Precautions should therefore be taken if work must be done inside this cage.

## WHAT YOU HAVE LEARNED

1. A TV receiver contains many circuits that can be grouped into a few electronic functions. These include the RF section (front-end), IF section, sound section, video section, vertical-sync control, horizontal-sync control, cathode-ray tube, and low- and high-voltage power supplies. Many of the functions are similar to those found in a radio receiver.
2. The RF amplifier, mixer, and oscillator select the desired channel among the many appearing on the antenna and convert the sound and video-carrier frequencies to appropriate intermediate frequencies.
3. The sound section, containing an IF stage for amplification, a detector (or discriminator) for removal of the audio component, and audio amplifiers for further amplitude gain, processes the signal for operation of the speaker.
4. The video section contains similar circuits to extract the video signal and amplify it to a level required for operating the beam-control portion of the CRT.
5. Vertical- and horizontal-sync pulses are taken from the video signal and channeled through corresponding vertical- and horizontal-sweep circuits. The sawtooth waveforms developed by these circuits control the movement of the electron beam, causing the image to be placed on the screen, a line at a time, in precise synchronization with the camera scan beam.
6. Highly dangerous voltages exist on the cathode-ray tube and inside the cage of the high-voltage power supply. Extreme caution should be used when working in these areas.
7. Most of all, you have learned a great deal more about electronics. You should now have acquired a fairly good understanding of how electronic circuits work. A mental image of circuit and equipment operation will give you a solid reference against which you can base the details of current, voltage, resistance, inductance, and capacitance principles. You need a clear understanding of these principles if you plan to become technically competent when working with electronic equipment. ■

## Bose Lab Check

*Continued from page 80*

special, long excursion, high compliance cone, wide range speakers in each pentagonal housing. Arranged in an in-phase array these can move large amounts of air, which, along with the special equalizer, accounts for the spectacular bass and clean mid and high range response of the 901 system.

**High Power Capacity.** Since each of the nine speakers individually can handle 30 watts of audio power, the complete system is capable of operating at very high power levels (upwards of 270 watts), that may be required to reproduce low frequencies of sufficient loudness. Bose recommends that amplifiers having a minimum of 20 watts power output be used. This is necessary to overcome the losses created by the equalizer and still have sufficient power output to recreate the dynamic range necessary to produce the illusion of natural reproduction.

**The Active Filter.** Regardless of the design of any speaker system, its overall performance can be improved somewhat by the application of correctly designed electronic networks that compensate for its variations from a uniform frequency response. Because it is impractical to equalize for variations created by resonances, speaker systems have suffered. However, since the Bose 901 speaker has been designed to be virtually free of resonance effects, the active equalizer that is part of this speaker system, produces uniformity of radiated power vs frequency not attainable in other commercially available speaker systems. This equalizer is a sophisticated, transistorized, active unit that accurately compensates stereo response for the effects of speaker characteristics, enclosure dimensions, radiation impedances and even the grille cloth covering the baffles. Equalization is accomplished without introducing distortion. This is achieved by equalizing the signal between the preamp and the power amplifier which, therefore, removes the necessity of employing the iron core inductors and capacitors capable of handling high power, that introduce distortion in passive filters. Further to this, it is possible to get a greater degree of accuracy in equalization by the use of more elements in an active filter than is practical in a passive one.

**Tailoring Response.** Besides affording the compensation required to produce flat acoustic response, this equalizer provides a selection of nineteen additional contours, selectable from the front panel of the equalizer. This flexibility of control of equalization permits the listener to tailor the response to meet his particular tastes in compensating for room characteristics, recording techniques, and other variables. A separate switch produces steep, uniform attenuation below 40 Hz to remove turntable rumble without affecting bass response from 50 Hz on.

**Conclusion.** The Bose 901 speaker system delivers the most natural stereo sound, creating the illusion of being in a concert hall, with a uniformity of frequency response and freedom from distortion that is unbelievable, particularly if the listener takes into account the physical size. Considering all its advantages, the price tag of just under \$500.00 for the complete system, which includes two speaker assemblies and the active equalizer, is modest. It is our opinion that this is the speaker system to own, regardless of price, if one wants the ultimate in listening pleasure.

For further information and literature, write The Bose Corp., Dept. E, Natick, Mass. 01760

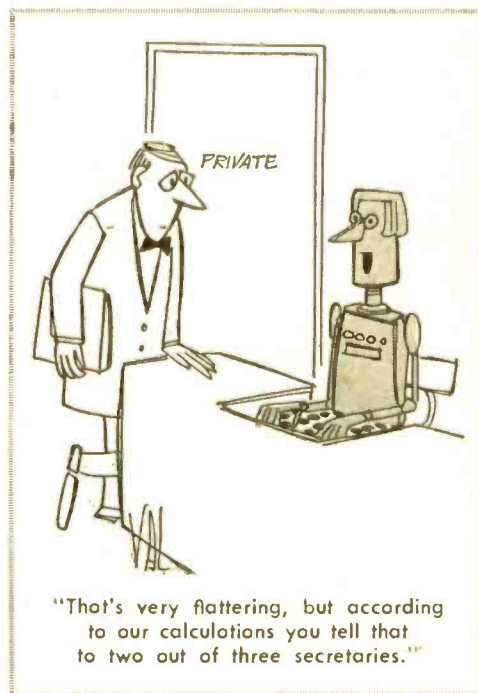

## Handy-Dandy Radio

*Continued from page 63*

connect a mic, or phono, or tape deck or FM tuner or what have you to clips #1 (Common) and #3 (Amplifier Input). If you want better tone and volume plug in a larger PM speaker into the jack on the front panel. This same connection plan can be used to listen to records, thus using the Handy-Dandy Combo as a phono amplifier.

You need an AF probe to trace audio signals lost in a defective amplifier stage. Make a probe, using single conductor shielded

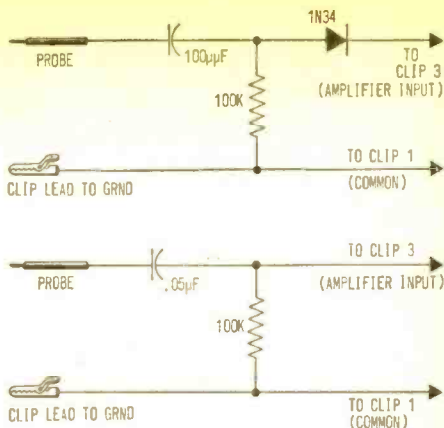

Above, RF probe made from a short length of coax cable. Below, AF probe made from short length of shielded or coax cable.

### PARTS LIST FOR HANDY-DANDY TRANSISTOR RADIO

- 1—"Build-In" three part transistor radio (Radio Shack 12-1150 or equiv.)
- 1—9 volt transistor battery (Radio Shack 23-464 or equiv.)
- 1—100 pF ceramic disk capacitor (Radio Shack 71-5106 or equiv.)
- 1—.05 µF, 600 V. capacitor (Radio Shack 71-0458 or equiv.)
- 2—Miniature alligator clips (Radio Shack 270-348 or equiv.)
- 3—Fahnestack clips (Radio Shack 270-393 or equiv.)
- 2—Calibrated knobs (Radio Shack 274-392 or equiv.)
- 2—100,000 ohm, 1/2 watt, 10% resistor
- 1—3 1/2 x 1/2 18 gauge metal strap for holding battery
- 1—8 1/2 x 3 1/4 x 1/8-in. Masonite or fiber board panel
- 1—8 1/2 x 4 x 3/4-in. wooden baseboard
- Misc. Wood and machine screws, solder, wire, etc.

cable, as detailed in the schematic and connect it as shown there. Using the probe side of the lead you can trace the audio signal through the different stages till you locate the place where the signal no longer exists. Now you have found the defective portion of the unit under test.

For RF signal tracing make a comparable probe lead, following the schematic for the RF probe. Use it in a similar manner. Oh yes, one thing we did not mention. if you want to use the Handy-Dandy just as a transistor radio, no special uses. you will have to run a jumper from clip #2 to clip #3. As you trace the signal path you will see that without the jumper the rf output of the receiver could not get to the input to the audio amp in the Handy-Dandy. ■

## En Passant

*Continued from page 86*

A. If 28 . . . K-B2 (if 28 . . . K-B1 29 QxR# R-K1 30 QxR# K-B2 31 Q-Q8 mate) 29 QxR/8 (threatening 30 Q-Q8 mate) R-Q2 30 R-B1# Q-B3 31 BxQ, PxB 32 Q-B6, P-N4 33 QxKP and White romps to victory.

B. If 28 . . . K-K1 (28 . . . Q-Q3 29 RxQ# and mate is soon forced) 29 QxR/8# K-B2 30 Q-B6# K-K1 31 QxN wins.

C. If 28 . . . K-B2 29 QxR# (White has the happy choice between this and the above 29 QxR/8) K-N1 30 QxN and, with an extra Bishop and Pawn, White wins easily.

Logic and accuracy in good measure.

**Problem 20.** By Carl Schlechter from the Sports Newspaper, 1908—how do you fare?

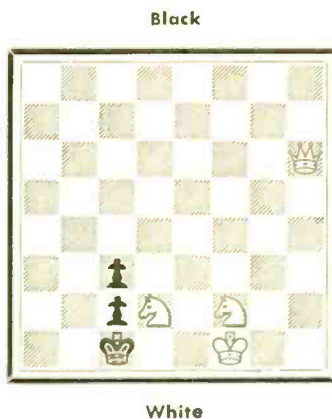

White to move and mate in two.  
Solution in next issue. ■

## Sunspot Special

*Continued from page 44*

you want to check the accuracy of the signal generator, or, if you do not have a generator covering the CB bands, why not use a 23 band CB transmitter as the source of your calibrating signals. Connect the transmitter to a 75 ohm dummy load, loosely couple a pickup coil, connected to J1, to the transmitter output. You'll get plenty of signal that can't help but be on frequency.

Remove the CB band coils and plug in the 10-Meter coil set. Repeat the same alignment steps detailed for the CB coils with the exception that the signal generator should now be tuned to 28 MHz. Adjust L1B and L2B for maximum signal output of the broadcast receiver. With C5A/C5B at nearly minimum capacity (almost fully open), the signal generator tuned to 29.7 MHz adjust C15 on each coil for maximum signal output at the broadcast receiver, then again repeat these adjustments to double check their accuracy. Calibrate the dial, based on signals from the generator, at several points in the band between 28.0 and 29.7 MHz.

Now remove the 10-Meter coils and plug in the 6-Meter ones. Again repeat the alignment steps detailed for the CB band, but with the signal generator tuned at 50.0 MHz for the lowest frequency and at 52.0 MHz for the highest frequency, adjusting L1C and

### CB Channel Allocations

Chan.	Freq.	Chan.	Freq.
1	26.965	13	27.115
2	26.975	14	27.125
3	26.985	15	27.135
4	27.005	16	27.155
5	27.015	17	27.165
6	27.025	18	27.175
7	27.035	19	27.185
8	27.055	20	27.205
9	27.065	21	27.215
10	27.075	22	27.225
11	27.085	23	27.255
12	27.105		

L2C at 50.0 MHz and C15 on each coil at 52.0 MHz. After calibrating the dial for the 6-Meter band disconnect the signal generator from the converter. (Note: Use the lowest output level possible from your signal generator that will permit you to make alignment adjustments. Too high a signal level will overload the adaptor input stage.)

**Operation.** In order to take advantage of the DX signals made available because the sun spots altered the ionosphere, the receiving antenna must be located as high above ground as possible. When not affected by sun spot activity, reception of signals, at distances normally expected for the band and available power, is line of sight, similar to your reception of TV. A CB antenna (without a loading coil), or a 6-ft. whip, connected to the converter via coaxial cable, is good for receiving vertically polarized signals. A TV antenna can be tried for receiving

horizontally polarized signals. When the sun spot skip is affecting reception, polarization of the antenna does not seem to have any effect on the reception.

When tuning the converter searching for a signal, turn the dial slowly and, if necessary, use the broadcast receiver dial for bandspread, to separate a group of stations. Local activity is usually greatest in the evening and on week-ends. Sun spot skip reception will usually occur during the daylight hours. Now that you have completed the project you should enjoy many hours of local as well as DX skip reception on any of the three bands for which the converter has been designed. ■

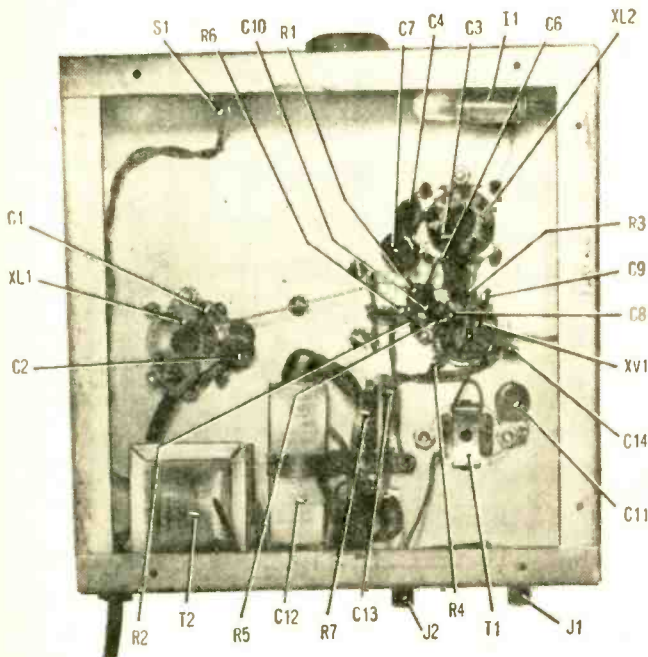

## Transistor Tester

Continued from page 61

you reverse S1, as required for the type of transistor being tested, use a dpdt switch, wired as shown in Fig. 3a. As a second alternative, use a 10-0-10 mA. meter in place of the 0 to 10 mA. meter.

**Beta Tests.** Once you have determined if the transistor is a pnp or an npn, and that it will function as an oscillator, connect it for the gain measurement test. Set S1 to the proper position (*pnp* or *npn*), depending on the type of transistor under test, and place S2 to the X100 position. If the meter barely indicates current is flowing set S2 to the X10 position. Multiply the meter reading by the scale factor used to arrive at the beta of the transistor being tested.

If a 0 to 10mA. meter is being used, and the needle goes below zero, you will have to reverse the polarity of the meter circuit, either manually or by the reversing switch shown in Fig. 3a. If you use a 10-0-10 mA. meter then the reading will be either to the right or left of 0 on the scale, depending on

what type of transistor is being tested.

**Leakage And Shorts.** If your junk box can supply you with a 0 to 100 mA. meter and a 1000 ohm potentiometer, you can test transistors for leakage and/or shorts. If you don't find a 100 mA. meter in your stock of parts, or, if you would prefer just one instrument with a dual range, you can add resistor R7 as a shunt across the meter to make it possible to read higher current (see Fig. 4a.). You will need a wire wound potentiometer used as a rheostat and a battery plus your VOM to arrive at the correct resistance for the shunt. Connect the battery, VOM and pot (using maximum resistance to start with) in the circuit shown in Fig. 4a., using at least a range of 100 mA. After adjusting R7 until the VOM reads 100 mA. without changing setting of R7 parallel it across the 0 to 10 mA. meter. The 0 to 10mA. meter will now be reading full scale (which actually will be 100 mA.). With the shunt across the 0 to 10 mA. meter, any reading on its scale must be multiplied by ten to arrive at the correct value (e.g. 3 mA. on the 10 mA. scale now really is 3 x 10 or 30 mA.).

These tests definitely establish whether or not the transistor is worth anything. Any

## Other circuits you can try

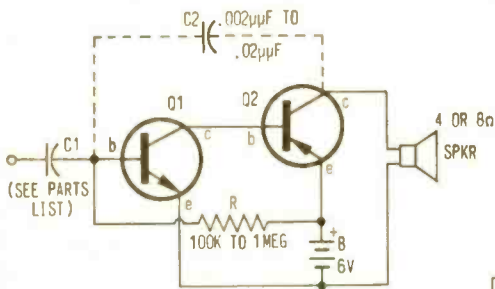

### Complementary Amplifier/CPO (see fig. 5.)

- 1—Battery holder for four type AA cell (Lafayette 34T5009 or equiv.)
- 4—1.5 V. type AA penlight cell (Lafayette 99T6258 or equiv.)
- C1—Input capacitor, used only if unit is employed as an amplifier (.25µF.)
- C2—Feedback capacitor if unit is used as a CPO (.005 to .02 µF.)
- Q1—Any npn transistor having a beta of 120-150
- Q2—Any pnp power transistor
- R—100,000 to 1.0 meg. ½ watt, 10% resistor
- 1—4 or 8 ohm speaker (Lafayette 99T6039 or equiv.)

Fig. 5. Left, circuit for two-transistor complementary amplifier that can be converted to a CPO by adding feedback capacitor C2.

Fig. 6. Below, use this AM-BCB Hartley oscillator as a CPO, signal tracer, etc. Bargain transistors can be erratic, so use one with a Beta near 108. For CP, try using a 2N579.

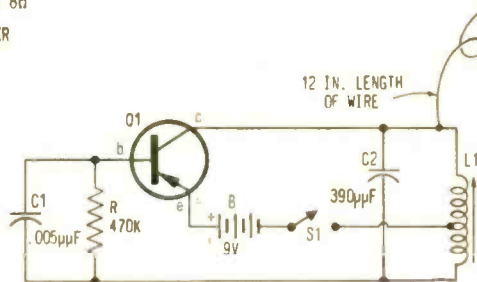

### AM Broadcast Band Hartley Oscillator (see fig. 6.)

- 1—Battery holder for one type AA cell (Lafayette 34T5005 or equiv.)
- 1—1.5 V. Type AA penlight cell (Lafayette 99T6258 or equiv.)
- C1—.005 µF. capacitor
- C2—390 pF. capacitor
- L1—Tapped loopstick antenna (Lafayette 32T-8201 or equiv.)
- Q1—any npn transistor having beta of 100-110

## Transistor Tester

*Continued from page 107*

transistor drawing more than 50 mA., regardless of the setting of R6, is no good. This is the test that will tell you what to do with those transistors that would not oscillate on the initial test. Since a high-current reading indicates excessive leakage, or a short—forget it. Don't waste any more time hoping that you may find a circuit in which the transistor can be made to work by fudging component values.

**Try Various Circuits.** Now then, you have been able to classify and grade all of the transistors you got in the bargain bag, what will you do with them? They cost just a few pennies apiece so you can live dangerously and experiment with them without suffering any great financial loss if, accidentally you should ruin a few by trying a runaway circuit or reverse polarity, etc., etc. Why not build a CPO, a power amplifier, a flip-flop, an electric organ oscillator, or an audio oscillator? There are literally hundreds of circuits and construction projects described in the various issues of our magazine, as well as others, that are easily within your grasp. Now that you have a supply of various types of transistors that cost just pennies.

True, you may not be certain that you have exactly the one called for in the construction article, but from the information you have been able to gather in the tests you made with the Junk Box Tester you will, in all probability, be able to select one that closely resembles the one actually specified. Why not breadboard the circuit? Then by intelligent cut-and-try substitution of resistors and capacitors for the ones specified, you should be able to either come close or duplicate the results outlined in the article, even if you did not have the transistor originally called for. When substituting a bargain type in a circuit, try to match the gain as closely as possible. If the substitute transistor will not work either try another one of the same type or, experiment with the value of the base bias resistor, or both. Base bias is critical when dealing with small signal transistors and just a small change in bias may produce the desired result. Current gain is not so important for power types, if they pass the go-no-go tests you can be sure that they have some gain.

**Breadboarding.** Mount a number of Fahnestock clips on a piece of perforated board, or Masonite, or a cigar box lid. The clips are quite inexpensive and make it easy to change connections or substitute parts without soldering the connections. You will not have to worry that excessive heat from numerous soldering operations will damage the transistor, nor will you have to snip its leads short to fit a particular space which might ruin it for other applications. Once you are satisfied with your breadboarding you can transfer the circuit and parts to a more permanent structure.

We have included several circuits, along with parts lists, that are typical and which we have tried out to show you what can be accomplished. For example we show a circuit for a 2-transistor complementary amplifier that converts to a CPO with the addition of a feedback capacitor. We also show a Hartley oscillator that generates a fairly strong signal in the AM broadcast band. Performance of the bargain transistors was erratic. Some would not work, several gave a pure tone and others just a carrier. Those that did work well had betas around 108. If you would like to purchase a standard type to give a definite tone for code practice try a 2N579. This unit can be used for troubleshooting radio receivers or as a wireless microphone. A word of caution: always keep the output low so as not to cause interference. (FCC regulations limit output of these devices to 100 milliwatts.)

We have started you on the road to transistor experimentation, from here on you are on your own, have fun! ■

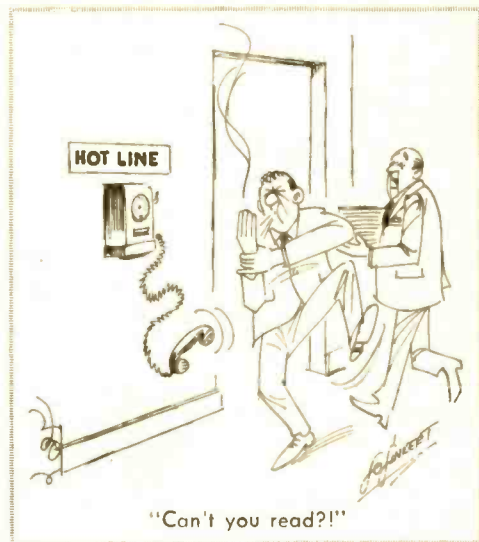

## Dirty Decibels

*Continued from page 40*

on to the cochlear system by pushing against a small membranous oval window in the vestibule leading to the cochlea. The oval window is much smaller in area than is the eardrum, hence the concentration of the vibrations into this relatively small area affords a second means of amplifying the initial signal received by the eardrum. The end result is amplification of the original vibrational power by about 90 times.

**AVC System.** The impedance-matching amplifying system built into the ear would, in itself, be remarkable enough, yet the three small bones have still another important function. They, along with associated control muscles, form a sort of biological automatic volume control (AVC) system. Radio buffs know that constant voice intensity can be maintained more or less in radio communications by use of electronic AVC systems. The ear also tries to control excessive sound intensities in order to protect itself.

**How Is It Done?** The three lever bones have a muscle-controlled slippage capability. When a loud sound begins to build up, the brain signals these muscles to adjust the bones so as to reduce the amount of leverage, and thereby reduce the degree of signal amplification. Simultaneously, another muscle tightens the eardrum to reduce its ability to vibrate.

This AVC system works well, up to a point. Unfortunately, it cannot respond quickly enough to sudden loud sounds, only to those that build up more or less gradually to high intensities. This is why such sounds as gun shots and other explosions can be so hazardous.

Why does this defensive AVC system fail to protect the ears of Rock 'n Roll fans? Because there is a limit to the amount of overload compensation that the ear can provide even if the sound is continuous. Remember that in nature (for which the ear is really designed) there are few sounds as loud and as continually heard as such manmade sounds as loud music and the noise of jet planes, vacuum cleaners, industrial machinery and a host of other mechanical devices. Unfortunately, evolutionary adaptation is too slow a process to cope with the burgeoning noise problems created by man.

Consequently the inner ear receives increasing amounts of over-amplified sound signals. Eventually, the sensory cells in the cochlea begin to break down. This cell degeneration is a normal part of the biological aging process, and most people suffer from a substantial lowering of their high-frequency hearing thresholds as they grow older. The worrisome thing is that young people—even teenagers—are hastening this degenerative process greatly by grossly overloading their irreplaceable hearing organs.

**Acoustic Bias.** Wherever we go, there is always some background noise even if we do not seem to hear it always because we are so accustomed to it. We of course hear the sounds, but we can also automatically disregard uninteresting sounds if they are not annoying. For example, during daylight hours you may not even be aware that the neighbor's dog is barking; but if the same mutt yaps at one a.m., you are ready to throw a shoe!

The ability of the brain to select certain interesting sounds from a melange of other sounds is manifested in a phenomenon called the cocktail party effect. You may be in a room filled with people who are conversing, and yet be able to tune in on the conversation of one particular individual or group relatively far from you in the crowd. When you lose interest in what is being said, their conversation again melts into the general background noise.

The advantages of being able to disregard many background noises are obvious. But it also has a serious drawback: by becoming used to these noises, one is less likely to appreciate how damaging they are to our hearing.

A moderate amount of background noise—call it acoustic bias—is a good thing because it masks many still weaker noises that could be most annoying. Take, for example, body noises. In a perfectly quiet environment, you would be able to hear the beat of your heart, the flow of air through your lungs, and even the squeaks and clicks of your muscles and tendons!

You don't believe it? Then try this. Plug both ears carefully with wax type earplugs to block out most environmental sounds (earplugs are not 100 percent efficient). Now roll your head around and gnash your teeth. Hear some strange crackling and swishing sounds?

Or, do this, stick a fingertip tightly into

each ear. Do you hear a low-pitched "roar" not unlike the sound of a distant waterfall? Scientists say the sound is caused by biological pulsations in your fingertips. If you doubt this, plug your ears with pencil erasers instead of with your fingers. No roar now—because erasers do not have movable tendons and blood vessels.

**What To Do.** By this time it should be obvious that if you do not want to be saying "Eh? How's that again?" before your time, you should, at least, take minimal precautions to protect your irreplaceable hearing organs.

If you engage in a noisy occupation, use ear protectors. If you go in for sport shooting, obtain special "valve" protectors that soften gunshot sounds without interfering with normal conversation. Use wax earplugs when you practice your drums or run the power lawnmower. Put a muffler on your car—please! And stay out of the kitchen when noisy appliances are in operation.

Unquestionably, Mother Nature will do her best to modify our hearing organs to compensate for the steadily increasing noise levels in our society. But she works very slowly, over many generations. Perhaps her first try at reducing the sound levels will be to remove the outer ears gradually, leaving only small holes in the sides of the head. Some mammals that live in water—porpoises and whales—have no need of external ears to help them gather sounds because, living in a liquid environment, they have less of an impedance-matching problem.

It may happen yet that we—mankind, that is—will someday find our ears dropping off. In the meantime, about all we can do to cope with the increasing sound pollution—the dangers of dirty decibels—is to try to make things quieter, and—when we can't do that—cover our ears to avoid the worst of these evils. If we don't learn to act like wise monkeys, we all may very well end up going ape! ■

## How I Got Started

*Continued from page 45*

(SWL). There's even a new language to be learned in this hobby—Dxing, as the common jargon goes. The further away or weaker the station, the greater challenge to the SWL.

The custom is for the SWL to submit a report of reception to a station heard in accordance with internationally known standards. This, in short, simply means how the signal came through in terms of strength, noise, fading, etc. You also give some de-

tails of the programming heard to authenticate your report. In return, most stations will verify your report with a QSL—a decorative, sometimes colorful card with the station's identification on it. This is returned to the SWL for his collection. For many shortwave listeners, the more QSLs received from hard-to-hear stations, the more fun the hobby becomes.

It takes practice at first to learn the art and technique of shortwave tuning. But after a while it's nothing to flip on the receiver and settle back with a glass of something or other to listen to the strum of fado guitar music from Portugal. I think it's the greatest hobby ever. ■

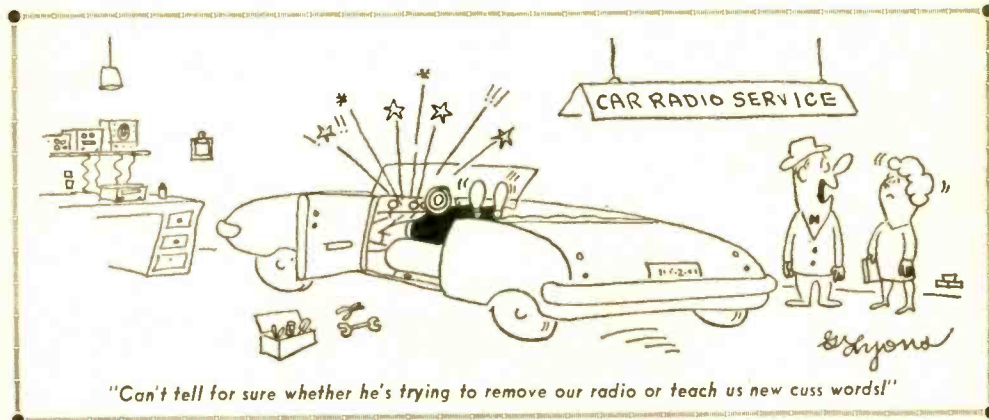



# CLASSIFIED Market Place

FOR BIGGER PROFITS! NEW CAREER OPPORTUNITIES!  
READ AND REPLY TO THESE CLASSIFIED ADS

Classified Ads 65¢ per word, each insertion, minimum 10 words, payable in advance. To be included in the next available issue of **ELEMENTARY ELECTRONICS**, copy must be in our New York Office by August 10th. Address orders to C. D. Wilson, Manager, Classified Advertising, **ELEMENTARY ELECTRONICS**, 229 Park Avenue South, New York, N. Y. 10003.

## ADDITIONAL INCOME

**MONEY**—Sparetime Opportunity Panelists At Home Wanted By New York Researcher. Leading research firm seeking people to furnish honest opinions by mail from home. Pays cash for all opinions rendered. Clients' products supplied at no cost. For information write: Research 669, Mineola, N. Y. 11501. Dept. 633-EE.

**MAKE** Your Classified Ad Pay. Get "How To Write a Classified Ad That Pulls." Includes certificate worth \$2.00 towards classified ad. Send \$1.25 to C. D. Wilson, Science & Mechanics, 229 Park Avenue South, New York, N. Y. 10003.

## AUTHOR'S SERVICE

**PUBLISH** your book! Join our successful authors' publicity advertising promotion, beautiful books. All subjects invited. Send for free manuscript report and detailed booklet. Carlton Press, SMH. 84 Fifth Avenue, New York, 10011.

## BUSINESS OPPORTUNITIES

**I MADE \$40,000.00** Year by Mailorder! Helped others make money! Start with \$10.00—Free Proof! Torrey, Box 318-T, Ypsilanti, Michigan 48197.

**FREE** Book "900 Successful, Little-Known Businesses." Fascinating! Work home! Plymouth 311-J, Brooklyn, N. Y. 11218.

**\$20,000.00 ANNUALLY** you can make—selling Automobiles. Complete course \$3.00. Mar-Lo Products, Dept. 13, 8150 Roselawn, Detroit, Mich. 48204.

## DO IT YOURSELF

**BURGLAR ALARM** Stickers—Scares Burglars Away. Sample 50¢. 10, \$2.00. Surety, 1018, Plattsburg, N. Y. 12901.

**FULL SIZE FURNITURE PLANS!** 72 attractive designs developed for the Home Workshop. Traditional, Early American, Danish Modern, Mediterranean. Catalog 50¢. Furniture Design, Dept. D-70, 1425 Sherman, Evanston, Illinois 60201.

**CATALOG** of all Science & Mechanics Craftprints. Send 25¢ to cover postage to Craftprint Div., Science & Mechanics, 229 Park Ave., South, New York 10003.

## EDUCATION & INSTRUCTION

**LEARN BARTENDING.** Correspondence School, 426-G East Seventh St., Tucson, Arizona 85705.

## ELECTRONIC COMPONENTS & KITS

**KITS!** Color Light Organ (3 channel electronics) \$12.95. Plans \$1.00. Workshop, Box 393DP, Bethpage, New York 11714.

**WHOLESALE** Stereo and Experimenter Parts and Accessories. Free Catalog. N.C.I. Distributing, P.O. Box 415, Terre Haute, Indiana 47801.

## HOBBIES & COLLECTIONS

**WE** Guarantee HOBBY-WORLD Magazine is pleasantly different: For sportsmen, mallorder, opportunist. Sample subscription \$2.00. United, Oakton, Va. 22124.

**WINNING** Secrets Revealed "How I Won \$10,000 In A Nationwide Sweepstakes Contest." \$1.00. Benro Enterprises, P.O. Box 6656, Philadelphia, Pa. 19149.

## INVENTIONS WANTED

**WE** either sell your invention or pay cash bonus. Write for details. Universal Inventions, 298-3, Marion, Ohio 43302.

## MAGNETS

**MAGNETS.** All types. Specials—20 disc magnets or 2 stick magnets, on 10 small bar magnets, or 8 assorted magnets, \$1.00. Maryland Magnet Company, 5412-R, Gist, Baltimore, Md. 21215.

## MISCELLANEOUS

**"ADULT"** Books, Magazines. Free illustrated catalogue. Slate age, Clifton's, Box 1068-M8, Saurus, Calif. 91350.

**PLANS**—Analog Computer programmed to make optimal strategy decisions in BLACKJACK. \$5.00. D. Tweedy, Box 11282, Santa Ana, Calif. 92711.

## MONEYMAKING OPPORTUNITIES

**EASY**—To-Start rubber stamp business at home in spare time. Make up to \$16.50 an hour without experience. Facts free. Write to: Roberts, 1512 Jarvis, Room CR-107-B, Chicago, Ill. 60626.

**FREE!** The World's Leading Money-making Magazine. How and when to earn a Second Income, develop a Spare-time Business, get into Profitable Franchising, become a successful Agent. For your free copy—write Income Opportunities, 229 Park Ave., South, New York, 10003.

## PERSONAL

**ELIMINATE** Debts Without Borrowing! Particulars Free. Helper, 10639 Riverside, No. Hollywood, Calif. 91602.

## PRINTING, MIMEOGRAPHING & MULTIGRAPHING

**250 EACH**—Letterheads, Statements, Envelopes and Business Cards. Send copy (up to 5 lines) and \$17.75 to The Wrightway, 404 East Green, Champaign, Ill. 61820.

## RADIO & TELEVISION

**THOUSANDS** and thousands of types of electronic parts, tubes, transistors, instruments, etc. Send for Free Catalog. Arcurus Electronics Corp., EME, 502—22nd St., Union City, N. J. 07087.

**POLICE**—Fire—Aircraft—Marine—Amateur calls on your broadcast radio! Free catalog. Saich Company, Woodsboro EE14, Texas 78393.

**"DISTANCE** Crystal Set Construction" Handbook—50¢. "Coil Winding"—50¢. Catalog. Laboratories, 12041-G Sheridan, Garden Grove, Calif. 92640.

**RADIO & TV Tubes** 33¢. Free Catalog. Cornell, 4217 West University, San Diego, California 92105.

**RECEIVING & INDUSTRIAL TUBES, TRANSISTORS.** All Brands—Biggest Discounts. Technicians, Hobbyists, Experimenters—Request Free Giant Catalog and Save! Zalytron, 469 Jericho Turnpike, Mineola, N. Y. 11501.

**BATTERY ELIMINATOR & Charger** for Transistor Radios. Lifetime Guarantee \$3.00. Surety, 1018, Plattsburg, N. Y. 12901.

**GERMAN and JAPANESE TUBES**—Parts. Send \$1.00 for Price List. The Matthews Company, Box 151, Lawton, Oklahoma 73501.

**C.B. BUYERS' Guide**—A new magazine for the buyers of Citizens' Band Electronic Equipment. Send \$1.25—includes Postage to C. B. Buyers' Guide, 229 Park Avenue South, New York, N. Y. 10003.

## SALESMEN—DISTRIBUTORS

**PERFUMES** Most fantastic deal for Agents, Salesmen, Distributors. Murat, 232 Northwest Eleventh Avenue, Miami, Florida 33127.

For Greater Classified Profits  
why not try the new combination classified ad medium  
Your classified ad will appear in **SCIENCE & MECHANICS MAGAZINE** as well as in a minimum of four other **SCIENCE & MECHANICS PUBLICATIONS**. Write now for information to C. D. Wilson, Manager, Classified Advertising, **SCIENCE & MECHANICS**, 229 Park Avenue South, New York, N. Y. 10003.

# How to get into One of the hottest money-making fields in electronics today— servicing two-way radios!



**HE'S FLYING HIGH.** Before he got his CIE training and FCC License, Ed Dulaney's only professional skill was as a commercial pilot engaged in crop dusting. Today he has his own two-way radio company, with seven full-time employees. "I am much better off financially, and really enjoy my work," he says. Read here how you can break into this profitable field.

**More than 5 million two-way transmitters have skyrocketed the demand for service men and field, system, and R&D engineers. Topnotch licensed experts can earn \$12,000 a year or more. You can be your own boss, build your own company. And you don't need a college education to break in.**

**H**OW WOULD YOU LIKE to start collecting your share of the big money being made in electronics today? To start earning \$5 to \$7 an hour... \$200 to \$300 a week... \$10,000 to \$15,000 a year?

Your best bet today, especially if you

don't have a college education, is probably in the field of two-way radio.

Two-way radio is booming. Today there are more than *five million* two-way transmitters for police cars, fire department vehicles, taxis, trucks, boats, planes, etc. and Citizen's Band uses—

and the number is still growing at the rate of 80,000 new transmitters per month.

This wildfire boom presents a solid gold opportunity for trained two-way radio service experts. Many of them are earning \$5,000 to \$10,000 a year *more* than the average radio-TV repair man.

#### Why You'll Earn Top Pay

One reason is that the United States Government doesn't permit anyone to service two-way radio systems unless he is *licensed* by the Federal Communications Commission. And there simply aren't enough licensed electronics experts to go around.

Another reason two-way radio men earn so much more than radio-TV service men is that they are needed more often and more desperately. A home radio or television set may need repair only once every year or two, and there's no real emergency when it does. But a two-way radio user must keep those transmitters operating at all times, and *must* have their frequency modulation and plate power input checked at regular intervals by licensed personnel to meet FCC requirements.

This means that the available licensed experts can "write their own ticket" when it comes to earnings. Some work by the hour and usually charge at least \$5.00 per hour, \$7.50 on evenings and Sundays, plus travel expenses. A more common arrangement is to be paid a monthly retainer fee by each customer. Although rates vary widely, this fixed charge might be \$20 a month for the base station and \$7.50 for each mobile station. A survey showed that one man can easily maintain at least 100 stations, averaging 15 base stations and 85 mobiles. This would add up to at least \$12,000 a year.

#### Be Your Own Boss

There are other advantages too. You can become your own boss—work entirely by yourself or gradually build your own fully staffed service company. Instead of being chained to a workbench, machine, or desk all day, you'll move around, see lots of action, rub shoulders with important police and fire officials and business executives who depend on two-way radio for their daily operations. You may even be tapped for a big job working for one of the two-way radio manufacturers in field service, factory quality control, or laboratory research and development.

#### How To Get Started

How do you break into the ranks of the big-money earners in two-way radio? This is probably the best way:

1. Without quitting your present job, learn enough about electronics fundamentals to pass the Government FCC Exam and get your Commercial FCC License.
2. Then get a job in a two-way radio service shop and "learn the ropes" of the business.
3. As soon as you've earned a reputation as an expert, there are several ways you can go. You can move *out* and start signing up and servicing your own customers. You might become a franchised service representative of a big manufacturer and then start getting into two-way radio sales, where one sales contract might net

you \$5,000. Or you may even be invited to move *up* into a high-prestige salaried job with one of the major manufacturers either in the plant or out in the field.

The first step—mastering the fundamentals of Electronics in your spare time and getting your FCC License—can be easier than you think.

Cleveland Institute of Electronics has been successfully teaching electronics by mail for over thirty years. Right at home, in your spare time, you learn electronics step by step. Our **AI TO PROGRAMMED®** lessons and coaching by expert instructors make everything clear and easy, even for men who thought they were "poor learners." You'll learn not only the fundamentals that apply to all electronics design and servicing, but also the specific procedures for installing, troubleshooting, and maintaining two-way mobile equipment.

#### Get Your FCC License... or Your Money Back!

By the time you've finished your CIE course, you'll be able to pass the FCC License Exam with ease. Better than nine out of ten CIE-trained men pass the FCC Exam the first time they try, even though two out of three non-CIE men fail. This startling record of achieve-

ment makes possible the famous CIE warranty: you'll pass the FCC Exam upon completion of your course or your tuition will be refunded in full.

Ed Dulaney is an outstanding example of the success possible through CIE training. Before he studied with CIE, Dulaney was a crop duster. Today he owns the Dulaney Communications Service, with seven people working for him repairing and manufacturing two-way equipment. Says Dulaney: "I found the CIE training thorough and the lessons easy to understand. No question about it—the CIE course was the best investment I ever made."

Find out more about how to get ahead in all fields of electronics, including two-way radio. Mail the bound-in postpaid reply card for two FREE books, "How To Get A Commercial FCC License" and "How To Succeed In Electronics." If card has been removed, just mail the coupon below.

#### ENROLL UNDER NEW G.I. BILL

All CIE courses are available under the new G.I. Bill. If you served on active duty since January 31, 1955, OR are in service now, check box on reply card for G.I. Bill information.

**CIE** Cleveland Institute of Electronics  
1776 East 17th Street, Cleveland, Ohio 44114

A Leader in Electronics Training • Since 1934 • Accredited Member National Home Study Council



## 2 New CIE CAREER COURSES

**1 BROADCAST (Radio & TV) ENGINEERING**...now includes Video Systems, Monitors, FM Stereo Multiplex, Color Transmitter Operation and CATV.

**2 ELECTRONICS ENGINEERING**...covers steady-state and transient network theory, solid-state physics and circuitry, pulse techniques, computer logic and mathematics through calculus. A college-level course for men already working in Electronics.

Cleveland Institute of Electronics  
1776 East 17th Street, Cleveland, Ohio 44114

Please send me without cost or obligation:  
Your 40-page book "How To Succeed In Electronics" describing the job opportunities in Electronics today, and how your courses can prepare me for them.  
Your book on "How To Get A Commercial FCC License."

I am especially interested in:

- Electronics Technology     Electronic Communications  
 Broadcast Engineering     Industrial Electronics  
 First Class FCC License     Electronics Engineering

Name \_\_\_\_\_ (PLEASE PRINT)

Address \_\_\_\_\_

City \_\_\_\_\_

State \_\_\_\_\_ Zip \_\_\_\_\_ Age \_\_\_\_\_

Check here for G.I. Bill information.

EL-16

# BUILD YOUR OWN RADIO

Reg. U. S. Pat. Off.



Training Electronics Technicians Since 1946

**CIRCUITS AT HOME**  
with the New Improved  
**PROGRESSIVE RADIO "EDU-KIT"®**

only  
**\$26.95**

## A Practical Home Radio Course

### Now Includes

- ★ 12 RECEIVERS
- ★ 3 TRANSMITTERS
- ★ SQ. WAVE GENERATOR
- ★ SIGNAL TRACER
- ★ AMPLIFIER
- ★ SIGNAL INJECTOR
- ★ CODE OSCILLATOR

- ★ No Knowledge of Radio Necessary
- ★ No Additional Parts or Tools Needed
- ★ EXCELLENT BACKGROUND FOR TV
- ★ SCHOOL INQUIRIES INVITED
- ★ Sold In 79 Countries

**YOU DON'T HAVE TO SPEND  
HUNDREDS OF DOLLARS FOR A RADIO COURSE**

The "Edu-Kit" offers you an outstanding PRACTICAL HOME RADIO COURSE at a rock-bottom price. Our Kit is designed to train Radio & Electronics Technicians, making use of the most modern methods of home training. You will learn radio theory, construction practice and servicing. THIS IS A COMPLETE RADIO COURSE IN EVERY DETAIL. You will learn how to build radios, using regular schematics; how to wire and solder in a professional manner; how to service radios. You will work with the standard type of Punched metal chassis as well as the latest development of Printed Circuit chassis.

You will learn basic principles of radio. You will construct, study and work with RF and AF amplifiers and oscillators, detectors, rectifiers, test equipment. You will learn and practice code, using the Progressive Code Oscillator. You will learn and practice trouble-shooting, using the Progressive Signal Tracer, Progressive Signal Injector, Progressive Dynamic Radio & Electronics Tester, Square Wave Generator and the accompanying instructional material.

You will receive training for the Novice, Technician and General Classes of F.C.C. Radio Amateur License. You will build Receiver, Transmitter, Square Wave Generator, Code Oscillator, Signal Tracer and Signal Injector Circuits, and learn how to operate them. You will receive an excellent background for television, H.F. and Electronics.

Absolutely no previous knowledge of radio or science is required. The "Edu-Kit" is the product of many years of teaching and engineering experience. The "Edu-Kit" will provide you with education in Electronics and Radio, worth many times the low price you pay. The Signal Tracer alone is worth more than the price of the kit.

## THE KIT FOR EVERYONE

You do not need the slightest background in radio or science. Whether you are interested in Radio & Electronics because you want an interesting hobby, a well paying business, or a job with a future, you will find the "Edu-Kit" a worth-while investment. Many thousands of individuals of all

ages and backgrounds have successfully used the "Edu-Kit" in more than 79 countries of the world. The "Edu-Kit" has been carefully designed, step by step, so that you cannot make a mistake. The "Edu-Kit" allows you to teach yourself at your own rate. No instructor is necessary.

## PROGRESSIVE TEACHING METHOD

The Progressive Radio "Edu-Kit" is the foremost educational radio kit in the world, and is universally accepted as the standard in the field of electronics training. The "Edu-Kit" uses the modern educational principle of "Learn by Doing." Therefore you construct, learn schematics, study theory, practice trouble shooting—all in a closely integrated program designed to provide an easily-learned, thorough and interesting background in radio.

You begin by examining the various radio parts of the "Edu-Kit." You then learn the function, theory and use of these parts. Then you build a simple radio. With this first set you will enjoy listening to regular broadcast stations, learn theory, practice testing and trouble-shooting. Then you build a more advanced radio, learn more advanced theory and techniques, and practice in a progressive manner, and at your own rate, you will find yourself constructing more advanced multi-tube radio circuits, and doing work like a professional Radio Technician.

Included in the "Edu-Kit" course are Receiver, Transmitter, Code Oscillator, Signal Tracer, Square Wave Generator and Signal Injector Circuits. These are not unprofessional "breadboard" experiments, but genuine radio circuits, constructed by means of professional wiring and soldering on metal chassis, plus the new method of radio construction known as "Printed Circuitry." These circuits operate on your regular AC or DC house current.

## THE "EDU-KIT" IS COMPLETE

You will receive all parts and instructions necessary to build twenty different radio and electronics circuits, each guaranteed to operate. Our Kits contain tubes, tube sockets, variable electrolytic, mica, ceramic and paper dielectric condensers, resistors, tie strips, hardware, tubing, punched metal chassis, Instruction Manuals, hook-up wire, solder, selenium rectifiers, coils, volume controls and switches, etc.

In addition, you receive Printed Circuit materials, including Printed Circuit chassis, special tube sockets, hardware and instructions. You also receive a useful set of tools, a professional electric soldering iron, and a self-powered Dynamic Radio and Electronics Tester. The "Edu-Kit" also includes Code Instructions and the Progressive Code Oscillator, in addition F.C.C. Radio Amateur License training. You will also receive lessons for servicing with the Progressive Signal Tracer and the Progressive Signal Injector, a High Fidelity Guide and a Quiz Book. You receive Membership in Radio-TV Club, Free Consultation Service, Certificate of Merit and Discount Privileges. You receive all parts, tools, instructions, etc. Everything is yours to keep.

Progressive "Edu-Kits" Inc., 1186 Broadway, Dept. 533 DJ, Hewlett, N. Y. 11557

## UNCONDITIONAL MONEY-BACK GUARANTEE

Please rush my Progressive Radio "Edu-Kit" to me, as indicated below:  
Check one box to indicate choice of model

- Regular model \$26.95.
- Deluxe model \$31.95 (same as regular model except with superior parts and tools plus valuable Radio & TV Tube Checker).

Check one box to indicate manner of payment

- I enclose full payment. Ship "Edu-Kit" post paid.
- I enclose \$5 deposit. Ship "Edu-Kit" C.O.D. for balance plus postage.
- Send me FREE additional information describing "Edu-Kit."

Name

Address

City & State

Zip

## PROGRESSIVE "EDU-KITS" INC.

1186 Broadway, Dept. 533 DJ, Hewlett, N. Y. 11557

## FREE EXTRAS

- SET OF TOOLS
- SOLDERING IRON
- ELECTRONICS TESTER
- PLIERS-CUTTERS
- VALUABLE DISCOUNT CARD
- CERTIFICATE OF MERIT
- TESTER INSTRUCTION MANUAL
- HIGH FIDELITY GUIDE • QUIZZES
- TELEVISION BOOK • RADIO TROUBLE SHOOTING BOOK
- MEMBERSHIP IN RADIO-TV CLUB: CONSULTATION SERVICE • FCC AMATEUR LICENSE TRAINING
- PRINTED CIRCUITRY

## SERVICING LESSONS

You will learn trouble-shooting and servicing in a progressive manner. You will practice repairs on the sets that you construct. You will learn symptoms and causes of trouble in home, portable and car radios. You will learn how to use the professional Signal Tracer, the unique Signal Injector and the dynamic Radio & Electronics Tester. While you are learning in this practical way, you will be able to do many a repair job for your friends and neighbors, and charges which will far exceed the price of the "Edu-Kit." Our Consultation Service will help you with any technical problems you may have.

## FROM OUR MAIL BAG

J. Statistis, of 25 Poplar Pl., Waterbury, Conn., writes: "I have repaired several sets for my friends, and made money. The "Edu-Kit" paid for itself. I was ready to spend \$240 for a course, but I found your ad and sent for your Kit."

Ben Valerio, P. O. Box 21, Magna, Utah: "The Edu-Kits are wonderful. Here I am sending you the questions and also the answers for them. I have been in radio for the last seven years, but like to work with Radio Kits, and like to build Radio Testing Equipment. I enjoyed every minute I worked with the different kits; the Signal Tracer works fine. Also like to let you know that I feel proud of becoming a member of Your Radio-TV Club."

Robert L. Shuff, 1534 Monroe Ave., Huntington, W. Va.: "Thought I would drop you a few lines to say that I received my Edu-Kit, and was really amazed that such a bargain can be had at such a low price. I have already started repairing radios and phonographs. My friends were really surprised to see me get into the swing of it so quickly. The Trouble-shooting Tester that comes with the Kit is really swell, and finds the trouble, if there is any to be found."

## PRINTED CIRCUITRY

At no increase in price, the "Edu-Kit" now includes Printed Circuitry. You build a Printed Circuit Signal Injector, a unique servicing instrument that can detect many Radio and TV troubles. This revolutionary new technique of radio construction is now becoming popular in commercial radio and TV sets.

A Printed Circuit is a special Insulated Chassis on which has been deposited a conducting material which takes the place of wiring. The various parts are merely plugged in and soldered to terminals.

Printed Circuitry is the basis of modern Automation Electronics. A knowledge of this subject is a necessity today for anyone interested in Electronics.