

**THIS MINISUPER IS AIMED AT PARALLEL PROCESSING/56  
HOW AI WILL ADD BRAINS TO OFFICE AUTOMATION/63**

A MCGRAW-HILL PUBLICATION

SIX DOLLARS OCTOBER 30, 1986

# Electronics

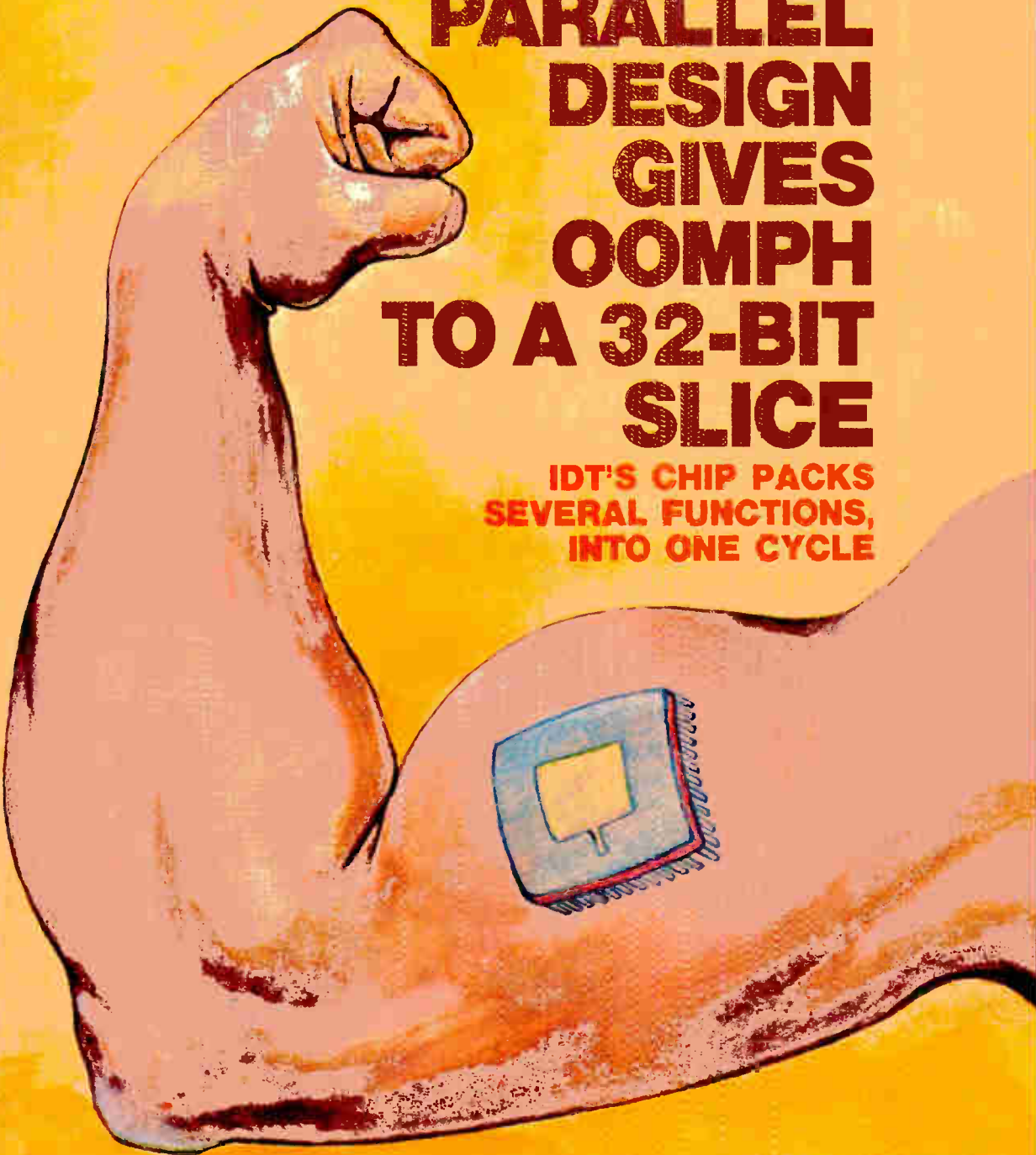

## **PARALLEL DESIGN GIVES OOMPH TO A 32-BIT SLICE**

**IDT'S CHIP PACKS  
SEVERAL FUNCTIONS,  
INTO ONE CYCLE**

PAGE 51

# ... AND FAIRCHILD CREATED FASTPLA.™

It began with FAST. A Fairchild innovation that made the world of TTL a better place. Thanks to its higher speeds and lower power consumption.

Now, Fairchild continues its great work by adding PLA to this wondrous family of FAST.

FASTPLA is the only family of programmable logic array devices that meets the more stringent specs required of FAST. And it's the only family that offers programmable output polarity with 15ns propagation delay. That's the kind of flexibility that lets you stretch your design horizons... gives you greater design control... lowers your design costs... improves your design performance and reduces your design time from months to days.

And when it comes to lightning fast delivery, nothing beats the computerized inventory of Schweber. One call to any Schweber location, coast to coast, gets you complete specifications (including MIL-SPEC) and instant, off-the-shelf delivery on all Fairchild FASTPLA parts.

FASTPLA from Fairchild and Schweber. A significant opportunity to enhance your own creativity.

FASTPLA is a registered trademark of Fairchild Semiconductor Corporation.

# SCHWEBER



**FASTPLA™**

**Northeast** Bedford, MA 617/275-5100 • Manchester, NH 603/625-2250 • Rochester, NY 716/424-2222 • Danbury, CT 203/748-7080 **Mid-Atlantic** Westbury, NY 516/334-7474  
Fairfield, NJ 201/227-7880 • Horsham, PA 215/441-0600 **Southeast** Baltimore, MD 301/792-4025 • Gaithersburg, MD 301/840-5900 • Raleigh, NC 919/876-0000  
Norcross, GA 404/449-9170 • Huntsville, AL 205/895-0480 • Altamonte Springs, FL 305/331-7555 • Pompano Beach, FL 305/977-7511 **Midwest** Pittsburgh, PA 412/782-1600  
Beachwood, OH 216/464-2970 • Livonia, MI 313/525-8100 • Dayton, OH 513/439-1800 • Elk Grove, IL 312/364-3750 • Brookfield, WI 414/784-9020 • Cedar Rapids, IA 319/373-1417  
St. Louis, MO 314/739-0526 • Kansas City, KS 913/492-2922 • Edina, MN 612/941-5280 **Southcentral** Houston, TX 713/784-3600 • Dallas, TX 214/661-5010  
Austin, TX 512/458-8253 • Tulsa, OK 918/622-8000 **Northwest** Englewood, CO 303/799-0258 • San Jose, CA 408/946-7171 • Sacramento, CA 916/929-9732  
Seattle, WA 206/624-1183 **Southwest** Phoenix, AZ 602/997-4874 • San Diego, CA 619/450-0454 • Irvine, CA 714/863-0200, 213/537-4321 • Gardena, CA 213/327-8409  
Canoga Park, CA 818/999-4702



**SCHWEBER  
ELECTRONICS**

© 1986 SCHWEBER ELECTRONICS CORPORATION

Circle 900 on reader service card

World Radio History

# ONLY HITACHI

## And only Hitachi CRT Readout Scopes offer:

- ScreenWriter™**    **CursorMeasurement™**
- GroundReference™ display**    **EventCounter™**

Exclusive ScreenWriter lets you write two 30-character lines of your own notes on the screen.

Exclusive EventCounter digitally displays number of pulses within delay time or delayed sweep time.

Built-in DVM and 5-digit, 0.1Hz resolution frequency counter display AC and DC voltage and frequency. Exclusive CursorMeasurement, with GroundReference level, displays values of all other important parameters. One Polaroid\* photo gives you a complete record of the measurement — including your comments. Three-year warranty.

Hitachi offers 150MHz, 100MHz, and 60MHz Microprocessor based CRT Readout Scopes. Find out how much more scope you get for your money from Hitachi. Call 516-921-7200.

Or write Hitachi Denshi America, Ltd., 175 Crossways Park West, Woodbury, NY 11797.

In Canada: Hitachi Denshi, Ltd.,  
65 Melford Drive, Scarborough,  
Ontario M1B2G6. Tel. 416-299-5900.



Circle 1 on reader service card

Model  
V1150:  
150MHz  
4 channels  
8 traces  
delayed sweep.  
Mfrs. suggested  
list price: \$2950

Convenient front panel key pad allows you to input Hitachi ScreenWriter characters, and set trigger conditions.

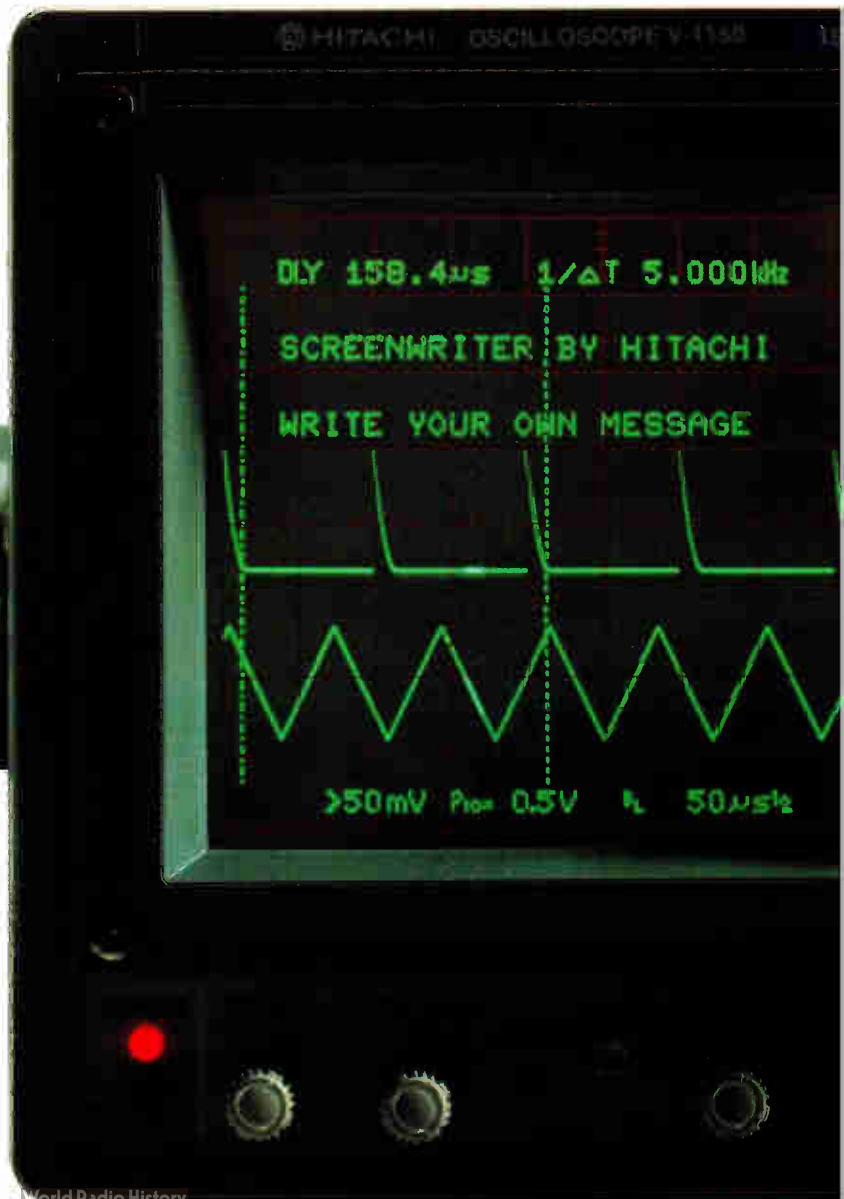
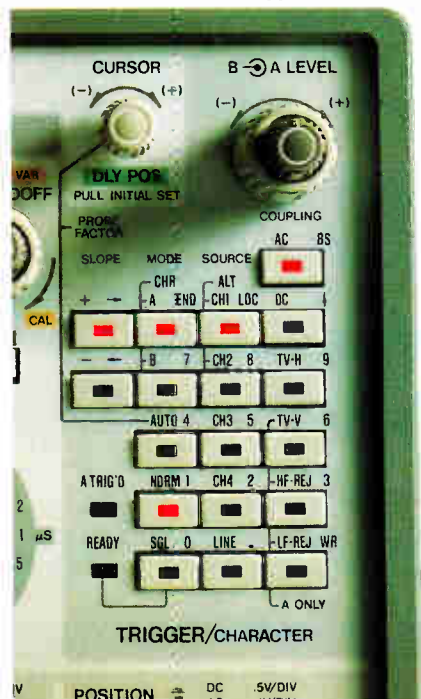

\*Polaroid is a trademark of Polaroid Corporation

# At The Mitel CMOS Foundry You're Invited In

Customer input is an essential element at our foundry. You know why your circuit was designed, what performance is expected from it, what its cost-constraints must be and what deadlines must be met by our shipments of your wafers.

Mitel Semiconductor has an excellent customer interface along with first-rate foundry capabilities. Nothing is more frustrating than explaining your needs without receiving any response. Our tracking system produces weekly reports or you can get updates by phone or by electronic mail at any time.

Most Mitel customers have tried other foundries, then come to us because of our emphasis on customer liaison and support. This emphasis gets the results you expect within the time frame that we agree on - normally five weeks from PG tape to completed wafers. After all, it's speed with high-yield production that counts!

The Mitel foundry can be your one-stop North American resource for all CMOS fabrication services from mask-making to final shipment. It's financially stable, completely approachable and consistently accountable to its clients for timely, quality production.

## Mitel Foundry Delivers On Time - Every Time



### UNITED STATES

San Diego, California. Telephone: (619) 276-3421.  
San Jose, California. Telephone: (408) 249-2111.  
Oakbrook, Illinois. Telephone: (312) 655-3930.  
Boca Raton, Florida. Telephone: (305) 994-8500.

### CANADA

Kanata, Ontario. Telephone: (613) 592-5630.

### UNITED KINGDOM

Portskewett, Gwent, South Wales Telephone: +44 291-423355.

### ASIA

Tsuen Wan, Hong Kong. Telephone: +652 0-463641.

### EUROPE

Denmark. Telephone: +45 1-612566.  
Milan, Italy. Telephone: +39 2-8245222/8245177.  
West Germany. Telephone: +49 711-7701522.

Circle 2 on reader service card



T.M. & Trademark of Mitel Corporation  
© Copyright 1986 Mitel Corporation

### EDITOR-IN-CHIEF

Robert W. Henkel

### EXECUTIVE EDITORS

Samuel Weber (technical), Arthur Erikson (news)

### MANAGING EDITORS GROUP

Bernard C. Cole, Tom Manuel,  
Benjamin A. Mason, Jonah McLeod,  
Howard Wolff, Jeremy Young

### ART DIRECTOR

Fred Sklenar

### DEPARTMENT EDITORS

**Communications:** Robert Rosenberg  
**Computers & Peripherals:** Tom Manuel  
**Government & Military:** Jerry Lyman  
**Industrial & Consumer:** Wesley R. Iversen  
(Chicago)  
**Packaging & Production:** Jerry Lyman  
**Semiconductors:** Bernard C. Cole (San Mateo)  
**Software & Microsystems:** Alexander Wolfe  
**Special Projects:** George Sideris (San Mateo)  
**Test & Measurement:** Jonah McLeod  
(San Mateo)

### NEWS DEPARTMENT

**Front of the Book:** Jeremy Young  
**Probing the News:** Howard Wolff  
**New Products:** Jack Shandle  
**Assistant News Editor:** Rick Elliot

### EDITORIAL PRODUCTION & COPY DESK

Benjamin A. Mason (Director)

#### Production

Charles D. Ciatto (Mgr.), Kathy O'Neill

#### Copy Editors

Larry King (Chief), George Ellis,  
Nancy J. Erickson

### ART

Sachiko Soskin (Associate Director)

### NEWS BUREAUS

**Boston:** Craig D. Rose (Mgr.), Debra Michals  
**Chicago:** Wesley R. Iversen (Mgr.)  
**Dallas:** J. Robert Lineback (Mgr.)  
**Los Angeles:** Larry Waller (Mgr.), Ellie Aguilar  
**New York:** Tobias Naegele (Mgr.)  
**San Mateo:** Clifford Barney (Mgr.)  
**Frankfurt:** John Gosch (Mgr.)  
**London:** Steve Rogerson  
**Paris**  
**Tokyo:** Charles L. Cohen (Mgr.),  
Ayako Hayashihara  
Michael Berger (World News Chief), Amy Borrus

### EDITORIAL ADMINISTRATION

Laura Aspery (Administrative Assistant),  
Lisa Costenbader, Ina Gruber

### PUBLISHER

Laurence Altman

**Director of Operations:** Thomas E. Vachon  
**Circulation Manager:** Leon Irgang  
**Production Director:** Thomas Egan  
**Manager of Sales Administration:**  
Evelyn Schmidt  
**Research Associate:** Diane Breder

There have been 11 Electronica shows, and John Gosch, our man in West Germany, has covered all but the first one, in 1964. So when he writes about the 12th edition of the big international components exposition in Munich, as he does in this issue on page 83, John brings to the table the depth of background that only two decades on the job can provide—and that only *Electronics* can share with you.



**GOSCH:** Recalling the early days and Miss Electronica.

Electronica, which is held in even-numbered years, has always been a good indicator of the industry's direction. At his first one, John says, "I reported, 'The trend toward solid-state applications is gaining momentum in Europe despite grumblings by some old-time designers who still cling to engineering practices of the past.' And, quoting a German engineer, I cabled New York, 'By and large, European integrated-circuit manufacturing methods are at best what can be termed large-scale laboratory production. And that will be the case for some time to come.' The big issue in those days was Europe's growing technology gap vis-à-vis the U.S.—no word of a Japanese threat back then. How things have changed."

Probably the most interesting thing about Electronica is how the show got started and how fast it has grown, says John. It began in the early 1960s, when

American electronics companies operating in Germany were looking for a forum where they could display their wares. They were turned down by the Hanover Industrial Fair, so they approached a number of cities, among them West Berlin, Munich, and Frankfurt, to organize an exhibition devoted solely to components. Munich was the first to say yes.

"The first show," says John, "was a regional affair, and it was given little chance of being repeated. There were around 100 companies (not only American, but many small German outfits that also couldn't get into Hanover), and they didn't even fill three exhibition halls. On their stands they displayed products from an additional 300 companies. Total attendance was 13,400." This year, there will be 2,284 exhibiting companies from 36 countries, with 125,000 visitors expected.

John finds Electronica an exciting event, but he misses the good old days when it was like a club where the competitors were also friends. "In fact, in 1968 it was decided to name a Miss Electronica—a woman working at the stand of a UK company won. But at the next show, when the big German companies came aboard, it became a no-nonsense, strictly professional and businesslike affair. No more Miss Electronica contests after that."

October 30, 1986 Volume 59, Number 34  
107,225 copies of this issue printed

Electronics (ISSN 0883-4989) Published biweekly by McGraw-Hill Inc. Founder: James H. McGraw 1860-1948. Publication office, 1221 Avenue of the Americas, N.Y., N.Y. 10020; second class postage paid at New York, New York and additional mailing offices. Postage paid at Montreal, P. Q. Registration Number 9034.

Executive, editorial, circulation, and advertising addresses: Electronics, McGraw-Hill Building, 1221 Avenue of the Americas, New York, N.Y. 10020. Telephone (212) 512-2000. Teletype 12-7960 TWX 710-581-4879. Cable address: MCGRAW HILL L L N E W Y O R K

Subscriptions limited to professional persons with active responsibility in electronics technology. No subscriptions accepted without complete identification of subscriber name, title or job function, company or organization, and product manufactured or services performed. Based on information supplied, the publisher reserves the right to reject nonqualified requests. Subscription rates: the United States and possessions \$32 one year, \$55 two years, \$76 three years; company addresses and company libraries \$40 one year, \$67 two years, \$93 three years; Canada and Mexico \$34 one year, \$57 two years, \$78 three years; Europe \$50 one year, \$85 two years, \$125 three years; Japan, Israel, and Brazil \$85 one year, \$140 two years, \$200 three years; Australia and New Zealand \$95 one year, \$170 two years, \$240 three years, including air freight; all other countries \$50 one year, \$85 two years, \$125 three years. Limited quota of subscriptions available at higher-than-basic rate for persons allied to field served. Check with publisher for these rates. Single copies: \$6.00. Please allow four to eight weeks for shipment.

Officers of McGraw-Hill Information Systems Company: President, Richard B. Miller, Executive Vice Presidents: Fredrick P. Jannco, Construction Information Group, Russell C. White, Computers and Communications Information Group, J. Thomas Ryan, Marketing and International, Senior Vice President, Francis A. Sural, Controller, Senior Vice Presidents: Publishers: Laurence Altman, Electronics; Harry L. Brown, BYTE; David J. McGrath, Engineering News-Record. Group Vice President: Peter B.

McGuen, Communications.

Vice Presidents: Fred O. Jensen, Planning and Development; Michael J. Koeller, Human Resources; Talat M. Saig, Systems Planning and Technology; Vice President-Publisher: Paul B. Beatty, Architectural Record and Building Economics.

Officers of McGraw-Hill Inc.: Harold W. McGraw Jr., Chairman; Joseph L. Dionne, President and Chief Executive Officer; Robert N. Landes, Executive Vice President and Secretary; Walter D. Serwatka, Executive Vice President and Chief Financial Officer; Shai F. Asen, Senior Vice President; Manufacturing: Robert J. Bahash, Senior Vice President, Finance and Manufacturing; Ralph R. Schulz, Senior Vice President, Editorial; George R. Eisinger, Vice President, Circulation; Ralph J. Webb, Vice President and Treasurer.

Title registered in U.S. Patent Office; Copyright 1986 by McGraw-Hill Inc. All rights reserved. The contents of this publication may not be reproduced in whole or in part without the consent of copyright owner.

Where necessary, permission is granted by the copyright owner for libraries and others registered with the Copyright Clearance Center (CCC), 21 Congress Street, Salem, Mass. 01970, to photocopy any article herein for the base fee of \$0.50 per copy of the article plus \$0.25 per page. Payment should be sent directly to the CCC. Copying done for other than personal or internal reference use without the express permission of McGraw-Hill is prohibited. Requests for special permission or bulk orders should be addressed to the publisher. ISSN 0883-4989/86 \$0.50 + .25.

Subscribers: The publisher, upon written request to our New York office from any subscriber, agrees to refund that part of the subscription price applying to copies not yet mailed. Please send change-of-address notices or complaints to Fulfillment Manager, subscription orders to Circulation Manager, Electronics, at address below. Change-of-address notices should provide old as well as new address, including zip codes. Attach address label from recent issue. Allow one month for change to become effective. Subscriber Service: call (201) 981-1064, 9 a.m. to 4 p.m. EST. Postmaster: Please send address changes to Electronics, att Fulfillment Manager, CN 808, Martinsville, N.J. 08836

**Editorial department phones:** Administration (212) 512-2645, News and New Products (212) 512-2685, Technology (212) 512-2666, Bureaus: Boston (617) 262-1160, Chicago (312) 751-3811, Dallas (214) 458-2400, Los Angeles (213) 480-5234, New York (212) 512-3322, San Francisco/San Mateo (415) 349-4100, Washington (202) 463-1650, Frankfurt 72-5566, London 493-1451, Paris 42-89-03-80, Tokyo 581-9816.  
**Business departments:** (212) 512-6435 (Business departments follow the Advertisers' Index).

# Electronics

NEWS	INSIDE TECHNOLOGY
<p><b>Newsletters</b></p> <p><b>Electronics, 19</b></p> <ul style="list-style-type: none"> <li>• TI enlists Video-7 to help develop graphics interface</li> <li>• AMD and Siemens schedule a pixel-control chip</li> <li>• With investors frightened off by suit, Lattice skips payday</li> </ul> <p><b>International, 48</b></p> <ul style="list-style-type: none"> <li>• European co-operative will spend billions on submicron technology</li> <li>• British aim to double ion-implanter throughput</li> <li>• Japanese cut back on chip production</li> </ul>	<p><b>COVER: Parallel design gives oomph to a 32-bit slice, 51</b> A powerful 32-bit-slice processor from Integrated Device Technology Inc. can perform several operations simultaneously in one clock cycle. It can yield highly parallel system designs that boost throughput 4 to 20 times over other 32-bit slice chips</p> <p><b>This minisuper is aimed at parallel processing, 56</b> For less than \$1 million per machine, Convex Corp.'s C1 minisupercomputer family features upgraded processors and memory along with a high-speed fiber-optic interconnection system</p> <p><b>Convex has a master plan to be king of the hill, 59</b> The company will use its new computers to separate itself from a growing crowd of competitors, as well as to serve as a wedge into parallel processing</p> <p><b>SPECIAL REPORT: How AI will add brains to office automation, 63</b> Artificial intelligence is getting ready to move into the mainstream of information management in the workplace. In development are systems that do such tasks as centrally organize knowledge in engineering projects, distribute messages in line with users' interests, and juggle a work group's schedules.</p> <p><b>How Weitek's chips run Fortran and C at 25 megaflops, 69</b> Three new processor sets combine optimizing compilers for high-level languages with a hardware architecture that incorporates the best features of reduced-instruction-set computers</p> <p><b>Logic timing analyzer has 100-ps resolution, 72</b> With new equivalent time recording and synchronous harmonic sampling modes, Outlook Technology's instrument speeds debugging of systems with clocks to 200 MHz</p> <p><b>How designers can save time in laying out a sea of gates, 77</b> California Devices' software slashes turnaround time by running on a work station instead of a mainframe computer to place and route 10,000-gate channelless arrays</p> <p><b>Saber cuts Spice out of analog simulation, 80</b> Based on a library of behavioral models, Analogy's new software tool can simulate any physical system and is faster, more flexible, and easier to use</p>
<p><b>Military, 29</b></p> <ul style="list-style-type: none"> <li>• The race is on to develop microwave GaAs ICs for the Department of Defense</li> <li>• IBM hits the 1-<math>\mu</math>m level on Phase 2 VHSIC chips</li> </ul>	<p><b>PROBING THE NEWS</b></p> <p><b>Munich's microelectronics conference takes a new tack, 83</b> The meeting that runs concurrently with Electronica—a show that is bursting its seams—has decided to aim at technical executives and beginning engineers. The theme of this year's papers is competition</p>
<p><b>International trade, 30</b></p> <ul style="list-style-type: none"> <li>• Equipment makers bid to modify the U. S.-Japanese semiconductor trade pact</li> <li>• The trade pact sparks a thriving gray market</li> </ul>	
<p><b>Data processing, 32</b> A new way to tighten security in personal-computer networks</p>	
<p><b>Packaging, 36</b> High-pin-count ASICs may get new JEDEC package</p>	
<p><b>Networking, 36</b> Software makes network transparent to users</p>	
<p><b>Consumer, 38</b> In 1,500 centuries, this clock will lose only 1 second</p>	
<p><b>AI, 44</b> NTT builds a Lisp machine</p>	

# PARALLEL DESIGN GIVES OOMPH TO A 32-BIT SLICE

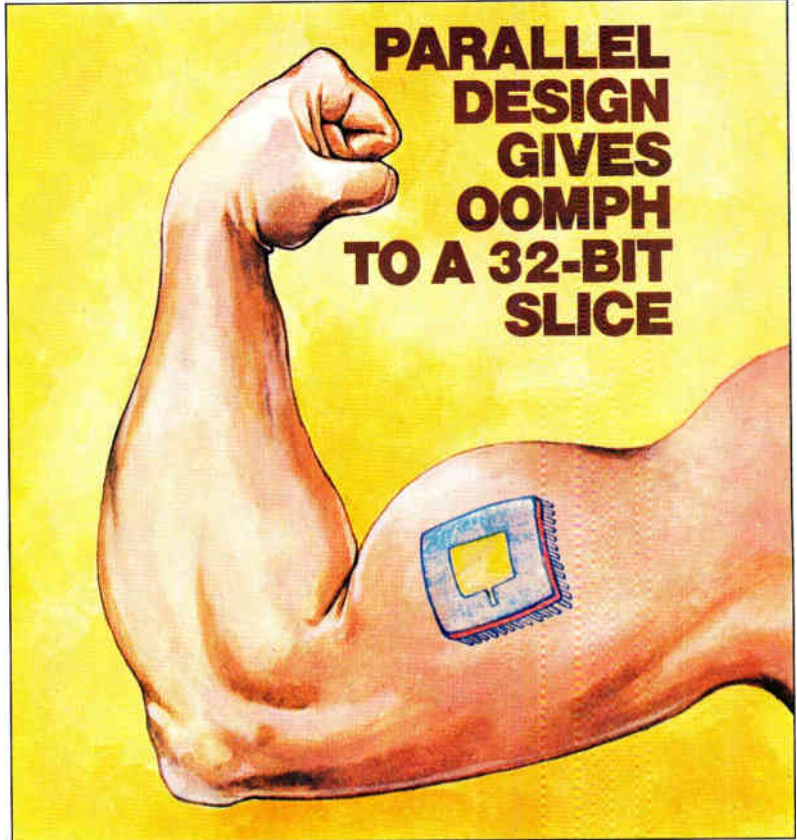

PAGE 51

## NEW PRODUCTS

### Newsletter, 25

- Two CMOS versions of the 1750A microprocessor bow
- Design tools for low-density gate arrays run on IBM PC AT
- Reactor promises \$75 epitaxy cost for GaAs wafers

### Semiconductors, 91

- Honeywell Inc.'s analog-to-digital flash converters operate at 125 megasamples/s by clipping the drive requirement and the kickback current
- Winchester-drive controller chips from Cirrus Logic Inc. outperform the industry standard and add a customization option

### Computers & Peripherals, 94

- Micro-Term Inc.'s black-on-white screen rivals letter-quality printing, thanks to high-resolution characters and a flickerless background
- Ariel Corp.'s data-acquisition board achieves real-time operation by incorporating TI's TMS32020 digital signal processor

### Design & Test, 98

- Quadtree Software Corp.'s simulation models for the Motorola 68000 family execute the chips' full instruction set
- Four oscilloscopes from Tektronix Inc. offer high resolution and bandwidth

### Production Equipment, 99

- A metal-organic chemical-vapor-deposition system from Spire Corp. that targets the laboratory research market yields high performance while operating at atmospheric pressure

## DEPARTMENTS

### Publisher's letter, 3

Our man in West Germany, John Gosch, has watched the Electronica show grow up

### FYI, 8

Wyle's Clough is also an optimist: 'If my assumptions are right, we're looking at a good, strong, up year in 1987 for the U. S. semiconductor business

### Meetings, 12

### People, 16

A "crazy idea" wins the Nobel Prize in Physics for IBM's Gerd Binnig and Heinrich Rohrer

### Electronics Week, 104

- IBM pulls out of South Africa
- Siemens produces its first 1-Mb random-access memories
- Siemens and BASF join in a mainframe marketing venture
- Brazil cracks opens the door to its computer-service industry
- RCA Astro-Electronics Division signs a \$200 million deal to build direct-broadcast satellites



World Radio History



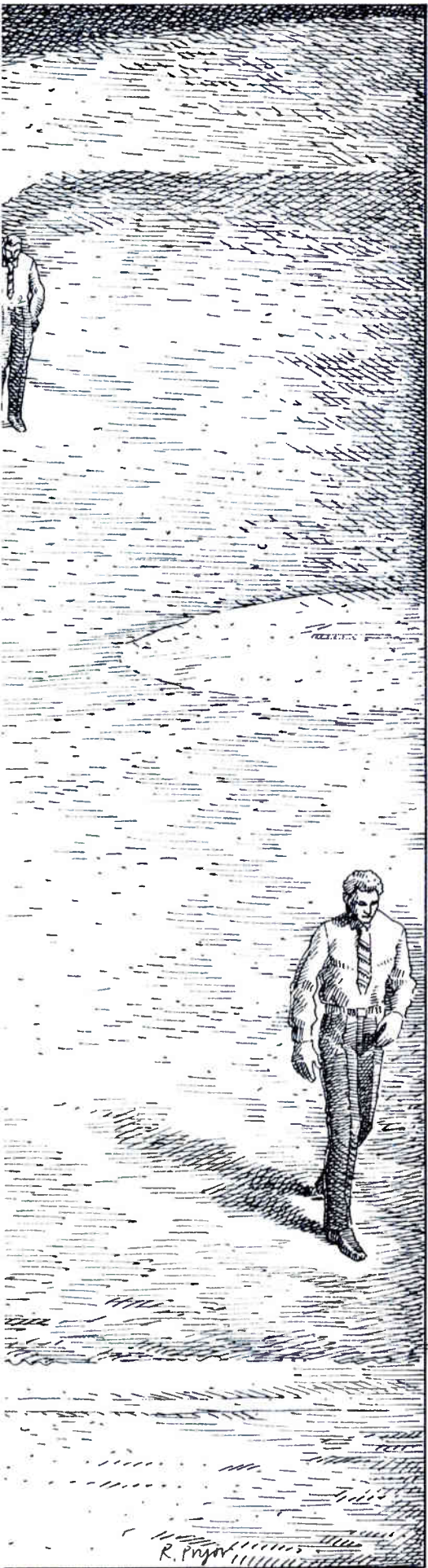

What a season!

Advanced Micro Devices has delivered sixty-four new products in fifty-two weeks. At least one a week every week. On the shelf. In volume.

32-bits. CMOS. Peripherals. ISDN. Micro-processors. Graphics. Networking. EPROMs. EEPROMs. Super-fast RAMs.

How did we do it?

We took a group of gifted, motivated people. Gave them a nearly impossible goal. Then backed them with the R&D dollars needed to get the job done.

And luck? Sure. You don't go sixty-four for fifty-two without luck. But as Branch Rickey used to say, "Luck is the residue of design."

**Advanced Micro Devices** 

901 Thompson Place, P.O. Box 3453, Sunnyvale, CA 94088

Circle 7 on reader service card



## Quality Price Availability

Venus Scientific offers over 400 power supply systems; from 5 to 30,000 volts, up to 2,500 watts.

Venus has the power supply solution for:

- Lasers
- Military
- Communications
- Aerospace
- Electronic Displays
- Research Labs

399 SMITH STREET  
FARMINGDALE, N.Y.  
11735  
(516) 293-4100  
TWX 510 224 6492

A small graphic of a light blue sticky note with the letters "FYI" written in black marker. A silver paperclip is attached to the top right corner of the note.

*Wyle's Clough is also an optimist: 'If my assumptions are right, we're looking at a good, strong, up year in 1987 for the U.S. semiconductor business'*

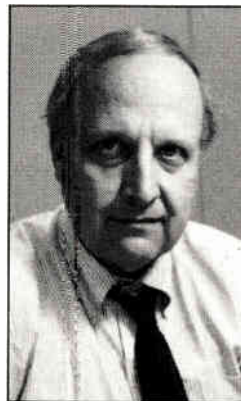

One more optimist has checked in to support our Sept. 4 column. We had stuck out our neck to declare that every time we heard grim forecasts for the semiconductor industry, it would end up bouncing back higher than ever. And that this was going to happen once again. "In every past cycle, the gloom and doom is at its deepest level just before the upturn," reminds Charlie Clough, president of Wyle Laboratories, the El Segundo, Calif.-based semiconductor distributor.

A long-time industry watcher, Charlie makes a strong case for a big 1987 for the U.S. semiconductor industry. "If my assumptions are right," he maintains, "we're looking at a good, strong, up year in 1987 for the U.S. semiconductor business—on the order of 30% to 35% industry growth." Here is how Charlie dopes it out:

The primary reason for his bullishness is the extremely low level of semiconductor inventories at U.S. equipment makers. As these companies burned chip inventory in 1985 and again in 1986, they caused the deepest decline in semiconductor history. Inventories fell more than \$3 billion, and they are still dropping. They had doubled from \$3 billion in 1983 to \$6 billion in 1984, the single largest factor driving the chip market to a record high that year.

"We are now at the same point in the semiconductor cycle that we were in early 1982," Charlie figures. The industry then had just gone through the first wave in a cycle that was later called the "false blip." The error signal had come from the small-to-medium equipment builders who had finally balanced their semiconductor inventories after a long and deep recession. When distributor orders started soaring as a result, in April of that year, chip makers turned euphoric and believed their recession was over. But an eight-month period of discouraging decline followed, Charlie reminds us, because the large mainframe makers didn't return to the market until the end of 1982.

"Now I believe we are approaching a point where the large electronics manufacturers will have their inventories below their end-equipment run-rate requirements, just as happened at the small-to-medium size electronics company in the first quarter of 1986," Charlie says. And when that happens, "their return to the marketplace after a two-year absence will cause a very sudden and high demand on the semiconductor industry."

**ROBERT W. HENKEL**

# INFINITELY FASTER WAVEFORM RECORDING

## 1.3 GIGASAMPLES/SEC!

INTRODUCING THE WORLD'S  
FASTEST SOLID-STATE WAVEFORM  
DIGITIZER...THE AWARD-WINNING

**LeCROY 6880** ■ 1.3 GIGASAMPLES/SEC!

- 8-BIT RESOLUTION ■ 250 MHz BANDWIDTH
- TRUE, SOLID-STATE A/D CONVERSION

**SEE MORE** LeCroy's new 6880 is the first, and the only, all-solid-state digitizer that accurately captures complex, single-shot phenomena within a 250 MHz bandwidth at a stunning 1.35 gigasamples/sec! What's more, the 6880 achieves this spectacular speed with true precision solid-state A/D conversion, yielding a resolution of 8 bits with exceptional dynamic performance.

**STORE MORE** Your signals are digitized to a deep 10,000 sample point memory providing a long recording window on fast signals and events. Up to 100% pretrigger and 1.5 msec post-trigger delay assures a flexible time window for capturing, viewing, and comparing complex waveforms or random transients.

**DISPLAY AND ANALYZE MORE** Display and analyze captured waveforms on a video monitor or with LeCroy's WAVEFORM-CATALYST Digital Storage Oscilloscope Software and an IBM-PC. And of course the Model 6880 is fully programmable over GPIB (IEEE-488) and RS-232-C providing friendly remote control and high speed data transfer.

**CAPTURE YOUR HIGH SPEED WAVEFORMS BETTER, FASTER, AND FOR LESS.**

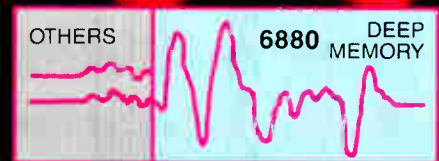

# LeCroy

Circle 9 For Information

For more information simply circle the reader service card or call (914) 578-6038

700 SOUTH MAIN STREET, SPRING VALLEY, NY 10977 TWX: 710-577-2832

Circle 127 For Demonstration

**At last, the ordinary  
microprocessor  
can take its rightful  
place in history.**



It had to happen—the conventional microprocessor has had its day. Relegated to the ranks of yesterday's devices by the new transputer family from INMOS. It's history in the making.

The IMS T414 transputer is a fast, easy-to-use VLSI component, integrating a 32-bit processor, four inter-transputer communication links, 2K bytes Static RAM, 32-bit memory interface and DRAM controller. All on a single CMOS chip—offering execution rates up to 10 MIPs.

While transputers excel in single-processor systems, their real power can be unleashed by connecting any number of transputers together via the high-speed serial links. Multi-transputer systems can deliver the performance you need today, and can be easily expanded in the future as your processing requirements increase.

And there's more. Programming multiprocessor systems has never been easier. The Transputer Development System (TDS) supports C, Fortran, Pascal and OCCAM, providing a complete software development environment, and is available for a number of popular hosts. Software developed on the TDS can be executed on one or more transputers, enabling cost-performance tradeoffs to be made.

INMOS transputers are available now and have already found their way into companies who are evaluating, prototyping and manufacturing transputer-based systems. Applications include supercomputers, DSP, graphics, robotics, AI, distributed control systems, PC's, engineering workstations and many others.

Write or phone for more information on the transputer family and start making history yourself.

TRANSPUTER PRODUCTS	
IMS T414	32 bit Transputer—2Kbyte —4 links
IMS T212	16 bit Transputer—2Kbyte —4 links
IMS M212	16 bit Disc Processor—1Kbyte—2 links
DEVELOPMENT TOOLS	
IMS D701-2	IBM PC—Transputer Development System.
IMS D600	VAX/VMS—Transputer Development System.
EVALUATION BOARDS	
IMS B002-2	Double Eurocard + IMS T414 + 2Mbyte DRAM + 2 x RS232.
IMS B003-1	Double Eurocard + 4 x IMS T414 + 4 x 256Kbyte DRAM.
IMS B004-2	IBM PC Format + IMS T414 + 2Mbyte DRAM.
IMS B006-2	Double Eurocard + 9 x IMS T212 - 128Kbyte SRAM.
IMS B007-1	Double Eurocard + IMS T414 + 0.5Mbyte DRAM + 0.5Mbyte VideoRAM.
HIGH PERFORMANCE VLSI MEMORIES	
16K CMOS SRAM, 25-45ns, 64K CMOS SRAM, 35-70ns 256K CMOS DRAM, 60-100ns	

# THE TRANSPUTER

PARALLEL PROCESSING. UNPARALLELED POTENTIAL.



INMOS, P.O. Box 16000, Colorado Springs, CO 80935, Tel. (303) 630-4000;  
Bristol, England, Tel. 454-616616; Paris, France, Tel. (14) 687-2201;  
Munich, Germany, Tel. (089) 319-1028; Tokyo, Japan, Tel. 03-505-2840.

Circle 11 on reader service card



# PEARSON

Wide Band, Precision

# CURRENT MONITOR

With a Pearson current monitor and an oscilloscope, you can measure pulse or ac currents from milliamperes to kiloamperes, in any conductor or beam of charged particles, including those at very high voltage levels.

This monitor is physically isolated from the circuit. It is a terminated current transformer whose output voltage precisely follows the current amplitude and waveshape. A typical model gives an amplitude accuracy of +1%, -0%, 20 nanosecond rise time, droop of 0.5% per millisecond, and a 3 db bandwidth of 1 Hz to 35 MHz. Other models feature 2 nanosecond rise time, or a droop as low as 1% per second.

Whether you wish to measure current in a conductor, an electron device, or a particle accelerator, it is likely that one of our off-the-shelf models (ranging from 1/2" to 10 3/4" ID) will do the job. We also provide custom designs to meet individual specifications.

Contact us and we will send you engineering data.

## PEARSON ELECTRONICS, INC.

1860 Embarcadero Road  
Palo Alto, Calif. 94303, U.S.A.  
Telephone (415) 494-6444  
Telex 171-412

## MEETINGS

**Sensors '86 and Autofact '86**, Society of Manufacturing Engineers (One SME Drive, P.O. Box 930, Dearborn, Mich. 48121), Westin Hotel, Dearborn, Mich., Nov. 11-13.

**Electronica '86 and 12th International Microelectronics Conference**, Munich Fair and Expositions GmbH, *et al.* (Postfach 12 1009, D-8000 München 12, West Germany), Munich Trade Fair Center, Munich, Nov. 11-15.

**International Workshop on Moisture, Measurement, and Control for Microelectronics**, National Bureau of Standards, *et al.* (Dr. Didier Kane, Rome Air Development Ctr., Griffiss AFB, N.Y. 13441), NBS, Gaithersburg, Md., Nov. 12-14.

**International Electronics Packaging Conference**, International Electronics Packaging Society (114 N. Hale St., Suite 2B, Wheaton, Ill. 60187), Sheraton on Harbor Island-East, San Diego, Calif., Nov. 17-19.

**Conference on Magnetism and Magnetic Materials**, American Institute of Physics, *et al.* (Diane S. Suiters, Courtesy Associates, 655 15th St., N.W., Suite 300, Washington, D.C. 20005), Hyatt Regency, Baltimore, Md., Nov. 17-20.

**Scientific Software for Supercomputing**, National Bureau of Standards (Francis Sullivan, A151 Technology Building, NBS, Gaithersburg, Md. 20899), NBS, Gaithersburg, Md., Nov. 17-20.

**Plastics in Electronics**, Business Communications Inc. (9 Viaduct Rd., Stamford, Conn. 06907), Crowne Plaza Holiday Inn, Stamford, Conn., Nov. 18-19.

**Wescon '86**, IEEE (Electronics Conventions Inc., 8110 Airport Blvd., Los Angeles, Calif. 94303), Convention Center, Anaheim, Calif., Nov. 18-21.

**PRONIC '86**: International Exhibition of Equipment and Products for Electronics, Société de Diffusion des Sciences et des Arts (20, rue Hamelin, F 75116 Paris, France), Porte de Versailles Exhibition, Paris, Nov. 18-21.

**Microcontamination Conference and Exposition**, Microcontamination Magazine (Expocon Management Associates Inc., 3695 Post Rd., Southport, Conn. 06490), Santa Clara, Calif., Nov. 18-21.

**MIL-STD-1553B**: Applications, Developments, and Components, ERA Technology, Ltd. (Laura Christie, Seminar Organiser, ERA Technology Ltd., Cleeve

Road, Leatherhead, Surrey KT22 7SA, UK), Regent Crest Hotel, London, Nov. 25-26.

**Power Electronics and Variable-Speed Drives '86**, Institution of Electrical Engineers (Savoy Place, London WC2R 0BL, U.K.), National Exhibition Centre, Birmingham, England, Nov. 25-27.

**Electronicom '86**, IEEE (Richard Brostrom, Berger & Associates Canada Inc., 133 Richmond Street W., Suite 203, Toronto, Ontario M5H 2L5), Toronto Convention Centre, Toronto, Canada, Dec. 1-3.

**GLOBECOM '86**: Global Telecommunications Conference 1986, IEEE (Ross Anderson, Southwestern Bell, Room 706, 3100 Main Street, Houston, Tex. 77002), Westin Galleria Hotel, Houston, Tex., Dec. 1-4.

**National Database and 4th Generation Language Symposium**, Digital Consulting Associates, Inc. (6 Windsor St., Andover, Mass. 01810), Ritz Carlton Hotel, Boston, Dec. 2-5.

**2nd International Conference on Artificial Intelligence**, Institut International de Robotique Et d'Intelligence Artificielle de Marseille (Viviane Bernadac, IIR-IAM, 2 Rue H. Barbuss, 13241 Marseille Cedex 1, France), Marseilles, France, Dec. 2-5.

**Controls West '86**, Tower Conference Management Co. (331 W. Wesley St., Wheaton, Ill. 60187), Long Beach Convention Center, Long Beach, Calif., Dec. 3-5.

**IEDM '86**: International Electron Devices Meeting, IEEE (Melissa Widerkehr, Courtesy Associates, Inc., 655 15th St., N.W., Washington, D.C. 20005), Westin Bonaventure Hotel, Los Angeles, Calif., Dec. 7-10.

**International OEM**, Penton Exhibitions (Bill Little, Penton Expositions, 122 E. 42nd St., New York, N.Y. 10168), Jacob Javits Convention Center, New York, Dec. 9-11.

**Microcomputer Graphics Show and Conference**, Expoconsul International Inc. (3 Independence Way, Princeton, N.J. 08540) Jacob Javits Convention Center, New York, Dec. 17-19.

**International Winter Consumer Electronics Show**, EIA Consumer Electronics Group (2001 Eye St., N.W., Washington, D.C. 20006), Las Vegas Convention Center, Las Vegas, Nev., Jan. 8-11.

# LEADER

LFG-1300S  
0.002 Hz-2 MHz



2 MHz

LBO-518  
100-MHz Four Channel  
Oscilloscope

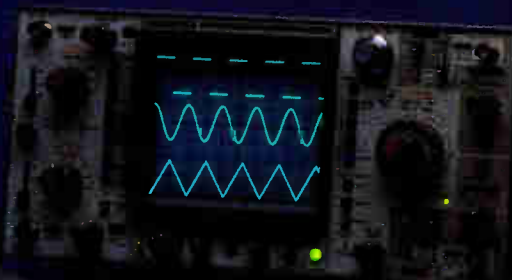

LFG-1310  
0.01 Hz-10 MHz



10 MHz

## Sweep- Function Generators

Leader 10-MHz and 2-MHz Sweep-Function Generators are exceptionally durable and versatile. They have every important feature, and every required waveform including:

- Sine, square, triangle, sawtooth, ramp, pulse and TTL outputs • 1000:1 and 100:1 ranges
- Adjustable waveform symmetry • AM or FM modulation • VCO and GCV • Linear and log sweep • Plus CW, triggered, gate and burst modes (1310 only) • And lots more!

Call toll-free  
**(800) 645-5104**

In NY State  
**(516) 231-6900**

Request an evaluation unit, our latest Test Instrument Catalog with over 100 outstanding products, the name and address of your nearest "Select" Leader Distributor, or additional information.

For professionals  
who  
know  
the  
difference.

**LEADER**  
Instruments Corporation

380 Oser Avenue Hauppauge, New York 11788  
Regional Offices: Chicago, Dallas, Los Angeles, Boston, Atlanta  
In Canada call Omnitronix Ltd. (514) 337-9500

Circle 80 For Product Demonstration

Circle 13 For Product Information

# 5 MIPS 40 MHz

Performance's PACE 1750A real-time processor has the best component support ever produced for high-performance applications. All components function compatibly at 40MHz.

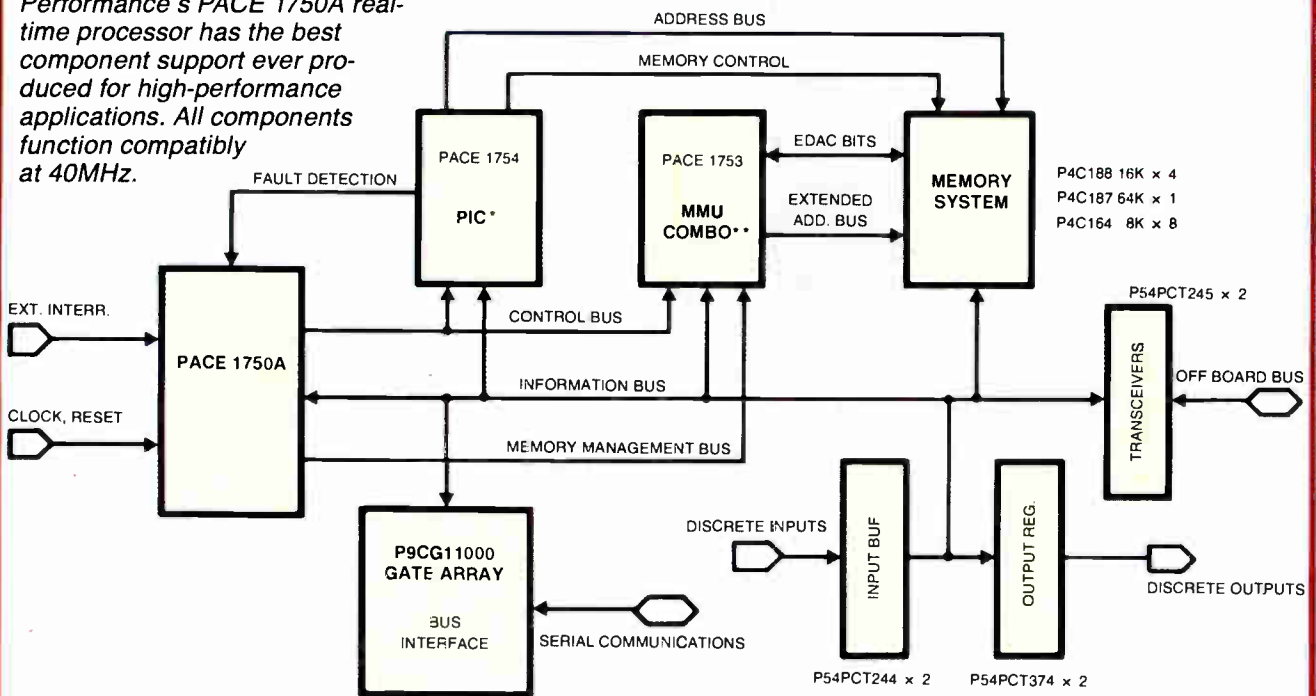

\* PIC 1750: TIMING AND READY GENERATION, ADD. LATCHES, SYSTEM SELF-TEST

\*\* MMU COMBO: MMU, BPU, MAPPING MEMORIES, EDAC, MULTI-MASTER ARBITRATION

- CMOS single-chip 1750A military standard for 16 bit—20, 30, or 40MHz
- 5 MIPS integer processing at 40MHz
- 32-bit and 48-bit floating point
- 2.6 MIPS at 40MHz for DAIS floating point instruction mix
- Less than 1 watt at 40MHz
- -55°C to +125°C

- Complete component support includes three ultra-fast 64K SRAMs: 16Kx4, 64Kx1, and 8Kx8 (over full military temperature), bus interface octals, Memory Management Unit, Processor Interface Circuit, and gate arrays with 11,000 gates for any remaining customizing functions.

NAME \_\_\_\_\_  
 TITLE \_\_\_\_\_  
 COMPANY \_\_\_\_\_  
 ADDRESS \_\_\_\_\_  
 CITY/ST/ZIP \_\_\_\_\_  
 PHONE \_\_\_\_\_

Send me information on:

PACE 1750A and component support

PACE Bus Interface Octals

PACE Static RAMs

My need is:

Immediate     6 months     Longer



# THE MAKING OF A BREAKTHROUGH

1750A. 40MHz. Single-chip CMOS implementation of the military standard. Pretty impressive specs, and no small feat. Why did we do it? Because we knew you needed it. How did we do it? The unusual way. We planned and managed for early success.

We started by creating a fresh new conceptual architecture and logic design; it improved the chip's performance by a factor of 2.

We put the chip through its paces against the 1750A instruction set in exhaustive ATP tests.

We pushed our advanced CAE tools to the limit, and debugged them designing Performance static RAMs and logic circuits. Then we put the tools to work on the 1750A.

Thousands of man days later, we achieved a complete chip layout verification on the computer against the circuit schematic. An impressive feat in itself.



*Our Class-2 facility produces 6-inch wafers with 0.8 micron CMOS technology.*



*Performance engineering put 200,000 transistors in just 52,000 square mils.*

## PACE TECHNOLOGY

As a designer, you know that you can't create advanced products without advanced manufacturing methods. That's why our process people built a Class-2 facility to process 6-inch wafers, and developed PACE Technology, the most advanced CMOS technology available today: 0.8 micron effective channel lengths, 2.75 micron metal pitch, and internal loaded gate delays of 500 picoseconds. PACE Technology made it possible to achieve a 40MHz clock rate on the 1750A.

We debugged PACE Technology on a 400,000 transistor 64K SRAM, a good test prior to processing the 200,000 transistor PACE 1750A.

But advanced technology alone cannot assure success. That's why we depended on the ideas and skills of our managers. Our top fifteen managers each have an average of over fifteen years of semiconductor industry experience.

The payoff? *Working chips in the first wafers of our first pass of silicon.*

The 1750A passed the full 100,000 vector test program, over the full military temperature range, 5 volts  $\pm$  10%.



*It was gratifying to watch 1750A chips from the very first wafers pass Sentry test.*



PACE Technology is a trademark of Performance Semiconductor Corporation.  
© 1986 Performance Semiconductor Corporation

610 E. Weddell Drive, Sunnyvale, CA 94089  
Telephone: 408-734-9000 Telex: 6502715784



Art from 'The Cat in the Hat' © 1988 by Dr. Seuss. Reproduced by permission of Random House, Inc.

## We let the cat out of the bag.

Millions of children might never have met Dr. Seuss and his famous Cat had it not been for The New York Public Library. That's because our renowned children's librarian, Anne Carroll Moore, gave his first book an outstanding review. He became famous overnight, and Dr. Seuss himself credits her with his success.

Others too, credit our librarians. "The people who work here," says author David McCullough, "provide a service to the whole of society that's never sung enough." Indeed, the librarians are the very heart of the Library.

They are the ten librarians who answer five million telephone inquiries a year. They are the librarians who introduce children to the magic of literature and help adults find employment through our Job Information Center. They are also the librarians who select and preserve books for users of tomorrow.

The Library can help just about anyone with anything. Even a Doctor with his Cat.



**The New York Public Library**  
WHERE THE FUTURE IS  
AN OPEN BOOK

## PEOPLE

# 'CRAZY IDEA' WINS NOBEL FOR BINNIG AND ROHRER

### NEW YORK

**W**hen Gerd Binnig and Heinrich Rohrer set out eight years ago to build a device that could see individual atoms, their colleagues told them they were "completely crazy." On the other hand, Rohrer recalls, "they also said that if we succeeded we would win the Nobel Prize."

Now the prophecy has come true. The researchers, both career staff members at IBM Corp.'s Research Laboratory in Zurich, will share the 1986 Nobel Prize in Physics with 79-year-old Ernst Ruska, who developed the scanning electron microscope in 1931. Binnig and Rohrer are credited with developing the scanning tunneling microscope, which allows scientists to study the surface of materials in atomic detail. Their invention has already found wide application in materials research at IBM and other electronics companies, and the scientists believe it is also well-suited for biological studies on viruses, cancer, and DNA.

Rohrer sees some important applications for the technology, especially in next-generation computing, which will require submicron geometries and ultrahigh levels of integration on complex silicon and gallium arsenide substrates. "There is already talk of doing lithography with this technique," he says. The technology may eventually be used to make physical changes to a material, he says.

Binnig, a native of West Germany, and Rohrer, a Swiss, will share their half of the \$290,000 cash prize; Ruska will collect the rest. But Binnig, 39, and Rohrer, 53, say they have not thought much about what they will do with their cash award. Rohrer says that he might build a new house.

When news came earlier this month that they had won, the two were swamped with congratulations from their 120 colleagues at the Zurich labs, and by phone calls from news organizations and friends. "I never experienced anything in my life like this," says Binnig, who joined IBM in 1978 after earning his PhD in physics from Johann Wolfgang Goethe University in Frankfurt, West Germany. "It was really something, all this excitement and all these people coming to shake hands."

The research project was not the result of years of academic contemplation, but rather the fruit of a short discussion on the physical phenomenon of tunnel-

ing, in which electrons will jump from one surface to another when the two surfaces are held close together and a current is applied. Still, it took 30 months before Binnig and Rohrer saw their first pictures.

"When we started, I was personally convinced that it would work, but when it did, it really surprised me," says Rohrer, who joined IBM in 1963 after earning his PhD at the Federal Institute of Technology in Switzerland. "It's so amazing that such a primitive instrument could work. Really—it's like a rusty nail you drag across a surface."

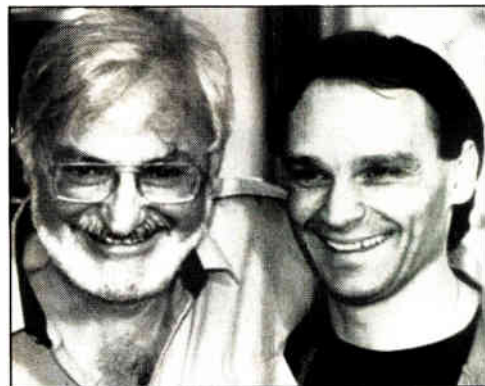

**LAUREATES.** IBM's Heinrich Rohrer, left, and Gerd Binnig share the 1986 Nobel Prize in Physics.

The microscope is not that simple. The primary components are a tiny tungsten probe, so fine that its tip is a single atom, and a small clamp to hold the material under study. A small current is applied, creating an electric field between the probe and the material surface, and the probe slowly scans the surface, following its contours atom by atom.

The result is a TV-like image that maps the landscape on the material's surface; each hill is an atom. The technique allows researchers to actually see how atoms bond. Moreover, Rohrer says that the design has been refined so that now resolution is between 0.7Å and 0.8Å. "Now you can actually see the shape of individual atoms," he says.

The most difficult development challenge may have been finding a way to keep the material and probe completely free of vibration. The probe and the material must stay within 5Å to 6Å of each other for the phenomenon to work, so scanning tunneling microscopes consist primarily of shock-absorbing equipment. The systems, which can be about as small as a grapefruit, must be operated in a vacuum.

—Tobias Naegele

# ALL OTHERS PALE BEFORE US.

No other color graphics terminal can compare to the GR-1105. In fact, you'd have to spend an extra five or ten thousand dollars to get something even close.

The GR-1105's screen is brighter than anything else in its price class. It's also sharper. With three times the resolution of similarly priced terminals. And sixty times more addressable points (32K x 32K).

Plus the GR-1105 is perfect for people who hate to wait. It's twice as fast as its price competitors. And updates over one and a half times more data.

So look into the GR-1105. You'll see it's the one terminal that makes all others look pale.

Call Martin Nelson  
at (408) 943-9100  
today.

**SEIKO**  
INSTRUMENTS

© 1986 Seiko Instruments U.S.A., Inc.

Circle 17 on reader service card

You're looking at an image on the GR-1105's 14" 1024 x 780, 60Hz non-interlaced monitor. Image produced with Vectart Software from Prosperity Systems.



# NOW. A FAMILY OF "HDD" DATA RECOVERY CHIPS—EACH WITH A FULL SPECTRUM OF FEATURES.

2,7 ENDEC  
15 MBITS/SEC  
WINDOW SYMMETRY CONTROL  
ENHANCED HDD TESTABILITY  
INTERNAL TIMING ELEMENTS  
FAST ACQUISITION PLL



For mass storage disk drive electronics—Silicon Systems supports you best with total "head to host" IC solutions. Example: the Silicon Systems Data Recovery IC family. The flagship of this exciting new series is the SSI 532—the industry's most advanced single chip solution integrating data synchronization and ENDEC functions. Designed as a companion device to the SSI 452 and AIC 010 families of controllers, the 532 is destined to become the industry standard. And for good reason: it offers the type of raw performance and exclusive enhancements that really can separate your hard disk drive from the rest.

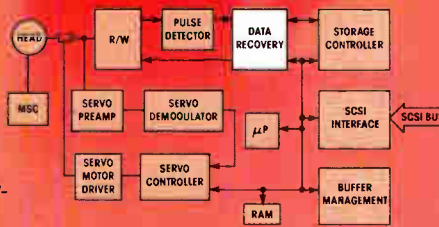

Just look at what this space-saver offers: 2,7 RLL encoding/decoding; window symmetry control with  $\mu$ P port for enhanced HDD testability; internal timing elements with a single external resistor to set the data rate; a precision decode window without the requirement of an accurate 1/4 cell delay; 15Mbits/sec. operation; fast acquisition PLL; plus a host of other dynamic features that will give your product the competitive edge.

But the SSI 532 is just one chip in Silicon Systems family of five Data Recovery IC's. Each is optimized for a specific type of drive—one is right for your type of drive. In addition to data recovery, Silicon Systems also offers broad IC families to cover virtually all other functions in HDD and FDD disk drive electronics.

For more information on the SSI 532 and other exciting product families in the SCSI chip set, contact Silicon Systems today.

**Silicon Systems**, 14351 Myford Road,  
Tustin, CA 92680, (714) 731-7110,  
Ext. 575.

*silicon systems*<sup>TM</sup>  
INNOVATORS IN INTEGRATION

# ELECTRONICS NEWSLETTER

## TI ENLISTS VIDEO-7 TO HELP DEVELOP GRAPHICS INTERFACE

**T**here's a war raging in the 32-bit graphics-processor market between Texas Instruments Inc. and Intel Corp. as each tries to get makers of graphics products to use its chip. In the latest round, TI has signed up Video-7 Inc. to help it develop a standard interface, based on the TI TMS34010 Graphics System Processor chip, for the IBM PC and PC AT. The work will include both silicon and software that will be made available as part of the TMS 340 family. Video-7, Milpitas, Calif., is already a major player in the market for Enhanced Graphics Adapter cards; it says that it will be the first to incorporate the new Microsoft Windows driver of the TMS34010 into a high-resolution graphics product. TI's chip was announced last January [*Electronics*, Jan. 27, 1986, p. 67]. Intel's, the 82786, came out in the spring [*Electronics*, May 19, 1986, p. 57]. □

## AMD AND SIEMENS SCHEDULE A PIXEL-CONTROL CHIP

**T**I and Intel are pushing complete graphics coprocessor ICs, but others play on a lower level of integration by developing chips to be used as parts of coprocessors. One of those players, Advanced Micro Devices Inc. of Sunnyvale, Calif., says it will begin shipping samples of its own graphics chip, the Am95C60 quad pixel dataflow manager, in the first quarter of next year. Siemens AG of Munich will second-source the chip in Europe. AMD, now in beta test, promises full production by the second quarter of 1987. □

## WITH INVESTORS FRIGHTENED OFF BY SUIT, LATTICE SKIPS PAYDAY

**T**he patent infringement suit brought against Lattice Semiconductor Corp. by Monolithic Memories Inc. apparently has indirectly dealt a powerful blow to the 3½-year-old Portland, Ore., firm. Lattice said last week that because of the suit, several current investors had refused to take part in its \$10 million fifth round of financing. In order to keep afloat, Lattice stopped paying its professional employees, offering them stock and bonuses instead if they stayed on. Nevertheless, 33 of the 176 people in the company's total workforce quit their jobs rather than wait, the company says. The salary holdup may last as long as three months, an internal memo said. Secretaries and employees covered by minimum-wage laws are being paid. The company also persuaded its suppliers to accept deferred payments. "We haven't run out of money," a spokesman says. "However, we are paying essential bills only." Meanwhile, the investment house of Drexel Burnham Lambert is trying to recruit more investors to complete the financing. In its suit, Monolithic Memories, of Santa Clara, Calif., charged that the programmable logic circuits made by Lattice and Altera Corp. were infringing on its programmable array logic patents [*Electronics*, Sept. 18, p. 23]. Lattice has since filed a \$100 million countersuit. A Lattice spokesman says that bookings remain high, with the largest single-day bookings, \$1.8 million, occurring this month. □

## MOTOROLA TO STAGE SRAM SPEED RACE AT WESCON

**M**otorola Inc. is reacting to the fierce competition in fast static random-access memories with a whimsical marketing gimmick. The Austin, Texas, operation, which offers 64-K parts with speeds of 25 ns, will challenge its SRAM competitors to an access-time race on the floor of next month's Wescon '86 in Anaheim, Calif. Motorola managers in Austin, Texas, plan to have a high-speed tester installed in their booth to measure the speed of parts submitted by customers and competitors. The stunt will be called "The Motorola Shmoo-out at the Wescon Corral." Test programs will record each chip's access time on a Shmoo plot. □

# ELECTRONICS NEWSLETTER

## UNIVERSITY OF ILLINOIS FINALLY GETS PLATO'S PRICE DOWN...

**P**lato, the computer-based instruction system that has always been too expensive to fulfill its once-heralded potential, is about to get significantly cheaper. Researchers at the University of Illinois, where Plato was developed 26 years ago, have come up with an approach that relies on new, inexpensive computer hardware as well as satellite transmission to deliver instructional materials more cost-effectively from a central mainframe to remote terminals. Conventional Plato systems rely on older computer hardware and land-based phone lines, and can cost a user around \$60 per month per terminal in long-distance charges. The so-called NovaNET system can run for one-tenth that price, says an official. Control Data Corp. of Minneapolis, which has rights to market Plato, has chosen not to license the satellite-based technology. So NovaNET will be marketed by a university spin-off company, University Communications Inc., in Urbana, Ill. □

## ...BUT CONTROL DATA SAYS IT HAS A BETTER IDEA

**N**ow that it has decided not to license the NovaNET technology for Plato, Control Data Corp. says it plans to pursue an even less-expensive approach for low- to medium-volume users, one that does away with mainframe communications costs—which can be as much as 50% of delivery cost. The first example is at an American Airlines training facility, where CDC is installing a Plato system that uses IBM PC AT-compatible work stations teamed with central file servers. CDC has offered work-station-based Plato before, but never on such a powerful machine and always for stand-alone use. The installation is the first Plato from CDC to rely on a local-area network. □

## BUILT-IN SELF-TEST EASES CHECK OF ASIC-EMBEDDED MEMORY

**T**esting the memories embedded in application-specific integrated circuits may be one of the most time-consuming and expensive tasks an ASIC user encounters while building custom parts into a system. AT&T Co. is taking aim at that problem with built-in self-test circuitry, which makes testing embedded random-access memories almost automatic. At a cost of about 3% of the chip's total area for each on-chip memory block, it can track memory faults to a single pin or gate and can study bridging faults and pattern sensitivities, says David Aadsen, the Bell Laboratories staffer who incorporated this approach into AT&T's ASIC compiler. Aadsen estimates that this self-testing can cut development costs by 10% or more, but he points out that there may be a more significant advantage to the added circuitry: system designers can use it in system-level testing. □

## GaAs MARKET ESTIMATES ARE CALLED OVERLY OPTIMISTIC

**T**hose market studies that several years ago predicted gallium arsenide chip sales would soon amount to billions of dollars missed the mark badly, says a new report by The Information Network. The San Francisco market researcher says the main reason is that the low levels of integration of initial GaAs chips did not provide enough functionality to be cost-effective to customers. "Suppliers are wasting their time trying to establish an MSI and SSI [medium- and small-scale-integration] standard," says Robert N. Castellano, who wrote the report. Also, the suppliers underestimated the lead times from design to chip insertion for military equipment, which drives the GaAs market (see p. 29). As a result, the worldwide market for GaAs devices will not reach the billion-dollar level until 1991, when sales will be \$1.184 billion, he says. Analog integrated circuits will have the lion's share, some \$667 million, compared with \$85 million in 1986. □

# Digital has

# it now.



A totally integrated development system for software engineering projects of any size.

Now there's a way you can meet software development challenges from integrated circuits to satellites within a single programming environment. It's Digital's integrated set of software tools with third-party applications, all running on our VAXstation™ family.

For microprocessor applications, use LANDS from Tektronix® and software tools from B.S.O. For analysis and design of larger software projects, choose SA/SD Tools from Tektronix CASE Division and DesignAid® from Nastec. Add VAXset™ software – Digital's own integrated coding, testing and implementation tools – to complete the development cycle. To find out more, write: Digital Equipment Corporation, 200 Baker Ave., West Concord, MA 01742. Or call your local sales office.

**digital**™

At 11:40 p.m. on April 14th 1912, the *RMS Titanic* struck an iceberg some 400 miles off the coast of Newfoundland. In less than three hours, the 'unsinkable' luxury liner had sunk to the sea bottom in one of the worst maritime disasters of the century. Finding her became a commitment by oceanologists and technologists alike.

Several tried. All failed. For the problems, like the tragedy, were on a grand scale. The North Atlantic is not known for its hospitality. And the freezing waters are nearly 2.5 miles deep. To add to these difficulties, not only was *Titanic's* last radio position known to be inaccurate, but fierce currents had also swept her away in a south-easterly direction.

Last year, however, after the French ship *le Suroît* had covered 80% of the target zone, the French-American expedition team embarked on the high-technology research ship *Knorr*.

This high-technology included a pair of MAGNAVOX® satellite navigation receivers - one providing highly accurate position information by tracking satellites of the new global positioning system, the other providing periodic position updates from transit satellites. With these two receivers onboard, the *Knorr* was equipped with the most precise and sophisticated marine navigation system available.

The MAGNAVOX receivers were used to criss-cross the remaining 20% of the search area, working to a position accuracy of just 35 meters. Even in heavy seas. Then, starting from the most likely spot, the underwater search vehicle *Argo* was lowered to begin close-up investigation.

At 1:05 a.m. on September 1st, 1985, her video cameras recorded the eerie outline of one of *Titanic's* mighty boilers. The seventy-three year search was over.

Little wonder that our satellite navigators are used aboard thousands of offshore platforms, rigs and ships - including *Queen Elizabeth II* - and that our global positioning system receivers are leading the way in precise navigation, on land, at sea and in the air.

Because no matter where you look, you won't find anything better.

# The secret of finding is kno



DOC-ESA/NASA





© WOODS HOLE OCEANOGRAPHIC INSTITUTION

# Knowing where to look. Philips.

From the depths of the ocean to the depths of space. One of the most demanding endeavours is the scientific exploration of the sun - a research programme conducted by NASA in collaboration with the European Space Agency, ESA.

Key to this research is SPACELAB 2; fifteen tons of advanced space technology launched in August 1985. The problem was how to ensure that, once in orbit, SPACELAB 2's platform, with the powerful telescope, could be manoeuvred under remote control without any sensitivity to the shuttle motions.

The solution was provided by three SODERN\*\* SED 04 star trackers integrated by Dornier in the Instrument Pointing System responsible for positioning the platform. Each of these electronic sensors operates to an accuracy of 0.75 seconds of arc - which is roughly equivalent to a golf ball seen from 10,000 meters. Distance, however, is no problem, for the platform responds perfectly to every command from mission control some 300 km below. Which is hardly surprising, for similar SED trackers have been operating on EXOSAT for over 3 years.

In fact, SODERN, as world leader in attitude measurement and star tracking, has been involved in major European and U.S. space programmes, providing over 90 opto-electronic systems with more than 200 years of operation without a single failure.

A convincing record of technology at the highest possible level.

**Philips. The sure sign of expertise worldwide.**

\* MAGNAVOX - a high tech North American Philips research company. The operations of Magnavox Government and Industrial Electronics Company (MAGI/EC) and its subsidiaries are conducted on a substantially autonomous basis. The stock of MAGI/EC has been placed in a voting trust to facilitate MAGI/EC's industrial security clearance with the U.S. Department of Defence.

\*\* SODERN - a high-tech French Philips research company specializing in e.g. attitude sensors for satellites and spacecraft; positioning and alignment of inertial platforms; rendezvous and docking; remote sensing of Earth resources, etc.



# PHILIPS

Circle 23 on reader service card

Philips Corporate Marketing Communications, Eindhoven, the Netherlands.  
World Radio History



Fred Molinari, President

# Here comes the most amazing data acquisition board in the VME world.

The DT1401 gives you all major input/output functions on one board – so it's literally four boards in one. You get up to 32 channels of analog input for measurement, two digital-to-analog converters, and 16 digital I/O lines for control. There's even a real-time clock for controlling the A/D sampling rate.

This amazing board gives you different A/D options for different applications. 12 or 16 bit resolution. Different gains for different input ranges. Simultaneous sampling. High speed. If you need it, this board delivers it.

For example, if you need flexibility of A/D operation, this board gives you single channel sampling or channel scanning with triggering by program control, by clock tick, or by an external event. It even has interrupt with seven-level priority.

Of course, we realize that

not all of you will need the best data acquisition board in the world, so for you we also designed the widest selection of VME data acquisition boards in the world.

Call today. As a further convenience to our customers, Data Translation provides the fastest delivery in the world.

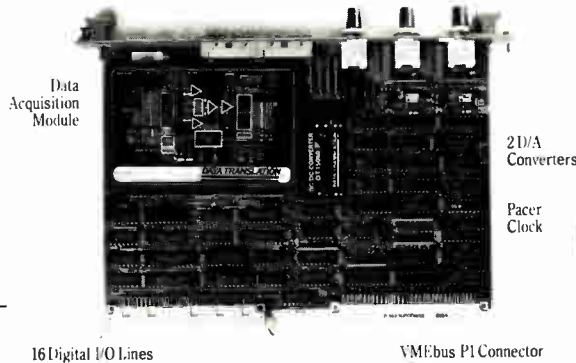

See our new 646 pg. catalog/handbook or see us in Gold Book 1986. Or call for your personal copy today.



Call (617) 481-3700

# DATA TRANSLATION

World Headquarters: Data Translation, Inc., 100 Locke Dr., Marlboro, MA 01752 (617) 481-3700 Tlx 951 646

European Headquarters: Data Translation, Ltd., 13 The Business Centre, Molly Millars Lane, Wokingham Berks, RG11 2QZ, England Tlx 851849862 (#0)

International Sales Offices: Australia (61) 2 6635289; Belgium (32) 2 7352135; Canada (416) 625 1907; Chile (2) 2-253689; China (408) 727-8222; (86) 87214017; Denmark (02) 137188; England (44) 0734 793838; Finland (358) 0 372 144; France (33) 146306839; Greece (30) 031-527039; (30) 13-614300; (30) 95 14944; Hong Kong (852) 3-324563; India (91) 2-231040; Israel (972) 3-324298; Italy (39) 2349751; Japan (81) 3 502-5550; (81) 3-348-8301; (81) 3-355-1111; Korea (82) 753-3101; Malaysia (60) 3-36299; Morocco (21) 9 30-6949; Netherlands (31) 70996360; New Zealand (61) 2 663-5289; Norway (47) (02) 559050; Peru (51) (14) 31-8060; Philippines 818 0103; Portugal (351) 1545313; Singapore (65) 271 3163; South Africa (27) 12469221; Spain (34) 14558112; Sweden (46) 87617820; Switzerland (41) 17231410; (41) 22360830; Taiwan (86) 2-721-7864; (86) 2-531-2434; West Germany (49) 89809020.

# PRODUCTS NEWSLETTER

## TWO CMOS VERSIONS OF 1750A MICROPROCESSOR INTRODUCED

**S**quaring off in toe-to-toe competition for the military digital avionics microprocessor market, Performance Semiconductor Corp. and LSI Logic Corp. have each announced CMOS chips functionally equivalent to Performance's 1750 bipolar device. Performance, of Sunnyvale, Calif., calls its 1750A the world's fastest single-chip implementation of the MIL-STD-1750A instruction set. Available in 20-, 30-, and 40-MHz versions, the fastest version executes the complete Digital Avionics Information System benchmark at 2.6 mips and consumes less than 1 W. LSI Logic's 1750A implementation is rated at 25 MHz and is available as a single device or as a cell in a larger chip. The Milpitas, Calif., company will introduce it at the 1750 users conference next week in New Orleans. □

## DESIGN TOOLS FOR LOW-DENSITY GATE ARRAYS RUN ON IBM PC AT

**M**onolithic Memories Inc. is pegging its move into the low-density gate-array market to a set of menu-driven design tools that execute all design functions, including simulation, on IBM Corp. PC AT and compatible computers. Monolithic Memory's gate-array family, built in a sub-2- $\mu$ m twin-well, double-layer CMOS process, has eight members ranging from 720 to 6,000 gates. The Santa Clara, Calif., company offers an integrator module that converts PAL designs to gate arrays, and a library of 200 TTL macros. The complete system, with the PC AT, costs \$30,000. □

## REACTOR PROMISES \$75 EPITAXY COST FOR GaAs WAFERS

**C**ystal Specialties Inc. should draw a lot of attention at Semicon in Tokyo this December. Its Model 411 metal-organic chemical-vapor-deposition reactor offers the promise of a seven-fold cut in the cost of growing epitaxial layers on 3-in. wafers in production volumes compared with molecular-beam epitaxy. Claiming a yield of 1,000 wafers a month in continuous operation, the Portland, Ore., company estimates an average epitaxy cost of about \$75 per wafer, compared with \$500 per wafer using MBE. A producer of laboratory epitaxy equipment for 12 years, Crystal claims its \$350,000 Model 411 yields research-grade results in high-volume production—specifically, high uniformity and precise junction lines for gallium arsenide and other III-V and II-VI materials. □

## FIBER-OPTIC MODEM MULTIPLEXES TO GET 19.2-K-BYTE/S DATA TRANSFER

**A** new fiber-optic modem from AT&T Technology Systems Inc. transmits data in full duplex over a single strand of fiber, multiplexing fast enough to be fully transparent to the user while maintaining the 19.2-kilobyte/s rate called for by the RS-232-C standard. Designed to replace the standard RS-232-C connector, the asynchronous RS-232-2 has two control lines and two data lines. It costs \$105 in 100-unit quantities; \$85 in orders of 1,000. □

## INMOS CASCADABLE DSP RUNS AT 320 MILLION OPERATIONS/S

**B**y combining thirty-two 16-by-16 multipliers and thirty-two 36-bit adders on a single CMOS chip, Inmos Corp. has attained processing speeds of 320 mips in its IMS A100 cascadable digital signal processor. The Colorado Springs subsidiary of the Bristol, England, company is aiming the device toward high-speed communications, radar, speech processing, and image processing. The chip will be shown at Wescon in Anaheim, Calif., Nov. 18-22 and at Electronica in Munich Nov. 11-15. The IMS A100 costs \$406 each in 100-unit lots. □

# This is a Motorola semi-custom chip.

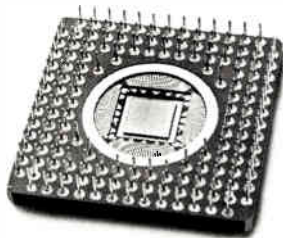

Our Application Specific Integrated Circuits offer an economical path to a wide variety of devices. Using Computer Aided Design, our customers can develop instructions that we can transform into fully-tested prototype chips in as little as three weeks.

© 1986 Motorola, Inc. Motorola and  are registered trademarks of Motorola, Inc.

**It counts.  
It compares.  
It almost thinks.  
It makes  
new products  
more helpful,  
friendly,  
courteous,  
kind and,  
saleable.**



**MOTOROLA**

Advanced Electronics for  
a More Productive World.

# EVERY BUSINESS NEEDS AN IBM-PC

## WHO WANTS TO PAY IBM PRICES?

### WE HAVE A SOLUTION!!!

FACTORY  
DIRECT

**\$799.**

STANDARD  
MODEL

~~100% IBM Compatible PC-XT~~

~~BASE PRICE \$950.00 LEASE \$39/MO~~

~~With 20 MEG Hard Disk \$1399.00 LEASE \$56/MO~~

Upon Approved Credit

Our **PC-XT SUPER TURBO COMPUTER** runs all the popular Business Programs, like Lotus 1, 2, 3, Word Perfect, Wordstar, dBase III, Homebase, Sidekick, and Flight Simulator. In addition to running the programs at the standard IBM clock speed of 4.77 Mhz, it also runs at 8 Mhz — **almost twice as fast as IBM.**

ACS has developed the fastest, most powerful XT and AT computers available today. We have also researched the numerous software programs available to automate your office. If you are considering buying a computer, call ACS. We can recommend the software and hardware system that will best solve your business needs.

#### HERE'S WHAT YOU GET

ACS-Turbo Mother Board 4.77/8.0 Mhz  
640K of RAM  
Two 360K Floppy Drives  
Heavy Duty 135 Watt Power Supply  
Keyboard New "AT" Type with Large Enter Key  
Parallel Printer Port  
Monochrome Graphics Display Card  
High Resolution Mono Monitor  
with Swivel Base and Anti-Glare Screen

#### OPTIONS

20 MEG Hard Disk	\$449.00
20 MEG Tape Back-Up	\$595.00
Clock/Calendar	\$ 59.00
Internal Modem 300/1200 BAUD	\$199.00
Okidata 192 Printer	\$399.00

#### PROGRAMS INCLUDED

Included in the purchase price is MS-DOS, the standard IBM operating system. With our Hard Disk Computer, you also get HOMEBASE, a general purpose multi-function program to perform word processing, electronic filing, and data base management. HOMEBASE has a built-in calendar, with monthly, weekly, and daily scheduling. The Homebase Calculator lets you perform calculations on the monitor and the ability to print a paper tape if desired. HOMEBASE also includes a communication program with autodialer for communication with other computers (requires a modem).



5 YEAR WARRANTY AVAILABLE

#### GUARANTEE & WARRANTY

We guarantee you will be delighted with our ACS-Turbo Computer or return it within 30 days for a refund (less shipping charges). We warranty our Turbo Computer 100% Parts & Labor for 1 year. We believe our computer is even more reliable than IBM — that's why we're offering a five-year extended warranty for only \$30.00 a year. Order early for the holidays — delivery may take over 30 days.

#### HOW TO ORDER

Call us at (818) 889-1092. We have experienced salespeople to advise you with your computer requirements. Ask for our experts — ask for Department FD.

You can charge our ACS-Turbo Computer with a VISA or MasterCard. We also have a lease plan available for qualified businesses, with payments from 36 months to 60 months.

\*IBM is a registered trademark of International Business Machines.

DEALERS  
WANTED

# ACS

5311 Derry Avenue, Suite A, Agoura Hills, CA 91301

Phone: 818/889-1092 Fax: 818/889-5605 Telex: 299 353 POST UR

EASY LINK Mailbox: 62941735 Telex: 5106018224 ACS AGRA HILLS UQ

# Electronics

## THE RACE IS ON TO DEVELOP MICROWAVE GaAs ICs FOR DOD

### MIMIC COULD DO FOR GaAs WHAT VHSIC IS DOING FOR SILICON

#### WASHINGTON

**A**dozen or more contractors submitted proposals last week to run a major new military development program that could do for gallium arsenide what VHSIC is doing for silicon technology—vastly accelerate the technological learning process. Called MIMIC, for microwave and millimeter-wave monolithic integrated circuits, the effort should give the U.S. a big boost in an area where experts say Japan currently leads.

While VHSIC (for very high-speed integrated circuits) aims primarily at logic circuitry such as microprocessors and other computational elements, MIMIC aims at producing a reliable and affordable supply of complex GaAs chips for the next generation of communications and weapons-sensor hardware. As Kenneth Entwistle, contract officer for the MIMIC effort, says, "VHSIC is the brains, while MIMIC is the eyes and ears."

Such GaAs devices are not being produced commercially because of excessive costs and technology limitations. DOD planners concluded last year that these parts might never surface without a program to encourage their development.

Procedurally, MIMIC resembles the VHSIC effort, which was launched for similar reasons more than five years ago and is now starting to turn out silicon ICs for military customers. And as MIMIC picks up momentum, the tie between the two will become closer, since they will be run by the same officials, according to a spokeswoman in the VHSIC office. Lead agency for MIMIC is the U.S. Army's Electronics Technology and Devices Laboratory in Ft. Monmouth, N.J., which received last week's industry bids for the initial Phase 0 stage.

The reliability goals of MIMIC are much more stringent than for previous GaAs chips. Failure rates for packaged chips cannot exceed 0.006% per 1,000 hours, at a 60% statistical confidence level, operating over the full military

temperature range of  $-55^{\circ}$  to  $+125^{\circ}\text{C}$ .

The Army document that seeks Phase 0 proposals is called a Broad Agency Announcement and is considered by military contractors to be a way of streamlining initial procurement. About 300 announcements went out, and—based on the DOD's experience—up to 15 contractors, most of them working in teams, are likely to respond. The VHSIC office plans to issue a formal request of its own for proposals later this year, but contractor sources say that the same companies will likely take part, and the Army and VHSIC-office MIMIC programs would essentially merge.

Among the teams bidding on MIMIC

"technology road-map/plan" leading to building devices in Phases 1 and 2, the outlines of the entire program are clearly visible. Besides calling for the expected requirements for computer-aided design techniques, circuit layout, and testing, MIMIC also emphasizes the need to improve materials and manufacturing processes in order to achieve higher-volume production and reasonable yields, both of which are major problems for GaAs chip makers. Phase 3 sets up research programs at industry and university labs at the same time as the Phase 1 and 2 devices are developed.

Volume "is the key issue for the kinds of very complex circuits MIMIC needs," says Robert N. Castellano, a San Francisco-based market analyst. "Not enough experience has been gained so far in turning out large-scale GaAs ICs. Everybody is still at the SSI and/or MSI level." Castellano, president of The Information Network, recently completed an extensive study of the GaAs business. He says that only the U.S. military has the buying clout to spur GaAs development.

The small circle of GaAs chip makers is enthusiastic about MIMIC, which can foot the bills for expensive, and heretofore largely neglected, research. "There's a tremendous need for improving the technology across the board," says Hughes Aircraft Co.'s Eugene H. Gregory, in a typical view. He agrees that yields and volume have high priority, but he says the basic materials step—growing better GaAs crystals—is a key job. Gregory heads Hughes' MIMIC effort for the Radar Systems Group, El Segundo, Calif., where he also is chief scientist of the Rf System Laboratory.

The types of circuits sought by MIMIC typically operate above 2 GHz, combine digital and analog functions, and integrate a number of passive and active components (see figure). Castellano points out that their complexity makes

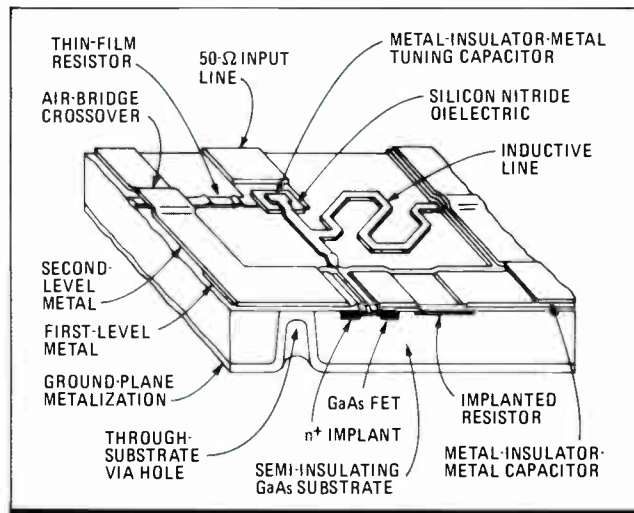

**TRICKY.** The Pentagon is moving to spur development of microwave GaAs chips, whose many features make their fabrication complex.

are GM-Hughes Electronics and General Electric, Texas Instruments with Raytheon, Westinghouse Electric and Rockwell International, and TRW with Honeywell.

The word among contractors is that perhaps nine will be chosen around late January for the 12-month Phase 0. Follow-on Phases 1 and 2 will likely run 36 months each, and Phase 3 will be carried out in parallel with them. DOD is asking for upwards of \$135 million to fund MIMIC for the 1987 fiscal year.

Although the Phase 0 announcement asks prospective suppliers only for a

them very difficult to build—they require up to 11 mask levels, including a metal-semiconductor FET structure.

But the GaAs performance is indispensable for transmitter and receiver modules in new phased-array radar systems, satellites, and avionics packages. Such top-priority programs as the Milstar satellite program and radar for the Strategic Defense Initiative are among

many potential applications.

Because speed is inherent in GaAs devices, MIMIC does not emphasize performance, as does VHSIC, but it does require substantial radiation hardening. The MIMIC circuits must operate in a radiation environment of at least  $10^6$  rads, compared to the total-dose requirement of  $5 \times 10^4$  rads for VHSIC Phase 2 devices. —Larry Waller

One reason for IBM's two-tiered approach of first proving designs at  $1 \mu\text{m}$  and then shrinking them by half may be a switch in tactics—though Big Blue isn't offering an explanation. In Phase 1, it used n-MOS technology to produce its  $1.25\text{-}\mu\text{m}$  parts. Now it is switching to CMOS, essentially starting over. Bob Estrada, VHSIC program manager at the Federal Systems Division, says IBM shifted because "we believe CMOS is really a preferred technology for DOD systems."

CMOS technology's small appetite for power makes it ideal for military systems that often rely on battery or generator power, Estrada says. Moreover, "the real benefit of CMOS is that it is also attractive from a radiation-hardening point-of-view," an important consideration since such hardening is mandated in the VHSIC contract. CMOS also offers very good performance and density profiles when contrasted with competing technologies, he says.

**GROUNDWORK.** In proving its  $1\text{-}\mu\text{m}$  CMOS process, IBM is laying the groundwork for what it hopes will be an easy migration to smaller line widths. The  $1\text{-}\mu\text{m}$  technology supports between 20,000 and 50,000 equivalent gates on each chip. So far, it has produced functional  $1\text{-}\mu\text{m}$  devices for its bus interface unit and an 18-K configurable static RAM chip, which carries some logic in addition to memory. IBM's other three parts are on the  $1\text{-}\mu\text{m}$  pilot line now.

One of the three chips is a signal processor for which IBM is building elements—memory modules, switching modules, and processor modules—that can be tailored for service in a number of military programs, including the Generic Space-Borne Computer being developed for the Strategic Defense Initiative. —Tobias Naegele

## MILITARY

# IBM HITS 1-MICRON LEVEL ON PHASE 2 VHSIC CHIPS

### NEW YORK

The race to produce  $0.5\text{-}\mu\text{m}$  chips for Phase 2 of the Defense Department's Very High Speed Integrated Circuits program is tightening up. IBM Corp. revealed last week that it has produced functional prototypes of two  $1\text{-}\mu\text{m}$  chips for Phase 2. It says it will have first silicon of  $0.5\text{-}\mu\text{m}$  parts by mid-1987.

The other two competitors in the hard-fought race, TRW and Honeywell, also have recently delivered test chips to the DOD. All three companies are proving out their technology.

To meet the requirements of the four-year Phase 2, the contractors must produce working chips with  $0.5\text{-}\mu\text{m}$  design rules by 1988. The three are following different strategies—IBM, for example, is using CMOS for its five-chip set, and Honeywell is using bipolar technology to produce its five devices. TRW plans a set of six "superchips," which will incorporate features such as self-configuration, a triple-redundant bus, and automatic repair using on-chip spare components. Four of them will be built in CMOS, and the other two will use triple-diffusion bipolar technology [*Electronics*, July 10, 1986, p. 49].

IBM's Federal Systems Division, Manassas, Va., appears to have a slight edge over TRW and Honeywell with its new  $1\text{-}\mu\text{m}$  prototypes. Shrinking the designs to the required  $0.5 \mu\text{m}$  is still a major challenge, but the company has processed some test devices at  $0.5 \mu\text{m}$ .

**GOING FOR BROKE.** Honeywell, however, is the surprise contender. It is pushing directly from the  $1.25\text{-}\mu\text{m}$  technology of Phase 1 to the  $0.5\text{-}\mu\text{m}$  requirements of Phase 2. George A. Anderson, VHSIC submicron program director for Honeywell's Solid State Electronics Division in Plymouth, Minn., says the company expects to send its first  $0.5\text{-}\mu\text{m}$  circuit design, a bus interface unit, to the foundry before the year's end.

The bus-interface chip, which is scheduled for September 1987 delivery, will be joined on the line by an array processor unit, the largest of the set with

about 30,000 gates, and an 18,000-gate array processor controller. The final ICs in Honeywell's set are two 50-MHz memories built with Phase 1 technology: an 18-K random-access memory and a 144-K read-only memory.

The Honeywell bus-interface chip will integrate about 16,000 gates. It will eventually be enlarged to encompass about 28,000 gates for use in a brass-board demonstration of an electro-optic signal processor scheduled for October 1988. Honeywell, which is using electron-beam technology for 12 of the 14 production steps, will get first-pass parts on the other two logic circuits late in the third quarter of 1987, according to Anderson.

TRW Inc., meanwhile, is developing and testing its technology piecemeal, producing devices that incorporate only elements of the circuits it hopes to produce. This approach tests the macrocell architecture of TRW's superchips. TRW says it has a 750-K memory now in fabrication using both the  $1.25\text{-}\mu\text{m}$  CMOS design rules developed under Phase 1 and some  $1\text{-}\mu\text{m}$  features.

## INTERNATIONAL TRADE

# EQUIPMENT MAKERS BID TO MODIFY IC TRADE PACT

### SAN MATEO, CALIF.

Increasingly worried that high prices being set for Japanese memory chips by the Commerce Department will drive their manufacturing offshore, U.S. equipment makers are trying hard to meet as soon as possible with U.S. chip makers. Their goal simply is to gain the support of semiconductor manufacturers in modifying the U.S.-Japan semiconductor trade agreement. "An alliance between users and semiconductor management is one way to get a lot of

political leverage in Washington," says Andrew J. Kessler, industry analyst at PaineWebber Inc., in New York.

The American Electronics Association is the prime mover in setting up the talks, which will not include either Commerce or the Office of the U.S. Trade Representative. "There is a very clear need for a producer-user dialogue," says AEA vice president Ralph Thomp-



**THOMPSON:** U.S. chip makers and users need to set up dialogue, says AEA vice president.



son. For three months, chip users have waited for relief from the high "foreign market values" set under the terms of the trade agreement—and they found the prices released in mid-October not much more satisfying than the initial figures, which came under heavy fire from users when they were set in August [*Electronics*, Sept. 18, 1986, p. 32].

"While the new FMVs are lower than the first round, they are still too high," says users' group chairman Stephen C. Schmidt, chief operating officer of Tandem Computers Inc., Cupertino, Calif. "There is a real risk that the electronics industry is going to continue to seek alternative methods—specifically offshore purchasing and manufacturing—rather than buy at these prices."

But the users leave no doubt that they would rather talk than flee offshore. "We want to meet with the semiconductor makers to find a more viable, proactive way to revitalize the semiconductor industry," Schmidt says. "Putting higher prices on parts not made here anyway won't help them."

It is the pricing assigned to dynamic random-access memories, for which there are few U.S. suppliers, that is the burr under the users' saddles. Accustomed to stuffing boards with cheap Japanese DRAMs, chip users balk at paying a premium that they claim handicaps them against foreign competition. There is much less controversy over erasable programmable read-only memories, for which there are many U.S. suppliers and no big price differentials.

Chip makers say the FMV structure is based on true costs and that the users are trying to perpetuate an unfair market practice in which they can buy below cost.

The AEA, whose membership includes both producers and users of semiconductors, took the lead in arranging a meeting between them, and last week Thompson began contacting each side. The initial response from the semiconductor faction was cautious but positive. "Any extent to which we can develop further understanding of the trade agreement is worthwhile," said George Scalise, vice president of chip maker Advanced Micro Devices of Santa Clara, Calif., and government affairs representative of the Semiconductor Industry Association.

The plan for negotiations is one of the first suggestions from the AEA semiconductor users' group, which was

formed last month to make a belated response to the chip agreement. The systems houses did not take part in the long negotiations leading to the agreement, an omission they are beginning to see as a serious mistake.

"The semiconductor group has been working on this problem for a year and a half," says Edwin Lee of Prolog Corp., Monterey, Calif. "The process went on without adequate involvement of the downstream people. There was an honest attempt to protect us, but it wasn't good enough."

Having missed the chance to influ-

### *System builders want a say in how the trade pact is implemented*

ence the agreement itself, the AEA group wants a say in how it is implemented. It would like to eliminate the setting of FMVs, for instance, on chips that are not offered by any U.S. supplier, such as certain high-performance 1-Mb DRAMs. The AEA will promote such goals in further meetings with Commerce Secretary Malcolm Baldrige and Under Secretary Bruce Smart.

The users agree that they can not live with the new FMVs, Tandem's Schmidt says. Even the lower 256-K DRAM prices of \$2.50 to \$4 are too high, they say, because the parts are available in

Japan for \$1.75. With that kind of differential, says Lee, "there will be a migration of jobs to Japan to do board- and system-level manufacturing."

Users trying to buy U.S.-made DRAMs have few choices. Micron Technology Inc. of Boise, Idaho, is about the only game in town. Texas Instruments Inc. is just beginning to ramp up production in its new Dallas DMOS IV line. **LINE FIXED.** While TI says "a significant share" of its fourth-quarter DRAM production will come from Dallas, the new plant lags far behind its twin in Miho, Japan. The Dallas plant, which was opened a year ago, has been modified since coming under the control of the Miho management last spring [*Electronics*, June 2, 1986, p. 11].

NEC America Inc., Mountain View, Calif., the subsidiary of Japan's NEC Corp. that is the other U.S. DRAM source, says it is not accelerating production at its Roseville, Calif., plant beyond normal rates. In fact, most Japanese DRAM makers are reportedly cutting production in the face of a glut that is overflowing into the gray market.

Schmidt says the lure of Japanese parts and offshore production could change purchasing habits in ways that would be hard to reverse. "There are other parts on those boards besides memories," he says. "There will be a tendency to buy those overseas, too."

Moving offshore, however, is not a panacea. Michael Boman, purchasing di-

## THE TRADE PACT SPARKS A THRIVING GRAY MARKET

**At least one** form of Japanese export business has taken off since the U.S.-Japan semiconductor trade pact was signed: the gray market.

Small trading houses shipping 256-K dynamic random-access memories to customers in Taiwan and Southeast Asia at unit prices close to \$1.85 are apparently getting all the business they can handle. But the major Japanese chip makers' exports generally are as flat as a wafer, although the products of each had different "foreign market values" (FMVs) assigned to them by the U.S. Commerce Department in mid-October, and at least two Japanese companies are fairly well pleased with the FMVs they were assigned.

The Japanese Ministry of International Trade and Industry is demanding full production information from the major makers before it will grant export licenses, but it

hasn't cracked down on the small exporters, perhaps because they're shipping to Asian markets, not the U.S.

Chip users in the U.S. say there's no shortage of cheap memory in Asia. "Both governments have been optimistic about their ability to police these markets, but they haven't been able to do it," says one user, who declines to be identified. "Even within the context of the agreement, there are lots of ways to get cheap parts. They are available in Japan: a broker who buys parts from a Japanese company will have to agree not to ship them out of the country, but that buyer can resell to another party without that provision."

The major chip makers depend heavily on the U.S. market, and they are reporting mixed effects from the trade pact. NEC Corp. appears to be in the best position to sell in the U.S. Its

FMV price is about \$3 for 256-K DRAMs, and it has a U.S. plant that makes DRAMs, which it can sell for any price it chooses.

Toshiba Corp., the leading 1-Mb DRAM maker, is said to be delighted with the \$19.31 value assigned to it for those chips. Industry sources say the company is selling 1-Mb products for as little as \$15 in the Japanese market, where the average price is close to \$22.

At Hitachi Ltd., third-quarter U.S. sales are down from the second quarter, and its FMV of \$4.01 for 256-K parts is not helping. Fujitsu Ltd., which didn't provide enough data for FMV evaluation, reportedly has been tagged with an even higher \$4.50 figure, and industry sources say the company, more dependent on memory-chip sales than the other DRAM makers, is in deep trouble.

—Michael Berger

rector of the Kaypro Corp., San Diego, says the rush of systems houses to establish offshore facilities has clogged up the channels to the point at which it may take three to six months to set up a reliable manufacturing site. "By the time the bugs are out of it, we could be past the DRAM problem," he says.

Many users pin their hopes on achieving some sort of détente with semicon-

ductor suppliers. There's no clear idea of how to do that, though, because the chip makers, still mired in the worst slump in industry history, see the trade pact as an important barrier to further encroachment by Japanese firms. "We need to work in an interdependent way to recapture semiconductor manufacturing in the U.S.," the AEA's Thompson says.

-Clifford Barney

of the encrypted label to see who owns it. If the user is not authorized to access the file, the system will put the label back and leave the file safely on the disk," explains Goode.

The label does not interfere with the operating system or application programs. It provides what is called access control to data objects, such as spreadsheet and word-processing files. This opens up the possibility of adding utilities and operating-system services for access control similar to those used in large multiuser environments.

Goode says the system has hooks in it to incorporate the security features into other software packages. Micronyx is negotiating with several large software houses in Europe and personal-computer program vendors in the U.S. to modify their software so it will support Triad.

"We don't claim that this is hacker-proof," Goode says. But he adds that his engineers have cracked all competing products on the market in about 30 minutes.

**HARD TO COME BY.** Triad's kind of security doesn't come easy. Goode says he talked with seven U.S. federal agencies, the armed services, the White House, three British government branches, and nearly 50 companies as part of the research and development work on Triad. He came up with 25 principles aimed at securing personal computers without disturbing their operation. "We have erected a very sophisticated technical gateway that forces a user to expend an enormous amount of time and money before he can steal anything," he says.

The National Computer Security Center, a division of the Defense Department, has begun an initial evaluation of Triad and Micronyx's underlying personal-computer-security system, which is known as the Workstation Management Architecture. Micronyx hopes the two-stage evaluation and development process—which can take up to three years to complete—will result in a DOD-approved high-security personal-computer system for the military.

One way the Triad technology could be tailored for government use is in a file-backup system that would allow a mainframe to copy all the hard disks in the attached PCs and then erase the original data at the end of a work day. "This happens every day in the government environment, where sensitive files are collected at the end of the day

**LOCK IT UP.** Micronyx's personal-computer-security system uses an electronic key and encrypts files.

## DATA PROCESSING

# A NEW WAY TO TIGHTEN SECURITY IN PC NETWORKS

### RICHARDSON, TEXAS

User-friendliness is something everybody wants in a personal computer—except security-conscious managers who are worried about the vulnerability of PC networks to unauthorized access. Now, however, a Texas microsystems-engineering company says it can resolve the conflict between easy operation and secure operation with a protection mechanism that can lock out unwanted access to hardware or software.

Triad, which Micronyx Inc. plans to introduce next month at Comdex in Las Vegas, is one of the latest personal-computer-security products aimed at assuaging fears over the unbridled use of desktop computers in large networks—fears that executives at Micronyx, in the Dallas suburb of Richardson, say are far from unfounded. Information leaks cost U.S. businesses between \$100 million and \$500 million worth of data every year, the company says. Personal computers in large networks can aggravate the problem—they function as a giant, unlocked file cabinet, connected to a lot of built-in, high-speed copiers. Micronyx and others in the business want to reconcile the inherent lack of security of single-user personal computers with network environments, says Micronyx president W. Mark Goode.

**NEW TWISTS.** As its name implies, Triad takes a three-pronged approach to security. Like some existing security products, it puts proprietary software and expansion boards to work behind the scenes while application programs run on IBM-compatible personal computers. But to better prevent unauthorized access to personal computers, peripheral ports, and encrypted files stored on disk, Triad adds a couple of new twists. First, the system double-checks users after they turn on the machine. It uses an electronic "key" inserted into a socket in a half-sized expansion card. Second, a file-labeling technique limits access to files to authorized users.

The card, which contains memory and both semicustom and standard logic,

performs background processing to prevent the security tasks from bogging down the computer's central processing unit. The key, made by Dallas Semiconductor Corp., is a small cartridge containing user-verification data in memory kept alive by a lithium battery. The key cartridge has built-in mechanisms that prevent its data from being copied.

Micronyx's file-labeling technique allows computer users exclusive access to designated software and data. The labels, which consist of 24 bytes of ownership information, tell Micronyx's hardware who created the data object, when it was created, and what can be done with it. The data or software is encrypted by Triad, which intercepts the files and inserts the label before they are stored on disk. The label itself is also encrypted.

"When a file is called up by a PC user, the system takes out just enough



# A new direction in interconnection technology.

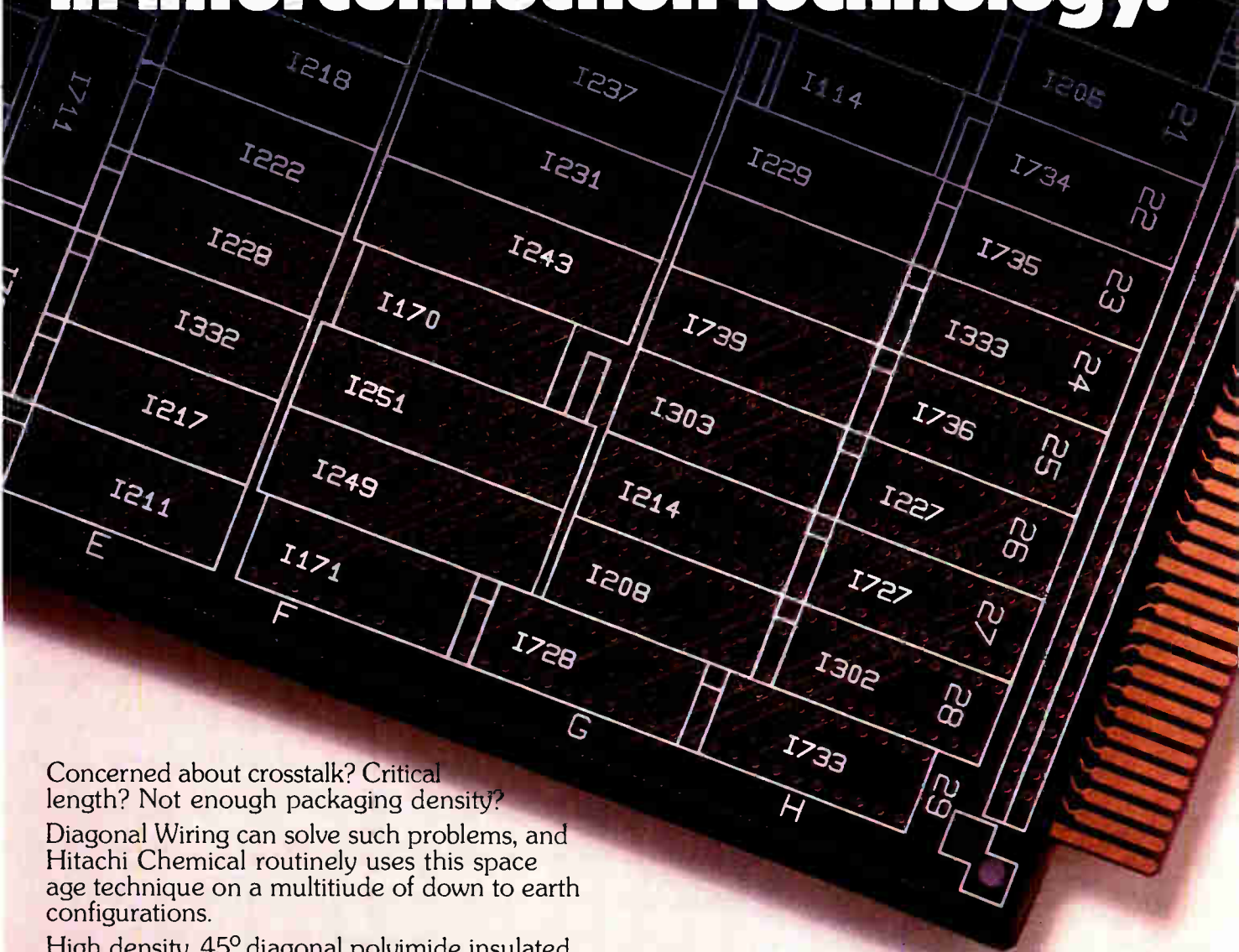

Concerned about crosstalk? Critical length? Not enough packaging density?

Diagonal Wiring can solve such problems, and Hitachi Chemical routinely uses this space age technique on a multitude of down to earth configurations.

High density, 45° diagonal polyimide insulated wiring reduces parallel lengths of critical conductors and decreases point to point routing distance.

This minimizes crosstalk, facilitates critical length considerations, isolates special logic families like ECL, and greatly increases packing density. Multiwire® interconnection technology also makes controlled impedance easy.

Let us help you with your next board design. Hitachi offers a different angle with Multiwire interconnection boards including SMT and the latest trends.

## HITACHI CHEMICAL COMPANY AMERICA LTD.

**Sales Offices:** 3469 Lawrenceville Hwy.  
Suite 205  
Tucker, GA 30085  
(404) 938-9388

420 Lexington Ave.  
New York, NY 10170  
1-800-227-1529

4141 Blue Lake Circle  
Dallas, TX 75234  
(214) 960-9675

1333 Lawrence Expwy.  
Santa Clara, CA 95051  
(408) 244-2570

2000 West Park Drive  
Westborough, MA 01581  
(617) 366-4092

Multiwire® is a registered U.S. trademark of the Kollmorgen Corp.



**Hitachi Chemical Co. Ltd.**

Circle 33 on reader service card

# How BURR-BROWN Create The High Resolution

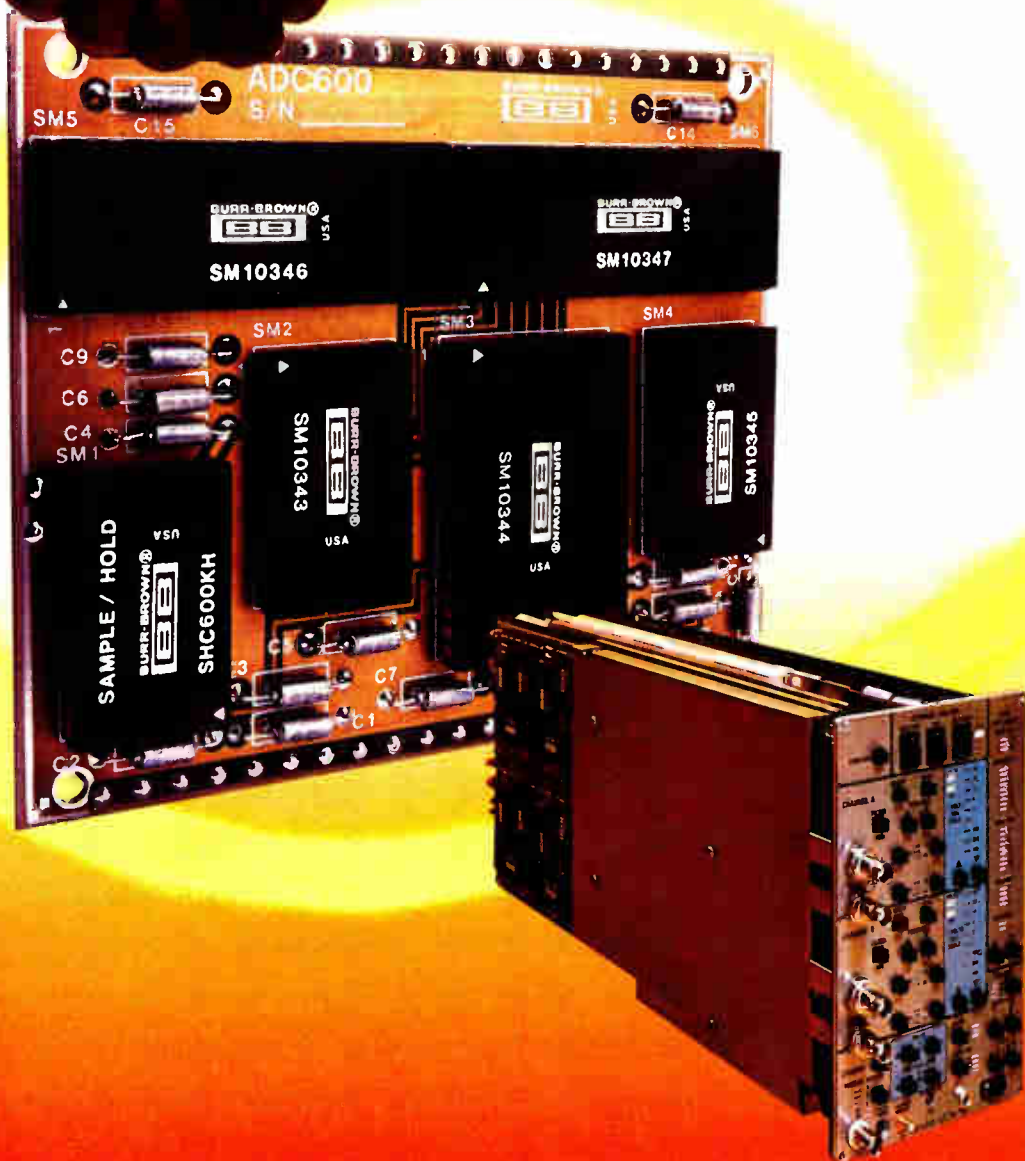

# Helped Nicolet Industry's Fastest Digital Storage Oscilloscope

## The new ADC600 gives Nicolet's 4094 DSO System 12-bit resolution with 8-bit speed

When Nicolet wanted both high resolution and ultra-high speed for its new DSO digitizer module, they brought their specs to Burr-Brown, the leader in high performance analog-to-digital conversion technology. They left with a handshake commitment to solve their problem. They got the ADC600 12-bit, 10MHz sampling A/D converter.

*"... more than we asked for."*

*"We subjected the Burr-Brown ADC600 to a series of tests including noise, distortion, linearity (differential and integral), and bandwidth at frequencies from DC to above 10MHz. The results of these tests, plus the straightforward interface to our system, convinced us to select the ADC600 for our application. They gave us more than we asked for."*

**Jim Hyatt**  
Product Design Manager  
Nicolet Test Instruments Division

ADC600 is the first high resolution, ultra-high-speed sampling converter to combine small size, low power dissipation, and straightforward interfacing in a reliable, low cost design. It's complete with sample/hold, encoders, reference DAC, and timing circuits on a space-saving,

17-square-inch printed-circuit card. And it's easy to use, requiring only external power supplies and CONVERT command for operation.

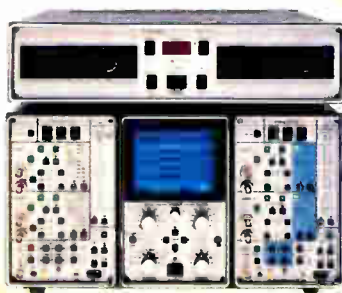

### Key ADC600 Specifications

Resolution .....	12 bits
Sampling rate .....	10MHz min
Linearity error (200Hz) ..	$\pm 1.25$ LSB max
Harmonic distortion ( $F_{IN} = 1$ MHz to 5MHz) .....	65dB
Input range .....	$\pm 1.25$ V
Signal-to-Noise Ratio .....	70dB
Power dissipation .....	8.5W
No missing codes .....	0 to +70°C

With ADC600, Burr-Brown continues a thirty-year tradition of solving customer problems through innovative designs, high quality manufacturing, and dedicated customer service and assistance.

*"Customer response  
has been excellent."*

*"The ADC600 provides state-of-the-art high-resolution digitizer performance in our already powerful 4094 digital scope. Many applications require 12-bit precision but also 8-bit speed; the Burr-Brown modules do both. Customer response has been excellent."*

**Dale Baldwin**  
Marketing Manager  
Nicolet Test Instruments Division

If you have a data conversion problem, we invite you to contact Burr-Brown. You may be only a handshake away from the solution.

Burr-Brown Corporation  
P.O. Box 11400, Tucson, AZ 85734  
602/746-1111



Improving Data Conversion  
Productivity

and put under lock and key," Goode notes.

Micronyx is not alone in its pursuit of government and corporate personal-computer-security business. For example, Fischer-Innis Systems Corp., Naples, Fla., has been marketing Watchdog, a software-based product, since 1983.

While Triad's end-user cost will be \$795 in single-piece quantities, Fisher's all-software approach keeps the retail price down to \$295 and avoids the use of expansion slots. Some competitors, however, say protection packages that rely solely on software are vulnerable to hackers.

-J. Robert Lineback

several years. Harry Scholz, the IC packaging expert at Bell Labs in Allentown, Pa., who led AT&T's delegation to the meetings, was surprised that competitors were unwilling to go along. "We thought using bumpers was the best way to go about protecting the leads, but we really got shouted down," he says. "We kind of went away with our tail between our legs."

## PACKAGING

# HIGH PIN-COUNT ASICs MAY GET NEW JEDEC PACKAGE

### NEW YORK

**A** new family of high-pin-count chip carriers for application-specific integrated circuits has a good chance of becoming a Jecdec standard before the year is out. The new package is the result of the efforts of Indy Electronics Inc., a Manteca, Calif., company that assembles chips in packages, and a group of chip vendors that agreed that far too many package types are being used for high-pin-count ASICs.

The seven plastic carriers, with pin counts ranging from 52 to 244 pins, use gull-wing leads set on 25-mil centers. Small bumpers protruding from the flat packages' corners protect the delicate leads during board assembly and allow chips to be mounted for maximum board density. The technique was pioneered by AT&T Co.

Indy Electronics set out to organize a committee of industry experts to develop a standard when orders for packages with more than 100 pins started coming in last winter. Indy sold the idea to several major chipmakers, among them Intel, Motorola, National Semiconductor, IBM, and AT&T. After several months of wrangling over competing designs and methodologies, the Ad Hoc Committee on High-Pin-Count Plastic Chip Carrier Standardization emerged from a meeting in August with a proposal for Jecdec's JC-11 packaging committee. Late last month, the Jecdec committee overwhelmingly approved the measure. It is now before the general membership on a special ballot, and the vote should be in by mid-November.

**100 PINS.** "We received numerous calls in the last year from customers who were going to require packages that had more than 100 pins," says Jeffrey Braden, vice president for advanced technology at Indy. "So we perceived a need, especially for ASIC and systems-house guys, to develop a standard."

The first meeting, held at Semicon West in May and scheduled to last only half a day, drew 13 companies and about 20 engineers, Braden says. Support grew. Forty-eight people from about 20 companies attended the second

meeting, and at the third meeting, in August, more than 50 people from 33 companies were on hand. It was at that gathering that the issue of whether or not the packages should include the protective bumpers came to a head.

"When you're dealing with fine-pitch packages, the leads are very difficult," Braden says, explaining why bumpers

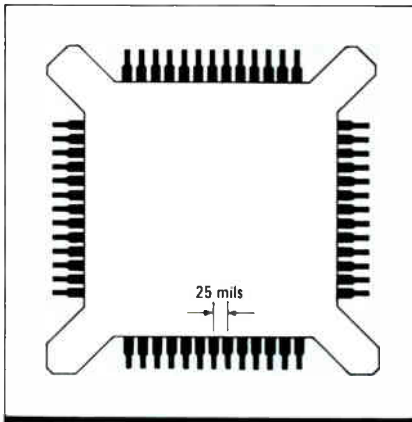

**BUMPERS.** AT&T's chip carrier with lead-protecting bumpers may soon be a standard.

are useful. "At the second meeting, the committee almost overwhelmingly voted down the bumpers. It wasn't until the third meeting that we began to see a strong sentiment to keep them."

The bumped package was developed at AT&T Co.'s Bell Laboratories and has been in use for certain AT&T parts for

several years. "That swayed a lot of our competitors," Scholz recalls. It didn't sway everyone. Signetics, the Sunnyvale, Calif., subsidiary of Philips NV, for example, opposed the proposal at the August meeting. "The addition of a new package family will only increase confusion, because we already have so many different packages for surface-mounting," says Francisco Osegueda, a Signetics packaging engineer.

**COMPROMISE.** Signetics has softened its stand, however, adopting a wait-and-see position. The design has merit, Osegueda says, adding that using bumpers is "a very good concept." Scholz says AT&T was willing to compromise on some of the finer issues to get its basic package accepted as a standard.

The job is not finished yet. Indy and Intel Corp. are still working on a standard for the lead frames the packages will need, and Jecdec approval is likely. Braden believes "there is about a 50% chance it will become a standard at the December Jecdec meeting." Failing that, he puts odds at 99.9% that it will be a standard by March.

Indy is already gearing up to make the packages. "We will have the 100-lead version tooled and ready for samples by Nov. 1," Braden says. "The 132-lead part will be ready by Feb. 1."

-Tobias Naegele

## NETWORKING

# SOFTWARE MAKES NETS TRANSPARENT TO USERS

### NEW YORK

**A** communications software package could go a long way toward rendering moot the competition among supporters of Ethernet, token-ring, and other local-area-network technologies. Touch Communications Inc. says its product allows different LAN implementations to work so well together that

users won't care what kind of network it is to which they're connected. The LANs themselves will become invisible.

The software, called Touch OSI, is now being tested at the Boeing Computer Services Group, a Seattle-based subsidiary of The Boeing Co. Boeing is using it to connect computers that use different operating systems—IBM Corp.

# Before you explore outer space, explore our rad-hard 16K RAMs that survive mega-rad doses!

## Mega-rad RAMs with guaranteed survivability!



When you want mega-rad parts — not mega-promises — come to Harris, the mega-rad leader. We'll give you guaranteed performance:

- **Latchup free**...achieved using epitaxial starting material.
- **SEU immunity option**...cross-coupled resistors in the memory cells prevent soft errors.
- **DASH-Q Hi-Rel flow**...for space applications; perfect for communication, scientific, and military satellites.
- **6-Transistor memory cell**...lowest power consumption, maximum cell stability, radiation-hardened data protection no 4-T design can match.
- **CMOS/TTL compatible**...completely static operation with three-state output and CMOS or TTL-compatible inputs.

### • Selection of rad-hard CMOS RAMs:

Organization	Part Number	Access Time (Typ.)
<b>Synchronous</b>		
1K x 1	HS-6508RH	160 ns
256 x 4	HS-6551RH	160 ns
4K x 1	HS-6504RH	150 ns
1K x 4	HS-6514RH	150 ns
64K Module 8K x 8 16K x 4	HS-6564RH	250 ns
<b>Asynchronous</b>		
16K x 1	HS-65262RH	100 ns
2K x 8*	HS-65162RH	100 ns

\*Samples available 4 Qtr. 1986

For more information on the HS-65262RH RAM and the complete Harris rad-hard family of Memories, MUXes, Op Amps,  $\mu$ Ps, Analog Switches and Gate Arrays call (305) 724-7521. Or write: Harris Custom Integrated Circuits Division, P.O. Box 883, MS 53-035, Melbourne, Florida 32902-0883.



FOR YOUR INFORMATION,  
OUR NAME IS

# HARRIS

Harris Semiconductor: Analog - CMOS Digital  
Gallium Arsenide - Semicustom - Custom



"What can Harris  
rad-hard ICs  
add to your career?"

"Guaranteed survivability!"





**NETWORK ERASERS.** Touch Communications' Bass and McGann are working to make networks transparent to users.

Personal Computers running under PC-DOS and Digital Equipment Corp. machines running under VMS.

Touch Communications, Scotts Valley, Calif., is the newest venture of networking veteran Charlie C. Bass, cofounder of the well-known LAN vendor Ungermann-Bass Inc. The company has already demonstrated that its new software can act as an internetwork router, connecting Manufacturing Automation Protocol and Technical Office Protocol (MAP and TOP) networks.

**NO INTERVENTION.** If the Boeing tests go well, applications running on DEC equipment situated at Ethernet nodes will be drawing data from IBM gear at token-ring nodes, and vice versa, without user intervention. Although a similar product, from Retix, a Santa Monica, Calif., software house, can also connect dissimilar equipment, it requires the user to integrate the LAN package with the various local operating systems.

Touch OSI is based on the higher levels—layers 3 through 7—of the Open Systems Interconnection reference model, which provides a framework for communications between dissimilar processors. Developed by the International Organization for Standardization, OSI is a seven-layer partitioning of logical entities that provide different classes of network services: the lower layers provide transmission services and the upper layers support applications processes.

Touch OSI intercepts input/output requests and maps them to basic file-transfer access management (FTAM) operations described in the OSI model. By doing so, it makes all networks and services appear as extensions of the user's computer. "The significant value [Touch Communications] is adding is transparency" between the two operating systems, says Laurie Bride, manager of networking technology in Boeing's Network Services Group.

To implement that transparency, the Touch software acts as an interface that appears as a set of modules for applications programmers writing I/O routines

for file-based operations. The modules match the various models and libraries that accompany the programming languages the developer is already familiar with. They make it as easy to write an I/O operation for a remote printer or disk drive as it is to write one for a local device.

"The common [programming] model for integrating Touch OSI is to intercept local I/O requests," says L. Brian McGann, Touch's vice president of engineering. "We work with any local file access, turning it into an elemental file-system request and determining if there is a network request. If it is a network request, we map the I/O request to a sequence of FTAM operations. Any remote machine that is FTAM-compliant reacts, and then we map the data back into the local environment. This is at such a low level that the user and application don't know that they are not operating in the local environment."

Similar software from Retix provides implementation of layers 2 through 7 of the OSI model; it has been available for about a year. But Retix leaves it up to the buyer to integrate the OSI protocols into the local operating system, unless

the buyer signs a contract to have Retix do the work, says M. Charles Fog, vice president of marketing for the Santa Monica company.

Like Retix, Touch Communications claims its products conform to MAP and to TOP, MAP's counterpart for office-automation communication, as well. The product does not have formal MAP certification, concedes Dennis Morrison, general manager of Touch OSI products. But he points out that it has been used for linking MAP and TOP networks. He cites the successful May demonstration of a layer-3 network router between IEEE 802.3 Ethernet networks and 802.5 token-ring networks at the first combined meeting of MAP and TOP users' groups, which was held in Seattle last May.

**'CULTURALLY CONSISTENT.'** However, Touch Communications executives insist that Touch OSI is more than a gateway between two dissimilar networks. What makes it important is its potential for ease of communication among different kinds of computers, Morrison says, since it provides a "culturally consistent" interface for users: as they create, copy, or move files between dissimilar machines, they use the command syntax of their own machine. Users do not have to learn operating-system command structures they don't already know, Morrison says, because "all network resources appear in a syntax the user is familiar with." —Robert Rosenberg

## CONSUMER

# IN 1,500 CENTURIES, THIS CLOCK WILL LOSE 1 SECOND

### SCHRAMBERG, WEST GERMANY

One of technological man's oldest dreams is a device that measures time with the utmost accuracy and that runs indefinitely without human intervention. Such a perfect timepiece has become reality at Junghans Uhren

GmbH, a 125-year-old Schramberg company.

The RCS 1—for radio-controlled solar—keeps track of time so precisely that it will take 150,000 years for it to deviate 1 second from astronomical time. This precision derives from a cesium atomic clock, the most exact time standard today.

There are no plans to enter the mass market with the RCS 1 as it is built now. Rather, now that a prototype has been made, plans call for building another 156 by the year 2000—that is, one per month till the end of this century—at a prestige price of more than \$20,000.

Junghans expects competition, however, and to stay a step ahead, it is working to miniaturize the design and to get the cost down to a level that consumers will accept. Wolfgang Ganter, director of development

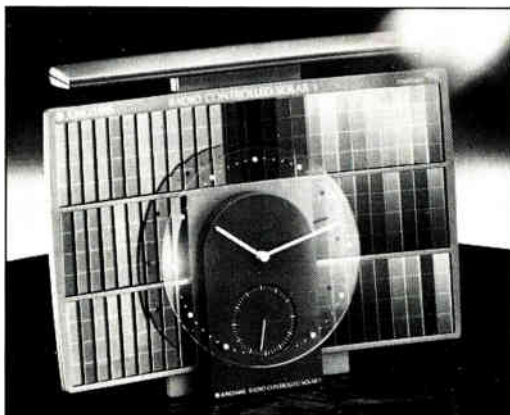

**ULTRAPRECISE.** The RCS 1 clock picks up radio signals controlled by a cesium clock and adjusts itself.



# WANTED CYPHER-1™

Our NSA-endorsed encryption chip:  
more speed, less space than DES.

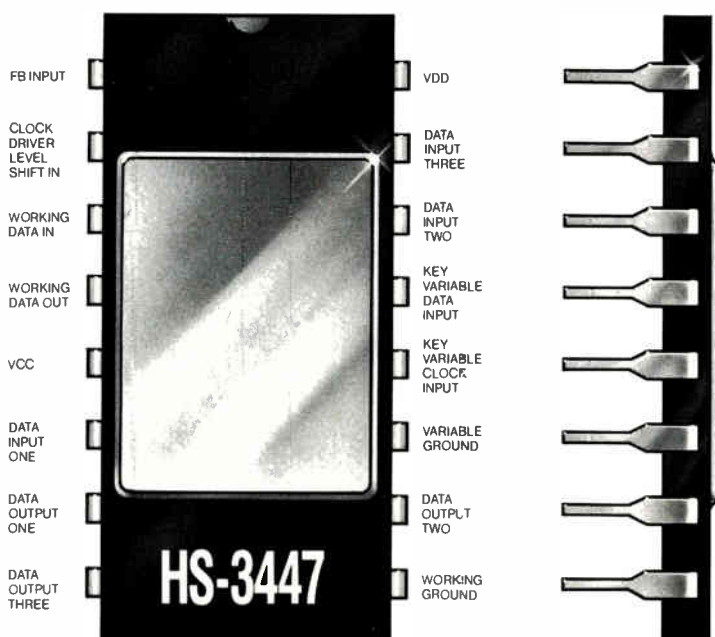

Now the high-speed data encryption chip once reserved for protecting America's defense secrets is available to communications equipment makers to protect sensitive but unclassified government or government-derived information, the loss of which could adversely affect the national security interest.

The Harris CYPHER-1™ circuit is embeddable and built with our proven low-power CMOS process. Compared with the decade-old DES chip, CYPHER-1™ is nearly 50% faster (20 megabits/second)—and its smaller size (16 pins versus DES' 40) makes it flexible enough to interface with almost any communications channel.

You'll find the CYPHER-1™ is the perfect encryption circuit in EDP applications—computer-to-computer links, telecommunications, satellite communications and local area networks.

The CYPHER-1™ circuit encrypts/decrypts via a serial data stream, rather than using the slower traditional block cypher process. In addition to cryptosecurity, the CYPHER-1™ chip is also perfect in systems using spread spectrum transmissions. Use it to build-in immunity to frequency jamming and signal interception in electronic warfare applications.

It's available in production quantities now.

DES is yesterday's technology. CYPHER-1™ is tomorrow's. Call Harris today.

For a data sheet and application information, call (305) 729-5757. Or write: Harris Custom Integrated Circuits Division, P.O. Box 883, MS 53-175, Melbourne, Florida 32902-0883.



CYPHER-1™ is a trademark of Harris Semiconductor.

Circle 39 on reader service card

Harris Semiconductor: Analog · CMOS Digital · Gallium Arsenide · Semicustom · Custom

FOR YOUR INFORMATION, OUR NAME IS **HARRIS**

World Radio History

# TOSHIBA. NOW, 1 MB DRAMS



**AREA SALES OFFICES:** CENTRAL AREA, Toshiba America, Inc., (312) 945-1500; EASTERN AREA, Toshiba America, Inc., (617) 272-4352; NORTHWESTERN AREA, Toshiba America, Inc., (408) 244-4070; SOUTHWESTERN REGION, Toshiba America, Inc., (714) 752-0373; SOUTH CENTRAL REGION, Toshiba America, Inc., (214) 480-0470; SOUTHEASTERN REGION, Toshiba America, Inc., (404) 493-4401; MAJOR ACCOUNT OFFICE, POUGHKEEPSIE, NEW YORK, Toshiba America, Inc., (914) 462-5710; MAJOR ACCOUNT OFFICE, BOCA RATON, FLORIDA, Toshiba America, Inc., (305) 394-3004. **REPRESENTATIVE OFFICES:** ALABAMA, Montgomery Marketing, Inc., (205) 830-0498; ARIZONA, Summit Sales, (602) 998-4850; ARKANSAS, MIL-REP Associates, (512) 459-8602; CALIFORNIA (Northern) Elrepro, Inc., (415) 962-0660; CALIFORNIA (L.A. & Orange County) Bager Electronics, Inc., (818) 712-0011, (714) 957-3367, (San Diego County) Eagle Technical Sales, (619) 743-6550; COLORADO, Straube Associates Mountain States, Inc., (303) 426-0890; CONNECTICUT, Datcom, Inc., (203) 288-7005; DISTRICT OF COLUMBIA, ArboTek (301) 825-0775; FLORIDA, Sales Engineering Concepts, (305) 834-7656, (305) 426-4601, (813) 963-1042; GEORGIA, Montgomery Marketing, Inc., (404) 447-6124; IDAHO, Components West, (509) 255-6224; ILLINOIS, Carlson Electronic Sales, (312) 956-8240, R.E.P.S., (217) 529-5711; INDIANA, Leslie M. DeVoe Company, (317) 842-3245; IOWA, C.H. Horn, (319) 393-8703; KANSAS, D.L.E. Electronics, (316) 744-1229; KENTUCKY, Leslie M. DeVoe Company, (317) 842-3245; LOUISIANA, MIL-REP Associates, (713) 444-2557; MAINE, Datcom, Inc., (617) 891-4600; MARYLAND, ArboTek, (301) 825-0775; MASSACHUSETTS, Datcom, Inc., (617) 891-4600; MICHIGAN, Action Components Sales, (313) 349-3940; MINNESOTA, Electric Component Sales, (612) 933-2594; MISSISSIPPI, Montgomery Marketing, Inc.,

# FIRST AGAIN. AND 256 K CRAMS.

Toshiba technology leads the way again with the development of Ultra Large Scale memory devices that feature high speed access times.

## 1 MB CMOS DRAMS



TOSHIBA is delivering now ... all the 1Mb product you can use. In three different access modes.

With speeds of 100 and 120 ns. You have a choice of fast page mode, static column or nibble mode. And you can get production quantities now.

TOSHIBA 1 Mb DRAMS					
Part Number	Organization	Process	Speed	Mode	Package
TC511000 - 10	1 Mb x 1	CMOS	100 ns	Fast Page	18 pin
TC511000 - 12	1 Mb x 1	CMOS	120 ns	Fast Page	18 pin
TC511001 - 10	1 Mb x 1	CMOS	100 ns	Nibble	18 pin
TC511001 - 12	1 Mb x 1	CMOS	120 ns	Nibble	18 pin
TC511002 - 10	1 Mb x 1	CMOS	100 ns	Static Column	18 pin
TC511002 - 12	1 Mb x 1	CMOS	120 ns	Static Column	18 pin
TC514256 - 10	256K x 4	CMOS	100 ns	Fast Page	20 pin
TC514256 - 12	256K x 4	CMOS	120 ns	Fast Page	20 pin
TC514258 - 10	256K x 4	CMOS	100 ns	Static Column	20 pin
TC514258 - 12	256K x 4	CMOS	120 ns	Static Column	20 pin

## 256K CMOS STATIC RAM



Toshiba's product development leadership continues. We were first with 16K CMOS RAMs.

First with 64K CMOS RAMs. And now first again—with 256K CMOS static RAMs. This 32K x 8 device features the lowest power consumption available today—only 5mA/MHz. Lower than any competitive product. And we offer speeds to 100 ns.

TOSHIBA 256K CRAMS					
Part Number	Organization	Process	Speed	Standby Power	Package
TC55257 - 10	32K x 8	CMOS	100 ns	1mA MAX	28 pin
TC55257 - 12	32K x 8	CMOS	120 ns	1mA MAX	28 pin
TC55257L - 10	32K x 8	CMOS	100 ns	100µA MAX	28 pin
TC55257L - 12	32K x 8	CMOS	120 ns	100µA MAX	28 pin

## ULTRA LEADERSHIP

Again Toshiba leads the way. With high speed access times. Now with Ultra Large Scale products. With ultra high quality. With ultra fast deliveries. Toshiba. The power in memories.

**TOSHIBA. THE POWER IN MEMORIES.**

**TOSHIBA AMERICA, INC.**

© 1986 Toshiba America, Inc.

(205) 830-0498; MISSOURI, D.L.E. Electronics, (316) 744-1229, R.E.P.S., (618) 345-1808; MONTANA, Components West, (206) 885-5880; NEVADA, Elreppo, Inc., (415) 962-0660; NEW ENGLAND, Datcom, Inc., (617) 891-4600; NEW HAMPSHIRE, Datcom, Inc., (617) 891-4600; NEW MEXICO, Summit Sales, (602) 998-4850; NEW YORK, Nexus Technology, (201) 947-0151; PI-tronics, (315) 455-7346; NORTH CAROLINA/SOUTH CAROLINA, Montgomery Marketing, Inc., (919) 467-6319; NORTH DAKOTA/SOUTH DAKOTA, Electric Component Sales, (612) 933-2594; OHIO, Steffen & Associates, (216) 461-8333; (419) 884-2313, (513) 293-3145; OKLAHOMA, MIL-REP Associates, (214) 644-6731; OREGON, Components West, (503) 684-1671; PENNSYLVANIA, Nexus Technology, (215) 295-6549, Steffen & Associates, (412) 276-7366; RHODE ISLAND, Datcom, Inc., (617) 891-4600; TENNESSEE, Montgomery Marketing, Inc., (615) 984-7080; TEXAS, MIL-REP Associates, (512) 459-8602, (713) 444-2557, (214) 644-6731; UTAH, Straube Associates Mountain States, Inc., (801) 263-2640; VERMONT, Datcom, Inc., (617) 891-4600; VIRGINIA, ArboTek, (301) 825-0775; WEST VIRGINIA, Steffen & Associates, (419) 884-2313; WASHINGTON, Components West, (206) 885-5880; WISCONSIN, Carlson Electronics, (414) 476-2790, Electric Component Sales, (612) 933-2594; WYOMING, Straube Associates Mountain States, Inc., (303) 426-0890; CANADA, BRITISH COLUMBIA, Components West, (206) 885-5880; ONTARIO, Electro Source, Inc., (416) 675-4490, (613) 726-1452.

## Another high voltage power supply cut in half...



### The WH Series... 500 watts, 1/2 the space, 1/2 the weight and we even cut the price!

When Glassman packed 500 Watts @ 80kV into 10 1/2" of rack space a few years ago, it was a pretty impressive feat.

Although that may seem commonplace today, the next step, which we've just taken, isn't. We've packed 500 watts @ up to 75kV in half that space... 5 1/4". The WH Series is one half the size and weight of the PG Series models it replaces. In it, you get more regulated high voltage in less space than any other supply we know of.

To accomplish this, we've developed some new circuitry that we believe has increased the reliability of our already sound, field proven switch-mode technology.

If light weight, compactness, tight regulation, and high reliability are major factors in your high voltage power supply requirements, then call John Belden at 201-534-9007 for complete details on the new WH Series.

*Innovations in high voltage power supply technology.*

## GLASSMAN HIGH VOLTAGE INC.

Route #22 (East), Salem Industrial Park, P.O. Box 551, Whitehouse Station, N.J. 08889  
(201) 534-9007 • TWX 710-480-2839



Circle 42 on reader service card

## SMART WOMEN KNOW HOW TO MAKE MONEY.

It's easy, with U.S. Savings Bonds. Today's Bonds earn competitive, market-based interest rates—like money market accounts. Plus, there's a guaranteed minimum return and big tax advantages. For more information, call 1-800-US-BONDS.

**U.S. SAVINGS BONDS** 



42 Bonds held less than five years earn a lower rate than the guaranteed minimum. A public service of this publication.

at Junghans, says wristwatches based on the same principles are conceivable.

The RCS 1 picks up radio signals that carry time-data messages. Controlling this signal is the cesium clock at West Germany's Physical-Technical Institute in Braunschweig, an agency akin to the U.S. National Bureau of Standards, which keeps a similar clock and transmitter in operation in Boulder and Ft. Collins, Colo., respectively.

The West German agency continuously transmits the time messages from Mainflingen, near Frankfurt, as part of its service to research laboratories and other scientific organizations. The transmitter's range is about 1,200 miles, which covers most of Europe. The message contains signals that automatically switch the RCS 1 clock to show daylight-savings or standard time, so the user never need set the clock himself.

Before a truly worldwide market can develop, time-data signals must be transmitted over more regions than Eu-

### *The clock picks up radio signals from a cesium time standard*

rope and the U.S. Ganter expects that some day they will be broadcast from satellites.

The RCS 1 uses a ferrite antenna to pick up the time data, which is amplitude-modulated on a 77.5-kHz signal. A bipolar integrated circuit from West Germany's Telefunken electronic GmbH makes up most of the receiver. The time data is passed to a 4-bit single-chip CMOS microprocessor from Eurosil GmbH, a Telefunken subsidiary.

**SELF-ADJUSTING.** The microprocessor switches the receiver on and off and decodes the message. It compares the information with the time shown by the clock. If necessary, it delivers pulses to the drive mechanism to adjust the clock hands.

The RCS 1 gets its power from 58 amorphous-silicon solar cells arranged on a panel behind the clock. Together, these cells put out about 1 W when exposed to sunlight. Of that power, however, only 1/6,000 is needed to drive the quartz-controlled clockwork, according to Ganter.

The surplus energy is stored in a capacitor network and is tapped when there is no ambient light. When the panel is not exposed to light, the clock can run in the dark for as long as two weeks. Also, it will operate at light levels as low as 20 lux. If the clock is placed in a dark area, the panel can be detached and put where light will reach it.

The company likes to point out that

# VHF-UHF SYNTHESIZERS

Front  
or Rear  
Output

Rack or Bench  
Cabinet

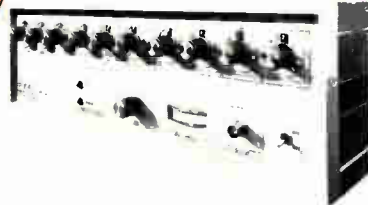

Resolution (7 available steps,  
100 KHz, 10 KHz, 1 KHz, 100 Hz, 10 Hz  
1 Hz, .1 Hz)

Frequency Standard

Oven ( $3 \times 10^{-9}$ /day) ( $\pm 1 \times 10^{-8}$ /0-50°C)

TCXO ( $1 \times 10^{-9}$ /day) ( $\pm 1 \times 10^{-6}$ /0-50°C)



Extra 10 MHz Outputs (replaces the normal 10 MHz output  
with 3 passively decoupled outputs which deliver 0dBm into 50 ohms)

Picket Fence Output (A pulse containing all 10 MHz multiples  
from 10 MHz to 140 MHz, at a level of -5dBm each)

Filtered Comb (A single frequency output of any 10 MHz multiple from  
20 MHz to 140 MHz at a level of 0dBm)

1 MHz External Drive

90° Phase Shifter

Manual and/or Remote Controls  
(BCD or GPIB)

TLU Resolution Block (1 Hz or 0.1 Hz resolution  
with steady-phase-switching)

Programmable 90dB Attenuator  
(fast switching)

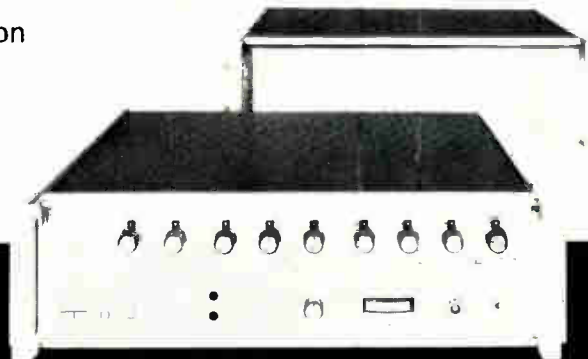

NO NRE FOR THESE OPTIONS

**All of these  
"stock options"  
are yours  
for the  
asking**

**PTS 500, PTS 250,  
PTS 160, PTS 120  
and PTS 040  
0.1-500 MHz  
fast switching  
low noise**

**PTS**

PROGRAMMED TEST SOURCES, INC.

9 Beaver Brook Rd., P.O. Box 617, Littleton, MA 01460 — (617) 486-3008

World Radio History

Circle 43 on reader service card

# Intelligent axis card brings new smarts to robots and automatic positioning.

- Complete control of a DC servo stage.
- Uses input from encoders or interferometers.
- Eliminates all electronic adjustments.
- Accepts simple commands from your host or personal computer.
- Allows fully coordinated multi-axis system (up to 30 axes).

Let us tell you more.



**ANORAD**

110 Oser Avenue  
Hauppauge, NY 11788  
Tel: 516-231-1990  
TWX 510-227-9894

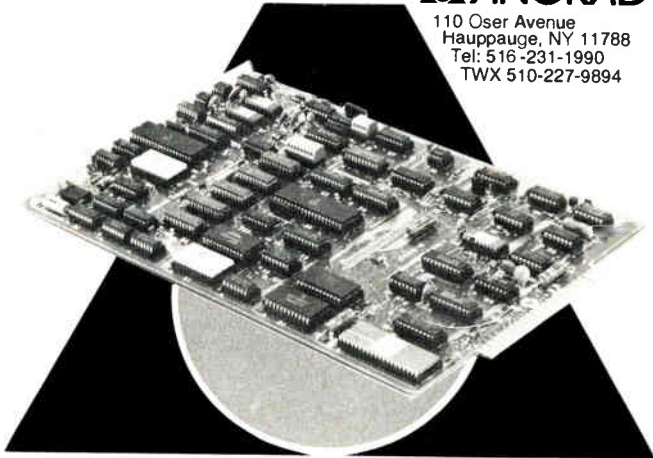

For information Circle 44 To have an application engineer call, Circle 154

## The design engineer's dream: PC software plus the power & reliability of the STD BUS.

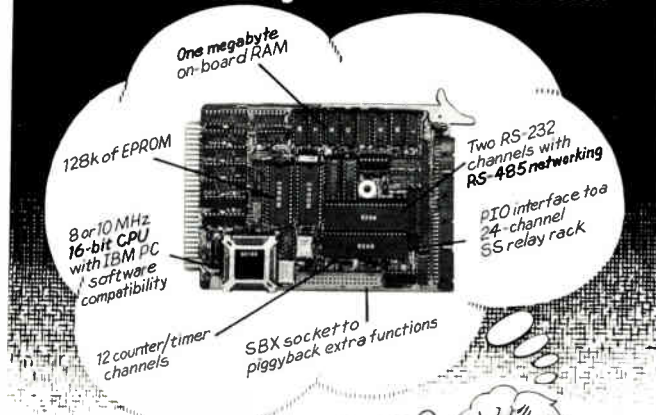

### It's real on the CPU-188.

The STD BUS single board computer linking the engineer's desk with the factory floor. From \$425 in single quantities.

**Computer DYNAMICS**  
COMPUTER DYNAMICS SALES

107 S. Main St., Greer, SC 29651  
(803) 877-8700

IBM PC is a registered trademark of International Business Machines Corporation

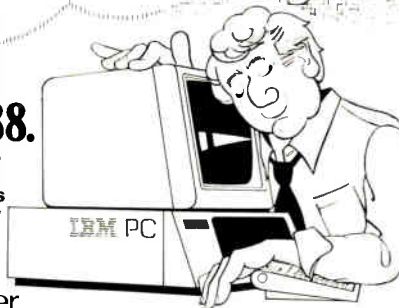

Circle 135 on reader service card

the RCS 1 takes 50 centuries of clock-technology development work back to the sun, where it began when the Egyptians invented the sundial. "With our new clock we have come full circle," says a Junghans spokesman. "It all started with solar power, and we are now back to solar power." —John Gosch

## ARTIFICIAL INTELLIGENCE

### NTT BUILDS A LISP MACHINE FOR JAPAN

#### YOKOSUKA, JAPAN

When researchers at Tokyo's Institute for New Generation Computer Technology established directions for Japan's government-backed fifth-generation computer project six years ago, they placed their bets on what was then a relatively obscure artificial-intelligence language: Prolog. Despite the considerable influence of the fifth-generation project, however, Lisp—the AI language most popular in the U.S.—continues to gain popularity in Japan. Recognizing this, Nippon Telegraph & Telephone Corp. has unveiled Elis, a work-station designed to run Lisp programs.

A number of U.S.-made Lisp engines are available in Japan, but none have facilities for use in the Japanese language, as does NTT's Elis. The work station's 64-bit microcoded central processing unit and stack-based memory architecture give it a high level of performance, too. It is said to be several times faster than 3600-series machines from Symbolics Inc. of Cambridge, Mass.

"We chose Lisp because our research showed there is more demand for it [in Japan], but we're not rejecting Prolog," maintains Takashi Sakai, who heads the Data Entry Equipment Section at NTT's Integrated Communications Laboratories in Yokosuka. Elis can also run Prolog programs, but not with the performance it brings to Lisp processing.

The reason for Lisp's continuing popularity, Sakai says, is that Lisp's greater flexibility makes it easier to use in compiling complex data for specific tasks. "The fifth-generation project chose Prolog," says an industry executive, "because it wanted to try something new, and be less dependent on Lisp, which is dominant in the U.S."

Most expert-system programs marketed in Japan are in Lisp, but a lack of data-base material, especially in the medical field, and a lack of AI specialists (industry sources say there are only a few hundred at present) are restricting market growth. Nonetheless, analysts predict the market for AI systems in Japan will grow from its current modest 20 billion yen (\$130 million at

# Potter & Brumfield solves your design puzzle with the industry's lowest priced DIP SSRs and I/O modules.

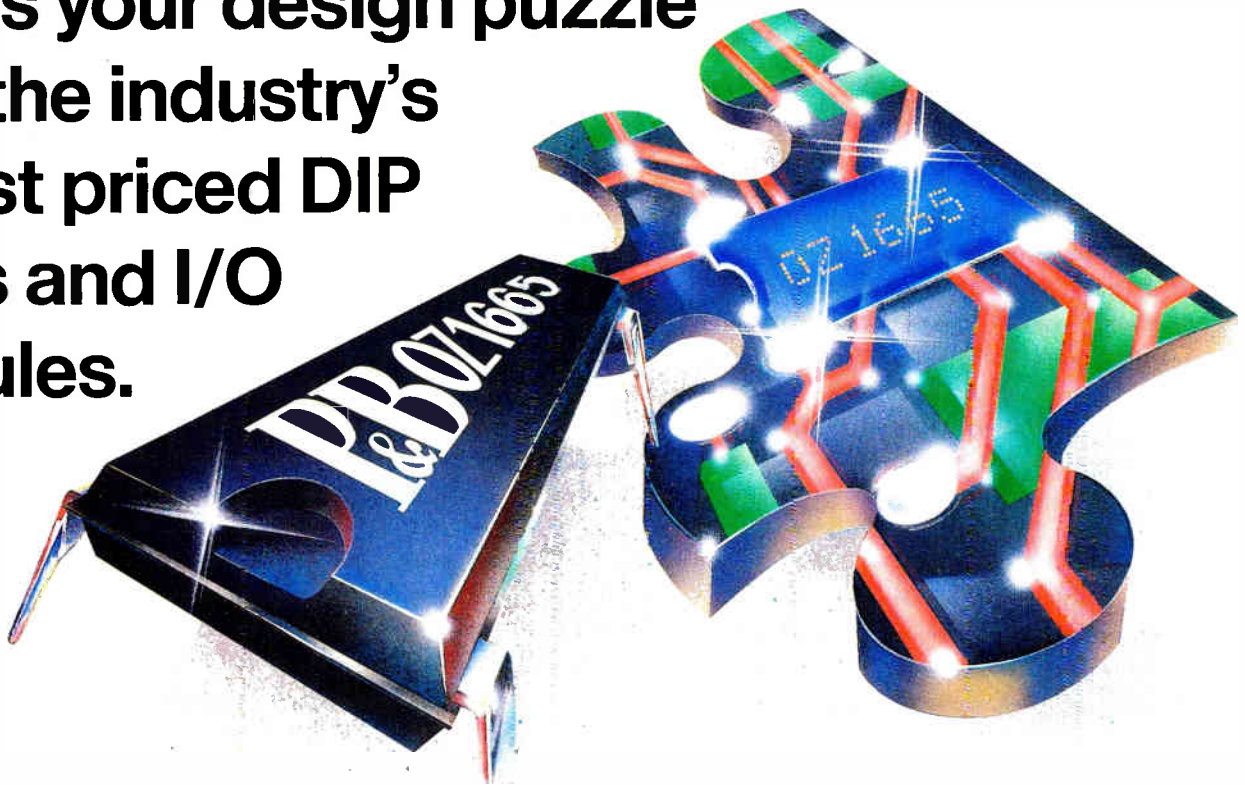

## 42 New DIP Models

Now P&B quality and the lowest prices in the industry join to provide the perfect solution to your design puzzle. Our 42 new solid state relays and I/O modules are the ideal interface between your microprocessors or control systems and real-world sensors and loads. These hybrid thick film devices are optically isolated from input to output and are available in standard and surface-mountable DIP packages. All models meet applicable UL, CSA, & VDE requirements.

## Solid State Relays

The new OZ16 series brings P&B quality to your 5mA to 1A rms switching chores. Input to the OZ16 can be either TTL-compatible 5V DC or DC current. Output circuitry features a zero voltage detector and inverse parallel SCRs. And output rating is 12 to 280V AC.

## I/O Modules

Four different product lines allow you to meet a variety of your I/O needs. Input modules provide an active low output; output modules can be controlled from active low or active high logic. AC output modules use zero crossover switching to virtually eliminate transients and generated

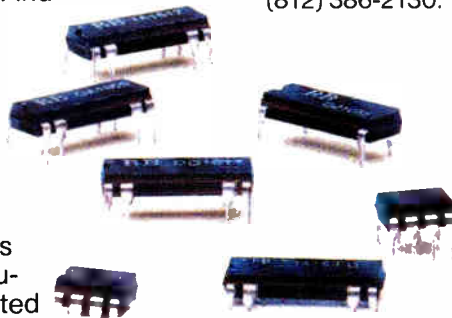

EMI noise. And the IA8 series, which occupies just half the space of 16-pin models, can act as an AC/DC input module or a DC output module.

## Find Out More

Complete your design puzzle with P&B quality — and the lowest price in the industry. To find out more about P&B relays and I/O modules, or for a copy of our new 1986/1987 General Stock Catalog, contact us today. Call toll-free 1-800-255-2550 for the name of your nearest P&B distributor or sales representative. Potter & Brumfield, A Siemens Company, 200 South Richland Creek Drive, Princeton, Indiana 47671-0001.

**Regional Sales:** Braintree, MA, (617) 848-6550; San Juan Capistrano, CA, (714) 493-4503; Princeton, IN, (812) 386-2130.

**Potter & Brumfield** A Siemens Company

Circle 45 on reader service card

Please send more information about P&B SSRs & I/Os.  
 Please send 1986/87 General Stock Catalog.

Potter & Brumfield Inc.

Name \_\_\_\_\_  
 Firm \_\_\_\_\_  
 Address \_\_\_\_\_  
 City \_\_\_\_\_ State \_\_\_\_\_  
 Phone \_\_\_\_\_ Title \_\_\_\_\_ Zip \_\_\_\_\_

200 S. Richland Creek Dr., Princeton,  
 IN 47671-0001

# Score A Winning Touchdown with UMC



With backing from UNITED MICROELECTRONICS CORPORATION, one of our customers scored a winning touchdown with a voice control IC last year. He netted a profit of 2.5 million dollars on just one product. This is one of the many examples of how UMC helps its customers score financial goals.

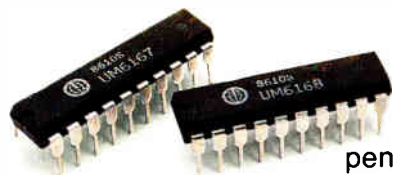

UMC scored its first touchdown by becoming profitable 6 months after it went into operation and has been making a profit and registering phenomenal sales growth annually since then. Last year, 4 quarters of penalties left most companies sitting on the bench and several others were ejected from the game. UMC, however, still romped to a sales growth rate of 24.4%, which was the fourth best in the world and outscored 92% of the IC industry.

If you want to be on a winning team, go with a proven winner.....UMC.



**UMC**

**UNITED MICROELECTRONICS CORPORATION**

CORPORATE HEADQUARTERS: NO. 3, INDUSTRIAL EAST THIRD ROAD SCIENCE BASED INDUSTRIAL PARK, HSINCHU CITY, TAIWAN, REPUBLIC OF CHINA  
SALES OFFICE: 9TH FLOOR, NO. 201-26, TUNHUA NORTH ROAD TAIPEI, TAIWAN, REPUBLIC OF CHINA TEL: (02)7152455 TLX: 28560 UMCTPE FAX: (02) 7166291  
U.S.A. HEADQUARTERS: NMC CORPORATION 3054 SCOTT BLVD. SANTA CLARA, CA95054 U.S.A. TEL: 408-7279239 TLX: 172730 NMC SNTA FAX: 408-9700548



current rates) per year to 1 trillion yen (\$6.45 billion) by 1990.

Lisp engines from Symbolics are among the U. S. AI machines marketed in Japan. They are sold by Nippon Symbolics Ltd., a joint venture of Symbolics and the Nichimen trading house. IBM, Digital Equipment Corp., and Symbolics hardware is also available as platforms for Intellicorp.'s Knowledge Engineering Environment through CSK Research Institute Ltd.

None of the U. S. machines, however, has Japanese-language support. For Elis, NTT has developed Japanese-language data-input facilities for use with English-language programs.

The result of a four-year project, Elis will be on the Japanese market by late next summer, say NTT engineers. Production in the first year will be small, only 20 to 50 units, manufactured by Oki Electric Industrial Co.'s plant at Takasaki. NTT says it hasn't set a price yet for Elis, but NTT feels the product will eventually be a money-earner.

The first Elis prototype had about half the logic of its 64-bit CPU implemented in 2900-family bit-slice chips from Advanced Micro Devices Inc. and

### *Despite fifth-generation project's use of Prolog, Japanese prefer Lisp*

the remainder in Schottky TTL [*Electronics*, Nov. 3, 1983, p. 134]. Much of that logic has now been replaced by one 20,000-gate array chip. This makes it a more compact unit that can sit beside a desk and accommodate four terminals.

A Motorola 68010 microprocessor serves the work station as a front-end processor handling all input/output tasks. It controls a 16-bit bus to which disks, terminals, and other peripherals are connected. A direct-memory-access controller ties this bus to the 64-bit CPU bus. A floating-point accelerator and main memory are tied to the CPU bus.

Among the notable features of the CPU are a very large writable control store—64-K words of 64 bits each—for microinstructions, which support a Tao interpreter. Tao is a dialect of Lisp.

To run programs written in Common Lisp, some functions not found in Tao—about 10% of the functions of Common Lisp—are added in a separate software package. Tao also has functions that support Prolog and Smalltalk.

Fast memory access is a major performance factor, Sakai says. In addition to main memory, which can be as large as 128 megabytes, there is a 32-K-by-32-bit bank of fast static random-access memory configured as a first-in, last-out stack.

—Michael Berger

# Militarized Microprocessors

8086, 80186, 80286, 68000, 68020

**Multibus & VME Compatible  
Engineered for the  
Military User**

- All I/O from bottom of boards
- Copper heat sinks
- Low insertion force connector
- On-board PROM programming
- ATR form factor (Multibus & VME)



**AEROFLEX LABORATORIES, INC.**

35 South Service Road  
Plainview, NY 11803

**For Immediate Information Call:  
(516) 694-6700 or (516) 752-2300**

*Multibus is a trademark of Intel Corp.*

Circle 47 on reader service card

## UM65xx Series IC

*The one and only perpetual supplier  
of 65xx series IC*

P/N	Description
UM6502/7	8 Bit CPU
UM6512	8 Bit CPU
UM6520	PIA
UM6521	Enhanced UM6520 PIA
UM6522	VIA
UM6532	RAM I/O Timer Array
UM6551	ACIA



**UNITED MICROELECTRONICS CORPORATION**

**U.S.A. HEADQUARTERS:  
NMC CORPORATION**  
3054 SCOTT BLVD, SANTA CLARA,  
CA. 95054 U.S.A.  
TEL: 408-727-9239  
TLX: 172730 NMC SNTA  
FAX: 408-9700548



Circle 137 on reader service card

# INTERNATIONAL NEWSLETTER

## EUROPEAN CO-OP TO SPEND BILLIONS ON SUBMICRON TECHNOLOGY

**A**greement is near on a \$2.5 billion European research effort to develop 0.3- $\mu$ m chip technology by the middle of the next decade. Three government-industry committees, from France, West Germany, and the Netherlands, are now organizing the Joint European Silicon Submicron Initiative; they are also determining whether to make it part of Eureka [*Electronics*, Dec. 2, 1985, p. 53], Europe's alternative to the U. S. Strategic Defense Initiative. The aim is a research institute set up by West Germany's Siemens AG, France's Thomson Group, and the Netherlands' Philips International NV, with Italy's SGS-ATES likely to join soon. Details on organization, financing, intermediate targets, and government support of the Silicon Submicron Initiative may come by the end of this year. □

## BRITISH AIM TO DOUBLE ION-IMPLANTER THROUGHPUT

**R**esearchers in a \$5.5 million project funded mostly by the British government have developed an oxygen ion implanter they say can eventually make up to 2,000 silicon-on-silicon-dioxide wafers per week, though they won't say when. The fastest equipment now on the market can produce 500 wafers. The implanter, called Oxis 100, generates a 200-kV, 100-mA beam. That strength is key to the high throughput. The wafers are produced in a vacuum between 400°C and 750°C, a range that maintains the crystallinity of the top silicon surface layer. VG Semicon Ltd. developed the machine with two Atomic Energy Authority facilities, Harwell Laboratory and Culham Laboratory, and semiconductor manufacturers Plessey, British Telecom, and General Electric Ltd. Chips from the wafers have already been sold into the radiation-hardened market, and telecommunications chips have been sold to users in Britain, the U. S., and Japan, says Steve Moffatt, project manager at VG Semicon, which will make and market both the equipment and the wafers. He would not name the customers. Moffatt also refuses to discuss yield and production numbers and won't say when VG Semicon might reach output of 2,000 wafers a week. □

## JAPANESE CUT BACK ON CHIP PRODUCTION

**B**edeveloped by continued soft demand and frustrated by the new Japan-U. S. semiconductor trade agreement regulating prices of dynamic random-access memories exported to the U. S., Hitachi Ltd. has cut production of all chips by 20%, including a virtual shutdown of all production of DRAMS. It is also switching from memory- to logic-chip assembly at its U. S. plants. Industry sources in Tokyo say that Fujitsu Ltd. has made similar cutbacks because of sluggish memory sales in the U. S., which may have dropped drastically in recent months. Prices in Japan for typical 256-K DRAM products have dropped to \$1.83 from \$1.96. □

## STC DEVELOPS LOW-NOISE BIMOS PROCESS

**A** bipolar-CMOS process from STC Semiconductors Ltd. will yield chips with a noise level of 1 dB at 150 MHz, which "pushes the noise performance of GaAs," says Roger Baker, advanced technology manager. The technology, developed at STC's facility at Foots Cray in South London, uses a 2- $\mu$ m CMOS process that is a version of STC's planned 1.25- $\mu$ m process. The first product from the technology, a one-chip telephone containing all functions except a ringing circuit, is expected about mid-1987. The company is also about to start shipping samples of a 45-ns byte-wide 64-K static random-access memory using just the 2- $\mu$ m CMOS process and plans to have a 1.25- $\mu$ m version out next with speeds of 25 to 35 ns. □

# 5000 MHz PULSE GENERATOR WITH 30 ps RISE TIME

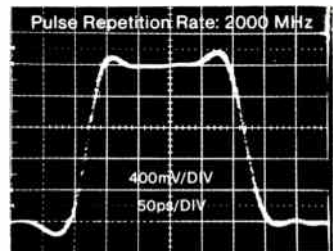
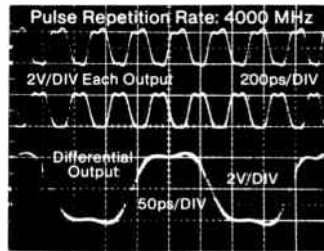

Above Photos Include the 30ps Risetime of the Sampling Head.

Our newest pulse generator is ideally suited for testing GaAs systems and for driving fast laser diodes. It features pulse repetition rates from 10 - 5000 MHz, risetimes as low as 30ps, a true dual-channel capability, independent amplitude (2V max.), and offset controls (-5V to +5V) for each output. All settings are digitally displayed (Model PG 5000A: \$17,500). A 5V dual-channel version is also available for repetition rates up to 3000 MHz, Model PG 3000A at \$19,500. High power single-output versions include the Models PG 5000A-4V to 5000 MHz and 4V output, and PG 3000A-10V to 3000 MHz and 10V output, at \$22,500 each. For your system integration applications, the output drivers of the above pulse generators are offered separately as clock drivers (\$4,800 to \$9,500). We also furnish six different dc-coupled clock drivers which operate to 2200 MHz and to 5V per output. They feature variable risetime and duty cycle, programmable output amplitude and output offset, and sub-nanosecond gating capability (\$995 to \$3,500).

In addition, our popular PG 1000A pulse generator offers both differential TTL (to 350 MHz) and differential ECL (to 1000 MHz) with built-in source and variable duty cycle (1V ECL: \$7,700; 2V option: add \$800). All prices quoted are U.S.A. list prices only. Complete specifications on all of our products are available on request. We also offer custom modifications to suit specific needs.



## Colby Instruments, Inc.

Electronics Research & Development  
1810 14th Street, Santa Monica, CA 90404  
(213) 450-0261

Circle 87 on reader service card

**E**ver notice how some people always seem to have the right answer? No matter what the situation, they always seem to be a step ahead.

And they're successful...the first in line to lead an important project...the first in line for a promotion. It's certainly not magic. Usually it's a combination of hard work, brains, guts and desire.

It probably means they read Electronics... regularly.

Electronics has helped propel many a manager and engineer to the front line...to the "leading edge" of the industry. And just as we've been providing many of your colleagues with the right information, the *important* information—when they need it most—so too can we provide it for you.

Every week an Electronics subscriber receives an issue crammed with the latest information on new products, developments, concerns and trends in the worldwide electronics industry.

When you become a subscriber, we'll supply you with the intelligence you need to make the big decision, or the every day decision to further your career and reap profits for your company. For a taste, just browse through the issue you're holding.

But, you really don't have to believe us. Just ask the person who's always a step ahead.

To become a subscriber, just complete and mail the insert card in this magazine. If subscription card is missing, write: Circulation Manager, Electronics, P.O. Box 511, Hightstown, N.J. 08520.

**Electronics**  
The Voice of the industry



## Striking Ideas

Matching long experience with innovative ideas to develop new products and pioneering new designs, we have pushed subminiature fuse technology towards its limits as shown by our successful new subminiature fuse generations TR 5, meeting international approvals, TR 3, Micro- and Picofuse. For more information complete and return the coupon before November 5, 1986 and you could also win one of ten golden lighters if your answer is correct.

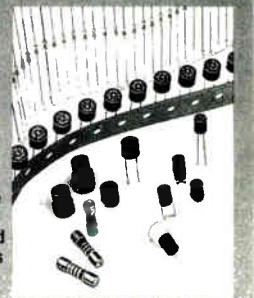

**COUPON** I wish to receive detailed information

Question: Which sub-miniature fuse meets international approval: \_\_\_\_\_  
 Approximation: \_\_\_\_\_  
 My address: \_\_\_\_\_



## Wickmann-Werke GmbH

Annenstr. 113 · Postbox 2520 · Tel. 02302/6620  
D-5810 Witten 6/W.-Germany  
Telex 8229145 wwg d · Fax (02302) 662111

Circle 140 on reader service card 49

# INTERPHASE PULLS A FAST ONE

## V/SMD 4200

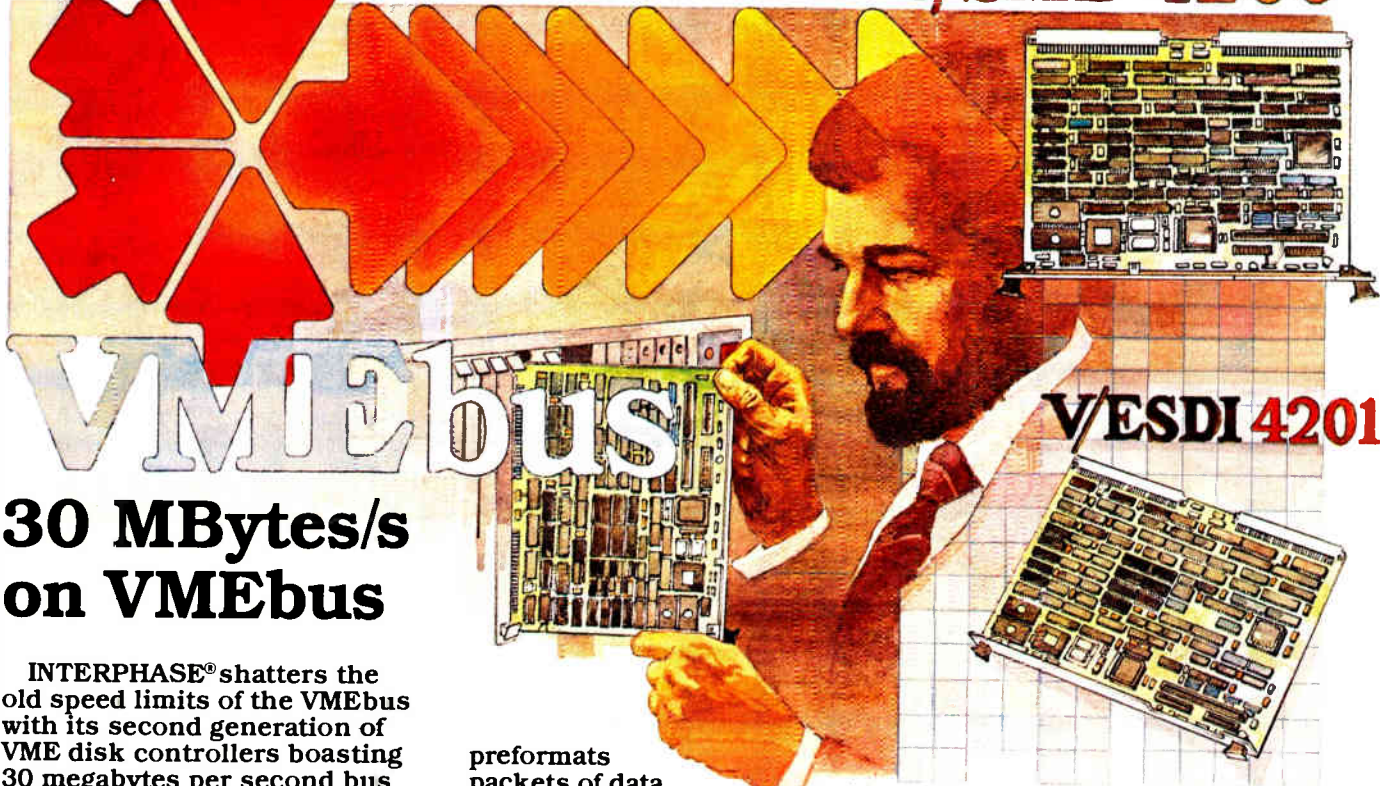

## 30 MBytes/s on VMEbus

INTERPHASE® shatters the old speed limits of the VMEbus with its second generation of VME disk controllers boasting 30 megabytes per second bus speeds and above. Using a new INTERPHASE technology breakthrough called the BUSpacket Interface<sup>SM</sup> ... the new V/SMD 4200 Cheetah and V/ESDI 4201 Panther triple existing VMEbus speeds and approach the VMEbus theoretical bandwidth of 40 megabytes per second!

**SIMPLY THE FASTEST**

The combination of the BUSpacket Interface and a large (128 KBytes) cache memory provide the V/SMD 4200 and V/ESDI 4201 with unequalled speed, and make them the fastest SMD and ESDI controllers by a factor of three. No one even comes close!

In simple terms, the new INTERPHASE technology

preformats packets of data to go across the bus before acquiring it. The INTERPHASE BUSpacket approach unharnesses the VMEbus from slow devices through deep, high-speed bus FIFOs and an asynchronous delay line-based state machine, which controls bus transfers. Data is emptied onto the bus in packets at speeds 30 megabytes per second and above.

### STICK WITH THE WINNERS

The V/SMD 4200 and V/ESDI 4201 also incorporate the proven INTERPHASE features of the multitasking Virtual Buffer Architecture<sup>SM</sup>, Intelligent Caching, and zero latency operation found on other popular INTERPHASE

products. The four drive V/ESDI 4201 Panther even adds an integral SCSI port for easy addition of back up devices.

Both products complement INTERPHASE's high-performance V/Tape 3209 1/2" tape controller, and are **PLUG & PLAY** software compatible with the industry's most successful SMD and ESDI controllers, our V/SMD 3200 and V/ESDI 3201.

### THEY'RE GOING FAST

To learn more about the fastest SMD, ESDI and 1/2" tape controllers around, call or write today ... but you better move fast ... INTERPHASE certainly is.

(214) 350-9000



**INTERPHASE**  
corporation

2925 Merrell Road • Dallas, Texas 75229 • Telex: 9109976245 NASDAQ-NMS:INPH

Interphase International  
93a New Street, Aylesbury, Bucks. HP20 2NY, England (0296)35661 Telex: 826715 AERO G

Interphase is a registered trademark of Interphase Corporation. BUSpacket Interface and Virtual Buffer Architecture, are service marks of Interphase Corporation.

## INSIDE TECHNOLOGY

# PARALLEL DESIGN GIVES OOMPH TO A 32-BIT SLICE

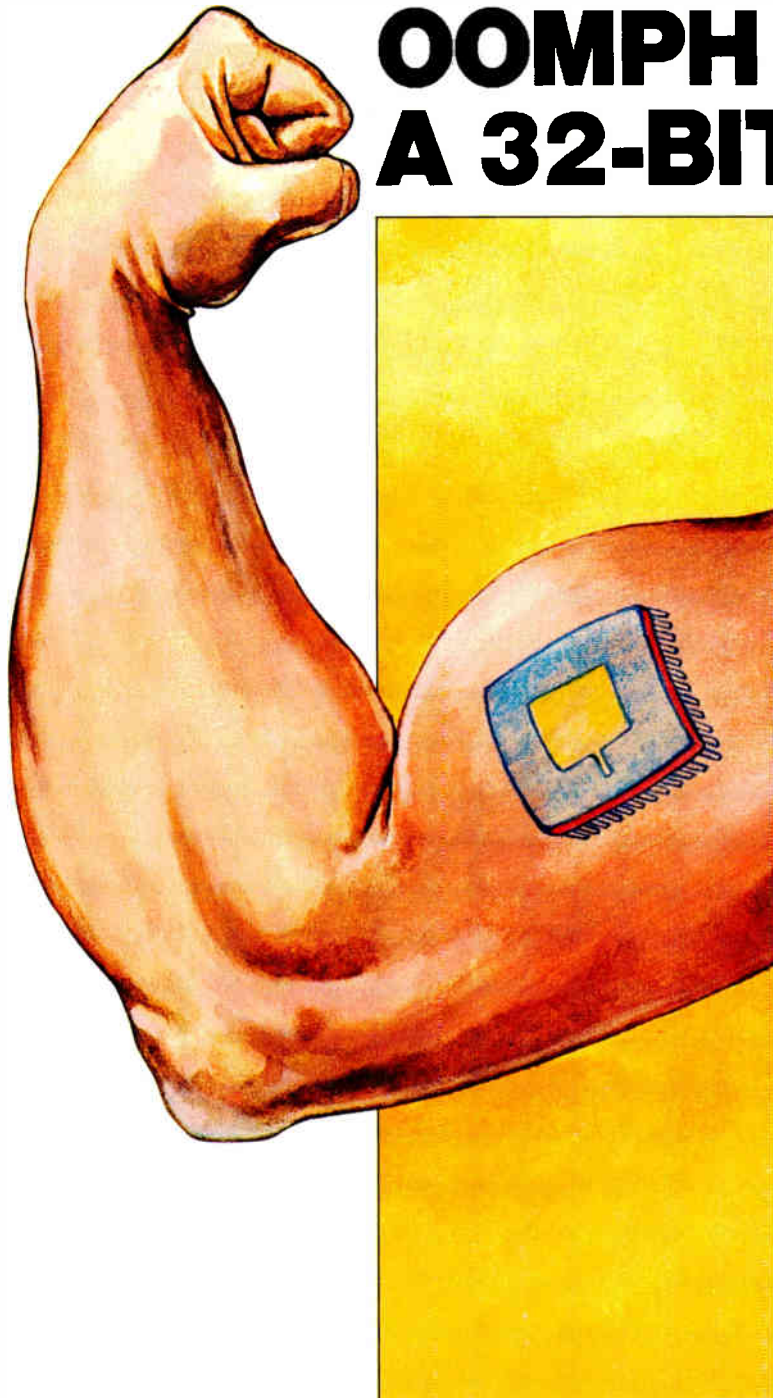

**A** powerful 32-bit slice processor, able to perform several operations on data simultaneously in a single clock cycle, can yield highly parallel system designs that boost throughput 4 to 20 times over other available 32-bit slice chips. Integrated Device Technology Inc.'s IDT49C404 is optimized for parallel operations and bit-field manipulation, and it can be expanded into 64-bit word configurations. This new candidate in the 32-bit slice sweepstakes

[*Electronics*, Sept. 4, 1986, p. 64] is a 1.2- $\mu\text{m}$  bipolar-enhanced CMOS design that features an 80- to 100-ns system cycle time—comparable to many bipolar implementations.

More important than raw cycle time, the architectural innovations incorporated into the IDT49C404 make possible the design of highly parallel system architectures that boost throughput dramatically over other 32-bit designs, says John Mick, director of product definition and applications engineering at IDT.

These innovations include a register file with four output ports and three input ports, plus an on-board funnel shifter that is linked sequentially to an eight-function, 32-bit arithmetic logic unit and a 32-bit-wide merge-logic block. This combination allows shift, rotate, mask, and merge operations in a single 80- to 100-ns clock cycle (Fig. 1), says Michael Miller, IDT's manager of product definition and applications engineering. Another innovation is a three-bus architecture designed for bidirectional operations.

Also contained on chip is a powerful 32-bit mask generator, 32-bit counting for matrix operations, and various other features such as byte, word, and double-word operations. The IDT49C404 also incorporates a powerful internal diagnostic capability for detecting and pinpointing hardware failures in a system at any point in the engineering or manufacturing cycles, or at the customer facility after delivery, Miller says. The processor uses a serial diagnostic scheme that requires the use of only four pins; devices with diagnostic capability are cascaded, output

to input, into one long serial shift register.

For the 32-bit slice, IDT has developed a CMOS process that combines the low power, high noise immunity, and wide operating-temperature range of traditional CMOS with speed and output-drive capability equal or superior to those of bipolar Schottky TTL. Called Cemos-IIC, it's a 1.2- $\mu\text{m}$  double-layer-metal, twin-well process (Fig. 2) that incorporates both a deep underlying p-well and a shallower n-well formed by altering the doping profile near the surface of the p-channel transistor regions. That makes possible the fabrication of high-performance transistors in both polarities. In addition, to enhance performance and output drive, bipolar devices are used as needed; they are formed from the parasitic structures inherent in the CMOS process.

### OPENING UP THE I/O BOTTLENECK

In many advanced applications, the gating factor—the key element or node in a design that determines overall system throughput—is the ability of the system's register-file static random-access memory to transfer data in and out of memory, says Mick. "No matter how much we improved the ability of the IDT49C404 to manipulate data internally, it would have all come to naught if there were no way to get data in and out without compromising performance."

In systems using the IDT design, this will not be a problem, he adds, because company designers have incorporated an on-board register file (Fig. 3) that is unusual in two respects. First of all, at 2 K, it is two to four times the size of that available on any other bit-slice design. Second, it has a seven-port configuration.

"We considered designs with two, three, and four independent on-board register files, and single-memory designs with two, three, and four ports," Mick recalls. "After analyzing the tradeoffs, we decided that the seven-port approach was the optimal design for the kinds of applications we are targeting. When we examined typical high-end applications, such as digital signal processing, image processing, and graphics manipulation, we found they were often I/O-bound. In other words, the applications were often limited by the rates at which they could transfer data in and out of memory."

Organized into an array of 64-word-by-32-bit registers, the seven-port SRAM has three dedicated input ports—A-in, B-in—and one dedicated output port—A-out, B-out, T-out, and Q-out. There is a latch at each of the outputs.

Any four RAM locations can be addressed at the address ports by us-

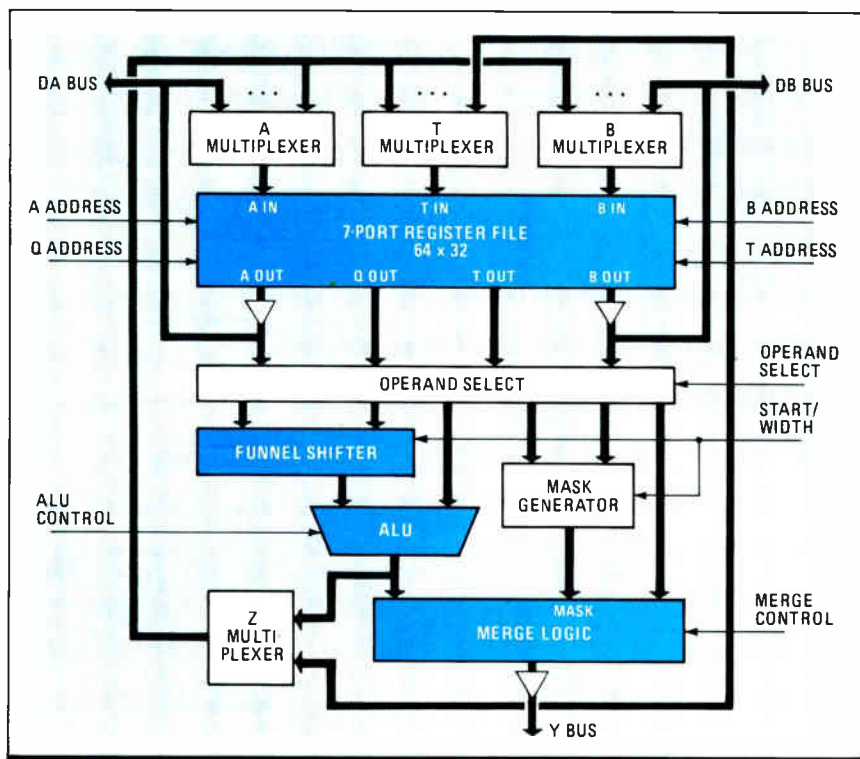

**1. SPEED SECRETS.** IDT's 32-bit slice achieves its speed with a highly parallel three-bus architecture, a seven-port SRAM, and an on-chip funnel shifter, ALU, and merge-logic combo.

ing the A, B, T, and Q address fields, and data can be read simultaneously from all four ports. Identical data will appear at the four output ports when the same addresses are applied at the three address inputs. When the clock is high, the internal latches are transparent on the output ports; when it is low, data is held at the latches. Each data input path has a multiplexer that allows selection of data from any of the chip's three bidirectional data and address buses.

A key element in the IDT49C404 architecture is the 32-bit funnel shifter, which operates on two 32-bit inputs and generates a 32-bit output. It can perform all basic barrel-shift functions such as shift up, shift down, rotate up, or rotate down any number of positions. This high-speed shifting is very useful in operations such as the normalization of mantissas for floating-point arithmetic and in applications in which the packing and unpacking of data are frequent operations. In addition, the funnel shifter can be used to extract a 32-bit output from a sliding window applied to a 64-bit input.

The processor also contains a 32-bit merge-logic-block capability that is under the control of a 32-bit mask generator, as well as a priority encoder for use in floating-point operations and various types of polled interrupt systems.

The ALU can operate in eight functional modes: three arithmetic, four logic, and one special-instruction mode. The three arithmetic functions are to add registers R and S, subtract S from R, and subtract R from S. The four logic functions include OR, AND, exclusive-OR, and exclusive-NOR. In the eighth mode, the programmer can make use of a variety of special high-level instructions, including unsigned and 2's complement, multiply, divide, prioritize, load immediate, load the internal counters, exchange words, test bit field, clear bit field, and sign magnitude to 2's complement conversion.

IDT's contribution to the state of the art in bit-slice design lies in the way the company has combined these three elements—the cascadable funnel shifter, the merge logic, and the ALU—with the seven-port register file to increase system throughput dramatically.

In simplified form, Mick says, the IDT49C404 can be viewed as a seven-port register file feeding into a funnel shifter, then into an ALU, and finally ending in merge logic. "The importance of this particular sequence of operations is that it allows

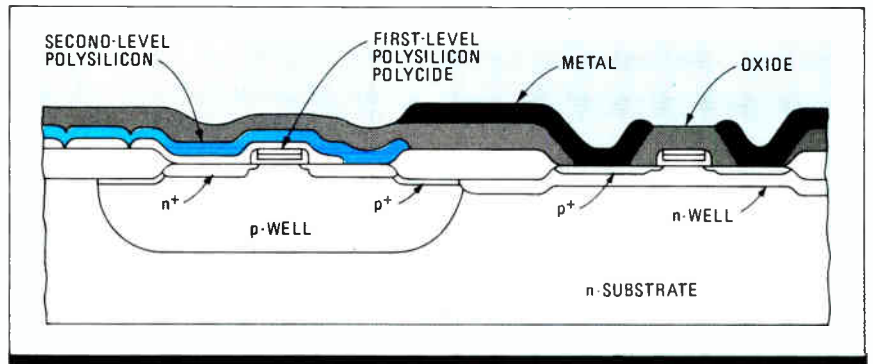

**2. SPECIAL PROCESS.** The key to the short cycle time of the IDT49C404 is a bipolar-optimized 1.2- $\mu\text{m}$  twin-well CMOS process.

the user to select data from the registers, shift it, operate on it with the ALU, and then merge it in one 80- to 100-ns cycle," he says. "In most other 32-bit slice designs, it requires multiple cycles, anywhere from 4 to 20, to extract a field, operate on it, and return it back to the register file and shift it to an output."

In addition, with this design the user can bypass the funnel shifter, the ALU, or both. He then avoids the performance penalty that would be incurred when the algorithm being implemented requires only one of the two, or neither of them, in combination with the merge function. "With the IDT49C404, the cycle time can be tailored to match the specific processing requirements of the system being implemented," Mick says.

To perform comparable operations using competing 32-bit slices requires at least two to four external components, which further degrade system throughput, says Miller. In addition, he

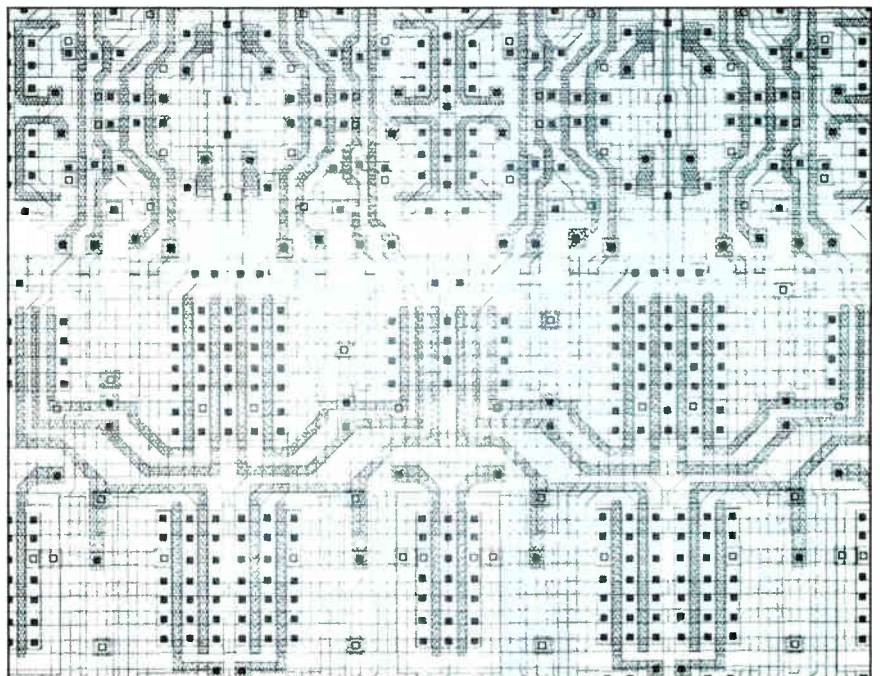

**3. INSIDE THE REGISTER.** In IDT's 32-bit slice, the seven-port register contains proprietary SRAM cells organized into a 32-by-64-bit array—much larger than other bit-slice designs.

says, it is much harder to configure these processors to the specific requirements of a system.

For example, although Advanced Micro Devices Inc.'s 32-bit 29332 has an on-board funnel shifter similar to the IDT design, it can be used only in conjunction with the merge logic. According to Mick, the 29332's ALU cannot be used in series with the funnel shifter, making it impossible to shift and merge in one cycle and do arithmetic operations during alternate cycles.

The IDT49C404 also stacks up well against Texas Instruments Inc.'s 74AS8832 central processing unit, says Miller. While the TI part also has an on-chip register file, it has only three ports and is one fourth the size of the CPU on the IDT chip. Moreover, it does not include an internal funnel shifter.

The final ingredient that enables the IDT49C404 to operate at such high system speeds is the use of three bidirectional data buses to enhance the concurrent operation of the seven-port register file and the ALU. In this design, the register file's A and B outputs go onto the DA and DB buses, which go directly on and off the chip. "The advantage of this configuration over competing designs is that data can be read out of the register file on either DA and DB, or both; or data can be brought in independently on either bus," says Miller.

The third bidirectional data bus is the Y bus, which links the output of the merge-logic block to the input of the register file, via the T input port and the Z multiplexer. When the output of the ALU is selected, the results of the ALU operations can be stored back into the register file while data is brought out through the merge path onto the Y bus, allowing ALU operations to be performed in parallel with the extraction of data out of the register file. Alternatively, the Y bus can be linked directly to the T multiplexer, enabling data to be written from the ALU back into the register file while data is being sent over the Y bus to the register file.

With the processor, IDT is looking to stake out a position in such high-end applications as robotics, superminis, image processing, telecommunications, digital signal processing, and CAD/CAM graphics controllers and accelerators. The IDT49C404 is scheduled to come to market in the first quarter of 1987 in sample quantities. □

*TECHNOLOGY TO WATCH is a regular feature of Electronics that provides readers with exclusive, in-depth reports on important technical innovations from companies around the world. It covers significant technology, processes, and developments incorporated in major new products.*

## THEY'RE BETTING ON CMOS FOR ADVANCED BIT-SLICE COMPONENTS

The development of high-performance, high-density processes—such as Integrated Device Technology Inc.'s Cmos-IIC—is making complex parallel designs feasible, says John Mick, director of product definition and applications engineering at the Santa Clara, Calif., company. "Bit-slice designers have been thinking about advanced architectures for a long time. But as long as bit-slice components were built with bipolar technology, most of these ideas were just wishful thinking, because of the density, packaging, and power limitations of bipolar technology."

Except for the extreme leading edge, where raw speed is imperative, CMOS is the wave of the future in bit-slice design, Mick says. And even there, he believes, the combination of submicron CMOS and advanced parallel architectures will give bipolar implementations a run for their money.

Although it's a latecomer as a manufacturer of bit-slice microprocessors, IDT has wasted no time catching up. Within the past year the company has introduced almost 50 CMOS-

based bipolar 4- and 16-bit slice components, including the IDT39C300 family of low-power drop-in replacements for AMD's 2900 family, and the more recent IDT49C400 series, which are high-integration versions of the 2900s. Capping the effort is the high-throughput, 32-bit slice processor, the IDT49C404.

A key element in IDT's quick sprint to market prominence has been the accumulated experience of the bit-slice design team, headed by Mick and by Michael Miller, manager of product defini-

tion and applications engineering.

Mick, 45, previously worked at Advanced Micro Devices. In 1973, he came up with the concept of AMD's original 4-bit 2901 and proceeded to direct the development of all devices in the family. In addition, as director of bipolar product planning, he was responsible for the development of 150 AMD circuits, including 4-, 16-, and 32-bit slice components, as well as bipolar memory, interface logic, gate arrays, and programmable logic arrays. He is coauthor of *Bit-Slice Microprocessor Design* (McGraw-Hill, New York).

Miller worked with Mick at AMD and was a contributing author to the book. At AMD, Miller was responsible for product planning, applications, and logic design for the 2901C, 2903A, 2910A, and 29818.

Other key members of the design team include Ying Long Tsui, design engineering manager; senior design engineer Fu Lam Au; design engineer Shyun Wang; applications manager Danh Le Ngoc; and Keith Hickox, who developed the software tools.



**SLICE TEAM.** The IDT49C404 design team includes (standing, l. to r.) Au, Tsui, Wang, Le Ngoc, and (seated, l. to r.) Miller, Hickox, and Mick.



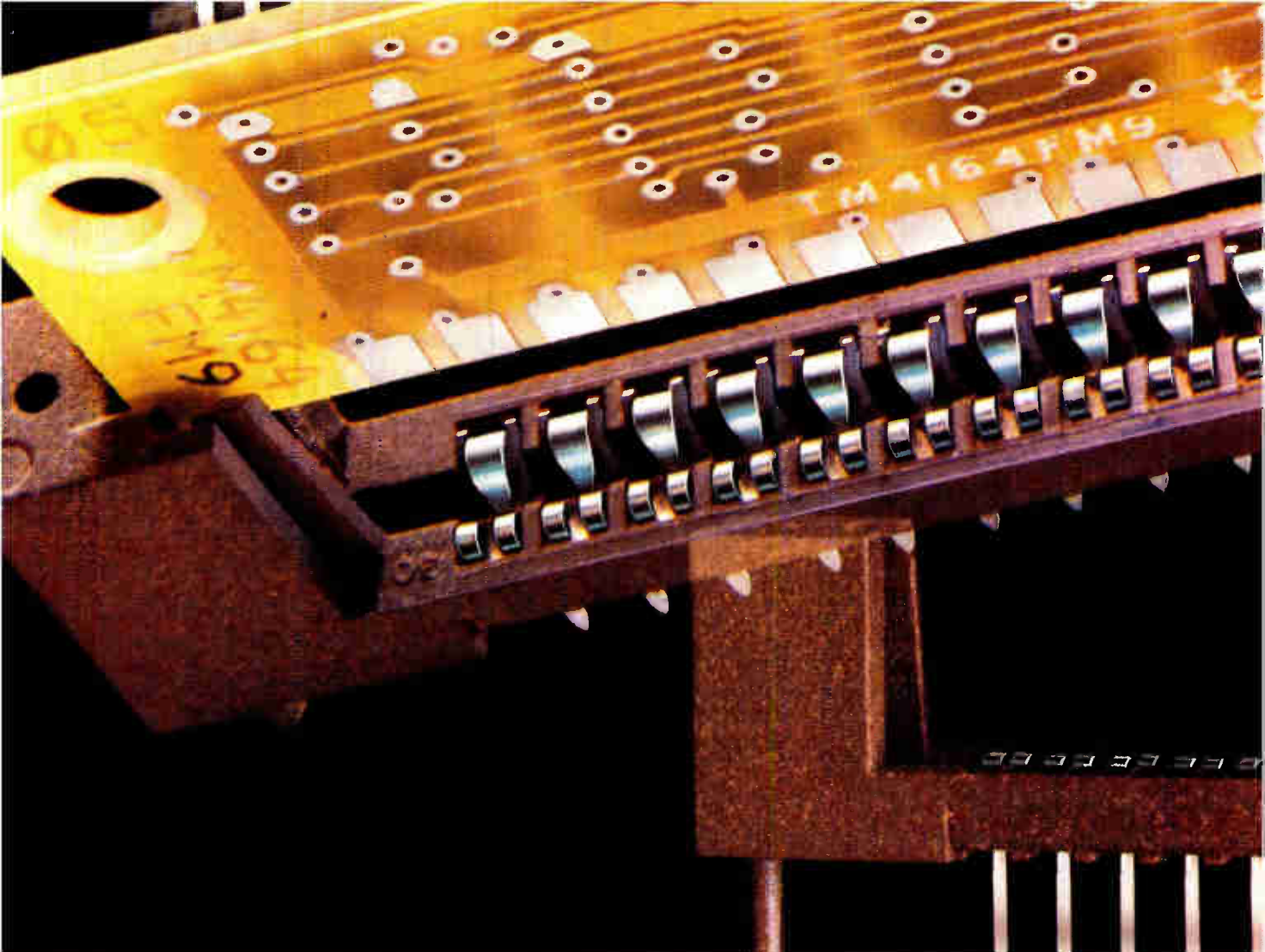

## Fast field upgrade for modular memories.

## SIMMple solutions, from AMP.

Now, AMP makes single in-line modular memory a very practical idea, with a family of inexpensive SIMM sockets.

What could be simpler than field replacement of modules in seconds, without tools? Our standard SIMM sockets feature polarized card-guide housings with built-in retention latches.

Count on higher yield and fewer "problem" boards, too. Our high-pressure tin contacts accommodate warped module boards without com-

promising performance. And we've brought the module leads to within .050" of the board for high-speed applications.

All this, in a socket that still makes solid economic sense. It's just the sort of thing that makes AMP worth remembering.

Call (717) 780-4400 and ask for the AMP SIMM Socket Desk. AMP Incorporated, Harrisburg, PA 17105-3608.

# AMP Interconnecting ideas

Standard sockets in 10 through 42 positions and low-profile sockets in 30 and 34 positions are available. Angled sockets to address tight board-to-board space applications to be available shortly. SIMM sockets accommodate standard 64K, 256K, and proposed 1M modules.

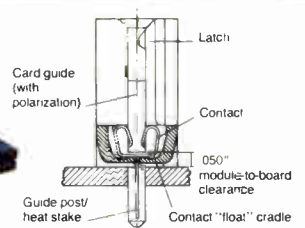

Redundant tin-to-tin contacts provide reliable performance without the cost of gold plating.

Circle 55 on reader service card

# THIS MINISUPER IS AIMED AT PARALLEL PROCESSING

*Convex Corp.'s C1 family features upgraded processors and memory with a high-speed fiber-optic interconnection for under \$1 million*

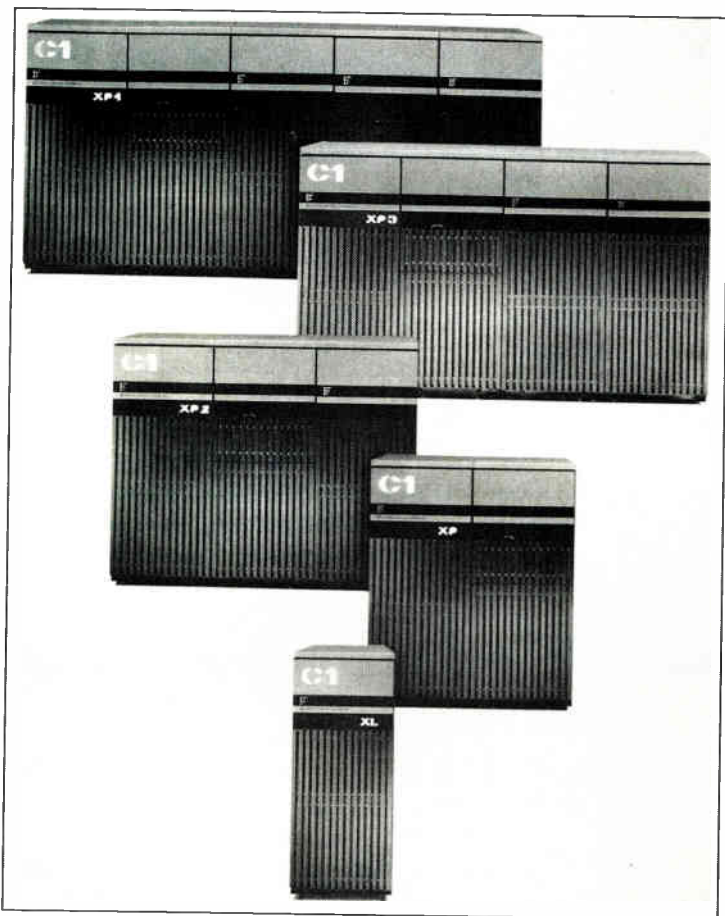

**1. NEW FAMILY.** Convex's new systems range from the C1 XP4 (top), with four C1 XP processors, to the C1 XL, a lower-priced version of the original C1

**C**onvex Computer Corp., the company that invented the minisupercomputer, is about to introduce a second-generation product line. The Richardson, Texas company revamped the architecture of its current product and developed a new interconnection scheme to come up with a line that's aimed at the multiple computer market and a move into parallel processing. According to Convex, the new computers will also provide better price-performance than its original C1 machine, offering an upgraded memory and greater speed at a lower cost.

The minisupercomputer market has turned into a hot spot in what overall has been a rather temperate computer business. Convex alone has sold more than 80 of its C1 supercomputers in less than two years. Now it is using this machine as the basis for a family of compatible, expandable low-cost supercomputers (Fig. 1).

The new C1 product line includes the C1 XP, a new processor, the C1 XL, a repackaged and repriced version of the old processor, and a fiber-optic-based system for connecting the processors called the Convex Extended Supercomputing Interconnect (CXSI). An architectural extension called CXS allows the interconnection of multiple C1 XP, C1 XL, and original C1 processors in a cooperating supercomputer environment with transparent file sharing.

The C1 XP is implemented with 20,000-gate CMOS arrays to provide up to 1½ times the performance of the original C1 processor. Memory has been upgraded too, by as much as one gigabyte per central processing unit, using 1-Mb chips. The 80-Mb/s fiber-optic interconnection can link up to 32 C1 supercomputers—in any mixture of new C1 XP, C1 XL, or C1 machines—for transparent load management and file sharing. The CXSI link is designed as a foundation for multiple supercomputer configurations.

To take full advantage of the multiple computers in the CSX architecture, Convex has also implemented distributed system-wide batch-management software. The features of CXS are designed to run more multiple-user jobs faster and run any given job in a shorter period of time, as well as to provide incremental upgrades.

The CXS system is very flexible in the number of processors used and in the different ways they can be connected. Although it can be expanded as necessary, the company is offering a family of four preconfigured systems with one to four of the new XP processors providing graduated levels of performance (Table). Customers can add additional CPUs, I/O processors, memory,

and peripherals to any of the preconfigured systems. The base price of the C1 XL is \$350,000. A typical preconfigured system XP1 costs \$475,000; a typical XP2 costs \$775,000.

Convex plans to focus on the commercial needs of scientific-computer users, rather than the research-oriented requirements of computer-science theorists. These plans led it to emphasize practical capabilities in the new computer family: improving throughput of a variety of jobs with multicomputer systems, making individual jobs run faster by offering a basic processor with higher performance, continuing software developments, and reducing the price of C1 systems.

## TWO PATHS TO FASTER COMPUTING

The two basic ways to speed computation are to build faster processors or to add more processors. Convex has done both. The C1 XP is a faster processor; the C1 CXS multicomputer system puts more of the processors to work.

To upgrade the C1, Convex went to new Fujitsu gate arrays. The original C1 processor was implemented with many Fujitsu 8,000-gate CMOS arrays. All the scalar floating-point calculations used the vector floating-point arithmetic and logic-unit pipeline to save on hardware.

The new C1 XP processor uses 20,000-gate CMOS arrays to provide the scalar part of the CPU with its own very fast scalar floating-point calculation unit. Therefore, the C1 XP delivers the greatest power boost to scalar-dominant programs—acceptable because the vector part of the machine is already very fast and the offloading of the scalar calculations leaves more time for vector calculations.

Several other speed benefits result from this upgrade. First, the new scalar ALU unit is optimized for scalar floating-point work and therefore does a better job than the vector ALU. And since the scalar floating-point calculation unit is now on board with the scalar registers, the time to exchange data between the scalar and vector units is saved. Because the greater number of gates on the new logic chips mean more pins—220 out of 256 for logic versus 160 out of 179 available on the 8-K arrays—data can be moved on and off the chip faster.

Although getting the data on and off the logic chips is desirable, the data also has to go somewhere—the main memory. The basic architecture of the original C1 already provided a large main memory and a wideband path between it and the processing units. Convex now is increasing the maximum main memory of the C1 XP processor up to 1 gigabyte—eight times the old maximum of 128 megabytes. Using 1-Mb chips and surface mounting, the engineers have developed 128-megabyte memory boards.

Convex customers want to run programs that need physical memory beyond 128 megabytes. "All the installed base can be field-upgraded with these new memory boards," says Steve Wallach, Convex's vice president of technology. This is one of the major advantages of an extendable architecture like the C1 CXS. Large, memory-hungry applications such as structural analysis will reap an immediate performance benefit from the large gigabyte physical memory, he says. And a C1 CXS system can go beyond 1 gigabyte of main memory when multiple processors are interconnected, because each C1 XP can have a gigabyte.

The backbone that interconnects multiple C1 XP processors, CXSI, is an 80-Mb/s token-passing ring implemented with noise-immune fiber-optic cable; a more economical coaxial-cable version is also available. Processors on the ring can be up to 2.5 km apart. Redundant links can be configured.

With the flexibility and speed of CXSI and the fast C1 XP, Convex has created a foundation for building a variety of multicomputing and multiprocessing systems. The C1 CXS systems introduced now are loosely coupled multicomputers with their own large local memory that can be easily used to run a mix of existing applications concurrently. The computers can be tied in a variety of ways, depending on the computational needs of the customer. An example of a C1 CXS system is one with four C1 XP computers linked

CONVEX XP SYSTEM CONFIGURATIONS				
Feature	XP1	XP2	XP3	XP4
Number of processing units	1	2	3	4
Maximum memory (gigabytes)	1	2	3	4
I/O speed (Mbytes/s)	80	160	240	320
Floating-point operations (Mflops)	40	80	120	160
Maximum mips	6.4	12.8	19.2	25.6
Number of Ansys jobs per hour	24	48	72	98

SOURCE: CONVEX COMPUTER CORP.

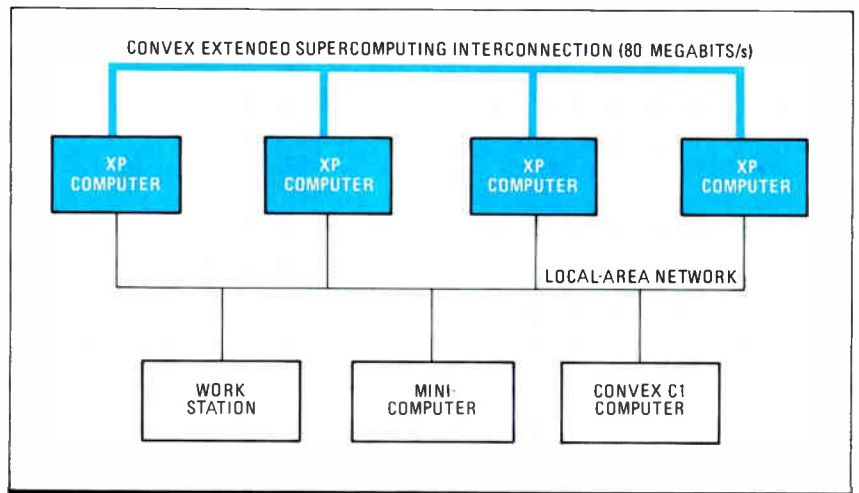

**2. TEAMWORK.** A four-processor C1 XP4, one configuration of C1 CXS multicomputer systems, can also be teamed with Convex's original C1, a minicomputer, and a work station.

through CXSI and tied to an original C1 computer, a minicomputer, and a work station with a local-area network (Fig. 2).

Another interconnection scheme for loosely coupled multicomputers is the cosmic cube or hypercube architecture, in which each computer is directly connected to all other processors in the cube. The C1 XP processors also can be configured as a hypercube using CXSI links.

Convex's next step, although the company won't say when, is to provide tightly coupled parallel processors that share a large memory and can quickly solve one problem. Then multi-computer configurations will be able to have some of these parallel processors as nodes in the CXSI network, mixing both loosely and tightly coupled processors in one system.

The parallel processors and the mixed systems will require some special software for efficient use. Convex is working on parallelization software and already has a set of vectorizing compilers and software development tools for the C1. For the C1 CXS system, the company is introducing a distributed system-wide batch-management software package.

Convex software engineers learned from C1 users that the machines typically run large job mixes. The majority of individual jobs in the mix are large, taking up to an hour to complete. The long jobs typically run in batch mode rather than in an interactive user mode—the user starts a job and goes on to something else. The new batch-management software manages the many jobs in a sophisticated way. The package works closely with the operating system to dispatch jobs transparently among all the processors in the system, based on the estimated job length and computer resources needed.

The batch-management system, combined with other features of the C1 CXS architecture, are designed to run more jobs for more users and run the whole mix faster. In addition, individual users' single jobs will be completed in less time because the individual C1 XP processors run faster than the original C1 processor. Thus the new features announced by Convex for its second generation of supercomputers address two of the most important user aspects of multiprocessor system design—greater throughput and faster job completion. □

## CONVEX STICKS WITH A WINNING MINISUPERCOMPUTER TEAM

It does not pay to tamper with a winning team, and Convex Corp. doesn't intend to. Essentially the same team of hardware and software engineers that designed its original C1 computer also worked on the CXS multicomputer system and XP processor designs. CXS and XP join the C1 computer to make up the building blocks of the C1 series, the name given to the Convex architecture.

The development projects that result in the current announcements advance Convex into the ranks of multi-product companies. The C1 computer development team, which in 1984 launched the affordable supercomputer, has extended the technology into a family of compatible and modularly expandable supercomputers.

Co-founders Robert J. Paluck, president, and Steven J. Wallach, vice president for technology, originators of the minisupercomputer concept, are still active in directing new-product development. Paluck and his startup team were confident they would bridge a market gap between superminicomputers and supercomputers with their new class of computer. They still were excited, though, when the machine started to sell—proof that the need was real.

But the development team, which also included Frank Marshall, vice president of development; Harold Dozier, manager of very large-scale integration; and

John Clark, manager of system engineering, recognized along with Convex's customers that they must move beyond a single-CPU system to meet the growing need for better performance and throughput.

The Convex design team decided that the company's first approach to multiple processors should be the loosely coupled multicomputer architecture that became CXS. According to Wallach, "We heard

from many users that the way they would most often use multiple processors would be to run more jobs simultaneously—they were not so interested in applying multiple processors to the same job."

Parallel processing requires that the application be broken down into parts that can be executed simultaneously. But running many jobs on multiple processors—multicomputing—usually does not involve any program changes. "The [multicomputing] solution solves 95% of the user's problems," says Wallach. For example, Convex learned that about 90% to 95% of the work done on the four-processor X-MP/48 supercomputer from Cray Research Inc. uses the machine as four separate computers.

Those findings heavily influenced the design team. "A key factor in what Convex is announcing this month is that these developments are a foundation for [future systems] that address two aspects of multiprocessor systems—running multiuser jobs faster and speeding up single jobs—with either a multicomputer or multiprocessor configurations," Wallach says.



**BOB PALUCK**

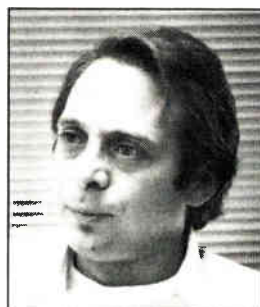

**STEVE WALLACH**

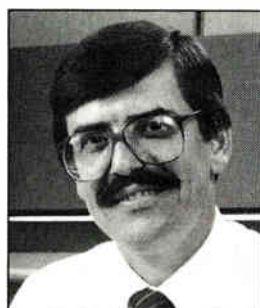

**FRANK MARSHALL**



**HAROLD DOZIER**

# CONVEX HAS A MASTER PLAN TO BE KING OF THE HILL

**C**onvex Computer Corp. is so determined to dominate the market for scientific computers costing less than \$1 million—the minisupercomputer market—that its engineers are willing to learn Japanese to give themselves an edge. Hardware designers at the Richardson, Texas, company have taught themselves enough kanji to read Japanese new-product specifications before they are translated for the American market. Their enterprise helped make Convex the first company in the U.S. to use new 20,000-gate CMOS logic arrays from Fujitsu Ltd. in its latest and most powerful C1 family.

Another secret of Convex's success is its blend of semiconductor and system talents. "This company probably has more VLSI expertise than most of its largest competitors. That's a remarkable quality. Many of the Convex engineers are ex-designers right out of the chip industry," says Convex chairman L.J. Sevin, a semiconductor executive turned venture capitalist who introduced the two company founders, Robert J. Paluck and Steven J. Wallach, in 1982.

That expertise played a key role in getting Fujitsu interested in Convex's original C1, the first CMOS-based 64-bit computer that integrated vector and scalar processing in a small, air-cooled cabinet, says Sevin, a founder of Mostek Corp. and its chairman before he left in 1981. "I knew the Fujitsu folks from the Mostek days. I just called them up and we went over to see them. Lo and behold, Fujitsu agreed to develop 8,000-gate CMOS array chips for a startup. That was a little surprising, but I think they've concluded startups can be a good market now."

The initiative Convex showed then has led some industry analysts to suggest that the company's development strategy will be a model for other U.S. computer makers. Hal Feeney, director of the technical computer systems industry service at Dataquest Inc., says, "The Japanese companies seem to be very good at exporting the raw

*The minisuper maker will use its new computer to separate itself from a growing crowd of competitors and also as a wedge into the parallel-processing field*

by J. Robert Lineback

CONVEX'S REVENUE AND INCOME CLIMB

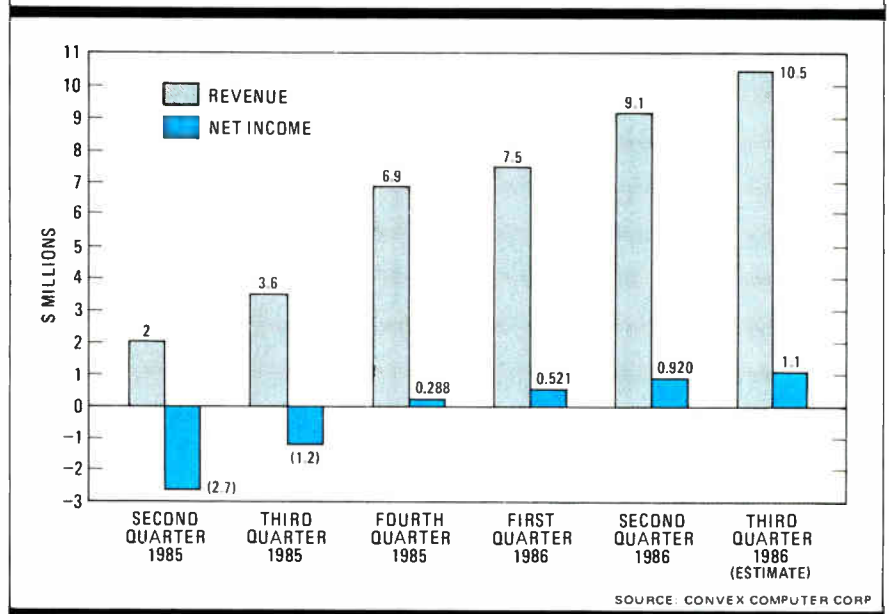



**TURNING 'EM OUT.** Convex Corp. factory-floor workers assemble C1 computers at the Richardson, Texas, plant.

resources—nuts and bolts of computer technology, if you will—but they have had difficulties bridging the gap to implement systems in the systems market.”

Four-year-old Convex’s design strategy combines CMOS chip integration from Japan with American know-how in hardware architectures and software technology. The latest results of that strategy, announced this week, pair the powerful C1 XP processor with a new, lower-cost C1 XL model, a repackaged C1 selling for about \$100,000 less. They represent aggressive moves by Convex on two fronts: one warding off a growing number of competitors peddling new scientific and parallel-processing systems, the second making the XP the baseline for Convex’s eventual entry into parallel processing.

The American-Japanese combination was the approach the company successfully used with the two-year-old C1. The original C1 in turn helped create the scientific computer market, bridging the gap between 32-bit minis and larger 64-bit supercomputers from the likes of Cray Research Inc.

With the new 20,000-gate arrays, Convex designers made the new C1 XP an average of 25% faster than the original C1 system (which exe-

cutes up to 60 million operations per second). Besides running faster, the C1 XP can contain up to four 64-bit central-processing units, each capable of performing vector and scalar computations simultaneously. Initially, Convex officials expect most multi-CPU C1 XP systems to be used as multiple computers, with each processing unit performing separate tasks. Eventually, though, software and high-speed interconnections are likely to turn the equipment into a full-fledged parallel-processing system. It is Convex’s “baseline to move forward,” says Wallach, who is vice president of technology and chief systems architect at Convex.

### AN ALL-FRONTS STRATEGY

“To be the leader in supercomputers, you must be the leader in supercomputer software. You must also be the leader in tightly coupled parallel approaches; you must be the leader in loosely coupled parallel approaches; you must be the leader in hooking multiple machines together; and you must do it in a way that users can make their applications work on your machine,” says Wallach.

“There is a need for [parallel-processing] software, where users have to do a minimal amount of restructuring because compilers do all the work. They want the operating systems to be as transparent as possible, because users don’t want to be computer scientists. We know how to do it and are doing it,” he says, hinting that some of Convex’s customers have been given a peek at prototypes. For the moment, however, Convex bases its marketing of the C1 XP and C1 XL on the virtues of single-CPU computing and the company’s compiler, which automatically vectorizes and optimizes code for execution on its 64-bit hardware.

The market Convex pioneered keeps growing. Dataquest estimates it was worth \$395 million in 1985, and the market-research firm expects sales to reach \$1.8 billion by 1990. Convex intends to be the leader in those sales. “Our goal is to offer the highest-performing supercomputers for under \$1 million, and we want to dominate the market,” says Paluck, the company president. “You won’t see us doing a low-end work station or high-end luxury supercomputers.”

So far, the highly focused strategy has paid off. Convex has been profitable since the final three months of 1985 (see chart). It is shipping an average of 20 systems each quarter; more than 80 of the original C1 computers have been installed.

The company also went public this month in a second pass at an initial stock offering. The first offering was postponed last July when the investment market soured on the news of sudden losses and layoffs at rival Floating Point Systems Inc. in Beaverton, Ore. After waiting for the stock market to firm up, Convex made an offering of 3.135 million shares at \$7.50 apiece, worth a total of \$23.5 million. □

# MACSYMA solves mathematical problems analytically.

**Now you can do algebra, calculus, differential equations. Simplify, factor and expand equations. Compute with matrices. And more. Symbolically.**

If you work with quantitative models in scientific or engineering disciplines, MACSYMA can increase your modelling power. MACSYMA combines symbolic and numeric computation. And enables you to accurately manipulate symbolic expressions in a fraction of the time required manually.

## Wide range of capabilities

MACSYMA offers the widest range of capabilities for symbolic computations in applied mathematics of any commercially available program. For example:

**Algebra:** MACSYMA can manipulate large expressions, expand, simplify and factor expressions, handle matrices and arrays and solve systems of equations.

**Calculus:** MACSYMA can differentiate, perform definite and indefinite integration, take limits, expand functions in Taylor or Laurent series, solve differential equations and compute Laplace transforms.

## Symbolic-Numeric interface:

MACSYMA can generate FORTRAN coding of expressions for numerical analysis or perform numerical analysis in the powerful MACSYMA™ language.

**Post-Processing:** MACSYMA can plot in 2 or 3 dimensions and interface to standard mathematical text composers.

## Broad base of applications

Throughout the world thousands of scientists, engineers and mathematicians are using MACSYMA in such diverse applications as structural engineering, fluid mechanics, acoustics, CAD, electronic and VLSI circuit design, electromagnetic field problems, plasma physics, atomic scattering cross sections, control theory, maximum likelihood estimation, genetic studies and more.

## Compatible with many computer systems

Current systems include:

- Micro VAX II™, VMS™
- Symbolics 3600™ Series
- SUN-2™ & SUN-3™
- VAX™, VMS™ & UNIX™
- Masscomp™ MC5500™

Other versions will be following soon.

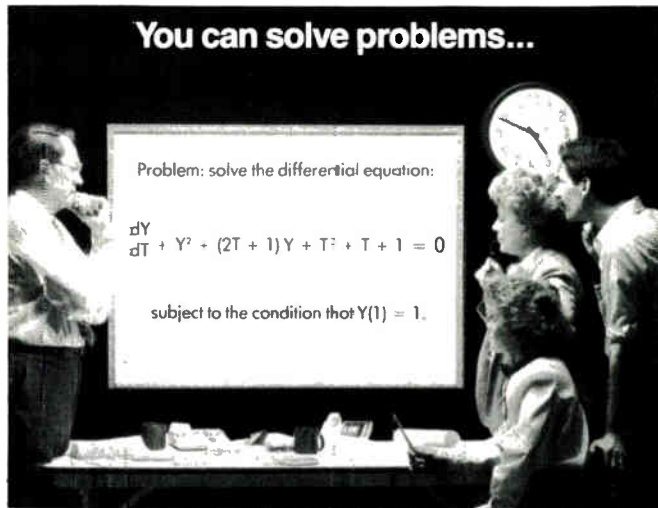

## Symbolically...

```
(C1) DEPENDS(Y,T)$
(C2) DIFF(Y,T)+Y^2+(2*T+1)*Y+T^2+T+1;
(D2) dY/dT + Y^2 + (2T + 1)Y + T^2 + T + 1
(C3) SOLN:ODE(D2,Y,T);
(D3) Y = - (%C %E^T - T - 1) / (%C %E^T - 1)
(C4) SOLVE(SUBST([Y=1, T=1],D3),%C),NUMER;
(D4) [%C = 0.5518192]
(C5) SPECIFIC.SOLN:SUBST(D4,SOLN);
(D5) Y = - 0.5518192 T %E^T - T - 1 / 0.5518192 %E^T - 1
```

## and Numerically.

```
(C6) FORTRAN(D5)$
Y = -(0.5518192*T*EXP(T) - T - 1)
1 / (0.5518192*EXP(T) - 1)
```

For an information kit about all the ways MACSYMA can work for you, just call

**1-800-MACSYMA.**

In Mass., Alaska or Hawaii only call: (617) 577-7770.

Or please write to us at:

**Computer-Aided Math Group - Dept. M-EL-3**  
**Symbolics, Inc.**  
**Eleven Cambridge Center**  
**Cambridge, MA 02142**

Name \_\_\_\_\_

Title \_\_\_\_\_

Company \_\_\_\_\_

Address \_\_\_\_\_

City \_\_\_\_\_ State \_\_\_\_\_ Zip \_\_\_\_\_

Telephone \_\_\_\_\_ Extension \_\_\_\_\_

**MACSYMA is available to colleges and universities at special rates.**

# MACSYMA

The most comprehensive software approach to symbolic mathematical computations.

*symbolics*™

Your next step in computing.™

MACSYMA, Symbolics and SYMBOLICS 3600 are trademarks of Symbolics, Inc. Micro VAX II, VAX and VMS are trademarks of the Digital Equipment Corporation. UNIX is a trademark of AT&T Bell Laboratories. Masscomp is a trademark of the Massachusetts Computer Corporation. SUN-2 and SUN-3 are trademarks of SUN Microsystems, Inc. Copyright 1986 Symbolics, Inc.

**“Oh dear! Philips new UNIX™ port on VMEbus has too many features”**



**Indeed! Philips offers you more:**

UNIFIVE, the Philips UNIX port on VMEbus, is fully compatible with UNIX System V.2. Numerous software options like database systems and compilers together with modular and configurable VMEbus hardware create an ideal offer for OEM users and system integrators. Combined with Philips monitors and debuggers UNIFIVE supports the development of real-time applications. The B-Net™ option allows for communication with other systems connected via Ethernet™.

*UNIX is a trademark of Bell Laboratories.  
Ethernet is a trademark of Xerox Corporation.  
B-Net is a trademark of UniSoft Corporation.*

For more information:

<b>Building HKF 49</b> 5600 MD Eindhoven, The Netherlands, Tx: 35000 PHTC (NL)	<b>AUSTRALIA</b> 02-8888222	<b>FRANCE</b> 01-8301111	<b>ITALY</b> 039-3635207	<b>NORDIC</b> 08-7821091 (Sweden)	<b>SINGAPORE</b> 2538811	<b>SWITZERLAND</b> 01-4882403	<b>U.S.A./CANADA</b> (800)-227-1817 ext. 957 K
	<b>AUSTRIA</b> 0222-629141/740	<b>HONG KONG</b> 05-283298	<b>NETHERLANDS</b> 040-788325	<b>PORTUGAL</b> 01-683121	<b>SPAIN</b> 01-44042200	<b>U.K.</b> 0223-358866	<b>WEST GERMANY</b> 0211-3616241
	<b>BELGIUM</b> <b>LUXEMBURG</b> 02-5256646	<b>INDIA</b> 022-4921500	<b>NEW ZEALAND</b> 09-894160				



**Industrial  
Automation**

**PHILIPS**

Circle 62 on reader service card

World Radio History



# HOW AI WILL ADD BRAINS TO OFFICE AUTOMATION

**A**rtificial intelligence, which cut its teeth on specialized applications such as expert systems, is about to move into the mainstream in a big way. The ambitious goal of developers is nothing less than taking over the job of managing information in the workplace. Breakthroughs are starting to come from a tiny band of researchers who are applying AI techniques to office automation.

Finding a way to knit together AI and office automation has not been an easy task. But early systems now being developed in the laboratory will create a central pool of knowledge about engineering projects, clue in users on any elec-

*Artificial-intelligence techniques will manage the flow of information; one goal is automatic updating of a pool of information for the engineers working on a project*

by Alexander Wolfe

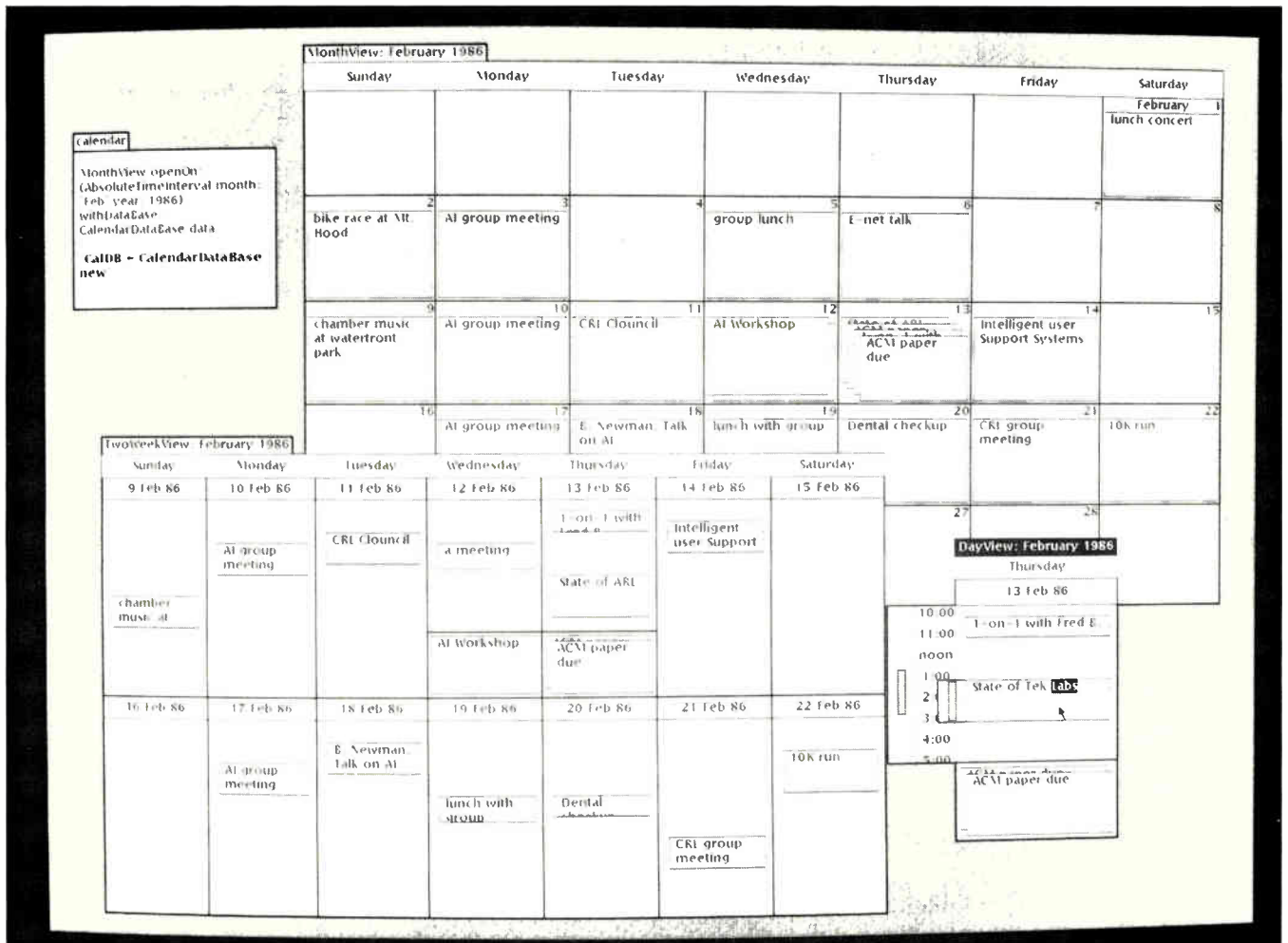

1. DAYS OF OUR LIVES. IPSE's intelligent electronic calendar will use AI to coordinate scheduling of people, office space, and equipment.

tronic mail messages that fit their interests, and automatically juggle an entire work group's schedules to resolve any conflicts. Results should begin to emerge from the lab within the next 18 to 24 months, offering vast productivity improvements to end users of the roughly \$250 billion of office-automation hardware and software that is expected to be sold over the next five years.

Most ambitious are the separate efforts under way by researchers at Tektronix Laboratories, Beaverton, Ore., and at the Massachusetts Institute of Technology. The two groups have already demonstrated prototypes of new office-automation systems incorporating some AI features. Tektronix Inc. is enhancing its Intelligent Project Support Environment (IPSE). And a version of the MIT Information Lens will soon be up and running at Xerox Corp.'s Palo Alto Research Center, a sponsor of the effort. Office-automation giants Data General Corp. and Wang Laboratories Inc. also say they're pursuing research, but they decline to discuss specifics.

"The potential to use artificial intelligence in office automation is tremendous," says Jit Saxena, president of Applix Inc., a Westboro, Mass., office-automation software house. AI-enhanced office automation will take the form of integrated software packages running on networks of high-powered desktop work stations or personal computers. That software will typically provide each user with access to individual word processing and spreadsheet applications. On a system level, features will include an electronic calendar or scheduler for keeping track of meetings and



**2. PHILLIPS.** "A lot of difficulties on projects arise because people fail to mesh correctly."

appointments, electronic mail for communicating with other system users, and perhaps a document-management and -tracking feature. All these functions will be tied together via a huge data base. AI will help manage that data base, controlling the flow of information.

Controlling the flow for engineers working on large-scale technical projects is the idea behind Tektronix's IPSE system. "A lot of difficulties on projects arise because people fail to mesh correctly," says Brian Phillips, a principal scientist in the Computer Research Laboratory portion of Tektronix Laboratories and head of

the IPSE effort. Indeed, problems often arise because programmers and engineers become isolated from key "outsiders" such as management and support personnel. "We need to increase the access to information beyond the project team. This is not a trivial task," says Phillips.

To provide that access, IPSE brings together three main parts: a project encyclopedia, or data base; an intelligent electronic calendar; and an electronic mail system. The IPSE will use AI as a key ingredient in each of those features, as well as for tying together the information they contain. AI will allow the system to act as a filter that makes decisions about efficiently routing information to the system's users.

### FACING UP TO AI

Phillips and colleagues Jeff Staley and Eric Gold are integrating the calendar, encyclopedia, and electronic-mail components. Prototypes of some of the system's AI components also exist; more AI power will be added during the next year. Although the toughest obstacle to fully realizing IPSE's proposed capacities will be development of the natural-language software—programs that can "understand" written text—"we strongly believe we can get some subset of that to work fairly quickly," says Staley.

The completeness of the project encyclopedia is crucial to IPSE's success, says Phillips. As a data base containing the complete history and state of the engineering project that IPSE users are working on, the project encyclopedia is the ultimate source of all information that the system's AI-enhanced software processes.

Internally, the project encyclopedia is modeled as a semantic network, a knowledge-representation form used in AI. In many ways, this model is like a filing system that features extensive cross-referencing. Roughly, "primitives," or nodes containing abstract concepts, are linked to more detailed explanations. At the same time, groups of primitives, as well as groups of detailed explanations, can also be linked together.



**3. MALONE:** His Information Lens acts as a filter in electronic-mail systems to control and manage the flow of information.

In this way, the complete volume of project data can be accessed by dipping into the system through a relatively small number of primitives.

The intelligent electronic calendar (Fig. 1) is much like a desk diary in electronic form. IPSE users can note their appointments and schedules on their calendar; their input automatically becomes part of the project encyclopedia. Using that input, the system will assist in coordinating the use of all time-restricted resources—people, office and lab space, and equipment. A goal is to be able to use the calendar to help automatically schedule an engineer's or programmer's day. "To do this, it [the calendar] has to know something about the idiosyncratic preferences of the user. For example, they [the user] may want to keep Wednesdays free of meetings so they can get some work done," says Phillips (Fig 2). Much more complex constraints would also have to be handled: the calendar provides facilities to access the project encyclopedia, view multiple schedules, summarize a schedule, automatically schedule repetitive meetings (such as weekly staff meetings), and automatically negotiate a meeting time.

The communications system consists of an electronic-mail system combined with an AI component that will analyze the messages. The electronic-mail system will feed its information into the IPSE via the project encyclopedia. Because of its file-linkage model, the project encyclopedia is adept at processing information input from the electronic-mail system.

AI software in the form of a local reasoning system will make decisions on message routing based on knowledge about that message, knowledge about the project, and information gleaned from previous messages. In addition, a user may instruct the system on how to make message-routing decisions by entering rules. For example, a user might enter a rule commanding IPSE to route a copy of all messages to the project's department secretary. A more complex set of rules might detail the steps to take if a member of the IPSE team is out of town. IPSE might sort the absent member's arriving messages by content and resend messages covering different topics to different group members.

At times, the local reasoning software will need information on the status of other IPSE users to make its routing decisions. For that reason, the communications system will also contain a remote reasoning system to automatically send the necessary data to other local reasoning points in IPSE.

IPSE is being implemented on the Tektronix 4404 AI work station in the AI programming language Smalltalk. To operate IPSE, users select system functions using pop-up menus and a mouse. The menus allow users to call up screens

4. TELE-GRAPHIC. Templates, or blank forms containing category headings, are the basis of the Information Lens.

to enter information in the encyclopedia, update the calendar, or send electronic mail. Windowing lets several tasks be processed simultaneously.

Future work on IPSE will also seek to extend the breadth of information stored in the project encyclopedia, so the system will have more project data to share among users. But this will be no easy task. "The burden of entering information must be minimized. We are seeking as many ways as possible to reduce the manual effort involved. We are exploring optical character-recognition techniques. Another idea is to automatically capture information from the communication channels and place it in the encyclopedia," Phillips, Staley and Gold wrote in a recent paper describing the project. "Nevertheless, relevant information will [also] be generated in informal, off-line situations: 'at the coffee machine.' Collecting this information is a future challenge."

#### WILL THE SOFTWARE UNDERSTAND?

Ultimately, IPSE's future will ride on the success of its natural-language-understanding software. Writing software that can understand free-form unstructured paragraphs and pages is an immensely complex process. Indeed, the comprehension capacity of current natural-language systems is severely limited. In the commercial arena, natural-language front ends have scored some successes; they convert English-language input into programming-language queries intended for data-base-management systems. The natural-language front ends can do this because they can handle limited, single-sentence messages quite handily. Long multisentence passages, on the other hand, press AI researchers to the limit.

Thomas W. Malone (Fig. 3) took a detour around that natural-language roadblock in developing the Information Lens. It uses templates—

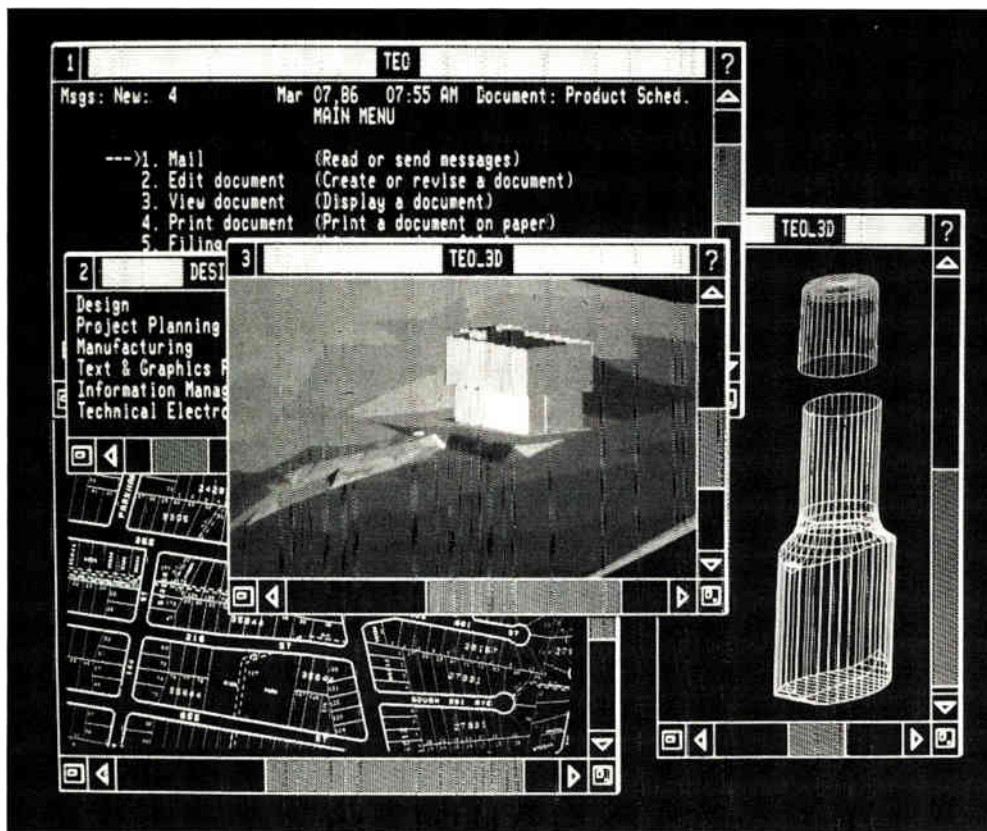

**5. A TOOL FOR ENGINEERS.** Data General Corp.'s TEO helps engineers work with CAD applications that include AI software, but does not itself use AI-based analysis.

blank forms containing category headings (Fig. 4)—instead of software that understands natural language. “What our system does is allow you to communicate a much wider range of information that may be beyond the power of current natural-language-understanding systems,” says Malone, who is an associate professor of information and technology at MIT’s Sloan School of Management in Cambridge.

### A GIANT FILTER

Billed as “an intelligent system for information sharing in organizations,” the Information Lens handles the electronic-mail component of office automation. “One of the ideas behind the system is that, by giving people tools for selecting what is important to them, they gain access to information without being overloaded,” says Malone. The system, running on 25 Xerox 1100 work stations scattered throughout the Sloan School, is the most sophisticated electronic-mail network ever implemented, Malone claims.

The Information Lens acts as a giant filter operating on all the electronic-mail messages that travel throughout the network of work stations. It monitors the information content of all of those messages; its ‘filtering’ function determines the significance of the information to each of the many users logged on to system.

To this end, a detailed representation of each user’s interests is programmed into the Informa-

tion Lens. When message content matches that stored representation, the system picks off the information and routes it to the user. In this manner, the Information Lens can sort and prioritize messages that are already addressed to a user. But more important, it can deliver messages to users who otherwise would not have received them.

Users enter their outgoing-message text into a template. For example, a template announcing a meeting might include fields for ‘time,’ ‘place,’ ‘organizer,’ and ‘topic.’

The templates lock the messages into a structure the Information Lens’s software can easily decompose into informational components. The template concept is also used to help users program in rules to capture and categorize incoming information. Customized tem-

plates could be added to extend the range of the system. By using templates to structure information, Malone avoided one of the toughest AI-development problems. “One of the things that’s unusual about our system is that our combination of AI techniques and user-interface techniques avoided the need to do natural-language understanding,” he says. The templates make the Information Lens user do work that would otherwise be left to a natural-language system.

Another office-automation giant, Data General Corp., recently released TEO, a state-of-the-art office-automation package for engineers (Fig. 5). While the package allows users to work with AI-based computer-aided-design applications programs, it does not contain any “global” AI information-analysis tools. “We see [AI] as an important area, but nothing that can be integrated into office automation quite yet,” says a company spokesman. “You can’t hand people technology before it’s ready.” Nevertheless, Data General is investigating AI and says future systems are likely to contain some of the information-sorting and -sifting tools that appear to be an increasing focus of AI researchers.

A Wang spokesman says that the Lowell, Mass., company is also pursuing office-automation research in the AI areas of natural language, knowledge-based systems, and voice applications. But the company would not discuss specific projects. □

# Gould solutions adapt to your needs.

Gould has the flexibility to adapt to your situation with the skill of a chameleon.

Gould's 32-bit CONCEPT/32® series provides a lot more computer for the price. Using Gould's real-time operating system, MPX-32®, the CONCEPT/32 product line gives you the performance needed to handle your particular requirements.

The PowerNode® series gives you the flexibility and versatility of UNIX®: Gould's UTX/32 operating system is a unique combination of Berkeley BSD 4.2 with AT&T System V.

Our "Compatibility Suite" of application software packages are operational across the entire Gould

PowerNode series . . . the widest range of Unix-based systems in the world.

To succeed, Gould has evolved to meet the needs of our customers. Year after year. Gould continues to innovate with products like Hypersearch — a superior text retrieval system, and our unmatched, complete computer-based training package.

For more information on how we can adapt to your needs, contact Gould Inc., Information Systems Computer Systems Division, 6901 West Sunrise Boulevard, Fort Lauderdale, Florida 33313 1-800-327-9716.

**High Performance Solutions in Factory Automation, Computers, Instrumentation, Defense, and Semiconductors.**

CONCEPT/32, MPX-32, PowerNode and UTX/32 are registered trademarks of Gould Inc.  
UNIX is a registered trademark of AT&T Bell Labs

Circle 67 on reader service card



**GOULD**  
*Electronics*



# HOW TO CONTROL PCB QUALITY ACROSS THE BOARD.

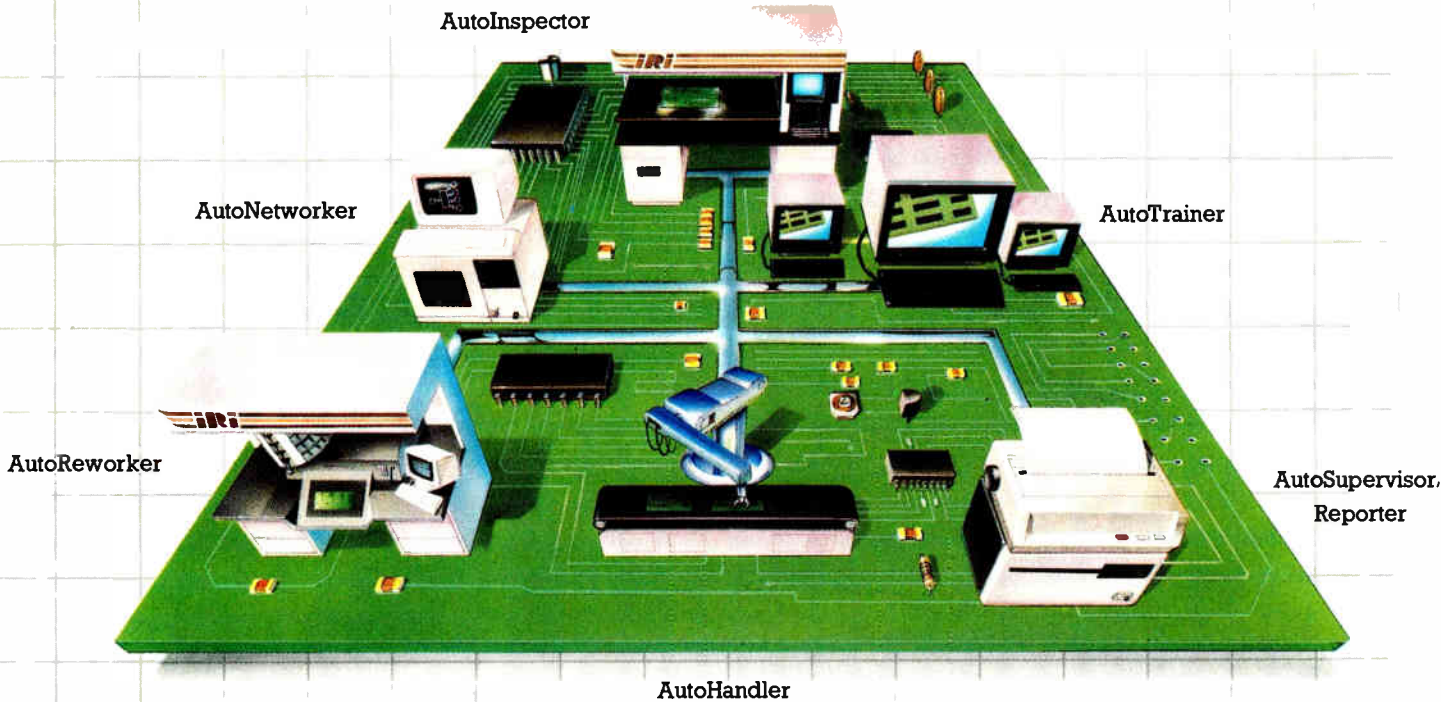

## NOW THE IRI VISION INSPECTOR WORKCELL CAN OVERSEE THE ASSEMBLY QUALITY OF ALL YOUR ELECTRONIC COMPONENTS.

Now, with one automated vision product family, you can inspect SMDs, thru-hole components, solder paste, pre- and post-solder and bare boards and back plane and connector pins. Automatically.

**The IRI Vision Inspector Workcell Series** is a modular product system that can be configured to your manufacturing and assembly applications to perform inspection, rework, training, handling, supervision and reporting tasks across your inspection workcell.

**The IRI AutoInspector.** This multi-task, top and bottom board inspector performs high-throughput inspection of today's advanced SMDs, PLCCs, SOICs, and other SMT components with unprecedented speed and accuracy.

**The IRI AutoReworker.** When component placement errors are detected, this module provides a work repair station for expedited rework with board identification, laser guidance for location of the defective area, automatic parts presentation and vision verification.

**The IRI AutoTrainer.** Using color graphics, pull down menus and mouse-type controls, this user-friendly trainer reduces PCB inspection training to simple data base manipulations and down loading of CAD data bases.

**The IRI AutoHandler.** This module automates the handling of materials between stations, provides loading, unloading, robot transport and position registration for inspector workcell stations.

**The IRI AutoSupervisor/Reporter.** To keep management informed, a UNIX-based relational data base manager generates reports including part/board error analysis, product tracking, report generation, job/order status and part purging.

**The IRI AutoNetworker.** This network connection system provides network communications within the inspector workcell. External communication interface is provided to LAN, e.g. MAP, and X.25 networks in the factory.

For more information, call: Richard Carroll, V.P. Sales (619) 438-4424. International Robomation/Intelligence, 2281 Las Palmas Drive, Carlsbad, CA 92008



**THE BEST VISION INDUSTRY HAS EVER SEEN.**

Circle 68 on reader service card

World Radio History

# HOW WEITEK'S CHIPS RUN FORTRAN AT 25 MEGAFLOPS

**A** major advance aimed at easing the task of designing high-performance numerical processing systems comes in the form of three new processor chip sets from Weitek Corp. The Accel processors couple a rich software-development environment with a powerful hardware architecture using some features of reduced-instruction-set computers to yield peak performance of 25 million floating-point operations per second (Fig. 1).

That combination should spell relief—in time and costs—for developers of supercomputers, work stations, two- and three-dimensional graphics systems, digital signal processors, and other power-hungry number-crunching applications. “We offer the ease of software development of microprocessors with the performance that you find in bit-slice building-block products,” says Julie Cates, Accel product marketing manager for the Sunnyvale, Calif., company.

Key to the Accel family's software arsenal is a set of optimizing C, Fortran, and Pascal compilers that allow users to code directly in high-level languages, eliminating the reliance on the cumbersome microcoded approach of bit-slice building blocks. An instruction set utilizing the best of both the RISC and non-RISC worlds allows the compilers to generate the most efficient code possible. A parallelizing instruction scheduler further optimizes that compiled code. And an optional development system attaches to an IBM Corp. Personal Computer AT to allow rapid prototyping and debugging of Accel applications.

Those tools have helped the Accel processors, which are available in sample quantities, get off the dime quickly. The Jet Propulsion Laboratory, Pasadena, Calif., is using Accel processors in a new version of its Hypercube parallel processing computer. Pixar Inc., a high-end graphics systems manufacturer, and Evans & Sutherland Inc., a maker of graphics terminals, are also using Accel chips.

The Accel 8000, 8032, and 8064,

*Three new processor chip sets combine optimizing compilers for high-level languages with a hardware architecture that uses the best features of RISC*

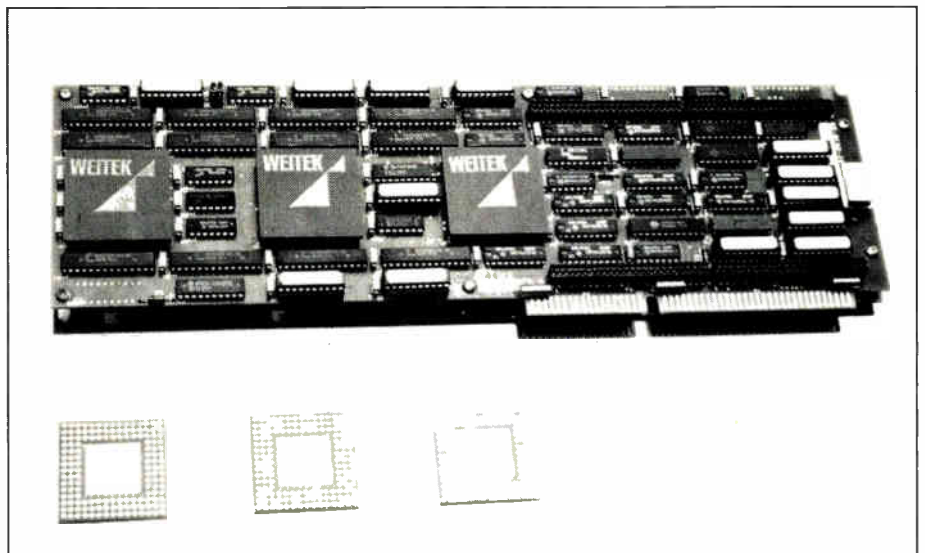

**1. ACCEL-ERATOR.** The Accel-DS design system helps ease software development for the three-chip Accel 8064 processor, aimed at numeric processing applications.

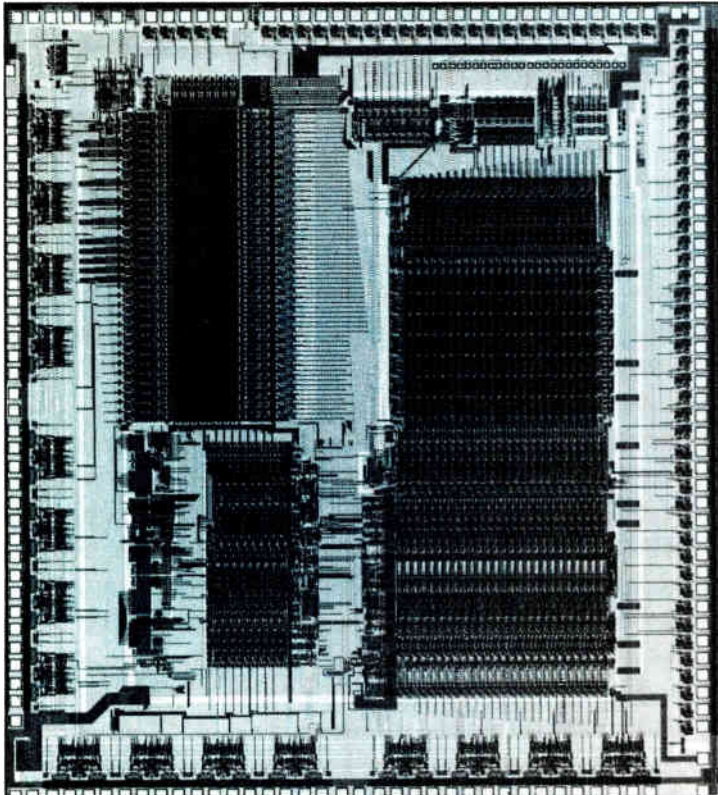

**2. NUMBER-CRUNCHER.** The floating-point processor in the Accel 8032 and 8064 offers 25-megaflops peak performance.

all fabricated using 1.5- $\mu\text{m}$  CMOS technology, make up the new line. At the low end of the family, the Accel 8000 32-bit integer processor is ideal for 2-d graphics and simulation applications. Execution speed is 5 million instructions per second sustained and 12.5 mips peak. In graphics applications, such performance equates to line-drawing rates of 5 million pixels/s, polygon shading at 3 million pixels/s, and two-dimensional image transformation and clipping at 2 million vectors/s.

The Accel 8000 processor is composed of two very large-scale integrated circuits, an integer processing unit and a program sequencing unit. The IPU performs all integer-based computation, such as data address generation and integer control operations. The PSU controls program flow, ensuring that instructions execute in the proper sequence. It also manages branching, subroutine jumps, and interrupt response.

The additional power of the next processor in the Accel lineup, the 8032, is aimed at digital signal processing and 3-d graphics applications. While the 8032 maintains the 5-mips processing capacity of the 8000, it adds 10 million floating-point operations/s of 32-bit single-precision calculations. In DSP applications, this allows calculation of a 1,024-point fast Fourier transform in 2.8 ms. With 3-d graphics, the transformation and clipping speed of 500,000 points/s is at the level of real-time computer graphics animation. The 8032 consists of three VLSI chips: an IPU, a PSU,

and the single-precision floating-point unit.

At the top of the line is the Accel 8064, featuring 64-bit double-precision floating-point power for high-end Fortran, scientific, and graphics applications. Using a full 64-bit design, including 64-bit instructions and a 64-bit-wide data path, and a 200-megabyte/s memory bandwidth, the 8064 executes 5 mips and 5 megaflops (single or double precision). Running Spice, a standard simulation program, the 8064 can perform up to 48 times faster than a VAX 11/780, Weitek says. Using a standard floating-point benchmark, the 8064 has a single-precision Linpack rating of 2 megaflops. The three-chip 8064 set consists of an IPU, PSU, and a double-precision FPU (Fig. 2). The Accel 8000, 8032, and 8064 will sell for \$600, \$1,000, and \$1,500, respectively, in hundreds.

## A CRUCIAL GOAL

In constructing the Accel processors' instruction set, a crucial goal was to make it work well with high-level-language compilers. Designing a compiler that converts programs written in Pascal, Fortran, or C into optimized code targeted at a numeric processor is itself no easy task—but a properly chosen instruction set allows for a more efficient compiler to generate more compact code. To that end, Accel combines the best characteristics of both RISC and non-RISC instruction sets.

As in RISC processors, all instruction-set operations are register-based; the only memory operations are data loads and data stores. As a result of this streamlining, a single three-address, register-to-register operation takes a cycle time of only 80 ns.

Yet the Accel processors execute arithmetic operations, such as integer multiply and divide and floating-point add, multiply, and divide, as single instructions. In traditional RISC processors, such operations are executed as a lengthy stream of instructions. The Accel processors also treat a floating-point multiply-accumulate as a single instruction. As a result, floating-point operations may be initiated every clock cycle, allowing a peak throughput of up to 25 megaflops.

The instruction set further boosts performance by supporting more parallelism than traditional RISC processors. It performs data-address generation—including powerful indexing modes—in parallel with computation. Memory load and store operations also parallel the computational processing.

Instruction-set features also help tighten the loops, which can take up 90% of the execution time in a numerical processing program. Available are loop control, endloop, subtract, and branch instructions. An instruction-neutralization feature helps optimize program paths containing conditional branch instructions. And instructions that can generate an address and load data into a register every clock cycle speedily handle arrays, which are critical to



many numerical processing applications.

Accel's software lineup includes a range of optimizing compilers to generate efficient code, the parallelizing instruction scheduler to further speed execution of that code as it runs on the processor hardware, and a variety of development tools such as assemblers and debuggers.

The C, Fortran 77, and Pascal optimizing compilers were developed by Weitek in conjunction with Green Hills Software Inc., Glendale, Calif. To develop efficient target code, the compilers apply standard optimization techniques, including elimination of common subexpressions and elimination of redundant load and store instructions.

The parallelizing instruction scheduler significantly enhances the performance of the compiled code by examining the instruction stream and rearranging the instruction flow where possible. Integer, floating-point, and address-generation actions can occur simultaneously within the Accel processor: the scheduler attempts to maximize the parallel execution of these functions. It also resequences instructions to make the most efficient use of the inherent latencies, pipelines, and branch delays of the Accel processors. It achieves this by overlapping single-cycle instructions, such as integer ALU or address generation instructions, with multicycle instructions, such as floating-point operations. Using these methods, the scheduler can reduce program cycle times up to 50%.

The difficulties of software development are the biggest barrier to the development of appli-

cations heavily dependent upon floating-point operations. Development tools offered for the Accel processors include an assembler, disassembler, linker, and simulator. The assembler uses syntax and directives similar to that of a Unix BSD 4.2 assembler. It generates relocatable object code and supports multiple sections, expression evaluation, and symbol table generation for symbolic debugging. The disassembler converts native-code instructions back to their assembly syntax, a useful aid in testing new assembly-language applications. The linker converts object modules created by the assembler into executable modules that can run on the Accel processors. The simulator provides an architectural simulation of an Accel processor. Its user interface includes a debugger that features register and memory status display, breakpointing, macros, and limited symbolic debugging.

Also, to help prepare programs for the Accel processors, a powerful software development environment is available separately. The environment, the Accel-DS design system, is a set of two boards containing one of the three Accel processors, 4 megabytes of random-access memory, 4 kilobytes of program code, and data cache memory. Plugged into an IBM PC AT, the boards provide a platform on which to develop Accel software. C, Fortran, or Pascal programs can be tested and debugged. The \$10,000 Accel-DS will be available in the first quarter of 1987. For users developing software on a VAX machine, Weitek will offer a simulator that models the behavior of the Accel processors. □

## DEVELOPING THE ACCEL CHIPS STRETCHED THE PROJECT MANAGERS

With the Accel processor project, Weitek managers Fred Ware and Greg Lee tackled new challenges. Ware, 34, took on his first project-manager role. "This is the first time I've directed an effort of this magnitude," he says. Lee, 38, manager of the Accel software team, faced a different kind of challenge. Until now, Weitek has been largely known for its chips. But with Accel, "Weitek has to establish itself as a credible vendor of software," says Lee.

Ware had been a chip designer since graduating with honors in applied physics from the California Institute of Technology and adding a computer science MS at the University of California at Berkeley. At Hewlett-Packard Co., where he worked starting in 1975 through 1982, Ware designed custom integrated circuits for minicomputers, including, in 1979, a float-

ing-point chip set for Hewlett-Packard's HP1000 mincomputer.

After joining Weitek in 1982 as R&D manager, Ware immediately racked up designs as chief architect of the 1032 series of floating-point chips. In 1984, he added design of the 1064 series of floating-point chips to his resume.

But when Ware put on his management cap for Accel, he found there were some adjustments to make. "It's not always real easy to do—you have to fig-

ure out what each person's strengths and weaknesses are," he says. Nevertheless, "so far though I find it a fairly rewarding thing."

Lee shifted to programming after years as an academic. After he graduated from Reed College in 1970, he went on to earn a PhD in mathematics at the Massachusetts Institute of Technology. He taught for three years at New York's Fordham University and then spent a year as a Congressional Science Fellow.

But in 1979, Lee made his move and joined Oregon-based Floating Point Systems, a maker of array processors. In 1981, he moved to Applicon, a graphics house. After joining Weitek in 1984, Lee participated in microcode development on custom graphics projects. And although he managed a team of six on the Accel project, he hasn't abandoned design entirely. "Let's say I'm a technical manager in the sense that I'm very much involved every day with technical details," he says.



FRED WARE



GREG LEE

# LOGIC TIMING ANALYZER HAS 100-ps RESOLUTION

*With new equivalent time recording and synchronous harmonic sampling modes, Outlook's instrument speeds debugging of systems with clocks to 200 MHz*

Coming early next year from the team that sired the first generation of logic timing analyzers is a new instrument that will kick off the second generation. Outlook Technology Inc.'s T-100 analyzer will combine the system-debugging capabilities of timing analyzers with the precision of sampling oscilloscopes—and will introduce several brand-new operating modes.

Basic operating modes haven't changed much since Outlook's president, B.J. Moore, and its chief scientist, Curtis Blanding, designed the first timing analyzers at Biomation Inc. Moreover, only a few modes can be synchronized to system clocks. The new analyzer corrects these shortcomings, the Campbell, Calif., startup company says, so it will save much of the time designers must now spend debugging system hardware built with very high-speed integrated circuits and other advanced silicon and gallium-arsenide ICs. The T-100's new architecture also contributes to the higher resolution.

At its maximum sampling rate of 2 GHz, the Outlook T-100 will be as fast as any logic timing analyzer made today. And with prices starting at \$27,500, it will be at least as expensive. However, the T-100 offers the resolution of a 10-GHz instrument—100 ps instead of 500 ps. This alone will be a boon to system designers, notes James Sheldon, marketing and sales vice president. With system clock rates rising into the 200-MHz range, the small timing variations that could cause mysterious intermittent failures in the field are hard to find, he explains. "Logic analyzer users have been plagued by the need to know what to look for before they can find it."

To boost resolution, Outlook partitioned all the

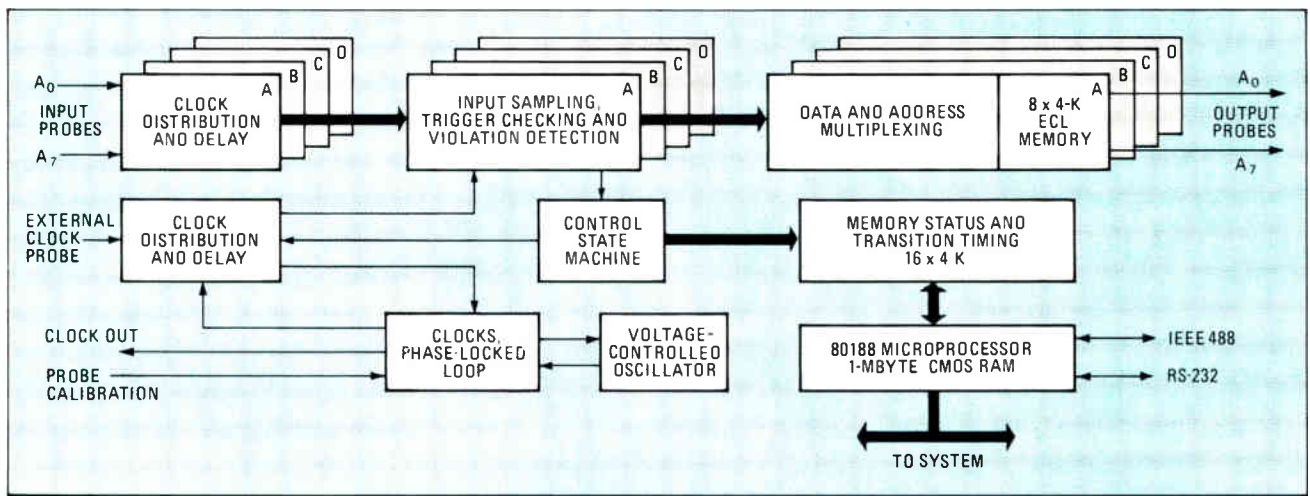

1. **PLUG-IN ARRAYS.** All clock and input subsystems of the T-100 analyzer are ECL gate arrays plugged into a single circuit board.

high-speed logic circuits into the five emitter-coupled-logic gate arrays, three of which are replicated to build up a 32-channel analyzer (Fig. 1). The arrays' major functions are clock distribution and delay; input sampling, trigger checking, and timing-violation detection; data and address multiplexing; clocks and phased-locked loop; and a control state machine. As usual, input channels are multiplexed into small, high-speed memories so that recording-memory depth ranges from 4-K bytes with 32 channels to 32-K bytes with 4 channels. When this ECL memory is filled, the recording is transferred to a 1-megabyte CMOS memory.

Sheldon expects deliveries to begin in January or February, depending on when Outlook receives the set of five ECL gate arrays. The T-100 was designed around 2,000- and 2,500-gate ECL arrays now in the production queue at Fairchild Semiconductor Corp.

## THE NEW MODES

To perform the classic analyzer debugging functions, the T-100 will operate synchronously with the system under test at rates to 2 GHz—10 times as high as other timing analyzers' synchronous operation—as well as asynchronously at sampling rates ranging from 250 MHz with 32 channels to 2 GHz with 4 channels. Then, to zoom in on problem areas, it will operate in a new equivalent time recording mode that's similar to equivalent time sampling with a digital oscilloscope. In this mode, the analyzer will record repetitive inputs as though it were a bank of synchronized sampling scopes.

Recordings of samples will be offset by 100 ps, stored in a 1-megabyte random-access memory and used to build a composite recording with 100-ps resolution. The technique will help designers to focus more rapidly on marginal components, mismatches in propagation delays, and other design errors. For instance, Sheldon explains, synchronous equivalent time recordings will help designers see exactly how far logic transitions move back and forth with respect to system clock edges during variations in operating environments and supply voltages.

Without equivalent time recording, designers would still need to make primary measurements with other instruments to find out whether the analyzer was triggered at one end of the sampling interval or another, or in between. In contrast, equivalent time recording will provide 100-ps resolution on as many as 16 channels at a rate of 250 MHz. With every other input probe attached to the system under test, the analyzer will split each sample point into a reference channel and an offset channel. The first recording is made with the offset channel at 0. Then, the second sample is recorded with a 100-ps offset, the third with a 200-ps offset, and so forth. The system tested must put out repetitive signals, but that's no problem in a lab.

Another new mode, synchronous harmonic

sampling, samples at harmonics of the system clock frequencies. Outlook invented it for such applications as debugging systems with multi-phase clocks and for determining whether signals from parallel processors are aligned. The T-100 will sample inputs within the system clock period at intervals as short as the 16th harmonic of the clock rate (Fig. 2). For a still closer look, it will use a new synchronous phase-shifted mode to step through input samples at 100-ps increments.

In synchronous harmonic sampling, the T-100 will generate a higher-frequency harmonic—up to the 16th—of the system under test's clock and phase-lock it to the clock. For example, if the system clock rate is 50 MHz and the eighth harmonic is programmed, the analyzer will operate on 16 channels at 400 MHz and sample data twice during each quadrant of the clock of the device under test. Synchronous phase shifting samples inputs at 100-ps increments over a range of  $\pm 4$  ns relative to the clock edge. Here, the analyzer operates at 250 MHz on 32 channels.

Since violations of the specifications for setup and hold times are a common cause of intermittent data errors, the T-100 can be preset to monitor every input in every configuration all the time and to trigger whenever a sample violates a set-up and hold time. For example, a designer can start with a wide window, then narrow it in 100-ps increments until inputs trigger the T-100 now and then—a warning that the system will fail intermittently in the field. Then he can decide how to adjust system margins by widening the window bit by bit while varying supply voltage and operating environment to determine what margins will prevent intermittents.

To ice the cake, sample rates will come from an on-board frequency synthesizer. Users will be able to crank through thousands of programmable sample rates in the various modes to opti-

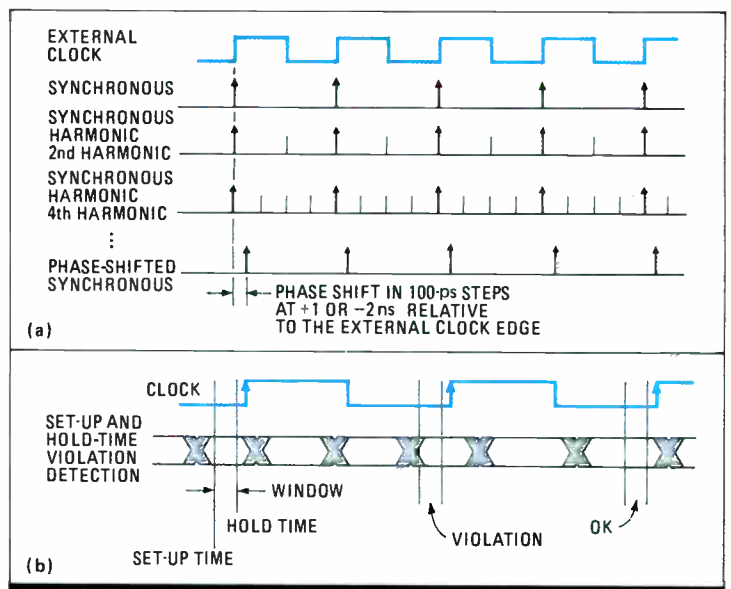

**2. SYNCHRONIZED.** New modes key sampling to a system clock, expediting detection of high-speed faults and intermittent problems.



**3. PARTNERS.** The T100 analyzer can work with an IBM PC in a timing-analysis mode. Windows give user four views of recorded data.

mize analyzer setups. Rates from less than 100 Hz to 1 GHz can be programmed in 1% increments. With the conventional crystal-controlled 1, 2, 5 sequence, the choices were 10, 20, and 50 MHz, followed by 100, 200, and 500 MHz, and 1 and 2 GHz.

In its pattern-generation mode, the T-100 will generate 250-MHz output patterns up to 32 bits wide. It also will operate in mixed input/output modes and separately record glitches and data. These modes locate logic transitions and glitches

PC/XT provides menu-driven setup displays, trace displays, and other interfaces. It can also collect large numbers of recordings on disk drives for additional reviews or analyses.

Programs that run the analyzer in real time are downloaded to an 80188 microprocessor in the T-100. The instrument can also be programmed to operate as a black box in host systems. For example, it could be embedded in a mainframe to monitor critical paths and to determine when preventive maintenance is needed. □

in real time within apertures as small as 500 ps, which is state of the art.

Computer simulations indicate that the arrays will operate with the performance matches needed to reach 100-ps resolution, according to Curtis Blanding, vice president and chief scientist. But just in case the first model needs a little tuning to reach 100-ps resolution, he says he "mixed a little art with the science" and designed the printed-circuit boards with "trombones"—sets of wiring traces for adjusting propagation delays.

Also nearing completion is the system software, which is written in the C high-level language and has a layered architecture for easier upgrading. The software runs on an IBM Corp. Personal Computer XT or compatible machine with a high-resolution color display. Acting as a host, the

## CHANGE THE RULES TO GET AHEAD, SAYS OUTLOOK'S CURT BLANDING

"I hope we've changed the rules," says Curtis Blanding, the engineer who started Outlook Technology and headed the team that designed the firm's 100-ps logic analyzer. "One of the rules was 'To get more resolution you have to go faster.' We're not under that constraint anymore. Everybody else still is—but they won't be in the future, because equivalent time recording is a concept, not something you can patent. We'll get 100-ps resolution or better, not because the chips run faster but because the T-100's architecture allowed us to do things that could not be done before."

Computer-aided design systems are changing the rules, too, Blanding adds. "That's a dream come true. We can design circuit boards that provide clean edges, design chips that match each other very well and cut down noise and jitter. This has changed the rule from 'How fast can you run?' to 'How precisely can you put your feet down on a line?'" as you run.

What hasn't changed, he says, is the need to make instruments simple to operate. "The hardest job in the world is to make something simple, but it has to

be done because computer designers work on complex systems. They don't need complex tools, too."

During his 10 years at Biomation and Gould Inc. (Biomation became part of Gould in 1978), Blanding led the development of some of the industry's most widely used logic analyzers. They were popular, he believes, because each was easier to use than the previous model.

Blanding, now vice president and chief scientist, founded Outlook in March 1984 with two other men from Gould: James Sheldon, vice president of marketing and sales; and William Shoemaker, vice president of engineering. B. J. Moore, who developed the first logic analyzer and headed Biomation, joined as president last year. Mark van Hook was the software architect for the T-100.



**B. J. MOORE**



**MARK VAN HOOK**

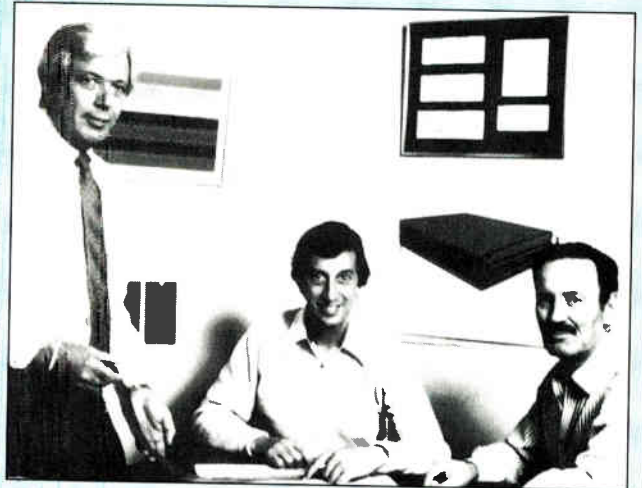

**FOUNDERS.** The three founders of Outlook Technology are, from left, James Sheldon, Curtis Blanding, and William Shoemaker.

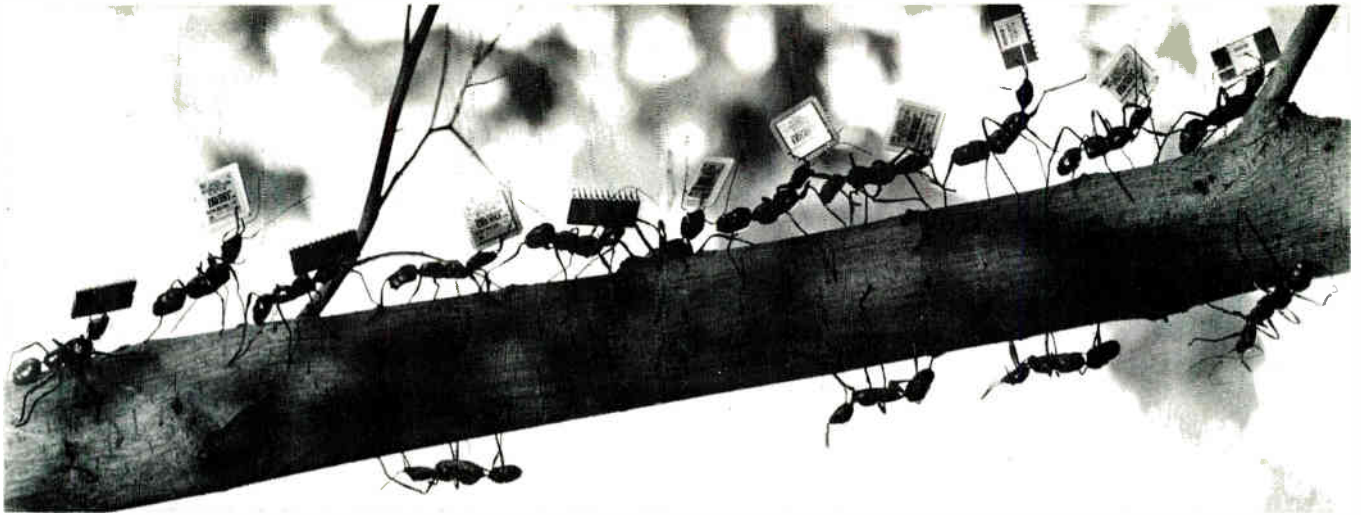

## Burr-Brown came to Livingston for the workforce.

For Burr-Brown, the requirements for their European location were relatively straightforward.

A clean environment, modern facilities and direct transport and communication links with continental Europe.

They found all this in Livingston, Scotland.

A town purpose-built for new industries situated at the heart of one of the greatest concentrations of electronic companies in Europe.

And they found much more.

They found investment grants of up to 35%, rent-free periods plus European Community assistance. They found Kirkton Campus, a high-technology park ready-made to receive them.

And they found us.

A Development Corporation that could help them develop at every turn and a workforce that was both skilful and conscientious.

In Burr-Brown's words, one whose productivity was 'second to none in the world'.

A 20 minute drive down the M8 motorway and they're in Edinburgh. Scotland's capital city and a distinguished I.T. community that's home to no less than four Technology Transfer units.

Including Wolfson Micro electronics Limited and the Centre for Applications Software Technology.

Today, Burr-Brown is one of a long list of blue chip Livingston residents with firm plans for expansion.

A list that we can offer you every incentive to join.

To: C. Anne Robins, PO Box 345, Old Greenwich, CT 06870. Tel: (203) 629-3496.  
 Prove that Livingston is Europe's most logical location for my company. BLOCK LETTERS PLEASE

Name \_\_\_\_\_

Position \_\_\_\_\_

Company \_\_\_\_\_

Address \_\_\_\_\_

Zip Code \_\_\_\_\_

Telephone \_\_\_\_\_



**MAKE IT IN  
LIVINGSTON**

EIC

Europe's most logical location.

Circle 75 on reader service card



The designer's in San Jose.  
The factory's in Seoul.  
The customer's in Detroit.  
And your schedule's in trouble.

## Introducing *The Global Office*.<sup>SM</sup>

It's all you need. The NetExpress 2100™ *Global Office Information System* enables you to expedite worldwide hard copy communication via the *Docu-Conference*<sup>SM</sup>—the teleconference on paper.

The NetExpress 2100. An innovative office information and communications system, featuring a modified Canon® laser printer/copier and enhanced IBM AT.\* It can create, edit, file, transmit, print, and copy documents. Scan text and image into computer memory. Merge computer generated input. And transmit worldwide via satellite, phone line, or data network. For locations without a NetExpress 2100, DHL Worldwide Express delivers within hours.

*The Global Office* also supports up to 15 work stations for many business software programs and links to existing PC LANs. So it helps you work more efficiently around the world—or down the hall. For more information or a free demonstration, call today.

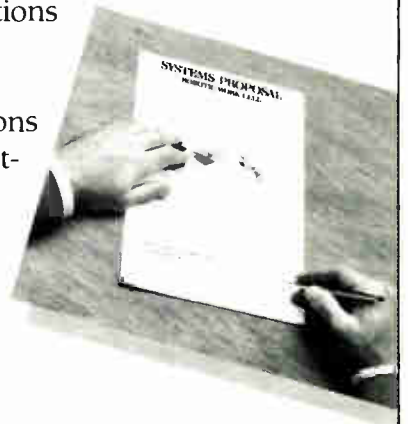

We make your world work.  
1-800-THE-2100



**NetExpress**

An affiliate of DHL Worldwide Express

NetExpress 2100, The Global Office, and Docu-Conference are trademarks or service marks of NetExpress Systems, Inc. Canon is a registered trademark of Canon U.S.A., Inc. IBM AT is a registered trademark of International Business Machines Corporation.

Circle 76 on reader service card

World Radio History

**D**esigners can now create large sea-of-gates arrays on an engineering work station, rather than having to farm them out to a foundry for layout on a mainframe, thanks to California Devices' new Wise II place-and-route tool. The San Jose, Calif., company says that although some channeled-architecture tools can do a limited amount of sea-of-gates routing, Wise II is the first based on channelless architecture.

California Devices' place-and-route software [*Electronics*, Oct. 16, 1986, p. 28] is able to handle large arrays of up to 10,000 gates. Until now, automatic place-and-route tools have not been able to lay out arrays larger than about 4,000 gates, because vendors' device architectures and place-and-route tools have been developed to handle channeled arrays, as opposed to the sea-of-gates arrays. These channelless arrays, as California Devices calls them, are becoming popular because they allow much more efficient use of chip real estate (Fig. 1).

With Wise II, a designer can save the week or two of turnaround time spent waiting for a run on the foundry's mainframe, as well as saving the cost of that run. Since there may be several iterations for a given design, the savings in both time and money can be dramatic.

Wise II was developed in conjunction with Daisy Systems Inc., Mountain View, Calif., and runs on Daisy's Megalogician work station. "We provide the work station with a data base, gate array foundations, and the physical macro library," says John Burchfield, CAE work-station

## HOW DESIGNERS CAN SAVE TIME IN LAYING OUT A SEA OF GATES

*California Devices' software slashes turnaround time by using a work station instead of a mainframe computer to place and route 10,000-gate arrays*

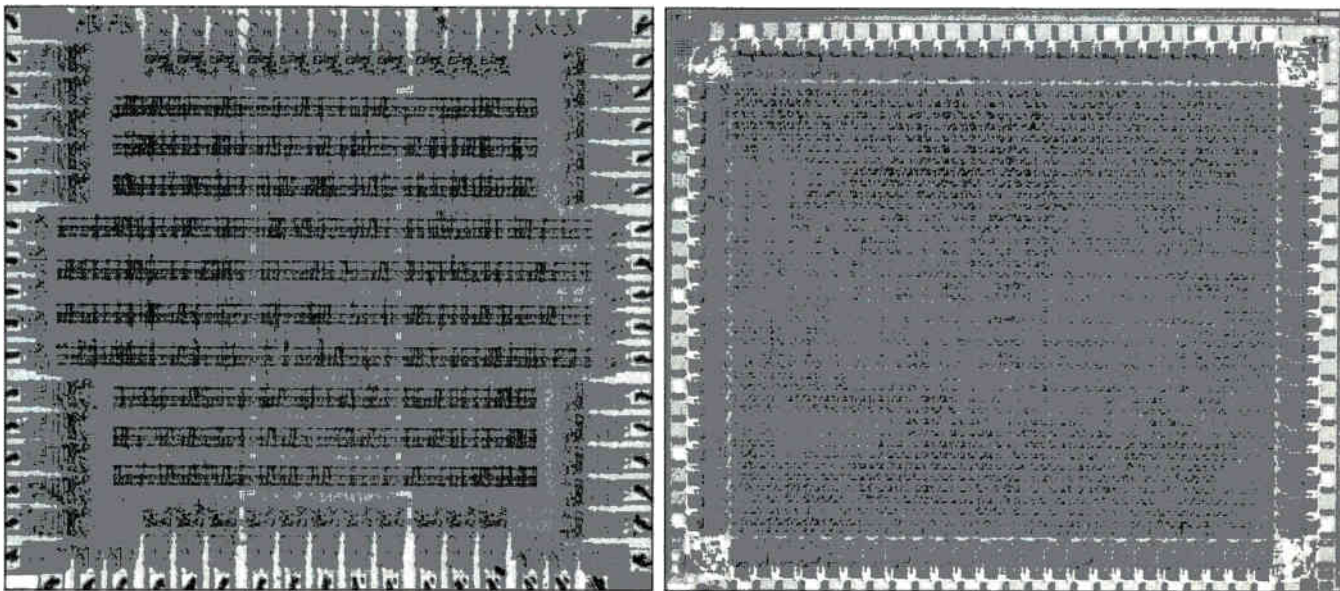

1. **EFFICIENCY.** Channeled array (left) on 40,000-mil<sup>2</sup> chip can yield only 1,200 gates; channelless array (right) can reach 2,800.

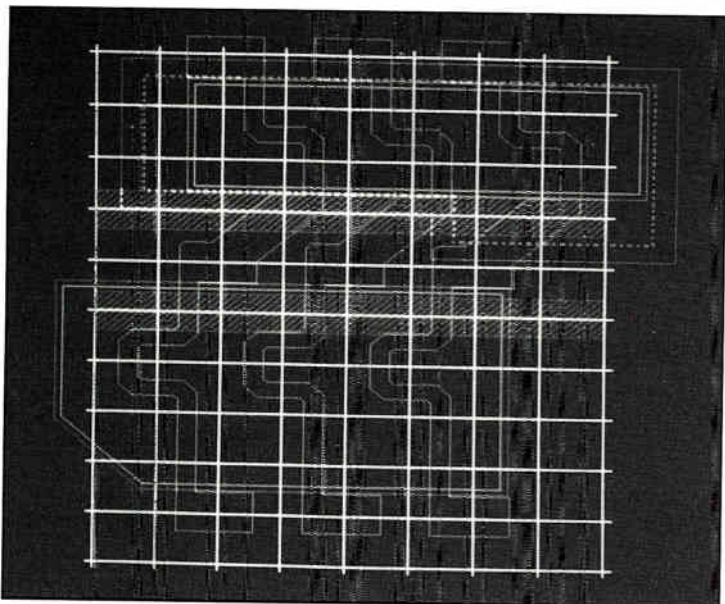

**2. CELL.** Typical channelless cell, as seen on Daisy workstation, contains three p-channel and three n-channel transistors.

tools manager at California Devices. Daisy provided the place-and-route algorithms, which were modified for the channelless architecture.

California Devices' library contains symbols of functions, such as flip-flops and gates, and specifies how to implement them in silicon. It specifies the input and outputs of a flip-flop, for example; on silicon, the library's gate array foundation consists of six-transistor cells.

### CHANNELED VS CHANNELLESS

When software vendors began automating the place-and-route function for gate arrays, they borrowed the channel-routing algorithm already implemented on layout tools for printed-circuit boards. In the usual pc-board routing process, chips are laid out in a row, and routing channels are reserved on either side of the row. In similar fashion, channeled gate-array routers set aside channels between rows of cells and use them to interconnect gates in different rows or in the same row.

"Suppliers of this type of tool approach the problem of getting more functions on a given array by shrinking the process," says Martin Harding, director of strategic development at California Devices. But at a certain point it is no longer cost-effective to shrink the process to get more gates on a chip.

So vendors will have to rely on compaction to get the 50,000- to 100,000-gate densities needed in the next generation of arrays. But channeled architecture, even with 1- $\mu$ m process technology, will be unable to achieve this kind of density. And as vendors seek to support gate arrays implemented with a channelless architecture, they will have to build a new set of place-and-route tools, since the routing algorithms for the two array architectures are different.

"The advantage of channelless arrays would not have been realized without dual-layer metal," says Douglas Ritchie, president of California Devices. The advent of dual layers allows metal channels to be laid down over active areas in two directions (along the  $x$  and  $y$  axes). Channeled gate arrays can use dual-layer metal too, but the advantage of channelless arrays can be best understood by comparing the way the two architectures are routed.

In both a conventional channeled array and a channelless one, the two metal layers form a grid, with layer 1 below layer 2. The lines of the two layers are perpendicular to each other, and the resulting grid can be used to interconnect gates. The lengths of metal required to make these connections can be several thousand microns, crossing over several cells, or a few hundred microns, connecting nodes within a cell.

Where a layer 1 line crosses a layer 2 line, a connection, or via, can be made between the two layers. Layer 1 routing is parallel to the routing channels (on the  $x$  axis), and layer 2 routes perpendicular to the routing channels (the  $y$  axis). Sea-of-gates routing uses the same rules, but without the routing channels.

Routing channels are real-estate hogs. "Conventional gate arrays require a larger die size to contain a given number of gates than a channelless array, because silicon area is being devoted to the routing channels," says Burchfield.

The sea-of-gates approach can yield much higher gate densities. But laying out compact channelless gate arrays in dual-layer metal requires a design tool that understands unstructured placement and routing. The Wise II software for performing unstructured placement is based on an algorithm called simulated annealing. The routing is done by a maze router, which finds the tightest three-dimensional "weave" that will interconnect the gates to build the desired function for the chip.

### PLACING CELLS IN A SEA-OF-GATES

Simulated annealing is an algorithm developed by IBM Corp. to simulate the way metals cool. As any metal cools, it reaches impasses in molecular compaction in which intermolecular friction causes the metal to heat up briefly, expanding it slightly and allowing the molecules to become realigned so that they may then become more closely compacted. The same mathematical model is used for channelless gate-array placement.

To reduce wire lengths to a minimum, the algorithm measures overall wire lengths between gates in an array. The software performs an initial placement and then calculates the total point-to-point distances of all these connections. Then it performs another placement to minimize the distances and computes the total point-to-point distances of all these connections again. The iterative process continues until the software can reduce the distance no further.



Then, mimicking the temporary expansion model of cooling metal, the algorithm will make a placement that results in greater distances if it can see that subsequent placements will result in further reductions in overall distances. Furthermore, to optimize the performance of a circuit, the designer can direct the placement tool to give greater weight to placing a group of gates with critical timing requirements closer together than other gates. He may choose to assign much less weight to global connections, such as resets and clock lines, where placing these connections close together is not critical.

After placement, the designer invokes the maze router. As with the placement algorithm, the designer can control the approach the router takes in laying out a circuit: starting with the shortest connections, or nets, and moving to the longest nets; or longest nets first, then shortest nets; or some other approach he wishes to set. If the router must choose between making a 100- $\mu\text{m}$ -long connection between two adjacent cells and a 2,000- $\mu\text{m}$ -long connection between two separated cells, it will choose the shorter with the shorter-to-longer-nets approach. Typically, all cells must connect to voltage supplies  $V_{\text{dd}}$  and  $V_{\text{ss}}$  via shorter local connections, and therefore these are routed first.

In a typical channelless array, there are three transistor pairs (six transistors) in a cell (Fig. 2).

They form one three-input NAND gate. If only a two-input NAND gate is needed, there remains an extra transistor pair. The metal that would have been used to connect the extra transistor pair can now be used for routing. "In a conventional gate array, the router never routes through a cell [in layer 1]; it routes over a cell [in layer 2]," says Burchfield. With a channelless array, the metal that would have been used to connect the unused transistor pair can now be used to route through a cell (in layer 1).

The software comes in two versions. One supports arrays of up to 4,000 gates. The other, for arrays up to 10,000 gates, requires a Daisy MegaGatemaster accelerator for both placement and routing. A disadvantage of a placement algorithm based on simulated annealing is that it requires large amounts of computing power; the accelerator provides sufficient power to make it practical to run Wise II on a work station.

California Devices is not resting on its laurels. The company believes that its competitive edge will erode as other vendors bring their sea-of-gates products to market. So just as the competition gets their first products on the market, California Devices plans to jump ahead again. "We're going to announce early next year a new product that is going to be the biggest gate array in the world," says Harding. How big? "Better than 70,000 gates," he grins.  $\square$

## WHAT DREW THREE SEASONED PROS TO A STRUGGLING STARTUP

The gate-array technology developed by California Devices Inc. was a powerful attraction for Douglas Ritchie, Martin Harding, and John Burchfield. All three recognized the advantages of its channelless architecture and signed on even though the San Jose, Calif., company was going through some tough times.

In April 1985, California Devices' founders and investors were in search of a chief executive officer who could help get financing and who could exploit the technical advantages they believed the company had. They chose Ritchie, who had previously headed National Semiconductor Corp.'s custom and semi-custom chip division, because the rest of his 17 years of experience—six at Burroughs Corp. and nine at Tektronix—had involved semicustom work.

"I came to the company because I was intrigued by the channelless architecture CDI had developed," Ritchie says. "The technology was a couple of years ahead of anyone else in the gate array business when I joined. The only thing missing was the design tools needed to automate the process."

Burchfield, who worked for Ritchie at National Semiconductor, went to Cali-

formia Devices in 1984. He is now manager of CAE work-station tools at California Devices and is responsible for getting the Wise II automatic place-and-route tool developed. Burchfield early on recognized the trend toward work stations and the desire on the part of customers to do the place-and-route themselves. "It gives them faster feedback on what needs to be changed in their design to get it to work in silicon," he says.

Harding joined California Devices in 1984 after developing gate arrays at

Fairchild. "I came to the company during the bleak period in its history, but I could see they had a technology that was well ahead of every other gate-array company at the time," he says. Harding is director of strategic marketing.

The three men's assessment has proven correct. Competitors LSI Logic Inc. and VLSI Technology Inc., both of San Jose, now offer their own sea-of-gates products. With new funding and a complete tool set, California Devices seems well positioned to fulfill the potential all three men saw when they joined.



**BELIEVERS.** Channelless arrays attracted (from left) Burchfield, Ritchie, and Harding.

# SABER CUTS SPICE OUT OF ANALOG SIMULATION

*Based on a library of behavioral models, Analog's new software tool can simulate any physical system and is faster, more flexible, and much easier to use*

**A** new analog simulation software tool is far faster, more flexible, and much easier to use than Spice, currently the most popular analog simulation program. Called Saber, the package was developed by Analog Inc., which says it can simulate any physical system that can be described using mathematical equations—electronic, electromechanical, mechanical, or optoelectronic.

Saber resembles the analog-digital circuit simulator recently introduced by Sierra Semiconductor [*Electronics*, Oct. 16, p. 60] for its standard cell library in that both use behavioral models to describe circuit or system action. This approach is fundamentally different from Spice, which mathematically models each individual device in the circuit. While Sierra's software is aimed primarily at ASIC designs with mixed analog and digital circuitry, Analog's software is suitable also for systems containing a mix of electronic, electromechanical, or optoelectronic devices.

Saber will run on work stations or minicomputers, and it is more than an order of magnitude faster than Spice, which was developed 14 years ago at the University of California at

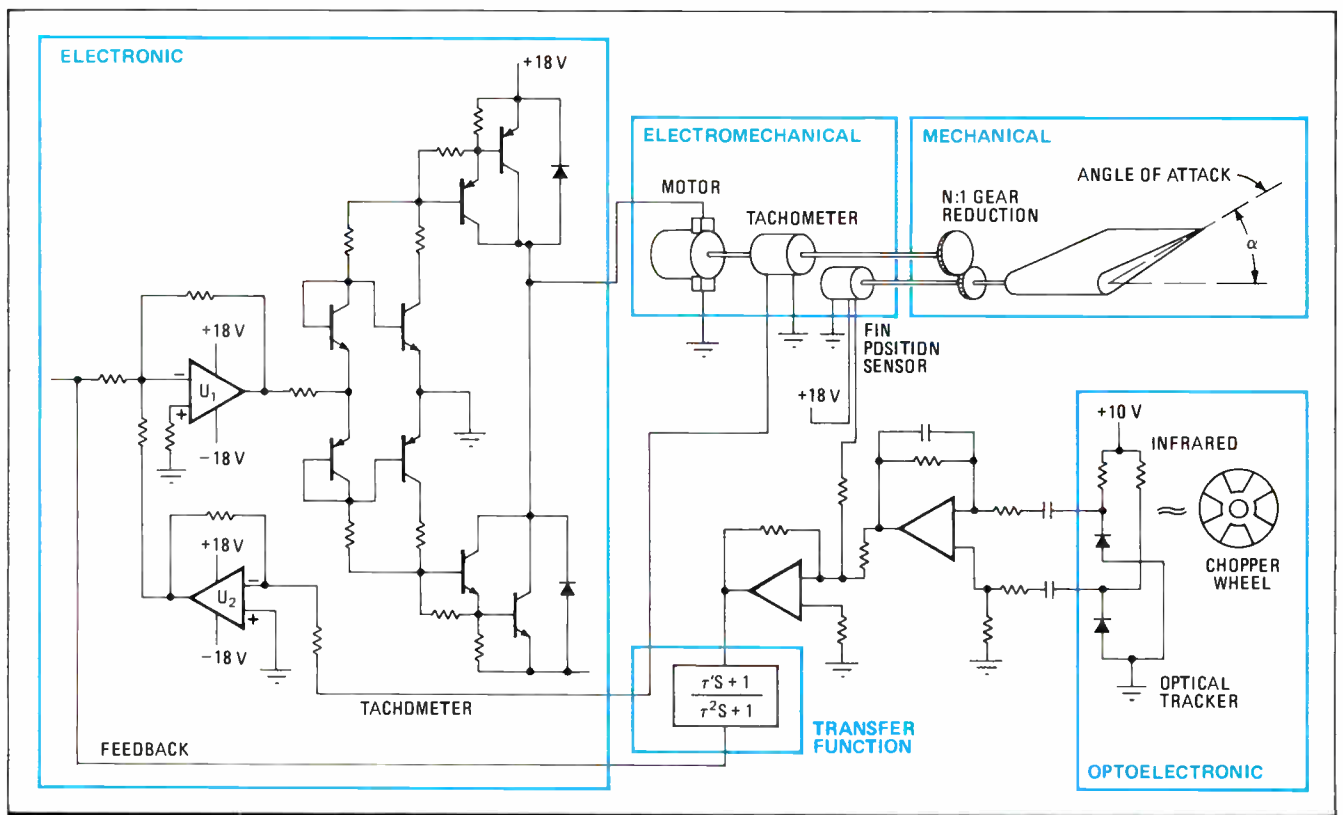

**1. VERSATILE TOOL.** Saber can be used to design any physical system that is capable of being described in mathematical terms—including this wing-flap controller, for which a combination of several electronic, optical, and electromechanical functions must be simulated.

Berkeley. Spice has been improved since then [*Electronics*, Aug. 26, 1985, p. 50]. Initially, it ran on a mainframe and permitted no designer interaction during processing; now it operates interactively on work stations—but it is still inflexible, slow, difficult to use, and sometimes incapable of producing a useful simulation.

The major advantage Saber has over Spice is its flexible modeling. Like Spice, it works by creating models based on mathematical equations that represent various characteristics of whatever is being simulated. However, Analogy, a startup in Beaverton, Ore., designed Saber so that it could work with the mathematically based models for a vast array of components, or with models created by the user.

By contrast, Spice was designed to work with a limited number of models, all of which originally were created to represent transistors used in designing integrated circuits. A designer who wanted to create, for example, a radio circuit, would have to find a way to use those models to represent the different radio-circuit components, instead of the IC transistors they were intended to represent. Doing so was usually tedious and time-consuming—and sometimes impossible.

Saber allows engineers to use models that were designed to represent the components they are working with, not modified models that once represented something else. For example, an engineer who is designing the control system for a mechanical flap on an airplane wing would begin with a high-level block diagram of the design. The mechanism has a motor, a tachometer for measuring rate feedback, a power amplifier for driving the motor, and an encoder with a potentiometer or optoelectronic encoder for sensing motor position (Fig. 1).

Using Saber, the engineer can begin entering transfer functions of every major block in the design into a high-level, top-down block-diagram model. Transfer functions are the characteristic equations of a system, subsystem, or device. The motor, for example, has a transfer function that describes inertia characteristics and its mechanical and electrical time constants. These variables are all available in the data book on each motor.

### PLAYING THE "WHAT-IF" GAME

"By entering transfer functions, the designer can evaluate various options in a 'what-if' type analysis to determine, for example, the amount of amplifier gain needed to position the motor in a given time," says Larry Jacob, president and chief executive officer of Analogy. "He can try several different motors to see which positions the fastest and which will be the most cost-effective." The simulator allows the designer to create a simulated breadboard for each of the design blocks, and evaluate each as if he had built the circuit with real components.

Simulating all the functions of this design with Spice would be difficult. The optoelectronic

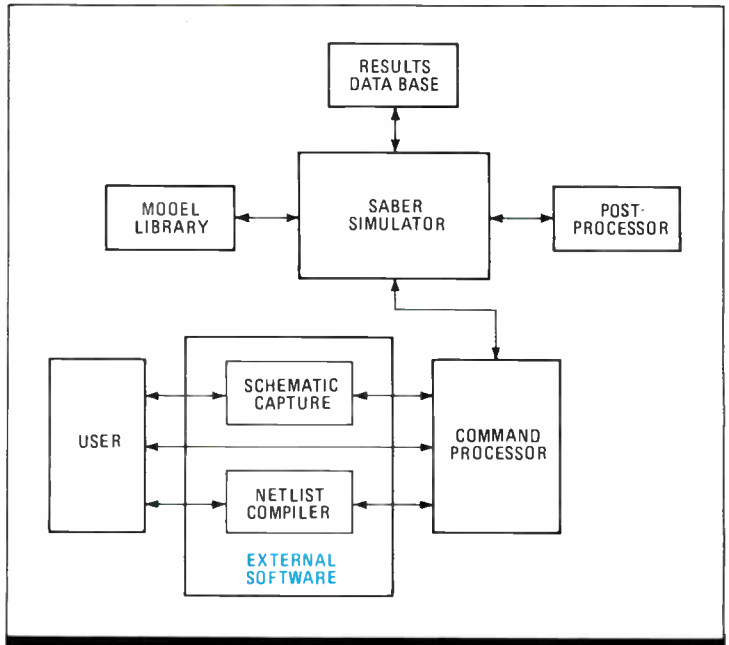

**2. MALLEABLE MODELS.** Templates in the model library can be modified without affecting the performance of Saber itself.

and electromechanical components would have to be reduced to an electrical-equivalent circuit, using components already defined in Spice. Saber is far more flexible. The designer can define the operating parameters of each model in its own measurement units—the motor, for example, is defined in terms of torque, inertia, and so on, depending on the function being simulated.

This flexibility arises from Saber's design, which takes advantage of the mathematical nature of simulation. The model of a component in any simulator is the mathematical expression of its parameters. It has two parts: the template, which is the generic component model, and the parameters, which define a specific component.

With any Spice variation, "the model templates are an integral part of the program, and cannot be changed or added to," says Douglas Johnson, Analogy vice president. "Adding new templates requires changing the algorithm portion of the simulator. In these simulators, therefore, system components must be modeled from combinations of existing model templates, which places restrictions on what can be simulated."

In Saber, models are created from templates that are modular, not integral to the software; they can be modified by the designer. For frequently used models, such as transistors, the operating parameters are included as part of the template. For other models, such as motors and tachometers, the parameters are added later by the designer, who takes them from measurements or from data sheets.

Once a model is created by generating a template, it is entered into the simulation library (Fig. 2). The library is separate from the Saber simulator, so it can be constantly changed with-

out affecting the simulator itself. In addition, users who need to create models for which no template exists can do so using a modeling language supplied with the software.

During operation, the simulator draws models from the library; which models to use is determined by components described in the circuit netlist or a schematic supplied through a schematic-capture package. From these, Saber computes how the circuit will behave. It calculates the voltage and currents at each circuit node, either at one point in time or in time increments. The intermediate and final results of the calculations are stored in a results data base. Post-processing software uses the final results to produce waveform graphs that the designer can analyze.

### SPEEDING THE SIMULATION PROCESS

Saber gets much of its speed advantage by eliminating Spice's initial step of flattening the design. Flattening means reducing a circuit design to its elementary devices, resistors, capacitors, and transistors. Then, to simulate an input

signal, the waveform is divided into a series of time steps. At each time step, the resulting electrical values for each node in the path of the signal are calculated.

Saber gains additional speed by recalculating for each time step only at the nodes where values have changed. Optimizing the code for vector and parallel processing makes Saber even faster when it is run on dedicated simulation accelerators. Also, it can halt simulation, change values and parameters inside the simulated circuit, and resume operation from an arbitrary point. With Spice, any change requires recompiling the netlist, then rerunning the simulation.

The flexibility and speed of Saber enable it to simulate large circuits all at once; Spice must break circuits down into smaller sections and simulate them individually. "Saber has already been used on a mainframe to simulate an 8,000-device circuit in 15 minutes," says Johnson.

Analogy has further refinements in mind. A series of enhancements to the basic simulator package is scheduled for introduction by the third quarter of next year. They will allow designers to do "sensitivity analysis in which the value of each part—capacitance, resistance, etc.—is varied over its tolerance range to determine the sensitivity of the performance of the circuit," Jacobs says. Other features will allow designers to do optimization analyses, to find the ideal values for circuit components to achieve at given performance levels, and to evaluate the circuit's long-term reliability.

In addition, designers will be able to perform a worst-case analysis that checks every component at its tolerance limits, which helps ensure that if the tolerance builds up in the worst case, the circuit will still perform within specification. The simulator also will be able to provide an evaluation of the circuit's average performance over its lifetime. Finally, the company plans to add a digital functional simulator to allow mixed simultaneous analog-circuit and digital-logic simulation.

Thus, with one tool a designer sitting at a work station can complete his design all the way from a high-level block-diagram description to test program generation without ever building a single piece of hardware. Moreover, once the design has been developed on the work station, it should be sufficiently characterized that it will need little debugging. □

## HOW JACOB GOT INTO ANALOG SIMULATION

Larry Jacob spent a big chunk of 1983 looking for the right opportunity for a new business. He found it in design simulation for analog circuitry. "The one simulation tool available to do analog design was Spice," he says, "but it had and continues to have many limitations."

Seeking a new challenge, Jacob had just left Flight Dynamics Inc., a Portland, Ore., company that makes aircraft instrumentation. He had founded the company and taken it public, which gave him the cash he would eventually use to start Analogy Inc. in Beaverton, Ore.

Designers' dissatisfaction with Spice had convinced Jacob that he had found the motherlode. Next, he had to find people to help him mine it.

He went to the library, to find out who was writing on simulation tools, and found Jiri Vlach and Kishore Singhal, both professors at the University of Waterloo in Ottawa. Jacob met them at the 1984 Design Automation Conference in Albuquerque, N. M. They were interested in his ideas; both eventually became technical consultants to Analogy.

They also led him to Martin Vlach, Jiri Vlach's son. Martin

had recently gotten his PhD from the University of Waterloo and, in the process, had written a new simulator that matched what Jacob had in mind. He also had just applied for a professorship at the University of Waterloo, but in January 1985, the school—and the Canadian winter—helped him change his mind about his career plans. "The university turned down my request for the position. It was 20 degrees below zero outside in Ottawa," he says. "I decided to take Larry up on his offer to move to Oregon and join the company."

Jacob, meanwhile, had met Douglas Johnson, then at Methus-CV in Hillsboro, Ore., who became interested in Jacob's ideas about analog simulation. By the time Analogy opened for business early in 1985, Johnson had joined up: he saw the new company was in the right place at the right time. CAE hardware vendors are going after the printed-circuit-board design and layout market. Printed-circuit boards have much larger analog content than integrated circuits. "Spice is something they can offer immediately, but eventually they are going to need something better. We expect to be that something."



JACOB

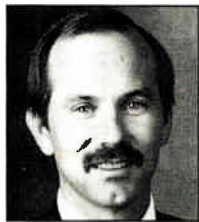

JOHNSON



VLACH

# PROBING THE NEWS

## MUNICH'S MICROELECTRONICS CONFERENCE TAKES A NEW TACK

### ELECTRONICA MEETING BECOMES A TECHNICAL EXECUTIVES' GATHERING

by John Gosch

#### MUNICH

**A**s international conferences go, it's a small meeting—23 papers and an anticipated attendance of 400 to 500—and it only lasts a day and a half. But Munich's biennial Microelectronics Conference is a good-sized and ambitious show—nine of the papers are invited from the big names in Europe, Japan, and the U.S. Their common thread is competition.

The 12th edition of the conference, to be held Nov. 10 and 11 concurrently with the giant Electronica show (see "Electronica is bursting at the seams and still growing," p. 84), is trying a new tack this year by appealing to the technical executive and the beginning engineer rather than the designer—in effect, the present and the future buyers of microelectronic parts. The result is that the main subjects cover technology and economics in broad terms. Discussions are scheduled on the renaissance of bipolar technology, the emerging market for gallium arsenide devices, and the direction that standard integrated circuits will take.

**SHARP DEPARTURE.** The new focus, says conference chairman Leo Steipe, president of Munich-based Stenocord Electronic GmbH, is a sharp departure from past practices. "In former years we tried to cover as much ground in integrated circuits as possible," he says. The result: many sessions became so mired in details that they appealed only to a select few.

Not this year. Following the new format and theme, most of the main subjects concern some form of competition—between bipolar and MOS technologies, between silicon and gallium arsenide materials, and between standard parts and application-specific integrated circuits. Though none of these conflicts is new, the conference organizers hope the speakers and their papers will illuminate them from different angles, and in the process provide those attending the show with the latest perspectives.

Typical is the bipolar-MOS matchup.



**SHOW SITE.** Congress Hall will house the Electronica conference, as it did in 1984.

Kenji Taniguchi of the Hitachi Device Development Center in Tokyo will discuss the latest changes in both technologies, and what those changes mean for those who are applying CMOS and bipolar techniques to very large-scale integrated circuits.

Taniguchi will confirm that constant improvements in speed and density have made bipolar the leading technology for ultrafast computer logic, while CMOS will become dominant in medium-speed logic and memory, where the emphasis is on cost, and also play a principal role in gate arrays and polycell-type VLSI circuits. But there is a third element in the equation: BiCMOS, which merges bipolar with CMOS devices and is about twice as fast as CMOS. Its place will be in applications where high speed—typically above 100 MHz—and low power dissipation are required, or where bipolar interfaces are needed. Further, BiCMOS may play a big role in static random-access memories, providing 25-ns access times—twice as fast as CMOS.

Picking up the cudgel for bipolar in his invited paper, Armin Wieder of the Siemens Research Laboratories in Mu-

nich will single out the revival of bipolar techniques in the submicron range. After 15 years of competing with MOS, bipolar is still going strong because of its analog characteristics, very high intrinsic speed (gate delays less than 50 ps), and excellent device performance because of high transconductance. Those are exactly the properties that designers of the upcoming integrated services digital networks will look for.

**ON THE MOVE.** And with silicided contacts and very shallow doping profiles, bipolar transistors will open new fields of performance, with room-temperature gate delays of less than 5 ps, Wieder says. Applications ranging from analog circuits and real-time signal-processing devices to advanced communication circuits will, with bipolar's reliability and low cost, keep it on the move.

But what is coming after silicon? Bernard T. Murphy, a researcher at AT&T Bell Laboratories in Reading, Pa., believes the market is developing in compound semiconductors such as gallium arsenide.

In an invited paper, Murphy will cite several reasons. For one, although sili-

con still has a lot going for it, the rate of innovation in MOS is slowing. For another, there are high-performance jobs (as in monolithic microwave circuits) that silicon cannot do. What's more, owing to work on materials for laser and light-emitting diodes as well as on microwave field-effect transistor technology, a GaAs IC capability has already emerged.

But silicon is far from dead. Disputing Murphy about what is to come after silicon is Joseph Borel of Thomson Semiconducteurs in Grenoble, France. He will predict that a new silicon era is in the offing. Silicon, he says, has been gaining market share in many fields, particularly in memories, because it has provided an increasing number of functions per square millimeter at a constant price. This follows the rule that says the number of elements per chip doubles every two years but the price stays about the same.

At the same time, smaller and smaller dimensions, extending into the submicron range, allow a performance increase both with MOS and silicon bipolar technology, which should make them more competitive with gallium arsenide in the digital field. Further, advances in device structures, such as permeable-base transistors, will provide still higher performance, as will be the case with ballistic transistors.

Technologies aside, an invited paper by Peter Verhofstadt of Fairchild Semiconductor Corp. in Mountain View, Calif., will discuss standard chips versus ASICs. He will make the point that standard chips' growth potential—as well as that of the nonstandards—will still be significant for a while. However, standard circuits' slice of the total worldwide IC pie will continue to shrink.

The ASICs will make their greatest gains in VLSI logic, Verhofstadt predicts. Despite continued growth in memories, the worldwide sales of standard VLSI circuits should drop to 60% of the total market by the end of this decade. The figure in 1983 was more than 70%.

**GETTING SPECIAL.** Verhofstadt will predict that in memories, the number of bits per chip will continue to grow, but more and more special-purpose chips (such as video random-access memories) will appear. In microprocessors, performance of central-processor units (in terms of mips) will keep increasing. But there seems to be little need to go beyond 32-bit word lengths, the Fairchild expert says.

Although standard logic circuits will remain important well into the 1990s, a shift from TTL to CMOS will take place. The circuits will also move up in complexity to the level of large-scale ICs, in an effort to minimize the impact of off-chip delays on system speed.

What should also attract much attention is an invited paper from Bernd Höfflinger, head of the Institute for Microelectronics in Stuttgart, West Germany. Höfflinger will discuss application-specific VLSI and its effect on customer-vendor relations. He will point out that the customer, using work stations and hierarchically organized design tools, will have an increasing role in chip design. The role of the vendor, on the other hand, will be to teach the customer how to use the tools.

Also of note are invited papers from Peter Draheim of the Philips components-producing subsidiary, Valvo GmbH in Hamburg, and Paul Lin of the Motorola Microprocessor Products Group in Austin, Texas.

Draheim, discussing new approaches in digital signal processing through VLSI, will point to new uses of such devices in, for example, speech and video processing. Among these will be fast speech codecs for digital mobile phones, and memories to enhance TV displays.

Lin, discussing trends in VLSI high pin-count packaging, will predict that the fine-pitch plastic-leaded chip carrier, or FPPLC, with 25-mil pitch will be a major package in the near future. Lin also foresees hermetic chip approaches such as bumped-die, capped-die, or flip-chip technologies emerging in the pursuit of high reliability. □

## ELECTRONICA IS BURSTING AT THE SEAMS AND STILL GROWING

The components industry it serves may have its ups and downs, but for the biennial Electronica exhibition in Munich, things are always up, in good times and bad. True to form, this year's biennial show, Nov. 11-15, will again be bigger than the one before. "We are bursting at the seams," says an official.

There will be some 2,300 companies—about 120 more than in 1984—exhibiting components and electronic assemblies on nearly 1 million ft<sup>2</sup> of floor space. They'll come from 36 countries in both East and West, on five continents—even from the tiny principality of Monaco.

The U.S. will check in as the biggest foreign exhibitor, with a total of 293 companies represented. Flocking to the Bavarian capital will be an estimated 120,000 visitors.

But it is not only the exhibits that make Electronica so popular. Held concurrently are symposiums and congresses, the most notable of

which is the International Conference on Microelectronics. It will meet on Nov. 10 and 11 in the fairground's congress hall, a short walk from the exhibition area (see accompanying story). Then there is the Macroelectronics Conference on Nov. 13 (smart power devices, thyristors, and power supplies). Also of note are a symposium on quality assurance on Nov. 12 and a technical session on sensors on Nov. 14.

And Electronica is always a good place for spotting

trends and recognizing what's hot in the industry. If in former years it was the microprocessor that captured the most attention, this year the digital signal processor will move into the limelight.

Visitors will no doubt hear of the exploding DSP market. In West Germany alone, consumption will rise from a meager \$4 million last year to at least \$40 million by the end of this decade. The impetus is the widening use of DSPs: today 75% are used in communications, but the big

growth will be in the automotive market. The auto industry worldwide now uses 7% of total DSP consumption. But by 1996 its share should double, to roughly \$150 million—with total DSP sales reaching \$1.14 billion.

Another hot item at Electronica will be gallium arsenide devices, where the experts also see tremendous growth ahead. Europe, they say, will consume some \$1 billion worth of GaAs devices by the end of this decade, which would translate into a 20% annual growth rate.

This year, GaAs parts will account for some 8% to 9% of the European semiconductor market, a share that should rise to 11% by 1996. At present, West Germany is the leader in consumption, followed by France, England, and the Benelux countries. About half of all GaAs parts are used in the civilian sector, with telecommunications accounting for about 75% of that total. —John Gosch



**AISLE TIME.** Some 120,000 visitors, like these at the 1984 show, are expected to attend next month's twelfth edition of Electronica.

# CADDStation™

## HOW DOES YOUR CAD/CAM SYSTEM COMPARE?

CADDStation™

YES NO

### UNIX® POWER

A UNIX® Operating System offering ease-of-use, windowing, multi-tasking, inter-process communication, flexibility and a rich programming environment.

Your System

YES NO

### FULL INTEGRATION

Industry standard systems technology such as a true high-speed 32-bit VME bus, a 32-bit MC 68020 CPU and Ethernet® interface. Combined with TCP/IP network protocols and graphics subsystems.

### OPEN NETWORK

Able to operate alone, as nodes in LANs, or as diskless machines. Compatible with IBM, BSC and SNA. Plus the latest industry Network File System (NFS) based on Sun Microsystems technology.

### LOW COSTS

Offered in a wide range of configurations, capabilities and prices. Options are available to you from \$20,000 for a network add-on. From \$50,000 for a stand-alone system. A price-performance ratio that maximizes ROI.

### CADDS® 4x SOFTWARE

Simply put, the most widely installed and highly regarded CAE/CAD/CAM applications software in the world, and it's available now. Plus, other UNIX® third party software.

### PROTECTED INVESTMENT

Makes obsolescence obsolete by developing and maintaining constantly compatible hardware and database systems that are your company's most valuable assets. And backs it up with worldwide service and support, training and ongoing R&D.

IBM is a registered trademark of International Business Machines Corp. UNIX is a registered trademark of AT&T Bell Laboratories. Ethernet is a registered trademark of Xerox Corp.



EL

I've compared! Please tell me more about the power, performance and price of CADDStation™ by Computervision. I'm considering CAD/CAM  Now  Please call me  I'm gathering information at this time.

Name: \_\_\_\_\_ Title: \_\_\_\_\_

Company: \_\_\_\_\_

Street \_\_\_\_\_ City/Zip \_\_\_\_\_ ( ) Phone \_\_\_\_\_

Mail to:  
Computervision Corp.  
Dept. 425A  
100 Crosby Drive  
Bedford, MA 01730



# State-of-the-past.

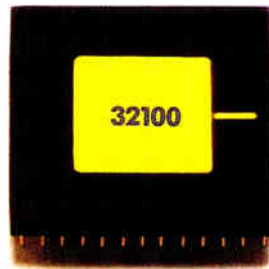
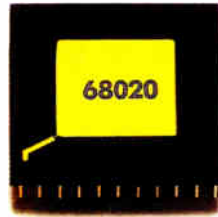



# State-of-the-art.

CLIPPER™ from Fairchild. The most significant advance in microprocessors since microprocessors themselves.

Unlike the others, its performance isn't limited by an architecture designed back at the dawn of the microprocessor era. It's built from the ground up with a brand *new* architecture, for today's high-performance applications. And it's the only microprocessor that can bridge the architectural gap to true supercomputer performance.

CLIPPER. The new definition of state-of-the-art.

## How the competition wishes they'd done it.

In a highly integrated three-chip set, you get an architecturally advanced, very high performance, CMOS 32-bit compute engine, optimized for scientific and professional computing applications in the UNIX® operating system environment. In fact, you get everything in the three CLIPPER chips that it takes the competition's entire CPU board to give you.

Designed for high bandwidth and true concurrent execution of instructions, CLIPPER runs at 33 MHz. Which, until we proved otherwise, was considered impossible. CLIPPER achieves a peak execution rate of 33 MIPS, with average performance greater than a VAX™ 8600 – twice as fast as any other microprocessor in existence, five *times* as fast as a VAX 11/780. And floating-point performance exceeds 2 MFLOPS, while simple instructions execute in a scant 30 ns.

Electronics/October 30, 1986

## Supercomputer technology on a chip.

Unlike any other microprocessor architecture, CLIPPER uses proven supercomputer and mainframe architectural concepts.

Such as extensive pipelining. An on-chip floating point unit processing in parallel to a three-

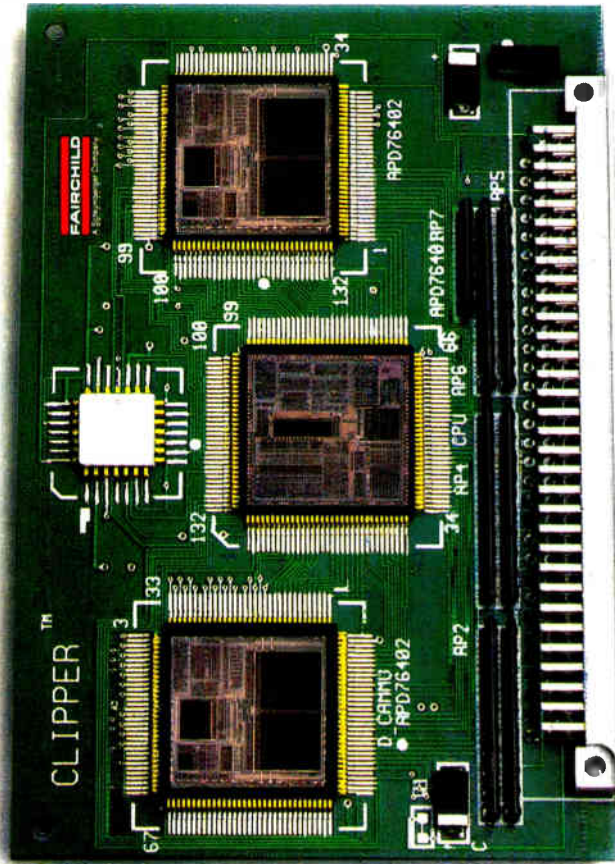

Actual die size approximately 140mil. x 440 mil.

stage, pipelined integer execution unit. Two 32-bit buses, one for instructions, one for data, delivering up to 133M bytes per second to the CPU, eliminating bandwidth as a performance bottleneck.

Two large 4K-byte cache/memory management units (CAMMUs) provide mainframe-style, copyback caching concurrent with virtual address translation.

Then there's our Streamlined Instruction Set. With 101 instructions hardwired instead of micro-coded for performance. There's also a macro-instruction unit, providing 67 high-level instructions

and system functions. For all the advantages of RISC and the robustness of a CISC.

## What got into CLIPPER.

Residing on a 3.0 x 4.5-inch printed circuit card, the CLIPPER three-chip module includes a pipelined CPU with an on-chip, IEEE-standard FPU, and two 4K-byte cache/memory-management units. A clock generator completes the package, adding up to a staggering total of 846,000 transistors.

## How CLIPPER backs you up.

CLIPPER is supported by a powerful software environment. Including a port based on the UNIX System V operating system. Optimized FORTRAN, C and Pascal compilers. Plus numerous utilities.

Or you can choose a complete VAX cross-support package.

And you're further supported by our application engineers and system designers. Each of them experts on CLIPPER.

For more information on the most advanced microprocessor since the advent of microprocessors themselves, just give us a call. You'll find us at The Fairchild Customer Information Center, 1-800-554-4443.

CLIPPER from Fairchild. All of a sudden, it's *the* state-of-the-art microprocessor on the market.

© 1986 Fairchild Semiconductor Corporation. CLIPPER is a trademark of Fairchild Semiconductor Corporation. UNIX is a registered trademark of AT&T. VAX is a trademark of Digital Equipment Corporation.

## We're taking the high ground.

# FAIRCHILD

A Schlumberger Company

Circle 147 on reader service card

87

**POSITIONS VACANT**

**South? Technical/Professional Placement**  
Network-Fee paid. Murkett Associates, Box  
527, Montgomery, AL 36101.

**POSITIONS WANTED**

**Electronic Engr, for hire. Microprocessor**  
based designs, controls, telecom. Contact  
or per diem. Mr. Barry Masel. 718-  
476-1516.

**EMPLOYMENT SERVICES**

**Overseas — 75 Countries — Interviewing**  
now. All Fields — for Conn. interview. Send  
resume: Global Services, Ltd. Clinton, CT  
06413. Transportation not paid to Connect-  
icut.

**RESUMES**

**Resumes — Complete instructions and**  
examples; \$4. Consultants, Box 567—J.  
Bergenfield, N.J. 07621.



**To 27 million  
Americans,  
this scene is  
a fairy tale.**

Simply because they  
can't read.

Functional illiteracy is a  
problem that now affects  
1 out of 5 American adults.

You can change that by  
making a tax-deductible  
contribution to the Coalition  
for Literacy. Call us toll-free  
at **1-800-228-8813** and bill  
it directly to your credit card.

**Volunteer Against  
Illiteracy.**  
**The only degree  
you need is a  
degree of caring.**



**FREE DEMO DISK**

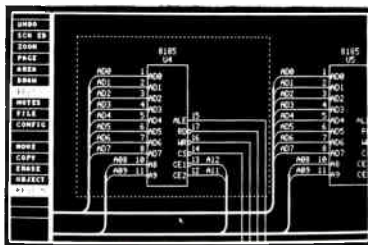

**SCHEMA** is a complete, integrated schematic  
drawing software package for IBM Personal Com-  
puters. Use **SCHEMA** with your PC to draw sche-  
matics and automatically generate design docu-  
mentation such as Wire and Net Lists, Bills of  
Materials, Design Rule Checks, etc. **SCHEMA** is  
\$495 and supports most common PC hardware  
configurations. Call or write today for a free demo  
disk and brochure.

**OMATION, INC.**  
1701 N. Greenville Ave., Suite 809  
Richardson, TX 75081  
(214) 231-5167



**RELIABILITY PREDICTION  
SOFTWARE**

**ARE YOUR PRODUCTS RELIABLE?**

RelCalc 2 automates MIL-HDBK-217D on your IBM PC!  
Very easy to use. Demo package \$25.

**T-CUBED SYSTEMS** 31220 La Baya Drive, #110  
(818) 991-0057 Westlake Village, CA 91362

**SPICE up your PC**

Z/SPICE professional circuit simulation  
Full version \$300 Student version \$79  
**ZTEC** box 737, college place, wa 99324  
(509)-529-7025

**THE BEST  
Schematic Capture**  
IS ONLY **\$495**

- Runs on IBM PC/XT/AT or compatible, supporting most common graphic boards, printers and plotters
- Over 2000 unique library parts
- Part rotation & mirroring
- Rubberbanding of wires & buses when objects are moved
- Supports A through E size sheets
- True unlimited level hierarchy
- Visible grids, 5 zoom levels
- Color & monochrome graphics
- Draws non-orthogonal wires & buses
- Step & repeat with auto increment/decrement of labels
- Powerful keyboard macros & auto panning
- Net/wire list, BOM, design check & library creation utilities

OrCAD gives you so many features, nothing else even comes close. Why settle for anything less? At only \$495 you will discover that OrCAD/SDT is the most powerful and cost effective schematic design tool available... at any price!

Call today for your Free Demo Disk and brochure. All orders are shipped from stock for immediate delivery!

OrCAD Systems Corporation  
1049 S.W. Baseline St., Suite 500  
Hillsboro, OR 97123  
(503) 640-5007



**HOT LINE**

**To place your  
Computer Software Ad  
Call Ilene Fader  
212-512-2984**

# LIQUIDATION SALE NOW IN PROGRESS

Machinery & Equipment no Longer Required in the Continuing Operations of  
**A T & T TELETYPE CORP.** 5555 Touhy Avenue  
 Skokie, Illinois  
**MOS MANUFACTURING FACILITY**

- GCA 6300A Step-On Wafer System
- GCA Wafetrac 1006 Wafer Processing System (1985)
- GCA Wafetrac 1000 Wafer Processing Systems
- Perkin Elmer No. 4480 Delta Cathode Production Sputtering System
- SFI System 24 S-Gun Turbo Sputtering Machine
- Varion/Extrion 120-10 High Current Ion Implanter
- Varion/Extrion 3500 Medium Current Ion Implanter
- Extrion 200-20 A2F Ion Implanter
- Perkin Elmer 343HT, 344, 341, 242 & 222 Micralign Projection Mask Alignment & Exposure Systems
- KLA 100 Automatic Photomask Inspection System
- Varian 3125 E-Beam Aluminum Deposition System
- MTI 75-Ton Hydraulic Semiconductor Encapsulation Press (1985)
- Continental 18 MEG-OHM-CM D.I. Water System ('84)
- Fluorocarbon Laser Scan Particle Counter
- Fairchild Sentry VII LSI Package Test Systems
- Fairchild Xincom III I.C. Test Systems
- Tektronic S-3260 Electronic Component Test System
- Bruce BDF-4 4-Stack Diffusion Furnaces
- Allied Process Tech. 990 Automatic Alum. Etcher
- AMS 2001 Continuous Silox Reactor Systems
- Kulicke & Soffa 1419 Gold Ball Wire Bonders
- SPC Wet Chemistry Benches • Dexon Clean Work Stations • Dexon HEPA Air Filters • Final I.C. Test • Final Package Test • Ion Implant Systems • Deposition Furnaces • Wafer Processing • Mask Aligners • Step On Wafer System • Wafer & Mask Scrubbers • Plasma Etcher • Probers • Dicers • Bonders • Sputtering Systems • Lab Equipment • Ovens, etc.

**Inspection:**  
 Beginning October 27th thru 31st  
 Continuing November 10th - 14th  
**BY APPOINTMENT ONLY**

**Please  
 Contact**  
 →

**NORMAN LEVY ASSOCIATES, INC.**  
 21415 Civic Center Drive  
 Southfield, Michigan 48076  
 Phone 313-353-8640 Telex 23-0701  
 London, England Office: Phone 01-631-0701, Telex 887291  
**Auctioneers/Liquidators/Appraisers**

## HIRE 1988 & 1989 GRADUATING ENGINEERS — NEXT SUMMER! —

First, it's in our industry's best interest to hold and encourage its life-blood by providing career-conscious undergraduate engineering students with meaningful summer job experience in their future profession.

Second, since there'll always be more anxious applicants than openings, you'll be able to select the cream of the crop, then evaluate them under "game-conditions" with an eye towards hiring them as coveted graduates.

By filling out and returning the coupon below, your organization will be included in summer job listings to be featured in the January 1987 issue of McGraw-Hill's GRADUATING ENGINEER.

This edition will be distributed to 90,000 engineering students on over 300 campuses by Deans and engineering department heads.

Please supply the name of the person students should contact, and a phone number for our checking purposes only.

PLEASE PRINT OR TYPE

### Free summer job listing

MAIL TO: ELECTRONICS/POST OFFICE BOX 900/NEW YORK/NY 10020

NAME/TITLE of individual to be contacted Your Signature

NAME OF ORGANIZATION Telephone (our use only)

ADDRESS: Mailing address of your personnel office

TYPE AND NUMBER OF STUDENTS SOUGHT: Electronics Avionics

Electrical Computer Mechanical Computer Science Other(Draftsman, etc.)

Note: Last date coupons can be accepted for this year's summer job listings is November 19, 1986

## PROFESSIONAL SERVICES

For Information

Regarding

This Section

Call

212-512-2556

### PATENT SERVICES

Patentability Searches, Applications & Prosecutions • Marketing • Technology Transfer • Over a decade of service to the inventor.

CALL FOR FREE INFORMATION

**AMERICAN INVENTORS CORPORATION**  
 (800) 338-5656 In MA (413) 568-3753



# SELECT YOUR RESOLUTION

from Imagraph's proven family of IBM XT/AT/RT  
Compatible Advanced Graphic Controllers

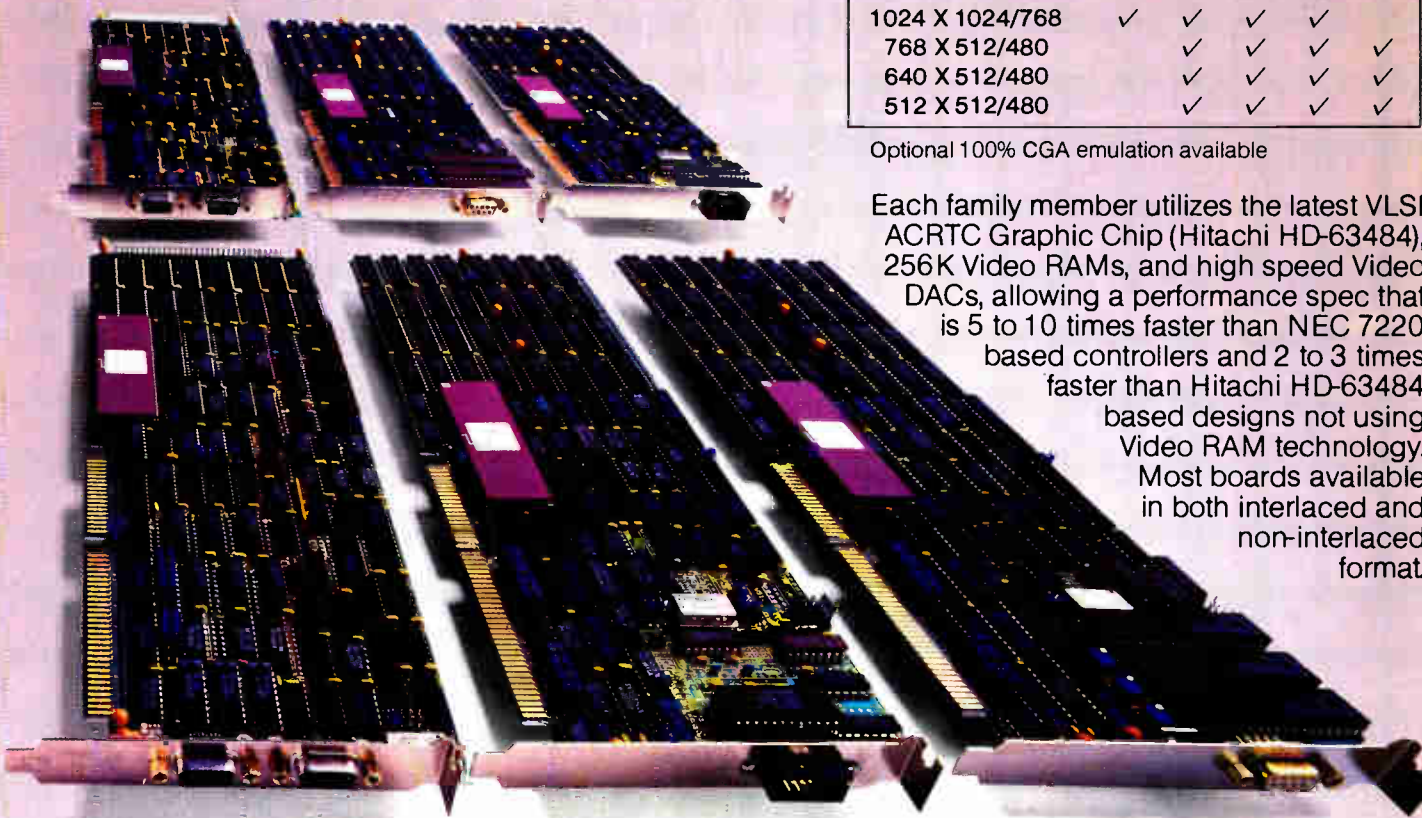

Display Resolution	Bits / Pixel				
	4	8	16	24	32
1280 X 1024/960	✓	✓		✓	
1024 X 1024/768	✓	✓	✓	✓	
768 X 512/480		✓	✓	✓	✓
640 X 512/480		✓	✓	✓	✓
512 X 512/480		✓	✓	✓	✓

Optional 100% CGA emulation available

Each family member utilizes the latest VLSI ACRTC Graphic Chip (Hitachi HD-63484), 256K Video RAMs, and high speed Video DACs, allowing a performance spec that is 5 to 10 times faster than NEC 7220 based controllers and 2 to 3 times faster than Hitachi HD-63484 based designs not using Video RAM technology. Most boards available in both interlaced and non-interlaced format.

## FOR YOUR IMAGING & GRAPHICS APPLICATIONS

2D/3D Mechanical CAD



CADKEY

Tektronix 4115 Emulation



TGRAF

General CAD

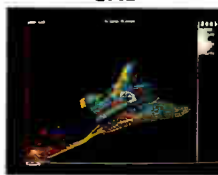

AUTOCAD

Image Analysis



IMAGEPRO 1000

Electronic CAD



P-CAD

Designer Graphics



ARTWORK

Imagraph's family of Advanced Graphic Controllers (AGC) are state-of-the-art, medium to high resolution display boards designed specifically for OEM and End Users' requirements in CAD, CAE, Graphic Arts, Presentation Graphics, Landsat, Medical and Scientific/Industrial Displays. All boards warranted for one year.

VME Bus versions also available.

# IMAGRAPH

CORPORATION

800 West Cummings Park, Woburn, MA 01801  
Telephone: (617) 938-5480... Telex: 4946300 IMAGTGI  
Circle 90 on reader service card

ImagePro is a registered trademark of Media Cybernetics, Inc. Cadkey is a registered trademark of Micro Control Systems. Autocad is a registered trademark of Autodesk. P-Cad is a registered trademark of Personal CAD Systems, Inc. TGRAF is a trademark of Grafpoint, Inc. Artwork is a trademark of West End Film, Inc. Tektronix 4115 is a registered trademark of Tektronix Inc. IBM is a registered trademark of International Business Machines, Inc.

# NEW PRODUCTS

## FLASH CHIPS CONVERT A TO D AT 125 MEGASAMPLES/S RATE

### HONEYWELL CLIPS DRIVE REQUIREMENT, KICKBACK CURRENT

**B**y minimizing drive requirements and damping kickback transients, Honeywell Inc. has designed a pair of analog-to-digital flash converters that convert a 2-V analog input signal with full-scale Nyquist frequency components into 8-bit digital words at a rate of 125 megasamples/s.

Fabricated in Honeywell's 2.4- $\mu$ m Advanced Bipolar Digital II process, the new 8-bit, single-chip devices integrate 256 input preamplifiers between the circuit's reference ladder and its input comparators. Competitive flash-converter architecture is subject to variable input capacitance—a condition that leads to unstable input frequency and voltage. By buffering each of the circuit's 256 input comparators with preamplifiers, Honeywell makes its HADC77100 and 77200 chips easier to drive by holding capacitance at 60 pF. Moreover, comparator-preamplifier pairings increase input-signal gain sixfold, which gives each comparator a wider threshold range. This, in turn, reduces output errors caused by metastable states within the circuit.

**LESS KICKBACK.** Situating the preamplifiers between the circuit's reference ladder and its comparators reduces kickback in the analog circuit to 40  $\mu$ A, the company says. Typical kickback for 8-bit converters is  $\mu$ A.

Honeywell's Signal Processing Technologies operation in Colorado Springs, Colo., has targeted a number of high-performance A-D applications for the new chips, including high-definition video equipment, digital oscilloscopes, transient-capture systems, radar, medical electronics, instrumentation, and direct radio-frequency downconversion systems. Steven J. Sockolov, marketing manager for high-speed data acquisition, believes the converters are the fastest flash A-D parts commercially available.

Housed in a 42-pin ceramic dual in-line package, the 77100 is compatible with Sony Corp.'s CX20116. The 48-pin 77200 has additional features, including five external reference-ladder taps—compared with three on the Sony-compatible part—and a data-ready pin for clocking

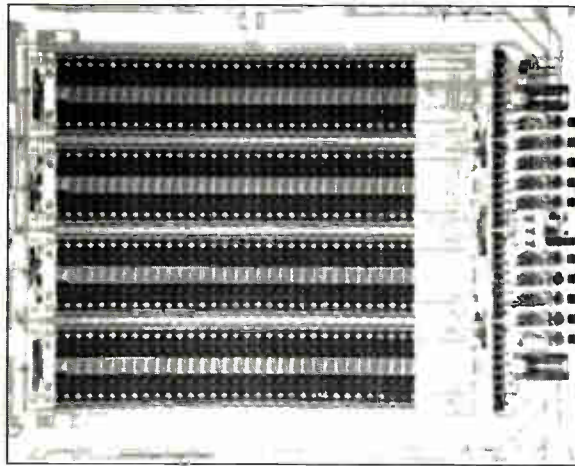

**SYSTEM ENHANCERS.** Integrating preamplifiers on-chip enhances system performance.

outputs to high-speed memory chips or latches. The 77200 also has reference-force pins and an overrange bit for systems demanding higher resolution.

In most applications, external sample-and-hold circuitry is not required for accurate conversions because of the part's bandwidth. On board the chip are a tapped reference resistor and encoding

logic and output register.

The 77100 and 77200 feature emitter-coupled-logic compatibility, with output drive of 50  $\Omega$  compared with 100  $\Omega$  for other flash converters. Operated from a single -5.2 V power supply, the devices dissipate a maximum of 2.2 W. They are available with operating ranges of -25° C to +85° C.

In quantities of 100, the 77100 costs \$593.75 each; samples are available at a single-unit price of \$350. Honeywell plans to offer 77200 samples in December at an introductory price of \$350. When avail-

able in production quantities during the first quarter of 1987, the 77200 will cost \$653 each in 100-piece lots.

—J. Robert Lineback

Honeywell Inc., Signal Processing Technologies, 1150 E. Cheyenne Mountain Blvd., Colorado Springs, Colo. 80906. Phone (303) 577-3705 [Circle 360]

## CIRRUS CAN CUSTOMIZE DISK-CONTROLLER CHIPS

**U**sing a proprietary, compiled-design methodology that yields circuits as dense and as fast as full-custom chips, Cirrus Logic Inc. has built an enhanced version of the industry-standard hard-disk-controller chip set. In addition, the new chips can be customized to include special functions.

In off-the-shelf versions that are software- and hardware-compatible with Adaptec Inc.'s AIC 300 and AIC 010 industry-standard chip set, the CL-SH120 buffer-storage manager and the CL-SH130 Winchester controller offer power savings of more than 50%. Specifically, the CL-SH130 consumes 400 mW at 20 MHz compared with 1,050 mW at 15 MHz for the AIC 010, and the CL-SH120

consumes 130 mW at 5 MHz compared with the AIC 300's 450 mW at 3 MHz.

But adaptability is the key advantage the Cirrus chip-set combination has over other Winchester disk-controller sets. Because they are fabricated using Cirrus' semistandard "redefinable" IC design methodology, "you can buy these chips as they are, or have them customized by us to your exact system requirements," says Cirrus President Michael Hackworth.

**MADE TO ORDER.** The CL-SH130 can be quickly customized to add I/O ports, add to or modify the writable control-store memory, expand or change the error-correction code polynomial, and add encode/decode to modify the microproces-



## UNITED WE STAND TO SAY THANK YOU.

To those of you who volunteer and to those of you who contribute to help stop drug and alcohol abuse, domestic violence, hunger and so many other social problems, we say thank you.

To those of you who give your time or your gifts for day care for the young, health care for the elderly, and mental health programs for all Americans, we say thank you.

We are your neighbors, your friends, members of the community who benefit from your generosity.

Thank you for giving. Thank you for caring. Thank you for becoming united.



**United Way**

THANKS TO YOU IT WORKS FOR ALL OF US.

sor interface. Examples of customization on the buffer storage manager include additions such as logic for advanced Small Computer Standard Interface functions, on-chip buffer random-access memory, IEEE-488 bus interface logic, a dynamic RAM interface, processor address/data bus interfaces, logic for sector counting, and an on-chip formatter/controller function. Although software compatibility with the Adaptec chips is not preserved in customized chips, the user can request further customization, such as modifying the register set and the direct-memory-access management scheme.

Fabricated with a 2- $\mu$ m CMOS process, the off-the-shelf versions are hardware- and software-compatible with the Adaptec chips, which are fabricated in 4- $\mu$ m n-MOS. Although the chips target the high-performance disk-drive market, they can also be used to upgrade existing drives, says Hackworth. The set will be second-sourced by Silicon Systems Inc., of Tustin, Calif.

**TESTS BETTER.** Compared with earlier devices, the CL-SH130 Winchester controller offers important performance improvements, including additions to on-chip registers that improve testability. Besides offering speed and power enhancements, the CL-SH120 is designed to maximize throughput and simplify buffering of block-oriented peripheral controllers, the company says. Key performance improvements include a host-bus data-transfer rate of 2.5 megabytes/s.—twice the speed of previous devices.

The CL-SH120 can address up to 16-K bytes without multiplexing, and any buffer size greater than 16-K bytes in the extended-memory multiplexed mode, compared with a 1-K-byte limitation on previous devices.

The chip set supports most drive interfaces without modification, including Enhanced Small Disk Interface, Storage Module Drive, ST506/412, QIC-36 tape, and a variety of custom drive interfaces. Users can fully reprogram the CL-SH130's 32-bit error-correction-code polynomial and RAM-based sequencer to operate with a variety of drive interfaces and to define unique track formats. The CL-SH120 is designed to work with the CL-SH130.

Available now in a 44-pin plastic leaded chip-carrier package, the CL-SH120 costs \$17.50 each in 100-lot quantities. The CL-SH130 10-MHz version costs \$48 each and the 15-MHz version \$52 each, in 100-lot quantities. The 20-MHz version's price depends on quantity.

—Bernard Conrad Cole

Cirrus Logic Inc., 1463 Centre Pointe Dr., Milpitas, Calif. 95035. Phone (408) 945-8300

[Circle 361]

# Here's how IMC can help you...

Just circle any of these numbers on the reader service card and let **IMC** come to the rescue.

## DC Motors and Motor/Encoders



**IMC** UNIVERSAL MAGNETICS CORP.  
DIVISION OF IMC MAGNETICS CORP.  
100 Jericho Quadrangle, Suite 221, Jericho, NY 11753

### Circle Reader Service No.118

Catalog features DC motors and motor/encoders along with performance data and specifications.

## Custom Power Supplies



**IMC** IMC MAGNETICS CORP.  
DIVISION OF IMC MAGNETICS CORP.  
100 Jericho Quadrangle, Suite 221, Jericho, NY 11753

### Circle Reader Service No.119

Catalog shows how you can benefit from IMC's consolidation of resources as well as other information pertaining to their custom built power supplies.

## TORMAX

### Steppers and Controls



**IMC** IMC MAGNETICS CORP.  
DIVISION OF IMC MAGNETICS CORP.  
100 Jericho Quadrangle, Suite 221, Jericho, NY 11753

### Circle Reader Service No.120

Catalog features specialty stepping motors and listing of controllers to drive them. Also chapters on theory of operation, excitation modes and applications.

## Synchron

- AC Timing Motors
- DC Motors
- Clock Movements
- Stepping Motors



**IMC** IMC MAGNETICS CORP.  
DIVISION OF IMC MAGNETICS CORP.  
100 Jericho Quadrangle, Suite 221, Jericho, NY 11753

### Circle Reader Service No. 121

Catalog gives general specifications on Synchron® AC timing motors as well as Magna-Torc DC motors. Products include clock movements, chart drives and slip ring assemblies.

## IMC VANEAXIAL FANS

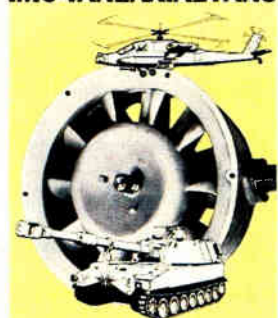

**IMC** IMC MAGNETICS CORP.  
DIVISION OF IMC MAGNETICS CORP.  
100 Jericho Quadrangle, Suite 221, Jericho, NY 11753

### Circle Reader Service No.122

Portfolio contains spec. sheets on IMC's complete line of large vaneaxial units. Fans are ideally suited for cooling applications requiring a large volume of air.



## Vaneaxials

**IMC** IMC MAGNETICS CORP.  
DIVISION OF IMC MAGNETICS CORP.  
100 Jericho Quadrangle, Suite 221, Jericho, NY 11753

### Circle Reader Service No.123

Catalog contains information on air-movers rated for highest efficiencies. Included are charts as well as data on aerospace applications.

## CENTRIFUGAL BLOWERS



**IMC** IMC MAGNETICS CORP.  
DIVISION OF IMC MAGNETICS CORP.  
100 Jericho Quadrangle, Suite 221, Jericho, NY 11753

### Circle Reader Service No.124

Catalog contains an extensive range of centrifugal blowers to meet a variety of cooling requirements.

## The Motor Catalog

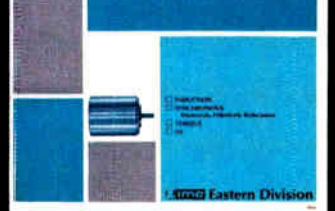

**IMC** IMC MAGNETICS CORP.  
DIVISION OF IMC MAGNETICS CORP.  
100 Jericho Quadrangle, Suite 221, Jericho, NY 11753

### Circle Reader Service No.125

Catalog is divided into sections for induction, torque and DC motors with sections devoted to technical information.

Keep Your Eye on IMC



**IMC MAGNETICS CORP.**  
CORPORATE OFFICES Tel:(516)938-0800  
100 Jericho Quadrangle, Suite 221 • Jericho, NY 11753

## BLACK-ON-WHITE SCREEN RIVALS LETTER-QUALITY

### MICRO-TERM DOUBLES THE NUMBER OF DOTS PER CHARACTER AND REDUCES FLICKER ON DEC VT-COMPATIBLE TERMINALS

A family of computer terminals from Micro-Term Inc. solves the problems inherent in displaying black characters on an all-white screen and gives a crisp appearance rivaling the look of high-quality printing on paper. The Foresight Edition 4500 series is compatible with Digital Equipment Corp.'s VT terminals.

Although other attempts to implement reverse-video—black on white—displays have fallen short of simulating a printed page, there was always reason to keep trying: experts believe that they would reduce eye-strain for operators who constantly look back and forth from printed page to video screen. Early attempts to do reverse video failed primarily because the large, brightly lit white area flickered too noticeably. Moreover, the small, black characters were hard to read because they were not as well-formed as those on letter-quality printers.

The 4500 series uses new monitor technology with better phosphors and innovative scan techniques to provide clean, crisp characters with twice as many black dots as usual against a soft-white, flickerless screen. The dots are so close together the user cannot see them; instead, fully formed, letter-quality characters appear on the screen, which has been overscanned—that is, scanned from top to bottom, edge to edge—to make it completely white.

**HALF-DOT SHIFT.** To eliminate spacing between the dots on the vertical axis, the designers raised the number of scan lines from 240 to 500. Closing the spaces between dots on the horizontal axis while maintaining character-cell compatibility with DEC's VT series terminals was more of a challenge. The engineers developed a timing technique called half-dot shift to combine a 20-by-20-dot character cell with 15-by-18-dot characters. DEC and other makers of VT-compatible terminals use a 10-by-16-dot character cell.

The half-dot shift is a timing maneuver performed during the horizontal scan. Successive dots are turned on or

off a half-clock-cycle apart. To maintain compatibility with the 10-cell-wide character cell of DEC VT terminals while using new cells that are 20 dots wide, 10 cycles must be used to scan 20 dots. One-half cycle after the first dot is switched on or off, the second dot is switched—but the first one is not changed. At the beginning of the second cycle, the first dot is turned off or on,



**CRISP DISPLAY.** Better phosphors and scanning techniques give Micro-Term's display a sharper image.

and the third dot is switched to its correct state. The process continues across all 20 dots in a cell. The first and third dots are equivalent to the first and second in a DEC VT terminal.

By doubling the scan rate to 34.2 MHz, Micro-Term designers reduced the flicker of the white background to the point where it is unnoticeable. This reduces eye strain for operators using the terminal for prolonged periods.

The Foresight Edition family's three models come with a 14-in. tilt-and-swivel monitor and three pages of display memory, each with space for 4,000 by 4,000 pixels. Terminals are controlled by a Zilog Corp. Z80 microprocessor and two gate arrays.

One array, which replaces about 100 discrete components and ICs, has everything required to run the display, such as the CRT controller, which handles scrolling, the memory interface, cursor generation, and horizontal and vertical timing. The other array takes care of video shifting, display blanking, and signal mixing.

**GRAPHICS.** The 4520 is an alphanumeric terminal with no graphics capability and is compatible with the DEC VT220, VT100, and VT52 terminals. The model 4525 is the same as the 4520 but with graphics capability. A plug-in monochrome graphics card with two kinds of graphics—DEC's Regis-compatible graphics and Tektronix Plot-10 compatibility—is available for the 4525.

A top-of-the-line fast graphics terminal, the model 4560, draws monochromatic graphics at the rate of 2 million pixels per second—comparable to the best midrange graphics on work stations and high-end graphics boards for personal computers. The 4560 provides DEC VT alphanumeric terminal emulation along with Tektronix 4010/4014 graphics compatibility to run Plot-10 applications software. The high-speed graphics on the 4560 are delivered by a team of processors—a Motorola 68000 microprocessor and a Hitachi Inc. ACRTC 63484 graphics processor.

The Foresight Edition 4500-series products, to be unveiled at the Comdex/Fall '86 show in Las Vegas next month, have a two-year warranty. The 4560 is priced at \$1,296, the 4525 at \$795, and the 4520 at \$695. All three models will be available in December.—Tom Manuel

Micro-Term Inc., 512 Rudder Rd., St. Louis, Mo. 63026.

Phone (314) 343-6515 [Circle 340]

## PLUG-IN CARD ACQUIRES ANALOG DATA IN REAL-TIME

Hitching an IBM PC, PC/XT, or AT directly to an incoming analog signal holds the promise of instant signal analysis and high-powered data manipulation, but, like many shortcuts, this one can end in frustration for users whose data-acquisition processor cannot keep pace with the incoming signal.

A plug-in card from Ariel Corp. offers a solution to that problem. The card provides 16-bit resolution and real-time data

acquisition on two input and two output channels at a maximum 50-KHz sample rate.

High resolution and high speed tend to be mutually exclusive, and using multiple channels can further degrade system performance. But chiefly because Ariel's DSP-16 utilizes Texas Instrument's TMS32020 digital signal processor—one of the most recent and most powerful single-chip DSPs available—it



# DOES WINDOWS.

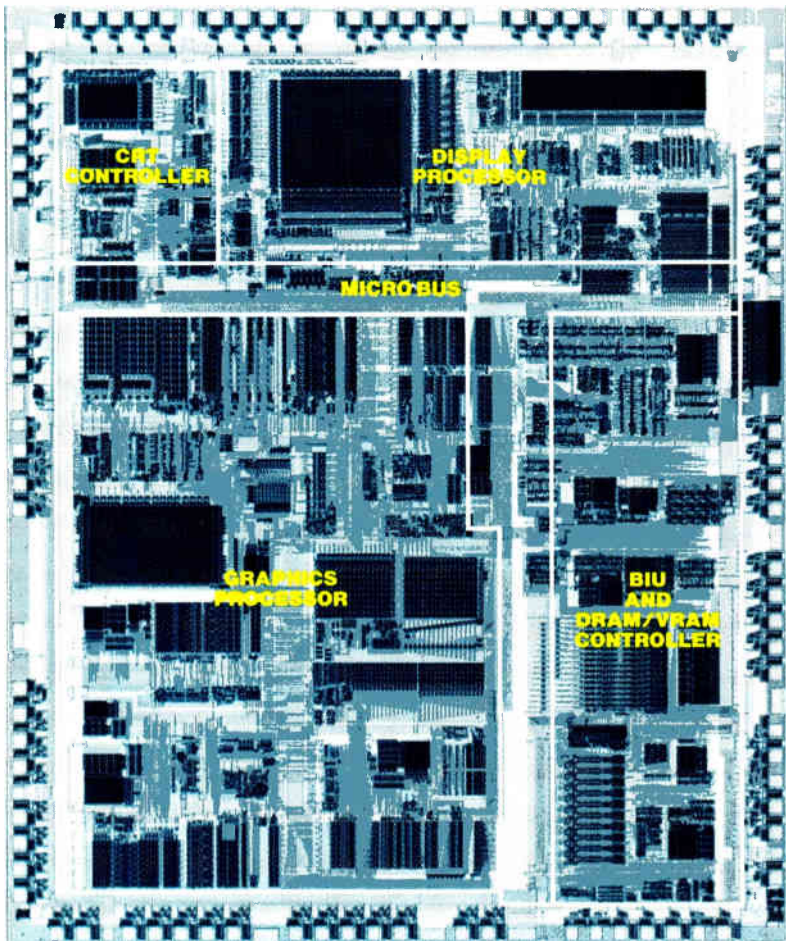

Intel's 82786 graphics coprocessor supports its family of 16- and 32-bit central processing units.

“Two completely different kinds of end customers seem to be fueling the embryonic graphics chip market: the personal computer user in business, and the designer on a work station. Intel Corp., long reported to be developing a graphics-oriented microprocessor, is finally announcing its 82786 graphics coprocessor for both applications.

Demand for multiple-windowing capability is on the rise, especially for multitasking chores in the office environment. The 82786 implements this capability in hardware. Each application can have its text and graphics drawn into separate regions of memory, which are then combined within windows of the same display. Large amounts of overhead associated with graphics tasks can be offloaded from the main system CPU by storing more text and graphics information in memory than is shown in the display...”

*Excerpted from an exclusive article in the May 19, 1986 issue.*



## Electronics

**THE LEADER IN NEW  
TECHNOLOGY COVERAGE**

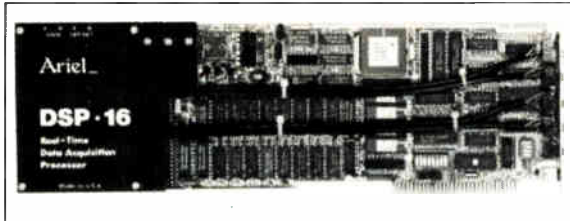

**NO-COST SOFTWARE.** The DSP-16 comes bundled with six application software packages at no extra cost.

can operate on both channels of input and output with 16-bit precision at its maximum sample rate, with horsepower left over for real-time processing, says Mark Clayton, president of the New York company.

The card is both compact and affordable, using a single expansion slot of the computer's backplane and costing \$2,495. Configuring an equivalent system with components would require no fewer than four devices: a high-performance data-acquisition board; a processing card; an analog-to-digital converter; and extensive PC-accessible memory, Clayton says.

The 32020's 5-million-instruction/s throughput makes possible complex processing and analysis of the acquired signal in real time. "We can guarantee throughput because our board doesn't involve the central-processing unit at all," Clayton says. In fact, the PC is left to do what it does best: set up and control the DSP-16 applications programs, and display, store, or retrieve the processed signal, Clayton says.

Another key to the DSP-16's performance is the combination of on-board sample-and-hold filters with memory capability. The standard memory buffer of 512-K bytes can capture and hold 5.25 s of data flow at the 50-MHz maximum

sampling rate—plenty for most applications. Upgrades to 2 megabytes stretch retention to 21 s of data flow at a 50-MHz sampling rate. "Although other boards may claim higher sampling rates, their performance in real-life situations is limited by their data-buffering capacity," Clayton says.

Applications programs are loaded from the PC to 16-K words of high-speed, zero-wait-state random-access memory. A separate DSP-to-host interface permits program modification and data transfer even while the 32020 processes the incoming signal.

**APPLICATIONS.** To demonstrate the DSP-16's flexibility, Ariel has bundled six application programs with it, at no extra cost. Written in Microsoft Corp.'s C and 32020 assembly language, the software transforms the board into several devices, including a digital storage oscilloscope; a dual-channel, digital audio-delay line; a waveform synthesizer; an audio-loop editor that captures and edits sound; and a general-purpose program developer. Ariel invites further software development by original equipment manufacturers, Clayton says; he expects them to respond, since OEMs should find many uses for the card.

Ariel plans to introduce the DSP-16 at the Scientific Computing and Automation Show in Atlantic City, N.J., on Nov. 5. The board will be available later in the month. OEM discounts will be offered.

—Jack Shandle

Ariel Corp., 110 Greene St., Suite 404, New York, N.Y. 10012.

Phone (212) 925-4155

[Circle 341]

## CARTRIDGE PACKS 630 MBYTES ON TAPE

A half-inch cartridge streamer with a formatted capacity of 630 megabytes and an industry-standard Pertek interface marketed by MegaTape Corp. targets a growing data-backup market for increased-capacity hard-disk drives.

The cartridge's companion MT-750 drive is compatible with Digital Equipment Corp., Data General Corp., and Apollo Computer Inc. systems. The move to higher tape-storage capacity permits one-cartridge-per-disk backup and reflects the increasing number of Fujitsu Corp. Eagle XP and other high-capacity disk drives on the market.

MDC-750 tape cartridges have a data-density of 16,000 bits/in. and a 240-K-byte/s data-transfer rate. Backing up a 630-megabyte hard disk usually takes less than an hour, the company says. A 128-K-byte error-correction cache is standard on all models, and some models are compatible with the company's 500-megabyte products.

Available now, a system consisting of an MT-750 drive, 10 MDC-750 data cartridges, and accessories costs \$15,500. Discounts are available for OEM-quantity purchases.

MegaTape Corp., 1041 Hamilton Rd., Duarte, Calif. 91010.

Phone (818) 357-9921

[Circle 345]



# Test this pioneering feature for yourself. 45% capacity after 12 months storage.

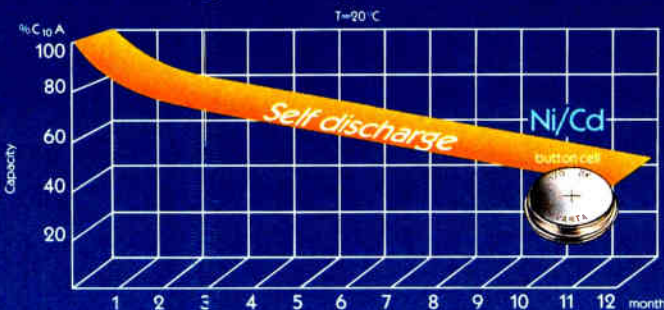

Rechargeable VARTA button cell batteries with mass electrodes have an extremely low self-discharge rate. Progress is outstanding: higher autonomy of the module — more

available capacity for long-term operation and display features.

Order your test batteries now!

VARTA Batterie AG, Am Leineufer 51, D-3000 Hannover 21

VARTA Batteries, Inc., 300 Executive Boulevard, Elmford N.Y. 10523-1202, USA

VARTA Private Ltd., P.O. Box 55, Bedok North Post Office, Singapore 9146

World Radio Directory 96 on reader service card



# VARTA

Count on OKI to expand your CMOS CSIC options.

# Gate Arrays

1.5-micron & 2-micron				3-micron	
70V000 Series VERY HIGH SPEED		70H000 Series HIGH SPEED		70000 Series	
# Gates	# I/Os	# Gates	# I/Os	# Gates	# I/Os
700	66	3289	86	387	44
1000	66	4290	104	720	62
1500	66	6000	130	1445	88
2000	80	8024	148	2000	106
2500	80	10008	172	4205	120

OKI CMOS

**NOW:** Expanded Gate Array options from OKI, supported by world-class CSIC capabilities.

**Expanded** product families and packaging. For more cost-effective, more flexible single-chip logic integration, OKI supplies more pre-designed Gate Array options—in the most advanced package types: plastic or ceramic through-hole DIPs or pin grid arrays; or plastic surface-mount PLCC or flatpack.

**Expanded** services, plus world-leading production automation. OKI CSIC\* design expertise is accessible at any development stage. And OKI's CSIC manufacturing/testing facilities—among the world's most highly automated—assure high quality, high volume fabrication.

For RFQ or technical data, complete form below and return to: CSIC Marketing, OKI Semiconductor, 650 N. Mary Ave., Sunnyvale, CA 94086. (408) 720-1900.

\*Customer-Specific Integrated Circuit

## RFQ

Request for Quote

### OKI CMOS Gate Arrays

For prompt response to your Request for Quote (returned with complete technical data), please fill out these brief specifications.

# OKI

SEMICONDUCTOR

#### My application requires:

1. Gate count: \_\_\_\_\_
2. Pin count: \_\_\_\_\_
3. **CMOS process:**  
 1.5 micron  
 2 micron  
 3 micron
4. **Packaging preferred:**  
 Surface-mount  
 PLCC  
 Flatpack  
 Through-hole  
 Pin Grid Array  
 DIP

#### 5. Anticipated volume:

- \_\_\_\_\_ pieces/month
- Please call me for immediate consultation.
- Request for Data**
- Please rush complete technical input on:
- CMOS Gate Arrays  
 CMOS Standard Cells  
 CMOS Custom VLSI Logic



Name/Title \_\_\_\_\_ Company \_\_\_\_\_ Tel: (\_\_\_\_) \_\_\_\_\_

Address \_\_\_\_\_ City \_\_\_\_\_ State \_\_\_\_\_ Zip \_\_\_\_\_

EL 10/30/85

World Radio History

Circle 97 on reader service card

# SIMULATION MODEL MIMICS ALL 68000 FUNCTIONS

## QUADTREE'S CHIP MODEL SIMULATES MOTOROLA'S FULL INSTRUCTION SET, REGISTER STATES, AND PIN TIMING

Quadtree Software Corp., a two-year-old company specializing in modeling very large-scale integrated circuits, has reached new heights of simulation sophistication with full-function models of Motorola Inc.'s 68000 and 68010 microprocessors, along with a family of microprocessor peripheral chips.

In contrast to competing models that simulate only bus functions, Quadtree claims its Designers' Choice models handle all functions, including execution of the full instruction set, the state of internal registers, and the timing at the pins according to data-book specifications. Bus-level models do not permit the full simulation of a board design, and so they do not fully replace the breadboard prototyping stage, according to William Billowitch, executive vice president of Quadtree.

"Only full-function microprocessor models simulate the complex interactions between instruction execution, bus timing, and asynchronous interrupt handling," he says. "Timing information can be analyzed that would be unobtainable in a partial or bus-function model."

**DEVELOPMENT SOFTWARE.** To complement its Motorola chip models, Quadtree offers development-system software that allows a designer to proceed as if a hardware prototype were available and connected to a conventional development system. With this interactive, graphic environment, designers can set breakpoints, step through instructions, and observe and modify the contents of internal registers—including the program counter—to debug hardware and assembly-language software at the same time.

The models mimic the detailed timing characteristics of all instructions executed by the microprocessors. Instruction prefetching and pipelining occur as they do in the actual devices, and interrupt handling is performed with the proper clock-edge timing and protocols.

The models therefore can simulate detailed bus-protocol timing, which is intimately dependent on instruction flow. Interrupts are serviced at the precise moment in the simulation that the prefetch and execution sequences of the actual processor dictate.

Included in the package are Quadtree's X-Handling routines that deal intelligently with unknown conditions on the processor's pins. The routines report these conditions to the user when appro-

priate, but do not necessarily halt the simulation because of them, as other models generally do. For example, unknown data from failed components or sensors can be allowed to ripple through the system to study its effects. X-Handling software avoids burdening the designer with a flood of error messages. He is warned of unknowns on control lines that can affect the performance of the processor, but unknowns in the data stream of a block-move instruction, which might be data from bad sensors, can pass through without delaying simulation.

**PERIPHERALS.** Quadtree has many models for 68000-family peripherals, including the 68121 intelligent peripheral controller, the 68153 bus-interrupt controller, the 68230 parallel interface/timer, the 68440 two-channel direct-memory-access controller, the 68450 four-channel DMA controller, the 68451 memory-management unit, the 68488 IEEE-488-bus interface, and the 68681 dual universal asynchronous receiver/transmitter.

The company also plans to build models for Intel Corp.'s microprocessors, Advanced Micro Devices Inc.'s 2900-family bit-slice processors, and other manufacturers' memory ICs, says Billowitch. Quadtree already markets a model for Weitek floating-point math chips.

The models run on work stations from Sun Microsystems Inc. and Apollo Computer Corp. The single-host license fee for either the 68000 or the 68010 model is \$3,500. Prices for the peripheral-chip models range from \$500 to \$3,000 when licensed individually, or \$7,878 for the entire peripheral library (\$6,500 if licensed in conjunction with one of the microprocessor models). The optional development-environment package costs \$3,500. All are available 30 days after receipt of order. —Jeremy Young

Quadtree Software Corp., 1170 Route 22 East, Bridgewater, N. J. 08807.  
Phone (201) 725-2272 [Circle 380]

## OSCILLOSCOPES HANDLE 1 GHz

Bandwidths of 1 GHz, 10- to 14-bit resolution, and up to 12 input channels highlight Tektronix Inc.'s 11000 series of oscilloscopes. Two digitizing and two analog versions are offered, all incorporating touch-screen control, interactive

menus, and intelligent functions into the user interface.

Both digitizing models offer 10,240 sample-point waveform records and a 9-in. screen. The top-of-the-line 11402 has a 1-GHz bandwidth; the 11401, 500 MHz. The 11402 combines its high bandwidth with 10-ps horizontal resolution and 10-bit vertical resolution. Using signal averaging, it can achieve 14-bit vertical resolution.

The 11401 and 11402 accommodate 12 input channels, as many as eight of which may be displayed in any combination. With three optional vertical amplifiers, for example, the 11402 can display eight traces at 300 MHz, six traces at 600 MHz, and three at 1 GHz. Both oscilloscopes are accurate to within 1% of full scale and adjustable in 0.1% increments.

Major user-interface menus for the 11400 series include waveform, trigger, measure, store/recall, and utility. Controls are grouped on or near the infra-red touch screen so users can focus on the display. To enhance measurement accuracy, the 11400 series includes 100-K bytes of data-point memory. It can display waveforms on the screen in one

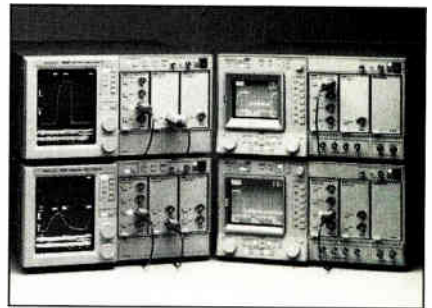

or two windows, facilitating comparative measurements.

Tektronix's 11300 series of programmable analog oscilloscopes feature built-in, full-function counter-timers. The 11302 offers a 500-MHz bandwidth; the 11301, 400 MHz. Both can display a counter-view trace that allows the user to see the exact portion of the waveform being measured by the counter-timer.

Equipped with two vertical amplifiers, the 11300 series oscilloscopes can display eight traces at 250 MHz, and two at 500 MHz. Traces from other signals can be added or subtracted. Time intervals can be measured to  $\pm 0.5\%$  full-scale and  $\pm 0.3\%$  if dual delayed sweeps are employed.

The 11300-series user-interface menus add adjust/focus and numeric entry to the 11400-series menus. All four instruments are available now. The 11401 costs \$13,000; the 11402, \$15,500; the 11301, \$8,550; and, the 11302, \$12,950. Tektronix Inc., P.O. Box 1700, Beaverton, Ore. 97077.

Phone (800) 547-1512 [Circle 385]

# DEPOSITION SYSTEM AIMED AT WAFER RESEARCH LABS

**SMALL-SCALE SYSTEM OFFERS HIGH REPRODUCIBILITY AND EPITAXIAL LAYER GROWTH AT ATMOSPHERIC PRESSURE**

**B**uilding on six years of experience growing epitaxial layers in multi-wafer production applications for the IC industry, Spire Corp. has targeted the research-laboratory market for its newest metal-organic chemical vapor deposition system.

The SPI-MO CVD 240 was designed by the Bedford, Mass., company to grow high-quality epitaxial layers of III-V and II-VI compounds. Although the system's capacity is only two two-inch wafers, its reduced throughput allows a high level of uniformity in creating epitaxial layers and flexibility.

"It's a small system designed to do high-electron-mobility transistor (HEMT) devices at atmospheric pressure," says Spire sales manager Thomas C. Dearmin. This is the first instance of a small system working reliably at atmospheric pressure, according to the company.

The 240 offers fully automated process control through an IBM Personal Computer. It utilizes a vertically oriented radio-frequency-heated susceptor for uniformity of layer growth.

Operating temperature, which typically ranges between 400° and 1,100° C, is controlled to one degree by a feedback loop. Models are available for both atmospheric and low-pressure operation.

Type III-V and II-VI compounds grown in Spire vapor-deposition reactors include gallium arsenide, aluminum gallium arsenide, gallium phosphide, gallium arsenide phosphide, and gallium indium arsenide. According to Dearmin, one of the system's strongest features is its compatibility with other Spire vapor-deposition reactors, some of which have been marketed for six years. The 240 provides the same proven performance as Spire's other models, he says, and Spire has parts in stock.

As many as six metal-organic sources can be used in large-volume cooling baths. An upstream liquid trap is included for each metal-organic source to prevent accidental back-diffusion. Also available is a hydrogen-dilution system on either the metal-organic or the gas lines.

Process gases are switched using an injection manifold composed of four-port and three-port pneumatic bellows valves. Options allow a maximum of 15 gas lines to be introduced into the system.

A typical growth rate for the 240 is

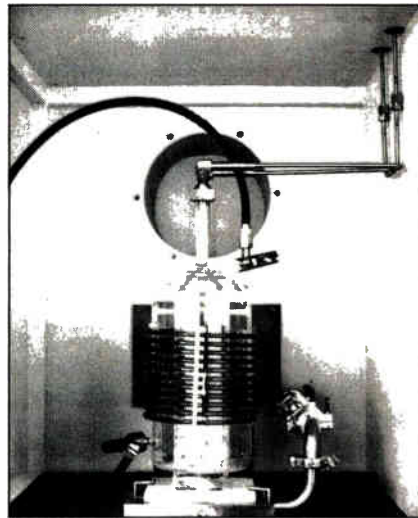

**EXACT.** Spire's research deposition system reproduces epitaxial layers uniformly.

0.06  $\mu\text{m}/\text{min}$ , with an eight-hour day yielding between one and three two-wafer sets. Sheet-resistance uniformity exceeds 5%. The 240 system costs between \$225,000 and \$300,000, depending on selected options, and delivery takes about five months.

-Rick Elliot

Spire Corp., Patriots Park, Bedford, Mass. 01730. Phone (617) 275-6000 [Circle 420]

## SOLDER REPAIR UNIT FEATURES LOW HEAT

A pc-board repair/rework unit employs a recirculating molten wave of solder to avoid exposing the board to possible damage associated with the high temperatures of hot iron or iron/air vacuum techniques.

Virtually any size pc board can be reworked by operators with minimum skill with the Soldapak repair station from Electrovert USA Corp., the company



claims. The solder wave is controlled by interchangeable nozzles that match the size and configuration of most components. A hand-held tool that is activated by downward pressure on the pc board uses low-pressure compressed air to clear lead holes. Soldapak will operate at temperatures as high as 650° F. Available now, the Soldapak costs \$6,000.

Electrovert USA Corp., 4330 Beltway Place, Arlington, Texas 76018.

Phone (817) 468-5171 [Circle 426]

## QUICK-CHANGE HEADS SPEED PRODUCTION

Production of pc boards that require several different pin and terminal types or a specific angle for insertable components can be speeded up with a pin/terminal insertion system from Autosplice Inc. that features quick-change heads.

Head changes take only 15 minutes, the company claims. The system includes a microcomputer that can be programmed by keyboard, microcassette, or joystick. The insertable pins, terminal jumpers, and sockets are supplied to the machine on a continuous-reel tape. The complete system includes a rotary table that processes the pc boards and presents them to an operator. Available now, it costs \$45,000 to \$53,000, depending on table size.

Autosplice Division of General Staple Inc., 59-12 37th Ave., Woodside, N.Y. 11377. Phone (718) 429-0500 [Circle 427]

## DETECTOR CAN SPOT 0.2-MICRON PARTICLES

A laser-light surface-contamination analyzer that can detect particles as small as 0.2  $\mu\text{m}$  also features haze contamination sensitivity as low as 0.6 parts per million and extended upper-range particle detection.

Upgraded front-end electronics enables the Surfscan 4500 from Tencor Instruments Inc. to detect and analyze particles from 0.4 to 1,024  $\mu\text{m}^2$  and particle haze as high as 102,400 ppm. The increased particle-haze range is useful for inspecting surfaces with high background-light scatter, such as polysilicon, the company says.

The Surfscan 4500 includes one direct-access sending cassette and one receiving cassette. Pass/fail sorting can be done with two cassettes.

After each laser scan is complete, five color displays are available on the user's control monitor, including particle maps, haze maps, and a histogram showing particle-analysis data. Available now, the instrument costs \$115,550.

Tencor Instruments Inc., 2400 Charleston Rd., Mountain View, Calif. 94043.

Phone (415) 969-6767 [Circle 425]

# Electronics CAREER OPPORTUNITIES

Fall 1986 Planning Guide

Issue		Closing
November 13	<b>Wescon Preview</b> Bonus Distribution at Wescon <b>Instruments Technology</b> Automatic Test Equipment	October 27
November 27	<b>Communications Technology</b> Fiber Optics Special Communication Career Section	November 10
December 11	<b>Year-End Double Issue</b> Executive Outlook <b>Semiconductor Technology</b> Linear ICs ISSCC <b>Military Technology</b> Special Section: Military Electronics	November 24

For more information, contact Susan Barnes-Ronga, National Recruitment Sales Representative, at (212) 512-2787

**Project Engineer.** Responsible for the design of custom switchmode power supplies; takes the project from its inception thru to final production; utilizes a variety of switchmode power supply circuit topologies that must include feedback control systems and off-line topologies of flyback, forward converter, full and half-bridge types; analog circuit design; power digital circuit design; heat transfer techniques; high voltage switching transistors; high frequency magnetics, and advanced mathematical/analytical skills; utilizes design and measurement techniques to assure product compliance to the FCC and VDE requirements of line conducted EMI (electromagnetic interference). Requirements: M.S. in Electronics Engineering and four years experience in the offered position or four years experience as Senior Electronics Engineer/Power Supply Systems. Experience must include working on the design and development of switchmode power supply units; this additional experience may be part of the experience required above. 40 hours per week. 8:00 A.M. to 4:30 P.M. \$42,000 per year. Send resume to: Illinois Job Service, 910 South Michigan Avenue, Room 333, Chicago, Illinois 60605. Attention: L. Donegan. Reference No. 6223-L. An employer paid ad.

JUST PUBLISHED!

## EASY, RELIABLE SOLUTIONS TO YOUR DESIGN PROBLEMS

ORDER TODAY!

Focused strictly on design problems, **CIRCUITS AND SOFTWARE FOR ELECTRONICS ENGINEERS** delivers professional, innovative solutions for your most demanding projects.

**CIRCUITS AND SOFTWARE FOR ELECTRONICS ENGINEERS** covers a vast array of design problems conveniently organized into 25 vital categories by function.

**CIRCUITS AND SOFTWARE FOR ELECTRONICS ENGINEERS** contains hundreds of circuit schematics and computer programs that have been proven to work and meet the highest standards of performance.

**These creative, new ideas and approaches keep you on top of what's happening in the latest circuitry developments.**

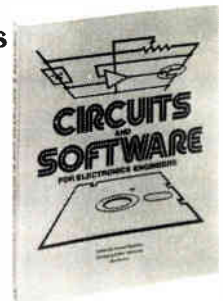

So whether you are a design engineer, technician or supervisor—don't take the chance of being less than on top of the latest circuitry developments! Order your copy today!

Before you tackle your next project, order this valuable resource today!

Use the coupon or send in your company purchase order.



### Electronics Magazine Books

P.O. Box 541  
Hightstown, NJ 05820  
(609) 426-5070

Send me \_\_\_\_\_ copy (copies) of **CIRCUITS AND SOFTWARE FOR ELECTRONICS ENGINEERS** for \$19.95 each. U.S. residents please include local sales tax.

- Payment enclosed (postage & handling included)
- Bill me (postage, handling & tax will be added)
- NOTE: All orders under \$25 will be sent a pro-forma invoice requiring prepayment.
- Bill my company. Purchase order is attached.

Ship to:

Name \_\_\_\_\_

Company \_\_\_\_\_

Street Address \_\_\_\_\_

City \_\_\_\_\_

State \_\_\_\_\_

Zip \_\_\_\_\_

Country \_\_\_\_\_

Please allow four to six weeks for delivery. McGraw-Hill knows you will be satisfied, but if for some reason you're not, there is a ten-day money-back guarantee that applies on all books.

# We have what you're looking for.

If you want a high-technology environment, unlimited opportunity and long-range stability, you owe it to yourself to take a closer look at General Dynamics Pomona Division, a leading supplier of advanced tactical defense systems.

## **MILITARY OPERATIONS RESEARCH ANALYSTS**

We currently have requirements for Operations Research Professionals in the following specialized areas:

### **ARMY AIR DEFENSE SYSTEMS**

Selected candidates will conduct Army Air Defense Mission requirements analyses, concept definition studies, trade-off analyses, simulation modeling of military problems, and effectiveness evaluations of weapons systems. Positions require a B.S. degree, familiarity with Army HIMAD requirements and/or ballistic missile defense, and a minimum of four years experience or equivalent.

### **TACTICAL AIR WEAPONS SYSTEMS**

We are a major producer of Tactical Weapons Systems for the U.S. Airforce including SPARROW and Standard ARM. Exciting new projects have created openings for individuals to perform mission operation requirements studies, weapons systems requirements analyses, systems level trade-off analyses and performance requirements studies with emphasis on Tactical Air Superiority and Air-to-Ground munitions delivery. Positions require a B.S. degree and familiarity in Tactical Air Warfare Missions.

### **NAVAL WARFARE MISSION SYSTEMS**

We are a major producer of Navy Tactical Weapons and Systems, including Standard Missile, SPARROW, and the PHALANX CIWS. Exciting new projects have created openings for individuals to perform mission operation requirements studies, weapons systems requirements analyses, systems level trade-off analyses and performance requirements studies with emphasis on Naval Anti-Air Warfare and Anti-Submarine Warfare. Positions require a B.S. degree and experience in Navy AAW or ASW.

Technology. Opportunity. Stability. We have them all. If you're looking for a way to join us, you can start by sending your resume to: **General Dynamics Pomona Division, P.O. Box 3011, MZ 4-15, Drawer H-612, Pomona, CA 91769.**

**We're looking forward  
to meeting you.**

**GENERAL DYNAMICS**  
*Pomona Division*

Equal Opportunity Employer/U.S. Citizenship Required

# "YOU CAN HELP FREE ENTERPRISE WORK WORLD- WIDE!"



David E. McKinney,  
President,  
IBM World Trade  
Americas/Far East Corp.

I'm a volunteer supporter of the International Executive Service Corps, a not-for-profit organization with a vital mission:

We build free enterprise worldwide by sending retired U.S. executives to help companies in developing countries. The executives receive expenses, but no salary.

Our main purpose is to help developing countries succeed in business. But the benefit doesn't stop there. These countries buy about 40 percent of U.S. exports.

With the support of over 800 U.S. companies, we have completed 9,000 projects in 77 countries. Our Board of Directors and Advisory Council include the CEOs of many of America's largest companies.

Join me in building free enterprise throughout the free world. Write to: David E. McKinney, President, IBM World Trade Americas/Far East Corp. at P.O. Box 10005, Stamford, CT 06904-2005.



**International Executive  
Service Corps**

It's not just doing good. It's doing good business.



## Advertising Sales Staff

**Atlanta, Ga. 30319:** Joseph Milroy  
4170 Ashford-Dunwoody Road N.E.  
[404] 252-0626

**Boston, Mass. 02116:**  
M. E. "Casey" McKibben, Jr.  
575 Boylston St.  
[617] 262-1160

633-0155 Mobil Phone  
**Chicago, Ill. 60611:** William J. Walker  
[312] 751-3738

645 North Michigan Avenue  
**Cleveland, Ohio 44113:**  
[216] 496-3800

**Costa Mesa, Calif. 92626:** Fran Cowen  
3001 Red Hill Ave. Bldg. # 1 Suite 222  
[714] 557-6292

**Dallas, Texas 75240:** Harry B. Doyle, Jr.  
5151 Belt Line Road, Suite 907  
[214] 458-2400

**Englewood, Co. 80112:** Harry B. Doyle, Jr.  
7400 South Alton Court Suite 111  
[303] 740-4633

**Houston, Texas 77040:** Harry B. Doyle, Jr.  
7600 West Tidwell, Suite 500  
[713] 462-0757

**Los Angeles, Calif. 90010:** Chuck Crowe  
3333 Wilshire Blvd.  
[213] 480-5210

**New York, N.Y. 10020**  
Matthew T. Reseska [212] 512-3617  
John Gallie [212] 512-4420  
1221 Avenue of the Americas

**Stamford, Ct. 06902**  
Albert J. Liedel  
777 Long Ridge Road. Bldg. A  
[203] 958-7115

**San Mateo, Ca 94404:**  
Larry Goldstein, Jeffrey C. Hoopes, William H. Sleight  
3rd Floor  
951 Mariner's Island Blvd.  
[415] 349-4100

**Philadelphia, Pa. 19102:** Joseph Milroy  
Three Parkway, [215] 496-3800

**Pittsburgh, Pa. 15222:** Joseph Milroy  
Suite 215, 6 Gateway Center, [215] 496-3800

**Southfield, Michigan 48075:**  
4000 Town Center, Suite 770, Tower 2  
[313] 352-9760

**San Francisco, Calif. 94111:**  
Larry Goldstein, Jeffrey C. Hoopes, William H. Sleight  
425 Battery Street  
[415] 362-4600

**Frankfurt/Main:** Fritz Krusebecker, Dieter Rothenbach  
19 Liebigstrasse, Germany  
Tel: 72-01-81

**Milan:** Manuela Capuano  
1 via Baracchini, Italy  
Tel: 86-90-656

**Paris:** Jean - Christian Acis, Alain Faure  
128 Faubourg Saint Honore, 75008 Paris, France  
Tel: [1] 42-89-0381

**Scandinavia:** Andrew Karnig  
Finnbodavagen  
S-131 31 Nacka  
Sweden  
Tel. 46-8-440005  
Telex: 17951 AKA S  
**Tokyo:** Hirokazu Morita  
McGraw-Hill Publications Overseas Corporation,  
Kasumigaseki Building 2-5, 3-chome,  
Kasumigaseki, Chiyoda-Ku, Tokyo, Japan  
[581] 9811

**United Kingdom:** Art Scheffer  
34 Dover Street, London W1  
Tel: 01-493-1451

## Business Department

**Thomas E. Vachon**  
Director of Operations  
[212] 512-2627

**Leon Irgang**  
Circulation Director  
[609] 426-5542

**Roseann Lehmann**  
Office Administrator  
[212] 512-3469

Customer Service  
[212] 512-6643

**Frances M. Vallone**  
Mgr./Marketing Adm.  
[212] 512-6058

**Patricia Parks**  
Billing Specialist  
[212] 512-2589

**Thomas M. Egan**  
Production Director  
[212] 512-3140

**Carol Gallagher**  
Production Manager  
[212] 512-2045

**Evelyn Dillon**  
Production Manager Related Products  
[212] 512-2044

## Classified Advertising

[212] 512-2556

## Recruitment Advertising

**Susan Barnes-Ronga**  
[212] 512-2787  
[212] 512-2788



# Advertisers Index

ACS Imports	28	Imagraph Corporation	90	Phillips CPMS	22, 23
Advanced Micro Devices	6, 7	‡ IMC Magnetics Corp.	93	* Philips T&M	13
‡ Aeroflex Laboratories	47	Inmos Corporation	10, 11	‡ Potter & Brumfield Inc.	45
AMP Incorporated	55	Interphase Corporation	50	* Precimation AG	1E
‡ Anarod Corporation	44	International Robamation Intelligence	68	Programmed Test Sources	43
* ASIC	6E, 7E	* Italtel	93	Rantec	3rd C
* Bavarian State	37E	* Krupp Widia	17E	* Rohde & Schwarz	30E, 31E
* Bayer AG	26E, 27E	‡ Leader Instruments	13	Schweber Electronics	2nd C
Burr Brown Corporation	34, 35	LeCroy Corporation	9	‡ Seiko Instrument	17
Colby Instruments Inc.	49	‡ Livingston Development Corporation	75	SGS	84A, B
‡ Computer Dynamics	44	MACSYMA	61	* Siemens AG	2E, 3E, 14E, 15E
Computer Vision	85	Matrox Electronic Systems Ltd.	4th C	Silicon Systems Incorporated	18
* Consumer Microcircuits	21	* Mietec	45	* Sonnenshein	10E
* Cypress Semiconductor	40, 41	Mitel Corporation	2	* Techmasexport	8E
Data Translation	24	* Mitsubishi	19E	* Toshiba America Inc.	40, 41
‡ Digital Equipment Corporation	21	* Molex	1	‡ Toshiba Semiconductor	23E
* Dr. Johannes Heidenhain GmbH	38E, 39E	Motorola Corporate	26, 27	* Vacuumschelze	33E
* Electro Test Instruments	75	* Munich Fair	40E	Varta	96
Fairchild Semiconductor	86, 87	* Murata Mfg. Co.	76	Venus Scientific	8
* Ferranti	17	‡ National Microelectronics (UMC Corporation)	46, 47	* Wandel & Goltermann	33
* Force	13E	* NEC Electronics (Europe GMBH)	20E, 21E	Wickman Werke	49
* F.W. Bell	97	‡ NET Express	76		
Glassman High Voltage	42	‡ OKI Semiconductor	97		
Gould Computer	67	* Papst	25E		
* Guenther	29E	Pearson Electronics Inc.	12		
Harris Semiconductor	37, 39	* PEP GmbH	34E, 35E		
‡ Hitachi Chemical Co.	33	Performance Semiconductor Corporation	14, 15		
‡ Hitachi Denshi	1	Philips	62		
		* Philips Elcoma	4E, 5E		

## Classified and employment advertising

American Inventors Corporation	88
Norman Levy Associates Inc.	88
Orcad Systems Corp.	89
Omaton Inc.	89
T-Cubed Systems	89
ZTEC	89
Career Opportunity	
General Dynamics Pomona	101
Illinois Job Service	100

■ For more information of complete product line see advertisement in the latest Electronics Buyers Guide  
 \* Advertisers in Electronics International  
 ‡ Advertisers in Electronics domestic edition

# ELECTRONICS WEEK

## IBM PULLS OUT OF SOUTH AFRICA

IBM Corp. said last week it would sell its South African subsidiary to a holding company set up for the employees of IBM South Africa Ltd. The deal, which followed a similar announcement by General Motors Corp., will allow the new company to represent other vendors. The sale should go through by March. Other U.S. firms are expected to follow IBM and GM's lead.

## SIEMENS PRODUCES FIRST 1-MB DRAMS

Siemens AG's new chip factory in Regensburg, West Germany, has turned out its first 1-Mb dynamic random-access memories. Samples of the CMOS chips, which use 1.2- $\mu$ m geometries, will be available in early 1987; volume production will start later next year. Meanwhile, at the Siemens Central Research Laboratories in Munich, parts from a next-generation 4-Mb DRAM, which will use 0.8- $\mu$ m design rules, have already been tested successfully.

## SIEMENS, BASF JOIN IN MAINFRAME DEAL

A new alliance looming in West Germany could spell trouble for IBM Corp. Siemens and BASF AG are setting up a joint venture to market IBM-compatible mainframe computers built in Japan. The new company will pool Siemens's sales of the Fujitsu 7800 computer line and BASF's sales of Hitachi's Series 7/XX mainframes.

## BRAZIL OPENS DOOR A CRACK

Foreign firms that want a piece of Brazil's growing computer services market—worth \$1 billion this year and growing 20% annually—can take a leaf from IBM Corp.'s book. The computer giant

has become a 30% partner in a new teleprocessing service, Gerdau Servicos de Informatica (GSI) SA, with the Gerdau Group, the country's largest native steel producer. But tough protectionist laws still block foreign investment in hardware manufacture and sale.

## RCA ASTRO SIGNS \$200 MILLION DEAL

RCA Astro-Electronics Division has signed a \$200 million contract to design and build two 16-channel, high-power, direct-broadcast satellites for Advanced Communications Corp., a new company setting up headquarters in Washington. The satellites, which will be delivered by early 1990, will be powered by 125-w travelling-wave tube amplifiers and will transmit a variety of programming.

## UNISON APPEALING COPYRIGHT RULING

A landmark decision that could establish copyright protection for the displays created by software programs as well as the code used to generate them is being appealed. The decision found that Unison World, Berkeley, Calif., had infringed on the copyright of a graphics program from Broderbund Software Inc. because of a similarity in screen appearance, not in computer code. Unison World plans to appeal the decision of a U.S. District Court in San Francisco. Unison says its program was independently designed and is written in a different language from the Broderbund package.

## NATIONAL FIGHTS COURT BATTLE

National Semiconductor Corp. has filed in California Superior Court to block United Microelectronics Corp., a Taiwanese company, from selling in the U.S. a part that the San Jose, Calif., company claims is based on

its design. United Micro wants to market a universal receiver/transmitter here, but National claims the circuit is based on documentation it supplied as part of an earlier foundry agreement.

## COMSAT LENGTHENS SATELLITE LIFE

Comsat Corp., the U.S. arm of Intelsat, says a slight change in satellite operation can make geosynchronous satellites about 10 times more fuel-efficient—significantly lengthening their seven-year life-spans. By shifting the angle at which the satellite orbits relative to Earth, Washington-based Comsat says, the north-south drift (correction of which accounts for as much as 90% of a satellite's total fuel consumption) is reduced—without affecting the way the satellite appears to earth stations.

## TURNER QUILTS AT FLOATING POINT

Lloyd D. Turner has stepped down as president of Floating Point Systems Inc. His replacement is George P. O'Leary, who left the Beaverton, Ore., company in 1983, after 11 years as vice president, for an independent venture. Floating Point lost nearly \$4 million on sharply reduced sales in the third quarter of 1986 and expects an even worse fourth quarter.

## DEC IS DOING WELL IN GERMANY, TOO

Munich-based Digital Equipment GmbH topped \$500 million in sales in fiscal 1986, which ended June 30. The West German subsidiary of Digital Equipment Corp., Maynard, Mass., scored a 20% sales gain for the year—more than double that of Europe's data-processing industry as a whole and one-third better than its parent's fiscal 1986 growth rate of 14%.

## NEC IS BOOSTING V SERIES OUTPUT

NEC Corp. is increasing production of its V Series microprocessors from 250,000 to 300,000 per month by the end of the year, industry sources say. NEC claims that close to 100 companies are working on applications for the parts and that 30 firms have expressed interest in the 32-bit V60, samples of which are being shipped this month. NEC reportedly has a 1990 target date for producing a microprocessor based on 1- $\mu$ m design rules capable of performing 10 million operations/s.

## CARROLL TOUCH BUYS TOUCH TECH

Carroll Touch Inc., a leading maker of infrared touch-screen systems [*Electronics*, May 5, 1986, p. 42], has acquired Touch Technology Inc., an Annapolis, Md., maker of resistive overlay-touch input systems. Carroll Touch, a Round Rock, Texas, subsidiary of Amp Inc., claims the combined company now controls 40% of the nearly \$32 million touch-screen market.

## LOTUS LINKS 1-2-3 TO INSTRUMENT BUS

Lotus Development Corp. is trying to crack the market for scientific data-acquisition software with Measure, a new package that plugs instrument data directly into the Lotus' 1-2-3 spreadsheet program. At the same time, it introduced Manuscript, a word-processing program designed for technical professionals that also handles 1-2-3 inputs. Measure, which is the Cambridge, Mass., company's first product for engineers and scientists, can handle up to 15 devices simultaneously on the IEEE-488 bus. It runs on the IBM Corp. line of Personal Computers, Hewlett-Packard's Vectra, and Compaq's Portable. Both programs cost \$495.

If the card below has already been used, you may obtain the needed information by writing directly to the manufacturer, or by sending your name and address,

plus the Reader Service card number and issue date, to Electronics Reader Service Department, P.O. Box 2713, Clinton, Iowa 52735.

## Electronics

October 30, 1986 This Reader Service Card expires January 30, 1987

Name \_\_\_\_\_ Title \_\_\_\_\_

Phone \_\_\_\_\_ Company \_\_\_\_\_

Street address (company | | or home | | check one) \_\_\_\_\_

City \_\_\_\_\_ State \_\_\_\_\_ Zip \_\_\_\_\_

Signature \_\_\_\_\_ Date \_\_\_\_\_

Was this magazine personally addressed to you?  Yes  No 5 Source of Inquiry Domestic

### Industry classification (check one)

- |  |  |   |
|--|--|---|
| <input type="checkbox"/> A. Computers, Computer Systems and Equipment            | <input type="checkbox"/> F. Test and Measurement Equipment | <input type="checkbox"/> J. Research & Development                  |
| <input type="checkbox"/> B. Communications, Communications Systems and Equipment | <input type="checkbox"/> G. Consumer Products              | <input type="checkbox"/> K. Educational 2-4 Year College University |
| <input type="checkbox"/> C. Military, Space Systems and Equipment                | <input type="checkbox"/> H. Medical Systems and Equipment  | <input type="checkbox"/> L. Other _____                             |
| <input type="checkbox"/> D. Industrial Systems, Controls and Equipment           | <input type="checkbox"/> I. Software                       | Please specify _____  |
| <input type="checkbox"/> E. Electronics Subassemblies, Components and Materials  |  |   |

### Your principal job responsibility (check one)

- |   |  |  |
|---|--|--|
| <input type="checkbox"/> A. Corporate, Operating and General Management | <input type="checkbox"/> C. Engineering Services | <input type="checkbox"/> E. Manufacturing & Production |
| <input type="checkbox"/> B. Design & Development Engineering            | <input type="checkbox"/> D. Basic Research       | <input type="checkbox"/> F. Other _____                |

Estimate number of employees (at this location): 1.  under 20 2.  20-99 3.  100-999 4.  over 1000

1	16	31	46	61	76	91	106	121	136	151	166	181	196	211	226	241	256	271	348	363	378	393	408	423	438	453	468	483	498	703	718
2	17	32	47	62	77	92	107	122	137	152	167	182	197	212	227	242	257	272	349	364	379	394	409	424	439	454	469	484	499	704	719
3	18	33	48	63	78	93	108	123	138	153	168	183	198	213	228	243	258	273	350	365	380	395	410	425	440	455	470	485	500	705	720
4	19	34	49	64	79	94	109	124	139	154	169	184	199	214	229	244	259	274	351	366	381	396	411	426	441	456	471	486	501	706	900
5	20	35	50	65	80	95	110	125	140	155	170	185	200	215	230	245	260	275	352	367	382	397	412	427	442	457	472	487	502	707	901
6	21	36	51	66	81	96	111	126	141	156	171	186	201	216	231	246	261	338	353	368	383	398	413	428	443	458	473	488	503	708	902
7	22	37	52	67	82	97	112	127	142	157	172	187	202	217	232	247	262	339	354	369	384	399	414	429	444	459	474	489	504	709	951
8	23	38	53	68	83	98	113	128	143	158	173	188	203	218	233	248	263	340	355	370	385	400	415	430	445	460	475	490	505	710	952
9	24	39	54	69	84	99	114	129	144	159	174	189	204	219	234	249	264	341	356	371	386	401	416	431	446	461	476	491	506	711	953
10	25	40	55	70	85	100	115	130	145	160	175	190	205	220	235	250	265	342	357	372	387	402	417	432	447	462	477	492	507	712	954
11	26	41	56	71	86	101	116	131	146	161	176	191	206	221	236	251	266	343	358	373	388	403	418	433	448	463	478	493	508	713	956
12	27	42	57	72	87	102	117	132	147	162	177	192	207	222	237	252	267	344	359	374	389	404	419	434	449	464	479	494	509	714	957
13	28	43	58	73	88	103	118	133	148	163	178	193	208	223	238	253	268	345	360	375	390	405	420	435	450	465	480	495	510	715	958
14	29	44	59	74	89	104	119	134	149	164	179	194	209	224	239	254	269	346	361	376	391	406	421	436	451	466	481	496	701	716	959
15	30	45	60	75	90	105	120	135	150	165	180	195	210	225	240	255	270	347	362	377	392	407	422	437	452	467	482	497	702	717	960

## YES, please enter my subscription to Electronics for the term checked below: Subscription Card

Name \_\_\_\_\_  
 Title \_\_\_\_\_  
 Company \_\_\_\_\_  
 Div. or Dept. \_\_\_\_\_  
 Co. address \_\_\_\_\_  
 City \_\_\_\_\_ State \_\_\_\_\_ Zip \_\_\_\_\_  
 Check here if you wish publication to be sent to home address:  
 Street \_\_\_\_\_  
 City \_\_\_\_\_ State \_\_\_\_\_ Zip \_\_\_\_\_  
 Signature \_\_\_\_\_

Those not qualifying may pay higher than basic price.

	US	CANADA	MEXICO
<input type="checkbox"/> One Year:	\$32	\$ 51 CDN	17,850 Pesos
<input type="checkbox"/> Two Years:	\$55	\$ 86 CDN	29,925 Pesos
<input type="checkbox"/> Three Years:	\$76	\$117 CDN	40,950 Pesos

Payment enclosed  Bill me  
 Charge my subscription to:  AMEX  DC  VISA  
 MC-Bank# \_\_\_\_\_  
 Acct# \_\_\_\_\_ Exp. \_\_\_\_\_  
 Signature \_\_\_\_\_

Subscriptions are normally entered within 2 weeks, but please allow 4 weeks for shipment.

Please check which best describes your company's business at your location:  
 Manufacturing  Distribution  Retailing  Other

Indicate the primary product manufactured or services performed at your plant (place applicable letter in box)

- A. Computers, data processing and peripheral equipment; office and business machines
- B. Communications, data communications, telecommunications systems and equipment
- C. Navigation and guidance, aircraft and missile systems or equipment (oceanography)
- D. Test and measurement equipment
- E. Consumer products (TV, radio, hi-fi, recorders, home computers, appliances)
- F. Medical, industrial controls, systems or equipment
- G. Semiconductor production equipment (component insertion, coil winding, etc.)
- H. Electronic sub-assemblies, components and materials (passive, active components, IC's, discretes, hybrids, power supplies)
- I. Other manufacturers using electronics equipment as part of their product (machine tools, chemicals, metals, plastics, pharmaceuticals, etc.)
- J. Government and military
- K. Independent research and development laboratory or consultant
- L. Research and development organizations which are part of an educational institution
- M. Independent software developers
- N. Operators of communications equipment (utilities, railroads, police and airlines, broadcasting, etc.)
- O. Educational, 2-4 year college, university
- P. Other \_\_\_\_\_

Indicate your principal job function, occupation and/or title (place applicable letter in box; if letters O, P, or Q are used, fill in name of college or university)

- A. Corporate Management (Owners, Partners, Presidents, V.P.'s, etc.)
- B. Operating Management (General Managers, Group Managers, Division Heads, etc.)
- C. Engineering Management (Project Manager, Chief Engineer, Section Heads, V.P. Engineering)
- D. V.P. Research and Development, V.P. Quality Control, etc.)
- E. Software Engineering
- F. Systems Engineering/Integration
- G. Quality Control Engineering (Reliability and Standards)
- H. Design Engineering
- I. Engineering Support (Lab Assistants, etc.)
- J. Test Engineering (Materials, Test Evaluation)
- K. Field Service Engineering
- L. Research and Development (Scientists, Chemists, Physicists)
- M. Manufacturing and Production
- N. Purchasing and Procurement
- O. Marketing and Sales
- P. Professor/Instructor at \_\_\_\_\_
- Q. Senior Student at \_\_\_\_\_
- R. Graduate Student at \_\_\_\_\_

Indicate your principal job responsibility (place the appropriate number in box)  
 1. Management 2. Engineering Management 3. Engineering

Estimated number of employees at this location (check one)  
 1 to 49 \_\_\_\_\_ 50 to 249 \_\_\_\_\_ 250 to 999 \_\_\_\_\_ over 1,000 \_\_\_\_\_

Date \_\_\_\_\_ Signature \_\_\_\_\_

All information is required for reentry of subscription

55J3

**For additional information on products advertised, new products or new literature, use these business reply cards.**

Complete entire card.

Please print or type.

Circle the number on the Reader Service postcard that corresponds to the number at the bottom of the advertisement, new product item, or new literature in which you are interested.

To aid the manufacturer in filling your request, please answer the three questions.

All inquiries from outside the U.S. that cannot reach Electronics before the expiration date noted on the Reader Service postcard must be mailed directly to the manufacturer. The manufacturer assumes all responsibilities for responding to inquiries.

### Subscriptions & Renewals

Fill in the subscription card adjoining this card. Electronics will bill you at the address indicated on the card.

AFFIX  
POSTAGE  
STAMP  
HERE

## Electronics

P.O. BOX NO. 2713  
CLINTON, IOWA 52735

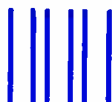

NO POSTAGE  
NECESSARY  
IF MAILED  
IN THE  
UNITED STATES



### BUSINESS REPLY MAIL

FIRST CLASS

PERMIT NO. 55

MARTINSVILLE, NJ

Postage will be paid by Addressee

## Electronics

CN 807  
MARTINSVILLE, NJ 08836



# MORE BANG. LESS BUCK.

Why weapons systems designers are using Rantec standard military power supplies.

Rantec's standard military power supplies save weapons systems programs money. No costly non-recurring engineering expenses. No costly retooling. And, with over 600 different models to choose from, no costly design compromises on your part.

Also, no costly time delays waiting for product to develop or for manufacture. Which is very important when you consider it takes from 13 to 18 months and between \$125,000 and \$300,000 to get a custom military power supply.\*

Giving up reliability by going standard? No way. First of all, our quality program complies with MIL-I-

45208 and meets the intent of MIL-Q-9858. Secondly, all of our power supplies meet or exceed MIL-E-5400, MIL-E-16400, MIL-STD-704, MIL-STD-1399, MIL-I-6181, and MIL-STD-461.

This extensive product line includes single and three phase AC input power supplies and DC-DC converters in single and multiple output power ratings to 1KW.

To find out how you can save money like your contemporaries by using Rantec standard power supplies which are qualified for airborne, shipboard, ground-fixed and ground-mobile use, contact us today.



Division of Emerson Electric Co.

9401 Oso Avenue, Chatsworth, CA 91311 • Tel: (213) 885-8223 TWX: 910-493-1247

\*U.S. Navy/Industry Power Supply Ad Hoc Committee Estimates for Time and Cost.

Circle 901 on reader service card



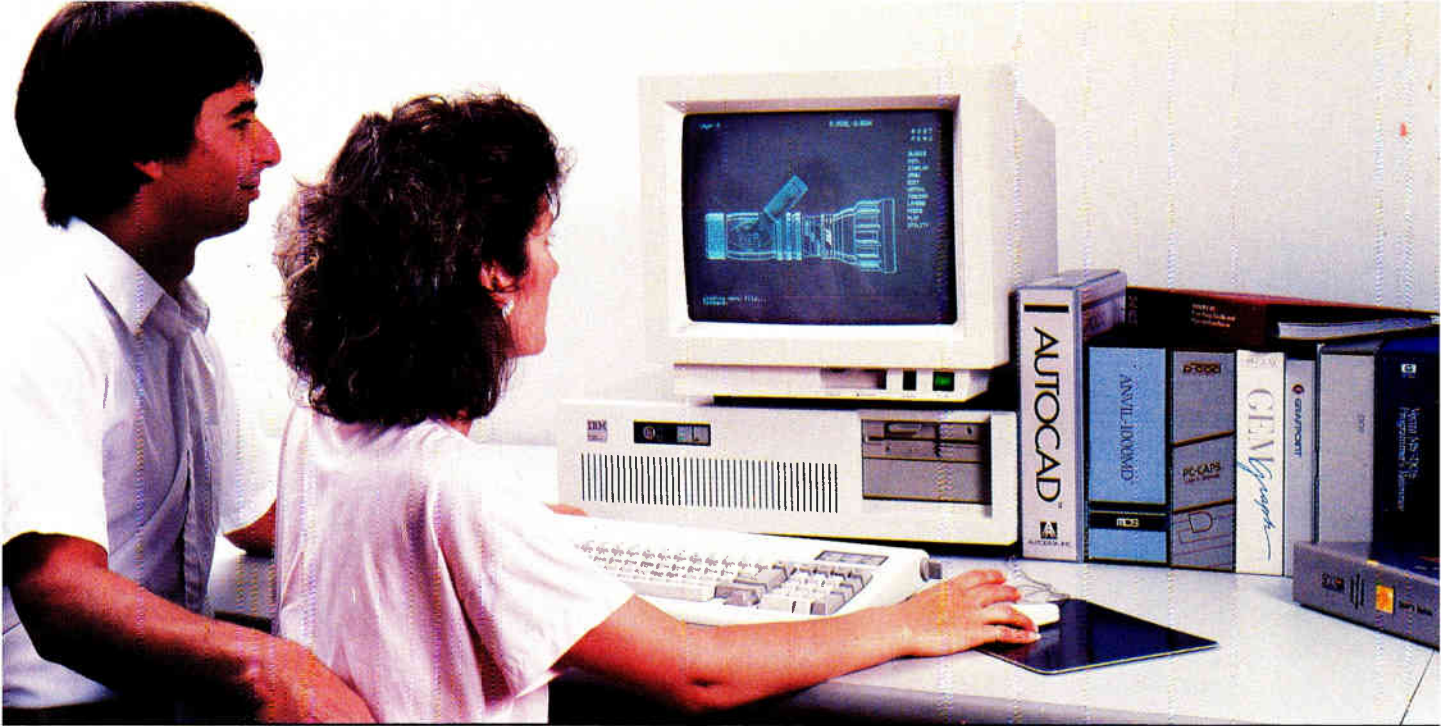

# PROFESSIONAL 1280 x 1024

**Only the Matrox PG-1280 graphics card satisfies the workstation display needs of technical professionals.**

## Plug

Select any PC AT compatible machine. The PG-1280 plugs directly into IBM's PC AT and RT PC, the Hewlett Packard Vectra, Olivetti M28, Tandy 3000, PC's Limited AT and more. The board requires two full size slots and a modest 32 watts of power.

## Play

Run virtually any PC-based software package or utility imaginable. The PG-1280 is 100% compatible with both VDI and IBM's CGA and PGA standards. We support most popular applications packages including the following:

Autocad (Autodesk Inc)  
Anvil 1000MD (MCS)

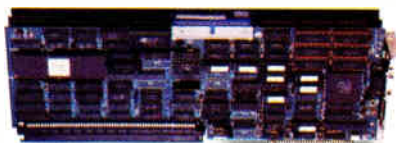

p-cad (Personal Cad Systems Inc)  
VERSACAD (T & W Systems Inc)  
Personal Designer Software (Computervision Inc)  
TGRAF-07 (Grafpoint)  
GKS (Prior Data Sciences)  
HALO (Media Cybernetics Inc)  
dBASE III Plus (Ashton Tate)  
Lotus 1-2-3 (Lotus Development Corp)

## Precision

See the details you have been missing. Our 1280 x 1024 bit mapped display eliminates jagged lines and fuzzy characters. The PG-1280 ensures a clear detailed display of complex drawings and schematics. The 60HZ non-

interlaced refresh rate provides a crisp flicker-free display that is easy on your eyes.

## Palette

Choose the colors you want. The high-res 2 Megabyte frame buffer comprises 8 memory planes, yielding 256 colors from a palette of 16.7 million shades. A separate low-res buffer with its own color palette provides CGA emulation. Both buffers are displayed on a single high resolution RGB color monitor.

## Performance

Get the job done quickly. Fast response is guaranteed by a powerful new 32-bit graphics engine. Eight custom gate arrays deliver raster op (BitBit) performance in excess of 13 million pixels per second. And, a VLSI drawing processor blasts images onto the screen at a rate of 20,000 vectors per second.

Now, if you want more information, talk with your local dealer or call us toll-free. Ask for department 16.

IBM, PC AT, RT PC, CGA, PGA are trademarks of International Business Machines.

Circle 902 on reader service card



# matrox

1055 St. Régis,  
Dorval, Quebec, Canada H9P 2T4  
Tel.: (514) 685-2630 Tel.: 05-82279  
Toll-free no.: 1-800-361-4903