

AUGUST 3, 1978

AT&T BID FOR SWITCHED DIGITAL SERVICE JARS INDUSTRY/79

What designers should know about thin-film resistor networks/99

High-level languages aid microcomputer programming/115

FOUR DOLLARS A MCGRAW-HILL PUBLICATION

Electronics®

**Part 1
EVALUATING
BIT-SLICE
PROCESSORS**



Now, Pushbutton Pots...



Simply set and reset— right on the button!

Just push the PLUS or MINUS buttons for the precise setting you want. It's that simple. The newly designed Model 3680 Series of Digital Pushbutton Potentiometers let you set and reset with absolute accuracy.

Fast data entry and information readout on large easy-to-read digital displays.

A modular potentiometer "system," the Model 3680 Series consists of from one to five decades. Resolution is related to the number of decades used. Laser tailored, built-in cermet elements provide a wide choice of standard resistance values from 10 ohms to 1 Megohm.

Model Number	Number of Decades	Resolution	Standard Resistances (Ohms)
3681	1	10%	10 · 100K
3682	2	1%	100 · 1Meg
3683	3	.1%	1K · 1Meg
3684	4	.01%	10K · 1Meg
3685	5	.001%	100K · 1Meg

Installation is a snap. Convenient snap-in mounting reduces installation time and eliminates the need for mounting hardware. An integral bezel covers irregular panel cutouts and minor panel edge blemishes. Rear dual-purpose terminals can be soldered or connected to standard interconnections.

All flame retardant material is used for fabrication. Glass-filled thermoplastic is UL listed 94V-0 (pushbutton material is UL listed 94V-1). Specifications include 100 PPM/°C tempco, 2 watts power rating, and -25°C to +85°C operating temperature range. Typical cost is \$11.28* in 1,000 quantities (three decade Model 3683) — comparable to the cost of separate precision potentiometers and dials.

Simple, fast and accurate Pushbutton Pots from Bourns. A concept that's right on the button with your design needs. Send today for Model 3680 catalog.

TRIMPOT PRODUCTS DIVISION, BOURNS, INC., 1200 Columbia Avenue, Riverside, CA 92507. Phone: 714 781-5122. TWX: 910 332-1252.

*Domestic U.S.A. price only.



BOURNS®

For Immediate Application—Circle 120 or for Future Application—Circle 220

World Radio History

Behind all these pretty faces...

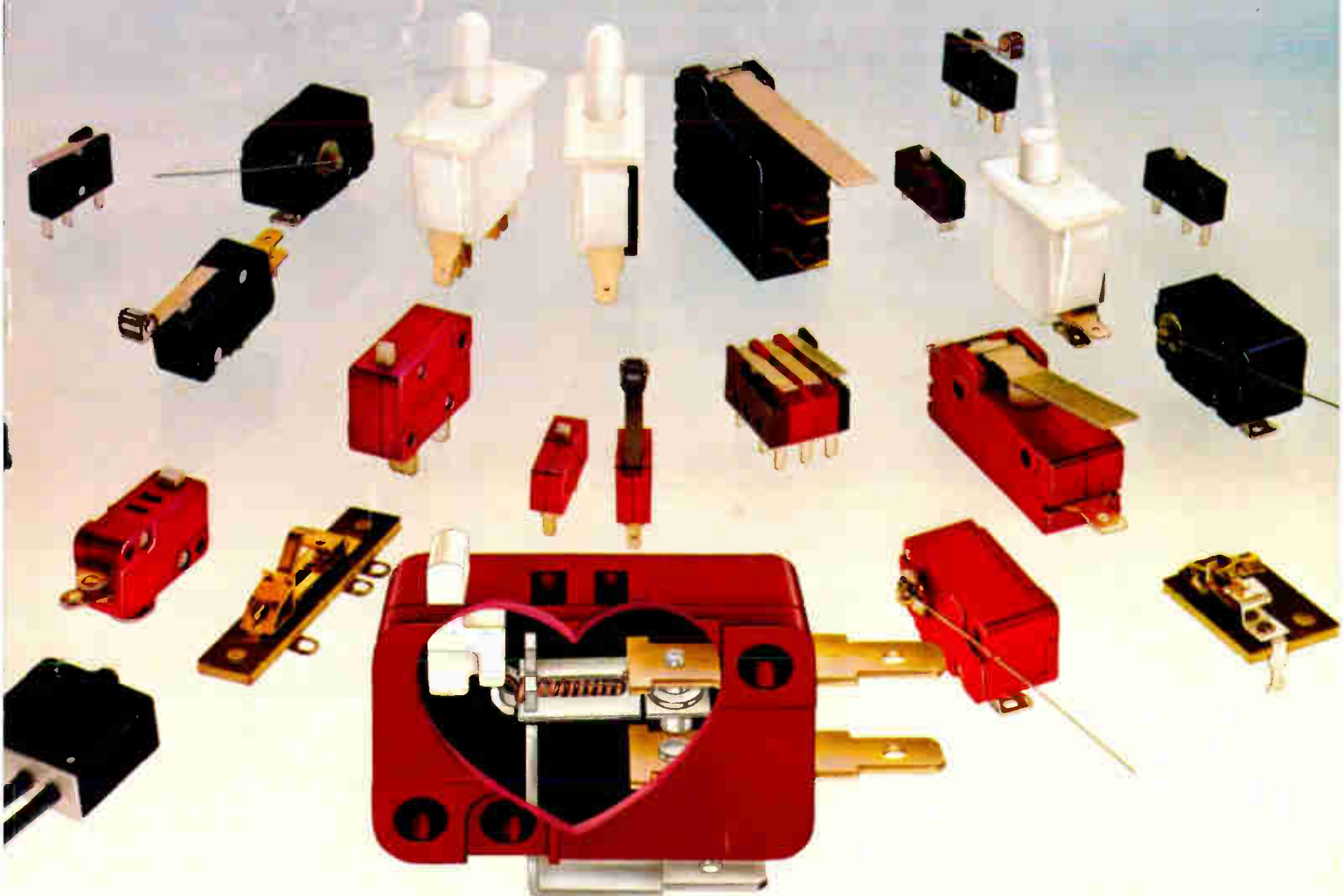

beats a heart of coiled stainless steel.

No Cherry snap-action switch has ever died of a broken heart. Because there's a coil spring at the heart of every Cherry switch that expands and contracts again and again and never gets tired. Or breaks. Compare *that* to the stamped spring many switch builders use. The kind of spring that gets tired . . . and breaks. (Snap. Drat!)

This stainless steel coil spring mechanism not only insures long life, it provides large overtravel to make our switches quicker, easier to design-in and to install. Which is why more than 300 million of them have been designed-

in and installed. So far.

Cherry snap-action switches are available in gold crosspoint design for low energy switching. In general purpose, miniature and subminiature designs. In low torque. Light force. Open or enclosed. Panel mount pushbutton. And more.

For free catalog of all the Cherry switches, just circle the reader service number below. If you're in a hurry, our direct line number is 312/689-7700 . . . and we'll throw in a switch sample of your choice.



CHERRY ELECTRICAL PRODUCTS CORP.
3608 Sunset Avenue, Waukegan, Illinois 60085

SWITCHES and KEYBOARDS — Available locally from authorized distributors.

Electronics / August 3, 1978

Circle 1 on reader service card 1

The MAXIcatalog of MICROelectronics.

Microprocessor

Microcomputer

Memory

Telecom

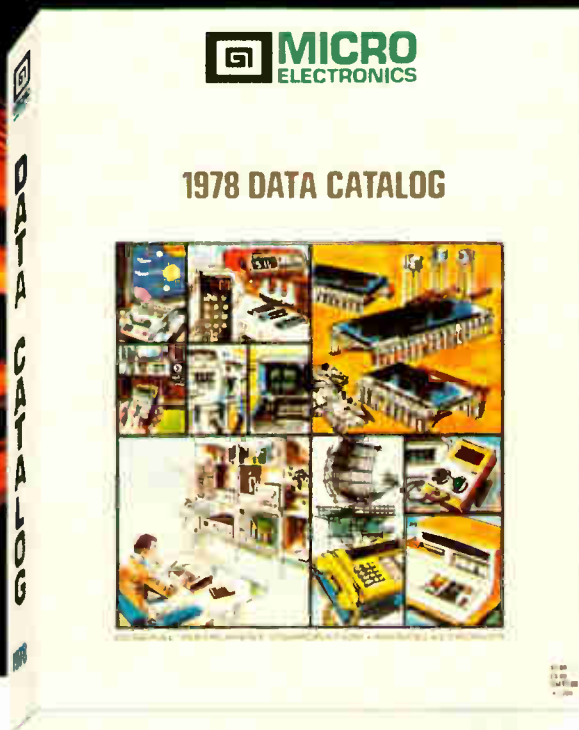

Entertainment

TV Games

Consumer

Industrial/Mosfet

Bigger, better than ever and jam-packed with helpful information, the GI Microelectronics 1978 Data Catalog features the widest range of standard microcircuits in the industry. The new catalog presents more than 800 pages of detailed design and technical data including circuit characteristics and applications examples.

You'll find complete specs on our "star" performers—more than 350 off-the-shelf products in nine families—applicable to the data, telecommunications and consumer markets. Product categories covered include microprocessors, microcomputers, memories, telecommunications circuits and industrial/MOSFET products as well as home

entertainment, TV games and other consumer microcircuits.

For your convenience you can order a copy direct from GI. Send your order with a \$5.00 prepayment enclosed to General Instrument Microelectronics, Dept. C4, 600 West John Street, Hicksville, New York 11802.

Or get a preview, FREE.

A brief description of our complete microelectronics product line is available by writing to the above address, or by calling 516-733-3107, for a FREE copy of our 24-page 1978 Product Guide.

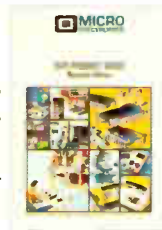

We help you compete.

**GENERAL INSTRUMENT CORPORATION
MICROELECTRONICS**



41 Electronics Review

MICROWAVES: Most of rf receiver fits on single LSI chip, 41
COMPANIES: United Kingdom venture launched amid doubts in U. S., 42
DISPLAYS: Flat LCD panel has big potential if . . . , 43
CONSUMER: Electronic watch has LCD hands, 44
COMMUNICATIONS: Laser, Trapatt yield high speed, power, 46
MICROPROCESSORS: C-MOS debuts in TI's 4-bit controller, 46
National Semiconductor aims at low-end units, 48
COMMUNICATIONS: Deregulation seen as easy by Justice, 50
NEWS BRIEFS: 52

69 Electronics International

JAPAN: X-ray lithography unit licks alignment problem, 69
WEST GERMANY: Digitized TV picture looks good after satellite trip, 70
SWITZERLAND: Voltage-measuring unit tests workpiece hardness, 70
JAPAN: Checkerboard pattern boosts JFET gain up to 11 times, 72
GREAT BRITAIN: CAD service zips through design work, 74

79 Probing the News

DATA COMMUNICATIONS: Industry takes wary view of AT&T plan, 79
COMPANIES: At Nedco, simplicity pays off, 82
ABROAD: Italian government plans aid for R&D, 84
COMPANIES: Western Digital gets off the mat, 86

91 Technical Articles

MICROPROCESSORS: How bit-slice families compare:
Part 1, evaluating processor elements, 91
COMPONENTS: Why designers favor thin-film resistor networks, 99
DESIGNER'S CASEBOOK: Photodiode, op amps monitor radiation, 106
Vehicle-intruder alarm has automatic set/reset switching, 107
INSTRUMENTS: Expansion storage CRT writes fast, 110
SOFTWARE: High-level languages ease programming, 115
ENGINEER'S NOTEBOOK: Boosting roll-off extends filters' range, 120
Extending the range of an intermodulation distortion test, 121

125 New Products

IN THE SPOTLIGHT: D-a subsystem runs at 100 MHz, 125
PACKAGING & PRODUCTION: System tests boards completely, 126
MICROCOMPUTERS & SYSTEMS: Unit controls communications, 128
INSTRUMENTS: Battery-powered meter measures up to 1 farad, 132
COMPONENTS: Touch-activated switches behave better, 134
DATA ACQUISITION: D-a converter needs little power, 136
SEMICONDUCTORS: Fast rectifiers protect V-FETs, 138

Departments

Publisher's letter, 4
Readers' comments, 6
News update, 8
Editorial, 12
People, 14
Meetings, 30
Electronics newsletter, 35
Washington newsletter, 59
Washington commentary, 60
International newsletter, 65
Engineer's newsletter, 124
Products newsletter, 151

Services

Reprints available, 123
Employment opportunities, 152
Reader service card, 161

Highlights

Cover: Evaluating bit-slice processor elements, 91

The world of bit-slice microprogrammable processor sets is a complex one, so this comparison of the processor chips aims at easing designers' choices. A second article, in the next issue, will deal with the other half of the sets: the microcontroller that sequences the instructions.

Cover is by Art Director Fred Sklenar.

Government to aid Italian electronics R&D, 84

The data-processing, components, and telecommunications industries in Italy will benefit from the government's financial-aid plan, now working its way through the multilevel approval process. Though the subsidies and low-cost loans, mostly to finance research and development, total \$605 million, sources in these three electronics sectors see the effort as merely adequate.

All about monolithic thin-film resistor nets, 99

Adapting wafer batch processing from semiconductor manufacture has produced microminiature integrated resistor networks that offer precise performance, convenience, and low cost. A look at the manufacturing techniques gives an idea of the design considerations in using them.

Expansion storage CRT speeds oscilloscope, 110

Adding a magnifying image-projection lens to a variable-persistence storage cathode-ray tube gives an oscilloscope a 1,800-cm/ μ s writing speed and a 100-MHz bandwidth. The lens expands the display image about 10 times over the image written on the storage surface, thereby increasing the write speed a like amount.

In the next issue . . .

A distributed microprocessor-development system . . . all about plasma etching . . . a programmable communications controller with on-board random-access memory.

EDITOR-IN-CHIEF: Kemp Anderson

EXECUTIVE EDITOR: Samuel Weber

MANAGING EDITORS: Arthur Erikson,
Gerald M. Walker

SENIOR EDITORS: William F. Arnold,
Ray Connolly, Lawrence Curran

ART DIRECTOR: Fred Sklenar

ASSOCIATE EDITORS: Howard Wolff,
Alfred Rosenblatt

DEPARTMENT EDITORS

Aerospace/Military: Ray Connolly
Circuit Design: Vincent Biancomano
Communications & Microwave:

Harvey J. Hindin

Components: Nicolas Mokhoff

Computers: Anthony Durniak

Industrial: John G. Posa

Instrumentation: Albert F. Shackil

New Products: Michael J. Riezenman,

Richard W. Comerford

Packaging & Production: Jerry Lyman

Solid State: Raymond P. Capece

CHIEF COPY EDITOR: Margaret Eastman

COPY EDITORS: Ben Mason, Mike Robinson

ART: Charles D. Ciatto, *Associate Director*
Paula Piazza, *Assistant Director*

EDITORIAL SECRETARIES: Janet Noto,
Penny Kaplan

EDITORIAL ASSISTANT: Marilyn B. Rosoff

REGIONAL EDITORS

Boston: Lawrence Curran

Pamela Hamilton (617) 262-1160

Los Angeles: Larry Waller (213) 487-1160

New York: Bruce LeBoss (212) 997-3444

San Francisco: William F. Arnold

Robert Brownstein (415) 968-2712

Washington: Ray Connolly (202) 624-7592

Frankfurt: John Gosch

London: Kevin Smith

Paris: Arthur Erikson

Tokyo: Charles Cohen

McGRAW-HILL WORLD NEWS

Editor: Michael Johnson

Brussels: James Smith

Milan: Andrew Heath

Moscow: Peter Hann

Paris: Andrew Lloyd

Stockholm: Robert Skole

Tokyo: Robert E. Lee

PUBLISHER: Dan McMillan

ADVERTISING SALES MANAGER:

Paul W. Reiss

MARKETING ADMINISTRATION MANAGER:

Wallis Clarke

CIRCULATION MANAGER: Karl Peterson

MARKETING SERVICES MANAGER:

Tomlinson Howland

RESEARCH MANAGER: Margery D. Sholes

Few engineers today have the chance to learn about the various bit-slice families from the ground up that Scott Smith and Tom Adams have enjoyed. Their two-part article, which starts in this issue (p. 91), is a result of this experience.

Actually, Smith and Adams worked with bit slices independently at first; Smith at Texas Instruments, Adams at Raytheon. They then pooled their know-how working together on a Navy contract at the Applied Research Laboratories of the University of Texas, Austin, Texas. (Both now work for IBM.)

"We had worked on several bit-slice families between us," Smith reports. "Then the Navy contract got us together, and we felt it was time to publish our findings."

Smith's first brush with bit slices at TI was in the design of peripherals for minicomputers. Meanwhile, Adams at Raytheon was working with bit slices for interfacing sonar equipment with militarized minicomputers aboard Navy submarines. His interest in bit-slice processors grew to the point where he studied each new family of parts.

Adams was at the Applied Research Laboratory when Advanced Micro Devices first announced the now-famous 2900, and he felt from the start that the device would catch on. "I even built a test box for it as a learning aid," he recalls. At the time, there was a minimum of support from manufacturers. Today, vendors are better at supporting these products, he believes.

The two worked closely together at the lab to prepare the article. But they didn't rely entirely on their personal experience. They also studied all the available parts and

consulted with co-workers who were more familiar with certain bit-slice families.

Part 1 of the article focuses on the processor elements of six bit-slice families. Part 2, which will appear in the next issue, will cover the equally important microcontroller elements, as well as special-purpose chips and development aids.

It may be years before the full impact of the AT&T proposal for Advanced Communications Service can be appreciated. As the story on page 79 points out, the shock wave concerning the telephone company's desire to operate a dial-up digital data-communications service has hit two electronics industries—data communications and computers.

The complex proposal will be the responsibility of the Federal Communications Commission, which is itself undergoing close scrutiny by the Congress as part of the communications reform bill. (Items on this legislation appear on pages 52 and 60.) To complicate matters more, Walter Hinchman, the veteran chief of the Common Carrier Bureau, a key unit in handling the AT&T petition, is leaving the FCC.

One thing is certain: ACS will provide a long-running story as it wends its way through the regulatory process. "The subject is becoming an industry in itself," reports Computer Editor Tony Durniak. "Consulting firms are already setting up seminars on ACS, and it looks as if they will be well attended."



August 3, 1978 Volume 51, Number 16 98,301 copies of this issue printed

Published every other Thursday by McGraw-Hill, Inc. Founder James H. McGraw 1860-1948. Publication office 1221 Avenue of the Americas, N.Y., N.Y. 10020, second class postage paid at New York, N.Y. and additional mailing offices.

Executive, editorial, circulation and advertising addresses: Electronics, McGraw-Hill Building, 1221 Avenue of the Americas, New York, N.Y. 10020. Telephone (212) 997-1221. Teletype 12-7950. TWX 710-581-4879. Cable address: MCGRAW HILL NEW YORK.

Subscriptions limited to professional persons with active responsibility in electronics technology. No subscriptions accepted without complete identification of subscriber name, title or job function, company or organization, and product manufactured or services performed. Based on information supplied, the publisher reserves the right to reject non-qualified requests. Subscription rates in the United States and possessions: \$15 one year, \$26 two years, \$38 three years, company addressed and company libraries \$20 one year, \$36 two years, \$50 three years, APO/FPO addressed \$35 one year only. Canada and Mexico \$17 one year, \$29 two years, \$43 three years. Europe \$42 one year, \$71 two years, \$100 three years. Japan, Israel and Brazil \$70 one year, \$115 two years, \$165 three years. Australia and New Zealand \$95 one year, \$170 two years, \$240 three years, including air freight, all other countries \$45 one year, \$80 two years, \$112 three years. Limited quota of subscriptions available at higher-than-basic rate for persons allied to held served. Check with publisher for these rates. Single copies \$4.00. Please allow four to eight weeks for shipment.

Officers of McGraw-Hill Publications Company: Gordon L. Jones, President; Paul J. McPherson, Executive Vice-President; Group Vice-President Gene W. Simpson, Senior Vice-Presidents Russell F. Anderson, James E. Boddorf, Planning & Development, David G. Jensen, Manufacturing, Ralph R. Schulz, Editorial, Vice-Presidents: Denis C. Beran, European Operations, David P. Forsyth, Research, Eric B. Herr, Economics, James E. Hackett, Controller, Robert L. Leyburn, Circulation, Edward E. Schirmer, Sales.

Officers of the Corporation: Harold W. McGraw, Jr., President, Chief Executive Officer, and Chairman of the Board, Robert N. Landes, Senior Vice President and Secretary; Ralph J. Webb, Treasurer.

Title registered in U.S. Patent Office. Copyright © 1978 by McGraw-Hill, Inc. All rights reserved. The contents of this publication may not be reproduced in whole or in part without the consent of copyright owner.

Subscribers: The publisher, upon written request to our New York office from any subscriber, agrees to refund that part of the subscription price applicable to copies not yet mailed. Please send change-of-address notices or complaints to Fulfillment Manager, subscription orders to Circulation Manager, Electronics, at address below. Change-of-address notices should provide old as well as new address, including postal zip code number. If possible, attach address label from recent issue. Allow one month for change to become effective.

Postmaster: Please send form 3579 to Fulfillment Manager, Electronics, P.O. Box 430, Hightstown, N.J. 08520.

power supplies for your automatic test equipment

KEPCO
series*

ATE

*38 Models from 50-1000 Watts;
0-6V to 0-150V. Programmable
from your GPIB / IEEE-488 Bus
using Kepco SN Programmings.

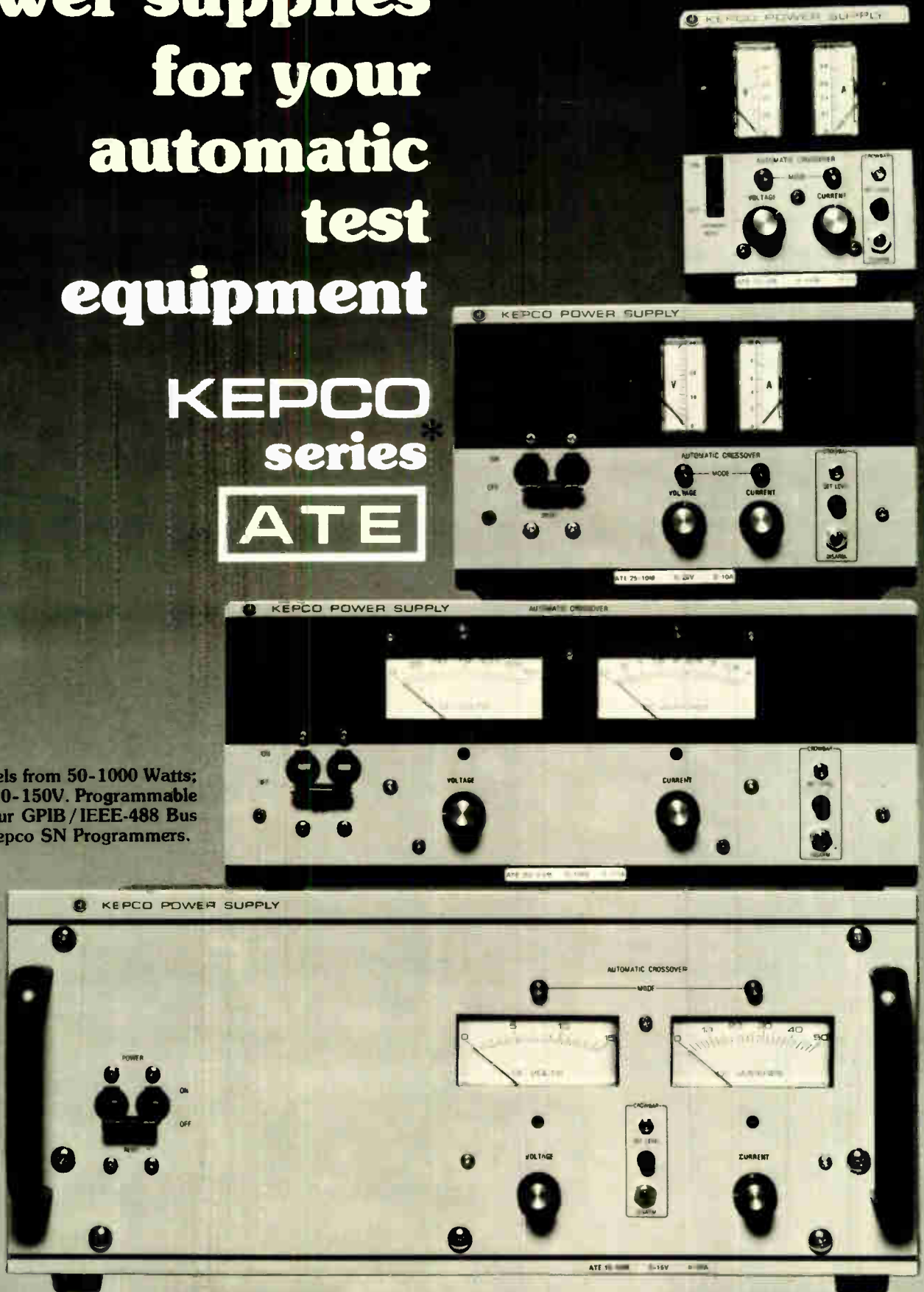

KEPCO®

For complete specifications, write Dept. CJF-14.

KEPCO, INC. • 131-38 SANFORD AVENUE • FLUSHING, N.Y. 11352 U.S.A. • (212) 461-7000 • TWX #710-582-2631 • Cable: KEPCOPOWER NEWYORK

World Radio History

Circle 5 on reader service card

INTERNATIONAL

OE CRYSTAL OSCILLATOR ELEMENTS

International's OE series of Crystal Oscillator Elements provide a complete crystal controlled signal source. The OE units cover the range 2000 KHz to 160 MHz. The standard OE unit is designed to mount direct on a printed circuit board. Also available is printed circuit board plug-in type.

The various OE units are divided into groups by frequency and by temperature stability. Models OE-20 and OE-30 are temperature compensated units. The listed "Overall Accuracy" includes room temperature or 25° C tolerance and may be considered a maximum value rather than nominal.

All OE units are designed for 9.5 to 15 volts dc operation. The OE-20 and OE-30 require a regulated source to maintain the listed tolerance with input supply less than 12 vdc.

Prices listed include oscillator and crystal. For the plug-in type add the suffix "P" after the OE number; eg OE-1P.

OE-1, 5 and 10 can be supplied to operate at 5 vdc with reduced rf output. Specify 5 vdc when ordering.

Output — 10 dbm min. All oscillators over 66 MHz do not have frequency adjust trimmers.



Catalog	Oscillator Element Type	2000 KHz to 66 MHz	67 MHz to 139 MHz	140 MHz to 160 MHz	Overall Accuracy	25° C Tolerance
035213	OE-1	\$13.50			±.01% -30° to +60°C	±.005%
035214	OE-1		\$15.50			
035215	OE-1			\$19.50		
035216	OE-5	\$16.75			±.002% -10° to +60°C	±.0005% 2 - 66MHz ±.001% 67 to 139 MHz ±.0025% 140 to 160 MHz
035217	OE-5		\$19.75			
035218	OE-5			\$26.00		
Catalog Number	Oscillator Element Type	4000 KHz to 20000 KHz			Overall Accuracy	25° C Tolerance
035219	OE-10	\$19.75			±.0005% -10° to +60°C	Zero trimmer
035220	OE-20	\$29.00			±.0005% -30° to +60°C	Zero trimmer
035221	OE-30	\$60.00			±.0002% -30° to +60°C	Zero trimmer

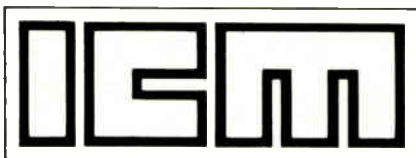

INTERNATIONAL CRYSTAL MFG. CO., INC.
10 North Lee, Oklahoma City, Oklahoma 73102
405/236-3741

Readers' comments

Revising the table

To the Editor: Table 4 of Alan Weisberger's article, "Data-link control chips: bringing order to data protocols" [June 8, p. 104], which compares available data-communications controller chips, contains some inaccuracies about Zilog's S10 device.

To be specific, the S10 provides a character length of 1 to 8 bits in the transmitting mode; it does have separate interrupt vectors for transmitting and receiving in both channels; and it has a much more elaborate line-fill scheme than the simple FCS-flag listed.

Janak Pathak
Zilog Inc.
Cupertino, Calif.

More revisions

To the Editor: The June 8 cover article, "Data-link control chips: bringing order to data protocols" [p. 104], is a well-written tutorial describing the latest in large-scale integrated devices for data communications. There are, however, several errors concerning the Motorola 6854 in Table 4 on page 112.

The following features should be changed to read: maximum data rate (b/s), 660-K/1-M/1.5-M; receiver FIFO buffers, 3; transmitter FIFO buffers, 3; loop-back self-test mode, yes; underrun line fill (BOP), abort/flag.

Mike Newman
Motorola Semiconductor
Products Inc.
Austin, Texas

Inhibiting cranks

To the Editor: The Probing the News article on fancy new telephone instruments ["New firms rush into new phone market," July 6, p. 81] was very interesting. But what would be most useful and what I would really like to have on my phone is a display of the number *from* which I am being called. Of course, that would require a central-office modification, but it would cut down crank calls significantly.

J. Dale Holt, USAF
Wright Patterson AFB
Dayton, Ohio

Stay in total touch with d/pad three

Total Telemetry Testing capabilities and real time flight decommutation are now available in one small portable package . . . designed for easy interface with people.



The versatile d/pad three provides all the functions necessary for total telemetry data monitoring all the way from ground testing to inflight decommutation operations. Simply and accurately.

No-sweat fingertip control features front panel keyboard programming and CRT visual display of feedback data, to keep an operator in total touch at all times.

Fully computer compatible, the d/pad three is a complete PCM/PAM decommutation system with programmable analog and digital ports, in addition to the comprehensive data display. And it's all contained in one small, easily transported package.

Engineering Conversion and Continuous Limit Checking

The d/pad three converts and displays incoming data in engineering units, averages the data, does peak-to-peak computation and continuously limit checks up to 200 channels without the need for any additional programming.

Data Displays Independent from Data Outputs

Data selected for display is independent of other data outputs such as the analog or digital ports, giving the operator the option of observing the desired channels without affecting any of the programmable data ports.

Software Flexibility and Hardcopy

Conic Data Systems can provide additional software to perform such complex operations as FFT and 4th order polynomial conversion. The basic program can be altered by simply overlaying a new software package to change the system characteristics.

The d/pad three is provided with an ASC II port for the purpose of interfacing with a printer to supply a complete print-out of all data. Or automatically print only channels that are out of tolerance.

For the 'total telemetry touch' story, contact Russ Smith, Conic Data Systems, 9020 Balboa Ave., San Diego, CA 92123. Phone (714) 279-0411.

CONIC DATA SYSTEMS

A Division of Conic Corporation

A subsidiary of Loral Corporation

*Stay in Total Telemetry Touch
with d/pad three*

Circle 7 on reader service card

WIMA Capacitors

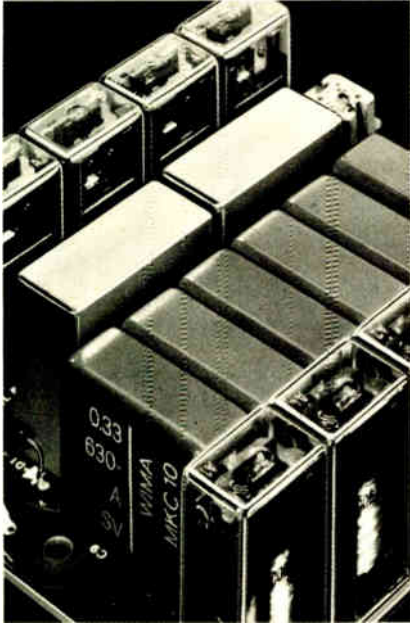

Reproduced by permission of Grundig AG, Fürth, Germany

RAY Circuit for motor control of a Video Recorder. Electronic control of the drives of a 4-motor gear unit. A total of 10 control relays monitor the following functions: Start, reverse wind, forward wind, search, record, pole change, accelerate, search in reverse mode, and tape tension switch-over. The two WIMA MKB S-C capacitors are used as phase compensation for an asynchronous motor which operates as a head drive. The WIMA MKC 10 capacitors are used for interference suppression.



WIMA Capacitors:
*High Quality Components
for Electronic Equipment*

WILH. WESTERMANN

Spezialvertrieb elektron. Bauelemente
P.O. Box 2345 · D-6800 Mannheim 1
Fed. Rep. of Germany

U.S. Sales Offices:
BOSL & ROUNDY · 3333, Delray Drive
Ft. Wayne · Indiana 46805
(219) 483-3378

THE INTER-TECHNICAL GROUP INC.
North Dearman Street · P.O. Box 23
Irvington · New York 10533
(914) 591-8822

TAW ELECTRONICS CO.
4215 W. Burbank Blvd., Burbank
California 91505 · (213) 846-3911

8 Circle 8 on reader service card

News update

■ Westinghouse Electric Corp.'s Integrated Logistics Support division in Hunt Valley, Md., and Sperry Rand Corp.'s Sperry division in Great Neck, N. Y., have won \$3,752,589 and \$3,482,697 contracts, respectively, to design and fabricate engineering models of a modular automatic test equipment (MATE) system for use with all Air Force avionic systems. Awarded by the Aeronautical Systems division at Wright-Patterson Air Force Base, Ohio, the 33-month contracts are the first under the MATE program, which aims to stop the proliferation of expensive automatic test equipment that is dedicated to only one kind of aircraft [*Electronics*, Sept. 15, 1977, p. 50].

The Air Force wants hardware and software standards for ATE to be used at all maintenance levels—factory, field organization, intermediate shop, and depot. The program calls for the Air Force to develop interchangeable hardware and software modules to be used in fabricating specific test systems tailored to specific weapons systems, notes program manager Lt. Col. Kenneth D. Wilkinson.

"If the maintenance man can't find a shorted-out \$2 circuit board that's preventing a \$15 million aircraft from flying, there's a tremendous cost incurred by the Air Force," he adds. "Eventually, modular ATE will drastically cut the \$700 million spent annually by the Air Force for separate pieces of ATE."

Engineering models to be built include four different test-station configurations for four kinds of electronic equipment. Other phases of the parallel efforts require contractors to define levels of test hardware modularity, develop software, and conduct human engineering studies, as well as develop guides and handbooks for electronic testability design and guides for test equipment acquisition and application.

The next major MATE contract will be awarded in three years to one contractor for the design and fabrication of a prototype system for a specific aircraft system, not yet determined. **Bruce LeBoss**

CABLE TESTING THE WAY IT SHOULD BE

Quickly and inexpensively.
Tests 1 to 50 conductors with continuous readout. Locates shorts, open, pair reversals, intermittent connections, ground shorts and shield shorts.

All for under \$200. Call or write us for information.

CORECTOR 1000

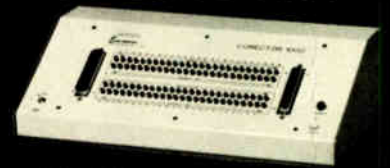

ELECTRONICS

... cost savers in electronics

11035 Harry Hines Blvd, Suite 212
Dallas, Texas 75229
(214) 350-6714 or 350-6829

Circle 163 on reader service card

Gas Sensing Semiconductor

FIGARO TGS GAS SENSOR

quickly senses
even small
amount
of gas.

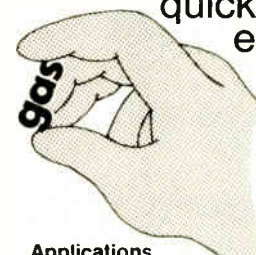

Applications

1. Natural Gas-Leak Alarm
2. Propane Gas-Leak Alarm
3. Carbon Monoxide Detector
4. Automatic Fan Control
5. Fire Alarm (Detecting combustible gases contained in smoke)
6. Alcohol Detector (Detector for drunken driver)
7. Air Pollution Monitor

Please contact any of the addresses below directly for catalogs and price/delivery information

FIGARO ENGINEERING INC.

3-7-3 Higashitoyonaka, Toyonaka City,
Osaka, 560, JAPAN TELEX 05286155
FIGARO J. CABLE FIGARO TOYONAKA
TEL: (06) 848-6171

Circle 164 on reader service card

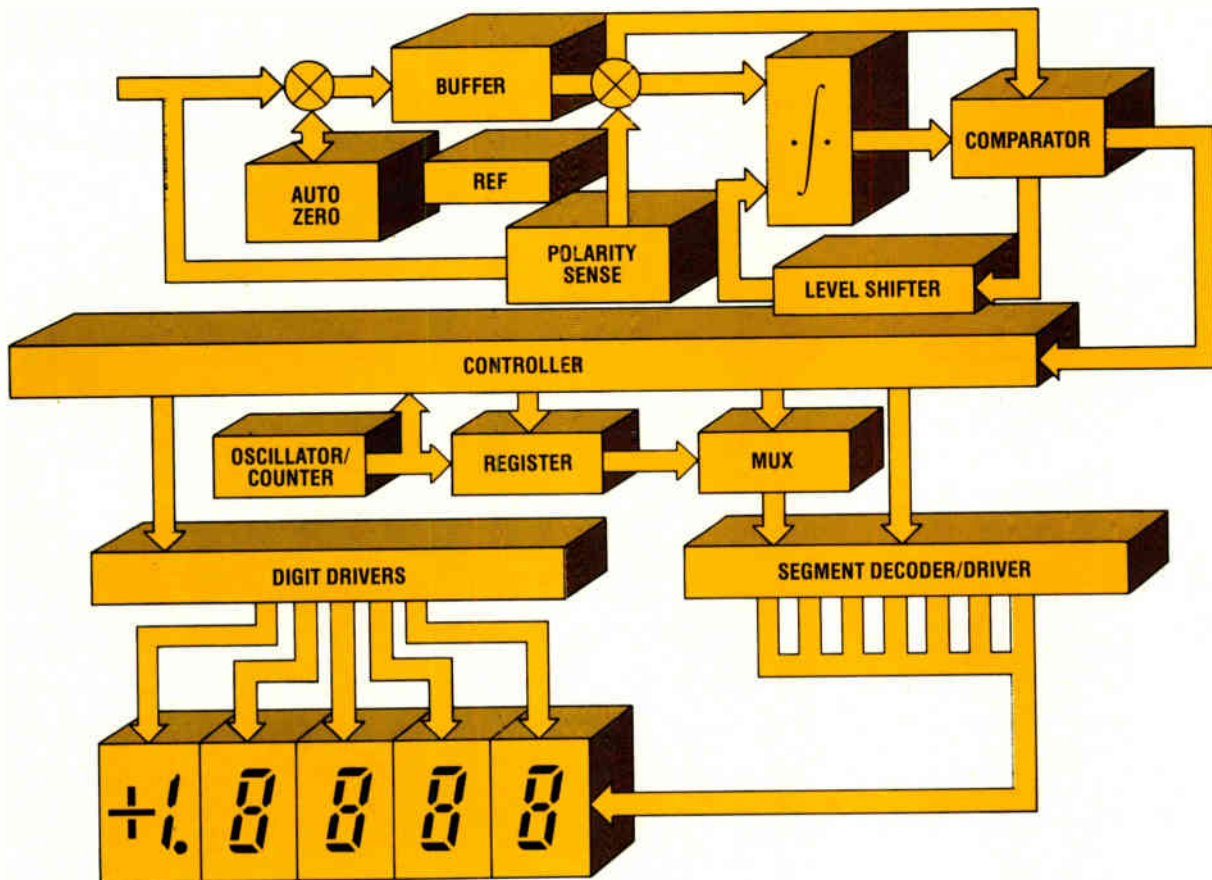

from Texas Instruments

Cut component and assembly costs with A/D converters.

You can improve the performance and reduce manufacturing costs of digital panel meters and similar equipment with these monolithic analog-to-digital converters.

TL500 Converter

This is our highest performance converter for high accuracy applications. Features include:

- Full 4½-digit accuracy
- 0.005% linearity
- True differential input
- High impedance input
- Automatic zero and polarity
- On chip reference
- 100 piece price \$5.40

The TL500, when used with the TL502, gives the industry's only 4½-digit system for under \$10.00.

TL501 Converter

This low-cost converter has all features of the TL500 except accuracy

is 3½ digits, linearity is 0.02%. It is preferred in many applications where cost is a vital consideration. 100 piece price is only \$3.01.

TL505 Converter

This is TI's lowest-cost converter designed especially for use with TMS 1000-type microprocessors. Features include:

- 3-digit accuracy (0.1%)
- High impedance MOS input
- Automatic zero
- On chip reference
- Single supply operation
- 100 piece price \$2.52

TL502 Controller

This logic control interface device is designed to be used with the TL500, TL501 or TL505 converters and drive common-anode 7 segment displays such as the TIL321.

Features include:

- Single 5-volt supply
- Over-range blanking
- 20-mA digit-base drive outputs
- 100-mA internal segment drivers
- 100 piece price \$4.55

TL503 Controller

This controller shares all features of the TL502 except that it offers BCD outputs. 100 piece price is only \$3.47.

Free Brochure

This new 16-page brochure (CL-367) gives full information on all TI's A/D converters. For copy, write Texas Instruments Incorporated, P.O. Box 225012, M/S 308, Dallas, Texas 75265.

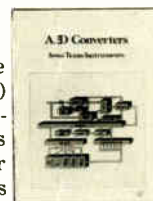

TEXAS INSTRUMENTS
INCORPORATED

Advanced Micro Devices is second sourcing the industry standard 8085A, and that's two kinds of good news.



**IT'S
OFFICIAL.**

First, the part. It's the next generation CPU. It significantly reduces the chip count. And it's totally compatible with all 8080A software.

Now the whole: Advanced Micro Devices.

That "Am" on the front of the Am8085A is like the "Am" on the front of the Am9080A. It means a continued commitment to better proprietary peripherals, better prices and absolutely no-lag, leading-edge second-sourcing. It means the rapid introduction of the 8155/56 (a 256-byte RAM) and the 8355 ROM. And of course it means MIL-STD-883 for free.

When you want to talk about the 8085A, talk to the people who made it official.



**Advanced
Micro Devices**



Multiple technologies. One product: excellence.
901 Thompson Place, Sunnyvale, California 94086
Telephone (408) 732-2400

Circle 10 on reader service card

Let's not rush to answer the phone

The proposal by AT&T to weld its phone system and digital data services into a single giant data-communications network is of the kind that casts its shadow over vast territories of business and technology. It involves not merely questions of tariffs and terminals, but extends into broad philosophical areas of free competition and to what extent small, young businesses should be nurtured by a protective government.

Only a fool would predict at this early stage whether the phone company will eventually receive permission to implement its Advanced Communications Service, or ACS: the tortuous process of application, approval, and appeal could very well keep a generation of lawyers in three-piece suits. But even as the lawyers prepare their arguments, there are questions that transcend approval or disapproval, questions that lie at the very roots of the way technology is born and nourished in this country.

It must be conceded right at the top that AT&T's plan is based on a sound concept of service—and the key word here is “service.” After all, if the object is to deliver more data to more people more efficiently, then the phone company's network is a neat way of doing it. That's good.

But what price in competitiveness are we willing to pay for that service? Or, putting it another way, would ACS plunge Bell too deeply into data processing as opposed to data communications?

Assume the perspective of the small, young, technologically innovative manufacturer of data-communications equipment. Such a network would efficiently siphon of all his customers by adding data processing to the intelligence it already contains. Those customers

would no longer have to come to him for their intelligent terminals—that need would be met by the phone company.

But couldn't such a small manufacturer build equipment to fit ACS and, in the time-honored American tradition, do it more efficiently and cheaply than Bell itself? The need would certainly be there, and so would the desire. But not so fast—that route seems to be blocked already, because Bell has disclosed only the sketchiest technical details of its network. This has the effect of giving the phone company's manufacturing arm, Western Electric, a manufacturing and marketing headstart, one that would last perhaps as long as two years (see p. 79).

A service and equipment monopoly of that duration would be enough to put many a small competitor out of business. Also lost would be the opportunity for technological competition that is the wellspring of innovation. That's bad.

As if that weren't enough, the Federal Communications Commission, which must decide for or against ACS, could be a lame duck agency. The proposed revision of the 1934 Communications Act would eliminate the FCC—and, incidentally, separate Western Electric from its parent. While that bill has a long route of its own to go before passage, its shadow, too, is hanging over the proceedings.

One conclusion to be drawn from all this is that now is a nice time not to be an FCC commissioner. More seriously, though, the FCC cannot be too careful in its examination of ACS and the precedent-making implications of any decision. In fact, the more one thinks about it, the more one likes the idea of all the hearings and deliberations that will take place. This is not the time for hasty decisions.

Don't waste money and ruin PROMs. Move up to a first-rate programmer.

What defines a first-rate programmer?

A first-rate programmer is easy to use, safe (U.L. listed), reliable, backed with a long-term warranty, and flexible enough to handle advances in PROM technology, a combination you get only with a Pro-Log programmer.

Our systems treat your PROMs like solid gold.

Our Series 90 PROM Programmer walks you through the programming process so there's less chance for misprogramming. Separate sockets for master and copy PROMs make it impossible to accidentally destroy a valuable master.

Vendor-approved programming, full portability, free 2-year warranty.

Using vendor-approved PROM personality modules, Pro-Log's field-proven programmers program every major MOS and bipolar PROM. They also program generic PROM families and do gang programming.



Our programmers weigh less than 20 pounds so they go where you need them. And they're backed by the longest warranty in the industry, 2 full years parts and labor.

A first-rate programmer is economical, too.

A complete Series 90 consists of a master control unit, a PROM personality module, and options. An M900 master control unit costs only \$1,800. An M920 PROM Duplicator master control unit costs only \$1,145. Single PROM personality modules cost from \$325 to \$450. Generic modules start at \$350. Gang modules which program 8 PROMs simultaneously are \$895. All modules come U.L. listed and fit both the M900 and the M920. Options include CMOS RAM buffer (to 4K bytes), RS-232 (terminal or modem) interface, TTY, parallel interfaces, paper tape reader,

U.L. listed erase light, checksum option, and Auto-baud.

Find out what else a truly first-rate programmer has to offer.

Call or write for a free pamphlet giving you comparison check-points. Pro-Log Corporation, 2411 Garden Road, Monterey, CA 93940. Phone (408) 372-4593.

 **PRO-LOG**
CORPORATION

Microprocessors at your fingertips.

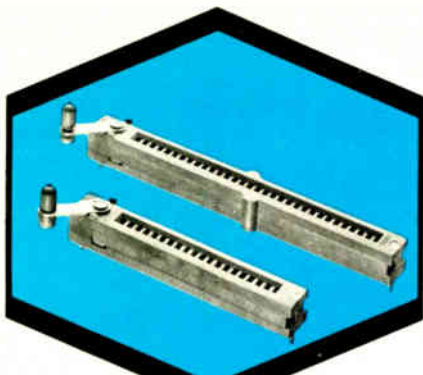

ZIP STRIP® TEST SOCKETS

Highly versatile TEXTOOL zero insertion pressure sockets allow "custom" installations for testing dual-in-line devices.

TEXTOOL's versatile ZIP STRIP sockets make it possible to "customize" socket installations for zero insertion pressure (ZIP) testing of dual-in-line devices with .100" spaced leads regardless of spacing between rows (.300" minimum).

Two ZIP STRIP sockets may be placed on any convenient centers, or several socket locking levers may be ganged together for easy mass testing of devices. Since all ZIP STRIP models feature zero insertion pressure, expensive and highly sophisticated circuits may be safely tested without fear of mechanical damage to the package.



Simple mechanical action plus a thoughtful system of ramps and bevels to guide device leads into

the contacts allow a device literally to be dropped loosely and with a simple flick of a locking lever be ready to operate with exceptionally good electrical contacts. A quick release of the locking lever lets a device be extracted with zero pressure being exerted on the leads by the socket contacts.

When ganged in an array, ZIP STRIP sockets easily accept dozens of devices and secure them with a single locking lever. Unpending the array and releasing the lever unloads the devices since there is no contact pressure to retain them in the socket.

ZIP STRIP sockets are available in strips for 10, 20 and 32 leads on .100" spacing.

Detailed technical information on the complete line of TEXTOOL's zero insertion pressure sockets is available on request.



PRODUCTS, INC.

1410 W. Pioneer Drive • Irving, Texas 75061
214/259-2676

People

Five months, and Blanchette moves to the top of CTC

Gene Blanchette concedes that being made president only five months after joining Communications Transistor Corp. is a meteoric rise, but after top management posts in the semiconductor operations of Fairchild, Motorola, Teledyne, and Nor-tec, the 44-year-old industry veteran is ready for anything. Having run plants with 5 to 5,000 people, he says that the management principles are the same for a large semiconductor maker or a \$12 million very-high-frequency microwave power-semiconductor house like CTC.

Blanchette moves up from operations vice president as founder Thomas E. Ciocchetti takes on new duties as special assistant to the president of parent Varian Associates' Electron Device Group, to which CTC belongs.

The basic job is managing people so that "you create discipline without disturbing creativity," says Blanchette, an Englishman who holds a degree in physics. "In a high-technology company, you must ensure that all the key people believe you are fair, open, and competent."

But managing the San Carlos, Calif., company, which typically makes products on the leading edge of microwave power technology, does present some special problems. Though 1/40 the size of Intel Corp., it makes 100 times as many devices or 1,500 different device types among the 1 million devices produced each year. "We're the biggest custom house in the discrete business," Blanchette observes.

GaAs coming. To survive and prosper in the microwave power business, "we will have to eventually go to the next level of integration" in hybrid modules and power modules, he continues. Also, "we'll have to take a look at gallium arsenide, because silicon runs out of steam above 4 gigahertz." This major undertaking will "almost be like starting a new company," he says.

Meanwhile, CTC, which plows about 11% of its revenues back into



Growing. Gene Blanchette sees lots of semiconductor growth at 1 GHz and above.

research and development, will continue to perfect microwave and field-effect transistors and the gold metallization techniques required in high-reliability silicon power devices.

Blanchette, who looks for 15% growth this year and 25% the next, says the market is expanding and that semiconductors of 1 gigahertz and up show tremendous potential. One market is the 900-megahertz mobile-telephone market, "which is almost a high-performance microwave semiconductor market."

Other growing markets include point-to-point communications, L- and S-band radar, and the ultra-wide-band gear needed for electronic-countermeasures equipment. Blanchette says that CTC is readying parts for all those markets, including devices with tens of watts output.

RCA's Krall sees computer, CCD cameras in home

A color TV camera the size of a thick novel is only about a year away from being good enough and cheap enough to hit the consumer market with a bang. So says Harold R. Krall, who recently was named product line director for systems and equipment within RCA Corp.'s Electro Optics and Devices operation.

Krall, 39, has an unusual vantage

Ride high with Mostek!

Don't wait for your career to "peak in the Valley" when you can ride high with Mostek today. A Mostek career combines the flexibility and upward mobility of a small company with the security and prestige of an industry leader. Look at what Mostek has to offer you:

A growth company. A technology leader in memories, microcomputers, memory systems, telecommunications, and more. Plus an unbeatable location in Carrollton, a northern suburb of Dallas.

Dedicated professionals brought us to the forefront, and we want the same to keep us there. We're looking for design, product, test and process engineers, as well as planners, marketers, and technicians.

Interested candidates are invited to return the coupon below. We'll get back to you for a prompt consultation.

Name _____ Job Title _____

Address _____

Telephone _____

Present Employer _____ Degree _____

My career interests are _____

EL 83

Direct response to the Professional Placement Department, Mostek, 1215 West Crosby Road, Carrollton, Texas 75006.

We are an equal opportunity employer, m/f.

MOSTEK®

Circle 15 on reader service card



People

point from which to gage what the home-of-the-future will be like, electronically speaking. His several-hundred-person operation in Lancaster, Pa., part of RCA's Solid State division, builds several systems he believes will have an important place in the home. These range from the TV camera, built around charge-

coupled devices, to closed-circuit TV systems, which now use conventional vidicons, and the increasingly popular personal computer.

Right now, he is most enthusiastic about the color CCD camera he says his group will eventually be able to introduce for less than \$500—one that will "play" with RCA's Selectav-

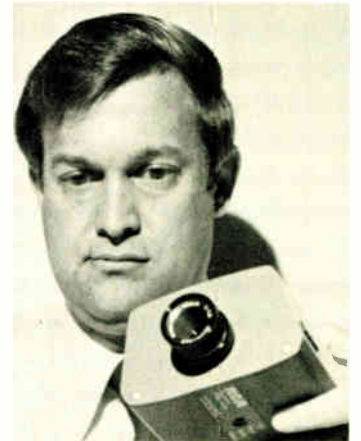

Coming. CCD color TV cameras like this one will attract consumers, Krall says.

Not just another pretty case.

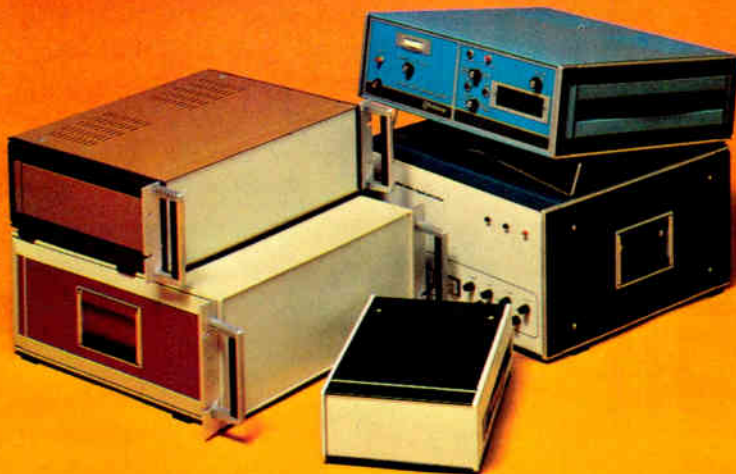

The VIP 6-Way looks good. And that's important. Because research shows that 48% of your sales are based on the appearance of your enclosure. But the VIP 6-Way is more than just good looking. It also happens to be the most versatile enclosure on the market.

It can be hard-mounted, slide-mounted, used as a table top or portable unit, tilted, stacked or racked.

Its modular design and a wide variety of options and accessories lets you take a basic chassis as far toward specialization as you want. Without paying custom prices. And standardization of components gives you two-week delivery.

You might say that part of the beauty of the 6-Way is its versatility. And its price. Send for a free catalog. There's a lot more to us than just face value.

ZERO
We make you look good.

Burbank, CA 213/846-4191 • Monson, MA 413/267-5561 • Clearwater, FL 813/531-8991

ision video cassette recorder.

But he also looks for CCD cameras to be widely used in closed-circuit TV surveillance systems. And there will be more and more of those in homes, he says. "At one time, people only bought CCTV systems after they were robbed," he explains. "Now, brand-new homes are being equipped."

Tying together the cameras for surveillance to those for home entertainment is the home computer, says Krall. "The CCD camera and computer combination is a natural—the serial digital nature of the camera's output can easily be processed by the computer."

The processing results in the computer "learning" the image of the scene, so that an alarm may be sounded if things change—as when someone has entered an area that is supposed to be empty. And of course, the home computers will be applied to entertainment and learning systems, as well as to burglar alarms and systems for controlling appliances, he says.

Krall points out it will be easy to phase the CCD cameras into the TV equipment line, but he intends to see to it that they mesh with the computers as well. RCA's VIP personal computer, which has just graduated from a kind of learning-aid kit to the status of an assembled, full-blown microcomputer, will be continually improved with new programs so that there will soon be "at least one new-product announcement a month," Krall says. □

hp MEASUREMENT COMPUTATION **news**

product advances from Hewlett-Packard

AUGUST, 1978

HP's new intelligent graphics terminal is programmable and speaks BASIC



The HP 2647A brings a new level of intelligence to our growing family of terminals. It combines user programmability in BASIC with sophisticated graphics capabilities to help you process and visualize complex data, or detail an idea from concept to execution—with or without the assistance of a CPU depending on the complexity of the task.

By virtue of its microprocessor intelligence, plus 220K bytes of local storage on dual tape cartridges, the HP 2647A terminal is able to come up with some bright ideas:

- Tabular data can be entered, the desired type of graph selected (bar, pie, X-Y, Cartesian, or logarithmic), and the terminal will automatically label, scale, and plot the data for you.
- A simple BASIC program in the terminal can reformat or post-process data from a CPU into an appropriate graphic form, or check the accuracy of data prior to transmission to the CPU data base.
- Processing loads can be effectively shared or distributed between terminal and CPU; for example, repetitive tasks can be performed by the terminal leaving the CPU free to perform complex tasks



The HP 2647's multiple automatic plotting capability can display tabular data in formats of your choice, even if you have little or no programming knowledge. A simple menu helps you enter your data parameters on the keyboard, after which a single keystroke plots the data automatically.

using its full power.

Other graphics capabilities of the HP 2647A include: multiple automatic plotting, zoom and pan, user definable area shading, independent display memories, and rubber band line. Optional hard copy

of the terminal screen display can be obtained from HP's 9872A four-color plotter or 7245A plotter/printer.

For complete details, check B on the HP Reply Card.

IN THIS ISSUE

New computer for fast FORTRAN • μ P controlled digitizer • Low cost linear power transistor

Transpose a 2 megabyte matrix in 44 seconds with new F-Series minicomputer

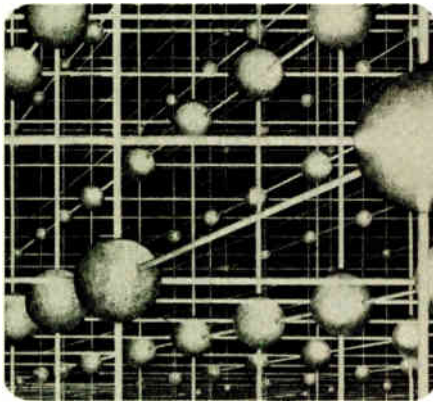

The new F-Series computer is top-of-the-line for the HP 1000 family. Its design has been optimized to provide users with the high speed and accurate computation so needed in scientific, industrial, and engineering applications.

Fast FORTRAN

The cumulative effect of the F-Series computer's features is an amazingly fast execution of FORTRAN programs. To achieve it, we took a control processor with a base instruction set whose execution speed was one million instructions per second. Then, a second processor was dedicated to floating point operations. Next, we established a library of "Scientific Instructions" that quickly calculate commonly used trig and log functions. Finally a subroutine set common to FORTRAN and crucial to performance was microcoded. The result is fast FORTRAN.

Megabyte data arrays

Even further power in FORTRAN is available for all HP 1000 computer systems with the addition of a new version of our real time operations system—RTE-IV. It enables users to quickly access memory resident data arrays of nearly two million bytes of CPU memory with simple FORTRAN statements. The combination of fast FORTRAN and the megabyte arrays, enables the F-Series to transpose a two million byte matrix in just 44 seconds—a significant contribution for a 16-bit machine.

Check C on the HP Reply Card for details.

For testing today's logic, serial data stimulus delivers over one-million-bit data streams

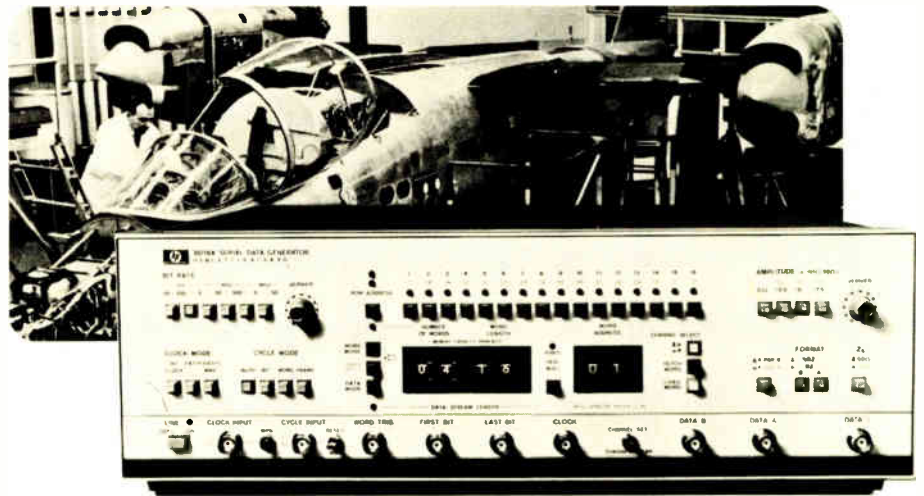

Hewlett-Packard's Model 8018A is a high-performance data generator that meets all of your requirements for serial stimulus up to 50 M bits. Included is an innovative new technique for mixing PRBS and programmable data words in a single stream over one million bits long. This technique is perfect for stimulating preamble-data-postamble patterns.

DC to 50 MHz clocking rates and clean 15V output pulses provide speed and signal levels to work directly with logic families from ECL to CMOS. A switchable

50 Ω source lets you choose the termination configuration that delivers the best pulses in your test set-up, and a full complement of cycling modes and trigger signals allow easy synchronization to it.

Memory contents and data output format are remotely programmable via the optional HP-IB. This gives even faster data loading and affords application of its serial data generation capabilities in automatic test systems.

For more information, check D on the HP Reply Card.

General purpose lab instrument offers power and performance

The new HP 214B, a 10 MHz pulse generator, employs semiconductor technology for high power pulse generation 10 times faster than its predecessor, the 214A. Delivering 100 V pulses with 15 ns risetimes, the 214B meets the speed demands of today's high power applications.

State-of-the-art VMOS FETs used as current sources for the output amplifier tubes enable pulse width to be specified down to 25 ns. The 214B is thus well-equipped for low duty cycle applications such as laser diode pulsing or transient simulation on power transmission lines.

Where changing duty cycle threatens device destruction, the 214B Constant Duty Cycle (CDC) mode provides device protection. In CDC operation, power remains constant as frequency is varied. Operating out of CDC mode, the 214B is protected against excessive duty cycles via an overload detect circuit.

External trigger, synchronous gate, man-



ual trigger, single pulse, double pulse, pulse delay/advance, selectable output polarity, and optional counted burst equip the 214B for the many applications encountered in general labs use. Easy operation is assured by the timing error indication. Calibrated dials enable fast, accurate adjustments.

Operating into unmatched loads, clean pulse shape is guaranteed by the low reactance 50 Ω source impedance. Typical pulse distortions such as preshoot, overshoot, and, ringing are only 5% specified at all amplitudes. All specifications are guaranteed in ambient temperatures from 0-50°C.

For more details, check E on the HP Reply Card.

Sophisticated yet convenient new digitizer converts analog data from virtually any graphical form

The 9874A is the first digitizer to have an adjustable glass platen, microprocessor intelligence, built-in memory (16K bytes), cursor vacuum system, and control key pad all in one compact, easy-to-use unit.

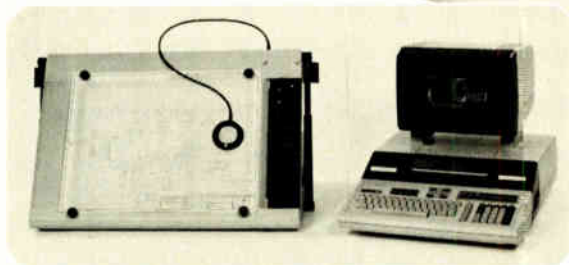

System 45 and the 9874A Digitizer provide you with a powerful graphics system that lets you plot your digitized data on the CRT for analysis.

A new, microprocessor-controlled peripheral, the HP 9874A Digitizer, provides an accurate, speedy, and convenient method of entering your analog data into any 9800 Series desktop computer or other HP-IB devices. The 9874A will convert your graphic information, such as maps, 35 mm slides, x-rays, photos, and movies, into numeric form for computer analysis. In fact, this sophisticated digitizer will convert analog data from virtually any graphical form placed on its adjustable glass platen into a series of discreet X, Y coordinates.

A valuable tool for a broad range of applications, including engineering, business, manufacturing, medicine, and research, the 9874A can digitize with optimum efficiency and less operator dependence than you would expect. Simply turn it on, place your document on the platen, load the program into your desktop computer, and digitize.

This HP digitizer integrates an assortment of advanced, yet easy-to-use features:

- 16K bytes of built-in memory control
- microprocessor intelligence

- system resolution of 25 microns
- an adjustable glass platen for rear projection of graphic images
- a unique cursor vacuum system that lets you position the cursor with pinpoint precision and leave it unattended, regardless of the platen angle
- a keyboard with control, special function, and numeric entry keys that allow commands to be made directly from the digitizer
- a stylus for fast tracing of curves, lines, irregular shapes, as well as complex documents
- ready made HP-IB interface capability
- 40 different graphic instructions to simplify programming and increase communication efficiency.

In addition, there are numerous other advantages to digitizing with the 9874A.

The Axis Align key automatically aligns the X and Y axes of the digitizer with those of your document. It establishes the new coordinate system, and all points it sends to the computer are based on that coordinate system. It does all the rotation and translation automatically.

Special Function keys initiate

branching routines in your program so there's no need to dash back and forth between the digitizer and computer.

The key pad lets you enter numerical annotations to be attached to specific points. The display verifies the annotation before you enter it into the computer.

The Axis Extend key allows you to digitize documents up to 53 kilometers long, and the points transferred into the computer will still be referenced to the initial origin. To further enhance your digitizing system, HP manufactures a continuum of computers and peripherals to meet today's needs as well as to provide a growth path to the future.

System 45, HP's powerful graphic desktop computer, makes an ideal partner for the 9874A. Its enhanced BASIC language has many of the powerful features of FORTRAN and APL to make programming fast and easy.

Whether you're already using another digitizer or thinking of adding one to your application, find out more about the advantages of HP's 9874A. Check F on the HP Reply Card.

New delta-time scope features convenience in multi-channel time interval measurements

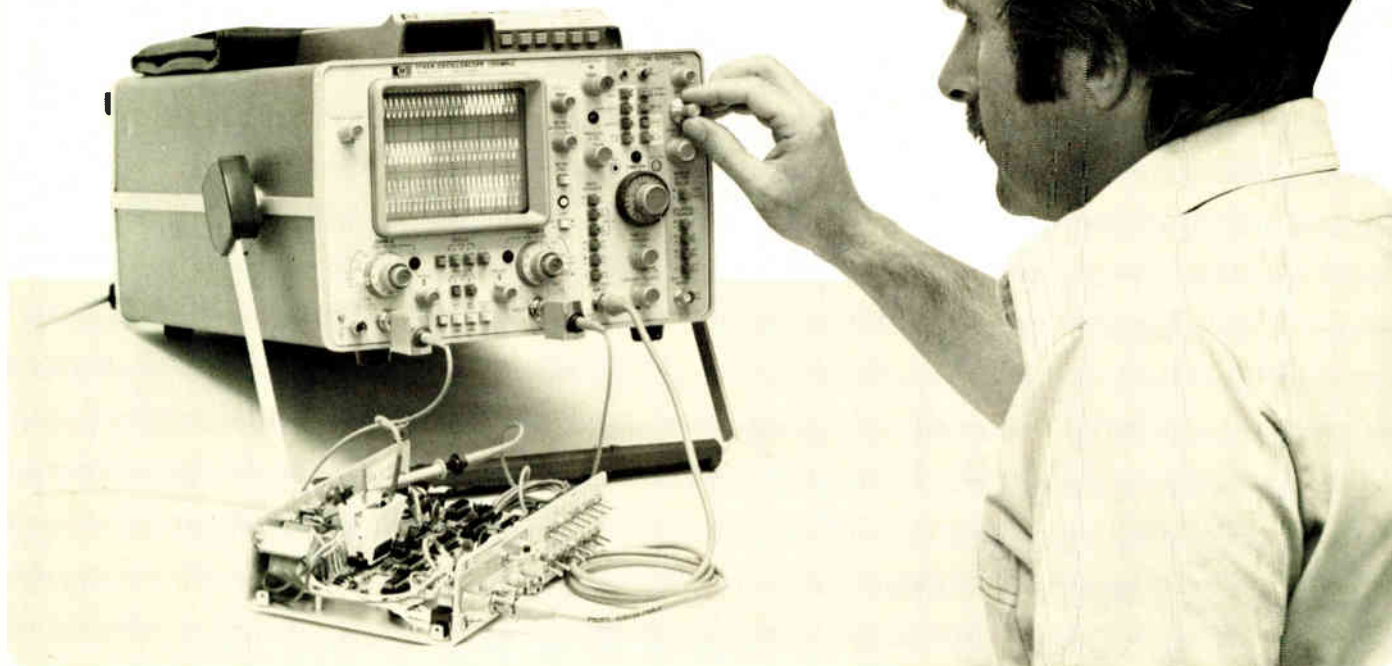

HP's Model 1742A, 100 MHz oscilloscope offers convenient single-, dual-, or three-channel time interval measurements with easily obtained accuracies of 0.5% of reading $\pm 0.05\%$ of full scale.

The new HP 1742A oscilloscope combines the time interval measurement benefits of the two-marker delta-time system with the capabilities of the general purpose 1740A oscilloscope. This analog referenced delta-time system with an optional DMM readout provides the same accurate, time interval measurements in the 100 MHz bandwidth range which have proven so useful in the 1715A (200 MHz) and 1725A (275 MHz) oscilloscopes.

Time-interval readout is provided in three ways: 1) on the optional built-in DMM, 2) on an external DVM from a rear panel analog output voltage, and 3) on the calibrated delay dial.

The two-marker delta-time system offers improved accuracy (0.5% of reading $\pm 0.05\%$ of full scale) over the single-marker delayed-sweep system. Because two events separated in time can be displayed simultaneously, measurements such as period and width jitter can be easily performed.

Multi-channel measurements are also easily performed and the need to move probes in a circuit is eliminated with an A Start/B Start switch. Simply select the desired start channel with the switch and the start marker can be positioned at the start of the time interval of interest. By using the 1742A's third-channel trigger display

mode, time-interval measurements from an external trigger signal to either vertical channel can also be accomplished.

A Delta Time Off mode can be selected for conventional single-marker delayed sweep applications such as trace magnification. In this single-marker mode, delayed gate output can be used to trigger other instruments such as a frequency counter for pulse RF measurements.

For more information, check G on the HP Reply Card.

New AM capability added to HP's 8165A Programmable Signal Source

For increased versatility, sweep and amplitude modulation capability have been combined in the new option 002 for HP's 8165A. Sweep can be initiated externally or internally and extends over a range of three decades maximum. AM allows modulation of the output signal by an external voltage at a modulation depth

from 0-100% and a modulation frequency of up to 10 MHz. These features emphasize the usefulness of the 8165A in linear circuit applications as well as in general-purpose automatic test systems.

For more information, check H on the HP Reply Card.

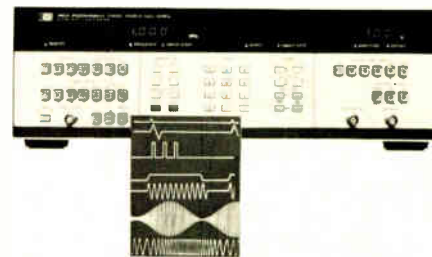

Distortion measurement set makes true-rms THD measurements of audio amplifier performance

An industry-wide effort to promote uniformity in the field of audio amplifier performance recently culminated in the establishment of a new standard method for such measurements. This 16-page standard, (IHF-A-202-1978), is available from the Institute of High Fidelity, Inc. in New York. It recommends music waveform signals be used in testing amplifier power output rather than continuous sine-wave signals. That recommendation, along with others outlined in the standard, provides for meaningful comparisons of audio amplifier performance by high-fidelity system consumers.

HP's 339A Distortion Measurement Set is an excellent instrument for true-rms signal measurements as required on page

9, paragraph 2.9 in the standard. A combination of true-rms analyzer, AC voltmeter and low distortion oscillator, the 339A makes true-rms THD measurements as low as 0.0018% from 10 Hz to 110 kHz, including harmonics to 330 kHz.

As a true-rms voltmeter, the 339A can also measure inputs from 1 mV to 300 V full scale over a 10 Hz to 110 kHz range. It is calibrated in volts, dBV, and dBm into 600Ω. As a low distortion oscillator, the 339A provides sine-wave output from 10 Hz to 110 kHz, with distortion from 20 Hz to 20 kHz specified as low as 0.0018%.

To find out more about HP's 339A, check I on the HP Reply Card.



New low distortion audio test source



Light-weight and small enough to pick up with one hand, the 239A is convenient to use on the bench or easy to carry for remote tests.

A new low distortion audio test source from Hewlett-Packard can deliver sine waves over a 10 Hz to 110 kHz frequency range with THD < -95 dB to 20 kHz and >3 rms into 600 Ω. Called the Model 239A Oscillator, this instrument is designed for engineers in audio, broadcast, hi-fi, and amplifier design and development. The 239A is also an excellent companion oscillator for distortion analyzers and spectrum analyzers in low distortion stimulus applications.

The 239A has an accurately calibrated step attenuator with 60 dB of range and a vernier for continuous adjustment between steps. With the amplitude vernier in CAL, the output level is known across the full frequency range, eliminating the need for time-consuming recalibration at each frequency.

Check J on the HP Reply Card for complete details.

Latest application note in microwave power series

By combining a desktop computer with a programmable signal source and three programmable power meters, a very powerful, accurate, microwave measurement system can be assembled from bench instruments. Such a system is described in Application Note 64-2, *Extended Applications of Automatic Power Meters*.

One of the more difficult and tedious jobs done in metrology laboratories is the periodic recalibration of power sensors for calibration factor and effective efficiency against a traceable standard sensor. The system described in AN 64-2 measures calibration factor and computes its own

measurement uncertainty at each cardinal frequency by using stored calibration data for the system components.

The usual 40-50 dB of sensor dynamic range can be doubled to 80 dB by using a signal source with programmable output level. In this way, the sensor which monitors input power uses up its 40 dB range after which the 40 dB range of the sensor is used. A broadband coupler allows both SWR and attenuation to be measured at one time, with high accuracy and high resolution.

For a complimentary copy of AN 64-2, check K on the HP Reply Card.

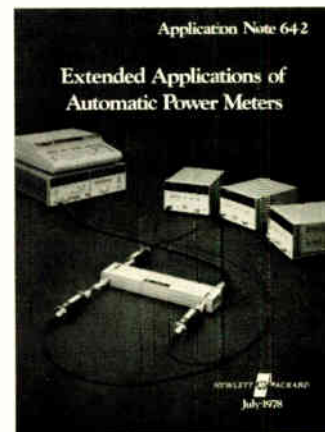

New HP scientific calculators put unequalled performance within your reach

The new Series E scientific calculators provide more calculating power, more ease-of-use features, and a lower price than any comparable calculators HP has ever designed.

Each calculator features a larger, easy-to-read display plus commas to help you read long numbers. What's more, every Series E scientific calculator includes an exclusive self-check capability, error codes, and a new level of accuracy. These qualities, coupled with the time-proven RPN logic system and traditional HP attention to detail, add up to outstanding values.

The new Series E scientific calculators have been designed in every detail to be the finest of their kind in the world.

Convince yourself by visiting the nearest HP dealer, or send for detailed literature by checking A on the HP Reply Card.



HP-31E, Scientific. Trigonometric, exponential, and math functions. Metric conversions. Fixed and scientific display modes, 10-digit display, and 4 user memories.



HP-32E, Advanced Scientific with Statistics. More math and metric capabilities than HP-31E, plus 15 user memories, hyperbolics, comprehensive statistics.



HP-33E, Programmable Scientific. 49 program lines of fully merged key codes. Editing, control, and full range conditional keys, plus 8 user memories.

A more accurate solution for 30 W power measurements to 18 GHz

Previous methods of measuring medium power levels usually involved adding a separate 30 W attenuator in front of a 100 mW sensor. Such a combination created significant measurement ambiguities because each element had its own accuracy specification and an interacting mismatch effect. Now, two new HP power sensors for 30 W measurements combine the attenuator and sensor into one unit. This reduces mismatch uncertainty errors and improves accuracy by including the attenuator in the measured Calibration Factor curve. Calibration data is traceable to the National Bureau of Standards and when used along with the Calibration Factor control on the power meter, compensates for the effects of power sensor efficiency.

These sensors, the 8481B and 8482B, were built to be used with the well-known HP 435A and 436A Power Meters. Model 8481B has a frequency range of 10 MHz to 18 GHz and the 8482B covers 100 kHz to 4.2 GHz. Both models have a 50 dB dynamic range (-5 dBm to +45 dBm), a peak power rating of 500 W, and are supplied with type N connectors. In addition, the design of the 8481/82B incorporates light-weight, heat dissipating fins to

prevent burns from the heated attenuator.

The SWR specification for the 8481B is 1.10, 10 MHz to 2 GHz; 1.18, 2 to 12.4 GHz; 1.28, 12.4 to 18 GHz. The 8482A SWR specification is 1.10, 100 kHz to 2 GHz; 1.18, 2 to 4.2 GHz.

Additional information can be obtained by checking L on the HP Reply Card.



Measurement accuracy of medium power levels is improved since the attenuator is included in the Calibration Factor curve.

Hard-copy graphics benefit a multitude of instrument systems



The importance of hard-copy graphics to instrument systems is evidenced by the variety of applications that make use of them. Two HP plotters, the 9872A four-color plotter and the 7245A plotter/printer, are used with a large number of different HP instrument systems in applications ranging from highly dedicated electronic design, to process monitoring in a cement plant.

HP 5420 Fourier Analysis Systems in mechanical applications, use the HP plotters not only to produce necessary hard copy of the CRT display but also to provide four-color plotting grid lines, individualized line styles, and changes of plot size.

With transceiver test systems, four-color plotters provide hard-copy Bode plots of circuit performance quickly, accurately and through remote control.

A versatile graphic instrument, such as HP's 8568A Spectrum Analyzer finds an able accomplice in the 7245A plotter/printer which easily reproduces hard copy of the instrument's CRT display, be it any form of graphs or words.

For details on HP's plotters, check M on the HP Reply Card.

HP publishes optoelectronics applications manual

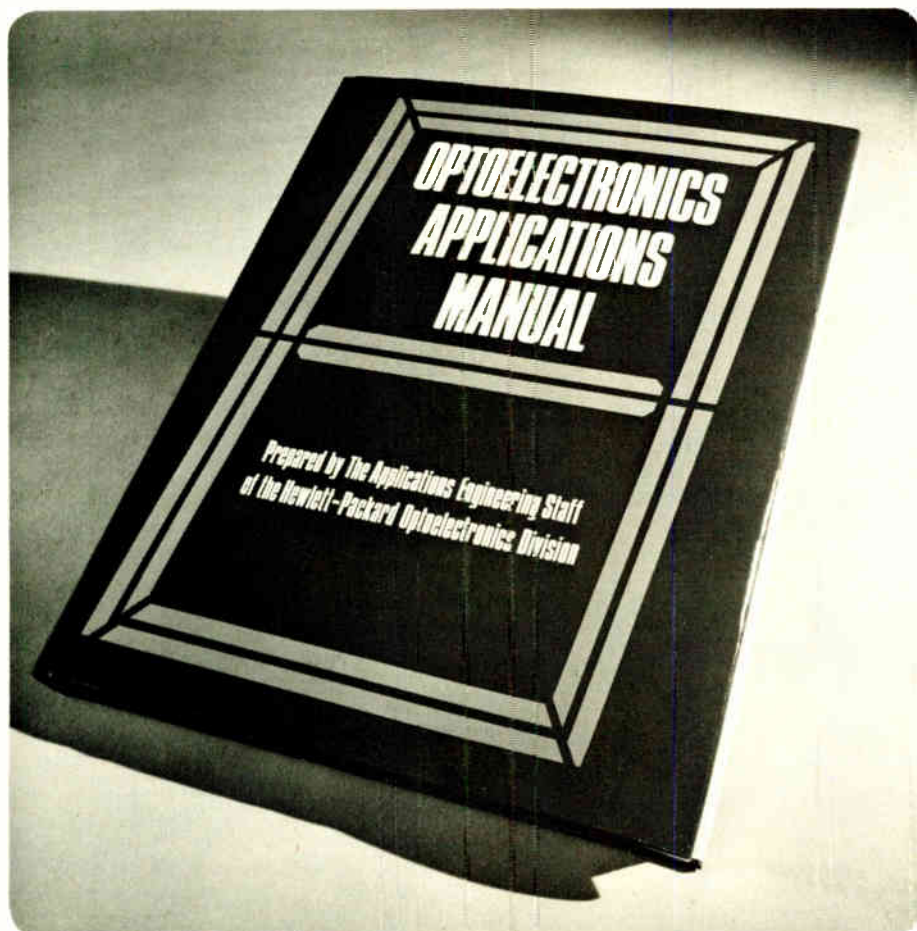

Practical solutions to the most common applications problems of optoelectronic devices are fully analyzed in Hewlett-Packard's *Optoelectronics Applications Manual*, one of the first books on these versatile design tools from a leading firm in the field.

The *Manual* covers such subjects as photometry/radiometry, contrast enhancement in visible displays, and reliability of optoelectronic components and their mechanical handling.

Designed both as a practical guide to the use of optoelectronic devices and as a foundation for the development of new de-

sign ideas, this volume demonstrates the broad potential for these components that exists in systems being designed today.

Of special interest to experienced designers is the *Manual's* treatment of CTR degradation, a controversial and frequently misunderstood subject among users of optically coupled isolators.

Members of the applications engineering staff of the Hewlett-Packard Optoelectronics Division were involved in the preparation of the *Manual*, published by McGraw-Hill.

Copies are available from your HP franchised distributor.

Guaranteed power and gain in new linear microwave transistor

Low cost, accompanied by ruggedness and reliability, establish the Hewlett-Packard HXTR-5101 as a standard for general purpose linear power transistors. If your amplifier design objectives dictate fewer stages with no accompanying reduction in output power, the HXTR-5101 may well be the answer. It provides a *guaranteed* linear power of 21 dBm at 1 dB gain compression and a superior, guaranteed associated gain of 6.5 dB at 4 GHz.

The reliability and consistency inherent in the design of this new silicon, NPN, bipolar transistor make it an excellent choice for high reliability applications such as radar, telecommunications, and fuses in the 1 to 6 GHz frequency range. The transistor is well suited for systems requiring intermediate linear power in excess of 100 mW, with minimal distortion, as the final state on a receiver amplifier, or as a driver for a subsequent linear or Class C state in a transmitter.

The HXTR-5101 comes in the HPAC-100.

Check N on the HP Reply Card for more information on this product.

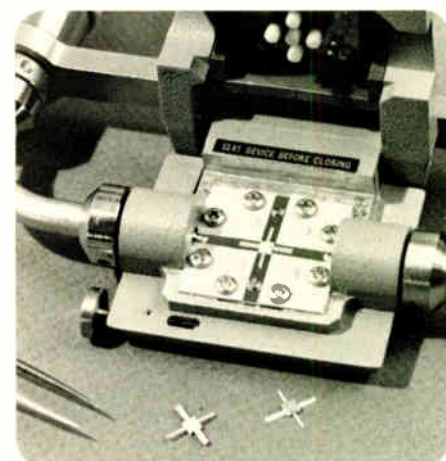

Test for yourself the power and gain of HP's HXTR-5101 linear power transistor.

Which of HP's IC troubleshooters is best for you?



HP's IC Troubleshooters are available in various combinations, including the 5022A Kit shown here (545A Probe, 546A Pulser, 547A Current Tracer, 548A Clip).

Each of HP's seven IC troubleshooters provides outstanding benefits in troubleshooting digital circuits. For example, the *logic probe's* lamp indicates voltage pulses, while the *logic clip* shows the state of all pins of an IC at once. In contrast, the *current tracer* indicates current pulses—inductively. It is used where the logic probe has located a fault that cannot be isolated lower than the node level—as in a bus where all components are stuck low by a faulty one. For stimulus-response testing, use the *logic pulser* with the logic probe or current tracer—it generates the circuit input signals needed.

For details on all of HP's IC Troubleshooters, check O on the HP Reply Card.

FAULT	STIMULUS	RESPONSE	TEST METHOD
Shorted Node	546A Pulser ¹	547A Current Tracer	<ul style="list-style-type: none"> ● Pulse shorted node ● Follow current pulses to short
Stuck Data Bus	546A Pulser ¹	547A Current Tracer	<ul style="list-style-type: none"> ● Pulse bus line(s) ● Trace current to device holding the bus in a stuck condition
Signal Line Short to Vcc or Ground	546A Pulser	545A Probe Current Tracer	<ul style="list-style-type: none"> ● Pulse and probe test point simultaneously ● Short to Vcc or Ground cannot be overridden by pulsing ● Pulse test point, and follow current pulses to the short
Vcc to Ground Short	546A Pulser	547A Current Tracer	<ul style="list-style-type: none"> ● Remove power from test circuit ● Disconnect electrolytic bypass capacitors ● Pulse across Vcc and ground using accessory connectors provided ● Trace current to fault
Internally Open IC	546A Pulser ¹	545A Probe	<ul style="list-style-type: none"> ● Pulse device input(s) ● Probe output for response
Solder Bridge	546A Pulser ¹	547A Current Tracer	<ul style="list-style-type: none"> ● Pulse suspect line(s) ● Trace current pulses to the fault ● Light goes out when solder bridge passed
Sequential Logic Fault in Counter or Shift Register	546A Pulser	548A Clip	<ul style="list-style-type: none"> ● Circuit clock de-activated ● Use Pulser to enter desired number of pulses ● Clip onto counter or shift register and verify devices truth table

1. Use the Pulser to provide stimulus, or use normal circuit signals, whichever is most convenient.

East—1 Choke Cherry Road, Rockville, MD 20850.
Ph. (301) 948-6370.
South—P.O. Box 10505, 150 Interstate North Pkwy.,
Atlanta, GA 30348, Ph. (404) 434-4000.
Midwest—5201 Tallview Dr., Rolling Meadows, IL 60008,
Ph. (312) 255-9800.
West—3939 Lankenshim Blvd, North Hollywood, CA
91604, Ph. (213) 877-1282.
Europe—Central Mailing Depot., P.O. Box 529,
Amstelveen-1134, Netherlands,
Ph. (020) 47 20 21
Japan—Yokogawa-Hewlett-Packard Ltd.
29-21 Takaido-Higashi 3-chome
Suginami-ku, Tokyo 168, Ph. 03-331-6111.



MEASUREMENT **news**
COMPUTATION
product advances from Hewlett-Packard

July/August 1978

New product information from

HEWLETT-PACKARD

Editor: Bojana Fazarinc-Bitencourt

Editorial Offices:

1507 Page Mill Road
Palo Alto, California, 94304 U.S.A.

TO-5 RELAY UPDATE

The world's smallest RF relay

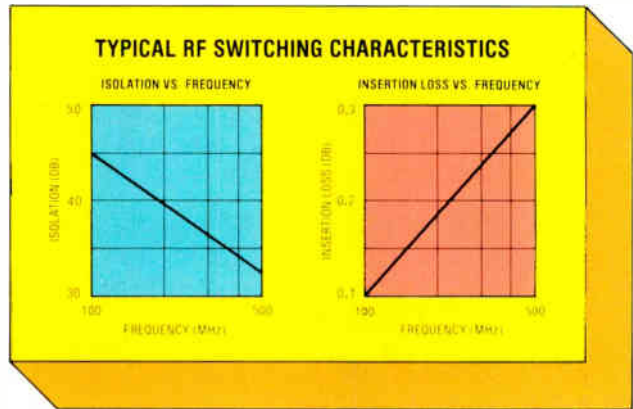

Inherently low inter-contact capacitance and contact circuit losses have established the Teledyne TO-5 relay as an excellent subminiature RF switch for frequencies up through UHF. Typical RF performance: 45db isolation and 0.1db insertion loss at 100MHz.

Added to this, our TO-5 relay requires very low coil power compared to other miniature relays — as much as 75% less than a half crystal can relay.

For hand held radio transceivers, for example, where battery power drain as well as good RF performance are key factors, Teledyne's TO-5 relay is the logical choice for T-R switching.

Our complete line of TO-5 relays includes military and commercial/industrial types, with virtually all military versions qualified to established reliability MIL specs. For complete data, contact Teledyne Relays — the people who pioneered the TO-5 relay.

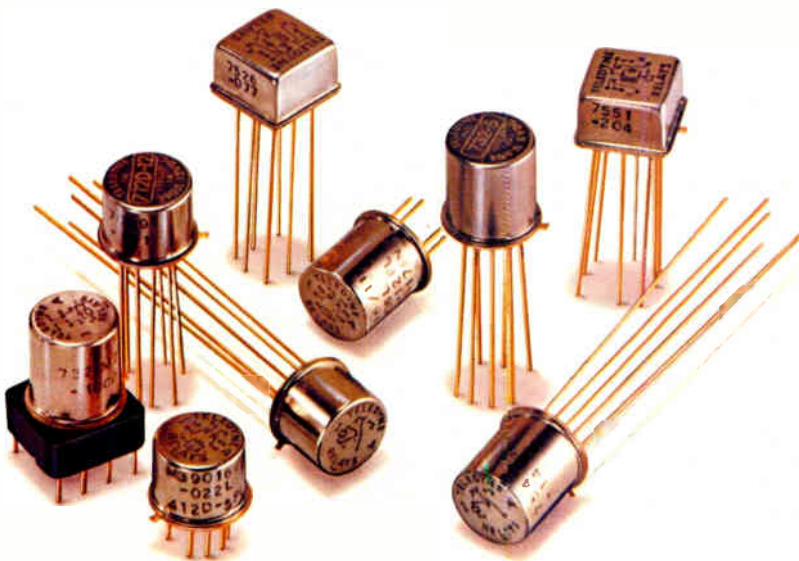

- **Hybrid "T" Series**
SPDT & DPDT types with internal transistor driver and suppression diode. Military and commercial/industrial versions.
- **"D" and "DD" Series**
With internal suppression and steering diodes. Military and commercial/industrial versions.
- **Maglatch Series**
SPDT, DPDT, and 4PST magnetic latching types. Military and commercial/industrial versions.
- **Centigrad® Series**
World's smallest relay—only .225" (5.72mm) high x .370" (9.40mm) square. DPDT, with optional internal suppression and steering diodes.
- **Hi-Rel Series**
Screened versions for space flight applications (NASA qualified)
- **High Environment Series**
Hi-temperature, Hi-shock, and Hi-vibration types

 **TELEDYNE RELAYS**

3155 West El Segundo Boulevard, Hawthorne, California 90250
Telephone (213) 973-4545

Why microcomputer with our 2716

We've just introduced two new speed selections of our 2716 16K EPROM. The 2716-2 access time is 390 nanoseconds, the 2716-1 is just 350 ns—fast enough to take full advantage of the new multiplexed microprocessors, such as the 5MHz 8085A-2 and the HMOS, 16-bit 8086.

To enable you to operate your system at high clock rates without bus contention problems, we've built the 2716 with two separate control functions—Output Enable (pin 20) and Chip Enable (pin 18). Using both control functions is your key to high performance.

And because the 2716 is a +5 volt part, you can design your entire system—EPROMs, ROMs, RAMs, CPU and peripherals—all operating from a single +5 volt supply.

Using the 2716 gets you to market sooner, too, with fast, easy reprogrammability and no “turnaround time” for

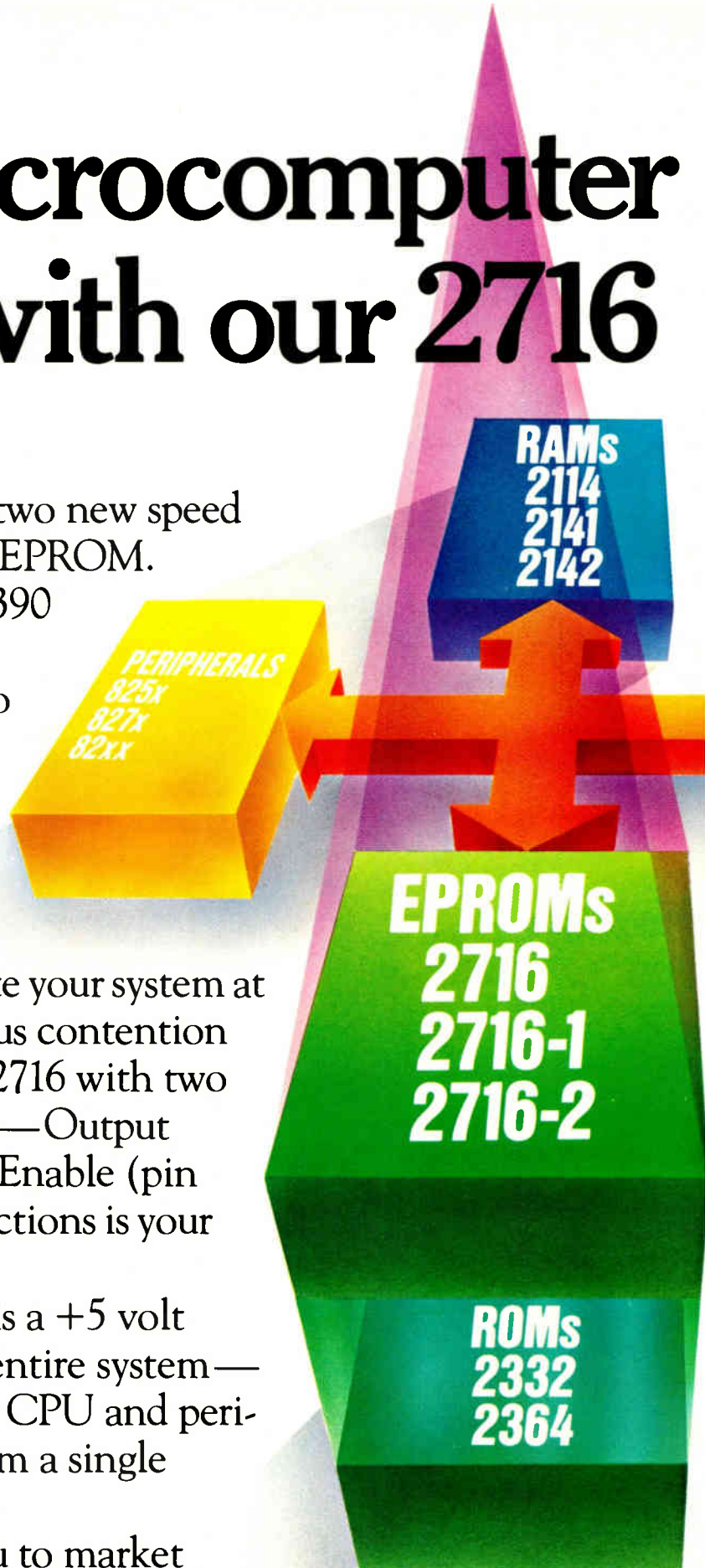

system design starts 16K EPROM.

program changes. Then, when you're ready for volume production, there's the

economy and upgrade capability of pin-for-pin interchangeable ROMs—

the 2316E (16K), 2332 (32K) and 2364 (64K).

Just as important, designing with the 2716 today assures you of easy mobility to the higher density memories needed for the system upgrades you'll be implementing tomorrow. Utilizing the 2716's pinout, for example, not only gives you compatibility with our 32K and 64K ROMs, but gives you the design flexibility to move to our 32K EPROM when it's introduced.

Design flexibility is such an important consideration for maximizing your product's life cycle that we've devoted an entire application note to it. For a copy of AP30, with the complete story on the ROM/EPROM upgrade path, along with an updated 2716 data sheet, write: Intel Corporation, 3065 Bowers Avenue, Santa Clara, CA 95051.

	2716	2332	2364
Organization	2K x 8	4K x 8	8K x 8
Active Icc (max)	100 mA	40 mA	40 mA
Standby Icc (max)	25 mA	15 mA	15 mA
Access Time (max)	350-450 ns	300 ns	300 ns

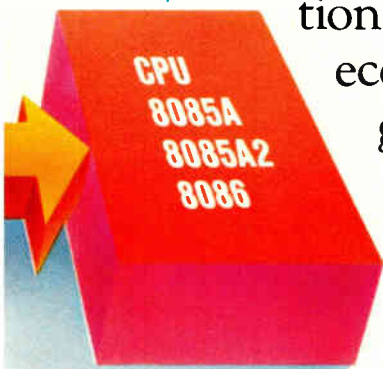

intel® delivers.

Europe: Intel International, Rue du Moulin à Papier, 51-Boite 1, B-1160, Brussels, Belgium. Telex 24814.

Japan: Intel Japan, K.K., Flower Hill-Shinmachi East Bldg. 1-23-9, Shinmachi, Setagaya-ku, Tokyo 154. Telex 781-28426.

US and Canadian distributors: Almac/Strom, Component Specialties, Cramer, Hamilton/Avnet, Harvey, Industrial Components, Pioneer, Sheridan, Wyle/Elmar, Wyle/Liberty, or L.A. Varah, Zentronics.

Circle 29 on reader service card

Courtesy of Library, State Historical Society of Colorado



A special breed of men has always sought fame and fortune in Colorado.

First, they were trappers, with sharp eyes for wild game and a profitable trade. Next came the miners, as hard as the rocks they cracked in search of the Mother Lode. Then they were farmers and cattlemen, raising food for themselves and for a growing country.

Today, individualistic men still come to Colorado, bringing their companies with them because Colorado still offers so much: an efficient transportation network, abundant energy, natural resources, room to expand and a well-educated work force. In fact, it's Colorado itself — the ultimate fringe benefit — that brings so many here in the first

place. And keeps them here. With its lifestyle and unlimited recreational activities such as skiing, hunting, fishing, camping and so much more.

Many special companies (like IBM, Kodak, Hewlett-Packard, Fibreboard, Johns-Manville, Outdoor Sports Industries, Michelin Tire, and hundreds of others) have already staked their claim in Colorado. Now it could be your turn. For complete details, mail the coupon today.

COLORADO

the ultimate fringe benefit

William C. Hacker
Director of Community Development
Dept. 1532
500 State Centennial Bldg.
Denver, CO 80203

- Please send information about opportunities for my company in Colorado.
 Also send me facts on Colorado export products.

Name _____ Title _____
Company _____
Type of Business _____
Address _____
City _____ State _____ Zip _____

Meetings

Time and Frequency: Standards, Measurements, Usage, National Bureau of Standards, Boulder, Colo., Aug. 22-26.

Sixth Colloquium on Microwave Communications, International Union of Radio Science, Budapest, Aug. 29-Sept. 1.

Eighth European Microwave Conference, Microwave Exhibitions and Publishers Ltd. (Sevenoaks, Kent, England) Hotel Meriden, Paris, Sept. 4-8.

International Optical Computing Conference, IEEE, Imperial College, London, Sept. 5-7.

CompCon 78—17th IEEE Computer Society International Conference, Capital Hilton Hotel, Washington, D. C., Sept. 5-8.

International Machine Tool Show 1978, National Machine Tool Builders' Association (McLean, Va.), McCormick Place, Chicago, Sept. 6-15.

Wescon/78 Show and Convention, Electronic Conventions Inc. (El Segundo, Calif.), Los Angeles Convention Center, Los Angeles, Sept. 12-14.

ECOC—Fourth European Conference on Optical Communications, IEEE Italian Section (for information contact Istituto Internazionale Comunicazioni, Genoa), Genoa, Italy, Sept. 12-15.

Conference on Information and Systems Theory Used in Digital Communications, IEEE German Section (for information contact VDE-Zentralstelle Tagungen, Frankfurt), Technical University, West Berlin, West Germany, Sept. 18-20.

ESSCIRC 78—Fourth European Solid State Circuits Conference, IEEE Benelux Section (for information contact ESSCIRC 78, Delft University of Technology, Delft Tropen Instituut, Amsterdam, the Netherlands, Sept. 18-21.

Mostek's tone receiver. The 16-pin solution to reducing system cost.

The cost of digital communication systems is coming down. With Mostek's new MK5102 tone receiver, the complete tone decoding function can now be implemented using a single 16-pin IC plus minimal pre-filtering. That means your system can be less

expensive, less complex and easier to design.

Mostek's 5102 tone receiver features 5-volt $\pm 10\%$ power supply, latched three-state outputs with data valid strobe, low pre-filtering requirements and superior talk-off protection. This CMOS circuit operates at a low 5mA typical current. And the compact 16-pin package makes it a natural for high system density.

Use the 5102 with our 5087 tone dialer. Both microprocessor-compatible IC's

16pins vs. 24pins		
	Mostek MK5102N-5	Rockwell- Collins CRC6930
Number of pins	16	24
TTL compatible outputs	YES	NO
Filtering required for typical system	33dB	40dB
Number of power supplies	1	2

reference the economical TV color crystal (3.58MHz) and use the world recognized TOUCH TONE* DTMF system. And both meet or exceed standards for stability, distortion, and timing.

Mostek's Communication Family includes a wide

choice of tone dialers, pulse dialers, and now a full line of industry's most versatile codecs. All provide low-cost solutions for fixed supply and direct phone line applications.

For more information on Mostek's communication products, contact Mostek at 1215 West Crosby Road, Carrollton, Texas 75006. Telephone: (214) 242-0444. In Europe, contact Mostek Brussels; Telephone: (49)(0711) 701045.

MOSTEK.



© 1978 Mostek Corporation
*TOUCH TONE is a registered trademark of AT&T



How Fairchild Takes the Thorns out of LSI Testing.

Choosing the right LSI test system is tough. There are many things to consider, and one of the most important is customer support. Here's how Fairchild makes the difference. Whether you buy our Sentry general purpose LSI tester or our Xincom memory test system, we'll back you with the largest and most professional service and support team in the industry.

Applications Engineering. Our team of applications specialists will program our systems to give you all the information you need about how to test your device. Whether you buy a system or not. If you do buy, all that information and programming are yours.

A world of training. Even the best system is only as good as the people who run it. To make sure your people know everything they have to about LSI testing, we've built the largest and most comprehensive training center in the world. With every Sentry or Xincom system, you're covered with course credits. Even before your system is installed, your people will learn operation and maintenance, basic programming and assembly language. They can also take special courses in programming and advanced LSI testing techniques. And they'll get all the hands-on training they'll need in our test lab.

On-site preparation. While your people are training at one of our centers in the U.S., Europe or Asia, our engineers are at your plant helping you get ready for delivery. Our product specialists help you find the best locations for your system. They make sure all your device programs have been checked out. And they make sure your system gets up and running fast.

Service is our specialty. No matter where you are, we've got you covered. More than 100 field engineers around the world assure fast response whenever you need help. You can choose from a variety of service con-

tracts. One gives you complete calibration and servicing, free parts replacement and a guarantee to be there within 24 hours. Another provides a spare parts kit that offers even faster turnaround. And if your operation needs it, we can provide a resident service or applications engineer.

We won't let you forget. If you need additional or special training, we can help. Our programmed learning center offers video tapes, audio cassettes and special workbooks. On-site courses can also be arranged. Nearly a hundred application notes are available to help you solve almost any LSI testing problem. There's even a User's Club, which gives you a chance to exchange programs and experiences with others in your field.

There's more. Whether you choose Sentry or Xincom, we'll make sure you don't get stuck. We'll help get rid of the thorns all along the way. Before, during and after your system arrives.

Find out more about Fairchild's total support program. Mail the coupon today. Or contact: Fairchild Systems Technology, 1725 Technology Drive, San Jose, CA. 95110 (408) 998-0123

Fairchild: First in LSI testing

Please have a representative call.

Send your Total Support brochure.

My test needs include _____



Name _____

Title _____

Company _____

Address _____

City/State/Zip _____

Area Code () Phone _____

FAIRCHILD



Model Z-2
Up to 512K of RAM/ROM

Model Z-2D
One or two disks
Up to 512K of RAM/ROM
Up to 184K of disk

System Two
Dual disk
Up to 512K of RAM/ROM
Up to 184K of disk

Fill your computer needs with the industry's most professional microcomputers

#1 IN RELIABILITY

When you choose Cromemco you get not only the industry's finest microcomputers but also the industry's widest microcomputer selection.

What's more, you get a computer from the manufacturer that computer dealers rate #1 in product reliability.*

Your range of choice includes our advanced System Three with up to four 8" disk drives. Or choose from the System Two and Z-2D with 5" drives. Then for ROM-based work there's the Z2. Each of these computers further offers up to 1/2 megabyte of RAM (or ROM).

We say these are the industry's most professional microcomputers because they have outstanding features like these:

- **Z-80A microprocessor** — operates at 250 nano second cycle time — nearly twice the speed of most others.

*Rated in *The 1977 Computer Store Survey* by Image Resources, Westlake Village, CA.

Up to 512 kilobytes of RAM and 1 megabyte of disk storage



System Three
Two to four disks
Up to 512K of RAM/ROM
Up to 1 megabyte of disk

- **30-amp power supply** — more than adequate for your most demanding application.
- **21 card slots** to allow for unparalleled system expansion using industry-standard S-100 cards.
- **S-100 bus** — don't overlook how important this is. It has the industry's widest support and Cromemco has professionally implemented it in a fully-shielded design.

- **Cromemco card support** of more than a dozen circuit cards for process control, business systems, and data acquisition including cards for A-D and D-A conversion, for interfacing daisy-wheel or dot-matrix printers, even a card for programming PROMs.
- **The industry's most professional software support**, including COBOL, FORTRAN IV, 16K Disk-Extended BASIC, Z-80 Macro Assembler, Cromemco Multi-User Operating System — and more coming.
- **Rugged, professional all-metal construction** for rack (or bench or floor cabinet) mounting. Cabinets available.

FOR TODAY AND TOMORROW

Cromemco computers will meet your needs now and in the future because of their unquestioned technical leadership, professionalism and enormous expandability.

See them today at your dealer.

There's no substitute for getting the best.



Cromemco

incorporated

Specialists in computers and peripherals

280 BERNARDO AVE., MOUNTAIN VIEW, CA 94040 • (415) 964-7400

IBM uses tunable dye laser to store more data

Scientists at IBM Corp.'s San Jose, Calif., research laboratory are using a tunable dye laser, which can be adjusted to emit light of various frequencies, to further refine a new method of increasing the amount of information that can be packed into a given space. In this method, **computer data is stored and identified by its location in the frequency range as well as its spatial position.**

The monochromatic laser light is directed onto a small sample of photoreactive material cooled to a few degrees Kelvin. A few of the molecules absorb energy at the beam's frequency and are altered into slightly different compounds. A shift in the frequency targets a new set of molecules. The encoded information can subsequently be read out by reducing the laser's power, varying its frequency over the same range used for writing, and monitoring absorption.

George Castro, one of the patent recipients, cautions that a new technology is still a long way off. "You aren't going to make any products with the dye laser right now. The tunable laser itself is still in the research stage," he says.

Shared elements cut cost of multistation MDS

Aiming to beat the rising cost of microcomputer development systems, a Los Angeles firm has put together a multistation network that it says will drive the price under \$7,700 per station. The key is that the stations will share use of the most expensive elements, like disk drives and printers, in common. "Sharing disk memory storage and printer resources," says Bruce Gladstone, vice president of Futuredata Computer Corp., "our network **allows up to eight stations to operate simultaneously,** and each designer has his own terminal and target processor." The system presently provides software support for the 8080, 8085, 8086, 6800, 6802, and Z80 processors. Each station is fitted with 64 kilobytes of random-access memory and can also operate as a stand-alone unit.

National aims Starplex at two markets

Driven by 1978 market estimates of \$100 million for microprocessor development systems and more than \$500 million for small computers, National Semiconductor Corp., Santa Clara, Calif., will unveil a disk-based development system at next month's Wescon/78 that is designed to grab a share of both. Called Starplex, the product, which is to compete with other high-end development systems, has a \$13,800 price tag. The company's Microcomputer Systems group counts on Starplex's Basic and Fortran language capabilities **to give it small-computer application appeal.** Slated for October availability to original-equipment manufacturers, the system includes 64 kilobytes of random-access memory, a 12-inch display, 96-key multifunction keyboard, 50-character-per-second thermal printer, and a 512-kilobyte dual floppy-disk drive.

Mostek fleshes out one-chip line of microprocessors

Once known only for its memories, Mostek Corp., Carrollton, Texas, will soon bring out products to solidify its position as a microcomputer manufacturer. **The first of two new one-chip microcomputers will be the 3876,** which is a 3872 with half as much read-only memory, followed by the 3873, essentially a 3870 (the first Mostek processor, a second-source version of the Fairchild F-8) with a serial input/output port. The 3876, to be available in sample quantities in the fall, has 2,048 bytes of ROM, a power-drain mode, and 128 bytes of random-access memory, half of which

is executable. The 3873, also with 2 kilobytes of ROM but with 64 bytes of RAM, has a fully programmable bidirectional serial I/O port; samples will be available around the New Year.

**Air Force to buy
\$14 million
Sperry Lorans**

The first all-solid-state operational Loran systems to support tactical air operations have been purchased by the Air Force Electronic Systems Division from the Sperry Gyroscope Company of Great Neck, N. Y. **Each of the \$14 million transportable systems, to be delivered in January 1980, features three 400-foot antenna towers** placed in a triangular pattern 400 miles apart. Each tower sends out a computer-controlled signal to Loran-equipped aircraft or ground troops. The differences in time of arrival of the three signals allow the exact calculation of receiver location.

**DEC opens
LSI-11 to user
microprogramming**

Users of Digital Equipment Corp.'s LSI-11 microcomputer and its half brother, the LSI-11/21, may write their own instruction sets. The Maynard, Mass., firm is allowing them up to 1,024 22-bit words of writeable control storage, **marking the first time a microprogramming option has been offered in a microcomputer.** DEC will mask-program users' microcode into 512-by-22-bit read-only memories, two of which are usually used for the PDP-11 instruction set. Through microprogramming, users can design in lookup tables, special functions that compute fast Fourier transforms, for example, and even emulators of other processors' instruction sets.

**Intel soups up
its 4-K PROM
to guaranteed 50 ns**

Intel Corp. of Santa Clara, Calif., has redesigned its 3605 512-by-8-bit bipolar programmable read-only memory with double layer metalization to shrink cell size and boost speed. **The result: the 3605A, which has a guaranteed worst-case access time of 50 ns.** The part, to be available in sample quantities later this year, has a cell size of 1.3 mil²—some 30% smaller than that of most other PROMS.

**16-K ROM, PROM
rated at 250 ns**

Most chip makers might be investing in the 23,768- and 65,536-bit read-only memories and programmable ROMs, **but American Microsystems Inc. is about to spring a matching pair of parts:** a 16,384-bit ROM and PROM. Built with V-groove MOS technology, the parts have a maximum access time of 250 ns. Samples of the S4216 ROM and the S4716 PROM are being shipped this month.

Addenda

Mass production of lasers for short-haul and medium-distance fiber-optic communications systems as well as other high-volume applications will result in a dramatic drop in laser pricing, predicts International Resource Development Corp. of New Canaan, Conn. The specialized research and management consulting firm projects that **today's price of approximately \$1,000 per laser will fall to below \$20, and perhaps even below \$10, by 1988.** . . . Attracted by the high speed of V-groove MOS, IBM Corp. has contracted with American Microsystems Inc. of Santa Clara, Calif., **to develop 40-ns static random-access memories for mainframe-memory add-ons.** The deal, which could run to \$10 million, covers R&D on 4,096-bit devices but does not provide for production.

Perfect harmony from 8K to 64K with this Motorola ROM quartet.

- Industry-standard pinouts — 24-pin package
- Upward compatible — easy memory expansion
- EPROM compatible • TTL and DTL compatible
- All fully static — 10% +5 V single supply operation

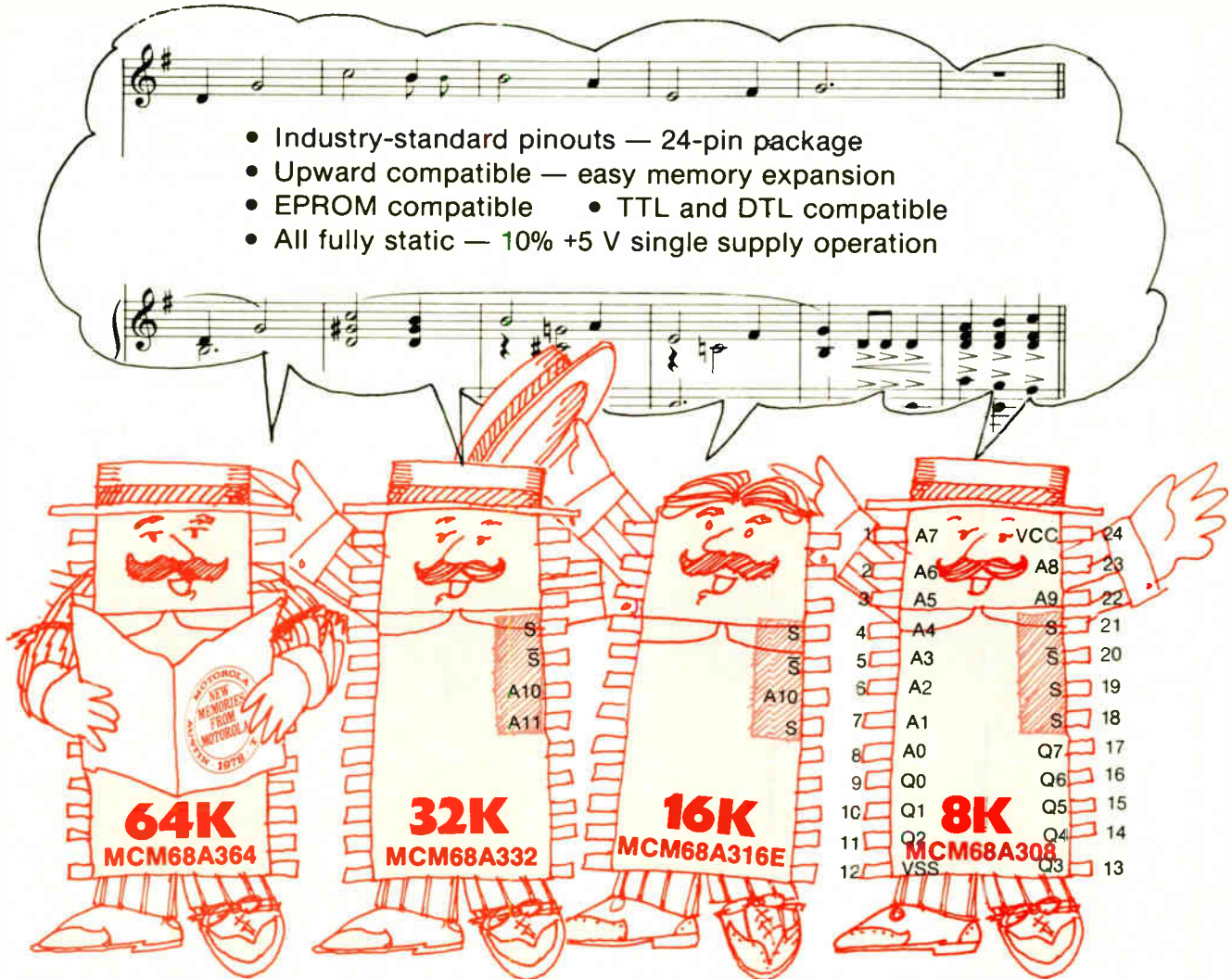

Or call it compatibility if you like.

Four mask-programmable ROMs singing from the same sheet of music: plug-in compatibility is the name of that tune. The 8K, 16K, and 32K parts are available in volume now. The MCM68A364 64K ROM will be available soon.

Use these industry standard pinout ROMs with the confidence that comes from knowing they're from Motorola, the industry's leading ROM supplier. They're likely to be a little less expensive, too, than ROMs you might obtain elsewhere.

The same applies to Motorola's full line of MOS memories, including EPROMs like the pin-compatible MCM2708L and MCM68708L, and our other 24-pin binary ROMs: the 8K MCM68A30A and 250 ns MCM68B30A, and the 16K MCM68A316A.

Why not join the chorus. Compose your next read-only storage with Motorola EPROMs and ROMs. Contact your Motorola sales office or authorized Motorola distributor.

For data sheets on Motorola's industry-standard pinout ROM quartet, write to Motorola Semiconductor Products Inc., P.O. Box 20912, Phoenix, AZ 85036, or circle the reader service number.



MOTOROLA
Semiconductor Group

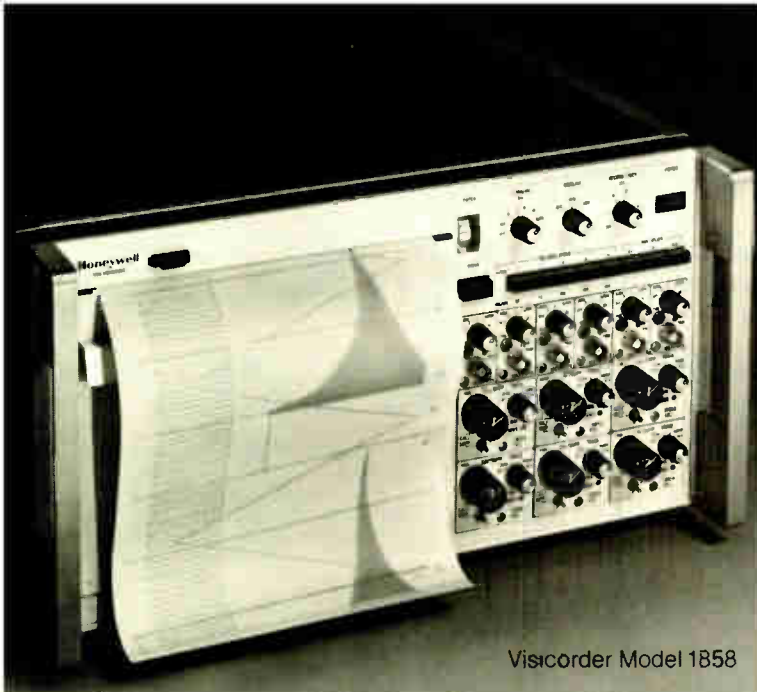

Viscorder Model 1858



Viscorder Model 1508B



Viscorder Model 1508C

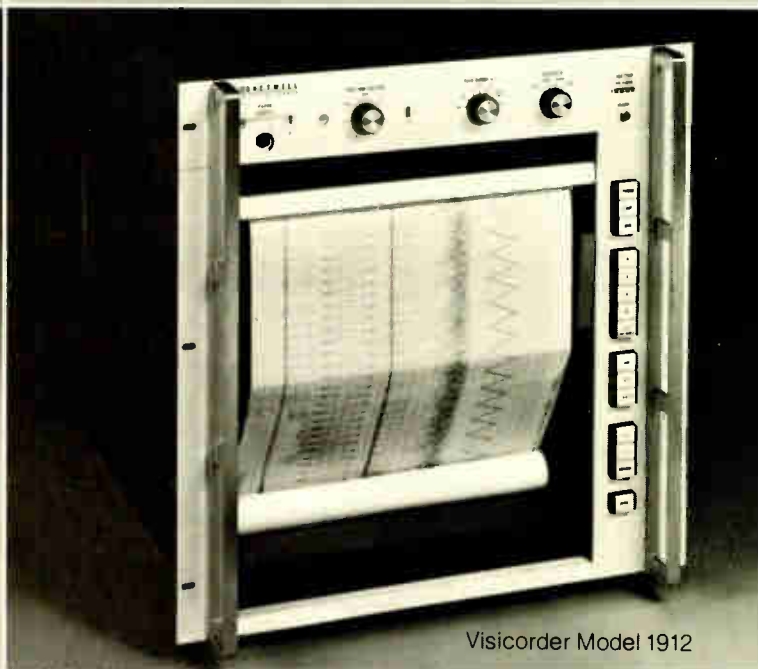

Viscorder Model 1912

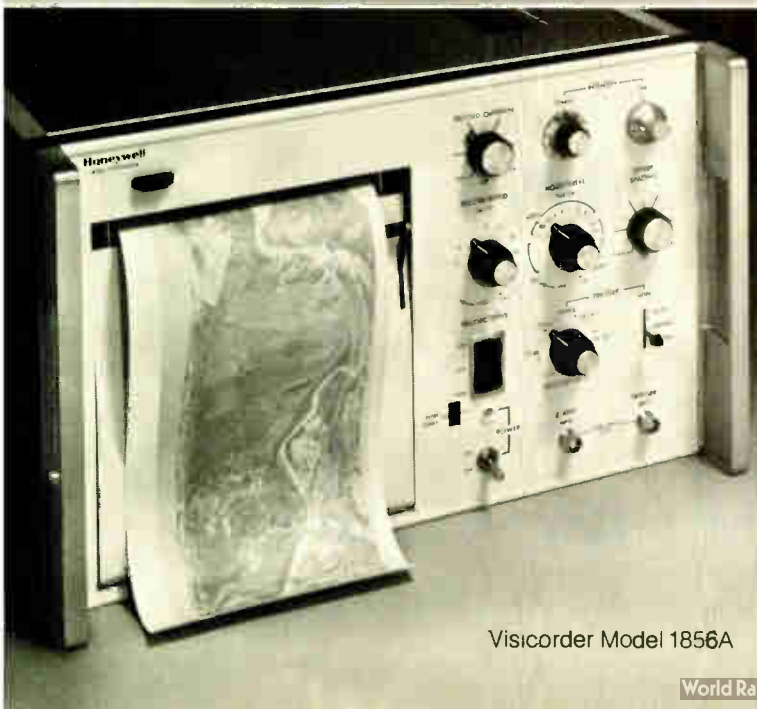

Viscorder Model 1856A

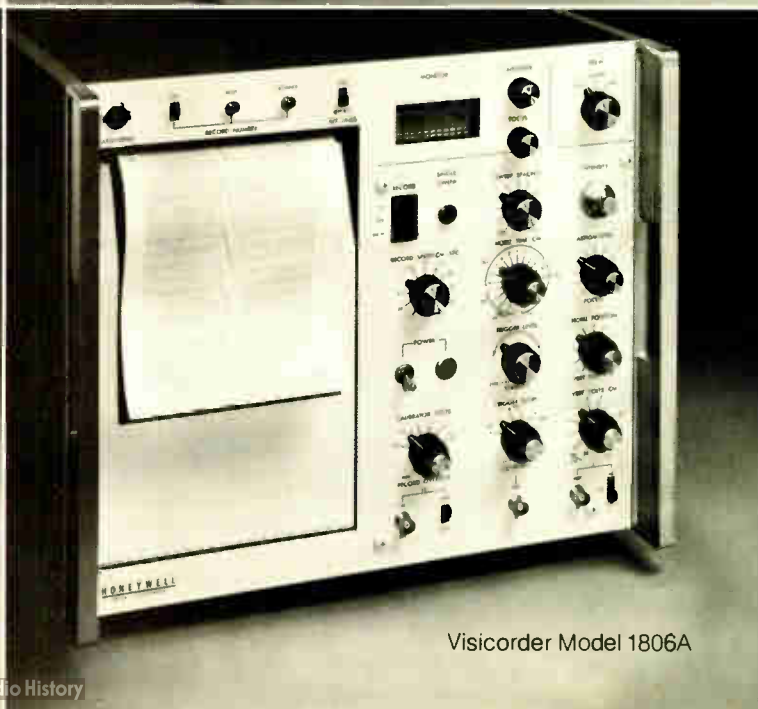

Viscorder Model 1806A

MEET SIX TOP RECORD MAKERS.

Perhaps the data you need can best be obtained by a high-performance oscillographic recorder with excellent trace resolution. Or you may require a linescan image recorder having very fast scan rates and a broad gray scale. Whatever it takes to get your data, chances are you will get it faster and easier with one of the recorders shown here.

These Visicorder oscillographs set the standard for high-performance graphic recording.

Visicorder Model 1858 is a completely self-contained system with up to 18 channels, yet it stands less than nine inches high. This unexcelled portability, enhanced by a wide selection of miniature, plug-in signal conditioners, makes the Model 1858 ideal for field or mobile use. And its dc to 5 kHz response, wide chart speed range, 100 μ V-300V input sensitivity, and the ease with which it expands to 32 channels also make it a favorite in the lab. A fiber-optic CRT assures sharp traces of high resolution across the entire 8-inch record.

Visicorder Models 1508B and 1508C offer dc to 25 kHz response, wide chart speed range and writing speeds greater than 50,000 inch/sec. Both combine

high-linearity optical systems with sensitive galvanometers to produce extremely accurate 8-inch-wide recordings. The Model 1508B has 24 data channels plus 4 for event recording; Model 1508C has 12 data channels plus 2 for event recording.

Visicorder Model 1912 offers the most data channels, widest recording paper, and widest transport speed range of all Honeywell galvanometer-type oscillographs. This versatile recorder can handle up to 36 channels of data, in addition to 6 channels of event recording. It accommodates 12-inch-wide paper at speeds from .005 to 200 inch/sec.

Do you need 4-axis recording capability? Our linescan image recorders give you the kind of record quality you can only get with a direct writing fiber-optic CRT.

Visicorder Model 1856A produces 6-inch-wide records that have exceptionally high resolution and wide gray scale. This makes the recorder particularly suited for such applications as facsimile, spectrum analyzer readouts, IR mapping and echocardiography. Z-axis response is dc to 8 MHz, Y-axis is dc to 75 kHz, and the X-axis is capable of scan rates to 18,000/sec. Accessories are available for film records.

Visicorder Model 1806A can record, on 6-inch-wide paper,

high-frequency signals that would otherwise require magnetic tape or oscilloscope camera techniques. It offers Y-axis response from dc to 1 MHz, Z-axis to 10 MHz, X-axis to 1 MHz and writing speeds greater than 1,000,000 inch/sec. The Model 1806A also accommodates accessories for film records.

Honeywell's Accudata signal conditioning modules speed most recording and measurement tasks.

Whether you need to control and amplify strain-gage signals, drive oscillograph galvanometers or magnetic tape recorders, or amplify low-level signals where relatively high common mode voltages are encountered, we have the modules to do the job easily and economically. Just give us your requirements and we'll show you an Accudata signal conditioner than can meet them.

For detailed information on any of these recorders or Accudata modules, call Lloyd Moyer at (303) 771-4700. Or write for our technical data sheets and a free brochure that describes all of Honeywell's Visicorders, magnetic tape systems and Accudata modules. Honeywell Test Instruments Division, Box 5227, Denver, CO 80217.

WE'LL SHOW YOU A BETTER WAY.

Honeywell

Finally. A dependable microcomputer board.

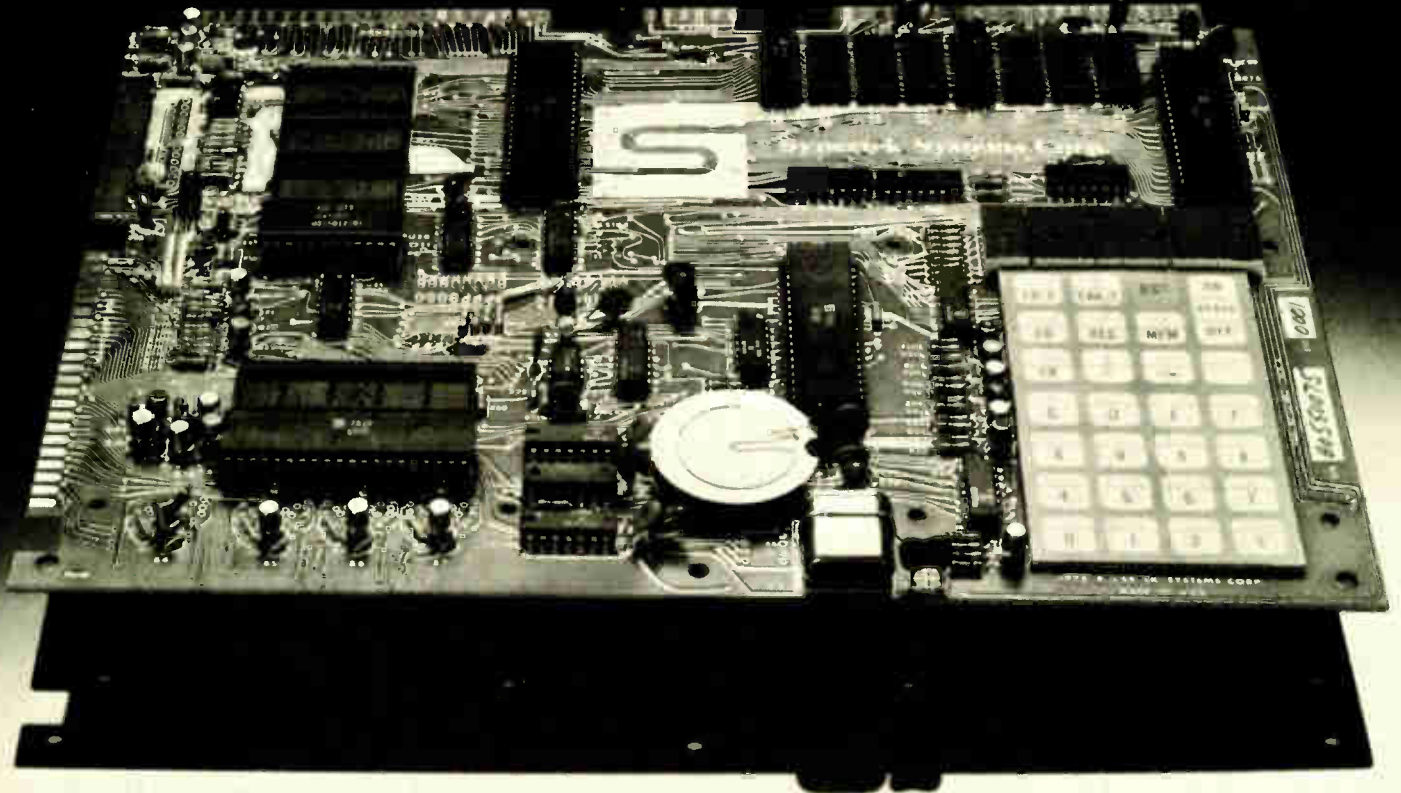

In performance. In quality. In availability. OEMs, educators, engineers, hobbyists, students, industrial users: Here's our Versatile Interface Module, a fully-assembled, tested and warranted microcomputer board that's a true single-board computer, complete with keyboard and display. All you do is provide a +5V power supply and the Versatile Interface Module gives you the rest—and that includes fast delivery and superior quality.

Key features include:

- Hardware compatibility with KIM-1 (MOS Technology) products.
- Standard interfaces include audio cassette with remote control; both 8 bytes/second (KIM) and 185 bytes/second (Versatile Interface Module) cassette formats; TTY and RS232; system expansion bus; TV/KB expansion board interface; four I/O buffers; and an oscilloscope single-line display.

- 28 double-function keypad with audio response.
- 4K byte ROM resident SUPERMON monitor including over 30 standard monitor functions and user expandable.
- Three ROM/EPROM expansion sockets for up to 24K bytes total program size.
- 1K bytes 2114 static RAM, expandable to 4K bytes on-board and more off-board.
- 50 I/O lines expandable to 70.
- Single +5V power requirements.
- Priced attractively in single unit quantities with OEM discounts available for larger quantities.

**Synertek Systems
Corporation.**

2589 Scott Blvd., Santa Clara, California 95050. (408) 988-5690.

To place your order now, contact your local area distributor or dealer.

OEM Distributors

Kierulff Electronics
Sterling Electronics (Seattle only)
Zeus Components
Century/Bell
Lionex
Hallmark
Intermark Electronics
Quality Components

Technico
General Radio
Western Microtechnology
Future Electronics
Alliance Electronics
Arrow Electronics

Personal Computer Dealers

Newman Computer Exchange
Ann Arbor, Michigan

Technico
Columbia, Maryland
Computerland
Mayfield Heights, Ohio
RNB Enterprises
King of Prussia, Pennsylvania
Computer Shop
Cambridge, Massachusetts
Computer Cash
Anchorage, Alaska

Energy Electronic Products
Los Angeles, California
General Radio
Camden, New Jersey
Advanced Computer Products
Santa Ana, California
Computer Components
Van Nuys, California

Circle 40 on reader service card

TRW puts most of an rf receiver on single silicon LSI chip

L-band receiver is close to completion; oxide-aligned process used for transistors, films for discrete components

Radio-frequency receivers have long resisted the onslaught of large-scale integration. LSI transistors have not operated at high enough frequencies, diffused resistors have not been accurate and stable enough, and on-chip capacitors have just not had the capacitance to couple wideband signals. The result: higher-frequency receivers, especially for the military, must depend on hundreds of discrete devices. This keeps not only costs but physical size from shrinking, and it penalizes reliability.

TRW Inc.'s Microelectronics Center in Redondo Beach, Calif., says it has licked all three of these problems. It is coming up with an L-band, 1,200-to-1,600-megahertz receiver on a single silicon chip. The first major step was in the transistors.

"The key for integrating analog or rf functions in a monolithic form is oxide-aligned transistor technology," says Barry Dunbridge, who manages the center. This technique relies on an Isoplanar variation of high-density bipolar processing the TRW unit has polished for years (see "TRW knows its OATS"). It doubles mask-alignment resolution, so that transistors can be built with a narrow enough emitter structure to have unity-gain frequencies (f_t) of 4 to 5 gigahertz.

Complementing the high-frequency transistors in the LSI receiver are

cermet resistors, thin-film devices that are actually deposited on the monolithic substrate. Diffused resistors, which ordinarily bias active elements in a monolithic design, are difficult to produce with any accuracy. Also, they have a poor temperature coefficient and stability. TRW's technique for depositing the cermet, which are composed of chromium-silicon-dioxide material, even permits laser trimming to high precision, although the trimming is not necessary in the receiver.

Finally, the relatively large values of coupling capacitors needed by the receiver have also been attained by laying thin films down on the chip. TRW uses a metal-oxide-metal sandwich made with an extremely thin deposition—1 micrometer—of silicon dioxide that serves as the dielectric between aluminum and a final metalization layer.

These three advances have al-

lowed the chip to operate up as high as 2 GHz. "It's the only LSI receiver I know about that goes above 50 MHz," says Dunbridge.

The receiver chip consists of a phase-logic, bandpass shift-key (BPSK) demodulator that accepts input data between -100 to -70 dBm, supplied from an antenna, as shown in the diagram. The analog output from the demodulator feeds an automatic gain control circuit that holds the input to the demodulator at -20 dBm. At the input to the chip, the data signal is amplified by 30 decibels and mixed with a 700-MHz-wide signal from an off-chip surface-acoustic-wave filter. The chip's output data stream is accompanied by a separate acquisition signal.

System to come. By the end of the year, Dunbridge will have an L-band chip ready to design into a system. Although what system is not yet

On chip. All components of TRW's L-band (1200-1600 MHz) receiver, save for surface acoustic wave filter, fit on one chip. Thin-film resistors and capacitors placed on the monolithic silicon do the job of discrete parts.

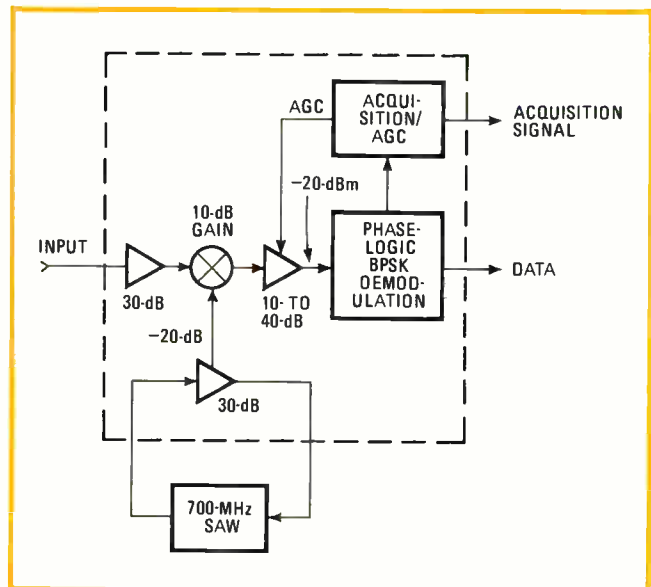

TRW knows its "OATs"

The key to the gigahertz transistors TRW uses in its L-band receiver-on-a-chip is the company's self-aligning bipolar process, called OAT for oxide-aligned transistors. OAT was developed several years ago to boost the operating frequency of transistors in large-scale integrated circuits and to improve yields. Transistors with unity-gain frequencies of several gigahertz require extremely narrow emitter structures on the order of 2 micrometers across, which would necessitate special processing and cripple yields. The OAT process, however, extracts 2- μm resolution from conservative 4- μm geometries.

The process puts deep oxide wells into the n-type epitaxial layer normally grown on a p-type substrate for npn transistors. These wells serve as boundaries, so that both the masks used for subsequent isolation and the collector, base, and emitter diffusions can have a degree of play yet still resolve a fine emitter structure.

TRW has used the OAT process in place of standard epitaxial processes for all high-speed devices since 1976. Improvements since then include a more-than-doubled yield, better step-coverage in first-layer metalization, better contact and etching of second-layer metal, and reduced photoresist defects because of proximity printing.

OAT is at present used by TRW for analog-to-digital converters, subnano-second digital logic, and rf analog circuits. In digital logic, for example, the high-frequency transistors have been used in D-type flip-flops that toggle at an exceptionally high 1,300 megahertz. All the work that TRW has done has been on 2 $\frac{1}{4}$ -inch wafers.

certain, the company is considering a receiver for the Air Force's Global Positioning System [*Electronics*, June 22, p. 48], which could become operational in the early 1980s. Large numbers of low-cost receivers will be needed for the system, which will obtain position data from an orbiting network of satellites.

The chip itself will "replace something on the order of 100 discrettes," Dunbridge says. It will measure 140 by 60 mils and dissipate less than 750 milliwatts. In its final package, the receiver will occupy a volume of 1 cubic inch—about a fifth the size of a unit with discrete components, according to Dunbridge.

He is reluctant to be pinned down on what a complete receiver might cost. A few thousand dollars each in large quantities seems reasonable, he says. This figure is well below present prices.

Building blocks. Beyond the L-band receiver chip, the LSI building-block chips could be designed for bands of frequencies anywhere between 100 and 2,000 MHz, for communications, radar, and electronic warfare systems, Dunbridge says. And frequencies could go even

higher because of the results of a parallel effort also under way under Dunbridge's direction. "Using gallium arsenide, 10 gigahertz is in sight by 1981," he says. □

Companies

UK venture launched amid U. S. doubts

Can a new British semiconductor company with over \$45 million in startup funds from the UK's National Enterprise Board find success in the U. S. by concentrating on advanced microprocessor and memory design?

The answer is no, according to industry analysts on this side of the Atlantic as the wraps came off Inmos Ltd. in England late last month. They point to the poor potential they see for any government-sponsored semiconductor startup, the international shortage of experienced personnel, and the highly competitive nature of the markets.

American companies have quite a head of steam up and will be very

hard to catch, says Lee Allgood, manager of MOS memory marketing at Signetics Corp., Sunnyvale, Calif. The British company will really have to work hard to intercept us competitively some time in the future, he says.

"The big hurdle will be whether they can draw the people they will need to do the job from the United States," he continues. "There's too much money still to be made over here—they may get a few of the entrepreneurial types they'll need, but they'll probably never put together the whole team."

Asks an observer from Wall Street, "If the British government wanted to get into advanced semiconductors, why didn't it invest in a going concern that would perform on the incentive of profits?"

But the Inmos sponsors have already attracted a proven and highly talented management team. At the top, as anticipated, is Richard L. Petritz, one-time president of Mostek Corp. and former head of strategic planning for Texas Instruments Inc., who masterminded the venture [*Electronics*, July 6, p. 86]. On the technical side are Paul Schroeder, a superstar in memory design lured away from Mostek, and Iann Barron, one of the UK's leading computer systems designers (see "Meet the designers").

The new company will have plants in the UK and U. S. The critical process development will take place in the United States, at a site to be named. Volume production will be in the United Kingdom also at an unnamed site. The company will concentrate initially on n-channel large-scale integrated devices of its own design and has no intention of being a second source.

Barron will head up a design operation in the UK concentrating on microprocessor technology, and Schroeder will head up a U. S. team working on memory products. The aim is to have a U. S. pilot plant up and running in six months to a year and volume production in a British plant by 1981. By then, financial support from the NEB could rise to a total of \$90 million. In addition, key



British are coming. Founders of Inmos Ltd., new semiconductor firm supported by the U.K.'s National Enterprise Board, (from left) are Iann Barron, Paul Schroeder, and Richard Petritz.

employees will be able to invest in up to 27.5% of the company's voting shares.

Undeterred by criticism, Inmos' founders argue that there has never been a better opportunity to establish a leading-edge semiconductor company because there is a world shortage of LSI parts, particularly in computer and automotive fields.

The firm's product strategy is still unclear. It is assumed that its target, like everyone else's, is a 64-K random-access memory. Petritz believes that Inmos does not have to be first to make it big with this product. In the meantime, he observes that production of 16-K RAMs is only now building, a clue that this will be Inmos' entry point.

The Inmos executives concede that the most critical element in the whole project remains the task of starting a high-yield, high-density process very quickly. Pointing out that there is no production equipment around today that will put out 64-K RAMs in volume, they have precise ideas of what equipment they want, according to Schroeder. They will not go immediately to direct electron-beam lithography on wafers, though they have made provi-

sion for phasing in some electron-beam technology. Apparently, Inmos is going to start with conventional optical exposure techniques, which does not rule out the use of masks generated by electron beam. □

Displays

Flat LCD panel has big potential if . . .

Take some liquid-crystal displays, add fiber-optic light pipes, illuminate with a very bright lamp—and *voilà*, a new kind of flat, TV-like display that could be as large as several feet on a side. The idea belongs to Izon Corp. of Stamford, Conn., but unless the privately held company attracts a partner with money, electronics expertise, and marketing knowledge, "it won't go anywhere," says marketing vice president Peter Genereaux.

The display would use much the same technology as a microfilm page reader the size of a textbook Izon brought to market in the spring. But it took more than \$6.5 million and three years to develop the reader,

Meet the designers

Paul Schroeder and Iann Barron get Inmos Ltd., the new British semiconductor company, off to a pretty good start in technology. Schroeder, for example, has put Mostek on the map in memory. He has supervised the firm's present 64-K RAM development effort, headed design of a sub-100-nanosecond 8-K static RAM, and spearheaded the first 64-K read-only memory, to name a few projects. He also knows metal-oxide-semiconductor technology for dynamic RAMs.

Less well-known in the U.S., Barron, now a consultant, founded the UK's first minicomputer company, Computer Technology Ltd., in 1965. His Modular One, built with fast emitter-coupled logic, pioneered many distributed-processing concepts.

and apparently the firm is too exhausted to develop the technology further.

What Izon would like to do first is develop a demonstration display measuring 10 inches on a side and about 4 in. deep. The imaging core of the panel would be a 10-by-10 array of individual LCDs, each measuring 0.2 in. square and able to address a 100-by-100-dot matrix. In front of each LCD would be a compound lens, and behind it an optical fiber connected to a light source—an intensely bright halogen lamp, for example.

Light would pass through the LCD, whose image would be magnified and focused by the lens onto a translucent viewing screen. The optics would be arranged so that the dot matrixes on the viewing screen would butt up against each other to form a continuous matrix of dots, 10,000 on a side. Images would be formed by controlling the pattern of 0.1-mil-square dots in the individual LCDs, thereby controlling the light transmitted to the lenses. The size of the display would be varied by adjusting the optics. Genereaux says he will be content with a demonstration model with only two LCDs and



Distributor. Optical fibers in page reader distribute light to lenses from bright source, placed to shine into dark circle at bottom. In new flat display, light from each fiber would project the dot matrix of individual LCDs onto a translucent screen.

their electronics in place.

Many of the individual design elements have been proven out in the micrographics reader, which sells for \$275, according to Genereaux. He points out that Izon holds a patent for using optics in parallel for recording and display. In the reader, a piece of film measuring 8 by 10 in. and containing segmented images of as many as 195 different pictures is used instead of the liquid crystals. And the technique for making the lenses—they are injection-molded all at once in a single piece of acrylic—has been perfected.

Series of blocks. As stored on the film, the picture segments appear as an incoherent series of blocks of light and dark. A coherent image is produced on the viewing screen by moving the film into position, illuminating it with the fiber-optic light sources, and focusing each segment with the lenses. A slightly different film position yields a different picture. Izon produces the film using its own optical equipment.

"The new idea will be even easier to implement," Genereaux says. The

main reason is that the display must project fewer individual picture elements. Only 100 optical fibers and 100 lenses would be needed in the display; the reader has 504 of each, he points out. "Since the lenses will be further apart, they can be made larger, which will reduce processing costs," he says. The hard part will be to design the X-Y drive electronics to fit on the same ceramic substrate containing the LCD. Genereaux points out, though, that the ability to distribute the interconnections around each LCD is a great advantage over other flat-panel approaches that butt the display elements against each other. □

Consumer

Electronic watch has LCD hands

With 120 separate elements on the face of a new watch with liquid-crystal hands, Texas Instruments Inc.'s engineers had to go some to be able to connect to all of them. They do it with a multiplexing technique that uses only 26 contacts, as well as a programmable logic array built with integrated-injection-logic technology. The use of I^2L also allows a voltage regulator to be built into the 154-by-268-mil chip.

"It's an overall system achievement," says Hector Cardenas, manager of advanced technology development for the Consumer Products group. "We're able to drive highly capacitive LCD elements from I^2L circuits, which hasn't been done before. And we have designed an on-chip voltage regulator that provides automatic temperature compensation to match the temperature coefficient of the display."

Complementary-metal-oxide-semiconductor technology is favored for LCD watches because it uses little power, but it would not have been feasible to build the regulator on a C-MOS chip, Cardenas says.

TI would not have been happy with C-MOS for another reason as well. It can only drive a type of liquid-

crystal display that must be protected with either a yellow- or green-tinted filter against ultraviolet light. This would have limited the styling of the watch, as well as the viewing angle of the display.

Styling is one thing Cardenas and TI are certainly concerned about. Priced from \$275 to \$325 and in gold-plated cases, the watch, called The Time Indicator, is pegged at the high end of the firm's line.

Until now, TI has concentrated on high-volume digital products, with a \$10 light-emitting-diode display watch at the low end and an \$80 LCD watch at the other. The new watch, which also operates as a stopwatch and will be available in October, will not remain at the high end for long.

"We [will] take on the whole analog watch spectrum," says Bob Zlotky, TI's manager of time products. "You can expect the same technology in stainless-steel cases selling for under \$50 within 12 months."

Competition. TI's new high-end watch competes against electronic watches with mechanical hands made by Seiko Time Corp., the U. S. marketing arm of the leading Japanese watch maker. Like all electronic watches, these keep time with a quartz-crystal oscillator, but they use a stepping motor to move the hands. Hideaki Moriya, president of Seiko Time, says his company's market research showed that an analog LCD display like TI's will not be accepted by the consumer.

Also last month, Seiko announced the world's thinnest watch—a 0.95-millimeter-thick case housing quartz oscillator, stepping motor, 0.9-mm-thick silicon-oxide battery, and C-MOS chip. With an 18-carat-gold case, the watch is in the \$5,000-to-\$10,000 price range.

TI uses a special low-voltage ester mixture for the LCDs, of the twisted-nematic field-effect type used in many LCDs. The on-board voltage regulator compensates for the negative temperature coefficient of the material, as well as for the variable voltage output of the lithium-manganese-dioxide battery. The regulator provides on and off drive voltages (2.6 and 1.3 volts) to bipolar drivers

SCIENCE/SCOPE

For the first time, airborne radar can be reprogrammed without the expense and delay of changing hardware. A new Programmable Signal Processor (PSP), developed for use in the U.S. Navy and Marine Corps F/A-18A Hornet, the Navy F-14 Tomcat, and the Air Force F-15 Eagle, gives their radar systems exceptional automation and mode flexibility. The processor's heart consists of 21 circuit boards, some with as many as 256 chips, each chip the equivalent of 4000 transistors. These highly complex circuits enable the radar systems to be reprogrammed almost immediately, and on a service-wide basis to meet future threats, or to be upgraded as new weapons are introduced. Developed by Hughes, this new design is expected to effect substantial cost savings now and in the future.

A bright, high-resolution, large screen liquid crystal projection system that can display dynamic tactical military situations in real time has been delivered to the U.S. Navy for evaluation. It can project virtually anything that can be displayed on a cathode ray tube either in raster scan or random scan mode. Typical applications include symbols, alphanumerics, geographical maps, and text. Its bright, clear display reduces requirements for specially controlled lighting during briefing sessions or command conferences.

The system uses a liquid crystal light valve developed by Hughes, and has a reliability never before achieved in large screen displays. Mean-time-between-failure is estimated at 5000 hours, and, as no consumables are required, this results in lower operating and maintenance costs. Other features are 1000 line resolution and 30 millisecond response time.

Hughes Missile Systems Group has many immediate openings, in the San Fernando Valley area of Southern California, for engineers and scientists in new, expanding, long-range R&D programs associated with the design and development of advanced radar and electro-optical guided missiles. Typical openings include systems analysts to perform preliminary design in the areas of control systems and signal processing; RF/IF, digital and analog circuits engineers, aerodynamicists, product engineers, digital system design engineers, microwave and electro-optical engineers and many others. For immediate consideration, please send your resume to: Engineering Employment, Hughes Aircraft Company, Canoga Park, CA 91304.

Canada was the first nation to launch a national communications satellite program (1972). Now it will utilize a third-generation series of satellites (called Anik-C) to handle digitized telephone traffic across the densely populated southern border region. The new Anik ("brother" in Eskimo) space vehicles will also provide additional TV channels. Their K-band frequencies will provide 16 channels -- or four more than the first model has. After completing contract negotiations with Telesat Canada, Hughes will develop the Anik-C satellite for launch from Space Shuttle or by expendable rocket. Initial scheduled liftoff date: late 1980.

Creating a new world with electronics



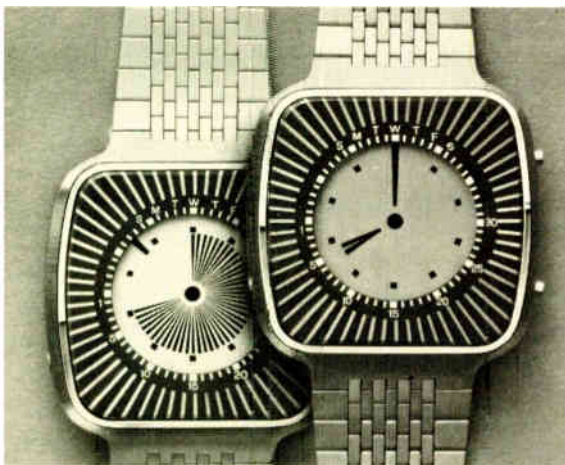

Hands. TI's watch with its 120 LCD segments also functions like a stopwatch (shown at left) at the push of a button.

designed to rapidly charge up the highly capacitive display elements. The drivers supply 100 to 150 microamperes of drive current for 100 microseconds and power down to a low sustaining current of 100 nanoamperes when the display is off. □

Communications

Laser, Trapatt diode yield speed, power

A major problem for designers of coded burst-communications systems requiring both high speed and high power is to achieve these characteristics in a simple device. Perhaps the record for simplicity is being set by researchers R. A. Kiehl, R. E. Hibray, and E. P. EerNisse of Sandia Laboratories in Albuquerque, N. M. They are doing it by illuminating a Trapatt diode transmitter, a three-layer device used for pulsed microwave-frequency oscillators, with a stream of optical pulses from a gallium-aluminum-arsenide laser diode.

A first. Their transmitter is probably the first ever to generate an information-bearing microwave signal by using light to directly control the internal operation of a microwave source. This is achieved with an actual data rate of 120 megabits per second with 64 watts of radio-

frequency power for some modes of operation. Since the digital modulation rate is limited only by the laser, Kiehl feels that "speeds up to multi-gigabits are possible with millimeter-wave Trapatts."

In addition, because the modulator is optically isolated from the radio-frequency energy being transmitted, there is no interaction to cause loading effects. Arbitrarily high transmitted power levels are possible, Kiehl says.

The single-stage laser-modulated transmitter is far simpler than the previous approach that uses an oscillator followed by multiple amplifier stages. There, the modulation was done in an early low-power stage. Other approaches such as modulation of the transmitter with varactors or p-i-n diodes just cannot be made to switch fast enough at high power levels.

Structure. In Sandia's approach, the Trapatt diode is mounted in a slug-tuned coaxial cavity with electrical contact to the diode layers made so that 80% of the active diode region is illuminated by the laser. This illumination produces rapid changes in the diode's oscillation frequency and amplitude as a result of the diode's constantly changing internal carrier dynamics.

Both the Trapatt and the laser are commercially available devices. The laser itself is a double-heterostructure stripe-geometry diode that emits 7 milliwatts of continuous-wave power at 890 nanometers. It is modulated by a simple transistor driver circuit in which the laser looks like a collector load in an emitter-coupled pair.

The Trapatt diode is pulse-biased and illuminated by a synchronized optical pulse stream from the laser. Either frequency-shift or amplitude-shift keying is obtained by simply tuning the Trapatt oscillator circuit.

Transponders. Kiehl believes there are applications for the new device in transponders where the communication is done in short, digitally coded bursts. Downstream possibilities include high-speed digital radio links, spread-spectrum systems with high percentage bandwidth, and high-

resolution radars, he says.

So far, Sandia has worked mostly with pulsed systems. With a Department of Energy contract, it is now beginning to develop a system built around a continuous-wave Impatt diode. Commercial Impatts are used, and it is hard to couple enough light to the diode's interior because its electrode connections are in the way, Kiehl explains. The connections could be etched away, however.

Others are interested in optical modulation of solid-state oscillators as a result of Sandia's work. For example, the Defense Advanced Research Projects Agency is supporting a study by Hughes Aircraft Co., Culver City, Calif., of injection-locking transistors with light beams for phased arrays. And the Harry Diamond Laboratory in Washington, D. C., is looking into amplitude modulation of 70-gigahertz Impatts with laser light. □

Microprocessors

C-MOS bows in TI's 4-bit controller

That Texas Instruments Inc. is now offering its 4-bit microprocessor-controller family in a lower-power technology seems to make sense. The reason: the Houston consumer and automotive division handling the part has corralled the business of a major share of the cost-sensitive electronic toy and game manufacturers, who want low power to conserve battery life.

But, in fact, the game makers are not the first in line for the new TMS 1000C family—TI is aiming it initially at more sophisticated applications like telecommunications and industrial controls. Prime examples are repertory dialers and call-routers that use the chips directly off the telephone lines.

TI did not just reduce power by moving from p-channel to complementary metal-oxide-semiconductor technology. It also enhanced the microcontroller's performance by adding some desirable features like

DESIGN a voice command system with the Siliconix CODEC

Enter the Siliconix CODEC Design Contest and win an Apple II — the world's best-selling personal computer — or another great prize. All you have to do is use Siliconix' CODEC to design a microprocessor-based system which responds to your spoken words (or talks back to you). Our CODEC is a two-chip set: the DF331 coder is a high-speed serial output A/D converter — a complete subsystem-on-a-chip; the DF332 decoder converts high-speed digital bit streams into analog signals. The system you design must be capable of understanding or speaking at least 16 words.

Here's what you can win:

1st prize: Apple II personal computer (retail value \$1,445). A completely self-contained computer system with high resolution color graphics in 15 colors (with color TV); BASIC in ROM, 16K bytes of RAM, built-in video interface, cassette I/O, four A/D inputs with two game paddles supplied, eight peripheral slots, three TTL inputs and four TTL outputs. Apple II plugs into any standard TV using a modulator.

2nd prize: Siliconix LCD Stopwatch-In-A-Wristwatch. Features time, day, date, plus split timing stopwatch functions.

3rd prize: Siliconix LED Stopwatch. Includes split timing function.

4th prize: Siliconix Telephone Timer. Includes start/stop and timeout.

5th prize: Siliconix LED Stopwatch. Features a digital start/stop timer.

All entries must be accompanied by our official entry blank. Get yours, along with complete contest rules, data sheets and other information, by filling out the coupon below.



& WIN an Apple!®



Mail to:

Siliconix CODEC Design Contest
2201 Laurelwood Road
Santa Clara, CA 95054

Yes, I want to know more about the Siliconix CODEC Design Contest. Please send me details and the official entry blank.

Name: _____ Title: _____

Company: _____ (Optional)

Address: _____ Mail Station: _____

City: _____ State: _____ Zip: _____

Low cost* Data General Mini- computer compatible analog I/O systems.

The ADAC 535 Series of analog I/O systems are field proven, high performance systems that plug directly into the bus of any Data General Minicomputer.

The systems are hardware and software compatible with Data General Mini's and feature 12 bit A/D resolution, 35 or 100 KHz throughput, 16 to 64 analog inputs, 1 to 4 12 bit D/A converters, program control/program interrupt/DMA interface, programmable gain amplifier with auto zeroing and DC/DC converter.

Send for full technical data on the 535 Series and other mini/microcomputer data acquisition and control systems:

ADAC Corporation,
15 Cummings Park, Woburn,
MA 01801. (617) 935-6668.

* Basic System Price in single quantities..... \$1,295

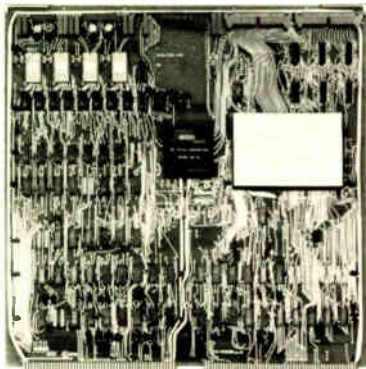

GSA Contract
Group 66

adac

corporation

Electronics review

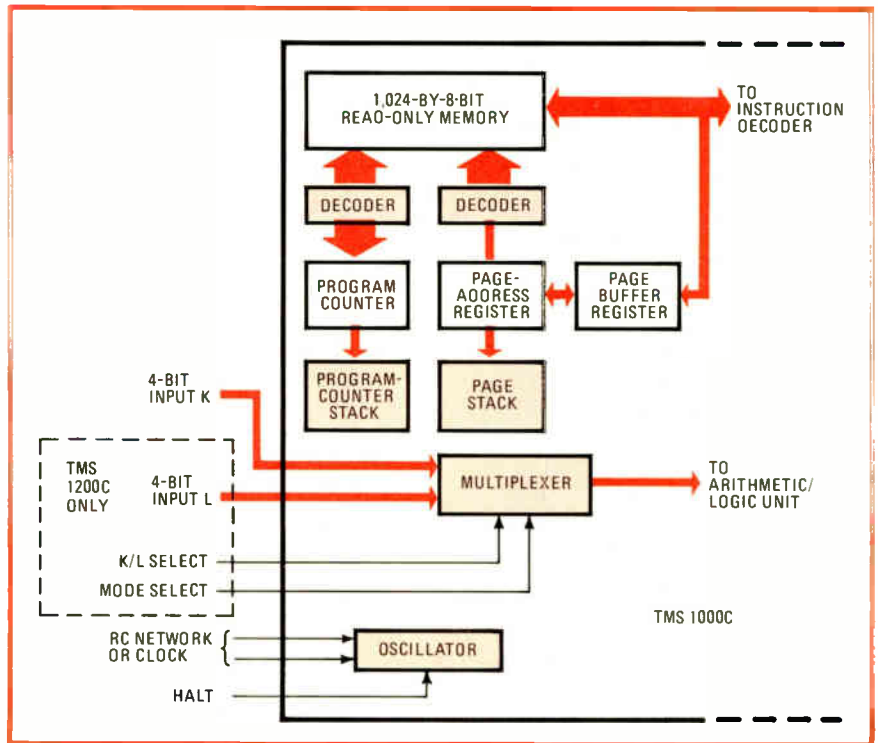

Enhanced. TMS 1000 family, now made in C-MOS, has added features, including a stack for subroutines, a halt line for the clock, and, in the TMS 1200C, four extra inputs.

faster operating speed and more inputs and subroutine levels.

"Right now, the aim is toward more functions and better performance," says Andy Brock, strategy manager for the 4-bit TMS 1000 microcontroller family to which the new C-MOS devices belong. "Until the games manufacturers move to liquid-crystal displays, there'll be no need to move to lower-power chips—the light-emitting diodes and other displays they use draw lots more power than any of the microcomputer chips, even those built with p-channel technology."

Standby. The cut in power using C-MOS instead of p-MOS is significant: the 28-pin TMS 1000C typically dissipates 5 milliwatts (at 5 volts), compared with 68 mw (at 15 v) for the older part. But it is with a new standby mode that the C-MOS parts really shine—standby power is a tiny 7.5 microwatts. The earlier TMS 1000 designs could operate only in the active mode.

Also, Brock notes, C-MOS has other desirable features like high noise immunity and inherently higher speed than the p-channel MOS of

the TMS 1000 line. The 1.3-megahertz upper operating frequency of the 1000C family triples that of the p-MOS parts, which top out at 400 kilohertz. "Customers are always asking for higher speed, for applications from industrial control to audio systems," Brock says.

More ROM. Among the other enhancements, shown in the partial block diagram of the chip at the top of the page, are additional subroutines, which, Brock points out, mean that less memory would be needed by a cleverly written program. The savings translates into the equivalent of 20% more read-only memory, he says.

Added to the oscillator is a halt line, also shown in the diagram, that stops the clock while preserving the machine state. It is useful in duty-cycling the microcontroller to a very low average power consumption in power-critical applications.

Finally, the company has added an input multiplexer to a version of the new line, called the TMS 1200C, that has 13 outputs instead of 11. The new multiplexer doubles the available inputs to 8, answering

abbott

POWER SUPPLIES

Fit for land, sea and air.

For over 15 years Abbott power supplies have seen service with every branch of the military . . . from the XM-1 tank to the Trident submarine to NASA's SKYLAB. Proven performance in these and other critical military and aerospace applications is the result of Abbott's unique capabilities and experience in power supply design.

The Model "W" family, for example, because of its unique combination of laboratory-type performance and aerospace size, has become a standard throughout the world. Over 10,000 units are in service, featuring output voltages from 5 to 100 VDC, with current levels from 0.3 to 20 amps . . . in packages as small as 2 1/8" x 3 1/4" x 3 1/4".

Today, Abbott offers a choice of over 1500 versions of high efficiency, hermetically sealed, single or dual output power supplies and switcher modules. They include 60 and 400Hz to DC modules, DC to DC converters, and DC to AC inverters, with outputs from 3 VDC to 740 VDC, 1 to 250 watts. And prices are as low as \$174 for 2-4 units.

So, for quality, reliability, performance and low cost, call Abbott. As for delivery, we can probably ship from stock. For additional information, see your EEM or GOLD BOOK power supply sections, or write us for a free catalog.



See Power Supply Section 4000, and Transformer Section 5600, Vol. 2, of your EEM catalog; or Power Supply Section 4500, and Transformer Section 0400, Vol. 2, of your GOLD BOOK for complete information on Abbott products.

abbott

transistor

LABORATORIES, INCORPORATED

General Offices
5200 W. Jefferson Blvd., Los Angeles, CA 90016
(213) 936-8185 Telex: 69-1398

Eastern Offices
1224 Anderson Ave., Fort Lee, NJ 07024
(201) 224-6900 Telex: 13-5332





MITEL

MILITARY OR COMMERCIAL ANALOG SWITCH

CMOS ANALOG SWITCHES FOR MANY APPLICATIONS - CROSS-POINT, ANALOG-TO-DIGITAL AND DIGITAL-TO-ANALOG CONVERSION, ANALOG OR DIGITAL MIXING, TRANSMISSION GATING, ETC.

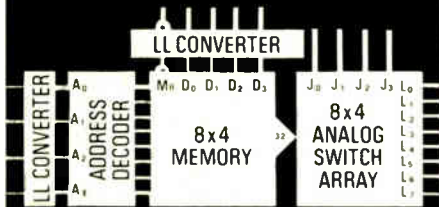

MT8804B CMOS/LSI 8804B 8 x 4 ANALOG SWITCH ARRAY

- FEATURING:**
- TO 18v, 9v PEAK DIGITAL AND ANALOG SIGNAL LEVELS
 - 50Ω "ON" RESISTANCE OF SWITCHES (TYP.)
 - 5Ω BETWEEN "ON" VALUES OF SWITCHES (TYP.)
 - -50db CROSSTALK AT F_{IS} = 1 MHz BETWEEN SWITCHES
 - 85 db "ON OFF" OUTPUT VOLTAGE RATIO (TYP.)
 - LESS THAN 0.5% DISTORTION AT F_{IS} = 1 KHz
 - MASTER RESET OF CONTROL MEMORY
- OTHER CMOS ANALOG SWITCHES INCLUDE:**
- MD4016B - QUAD BILATERAL ANALOG SWITCH/TRANSMISSION GATE
 - MD4066B - QUAD BILATERAL ANALOG SWITCH/TRANSMISSION GATE
 - MD4051B - 8-CHANNEL ANALOG MULTIPLEXER/DEMULTIPLEXER
 - MD4052B - DIFFERENTIAL 4-CHANNEL ANALOG MULTIPLEXER/DEMULTIPLEXER
 - MD4053B - TRIPLE 2-CHANNEL ANALOG MULTIPLEXER/DEMULTIPLEXER

For more information write or phone



1745 JEFFERSON DAVIS HWY
SUITE 611
ARLINGTON, VA. 22202
TEL 703-243-1600

MITEL

Semiconductor

Electronics review

another customer concern, Brock says. In addition, a mode-select pin used with the input-select pin latches data in, a handy feature for transient data, he points out.

The toys and game market is not really out of the reach of the TMS 1000C, which will cost less than \$5 each in large quantities, Brock continues. "The way we see it, by the time toy manufacturers are ready to go to C-MOS—in about a year or two—we'll have the price down to one they can afford," he says. □

National aims at low-end units

"Customers don't want cost-effective—they want cheap," declares National Semiconductor Corp.'s Fred Horne, manager of engineering for the Santa Clara, Calif., company's new line of 4-bit microcomputer chips. National is out to sweep the low-end microprocessor field with the COP 400 (for control-oriented processor) family n-channel silicon-gate devices that will range in price from \$3 down to a meager 99 cents in large quantities.

Unlike Texas Instruments with its new TMS 1000C line (see story above), National, often called a "jelly bean" semiconductor house because of its commodity lines of linear and discrete components, is using price pressure to try to garner more of a market share. The company concedes that it did not have much of a chance to catch industry leaders Texas Instruments Inc. and Rockwell International Corp. with its old COP (for calculator-oriented processor) line because the p-channel metal-oxide-semiconductor devices were not very well thought out and the company did not really push them.

Texas Instruments and Rockwell have a nearly equal share of more than 90% of the low-end microcontroller market. But Horne emphasizes that this market, encompassing such high-volume consumer products as intelligent light switches and handheld games, demands low price.

Low-end microcontrollers have been offered for less than \$2 by some manufacturers in 100,000-piece quantities and have gone as low as around \$1.75.

More options. In addition to price considerations, National's rethinking included two other objectives: a wide offering of memory and instruction-set options and enough speed-power combinations to extend the COP 400 applications over the microcontroller gamut.

The result is a family of 12 devices having various mixes of read-only memory (from 512 to 2,048 bytes), random-access memory (from 32 to 128 4-bit nibbles), five output options, and a set of either 43 or 57 instructions.

Of course, National has competition in chasing TI and Rockwell. American Microsystems Inc. is pushing its S2000 family of 4-bit parts, and Panasonic Corp. has its MN1400 series. General Instrument Corp. sells the 8-bit PIC1600 in the same market. Sharing the 8-bit perspective is Intel Corp., which recently added its 8022 with on-chip analog-to-digital conversion to its microcontroller family [*Electronics*, May 11, p. 183].

For its part, National plans to broaden its attack by bringing out a low-power complementary-MOS version of COP 400 in January for a little over \$3, and in a few weeks will add muscle to its effort by nailing down a second source. □

Communications

Deregulation seen as easy by Justice

The rapid economic growth and fast pace of technological change in U. S. telecommunications should make Federal deregulation of the market relatively easy, says the Justice Department. John Shenefield, assistant attorney general for antitrust, says the industry's \$120 billion estimated annual revenues are expanding 10% to 20% a year. Compared to less dynamic industries, he says,

Robert Bosch Mini-Giants® in a nutshell

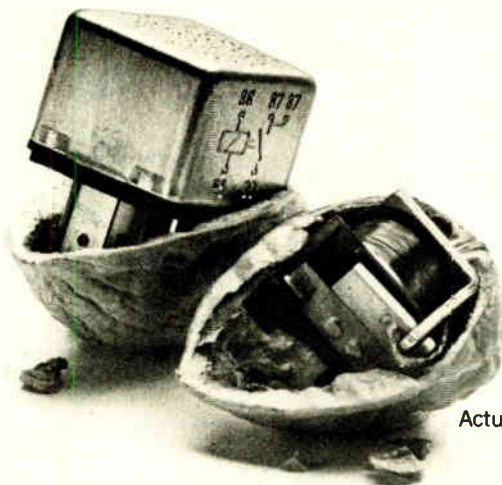

Actual Size

Smallest 30-amp, quarter-million-cycle relay for the price

Capacity. Plug-in Mini-Giants rated at 30 amps, with 60-amp peak. Standard PC board rated at 15 amps, with 30-amp version also available.

Size. PC relay is 0.56 cubic inch. Plug-in is 0.8 cubic inch. Both measurements less terminals.

Switching life. All Mini-Giants built for 250,000 cycles at full rated load (or 10 million at no load). This compares to 100,000 cycles in many comparable relays from other makers.

Versatility. Mini-Giants can be used in 6, 12 or 24 VDC applications: remote controls, alarms, car systems, agricultural and construction equipment, and much more.

Cost. Mini-Giants give you all these features combined at a surprisingly low price. Fill out this coupon and we will contact you to discuss your specific needs. Or call Dave Robson at (312) 865-5200 and ask about relays. Either way, do it now.

Name _____

Title _____

Company _____

Address _____

City, State, Zip _____

Phone _____

ROBERT BOSCH
CORPORATION

2800 S. 25th Ave., Broadview, IL 60153
Attn: O/ESL3-Relay Sales

©1978 Robert Bosch Corporation

103

**MORE
POWER
MORE
BANDWIDTH
LESS COST**



Our Model 601L is an ultra-wideband RF Power Amplifier whose wide range of frequency coverage and power output provides the user with the ultimate in flexibility and versatility in a laboratory instrument. Easily mated with any signal generator, this completely solid state unit amplifies AM, FM, SSB, TV pulse and other complex modulations with minimum distortion.

With a flat frequency response from 0.8 to 1000MHz the Model 601L will provide a linear class A output of 1.2 watts and a maximum saturated power output of 2 watts.

Constant forward power is continuously available regardless of the output load impedance match, making the 601L ideal for driving reactive as well as resistive loads.

Unconditional stability and instantaneous failsafe provisions in the unit provide absolute protection from damage due to transients and overloads.

Priced at \$1195 U.S.A.

APPLICATIONS INCLUDE:

- Laboratory Instrumentation
- RFI/EMI Testing
- NMR Spectroscopy
- TV Signal Distribution
- Communication Systems

For further information or a demonstration, contact:

ENI
3000 Winton Road South
Rochester, New York 14623
Call 716-473-6900, or
Telex 97-8283 ENI ROC

ENI

The world's leader in power amplifiers

Electronics review

News briefs

4-K RAM shortage seen throughout rest of year

The shortage of 4,096-bit dynamic random-access memories currently plaguing the industry is expected to continue to the end of the year, according to consensus opinions among marketing executives at Intel, Mostek, Motorola, National Semiconductor, Signetics, and Texas Instruments. Current lead times stretch from 8 to 18 weeks for 16-pin versions and from 16 to 18 weeks for most 22-pin packages. In gearing up for 16-K RAMs, chip makers were wrong about 1978 demand for 4-Ks, which was accelerated in part by aggressive pricing that tags 4-Ks from \$3 to less than \$1.50 depending on quantity, package, and access time. Many believe that 4-K shipments this year will easily exceed last year's. However, some say that 16-Ks, now in the \$10-and-up range will attract 4-K users when the bigger units decline in price to between \$7 and \$8.

TRW negotiating for space materials processing

TRW Defense and Space Systems Group is expected to be named prime contractor for the National Aeronautics and Space Administration's space material processing program—recently subjected to strong criticism by the National Research Council [*Electronics*, July 6, p. 56]. NASA says it is negotiating a \$9.7 million proposal with the TRW group in Redondo Beach, Calif., for the initial three-year phase of the program set to begin in September. Under the proposal, TRW would develop experimental payloads for the space shuttle and Spacelab to produce purer materials—such as silicon crystals for semiconductors—in a gravity-free environment.

Cable & Wireless to study 4-to-6-GHz interference

Britain's Cable and Wireless Ltd. will begin a study in Hong Kong next year to try and find out why apparent ionospheric changes are impairing communications-satellite transmissions. Intelsat, the 102-nation consortium sponsoring the study, believes the signal fluctuations—which occur only during the evening and mainly during the equinox periods, when the sun crosses the celestial equator—are produced by sunspot activity. Since 1979 is forecast to be a year of high sunspot activity, Intelsat is eager to discover the cause, extent of, and remedy for the problem.

NASA prepares launch of second Venus probe

Countdown checkout continues as the National Aeronautics and Space Administration prepares for the August 7 launching of the second part of its \$175 million Pioneer probe of the atmosphere of Venus. When the multiprobe craft nears the planet next December, it will split into five separate spacecraft that will descend into the hot, hostile atmosphere. The multiprobe and a Venus orbiter that was launched in May are expected to yield data to answer questions like why a planet so similar in many respects to earth is so different in atmosphere and whether that atmosphere can provide clues about our own weather system.

such growth leaves a lot of room to accommodate new companies with new ideas.

The Justice Department disclosure of its estimates on market size and growth came in congressional testimony late last month that generally supported the pro-competition stance of H. R. 13015, the rewrite of Federal communications regulation [*Electronics*, June 22, p. 84]. However, Shenefield hedged on the bill's specifics in his preliminary views,

reserving these for later judgment.

The market estimates embrace everything from broadcast and cable television, plus radio, to telephone and satellite hardware and services. More hearings are set for later this month before the House subcommittee on communications.

Cable conflict. With cable TV markets still having room to grow in most rural and many urban areas, the bill's proposal to eliminate Federal regulation altogether produced

The OEM terminal that is built to do more for your customers...and your nameplate.

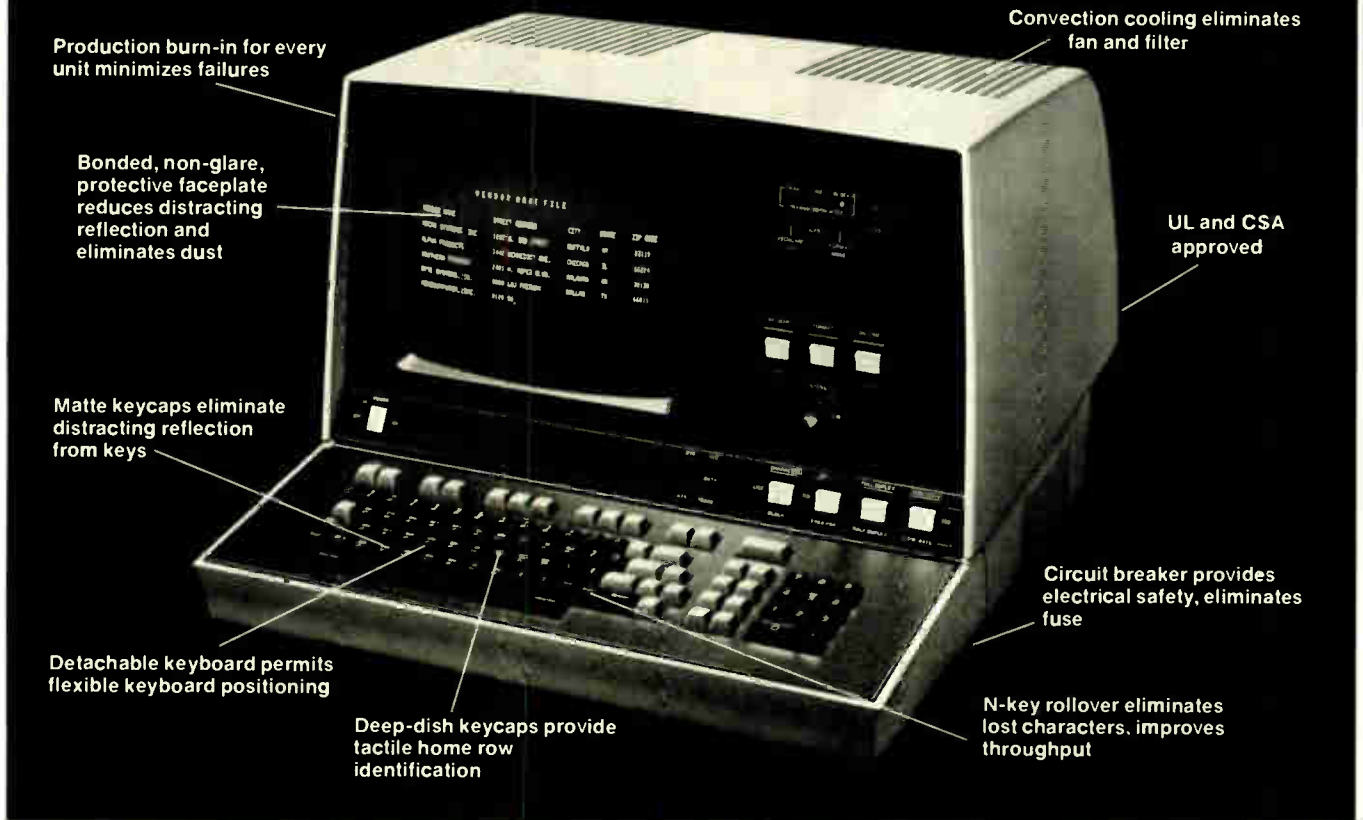

30 Day Free Trial.

Get all the features shown above in a terminal that can be programmed at any time for additional processing functions. It can be used to control printers or flexible disks. Or interface it with industry-specific devices like ticket printers or credit card readers.

We also manufacture conversational display and edit display terminals. They're simpler, but we put the same concern for quality into all of them. All feature modular construction for simpler maintenance and installation, and we've added features to enhance operator efficiency. And we back them all with a one-year warranty.

Control Data people know terminals. We've been making them for more than twenty years. We can help you put quality behind your nameplate.

For the 30-day no-obligation evaluation now available to qualified OEM's, or for further information, call us at 612/482-4229. In Europe, contact one of our European representatives. Or return coupon to:

Bob Bell, Product Sales Manager,
Control Data Corporation,
2401 North Fairview Ave., Roseville, MN 55113

E-8-3

Tell me more about Control Data OEM terminals.

Name _____ Title _____

Firm _____ Address _____

City _____ State _____ Zip _____

Phone _____

CD CONTROL DATA CORPORATION

More than a computer company

Imagine!

A dot-matrix impact printer for only \$66.50 each*!

- Large, easy-to-read characters.
- 40 col. capacity (12 char./in.).
- 2-copy capability.
- Variable font and density capability.
- Several standard control chips available.
- Mechanically simple; few moving parts.
- Optional built-in paper roll holder with low-paper sensing.
- Optional journal re-wind mechanism for second copy.
- Ticket printer versions available.
- Over 90,000 units shipped.

*1000-pc. qty.



Developed and
manufactured by LRC, Inc.
Riverton, Wyoming 82501

SEND FOR CATALOG

LRC, Inc., 99 E. Magnolia Blvd., Burbank, CA 91502
Tel: (213) 848-5556 TWX: 910-498-2255

LRC

Circle 54 on reader service card

***t.t.b.**

***TOTAL TAX BITE**
Computed by estimating effect
of exemptions and subsidies.

ONLY *5%
OF YOUR NET INCOME

United States Virgin Islands

OFFERS A TOTAL TAX PACKAGE.

AND WE MEAN TOTAL!

Benefits include subsidies or exemption of income, real property, gross receipts, and excise taxes as well as customs duties; AND the Federal Government grants duty free entry into the United States even if your product contains an allowable percentage of foreign materials and components.

DO YOU QUALIFY?

write

**VIRGIN ISLANDS
INDUSTRIAL DEVELOPMENT
COMMISSION**

MORRIS MOSES—DIRECTOR
P.O. Box 1692 St. Thomas
UNITED STATES VIRGIN ISLANDS 00801
Phone 809/774-1417 Telex DEPTCOM 3470063

Electronics review

sharply conflicting views. A fully developed market, industry officials estimate, could balloon receiver sales by 2 million to 3 million units a year from 1978's most optimistic forecast of a record 10 million.

Nevertheless, the bill's plan to define community-antenna TV as an intrastate service and permit telephone companies to enter the market came under fire. Leaving CATV regulation and licensing to the 50 states and an estimated 9,400 municipalities would create "a crazy quilt" of rules based on "parochial and not national interests," complains Robert Hughes, chairman of the National Cable Television Association.

Interstate service. His association's insistence that cable television's increasing use of satellites and its importation of distant signals make it an interstate service subject to Federal oversight was supported by Federal Communications Commission chairman Charles Ferris, former chairman Dean Burch, and other past and present FCC commissioners who testified.

Nearly all agreed that a diversity of regulations and fees would inhibit further development and use of the technology even more than the FCC's rigid supervision in the past. The commission has been widely criticized by CATV advocates as protecting market shares of over-the-air broadcasters by limiting CATV growth. Nevertheless, most NCTA members now operating systems also predict disaster if they are obliged to compete with telephone companies previously barred from the market.

Richard Elkin, president of the National Association of Regulatory Utility Commissioners, representing state and local governments, predictably favored giving CATV control to the states in cases where signal distribution is within a state.

Justice's Shenefield hinted that he may later come out in favor of retaining Federal jurisdiction over cable television, since the increasing use of satellites for distribution "may result in cable television emerging as a national service much more effectively competitive with existing network television." □

How do you best test a PCB?

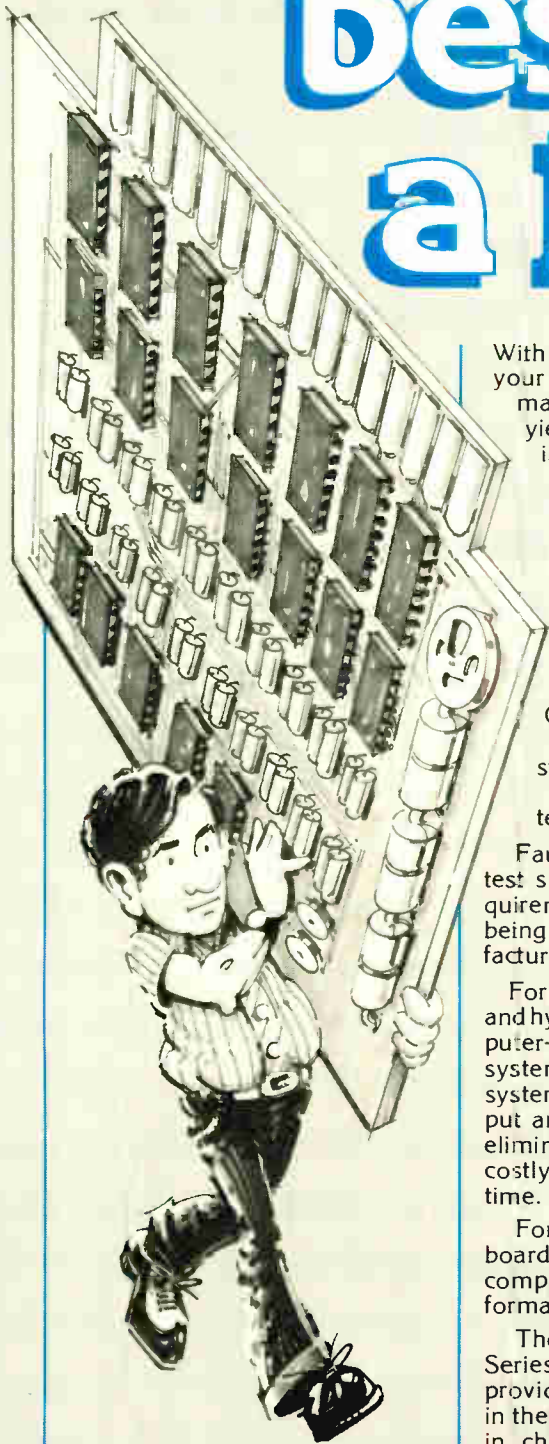

With a method that not only can test your PCB's, but will assure you maximum cost savings and higher yields. You'll want a system that is highly reliable and well known throughout the electronics industry. A system that will quickly pinpoint faults for subsequent repairs.

The systems should have flexible software that allows you to edit, adapt and expand as your production or state-of-the-art changes occur. Complementing the system, you'll want dependable, easily stored and easily handled test fixtures to interface with each test system.

Faultfinders automatic in-circuit test systems fulfill all of these requirements. They are presently being used by the largest manufacturers of PCB assemblies.

For testing highly complex digital and hybrid PCB's the powerful, computer-based FF303 and FF303D systems are your answer. These systems will give you high throughput and, in most cases, reduce or eliminate a high percentage of costly functional test and repair time.

For smaller hybrid boards and boards with a higher ratio of analog components, you'll get similar performance with the FF101C.

The self-programming FF200 Series shorts and continuity testers provide significant improvements in the throughput of bareboards or in checking wiring harnesses or backplanes.

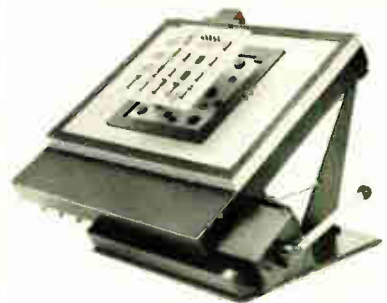

Each Faultfinders test system is equipped with a low cost, easily operated interface... the Thinline™ or Standardline™ fixtures.

The best test of Faultfinders test systems is to see them in action at our home office or at the Faultfinders Test Center nearest you. Call or write to arrange a demonstration and to learn what Faultfinders test systems can do for you.

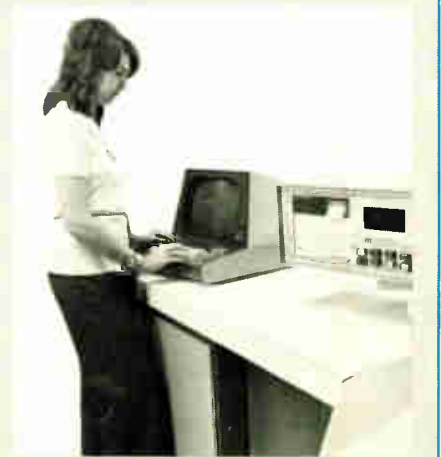

FF **FAULTFINDERS**

15 Avis Drive, Latham, N. Y. 12110 (518) 783-3600
17971 Suite E. Sky Park Circle, Irvine, CA 92714 (714) 549-4901
525B Del Rey Avenue, Sunnyvale, CA 94086 (408) 732-9020

646 N. Busse Highway, Park Ridge, IL 60068 (312) 696-0335
235 Bear Hill Road, Waltham, MA 02154 (617) 890-4717
7747 LaRisa, Dallas, TX 75258 (214) 423-7731

Circle 55 on reader service card

NEC Newscope

Facsimile Readout Revolution By Tiny New NEC Image Sensor



Actual size of the "μPD792D" linear image sensor.

NEC recently unveiled a completely new device which will revolutionize facsimile equipment.

The device, a CCD (charge coupled device) linear image sensor named "μPD792D", incorporates 2,048 picture elements, and converts a photosignal into a voltage signal. It consists of a charge input circuit, a sensor array made up of 2,048 MOS capacitors driven by a single photogate, two CCD shift registers located one on either side of the sensor, a transfer gate and a charge detector with noise compensation circuit.

The μPD792D, having 2,048 elements, a preamplifier and a compensation amplifier on a 3 x 30mm chip, can resolve patterns over B4 size paper (25.6cm wide) at a rate of 8 lines/mm. In addition, it features a wide dynamic range and a high transfer efficiency of more than 99.996%. Power supplies required are all below 15V.

Thanks to its outstanding features including long service life and low cost as well as trouble-free performance, the new image sensor is expected to revolutionize "readout" performance of facsimile equipment.

NEC has adopted this new product for its NEFAX series facsimile equipment.

Full-Electronic Key System



The latest addition to the versatile Patrician key telephone family is the stored program control Electra-28.

It is the first commercially-available full-electronic type in the world. Drastic cuts in installation costs are achieved because thin 3-pair cables are used for connection of the key service unit and the telephones. Conventional types require thick 25/50-pair cables. With a built-in microprocessor, the Electra-28 offers a wide scope of standard and optional services including such unique features as "Meet-me-answer," "Call pickup" and "Add-on conference."

It can accommodate up to 28 stations with 10 CO/PBX and 4 intercom or 11 CO/PBX and 3 intercom or 12 CO/PBX and 2 intercom lines.

More than 2,000 systems were installed in the U.S. during the past 12 months.

1,300-km Australian Microwave System To Be Powered By Solar Cells

Australia is to have a 1,300-kilometer, solar-powered microwave communications link extending through the central desert.

The link will consist of a 4,000 MHz low power consumption, high reliability heterodyne relay microwave system covering a distance of 500 kilometers between Tennant Creek in the central north and Alice Springs in the central area, and a 2,000 MHz low power consumption, high reliability baseband relay microwave system between Alice Springs and Tarcoola in the south, a distance of 807 kilometers.

The 4,000 MHz Tennant Creek-Alice Springs system, to be constructed by Telecom Australia, will provide 1,260 high-grade telephone channels or one color television channel. On the other hand, the 2,000 MHz Alice Springs-Tarcoola system will be built by the Australian National Railway (ANR), and will have a channel capacity of 300.



Route map of NEC-equipped microwave radio relay systems in Australia. Broken lines show new desert links to be powered by solar cells.

As there is no commercial power supply available along the projected link running mostly through barren areas, the 1,300 kilometer Tennant Creek-Tarcoola link will be equipped with compact, economical low power consumption and high reliability equipment, and will be designed to run on solar cells. The new microwave link will be the first of its kind to extend 1,300 kilometers.

In Australia, NEC-made microwave systems are now in service in major microwave links which form a nationwide network. The first NEC-equipped link was put in service in April of 1966 between Brisbane and Cairns, a distance of 1,500 kilometers along the east coast. This, the world's first solid-state microwave system, is now acting as a vital link between the SEACOM (Southeast Asia Commonwealth) submarine cable landing at Cairns and the COMPAC (Commonwealth Pacific) submarine cable extending to New Zealand and Canada from Sydney.

The Tennant Creek-Alice Springs system will be completed in December 1978 and the Alice Springs-Tarcoola system in December 1979.

1978 Annual Report



Our annual report for the fiscal year ended March 31, '78 has been published. To receive your copy, please write the Customer Relations Division, Nippon Electric Co., Ltd., P.O. Box 1, Takanawa, Tokyo 108, Japan.

DSI Terminal Doubles Digital Voice Transmission Capacity

NEC has developed a compact, fully-digitized device capable of doubling the transmission capacity of digital voice systems.

The new device, Digital Speech Interpolation (DSI) terminal, is designed to utilize the idle time in normal telephone conversations. Actual speech in normal telephone conversation is said to occupy considerably less than 50% of the total time and the remainder is left unutilized.

The DSI terminal compresses four 1.544 Mb/s T1 type PCM signal streams carrying 96 digitized speech signals into two 1.544 Mb/s T1 compatible bit signal streams. To attain this two-to-one bit rate compression, the status of each telephone channel is examined in the terminal and only active portions of speech are transmitted, thus allowing transmission of other speech in the idle time through the same channel and enabling the channel capacity of a digital voice transmission system to be doubled.

Use of a microprocessor has made it possible to develop a compact, inexpensive DSI terminal having extensive operating and maintenance monitoring features.

The new DSI terminal will contribute greatly to the reduction of transmission costs through efficient utilization of frequencies in digital voice transmission.

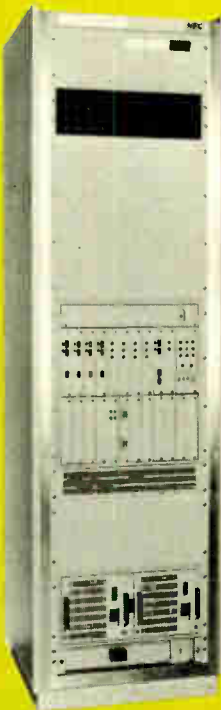

Two DSI terminals with a total capacity of 192 channels are mountable in the standard 7-ft high, 19-inch wide and 20-inch deep rack.

NEC-Equipped Microwave Network In Brazil Now Covers 20,000 km



Commander Euclides Quandt de Oliveira, Brazilian Minister of Communications, inaugurates completion of the Recife-Petrolina 1,100-km microwave link with a call from Petrolina to Mr. José de Moura Cavalcante, Governor of Pernambuco, in Recife.

People living in the State of Pernambuco in east central Brazil can now enjoy improved telephone and television services with completion early this year of a new microwave link running across the state from Recife in the east to Petrolina in the west.

The microwave link, which covers a total distance of about 1,100 kilometers, was installed for the Telecomunicações de Pernambuco S/A in Recife.

The link, consisting of a total of 31 hops, is equipped mostly with NEC's 2GHz and 7GHz 960-channel systems. It can handle 960 telephone channels and a television channel.

In addition to manufacturing, supplying and installing all the necessary equipment including supervisory equipment for the new microwave link, NEC has also installed coaxial cable systems to connect local stations with the link and is completing a total of 300-kilometer UHF links. NEC also conducted the site and route survey for the project.

In conjunction with a number of cable PCM systems supplied by NEC, which have been in operation in Recife and its vicinity since the beginning of last year, the new microwave link covers almost the entire area of the State of Pernambuco.

With the completion of the Recife-Petrolina link, the total length of NEC-equipped microwave links now in service in Brazil has reached about 20,000 kilometers, equal to the distance from Japan to Brazil. About 50% of them, including a 1,500-kilometer trans-horizon system linking Manaus in the north central region to Belém located at the mouth of the Amazon River, were built for the Empresa Brasileira de Telecomunicações (EMBRATEL). The rest is shared more or less equally among state telephone companies and power companies.

NEC
Nippon Electric Co., Ltd.
P.O. Box 1, Takanawa, Tokyo, Japan

From the Leader in High-Voltage Interface IC Technology

HERE'S COMPREHENSIVE DATA ON HIGH-PERFORMANCE INTEGRATED CIRCUITS

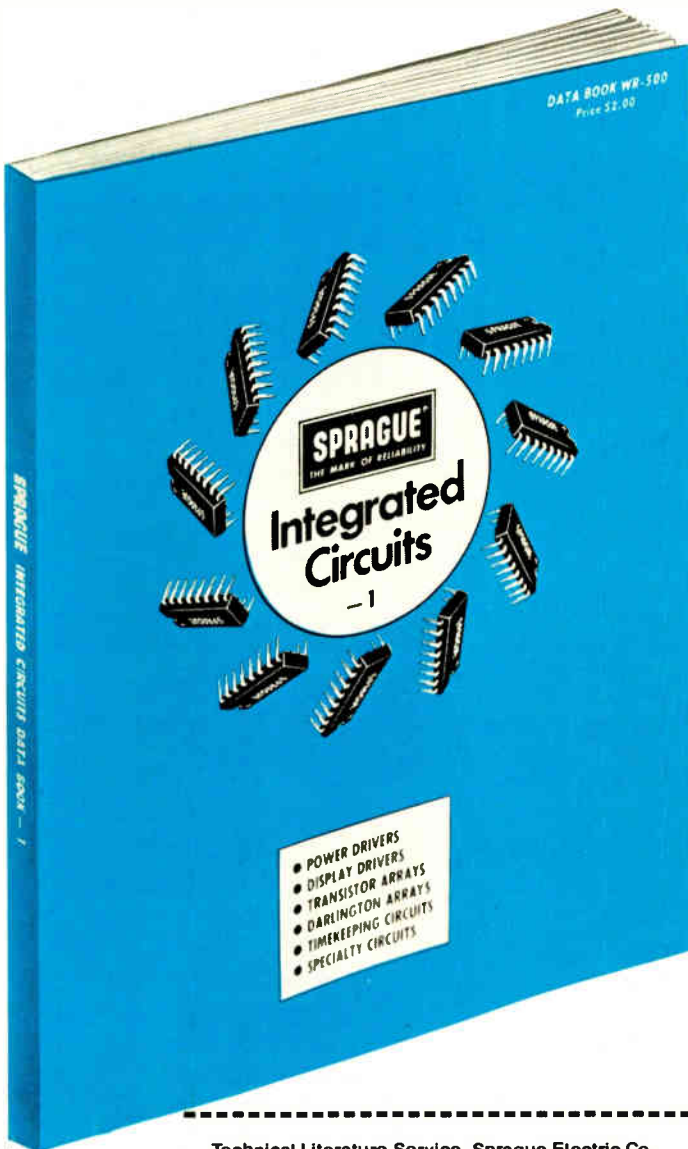

Just off the press is a *new* 240-page 7" x 9" data book which provides a comprehensive guide to high-performance ICs, with special emphasis on interface circuits.

This *new* Sprague Integrated Circuit Data Book features essential technical data on power-peripheral drivers; high-voltage display drivers; high-current transistor and Darlington arrays; MOS, CMOS, and BiMOS circuits; and specialty devices such as op amps, quad current switches, and amplifier-detector/SCR firing circuits.

To secure this valuable book, call your nearest Sprague district office, sales representative, or franchised semiconductor distributor. Or, if you prefer, mail the handy order form today.

DISTRICT OFFICES AND SALES REPRESENTATIVES:

ALABAMA, Sprague Electric Co., 205/883-0520 • **ARIZONA**, Sprague Electric Co., 602/279-5435 • **CALIFORNIA**, Sprague Electric Co., 213/649-2600; Wm. J. Purdy Co., 415/347-7701; KCE Corp., 714/278-7640 • **COLORADO**, Wm. J. Purdy Co., 303/777-1411 • **CONNECTICUT**, Sprague Electric Co., 203/261-2551 • **DIST. OF COLUMBIA**, Sprague Electric Co. (Govt. sales only), 202/337-7820 • **FLORIDA**, Sprague Electric Co., 305/831-3636 • **ILLINOIS**, Sprague Electric Co., 312/296-6620; D. Dolan Sales, 312/286-6200 • **INDIANA**, Sprague Electric Co., 317/253-4247 • **MASSACHUSETTS**, Sprague Electric Co., 617/899-9100; Sprague Electric Co., 413/664-4411 • **MICHIGAN**, Sprague Electric Co., 517/787-3934 • **MINNESOTA**, HMR, Inc., 612/920-8200 • **MISSOURI**, Sprague Electric Co., 314/781-2420 • **NEW JERSEY**, Sprague Electric Co., 201/696-8200; Sprague Electric Co., 609/795-2299; Trinkle Sales Inc., 609/795-4200 • **NEW MEXICO**, Wm. J. Purdy Co., 505/266-7959 • **NEW YORK**, Sprague Electric Co., 516/549-4141; Wm. Rutt, Inc., 914/698-8600; Sprague Electric Co., 315/437-7311; Mar-Com Associates, 315/437-2843 • **NORTH CAROLINA**, Electronic Marketing Associates, 919/722-5151 • **OHIO**, Sprague Electric Co., 513/866-2170; Electronic Salesmasters Inc., 800/362-2616 • **PENNSYLVANIA**, Sprague Electric Co., 215/467-5252; Trinkle Sales Inc., 215/922-2080 • **TEXAS**, Sprague Electric Co., 214/235-1256 • **VERMONT**, Ray Perron & Co., Inc., 617/762-8114 • **VIRGINIA**, Sprague Electric Co., 703/463-9161 • **WASHINGTON**, Sprague Electric Co., 206/632-7761 • **WISCONSIN**, D. Dotan Sales, 414/482-1111 • **CANADA**, Sprague Electric of Canada, Ltd., 416/766-6123 or 613/238-2542

Technical Literature Service, Sprague Electric Co.
35 Marshall Street, North Adams, Mass. 01247

Enclosed is check (or money order) for \$2.00;
please send *new* IC Data Book to:

(name) (title)

(company) (mail section or dept.)

(city) (state) (zip)

Mass. residents add 5% sales tax. No stamps or cash, please.



... and you thought we only make great capacitors.

U. S. widens issues after Japan offers cuts in tariffs

Japan's compromise offer to cut import duties on integrated circuits and computer mainframes by more than half and to slash tariffs on peripherals by two thirds still isn't enough for U. S. Special Trade Representative Robert Strauss. White House sources say Strauss "isn't ready yet to take the offer and run." Instead, he wants to wrap it up in a totally new and complete package for both industrial and agricultural products, plus broad international trade rules covering new areas such as brand-name counterfeiting, government subsidies to industries, and government procurement.

Officials in the Commerce Department and affected U. S. electronics companies question whether even the hard-driving Strauss can achieve that goal and **are nervous that Japan's offer might be lost in the subsequent bargaining shuffle.** Japan proposed to cut tariffs on mainframes and peripherals to 4.9% and 6%, respectively, beginning in 1980, from present levels of 10.5% and 18.5%. Duties on ICs would drop to 4.2% from the current 12%. When might a broader agreement come? "By the end of the year with luck," opines one ranking official, "but don't hold your breath."

1981 implementation of common language seen by DARPA . . .

The Defense Advanced Research Projects Agency is shooting for a 1981 release of specifications and first procurement of production compilers for its DOD-1 standard higher-order language for military computers [*Electronics*, June 10, 1976, p. 45]. Development of DOD-1, which evolved from the Strawman/Steelman programs, has taken a major forward step with DARPA's selection of Honeywell Inc., Minneapolis, and Intermetrics Inc., Cambridge, Mass., as finalists for development of software specifications and test translators. Honeywell is getting \$800,000 and Intermetrics approximately half that amount under 10-month awards for the second development phase, scheduled for completion by April. One will be selected next year for the third and final development phase. **Successful development of DOD-1 and its compiler is expected to produce significant reductions in the military's annual \$6 billion software budget. This could spread the system's use throughout other Federal agencies and effectively leapfrog the National Bureau of Standards' lagging standardization program** [*Electronics*, Feb. 2, p. 39].

. . . with Honeywell to develop DOD-1 at French affiliate

A novel aspect of DOD-1's second development phase is that Honeywell's entry will evolve largely from a language developed in France called LIS. **Developer was the company's affiliate there, CIT-Honeywell Bull, which will perform most of the contract work.** The job will be monitored by Honeywell's Systems and Research Center, named by DARPA as the contractor. All four competitors in last year's first-phase competition began their development using the Pascal language.

India's satellite to combine TV and meteorology

The first multipurpose satellites to combine direct TV broadcasting, domestic public telecommunications, and meteorology services will be launched in 1981 for India aboard the National Aeronautics and Aviation Administration's space shuttle. Known as Insat, **the satellite and a twin will be built by Ford Aerospace & Communications Corp., San Francisco.** Dollar value was not disclosed. The geostationary spacecraft will be three-axis-stabilized and was described by a Ford official as "similar to NASA's ATS-6 applications-technology satellite but with much greater capacity."

Reforming the FCC: views of the veterans

A rare gathering of five former chairmen of the Federal Communications Commission resulted last month in an even rarer event: agreement among them that significant deficiencies exist in the bill now before Congress to rewrite telecommunications regulation in the United States [*Electronics*, June 22, p. 84]. Many of their views were echoed by the six out of the seven current FCC commissioners who also appeared to critique H. R. 13015 in initial hearings before the House Communications subcommittee.

The bill's elimination of the FCC's mandate to be guided by "the public interest, convenience and necessity" and the limitation of its regulatory powers only "to the extent that marketplace forces are deficient" provoked much criticism. No one disputed the need for greater competition, rather than regulation. Yet all the commissioners past and present agreed that the public interest should not be set aside. "Deficiencies vary from market to market," noted Charles Ferris, the FCC's present chairman, "and vary as technology changes. All communications markets are highly dynamic, and future 'market deficiencies' cannot all be foreseen or predicted. I would recommend inclusion in any rewrite of a 'public interest' standard, and along with it clear congressional direction that the public interest is served by competition and diversity." The bill's failure to define its terms was clearly of concern to every witness in the early hearings.

Chairman or czar?

The FCC's leaders agreed that the bill is weak not only in defining the terms it uses to express Federal policy, but also in becoming too specific in a number of administrative and procedural areas. For example, it seeks to speed up the regulatory process by giving the chairman of the proposed new five-member Communications Regulatory Commission full authority to determine the commission's agenda and control expenditure of its funds. That comes close to establishing a Federal communications czar, a concept no one is ready to buy.

Nor do any of the present or past FCC commissioners like the bill's idea of assigning frequency allocation responsibilities not to the independent CRC but to the presidentially appointed administrator of a new National Telecommunications Agency. "By giving the CRC a secondary role in frequency allocation," complains former chairman Dean Burch, the legislation would be "building in an inevitable conflict between the CRC and NTA."

FCC chairman Ferris goes further, noting that

the price of achieving administrative efficiency by taking Federal communications policy responsibility away from the CRC and assigning it to a single NTA administrator might be too high. "How long would policies made in such a manner last? Ferris asks. "Would those on the losing side push their arguments into the political arena? Would 'invisible' executive branch officials, using 'invisible' procedures, make mysterious deals, bartering policy positions for political considerations—without evidence, without a [public] record, and without even the pretense of reasoned opinions?"

The hearings quickly made clear that the new legislation's authors were ignorant of the caution advanced by an earlier Congress when it created the Federal Radio Commission, the FCC's predecessor. Communications technology and its potential impact on American society is powerful, Congress wrote in 1926. "The exercise of this power is fraught with such great possibilities that it should not be entrusted to any one man nor to any administrative department" but rather to "an entirely independent body." This regulatory power "should be as free from political influence or arbitrary control as possible."

A separation of powers

Newton Minow, perhaps the most articulate of the FCC's former chairmen, offers an alternative solution to the commission's proclivity to entanglement in its own rules. Concurring with former chairman Fred Ford's view that "the FCC has been due-processed to death," Minow believes the problem can be resolved by separating the responsibilities for drafting, administering, and enforcing communications regulations. The Internal Revenue Service, he points out, has operated that way for years, with the commissioner of internal revenue drafting regulations, while all challenges are decided independently by the U. S. tax court. A communications court separate from the CRC could conceivably resolve disputes between the commission and the industries it monitors by legally binding judgments. Moreover, it could operate without the inhibitions of the administrative law judges who are now FCC employees and who, Minow recalls, can almost guarantee that issues assigned to them will remain unresolved for three years.

Minow's solution to a complex problem sounds simple. But it is the product of years of reflection on FCC service that made him feel "I was in a straitjacket." The Congress should consider it well as it begins searching for ways to improve on H. R. 13015. **Ray Connolly**

Talk about a matched pair!

Just 3mV gate source differential *off-the-shelf.*



It's our new series of N-channel dual monolithic J-FETs. And its available off the shelf with a gate source voltage differential of only 3mV.

That's right. Off the shelf. Never before has the designer been able to buy a device this closely matched without paying extra, and running the risk of delivery delays or defaults.

Not only do you get the close match, you get a lot more besides. For instance:

- CMRR: 100 dB minimum
- Input Impedance: I_G less than 25 pA
- Noise: $10\text{nV}/\sqrt{\text{Hz}}$ Typ @ 10Hz
- g_{os} : less than $1\ \mu\text{mho}$
- Choice of hermetic TO-71 or 8-pin miniDIP with symmetric pinout for automatic insertion.

Typical applications for our new 2650 series of dual monolithic N-channel JFETs include low and medium frequency amplifiers, low noise input amplifiers, differential amplifiers, impedance converters, precision instrumentation amplifiers, and comparators.

For complete technical information, design assistance, or evaluation samples, contact us at the address below, or call Jerry Kramer, (415) 968-9241.

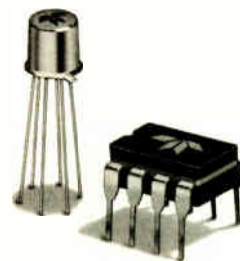

TELEDYNE SEMICONDUCTOR

1300 Terra Bella Avenue, Mountain View, California 94043 • (415) 968-9241

SALES OFFICES: DOMESTIC: Salam, N.H. (603) 893-9551; Stony Brook, N.Y. (516) 751-5640;
Des Plaines, IL (312) 299-6196; Los Angeles, CA (213) 826-6639; Mountain View, CA (415) 968-9241
INTERNATIONAL: Hounslow, Middlesex, England (44) 01-897-2503; Tiengen, West Germany 7741-5066;
Kowloon, Hong Kong 3-240122; Tokyo, Japan 03-403-8141

For every subscriber who pays to read Electronics, three others read the magazine 'over his shoulder.'

Do they count? As much as the circulation of any free magazine in the field.

90,000 people all over the world pay from \$15 to \$95 per year to read Electronics. For every one of these paid subscribers, three more readers – called “passalongs” – borrow the magazine and read it free.

Advertisers value our paid subscribers most, because they have proved their interest in the magazine with money. Our pass-along readership is a bonus.

But what a bonus! In a one-for-one comparison, this huge audience of passalong readers is the equivalent of the primary circulation of any free magazine in the field.

As for our paid subscribers, there is no way to compare them with the unpaid distribution of a free magazine unless you know how many free recipients equal one paid reader – and that's one answer research has not come up with yet!

Electronics Magazine
1221 Avenue of the Americas
New York, N.Y. 10020

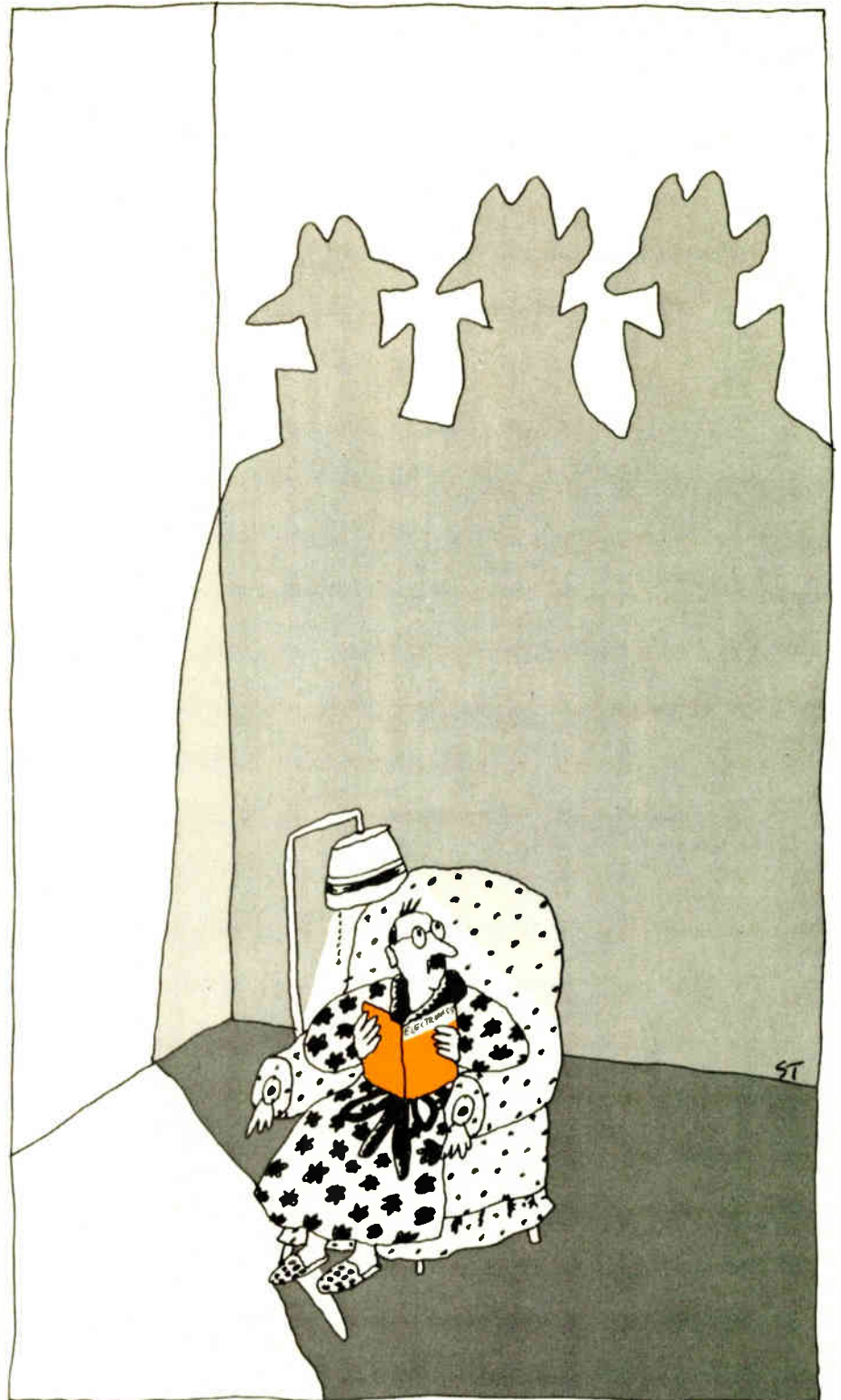

**Passalong readers.
Another reason your ad sells best in Electronics.**

Why take a chance?

If you're not up to date on new electronics products, you might make a costly mistake. Don't risk it.

New Product Trends In Electronics

Number One

by the editors of Electronics Magazine
333 pages, \$14.95

Every year thousands of new electronics products enter the market and compete for your attention. With all the demands on your time, it's hard to select out the few that are really significant. And it's very easy to miss those that can make a difference in the success of your projects. Until now.

Only the most important...

new equipment and materials are chosen to appear in the "New Products" section of *Electronics*. Now these stories—from December 1976 through November 1977—are brought together in this instant-access information resource. No more going back through past issues. No more wondering if you've overlooked something you really needed to know about.

Technology plus marketing...

Product descriptions, applications, and operation are meticulously researched by our team of specialists in direct contact with the people responsible for each product's development. An insider's view of market and technology trends is presented to keep you up-to-date on where product development is... and where it's going.

Emphasizing function, more than 800 products are divided into 60 categories. You can pick up this catalog of important new products and instantly find the one that solves a specific problem you're having right now. Cross-references make it easy to match products to needs across a wide range of technology.

Or just browse through it when you have a few minutes to explore all the exciting developments throughout the industry.

Either way, it's a great way to stay in touch—professionally and enjoyably.

Order today, using the coupon below, and don't forget the other valuable books in the Electronics Books Series.



- amplifiers
- industrial equipment
- semiconductors
- power supplies
- displays
- memory products
- communications equipment
- computers
- components
- instruments
- packaging and production equipment
- data converters

Electronics Book Series

P.O. Box 669, Hightstown, NJ 08520



1. Microprocessors

Send me _____ copies at \$8.95 per copy.

2. Applying Microprocessors

Send me _____ copies at \$9.95 per copy.

3. Large Scale Integration

Send me _____ copies at \$9.95 per copy.

4. Basics of Data Communications

Send me _____ copies at \$12.95 per copy.

5. Circuits for Electronics Engineers

Send me _____ copies at \$15.95 per copy.

6. Design Techniques for Electronics Engineers

Send me _____ copies at \$15.95 per copy.

7. Memory Design: Microcomputers to Mainframes

Send me _____ copies at \$12.95 per copy.

8. New Product Trends in Electronics

Send me _____ copies at \$14.95 per copy.

Discounts of 40% on orders of 10 or more copies of each book.

If after my 10-day free-trial examination I am not fully satisfied I understand that my payment will be refunded.

Payment enclosed Bill firm Bill me

Charge to my credit card:

American Express Diners Club
 BankAmericard/Visa Master Charge*

Acct No. _____ Date Exp. _____

*On Master Charge only, first numbers above name _____

Name _____ Title _____

Company _____

Street _____

City _____ State _____ Zip _____

Signature _____

RCA first in CMOS.

The go-everywhere μ P now has a do-everything design aid.

Now you can quickly and economically prove out the RCA 1800...our cost-effective, environmentally rugged, CMOS microprocessor.

Our new COSMAC Micromonitor CDP18S030 is a complete portable μ P system diagnostic tool. The best tool, in fact, to perform breadboard debugging and factory checkouts and field tests without additional diagnostic equipment. The Micromonitor can take instructions electronically, supply hardcopy or CRT display through your terminal, and

become more powerful via our COSMAC Development system with floppy disk.

Prototype debugging. Simply plug the CPU of your system under test into the Micromonitor. You now have control of both hardware interfaces and program execution. You can plug memory into the Micromonitor to emulate ROM. Using the keyboard and display, you can start/stop, examine any portion of the system, and make changes.

Unique automated testing. The Micromonitor can be used with any of its configurations to provide the factory test system you require.

Field service. Its self-contained package is designed to be carried easily to any place RCA 1800 microprocessor systems are in operation.

Operation software. An optional Micromonitor Operating System (MOPS) CDP18S831 gives you an extended set of commands. MOPS, on the COSMAC Development System with floppy disk option, helps the Micromonitor do everything from simple terminal-Micromonitor dialog to fully automated system testing.



RCA Solid State, Box 3200
Somerville, NJ 08876

Tell me more about why the Micromonitor is one more reason to go RCA 1800. My microprocessor application is:

Name _____

Title _____

Company _____

Address _____

RCA 1800. Our systems are go.

Toshiba markets double-duty electron-beam unit

For a little more than \$2 million, Japanese semiconductor manufacturers now can buy a Toshiba electron-beam exposure system that makes both full-wafer masks and single-device reticles. In its most precise mask-making mode, the minimum line width is $1\ \mu\text{m} \pm 0.1\ \mu\text{m}$. **The patterns formed can occupy a 105-mm² area on a 125-mm² mask, which can be used with 4-in. semiconductor wafers.** For making step-and-repeat reticles, which will be reduced 10 times during optical printing, minimum line width is $4\ \mu\text{m} \pm 0.15\ \mu\text{m}$. The machine will also be available overseas.

Hitachi to push fast 16-K RAM with single supply

After recent visits to U. S. computer makers, Hitachi is ready to push a new 16-k dynamic random-access memory. The 4816 operates from a single +5-v supply and has a worst-case access time of 100 ns through a narrow, 15-ns window to multiplex the address. Sample quantities will be available in September, about the time that Intel is expected to jump into the fray with a similar part.

Branler radar planned for UK Tornado

Details are skimpy for security reasons, but the Royal Air Force's version of the upcoming all-European Tornado aircraft will get a radar with significantly greater capabilities than present systems. The equipment, to be developed by Marconi Space and Defence Systems Ltd., **will provide information on the sector and direction of any airborne intruder, as well as being largely able to determine the type of threat.** It will also assist the pilot in deciding the type of counteraction he should take. The system will be modular so that it can be readily fitted to other aircraft.

64-K ROM is pin-compatible with Mostek part

Launching Japan into the 64-k ROM market, Nippon Electric Co. will be accepting orders next month for a read-only memory that is pin-compatible with Mostek's MK36000. Access time is 450 ns maximum, and power dissipation is 450 mw typical from a +5-v power supply. **The pin compatibility with the Mostek part puts NEC in the camp of all other makers of 64-k ROMs—save for Intel, which is going its own way just as it did with 32-k parts.** NEC says that initially it will fabricate 30,000 of the $\mu\text{PD}2364\text{D}$ a month, with price in lots of 1,000 to 2,000 at \$1.50. The part will be available overseas.

Chip converts 525-line TV set into data terminal

Coming up from Sescosem, Thomson-CSF's semiconductor division, is a 60-HZ, 525-line version of its successful interface chip for cathode-ray tubes. It is aimed at the U. S. and Japanese markets. **The chip, the SF.F 96364 is based on n-channel MOS silicon-gate technology** and provides the control circuitry needed to convert a standard TV receiver into a data terminal. It costs between \$15 and \$20, depending on quantity. The present 50-HZ, 625-line version, on the market for nearly a year, has already picked up a roster of users that includes some U. S. firms.

Now, 110 millimhos in a JFET

Japanese semiconductor firms seem well launched on a race to hike the transconductance of junction field-effect transistors: hard on the heels of new models from Toshiba (p. 72) and NEC, Mitsubishi Electric Corp. is

International newsletter

introducing a chip with a typical rating of 110 millimhos, more than twice that of the competitive models. Rather than employing the exotic geometry of the competing new models, **the Mitsubishi devices use very fine patterns to get a short gate length of 2 μm** , together with small source and drain regions. The firm's engineers opted for large, 1.5-mm-square chips to achieve a total gate width of almost 10 cm. Two matched chips in a single in-line package will cost \$4.50 in sample quantities.

Time-encoded speech uses bits economically

There's a new voice transmission technique on the horizon in Great Britain, based on the principle of time-encoded speech. Computer simulations show that a transmission meeting the European standard for voice quality can be encoded and reproduced at a bit rate of 16,000 bits per second, **which allows four channels instead of one in a conventional 64,000-b/s pulse-code-modulated link**. A prototype using an analog-to-digital converter, buffer, store, and microprocessor will be ready in 18 months, but the developers say that optimizing the basic coding strategies could take five years.

China buys computer; Ghana, Eire go for communications gear

West Germany's Siemens AG is about to ship a data-processing system to the People's Republic of China: a model 7,738 medium-sized machine to **perform calculations on industrial steam-turbine design** and to support the planning and manufacturing operations. . . . Montreal-based Spar Technology Ltd. will supply and **install Ghana's standard satellite telecommunications system, including an international switching center**. The Canadian government's Federal Export Development Corp. is lending Ghana \$6 million to underwrite the Spar contract. . . . Fujitsu Ltd. of Japan has a \$3.5 million contract with Eire's Department of Posts and Telegraph **for a computer-controlled time-division-switching system for Telex traffic** and for three line concentrators to work as remote message controllers under direction of the central computer.

Addenda

The USSR has announced the Elbrus-2, said to be a fourth-generation multiprocessor of 100 million operations a second. The announcement says **that speed is superior to most foreign computers, but direct comparisons are difficult** because of the vagueness inherent in the MOPS measurement. . . . Official total for the UK five-year support scheme for the semiconductor industry is \$127 million. However, **there will be \$27 million in development grants** to encourage the adoption of microprocessor technology by general industry, and there is the substantial support planned for the new Inmos firm (p. 42). . . . Researchers at Siemens AG are working with samples of semiconductor stripe-geometry lasers **that promise an operating life of more than 100,000 hours at room temperature while allowing a maximum increase in threshold current of 10%**. The devices are gallium-arsenide/gallium-aluminum-arsenide double-heterostructure laser diodes with stripe widths of 6 to 13 μm Thyristors that boast **a forward current rating of 3,000 A and reverse and forward blocking ratings of 4,000 v** are about to go into production at Toshiba Corp. The company will start using the devices soon and expects to be selling them for \$5,000 each next spring. . . . Sweden plans to investigate the **effects of industrial robots on employment, industry survival, and factory environment**. There should be about 5,000 such machines in Swedish factories by 1985.

Knowhow. And where.

“Bussmann can help you choose the right fuse for the right place.”

When you do something better than anyone else, people usually take for granted that it's all you *can* do.

Like Bussmann. You probably know us as the electronic industry's most complete source for fast-acting, dependable, state-of-the-art circuit protection. And you're right.

But only half right.

Because Bussmann can also be your most valuable source of expert technical help.

Take your Bussmann salesman, for example. He's more than just a salesman. He's an electrical protection expert.

So he's got the technical know-how and experience to

simplify and solve your most complicated circuit protection problems.

He can help you decide which fuse from our complete line fits the application you have in mind. Or he can put you in touch with one of our staff engineers for in-depth technical assistance.

Your Bussmann representative can also keep your staff up-to-date on the latest trends in circuit protection. New fusing technology. Or where and how to use the right fuse for the best results.

So call your Bussmann representative today. And trust him for sound technical advice.

He'll show you why Bussmann means protection in more ways than one.

McGraw-Edison

**Bussmann.
The Protection
Experts.**

Bussmann Manufacturing Division
McGraw-Edison Company
P.O. Box 14460
St. Louis, Missouri 63178

Circle 67 on reader service card



Boschert low-power switchers win OEMs' stamp of approval. Here's why.

Low cost. Only Boschert is delivering switching power supplies that are cost-competitive with linears in the 25 to 400 watt range. That's because Boschert is focusing exclusively on the design and production of low-power switchers. Our modular design techniques are lowering prices while maintaining quality and reliability.

Small, light and efficient.

Boschert power supplies are perfect for microprocessor-based systems and other digital equipment because they're five times smaller than comparable linear supplies, and nine times lighter. Because little power is wasted as heat, they require no fans — only convection cooling. And Boschert switchers are well-suited for high pulse-load environments such as printers: when additional power is required, it is available instantaneously — at any output.

Multiple outputs. Boschert power supplies are convenient for system designers because they offer as many as six outputs in flexible voltage configurations. Our

computer-evaluated modular design approach with 90 percent common components allows us to meet your unique technical requirements at low cost, with a minimum of design time.

Boschert experience and reliability.

Boschert has assembled the finest switching power supply design and production team anywhere. Our facilities are prepared to meet expanded production schedules rapidly and reliably — with rigorous automatic burn-in, wave soldering and testing techniques. With over 50,000 of our power systems in operation today, we're the leading company for low-power, low-cost OEM switchers.

For information, contact a Boschert representative. Or write Boschert Incorporated, 384 Santa Trinita Ave., Sunnyvale, CA 94086. Phone (408) 732-2440. TWX 910-339-9241. The finest microprocessor-based systems are powered by Boschert. What about yours?



X-ray lithography system achieves ultrafine resolution

NTT lab's experimental unit overcomes alignment problem of X-ray systems and cuts exposure times as well

The ultrafine resolution of electron-beam lithography plus the speed and convenience of optical pattern making: that's a combination that should prove a hit in the era of very-large-scale integration. It is embodied in an X-ray exposure system under development at the Musashino Electrical Communication Laboratory.

As well as putting down lines 1 micrometer wide, the prototype system can achieve a positioning accuracy of better than $\pm 0.1 \mu\text{m}$. Thus it overcomes the alignment problem plaguing the still nascent field of X-ray lithography [*Electronics*, July 20, p. 84].

What's more, the Nippon Telegraph and Telephone Public Corp.'s lab has already achieved pattern-exposure times comparable to optical lithography: 5 to 10 minutes with positive photoresists, and about 1 minute with negative resists.

Experimental. The Tokyo lab's work is just reaching the point of fabricating practical semiconductor devices. Nippon Kogaku KK (Nikon) of Tokyo built the prototype for Musashino and is working on a commercial prototype scheduled for completion next spring. When sales begin, the price should be between a fifth and a fourth that of the \$1.5 million electron-beam units.

The positioning accuracy begins with the system's masks, which are transparent to light, although the

gold film that makes up the pattern to be exposed is opaque to both light and X rays. An automatic photoelectric microscope aligns mask and wafer using their target reflections.

Five positioning axes are used in the prototype aligner and exposure unit. They are: wafer horizontal and vertical positions, wafer rotation with respect to the mask's axes, the spacing between mask and wafer, and correction of parallelism of the mask-to-wafer spacing. The leaf-spring support of the positioning table permits fine movements without friction or backlash.

The result is positioning accuracy as high as $0.03 \mu\text{m}$ in experiments (see photo). Overall accuracy, including sensing, positioning and etching, is within $0.2 \mu\text{m}$.

Operation. In the X-ray tube, a potential of 20 to 25 kilovolts accelerates electrons, which strike a rotary target made of copper with a thin film of silicon. The target emits X-rays with a wavelength of 7.13 angstroms, comparable to other experimental X-ray exposure systems.

Where the NTT system exceeds state-of-the-art performance is in its input power of 20 kilowatts, leading to an X-ray output power on the order of 100 microwatts per square centimeter. It is this power that gives the low exposure times.

Exposure is carried out at a predetermined spacing from mask to wafer of $5 \text{ to } 10 \mu\text{m} \pm 1 \mu\text{m}$, with a distance from wafer to X-ray source

Clean-cut. Experimental Japanese X-ray lithographic unit exposed the same pattern twice on the wafer. The pattern's clean edges show the precision with which alignment and exposure were carried out.

of 350 millimeters. While the X rays' slant does cause a $0.05\text{-}\mu\text{m}$ displacement between mask and wafer image (for features at the edge of the mask), this is within the guaranteed positioning accuracy.

Exposure is performed in air, for much more convenient operation than with electron-beam systems, in

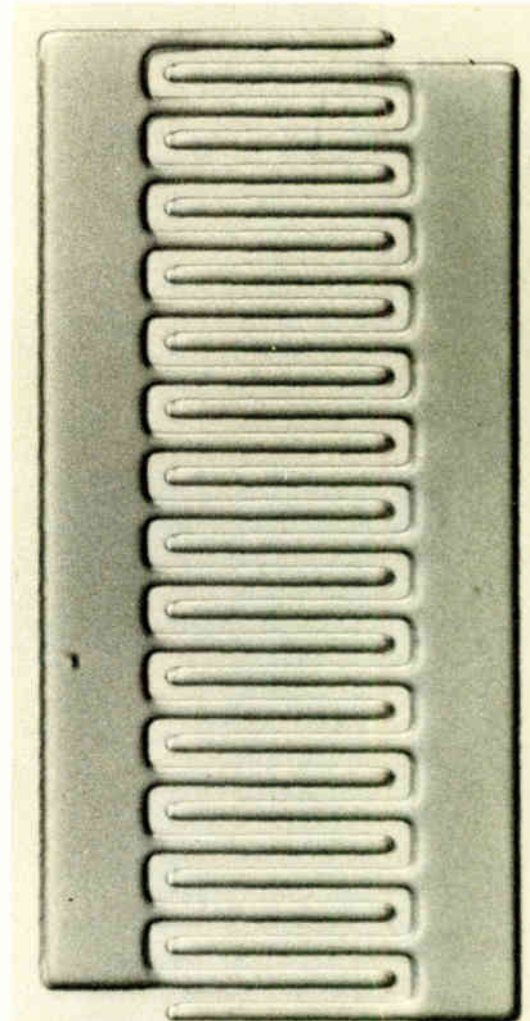

which vacuum locks are required. Yet another advantage of an X-ray system is that it is unaffected by dust on either resist or mask. Dust is transparent to X rays.

Mindful of the fragility of the ultrathin membranes that make up the masks in X-ray exposure, Mushashino researchers have devised a three-layer film that permits balancing of compressive and tensile stress for maximum strength. The film, silicon dioxide sandwiched between silicon nitride, is about $1.2 \mu\text{m}$ thick and is fabricated on a silicon wafer that is etched away in the regions that will correspond to chip locations on the wafer to be processed. The circuit patterns are defined by electron-beam lithography on a layer of gold less than a micrometer thick. □

West Germany

TV picture looks good after long trip

The pictures on the two color-television monitors were identical, and while the scene wasn't exciting, the duplication was. One, the original picture, came from a tape, but the other had made a 70,000-kilometer round trip to a satellite and back to West Germany's ground terminal in Raisting.



Good show. Sending a test TV picture on a 70,000-km round trip to a satellite hardly affected quality when SEL used its experimental 34-Mb/s equipment with a 10^{-9} bit-error rate.

The test was Europe's first transmission of digital TV signals by satellite. The quality of the resulting picture points the way to full-scale commercial development.

Conducting the still ongoing trials is the German ITT subsidiary Standard Elektrik Lorenz AG. Serving as the space relay is the Franco-German communications satellite *Symphonie 2*. Bonn's ministry for research and technology is sponsoring SEL's work, which began in 1973 with terrestrial digital TV links.

Differential modulation. As is common in terrestrial digital TV transmissions, SEL is using differential pulse-code modulation for its satellite trials. In DPCM, only the differences between adjacent picture elements on the scanning lines (or the differences between a specific element and an estimated value for several neighboring elements—the prediction value) are transmitted.

To be sure, the differential technique calls for more elaborate equipment than does straight PCM. But this drawback is offset by a roughly two-thirds reduction from the PCM bit rate about 100 megabits per second. Hence, DPCM can accommodate much more information in a given bandwidth than normal PCM.

Significantly, the SEL engineers settled on 34 Mb/s for their satellite trials. This bit rate is widely used in terrestrial PCM links, and the Euro-

pean Broadcasting Union favors it as a worldwide standard for satellite PCM systems. The 34-Mb/s rate is suitable for transmitting 480 telephone channels or one complete TV channel together with two high-quality sound channels.

"The aim of our trials is to find out how well the 34-Mb/s rate is suited for satellite TV-signal transmissions under varying conditions," says Roland Burghardt, head of SEL's department for advanced communications development. First results are heartening: on the internationally used 1-to-5 picture-quality scale, the satellite-transmitted picture scored between 4 and 5.

Bit-error rate. That rating is achieved with a bit-error rate of better than 10^{-9} but at the fairly high equivalent isotropic radiated power (EIRP) of 80 decibels above 1 watt for the ground terminal. However, suitable bit-error protection equipment will make possible an EIRP of 75.4 dBW with the same 10^{-9} bit-error rate, Burghardt says.

SEL's experimental DPCM setup uses an 8-bit coding scheme for the picture. The sound signals are digitized with normal PCM techniques and with 14-bit coding. After multiplexing both TV and sound signals, a 34-Mb/s rate is obtained.

The 34-Mb/s signal, together with digital synchronization signals, is fed over a four-phase modulator to the transmitter and then to the satellite. After its reception at the ground terminal, the signal is demodulated and converted into its original analog form. □

Switzerland

Voltage measuring tests hardness

Traditionally, engineers and scientists have checked the hardness of a workpiece by forcing a hardened steel ball or a diamond pyramid against its surface and measuring the resulting dent with a calibrated magnifier. There is a simpler way, says a Swiss company marketing an

Are Your Field Service Costs Becoming Astronomical?

... then GenRad's new 2225 Portable Service Tester is what you need to bring them under control. The GR 2225 is a digital board test system with automatic guided-probe diagnostics that can provide your local service office with a test and repair capability similar to that of your factory's production test department. Being portable, the unit can be taken on-site and so provide efficient component-level fault isolation in situations where this is either necessary or desirable.

Hopefully, your board-repair pipeline is not as long as that of the field service engineer making a call in the

illustration below. The chances are, however, that it's a lot longer than you would like it to be. The length of the repair pipeline is one of the major factors leading to the need for large inventories of spare boards which, in turn, is a major cause of escalating service costs.

Deploying the GR 2225 in your field service offices shortens the pipeline considerably, with a resultant dramatic reduction in the inventories required for an efficient board-swapping program.

For more information on how you can save money in your service organization, ask for our brochure.



Circle 71 on reader service card

300 Baker Avenue, Concord, Massachusetts 01742
• Atlanta 404 394 5380 • Boston 617 646 0550 • Chicago 312 884 6900
• Dallas 214 234 3357 • Dayton 513 294 1500 • Los Angeles 714 540 9830
• New York (NY) 212 964 2722 • NJ 201 791 8990 • San Francisco 408 985 0662
• Washington, DC 301 948 7071 • Toronto 416 252 3395 • Bourne End (UK) (06285) 2 66 11



GenRad

electronic hardness tester that in effect measures the voltages induced in a coil when a small test head carrying a magnet is bounced off a workpiece.

There is nothing to measure afterward: the hardness value shows up on the Equotip's three-digit liquid-crystal display, which is linked by cable to the test head. The instrument covers almost the entire range of conventional hardness scales, from the low end of the Brinell soft-material scale up the 940 value of tool steel on the Vickers scale. It provides a readout in L value, a scale named after Dietmar Leeb, the Austrian inventor of the technique. Included with the operating instructions are conversion curves to other hardness scales.

The modulus of elasticity of the material under test affects the rebound as well, and this is taken into account in the conversion curves. Among samples of similar materials—mild steels, for example—the L value gives a direct comparison of hardness.

Ratio. There is nothing mysterious about the L value. It is simply the ratio of the rebound and impact velocities of the test head multiplied by 1,000. The harder the material, the faster the rebound speed.

To make the measurement, a spring projects the test head, tipped with a 3-millimeter tungsten carbide ball, off the surface under test. The configuration of the head's permanent magnet and the coil around the guide tube ensure that a voltage pulse develops when the tip is about 1 mm from the surface and headed toward it. A pulse of opposite polarity follows when the head reaches the same point on its rebound.

The two pulses, up to 200 millivolts maximum, go to the instrument's indicator unit, powered by three 1.5-volt dry cells. After amplification, the peak value of each pulse is translated by a dual-slope analog-to-digital converter.

The two values feed to counting circuits that divide them and multiply the result by 1,000 to get the L value for the readout. The result stays displayed until the next test or

until the instrument is shut off; there is a jack for a printer as well.

Proceq, the Zurich-based company marketing the Equotip, has priced it at just under \$1,800, in-

cluding carrying case and a test block. It figures the instrument will appeal particularly to users testing the hardness of items too large to go to a standards laboratory. □

Japan

Checkerboard pattern boosts gain up to 11 times in junction field-effect transistors

A new angle on layout and a better-quality junction should open a world of new applications for junction field-effect transistors designed by Toshiba Corp. The new layout increases gain, and the process change cuts an already low noise level.

What all FETs have over bipolar transistors is intrinsically low noise and high input impedance. Also, since they can operate at zero bias, they can sometimes do without an input coupling capacitor, which often is a source of noise. But the limited gain of conventional JFETs has restricted use to impedance converters and switches, whereas Toshiba's new devices look like naturals for use in low-level audio amplifiers, equalizers, and tone controls.

Conventional n-channel JFETs have

the layout shown at the left in the figure. To obtain high yield and reliability, the area of the active region is kept to a moderate value, but this limits gain.

In forming the gates, boron is diffused from a doped silicon oxide, which must be stripped off and replaced with new oxide because it is unstable. However, the exposed junction risks contamination.

Another process problem is that parasitic channels can occur where metalization connecting the drain with bonding pads passes over oxide overlying gates around the periphery of the active region.

The new. Toshiba's new layout looks like the righthand part of the figure. As the colored lines show, the new geometry nets about a 40% greater total channel width with the

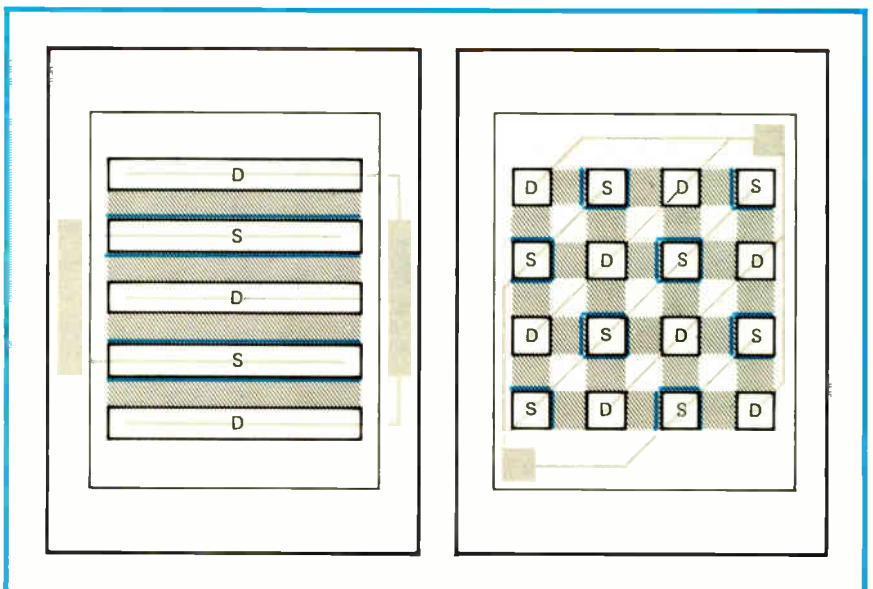

Gain up. In new Toshiba JFET (right), channels between source and drain elements have greater overall width, as red lines show, than conventional chip (left). Cross-hatching indicates gate regions; gray lines indicate connections to source and drain contacts.

A Place to See

Oregon. A place of constantly changing scenes; natural paintings that seem to shift their colors and patterns so that no two days are ever quite the same. That's part of the magic of our state. Some of us came here from the technology and business communities... tired of pushing out the edges of the state-of-the-art at work, and then pushing through the traffic jams to get home. We built our own electronics community in Beaverton, Oregon: 18,000 people contributing to the research, development, and manufacture of advanced electronic instrumentation, graphic display systems, and computer peripherals. The name is Tektronix. The place is Oregon. The reason is people. Think about it. If you have any of the skills a Fortune 500 electronics manufacturer and marketer needs to maintain steady growth, contact us. Professional Staffing, TEKTRONIX, INC., P.O. Box 500, 8-E, Beaverton, Oregon 97077.

A full color print of this scene is available at no obligation. Just drop a note to Bill Eppick at the above address.

Equal Opportunity Employer

Tektronix®
COMMITTED TO EXCELLENCE

same design rules and chip size. The greater width gives transconductance of up to 40 millimhos typical, or up to 11 times that of earlier Toshiba JFET devices. A similar layout appears in new JFETs from Nippon Electric Co.

In the Toshiba devices, better-quality junctions reduce noise to a fifth or sixth that of earlier devices. The better quality comes from a process improvement: a doped polysilicon layer, which is stable and need not be removed, replaces the doped silicon oxide for the boron-diffusion step. Furthermore, the polysilicon shields the substrate from the metalization connecting the drains with bonding pads, thus preventing the occurrence of parasitic channels.

Toshiba is making three basic chips with the new layout and process. One chip appears in the 75¢ 2SK147, usually operated at zero bias and typically drawing drain currents on the order of 10 to 20 milliwatts. It has a dissipation rating of 600 mw. The \$1.60 2SK146, a dual with two matched chips of the 147 version, has double the dissipation. Also available are the 2SK117, a smaller 20¢ single unit with a transconductance of 15 millimhos, and the 2SK150, a 75¢ monolithic dual in which each transistor has a transconductance of 12 millimhos. □

Great Britain

CAD service zips through its work

Completed layouts of complementary-metal-oxide-semiconductor integrated circuits within minutes is the promise made by GEC Semiconductors Ltd. for its new computer-aided-design service. Its highly automated process uses a library of logic-cell designs and can perform cell placement and interconnection tasks without designer intervention.

Fast. "We have had a customer come in with a logic diagram to discuss a custom solution, and by the time he has left the meeting, we have

Different approaches to a CAD service

Like GEC Semiconductors, Hughes Microelectronics Ltd. in Glenrothes, Scotland, and Racal-Redac Ltd. in Tewksbury are offering computer-aided design services for designers of complementary-metal-oxide-semiconductor integrated circuits. All three approaches share the concept of a library of standard logic-cell designs, but they differ considerably in the degree of design automation.

Hughes offers its Comic service, and spelling out the acronym gives an idea of the degree of automation: the customer-organized MOS-integrated circuits service hands over the design responsibility to the circuit designer. It is an easy-to-use process with wide-tolerance design rules. Its development was financed by the United Kingdom Ministry of Defence, with the aim of setting up an inexpensive CAD service producing C-MOS custom circuits that could be multisourced. So design tolerances have been relaxed to accommodate different manufacturers' processes.

The customer takes about half a day to lay out his design in a special format and to enter it on a Hughes Calma graphics terminal. Then the computer takes over and produces a block diagram complete with interconnections and a logic diagram with all necessary labeling. After the customer enters any necessary editing, the computer spews out the final plot.

The Racal-Redac system uses semiautomated layout techniques, and the firm takes full responsibility for the design from the customer's complete logic diagram. "We can use more finely toleranced design rules than Hughes, and consequently can produce more economic chips," says Ian Truson, marketing manager for the Redmos process.

However, Hughes points out that for small production runs, the absolute minimum chip size may not be critical; moreover, their service has guaranteed confidentiality since the designer retains control at every stage. All three companies agree that there is room for each in the custom-design marketplace, where a fourth competitor—Swindon Silicon Systems Ltd., formed by a group of ex-Plessey engineers—is ready to start offering designer-crafted circuits in a variety of processes.

been able to give him the proposed cell layout complete with interconnections and an estimate of the chip size," says David Broster, section manager for the firm's Cellmos design service.

The CAD service of the Wembley, Middlesex, subsidiary of General Electric Co. Ltd. is cheaper, as well as faster. Thus it makes computer-aided design much more attractive for relatively low-volume applications where the cost must be spread over fewer ICs. The lower cost is largely due to the library of standard cell designs, a feature Cellmos shares with the CAD services of two other British companies (see "Different approaches to a CAD service," above).

To use Cellmos, the designer need only list the logic cells in his system and all interconnections on a symbolic logic diagram. After compatibility checks, the GEC4070 mainframe computer initiates an auto-

matic placement and routing program. Guided by a complex algorithm, this program works through different permutations of cell configurations to minimize the interconnecting tracks.

Real estate. Laid between the rows of cells, these interconnection tracks can account for as much as 50% of the IC's real estate. GEC Semiconductors thinks its algorithm will reduce this wastage even below the savings possible with a designer doing an optimized layout.

The computer also carries out a full logic-circuit simulation, producing a set of waveforms in 1 to 13 minutes. From these, the customer can verify that the IC works as intended.

"It's a simple matter to generate a test tape," says Broster. "Each gate in turn is exercised until a discrepancy shows in the output. Other gates are averted, and patterns are identified to check all logic gates." □

Dialight is your second source to C&K for miniature rockers and toggles...



Come to the people who've always been specialists in having more good ways to solve problems: Dialight. What we've done in indicator lights, illuminated switches, readouts and LEDs, we're doing now in miniature rockers and toggles.

This new Dialight family of switches, which comes in a full range of sizes is, we're proud to point out, all-American made.

When you consider all the configurations of styles, sizes, life and safety ratings, colors and mountings, you'll find there are literally hundreds of thousands of design combinations. Such a number of possibilities

can in itself be a problem, except that the new Dialight catalog is specifically designed to prevent confusion and help you quickly and easily find the most advantageous combination of features for your applications.

If you'd like to see what Dialight quality rockers and toggles can do for the looks, durability and economics of your products, contact us today for the Dialight "Meets Your Need" Book. Your free copy will include a list of stocking distributors in the U.S. and Canada.

DIALIGHT

A North American Philips Company

American made by DIALIGHT in Brooklyn, N.Y.

Dialight meets your needs.

Dialight, 203 Harrison Place, Brooklyn, N.Y. 11237 (212) 497-7600

World Radio History

Circle 75 on reader service card

Total cpu control
High level command keys and binary/hexadecimal displays provide complete system control, easy operation.

Worldwide portability
 μ Scope 820 is fully self-contained, with accessory storage space. Operates on all standard U.S. and worldwide power sources.

Preprogrammed diagnostics
Overlay memory socket enables designers to plug in and execute customized diagnostics for each end product.

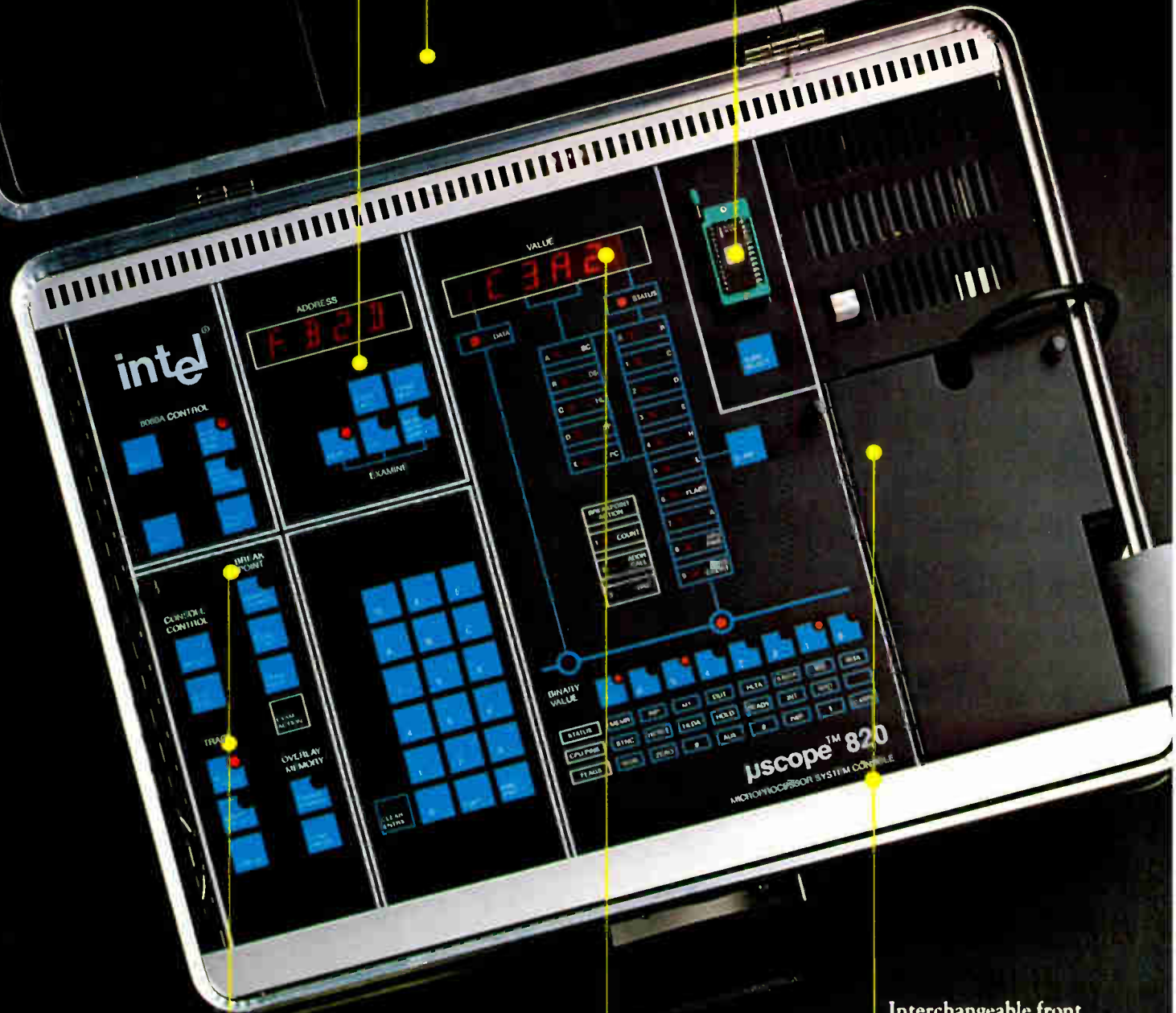

Breakpoint control and trace memory
Built-in high level diagnostics speed and simplify isolation of even the most difficult system problems.

Human engineered
Extensive prompting simplifies operation for test and service personnel, minimizes training time.

Interchangeable front panels, personality cards and personality probes
 μ Scope 820 adapts to a variety of microprocessors. Probe plugs directly into system microprocessor socket.

Intel delivers μ ScopeTM 820. Finally, a diagnostic instrument just right for the Age of the Microprocessor.

Troubleshooting microprocessor systems is easier than ever with Intel's new μ ScopeTM 820 Microprocessor System Console. It's a powerful, programmable, fully portable real-time diagnostic instrument. And it's designed specifically to speed and simplify system checkout of your microprocessor-based products.

μ Scope 820 is really the first test instrument of its kind. It's built around its own microprocessor, to provide a "smart" solution that's highly sophisticated, yet easy to use. Because it's user programmable with interchangeable plug-in ROMs or PROMs, it's like taking a design engineer along on every service call. And because it's fully portable, the μ Scope 820 console goes wherever the action is—to the design lab, the production line or into the field.

Unlike logic analyzers, the μ Scope 820 console provides a genuine solution for test and service personnel. It provides the same inside look at system operation that you get with a logic analyzer. But the μ Scope 820

goes far beyond the mere collection of data. Its internal microprocessor system can actually analyze the data it collects. It does that with diagnostic programs you design specifically for your end product.

Rather than passively watching system operation, the μ Scope 820 console lets you execute application programs or diagnostics you develop, in real time or single steps. And it provides full breakpoint capability and a large trace memory.



High level command keys, operator prompting, and binary/hexadecimal display of all system registers, I/O ports and memory give you greater control and make it easier to use than any other test instrument.

Until now the only way to get this kind of diagnostic capability was to use your Intel[®] Microcomputer Development System. Now we've taken the Intel[®] features that have proven most useful for field service and production-level system checkout and have packaged them in this self-contained 21-lb attache case. That's portability.

And μ Scope 820 is priced to enable you to take advantage of its portability. At \$2495,* you can afford to put a μ Scope 820 console wherever you need one, and free your development lab instruments to concentrate on development.

No longer must you invest in in-house-designed custom test instruments for each of your end products. The μ Scope 820 console will be available with a selection of front panel overlays, "personality" cards and system probes to support a variety of microprocessors. And, our new iSBC[™] 80/10 diagnostic is available for our Single Board Computer users, and to serve as a step-by-step example how to write your own diagnostics.

To get your copy of our μ Scope 820 brochure and application note, or to arrange for a demonstration right in your lab, contact your local Intel distributor or sales representative. Or write: Intel Corporation, 3065 Bowers Avenue, Santa Clara, California 95051. Telephone (408) 987-8080.

intel delivers.

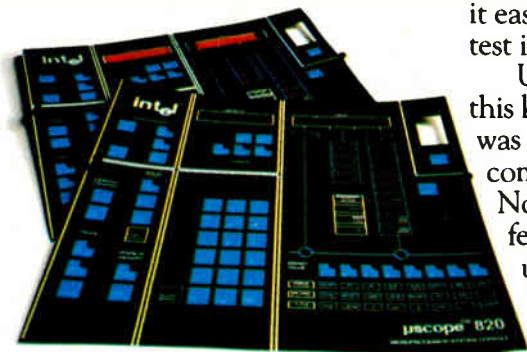

*Domestic U.S. price only, quantities 1-10.

Circle No. 77 for information
Circle No. 205 for information and demonstration

Teradyne finds the practical solution.
No. 7 in a series.

The electronic knife

On the cutting edge of board-testing technology

Ever since its introduction by Teradyne in 1972, guided probing has been the accepted technique for tracking down functional faults on a circuit board. All the leading functional board test systems now include guided probes, and Teradyne offers an automated version for high-volume applications.

Conventional guided probing does, however, have one shortcoming: Its fault diagnosis is almost always ambiguous to some degree, because it cannot discriminate between electrically common points. In the past, that has not proved a serious limitation, since workmanship errors (the most common type of fault) are easy to spot once the guided probe narrows the search to a specific section of the board. Today, however, with in-circuit testers increasingly used to screen out workmanship errors, the functional board test system is left with mostly device failures, which are of course impossible to detect visually. The increasing use of bus-oriented LSI boards further complicates the problem, since a great many ICs may be connected to the failing node. One can replace each of the suspect ICs in turn, of course, but that's usually too time-consuming to be practical. Besides, trial-and-error replacement of 40-pin LSI devices can easily do the board more harm than good.

Teradyne's answer to this problem is the "Electronic Knife," a revolutionary new probe designed to sense the impedance of an IC relative to the impedance on the rest of the node. Since the IC with the lowest relative impedance is generally the one controlling voltage on the node (and thus responsible for any node failure), the Knife is far and away the best

method devised for finding a bad IC without pulling it off the board.

To sense the relative impedance, the probe contacts the IC lead at three points, thus:

The Electronic Knife injects ac at point A, and the fraction of the injected current flowing away from the device causes a voltage drop, V_1 , from B to C. The

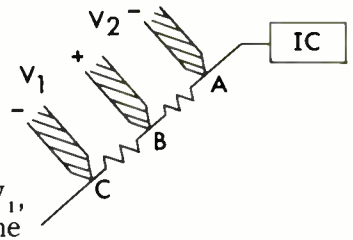

Knife measures and stores this value.

Then the same ac is injected at point C, and the Knife measures and stores V_2 , the voltage drop caused by the fraction of the injected current flowing into the IC. From the measurements of V_1 and V_2 the Knife derives the relative impedance of the probed IC.

The voltage drops that must be measured are in the nanovolt region, which means that an ac approach is essential to avoid the effects of dc probe-to-lead contact potentials. Moreover, with the resistivity of various lead materials differing by as much as an order of magnitude, meaningful measurements would be out of the question without the three-point probe approach, which cancels lead resistances out of the calculations. Even then, the measurement technique called for skillful and innovative circuit design.

Before its introduction on the L135 LSI Board Test System, the Electronic Knife took its first cuts on a variety of boards at Teradyne, including many with microprocessors. In almost every instance, the Knife zeroed in on defective ICs with deadly precision. Clearly, the fast-moving technology of circuit-board testing has just made another fast move.

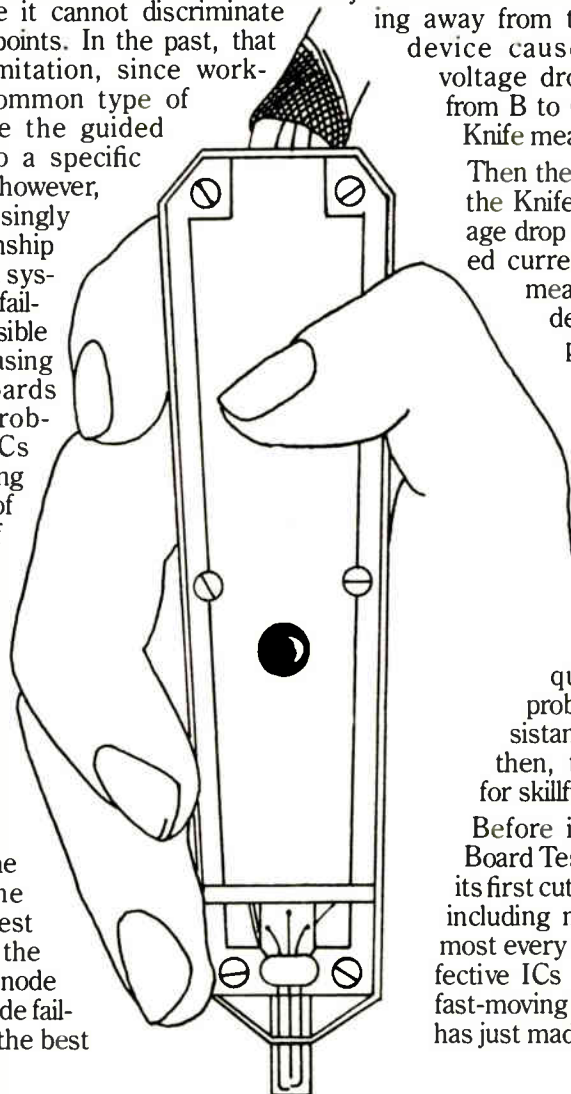

Early reaction to ACS is wary

Even though AT&T's proposed dial-up digital service seems to aim at IBM, computer and communications firms are not happy

by Anthony Durniak, Computers Editor

In proposing to operate a dial-up digital data-communications service, the American Telephone & Telegraph Co. has sent shock waves through the data-communications and computer industries. As is to be expected, companies are divided about whether the shock will generate good or ill.

Considered by many to be aimed against IBM Corp., the proposed Advanced Communications Service [*Electronics*, July 20, p. 41] would therefore also help IBM's competitors establish a beachhead in the giant computer firm's installed base of computer and terminal users, now estimated at almost 80% of the market.

But the industries are not welcoming AT&T and its ACS as allies just yet. Instead, they fear that the phone company, with its regulated monopoly

status, will have an unfair advantage in offering services and equipment similar to what they provide now.

At the heart of the controversy is whether the protocol transparency and other advanced message-editing and -handling features of ACS constitute data processing and are thus ineligible to be offered by a regulated common carrier such as AT&T. Similar issues were raised when the phone company introduced its Dataspeed 40/4 synchronous cathode-ray-tube terminal with editing capabilities. But a Federal court of appeals upheld a decision by the Federal Communications Commission that the editing functions were not data processing.

For its part, AT&T cites the Dataspeed decision as precedent and claims that "the provision of ACS as

a common-carrier communications service is fully consistent with well-settled FCC policies and decision." Still, the industry is not convinced. A. G. W. (Jack) Biddle, president of the Computer and Communications Industry Association, which speaks for many of the vendors, says he "is very concerned that the proposals for storage of the user's data and programs by ACS will be expanded to the point where, in fact, AT&T will be providing a full range of data-processing services."

IBM itself also jumped into the fray. "Since ACS includes functions which go far beyond pure transmission," it said, "AT&T should be free to offer it as a separate nonregulated service but not as part of its regulated transmission service."

Associated with the regulatory issue is the question of how to

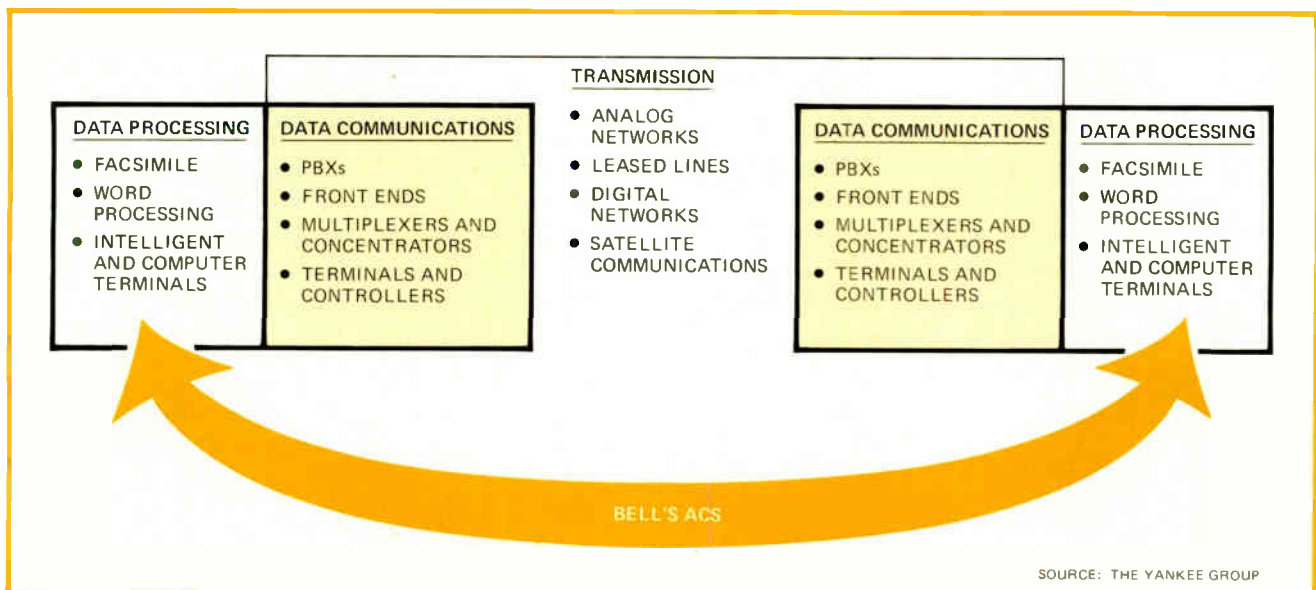

Battle map. In the communications data-processing marketplace, computer makers want to keep AT&T restricted to the transmission area, and AT&T wants to pin the computer and terminal makers in data processing. The areas of overlap, are where battle is going on.

Probing the news

prevent AT&T from using revenues derived from its regulated monopoly communications activities to cross-subsidize its development of equipment and services that compete with the unregulated computer industry.

"What they've proposed to do is provide data processing," says Charles Johnson, president of General DataComm Industries Inc., Wilton, Conn., a maker of modems. "I have no objection to that, but they should separate out the research and development funds used for it."

In addition, ACS could encroach on units offered by word-processing and facsimile equipment makers and on services offered by the few specialized common carriers that now offer packet switched services.

However, one of these common carriers, Telenet Communications Corp. of Washington, D. C., welcomes the competition. "We believe that AT&T's belated plan to enter our

business will significantly stimulate user interest in packet data-network service," says company president Anthony A. Barnett.

Data-communications equipment suppliers that now offer modems, multiplexers, data concentrators, and network-monitoring and -control equipment are more unsure of the extent of the impact ACS could have on their business. As Arthur Carr, president of the Codex subsidiary of Motorola Inc., notes, "There is no one company or technique that captures 100% of the market. It won't eliminate networking by the larger and more sophisticated user who wants control over his network."

The one group with the most to gain appears to be the users. For example, Robert Kaufman, manager of data communications at Damon Corp., a medical laboratory service based in Needham, Mass., says: "ACS will offer high-speed synchronous services not currently available from anyone. As a potential user, I'm looking forward to it. I'm betting

on it being better and cheaper."

Encouragement. In theory, at least, many industry members and observers agree that a nationwide dial-up digital communications network that would be protocol-transparent would make data communications easier and thus encourage new users and broaden the market. "Anything that ultimately lowers communications costs stimulates demand for hardware and services," notes William Becklean, a securities analyst with Bache Halsey Stuart Shields Inc. in New York.

At the same time, such a system would free the equipment suppliers from worrying about spending development money on communications procedures. "If I can deal with one protocol, I can give more functions to the user and spend less time and equipment power in emulating various protocols," says Elliott D. James, vice president and general manager of Harris Corp.'s Data Communications division, Dallas. "It reduces my front-end development costs."

Delay. In any case, it appears that it will be many years before the FCC will reach a decision and, if favorable, before AT&T can start to implement the service and make it available to users. The commission has called for comments on AT&T's request for a declaratory ruling that it be allowed to file for a tariff, and most members of the industry are preparing such documents.

The summer will be gone, says one FCC staff member, before those comments can be assembled and evaluated by the Common Carrier Bureau for presentation to the commissioners, who must then find a place on their crowded calendar to begin consideration of the issue.

In view of the heated opposition that appears to be brewing, betting now within the FCC and the telecommunications industry is that the commissioners will be obliged to forgo a declaratory ruling and assign a docket number to the proposal. Such a decision would guarantee a prolonged inquiry with extended hearings. Compounding the FCC's internal problems in handling the petition is the mid-July departure of the Common Carrier Bureau chief, Walter Hinchman, leaving the bureau temporarily leaderless. □

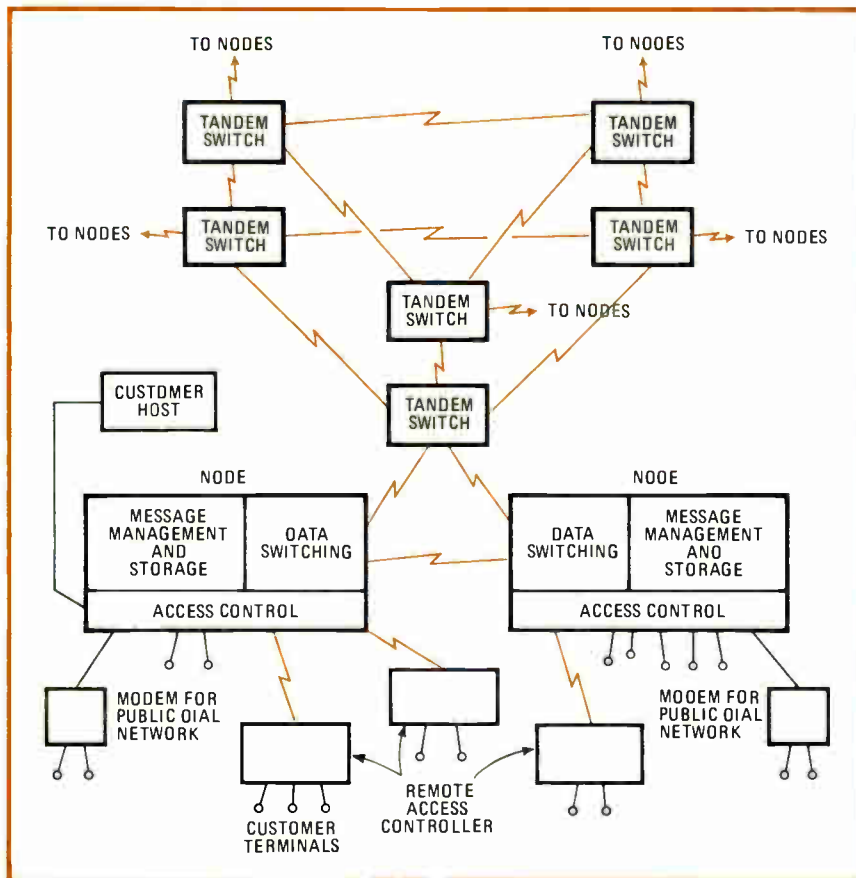

Connections. Customers are connected to access control units at ACS nodes. Message-management portion stores and forwards and executes custom programs. Data-switching area forms and switches data packets. Shared lines connect nodes, switches.

MINIATURE DC-DC 21 WATTS MULTIPLE OUTPUT CONVERTER IS OFTEN THE DESIGNER CHOICE

Powercube's low cost, high performance, rugged DC-DC converters with multiple outputs are being designed into a wide variety of equipment with small power requirements.

- Hand held portable instruments
- Railroad signaling systems
- Automotive testing systems
- Computer controlled heavy equipment
- Aircraft on board electronic systems
- Military ground equipment
- Oil and land surveying equipment
- Small craft sonar

All units are regulated and isolated, short circuit and overvoltage protected, and offer your choice of standard input and output voltages. Power density is 5 watts per cubic inch. You may series or parallel connect outputs to get non-standard voltages. Unit dimensions are 2" x 2" x 1.5".

For further information, circle reader service number or call: Powercube, Eight Suburban Park Drive, Billerica, Mass. 01821 (617)667-9500

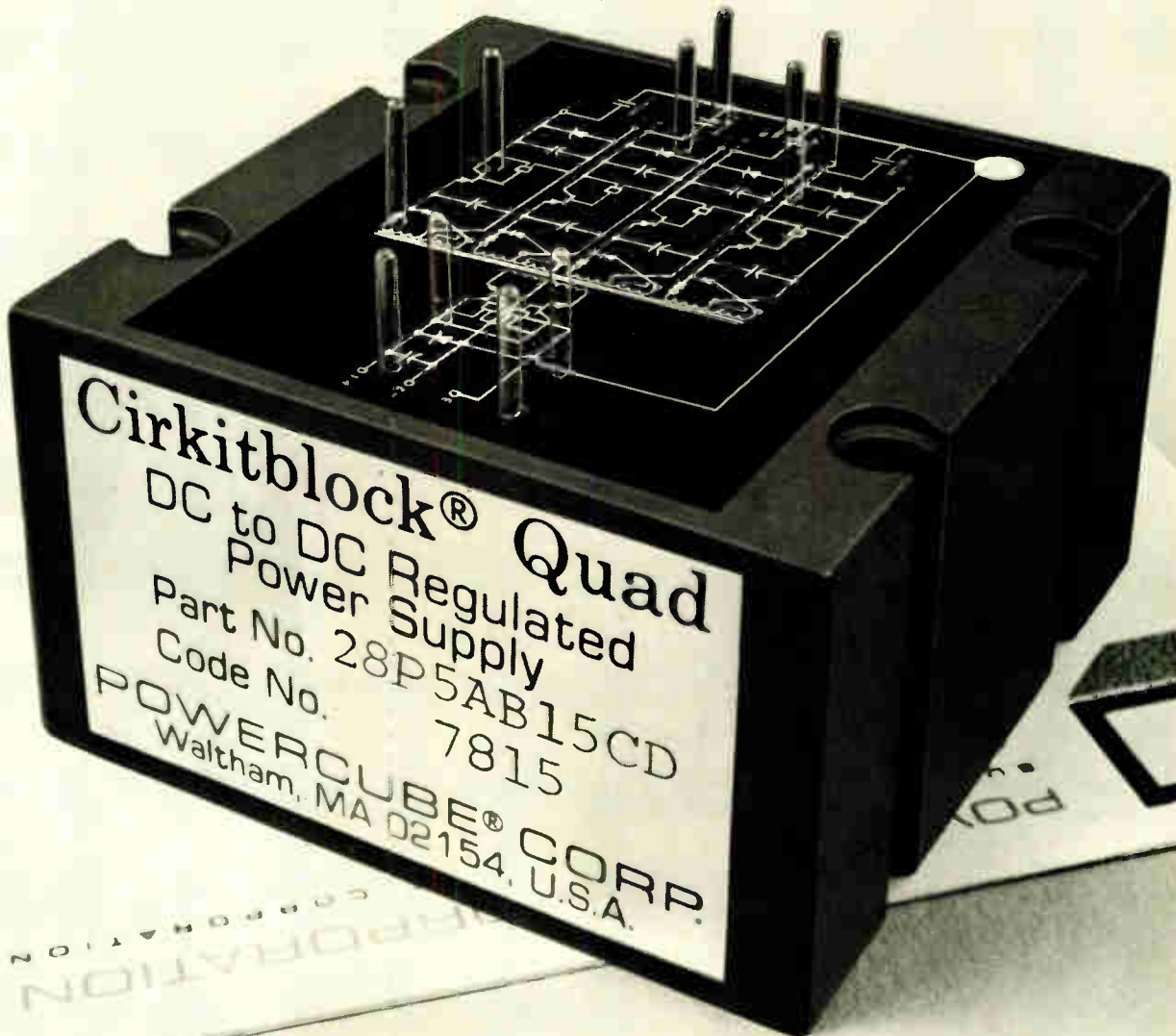

 **POWERCUBE**
A SUBSIDIARY OF UNITRODE CORPORATION

POWERCUBE CORPORATION
EIGHT SUBURBAN PARK DRIVE
BILLERICA, MASSACHUSETTS 01821
(617) 667-9500

Companies

Simplicity pays off at Nedco

Two-year-old minicomputer company features systems that are inexpensive and require little maintenance

by Lawrence Curran, Boston bureau manager

If someone asked you to name a minicomputer company that got its start within the last five years and can be considered successful today, chances are you couldn't. But little-known New England Digital Corp. may have the staying power to become a success.

The vital signs to date are good. Located in rustic Norwich, Vt., the company shipped its first 16-bit minicomputer in 1976 and now has more than 50 systems installed, most of them in scientific applications at nearby Dartmouth College, just across the Connecticut River in Hanover, N. H.

But competition in the mini market can be withering for a company Nedco's size, and officials there know that established mini vendors will not make it easy for them once Nedco gets more visibility. "The sell is uphill," concedes Yale Grayson, vice president for marketing, "but once sold, our current customer base is our best referral sales too." If so, having Dartmouth as its biggest customer and having a marketing representative only in New England, Nedco evidently has to tell its story—a simple system requiring little maintenance—more broadly outside that region.

Nevertheless, Nedco has fiscal (and calendar) 1978 bookings of about \$1.5 million and is financed entirely out of profits. The average price of its ABLE systems (see "The ABLE series," p. 83) is \$10,000 to \$11,000 in single units, or approximately \$7,000 each in volume. Grayson is projecting 1979 bookings of some \$4 million.

The nonstatistical part of the Nedco story is fascinating. The

The ABLE series

New England Digital Corp.'s ABLE series of minicomputers encompasses four 16-bit models that operate asynchronously with an average execution time of 200 to 300 nanoseconds: the ABLE/20, 40, 60 and 80. Memory interleaving results in an apparent access time of 593 ns. Memory addressing is by word, using the 16-bit memory address bus to directly address 65,536 words. A typical ABLE/40 includes 32 kilobytes of main memory, automatic program load in firmware, a real-time clock, an RS-232 interface line, two mini-floppy disks and controller, power supply, and handcrafted wooden cabinet. The price of this configuration is \$4,650 in hundreds. All four models are in production, and Nedco is quoting 30-day delivery from its plant, a converted residence in Norwich, Vt.

company traces its origin to 1973, when Sydney Alonso, now president, started out to build electronic music synthesizers at Dartmouth. With a Sloan Foundation grant to develop a computer-aided instruction program that would teach the instrument to eight students at once, Alonso bought a minicomputer to develop the software. Not being optimized for the music application, the mini was too slow to drive a synthesizer, "so we decided to develop our own computer," Alonso says. Wisely, however, he and Cameron Jones, then a Dartmouth freshman and now Nedco's vice president for software, set out to write the software first.

This led them to select a real-time operating system called XPL, which has been carried over into Nedco's nonsynthesizer-related stand-alone ABLE series. The operating system includes a language compiler that translates a subset of the PL/1 programming language into executable machine instructions for the ABLE series.

The XPL compiler took a year to develop, but just three months after it was finished Alonso and Jones had



Leaders. Cameron Jones writes program on ABLE/60 for president Sydney Alonso, right, and marketing chief Yale Grayson.

written a complete time-sharing system for the synthesizer, all the computer-aided music exercises, and synthesizer driver programs. The computer-aided-instruction system went on the air with the outside vendor's mini in January 1974, and only then did the group set out to

design its own machine.

"We wanted a machine that would look good putting out code from the XPL compiler and an architecture that would represent a good object machine for a compiler," Alonso says. The 16-bit ABLE design is organized around 16 registers and a bus structure Nedco calls the EZbus, consisting of three main buses. Data transfers are made using a 16-bit bidirectional data bus. An 8-bit address/instruction bus addresses all input/output devices and carries instruction information to the registers and arithmetic-and-logic unit. Memory addressing is done on an independent 16-bit memory-address bus.

Minimal maintenance. To keep reliability high and costs low, medium-scale integrated-circuit technology was chosen for the processor, says marketer Grayson, who hammers away at high reliability in his sales efforts. The two-board central processor uses 74S Schottky transistor-transistor logic for high speed, the main memory is implemented with Intel's high-speed 2114 fully static 4-kilobit random-access memory. "Our philosophy is to build equipment that will work in any reasonable environment without monthly maintenance," Grayson asserts.

Nedco customers do not care how computers work so long as they are as reliable as appliances.

The strategy was worked so far at Dartmouth, which has replaced minicomputers from two other vendors with ABLE systems. And at Creare Innovations Inc., also in Hanover, engineer Paul Hoisington chose a Nedco machine over Data General Corp. and Digital Equipment Corp. systems, principally because the Nedco computer did his job efficiently for an initial outlay of \$4,000. Creare is a small research and development firm that is developing hardware and software for pharmaceutical process controls, among other things. "We had a price range of \$3,000 to \$10,000," he says, "and Nedco was able to meet it."

Now Nedco has to convince some of the world outside the upper Connecticut River Valley that the ABLE's simplicity makes it an attractive alternative to other machines.

Electronics Magazine Book Series.

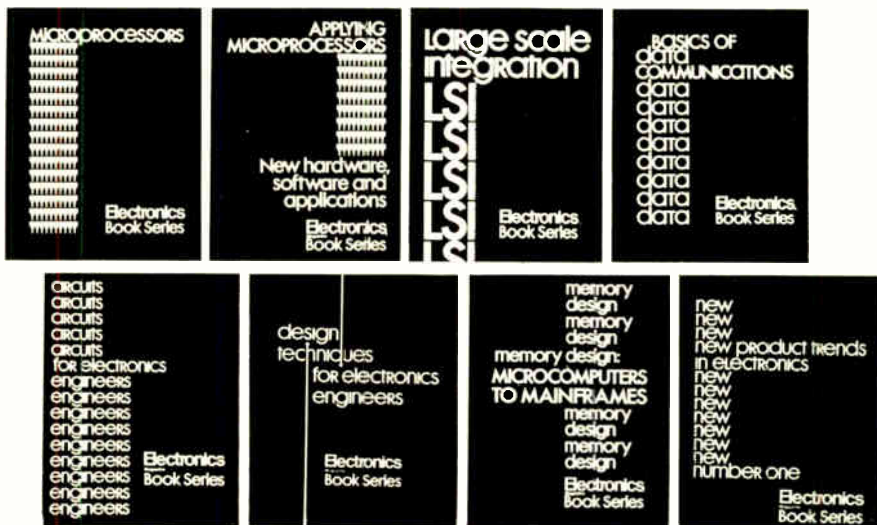

- 1. Microprocessors** What you must know about available microprocessor technology, devices, information, 4th printing. \$8.95
- 2. Applying Microprocessors** 2nd and 3rd generation technology. 26 detailed applications from data networks to video games. \$9.95
- 3. Large Scale Integration** Covers the basic technology, new LSI devices, LSI testing procedures, plus system design and applications. \$9.95
- 4. Basics of Data Communications** Includes 47 articles from Data Communications magazine covering more than 11 key areas. \$12.95
- 5. Circuits for Electronics Engineers** Contains 306 circuits arranged by 51 functions from Amplifiers to Voltage Regulating Circuits. Saves design drudgery. \$15.95
- 6. Design Techniques for Electronics Engineers** Nearly 300 articles drawn from "Engineer's Notebook." A storehouse of design problem solutions. \$15.95
- 7. Memory Design: Microcomputers to Mainframes** The technology, devices, and applications that link memory components and system design. \$12.95
- 8. New Product Trends in Electronics, Number One** From "New Products," state-of-the-art materials and equipment, arranged according to function. \$14.95

Electronics Book Series P.O. Box 669, Hightstown, N.J. 08520

1. Send me _____ copies of "Microprocessors" at \$8.95 per copy.
 2. Send me _____ copies of "Applying Microprocessors" at \$9.95 per copy.
 3. Send me _____ copies of "Large Scale Integration" at \$9.95 per copy.
 4. Send me _____ copies of "Basics of Data Communications" at \$12.95 per copy.
 5. Send me _____ copies of "Circuits for Electronics Engineers" at \$15.95 per copy.
 6. Send me _____ copies of "Design Techniques for Electronics Engineers" at \$15.95 per copy.
 7. Send me _____ copies of "Memory Design: Microprocessors to Mainframes" at \$12.95 per copy.
 8. Send me _____ copies of "New Product Trends in Electronics" at \$14.95 per copy.
- Discounts of 40% on orders of 10 or more copies of each book.

I must be fully satisfied or you will refund full payment if the book is returned after ten-day trial examination.

- Payment enclosed Bill Firm Bill me
- Charge to my credit card:
- American Express Diners Club
- BankAmericard/Visa Master Charge

Acc't No. _____ Date exp. _____

On Master Charge only, first numbers above name _____

Name _____ Title _____

Company _____

Street _____

City _____ State _____ Zip _____

Signature _____

Electronics abroad

Italy to push R&D

Government will provide \$605 million in subsidies and loans over the next four years to EDP, telecommunications, components

by Jeff Ryser, McGraw-Hill World News



Communications. Italy's government is concerned about telecommunications. Umberto Pellegrini, head of the technology federation, says phone company is key.

Nothing that involves Italian politicians and union leaders can ever be considered a sure thing. But about as close as one can come to it is the Italian government's plan to bolster the electronics industries over the next four years with \$605 million in subsidies and low-cost loans, mainly to finance research and development projects.

Already, the money has been allocated by parliament and the guidelines for spending it were spelled out in late June by a special commission under the wing of the ministry of industry. All that is needed to get things going is the accord of regional governments and the unions whose workers are involved. That should come by September, backers of the plan figure.

The plan focuses primarily on three sectors: electronic data processing, telecommunications, and components. However, company executives in these sectors generally rate the governmental effort envisaged as "merely adequate."

Data-processing firms will have access to some \$150 million in cash payments disbursed by the government, plus an additional \$90 million in low-cost loans channeled through the state credit agency, Istituto Mobiliare Italiano. For telecommunications hardware makers, there is \$115 million in grants and a like sum in loans. Finally, components makers will be able to draw on a \$80 million government cash fund over the four years that the plan will run and have a credit line of \$55 million at the government's credit agency.

Zero. As for the set makers, too many and most too small in the special commission's view, they are down for nothing. "It would be folly to subsidize that sector," says Giancarlo Lizzeri, an aide to the minister of industry and head of the commission. "It would be like throwing money away." Adds another commission member, "What we are hoping is that a company—perhaps Zanussi—will step forward, truly assert itself as a leader, and present the government with its own plan for coordination."

In data processing, the government's aim is to halt a projected decline in R&D spending over the next few years. In the aggregate, funds for research projects now are running about 2.8% of sales. The idea is to boost that level until it reaches about 5%, which would put the Italians about one percentage



Nothing for TV. Giancarlo Lizzeri, a government economics aide, believes Italian TV industry is too small and too splintered to qualify for R&D aid under new program.

point below the U. S. spending level. Under the plan, companies that qualify can get up to 90% of the funding for R&D projects from the government and IMI.

No trouble. Needless to say, the company most likely to qualify with the least difficulty is Ing. C. Olivetti et Cie., the sole major Italian-owned office-equipment and computer maker. However, the plan does not necessarily shut out the multinationals, even though many union leaders insist that subsidies should not be handed out to non-Italian companies. As Lizzeri points out, the government and the Communist Party members of the special commission agreed that multinational firms could get R&D grants if their Italian operations are net exporters

and they are not merely selling their products in Italy.

Hence the reaction of Carlo Peretti, general manager of Honeywell Information Systems Italia, which meets the criterion. He says that he "views the plan in a substantially positive way." Indeed, his firm is now preparing to submit a proposal to the government to obtain additional research funds.

At IBM Italia, which the government would like to see do more exporting, the reaction was about what one would expect. General manager Renato Rivero thinks that "the plan could be beneficial to the country in the sense that it would improve productivity." But his company, he makes clear, also believes that there should be no provision for protectionism and that "only efficiency and quality of products and services should remain as the basic yardstick for competitive presence in the industry."

Along with the low level of R&D spending in data processing, Lizzeri says that "one of our main concerns is the lack of public spending in this area. That is why we have called for a special commission to study ways in which public agencies can modernize their methods of doing business." Software, too, is a concern, and the government will push for joint ventures among the smaller software houses.

Hoping for two. But it is in telecommunications that the government is most anxious to add muscle by consolidations among existing companies. Although firms will not be forced by law to merge their operations, the government would like to see two groups evolve, one focused on the domestic market and one on foreign markets.

It is hard to see, though, how a group concentrating on exports could thrive without a home market to fall back on. Both Lizzeri and Umberto Pellegrini, president of the national federation of science and technology associations, out of whose study of the electronics industries two years ago came the premises for the government's plan, say the key is the Italian telephone company, SIP (Societa Italiana per L'Esercizio Telefonico).

"Up to now, they have proposed

nothing, as it seems they consider the situation uncontrollable," Lizzeri says. "Lack of leadership in the field has forced Italian-based companies to turn to the export market. Though some have been successful, the figures show that on the whole sales are falling off. Personally, I'm not optimistic that our companies can do that much more telephone business abroad."

Similar thoughts about the need for leadership from SIP are on the mind of Simone Fubini, general manager of Telettra SPA, a telecommunications hardware producer in the Fiat group. "SIP is a good company, very well managed," he says, "but it must delineate more clearly a future direction so that suppliers have a better idea of how to proceed." Meanwhile, he anticipates a more cooperative approach to research between his company and SIT-Siemens (which is known outside Italy as Italtel and like SIP is a unit in the government's telecommunications holding company, STET). This is the kind of talk the government likes to hear.

Components. As for components, the government's goal is to ward off the loss of jobs that is sure to come if Italian suppliers cannot stay competitive. Already, government officials point out, foreign firms have more than half of the Italian components market. To keep the foreign companies from becoming even more dominant, the government is counting heavily on SGS-ATES, the leading native semiconductor maker and part of the STET group.

To that company, apparently, will go a substantial chunk of the \$135 million that is earmarked for the components sector. Says an SGS-ATES official, "It's apparent that the government is hoping that we can pull some of the other national companies along with us, first through joint ventures and then through subcontract work. We are now working on such a plan."

It figures to be a tough pull for SGS-ATES. Speaking of the components sector, Lizzeri notes, "In Italy it's neither healthy nor controllable. And though this is the area we have the greatest need to manage, it's the one for which we have offered the fewest real suggestions." □

No short-cuts!

Grayhill Solid State Relays

are made
to keep switching
reliably

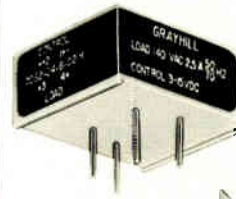

Micro Cube package

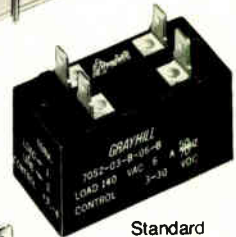

Standard package

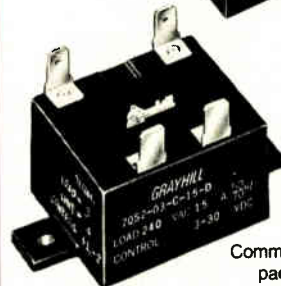

Commercial package

If you are concerned with product performance, nothing less than Grayhill Solid State Relays will satisfy your quality needs, because they are manufactured without the short-cuts that can adversely affect performance. Designed to switch inductive loads, Grayhill Solid State Relays have built-in snubber networks with high DV/DT characteristics and a high blocking voltage rating. This means continuing reliable performance, and lower total product cost. Grayhill Solid State Relays are available in optically isolated, transformer isolated and reed relay (Hybrid) versions (most with zero voltage turn-on), in six package styles. Ask for your free copy of our Engineering Bulletins on Grayhill Solid State Relays.

Grayhill
INC

561 Hillgrove Avenue • LaGrange, Illinois 60525
(312) 354-1040

Companies

Western Digital starts climb back

Starts new year looking to double last year's \$7 million in revenues with restructured management and sound products

by Larry Waller, Los Angeles bureau manager

After racking up losses that reached \$9 million in the last four years and almost forced it to fold, Western Digital Corp. has cleaned up its act and is making a fresh start. The eight-year-old Newport Beach, Calif., semiconductor firm, noted for a meteoric rise and fall tied to the handheld calculator market, launches its new fiscal year this month with changed management and restructured operations. That Western Digital survived at all to emerge last February after nearly 18 months of operating under Chapter XI of the Federal Bankruptcy Act surprises many observers, including the company's aggressive president and chairman.

"It's very unusual to make it out," says Charles W. Missler, who has

Leader. President C. W. Missler is leading Western Digital to profitability by emphasizing its strengths in data-communications interface chips.



Divisions. C. A. Von Urff, left, heads Western Digital's data-communications products division, while L.A. Lotito runs a new division handling computer products.

steered Western Digital since May 1977. Tapped by the firm's bankers for the job, Missler knows about Chapter XI, having acted as a consultant to three other companies in similar circumstances. He says revenues for the just-completed year were about \$7 million, at breakeven profitability, and the current rate leads him to predict \$14 million in sales for this year. Profits should improve steadily, he thinks.

Strengths. On taking over, Missler concentrated on using the strengths he found at Western Digital. One was "a core of good people, here for the two years of trouble, with the quick-buck artists gone and the incompetents fired." He also felt the company's products were sound, "principally data-communications interface chips—and the n-channel silicon-gate technology is as proven, with eight years of experience, as anybody's in the industry." What especially impressed Missler, and gave him hope for recovery, was that "cash flow from the chips paid virtually all operating bills during

Chapter XI, which is unusual."

Missler does confess to a concern that Western Digital's thinly traded issue stock, almost entirely handled by a few Southern California regional brokerage houses, has started to move up, trading recently in the \$3-a-share range. "This worries me," he says, "since it is getting ahead of itself."

He feels that unwarranted emphasis on stock price is not consistent with his measured plans for growth. So far, analysts have not been beating down his door, but more months of good financial results could reawaken this interest.

Missler also mentions that Western is tight for capital, "but if we perform soundly, we'll find ways to get it." As word of the company's recovery gets around, offers come in, but Missler emphasizes that he is not looking for any fast deals.

From the customer's point of view, Western Digital may be having its financial problems, but there is one good reason to continue using the firm as a supplier: quality of prod-

uct. Typical of the attitude is the appraisal offered by the head of a small microsystems firm that uses Western as a vendor. For him, he says, the answer was simple: "They were not just the best datacom chips around, they were the first and only ones at that time that did this job."

While a number of firms, including big semiconductor houses, now make such communication interface devices, Western Digital's head start in the early 1970s and subsequent product improvements kept it moving despite the financial pressures. The result is that its major customers today are minicomputer makers that are heavily involved in distributed data processing.

The integrated-circuit chips that carried Western Digital through its lean times are families of universal asynchronous receiver/transmitters and asynchronous/synchronous receiver/transmitters, called the Astro line. These ICs, since improved, caught on as interface devices for linking the burgeoning microprocessor population.

Microprocessor. Not surprisingly, Missler downplays Western Digital's own microprocessor offering, the 16-bit chip set that was one of the first on the market nearly three years ago. The firm not only supplied them to Digital Equipment Corp. for the LSI-11 one-board minicomputer, but the computer company still manufactures a four-chip proprietary configuration for itself. Trying to turn this processor into a standard line overtaxed the small company, even though performance was praised by users. "Our mistake was underestimating the resources it took to be a success with that business," recalls a company veteran.

But Missler is sure about his data-communications prospects and has allotted them a separate division, headed since May by a 20-year semiconductor veteran, Charles A. Von Urff, who ran telecommunications marketing for General Instrument Corp. Along with another new division for computer products, which Larry Lotito was hired in May from nearby Computer Automation Inc. to run, it is expected to account for more than 90% of sales [*Electronics*, July 14, p. 14]. A third division is for control systems products.

Moreover, von Urff is taking over a thriving chip business and Lotito is being handed a hot product that Missler says illustrates both Western Digital's technology and its ability to move fast. "We were able to come up with the 1791 dual-density floppy-disk controller, which is IBM-compatible, in seven months from idea to chip because this is our turf," he says. The company started design in December, providing samples now

and production units in August, which Missler believes will give it a six-month edge over competitors.

As for microprocessors, Missler says that "building a general-purpose microprocessor doesn't make sense." But the company is in the nice position of being able to respond to custom applications. These are being evaluated and some will develop into small production contracts, he thinks. □

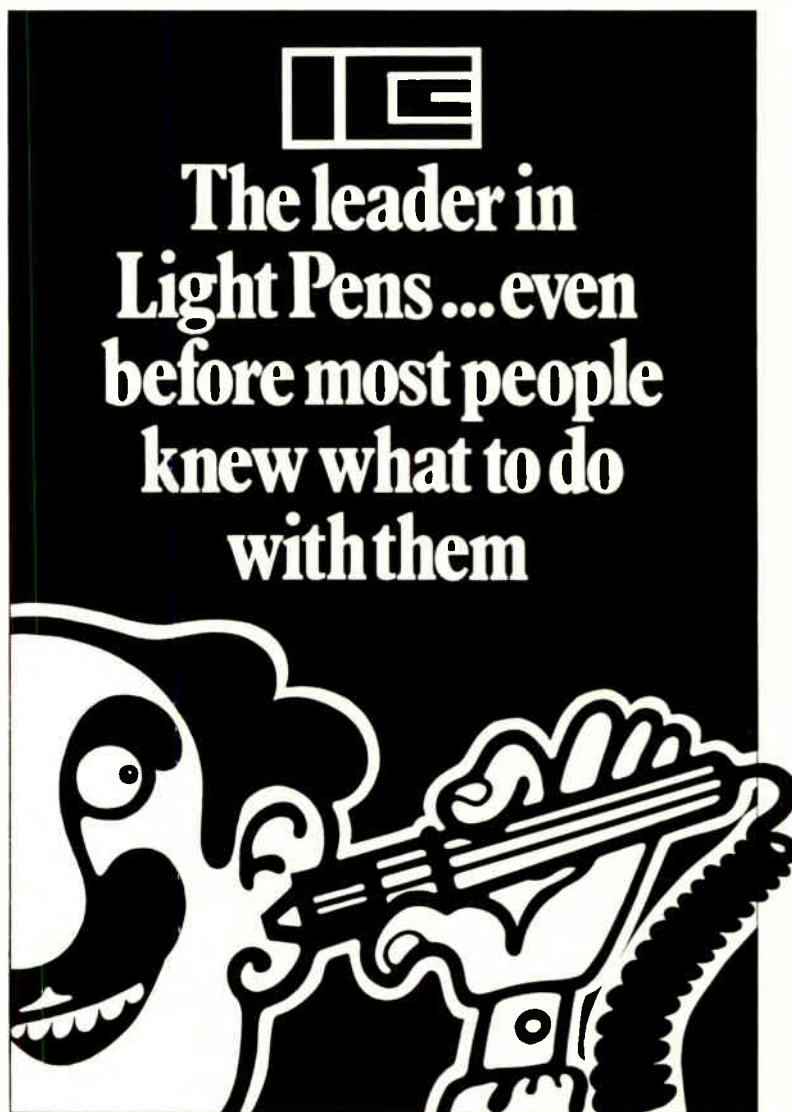

ICC. The leader in light pens since 1966. Now offering improved performance. Lower prices too. What are you waiting for? Write for full details or call, today.



INFORMATION CONTROL CORPORATION
9610 Bellanca Ave., Los Angeles, Ca. 90045 (213) 641-8520



Model	No. of Digits	DC Volts	AC Volts	True rms AC	OHMS	Programmable Parallel	GPiB	Auto-Range	MP Based	AC/AC Ratio	Basic DC Accuracy	Base Price (U.S. List)
2000	3½	*	*		*						0.5%	\$ 199.50
2100	3½	*	*		*						0.25%-1yr.	\$ 249.00
4200	4½	*	*		*						.05%-1yr.	\$ 399.00
4324†	4½	*	*		*						.01% 6mo.	\$3,295.00
4600	4½	*	*		*			*			.01% 6mo.	\$ 549.00
4800	4½	*	opt.	*	opt.	*		*			0.1%	\$2,995.00
5000	5½	*	opt.	*	opt.	*	*	*			.005%	\$ 995.00
5100	5½	*	opt.	*	*			*			.0025%	\$ 995.00
5900	5½	*	opt.	*	opt.	*	*	*			.001%	\$2,195.00
5940	5½	*	opt.	*	opt.	*	*	*		*	.001%	\$3,695.00
6000	6½	*	opt.	*	opt.	*	*	*	*	*	.001%	\$2,995.00
6900	6½	*	opt.	*	opt.	*	*	*			3PPM	\$3,495.00

† MIL-Spec

Tomorrow has arrived.

Today we can deliver whatever you need in digital multimeters, from the simplest to the most advanced.

We don't make more digital multimeters than anyone else in the world. We just make them better.

They're designed to solve problems, to make your measurements easier and more accurate, and to deliver the highest standards of performance. For a lot less than you're used to paying.

From the 3½ digit Series 2000 portable DMM to the revolutionary Series 6000 microprocessor-powered Amplitude Measurement System, Racal-Dana gives you the best buy for your instrument dollar.

If you need anything in digital multimeters, don't wait until tomorrow. It's already here. Call or write today.

Racal-Dana Instruments Inc.,
18912 Von Karman Avenue, Irvine, CA
92715. Telephone: 714/833-1234.



RACAL-DANA
RACAL

For demonstration, circle No. 176
For literature, circle No. 89

Say you've been doing some IF testing in the kHz range, and now you need to switch to the RF MHz range. With the high performance Model 3002, you just change the lever indicator switches on the front panel. With anyone else's signal generator you reach for a different model—and drop a few thousand more dollars.

So if your testing needs go from as low as 1 kHz to as high as 520 MHz, you should go with Wavetek's Model 3002. It's also programmable and GPIB compatible, so it knows its way



around any automatic test system.

Of course your primary concerns may be accuracy and stability. In that case, Model 3002's 0.001% accuracy and 0.2 ppm/hr stability will be two primary reasons to buy it. The unit also has internal and external AM and FM modulation capability

and +13 dBm (1 Volt) of leveled output power.

You can get into Model 3002 for as little as \$3,300. The GPIB compatible version with an optional programmable attenuator and reverse power protection will set you back about \$4,575. But think how far it'll take you. Wavetek Indiana, Inc., 66 N. First Ave., P.O. Box 190, Beech Grove, Indiana 46107. Telephone (317) 783-3221, TWX 810-341-3226.

WAVETEK[®]

Now you can go from 1 kHz to 520 MHz by changing settings... instead of signal generators.

FREQUENCY
1KHz-520 MHz



Circle 90 on reader service card

World Radio History

The complexity of bit-slice processor parts, compounded by minimal support from their manufacturers, has won them a poorer welcome than they deserve from designers. Although processors built with bit slices can be extremely powerful, the design flexibility of the parts in both hardware and instruction sets demands an intimate familiarity with a particular family before a designer can be confident of success.

The article that follows opens a two-part series intended as an introduction and general comparison of the various bit-slice products available. Based largely on the authors' many years of experience, it also draws upon the work they did at the Applied Research Laboratories of the University of Texas at Austin on the development of a bit-slice-based sonar interface controller for the Naval Sea Systems Command.

The first article is devoted to the processor element—the chip that manipulates the data. The second deals with the other half of basic bit-slice design—the microcontroller that sequences the instructions—as well as the support products and literature supplied by the manufacturers of families of bit-slice parts. It will appear in the next issue.

How bit-slice families compare: Part 1, evaluating processor elements

by W. Thomas Adams and Scott M. Smith, *

Applied Research Laboratories, University of Texas, Austin, Texas

□ When they first came on the market, bipolar bit-slice processors were almost totally unsupported by surrounding circuits or design aids, much less by documentation or even advertising. Then, as more device types were brought out by the various manufacturers, it seemed that users had even less way of knowing which bit-slice processors were best suited to their applications.

What follows is a comparative survey, as complete and objective as possible, of both the parts available and the design support offered by the various manufacturers. Such a survey is all the more necessary because of the high level of skill needed to build a bit-slice processor.

Designing with a byte-oriented metal-oxide-semiconductor microprocessor, after all, consists mainly of programming a system made up of components hooked together according to the manufacturer's specifications. But bit-slice processor design involves critical hardware decisions and the creation of an instruction set as well—and only then comes the programming. Moreover, since bit-slice processor parts of different manufacturers can be mixed in one and the same design, consideration must be given individually to each of them.

A look back

In 1974, Monolithic Memories Inc. introduced the first bit-slice microprocessor device, the 4-bit-wide 6701 processor element, though it was marketed as a microcontroller rather than a microprocessor. No family of surrounding circuits and no design aids of any kind were offered to make its use any easier. In 1974 and early 1975, Intel Corp. and Advanced Micro Devices Inc. introduced families of bipolar large-scale integrated circuits promoted as "bipolar microprocessors." That marketing strategy, together with the wide acceptance of the MOS processors, brought customers' attention to the bit-slice devices. These three manufacturers were then joined by Fairchild Camera & Instrument Corp., Texas Instruments Inc., Scientific Micro Systems, Motorola Inc., Raytheon Corp., Signetics Corp., and National Semiconductor Corp., so that now there is a wide variety

*Both authors are now at IBM Corp., Office Products Division, Austin, Texas.

of bit-slice processor parts available to choose from.

A bit-slice processor is built with a multiple-chip set of large-scale integrated circuits that handle data not in complete bytes or words but in 2- or 4-bit chunks. Most often it uses transistor-transistor-logic technology. Such a processor has several features that make it attractive for applications requiring performance beyond the capability of the byte-oriented MOS devices or even such bipolar microprocessors as Texas Instruments' SBP9900 or Signetics' 8X300. These applications include mini-computers, high-speed peripheral controllers, signal processors, and some types of stand-alone process controllers. Also, bit-slice designs use fewer parts than a system built with discrete logic, though they do require more components than other microprocessor designs.

Bit-slice systems are microprogrammable: the designer himself—not the device manufacturer—determines the instruction set of a given processor. Such a feature is invaluable for emulating an existing machine, for example. In addition to being expandable in terms of processor and control-memory word widths, the bit-slice devices are expandable in processing power. Auxiliary arithmetic processors, special input/output devices, and other features may be added to the basic design to provide virtually any reasonable processing capability.

At present, there are six families of devices classified as bit-slice microprogrammable processor sets. These are the 6701/67110 from Monolithic Memories, Intel's 3000

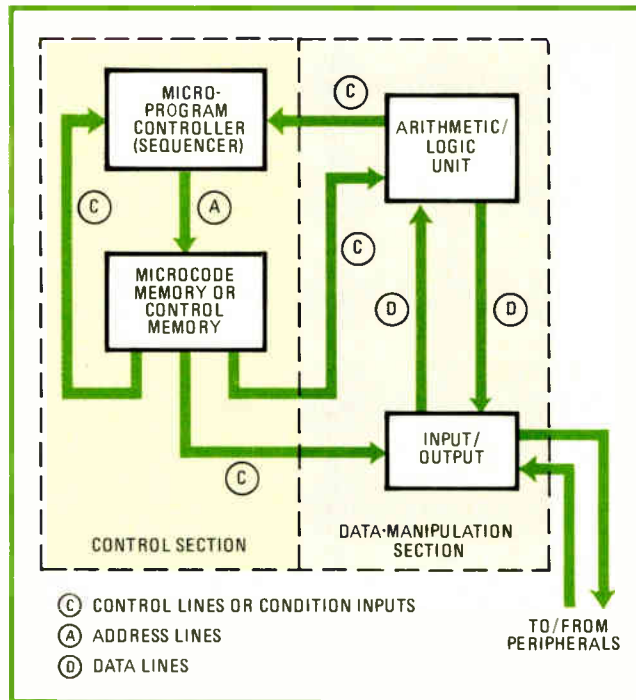

1. Bit-slice basics. Two sections make up a bit-slice processor. One, built around the processor-element chip, manipulates the data. Control and sequencing of microinstructions is handled by the second section, which is built around the microcontroller chip.

TABLE 1: GENERAL CHARACTERISTICS AND ARCHITECTURAL FEATURES OF THE PROCESSOR ELEMENTS

Bit-slice device	Manufacturer	Second sources	Technology	Slice width (bits)	Pins/pack	Typical power required (mW)
9405	Fairchild	Sig	Schottky TTL/C MOS	4	24 DIP	500 (TTL)
3002	Intel	Sig	Schottky TTL	2	28 DIP	725
6701	MMI	ITT	Schottky TTL	4	40 DIP	1,075
Am2901(A)	AMD	Fairchild, MMI, Mot, Ray, Sig, Nat'l	Schottky TTL	4	40 DIP 42 FP	925
SBP0400A SBP0401A	TI	—	I ² L	4	40 DIP	1,000 ⁶ (programmable)
SN74S481	TI	—	Schottky TTL	4	48 QIP	1,125
MC10800	Mot	Fairchild	ECL	4	48 QUIL	1,374
Am2903	AMD	Nat'l	Schottky TTL	4	48	1,155

¹ Indicated as accumulators + register file + buffer registers.

² Two registers in register file are addressed simultaneously.

³ The program counter is part of the register file, but also serves as a buffer register.

⁴ Devices intended to be used with external register-file parts.

⁵ The program counter and memory counter are incrementable registers and, in addition, the former feeds back into the 74S481's ALU section.

⁶ Has a mask input (2 lines) that may be forced to all 1s or 0s requiring 1 extra bit of control or up to N bits for an N-bit processor if each bit is controlled separately.

TABLE 2: ARITHMETIC AND LOGIC CAPABILITIES OF PROCESSOR ELEMENTS

Bit-slice device	Logical operations ¹	Add/subtract operations ²	BCD add	Multiply	Divide	Cyclic redundancy checking generator	Normalize	2's complement sign/magnitude conversion	Parity	Decoded status ³
9405	C,A,O,EO	A	-	-	-	-	-	-	-	Z
3002	C,A,O,EN	A,D1,2C	-	-	-	-	-	-	-	Z ⁴
6701	C,A,O,EO	A,S,D1,2C	-	-	-	-	-	-	-	O,Z
Am2901(A)	C,A,O,EO,EN	A,S,D1,2C	-	-	-	-	-	-	-	O,Z
SBP0400A SBP0401A	C,A,O,EO,EN	A,S,I1,2C	-	-	-	-	-	-	-	Z
SN74S481	C,A,O,NA, NO,EO,EN	A,S,I1,D1, 2C	-	yes	yes	yes	-	-	-	O,E,AG,LG
MC10800	C,A,O,NA,NO EO,EN	A,S,D1,D2, I1,I2,2C	yes	-	-	-	-	-	yes	O,Z
Am2903	C,A,O,NA,NO, EO,EN	A,S,I1,I2 2C	-	yes	yes	-	yes	yes	yes	O,Z

¹ Logical operations are:

- C Complement
- A AND
- O OR
- NA NAND
- NO NOR
- EO Exclusive-OR
- EN Exclusive-NOR

² Add/subtract operations are:

- A Add
- S Subtract
- Di Decrement by i
- Ii Increment by i
- 2C 2C 2's complement

³ Decoded status is:

- O Overflow
- E Equal
- Z Zero
- AG Arithmetic greater than
- LG Arithmetic less than

⁴ Indicated on carryout line during logic operations only.

Registers ¹	Data ports			Control lines
	Input	Output	Bidirectional	
0 + 8 + 1	1	1	0	8
1 + 11 + 1	3	2	0	9 ⁶
1 + 16 ² + 0	1	1	0	17
1 + 16 ² + 0	1	1	0	18
2 + 8 + 0 ²	1	2	0	11
2 + 0 ⁴ + 2 ⁵	1	2	1	17 ⁷
1 + 0 ⁴ + 1	1	0	2	17 ⁷
1 + 16 ² + 0	1	0	2	21

⁷ Does not include bits necessary to address an external register file if one is used.

⁸ The SBP0400A/SBP0401A specs are written for 200-mA injector currents. If a 5-V supply is used, total power required by device and injector resistor is 1,000 mW. Both are maximum-speed configurations.

series, Advanced Micro Devices' 2900 series, the Macrologic series from Fairchild, Texas Instruments' 74S481/82 and SBP0400, and the 10800 series from Motorola. The manufacturers market their parts as families of devices that are to be used together to implement a processor.

The basics of a bit-slice processor are illustrated in Fig. 1, which shows a system divided into a control or sequencing section and a data-manipulating section. Accordingly, the two basic parts in any bit-slice family are the microcontroller, which sequences the microinstructions, and the processor element, or arithmetic and logic section. A given bit-slice family may also contain several parts that perform special functions, acting as controllers for interrupt, memory, and input/output, for instance. Other devices like random-access memories, programmable read-only memories, and bus drivers may be marketed as family members or separately.

The processor elements

The processor element consists basically of an arithmetic and logic unit and associated registers. It gives the bit-slice microprocessor its name, because it generally handles data 2 or 4 bits wide at a time. The 2- or 4-bit slices are cascaded to form arithmetic processors of the desired word size. Table 1 lists the general characteristics and architectural features of the processor elements. The ALU instruction capabilities of each of the processor elements are shown in Table 2.

The 9405 from Fairchild (Fig. 2) is a relatively simple processor element. It can, however, be combined with Fairchild's 9404 data-path switch (also shown) to obtain a more capable arithmetic processor. Although a two-

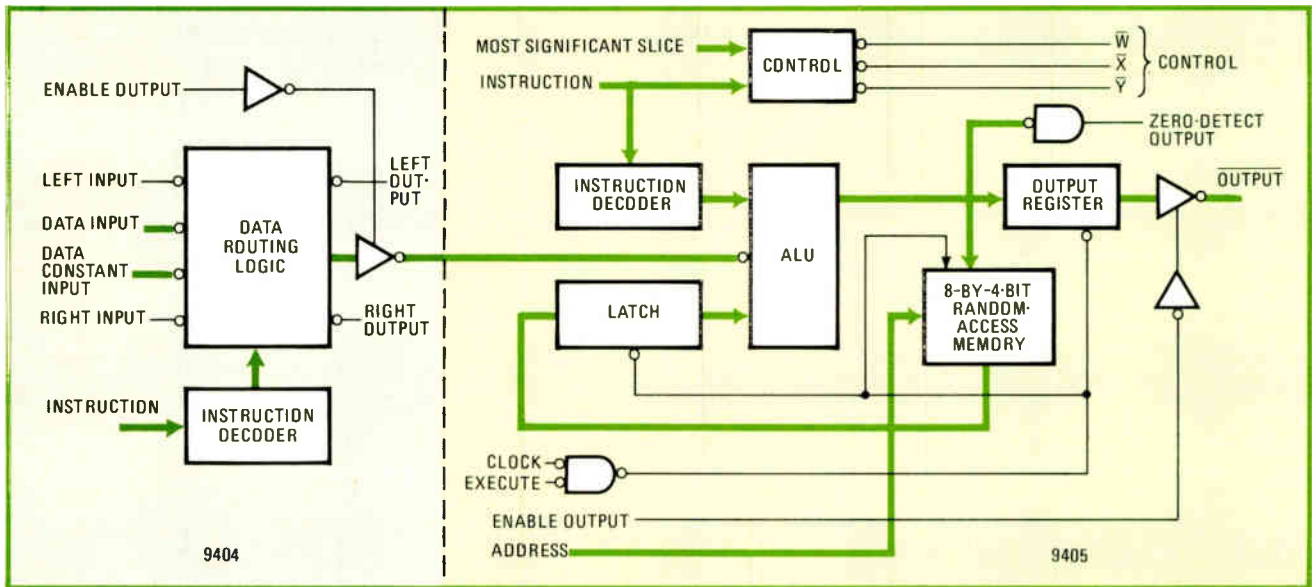

2. Two-chipper. Fairchild's 9405, a relatively simple processor element, becomes a capable arithmetic processor when hooked to a 9404 data-path switch. The chip set is also available in a complementary-MOS version ideally suited for low-power applications.

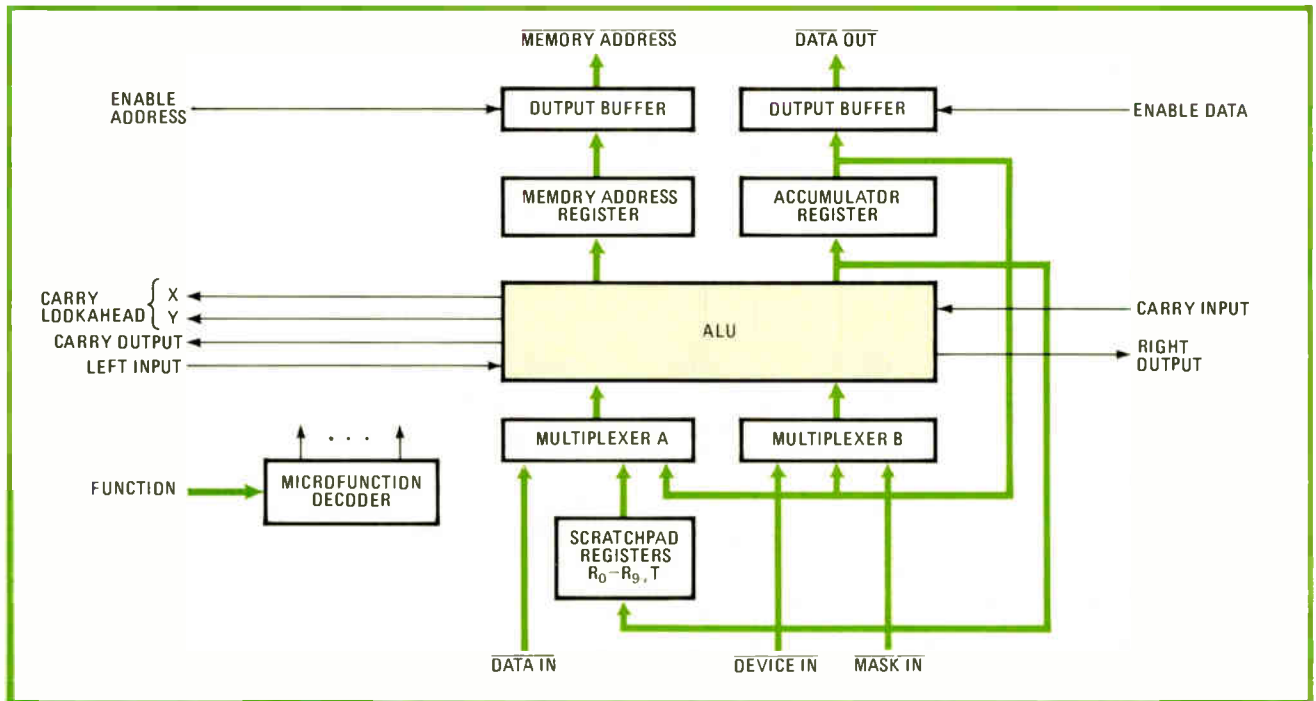

3. Two bits. One of the earlier processor-element designs is Intel's 2-bit-wide 3002. Twice as many 3002s as 4-bit devices are required to build a processor of a given width, but the Intel part compensates by offering more I/O ports than any other processor element.

chip set results, each device is housed in a space-saving 400-mil-wide 24-pin package.

Being on the lower end of the performance scale, the 9405 is best suited for controller and processor applications that are just beyond the capabilities of the MOS and bipolar microprocessors. A plus is that complementary-MOS versions of the 9404 and 9405, ideally suited to low-power applications, are also available.

Figure 3 shows one of the earlier designs, the Intel 3002. Since it handles only a 2-bit-wide slice, twice as many 3002s as 9405s are required to implement a processor of a given width. However, Intel's part

compensates by offering a larger number of I/O ports than any other device.

Since the 3002 has a single-port register file, more instructions may be required for some tasks. The trade-off here is the increased number of instructions—and longer execution time—versus the larger number of control lines required for the multiple-port register file.

With its excellent I/O capabilities, the 3002 works better in data-manipulation applications than in number crunching. Signetics offers a version, the N3002, that is significantly faster than Intel's original part.

Although not exactly identical, Monolithic Memories'

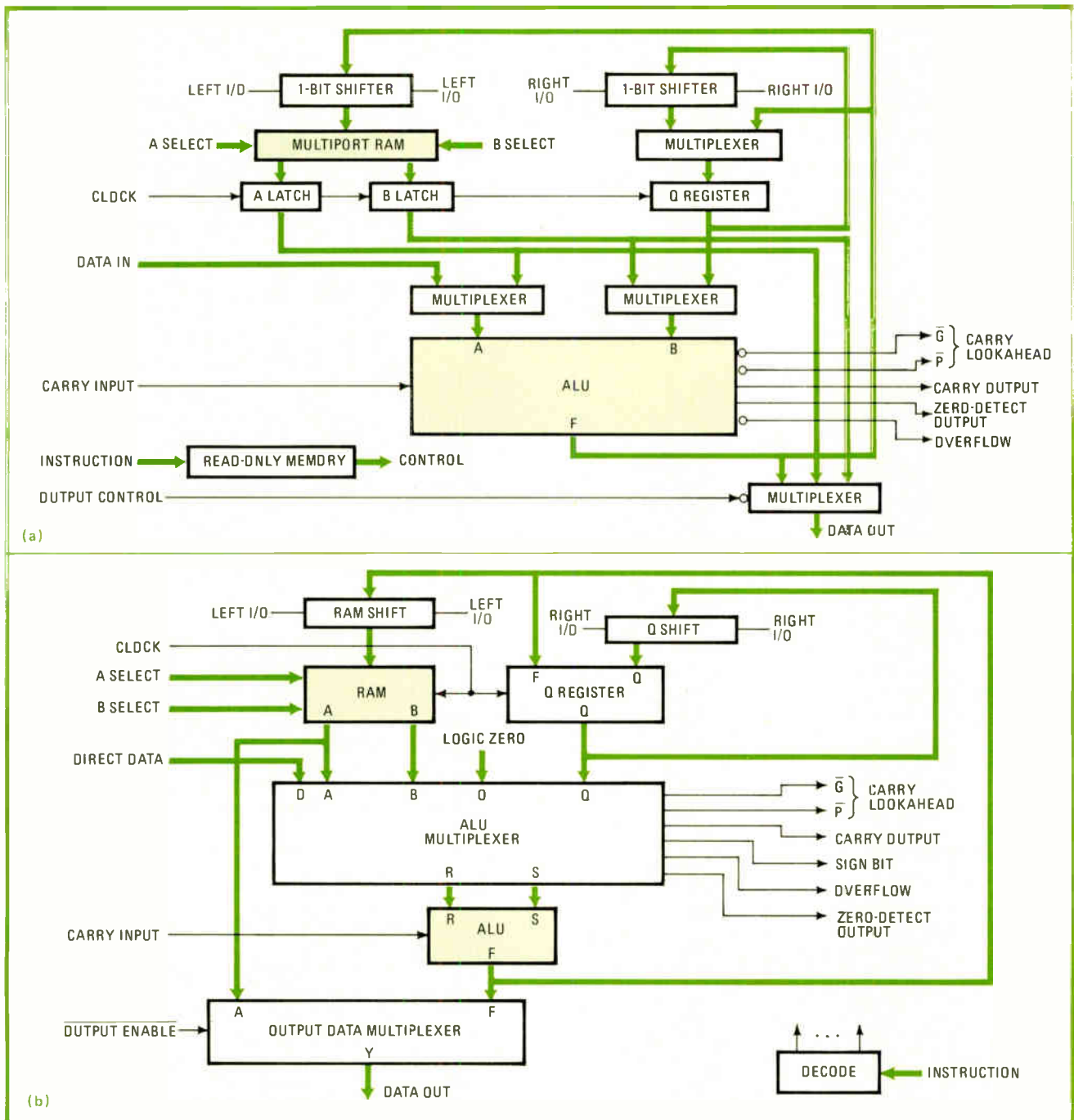

4. Similar slices. The 6701 from Monolithic Memories (a) and the Am2901 from Advanced Micro Devices (b) are architecturally similar processor elements. Outstanding in these are the dual-port, 16-register files and the cascading of ALU and shift matrixes.

6701 and AMD's Am2901 are quite similar architecturally, as can be seen in Fig. 4. The dual-port 16-register file and cascading of the ALU and shift matrixes are the most outstanding features of these processor elements. A separate accumulator with its own shift network is also provided to facilitate multiply and divide operations.

The I/O port structures of the 6701 and 2901 might at first seem limited, but are sufficient in most cases. These devices are competent to handle a large number of minicomputer and controller applications (as evidenced in particular by the sales record of the 2901). A higher-speed version of the 2901, the 2901A, is also available.

There are several other higher-speed versions of the 2901, including an interesting one from National Semiconductor that integrates emitter-coupled logic within the TTL framework. The designer should be aware when using such devices, however, that the slower versions may no longer work in his design, so that he may no longer have a second source.

Texas Instruments' first commercial device to use digital integrated injection logic was the SBP0400 bit-slice processor element (Fig. 5). However, it is slower than any of the TTL processor elements, as is even a later and much faster version, the SBP0400A. The SBP0400's

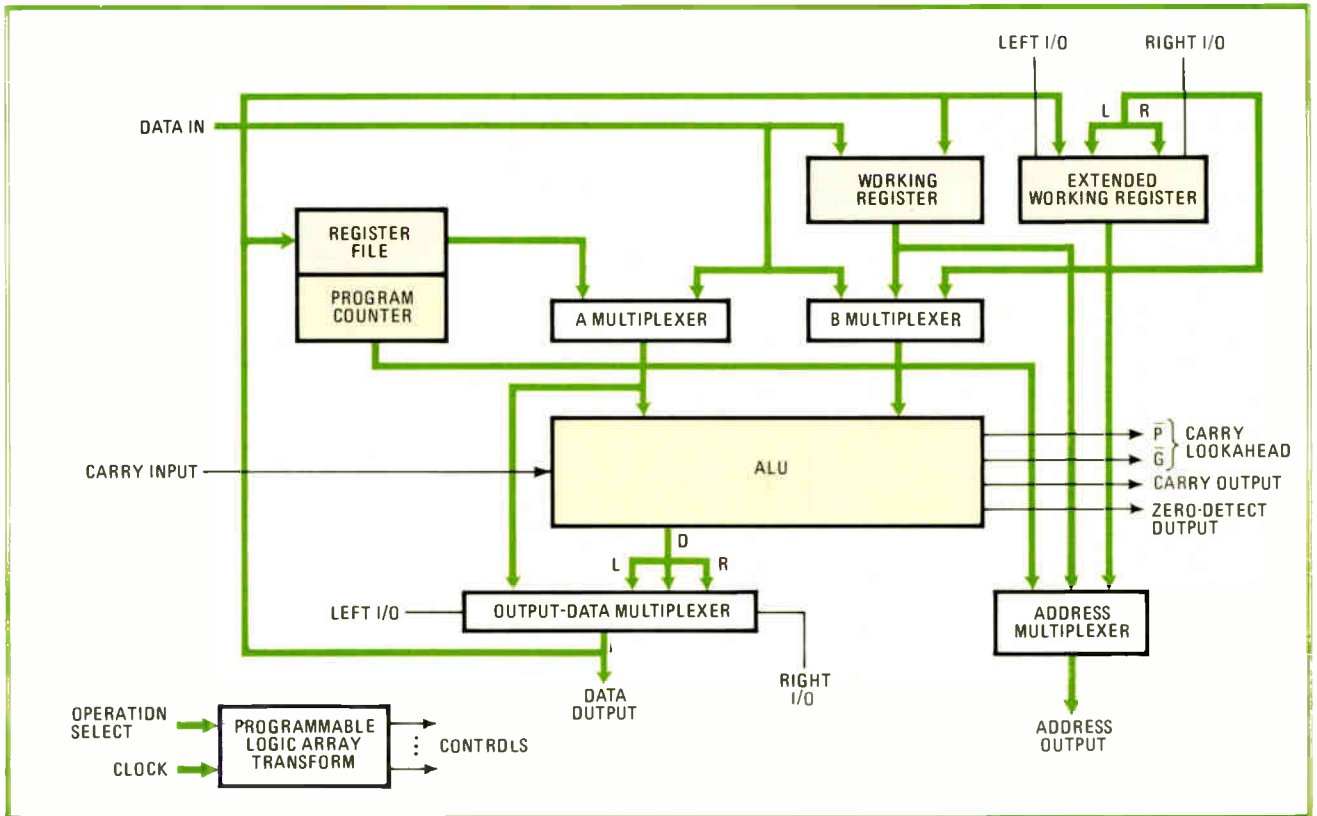

5. PL version. Texas Instruments' SBP0400, built with integrated injection logic, runs more slowly than TTL processor elements. Unique to the devices, however, is a programmable power dissipation that can be selected over a 1,000:1 range for a constant speed-power product.

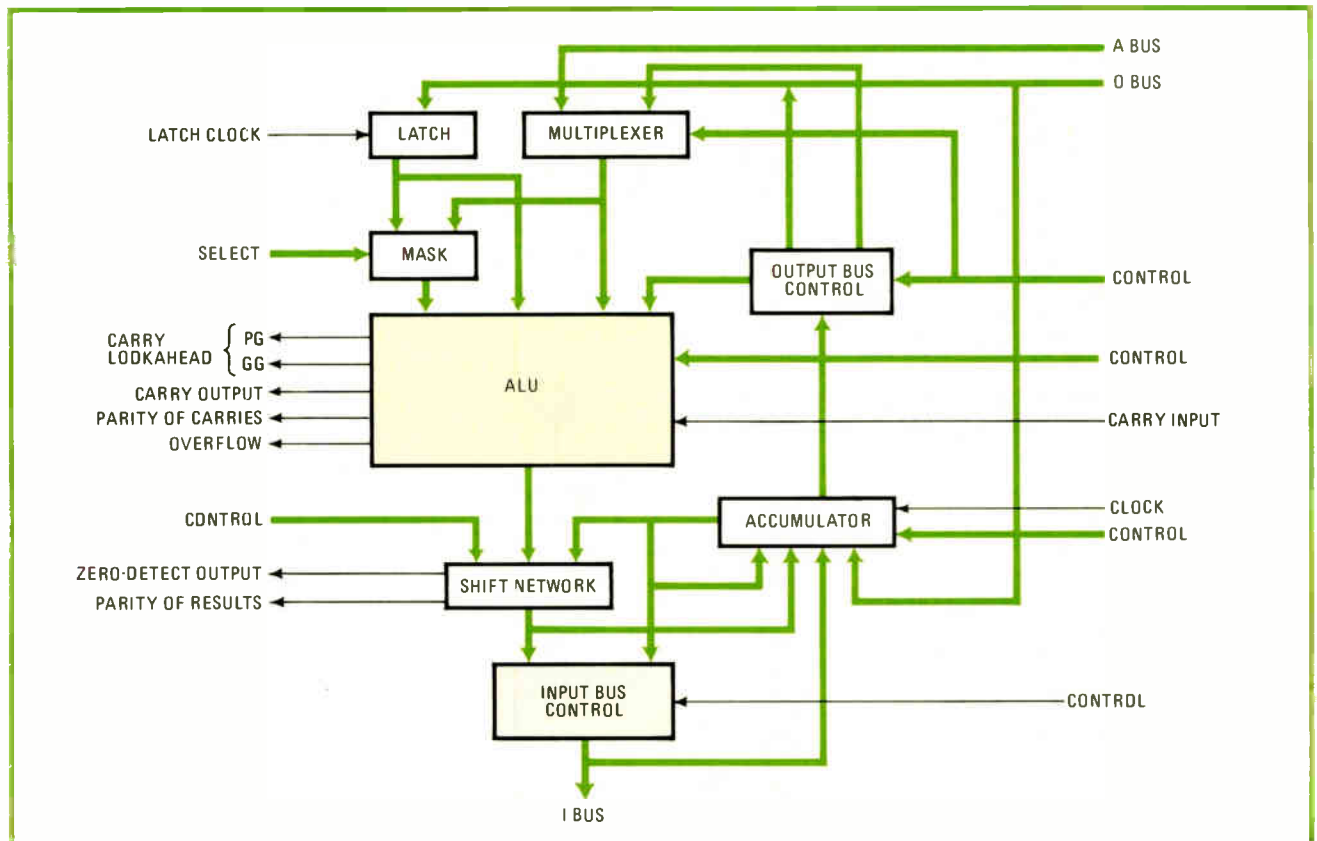

6. All ECL. The only processor element built entirely of emitter-coupled logic is Motorola's MC10800. Its pluses include binary-coded-decimal addition and internal parity generation for error checking. Mixing the ECL part with TTL bit-slice families is generally not recommended.

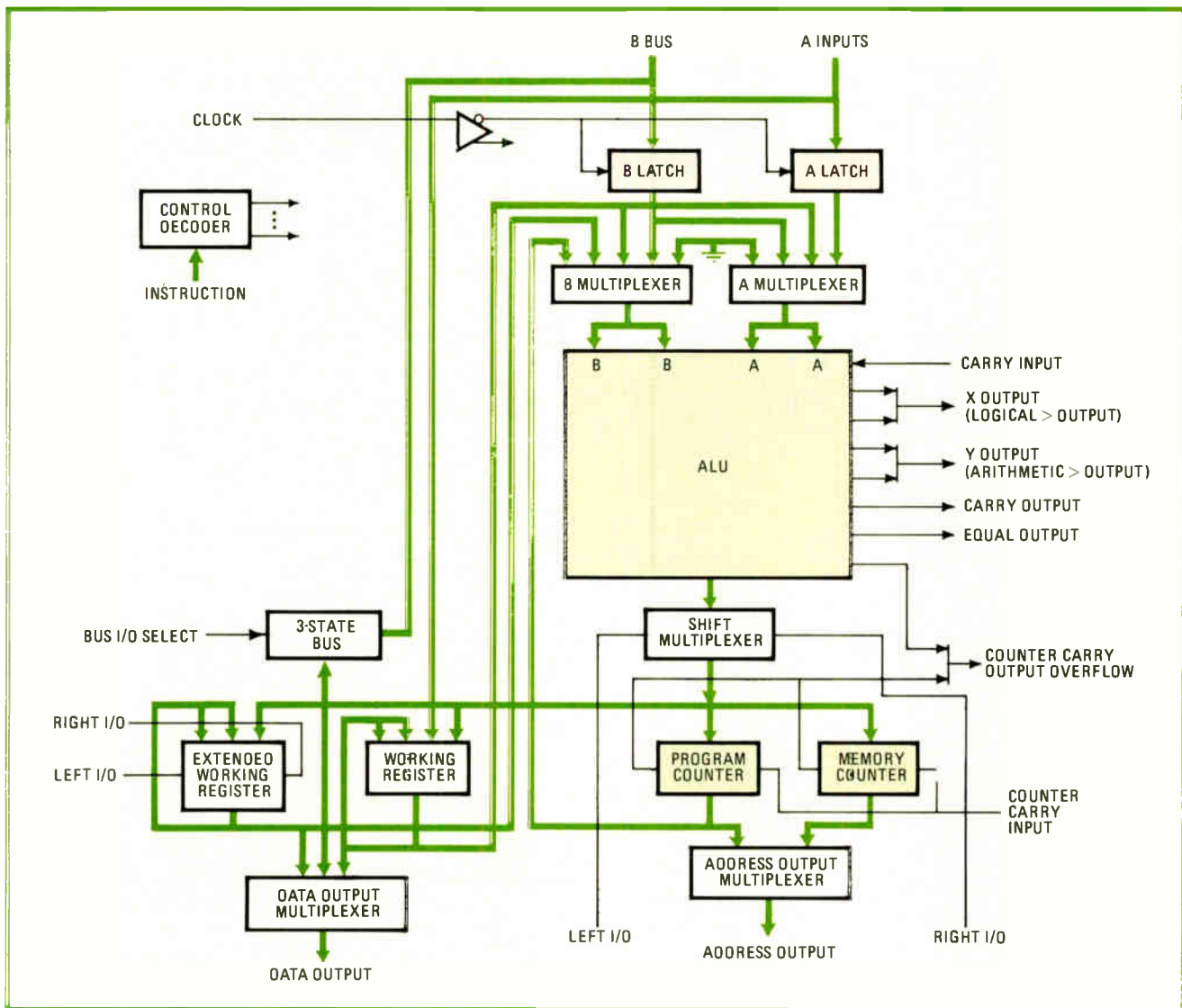

7. Complex. Structurally the most complex processor element available is Texas Instruments' SN74S481. Because of strong arithmetic capabilities, including preprogrammed multiply and divide, the part is optimized towards minicomputer and signal-processing applications.

most outstanding feature is its programmable power dissipation. The power it uses can be programmed over a 1,000-to-1 range while the speed-power product remains constant. But the device would be much more useful if there were other I^2L parts to go with it.

The SBP0400 has several convenient features. Although its register file is essentially a single-port unit, one register designated the program counter may be accessed separately through the address port. What's more, a separate accumulator and extension are provided to support multiply and divide operations, and those registers may be accessed directly through the address port. Any register in the register file may be accessed directly through the data port, bypassing the ALU. In sum, the design of the SBP0400 is convenient and well thought out, but the I^2L technology decreases its usefulness in high-throughput applications.

Motorola's MC10800 (Fig. 6) is the only processor element built entirely with ECL and is the fastest part in the group. Although the 10800, like the 74S481, lacks an internal register file, it has an I/O-bus configuration that

easily supports an external file. One register file device in the family, the MC10143, has two input ports and one output port; since all of its ports are separately addressable, it is tailored to implementing external register files in MC10800 designs.

While the 10800 has no built-in multiply or divide hardware, it can be microprogrammed to perform these operations. It is unique, however, in providing binary-coded-decimal addition, and it is one of only two devices that provide internal parity generation for error control.

In general, the use of the 10800 with members of the TTL bit-slice families is not recommended in the processor itself because of the required logic level translation and the inherent differences in speed potential between ECL and TTL. The 10800 is a member of a well-designed family of parts that is optimized for use in minicomputers, signal processors, and some types of controllers.

The most complex processor element available is TI's 74S481 (Fig. 7). In number of input and output ports, the 74S481 is second only to Intel's 3002; however, the strong I/O capability is more of a necessity in the TI

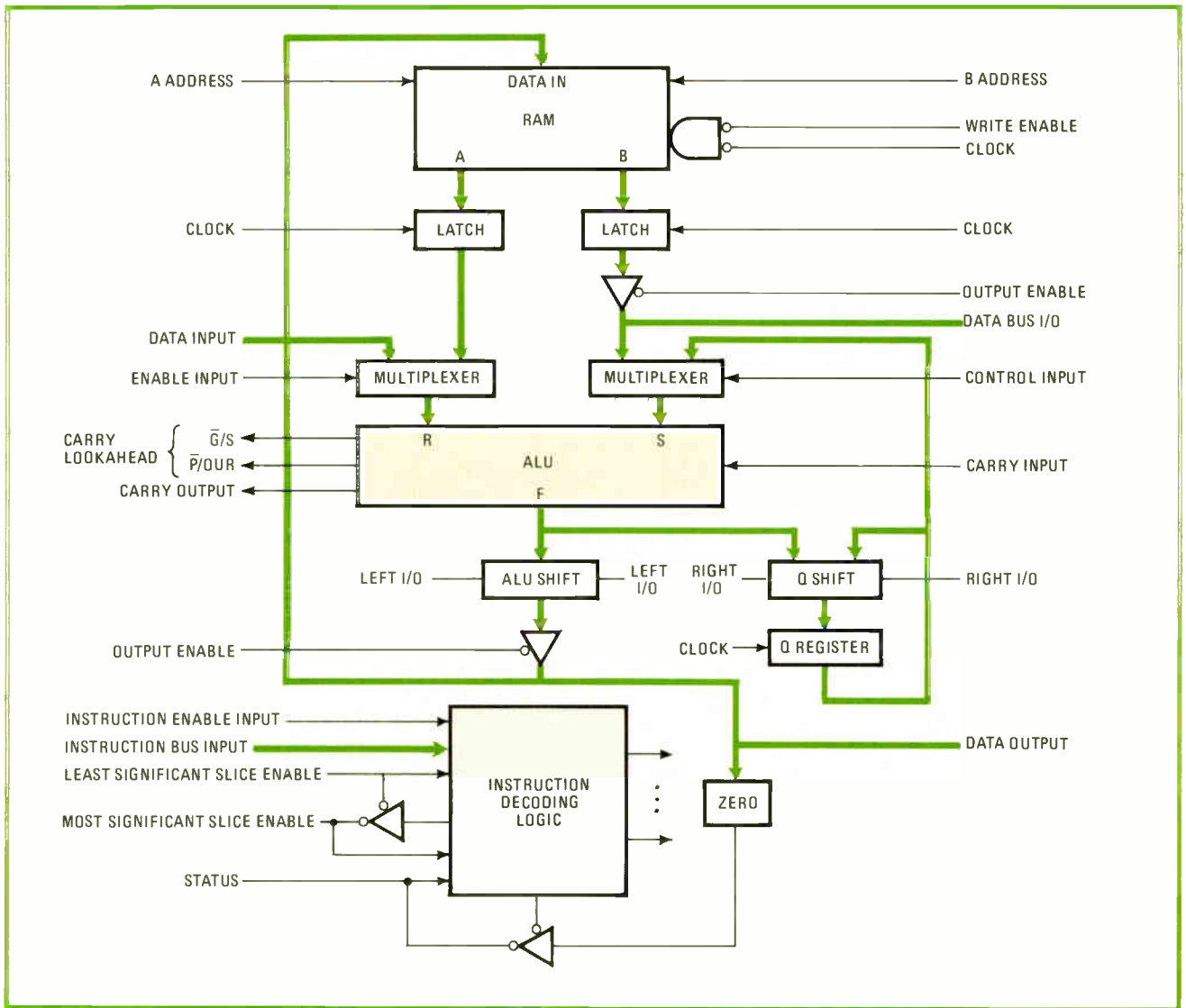

8. Refined. The Advanced Micro Devices Am2903 is a refinement of the Am2901. Normalization logic allows the mantissa and exponent of floating-point numbers to be adjusted simultaneously, and multiply and divide logic is also built in, making the 2903 a good number-cruncher.

device because it lacks an internal register file. TI's idea for the 74S481 is for it to be used in a memory-to-memory architecture similar in principle to that of its 990 minicomputer. Latches on both input ports make it easy to use any of several multiple-port RAMs in the TTL family for an external register file.

In addition to the accumulator and its extension, two other registers (which are actually counters) are provided for the express purpose of addressing memory. Either or both of these counters may be incremented while an operation is being performed in the ALU, making the 74S481 the only processor element to offer any form of multiple-ALU capability. Because of its arithmetic strength (it features preprogrammed multiply and divide), as well as the large corresponding number of instruction-control lines and its lack of an internal register file, the 74S481 is clearly optimized toward minicomputer and signal-processing applications.

A recently announced processor element is AMD's Am2903. As can be seen by comparing its diagram (Fig. 8) with that of the 2901 (Fig. 5), the 2903 is basically a

refined version of the earlier device. It contains the same internal register file, but is unique in its provision of hooks to expand the file externally if needed. In addition to built-in multiply and divide logic, the 2903 contains normalization logic that allows the mantissa and the exponent of a floating-point number to be adjusted simultaneously. Moreover, as in the 10800, parity is generated for the ALU output, to facilitate error detection and for generating cyclic-redundancy-checking codes.

The 2903 requires four more instruction lines than the 2901 and is housed in a 48-pin dual in-line package as against the 2901's 40-pin DIP. Although the 2903 has several additional basic arithmetic and logic instructions, the 2901 is probably preferable in most controllers and medium-speed minicomputer applications. But the 2903 is an excellent choice for number-crunching applications because of its added capabilities. AMD is in the unique position of having two processor elements in its bit-slice family, each optimized for different applications. □

Part 2 of this article on bit-slice processors will cover their microcontroller elements, related chips, and design support considerations. It will appear in *Electronics*'s next issue.

Why the design nod goes to resistors made as thin-film monolithic networks

Process adapted from IC making gives microminiature resistors that offer precision performance, convenience, and low cost

by Donald B. Bruck and Allen L. Pollens, *Hybrid Systems Corp., Bedford, Mass.*

□ Monolithic thin-film resistor networks are rapidly winning affections away from matched assortments of wire-wound and metal-film discrete resistors. Capitalizing on advances in integrated-circuit manufacturing, these microminiature resistors are attractive, not just for small size, but for precision performance, convenience, and low cost, also. By and large, they owe these lures to wafer batch processing adapted from IC manufacture—

including vacuum deposition, etching, photolithography, and computer-controlled laser trimming.

Today's thin-film resistor networks are routinely characterized by a ratio match within 0.01%, an absolute accuracy within 1%, a tracking temperature coefficient of 2 parts per million per degree centigrade, noise of less than 0.1 microvolt per volt, absolute drift of less than 0.1% per 1,000 hours (at 125°C), and ratio drift of less than 0.01% per 1,000 hours (at 125°C).

Furthermore, designers find it simpler to specify, purchase, and test a monolithic resistive network than to work with one built with discrete parts. In addition, a thin-film network eliminates all assembly of matched components. Standard and custom configurations are available in TO cans and dual in-line packages, and, if standard IC packages are not small enough, the networks are available in chip form for use in thick- and thin-film hybrids.

Monolithic thin-film networks are now used in sample-and-hold circuits, precision voltage references, digital-to-analog and analog-to-digital converters, instrumentation amplifiers and preamplifiers, active filters—in fact, wherever resistor accuracy and stability

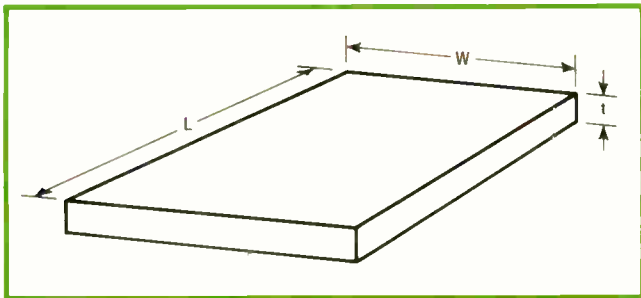

1. Thin-film resistor. The resistance of a thin film is given by the equation $R = (\rho t)(L/W)$ where ρ is resistivity, t is material thickness, and L/W is the aspect ratio. Metallic films are usually Nichrome or tantalum nitride, depending on the resistance value required.

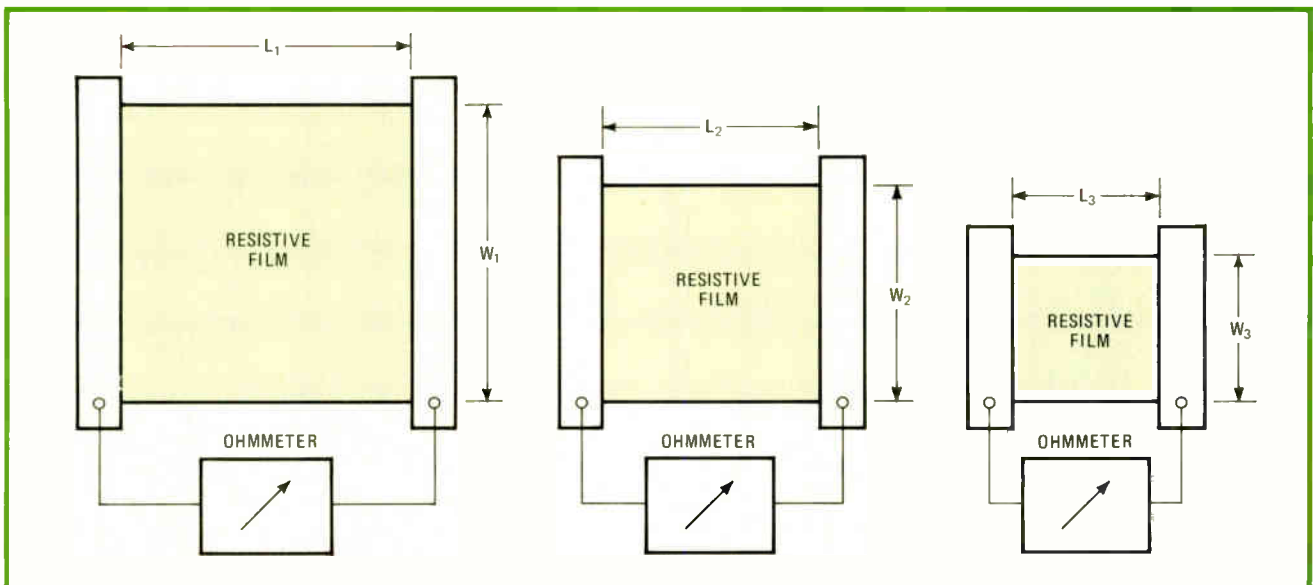

2. Ohms/square measurement. The ohms-per-square parameter (ρ/t) can be measured by connecting an ohmmeter across the contacts of a film of known exact dimensions. In the case shown, the constant-aspect ratio would result in equal values for each resistive film.

3. Film deposition. Thin films may be deposited on a substrate in one of two ways. In a sputtering system, below, an ion beam hits a metal target causing metallic atoms to land on the substrate. An evaporator, right, is a heat source that boils off metal atoms.

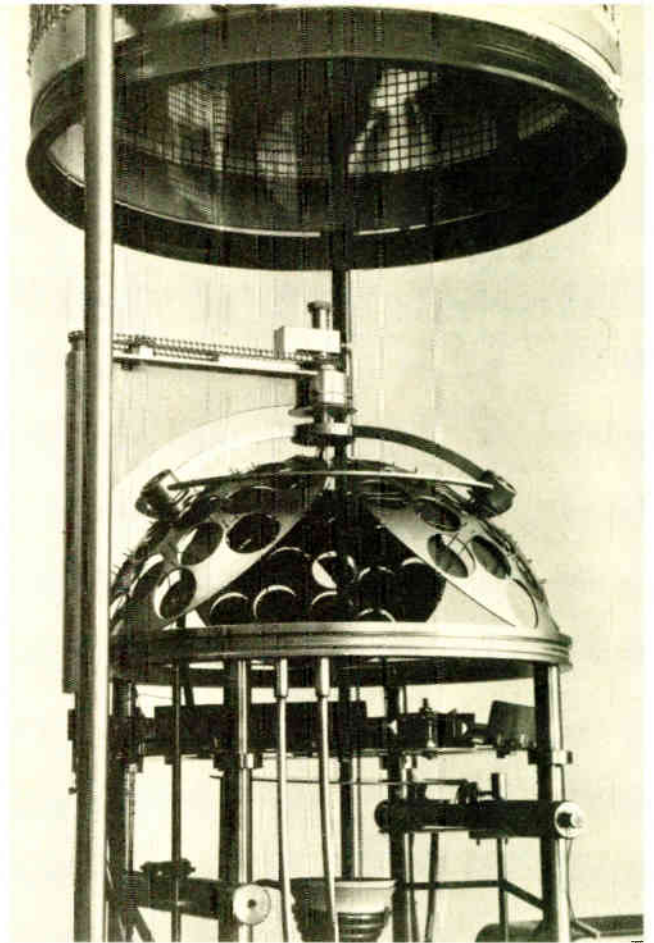
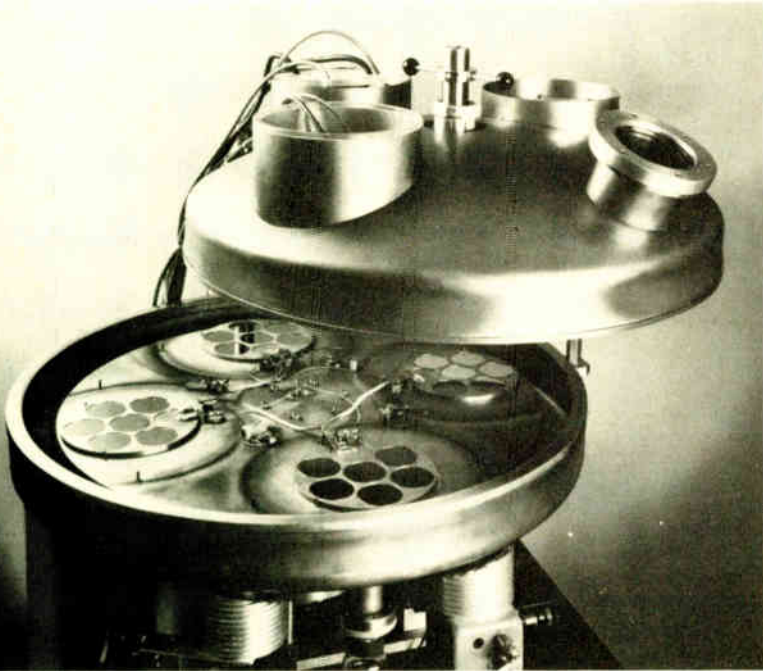

are important to achieving desired circuit and system performance. Such accuracy and stability could not be achieved without the specialized techniques of the thin-film manufacturing process.

The thin-film process is based upon deposition of a metal film, typically of 100-angstrom thickness, on a flat, nonconductive substrate. From Fig. 1, the resistance, R , is equal to the sheet resistance times its aspect ratio, or:

$$R = (\rho/t) (L/W)$$

where ρ is material resistivity and t is film thickness. The ratio of ρ/t is known as the ohms-per-square resistance, and the L/W relationship of the sheet's length and width is the aspect ratio. For a constant t , the value of R is a function only of the aspect ratio, so that theoretically the resistor can be any size.

Sheet resistance

Figure 2 shows how the Ω/sq sheet resistance can be measured. Since the aspect ratios of (a), (b), and (c) are all equal:

$$L_1/W_1 = L_2/W_2 = L_3/W_3$$

Therefore, the resistances of each of the different squares of material should measure the same.

There should be no limit to how small a thin-film resistor could be. In practice, minimum line widths are dictated by power-dissipation requirements, the difficulty of etching excessively narrow lines, and so on. Line widths are typically 1 mil and are seldom less than 0.5 mil. For maximum temperature tracking, all the resistors in a network should be of uniform width.

Alumina, glass, and silicon are the three commonly used substrates for thin-film deposition. Substrate choice is a function of the special demands of the application, plus cost and ease of manufacture. Alumina (ceramic) offers the advantage of low substrate-to-network capacitance but must be laser-cut or sawed. Glass can be scribed and broken apart but has comparatively poor heat-transfer capability. Silicon is frequently the material of choice.

Silicon substrate

Silicon wafers with an oxide insulating layer scribe exceedingly well and have excellent thermal-conduction properties. Handling techniques for the types of silicon wafers used in the manufacture of semiconductors are now well established and can be applied to processing of thin-film networks. Moreover, substrates of silicon can be packaged and bonded by thermocompression or epoxy to another substrate in the same way semiconductor chips are bonded to an alumina substrate in hybrid manufacture.

Silicon's network-to-substrate capacitance does limit its operation in high-frequency, submicrosecond switching applications. Here, glass is the usual choice for a substrate material.

Metal-film materials

The most common materials for thin-film resistor deposition on a substrate are nickel chromium (commonly called Nichrome) and tantalum nitride. Others, such as chrome silicon, are occasionally used for high-resistivity applications.

But Nichrome and tantalum nitride are most often

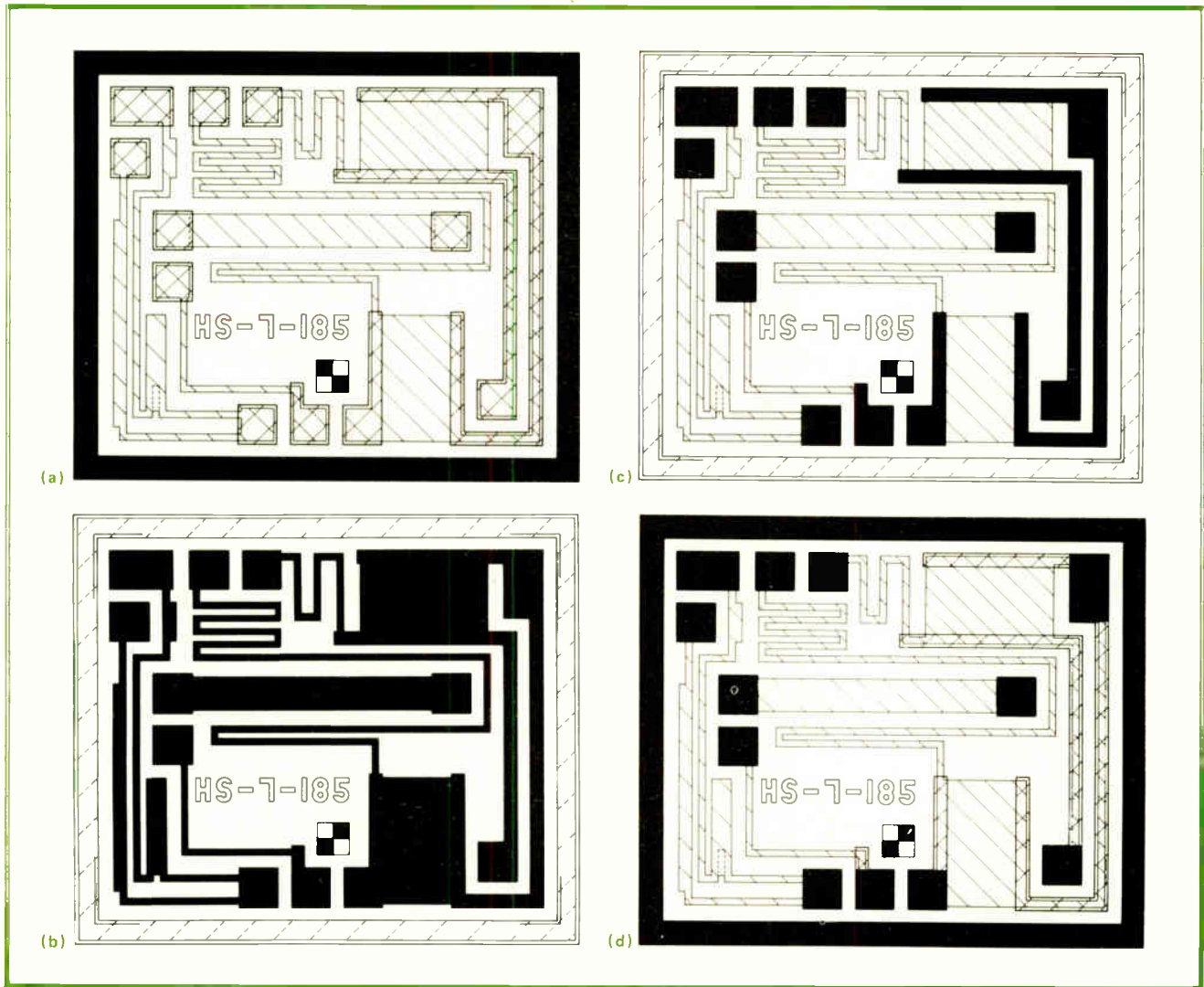

4. Masked resistor. Four masks are needed to fabricate a thin-film resistive network: (a) the grid mask, (b) the Nichrome mask, (c) the aluminum mask, and (d) a glass passivation mask. All are the size of the resistor and are stepped and repeated across the wafer.

used at a sheet resistivity of approximately $300 \Omega/\text{sq}$. At this level, Nichrome has absolute temperature coefficients that are in the range of 0 to $+50 \text{ ppm}/^\circ\text{C}$ with $30 \text{ ppm}/^\circ\text{C}$ being typical. At $300 \Omega/\text{sq}$, tantalum nitride produces coefficients from -50 to $-200 \text{ ppm}/^\circ\text{C}$ with $-75 \text{ ppm}/^\circ\text{C}$ being typical.

Above $400 \Omega/\text{sq}$, Nichrome resistor values tend to become unstable. However, with tantalum nitride, $1,000$ to $1,200 \Omega/\text{sq}$ can be obtained before values become unstable. On the other hand, worsening of the absolute temperature coefficient to perhaps $-200 \text{ ppm}/^\circ\text{C}$ may render the high resistivity useless. Variables that affect sheet resistivity include the ratio of the metals in the alloy to one another, film thickness, substrate temperature during deposition, postdeposition heat treatment, and so on.

Tantalum nitride was the first metal to be used, and it continues to be specified for older, on-going resistive requirements. Nichrome is the more usual choice for new requirements. Earlier reservations concerning its ability to withstand moist environments have generally been eliminated by the use of passivation techniques

such as glassivation and ultra-dry packaging (vacuum baking and hermetic sealing).

Deposition of these metal films on wafer substrates is accomplished by either of two vacuum techniques: sputtering or evaporation. Generally speaking, tantalum nitride and chrome silicon are sputtered, and nickel chromium is sputtered or evaporated.

Film deposition

In sputtering, an ion beam bombards the metal target, causing the metal atoms to disperse and land on the substrate material. Figure 3 shows an open tantalum-nitride sputtering chamber. The wafers are loaded onto the four circular pallets, six per pallet, with a seventh position occupied by a thickness sensor.

The chamber sputters the metal film onto one pallet of wafers at a time. Upon completion of the sputtering onto a given pallet, the interior table is rotated to place a new pallet under the target. This procedure is repeated two more times, whereupon the metal film will have been deposited on the wafers of all four pallets.

An open nickel-chromium evaporator is also shown in

5. A layered resistor. A typical thin-film resistor, shown in cross section, is composed of five layers. The bottom layer is silicon, followed by a layer of silicon oxide. Successive layers of metal film, aluminum, and glass complete the resistor structure.

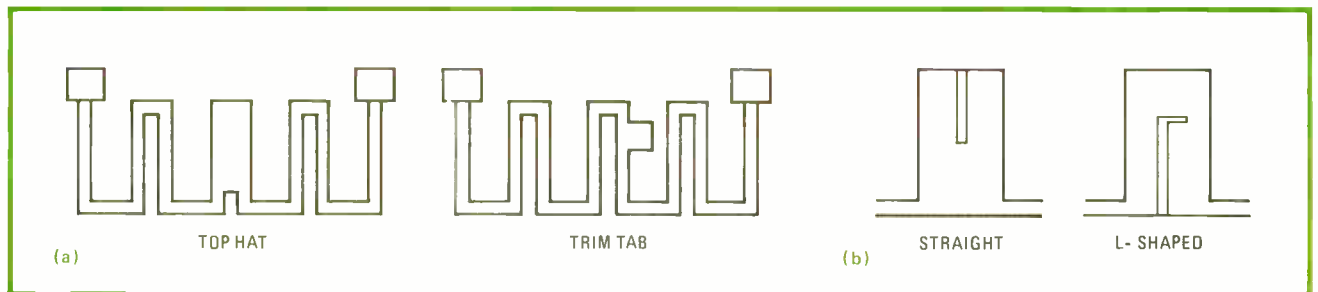
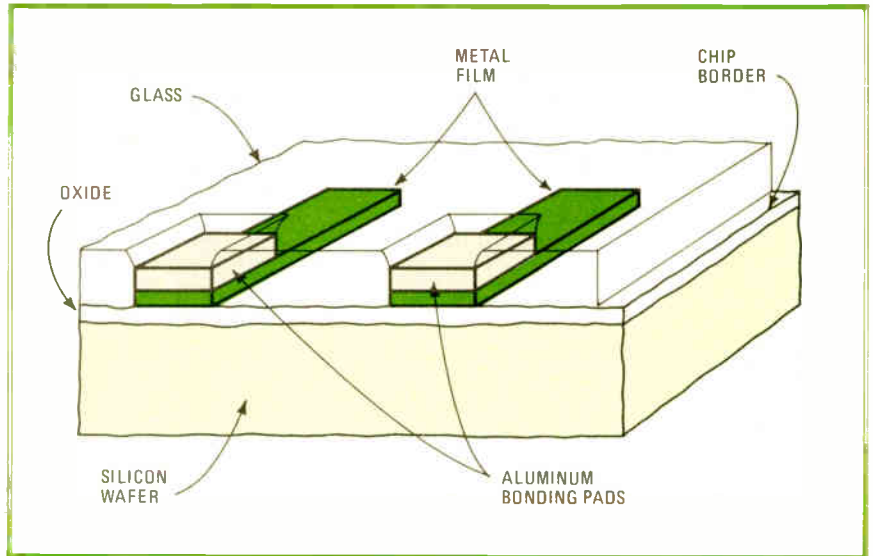

6. Laser trim. Monolithic thin-film resistors may be trimmed to their final values with a laser. To facilitate trimming top hats or trim tabs (a) are added to the resistor pattern. The actual laser trim may be a straight or L-shaped cut (b), but usually the latter has much greater effect.

Fig. 3. Here, 36 silicon wafers are on a planetary fixture that rotates about several axes during deposition to ensure film uniformity. The evaporator uses a heat source to “boil off” the metal atoms at typical temperatures of 1,200° to 1,500°C. A single evaporator of this type can complete three deposition runs per 8-hour shift, producing 108 wafers per shift, or as many as 200,000 40-mil-by-40-mil chips from 2-inch wafers.

No matter what choice is made among substrates, resistive materials, and deposition methods, the overall manufacturing process is pretty much the same. Usually the first step in thin-film processing is to create the 1:1 masks needed for the various steps of this process.

Resistor masks

Several masks (Fig. 4) are required in the manufacturing sequence of a resistive network. The first defines the boundaries between the many networks on the silicon substrate. These boundaries are used for scribing and breaking apart the individual chips after trimming and testing.

The second mask is the basis for the resistor pattern, and a third puts down aluminum bonding pads and conductor runs. The final mask removes glass from the bonding pads and chip boundaries subsequent to glassivation, a sealing process that deposits a layer of silicon dioxide (glass) over the entire wafer.

A resistor network of average complexity would require chip area of 30 by 60 mils. A chip with a

center-tapped resistor, on the other hand, would typically have 30-by-30-mil dimensions. Mask patterns for either of these resistor designs are typically drawn at 200× scale, and a rbylith (cut and stripped film) of the pattern is cut on a coordinatograph.

Then the rbyliths are photographically reduced to the actual size of a resistor chip. Each chip’s image is reproduced on the wafer surface on an automatic step-and-repeat basis as many times as can be accommodated by the size of the wafer. A 2-in.-diameter wafer, for example, has enough area for nearly 3,500 30-by-30-mil chips. Since the photographic plate is square rather than round, the mask pattern is actually repeated nearly 4,500 times.

Once all masks for a typical monolithic thin-film resistor network have been created by photoreduction, the actual production process flow (assuming it starts with a silicon substrate that has an oxide insulating layer) is straightforward.

Initially, a layer of photoresist (a photosensitive lacquer-like film) is uniformly applied to the oxidized silicon and allowed to dry. The grid mask is positioned over the photoresist surface and the light-sensitive surface is exposed. Chemical processing leaves photoresist only in those areas not exposed. The oxide layer, in the light-exposed borders between the chips, can then be etched away to facilitate scribing and separation.

Next, the metal film is coated on the silicon wafers by one of the vacuum-deposition methods. Another layer of

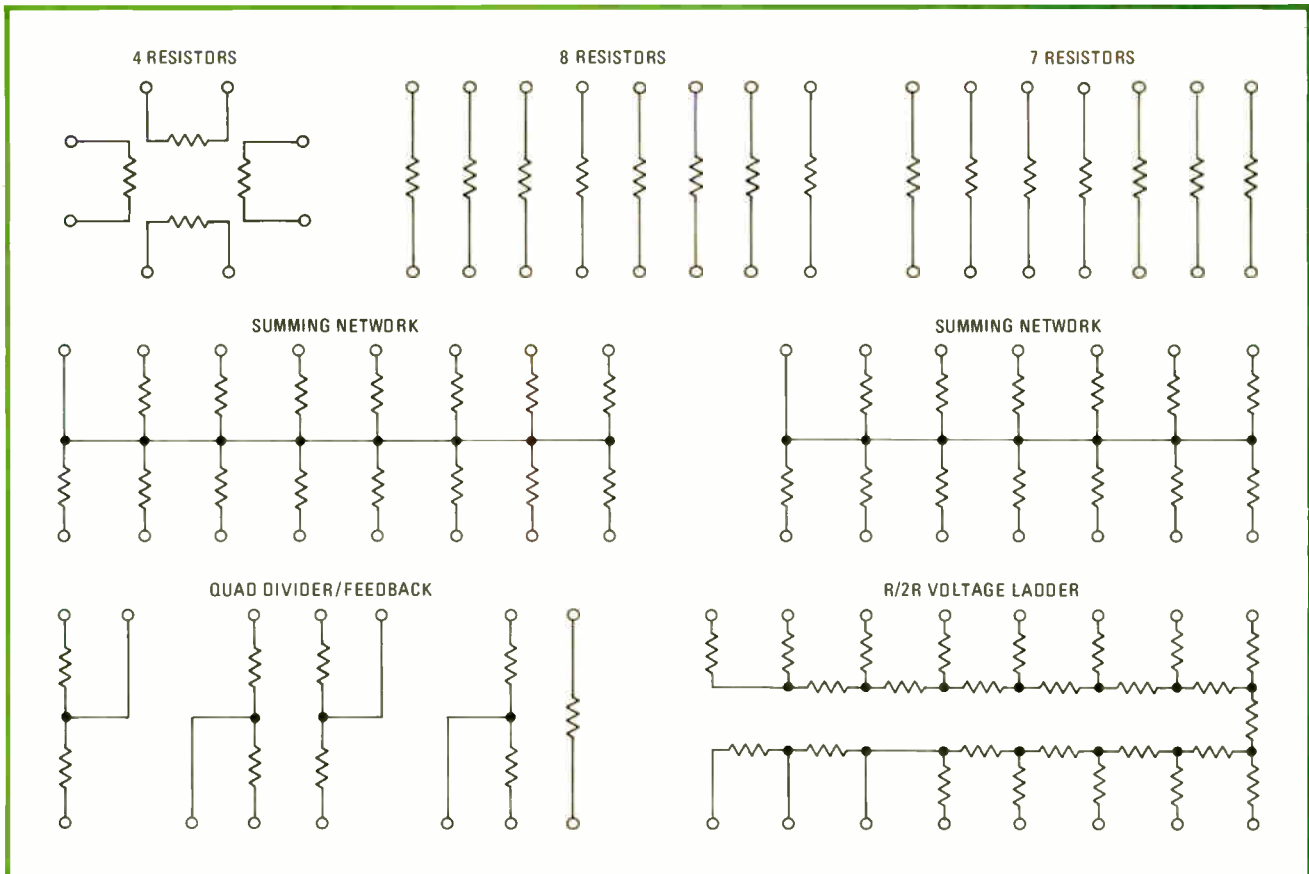

7. Off-the-shelf. Thin-film resistive networks are supplied in the seven standard forms shown. Most popular are the summing networks that are used for operational amplifiers and the R/2R voltage ladder that is used for analog-to-digital and digital-to-analog conversion.

photoresist is applied, and, with the resistor mask in position, the wafer is exposed to light. As before, the light-exposed photoresist is removed, and an etchant removes thin-film material from between resistor runs and other places where it is inappropriate.

A layer of aluminum next is vacuum-deposited on the wafers. In similar fashion to the prior two operations, photolithography and etching leave the aluminum only where desired for bonding pads and conductor runs and do not disturb the thin-film material or the oxide layer.

After the glassivation, the fourth and final use of photolithography and etching removes the glass seal from atop the bonding pads and grid borders. The resulting layered structure is shown in Fig. 5.

Trimming and testing chips

With the manufacturing techniques discussed, films can be within 10% of target resistance values. If greater precision is desired, wafers may be subjected to a trimming procedure.

Early in the history of thin-film resistor manufacturing, when tantalum nitride was the metal most often used, networks were trimmed by an anodizing process. Now it is far more common for resistance values to be adjusted by a laser beam.

With a laser, active trimming can take place. The laser beam is used to burn away portions of the resistor film, thereby altering its physical dimensions and the resistance value. The resistor can be probed and its value

can be continuously monitored to determine when the laser has cut sufficiently to produce the value and precision required.

To facilitate such trimming, features called top hats and trim tabs (Fig. 6a) are added to the layout of a thin-film resistor network. The trimming is performed on them. The top hat has greater effect and is therefore used for coarse trim. The trim tab has significantly less effect and is used for fine trim.

An L cut

It may appear that considerable latitude exists for both the shape and size of the cut made on the top hats and trim tabs. However, it can be demonstrated theoretically and proven in practice that trimming methods can have a significant impact on resistor stability and reliability. In fact, an L-shaped cut has much greater effect than does a straight cut (Fig. 6b).

Laser trimming is usually computer-controlled and automatic, a big advantage considering the large number of networks on each wafer. In the automated operation, defective chips (those that cannot be trimmed to the desired values) have an X burned into them. This mark allows them to be readily recognized and culled later during visual inspection.

A useful byproduct of computerized operation is the tabulation of measurement and yield statistics. If trimming is not required, automatic probing, measurement, and inking of defective networks is done instead. After

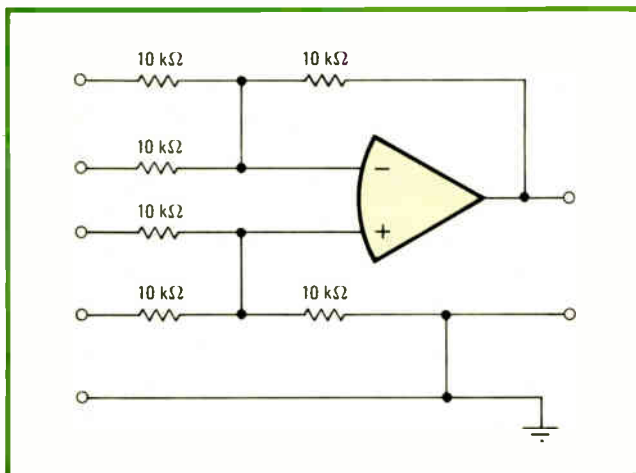

8. Thin- vs metal-film. For this typical operational amplifier resistive network with its 0.01% ratio accuracy and its 2-ppm/°C tracking, bulk- or metal-film discrete resistors would cost about \$35 versus \$10 or less for a standard thin-film monolithic resistive network.

laser trimming and testing, the borders between the many networks on each substrate are scribed, and the chips are broken apart by pressure. The individual chips are loaded into waffle packs for microscopic inspection, typically by 100× magnification. Those chips with scratches or other blemishes are removed. For military requirements, the inspection is performed in accordance with MIL-STD-883A, method 2010.

Networks in unpackaged chip form are often used by hybrid-IC manufacturers. The trimming is frequently done after the chip has been incorporated into the IC. It can be based on the performance requirements of the completed circuit, thereby taking variations in other components into account.

For those users that require packaged networks, chips can be mounted in TO cans, flat packs, or DIPs by eutectic or epoxy die attachment. Wires are connected between the chip pads and the interior terminations of the package leads. Aluminum ultrasonic or gold thermo-compression bonding of the same type used in the packaging of monolithic ICs is employed. After vacuum bake to eliminate any traces of moisture, the package is hermetically sealed.

Manufacturing precautions must be observed and procedures followed to avoid network damage such as permanent resistance shifts that can result from the high temperatures encountered in bonding and other packaging operations. Labor and materials constitute the largest share of packaged-network manufacturing costs.

Cost factors

Wafer-manufacturing costs are essentially independent of the particulars of the mask patterns. Consequently, the cost of resistor chips is primarily a matter of how many can be contained on the wafer and what kinds of yields can be obtained. A good rule of thumb is: the more chips per wafer, the lower the cost per chip.

Networks of smaller total resistance require less metal film, use less chip area, pack more chips per wafer, and so cost less. Similarly, more terminations per network mean more bonding pads per chip, a larger chip, fewer

chips per wafer, and therefore produce a higher cost per chip. Power rating and required trim range also affect chip size and cost.

Actually, doubling the size of the chip produces less than half the number of chips and more than doubles the cost per chip. A major factor is the very small imperfections in the original silicon wafers. Larger chips with fewer total chips per wafer will have a higher percentage of defective, less usable wafer area. Another way to look at this is to realize that the larger the chip, the greater the likelihood of an imperfection being included in it. In the extreme, a one-chip-per-wafer design that occupies the whole wafer would have a 0% yield because the imperfections would have to be part of the chip.

Custom charges

Another cost factor is nonrecurring charges for custom networks. Although a customized network can be produced for a nominal one-time charge (typically \$2,000 to cover special masks, the trim program, probe cards, and so on), standard designs (Fig. 7) can satisfy many requirements.

Furthermore, it is frequently possible to adapt an existing design, particularly where the manufacturer's original judicious inclusion of trim tabs and top hats allows alteration of resistor values to meet a wide range of requirements. In some cases, it may only be necessary to modify the bonding-pad mask in order to tap the network at a different location. Thin-film resistor manufacturers now have substantial libraries of mask sets, and it behooves a prospective user to discuss his custom requirements with manufacturers before freezing his resistor specifications.

The economic benefits of using monolithic thin-film resistor networks can be demonstrated by considering a thin-film net versus discrete bulk-film resistors in the construction of the typical operational-amplifier circuit shown in Fig. 8, which is based upon 0.01% ratio accuracy and 2 ppm/°C tracking. In hundreds, standard thin-film monolithic resistors for this circuit would cost about \$10 versus \$35 for a bulk-film network.

Thin vs bulk-film resistors

With the thin-film network, the circuit's gain accuracy can be controlled by simply specifying the ratio tolerance. In contrast, with discrete resistors, the gain precision can only be assured by specification of tight absolute tolerances, which costs extra. In addition, the monolithic network, by virtue of being packaged in a single DIP, can be assembled into a printed-circuit board with less labor and, in fact, may be used with automatic insertion equipment.

The future may be expected to bring improved materials and processing that will facilitate the creation of networks with better absolute accuracies, reduced temperature drift, and increased long-term stability. Higher sheet resistivity will make possible greater total network resistance and smaller chip size which, in turn, will reduce chip costs.

Further work will reduce costs of packaging networks. Finally, costs will come down as quantities continue to grow and further economies of scale are realized. □

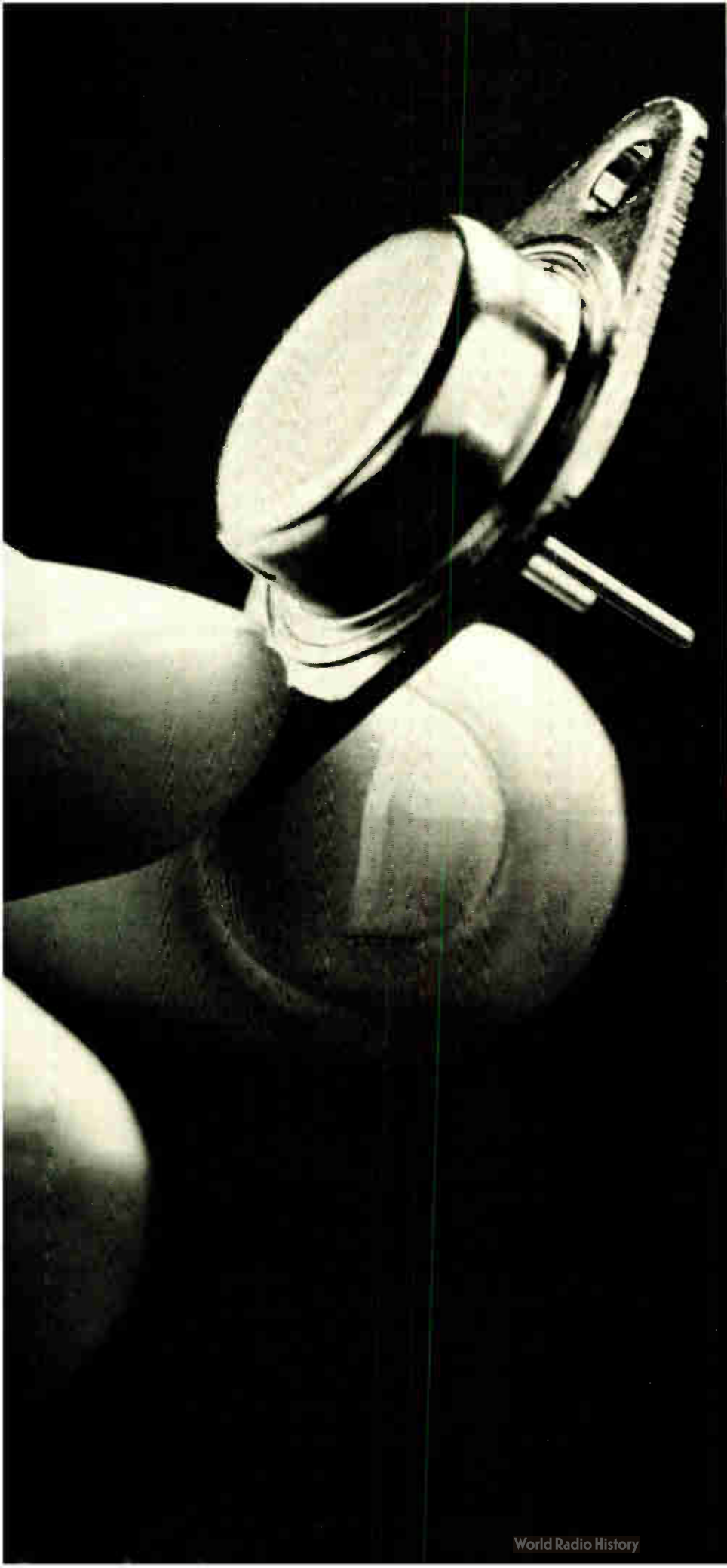

THEY'RE EASIER TO TEST WHEN YOUR SYSTEM IS EASY TO USE.

In the testing of discrete semiconductors, the big time wasters are program writing and system set-up. So in designing our new T347C, we took dead aim at these issues. Of course, we also paid attention to basic capabilities (2000 volts, 50 amperes) and throughput. But most of all, we made it easy to use.

For example: the T347C tells you when and where you've made a mistake. A useful feature when you're writing complex test programs.

To save time, the system sets up test formats only when you ask for them. This "on demand" prompting means much more efficient operation.

Naturally, the system speaks in device language. Whether the device is a transistor, a diode, an FET or an SCR.

And, always helpful, the T347C lets you put recurring operator system dialogs in memory for fast, single-keystroke retrieval.

Of course, moving parts through quickly is what automatic testing is all about. So the T347C provides fast test times. And the use of an A to D converter for voltage tests further speeds datalogging.

Throughput is also enhanced by the T347C's peerless reliability. There are no calibration adjustments to make. A 10-year circuit module warranty. Worldwide parts stocking centers. And telephone troubleshooting service.

When you buy T347C, you're buying the best and easiest-to-use incoming inspection system available today. Learn more. Write Teradyne, Inc., 183 Essex Street, Boston, MA 02111.

TERADYNE

Circle 105 on reader service card

Photodiode and op amps form wideband radiation monitor

by Grzegorz Hahn
Institute of Nuclear Research, Swierk, Poland

A sensitive radiation monitor may be simply constructed with a large-area photodiode and a quad operational amplifier. Replacing the glass window of the diode with Mylar foil will shield it from light and infrared energy, enabling it to respond to such nuclear radiation as alpha and beta particles and gamma rays.

The general circuit is shown in Fig. 1. The HP-5082-4203 device is a p-i-n photodiode, called that because there is a thin layer of undoped, or intrinsic, material between the p and n type regions of the diode. The intrinsic material acts to lower junction capacitance, so that the device has a higher frequency response than a

1. Energy count. Broadband characteristics of p-i-n photodiode enables it to respond to α , β , and γ radiation when pn junction is shielded from visible and infrared wavelengths. Op-amp circuit amplifies and integrates pulses for meter or loudspeaker. Circuit has uniform response to radiation, independent of energy class.

standard photodiode, making possible the detection of beta particles and gamma rays (alpha particles could be detected with a standard photodiode).

As a consequence of the p-i-n semiconductor structure, the device bandwidth is large. Hole-electron pairs, and thus charge (Q), can be accumulated across the photodiode by all forms of ionizing radiation. When the junction is shielded from visible and infrared light, the photodiode output is a function of the nuclear-type radiation only.

The junction charge generated by the ionizing radiation is $Q = \Delta E / \epsilon$, where ϵ is the ionizing constant of

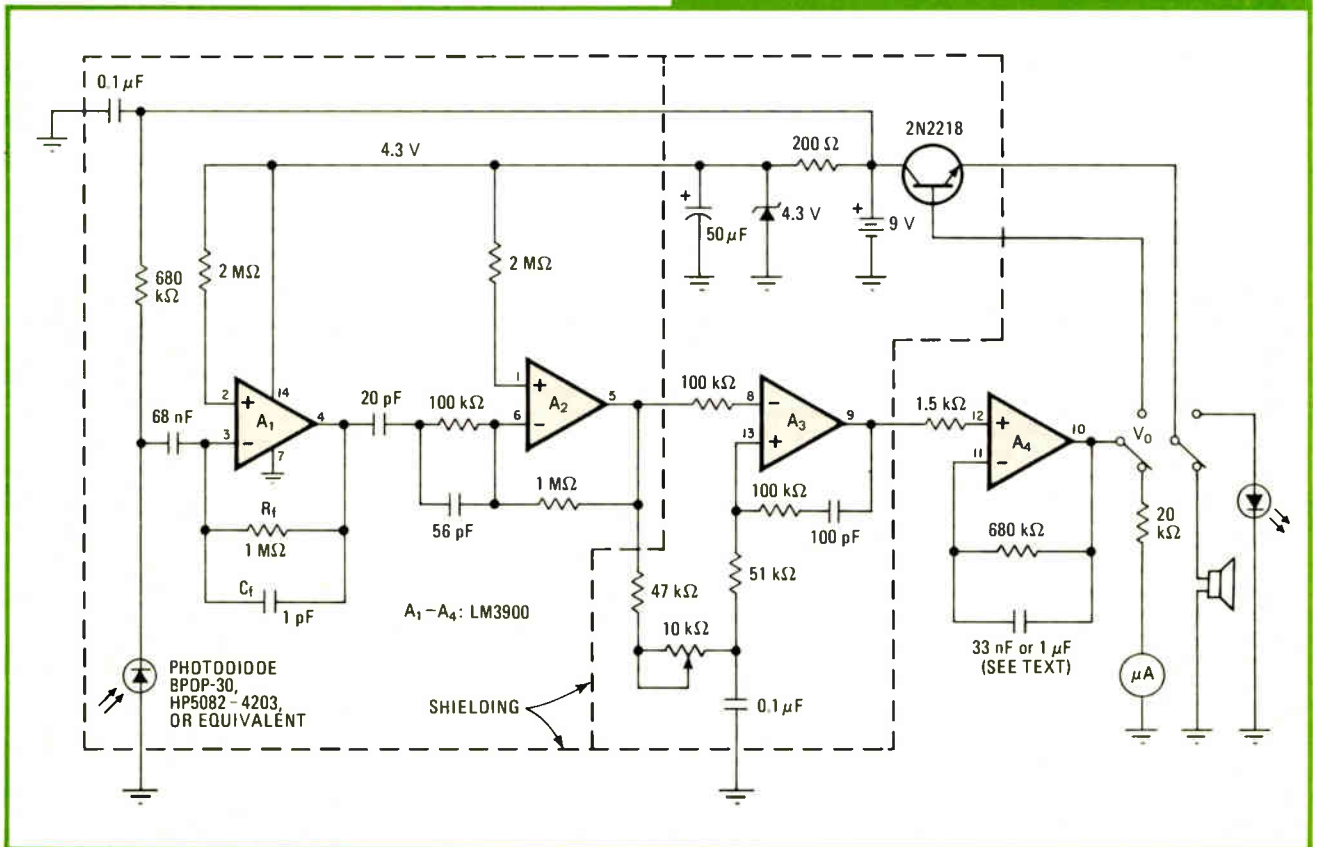
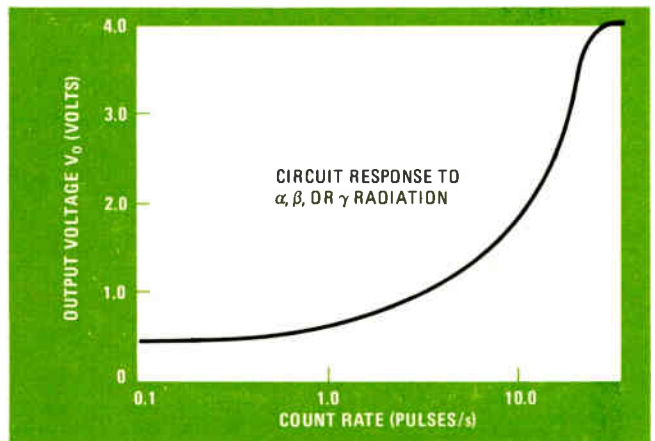



YOURS FREE
when you subscribe
to Electronics.

**This Designers
Casebook—
Number 2**

PLEASE ENTER MY SUBSCRIPTION TO ELECTRONICS FOR:
 ONE YEAR AT \$15 TWO YEARS AT \$26 THREE YEARS AT \$38
 Payment Enclosed Bill My Company Bill Me

CHARGE MY SUBSCRIPTION TO

AMERICAN EXPRESS MASTER CHARGE
 DINERS CLUB BANKAMERICARD VISA
 ACCT NO _____
 DATE CARD EXPIRES _____
 INTERBANK NO _____ 1st No s above name on Master Charge only

NAME Mr. Mrs. Ms. _____ TITLE _____ 53460
 COMPANY _____ DIV or DEPT _____
 COMPANY ADDRESS _____
 CITY _____ STATE _____ ZIP _____
 Check here if you wish publication to be sent to home address STREET _____ CITY _____ STATE _____ ZIP _____

Qualification for above rates is based on answers to all questions listed below. Those not qualifying may pay higher than basic price of \$25 one year or \$62.50 for three years.

Signature _____

2. 1 PLANT 2 DEPARTMENT

- A Large computers
- B Mini-computers
- C Computer peripheral equipment
- D Data Processing Systems (systems integration)
- E Office and business machines
- F Test and measuring equipment
- G Communications systems and equipment
- H Navigation and guidance or control systems
- I Consumer entertainment electronic equipment
- J Other consumer electronic equip (appliances, autos, hand tools)

Indicate the primary product manufactured or service performed at your plant (Box 1) and in your department (Box 2). Be sure to indicate applicable letter in each of the two boxes even if they are the same letter.

- K Industrial controls systems and equipment
- L Sub-assemblies
- M Passive electronic components
- N Active electronic components
- O Materials and Hardware
- P Aircraft, Missiles space and ground support equipment
- Q Oceanography and support equipment
- R Medical electronics
- S Industrial equipment containing electronic components or products
- T Independent R&D laboratory and consultant
- U Research and development organizations which are a part of an educational institution
- V Government Agency and military
- W Industrial companies using and or incorporating electronic products in their mfg research or development activities
- X Utilities
- Y Broadcasting sound and motion pictures and recording studios
- Z Commercial users of electronic equipment (railroads, pipelines, police, airlines)
- 9 College University

3. Indicate your principal job function (place applicable number in box. If numbers 9, 10, or 11 are used, fill in name of college or university)

- 1 General and corporate management
- 2 Design and development engineering
- 3 Engineering services (evaluation, quality control, reliability, standards, test)
- 4 Basic research
- 5 Manufacturing and production
- 6 Engineering support (lab assistant, technician)
- 7 Purchasing and procurement
- 8 Marketing and sales
- 9 Professor at _____
- 10 Senior student at _____
- 11 Graduate student at _____

Senior and graduate students are eligible for professional rate for one year subscription only.

4. Indicate your principal job responsibility (place applicable number in box)

- 1 Management
- 2 Engineering

5. Your design function: (Insert each letter that applies)

- A I do electronic design or development engineering work
- B I supervise electronic design or development engineering work
- C I set standards for, or evaluate electronic design components, systems and materials

6. Estimated number of employees at this location (check one)

- 1 to 49
- 50 to 249
- 250 to 999
- over 1,000

First Class
Permit No. 42
Hightstown, N.J.

BUSINESS REPLY MAIL

No postage stamp necessary if Mailed in the United States

POSTAGE WILL BE PAID BY

Electronics

McGRAW-HILL, INC.
SUBSCRIPTION DEPT.
P.O. BOX 514
HIGHTSTOWN, N.J. 08520



- 1 - PHOTODIODE CHIP
- 2 - ELECTRIC CONTACT
- 3 - GLASS HEADER
- 4 - ELECTRIC CONNECTIONS

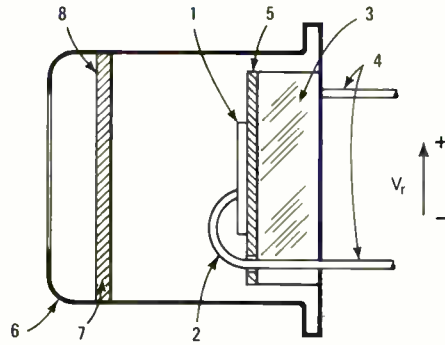

- 5 - PROTECTIVE LAYER
- 6 - TO-39 CASE
- 7 - 12-μm-THICK ALUMINIZED MYLAR FOIL
- 8 - LAYER OF STYCAST GLUE

(a)

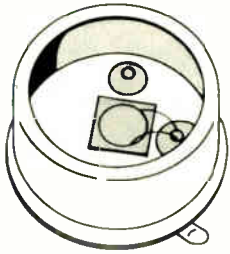

(b)

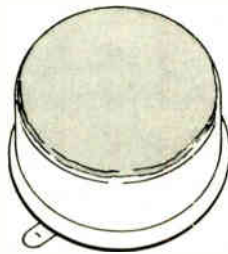

(c)

2. Adaptation. Glass window of photodiode (a) must be removed and replaced by opaque material to shield pn junction from light. Top of photodiode case is first cut out (b) by turning lathe, then layer of aluminized Mylar foil is secured in place (c) with Stycastr glue.

silicon (3.66 electronvolts at 300 K), and ΔE is the energy stored across the active region of the photodiode. The output voltage from integrator A_1 is thus:

$$V = (Q/C_f) (1 - e^{-t/R_f C_f})$$

where t is measured from the instant ΔE appears across the junction and $R_f C_f$ is the time constant of the integrating network. A_2 is a quasi-Gaussian filter that shapes the pulse in order to improve the signal-to-noise ratio of the small output signal at A_1 . A_3 generates a rectangular pulse with a width proportional to the input amplitude for every signal that exceeds a threshold set by the user.

The threshold control is used if a radiation alarm

circuit is desired (indicating maximum limits have been exceeded) or if it is necessary to discriminate against hash in high-noise environments. It should be noted that A_3 is in principle a current discriminator and that its temperature-drift coefficient is probably lower than that of conventional voltage discriminators, which are often used in radiation monitors.

A_4 integrates the output of A_3 in order to drive a microammeter. A 1-microfarad capacitor is used in the integrating network. A lower value, say, 33 nanofarads, will make it possible to drive a small loudspeaker (50-hertz output signal) or light-emitting diode.

Figure 2 illustrates the procedure used to replace the photodiode's glass window with a 10-micrometer-thick aluminized Mylar foil. The photodiode shown here is the BDPD-30, a European make, but most photodiodes made in the U. S. are very similar.

As shown in Fig. 2b, the top of the TO-39 case containing the window must be cut away with a turning lathe. Care should be taken not to touch the pn junction within. Sharp edges are then filed smooth with care. The new window is then secured to the edges of the device by means of black Stycastr glue (available from Emerson and Cuming Inc., Canton, Mass.). Figure 2c is a view of the completed diode.

The circuit response is seen in the upper part of Fig. 1. Note that this device is a radiation monitor, as opposed to a radiation meter, and so cannot distinguish between α , β , and γ radiation. Because of the photodiode's wide bandwidth, each energy class generates the same output voltage for a given radiation intensity. Thus the monitor is intended for use where an *a priori* knowledge exists of the type of energy to be encountered. □

Vehicle-intruder alarm has automatic set/reset switching

by M. B. Horan
Derby, England

Providing fully automatic operation at negligible stand-by current, this low-cost burglar alarm for automobiles

will sound the horn if any door is opened. No alarm-set switch is required on the body of the automobile: there is a built-in time delay between the opening of the door and the sounding of the alarm, which gives the driver time to activate the ignition circuit and so disengage the alarm. Resetting the circuit requires only that the driver open a car door before the ignition key is removed, thereby engaging the alarm circuit.

The alarm has been designed using complementary-metal-oxide-semiconductor logic, because it is inexpensive, rugged, reliable, and available, requires only a few

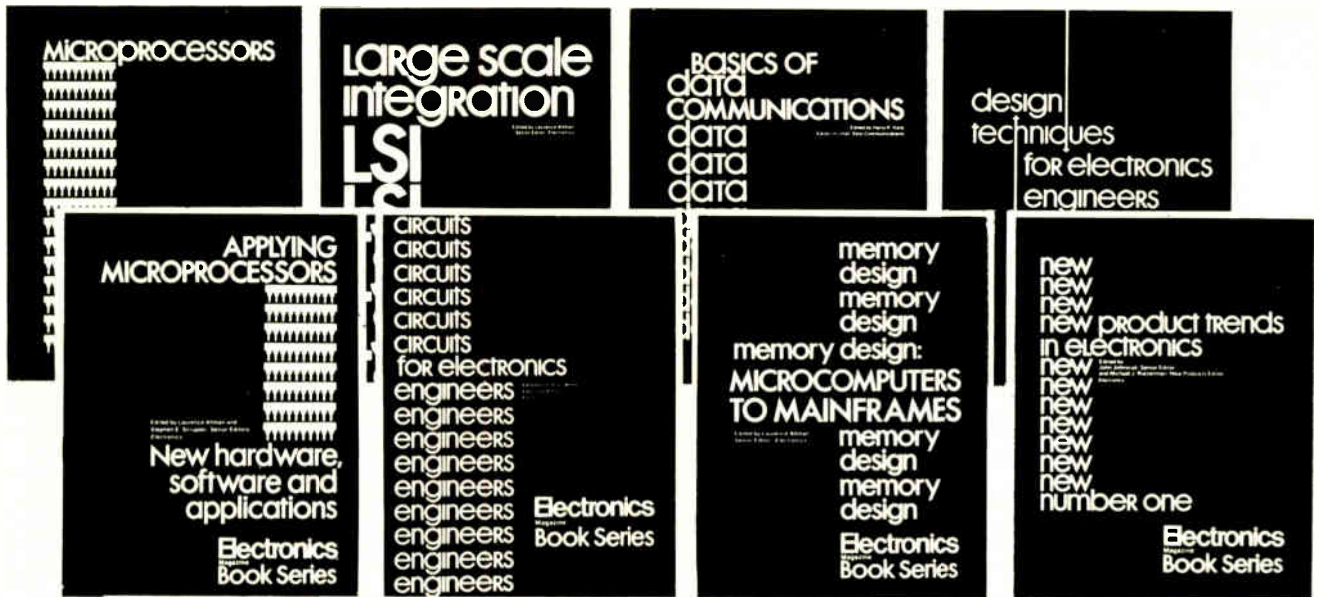

Electronics Magazine Book Series

1. Microprocessors

What you must know about available microprocessor technology, devices, information, 4th printing. \$8.95

2. Applying Microprocessors

2nd and 3rd generation technology. 26 detailed applications from data networks to video games. \$9.95

3. Large Scale Integration

Covers the basic technology, new LSI devices, LSI testing procedures, plus system design and applications. \$9.95

4. Basics of Data Communications

Includes 47 articles from Data Communications magazine covering more than 11 key areas. \$12.95

5. Circuits for Electronics Engineers

Contains 306 circuits arranged by 51 functions from Amplifiers to Voltage Regulating Circuits. Saves design drudgery. \$15.95

6. Design Techniques for Electronics Engineers

Nearly 300 articles drawn from "Engineer's Notebook." A storehouse of design problem solutions. \$15.95

7. Memory Design: Microcomputers to Mainframes

The technology, devices, and applications that link memory components and system design. \$12.95

8. New Product Trends in Electronics, Number One

From "New Products," state-of-the-art materials and equipment, arranged according to function. \$14.95

Electronics Book Series
P.O. Box 669, Hightstown, NJ 08520

1. Microprocessors

Send me _____ copies at \$8.95 per copy.

2. Applying Microprocessors

Send me _____ copies at \$9.95 per copy.

3. Large Scale Integration

Send me _____ copies at \$9.95 per copy.

4. Basics of Data Communications

Send me _____ copies at \$12.95 per copy.

5. Circuits for Electronics Engineers

Send me _____ copies at \$15.95 per copy.

6. Design Techniques for Electronics Engineers

Send me _____ copies at \$15.95 per copy.

7. Memory Design: Microcomputers to Mainframes

Send me _____ copies at \$12.95 per copy.

8. New Product Trends in Electronics

Send me _____ copies at \$14.95 per copy.

Discounts of 40% on orders of 10 or more copies of each book.



If after my 10-day free-trial examination I am not fully satisfied I understand that my payment will be refunded.

Payment enclosed Bill firm Bill me

Charge to my credit card:

American Express Diners Club
 BankAmericard/Visa Master Charge*

Acct No. _____ Date Exp. _____

*On Master Charge only, first numbers above name. _____

Name _____ Title _____

Company _____

Street _____

City _____ State _____ Zip _____

Signature _____

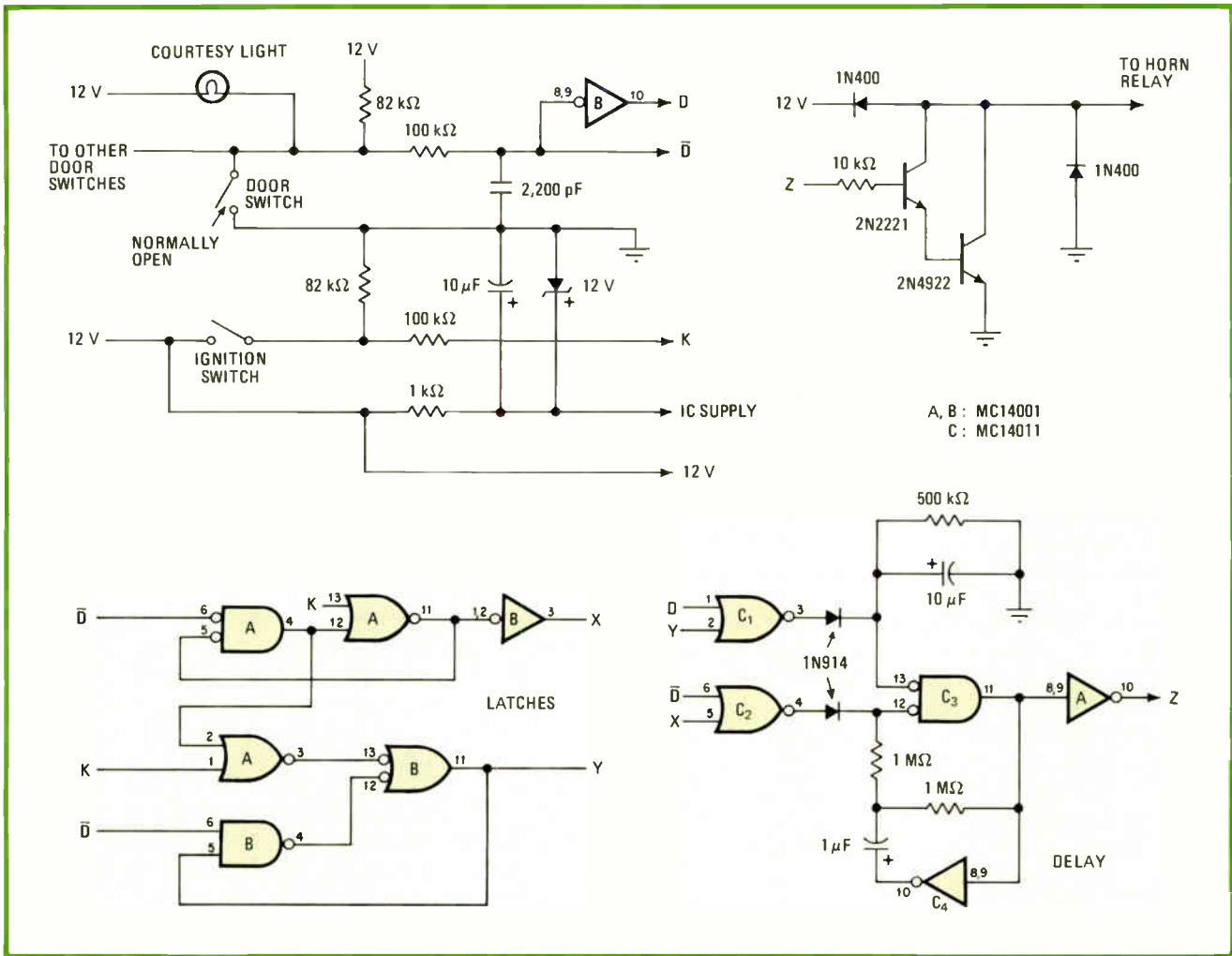

Invisible sentry. Automobile burglar alarm sounds car horn if any door is opened. Five-second-delay circuit enables user to disengage alarm just by turning on ignition. Alarm is reset by opening car door before ignition circuit is disengaged.

microwatts of power, and has good noise immunity. The circuit is simple, as the figure shows. Only six connections are required to interface it with the auto—two for the ignition, two for the door switches, and two for the horn relay.

The circuit must distinguish between several asynchronous events encountered in normal operation and store their present states so that:

- The horn will sound approximately 5 seconds after the time any door is opened, provided the ignition switch is not engaged.
- Once the horn sounds, it will continue to do so, independent of the position of any door.
- The alarm can always be reset by engaging the ignition switch.
- If the door is opened with the ignition on, and then the ignition is turned off and the door subsequently closed within 5 seconds, the horn will not sound.

In order to perform these tasks, the circuit implements the function:

$$Z = (D + Y)(\bar{D} + X)$$

where $X = K + DX$, $Y = K + DX + \bar{D}Y$, and K is true high for ignition switch-on, D is true high for an open

door, and Z is true high for detection of an intruder.

Implementing the logic for the condition where one is entering the vehicle is simple. The equation given becomes more involved, however, because the circuit must allow the operator to leave the auto while setting the alarm without triggering the horn. The logic to implement this fourth condition is controlled by two latches, one of which generates the secondary variable X and the other generating Y . X is set high, also allowing Y to be set high when the condition occurs. Latch Y remains high, ready to reset on the opening of any door. Latches X and Y and the door signal are then gated to preset the alarm signal.

The alarm-gating signal (Z) is actually generated once the 1-microfarad capacitor in the delay oscillator discharges below gate C_3 's logic-1 point, about 5 seconds after the X signal arrives at C_2 . The inverting-gate astable multivibrator, C_4 , modulates the horn at 1 hertz to enhance effectiveness as an alarm signal. Other components are included in the circuit for protection against switching transients. □

Designer's casebook is a regular feature in *Electronics*. We invite readers to submit original and unpublished circuit ideas and solutions to design problems. Explain briefly but thoroughly the circuit's operating principle and purpose. We'll pay \$50 for each item published.

Variable-persistence storage CRT achieves high writing speed

Adding a magnifying image-projection lens allows
1,800-cm/ μ s rate and 100-MHz bandwidth
without reduced display

by Van Harrison,* Paul Carnahan, and James F. Haley, *Hewlett-Packard Co., Colorado Springs (Colo.) Division*

□ The variable-persistence storage oscilloscope is a versatile and useful instrument for capturing and analyzing transient or anomalous electronic events. But the conventional storage tube at its heart has a writing speed and contrast that restrict its use to relatively low-frequency signals or pulses with long rise times, unless certain design tradeoffs are made.

A new design, however, the 1744A expansion storage cathode-ray tube, achieves a writing speed of more than 1,800 centimeters/microsecond. Using this tube, a variable-persistence storage scope can capture low-duty-cycle, high-speed pulses or waveforms with an equivalent bandwidth of 100 megahertz, as well as attain extremely high single-shot trace resolution. Up to three channels of such waveforms can be analyzed in either the variable-persistence or the automatic-storage mode.

The new tube (Fig. 1) uses a static-electric-field crossover lens to expand the image before it is displayed on a

conventional phosphor screen. The active display area is about 10 times larger than the image written on the storage surface and the CRT's writing speed is increased by the same factor.

How does it work?

The expansion storage CRT is similar to the older variable-persistence type except for the region between the storage mesh and the phosphor viewing screen. In the conventional tube, the storage mesh is next to the screen. In the expansion tube, a high-voltage mesh is placed in front of the storage mesh to accelerate the flood-gun electrons transmitted through the stored image (Fig. 2a). The electrons are then directed through a newly developed crossover lens system to the phosphor screen, forming well-defined trajectories (Fig. 2b). The crossover lens inverts and expands the stored image before it reaches the screen.

The storage mesh is about $1/10$ the size of the viewing

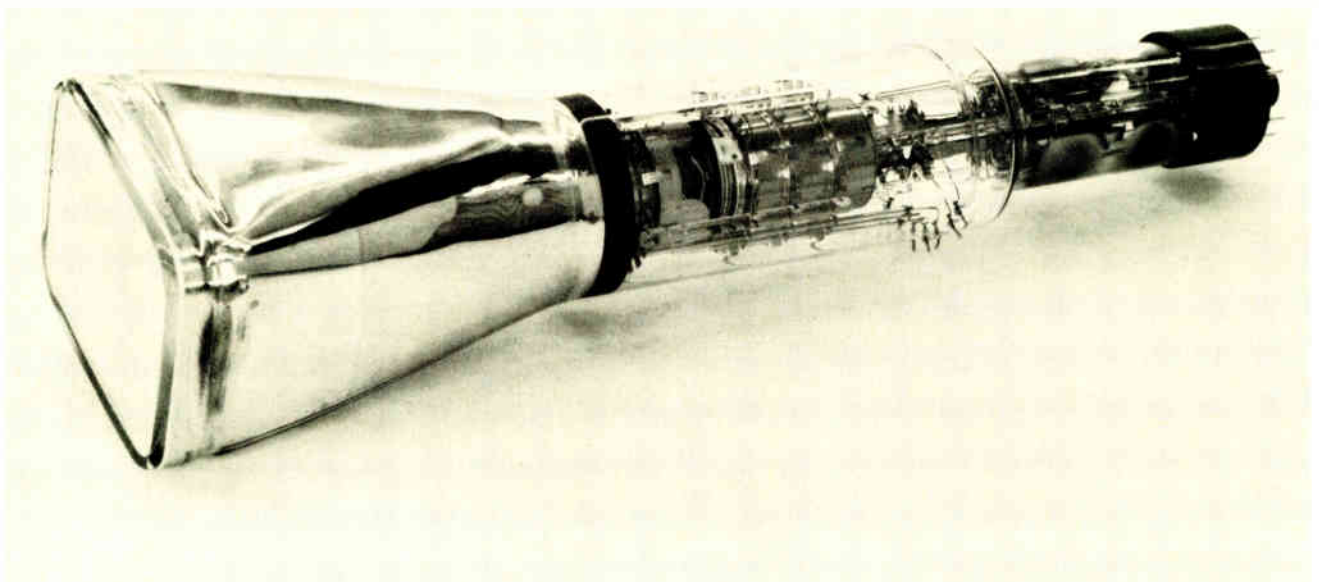

1. Expansion storage. Newly developed CRT has a computer-refined lens system. Used in an oscilloscope, it offers fast writing capability, variable persistence, full-screen display, and 100-MHz bandwidth for observing fast and single-shot waveforms.

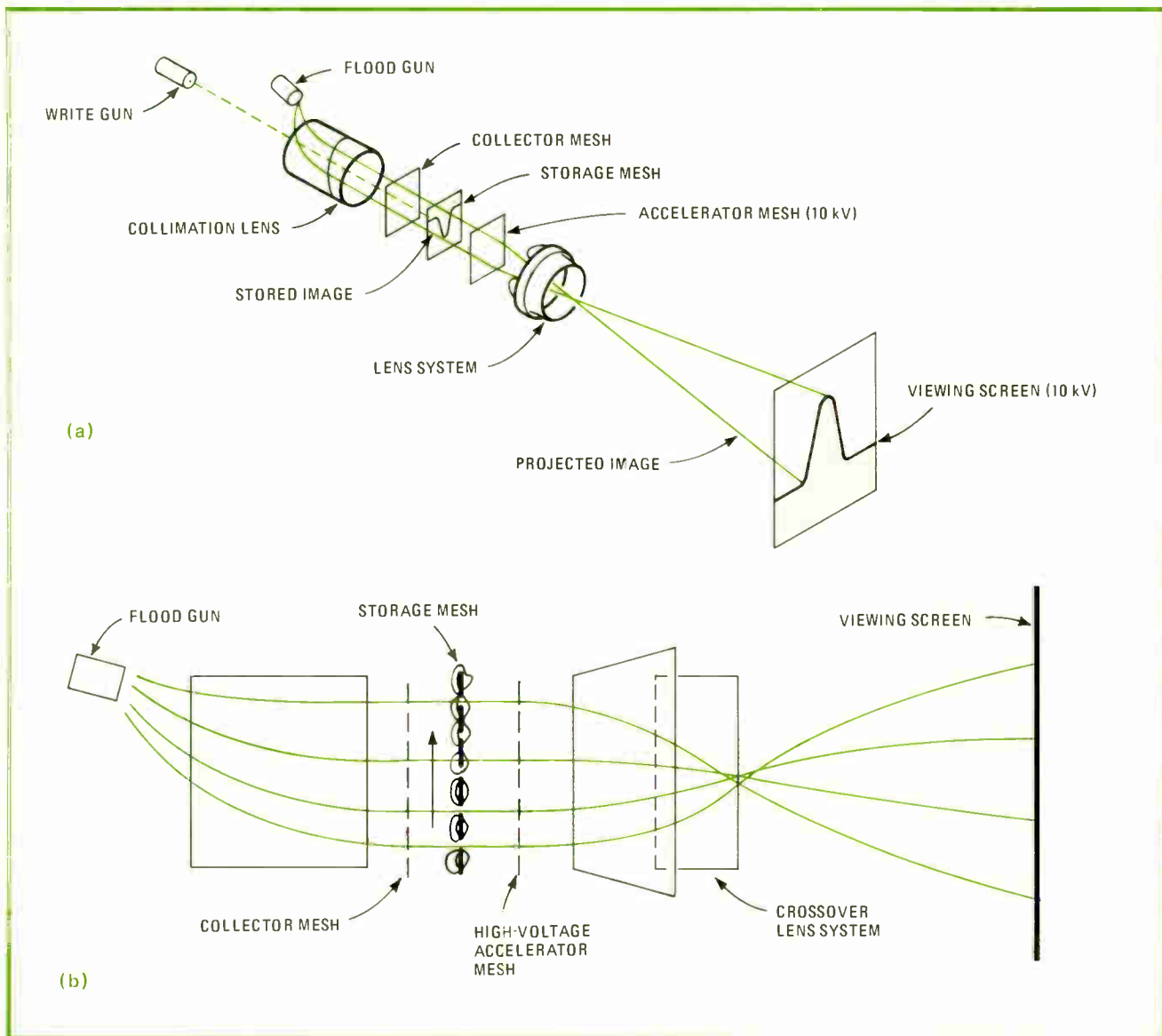

2. More parts. The internal geometry of the expansion storage CRT (a) is more complex than that of conventional storage tubes. Crossover lens inverts and expands the stored image by a factor of 10 before it reaches the phosphor viewing screen. Writing speed is increased by the same amount. Flood-gun electron trajectories (b) must be precisely controlled for optimal CRT operation.

screen, in contrast to other storage meshes, which are the same size as the screen. Thus the image to be viewed is magnified 10 times. In a given interval, a display spot moves 10 times farther on the phosphor screen than it does on the storage mesh. Consequently, the crossover lens system increases the writing speed by the same factor of 10.

The lens system acts by means of the electrostatic fields formed in the region between the final accelerator mesh and the viewing screen. The effect of these fields on flood-gun electrons can be understood by observing the pattern formed by the region's equipotential lines, which are influenced by the accelerator mesh (Fig. 3).

The electrons leaving the accelerator mesh travel almost parallel to the axis of the tube at a relatively high speed. The crossover lens is held at a voltage that is lower than the potential of the accelerator mesh, and the lower voltage causes the electron beam to decelerate and

bend toward the axis of the CRT. Other electrons, coming from various locations on the storage mesh, are also forced to converge along the axis of the tube near the center of the lens area.

Restoring the electrons

On the screen side of the crossover region, the electrons are once again presented with an acceleration field that causes them gradually to regain their initial speed and bends them toward the field lines that are normal to the equipotential contours on this side of the region. When the voltages on the lens are properly adjusted, an inverted real image from the storage mesh is produced on the screen.

The quality of the image formed depends primarily on the aberrations introduced by the lens system. The main problem encountered in designing the lenses was the definition of the shapes of the electrodes for the

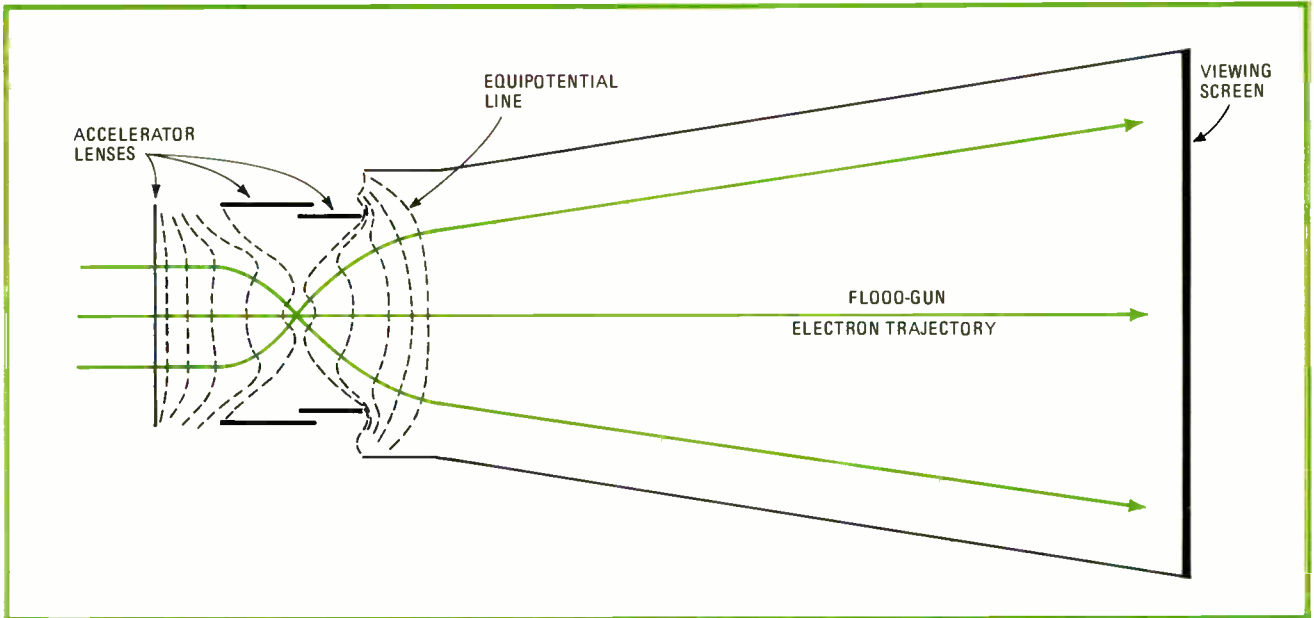

3. Equipotentials. Accelerator mesh helps define the electron trajectories for minimum picture distortion. The equipotential lines must also form specific curves so as to properly accelerate and decelerate the electrons, especially in the crossover region.

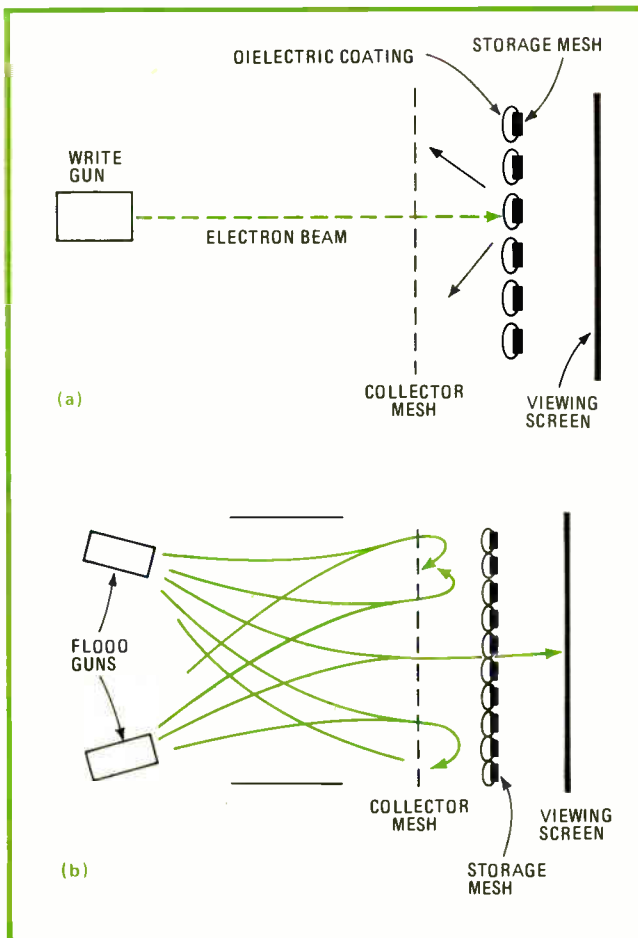

4. Old system design. The older direct-viewing storage system has a simpler design. Relative positive charge is held on the storage mesh dielectric coating (a). Later it is either purposely erased or allowed to fade into the background. Flood-gun electrons help to form the viewing-screen image in the variable-persistence mode (b). They also erase the images written by the write gun.

elements. These electrodes had to be easily producible, use voltages that could be readily generated by the instrument, and cause minimal distortion of the projected image.

Initially, in order to work out the design, experimental tubes with different lens shapes were built. This trial-and-error approach produced surprisingly good results and in fact yielded the basis of the final design, which was refined using an in-house computer program. The model set up by the program allowed the direct calculation of the effects of different lens shapes on the various electron trajectories.

A new write gun also had to be designed, because the crossover lens expands the trace width as much as it expands the image, and the wider trace can cause distortion. Therefore the initial spot had to be made small enough not to cause such problems when magnified. In addition, the write beam had to have a very high current density so that the writing speed would not have to be reduced. The resulting gun has a spot size at the viewing screen of less than 0.002 inch typically and less than 0.02 in. maximum when expanded under high-drive single-shot conditions.

Why the old method isn't good enough

In other variable-persistence storage cathode-ray tubes, the image is retained on a dielectric-coated storage mesh positioned behind the phosphor writing screen (Fig. 4a). To store a picture, a write gun writes on the dielectric surface with a high-energy electron beam. Energy from the write-gun electrons frees secondary electrons from the dielectric coating, and thus the written areas on the surface facing the write gun become relatively positively charged.

These secondary electrons are gathered by a collector mesh located between the storage mesh and the write gun. The secondary charge established by the write gun then remains stored on the dielectric coating of the

How much writing speed is required

Writing speed is a key specification in selecting a storage oscilloscope. It is defined as the highest spot velocity that produces a visible trace on the cathode-ray-tube viewing screen. This spot velocity has a maximum vertical (V_y) and a maximum horizontal (V_x) component. The maximum spot velocity is equal to the square root of the sum of the squares of these two values.

The writing speed required to display only the sweep base line is calculated by dividing the scope face calibration (centimeters per division) by the sweep rate (nanoseconds per division). The result is in centimeters per microsecond, which is most useful because storage scopes have storage writing speeds in microseconds.

Although this example does not cover all cases and calculating the writing speed for complex waveforms is

difficult, it is practical enough to allow a first approximation of the sweep speed for the purpose of selecting an oscilloscope.

When the variable persistence feature is used, the writing speed also directly affects the speed with which the light output is enhanced. For example, if an oscilloscope with a variable-persistence writing speed of $100 \text{ cm}/\mu\text{s}$ is to display a 25-megahertz signal with a 4-cm on-screen amplitude, a single-shot writing speed of about $600 \text{ cm}/\mu\text{s}$ is required. However, for a low-duty-cycle repetitive signal, a $100\text{-cm}/\mu\text{s}$ variable-persistence writing speed allows the signal to be displayed after it is integrated about six times. With a variable-persistence writing speed of $5 \text{ cm}/\mu\text{s}$, it would take about 20 times as long to obtain a viewable display.

storage mesh until it either is erased or fades into the background.

To display a stored image with this system, a pair of flood electron guns is used (Fig. 4b). The flood guns emit low-energy electrons that either go through the positively charged, written areas of the storage mesh or are repelled from the negative, unwritten areas. These electrons are collimated with a lens system set up so that they strike the storage surface at right angles. Resolution is thereby optimized, and the display image is the same size as the image on the storage mesh.

The flood-gun and write-gun electrons add to form the image on the viewing screen in the variable-persistence mode. However, in the single-shot or storage mode, only the flood-gun electrons striking the phosphor are visible. When desired, the flood guns erase the images written by the write gun.

Solving some problems

The writing speed obtainable is proportional to the product of the beam current and the secondary emission ratio of the dielectric coating on the storage mesh divided by the storage-mesh capacitance. Therefore, to get higher writing speeds, either the secondary emission ratio or the beam current must be increased, or the storage-mesh capacitance must be reduced.

The secondary emission ratio of the dielectric coating is a physical property of the material, and the only way to increase it is to employ very expensive and hard-to-use, exotic materials. Obviously, that is not practical. As for the beam current, the guns in most storage CRTs are at the limit of their current-density producing abilities, and thus there is no way to increase this current while maintaining other important CRT parameters.

The storage-mesh capacitance can be varied to increase the writing speed of the CRT, but reducing it also reduces the viewing time proportionally, making the instrument less useful. However, this problem can be got around by transferring the written image from a high-speed, low-capacitance storage-mesh to a low-speed high-capacitance one. This approach allows CRTs to be made with very high single-shot writing speeds and very long viewing times. The one disadvantage for the user is

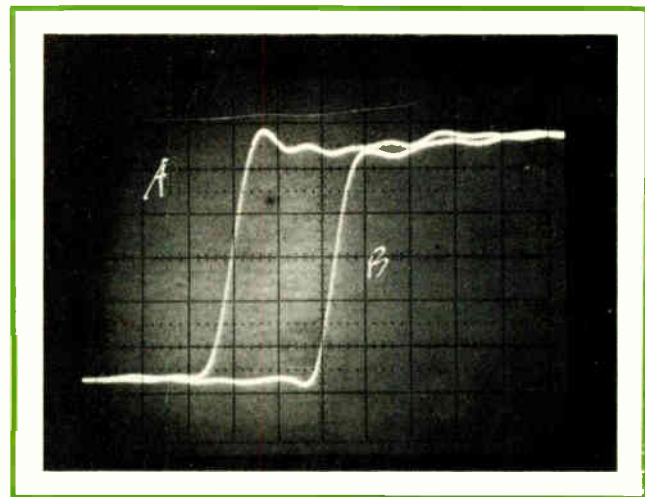

5. **Data and clock.** Curves A and B represent typical device clock and data signals, respectively, with a horizontal scale of 5 nanoseconds per division for both. The bright picture allows the time interval between the two to be determined by direct observation.

that he cannot have a high-speed variable-persistence writing rate in a continuous operating mode.

The 1744 high-speed variable-persistence storage scope, made possible with the new cathode-ray tube, is useful for displaying such signals as radar pulses, glitches and noise pulses in digital systems, nonperiodic, hard-to-trigger-on data streams, tone-burst signals, and X-ray signals, which would be impossible or difficult for conventional storage oscilloscopes to handle.

What a high-speed storage scope can do

If the signal is one that can be repeated manually—for example, by pressing a button that makes a signal appear—then the high-speed variable-persistence feature can optically integrate it over several sweeps to obtain a bright, high-contrast display. In this mode and for all low-repetition-rate applications where fast transitions occur, variable persistence leads to high contrast in less time than conventional storage oscilloscopes require.

The high writing speed also extends the capacity of the instrument to capture, store, and display nonrepeti-

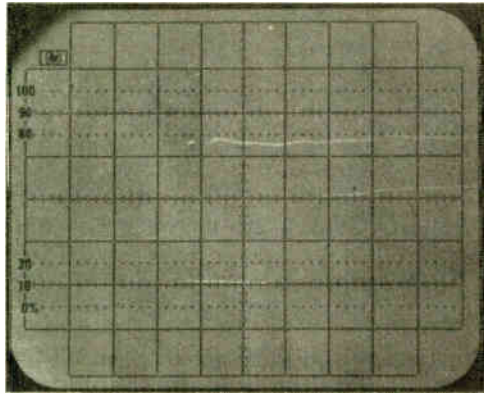

(a)

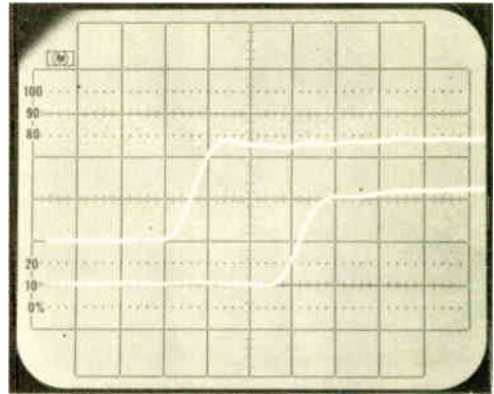

(b)

6. Better contrast. Conventional picture (a) has little contrast. Variable-persistence picture (b) is much easier to see. Same waveform with variable persistence stands out from the background. Horizontal scale is 5 ns/division in both cases.

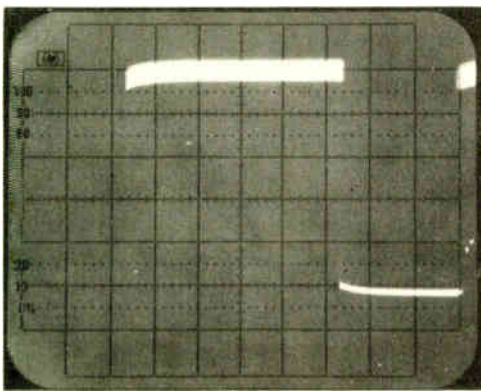

(a)

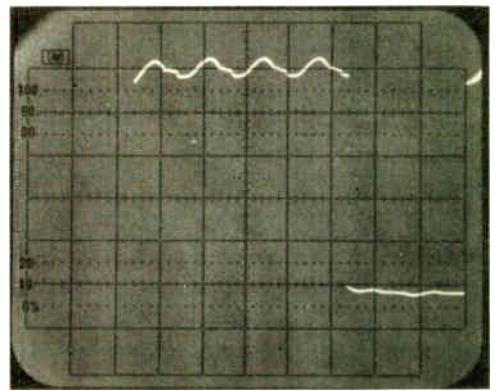

(b)

7. Better noise. Noise waveform shapes are readily observed with the 1744 oscilloscope. Triggering on the signal causes noise smearing in a conventional display (a). With the new CRT, the noise is not distorted (b), since the automatic-erasing and variable-persistence features eliminate smear and jitter. Conventional triggering on the signal, rather than on the noise (which is far harder to do), is still possible.

tive waveforms. When the automatic-erasing feature is used, the instrument can display fast nonperiodic and complex waveforms while filtering out unwanted signals for easier viewing.

Consider, for example, a typical clock pulse that generates a data pulse in some device. The oscilloscope is set up in the dual-channel auto-erasing mode (Fig. 5). The data pulse occurs about once every 200 milliseconds, making it very hard to view on a conventional storage scope, since the data-generating device under test has a 3-nanosecond set-up time.

With the high-speed storage scope, the leading edge of this pulse can be easily seen. The time between the leading edge of the data pulse and the clock pulse can be measured by direct observation even in the 10-ns range. For the pulses shown, the measured time is about 12 ns, which easily exceeds the device specification of 3 ns.

Low-duty-cycle signals with fast edges can also be made more readily viewable. The photograph in Fig. 6a was taken in the minimum-persistence mode, which results in performance similar to that of a nonstorage oscilloscope. The high-speed variable-persistence feature provides a much brighter display (Fig. 6b).

High-speed automatic erasure is also helpful when noise or some other asynchronous signal couples into a pulse or digital waveform. With a nonstorage oscilloscope, triggering on the pulse causes the noise to smear. The smear is displayed as a thick, solid line (Fig. 7a) with no information content. With a conventional storage scope, it may be possible to see the noise, depending on its frequency and type. But with high-speed variable persistence and auto-erasure, it is unnecessary to attempt to trigger on the noise in order to see its waveform (Fig. 7b). □

High-level languages ease microcomputer programming

Closer to English than assembly language, they shorten the time needed for development and debugging

by J. Lynn Saunders and Larry E. Lewis,* *Tektronix Inc., Beaverton, Ore.*

□ High-level languages are to assembly- or machine-language programming what integrated circuits are to discrete logic—they collect small, related elements into neat modules. The benefits, too, are similar. Just as the hardware designer needs fewer components to build a system, the programmer thinking in a high-level language needs fewer lines of code to make a system go.

Such languages are not the perfect solution for all programming problems. They require a lot of memory, for example, and in the case of microcomputers, that was economically impractical till quite recently. But now they can often be used to cut expensive microcomputer-firmware development time, especially if their user is aware of the languages' strengths and weaknesses.

Advantages are many

The number of statements a programmer writes per unit time is a good measure of his or her productivity. But the number of machine instructions produced from a statement can vary all the way from 1 to a high of about 12. In general, the higher the level of the statement, the greater the portion of the task the statement executes, and the fewer the statements that are required. For a constant statement rate, then, high-level languages decrease coding time.

When thinking in an HLL rather than an assembly language, the mind is free of such detailed and tedious tasks as keeping track of what each accumulator holds. The programmer can focus on the problem to be solved rather than on the idiosyncracies of the machine.

For one thing, modern HLLs use so-called friendly instructions that closely parallel the English language. Mnemonics like IF, THEN, ELSE; DO, WHILE; REPEAT, UNTIL; and CASE, OF are obvious to the programmer and ease the task of translating thoughts into a language the computer can understand.

For another, friendly keywords also make programs easier to understand because HLL source statements are easier to read than an assembly-language source listing. This greatly reduces the need for comments and may also eliminate the flow-charting phase of the development process. Indeed, one way to evaluate a language's performance is to see how easily the programmer's peers can read his code. The HLL code can be understood with

Larry E. Lewis is now the director of software at Futuredata Computer Corp., Los Angeles, Calif.

```
FRIENDLY SUBROUTINE
1      PROCEDURE /PROGRAM.ENTRY/
2      V      VAR
3      V      BINARY*8:KEYCODE
4      V      LOGICAL*8:STEPMODE,QEMPTY
5      V      ENDV
6      C      CON
7      C      BINARY*8:STEPKEY/13H/
8      C      ENDC
9      E      EXT
10     E      PROCESS.COMMAND,DISPLAY.INSTRUCTION
11     E      GET.KEYPUSH,DISGARD.KEYPUSH,QTEST
12     E      ENDE
13     R      REPEAT
14     R      IF NOT STEPMODE THEN
15     RI     PROCESS.COMMAND(STEPMODE)
16     RI     ENDI
17     R      IF STEPMODE THEN
18     RI     DISPLAY.INSTRUCTION
19     RI     GET.KEYPUSH(KEYCODE)
20     R      IF KEYCODE=STEPKEY THEN
21     RII    DISGARD.KEYPUSH
22     -RII   ELSE
23     RII    STEPMODE=FALSE
24     RII    ENDI
25     RI     ENDI
26     R      QTEST(QEMPTY)
27     R      UNTIL QEMPTY OR STEPMODE
28     R      ENDR
29     RETURN
30     END.
```

1. Easy to read. This subroutine is part of a program for scanning the keyboard and illuminating the display of a front-panel controller. It is written in a high-level language called Tesla, an Algol derivative similar to Pascal. With few comments, this language is relatively simple to understand even without prior exposure to it.

The pros and cons of assembly and high-level languages . . .

High-level languages designed especially for microcomputers are very much in the cards these days. But this wasn't always the case. For a long time the high cost of memory restricted microcomputer-system programmers to assembly language.

Assembly-language programming is the most basic form of firmware development. It consists of learning a particular processor's mnemonics and composing a program in accordance with the operations they perform. The assembly process can then be handled in one of two ways: by machine or by hand.

Besides translating mnemonics and data into binary machine code, a software assembler automatically builds a symbol table and assigns addresses to appropriate routines and data tables, not to mention flagging errors that hand assembly may often overlook. Also, because an assembler is part of a development system or general-purpose computer, bells and whistles like extended macro capabilities, linking of relocatable code blocks, and hard copy are generally available. In short, the benefits of a machine assembler are such that hand assembly is only

practical for small systems in limited editions.

One distinct advantage of assembly-language programming is its efficiency. The assembly-language instructions are so intimately related to the machine code (in fact, there is a one-to-one correspondence) that the clever programmer can often develop programs with minimal execution times and memory requirements. Indeed, a few applications can be dealt with only by coding in assembly language. These include problems with very intricate timing requirements or cost sensitivity, such as the inability to allocate more than one small read-only memory to run an entire system.

Developing firmware with a high-level language, however, is much more convenient. Routines written with an HLL are shorter, more portable, and closer in form to English. One HLL instruction may produce as few as one or as many as a dozen assembly-language instructions. In general, a particular HLL instruction will not always compile into the same set of machine code. This is because at the time of compilation, the contents of the various registers and stack/memory pointers will be differ-

few or no comments, as Fig. 1 makes clear.

Moreover, errors are proportional to the number of instructions written. Since HLLs produce more machine code per instruction, there will be fewer errors to debug. More than half of the errors associated with hand-coded assembly-language programs can be eliminated using the compiler of the HLL. For example, keeping track of what is in each index register is an activity that may produce errors in assembly-language coding, but is performed automatically by an HLL compiler.

Structured and portable

Block-structured HLLs with rich control features allow and even encourage the designer to use block-structured programming techniques in solving a particular problem. Such a modular design reduces development costs and improves program reliability.

Some HLLs available for microprocessor firmware development are similar to programming design languages. Many programmers are successfully implementing the flow-chart phase of the firmware design process with the aid of these PDLs, since they are essentially the same, in keywords and structure, as the HLL used in the coding phase. The translation is a trivial one, and the programmer feels he has a machine that executes his flow charts.

Using a high-level language to develop firmware means the product designer can check a design sooner. A myriad of products now on the market are microprocessor-based, but they have unproven user interfaces. It is very important to check out these interfaces early in the design stages, and HLLs make this possible.

HLLs are much less machine-dependent than assembly languages. Hence, code written in a HLL is inherently more portable than that written in assembly language. Utility routines, such as stack and queue manipulators, floating-point math packages, and number-conversion packages, are common to many projects, so that in the

ROM CONTENTS CHANGE						
Original version	Version 2	Version 3	Version 4	Version 5	Version 6	Version 7
ROM A	new		new			
ROM B	new					
ROM C	new					
ROM D	new					
ROM E	new					
ROM F	new		new			
ROM G	new	new				
ROM H	new					
ROM J	new		new			
ROM K	new			new		new
ROM L	new					
ROM M	new					
ROM N	new		new			
ROM P	new			new		
ROM Q	new		new		new	
ROM R	new					
Changes	16	1	5	2	1	1
Total changes - 26						

2. Maintenance. It is not true that once the read-only memories have been programmed, the listings can be discarded and the disk-files expunged. Shown here are the revisions demanded for a typical set of ROMs over a span of two years. Because high-level languages are easier to read and write, maintenance is less arduous.

long run, portability turns out to be cost-effective.

The idea that "once the read-only memories are programmed, the maintenance is over" is simply not true. Figure 2 shows a number of ROM packages that have undergone seven releases in two years of production. Obviously, then, it cannot be assumed that once the product is in production, the software task is complete. Life-cycle costs for firmware products are similar to those for software products. Maintenance is as important in firmware as it is in software, and that maintenance is simplified when the programming medium is a HLL.

. . . for microcomputer programming

ent and a certain amount of "cleaning up" is required before meaningful assembly-language instructions are generated.

A growing number of microprocessor development system manufacturers and software houses are offering high-level languages for firmware development. Besides the well-known general-purpose languages like Basic, Fortran, and Cobol, there are dedicated languages such as Intel's PL/M and Zilog's PL/Z. Many semiconductor manufacturers are taking a good hard look at Pascal, known for its data-handling versatility and block structure.

Forth Inc., in Manhattan Beach, Calif., offers microForth and miniForth as software design tools. The Forth language is one of many attempts to reduce the memory requirements and enhance the speed of high-level languages.

Traditionally, HLLs have needed mass-storage devices, like disks. With the expansion in size of solid-state read-only memories, however, many high-level languages are finding their way onto chips, and this is just the beginning. National Semiconductor now has three versions of Basic

on a chip. Rudy Langer, a manager of microprocessor systems and software at National, feels that with the availability of integrated interpreters, systems can be put together that actually execute Basic instructions at the board level. One ROM would hold the interpreter, another the instructions. With the addition of one inexpensive integrated circuit (the interpreter), Basic instructions could be executed on the spot, if the system could hack the lower speed, as many can.

There is also serious talk about a standard high-level language for microcomputers. A universal language would forestall dependence on a particular hardware vendor and help control the rising cost of software development. The language chosen should be general-purpose and self-documenting and have flexible data-handling and input/output capabilities. The two leading contenders appear to be Pascal and C, a structured language developed at Bell Labs in Murray Hill, N. J. Proponents of C like its data-structuring capabilities. A variety of constructed data types can be declared, manipulated, pointed to, and dimensioned by the user in C, they say. **J. G. Posa**

BEWARE OF INEFFICIENT CODE

1	PROCEDURE /TEST2/	41	*		
2	V VAR	42	*****	13	COPYFROM=READYMSG(5)
3	V ADDRESS*16: COPYFROM, COPYTO	43	*		
4	V CHAR*8: DISPLAY(10)	44	0000 C6 05	TEST2	LDA B #5
5	V BINARY*8: COPYLEN	45	0002 4F		CLR A
6	V ENDV	46	0003 FB 0013 1		ADD B 1+LIS.0004
7	C CDN	47	0006 B9 0012 1		ADC A LIS.0004
8	C CHAR*8: READYMSG(10)/READY	48	0009 F7 0001 0		STA B 1+COPYFROM
9	C ENDC	49	000C B7 0000 0		STA A COPYFROM
10	E EXT	50	*		
11	E COPY	51	*****	14	COPYTO=DISPLAY(10)
12	E ENDE	52	*		
13	COPYFROM=READYMSG(5)	53	000F C6 0A		LDA B #10
14	COPYTO=DISPLAY(10)	54	0011 4F		CLR A
15	COPYLEN=10	55	0012 FB 0015 1		ADD B 1+LIS.0002
16	COPY(COPYFROM, COPYTO, COPYLEN)	56	0015 B9 0014 1		ADC A LIS.0002
17	RETURN	57	0018 F7 0003 0		STA B 1+COPYTO
18	END.	58	001B B7 0002 0		STA A COPYTO

3. Before optimizing. Being unable to recognize constant subscripts, the compiler here produced less than optimal code. The high-level source lines—13 and 14 in (a)—each produced six assembly-language instructions in the object code (b), three times the necessary amount.

A programmer needs to become familiar with the type of code the HLL produces in order to employ those constructs that produce efficient code and avoid those that do not. An HLL compiler can be thought of as a sophisticated assembler with an extensive, predefined macroinstruction capability. The task of learning any particular compiler is simplified if it produces assembly-language object code and can also furnish a listing with the corresponding assembly statements embedded in the source code. The form of listing produced is important: there is a need for assembly-type mnemonics that depict the code produced from a particular construct (as shown in Figs. 3b and 4b) immediately after the construct, with clear indications of the associated physical addresses and their contents. A block nesting indicator for each execut-

able source statement is also useful.

Once the compiler's output is executed, its performance can be evaluated. By selectively optimizing critical paths in assembly language, it is possible to increase efficiency substantially, especially in terms of speed. An effective way to document this is to enclose the inefficient code in comment delimiters, so that the enclosed code becomes the comment describing what the assembly-language statements do, as shown in Fig. 4.

Optimize by hand

Thus, if a loop contains 20% of the code but uses up 80% of the execution time, it would probably be wise to re-code parts of that loop by hand in assembly language. Programs typically spend rather more than 90% of their

HAND-CODE CRITICAL PATHS	
<pre> 13 # COPYFROM=READYMSG(5) # 14 A ASM 15 A LDX # READYMSG+4 16 A STX COPYFROM 17 A ENDA 18 # COPYTO=DISPLAY(10) 19 A ASM 20 A LOX # DISPLAY+9 21 A STX COPYTO 22 A ENDA </pre> <p>(a)</p>	<pre> 38 ***** 13 # COPYFROM=REA YMSG(5) # 39 * 40 ENTRY TEST2 41 SECTION CODES 42 * 43 ***** 44 * 45 0000 2 TEST2 EQU * 46 0000 CE 0004 1 LDX # READYMSG+4 47 0003 FF 0000 0 STX COPYFROM 48 * 49 ***** 18 # COPYTO=DISPL Y(10) # 50 ***** 51 * 52 0006 CE 0000 0 LDX # DISPLAY+9 53 0009 FF 0002 0 STX COPYTO 54 * 55 ***** 56 * 57 000C C6 0A LDA B =10 58 000E F7 000E 0 STA B COPYLEN 59 * </pre> <p>(b)</p>

4. After optimizing. Original inefficient HLL instructions were enclosed in comment delimiters (for documentation purposes) and hand-coded in assembly language. Note that only two instructions were really necessary, and that both ROM space and execution time were reduced.

SHORTER DEVELOPMENT TIME						
Language used	Job 1	Job 2	Job 3	Job 4	Job 5	Job 6
	Assembly				High-level	
Number of functions	10	9	13	45	35	40
Stored program ?	no	no	no	yes	yes	yes
Editing 1 (1)	—	—	—	yes	yes	yes
Editing 2 (2)	—	—	—	yes	no	no
Algebraic calculations?	no	no	no	no	yes	yes
RAM space (bytes)	128	512	1 K	1.5 K	1 K	1.5 K
ROM space (bytes)	4 K	12 K	12 K	20 K	16 K	20 K
Development time (man months)	10	22	22	42	11	9
Design time (man months)	4	8	7	18	5	4
Coding time (man months)	4	7	8	11	4	3
Debug time (man months)	2	7	7	13	2	1

5. Firmware. Shown above are the attributes of six typical firmware-development projects. Probably the most important difference between the use of assembly language and a high-level language is the development time, which is 25% to 20% shorter with the HLL.

time executing rather less than 10% of their code.

Tailoring utility routines to the task at hand and writing them in assembly language can save much time and space. Figure 5 summarizes the attributes of six firmware development projects; the sixth job is similar to the fifth and used some common design coding time. Here, “number of functions” is a measure of the overall complexity of the task implemented and correlates with the ROM image size. “Stored program?” indicates whether or not the task supports programs definable by the user—some kind of memory management is implied. “Editing 1” is an indication of whether or not simple editing (say, deleting from and adding to the end of the user program) is allowed, whereas insertions and deletion within the program are permitted by “Editing 2.”

In Fig. 5, the number of functions required by the

third, fourth and fifth projects are similar. However, the development time of the HLL programs is one fourth to a fifth that of the assembly programs. The space efficiencies are about the same. It is unnecessary to compare time efficiencies, because all tasks operate with similar timing constraints and all met the design requirements imposed at product conception.

If an HLL is used for firmware development, a handle on the physical address space is necessary. Certain absolute addresses like interface ports and common areas with assembly-language routines need to be easily accessible. Ideally, procedures should be able to access global variables across their boundaries, whether written in assembly language or an HLL. If the compiler produces assembly code as object code, many of these criteria are met. The resulting modules can be easily linked into one firmware module.

Seeing the big picture

The examples used by many evaluators of HLLs are too simple to measure accurately how well the HLL will handle a task where modularity and structure are forced on the programmer. The structure of a firmware module longer than 1,000 statements is practically impossible to comprehend as a whole. Yet to make global optimizations, such understanding is critical. This threshold of comprehension loss is reached sooner when writing in assembly language. When coding in an HLL, however, much more of the overall problem can be recalled.

Most benchmark routines assume the programmer uses the full power of the language without knowledge of the type of code it produces. In reality, much more efficient code can be produced by intelligent use of the HLL—by keeping in mind the things it does well and the things it does poorly. An efficiency increase of 30% can be realized in just two weeks if this time is spent learning the HLL’s strengths and weaknesses. □

Boosting op amps' roll-off extends range of active filters

by C. A. J. van der Geer
FOM Institute for Plasma Physics, Jutphaas, the Netherlands

The upper frequency limit of a low-pass active operational-amplifier filter can be extended by making use of the op amp's roll-off. By simply cascading a number of op amps that have been individually compensated, the effect of roll-off (gradual loss of gain beyond the flat portion of its mid-frequency amplitude curve) is reduced, and a filter having at least 10 times the maximum cutoff frequency of conventional units can be obtained. The high-order filter response is almost identical to that of a maximally flat (Bessel) filter.

The method used to achieve optimum response will be best understood by observing the op amp's open-loop transfer function. The open-loop response without internal compensation is approximately:

$$A(s) = A_o \left[\frac{\sigma_1 \sigma_2 \sigma_3}{(s - \sigma_1)(s - \sigma_2)(s - \sigma_3)} \right]$$

where A_o is the low-frequency gain and σ_1 , σ_2 , and σ_3 are the open-loop poles, or the break points, in the frequency-response curve.

When negative feedback is applied without external compensation to the op amp in its standard inverting configuration (Fig. 1a), the closed-loop function becomes:

$$\frac{V_o(s)}{V_i(s)} = \frac{-A(s)}{1 + \beta[1 + A(s)]}$$

where β equals the ratio of the feedback resistor, R_f , to the input resistor, R_i . The resistive feedback neither introduces new poles or zeros in $A(s)$ nor cancels them, but it does alter their location in the s -plane. When the feedback is gradually increased from zero to infinity by decreasing the input resistor to zero, the poles of the closed-loop function depart from σ_1 , σ_2 , and σ_3 and follow a particular trajectory, terminating in the zeros of $A(s)$. These trajectories are the root loci, examples of which are shown in Fig. 1b, one for each of the closed-

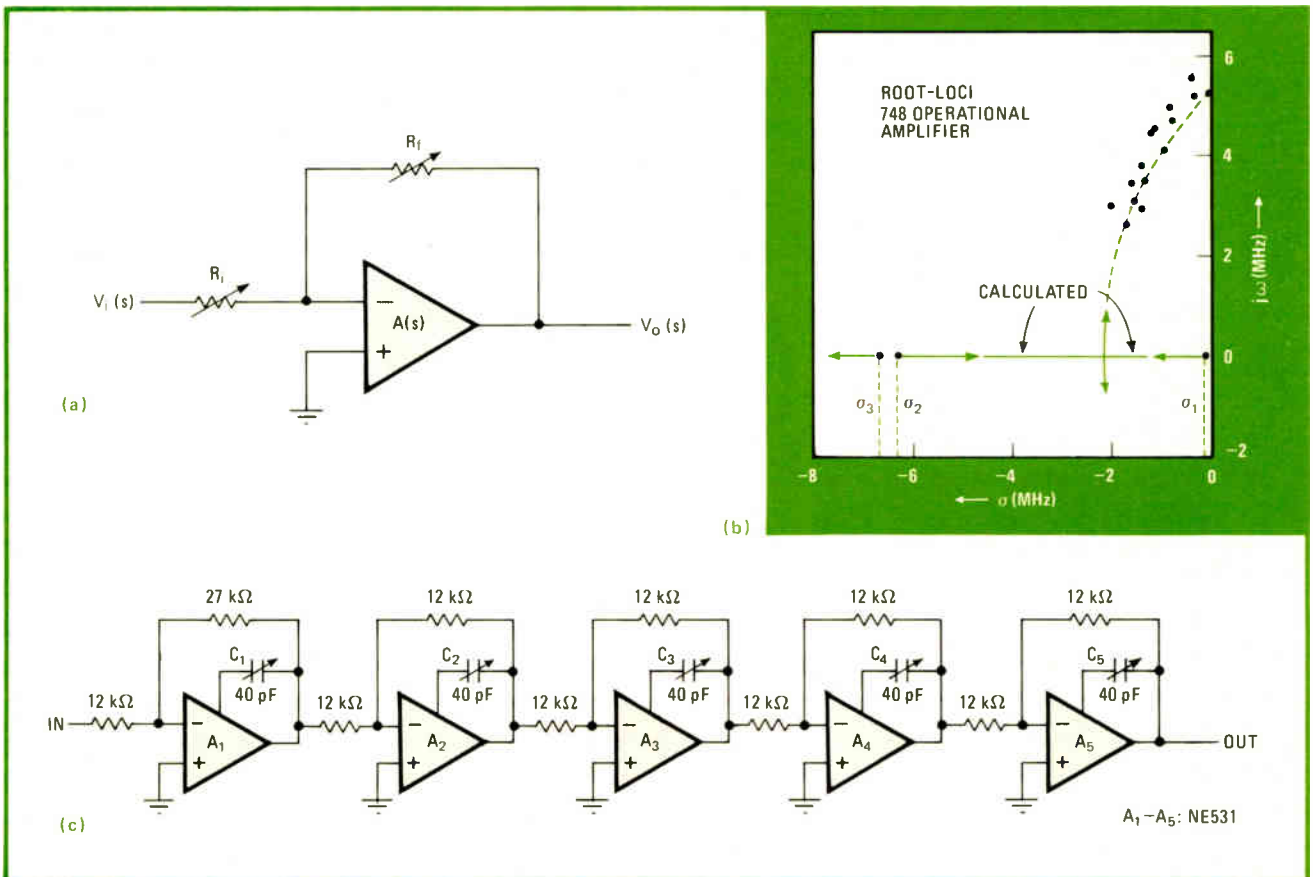

1. Pole position. Adding negative feedback (a) to op amp alters pole-zero location in s -plane, enables plot of root loci (b) when feedback is gradually increased. Root loci resemble Gaussian low-pass filter curves, and suitably compensated op amp filter (c) can duplicate response at an upper frequency limit far beyond that of conventional active filters by boosting roll-off, which becomes more than 60 dB per decade.

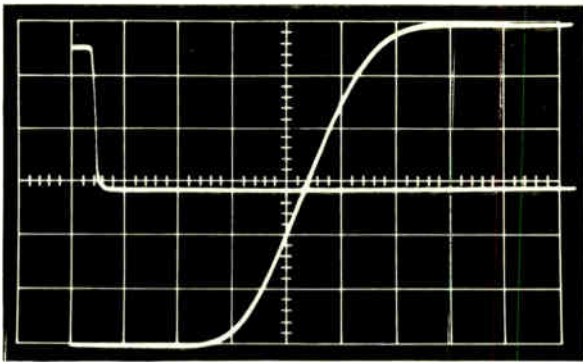

(a)

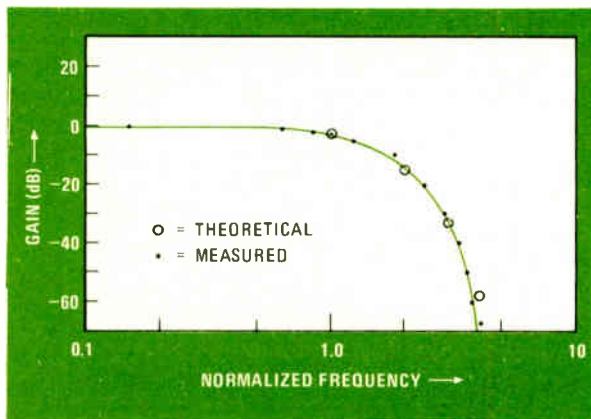

(b)

2. Response. Filter is optimized by adjusting filter's compensating capacitors for the rise time required (large curve) using a step input (negative-going pulse). On plot of normalized frequency response (b), op-amp filter closely matches theoretical 10th-order Bessel filter.

loop poles of a 748 op amp. Only the root loci for the positive values of $j\omega$ are shown.¹

The root loci resemble the curves on which the poles of the Gaussian family of filters are situated,² and these curves may be virtually duplicated if several cascaded op-amp stages are set so that their individual root loci align in a pattern that makes possible a circuit response well above the normal passband of one op amp. In essence, this technique allows the combining of staggering with the boosting of the individual high-frequency responses of each amplifier.

The overall response of the filter can be extended by varying each op amp's compensating capacitor in order to move the location of the individual poles. Of course, the poles can also be moved by changing the ratio of feedback-to-input resistors as mentioned, but the former method is more practical because it is easier to trim the circuit when the amplifier gain is held constant.

Figure 1c shows a 10th-order low-pass filter, built with 561 op amps, having a gain of about 2 and a 1-megahertz cutoff frequency (at which point the output voltage is -3 dB down from its peak value). The roll-off is more than 60 dB per decade. The gain of any filter built using this technique should be above unity to ensure minimum difficulty in trimming the circuit.

Figure 2a shows the response of the filter for a step input. The scope's time base is set at 200 nanoseconds per division. For optimum response at a given cutoff frequency, the trimmers C_1 - C_5 are adjusted in sequence to obtain the rise time required. The normalized frequency response is plotted in Fig. 2b. The circles represent the corresponding points for a theoretical 10th-order Bessel filter. □

References

1. S. S. Hakim, "Feedback Circuit Analysis," Iliffe Books Ltd., London, 1966.
2. A. I. Zverev, "Handbook of Filter Synthesis," John Wiley and Sons Inc., New York, 1967.

Extending the range of an intermodulation distortion test

by Don Feeney
TRW Semiconductors, Linear RF Products, Lawndale, Calif.

More often than not, a system's intermodulation distortion is characterized by its third-order intercept value, the most widely accepted figure of merit for indicating the linearity of a system. Even though IMD is extremely difficult to measure accurately and with repeatability when low signal levels are introduced into the device under test, precise measurements can be made at levels as low as 100 decibels below the desired carrier (input-signal) point. The secret is to add a tunable bandpass filter to the measuring system and to reduce the nonlinearities inherent in the test system, thus making it possible to determine third-order intercept values of up to +50 dBm, which is more than 20 dB above that of most measuring systems now in use.

Third-order intermodulation products are generated as shown in part (a) of the figure. Consider two signals, f_1 and f_2 , that are applied to the input of a device that has a nonlinear transfer function. If the output power is equally distributed at both frequencies and the frequencies are close together, equal power-distortion products will occur at $2f_1 - f_2$ and $2f_2 - f_1$.

The magnitude of these unwanted products, expressed in decibels below the output P_0 , is defined as the system IMD. The third-order intercept may then be found by its defining equation:

$$I = P(\text{dBm}) + \text{IMD}(\text{dB})/2 \quad (1)$$

where IMD is the third-order product produced by the I intercept value, measured in decibels.

An IMD setup having wide dynamic range is shown in (b). In this case, measurements are performed at 30 to 500 MHz, although the guidelines set forth here will allow accurate measurements at any frequency.

The first step in measuring IMD and thus securing the third-order intercept of a device is frequently the most difficult to attain—that of combining two input tones to the device under test without introducing distortion or

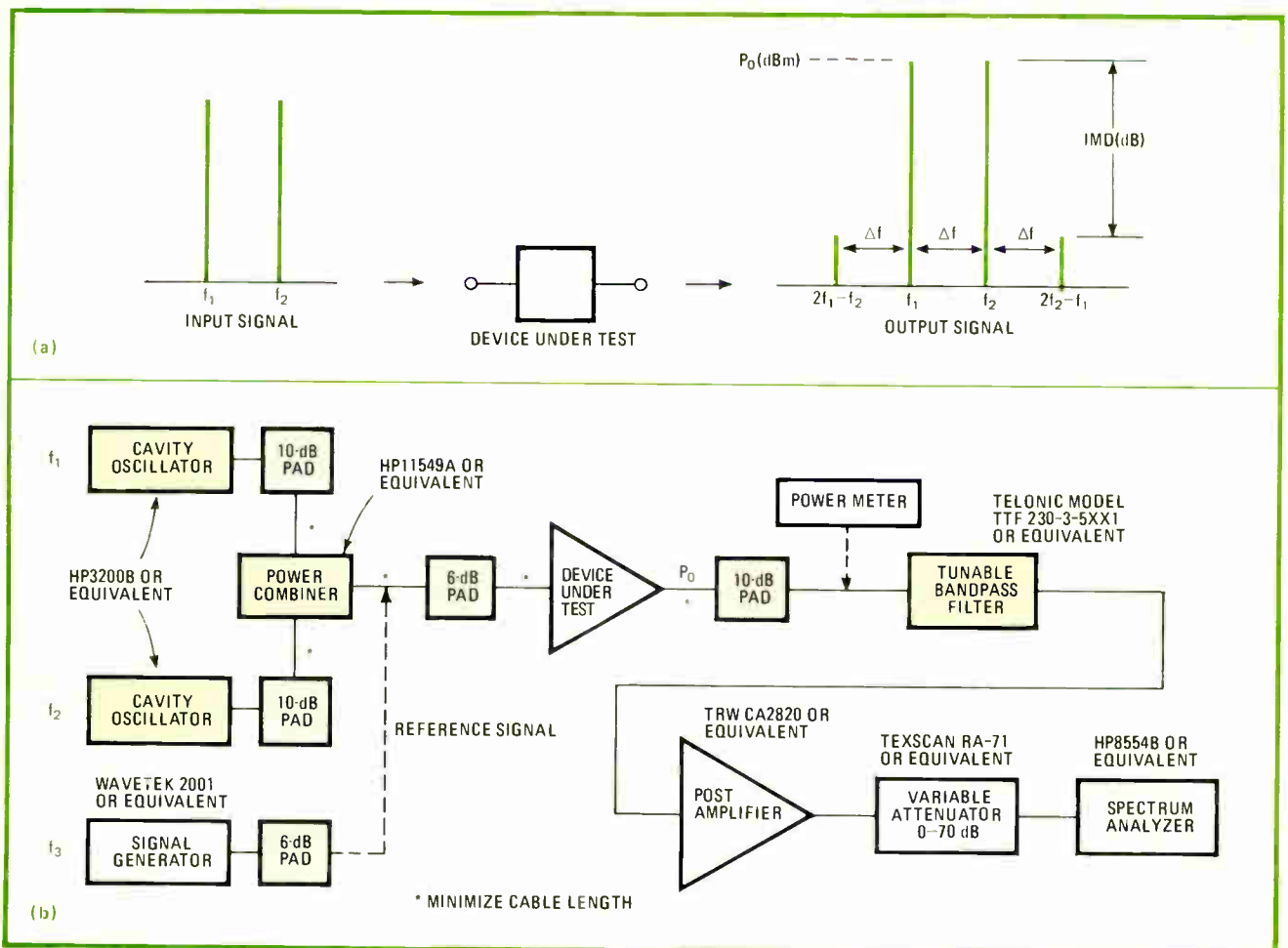

Wide range. Intermodulation distortion is created if two input frequencies pass through a nonlinear device (a). System measures IMD over wider range than standard setups by using cavity oscillators to reduce harmonic generation, tunable bandpass filter for rejection of IM components not measured against f_1 or f_2 ($2f_2 - f_1$ or $2f_1 - f_2$, respectively), and power-splitter for linear combiner of f_1 and f_2 . Pads (6 dB and 10dB) offer isolation between system elements. With setup, measurements of IMD can be made at levels 100 dB below carrier.

spurious responses. For fixed-input-frequency setups, filters can be employed to eliminate harmonics generated by f_1 and f_2 . If the input frequencies are variable, cavity oscillators should be used instead of sweep generators, because the latter's harmonic content is too high.

The best method for combining the two signals linearly is to use a resistive power combiner as shown, so that the composite signal generated will be virtually clean (no nonlinearities). To reduce third-harmonic distortion between the f_1 and f_2 generators, 10-dB attenuator pads should be used between the cavity oscillators and the power combiner. Using both the pads and the combiner guarantees a broadband input source with constant characteristic impedance facing the device under test. As the requirement for a broadband resistive source of constant impedance also applies to the load for the test device, it is wise to use a 10-dB attenuator here, as well.

The system's measuring range is improved by placing a five-pole bandpass filter in the postamplifier chain. Having a bandwidth of less than Δf , this filter rejects unwanted signals f_1 , f_2 , their harmonics, and $2f_2 - f_1$ when measuring IMD at $2f_1 - f_2$, thus eliminating strong but unwanted signal responses that tend to limit the dynamic range of (that is, desensitize) the test system.

For those not familiar with the procedure, IMD and third-order intercept are found as follows:

- Set channel spacing to the desired Δf (6 megahertz for the system shown in the figure).
- Set reference signal f_3 to $2f_1 - f_2$.
- Using a power meter, set P_0 to the desired output power level for each of the three sources independently. Connect only one source at a time.
- With f_3 connected, tune the bandpass filter to f_3 . With the variable attenuation at 30 to 50 dB, set a reference level on the spectrum analyzer. Make sure the postamplifier is not in compression by inserting 30 to 50 dB of additional attenuation. One should then observe 30 to 50 dB of signal reduction on the spectrum analyzer.
- Apply f_1 and f_2 . Decrease attenuation in the variable attenuator to bring the signal within range of the analyzer. Add the change in attenuation to the value of suppression as read on the analyzer to obtain IMD.
- Adjust f_3 and filter to $2f_2 - f_1$ and repeat all steps. IMD should be within 3 dB of the first measurement.
- Calculate the third-order intercept from Eq. 1. □

Engineer's notebook is a regular feature in *Electronics*. We invite readers to submit original design shortcuts, calculation aids, measurement and test techniques, and other ideas for saving engineering time or cost. We'll pay \$50 for each item published.

ELECTRONICS REPRINTS

No of copies wanted

New reprints

- R-801 World market report 1978 24 pp \$4.00
- R-734 Microcomputer families expand 20 pp. \$4.00
- R-730 Special Report—Automotive electronics gets the green light 10 pp \$3.00
- R-728 Flexible circuits bend to designers' will 10 pp \$3.00
- R-724 Special Report—Technologies squeeze more performance from LSI 22 pp. \$3.00
- R-722 Demands of LSI are turning chip makers towards automation 12 pp \$3.00
- R-720 How EEs Feel About Engineering—3-part series 26 pp \$5.00
- R-718 Display makers strive to refine their technologies 8 pp \$3.00

Books

- R-803 New product trends in electronics—Electronics Book Series 333 pp \$14.95
- R-732 Memory Design—Microcomputers to Mainframes—Electronics Book Series 180 pp \$12.95
- R-726 Design Techniques for Electronics Engineers—Electronics Book Series 370 pp \$15.95
- R-711 Circuits for electronics engineers: 306 circuits in 51 functional groups—Electronics Book Series 396 pp \$15.95
- R-704 Thermal design in electronics \$5.00
- R-701 Applying microprocessors—Electronics Book Series 191 pp \$9.95
- R-608 Basics of Data Communications—Electronics Book Series \$12.50
- R-602 Large Scale Integration—Electronics Book Series 208 pp \$9.95
- R-520 Microprocessors—Electronics Book Series 154 pp \$8.95

Payment must accompany your order

Make check or money order payable to Electronics Reprints. All orders are shipped prepaid by parcel post. Allow two to three weeks for delivery. For additional information call (609) 448-1700 ext. 5494.

Mail your order to:

Janice Austin
ELECTRONICS REPRINTS
P.O. Box 669
Hightstown, N.J. 08520

FREE Washer Catalog and Sample Pack

Catalog lists 3000 sizes of non-standard washers and spacers available without die charge

All metal washers are flat and tumble de-burred. They are made immediately to your order from existing dies. Materials certified if needed.

Boker's complete stamping capability includes tooling, welding, metallurgical lab, assembly, and quality control. Let us give you a quick quote.

For your convenience our complete catalog is reprinted in ThomCat. Look under BOKER'S in Volume 9.

Satisfied customers from coast to coast.

BOKER'S, INC.

3104 Snelling Ave. So., Mpls., MN 55406 Phone 612-729-9365
Circle 123 on reader service card

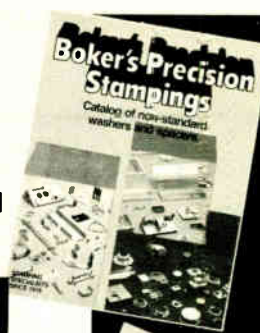

OD's from .086" to 1.936"
ID's from .027" to 1.637"
Thicknesses: .005" to .125"
Any stampable material

Stamping Specialists Since 1919.

Just published: 1978 EBG!

Completely new listings of catalogs, new phone numbers, new addresses, new manufacturers, sales reps, and distributors! The total market in a book—four directories in one!



Electronics Buyers' Guide
1221 Ave. of the Americas
New York, N.Y. 10020

Yes, please send me _____ copy(ies) of 1978 EBG.

I've enclosed \$25 per copy delivered in the USA or Canada.

I've enclosed \$35 per copy for delivery elsewhere (\$47 if shipped by Air). Full money-back guarantee if returned in 10 days.

Name _____

Company _____

Street _____

City _____ State _____ Zip _____

One way to mate ECL and TTL

It's often convenient to mate transistor-transistor logic with some unique emitter-coupled-logic functions such as the MC1648 vhf oscillator or the MC12002 analog mixer. Vernon P. O'Neil of Motorola Inc.'s Discrete Semiconductor division says that if system speed requirements are not too high, there is a convenient IC for transforming ECL levels into TTL levels—the MC3486 line receiver. **Using the complementary ECL outputs as the input to the line receiver transforms them into TTL inputs**—and with the added advantage of three-state output.

Alternatively, if the speed of the MC3486 would limit the performance of the system, then use the built-in ECL/TTL converter of the MC12000 digital mixer, which operates at frequencies above 40 MHz. Both the MC 3486 and the MC12000 operate from a single 5-v supply.

A teach-yourself trainer in logic for technicians

Do you have to train technicians and production personnel in combinational or sequential digital logic based on standard gates and flip-flops? At \$69.95, the Broder model 100 Logic Trainer appears to be a simple, low-cost method. It comes in a plastic box 9³/₁₆ by 4³/₄ by 1⁹/₁₆ inches in size with a series of eight switches on its left side. Across from the switches is a liquid-crystal horizontal-bar indicator. The circuitry is powered by an internal battery.

To operate it, you put a "problem" card in a cavity between the switches and the readout. The card indicates the necessary logic switches and the bar position for a proper solution of its logic configuration. The user simply has to program the indicated switches to force a logic 1 at the card's output to turn on the correct bar indicator. No wiring or IC manipulation is required. A manual, 40 problem cards, and a 9-v battery are included. For additional information, contact L. J. Broder Enterprises Inc., 3912 Darvany Dr., Dallas, Texas 75220, or call (214) 357-7763.

What's a Kelvin contact?

Wherever high-current, low-voltage measurements have to be made, Kelvin contacts are needed. But most engineers either have forgotten or don't know the technique for making measurements with them. So Sage Enterprises has put out a technical brief, TB 7801, describing **the application and theory of Kelvin contacts in some detail**. For a free copy, write to Sage Enterprises, 1080 Linda Vista Ave., Mountain View, Calif. 94043.

Tektronix to teach about microprocessors

Tektronix Inc. is setting up four permanent training centers in microprocessor design and development. Two are already in operation in Rockville, Md., and Santa Clara, Calif., and the others will open in Boston and Dallas next October and January.

Scheduled to run altogether 65 times through June 1979, the courses are: **a microprocessor design workshop (five days for \$595) and a microprocessor development lab workshop (three days for \$395)**. The longer one will focus on software development and system integration for the 8080 and 6800 family microprocessors; it takes the designer from flow charts to debugging and emphasizes hands-on experience with the Tektronix 8002 microprocessor development lab. The other makes use of the firm's 8002 development system.

First courses at the centers are scheduled for Aug. 21, Sept. 11, and Sept. 25. For more information, contact Tektronix, P. O. Box 500, Beaverton, Ore. 97077, or call (503) 644-0161. **Jerry Lyman**

D-a subsystem runs at 100-MHz

Glitch-free 8-bit video module includes composite sync and blanking inputs; sells for \$85

by Pamela Hamilton, Boston bureau

As a 100-MHz digital-to-analog converter that sells for \$85 in 100-piece quantities, the MP8308 is impressive enough. But the 8-bit module goes further—it is a complete video subsystem that accepts standard video control inputs and interfaces directly with 75-Ω cable on its output. And on top of all that it comes in a fully shielded package measuring only 2 by 3 by 0.35 inches.

"When this project finally gelled, we'd decided we didn't want to build just another high-speed d-a converter," comments Matthew Mahoney, group manager for a/d/a modular products. "We wanted a complete subsystem, instead." Most high-speed, or video, d-a converters have to be connected to a deglitcher to avoid sudden changes in the output signal caused by slight differences in the switching time of their current switches. But by carefully matching the switching times of its switches, the designers of the MP8308 have avoided the need for deglitching entirely, according to Mahoney.

The glitch-adjust terminal in the block diagram may suggest that glitch-free operation requires user trimming. Actually, the terminal may be left open provided the negative supply voltage is exactly -5.0 v. The terminal allows trimming of the delay of the most-significant-bit switch to accommodate voltages from -4.75 to -5.5 v.

No ringing. Interfacing a d-a converter to a 75-Ω transmission line usually necessitates the use of an output buffer amplifier with its related problems of overshoot, settling time, and ringing. The designers of the MP8308 cleverly avoided this problem by eliminating the

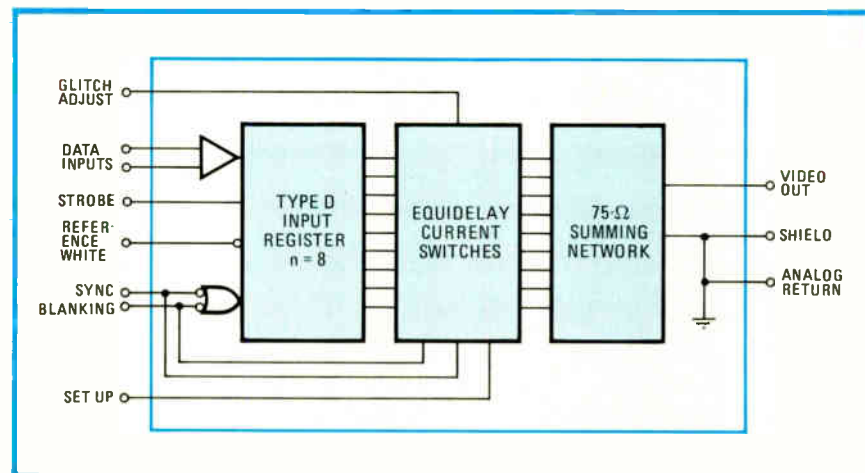

amplifier. Their R-2R resistive summing network has an impedance of 75-Ω all by itself, making extra matching circuitry unnecessary.

Adds Mahoney: "As a byproduct—because you're looking into a resistive network—the device is very flexible. It's very easy to add on other resistive levels. For example, you can make the signal brighter or darker with additional resistors." The output is compatible with EIA standards RS-170 and RS-343A and will drive high-resolution monitors directly.

Two versions of the converter are offered: the 100-MHz unit, whose data inputs must be driven by emitter-coupled logic, and a transistor-transistor-logic unit with a maximum update rate of 40 MHz. Both versions contain eight ECL type D flip-flops, but the TTL device includes TTL-ECL translators in its input data lines. Both units use TTL control signals; the ECL version requires ECL signals only on its input data lines.

Both converters require nominal

power supplies of ± 5 v. The ± 5 -v supply can vary by 5% from nominal and must be capable of delivering 25 mA for the ECL converter and 50 mA for the TTL. The -5-v supply may vary from -4.75 to -5.5 v and must supply 300 mA to the 100-MHz converter and 400 mA to the 40-MHz device.

The MP8308 has a full-step settling time, to within one least significant bit, of 7.5 ns, typical. Rise and fall times (10% to 90%) are a maximum of 4 ns, but typically 3 ns. Operating temperature range is 0° to 55°C.

The device will be used mainly in graphic display systems of the raster-scan Z-axis-modulation type. For multicolor displays, multiple converters can be used.

The \$85 price applies to the ECL unit. The TTL version sells for \$89. Production quantities are expected to be available in October, according to the company.

Analogic Corp., Audubon Road, Wakefield, Mass. 01880. Phone Dick Ferrero at (617) 246-0300 [338]

New products

Packaging & production

System performs complete tests

Combined analog and digital unit does both in-circuit and functional testing

Electronics manufacturers can reduce warranty and manufacturing costs, increase productivity, and reduce excess inventory by exploiting the capability of the 3060A board test system. It can perform both advanced in-circuit component measurements and board-level functional stimulus-response tests. This improvement in testing efficiency not only allows the checking of boards to a high confidence level in a single operation, it also minimizes board handling and eliminates the need for two separate test systems.

Moreover the functional testing provided by the 3060A is not only digital. The system can check out a digital-to-analog converter as easily as it can a board full of straight transistor-transistor logic.

Functional tests are performed using the same bed-of-nails fixture used for in-circuit component test-

ing, so they are greatly simplified and speeded up. The response of internal circuit nodes is available, eliminating the guided probe.

Testing with the 3060A follows a logical sequence, which minimizes both the stress placed on the board and the testing time. First, in-circuit testing verifies that discrete components, such as diodes and resistors, are correctly loaded and are within specified tolerances. Accurate in-circuit tests are not possible without isolation of each tested part from the effects of parallel components.

To do this, the 3060A uses the simple guarding found in other systems, extended guarding to remove the effects of lead length and relay contact resistance, and accuracy enhancement to remove the effects of scanner thermal offsets. Phase-synchronous detection also enhances measurement capability by separating the impedance contributions of parallel resistive and reactive elements.

The 3060A has two separate digital testing modes: static pattern testing and dynamic signature analysis. Static pattern testing is best for combined digital and analog circuits, such as the d-a converter.

Signature analysis adds the capability of testing large-scale integrated circuits, including microprocessors, at full operating speed (up to

10 MHz). In addition, a portable HP 5004A signature analyzer can be used to troubleshoot these same boards when the product requires service in the field.

To eliminate programming problems—often the most troublesome part of an automatic test system—HP uses High-Level Programming Language (HPL), which provides immediate feedback when errors occur. It also allows on-line editing to reduce programming time.

The system software package also includes a special Board Test Language (BTL) and an in-circuit program generator (IPG). IPG automatically generates the in-circuit portion of the program, prints out the finished program in BTL, and generates a fixturing map for faster programming.

The U.S. price for the 3060A starts at \$74,000. Deliveries will begin in September.

Hewlett-Packard Co., 1507 Page Mill Rd., Palo Alto, Calif. 94304 [391]

Tape takes bumps out of wafer preparation

Automated production of integrated circuits has involved the use of microinterconnect tapes or film carriers for some time [*Electronics*, Dec. 25, 1975, p. 61]. But the process has until now required an extra wafer-processing step before the tape and the chip could be joined; a metal bump had to be added at the interconnect point to prevent the pad from collapsing when normal thermocompression or alloy-type bonding was used.

This step, which added to produc-

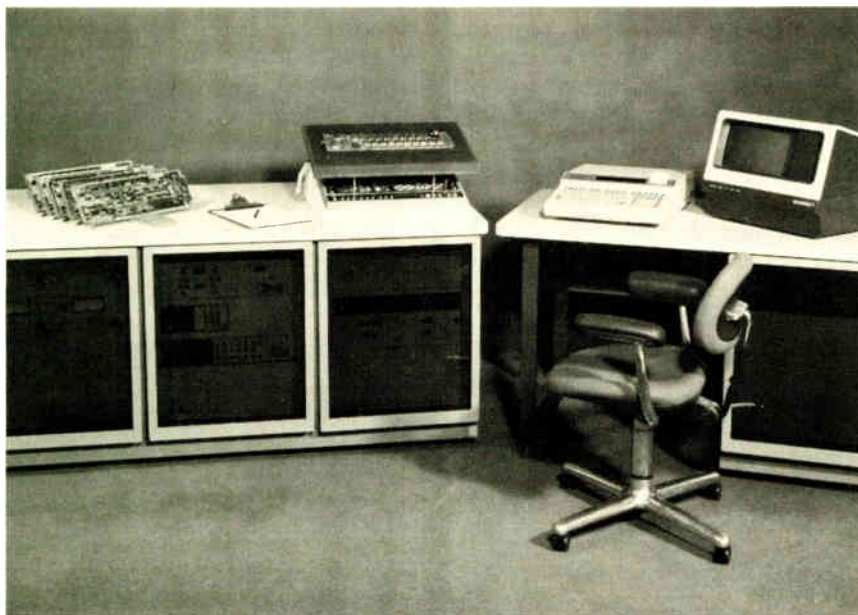

tion costs and reduced chip yield, can now be eliminated by using an 11-mm microinterconnect tape. The tape has a 1.3-mil-high bump etched on the tip of each 1.3-mil-thick lead. A few mils from the bump, the lead is thickened to 2.6 mils to improve lead rigidity.

The 2-oz single-layer copper tapes are supplied on reels and are at present available either bare or gold- or nickel-plated, to complement the metallurgy used in wafer manufacture. For unplated 11-mm, nontestable bumped tape, large-quantity orders result in a price of less than 1 cent per unit for a standard pitch. Making tapes from purchaser's artwork takes about five weeks.

Dyna-craft Inc., a division of National Semiconductor Corp., 2900 Semiconductor Dr., Santa Clara, Calif. 95051. Phone Dick Presby at (408) 739-6321 [393]

Card specified by user probes ICs on film carriers

A probe card developed by Probe-Rite permits automatic testing of integrated circuits on continuous film carriers. Testing does not damage the film substrate. The card can be used with standard or specially designed probing equipment and has gold-plated probes.

Cards are configured to the user's specification and are identified according to the chip for which each is intended.

Prices for the cards begin at \$60 and are available two weeks after receipt of order.

Probe-Rite Inc., 2725 Lafayette St., Santa Clara, Calif. 95050. Phone (408) 249-1255 [395]

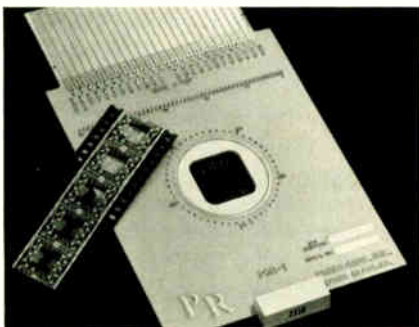

STOP TRANSIENT NOISE

ELIMINATE ERRORS IN YOUR COMPUTER OR INSTRUMENT SYSTEM



DELTEC DT series isolation transformers drastically reduce memory and transmission errors caused by transient noise on commercial power lines. Common Mode Rejection is 140dB and interwinding capacitance is less than 1 femtofarad (0.001 pf). Stock models are available from 250 VA to 5 KVA 1 ϕ and 3 ϕ , 50/60Hz. For detailed specifications write or call:

AC POWER HANDBOOK

... gives you hard answers on how to solve AC Power problems. Now available at our cost of \$3.00. Write or call for a copy.

DELTEC

CORPORATION
980 Buenos Ave., San Diego, CA 92110
Telephone (714) 275-1331

Circle 127 on reader service card

The magazine you're reading now, could be your own.

Drop off the routing list. Get your own fresh, unclipped copy mailed to your home or office. Turn to the subscription card in the back of the magazine. If somebody has beat you to it, write: Electronics, P.O. Box 430, Hightstown, N.J. 08520.

Microcomputers & systems

Unit controls communications

Single-board computer
frees system bus from
long-winded conversations

Hanging more processors onto a microcomputer-based system may add some computing power, but it often yields headaches as well. The reason: it's hard to get the microprocessors to talk to each other, and when they do, they take up valuable time on the system bus. Now, Intel Corp. is about to announce a new single-board computer that not only solves those problems but can function as either an off-bus processor for communications slaved to one or more master processors or as a stand-alone communications controller.

"You can look at it two ways, as an intelligent slave or as a single-board computer with I/O on it," declares Gary G. Sawyer, SBC 80 product manager, OEM Microcomputer Systems division, Aloha, Ore. Called the iSBC 544, the single-board computer employs a dual-port random-access memory of 16,384 bytes and a three-bus architecture, which it shares with the newly introduced 80/30 single-board microcom-

puter. Together, these two features mean that the 544 performs all of its processing of communications traffic off the system bus, so that "it doesn't occupy system time," according to Craig Kinnie, project manager for board products.

The buses are the dedicated processor bus with its own input/output and read-only-memory and programmable ROM section, the system bus, and the dual-port bus for access to the 16 kilobytes of RAM. The dual-port bus is governed by an "arbiter" circuit "which determines which of the first two can access the dual-port bus," Kinnie explains.

The significance of the 544 is that "for the first time a user has intelligence built into a slave device," declares Sawyer. "He now has the capability to offload a bus master to perform communications activities locally on the board." He adds that the 16 kilobytes of dual-port RAM "minimizes the need for dedicated RAM boards."

Kinnie emphasizes the functional density of the 544, noting that it packs "a lot of power in one card" measuring 6.75 by 12 inches. Powering the SBC is a 2.6-MHz version of Intel's popular 8085A 8-bit microprocessor. The communications board contains four programmable synchronous or asynchronous serial channels, capacity for up to four kilobytes of PROM or eight kilobytes of ROM, four programmable baud rate generators, three interval timers a programmable interrupt control, a

10-bit input/output interface compatible with a Bell 801 automatic calling unit, and an interface control for auto-answer/auto-originate modems.

Specifications seem powerful, too. Sawyer says that the processor speed is 1.45 μ s for the fastest executable instruction, which is the way Intel specifies its single-board computers. The synchronous baud rate ranges from 4.8 kHz to 56 kHz, and the asynchronous baud rate ranges from 75 Hz to 19.2 kHz. Temperature range is 0° to 55°C, and the unit requires power supplies of +5 and -12 v dc.

As an intelligent slave, the 544 could be used as a front-end processor or terminal multiplexer in a system controller, perhaps by the 80/30 microcomputer board. The 544 would handle the communications chores such as format control, code conversion, data-link control, error checking, data compression, and protocol management without bothering a bus master such as the 80/30 or disturbing the system bus. In its stand-alone mode, it may act as an intelligent terminal controller, connecting one or more dumb terminals to a data link and providing the required buffering, code conversion, and data link control functions.

The 544 is expected out later in August. For pricing information, contact local Intel sales office.

Intel Corp., OEM Microcomputer Systems Division, 3065 Bowers Ave., Santa Clara, Calif. 95051 [371]

Single-board display
has control system, too

The first members of a family of low-cost, self-contained alphanumeric display subsystems, the MTX-A2 and MTX-B2, are based on an intelligent single chip that controls both display and keyboard functions. Known as the alpha chip, it permits the complete display subsystem, including the controller, display drivers, and alphanumeric light-emitting-diode displays, to be contained on a single printed-circuit board

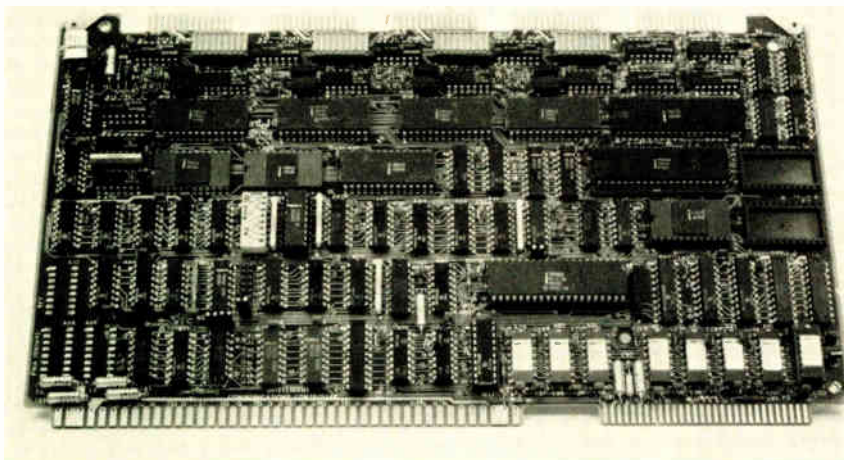

that measures 8 by 3.25 inches.

The MTX display boards interface directly with an 8-bit bidirectional data bus or input/output port, so they can be directly connected to microprocessors such as the 8080A and the 6800. The MTX-A2's display consists of 16 five-by-seven-dot-matrix LEDs that are 0.3 in. high, whereas the MTX-B2 uses the two 16-character rows of 14-segment, 0.5-in.-high LEDs for its display.

The on-board alpha chip offers 22 commands for display manipulation, including clear-display, blink, shift, rotate, and cursor manipulation commands. It can control scanning and debouncing of up to 64 keys.

Each display requires a single 5-v, 800-mA power supply. The column-driver voltage can be varied between 2 and 6 v to change the display intensity or to decrease power consumption.

All mounting hardware and a red filter are included with the single-board units. Prices begin at \$280 for a single 16-character display, and quantity discounts are available. Delivery time is two to four weeks.

Matrox Electronic Systems Ltd., P. O. Box 56, Ahuntsic Sta., Montreal, Que. H3L 3N5. Phone (514) 481-6838 [373]

Operating system helps clean out bugs

The Micromonitor operating system CDP18S831, tidily known as MOPS, is a software package of enhanced debugging techniques ranging from simple terminal-Micromonitor dialog to hands-off system testing for users of the Cosmac Micromonitor CDP18S030. The Micromonitor is a self-contained debugging tool usable with any system based on the CDP1802 microprocessor. It permits real-time, in-circuit debugging of hardware and software problems.

MOPS adds to the performance of the Micromonitor by allowing users access to the processing and storage capabilities of a Cosmac development system II equipped with a floppy-disk drive. The software package consists of a diskette, a universal



asynchronous receiver/transmitter module, connecting cable, and a user's guide with several examples of MOPS application. In single quantities, it is priced at \$350 in the U. S.

RCA Solid State Division, P. O. Box 3200, Somerville, N. J. 08876. Phone (201) 685-6380 [374]

Software for 6500 family debugs at assembly level

A stand-alone debugging system for the 6500 microprocessor family, the DB/65 comes with a programmable read-only memory in which its monitor program resides, 2 kilobits of random-access memory, and an emulation cable. Sockets are provided for adding 6 kilobits of RAM.

With the PROM-resident monitor, users may examine and modify memory and registers, set breakpoints, load memory, trace history by exercising a single instruction at a time, and write memory-protection blocks by keeping the write line high.

The system also features automatic symbolic disassembly that, after a user-program halt, displays the next instruction in assembly language with symbols inserted for the label and operand fields. Thus, the programmer can debug the system at the same level at which it was created.

The DB/65 may be loaded from a System 65 or similar system via the parallel input port—a 4-k program can be loaded in about 5 seconds—or from the serial port.

It is priced at \$1,450, with delivery from stock to 60 days. Purchasers must specify the type of system, available RAM, and starting address.

Computer Applications Corp., 413 Kellogg, Ames, Iowa 50010. Phone (515) 232-8181 [375]

Current Record Holder In Relays: Electrodyne

Consumes only
50
milliwatts



Don't be fooled by others' claims of low relay power consumption. The world record holders are Electrodyne's family of sensitive relays. These double-pole, double-throw relays fill the gap that formerly existed between non-sealed, space-wasting general purpose relays and expensive militarized relays... and use a fraction of the power. An Electrodyne electromechanical relay incorporates features such as a new, efficient magnetic circuit, a gold alloy contact system and all-welded internal construction. (U.S. Pat. #3906416)

Four basic types of relays come with a variety of coil ratings and features:

- Type 10 Series, DPDT, Sensitive
- Type 11 Series, SPDT, Sensitive
- Type 15 Series, DPDT Magnetic Latch, Dual Coil
- Type 18 Series, 2-SPDT Relays, Dual Coil, Sensitive (Exclusive "OR" function)

All come in "DIP" environmentally-sealed packages and may be direct driven from CMOS circuits (4049 hex buffer). Available with internal suppression diodes.

Applications include interfaces with TTL and CMOS logic and power circuits, telecommunication-loop sensors, trans-receivers, attenuators and test equipment.

For complete information, contact Electrodyne, the people who pioneered the first balanced armature electromechanical "DIP" relay.

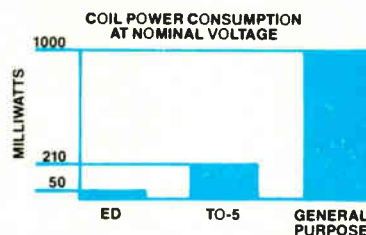

ELECTRODYNE, INC.

11200 S. E. 21st Street,
Milwaukie, Oregon 97222,
Phone (503) 654-0711

“All we got for our connector dollar were connectors.

Until we used AMP Latch—and AMP”

Too many times you may select a connector that does the job—but that’s all it does. You can’t expand with it. With AMP Latch connectors we make sure that won’t happen.

The complete approach. Every AMP Latch connector is designed as part of a larger approach to packaging. For example, AMP Latch is available in cable-to-cable, edge card, DIP and receptacle connectors. And it works with twisted pair cable, round conductor ribbon cable and round conductor bonded cable. In addition, it mates with the full range of AMPMODU headers including standard right angle and feed-thru types, as well as header barriers for mixing a variety of connector families.

The quality approach. AMP Latch connectors are built to meet extra-ordinary requirements. They incorporate extra features such as redundant, duplex-plated contacts and heavy-duty strain relief covers for reliable electrical and mechanical performance. Polarization and positive latching assure accurate mating to headers. They have built-in inspection ports to facilitate inspection, test and repair. And they are quickly terminated by AMP Latch tooling so you have the capability of using virtually all popular types of round conductor flexible cable as efficiently as possible.

The AMP approach. Of course, AMP Latch connectors, and all AMP products, are backed by AMP technical service. Not just ordinary service, but the kind that says we’ll help you with system design. Application tooling. Training your people. And more.

We invite you to find out more about AMP Latch and the AMP approach. Just call Customer Service at (717) 564-0100. Or write AMP Incorporated, Harrisburg, PA 17105.

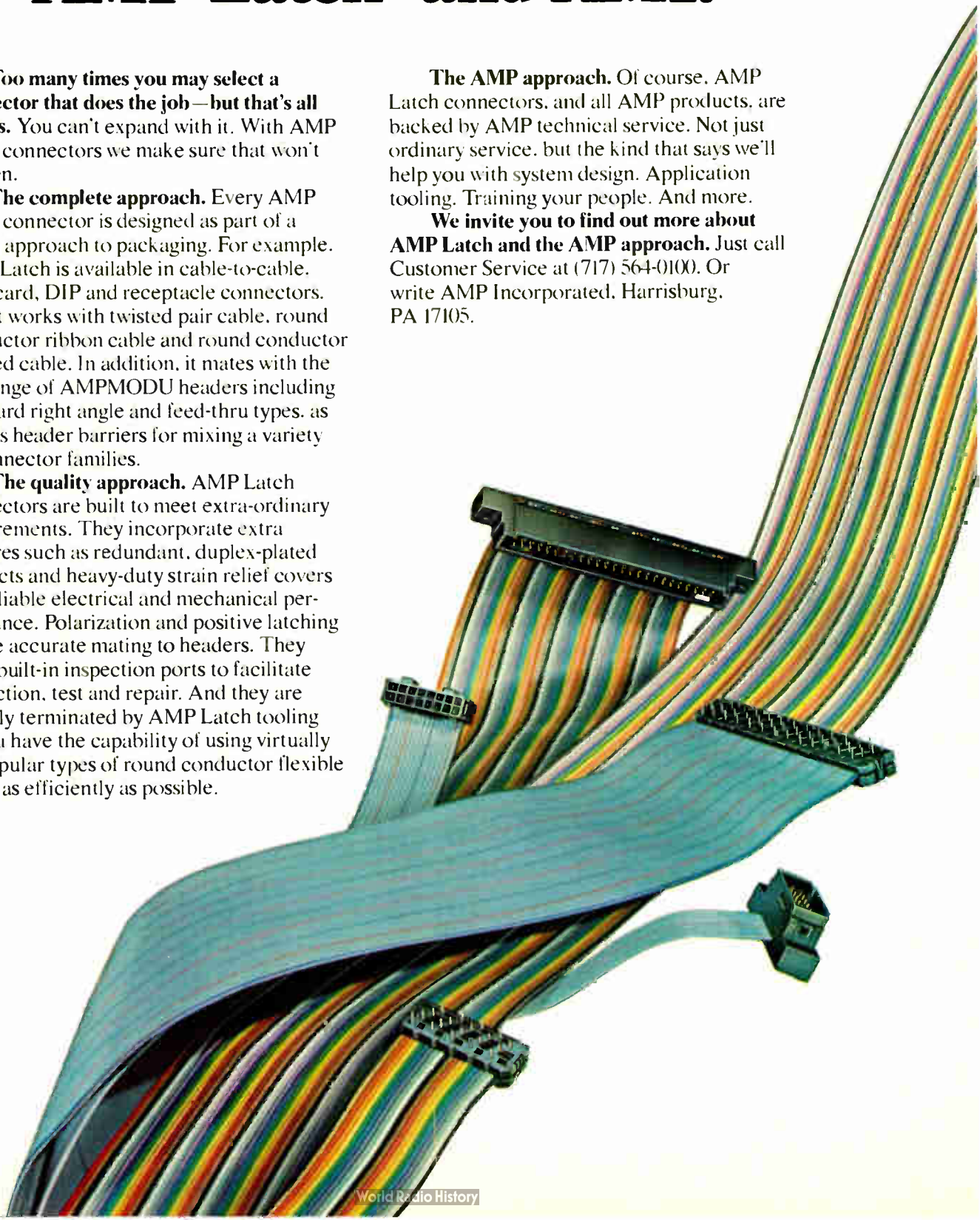

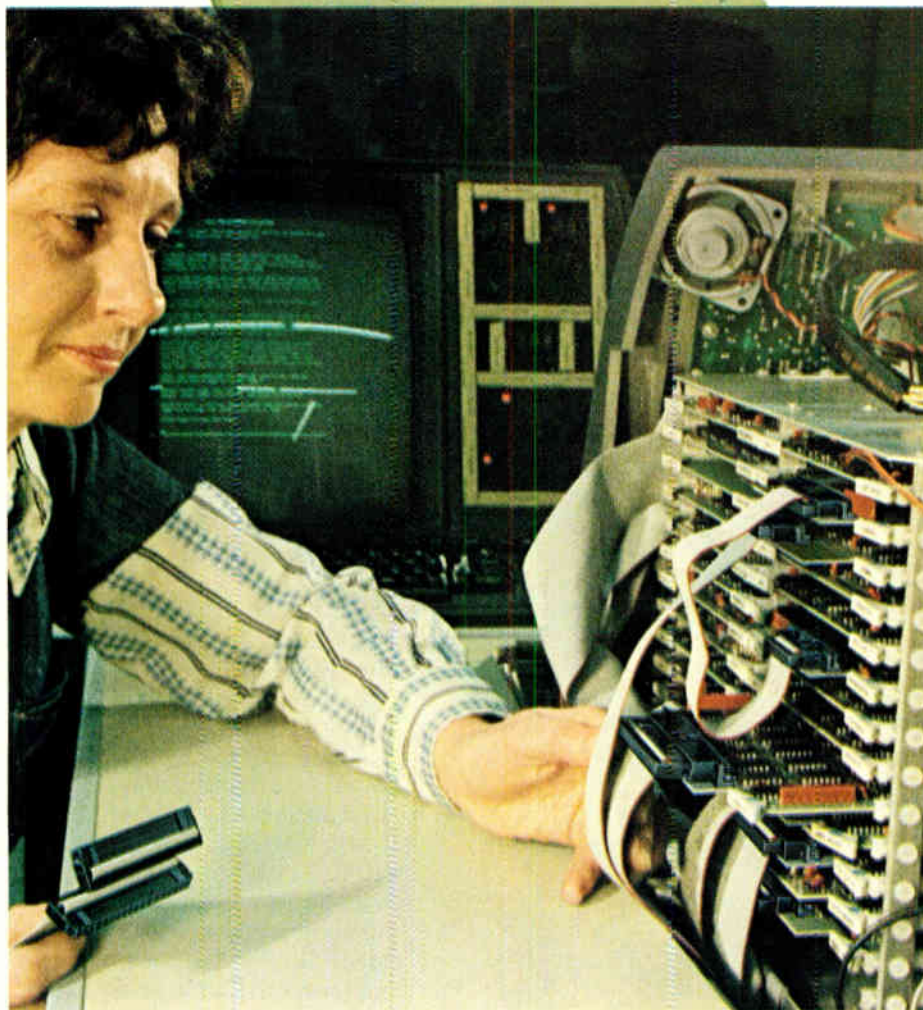
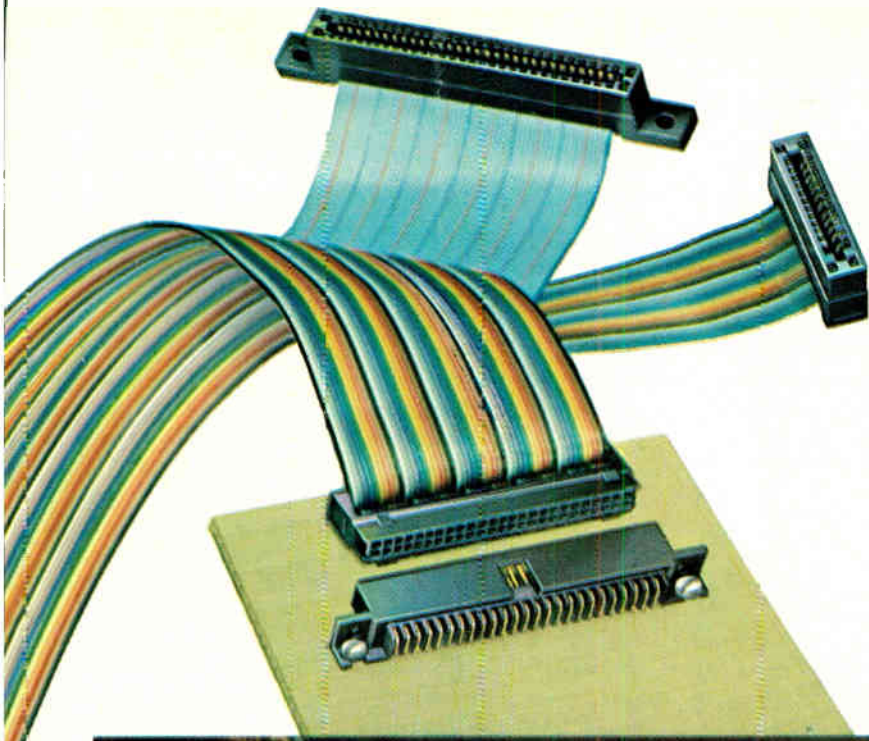

AMP has a better way... Mass Termination.

AMP pioneered the concept and today is the acknowledged leader with the industry's widest range of application experience.

We have mass termination connectors for discrete wire and virtually any type of cable: ribbon coaxial, flat etched, twisted pair, round conductor, flat flexible. All have preassembled contacts, eliminate costly wire preparation and offer productivity savings and benefits never before possible. If you would like details on any of our Mass Termination ideas, call Customer Service at (717) 564-0100.

AMP and AMPMODU are trademarks of AMP Incorporated.

AMP

INCORPORATED

Circle 131 on reader service card

New products

Instruments

Meter measures up to 1 farad

Battery-powered 10-range instrument resolves 0.1 pF; sells for \$120

Designers and field-service personnel to whom low cost is more important than programmability or other special features will appreciate the model 820 digital capacitance meter. Priced at only \$120, the four-digit instrument has 10 ranges, from 999.9 pF to 999.9 mF. Its maximum error is 0.5% of full scale plus one count up to 100 μ F, increasing to 1.0% of full scale plus one count from 1 mF to 1 F.

Weighing only 1.51 lb complete with four standard C cells, the 820 is as useful in the field as it is in the laboratory. Although it is not a precision instrument, its measurement uncertainty is much less than the tolerance of most capacitors. It is therefore useful for matching capacitors in critical applications, spot checking for quality assurance, mea-

suring the capacitance of complex series-parallel networks, and simply identifying unmarked components.

A pair of front-panel lead-insertion jacks makes possible fast in-out testing of small components. For connection to large capacitors or circuits, there is also a pair of standard banana jacks.

Readings on the four-digit light-emitting-diode display stabilize within 300 ms for capacitance values up to 1,000 μ F; above that value, the required time increases to a maximum of 35 s at 1 F.

Available accessories include a rechargeable battery pack, a charger, and a carrying case.

B&K Precision, 6460 West Cortland Ave., Chicago, Ill. 60635. Phone (312) 889-9087 [351]

3 $\frac{1}{2}$ -digit multimeter spans 50 kHz, resolves 10 μ V

Although it sells for only \$365, the model 3030A multimeter is a 3 $\frac{1}{2}$ -digit instrument that offers such unusual features as true-rms measurements out to 50 kHz, resolutions of 10 μ V, 10 nA, and 10 m Ω , and direct readout in decibels. The 3.5-lb portable instrument measures ac and

dc voltage, ac and dc current, and resistance. Its ac capabilities, however, are what really set the 3030A apart from the pack.

The meter has four ac modes—average, peak, rms, and decibel. A front-panel control allows the user to set the decibel reference level. Frequency response in the average mode extends from 50 Hz to 110 kHz; for peak readings, it goes from 20 Hz to 20 kHz; and for rms measurements, it covers 20 Hz to 50 kHz. Maximum crest factor for full-scale inputs in the rms mode is 3 over the full frequency range.

Both ac and dc voltage functions are served by six ranges, from 20 mV full scale to 1,200 V. Similarly, there are six current ranges, from 20 μ A full scale to 2 A. The seven resistance ranges are broken into two overlapping groups: the low scales, which go from 20 Ω full scale to 2 M Ω , use an excitation voltage of 200 mV; the high ranges (2 k Ω to 20 M Ω) use 2 V. The benefit is easy in-circuit measurements on diodes and transistors. Available options include a \$45 internal rechargeable battery pack. Ballantine Laboratories Inc., P. O. Box 97, Boonton, N. J. 07005. Phone (201) 335-0900 [354]

High-speed unit analyzes five logic families

The Scanmaster 5700B is a high-speed logic analyzer for in-circuit troubleshooting of 14- and 16-pin digital integrated circuits. Users can select the appropriate high and low threshold levels for any of these logic families: complementary-metal-oxide-semiconductor (5, 10, 12, and 15 V), high-threshold, resistor-transistor, transistor-transistor, and diode-transistor logic.

Two operating modes are provided. In the fast-scan mode, the unit checks the threshold status of each pin in sequence, stopping only when a particular pin's logic level is out of tolerance. If that should occur, the pin number and logic condition are displayed; also, use of a hand-held probe enables the logic



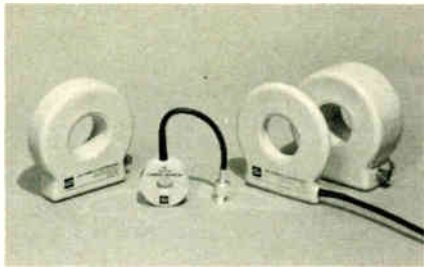

CURRENT MONITORS

With our monitor and your oscilloscope, read fast pulsed currents (nsec to millisec) of any conductor. Prices range from \$66 to \$286 for standard, in-stock models. Sensitivities from 1 V/A to .01 V/A; no physical connection required; readings without ground loops; BNC standard; specials upon request.

For further information write or call: Ion Physics Company, P.O. Box 416, Burlington, Mass. 01803. Tel. 617-272-2800.



ION PHYSICS COMPANY
A DIVISION OF HIGH VOLTAGE ENGINEERING CORPORATION

Circle 179 on reader service card

New products

level to be displayed by an on-panel digital voltmeter. If no level fault is detected, the scan cycles to the last pin, and light-emitting diodes display the logic status of each. The manual mode allows each pin to be checked individually.

The probe may also be used as a pulser to inject a signal of appropriate amplitude and width, and the analyzer can be used with an oscilloscope or recorder to further display or retain data. In addition, static or dynamic failures can be stored in the unit's memory.

Priced at \$1,295, the 5700B is deliverable in 30 days.

Information Scan Technology, 1725 Rogers Ave., San Jose, Calif. 95112. Phone Tony Lee at (408) 292-7196 [355]

4 1/2-digit panel meter
offers BCD output option

A 4 1/2-digit panel instrument with 100- or 10- μ v sensitivity, the AN2574 can be optionally configured with a word-programmable, three-state output in binary-coded decimals that lets it converse with, say, a microprocessor. Its data can be multiplexed onto a single set of data bus lines in 4-, 8-, 12-, 16-, or 20-bit words, along with information from other units.

The unit features 1,000-M Ω differential input impedance, autozero, and autopolarity. Capable of a $\pm 20,000$ count, it has a resolution of within 0.005% and an accuracy of within 0.01% of the reading ± 1 digit. When operating from either 110- or 220-v ac lines, it has a ground-to-line isolation of 1,400 v.

In quantities of 100 or more, individual AN2574s cost \$99.

Analogic Corp., Audubon Road., Wakefield, Mass. 01880. Phone (617) 246-0300 [356]



A GOOD MARRIAGE . . .



. . . REQUIRES COMPATIBILITY

Steel has many good features . . . including compatibility with glazed porcelain coatings.

TFS products have many good features . . . including compatibility with glazed porcelain coatings.

Nothing very new but the marriage is perfect.

SCREEN PRINTABLE THICK FILM PASTES

developed 3 years ago for use on glass have found the perfect partner with porcelainized steel.

600 SERIES RESISTORS

Resistivity: 100 to 1,000,000 ohms/sq.
TCR: 0 to ± 200 ppm/ $^{\circ}$ C

COMPATIBLE CONDUCTORS

3045 Gold 3347 Silver
3106 Platinum-Gold
3404 Palladium-Silver
3408 Palladium-Silver
3535 Platinum-Palladium-Silver

DIELECTRICS

1126 White-opaque multilayer
1126 RCB Black multilayer
1141 Resistor overglaze

FEATURES:

- Complete system firing at 600 $^{\circ}$ C
- TFS FAST FIRE 25 minute cycle
- Solderable and bondable conductors
- All Pastes Contain PARTILOK[®]
- No jar rolling, no stirring and indefinite shelf life when packaged in syringes.
- Compatibility



for full
information contact
THE PASTEMAKER

THICK FILM SYSTEMS, INC.

324 PALM AVE., SANTA BARBARA, CA. 93101
TEL (805) 963-7757

From Electronics Magazine Book Series. Zero-risk trial offer.

New Product Trends in Electronics, Number One

From "New Products," state-of-the-art materials and equipment, arranged according to function. \$14.95

Electronics Book Series

P.O. Box 669, Hightstown, N.J. 08520

Send me _____ copies of "New Product Trends in Electronics, Number One" at \$14.95 per copy

Discounts of 40% on orders of 10 or more copies. I must be fully satisfied or you will refund full payment if the book is returned after ten-day trial examination.

Payment enclosed Bill firm Bill me

Charge to my credit card:

American Express Diners Club
 Visa Master Charge

Acc't No. _____ Date exp. _____

On Master Charge only,
first numbers above name _____

Name _____ Title _____

Company _____

Street _____

City _____ State _____ Zip _____

Signature _____

World's most popular —



SINGLE PLATE Ceramic Capacitors



Temperature Compensating Stable and General Purpose

ERIE Red Cap "Weecon®" Ceramic Capacitors long have been the standard of the industry, offering the broadest selection of ceramic formulations available.

Additionally, the Red Cap Weecon line is available in a wide variety of package sizes. This all adds up to the most comprehensive capability in miniature ceramic capacitors in the industry.

So specify ERIE Red Cap single plate Ceramic Capacitors. For even higher capacitance values, ERIE Red Cap Monoblocs® are preferred by design engineers.

- Capacitance range 1 pF. thru .039 μ F.
- 25, 50, 100, 200, 500 Volts
- Wide range of TC materials and tolerances
- Delivery to meet your needs

Write for catalog 8100.

ERIE

ERIE TECHNOLOGICAL PRODUCTS, INC.
State College, Pa. 16802
814-237-1431

New products

Components

Touch switches behave better

Keyboard and position sensor designed for the ungrounded and the "hard-of-touching"

After three years of intensive research, Touch Activated Switch Arrays Inc. has triumphed with a \$49 solid-state keyboard and a touch-activated solid-state control module called the Ferenstat. Both new products feature the company's pioneering micro-proximity touch-sensor technology.

Touch-activated switches are currently found in elevators, point-of-sale terminals, and a variety of control panels. But they are often unreliable. Many will not switch on unless the operator is electrically near ground. Others have been damaged by users pushing them too hard. Still others may react when it is an adjacent switch that has been touched.

In the Ferenstat's touch-activated array, "the sensors are $\frac{1}{16}$ inch apart," says Ferenc Ledniczki, TASA president. "Yet there's no interaction problem and the user can be floating in space but still activate the switch." Both the Ferenstat and keyboard are sealed and covered

with a durable, polycarbonate plastic, so that "even ham-fisted button pushers can't damage them," Ledniczki quips.

A Ferenstat module converts finger motion along its 7-inch sensor surface into a series of logic-state changes, or counts, proportional to how far the finger has traveled and in which direction—up or down. It is a way to convert the human hand's motion into a digital format for use by a computer or process controller, for example.

The Ferenstat's designers arranged its 105 touch sensors so that they are in seven successive groups of 15 sensors each. Individual sensors from each group are connected in parallel to form 15 parallel output lines. These, in turn, form the input to a parallel-load shift register that outputs parallel data to a pattern-comparison motion detector, and the same data in serial form to a serial-load shift register.

To accept the data from the parallel-load register, the serial-load register must load its contents from a previous transfer into the motion detector, where it is compared with that of the parallel-load register. Thus, outputs from the parallel-load register indicate present position pattern and those from the serial-load register, the previous position pattern.

At the outset, with no finger on the surface, the outputs of the present and previous position registers are all in a low state. When a user



places his finger anywhere on the surface, some of the sensors in one or two of the seven groups will change to a high state, but if the finger does not move, this new pattern will not be shifted to the parallel outputs of the present-position register.

With the finger in motion, however, shifting will take place, and the comparison circuitry will see a difference between the inputs from the present- and the previous-position registers. The rate of the change and the order in which sensors are being activated determine the rate and count direction—up or down—of the Ferenstat's output.

The first 28-pin Ferenstat models will be available in sample quantities at the end of August; they are identical except for the output format. One will use a quadrature output like that of a shaft encoder, others will have a count output plus an up/down output pin. These samples will cost \$125, but Ledniczki believes prices could eventually fall to between \$5 and \$10 for large-volume orders.

TASA's touch-activated ASCII keyboard will also be available at the end of August, in sample quantities, for \$49, according to Ledniczki. Here, too, with large orders, keyboard prices may drop to below \$15, he says.

Unlike a push-button switch keyboard, there is absolutely no tactile feel with this keyboard. It would not be useful, therefore, for an electric typewriter, but Ledniczki feels that for data entry—where the user enters only one or two characters, looks up at the CRT screen, then enters a few more—this tactile lack is no handicap. In any case, there is no present technology that enables a push-button keyboard manufacturer to make as reliable a keyboard at as competitive a price. That fact, rather than the TASA keyboard's utility, is likely to generate interest, especially among the manufacturers and users of such equipment as home computer terminals.

Touch Activated Switch Arrays Inc., 2346 Walsh Ave., Santa Clara, Calif. 95050. Phone (408) 247-2301 [341]

For instrumentation amplifier programmable is a 4-bit word

The term "programmable" in programmable-gain instrumentation amplifiers is taking on a new meaning. Whereas it once referred exclusively to gain selectability obtained through external resistors, it is now beginning to mean the ability to control gain directly with a simple logic word.

The latest example of this linguistic switch is the 3606 instrumentation amplifier, which offers 11 binary gains from 1 to 1,024 selected by a 4-bit transistor-transistor-logic-level word. When used in a microprocessor-controlled data-acquisition system with a 10-bit analog-to-digital converter, a system resolution of 1 ppm is achievable.

As an instrumentation amplifier alone, the unit's specifications are very respectable. Maximum gain nonlinearity is 0.01% even at its highest gain, maximum gain error is 0.02%, and maximum gain drift is 10 ppm/°C. Common-mode rejection is a minimum of 110 dB, and input resistance is 10 GΩ.

For gains of 1 and 1,024, the maximum input offset voltages are 2 mV and 22 μV, respectively. Change in offset voltage is limited to a maximum of 25 mV for any gain change without external adjustment, but with two simple offset adjustments, the change is limited to 2 mV.

The amplifier is housed in a ceramic or metal 32-pin dual in-line package that measures only 1.75 by 1.15 by 0.23 in. For quantities of 100 and up, unit prices begin at \$51.50.

Burr-Brown Research Corp., P. O. Box 11400, International Airport Industrial Park, Tucson, Ariz. 85734. Phone Dennis Haynes at (602) 746-1111 [343]

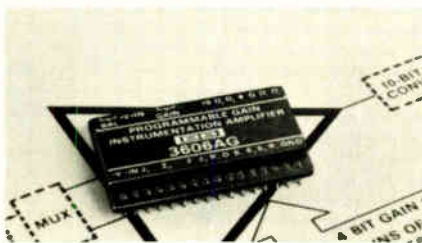

REDUCE CIRCUIT COSTS

3 WAYS

ERIE Tubular & Feed Thru Ceramic Capacitors

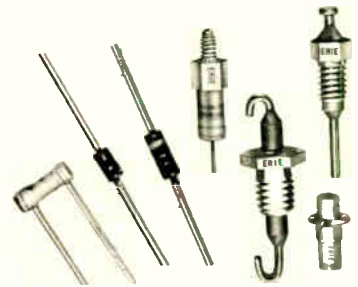

ERIE TUBULAR CAPACITORS

- Low cost
- Tubular shape is ideal for automatic insertion
- Low profile blends with high density packaging

ERIE Tubular Ceramic Capacitors are truly "a better way" to reduce circuit costs. In addition to these low cost, reliable capacitors, ERIE offers a broad range of Feed-Thru Ceramic Capacitors in mounting styles, capacitance ranges, TC types and voltages to suit any application.

These two ERIE-pioneered capacitor families are the finest quality in the industry. But then they should be, we've been building them for decades.

So check ERIE on your next capacitor buy. We probably have a standard design for your application.

Write for our new Fixed Capacitor catalog . . . or call 602-624-8231.

ERIE

ERIE TECHNOLOGICAL PRODUCTS, INC.
Erie, Pennsylvania 16501
602-624-8231

Data acquisition

Converter needs little power

12-bit hybrid d-a unit
with internal reference
consumes only 150 mW

In the hotly contested 12-bit digital-to-analog converter market, companies scrambling for position candidly admit engaging in product gamesmanship to seek an edge, if only for a few months until the competition comes up with a counterploit. The latest example is Beckman Instrument's complementary-metal-oxide-semiconductor 12-bit converters, which are low-power pin-for-pin replacements for what is probably the most popular d-a converter—Burr-Brown's DAC-80.

"There's no question the C-MOS converter has an advantage," claims Lyle F. Pittroff, who manages the Beckman Advanced Electro-Products division's hybrid microcircuit lines. "Our model 7580 uses only 150 mW typically, against 800 mW. For process-control uses, where the big market is, C-MOS can go to backup power, which is not possible with the DAC-80."

Two versions of the 7580 are offered: the 7580I current-output model and the 7580V voltage-output

unit, which includes an output buffer amplifier. Both units operate from ± 12 -v to ± 17 -v power supplies; neither requires +5 v or -5 v, thus providing isolation from the logic supply, according to Pittroff. Both models have an internal reference and both can be driven by either transistor-transistor or C-MOS logic.

The current-output 7580I has a typical settling time of 2 μ s, whereas the 7580V requires 25 μ s because of its buffer amplifier. Pittroff terms these times "ideal for most applications in industrial and process control, test instrumentation, machine control, and computer numerical controls." Only one such application, he says, needs a faster settling time than 25 μ s—driving the deflection circuitry of a cathode-ray-tube display, but this function seldom occurs in industrial systems.

To keep their power dissipation low, the new converters use a proprietary C-MOS switch design combined with a thin-film R-2R ladder network. The switches were used previously in two earlier d-a converters: the 7545 multiplying converter and the 7546, a general-purpose unit. When an ac signal is applied to their reference input, the new converters can operate as four-quadrant multipliers.

In industrial applications, Pittroff explains, linearity is the critical parameter. Nonlinearity should not exceed $\frac{1}{4}$ least significant bit, he says, for proper operation of feedback control systems. Typically,

both of his new units meet this requirement over the range from 0° to 70°C. Their guaranteed maximum nonlinearity is half an LSB. The units are also guaranteed to be monotonic over temperature. Power-supply rejection is within 0.002% of full scale/%v for both supplies. The offset is trimmed to less than 0.02%.

The 7580V is priced at \$15.90 each for 1,000 or more units, the 7580I at \$14.90. These prices, Pittroff says, are "competitive with [that of] the DAC-80, since our intent is not to bomb the price, but to offer improved performance." Delivery of either 7580 model is from stock to our weeks.

Beckman Instruments Inc., Technical Information Section, Advanced Electro-Products Division, 2500 Harbor Blvd., P. O. Box 3100, Fullerton, Calif. 92634. Phone (714) 691-0841 [381]

12-bit monolithic C-MOS d-a converter needs no trimming

In making precision digital-to-analog converters, be they hybrid or monolithic, manufacturers generally find it necessary to trim the units' resistor ladder networks to meet the converter accuracy and linearity specifications. How best to perform this adjustment—with zener zapping or laser trimming—is the subject of lively controversy in the industry. Proponents of each technique point out that the other has long-term stability problems.

The engineers at Micro Power Systems think that both sides may be right, so they have come up with a monolithic 12-bit converter that needs no trimming at all. The key to the operation of the complementary-metal-oxide-semiconductor circuit is a combination of highly uniform film deposition with special etching and contacting procedures. But "even with perfectly matched resistors, errors in the solid-state switches could ruin the linearity," explains John M. Caruso, project manager for the new model 7621. So his unit incorporates an improved switch design as well.

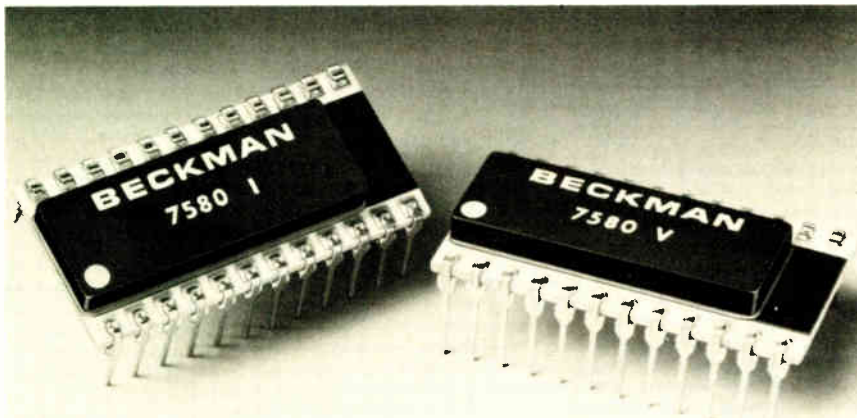

The resulting d-a converter is a current-output device with a settling time of about 2 μ s and a power consumption of 20 mw. Its full-scale drift temperature coefficient is no more than 2 ppm/ $^{\circ}$ C. These specifications are similar to those of competitive converters like Analog Devices' model 7541. The price of \$21 each for quantities of 100 or more is also similar.

The difference, if any, is in long-term stability. According to its detractors, laser trimming of resistor networks leads to long-term stability problems because the heat of the laser beam alters the composition of the material along the trimming path. Laser-trimming devotees point out that zener zapping—using junction shorting to adjust resistor values by removing individual resistive elements from series arrays—is subject to self-healing. When that happens, the junction short caused by the reverse-bias or zener-trimming technique becomes resistive with the passage of time.

Production of the new converters is scheduled for late September.

Micro Power Systems Inc., 3100 Alfred St., Santa Clara, Calif. 95050. Phone (408) 247-5350 [382]

Automatic a-d systems lets desktop unit do the thinking

The GMAD-3/HP-9825A analog-to-digital conversion system can interface with Hewlett-Packard's 9825A desktop computer to provide such automatic functions as gain control of any channel or group of channels, digital addressing of channels by the computer, repeat channel addressing for multisignal averaging and special functions, and timing control with verification of function. The system is available with 12-, 13-, 14-, or 15-bit resolution, has signal conversion errors as low as 0.01%, and provides a 20- μ s conversion time. With as many as 16 input channels, the system can be bought for less than \$19,000.

Preston Scientific Inc., 805 E. Cerritos Ave., Anaheim, Calif. 92805 [384]

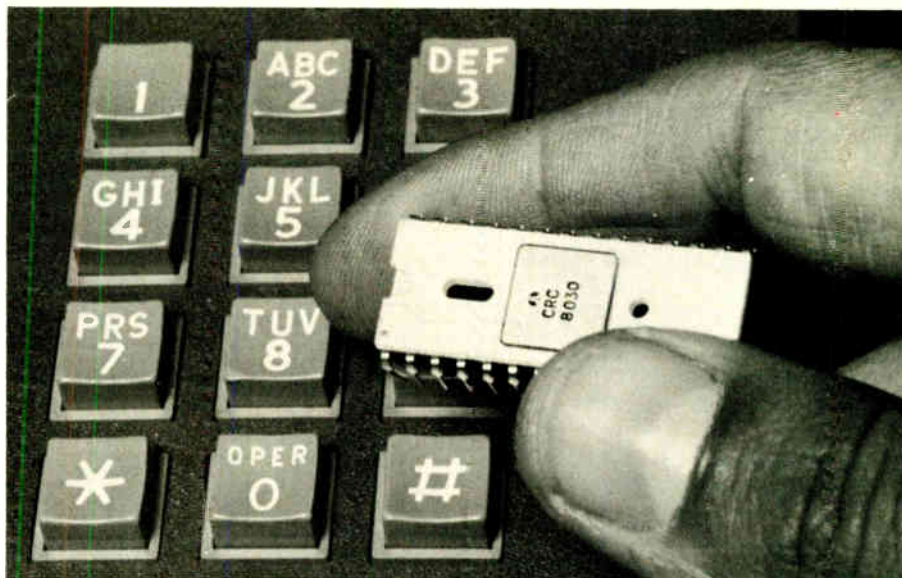

Rockwell MOS/LSI Touch Tone[®] detection can get you into more products.

CRC-8030, Rockwell's MOS/LSI digital Touch Tone[®] detector, can open up new markets for your products by providing a low cost, high performance solution for dual tone multi-frequency (DTMF) detection.

A product of Collins high-technology telecommunications experience coupled with Rockwell's extensive MOS/LSI production capability, CRC-8030 has been in quantity production for over a year. Besides traditional telephony systems, it can be used in a growing number of applications including computer signaling and control systems.

CRC-8030 reduces costs versus conventional systems (in some cases as much as one fifth the cost) and offers the size and reliability benefits of MOS/LSI. You get: detection in 22-39 MS; on-chip oscillator operating at 3.579545 MHz color burst crystal frequency; binary or 2-of-8 coded outputs; operation with single or dual power supply.

The CRC-8030 performs the key critical functions of DTMF detection. To implement a complete DTMF receiver, a number of front-end band-split filters are available. And, if you need DTMF-to-dial pulse conversion, use the CRC-8030 in conjunction with Rockwell's MOS/LSI Binary-to-Dial Pulse Dialer, the CRC-8001.

For more information on telecommunications devices and applications services, contact your nearest Hamilton/Avnet distributor. Or use the coupon below.

Touch Tone is a registered trademark of AT & T.

Get the full story.

E-8/3

Microelectronic Devices
Rockwell International
P.O. Box 3669, Anaheim, CA 92803
Attn: Marketing Services D/727 RC55 • (714) 632-3698

I want information on CRC-8030 CRC-8001
 Send it by mail Have a salesman call me.

Name _____ Title _____

Company _____

Address _____ City _____

State _____ Zip Code _____ Telephone _____



Rockwell International

...where science gets down to business

New products

Semiconductors

Fast rectifiers protect V-FETs

Ion-implanted devices block up to 100 V, recover in 20 ns

The advent of vertical-groove metal-oxide-semiconductor field-effect transistors as fast power-switching devices has raised an important design question: how does one cope with ever-present transient voltages that could damage the gates? The diodes that normally do this job are either too slow or, in the case of Schottky rectifiers, incapable of blocking more than about 40 v.

A solution offered by Solid State Devices is its HSR-2-52 series of ion-implanted rectifiers, which have a typical reverse-recovery time of 15 ns (20 ns maximum) and blocking-voltage ratings from 20 to 100 v dc. "We see their use as gate clamps as a significant market," says Arnold N. Applebaum, president. "In such applications, where FETs are being contemplated for phased-array antennas, several thousand of them will be needed." The key requirement in this sort of application is for the rectifier to be faster than the device it is protecting.

But protection isn't the only application Applebaum envisions for the miniature 6-A devices. They can be useful wherever the intent is to speed transistor switching. Inverter power supplies are a major possibility, he says.

Manufactured with the company's patented Epion ion-implantation process, the rectifiers are packaged in modified TO-18 transistor cases with a diameter of 0.23 in. and a height of 0.15 in. Key specifications include a maximum forward-voltage drop of 825 mv at a junction temperature of 100°C and a maximum reverse leakage current of 20 μ A. In comparison, Applebaum says, conventional high-speed rectifiers have

typical reverse-recovery times of 30 to 50 ns and forward drops of about 1 v. Reverse leakage current is typically about the same.

Another important feature of the new rectifier series is its inherent radiation resistance. This results from the low minority-carrier lifetime, which in turn is a consequence of the units' narrow junction width of less than 1 μ m. Moreover, the small size of the rectifiers—70 mils square—also contributes to radiation tolerance, the company says.

As with most high-power-density devices, the secret behind the performance is in the packaging. As Applebaum explains, the dice in the HSR-2-52 series are eutectically bonded to the modified TO-18 case, which, along with one lead, serves as a high-current anode. Then the other two leads, normally attached to the emitter and the base of a transistor, are ultrasonically bonded in parallel to the chip with 10-mil wires; together they constitute the cathode. The resulting large contact areas contribute to the low forward-voltage drop. The entire diode is hermetically sealed.

The series consists of seven devices with maximum repetitive reverse voltages from 20 to 100 v and maximum rms voltages from 15 to 70 v. For all seven units, the average half-wave rectified current rating is 6 A, with nonrepetitive surges to 125 A. Operating temperature range is -55° to +175°C.

Production of the new diodes is particularly suitable for highly automated techniques, and the company expects to be turning out large quantities. Present prices, for lots of 100 to 999 pieces, begin at \$1.90. Delivery time is four weeks.

Solid State Devices Inc., 14830 Valley View Ave., La Mirada, Calif. 90638. Phone (213) 921-9660 [411]

Inexpensive triacs block up to 600 V

To increase production speed for appliances and industrial goods while reducing their assembly costs,

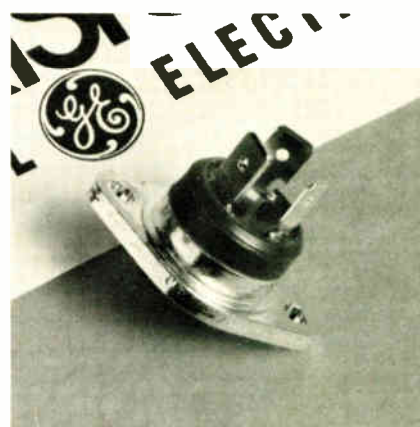

the manufacturer of the SC160 triac has packaged the thyristor in a cleverly modified TO-3 case. With its electrically isolated package, the unit can be directly riveted or screwed onto a heat sink without extra insulation. Furthermore, the device provides "fast-on" terminals that accept slip-on connectors, eliminating the need for soldered connections.

Dubbed the Econopower, the SC160 responds to a need for a low-cost ac power control unit in a mechanically rugged package. It is fabricated using a glass-passivated pellet to provide low leakage and stable blocking life. The pellet subassembly, with copper metallization directly bonded by a patented process, is encapsulated with epoxy to ensure ruggedness.

The unit is rated for a current of 25 A rms and voltages as high as 600 v. In quantities of 10,000 or more, individual SC160s cost \$2.78.

General Electric Co., Semiconductor Products Dept., Building 7-49, Syracuse, N. Y. 13221 [413]

Switching regulators offer increased power efficiency

A pin-for-pin replacement for SG-1524 regulators, the XR-1524 family of pulse-width-modulating regulators is based on a monolithic chip that includes an internal voltage regulator, error amplifiers, an RC oscillator, pulse-steering flip-flops, and output driver transistors. These transistors can be used in either

**The only low cost power supplies
that meet these tough standards:**

MIL STD 810C

UL / VDE / CSA *

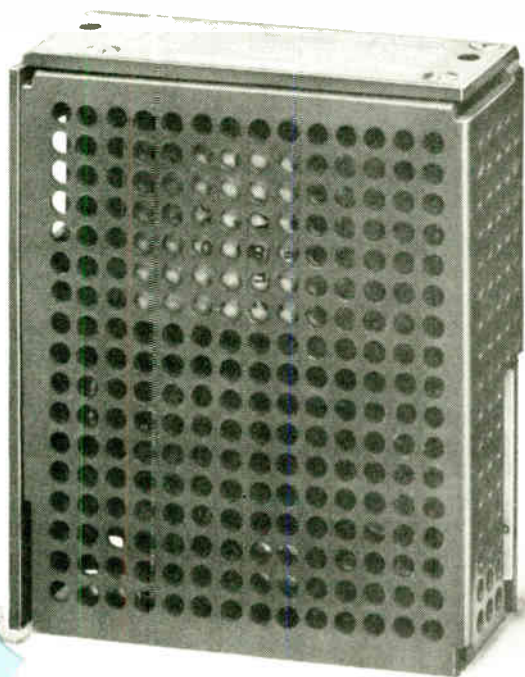

LNS-Z-5-OV
5V, 3A

LAMBDA LN SERIES

42 MODELS IN 5 POWER PACKAGES
up to 28 volts — up to 22 amps

ALL 5 YEAR GUARANTEED

 **LAMBDA ELECTRONICS**

*Recognized under the Components Program of Underwriters Laboratories, Inc.,
listed in VDE, Certified by CSA.

LN series power su OEM, industrial and

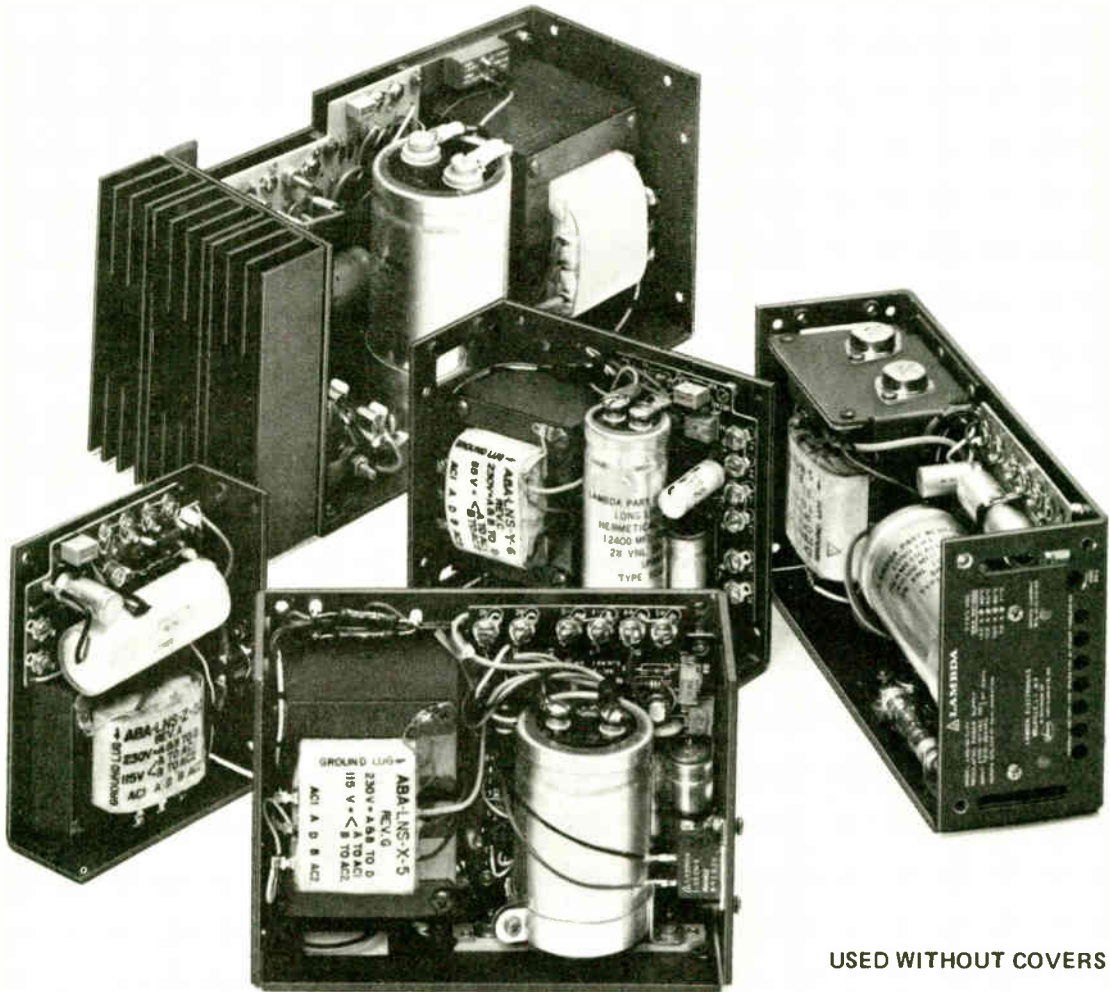

USED WITHOUT COVERS

5 Package Sizes, 40 Models

Single, Dual, — mpu
compatible models
up to 28 volts
up to 22 amps

Regulation

line and load — 0.1%

Ripple and Noise

1.5 mV rms, 5mV pk-pk

Dual Input

105-127 VAC, 47-440 Hz.
210-254 VAC, 47-440 Hz

**Designed for Listing in UL
Recognized Component Index**

Tested and Meets All These MIL STD-810C Requirements

- | | | | |
|---|------------------|-------------------------------------|-----------------|
| • Low Temperature . . . Method 502.1 | Procedure I | • Vibration Method 514.2 | Procedure X, XI |
| • High Temperature . . . Method 501.1 | Procedure I & II | • Shock Method 516.2 | Procedure I |
| • Low Pressure Method 500.1 | Procedure I | • Temperature Shock . Method 503.0 | Procedure I |
| • Humidity Method 507.1 | Procedure I & II | • Fungus Method 508.1 | Procedure I |
| • Temperature — Altitude Method 502.1 | | Procedure I Class 2 (0°C operating) | |

and guaran

plies designed for military applications

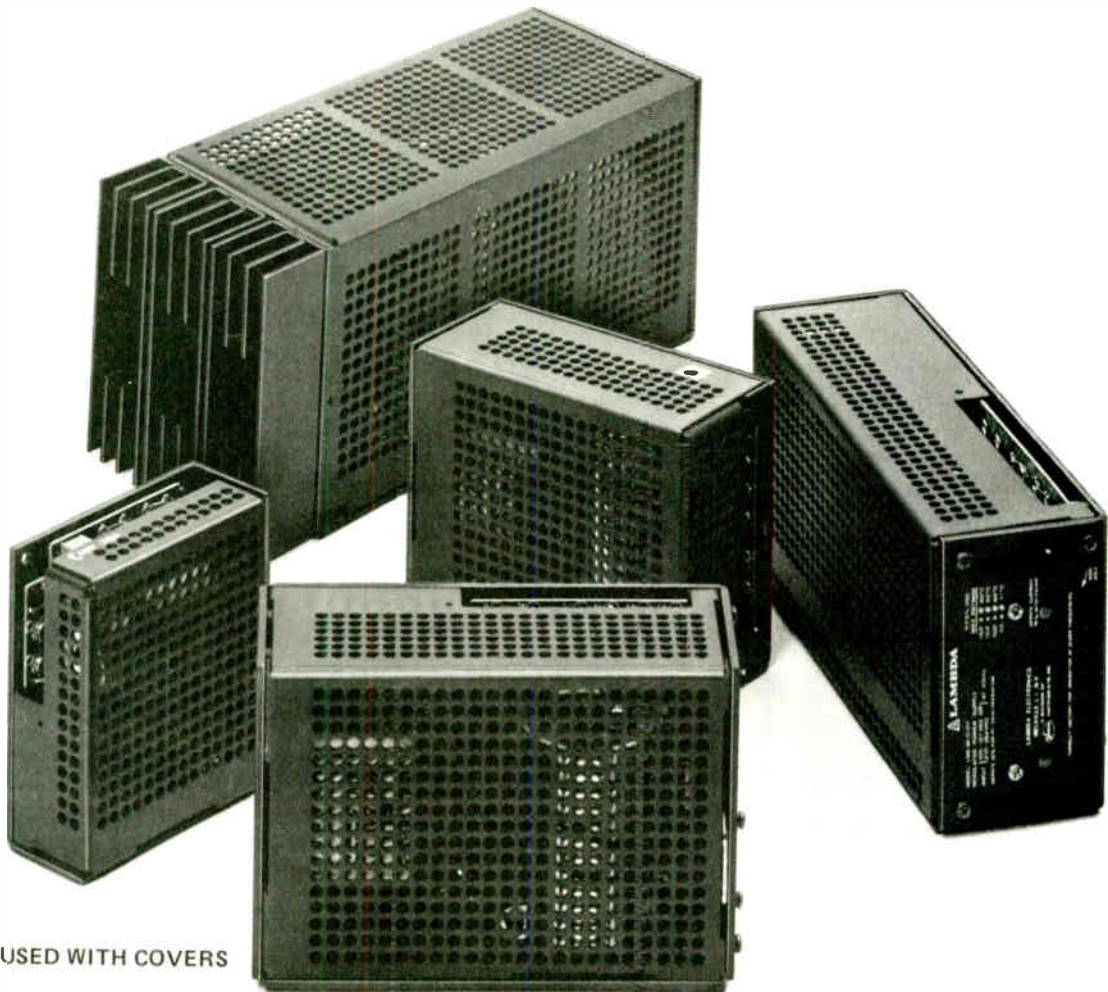

USED WITH COVERS

New Monolithic and Hybrid OV
overvoltage protection standard
on 5V models — available as
an option on other models

Designed to Meet
VDE Specs.

Isolation Resistance
10 Meg ohms

Isolation Voltage
input to output — 4000V

Thermally Engineered
Ventilation Holes

Convection Cooled
no external heatsinks or
blowers necessary

Mounting
3 positions; 3 surfaces

Fungus Proof
No fungus nutrient material used

Shipped Complete with Cover
can be used with and
without cover, depending
on your application

teed 5 years

Lambda I designed for min

△ LAMBDA
**MIL-T-27C
Grade 6 Transformer**
layer-wound with electrostatic shield

MIL-W-16878 Wire

△ LAMBDA
**Perforated 0.075 inch
Thick Steel Cover**

Thermostat - automatically
resets when overtemperature
condition is eliminated

Sprague 602D high temperature,
premium computer grade hermetically
sealed electrolytic capacitor

△ LAMBDA
LAS-1100
monolithic voltage
regulator (TO-96)

Sprague 601D, 672D
high temperature, long life
electrolytic capacitors

△ LAMBDA
CC4®* Printed Circuit Board
plated thru-holes
fungus inert, flame retardant

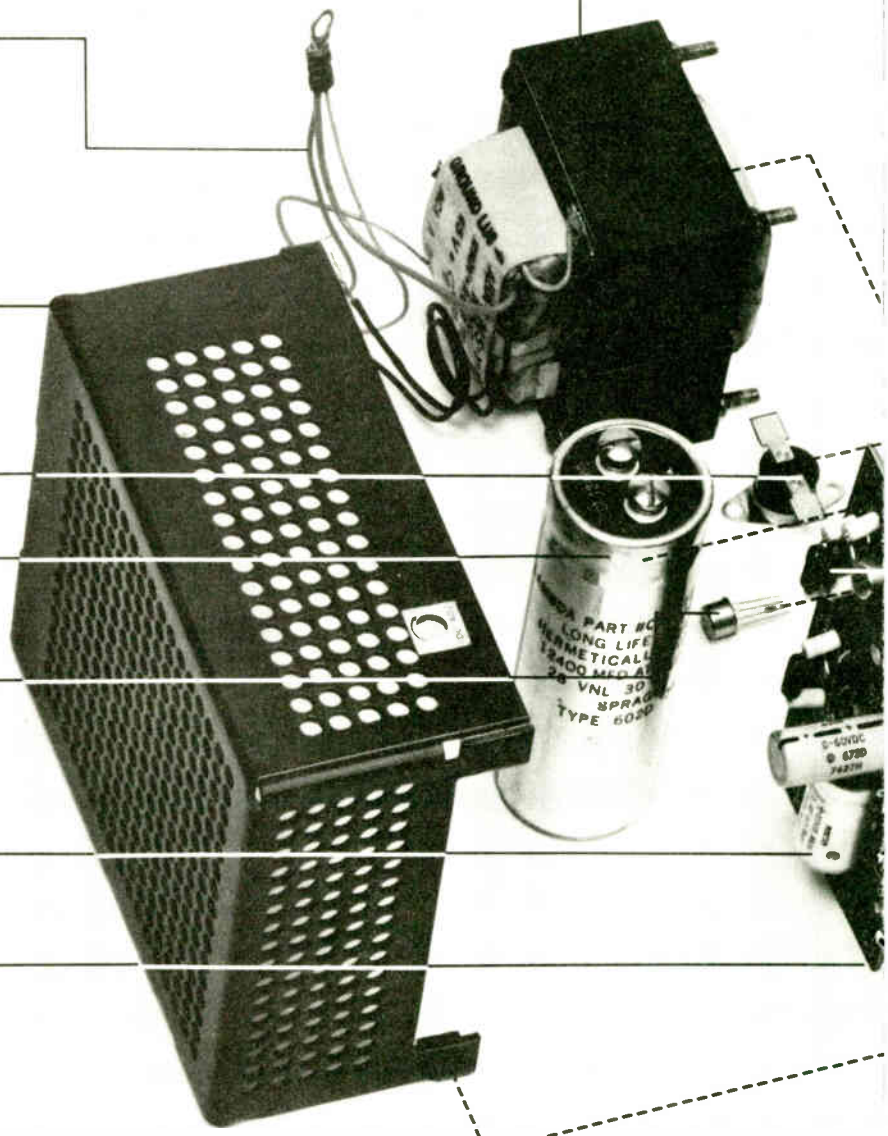

.N Series **imum repair time**

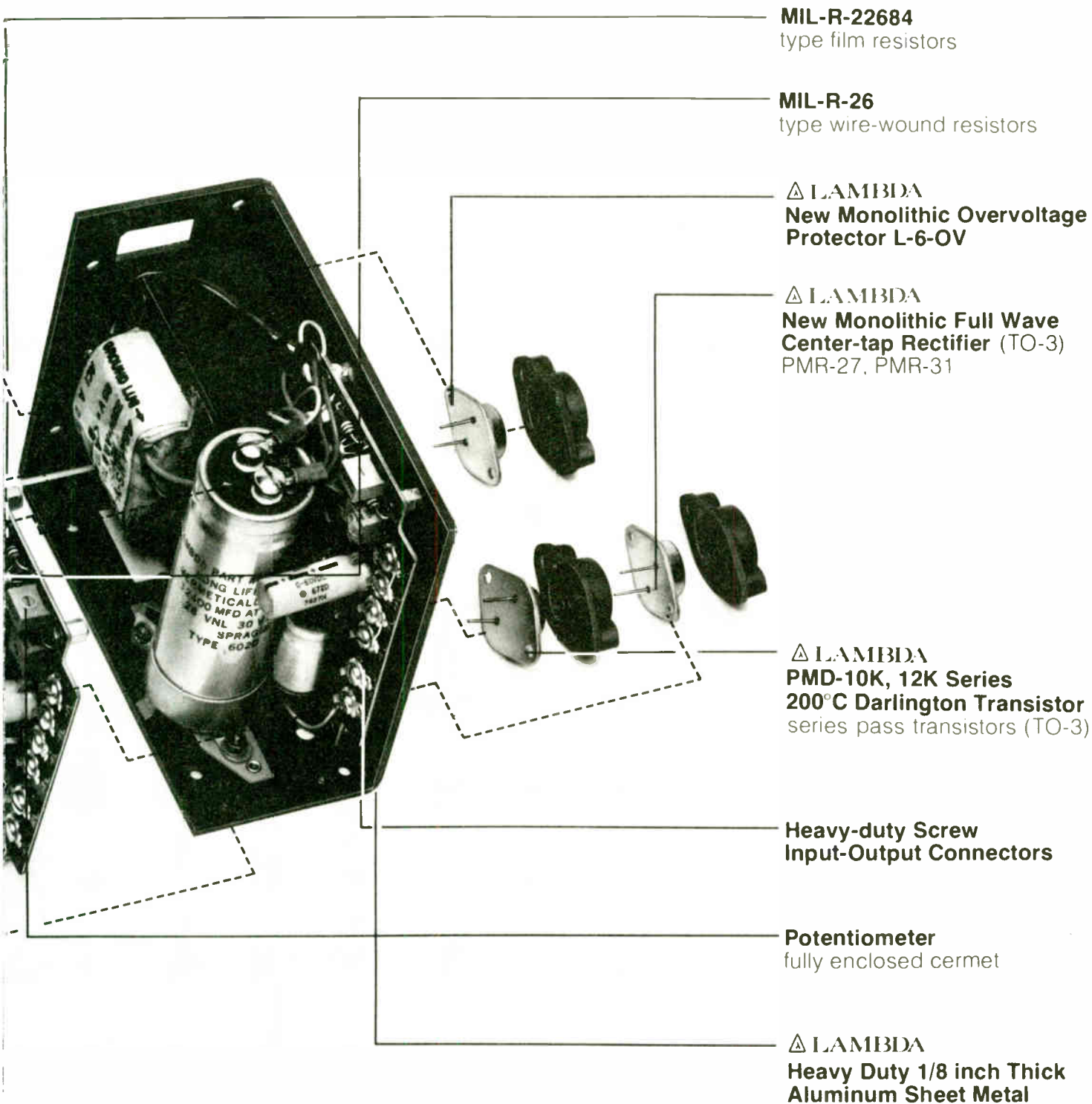

VOLTAGE AND CURRENT RATINGS

DUAL OUTPUT

5 VOLTS ± 5% ADJ, 9V-12V ADJ

MODEL	REGULATION (LINE OR LOAD)	RIPPLE (RMS)	VOLT. VDC.	⁽¹⁾ MAX CURRENT AMPS AT				PKG SIZE	DIMENSIONS ⁽²⁾ (INCHES)	PRICE
				40°C	50°C	60°C	71°C			
LND-X-MPU ⁽³⁾	0.1%	1.5	5±5% 9-12	7.0(5.95) 1.2(1.02)	6.0(5.11) 1.1(0.94)	4.7(4.0) 1.0(0.85)	3.2(2.72) 0.8(0.68)	X	7 x 4 7/8 x 2 7/8	\$172
LND-P-MPU ⁽³⁾	0.1%	1.5	5±5% 9-12	14.0(13.3) 2.5(2.38)	12.2(11.59) 2.2(2.09)	10.0(9.5) 1.8(1.71)	7.5(7.13) 1.35(1.28)	P	11 x 4-7/8 x 4-13/32	245

± 15 VOLTS TO ± 12 VOLTS ADJ

DUAL TRACKING

MODEL	REGULATION (LINE OR LOAD)	RIPPLE (RMS)	± 15 to ± 12	⁽¹⁾ MAX CURRENT AMPS AT				PKG SIZE	DIMENSIONS ⁽²⁾ (INCHES)	PRICE
				40°C	50°C	60°C	71°C			
LND-Z-152	0.15%	1.5	± 15 to ± 12	0.6(0.54) 0.6(0.54)	0.55(0.5) 0.55(0.5)	0.45(0.41) 0.45(0.41)	0.3(0.27) 0.3(0.27)	Z	4 7/8 x 4 x 1 3/4	\$ 85
LND-Y-152	0.1%	1.5	± 15 to ± 12	1.4(1.20) 1.2(1.02)	1.2(1.02) 1.1(0.94)	0.9(0.77) 0.8(0.68)	0.6(0.51) 0.5(0.43)	Y	5 5/8 x 4 7/8 x 2 5/8	120
LND-X-152	0.1%	1.5	± 15 to ± 12	2.5(2.13) 2.3(1.96)	2.1(1.79) 1.9(1.62)	1.6(1.37) 1.4(1.2)	1.1(0.94) 0.9(0.77)	X	7 x 4 7/8 x 2 7/8	150
LND-W-152	0.1%	1.5	± 15 to ± 12	3.3(3.0) 3.1(2.8)	3.1(2.8) 2.8(2.52)	2.6(2.34) 2.3(2.07)	2.0(1.8) 1.6(1.44)	W	9 x 5 x 2 7/8	170
LND-P-152	0.1%	1.5	± 15 to ± 12	5.3(5.04) 4.6(4.37)	4.7(4.47) 4.0(3.80)	3.9(3.71) 3.3(3.14)	2.9(2.76) 2.5(2.38)	P	11 x 4-7/8 x 4-13/32	240

5 VOLTS ± 5% ADJ

SINGLE OUTPUT

MODEL	REGULATION (LINE OR LOAD)	RIPPLE (RMS)	40°C	⁽¹⁾ MAX CURRENT AMPS AT				PKG SIZE	DIMENSIONS ⁽²⁾ (INCHES)	PRICE
				50°C	60°C	71°C				
LNS-Z-5-OV	0.15%	1.5	3.0(2.7)	2.7(2.4)	2.3(2.1)	1.7(1.5)	Z	4 7/8 x 4 x 1 3/4	\$ 80	
LNS-Y-5-OV	0.1%	1.5	6.0(5.4)	5.1(4.6)	4.2(3.8)	3.1(2.8)	Y	5 5/8 x 4 7/8 x 2 5/8	115	
LNS-X-5-OV	0.1%	1.5	10.0(8.5)	8.9(7.6)	7.3(6.2)	5.3(4.5)	X	7 x 4 7/8 x 2 7/8	140	
LNS-W-5-OV	0.1%	1.5	14.0(11.9)	12.2(10.4)	10.0(8.5)	7.5(6.4)	W	9 x 5 x 2 7/8	175	
LNS-P-5-OV	0.1%	1.5	22.0(20.9)	19.5(18.53)	16.5(15.68)	13.0(12.35)	P	11 x 4-7/8 x 4-13/32	220	

6 VOLTS ± 5% ADJ

LNS-Z-6	0.15%	1.5	2.5(2.25)	2.2(2.0)	1.9(1.7)	1.4(1.3)	Z	4 7/8 x 4 x 1 3/4	\$ 75
LNS-Y-6	0.1%	1.5	5.6(5.0)	4.9(4.4)	4.0(3.6)	2.9(2.61)	Y	5 5/8 x 4 7/8 x 2 5/8	110
LNS-X-6	0.1%	1.5	9.5(8.1)	8.4(7.15)	7.1(6.0)	5.0(4.25)	X	7 x 4 7/8 x 2 7/8	130
LNS-W-6	0.1%	1.5	13.0(11.0)	11.2(9.5)	9.3(7.9)	6.8(5.9)	W	9 x 5 x 2 7/8	165
LNS-P-6	0.1%	1.5	20.5(19.48)	18.1(17.2)	15.3(14.54)	12.0(11.4)	P	11 x 4-7/8 x 4-13/32	200

12 VOLTS ± 5% ADJ

LNS-Z-12	0.15%	1.5	1.7(1.55)	1.6(1.45)	1.5(1.4)	1.3(1.2)	Z	4 7/8 x 4 x 1 3/4	\$ 75
LNS-Y-12	0.1%	1.5	4.0(3.6)	3.5(3.15)	2.9(2.6)	2.2(2.0)	Y	5 5/8 x 4 7/8 x 2 5/8	110
LNS-X-12	0.1%	1.5	6.5(5.5)	5.5(4.7)	4.5(3.8)	3.3(2.8)	X	7 x 4 7/8 x 2 7/8	130
LNS-W-12	0.1%	1.5	8.5(7.2)	7.2(6.1)	5.9(5.0)	4.2(3.6)	W	9 x 5 x 2 7/8	165
LNS-P-12	0.1%	1.5	14.0(13.3)	12.4(11.8)	10.0(9.5)	7.3(6.94)	P	11 x 4-7/8 x 4-13/32	200

15 VOLTS ± 5% ADJ

LNS-Z-15	0.15%	1.5	1.4(1.3)	1.3(1.62)	1.2(1.1)	1.0(0.9)	Z	4 7/8 x 4 x 1 3/4	\$ 75
LNS-Y-15	0.1%	1.5	3.4(3.1)	3.1(2.8)	2.6(2.35)	2.0(1.8)	Y	5 5/8 x 4 7/8 x 2 5/8	110
LNS-X-15	0.1%	1.5	5.5(4.7)	4.8(4.1)	3.9(3.35)	2.8(2.4)	X	7 x 4 7/8 x 2 7/8	130
LNS-W-15	0.1%	1.5	7.7(6.55)	6.7(5.7)	5.5(4.7)	3.8(3.15)	W	9 x 5 x 2 7/8	165
LNS-P-15	0.1%	1.5	12.0(11.4)	10.6(10.1)	8.5(8.1)	6.3(6.0)	P	11 x 4-7/8 x 4-13/32	200

20 VOLTS ± 5% ADJ

LNS-Z-20	0.15%	1.5	1.0(0.69)	0.85(0.77)	0.65(0.59)	0.45(0.41)	Z	4 7/8 x 4 x 1 3/4	\$ 75
LNS-Y-20	0.1%	1.5	2.7(2.45)	2.5(2.25)	2.0(1.08)	1.3(1.2)	Y	5 5/8 x 4 7/8 x 2 5/8	110
LNS-X-20	0.1%	1.5	4.4(3.75)	3.6(3.1)	2.6(2.2)	1.6(1.4)	X	7 x 4 7/8 x 2 7/8	130
LNS-W-20	0.1%	1.5	6.1(5.2)	5.2(4.4)	4.2(3.6)	3.0(2.6)	W	9 x 5 x 2 7/8	165
LNS-P-20	0.1%	1.5	10.0(9.5)	8.9(8.46)	7.5(7.13)	5.5(5.23)	P	11 x 4-7/8 x 4-13/32	200

24 VOLTS ± 5% ADJ

LNS-Z-24	0.15%	1.5	0.9(0.81)	0.75(0.68)	0.6(0.55)	0.4(0.36)	Z	4 7/8 x 4 x 1 3/4	\$ 75
LNS-Y-24	0.1%	1.5	2.3(2.1)	2.1(1.9)	1.7(1.5)	1.1(1.0)	Y	5 5/8 x 4-7/8 x 2 5/8	110
LNS-X-24	0.1%	1.5	3.8(3.25)	3.2(2.75)	2.4(2.0)	1.4(1.62)	X	7 x 4-7/8 x 2 7/8	130
LNS-W-24	0.1%	1.5	5.4(4.6)	4.6(3.9)	3.7(3.1)	2.5(2.1)	W	9 x 5 x 2 7/8	165
LNS-P-24	0.1%	1.5	9.0(8.55)	8.0(7.6)	6.7(6.37)	5.0(4.75)	P	11 x 4-7/8 x 4-13/32	200

28 VOLTS ± 5% ADJ

LNS-Z-28	0.15%	1.5	0.8(0.75)	0.65(0.6)	0.5(0.45)	0.35(0.32)	Z	4 7/8 x 4 x 1 3/4	\$ 75
LNS-Y-28	0.1%	1.5	2.0(1.8)	1.8(1.65)	1.5(1.35)	1.0(0.9)	Y	5 5/8 x 4 7/8 x 2 5/8	110
LNS-X-28	0.1%	1.5	3.4(2.9)	2.9(2.5)	2.2(1.5)	1.2(1.0)	X	7 x 4-7/8 x 2 7/8	130
LNS-W-28	0.1%	1.5	4.7(4.0)	4.0(3.4)	3.2(2.75)	2.2(1.9)	W	9 x 5 x 2 7/8	165
LNS-P-28	0.1%	1.5	8.0(7.6)	7.1(6.75)	6.0(5.7)	4.5(4.28)	P	11 x 4-7/8 x 4-13/32	200

- NOTE: 1. Rating in Parenthesis for LN Series when cover is used
 2. Dimensions include cover
 3. Includes OV protection on both outputs (5V OV trip point is 6.6 ± .2V fixed; 9-12V OV trip points is 13.7 ± .4V fixed)

SPECIFICATIONS OF LN SERIES

DC Output

Voltage range shown in tables

Regulated Voltage

regulation, line 0.1% (0.15% for LN-Z)
 regulation, load 0.1% (0.15% for LN-Z)
 ripple and noise 1.5mv RMS, 5mV pk-pk with
 either positive or negative terminal grounded.

temperature

coefficient 0.03% /°C
 remote programming
 resistance 200 ohms per volt nominal
 remote programming
 voltage volt per volt

AC Input

line 105-127 VAC, 210-254 VAC
 (by transformer tap change)
 47-440 Hz. Consult factory for
 operation at frequencies other
 than 57-63 Hz.

Efficiency (Typical) . . . 30%-5V and 6V models, 42%
 12V and 15V models, 49%-20V,
 24V and 28V models, 42% for
 LN duals except LND-MPU
 which are 34%.

Ambient Operating Temperature Range

Continuous duty from 0° to +71°C with corresponding
 load current ratings for all modes of operation.

Storage Temperature Range

-55°C to 85°C

Overload Protection

Electrical

External overload protection, automatic electronic
 current limiting circuit limits the output current to a
 preset value, thereby providing protection for the load as
 well as the power supply.

Thermal

Thermostat - automatically reset when overtemperature
 condition is eliminated.

Overshoot

No overshoot on turn-on, turn-off or power failure.

Overvoltage Protection

Overvoltage protection module crowbars output when
 trip level is exceeded - standard on all 5V models and
 both outputs of models LND-X-MPU and LND-P-MPU.
 For other models see back cover.

Input and Output Connections

Heavy-duty screw terminals on printed circuit board.

DC Output Controls

Simple screwdriver adjustment over the entire voltage
 range.

Tracking Accuracy (Dual Tracking Models Only)

3% absolute voltage difference, 0.2% change for all con-
 ditions of line, load and temperature.

Remote Sensing

Provision is made for remote sensing to eliminate effect
 of power output lead resistance on DC regulation.

Mounting

Three Mounting surfaces, three mounting position. One
 mounting position for LN-P models.

Convection Cooled

No external heat sinking or forced air required.

Transformer

MIL T-27C, Grade 6, Electrostatic shield; 4000 VAC
 input/output isolation.

Isolation Rating

Minimum 10 Megohm isolation from DC to ground at
 ground at 1000 VDC.

Fungus Proof

No fungi nutrient material used

Military Specifications

The LNS series has passed the following tests in accor-
 dance with MIL STD 810C

- 1) Low Pressure - Method 500.1, Procedure I.
- 2) High Temperature - Method 501.1, Procedure I & II.
- 3) Low Temperature - Method 502.1, Procedure I
- 4) Temperature Shock - Method 503.0, Procedure I.
- 5) Temperature - Altitude - Method 504.1, Procedure I.
 Class 2 (0°C operating)
- 6) Humidity - Method 507.1, Procedures I & II.
- 7) Fungus - Method 508.1, Procedure I
- 8) Vibration - Method 514.2, Procedures X & XI
- 9) Shock - Method 516.2, Procedures I & III

MIL I-6181D - Conducted and radiated EMI with one
 output terminal grounded.

Physical Data

Package Model	Weight		Size Inches
	Lbs. Net	Lbs. Ship	
LN Z	3	3 1/4	4 7/8 x 4 x 1 3/4 (w/cover) 4 7/8 x 4 x 1 5/8 (w/o cover)
LN Y	5	5 1/2	5 5/8 x 4 7/8 x 2 5/8 (w/cover) 5 5/8 x 4 7/8 x 2 1/2 (w/o cover)
LN X	7 3/4	8 1/4	7 x 4 7/8 x 2 7/8 (w/cover) 7 x 4 7/8 x 2 3/4 (w/o cover)
LN W	9	9 1/2	9 x 5 x 2 7/8 (w/cover) 9 x 4 7/8 x 2 3/4 (w/o cover)
LN P	14	15 1/2	11 x 4-7/8 x 4-13/32 (w & w/o cover)
LND-P	15-1/2	17	11 x 4-7/8 x 4-13/32 (w & w/o cover)

Finish

Gray, Fed. Std. 595 No. 26081.

UL/VDE

Designed for listing in UL Recognized Components
 Index.

Designed for listing in VDE Index.

Accessories

Overvoltage protectors (standard on 5V models and
 models LND-X-MPU and LND-P-MPU).

Guaranteed for 5 Years

5-year guarantee includes labor as well as parts.
 Guarantee applies to operation at full published
 specifications at end of 5 years.

6 Amp Monolithic OV Protectors

\$5.00 Qty 1 \$3.40 Qty 1000

TO-3 PACKAGE, NO EXTERNAL COMPONENTS NEEDED

LAMBDA OVERVOLTAGE PROTECTORS L-6-OV, L-12-OV, L-20-OV, L-35-OV Series

General Description

The Lambda overvoltage protector prevents damage to the load caused by excessive power supply output voltage due to improper adjustment, improper connection, or failure of the power supply. Load protection is accomplished automatically by effectively short circuiting the output terminals of the power supply when a preset limit voltage has been exceeded. The trip-point limit voltage cannot be adjusted. To reset overvoltage protector, remove AC input to power supply allow overvoltage protector to cool, and reapply power.

Overvoltage Protector Performance Specifications

PARAMETER	SYMBOL	L-6-OV SERIES		L-12-OV SERIES		L-20-OV SERIES		L-35-OV SERIES	
		MIN	MAX	MIN	MAX	MIN	MAX	MIN	MAX
On State Current	I_{OC}	-	6A	-	12A	-	20A	-	35A
On State Voltage	V_{OC}	-	2.5V	-	1.3V	-	1.4V	-	1.6V
Non Repetitive Peak Surge Current*	I_p	-	70A	-	200A	-	260A	-	350A
Standby Current	I_S	-	25mA	-	5mA	-	5mA	-	5mA
Operating Temperature (Blocking)**	T_{CB}	-40°C	+100°C	-40°C	+100°C	-40°C	+100°C	-40°C	+100°C
Operating Temperature (Conducting)***	T_{CC}	-40°C	+150°C	-40°C	+140°C	-40°C	+140°C	-40°C	+140°C
Storage Temperature	T_S	-40°C	+150°C	-40°C	+125°C	-40°C	+125°C	-40°C	+125°C
Power Dissipation @ 25°C Derate @ 1.5W/°C above 50°C	P_D		150 Watts						
Thermal Resistance	$R_{\theta JC}$		1.0°C/W						

*For sinusoidal current duration of 8.3 milliseconds max.

**Case temperature for overvoltage protector in non-conducting or "OFF" state.

***Case temperature for overvoltage protector in conducting or "ON" state. Power must be removed and case temperature allowed to drop to 100°C before application of output voltage.

The overvoltage protector must be mounted on external heat sink to maintain case temperature below rated limit. When the overvoltage protector is used with a Lambda power supply, the power supply chassis acts as the heat sink. The L-12-OV, L-20-OV, L-35-OV, overvoltage protector is supplied with mating connectors for pins on overvoltage protector (+V and -V engraved on unit).

OVERVOLTAGE PROTECTORS

NOM SUPPLY VOLTAGE (VOLTS)	TRIP POINT VOLTAGE ^A (VOLTS)	6 AMP MODELS				12 AMP MODELS				20 AMP MODELS				35 AMP MODELS							
		QTY 1	QTY 100	QTY 250	QTY 1000	QTY 1	QTY 100	QTY 250	QTY 1000	QTY 1	QTY 100	QTY 250	QTY 1000	QTY 1	QTY 100	QTY 250	QTY 1000				
5	6.6 ± .2	L-6-OV-5	\$5	\$4	\$3.75	\$3.40	L-12-OV-5	\$11	\$8	\$7.50	\$6.80	L-20-OV-5	\$16	\$11.20	\$10.50	\$9.50	L-35-OV-5	\$20	\$14.40	\$13.60	\$12.30
6	7.3 ± .2	L-6-OV-6	5	4	3.75	3.40	L-12-OV-6	11	8	7.50	6.80	L-20-OV-6	16	11.20	10.50	9.50	L-35-OV-6	20	14.40	13.60	12.30
9	10.5 ± .4	L-6-OV-9	5	4	3.75	3.40	L-12-OV-9	11	8	7.50	6.80										
10	11.0 ± .5	L-6-OV-10	5	4	3.75	3.40															
12	13.7 ± .4	L-6-OV-12	5	4	3.75	3.40	L-12-OV-12	11	8	7.50	6.80	L-20-OV-12	16	11.20	10.50	9.50	L-35-OV-12	20	14.40	13.60	12.30
15	17.0 ± .5	L-6-OV-15	5	4	3.75	3.40	L-12-OV-15	11	8	7.50	6.80	L-20-OV-15	16	11.20	10.50	9.50					
18	20.5 ± 1.0	L-6-OV-18	5	4	3.75	3.40															
20	22.8 ± .7	L-6-OV-20	5	4	3.75	3.40	L-12-OV-20	11	8	7.50	6.80	L-20-OV-20	16	11.20	10.50	9.50					
24	27.3 ± .6	L-6-OV-24	5	4	3.75	3.40	L-12-OV-24	11	8	7.50	6.80	L-20-OV-24	16	11.20	10.50	9.50					
28	31.9 ± 1.0	L-6-OV-28	5	4	3.75	3.40	L-12-OV-28	11	8	7.50	6.80	L-20-OV-28	16	11.20	10.50	9.50					
30	33.5 ± 1.0	L-6-OV-30	5	4	3.75	3.40	L-12-OV-30	11	8	7.50	6.80	L-20-OV-30	16	11.20	10.50	9.50					

^A VOLTAGE TOLERANCE MAINTAINED OVER 0-71°C DUE TO POWER DESIGN

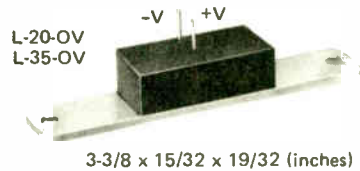

Lambda staffed sales and service offices

1
ATLANTIC REGION
Melville, New York 11746
515 Broad Hollow Road
Tel 516 694 4200
TWX 510 224 6484

Long Island, N.Y.; New York, N.Y.;
Northern New Jersey
Tel 516-694-4200

Delaware; Eastern Pennsylvania;
Southern New Jersey
Tel 215 279 5644

Maryland; Dist. of Columbia;
Northern Virginia
Tel 703 451 9340

Southern Virginia;
North & South Carolina;
Alabama; Georgia;
Tennessee; Mississippi
Tel 704 542 1991

Largo, Florida
Tel 813 596 5151

Poughkeepsie, New York
Tel 914 297 4800

2
NORTH-EASTERN REGION
Lexington, Massachusetts 02173
2 Militia Drive
Tel 617 861 8585
TWX 710 326 7558

Rochester, New York
Tel 716 454 6770

3
SOUTH-WESTERN REGION
Dallas, Texas 75231
6950 Winchester
Tel 214 341 5130
TWX 910 861 9048

Oklahoma
Tel Enterprise 2 183

4
MID-WESTERN REGION
Arlington Heights, Ill. 60005
2420 East Oakton St. Unit G
Tel 312 593 2550
TWX 910 222 2856

Minneapolis, Minnesota
Tel 612 935 6194

Cleveland, Ohio;
Western Pennsylvania
Tel 216 585 7808

Detroit, Michigan
Tel 313 881 7886

5
FAR-WESTERN REGION
Carson, Calif. 90746
20601 S. Annalee Ave
Tel 213 537-8341
TWX 910-346-7649

Denver, Colorado
Tel 303 779-9561

6
NORTH-WESTERN REGION
Sunnyvale, California 94086
599 N. Mathilda Ave., Suite 210
Tel 408 738 7541
TWX 910 339 9243

LAMBDA MANUFACTURING PLANTS
Melville, N.Y.
Plant 1 515 Broad Hollow Rd
Plant II 1770 Walt Whitman Rd
Reynosa, Mexico
Corpus Christi, Texas
121 International Dr

LAMBDA
ELECTRONICS
DIVISION of (Veeeco) INSTRUMENTS INC

New products

single-ended or push-pull modes to increase power transfer efficiency.

Two or more units may be interconnected and synchronized in master-slave fashion for use in complex power-control systems, and the output stage is protected against shorting or overload.

The three members of the family, the XR-1524, the XR-2524, and the XR-3524, are intended for application in military, industrial, and commercial switching power supplies or dc-dc converters. Prices begin at \$4 each in quantities of 100 or more and decrease with large orders. Delivery is from stock.

Exar Integrated Systems Inc., 750 Palomar Ave., Sunnyvale, Calif. 94086. Phone (408) 732-7970 [414]

Free-floating SCR survives the heat with less fatigue

By allowing the heart of their silicon controlled rectifiers to "float" within the package, designers of the 174, 176, and 179 series have produced SCRs with better thermal fatigue characteristics and consistent thermal impedances of only $0.14^{\circ}\text{C}/\text{w}$.

The 174 family consists of phase-control devices rated at 275 A rms; blocking voltages ranging from 100 to 1,400 v in 100-v increments are available.

The 176 and 179 families comprise fast-turn-off inverter SCRs rated at 235 and 275 A rms, respectively. SCRs of the 176 family can be furnished with blocking voltages from 700 to 1,200 v and turn-off times of 30 to 40 μs , while those of the 179 group are available with blocking voltages between 100 and 600 v and turn-off times of 10, 15, and 20 μs . Both the 176 and the 179 series can withstand surge currents of 4,500 A.

Typical units within the 174, 176 and 179 series are priced at \$84.55, \$73.25, and \$62.40 each, respectively, in quantities from 10 to 99. Small quantities are available now.

FMC Corp., Semiconductor Products Division, 800 Hoyt St., Broomfield, Colo. 80020. Phone Art Connolly at (303) 469-2161 [415]

THE GREAT ESCAPE

It's not only the 361 days of sunshine

It's also seagulls and beaches . . . and community leaders who recognize the importance of an industrial base for economic and cultural progress.

Pinellas County on Florida's West Coast offers all of these plus the things you always hope will be at an expansion site, or a relocation for your business — excellent transportation systems, low living costs, a skilled and productive work force, who take pride in a job well done, and the tenth lowest state in local taxes in the U.S. The Pinellas County Industry Council is ready to assist you with your relocation or new location plans

Make your **Great Escape** to Florida's West Coast!

Pinellas County
Industry Council

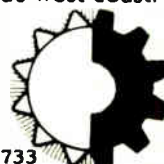

P.O. BOX 13000P St. Petersburg, Fl. 33733

Name _____
Company _____
Street _____
City _____ State _____ Zip _____
Telephone _____

In cooperation with the Division of Economic Development, Florida Department of Commerce.

Circle 149 on reader service card

FOR SALE
25% OFF PURCHASE PRICE
USED 3 MONTHS

Immediate Delivery

1 Fault Finder model FF101A Programmable Automatic PC Board Tester. 1-K mode digital test capability. 300 test point capability. Double programmable 0-60 volt supply, dual headed, optional auxiliary power supply.

Box 1100 GLOVERSVILLE, N.Y. 12078
Telephone: (518) 725-8601

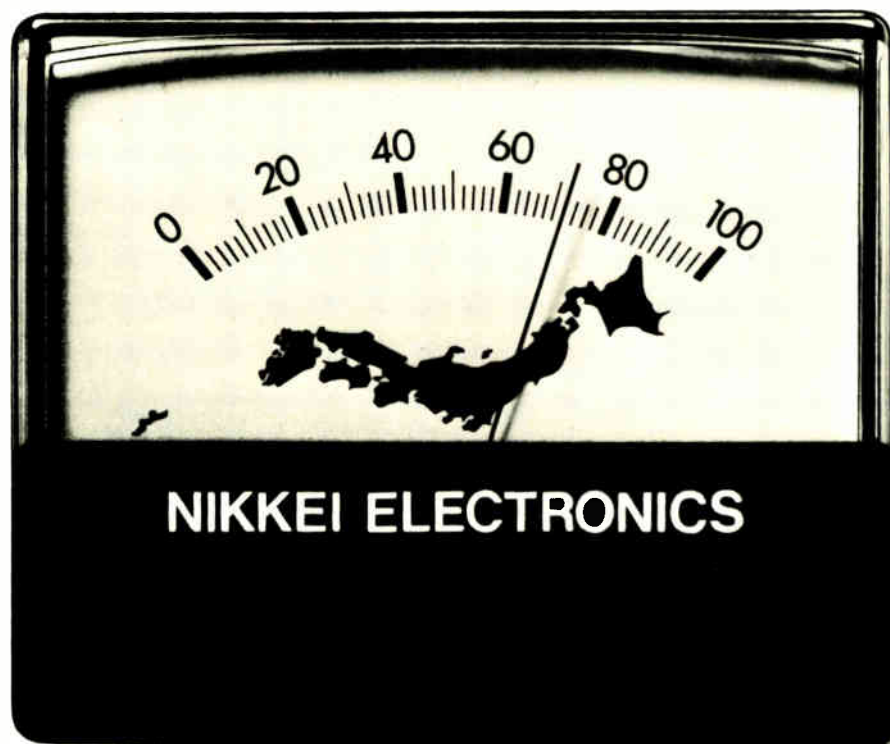

The Japan Output Check.

If the output isn't measuring up to your input in your approach to the Japanese market, it may be that you are switched to the wrong setting.

And since we are talking about a ¥164 trillion market, you can't afford to take chances.

You need to do things the right way in Japan.

And make your name known to the right people.

Which is where we come in.

As Japan's leading electronics magazine, we are in a unique position to help get your message across. A bi-weekly, Nikkei Electronics is delivered

direct to the desks of more than 37,000 key decision makers in the electronics industry.

Nikkei Electronics. For sure feedback from Japan.

Subscriptions: 36,550 (as of Jan. 23rd, 1978)
Regularly audited by the Japan ABC.

For further information, write to:
H.T. Howland, Marketing Services Manager,
Electronics, McGraw-Hill Publications Co.,
1221 Avenue of the Americas, New York,
N.Y. 10020, U.S.A. Tel: (212) 997-6642

Japan's foremost electronics publication

Nikkei Electronics

NIKKEI-McGRAW-HILL, INC.
The publisher of Nikkei Electronics
Wataru Makishima, Manager, Advertising.
Nikkei Annex Bldg 2-1-2, Uchi-Kanda, Chiyoda k.u.,
Tokyo, Japan. Telex: J26296 NKMCGRAW

Products newsletter

Motorola enters codec market

Taking dead aim at the needs of Ma Bell, Motorola's Semiconductor division, Phoenix, Ariz., has developed a one-chip coder-decoder (codec) that operates off a single 5-v supply and dissipates between 50 and 100 mw. The commercial version of the complementary-MOS unit is designated the MC14406; the military, the MC14407. Both have a power-down capability that cuts consumption to less than a milliwatt.

Look for a compatible monolithic active filter from Motorola by the first quarter of 1979. It will be housed in a 16-pin dual in-line package and will also be fabricated in C-MOS.

Microcomputer board gets dual-port memory

A three-bus architecture in Intel Corp.'s new iSBC 80/30 one-board microcomputer gives it dual-port access to a whopping 16,384 bytes of on-board RAM. Previous SBC one-board designs lacked the dual-port bus that allows data exchange with external devices via memory. Useful for multiprocessing, the new bus structure also has an ulterior motive—interconnection of 8-bit boards and a 16-bit family to come.

Ink-jet printer mechanism offered without electronics

Manufacturers of printers and other original equipment who want to take advantage of Silonix Inc.'s drop-on-demand ink-jet printing technology without buying a complete printer can now purchase the mechanism less the electronic control board and power supply. The full printer sells for \$2,495, but the OEM parts are available in 500-piece quantity for \$500, according to the Sunnyvale, Calif., company.

Analog dividers grow more accurate

A monolithic IC analog voltage divider from Analog Devices, Norwood, Mass., promises to make life easier for people who are dissatisfied with the performance of analog multipliers in the division mode. The two-quadrant model AD535K has a maximum divider error of 0.5% over a denominator range of 10:1 with no external trimming. Over a denominator range of 50:1 the error may be 2%. The unit sells for \$24 in hundreds.

Second-source coming for DEC LPS-11

A single-board laboratory system for Digital Equipment Corp.'s PDP-11 minicomputers will soon be available from Data Translation, Natick, Mass. The DT1711-LPS is a second source for the DEC LPS-11 system and should sell for about half the price.

Correcter reduces time-base errors

Time-base errors in instrumentation tape recorders can be reduced by from 8 to more than 20 times, depending upon tape speed, regardless of the type of recorder being used. The digital time-base correcter that performs this feat is called the Tymcor 1000. It sells for less than \$7,000 and is available from Bancomm Corp., Palo Alto, Calif.

Chip set designed for speech synthesis

A pair of 40-pin digital ICs from Telesensory Systems Inc., Palo Alto, Calif., will work with standard memories and digital-to-analog converters to form the heart of a speech synthesizer. Specifically designed to simulate the human vocal tract, the chip set differs from a recent speech-synthesizing chip that "plays back" from read-only memories in that it is completely programmable, offering a wide range of "voicings."

Classified section FOR ENGINEERING/TECHNICAL EMPLOYMENT OPPORTUNITIES

CLASSIFIED SALES REPRESENTATIVES

Atlanta	404/892-2868	Cleveland	Mac Huestis	216/781-7000	Houston	Mike Taylor	713/659-8381	Pittsburgh	William Eyd	412/391-1314	
Boston	Jim McClure	617/262-1160	Dallas	Mike Taylor	214/742-1747	Los Angeles	Stan Kassir	213/487-1160	San Francisco	M.E. Kenny	415/362-4600
Chicago	Bill Higgins	312/751-3733	Denver	Shirley Klotz	303/837-1010	New York	Larry Kelly	212/997-3594	Stamford	Jim McClure	203/359-2860
			Detroit	Mac Huestis	313/873-7410	Philadelphia	Dan Ferro	215/568-6161	XEROX 400 TELECOPIER	212/997-6800	



Electron Display Design

Present and future product growth has created positions in our Applied Research and Development group for Electron Display Designers.

Positions are open for designers and project leaders who will conceive and/or implement CRT designs which are new technically or in their manufacturing methods.

Your responsibilities will range from initial design to manufacturing prototyping and will interface closely with our instrument designers.

Designers:

Background might include experience in electron display research and development, a physics background and computational skills which are applicable to electronic optics.

Project Engineers:

You will have experience in vacuum electron devices design and development and knowledge of fabrication methods and materials used. Experience in engineering project management is desired.

Tektronix, Inc. develops, manufactures and markets internationally recognized precision electronic measurement instruments, computer peripherals and related electronic instrumentation.

Salary is open. Benefits include educational support, insurance and profit sharing programs.

Send detailed resume and salary history to Roy Epperson, TEKTRONIX, Inc., P.O. Box 500, L73, Beaverton, Oregon 97077 or call 1-800-541-1164.

An Equal Opportunity Employer M/F/H

Tektronix
COMMITTED TO EXCELLENCE

ELECTRONICS TRAINING OVERSEAS

Our Midwest based Electronics Training Project has immediate openings in the following areas:

● TECHNICAL TRAINING SUPERVISOR

Position requires BA in Industrial/Technical Education or equivalent field. Minimum 5 years teaching experience with two years at supervisory level. Ideal candidate will have experience with AN/VRC and AN/PRC radio equipment and strong background in Electronics.

● ELECTRONIC INSTRUCTORS

Requires graduate of accredited electronic school with an Associate Degree. Minimum one year teaching experience required. Candidate must have thorough knowledge of solid state electronics as associated with communications equipment, and be able to teach circuit analysis in advanced electronics courses. Experience with AN/PRC and AN/VRC would be a plus.

● CURRICULUM ANALYST

Requires BA or BS in Education, Psychology, Engineering, or equivalent. Background must include three years developing training aids and requires previous experience in establishing curriculum and testing for advanced electronics courses.

Liberal salary, vacation and bonus offered.

Qualified, interested applicant should send resume in confidence to:

 **AVCO**

INTERNATIONAL SERVICES DIVISION

Industrial Relations Dept. LJ
P.O. Box 41300
Cincinnati, Ohio 45241

An equal opportunity employer M/F/H

GTE Labs and Research... ...the broader definition.

Many research laboratories are dedicated to advancing the state-of-the-art in a given technology. At GTE Laboratories we're dedicated to research that will allow the GTE Companies to maximize and capitalize on GTE's technologies in the world-wide marketplaces. For the engineer or scientist who chooses a GTE Laboratories' career, this means a variety of assignments not available in most positions. And our facilities and existing technical staff are among the finest in the world. Because people and their ideas are our products, we're looking for the best men and women in their field. Specific opportunities for you to become a part of GTE Labs exist in the following areas:

SEMICONDUCTOR/MICROWAVE ENGINEERS

We are currently seeking several innovative semiconductor engineers to assume responsibility for the design and fabrication of prototype novel microwave power devices and integrated power sources at L-band frequencies. Research and development will be required to achieve high power efficiency and miniaturization.

MS/PhD. in EE or Physics is required with experience in the design and fabrication of semiconductor microwave devices and power sources.

SEMICONDUCTOR DEVICE PHYSICIST

Responsibilities will include the design and characterization of opto-electronic devices based on III-V semiconducting materials. The qualified candidate should have a PhD. in the area of semiconductor devices and materials with a strong background in experimental and theoretical characterization of p-n junction devices. A familiarity with vacuum or epitaxial thin film techniques is desirable. MS with several years experience will also be acceptable.

SOFTWARE R&D

Several opportunities exist for individuals who have an MS/PhD in Computer Science to join Dr. Tomlinson Rauscher's group in developing software engineering tools and techniques to use throughout the corporation that will improve software reliability while reducing development and maintenance costs. Activities will include development of requirements language processor and design of language processor and test processors.

OPTICAL NETWORK COMPONENTS

Will perform research and development work in integrated optics and optical fiber components for application in optical communications systems. Will conduct theoretical and experimental investigation of passive fiber and integrated optical components such as branches, directional couplers, and wavelength multiplexors. Active components such as optical switches and modulators will also be investigated. A minimum of a BS in Physics or Electrical Engineering with experience in the development of optical guided wave devices or laser optics is required.

BROADBAND MULTI-CHANNEL TRANSMISSION

Will participate in the design and analysis of advanced optical communication systems for use in broadband multi-channel trunking. Both analog and digital systems will be analyzed. Selected designs will be built and tested. A minimum of BSEE with related graduate course work is required. MS EE preferred.

LSI CIRCUIT DESIGN

Challenging opportunities for BS or MS in EE to join an engineering team in the development of advanced LSI technology for applications to telecommunications and high frequency signal processing. The programs require MOS/Bipolar circuit design, and computer simulations for fabricating LSI chips.

COMMUNICATIONS SATELLITE SYSTEMS

Excellent opportunities for BS or MS in EE to join team advancing technological art in satellite communications system design through concepts analysis, experiments and construction. Experience in the following will be helpful: broad-band techniques, digital system characterization and design, modulation, coding, digital modems and video techniques. On-going active projects in the 4/6, 12/14, 18/30 GHz bands.

OPTICAL FIBER TRANSMISSION

Opening for an engineer to join a team working on CODECS, detectors and modulation techniques for optical transmission systems at rate up to 140^{mb/s}. GTE Labs designed and installed the first optical fiber system in the U.S. to carry regular telephone traffic. BS/MS EE.

DIGITAL TELEPHONES

New telephones will employ extensive electronics in the handset, including A/D conversion. GTE Laboratories is developing new techniques for coding, filtering and transmission of these digital signals. We have an opening for a telecommunications engineer to join a team in designing and testing feasibility models of this new equipment. BS/MS EE.

COMMUNICATIONS SYSTEMS DEVELOPMENT

A novel, multi-service switching system under development creates needs for engineers with BS or MS in EE and backgrounds in digital and wide-band analog switching and transmission.

One individual is needed with background and interest in TDM switching, digital transmission or wire, and microprocessor application. Will participate in the development of a modern data switch and central control.

Two individuals are needed whose field is wideband analog equipment design. Will develop the video switching, transmission and picture processing systems. Background in television signal processing and optical fiber transmission is highly desirable for these openings.

BATTERY DESIGN ENGINEER

Will be responsible for design, testing and assembly of battery prototypes. This includes design and assembly of jigs, fixtures and tooling for fabrication of components used in development of batteries.

BS in EE or related field is required. Several years of experience in battery development or similar relevant experience in electrochemical systems is desirable.

GTE Laboratories offers a compensation and benefits program that is designed to attract and retain quality professionals. We recognize the competitive demand for outstanding technical personnel and will respond promptly to all qualified applicants. Direct your resume or a detailed letter describing your background to Diane Coletti, Dept. 7E, GTE Laboratories, Inc., 40 Sylvan Road, Waltham, MA 02154. Please indicate your specific area of interest and salary requirements. If for some reason you cannot submit your resume, you are invited to call Diane, collect at (617) 890-8473.

GTE LABORATORIES
INCORPORATED

An equal opportunity employer, M/F.

PROJECT ENGINEER

Continued, rapid growth of north suburban Chicago manufacturer of telecommunications equipment creates an opportunity for a results-oriented individual with a minimum of 3 years experience in analog and digital design. Any exposure to 8080 or Z80 microprocessors is a definite plus. Projects will involve telecommunication circuit designs from conception to completion. Required B.S.E.E. or equivalent in addition to above experience.

We offer an attractive salary and excellent benefits including paid health, life and dental insurance, profit sharing and tuition reimbursement. For consideration, please submit resume of work and salary history, to:

EXTEL[®]
CORPORATION

Employment Manager
310 Anthony Trail
Northbrook, IL 60062

Equal Opportunity Employer m/f

Computer Design Engineers

San Francisco Peninsula

Expansion of our Systems Development staff has created opportunities for:

Manager Digital Communications Hardware

BSEE/MSEE with 10 years experience and demonstrated management skills required.

Engineers/ Sr. Engineers

Openings at all levels in the areas of:

- Central Processor Design
- Peripherals Controllers
- Memory Systems Design
- I/O Systems Design

These positions require BSEE/CS or MSEE/CS plus 2-5 years design experience. Familiarity with 1 or more of the following: MOS/LSI, Bit Slice devices; telecommunications, minicomputer I/O systems, and Assembly language.

Four-Phase Systems offers excellent compensation in a stable growth environment where **INDIVIDUAL ACHIEVEMENT IS RECOGNIZED**. Contact C. Horn, 800/538-9660, or 408/255-0900, or send resume to Professional Employment, **FOUR-PHASE SYSTEMS**, 10700 N. De Anza Blvd., Cupertino, CA 95014. Equal employment opportunity is our pledge & practice. Four-Phase Systems

 **Four-Phase Systems**
Advanced Technology for Distributed Processing

ELECTRONIC FIELD SERVICE ENGINEERS

If you know where you're
going, you've got a good start...
but that's all
you've got.

The Woodward Governor Company, manufacturer of prime mover controls exclusively since 1870 has immediate need for Electronic Field Service Engineers.

Position requires an EE Degree with analog and digital background. Prefer exposure to microprocessors. You must be willing to travel over 50% of the time, primarily in the U.S. with occasional trips abroad.

Become a member of our well established, stable organization which offers an outstanding profit sharing plan, benefit program and excellent working conditions. Please send your resume to: Personnel Department, Woodward Governor Company, P.O. Box 1519, Fort Collins, Colorado 80522. We are an equal opportunity employer m/f.

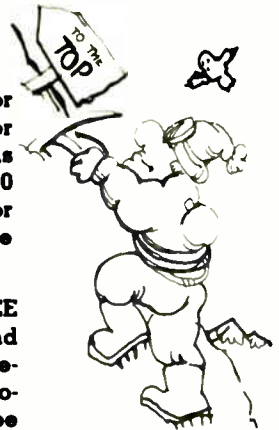

WOODWARD

EEs for Programmable Industrial Controls

New England Openings

If you want to be part of a new creative frontier with technical challenges, career growth and opportunities, join us at Texas Instruments in Attleboro, Massachusetts. We are working on the frontier of reducing and eliminating the high cost of program development. This involves defining microprocessor and microcomputer hardware with an architecture specifically tailored for broad classes of industrial control problems.

At beautiful, suburban Attleboro, you'll be close to Boston and Providence, yet far from smog and city problems. You'll enjoy good schools and affordable living. TI Attleboro is the principal manufacturing facility for TI's worldwide Materials and Electrical Products Group, a long-established leader in the manufacture of controls and metallurgical materials.

Analog Circuit Design Engineer

Responsibilities will include the designing of analog control circuits for a rapidly growing family of industrial controls products. Initial assignment will be implementation of cost reduction of present product line.

Subsequent assignments will include product design responsibilities extending from conception through production of new analog interface modules for TI's industrial controllers. BSEE and up to 3 years' experience required.

Sr. Digital Design Engineer

Responsible for hardware design of industrial controllers and peripheral products extending from the product's definition stage

into and through the pilot production phase. Requires BSEE/MSEE with 4-7 years' experience in TTL circuit design, microprocessor-based design and software design.

Digital Design Engineer

Responsibilities to include the designing of various digital subsystems in TI's industrial controls product family and will extend from circuit design, prototyping, worst case analysis through pilot production of new products and engineering support for existing product line. Requires BSEE with up to 3 years' experience in TTL circuit design and microprocessor related design. Software design experience extremely desirable.

Design Engineer (Hardware & Software)

Responsibilities to include designing and developing as part of a team working on "state-of-the-art" real time operating microprocessor systems, utility routines and communication routines. Knowledge and understanding of top down design a real advantage. BSEE/Computer Science required, MSEE/Computer Science desirable. Must have 2-5 years' related experience.

Sustaining Engineering Supervisor

Strong individual with electrical engineering background to supervise engineers in the developing stage for a new product design of microprocessor-based industrial controls. Responsibilities include new product introduction into manufacturing, test yield analysis and improvement,

cost reduction programs – which will include some product redesign. The successful candidate should possess the ability to instill team involvement to improve productivity and must have working knowledge of TTL, microprocessors and computer-based technology with a minimum of 3 years' in electronics manufacturing environment. Prefer MBA with BSEE, MSEE desirable.

Systems Test Engineer

Designing computer-based test equipment to be used by manufacturing to test microprocessor-based industrial controls products. Responsibilities include executing both hardware and software designs associated with all test stations. Requires a BSEE/Computer Science with a working knowledge of computer architecture, 8080, Z-80, 990 microprocessors, software and digital design.

Process Engineers

Responsible for general manufacturing engineering duties connected with the production of industrial controls product lines. Duties include cost reduction, yield/quality improvement, equipment and process design. Requires BSME or EE with up to 5 years of experience.

If you qualify for one of these openings and if you are familiar with volume manufacturing of technical electronics products, send your resume in complete confidence to: Bill Forgiione at 34 Forest Street, M.S. 12-3, Attleboro, Mass. 02703.



TEXAS INSTRUMENTS

INCORPORATED

An equal opportunity employer M/F

Engineer

CONFIGURATION MANAGEMENT

The rapidly accelerating development of new, more sophisticated telephone switching systems has created this outstanding career opportunity for a specialist in configuration management.

The selected candidate's primary objective will focus on insuring that all hardware, software, and documentation components are incorporated into newly released system product packages. Working in close conjunction with the laboratory, marketing, manufacturing and installation departments, the individual will be actively involved in the initial planning stages, scheduling and the defining of new products and major revisions of existing products for domestic and international markets.

This key coordinating position calls for a BS degree and a basic knowledge of the combined areas of computer science, electronics and production control. Good understanding of computer based tools utilized in scheduling, stocklist generation, program product generation and documentation product generation essential.

We offer an excellent package of compensation, top benefits and outstanding opportunities for growth to the candidate capable of measuring up to the high priority responsibilities this position entails. For consideration:

CALL TOLL FREE (800) 323-1966
In Illinois (800) 942-0491
Monday thru Friday from 8am to 5pm cdt

If unable to call, send resume with salary history, in confidence to:

Technical Employment Representative, Dept 471D A6

GTE AUTOMATIC ELECTRIC
LABORATORIES

400 N. Wolf Road
Northlake, IL 60164

An Equal Opportunity Employer M/F

Innovators in Electronics

Instrument Scientist- Instrument Technology

The continued success of our growing international organization has created a career opportunity for a qualified Instrument Scientist.

The qualified candidate for this position will act as the senior member of a research team set up to do original research and development on the automation of various diagnostic technologies. Responsibilities will involve electronic design, data handling, mechanical applications, prototype instrumentation development, etc. A PhD in EE, Chem E, Physics, Optics or related areas will be essential. A proven track record in the development of diagnostic instrumentation is highly desirable.

As an industry leader, Abbott can offer exceptional potential for career development in addition to an attractive compensation program. For consideration, send a resume with salary history, in complete confidence, to:

ABBOTT
NORTH CHICAGO, ILL. 60064

Maria Marciano
Corporate
Placement

Abbott is an Affirmative Action Employer



This week's ad
is to let you
know we
ALWAYS have
a place for
good people.

Send your resume to the good people company, Signetics, MS 300, 811 East Arques Avenue, Sunnyvale, CA 94086. We are an equal opportunity employer m/f.

The Good People Company.
Signetics
a subsidiary of U.S. Philips Corporation

engineers

For a change, join a people-oriented company that wants to work for you!

At GTE LENKURT an employee is first and foremost a human being and not a component.

Our customers depend on us for excellence in design, manufacture, and service of sophisticated video, voice, and data communications systems. You can trust us for a rewarding career, endless advancement potential, interface with the best and the brightest people in the industry, and personal growth and development in a dynamic organization.

If you wish to upgrade your position, send your resume for prompt and confidential consideration to :

Kazim Ali,
Employment Manager
GTE LENKURT, INC.
1105 County Road
San Carlos, Calif. 94070
(415) 595-3000

development engineers

Electrical Engineers at all levels for projects in subscriber carriers, signalling and VF equipment design, PCM carrier and switching as well as digital microwave radio. Experience is either linear, digital or microprocessor control circuit design.

SUBSCRIBER CARRIER CONCENTRATORS

Systems and circuit design Engineers to develop microprocessor controlled subscriber pair gain systems. Knowledge of PCM signal processing and digital switching techniques is desirable.

PCM TRANSMISSION

Responsibilities include circuit design of PCM line repeaters and office equipment. Position requires 1-5 years experience in analog and digital circuit design and BSEE minimum requirements.

VF EQUIPMENT

Openings at all levels for planning, design and development of voice band loop extension and conditioning equipment aimed at private line special services applications.

FIBER OPTICS

We seek an experienced Engineer desiring to work on the design and circuit applications of fiber optics components such as laser diodes, light emitting diodes, avalanche photodiode receivers, single fiber connectors and cable-to-cablesplcing.

FIBER OPTICS CIRCUIT DESIGN

You will design transmitters, receivers and line repeaters for medium and high bit rate Fiber Optics systems. You must have H.F. analog design experience. Fiber Optics experience desirable. BS with 2-5 years experience minimum requirements.

DIGITAL SYSTEMS

Responsible for defining characteristics, evaluating new applications and developing customer documentation on evolving multi-line PCM subscriber pair gain systems, channel banks, multiplexers and re-peater lines. Should have electrical engineering background and be familiar with Telephone Operating Company switching and digital transmission plant.

MICROPROCESSOR CHIEF PROGRAMMER

Real time programming experience. Knowledge of structured programming. BS/MSEE education with experience preferably in communications and/or telephone switching.

CUSTOM I.C. DESIGN

Development of Custom Integrated Circuits, Analog and/or Digital Design and computer simulation desirable. Willing to train an engineer with solid experience in discrete circuit design. Will work with Bipolar and N-MOS technologies.

PROCESS EQUIPMENT PROGRAMMING

Development of Automatic programs for high speed laser trim and test of hybrid circuits. Solid background in linear or digital circuit analysis and aptitude in mini-computer programming required.

DESIGN SUPPORT

Electrical Engineers at various levels to maintain, modify and assist the current production of electrical designs in various product lines.

EQUIPMENT DESIGNERS

For Physical design of Proprietary Products. Equipment Designers must have knowledge of electro-mechanical packaging and/or printed circuit board layout. No degree necessary.

other openings at LENKURT

SEMICONDUCTOR TEST ENGINEER

We seek an Engineer with a BSEE (or equivalent) and 2-5 years experience testing and evaluating low and high frequency semiconductor components such as Diodes, Transistors, Linear and Digital Integrated Circuits. Knowledge of component failure analysis, Sentry II programming and some circuit design experience is desirable. (Job # HM-007)

TEST EQUIPMENT ENGINEER

Position requires experience in analog and digital circuit design, preferably in the area of test equipment. Some programming background desirable. Ability to convert engineering test requirements into finished production test equipment. You must be able to analyze existing test facilities and processes, and design and implement cost effect improvements. BSEE or equivalent experience required. MSEE preferred. (Job # JC1)

SENIOR TEST ENGINEER

Responsibilities include the ability to test and troubleshoot thick film circuit hybrids, evaluate yield data and take corrective action in hybrid assembly operations. The engineer should have experience with computer controlled laser trimming and be capable of programming and evaluating of hybrid test equipment and complete controlled laser systems for functional trimming. The position requires an Electrical Engineering degree or equivalent with 3-5 years manufacturing experience. (Job # MCK2)

INDUSTRIAL METHODS IMPROVEMENT

Responsibilities include methods improvement, equipment selection, facilities layout and work flow, materials handling and packaging, computer applications to manufacturing problems and solution of production problems during new product introduction. Electronic assembly experience desirable. Minimum BSIE or equivalent with 1-2 years experience desired. (Job # MCK1)

STAFF ENGINEER, TOOL & MACHINE ENGINEERING

BSME and 8 years of experience or Professional Manufacturing Engineer in the field of Electronics Manufacturing. Responsibilities include tool design for sheetmetal and small machined parts, the design of process and assembly equipment used for electronics manufacturing, and the design of unsophisticated production machines including electrical and air-hydraulic controls. (Job # HL1)

PROJECT ENGINEER

Be responsible for analyzing contract orders for Microwave and Multiplex Systems. Determine exact details of equipment required (omit the contractual obligations. This includes office requirements for power, antennas, towers, and other ancillary equipment. This effort requires performing varying amounts of System Engineering, scheduling, contract interpretation and direct customer contact. BSEE degree desirable for an AA degree with equivalent experience. Technical experience in the following areas: Microwave Radio, Multiplex, Supervisory and Control and Switching Systems. Will consider some recent graduates for junior or entry level positions. (Job # GM 2)

SENIOR SYSTEMS ENGINEER

Determine the proper configuration of radio, FDM or PCM multiplex and data equipment to meet customers' communications requirements. System problems such as electrical interfacing with existing networks, calculation of channel signal-to-noise ratios, and analysis of potential microwave radio interference situations will be solved. BSEE or equivalent degree and some experience required. (Job # RW1)

TRANSMISSION ENGINEER

Utilize topographic and other maps to select radio repeater sites, determine tower heights and antenna equipment needed to meet customers' communications requirements. You will also calculate system noise performance, predict radio propagation reliability and analyze potential microwave interference situations. BSEE or equivalent degree and 0-2 years experience required. (Job # RW2)

FIELD SERVICE ENGINEER

BSEE (or equivalent Telecommunications Electronics experience) You will work closely with Development Engineers and troubleshooting with customers via telephone or in the field. Position requires responsible person, capable of exercising good judgement in customer relations and able to make independent decisions as necessary. 20% travel involved. (Job # T1 4)

MICROCIRCUIT PROCESS ENGINEER

Position will include development and evaluation of thick and thin film materials and processes plus the development of microcircuit packaging techniques for semiconductors used in telecommunications equipment. Applicant should have BS/Chemistry, Chemical Engineering or Material Science. Experience in microcircuit technologies required. (Job # BW2)

ENGINEERING WRITER

This position requires a strong electronics background plus working knowledge of microwave radio for telephone systems. Min 2 years experience in writing commercial instructions, manuals or engineering level documents. (Job # FF-31)

SYSTEMS ANALYST

Bachelor's degree plus 1-5 years experience in analysis and design of computerized business information systems. Experience in data base/data communications-oriented applications for a manufacturing company desired. Must have sound knowledge of business functions and have strong verbal and written communications skills. (Job # SL1)

ANALYST PROGRAMMER

To work in an IBM 370-148 SVS environment. Must have in-depth knowledge of COBOL, JCL, utilities, etc. BS or BA degree preferred, AA acceptable or related work experience. (Job # EC1)

GTE Lenkurt benefits are an outgrowth of a feeling of responsibility toward the Employee that has always prevailed. Some benefits are entirely at the option of the Employee — as they should be. Others are automatic. Taken as a whole, they represent a comprehensive, competitive package that can offer a distinct advantage to the user. Consider the following:

Excellent salaries; paid vacations and Holidays; Medical, Life and Disability Insurance; stock purchase; savings and investment program; 100% tuition refund; pension plan; Employee store, Credit Union and Recreation Club privileges. We are an Equal Opportunity/Affirmative Action Employer.

GTE LENKURT

A Part of General Telephone & Electronics Corporation on the beautiful SAN FRANCISCO PENINSULA

Senior Electronic Engineers

This is a rare opportunity for innovative design engineers to join the world's leading innovator in instant still and motion picture photography. Polaroid. The people we select must have proven track records of creative conceptual design in analog or digital circuitry as they apply to small, electro-mechanical devices. The successful candidates will become members of an interdisciplinary team and be responsible for finding ways to apply electronic circuits and systems to the development of unique, new cameras and camera accessories. For those with an interest in the complete development spectrum, there are also opportunities to guide the development of our electronic devices from the design stage right through to production. A demonstrated ability to interface with others and communicate effectively both orally and in writing is mandatory in both areas.

Polaroid is a dynamic, people-oriented company headquartered in Cambridge, Massachusetts. Our continued growth and leadership in instant photography depends, to a great degree, on the bright, innovative ideas contributed by engineers in jobs such as these.

If you have a BS or MS in Electrical Engineering and at least four years experience as described above, please forward your resume to George Austermann, Polaroid Corp., 565 Technology Square, Cambridge, MA 02139.

An equal opportunity employer M/F

Polaroid

TECHNICAL TRANSLATOR

As an experienced free lance technical translator I speak English and French Electronics fairly well. So, for technically accurate translations contact:

**J.L. AVRIL
TRANDUCTIONS**

**B.P. 24
92310 SEVRES
FRANCE
TEL. (1) 027.68.99
TELEX TRANG 203936 F**

POSITION VACANT

Electrical Engineering Technology—Expanding upper division E.C.P.D. accredited Bachelor of Technology Program seeks two visiting professors to teach in the linear and digital electronics areas. Courses to be taught include active filters, power electronics, basic digital logic, TTL digital design, and the 6800 and 8085 microprocessor systems. M.S. Degree in Electrical Engineering required with teaching and industrial experience desirable. Excellent salary and benefits. Ten month contract with Summer teaching possible. Position available Fall, 1978. Send resume and references to Professor J. Adams, Department of Electrical Technology, Rochester Institute of Technology, One Lomb Memorial Drive, Rochester, New York 14623. RIT is an Affirmative Action/Equal Opportunity Employer.

FIBER OPTICS ENGINEER / PHYSICIST

An established Conn. based company in pleasant suburban surroundings seeks an Engineer or Physicist for work on research development and testing of fiber optics circuit components.

The position will involve the design and development of E/O receiver and transmitter modules as well as the development of new products and applications in optical fiber communication systems.

B.S. Degree with 2-5 years related experience in optics or electro optics is desired.

Attractive salary and benefit package.

Please submit your resume and salary history to:

**J. E. SLOANE; E. B. INDUSTRIES
660 HOPMEADOW ST.
SIMSBURY, CT. 06070
an equal opportunity employer**

ELECTRONICS ENGINEERS

Specializing in the placement of Electrical Engineers Nationally. All fees company paid. This is only a partial listing. Send resume.

Project Mgr.	30K	Power Eng.	23K
Design E.E.	21K	Controls Eng.	23K
Installation	22K	Systems Eng.	22K
Sr. Systems	25K	Facilities	25K
Project Eng.	22K	Mechanical Des.	24K

COREY ASSOCIATES

Suite 230, 105 Wolf Rd., Albany, NY 12205

EMPLOYMENT SERVICES

Electronic engineering growth positions with clients located nationally. We would be glad to consider your resume. Joe Torcassi (EE), Director, R.J. Bushee & Associates, 1001 Carew Tower, Cincinnati, OH 45202. 513/621-2015.

Engineers—discrete, personal, reputable national fee paid placement serv. Murkett Assoc. Box 281, Montgomery, AL 36101.

EMPLOYMENT SERVICE

M.E.s, I.E.s, E.E.s, Ch.E.s—Let our search firm represent you to our clients nationally and overseas. If you are seeking a more prestigious position with increased responsibilities and a better future. send a resume or request a position profile and at no charge we will provide you with interview opportunities. Register in our exclusive Executive Search Program. All replies strictly confidential. All Fees employer paid at Management Recruiters, 1900 Point West Way, Suite 281, Sacramento, CA 95815. (916) 920-0441.

▪ Abbott Transistor Labs	49	Mitel Semiconductor Inc.	50
ADAC	48	‡ Mostek Corp.	15, 31
Advanced Micro Devices	10-11	Motorola Semiconductor Products	37
▪ Amp., Inc.	130-131	McGraw Edison Co. Bussmann Mfg. Division	67
• Anritsu Electric Co., Ltd.	10E	‡ Nikkei Electronics	62
Bokers Inc.	123	Nippon Electric Co., Ltd.	56-57
‡ Robert Bosch	51	• Oscilloquartz	51
Boschert	68	• Philips Elcoma	11E
▪ Bourns, Inc.	2nd cover	• Philips Elcoma Market Promotion	5E
▪ Burr Brown Research Corp.	4E	Pinellas County	149
Caleco	149	Powercube Corporation (Div. of Unitrode)	81
Centralab Electronics Division	3rd cover	• Preh Vertriebsges mbH	15
▪ Cherry Electrical Products	1	Pro-Log	13
▪ Clairax Electronics	4th cover	Racal-Dana Instruments, Inc.	88-89
State of Colorado Div. Commerce & Development	30	RCA Solid State	64
Conic Data Systems	7	• Rohde & Schwarz	1E
▪ Continental Specialties	160	• Riken Denki Co., Ltd.	12E
▪ Control Data Corporation	43	Rockwell International Telecom Circuits	137
Control Electronics	8	• Siemens A G Karlsruhe	62
Cromemco	34	‡ Siliconix	47
▪ Dellec Corp.	129	Sprague Electric	58
▪ Dialight	75	• SRA Communications AB	6E
▪ Eagle Magnetic Company	119	Synertek	40
Electrodyn Inc.	127	▪ Tektronix, Inc.	73
▪ Electronic Navigation Industries	52	▪ Teledyne Relays	27
▪ Erie Technological Products	134-135	Teledyne Semiconductor	61
Fairchild Systems Technology	32-33	Teredyne, Inc.	78, 105
Faultfinders, Inc.	55	Texas Instruments Components	9
Figaro Engineering Inc.	8	Textool Products Inc.	14
• Ganz Measuring Works	8E	Thick Film Systems, Inc.	133
▪ General Instrument Microelectronics	2	• Vareadyne Industries Inc.	77
▪ Genrad	71	Virgin Islands of the US Ind. Devel. Comm.	54
▪ Grayhill Inc.	85	▪ Wavetek Indians	90
▪ Hewlett-Packard	17-26	Wilhelm Westermann	8
▪ Honeywell TID	38-39	Wintek Corp.	119
▪ Hughes Aircraft	45	Zero Corporation	16
Information Control Corporation	87		
• Italtel/SIT	3E, 7E		
‡ Intel-Microcomputer Components	76-77		
Intel Special Products Division	28-29		
International Crystal Mfg. Co.	6		
Ion Physics Company	133		
• Jepico Co. Ltd.	9E		
▪ Kepeco, Inc.	5		
▪ Lambda Electronics Corporation	139-148		
LRC Inc.	54		
Mallory Capacitor Co.	119		
• Membrain Limited	47		

Classified and employment advertising

F. J. Eberle, Manager 212-997-2557

Abbott Laboratories	156
AVCO International Service Div.	152
Avril, J L	158
Corey Associates	58
E.B. Industries	58
Extel Corporation	154
Four-Phase Systems	154
GTE Automatic Elec. Labs.	156
GTE Laboratories	153
GTE Lenkurt	157
Polaroid	158
Signetics	156
Tektronix	152
Texas Instruments Inc.	155
Woodward Governor	154

▪ For more information of complete product line see advertisement in the latest Electronics Buyers Guide

* Advertisers in Electronics International

‡ Advertisers in Electronics domestic edition

Advertising sales manager: Paul W. Reiss

1221 Avenue of the Americas, New York, N.Y. 10020

[212] 997-4371

Atlanta, Ga. 30309: Michael Charlton

100 Colony Square, 1175 Peachtree St., N.E.

[404] 892-2868

Boston, Mass. 02116: Frank Mitchell

607 Boylston St.

[617] 262-1160

Chicago, Ill. 60611

645 North Michigan Avenue

Jack Anderson [312] 751-3739

Robert M. Denmead [312] 751-3738

Cleveland, Ohio 44113: William J. Boyle

[716] 586-5040

Dallas, Texas 75201: John J. Uphues

2001 Bryant Tower, Suite 1070

[214] 742-1747

Denver, Colo. 80203: Harry B. Doyle, Jr.

123 Speer Blvd. #400

[303] 837-1010

Detroit, Michigan 48202: Jack Anderson

1400 Fisher Bldg.

[313] 873-7410

Fort Lauderdale, Fla. 33306: Michael Charlton

3000 N.E. 30th Place

[305] 563-9111

Houston, Texas 77002: John J. Uphues

601 Jefferson Street, Dresser Tower

[713] 659-8381

Los Angeles, Calif. 90010: Robert J. Rielly

Robert E. Boedicker, 3200 Wilshire Blvd., South Tower

[415] 487-1160

Minneapolis, Minn. 55435: Robert M. Denmead

4015 W. 65th St.

[312] 751-3738

New York, N.Y. 10020

1221 Avenue of the Americas

Michael J. Stoller [212] 997-3616

Matthew T. Reseska [212] 997-3617

Philadelphia, Pa. 19102: Matthew T. Reseska

Three Parkway

[212] 997-3617

Pittsburgh, Pa. 15222: Matthew T. Reseska

4 Gateway Center

[212] 997-3617

Rochester, N.Y. 14534: William J. Boyle

1175 Pittsford-Victor Rd., Pittsford, N.Y.

[716] 248-5620

San Francisco, Calif. 94111: Don Farris

Dean Genge, 425 Battery Street,

[415] 362-4600

Paris: Patrick Mouillard

17 Rue-Georges Bizet, 75116 Paris, France

Tel: 720-73-01

United Kingdom & Scandinavia: Robert Ghey

34 Dover Street, London W1

Tel: 01-493-1451

Scandinavia: Andrew Karnig and Assoc.

Kungsholmsgatan 10

112 27 Stockholm, Sweden

Tel: 08 51 68 70 Telex: 179 51

Milan: Luigi Rancati

1 via Baracchini, Italy

Phone 86-90-656

Brussels:

23 Chaussee de Wavre

Brussels 1040, Belgium

Tel: 13-73-95

Frankfurt/Main: Fritz Krusebecker

Liebigstrasse 27c, Germany

Phone 72 01 81

Tokyo: Tatsumi Katagiri, McGraw-Hill

Publications Overseas Corporation,

Kasumigaseki Building 2-5, 3-chome,

Kasumigaseki, Chiyoda-Ku, Tokyo, Japan

[581] 9811

Business Department

Thomas M. Egan

Production Manager [212] 997-3140

Carol Gallagher

Production Manager International

[212] 997-2045

Betty Preis

Production Manager Domestic

[212] 997-2908

Roberta Cummings

Production Manager Related Products [212] 997-

2044

Thomas Kazich, **Production Assistant**

[212] 997-2843

Frances Vallone

Reader Service Manager

[212] 997-6057

Electronics Buyers' Guide

H.T. Howland, **General Manager**

[212] 997-6642

Regina Hera, **Directory Manager**

[212] 997-2544

Roberta Cummings **Production Manager**

[212] 997-2044

Thomas Kazich, **Production Assistant**

[212] 997-2843

Frances Vallone, **Reader Service Manager**

[212] 997-6057

Classified and Employment Advertising

Frank Eberle, **Manager**

[212] 997-2557

10 nsec. \$69.95

Meet CSC's LP-3. The multi-family logic probe that's as fast as a high-speed memory scope. At about 1/100th the price.

You won't want to be without this compact, enormously versatile test and troubleshooting tool that does the work of a level detector, pulse detector, pulse stretcher and memory probe. It gives you instant, positive indications of circuit conditions—capturing one-shot and low-rep-rate pulses (down to 10nsec) that are barely visible, even on a fast scope.

Easy to use. No sync, polarity or circuit loading to worry about: just set a switch to the proper logic family, connect two clip leads to the circuit's supply and touch the probe tip to the node under test. You get an instant picture of circuit conditions: Separate LED's indicate logic "1", logic "0" and all pulse transitions. To store single-shot and low-rep-rate pulses, set the PULSE/MEMORY switch to MEMORY.

At \$69.95, LP-3 simplifies testing, debugging and servicing all types of digital circuits.

Order today. Call 203-624-3103 (East Coast) or 415-421-8872 (West Coast): 9 a.m.-5 p.m. local time. Major credit cards accepted. Or see your CSC dealer. Prices slightly higher outside USA.

Logic Family Switch—TTL/DTL or CMOS matches Logic "1" and "0" levels; CMOS position also compatible with HTL, HINIL and MOS logic.

PULSE/MEMORY Switch & LED—PULSE position detects and stretches pulses as narrow as 10 nanoseconds to 1/10 sec.; MEMORY stores single-shot and low-rep-rate events indefinitely; HI/LO LED's remain active.

HI/LO LED's—Display level (HI-logic "1" LO-logic "0") of signal activity.

Interchangeable probe tips—Straight tip supplied; optional alligator clip and insulated quick-connecting clip available. Optional input ground lead.

Plug-in leads—24" supplied, with alligator clips. Virtually any length leads may be connected via phono jack.

*Manufacturer's Recommended Resale
© 1977 Continental Specialties Corp.

Specifications

Input impedance 500,000Ω

Thresholds (switch selectable)	DTL/TTL	HTL/CMOS
logic 1 thresholds (HI-LED)	2.25V ± .10V	70% Vcc ± 10%
logic 0 thresholds (LO-LED)	0.80V ± .05V	30% Vcc ± 10%

Min. detectable pulse width 10nsec. guaranteed

Pulse detector (PULSE LED) in PULSE position of PULSE/MEMORY switch, 1/10-sec. pulse stretcher makes high-speed pulse train or single events (+ or - transitions) visible; in MEMORY position, first transition lights and latches LED

Operating temperature 0-50°C

Physical size (l x w x d)

5.8 x 1.0 x 0.7" (147 x 25.4 x 17.8mm)

Weight 3oz. (0.85Kg)

Power leads removable 24" (610mm) with color-coded insulated clips; others available

Input protection overload, ±25V continuous; 117 VAC for less than 10 sec.; reverse polarity, 50V

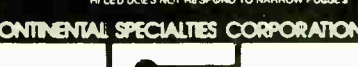
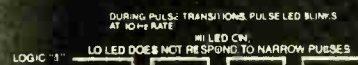
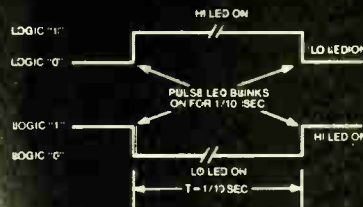
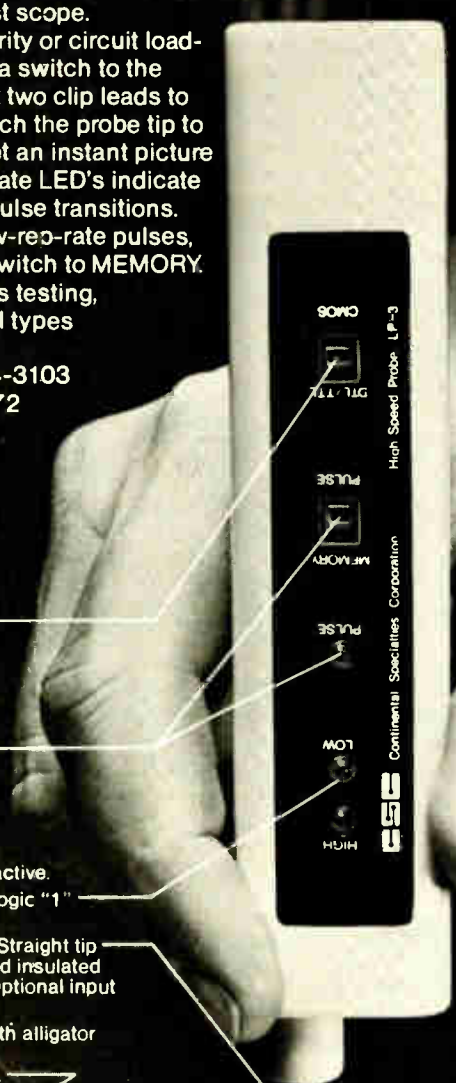

CONTINENTAL SPECIALTIES CORPORATION



70 Fulton Terrace, Box 1492, New Haven, Ct 06509

203-624-3103 TWX 710-465-1227

WEST COAST: 351 California St., San Francisco, CA 94104,

415-421-8872 TWX 910-372-7992

GREAT BRITAIN: CSC UK LTD.

Spur Road, North Feltham Trading Estate,

Feltham, Middlesex, England.

01-890-0792 Int'l Telex: 851-881-3669

Circle 160 on reader service card

NEW LP-3!

From MIL spec to YOUR spec...



Your best buy is Centralab Hi-Rel Capacitors

That's why we're your best source when specs are tough

When it comes to high reliability monolithic ceramic capacitors, there's more than one reason why so many buyers come to Centralab. Their demanding specifications can only be met by a company with proven experience and capability. That's what has made us the leader.

Today, we point with pride to our complete line of hi-rel ceramic capacitors that recognizes the needs of contemporary applications and technology, including MIL-C-39014.

For more than 18 years we've pioneered with design innovations and technological breakthroughs. Our experience includes an impressive record of supplying most major military/aerospace programs including Cruise, Minuteman and Sparrow. But our hi-rel accomplishments don't stop there. We've kept pace with the market, supplying high quality, "tight-spec" capacitors to an ever-growing list of blue chip electronics manufacturers.

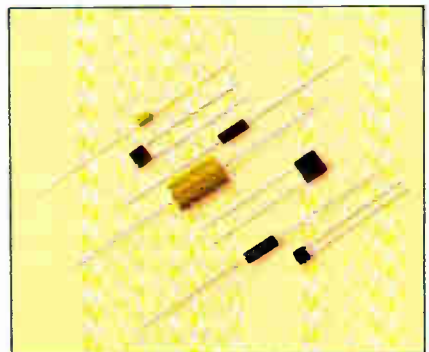

Investigate all the reasons why Centralab is the leader in hi-rel ceramic capacitors. Send for our complete catalog by checking the reader service card or call Jerry Weber at 213/240-4880.

A commitment to hi-rel production

At Centralab, you'll find a major facility that is solely dedicated to the production of hi-rel ceramic capacitors. We offer you application engineering assistance, for the best in design... rigid process control at every stage of manufacture, to guarantee performance... testing procedures — through our QA and Hi-Rel Labs — to insure the highest quality.

This commitment to hi-rel production has not only built our enviable record for facility and QA approval from customers, it's the reason we're their first source. Shouldn't we be yours?

*Products you need
from people who care.*



CENTRALAB

ELECTRONICS DIVISION
GLOBE-UNION INC.

4561 Colorado Boulevard
Los Angeles, California 90039

CERAMIC CAPACITORS • FILTERS • THICK FILM CIRCUITS • SWITCHES • POTENTIOMETERS • TRIMMER RESISTORS

Circle 901 on reader service card

First in the Industry!

LEDs with PHOTOCONDUCTORS

in DIP OPTO-ISOLATORS

Clairex has developed these four LED/photoconductive cell isolators in the conventional dual-in-line package. They are truly an industry first! The inherent slower speed response of a photoconductive cell, as compared to a silicon detector, provides an ideal unit for

noise and transient immunity.

All four units have a photoconductive cell output capability of 250 volts PAC along with an isolation voltage of 1500V PAC. They also feature a minimum R_{OFF} of one megohm and guaranteed R_{ON} maximums

at I_f biases of 16 ma and 1 ma respectively.

The CLM 50 and CLM 51 incorporate a GaP LED with a photoconductive cell for both linear and logic functions. The CLM 60 and CLM 61 feature two GaP LEDs connected in inverse parallel in their input cir-

cuits to facilitate an a-c input signal to the isolator.

For complete details or any other assistance with your opto-electronic problems, call 914-664-6602 or write Clairex®, 560 South Third Avenue, Mount Vernon, New York 10550.

LED- PHOTOCONDUCTOR DIP ISOLATORS

The CLM50 and CLM51 incorporate a GaP LED connected in inverse parallel and coupled to a photoconductive cell thereby featuring a 250V PAC isolation voltage. The photoconductive cell outputs range with 1 Meg ohm maximum R_{OFF} and 1500V PAC isolation voltage. Guaranteed R_{ON} maximums at 16mA and 1mA respectively. Controlled resistances are featured at 16mA and 1mA respectively.

TECHNICAL DATA

LED	CHARACTERISTICS	TEST CONDITIONS	Min.	CLM50 Typ.	Max.	CLM51 Typ.	Max.	UNIT
I_f max	Maximum forward current	$I_f = 16 \text{ mA}$	20	40	20	25	40	mA
V_f	Forward voltage	$I_f = 16 \text{ mA}$	2.0	2.5	2.0	2.6	volts	
I_R	Reverse current	$V_R = 3 \text{ V}$	1	1	1	1	250	µA DC or PAC
PHOTOCELL V_{max}	Cell voltage		50	50	50	50	volts	
P	Power dissipation	25° C	1	1	1	1	1.75W	ohms
PHOTOMOD R_{ON}	On resistance	$I_f = 1 \text{ mA}$ $I_f = 16 \text{ mA}$ 5 sec after $I_f = 0$ 4 VDC on cell	1 Meg	1.5M	2M	4M	1.5M	ohms
R_{OFF}	Off resistance		500	500	500	500	500	ohms
t_r	Rise time	Time to 63% of final condition at $I_f = 16 \text{ mA}$	60	60	60	60	60	µsec
t_d	Decay time	Time to 100%	1500	1500	1500	1500	1500	µsec
V_{iso}	Isolation		1	1	1	1	1	1500V PAC
θ_{J-C}	Case temperature coefficient	$I_f > 1 \text{ mA}$	1	1	1	1	1	1/°C

DUAL LED - PHOTOCONDUCTOR DIP ISOLATORS

The CLM60 and CLM61 incorporate two GaP LEDs connected in inverse parallel and coupled to a photoconductive cell thereby featuring a 250V PAC isolation voltage. The photoconductive cell outputs range with 1 Meg ohm maximum R_{OFF} and 1500V PAC isolation voltage. Guaranteed R_{ON} maximums at 16mA and 1mA respectively. Controlled resistances are featured at 16mA and 1mA respectively.

TECHNICAL DATA

LED	CHARACTERISTICS	TEST CONDITIONS	Min.	CLM60 Typ.	Max.	CLM61 Typ.	Max.	UNIT
I_f max	Maximum forward current	$I_f = 16 \text{ mA}$	20	40	20	25	40	mA
V_f	Forward voltage	$I_f = 16 \text{ mA}$	2.0	2.5	2.0	2.6	volts	
I_R	Reverse current	$V_R = 3 \text{ V}$	1	1	1	1	250	µA DC or PAC
PHOTOCELL V_{max}	Cell voltage		50	50	50	50	50	volts
P	Power dissipation	25° C	1	1	1	1	1.75W	ohms
PHOTOMOD R_{ON}	On resistance	$I_f = 1 \text{ mA}$ $I_f = 16 \text{ mA}$ 5 sec after $I_f = 0$ 4 VDC on cell	1 Meg	1.5M	2M	4M	1.5M	ohms
R_{OFF}	Off resistance		500	500	500	500	500	ohms
t_r	Rise time	Time to 63% of final condition at $I_f = 16 \text{ mA}$	60	60	60	60	60	µsec
t_d	Decay time	Time to 100%	1500	1500	1500	1500	1500	µsec
V_{iso}	Isolation		1	1	1	1	1	1500V PAC
θ_{J-C}	Case temperature coefficient	$I_f > 1 \text{ mA}$	1	1	1	1	1	1/°C

CLAIREX ELECTRONICS
A DIVISION OF CLAIREX CORPORATION
560 South Third Avenue, Mount Vernon, N.Y. 10550

CLAIREX ELECTRONICS
A DIVISION OF CLAIREX CORPORATION
560 South Third Avenue, Mount Vernon, N.Y. 10550 (914) 664-6602

CLAIREX ELECTRONICS

A Division of Clairex Corporation
Circle 902 on reader service card