

MAY 1, 1975

**WHAT TO EXPECT AT THE NATIONAL COMPUTER CONFERENCE/104**

Achieving fast data transfer with tape storage/86

Super-Sceptre: software for analyzing complex digital systems/93

FOUR DOLLARS A MCGRAW-HILL PUBLICATION

# Electronics®

**EXPLORING THE DATA DOMAIN**

440 Y4598 MCSA9 JUN75  
STATE TECH INST  
LIBRARY  
MCGRAW HILL COME



# Value Packed Spectrum Analyzers

**Communications**  
10Hz - 43MHz  
(or 400MHz)

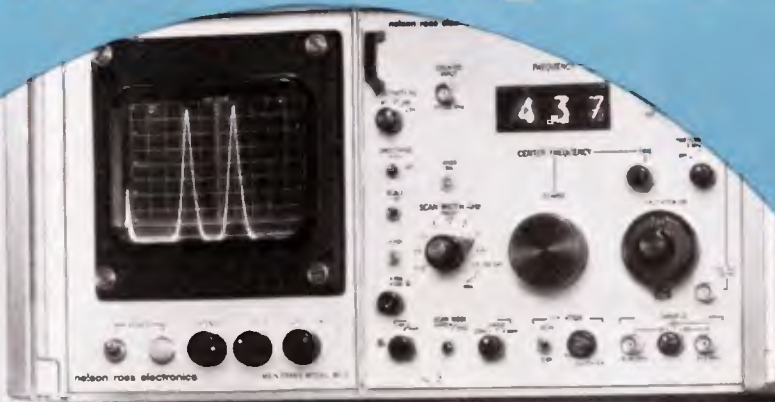

**Broadband**  
100Hz - 25MHz



**Microwave**  
10MHz - 6.5GHz



**Sub-Audio thru Microwave 0.5Hz to 6.5GHz**  
**Self-Contained Analyzers or Plug-Ins for hp & Tek Scopes**

Nelson Ross, the "SPECIALIST" in Spectrum Analyzers, offers you the most comprehensive selection of reliable, easy-to-use instruments — and backed by 15 years of spectrum analysis leadership.

Select from more than 30 models: Sub-Audio, Audio, Ultrasonic, Broadband, Telemetry, RF/SSB, RF/UHF, TV, Microwave . . . all at lowest cost.

Ask for your new NR SPECTRUM ANALYZER CATALOG with specifications and prices. Chances are that we have the right Spectrum Analyzer for you.

## nelson • ross electronics

*A Division of Polarad Electronics Corp.*

5 Delaware Drive / Lake Success, New York 11040 / 516-328-1100 / TWX 510-223-0414



Circle 900 on reader service card

Never heard of 65K words for ~~\$17,400~~? **\$15,350\***  
 Never heard of 96K words for ~~\$25,740~~? **\$19,350\***  
 Never heard of 21MX Dynamic Mapping?

## You're hearing it now!

Now you can expand your memory addressing space up to 1 million words. And that's not all.

- built-in memory parity
- no increase in cycle time (still 650 nsec)
- DMA channels mapped independently of system and user
- scatter loading capability, multiple base pages
- 38 new instructions for memory management or plug in your own
- read and/or write protection for each page
- memory protection fence, base page fence
- 65K words in 8¾ inches
- 196K words in 17½ inches

There is one company that offers Dynamic Mapping.  
 Hewlett-Packard.

Of course, since reliability is as important as features and price you'll want to read our just-completed "Engineering Evaluation Report." It proves that the 4K RAM based 21MX minicomputer series is already 50% more reliable than our previous "core" type computers.

For your free copy, call or write.

## HP minicomputers. They work for a living.

HEWLETT  PACKARD

Sales and service from 172 offices in 65 countries.  
 1901 Page Mill Road, Palo Alto, California 94304



\*Domestic USA prices only 22502D

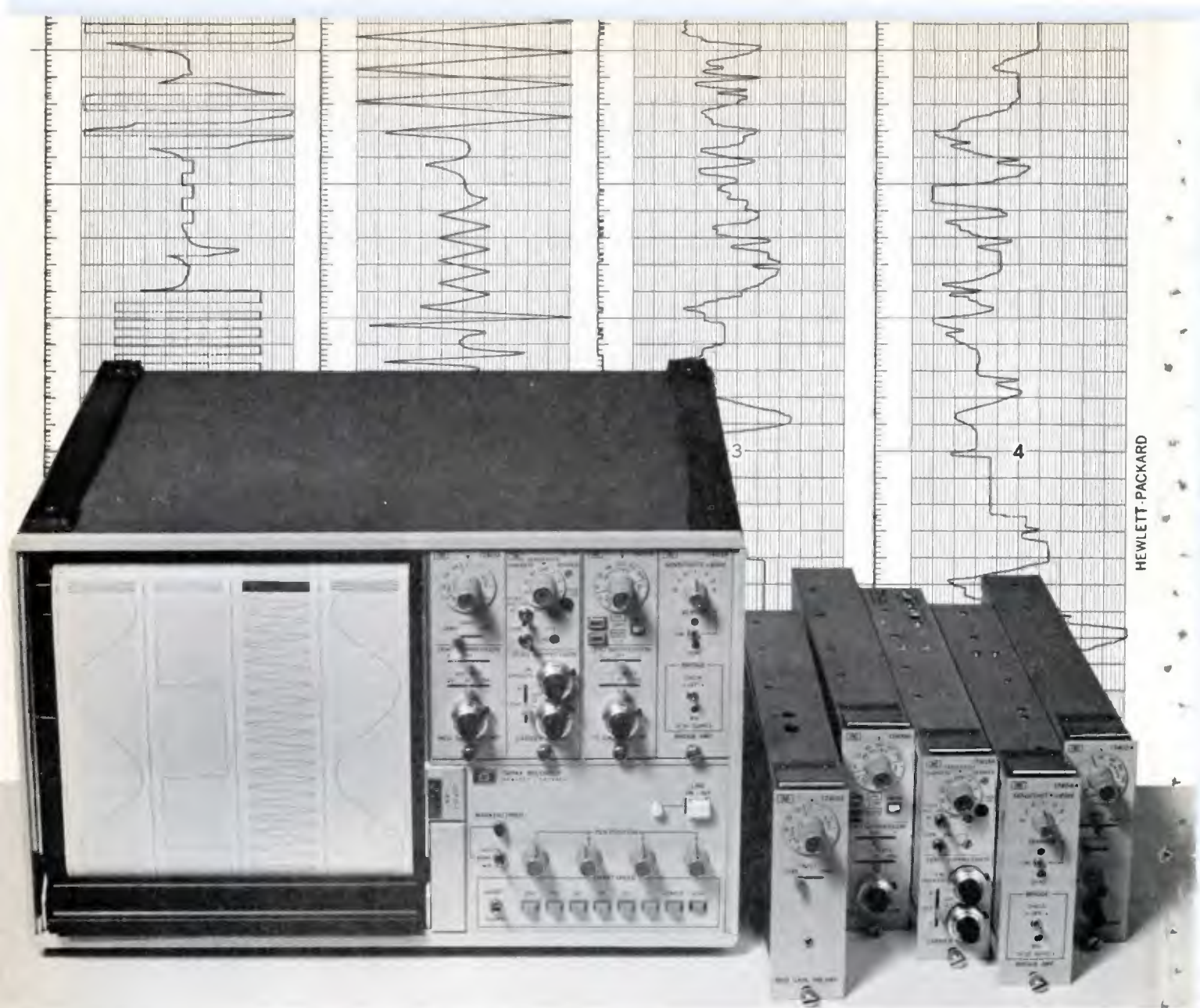

**Now the oscillographic recorder that gives you more of everything, gives you two more channels.**

## **Introducing HP's new 4-channel oscillographic recorder.**

Shop around. Compare performance, trace quality, standard features and options. Compare price.

It's the only way to see exactly why HP oscillographic recorders give you more of everything. In the two channel model 7402A. And the versatile new four channel model 7404A.

Trace quality is just what you see here. Crisp and clear. Instantly dry. No blobs or smears, even at high speeds. At the flip of a switch, those four channels convert to two double-width channels that provide twice the resolution. Non-fatiguing stainless steel pens, with

long-life carbide tips, can't be damaged by input signal frequency.

Like the two channel machine, the 7404A has handy front panel controls including a remote pushbutton for speed selection by TTL or contact closure. And there's the added flexibility of event markers, timer and a 60:1 "seconds-to-minutes" speed reducer. (Standard on the 7404A and optional on the 7402A.)

An assortment of options, including paper take up, along with interchangeable plug-in signal conditioners let you adapt either machine to specific appli-

cations. Amplify and measure a broad range of DC signals, or record AC/DC excited transducer outputs.

Base price for our new four channel machine is \$4400 (domestic USA price only). Compare the value against any other recorder. At any price. You'll see for yourself just how much more you're getting.

11/69

**HEWLETT  PACKARD**

Sales and service from 172 offices in 65 countries  
1501 Page Mill Road, Palo Alto, California 94304

## 29 Electronics Review

**PACKAGING & PRODUCTION:** Tri-metal process seals ICs, 29  
Thick-film hybrids shrink digital logic circuitry, 30  
**MEASUREMENT:** Laser, silicon team in super-fast switch, 31  
**COMPUTERS:** Japan won't choose used U.S. computers, 31  
**AVIONICS:** Kearfott and Europeans gear up for F-16, 32  
**AIR-TRAFFIC CONTROL:** Recordings may help small airports, 34  
**AUTOMOTIVE:** Indy car telemeters conditions to pit, 34  
**NEWS BRIEFS:** 36  
**DISPLAYS:** Electrochromic displays may rival LEDs and LCDs, 38  
**COMMUNICATIONS:** Intelsat RFPs could come by October, 40  
**CONSUMER:** Calculator/watch combination fits on the wrist, 40

## 53 Electronics International

**JAPAN:** Non-contact switch uses magnetoresistance, 53  
**AROUND THE WORLD:** 53

## 59 Probing the News

**MILITARY ELECTRONICS:** Laser work to be rewarded, 59  
**TRANSPORTATION:** The great West Virginia compromise, 63  
**MANAGEMENT:** Getting the big picture, 68  
**COMMERCIAL ELECTRONICS:** 'Thinking' traffic lights for Europe, 70  
**COMPANIES:** How Inselek was strangled, 72

## 75 Technical Articles

**INSTRUMENTS:** Data domain requires new kind of measurements, 75  
**DESIGNER'S CASEBOOK:** Buffer avoids triggering of thyristor, 82  
Two diodes protect logic-level translator, 83  
Power-supply add-on yields variable-ratio output, 85  
**COMPUTERS:** Boosting data-transfer rate by optimization, 86  
**CIRCUIT DESIGN:** Analysis program can model many digital ICs, 93  
**ENGINEER'S NOTEBOOK:** C-MOS phasemeter can be built in lab, 98  
Back-bias continuity checks TTL wire bonds, 98  
Low-drift ICs form instrumentation amplifier, 99

## 104 National Computer Conference

Fast-moving technology attracts many to 1975 NCC, 104  
Highlights of new products debuting at NCC, 108

## 113 New Products

**IN THE SPOTLIGHT:** Cutting relays down to size, 113  
Software aids microcomputer design, 116  
**DATA HANDLING:** Computers designed for first-time users, 118  
**SEMICONDUCTORS:** C-MOS chip for watches does the whole job, 124  
**INSTRUMENTS:** Function generators lock onto crystals, 130  
**SUBASSEMBLIES:** Amplifier has low input drift, 136

## Departments

Publisher's letter, 4  
Readers comment, 6  
News update, 8  
Editorial, 10  
People, 16  
Meetings, 23  
Electronics newsletter, 25  
Washington newsletter, 49  
Washington commentary, 50  
International newsletter, 55  
Engineer's newsletter, 102  
New literature, 139

## Highlights

### The cover: The logic of digital-system testing, 75

The data domain in which digital equipment operates is radically different from the time or frequency domain of analog devices and must be checked out by quite different test instrumentation. Part 1 of this two-part article discusses the rationale underlying logic-state and -timing analyzers and logic triggers for oscilloscopes. Cover illustration is by Gabor Kiss.

### Military laser R&D is paying off, 59

Though rangefinders are the only laser-based weapons in production, the Army will shortly receive prototypes of a laser target designator, the Air Force is interested in laser tracking systems for rockets, and all three services are exploring laser-based communications and data links.

### Tape memory achieves high data-transfer rate, 86

The combination of a fast but efficient recording technique with a time-saving error-correction method boosts both bit density and tape speed in a magnetic-tape storage unit.

### NCC rides high on new technology, 104

This month, over 25,000 are expected to attend the National Computer Conference to learn how microprocessors, mass storage, and data links are expanding computer applications and capabilities. Some of the new hardware to be displayed is described on pages 108-9.

### And in the next issue . . .

Data-domain measuring instruments, Part 2 . . . where C-MOS is today, a special report . . . the new popularity of voltage-frequency converters.

# Electronics

EDITOR-IN-CHIEF: Kemp Anderson

EXECUTIVE EDITOR: Samuel Weber

MANAGING EDITORS: Lawrence Curran, *News*;  
Arthur Erikson, *International*

SENIOR EDITORS: John Johnsrud,  
H. Thomas Maguire, Laurence Altman,  
Ray Connolly, Stephen E. Scrupski

ART DIRECTOR: Fred Sklener

ASSOCIATE EDITORS: Howard Wolff,  
Gerald M. Walker, Alfred Rosenblatt

## DEPARTMENT EDITORS

*Aerospace/Military*: Ray Connolly

*Circuit Design*: Don Blattner

*Components*: Lucinda Mattera

*Computers*: Stephen E. Scrupski

*Consumer*: Gerald M. Walker

*Industrial*: Margaret A. Maas

*Instrumentation*: Andy Santoni

*New Products*: H. Thomas Maguire,  
Michael J. Riezenman

*Packaging & Production*: Jerry Lyman

*Solid State*: Laurence Altman

COPY EDITORS: Margaret Eastman,  
Everett C. Terry, Bill Dunne

ART: Charles D. Clatto, *Associate Director*

Patricia Cybulski, *Assistant Director*

PRODUCTION EDITOR: Arthur C. Miller

EDITORIAL SECRETARIES: Janet Noto,  
Julie Gorgoglione, Penny Roberts

## FIELD EDITORS

*Boston*: Gail Farrell (Mgr.), Pamela Leven

*Los Angeles*: Paul Franson (Mgr.)  
Judy Phelps

*Midwest*: Larry Armstrong (Mgr.)

*New York*: Ron Schneideman (Mgr.)

*San Francisco*: Bernard Cole (Mgr.)  
Judith Curtis

*Washington*: Ray Connolly (Mgr.)  
Larry Marion

*Frankfurt*: John Gosch

*London*: William F. Arnold

*Paris*: Arthur Erikson

*Tokyo*: Charles Cohen

## McGraw-Hill WORLD NEWS

*Director*: Ralph R. Schulz

*Bonn*: Robert Ingersoll

*Brussels*: James Smith

*London*: James Trotter

*Madrid*: Dom Curcio

*Milan*: Andrew Heath

*Moscow*: Peter Gail

*Paris*: Michael Johnson, Richard Shepherd

*Stockholm*: Robert Skole

*Tokyo*: Mike Mealey

PUBLISHER: Dan McMillan

DIRECTOR OF MARKETING: Pierre J. Braudé

ADVERTISING SALES SERVICE MANAGER:  
Wallis Clarke

BUSINESS MANAGER: Stephen R. Weiss

CIRCULATION MANAGER: Nancy L. Merritt

MARKETING SERVICES MANAGER:  
Tomlinson Howland

RESEARCH MANAGER: Margery D. Sholes

**It's National Computer Conference** time again, and starting on page 104 you'll find a preview of the technological developments that will surface there. First, there is a four-page summary of the technical sessions, featuring highlights of the 89-session program that is being presented to an estimated 25,000 attendees. Then, on page 108, is a cross section of some of the many interesting new products that will make their debut at show time.

But our computer coverage this issue doesn't stop there. We didn't actually plan it that way, but this issue ended up with a large share of space devoted to computers and systems that rely on computers. It's really more than just a coincidence. It's just another indication of how pervasively computers cut across electronics, just as electronics pervades all of industry.

All of our technical articles, for example, stem from the realm of the computer. On page 75 you'll find "Engineering in the data domain calls for a new kind of digital instrument," which is the first of a series on instrumentation designed especially for the digital world of computers and related equipment.

Then, on page 89, there's a detailed article on packing more data into a magnetic-tape storage system. Combining synchronization advantages of group-coded recording with efficient error correction, the approach gives a density of 6,250 bits per inch as the tape speeds along at 200 in. per second.

A third article, this one on page 93, describes a computer software program that simplifies the design of digital integrated circuits. An extension of the Sceptre program, Su-

## Publisher's letter

per-Sceptre approaches digital circuit analysis by allowing digital ICs to be described in terms of the behavior of their terminals, rather than as a collection of many individual devices.

**O**ur news departments, too, are big on computer stories. In the Probing the News section, for instance, there are two stories about systems that would not exist were it not for computers. One tells of the work now afoot in Europe to end the traffic chaos at complex old-world intersections by putting "brains" in each traffic light. And the key to the work is the micro-processor, says our Frankfurt bureau manager, John Gosch, who put together the story (see p. 70) from his and other bureau reporting.

And, another chapter in the Morgantown, W. Va., people-mover saga is presented on page 63. The computer-controlled rapid-transit system has been beset by troubles—political, economic, and technical—but now, thanks to an infusion of funds, it looks to be on track again. Larry Marion, of our Washington bureau, wrote the story after visiting the ill-starred project. "I would have had to have been the second fare-paying passenger of the system, but Boeing officials refused to take my money. I did take a ride on the system, from the Boeing maintenance facility to the downtown stop. It was very bumpy, much like the system's history, but I was told that was because the car I was in had too much air in the tires."



May 1, 1975 Volume 48, Number 9  
94,203 copies of this issue printed

Published every other Thursday by McGraw-Hill, Inc. Founder: James H. McGraw 1860-1948. Publication office: 1221 Avenue of the Americas, N.Y., N.Y. 10020, second class postage paid at New York, N.Y. and additional mailing offices.

Executive, editorial, circulation and advertising addresses: Electronics, McGraw-Hill Building, 1221 Avenue of the Americas, New York, N.Y. 10020. Telephone: (212) 997-1221. Teletype: TWX N.Y. 710-581-5234. Cable address: MCGRAW HILL N.Y.

Subscriptions limited to persons with active, professional, functional responsibility in electronics technology. Publisher reserves the right to reject non-qualified requests. No subscriptions accepted without complete identification of subscriber name, title, or job function, company or organization, including product manufactured or services performed. Subscription rates: qualified subscribers in the United States and possessions, Canada, and Mexico \$12.00 one year, \$24.00 three years; all other countries \$25.00 per year, except Japan and Israel \$50.00 per year, Brazil \$40.00 per year, Australia and New Zealand \$60.00 per year, including air freight. Limited quota of subscriptions available at higher-than-basic rate for persons outside of field served, as follows: U.S. and possessions and Canada, \$25.00 one year; all other countries \$50.00. Single copies, \$4.00.

Officers of the McGraw-Hill Publications Company: John R. Emery, President; J. Elton Tushig, Executive Vice President-Administration; Gene W. Simpson, Group Publisher-Vice President; Senior Vice Presidents: Ralph Blackburn, Circulation; Walter A. Starbury, Editorial; John D. Hoglund, Controller; David G. Jensen, Manufacturing; Gordon L. Jones, Marketing; Jerome D. Luntz, Planning & Development.

Officers of the Corporation: Shelton Fisher, Chairman of the Board and Chief Executive Officer; Harold W. McGraw, Jr., President and Chief Operating Officer; Wallace F. Traudt, Group President, McGraw-Hill Publications Company and McGraw-Hill Information Systems Company; Robert N. Landes, Senior Vice President and Secretary; Ralph J. Webb, Treasurer.

The registered in U.S. Patent Office. Copyright ©1975 by McGraw-Hill, Inc. All rights reserved. The contents of this publication may not be reproduced in whole or in part without the consent of copyright owner.

Subscribers: The publisher, upon written request to our New York office from any subscriber, agrees to refund that part of the subscription price applying to copies not yet mailed. Please send change of address notices of complaints to Fulfillment Manager; subscription orders to Circulation Manager, Electronics; at address below. Change of address notices should provide old as well as new address, including postal zip code number, if possible, attach address label from recent issue. Allow one month for change to become effective.

Postmaster: Please send form 3579 to Fulfillment Manager, Electronics, P.O. Box 430, Hightstown, N.J. 08520.

# 4 filters in 1

Model 3202 offers two independent low-pass or high-pass channels or single channel band-pass or band-reject from 20 Hz to 2 MHz.

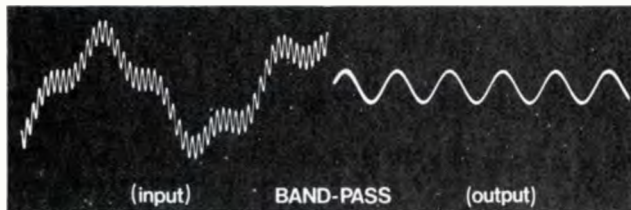
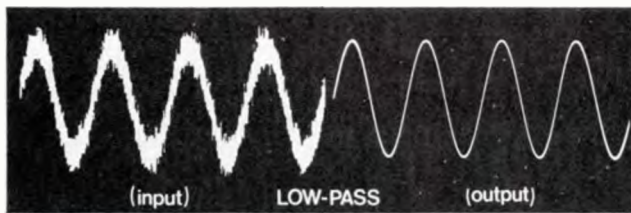

For only \$895, Model 3202 provides the flexibility essential for complex frequency or time domain measurements.

**FUNCTIONS:** Low-pass—direct coupled with low drift.  
High-pass—upper 3 dB at 10 MHz. Band-pass—continuously variable. Band-rejection—variable broad band or sharp null.

**TWO RESPONSE CHARACTERISTICS:** (1) Fourth-order Butterworth or (2) simple R-C (transient free).

**ZERO-dB INSERTION LOSS:** All-silicon amplifiers provide unity gain passband response. 24 dB per octave slopes per channel extend to at least 80 dB.

**90-dB DYNAMIC RANGE:** Low hum and noise (less than 100 microvolts) eliminate costly preamplifiers.

For fast action, call: (617) 491-3211

TWX: 710-320-6583, Krohn-Hite Corporation, 580 Massachusetts Ave., Cambridge, Mass. 02139, U.S.A.



**KH KROHN-HITE CORPORATION**  
580 Massachusetts Avenue, Cambridge, Massachusetts 02139

SALES OFFICES: ALA, Huntsville (205) 534-9771; ARIZ., Scottsdale (602) 947-7841; CAL., San Jose (408) 292-3220, Inglewood (213) 674-6850; COLO., Denver (303) 934-5505; CONN., Glastonbury (203) 633-0777; FLA., Orlando (305) 894-4401; HAWAII, Honolulu (808) 941-1574; ILL., Des Plaines (312) 298-3600; IND., Indianapolis (317) 244-2456; MASS., Lexington (617) 861-8620; MICH., Detroit (313) 526-8800; MINN., Minneapolis (612) 884-4336; MO., St. Louis (314) 423-1234; N.C., Burlington (919) 227-3639; N.J., Haddonfield (609) 795-1700; N.M., Albuquerque (505) 299-7658; N.Y., E. Syracuse (315) 437-6666, Rochester (716) 328-2230, Vestal (607) 785-9947, Elmont (516) 488-2100; OHIO, Cleveland (216) 261-5440, Dayton (513) 426-5551; PA., Pittsburgh (412) 371-9449; TEX., Houston (713) 688-9971, Richardson (214) 231-2573; VA., Alexandria (703) 354-1222; WASH., Seattle (206) 624-9020; CANADA, Montreal, Quebec (514) 636-0525, Toronto, Ontario (416) 444-9111, Stittsville, Ontario (613) 836-4411, Vancouver, British Columbia (604) 688-2619.

Circle 5 on reader service card



## Tansitor Miniature solids... designed to meet your tantalum capacitor needs...3 ways.

**in performance.** These tantalum HA (cylindrical) and TC (rectangular) deliver a capacitance range from .01 to 68 uf and .01 to 470 uf. Both carry a 2-50VDC and an operating range of -55°F to 85°C with voltage derating to 125°C. Our polar and non-polar miniatures are encased in plastic with epoxy seals and offer a choice of radial or axial leads. With 24 case sizes one of our standards will meet your needs... perfectly.

**in price.** Ask for a quote. You'll find us extremely competitive. That's why we're a leading manufacturer of tantalum mini-solids.

**and in delivery.** At Tansitor, we're different. Our delivery schedule is tailored to your needs. Need we say more? For more information or spec sheets, call your Tansitor representative or write:

**Tansitor**  
ELECTRONICS  
DIVISION OF AEROTRON, INC

West Rd. • Bennington, VT 05201  
Phone: 802/442-5473 TWX: 710/360-1782

## Readers comment

### Feerst on Schulke

**To the Editor:** It is gratifying to observe that a leading magazine has consistently expressed interest in the professional lives of its readers. However, your editorial proposal that IEEE's general manager be given the principal responsibility for carrying out the mandate of the membership to move forward in the professional area [*Electronics*, March 20, p. 10] overlooks the important fact that the position of general manager is appointive, not elective.

We do not fault the incumbent general manager, Major General [Herbert A.] Schulke, for what he is—a West Point graduate and a career Army officer. Instead, his appointment is subject to criticism for what he is not. By his own admission, Schulke has never worked a day in his life as a civilian EE. Thus, he cannot be fully aware of the oversupply and underutilization of EEs; he cannot be sensitive to the wishes of the membership for meaningful pension protection (Is it too indelicate to point out that Schulke's own retirement pay is more than \$18,000 per year?); he has never had the pleasure of sitting at his desk on a Friday afternoon wondering if he would be laid off within the hour. In short, Schulke is not cut from the same cloth as is the typical IEEE member. A far better suggestion, which unfortunately was rejected by the membership (at the urging of the Board of Directors), would be to elect a salaried president for a three-year term.

The editorial also fails to take note of the increasingly loud cries from IEEE members that the organization should limit entry into the profession. This has been done successfully by other organizations and can serve to end the senseless execution of the over-40 EE.

Irwin Feerst  
Committee of Concerned EEs

**Editor's note:** As Mr. Feerst's views are of a controversial nature, some readers may wish to write him directly. His address is P.O. Box 19, Massapequa Park, N.Y. 11762.

# The price match to the micro- processor



## A NEW PAPER TAPE PERFORATOR/READER COMBINATION!

The lower cost of processing with micros and minis means paper tape still makes dollars and sense.

**The micro cost perf/reader combo**  
Punch... read... duplicate... complete I/O capability in one package. A plug-in interface to your processor. Integral tape supply and take-up. Designed for fan-fold or roll tape. Everything fits within a compact 10½" x 19" panel. Completely emulates other perforator/reader combos.

**Only \$1360**  
\$1360 in quantity of one. Healthy OEM discounts! A little price tag, but big performance.

The tape perforator operates asynchronously up to 30 characters per second. The tape reader photoelectrically reads up to 150 characters per second asynchronously and at 300 characters per second slew.

Tape handling is designed for optimum performance and operator accessibility. The punch and reader are easy to load and unload. Fan-fold or roll tape. The chad box, controls, everything is conveniently out front. The unit can be rack or cabinet mounted.

**The dollar difference**  
With the processor swing to low-cost data management, Tally has the product with the matching price tag. There's just about a thousand dollar bill difference before the next alternative.

We invite your inquiry.  
Tally Corporation, 8301 S. 180th St.,  
Kent, Washington 98031.  
Phone (206) 251-6771.

# TALLY

has something new



# Great American Logic. From Jefferson, Franklin, Madison, and HiNIL.



Give your industrial control system a great constitution with HiNIL, the high noise immunity logic from Teledyne. It works reliably in adversity—like the great political logic our Founding Fathers used in the Constitutional system.

HiNIL doesn't operate illogically when it sees electrical noise and high voltage transients. With a

3.5 volt guaranteed noise margin (versus 1.0 V for CMOS and 400 mV for TTL), it runs without shielding.

HiNIL also runs true when the power supply doesn't. It doesn't need expensive regulated supplies, filters and spot regulators because HiNIL's power supply tolerance is a comfortable  $\pm 1$  V.

And HiNIL is slow—that's right, slow not fast. Its 100 nanosecond propagation delay is fast enough for most control systems. But it won't be switched falsely by noise spikes when a fork lift rolls by (can you say the same for the hair-trigger logic you've been using?).

Like the Constitution, HiNIL is adaptable. It interfaces easily with TTL, DTL, RTL, MOS and CMOS directly, through open-collector outputs or through interface circuits. And it comes in about 40 types: from diode-expandable gates to quad schmitt triggers, shift registers, display decoder/drivers and a dozen other complex MSI functions. All conveniently packaged in ceramic or molded silicone DIPs.

Finally, HiNIL is cheap. It's priced right in there with TTL so you can save a small fortune on supply regulation, noise suppression and other 'extras' you'll no longer need.

So if you want to read about great logic, trade in your history books for Teledyne's free literature on HiNIL. Better yet, experience HiNIL in your own designs. Get it from Teledyne, reps or distributors. Write or call now.

 **TELEDYNE**  
**SEMICONDUCTOR**

1300 Terra Bella Avenue Mountain View, California 94043

(415) 968-9241 TWX: 910-379-6494 Telex: 34-8416

## USE INSTRUMENT MOTORS?

# Step Up To CRAMER QUALITY For Less Than You're Paying!

## CALL COLLECT... Cramer Sales Offices

AID ENGINEERING SALES CO.	Conn., Me., Mass., N.H., R.I., Vt.	203-673-3692 203-434-8223 617-890-8181
JAMES H. ANDERSEN ASSOCIATES CANTRONICS, LTD.	No. Idaho, Or., Wa.	206-232-0484 503-289-5504 416-661-2494 514-341-5207
COL-INS CO., INC.	Canada-Provinces of Saskatchewan, Manitoba, Quebec and the Maritime Provinces Ga., Al., Fl., N.C., S.C., Tn., Va. — State of up to and including counties of Rock- ingham, Greene, Albemarle, Louisa, Hanover, New Kent, James City & York N.Y./N.J.	305-423-7615 205-539-1771 919-834-6591 919-876-2187 813-343-0978 813-581-8233 404-934-7280 404-934-3138 914-592-5500
CRAMER DIV. GLIDDEN ELECTRO EQUIPMENT CO. HELD AND MOLLARD INC.	La., Ms., Ok., Tx. (Ex- cept El Paso County) No. Ca., Nv. (Except Clark County) Ky., Oh., Pa., W. Va., Mi.	214-363-6539 713-681-1415 415-965-9321 216-725-4477 216-241-4880 513-296-1010 313-646-3635 612-835-5858
J. C. HOFSTETTER COMPANY	Mn., N.D., S.D., Wi.	
JOS-CO SALES ENGINEERING MARTEC ASSOCIATES L. G. WHITE & CO., INC.	Il., Mi., Wi. 312-956-8090, 91, 92 Md.; Wa., D.C., W. Va., Va. 301-770-6556	
PACIFIC CONTROLS LTD.	Canada — Provinces of British Columbia and Yukon Territory	604-879-6711
SPECTRUM ASSOCIATES	Az., S. Ca., Nv. (Clark County only)	714-835-4114 213-323-0603 602-997-6324 303-292-6900
I. W. STRONG & ASSOCIATES INC.	Co., N.M., Ut., Wy., S. Id., W. Ks., Tx. (El Paso County only)	317-253-1215 716-288-1080
SUKUP & COX, INC. UPSTATE COMPONENT SALES INC. HARLAN J. WEISLER & ASSOC., INC. JOHN C. WHIDDETT CO. SEMEX, S.A.	la., Mo., S. Il., E. Ks., E. Ne., Ar. De., S. N.J., E. Pa. Mexico 58-40-90 • 58-47-10	

## CRAMER: FOR ENGINEERED OEM PRODUCTS

**CONRAC**  
CORPORATION

### CRAMER DIVISION

MILL ROCK ROAD, OLD SAYBROOK, CT. 06475  
TELEPHONE (203) 388-3574 TELEX 966-453

## News update

■ The Mitre Corp.'s pilot solar-cell system to generate electricity has run into some cloudy skies, both literally and figuratively. Spurred by last year's energy crisis, Mitre put a rooftop solar-cell array on its McLean, Va., headquarters [March 21, 1974, p. 25]. Up to that time, the installation, designed to generate 1 kilowatt of electric power, was the world's largest terrestrial photovoltaic installation ever to be put into place.

There hasn't been enough sunshine for a full-up power test, but the unit has produced two thirds of its designed output under certain sunlight conditions, says a Mitre official. And the fuel-cell system that is to store energy for use during darkness has been installed but isn't operating. "We have connected the system but are having some problems," says the official. Mitre has had to add a computer monitoring system and some more weather sensors for the test.

■ The National Weather Service is pushing ahead with development of its Aviation Automated Weather Station program [March 21, 1974, p. 36]. It has awarded a three-year negotiated task order contract leading to a prototype to Harris Corp. So far, Harris has received about \$75,000 for three tasks—work on the input/output operations of the computer system; defining algorithms for output sensor data; and computer programming. But final design and development of the prototype automated weather station, a task bigger than any thus far, is expected to be negotiated by late summer, says Roy Wyett of the National Weather Service's Systems Development Office. This will be followed by evaluation of the prototype at Patrick Henry Air Force Base in Virginia. The program, a cooperative one between the weather service and the Federal Aviation Administration, could lead to a national network of as many as 155 automated weather stations.—

Howard Wolff

RIGHT ON TARGET AGAIN

**SGS** **ATES**

**Bearing it well!**



## Complementary power pairs in plastic

### Epibase-darlingtons

#### 4 Amperes - TO 126 pack

NPN	PNP
2N 6037	2N 6034
2N 6038	2N 6035
2N 6039	2N 6036
SJE 800	SJE 700
SJE 801	SJE 701
SJE 802	SJE 702
SJE 803	SJE 703

#### 8 Amperes - TO 220 pack

NPN	PNP
BDX 53/A/B/C	BDX 54/A/B/C

### Epibase-transistors

#### 2 Amperes - TO 126 pack

NPN	PNP
2N 4921/22/23	2N 4918/19/20
SJE 720/21/22	SJE 710/11/12

#### 4 Amperes - TO 126 pack

NPN	PNP
2N 5190/91/92	2N 5193/94/95
SJE 220/1/2/3/4/5	SJE 230/1/2/3/4/5

#### 4 Amperes - TO 220 pack

NPN	PNP
2N 6121/22/23	2N 6124/25/26
SIP 31/A/B	SIP 32/A/B

SGS - ATEs Semiconductor Corporation - Newtonville, Mass. 02160 - 435 Newtonville Avenue - Tel: 617-9691610 - Telex 922428  
Stocking Distributors: Edmar Electronics Co., Des Plaines, ILL., (312) 298-8580 - Energy Electronic Products, Los Angeles, CA, (213) 641-9020 - Esco Inc., Dayton, OHIO, (513) 226-1133 - KA Electronic Sales, Dallas TX, (214) 634-7870 - Radar Electric Co., Seattle, WA, (206) 282-2511 - Rosyl Electronics, Bayshore, NY, (516) 586-1800 - Wilshire Electronics, Burlington, MASS., (617) 272-8200 -  
Prelco Electronics Ltd., Montreal 357, Quebec, (514) 389-8051

Circle 9 on reader service card

## Making Washington listen

*It's easy enough to bemoan the less-than-ideal state of technological input in the Government's decision-making processes. The difficult thing is coming up with practical and sensible alternatives to what looks like a case of technological tunnel vision in Washington.*

*An important first step, therefore, is to stop waiting for Washington to come looking for answers and to start actively proposing solutions. Planned participation is the key to this approach, which uses the channels into decision-making procedures that are open to all citizens, but traditionally traveled only by special-interest groups.*

*The real question is how to provide the decision-makers, whoever they are, with well-researched options. Several proposals have been made that deserve serious consideration. One is that more corporations should adopt programs well-known within the academic community whereby talented staffers are granted leaves of 12 to 18 months without pay for paid Government service. In the opinion of John Granger, former president of the IEEE and newly-appointed executive secretary of the Federal Council for Science and Technology, such extended leaves have benefits for the companies as well as government. "When a man gets back to his company, he will have first-hand knowledge about how an agency and the governmental process works."*

*And such involvement need not be restricted to corporate contributions of talent. As an active professional society member, Granger sees a need for greater participation by individual members of IEEE in issues beyond those in which they have a special parochial interest, such as pension reform. The key to broadening the awareness of engineering professionals in governmental activities is for their professional*

*societies to provide them with more information more often.*

*With increased participation by concerned individuals, admittedly, comes the threat of conflict of interest. General Accounting Office investigators, of course, see this as a very real threat. Univac's Carl Hammer, director of computer sciences for the Sperry-Rand division, however, believes it can be largely nullified by adopting generally the oath employed by some Federal advisory groups that make members swear they will act only in the public interest.*

*Participation in such advisory bodies, in Hammer's view, is a very effective way for companies and professional societies to enhance the Government's technological expertise. His preference: more extensive and dedicated participation in the many commissions and ad hoc committees, created regularly by Government, which cry out for competent professional participation. States and cities, he notes, are even more desperate for good professional advice than Washington.*

*The roads into the congressional decision-making process are also open to citizens, individual as well as corporate. Hearings by committees and subcommittees on Capitol Hill are just that, a chance for those people concerned about the subject of a bill to be heard. Furthermore, the committee staffs gather mountains of material in their research on pending bills, and their conclusions and summaries very often make or break a bill. Yet even the committees with the most to say about science and technology have slight technical competence. Unfortunately, that weighting shows no signs of change. Providing them with the best arguments for and against proposed laws is an obvious, yet too often overlooked, way to balance the scales.*

# The no-trade-off comparator.

Honest. It's guaranteed 12 nanoseconds fast. It's 5 millivolts accurate.

Advanced Micro Devices' 686 — an all-new part for TTL systems with none of the limiting factors, none of the heartaches, none of the trade-offs you thought you had to live with.

Look, you know what TTL comparators have been like until now:

A National 111 gives you 5 millivolt accuracy. And 200 nanosecond speed. The Signetics 529 gets you down to 20 nanoseconds at a cost of 50 millivolts. And Fairchild's 760 gives you 5 millivolt accuracy at 16 nanoseconds, but that's typical.

That's all over now.

Get the Am686. It's yours off the shelf. And, because we like you, MIL-STD-883 for free.

## Advanced Linear



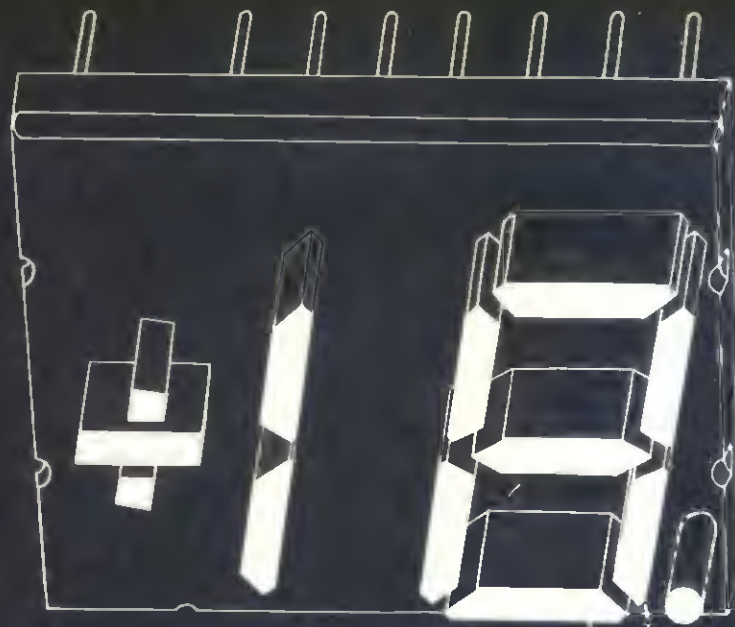

# Announcing the first 0.5" multi-digit LEDs

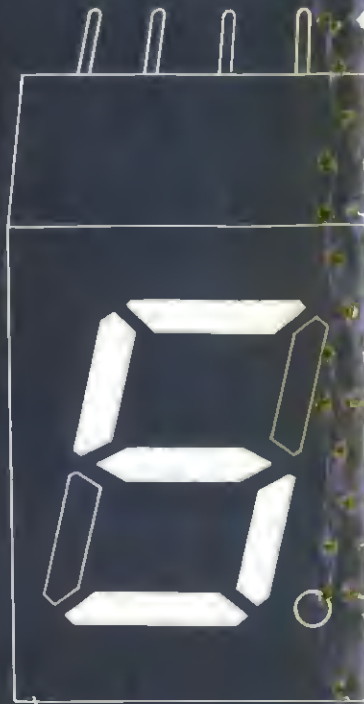

One DIP  
handles  
two digits

Mitered corners  
increase  
eye appeal

Light pipes spread  
illumination evenly  
over broad segments



Here we go again. It's another first from Litronix: multi-digit 0.5"-high LEDs.

These two-in-one packages are tailor made for anyone who wants to save money in lower production costs. They require only half the inventory. Half the handling. Half as many components to assemble and test.

Makers of digital time pieces will find them ideal, as will those who manufacture point-of-sale terminals. FM digital readout tuning systems. TV channel tuners, and instrumentation.

The modules are end-stackable to produce any combination of 0.5" digits on 0.5" centers. The DL-727 is a two-digit module that's ideal for clocks. And our DL-721 module offers a  $\pm$  sign and a "1" for polarity and over-range indications on instruments.

Each module has the same drive requirements. Power required is only 30 to 40 mW per segment from standard logic voltage supplies. Modules are packaged in standard DIPs.

Naturally, you enjoy all the solid state advantages of LEDs. They're compatible with today's IC circuits. Rugged. Easy to multiplex. And offer fast response.

In any business lower costs make a difference. Our dual 0.5"-high digits help your products keep a competitive edge.

Our data sheets tell all. Contact Litronix, 19000 Homestead Road, Cupertino, Calif. 95014. Phone (408) 257-7910.

**No wonder  
we're No.1  
in LEDs**

# litronix

# Think of yourself as a heart specialist

The system is your patient and its power supply is your responsibility. For a long, happy system life, prescribe Sorensen STM modular switchers.

Compared to equivalent series-pass power supplies, STMs are twice as efficient, less than half the size, and price competitive. Yet they offer all of the inherent advantages of series-pass.

We've got a catalog that describes all 40 models, from 3.0 to 56 Vdc. It even has a prescription form ready to fill out. Simply circle the inquiry number. Sorensen Company, a unit of Raytheon, 676 Island Pond Road, Manchester, N.H. 03103. (603) 668-4500.

**Sorensen**  
**POWER SUPPLIES**





OUTPUT

A terminal block with eight screws arranged in two rows of four. The top row screws are partially covered by a black plastic component.

6A

**CORPSEN**  
POWER SUPPLIES

STM

12-12

FUSE

+

GND

INPUT

A terminal block with seven screws in a single row.

VOLT

1 2 3 4 5 6 7

# a little A-300 goes a long way.



In high frequency transmission. RF power generation for industrial and research processes. RFI/EMI and general laboratory applications, too.

The Model A-300 is a totally solid state power amplifier, covering the frequency range of 0.3 to 35MHz with a gain of 55dB. Capable of delivering 300 watts of linear Class A power and up to 500 watts in the CW and pulse mode, the A-300 is the ultimate in reliability.

Although the unit is perfectly matched to a 50 ohm load, it will deliver its full output power to any load (from an open to a short circuit) without oscillation or damage.

Complete with power supply, RF output meter and rack mount, the A-300 weighs a mere 89 pounds and operates from ordinary single phase power.

High power portability goes a long way for \$5350.

For further information or a demonstration, contact ENI, 3000 Winton Road South, Rochester, New York 14623. Call 716-473-6900 or TELEX 97-8283 E N I ROC

## ENI

The World's Leader  
in Solid State  
Power Amplifiers

## People

### Aerospace Corp.'s Krause turns toward civilian business

Mention the name Aerospace Corp., and people think of the development of complex missile and satellite systems—particularly for the Air Force. But that image will change in the next two to three years if Ernst H. Krause has his way. Krause



**New areas.** Wrist alarm is one of civil-sector programs being managed by Ernst Krause.

heads the non-profit El Segundo, Calif., organization's recently formed Civil Operations group.

"Civil work is now only about 10% of our \$90 million revenue, but I expect the value to double in the next two or three years," says the senior vice president and director of technology development. A 62-year-old Milwaukee native who began his engineering career at the Naval Research Laboratory during World War II, Krause is applying technology developed for the military to civil programs. And with the aid of funds from the Federal Government's Law Enforcement Assistance Administration, police departments around the country may soon see what Aerospace has to offer.

"Labor represents a big chunk of police cost," points out Krause, who believes that electronics could make the police officer more efficient. "For example, we'd like to be able to use one man in a patrol car, where two are now needed." He is referring to the communications

and paperwork police officers now must do. "We've been working on this kind of thing for years in military aircraft."

Krause also believes digital communications can make police far more effective, and not merely by unclogging voice channels. He envisions increasing numbers of central crime data bases, which police in patrol cars could immediately call through microcomputer-controlled terminals.

Krause's group is also working on a wrist-watch-size civilian trouble alarm [*Electronics*, Aug. 22, 1974, p. 29, and April 3, 1975, p. 51], as well as methods to combat truck hijacking. "There's no technical obstacle to keeping track of every truck on the road," he says. "The problem is doing it in a practical way."

Not all of Aerospace Corp.'s civil-electronics activities are in law-enforcement applications, however. The company is also helping evaluate night-vision and infrared detection equipment for firefighting, working on transportation systems, and studying solar energy.

In all these projects, Krause emphasizes, "we feel very strongly that our function—in civil as well as military work—is to muster the R&D resources of the country—not try to do everything ourselves."

### Bell turns Electronic Arrays to n-channel memories again

It will have taken three years, but Electronic Arrays Inc. by next month should finally begin erasing the flawed image it has had since it first entered the random-access-memory business. Company president W. Donald Bell has his company geared up to provide samples of a 4,096-bit metal-oxide-semiconductor n-channel RAM. The Mountain View, Calif., MOS maker was the first to announce an n-channel RAM, the 1,024-bit EA1500, in 1972. But then it couldn't produce.

Bell insists the process is under control now, and Electronic Arrays' device will be a second source for a Mostek-type 16-pin array. The com-

# Not New...Just the Best



## **ERIE RED CAP** **Miniature Ceramic Capacitors**

CAPACITANCE  
RANGE  
1pF to 10uF

21  
TEMPERATURE  
Characteristics

Voltage Range  
25 to 500 Vdc

Encapsulated  
by  
"JET-SEAL"

Meet or Exceed  
Requirements  
of MIL-C-20  
MIL-C-11015  
As applicable

### WIDEST SELECTION OF MINIATURIZED CERAMIC CAPACITORS IN THE INDUSTRY!

Erie is in the Red Cap winner's circle because of a well engineered component that's backed by a unique process control system. Combine this with talented, motivated people and you have Erie as the leader in its field. These tiny high quality capacitors are not new . . . but they are the best. Our customers attest to it. Our test laboratories prove it.

Red Cap dielectrics are manufactured by Erie's exclusive Monobloc Process<sup>®</sup> . . . a modern, time-proven ceramic film technology. And tough environmental extremes routinely are endured by our own Jet-Seal, a hard, bright red polymeric protective coating. (The superior aesthetic appearance of Jet-Seal comes to you at no charge.)

Erie Red Caps have it all. 21 temperature characteristics. 1pF to 10uF capacitance range. Ratings from 25 to 500 Vdc. You name the application . . . we've got a Red Cap for the job. All this is due to Erie's total in-house capability . . . from exclusive ceramic formulations to unique packaging. So on your very next buy of ceramic capacitors, do it the easy way . . . specify Erie Red Caps.

Write TODAY for Red Cap brochure 8000 . . .  
or call our nearby factory representative.

ERIE TECHNOLOGICAL PRODUCTS, INC.  
Erie, Pennsylvania 16512

Circle 17 on reader service card

# The new chip inductor. A miniature specifically designed for reflow soldering and hybrid circuits.

Delevan proudly announces another first in hybrid circuit component design. Only .1" square by .075" high, the newest member of the Delevan Micro-i, inductor series was engineered to withstand the hi-temperature exposure of reflow soldering used for thick film processing.

High temperature insulated magnet wire is thermal compression bonded to gold plated metallic solder rails. The solder rails wrap around the sides of an alumina substrate to provide a visual indication of the solder bond.

Thermal exposure during assembly or rework is a severe test of component capability . . . and can be a controlling factor in reliability and performance.

When dependability is first priority, check out the new series 103 miniature leadless chip inductor . . . built to stand the heat. Ask for bulletin 103.

**Delevan**  
Division



AMERICAN  
PRECISION  
INDUSTRIES INC.

270 QUAKER RD. / EAST AURORA, N. Y. 14052  
TELEPHONE 716/852-3600 TELEEX 091-293

OTHER DIVISIONS OF AMERICAN PRECISION INDUSTRIES INC.  
BASCO • OURTEX

## People



**Mixer.** Changing his company's mix of products is getting Don Bell's top priority.

pany will also soon second-source the Texas Instruments 22-pin TMS4060 4-k RAM.

"Our main effort in RAMs now is to make the 4-k parts smaller and faster," as Electronic Arrays strives for credibility in that market and for the right product mix, Bell says. Product mix has been one of his chief concerns since he became president last November and moved to shelve development of a microprocessor that would have butted head-on with the Intel 8080.

Instead, the 37-year-old chief executive officer ordered work begun on what will be the EA9002, an 8-bit logic processor aimed at application complexity below the 8080. That product bows in the third quarter, and will eventually be complemented by a second source to the 8080 or similar microprocessor.

Both the microprocessor and 4-k RAM are efforts Bell is pushing to change Electronic Arrays' \$16 million mix from 65% calculator chips (the remainder is MOS memories) to 80% memories and microprocessors two to three years hence.

He's also looking for continued strength in the printing calculator chip market. "We have the resources," Bell says of Electronic Arrays' cash position, and he argues persuasively that he has control of a company that suffered from recent changes in top management. Bell is out to re-establish momentum and, as he puts it, "commit our resources in the right direction."

**Fairchild introduces  
a universal standard 8-bit microprocessor  
that's simple to configure,  
easy to program,  
handles more than half  
of all small systems applications  
and costs less to use.**

# THE F8.

**MADE IN  
FAIRCHILD**

Fairchild's new 8-bit F8 microprocessor is simply the best ever.

Because basically, it's the most *simple* to use.

And one look at our before-and-after comparison shows why.

**The first complete microprocessor system on 2 chips.**

Now for the first time, you can build a functionally complete, self-contained, practical 8-bit microprocessor system using just two chips.

*Two chips.*

For the first time, you don't need additional packages for I/O logic and latches, address logic, clock generation,

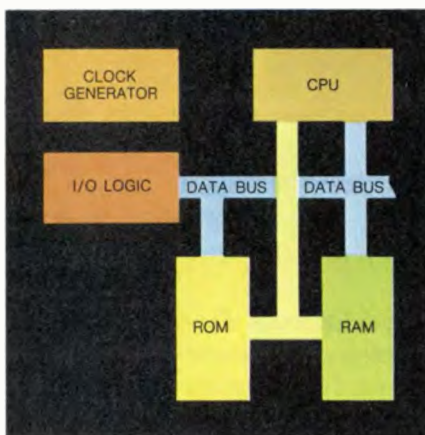

Minimal microprocessor system before the Fairchild F8.

RAM storage or power-on reset.

Because they're already there—tucked right on our two basic chips.

The F8 CPU.

And the F8 ROM.

**The F8 supercontroller. How simplicity was achieved.**

To reach the functional densities and speed of the F8, we turned to our proven Iso-

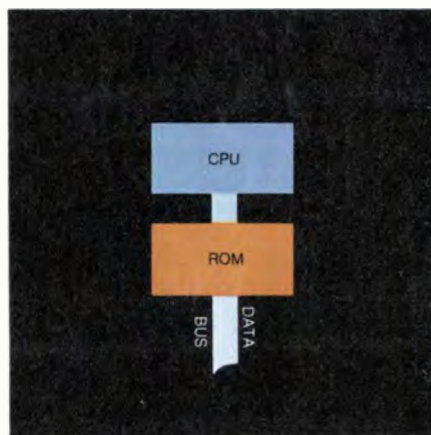

Minimal microprocessor system after the Fairchild F8.

planar, ion-implanted, N-channel technology, which allows up to 40% more function per unit area.

This permitted added functions to be included on both CPU and ROM chips. Yet, the F8's CPU remains the smallest 8-bit, N-channel chip in the business.

With lower power. And high speed.

Continued.

## Introducing the basic F8 system. And 5 key changes.

In developing the new F8, Fairchild designers have introduced a number of important hardware features available with no previous system.

Changes inspired by the hard-earned experience of users themselves:

1. Two 8-bit I/O ports on the CPU chip. And two more on the ROM chip. 32 bidirectional lines in all.

2. 64-bytes of fast RAM scratchpad *built into* the CPU chip.

3. A clock generator and power-on reset *built into* the CPU chip, too.

4. A programmable interval timer *built into* the ROM chip.

5. 60% of the 70 instructions are 1-byte.

Other F8 features and refinements include:

A speedy 2  $\mu$ s minimum instruction execution time.

Direct TTL I/O compatibility.

A typical power dissipation of less than 300 MW per chip.

Local interrupt with automatic address vector.

And much more.

Result—a complete 2-chip microprocessor system that's really *just 2 chips*. Easier to handle, much more versatile,

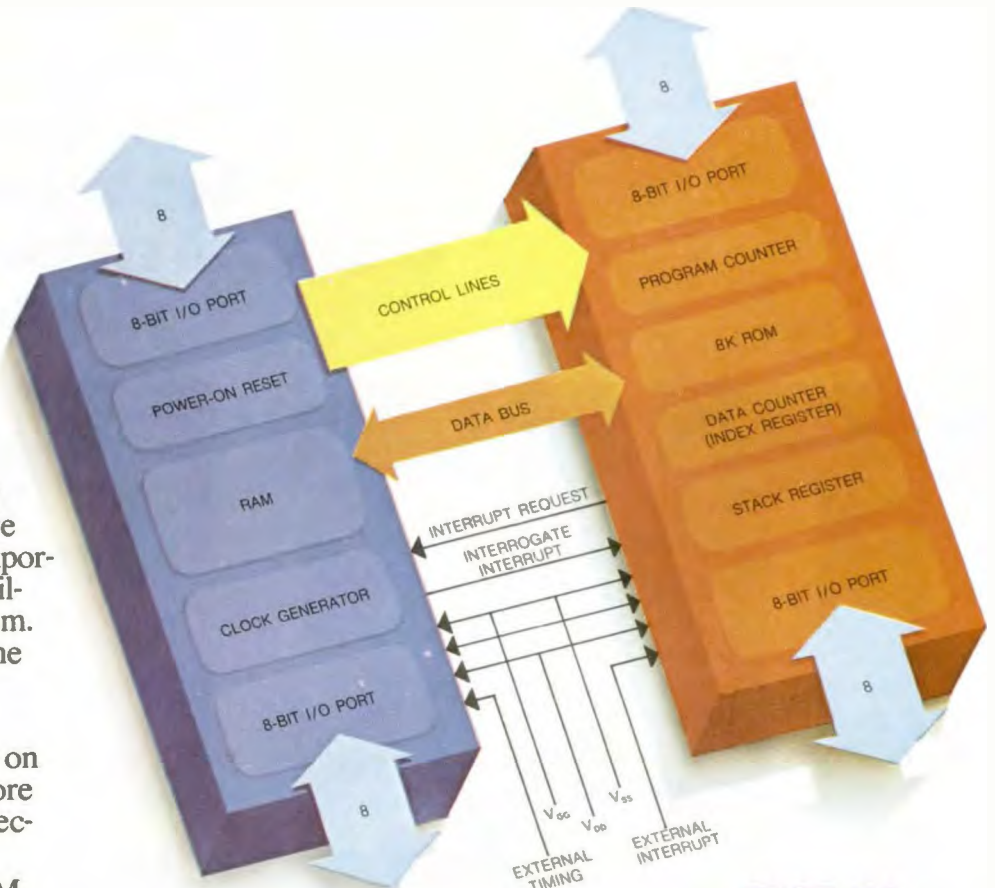

## THE F8. MICROPROCESSOR SYSTEM

generally less expensive and just a pleasure to use.

### 3 additional devices for mid-size, memory-intensive or multiprocessing systems.

Along with the basic 2-chip configuration, Fairchild has designed three additional F8 devices for easy system expansion:

1. *The 3852 Dynamic Memory Interface Circuit* allows the user to expand his system using standard dynamic memory—such as the Fairchild 4096-bit RAM.

In addition, synchronous DMA channel control signals are generated by the 3852.

2. *The 3853 Static Memory Interface Circuit* permits the

user to expand his system using standard static memories including Fairchild's 2102 and 3538 RAMs, and 3514 and 3515 ROMs.

The 3853 also features interrupt control circuits and a programmable timer.

3. *The 3854 DMA Direct Memory Access Circuit* provides a fast, direct data path between a high-speed peripheral device and F8 processor memory without tying up and slowing down the CPU.

The 3854 can also be used to provide a synchronous data path between multiple processors.

All three additional F8 chips are in final development or production now.

**F8 applications.**  
**The first standard super-controller goes to work.**

The advantages of the F8 design become still more evident when its range of applications is considered.

In fact, the new F8 covers a broader spectrum of applications than any other microprocessor. (See chart.)

Applications which the chart indicates are cost-sensitive are ones in which total system performance is limited by the fact that data is entered manually (like cash registers and calculators).

In these applications, the reduced parts count of the 2-chip F8 system will usually be the lowest cost solution.

For applications requiring fast data processing or numerical analysis, benchmark performance of the economical F8 generally meets or exceeds

that of other microprocessors. For the designer whose primary concern is economy in one application and performance the next, the F8 provides one system for virtually every need.

Because of the breadth of F8 applications, it is a logical candidate to become an industry standard.

**Traffic-light controller.** Designed around a basic 2-chip system, the F8 traffic light controller handles crosswalk lights, crosswalk button interrupt, street signal lamps and road traffic detectors. The controller automatically adjusts signals for optimum flow for different traffic conditions throughout the day.

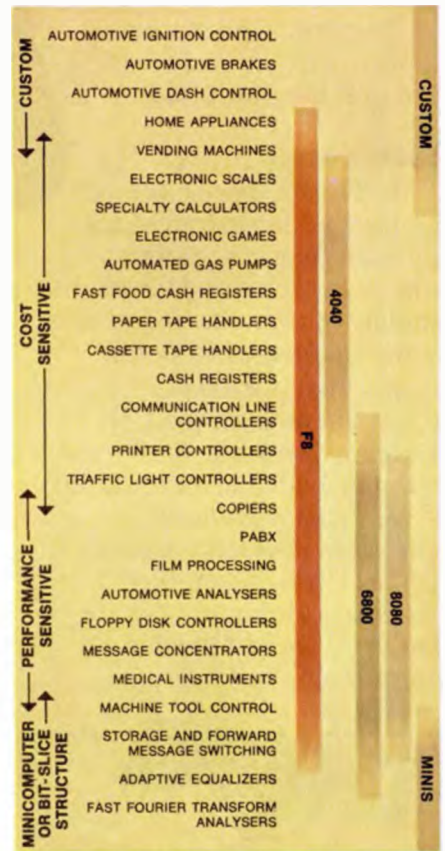
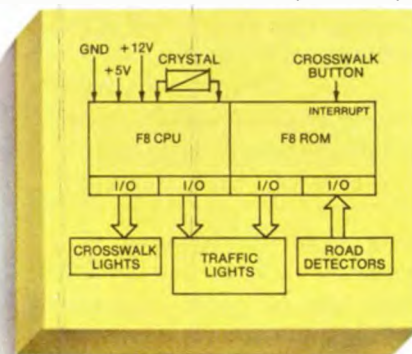

Microprocessor Application Spectrum

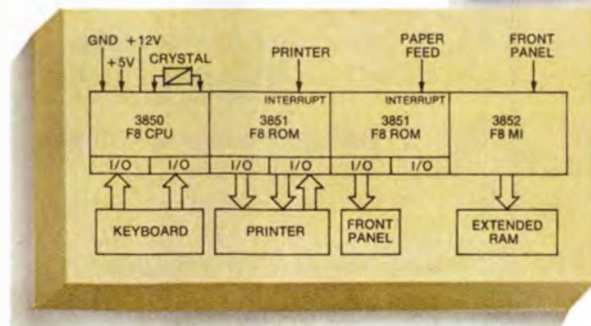

**Intelligent terminal.** Only four F8 chips are required to handle this smart terminal's keyboard input and printer, as well as provide memory interface for external RAM storage.

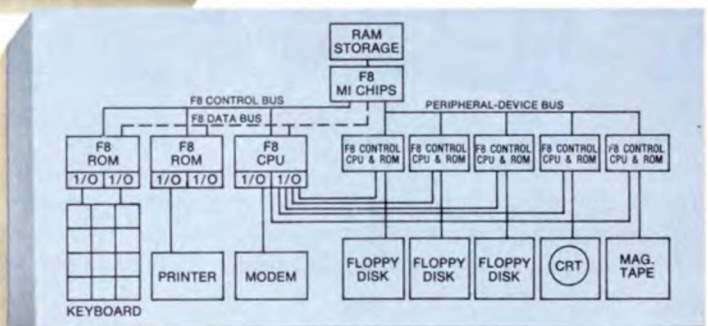

**Key-to-floppy-disk.** Multiple F8 processors are used in this key-to-floppy-disk system. Each controller consists of a CPU and a ROM. The processors are linked through a multiplexed memory channel provided by a DMA chip. This system illustrates the modular approach to expansion achievable with the F8. Because all controllers can operate simultaneously, total system throughput is increased.

Fairchild's F8 system is supported by extensive software and hardware aids.

**F8 software.**

1. *The F8 User's Manual.*  
The User's Manual provides chip specifications, defines Cross Assembler and Cross Simulator programs and covers the instruction set in detail.

2. *Cross Assembler.*  
Accessible now on the G.E. Timeshare Network. Additional networks available as required.

3. *Cross Simulator.*  
Accessible now on the same basis as Cross Assembler.

Plus additional software developed for our special F8 programming hardware.



**F8 program development hardware.**

To make F8 program development even easier, Fairchild has developed three hardware subsystems.

1. *F8M Program Development Module.* Available now, the F8M offers a basic devel-

opment system for micro-processor programs.

The module features teleprinter interface capability, 32 I/O lines, external interrupt, 1024 bytes of RAM and 2048 bytes of plug-in PROM, full operator controls and display.

The F8M is also available in kit form.

2. *F8S Program Development Module.* Available in 3rd Quarter, this PDM will provide expanded capability for memory-intensive applications.

3. *F8C Microcomputer.* Available in 4th Quarter, the F8C is a complete microcomputer system including power supplies and control panel housed in a bench-top cabinet. I/O ports are brought out to connectors, ready to interface with user peripheral equipment. The F8C is provided with a native Assembler.

**Take your choice.**

You can find out more about Fairchild's new F8 super-controller several ways.

For general data, you can mail our coupon.

Or for more specific F8 facts, you may elect to write to us on your company letterhead, describing your particular needs in detail.

Or you may call your Fairchild Sales Office, Representative or Distributor today.

Semiconductor Components Group, Fairchild Camera & Instrument Corp., 464 Ellis St., Mountain View, CA 94040. Telephone (415) 962-5011, TWX: 910-379-6435.

**THE F8.**  
**MADE IN FAIRCHILD**

Send to: P.O. Box 880A,  
Mountain View, California 94042  
Please send me more information  
on Fairchild's new F8 Microprocessor  
System. My specific area of  
application:

---

Products are manufactured at my location in the following categories:  
 Industrial    Government/Military    Instruments  
 Communications    Consumer    Computer    Business Machines

NAME \_\_\_\_\_ TITLE \_\_\_\_\_  
 COMPANY \_\_\_\_\_  
 ADDRESS \_\_\_\_\_ PHONE \_\_\_\_\_  
 CITY \_\_\_\_\_ STATE \_\_\_\_\_ ZIP \_\_\_\_\_



## Meetings

**American Ceramics Society Electronics division Meeting**, Sheraton Park and Shoreham Americana Hotels, Washington, D.C., May 3-8.

**Photovoltaic Specialists Conference**, IEEE, Hotel Valley Ho, Scottsdale, Ariz., May 6-8.

**9th Annual Carnahan Conference on Crime Countermeasures**, University of Kentucky and IEEE, Lexington, Ky., May 7-9.

**International Microwave Symposium**, IEEE, Rickey's Hyatt House, Palo Alto, Calif., May 12-14.

**Electronic Components Conference**, IEEE, EIA, Statler Hilton Hotel, Washington, D.C., May 12-14.

**Electrical and Electronic Measurement and Test Instrument Conference**, IEEE, Skyline Hotel, Ottawa, Ont., Canada, May 13-15.

**Audio Engineering Society 51st Convention**, AES, Los Angeles Hilton, May 13-16.

**National Computer Conference**, IEEE, AFIPS, Convention Center, Anaheim, Calif., May 19-22.

**Semicon/West '75**, SEMI Inc. (Mountain View, Calif.), San Mateo County Fairgrounds, San Mateo, Calif., May 20-22.

**29th Annual Frequency Control Symposium**, U.S. Army Electronics Command, (Fort Monmouth, N. J.), Howard Johnson Motor Inn, Atlantic City, N.J., May 28-30.

**Laser Engineering & Applications Conference**, IEEE, OSA, Washington Hilton Hotel, Washington, D.C., May 28-30.

**Summer Consumer Electronics Show**, EIA, McCormick Place, Chicago, June 1-4.

**NAECON—Aerospace Electronics Conference**, IEEE, Sheraton Dayton Hotel, Dayton, Ohio, June 10-12.

# WHAT'S GOOD FOR THE STUDENT SERVES INDUSTRY BEST.....not the reverse!

There's only one manufacturer of a broad line of high quality electronic test and measuring instruments emphasizing optimal design benefits for the educational field.

**Ergonomics - human engineering . . . ease of operation . . . logical panel layout** An indication of the importance Philips attaches to this subject is the fact that the company maintains the largest industrial design center in the Western World. Here, industrial products, such as oscilloscopes, multimeters, waveform generators and many other test and measuring instruments, are not only designed, but exhaustively tested by typical users. By filming the method by which the instruments are used, a truly objective user-oriented evaluation is achieved. The layout is designed with group controls, that fall naturally to hand. Cable connections are placed away from oscilloscope displays and functional controls. Special contoured knobs and pushbuttons are designed to give the user unambiguous touch control. It is the attention to the small details in design with constant concern for overload characteristics, ruggedness and reliability that causes educators to gravitate towards Philips test equipment as a genuine aid in the electronic teaching process.

Our 10 MHz dual beam oscilloscope PM3232 is typical of the design of many of our products using the approach of combining sophisticated specifications with ease of operations. People are usually surprised . . . and very pleased to learn that this instrument is so inexpensive; it's only \$ 875.00. Small wonder that for oscilloscopes, as well as the rest of the broad line of test and measuring instruments, industry is leaning more and more toward Philips for the design features so beneficial to education.

To obtain further information about the Philips PM3232 or other test instruments; or to have a field engineer visit you for a demonstration, use our toll-free HOT LINE number (800) 645-3043. New York State residents call (516) 921-8880 collect.

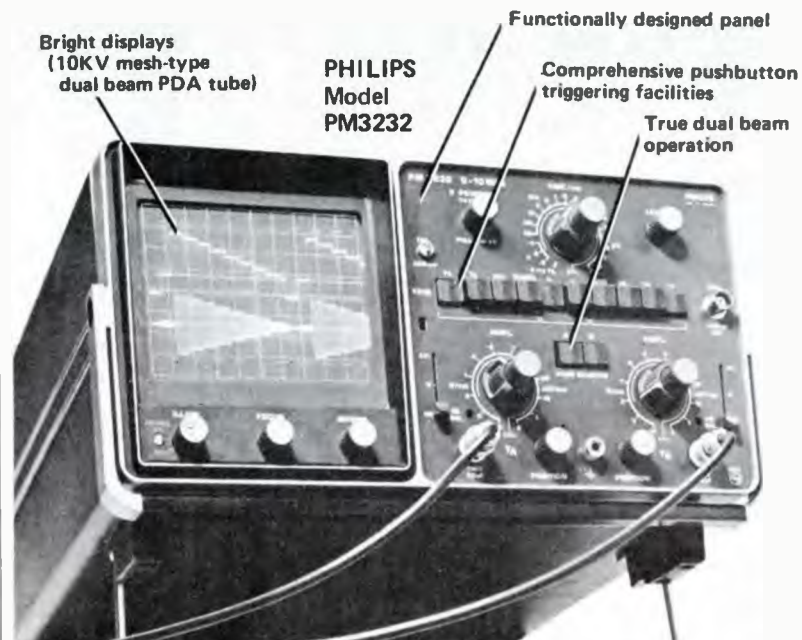

**Philips Test & Measuring Instruments, Inc.**  
A NORTH AMERICAN PHILIPS COMPANY  
400 Crossways Park Drive Woodbury, N.Y. 11797

# PHILIPS

For demonstration circle 148 on reader service card.

For information circle 23 on reader service card.

# This one resistor can shrink your inventory costs

Type CC. It's a 1/4w size 1% cermet film resistor that far exceeds RN55D specs. Use it for your needs from 1/8w at 125° to 1/2w at 70°C (max. 250 V) and 10 ohms to 10 megs.

TCR is well below 100 PPM/°C. Now available from A-B distributors: 10 ohms to 10 megs off the shelf. Write for publication EC33.



*Elmar*  
Electronics, Inc.  
Mountain View,  
California



*Newark*  
Electronics  
Chicago, Illinois



*Cesco*  
Electronics Ltd.  
Montreal, Quebec, Canada



*Cramer*  
Electronics, Inc.  
Newton, Massachusetts

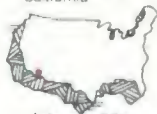

*Kierulff*  
Electronics, Inc.  
Los Angeles, California



*Solid State*  
Electronics Co. of Texas  
Dallas, Texas



*Graham*  
Electronics Supply, Inc.  
Indianapolis, Indiana



*Schweber*  
Electronics  
Westbury, New York



*Liberty*  
Electronics  
El Segundo, California



*Harrison*  
Equipment Co., Inc.  
Houston, Texas



*Almo*  
Electronics Corporation  
Philadelphia, Pennsylvania



**Quality in the best tradition.**



**ALLEN-BRADLEY**

Electronics Division  
Milwaukee, Wisconsin 53204

### **Wema sees 17% dip during 1975 for semiconductors**

Wema has revised its projections of 1975 worldwide semiconductor consumption sharply downward. From its prediction of 2% to 3% growth [*Electronics*, Oct. 31, 1974, p. 27], **Wema has switched to a 17% decline**—to \$3.875 billion from the 1974 total of \$4.677 billion.

However, 1976 will see a growth much more dramatic than originally forecast, Wema adds. The new picture painted by the West Coast-based association of electronics companies shows a **25% increase, rather than 15%, to \$4.486 billion**. Then 1977 should level off a bit with an increase of 18% to \$5.707 billion.

As for ICs in particular, the interim forecast projects a 15% decline in world consumption, from \$2.155 billion in 1974 to \$1.776 billion this year, to be followed next year by a 39% increase to \$2.474 billion and by a 23% increase to \$3.052 billion in 1977. **The earlier projection was for a 7% increase in 1975**. MOS consumption worldwide will be down 7% this year from last year, from \$725 million to \$675 million, followed by a 49% increase to \$1.004 billion in 1976 and a 24% growth in 1977 to \$1.249 billion. Most of the decline this year, the forecasters say, is due to a lessening in demand for p-MOS, from \$520 million to \$440 million. N-channel MOS consumption will grow modestly this year, from \$90 million to \$110 million, as will C-MOS, from \$115 million to \$125 million. In terms of function, most of the decline in IC consumption will be in the logic area, from \$459 million to \$375 million, but memory will grow from \$266 million to \$300 million.

### **U.S. firm to use surface waves for I-f filters**

The first U.S. company to announce plans to use **surface-acoustic-wave technology to produce intermediate-frequency filters** is Crystal Technology Inc. of Mountain View, Calif. Crystal Technology, supplier of the lithium-niobate substrate used by i-f filter producers Plessey Semiconductors in Britain and Thomson-CSF in France, expects to begin production by the end of this year, says marketing vice president Robert Carlson. The filter, designed for U.S. NTSC color-TV systems, will sell for \$1 to \$2, and have insertion losses under 10 decibels.

### **McDonnell picks Litton Inertial nav for YC-15 craft**

McDonnell Douglas Corp. has picked Litton Industries' LTN-51 inertial navigation system for its **two Air Force YC-15 advanced medium STOL transport (AMST) prototypes** that will begin flight tests in August. Litton says the software of its off-the-shelf LTN-51 has been modified to provide data on vertical velocity in addition to normal navigational outputs. The initial award is worth about \$200,000.

The YC-15, a high-wing, four-engine jet, is competing with Boeing's YC-14 for the Air Force short-takeoff-and-landing transport mission to follow the C-130. The R&D program is budgeted for \$85 million in fiscal 1976, a 52% increase from this year's \$55.8 million.

### **Fairchild seeks liquid-crystal firm**

Fairchild Camera & Instrument Corp. is strengthening its commitment to the digital-watch market by **offering to acquire Princeton Materials Science Inc.** of Princeton, N.J., which makes liquid-crystal materials and displays. Fairchild had already offered to buy the assets of Exetron

# Electronics newsletter

Corp. and its two subsidiaries, Exetron Time and Minitex, for \$280,600. However, some of Exetron's creditors are said to be balking at Fairchild's proposed terms. Exetron filed a Chapter 11 petition under Federal bankruptcy laws in San Jose, Calif., in March.

## **New MCI unit to offer non-tariff phone services**

MCI Telecommunications Inc. is forming a new subsidiary to provide **non-tariff and non-common carrier services**. The New York-based specialized carrier's plans include remote telephone routing, station billing and traffic analysis, private-line network switching, and a computerized telemanagement service. The last is designed to allow high-volume users without a great number of lines to optimize their service through "least-cost" line usage. MCI's analysis services will be available in mid-July, but its private-line network service isn't expected to be operating until mid-1976.

## **Separable camera, 525-line display, fax added to Picturephone**

AT&T's Picturephone, which was sent back to the drawing board two years ago [*Electronics*, Sept. 13, 1973, p. 75], might emerge with at least three new features designed to make it more palatable to customers. Bell Laboratories in Holmdel, N.J., is trying various approaches on its experimental Mod 3 system. **Among them: a separable camera, 525-line resolution, and the capability to receive facsimile.**

## **Japanese build a 16-bit n-MOS microprocessor**

Matsushita Electronics Corp. has built **Japan's first 16-bit microprocessor on a single chip**, the MN1610, in a 40-pin package. Using silicon-gate n-channel MOS technology, the designers have been able to get the equivalent of 1,391 gates on a 5.58-by-5.5-millimeter chip that operates at a minimum clock rate of 2 megahertz.

The MN1510, along with the MN1630 subchannel adapter, MN1650 direct-memory-access control, and memory devices—together called the PFL-16A—provides minicomputer capabilities, says Matsushita. Instruction execution time is 3 microseconds, and the memory capacity is 64,000 16-bit words.

The CPU was developed jointly by Matsushita and Panafacom Ltd., a minicomputer maker. **First deliveries of the devices will be in September.** In the U.S., standard 16-bit CPUs are available from General Instrument Corp., National Semiconductor Corp., and others.

## **Addenda**

Following Intel Corp. and Motorola Semiconductor [*Electronics*, April 3, p. 44], Fairchild Semiconductor plans a 16-kilobit n-MOS random-access memory. Thomas Longo, vice president and general manager of the IC group, says he expects to see **a prototype by mid-1976 with production starting in 1977.** Longo won't discuss details of the part. . . . Look for Data General Corp. to announce **a package of data-communications products** for its Nova and Eclipse computers. Included are a \$3,000 user-programable communications controller utilizing a 2,048-bit bipolar RAM, the DUC/50, and three multiplexers: the \$2,640 ALM-16 (16-line asynchronous); the \$2,000 ALM-8 (eight-line asynchronous with full modern control); and the \$1,500 SLM-2 (two-line synchronous).

# Our plastic 400V TO-92 SCR.

**We'll help you put it to work,  
even if you've never used  
an SCR before.**

Meet our new plastic TO-92 SCR:  
800mA RMS, 400V, with  
200 $\mu$ A gate sensitivity and a  
maximum holding current of  
5mA. It sells for less than 50¢  
in quantities of ten thousand.

If you know SCRs, you know you  
can't get anything like it at the price.  
(Except our plastic 300V SCR,  
which is even less expensive.)

If you don't know SCRs, we'll  
introduce you. Our introductory kit  
includes dozens of designs and  
descriptions for a variety of SCR  
applications. It'll help you take  
advantage of the fast, low-cost  
power-handling capability that SCRs  
deliver in high voltage circuits.

Just fill out the coupon at right.



- I'm using SCRs now, and I'd like to evaluate your new low-cost 400V SCR.
- I've never used an SCR before, but I sure am interested in them. Please send me your introductory kit.

\_\_\_\_\_  
Name  
\_\_\_\_\_  
Title  
\_\_\_\_\_  
Company  
\_\_\_\_\_  
Address  
\_\_\_\_\_  
City State Zip

Mail to: Mr. V. Savoie  
Unitrode Corporation,  
580 Pleasant St., Watertown, Mass. 02172.



**UNITRODE**

# A new and better way to get crisp, clear facsimile-type records of sonar, radar, or IR thermography.

## Honeywell's new 1856A linescan recorder.

The Model 1856A from Honeywell reflects a real advancement in fiber-optic CRT technology. Offers high resolution recordings (greater than 100 line pairs/inch), a broad gray scale capability, intensity modulation to 8 MHz, variable sweep range of  $2\mu\text{sec}$  to 1 sec/cm and 1 cm pk-pk vertical recordings from dc to 75 kHz, with a choice of recording media.

In addition to print-out papers, the 1856A offers even greater flexibility through your choice of two accessory magazine assemblies. The Model 1218A, light-tight and self-contained, permits the use of recording papers and films for wet chemical photoprocessing to obtain an even

wider resolution, and optimum reproducibility. When high writing and record speeds are not required, the Model 1219 Processor provides dry-processed high contrast or gray scale recordings on paper or film.

For complete technical specifications, call or write Bob Shipman, Honeywell Test Instruments Division, P.O. Box 5227, Denver, Colorado 80217. (303) 771-4700.



**TEST  
INSTRUMENTS  
DIVISION**

# Honeywell

## New tri-metal process brings hermeticity to plastic-packaged ICs

RCA says chip fabrication does job of hermetic seals; prices will be same as for ordinary plastic devices

A new way to beat moisture-caused corrosion in integrated circuits packaged in plastic has been developed by the RCA Corp. Solid State division in Somerville, N.J. The "hermetic in plastic" seal was achieved by using silicon-nitride passivation with three precious metals—titanium, platinum, and gold—in small quantities over the conducting runs that interconnect the individual transistors on the IC.

Initially, RCA is offering six standard types of devices in the new packages, aimed at mobile communications, automotive, and marine electronic-equipment makers. But the military will be using the devices as well. According to Bernard Reich, a special assistant for reliability at the U.S. Army Electronics Command's Electronic Technology and Devices section, the Army is bypassing its own MIL-M-38510 and MIL-S-19500 reliability specifications, which prohibit the use of plastic in military systems, to use the new RCA devices in an electronic warfare system.

RCA's new commercial circuits will be priced the same as its other plastic-encapsulated ICs, which are not hermetically sealed, says Bernard V. Vonderschmitt, vice president and division general manager. But their prices will be as much as 25% below ICs in hermetic metal packages, he says.

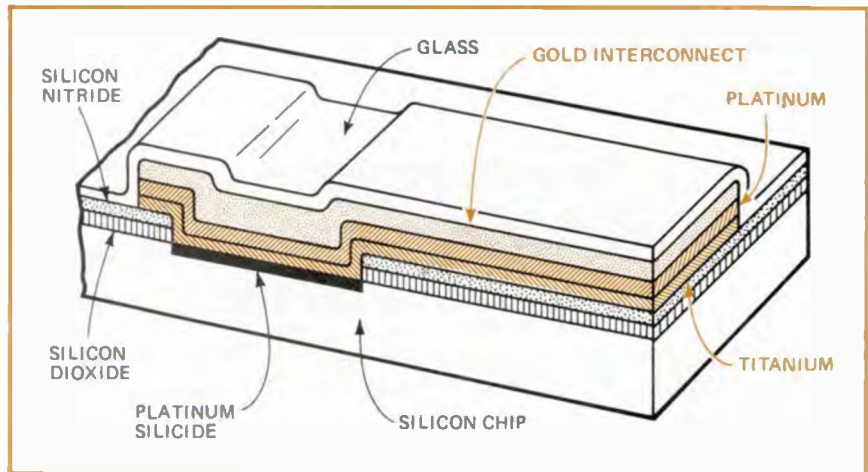

**Seal.** RCA uses silicon nitride for hermeticity, platinum silicide for non-corrosive ohmic contact, titanium for adherence, and platinum for a diffusion barrier layer. Thin gold (photo) replaces conducting aluminum.

The new devices include two popular operational amplifiers, the CA741G and CA747G; a quad op amp, the CA324G, a quad voltage comparator, the CA339G; and two high-current npn transistor arrays, CA3724G and CA3725G. Other plastic-encapsulated devices including complementary-MOS and n-channel MOS types will follow.

**Testing.** The hermetic-in-plastic parts were operated continuously for 14,232 hours per device without a single failure at the Electronics Command's Panama Canal Tropical Zone Test Center. Failure rate was 0.25% per 1,000 hours at 80°F, 90% to 98% humidity, and a 90% confidence level. This rate parallels the rate for hermetically sealed parts, says RCA, but the number tested—only 63—was small and the tests continue.

In standard monolithic chips,

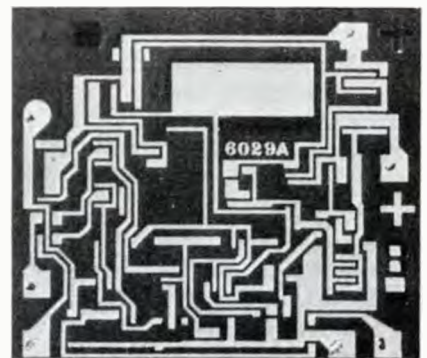

aluminum metalization is used for interconnecting devices. When moisture penetrates a plastic IC package, aluminum oxides and hydroxides form. Since these compounds are non-conductive, plastic-packaged devices often fail.

In producing the chip, RCA follows normal processing techniques until the final oxide step. At this point, a silicon-nitride layer is applied to hermetically seal the junctions. A standard masking operation is then used to open contact windows, and platinum is sputtered over the wafer and sintered in the

contact areas to form platinum silicide. Finally, titanium and platinum layers are sputtered sequentially on the wafer surface.

The silicon-nitride passivation and the titanium-platinum-gold metalization system used in the processing of the hermetic ICs is similar to that developed by Bell Laboratories for beam-lead wafer technology. The RCA device, however, uses a second layer of silicon dioxide glass for device passivation, and mechanical protection.

Standard photoresist techniques are used to define the interconnect

pattern in the platinum layer. Gold interconnect runs are electrolytically plated on the platinum. The titanium enhances adherence to the silicon nitride, and the platinum is a barrier layer between the titanium and the gold conductor. Vonderschmitt admits that RCA is absorbing most costs of developing the new process and generating reliability data to develop a market for hermetic-in-plastic ICs. He points out, however, that the precious metals are used in such small quantities that they add negligibly to device cost.

---

### Packaging & production

---

## Thick-film, large-scale hybrids shrink digital logic circuitry to small size

Thick-film hybrids are generally considered best for fitting analog signal-processing circuitry into a small space. And now a Syosset, N.Y., design house has produced computer-aided design programs that facilitate the fabrication of complex digital systems in compact, hybrid packages. And component density is unusually high.

"We can offer the low weight and volume of custom monolithic LSI, and we can produce a design in much, much less time," asserts Jeff Waxweiler, a vice president at Algorex Data Corp. Users of these large-

scale digital hybrids, as Waxweiler calls them, are exclusively military and aerospace customers requiring extremely small packages for tough environments. Moreover, different logic families and integrated-circuit technologies can readily be combined to achieve high performance in a single package.

**Mariner to Jupiter, Saturn.** The latest example of this is the memory being built by Algorex for the flight data system aboard a Mariner spacecraft. Jet Propulsion Laboratory is prime contractor for the Mariner, which will be launched in

1977 for a rendezvous with the planets Jupiter and Saturn. It was only last month that JPL chose the thick-film hybrid design over a conventional one that would have used flat packs attached to multilayer printed-circuit boards. The memory for the Mariner will consist of four 3-by-3-inch four-layer hybrid "boards," each containing 2,048 16-bit words or a total of 32,768 bits.

There are 140 chips on each hybrid—128 complementary metal-oxide-semiconductor memory chips and a dozen driver chips, as shown in the photograph, below left. The C-MOS chips are RCA Corp.'s CD4061 type, a 256-by-1-bit static random-access device. According to Waxweiler, the four hybrids do the job of a pair of multilayer circuit boards measuring 7 by 14 inches each. He also points out that it took only three months to go from a logic diagram to hardware that could be tested by JPL, and that the cost of the memory, which is in the low hundred-thousand-dollar range, is half that of the conventional approach.

Another system being built with the digital hybrids is a high-speed 20-megahertz-clock-time, 16-bit central processing unit going aboard a missile system, which Waxweiler declines to name.

**Packing.** The CPU is made up of 75 digital ICs plus 25 discrete active and passive chips. They fit on a 10-layer, 2-inch-square ceramic substrate that's 0.2 in. thick. This amounts to an IC density of 25 chips per square inch. Densities to 30 chips per in.<sup>2</sup> can be fabricated.

How does Algorex pack the circuitry on the small boards? The answer is its computer-aided design scheme. Conductor routings are calculated automatically, taking into account such parameters as circuit speed, capacitive loadings, and the need for isolating signal and clock lines. Making these calculations without what Algorex calls its Automated Integrated Design and Engineering System would take a prohibitive amount of time. The system even takes into account tolerances of the manufacturing process, ad-

---

**Large scale.** Memory module with 32,768 bits squeezes 128 C-MOS 256-by-1-bit devices plus 12 driver chips on a multilayer thick-film hybrid circuit measuring only 3 by 3 inches.

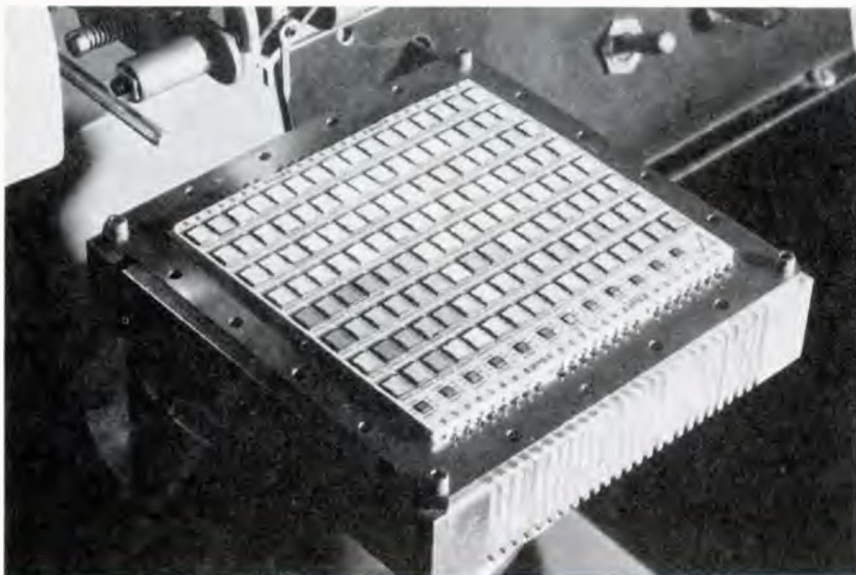



justing line widths and thicknesses accordingly.

Algorex starts with a customer's logic diagram and the desired volume of the finished circuit. The program first checks the design against a set of standard design rules, indicating where changes must be made. Once the logic is correct, the program then will generate the substrate drawings and the documents, including parts lists and assembly information.

Next, a computer-controlled plotter creates the masks needed for the screening and firing of the various substrate layers. Algorex doesn't do any manufacturing itself but sends the documents, masks, and tested chips to an outside hybrid manufacturer for assembly. It then tests the completed unit itself. □

---

### Measurement

---

## Laser, silicon team in super-fast switch

A semiconductor switch that operates in 10 picoseconds, or 10 trillionths of a second—10 to 100 times faster than conventional junction semiconductor switches—has been developed at Bell Laboratories, Murray Hill, N.J.

Bell Labs believes the new switch, which uses laser beams to start and stop an electrical signal, is the first use of picosecond optical pulses for switching electrical currents. According to David H. Auston, a member of the solid-state spectroscopy research department that designed the switch, electrical signals up to 100 volts can be switched by only a few microjoules of optical energy.

**Laser beam.** Laser light focused on a piece of light-sensitive semiconductor material causes the switching action, says Auston. In his experiments, a pulse in the green wavelength turns the switch on, another in the infrared turns it off. A solid-state laser produces the infrared pulse, with part of it converted to the green wavelength in a



**Switcher.** Bell Labs' David Auston examines experimental setup that switches silicon in 10 picoseconds. The system could be made to work as fast as 1 ps, he says.

frequency-doubling crystal. The green pulse is focused through a narrow gap between two aluminum conductors atop the switch onto a thin slice of electrically charged silicon. The pulse makes the surface of the silicon highly conducting, closing the electrical gap in the aluminum and turning the switch on.

Next, the infrared pulse penetrates the silicon, producing a conducting region that short-circuits the current to turn the switch off. The timing of the pulse pairs is controlled within a few picoseconds by manipulating a system of lenses and reflectors to vary the distances the infrared and green pulses travel before reaching the high-resistivity silicon, valued at  $10^4$  ohm-cm.

"The device should work as fast as 1 picosecond, or less," says Auston. "The speeds we've attained are limited by the duration of the optical pulses," generated by a mode-locked neodymium glass laser.

Initial applications of the switch will probably be limited to scientific uses such as the study of electrical properties of semiconductor materials, and the evaluation of conventional high-speed electronic devices. In the future, however, the switching technique may find broader applications in such things as high-speed electronic measuring instruments and short-pulse microwave radar and transmission systems.

Because there is no conventional instrument capable of measuring electronic switching times of a few picoseconds, it was necessary to devise a special technique to deter-

mine just how fast the switching occurs. To do this, Auston uses two switches connected in tandem, the second one being used to measure the electrical signal produced by the first. The results of this experiment, Auston believes, so far represent the fastest electronic measurement anywhere, although he points out that the National Bureau of Standards is conducting experiments similar to those at Bell Labs. □

---

### Computers

---

## Japan won't choose used U.S. computers

Image-conscious Japanese computer users are unlikely to import used U.S. computers in quantity following the scheduled liberalization of import quotas in December, according to a report to the U.S. State Department from its Tokyo embassy in April. Since old computers appear to lack status in Japanese eyes, the Tokyo Government has no immediate plans to slap stiff tariffs on such imports, letting them come in instead at the same duty rate as new data-processing hardware.

The option of higher tariffs is probably being held open, however, since the Ministry of International Trade and Industry would neither confirm nor deny to the U.S. that such a plan existed, according to the report. Even though "several U.S. companies see a potential market in Japan for used equipment, especially IBM 360 systems," the U.S. study sees such sales unlikely.

The embassy observes that "the computer in Japan still carries an

aura of mystique and one major consideration is the prestige value of the machine." The Japanese want the newest models, "even if it costs more and is more sophisticated than their needs require." No IBM 360 import rush is expected, therefore, since that line may be two models old by the end of 1976 and "will have lost most of its glamor."

MITI "will probably not panic into preparing elaborate counter-measures against what will most likely turn out to be a non-problem," in the U.S. view. Earlier liberalization of import restrictions of integrated circuits produced no market disruption, the report notes, adding that the Japanese commitment to EDP import liberalization would make it "very difficult to impose a tariff on used equipment until the threat is proven." □

### Avionics

## Kearfott, Europeans gear up for F-16

Contractors for the avionics systems that will fly on the F-16 fighter are being lined up on both sides of the Atlantic Ocean. One of the lucrative awards—for the inertial navigation system—went to Singer Co.'s Kearfott division last month. And the Norwegian firm, Kongsberg Vapenfabrikk, is slated to handle systems work on the inertial gear. In addition, Kearfott has already placed orders with Manufacture Belge de Lampes et de Matériel Electronique in Brussels, Belgium, for various



## Marine landing system goes to Kearfott

April was a good month indeed for Singer's Kearfott division. In addition to the F-16 inertial navigation system award, it won a Navy contract for a microwave scanning-beam landing system for Marine Corps helicopters and short takeoff and landing aircraft.

Kearfott beat out Bell Aerospace Co., Buffalo, N. Y. to furnish the Marine Corps' remote area approach and landing systems (MRAALS). The \$8.5 million contract calls for the delivery of 81 ground systems over three years to the Naval Electronic Systems Command. A follow-on \$4.5 million contract for airborne receivers is being negotiated by Kearfott with the Naval Air Systems Command. Bell Aerospace, meanwhile, says it plans a formal protest of the award to the General Accounting Office.

The Marines' Ku-band [*Electronics*, Feb. 1, 1973, p. 72] is designed for use in remote Category 2 landing conditions—ceiling 100 feet and runway visibility to 1,200 feet. It covers  $\pm 20^\circ$  in azimuth, and  $0^\circ$  to  $20^\circ$  in elevation. Glide slopes are to be selectable in the aircraft from  $3^\circ$  to  $12^\circ$ , and the signals are to be compatible with the AN/ARA-63 receiver/decoder systems.

Aircraft expected to use MRAALS include the CH-53, CH-46, and UH-1 helicopters, and at a later date, the AV-8A STOL. The MRAALS will be compatible with existing approach aids located at forward military air bases and aboard aircraft carriers.

types of hybrid integrated circuits for the inertial equipment.

For the F-16 system, Kearfott beat its competitors Litton Industries Inc. and the General Motors Corp. Delco Electronics division to win an initial \$1.5 million contract to supply eight systems. A Kearfott spokesman estimates that \$60 million is a "good ball-park figure" for the division's prospective sales of F-16 inertial sets to the Air Force and if, as anticipated, a North Atlantic Treaty Organization consortium of four countries buys the plane for its own forces.

If ordered into full production, General Dynamics Corp., the prime contractor, will build approximately 650 aircraft over the next several years; NATO could order 350 more to replace its aging F-104s [*Electronics*, Jan. 23, p. 30].

**Cost-saving attraction.** To make the F-16 more attractive to the NATO countries, the U.S. would allow the Netherlands, Denmark, Belgium, and Norway to build portions of all of the aircraft, including even those going to the U.S. Air Force. Under this arrangement, consortium firms would produce 10% of the procurement value of the 650 Air Force

planes, 40% of the procurement value of the 350 NATO consortium aircraft, and 15% of the procurement value of third-country sales.

The Belgian MBL, which is also a licensee of Kearfott for its doppler-radar navigation system, has already submitted prototypes of Kearfott-designed circuits for evaluation. These hybrids are destined for Kearfott's SKD-3000 digital computer, an integral part of the inertial system.

The European avionics effort on the F-16 could amount to at least \$560 million. Marconi-Elliott Microelectronics Ltd., the British company, and Kaiser Aerospace & Electronics Corp. are vying for the head-up display, and IBM Corp., General Motors' Delco division, and Litton Industries Inc. are competing in a second round of bidding after the USAF overruled General Dynamics Corp's initial selection of IBM for the fire-control computer.

Another major avionics package, the fire-control radar, is undergoing flight-testing and is not expected to be selected until at least November, although efforts are underway to accelerate a decision on that contract. U.S. radar contenders include Westinghouse Electric Co. and Hughes Aircraft Co., but Philips NV in the Netherlands and MBL share the

**Guide.** Off-the-shelf inertial system from Kearfott will go aboard the F-16 fighter.

# Tektronix TM 500

a line  
of 29 test  
instruments

that go  
six-in-a-rack  
including  
custom circuits.

- digital multimeters
- counters
- generators
- amplifiers
- power supplies
- oscilloscopes
- a blank plug-in for your own circuitry
- and more

TEKTRONIX modular instrumentation offers your QC, production test, or built-in test equipment a highly compact, extensive line of test instruments . . . TM 500. They are designed to work totally independently or as a system with each other. Blank plug-in kits make it easier for you to build in your own testing circuits compatible with TM 500. The RTM 506 rackmounting power module/mainframe (only 5¼" high) provides six compartments to accommodate TM 500 plug-in modular instruments and the plug-in kits. It is available for benchtop or portable use (TM 506), as well as for rackmounting (RTM 506).

A common Interface circuit board within the mainframe permits the intercommunication of inputs, output, and various parameters among the plug-ins. Tektronix will supply you with data on voltages, currents, and pin connection diagrams, so you can determine the feasibility of assembling your special circuits in blank TM 500 plug-in kits.

The TM 500 family of instruments is designed to fulfill your test and system needs in such widely divergent areas as high-speed logic; dc, power line frequency, audio, and rf to 550 MHz; oscilloscope and other instrumentation calibration; and even medical instrumentation calibration. They represent Tektronix standards of quality in design, performance, and ease of opera-

For Demonstration circle 150 on reader service card.  
For Information circle 33 on reader service card.

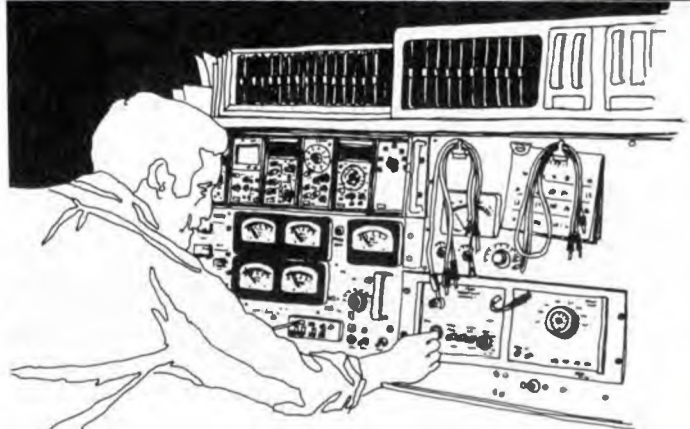

tion. Included are pulse generators with features such as independent pulse top and bottom controls and repetition rate to 250 MHz. And the DC 505A Universal Counter/Timer features direct counting to 225 MHz and time interval averaging with resolution to 100 ps.

Here is a growing, compatible family of 29 plug-in modular instruments, accessories, and one, three, four, and six-compartment mainframes providing the common power supply. All mainframe/power modules may be hand-carried, all go on the bench, and there are SCOPE-MOBILE® configurations as well. Some instruments are general purpose, such as DMMs, some are highly specialized, such as those for oscilloscope calibration. They comprise test and measurement systems that are difficult to duplicate with monolithic instruments.

Send for the 56-page TM 500 catalog A-3072 with full specifications and suggested selections of instruments for typical applications. Or contact your local Tektronix Field Engineer for a demonstration of how TM 500 instruments can solve your needs. Write to Tektronix, Inc., P.O. Box 500, Beaverton, Oregon 97077. In Europe write Tektronix Limited, P.O. Box 36, St. Peter Port Guernsey, Channel Islands.



**TEKTRONIX®**

committed to  
technical excellence



## Electronics review

primary radar responsibility for the NATO consortium.

In addition, the fire-control computer will be in the hands of Danish firm Disa Elektronik A/S. Also, the optical part of the head-up display would go to Oude Delft in the Netherlands and the electronics portion to Kongsberg.

**Navigator.** Kearfott will supply General Dynamics with off-the-shelf gear—the SKN-2400/2600-series inertial navigator, designed essentially around the division's KT-70 inertial system, which is already flying on the Navy's P-3C antisubmarine-warfare craft and A-7D/E attack plane. Versions of this navigator were delivered last year to Sweden for that country's JA-37 Viggen fighter and to the French navy for its Super Etendard, a new carrier-based aircraft. □

### Air-traffic control

## Recordings may help small airports

Remember the old joke about the pilot's voice coming over the aircraft intercom that begins with, "Good morning. This is your pilot speaking," and ends with, "Relax. Enjoy your flight. This message has been prerecorded?"

In fact, a research and development arm of the Department of Transportation—the Transportation Systems Center of Cambridge, Mass.—thinks recorded messages could make things a lot safer for aircraft flying in and out of small airports that lack control towers. The center proposed to the DOT's Federal Aviation Administration that an automated terminal-service system be developed that would broadcast recorded messages with up-to-the-minute details needed for safe landings.

"The pilot would get a radar position fix of his range and azimuth relative to the airport," explains Paul Abramson, program manager of the ATC processing project office in Cambridge. "And the system

would also broadcast information about such things as the traffic and terrain around the airport, and wind direction and velocity."

Abramson is shooting for a \$200,000 price tag on the system, plus another \$20,000 to \$30,000 each year to run it. He estimates it could be used by 50 to 100 airports; these are facilities such as Harvey Young Airport near Tulsa, Okla., and James Field near Minneapolis, with 50,000 to 100,000 operations each year that might otherwise decide to buy control towers in the next five to 10 years.

**Accidents higher.** Control towers, on the other hand, cost at least \$500,000 plus \$140,000 yearly to staff and maintain. And only about 500 of the 12,000 airports in the United States have them. Midair accident rates at the so-called unattended airports are double those at tower-equipped fields.

Abramson says the automated system basically would consist of a processor—most likely a mini-computer—and a voice-response unit that would broadcast over the ultra high-frequency aircraft radio channels. Input would come via the airport's air-traffic-control radar-beacon system. This radar interrogates aircraft equipped with ATCRB transponders and receives a four-digit code dialed in by the pilot that identifies the aircraft.

"The system will detect the aircraft and identify itself on the voice-response unit," Abramson explains. "The pilot would then give his identity, usually the aircraft's tail number, by voice. The system will record the pilot's voice and whenever it

wants to talk to the pilot, it will play back the voice it has recorded." The pilot will also be given a unique code to dial into his transponder to confirm that he is, in fact, in the system. A pilot without a transponder-equipped aircraft could listen to advisories sent to other planes.

Right now, Abramson's group is trying to convince the FAA that it should get the go-ahead. Abramson says he could have a demonstration system built from off-the-shelf hardware within a year. □

## Automotive

### Indy car gets telemetry check

Riding alongside the Goodyear and Gatorade decals on Team McLaren's 1975 entry in the Indianapolis 500 auto race will be those of two of the newest sponsors to autoracing—Data General Corp. and EMR Telemetry. And inside the car will be a 35-pound package of electronic sensors and telemetry gear that McLaren hopes will give it that infinitesimal edge that's needed to win the big race.

"There's never been a successful light-weight data-acquisition system for improving race-car performance," comments Gary Knutson, the man heading up engineering for McLaren Engines Inc., Livonia, Mich. "It's not that the components

**Racer.** Data General's Nova 2 computer (rear) controls telemetry system being readied for Indianapolis 500 racing car.



# Take a big byte out of data requirements with conography.



TM—Conographic is a trademark of Hughes Aircraft Company.

What's conography? It's a new space-age technology which uses conic curves to digitize and store graphic and symbolic information.

Conography not only reduces data requirements, it produces a better image. (It's like using a french curve instead of a straight-edge to draw contours and curved images — a lot easier and with smoother results.) The computation of these special curves is so fast that a mini-computer can interactively change curved images in real time.

The Conographic™-12 advanced display terminal uses a standard video format, so you can receive, transmit and process information by video data transmission. It has complete graphic and alphanumeric capability, high resolution video (1029-line), selective erasure and extensive line texturing capability.

Since it requires less data to operate, the Conographic-12 system needs less support

hardware, simpler software, and less computer time for most applications.

In other words, conography can save you a lot of time and money.

Write for our brochure, "Image Processing with Conography." Hughes Conographic Products: 6855 El Camino Real, Carlsbad, CA 92008, (714) 729-9191. Or 1284 North Broad Street, Hillside, New Jersey 07205, (201) 289-7770.



**Creative Image Processing**

**HUGHES**  
HUGHES AIRCRAFT COMPANY  
INDUSTRIAL PRODUCTS DIVISION  
IMAGE DEVICES

Circle 35 on reader service card

weren't available; it's just that no one could figure out how to apply them to racing." The best systems in the past have been on-board multi-channel fm recorders, which serve well for race-car design and development, "but they weren't at all practical in a race," he notes.

**Variables.** In contrast, the Indy car, designed and built by Bruce McLaren Motor Racing Ltd., Colnbrook, England, will rely on a real-time, 14-channel multiplexed system to sense and transmit to the maintenance pit during the race such variables as fuel flow, manifold pressure, water and oil pressure and temperature, and cockpit and tire-surface temperature. Team McLaren will enter two cars in the Memorial Day race; an instrumented one will be driven by Johnny Rutherford, the Fort Worth, Texas, winner of last year's Indy 500.

The aerospace-grade sensors that Team McLaren plans to use are potentiometer types, except the turbine-pulse flow meter for monitoring fuel flow. "One of the biggest problems around any racing vehicle is the unshielded ignition," Knutson explains. "So all the equipment must be shielded, and the high-level signals from potentiometric transducers are much easier to work with." The sensors are mostly from AST/Servo Systems, Newark, N.J.

During the race, McLaren pit crews will see data on:

- **Fuel flow.** "This can win or lose a race, so the primary transducer during the race is the flow meter," Knutson says. Fuel consumption is now estimated before the race from average engine power-level data, since racing cars' fuel cells contain a spongelike safety material that prohibits using level sensors. Developed by Flow Technology, Phoenix, the propeller-like device is mounted in the fuel line between the pump and the engine.
- **Manifold pressure.** Working hand-in-hand with fuel-consumption data, this can be adjusted by the driver to suit race conditions.
- **Water and oil temperature and pressure,** monitored mostly for

## News briefs

### Liquid-crystal display is built on sapphire

Hughes Aircraft Co. has improved its liquid-crystal graphic display by building it on a sapphire substrate. Previously, the liquid-crystal had been placed on a bulk silicon substrate containing the addressing and switching circuits [*Electronics*, Nov. 22, 1973, p. 34]. The sapphire permits simpler processing and better yield than silicon, as well as isolation between elements. A 1-inch-square display with 10,000 picture elements has been fabricated. Next step is a 2-by-2-inch display. Eventual applications could include portable TV receivers, oscilloscopes, and special displays.

### CDC tries solid-state memory in tubes

A memory addressed by electron beams is getting a tryout at Control Data Corp.'s Advanced Design Laboratory, St. Paul, Minn. The engineering prototype, developed by Micro-Bit Corp., has nine vacuum tubes, each with a metal-oxide-semiconductor target that stores 128,000 bits. By the end of the year, Micro-Bit, of Lexington, Mass., hopes to have a system with 24 tubes, each with a capacity of 4.2 million bits (see related story, p. 104). Last year, Stanford Research Institute delivered its version of a beam-addressable memory to the Air Force [*Electronics*, Oct. 3, 1974, p. 44], but this program was discontinued because of budgetary constraints.

### Pilots test infrared scanner at night fires

A forward-looking infrared scanner will be evaluated by the Los Angeles County Fire Department as a navigation aid for helicopter pilots when they combat forest fires at night. Developed by Aeronutronic Ford Corp., Newport Beach, Calif., the 72-pound scanner consists of an infrared sensor/scanner, a cooling unit, gimbals to point the sensor, and a pair of cathode-ray-tube displays. The military system from which the basic design was taken weighed 650 lb. The fire fighters are already using another military development—night-vision goggles.

### Competitors ready data modules for IBM 3340

Two companies—one American and the other Japanese—have developed plug-compatible data modules for the IBM 3340 Winchester disk drive. Nippon Peripherals Ltd. has also introduced a plug-compatible drive. Memorex Corp., Santa Clara, Calif., will begin deliveries of its \$2,000 70-megabyte Data Mark 70 in June, and a \$4,000 fixed-head Data Mark 70F is scheduled for September. Nippon Peripherals will start delivering its NP20 disk drive and NP21 data module by the end of the year.

### CDC and Honeywell form mass-memory company

Control Data Corp. and Honeywell Inc. have formed a jointly owned company to produce rotating mass-memories—mostly disks. Magnetic Peripherals Inc., to be headquartered in Minneapolis, will take over Control Data plants in Minneapolis, Redwood Falls, Minn., Rapid City, S.D., Hawthorne, Calif., and Lisbon, Portugal. Honeywell will contribute its Oklahoma City plant. Magnetic Peripherals will sell its entire output to the two owners.

### GTE wins \$500 million Iranian contract

General Telephone & Electronics Corp.'s GTE International subsidiary beat out five foreign telecommunications equipment suppliers to win a contract worth an estimated \$500 million to double the capacity of Iran's telephone network. GTE plans to begin installing equipment later this year.

### EIA communications makers to visit China

Ten communications-equipment makers from the Electronic Industries Association will tour the People's Republic of China for 10 days, beginning July 27. EIA Chairman Glen R. Solomon of IBM's Federal Systems division will lead the trade delegation, whose members will be announced in June.

# More designers are choosing McMOS today

## Because today it's the CMOS that offers more

As business has become increasingly tighter, more design and purchasing people have turned to Motorola's McMOS\* family of CMOS logic for new design requirements. Careful evaluation of relative merits convinced them that they would benefit more ways with McMOS.

*broader*

### FUNCTIONAL COVERAGE

More than 80 different MC14000/14500 devices form a balanced mixture of the industry's richest MSI line-up and the necessary simple gate and flip-flop types. This includes functions most TTL and CMOS suppliers haven't even attempted yet; and 25 new line additions are scheduled in 1975.

### RELIABILITY

Word gets around when product is reliable; and, of course, when it isn't. The word's around that McMOS is reliable. That's based on users' experience . . . and on test documentation. If the latter is important to you, contact the nearest Motorola sales office for a copy of the latest on plastic McMOS documented reliability. Motorola's standard off-the-shelf CMOS will do the job without gimmicky, expensive special programs.

Motorola McMOS vs. Major CMOS Competition  
(Testing completed December, 1974)

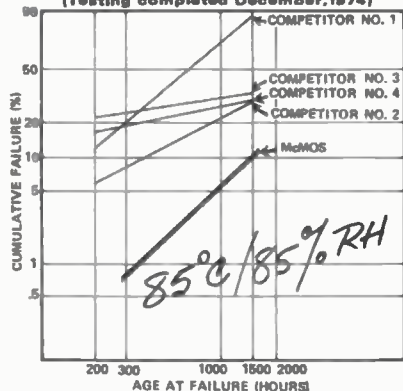

*easy*

### TTL-CMOS CONVERSION

Now Motorola makes it easy to cross over to CMOS and get the low power, high noise immunity combination no other present logic form offers. There's an up-to-date TTL-CMOS Function Cross Reference you'll get if you circle the bingo number on this ad.

### TTL-LIKE PRICING

Production and technological breakthroughs like those achieved at Motorola's ultra-modern CMOS facility in CMOS follows the TTL pattern, but accelerates the pace

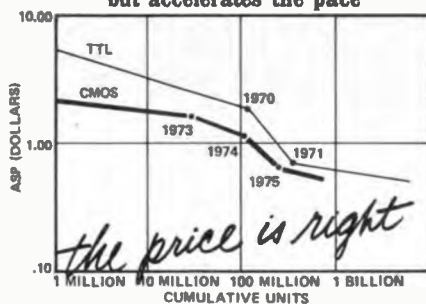

Austin, Texas have created record breaking availability and pricing. We're able to price McMOS much lower now than was originally anticipated for this time. Now, for comparable functions, CMOS is selling competitively with TTL.

*most*

### MSI FUNCTIONS

That the McMOS family is heavy in MSI is no accident. It's been structured that way from the beginning because designers have indicated from the beginning that MSI had to be the cost-effective way to go in CMOS.

*new*

### SPECIALIZED FUNCTION SERIES

Now there's a whole new dimension to McMOS. The MC14400 Series is a growing set of specialized function MSI subsystems. It all started with the MC-14435 A/D logic subsystem, followed by the MC14490 Hex Contact Bounce Eliminator, MC14411 Bit-Rate Generator and the MC14415 Quad Hammer Driver. Others, for specialized application in telephony, data handling, and watch/clock circuitry, will be available during 1975. Several of these are just coming out now: the MC14410 Two-of-Eight Tone Encoder, MC14440/50/51 Timepiece units, and MC14419 Keyboard Encoder.

*more*

### INFORMATION AVAILABLE

McMOS, the CMOS of today; offering more, doing more, for more people. For information that will inform you if you're curious, and help you if you're serious, write to Motorola Semiconductor Products Inc., P.O. Box 20912, Phoenix, AZ 85036, or circle the reader service number.



**MOTOROLA McMOS**  
- complementary MOS for contemporary systems



# from Grayhill

## the different DIP switch



- Exclusive sliding ball contact system for positive wiping action

- Life tested to 50,000 mechanical operations, with commensurate electrical life

- Available in 9 sizes, even a hard-to-find 2 rocker version, on up to 10 rockers

- All SPST, each switch independent, rocker actuated

Of course, the different DIP Switch—Grayhill's Series 76—also offers the standard DIP benefits of easy PC board mounting, compact high density design and a multitude of cost savings. Get the full story, including detailed specifications and prices, in Grayhill Engineering Bulletin # 238, available free on request.



581 Hillgrove Avenue • La Grange, Illinois 60525  
Phone (312) 354-1040

### Electronics review

safety. "We might be able to do something if we detect an over-temperature condition," Knutson says.

- Tire surface temperature. "If a tire is overheating, it's a pretty good indication that we're going to have to slow down or change at the next stop to a tire of a slightly different rubber compound," Knutson says. Temperature will be monitored across the tread surface by mounting thermistors close to the wheels.

**Telemetry package.** The prototype on-board telemetry package weighs about 35 pounds. It includes signal-conditioning gear, voltage-controlled oscillators for frequency-multiplexing, radio-frequency transmitter and antenna, and a large rechargeable-battery pack that's good for six hours of continuous, all-channel operation.

Bringing everything together in the pit will be a Data General Nova 2 with 32,768 words of memory, and Teletype and cathode-ray-tube terminals for data display. Data General is also writing the software and lending the team an analog-digital converter. EMR is providing the pit receiver and antenna demultiplexer. Because the receiver has a narrow acceptance angle, the system also gives an accurate count of the number of laps completed and can calculate speeds and fuel rates. □

### Displays

## LEDs, LCDs may have rival in ECDs

Light-emitting diodes and liquid crystals so far have been the best displays for the fast-growing number of electronic watches. But a third type—electrochromic displays—may be close to application. For that matter, ECDs could challenge the other two in all display applications, including calculators, instruments, and the like, according to electrochromics developers.

ECDs have been in the laboratory for some time, but at the recent Society for Information Display International Symposium in Washing-

ton, two firms working on this chemical approach to electronic optics, American Cyanamid and Zenith, seemed close to applying it to watches and instruments [*Electronics*, Dec. 6, 1973, p. 87].

The advantages of ECDs, Zenith developers pointed out at the SID meeting, are not only contrast and legibility in dimly lit ambients, but wide viewing angles, memory, and compatibility with IC technology. Display-electrode longevity is at present the primary barrier to the development of an ECD for time-piece use, Zenith spokesmen added, but it is not a fundamental problem.

American Cyanamid Co., Wayne, N.J., which has been working on electrochromics for at least 10 years, has already signed an exclusive license with Ebauches SA, the Swiss watch maker, that will eventually lead to an ECD watch display. Cyanamid has set its sights on calculators and instruments as well as just about every application now performed by LEDs and LCDs.

**Direct line.** Zenith Radio Corp., Chicago, has also been working on ECDs and, although it's silent on specific applications, has a direct line to watch makers through its Movado (U.S.) and Zenith Time SA (Switzerland) operations. In addition, of course, Zenith could find a need for an ECD in the solid-state digital television tuner, now being designed for more and more television receivers.

Yet to be established is the cost comparison between ECDs and the other two types. As a display, electrochromics offer advantages over LCDs in appearance, temperature range, and shock resistance. Compared to LEDs, ECDs are claimed to use less power at constant-operation and offer color combinations that are easily visible in high ambient light. In addition, says Cyanamid's Thomas Whitehead, product manager for electrochromics, this technology could be used in other optical devices, such as a rear-view mirror for autos that adjusts to the glare of headlights.

Neither Zenith nor Cyanamid has ventured a prediction of when ECDs



# if it's a meter or meter relay,

# Simpson

Stock or Special . . .  
Digital, Analog, AnaLed . . .

# makes it.

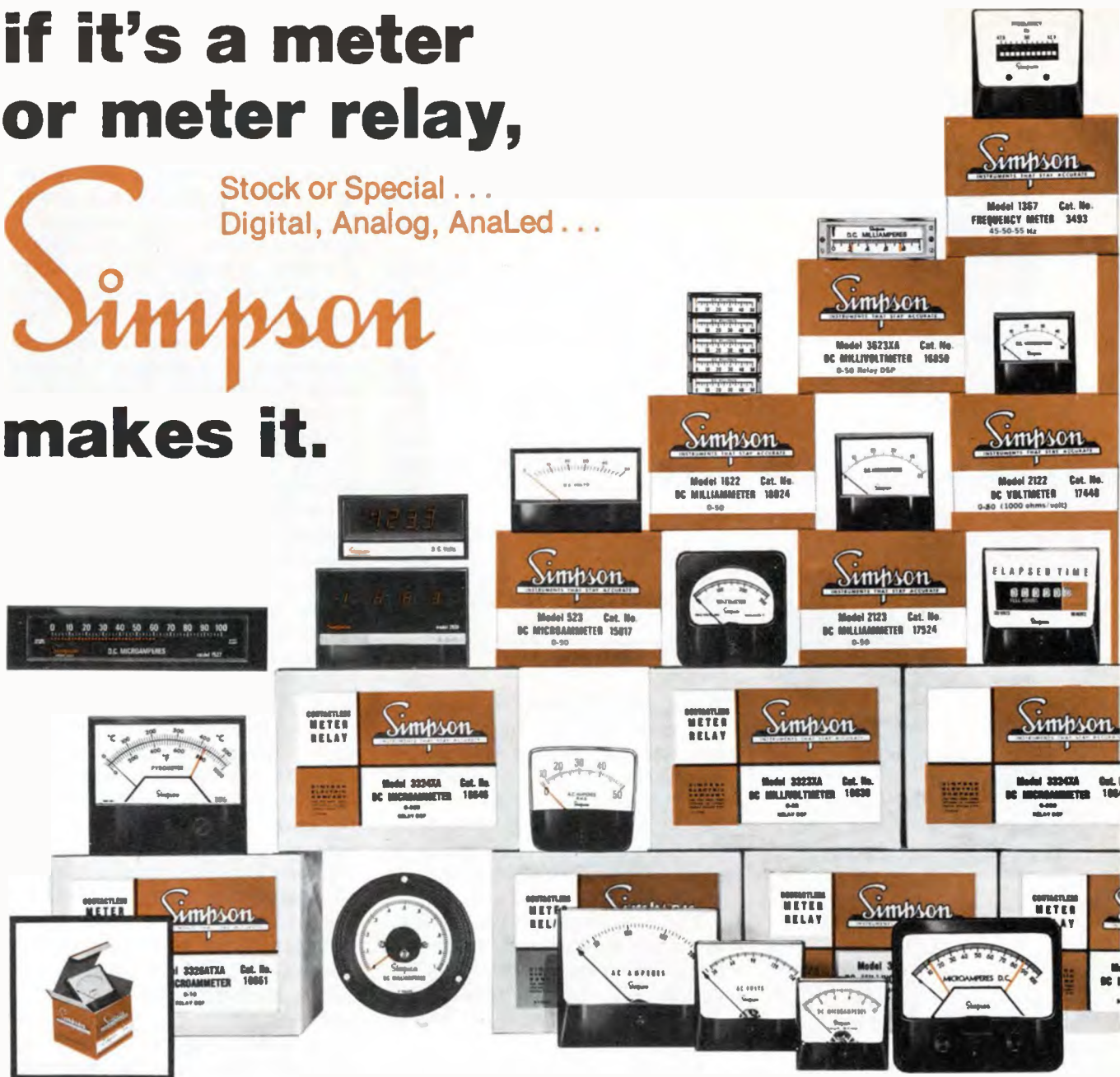

## Stock:

Simpson distributors nationwide stock over 2,000 types, ranges, styles and sizes of panel meters, relays and controllers. They're all listed in our new Catalog 4400. Write for your free copy.

## Special:

Need a special or unusual meter? Let Simpson help you custom design it. Send us your specs and we'll send you a quote. But check our catalog first—that "special" may be a standard Simpson stock item.

*Get off-the-shelf delivery from your local electronics and electrical equipment distributors.*



**SIMPSON ELECTRIC COMPANY**  
853 Dundee Avenue, Elgin, Illinois 60120  
(312) 697-2260 • Cable: SIMELCO • Telex: 72-2416

IN CANADA: Bach-Simpson, Ltd., London, Ontario  
IN ENGLAND: Bach-Simpson (U.K.) Limited, Wadebridge, Cornwall  
IN INDIA: Ruttonsha-Simpson Private, Ltd., Vikhroli, Bombay

KATY INDUSTRIES



INDUSTRIAL  
EQUIPMENT  
GROUP

# SWITCHING POWER SUPPLY



HR0510

High Efficiency

Compact and Lightweight

Competitive Price



ELECTRICAL CHARACTERISTICS HR0510

Output	5V10A
Efficiency	74%
AC Input voltage	117V±10%, 220V±10%
Line Regulation	±0.2% or less
Load Regulation	±0.2% or less
Ripple & noise (max)	40mV (p-p)
Overload protection	Current Limit Type
Overload protection	Signal Inhibit Type
Output on/off control level	TTL
Withstand voltage	1.5KV AC for one minute
Isolation resistance	100MΩ or more at 500V DC
Temperature rise	30° C or less
Ambient temperature range (operating)	0-50° C
Temperature coefficient	0.02%/C°
Weight	1.7 Pounds
Size (WxHxD)	1.77"×4.72"×7.87"

HR0510 · HR0520 · HR0530 · HR0905  
5V 10A 5V 20A 5V 30A 9V 5A

HR1204 · HR1506 · HR2406  
12V 4A 15V 6A 24V 6A

Corporations interested in acquiring the right to manufacture our products introduced above, please contact

**NEMIC**

**Nippon Electronic Memory Industry Co., Ltd.**

1-20-1, Sendagaya, Shibuya-ku, Tokyo  
151, Japan Tel: (03) 478-3935  
Telex: 3232-190 NEMIC J

## Electronics review

will be marketable. The main problem, SID speakers agreed, has been to develop the right materials and then establish suitable operating life.

The basis for an ECD is an electrically controlled chemical reaction that occurs along electrodes arranged in segments. The segments in the reversible reaction either absorb or reflect visible light. In general, this type of display would have both an optical and electrical memory; other optical displays have an electrical memory only. □

## Communications

### New Intelsat RFPs may come by Fall

A request for proposals to design and build the Intelsat V series of satellites represents a \$250 million hardware plum for the winner. The award could come as early as October, says a spokesman for Intelsat, the International Telecommunications Satellite Organization in Washington.

The new satellite series, planned to meet international traffic demands expected by the end of the decade, will succeed Intelsat IV-A satellites, the first of which will be launched in July.

Five or six of the Intelsat V craft will go into service in 1979. The next step is for the approval for the new satellites to be given by the Intelsat board of governors, which will meet in July.

**Competition.** Expected to bid on the satellites are Lockheed Missiles and Space Co., Sunnyvale, Calif., TRW Systems Group, Redondo Beach, Calif., and Hughes Aircraft Co., Culver City, Calif. Lockheed and TRW will submit proposals for three-axis stabilized satellites, and Hughes is expected to propose a spin-stabilized model similar to earlier Intelsats and other commercial communications satellites used to relay voice, TV and data [*Electronics*, Oct. 3, 1974, p. 95].

Intelsat wants the Intelsat V craft

to relay the C-band frequencies of present Intelsats and to add bands for 11 and 14 gigahertz. As much as 750 watts of power will be needed to operate between 10,000 and 14,000 channels—up sharply from the 6,000 in the IV-A series of which Hughes has built six for \$119 million. "This power is not achievable within the constraints of a spinner," declares John Hockenberry, Lockheed's director of communication satellite programs. Hughes, of course, disagrees. Intelsat IV-A requires but 600 watts of power.

Only about one third of the solar cells on a spinning satellite produce power at any one time, and the diameter of the launch vehicle precludes enlargement of the satellite to accommodate more cells, Hockenberry explains.

**Transponders.** Intelsat has not yet decided on the number of transponders it wants for the two frequency bands. But industry sources say that five satellites with more than 20 transponders each will be required. The C-band frequency will have 36-megahertz bandwidths, while the 11/14 GHz band will be 72 MHz wide, says Simon B. Bennett, Intelsat's engineering department manager. Traveling-wave tubes of up to 15 watts output will be required. Intelsat IV and IV-A have 5- and 6-w TWTs. The effective isotropic radiated power required for the next series will be "approximately the same as the 29 dbw of Intelsat IV-A," Bennett adds.

Two or three of the new satellites (depending on how many transponders each will carry) will be positioned over the Atlantic Ocean, two over the Pacific and one over the Indian Ocean. □

## Consumer

### Calculator/watch fits on the wrist

Multiplexed circuits connecting the display segments have helped cut the size of a new calculator/watch combination so that it fits on the

# Another technical knockout

## *the first 80 W, VHF transistor*

The industry's biggest VHF die (80 x 221 mils) now offers unprecedented simplicity and minimized component count for land-mobile designs.

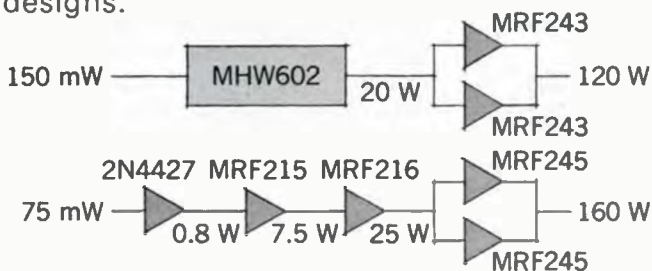

The MRF245 outperforms them all with saturated power in excess of 100 W at 12.5 V.

You use 2 parts in place of 4 — fewer passive components and lower power drivers. And, for the same  $P_{in}$  as other devices, get 10 more watts out... 80 instead of 70. For lower power radio, the

new design MRF243 provides 60 W  $P_{out}$ .

The device is L-matched CQ\* for better broadbanding than conventional T-matching. Typical power gain for the '245 is 6.4 dB at 175 MHz. Optimized thermal characteristics ensure 20:1 minimum VSWR at rated  $P_{out}$  and 16 V high line.

The computer-designed chip is thermally optimized, affords very high figure-of-merit geometrical design and rugged structuring with no sacrifice in power gain.

WriteBox 20912, Phoenix, AZ 85036 for data sheet and Engineering Bulletin EB-46 on 80 W amplifier design. Be first with the first...

\*Trademark of Motorola Inc.

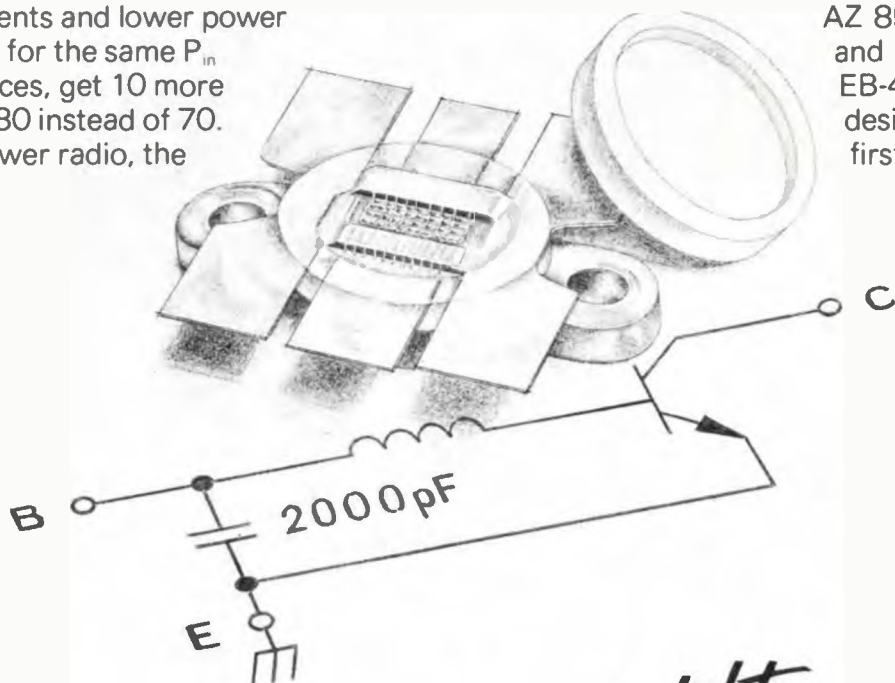

*heavyweight*  
**from Motorola, the RF producer.**

# THE POWER SUPPLY AN ENGINEER COULD LOVE



If you're an engineer, or in engineering management, you might find our new SCR Series Single Phase Input Power Supplies very attractive. They provide 800, 1600 or 2400 watts of power and precise 0.1% regulation in both voltage and current modes (for higher power ask about our three phase input SCR units). All offer the highest power output per mechanical volume in the industry.

**Check these superior benefits:**

- \* High Efficiency
- \* Remote Sensing
- \* Remote Programming
- \* Series or Parallel Operation
- \* 5 Year Warranty
- \* Rack or Bench Mount
- \* Overvoltage Protected (optional)
- \* Constant voltage or current with automatic crossover
- \* Optional Input Voltages

For applications assistance and technical information, phone TOLL FREE (800) 631-4298

VOLTAGE	CURRENT	CV rms RIPPLE	CC rms RIPPLE	% EFF.	AC input I NOM.E	PRICE \$
0.75	100	75 mv	1000 ma	63	13	650
	180	80 mv	1920 ma	65	26	850
	250	80 mv	2990 ma	66	20	1100
0.10	80	75 mv	600 ma	65	13	600
	150	80 mv	1200 ma	68	26	850
	210	80 mv	1680 ma	69	19	1100
0.20	40	60 mv	120 ma	67	13	600
	80	80 mv	320 ma	70	25	800
	120	80 mv	480 ma	73	18	1000
0.40	20	60 mv	30 ma	68	13	500
	40	100 mv	100 ma	75	24	750
	60*	100 mv	150 ma	80	18	900
0.60	13	70 mv	15 ma	70	13	500
	26	90 mv	39 ma	81	23	850
	40	90 mv	60 ma	81	18	1000
0.80	10	80 mv	10 ma	77	12	500
	20	120 mv	30 ma	83	21	850
	30**	100 mv	35 ma	82	18	1000
0.150	5	150 mv	5 ma	80	10	500
	10	200 mv	13 ma	87	20	850
	15	200 mv	20 ma	84	18	1000
0.300	3	250 mv	3 ma	85	6	550
	5	300 mv	5 ma	87	20	850
	8	300 mv	8 ma	85	17	1000
0.600	2	700 mv	2 ma	87	6	650
	3	700 mv	4 ma	88	20	850
	4	750 mv	5 ma	85	17	1100

\*Specify Model No. SCR40-58  
 \*\*Specify Model No. SCR80-28



**ELECTRONIC MEASUREMENTS INC.**

405 Essex Road, Neptune, N. J. 07753  
 Phone: (New Jersey) 201 - 922-9300 • (Toll-Free) 800 - 631-4298  
 Specialists in Power Conversion Equipment

wrist. The all-electronic calculator/wristwatch was exhibited by Optel Corp., Princeton, N.J., in Switzerland at the Basel watch and jewelry fair, April 12 to 21. Prototypes will be ready for sampling at the end of May, and small production quantities are scheduled for mid-July.

Called the Optel I, the calculator/watch is designed around complementary-MOS circuits and a field-effect liquid-crystal display. It uses multiplexing to wire the display segments, simplifying the design. Optel president Zoltan Kiss said at the fair that this is the first watch with multiplexed circuits to be shown. Kiss claims the throwaway batteries will operate longer than a year, "even when an average of 100 calculations are made per day."

The display has eight digits, six of which are used in the normal time-keeping mode to show hours, minutes, and seconds. All eight are operable when the device is switched by pushbutton to the four-function calculating mode.

**Prices.** Succeeding versions will have memory and calculator functions for scientific applications. Prices for the first two models will be between \$500 and \$550 for the standard version and \$975 for the fancier one.

At these prices, "we don't expect a market of hundreds of thousands of units right away," says Stephen L. Finta, director of Conel GmbH, of Wiesbaden, West Germany, distributor of Optel products in Europe, the Mideast, and Africa.

**Configuration.** The Optel I packs three C-MOS chips into its case, measuring 3.3 by 4.57 by 0.953 centimeters. One chip contains the countdown circuitry for time-keeping, the second integrates the calculator circuitry, and the third the buffer and driver stages for the display. The 1-second time pulses are derived from a 32-kilohertz crystal oscillator whose frequency is counted down by a 15-step divider network.

The power pack consists of four 1.5-volt silver-oxide batteries, each about 15 millimeters in diameter and 4 mm thick. □

# Sprague puts more passive component families into dual in-line packages than any other manufacturer.

## Call Sprague First!

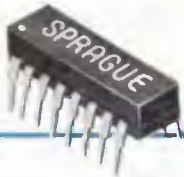

plus improved performance and compatibility with DIP microcircuits

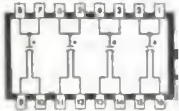

**DIP  
MULTIPLE  
TANTALUM CAPACITORS**

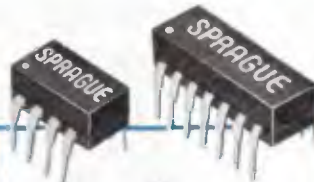

Solid-electrolyte tantalum capacitors with 2 or 4 sections per package. 8- or 16-pin configurations. Standard ratings are 6.8  $\mu$ F @ 35V, 15  $\mu$ F @ 20V, 22  $\mu$ F @ 15V, 33  $\mu$ F @ 10V. Capacitance tolerance,  $\pm 20\%$ . Operating temperature range,  $-55^{\circ}\text{C}$  to  $+85^{\circ}\text{C}$ . Write for Bulletin 3542 or circle 151 on reader service card.



**DIP  
MULTIPLE  
CERAMIC CAPACITORS**

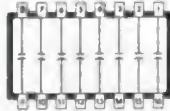

Monolithic<sup>®</sup> construction . . . alternate layers of ceramic dielectric material and metallic electrodes are fired into a solid homogenous block. 2, 4, 7, or 8 capacitor sections per package. Standard ratings, 18 pF to 0.1  $\mu$ F @ 100V. Capacitance tolerance,  $\pm 20\%$ . Write for Bulletin 6242 or circle 152 on reader service card.



**DIP  
TANTALUM/CERAMIC  
CAPACITOR ASSEMBLIES**



Solid tantalum and Monolithic<sup>®</sup> ceramic alternating isolated sections. Choice of 4 or 8 sections per package. Standard tantalum ratings, 6.8  $\mu$ F @ 35V, 15  $\mu$ F @ 20V, 22  $\mu$ F @ 15V, 33  $\mu$ F @ 10V. Ceramic ratings, .01, .047, .1  $\mu$ F @ 100V. Cap. tol.,  $\pm 20\%$ . Write for Engineering Bulletin 6642 or circle 153 on reader service card.



**DIP  
RESISTOR/CAPACITOR  
NETWORKS**

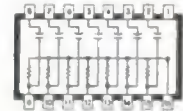

(1 of 3 designs)

Metanet<sup>®</sup> metal-film resistors and Monolithic<sup>®</sup> ceramic capacitors in bypassed pull-up, R-C coupling, speed-up, and active terminator networks. Resistor ratings, 100 to 6800  $\Omega$  with 125 mW power dissipation. Capacitor ratings, 100 pF to .01  $\mu$ F @ 100V. Write for Engineering Bulletin 6612 or circle 154 on reader service card.

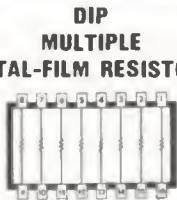

**DIP  
MULTIPLE  
METAL-FILM RESISTORS**

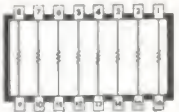

Noble metal film resistors encased in protective glass. Choice of 7 or 8 resistors per 14- or 16-pin package. Resistance values, 50  $\Omega$  to 100,000  $\Omega$ . Power dissipation, 125 mW. Standard resistance tolerance,  $\pm 5\%$ . Operating temperature range,  $-55^{\circ}\text{C}$  to  $+70^{\circ}\text{C}$ . Write for Bulletin 7042 or circle 155 on reader service card.

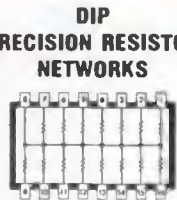

**DIP  
PRECISION RESISTOR  
NETWORKS**

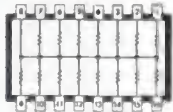

(1 of 5 designs)

Noble metal film resistors in pull-up, pull-down, interfacing, and terminating configurations, for applications requiring repetitive resistance patterns. 14- or 16-pins. Up to 28 resistors per package. Individual resistors from 50 to 100,000  $\Omega$ . Dissipation, 125 mW. Write for Bulletin 7042 or circle 156 on reader service card.



**DIP  
MULTIPLE  
PULSE TRANSFORMERS**

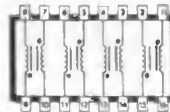

(1 of 2 designs)

Four transformers in 16-pin package. All cores have exclusive protective coating. Inductance values from 10 to 1000  $\mu$ H. ET product values of 5 volt- $\mu$ sec. Choice of four turns ratios . . . 1:1, 2:1, 3:1, 4:1. Operating temperature range, 0  $^{\circ}\text{C}$  to  $+70^{\circ}\text{C}$ . Write for Engineering Bulletin 40400 or circle 157 on reader service card.

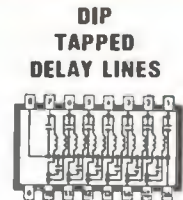

**DIP  
TAPPED  
DELAY LINES**

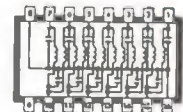

Lumped constant delay lines . . . ideal for timing and pulse synchronization circuits. 14- or 16-pin packages with delays of 50, 100, or 150 nanoseconds at a characteristic impedance of 100  $\Omega$ . Working voltage, 50 VDC. Operating temp. range, 0  $^{\circ}\text{C}$  to  $+70^{\circ}\text{C}$ . Write for Bulletin 45004 or circle 158 on reader service card.

**Popular Types Now Available OFF-THE-SHELF From Your Sprague Industrial Distributor.**

For complete technical data, write for any of the above-mentioned Engineering Bulletins to: Technical Literature Service, Sprague Electric Company, 35 Marshall Street, North Adams, Mass. 01247.

**THE BROAD-LINE PRODUCER OF ELECTRONIC PARTS**



# A tough semiconductor in the hands of a wise

We put a lot of time and money into the development and production of reliable Delco Electronics semiconductor devices for a wide range of industrial, military and automotive applications.

So, understandably, we don't fool around when it comes to selecting our Delco semiconductor distributors.

We handpick

them for their excellence in customer service.

We insist that they give us—and you—their best distribution services.

Delco Electronics semiconductor distributors are strategically located across the country in locations that make fast service practical.

The people you'll find listed on the facing page are front-line members of our sales force. They handle our entire line of Delco Electronics semiconductor devices. They know how to get immediate assistance and advice from our factory personnel.

Next time you need a reliable power semiconductor, get it from a reliable semiconductor distributor.

Your Delco Electronics distributor.



# ctor has no business hy-washy distributor.

**ALABAMA, Birmingham**  
Forbes Distributing Co., Inc.  
(205) 251-4104

**ALABAMA, Huntsville**  
Powell Electronics  
(205) 539-2731

**ARIZONA, Phoenix**  
Sterling Electronics, Inc.  
(602) 258-4531

**CALIFORNIA, Goleta**  
R.P.S. Electronics, Inc.  
(805) 964-6823

**CALIFORNIA, Los Angeles**  
Kierulff Electronics, Inc.  
(213) 685-5511

**CALIFORNIA, Los Angeles**  
R.P.S. Electronics, Inc.  
(213) 748-1271

**CALIFORNIA, Palo Alto**  
Kierulff Electronics, Inc.  
(415) 968-6292

**CALIFORNIA, San Diego**  
Kierulff Electronics, Inc.  
(714) 278-2112

**CALIFORNIA, San Diego**  
R.P.S. Electronics, Inc.  
(714) 292-5611

**CALIFORNIA, Sunnyvale**  
Bell Industries  
(408) 734-8570

**COLORADO, Denver**  
Kierulff Electronics, Inc.  
(303) 371-6500

**CONNECTICUT, Norwalk**  
Harvey Electronics  
(203) 853-1515

**FLORIDA, Miami Springs**  
Powell Electronics/Florida  
(305) 592-3260

**ILLINOIS, Rosemont**  
Kierulff Electronics, Inc.  
(312) 678-8560

**ILLINOIS, Skokie**  
Bell Industries  
Electronics Distributors Div.  
(312) 282-5400

**INDIANA, Indianapolis**  
Graham Electronics Supply, Inc.  
(317) 634-8202

**MARYLAND, Baltimore**  
Radio Electric Service Co.  
(301) 823-0070

**MASSACHUSETTS, Billerica**  
Kierulff Electronics, Inc.  
(617) 935-5134  
(617) 667-8331

**MASSACHUSETTS, Newton**  
The Greene-Shaw Co., Inc.  
(617) 969-8900

**MICHIGAN, Livonia**  
Pioneer/Michigan  
(313) 525-1800

**MINNESOTA, Minneapolis**  
Stark Electronics Supply Co.  
(612) 332-1325

**MISSOURI, Kansas City**  
Walters Radio Supply, Inc.  
(816) 531-7015

**MISSOURI, St. Louis**  
LCOMP-St. Louis  
(314) 647-5505

**NEW JERSEY, Cinnaminson**  
Wilshire Electronics/Philadelphia  
(609) 786-8990 (215) 627-1920

**NEW JERSEY, Clifton**  
Wilshire Electronics/New Jersey  
(201) 365-2600 (212) 244-8930

**NEW MEXICO, Albuquerque**  
Sterling Electronics  
(505) 345-6601

**NEW YORK, Binghamton**  
Harvey Electronics  
(607) 748-8211

**NEW YORK, Buffalo**  
Summit Distributors, Inc.  
(716) 884-3450

**NEW YORK, Farmingdale**  
Wilshire Electronics/Long Island  
(516) 293-5775

**NEW YORK, Woodbury**  
Harvey Electronics  
(516) 921-8700 (212) 895-9260

**OHIO, Cincinnati**  
United Radio, Inc.  
(513) 761-4030



**OHIO, Cleveland**  
Pattison Supply Co.  
Industrial Electronics Division  
(216) 441-3000

**OHIO, Dayton**  
Pioneer/Dayton  
(513) 236-9900

**PENNSYLVANIA, Philadelphia**  
Almo Electronics  
(215) 698-4000

**PENNSYLVANIA, Pittsburgh**  
Cameradio Electronics  
(412) 288-2600

**SOUTH CAROLINA, Columbia**  
Dixie Radio Supply Co., Inc.  
(803) 253-5333

**TEXAS, Dallas**  
Sterling Electronics  
(214) 263-1711

**TEXAS, Houston**  
Harrison Equipment Co., Inc.  
(713) 224-9131

**WASHINGTON, Seattle**  
Kierulff Electronics, Inc.  
(206) 763-1550

**IN CANADA: ONTARIO, Scarborough**  
Lake Engineering Co., Ltd.  
(416) 751-5980

**ALL OVERSEAS INQUIRIES:**  
General Motors Overseas  
Operations  
Power and Industrial Products  
Dept.,  
767 Fifth Avenue, New York, N.Y.  
10022  
PHONE: (212) 486-3723

**Delco Electronics Regional Sales Offices**  
Union, New Jersey 07083  
Box 1018 Chestnut Station  
(201) 687-3770

Van Nuys, California 91404  
Box 2968  
(213) 988-7550

General Sales Office  
700 E. Firmin, Kokomo, Ind. 46901  
(317) 459-2175

**Delco Electronics.**  
**The Power Specialists.**

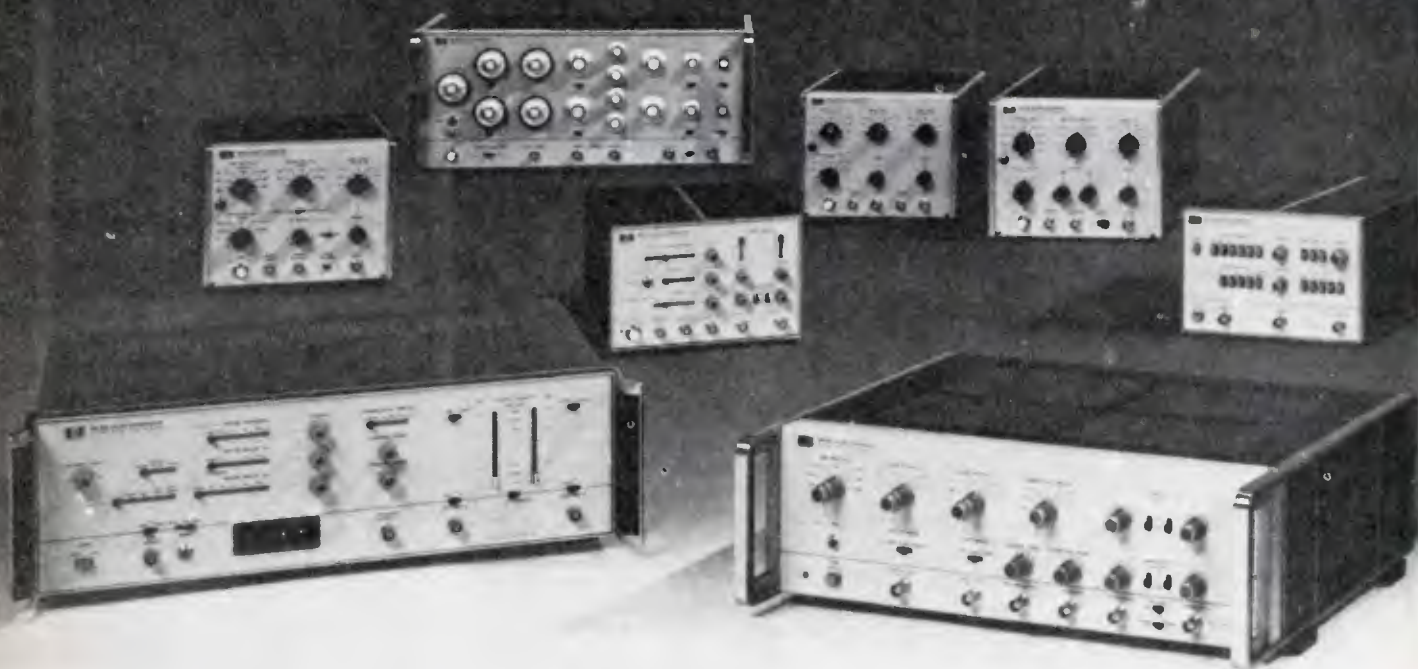

# MOS·CMOS, TTL·HTL, HP pulser solutions for

Before you choose your next pulse generator, look into THE broad line... from HP. We'll give you a choice of several instruments for your particular logic family... whether it's high-speed bipolar, MOS, high-threshold, or general-purpose bipolar logic.

Need to test above 200 MHz? Our newest pulse generator gives you a rep rate to 250 MHz for testing high-speed bipolar logic at operational frequency limits. And its UNMATCHED variable transition time down to 1 nsec lets you meet manufacturers' conditions for propagation-delay

tests... or degrade transition times for worst-case testing.

Maybe you need high output levels for MOS. We have instruments with outputs up to 16V (30V swing on dual outputs) and rep rates to 50 MHz for the most advanced MOS circuits. Other units handle lower rep rates with outputs to 100V.

TTL?... HTL? We offer a variety of instruments with single or dual outputs, selectable output impedance levels, fixed or variable transition times and pulse-burst options.

We even have a plug-in series that lets you





# ECL·S/TTL... your IC problems

put together your own logic-testing system to include programming, word generation, pseudorandom sequences, multiphase clock generation, and more.

In this family, there's a pulse generator to satisfy your particular testing requirements. And you'll find human-engineered instruments to simplify your setups and reduce testing errors.

So if you're thinking digital testing, find out what HP has to offer. Give your local HP field sales engineer a call today. Or, write for a free copy of our new pulse generator brochure.

HEWLETT  PACKARD

Sales and service from 172 offices in 65 countries  
1501 Page Mill Road, Palo Alto, California 94304

For technical information circle 46 on reader service card <sup>1981</sup> For immediate applications assistance circle 47 on reader service card

# Let's get the facts straight on IC packaging panels.

**T**he IC packaging panel, or "Augat board," has become so widely accepted, you'd think Augat would be happy.

But frankly, we're concerned.

People have gotten so used to IC panels that they may have lost sight of the reason for buying panels in the first place: flexibility in design, production and service. With the result that they may not be getting all the benefits panels can provide.

We'd like to correct this situation by reviewing exactly what's at stake in your choice of a panel supplier.

## GETTING THE RIGHT PANEL.

People often select a panel from a limited catalog without realizing the wide selection of stock panels available.

When in fact, they can get exactly what they need right off the shelves of Augat distributors all over the world.

With the largest product line anywhere, we're sure to have a standard board that fits virtually all your development and production needs—including ECL and Schottky.

For really special requirements, though, you should probably consider a custom-designed panel. If you're dealing with an experienced engineering staff like Augat's, it's surprisingly easy. And it won't cost you any premium—it might even save you money.

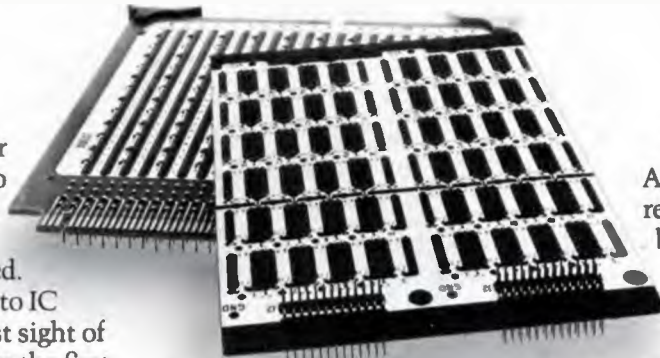

Whatever your requirements, you shouldn't settle for an approximation. Because you don't have to.

## HOW GOOD IS GOOD ENOUGH?

The payoff for getting the right panel is faultless performance. No surprises in product development, production, or field service.

It's the reason for Augat's no-compromise approach to quality control. And it's why Augat uses the best precision-machining technology in the world, rather than conventional stamping methods, to produce the contact assemblies that are the heart of Augat panels.

The result speaks for itself. The elimination of these common contact pitfalls:

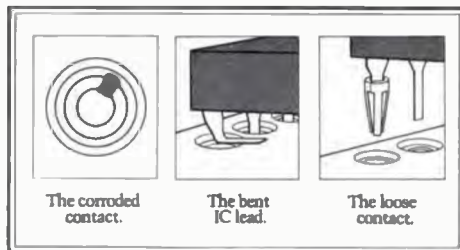

The corroded contact.

The bent IC lead.

The loose contact.

When others succeed in duplicating Augat's machining technology, the result will be better panels for everybody. But until then, there's only one place in the world to get this degree of fail-safe protection: Augat.

## DELIVERY YOU CAN COUNT ON.

In 1974 Augat completed a multi-million-dollar program to automate production and bring the manufacture of IC panels under 100% in-house control.

Result: The fastest turnaround the industry's ever seen.

Most standard panels are on the shelf. But if the one you want isn't, you can still get it in no more than 2 weeks. And our custom panels are being turned out in volume to meet the most stringent delivery standards in the industry.

So next time you're selecting IC panels, consider all the facts. For full information, send for our new brochure. Or phone George P. Howland, Engineering Manager, at (617) 222-2202. Augat, Inc., 33 Perry Avenue, Attleboro, Massachusetts 02703.

## YOU ONLY GET IT ALL FROM AUGAT.

# AUGAT®

Europe—Augat N.V., Boulevard A. Reyers, 103, 1040 Brussels, Belgium, Tel. (02) 7369399.  
Japan—Kyokuto Boeki Kaisha Ltd., New Otemachi Bldg., 2-1, 2-Chome Otemachi, Chiyoda-Ku, Tokyo 100-91, Japan, Tel. (03) 244-3788.  
Canada—A.C. Simmonds & Sons Ltd., 285 Yorkland Blvd., Willowdale, Ont. M2J1S8, Tel. (416) 491-1010.

## Washington newsletter

### **Recession's impact on aerospace jobs seen slight in '75**

Jobs for engineers and scientists in America's aerospace industries **will remain more stable in 1975 than for other categories of employment**, according to a new forecast from the Aerospace Industries Association. Engineering and scientific employment is expected to decline 1.8% to 163,000, compared to a 2.8% drop to 973,000 from the 1974 level in all aerospace job categories. The forecast puts most of the job losses among production workers, particularly in the transport aircraft segment. Stretchouts in deliveries of large-transport will reduce jobs to a level of 55,400 by year's end, down 13% from 1974. Employment by government contractors making missiles, spacecraft, and parts, on the other hand, is expected to remain at 209,000, unchanged from last year. The AIA developed its forecast using data from 48 member companies and the Bureau of Labor Statistics.

### **NASA gets design for 100-megabit bubble recorder**

The design for a 100-megabit magnetic-bubble replacement for spacecraft tape recorders has been delivered to NASA's Langley Research Center by the Applied Physics Laboratory (APL) of Johns Hopkins University. **APL researchers estimate that the bubble recorder's reliability would be 4.5 times better than mechanically-driven tape units.** The 270 cubic-inch package would weigh 11.6 pounds and consume between 2.7 and 8 watts, depending on mode and bit rate. Of the \$187,370 system cost estimate, parts costs are estimated at only \$57,370. Fabrication and testing would account for the rest.

Magnetic bubble chips with 262,144 bits on each 250-mil-square chip are called for in the recorder. The \$50 chips, arranged in a non-recirculating delay-line shift-register configuration, would have bubble diameters of 2.3 micrometers. APL says NASA has favored bubble technology over charge-coupled devices because bubbles "have the edge in storage density, power consumption, and radiation hardness," and don't lose their data when power is removed, as CCDs do.

### **Up to \$20 million for surveillance in plane studied**

Up to \$20 million in electronic surveillance gear may be needed for the 41 coastal-patrol aircraft the U.S. Coast Guard is considering. A Coast Guard official says **a decision on the twin-engine planes is expected in June or July.** The special sensors needed would include microwave radiometers, low-light television cameras and infrared and ultraviolet line scanners, he says, adding that such orders would average about \$500,000 per plane. It's known that Rockwell International, Hawker Siddeley, and the German-Dutch combine VFW-Fokker GmbH are vying for the aircraft award.

### **Huge market seen in FAA R&D plan for VOR systems**

The FAA next year will begin **R&D on solid state VOR and Vortac airport transmitters to replace aging tube-type vhf and uhf units.** A request for proposals on prototypes will be released in 1976. Meanwhile a senior FAA official predicts an eventual "billion-dollar market worldwide." About 1,000 tube-type VOR and Vortac transmitters, many of them close to 30 years old, are currently in use for commercial and high-performance general-aviation pilots to give them bearings at more than 10 miles from an airport.

# Washington commentary

## The coming COM explosion

Nowhere is it more difficult to change the status quo than in the Federal Government. Usually it takes a crisis of major proportions to redirect Federal policies or programs—and one such crisis is developing as Government computer use increases. Agencies find they are drowning in inventories of paper printouts. Government production of paper reports, studies, regulations and rules has always been huge, of course, but now, thanks to the computer, it is not only overwhelming but expensive as well.

The General Accounting Office, in cooperation with the Office of Management and Budget, the Department of Defense, the General Services Administration, and others, hopes to change all that. Their weapon in the fight to cut back on the cost and bulk of EDP printouts is computer-output-microfilm—the combination of electronics and microphotography known as COM that converts computer printouts directly to microfilm.

### Slow to grow

If GAO succeeds in getting Federal computer users to follow the Pentagon's lead in converting to COM systems, then the market can be expected to expand far more rapidly than it has since the technology was first developed in 1958. By the end of this year, only 3,000 COM systems will have been installed nationwide. Compared to the number of computers in use, the market is still small—the Federal Government alone either owned or leased 7,830 computers in 1974.

The economies inherent in COM are formidable, in GAO's view. A system usually consists of recorder/developer with an annual rental of about \$50,000, plus a microfilm or microfiche reader with a purchase price ranging from \$70 and \$1,400, depending on its size and sophistication. Machine readers able to print out full-size copies of the film on demand are an option and cost between \$1,000 and \$4,000.

With a system of this sort, GAO figures the production cost of 5,000 pages of computer output could be cut from \$194—\$44 for paper and \$150 for labor—to \$20.50, of which \$8 would be for film and \$12.50 for labor. Storage and shipment of the film or microfiche would be far less than for paper, of course, cutting costs even more. An agency generating 500,000 pages of paper reports per month could halve its output cost by converting to COM.

One of the big economies for large-scale COM users is the system's high-speed output: one

COM recorder can produce as much as 30 paper printers. Some computer printers can run as fast as 2,000 lines a minute, although a 1,000-line rate is more typical. The average COM recorder, on the other hand, generates 20,000 lines a minute, and some can go to 50,000. Moreover, they can handle colors, charts, graphs, and varying sizes and styles of type, all of which, GAO points out, "make reports more meaningful to users."

An obvious question emerges: if COM is so great, why don't more people use it? GAO's answer translates simply as widespread ignorance of COM's existence among Government systems designers, compounded by human resistance to change.

Most systems planners either don't even consider COM or, if they do, they limit themselves to simple feasibility studies comparing only the costs of paper and film. GAO wants more "comprehensive costing of alternatives," including all direct and indirect charges. Acknowledging the human factor, GAO admits that "almost everyone has worked with paper and is comfortable with it," while COM reports require a machine reader and can't be marked up. Only a good training program could change this bias for marking up paper printouts.

### Beating the drums

By July, the GAO-sponsored steering committee set up two years ago plans to issue its final report on the performance of a pilot COM center set up at a Navy installation near Norfolk, Va. Beyond that, the group is considering proposing a Federal policy on acquiring and using COM systems, as well as the need for equipment standards. The General Services Administration, chief Government computer buyer, is readying a handbook for all agency managers covering analysis and design of COM systems. In addition, it has set up a Federal Government Micrographic Council to promote COM and similar cost-saving technologies.

As for promoting the use of COM centers for multi-agency use, GSA says its efforts "have been discouraging." Though the centers—a concept that turns on the ever-economical GAO—are unlikely to be widely accepted by agencies that prefer their own computers to be complete with output devices, the prospects for getting more users to adopt COM for their in-house systems are encouraging indeed. When the Government leads, others will surely follow.

—Ray Connolly

# New... OEM II

**Powertec's second generation  
open-frame D.C. Power Supplies  
featuring**

**3 great new packages**



For years, our original OEM's have been recognized as the finest on the market. Now, we're introducing the OEM II Series . . . and it is even better!

First, to help you avoid costly "over-buying," we've expanded the line by adding 3 new packages and 9 new models. Take our new Model 2A5-1.2A, for example. 5V at 1.2A — the smallest open-frame standard power supply available today. Anywhere.

Second, there are completely new electronics. Fewer components, simplified circuitry. Higher efficiency and increased reliability. Improved specs for every model.

- And features: • Remote sensing and programming • IC regulated design
- Output screw terminals, fanning strip compatible • All hermetic transistors and diodes
- Reverse polarity protection • Open remote sense lead protection
- Improved temperature rating • 100% interchangeable with previous models
- Conservative component selection. And more. Much more.

It all adds up to *extra performance at no extra cost.*

**FOR COMPLETE DETAILS, SEND FOR THE NEW OEM II BROCHURE**  
Powertec, Inc., 9168 DeSoto Ave., Chatsworth, CA 91311 • (213) 882-0004

MODEL 2A — FROM 5V, 1.2A  
**\$24<sup>95</sup>**

MODEL 2CC — FROM 5V, 9A  
**\$67<sup>00</sup>**

MODEL 2DD — FROM 5V, 18A  
**\$109<sup>00</sup>**

Model Number	Voltage-Current	Price	Model Number	Voltage-Current	Price	Model Number	Voltage-Current	Price
2A5-1.2A	5V - 1.2A 6V - 1.0A	\$24.95	2C5-6A	5V - 6.0A 6V - 5.0A	\$54.00	2D5-12A	5V - 12.0A 6V - 10.0A	\$ 87.00
2A15-5A	12V - 0.5A 15V - 0.5A	\$24.95	2C15-2.8A	12V - 3.0A 15V - 2.8A	\$54.00	2D15-6A	12V - 6.5A 15V - 6.0A	\$ 87.00
2A24-4A	18V - 0.4A 20V - 0.4A 24V - 0.4A	\$24.95	2C24-2.3A	18V - 2.0A 20V - 2.3A 24V - 2.3A	\$54.00	2D24-5A	18V - 4.5A 20V - 5.0A 24V - 5.0A	\$ 87.00
2B5-3A	5V - 3.0A 6V - 2.5A	\$32.00	2CC5-9A	5V - 9.0A 6V - 7.5A	\$67.00	2DD5-18A	5V - 18.0A 6V - 16.0A	\$109.00
2B15-1.3A	12V - 1.5A 15V - 1.3A	\$32.00	2CC15-4.4A	12V - 4.8A 15V - 4.4A	\$67.00	2DD15-9A	12V - 10.0A 15V - 9.0A	\$109.00
2B24-1A	18V - 1.0A 20V - 1.0A 24V - 1.0A	\$32.00	2CC24-3.7A	18V - 3.3A 20V - 3.7A 24V - 3.7A	\$67.00	2DD24-7.5A	18V - 6.8A 20V - 7.5A 24V - 7.5A	\$109.00

Regulation: 5V Models      Line      Load  
 15V & 24V Models      0.1%      0.15%      Ripple: 3 mV PK-PK  
    0.05%      0.05%

# POWERTEC

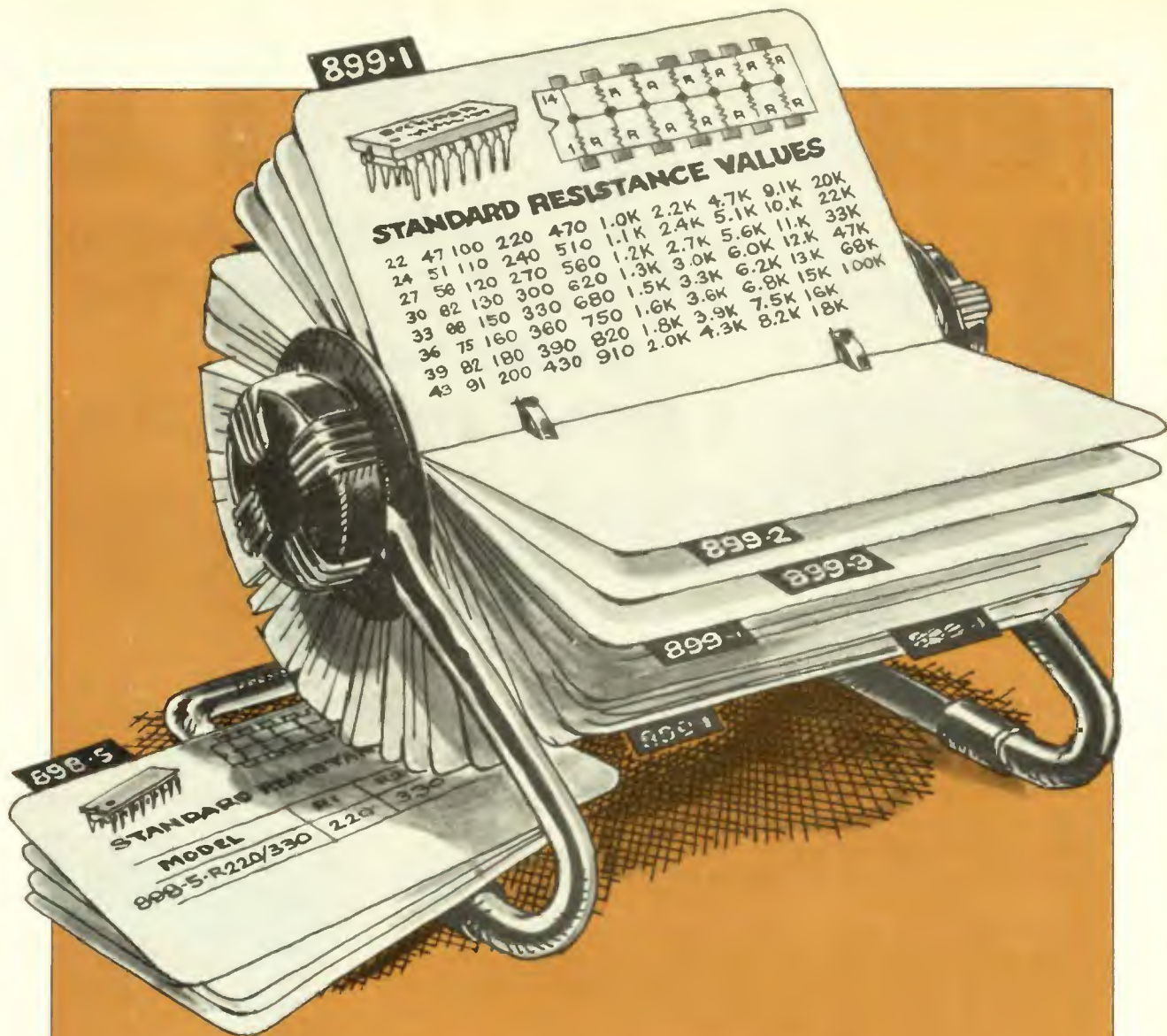

## Still rolling up the score. Now, 223 standard Beckman DIPs.

We're adding more and more models to the RESNET™ DIP resistor line to make things easier for you.

Now there are 223 standard RESNET DIPs to give you wider selection, greater variety of resistance values, and less need for custom components.

Use them for applications involving pull-up/pull-down, line termination, LED current limiting, ECL termination, or interface networks. And most models are second-sourced, too.

RESNET DIPs are dimensionally uniform, ideal for automatic insertion techniques. They're also laser-tailored for precise resistance values. And every part is 100% tested.

Ours is the broadest line available and it's stocked locally by your Beckman/Helipot distributor for immediate delivery.

Prices? Truly competitive, actually giving you the quality of cermet technology at plastic prices.

Considering breadth of line, quality, availability, and good pricing, you don't have to look farther than Beckman for standard resistor networks. Or for expertly produced custom versions as well.

Check us out. For immediate literature or the phone number of your Beckman/Helipot representative, call toll-free (800) 437-4677.

**Beckman®**

**HELIPOT DIVISION**

## Sony develops non-contact switch that operates by magnetoresistance

The key ingredient in a precise non-contact switch for industrial control systems is a venerable physical effect—magnetoresistance. After workers at the Sony Corp. Research Center developed a small transducer using the effect, the company's subsidiary Sony Magnescale Inc. was brought in to develop systems. The resulting products show positioning repeatability of better than  $\pm 1$  micrometer.

Sony claims that by using magnetoresistance it can produce devices that are remarkably free from temperature effects, compared with other magnetic sensing devices. These devices can statically detect magnetic information recorded on ribbons, cards, or drums. This ability should enlarge the field of application for the magnetoresistance devices to a large range of jobs in control, measurement, and retailing.

The basic transducer uses serpentine patterns of thin-film ferromagnetic material on a glass-coated alumina substrate. Each pattern is designed so that most of the path length is along parallel lines, which are connected to each other by short lines at alternate ends. Two of these patterns, on the same plane but running at right angles to each other, a bias magnet, the package, and leads complete the transducer.

**Bias direction.** Two types of transducers are available. Based on the same type of magnetoresistance device, they differ in their direction of magnetic bias. For one type, the activating element is a magnet that can be mounted to pass as far as 6 millimeters from the transducers. Although the system provides relay closure as output, the transducer signal is analog. Output is relatively large—70–80 millivolts for a 10- $\mu$ m motion—and a long cable can be used to link the transducer to the remainder of the system.

For the second type of transducer,

the sender is unmagnetized magnetic material, which can be as small as a 0.5-mm-diameter wire or needle. With this arrangement, the sensitivity is lower, and the clearance must not exceed 0.8 mm.

The thin film used in these devices is an alloy of nickel and cobalt. When current flows through the thin film while subjected to a magnetic field, the alloy's anisotropy leads to a change in resistance proportional to the change in the direction of the magnetic field. In general, resistance is maximum when the direction of the current and the magnetic field are parallel, but minimum when they are perpendicular.

The device's two thin-film patterns form a center-tapped resistor,

which is attached to a bias magnet and become two arms of a bridge circuit. Disturbance of the bias field by the sender magnet's field produces an analog output curve that resembles a somewhat rounded top hat. Addition of waveshaping and power circuits enables the signal to drive a relay.

Normally, the bias magnet biases the device to saturation. Then, performance depends only on the direction of the magnetic field, not on its value. Saturation bias is on the order of 50 oersteds. Peak-to-peak output voltage is 160 millivolts with an 8-volt power supply and 270 millivolts with a 12-v supply. Power dissipation is 25 and 100 milliwatts, respectively.  $\square$

### Around the world

#### Laser and computer aim British tank's guns

The British army may retrofit its 900 54-ton Chieftain tanks with a fire-control system that uses a laser and digital computer to aim their 120-millimeter guns with a new degree of accuracy. The system may also be adaptable to other tanks. Marconi Space and Defense Systems Ltd. has received a \$2.4 million contract to complete development of the system, which is so compact that it allows the tank to carry just as much ammunition as before.

The laser range-finder, made by Barr and Stroud, has about a 10-kilometer range, and the Marconi 12-12P computer measures only 11 by 12 by 20 inches. The laser is charged automatically when the gunner selects the ammunition by means of controls on a handle he manipulates with his left hand. As the gun is loaded, the gunner lays the sight's aiming mark on the target and tracks it. When he presses a switch, the computer calculates the speed and range of the target, adjusts the aiming mark, and aims the gun.

#### Minicomputer runs pattern analyzer

Classification of chromosomes has been reduced to only a few minutes by a digital system based on an industrial-television camera, a memory, a minicomputer, and a TV monitor. The pattern-recognition system, which may be adapted for such uses as analysis of cell structures, was developed by French researchers, mostly engineers working on doctorates at the Commissariat à l'Energie Atomique's Saclay Center, near Paris. Analog signals from the camera are converted to digital format, and the data is compressed by a factor of five to 10. The data then passes to a 32-kilobyte memory, built around Intel 1103s interleaved to operate at 10 megahertz. Each byte has 4 bits that indicate gray level. Cabled logic identifies connected points and isolates the patterns they form. The pattern-identifying data is fed into an Intertechnique Multi-20 minicomputer for analysis. A display channel then decompresses the data, converts it back to video format, and displays the image on the TV monitor.

# Here's why REI can rent you what you want when you want it.



Our inventory. It's the biggest in the industry, with over 8,000 items of electronic test equipment in stock and ready to go. And it's getting better all the time, because we add more state-of-the-art equipment every month. This means we can deliver one special instrument... or a dozen... within hours of the time you place your order.

Now, more than ever, renting makes sense... to stretch your equipment budget, to fill temporary needs, and to avoid the long delivery lead times associated with purchasing. And renting from REI makes even more sense... because we're better equipped to fill your needs than any other rental company.

REI is backed by the tremendous resources of the PepsiCo organization, which gives us the financial strength to keep on hand whatever test equipment you may need. And renting from us helps *your* financial strength,

too. Since you pay only for the time you have your instruments, you'll never have to spend your money on idle equipment.

Send for our catalog today for a description of our rental, rental/purchase and leasing plans, and for our low rental prices. Or call the instant inventory center nearest you for immediate assistance.

Rental Electronics, Inc.,  
99 Hartwell Avenue, Lexington, Mass. 02173.  
Please send me your free instrument rental catalog:

Name \_\_\_\_\_ Title \_\_\_\_\_

Company \_\_\_\_\_

Address \_\_\_\_\_

City \_\_\_\_\_ State \_\_\_\_\_ Zip \_\_\_\_\_

Tel. Number \_\_\_\_\_

## Rental Electronics, Inc.

A PEPSICO LEASING COMPANY

Burlington, MA (617) 273-2770 • Gaithersburg, MD (301) 948-0620 • Oakland, NJ (201) 337-3757 • Ft. Lauderdale, FL (305) 771-3500  
Des Plaines, IL (312) 827-6670 • Dallas, TX (214) 661-8082 • Mountain View, CA (415) 968-8845 • Anaheim, CA (714) 879-0561  
Rexdale, Ontario (PLC Leasing Ltd.) (416) 677-7513

Circle 54 on reader service card



## International newsletter

### Low point reached in West German components market

West Germany's components market has reached the bottom of its downward spiral, but it will remain there for some time before things start picking up again. That was the consensus of marketing men at the recent Hanover Fair, which is always a good barometer for the climate of the country's electronics industries. **Significantly, they don't foresee an improvement in component sales before the final third of this year.** Components manufacturers, whose output last year climbed by a nominal 13% to \$1.71 billion, are still suffering from sluggish orders from both consumer and industrial equipment makers. **Aggravating the situation are declining export markets, which in good times account for about 30% of total production.**

The downward trend in output started about a year ago, when the rate of increase in components production value fell from 22% during the first half of 1974 to 0.5% during the second half. As a result, components makers drastically curtailed factory capability—some by as much as 50% for certain types of devices. **Such sharply reduced capacity, industry people say, could once more lead to supply problems if demand jumps suddenly when it picks up again, as observers say it will.**

### \$1 billion investment planned by French for telephone upgrading

French telephone equipment makers are getting a windfall of supplementary investment from the government that should help France recover a bit from its lag in telephone service. **President Valery Giscard d'Estaing announced this week that an extra \$1 billion will be added to the normal telecommunications budget over the next two years to finance a step-up in production of switching equipment and telephone lines.** The breakdown between electronic switching equipment and electro-mechanical systems has not been decided. Giscard says that he wants the money to result in the installation of 900,000 more lines in France, which is among the worst-equipped countries in Europe.

### Tax hike not all bad for UK consumer products makers

Industry analysts are finding a possible silver lining in the British government's April 15 announcement that it will hike the value-added tax from 8% to 25% on TV sets, radios, and audio equipment, effective May 1. Although sales of color-TV receivers are expected to drop anywhere from 10% to 30% below the once-estimated level of 2 million sets this year, the net result may bring stability—if not growth—to the industry, they reason. **One analyst believes that sales of black-and-white sets will rise 15%, and audio equipment will remain stable.**

Since the huge stocks of unsold sets have been wiped out by buyers rushing out to beat the deadline, **set and components makers may now plan realistically for the new production levels,** says one components-company executive. An industry consumer survey indicates, however, that plunging color-TV sales may have also been caused by the increasing number of rerun programs on the BBC and commercial channels.

### West Germans develop variant of spider-bonding

Yet another variation on the automated-bonding of integrated circuits is being tried by researchers at West Germany's AEG-Telefunken. Developed by Georg Birglechner and his associates, the Sicon process features the galvanic growth of gold bumps at the point of contact with a spider-like frame that is used to interconnect the chip with the leads in

## International newsletter

a dual in-line package. While the company won't release many details, it says the proprietary process uses **an adhesive intermediate made of an epoxy with good thermal conductivity, tinned nickel for the interconnection frame, and a tungsten-titanium-gold metalization.**

The company says that in extreme-temperature-cycle tests, bonds made by the process showed a 50% failure rate after 400,000 cycles, compared with only 2,100 cycles for wire-bonded devices. What's more, throughput has been substantially improved. Where hourly output was 65 units, the new process allows 1,000 units to be finished.

### **Support gains for French anesthesia system**

A French-developed electronic anesthesia system is slowly winning support at home and abroad as surgeons watch the progress of the pilot team that first introduced the method at Necker Hospital in Paris three years ago. **At the end of this year, all 50 French state-owned hospitals will add the Anesthelec signal generator, recently marketed by Thomson Medico-Telco, to their operating-room equipment.** Austrian and Japanese teams also are using the French system on a smaller scale. At the World Congress on Electronic-Anesthetic Research in Paris this month, U. S. doctors revealed that Food and Drug Administration controls still prevent them from using the system on humans within the boundaries of the U. S.

### **French makers market new one-board computers**

French computer makers are scurrying to market with a batch of new microcomputers. **Intertechnique, so far mainly a minimaker, has pushed its range down into the "less-than-\$1,000" category with the Multi 2.** This computer, with its central processor and 1,024 words of microprogram on a single board, contains 15 general-purpose registers and has an execution time of 220 nanoseconds. The memory can be expanded to 32 kilobytes of ferrite-core plus 8 kilobytes of semiconductor memory. Intertechnique will start deliveries—in quantities of 16 or more only—toward the end of the year.

**Telemecanique also has extended its range downward with a new entry, called the Solar 16-05.** It, too, has a single-board CPU, tied through a single bus to the memory and peripherals. There are 131 basic instructions and a main-memory capacity of 32,000 16-bit words. Compagnie Internationale pour l'Informatique, the French partner in Unidata, will follow in June with a group of new products including—presumably—a one-board computer.

### **Sony's newest video projector fills 8-ft screen**

**Three 13-inch picture tubes add up to a 48-square-foot TV image that is twice as bright as the average movie screen.** A new Sony Corp. color projection system uses three modified Chromatron color tubes, each having its entire faceplate coated with one phosphor. The usual shadow mask is absent from these tubes. The projector is placed about 11 feet in front of the screen, which measures 8 feet wide by 6 ft high. The image has a screen brightness in excess of 20 foot lamberts.

**This projector is Sony's second entry in the big-screen market.** Early in 1973, Sony demonstrated a projection system with a 51-in. screen. This smaller system was based on a single picture tube, using a shadow mask and single lens to project a color picture.

# For the Protection of ALL ELECTRONIC CIRCUITS

## FUSETRON®

dual-element — time-delay fuses



Avoid nuisance opening, yet get full short-circuit protection. Available from 1/100 amp. to 40. Size  $\frac{1}{4}$  x  $1\frac{1}{4}$  in. and  $9/32$  x  $1\frac{1}{4}$  in.

## TRON® rectifier fuses

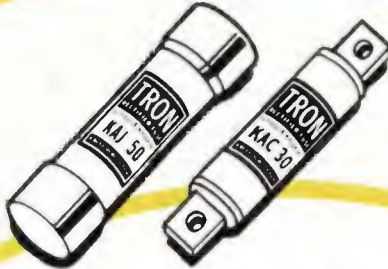

Provide extremely fast opening and high degree of restriction of let-thru current to protect Solid State Devices. Ampere rating  $\frac{1}{2}$  to 1000 in voltages up to 1500.

## BUSS GLASS TUBE FUSES

"quick-acting"

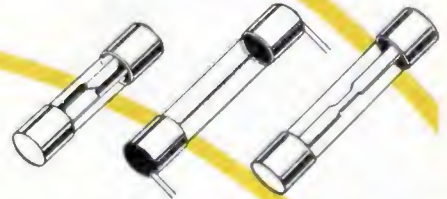

Provide high speed action to protect delicate instruments and apparatus. Available from 1/500 to 30 amp. Sixe  $\frac{1}{4}$  x 1 in. and  $\frac{1}{4}$  x  $1\frac{1}{4}$  in.

## BUSS Signal-Indicating Alarm-Activating FUSES



Available with time-delay or quick-acting characteristics. Available from 1/10 to 30 amp. Size  $\frac{1}{4}$  x  $1\frac{1}{4}$  in. and  $13/32$  x  $1\frac{1}{2}$  in.



## TRON® Sub-Miniature Pigtail Fuses

Size only .145 x .300 in. Glass tube permits visual inspection. Hermetically sealed. Available from 1/200 to 15 amp.

## BUSS Fuses for TELEPHONE COMMUNICATIONS Similar equipment



HLT holder

GMT fuse

## BUSS Sub-Miniature GMW fuse



and HWA fuseholder. Full size .270 x .250 in. with window to check fuse element. Available 1/200 to 5 amp.

## BUSS SNAP-LOCK FUSEHOLDER



Rear panel mount fuseholder for  $\frac{1}{4}$  x  $1\frac{1}{4}$  in. fuses. Snaps into place. Specify HTA-00 for space saver type, HLD-00 to take visual indicating fuses, HKP-00 for standard fuseholder, HJM-00 to take  $\frac{1}{4}$  x 1 in. fuses.



HKP panel mounted fuseholder for  $\frac{1}{4}$  x  $1\frac{1}{4}$  in. fuses.



HKA lamp indicating, signal-activating fuseholder.



## BLOCKS FOR BUSS FUSES

All types available for every application. Single pole, multiple pole, small base, laminated base, porcelain base for fuses from  $\frac{1}{4}$  x  $\frac{3}{8}$  in. up. Also signal fuse blocks and special blocks of all types.

# BUSS® FUSES

## For Quality — Reliability

For anything you need in protecting electronic circuits and devices —

Write for Bulletin SFB

— See for yourself —



BUSSMANN MANUFACTURING  
a McGraw-Edison Company Division  
St. Louis, Missouri 63107



# Some people will pay any price for a bad linear IC.



In rework, field service, and lost business.

Adding value to a bad part has never made sense. That's why our digital IC tester, the J133C, is so popular. And it's one reason why we're now offering a comparable linear IC test system.

The benchtop J149 thoroughly tests all popular op amps (including duals and quads), voltage regulators, and comparators.

The system includes features like built-in oscillation detection to prevent unreliable test results. And automatic continuity screening to protect the tester and IC from damage. You can insert the wrong IC, or the right one backward, without harming the device.

Like the J133C, our new linear tester requires no user programming. All programming is done by Teradyne. All you do is plug in the preprogrammed family and device cards appropriate to the devices being tested.

If IC inspection is what you want, the J149 will give you high throughput. If you want evaluation, the system comes equipped with all the digital readouts, operating modes, and test capacity you need to analyze a device thoroughly.

As you would expect, the J149 needs no calibration adjustments and is designed for hard industrial use. Naturally, its circuit boards are covered by Teradyne's unique 10-year warranty.

High yield is the difference between finding bad parts early and finding them late. The J149 could be spotting the no-goods for you right now. Boosting your yield and your profits.

Think yield.

For a closer look at the new J149 linear IC test system, write: Teradyne, Inc., 183 Essex Street, Boston, Massachusetts. In Europe: Teradyne Ltd., Clive House, Weybridge, Surrey, England.

## The **J149** Linear IC Test System



# TERADYNE

CHICAGO (312) 298-8610 / DALLAS (214) 231-5384 / NEW ENGLAND (617) 458-1256 / NEW YORK (201) 334-9770 / SUNNYVALE (408) 732-8770  
LONDON (0832) 51431 / PARIS 265 72 62 / ROME 59 47 62 / MUNICH (089) 33 50 61 / TOKYO (03) 408-4021

# Probing the news

Analysis of technology and business developments

## Military's laser work to be rewarded

Services don't have rangefinders, designators, communicators, and other devices in stock yet, but prototypes are coming, with production in the wings

by Larry Armstrong, Midwest bureau manager

Lasers have yet to reach the military inventory in great numbers. But unflagging interest in laser research has poised the three services on the threshold of laser-based systems for navigation, reconnaissance and surveillance, intelligence and countermeasures, communications, and "smart" ordnance.

For example, Hughes Aircraft Co. has delivered 12 prototypes of a lightweight laser target designator to the Army Electronics Command, Fort Monmouth, N.J. One military official quips that the tri-service designator is to be "an ultracheap device that they can give to every man—just like a canteen." The Hughes prototype won't be quite that ubiquitous, but since the production price is estimated as low as \$150, the market potential is vast. And RCA Corp. has received a \$1.5 million development contract from the Army for a hand-held laser rangefinder.

In fact, "the only lasers in production now for military applications are in rangefinders, and Hughes is the only company producing them," comments Arthur W. Eichmann, manager of advanced-laser applications at Hughes in Culver City, Calif. The firm has delivered about 1,200 rangefinders and has contracts for about 500 more. The Army uses them primarily on tanks, which are too close to the ground to use radar.

**Designators.** Rangefinders, however, are only a subset of target designators. "When you design a better designator, you automatically get a better rangefinder," notes Stanley E. Wagner, chief of the Electro-optics Device branch at the Air Force Avionics Laboratory, Wright-Pat-

erson AFB, Ohio. "The only difference is the pulse-repetition rate—ranging is a one-pulse operation," he says. As a result, many new target designators are designed with the silicon detector and timing circuitry needed for the ranging function.

Another Army-developed tri-service designator is the ground laser-locator designator. Mounted on a tripod, it can be carried by one man and is aimed visually. The device was developed by the Army Missile Command in support of future homing systems, such as the cannon-launched guided projectile, and Hellfire, a battlefield-support missile.

Called GLID—for its initials GLLD—it will be used by Army,

Navy, and Marine forward observers and by Air Force forward air controllers, says William Tidwell, deputy product manager at the Missile Command's Precision Laser Designator office at Redstone Arsenal, near Huntsville, Ala. Developed under an \$11.1 million engineering-development contract by Hughes, the ground designator provides an interface for the Army's infrared common night sight, and a modular laser designator/rangefinder that will be used in future Army systems.

**Airborne.** One of those applications will be in the airborne target-acquisition and fire-control system—until last month known as the airborne laser locator designator. "The designator is only a minor part

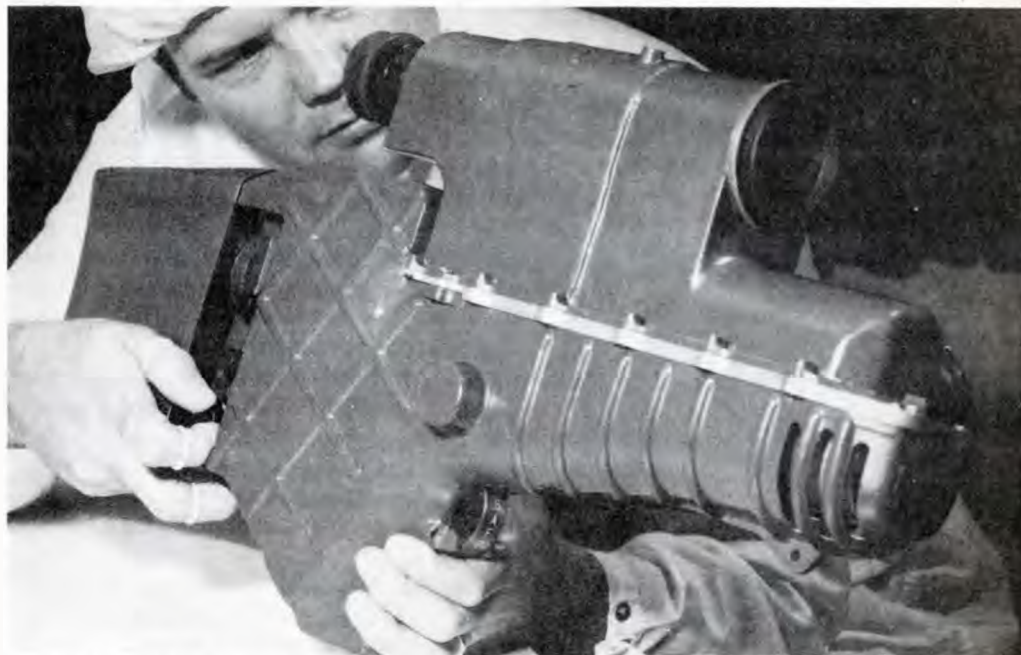

**Light touch.** The sight is adjusted on an advanced prototype of the lightweight laser designator being built for the Army by Hughes. Device is designed to be used by infantry.

## Probing the news

of the system." Tidwell says. "It can acquire targets, track targets, and identify and recognize targets at small standoff ranges." The laser tracker gives the system, in advanced development at Aeronutronic Ford, Newport Beach, Calif., the ability to hand off targets from ground to airborne designators.

The Aeronautical Systems division has exercised production options for 77 Pave Spike pods, containing both television and laser systems from the Westinghouse Defense and Electronic Systems Center, Baltimore, and will probably pick up an additional 60 pods this year. Pave Spike will replace the earlier Air Force Pave Knife System, an Aeronutronic Ford pod that first demonstrated the potential of laser-guided weapons.

Also coming along fast is Pave Tack, another Aeronutronic Ford pod that contains a modular laser ranger/designator that's become known as the Air Force common laser. The contract for the competitively bid laser system was won last November by International Laser Systems, Orlando, Fla.

**Reliability.** "There have been lasers built with similar or better performance," comments Richard Wallis, chief avionics engineer for the Pave Tack program, "but on this one, we're pushing for better reliability, better maintainability." Mean time between failures is now 250 hours, but that will go to 350 hours when the device goes into production; MTBF on Pave Spike is 125 hours. The Pave Tack laser transmitter, smaller than its predecessor, fits into a package of 14 by 4½ by 6 inches. Pave Tack also has higher power and more flexibility, including faster tracking rates and better beam divergence. In all, the Pave Tack laser system consists of four line-replaceable packages—a transmitter/heat exchanger, power supply, range receiver, and electronic logic unit.

The military is just beginning to look at lasers for uses other than target designation. The Missile Command, for example, has flight-tested its Beam Rider, a missile that rides a

## Military's laser shopping list

The neodymium YAG laser—Nd<sup>3+</sup> ions doped into an yttrium-aluminum-garnet host—is the military's prime laser for rangefinders and target designators. Although the laser can be operated in a continuous-wave mode, the military is more interested in obtaining the high peak powers of the Q-switched, or pulsed, version. Typically, Nd YAG lasers can achieve peak powers of 10<sup>6</sup> to 10<sup>7</sup> watts with a pulse width of less than 30 nanoseconds.

Although the laser is most frequently used at its 1.06-micrometer wavelength, its impact can be extended by using it to drive a nonlinear process. For example, researchers in the 405B space-communications program use a Nd YAG laser frequency-doubled to 0.53 μm to take advantage of more highly refined detectors and modulators available for the visible spectrum. Doubling is done inside the optical cavity by interaction of the fundamental output with sodium-barium-niobate crystals.

But the military is looking for other lasers to handle jobs that the Nd YAG, with its average power of 1 to 10 W, just can't handle. Reconnaissance applications—particularly serial imaging—require a minimum of 100 W to raster-scan an image, as well as to collect, and process the reflected light. Because of its coherent beam, a laser imager could operate at much higher altitudes than today's camera-and-flash units and image intensifiers.

For imaging, the Air Force Avionics Lab has demonstrated a 10.6-μm carbon-dioxide laser with 6% efficiency. The 200-W device weighs only 100 pounds and occupies only two cubic feet. Another candidate is the 5-μm, 10% efficient, carbon-monoxide laser, which has an average power of 500 W [*Electronics*, March 20, p. 40]. Since different targets respond at different wavelengths and since operation at several wavelengths will eventually be necessary for combatting laser countermeasures, the military is working on a stable of devices that emit across the spectrum.

In the visible region, 0.4 to 0.7 μm, prime candidates are dye and metal-vapor lasers, including copper, gold, and zinc. In the infrared region, most of the activity is focused on the TEA (for transverse electric atmospheric pressure) waveguide laser, which some researchers claim is the best technique for getting high peak power out of a small package. Capable of operating on any of a number of gases or chemicals, its potential spans the region from 2 to 5 μm.

laser beam and corrects itself according to the beam coming through the aft portion of the missile. "We're looking to Beam Rider to provide a basis for the future upgrading of command to line-of-sight systems," says Julian Kobler, project director for missile research, development, and engineering at the command. In Dragon and Tow, as well as other air-defense and anti-tank systems, for example, the laser beam would replace the wires or infrared now used.

**Preguidance.** The missile people are also looking at preguidance, "using a tracking system with a laser data link to remove various bias errors from free-flight rockets without adding a guidance system to the rocket," Kobler says. And later this year, Missile Command researchers will begin looking at pattern recognition and active imaging.

Laser data links and laser communications, in general, are of inter-

est to all three services. The Navy, for example, is developing a handheld voice-communications system that looks like a heavy pair of binoculars. Based on a gallium-arsenide-diode laser, the system is designed for amphibious point-to-point communications.

But the most ambitious communications project under way is the Air Force 405B program. Aiming for space-data relay rates of 1 gigabit per second between synchronously orbiting satellites, from low orbit to synchronous satellites and from them to earth, the Air Force originally funded two preliminary systems in parallel. But McDonnell Douglas Astronautics Co., St. Louis, has edged out Lockheed Missiles and Space Co., Palo Alto, Calif., for the engineering-feasibility model, to be delivered to the Avionics Lab this June—a 20-month program that's received almost \$4 million in Air Force money. □

# Why pay \$2400 for a TRUE RMS Digital Voltmeter that won't do as much as ours for \$1395...

*Make Us Prove It...*

Send for the "TRUE EVIDENCE"  
and/or request a demonstration.



## BALLANTINE LABORATORIES

P.O. Box 97, Boonton, New Jersey 07005,  
Phone (201) 335-0900, TWX (810) 987-8380

*Four Decades of Innovation in Electronic Instrumentation*

The Ballantine Model 3620A measures pure sine, complex and pulse waveforms from over 1 MHz down to below 1 Hz . . . to 0.1 Hz optionally. Full scale ranges are from 10 mV to 1000V. Push "DC Coupled" button to read true rms of combined ac and dc component present.

### Now just check these other important features:

- Measures ac, dc and ac+dc to beyond 1 MHz
- Accuracy  $\pm$  (0.1% RDG +0.1% Range)
- Resolution to  $1\mu\text{V}$
- ac measurements to 1 Hz
- Line or Battery operation
- Fully guarded input; floating or grounded
- 90dB common mode rejection @ 60 Hz
- No thermal lag — direct computation of true rms — fast response to 300 msec
- $4\frac{1}{2}$  digits, high contrast,  $\frac{1}{2}$ " high; 19,999 counts
- Automatic test equipment systems compatibility
- dB display 120dB total range; resolution to 0.01dB.



# The best power supplies you can buy for applications that don't need the best power supply you can buy.

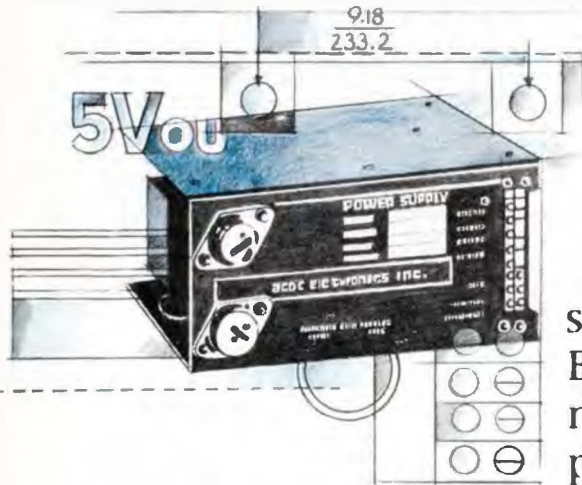

Sure, you can buy cheaper power supplies...and more expensive ones, too. But ACDC's OEM series gives you the most for your dollar...modestly priced power supplies with high priced performance...power supplies that will give you just what you need...at a price you can afford.

Compare our OEM series with the highest priced supplies on the market. We offer 0.1% regulation instead of 0.01% and open frame construction instead of a closed black box. Aside from that, you might never notice any other difference. The OEM series features the same excellent stability, same dependable overload protection, same versatile mounting capability and the same long term performance guarantee. The only conspicuous difference is the price.

There are over 100 U.L. recognized models in the series from 4 to 36 volts, up to 36 amps. They're detailed in our new 72-page Product and Application Guide. Forty-eight pages crammed with specifications, dimensions and technical information on these and 300 other standard power supplies, plus rack systems and custom designs. And, there's another 24 pages of engineering data...information that will make it easier for you to choose the correct power supply for your system. The catalog is free. Just write for it.

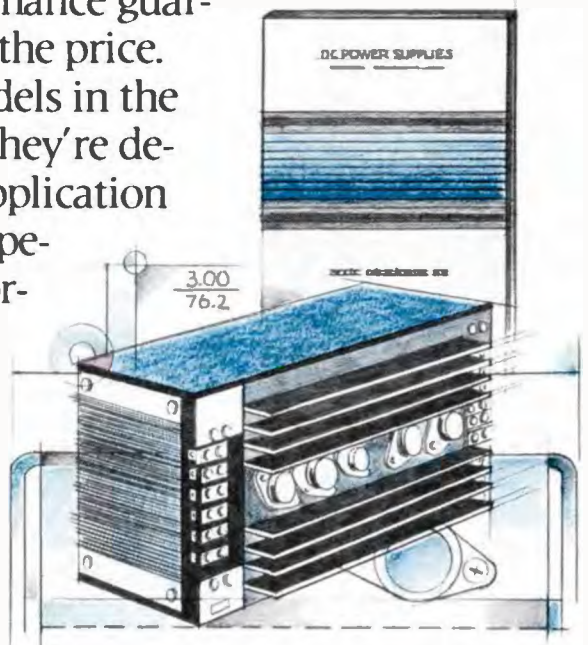

## **acdc electronics inc.**

401 Jones Road, Oceanside, CA 92054 (714) 757-1880, TWX: 910-322-1470



Transportation

# The great West Virginia compromise

U.S. to finish Phase I of Morgantown people mover for an additional \$40 million in exchange for university's acceptance of system

by Larry Marion, Washington bureau

Officials at the Urban Mass Transportation Administration hope to have something special to celebrate during National Transportation Week, May 11 to 17—an agreement with West Virginia University concerning the troubled personal rapid transit system in Morgantown, W. Va. UMTA administrator Frank C. Herringer will disclose at a House Appropriations Committee hearing May 5 that university officials have agreed to permit completion of the controversial four-year-old demonstration project—at an additional Federal cost of \$40 million—in return for a pledge to accept the system.

UMTA has offered to pay 80% of the estimated \$3.5 million in start-up costs to operate the completed phase 1 system—three stations, 45 cars, and 2.25 miles of guideway—which is now in place and undergoing full-scale testing. The system, which has 21-passenger automated cars, connects the downtown campus with two new complexes on the outskirts of Morgantown [*Electronics*, Sept. 11, 1972, p. 73]. UMTA officials estimate that the \$40 million will be needed to build another mile of guideway and two stations, and buy 30 more cars to complete the system. Total cost now stands at \$104 million. A sixth station and 25 cars have been dropped from the original contract.

**Cost overruns.** Boeing Aerospace Co., Seattle, is the prime contractor for the \$60 million-plus phase 1. But \$4 million was first spent by UMTA on partially completed sole-source procurement designs by Jet Propulsion Laboratory of Pasadena, Calif., the project manager, and Alden



Self-Transit Systems Corp., Milford, Mass., the original prime contractor. Initially, in 1967, university officials estimated that the system would cost \$18 million. By 1970, however, JPL had put the bill at \$37 million. UMTA then canceled the Alden and JPL contracts and gave Boeing a competitively bid contract in 1971 for up to \$60, but even that has been exceeded as construction and R&D costs again skyrocketed.

R&D accounted for about half the total project costs, UMTA and Boeing officials say, and electronics took a big part of that—\$15 million, according to the General Accounting Office, Congress's investigative arm. Frank Musil, engineering manager for Boeing in Morgantown, says, "We redesigned and remanufactured hardware because we wanted to improve reliability and the margin of capability. We also wanted to increase system availability. Better components and circuit design were needed."

**Moving people mover.** Vehicle to be used in Morgantown is shown operating automatically at Boeing's test facility.

Bendix Corp.'s Aerospace Electronics Products division, Ann Arbor, Mich., designed the original command and control system, and built the first five prototype electronics packages. "We did not throw out the Bendix design. It was the starting point," Musil says.

**A bumpy ride.** Each driverless car contains an on-board computer that takes frequency-shift-keyed signals for speed, direction, and control from loops embedded in the concrete guideway. The on-board Bendix box had transistor-transistor-logic components to brake the vehicle. But the go/no-go brake system was inadequate, Boeing officials say. Musil says, "We had to control the cars more accurately. The cars couldn't stop within six inches of the loading gate, as specified."

Subsequently, Boeing designed

## Probing the news

and built a "smarter" control system, using programable read-only memories to store an appropriate program for stopping the vehicle.

Boeing's vehicle-command and control system underwent the biggest change in electronics from the original, installed for the October 1972 dedication. But "the whole sys-

tem, from inputs to outputs, was made redundant," Musil says. So it was shut for a year late in 1973 while the electronics and propulsion portions were replaced and new software was designed.

Says Boeing's Jack Gewin, "Bendix didn't have that much redundancy." Redundancy now includes everything from duplicate signal sensors and interface between the propulsion and command and control

systems to dual Digital Computer Corp. PDP-11 minicomputers at control stations. Many changes were the product of the normal learning curve, officials say. But critics charge that many changes came about because quick fixes were needed to demonstrate the set-up before the 1972 presidential election.

**Edict.** "There was an edict placed on the program—it had to be demonstrated before Nixon's reelection [in 1972]," says Vernon E. Hutton, who was the Bendix project manager. UMTA's Herringer denies this, but concedes that former Secretary of Transportation John Volpe established on October 1972 deadline for demonstrating it.

Critics, including the GAO, say the system was built while it was still being designed. "UMTA's failure to develop definitive engineering plans of an integrated system was the primary reason for the cost increases," says Earle T. Andrews, an engineer and member of the university's board of regents. "Also contributing to the excess cost was adherence to a time schedule requiring considerable overtime work."

Bendix project manager Hutton claims that Boeing took over design and manufacture of the control systems from Bendix because of poor coordination of subsystem work and high R&D costs. "There were problems with the control system. Two separate contracts—Bendix on elec-

## New SCRs FOR YOUR DESIGNS

NEW NL-C601



1200 amperes rms  
800-1700 volts

NEW NL-C602



950 amperes rms  
1700-2500 volts

NEW NL-F701



1600 amperes rms  
500-1700 volts

### POINT THE WAY TO PROFITS

- Power and inverter SCRs available in assembled Heat Exchangers.
- Other SCRs available from 16 amps and 25 volts.
- Call or write for full details



**NATIONAL ELECTRONICS**

a varian division

geneva, illinois 60134 (312) 232-4300

### Tab is steep

When the Morgantown personal rapid transit system goes into operation linking the three campuses of West Virginia University, riders will have to pay three to four times the current campus-bus rate for a system that won't be able to carry the estimated rush-hour load, according to a recent consultant study. University officials estimate that students will be charged \$21 to \$26 a term, compared to \$7 for bus service. The study, by Barton-Aschman Associates Inc., Chicago, claims that system demand will exceed 2,700 persons per hour, 200 an hour more than the capacity of the planned five-station system.

# THE WORLD'S FIRST CIRCULAR IMAGE SENSOR.

tronics and Boeing on propulsion—were not being properly coordinated. Stopping at stations and braking controls got intertwined, and Boeing felt it would be difficult to coordinate two contractors," he says.

Boeing's Musil says the change was "principally due to cost. We felt we could get a better product for the money," he says. Herringer and GAO say that Boeing spent \$3 million of its own funds to redesign the control system. Boeing was allowed to claim proprietary rights to the new system, although it must license it to royalty-paying users, he says.

Boeing has yet to fully test the electronics. The hard-wired collision-avoidance system, which automatically stops a car if it approaches a stalled vehicle, has been augmented by a software shut-down program at the control station, Musil says. Car tests began last month, although full-scale operation will begin next fall, according to the original plan, he notes.

Samy Elias, representative of the university, says that UMTA offered the university the right to refuse the project. But an "agreement in principle" has been made, Elias says, to accept the system. The present system is not what he envisioned eight years ago, though. "We really didn't want such a sophisticated project," he says. But, says Herringer, the "sophisticated project" accomplished its national mission to demonstrate a new technology.

It also taught the aerospace industry a lot, say Boeing and Bendix engineers. Bendix's Hutton points out, "we learned a lot on safety areas. Safety in [ground] transportation is the opposite of an airplane. In the aerospace industry, you put redundancy in to keep the plane going at all costs. The whole design philosophy is to keep it going. But in transportation, a different kind of safety is needed. If something fails, you don't want the vehicle to keep going, you want the vehicle to stop." Boeing knew that it needed more redundancy when PRT was first designed, but, Musil says they didn't realize how much would be needed. "We can't plead total ignorance [of what would be needed], but we did learn a lot." □

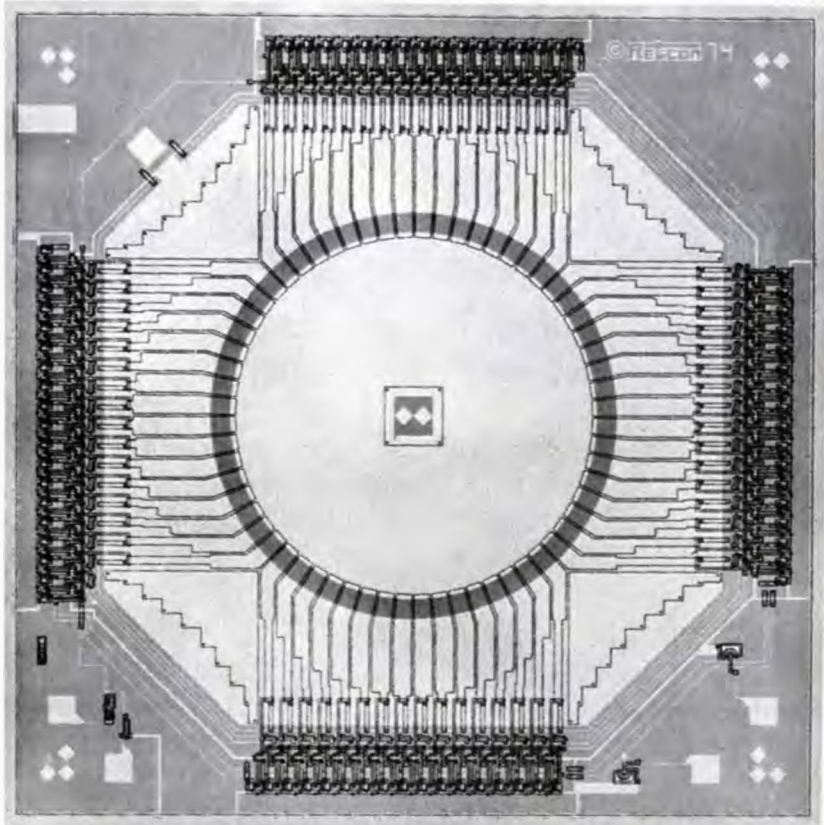

## CIRCULAR?

**YES.** And with on-chip scanning to provide serial output on a single pin. The 64 sensors of the RO-64 are each 0.1 mm x 0.1 mm in size and are uniformly spaced on a 2 mm diameter circle. The array can be operated at scan rates as low as 30 scans per second or as high as 40,000 scans per second. The device is packaged in a 16 lead ceramic DIP and sealed with an optical quality quartz window. The RO-64 is designed for applications in tracking, automatic alignment, automatic focusing, pattern recognition and many others.

RETICON also continues to offer the most complete line of standard linear and matrix arrays in the industry. Our "C" series linear arrays provide from 128 through 1024 elements of resolution on a single monolithic chip and are considered the standard in facsimile, OCR, and industrial control applications.

Custom devices have been developed for a wide variety of applications from point-of-sale to spectroscopy.

In solid state image sensing, our technical leadership backed by over 60 salesmen and 14 distributors over the world makes RETICON the most viable source.

## RETICON®

910 BENICIA AVENUE • SUNNYVALE, CA 94086  
PHONE: (408) 738-4266 • TWX: 910-339-9343

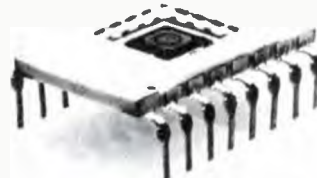

What's new in solid state...

# More RCA Power More ways to boost

## 13 new types widen the range of applications, from audio to autos.

In certain high-gain applications, nothing beats a Darlington. And you gain even more when you specify RCA Darlingtons.

Wide selection, for instance. RCA has added 13 new types, bringing to 29 our wide choice within the popular 40-V to 120-V

range. At low prices. Ranging from \$0.85 to \$1.60 at 1K.

All these Darlingtons have the ruggedness and performance you'd expect from RCA. Monolithic-chip reliability. Rugged clip-lead construction. Real-time process controls. Plus RCA power transistor experience. The kind that comes from serving volume customers in the auto, TV, computer and

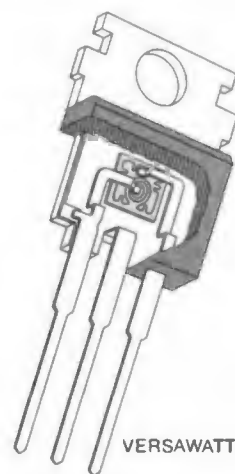

VERSAWATT CUTAWAY



Type	Beta	Vceo	NPN/PNP
<b>TO-3 hermetic package</b>			
RCA8350/50A/50B	1000 @ 5A	40/60/80	PNP
2N6383/84/85	1000 @ 5A	40/60/80	NPN
2N6055/56	750 @ 4A	60/80	NPN
RCA1B07/08	1000 @ 5A	80	NPN/PNP
<b>Plastic VERSAWATT: cost- and space-saving</b>			
RCA8203/3A*/3B*	1000 @ 3A/1000 @ 5A*	40/60/80	PNP
2N6386/87*/88*	1000 @ 3A/1000 @ 5A*	40/60/80	NPN
2N6530/32/33*	1000 @ 5A/1000 @ 3A*	80/100/120	NPN
2N6531	500 @ 3A	100	NPN
RCA120/21/22	1000 @ 3A	60/80/100	NPN
RCA125/126	1000 @ 3A	60/80	NPN
<b>TO-66: space-saving hermetic</b>			
2N6534/36/37*	1000 @ 5A/1000 @ 3A*	80/100/120	NPN
2N6535	500 @ 3A	100	NPN

power supply industries. So we know how to keep costs down and quality up.

What are RCA Power Darlingtons doing today? Here are some typical ways that RCA customers are taking advantage of Darlington features. With resulting fewer components, lower cost, less space, and greater reliability. Check these applications. Then see what we'll do for you.

**1 Reduce audio costs**  
RCA1B07 and RCA1B08, used as outputs, each replace 5 components (2 transistors, 2 resistors, 1 diode) in a 40-watt audio amplifier—for a cost saving of almost 30% on the

RCA. Powerhouse

# Darlingtons. cost effectiveness.

transistors alone.

## 2 Simplify a regulator

Voltage regulators are being made simpler and smaller because of the Darlington's high gain. Both linear and switching types. RCA Darlingtons offer designers a choice of power in three packages, in NPN or PNP to meet circuit objectives.

## 3 Drive a wheel

Our 2N6385 and RCA8350B are good choices for controlling motors such as spindle and tape drives. They work with extremely low drive currents, like those available from integrated circuits. In the typical bidirectional DC motor, these types offer excellent second breakdown current characteristics which protect against plugging: the effects of back emf when reversing direction at high speed.

## 4 Drive a hammer

Inductively loaded computer printer hammers use the 2N6530 Darlington. Conveniently, it comes in the space-saving TO-66 package and can handle up to 120 V. Which trans-

lates into large savings due to much lower current needs.

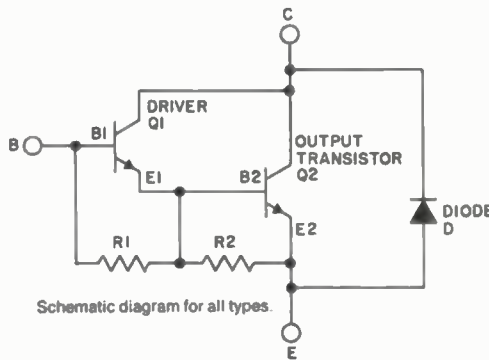

Schematic diagram for all types.

## 5 Spark an engine

In auto ignition, our IC-driven Darlington drives a H-V switching transistor which switches high current through an inductive load. And right

there, under the hood, RCA's high-volume quality, ruggedness and product characterization are all-important. Especially thermal fatigue capability. The 2N6385 is our hermetic type. 2N6388 is our plastic cost- and space-saver.

## 6 Try one! Our 1-for-2 offer

Now we'd like to know how RCA Darlingtons might help you improve your cost effectiveness. Give us the type numbers of 2 discretes you want replaced by an RCA Darlington and we'll give you the Darlington you select.

E51

**Mail to RCA Solid State,  
Box 3200,  
Somerville, N.J. 08876.**

Application: \_\_\_\_\_

New design?  Old design?

Est. annual requirements \_\_\_\_\_

My firm buys discretes: Through distributor  Direct from RCA

Distributor name \_\_\_\_\_

My name \_\_\_\_\_ Company \_\_\_\_\_

Address \_\_\_\_\_

City, State, ZIP \_\_\_\_\_



Ste. Anne de Bellevue 810. Canada; Sunbury-on-Thames, U.K.; Fuji Bldg., Tokyo, Japan.

in Transistors.

Management

## Rockwell's Williams sees the big picture



The president of \$898 million Electronics Operation must watch all areas of activity

Rockwell International is determined to have its business evenly divided among Government, commercial-industrial, and consumer sectors, and that puts Donn Williams in a pivotal position. Williams is president of Rockwell's Electronics Operation, which had \$898 million in sales for the fiscal year ending Sept. 30, 1974, involving products that cover all three major target areas. This should make Williams' perceptions of what's ahead for electronics a factor to reckon with at Rockwell International, and a matter of interest in related quarters of industry.

In the following interview with the editors of *Electronics*, Williams ranges across the technology spectrum from avionics to submarine navigation to wristwatch displays.

*Q: How's the recession affecting you?*

*A:* In the context of the three segments I've got [Autonetics Group, Microelectronics Group, and Collins Radio Group], let's take the ones that are doing the best. Collins is having its best year ever; its orders are ahead of what we had anticipated. We're doing extremely

well in our industrial-commercial microwave communications, communications switching, and automatic call-distribution systems. Profitability has increased substantially and will continue to increase in this area. We have not really seen enough to indicate the softening of the avionics market, but I can't help but believe that there must be some stretchouts for business jets and for air transport.

*Q: We keep hearing that military business is holding steady in the recession. Does Autonetics reflect that?*

*A:* We are ahead of where we thought we would be on new awards, partially because some of them were slipped from last year into this year. One thing we have noticed is a shift in the placement of buys; they tend to slip. At the end of the year, we don't expect to be ahead but we expect to be pretty close to our forecast for orders. We expect to be slightly under on sales, but on target on profitability.

*Q: Have there been any major new programs?*

*A:* No. This goes back five years when I came down here and we only

had the Minuteman, the Mark II, and a little bit of SINS [Ships Inertial Navigation Systems] work. We began a whole bunch of seed efforts trying to grow small businesses. These seeds are beginning to sprout and bring some return. For example, we decided to expand in navigation, which was just in missile submarines, so we moved in and now we have all the SSN 688 attack boat navigators and we're looking forward to trying to move that into retrofit for the rest of the attack boats. Recently we convinced the Navy to put one of these on a carrier to see if it could effectively do the job of carrier alignment, and it has done it. We hope that will give us an opportunity to move into carriers.

*Q: What are some of the other areas?*

*A:* We now have small contracts in ships control for both Trident and the attack submarines. We're doing work on information transfer for ships, multiplexing on ships that we began some time ago. We began doing some work on fast Fourier analysis of sonar data to determine rapidly what's out there. We have

put those in most of the Navy bases where they have P-3 stations. We are now moving into the carrier fleet. Our plan is to work with the Navy to move it into submarines so the submarine commander will have a real-time visual display. Also, we're Bell's team-member on the 2,000-ton surface-effect ship for ships control.

*Q: What about other than the military?*

A: Computerized fingerprint readers are going to be a tremendous business for us. There will be small terminals which would be able to tap into the bigger centers. It would enable an arresting officer to rapidly identify whether he has John Dillinger or John Q. Public.

*Q: How long have you been working on this?*

A: Four or five years, and we now have a contract—some \$5 to \$10 million—to build some of the major ones for the FBI. There are other applications—for example, identification for secure-access areas.

*Q: How are things going in Micro-electronics?*

A: I wish I could say they are going as well as in Collins and Autonetics. I think they are going better now. We've done many things to make them better. In July of last year we went into an unstable period in the device business. There were ups and downs, and it was very difficult for us, but it was good for us too. Up until July we were what I call a silicon-stuffing plant: you want more, you stuff in more silicon. After July we became a productivity-, a yield-improvement plant. Everything we have done since then has been addressed to improving productivity, improving yield, establishing more standardization among the devices, so we can have bigger runs of a common thing. In the last two to three months we have been turning around.

*Q: What areas dropped?*

A: Primarily devices for calculators. Other devices, such as parallel processing systems, grow. We're doing well in automotive.

*Q: What parts of the auto market?*

A: We've been working for some time on a contract with General Motors on LSI devices for various applications. We stayed out of seat

belts. That was not large enough integration. The main system we're selling today is the antiskid device. We're working on hydraulic antiskid with another company.

*Q: Do you see the placing of a controller under the hood of a car?*

A: I think it has to be there. The car has to have a microprocessor.

*Q: When do you see this happening?*

A: I think it's evolutionary rather than revolutionary, but I think the energy situation will force lighter and smaller cars, and better use of fuel. This is going to have to lead to a microprocessor under the hood. And when they've got that microprocessor, I think they've got a tremendous number of additional things that will soon come about.

*Q: Do you have an advantage as a member of the Rockwell operation?*

A: I think so. The people who are somewhat concerned about automotive electronics know that Rockwell does a substantial amount of automotive business, and if anything goes wrong electronically they can come over and conk Rockwell and get a response. If they go to any of our friendly competitors, like AMI or TI, or Fairchild, and it isn't working, the competitor might say, "Well Jack, it just doesn't work—we've done our best." With us they've got a million clubs hanging over our head and they know it.

*Q: What about the device business?*

A: The big areas of device sales in the future are going to be in microprocessors. The whole memory thing is going to be up for grabs again as you come up with things faster and cheaper. That's one that we believe is an opportunity for us. The calculator device market, particularly the hand-held device market, is going to be characterized by substantially more devices. But the total revenue isn't going to be any higher.

*Q: Is Rockwell firmly convinced it wants to be in the microelectronics business?*

A: The answer to that is yes. Our chairman of the board has said, without equivocation, "I want to build this company for one third Government, one third commercial-industrial, one third consumer." Both he and the president have encouraged me on a continuing basis

to do the right thing, nor have they ever denied me any resource I asked for—even when I built two plants I didn't need.

*Q: How do you see the watch business?*

A: In the watch business the distribution channels were set by the Swiss watchmakers. As a result I don't see a break in the distribution channels as there was in calculators. And I don't really believe liquid crystals or LED displays will be the final answer.

*Q: What type of displays do you forecast?*

A: I think electrochromics is coming along. We're working on it—it looks good. The rise and fall time isn't as good as we'd like it, and we don't know what kind of life it has. Other people are working on it, too. I think electrochromic technology offers the best chance for a good-looking display that the public will accept almost as much as it will the analog type.

*Q: How will you participate in the watch business?*

A: We believe that the jewelry end of it is not really our bag, although we are keeping our options open. We have designed a device. We'll sell it, or the module, and we'll do assembly work. We'll do development work on the electrochromic displays and see where it goes.

*Q: What about SOS? Do you see this as a viable technology?*

A: Yes. It's going to be here. It's going to be here for certain applications.

*Q: What about planning? Are you satisfied with the setup you now have in Collins, Autonetics, and Micro-electronics?*

A: I said in 1970 my goal was a \$1 billion organization in electronics and we're essentially there. I said my goal was to build a broad-based, or reasonably broad-based, electronics concern. For the next few years we'll be digesting and codifying what we've got. Whenever you bring a group of people together, adjustments have to be made. We're still working them out.

*Q: For the foreseeable future, is growth going to be from within?*

A: Near term, I think that's right, because the capital situation is not very good at the moment. □

Commercial electronics

## Europe gets 'thinking' traffic lights

Philips plans international sales blitz with its modular system, which uses microprocessors for individual signal controllers

by John Gosch, Frankfurt bureau manager

European cities are dotted with squares, circles, and other complex intersections. This often makes them a tourist's dream but a motorist's nightmare—and a bright hope for makers of "intelligent" traffic signals individually controlled by microprocessors.

The U.S. has more computer-controlled intersections than Western Europe, but most American city streets are laid out in checkerboard fashion. This makes it easier for one computer to handle an entire grid. So while some American intersections are managed by mini-computers, there is no pressing need for such on-site intelligence. But European cities are another story.

There, a new approach utilizing intelligent modules made by Philips Telecommunications Industries in Hilversum, the Netherlands, allows traffic authorities to buy only what they need or can afford. In that way, they can extend control piece by piece from isolated intersections to larger city districts.

Local intelligence in traffic signals is provided by a rugged microprocessor developed specifically for use outdoors. On printed-circuit boards installed in roadside cabinets, the processor operates at  $-20^{\circ}\text{C}$  to  $+70^{\circ}\text{C}$ . A prototype system is already operating in the Hague, capital of the Netherlands, and another one will go to Pietermaritzburg, South Africa.

**Development.** "We have poured millions of dollars into developing the new hardware, its software, and

for studying the market our equipment will enter," says Albert L. Bloemendaal, assistant marketing manager at the Philips traffic-control group in Hilversum. And as might be expected, the Dutch electronics giant is aiming its new equipment at the international market.

That market promises to be an enormous one. Although Western Europe is already well advanced in traffic-control equipment—it's ahead of the U.S. in handling complex intersections—Bloemendaal says the old continent still offers a large sales potential. Of the vast number of conventionally controlled intersections, "only" 20,000 of them are controlled by computer. Even in West Germany, whose 9,000 computer-controlled intersections are



In and out. This Dutch intersection is typical of the many in Europe that could be controlled by new Philips concept.

the most in Europe, sales prospects are good as cities automate lights.

The Philips concept offers savings in cables, particularly in small networks where lines need be run only between the roadside cabinets and to individual traffic lights. There is also the advantage of easy programming, especially in developing countries where there's a lack of trained personnel. "With programming simple enough for even traffic engineers, there is no need to call on computer experts every time a new

### The process of control

The Philips intelligent-module concept has been implemented in three controllers with different microprocessor configurations.

The 86AD190 intersection controller has a processor in which are programmed the traffic-control strategies for complex intersections. It has as many as 32 instruction sequences in a vehicle-actuated or fixed-time mode. The second is the 86AD146 master controller for city districts. It coordinates and supervises the operation of a number of intersection controllers and concentrates their data. The third, the 86AD147 area controller, supervises and coordinates a number of district controllers.

The microprocessor, which has modular expandable memories for a maximum of 16,000 8-bit words, accepts the data from detectors, and processes it past one- or two-word instructions for the traffic lights.

In addition, Philips has developed a small electronic 86AD182 intersection controller that doesn't contain a microprocessor and is intended primarily for the market now dominated by the simple electromechanical controller. In all four systems, a new detection-system design makes it possible to bury in the roadbed the defector/evaluator device itself.





program must be entered," Bloemendaal asserts.

Philips estimates that Europe will spend some \$300 million through 1980 for traffic control. To be sure, most of that money will be for new or modified light posts and cables, or for traffic studies, software preparation, and labor. But producers of electronic hardware will get a hefty chunk of it—about one third, or \$100 million.

Philips, which has maintained a low profile on overseas markets thus far, is determined to grab at least 20% to 30% of system sales in Europe and Latin America. However, the competition is unlikely to be caught napping. Some European companies active in traffic control are already taking a close look at microprocessors. West Germany's Siemens AG, which has thus far installed 125 traffic-control systems worldwide and is Europe's No. 1 vendor of such systems, "is busying itself with microprocessors," says Walter Hieber, European sales manager for traffic-control systems.

**Competitors.** In France, at least one manufacturer has developed a traffic-control system that uses a decentralized computer, but is based on cabled logic, rather than a microprocessor. Electronique Marcel Dassault's controller also offers more flexible operating modes than conventional traffic systems that depend on single central computers. Like Philips, Marcel Dassault says that a single intersection controller should be intelligent enough to adapt to particular traffic characteristics in its own zone.

In Britain, central computers for running automated traffic-control systems are preferred—partly because of a preference for the tried and true. "We are looking at microprocessors, but compared with what we've got, microprocessors are more costly," comments Albert Gregory, sales manager for GEC-Elliott Traffic Automation Ltd.

Also in Britain, Harry Phillips, sales manager for power and transport systems at Ferranti Ltd., says microprocessors have a future either as sequence controllers at individual intersections or in small-area systems controlling 30 intersections for small towns. □

## LOW COST?

Beware—"low cost" may mean "low value!"



Compare the features of DATUM's Low Cost Timing Units with other so-called "Low Cost" units and see.

### Datum's Low Cost means High Value!

- Large Solid-State LED Display
- Forward and Reverse Reading
- Tape Search Compatibility
- Wide Dynamic Range
- Day-Of-Year at No Additional Cost
- Plus!
- A Long List of Customer Options

DATUM's Timing Division is the undisputed leader in Timing Instrumentation. Our Range Instrumentation experience dates to 1958, with such programs and facilities as:

ATLAS, CENTAUR, PMR, WHITE SANDS, EDWARDS AFB, STADAN, APOLLO

the list goes on and on . . .

Datum's five-man senior staff offers 85 man-years of Timing experience, has produced tons of equipment operating all over the world. No other manufacturer can match this record and experience!

As well as a complete product line of off-the-shelf Timing equipment, our specialties include • Complete range instrumentation • Airborne, High Environment equipment • Ultra Low Power Equipment • Computer-Peripheral Timing

Call or Write for detailed information.

Timing Division

# Datum inc

1363 S. State College Boulevard, Anaheim, California 92806 ■ 714/533-6333

Companies

## How Inselek was strangled

Shrinking cash flow tightened noose around SOS maker, but decision by Rockwell to drop commercial sapphire work provided fatal yank

by Ron Schneiderman, New York bureau manager

Sometimes, when you're only four years old, you get the feeling that the bigger boys are picking on you. That was the way Inselek Co. has been feeling—with some justification. Just as it was about to turn the profit corner for the first time last December, Inselek's hopes of becoming a factor in a new and still developing semiconductor technology—silicon-on-sapphire—began to waver seriously. What happened subsequently could serve as a classic case study of a small company waiting for an idea to pay off.

"We were going to coin money in January," said Inselek president Joseph R. Burns, as he sat in the quiet of his nearly vacant offices in Princeton, N. J. But the company manufactured and shipped only until the middle of January. Then, on Jan. 15, Inselek filed a Chapter 11 petition under Federal bankruptcy laws.

What happened? Burns says the company's troubles actually began some time ago when it got caught between its customers and suppliers. Burns says that his customers, mostly sizable electronic-equipment makers, delayed payments to Inselek; meanwhile, his suppliers, also big companies, insisted on being paid on time. "The accounts-receivables situation just got out of sight," Burns complains. "We were running profitably, but couldn't generate cash."

**Disaster.** Then disaster struck. In December, Rockwell International Corp. dropped its commercial SOS operation, leaving its Anaheim, Calif., neighbor, General Automation Inc., without a source for what was to serve as the single-chip cen-



**Pitch.** Inselek's Joseph Burns might be thinking he should have stayed in baseball.

tral processor in its LSI-12 mini-computer [*Electronics*, Dec. 6, 1974, p. 39]. That decision not only gave SOS a black eye, but it was a stunning blow to Inselek, which had been working with Rockwell on some second-source programs.

"Without question, the publicity hurt us," says Burns. "It scared away the financial people. They took the view that if Rockwell can't do it, how can a little company like Inselek make this stuff?" Tragically for Burns, what the financiers and some industry people apparently didn't understand was that Rockwell was trying to make a smaller, less expensive n-channel device for General Automation, instead of using the much more successful complementary-MOS-on-sapphire process.

As early as last June, Burns circulated a memo among his staff stress-

ing Rockwell's n-channel approach. He said Rockwell's SOS-development problems at that time were "very serious." Burns's memo briefly described an n-channel switching device with p-type resistors, noting that it "appears the resistors are causing most of the problems." Ironically, Burns's memo ends with the comment that "Fortunately, Inselek is not involved" in this program.

**Match-up.** How does Burns rate SOS against integrated injection logic? "It depends on the company," says Burns. "Those companies that are strong in bipolar will probably stay with I<sup>2</sup>L. SOS is not for Texas Instruments, but it's a golden opportunity for RCA, which has gone completely C-MOS on sapphire." In fact, Burns says that SOS will capture 15% of the total C-MOS market in two to three years. Pointing to a recent survey indicating that SOS will be a \$150 million business by 1980, he says, "I can believe that number."

Meanwhile, Burns is talking with a number of semiconductor makers he says are interested in licenses on Inselek's proprietary production process and designs. "At a minimum, this will be a company that will collect royalties." Inselek's chances of ever manufacturing again are "very slim, if not impossible," admits Burns.

Burns, a star basketball and baseball player at Princeton University, turned down a bonus to pitch for the Milwaukee Braves. Instead, he continued his electrical engineering studies at Rutgers University, and he muses with a hint of a smile, "I'm not sure now that I made the right decision." □

# SUPER SWITCH



#### **100 NANO second Trr DO-5**

FMC has developed a very fast switching, high power diode, having a low  $V_f$  of .90\* volts at 60 amp peak. Designed specifically for UPS systems requiring reliability and high efficiency operation.

For detailed information, contact:  
FMC Corporation  
Semiconductor Products Operation  
Homer City, Penna. 15748  
(412) 479-8011

**FMC** Special  
Products

\* at 150°C

75EP-1

# If you're worrying about Gallium, you haven't heard the news.

A large stable supply of gallium is now available.

From Alcoa's new plant in Bauxite, Arkansas.

It's already processing Alcoa's own gallium-rich Arkansas bauxite in significant quantities.

So don't worry. Long term availability is here. Enough for major applications . . . from stock . . . as close as your nearest airport.

Keep thinking about electroluminescence, optocoupling, photovoltaic conversion, magnetic bubble memories and other uses of gallium.

Because gallium from Alcoa will stay available.

Gallium is found in bauxite. And Alcoa has extensive reserves of bauxite in Arkansas. So Alcoa will be extracting gallium from Arkansas bauxite for a long time to come.

That's the news.

And there's more. Just write Aluminum Company of America, 850-E Alcoa Building, Pittsburgh, PA 15219.

Change for the better with  
Alcoa® Gallium

 **ALCOA**

# Engineering in the data domain calls for a new kind of digital instrument

Equipment based on concepts of frequency and time domain is no longer adequate for analyzing today's complex digital systems

by Charles H. House,  
Hewlett-Packard Co., Colorado Springs, Colo.

□ Debugging and troubleshooting a digital system can be an onerous task. Although many presently available test instruments are suitable for making gross checks or in-depth analyses, they aren't designed to handle most faults found in digital systems.

These shortcomings are not the fault of the instruments, which were designed to serve equipment operating either in the time domain, as defined by the mathematics of Heaviside and Laplace, or the frequency domain, as exemplified by the calculations of Maxwell and Fourier. Digital equipment operates in the entirely different data domain, according to rules laid down by Boole and von Neumann.

The importance of the data domain lies in the differences between digital and analog circuits. By understanding the concept, an engineer can more easily take the step from design requirements to hardware. The data domain is characterized by state-space concepts, data formats, data flows, and equipment architecture. Electronic-circuit design to implement these ideas plays a large part in the shift from analog to digital emphasis.

### The data-domain problem

A typical data stream to be analyzed is composed of many bits of information, and, not surprisingly, every bit looks just like every other bit. Digital pulses are differentiated primarily by the choice of data format—how the bit pattern is organized into meaningful data words. For example, if one word is 8 bits long, it is possible to organize the word into 8 serial bits, 8 parallel bits, or 4 parallel bits followed by 4 more parallel bits. These formats, called bit-serial, word-serial, and byte-serial, respectively, are common in digital systems (Fig. 1).

Assume the message "data domain" is sent in ASCII code. Table 1 shows the ASCII code set, and Fig. 2 shows the data waveforms that would be sent over synchronous systems for this message in each of the three format structures. If a fault occurs—say the letter "i" is received as "y"—where can an oscilloscope be triggered, and how can the resulting display be analyzed? The answer is uncertain, and sometimes a designer or service technician must keep searching for days with instruments designed for analog analysis.

### The digital world

Digital designs are based on words or data as a function of time or sequence more often than on voltage as a function of time or frequency. Only when the word flow

*This article defines what the data domain is and why it is important in digital design and troubleshooting. It is the first of a two-part series. In the second part, William Farnbach of Hewlett-Packard will describe how to use data-domain instruments to solve problems in digital circuits.*

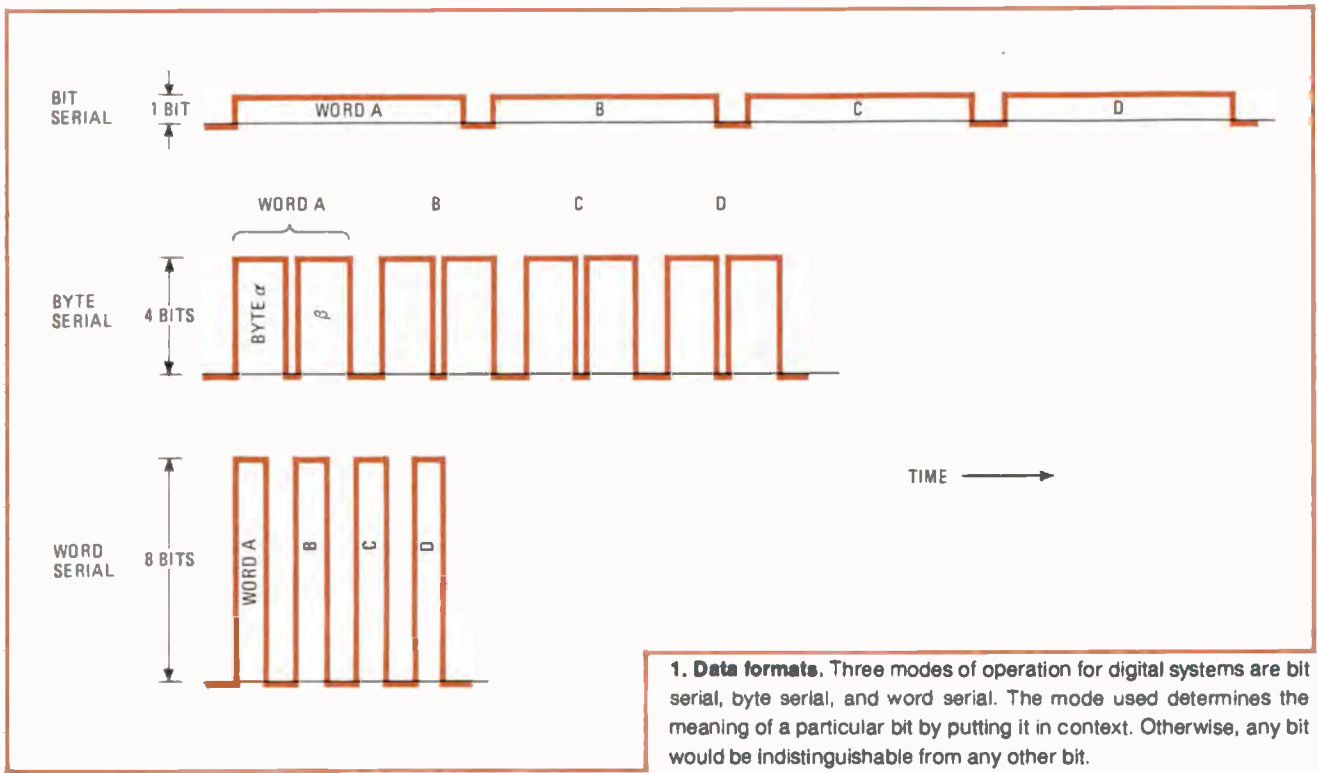

**1. Data formats.** Three modes of operation for digital systems are bit serial, byte serial, and word serial. The mode used determines the meaning of a particular bit by putting it in context. Otherwise, any bit would be indistinguishable from any other bit.

**TABLE 1:  
PROPOSED AMERICAN STANDARD CODE FOR  
INFORMATION INTERCHANGE (ASCII)**

BIT=	121+567	129+567	123+567	123+567			
A	1000001	a	1000011	0	0000110	\$	0010010
B	0100001	b	0100011	1	1000110	%	1010010
C	1100001	c	1100011	2	0100110	^	1101111
D	0010001	d	0010011	3	1100110	_	1011111
E	1010001	e	1010011	4	0010110	`	1101101
F	0110001	f	0110011	5	1010110	~	1011101
G	1110001	g	1110011	6	0110110	BELL	1110000
H	0001001	h	0001011	7	1110110	CR	1011000
I	1001001	i	1001011	8	0001110	LF	0101000
J	0101001	j	0101011	9	1001110	BS	0001000
K	1101001	k	1101011			HT	1001000
L	0011001	l	0011011	.	0111010	VT	1101000
M	1011001	m	1011011	,	0011010	SOH	1000000
N	0111001	n	0111011	:	0101110	STX	0100000
O	1111001	o	1111011	;	1101110	ETX	1100000
P	0000101	p	0000111	?	1111110	EDT	0010000
Q	1000101	q	1000111	!	1110010	ACK	0110000
R	0100101	r	0100111	{	0001010	DC <sub>1</sub>	1000100
S	1100101	s	1100111	}	1001010	DC <sub>2</sub>	0100100
T	0010101	t	0010111	+	1011010	DC <sub>3</sub>	1100100
U	1010101	u	1010111	-	1101010	DC <sub>4</sub>	0010100
V	0110101	v	0110111	=	1011110		
W	1110101	w	1110111	/	1111010		
X	0001101	x	0001111	*	0101010		
Y	1001101	y	1001111	#	1100010		
Z	0101101	z	0101111	@	0100010		

Abbreviations:  
 CR = Carriage return, LF = Line feed, BS = Back space  
 HT = Horizontal tabulation, VT = Vertical tabulation  
 SOH = Start of header, STX = Start of text, ETX = End of text,  
 EDT = End of transmission, ACK = Acknowledge, DC = Device control.

for testing digital systems is aided by clues from the major signal characteristics of data-domain systems:

- Digital signals are almost invariably multiline. As shown in Fig. 2, even the bit-serial format of data transmission implies use of a clock and a word-frame-counter line, yielding a minimum of three simultaneous signal lines even before control signals are considered.
- Many signals occur only once—single-shot—as the program is executed, or else the concern is only about a single occurrence. In a page of transmitted text, for example, the letter “a” may occur many times, but be in the wrong location only once.
- Many more signals occur repetitively, but aperiodically. There is no periodicity to the occurrence of the letter “a,” for example. Even in architectures usually considered synchronous and periodic, such as central-processing units, variable-rate cycle times for different functions are becoming common. The present generation of microprocessors routinely operates in this way.
- Because the stimulus is seldom controllable, it is impossible to answer the classical time-domain question, “What happens after the switch is closed (or the pulse edge occurs) at time  $t_0$ ?” Also, since an error typically occurs in a vast flow of correct data, it becomes practical to recognize the error only after it has occurred. This situation obviously requires capturing and storing the pertinent causes of error that occur prior to the error—negative-time signals—because they occur before the trigger at time  $t_0$ .
- Registration within a digital data stream is accomplished by unique Boolean expressions or data words. Thus instrumentation could be designed to trigger on and index the display from the trigger event as a function of words.
- The speed of digital signals varies dramatically. If

is incorrect need a technician be concerned with the voltage conditions that created the words. Even when word-flow errors require analysis of electrical parameters, the number of signal nodes in the vicinity of the error complicates the use of traditional oscilloscopes in the analysis. Thus, it is helpful to define scope functions—probing, triggering, and display—in terms either of words versus event or sequence, or words versus time, rather than in volts versus time.

The job of defining instrument capabilities desirable

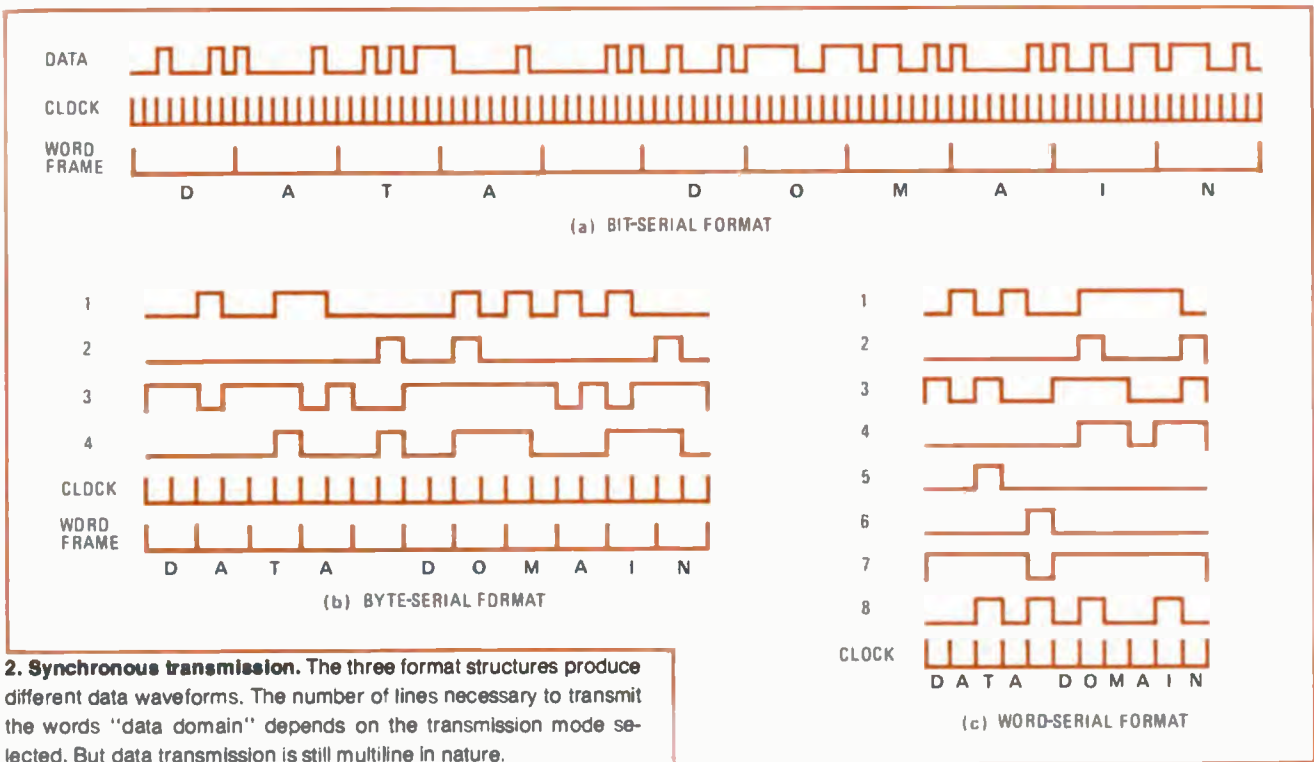

**2. Synchronous transmission.** The three format structures produce different data waveforms. The number of lines necessary to transmit the words "data domain" depends on the transmission mode selected. But data transmission is still multiline in nature.

one is concerned about potential overlap of two pulses in a high-speed central processor, time resolution of 50 picoseconds is desirable. In contrast, the registration of the strobe pulse for a keystroke on an electronic typewriter may be measured in milliseconds. If an instrument is to deal with data words, the speed can be considerably slower than if it is concerned with electrical portions or components of those words. For example, in monitoring the execution of an algorithm, all that is necessary is to watch the flow of data words. When an error is detected in the algorithm, one needs to analyze the cause of that error, which may require an instrument that operates at a much higher speed.

As an extension of this example, the types of problems that exist in a digital system should be considered in terms of equipment needed to show the parameters required for analysis. A designer would have to spend considerable time with a scope to trace the execution of an algorithm, even to discover that it has an error.

The problem may be functional in that the correct function in terms of the data domain did not occur. If it did not occur as expected, the cause needs to be analyzed after the problem is located by a display of word parameters. Basically, four probable causes exist: an incorrect functional instruction may be present, a functional problem exists in hardware, an electrical problem exists in hardware, or an electrical problem from elsewhere is intermittently causing a malfunction. Obviously, one display format will be insufficient for appropriate analysis of all of these causes.

**Data handling**

Several instrument companies have introduced products designed to solve the problem of testing in the data domain. In such applications, this new class of instru-

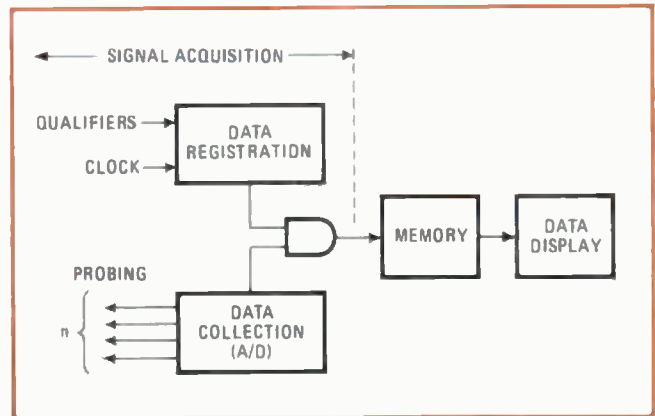

**3. Logic analyzer.** Data-domain testing differs from time- and frequency-domain testing in the means used for probing, data collecting, data registration, memory, and data display. Shown here are the data and control-signal paths in a logic analyzer.

ments, which may be called logic analyzers, offer several advantages over time-domain test instruments because of innovative approaches to signal acquisition, processing, and display (Fig. 3).

Signal acquisition may be divided into three stages: probing, data registration, and data collection. Probing, in both electrical and mechanical terms, requires attention to the multi-node, variable-level, physically restricted areas of access to densely packaged digital hardware (Fig. 4). Data registration is essentially the triggering function, but it may include sampling strobes to indicate when data should be collected. Data is now collected for analysis by using either single- or dual-level comparators that process at a clock edge. If the clock edge is generated by the system under test, the analyzer is said to operate synchronously. If the clock is

internal to the analyzer, it operates asynchronously to data.

Because the acquired signal is available in the instrument in digital form, it can easily be stored in memory. The data can then undergo further processing, if required. For example, the analyzer may generate displays other than the conventional curve of level versus time. And since events that occurred before the trigger can be stored in memory, the events leading up to a malfunction may be displayed and analyzed for probable causes of error.

Data registration—finding a unique point within a long data stream to establish the reference for a meaningful measurement—is a complex problem. Several requirements exist: a unique starting point must be recognized; a scanning area, or search window, as well as a display window, must be defined; if the scanning area is not adjacent to the starting point, a means must be provided for indexing the display with respect to the starting point, and a stopping point must be established.

In time-domain equipment, oscilloscope triggering and sweep circuits provide these functions. The starting point is determined by the slope, coupling, and threshold controls. The scanning area or display window is set by the sweep-time control. Indexing is commonly

provided by a delaying sweep, which sets a time-interval holdoff between the starting pulse and the scanning area. The stopping point is provided by the sweep-hold-off circuit, which allows all circuits to reset to their initial conditions after the sweep-time circuit has finished its traverse.

The data domain offers an analogous situation. The starting point, which may be termed a Boolean or word-pattern trigger, occurs at a certain time in the form of a unique word pattern. An indexing capability may be provided in whatever indexing parameter is convenient for the equipment under test—bits, words, time, frames, or blocks. A scanning area is defined by memory size or word-boundary conditions. And a stopping point may be determined, either by a filled memory or the recognition of another unique word pattern.

#### Instrument solutions

Data-domain test instruments that make use of these concepts are divided into three classes: logic-state analyzers, logic-timing analyzers, and logic triggers for oscilloscopes (Table 2).

Logic-state analyzers display binary data in a word-versus-event format. Because they concentrate on word sequences, they are useful in examining the functional

**4. High density.** Because digital systems are so densely packaged, data-domain test instruments must use innovative approaches to probing points under test. Small probes make it easy to connect these instruments to closely spaced test points.

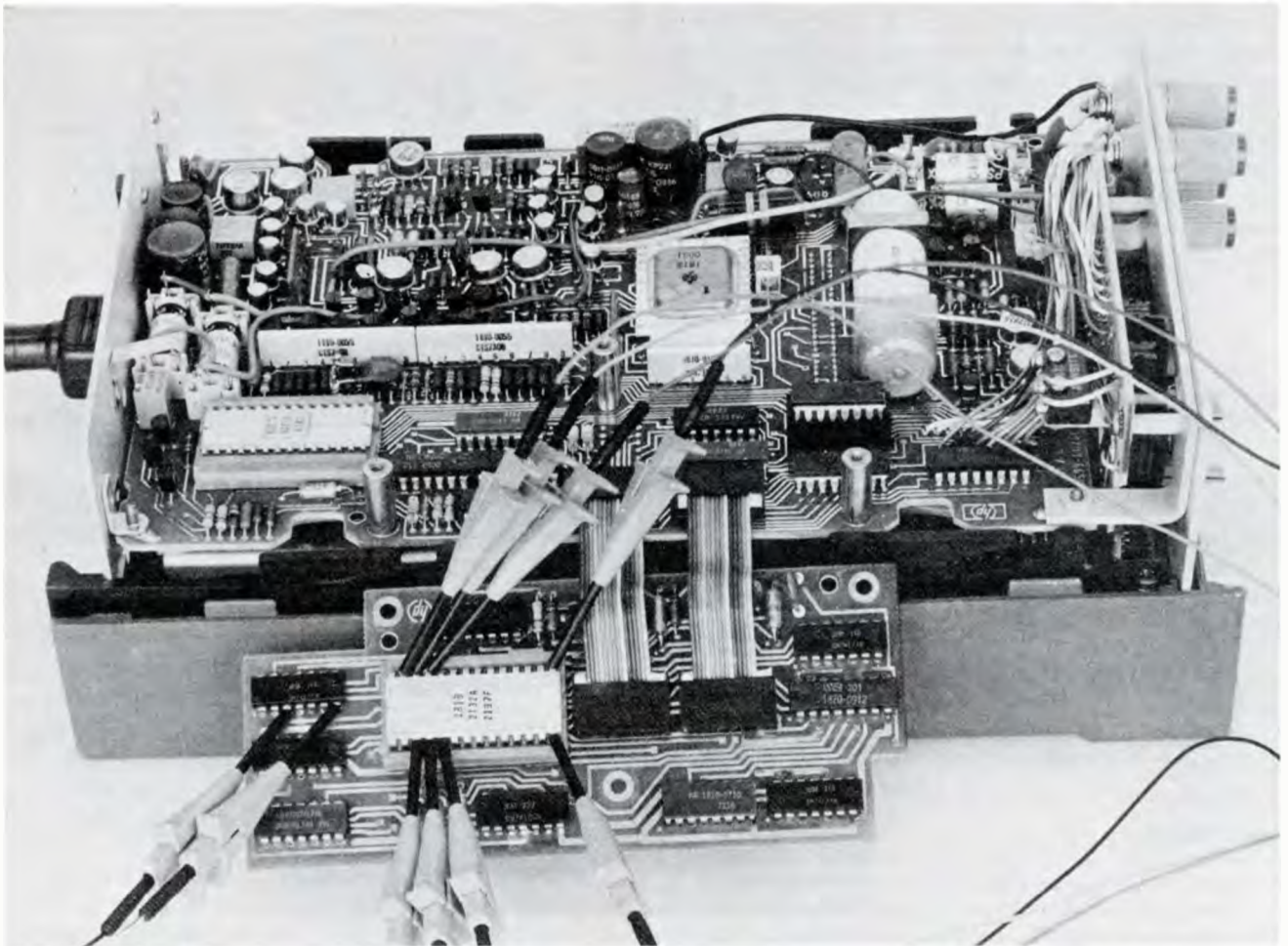



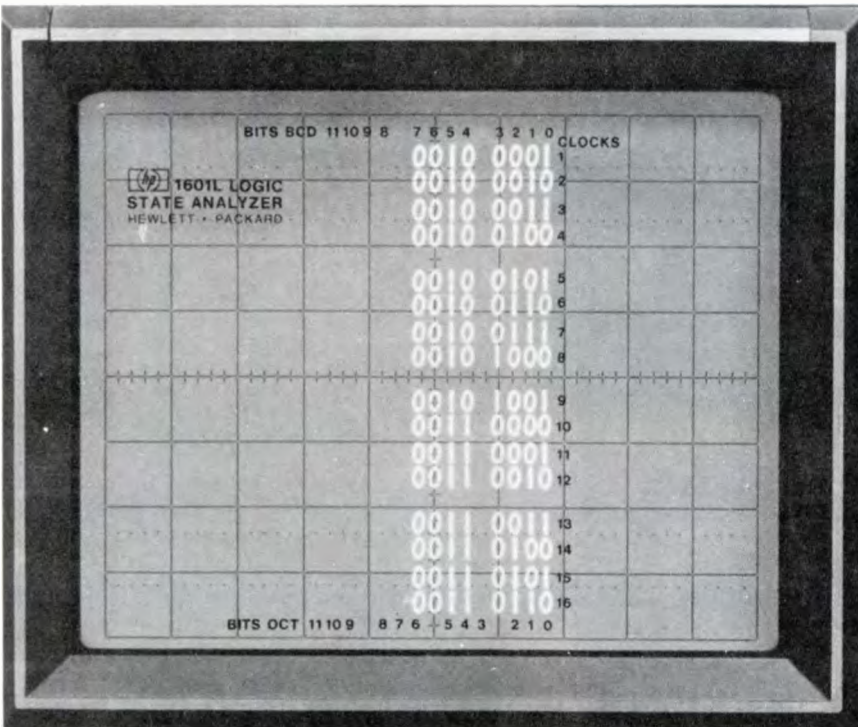
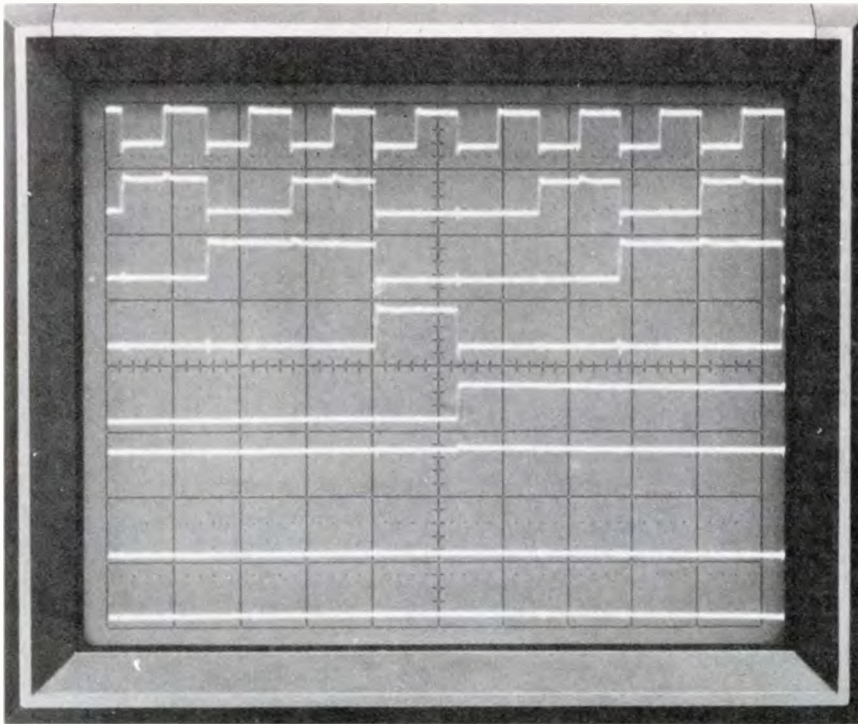

**5. Counter display.** The output of a two-decade counter can be displayed by either a logic-timing analyzer (top) or a logic-state analyzer (bottom). The logic-timing analyzer display yields more information about the timing relationships between signals, but the logic-state analyzer display is more easily read, and so is more useful when information about logic levels is all that is required.

behavior of digital systems. They may provide an output suitable for triggering an oscilloscope for voltage-versus-time displays when electrical analysis is required. The logic-state analyzer may also provide facilities for some correlation analyses, such as displaying a mathematical combination of two different data fields.

A logic-timing analyzer, on the other hand, displays binary data in a word-versus-time format, or it may reconstruct the original voltage waveform and display it in a pseudo-voltage-versus-time mode. Because these

instruments display bit sequences, they are most useful in examining the functional behavior of subsystems and components. Some capability to analyze electrical parameters is usually included in a logic-timing analyzer so that glitches, rise times, or pulse-ringing can be detected.

Logic-trigger generators, designed for use with oscilloscopes, are simpler instruments. They may be as simple as four-input AND gates connected to scope trigger inputs to synchronize the scope with the occurrence

TABLE 2: MEASUREMENT ABILITIES OF DIFFERENT INSTRUMENTS

INSTRUMENT	DATA ACQUISITION			MEMORY	DISPLAY FORMAT	
	Probing nodes	Collection repetition rate	Registration trigger and index	Negative-time information	Parameters	Speed
Logic state analyzer	Many	Single shot, aperiodic, periodic	f(Word), f(Event)	Yes N words	Word vs Event A ⊕ B	Word rate
Logic timing analyzer	Many	Single shot, aperiodic, periodic	f(Word), f(Event)	Yes mN words	Word vs Time Pseudo V vs Time	mWord rate ~Voltage rate
Oscilloscope trigger generator	Many	Single shot, aperiodic, periodic	f(Word), f(Event)	—	—	—
Oscilloscope	Few	Single shot — 1, 2 channels, periodic	f(Voltage), f(Time)	No	Voltage vs Time	Voltage rate

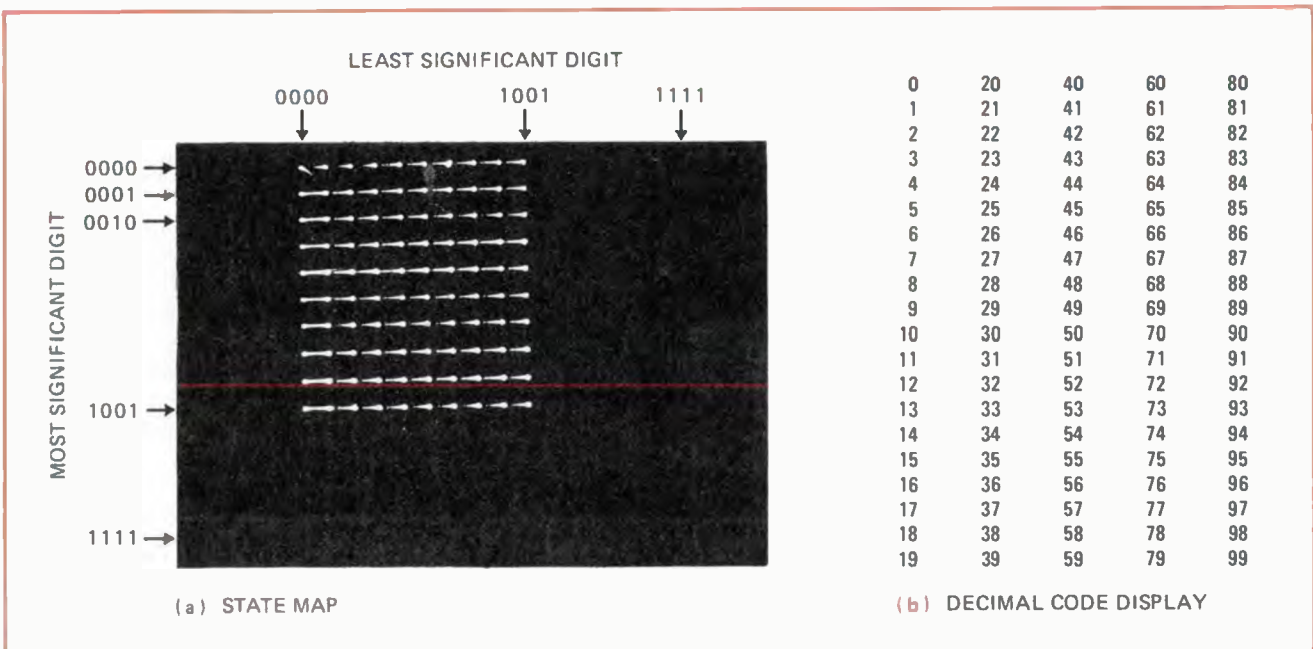

6. Variety. Logic states may be presented in many ways. Two of them are shown here. The state map (left) is a graphic presentation that clearly shows the stages through which a counter steps. The decimal code display (right) is another way to show the same thing.

of a particular parallel word. They may also include digital counters to delay triggering by a set number of events, or shift-register comparators to allow bit-serial word recognition for triggering.

Each type of data-domain instrument, of course, has both merits and limitations for different applications (Table 3). For example, a logic-state analyzer is the best choice for the purely functional tests of verifying a counter output sequence or checking a microprocessor program. A logic-timing analyzer is more suitable for such essentially electrical measurements as checking logic-threshold noise immunity and propagation-delay times. A logic-trigger generator may be adequate when cost is a consideration and an oscilloscope is readily available.

A common application can illustrate how these con-

siderations affect the choice of analysis tool. The count-sequence output of a two-decade decimal counter can be displayed by either a logic-state analyzer or a logic-timing analyzer (Fig. 5). The timing analyzer display looks much like what might be expected from an oscilloscope—if that time-domain instrument could handle eight channels simultaneously. Although this timing diagram yields more information than does a truth-table display, its greater complexity makes it less useful than a truth table when only functional representation of the circuit under test is required.

For multilevel data, the relative ease of reading a word-encoded sequence by means of a logic-state analyzer is obvious. In contrast, reading several binary-level channels by means of a logic-timing analyzer is extremely difficult. For example, checking the execution

TABLE 3: TYPES OF LOGIC ANALYZERS

TYPE	ADVANTAGES	LIMITATIONS	CURRENT EQUIPMENT
Logic state analyzers	Multichannel single-shot Multichannel negative-time Display of words	Lack of voltage-vs-time capability	Hewlett-Packard 1601L Hewlett-Packard 5000A
Logic timing analyzers	Multichannel single-shot Multichannel negative-time Familiar timing diagram	Lack of word format Higher cost for voltage-vs-time resolution	Biomation 810D, 8200 E·H Digiscope (AMC 1320) Iwatsu LS-6211
Logic trigger generators	Everyone owns a scope Lower cost for voltage-vs-time resolution	Lack of negative time Lack of multichannel single-shot Lack of word data	Hewlett-Packard 10250A, 10251A, 10252A Hewlett-Packard 1620A Dumont 2100A Tektronix 821A Tektronix DD501, 5B31, 7D11, 7D15

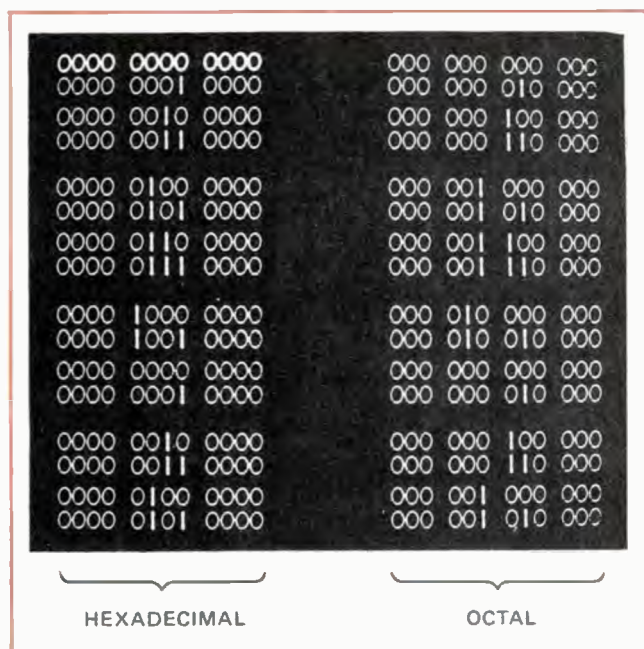

7. Legibility. Twelve-bit patterns can be broken up into groups of 3 or 4 bits to make reading easier.

of a branching algorithm is much easier with a logic-state display than with a logic-timing display, especially if long wait loops or idling loops are involved.

**Clearer presentations**

Of course, it is possible to develop displays that are even more easily readable for functional checks. Two are shown in Fig. 6. The first is a graphic map of the binary words of a counter output. The intersection of a row, which denotes the least significant digit, and a column, which represents the most significant digit, is a unique dot position signifying a unique word.

The dot at the upper left-hand corner represents the word 00000000, the dot in the upper right-hand corner the word 00001001, and the dot at the lower right-hand corner 10011001. The intensity of the display increases

as the trace nears a new point, so the direction of flow between states can be determined. If an unauthorized state occurs, the access path to that state can readily be determined. If a necessary state does not occur, it is obvious which did not and what occurred instead.

Figure 6 also shows a decimal-code display of a counter output. This is easier to read than its binary-coded-decimal equivalent, as the BCD equivalent is easier to read than a voltage-versus-time plot. The code conversions possible for the data domain are numerous and varied; instruments currently provide only the most elementary of them—binary equivalents that can be organized into 3- or 4-bit bytes for easier reading of octal, BCD, or hexadecimal data (Fig. 7).

When analyzing why a data error occurs, as opposed to finding whether or where, it frequently becomes important to display the word events line by line, usually as a function of time. For this task, scopes and logic-timing analyzers are better than logic-state analyzers. When an error has been found, the cause—a glitch, a noise spike, or a faulty instruction—must be found. A timing analyzer or a scope allows the user to magnify the area surrounding the fault and watch for unexpected level transitions. This analysis requires attention to occurrences of much shorter duration than a data word, which increases the required data-collection rate of the test equipment. Consequently, logic-timing analyzers should be *n* times faster than logic-state analyzers for the same data fields, where *n* subcycles of resolution are required to analyze a data error.

No single product covers all requirements, and even if all the capabilities were incorporated in a single instrument, it would cost too much and be too complex for many jobs that one instrument—a logic-state analyzer, logic-timing analyzer, or logic-trigger generator—could easily perform. The message is clear: digital-equipment problems require data-domain instruments for solutions. Instrument manufacturers are beginning to recognize the need and build appropriate test equipment. The digital designer can only benefit from this new approach to problem-solving. □

## Buffer keeps noise from triggering thyristor

by L. R. Rice  
Westinghouse Semiconductor Division, Youngwood, Pa.\*

Certain shortcomings in passive noise-rejection networks have led to development of an active circuit designed to prevent false triggering of thyristors. Such undesired firing can occur when noise transients cross the thyristor gate conductors, and can produce fluctuations of load power, oscillations in control circuits, and equipment damage. The offending pulses usually arise from reactive-load energization or de-energization, such as the discharge of a capacitor or the switching of a relay.

In the field, passive networks that discriminate against both signal and noise, such as those shown in Fig. 1, are often used, but they are impractical at times and some application problems simply cannot be solved with these techniques. Therefore an active circuit, consisting of a buffer connected between the trigger source and the thyristor gate, is needed.

As shown in Fig. 2, this buffer consists of an RC integrating circuit, a comparator, and a pulse generator. An incoming voltage, either signal or noise, charges 0.02-microfarad capacitor C through resistor R. The 2N697 comparator amplifier turns on when the capacitor voltage reaches the threshold value equal to the sum of the

\*Now with White-Westinghouse Corp., Mansfield, Ohio.

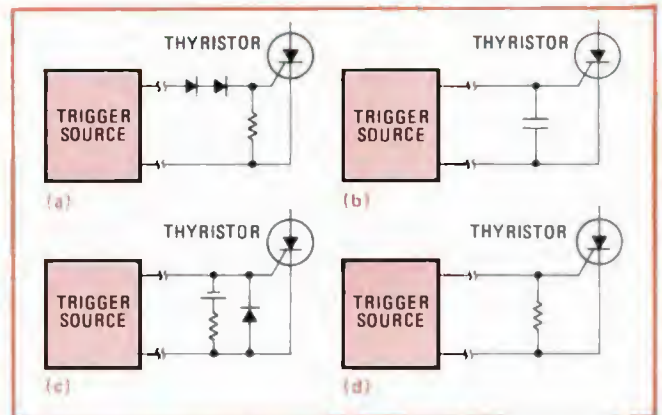

**1. Quick fixes.** Noise in thyristor gate lead is sometimes suppressed by one or another of these means: (a) diodes raise threshold voltage; (b) capacitor shunts high frequencies; (c) saturated diode reverse-biases gate; (d) resistor decreases gate sensitivity.

voltage drops in diode  $D_2$ , the base-to-emitter junction, and zener diode  $D_3$ . This threshold voltage is given by

$$\begin{aligned} V_{TH} &= V_{diode} + V_{BE} + V_{zener} \\ &= (1.0 + 0.45 + 6.0) \text{ volts} \\ &= 7.45 \text{ volts} \end{aligned}$$

When the capacitor voltage reaches this value and turns on the comparator, the 2N586 pulse generator starts to conduct and fires the thyristor.

Variable resistor R is adjusted so that the time constant RC is large enough to prevent noise pulses from charging C to threshold. For example, if the noise ambience can be represented by a 50-volt pulse of 1-micro-

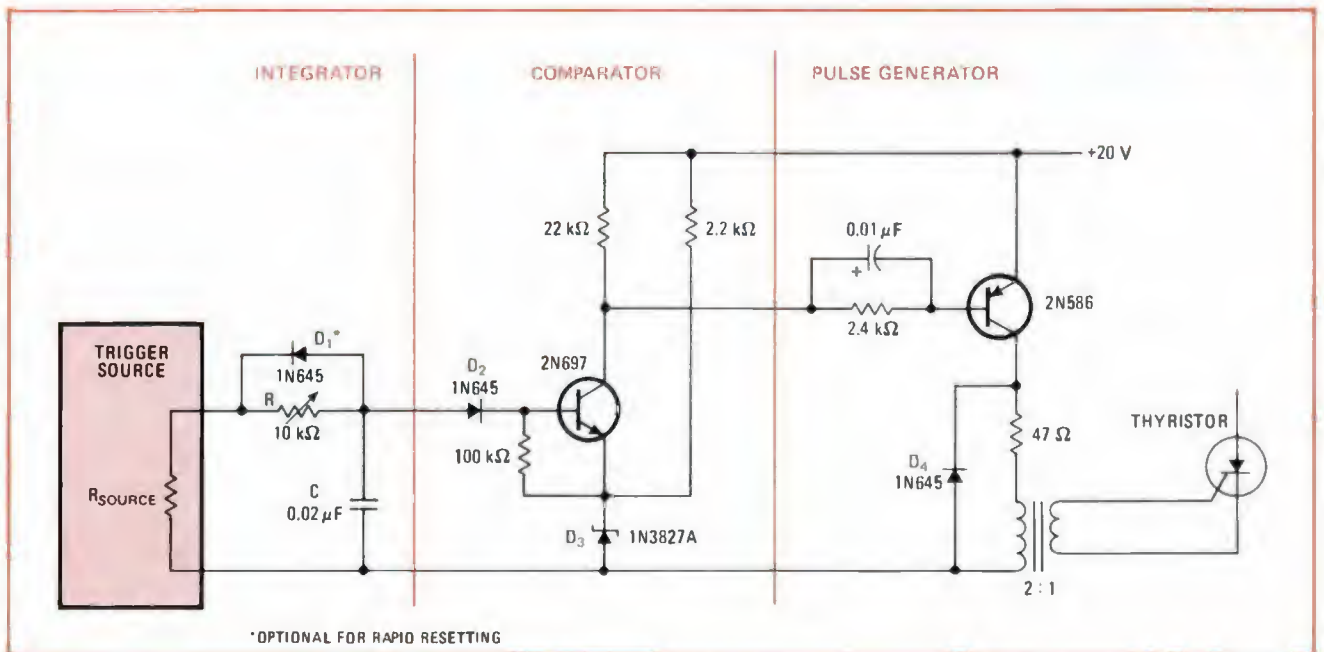

**2. Buffer.** Integrator prevents false triggering of thyristor by discriminating between genuine trigger signals and noise transients. Trigger signal must last long enough to charge capacitor C to the threshold voltage of the comparator, which then turns on the pulse generator. Variable resistor R permits adjustment of the charging-time constant so that noise pulses cannot charge C to the comparator's threshold.

second duration, the value of R that would allow C to just reach threshold in  $1 \mu\text{s}$  is found from the charging equation

$$\begin{aligned} V_C &= V_O - V_O \exp(-t/RC) \\ 7.45 &= 50 - 50 \exp(-1/0.02R) \\ \exp(-1/0.02R) &= 0.85 \\ R &= 300 \text{ ohms} \end{aligned}$$

Therefore, to prevent the 50-v/1- $\mu\text{s}$  noise pulse from firing the thyristor, R is made a bit larger than 300 ohms.

After the noise pulse has ended, capacitor C discharges back through R, or through diode  $D_1$  if quicker recovery is required.

A signal voltage from the trigger source charges up

the capacitor just as a noise pulse does, but the signal duration is made long enough for the capacitor to reach threshold. If the trigger signal is 12 volts, for example, and R has been set for 300 ohms, then the signal must be applied for at least a time duration t (in microseconds) given by

$$7.45 = 12 - 12 \exp[-t/(300 \times 0.02)]$$

or  $t = 6 \mu\text{s}$ . Thus the 12-v trigger signal must last for 6  $\mu\text{s}$  to fire the transistor.

Because this circuit delays the normal firing point to achieve noise rejection, timing in the trigger source may require adjustment if not controlled by feedback from the load.  $\square$

## Two diodes protect logic-level translator

by P. R. K. Chetty

Indian Scientific Satellite Project, Bangalore, India

A level translator is used to interface between two circuits that operate at different logic levels. But the translating transistor (or level-up transistor) is often burned out when its load is accidentally short-circuited to ground. The addition of two diodes to the conventional level-up circuit can protect the transistor. Even a transistor that operates at 30 volts (as well as those meeting lower voltage requirements) can be safeguarded by the circuit modification described here.

The conventional translation circuit (or logic level-up

circuit) is shown in Fig. 1(a), and a modified version with two protection diodes added is shown in Fig. 1(b). The component values shown are chosen to provide a normal load current of about 100 milliamperes. In normal operation, when the input logic is high (logic 1), diode  $D_1$  is forward-biased;  $Q_1$  is turned on, and therefore  $Q_2$  is turned on. Diode  $D_2$  is reverse-biased, so the output-logic voltage across the load is nearly  $V_{CC}$ . When the input logic is low (logic 0), the transistors are turned off, and the output logic is zero.

If the output load is shorted to ground when the input is a logic 1, the anode of  $D_1$  is above ground only by the amount of the forward-voltage drop through  $D_2$ . This voltage is not great enough to let  $Q_1$  conduct because a voltage of at least two diode drops,  $V_{D1}$  and  $V_{BE}$ , would be required to turn on  $Q_1$ . Therefore  $Q_1$  is turned off, and, as a result, transistor  $Q_2$  is turned off too, which prevents it from conducting a destructive current straight to ground. The circuit remains shut down as

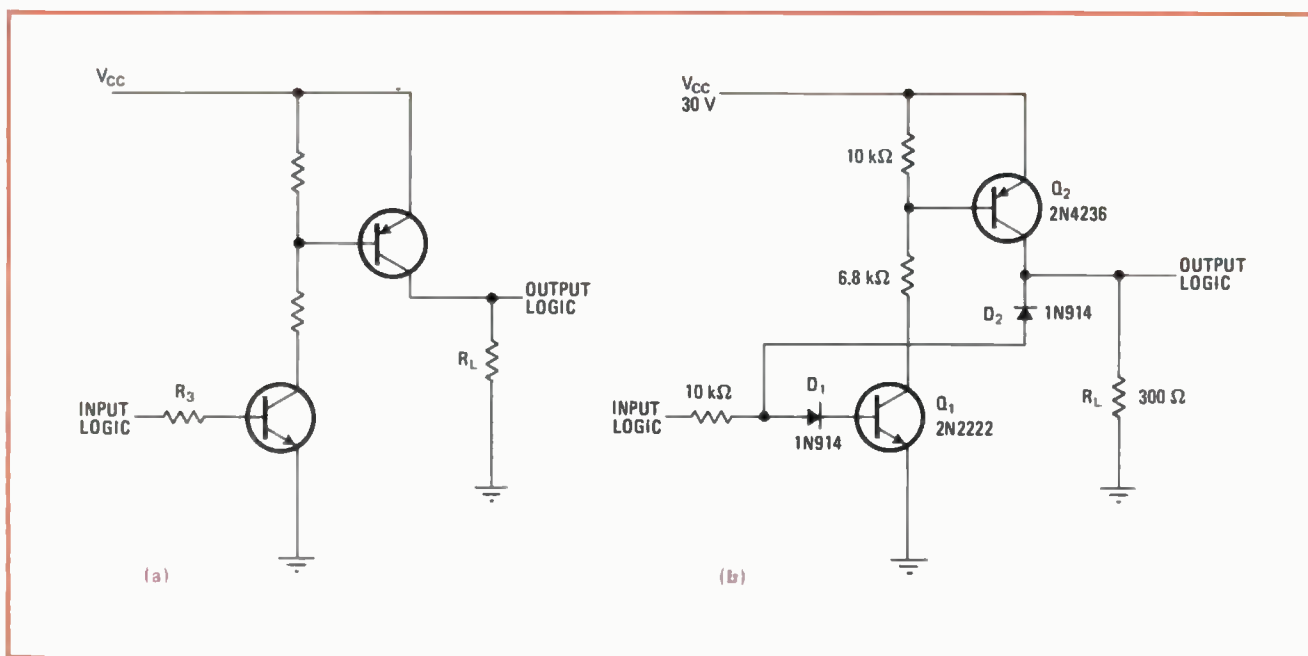

**1. Protection.** Conventional logic-level translator shown in (a) is modified by addition of two diodes in (b). Diodes protect translation transistor  $Q_2$  from destructive current that would otherwise flow if load resistor were short-circuited. Diodes turn off both transistors, so no current is drawn from supply while load is shorted. In normal operation, load current of about 100 milliamperes is unaffected by diodes.

# DOUBLE YOUR PDP 11/45 PERFORMANCE!

## All it takes is a little Cache.

### THE ONE AND ONLY

Introducing the Fabri-Tek Model 4511 Cache Buffer. Plug it into your PDP 11/45 . . . and see what happens to your effective processing speed. The Model 4511 operates in conjunction with the entire PDP 11/45 main core memory. It gets more out of your computer than you ever got before—without the high cost of MOS memory and 32K word address limitation. Nobody else has anything like it—not even DEC. For a fraction of your overall computer system investment, the Model 4511 isn't just a bargain—it's a necessity!

### PLUG-IN EASY

The Model 4511 Cache Buffer uses bipolar technology contained on just three printed circuit assemblies. The whole thing installs in min-

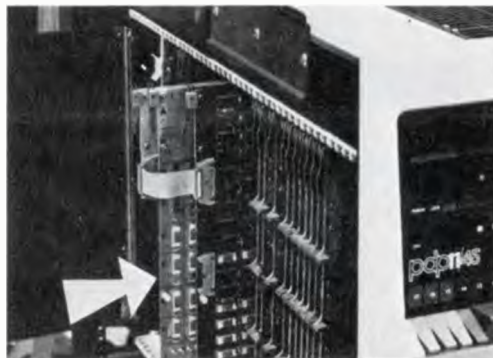

utes on the 11/45 Fast Bus. A +5.0 VDC Power Supply is also included to operate the system. Unlike semi-conductor memory, the Model 4511 guarantees protection of data against unexpected AC power failure and power turn on/off. There's also a switch within the Cache Buffer for ease of on/off line operation.

### GIVE IT A TRY

If hard facts are what you need, how about a demonstration? We'll plug our Model 4511 Cache Buffer into your PDP 11/45, then stand back while you run a few benchmarks. We'll guarantee a dramatic improvement. And we'll guarantee off-the-shelf delivery for one of your own. If you want to make a little Cache go a long way, there's only one place to look.

Call or write today.



**FABRI-TEK INC.**  
**COMPUTER SYSTEMS**

5901 South County Road 18 • Minneapolis, MN 55436 • (612) 935-8811  
Leader in Memory Technology for Over a Decade

**SALES  
OFFICES IN:**

Boston (617) 989-5077	Dallas (214) 661-3155	Detroit (313) 487-5940	New Jersey (201) 222-6250	Phoenix (602) 266-4448	Hong Kong K-331383	United Kingdom Maidenhead 37321-4
Chicago (312) 437-4116	Denver (303) 753-0631	Long Beach (213) 420-2493	Orlando (305) 857-1050	San Jose (408) 246-8391	Munich 089-755-8298	

**2. Waveforms.** During normal operation of the logic-level translator, the output voltage and the current from the  $V_{CC}$  supply go on and off as the input logic goes high and low. If output load is short-circuited, diodes turn off transistors so that no currents flow.

long as the load is short-circuited, and it returns to normal operation when the short is removed.

Levels of input-logic voltage, output-logic voltage, and current from the high-voltage supply are shown in Fig. 2 for both normal operation of the circuit and the short-circuited-output condition. No current is drawn from the  $V_{CC}$  supply while the load is grounded. □

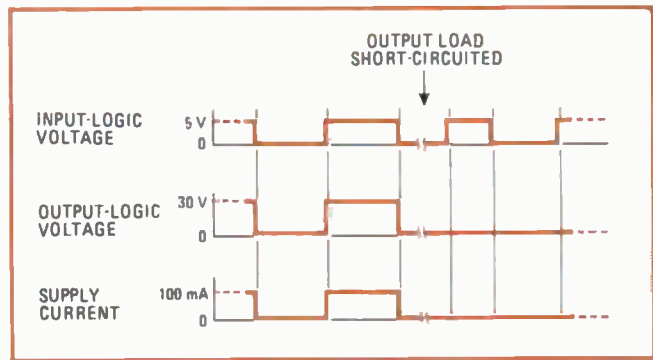

## Power-supply add-on yields variable-ratio output

by Ying-Lau Lee  
Cambridge, Mass.

A single-ended power supply can be converted into a double-ended supply with the addition of an operational amplifier, a transistor, and a few resistors. The two output voltages need not be equal and in fact can be made to have a ratio as big as 10:1 with the proper choice of resistor values.

The circuit is simple and works essentially as a parallel regulator. Potentiometer  $R_1$  is set to the desired ratio of  $V_1/V_2$ ; the 741 operational amplifier then compares the potentiometer voltage with the voltage at the collector of transistor Q and tries to minimize the difference by biasing Q to produce that ratio. If  $V_2$  is too large, for example, the op amp drives Q farther into conduction. The drop across Q (i.e.,  $V_2$ ) then decreases.

The values of resistors  $R_2$  and  $R_3$  depend upon the maximum load allowed, input voltage, output voltage ratio, and transistor current gain  $h_{FE}$ . Approximate val-

ues for these resistors are calculated as follows:

$$R_2 = 0.8 (V_1/V_2) R_{L2}$$

$$R_3 = h_{FE} V_{IN} R_{L1} R_2 / V_1 (R_{L1} + R_2)$$

With  $R_2$  and  $R_3$  fixed,  $V_1/V_2$  can be varied  $\pm 10\%$  by adjustment of  $R_3$ .

If the outputs were balanced, no current would flow to ground. For unbalanced outputs, Q and  $R_2$  carry the ground current. Transistor Q must be able to dissipate a power given by the following equation:

$$P_D = V_1 V_2 (R_{L1} + R_2) / R_{L1} R_2$$

The SK3021 transistor that is suggested in the schematic can dissipate 35 watts, but a lower-power device will be satisfactory in many cases. If Q drains too much current from the 741, a Darlington pair should be used to provide greater current gain.

Regulation of the output voltages is approximately that of the floating supply that is their source. The minimum value of output voltage  $V_2$  is about 3 v (limited by the 741). The 741 is used for the operational amplifier because it is internally compensated and has overload protection. □

Designer's casebook is a regular feature in Electronics. We invite readers to submit original and unpublished circuit ideas and solutions to design problems. Explain briefly but thoroughly the circuit's operating principle and purpose. We'll pay \$50 for each item published.

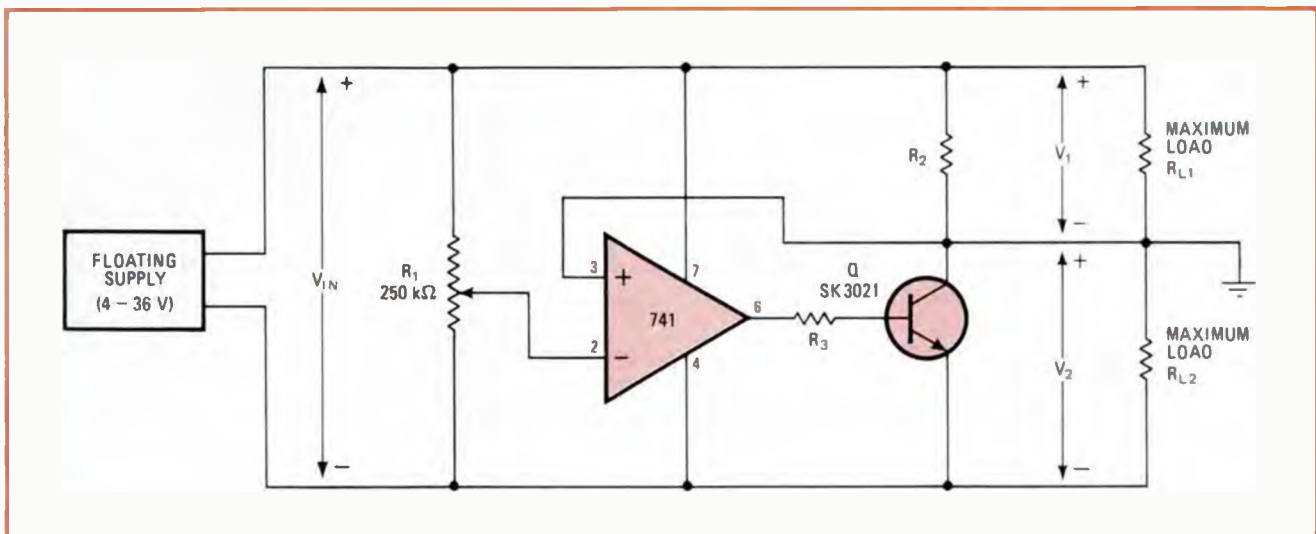

**Two for one.** Double-ended supply provides positive and negative voltages from a single source. Output voltages can be equal, or in ratio as great as 10:1. Potentiometer allows adjustment of  $V_1/V_2$  around a "ballpark" value determined by resistors in circuit.

# Achieving a fast data-transfer rate by optimizing existing technology

By combining the synchronization characteristics of group-coded recording with a time-saving error-correction method, a magnetic-tape storage system attains a density of 6,250 bits/inch at a tape speed of 200 inches/second

by Erik T. Ringkjøb, *Storage Technology Corp., Louisville, Colo.*

□ Speeding up the tape and packing it more tightly with data are the two ways of improving the performance of magnetic-tape storage systems. But while electromechanical limitations make it hard to raise tape speeds much beyond 250 inches per second, it's still possible to increase bit density and transfer rates by careful selection of recording and error-detection and -correction methods.

The latest tape units achieve 6,250 bits per inch, or about four times the densities obtained less than two years ago. A 6,400-b/in. density and a quadrupled data rate were therefore the main objectives for a new tape system. Other objectives required the system also to:

- Use phase-encoding detection circuits to compensate for tape-speed variations and skew between read and write heads.
- Be able to read and write on today's tapes.
- Provide error-correction facilities that would correct errors in two tracks, rather than the usual one track.
- Shorten the gaps between blocks of recorded data from the usual 0.6 to 0.3 in., thus increasing density.

The magnetic tape that computers work with usually has a half-inch-wide Mylar base and is coated on one side with ferrite oxide. Each track on the tape has its own independent read and write head. Data is recorded

longitudinally, the coating being magnetized in one direction or the other in seven or nine parallel tracks (Fig. 1). The presence or absence and direction of these flux changes defines the recorded bit as a 1, a blank, or a 0. Each bit resides in an area of tape called a bit cell, which varies in size from  $1.25 \times 10^{-3}$  inch to  $1.6 \times 10^{-4}$  in. Bit density—in bits per inch—is the reciprocal of this number. Flux changes per inch (fc/in.) describe the actual magnetization pattern and, depending on recording format, may or may not equal bit density.

Figure 2 illustrates the three coding conventions in use today: non-return-to-zero (NRZI), phase encoding (PE), and the newest method, group-coded recording (GCR), which is used in the 6,250-b/in. systems.

NRZI is the oldest format. Data is recorded in nine tracks at 800 b/in., and the coding convention is that a flux change in a bit cell represents a 1, while no change in flux represents a 0.

Note that the flux change denoting a 1 can be in either direction—from high to low or from low to high. The NRZI recording efficiency, defined as the highest ratio of b/in. to fc/in. for a given format, is 1.0 (bit density equals flux-change density).

However, the NRZI format has one major drawback: the code is not self-clocking and therefore limits density and hence data-transfer rate. The NRZI detection system uses a single independently running clock in the tape subsystem, which strobbs the outputs of all nine read heads once every bit cell. But because the clock is not synchronized with data on the tape, it cannot compensate for variations of tape speed or for the skew between the writing transport and the reading transport.

This deficiency led the designers of the 1,600-b/in. systems to adopt the self-clocking PE format. With PE, each bit cell has a flux change at its center, and the direction of the flux change defines the bit as either 0 or 1 (0 is a change from high to low, while 1 is a change from low to high). The advantage here is that each track can have its own clocked detection circuit. Each circuit has a variable-frequency clock, which runs in a phase-locked loop with the signal from its track. Hence the clocks can track variations in tape speed, since a flux change is guaranteed to occur either once or twice per bit cell.

Also, having a separate detection circuit, each track can read independently of any other, and the bits can be grouped into bytes or characters at a later stage,

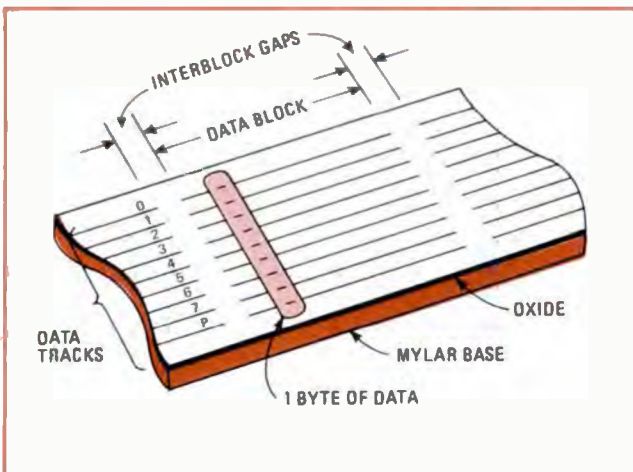

1. **Tape format.** A typical half-inch magnetic tape used for data recording has an oxide-coated Mylar base and records information in nine tracks. The bits are organized into 9-bit bytes, including a parity bit, across the tape and into data blocks along the tape.



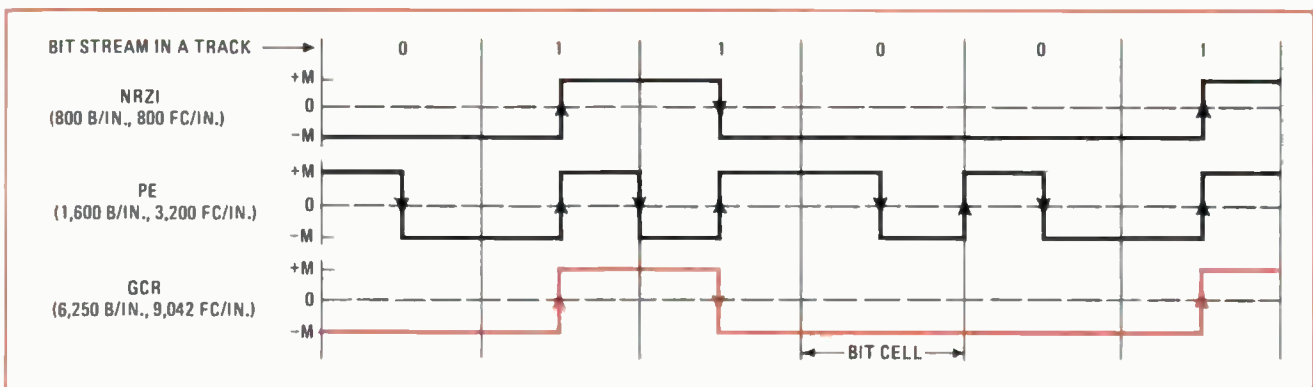

**2. Three choices.** Non-return-to-zero (NRZI) recording uses a flux change for a logic 1 and no flux change for a 0. Phase encoding (PE) uses the direction of flux change for 1s and 0s. Group-coded recording (GCR) is like NRZI, but data is coded before being recorded.

compensating for any skew difference between the writing and reading transports. However, note that the PE format is less efficient than NRZI, having an efficiency of only 0.5 because a bit density of 1,600 b/in. requires a flux density of 3,200 fc/in.

### GCR format has high density

The most desirable recording and reading method would have been today's PE format, since it would meet most of the basic requirements. However, with a 6,250-b/in. density and a recording efficiency of 0.5, the required flux-change density would have been 12,500 fc/in. But as Fig. 3 shows, when the flux density exceeds about 9,500 fc/in. on today's tape, the signal-to-noise ratio at the read head falls so low that it can not be read reliably.

The recording choice therefore was a method called run-length NRZI, which IBM has used as the basis for the format it calls group-coded recording. GCR permits the use of NRZI conventions for data recording along with the PE detection circuits and deskewing scheme. With a maximum flux-change density of 9,042 fc/in. and a bit density of 6,250 b/in., the recording efficiency is 0.69, which is 38% better than PE.

Basically, GCR uses the NRZI convention for 1s and 0s, but a restriction is added: there can be no more than two 0s in a row on tape. This guarantees that flux changes occur at least once in every three bit-cells, and the variable-frequency clock need only be able to lock onto three different frequencies—pulses corresponding to a succession of 1s, alternate 1s and 0s, and a 1 followed by two 0s. Obviously such a restriction cannot be placed on the actual data transmitted from the computer. Therefore, before data is written on tape, it is translated.

Every 4 bits received from the input-output channel are translated into 5 bits (see Fig. 4), which are then written on tape. Conversely, every group of 5 bits read off the tape are translated into 4 bits before being transmitted to the computer. Notice, in Fig. 4, that within the 5-bit recording subgroup there are no more than two consecutive 0s within the body of the group and no more than one 0 at either boundary of the group.

The data portion of the format can now be defined. An eight-byte buffer in the control unit (Fig. 5) holds seven data bytes (bytes 1-7) and one error-checking and

-correction (ECC) byte which is generated in the subsystem. This eight-byte set is called a data group, and each four-byte half is called a data subgroup. Grouping data into eight-byte groups is for error-correction purposes, while the subgroups are for purposes of translation.

Data is written by translating corresponding bits (e.g. bit 1) of the four first bytes in the four-to-five code, and then recording them as 5 bits in the logical track corresponding to the bits (e.g. track 1). This takes place for all nine tracks simultaneously. After the first four bytes in the data group have been written on tape, the second four bytes are translated and written in the same manner. The resultant 10-byte group on tape is called a recording subgroup. Thus, a data subgroup translates into a recording subgroup and vice versa.

### Dealing with errors

The most common error-detection method is based on parity checks, which can detect (but not correct) all single-bit errors. However, parity checking, which is the only error-detection facility used in phase encoding, is not used in group-coded recording. To permit error correction with parity bits, two indicators are required, signal amplitude and phase, which are called pointers since they point out suspect tracks. GCR uses cyclic codes to perform error correction.

Read detection circuits perform best when the incom-

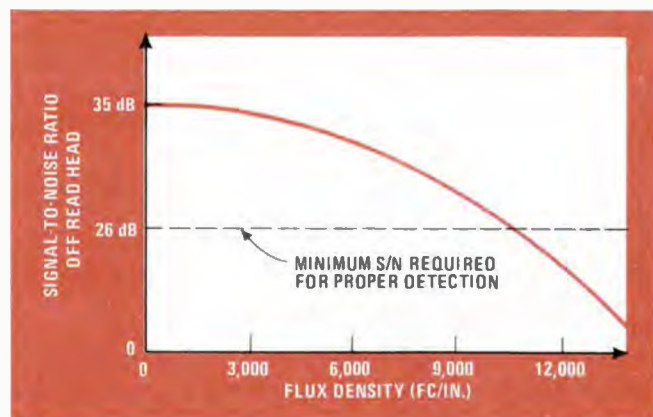

**3. Read margin.** Signal-to-noise ratio at the read head depends on how close together flux changes are on the tape. In GCR, flux-change density is about 9,000 fc/in., which allows a signal-to-noise ratio above the minimum needed for reliable operation.

4-BIT DATA VALUE		5-BIT RECORDING VALUE
0000		11001
0001		11011
0010		10010
0011		10011
0100		11101
0101		10101
0110		10110
0111		10111
1000		11010
1001		01001
1010		01010
1011		01011
1100		11110
1101		01101
1110		01110
1111		01111



**4. Translation.** In GCR method, 4 bits are translated into 5 bits before recording. This assures that, when data is applied to tape, there are no more than two successive zeros in any track, a feature that allows more reliable synchronization of the read head.

ing signal amplitude falls between 300 and 700 millivolts, with an optimum at 500 mv. When the signal strength falls below a certain threshold (typically 95 mv), a warning latch is set for that track, indicating a marginal signal. Setting this latch is called dead-tracking, and once set, the latch stays on for the remainder of the data block.

In phase encoding, error correction occurs after the parity checker finds a parity error in a byte, and then the warning latches for all nine tracks are checked to see if a track is dead-tracked. If one is, the assumption is made that the bit in error is in the dead-tracked track, and that bit is reversed before the byte is transmitted to the input/output channel.

For data to be detected properly in phase encoding requires that the flux reversals occur approximately in the middle of the bit cell. If the reversal takes place outside a window of about 12% on either side of the midpoint, a warning indicator is set. The phase-error indicator implies that the data detected for that track might be in error. Unlike dead-tracking, this indication lasts only for the time it takes the bit-cell to traverse the read head (from about 553 to 1,475 nanoseconds, depending on the speed of the transport). With phase error, the correction mechanism is the same as in dead-tracking—if a parity error is detected, the phase-error field is scanned to determine if a track is in error, and when found, the bit in that track is reversed.

There are deficiencies in the error-correction methods used in phase encoding. If more than one track is dead-tracked, or if a dead track and a phase error occur in the same byte, an ambiguous multitrack condition exists. Parity checking will not detect the error if both bits are wrong. Or, if only one bit is wrong, there is no way to determine which of the two tracks is in error.

However, note the phase-error correction ability significantly differs from the dead-tracked error-correction ability. In the dead-track approach, the errors in only one track in a data block can be corrected. The phase-error implementation permits any single-bit error in any byte in the data block to be corrected, regardless of the track in error.

With phase-error correction, the data from the head comes over the read bus into nine independent detection circuits (one for each track). From there the data flows into skew buffers (Fig. 6) which compensate for the lack of perpendicularity between tape and read/write head. Each track is gated into the buffers independently. The buffer collects the bits for each byte, and, when it has received all the bits, it gates the byte out as one entity.

However, the phase-error information on the output at the read detection circuit is available only as long as the data is. But adding a second skew buffer makes the phase-error information for each bit in a given byte available along with the complete byte.

#### Detecting and correcting GCR errors

The three most significant objectives in devising the GCR error-detection and correction scheme were: eliminate the problem of associating the error condition with a given byte; provide single- and double-bit error correction; and enhance the integrity of the data by giving it a final check before transmission to the computer.

Consequently, something more complex was required than simple parity checks. The choice fell on a system based on cyclic codes. Basically, this method takes a

### Genesis of 6,250-b/in. recording

When the IBM System 370 computers were introduced in 1970, there was a clear need for a tape subsystem with higher performance than the ones then available. In the system 370, most performance parameters were two to three times better than in the 360 series. But the 3420 tape subsystem still had a maximum transfer rate of only 320 kilobits per second and a capacity of only 40 megabits per reel—the same as in the system 360.

In 1972, Storage Technology Corp. introduced its 3480 tape drive, a 250-inch-per-second tape unit, that is still the fastest available today. Its transfer rate of 400 kb/s was a 25% increase over the 320 kb/s then available. But, recognizing that this improvement was still not up to long-term requirements, STC was simultaneously developing a 3,200 b/in. unit that would employ phase-encoded recording with a new format and improved error correction.

Then, in the spring of 1973, IBM announced its 6,250-b/in. subsystem, and STC had to change its goals, both for the sake of compatibility (since IBM formats automatically become industry standards) and for a better competitive stance (since 6,250 b/in. was twice as dense and so performed twice as well as what STC was developing). In November, 1973, IBM delivered its first 6,250-b/in. subsystem, and five months later, STC delivered its first IBM-compatible 6,250-b/in. subsystem.

block of data with  $N$  characters of  $n$  bits each and converts it to a new block of data with  $N + 1$  characters of  $n$  bits each. The first  $N$  characters of the new data block are the same as in the original data block, and the  $(N + 1)$ th character is the check character.

The principle behind the conversion is to treat each bit in each character as a coefficient of a dummy variable  $X$  and convert the data character to a message polynomial  $M(X)$ . The message polynomial is then divided by a generator polynomial  $G(X)$ , and the result is a quotient  $Q(X)$  and a non-zero remainder  $R(X)$ .

With the proper choice of generator polynomial, the message will appear, after the division, in its original form with the check bits (the remainder) appended to it. When this message (encoded data) is read back off the tape, error checking is performed by dividing the received message by the same generator polynomial. The correct message should be divisible without a remainder. If a remainder does result, it can be used to determine which bit or track is in error, and the correction can then be performed.

Three check characters are used in the GCR format: the error-checking and -correction character (ECC), the auxiliary cyclic redundancy check character (AuxCRC), and the cyclic redundancy check character (CRC). All are based on the principles of cyclic codes.

An 8-bit ECC character is generated for each data group (see "A GCR data block," p. 90). It detects and corrects any single-bit error without independent pointers. It also detects all double-bit errors, but can only correct them with the aid of the pointers provided by amplitude threshold and phase errors. These pointers use the same methods to identify the suspect tracks as does phase encoding.

The two CRC characters insure the integrity of the data after it has been read—a final check that experience with phase encoding has shown to be desirable. This check does not identify where an error exists, but only that one or more errors have occurred. A data-check condition is then flagged, so that the computer can invoke its retry procedures. Two characters are used to reduce the probability of having invalid data go undetected, since each code covers most of the holes in the other.

### Resync bursts allow long data blocks

To take full advantage of the GCR data density, the blocking factor (the number of bytes of data in each data block) should be high—about 8,000. Otherwise, too large a portion of the tape would be eaten up by inter-block gaps. (Blocking factors in phase encoding are usually much lower, around 3,000.)

However, the probability of an error occurring within a given data block is proportional to the length of that data block. As already mentioned, once a track is dead-tracked or the read-detection circuits have fallen out of sync, they cannot be reset and resynchronized until the next data block. In phase-encoding this is because a prescribed bit pattern is written only before and after a data block, yet the detection circuits can be synchronized properly with the data only by means of these patterns. In GCR, with the larger blocking factor, it is

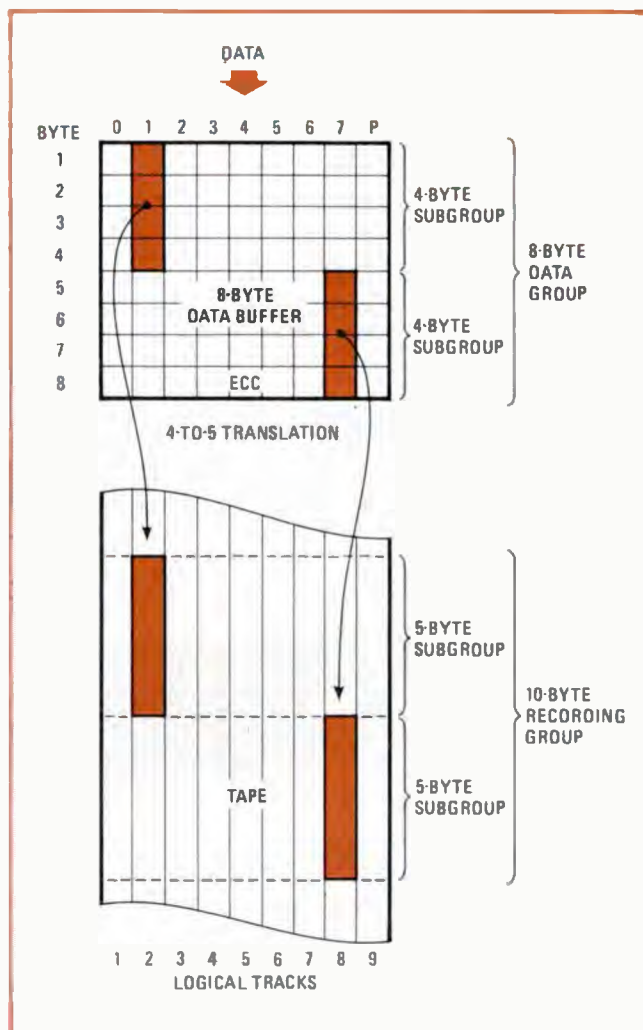

5. Buffer. Before recording in GCR format, seven bytes of data are collected in an eight-byte buffer and an error checking and control character is added. The first 4 bits of each byte then are translated into 5 bits and then the second four bytes are translated.

desirable to reset the dead-track register and resynchronize the read-detection circuits oftener than at the beginning of the block.

Therefore, resync bursts are used. A resync burst consists of 20 prespecified bits—a "Mark 2" group followed by two sync groups, followed by a "Mark 1" group (see "A GCR data block," p. 90). Since this burst is unique and self-defining, it permits the read detection circuits to resynchronize as desired. The resync bursts are spaced once every 158 data groups, and this spacing translates into one resync burst for every 1,106 data bytes. The burst therefore reduces the probability of an uncorrectable error in an 8,000-byte data block by a factor of about seven.

With these improvements in its error-detection and -correction facilities, GCR far exceeds PE in read-write performance (Fig. 7). The 5:1 improvement factor for temporary read errors (which disappear when the operation is retried) is much higher than on permanent read errors (1.3:1), which remain after repeat retries. In other words, the improvement primarily saves on system overhead, by permitting the time that would have been

## A GCR data block

In group-coded recording, the data block consists of:

- A preamble, which allows the read detection circuits to synchronize with data on the tape.
- Every 158 data groups, a resynchronization burst to maintain the read detection circuits in sync. Each data group comprises seven data bytes plus an error-checking and -control character (ECC).
- A residual group, which contains the final few "residual" data bytes in the block (any excess over an even multiple of seven), plus padded bytes, consisting of 0s, if

there are fewer than six residual data bytes, plus an auxiliary CRC and an ECC character.

- A CRC group, which contains two counts of the total number of data bytes in the block—one count in modulo 7 (since there are seven data bytes per group) and one in modulo 32. The modulo 7 count defines the number of data bytes in the preceding residual group, while the modulo 32 count sets up pointers for internal data buffering in the subsystem.
- A post-amble, to close out the data group.

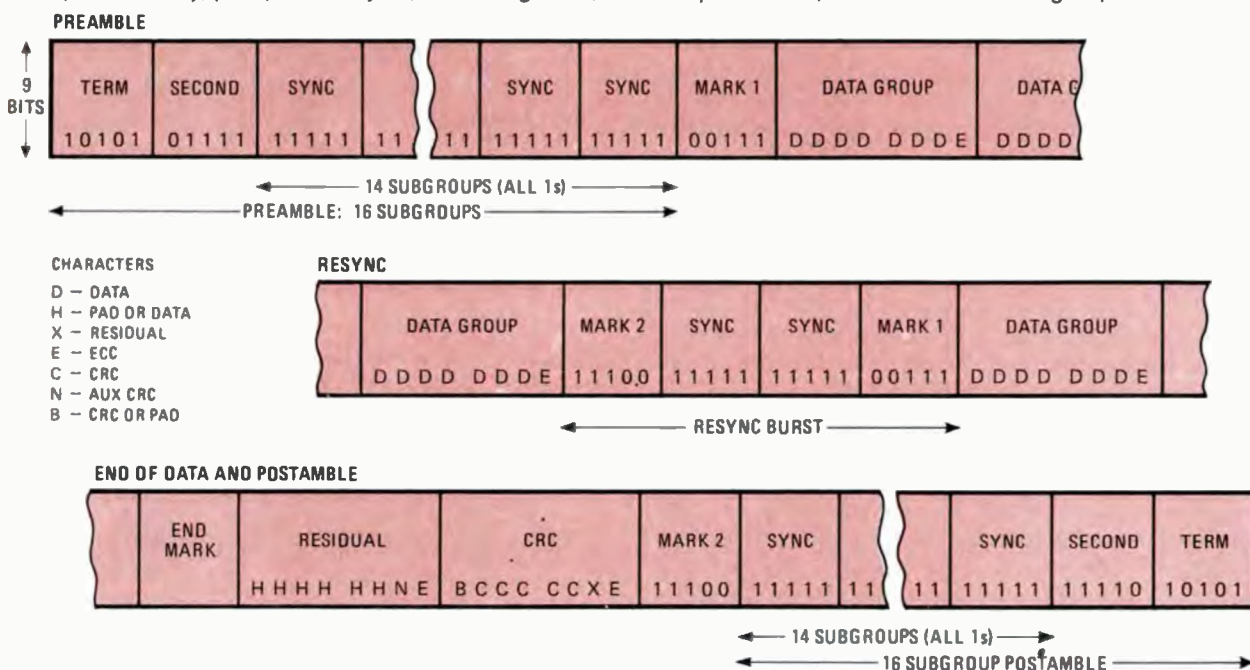

spent in the error-recovery procedures to be spent on productive processing.

### The mechanics of acceleration

In addition to considerations of the method of recording and error correction, 6,250-b/in. density presented significant challenges in the electromechanical portion of the transport. The first major problem was created by the reduction of the interblock gap from 0.6 inch to 0.3 in. The read head is separated from the write head by about 0.15 in., and, with worst-case stopping tolerances, the distance available for acceleration could dwindle to about 0.074 in. Thus the capstan system had to accelerate the tape to 90% velocity in this short distance.

The acceleration of the tape can be expressed as

$$a = K_t I R / J$$

where

$a$  = acceleration in in./s<sup>2</sup>

$K_t$  = torque constant of the motor in in.-oz./A

$R$  = radius of the capstan in inches

$I$  = current in the capstan motor in amperes

$J$  = inertia of the capstan system in in.-oz.-s<sup>2</sup>

The access time (the time it takes for the tape to pick up speed and reach the data block) on the 200-in./s

drive was specified as 0.95 ms and therefore requires accelerations of  $220 \times 10^3$  in./s<sup>2</sup>, as against  $133 \times 10^3$  in./s<sup>2</sup> with a 0.6-in. gap. Thus, acceleration had to increase 65%, although the inertia of today's capstan motors (the denominator of the equation) is still relatively high and system power considerations also limit the current to the 20-25-A range. However, by redesigning the capstan—increasing its radius but using a lighter-weight material with a mechanical design that provides low inertia—the ratio of radius to total inertia was reduced to a satisfactory level.

A second problem with high acceleration was the slippage that could occur between tape and capstan during both starting and stopping. This potential slippage was eliminated by applying a vacuum to the tape as it passes over the capstan, the surface of which is perforated, so that air is drawn through the capstan and increases the tape-to-capstan surface friction.

The final problem can best be highlighted by the following formula

$$L = 54.6 d / \lambda$$

where

$L$  is the loss, in decibels, in the magnetic field strength sensed in the read head

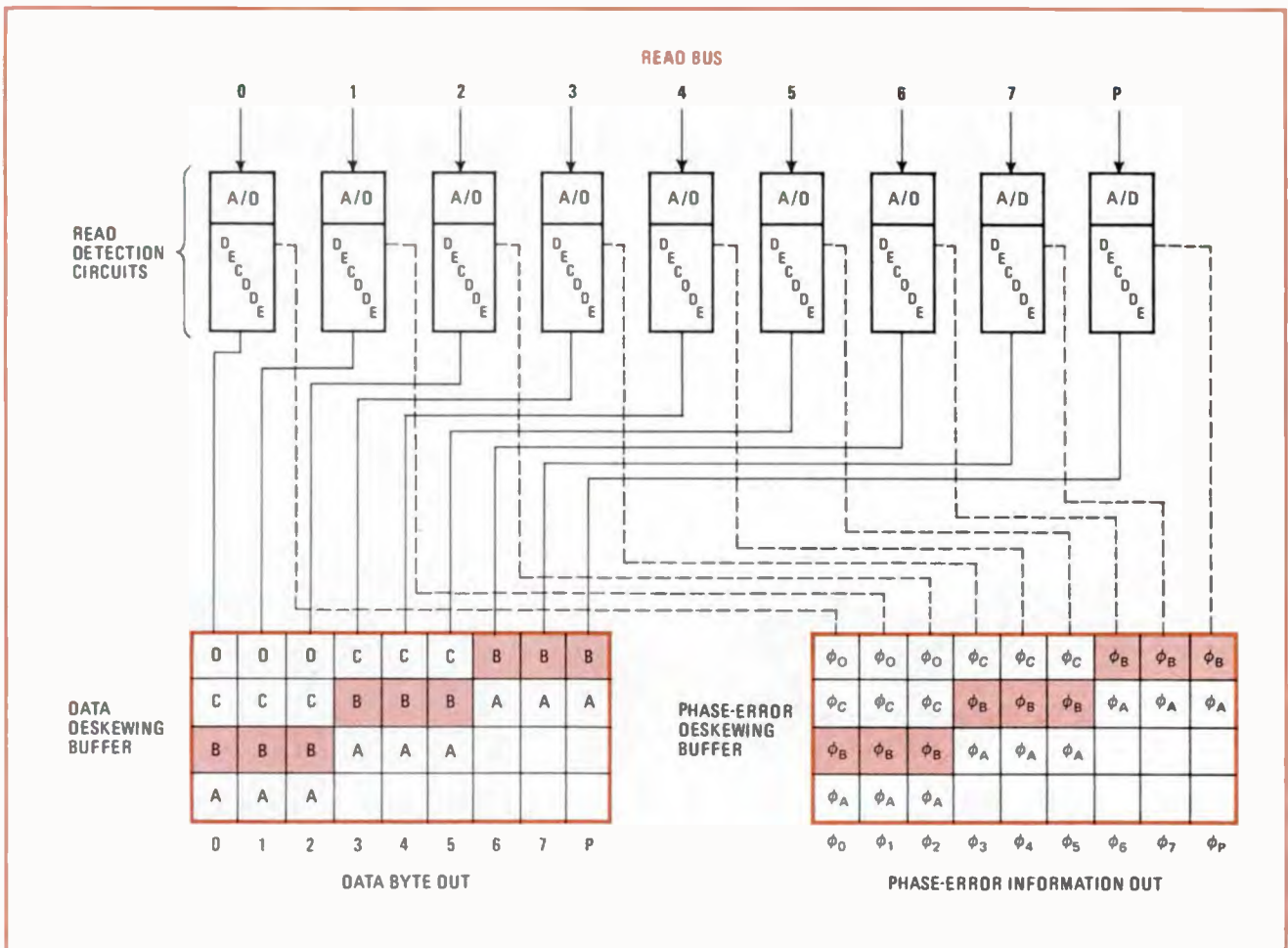

**6. Deskew.** Because the tape may be skewed as it is read, data from one byte may be read at different times. So a deskewing buffer collects and resynchronizes the bits before sending them on to the computer as one byte. Here, the three groups of 3 bits each are shown as skewed and corrected in the buffer. Similarly, phase errors are noted for each byte and corrected before being sent to the computer.

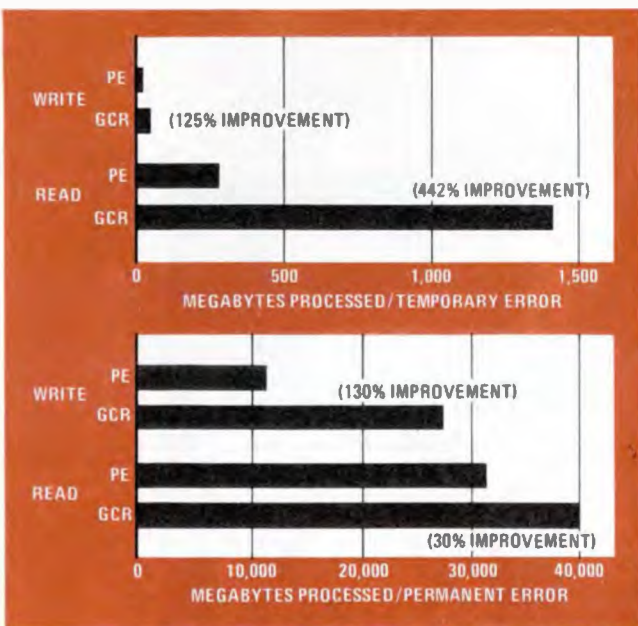

**7. Improvement.** Because of the error-detection and -correction facilities possible with group-coded recording, temporary errors, which disappear when the operation is repeated, and permanent errors, which remain, are much lower than with phase encoding.

$d$  is the separation between the read head and the magnetic tape

$\lambda$  is the minimum wavelength of magnetization waveform (the minimum distance between two successive flux changes on tape).

With PE's flux density of 3,200 fc/in. and GCR's density of 9,042 fc/in., the wavelength in GCR is a third that of PE. Consequently, the head-to-tape separation is much more critical in GCR and must be kept to no more than 80 microns (whereas with PE it could go up to 220  $\mu$ m. without losing the signal). The tape path therefore had to be designed to prevent the tape from fluttering as it passed over the head. Careful attention also had to be paid to the pneumatics of the transport, to permit it to accelerate fast while keeping the tape close to the head.

Finally, cleaning becomes more important, since the tape can also be lifted off a head on which there are dirt particles or a buildup of contamination. Most systems clean only the magnetic surface of the tape before it approaches the read and write heads. But both sides should be cleaned, since the writing surface could pick up dirt particles from the underside when the tape is wound on the take-up reel. This system, therefore, cleans both sides of the tape. □

The 70-lb. Sabre VI: It's a giant leap beyond any other small, high performance IRIG analog tape recorder/reproducer. Records at 8 electrically selectable speeds: 120 ips through 15/16 ips; reproduces at any 3 electrically selectable speeds; records from 15.3 minutes at the highest speed to 32.8 hours at the slowest on 14" reels. Remote speed selection and LED footage counter. LED bar data monitor. Let us give you full details.

## SANGAMO RECORDERS

THE INNOVATORS IN TAPE INSTRUMENTATION

Sangamo Electric Company

Data Systems

P.O. Box 3347 • Springfield, Illinois 62714

(217) 544-6411

**Introducing the  
carry-in recorder  
reproducer  
that will carry-on  
for 32.8 hours!**



# Circuit-analysis program can model many digital ICs automatically

By describing logic devices functionally, Super-Sceptre can quickly simulate systems that contain digital integrated circuits as well as other components; users do not need differential equations

by James Bowers and Gary Shaw,  
*University of South Florida, Tampa, Fla.,*  
and Meir Baran,  
*U.S. Army, Picatinny Arsenal, Dover, N.J.*

□ Digital circuits or systems made up of integrated circuits are easily analyzed with Super-Sceptre, a software package built around the powerful circuit-analysis program called Sceptre.

Without the added software, Sceptre could still handle digital ICs, but only by modeling them at great length, as huge collections of many individual devices. What Super-Sceptre does is to model them fairly simply, as functional blocks described in terms of the behavior of their terminals.

Known as terminal modeling, this technique saves both programing time and computer time. It works very well on digital ICs, since a logic gate can be characterized quite straightforwardly by its truth table, input switching threshold level, low and high voltage levels, and propagation delay. Altogether, 16 different logic functions can be generated automatically by Super-Sceptre—nine different gates, four different flip-flops, a monostable multivibrator, a full adder, and a clock.

Actually, Super-Sceptre is a preprocessor package used in conjunction with Sceptre (which stands for System for Circuit Evaluation and Prediction of Transient Radiation Effects). Being written entirely in Fortran, the new software interfaces easily with all current versions of Sceptre, regardless of whether it's on-line or time-shared and regardless of the type of computer being used. Two versions now exist for direct interfacing with either an IBM System/360 or System/370 machine or a Control Data Corp. series 6000 machine.

The preprocessor needs no core storage over and above that required by Sceptre, and the extra time needed by the central processor unit is typically no more than 10 seconds. Super-Sceptre retains the older program as a subset and has the same features and notations. Moreover, it adds 50 new diagnostic messages to those already in Sceptre, to aid the user in debugging his program listing.

## Capabilities are numerous

Super-Sceptre not only generates terminal models for logic devices automatically, but also provides for the direct input of transfer functions and one-dimensional mechanical systems. A transfer function is expressed as

LOGIC MODEL PARAMETERS		
Parameter	Keyword Specification Format	Default Value
Number of inputs	IN = number	device dependent
Number of outputs	OUT = number	1
Input switching threshold voltage	IN = (number)	(.5)
Low and high output voltage	OUT = (number, number)	(0, 1)
Initial output state	Q = LOW or HIGH	low
Initial input trigger state	T = LOW or HIGH	high
Propagation delay	OELAY = number	0
Logic expression for SPECIAL FUNCTION gate	FUNCTION = combinational logic expression	none
Monostable pulse width	PW = number	1
Duration of high clock output	T1 = number	1
Duration of low clock output	T2 = number	1
Clock starting time	START = number	0

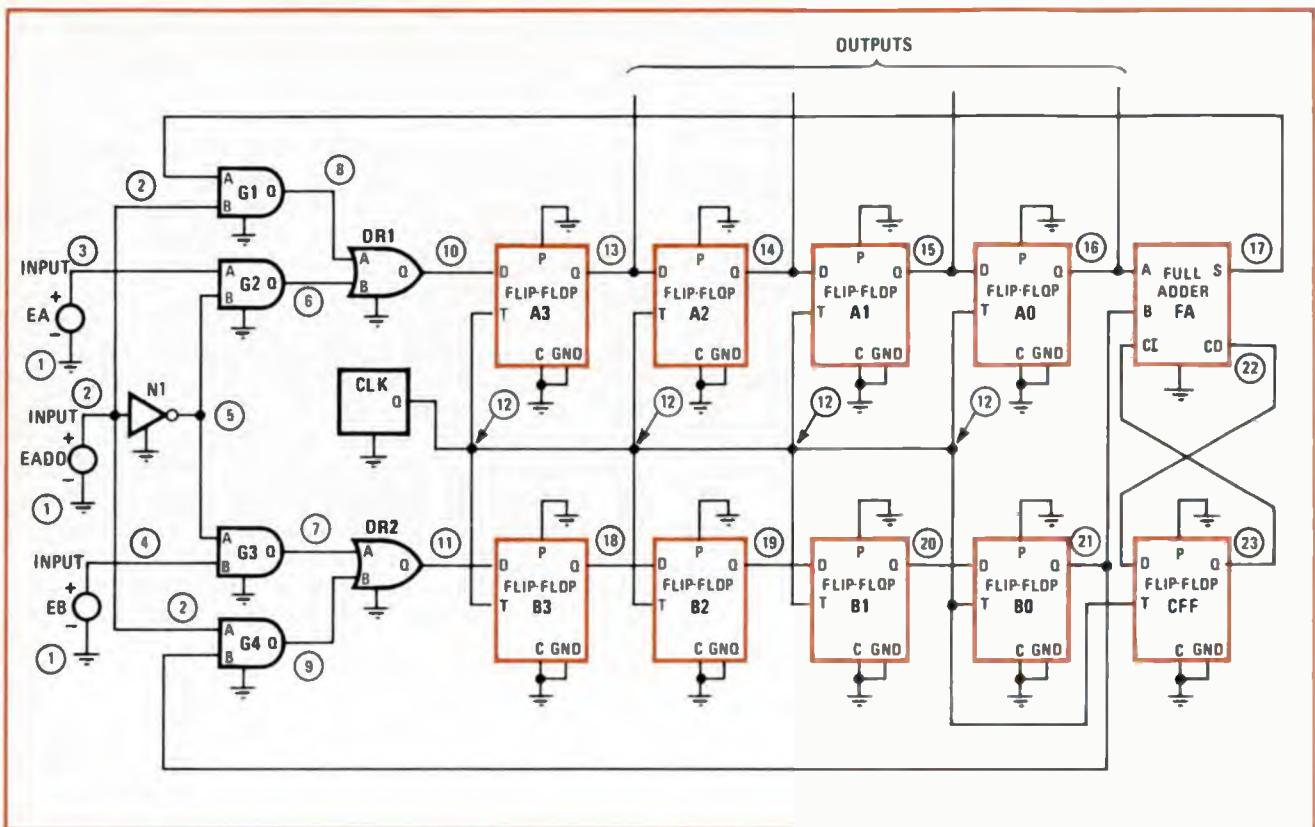

**1. Logic example.** Super-Sceptre program listing is simple, in relation to the complexity of the four-bit serial adder being simulated. The program offers built-in models for nine types of gates, four types of flip-flops, a monostable multivibrator, a clock, and a full adder. In this example, each logic device is represented by its appropriate built-in model. With the OUTPUTS statement, plots are being requested of the three inputs, the outputs of all the D-type flip-flops, and the output of the full adder.

a Laplace-transform equation, which can have an order as high as 36. In fact, Super-Sceptre is the only software package that permits a system to be represented by electrical elements, digital logic devices, transfer-function blocks, and mechanical elements in a single unified program, without the need to formulate any differential equations.

The logic-description language of Super-Sceptre is analogous to the circuit-description language of Sceptre. It has a field-free format, allowing program entries to be placed anywhere on an input data card. Moreover, multiple entries can be put on a single line, and spaces (blanks) can be inserted wherever desired for clarification.

A logic-description specification is composed of two elements: the LOGIC DESCRIPTION heading itself, and one or more MODEL subheadings. Under LOGIC DESCRIPTION, the program generates its 16 terminal models—gates, flip-flops, a monostable multivibrator, full adder, and clock. The nine gates are: an inverter, a buffer, an AND, a NAND, an OR, a NOR, an exclusive-OR, an exclusive-NOR, as well as a special-function gate that can be any combinational logic network having a single output and up to nine inputs. The four flip-flops are: a J-K type, a reset-set (R-S) type, a toggle type with

```

LOGIC DESCRIPTION
MODEL O FLIP FLOP (DFF)
  DELAY = .1
MODEL CLOCK (CLOCK)
  T1 = .5, T2 = .5
  START = .5
MODEL OR (OR)
MODEL AND (AND)
MODEL NOT (INVERTER)
MODEL FULLAOR (FULL ADDER)
CIRCUIT DESCRIPTION
FOUR BIT SERIAL ADDER
ELEMENTS
  EADD, 1-2 = TABLE1
  EA, 1-3 = TABLE2
  EB, 1-4 = TABLE3
  N1, 2-5-1 = MODEL NOT
  G4, 2-21-9-1 = MODEL AND
  G3, 4-5-7-1 = MODEL AND
  G2, 3-5-6-1 = MODEL AND
  G1, 2-17-8-1 = MODEL AND
  OR1, 6-8-10-1 = MODEL OR
  OR2, 7-9-11-1 = MODEL OR
  CLK, 12-1 = MODEL CLOCK
  A0, 12-15-1-1-16-1 = MODEL O FLIP FLOP
  A1, 12-14-1-1-15-1 = MODEL O FLIP FLOP
  A2, 12-13-1-1-14-1 = MODEL O FLIP FLOP
  A3, 12-10-1-1-13-1 = MODEL O FLIP FLOP
  B0, 12-20-1-1-21-1 = MODEL O FLIP FLOP
  B1, 12-19-1-1-20-1 = MODEL O FLIP FLOP
  B2, 12-18-1-1-19-1 = MODEL O FLIP FLOP
  B3, 12-11-1-1-18-1 = MODEL O FLIP FLOP
  CFF, 12-22-1-1-23-1 = MODEL O FLIP FLOP
  FA, 16-21-23-17-22-1 = MODEL FULLAOR
FUNCTIONS
  TABLE1 = 0,0, 4,0, 4,1, 10,1
  TABLE2 = 0,1, 1,1, 1,0, 2,0, 2,1, 3,1, 3,0, 10,0
  TABLE3 = 0,1, 4,1, 4,0, 10,0
OUTPUTS
  EADD, EA, EB, EQA0, EQA1, EQA2, EQA3,
  ESFA, EQCFF, EQCLK, PLOT
RUN CONTROLS
  STOP TIME = 10
  MAXIMUM PRINT POINTS = 50
END

```



set/reset capability, and a data (D) type.

The MODEL subheading contains the user-defined name for the model, as well as a keyword that indicates the type of device being modeled. Suppose the user wishes to model a two-input NAND gate. His entry would be:

#### LOGIC DESCRIPTION

##### MODEL TWO INPUT NAND GATE (NAND)

where the user-defined name is TWO INPUT NAND GATE, and the parenthetical keyword NAND is the type of device.

If no additional information is supplied by the user, all of the model parameters will be set to the default values shown in the table. For instance, the two-input NAND gate will have a high output voltage of 1, a low output voltage of 0, an input switching threshold voltage of 0.5 v, and a propagation delay of 0.

Any of these present parameter values can be overridden by using appropriate keyword specifications, which are also listed in the table. These keyword expressions can be entered in any order following the proper MODEL statement. For example, to describe a NAND gate that has four inputs, complementary outputs, an input threshold voltage of 3.2 v, and a propagation delay of 10 nanoseconds, an acceptable entry would be:

#### LOGIC DESCRIPTION

##### MODEL FOUR INPUT NAND GATE (NAND)

IN = 4 (.8)

OUT = 2 (.4, 3.2)

DELAY = 10E-9

The FUNCTION keyword is associated with the special-function gate, whose single output is determined from a user-supplied combinational logic expression. The inputs of this gate are represented by letters, while the FUNCTION keyword is used to define the logic expression. If an exclusive-OR gate were modeled as a special function, the program entry would be:

#### LOGIC DESCRIPTION

##### MODEL EXCLUSIVE OR (SPECIAL FUNCTION)

FUNCTION = (A.AND.(.NOT.B.))

.OR.(.NOT.A.).AND.B)

Any of the models specified under LOGIC DESCRIPTION are connected to other models and elements under a CIRCUIT DESCRIPTION heading. To do this, all the nodes of the network must first be numbered, and then the nodes of each model must be called out in proper sequence—input nodes first, output nodes next, and the reference (ground) node last.

For most applications, the input impedance of a logic device can be regarded as being very large, and the output impedance as being very small. Because of this, Super-Sceptre employs zero-valued current sources for inputs and variable voltage sources for outputs. Effectively, input impedance is taken to be infinite, and output impedance zero, thereby minimizing model complexity. A finite input impedance or a nonzero output impedance can be obtained by means of a simple model modification. The voltage at any model input and any model output can be requested directly as a program output.

Logic models can be stored in the program's model library for later use. A stored model is retrieved by just

inserting a CALL statement, which contains the appropriate model name, anywhere under the LOGIC DESCRIPTION heading.

### Simulating a logic network

A sample listing will help to illustrate how the program language works and how simply even a relatively complex logic network can be simulated. Figure 1 shows a four-bit serial adder and its Super-Sceptre listing. Briefly, a four-bit word can be entered into the upper and lower flip-flop string through inputs EA and EB, respectively. Input EADD serves as an enable line: when it is low, the flip-flop chains can be loaded; and when it is high, the numbers present in each chain are added together in the next four clock cycles. The upper flip-flop string acts as the accumulator register, while the lower flip-flop string is the input register. The two-bit full adder (FA) and the carry flip-flop (CFF) circulate each new sum back to the accumulator register.

In Super-Sceptre, the dimensional units of time are assigned by the user. Here, for example, the clock first goes high after 0.5 time units (START = .5). It remains high for 0.5 time units (T1 = .5), and then goes low for 0.5 time units (T2 = .5).

The three inputs—EADD, EA, and EB—are described by TABLE1, TABLE2, and TABLE3, respectively, under the FUNCTIONS heading. Each pair of numbers in a TABLE listing indicates the logic level of the signal at a particular point in time. The left-hand number is the time-unit factor, while the right-hand number is the logic level. TABLE1, for instance, describes input EADD as being low initially, going high after four time units, and remaining high up to and beyond 10 time units.

With the OUTPUTS statement, plots are being requested of the three input signals, the four output lines (EQA0, EQA1, EQA2, and EQA3) of the circuit, the output (ESFA) of the two-bit full adder, the output (EQCFF) of the carry flip-flop, and the output (EQCLK) of the clock. Under the RUN CONTROLS listing, the simulation time is limited (STOP TIME = 10), as is the number of printed solution points (MAXIMUM PRINT POINTS = 50).

### Solving an electromechanical problem

In addition to logic devices, Super-Sceptre can be used to simulate transfer functions and one-dimensional mechanical systems. Such inputs are entered under a TRANSFER FUNCTION DESCRIPTION heading or a MECHANICAL DESCRIPTION heading, in the same manner that circuit-description information is listed.

Figure 2 shows a tachometer system that involves all four of the simulations possible with Super-Sceptre. It contains electrical and mechanical elements, as well as a digital logic device and a transfer-function block. Only the positive half-cycles of the sinusoidal input pass through the one-shot to the two-pole low-pass filter, which drives a d'Arsonval-movement dc voltmeter.

In the Super-Sceptre listing, which is also given in Fig. 2, the one-shot is modeled by means of the MONO STABLE keyword. The one-shot has an input threshold of 0.8 v, a low output voltage level of 0.2 v, a high output voltage level of 3.4 v, and an output pulse width of

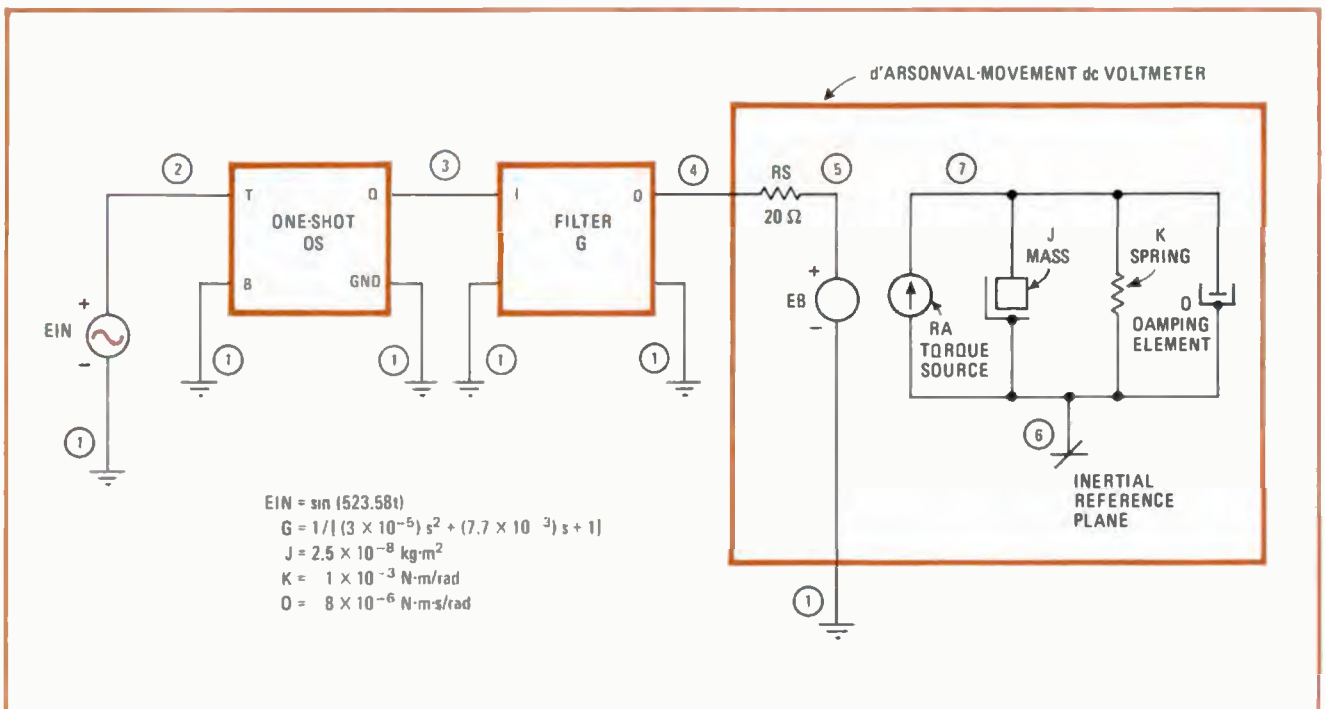

**LOGIC DESCRIPTION**  
 MODEL ONE SHOT (MONOSTABLE)  
 IN = (.8)  
 OUT = (.2, 3.4)  
 PW = 1E-2

**TRANSFER FUNCTION DESCRIPTION**  
 MODEL FILTER  
 DENOMINATOR = (3E-5, 7.7E-3, 1)

**CIRCUIT DESCRIPTION**  
 INTERDISCIPLINARY EXAMPLE-TACHOMETER  
 ELEMENTS  
 EIN, 1-2 = EXPRESSION1 (OSIN(523.58-TIME))  
 OS, 2-1-3-1 = MODEL ONE SHOT  
 G, 3-1-4-1 = MODEL FILTER  
 RS, 4-5 = 20  
 EB, 1-5 = EXPRESSION2 (5E-3-PWJ)  
 OUTPUTS  
 EIN, EQOS, EOG, EB, PLOT

**MECHANICAL DESCRIPTION**  
 ELEMENTS  
 RA, 6-7 = EXPRESSION3 (5E-3\*IEB)  
 J, 6-7 = 2.5E-8  
 K, 6-7 = 1E-3  
 D, 6-7 = 8E-6  
 DEFINED PARAMETERS  
 PWJ = EXPRESSION4 (WJ)  
 OUTPUTS  
 RA, AJ, WJ, SJ

**RUN CONTROLS**  
 INTEGRATION ROUTINE = IMPLICIT  
 STOP TIME = .1  
 MAXIMUM INTEGRATION PASSES = 1E6  
 MINIMUM STEP SIZE = 1E-30  
 MAXIMUM PRINT POINTS = 100  
 END

$10^{-2}$  time units. The filter is modeled by describing its transfer function. Here, this is done by writing an expression in terms of the denominator coefficients.

The constant-value mechanical elements that represent the meter movement—the mass moment of inertia (J), the torsional spring constant (K), and the damping coefficient (D)—are called out under the ELEMENTS sub-heading of the MECHANICAL DESCRIPTION section. The electromechanical coupling constant ( $U = 5 \times 10^{-3} \text{ v}\cdot\text{s}$ ) acts as the link between the electrical and mechanical properties of the meter. For example, the torque (RA) applied to the meter movement is expressed as a function of the current (IEB) through the meter winding:

$$RA = U \times IEB = (5 \times 10^{-3})IEB$$

This equation appears under the MECHANICAL DESCRIPTION statement, since torque is a mechanical property of the meter. In contrast, the back electromotive force generated in the meter winding is part of the CIRCUIT DESCRIPTION section. The back emf (EB) is a function of the angular velocity (PWJ) of the meter movement:

$$EB = U \times PWJ = (5 \times 10^{-3})PWJ$$

The input voltage being applied to the tachometer is a sine wave having a frequency of 523.58 radians per second. For this excitation, the OUTPUTS statement under MECHANICAL DESCRIPTION requests the value of the torque (RA), the angular acceleration (AJ), the angular velocity (WJ), and the angular displacement (SJ) of the meter movement.

A free user's manual for Super-Sceptre can be obtained by writing to: Hank Rand, Fuze Branch, Bldg. 62, U.S. Army, Picatinny Arsenal, Dover, N.J. 07801. A tape of the program for direct implementation on one of the machines mentioned earlier is available for a nominal charge of \$100. This fee includes an assistance manual, as well as installation documentation. □

**2. Electromechanical system.** Analysis of an analog dc voltmeter measuring a sinusoidal input involves the simulation of a logic device (one-shot), a transfer-function block (filter), electrical elements (meter resistance and back emf), and mechanical elements (meter-movement properties). With Super-Sceptre, such a simulation is easy because mechanical and electrical elements can be handled similarly. Here, the program computes the meter's torque, acceleration, velocity, and displacement.



# Standard & Custom Electronic Cabinetry

- CONSOLES
- VERTICAL CABINETS
- SLOPED PANEL CABINETS
- INSTRUMENT CASES
- DESK CABINETS
- CHASSIS BOXES

Full line of Accessory Fans, Blowers, Slides, Drawers, Writing Shelves, Hardware, etc., complete facilities through finishing.

**over 1300 standard items**  
write for complete catalog and prices



## PREMIER METAL PRODUCTS CO.



337 Manida Street, Bronx, New York 10474  
Phone: (212) 991-6600

Circle 131 on reader service card



## FREE Fiber Optics Catalog

Features the complete AO line of fiber optics products—from Inspection Fiberscopes and Light Guides to Illuminators, Image Conduits, Faceplates and Custom Components. Includes the four newest remote inspection fiberscopes now available.

Describes the principle, technology and techniques used to make flexible light and image transmissions a proven, practical fact. Write today for your FREE copy of the AO Fiber Optics catalog to American Optical Corporation, Fiber Optics Division, Southbridge, Mass. 01550.

**AO**  
American  
Optical

Circle 171 on reader service card

# instant pulse

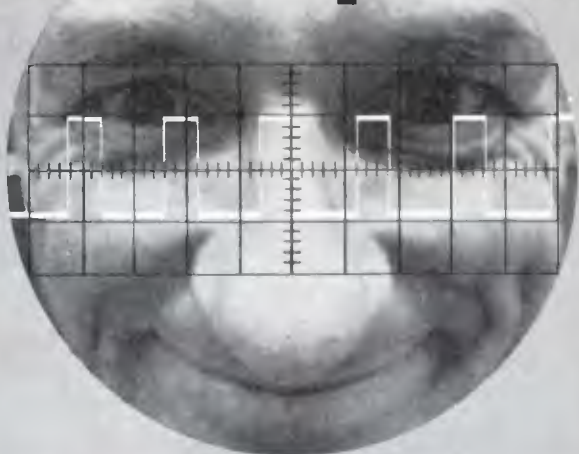

## Interstate Pulse Generators have Constant Duty Cycle

Engineers are always surprised when they select the Constant Duty Cycle mode and adjust the width control on an Interstate Series 20 Pulse Generator — they get an instant pulse. It's "countdown-free," too.

For the whole story on Interstate's Instant Pulsers, call John Norburg collect. He'll send you Interstate's Series 20 Pulse Generator catalog — instantly.

**IEC** INTERSTATE  
ELECTRONICS  
CORPORATION  
Subsidiary of A-T-O Inc.

Phone (714) 772-2811

Dept. 7000, Box 3117, Anaheim, California 92803  
TWX U.S.A. 910-591-1197 TELEX U.S.A. 655443 & 655419

Circle 132

# Engineer's notebook

## C-MOS phasemeter can be built in lab

by M. G. Fishel  
Free University of Brussels, Belgium

Since most electronic laboratories need a phasemeter only once in a while, here is a cheap alternative to buying one. All it needs is three identical C-MOS 4011 integrated circuits, some discrete components, and a good voltmeter to measure the output, and all of this should cost less than \$10.

The phasemeter accepts both analog and digital signals as inputs. Its usable frequency range starts at less than 5 hertz and goes up to several megahertz, depending on power-supply voltage.

The input signals are amplified by self-biased inverting ac amplifiers and then are shaped to obtain square waves. The square waves are then fed to two separate

circuits, each of which is built around a single IC.

The first of the two circuits is the actual phasemeter; it is in fact a simple EXCLUSIVE-OR gate. The phase comparator's output (at twice the input frequency) is filtered through an RC network to remove the ac ripple. The output voltage is proportional to the phase difference between the input signals. If they are in phase, the meter reading will be zero. A phase difference of  $90^\circ$  yields an output of  $(V_{DD} - V_{SS})/2$ , and the full supply voltage will appear at the output when the phase difference is  $180^\circ$ . The output can be adjusted to any full-scale value that is convenient by means of the calibration potentiometer.

The second circuit, which is an edge-triggered memory cell, indicates which input signal leads the other. This information is displayed by light-emitting diodes. If the phase at input 1 leads the phase at input 2,  $D_1$  lights, and if the phase at input 2 leads,  $D_2$  lights.

The impedance seen at the inputs is on the order of  $10^6$  ohms. Both inputs are protected against overvoltage by 1N914 diodes. Power-supply voltage is not critical;  $V_{DD}$  can be anywhere between 3 and 15 volts. □

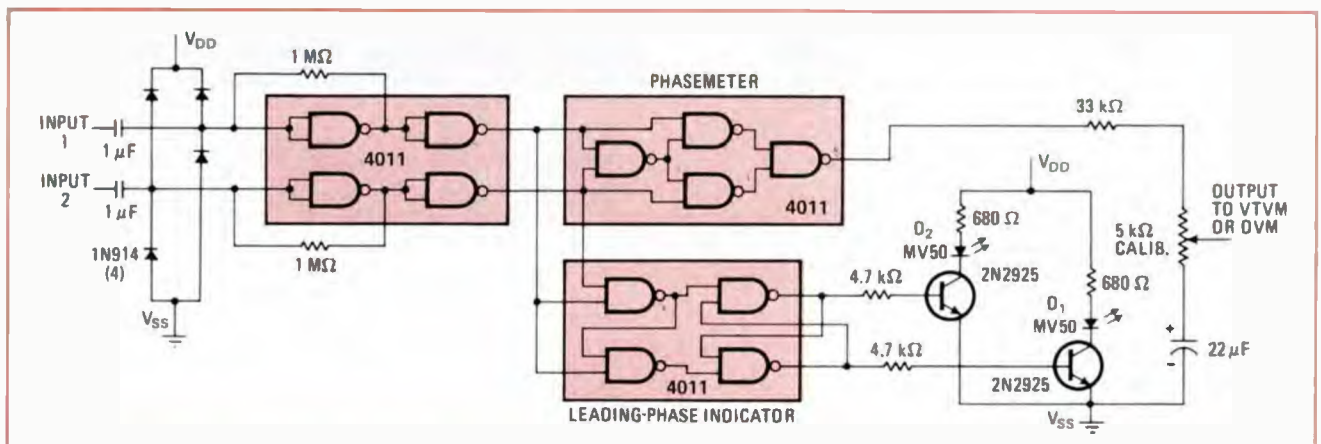

**Phasemeter.** Incoming digital or analog signals are shaped into square waves in first IC. Then phase difference is measured and displayed as an output voltage that is directly proportional to  $\Delta\phi$ . Light-emitting diodes indicate which signal has leading phase. Supply voltage can be anywhere in 3-to-15-volt range. Meter can be built for less than \$10 and operates at frequencies up to 5 MHz with  $V_{DD}$  of 12 volts.

## Back-bias continuity checks TTL wire bonds

by Shlomo Waser  
Monolithic Memories Inc., Sunnyvale, Calif.

All the connections between a TTL chip and its package pins can be checked quickly and simultaneously by an easily made tester. The packaged integrated circuit is simply slipped into a socket; if an indicator light goes on, one or more of the wire bonds is open. If the light

stays off, all of the pin-to-circuit connections are good.

This test can be used for incoming inspection, and samples can be checked during each production period to spot faulty wire-bonding operations in time to avoid expensive assembly failures. However, the test is not effective unless the device has clamping diodes on the input pins. The TTL units of a few years ago did not have these diodes. Now, although 14-pin and 16-pin units may or may not have them, most 24-pin devices are new enough to have the diodes.

Operation of the tester relies on the fact that most TTL devices have a reverse diode between each pin and the substrate. All the pins exhibit this diode effect, but for various reasons. Input pins have clamping diodes to

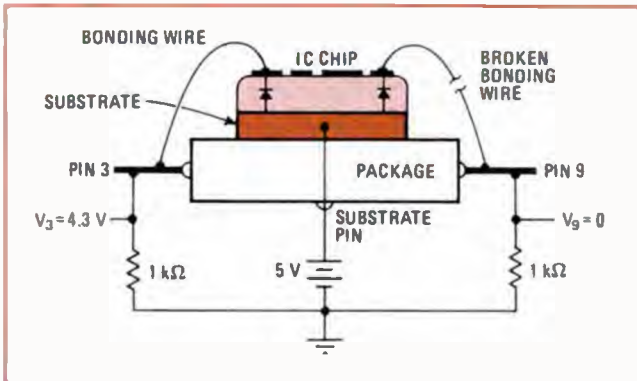

**1. Basic principle.** Equivalent circuit of TTL integrated circuit shows diodes between substrate and circuit contact points. When substrate is at positive voltage, diodes conduct current if chip-to-pin connections have continuity. Voltage drops across 1-kilohm pull-up resistors provide logic levels for simultaneous test of all bonding connections, as shown in Fig. 2.

reduce transmission reflections. Output pins show diode action between collector and substrate if the substrate is made positive. Similarly, there is a diode action between the  $V_{CC}$  pin and the substrate.

Under these conditions, the continuity of the connections from the chip (or die) to the pins can be tested by connecting the substrate to the positive side of a 5-V supply and providing pull-up resistors from each pin to the negative side of the supply. Figure 1 shows two typical pins in this test arrangement.

Pin 3 has a good bond to the die; therefore the voltage at pin 3 is the substrate voltage minus the voltage drop across the diode (i.e.,  $5.0 - 0.7 = 4.3$  v), which is a definite logic 1. However, since the bond between pin 9 and the chip is broken, the voltage at pin 9 is zero, which is a definite logic 0.

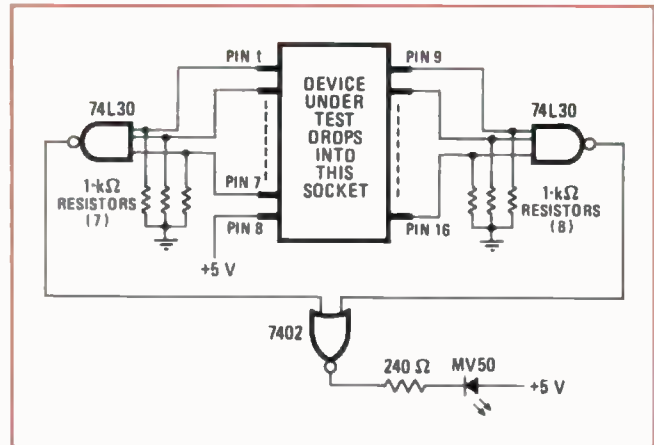

**2. Gate logic.** If all wire bonds are good, all pins are at high voltage, output of NOR gate is high, and LED remains dark. If any bonds are defective, LED glows red. This test, by monitoring performance of bonding operation, can prevent expensive assembly failures.

With the two distinct logic states, it is a simple matter to connect an OR gate to all pins so that a light-emitting diode will turn on if one or more pins has a defective bond. Figure 2 shows such a circuit for a 16-pin device. The terminals of the zero-force-insertion socket are connected to 74L30 NAND gates. The NAND-gate outputs go into a 7402 NOR gate. If the NOR output is low, the LED lights. Obviously this technique can be extended to devices with more than 16 pins.

The circuit of Fig. 2 uses the 74L30 low-power NAND gates because 1 kilohm is too much resistance to use with standard NAND gates (where the input current at low level is sometimes as much as 1.6 milliamperes). An apparent alternative is to use smaller resistors, but then the current through the substrate would be too large, especially for devices with 24 pins or more. □

## Low-drift ICs form instrumentation amplifier

by K. C. Seino

Fermi National Accelerator Laboratory, Batavia, Ill.

Accurate measurements sometimes require use of high-quality differential amplifiers that have high input impedances at both the inverting and noninverting input terminals, as well as high common-mode rejection ratio at all values of voltage gain. These instrumentation amplifiers are available commercially in both modular and integrated-circuit versions, each of which has its own advantages and disadvantages.

This instrumentation amplifier was built from three low-drift op amps. The circuit, designed for a gain of 10,

optimizes performance, cost, and size. Its performance matches that of the best modular instrumentation amplifiers. What's more, the low cost and convenient size are as advantageous as those of integrated instrumentation amplifiers for the desired performance. The entire circuit fits easily on a printed-circuit board in a limited area where it would be difficult to fit a modular amplifier. The cost of the ICs, which are the major components in the circuit, is less than \$30.

The characteristics of three modular instrumentation amplifiers are shown in the table. The Burr-Brown 3620 is estimated, by means of a formula in its data sheet, to have a maximum input offset voltage drift of about  $\pm 3$  microvolts/ $^{\circ}\text{C}$  at gain of 10. Over a temperature change of  $25^{\circ}\text{C}$ , the total drift of  $\pm 75$   $\mu\text{V}$  represents an error of only 0.4% on a 20-mV signal. Balanced against this good performance, however, are a size of 2 by 2 by 0.4 inches and a price of \$90.

Integrated-circuit instrumentation amplifiers, which

# The standard power supply is a minor consideration... until it fails.



One little power supply can put a big piece of equipment out of commission. And, that's when "bargain-level power" can get very expensive.

Besides downtime and repairs, the cost of 'unreliability' may also include some loss of reputation.

That's why it will pay you to take a good look at North. We've been the leading producer of custom power units for over 40 years. And our standard modules get the same reliability treatment—including rugged life tests, EMI analysis plus shock, vibration and humidity tests.

If reliability is worth more to you, send for a bulletin, or call your North Standard Power Manager at 419/468-8874.

Listed here are the more popular models—many other voltages are available.

MODEL	11000	12000	13200	14000	15000	16000	17000	18000
VDC								
	AMPERES							
5.0	3.8	5.3	11.3	13.0	20.0	32.5	49.0	87.0
12.0	2.8	4.2	8.0	10.5	16.0	23.0	36.0	68.0
15.0	2.4	3.7	7.5	9.5	14.0	20.5	27.0	47.0
18.0	2.1	3.3	6.0	8.0	12.0	18.0	26.0	40.0
24.0	1.5	2.8	4.2	7.0	11.0	15.0	21.0	33.0
28.0	1.4	2.4	4.0	6.3	9.0	14.0	20.0	29.0
36.0	1.2	2.2	3.1	5.6	8.0	11.8	14.0	23.0
48.0	0.9	1.5	2.6	4.2	6.0	8.0	10.0	18.0

MODEL	10000
VDC	AMPS
0.75	2.10
0.16	1.25
0.25	0.85
0.33	0.68

DUAL OUTPUT SUPPLIES	
MODEL	N03052
VDC	AMPS
±15	12 400MA
MODEL	N60052
VDC	AMPS
±15	12 1.0A

**NORTH**   
ELECTRIC COMPANY

North Electric Company / Galion, Ohio 44833 / A United Telecom Co.

SP-20

Circle 100 on reader service card

## NEW FROM AUGAT.

Our 28-pin, high-density cable plug assembly and socket offer twice the I/O density of conventional assemblies. Features include Augat's exclusive two-piece machined contact assembly, plus compatibility with other Augat boards, P.C. boards, or chassis mounts. Available now from your Augat distributor.

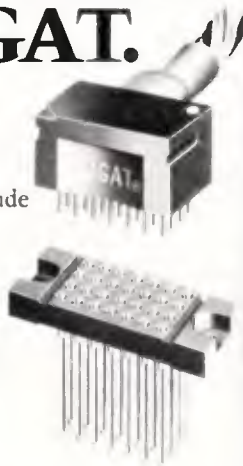

**AUGAT**

Augat, Inc., 33 Perry Avenue, Attleboro, Massachusetts 02703

Name \_\_\_\_\_

Title \_\_\_\_\_

Company \_\_\_\_\_

Address \_\_\_\_\_

City \_\_\_\_\_

State \_\_\_\_\_

Zip \_\_\_\_\_

## PDP-11 DMA Interface

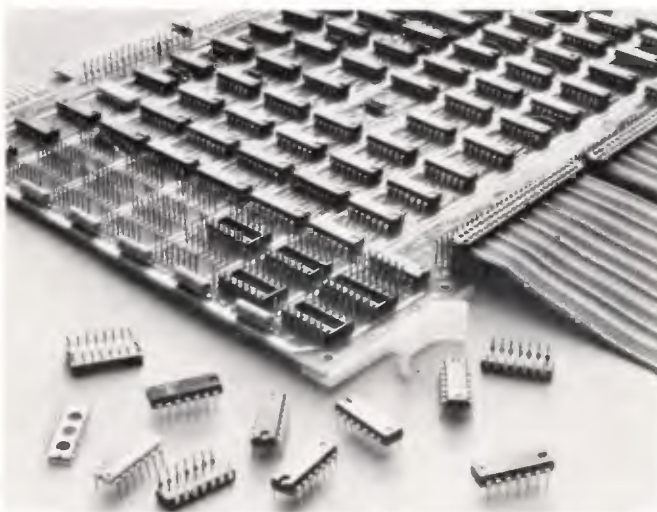

- Single Module. Requires Only One Quad Slot
- Space for 12 Positions of User Logic
- Expandable to 82 Positions of User Logic with One Additional Quad Slot
- Maximum Unibus Load is 1
- Selectable Command and Status Bit Assignments
- Has 16 Bit Input Register
- Price is \$850 versus \$1,490 from DEC, Delivery from Stock

**MOB** MDB Systems, Inc., 981 N. Main St.,  
Orange, CA 92667 (714) 639-7238

See us in booth 2553 at the NCC

100 Circle 164 on reader service card

Circle 165 on reader service card

are considerably less expensive than the modular units, are available in metal cases or in 14-pin dual in-line packages. Their input impedances and common-mode rejection are good, as shown in the table. However, at low gain, their offset-voltage drift becomes significant and affects the accuracy when measuring millivolt sig-

nals. At a gain of 10, the drift in input-offset voltage of the Burr-Brown 3660K is estimated, by means of the equation in the data sheet, to be  $\pm 52 \mu\text{V}/^\circ\text{C}$ . Therefore, a  $25^\circ\text{C}$  temperature change causes a voltage change of  $\pm 1.3 \text{ mV}$ , or a 6.5% error on a 20-mV signal.

To avoid tradeoffs between performance, size, and cost, the possibility of building an instrumentation amplifier from low-drift operational amplifiers was examined. The input voltage was 20 mV, and a 200-mV output was required; therefore, the amplifier was designed for a voltage gain of 10. The circuit was designed around the Burr-Brown 3500MP matched pair and the Fairchild  $\mu\text{A}741\text{E}$ . As the diagram shows, four potentiometers can be adjusted to achieve optimum performance from this circuit.

The first potentiometer balances voltage offsets at the outputs of the 3500MP units. It is important to adjust the offset at one output to equal the offset at the other, rather than zeroing each one. The second pot is the over-all gain adjustment; it is set to give a voltage gain of 10. The third pot is the common-mode-rejection adjustment. The gain difference between the upper and lower paths for common-mode signals is set so that a maximum rejection can be obtained at the 741E stage.

The last potentiometer zeros the voltage offset at the final output. The gain of 10 was obtained in the matched-pair low-drift stage so that drift in the last stage would have a minimum effect in the over-all thermal behavior of the circuit.

Over a temperature change of  $25^\circ\text{C}$ , the input-offset voltage drifts only  $\pm 75 \mu\text{V}$ , which is less than 0.4% error on a 20- $\mu\text{V}$  signal. Common-mode rejection is greater than 94 decibels at room temperature and greater than 70 dB at  $50^\circ\text{C}$ . □

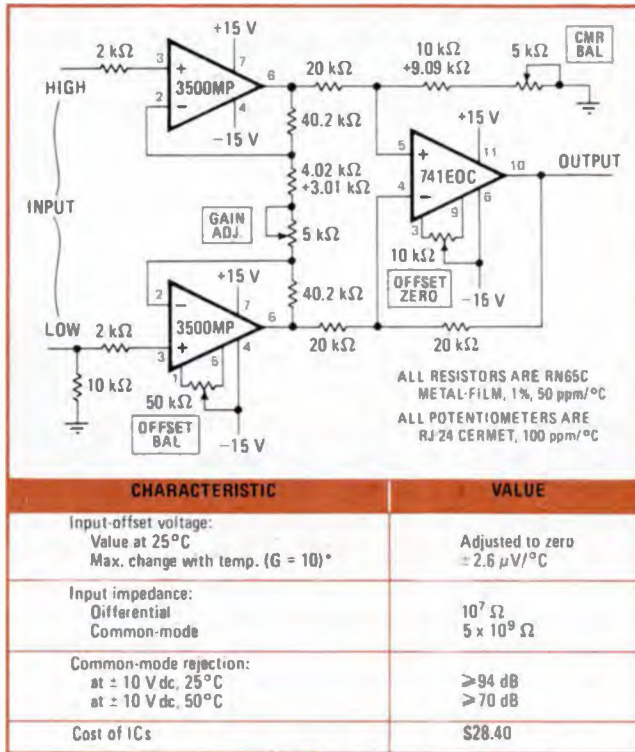

**Instrumentation amplifier.** Circuit with three ICs has high input impedances at both inverting and noninverting terminals, good common-mode rejection, and low offset-voltage drift. Gain is 10 and is adjustable. Four potentiometers are set for best performance.

Engineer's Notebook is a regular feature in Electronics. We invite readers to submit original design shortcuts, calculation aids, measurement and test techniques, and other ideas for saving engineering time or cost. We'll pay \$50 for each item published.

#### CHARACTERISTICS OF MODULAR AND IC INSTRUMENTATION AMPLIFIERS

UNIT	MODULES			INTEGRATED CIRCUITS	
	Analog Devices 605 K	Burr-Brown 3620J	Teledyne-Philbrick 4253-01	Analog Devices 520 K	Burr-Brown 3660 K
Input-offset voltage: Max. value at $25^\circ\text{C}$ Max. change with temp. ( $G = 1$ ) <sup>*</sup> Max. change with temp. ( $G = 1,000$ )	— $\pm 75 \mu\text{V}/^\circ\text{C}$ $\pm 1 \mu\text{V}/^\circ\text{C}$	$\pm (0.2 + 0.5/G) \text{ mV}$ $\pm 12 \mu\text{V}/^\circ\text{C}$ $\pm 2 \mu\text{V}/^\circ\text{C}$	$\pm 0.5 \text{ mV}$ $\pm 1 \mu\text{V}/^\circ\text{C}$ $\pm 2 \mu\text{V}/^\circ\text{C}$	— $\pm 0.5 \text{ mV}/^\circ\text{C}$ $\pm 5 \mu\text{V}/^\circ\text{C}$	$\pm (1 + 300/G) \text{ mV}$ $\pm 0.5 \text{ mV}/^\circ\text{C}$ $\pm 2.5 \mu\text{V}/^\circ\text{C}$
Input-bias current: Max. value at $25^\circ\text{C}$ Max. change with temp.	100 nA $-1 \text{ nA}/^\circ\text{C}$	$\pm 25 \text{ nA}$ $\pm 0.5 \text{ nA}/^\circ\text{C}$	$-10 \text{ pA}$ $1 \text{ pA}/^\circ\text{C}$	$\pm 40 \text{ nA}$ $\pm 0.2 \text{ nA}/^\circ\text{C}$	200 nA $-2 \text{ nA}/^\circ\text{C}$
Input-offset current: Max. value at $25^\circ\text{C}$ Max. change with temp.	$\pm 100 \text{ nA}$ $\pm 1 \text{ nA}/^\circ\text{C}$	— —	— —	$\pm 20 \text{ nA}$ —	$\pm 20 \text{ nA}$ $\pm 0.2 \text{ nA}/^\circ\text{C}$
Input impedance: Differential Common-mode	$10^9 \Omega$ $10^9 \Omega$	$3 \times 10^8 \Omega$ $10^9 \Omega$	$10^{13} \Omega$ $10^{13} \Omega$	$2 \times 10^9 \Omega$ $2 \times 10^9 \Omega$	$(2 \times 10^{10}/G) \Omega$ $2 \times 10^{10} \Omega$
Common-mode rejection: at $G = 1$ at $G = 10$ at $G = 1,000$	70 dB — 94 dB	— 74 dB 100 dB	80 dB 80 dB 120 dB	65 dB — 95 dB	70 dB — 110 dB
Package size (inches)	1.5 x 1.5 x 0.4	2 x 2 x 0.4	2 x 2 x 0.4	14-pin DIL package	T0-100 package

<sup>\*</sup>G = voltage gain

# Engineer's newsletter

## Cutting costs with quads

Many engineers using discrete transistors are missing out on the advantages of DIP-packaged quad transistors, according to John Von Dohlen and Christopher Field of Motorola. Low-priced discrete transistors are fine for short, low-volume production runs, but **multiple transistors in a DIP are ideal for automatic insertion equipment used with high-volume, densely packed cards.** In addition to assembly-cost savings, quad-packaged devices tend to have better beta and  $V_{BE}$  matching and better thermal tracking than discrete equivalents. Also, they are now available over broad parameter ranges.

## Indicating polarity with a pair of LEDs

Besides being useful as a tuning aid or null indicator, a pair of light-emitting diodes can also make a handy polarity indicator. According to engineer P. Vleck of Cheltenham, England, you simply **connect them in parallel, but with opposite polarities, between ground and the output of a comparator**—say, a 741-type operational amplifier. The input signal is applied to the inverting input of the comparator through a resistor, while the noninverting comparator input goes to ground through another resistor. Some hysteresis can be added if you run a feedback resistor from the comparator output to its noninverting input.

When one LED conducts, indicating a particular polarity at the comparator input, it draws the output short-circuit current of the op amp—typically 20 to 24 milliamperes, which is enough to turn on the LED. It also clamps the output of the op amp at about 1.6 volts, which is less than the reverse voltage allowed across the other diode.

## Bar-graph displays come in kit form

Not all displays have to be numerical—often bar graphs get a quicker response from an operator. If you'd like to try out some ideas in this area, Burroughs has put together a set of design kits for its Self-Scan flat-panel analog displays, which are based on neon-orange gas-discharge phenomena. The kit contains all the electronic components needed, already mounted on a printed-circuit board, in **any of three bar-graph configurations: 100-element dual linear bar, 200-element dual-linear, and 120-element circular.** Respective kit prices are \$79.95, \$99.95, and \$109.95. With a kit, you can design such displays as process-control monitors, automobile displays, panel meters, and level indicators. The kits are available from Burroughs distributors: Hamilton/Avnet Electronics, Cramer Electronics, Arnold Barnes Associates, and Jack Weiss Company Ltd.

## What you may need to know about IC sockets and glass

IC-socket manufacturers have a language all their own, which can confuse a socket user. **A concise booklet called "What to Look for in IC Interconnects" defines their terminology** and is free from Robinson-Nugent Inc., Dept. B, 800 East Eighth St., New Albany, Ind. 47150.

"Glasses for the Electrical/Electronic Industries," from Corning, describes the properties and uses of **many kinds of glass that can contain, control, transmit, or insulate electromagnetic energy** in many parts of the spectrum when used in substrates, photomasks, sealing glasses, and passive-component applications. Write: Public Relations Dept., Corning Glass Works, Corning, N. Y. 14830.

—Stephen E. Scrupski



# Please touch:



That "button" is as flat as this paper and has the same number of moving parts: none. Touch the photo and you'll know how easy it is to control things with Touch-MOS™ technology.

We engineered Touch-MOS controls for the solid-state kitchen range that does almost everything but choose your wine for dinner. The technology is such a logical alternative to dials, buttons, levers and switches that we predict a very smooth future for it.

A Touch-MOS panel is waterproof. It can be cleaned easily because the whole control panel is a single, flat piece. It's the "fashion breakthrough" that many consumer products need. It will last virtually forever. And, with fewer parts involved, it cuts your costs of assembly, inventory and repair.

Its uses are endless, from calculators, car instrument panels and airplane controls to telephones, appliances and vending machines. And Touch-MOS switching

is absolutely safe because no electrical current is involved. (Underwriters Laboratories will vouch for that.) By touching the glass panel, you interrupt an electronic field temporarily. Our custom MOS/LSI circuit responds to this and does the rest.

You should see what Touch-MOS controls can do for the system you're working on. And we'd be very glad to show you. Our long experience in custom LSI design and this new touch control will really get people turned onto your product—before the competition makes the switch.

Just get in touch with your nearest AMI sales office.

Manhattan Beach CA. (213) 379-2452 • Mountain View CA. (415) 969-0610 • Altamonte Springs FL. (305) 830-8889 • Elk Grove Village IL. (312) 437-6496 • Norwood MA. (617) 762-0726 • Livonia MI. (313) 478-9339 • Minneapolis MN. (612) 546-3354 • Monsey NY. (914) 352-5333 • Ambler PA. (215) 643-0217 • Richardson TX. (214) 231-5721 • Head Office: 3800 Homestead Road, Santa Clara CA 95051  
Phone (408) 246-0330.

**AMI**<sup>®</sup>  
AMERICAN MICROSYSTEMS, INC.

**first in custom LSI**

Touch MOS™ is a trademark of American Microsystems, Inc.



# Fast-moving technology draws many to 1975 National Computer Conference

---

Changing architectures, mass storage, digital networks, and microprocessors will be topics of key technical sessions

---

by Stephen E. Scrupski, *Computers Editor*

□ What with the cross-country expansion of computer networks and the spread of microprocessors into numerous new applications, more people are working with computers than ever before. So, despite slack business conditions, over 25,000 attendees will pour through the Anaheim, Calif., Convention Center during the National Computer Conference's four-day (May 19-22) run there.

The dominant trend is toward the decentralized computing system, in which intelligent terminals may eventually do all the computing that's necessary on data drawn from a central memory. Many new terminals and storage devices will therefore be on display in the exhibits area.

But for the engineer, the highlights will be those parts of the 89-session technical program that deal with the causes of all the change—the growing availability of digital communications, the spread of small, low-cost LSI microprocessors and memories, and the advent of integrated data bases that can be shared by several users. Moreover, the running of any large computer system, centralized or not, will be simplified by the use of mass-storage systems like the four-terabit IBM 3850 [*Electronics*, Oct. 31, 1974, p. 28].

Technical program chairman Stephen W. Miller, Stanford Research Institute, Menlo Park, Calif., sums up the situation thus: "In the past, system designs were a compromise between what was needed and what could be done. Today, you can do virtually anything, and the problem now is to fit the system to a customer's operations, rather than distorting his operating procedures to fit some centralized system."

## Changing shapes in architecture

Because of all the new technology, "we may be embarking on an era of significant improvements and innovations," predicts Ugo Gagliardi, Harvard University Research Center on Computing, who is technical coordinator for the five sessions on architecture. (Chairman Miller appointed 24 specialists to oversee the program for each technical area.) Software and hardware each get a tutorial and a technical session, and a panel discussion comes last.

As Gagliardi points out, in conventional computing systems today, the central processing unit plays the key role and forces a serial execution of software. But in the next five to 10 years, he says, there will be a move away from that approach, with distributed processors and parallel execution of software.

Backing up this view, Richard Case of IBM Corp.'s Systems Development division in Poughkeepsie, N.Y., points out that LSI is forcing two opposing trends: it is











# Microprocessors.

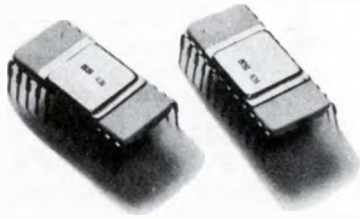



# Microprocessing.



superhuman effort on the part of our Field Applications Engineers and sales personnel



software and firmware aids



you'll need some support hardware, too

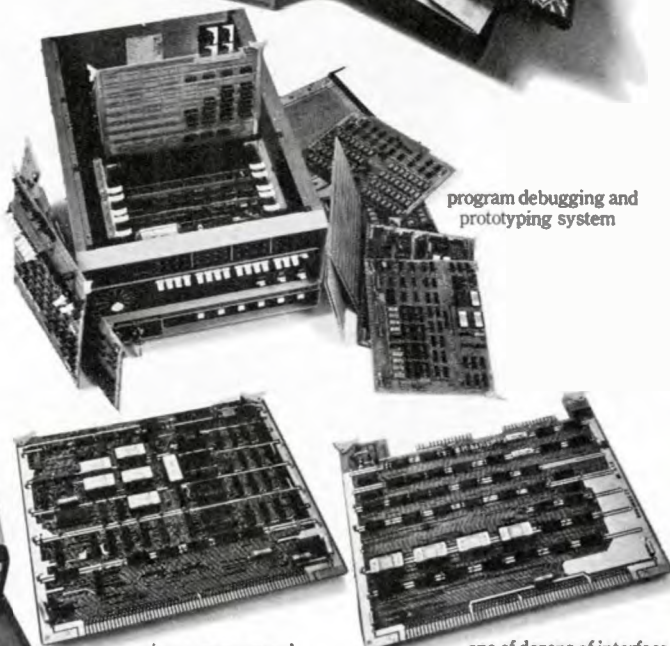

program debugging and prototyping system

microprocessor card

one of dozens of interface devices you may need

peripheral and support chips

## Only National has it all.

Gentlemen, E 51  
 I understand that there's a lot more to microprocessing than microprocessors, and that only you can give me everything I need, from chips through interfaces. Tell me more.  
 Name \_\_\_\_\_  
 Company \_\_\_\_\_  
 Address \_\_\_\_\_  
 City \_\_\_\_\_ State \_\_\_\_\_ Zip \_\_\_\_\_  
 Mail to: National Semiconductor, 2900 Semiconductor Dr.  
 Santa Clara, California 95051

**National**  
 There's more to microprocessing than microprocessors.

# Again. The heir apparent of the digital temperature indicator world is a chip off the old Doric block.

Using a single custom-designed "super chip", the Doric Series 400 Trendicators have 75% fewer parts. With less to fail, MTBF is 10 years. And since they need only 1.5 watts of power, they run nice and cool. They're reliable. Very.

Flexibility, versatility, or whatever you want to call it, is another strong feature. For example, you can measure six TC types with one unit (J,K,T,R,S & B). Switching from degrees F to degrees C or vice versa is a snap (built-in). Field range/type change is just as easy.

The looks are pretty snappy too. Big readable

LED's. Cast aluminum case, no tacky plastic. And a clean compact size (a little larger than a 1 lb. box of sugar).

Same stellar Doric performance, with prices starting at \$299 for onesey, twoseys. A paltry \$799 for the 12 range 1° model. A few coins more for the 0.1° version.

Call Frank Schulte COLLECT at (714) 565-4415 or write Doric Scientific, 3883 Ruffin Rd., San Diego, CA 92123.

Be sure to ask him about our infinite life warranty.

## Doric Scientific

An armadillo among the sheep.



## Cutting relays down to size

To satisfy today's needs for closely stacked printed-circuit boards, manufacturers are marketing low-profile units 0.45 inch high or less

by Larry Armstrong, Midwest bureau manager, and Lucinda Matterna, Components Editor

Until recently, low-profile relays were available from only a few sources, despite the increasing demand for greater board density, i.e., closer vertical spacing between component-loaded circuit boards.

Since last fall, however, relay manufacturers have been marketing the flatpack devices in earnest. And this month, two major suppliers—Sigma and C.P. Clare—are introducing new series of low-profile relays.

Standard spacing between stacked printed-circuit boards has been between 0.5 and 0.6 inch. But the designer who had to switch currents of more than 1 ampere had to cope with relays housed in the tall, ice-cube-type of packaging that required larger spacing.

The concept of a low-profile general-purpose relay originated in Germany, and U.S. suppliers have begun matching the German footprints. Potter & Brumfield configured its R50 series around the Zettler package, and, within the last two months, both Guardian and Sigma have joined that camp. Meanwhile, Siemens hammered out a licensing deal with Magnecraft. Earlier this year, the Chicago firm started marketing the broad Siemens low-profile family.

What's at stake, the makers agree, is a sizable new relay market—estimated by some to be as high as \$25 million in 1975, with the promise of a 25% growth in 1976. Besides sales to the computer and communications industries, some manufacturers see prospects in machine-tool and process-control systems, office equipment, elevators, and vending machines, as well as consumer and automotive applications. Quantity

prices range from about \$1.25 per pole for single-pole models to 50 cents per pole for the few six-pole versions available.

The growth, of course, is coming at the expense of other relay types, predominantly the cradle-type general-purpose device that was developed at Western Electric Co. "As

the next generation of equipment begins to come down the pike, you'll find the cradle relay designed out," predicts Richard A. Didriksen, Magnecraft's sales vice president.

And for some applications, the flatpack can replace reed relays—expensive devices that can't handle as much current as the electromechani-

LOW-PROFILE RELAYS

Company	Series number	Package height (inches)	Contact data			Reader service number
			Arrangement (Form C)	Rating (resistive)	Coil voltage (nominal)	
American Zettler Inc., 697 Randolph Ave., Costa Mesa, Calif. 92626	AZ-630	0.415	spdt, latching	2A @ 26 V dc, 1A @ 115 V ac	6 · 60 V dc	401
	AZ-531	0.415	dpdt	2A @ 26 V dc, 1A @ 115 V dc	6 · 110 V dc	402
	AZ-521	0.435	4pdt	3A @ 26 V dc, 2A @ 115 V dc	6 · 110 V dc	403
Arrow-M Corp., 250 Sheffield St., Mountainside, N.J. 07092	NF	0.425	dpdt, 4pdt	2A @ 30 V dc	6 · 48 V dc	404
C.P. Clare & Co., 3101 W. Pratt Ave., Chicago, Ill. 60645	511	0.350	dpdt, 4pdt	2A @ 28 V dc	6 · 48 V dc	405
Guardian Electric Mfg. Co., 1550 W. Carroll Ave., Chicago, Ill. 60607	1475	0.437	spdt, dpdt	3A @ 28 V dc and 120 V ac	5 · 48 V dc	406
Magnecraft Elec. Co., 5575 N. Lynch Ave., Chicago, Ill. 60630	63, 64	0.402	dpdt, 4pdt, 6pdt	1A @ 24 V dc, 0.3A @ 115 V ac	6 · 48 V dc	407
	65	0.402	spdt	8A @ 24 V dc and 120 V ac	6 · 48 V dc	408
	Midtex/Amco Div., 1950 Tower Blvd., No. Mankato, Minn. 56001	180, 181	0.340	dpdt 4pdt	2A @ 24 V dc and 120 V ac	5 · 48 V dc
Potter & Brumfield Div. of AMF Inc., 1200 Broadway, Princeton, Ind. 47670	R40	0.430	dpdt, 4pdt	10A @ 28 V dc and 115 V ac	3 · 115 V dc	410
	R50	0.425	spdt, dpdt	2A @ 28 V dc, 1A @ 120 V dc	5 · 48 V dc	371
	R50	0.445	spdt,	5A @ 28 V dc, 2½A @ 120 V dc	5 · 48 V dc	372
	T10	0.375	dpdt, 4pdt	3A @ 30 V dc	6 · 48 V dc	373
Siemens Corp., Components Div., 186 Wood Ave. So., Iselin, N.J. 08830	V23027	0.402	spdt	8A @ 30 V dc	2 · 60 V dc	374
	V23012	0.402	dpdt	1A @ 30 V dc	2 · 60 V dc	375
	V23030	0.402	4pdt, 6pdt	1A @ 30 V dc	4 · 115 V dc	376
Sigma Inst. Inc., 170 Pearl St., Braintree, Mass. 02185	60	0.415	spdt, dpdt	2A @ 28 V dc, 1A @ 120 V ac	5 · 110 V dc	377

# NEW DPVM's FROM NEWPORT



## BRIGHT 13MM LED DISPLAY, BCD OUTPUT, RATIO AND 2-YR WARRANTY

**\$81<sup>00\*</sup>**  
FOR 3½ DIGIT MODEL 203

- Four full scale ranges
- Auto-Polarity  $\pm$  1999 counts
- Voltage, Current and Ratio measurements
- Automatic Zero-Front panel F.S. adjust

(Model 2003, 4½ digit \$139\*)

Whether you need 3½ or 4½ digits, Newport will deliver the most reliable and versatile Digital Panel Volt Meter (DPVM) available. With a great reduction in parts and the addition of the new ½-inch LED display, we can now increase our warranty to a full 2 years. The life expectancy of the display is greater than 11 years. Full scale ranges are 200 millivolts, 2, 20, and 200 volts... and BCD output comes free.

Newport now has worldwide stocking representatives providing off-the-shelf deliveries and local support. For complete data, call or write:  
Newport Laboratories, Inc., 630 East Young Street, Santa Ana, CA 92705.

For immediate response, CALL COLLECT  
(714) 540-4686

(In Europe-Tele. Amsterdam [20] 45-20-52)

\*Quantities of 100

# NEWPORT

## New products

cal versions. And while the electrical life of the flatpacks—50,000 to a few million operations at rated loads from 1 to 10 amperes—doesn't approach that of reeds, some low-profile versions achieve up to 100 million operations when switching lower currents, comments Jerry Tuite, relay-marketing manager at Siemens.

Critical. Height of the device is critical; all available units (see table on p. 113) will fit pc cards with a center-to-center spacing of 0.6 or 0.625 inch, but only certain devices—from C.P. Clare, Midtex, and P&B—will unquestionably fit boards on half-inch centers, and none of those devices has alternate sources. For, besides the seated height of the relay, users must take into account the thickness of the pc card, usually 0.0625 inch, as well as room for solder lands and component tails on the back of the board. These can be shaved or milled easily down to 0.06 or 0.08 inch, a P&B official says, avoiding further risks of gouging the board.

Electrical specifications on the devices are surprisingly similar; differences crop up in claims of imperviousness to flux and solvents used in pc-board soldering and cleaning operations. Clare and Guardian mold the package bottom around the pins to avoid "wicking" of fluids into the relay by capillary action [*Electronics*, March 6, p. 38]. Others force pins through a premolded housing. Most, however, recommend spraying solvents instead of dipping during cleaning. The exception is the Matsushita relay, marketed here by Arrow-M Corp., which claims a hermetic epoxy seal [*Electronics*, Feb. 6, p. 127].

Other innovations, which more manufacturers plan to adopt as the products mature, include latching versions, available from American Zettler now and C.P. Clare in the near future, and more sensitive coil voltages. If a relay can fit on a board with logic, why not make it logic-compatible? P&B and Sigma, for example, have sensitive versions of their 5-v dc relays that require 50 milliamperes to energize, instead of

the 90 mA required for standard models. While that's not compatible with TTL shift registers, counters, or gates, it can be switched by TTL drivers.

There's also a move toward more contact configurations and materials. All the devices come with contacts of silver-cadmium-oxide or gold-flashed-silver, appropriate for their rated currents; some feature optional contacts of gold, palladium, and platinum alloys for switching down to dry-circuit levels.

C.P. Clare has dropped its series 311 general-purpose flatpack [*Electronics*, June 7, 1973, p. 145] in favor of its new 511 telephone-type relay, being introduced this month, which comes only with the permissive-make, precious-metal, bifurcated contacts used in the telephone industry. These series 511 units can be supplied in either two-pole or four-pole versions, with either Form C or Form D contact arrangements. The two-pole devices measure 0.35 by 1.32 by 1.22 inches, while the four-pole devices are 0.35 by 1.32 by 1.52 in. Life expectancy is 100,000 operations at rated load, increasing to 50 million operations for 0.1 A at 48 volts dc. Price ranges from \$3.30 to \$7.15, depending on the model and quantity. Delivery is from stock.

Two versions. Sigma is also introducing a series of low-profile relays. Both general-purpose and high-sensitivity versions are available. Contact rating for the sensitive series 60 devices is 1 A at 28 v dc or 0.5 A at 120 v ac. At full rated load, electrical life is 500,000 operations for the general-purpose models and 1 million operations for the sensitive models. In quantities of 1,000, price ranges from \$1.50 to \$2.20. All are available from stock.

At least two manufacturers are planning to announce additional new low-profile relays. Electrical specifications for the upcoming series 512 units from C.P. Clare are expected to be the same as those for the company's new 511 series. By July or August, Guardian will be releasing a four-pole double-throw device with a package height between 0.38 and 0.4 in. □

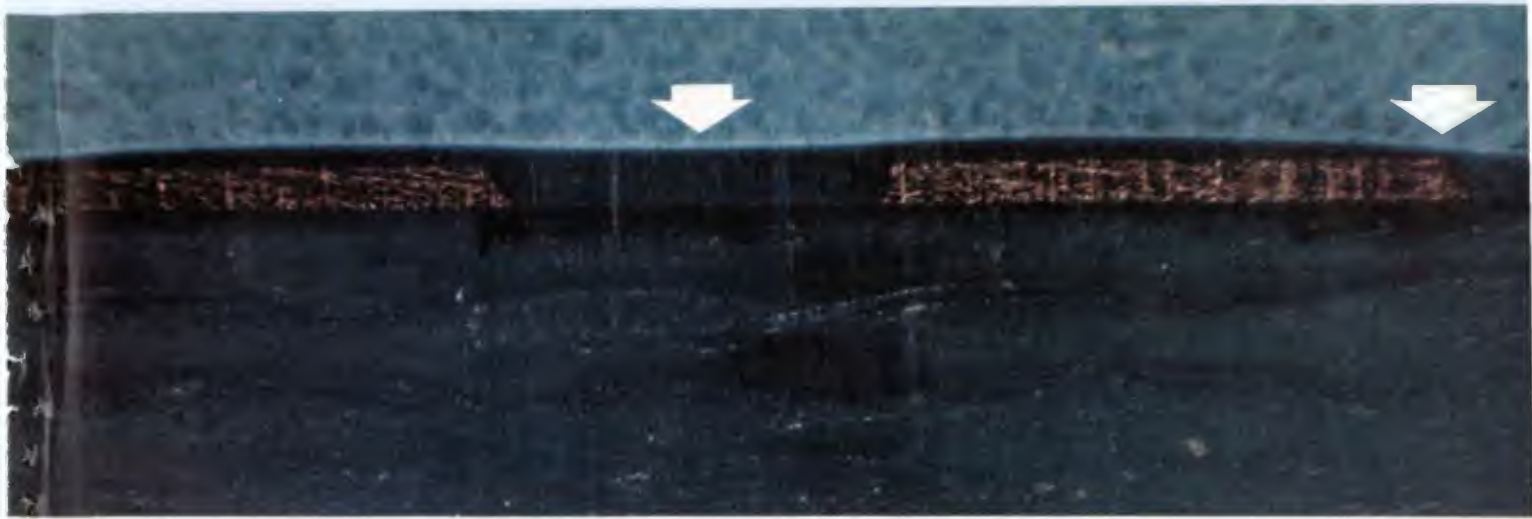

## When spray or dip coatings fail...

## Parylene works.



You are looking at magnified cross-sectional views of copper conductors on a circuit board . . . and why parylene protection brings the highest reliability to electronic circuitry.

The spray-applied urethane coating (top photo) bridges the channel between conductors, and offers scant protection at the edges. Urethane, silicone, epoxy . . . liquid coatings are uneven, and can produce potential failure points.

Parylene forms a thin and even coating, whatever the configuration, however complicated or delicate or densely populated. Without bridging. Without pinholes, voids, bubbles. We call it a conformal coating. From conformality comes reliability.

Parylene conformal coatings can be applied in precisely controlled thicknesses from 0.002 to 3 mils. *In one step.*

Parylene is applied at *room temperature*. No heat, no melting, no cure. No coating shrinkage. In other words, no discomfort for delicate components.

Parylene provides better barrier protection than urethanes, silicones or epoxies. It is extremely resistant to chemical attack,

exceptionally low in trace metal contamination, and compatible with all electronic solvents. Dielectrics are excellent .

Parylene has qualified under the stringent requirements of MIL-1-46058C; it does so with a 0.6 mil coating—parylene excels in the micro-electronic virtue of thinness.

Parylene conformal coatings have shown excellent cost effectiveness in many applications. On delicate, sophisticated and complex circuitry, in hybrid circuits and components, they may be the most cost effective answer for long term reliability.

Union Carbide invented the parylene system. The method is gas phase deposition, which is the only route to the reliability of conformal protection. Various patents apply; commercial use of the patented technology is licensed.

You can get complete information on parylene by writing for our 16-page brochure: Union Carbide Corp., 270 Park Ave., Dept. RB36, New York, N.Y. 10017. Further investigation will no doubt indicate a trial run, which we can perform at reasonable cost. If you would like to discuss that or any other related matters, please call Bill Loeb at (212) 551-6071 .



# Software aids microcomputer design

Floppy-disk-based operating system controls microcomputer, peripherals to generate application programs for 8008 and 8080 microprocessors

by Stephen E. Scrupski, Computers Editor

The problem in development of software programs for microcomputer-based systems is one of cost-effectiveness, balancing the availability and costs of time-shared programs, on the one hand, against in-house computers and prototyping systems supplied by semiconductor manufacturers on the other hand. In general, time-sharing offers the best design software, but it is also the most costly approach.

Now, a company called Millenium Information Systems Inc. has a software-development system, the MPD-1000, aimed at the Intel 8008 and 8080 microprocessors, that it says can match a disk-based mini-computer system in its capability for developing programs. "It has the programing efficiency of a time-sharing system, but not the recurring costs," says the company's president, Gerald S. Casilli.

The system hardware consists of an Intellec 8 microcomputer from Intel, a dual-drive floppy-disk subsystem (two Calcomp floppy-disk units), a high-speed printer, and a teletypewriter. The intelligent floppy-disk controller contains all the circuitry needed to handle up to eight floppy-disk drives. But the key development, says Casilli, is the disk operating system, which has a flexible management capability that en-

ables the Intellec 8 to be used for such applications as control of stored experimental data, as well as for program development.

The text editor and macro assembler incorporated in the operating system are the latest versions of standard Intel-supported programs. Both can be rapidly loaded into the Intellec 8: the text editor in less than



Call to assembly. Floppy disk with intelligent controller uses a new operating system built by Millenium to help develop applications programs for microcomputers.

2 seconds, and the macro assembler in less than 4 seconds. All design passes of the macro assembler are performed automatically, and only statements with assembly errors are printed out.

With the system, a user can assign names to disk files of varying lengths quickly and easily. Any input or output device can be assigned to any one of the named disk files on any one of a maximum of eight floppy-disk drives. Named files can also be merged and otherwise manipulated as the user desires.

In typical use, the system oper-

ator first enters his program, which the system then assembles, afterwards printing out a list of assembly errors. An edit program modifies the source program, and the whole program is then reassembled. Finally, the high-speed printer makes several printouts in order to maintain current error-free listings. The system also performs error checks and checks for "illegal" commands, such as to write in a nonexistent track.

Each disk can hold more than 300,000 bytes of data, recorded in 77 tracks. Transfer rate is 250,000 bits per second. The disk system includes an intelligent controller that can handle most Centronics printers. The hardware interface between

controller and printer is a simple cable attached to an edge-board connector, while the operating system contains all the software needed to support the printer.

Cost of the basic system, which includes the dual-drive floppy disk, the software, a programable read-only memory, and the cabling that goes to the other peripherals, is \$5,250. The required peripherals are also available through Millenium, but Casilli points out that many customers may already have them.

Millenium Information Systems Inc., 420 Mathew St., Santa Clara, Calif. 95050 [339]

# HD/CMOS achieves LSI circuit densities unmatched by any other CMOS process.

## HD/CMOS II is even better.

Our High-Density CMOS process for custom Large-Scale Integration was an innovative development that made CMOS ideal for use in dedicated LSI subsystems. Since its introduction over two years ago, HD/CMOS has been used in volume production for a wide variety of applications in the fields of electronic timekeeping, portable instrumentation, medical and consumer electronics.

Continuing refinement of this unique processing technology has resulted in a major new breakthrough. We call it HD/CMOS II. It gives you even greater circuit densities, lower power operation, and faster switching speeds. In fact, it's presently providing the highest density of circuit integration yet attained for random logic designs.

HD/CMOS may be ideal for improving your product. If so, it can produce exciting and profitable rewards in the marketplace.

Applying the advanced technologies of LSI to customer products is our sole business. We can help you answer questions about cost/quantity tradeoffs, long-term profitability of the host product, and choosing the right processes to optimize performance and reliability.

If you're considering LSI, consider Micro Power. We sell more than circuits. We sell solutions.

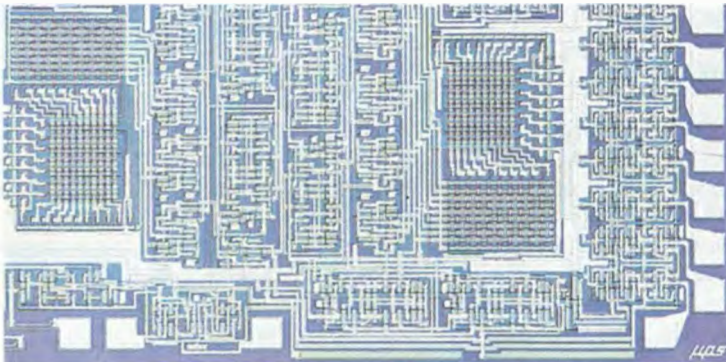

Contact us for complete details:

### **MICRO POWER SYSTEMS**

3100 Alfred Street  
Santa Clara, CA 95050  
Telephone (408) 247-5350  
TWX 910-338-0154

MPS/Japan  
21 Mori Bldg., 2-2-5 Roppongi  
Minato-ku, Tokyo, Japan  
Telephone 586-0471

---

## New products

---

Data handling

# Computers for first-time users

---

Line of small systems is designed for scientific, educational, industrial jobs

---

Someone who has never before used a computer system usually wants a small, relatively low-cost machine, one that's simple to operate, and designed for use with off-the-shelf software packages.

These requirements are met by a line of small systems developed by Wang Laboratories and aimed at the first-time user in business, science, education, and a variety of industrial applications.

The Wang Computer Systems all use a binary parallel byte-oriented central processor with an 8-bit byte and a cycle time of 1.6 microseconds. The main memory uses 2,048-byte metal-oxide-semiconductor random-access memories and the system is driven by read-only memories of 512 10-bit bytes that contain the interpretive Basic language and input/output sequences. The ROMs increase processing throughput by allowing major segments of software to remain in the main memory, Wang says. The company also simplified the

basic verb structure so that up to 32 special functions can be keyed in one stroke each.

At the low end of the new family is the WCS/10 (at left, below), which costs \$5,700 and is intended primarily for education markets. The CPU has 4,096 bytes of RAM, expandable to 32 kilobytes in 4-kilobyte increments, and 24 kilobytes of ROM. The system also includes a console with keyboard and 1,024-character cathode-ray-tube display and a single tape cassette for auxiliary data storage with a capacity of 78 kilobytes.

In the mid-range is the \$10,000 WCS/20, which has a larger, more powerful CPU with 8,192 bytes of RAM, expandable to 32-k, plus 42.5 bytes of ROM, and includes the keyboard and a larger CRT. It also has a single flexible disk drive, expandable to three drives, with a capacity of 262,144 bytes per disk, an access time averaging 401 milliseconds, and a transfer rate of 31,000 bytes per second. With an optional binary synchronous communications capability, it can be used as a remote batch-processing system in networks of Wang and other processors.

The WCS-30 is the largest of the new systems. To the CPU, console, and flexible disk drive it adds a disk drive with two disks, one fixed and one removable. Capacity is 2.50 megabytes per disk (single density) with an access time of 21 milliseconds and a transfer rate of 195 kilobytes per second. A double density disk holds 5.01 megabytes, has an access time of 38 milliseconds, and a transfer rate of 312.5 kilobytes per second. In the larger configuration 10 million bytes of storage are available, or more than in IBM's system/32, the company says.

A basic WCS/30 at \$29,100 includes 16,384 bytes of RAM, expandable to 32 kilobytes, 42.5 kilobytes of ROM, and Wang's new model 21W line printer. (The 21W is an impact typing, serial matrix printer, with a speed of 200 characters per second, or 65 lines of 132 columns per minute; unbundled, it costs \$5,600.) Aimed at the commercial

market, the WCS/30 can operate in interactive and on-line modes for teleprocessing applications, and can support data entry stations and Wang's 1200 family of word processors.

All the processors can support a number of peripheral devices, including the 21W line printer, and Wang can provide software.

Wang Laboratories Inc., 836 North Street, Tewksbury, Mass. 01876 [361]

---

## New model quadruples PDP-15 memory capacity



With the price of memory going down, the Digital Equipment Corp. has introduced a new version of its 18-bit PDP-15 computer called the XVM that, for the first time, can use all 18 bits under program control for indirect address. This allows a single program to address 131,068 words of memory rather than the previous limit of 32,786 words.

The basic unit is the XVM-100, which includes a slightly modified PDP-15 model 5 central processing unit with a 750-nanosecond cycle time, 32,768 words of core memory expandable to 96-k words, or 128-k words with an expander cabinet, a high-speed paper tape reader and punch, hardware multiply/divide, a real-time clock, an LA36 DECwriter II keyboard printer, and a memory processor.

Using Schottky TTL and multi-layer circuit boards, the memory processor combines a number of functions previously handled by separate devices. It has an automatic priority-interrupt unit, a





# The new Keithley Model 168 autoranging DMM... ...vive la différence!

There really is a difference in Digital Multimeters, and once you've experienced Keithley's 168 you'll know why we say *vive*! If you're tired of "general-purpose" promises that turn into run-of-the-mill

performances; if you want that bit extra that'll make your job easier, then *vive la différence*... here's the DMM for you! Send for our DMM Selector Guide or call us for demo now. Phone (216) 248-0400.

**AC** VOLTS  
**DC** AMPS  
OHMS

#### 5 functions

100  $\mu$ V to 1000 V dc  
100  $\mu$ V to 500 V ac  
0.1  $\mu$ A to 1 A dc  
0.1  $\mu$ A to 1 A ac  
100 m $\Omega$  to 20 M $\Omega$

#### price

Enough said? Order one... or two... or three now!

**\$31500**

#### two-terminal input

Simple to connect. You can't get it wrong. Eliminates the word "whoops" from your vocabulary. Saves temper, too.



#### options & accessories

Rechargeable batteries that you can install anytime. An RF probe for high frequencies. Test leads. A 50-amp current shunt too.



#### hi-lo ohms

Select either of two voltage levels, 1 V or 100 mV, for ohms measurements. You can have your PN junctions either way you want 'em on or off.



#### automatic ranging

You just connect the signal and push the function. The decimal point pops into position automatically and the display is direct reading. That does save time!



**KEITHLEY INSTRUMENTS**  
U.S.A. 28775 AURORA ROAD, CLEVELAND, OHIO 44139  
EUROPE 14, AVENUE VILLARON, 1009 PULLY, SUISSE

# THE PATTERN GENERATOR

Now that the pattern generator is definitely "in" — here are 5 good reasons why the swing is to Electromask!

1. The complex circuits of today and tomorrow cannot be handled by rubylith cutters or the old mechanical P.G.'s like the simple circuits of yesterday.

2. Now with circuits requiring 25,000 to 50,000 flashes per layer, you need the speed and accuracy — the throughput — that only Electromask's Pattern Generator's unique design and more powerful servo motors can provide.

3. The Electromask P.G.'s independent scale factor for X-Y position and for aperture flash size and its mini-

mum programmable increment of 10 microinches dramatically increase circuit design flexibility.

4. Lasometric™ position control and frictionless vacuum air bearings permit stage speeds of 2.5 inches per second — making it the fastest system on the market — and ensure precision and non-degradable accuracy over the long wear-free lifetime of the system.

5. When you swing to an Electromask P.G. today, you know that the new technologies won't make it obsolete tomorrow.

For more information, use the reader service card, or contact us directly at the number below.

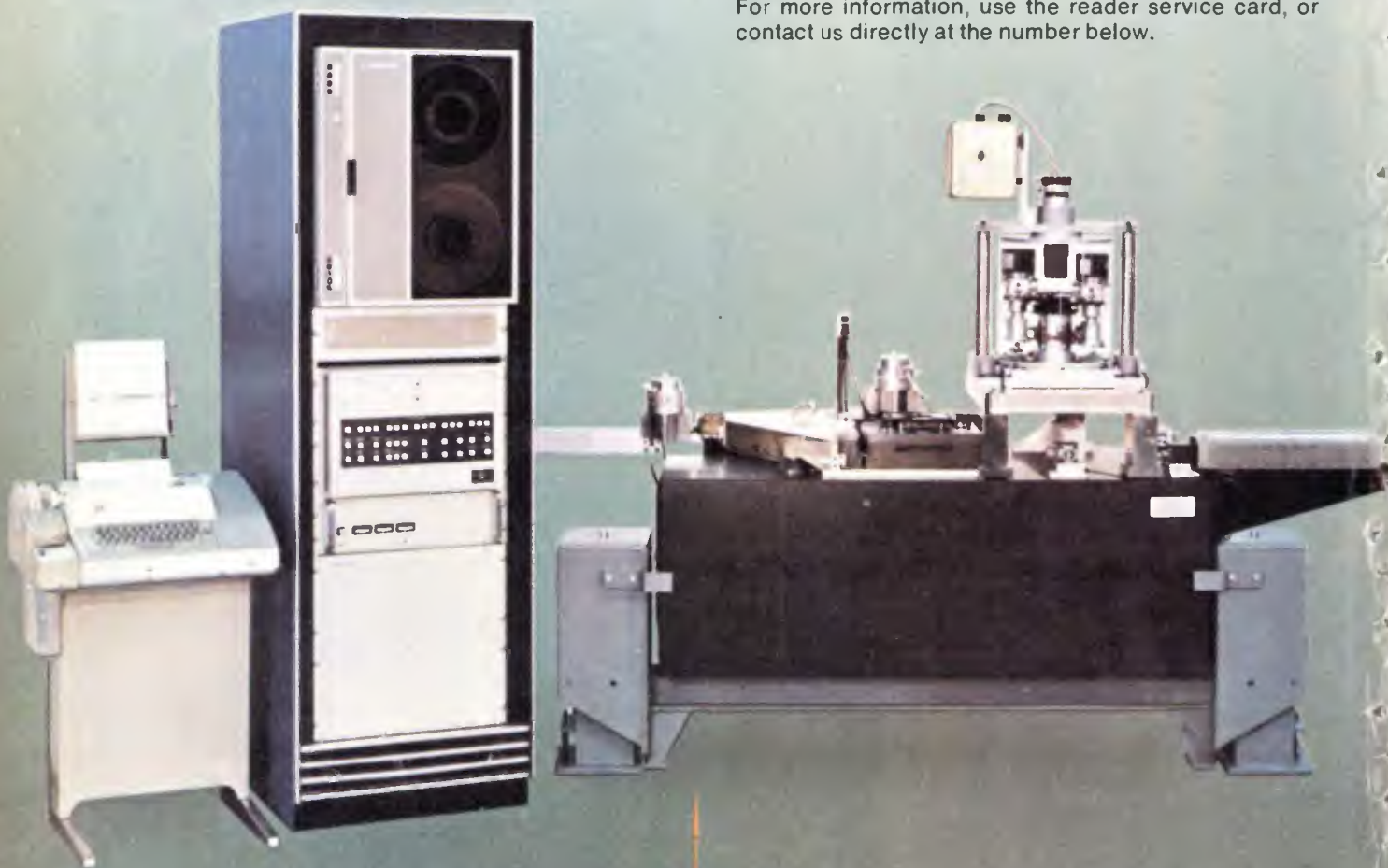

## ELECTROMASK, INC.

A subsidiary of TRE Corporation, 6109 De Soto Ave., Woodland Hills, Calif. 91364, Phone: (213) 884-5050, Telex 67-7143

Image Repeaters • Pattern Generators • Mask Savers • Environmental Chambers • Mask ID Printers • Precision Glass Cutters • Photomasking Services  
Circle 120 on reader service card

memory protection unit, a unichannel multiplexer for dual-processor arrangements, a memory bus interface, and a multiport adapter.

The XVM-200 includes an XVM-100 and a PDP-11 with 8-k-word memory and a 1.28-million-word cartridge disk. Control is in a dual-processor arrangement.

The bulk of PDP-15s are used in laboratory applications, and DEC thinks the XVM will make it even stronger in this area. In addition, the XVM-200 is aimed at the interactive graphics market. Three new software systems for the XVM are available. Prices for the XVM-100 start at \$37,500; and for the XVM-200 at \$57,500. Delivery will start in the fall.

Digital Equipment Corp., Maynard, Mass. 01754 [362]

### Semiconductor-memory card stores 294,912 bits

A standard semiconductor-memory card that is believed to be the highest-density memory on the market contains 294,912 bits, organized as either 16,384 18-bit words or 32,768



9-bit words. The model in-40 card, which measures only 8.175 by 10.5 inches, is available in word lengths of 8, 10, and 12 bits. The system, which is also offered on two 160 millimeter by 233.4 mm Euroboards each containing half the memory, is built around Intel 4,096-bit random-access memories. OEM prices are about 0.5 cent per bit for the stan-

dard card and 0.7 cent per bit for the Eurocard version.

Intel Memory Systems Div., 1302 North Mathilda Ave., Sunnyvale, Calif. 94086 [363]

### Floppy-disk subsystem can work with IBM 3740 diskettes

Designed to be fully compatible with diskettes generated by the IBM 3740, the AED floppy disk subsystem has a programable formatter and automatic IPL. The unit provides from one to four disk drives and all necessary electronics in a single rack-mountable cabinet that measures 10.5 inches high. Each disk in



the system can store 128,128 16-bit words in IBM format. Access time is 10 milliseconds per track, and data is transferred at a rate of 66.7 microseconds per word. The price of a single-drive AED 3100-P system with a minicomputer interface is \$2,040 in OEM quantities.

Advanced Electronics Design Inc., 754 Pas-toria St., Sunnyvale, Calif. 94086 [364]

### Dot-matrix impact printers run at 165 characters/s

Two serial dot-matrix impact printers operate at speeds to 165 characters per second. The model 301 prints an 80-column line at a rate of 70 lines per minute, and the model 501 prints a 132-column line at 50 lines per minute. Both printers extensively use large-scale integration to keep their small-quantity prices down to \$2,275 and \$3,315 for the 301 and 501 respectively. Both 5-by-7 and 7-by-9 dot-matrix character

## FIRST CHOICE of INDUSTRY

## Phoenix Data's ENCASED EDAC Series 3000 Converters

Time-proven reliability and ease of application in a wide range of products have made Phoenix Data's encased digital to analog converters a first choice with commercial and industrial equipment designers everywhere. Here are some of the reasons why:

- 20 different models.
- 12 to 16 bit resolution.
- Straight binary, offset binary, or 2's complement input.
- Programmable output range selection.
- Bipolar or unipolar output.
- Precision internal voltage reference.
- Pre-calibrated for specified temperature range.
- RFI and EMI shielded.
- Conversion times to 1  $\mu$ sec. for 13 bits, 3  $\mu$ sec. for 16 bits.
- Accuracy to 0.003% of FSR.
- Optional temperature ranges from  $-55^{\circ}\text{C}$  to  $90^{\circ}\text{C}$ .
- TTL compatible input holding register.
- Convenient printed circuit board mounting.

All of the EDAC modules are available to meet military specifications.



### PHOENIX DATA, INC.

3384 W. Osborn Rd. Phoenix, AZ 85017  
Ph. (602) 278-8528. TWX 910-951-1364

**YOU CAN DO IT  
YOURSELF...**

## **WITH UNIVERSAL'S MECHANIZED ELECTRONIC ASSEMBLY MACHINES**

For over 15 years Universal has been supplying Mechanized Electronic Assembly Equipment to nearly all the leading computer, communications, aerospace, automotive and consumer electronics companies in the world, regardless of their size. We feel we have given them the "in-house" capability to build their products profitably. We can do the same for you with:

- Axial Lead Component Processing Equipment.
- Transistor, DIP and Axial Lead Prepping Equipment.
- Transistor, Disc Capacitor and Axial Lead Taping Equipment.
- Disc Capacitor, DIP, Transistor, SIP and Axial Lead Insertion Equipment.
- As well as Pin Insertion and Wire Termination Equipment.

Universal's Semi-Automatic and Computer Controlled Systems reduce cost, improve quality and give your company the "in-house" production capability to assemble all your electronics . . . you can do it yourself. For details on how to purchase or lease a Universal Electronic Assembly Machine, call or write today.



**Universal**

Box 825 Binghamton, NY 13902  
607-772-7522 TWX: 510-252-1990

## **New products**



patterns produces five clear copies. A parallel computer interface is standard with the printers, although a serial communications interface is available as an option.

Centronics Data Computer Corp., Hudson, N. H. 03051 [365]

## **Single-card reader is rugged, reliable**

A low-cost, rugged, reliable single-card reader intended for data capture in commercial, retail, and manufacturing applications has a normal operating life of five years or 15,000 operating hours. The single-card reader is particularly good at reading with few errors damaged and dirty cards, such as the coffee-stained tabs that are encountered in fast-food stores. The unit, which sells in small quantities for \$1,000, can read pen- or pencil-marked cards, punched cards, or both. Delivery time is 30 days.

True Data Corp., 2701 South Halladay St., Santa Ana Calif. 92705 [366]



**...OR WE CAN  
DO IT FOR YOU**

## **WITH UNIVERSAL'S MECHANIZED ELECTRONIC ASSEMBLY SERVICES**

When you don't have the capacity to do all your own component preparation, assembly or wire wrapping—or when it doesn't pay you to do it yourself—let us do it for you, with no capital investment on your part. Working for you are the industry's most automated facilities including:

- Axial Lead Component Taping, Sequencing and Insertion.
- Transistor Prepping, Taping and Insertion.
- DIP Insertion.
- Pin Insertion.
- SIP Insertion.
- Computer-Aided Design Accessibilities.
- Wire Termination.
- Complete Systems Assembly.
- And, of course, complete testing for all services.

Universal's Mechanized Electronic Assembly (MEA) Division services provide close-tolerance production, on-time delivery and substantial savings in direct labor cost from two locations: Binghamton, New York, and Palatine, Illinois. Write or phone today for full details on what Universal's MEA can do for you.



**Universal**  
MEA

Box 825 Binghamton, NY 13902  
607-772-7522 TWX: 510-252-1990

**The New Brush 2400:  
the best performing, most versatile  
wide channel recorder you can buy.**

It is available in 2, 3 and 4 channel configurations utilizing combinations of 50 mm and 100 mm channels totalling 200 mm. It had a 99.65% linearity over the full 100 mm channel. Its frequency response is an outstanding 30 Hz at 100 mm, 50 Hz at 50 mm and up to 125 Hz less than 3dB down. It has a full range of plug-in signal conditioners for just about any industrial-scientific-medical application.

For full details on why the new Gould 2400 is the best performing direct writing recorder you can buy, write Gould Inc., Instrument Systems Division, 3631 Perkins Avenue, Cleveland, Ohio 44114. Or Kouterveldstraat 13, B 1920 Diegem, Belgium.



**GOULD**

Circle 168 on reader service card

**NO ONE**

**Customizes Switches Like CDI  
Nor Has a More Complete Line**

**THUMBWHEEL SWITCHES**



Completely sealed against hostile environments.

**ROTARY SWITCHES**

Snap-in, snap-out modules in seconds, eliminating downtime.

Tabet Pat.  
2841660,  
2971066,  
3015000,  
2956131,  
2988607.

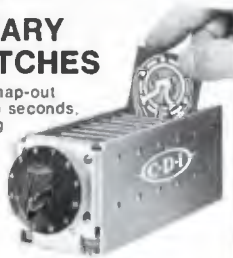

**PUSHBUTTON SWITCHES**



Mounts on 1/2" centers, retrofits most panel openings for miniature thumbwheel switches.

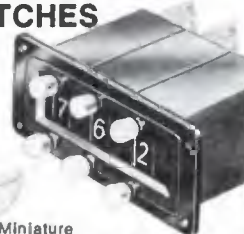

Miniature add/subtract units retrofit most minithumb-wheel switch panel openings.

**CDI earns its reputation every day for Consistently High Quality, Consistently Good Delivery.**



**CHICAGO DYNAMIC INDUSTRIES, INC.**

PRECISION PRODUCTS DIVISION  
1725 Diversey Blvd., Chicago, Illinois 60614  
Phone: 312. 935-4600

Circle 169 on reader service card

**Dialight  
sees a need:**

(Need: The widest choice for your every application.)



**LED, INCANDESCENT OR NEON  
ULTRA-MINIATURE DATALITES®**—Meet or exceed MIL-L-3661. Replaceable plug-in cartridges for 1.35-125V operation. Indicators mount as close as 1/2" centers; available with red, green, amber, blue, white translucent, light yellow or colorless lenses in wide range of lens shapes, legends and finishes. Stocked by local distributors.



**INCANDESCENT OR NEON SUB-MINIATURE INDICATORS**—Meet or exceed MIL-L-3661. Mounts in 15/32", 1/2" or 17/32" clearance holes. Incandescent for 1.35-28V; neon has patented built-in current limiting resistor. Choice of cylindrical, faceted, convex, flat, square and round lens shapes, finishes, legends. Stocked by local distributors.



Dialight, the company with the widest choice in switches, LEDs, indicator lights and readouts, looks for needs . . . your needs . . . and then they develop solutions for your every application. No other company offers you one-stop shopping in all these product areas. And no other company has more experience in the visual display field. Dialight helps you do more with these products than any other company in the business, because we are specialists that have done more with them. Talk to the specialists at Dialight first. You won't have to talk to anyone else. Send for your free new copy of Dialight's current catalog.

**DIALIGHT**

Dialight, A North American Philips Company  
203 Harrison Place, Brooklyn, N. Y. 11237  
(212) 497-7600

**See Dialight.**

Circle 123 on reader service card

123

---

## New products

---

Semiconductors

# Watch chip does whole job

---

C-MOS circuit powers decoders as well as driving 7- or 9-digit LED display

---

By using a variation of the standard interdigitated-finger technique developed for metal-oxide-semiconductor and bipolar power transistors, engineers at Intersil Inc. have built a one-chip complementary-MOS watch circuit that will also drive a light-emitting-diode display. Previously, manufacturers believed that because of high-current requirements, MOS digit and segment drivers powering the LEDs had to be separated from the C-MOS circuit chips. This separation is a distinct disadvantage to electronic watch makers seeking to reduce the size of their modules. For this reason, many of the designers have looked with interest to the development by Texas Instruments of one-chip watch circuits using integrated injection logic.

Now, however, the new 7200 family of C-MOS watch circuits introduced by Intersil has all the electronics—segment and digit drivers, oscillator, dividers and decoders—integrated onto the 125-by-125-mil chip. And the series of circuits also has the ability to drive either a seven-digit numeric or a nine-digit alphanumeric LED display.

Packaged in a 24-pin leadless hermetic package, the 7200 chip has a standby/off power dissipation of less than 4 microamperes at 3 volts. Output-current driver requirements are only 7 milliamperes per segment at a 25% duty cycle. The only external components the 3-v device requires are two silver-oxide batteries, a 32-kilohertz oscillator crystal, a trimming capacitor, and two switches.

Intersil's C-MOS watch chip not only has the segment and digit driv-

ers on the same chip as the rest of the electronics, but the drivers take up minimal space—only 15% to 18% of the 15,725 square mils of the chip. David Bingham, Intersil's manager of micropower products, says this is a direct result of the interdigitated-finger technique used in fabricating the power transistors for the digit and segment drivers.

"In terms of process technology, our approach is not much different from that used by other C-MOS watch-circuit makers," he says. "The differences are mainly a matter of degree." For example, Bingham says, in most other segment and digit drivers, interdigitation is also used, and each finger must be metalized. "That means adding as much as 30% to 50% to the area required for the drivers."

If this approach had been used in the 7200, Bingham says, the total area of the chip devoted to digit and segment drivers would have amounted to 4,700 to 5,700 square mils and necessitated the use of separate chips.

Intersil, however, does not metalize all of the fingers. As a result, the saturation resistance is made up of equal parts of dynamic and static components, instead of all dynamic units as on the conventional devices. What is lost in terms of dynamic response is, however, more than made up for in reduced chip size that has to be devoted to the drivers, Bingham points out.

Intersil has begun volume production of its seven-digit numeric watch circuit, the IM7202, and is sampling its nine-digit alphanumeric design, the ICM7200, which will be in volume production in July.

Intersil Inc., 10900 No. Tantau Ave., Cupertino, Calif. 95014 [411]

---

## Schottky mixer diodes span 1 to 18 GHz

Housed in a package 0.05 inch square to reduce parasitics, the 5082-2207 through 5082-2210 family of beam-lead Schottky-barrier



mixer diodes spans the frequency range from 1 to 18 gigahertz. Intended for microstrip and stripline microwave integrated circuits, the diodes come in two grades. The 5082-2207 has a maximum noise figure of 6 decibels at 9 GHz and has a maximum VSWR of 1.5, and the model 5082-2209 has a corresponding noise figure of 6.5 dB and a VSWR of 2.0. The diodes are also available as matched pairs. The low-noise version is designated 5082-2208, and the other is known as the 5082-2210. The single low-noise diode sells for \$19.50 in quantities of one to nine, and the 6.5-dB unit is priced at \$15.50 in similar quantities. Delivery is from stock.

Inquiries Manager, Hewlett-Packard Co., 1501 Page Mill Rd., Palo Alto, Calif. 94304 [413]

---

## Bipolar LSI family is fast and flexible

A family of high-speed LSI elements, built by Fairchild with advanced Schottky transistor-transistor logic, is designed both to work with present and future MOS LSI microprocessors and to help solve systems problems that are too fast for microprocessors to even be considered. Fairchild's Macrologic family, which carries 9400-series part numbers, consists of 12 logic and memory devices, including the 9401 cyclic redundancy check generator/checker, the 9403 serial/parallel first-in-first-out buffer memory, the 9404 data-path switch, the 9405 arithmetic logic register, the 9406 last-in-first-out register, the 9407 data-access register, and the

# MD-107



## Now! Test memory chips, boards, or systems and pinpoint the bad circuits!

For functional testing of memory chips, boards, or systems, Macrodata offers the MD-107 Memory System Analyzer. Employing Macrodata's field-proven cascaded-computer design, this new memory tester is ideally suited for LSI memory device manufacturers or users who want the flexibility of testing any kind of memory from chip to system without the expense of a large general-purpose test system.

The MD-107 is a low-cost dedicated system designed for zero overhead test pattern generation at up to 10-MHz rates. It is especially economical for testing memories requiring long test times. It is excellent for device evaluation of 4K RAMS's, or for parallel testing of up to 160 devices on a board or system for incoming inspection.

*Every single significant main-frame computer manufacturer is now using MD-107's for just these reasons. Many are testing devices such as the*

*Mostek Mk 4096, Intel 2107 Series, Motorola MC 6605, and the TI 4030 and 4050's on the MD 107.*

At a fraction of the cost of a general-purpose system, or a custom in-house set-up, the MD-107 dedicated tester not only thoroughly exercises the memory under test but also offers many special Macrodata features. Ask about our "diagnostic emulation." Check our powerful,

English-language, easy-to-use software, including such features as real-time error logging and CRT display of failed chips on a board. Find out for yourself why the MD-107 is the most useful and cost-effective memory tester you can buy for less than \$50K.

Send for a free brochure, or call or write for information about a demonstration.



## MACRODATA

Macrodata Corporation, 6203 Vanuel Avenue, Woodland Hills, California 91364, Phone: (213) 887-5550, Telex: 65-1345

Circle 125 on reader service card

# The EPC 2200.

## A hard copy recorder for spectrum analysis.

The new EPC Model 2200 is the first truly fine quality, low cost, hard copy recorder.

When matched with a spectrum analyzer or processor, the Model 2200 prints spectral data on a continuous dry paper display 19.2" wide. This hard copy history-plot presents 2,048 clearly defined data points per scan, revealing spectrum lines buried as much as 6db below the noise level.

The Model 2200 interfaces with digital and analog equipment, accepts a variable dump rate and permits flexible expansion or contractions of scale. It sweeps at speeds between 1/10 second and 8 seconds, and is mechanically virtually jitter-free.

The EPC Model 2200 is currently built in four modified formats. Further customization is possible. Write for information and a quote.

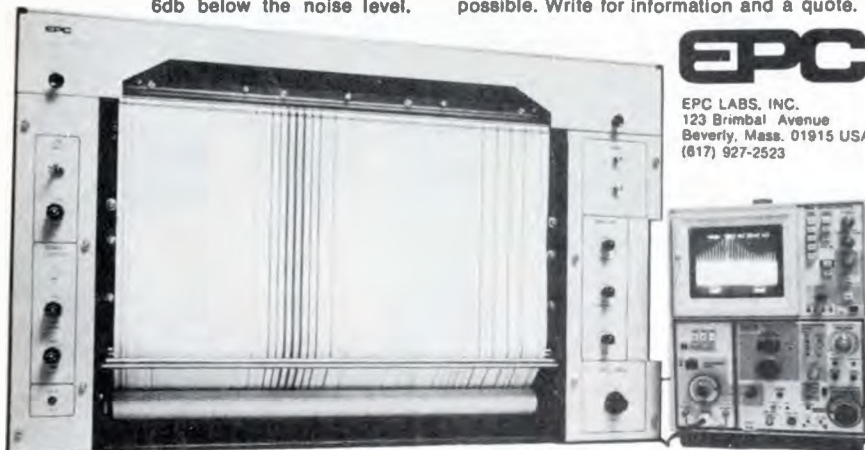

**EPC**

EPC LABS, INC.  
123 Brimbal Avenue  
Beverly, Mass. 01915 USA  
(617) 927-2523

Circle 126 on reader service card

## There's no RF energy crisis with RCA power tubes.

RCA's combined families of regular and large power tubes not only comprise the broadest line of such tubes in the industry, but they range in power all the way up to 250 kW... and in frequency to 1450 MHz.

Covering almost every major power tube application area, the RCA line also includes a comprehensive array of cavities and circuits. These cavities and circuits are specifically designed to enhance the advantages of RCA's power tubes. Together they achieve a total power package unmatched for reliable high performance.



For more information on the entire RCA power tube line, call your RCA Representative or RCA Industrial Tube Distributor, or complete and return the coupon.

**RCA Lancaster — where people and technology make the difference.**

Manager, Power Tube Marketing  
RCA, New Holland Avenue, Bldg. 100  
Lancaster, Pa. 17604

\_\_\_\_ Please send me the RCA Power, Frequency and Application Chart.

\_\_\_\_ Please have an RCA Representative call me. Telephone \_\_\_\_\_

— This is your mailing label. Please print. —

Name \_\_\_\_\_

Company \_\_\_\_\_

Street \_\_\_\_\_

City \_\_\_\_\_

State \_\_\_\_\_

Zip \_\_\_\_\_

**RCA** Power Tubes

### New products

9410 16-word-by-4-bit clocked read/write memory. In addition, the family contains five memories: two 1,024-bit RAMs, a 2,048-bit PROM, a 4,096-bit PROM, and an 8,192-bit ROM. The logic devices have a typical complexity of 150 to 250 gates per device. Propagation delays run about 3.5 nanoseconds per on-chip gate and about 5 ns per output buffer. Some of the devices are available immediately in sample quantities.

Fairchild Camera and Instrument Corp., Integrated Circuits Group, 464 Ellis St., Mountain View, Calif. 94042 [415]

### 25-ampere transistors

turn on in 300 nanoseconds

A family of high-current npn switching transistors has a power rating of 200 watts, a rise time of less than 300 nanoseconds, and a turn-off time of less than 1.25 micro-



seconds. Packaged in TO-3 cans, the transistors have maximum collector ratings of 25 amperes. Voltage ratings range from 100 v to 150 v. Prices, for 100-piece quantities, go from \$7.50 each for the 100-v 2N6338 to \$11.10 each for the 150-v 2N6341. Delivery is from stock.

General Semiconductor Industries Inc., P. O. Box 3078, Tempe, Ariz. 85281 [414]

Four-channel C-MOS driver stands by on only 2.5  $\mu$ W

Designed primarily to drive n-channel and p-channel multiple-FET analog switches, the model MEM 4900 four-channel driver uses C-MOS





# MOS memories

## TI's new 3rd generation 4K RAMs. 200ns speeds in 18-pin packages. And availability is now!

Texas Instruments brings you third generation 4K MOS RAMs: TMS4050-2 (200ns), TMS4050-1 (250ns) and TMS4050 (300ns). These compact 18-pin 4K RAMs offer even better board packing density than their 22-pin counterparts, as much as 70 to 100%.

Volume availability is now. The TMS4050s are in full production. They utilize the same single-transistor cell design and reliable N-channel silicon gate process as TI's popular TMS4030 4K RAM. This helps insure on-time delivery.

The TMS4050s have been made easy to use. All inputs, except clock, are compatible with Series 74 TTL,

	ACCESS TIME MAX	100-999 PRICE
TMS4050NL	300ns	\$19.64
TMS4050-1NL	250ns	\$21.64
TMS4050-2NL	200ns	\$24.62
TMS4050JL	300ns	\$22.78
TMS4050-1JL	250ns	\$25.07
TMS4050-2JL	200ns	\$28.56

while power dissipation is kept low (420mW operating, 0.1 mW standby, typically). A full 12-line address and single hi-level clock minimize system timing headaches. Plus, data input and output are multiplexed to provide a simple memory bus interface.

Compare prices (see insert). You can see that TI's TMS4050s offer the best performance at the lowest price. And why shouldn't they? TI has more experience in building 4K RAMs. Plus, volume production experience means lower cost-to-you – and higher PC board density.

The TMS4050-2, TMS4050-1, and TMS4050 are available through TI's authorized distributors in 18-pin plastic (NL) or ceramic (JL) packages. For data sheet, write Texas Instruments at P.O. Box 5012, M/S 308, Dallas, Texas 75222.



**TEXAS INSTRUMENTS**  
INCORPORATED



## Let's face it. People do judge by the cover.

Even the most sophisticated customers can't help being influenced by the way a product looks. That's why we're so careful about the design of our Optima enclosures. Because first impressions count.

Of course, we think about more than styling when we build our enclosures. We also design them with enough strength to last indefinitely. And we provide for just about any optional feature you might want. Detachable panels, chassis slides, hinged doors and the like.

The point of it all is real, honest quality. Optima enclosures are probably the very best you can buy. And they look it. And most important, that's how they can make your product look.

For a better idea of the broad range of Optima enclosures, ask for our color catalog.

### OPTIMA

Write Optima Enclosures, a division of Scientific-Atlanta, Inc.  
2166 Mountain Industrial Blvd., Tucker, Georgia 30084 or call (404) 939-6340  
Circle 128 on reader service card

## Cost Cutter

NEW Electronics Buyers' Guide...

Easy-to-use, single volume source for:

- Data on over 4,000 products
- Over 6,000 company listings and phone numbers.
- **EBG EXCLUSIVE:** quick access to over 1000 catalogs through a Direct Inquiry Service. The international world of electronics at your fingertips. Find suppliers... fast... accurately... and locally! For your copy send \$20.00 (USA and Canada only; elsewhere send \$30.00) to address shown below.



## Electronics Buyers' Guide

A McGraw-Hill Publication  
1221 Ave. of the Americas, New York, N.Y. 10020

## New products

technology to achieve a typical quiescent power dissipation of 2.5 microwatts. With TTL-compatible inputs, the quad driver can generate output swings to a peak of 15 volts. The MEM 4900 can therefore operate as a general-purpose voltage-level converter, as well as a switch driver. The device has an output capacitance of 8 picofarads, a propagation delay of 180 nanoseconds, and a frequency response to 5 megahertz. A chip-enable control allows the unit to perform logic operations on its inputs. The MEM 4900 is offered in 14-lead flatpack, 14-lead ceramic dual in-line package, and low-cost plastic packaging. The plastic units are priced at \$1.90 each in lots of 1,000. Delivery is from stock.

General Instrument Corp., MOSFET Marketing Group, 600 West John St., Hicksville, N. Y. 11802 [416]

## Electrically alterable ROM has access time of 2 $\mu$ s

Designed for applications that require frequent or periodic program changes, an electrically alterable read-only memory designated the PM-1000 provides storage capacity in increments of 256 words by 4 bits up to 1,024 words by 16 bits on a single 8-by-10-inch card. Applications include data security and scrambling, automatic telephone dialing systems, program storage for machine-tool control, table lookup, and transducer linearization and calibration. The PM-1000 uses MNOS storage devices and offers a write time of 11 milliseconds, a read time of 3.5 microseconds, and an access time of 2.0  $\mu$ s. Memory data is erasable in 100 ms and can be rewritten without removing the memory card from the user's system. The PM-1000 is sold in two basic configurations: the prototype version equipped with programing aids, and the bare version at OEM prices. Both are available with custom interfaces.

Plessey Microsystems Inc., 1674 McGaw Ave., Santa Ana, Calif. 92705 [417]



## Light-Reflecting Electromagnetic Display Components

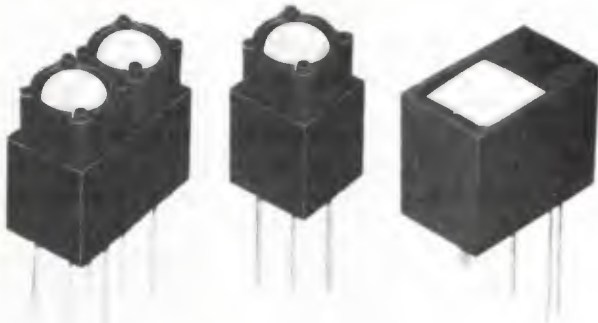

**SERIES 32**  
0.3 inch (7.62 mm)  
dual

**SERIES 30**  
0.3 inch (7.62 mm)  
single

**SERIES 50**  
0.5 inch (12.7 mm)  
single

### STATUS INDICATORS

**MEMORY** — inherent remanent magnetism maintains the display state.

**LOW POWER** — one milli-watt second set/reset energy. Zero power to retain state. Drive voltages from 3-48 volts.

**VISIBILITY** — rotating fluorescent discs and flags provide excellent visibility over a wide range of ambient light conditions and wide viewing angles.

**RELIABILITY** — only one moving part rated for over 20 million operations. No lights or mechanical linkages to wear out. Virtually maintenance free.

### FERRANTI-PACKARD STATUS INDICATORS

Ideal for

- Transient Recorders
- Industrial Process Displays
- Contact Status Indicators
- High Density Matrix Displays
- Portable Field Equipment.

Fluorescent discs and flags available in a range of colors.

The electromagnetic operation requires zero energy to maintain status.

Unique memory retention eliminates the need for memory circuits and reduces power supply and circuitry costs. Indicators are fully operational over a wide range of environmental conditions.

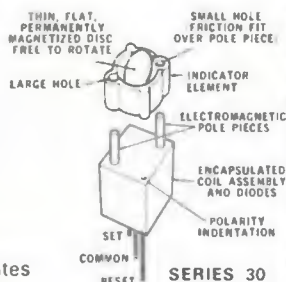

Ferranti-Packard's status indicators are light weight (Series 30, 0.17 oz (5 grams)) and are ideal for mounting on printed circuit boards and high density matrices.

For full information and specifications, contact the Display Components Department,

## FERRANTI-PACKARD LIMITED

ELECTRONICS DIVISION  
121 Industry Street,  
Toronto, Ontario, M6M 4M3, Canada.  
Telephone: (416) 762-3661  
Telex: 06-22007.

7304

Circle 170 on reader service card

# What's Practical Automation Doing With Digital Printers?



## Everything New!

When we designed our new miniature Matri-Dot Series of alphanumeric digital printers, we dedicated them to you and your customers. Matri-Dot printers represent a significant breakthrough in design, performance, and price.

### Built like a Practical Automation Printer means . . .

1. **Smallest Size** . . . only 3½"W x 3"H x 9"D
2. **Lowest Price** . . . \$140 in 100 unit quantity
3. **Full Alphanumerics** . . . a complete 63 character set
4. **Ribbonless Printing** . . . unique inked platen lasts for 75,000 lines
5. **Standard Interfaces** . . . RS232C and others
6. **18 Columns** . . . 110 character per second print rate

Six sound reasons to take the next important step . . . ask for a demonstration and become convinced!



**PRACTICAL  
AUTOMATION,  
INC.**

Trap Falls Road ■ Shelton, Connecticut 06484  
Tel: (203) 929-5381

Circle 129 on reader service card

### Instruments

# Generators lock to crystals

Function generators offer synthesizer precision at the major dial points

A crystal-controlled clock built into two models of its 180 series function generators allows Wavetek to add synthesizer-like precision to the versatility of a function generator. The clock circuitry causes the generators



to lock on frequency at the 20 or 25 major dial divisions on each of their higher-frequency ranges (those that span from 1 or 2 hertz on up). In addition to crystal stability, the models 181 and 183 offer full function-generator capability, including sinusoidal, triangular, square, TTL-pulse, ramp, and dc outputs; dc offset; voltage-controlled frequency; internal sweep; and 10-volt output into 50 ohms.

At each crystal-controlled frequency setting (XCG position), the generators have a maximum frequency error of 0.01%; the non-XCG specification for the 181 is 3% of full scale, while the 183 has a 2% spec. A panel indicator lights up to tell when the master oscillator is locked to the crystal. Lock time for the  $\times 1,000$  frequency range and higher is less than 500 milliseconds. For the  $\times 100$  range it's below 5 seconds, and for the  $\times 10$  range it is under 50 s.

The model 181 is priced at \$495. It covers 0.1 hertz to 2 megahertz in seven overlapping ranges. High (20

volts peak to peak unloaded) and low outputs (1 v pk-pk into 50 ohms), and a 30-decibel variable attenuator are included. Sweep time is continuously adjustable from 30 ms to 20 s. The unit is 11¼ inches wide, 3½ inches high and 10½ inches deep.

The model 183 covers 0.0001 Hz (2.7 hours per cycle) to 5 MHz. And in addition to the features of the 181, the 183 includes negative and positive pulse output, triggered and gated operating modes, frequency vernier, and an output attenuator that covers an 80-dB range (20 dB variable). This model is priced at \$695, and is similar in dimensions to the 181 except for its greater height of 5¾ inches.

Both generators have sine-wave distortion of less than 0.5% for the majority of their ranges. Square-wave rise and fall times are under 30 nanoseconds. Both instruments operate from all common international ac supplies.

Wavetek Corp., 9045 Balboa Ave., San Diego, Calif. 92123. [351]

### Analog Devices is 'second source' for meter

For the first time in its history, Analog Devices Inc. is producing a digital panel meter that is equivalent in form, fit, and function to another manufacturer's instrument—Weston's ac-line-powered, 3½-digit model 1230. Although generally known as an innovator, not a follower, Analog decided to effectively "second source" another company's product because, "we don't want to fight out in left field," explains Jim Hayes, marketing manager for digital panel meters.

Produced by Analog's Modular Instrumentation division, the new meter, called the AD2009, is quite similar to Weston's. It measures bipolar input voltages for full-scale ranges of either  $\pm 1.999$  volts or  $\pm 199.9$  millivolts, with a maximum error of  $\pm(0.1\%$  of reading + 1 count). The display is a 0.55-inch-high Beckman planar gas-discharge

unit with keep-alive cathodes that prolong tube life and maintain display brightness at low line voltages.

Where the Weston unit requires the use of an external resistor to set the decimal point, the AD2009 uses an internal resistor and an external jumper. Other than that, as far as the user is concerned, the instruments are essentially identical. They both use the industry-standard panel cutout of 3.924 by 1.682 inches, and the same pinouts for analog-high, analog-low, and power-supply connections. Hayes feels that eventually all DPM makers will have to go to a standard pinout, and he chose to model his meter on the 1230 "because it is a good unit and has the right form factor."

The AD2009 has DTL/TTL-compatible parallel BCD outputs and full conversion control including external trigger and hold as standard features. Another special feature of the AD2009 is its power transformer, which is mounted in a frame with two tabs that are crimped and soldered to the meter's printed-circuit board, thus helping it to better withstand shock and vibration.

The unit has an input impedance of 100 megohms, a bias current of 3 nanoamperes, and overvoltage protection to 200 v. It sells for \$140 in quantities of one to nine. Delivery is from stock.

Analog Devices Inc., Route 1 Industrial Park, Norwood, Mass. 02062 [352]

### Unit evaluates semiconductor power-handling capability

The heat-dissipation characteristics of power transistors and similar devices are hard to measure. So semiconductor manufacturers who have long been looking for a fast, convenient method for developing safe-operating-area curves for their devices, will welcome a system introduced by Zi-Tech last month at Intercon/75 in New York. Its PDA-1 power dissipation analyzer allows the user to investigate the thermal behavior of power devices by subjecting them to a programed

# 1953A Programmable Counter/Timer

## One of Fluke's 'New Breed' of powerful LSI/MOS counters

# \$849

U.S. price FOB Buffalo, N.Y.  
Remote programming and other options extra



**FLUKE**  
COUNTER DIVISION

John Fluke Mfg. Co. Ltd.  
Counter Division  
P.O. Box 1094 Station D  
Buffalo, N.Y. 14210  
Phone (716) 842-0311 TWX 610-492-3214

Circle 132 on reader service card

## NEW! OAK SNAP-IN TWO-LAMP PUSHBUTTON SWITCH



More circuitry for your money

- Up to 4 pole, 2 throw capacity
  - Single or split display
  - 100,000 cycle minimum life
  - Front relampable, T-1 3/4 lamp
- Contact your Oak Distributor for additional information on the Series 300 SL or write for Engineering Bulletin SP-730. For price and delivery quotations, call toll-free 800-435-6106

**OAK Industries Inc.**  
SWITCH DIVISION / CRYSTAL LAKE, ILLINOIS 60014

Circle 173 on reader service card

## PDP-11 DMA Interface

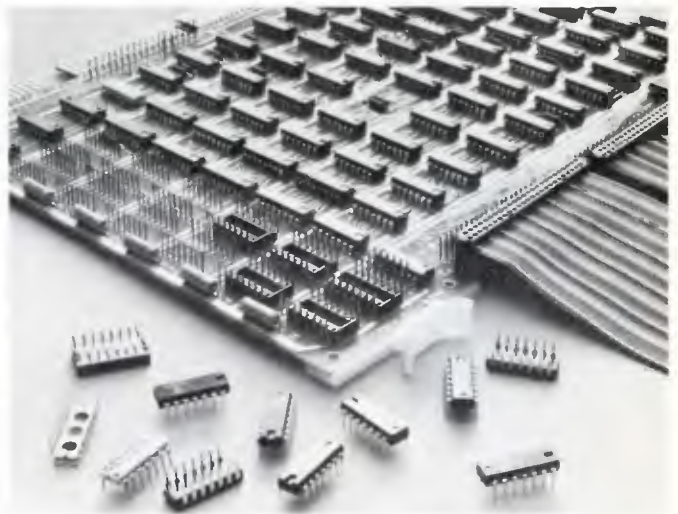

- Single Module, Requires Only One Quad Slot
- Space for 12 Positions of User Logic
- Expandable to 82 Positions of User Logic with One Additional Quad Slot
- Maximum Unibus Load is 1
- Selectable Command and Status Bit Assignments
- Has 16 Bit Input Register
- Price is \$850 versus \$1,490 from DEC, Delivery from Stock

**MOB** MDB Systems, Inc., 981 N. Main St.,  
Orange, CA 92667 (714) 639-7238

See us in booth 2553 at the NCC

Circle 174 on readerservice card 131

# Turn to page 7. Important? Sure...

By the time the office copy of **ELECTRONICS** gets to you, there's nothing left of page 7. It happens. Too often.

How often has **ELECTRONICS** wound up on your desk dog-eared and abused, with articles clipped out and ripped out? Or days, even weeks late?

How often has **ELECTRONICS**

never even made it to your desk?

You should be getting your copy of **ELECTRONICS** right off the press. You need it. Because it's important to stay on top of what's happening in your field. And **ELECTRONICS** is on top. **ELECTRONICS** is the Source. It's packed with up-to-date info, the breaking news of the electronic industries in the U.S. and worldwide.

You can get **ELECTRONICS** where you can find the time to read it—at home. Go to *the Source*, today. Fill out the subscription card enclosed in this issue, and send it off.

**Electronics**   
**IS THE SOURCE.**



## New products



amount of dissipation, and then measuring the rise in junction temperature. The temperature rise is determined by monitoring the device's base-emitter resistance.

According to Zi-Tech president G. C. Ziman, the PDA-1 is aimed at production test and quality assurance applications as well as at device engineering and evaluation. The instrument can be used to investigate secondary breakdown regions and is provided with circuitry for the detection of avalanche conditions.

The PDA-1 measures the resistance of a base-emitter junction by forward-biasing it with a constant current and measuring the resultant voltage drop. This drop is measured both before and after a programmed power dissipation. The dissipation can be programmed with respect to its voltage, current, and duration.

A complete PDA-1 thermal dissipation analyzer, including a 500-watt power supply and a display, sells for \$9,625. Delivery time is six to eight weeks.

Zi-Tech Div., Aikenwood Co., 223 Forest Ave., Palo Alto, Calif. 94302 [353]

## Dual variable filter

offers choice of responses

A dual variable filter consists of two identical filters in a common cabinet. Each filter can act as either a Butterworth (flat amplitude) or linear-phase (flat delay) device, and each can be either a low-pass or high-pass unit. The two response se-

# SCHOTT Makes Light Flexible ...UV-Light, too



SCHOTT

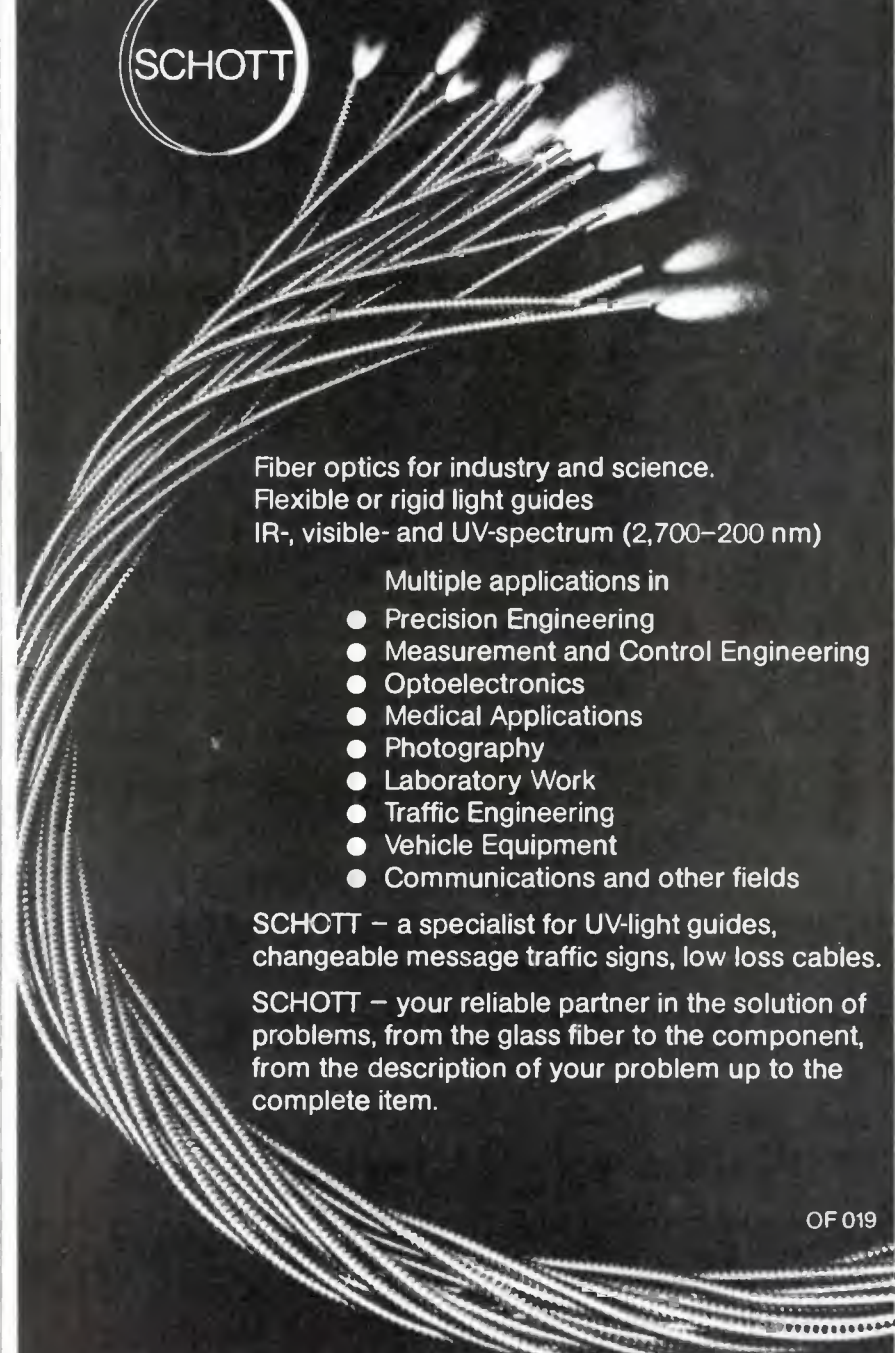

Fiber optics for industry and science.  
Flexible or rigid light guides  
IR-, visible- and UV-spectrum (2,700-200 nm)

Multiple applications in

- Precision Engineering
- Measurement and Control Engineering
- Optoelectronics
- Medical Applications
- Photography
- Laboratory Work
- Traffic Engineering
- Vehicle Equipment
- Communications and other fields

SCHOTT – a specialist for UV-light guides, changeable message traffic signs, low loss cables.

SCHOTT – your reliable partner in the solution of problems, from the glass fiber to the component, from the description of your problem up to the complete item.

OF 019

**Schott Optical Glass Inc.,**  
York Avenue DURYEA, PA 18642/USA  
telex 837 423, phone 001-717-457-7485

# No need to look further for a reliable R-F power source. MCL has one.



And here's what we built into it:

- solid state circuitry
- short and open circuit protection
- frequency stability  $\pm 0.1$  db
- external pulse or AM modulation
- internal square wave modulation
- low tube cost/operating hour
- qualified to MIL-STD-461 and 810

It has six different plug-in heads

Model	Freq. (MHz)	Pwr. (MIN)
6047	10-50	65
6048	50-200	65
6049	200-500	65
6050	500-1000	65
6051	1000-2000	40
6052	2000-2500	25

You have now ended your search for a stable, reliable 65 watt oscillator. Just call or write for detailed engineering data. Or ask for a demonstration

MCL, INC.,  
10 North Beach Avenue,  
LaGrange, Illinois, 60525.  
(312) 354-4350



Now on GSA contract GSOOS-27086 See us in EEM-Vol. 1 pp. 284-291

Circle 134 on reader service card

DESIGN ENGINEERING  
TECHNOLOGY AND CUSTOM  
MANUFACTURING  
FOR THE  
ELECTRONICS INDUSTRY  
PRECISION MACHINED  
FINISHED PARTS AND CLOSE  
TOLERANCE SHEET METAL  
ASSEMBLIES  
PROTOTYPES • PRODUCTION



**HARMONY ENGINEERING  
CORPORATION**

200 NORTH THIRD STREET, MINNEAPOLIS, MINNESOTA 55401  
CALL (612) 336-5784

LET US  
SAVE YOU  
TIME &  
MONEY

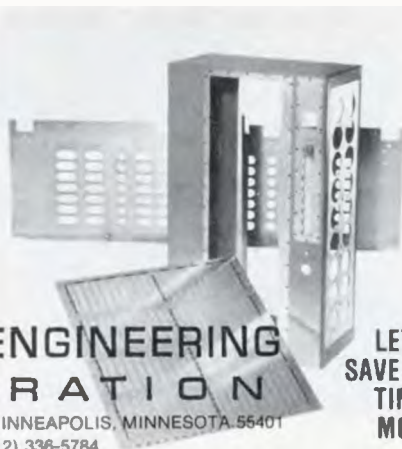

Circle 176 on reader service card

## New products



lections are made by means of front-panel push-button switches. The filters each span the frequency range from 0.1 hertz to 111 kilohertz and are adjustable with three-digit resolution. The filters may, of course, be connected in series or parallel for bandpass or band-reject operation. The dual filter comes in two models, identical except that the model 452 has a rolloff of 24 dB/octave while the model 852 has a rolloff of 48 dB/octave. Prices start at \$1,175. An option that extends the frequency range down to 0.01 Hz is available at extra cost.

Rockland Systems Corp., 230 West Nyack Rd., West Nyack, N. Y. 10994 [354]

## Unit aids in testing and designing with op amps

Designed to aid both in the testing of op amps and in the development of circuits using them, the model 101/102 is a self-powered instrument that requires no soldering for the interconnection of components. It contains two IC sockets for op amps, has a 10-kilohm potentiometer, includes two pairs of binding posts for input/output connections, and has 68 solderless tie points that work with ordinary 22-gauge solid wire. The \$19.75 model 101 comes with two 9-volt batteries, while the \$39 model 102 has a  $\pm 15$ -

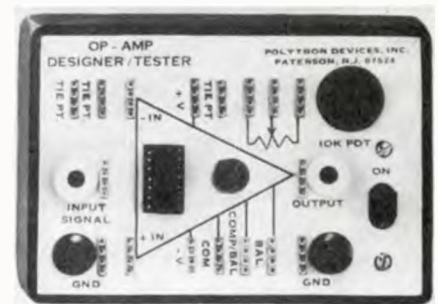

Electronics/May 1, 1975



v, 100-mA regulated supply. Delivery is from stock.

Polytron Devices Inc., P. O. Box 398, River Street Station, Paterson, N. J. 07524 [355]

### Dual-delayed-sweep scope resolves time to 100 ps

Capable of resolving time intervals to within 100 picoseconds, the model 1712A is essentially a lower-cost, stripped-down version of Hewlett-Packard's microprocessor-equipped 1722A oscilloscope. Instead of containing a microprocessor and a digital display, the 200-megahertz 1712A puts out an analog voltage proportional to the time interval indicated on the screen by a pair of markers. The analog voltage is sufficiently precise that its measurement with a 4½-digit voltmeter is justified. The 1712A has two switch-selectable input impedances: 50 ohms, and 1 megohm shunted by only 11 picofarads. It sells for \$3,100 (compared with \$4,500 for the 1722A). Delivery time is six to 10 weeks.

Inquiries Manager, Hewlett-Packard Co., 1501 Page Mill Rd., Palo Alto, Calif. 94304 [356]

### 11-MHz generator has pulse, sweep, and function modes

A combination pulse, sweep, and function generator, the model 7059, has a frequency range of 0.0001 hertz to 11 megahertz. The instrument provides all conventional function-generator waveforms—sine, square, triangle, and ramp signals—in addition to positive and negative pulses. Both the conventional function-generator waveforms and the pulses can be triggered or gated externally or from an internal trigger source. An internal sweep generator allows the 7059 to be swept over frequency ranges from 0 to 1,000:1. Carrying a price tag of \$895, the instrument is available from stock.

Dana Exact Electronics Inc., 455 S.E. Second Ave., Hillsboro Ore. 97123 [357]



## INTERNATIONAL'S **moe** CRYSTAL OSCILLATOR ELEMENTS

### A Complete Controlled Signal Source from 6000 KHz to 60 MHz

The MOE series is designed for direct plug-in to a standard dip socket. The miniature oscillator element is a complete source, crystal controlled, in an integrated circuit 14 pin dual-in-line package with a height of ½ inch.

Oscillators are grouped by frequency and temperature stability thus giving the user a selection of the overall accuracy desired. Operating voltage 6 vdc. Output wave shape — non sine.

TYPE	CRYSTAL RANGE	OVERALL ACCURACY	25°C TOLERANCE	PRICE
MOE-5	6000KHz to 60MHz	+ .002% -10° to +60°C	Zero Trimmer	\$35.00
MOE-10	6000KHz to 60MHz	+ .0005% -10° to +60°C	Zero Trimmer	\$50.00



Subassemblies

## Amplifier has low input drift

The latest addition to Analog Devices' 606 family of high-quality instrumentation amplifiers—the model 606M—has a maximum total input drift of 0.25 microvolt per degree celsius at a gain of 1,000. This, to-

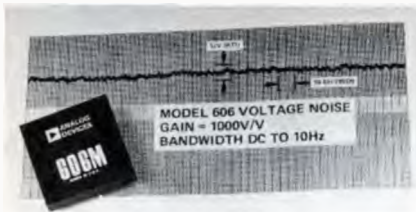

gether with the family's maximum nonlinearity of 0.002% [*Electronics*, Feb. 20, p. 147], makes the 606M the most nearly accurate commercially available instrumentation amplifier on the market today. Other key specifications include a maximum input-bias current of 60 nanoamperes, a maximum bias-current drift of  $-0.2 \text{ nA}/^\circ\text{C}$ , a maximum difference current drift of 1 nA, a maximum difference current drift of 20 picoamperes/ $^\circ\text{C}$ , and an input impedance (differential and common-mode) of 1,000 megohms shunted by 3 picofarads. The 606M is housed in a package 2 by 2 by 0.4 inch and consumes 75 milliwatts. Its small-quantity price is \$150.

Analog Devices Inc., P. O. Box 280, Norwood, Mass. 02062 [383]

### \$13 hybrid active filter spans 0.001 Hz to 25 kHz

Requiring at most four external resistors to make a complete low-pass, band-pass, high-pass, or band-reject filter, the UAF31 universal active filter is a hybrid integrated circuit that sells for only \$13 in hundreds. Covering the frequency range from 1 millihertz to 25 kilohertz, the two-pole unit allows the user to control resonant frequency, Q factor, and gain. The UAF31 uses the state-

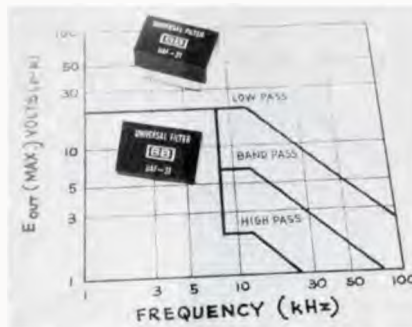

variable principle in which low-pass, band-pass, and high-pass outputs are available simultaneously. The band-reject function is obtained by summing the low-pass and high-pass outputs, using an uncommitted op amp that is included in the unit for this purpose. In unit quantities,

the UAF31 is priced at \$19 and is available from stock.

Burr-Brown, International Airport Industrial Park, Tucson, Ariz. 85734 [385]

### Hybrid reference source is accurate to within 0.02%

Packaged in a 14-pin hermetic dual in-line package, the MN2000 series of 10-volt precision reference sources offers a maximum initial error of less than 0.02% at 25°C, and the error is no more than 0.05% over the full operating-temperature range. For the commercial (0 to 70°C) units the small-quantity selling price is \$75 each, while the mili-

## Prices of data modules cut 60%

Bucking the price trend in subassemblies, Hybrid Systems Corp. has slashed by more than 60% the prices for a pair of data modules introduced a few years ago. One, originally called the 750 and now the 755, is a no-droop peak detector that can also operate as a sample-and-hold circuit. Its price drops from \$235 to \$99 each in purchases of one to nine. The second, originally the 850 and now the 855, is a peak-detecting 12-bit analog-to-digital converter. Its price plummets from \$235 to \$89.

Hybrid cites three factors in the cuts: components costs are lower today; the company is larger and can buy parts in higher volumes at lower unit prices; and it is hoped that the new prices will no longer confine the module to the laboratory but will open up commercial applications—in oil research, nuclear-power generation, and oceanography, for example.

Both modules monitor long-term or nonrepetitive signal variations. They use a digital storage technique that enables them to hold a sampled or peak analog voltage indefinitely. Basically, the external analog input and the output of an internal digital-to-analog converter are compared. When the two coincide, an internal clock is stopped and the information is held, virtually forever.

The analog output of the internal d-a converter is essentially the output of the 755's peak detector, and the digital inputs serve as the outputs for the 855's a-d converter. When operated in its sample-and-hold mode, the 755 has an acquisition time of 40 microseconds. As a peak detector, the device tracks at an average rate of  $0.25 \text{ V}/\mu\text{s}$ , according to the company.

The 855 offers a linearity within 0.2%. It is available with a 12-bit binary-coded output or a three-digit binary-coded-decimal output. Acquisition time is 1 ms and 250  $\mu\text{s}$ , respectively. Both modules are available from stock to within four weeks.

Hybrid Systems Corp., 22 Third Ave., Northwest Park, Burlington, Mass. 01803 [382]

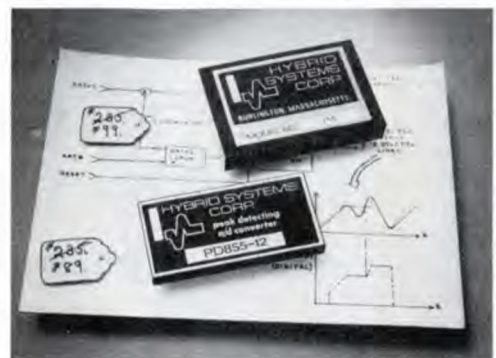

## New products

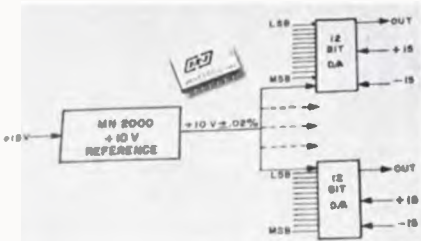

tary versions (-55 to 125°C) go for \$110 in similar quantities. Less-expensive units are also offered.

Micro Networks Corp., 324 Clark St., Worcester, Mass. 01606 [384]

## Eight-bit a-d converter has 1.25-MHz throughput

The model A-857 is an 8-bit analog-to-digital converter with a conversion time of less than 800 nanoseconds, corresponding to a data-throughput rate in excess of 1.25 million conversions per second. Packaged in a standard module of 2 by 2 by 0.4 inch, the unit contains its

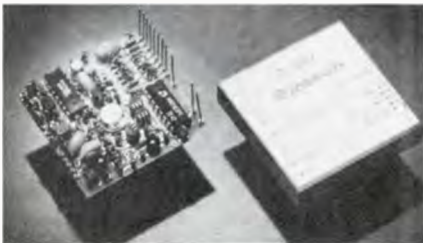

own precision voltage reference and clock. Maximum nonlinearity of the A-857 is half a least-significant bit, and maximum temperature drift is 100 ppm/°C. Price of the converter is \$199 in small quantities. Small-quantity delivery time is from stock to two weeks.

Intech Inc., 1220 Coleman Ave., Santa Clara, Calif. 95050 [386]

## 250-watt power supply weighs only seven pounds

A series of 250-watt switching regulated power supplies operate with efficiencies of about 80% and weigh only seven pounds. The units, which measure 3.65 by 5.05 by 12.25

## PINPOINT HEAT



Heat any I. C. or semiconductor component to its rated temperature with a heat probe. Accuracy  $\pm 1/2^\circ\text{C}$ . Or check the component's temperature with a thermocouple probe. Accuracy  $\pm 1^\circ\text{C}$ . Model 810 Thermo-Probe does both. Reads out directly in  $^\circ\text{C}$  and  $^\circ\text{F}$  on a large 4 1/2-inch meter.

**PRICE \$272.50 F.O.B. South Laguna**

Models with other temperature ranges available. For details write to:

**MTI MICRO-TECHNICAL INDUSTRIES**

P.O. Box 287 South Laguna, CA 92677  
714 545-3734 • TWX 910-587-3425 MICRO OHM ELM

Circle 177 on reader service card

## A new high performance low frequency generator

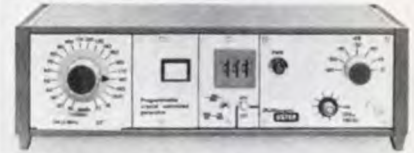

- 111 Hz–4000 Hz
- crystal controlled frequency
- phase locked loop system
- selector switch for 22 frequencies programmable in steps of 0.1 Hz by customer
- noise suppression for minimal phase locked loop phase jitter
- output: squarewave 10 V<sub>pp</sub> max into 50  $\Omega$ ; attenuator 0–60 dB in 10 dB-steps, accuracy  $\pm 0.1$  dB
- option: number of output-cycles presettable from 1 to 999 cycles

Please ask for further details

*Zellweger*  
**USTER**

Zellweger Uster Ltd.  
CH-8610 Uster/Switzerland  
Phone 01/87 67 11 Telex 53 587

Circle 137 on reader service card

## Could you build a \$200 Rolls?



Send for this free brochure and find out.

The classic Rolls Royce Phantom II Sedan Coupe. 26-1/2" long. Reproduced in exact 1/8 scale in Pocher d'Italia's incredibly authentic car model kit. You build it with nuts and bolts and screws. No painting, no special tools needed. Doors, hood and trunk open. Steering, crankshaft, connecting rods, gears, fan, generator operate. Windows open. Headlights turn on. 2,199 separate parts of brass, stainless steel, copper, rubber, high-impact plastic. Complete details on this and three other classic car kits from \$100 in our free full-color brochure.

Deluxe Classics, Dept. WE9  
5900 Wilshire Boulevard, Suite 2760  
Los Angeles, California 90036

Please send me your free full-color brochure.

Name: \_\_\_\_\_

Address: \_\_\_\_\_

City: \_\_\_\_\_

State/Zip: \_\_\_\_\_

## Top Quality MAGNETIC HEADS



model  
SM-SIS  
differential  
transformer type

ultra high sensitivity magnetic head for paper money exchanger, etc.



model  
MSP-6

- 6 in 1  
cassette stereo head for  
auto reverse  
play / record / erase

**SAN-E** SAN-E DENKI CO., LTD.

110-1, Minami Kawahori, Tennoji-ku,  
OSAKA, JAPAN  
PHONES: OSAKA (06) 779-1591  
CABLE: SANMAGNETICS OSAKA

Circle 138 on reader service card

## Is there a Teleprinter Serviceman in the House?

You can get one—quick. Just dial (609) 779-4129. You'll get the facts about RCA service: contractual, per call, or emergency. Coast-to-coast service is offered by RCA for the account of the manufacturer and large user. Check on it. Phone today, or if you prefer, write RCA Service Company, A Division of RCA, Bldg. 204-2, Camden, N.J. 08101.

# RCA

138 Circle 178 on reader service card

## New products



inches, come with five output voltages: 5, 12, 15, 18, and 24 v dc. Standard features include over-voltage protection, and selectable input voltages of 115 or 230 v ac from 47 to 440 Hz. Options include remote on-off control, paralleling, and master-slave paralleling of as many as 10 units. Price is \$360.

LH Research Inc., 2052 South Grand Ave., Santa Ana, Calif. 92705 [388]

## Thick-film circuit controls up to 240 volts

A thick-film hybrid circuit, designated Solid-Stat, controls ac voltages as high as 240 volts and is available in 5-, 10-, and 15-ampere ratings at 120 or 240 v ac. It is housed in a high-density molded package and offers void-free passivation and high thermal conductivity. The unit requires no additional components for operation and has an isolation of 1,600 v ac. It may be operated at full rated current up to 70°C. Price of the 15-A, 240-v unit is \$10 each in OEM quantities, and delivery time is stock to four weeks after receipt of order.

Electramation, 666 17th St., Santa Ana, Calif. 92701 [389]



## Large and medium scale integration: Keep up with this fast changing technology

Now, in one comprehensive volume, a complete working grasp at large and medium scale integration for electronics engineers engaged in the design of electronic systems, equipment and products.

A wealth of practical working data on large and medium scale integration has been culled from the most important articles in Electronics magazine by Samuel Weber, Executive Editor. Emphasis is on design problems at the system or subsystem level, as well as on the economics of today's design.

Whatever the design problem — from partitioning a digital system to working with a semiconductor company in producing the best LSI design, this book covers the full range of today's important technologies on a practical, rather than a theoretical, level.

It's yours for \$15.00. Keep up.

FREE 10-DAY EXAMINATION

McGraw-Hill Book Company  
1221 Ave. of the Americas,  
New York, N.Y. 10020



Send me a copy of Large and Medium Scale Integration (068815-X) for 10 days on approval. At the end of that time, I will either remit \$15.00, plus tax, postage, and handling, or return book without further obligation. (Remit in full with this coupon, plus any tax, and McGraw-Hill pays all postage and handling costs.)

Name \_\_\_\_\_

Address \_\_\_\_\_

City \_\_\_\_\_

State \_\_\_\_\_ Zip \_\_\_\_\_

Offer good only in the U.S. and subject to acceptance by McGraw-Hill. For prices outside U.S., contact McGraw-Hill Book Co.

23 K138-4018-3

## New literature

**Wirewound resistors.** A 36-page engineering handbook on precision and power wirewound resistors, including a military-style cross-reference chart, is being offered by RCL Electronics Division, AMF Inc., 700 South 21 St., Irvington, N. J. 07111. The handbook covers low-cost commercial resistors, DIP networks, 2-watt molded units, high-reliability devices, beryllia-core resistors, hermetically sealed precision units, and others. Circle 421 on reader service card.

**Handling magnet wire.** "Production Processing Tips for Magnet Wire Users" is a 12-page compilation of 14 articles on such topics as reducing winding tensions and breakage problems in the dereeling and winding of magnet wire. The booklet can be obtained from The Anaconda Co., Wire and Cable Division, Magnet Wire, Glen Hill Office Park 8, Glen Ellyn, Ill. 60137 [422]

**Wrought nickel silvers.** A technical bulletin on the physical, mechanical, and chemical properties of various nickel silvers (alloys of copper, nickel, and zinc), including a comparison with copper alloy No. 725, which is widely used in electronics applications, has been issued by The International Nickel Co., Inc., One New York Plaza, New York, N. Y. 10004. The bulletin is No. A-421, and is entitled "Engineering Properties of Wrought Nickel Silvers." [423]

**Disk care.** An eight-page brochure that describes recommended methods for cleaning, inspecting, handling, and storing disk packs and cartridges is available from Computer-Link Corp., 14 Cambridge St., Burlington, Mass. 01803 [424]

**Chip capacitors.** "Understanding Chip Capacitors" is the title of a reference handbook published by Johanson/Monolithic Dielectrics Division, Box 6456, Burbank, Calif. 91505. The 32-page handbook, which gives details on all phases of chip-capacitor technology, includes 22 graphs and seven tables. [426]

## Precision Resistor Networks. We Make Them All. In Quantity.

Need tight temperature performance . . . close ratios . . . tolerances better than 0.006% . . . HyComp's unique thin-film resistor capability is ready.

Whether in chip form, flat pack, or DIP, HyComp can guarantee <1ppm/°C ratio tracking, TC's <25ppm/°C, laser trimmed accuracy to better than 0.006%, and full processing to Mil-Std 883.

Who knows . . . our library of standard networks may have your network . . . with 46 off-the-shelf standards to pick from. Call (617) 897-4578 for applications assistance . . . they'll know.

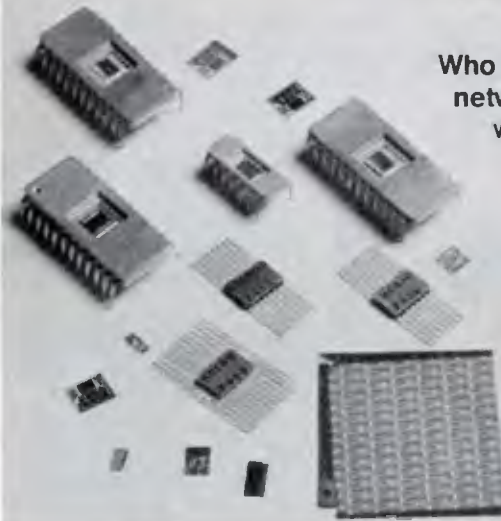

HyComp



HyComp, Inc.  
146 Main Street  
Box 250  
Maynard, MA 01754  
(617) 897-4578

Circle 139 on reader service card

## CUSTOM DESIGNED power supplies to your specs

- Small size • Lightweight • High efficiency • Low output noise • High reliability • Short and overload protection • Plug-in modular construction

TerraCom has developed high performance power supplies for use in critical applications. If your requirement is for a high frequency, low noise, lightweight and small power source, a TerraCom supply is the solution. TerraCom specializes in supplies for use in extreme environments where high reliability and excellent performance are important. Contact TerraCom for successful custom designs of the right supply for your requirement.

WRITE OR PHONE:  
for data sheets on  
typical power supplies  
TerraCom  
9020 Balboa Ave.  
San Diego, CA 92123  
(714) 278-4100

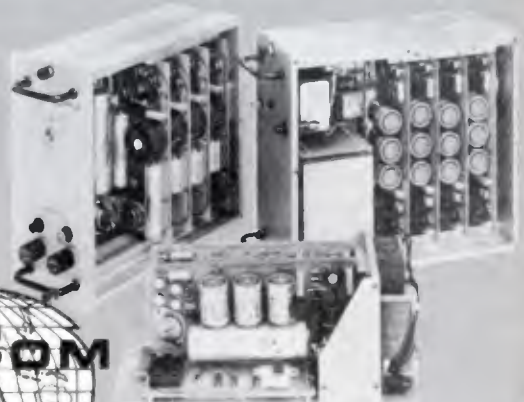

# “Business is lousy— let’s cut the advertising”

## Seven things to consider about advertising in a market downturn.

1.

*The boom didn't last forever—and neither will the bust.*

In mid-1973, we published the first editorial in this series. The headline was “*Advertise? I can't even deliver the orders I've booked.*” In that editorial, we pointed out that part of the boom wasn't real (multiple orders and inventory build), that the backlog crunch would be substantially over by mid-1974, and that *short-term* business conditions were no reason to change the *long-range* marketing strategy of which advertising is an important part.

The same kinds of comments are pertinent today. Many sectors of the electronics industries appear to have bottomed already. The others will start back up during the 2nd half of 1975, depending on how long it takes in each case to clean out

the excess inventory that was produced in 18 months of boom. We have to be thinking *now* about the kind of business we want to develop for the latter part of 1975 and beyond.

2.

*There are still lots of markets that are solid, even growing.*

Government-funded electronics markets are strong, and promise to remain so at least through 1976. Consumer electronics is soft, but really can't go much lower. TV and audio can show some growth this year, and specialized products like intrusion alarms, microwave ovens, and digital clocks and watches should show growth rates of at least 25% in 1975. In the industrial/commercial sector, lower interest rates should hypo the capital-goods markets in the latter part of the year, with microcomputers, minis, data communications hardware, and process control instrumentation achieving excellent gains. Your advertising can pinpoint your product offerings to these growth sectors to achieve *near-term* sales payoff.

3.

*Orders may drop, but they don't disappear.*

In the last three recessions, the average drop in orders was 21%, compared to the previous boom cycle. That means 79% of the orders were *still there*. But getting orders in a shrinking market means taking them away from competition. In the last boom, many of your Charley-Low-Ball competitors—who normally only get business on price—got business away from you on *delivery*. Business you deserved, based on the values you bring to the marketplace.

But in a buyers' market, buyers buy what they *prefer*. Advertising is the cheapest, most efficient way to build preference—to remind customers why they really *want* to buy from you, and to get that lost business back.

4.

*A downturn is a time of great marketing opportunity.*

The opportunity is twofold. First, to *improve share-of-market*. Your competitors are retrenching, pulling in their horns, cutting back on advertising, marketing, and new-product investment. The “noise level” is dropping. If you even *maintain* your marketing

# budget”

presence, your messages will be heard—and acted upon—much more clearly than before. If you *increase* your marketing investments, you will come out of the slump much stronger than you went into it.

7 Second, you have the *opportunity to be creative*. Gone are the days when you and your sales staffs were spending all your time expediting the factory. It is a pause during which you can seek new applications, plan new directions, and develop new business potentials for the future. Advertising can help. It is the lowest-cost market development tool available to you. Because it will help the new customer to *find you*.

## 5. *To take advantage of these opportunities, you must increase total selling effort.*

The problem, of course, is *how*? You are trying to hold down costs, to spend money prudently in the face of backlog and shipment declines. At the same time, the cost of everything is going up. The average cost of an industrial salesman's call is now over \$70. But advertising is cheap. It remains the *least expensive* way to make a major impression in your markets. If ever there was a time to re-think the allocation of your marketing expenditures between direct selling and advertising, the time is *now*.

## 6. *Dollar for dollar, good advertising is the most efficient sales tool in a market downturn.*

Every study ever made of industrial advertising in a recession period comes to this inescapable conclusion: Companies which do not cut advertising investment in a recession achieve higher sales and earnings *during* the recession, and come out of the recession with dramatically increased sales, earnings, and *share of market*—compared to companies which do cut advertising. The latest study, covering the 1970-71 downturn, has just been published. It is available from the American Business Press, Inc., 205 E. 42nd St., New York, N.Y. 10017. It costs \$1.08. Write for it.

## 7. *What kind of advertising works best in a downturn?*

Good advertising. Consistent advertising. Advertising that is honest, straightforward, well thought out, and based on the right kinds of objectives. The same kind of advertising that works in boom times and “normal” times. If you want to know more about our views on

what makes good advertising, write for the pamphlet mentioned below.

### *Do important customers read advertising?*

*Yes*. If you've gotten this far, you've helped prove our point. People don't stop reading ads in a recession. If it works for us, it will work for you.



Daniel A. McMillan III  
Publisher



*This is a reprint of a speech presented at 1974 WESCON on Fundamentals of Advertising in the Electronics Press. If you would like a copy, send me the coupon below.*

To: Dan McMillan, Publisher  
Electronics  
1221 Avenue of the Americas  
New York, N.Y. 10020

Please send me a reprint of "Fundamentals of Advertising in the Electronics Press."

Name \_\_\_\_\_

Company \_\_\_\_\_

Street \_\_\_\_\_

City/State/Zip \_\_\_\_\_

**Electronics**   
**THE SOURCE.**

# Electronics advertisers

May 1, 1975

■ <b>ACDC Electronics, Inc.</b> Rose Associates Advertising & Public Relations	62	■ <b>Grayhill, Inc.</b> Stral Advertising Company, Inc.	38	■ <b>Practical Automation, Inc.</b> Carol Marketing Associates	129
■ <b>Acme Electric</b> Rumrill-Hoyt, Inc.	3rd Cover	■ <b>Harmony Engineering Corporation</b>	134	■ <b>Premier Metal Products Corporation</b> Commercial Press, Inc.	97
• <b>Adelisy</b> Studio CPM	24	■ <b>Hewlett Packard</b> Tallant/Yates Advertising, Inc.	46-47	■ <b>RCA Service Company</b> Al Paul Lefton Company, Inc.	126,138
■ <b>Advanced Micro Devices</b> Keye Donna Pearlstein	11	■ <b>Hewlett Packard</b> Richardson, Seigle, Rolfs & McCoy, Inc.	1	■ <b>RCA - Solid State Division</b> Marsteller, Inc.	66-67
‡ <b>Allen Bradley Company</b> Hoffman, York, Baker & Johnson, Inc.	24	■ <b>Hewlett Packard</b> Phillips Ramsey Advertising & Public Relations	2	‡ <b>Rental Electronics, Inc.</b> Humphrey Browning MacDougall, Inc.	54
■ <b>Aluminum Company of America</b> Ketchum, MacLeod & Grove, Inc.	74	■ <b>Honeywell Test Instrument Division</b> Campbell-Mithun, Inc.	28	■ <b>Reticon Corporation</b> The House Agency	65
■ <b>American Microsystems, Inc.</b> Wilton Coombs & Colnett, Inc., Advertising	103	■ <b>Hughes Aircraft Company</b> Foots, Cone & Belding	35	• <b>Rhone Progil</b>	19E
■ <b>American Optical Corp., Fiber Optics &amp; Industrial Prod. Division</b> Wilson, Haight & Welch, Inc., Advertising	97	■ <b>HyComp, Inc.</b> Fred Molinar Associates	139	• <b>Rohde &amp; Schwarz</b>	1E
■ <b>American Used Computer Corporation</b> McDavitt Advertising	144	■ <b>International Crystal Manufacturing Company</b> Robert V. Freeland & Associates	135	■ <b>San-e Denki Company Limited</b>	138
■ <b>Augut</b> Creamer, Trowbridge, Case & Bastford, Inc.	48,100	■ <b>Interstate Electronics Corporation</b> Chris Art Studio, Inc.	97	■ <b>Sangamo Electric Company</b> Batz-Hodgson-Neuwoehner, Inc.	92
■ <b>Ballantine Laboratories, Inc.</b> MLF Graphics	61	• <b>Invest Export Import</b> Interwerbung	15E	■ <b>Scientific Atlanta/Division</b> Rantere, Saslaw, Mohr and Associates, Inc.	128
• <b>Beckman Instruments Limited</b>	57	• <b>ITT Cannon</b>	5E	• <b>Selmar</b> CPM Studio	13E
‡ <b>Beckman Instruments Inc., Hellpot Division</b> N.W. Ayer, Jorgensen, MacDonald, Inc.	52	■ <b>Jensar Glaswerk</b> Dipl.-Kfm	133	• <b>Seecom</b> Bazaine Publicite	23E
‡ <b>MGR/Bussmann Manufacturing Division</b> Media/Marketing Service Center, Inc.	57	■ <b>Kelthley Instruments</b> Chagrin Valley Marketing Associates	119	■ <b>SGS-ATES International</b> McCann-Erickson	9
■ <b>Chicago Dynamic Industries</b> Burton Browne Advertising	123	• <b>Kennedy Company</b> R.L. Thompson Advertising	25E	• <b>Siemens Karlsruhe</b> Linder Presse Union	52
■ <b>Cramer Division of Conrac</b> McCarthy, Scolba, DeBiasi Advertising Agency	8	■ <b>Krohn-Hite Corporation</b> Impact Advertising, Inc.	5	■ <b>Simpson Electric Company</b> Amerad Advertising Services, Inc.	39
■ <b>Dale Electronics., A Sub. of the Lionel Corporation</b> Swanson, Sinkay, Blits, Inc., Advertising	4th Cover	■ <b>Litronix, Inc.</b> Bonfield Associates	12-13	• <b>Sodeco SAIA</b> Stocker	54
■ <b>Datum, Inc.</b> Data Advertising	71	• <b>Logebax</b>	26E	■ <b>Sorensen</b> Grover & Erickson, Inc.	14-15
‡ <b>Delco Electronics Division, General Motors Corporation</b> Campbell-Ewald Company	44-45	■ <b>Macrodata Company</b> JMR Advertising	125	• <b>Spectrol Reliance Limited</b> JMR Advertising	20E-21E
■ <b>Delevan Division, American Precision Industries, Inc.</b> Comstock Advertising, Inc.	18	• <b>Magneti Marelli</b>	2E	■ <b>Sprague Electric Company</b> Harry P. Bridge Company	43
■ <b>Dialight Corporation</b> Michael-Cather, Inc.	123	■ <b>Martin Research Company</b> Studio 23	144	• <b>STS SpA</b> Studio Dr. giuliano Blei	7E
■ <b>Doric Scientific Corporation</b> Noonan Public Relations and Advertising	112	■ <b>MCL, Inc.</b> Huwen & Davlew, Inc.	134	■ <b>Tally Corporation</b> Bonfield Associates	8
• <b>Ducati Eletrotecnica Microferad</b> Studio Busoli Gastone	22E	■ <b>MDB Systems, Inc.</b> The Sunshine Group	100,131	■ <b>Tanator Electronics</b> Devey, Thompson & Vignola Advertising, Inc.	6
■ <b>Electromask, Inc.</b> JMR Advertising	120	■ <b>Micro Power Systems</b> Associated Ad Ventures, Inc.	117	• <b>Tekeloc Altronic</b> S.P.F.D.	27E
■ <b>Electronics Components Conference</b>	144	■ <b>Micro Technical Industries</b> R.E. Sylvester Advertising Agency	137	■ <b>Tektronix, Inc.</b> Tektronix Advertising	33
■ <b>Electronics/Deluxe Classics</b> Gumpertz Bentley Fried/Scott	137	■ <b>Motorola Semiconductor Products, Inc.</b> E.B. Lane & Associates, Inc.	37,41	■ <b>Teledyne Semiconductor</b> Regis McKenna, Inc.	7
■ <b>Electronic Measurements, Inc.</b> Hill Advertising Agency	42	■ <b>National Electronics</b> Lea Advertising	64	■ <b>Teradyne, Inc.</b> Quinn & Johnson, Inc.	58
■ <b>Electronic Navigation Industries</b> Hart/Conway Advertising - Public Relations	16	■ <b>National Semiconductor Corporation</b> Chiat/Day, Inc. Advertising	110-111	■ <b>TerraCom</b> Manning/Bowen and Associates	139
■ <b>EPC Labs, Inc.</b> Superfine Productions	126	■ <b>Nelson Ross Electronics, Division Polarad Electronics</b> McCarthy, Scolba, DeBiasi Advertising Agency, Inc.	2nd Cover	■ <b>Texas Instruments - Scientific Calculators</b> Tracy-Locke	127
■ <b>Erie Technological Products, Co., Inc.</b> Altman Hall Associates Advertising	17	■ <b>Newport Labs</b> Manning/Bowen and Associates	114	■ <b>Union Carbide Corporation</b> J.J. Lane, Inc.	115
■ <b>Fabri-Tek, Inc.</b> Midland Associates Inc., Marketing and Advertising Services	84	■ <b>Nippon Electronic Memory Ind. Co., Ltd.</b> Nihon Keizasha Advertising Ltd.	40	■ <b>Unitrode Corporation</b> Schneider Parker, Inc.	27
■ <b>Fairchild Semiconductor, Inc.</b> Carson/Roberts, Inc. Advertising Division of Ogilvy & Mather, Inc.	19-22	■ <b>North Electric Co. - Electronics Division</b> Marc Associates	100	■ <b>Universal Instrument Corporation</b> Commercial Art Service Graphics	122
■ <b>Ferranti-Packard</b> Huxley-Irwin-Price, Limited	129	■ <b>Oak Industries, Inc. Switch Division</b> Stral Advertising Company, Inc.	131	■ <b>U.S.C.C.</b> S. Michelson Advertising	16E-17E
■ <b>John Fluke Mfg. Co., Ltd.</b> Lennox Marketing Limited	131	• <b>Oscilloquartz SA, Neuchatel</b> Publicites Service International	28E	■ <b>Wavetek Indiana Inc.</b> Chapman Michetti Advertising	45
■ <b>FMC Corporation - Semiconductor Products Operation</b> DeSales Advertising, Inc.	73	• <b>Philips N.V. PR/T&amp;M Division</b> Brockles Communications Systems SA	10E-11E	■ <b>Zellweger AG</b> George & Thomas Vetter	137
• <b>Ganz Measuring Instruments</b> Hungexpo Varosliget	12E	■ <b>Philips Test &amp; Measuring Instruments, Inc.</b> G.A.D.	23		
■ <b>Gould Inc./Instrument Systems Division</b> Carr Liggett Advertising, Inc.	123	■ <b>Phoenix Data, Inc.</b> Craig Miller Advertising	121		
		• <b>Piher International Ltd.</b> Scott MacTaggart Advertising Limited	9E		
		■ <b>Powertec, Inc.</b> Warren C. Wilson & Associates	51		

■ For more information on complete product line see advertisement in the latest Electronics Buyers' Guide  
\* Advertisers in Electronics International  
‡ Advertisers in Electronics domestic edition



# FEATURE ARTICLES FROM ELECTRONICS MAGAZINE ARE NOW AVAILABLE IN REPRINT FORM!

Valuable additions to your electronics library are now available thru this exclusive reprint service. Just check the articles you wish to order and enclose check or money order for prompt service.

No. of Copies Wanted		No. of Copies Wanted	
_____	R- 11 Computer-Aided Design .....	_____	R-310 Penetration Color Tubes are Enhancing Information Displays .....
_____	R- 15 Special Report on LSI Packaging .....	_____	R-312 Leadless, Pluggable IC Packages Reduce Costs .....
_____	R-016 Special Report on The Transistor: Two Decades of Progress .....	_____	R-316 Hybrid Circuit Technology Solves Tough Design Problems .....
_____	R- 18 Reshaping the EE for the Seventies .....	_____	R-318 Buckling Up for the Bumpy Road to Detroit. ....
_____	R-023 Special Report: Tomorrow's Communications.....	_____	R-320 Planar Interconnection Techniques (Designer Must Plan Early for Flat Cable) .....
_____	R-027 Consumer Hazards: Why They Happen, How They Can Be Fixed .....	_____	R-322 Special Report: The New Displays Complement the Old .....
_____	R-031 Circuit Designer's Casebook (U.S. Only) .....	_____	R-324 Semiconductor Memories Are Taking Over Data-Storage Applications .....
_____	R-032 Active Filters .....	_____	R-326 Optical Spectrum Report and Optical Spectrum Chart .....
_____	Infra-Red Detector Chart	_____	R-328 Pervasiveness of Electronics Entire Issue of Electronics .....
_____	R-101 Special Report: The Right Numeric Readout, a Critical Choice for Designers .....	_____	R-500 Japanese Forecast 1975 .....
_____	R-104 The New Concept for Memory and Imaging: Charge Coupling .....	_____	R-502 European Forecast 1975 .....
_____	R-107 Wanted for the '70s: Easier-to-Program Computers .....	_____	R-504 U.S. Forecast 1975 .....
_____	R-110 Automation for Survival and Profit .....	_____	R-406 Logics New Design Tools .....
_____	R-113 Optoelectronics Makes It At Last (3 part series) .....	_____	R-408 Bringing Sight to the Blind .....
_____	R-203 East Europe Market Report .....	_____	R-410 Passive Components .....
_____	R-205 Bridging the Analog & Digital Worlds with Linear ICs .....	_____	R-412 Liquid Cooling Semiconductors .....
_____	R-207 Technology Gap Starts to Close for Computer Peripherals .....	_____	R-414 Simplified n-Channel Process .....
_____	R-209 Semiconductor RAMs Land Computer Mainframe Jobs .....	_____	R-416 Optical Waveguides Look Brighter .....
_____	R-211 Electromagnetic Spectrum Report and Foldout Chart .....	_____	R-418 Computer Analyses of RF Circuits .....
_____	R-213 Electromagnetic Spectrum Chart (rolled in mailing tube) .....	_____	R-420 Computerized Text-Editing and Typesetting ...
_____	R-306 Charge Coupling Improves Its Image, Challenging Video Camera .....	_____	R-422 A Microprogrammable Minicomputer .....
_____	R-308 Program for Transition from NonLinear to Linear Transistor Model .....	_____	R-424 Microprocessor Applications .....
		_____	R-426 Special Issue—Technology Update—1974 .....

3 FOR  
\$7.50

## Payment must accompany your order...USE THIS PAGE AS YOUR ORDER FORM

Make check or money order payable to Electronics Reprints. All orders shipped prepaid via parcel post. Allow two to three weeks for delivery.

Back Issues Now Available. 1960 to 1969 \$5.00 each. 1970 to 1973 \$3.00 each.

Mail Your Order To  
Janice Austin  
**ELECTRONICS REPRINTS**  
P.O. Box 669  
Hightstown, N.J. 08520

Amount of Order	\$ _____
Plus 10% Handling Charge	\$ _____
<b>TOTAL AMOUNT ENCLOSED</b>	<b>\$ _____</b>

### SEND REPRINTS TO

Name \_\_\_\_\_  
Company \_\_\_\_\_ Dept. \_\_\_\_\_  
Street \_\_\_\_\_  
City \_\_\_\_\_ State \_\_\_\_\_ Zip \_\_\_\_\_

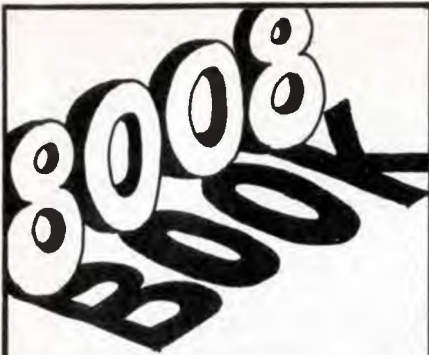

Designing a microcomputer around the 8008? You need *Microcomputer Design*. Over 300 pages of hardware design ideas simplify the tangled TTL in the published circuits. Helps build increased performance and lower cost into your system. Great for OEMs evaluating the 8008. Ideal for college-level study.

- Book with 8008 for \$100.
- With 8008-1 (60% faster) \$110.
- Book with 8080 for \$200.
- Book alone, \$75. Quantity discounts are available. (U.S. prices; Ill., + 5%)



**MARTIN RESEARCH**

Suite 330/1825 South Halsted St.  
Chicago, Ill. 60608/312 . 829 . 6932

Circle 144 on reader service card

**RENT A MINI**  
**1 DAY DELIVERY**  
DEC PDP 8I(4K)  
DEC PDP 8L(8K)  
ASR 33

**FOR SALE**

**MINIS DEC • DG • CAI • GTE**  
**HP • HIS • IBM • INT**  
**LOCK • MICRO • SEL**  
**VARIAN • XLO**

**PRINTERS MDS 4330—\$2950**  
**CDC 9322—\$2500**  
**DP 2440 — \$7500**

**CARD READERS GDI 100 \$450**  
**\$950**

**PAPER DIGITRONICS 2500 \$350**  
**TAPE CHALCO • BRPE 21 \$250**

**MAG PERTEC • WANGCO**  
**TAPE POTTER • AMPEX**

**617-261-1100**

**AMERICAN USED COMPUTER CORP.**  
P.O. Box 68, Kenmore Sta., Boston, MA 02215  
member COMPUTER DEALERS ASSOCIATION

**Advertising Sales Staff**

**Pierre J. Braudé** New York [212] 997-3468  
Paris Tel. 720-73-01  
Director of Marketing

**Atlanta, Ga. 30309:** Warren H. Gardner  
100 Colony Square, 1175 Peachtree St., N.E.  
[212] 997-3617

**Boston, Mass. 02116:** James R. Pierce  
607 Boylston St. [617] 262-1160

**Chicago, Ill. 60611:**  
645 North Michigan Avenue  
Robert W. Bartlett (312) 751-3739  
Paul L. Reiss (312) 751-3738

**Cleveland, Ohio 44113:** William J. Boyle  
[718] 586-5040

**Dallas, Texas 75201:** Charles G. Hubbard  
2001 Bryant Tower, Suite 1070  
[214] 742-1747

**Denver, Colo. 80202:** Harry B. Doyle, Jr.  
Tower Bldg., 1700 Broadway  
[303] 266-3863

**Detroit, Michigan 48202:** Robert W. Bartlett  
1400 Fisher Bldg.  
[313] 873-7410

**Houston, Texas 77002:** Charles G. Hubbard  
375 Dresser Tower, 601 Jefferson St. [713] CA 4-8381

**Los Angeles, Calif. 90010:** Robert J. Rielly  
Bradley K. Jones, 3200 Wilshire Blvd., South Tower  
[213] 487-1160

**New York, N.Y. 10020**  
1221 Avenue of the Americas  
Warren H. Gardner [212] 997-3617  
Michael J. Stoller [212] 997-3616

**Philadelphia, Pa. 19102:** Warren H. Gardner  
Three Parkway  
[212] 997-3617

**Pittsburgh, Pa. 15222:** Warren H. Gardner  
4 Gateway Center, [212] 997-3617

**Rochester, N.Y. 14534:** William J. Boyle  
9 Greylock Ridge, Pittsford, N.Y.  
[716] 586-5040

**San Francisco, Calif. 94111:** Don Farns  
Robert J. Rielly, 425 Battery Street.  
[415] 362-4600

**Paris:** Alain Offergeld  
17 Rue-Georges Bizet, 75 Paris 16, France  
Tel: 720-73-01

**Geneva:** Alain Offergeld  
1 rue du Temple, Geneva, Switzerland  
Tel: 32-35-83

**United Kingdom & Scandinavia:** Keith Mantle  
Tel: 01-493-1451, 34 Dover Street, London W1

**Milan:** Luigi Rancati  
Robert Saedel (Middle East)  
1 via Baracchini, Italy Phone 86-90-656

**Brussels:** Alain Offergeld  
23 Chaussee de Wavre  
Brussels 1040, Belgium  
Tel: 13-73-95

**Frankfurt/Main:** Fritz Krusebecker  
Dieter Rothenbach (East European Countries)  
Liebigstrasse 27c, Germany  
Phone 72 01 81

**Tokyo:** Tatsumi Katugin, McGraw-Hill  
Publications Overseas Corporation,  
Kasumigaseki Building 2-5, 3-chome,  
Kasumigaseki, Chiyoda-Ku, Tokyo, Japan  
[581] 9811

**Australia:** Warren E. Ball, IPO Box 5106,  
Tokyo, Japan 100-31  
Tel: (03) 667-7397

**Business Department**

**Stephen R. Weiss, Manager**  
[212] 997-2044

**Thomas M. Egan,**  
Assistant Business Manager [212] 997-3140

**Carol Gallagher**  
Production Manager International [212] 997-2045

**Dorothy Carter,** Production Manager Domestic  
[212] 997-2908

**Frances Vallone,** Reader Service Manager  
[212] 997-6057

**Lisa Hoenig,** Secretary  
[212] 997-6481

**Electronics Buyers' Guide**

**George F. Werner,** Associate Publisher  
[212] 997-3139

**Regina Hera,** Directory Manager  
[212] 997-2544

**25th**  
**ELECTRONIC**  
**COMPONENTS**  
**CONFERENCE**



**STATLER HILTON HOTEL,**  
**WASHINGTON, D.C.**

**MAY 12-14, 1975**

**JOINT SESSIONS:**

ISHM Standards Committee  
IEEE Manufacturing Technology Group

**IN CONJUNCTION WITH:**

Design Engineers' Electronic  
Components Show (DEEC), sponsored by  
EIA Parts Division

**PROGRAM**

- Hybrid Applications
- Automatic Bonding
- Electrolytic Capacitors
- Hybrid Technology
- Connectors
- Computerized Testing
- Fiber Optical Communications—Components and Applications
- Reliability
- ISHM Standards
- Discrete Components
- University Microelectronics
- Materials
- Film Capacitors
- Manufacturing Technology for the Late Seventies

**SPONSORED BY:**

EIA IEEE Parts, Hybrids and Packaging Group

**Tyler Nourse**  
**Electronic Industries Association**  
2001 Eye Street, NW  
Washington, DC 20006

I'm interested in preregistration for ECC. Please send me information on hotel reservations and conference technical program.

Name \_\_\_\_\_  
Title \_\_\_\_\_  
Company \_\_\_\_\_  
Address \_\_\_\_\_  
City \_\_\_\_\_ State \_\_\_\_\_ Zip \_\_\_\_\_