

NOVEMBER 28, 1974

High-rise fire laws spawn huge new market/78

Detroit woos cautious IC makers/87

Matching temperature sensors to the right readout/117

FOUR DOLLARS A MCGRAW-HILL PUBLICATION

Electronics®

JAPAN
Can its economy
mend
after the shock?



1470 KAS910 DBEAT NOV75
E KLASSEN
910 DUBLIN ST
NEW WESTMINSTER BC CAN



This is the county seat, home of the Freeport High Pretzels, and where a new miniature DC motor with low inertia is being made.

One of the advantages of our new 26EM miniature motor has to do with where it's made: in the U.S.A.

So if there's ever a service or application problem, there's no problem. You dial an area code. Not another country.

The other advantage of our new miniature motor has to do with who makes it. MICRO SWITCH. So it has the same innovative technology we build into all the other MICRO SWITCH high-performance DC control motors.

And that includes a hollow rotor to provide the lowest possible rotor mass, resulting in very low inertia. And to give you an extremely fast response time—the mechanical time constant is just 18 ms.

Competitively priced, its form, fit and function make the 26EM completely interchangeable with miniature motors made outside the U.S.A.

And ideally suited to applications that include digital cassette recorders and cartridge drives; advanced instrumentation; servo-drive systems; X-Y recorders; print head positioning; and virtually anywhere else there's a need for a high performance DC control motor of this size.

Especially one that can offer you service and application assistance in Freeport, Illinois. Plus a nationwide network of branch offices.

If you'd like more information on the 26EM or any of our other high-performance DC control motors, call toll-free, 800/645-9200 (in N.Y. 516/294-0990, collect) for the location and telephone number of your nearest MICRO SWITCH Branch Office.

This is the new MICRO SWITCH 26EM DC control motor. Smaller than a cassette, but with a lot of big advantages.



MICRO SWITCH

FREEPORT ILLINOIS 61032

A DIVISION OF HONEYWELL
Circle 900 on reader service card

Send for your IDIOM button today!
Wear it proudly!

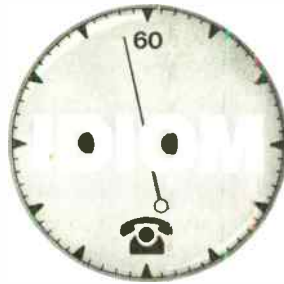

**But read this first and
see what you're getting into.**

IDIOM stands for Inventory and Delivery Information in One Minute. It is the rental industry's first and only nationwide real time computer system. What does it do for you? Just dial our number and tell us your rental requirements. Instantly, the computer queries all warehouses and gives you a firm commitment on availability, delivery and rental rate. No more runaround, delays or broken promises. Just a quick, accurate response.

IDIOM is a service of U.S. Instrument Rentals, Inc., a brand new company that was born well established, thanks to the resources of one of the country's leading financial institutions and the experience of the world's oldest and largest leasing organization, United States Leasing International.

We offer the largest on-the-shelf inventory of new, up-to-date instruments in the industry. And **IDIOM** and inventory are just the beginning. USIR has developed a number of unique programs tailored specifically with your needs in mind. Things like our *automatic return reminders*, to help you save money by terminating the rental when the job is over.

...our *New Product Evaluation Program*, under which you can get your hands on

selected newly introduced instruments at greatly reduced rental rates.

...the industry's only *service claims with teeth*: a money penalty if a unit fails in operation and we don't turn it around or ship a suitable replacement within 48 hours.

In all there are eight sound reasons why it makes more sense to rent from us than from someone else. There are also ten excellent reasons why you should consider renting in the first place. Not as an expedient, but as a prudent money management tool.

If you use (note: we didn't say "own") electronic instruments, send us this coupon or the reply card in the back and we will send you 1) your **IDIOM** button and 2) our catalog (including the rest of USIR's new rental ideas).

U.S. Instrument Rentals, Inc.
951 Industrial Road, San Carlos, CA 94070

Please send my button and your catalog.

Name _____

Title _____

Company _____

Address _____

City _____ State (Zip) _____

US
INSTRUMENT RENTALS, INC.

☎ (415) 592-9230

☎ (213) 849-5861

☎ (201) 381-3500

After your 360/370 massages the information, a Gould Plotmaster can draw you a picture within 3 seconds.

If alphanumeric information is what you want, a Gould Plotmaster can print it for you. At speeds up to 3000 lines per minute. But there are times when alphanumeric listings are just too much. Too much paper to handle, too tough to read, too difficult to digest.

And it's at times like these that a Gould Plotmaster can draw you a picture. A line chart, a bar chart, a pie chart, a graph. A picture that tells your story at a glance.

Employing high-speed electrostatic printer/plotters, Gould Plotmaster Systems give you power and versatility for both on-line and off-line operation. And they're designed to run on any IBM System/360 or 370 operating under DOS or OS, real or virtual.

Easy-to-use software packages help our Plotmaster Systems do the whole job. There's our DISPLAY package that provides even non-programmers with the capability of easily generating line, bar and pie charts. And there's our PLOT package which, due to the speed

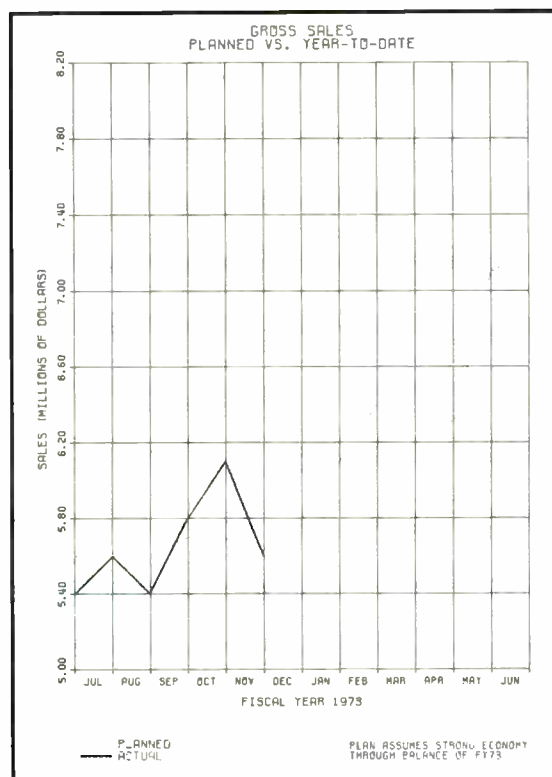

and flexibility of our printer/plotters, lets you do background grids, variable line weights, automatic stripping, text annotation, and allows you to erase previously programmed line segments.

In addition to business graphics, a Gould Plotmaster

can add engineering/scientific graphics and computer-aided-design capabilities to your operation. These optional software packages include DADS (Data Acquisition Display), PAL (Precision Artwork Language) and FAST-DRAW. As for the hardware itself, our Plotmaster Systems can provide on-line/off-line operation, paper widths up to 22 inches, resolution up to 100 dots per inch, output speeds up to 7 inches per second. And, of course, a printing capability, as well.

Get all the facts on Plotmaster Systems from Gould Inc., Instrument Systems Division, 20 Ossipee Road, Newton, Mass. 02164 U.S.A. or Kouterveldstraat 13, B 1920 Diegem, Belgium.

 **GOULD**

65 Electronics International

JAPAN: Two big new computers claimed to surpass IBM 370s, 62
Glutamate flavors pc-board process, 62
AROUND THE WORLD, 63

39 Electronics Review

SOLID STATE: Ion implantation boosts threshold of JFET breakdown, 39
COMPUTERS: Amdahl computer is now due in April, 39
COMPONENTS: Squeeze works for mercury switches, 40
AVIONICS: Uncertainty clouds outlook for Aerosat, 42
COMMERCIAL: Quasar moves for pay-TV entry, 44
TRANSPORTATION: Train controls proceed slowly, 46
NEWS BRIEFS: 46
SOLID STATE: TI also plans for low-end microprocessors, 48
INDUSTRIAL: Electronic cart delivers the mail, 50
THE ECONOMY: Prices dropping in sluggish semiconductor market, 52

75 Probing the News

GOVERNMENT: U.S. keeps hands off EFTS, 75
COMMUNICATIONS: N.Y.C. legislates \$200 million market, 78
MILITARY ELECTRONICS: Seek Bus contracts start to flow, 83
AUTOMOTIVE ELECTRONICS: Smoothing troubled waters, 87

91 Technical Articles

SPECIAL REPORT: Japan's industries try to recover, 91
CONSUMER ELECTRONICS: Dragged down by video slump, 93
SEMICONDUCTORS: Stymied by obese inventories, 97
COMPUTERS: Steeling for trade-liberalization shocks, 99
COMMUNICATIONS: Hung up by the phone company, 101
INDUSTRIAL ELECTRONICS: Curtailed by monetary controls, 102
SPACE ELECTRONICS: Soaring above it all, 103
DEFENSE ELECTRONICS: Shot down by inflation, 104
DESIGNER'S CASEBOOK: Regulator cuts amplifier distortion, 109
Timer circuit generates precision power-on reset, 109
Generator's duty cycle stays constant under load, 111
INSTRUMENTS: Matching readouts to temperature transducers, 117
ENGINEER'S NOTEBOOK: Smoke detector uses MOS transistor, 124
Pocket calculator converts to keyboard entry station, 125

131 New Products

IN THE SPOTLIGHT: Schottky components are byte-size, 131
COMPONENTS: Trimmer capacitor has layered construction, 134
INSTRUMENTS: Automatic microwave counter is low-priced, 140
SEMICONDUCTORS: PROMs include test bits and words, 147
DATA HANDLING: Drive can operate four flexible disks, 152
MATERIALS: 157

Departments

Publishers letter, 4
Readers comment, 6
40 years ago, 10
People, 14
Meetings, 30
Electronics newsletter, 35
News update, 54
Washington newsletter, 59
Washington commentary, 60
International newsletter, 65
Engineer's newsletter, 128
New literature, 159

Highlights

Cover: Economic shocks hit Japan hard, 91

Soaring oil prices and inflation have flattened Japan's rate of industrial growth, and just about all areas of electronics are affected, says this Special Report. Exceptions are computer sales, at least through 1975, and space projects. Cover design is by Art Director Fred Sklenar.

Government refuses to regulate EFTS—as yet, 75

Experimental electronic funds-transfer systems are being encouraged by Congress and Federal agencies in the hope that competition will eventually reveal which are most suitable for standardization.

Fire-alarm law creates \$200 million market, 78

New York City legislation now requires owners of high-rise buildings to install sophisticated automatic fire-alarm systems by January 1976. Some 20 companies stand to profit.

Matching readouts to temperature transducers, 117

A resolution of 0.0001°C in a transducer is useless if the readout displays it inaccurately. Five charts show how the sensor's and readout's requirements should mesh.

And in the next issue . . .

Special report on electronic watches . . . heat pipes: Part 10 of the thermal design series . . . electronic switching comes to private data-transmission services.

EDITOR-IN-CHIEF: Kemp Anderson

EXECUTIVE EDITOR: Samuel Weber

MANAGING EDITORS: Lawrence Curran, *News*;
Arthur Erikson, *International*

SENIOR EDITORS: John Johnsrud,
H. Thomas Maguire, Laurence Altman,
Ray Connolly, Stephen E. Scrupski

ART DIRECTOR: Fred Sklenar

ASSOCIATE EDITORS: Howard Wolff,
Gerald M. Walker, Alfred Rosenblatt

DEPARTMENT EDITORS
Aerospace/Military: Ray Connolly
Circuit Design: Wallace B. Riley
Communications & Microwave:
Stephen E. Scrupski
Components: Lucinda Matterna
Computers: Wallace B. Riley
Consumer: Gerald M. Walker
Industrial: Margaret A. Maas
Instrumentation: Andy Santoni
New Products: H. Thomas Maguire,
Michael J. Riezenman
Solid State: Laurence Altman

COPY EDITORS: Margaret Eastman,
Everett C. Terry, Bill Dunne

ART: Charles D. Ciatto, *Associate Director*
Patricia Cybulski, *Assistant Director*

PRODUCTION EDITOR: Arthur C. Miller

EDITORIAL SECRETARIES: Janet Noto,
Julie Gorgoglione, Penny Roberts

FIELD EDITORS

Boston: Gail Farrell
Los Angeles: Paul Franson (Mgr.)
Midwest: Larry Armstrong (Mgr.)
New York: Ron Schneiderman (Mgr.)
San Francisco: Bernard Cole (Mgr.)
Judith Curtis
Washington: Ray Connolly (Mgr.)
Larry Marion
Frankfurt: John Gosch
London: William F. Arnold
Paris: Arthur Erikson
Tokyo: Charles Cohen

McGRAW-HILL WORLD NEWS

Director: Ralph R. Schulz
Bonn: Robert Ingersoll
Brussels: James Smith
London: Marvin Petal
Madrid: Dom Curcio
Milan: Peter Hoffmann, Andrew Heath
Moscow: Peter Gall
Paris: Michael Johnson, Richard Shepherd
Stockholm: Robert Skole
Tokyo: Mike Mealey

PUBLISHER: Dan McMillan

DIRECTOR OF MARKETING: Pierre J. Braudé

ADVERTISING SALES SERVICE MANAGER:
Wallis Clarke

BUSINESS MANAGER: Stephen R. Weiss

CIRCULATION MANAGER: Nancy L. Merritt

MARKETING SERVICES MANAGER:
Tomlinson Howland

RESEARCH MANAGER: Margery D. Sholes

Japan, after years of phenomenal growth, has been hard hit by a series of "shocks"—a term that has deep roots in the earthquake-prone nation. As Charlie Cohen, our man in Tokyo, and Jerry Walker, associate editor, point out in our fifth annual Japan market report (see p. 91), 1974 has had its share of new, disturbing shocks.

"The balance of payments has dropped. Labor costs have skyrocketed an astounding 33% as a result of the 'spring offensive' by the unions. Inventories have bulged to unhealthy proportions. The inflation rate, one of the highest in the world, was well over 20%. Even the Shinkansen, Japan's high-speed train and the pride of the nation, ran into breakdowns and delays this year. In short, Japan's well-oiled economic wheels have slowed down."

Like our European market report, scheduled to appear in the Dec. 26 issue, and the U.S. market survey, which we will publish in the Jan. 9 issue, the Japan report relies heavily

on a detailed questionnaire sent to scores of government agencies and industrial organizations. The final three-week round of intensive reporting by Cohen and Walker is preceded by distribution of the questionnaire, a task that falls on Cohen's shoulders. A long-time resident of Japan and an accomplished linguist—to say nothing of being an electronics engineer—he compiles the questionnaires in two languages, haggles with the printer, and then painstakingly proofreads them. "Most Japanese sources prefer Japanese-language questionnaires," he says, "but a parallel one in English aids them in comparing with the final chart in the magazine, in which descriptions are abbreviated and some items combined. Also, we have foreign sources, such as U.S. semiconductor companies, which need an English-language version."



We're looking for a computer editor

The ideal candidate for this position will have an engineering degree, as well as extensive experience in the design of computers, or computer-based systems and components. The candidate must, of course, have writing ability.

In covering the stimulating new developments in technology our editors travel extensively, interview the people who make electronics the dynamic field it is, and write and edit technical articles.

As part of McGraw-Hill, one of the world's leading publishing companies, we offer excellent working conditions and fringe benefits. And, the salary level is as good as or better than industry rates for engineers.

If you are interested and have the necessary qualifications, send your résumé with salary requirements to: The Executive Editor, ELECTRONICS Magazine, 1221 Avenue of the Americas, New York, N.Y. 10020.

November 28, 1974 Volume 47, Number 24
94,593 copies of this issue printed

Published every other Thursday by McGraw-Hill, Inc. Founder James H. McGraw 1860-1948. Publication office 1221 Avenue of the Americas, N.Y., N.Y. 10020; second class postage paid at New York, N.Y. and additional mailing offices.

Executive, editorial, circulation and advertising addresses: Electronics, McGraw-Hill Building, 1221 Avenue of the Americas, New York, N.Y. 10020. Telephone (212) 997-1221 Teletype TWX N.Y. 710-581-5234 Cable address M C G R A W H I L L N Y.

Subscriptions limited to persons with active, professional, functional responsibility in electronics technology. Publisher reserves the right to reject non-qualified requests. No subscriptions accepted without complete identification of subscriber name, title, or job function, company or organization, including product manufactured or services performed. Subscription rates, qualified subscribers in the United States and possessions, Canada, and Mexico \$12.00 one year, \$24.00 three years, all other countries \$25.00 per year, except Japan and Israel \$50.00 per year, Brazil \$40.00 per year, Australia and New Zealand \$60.00 per year, including air freight. Limited quota of subscriptions available at higher-than-basic rate for persons outside of field served, as follows: U.S. and possessions and Canada, \$25.00 one year; all other countries \$50.00. Single copies \$4.00.

Officers of the McGraw-Hill Publications Company: John R. Emery, President; J. Elton Tuohig, Executive Vice President-Administration; Gene W. Simpson, Group Publisher-Vice President, Senior Vice Presidents: Ralph Blackburn, Circulation, Walter A. Stanbury, Editorial; John D. Hoglund, Controller; David G. Jensen, Manufacturing; Gordon L. Jones, Marketing; Jerome D. Luntz, Planning & Development.
Officers of the Corporation: Shelton Fisher, Chairman of the Board and Chief Executive Officer; Harold W. McGraw, Jr., President and Chief Operating Officer; Wallace F. Traendly, Group President, McGraw-Hill Publications Company and McGraw-Hill Information Systems Company; Robert N. Landes, Senior Vice President and Secretary; Ralph J. Webb, Treasurer.

Title registered in U.S. Patent Office. Copyright © 1974 by McGraw-Hill, Inc. All rights reserved. The contents of this publication may not be reproduced in whole or in part without the consent of copyright owner. Subscribers: The publisher, upon written request to our New York office from any subscriber, agrees to refund that part of the subscription price applying to copies not yet mailed. Please send change of address notices or complaints to Fulfillment Manager; subscription orders to Circulation Manager, Electronics, at address below. Change of address notices should provide old as well as new address, including postal zip code number. If possible, attach address label from recent issue. Allow one month for change to become effective.

Postmaster: Please send form 3579 to Fulfillment Manager, Electronics, P.O. Box 430, Hightstown, N.J. 08520.

KEPCO

your source for digitally programmed d-c power supplies



This, for example, is a typical digitally-controlled voltage stabilizer, comprising a standard Kepeco plug-in power supply with the new Kepeco SN Digital Interface.

The combination produces 0–100 volts, 0–200 mA with 12-bits resolution. The power supply is a Model PCX 100–0.2MAT programmed by an SN–12 Digital Interface Card mounted on a slide adapter and fitted to a dual-slot bench style enclosure.

There are hundreds of similar Kepeco Power Supplies, ranging from 0–6V @ 90 A to a model that can produce –5000V @ 5 mA. Because they're rated as *operationally programmable*, these models can be combined with one of the five Kepeco SN Digital Interfaces to produce a custom digital voltage or current source, tailored to your needs.

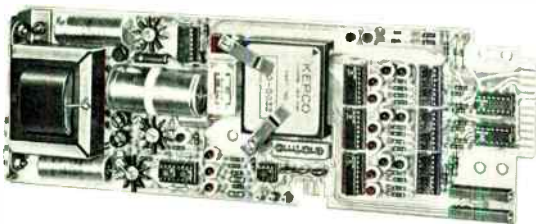

The SN Digital Interface Card accepts your data input on parallel lines, strobed for noise immunity, and stores the data in a buffer register. For isolation, the program is transferred across optical couplers so that your digital signal and the power supply it controls can be up to 1000V apart. The five SN Cards offer a choice of BCD or complementary binary programming.

The analog output from the SN Card is in the form of a 0–1V/0–10V range selected signal* that is linearly amplified by the companion power supply to produce the desired output. In the illustrated combination of SN–12 and a Kepeco Model PCX 100–0.2MAT, the power supply functions as a fixed gain-of-ten power amplifier to produce a digitally-controlled output, 0–100V with 12-bits (0.024%) resolution. The range selector on the SN allows the full resolution to be spread over the lowest 10% of the output: 0–10V d-c.

*The SN Card also produces $\pm 10V$ & $\pm 5V$ outputs to control bipolar power supplies and 0.5V, 1.0V outputs to control current stabilizers.

SN CARDS AVAILABLE

MODEL	RESOLUTION	LINEARITY
SN-2	2 BCD	$\pm 0.2\%$
SN-3	3 BCD	$\pm 0.05\%$
SN-8	8-bit	$\pm 0.2\%$
SN-10	10-bit	$\pm 0.05\%$
SN-12	12-bit	$\pm 0.01\%$

These SN Cards are fully self-contained digital programmers, featuring an on-card line operated power supply. Kepeco offers a variety of housings and accessories to accommodate them to various programmable power supplies. As many as eight cards can be accommodated in a standard 5¼" x 19" panel.

For complete specifications, write Dept. EH–14

KEPCO®



KEPCO, INC. • 131-38 SANFORD AVENUE • FLUSHING, N.Y. 11352 • (212) 461-7000
TWX = 710-582-2631 • Cable: KEPCOPOWER NEWYORK

A Smart Way to Beat Your Power Supply Size Problem

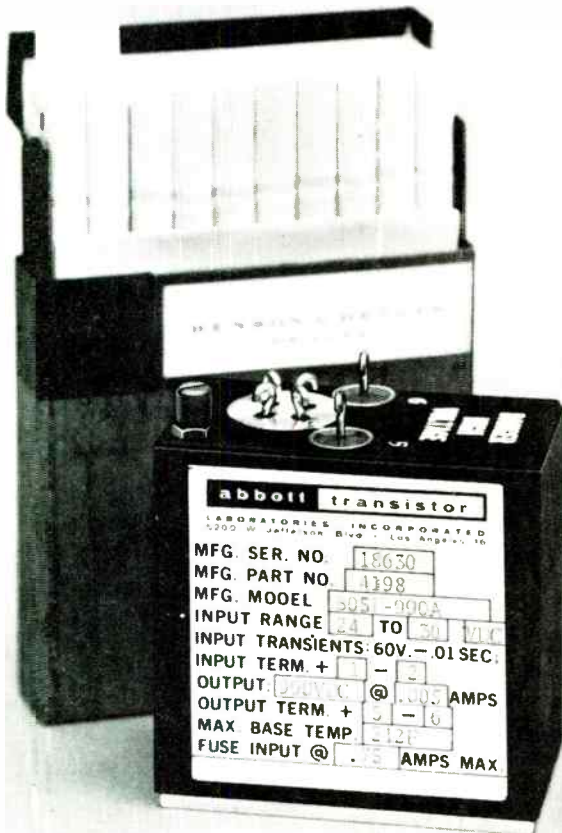

1½" thin, 2¾" narrow, 2¾" short

yet this converter produces 1000 volts DC, regulated, from a battery input of 28 VDC! It weighs less than 15 ounces. This is only one of our wide variety of many small light weight converters, inverters and power supplies — there are over 3000 models listed in our newest catalog, including size, weight and prices. If you have a size problem, why not send for an Abbott catalog?

MIL SPEC ENVIRONMENT — All of the hermetically sealed power modules listed in our new catalog have been designed to meet the severe environmental conditions required by modern aerospace systems, including MIL-STD-810B. They are hermetically sealed and encapsulated in heavy steel containers. New high performance units can meet MIL-STD-461A.

Please see pages 307-317 Volume 1 of your 1974-75 EEM (ELECTRONIC ENGINEERS MASTER Catalog) or pages 853-860 Volume 3 of your 1974-75 GOLD BOOK for complete information on Abbott Modules.

Send for our new 60 page FREE catalog.

RELIABLE — Highest quality components are used in Abbott power modules to yield the high MTBF (mean time between failure) as calculated in the MIL-HDBK-217 handbook. Typical power modules have over 100,000 hours MTBF — proving that the quality was built in from the beginning.

WIDE RANGE OF OUTPUTS — Any voltage from 5 volts DC to 740 VDC is available by selecting the correct model you need from our catalog with any of a variety of inputs including:

- 60 \sim to DC
- 400 \sim to DC
- 28 VDC to DC
- 28 VDC to 400 \sim
- 12-38 VDC to 60 \sim

abbott transistor

LABORATORIES, INCORPORATED

general offices

eastern office

5200 W. Jefferson Blvd./Los Angeles 90016
(213) 936-8185 Telex: 69-1398

1224 Anderson Ave./Fort Lee, N.J. 07024
(201) 224-6900 Telex: 13-5332

6 Circle 6 on reader service card

Readers comment

Astronomers worried

To the Editor: Stephen Scrupski's review of current communications satellite planning [*Electronics*, Oct. 3, p. 95] made no mention of the important impact of satellite transmission on radio astronomy.

Most of current radio astronomy is conducted at extremely weak signal levels: flux densities as low as .001 Jansky (1Jy = 10^{-26} W/m²Hz). Some frequencies of astrophysical interest have been protected by international agreement, but most molecular line transitions occur at unprotected frequencies.

Putting radio observatories in remote locations was, until recently, sufficient to control most interference situations. But orbiting transmitters operating at high power levels can and do create serious interference, even in the protected bands. Recent reports show that both the ATS-6 and SMS-1 satellites produce well in excess of the recommended harmful interference limit for radio astronomy. ATS-6 in particular has produced a flux density of about 500 Jy at the lower edge of the astronomy band of 2.69 to 2.7 gigahertz. This satellite has forced the three-element interferometer of the National Radio Astronomy Observatory to seriously restrict its bandwidth.

Radio astronomy has no large political or economic constituency, yet it is one of the most vital of the physical sciences. If one extrapolates from current satellite planning (with satellites requiring up to 500 megahertz bands each), it is clear that in only a few years there may be little, if any, spectrum available for high-sensitivity experiments between 1 and 30 GHz.

In short, mechanisms must be found for enforcing economy in spectrum utilization. (Surely the proposed 36 MHz channel for a single Muzak transmission is an extraordinary waste).

Martin S. Ewing
California Institute of Technology
Pasadena, Calif.

Waveguide even better

To the Editor: Corning's low-loss

a

SELF-SCAN[®] PANEL

says it all...

**ENGLISH • FRENCH • GERMAN • HEBREW • RUSSIAN
JAPANESE • SYMBOLS • GRAPHICS • and other languages**

No matter what you have to say or how you say it, a SELF-SCAN panel display provides the economical and practical solution to your readout problem. The only commercially available dot matrix pattern with five years of proven customer performance plus the following features:

- Low Cost
- Compact Packaging
- Few Connections
- Distinctive Appearance

The 5 x 7 dot matrix format of SELF-SCAN panels and our variety of MOS character generators allow you to communicate with maximum legibility and flexibility. Simultaneous bi-lingual display is also possible on certain models. SELF-SCAN panels are simple to interface to computers.

Single register displays of 16, 32, and 80 characters, and multi-register displays of 256 (8 x 32) characters are available. 0.2", 0.3", 0.4" characters with soft neon-orange glow are visible up to 25 feet.

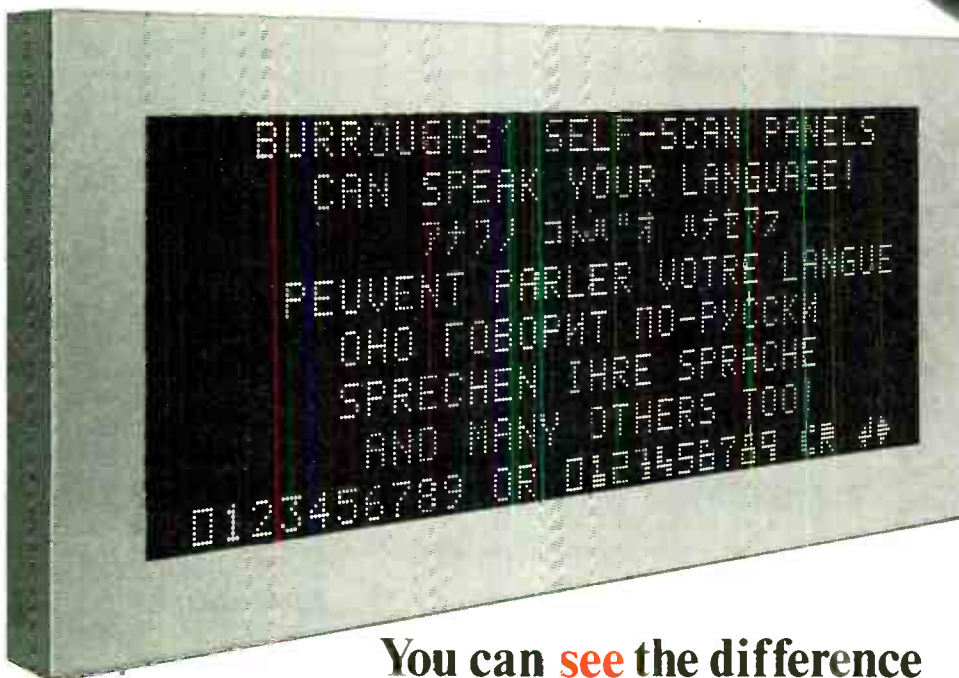

Call your Burroughs representative for a "briefcase" demonstration, or get in touch with Burroughs Corporation, Electronic Components Division, P.O. Box 1226, Plainfield, New Jersey 07061, Tel. (201) 757-3400 or (714) 835-7335.

You can see the difference

Burroughs



Circle 7 on reader service card

Did You Know Dearborn Makes 31 Styles of Film Capacitors?

HERMETICALLY-SEALED METAL CASE TUBULAR CAPACITORS



BARE METAL CASE

Style LP8, metallized polycarbonate film
Style MPF, metallized PETP-polyester film
Style AP8, polycarbonate film
Style AM8, PETP-polyester film
Style AS8, polystyrene film
Style AF8, PTFE-fluorocarbon film

METAL CASE WITH INSULATING SLEEVE

Style LP9, metallized polycarbonate film
Style MPIF, metallized PETP-polyester film
Style AP9, polycarbonate film
Style AM9, PETP-polyester film
Style AS9, polystyrene film
Style AF9, PTFE-fluorocarbon film

EPOXY-CASE RECTANGULAR CAPACITORS



AXIAL-LEAD

Style LP7A, metallized polycarbonate film
Style LM7A, metallized PETP-polyester film
Style AP7A, polycarbonate film
Style AM7A, PETP-polyester film
Style AS7A, polystyrene film

RADIAL-LEAD

Style LP7S, metallized polycarbonate film
Style LM7S, metallized PETP-polyester film
Style AP7S, polycarbonate film
Style AM7S, PETP-polyester film
Style AS7S, polystyrene film



WRAP-AND-FILL ROUND TUBULAR CAPACITORS



Style LP66, metallized polycarbonate film
Style AP66, polycarbonate film
Style AS66, polystyrene film

WRAP-AND-FILL OVAL TUBULAR CAPACITORS



Style LP77, metallized polycarbonate film

HERMETICALLY-SEALED GLASS CASE TUBULAR CAPACITORS



Style GML, high voltage paper/PETP-polyester film, 85 C
Style GTL, high voltage paper/PETP-polyester film, 125 C

HERMETICALLY-SEALED CERAMIC CASE TUBULAR CAPACITORS



Style SML, high voltage paper/PETP-polyester film, inserted tab construction.
Style SMLE, high voltage paper/PETP-polyester film, extended foil construction.

EPOXY CASE RECTANGULAR CAPACITORS



Style EFX, high voltage paper/PETP-polyester film.

Write for engineering bulletins on those capacitor styles in which you are interested.

SPRAGUE ELECTRIC COMPANY

Dearborn electronics division

P. O. BOX 1076, LONGWOOD, FLORIDA 32750



Readers comment

optical waveguide development is more advanced than was indicated in your "Technology Update" issue [*Electronics*, Oct. 17, p. 83]. The author states that Corning Glass is experimenting with single-mode fibers with losses down to 2.1 decibels per kilometer with a 1.05 micrometer wavelength.

It is true that Corning's original breakthrough in low-loss fibers was made using a single-mode fiber, but the 2.1 dB/km figure the author cites was achieved on a 1-kilometer length of *multimode* fiber, not single-mode. That was in May, 1973. Since then, attenuation as low as 1.2 dB/km with a 1.06 μ m wavelength has been measured on similar multimode fibers at Corning Glass Works.

David B. Stout
Corning Glass Works
Corning, N.Y.

LCD work continues

To the Editor: Your News update section of September 19th took note of our work on an 84-character liquid-crystal display. The project was funded internally, however, and had no relation to an anticipated Army contract. We are now developing drive electronics to permit us to market complete liquid-crystal display packages.

Applied Technology did develop engineering models of a vertical baragraph LCD for aircraft engine instrumentation, and that was under Army contract.

J. M. Finley
Applied Technology division
Itek Corp.
Sunnyvale, Calif.

'Bifocal' is trademark

To the editor: You make reference to "bifocal" in the article "Pacemakers quicken their market beat" [*Electronics*, Sept. 5, p. 65]. "Bifocal" is registered under Federal Trademark No. 921,619. It is the American Optical trademark for atrial ventricular, or AV, sequential pacemakers.

William C. Nealon
American Optical Corp.
Southbridge, Mass.

Here's proof that AZ positive photoresist gives better device yields than negative photoresist.

Shown here is a series of SEM's illustrating the unlimited capabilities of our AZ Positive Photoresist Systems. We want you to see for yourself the excellent resolution, edge acuity, and line width control our photoresists provide in both thick and thin coatings. AZ Systems excel in: contact, proximity and projection exposure; aqueous development and removal; wide processing latitudes; accurate reproducibility of photomask geometries in coatings 0.3 to 2.5 microns thick. All of these factors combine to give you increased yields and profitability: Shipley Company Inc., Newton, MA

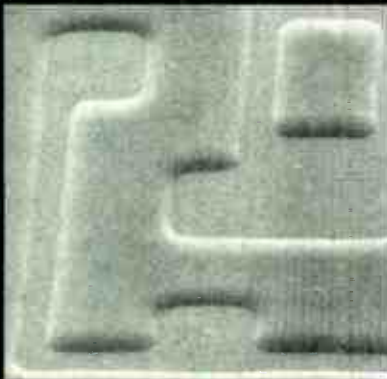

AZ-111 0.8 microns thick on silicon dioxide provides excellent edge acuity, etch resistance and line width control.



Contact layer coated with 1.8 microns of AZ-1350J is covering 1.5 micron steps. Thick coatings help eliminate pinholes and step breakdown.

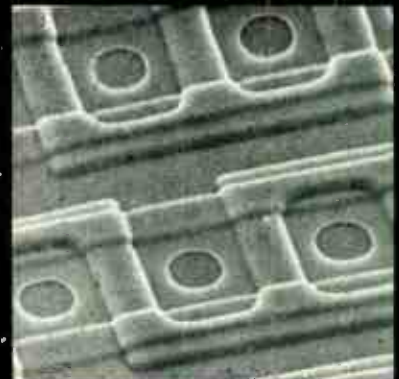

Contacts after etching and resist removal. Note absence of pinholing and sharp edge acuity.

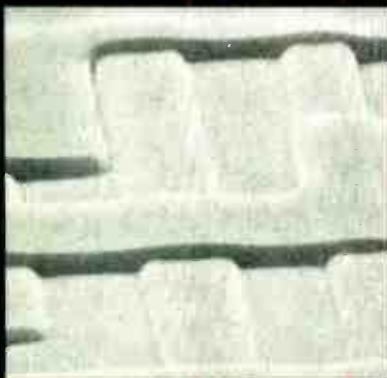

AZ-1350J on aluminum showing excellent step protection through the use of thick coatings.

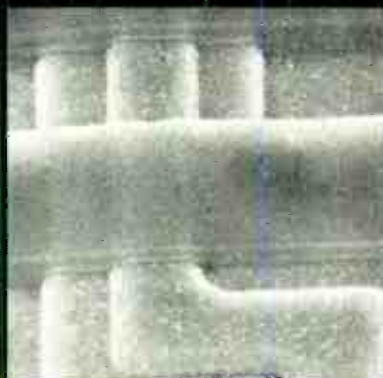

AZ-1350J on aluminum gives excellent edge acuity despite wide thickness variations.

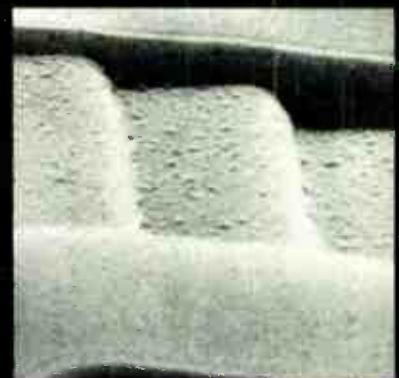

AZ-1350J allows "0" pinholing during etching.



World Radio History

Circle 9 on reader service card

Stop spoon feeding your DIP tester

If you're still hand-feeding your DIP tester for incoming or outgoing inspection, you're working too hard. Put our table-top Model 800 to work. Or any one of our other high-speed, automatic DIP test handlers and you can multiply your DIP test throughput by as much as ten—or more. To get all the profitable particulars write or call IPT Corporation, 1140 W. Evelyn Ave., Sunnyvale, California 94086. Phone (408) 732-7550.



IPT Corporation
High-Speed Automatic Test Handlers

40 years ago

From the pages of *Electronics*, November, 1934

Marconi reports on microwaves

"Although I have succeeded in receiving waves of 60 centimeters at 258 kilometers, which was in that case eight times the optical range, my later investigations on the propagation of these waves have brought to light not only their own well-known erratic behavior, but also a definite seasonal effect which so far limits their commercial use to about the optical range.

"Within that optical range we can say definitely that microwaves can be employed advantageously for short-distance inter-island and island-continental communications as well as overland, in spite of even complete visual obstruction."

—*Marchese Guglielmo Marconi in a transatlantic broadcast to American listeners from Rome on Oct. 29.*

Component makers challenged

Introduction of the "acorn" tubes is an immediate challenge to manufacturers of parts. There is a market for an exceedingly small radio, vest-pocket in size, perhaps. But in the past, set designers have felt nothing could be done because the essential elements, the tubes, were so large. That day is past.

Such components as variable condensers, coils, headphones and loud speakers, and resistors must be reduced in size if they are to appear in the ultra-midgets. There is much room for research here for new high capacity condenser dielectrics, for resistance materials of greater heat tolerance, for new emission surfaces to decrease the power required by the tubes, for compact long-life batteries. Such parts need not be cheaper or more fragile; they might be sturdier because of small size and perhaps more expensive—they need only be smaller.

Imports of electronic equipment

The Bureau of Foreign and Domestic Commerce announces that during August, 1934, the following imports of electron tubes were made: Radio apparatus and parts, \$3,027; X-ray tubes \$3,008.

CHOPPER AMP PERFORMANCE AT BIPOLAR PRICES... *it's easy!*

$V_{OS} - 10 \mu V$
 $TC V_{OS} - 0.2 \mu V/^{\circ}C$
 $V_{OS}/Time - 0.2 \mu V/Month$
 $e_n - 0.35 \mu V p-p$



NO EXTERNAL COMPONENTS - NO CHOPPER PROBLEMS!

Freedom at last! Freedom from zeroing potentiometers and periodic system recalibrations. Freedom from noisy, expensive chopper amplifiers. Freedom from bulky external components.

New monoOP-07 Ultra-Low Offset Voltage Op Amps combine ultra-low noise, ultra-stable performance

with applications ease and flexibility — at unbelievably low prices. Upgrade system performance, reduce design time, improve MTBF while saving money. The monoOP-07 is a direct replacement for 725, 108A/308A, 741 and most other op amps — they're off-the-shelf at your Precision Monolithics distributor now!

GUARANTEED MIN/MAX SPECIFICATIONS

	monoOP-07AJ	monoOP-07J	monoOP-07EJ	monoOP-07CJ	
Temp. Range	-55/ +125	-55/ +125	0/ +70	0/ +70	°C
V_{OS} @ 25°C	25	75	75	150	μV
V_{OS} @ Full Temp.	60	200	130	250	μV
TCV_{OS}	0.6	1.3	1.3	1.8	$\mu V/^{\circ}C$
Long Term Drift	1.0	1.0	1.5	2.0	$\mu V/Month$
Noise Voltage (.1 to 10 Hz)	0.6	0.6	0.6	0.65	$\mu Vp-p$
CMRR ($V_{IN} = \pm 13V$)	110	110	106	100	dB
Price @ 100 Pcs. (TO-99)	\$60.00	\$25.00	\$15.00	\$9.95	•



1500 SPACE PARK DRIVE, SANTA CLARA, CALIFORNIA 95050
TEL. (408) 246-9222 • TWX 910-338-0528 • CABLE MONO

AUTHORIZED DISTRIBUTORS:

NEW YORK METROPOLITAN AREA Harvey Radio, Woodbury, N.Y. : (516) 921-8700 • NEW ENGLAND AREA Gerber Electronics, Dedham, Mass. : (617) 329-2400 • UPSTATE NEW YORK Harvey Federal Electronics, Binghamton, N.Y. : (607) 748-8211 • NORTHEAST Newark Electronics, Woburn, Mass. : (617) 935-8350 • BALTIMORE WASHINGTON Whitney Distributors, Baltimore, Md. : (301) 944-8080 • PENNSYLVANIA Hallmark Electronics, Huntingdon Valley, Pa. : (215) 355-7300 • Pioneer/Pittsburgh : (412) 391-4846 • MICHIGAN RS Electronics, Detroit, Mich. : (313) 491-1000 • SOUTHEAST Kirkman Electronics, Winston-Salem, N.C. : (919) 724-0541 • EAST CENTRAL Pioneer/Cleveland, Cleveland, Ohio : (216) 587-3600 • Pioneer/Dayton, Dayton, Ohio : (513) 236-9900 • CENTRAL Hallmark Electronics, Elk Grove Village, Ill. : (312) 437-8800 • Minneapolis, Minn. : (612) 884-9056 • St. Louis, Mo. : (314) 521-3800 • TEXAS-OKLAHOMA Sterling Electronics, Houston, Texas : (713) 627-9800 • Dallas, Texas : (214) 357-9131 • SOUTHWEST Sterling Electronics, Albuquerque, N.M. : (505) 345-6601 • Phoenix, Ariz. : (602) 258-4531 • WEST Westates Electronics Corp., Chatsworth, Calif. : (213) 341-4411 • Sunnyvale, Calif. : (408) 733-8383 • Intermark Electronics, Sunnyvale, Calif. : (408) 738-1111 • Denver, Colo. : (303) 936-8284 • Salt Lake City, Utah : (801) 486-3411 • San Diego, Calif. : (714) 279-5200 • Santa Ana, Calif. : (714) 540-1322 • Almac-Stroum, Seattle, Wash. : (206) 763-2300 • Portland, Ore. : (503) 292-3534 • CANADA Intek Electronics, Vancouver, B.C. : (604) 324-6831.

MICROSYSTEMS'

MF2102. - 1024 X 1 bit static RAM - the original work horse for μ processor memory.

MF2102 by 4. - 256 x 4 bit static RAM family. New and tailor-made by Microsystems for systems versatility, we call them:

MF2111. - 16 lead package, common I/O.

MF2112. - 18 lead package, common I/O with Bus control.

MF2113. - 22 lead package, separate I/O.

MF8008. - 8 bit central processor. Add some Microsystems memory and this powerful little machine performs an almost endless variety of computing and control functions. And it's the only dual sourced CPU in volume production (in fact it has been for over a year).

MF8080. - The next generation CPU coming from Microsystems in the first quarter of 1975.

for immediate delivery give us a call!

U.S.A.

microsystems sales offices

CA., Palo Alto, (415)493-0848
CA., Santa Ana, (714)979-6522
IL., Schaumburg, (312)894-7660
MA., Waltham (617)890-2255
NJ., Morris Plains (201)539-8050
PA., Huntingdon Valley, (215)947-5641/2

sales representatives

AL., Huntsville, Rep Inc. (205)881-9270
AZ., Scottsdale, Barnhill Five (602)947-5745
CA., Los Alamitos, J.S. Heaton (213)598-6676
CA., Los Altos, W.W. Posey (415)948-7771
CA., San Diego, J.S. Heaton (714)452-1456
FL., Orlando, G.F. Bohman (305)855-0274
IL., Chicago, L.Tec (312)286-1500
IL., Westchester, Gassner & Clark (312)345-4245
IN., Fort Wayne, Gassner & Clark (219)456-1675
MD., Towson, L.H. Kolman (301)752-8756
MA., Waltham, Rantek (617)890-5110
MI., Milford, Tom Mulligan (313)363-5575
MN., Minneapolis, Comstrand (612)560-5300

MO., Hazelwood, Tech Rep. (314)731-5200
MO., Independence, Tech Reps (816)737-1414
NJ., Fenally, ABC (201)568-2354
NY., North Syracuse, Adv. Comp. (315)699-2651
NY., Tarrytown, ABC (914)631-2650
NY., Williston Park, ABC (516)747-6610
OH., Cincinnati, Ron Makis (513)232-5588
OH., Columbus, Tom Mulligan (614)457-2242
OR., Beaverton, Arneson (503)643-5754
PA., Huntingdon Valley, ABC (215)947-5641
TX., Dallas, J. Clay (214)350-1281
WA., Seattle, Arneson (206)762-7664

stocking distributors

AZ., Phoenix, Moltronics (602)272-7951
AZ., Phoenix, Sterling (602)258-4531
CA., Riverside, Electronic Supply (714)683-7300
CA., San Diego, Moltronics (714)278-5020
CA., San Diego, Sterling (714)565-2441
CA., San Carlos, Sterling (415)592-2353
CA., Southgate, Moltronics (714)521-7412
CA., Sunnyvale, Bell Industries (408)734-8570
CA., Sun Valley, Sterling (213)767-5030

CT., Westport, Hi-Rel (203)226-4731
FL., Clearwater, Diplomat (813)443-4514
IL., Elk Grove Village, Diplomat (312)595-1000
IL., Elmhurst, Semispecs (312)279-1000
IL., Skokie, Bell Industries (312)965-7500
IN., Indianapolis, Semispecs (317)243-8271
MD., Baltimore, Arrow (301)247-5200
MD., Rockville, Pioneer (301)424-3300
MA., Boston, Demambro (617)787-1200
MA., Dedham, Gerber (617)329-2400
MA., Watertown, Sterling (617)926-9720
MI., Farmington, Diplomat (313)477-3200
MI., Farmington, Semispecs (313)478-2700
MN., Minneapolis, Diplomat (612)788-86C1
MN., Minneapolis, Semispecs (612)854-8841
MO., Hazelwood, Semispecs (314)731-2400
MO., Kansas City, Semispecs (816)452-3900
MO., St. Louis, Diplomat (314)645-8550
NJ., Haddonfield, Mid-Atlantic (609)428-8288
NJ., Kenilworth, Newark (201)272-8410
NJ., Saddlebrook, Arrow (201)797-5800
NM., Albuquerque, Sterling (505)345-6602
NY., Farmingdale, Arrow (516)694-6800

NY., Freeport, Milgray (516)546-6000
NY., New York, C. Tennant (212)679-1300
NY., Rochester, Simcona (716)328-3230
NY., Woodbury, C. Tennant (516)364-9070
OH., Dayton, Diplomat (513)228-1080
OH., Dayton, Semispecs (513)278-9455
OH., Solon, Repco (216)248-8900
PA., Horsham, Pioneer (215)674-5710
PA., Pittsburgh, Semispecs (412)781-8120
TX., Dallas, K.A. Electronic Sales (214)634-7870
TX., Dallas, Semispecs (214)358-5211
TX., Dallas, Sterling (214)357-9131
TX., Houston, Sterling (713)623-6600
WA., Seattle, Sterling (206)762-9102
WI., Wauwatosa, Semispecs (414)257-1330
UT., Salt Lake City, Diplomat (801)486-7227

CANADA

microsystems sales offices

QUE., Montreal, (514)747-5880
ONT., Ottawa, (613)828-9191
ONT., Toronto, (416)239-6141

MICROPROCESSORS

ROMS

MF1702A.

The industry standard 256 x 8 bit, field erasable and reprogrammable ROM family. And MF 1702A-1 - the fast one at 750 nsec access time!

MF1302. - The mask programmed ROM version of the 1702A for longer runs.

MF8316. - The big ROM [2048 x 8 bit] for big systems.

PLUS

MOD 8. - Complete modular μ processor. RAMs, ROMs, pROMs, CPUs. Everything you need from Microsystems.

MONITOR 8. - Complete software operating system for the MOD 8.

FREE DATA PACK. - includes software listing, hardware description and data sheets for all associated components. Just drop us a line and its yours - free!

AVAILABLE. - Microsystems Microprocessors are available now, from stock only through Microsystems sales outlets and stocking distributors around the world. Microsystems International Limited, Box 3529, Station C, Ottawa, Canada K1Y 4J1, Tel. (613) 923-9191.

stocking distributors

BC., Vancouver, F.A.E. (604)587 2621
ONT., Milton, Semispecs (416)673 1444
ONT., Rexdale, Future (416)677 7820
ONT., Toronto, Zetronics (416)789 5811
QUE., Montreal, Future (514)735 5775

EUROPE

microsystems sales offices

W. GERMANY, Stuttgart, (0711)65 31 16/26
U.K., London, (01)573 6582/4

stocking distributors

throughout the Continent,
the U.K. and Scandinavia

JAPAN

Tokyo, Mitsubishi 210 2121

**MICRO
SYSTEMS** 
a Northern Electric company

RCL

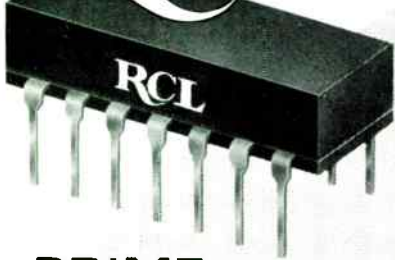

**PRIME
SUPPLIER
TO THE
COMPUTER
AND
PERIPHERAL
EQUIPMENT
INDUSTRY**



- **Electromagnetic Delay Lines**
(Including Subminiature DIPs)
- **Power Resistors**
- **Industry's Most Complete Selection And Best Delivery**

Call our hotline for prompt service and delivery.
(201) 374-3311

RCL

ELECTRONICS, Inc.

General Sales Office:
700 So. 21st Street
Irvington, N. J. 07111

People

Smith is adapting electronics to B&H



Emphasis. J.E. Smith hopes to give Bell & Howell a better feel for electronics.

Bell & Howell Co. has an identity crisis. The name is a household word—widely known for its consumer motion-picture-cameras and projectors. But half its earnings actually come from a line of specialized business equipment that includes microfilm systems, copiers, and duplicators, as well as equipment for folding, inserting, and handling paper.

Faced with the need to adapt electronics to its business equipment, the Chicago-based firm has brought in J. E. Smith as senior vice president and general manager for its Business Equipment group. B&H is counting on his experience. Most of his career has been spent interfacing electromechanical and electronic technologies. As president of Victor Comptometer Corp.'s Business Products group, for instance, the affable and sharply tailored Smith orchestrated its complete conversion from electromechanical to electronic calculators. And before that Smith spent 14 years in Litton Industries' Kimball Systems and Monroe divisions.

Think. While Smith doesn't expect as dramatic a change at B&H as he engineered at Victor, he admits that there will be a challenge in getting the company to think electronics. "Bell & Howell has for many years

had an Electronics and Instruments group, but has lacked an electronics orientation that's necessary for the future growth and development of the company," he points out. "We don't intend to go into the electronics business *per se*, but to make existing products as efficient as possible using electronics technology."

Smith's first step was the acquisition of a line of computer-output-microfilm (COM) systems from Per-tec Corp. "It fills a very large gap in our product line, if we are serious about becoming a full-service microfilm supplier," he says.

Although COM is based on electronics, most of his group's products are electromechanical. "COM has an impact across our entire product line, and we're already hard at work specifying our next-generation COM unit," he says. "It will form the foundation of an over-all electronics capability in the group."

Smith will also take a fresh look at his group's optical products. He hopes soon to be marketing an "intelligent version" of an optical document reader "that will make it essentially a remote-batch terminal." This type of product improvement is typical of Smith's plans for B&H in the future.

Stanford's Meindl sees ICs as strong medicine

Graduate students of electrical engineering at Stanford University may be making more visits to hospitals these days than injured football

Rewards. For Stanford's Meindl, the payoff in medical electronics is gratifying.



Ferrites from Ferroxcube ...

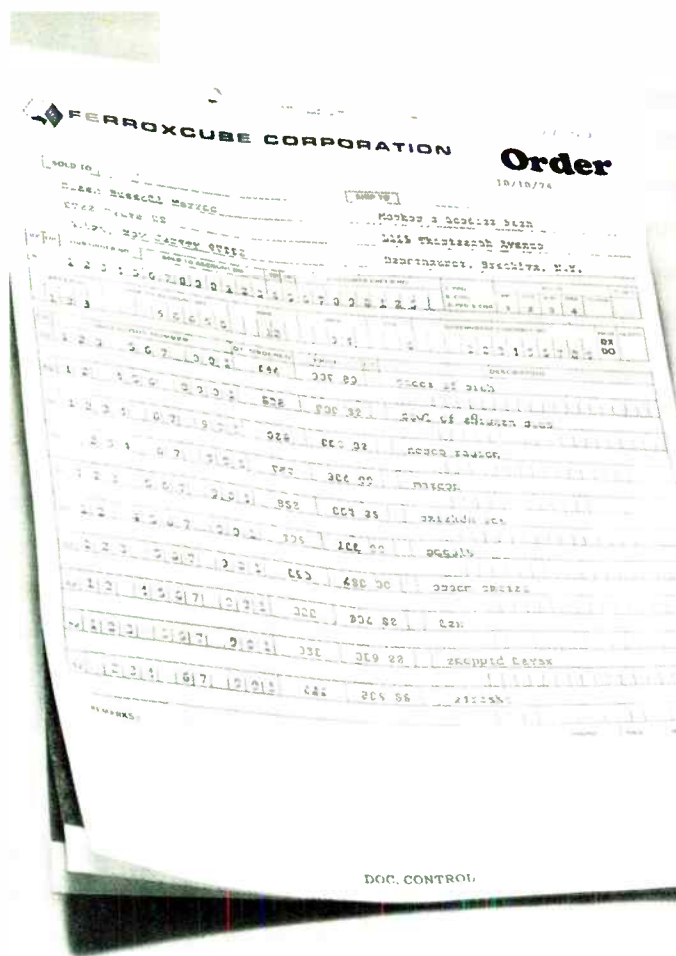

24 hour turnaround

Everything you need in ferrites. All sizes and shapes—pot cores, square cores, toroids, E's, U's, I's, and specials, too—in a variety of performance proved materials including new 3C8 for high flux density applications.

Made in Saugerties. Ferroxcube ferrites are made of the finest materials, in the most modern facilities, to the most rigid specifications, right here in Saugerties, New York. So there are none of the uncertainties of quality and delivery often associated with overseas supply.

Stocked nationwide. Six strategically located distribution points across the nation—in Boston, Saugerties, New York, Philadelphia, Chicago, and San Diego—keep over 50,000,000 ferrites ready and waiting for your order. Almost like having your own on-site supply.

Delivered immediately. With such a complete line of quality product, made domestically, and stocked strategically, your only worry when you order Ferroxcube ferrites may be whether you can get the receiving area open in time. See for yourself.



FERROXCUBE CORPORATION, SAUGERTIES, N.Y. 12477
A NORTH AMERICAN PHILIPS COMPANY

914•246-2811

617•899-7100

Distributed through North American Philips Electronic Components Corporation with warehouses in Boston 617•899-7100
New York 516•538-2300, Saugerties 914•246-5861 Philadelphia 215•836-1616, Chicago 312•593-8220, San Diego 714•453-5440

IC'S
require
small
C'S

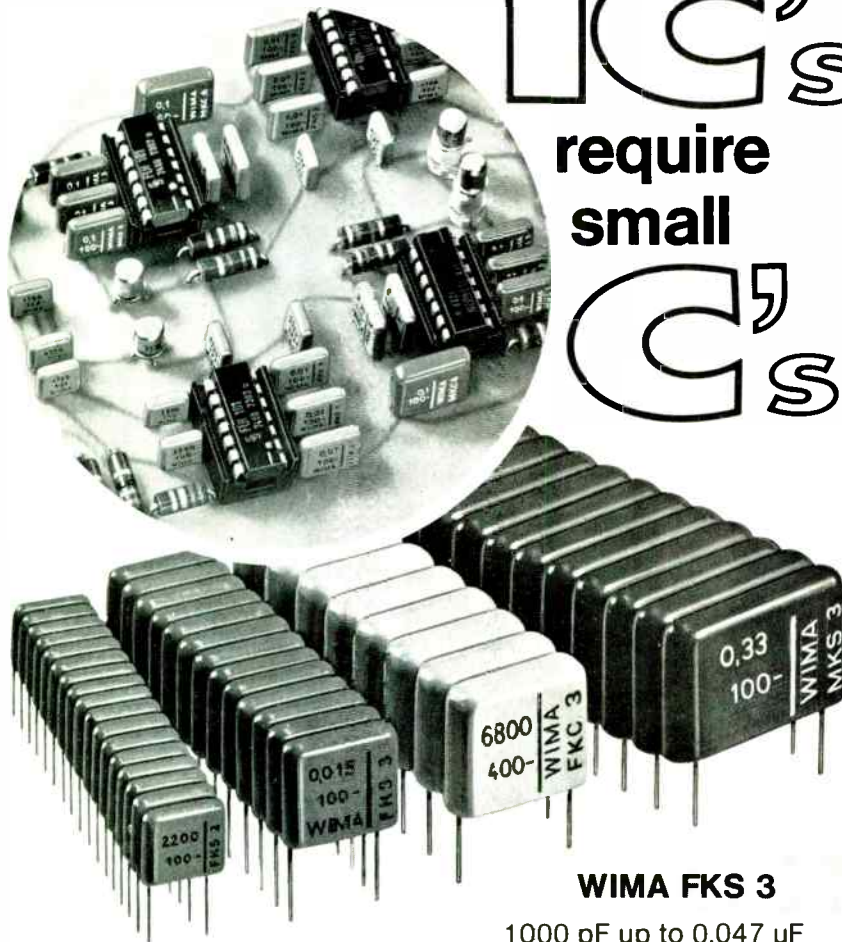

WIMA FKS 3

1000 pF up to 0.047 μ F

WIMA FKC 3

100 pF and up

WIMA MKS 3

Up to 0.47 μ F

WIMA FKS 2 min

P.C.M. 5 mm
1000 pF to 0.047 μ F

Cast-moulded capacitors

are an excellent aid in designing your IC-equipped printed boards. Use the new plug-in WIMA® capacitors which are smaller and have regular dimensions.

Write for our new catalogue.



WILHELM WESTERMANN

Spezialfabrik
für Kondensatoren
D-68 Mannheim 1
Fed. Rep. of Germany
Augusta-Anlage 56
P. O. Box 2345
Tel.: (0621) 40 80 12

pros. Instead of seeking treatment, however, they are searching for new ways to use integrated circuits in medicine. And James D. Meindl, chief of Stanford's Integrated Circuits Laboratory, believes this search offers students an "incomparable opportunity."

The rate of return from such studies is high, says the 41-year-old Meindl, who chaired a seminar on ICs in medicine at last month's annual conference of the Alliance for Engineering in biology and medicine. He notes that students easily associate with the humanistic nature of improved medical instrumentation.

And he's proud of the accomplishments of the 25 to 30 Ph.D. candidates working in the Stanford laboratory every year. "The bulk of the research involves medical electronics because there is an urgent need for these instruments," he says. The lead time between research and payoff is gratifyingly short, adds the crew-cut university professor.

Accomplishments. Included in the lab's developments are totally new devices, as well as programs aimed at producing miniature and more effective hardware. One new device for the blind, for example, uses a charge-coupled-device image sensor that converts printed words into a form that can be sensed by tactile means. And miniaturization projects have led to such things as transducers and signal transmitters that sense functions within the body and monitor blood flow ultrasonically.

One of the goals of the laboratory is to continue development of ultrasonic devices toward a full range of units for diagnostic use. One advantage that Stanford's EEs have is the chance to test their development at the medical facilities on campus in a relatively short time, explains Meindl, who himself holds a Ph.D. in electrical engineering.

His lab now has extensive Federal funding—including a \$3 million grant from the National Institutes of Health to conduct tests of recent innovations in ultrasonic-devices. And he predicts a continuing interest in ICs applied to medical gear.



MEASUREMENT COMPUTATION

innovations from Hewlett-Packard

NEWS

DECEMBER, 1974

in this issue

Versatile new
spectrum analyzer

Take the work out
of word generation

Not one, but *five*
new systems



New HP interface bus links instruments

A new approach has been adopted as a major interface standard for HP products. It means you can conveniently interconnect a wide range of HP instruments, calculators, and other devices having stimulus, response, display, control or computational capabilities. Indeed, you can now assemble relatively low-cost systems with minimum engineering effort.

Called the Hewlett-Packard Interface Bus (HP-IB), it accommodates high and low-speed devices in the same system. You can interconnect as many as 15 devices—voltmeter, printer, signal source, calculator, digital clock, etc.—over a total distance of up to 20 meters. Devices are linked via a passive cable network having 16 signal lines. These signal lines carry all information (addresses, commands, program data and

(continued on page 3)

New combinations of counters and calculators solve difficult measurement problems

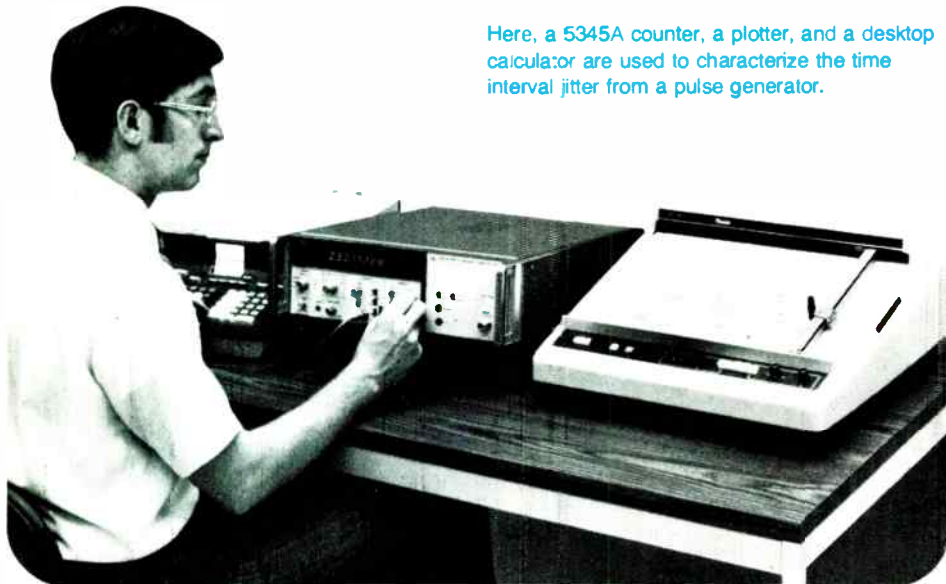

Here, a 5345A counter, a plotter, and a desktop calculator are used to characterize the time interval jitter from a pulse generator.

Thanks to the new HP interface bus, you can couple the speed and computational power of an HP calculator with the measurement capability of HP electronic counters and state-of-the-art accessories. Several new application notes describe how these versatile low-cost combinations solve difficult measurement problems.

AN 174, a new series of 13 application notes, describes HP interface bus systems configured around the 5345A counter and a 9820A, 9821A or 9830A calculator. These systems are used to:

- Spec VCOs with respect to tuning step transient response and post-tuning drift,
- Characterize digital receiver performance as a function of S/N by measuring the statistical variation in receiver delay time,
- Match the delays through two lengths of cable to within a few picoseconds for antenna feed systems.

The 174 series covers a wide variety of applications from phase measurements to complete VCO linearity testing. We'll be glad to send you an index so that you can order specific notes of interest.

You can also combine the 5340A microwave counter with a calculator to measure the linearity of VCOs operating at frequencies up to 23 GHz. Application note 181-1 describes how this synergistic counter/calculator combination

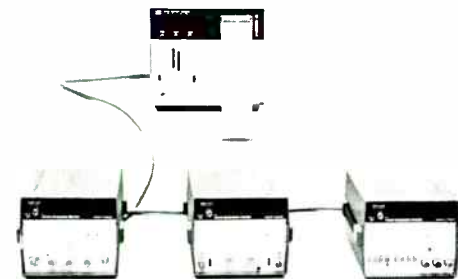

Low-cost data acquisition: three counters (with snap-on interface modules) send time interval, frequency, and voltage information to a thermal printer that also acts as a controller.

measures, computes and plots the transfer characteristic, differential, non-linearity, and integral nonlinearity of the VCO under test.

Application note 181-2 provides an example of a simple data acquisition system using HP low-cost counter modules, an interface, and a 9820A or 9821A calculator. A multimeter/counter measures frequency, ac volts, dc volts, or resistance and outputs these measurements to the calculator. The calculator computes the mean, standard deviation, and peak-to-peak deviation of the data and even plots a histogram.

For the two 181 application notes and 174 series index, check 5 on the HP Reply Card.

Two new timing instrument accessories

A timing generator and a digital clock are HP's newest ASCII-programmable instrument accessories. The two modules are compatible with the HP interface bus and, as such, can be linked to counters, digital voltmeters, and other HP instruments.

The 59308A timing generator provides precision time intervals from 1 μ s to greater than a day. These time intervals are defined by start/end pulses and HP interface bus start/end "flags." This flexible way of defining time intervals permits use in a wide variety of hardware and software applications. For example, the 59308A can be used to provide delayed gating pulses to counters or digital voltmeters to obtain frequency or voltage vs. time information. It can also be used to schedule subroutine execution in computer/calculator programs or to measure the time between events with μ s resolution.

The 59309A digital clock displays calendar and time data (month, day, hour, minute, second) and can be used for time logging to printers and calculators.

To learn more, check 1 on the HP Reply Card.

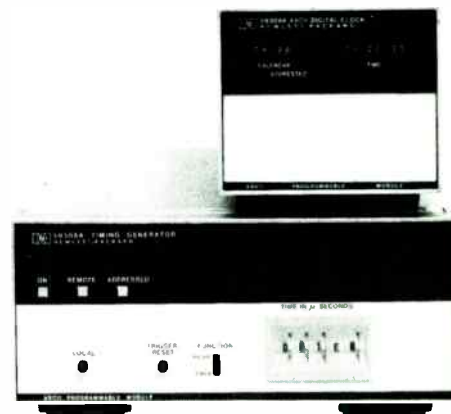

For digital timing applications that require precise intervals from μ s to days, use HP's new timing generator and digital clock.

Now, take the work out of word generation

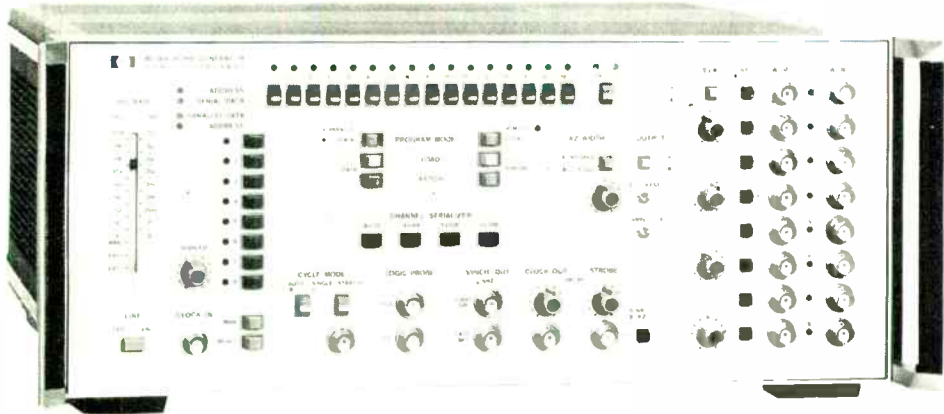

HP's new 8016A 50-MHz word generator is also fully compatible with the new HP interface bus.

High speed, high capacity, stability, bit pattern programmability, and competitive price put the new 8016A word generator at the top of its class. It's ideal for testing ICs, circuit boards, and data communication systems.

Freely-programmable bit patterns and high capacity produce a flexible output, both in content and format. Data output can be parallel (32 bytes each 8 bits wide) or serial (8 words each 32 bits long) at rates up to 50 megabits/second. The 8016A also has a strobe output (that can function as a ninth data channel or floating trigger), selectable ECL and TTL

output levels, and six independent delay circuits.

Unlike the confusing front panels of complex word generators, the 8016A front panel is simple and easy to use. Data can be loaded in either parallel or serial form. As an option, you can also load bit patterns via a card reader, at the rate of 256 data bits in 2 seconds.

The 8016A is especially effective for determining worst-case conditions in IC testing.

For specifications and details, check L on the HP Reply Card.

Interface links instruments

(continued from page 1)

status data) at data rates up to 1 mega-byte/sec.

Simple HP interface bus configurations do not require the use of a controller such as a calculator or computer (although HP-IB is compatible with both). In most cases, HP programmable calculators are the ideal controllers for customer-assembled systems whenever some degree of data manipulation is required. Our HP-IB calculator interface package provides everything necessary for interconnecting your HP 9820A, 9821A or 9830A calculator with up to 14 other HP-IB instruments and accessories.

Several popular measurement solutions are available in the form of complete, pre-assembled HP-IB systems. (See the 3050B data acquisition system in this issue.) They are fully integrated and documented from a hardware and software point of view, and HP takes full responsibility for overall performance of these pre-assembled systems.

Check Q on the HP Reply Card for details on the new HP interface bus and a list of currently available HP-IB products.

Two HP scopes for digital design, testing, and field service

If you work with digital systems, two HP oscilloscopes can make your job easier: the 1710B is a 200 MHz dual-channel scope for field servicing, while the 1720A is a 275 MHz dual-channel scope for digital logic design and testing.

Both have tight accuracy specs for those critical measurements—for example, calibrated sweep to 10 ns/cm (1 ns magnified times 10) and accurate to 3% over the full 10 cm of horizontal deflection. Differential time measurements are accurate to 1% for most applications. Both scopes offer delayed sweep, stable triggering, and selectable input impedance (50Ω or 1MΩ). And both scopes maintain specified performance from 0° to 55°C.

The 1710B with deflection factors to 5 mV/cm is ideal for servicing computers that use ECL 10K or TTL logic.

The precision 1720A has deflection factors to 10 mV/cm. It's used in the design, manufacture, and testing of fast logic systems—computers, peripherals, logic components, and communications equipment.

For the full scoop on these handy scopes, check C on the HP Reply Card.



Accuracy and environmental specifications make either the 1710B scope (shown here) or the 1720A model equally suitable for bench use or field service.

Now, simulate logic designs directly from your schematic

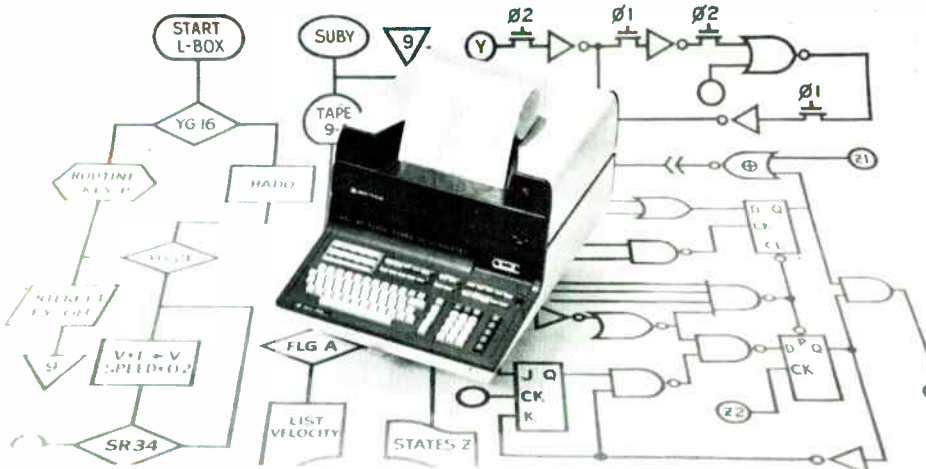

Digital simulation cuts design time and improves accuracy.

HP's new approach to logic circuit design provides a self-contained digital simulation technique that 1) improves the accuracy of complex designs, and 2) reduces the time engineers spend verifying logic behavior. The system uses an HP 9830A programmable calculator and newly available digital simulation software. Four programs handle:

- Combinational networks for all logic families,
- Synchronous one-clock networks for DTL/TTL/ECL families,
- Synchronous two-phase networks for

MOS/LSI families,

- Timing analysis including propagation delays.

You can use the new digital simulation system to generate truth tables, analyze sequential logic circuits, generate state-time maps, document designs, analyze MOS/LSI circuits, and generate timing diagrams.

A basic system consists of the calculator with 4K memory, a string-variables read-only-memory, and a thermal printer.

For more information, check R on the HP Reply Card.

New automatic spectrum analyzer delivers spectral, distortion and wave analysis

Now, you can perform spectral analysis, distortion analysis, and wave analysis quickly, automatically with the same system—the new 3045A automatic spectrum analyzer. Using the new HP interface bus, we combined the accuracy of a digital display in a spectrum analyzer with the high resolution of a synthesizer and the computational and control capability of a desktop calculator. The result: a fast, fully programmable, automatic system for production testing, quality control, and lab work.

Frequency ranges from 10 Hz to 13 MHz. Amplitude is displayed in dB on a digital display—to 0.01 dB resolution. It's easy to use: HP provides all the software for general measurements and programming instructions for more specific measurements.

The interface bus accommodates up to 15 devices, so you can easily add a plotter to graph relationships—for example, distortion vs. frequency or gain vs. frequency for audio amplifiers.

Multiprogrammer provides flexible computer access

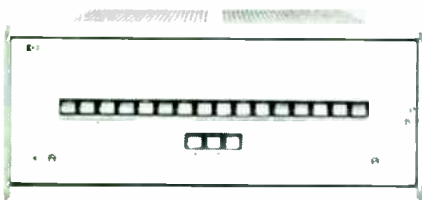

Attach HP's multiprogrammer to your computer and you can add up to 240 more I/O channels.

Now you can build your own control or data acquisition system—economically—with an HP 6940A multiprogrammer.

You need just one computer input/output channel to interface with the multiprogrammer. The 6940A itself holds up to 15 plug-in analog and digital I/O cards, mixed in any combination. Some plug-ins convert programmed

output into signals to drive stepping motors, control transducers, close contacts, or to stimulate units under test. Other cards convert responses from process instruments into digital data for computer input.

If you need more than 15 input/output channels, simply add the 6941A extender mainframes. Each extender holds 15 plug-ins, and you can add up to 15 extenders—giving you a total of 240 channels controlled from one computer I/O slot.

For details, check J on the HP Reply Card.

To learn more about automatic, low-cost analysis, check D on the HP Reply Card.



Eliminate tedious frequency tuning. The new 3045A system is the automatic and accurate way to test consumer electronic products.

New digital pattern analyzer works with any scope

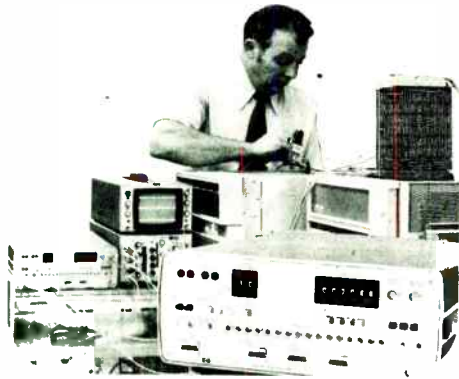

Troubleshooting a disc is a typical application for the new 1620A digital analyzer that scans parallel or serial bit patterns at rates up to 20 MHz.

The new 1620A digital pattern analyzer is a versatile trigger source compatible with any oscilloscope. The unit scans digital patterns up to 16 bits, serial or parallel, synchronous or asynchronous; and when it recognizes a preset pattern, it produces a trigger signal (2V, 25 ns). Essentially, the 1620A provides a dynamic window for checking your digital circuitry—using your existing oscilloscope, regardless of the manufacturer.

Use the front panel control to set the trigger word, i.e., the pattern that the analyzer will search for in the passing data stream. The trigger word can be simple (any pulse) or complex (a unique combination of ones and zeros).

Unlike a trigger that depends on a time delay, the pattern-recognition triggering technique eliminates accumulated timing error. If you want to examine the contents of a disc track or any long digital record step by step, the 1620A does have digital delay. You can move the measurement window up to 999,999 clock periods after pattern recognition.

Also to eliminate errors in asynchronous systems, a special filter ignores "glitches" of short duration that could cause spurious triggers.

For more information, check B on the HP Reply Card.

New precision power splitter aids swept measurements

A remarkably versatile and useful device for swept-frequency measurement applications is the new HP 11667A power splitter. Its dc to 18 GHz frequency range makes it an ideal companion for the HP 8755 frequency response test set and the new HP 86290A/8620A broadband (2-18 GHz) solid-state sweep oscillator.

Tracking between output arms is within .25 dB over the full range. When the splitter is used to level a sweeper or to divide signals in ratio measurements, this close tracking has the equivalent effect of improving output source match and frequency response tracking. Thus, your measurements are more accurate.

Some important uses for the new power splitter are described in the data sheet.

For your copy, check O on the HP Reply Card.

Wideband swept measurements to 18 GHz become easier and more accurate using the new HP 11667A power splitter.



Add a tracking generator to HP's RF spectrum analyzer



The HP 8558B RF spectrum analyzer now has a companion tracking generator for making swept-frequency response measurements from 500 kHz to 1300 MHz. The HP 8444A option 058 tracking generator's output signal is always the same frequency as the spectrum analyzer, making it possible to achieve more than 90 dB dynamic range in swept transmission and reflection measurements. The generator provides 0 dBm calibrated output with ± 0.5 dB full band flatness.

For precise frequency measurements, add a counter to the analyzer/generator combination, and you can selectively determine the frequency of any and all displayed signals.

Make wide dynamic range swept measurements with HP's 8558B spectrum analyzer and new tracking generator.

For more information check M on the HP Reply Card.

New low-cost system helps you gather data, make decisions and control instruments



Sitting at a calculator, you can monitor and act upon data being gathered at a remote location.

Automatic data gathering and reduction need not be expensive—if you choose HP's new 3050B automatic data acquisition system. This compact low-cost system scans up to 520 channels under calculator control; measures dc, ac and ohms at up to 4 readings/second; then calculates results either on-line or off-line.

Basically, we've used the new HP interface bus to team a multimeter and a scanner with a programmable calculator. The system measures:

- dc in 5 ranges from 100 mV to 200V with 1 μ V resolution
- ac in 4 ranges from 1V to 200V with 10 μ V resolution over a frequency range of 20 Hz to 100 kHz
- resistance from 100 Ω to 10 M Ω with 1 m Ω resolution

With the appropriate transducer, you can also measure pressure, torque, velocity, acceleration, and weight. The

calculator controls data logging and, at the same time, performs other required calculations, such as transducer linearization or statistical analysis.

You can easily use the 3050B to measure multiple physical parameters and to monitor devices. It's also suited for research work, as well as production testing. Now, you can test 100% of your pc boards or other electronic devices, at a fraction of the cost of a computerized system.

If you need to obtain or send data elsewhere from your test site, HP offers an optional common carrier interface, and arrangements can be rented from the phone company for remote transmission.

For full details, check E on the HP Reply Card.

New lab computer also handles data management

The new Scientific/310 data system provides multiprogramming, real time, and networking capabilities to give you more than just data from your laboratory.

The S/310's versatile multiprogramming lets you develop programs concurrently in FORTRAN, ALGOL, and assembly language; and we provide both an easy-to-use and efficient editor (EDIT II) and a powerful file manager.

The real-time executive software lets you sense and respond to time-critical events right away. To its already reliable system, HP has added fail-safe mechanisms that keep the S/310 operating even if the primary power is removed for as long as 2-1/2 cycles. And power fail/auto restart is provided to save operational status.

A number of options are available. User microprogrammability and batch processing with spooling can help reduce operator time by speeding up slow routines and spooling input and output for processing.

To learn more, check A on the HP Reply Card.



The S/310 can be linked to an HP S/250 data management system, HP 3000 computer systems, or an IBM/360 to share data and management information.

Two new compact recorders for end users and OEMs

HP announces two new compact X-Y recorders (8.5 in. by 11 in. or 20.3 cm by 28 cm DIN A4)—the 7010A OEM model and the 7015A laboratory version. Both models have mechanical pen lift, electrostatic paper holddown, continuous duty dc servo motors, and a universal pen holder that accepts most commercial fiber pens.

Slewing speed is 20 in./sec. (50.8 cm/sec.). Peak acceleration is 500 in./sec. (1270 cm/sec.) on the X axis and 1000 in./sec. (2540 cm/sec.) on the Y axis. Common mode rejection is 130 dB dc and 90 dB ac.

The 7010A OEM version has 100 mV/div. sensitivity. The 7015A is a general-purpose recorder for schools and laboratories and, as such, has three ranges: either 0.01 V/in., 0.1 V/in., and 1 V/in. or 0.01 V/cm, 0.1 V/cm, and 1 V/cm. Several options are available for both models.

To learn more, check K on the HP Reply Card.

The 7010A is a compact, durable OEM recorder with a reasonable price tag.

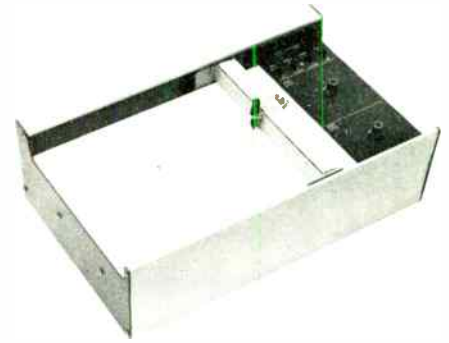

New polarity and overflow display expands LED family

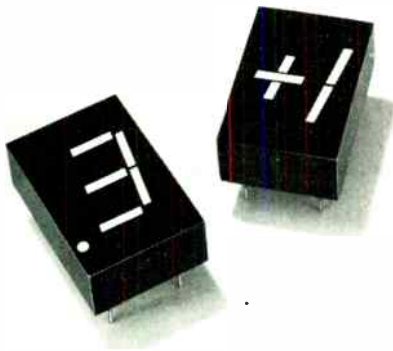

The new 5082-7750 series displays provide a high contrast ratio and wide viewing angle.

HP introduces the 5082-7752 "±1" overflow LED display. It's ideal for instrumentation such as digital voltmeters and digital multimeters. Designed for use with HP's 5082-7750 series of .43 in. (11 mm) display, it's bright enough to be viewed up to 20 feet away.

These common anode devices are IC compatible and come in a standard 0.3 in. (0.8 cm) DIP lead configuration. Contact any franchised HP distributor for immediate delivery.

For more information, check G on the HP Reply Card.

New calculator LED displays

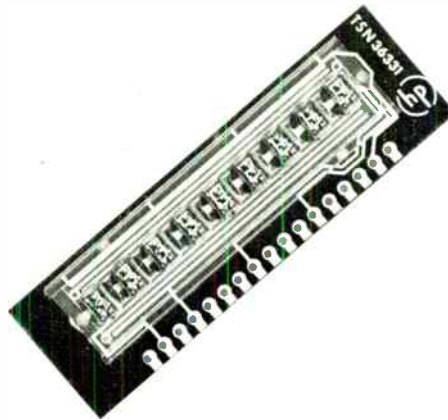

Nine digits, matched for brightness, are mounted on a single pc board.

Now, you can buy calculator displays, 0.1 in. or 2.67 mm high, in eight or nine-digit clusters on a printed circuit board. The new 5082-7440 series red LED displays have right-hand decimal points, are MOS compatible, and require low power (only 250 μ A average per segment). Mounted on 200 mil (5.08 mm) centers, they have a magnifying plastic lens for excellent readability. Use them in handheld calculators or any product that requires small, low-power, low-cost, long-life indicators.

For specifications, check F on the HP Reply Card.

New panel-mount microwave step-attenuators

OEM users of microwave turret attenuators now have an attractive alternative: a choice of four new step-attenuators covering dc to 4 GHz or dc to 18 GHz and available in either 70 dB or 110 dB models.

Typically, turret models must switch both center and outer conductors of the attenuating element so contact repeatability is a problem. The new HP 33320 series uses a new "edge-line" switching design with the attenuating pads connected in cascade. Only the center conductor is switched. Repeatability is within 0.02 dB even after 100,000 complete 11-step rotations.

Required panel space is less than 1 in. by 2 in. (2.5 cm by 5 cm). Bench models with type N or APC-7 connectors and a heavy base are also available.

For more information, check P on the HP Reply Card.

HP's new step-attenuators provide high accuracy, inherent stability, and excellent repeatability at microwave frequencies.

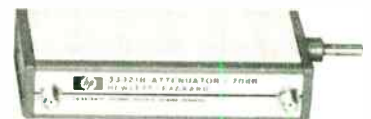
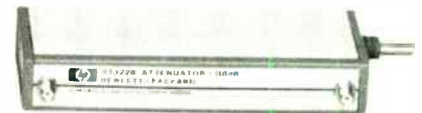

Five new measurement/control systems have MOS memory

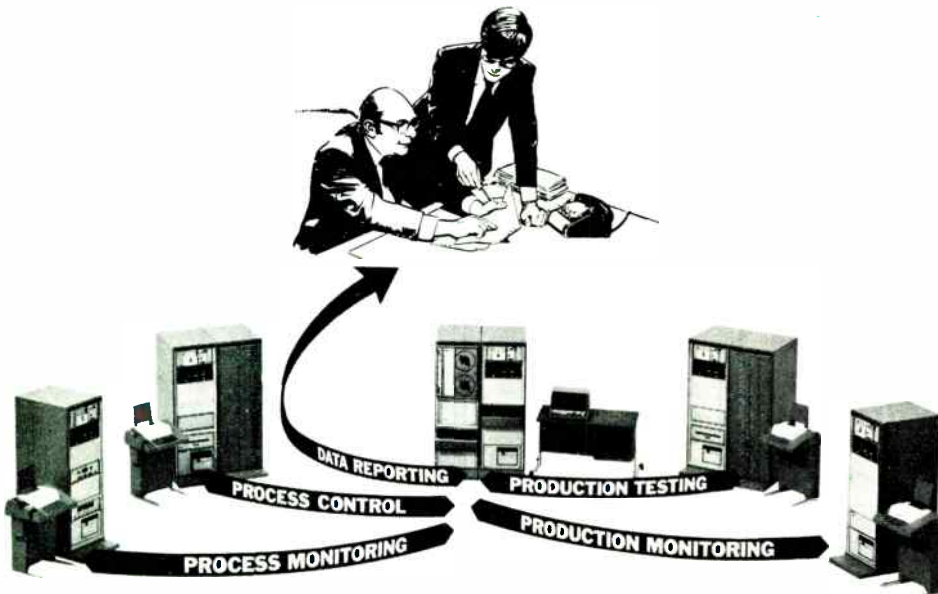

HP measurement/control systems operate independently or share workloads in a distributed systems network.

Now, HP introduces *five* new systems, all using our latest computer with semiconductor memory.

The new HP 9611A industrial measurement and control system features new analog and digital I/O capabilities: analog current input signal conditioning, event counter, programmable timer, stepping motor controller, stall alarm, and signal conditioning for 50 Vdc and

117 Vac digital inputs and outputs. It includes screw-type terminations and all other capabilities previously available with the HP 9610 system. All 9611A measurement/control capabilities can be remoted over serial cables up to 10,000 feet. (You avoid the installation problems, high costs and signal degradation associated with long runs of many multiple signal lines.)

A lower-cost system without screw terminations and signal conditioning, the new HP 9603A offers both the local and remote measurement/control capabilities of the HP 9611A. (Another low-cost system, the 9604A, is a single-task dedicated system without time-scheduling capability.)

A high-accuracy system, the new HP 9602A, provides an integrating A-to-D subsystem for maximum noise rejection. This system measures dc with optional digital I/O and ac, resistance, and frequency measurement capabilities.

The 9611A, 9603A, and 9602A offer a choice of 3 different real-time operating systems for time and event scheduling of multiple tasks—one of these in HP real-time BASIC. The other two are CPU memory-based and disc-based real-time executive systems. The disc-based system, built around the new RTE-II executive, provides two multi-user swapping partitions.

These new systems can be operated together as satellites in a distributed systems network coordinated by the new HP 9700A distributed systems central system. Thus, they can share workloads and benefit from the centralized program development, data storage, and file management facilities of the HP 9700A central system.

To learn more, check N on the HP Reply Card.

HEWLETT  **PACKARD**

East-20010 Century Blvd., Germantown, MD 20767, Ph. (301) 428-0700.

South-P.O. Box 2834, Atlanta, Ga. 30328, Ph. (404) 436-6181.

Mid-west-5500 Howard Street, Skokie, Ill. 60076, Ph. (312) 677-0400.

West-3939 Lankershim Boulevard, North Hollywood, Calif. 91604, Ph. (213) 877-1282.

Europe-Post Office Box 85, CH-1217 Meyrin 2, Geneva, Switzerland, Ph. (022) 41 54 00.

Canada-6877 Goreway Drive, Mississauga, Toronto, L4V 1L9, Ph. (416) 678-9430.

Japan-Yokogawa-Hewlett-Packard, 1-59-1, Yoyogi, Shibuya-ku, Tokyo, 151.

I'd like Literature Please contact me about:

- | | |
|--|---|
| <input type="checkbox"/> A. S/310 data system | <input type="checkbox"/> L. 8016A word generator |
| <input type="checkbox"/> B. 1620A pattern analyzer | <input type="checkbox"/> M. 8444A, opt. 058 tracking generator |
| <input type="checkbox"/> C. 1710B, 1720A oscilloscopes | <input type="checkbox"/> N. 9600 series measurement/control systems |
| <input type="checkbox"/> D. 3045A spectrum analyzer | <input type="checkbox"/> O. 11667A power splitter |
| <input type="checkbox"/> E. 3050B data acquisition system | <input type="checkbox"/> P. 33320 series step-attenuators |
| <input type="checkbox"/> F. 5082-7440 calculator digits | <input type="checkbox"/> Q. HP interface bus |
| <input type="checkbox"/> G. 5082-7752 LED display | <input type="checkbox"/> R. Digital simulation system (9830A) |
| <input type="checkbox"/> I. 59308A timing generator and 59309A clock | <input type="checkbox"/> S. Counter application notes (AN 181-1, 181-2 and 174 index) |
| <input type="checkbox"/> J. 6940A multiprogrammer | |
| <input type="checkbox"/> K. 7010A, 7015A x-y recorders | |

D20

PLEASE PRINT and include zip code

Name	Title	Department, Building, Mail Station, Etc.	Company	Post Office Box or Street No.	City	State	Zip
------	-------	--	---------	-------------------------------	------	-------	-----

I'd like Literature Please contact me about:

- | | |
|--|---|
| <input type="checkbox"/> A. S/310 data system | <input type="checkbox"/> L. 8016A word generator |
| <input type="checkbox"/> B. 1620A pattern analyzer | <input type="checkbox"/> M. 8444A, opt. 058 tracking generator |
| <input type="checkbox"/> C. 1710B, 1720A oscilloscopes | <input type="checkbox"/> N. 9600 series measurement/control systems |
| <input type="checkbox"/> D. 3045A spectrum analyzer | <input type="checkbox"/> O. 11667A power splitter |
| <input type="checkbox"/> E. 3050B data acquisition system | <input type="checkbox"/> P. 33320 series step-attenuators |
| <input type="checkbox"/> F. 5082-7440 calculator digits | <input type="checkbox"/> Q. HP interface bus |
| <input type="checkbox"/> G. 5082-7752 LED display | <input type="checkbox"/> R. Digital simulation system (9830A) |
| <input type="checkbox"/> I. 59308A timing generator and 59309A clock | <input type="checkbox"/> S. Counter application notes (AN 181-1, 181-2 and 174 index) |
| <input type="checkbox"/> J. 6940A multiprogrammer | |
| <input type="checkbox"/> K. 7010A, 7015A x-y recorders | |

D20

PLEASE PRINT and include zip code

Name	Title	Department, Building, Mail Station, Etc.	Company	Post Office Box or Street No.	City	State	Zip
------	-------	--	---------	-------------------------------	------	-------	-----

PRICES

The following are U.S.A. domestic prices only:

S/310	\$33,500	59308A	\$875
1620A	\$1,750	59309A	\$975
1710B	\$2,625	6940A	\$1,600
1720A	\$3,400	7010A	\$900
3045A	\$30,000	7015A	\$945
3050B	\$14,000 to \$25,000	8016A	\$7,560
5082-7440 (1K)	\$3,600	8444A, option 058	\$3,600
	\$1.50 per digit	11667A	\$475
5082-7752 (100)	\$3.50 each	33320	\$275 to \$535

DIRECT RESPONSE SYSTEM

For fast response, use the above reply cards. Please note that you can choose two types of HP response:

- Literature (You will receive more information on a product.)
- Please contact me. (You will receive product information and a follow-up call by an HP field engineer.)

If both reply cards on this page have been used, contact your nearest HP field office or one of the regional offices listed on the preceding page. Or write directly to the Hewlett-Packard Company, 195 Page Mill Road, Palo Alto, California 94306.

No Postage Necessary if Mailed in the United States

BUSINESS REPLY MAIL

Postage will be paid by

HEWLETT-PACKARD
195 Page Mill Road
Palo Alto, California 94304

First Class
Permit No. 201
Palo Alto
California

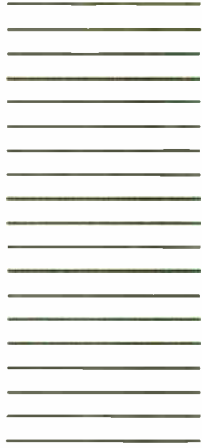

No Postage Necessary if Mailed in the United States

BUSINESS REPLY MAIL

Postage will be paid by

HEWLETT-PACKARD
195 Page Mill Road
Palo Alto, California 94304

First Class
Permit No. 201
Palo Alto
California

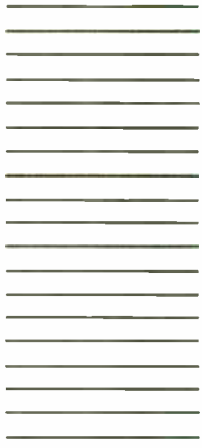

3,500,000 boards prove one thing.

A logic tester you install today and use tomorrow.

Programming delay is no delay for Trendar. Software is all but eliminated. Operator training is a matter of hours. The track record of the TRENDAR 2000A shows test stations are typically testing boards within 48 hours of delivery. And boards tested and passed by the TRENDAR 2000A work in the end product. Millions of boards of thousands of types have been accurately diagnosed and passed. The competition doesn't mention that other testers pass a significant number of still defective boards.

Don't take our word for it.

Ask companies like Tektronix, Hazeltine, Honeywell, or Datapoint about Trendar. They and companies like them have tested over 3,500,000 boards on our testers. Ask them why they're willing to put their reputation for quality on the line through reliance on the 2000A. They'll gladly tell you why they chose Trendar over systems costing three times more.

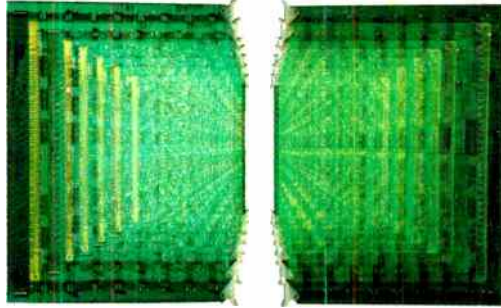

You don't need a computer to test logic boards.

You get more than you pay for!

In these days of tight money, the \$100,000 for a tester and \$200,000 for programs just aren't there to be spent. Fluke-Trendar logic testers are priced from only \$6,000. to \$26,000.* They save user companies thousands of dollars a month while they test tough sequential boards with up to 240 IC's. They find multiple and loop faults that cause other diagnostics to crash.

You have to see it to believe it.

We've said the TRENDAR 2000A will test your most difficult boards, with no software hassle, faster and for thousands of dollars less per month than computerized testers. If you're like most, it sounds too good to be true. Make us prove it right in your own factory. Call us. Collect. Fluke-Trendar. (415) 965-0350

*U.S. price



FLUKE TRENDAR

a subsidiary of John Fluke Mfg. Co., Inc.

500 Clyde Avenue Mountain View, CA 94043

Logic testers so sophisticated they don't need a computer.

Circle 27 on reader service card

**We've made
a
great tape
transport
a lot better.**

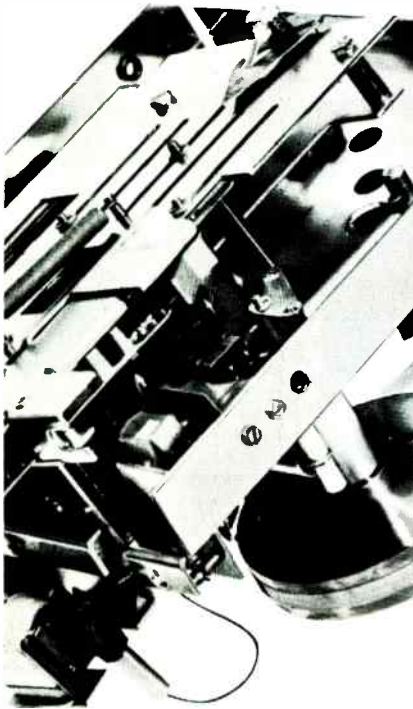

**take a look
at
CONRAC**

Now, there's no reason for you to "trade-off" when specifying an audio cassette tape transport...not if you specify the Conrac CAS-4. Here are only a few reasons why: • USA designed and manufactured • 3 motor design • No mechanical clutches or brake bands required • Designed for remote control • OEM priced. 501

Write for descriptive brochure

CONRAC CORPORATION CRAMER DIVISION

Mill Rock Road, Old Saybrook, Conn. 06475
(203) 388-3574

Meetings

First National Microprocessor Conference, Arthur D. Little Inc., Sheraton-Boston Hotel, Boston, Dec. 2-3.

National Telecommunications Conference, IEEE, Sheraton Inn, Harbor Island, San Diego, Calif., Dec. 2-4.

Eighth Asilomar Conference on Circuits, Systems, and Computers, Naval Postgraduate School (Monte-rey, Calif.), IEEE, et al., Asilomar Hotel and Conference Grounds, Pacific Grove, Calif., Dec. 3-5.

International Colloquium on Complex Integrated Circuits, Fédération Nationale des Industries Electroniques (Paris, France), Unesco Building, Paris, Dec. 3-6.

Twentieth Annual Conference on Magnetism and Magnetic Materials, IEEE and AIP, Jack Tar Hotel, San Francisco, Calif., Dec. 3-6.

Fall Conference on Broadcast and Television Receivers, IEEE, O'Hare Inn, Des Plaines, Ill., Dec. 9-10.

International Electron Devices Meeting, IEEE, Washington Hilton Hotel, Washington, D.C., Dec. 9-11.

ICMB 74, International Conference on Magnetic Bubbles, IEEE, APS, and IBM Corp., IBM Research Laboratory, San Jose, Calif., Dec. 9-11.

Nuclear Power Systems Symposium, IEEE, Shoreham Americana, Washington, D.C., Dec. 11-13.

Plated Printed Circuits Conference, New York University, Ambassador East, Chicago, Ill., Dec. 16-17.

Optical Fiber Transmission Topical Meeting, IEEE, Williamsburg Lodge, Williamsburg, Va., Jan. 7-9.

Computer Architecture, IEEE, University of Houston, Houston, Texas, Jan. 20-22.

Reliability and Maintainability Symposium, IEEE et al., Sheraton Park Hotel, Washington, D.C., Jan. 28-30.

EXETRON CORP. . . a better way

a better way for single chip C/MOS LCD & LED digital watches . . .

- 6002 - LCD watch circuit hrs-min
- 6002B - LCD clock circuit hrs-min
- 6002M - LCD watch module with plug-in display hrs-min
- 6003 - LCD watch circuit hrs-min mo-date sec AM/PM indication during setting American or European 1 year calendar
- 6003M - LCD watch module same features as 6003, with plug-in display
- 6004 - LED watch circuit same features as 6003
- 6004M - LED watch module, same features as 6003

a better way for semiconductor memories . . .

- 8701 - N/MOS 1K quasi static RAM access time 60 ns MAX pin compatible with AMS 7001

a better way for digital clock/calendar circuits . . .

7000 Timing Circuit Family — features include: 4/6 digit LCD display on chip backup oscillator for power failure 4 year calendar 10 min snooze alarm 12 hour AM/PM indication or 24 hour clock clock radio and timer controls true 24 hour alarm clock BCD output for printers and instrumentation logic to drive Sperry & Burroughs gas discharge displays European or American calendar sleep counter variable brightness control non-multiplexed output static drive to a battery operated clock module with a 3½ digit, 4" high, LCD display.

a better way for calculator circuits . . .

5000 Calculator Circuit Family — features ranging from 4-function to the more sophisticated calculator arrays with accumulating and automatic totaling memory 1/X Xⁿ floating point sign change X/Y register add mode add-on and discount avg % automatic constant self test. Available with 6, 8, 10, and 12 digit display output.

a better way for immediate results . . .

WESTERN U.S.:

N. Cal & Nev: Nor-Cal (451) 961-8121
S. Cal: Electronic Component Marketing (213) 340-1745
San Diego: J.T.L. Assoc. (714) 277-8044
Ariz & N.M.: Delta Electronic Sales (602) 966-9903
Ore, Wash, & N. Idaho: Western Technical Sales (206) 641-3900
Colo, N. Neb, S. Idaho, Utah: Straube Assoc. (303) 426-0890

CENTRAL U.S.:

Ala & Miss: Rakes Engineering & Marketing (601) 287-5369
N. Ill: Choisser & Clanfield Electronic Sales (312) 358-8900
Ohio: Del Steffen & Assoc. (216) 461-8333; (513) 293-3145
Kan, Mo, & S. Ill: Beneke & Mc Caul (314) 434-6242 (816) 765-2998
Okla & Tex: Merino Sales (214) 239-9719
N.C., S.C., Ga, Tenn: Rakes Engineering & Marketing (615) 968-4195
Mich: Elko Sales (313) 884-1955; (616) 949-1451
Wis: Choisser & Clanfield Electronic Sales (414) 476-0484

EASTERN U.S.:

Del, N.J., Pa: Barrett Assoc. (609) 429-1551
Fla: E.I.R. (305) 830-6900; (305) 585-6689; (305) 791-6390
New England: Contact Sales (617) 273-1520
NYC & N. N.J.: M.G.I. (201) 399-4350

INT'L. SALES OFFICES:

Aus, Benelux Countries, W. Ger: Contiflex AG (089) 266016
France: Int'l. Semiconductor Corp. 604 52 75
Sueden: AB Elektroflox 08-28 92 90
So. Africa: Truvelo Electronics Ltd. 6-9073
Switz: Contiflex AG 01-908181
U.K.: Walter Scott Indus. 01-949-2354
Hong Kong: Enterprise Systems Ltd. 5-458141
Japan: Microtek, Inc. 03-363-3649
Taiwan: LSI Electronics Ltd. 520138

EXETRON **EXETRON**
... excellence in electronics

EXETRON CORP. 3105 Alfred St., Santa Clara
CA 95050 (408) 247-7660 Telex: 357424

From the beginning man has searched for a better way.

From the beginning, Exetron has researched and implemented a better way. Our MOS/LSI technology has found a better way to keep time accurate to within 5 seconds a month. A better way to time an earth tremor at a remote location. A better way to combine more than 14 operations on a single calculator chip with a memory. A better way to retrieve information from memory in less than 60 ns.

To underscore this better way, we have chosen a new name, The Exetron Corporation, which now fields a sales organization covering more than 30 cities across the United States, Europe, and the Far East.

You may have already become acquainted with us as Cal-Tex Semiconductor, owners of the patent for one of the world's first single chip LCD quartz

digital watch circuits. Or, if you are involved with digital watches, clocks, or timekeeping instrumentation, chances are you have utilized Exetron technology, as we perform work for 1 out of every 3 watch or clock manufacturers.

From the beginning, Exetron Corporation has developed more than 9 standard digital watch & clock, and calculator circuits. Soon we will be introducing an additional 6 new products for LCD and LED watches and clocks, advanced calculator products, and semiconductor memories.

If you are looking for a better way, ask one of our sales representatives to show you how Exetron can help.

EXETRON CORPORATION ... excellence in electronics

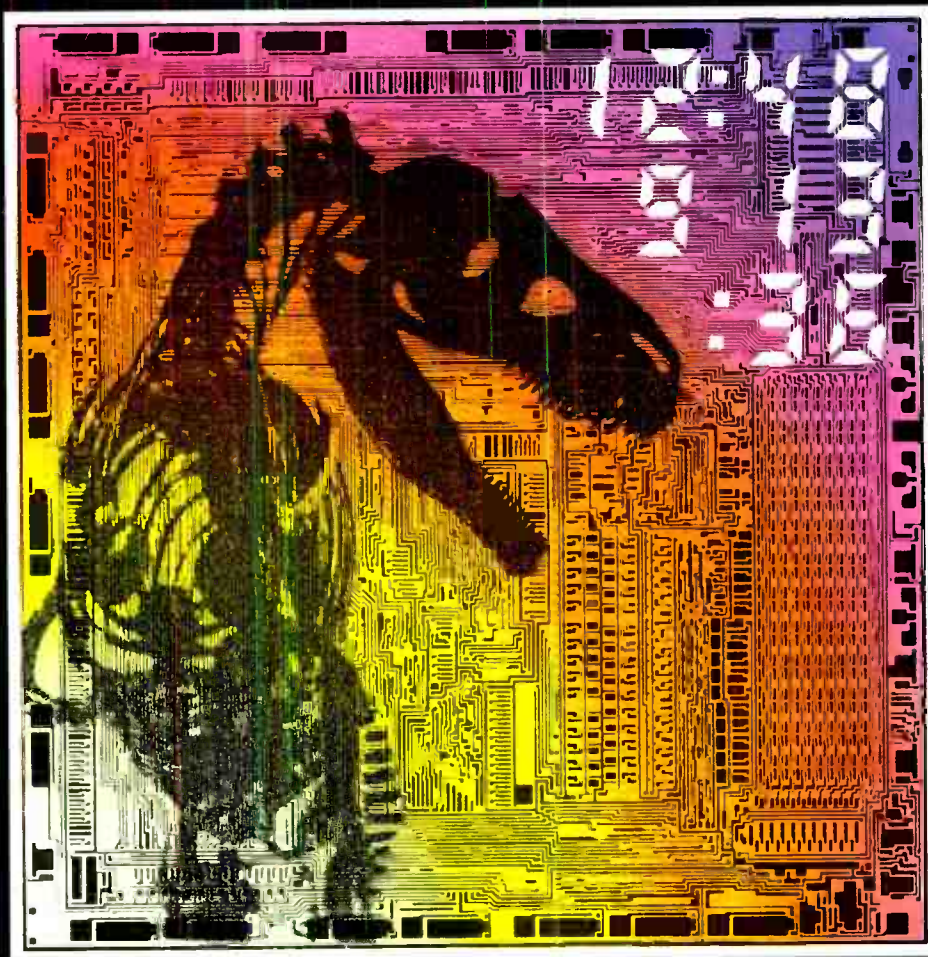

a better way
to compute hrs-min

a better way
to report mo-date ..

a better way
to count seconds ...

EXETRON
ex

EXETRON

EXETRON CORP.* 3105 Alfred Street, Santa Clara, California 95050 (408) 247-7660 telex: 357424

World Radio History

* FORMERLY CAL-TEX SEMICONDUCTOR, INC.

Circle 31 on reader service card

**“Starting this month,
the price of low-end computers
will never be the same.”**

William Long
VP OEM Group
Digital Equipment Corporation



As everybody knows, Digital brought out the first computer under \$20,000, the first under \$15,000, the first under \$10,000 and the first under \$5,000.

And everytime we made a breakthrough, one imitator or another would be forced to come out with a lower price.

Well now it's a whole new game.

Over the next few months, we're going to show you what can happen to prices when the world's

leading maker of small computers puts its mind to it.

And we're not talking about price cuts.

We're talking about economies of scale.

And new technology. Innovation. Service. Support. Software. Training. Documentation.

And, most important, the Digital label. Which stands for the most beautifully engineered computers on the market.

If you want in-depth informa-

tion on these new products, write Digital Equipment Corporation, Maynard, Massachusetts 01754 (617) 897-5111. European headquarters: 81 route de l'Aire, 1211 Geneva 26. Tel: 42 79 50. Digital Equipment of Canada Ltd., P. O. Box 11500, Ottawa, Ontario K2H 8K8. (613) 592-5111.

digital

Circle 33 on reader service card



Christmas could come early for designers using this versatile switch from Spectrol...



The Model 87 Half-inch Switch

- Up to 3 poles and up to 10 positions — a total of 18 switching combinations to choose from
 - Mounts directly on a printed circuit board
 - Design versatility permits unlimited applications and many cost saving benefits: logic switching, internal switching device for optional equipment add-ons, test point switching, adapting main-frame computers to peripheral equipment, standardizing printed circuit boards, selecting operational voltages, selecting calibration resistors, etc.
- Send for literature, and ask about free samples.

Spectrol

SPECTROL ELECTRONICS GROUP

UNITED STATES Spectrol Electronics Corporation 17070 E. Gale Avenue, City of Industry, Calif. 91745, U.S.A. • (213) 964-6565 • TWX (910) 584-1314
UNITED KINGDOM Spectrol Reliance Ltd. Drakes Way, Swindon, Wiltshire England • Swindon 21351 • TELEX: 44692
ITALY SP Elettronica spa Via Carlo Pisacane 7, 20016 Pero (Milan) Italy • 35 30 241 • TELEX: 36091

Circle 34 on reader service card

National to show 16-bit processor on single chip

The semiconductor industry's first 16-bit, single-chip microprocessor is soon to be introduced by National Semiconductor Corp. Called PACE (for processing and control element), the device will handle 16-bit instructions and addresses, and either 16-bit or 8-bit data. **It is being built with p-channel silicon-gate MOS technology** because, the company says, p-MOS is a more predictable and better established technology than n-MOS and meets both of PACE's main requirements: 10-microsecond execution time for instructions, and enough density to fit the entire circuit on a single chip.

PACE requires only two power supplies, +5 volts and -12 v, instead of the three required with n-channel fabrication. The company says it also is setting up a complete software and hardware package to support users in designing systems.

AT&T antitrust suit: fast interconnection, settlement seen . . .

American Telephone & Telegraph Co. **will quickly but gracefully drop its rigid resistance to equipment interconnection standards and also negotiate another consent agreement.** Those are expected to be the likely results of the Justice Department's long-anticipated antitrust suit calling for the breakup of the communications giant [*Electronics*, Oct. 31, p. 41]. The widespread view in the Washington electronics and legal communities that AT&T would accede to type acceptance certification of equipment for interconnection to the telephone network was concurred in by the Federal Communication Commission's Walter Hinchman. The Common Carrier Bureau chief saw one sign of this in the weeks immediately preceding the antitrust action when AT&T became **"much more cooperative" in negotiating local distribution tariffs for connecting competing carriers with the telephone network.**

Speculation by industry and Government insiders that AT&T ultimately will negotiate a consent agreement was spurred by AT&T chairman John D. deButts' prepared statement that skirted a strong specific commitment to a legal battle. However, questioned later by the press, he did say AT&T would fight. DeButts talked of "fragmentation of responsibility for the nation's telephone network," leading industry observers to conclude that AT&T might seek to **retain control of the network by consenting to the divestiture and subdivision of Western Electric Co.,** its manufacturing subsidiary which recorded \$7 billion in sales in 1973.

. . . as FCC readies type acceptance

The fact that the FCC will shortly call in a rulemaking, for action on development of **standards for equipment type acceptance certification for interconnection with the telephone net,** was generally overlooked in the furor immediately following the antitrust action, which charges AT&T and its subsidiaries with conspiring to obstruct interconnection at every level. When the FCC order comes down, the Electronics Industries Association expects to assume a lead role in standards development, according to John Sodolski, Communications division staff vice president. "EIA is the natural organization to do this," contends Sodolski, since Western Electric as well as other telecommunications equipment makers are all association members. William McGowan, president of MCI Communications Corp. and a Bell competitor, saw the suit as Government recognition that "the concept of monopoly does not apply to long lines of equipment operations."

Electronics newsletter

In addition to divestiture and the subdivision of Western Electric "to assure competition" in the production and sale of telecommunications hardware, the Government suit wants divestiture of either the Long Lines Department from the Bell System, or the spinoff of some or all of the Bell operating companies as separate and independent entities. Justice's preference "will depend on what is feasible based upon the evidence adduced at the trial," explained Thomas E. Kauper, assistant attorney general for antitrust. As for Bell Laboratories Inc., which has a \$500 million R&D budget this year and is also a defendant, **The Government made no specific recommendations** except to call on it "to abide and perform such orders and decrees as the court may make." Industry officials observed that new arrangements for funding Bell Labs would have to be developed if its principal source of revenues, Western Electric, is spun off and split up.

Benrus watch to use TI's I²L module

The Wells division of Benrus Corp. will make and market a digital watch with a light-emitting-diode display **using Texas Instruments' integrated injection logic modules**. The move ends speculation over how and when TI would get into the timepiece business [*Electronics*, Nov. 14, p. 25 and Oct. 31, p. 29]. As expected, the entry sets a new direction, bringing bipolar I²L into watches in place of the more common C-MOS technology. **The main advantage of I²L is size:** a single chip, an eighth of an inch on a side, contains logic, timing, and display drivers. Such a chip is about 25% smaller than the typical C-MOS version.

TI will supply a module with five parts; the I²L LSI circuit, quartz crystal oscillator, frequency adjust capacitor, substrate, and LED display. The watch, to sell at \$250 in a man's model, will have two 1.5-volt batteries and will display hours, minutes, and seconds.

Fairchild sets own 4-k RAM

Fairchild Semiconductor will begin sampling its own 16-pin 4,096-bit RAM in the first quarter. Fairchild has been second-sourcing the Mostek 16-pin 4-k device. The company also says it has sampled a 1,024-bit MOS RAM and would begin deliveries "**if we get an order,**" says **Wilfred J. Corrigan, president**. "**There's no business around,**" he adds. And in the charge-coupled-device area, Fairchild expects to introduce a 9-k memory by the end of this year.

BART seeks \$237 million from suppliers

The embattled Bay Area Rapid Transit district of San Francisco-Oakland has finally filed its much-threatened suit against Westinghouse Electric Corp. and other suppliers for the \$1.6-billion system. **BART is asking a total of \$237 million** for what it alleges were late deliveries and failure to live up to contract specifications.

Westinghouse, builder of the electronic train-control system, is the prime target. BART seeks \$55 million, alleging failure to provide equipment that continually detected presence of trains on tracks, and that the equipment did not "indicate protected zones as occupied when detection was lost." Westinghouse, which says it will fight the action, **has meanwhile sent BART a claim for \$15.7 million which it says represents back pay for delays** incurred during BART's construction—the same delays for which BART is suing Westinghouse.

We'll deliver 10,000 SCR's in three weeks.

Choose the plastic 2N5060 Series, or IP100 Series now available to 300V. Or the hermetically-sealed ID100 Series now available to 400V. Both with typical dv/dt capability of $75V/\mu\text{sec}$.

Unitrode also offers many other low-level SCR's. The widest choice in the industry. The right SCR for your specific environmental requirements, at the right price. All part of a growing family of Unitrode plastic or hermetic SCR's designed for a wide range of sensing and control applications.

Place an order. We'll deliver 10,000 of any of the SCR's listed — in three weeks or sooner.

Write for our latest data sheets. Or for faster action, call Vin Savoie at (617) 926-0404.



**Unitrode plastic
or hermetic SCR's**

Type	Blocking Voltage	Maximum Current, RMS	Gate Trigger Current I_{GT}	Gate Trigger Voltage V_{GT}	Holding Current I_{HX}	
TO-92	TO-92	TO-18	0.8A	200 μ A Maximum	0.8V Maximum	
2N5060	IP100	ID100				5mA Maximum at $R_{GK}=1K$
2N5061	IP101	ID101				
2N5062	IP102	ID102				
2N5063	IP103	ID103				
2N5064	IP104	ID104				
	IP105	ID105				
		D106				

See Electronics Buyers' Guide Semiconductors Section for more complete product listing.

Circle 36 on reader service card

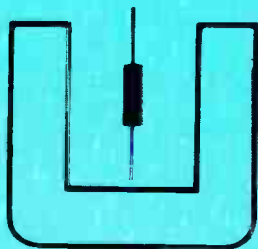

UNITRODE

580 PLEASANT STREET, WATERTOWN, MA 02172

New GE-MOV[®] Varistors

...Voltage transient protection -25¢*

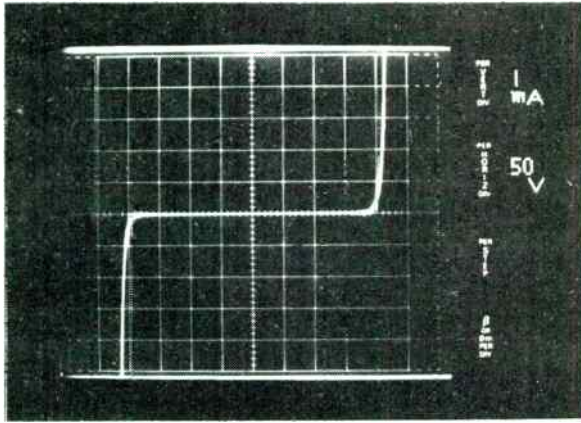

Actual photograph of V220MA2A characteristic

New axial lead "MA" series GE-MOV[®] Varistors offer both low cost, compatibility with automatic insertion.....and better voltage transient protection than back-to-back zener diodes because of 4-7 times better peak pulse current rating (20A @ 75°C).

■ 14 types in the "MA" series GE-MOV[®] Varistors offer ratings of - 88-264V RMS, - 121-365V DC

Type	Voltage RMS DC
V150MA1A	88 121*
V220MA2A	132 181
V220MA4B	138 191
V430MA3A	253 349
V430MA7B	264 365

■ Over 110 companion GE-MOV[®] Varistors in 5 different packages offer transient protection 12-100V RMS, 16 - 780 V DC, peak current ratings up to 2000A.

*Suggested resale price 10 000 lots 25¢

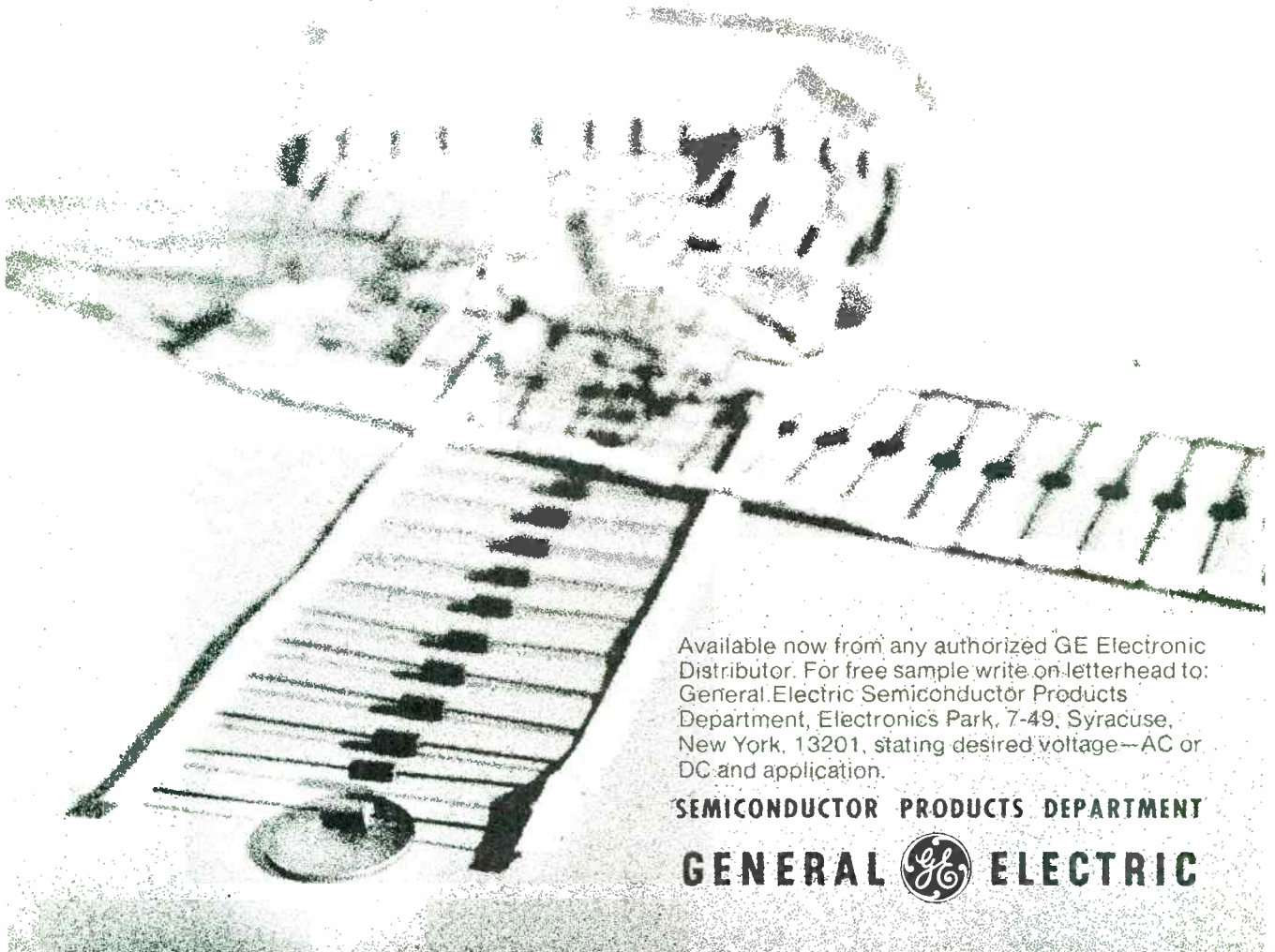

Available now from any authorized GE Electronic Distributor. For free sample write on letterhead to: General Electric Semiconductor Products Department, Electronics Park, 7-49, Syracuse, New York, 13201, stating desired voltage—AC or DC and application.

SEMICONDUCTOR PRODUCTS DEPARTMENT

GENERAL  ELECTRIC

Ion implantation boosts threshold of JFET breakdown

National Semiconductor raises tolerance of monolithic devices to 50- to 60-volt region

Ion implantation has been a production tool at most major semiconductor manufacturers' facilities for some years. But only recently has it been applied to junction field-effect transistors fabricated in a monolithic IC array. That's at National Semiconductor Corp., Santa Clara, Calif., and the results are a seven to eight times boost in the JFET breakdown thresholds over the levels of most other monolithic junction field-effect devices on the market, points out National's engineering design manager for advanced linear IC Bob Dobkin. The 50- to 60-volt breakdown threshold is comparable to values obtainable only with bulkier discrete JFET devices.

In addition, these devices have wider bandwidths (5 to 10 megahertz, compared with 1 MHz) and lower offset voltages (5 microvolts, compared with 25 to 50 μV) than other devices made by standard FET processing technologies.

Technology. "The important thing is not that we can make a better monolithic FET device, but that we have a new FET process technology—ion implantation—providing a new tool for the circuit designer," Dobkin says. "With ion implantation, it is possible to get very good control of FET characteristics and excellent—within 10 millivolts—matching."

National's first device fabricated

by the ion-implantation JFET technology is the recently announced LF-111 input comparator, which has typical input currents of 5 picoamperes. This will be followed in about three months, says George Urbani, marketing manager for linear products, by a general-purpose JFET operational amplifier with a bandwidth between 5 and 10 MHz and slew rates of 10 to 20 $\text{V}/\mu\text{s}$.

Other devices being considered for the family, Urbani says, are multiplexers, sample-and-holds, FET switches, analog-to-digital converters, and an instrumentation operational amplifier.

Useful. Junction-field-effect transistors have in the last few years become standard devices for achieving low-input characteristics for such linear circuits as operational amplifiers, comparators, and sample-and-hold circuits. The problem has been to build a JFET with high enough breakdown voltage and large enough bandwidth to be useful in general-purpose applications. With 50- to 60-v breakdowns, the National Semiconductor FETs may be squarely in the middle of the general-purpose arena.

In ordinary JFET monolithics of the depletion type, the FET channel between the source and drain is laid down on an n-type silicon substrate by diffusion. An n-type gate is then diffused into the FET channel, across which a positive gate voltage must be applied to repel and choke off hole current.

The problem, says Dobkin, is that the n-type gate is deposited in the same diffusion as the emitter of the transistor, resulting in an n-p breakdown of only 7 v.

"In our process, however, diffusion is used only to place the p-type source and drain on an n-type substrate," Dobkin explains. "Then we ion-implant between these two sites a very shallow p-layer channel."

Because this channel is completely ion-implanted, it is well controlled as to depth, thickness, and geometry, he continues. And because each wafer is scanned with an ion-implantation beam of a precise, relatively unvarying concentration, the characteristics of the resulting JFETs are closely matched.

"In normal monolithics, by contrast, the thickness of the FET channel and the concentration of p ions is dependent on diffusion," Dobkin says, "which in turn is dependent on the temperature gradient and air turbulence in the furnace. The result has been FETs of varying quality and performance." □

Computers

Amdahl computer is now due in April

After a grueling delay, Amdahl Corp.'s much ballyhooed super-speed but architecturally simple computer may soon hit the market [*Electronics*, March 29, 1973, p. 51]. Now, the Sunnyvale, Calif., company says it will deliver the first production model of its model 470 to the University of Georgia next April. And with more than 20 letters of intent from potential customers, Gene Amdahl, chairman of the board and founder of the company,

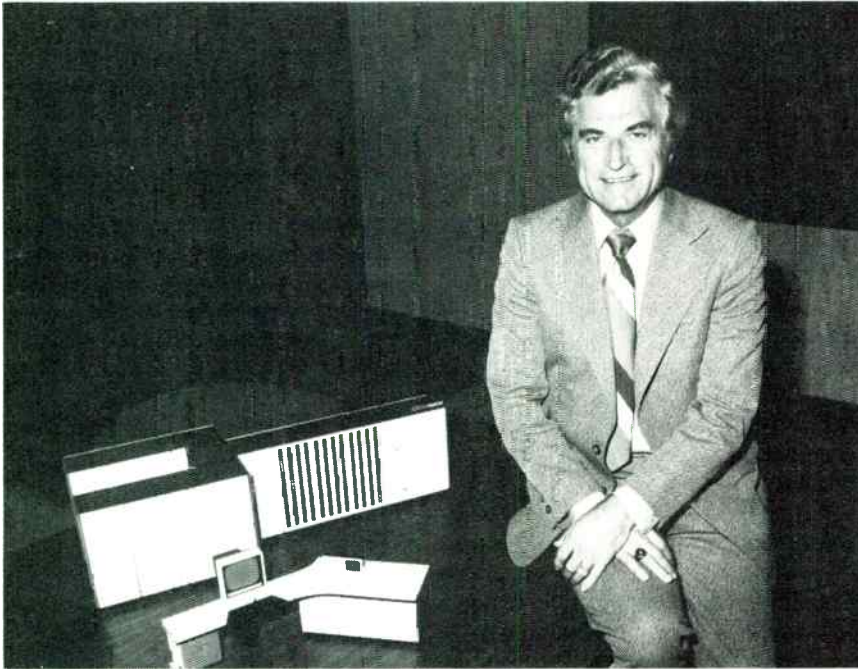

Coming. Gene Amdahl's super-speed model 470 computer, redesigned to surpass IBM's 370/168, is on track and will be in production, he says, during the first half of 1975.

expects to be in production by June 1975—a year later than scheduled.

However, things still are not going too smoothly for the company. It is now trying to raise more than \$20 million in additional working capital, and only two thirds of this has been committed, says president Eugene White. The need for new financing was triggered when Amdahl had to redirect its development effort because IBM, at which Amdahl is taking dead aim, came out in 1972 with a higher-performance computer than the one that the California company had expected to face in the marketplace.

"Despite our problems, I'm sure there are people out there who think we've still got something worth investing in," White says. Performance of the proposed new computer was what in 1970 enticed such original investors as Fujitsu Ltd. of Japan, Heizer Corp. of Chicago, and Nixdorf Computer of West Germany to invest \$27.5 million in a first round of financing. And performance is also enticing new investors to the current round.

Drain. To generate more internal working capital, Amdahl's relationship with Fujitsu was renegotiated,

and the Japanese company took over a major portion of the manufacturing and inventory. "Those two items alone were a tremendous drain on our development effort," says White. "With that removed, and with the additional \$20 million, we'll be in good shape."

Continues Amdahl: "When we started development on the system in 1970, our idea was to design a computer that was beyond the state of the art in performance, but that would be compatible with IBM's top-of-the-line model, particularly the 360/165."

But late in 1972, when Amdahl was well along in development, IBM announced its 370 system. "So we started another prototype development to piggyback the top of that line, the 370/168," explains Amdahl. "But by late 1973, we found we were being sucked dry, working on two systems at the same time. Added to that, the country was in the midst of the energy crisis, inflation was starting its spiral, and with the cost of money going up all our sources of credit were going dry. We concentrated on the 370/168 design alone."

About the only thing that hasn't

gone wrong, says Amdahl, has been the technical development of the 470. Fortunately, it was found that much of the hardware work and some of the software work on the 360-compatible system was applicable to the 370 system, he says. "Since the conversion, we've run into no real problems."

The 470. The new model 470 central processor, using an LSI version of bipolar emitter-coupled logic in the central processing unit, p-channel MOS LSI circuits in the main memory and high-speed bipolar devices in a cache memory, has a cycle time of less than 30 nanoseconds, and the delay on the CPU chip itself is about 600 picoseconds. Moreover, the number of mechanical interconnections and components such as printed-circuit boards has been reduced as much as a sixth to an eighth of the count in comparable systems.

With each system selling for roughly the same price as IBM's top-of-the-line models—about \$2.5 million for a 4-megabit system—Amdahl hopes his 470 will capture about 25% of the \$4 billion to \$8 billion market he foresees through 1978 for the IBM 370/168. Amdahl includes in his thinking IBM's FS computer [*Electronics*, Oct. 17, p. 70], which he predicts won't be shipped until late in 1978 and which he expects will be slower than his computer. Amdahl says his 470 will compete with any IBM system in the near future. □

Components

Squeeze works for mercury switches

Most people familiar with the mercury switch know it as a silent "click-less" light switch in the home. It's seldom found in industrial applications, despite its no-bounce operation and low contact resistance, partly because the pool of liquid mercury that acts as the switching element often relies on the force of

gravity and the device must be mounted in a fixed position. In addition, the switch is both difficult to package and expensive.

However, Inflo Systems Inc., a small R&D firm in Chester, N.J., has developed a mercury element that switches when squeezed and can therefore operate in any position. And because only a tiny ball of mercury is used, the switch is compact and relatively inexpensive.

Working prototypes have been made of two devices—a self-latching relay, and a keyboard switch intended for data entry and typewriter applications, as opposed to the smaller devices needed for the hand-held calculator market.

The keyboard switch is a momentary-action type that has a positive feel when contact is made. The

ball of mercury, which measures less than 100 mils in diameter, is held at the center of a cavity, walled in by a plastic that resists mercury wetting (see the figure below). Contact pins for the switching circuit are at opposite ends of the cavity and do not touch the mercury when the switch is in its normally open position.

When the push-button cap is depressed, the mercury sphere is squashed so that it fills the cavity and completes the circuit between the two contact pins. When the push button is released, the ceramic magnet surrounding the armature is attracted back to the ferrite keeper. Its own surface tension and the tapered shape of the cavity causes the mercury to become spherical again, disconnecting itself from the contacts, breaking the circuit, and returning

to be held in its resting “pocket.”

Contact resistance is only 30 milliohms, and breakdown voltage is 5,000 volts ac. The total absence of contact bounce is shown by the oscilloscope display for two consecutive switching operations. Life expectancy is 100 million operations at 24 v dc for a 10-milliampere resistive load. In large quantities, the switch could sell for about 30 cents, says Inflo’s president Donald S. Rich.

Relay. Like the keyboard switch, Inflo’s self-latching relay is free of contact bounce and can operate in any position. It is a low-power axial relay that can fit into an 8-pin dual in-line package that Rich says is suited for the telephone equipment market.

A mercury-wetted contact pin of

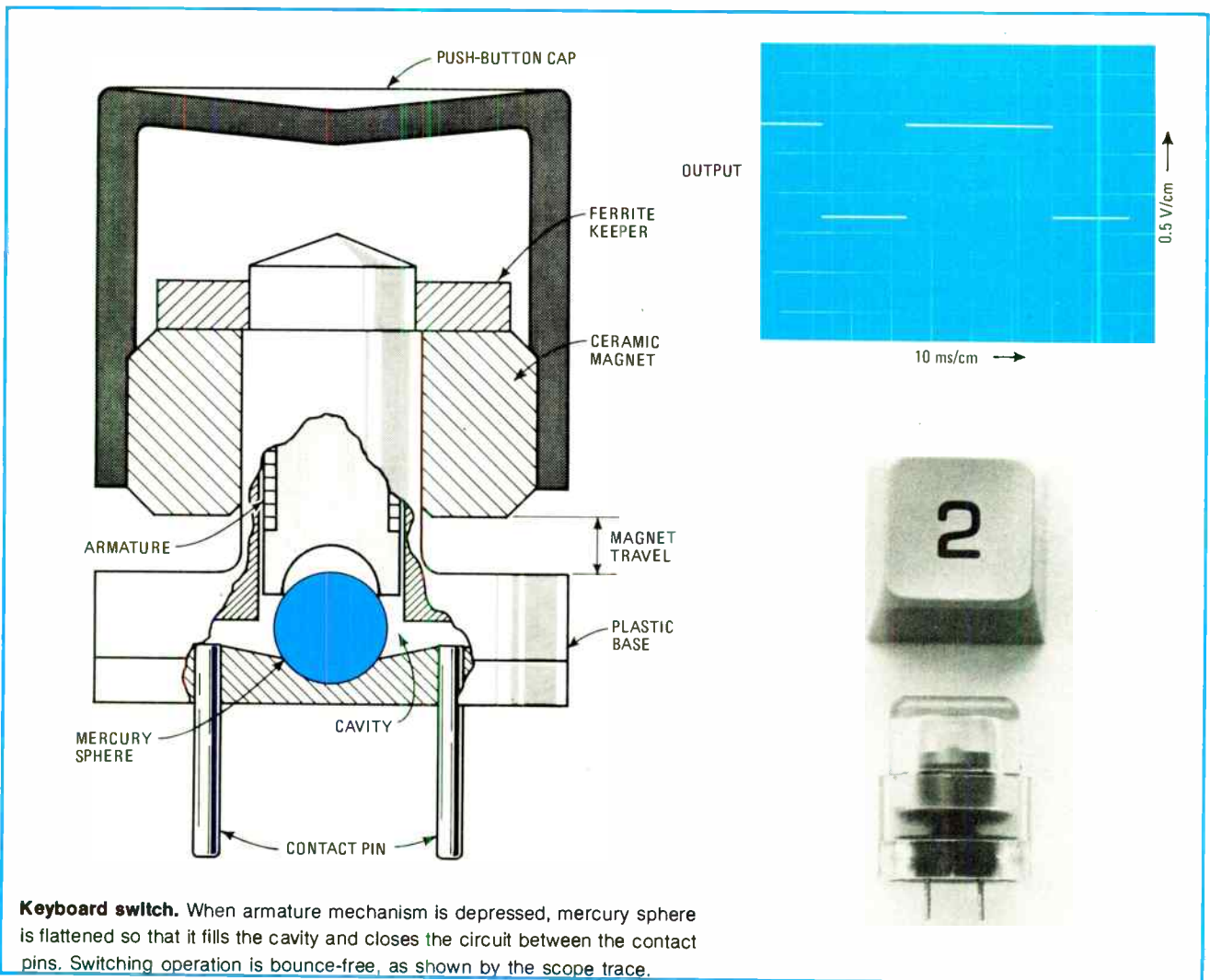

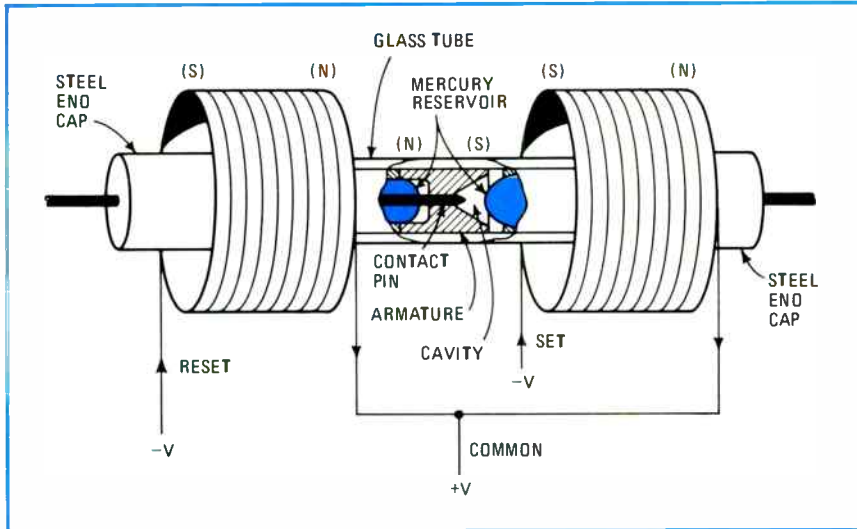

Self-latching relay. Switching mechanism of this axial relay is similar to that of the keyboard switch. When the relay latches, the armature moves towards the set coil, causing the mercury reservoir there to fill the tunnel cavity and contact the pin at the end of the cavity. This pin, which runs the length of the armature, is always in contact with the reset-coil side of the relay through the other mercury reservoir.

nickel wire runs through the length of the relay's ceramic-magnet armature (see the figure above). Continuous contact between the pin and the reset-coil side of the relay is made through a mercury reservoir. The other end of the pin protrudes into a cavity in the armature at the set-coil side. A second mercury reservoir at the set-coil side is kept normally separate from the contact pin. The entire contact system is enclosed in a hydrogen-filled glass tube.

When the relay's reset coil is energized, a magnetic force is created that repels the armature away from the steel end cap. The armature squeezes the mercury ball at the unit's set-coil side into the armature cavity, and the mercury contacts the pin there. The relay is now latched.

To unlatch the relay, the set coil is energized. Again, the coil voltage creates a magnetic force, only now the force repels the armature back to the reset coil side. The ball of mercury withdraws completely from the cavity, and the relay reverts to its normally open position. Total armature travel is only about 10 mils.

The relay's set and reset pulse times may be the same—approximately 2 milliseconds. But Rich indicates that this pulse time may eas-

ily be shortened to 0.5 ms. Maximum operating frequency is 200 hertz, and dielectric breakdown voltage is 600 v dc. Standard coil voltages can be used.

Manufacturing rights to both the keyboard switch and the relay are available from Inflo, the company may manufacture also. □

Avionics

Uncertainty clouds outlook for Aerosat

The energy crisis, the recession, and bureaucratic delays are threatening development of the Aeronautical Satellite (Aerosat) system for the world's aircraft, both industry and Government officials charge. The storm clouds on the Aerosat horizon are serious, they say, pointing to budget cutbacks in the Federal Aviation Administration and indications that France may postpone its contribution to the estimated \$150 million cost of a two-satellite system over the Atlantic.

Furthermore, the delay in selecting Comsat General Corp., Washington, D.C., as the U.S. partner in

the international venture will, because of inflation, boost costs at a time when money is hard to come by. Economics is expected to be topic "A" for Aerosat partners ESRO (European Space Research Organization), Canada, and Comsat when they meet in Washington Dec. 3 and 4. They're trying to develop a management structure, as well as to review costs of the international venture, which has the goals of providing a satellite-based air-traffic-control system over the Atlantic Ocean and increasing the number of available communications channels.

"They may have to debate what to do with a corpse," says one airline official, perhaps somewhat hopefully at a time when revenues have declined. Reduced traffic on the North Atlantic tourist runs, he points out, may mean that the costly new air-traffic-control system is not needed. Increased traffic was expected to require computerized separation of aircraft routes.

Moreover, the reduction in traffic could cancel the need to improve and expand the voice-communications system. And airline officials note that the International Civil Aviation Organization is expected to double the number of high-frequency airline communications channels by going to a single-sideband system, in which 3-kilohertz channel spacing will replace the 7-or 8-kHz double-sideband systems, further weighing against Aerosat.

Needed. However, David Israel, FAA's deputy assistant administrator for engineering and development, as well as the FAA representative to Aerosat, still believes the satellite system is needed. "I think those that say that air traffic is down are taking a very short-sighted approach. We have got to get off the high-frequency system sooner or later and go to either an L-band or a vhf system," he says.

Israel says the timetable for Aerosat hasn't slipped, despite the one-year delay in selecting the American partner. System specifications should be ready by mid-1975, a contractor selected by October, and construction begun in January 1976

Fingertip FFT/IFT...

...and a lot more

The TEKTRONIX Digital Processing Oscilloscope puts the Fast Fourier Transform and its inverse at your fingertip.

From time domain data . . .

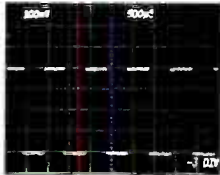

. . . powerful DPO software gives you magnitude vs frequency, phase vs frequency . . .

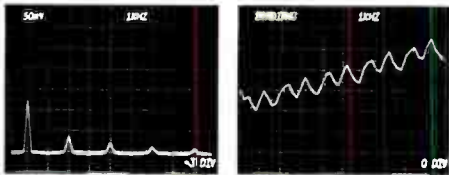

. . . real and imaginary vectorial values (with linear or logarithmic displays on either axis).

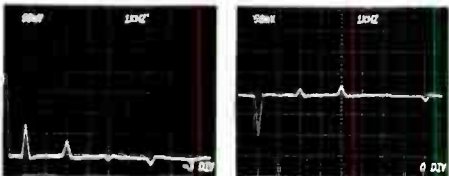

With FFT's and IFT's, the range of possible measurements is limited only by your imagination, not by a collection of dedicated hardwired devices. DPO program call buttons give you fingertip access to waveform processing from simple multiplication, addition, and subtraction to integration, differentiation, signal averaging, and correlation.

Get all the details from your local Tektronix Digital Applications Engineer. For your copy of the "Digital Processing Oscilloscope" brochure, contact: Tektronix, Inc., P.O. Box 500A, Beaverton, OR 97005. Phone: (503) 644-0161. In Europe: Tektronix Ltd., Guernsey, C.I., U.K.

For a demonstration circle 42 on reader service card

Circle 43 on reader service card

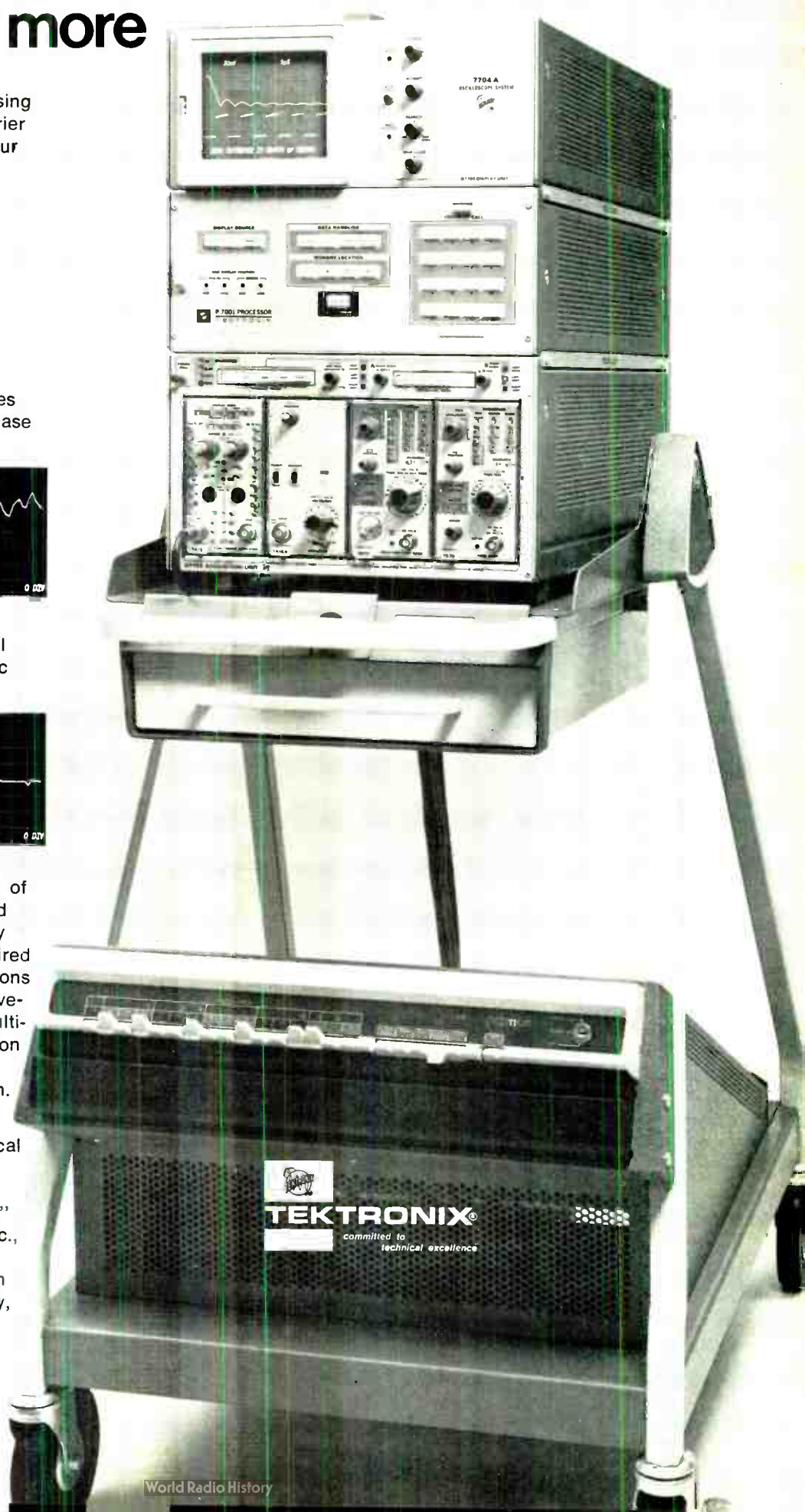

for a mid-1977 launch. This is a year earlier than the most optimistic industry predictions.

The domestic economic situation in the United States also threatens Aerosat's future. For full benefit, automated air-traffic-control equipment should be installed to receive and process Aerosat data. But FAA's own budget trimmers have already rejected a request for R&D funds for fiscal 1976 for an automated oceanic ATC system.

This system, now delayed at least a year to 1978, would have upgraded the nine en-route air-traffic-control centers located on the East and West Coasts to operate with digitized Aerosat-type flight plans. An experimental version of an automated ocean ATC system is, however, operating at the National Aviation Facilities Center (Nafec) near Atlantic City, N.J. It receives signals relayed from ATS-6, a NASA satellite used in an experimental version of an Aerosat-type system.

FAA officials say that the system at Nafec can be used to test Aerosat when and if it is launched. However, air-traffic controllers were told at a recent conference that funds for a complete oceanic ATC system would not be spent until a satellite system is launched. This is an indication of an attitude of "let's see it before we spend money" that could delay progress still longer. □

Commercial

Quasar moves for pay-TV entry

Quasar Electronics Corp., the Motorola offshoot acquired earlier this year by Matsushita Electric Industrial Corp., is itself developing an appetite for acquisition. Apparently seeking new outlets for its technology and television products, Quasar has signed an agreement with Telebeam Corp. that could lead to the absorption of Telebeam and its minicomputer-based system for hotel entertainment, security,



Key code. Plastic key unlocks control box in Telebeam system for room security, pay-TV, and hotel management.

management, and services.

The agreement gives Quasar options to buy 51% of the Paramus, N.J., company after Telebeam completes installation of its system at New York City's 1,847-room Americana Hotel. The system is already operating in almost 700 rooms on 18 of the hotel's 45 floors. Quasar may pick up the remaining 49% of Telebeam at various times in the future that are detailed in the agreement.

Sy Grodner, Telebeam president, says he expects to sell the system to at least 10 Americana-size hotels in New York during 1975, an ambitious program because there are fewer than 70 hotels of this size in the world.

Control. In the system for the Americana, Telebeam engineers have left the tuner in the TV receiver. But the usual channel-selection knob is gone. Instead, a box (see photo) sits atop the receiver and contains the controls for various services, as well as the room-alarm system. Twenty-six channels for pay TV, information services, and, eventually, electronic games can be selected by means of a single knob on the front panel of the box. In the future, Grodner says he expects to eliminate the separate box by mounting all controls in the TV receiver.

The Telebeam system currently involves four major features. The security service segment feature is called Gardtel. When a guest registers, he's handed a coded plastic card along with an ordinary door key. Once the door is opened with the ordinary key, the card must be inserted into the Telebeam control unit within 20 seconds to prevent an alarm buzzer from sounding in the room and in the hotel's central security office. Upon leaving the room, the guest may activate the secu-

urity system again from the control box atop the television receiver.

According to Grodner, since the system went into operation last January, property losses from burglaries at the Americana have dropped 45% from the previous comparable periods.

Paytel, the main revenue-producing portion of the hotel system, offers a choice of at least three full-length movies at any one time. The guest simply turns to the channel playing the movie of his choice—he has five minutes to switch to another pay-TV program or to a regular free TV channel, or to turn the set off before being billed \$3.50 by the computer. Under development at Quasar, says Grodner, is an electronic game for which the guest also can be billed.

Roomstat and Chargtel come under the management-services portion of the system. Roomstat enables the hotel management to know up-to-minute status of each room. A maid can push buttons on the control box to signal a room's availability to the minicomputer. Chargtel enables cashiers to check all points of sale within the hotel to make sure guest charges have been billed before the guest checks out.

Still under development is Datatel, which is being designed to dis-

COMPLETE LOW-FREQUENCY ANALYSIS PACKAGE -

SPECTRUM ANALYZER,
SCOPE,
TRACKING GENERATOR
FOR JUST \$3665.*

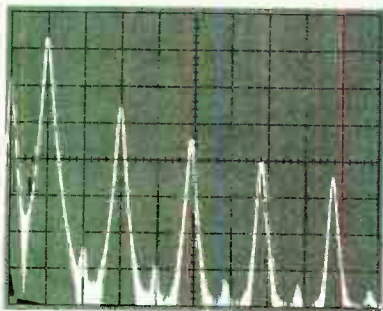

Spectrum analyzer display of square wave harmonics

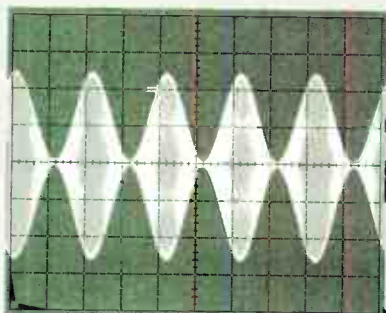

Oscilloscope display of modulated carrier

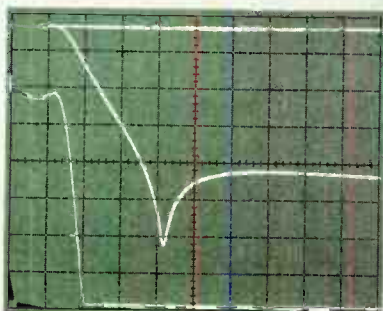

Spectrum analyzer displays of filter response at 10 dB/div and 2 dB/div using built-in tracking generator

You know that a spectrum analyzer displays information as it relates to frequency, somewhat like a scope relates information to time. But unlike the scope, the analyzer has a unique ability to display very low amplitude information even when large amplitude information is present. Analyzer sensitivity to low

amplitude information and ability to separate by frequency allow you to quantify all the components of a complex vibration waveform, or carefully tune the acoustic characteristics of a theatre, or know that an amplifier really meets distortion specs, or that a power supply filter design really works. With a spectrum analyzer and a scope your understanding can be complete in a wide variety of electronic and mechanical events.

Interested? Then tell us about your application. How? Write us, we will respond with application notes—or call your Field Engineer. If you prefer, use the reader service numbers—we will send you data sheets for the instruments in the package.

*The package includes: the 0-to-100 kHz 5L4N Spectrum Analyzer (\$2150) with built-in tracking generator, selectable impedance—50 ohm, 600 ohm, one megohm, single ended or differential modes, 20 Hz/div frequency span, 10 Hz and auto resolution. The tracking generator in the 5L4N is a sweeping signal source designed to make response and other tests such as the audio transformer test above. Also included for \$3665 are the 5103N/D11 storage main-frame (\$1175) plus optional 2 MHz scope amplifier 5A15N (\$135) and time base 5B10N (\$205).



Tektronix, Inc., Box 500, Beaverton, OR 97077

For a demonstration circle 44 on reader service card

Circle 45 on reader service card

Electronics review

play information about shops, restaurants, entertainment, and services available at the hotel and in the vicinity. □

Transportation

Train controls proceed slowly

The Federal Railroad Administration has dubbed a plan for a computerized train-sensing and control system a "new concept in rail-traffic dispatch and control." But the railroad agency's approval last month of only a test of the system and not its permanent installation is "very disappointing" from the railroad's point of view, says a disgruntled official of Cleveland-based Chessie System Inc., operator of the Chesapeake & Ohio and Baltimore & Ohio railroads.

Chessie wanted to install \$3 million worth of rf transceivers, display consoles, and other equipment as a permanent improvement to a 552-mile segment of the B&O railroad in central Ohio. But union pressure was to blame for the FRA's approval of only a three-year test, assert Chessie officials, who say they have to reconsider whether to spend so much money on just a trial run. They don't relish the possibility of having to take the expensive system out if the unions continue to object.

According to the unions, the system would eliminate the maintenance workers for the existing signal system, as well as signalmen. And dispatchers and controllers complain the new system would combine their jobs.

Transponders. Chessie officials want the system, on which they have been working for three years with TRW Systems Group, Dayton, Ohio, to replace existing electromechanical turn signals and slow-caution-stop signals. In addition, it would provide digital two-way communications links between train dispatchers and locomotive engineers. The new signal system is based on

News briefs

Semiconductor makers continue to trim employment. . . .

Layoffs continue to plague employees of semiconductor manufacturers as officials try to align production with current sales and forecasts. Motorola Semiconductor Products division, Phoenix, Ariz., has increased its layoffs from 3,000 [*Electronics*, Nov. 14, p. 26] to 4,500 of an estimated work force of 30,000. Similarly, Texas Instruments, which earlier reported idling more than 4,250, has begun to lay off an additional 2,500 to 3,000. Some 900 workers were dropped at its Dallas headquarters, and 440 people will be dismissed from its Attleboro, Mass., facility. TI spokesmen decline to say what product lines are involved. In September, TI had 73,800 employees.

RCA Solid State division, Somerville, N.J., has cut back 8% of its worldwide force of more than 11,000 across the board. Layoffs by other semiconductor companies include Signetics Corp., Sunnyvale, Calif., which has cut 4,000 from a high last June of 11,000, and Advanced Micro Devices Inc., Sunnyvale, which has dropped 26% of its domestic employees from a worldwide work force of 1,100.

Also, Intel Corp., Santa Clara, Calif., may have reduced its force of 2,200 by as many as 400, mainly through attrition, insiders say. And Rockwell International's electronics operations in Anaheim, Calif., has dropped 8% to 10% of its workers in calculators and other products.

. . . . as television-set manufacturers lay workers off too

Among consumer-electronics manufacturers, RCA cut back 350 persons, or about 7%, at its Bloomington, Ill., TV-production plant and also laid off some 200 at its Indianapolis components facility, about 6% of the total. Quasar Electronics Corp. laid off 296 last month, mostly at Pontiac, Ill., and anticipates similar cutbacks within a week or two. The largest layoff, however, has been in Rockwell's Admiral TV operation, which recently laid off 2,200, or about 38% of its workers at four plants, including Taiwan.

Nine suppliers file antitrust suit against AT&T

A \$900 million antitrust suit against American Telephone & Telegraph Co. and several of its subsidiaries was filed Nov. 18 in U.S. District Court, Washington, D. C., by nine small suppliers of telephone-terminal equipment. Led by Jarvis Electronics Inc., Richmond, Va., the group charges AT&T, Western Electric Co., Bell Laboratories, and Chesapeake & Potomac Telephone Co., the Washington area Bell System operating company, with illegally conspiring to restrain trade and drive out of business companies that compete for key-operated telephone-terminal equipment (see story p. 39).

The suit alleges that AT&T and its subsidiaries purchased some of the competitors' equipment on the pretext of testing it before purchasing more and then copied it. Specifically cited are the Bell System ComKey key-terminal models 718 and 1434. The suit also alleges that the telephone company has offered the equipment below cost in an attempt to force competition out of business and has discriminated unfairly against competitors by charging their customers for unnecessary network protective devices not required for comparable Bell System terminals.

IBM protests Justice motion to amend complaint

If the Justice Department is allowed to amend its complaint, as it has requested, it would delay the antitrust trial against IBM Corp. by six to nine months, IBM's special attorney has told Federal Judge David N. Edelstein. Justice now wants to add the charge that the computer giant has also monopolized the peripherals and add-on memory markets. Follow-up reviews could extend the trial by as much as two years, Thomas D. Barr, IBM's counsel, told the court.

Barr says the amended complaint is "in substance, a new lawsuit" that alleges new acts of monopolization. Justice also moved to clarify the words "general-purpose digital computer" by adding the word "systems" wherever reference to computers appears in the original complaint filed Jan. 17, 1969.

If You Use, Maintain, Specify, or Authorize Instrumentation,

You Need to Know About Tektronix TM 500



TM 500
Modular test and
measurement
instruments



it's multifunctional—

a continually growing family of
29 modular plug-in instruments

- digital multimeters
- counters to 550 MHz
- generators
- amplifiers
- power supplies
- oscilloscopes
- a blank plug-in kit for
your custom circuitry
... and more...

it's multiconfigurable—

compact one, three, and four-
hole mainframe enclosures

- bench-top
- portable
- rack mounting
- SCOPE-MOBILE[®] mounting

it's versatile—

you can group instruments that
fulfill your needs

- Digital Logic High Per-
formance System for TTL
or ECL
- Audio Frequency Instru-
mentation System
- Industrial Instrumenta-
tion System
- Medical Instrumentation
Calibration System
- Educational System
- Portable System for
Computer Service
- (Your System)

Whatever your field of electronics, whatever your responsibility, you need to know about Tektronix TM 500 Test and Measurement Instruments.

Send for the new 56-page TM 500 Booklet . . . includes full specifications on 29 modular plug-in instruments and three power mainframes, an explanation of the product line concept, and examples of special configurations and applications in high demand. Your Tektronix Field Engineer will assist you in selecting instruments to meet your needs.

Ask for TM 500 Booklet, A-3072. Contact your local Tektronix Field Engineer, or write to Tektronix, Inc., P.O. Box 500, Beaverton, Oregon, 97077. Telephone: (503) 644-0161 TWX: 910-467-8708. In Europe, write Tektronix Ltd., P.O. Box 36, St. Peter Port, Guernsey, Channel Islands.

For a demonstration circle 46 on reader service card

Circle 47 on reader service card

Special Handling

Please rush me the TM 500 Booklet, A-3072.

I would like to discuss grouping instruments for the following application:

I want a demonstration of TM 500 Instruments.

NAME _____ COMPANY _____

TEL. NO. _____ EXT. _____

ADDRESS _____

CITY _____

STATE _____ ZIP _____



TEKTRONIX[®]
committed to
technical excellence

Electronics review

transponders buried between track ties, an interrogator on each locomotive, and a control box with an alphanumeric display console in each locomotive cab. The system provides dispatchers up-to-the-minute train-locations to help in their scheduling and control.

Electronic equipment aboard the locomotive includes a microprocessor that helps decode a location signal sent from the fixed transponder, add a time signal, and control the relaying of the information to trackside monitors. A 30-to-50-watt amplifier transmits this train signal on a 200-kilohertz frequency to the monitors, which are 15 to 25 miles apart and linked to a central train-dispatcher's console by land lines. The system is patterned on train-location-sensing systems now operating in Canada and being installed in Germany, points out a TRW spokesman.

Stopper. However, the Chessie system differs in that the micro-

processor-based control will automatically stop a locomotive if the transponder signal indicates that the train has entered an off-limits area—for example, another train on the same track. "The system would function as if someone ran a red light. Once the transponder indicates the off-limits location, the microprocessor would activate shut-off circuits," says the spokesman.

This would happen automatically if the locomotive engineer failed to heed a dispatcher's instructions sent from the trackside monitors via the rf link and displayed on the console.

The transponders themselves would be buried between track ties at intervals of 50 feet in areas with heavy traffic or up to two miles in areas with little traffic. The topography of an area affects the deployment of the transponders, since the broadcast range is 100 feet or less and the devices have no power sources of their own. Rather, they are powered by transformer coils

linked inductively to the interrogator, which rides underneath the forward part of the locomotive.

TRW has high hopes for its systems. "Other railroads are interested, but they want to see what the FRA does with the Chessie test," says a TRW official. In its review, the railroad agency noted only that the system "is safer than non-signalized portions of the nation's railroads," but the FRA dodges comparison with the manpower-loaded, electromechanical signal systems in use.

FRA and TRW officials say that the system could replace electromechanical track signals, but TRW seems willing to settle for half a loaf. It estimates that half the country's railroad track has no signals. □

Solid State

TI also plans for low-end microchips

Just when it looked like Texas Instruments was taking a rifle-shot approach to the microprocessor chip market with a bipolar family of high-performance parts [*Electronics*, Nov. 14, p. 29], the Dallas-based company has let go a second shot. It plans to enter the lower end of the performance scale with p-channel metal-oxide semiconductors.

Expected to hit the market in January, the initial vehicle, the TMS 1000 microprocessor, is a derivative of TI's earlier work on calculator chips. Besides an arithmetic-logic unit and input/output circuitry, the device includes a 256-bit random-access memory for data storage and an 8,192-bit read-only memory for program storage. This is an exceptional amount of capability in a chip measuring only 200 mils square.

Moreover, although the TMS 1000 will be roughly comparable to the Intel 4004 in terms of instruction set and execution times, the on-chip memories with which the device is furnished may well undercut Intel system costs. Price of the TMS 1000 will start at \$20 and range down to

WHY NOT MAKE MARKED TUBE YOURSELF?

CHUO's Hot Marker makes possible quick and permanent markings on tubes as well as wires for instant identifications.

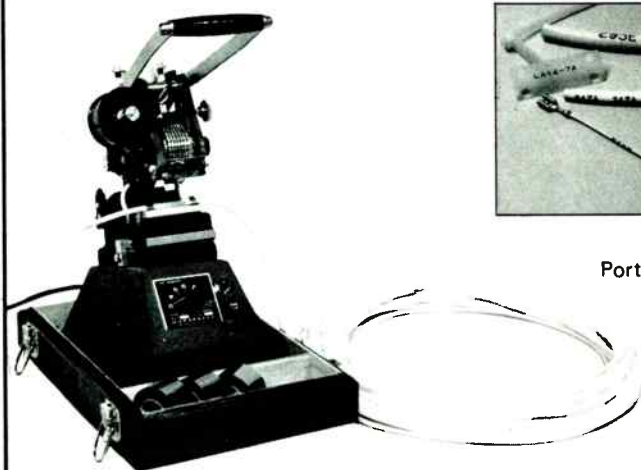

Portable—HOT MARKER
Model MM-30
Patented

- Easily carries weight only 9.7 kg and used during wiring operations.
- Up to 7 characters marked in a single operation.
- Continuous marking and simplified selection for complicated arrangements.
- 7 character wheels with 30 facets A-Z wheels (3) and 0-9 wheels (4).
- Tubes of any size and wires up to 10 mm diameter are available.
- Character colors: Black, red and white.
- In-put 115V (other voltages are available).

(Other machines 12 wheels 40 facets A-Z, 0-9, ., -, / and blank also available.)

CHUO TSUSHO KAISHA LTD. 1-151, Kanda Izumi-cho, Chiyoda-ku, Tokyo 101, Japan
Telex: 265-5597 CHUO J. Cables: CHUOTSUSHO TOKYO

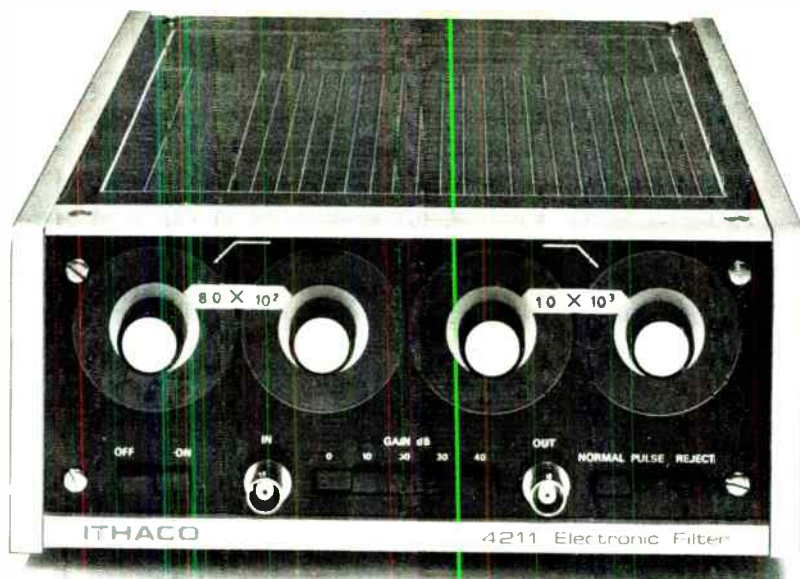

Chances are you own a continuously tunable electronic filter. So by now you probably realize that continuously tunable filters are low performance instruments with, at best, 5% accuracy. And with poor reproducibility of settings, poor frequency accuracy and poor phase drift characteristics. And although continuously tunable filters provide infinite resolution, most users find infinite resolution neither important nor desirable unless there's corresponding accuracy.

But all this isn't why we say "junk it."

WHAT YOU SET. ISN'T WHAT YOU GET.

Take a look at the graph. As you can see, the front panel filter settings don't tell you the -3dB cutoff frequencies, the bandwidth, the noise bandwidth, and the center frequency. Or the insertion loss. You have to measure them — a time consuming, costly procedure.

THERE'S A BETTER WAY.

Ithaco offers two types of filters with switch selectable frequency settings. One type has 3 decimal digit frequency resolution for the user who not only needs resolution but also wants to know where he is without measuring.

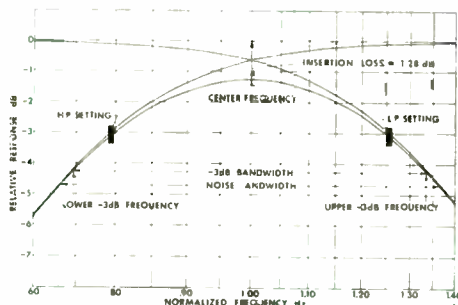

Normalized gain, attenuation, phase, and pulse response curves are printed on top of the filter. The other type uses the internationally accepted 1/10 decade [1/3 octave] frequency step — so you can operate with octave, decade and other convenient band pass settings, and still have sufficient frequency resolution for general lab and data acquisition applications. These filters have all the information shown on the graph printed on top — for all filter settings. And that's why we say "take your laboratory filter and junk it."

MORE NAILS IN YOUR FILTER'S COFFIN...

Standard accuracy of all Ithaco filters is $\pm 1\%$ in frequency, $\pm 2^\circ$ in phase, and $\pm .1\text{dB}$ insertion loss — all at least twice as good as the best the competition can offer. Plus, output drift is an order of magnitude lower than the competition. And self-noise is minimal. Best of all, Ithaco filters are competitively priced.

NOW THAT YOU NEED A NEW FILTER...

Write to Ithaco Inc., 735 W. Clinton Street, Ithaca, N. Y. 14850. Or, if you can't wait (we understand) call 607-272-7640, TWX 510-255-9307.

Take your laboratory filter and junk it.



Circle 49 on reader service card

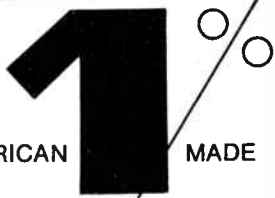

AMERICAN

MADE

Tolerance SCHAUER 1-Watt ZENERS

Immediate Shipment Low Prices

ANY voltage from 2.0 to 16.0

Quantity	Price each
1-99	\$1.07
100-499	.97
500-999	.91
1000-4999	.86
5000 up	.82

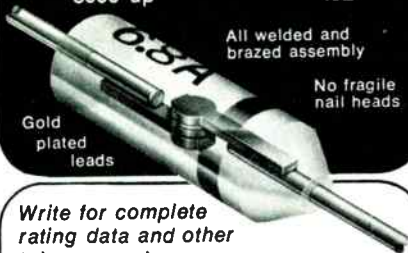

All welded and
brazed assembly

No fragile
lead heads

Gold
plated
leads

Write for complete
rating data and other
tolerance prices.

Buy the kit- Save a lot



Kit contains a 51-piece assortment of SCHAUER 1% tolerance 1-watt zeners covering the voltage range of 2.7 to 16.0. Three diodes of each voltage packaged in reusable poly bags. Stored in a handy file box. Contact your distributor or order direct.

A \$54.57 value for
ONLY \$24⁵⁰

Semiconductor Division

SCHAUER

Manufacturing Corp.

4514 Alpine Ave. Cincinnati, Ohio 45242
Telephone: 513/791-3030

Electronics review

\$10 for 10,000-piece quantities, according to TI. Already in volume production, the microprocessor's first customer was TI's own Calculator Products division where it has been used in the recently announced SR-16 slide rule.

Tailored. As with its calculator chips, TI's MOS microprocessor is mask-programable during the final gate-mask step. The ROM and output logic array on each chip can thus be tailored to meet the user's applications.

Applications, as defined by TI, cover a broad range of possibilities, including appliance controls, point-of-sale terminals, flow meters, automotive control instruments, consumer arcade games, intelligent instruments, telephone dialers, and controllers for serial or parallel printers.

Robert H. Burton, microprocessor marketing manager, says, for example, that a credit card verifier could be implemented with the TMS 1000, along with a TMS 6011 universal asynchronous receiver/transmitter to convert the parallel data to serial for transmission over phone lines, and eight transistor-transistor logic packages, including latches and digit drivers.

The logic accepts 4-bit parallel input, and there are 64 four-bit locations in the RAM to store working data. The chip's 8-kilobit ROM will accept up to 1,024 eight-bit instructions, and TI provides a set of 43 instructions that includes conditional branching capabilities that give it a single level of subroutine nesting. Instruction execution time is 12 microseconds; adding two eight-digit numbers takes 1.2 milliseconds. □

Industrial electronics

Electronic cart delivers the mail

Getting parts and mail delivered at a plant or office is simple enough, but it can be expensive. Many companies are beginning to look into

the economies of automating this procedure. One of them is Dresser Industries Inc., which is testing an electronic cart that's expected to pay for itself in 13 months.

In addition, some 500 hospitals already are using some form of wheeled electronically guided vehicles to deliver meals and supplies. Less extensively, the vehicles have been used in general office and plant areas. Besides Dresser, American Telephone & Telegraph Co., Sears, Roebuck & Co., and even the U.S. Air Force are some of the organizations using them.

About two months ago, Dresser's Industrial Valve & Instrument division, Stratford, Conn., installed a cart supplied by Control Engineering Co., Pellston, Mich., to deliver parts on the factory floor. Neal M. Priestley, Dresser's senior project specialist who guided the installation, makes the 13-month payout prediction based on a cost of about \$6,000 for the cart plus installation.

Guided. The Control Engineering unit runs at a sedate one mile per hour on three 12-volt nickel-cadmium rechargeable batteries. Once started, the vehicle's front wheels are locked onto a signal from a copper guide wire buried in the plant's concrete floor. The wire emits an electromagnetic field of either 10 kilohertz or 6.5 kHz. Steering coils keep the servo-motor-operated front wheel in line with the guide wire when it's running in a straight path. At the beginning of a turn, however, a second wire in the floor, tuned to 6.5 kHz, is sensed by the "inside" steering coil, and the 10-kHz frequency is cut out. As the cart moves around the turn, the 10-kHz wire is again sensed, and the cart resumes its straight path.

The cart can be set to make up to 30 preprogrammed stops by means of toggle switches that designate specific stations or departments. To stop, the cart has six relays that sense a pattern of north and south polarity in a set of two magnets imbedded in the floor at each pre-designated stop. Each stop has a different magnetic pattern.

An object-detection system is

From the
voltmeter
house...



Here's how we tested our 42,386th multimeter.

The world's best-selling 3½ digit multimeter is virtually indestructible.

Recently, two Fluke quality control engineers wanted to know if our 8000A 3½ digit multimeter would survive a fall from a 24-foot rack. We were shipping several to a phone company.

So they tossed one out the window. Two stories up. It still worked.

But 9944/100% of these out-of-the-ordinary tests we **don't** instigate.

They just seem to happen.

Our president talks about the time he picked up an 8000A at a trade show without knowing it was ready for case removal. The works crashed to the floor but it still played perfectly . . . to everyone's delight and the president's relief.

One reason why our DMM is so tough: it only has 99 parts. Major analog and digital circuitry are on LSI chips.

It's also flexible. This DMM has 26 ranges, including five ranges of ac and dc volts, five ranges of ac and dc current, and six ranges of resistance. And it's the only DMM using an A-to-D converter with inherent self-zeroing to completely eliminate offset uncertainty.



But it's the ruggedness that really makes the 8000A a conversation piece. Our sales force still laughs about the Fluke salesman who was so hot to make a sale that he took his Fluke multimeter and brought it down—crash!—right on his prospect's desk.

"See," he said, "it's really tough."

And so it was, but the op amp that was hidden under a pile of papers wasn't. P. S.—our salesman didn't make the sale.

On a more positive note, a UPS truck accidentally backed over an 8000A not long ago . . . without ill effect.

So there you are. The world's largest selling 3½ digit DMM. And the toughest. And for \$299 it could be yours.

For data out today, dial our toll-free number, 800-426-0361

In the continental U.S., dial our toll free number 800-426-0361 for the name and address of your nearest local source. Abroad and in Canada, call or write the office nearest you listed below, John Fluke Mfg. Co., Inc., P.O. Box 7428, Seattle, Washington 98133. Phone (206) 774-2211. TWX: 910-449-2850. In Europe, address Fluke Nederland (B.V.), P.O. Box 5053 Ledeborstraat 27, Tilburg, The Netherlands. Phone 013-67-3973. Telex: 844-52237. In the U.K., address Fluke International Corp., Garnett Close, Watford, WD2 4TT, England. Phone 0923-33066. Telex: 934583. In Canada, address ACA, Ltd., 6427 Northam Drive, Mississauga, Ontario. Phone 416-678-1500. TWX: 610-492-2119.



For information, circle # 206 For demonstration, circle # 51

THE NEW DIGITAL MULTI-METER DESIGNED FOR FIELD SERVICE

with laboratory accuracy

.02%

LM-4



\$227

- One year guarantee.
- Full four digits
- 100 microvolt resolution
- Automatic zeroing.
- Automatic polarity.
- Self-contained batteries and battery charger included.
- 1.9" H. x 2.7" W. x 3.9" D.

For immediate delivery fill in below.

Special offer of \$217 with coupon.		
<input type="checkbox"/> LM-4		
<input type="checkbox"/> Send more information.		
Name _____		
Company _____		
Address _____		
City _____	State _____	Zip _____
<input type="checkbox"/> Check enclosed <input type="checkbox"/> C.O.D.		

THE
NEW
NON-LINEAR SYSTEMS, INC.
Box N, Del Mar, Calif. 92014
(714) 755-1134

Electronics review

built into the cart to lessen the likelihood of collisions. It consists of three transmitters and two receiver heads mounted beneath the front bumper. The transmitters send out light beams that are reflected back, then amplified to operate a control relay, which brings the vehicle to a stop. The object-detection system, says Frank Stacy, Consolidated Engineering's product sales manager, is a proprietary item.

Stacy will be in Bernardville, N. J., next month to oversee the installation of a prototype unmanned cart at AT&T's new Long Lines department headquarters building. This unit, which will deliver mail only, will run along a strip of 1-inch-wide braided tape, developed by the 3M Co. The tape can be pulled up and the vehicle rerouted at any time. □

The economy

Prices dropping in semi market

In the face of a worsening economy and some estimates that an upturn won't occur before late 1975, semiconductor prices are beginning to erode as vendors scramble for their share of a shrinking market. (see related story, p. 128).

Serious drops have shown up in lines other than TTL, where prices have been exceedingly low for some time. The deepest price cuts are in complementary MOS gates and flip flops. Indeed, a C-MOS price war seems to have started.

In memories, although prices of dynamic 1-kilobit and 4-kilobit random access devices are holding, the situation is less secure for static 1-kilobit RAMs. Moreover, there will be significant drops in the price of microprocessor chips sets and cards. But National Semiconductor Corp., emerging as the most aggressive price cutter, attributes those cuts more to "learning curve considerations" than to a price war.

Tough talk. At National, in Santa

Clara, Calif., the C-MOS situation is described bluntly. "If there's going to be a lousy price war in C-MOS, then we intend to win," declares Tom Thorkelson, marketing manager for digital products.

To this end, National seems to have some of the lowest prices. It's MM5611N gate has gone from 67 to 33 cents each in lots of 100 to 999. (This part is equivalent to RCA's CD4011.) Price cuts for similar quantities of other devices include: from \$1.25 to 93 cents for the MM5613 flip flop; from \$1.26 to 93 cents for the MM5627 dual J-K flip flop; and from \$3.22 to \$2.28 for the MM5635 parallel shift register.

Earlier, RCA Corp.'s Solid State division, Somerville, N.J., had dropped its C-MOS prices as well—more than 30% on gates, and 20% on MSI circuits in its standard CD4000 series in 100 to 999 quantities. And at Signetics Corp., Sunnyvale, Calif., Jack Curtis, C-MOS marketing manager says, "You can expect us to be in there part-for-part price competitive with National by mid-December."

In other devices, National's Mauri Morin, MOS memory product marketing manager, says there has been as much as a 50% price cut on the 2102 1-kilobit static RAM in 10,000 to 100,000 piece quantities—from about \$6 to \$8 five months ago to about \$3 to \$4 each now. Intel Corp., Santa Clara, has just announced a 2102 plastic-packaged part at \$8.50 each in 100 to 999 quantities, down from \$15.40 in August. And Dave West, director of marketing at Mostek Corp., Carrollton, Texas, says, "We've seen quite a few [of the 2102s] sold in the \$4 ballpark, and not necessarily in very large quantities."

In microprocessors, National, with more production experience under its belt, is planning to drop prices on its cards and chip sets in January. In single units, IMP-16C cards will drop from \$950 to \$825. IMP-16 sets will drop from \$250 to \$136 in lots of 1000. IMP-8 chip sets will go from \$255 to \$86 for 1000-piece quantities. Intel declined comment on its price plans. □

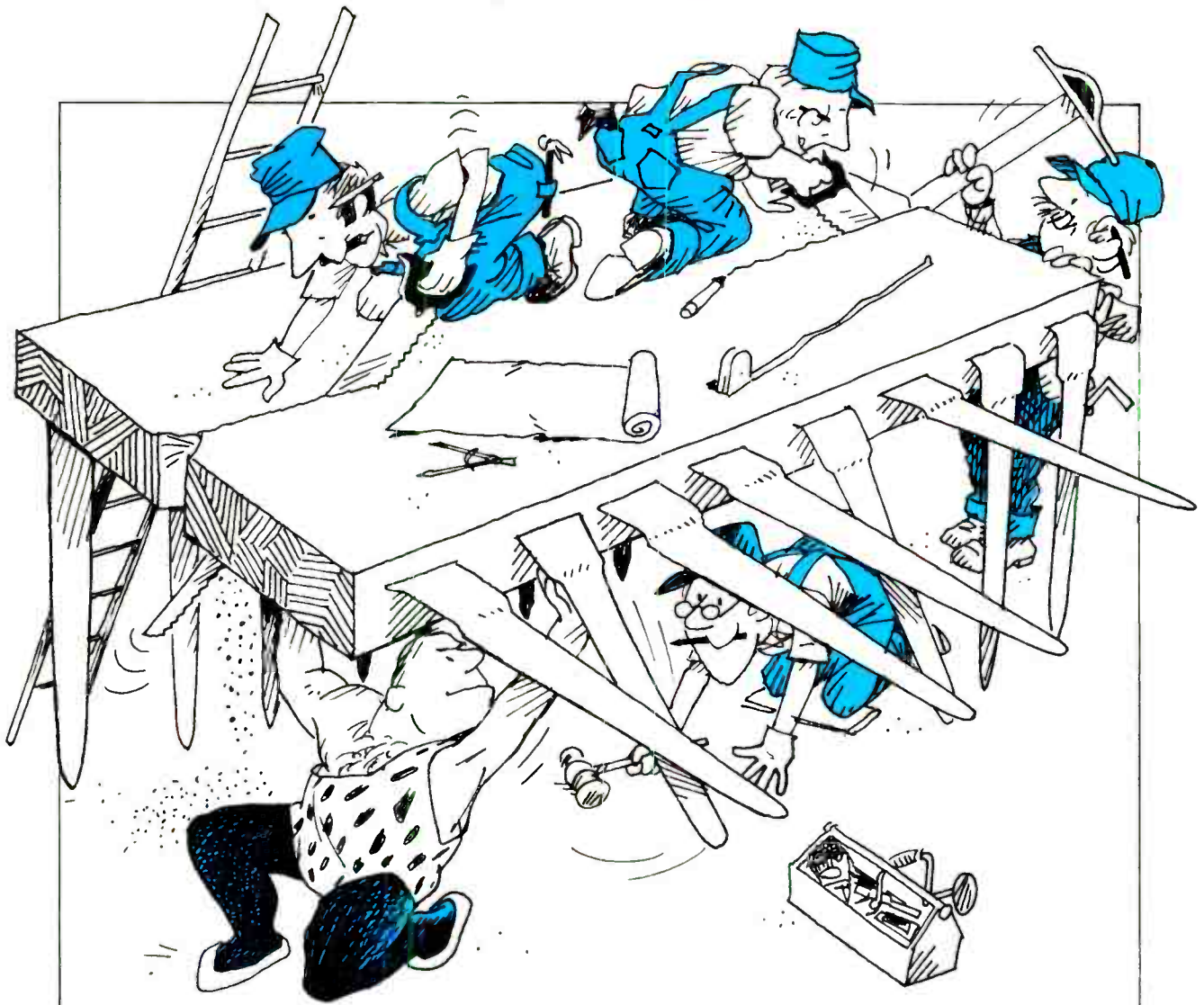

Our DIP crew makes great SIP resistor networks, too.

Leave it to our guys. They know you need a variety of space-stretchers to make your circuit-board packaging easier. And that's why these DIP experts also make Beckman RESNET™ standard SIP networks in 30 popular varieties.

These thick-film, cermet SIPs (.780" wide, .350" high, .090" thick) are standard 8-pin types, dimensionally uniform and ideal for automatic insertion techniques. Laser-tailoring assures precise resistance values, and every part is 100% tested.

Two convenient networks (see schematics)

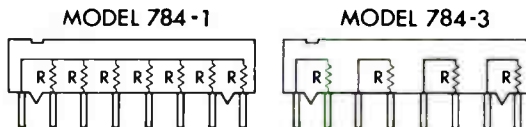

give you a 7-resistor model for applications like pull-up or pull-down networks, and a 4-resistor model for such typical uses as line termination and LED current limiting.

Resistance values available in both versions are 100, 150, 220, 330, 470, 680, 1K, 1.5K, 2.2K, 3.3K, 4.7K, 10K, 15K, and 22K.

And now for more good news. They're all stocked locally by your Beckman/Helipot distributor, ready for immediate delivery.

Cost? Truly competitive, actually giving you cermet quality at plastic prices.

Why wait? Let the new Beckman SIP line start making things a lot easier for you. For immediate literature or the phone number of your Beckman/Helipot representative, call toll-free (800) 437-4677. Right now.

Beckman®
HELIPOT DIVISION

News update

Motorola had feeling about watch module

When James A. Norling took over the Motorola corporate effort to make electronic watch modules, he predicted only "moderate success for semiconductor houses getting into the business" [Feb. 7, p. 14]. As it has turned out for Motorola, even that bearish view was a bit too optimistic. The company has since decided to disband its centralized Timepiece Electronics Unit in Phoenix, though it will remain in the watch-components business [Oct. 31, p. 20]. Says Stephen P. Levy, a senior vice president, "We finally decided that our money and expertise could be better spent elsewhere, on markets we understand better. Ultimately, the watch business is a jewelry business, and we aren't in that business," a realization that hasn't deterred such Motorola competitors as National Semiconductor and Texas Instruments. Looking back, Norling suspects that Motorola's involvement in the module business was overplayed. "We made a few sample liquid-crystal-display modules and mounted them in cases for evaluation, but never took orders," he says, sounding a bit like the girl who bought a gown for the prom but wasn't asked to go.

Liquid-vapor display on back burner

Frost a sheet of glass on one side, apply turpentine to the roughened surface, and you've got the start of a liquid-vapor display. That's what scientists at Princeton Material Science Inc. in Princeton, N.J., had [March 15, 1973, p. 38], and that's what they still have. The display, which has the advantages of being reflective and simple, has been put aside for now while the company concentrates its R&D efforts and funds on liquid-crystal displays. George W. Taylor, vice president for research and engineering, says, "We still have some plans for the liquid-vapor display, but at this point, they're only plans. We're very heavily involved in liquid-crystal-display work right now."

Tyox runs into a pair of problems

Take a pressure-sensitive material that permits active switches to be deposited on hybrid-circuit substrates in much the same way as conductors, resistors, and capacitors, and chances are you've got a product that should interest a wide range of customers. After all, it saves production costs by eliminating separate semiconductor switches and their bonding. There is such a material, called Tyox by E. I. duPont de Nemours and Co. [March 15, 1973, p. 34], but it continues to be a "fairly low-level activity," says Billy O. Moody, product manager. "We're still looking for applications, particularly in the temperature-sensing areas," he adds. The trouble with Tyox—actually, its active element is vanadium oxide—says Moody,

is that it isn't much good beyond 70°C. Not only that, but "everyone wants different temperature characteristics in the material, and that tends to make it a custom business."

CATV for business data shows surprising life

Goldmark Communications Corp. didn't expect to take the world by storm with its scheme for transmitting digital business data over cable-television lines [Dec. 6, 1973, p. 36]. The reason: the CATV business was in a severe slump. But despite the continued sluggishness of cable installation and the preoccupation of its operators with subscription TV, some efforts have been made in business-data communications. Joseph L. Stern, vice president of engineering for Goldmark, says trials are under way at General Motors, American Motors, Dow Chemical, and Kellogg Cereals plants in Michigan; Mitre Corp. in Bedford, Mass.; and Manhattan Cable in New York City.

Bus-controlled traffic jumps the gun

Some cities aren't waiting for a Federal Highway Administration report on the efficacy of a computerized traffic-signal-control system. Installed in Washington, D.C., traffic signals and commuter buses last year for evaluation [March 13, 1973, p. 40], the system permits bus drivers to hold the green light for themselves at downtown intersections. The capital system also allows a driver to signal a traffic-light controller at an intersection, whether his is an express or local bus. Field evaluation of the D.C. system has ended, the FHA review is under way, and a report is expected in three months. But Miami, Fla., and Los Angeles are already installing their own systems. FHA project manager Phillip Tarnoff says preliminary indications are that the innovation helps, and notes that publicity-conscious communities are anxious to get on the bandwagon.

System permits scan by 300 TV cameras

Industrial plant intruders and restless prison inmates face yet another form of surveillance in the TTS90 from Information Processing Systems Inc. of Belmont, Calif. The system approach allows users to look at as many as 300 cameras at one time on the machine at a rate of 30 cameras per second. The \$25,000 device compares the real-time picture against a stored picture and sounds an alarm if the two differ. Sales of the system, introduced a year ago with the ability to watch only one camera [Dec. 6, 1973, p. 36], have just begun, says vice president and general manager Robert Simmons. Potential users include law-enforcement agencies (the San Mateo County, Calif., sheriff's department has one that uses only 50 cameras), industrial plants, and governments.

Howard Wolff

Intended to bring *Electronics* readers up to date on news stories of the past months.

DATARAM SQUARES OFF AGAINST THE COMPETITION.

We're Dataram Corporation, the fastest-growing core memory company around, and the one to watch in the 16K single-board core memory market.

A look at the chart below will show you why . . . but if you want even more than specs from a company, consider this:

- Since the introduction of our 4K system in 1969, we've shipped thousands of 11.5" x 13.7" systems in our compatible 4K/8K/16K family.
- As the only company dedicated exclusively to core memory products, we make all of our own core, sell raw core to the outside market, string in high volume in three offshore locations, supply stacks to minicomputer manufacturers, maintain our own extensive manufacturing capability, and market a complete line of systems.

We're not alone in the 16K single-board core memory market. Familiar names like Ampex and EM&M are there too, but we can offer significant—and proven—performance and cost advantages. For more details, call Dataram at 609/799/0071. But don't take our word for it. Call Ampex (213/821/8933) and EM&M (213/644/9881) and hear their side of the story.

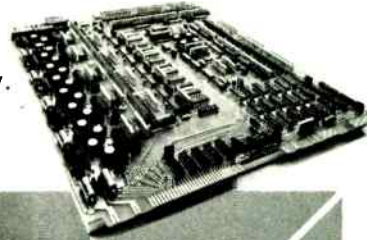

PICK THE WINNER.

16K Characteristic	Ampex 1600 Series	EM&M Micro 3000DD	Dataram DR-102
Cycle Time	650-900 ns	650 ns	850 ns (650 for compatible 8K x 20 DR-101)
Access Time	300-450 ns	300 ns	300 ns
Board Size	11.3" x 15.75"	11.75" x 15.4"	11.5" x 13.7"
DC Voltages Req'd.	2	3	2
Tolerances Req'd. on DC Voltages	±3% & ±5%	±3% & ±5%	±5%
Complete Component Accessibility	Yes	No	Yes
Maximum 16K Systems in Standard 5 1/4" Chassis	2	4	4
Other Compatible Sizes Available	8K	8K	4K, 8K
Standard Chassis Sizes	5 1/4" 12 1/4"	5 1/4" 12 1/4"	3 1/2" 5 1/4" 12 1/4"

If you're looking for add-on memory for your Varian or Data General minicomputer, look to Dataram for high performance, low cost.



Princeton-Hightstown Road
Cranbury, N.J. 08512
609/799/0071

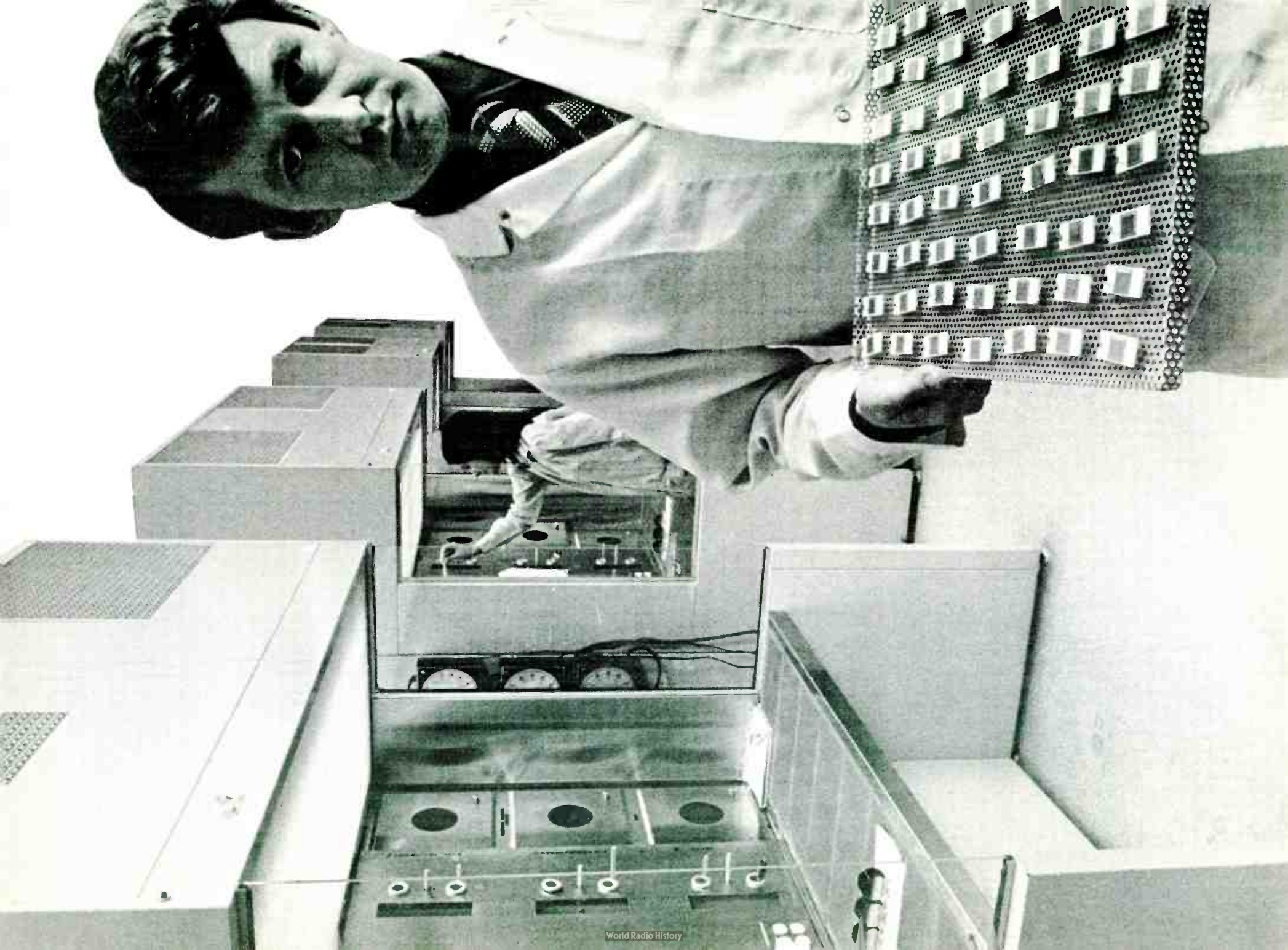

IT'S HERE. ANALOG DEVICES' \$39 12-BIT IC DAC.

No other 12-bit DAC-IC or module – gives you greater accuracy. Or a lower cost.

Introducing the AD562 – the revolutionary IC from Analog Devices Semiconductor that outperforms every other 12-bit DAC on the market.

Simply stated, the AD562 is a 12-bit IC digital to analog converter in a hermetically sealed, 24-pin DIL package.

It gives you guaranteed monotonicity over the full operating temperature range, with a maximum total error as low as $\frac{1}{4}$ LSB (0.006%) at 25°C, and a 3ppm/°C maximum gain temperature coefficient.

The logic inputs are positive-tri-state, and are specifically designed to be both TTL and CMOS compatible. In addition, both binary and BCD versions are available.

How the AD562 came about. The state-of-the-art AD562 could only come from a company like Analog Devices.

After all, we're the world's leading manufacturer of A/D and D/A converters for test and measurement instrumentation. And with converter products like the AD562, we're extending that leadership in integrated circuit form.

CMI – the new technology that made it possible. To give the AD562 its unmatched accuracy, we developed a process called CMI-Compound Monolithic Integration.

CMI is the partitioning of a complex function into a minimum number of monolithic chips, each specifically designed to work with the others, and assembled in a single package.

For greater performance, the AD562 features two chips. A monolithic, 12-bit precision, bipolar transistor current switch and control amplifier chip. And a compatible silicon-chromium thin-film resistor network containing the DAC bit-weighting and range resistors.

First, they're internally connected. Then, while the AD562 is powered, all the resistors are trimmed by a computer-controlled automatic laser trimmer.

The result is outstanding resolution and scale factor calibration. And state-of-the-art performance at a very low price.

The AD562 does even more for you. You'll find that the AD562 gives you a lot of operating advantages.

Like providing five pin-programmable output ranges, both bipolar and unipolar.

Acting as a two-quadrant multiplier when you apply a variable external reference voltage.

And offering a newly developed current switching cell structure which provides superior immunity to supply voltage variation, and reduces nonlinearities due to thermal transients as the bits are switched.

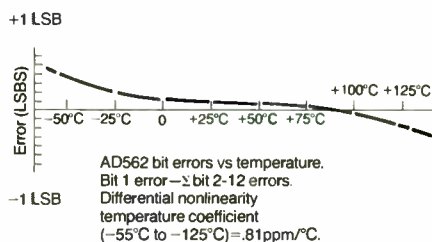

Three temperature ranges to choose from. You can specify the AD562 guaranteed for operation over three temperature ranges.

The model K: 0 to +70°C.

The model A: -25 to +85°C.

And the model S: -55 to +125°C.

And best of all, prices start as low as \$39 in hundreds.

If you'd like more information on the AD562, call Analog Devices Semiconductor, Norwood, MA. 02062.

East Coast: (617) 329-4700

Midwest: (312) 297-8710

West Coast: (213) 595-1783

 **ANALOG
DEVICES**

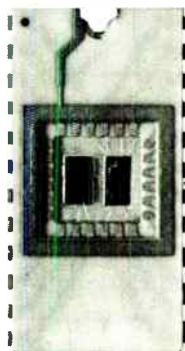

here's a low-cost sweep/function generator that doesn't act like one

price

- Model 196 \$350 (f.o.b. Hillsboro, Oregon).

performance

- Output amplitude 20V p-p open circuit, 10V p-p into 600 Ω .
- Frequency range 0.1 Hz to 1 MHz in 7 ranges with a frequency multiplier for continuously variable (1000:1) control.
- Sine, square, triangle, ramp, pulse and swept waveforms.
- Pulse output sufficient to sink 20 TTL loads.

internal sweep

- Internal sweep generator permits sweeping the frequency of the main generator.
- Sweep width continuously variable from 0 to 1000:1 (3 decades).
- Sweep rate continuously variable from 100 ms to 10 sec in two ranges.

DANA EXACT
electronics, inc.

(A subsidiary of Danalab, Inc.)

BOX 160, HILLSBORO, OREGON 97123
(503) 648-6661 TWX 910-460-8811

In Europe, Africa and the Middle East, contact
Danalab International s.a. 119/121 Rue Anatole
France 1030, Brussels, Belgium Tel: 2414550.
Telex: 846-23662.

application

- Audio testing . . . sweep the full range of amplifiers and other equipment without twisting a knob.
- Bench use . . . the Model 196 is an ideal signal source for bread-boarded circuits or any applications to 1 MHz. Low frequency end (down to 0.1 Hz) opens up new applications not possible with sine-square oscillators.
- Teaching . . . if you want your students to learn about signal sources with the kind of laboratory instrumentation they'll use later on, the Model 196 offers complete features at a price your budget can afford.

features

- VCF (voltage controlled frequency) input for frequency control from an external AC or DC source.
- Main output attenuation 30 db, continuously variable.
- DC offset . . . variable from +10 to -10 volts open circuit.
- Continuously variable amplitude control of output voltage.
- Ramp/pulse invert control to switch polarity.
- Continuously variable control for pulse and ramp duty cycle.

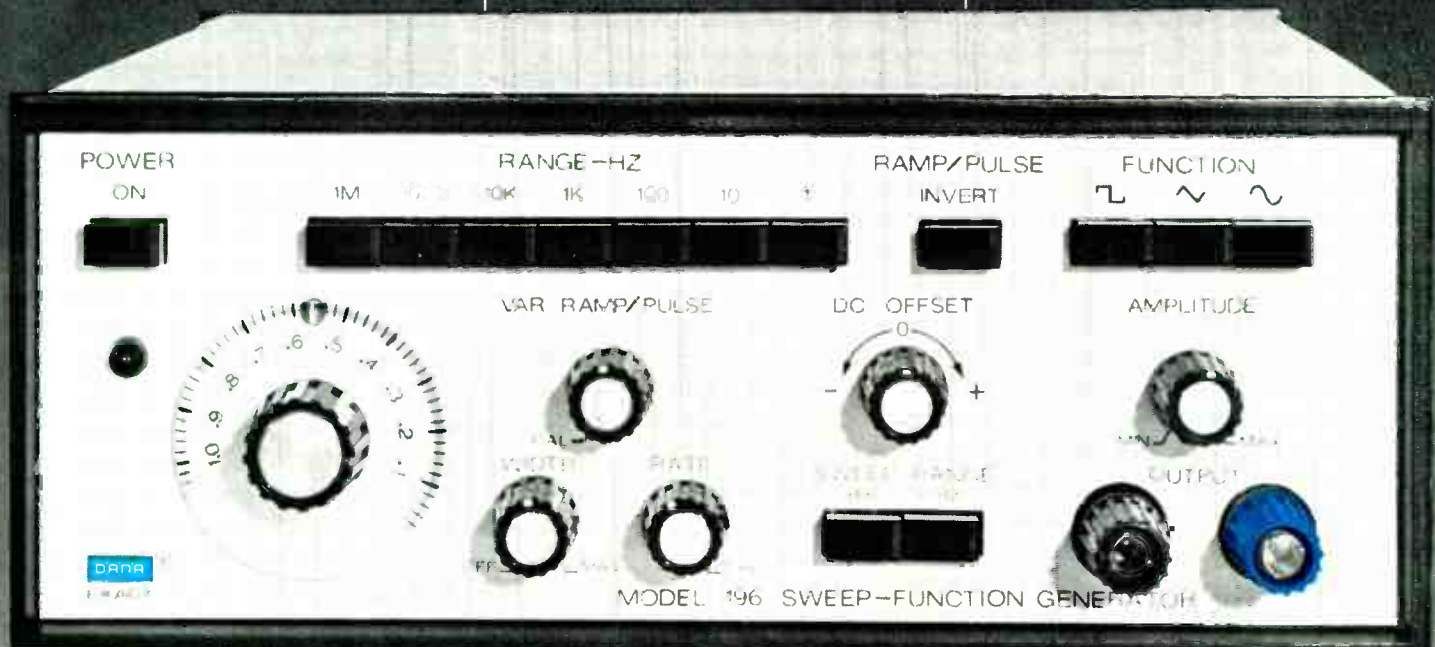

Ford proposes further curbs on spending

More presidential requests for deferral of spending on some programs and outright cancellation of others will be forthcoming by early December, says President Ford. He has asked Congress to overturn \$675 million in previously approved programs, and Budget Director Roy Ash says that the Department of Defense must add another \$500 million to the \$500 million in budget deferrals already announced in September and October. Electronics companies and others dependent on Federal agencies for business will soon begin to be hit by the earlier deferrals, which totalled more than \$23 billion.

Federal standards for medical electronics expected in 1975 . . .

Draft standards for medical electronic equipment, aimed at preventing it from electrocuting patients or performing erratically, will be coming off the Federal presses early next year, say officials of the Food and Drug Administration. Cardiac defibrillators will be dealt with first, followed by pacemakers, hearing aids, and the tolerance of hospital equipment to abuse. But enforcement of the standards will begin only after they have been subjected to industry review and public hearings, add officials of the agency.

Contracts to draft standards for Government consideration were awarded by the FDA to industry associations and corporate giants such as McDonnell Douglas Corp. Requirements for dialysis equipment and operating-room electronics have yet to be drafted, and the FDA is also expecting to review other devices.

. . . but stronger medical-device law may not pass Congress

Legislation that would give the Food and Drug Administration authority to test and evaluate electronic medical devices before they go on the market won't make it through Congress before the current session ends in December, say house staffers and FDA officials. Other attempts have failed in each of the last three years because other bills received higher priority as the end-of-session crunch neared. FDA and congressional advocates say they will be back next year, when they expect a more liberal House and Senate to give the measure higher priority. The agency currently is limited to reviewing device performance only after serious injury has resulted from public use, but it is developing standards in anticipation of the passing of the medical-device law. Small companies oppose pre-marketing review because it would bury them in paperwork, industry sources say.

FCC allocates frequencies for medical-services nets

Electronics companies waiting for the Federal Communications Commission to allocate frequencies for emergency-medical-services networks are one step closer to an estimated \$150 million market—the FCC has approved the frequency allocations proposed by the White House Office of Telecommunications Policy. Eight frequency pairs were allocated for communication and data transmission in 0.025-megahertz increments of the 463-MHz channel for stationary transceivers and the 468-MHz channel for mobile units. OTP officials say that telemetry standards, awaited by industry, may be out by the end of the year.

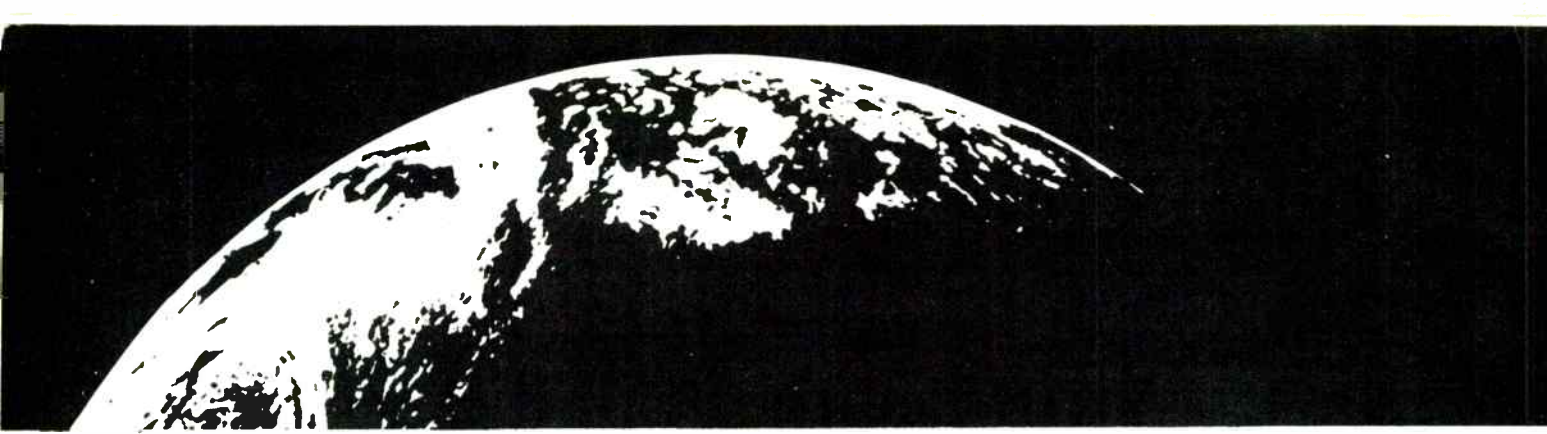

We're the world's leading manufacturer of miniature aluminum electrolytics... you should know us.

We sell over 60 million mini-lytic caps each month. Every one of our capacitors is automatically produced to rigid quality control standards.

This total automation control guarantees an unparalleled degree of product uniformity and reliability:

- We etch and form all the foil we use.
- We have completely automated down to 100% aging and testing.
- To further achieve complete control, our own machinery division designs, develops, and builds all our completely automated assembly equipment.

In total concept, United Chemicon provides local service through a U.S. network of sales, engineering, service, and warehousing.

Write, call 315/474-2954
or wire for full information
and latest technical bulletins.



United Chemicon.

World's largest manufacturer of miniature aluminum electrolytics. You should know us.

©1974 United Chemicon, Inc. 731 James Street Syracuse, New York 13203 315/474-2954 TELEX 937439

6.3 to 500 WV, op temps from -40° to +85° C.
We solicit inquiries to your specs, as broader temperature ranges and performance characteristics are available.



UK blasts layoff plan by Honeywell in Scottish plants

Honeywell's plan to lay off 1,150 Scottish workers is "completely irresponsible," charges the UK Department of Industries. **The department says there was no advance notice.** The government is sensitive to the layoffs amid the country's economic woes, but Honeywell says that a cut in demand requires it to reduce its work force in the four Scottish factories to 3,000. **Magnetic-tape equipment will be produced at the Oklahoma City plant, which, along with one in Heppenheim, West Germany, will make disk equipment.** Declining new housing starts and strikes in the appliance industry have hurt the Microswitch and temperature-control business, Honeywell says. **Other planned UK layoffs include several hundred at Plessey's Garrard audio-equipment plants and about 1,000 by Thorn, the TV-tube maker.**

Bonn prods R&D in components with \$112 million

In a drive to "occupy a forefront position in components application" by the end of the decade, the West German government has launched a \$112 million program to promote research and development of components. Bonn's minister for research and technology, Hans Matthöfer, says the **expenditure, programed through 1978, is three and a half times more than Bonn spent for components promotion during the previous half decade.**

Germany's aid program, rather than trying to improve on existing components, aims to concentrate R&D on promising new devices and manufacturing technologies, as well as ways to get components to the market quickly. **Five technologies will be emphasized—integrated circuits, optoelectronic devices, materials developments, production processes, and basic research on novel devices.**

Fujitsu, Hitachi prepare to launch supercomputers

Deliveries of two supercomputers from Fujitsu Ltd. and Hitachi Ltd. are to begin after Sept. 1, 1975. The computers were subsidized by Japan's Ministry of International Trade and Industry to compete with equipment from foreign manufacturers. **The computers are called—depending on the seller—Facom or Hitac M-180 and M-190. Both companies will sell and service all equipment in the entire M series.** Fujitsu is making the mainframe of the larger M-190, and Hitachi the smaller mainframe.

Company spokesmen say **M-190's performance is about triple that of IBM's 370-168, but the rental price will be about the same. The M-180's performance is said to equal IBM's 370-168, but rental will be equivalent to that of the IBM 370-158.** Mainframe logic is based on the MECL 10,000 series, and both Japanese companies plan to fabricate it. **Main memories now use 1,024-bit MOS chips, but production machines are expected to contain 4,096-bit chips. The 16-kilobyte buffer memories use 256-bit bipolar devices.**

Delay module simplifies test of military radars

A simple way to test sophisticated military radars in the field has been developed by researchers at GEC's Hirst Research Center. **They have integrated into a single unit a spinel bulk acoustic-delay line, amplifier, circulators, and diode switches.** Each module contains a passive line with delay of 22 microseconds and loss of 50 dB. The developers, David

International newsletter

Brown and D.G. Scotter, say that by stringing five modules together and adding gain, they can achieve a delay of 110 μ s with no loss—ideal for easy simulation of artificial targets. **Bandwidth is 500 megahertz for radars in the S and X bands.** The developers point out that conventional methods of coupling transmission pulses can cause interference. They described the system at the IEEE's 1974 Ultrasonics Symposium in November. Price of each module was estimated at about \$6,000.

NEC to launch fast n-MOS silicon-gate microprocessor

A 16-bit n-channel silicon-gate MOS microprocessor with an instruction-execution time of 1 microsecond is being introduced Nov. 29 by Nippon Electric Co. **NEC will initially market the microprocessors mainly for minicomputer emulators and data terminals.** Initial price of the six-chip central-processing unit in Japan will be about \$1,000.

The CPU consists of one control chip, one arithmetic/logic and register chip, and four read-only-memory chips for instructions. Each ROM has capacity of 1,024 8-bit words. Variable architecture includes a mapping array with 100 words of 10 bits each. Optional 8-bit latch drivers are available for bus interfacing. Random-access memories are not included with the basic chip set.

British Steel plans switched computer network

The British Steel Corp. plans to begin buying new hardware early in 1975 for a \$135 million packet-switched computer network, similar to the Arpanet in the U.S. **The seven-year development program would interconnect four administrative centers, one program-development center, and a research bureau with 10 production-planning and control centers for the nationalized complex.**

Initial hardware buys will include equipment for terminal-handling, host interfaces, and node processors. Initial equipment in the control centers is expected to be replaced eventually by newer and smaller processors. **Gear for the administrative and program-development bureaus will be split between IBM and International Computers Ltd., but a contract for the processor equipment for the research bureau is expected to be awarded competitively next year.**

Blaupunkt TV set flashes channel number on screen

Next year, West Germany's Blaupunkt-Werke GmbH, an entertainment-electronics manufacturer in the Bosch group, will introduce a **color-TV set that flashes the selected channel number three inches high on the screen for about five seconds.** For rechecking, the number can be recalled by pushing a button on the ultrasound remote-control unit. The number is gradually blended into the picture by a single MOS integrated circuit supplied by Intermetall GmbH.

Teams vie for pact on test gear for multirole fighter

Two project-definition studies on automatic test equipment for the Multirole Combat Aircraft (MRCA) are due by the end of the year. Pannavia, administrator for the cooperative fighter being developed for UK, West Germany, and Italy **is expected to pick a test-gear contract winner early next year from teams of either British Aircraft Corp. with Siemens and Aeritalia or Marconi Elliott with AEG-Telefunken and Selenia.**



The Great Billed Three Legged Single Sided Circuit.

(Rare. Only
1,000 in existence.)

To a bird watcher, a single sided Nomex® based hardboard reinforced circuit may not be much of a thrill. But if you're an engineer grappling with a brutal design problem involving limited space, circuitry needs on several planes, and low volume needs, then it just may be the answer that's been elusive.

Flexcircuits, like the small volume one you see here (we built only 1,000), get the same Sheldahl engineering attention, 100 per cent quality control and on-time delivery as high volume orders. Our customers don't come in different sizes. They come with different *needs*.

For short runs of flexcircuits we offer the same capabilities as for high volume production: single or double sided circuits, plated through holes, reflow coated circuits, solder plated conductors, solder fused pads, film or epoxy cover coated circuits, back bared pads and flexcircuit/hardboard hybrids.

So whether it's a new product, design change or a prototype to help start an idea toward reality, consider flexcircuit technology and quality. It's been the answer for many companies—large and small—and could be just the answer you've been looking for.

Call Sheldahl and find out.

(Flexcircuit watcher? To get an 11x14 reprint of the above bird, suitable for framing, just write on your letterhead.)

© DU PONT TRADEMARK



Sheldahl

Electrical Products Division
Northfield, Minnesota 55057
Phone: (507) 645-5633

© 1974 SHELD AHL, INC.

We couldn't have said



"Standing out among the industry giants—in both analogs and digitals—is Weston, a company that pioneered many of the advances in APMs. From optical indicators, to p & j's, to taut band; and from commercial to aerospace, you'll find it at Weston.

it better.



"If it's a DPM you're looking for, chances are you'll also find it at Weston: The company kicked off the industry when it introduced the first DPM just seven years ago."

Electronic Design, August 2, 1974

Circle 69 on reader service card

We're either first or best. Or both.

WESTON[®]



Weston Instruments, Inc.
614 Frelinghuysen Ave., Newark, N.J. 07114

In Europe: Schlumberger Instruments and Systems,
12 Place Des Etats Unis, 92120 Montrouge, France

I want to know more about:

Weston APMs Weston DPMs

I'm also interested in:

Weston DMMs Weston VOMs

Weston Frequency Counters

Name _____

Company _____

Address _____

City _____ State _____ Zip _____

Phone _____ Have salesman call.

Now there's i38510. It's three ways better than 883.

1. Scanning Electron Microscope analysis.



Intersil's high-resolution SEM inspects metal deposition and coverage of i38510 high-rel wafers. Normal wafer with perfectly deposited metal appears in circle at left. Cracks and faults, right, are easily identified and rejected.

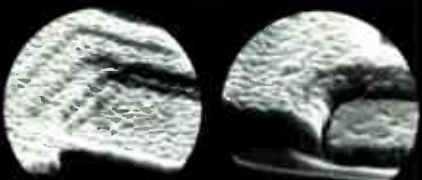

2. Off-the-shelf delivery from bonded inventory.

After final QA acceptance, i38510 product is placed in bonded inventory and held for immediate delivery.



3. Positive product traceability.

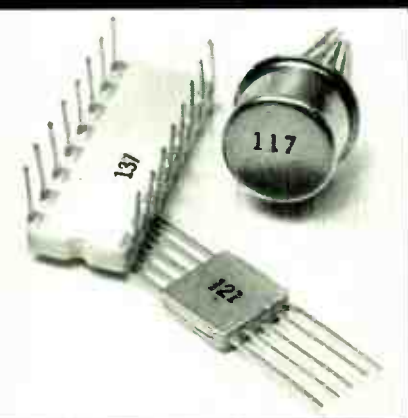

Each i38510 device is marked with its wafer-lot number and delivered with process documentation.

What is the i38510 Reliability Program?

It's Intersil's exclusive in-house program for military hi-rel products. These devices are made with MIL-M-38510A processing and MIL-STD-883 test methods, plus scanning electron microscope analysis and positive wafer traceability. They are delivered off-the-shelf with no minimum quantity required. In addition, Intersil will process to custom reliability specs; call Francis Azariah, (408) 257-5450 for details.

How does i38510 compare to MIL-M-38510A?

The object of i38510 is to provide microcircuits made to the exacting requirements of MIL-M-38510A, but not covered by specific MIL-M-38510A performance specifications. The i38510 program complies with all the requirements for systems, procedures and processing of MIL-M-38510A, except that electrical test conditions and limits are guaranteed to Intersil i38510 internal specifications.

Military Hi-Rel's an old story to us.

In June we received Manufacturer Certification under MIL-M-38510A for linear ICs. We've been qualified under MIL-S-19500 for 3 JAN-TX devices.

But more than that: At Intersil everything we make is processed to MIL-STD-883, Method 5004.1, Class B visual and environmental screening. It's been the production standard for all our products for years. All the more reason to talk to us for whatever you need in High-Rel. Intersil, 10900 North Tantau Ave., Cupertino, CA 95014.

Intersil



Here's where to get i38510 delivery.

Intersil stocking distributors.

Elmar/Liberty Electronics.
Schweber Electronics.
Semiconductor Specialists.
Weatherford.

Intersil area sales offices.

Boston (617) 273-2055.
Chicago (312) 371-1440.
Dallas (214) 387-0539.
Los Angeles (213) 532-3544.
Minneapolis (612) 925-1844.
New York (201) 567-5585.
San Diego (714) 278-6053.
San Francisco Bay Area
(home office) (408) 257-5450
Upstate New York/Canada
(315) 463-3368.

Representatives in all major cities.

Circle 71 on reader service card



The fresh, new approach to Low Cost System Design...

Winchester Electronics Low Cost Rack & Panel Connectors



They come in 10 colors. Like the others. They'll intermate with the others. They'll go into appliances, vending machines, business machines, computers and peripherals, consumer electronics, televisions, home entertainment equipment and more. Like the others are supposed to.

The peas-in-a-pod resemblance is intentional. But the similarity ends there. Because Winchester Electronics Series 56 (.062" dia. contacts) and Series 59 (.093" dia. contacts) connectors represent a whole, new fresh approach to *low cost* system design. Reflecting the consistent manufacturing quality controls and expertise behind our high performance, higher cost Winchester Electronics connectors. Unlike the others, the panel mounting ears on Series 56 and Series 59 connectors are molded so they snap directly into panel cutouts without bending . . . minimizing the risk of breakage. Rigid controls over nylon insulator moldings and contact construction mean that crimp removable contacts *stay put* and won't back out. With an electromechanical interface that locks in with an audible click. With tin-plated brass, crimp removable pin and socket contacts heavily formed and plated for

secure reliability, performance and greater resistance to corrosion.

A multitude of choices from the most comprehensive such line of low cost connectors anywhere is another plus . . . providing you with *design-by-specifying* ability numbering better than 720 possible specific configurations *each* for Series 56 and Series 59 connectors!

Add hand and automatic crimping equipment plus insertion/removal tools to speed your production and you'll see . . . Winchester Electronics new crimp removable rack & panel connectors will end a lot of complicated problems for you. From design, to production and into the field.

We've saved the best news for last. That Winchester Electronics low cost rack & panel connectors are *priced below* any of the look-alikes on the market. Send for details. And start planning, now. Winchester Electronics, Main Street & Hillside Avenue, Oakville, Connecticut 06779 (203) 274-8891.



WINCHESTER ELECTRONICS

Litton



The quickness of the eye never deceives the hand

Keeping up with the display is no problem on this new 50 MHz oscilloscope.

Every control falls naturally and quickly to the hand because we designed it that way. Ya, Yb, delayed and main time bases are all clearly separated with the main controls on exactly the same level. So you find what you want, when you want it, without the eye leaving the screen. Separating the two time bases also eliminates confusion and a

possible source of error.

As well as being easy to use the new PM 3240 is also light to carry - 8 kg light to be precise. So it's ideal for service applications, on computers and communications equipment, as well as for general laboratory use.

Neither does the eye get confused by difficult-to-see signals. The screen is a large 8 x 10 cm and 10 kV bright, enabling low duty cycles at high

sweep speeds to be displayed clearly.

Get your hands on this new instrument and you'll appreciate the difference that Philips' ergonomics can make. And if you need a higher bandwidth, there's an equally ergonomic 120 MHz model available.

For more information contact : Philips Test & Measuring Instruments Inc., 400 Crossways Park Drive, Woodbury, New York 11797.



Special Applications Information "HOT LINE"
Dial Toll Free Number (800) 645-3043
New York State, Call Collect (516) 921-8880

PHILIPS

Probing the news

Analysis of technology and business developments



Sweet touch. He doesn't know it, but the youngster charging his lollipop at a Hinky Dinky market is in the front lines of an electronic revolution in banking.

isolation and Executive Branch actions to encourage national EFTS operations that will not harm competition in the banking industry or threaten personal privacy.

Electronics manufacturers and bankers will be challenged to come up with competing systems in the next two or three years without uniform technical standards or Federal guidance. The American Bankers Association is one group that refuses to develop standards. "The minute we propose an industry standard, a group of banks would sue for anti-trust and restraint-of-trade relief," says an ABA spokesman.

What's more, the EFTS commission charter suggests that government and private industry refrain from permanent EFTS arrangements until the commission comes up with concrete proposals on how to protect banks not belonging to an EFTS from being overwhelmed by the giants. Justice Department officials also promote the "maximum competition" atmosphere, insisting that the "marketplace" must decide which system or systems should be institutionalized by standards, legislation, and regulatory-agency fiat. The prevailing attitude is "out of the chaos and confusion will come the best systems."

For electronics companies, Federal exhortations for increased competition among rival EFTS systems means several electronic funds-transfer systems using different technologies. This diversification may create a multitude of problems in future coordination, but it represents a lucrative new market for makers of data-processing and communications equipment, among others.

Meanwhile, various Federal agencies have begun permitting experiments with such EFTS subsys-

EFTS rules to evolve

Congress and agencies prefer to let standards for electronic funds-transfer systems grow through experimentation

by Larry Marion, Washington bureau

Proposals for electronic funds-transfer systems (EFTS) are pouring into Washington, but so far, the Congress and the three Federal agencies that regulate America's 20,000 banks are avoiding the temptation to legislate standards. Rather, they're beginning to encourage experimental systems in the expectation that uniformity will evolve.

To reinforce that thinking, President Gerald Ford last month signed a bill, backed by the banking industry, that authorizes a national commission on EFTS. This yet-to-be-selected group of 32 experts from the banking industry will conduct a two-year study to review technical advances and system concepts. The objective will be to recommend leg-

Probing the news

tems as electronic payment of Federal checks and point-of-sale terminals for banks, two services previously forbidden under anachronistic legislation. EFTS can run the gamut from automatic tellers to total electronic debiting and crediting without actual exchange of funds—the cashless society.

The biggest near-term impact on EFTS may be the nationwide deployment schedule for delivering payments from Social Security, welfare, and retirement funds. As announced by David Mosso, deputy assistant secretary of the treasury, a pilot EFTS program is expected within the next 24 months. By 1977, the department expects to be automatically depositing 3 million payments monthly in recipient accounts in Georgia and Florida via an electronic process, not yet defined.

The Federal Reserve Board, which has 36 offices and is the nation's financial clearinghouse and cash warehouse for national banks, would control the dispensing network for the estimated \$40 billion a year in Federal funds expected to be distributed by electronic processes by 1979. More than 16 million payments would be transmitted each month, if Mosso's schedule holds up.

Keep it open. To those in the banking industry, Donald I. Baker, deputy assistant attorney general for antitrust, is the apostle of competition. As the Justice Department's

leading spokesman on EFTS, he is a featured speaker at bankers' meetings. His message doesn't vary—the more competition among bank systems, the better Justice likes it.

"In this new field of point-of-sale technology, it is especially important to see that as many competing systems as possible be given a chance for survival," says Baker. "Accordingly, we will try to make sure that the joint ventures formed to offer local point-of-sale retail banking services are no larger than reasonably necessary."

The hottest things in banking, Baker and others say, are the retail point-of-sale and unattended-teller concepts. These are now being investigated by one of the big three in domestic bank regulation—the Federal Home Loan Bank Board. This Federal agency and the second of the big three, the U.S. comptroller of the currency, have concluded that unattended tellers and point-of-sale terminals do not "constitute a branch" and therefore are not prohibited by Federal laws that forbid branching. Many states' attorneys have gone along with that interpretation, and banks have begun petitioning state and Federal regulatory agencies for permission to experiment with various configurations. But banks cannot install permanent systems until Congress and the states amend banking laws, which must wait for the EFTS commission report.

The Federal Home Loan Bank Board, which regulates Federal savings and loans and mutual savings

banks, was under pressure to allow such experiments because S&Ls have been losing deposits to commercial banks, which offer higher interest rates on short-term notes. Now, the U.S. comptroller of the currency, James E. Smith, has been pressured by the commercial banks to even the score and allow commercial banks to enter retail marketplaces.

The home-loan board was the first to allow its banks to experiment with "remote service stations," its term for bank terminals in retail establishments or other nonbank locations such as shopping-center kiosks. Depositors can make cash withdrawals, deposit funds, or transfer funds between accounts.

The first operational system, on-line IBM 2730 terminals installed in two Hinky Dinky supermarkets in Lincoln, Neb., has been a "spectacular success" since startup last January, say the board and banking-industry officials. When credit cards are presented, the system dispenses cash to pay for purchases and automatically debits the purchaser's bank account. Suits in state and Federal courts interrupted operation, but Hinky Dinky received approval to expand its experimental system to five retail outlets, pending Nebraska Supreme Court and U.S. District Court rulings, which are not expected until mid-1975.

Six more S&Ls have signed up for other remote-teller systems with the home-loan board, and other applications are expected before the January 1975 deadline. TRW Inc. is about to start such an experiment with Ralph's markets and the Glendale Federal Savings and Loan in the Los Angeles area.

Comptroller Smith announced in September that he wants to permit national banks to install on-line or batch-processing terminals in retail locations, but pressure from independent bankers too small to operate on-line systems has delayed the proposal, banking sources say. Industry officials expect the comptroller's proposal to apply to banks in states where branching is permitted, circumventing conflicts with state prohibitions in Illinois, Florida, and elsewhere. Interstate branching, another expansion route forbidden to big-city banks, is also being eyed. □

In the works

Banks in New York City and elsewhere are lining up to propose new variations of electronic funds-transfer systems (EFTS). National BankAmericard and Interbank (Master Charge) may be joined by a new national system from Citicorp., parent of the First National City Bank of New York. Both the existing major bank-credit-card companies are studying national EFTS plans, under which cardholders can obtain cash from unattended terminals at airports, railroad stations, and major shopping centers.

Master Charge's plans are more advanced, say banking insiders. It would operate a cash-dispensing, credit-authorization, and funds-transfer network. Rival BankAmericard appears to lean toward the point-of-sale terminal with the operator authorized to distribute cash and transfer funds. Both companies intend "ultimately" to access customer checking accounts through a national network for complete electronic funds transfer, say banking observers. And American Express Co. also is in the EFTS market. It is proposing a nationwide debit account system.

**From instrumentation
to computers,
demanding OEMs**

turn to CTS

for the best cermet trimmer values

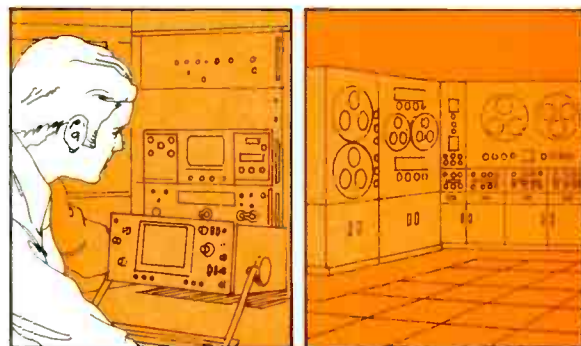
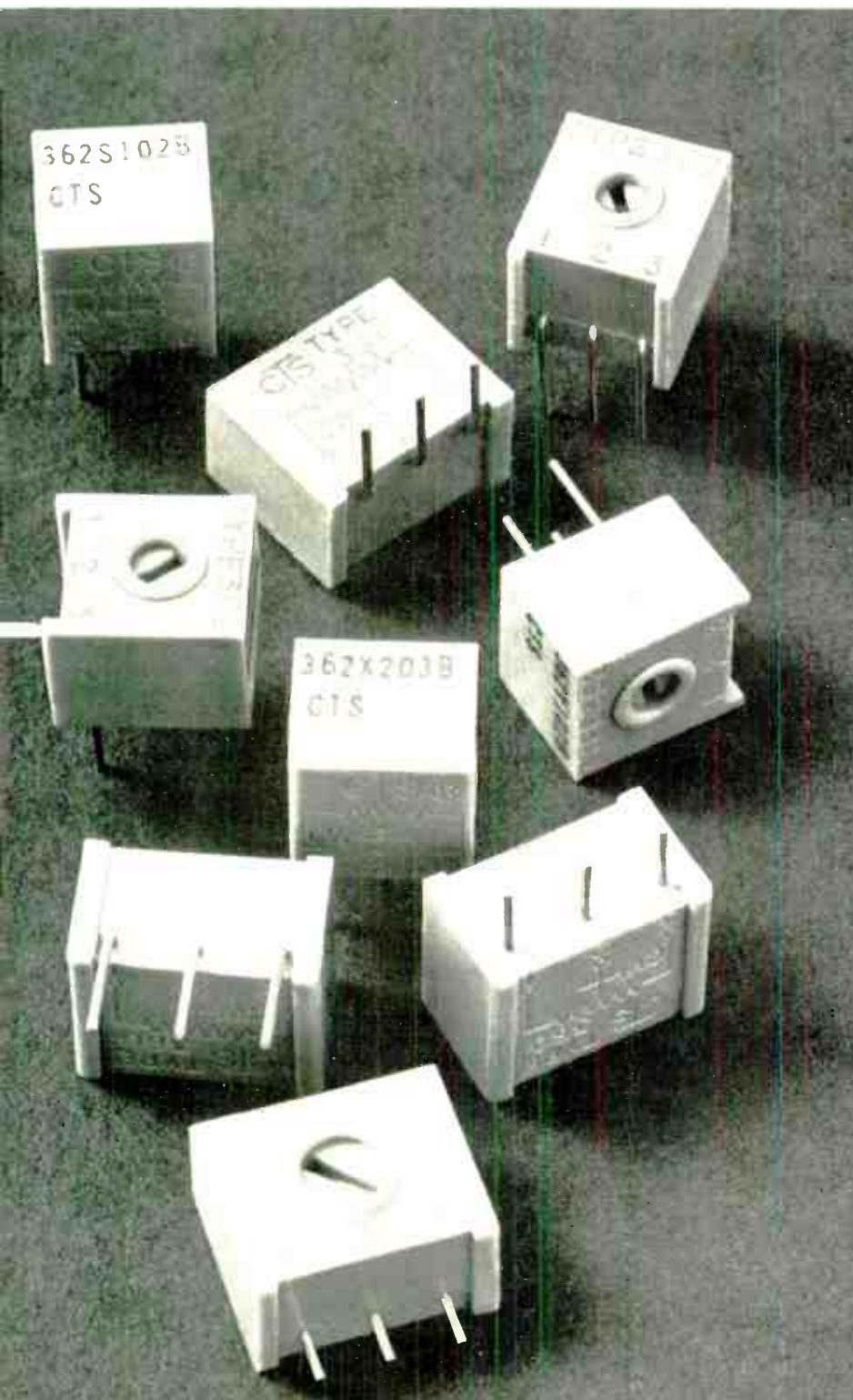

CTS is the "engineer's choice" for quality cermet trimmers. CTS delivers proven performance, uniformity and reliability . . . at economical prices. The best known calculators and all types of fine tolerance instruments incorporate CTS trimmers. Our industrial 360 Series satisfies a wide range of critical OEM applications.

Nine popular styles give you the pin spacing you need. Choose from top and side adjust .100", .125", .150" and TO-5. Plus top adjust .200" grid, too. Units are flux sealed, and feature a low TC cermet element. Settability: 0.03%.

- 1 watt power @ 25° C., ½ watt @ 85° C
- 1.5% average ENR noise resistance
- 0.5% average CRV

Available off-the-shelf from CTS Industrial Distributors. CTS of Berne, Inc., 406 Parr Road, Berne, Indiana 46711. Phone: (219) 589-3111.

Circle 77 on reader service card

CTS CORPORATION
ELKHART, INDIANA



A world leader in cermet and variable resistor technology.

Communications

N.Y.C. legislates \$200 million market

City's new law requiring sophisticated fire-alarm systems in high-rise buildings is considered a bonanza by 20 companies

by Ron Schneiderman, New York bureau manager

To many of the owners of high-rise office buildings in New York City, Code 5 is merely another costly regulation in an already over-regulated and financially burdened business. But to about 20 suppliers of fire-alarm systems, the law represents the gateway to a market for electronics and services that could top \$200 million.

Prompted by two major high-rise fires that took several lives in 1970, the city moved to amend its Class E fire-safety code, which covers office buildings. The result is Code 5, approved Jan. 18, 1973, which will take effect in January 1976. By that time, every office building in New York City that houses 500 or more persons, or is 100 feet or more high and houses 100 or more persons, must conform to the new Class E requirements for fire-alarm systems.

This "market by legislation," as one supplier calls it, is enhanced further by the need to treat individually each of the more than 800 buildings that qualify under Code 5. "Equipment requirements could vary as much as 300% from one 20-story building to another, based on the geography of the buildings," says William B. Taylor, ADT Security Systems' district coordinator for high-rise marketing, a post created by ADT to concentrate on the Code 5 market.

Market. No one knows how big the market is, but it's vast by any estimate. The "rough calculation" of \$250 million by Leonard Goldstein, regional protection systems specialist with Honeywell Inc.'s Commercial division in New York City, for example, assumes a start of 800 buildings—a conservative estimate

by most accounts—and an average of 15 stories per building. That's 12,000 floors at \$10,000 per floor. "But it could drop to \$5,000 per floor," says Goldstein, "because we're finding easier ways to make installations."

"I think everyone is going to get a piece of the New York business," says Goldstein, "because most of the building owners are going to wait until the last possible moment before signing anything. Then they're going to have to find someone to install their systems before the deadline or face a possible fine."

Moreover, the market isn't confined to New York City. San Francisco, Los Angeles, and Chicago are known to be investigating similar local legislation, while at a less sophisticated equipment level, Massachusetts recently passed a law requiring all homes for one, two, and three families started after Jan. 1, 1975, to have some type of automatic fire-detection system. But for now, New York is the place to be.

The New York City law requires some 14 functions for each fire-command station, including automatic smoke detection, monitoring of evacuation from a central station, trouble-signal indicators, power and sprinkler supervision, and test-mode indicators, in addition to a number of such functions as door-lock and elevator controls, signals for the fire-safety director, venting and pressurization controls, fire warden's control console, elevator monitor, and telephone and public address systems, all controlled by a mini-computer at the central fire-command station.

Typically, ionization sensors or

several smoke detectors will be placed on each floor. ADT plans to use ionization types, where heat entering an outer chamber changes the balance between two ionization chambers. This triggers a signal on a control panel and activates an alarm. The system also can be made to actuate switches cutting off power to various areas, release extinguishing agents, or perform other operations to help minimize fire and smoke damage.

Plans. ADT's Taylor says building owners have filed plans with the city on some 80% of the structures that qualify under the amendment, although very few of these owners have actually signed contracts for equipment. The law provides that a building owner who doesn't meet the deadline may have his certificate of occupancy lifted by the city's Department of Buildings after a violation summons is issued by the fire department.

Taylor says the city is "attempting to use a soft approach in its dealings with building owners, as far as the Class E installations are concerned, but that won't last long." Still, building owners are unhappy—in a tight money and slack real-estate market, they are reluctant to spend upwards of a million dollars for something that won't show any improvement in their own earnings. In fact, several are threatening to sue the city over the new law.

Thus far, about 14 companies have qualified with the city's Bureau of Standards to bid for Class E installations. An additional five or six firms are expected to enter the picture within the next few months. Honeywell's Goldstein says that,

“even if we all split the market up, it would still mean a nice chunk of business for all of us.” Indeed, ADT’s Taylor estimates that his company can handle only 30 40-story or equivalent buildings, leaving plenty of room for the other companies in the competition.

One of the smaller companies trying to get a foothold in the Code 5 market is Sycamore Industries Inc., a Freeport, N.Y. subsidiary of Futurionics Corp., which is a communications firm that develops information-handling systems. Sycamore vice president Arthur B. Gottesman says his company has bids out on \$10 million worth of business and is busily putting together proposals on other jobs.

Interconnection. Most of the major installations will use single dedicated coaxial cables to interconnect all system components. By multiplexing, most suppliers say that not only can they provide reliable fire-alarm networks that can each handle several system functions simultaneously—including voice and data—but they can go after new add-on business as well. “There will be a definite fallout for other electronics hardware in our approach,” points out ADT’s Taylor, “but we’d rather discuss Class E requirements with the customer first before going onto some other aspect of the system’s capabilities.”

In addition to the fire network, most basic systems lend themselves to such peripheral features as intrusion controls, monitoring of closed-circuit TV, water-flow detection and control, and control of heating, ventilating, and air-conditioning. (HVAC).

Goldstein says Honeywell already has signed contracts with several building owners, including the New York Times, that plan to use coaxial cables to control HVAC functions throughout their buildings. Most suppliers are expected to take the same approach to software, starting with a general program and then inserting device parameters to fit each system. □

Tall market. ADT Security Systems envisions this kind of layout for high-rise fire-detection systems. New York City will require such installations by January 1976.

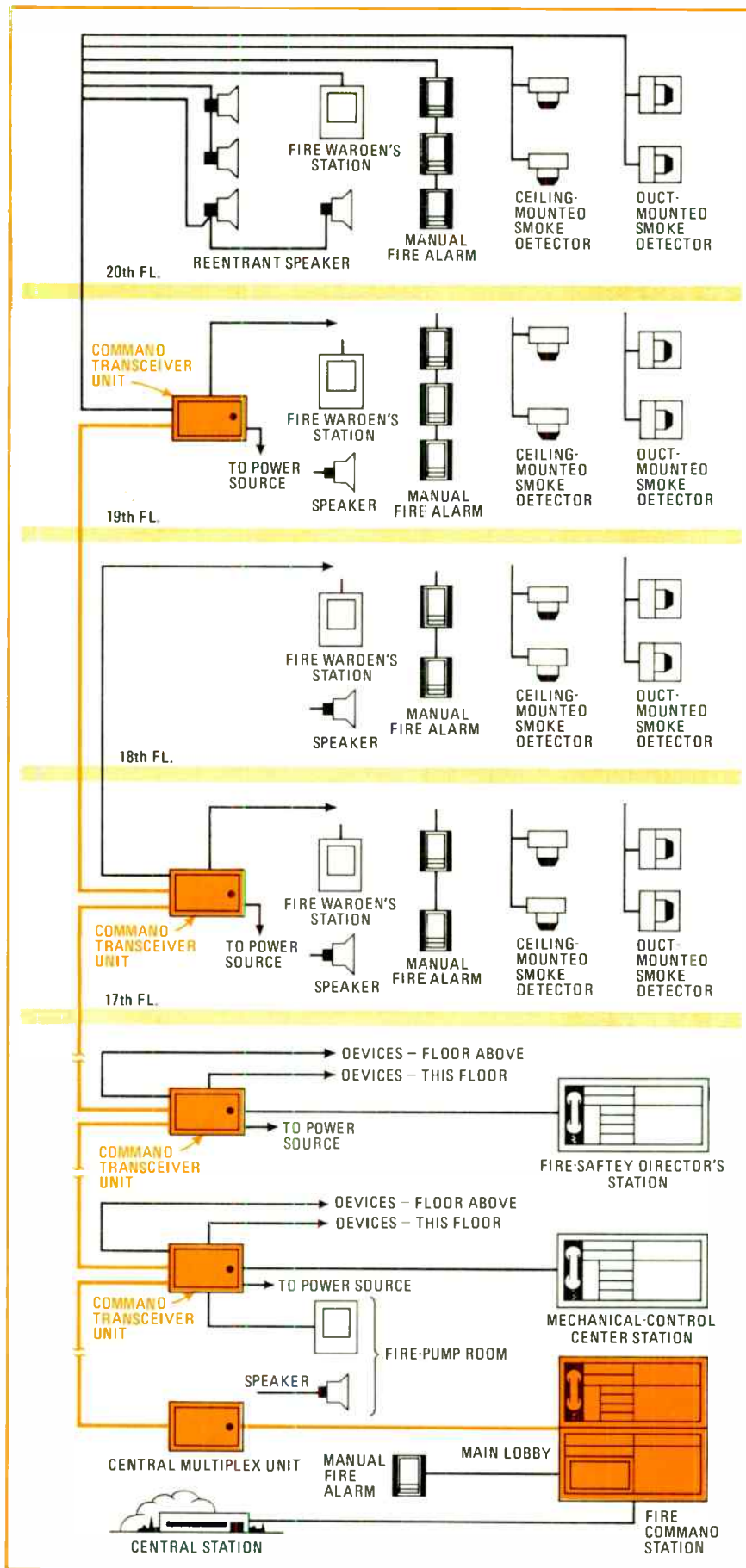



Why you should put RCA at the end of the line first in Linear ICs.

Product Categories	F	M	N	T	RCA
Op Amps					X
Gen. Purp.					X
Wideband					X
Precision					X
Micropower					X
High Current					X
Sense Amps					X
Comparators					X
Broadband Amps					X
Analog Mult.					X
Drivers/Receivers					
Mods/Demods					X
High Power Amps					X
Power Amps					X
Low Level Amps					X
RF/IF Amps					X
TV Circuits					X
Comm. Circuits					X
Ordnance Circuits					X
Trans. and Diode Arrays					X
Optoelectric circuits					X
Volt. Reg.					X
AC Power Cont. Circuits					X
Oscillators					X
A/D-D/A Conv.					X

You'll find there a broad selection of Op Amps, Comparators, Arrays and Power Control Circuits. And just about any other kind of linear IC you need.

In the above chart just "X" the appropriate blocks for your present suppliers and compare with the RCA column.

As the chart suggests, when you call your RCA Distributor there's a good chance you'll find what you need. On the shelf.

That includes the most asked-for numbers in the industry. Because in addition to everything else, we now offer a full line of standard types. Types from families like the 108A, 723, 101, 111, 741, and many more.

You've probably been aware of our capabilities in consumer LICs. Today, we offer a line of industrial LICs as broad as anyone in the business.

We've pioneered many of the advanced techniques in linear technology. So it goes without saying we're involved in more LIC technologies than any other company.

Our commitment is total. Whatever circuits your design requires, you can count on RCA to make them available. In short, RCA isn't just a half-way LIC house. But a full house. A house that offers original types, custom types, popular standard types, even chips.

There's more. A full house is complete engineering support. A full house is a wide range of packages, featuring our highly respected E-55 plastic package system. And a full house is a national distribution network of high volume distributors with current inventories of the most asked-for numbers.

Whatever your LIC needs, come to RCA. Contact your local distributor and put him to the test. See for yourself what a full house means.

That's the important point. We want you to try RCA. As a standard source. As a proprietary source. As a custom source. Because if we don't have what you need, chances are we can make what you have in mind.

For additional information, and a free cross reference guide and wall chart, write to your local RCA Solid State distributor or RCA Solid State, Box 3200, Somerville, N. J. 08876. Phone (201) 722-3200, Ext. 3145.

RCA Solid State
A full house in Linear ICs.

Circle 81 on reader service card

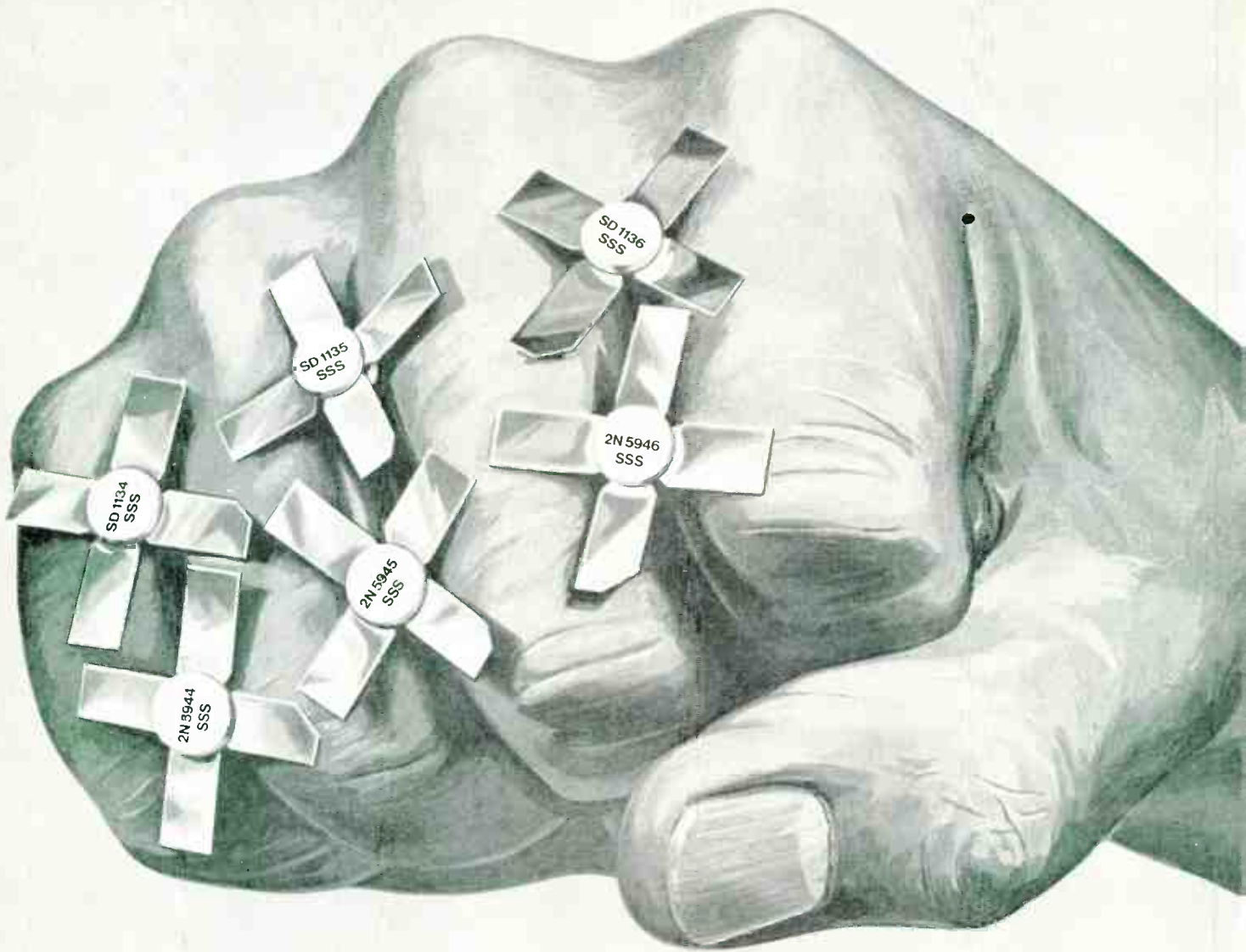

470 MHz power.

From the alternate source that's better than equal.

Six new RF power transistors. The SD1134, SD1135 and SD1136 are equivalent to the PT8809, 10, and 11 (2.0, 5.0 and 10 watts) respectively; three are equivalent to 2N5944, 45, and 46 (2.0, 4.0, and 10 watts) respectively. All are standard MT-90s. Available immediately.

These Solid State Scientific transistors are precisely identical, in all performance values, to those they replace. They're the products of our own rigorous internal lot and process controls, which assure com-

plete reproducibility of significant electrical characteristics.

They're 100% tested for VSWR and other RF parameters in end-use radios. And our outgoing inspection matches or exceeds your incoming.

We also produce a great many other RF power transistors for land, mobile, marine and aircraft radios; and CATV. All made by people who know exactly what they're doing. Write or call for data sheets, prices and consultation on circuit applications.



SOLID STATE SCIENTIFIC INC.

Montgomeryville, Pa. 18936/(215) 855-8400/TWX 510-661-7267

The RF power specialists

Circle 82 on reader service card

World Radio History

Military electronics

Seek Bus gets off the ground

First contract awarded for triservice tactical communication system that might result in billions of dollars in procurements

by Gail Farrell, Boston bureau manager

With the award of the first development contract for Seek Bus, the veil has been lifted from the triservice tactical communications system being billed airily as the data base in the sky. That contract, for \$5 million to Hughes Aircraft Co.'s Ground Systems group for a time-division multiple-access (TDMA) system to go into Airborne Warning and Control System aircraft, could be the forerunner of contracts totaling billions of dollars.

Seek Bus is conceived as a link among scattered surveillance, intelligence, and weapons systems of the Army, Navy, and Air Force. Development is being managed by the Air Force Electronic Systems division at Hanscom Field in Bedford, Mass. It is a high-capacity, digital, TDMA distribution system operating

on a single secure broadband communications channel. Each user transmits at designated intervals information available simultaneously to all participants in the system. In a way "data bus in the sky" is a misnomer: there is no dedicated, central installation—the network survives as long as any two users are still operating.

In operation, a participant enters into the network his position, status, identity, destination, and whatever else is required by the situation. Typically, the message may contain a label, the originator's code, element identification, fuel and ordnance status, mission code, position, speed, heading, altitude, and discrete indicators such as "emergency" or "bailout." Any other participant can use the 16-button

keyboard to call up only the information he needs. As new data pours into the coverage area, each receiver along the network is automatically updated.

Spread-spectrum techniques give protection against jamming, while cryptography ensures privacy. Access to information on the net can be controlled by a unit commander, or the user can select what information he needs.

The present program, which should begin to reach inventory in the late 1970s, is worth about \$200 million. However, final cost depends on how much equipment is needed to tie in all the organizations that will use it, says Col. Ronald E. Byrne Jr., program director. It will be installed first in units with the highest intrinsic value, such as AWACS planes, the F-15 aircraft, and major command and control centers. To date, AWACS, the Naval Tactical Data System, and some Air Force control and reporting centers can report to the Seek Bus net, says Byrne.

Current work includes engineering studies on installation, size, weight, and power of units for aircraft, and integration with onboard data processors and displays. Hughes has given a contract to International Business Machines Corp. for eight AP-1A communications processors, a new version of the System/4 π avionics computer, for delivery to the West Coast firm between September 1975 and March 1976.

The Mitre Corp. is the Air Force's technical adviser on Seek Bus, doing the conceptual work and generating specifications for equipment pro-

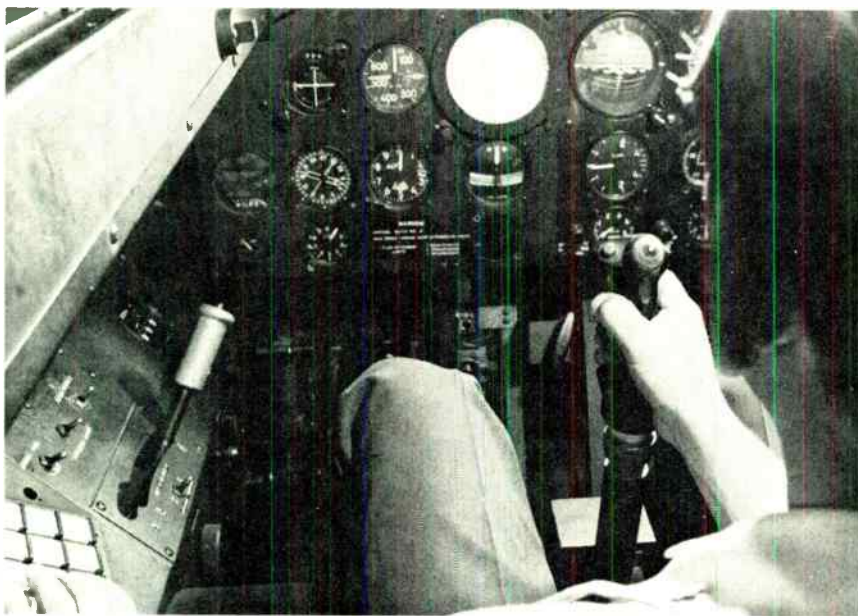

Getting the picture. Mockup of cockpit equipped with Seek Bus shows 16-button keyboard at lower left, and display for information acquired from so-called data bus in the sky.

Probing the news

curement. As developed by the Air Force, the prototype consists basically of a transmitter/receiver connected to the user's antenna and a signal processor. There are two versions of the solid-state transceiver; one for AWACS planes transmits with a power of 1,000 watts, and a smaller, lighter one for fighter aircraft operating at 100 w. The trans-

ceiver operates in the L band between 962 and 1,215 megahertz, a band already used by Tacan and IFF services. There will be no overlap with IFF, says C. Eric Ellingson, project leader at Mitre, because Seek Bus information is spread to bar jamming. Nor will it interfere with Tacan because in any given Tacan cycle Seek Bus will have a low duty cycle and power density. Seek Bus signals are spread in frequency and time, while Tacan's

have a fixed pattern in a precise frequency.

The channel has a basic time period of 12.8 minutes which is divided into 64 12-second frames, each with almost 1,500 8-millisecond slots. No user would be given less than one slot per 12.8-minute period for transmission (he can receive at almost any time), and each would be assigned as many slots as necessary—a fighter plane might need only one, while an AWACS plane might need more than 100. The net could have anywhere between two and almost 100,000 users, but Byrne says there would probably be about 1,000 users in a combat situation.

Since Seek Bus is limited to line of sight over a range of about 300 miles, users beyond that have to be connected to the system via a relay. Antennas are omnidirectional. But any terminal can act as a relay since it can be programed to receive or transmit at any time, setting aside part of its transmission time for relay.

The information bits from the transmitter are delivered to a signal processor, which spreads the narrow bandwidth signal over a large radio frequency. The same cryptographic device also encrypts and de-encrypts data. The processor also includes modulating and demodulating capabilities.

Alternatively, all 456 bits in the time slot can be used to transmit information, or else a redundant half-rate code that provides 228 bits of information in a slot can be used, so even if part of a message is lost it can be reconstructed. The reconstructed message is then put through an error-protection scheme to see if residual errors still occur; if any do, a bit is put in the message to indicate there is an error. A message can also be transmitted back to the sender for a system check and if incorrect will be automatically retransmitted.

The Mitre-designed signal processor is mostly digital. In a fighter, Ellingson says, LSI, C-MOS, and thin- and thick-film hybrids would probably be used to cut down on size and weight, while for AWACS planes small-scale ICs and a small amount of LSI would be used. □

Automatic 0.25% impedance measurement:

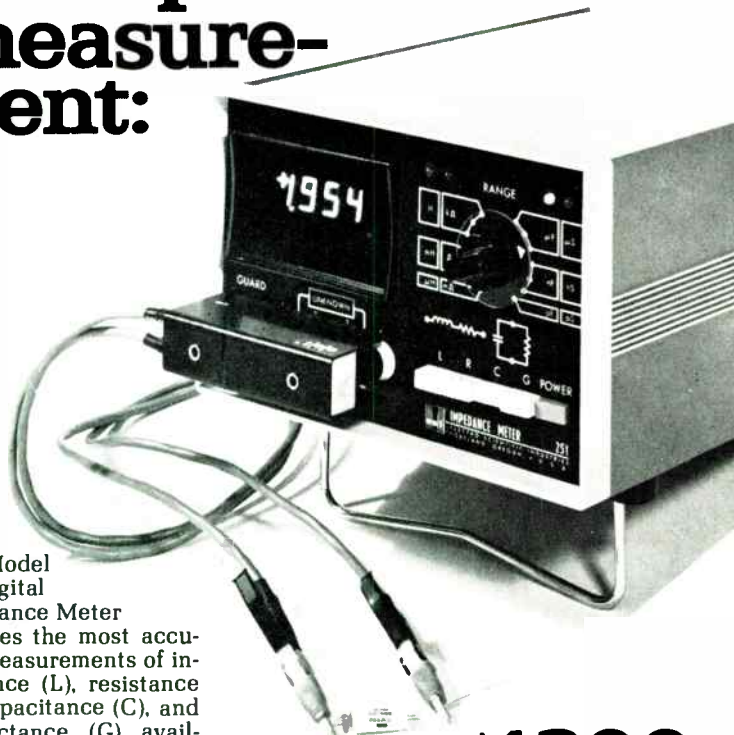

Our new Model 251 Digital Impedance Meter provides the most accurate measurements of inductance (L), resistance (R), capacitance (C), and conductance (G) available in any instrument up to five times the cost—plus it's fast and reliable.

Big, fat claims, right? But consider this: Accuracy of 0.25% + 1 digit, measurement speeds of a fraction of a second, high-intensity 3½-digit readout has overload blanking to prevent false readings, solid-state construction packed into a rugged 10-pound frame. And simple to operate.

You might consider this. Our reputation. We've led the building of precision impedance measur-

ing instruments for laboratory and quality control applications for 25 years.

Check us out, then call or write for the complete story. Ask about our discrete IC testers, too.

Electro Scientific Industries
13900 N. W. Science Park Drive
Portland, Oregon 97229
Phone: (503) 646-4141

\$1200.
(U.S.A.)

esi
ELECTRO
SCIENTIFIC

MEET THE FREQUENCY **STRETCHERS**

MINIATURE STRIPLINE COAXIAL COUPLERS

Model 4055 7.5 to 16 GHz

Model 4222 1 to 18 GHz



2 AND 4 WAY POWER DIVIDERS

Model 3305 7 to 18 GHz

Model 4343 2 to 8 GHz

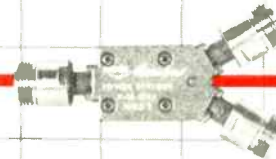

180° HYBRIDS

Model 4345 7 to 16 GHz

Model 3303 2 to 8 GHz

Model 4344 4 to 12.4 GHz

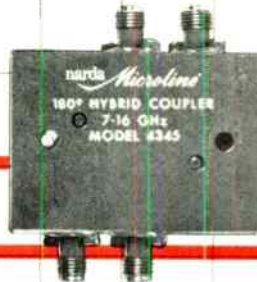

MINIATURE FIXED ATTENUATORS

Model 4779 DC to 18 GHz



STEP ATTENUATORS

Model 705-99 DC to 18 GHz



DC 2 4 6 8 10 12 14 16 18 GHz

You Get Wider Frequency Range In A Smaller Package With These Multi-Octave Devices

If you are squeezed for space, for weight, for money, then these mini, extended range components are the answers. Now you can extend your capabilities in system design with our ability to reduce the size and weight of these multi-octave couplers, hybrids, attenuators and power dividers. If you don't find exactly what you want in our standard line, our special capabilities can be made to fit to your measure.

Narda originated the "Broadband Generation" in components and instruments . . . test your systems with our Solid State Sweeper/Signal Generator (Model 9500 series) from 1 to 18.5 GHz, without the cost and inconvenience of plug-ins.

There are a lot more benefits to know about the Broadband Generation — write for new brochure.



wherever microwaves go... **narda**

238

THE NARDA MICROWAVE CORPORATION • PLAINVIEW, L.I., NEW YORK 11803

516-433-9000 • TWX: 510-221-1867 • CABLE: NARDACORP PLAINVIEW NEWYORK

Circle 85 on reader service card

IF WE CAN'T MAKE YOUR MINICOMPUTER SYSTEM DO MORE WORK FOR LESS MONEY, NOBODY CAN.

When we introduced the SPC-16, we promised it would be the world's most powerful, versatile, cost-effective family of minicomputers.

It was. It still is.

The SPC-16 isn't the lowest priced hardware you can buy. But it will give you the lowest cost solution.

Through advanced systems architecture, simplified interfacing and a powerful instruction repertoire, the SPC-16 allows you to minimize programming, interfacing and memory costs no matter what size your system is.

Six mighty minis.

The SPC-16 family consists of six minicomputers offering a choice of three memory cycle times (800ns, 960ns and 1440ns), memory expansion to 128K using efficient 16K boards, and two different packaging configurations.

If you build a system around the SPC-16, it will do more work for less money than any other system you could build.

And that translates into more profits.

We know it for a fact. In the past few years, we helped a lot of OEMs get the edge on their competition by designing our product into their products. We helped a lot of end users solve a lot of tough, tight-budget applications. And, we produced some cost-effective systems of our own.

Two hard working systems.

Take RTOS II for example. It's a multi-programming system offering real-time event driven foreground processing concurrent with background job development and computation.

You couldn't buy a better price/performance solution for applications such as process control, data acquisition, laboratory research, material handling, communications or overall manufacturing automation.

We also built a powerful disk-based general purpose system around the SPC-16. DBOS II lets you do more computation with less memory, in far less time, at a lower price than any system on the market. It offers both scientific and commercial languages and a combination of interactive and batch operation.

This system is perfect for service centers, research and development groups and system house dedicated applications.

That's the short form.

To really appreciate how much power we can deliver for your money, write for our book

"The Value of Power." It will give

you the facts to back up our claim:

If General Automation can't make your system do more work for less money, nobody can.

Write General Automation, 1055 South East Street, Anaheim, California 92805. Or call (714) 778-4800. In Europe, write General Automation, S.A., 24 rue du Sergent Bauchat, 75012 Paris, France. Telephone (1) 346/7973. In Canada, write G.A. Computer Ltd., 880 Lady Ellen Place, Ottawa K1Z5L9, Ontario. Telephone (613) 725-3626.

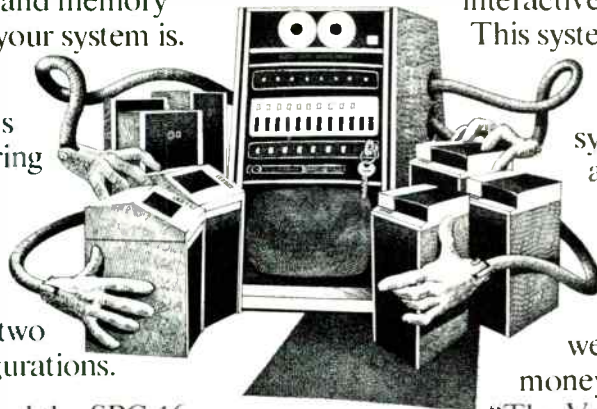

POWERFUL MINICOMPUTERS BY GENERAL AUTOMATION

Automotive electronics

Smoothing troubled waters

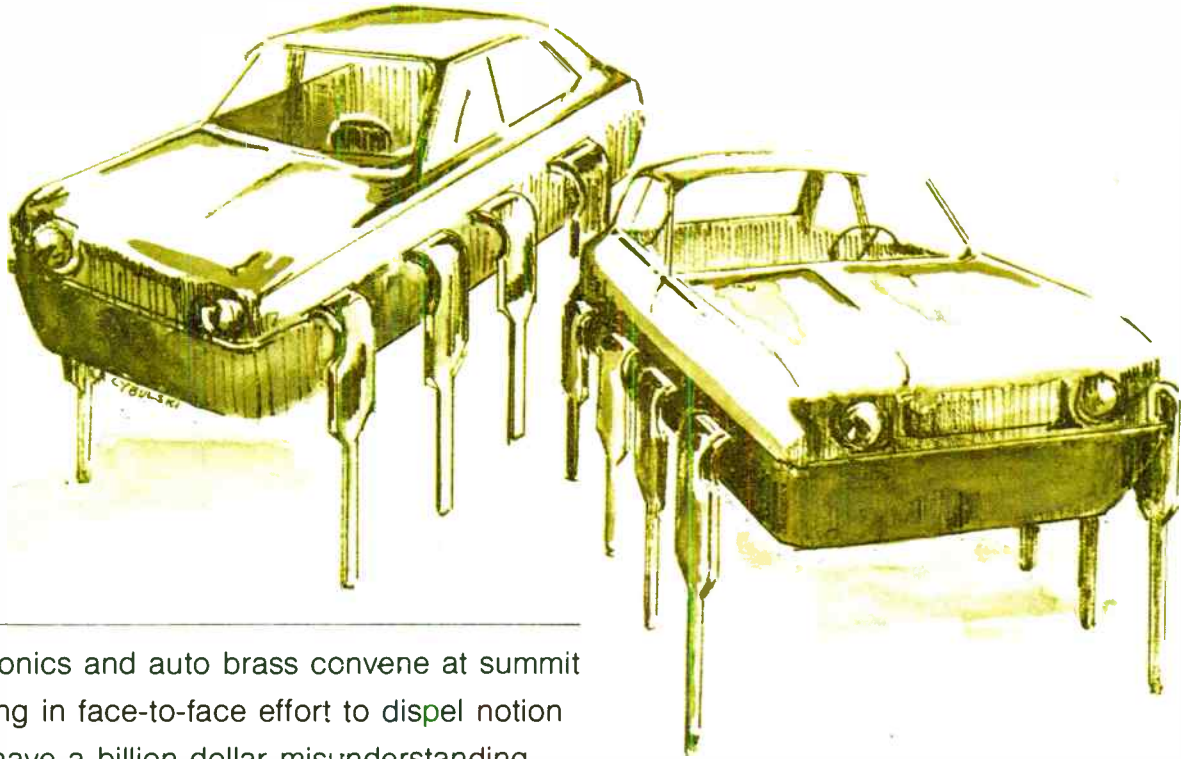

Electronics and auto brass convene at summit meeting in face-to-face effort to dispel notion they have a billion-dollar misunderstanding

by Gerald M. Walker, Associate Editor

Against a background of troubled relations with the semiconductor industry, the nation's automakers are about to accelerate trials of microprocessors and related sensing and display devices. The glow that once seemed to surround a profitable relationship is gone, and there has been a subtle role reversal.

There's an over-all reason for the deterioration in relations: lack of communications.

First of all, semiconductor firms are unhappy about the automakers' pricing policies. They feel those policies are delaying an acceptance of more automotive electronics, that traditional worry over pennies per part has obscured total systems cost analysis of electronics.

They're also discouraged by the shifting time frame for new applications. Projections indicated that

electronics would be worth 5% of the 1975 model value and 10% of the 1980 model value. But in reality, it may be half of these estimates.

On the other hand, the semiconductor suppliers have lost some credibility in Detroit. The complaint: oversell. Automobile engineering managers are unhappy to start with because of the stringent Government emission-control requirements. They feel the Federal regulators and the auto companies were led to believe that the technology was on hand to meet the standards at reasonable cost. This has not been so, and the electronics companies are under suspicion.

From the auto industry's point of view, the semiconductor engineers have still not come up with reliable transducers, low-cost actuators, and lower-cost MOS integrated circuits.

In an effort to re-establish relations on a more realistic basis, a summit meeting of electronics and automotive managers took place earlier this month outside Detroit under the rubric Convergence 74. Unofficially, it became an automotive microprocessor parley for the 700-plus attendees.

It was here that the role reversal took place. The semiconductor brass sounded uncharacteristically subdued and cautious, while the auto managers provided the pep talks on the future of electronics in cars. The director of electronic product development for one of the Big Three summed it up during a lull in the meeting when he admitted quietly, "We need the electronics industry so bad, we don't dare say it out loud."

This is not an exaggeration, because the auto makers are now up

FIRST IN THE WORLD ULTRA MINI BLACK LIGHT & COLOR LIGHT

BRACK LIGHT & COLOR LIGHT :

POWER CONSUMPTION 0.6W COLD CATHODE TYPE, AND SAME OPELATE CIRCUIT, VOLTAGE, DESIGN & CHARACTER

COLORS AVAILABLE :

YELLOW, BLUE, GREEN, WHITE, RED

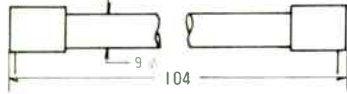

APPLICATIONS :

- ILLUMINATION OF DIGITAL CLOCK
- ILLUMINATION OF LIQUID CRYSTAL DISPLAY
- OTHER VARIOUS DISPLAYS

VARIOUS TYPES OF NEON LAMPS

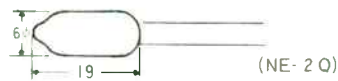

APPLICATIONS :

- DISPLAY, CIRCUIT ELEMENT, VOLTAGE REGURATOR, SURGE ABSORBER, VOLTAGE INDICATOR.

FLUORSCENT GLOW LAMPS

(Green Color)

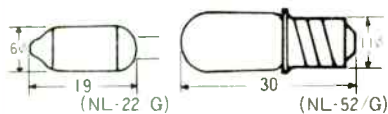

APPLICATIONS :

- VARIOUSTYPES OF DISPLAY

XENON FLASH TUBES

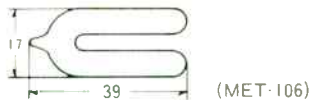

APPLICATIONS :

- STROBOSCOPE
- SIGNAL LIGHT
- IGNITION TIMING LIGHT
- DISPLAY LIGHTING SOURCE
- PSYCHEDELIC LIGHTING SOURCE

MAIN PRODUCTS :

NEON LAMPS, MINITYPE BLACK LIGHT, COLOR LIGHT (5 COLOR), XENON FLASH TUBES.

ELEVAM ELECTRONIC TUBE CO., LTD.

NO. 17-8 CHUO 2-CHOME OTA-KU, TOKYO
TEL : 03(774) 1231~5

Write now for your reference Catalogue.

EXPORT DIVISION

JAPAN NANOTRONIX CO., LTD.

TWIN-BUILDING 31-15, SAN-NOH 1-CHOME,

OTA-KU, TOKYO

TEL : 03(775) 4811 TELEX 246-6583 JNANOX

Probing the news

against the following "needs:"

■ *The 1977 emission control standards.* Without question, the only way they're going to be met is with a closed-loop electronic fuel-management system, probably injection, and it is going to take a micro-processor to control it. The Big Three are working on such systems.

■ *Diagnostics.* Selling features of yore—speed and power—are dead. Economy in gas mileage and in maintenance is the new pitch. Repair-shop diagnostic systems are therefore becoming a must. Safety requirements also are expected to push the need for on-board, micro-processor-controlled warning systems for brakes, ride control, windshield-wiper control, and the like.

■ *Seat belts.* The seat-belt interlock is dead, but its replacement may be just as demanding. Should the Department of Transportation decide on a sequential warning system with timed alarms, belts may continue to require ICs for memory and logic.

■ *Fuel economy.* President Ford recently called upon the auto industry to cut 40% off fuel consumption on cars. He mentioned parenthetically that if the industry does not do

it voluntarily, there may be legislated requirements. "That's the most important parenthetical phrase the auto industry's heard all year," remarked one conferee. "It adds up to pressure." When an effective solution is found to make this savings, microprocessors will have a part.

This is a partial shopping list. In describing the systems under development at General Motors, Trevor O. Jones, then director of advance product engineering and chairman of the conference, said GM's Alpha, Delta, Sigma, and Beta (now inactive) series test cars have identified 60 future electronic systems. But he questioned the electronics industry's ability to perfect these applications. For example, major transducer development is required in 35 applications while 25 still need effective actuators. Some 23 of the 60 involve adequate displays. More important, 25 face significant technical barriers, and 56 are blocked by cost barriers.

What was the response from the electronics executives to the automotive challenge? The prevailing attitude was, let's take another look at the problems before plunging into microprocessors.

Long an evangelist for auto electronics, Fairchild Semiconductor's vice chairman, C. Lester Hogan, has

How's that again?

One aspect of summity is that some statements from the podium may be diplomatically worded, rather than straight talk. Convergence 74 was no exception, as the private corridor conversation proved. Here are a few comparisons of the public remarks by the semiconductor industry speakers with the private responses of auto company engineers.

Podium: "There will be a marriage of the electronics industry and the automobile industry." *Reaction:* "We don't want to get married to the semiconductor industry. All we want is a good mistress. After all, Detroit had one marriage with the oil industry, and that's ended in divorce. Now we're all paying the alimony."

Podium: "Auto companies should design systems using standard microprocessors for more reliable results than custom designs." *Reaction:* "It's going to be custom, and we've told them [semiconductor suppliers] so. There are too many variations from engine type to engine type to use even the very flexible standard microprocessors."

Podium: "The application of semiconductors in cars is not advancing as fast as predicted." *Reaction:* "We told them so, but they wouldn't believe us."

Podium: "Field-failure experience of the seat-belt interlock system has proven the high reliability of ICs in cars. It's over 90%." *Reaction:* (laughter) "That's been the most unreported field failure in the history of automobiles."

Podium: "Automotive demand did not swamp the semiconductor industry's capacity." *Reaction:* "That may be true in the abstract, but they're still behind in deliveries."

lost some fervor, though he hasn't lost the faith. He told the auto company managers that the semiconductor industry had to go through a "nuts-and-bolts experience" to learn the car industry.

Said Donn L. Williams, president of Rockwell International's Electronics operations, "We have very big problems in turning blue sky into blueprints." He pointed out that the forced relations between auto and electronics engineers is creating a new discipline that he dubbed "autotronics."

Coolest toward the auto market were Robert N. Noyce, president of Intel Corp., and Bernard V. Vonderschmitt, vice president and general manager of the RCA Solid State division. Noyce remarked simply that if the data can be acquired and transmitted to the microprocessor, the computation is virtually free. The major costs are run up in sensors and transmission lines. Vonderschmitt said the impact of the autos on the semiconductor industry so far has been slight, worth only about \$85 million this year of a predicted total of \$2.3 billion. As a result, even though he expects automotive semiconductor sales to reach \$230 million by 1979, no solid-state technology has been developed especially for cars. Detroit will have to adapt devices designed for other applications, he concluded.

The auto companies are not accustomed to taking a back seat in their vendors' priorities. So conjecture has been rife concerning one or all of the Big Three starting in-house microprocessor operations. Admitting there would be certain advantages, GM's Jones said he thought the disadvantages are greater. "We don't make tires and we don't make glass, because there are industries that can do that better than we can. We prefer to leave semiconductor processing technology to the semiconductor industry. Our specialty is mass-production assembly."

How about buying a company? Not inconceivable, Jones avers. But for now, Detroit is prepared to smooth things out with the semiconductor industry, hoping that the summit meeting will lead to peaceful negotiation. □

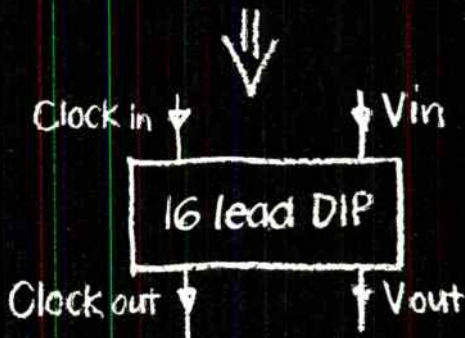

Analog Memory
70 DB S/N
Sample rate: 12 MHz
1 μsec - 40 msec delay
IN PRODUCTION!

Reticon Corporation, a pioneer in solid state image sensing, has now applied its technological leadership to the field of analog memories.

These devices are large scale integrated circuits which sequentially time sample an analog input signal and store each sample as an analog voltage level on one of a series of storage capacitors. The stored samples are then read-out in sequence to reconstruct the original input signal with a new time base. Several device types are available from inventory with up to 128 elements of storage.

Applications include time base correction (expansion or compression), tapped delay lines, correlation, digital filtering, real time Fourier transforms, chirp radars and many others.

Write or call for further information including detailed peripheral circuits.

There are over 60 salesmen and 14 distributors to serve you worldwide.

RETICON®

910 Benicia Avenue,
Sunnyvale, California 94086
Phone: (408) RET-ICON TWX: 910-339-9343

Ask The Man Who Uses One

... About Cost Effectiveness

He works for these companies . . .

Fairchild
Hamilton Standard
ITT-Avionics
ITT-Europe
NCR
Rank Xerox
Raytheon
RCA
Siemens
Sperry
Sycor
U.S. Air Force
U.S. Navy
Western Electric
Xerox

He knows how to evaluate automatic test systems and their cost effectiveness on the basis of . . .

- Hardware costs
- Software-controlled switching of peripherals, eliminating adaptors
- Use of sophisticated resident software system
- Use of efficient test-oriented English language, such as ATLAS
- Use as a MANAGEMENT INFORMATION SYSTEM

He also understands test system cost savings that can result from data logging for trend analysis reports, quality control reports, and configuration control. And he knows he can test new products and save costs by meeting test specification changes through fast, economical field modifications.

Ask the man who has proven the cost effectiveness of the System 390. He has paid for the system through cost savings realized over 5-to-15 months of use.

Send us your test requirements, and we'll show you how the System 390 can solve them efficiently and economically. We'll also send you our User Catalog.

Contact:

Instrumentation Engineering, Inc.
769 Susquehanna Avenue
Franklin Lakes, N.J. 07417;
telephone: 201-891-9300

Instrumentation
Engineering 

The System 390

Ask The Man Who Uses One.

Los Angeles Office: 213-973-6611
Washington, D.C. Office:
703-451-1422

Europe Offices:

Siemens AG
D 7500 Karlsruhe 21; 595-2591
D 8000 Munich; 7200-7131

JAPAN

after the shock

Oil shortages, inflation, labor unrest, and buyer resistance have shaken Japan's electronics industries; and now companies are striving to pick up the pieces of their former prosperity

By Gerald M. Walker, *Associate Editor*, and Charles L. Cohen, *Tokyo bureau manager*

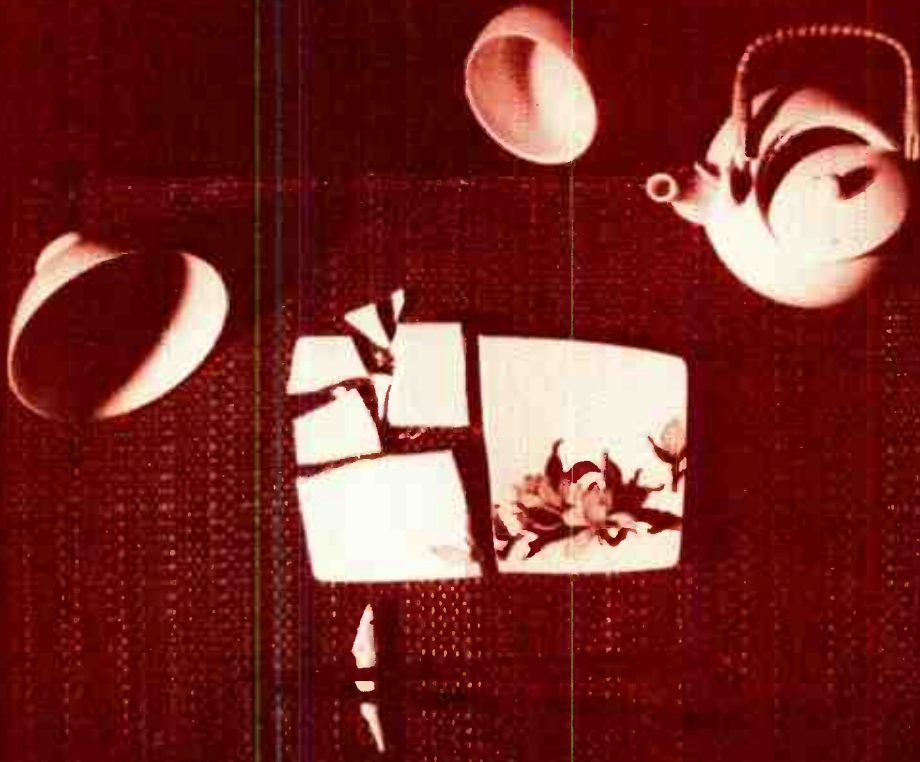

CONSUMER ELECTRONICS: Dragged down by video slump, p. 93

SEMICONDUCTORS: Stymied by obese inventories, p. 97

COMPUTERS: Steeling for trade-liberalization shocks, p. 99

COMMUNICATIONS: Hung up by the phone company, p. 101

INDUSTRIAL ELECTRONICS: Curtailed by monetary controls, p. 102

SPACE ELECTRONICS: Soaring above it all, p. 103

DEFENSE ELECTRONICS: Shot down by inflation, p. 104

□ Always mindful of earthquakes, the Japanese have a predilection to conceive of major national setbacks as "shocks." This year, the "oil shock" with its attendant inflation set off an economic tremor that has just about flattened Japan's industrial growth. A second common term, *infurebukure*, or over-expansion by inflation, added to the shock that triggered this year's economic calamity.

The balance of payments has dropped. Labor costs have rocketed an astounding 33% as a result of the "spring offensive" by the unions. Inventories have bulged to unhealthy proportions. The inflation rate, one of the highest in the world, was well over 20%. Even the Shinkansen, Japan's high-speed train and the pride of the nation, ran into breakdowns and delays this year. In short, Japan's well-oiled economic wheels have slowed down.

Knowing that the island nation is 100% dependent on oil imports and that 73.5% of its energy is produced by oil, economists discovered that between 1960 and 1970, for every 1% gain in gross national product, Japan required a 1.2% increase in energy consumption. The long-term implications of high-priced oil are clear.

Government provisions to halt inflation have acted as a depressant on industry at a time when investment in automation to increase productivity is vital. In the first quarter of 1974, GNP actually dropped 4.2% below the level for the same period in 1973. From April to June, there was a drop in the GNP of 2.8% from the corresponding 1973 quarter. Unless the second half scores higher, 1974 will be Japan's first no-growth year since the postwar resurgence. The previous low was scored in 1954, when the GNP actually rose 2.3%. And there's little reason to expect much improvement in 1975; in fact, one government minister has recently predicted a depression, which is another way of saying there'll be another drop in GNP.

Unemployment rates have little meaning in Japan because companies do not lay off employees unless they are *in extremis*. Welfare is a corporate responsibility, and idle workers are continued on the payroll. Unem-



Tamofusa Onoye, executive director for EIA-J, sizing up the stress in Japan's electronics industries, suggests future growth may depend on "gap" theory, finding a product too sophisticated for emerging nations and not interesting enough for advanced nations.

ployment will become a social problem, however, if small-to-medium size corporations go bankrupt, as predicted by some economists.

Key factors that might spur Japan's recovery in 1975 would be a controversial relaxation of monetary controls on plant investment, restraint by the labor force in the next wage offensive, improvement in the balance of payments, and a balanced government attack on inflation, including increased taxes on income and interest rates. Since it's extremely doubtful that all of these goals will be achieved next year, there is considerable uncertainty in forecasting business performance.

The electronics industries have suffered along with the rest of the economy. Virtually all of the predictions about 1974 that were made a year ago have failed to come true, largely because of the economic shocks. All the electronics industries, except computer manufacturing, registered declines this year (see table).

Next year, according to the consensus of Japanese manufacturers reporting, purchases of domestic electronics should recover to normal levels. But these forecasts must be hedged. Optimism may be wishful thinking, because manufacturers rarely concede pessimism or no growth unless the product is slipping down the obsolescence slope. On the other hand, some strong electronics products, such as hi-fi equipment and microwave ovens, seem to outperform the economy and partially make up for the losses.

By the end of the third quarter of 1974, most electronics executives thought that the worst had passed. Nevertheless, all of the hopeful signs could turn sour and make 1975 another shock. □

HOW THE "SHOCKS" SHOOK ELECTRONICS			
Estimated dollar value of Japanese electronics consumption based on an Electronics survey of manufacturers			
	(In millions of dollars)		
	1973	1974	1975
Consumer	4,273.6	3,840.6	4,348.2
Computers	3,329.4	3,839.6	4,878.8
Communications	1,397.3	1,295.2	1,494.4
Industrial, test, auto, medical equipment	1,555.4	1,499.2	1,810.0
Total	\$ 10,555.7	10,474.6	12,531.4
Semiconductors	1,261.7	1,164.7	1,309.9
Components and tubes	2,844.8	2,640.2	2,962.4
Total	\$ 4,106.5	3,804.9	4,272.3
Note: Yen value computed at 263 yen = \$1 for 1973; 295 yen = \$1 for 1974 and 1975.			

Color-TV picture dims, audio level gains

□ No plot in the typical samurai drama is complete unless the hero defies all odds by simultaneously overcoming the half dozen enemies arrayed against him. A similar plot is unfolding for the dominant color-television industry, but it remains to be seen how many antagonists will fall.

Simultaneously, Japanese set makers this year have faced a nearly 90% saturation of the color market, a cost-price squeeze, consumer demand for economy features, uncertain export markets, and steep increases in labor costs. The economic shocks of 1974 have worsened the blow of market saturation that had been anticipated for a few years. And now the question is, can the industry overcome these odds?

Smiling at the analogy of the samurai warrior, one TV executive exclaimed, "Yes, but we're looking for a good sword." By that he meant no exciting products—not even video-player systems—have been introduced to pull manufacturers through this trying year. Nor is there likely to be much improvement in 1975. The *Electronics* consensus chart indicates a mild 6% increase next year, following a devastating 20% drop this year.

The dilemma, usually referred to as the "post-color problem," has been the source of considerable blue-sky conjecture for at least three years. But now that the day has arrived, the only practical candidate that Japanese TV producers have for "post-color" is more color—replacements and second sets.

The VTR is not going to be developed past the luxury stage for many years, and, even then, it will be in the 1980s before a puny household market of 3 million players—a mere 10%—will be developed. And the big day of the video disk is even further in the future.

A shakeout is expected in the calculator market, and manufacturers are frantically devising new strategy to enable them to remain competitive. The market for solid-state watches offers a ray of hope, as the first mod-

els are now being introduced. Cut-throat competition is a probability, however, as vertically integrated companies enter the market against traditional watch makers. The market for microwave ovens is continuing to grow, but the demand for lower-priced models is forcing manufacturers to put out smaller models.

Color-TV picture is dim

Japan is clearly not over its economic ills, although there are signs of remission. Next year will continue to be difficult for the color-TV industry. Domestic consumption probably won't exceed about 5.8 million sets, compared to 6.5 to 6.6 million in 1973 and 5.0 to 5.5 million this year. Replacement sales in 1975, pegged to the beginning of the color boom in 1968, will still not surpass second-set buying and probably won't do so until 1976. It'll probably be 1976 before domestic-unit sales return to the 1973 level. And if the economy does not suffer another shock, 7.5 million sets should be sold in 1977, according to estimates of the Sharp Corp.

Equally important to the Japanese are foreign markets, which also promise hard times this year and next, primarily because the economies of all countries are in similar disarray. Expecting to register declines in both the U.S. and Europe, TV makers are looking toward Southeast Asia, Australia, and Brazil for new business.

More than ever, overseas sales depend on local production of all or part of the receivers, Susumu Yoshida, senior managing director for Sony, points out. This is true, not only for Sony's plants in San Diego, Calif., and the United Kingdom, but for developing nations. However, he emphasizes that the technological base will remain in Japan.

Along with the glum outlook for television sales have emerged inevitable predictions of a shakeout, or at least graceful withdrawal of two or three makers with minor participation in receiver production. Nippon Columbia,



Waiting for VTR. The home market for video players is just getting under way, but prospects for a mass market are dim until prices come down drastically. A recent entry is this unit, called V-Cord, being sold by Toshiba and Sanyo.



Yutaka Ikeda, Toshiba's TV division chief, says deflection-angle race is over.



Hayata Tokizane of Matsushita TV (right) feels automated assembly is key to profit.

for instance, has already announced that it will cease making its own television sets.

But the big color-TV producers are far from ready to call their \$2 billion-a-year business a has-been. For one thing, these companies have a wide technological base capable of concentrating considerable engineering talent on product development. For another, as international operators, they can juggle worldwide markets.

Until the oil shocks, TV producers had been gearing up for large-screen, high-priced receivers in the belief that the Japanese were ready for consoles as replacement models. Instead, consumers, hit by inflation and power cutbacks, held off replacement purchases. And those buying color receivers were more interested in small-screen economy models.

Design effort switched dramatically to conserving energy, materials, and labor. At the same time, as labor costs zoomed, producers were forced to intensify their automation investment, and receivers were designed to mesh with new automated assembly lines.

Matsushita Electric Industrial Co., for example, developed the new G4 chassis for 17-inch and 19-inch receivers. By the middle of next year, it will replace all previous chassis. Product of a 14- to 15-man team using computer-aided design, the G4 has five printed-circuit boards instead of 10; 31 lead wires instead of 68; 42 soldered points compared to 75; and 43 screws, rather than 78. The G4 weighs 1.6 kilograms less and consumes 10% less power than a conventional chassis. The savings in materials, plus automated assembly of the G4 should cut total cost by 20%.

Another change caused by the energy crisis has been a reversal of the race toward wide-angle deflection. Tokyo Shibaura Electric Co. (Toshiba), for example,

had tangled with Sony in a "4°-difference" match—when Sony came out with a 114° deflection tube, Toshiba announced a 15-inch receiver with 118° deflection. Toshiba has claimed that its 110° and 118° tubes consume less power than conventional 90° products.

This year, however, the company reversed direction by redesigning a 90° tube that takes advantage of the same technology—the simplified dynamic convergence, slotted mask, and in-line gun (SSI). Power for a 15-inch receiver was cut to 77 watts from the 95 W required for a conventional model.

Audio out-plays economy

Japan's major metropolitan centers, Tokyo and Osaka, have only two fm-radio-broadcasting stations each, compared to seven and six vhf television channels respectively. Stereo records in Japan cost from \$6.70 to \$9. A so-called "system stereo" installation sells from \$780 to \$525. High-end preamplifiers and power amplifiers range from \$700 to \$1,200.

In light of this and the state of the economy, the big increase in sales of hi-fi equipment in Japan this year is remarkable. According to the *Electronics* consensus, sales of all stereo equipment will be almost \$100 million higher this year than last, and will jump another \$116 million next year. Sales of audio-tape recorders and players, including car stereo players, although relatively flat this year, will increase by \$16 million in 1975.

In hi-fi components, Japanese manufacturers have found an apparently recession-proof product. As a result, mass marketers such as Sony, Matsushita, Sanyo, Toshiba, and Sharp, have joined the high-price/performance market formerly occupied by audio specialists Pioneer, Sansui, and Trio. In addition, highly re-

garded U.S. and British components makers are elbowing their way in.

The Japanese hi-fi market consists of three types of product: the sets, or separates (a cross between U.S. compacts and consoles) have about half of the hi-fi market, but have declined in popularity this year; individual components account for around 30% of sales and will almost double in value this year; and system stereo players have approximately 20% of sales.

System stereo players are matched individual components, sold as units. These matched packages are similar to configurations put together by some U.S. audio dealers, but the Japanese systems are made up of equipment from a single manufacturer. While individual components are most popular with the audiophiles, the system stereo combinations are aimed mainly at young marrieds, and sets, or separates, are designed for the older general public. In the next couple of years, system stereo will take over markets now held by sets, and at the same time many system owners will upgrade along the individual-components route.

Four-channel stereo has lost most of its momentum in Japan. Most separate stereo sets have built-in four-channel systems—regular matrix, SQ matrix, and CD-4 (discrete)—but there's been little interest in putting four-channel operation in the individual-components systems. Part of the problem has been the lack of compatibility among the three systems. Nippon Columbia has demonstrated yet another quadraphonic system, called UD4, that combines the matrix and discrete approaches in a single compatible system. Although Columbia was enthusiastic in proclaiming the end of four-channel confusion, other audio manufacturers have pronounced the UD4 system nice, but too late to do any good for the solidified domestic market. Other companies are content to wait and see how Nippon Columbia does.

Domestic radio sales have suffered an unaccustomed lapse. They are down this year about 15% in unit sales and 4% in value. Next year's domestic sales will be almost even with the 1974 level. The high-end, multiband model designed in a "military look" is still popular. A

few more-or-less novelty numbers have also hit the market. Among them Sony's new \$169 Skysenser Quartz model ICF-3000 which has a digital quartz clock based on a complementary-MOS chip and is powered by a 1.5-v battery. Matsushita has introduced the Marine One, a multiband radio that is waterproof and floats. Priced at \$61 in Japan, this model is intended to appeal to those who listen to the radio while relaxing in the deep Japanese tub.

The mini-size, shirt-pocket radio is back in Japan in a new high-price format. Boasting a high-sensitivity speaker and an improved small antenna, the R-155 a-m unit from Matsushita costs a little more than \$21. It measures 56 by 76 by 22 millimeters and weighs 175 grams. A new, smaller a-m/fm version is due out soon.

Hara-ki for calculator companies?

As in the U.S., the Japanese calculator industry is due for a shakeout. Even though total production will continue to increase, there may be only five companies integrated sufficiently to withstand steadily dropping prices, coupled with American competition, during the next three years.

Total domestic production of calculators for home and export sales this year should be about 14.63 million units, including 12.4 million consumer handhelds. Next year, the industry expects to produce 19.41 million units, but consumer types are projected to decline to 8.6 million units. The rising star for 1975, expected to reach 3 million units, will be the professional, dedicated machine. Tadashi Sasaki, corporate executive director and general manager of Sharp's Industrial Instruments group, predicts that both consumer and professional-type calculators will be the market mainstays.

He lists three alternatives for calculator makers. One, make technical innovations and cut costs to stay in the market; two, farm out production until the economy recovers; and three, drop the line completely. Sharp will introduce another technical innovation that will supersede the calculator-on-substrate developed last year.

Systek Corp., on the other hand, is banking on up-

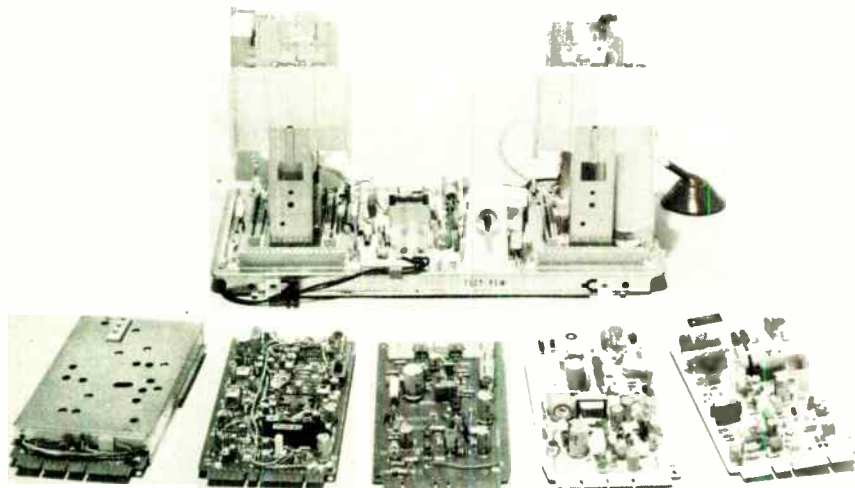

Savings in sight. Matsushita's new G4 chassis has five boards (left to right): video i-f amplifier; chroma circuit and video amp i-f; audio amplifier and supply-line regulator; horizontal oscillator and drive circuit, and vertical oscillator and drive circuit. Chassis costs about 20% less to produce than previous types.

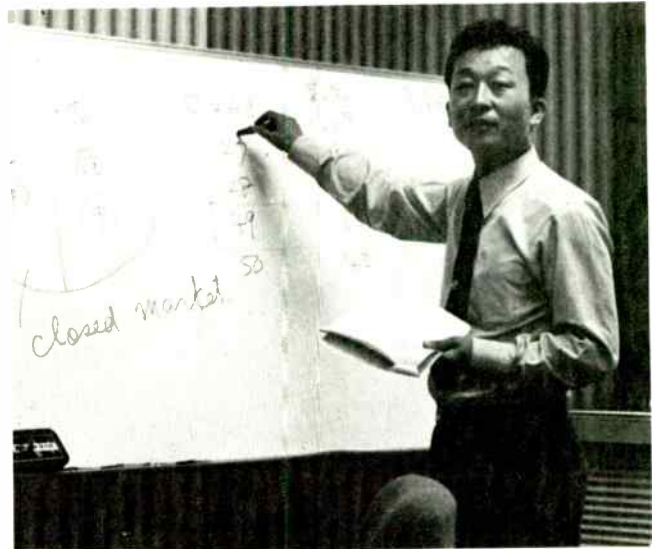
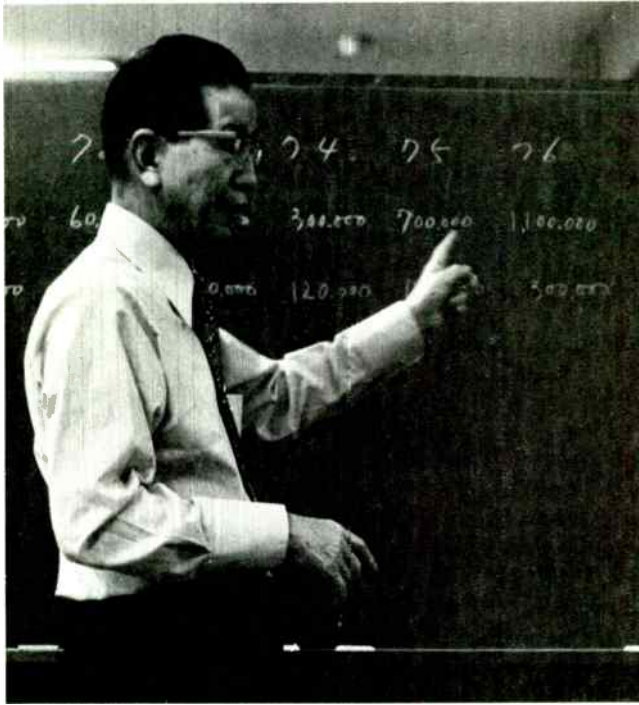

Yoizo Fujimoto, Sanyo's chief of domestic VTR sales (above), expects home market to pass the industrial/educational by next year.

Masao Matsumoto of Matsushita's video systems (left) gives VTRs a flunking grade in price, standards, and software.

grading its calculators to become virtually the equals of minicomputers. This fall, the company introduced a navigation calculator that enables private pilots to figure flight plans. It will sell for \$350 to \$390 in the United States. The company is also marketing a new programable calculator and a controller for typesetting machines, both of which are built around microprocessors.

Solid-state watches have just begun to emerge on the Japanese consumer market. Watch companies Citizen and Seiko have introduced models priced above \$330. The big consumer-electronics firms stayed out of the market until this month when Casio Computer Co. began sales of two liquid-crystal watches priced at \$197 and \$220. Sharp, in a joint effort with Orient Watch Co., recently announced a wristwatch with a liquid-crystal display that will go on sale next month for about \$160. This may herald the entry of firms other than watchmakers into the market.

Despite the economy, 1974 should be another growth year for microwave ovens in Japan. More than 1.5 million units will probably be sold this year and 1.6 to 1.8 million in 1975. Last year, the most popular seller was the 600-w model, but because of the energy crisis, preference has shifted to 500-w and 400-w models costing \$290 to \$325.

A small beginning for VTRs

If the Japanese video-tape industry were graded on a percentage scale, Masao Matsumoto, managing director of Matsushita's video equipment, would rate over-all performance at 58%. Considering five basic factors, he rates quality and performance at 80%, ease of operation for cassette and cartridge at 70%, interchangeability at 60%, price at 60%, and software at 20%. Matsumoto points out that before the video age can arrive in Japan, the last three categories, plus serviceability, must be

drastically improved for the home video systems.

At present, the selling prices of more than \$1,300 per player and \$3,400 to \$4,000 for camera/player combinations restrict the home VTR strictly to the wealthy. Yasumasa Noda, manager of VTR sales for Victor Co. of Japan Ltd., estimates that, of some 30 million households, only about 100,000 can afford VTRs at these prices. To reach the 1978-79 goal of placing VTRs in 10% of all households, or 3 million, a significant drop in prices will be needed, since consumer income is not expected to rise high enough to meet prices.

Domestic sales projections for this year are somewhat uncertain. Kunio Yarita, national sales manager for Akai Electric Co., estimates that in 1974, 12,000 portable VTRs will be sold, along with 30,000 to 40,000 cassette and cartridge players and 3,000 open-reel types.

Yoizo Fujimoto, chief of domestic video sales and planning for Sanyo Electric Co., figures that this year sales of VTRs will break down as 60% for industrial and educational use and 40% for homes. Next year, he expects the percentage of home sales to jump to 60%. He also predicts that the Japanese eventually will settle on one type of cassette and one cartridge, ending the conflict between 1/2-in. and 3/4-in. formats.

As for video disks, it's a waiting game in Japan. Disk developers Philips and RCA have demonstrated their systems this year, and Japanese companies are also working on their own designs. Behind the scenes, it's still a toss-up between optical-scan and mechanical-reading technologies and between foreign license and domestic development. Sanyo recently put off plans to market West Germany's Teldec TED system with the excuse the picture quality needed improvement. In happier times, when everyone's profits were high, the Japanese might have tried more than one approach, even by the same company. They may not be so bold in the years of the economic shocks. □

Scrambling for new markets

□ Japan's semiconductor industry started out 1974 in high style, but ended the third quarter with sales off badly and production being curtailed. Industry spokesmen insist that the sales drop in the second half does not indicate a decline in the use of integrated circuits, only a burning off of excess inventory fat. But observers differ on when to expect an upturn, putting it anywhere from the beginning to the middle of next year.

In fact, the only segment of the industry that seems likely to be off its feed next year is linear devices for television receivers. Other semiconductors, including discrete transistors, are basically sound, they say, the proof being that there has been no bloody price war on the Japanese market this year. Some older devices even jumped in price.

As for the IC market, Japan is going after MOS in a big way in the near future. Production has expanded among the Japanese producers as well as the 100% American-owned local manufacturer, Texas Instruments. In addition, two American-Japanese joint ventures, TDK-Fairchild Corp. and Alps-Motorola Corp., will soon have MOS-wafer facilities in operation.

Oddly enough, MOS sales did not rise as fast as the rest of the semiconductor market during the beginning of 1974. For one thing, Hitachi Ltd., which had the largest share of the calculator market, ran into yield problems when it switched from standard silicon-gate p-channel MOS to a MOS process that uses enhancement-type inverters and depletion-type loads. For another, several calculator manufacturers claim that TI was unable to deliver an eight-digit calculator chip because of production difficulties. (TI says only that orders outstripped capacity and many users had to wait.)

Now that the smoke has cleared somewhat, Hitachi and Nippon Electric Co. have the lion's share of the market in chips for sale to Japanese calculator manufacturers. Mitsubishi Electric Corp. says it is concentrating on more profitable devices, including custom chips for electronic cash registers. Tokyo Shibaura Electric Corp. (Toshiba) concedes that it is behind Hitachi and NEC in p-channel MOS for calculators, but it will continue to stress C-MOS.

Among those IC makers that supply their own calculator operations, however, Matsushita Electric Industrial Co. is easily the leader. Sharp Corp. at present makes a small number of its own devices, and Sanyo Electric Co. has given up making its own chips.

Toshiba is the only Japanese manufacturer to offer a line of RCA-type C-MOS logic to compete with TTL in peripherals and other equipment. Oki Electric Industry Co. makes similar circuits, but they are not completely interchangeable because the maximum voltage rating is lower. Joint ventures and U.S. importers are of course pushing the same C-MOS product lines that they sell in the United States.

Meanwhile, Mitsubishi Electric Corp. has been delivering seat-belt interlocks to Toyo Kogyo, but this busi-

ness may peter out after the U.S. change in seat-belt requirements since there is no domestic demand for interlocks. Electronic wristwatch circuits, however, should more than make up for this drop. Mitsubishi is supplying three C-MOS chips to Citizen Watch Co. Ltd., one analog and two digital.

The analog watch has a memory that tracks the second hand's motion and corrects errors in pulse-motor operation. This is necessary to maintain accuracy within 15 seconds a month. The memory also makes it possible to reset the second hand.

The digital watch has a liquid-crystal display that shows hours, minutes, seconds, day, and date. An unusual feature is an off switch for the LCD.

MITI makes mysterious move

There was another perturbation in the IC market this year. For a period of about two months during the spring, the Ministry of International Trade and Industry (MITI) clamped down on issuing import licenses for ICs with more than 200 elements by asking importers for documentation on the internal circuitry.

Most in the industry who were aware of this move feel that MITI's action was not for its stated purpose. It may have been an attempt at a last show of strength before the import of semiconductors is liberalized next year. Liberalization will end the Japanese government's restrictions on foreign semiconductor operations.

Another interpretation sees MITI's action as a kind of throttle on IC inventory stocking, which had reached panic proportions. Some years ago MITI clamped down in a similar manner when requests for import licenses for calculator chips were several times the total anticipated production of calculators in Japan for that year.

There is a third possibility. At about this time Japa-

Kazuaki Harada, deputy manager of MOS ICs for Mitsubishi, reports his company is supplying three C-MOS chips to Citizen Watch Co.

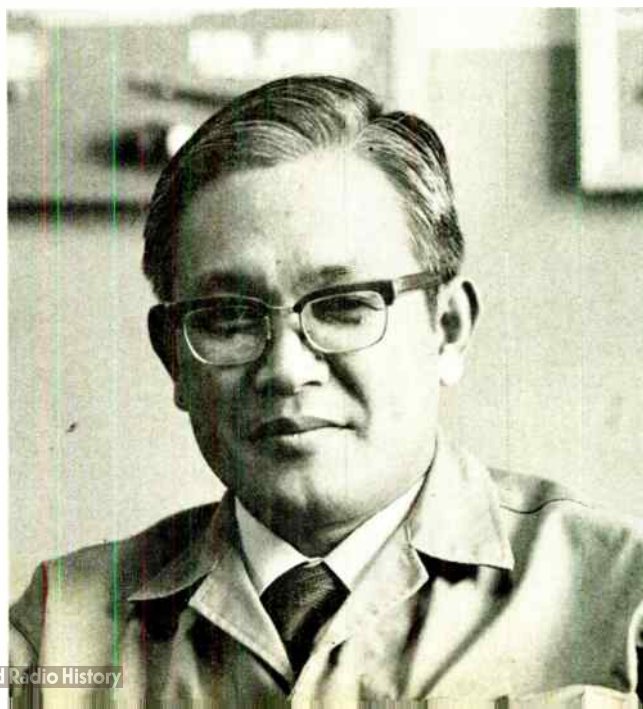



Akira Sonobe, manager of Toshiba's semiconductor sales, claims 200 kits of a 12-bit microprocessor are being sold each month.

Hiroe Osafune, vice president of NEC semiconductor operations, has high hopes for microprocessors in Japan, despite U.S. lead.



A.A. Procassini, marketing v.p. for TDK-Fairchild, right, says bipolar memories are selling well, including 256-bit TTL RAMs.

nese computer manufacturers were firming up their new lines, and MITI may have created uncertainty over the supply of foreign devices in an effort to encourage computer companies to buy Japanese.

Also, about this time MITI apparently prevailed upon the Japanese manufacturers to make standard families of high-speed logic and memories, including MECL-10,000 type emitter-coupled logic, for new high-speed computers. This was probably designed to reduce development time and ensure compatibility among their own and with imported products. The goal was to prevent unnecessary supply bottlenecks.

Still, ECL is far from predominant in bipolar ICs. Hiroe Osafune, vice president of Nippon Electric, estimates that only about 10% of NEC's bipolar production is ECL, another 10% is diode-transistor logic, and about 70% to 80% is transistor-transistor logic.

NEC is making a 1,024-bit n-channel dynamic MOS memory for a new computer line and has three types of n-channel 4,096-bit prototypes waiting in the wings. The wait may be over as NEC and Toshiba have announced new jointly developed computers in their ACOS series that will require 4-kilobit memories containing one transistor per bit. Toshiba, on the other hand, is mass-producing a device similar to the Intel 1103 and is developing its own 4-kilobit n-channel device, while Mitsubishi is developing 1- and 4-kilobit mainframe memories.

As for the American joint ventures, TDK-Fairchild says bipolar memories are selling well to computer manufacturers, including 256-bit TTL and 1-kilobit ECL types. The company is now pushing TTL RAMs.

Alps-Motorola is high on peripheral applications of transistor-resistor logic (which has a different circuit layout from RTL). According to Hal Pendergraft, marketing manager, TRL is replacing TTL in some sockets and will in turn be replaced by C-MOS or integrated injection logic (I²L). He figures TRL has a good two to five years of sales remaining on the Japanese market.

Toshiba and Nippon Electric are leading the way among Japanese manufacturers in the development of microprocessors. Toshiba claims sales of about 200 kits

a month of its 12-bit microprocessor at an average price of \$600. By the middle of next year, it expects volume to expand and average price per kit to halve.

Right now, Toshiba figures that Intel Corp. is the leading U.S. competitor in Japan, selling about 1,000 units a month. But by next fall, Toshiba promises to have a line of n-channel microprocessors both faster and smaller than the present Intel devices.

NEC also expects much from microprocessors. The company has a 4-bit unit that it uses inside chip bonders built for its own assembly plants. And it has an 8-bit unit that is software-compatible with Intel's 8080, though pinout is completely different. NEC is now developing a 16-bit microprocessor, scheduled to arrive on the market next year. Hitachi has a microprocessor CPU, but is not pushing in this market, and Mitsubishi will soon introduce an 8-bit device similar to the 8080.

Linears have ups and downs

Linear devices for consumer products have declined because of the slump in the economy. But there are pockets of prosperity in the automotive market and the steadily growing hi-fi market. A new Darlington transistor from Nippon Electric, for example, is used as a switch for a fuel-injection magnetic valve for cars. And, along with Sony Corp. and Yamaha, NEC has a line of vertical field-effect transistors for audio amplifiers, which it sells at a rate of 1,000 kits a month.

Toshiba has invested in refining linear ICs for consumer products, despite the decline, in the belief that introducing new products is the best way to increase its share of the market. Mitsubishi is also developing new bipolar linear circuits for consumer products such as video-tape recorders, low-cost video cameras, and photographic cameras. And, like many Japanese manufacturers these days, Hitachi is hurrying to automate in order to improve productivity of the highly competitive consumer-product circuits. According to Masao Adachi, deputy general manager of Hitachi's Electronic Devices group, automation should in the future halt or decrease the trend toward offshore assembly of semiconductor devices in low-cost labor areas. □

Liberalization will spur competition

□ Despite the shaky economy and the government's restrictions on capital investment, computer deliveries in Japan increased this year and may do the same in 1975. This has been attributed to orders placed during the recovery and boom of 1972 and 1973, yet current orders do not seem to be lagging to correspond with the 1974 downturn.

Computer users are upgrading, shifting to on-line systems and expanding central electronic data processing installations to branch operations, without regard for the no-growth GNP. Heavy industry has been the major dead spot, but it has been compensated for by customers from banks and hospitals and among distributors and retailers. Minicomputer sales have slowed, but continue to register satisfactory gains.

Still, the six Japanese computer manufacturers cannot feel completely happy, because the end of next year will mark the beginning of the domestic market's liberalization. The result of an agreement between the Japanese government and the United States, liberalization lifts the government-imposed restrictions on foreign computer operations—and in 1976 ends the direct subsidies given by the Ministry of International Trade and Industry (MITI) to domestic makers. It will undoubtedly be the shakiest period so far for the Japanese, since it threatens to unleash IBM on the market. For the period prior to complete liberalization, MITI agreed with the U.S. to maintain a 50-50 split between domestic ma-

chines and imports based on annual installed value.

The domestic manufacturers are not completely helpless. For one, they are beginning to enjoy the fruits of MITI's reorganization, a multibillion yen subsidy program which wedded Fujitsu Ltd. to Hitachi Ltd., Nippon Electric Co. to Toshiba, and Mitsubishi Electric Corp. to Oki Electric Industry Co. (see chart). The Mitsubishi-Oki offspring is a large-scale computer, called Cosmo Series, model 700, that will go up against the IBM 370/145.

Models 200, 300, and 400 in the NEC-Toshiba ACOS series 77 are equivalent to the IBM 370/115, 125, and 135 and are claimed to be faster. This computer is just like the Honeywell 200—unsurprisingly, since Honeywell has had licensing arrangements with both Japanese companies (see chart).

The Fujitsu-Hitachi group, which links the two largest Japanese makers, has yet to be heard from, but both promise announcements "in due time." In the meantime, the two have formed Facom-Hitac to deal with government and public offices and to negotiate joint orders. NEC-Toshiba has organized NTIS (Nippon-Toshiba Information System) as its marketing arm, while Mitsubishi-Oki has set plans for a customer service center.

Three of the domestic six, Fujitsu, Hitachi, and NEC, have also benefited from business with the telephone company, Nippon Telegraph and Telephone Public

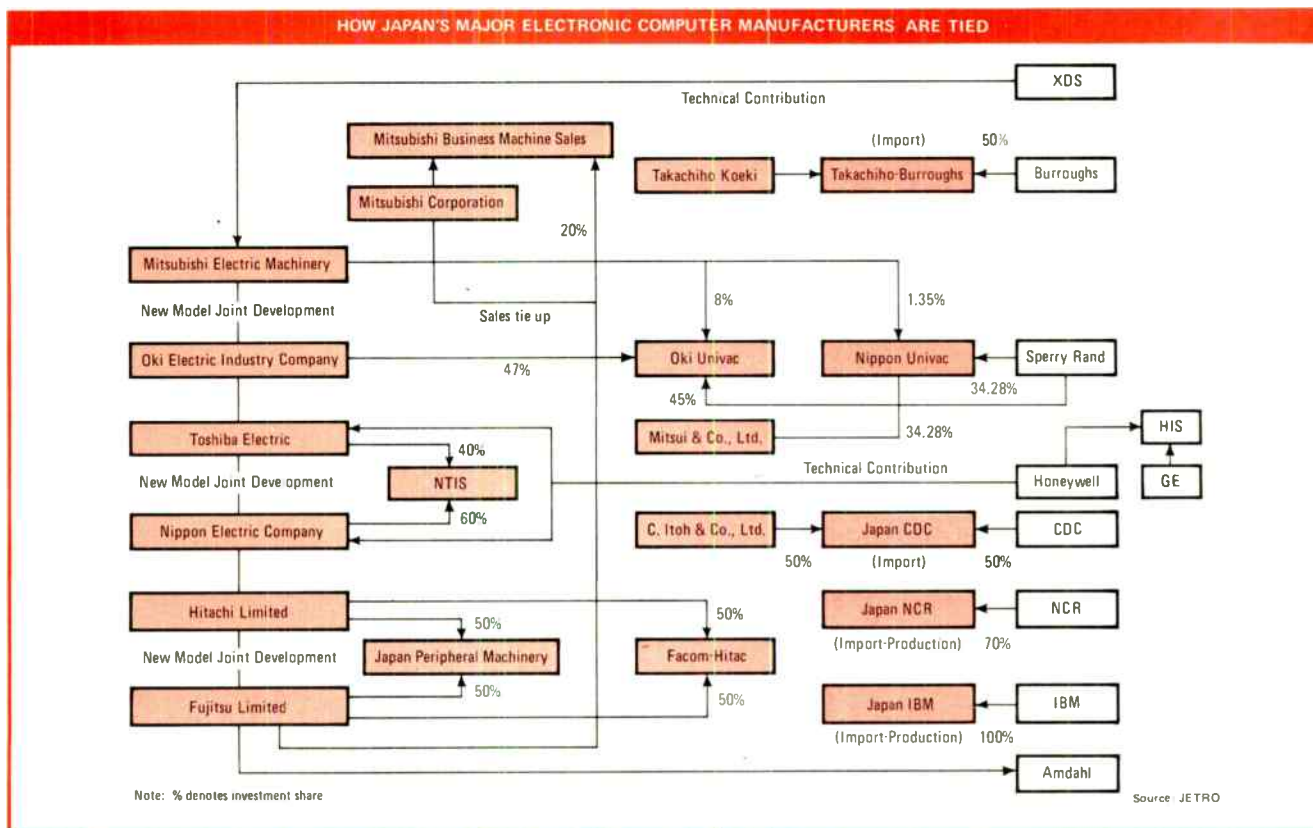

Corp. (NTT). Each is providing computers for NTT's information-processing system, called DIPS, which includes time-shared management and inventory-control systems linked by telephone lines. Now, the three are slated to deliver 30 units in the DIPS I program by 1976, though this schedule will probably be delayed by a tightening of NTT's capital budget.

Meanwhile, each is at work on the advanced DIPS II program. In August, 1975, Hitachi will deliver DIPS II model 10 to the NTT's Musashino Electrical Communication Laboratory. NEC is to complete model 20, with about one and a half times the capacity of the DIPS I, by December, 1975. In March 1976, Fujitsu will complete model 30, a unit with three times the capability of DIPS I. All these machines will go into service about a year after delivery to the NTT lab.

One problem with the DIPS program, according to Masasuke Morita, senior vice president and director for NEC, is that NTT expects the expensive R&D effort on DIPS II to proceed on schedule, yet is holding back orders for the profitable DIPS I. Thus, NEC has to continue investing in DIPS II, but has been hindered from delivering and collecting income from DIPS I.

For the long range, the Japanese Six have another source of confidence. The rapid change in Japan's economy is bound to make a leading export out of technology—knowledge-intensive products rather than labor-intensive goods—and information processing is one of the favored technologies. Consequently, Japanese computer manufacturers can expect to benefit from a national effort to establish international EDP goals, similar to previous commitments to textiles, automobiles, and consumer electronics.

Taiyu Kobayashi, executive director for Fujitsu, observes that overseas expansion by Japanese computer companies will have to be slower and more demanding than either the auto and consumer electronics bursts of the past. He adds that export effort will likely require joint ventures with foreign firms to ensure adequate software and maintenance. Fujitsu has negotiated with the governments in Brazil and in Spain, and the Canadian government has also expressed interest. The company has been active in Southeast Asia as well.

Hitachi is also surveying the international computer market, including the U.S. According to Kenichi Egami, section manager for marketing large-scale computers, financing an overseas effort will be as much a problem as meeting technological competition. For this reason, he believes exports to be a long-range goal, despite the industry's favored position.

Meanwhile, back home . . .

But before any grand design on the international market can be effective, the Japanese Six will have to survive on the domestic front. Coupled with impending liberalization are forebodings about IBM's next computer family, since it could threaten all the effort expended to catch up on the 370s. Thus, the question most often asked of inscrutable IBM these days is what will it do after liberalization. The company-blessed reply: essentially what it did before liberalization. An IBM spokesman states that to take over the Japanese market,



Hiroaki Yoshida of Nippon Mini-Computer explains that market's growth rate has reached maturity but will continue to increase.

the firm would have to invest heavily to increase capacity, a move IBM is not likely to undertake hastily. He insists that there is no strategy for "taking over."

Ironically, IBM eased the pressure on the domestic competition recently by announcing a price increase effective Jan. 1. Nippon Univac followed suit, boosting prices in February.

While the Japanese would like to increase their prices, too, they're in something of a bind. Since the domestic firms formed Japan Electronic Computer Co. (JECC) as a rental operation, there is no practical way to raise prices on machines sold to JECC. In addition, other customers, particularly the financial institutions, are not accustomed to getting price increases unless the product has been improved or there's a new line.

So to counteract increases in materials and labor costs, Japanese computer companies have begun to charge for services previously considered free. Even this move has had to be cautious because of the Japanese businessman's belief in *omake*—the custom of throwing extras in with high-value purchases, instead of discounting the selling price. In a sense, unbundling services is abandoning *omake*, and computer customers generally don't like it.

Minicomputers should log about a 16% increase in dollar value this year, according to the consensus of responses to the *Electronics* questionnaire. Minicomputer manufacturers expect another gain for next year of 26%, which is nowhere near the 50% to 60% annual growth

rate minis computers have enjoyed in the past.

One of the reasons for the declining growth rate, aside from the slowdown in automobile and machine-tool industries, is that the market has now matured past the early development stage, comments Hiroaki Yoshida, marketing director for Nippon Mini-Computer Corp. The Japanese market has reached the point where minicomputers will begin to pressure the medium-scale machines, much as in the U.S.

Cash dispensers, POS in the limelight

Although electronic equipment for funds transfer only represents \$2.3 million in 1974, this end of the computer peripheral business has attracted considerable competition. The two hottest items are electronic cash registers and cash dispensers located outside of banks. However, complete, on-line point-of-sale systems are expected to move quickly in the coming year as manufacturers devise programs that fit the special needs of the Japanese retail and distribution businesses.

Takachiko-Burroughs Corp., for instance, has taken a role in both banking terminals and POS systems. The company is even supplying some POS registers for General Instrument's Unitote/Regitel subsidiary in America. Takashi Hirahara, marketing manager for Takachiko-Burroughs, observes that the banking system in Japan is probably in a better position to initiate electronic funds transfer than the U.S. counterpart because Japanese consumers depend less on check-writing. Therefore the Japanese do not have to displace an entrenched paper-based system as the Americans will have to do. However, he adds that retail and credit-card systems are behind the U.S. in the ability to automate.

Concurring, Masaya Ito, director of Systems Services division for NCR Japan Ltd., which is No. 1 in electronic cash registers in Japan, explains that the benefit of the "cashless society" to the consumer, retailer, banker, and hardware supplier are all different. A common ground must be reached, he concludes, and it looks as if the bankers will be most interested in finding it. □

Communications

Stretching phone-company budget hurts

□ Japan's communications equipment market is just one more area of slack this year because of government-decreed anti-inflation curbs that call for a reduction in over-all economic demand. Nippon Telegraph and Telephone Public Corp. (NTT), by far Japan's biggest customer in communications equipment, has been compelled simply to buy less, even in the face of a growing demand for its services.

Yasuda Kitahara, NTT managing director and chief engineer, says restrictions imposed on NTT's budget this year have never been as tight. True, he says, NTT has been allowed a 5% increase in its budget, but the inflationary factor actually reduces that to an 8% decrease in real spending power. More to the point, the final tally of equipment procurement this fiscal year may be closer to four fifths of what it was last fiscal year, which ended March 31.

NTT has gone ahead with work on all its projects, Kitahara says, but at a slower pace. Nonetheless, NTT expects a budget deficit of about 100 billion yen (\$340 million) this fiscal year, for which it will need a supplemental budget approval from the Diet. About the only obvious bright spot for NTT is a decrease in the price of copper cables.

This is not to say that all is gloomy for suppliers of communications equipment. NTT's orders for electronic exchanges, for example, will increase. These exchanges, each roughly equivalent to a D-10 type, are supplied by NEC, Fujitsu, Hitachi, and Oki. NTT's budget currently allows for the purchase of 40 exchanges, a full 100% increase over last year. Furthermore, NTT hopes to buy 80 exchanges next year, and 120 the year after that. If funds become more restricted, however, NTT may have to accept delivery of only 30 exchanges this fiscal year, which ends March 31. The other 10 units would not be accepted until April, too late for inclusion in manufac-

turers' half-year sales reports, compounding the delay.

Despite the surging demand for electronic exchanges, sales of crossbar exchanges still display the larger figure. But it appears that last year was the peak year for crossbar. This year's orders will be 20% lower. Meanwhile, manufacturers have begun to phase out step-by-step switching equipment. Nevertheless, Takeo Kurokawa, executive vice president of Nippon Electric, maintains that large-scale changeover to electronic PABX equipment is still at least two years away. To buttress the point, he cites the higher cost of electronic exchanges.

In another product area, cable electronics technology



Yasuda Kitahara, senior managing director for NTT, says spending clamp will force delay of communications purchases.

has shown signs of life. In digital cables connecting analog systems, 50,000 to 60,000 24-channel pulse-code-modulated systems are added each year. This year, commercial tests began on a 100-megabit system for coaxial cable with a capacity equivalent to 1,440 telephone channels. Next year there will be lab testing of a 400-megabit system. In the analog end, 60-megahertz coaxial cable is being installed between Tokyo-Nagoya-Osaka-Kobe. This is a retrofit of a 12-MHz cable, which at the present time covers most of the country.

Moreover, 36-MHz submarine cables with 2,700 channels will also be installed, starting with a 30 kilometer line between Honshu and Hokkaido this year. Other links will be made between Okinawa and outlying islands Miyako Jima and Ishigaki Jima. And in 1976, a 300-km line will join Kyushu and Okinawa.

Upgrading the wireless

Perhaps the most important wireless system, technically speaking, is a 20-gigahertz-band digital system operating at 400 megabits per second that will be put into the Tokyo-Nagoya-Osaka-Kobe route starting next year. Also set for next year is upgrading of 6-GHz systems between Tokyo and Osaka from 1,800 channels per carrier to 2,700 channels per carrier. In addition, systems with 2,700 channels per carrier and operating at 11 and 15 GHz are going into short-haul routes around major cities. In a unique application of this type of system, NTT is putting a microwave repeater high atop a new office building in Shinjuku, which commands a clear shot at about 70 of Tokyo's 100 telephone exchanges. This system will be able to substitute for telephone cables lost during earthquakes, storms, or other emergencies.

Fax starts rolling

After a disappointing start in August 1973, NTT's subscriber facsimile service is finally starting to move, especially for Matsushita Graphic Communication Systems Inc. and NEC, suppliers of the telephone company's ter-

minals. Takeo Kurokawa of NEC says that NTT set its service rates so low that suppliers of facsimile units are not able to keep up with the demand. NTT's rate policy has served to make the NTT-ordered equipment so widespread that other makes sold to individual consumers will have to be compatible with NTT specifications.

Yuichi Makino, director of Toshiba, reports that although his company has developed a prototype of a 48-kHz high-speed fax for NTT, the mainstay of the business is the slow, four-to-six-minutes-a-sheet unit. Makino expects that sales of Toshiba's Copix are going to increase 20% to 30% next year. Copix features a non-pressurized ink jet in which the ink is pulled from the nozzle by electrostatic force. This approach allows use of inexpensive uncoated paper.

Toshiba, Fujitsu, Matsushita, and NEC all have digital facsimile systems capable of transmitting a standard printed page in one minute. But these products cost four to five times more than the slow systems, so sales are still relatively low.

Hold the videophone

Video telephones are still on the starting line in Japan. NTT's only plan for the immediate future is to offer conference service from special video equipped rooms at hotels in Tokyo and Osaka. Kanji Yamamoto, communications section director of Fujitsu, says future demand will depend on price/performance tradeoffs. Some customers may be willing to pay several times more than standard telephone service to get a video telephone, but he feels consumer use is limited.

Holding a more pessimistic view, Kurokawa of NEC asserts that video telephones are out of the question for individual subscribers and may not even be low enough in cost to attract corporate users. The solution might be to conserve bandwidth by transmitting only information relating to a change in a still picture. This method would be satisfactory for most uses, but would of course become unacceptable when everything in the picture frame changed simultaneously. □

Industrial electronics

Manufacturers want to expand plants

□ Industrial electronics this year was a mixed bag, but weighted on the down side. Some companies reported that billings were up, even though the quantity of goods shipped was at best the same or smaller than a year ago. But the dollar value fell by 4% to \$923.1 million, according to *Electronics'* survey.

Next year looks brighter. The need to build and replace equipment in such sectors as petrochemicals, steel, and pollution control is expected to increase demand for electronics. Moreover, the threat of imports should keep prices stable through next May and perhaps through the end of 1975, despite wage increases, predicts Masahiro Shimizu, president of Hokushin Electric Corp., so that sales figures during the coming year should be more substantial.

One person who is optimistic about the petrochemical

prospects is Morio Ono, manager of the marketing development section of Yokogawa Electric Works Ltd. He says there are plans to build four 400,000-ton-per-year ethylene plants by 1977, and he figures that, together with downstream facilities, a single ethylene plant generates capital investment of 300 billion yen (\$1 billion), of which up to 10%, or \$100 million, is for controls and instrumentation. Yokogawa claims a 50% market share in the petrochemical industry, even though its share of total process-control instrumentation is 40%.

The domestic steel market is soft, but the high export price has encouraged plans for four new integrated mills during the next three years. Instruments for a blast furnace run about 1.2 to 1.3 billion yen (\$4 million), while the remainder of the mill requires up to 10 billion yen (\$34 million) in instrumentation.

As for the pollution-control business, it represents a larger and larger percentage of instrument companies' sales. At Hokushin, for example, pollution-related equipment now accounts for 20% of sales, compared to 7% of smaller sales three years ago. This percentage should increase as the Tokyo metropolitan government sets up new limits for total discharge of harmful chemicals, expressed as product of effluent volume and concentration. The change will require more instrumentation in plants than previous regulations.

All instrumentation firms complain that analyzers are a bottleneck in pollution control. Analyzers have been difficult to install in on-line systems because traditionally they have been test instruments rather than control instruments and often fail when in constant use.

And when construction of large buildings, which has slowed down, picks up again, Goro Kako, vice president of Yamatake Honeywell Co. Ltd. predicts that much more instrumentation will be going into new buildings. Central control of air conditioning, smoke and fire alarms, security, and elevator controls will increase demand for computerized systems.

Industrial electronics companies are all investigating the application of microprocessors, although no control products have appeared yet. Such systems should make their debut next year, predict both Kako of Yamatake and Ono of Yokogawa—possibly at the Electric and Electronic Measuring Instrument-Automation Exhibition in mid-November, and probably in the guise of miscellaneous controllers that include calculator functions, especially logarithms. Isao Asai, engineering division coordinator at Hokushin, adds that the microprocessor may be a blessing in pollution control for processing analyzer output.

Test equipment registers flat response

It has not been a happy year for test-equipment manufacturers either, since there has been no growth in the electronics, automobile, textile, or construction industries. However, the Japanese manufacturers point out that rising labor costs are increasing the attractions of automation—and could therefore boost sales of automatic test systems. Meanwhile, automated-systems companies have had to wait out the economic ills and the government's limitation of demand.

The most notable exceptions are small low-cost dig-

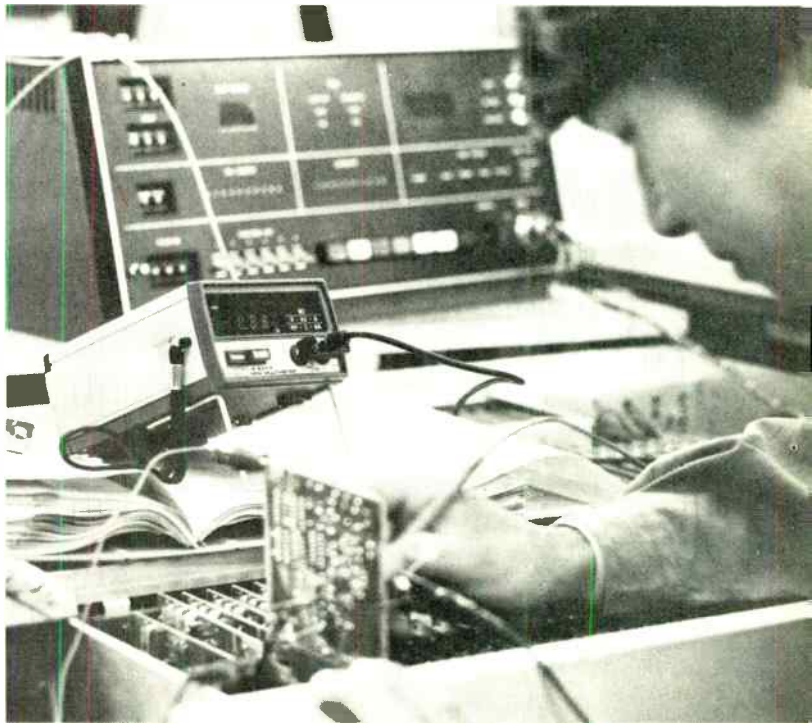

Bright spot. Selling well on the industrial market are low-cost portable instruments, like this Takeda Riken digital minimultimeter.

ital multimeters like those introduced by Iwatsu Electric Co. in the summer and Takeda Riken Industry Co. just recently. Both instruments have low-cost plastic cases. Kozo Uchida, chief engineer for Iwatsu's Electronic Instrument division, says his company is selling about 300 of its new multimeters a month. Tsukasa Yoshizumi, product manager for Takeda, expects sales of 6,000 of his unit in 1974—2,000 in Japan and 4,000 for exports.

Small oscilloscopes, like the plastic-encased multimeters have been selling because of low price and portability. The smallest is the model made by Matsushita Communication Industrial Co. and using a tiny cathode-ray tube supplied by Matsushita Electronics Corp.

At the upper price range, scopes with digital presentation of bit patterns are starting to pick up, reports manufacturer Yokogawa-Hewlett-Packard. Other YHP products holding their own are spectrum analyzers, sweep generators, and frequency synthesizers. □

Space electronics

Japanese-U. S. teams build satellites

□ Even though the government has tried to curtail national spending, investment in space continues to climb. Yasuhiro Kuroda, director of the systems planning department of the National Space Development Agency (Nasda), reports that the budget for this year is a huge 46 billion yen (\$155.9 million)—about one and a half times last year's figure. This amounts to about 79% of Japan's space budget. The remainder goes to the University of Tokyo, the Ministry of Posts and Telecommunications, and the Transportation Ministry.

Some of this budget will filter through to U.S. manufacturers. Three large geostationary satellites that have been ordered through Japanese manufacturers will be fabricated by American partners and launched by NASA with a Thor-Delta 2914 rocket. This move became necessary when requirements for satellites evolved earlier than initially planned, and Japanese manufacturers were not experienced enough to meet them. Moreover, missions of these satellites require weights of 300 to 350 kilograms, which exceed the capabilities of Japanese



Yasuhiro Kuroda of Nasda systems planning expects some Japanese space funds to sift through to U.S. aerospace companies.

launch vehicles designed for lighter payloads.

The team of Nippon Electric Co. and Hughes Aircraft Co. won the contract for GMS, a 350-kg geostationary meteorological satellite scheduled for launch early in 1977. This vehicle in Japan's entry in a global atmospheric research program that also includes satellites launched by the United States, the European Research Organization, and the Soviet Union.

The team of Mitsubishi Electric Corp. and Philco-Ford Corp. received the contract for CS, a 340-kg medium-capacity experimental communications satellite, to be launched early in 1977. CS objectives include ex-

periments in communications at frequencies just below the millimeter-wave region, establishment of techniques for satellite control and system operation, and experiments in communications with outlying islands.

The team of Toshiba and General Electric Co. is building the BS, a 330-kg medium-scale experimental broadcasting satellite, also scheduled for launch in early 1977. This satellite will have television transponders with power outputs of 100 watts per channel using the NTSC-type of TV signal, frequency-modulated with 25-megahertz deviation. Up frequencies will be in the 14-GHz region and down frequencies, 12 GHz.

Plans have been made to launch four types of satellites with the N rocket. Japan's first practical satellite, Engineering Test Satellite I (ETS-I), an 85-kg bird, is being manufactured by NEC. It will be launched during August or September 1975 into an elliptical orbit.

At the beginning of 1976, the 135-kg Ionosphere Sounding Satellite (ISS), made by Mitsubishi Electric Corp., will be launched into an elliptical orbit 1,000 kilometers high to make communications measurements of the ionosphere. Early in 1977, the 130-kg Engineering Test Satellite II (ETS II), made by Mitsubishi, will be launched into stationary orbit. The 130-kg Experimental Communications Satellite (ECS), will be launched into stationary orbit in 1978. The manufacturer has not been chosen yet, but the objectives include tracking and millimeter-wave communications. □

Defense electronics

Military is losing war with inflation

□ The Japanese Defense Agency (JDA) is getting less yield for its yen because of inflation. This year's budget, though about 15% larger than last year's, will buy less hardware. For next year's budget, the JDA will ask for an increase of 25%, the maximum the Finance Ministry will even consider under the country's present total demand limitation policy. This request may be cut in the final budget. There will be no major changes until the current five-year plan runs out in 1976.

Evidence for the tightness of funds is the fact that obsolete receiving and small transmitting tubes are being ordered for older equipment a year at a time. Last year, for the umpteenth time, tube suppliers asked the JDA to buy all the spares needed to maintain equipment for its estimated life. But as before, the JDA had funds enough to buy only the upcoming year's requirements. This time, though, the companies have proceeded at their own expense to stockpile tubes needed for the future and to shut down the lines.

Budgetary limitations this year curtailed production of planes, tanks, and ships—and with them the electronics equipment they would have used. Other communications equipment fared better, however.

One new item in this year's budget is an over-the-horizon communications system that will operate in the 1.6–1.9-gigahertz band between the southern-most main Japanese island of Kyushu and Okinawa. Appropriation for this year is 1.5 billion yen (\$5.1 million) for

the basic system of 48 telephone channels, with additional 0.2 billion yen (\$678,000) next year for another 48 channels. Though the manufacturer has not been chosen, it will probably be NEC, the only company with experience in this type of equipment.

Again this year, JDA purchased one unit of Mitsubishi Electric Corp.'s fixed three-dimensional radar, making a total of five. Three more systems during the next three years should complete the program. One somewhat less expensive portable system was bought from Nippon Electric, and another system might be bought next year.

Microwave communications did not do as well. The JDA owns some sections of its own network but rents about 70% from the Nippon Telegraph and Telephone Public Corp., owning only the terminals of these sections. Although the agency finds operating its own communications network much less expensive, it may take another 10 years to complete the system since appropriations for it are limited.

This March, Toshiba delivered a 1.2 billion yen (\$4.1 million) field computer for command operations to the Ground Self Defense Force. It is undergoing technical testing now and will undergo field testing next year. In actual use, two will be required—one for division headquarters and one for artillery. Since no other unit is scheduled for next year, testing will be carried out by changing memory contents. Operational units will probably contain more advanced hardware. □

ELECTRONICS MARKETS 1973 — 1975

	1973	1974	1975
PASSIVE AND ELECTROMECHANICAL			
Capacitors, fixed	436.8	401.3	455.5
Capacitors, variable	63.9	37.0	54.0
Connectors, plugs, and sockets	85.6	95.8	105.8
Loudspeakers (OEM type)	141.5	151.4	189.3
Microphones (OEM type)	38.0	39.0	46.8
Potentiometers, composition	128.5	121.4	131.9
Potentiometers, wirewound	20.6	16.2	18.7
Power supplies (OEM type)	54.4	52.3	65.4
Printed-circuit boards	161.2	169.5	203.4
Quartz crystals (includes mounts and ovens)	19.0	19.2	23.7
Readout devices (gas discharge, LCDs, etc.)	26.6	33.9	67.8
Relays (for communications and electronics)	121.7	119.3	123.6
Resistors, fixed (includes wirewound)	203.6	159.0	175.4
Servos, synchros, and resolvers	15.2	10.2	11.9
Switches (for communications and electronics)	95.1	130.5	128.2
Transformers, chokes, and coils	531.0	512.5	543.3
Transducers	9.1	12.2	16.3
Total	2,151.9	2,080.7	2,361.0
SEMICONDUCTORS, DISCRETE			
Microwave diodes, all types (above 1 GHz)	9.0	8.2	7.7
Rectifiers (includes diodes rated more than 100 mA)	158.6	141.2	146.8
Signal diodes (rated less than 100 mA, includes arrays)	94.9	85.8	94.2
Thyristors (SCRs, four-layer diodes, etc.)	38.2	32.9	38.7
Transistors, power (more than 1-W dissipation)	125.2	117.0	134.6
Transistors, small-signal (includes FETs and diodes)	246.9	222.4	210.6
Tuner varactor diodes	12.9	12.3	15.1
Zener diodes	13.9	12.3	16.0
Total	699.6	632.1	663.7
SEMICONDUCTORS, INTEGRATED CIRCUITS			
Hybrid ICs, all types	57.5	56.7	66.7
Linear ICs (except op amps)	35.4	85.4	99.4
Linear ICs, op amps (monolithic only)	7.7	8.3	10.1
Logic circuits, bipolar	111.8	119.7	120.1
Logic circuits, MOS and C-MOS	124.2	104.9	157.6
Memory circuits, bipolar	6.0	7.5	9.9
Memory circuits, MOS and C-MOS (except microprocessors)	14.0	17.6	22.6
Calculator chip sets	130.1	98.3	104.7
Microprocessor chip sets	1.0	11.0	27.6
Watch and clock chip sets	2.0	4.1	7.7
Total	539.7	514.0	626.4
SEMICONDUCTORS, OPTOELECTRONIC			
Total	22.4	18.6	19.8
TUBES			
Cathode-ray tubes (except for TV)	3.9	3.3	3.6
Cooker magnetrons	18.5	23.2	20.2
Power tubes (to 1 GHz)	38.0	35.6	40.9
Power tubes (above 1 GHz, except cooker magnetrons)	60.8	56.9	65.5
Receiving tubes	32.6	22.2	15.2
TV picture tubes, black and white	42.9	35.1	33.5
TV picture tubes, color	496.2	383.2	421.5
Total	692.9	559.5	601.4
TOTAL COMPONENTS CONSUMPTION	4,106.5	3,809.4	4,272.3

(Domestic consumption in millions of dollars)

Note: Dollar amounts based on conversion rate of \$1 = 263 yen for 1973 and \$1 = 295 yen for 1974 and 1975.

EQUIPMENT

	1973	1974	1975
CONSUMER			
Audio tape recorders and players (includes car stereo)	580.4	582.6	598.6
Citizen-band transceivers	8.0	7.3	8.3
Electronic ranges	184.8	227.6	304.0
Hi-fi component equipment	207.8	301.8	417.7
Musical instruments (organs, electric guitars, etc.)	74.1	84.7	100.0
Phonographs and phonoradio combinations	477.7	397.6	461.7
Radios (includes car radios)	192.4	184.8	183.4
Video tape recorders and players	37.6	56.9	134.9
TV sets, black-and-white	121.2	80.0	68.9
TV sets, color	2,323.1	1,832.6	1,943.6
Watches and clocks, electronic	66.5	84.7	127.1
Total	4,273.6	3,840.6	4,348.2
MEDICAL			
Diagnostic equipment (except X-ray)	190.1	186.4	213.6
Patient-monitoring equipment	7.6	8.1	9.4
Prosthetic equipment (hearing aids, pacemakers, etc.)	22.8	22.3	25.7
Therapeutic equipment (except X-ray)	6.7	6.7	8.1
X-ray equipment, diagnostic and therapeutic	106.5	104.2	114.4
Total	333.7	327.7	371.2
AUTOMOTIVE			
Alternator diode assemblies	25.2	21.0	22.3
Fuel-injection controls	2.5	2.1	7.5
Ignition controls	1.5	1.4	5.9
Seat-belt interlocks	4.4	11.4	11.4
Speedometers and tachometers	21.0	16.3	18.3
Voltage regulators	0.1	0.1	0.1
Windshield-wiper controls	0.5	0.4	0.5
Total	55.2	52.7	66.0
COMMUNICATIONS			
Broadcast equipment (for radio and TV, but not CATV)	73.6	70.3	69.8
CATV (studio and distribution)	26.6	30.2	36.8
Intercoms and intercom systems	24.3	24.7	27.1
Microwave relay systems	104.4	90.7	101.7
Navigation aids (except radar)	113.7	94.2	94.9
Radar (airborne, ground, and marine)	80.6	79.7	90.7
Radio communications (except broadcast)	364.8	277.6	331.4
Telephone switching, private (PABX, includes semielectronic)	10.5	7.5	11.2
Telephone switching, public (includes semielectronic)	72.9	111.9	169.5
Video recorders and playback equipment (nonconsumer)	44.7	42.4	44.9
Wire message equipment	216.9	233.8	250.3
Wire carrier equipment (includes FDM and PCM)	264.3	232.2	266.1
Total	1,397.3	1,295.2	1,494.4
COMPUTERS			
Analog and hybrid computers (except process control)	9.7	10.8	13.3
Data-processing systems (except minicomputer)	1,230.1	1,311.9	1,635.7
Data-processing systems, minicomputer	908.7	1,052.5	1,328.8
Add-on memories	100.0	101.7	129.3
Data-entry equipment	175.2	170.0	223.9
Data-output equipment	68.6	44.9	56.6
Data-storage devices	485.8	794.9	1,024.1
Data terminals	139.4	155.6	202.0
Electronic calculators, desk type (includes programables)	73.0	47.1	64.6
Electronic calculators, portable	138.3	147.9	190.1
Point-of-sale equipment	0.6	2.3	10.4
Total	3,329.4	3,839.6	4,878.8
INDUSTRIAL			
Machine-tool controls	60.8	50.8	67.8
Motor-speed controls	143.7	102.5	139.2
Pollution-monitoring equipment	20.0	19.3	36.4
Power electronics equipment	201.5	205.4	240.7
Process controls and related equipment	462.5	472.9	561.0
Ultrasonic cleaning and inspection equipment	73.0	72.2	84.5
Total	961.5	923.1	1,129.6
TEST AND MEASUREMENT			
Amplifiers, laboratory type	16.0	16.9	22.6
Calibrators and standards, active and passive	12.6	10.5	12.7
Components testers (capacitor, IC, transistor, tube, etc.)	17.1	13.7	15.8
Counters and timers	10.8	8.4	9.6
Lasers, all types	3.3	3.9	5.1
Meters, analog (except panel types)	7.3	7.6	8.0
Meters, digital (except panel types)	8.9	9.0	11.8
Meters, analog panel types	24.2	24.3	27.3
Meters, digital panel types	5.8	6.2	8.0
Microwave test and measuring instruments (above 1 GHz)	14.0	11.5	11.5
Oscillators	6.8	7.5	8.1
Oscilloscopes and accessories	27.4	27.7	36.0
Power supplies, laboratory type	34.5	28.0	17.8
Recorders, analog and digital	10.6	11.3	38.6
Signal generators, analog (to 1 GHz)	5.7	9.2	10.3
Total	205.0	195.7	243.2
TOTAL EQUIPMENT CONSUMPTION	10,556.7	10,474.6	12,531.4
	(Domestic consumption in millions of dollars)		

Note: Dollar amounts based on conversion rate of \$1 = 263 yen for 1973 and \$1 = 295 yen for 1974 and 1975.

For the price of a good adding machine, now you can have the silent electronic printing calculator with the big plus...

The Sharp Edge.



Until now, a lot of people have been forced into buying mechanical adding machines when what they really needed was a quality electronic printing calculator.

The small businessman, the accountant, the guy who keeps an office in his home — guys like yourself, most of them — all sharing a common problem... trying to run a business on a budget that simply doesn't accommodate adequate office hardware.

Well, now you've got it. The new Sharp CS-1151 — the latest development of Sharp Qualitronics... built with the same measure of quality and dependability that goes into our largest programmable costing thousands. And yet the CS-1151 comes in at a price that the small businessman can easily afford.



Electronics/November 28, 1974

Features? The new CS-1151 will probably surprise you. Who'd expect, for instance, an electronic printing calculator at this price to have a memory register? Or a percent key? Clear, easy-to-read printing, maybe... but in two colors? It's even got a 10-digit capacity, Add Mode, a raised plus bar and Total/Grand Total capability.

But that's only the beginning. The CS-1151 has features you'd expect to find only on the higher-priced machines... or on Sharp. Features as rugged as Sharp's heavy-duty casing... or as pleasant as the complete silence of the CS-1151 between operations.

All in all, we're justifiably proud of our new CS-1151. It's worthy of the name it carries... Sharp.

Incidentally, in case you're not familiar with just who we are, we're the people who gave America its very first electronic calculator. In fact, we've got more "firsts" to our credit than anyone in the business. And you'll find that same kind of innovative thinking in every corner of our CS-1151. The kind that can make the difference for you between just buying a calculator... and giving yourself the Sharp Edge.

To find your nearest Sharp dealer, call toll-free (800) 447-4700. In Illinois, (800) 322-4400.

SHARP® Electronics, Dept. EL-74-01
10 Keystone Place, Paramus, New Jersey 07652

Please send information on: CS-1151 Printers
 Display Models Programmables Full line.

Name _____

Company _____

Street _____

City _____

State _____ Zip _____

SHARP The Qualitronics Company.

Circle 107 on reader service card 107

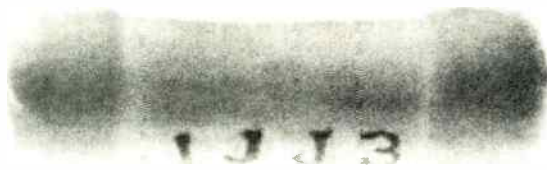
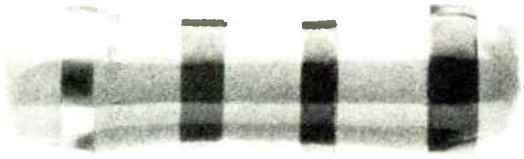
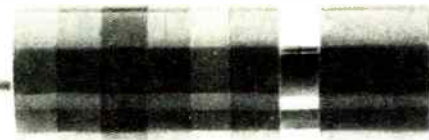

Get all four basic types of fixed resistors from Panasonic.

1. Hot molded carbon composition fixed resistors from Panasonic have an extremely high degree of resistance value stability. They are all uniform so you can design with dependability. Solidly built with superb appearance, Panasonic hot molded carbon composition resists cracking, gives you reliable performance. They are extremely small and light to give you design flexibility. Especially in digital circuitry where good pulse characteristics are necessary.

2. Carbon film resistors have proven stability. The carbon film is formed on the surface of high-grade ceramic cores. These resistors are all grooved and painted according to value. They have long product life and low noise level. Their superior coating provides excellent insulation and protection from humidity.

3. Precision type metal film resistors have a very wide range of operating temperatures. From -55°C to $+150^{\circ}\text{C}$. Panasonic's precision type metal film resistors operate within reliable resistance tolerances, from $\pm 1.0\%$ to $\pm 5.0\%$. Panasonic's newly developed epoxy resin coating gives them excellent resistance to humidity.

4. Flame-proof metal oxide film resistors are made with superior metal oxide film. This film is formed on heat proof, non-alkaline ceramic materials to provide flame-proof insulation. These Panasonic resistors deliver high frequency performance with little current noise. Very stable, they have a maximum operating temperature of 70°C .

All are readily available. All at a reasonable price. All made with the kind of quality that delivers high performance. It's what you expect from Panasonic. For more information on Panasonic fixed resistors, fill out this coupon.

Matsushita Electric Corp. of America,
Industrial Division, 200 Park Avenue, N.Y., N.Y. 10017

E3

Attn: Roger White

Please send fixed resistor literature.

Please have representative call.

Name _____

Title _____

Company _____

Address _____

City _____ State _____ Zip _____

Panasonic Electronic Components

our technology is all around you

Circle 110 on reader service card

World Radio History

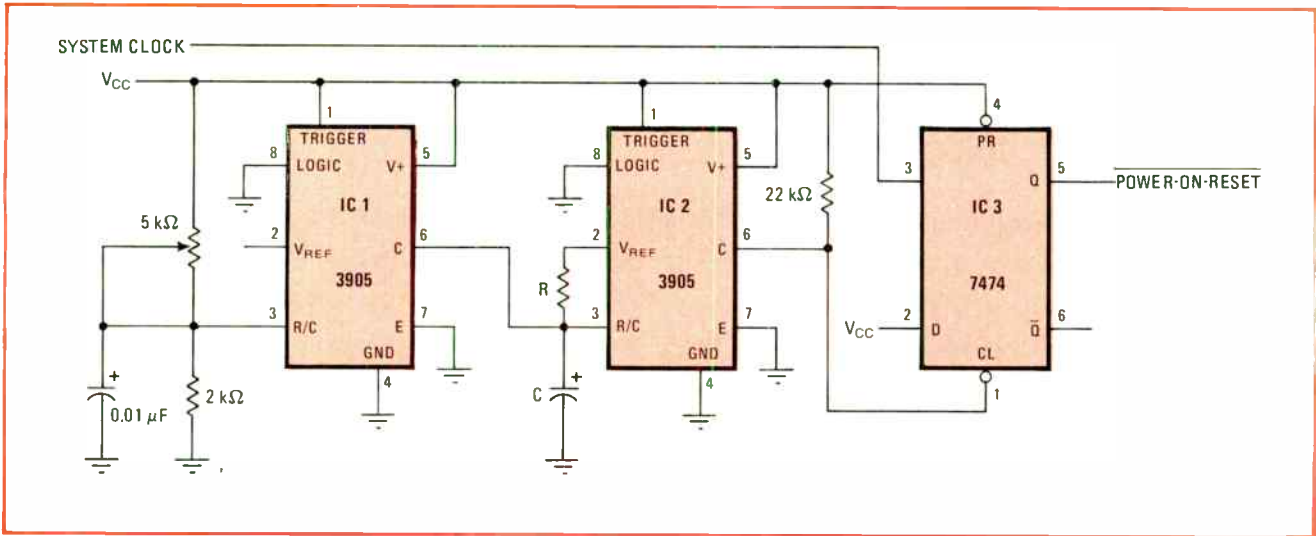

1. Reset generator. One comparator, one timer and a flip-flop join forces to produce a precisely timed power-on reset.

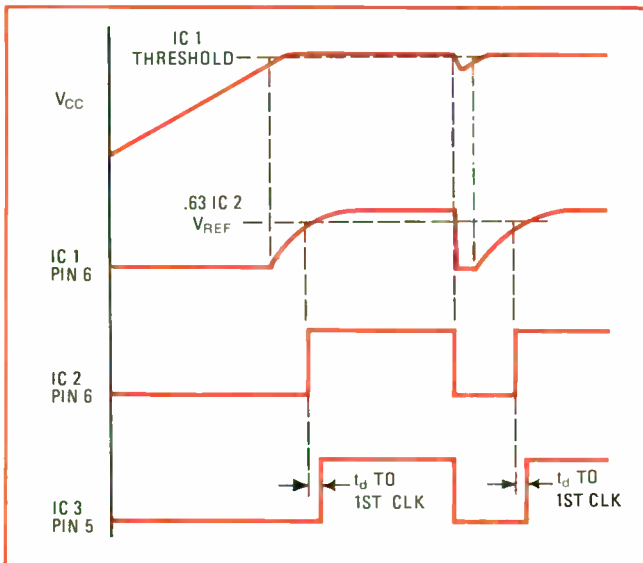

2. Sequence. When V_{cc} reaches a threshold defined by the setting of the 5-kilohm potentiometer, IC 1 turns on. Its rise is delayed by the RC network on IC 2. After one time constant, the clear input to IC 3 is released, and the flip-flop is set by the next clock pulse.

4.75 V; its triggering level is established by setting V_{cc} at 4.75 and adjusting the 5-kilohm potentiometer at the point where the circuit's output (pin 5 of IC 3) just switches. Thereafter, when power is turned on and V_{cc} rises above this 4.75-v threshold (Fig. 2), IC 2, a 3905 used as a timer, is released. One time constant later, as determined by the RC network connected to pins 2 and 3 of IC 2, an ordinary 7474 D-type flip-flop, IC 3, is released. By this time the system clock should be running smoothly; at the next positive-going clock pulse the flip-flop is set, thus removing the power-on reset.

If the level of V_{cc} drops below 4.75 v at any time, both timers and the flip-flop immediately go down, generating another reset to the rest of the system. Restoration of V_{cc} initiates the power-on sequence again.

If less precise reset timing is necessary, IC 2 may be omitted. The output of IC 1 then rises as soon as the threshold has been passed, and the flip-flop is set by the next clock pulse. If several power supplies have to reach their nominal levels before the reset terminates, a separate 3095 as comparator can be connected to each supply and all the outputs (pin 6) connected to each other as a wired OR. □

Generator's duty cycle stays constant under load

by Arthur R. Klinger
School of Health Care Sciences, Sheppard AFB, Wichita Falls, Texas

In the 555 timer, configured as a square-wave generator, adding one transistor and a diode to the RC timing network permits the frequency to be varied over a wide range while maintaining a constant 50% duty cycle [see also *Electronics*, Sept. 19, p. 112].

In one simple configuration, a capacitor's charge and discharge currents flow through only one resistor. The

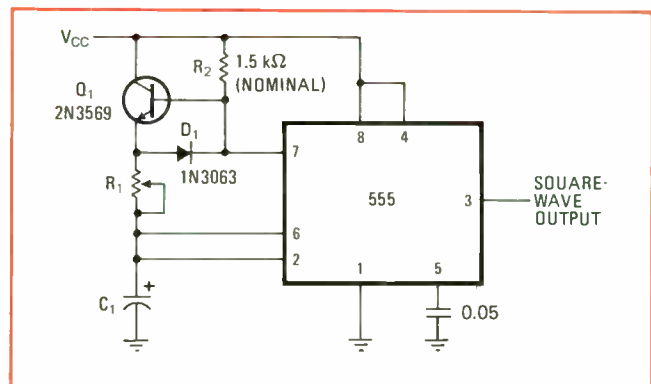

Workhorse. This configuration of the 555 timer can drive a heavy load without distorting its square-wave output, even over a very wide frequency range, unlike simpler hookups.

“We’ve Got A Lot of Great Instruments”



**Robert Shevlot,
Vice President Marketing**

Texscan Corporation, 2446 North Shadeland
Indianapolis, Indiana 46219 • Ph: 317-357-8781
TWX 810-341-3184, Telex 272110

But we’ve found we may have grown complacent. Complacent in telling you about a complete product line. That’s the reason for this ad.

No one, but no one, has Texscan’s line-up and range of sweep generators, oscilloscopes and spectrum analyzers.

In addition, we cover the filter, attenuator and oscillator markets. Write today for complete catalog information.

SWEEP/SIGNAL GENERATORS

Model	Frequency Range	Sweep Width	Price
VS-20	500 Hz to 25 MHz	500 Hz to 25 MHz	\$1,495.00
VS-30A	300 kHz to 100 MHz	100 kHz to 100 MHz	\$ 975.00
VS-40A	1 MHz to 300 MHz	200 kHz to 300 MHz	\$ 975.00
VS-50A	5 MHz to 500 MHz	500 kHz to 500 MHz	\$1,150.00
VS-60B	5 MHz to 1000MHz	100 kHz to 1000 MHz	\$1,795.00
VS-80	1 MHz to 1200 MHz	50 kHz to 400 MHz	\$1,450.00

Model	Frequency Range	Sweep Width	Price
VS-90B	5 MHz to 2350 MHz	100 kHz to 1100 MHz	\$2,695.00
VS-340	3.6 GHz to 4.3 GHz 5.8 GHz to 6.5 GHz	500 kHz to 700 MHz	\$4,650.00
WB-710	DC to 32 MHz in 2 bands	Band 1: 100 Hz to 6 MHz Band 2: 300 Hz to 32 MHz	\$1,095.00
WB-711	1 to 500 MHz in 1 band	0.1 to 500 MHz	\$875.00
WB-713	1 to 960 MHz in 2 bands	Band 1: 0.1 to 500 MHz Band 2: 0.1 to 500 MHz	\$ 995.00

In this day of shortages we have certain items on the shelf for jet delivery.

Texscan

**THE WORLD LEADER AND
COMING ON EVEN STRONGER.**

U. S. Sales Offices: Albuquerque 505-298-2575, Bayside (N.Y.) 212-423-7330, Binghamton (N.Y.) 607-748-0509, Blue Bell (Pa.) 215-542-1490, Cedar Rapids 319-363-2489, Cleveland 216-243-8430, Dallas 214-363-5291, Dayton 513-885-4171, Depew (N.Y.) 716-685-4111, Detroit 313-482-1229, Dover (N.J.) 201-366-7518, Hamden (Conn.) 203-288-5246, Hazelwood (Mo.) 314-731-5200, Hazlet (N.J.) 201-264-1851, Honolulu 808-941-1574, Huntsville (Ala.) 205-837-1601, Independence 816-737-1414, Indianapolis 317-257-7231, Los Angeles 213-478-1586, Mt. Penn (Pa.) 215-672-5565, Northbrook (Ill.) 312-498-4500, Orlando 305-859-2160, Palo Alto 415-494-3331, Seattle 206-763-2233, Syracuse 315-454-9314, Ulster Park (N.Y.) 518-372-6649, Winston-Salem 919-722-9671, Waban (Mass.) 617-969-3372, Wheaton (Md.) 301-942-9420. **Canadian Sales Offices:** Downsview 416-638-0218, Halifax 902-455-0670, Montreal 514-735-4565, Ottawa 613-728-4624, Vancouver 604-732-7317, Winnipeg 204-475-1732. **OVERSEAS OFFICES:** U K 04427-71138 WGermany 0811/695421

high and low periods should be equal at any frequency, but, with heavy loads, the output may be offset by 1 volt or more from V_{cc} or ground. This varies the potentials across the RC network, creating quite large changes in duty cycle or frequency. Noise on the output lines can also cause erratic changes in the periods.

The circuit shown in the diagram removes the timing network from the output. While the timer's output is high, Q_1 is biased into saturation by R_2 , so that charging current passes through Q_1 and R_1 to C. When the output goes low, the discharge switch (pin 7) cuts off Q_1 and discharges the capacitor through R_1 and D_1 . With the same impedance in both paths, the high and low periods of the square wave are equal.

Q_1 should have a high β value so that R_2 can be large and still drive the transistor into saturation. With R_2 large, the IC's discharge transistor, which can sink 20 to 30 milliamperes, gets most of that current from the discharging capacitor and very little through R_2 . The voltage drops in Q_1 , D_1 , and the internal discharge switch

decrease the effective voltage across R_1 , causing the actual periods to be slightly longer than those given by the astable and bistable formulas in the data sheets— $0.69RC$ and $1.1RC$, respectively. A high-conductance germanium or Schottky diode for D_1 would minimize these diode-voltage drops in D_1 and Q_1 .

For precise square waves, the on characteristic of Q_1 should be the same as that of D_1 and the IC's internal pull-down switch. To optimize this balance, set the timing network to its highest frequency range, and adjust R_2 while monitoring the square wave output. Once adjusted at this frequency, an excellent square wave is maintained for all combinations of R_1 and C_1 .

Since the usual current-limiting resistor is not needed, the minimum value of R_1 can be as little as a few hundred ohms. Such a small resistance carries large charge and discharge currents, leading to a frequency range twice as wide as the usual configuration provides. For example, if $R_1 = 10$ megohms, the frequency range can exceed 20,000 to 1 for a single choice of C. □

IC trio converts 7-segment code to decimal

by James Southway,
McDonnell Douglas Astronautics Co., St. Louis, Mo.

A device that converts a seven-segment display code into decimal code and is less expensive than the demultiplexer described in a previous article [*Electronics*, Aug. 8, p. 105], uses only three integrated circuits. The only other requirement is front-end buffering, and only if its TTL circuitry is to be used with a MOS system. Like the demultiplexer, this device enables a seven-segment display code to directly drive any kind of cold-cathode

gas discharge indicator tubes.

The small number of ICs is made possible, in part, by combining the logic of the binary-to-decimal decoder with a few external logic gates, and by cross-wiring the decoder outputs to the display inputs. In other words, output 1 of the decoder drives the display input for 2; output 4 drives the input 9, and so on. (The only uncrossed output is 0, as shown in the diagram.) The decoder is a 74141 or equivalent; the external logic is one dual four-input NAND, 7420, and one quad exclusive-OR, 7486. Another saving is made by using one of the four exclusive-OR gates in the 7486 as an inverter, and one of the two four-input NANDs in the 7420 as a two-input NAND. □

Designer's casebook is a regular feature in *Electronics*. We invite readers to submit original and unpublished circuit ideas and solutions to design problems. Explain briefly but thoroughly the circuit's operating principle and purpose. We'll pay \$50 for each item published.

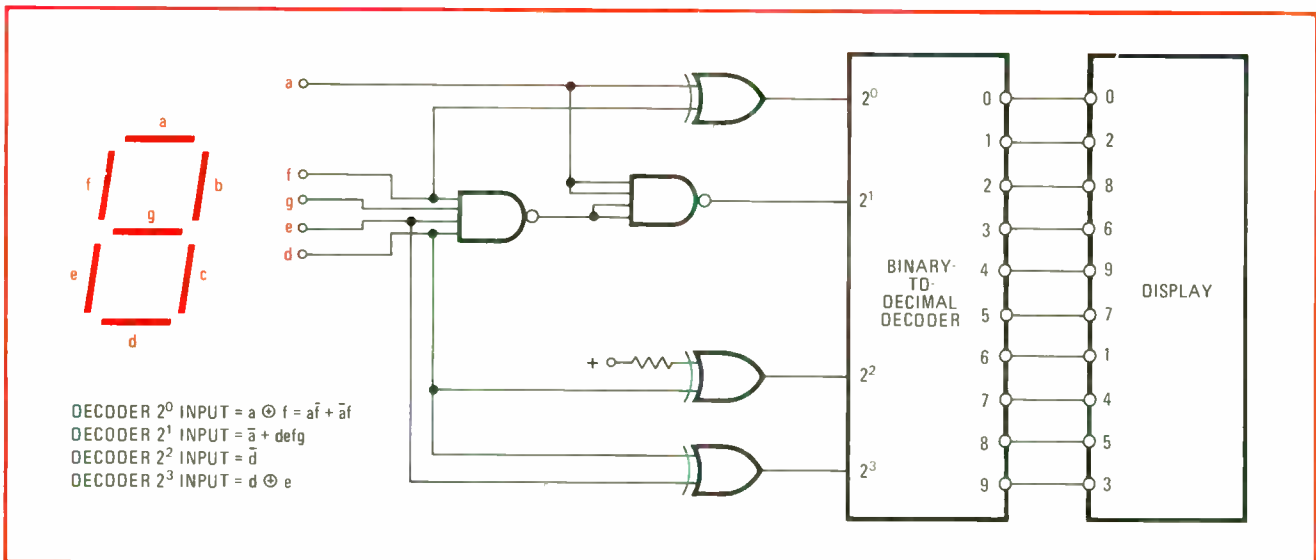

Converter. Seven-segment display code is converted into a 1-out-of-10 code for driving such things as indicator tubes, and uses only three integrated circuits. Decoder, external logic, and cross-wired outputs keep the IC count low.

GEORGIA. THE LOW-RISK STATE FOR ELECTRONICS.



Selecting a new plant site can be a highly speculative venture. Particularly in an unsure economy.

In Georgia, we're organized to lower your risks. Working with all other state-wide developers, we'll thoroughly review your company's individual needs. And conduct research based on those needs.

If worldwide shipping is crucial to your business, we'll include information on our international air terminal. And on our deep water

ports, which are efficiently operated by Georgia Ports Authority.

We'll give you an honest analysis of all pertinent information. Then, using computers, we'll match available plant sites and buildings with your requirements.

You'll have all the facts. Up front. So that when you make your decision, there'll be little room for doubt. Want to know more about our confidential site selection program? Mail in the coupon today.

Georgia Department of Community Development
Industry & Trade Division, Dept. EL-52
Box 38097
Atlanta, Georgia 30334



Name _____

Title _____

Company _____

Street _____

City _____ State _____ Zip _____

GEORGIA.
WE MEAN BUSINESS.

A 5-digit multimeter at a 3-digit price.

\$995. That's the basic price of the 5000. And that's the lowest price we've ever had for a 5-digit multimeter.

\$375 adds true RMS.

This converter can measure signals with crest factors ranging up to 22. All with typically 0.1% accuracy and settling times of less than 600 milliseconds. AC or AC+DC mode operation is also provided.

When you consider the

5000's total performance, there's really nothing comparable for the money. You get delayed dual slope integration for increased accuracy and linearity at a reduced cost, 100% over-ranging and autoranging to ensure complete flexibility in use. And a large LED display with leading zero blanking for easy viewing.

The 5000 is truly a classic technical achievement. Improved performance at lower cost.

Contact your Dana sales representative by calling toll-free 800-645-9200. In New York, phone 516-294-0990. In Europe, call 02-241 4550.

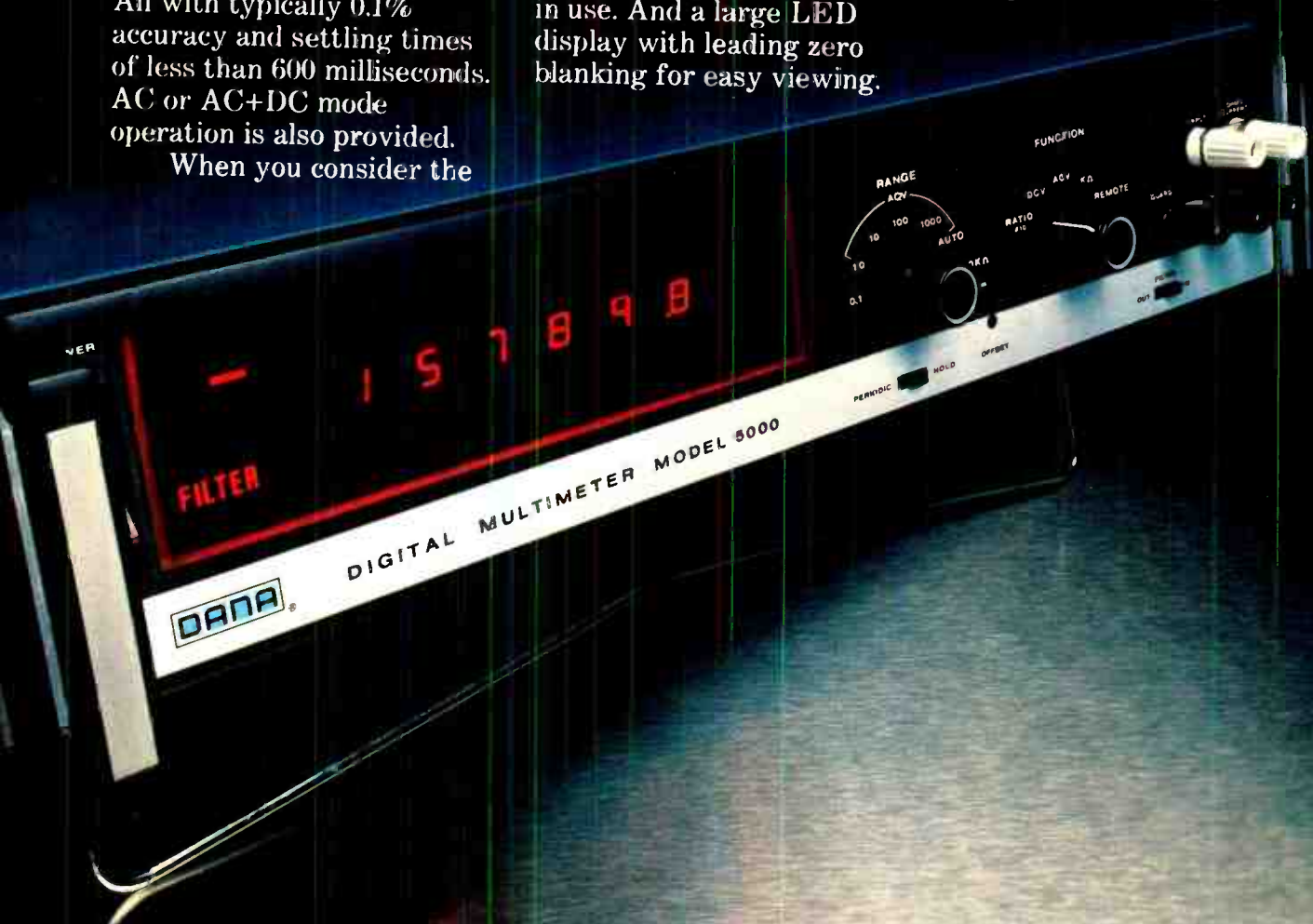

DANA®

Others measure by us.

It's so accurate, no other 5-digit multimeter can check its performance.

In order to check the readings of our 5900, you'll need a more accurate 5-digit multimeter. And no such instrument exists.

Because of its high stability, there is a minimum of recalibrations to ensure its .001% accuracy.

That's impressive enough. But the 5900 has a lot more going for it.

It provides true systems capability. The standard digital output and optional remote programming in

every 5900 are fully isolated and buffered. More than 20 readings per second can be made on all measurements. And there is a super-fast mode that allows 100 readings per second.

It has 5 DC ranges, 60% over-range and full ratio capability. Plus 350 volts RMS protection on all ohms measurements. Now it even has a true RMS converter.

The basic 5900 price is \$1,995. And at that price, nothing else is really comparable.

Contact your Dana sales representative by calling toll-free 800-645-9200. In New York, phone 516-294-0990. In Europe, phone 02-241 4550.



DANA[®]

Others measure by us.

How to match readouts to temperature transducers

Five charts define the characteristics a readout must have if it's to display the output of a thermocouple or resistive thermal device or thermistor with enough accuracy and precision

by Charles L. Garfinkel, *Keithley Instruments Inc., Cleveland, Ohio*

□ Since temperature is such an important control parameter, the ability to measure it has been continuously refined until today's transducers can routinely register minute differences of less than 0.0001°C . But such resolution is wasted on readout instrumentation that cannot display it accurately. Fortunately, choosing adequate readouts for the most common temperature transducers—thermocouples, resistive thermal devices (RTDs)

and thermistors—is not difficult if the procedures described here are used.

The characteristics of the transducer should, ideally, make the choice of readout pretty obvious. But as ever, there are practical considerations that make the job more complicated. In particular, care must be taken that the instrumentation has no adverse effects on the transducer's operation—a requirement that sometimes



Readout in action. Author watches as Stephen Douglass of Gilford Instrument Laboratories uses an ac-dc digital multimeter and a precision thermistor probe to verify temperature control calibration in a computer-directed analyzer. The system performs analytical chemical analysis by measuring reaction rates and final light absorbancy, both of which are temperature-dependent.

1. Thermocouples. For a type J thermocouple operating at a temperature of 300°C, the readout voltage resolution must be equal to the thermocouple output per °C (approximately 54.5 microvolts per °C from the graph) multiplied by the desired temperature resolution.

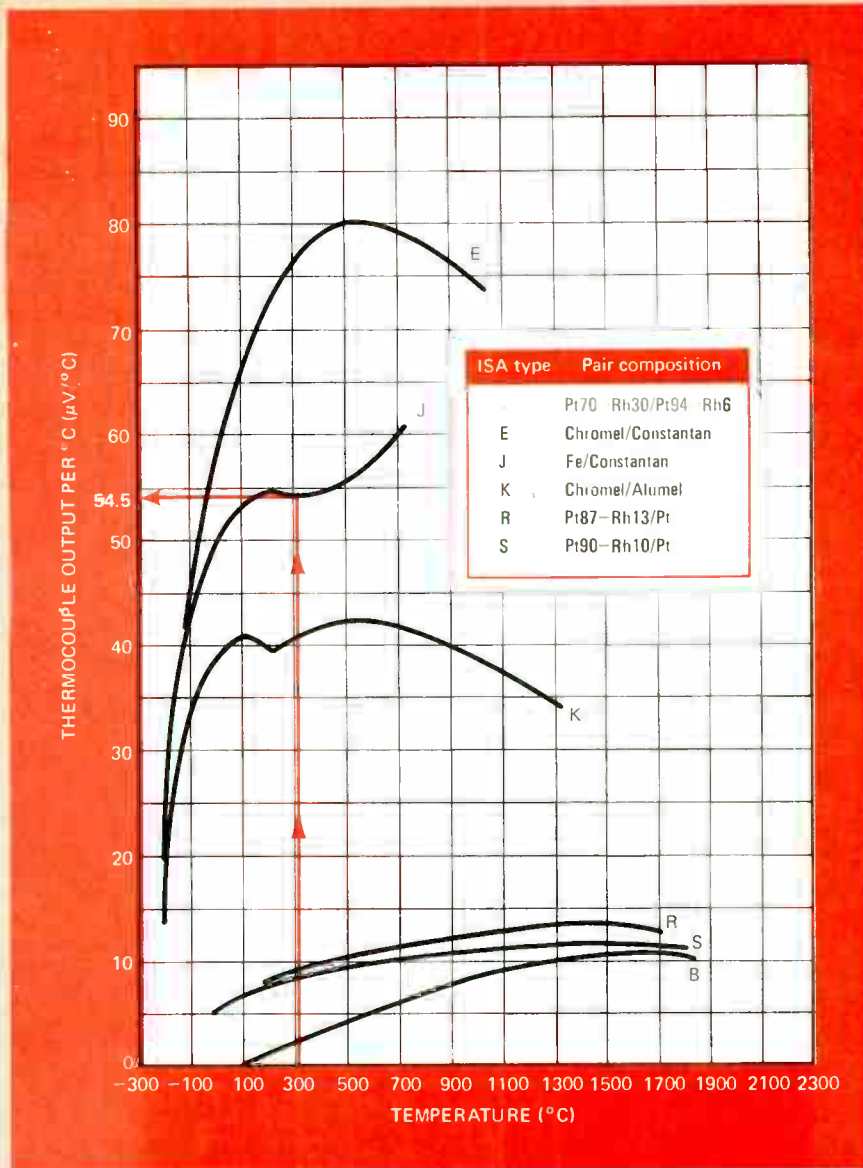

entails using a readout that's much more expensive than the transducer. Often a sensitive digital multimeter turns out to be the best choice, especially for the laboratory, since it can be used with most temperature sensors.

Thermocouple instrumentation

For maximum flexibility, a readout for use with thermocouples should indicate their actual voltage output rather than translate it into temperature, since the output level and linearity of different thermocouples vary considerably. A readout that indicates degrees will work only with one type of thermocouple—and sometimes even thermocouples of the same type must be individually calibrated to account for slight variations in composition. But if a standard thermocouple type is used in conjunction with a 0°C reference, its output voltage can be directly translated into temperature from

the conversion charts published by the National Bureau of Standards and others.

For most thermocouple applications, a sensitive digital multimeter (DMM) or digital voltmeter (DVM) is the best choice. Both are rapid, precise, and automatic and can readily detect even small shifts in temperature. In addition, some DMMs and DVMs provide an analog output to drive a chart recorder.

If the instrument has a digital output (BCD), data may be recorded on a printer or fed directly to a computer for analysis and, perhaps, process control. When a computer is used, conversion of thermocouple output to temperature becomes especially simple, since the NBS tables can be stored in memory.

Analog microvoltmeters and nanovoltmeters are often preferable, however, where sensitivity to extremely small temperature differences is required, perhaps to

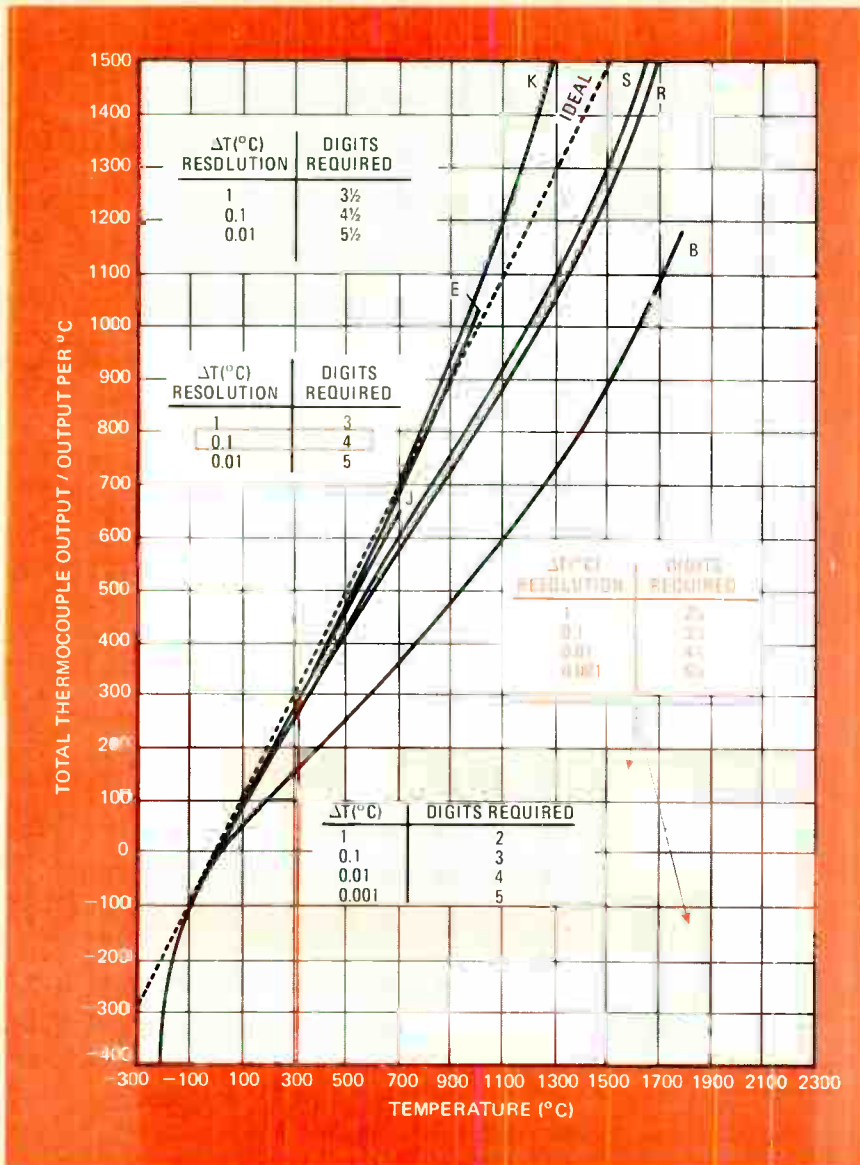

2. Required digits. Type J thermocouple operating at 300 °C requires at least four digits on a readout for a temperature resolution of 0.1 °C.

0.001 °C, or where only two-digit resolution is needed. Usually, though, these instruments have only an analog output and lack a digital output.

Some limiting factors

Any readout, however, will limit temperature resolution if its voltage resolution, input drift, or various spurious signals are larger than the smallest significant voltage change generated by the thermocouple.

The voltage resolution of a readout can be no better than the input peak-to-peak noise since the device, whether digital or analog, is basically an amplifier. Most thermocouples have an output of more than 10 microvolts per °C, (Fig. 1), so that instruments with a peak-to-peak input noise of less than 0.1 microvolt can resolve temperature differences as small as 0.01 °C.

Input drift may limit temperature resolution if mea-

surements occur over a number of minutes. In order to be detected, the temperature changes must produce a change in thermocouple output that is larger than the readout input drift.

The problem of ground-loop interference will be simplified by an instrument with a floating input. Such an input reduces the spurious signals that result from ground potential (voltage) variation in systems with multiple-grounding points. In some cases, these signals may be equal to or even larger than the thermocouple output voltage.

Other spurious signals that may also be sensed electromagnetically by the thermocouple circuit loop include line frequency or harmonics of the line frequency, both termed normal-mode noise. Shielding, though effective, is often inconvenient or difficult to accomplish. But if shielding is to be avoided, a high normal-mode

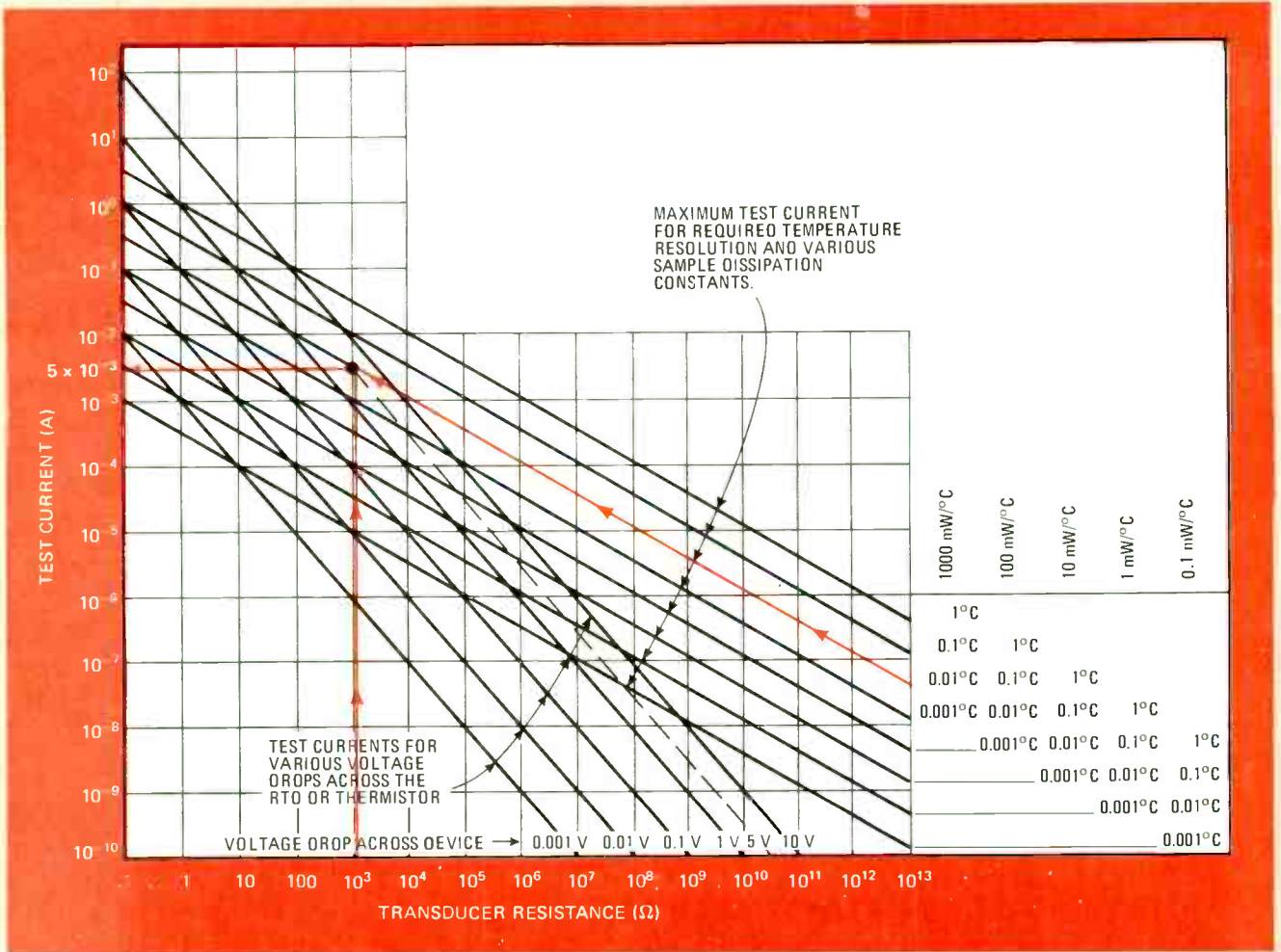

3. Meter compatibility. This graph indicates whether or not a resistance meter will be compatible with a particular thermistor or resistive thermal device. Assume the thermistor specifications list a dissipation constant of 1,000 mW/°C. If the desired temperature resolution is 0.01°C, this combination will determine a maximum test current line (see the righthand side of the graph). Find the intersection of this line with a vertical line corresponding to the transducer resistance at the temperature to be measured— 10^3 ohm in this example. A horizontal line extending from this point to the ordinate indicates that the thermistor is capable of handling approximately 5 mA. But many multimeters specify voltage drop instead of resistance. So in order to find the allowable voltage drop across the thermistor, extend a line from the intersection parallel to the voltage-drop plots. The maximum allowable voltage drop across the device is in the region of 5 V.

rejection ratio (NMRR) is essential since such voltages typically are orders of magnitude larger than thermocouple outputs.

Similarly, a high common-mode rejection ratio (CMRR) is required to avoid common-mode noise—the disturbance from signals generated electromagnetically between ground and the thermocouple circuit.

The measurement of temperature can be combined with its control when the DMM has an electronic trip feature. As the thermocouple output crosses preset levels, the built-in relay contacts will automatically switch ovens or other external devices and controls. A DMM with 1-microvolt resolution and both high-limit and low-limit trips can be used with most thermocouples to regulate oven temperature to better than 0.1°C.

If temperature difference rather than magnitude is to be measured, either an analog or digital microvoltmeter

or nanovoltmeter may be used. However, the analog instrument may provide the optimum balance between sensitivity and economy, without sacrificing convenience and speed. The most sensitive analog units have input noise of less than 0.001 microvolt (so that their resolution is better than 0.0001°C for thermocouples with outputs of greater than 10 V/°C). Amplifying micro- and nanovoltmeters usually have recorder outputs to allow continuous monitoring.

To select a meter for a thermocouple, find the intersection of the operating temperature with the appropriate thermocouple curve on Fig. 1. This determines the output voltage per degree centigrade delivered by that thermocouple. The necessary voltage resolution of the readout is simply this figure multiplied by the desired temperature resolution in °C.

If actual temperature, in addition to temperature

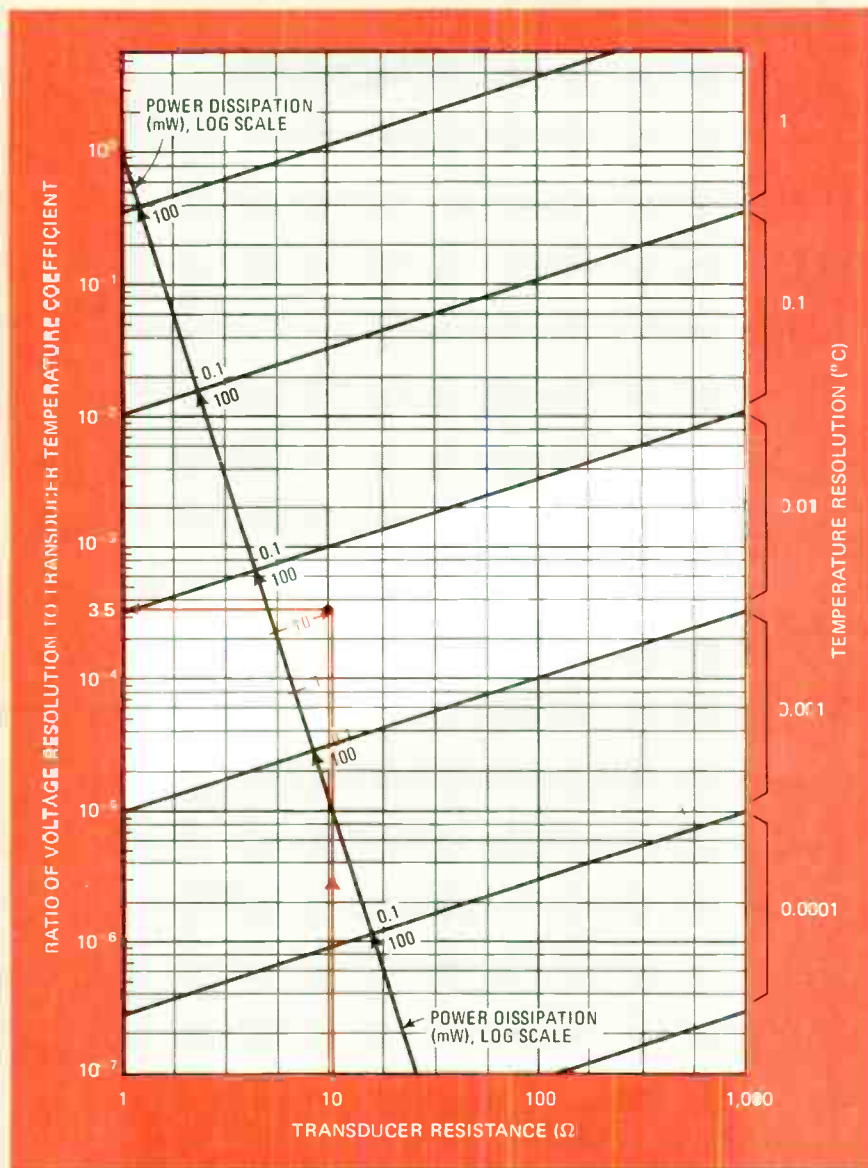

4. Thermistor or RTD readout. This graph can be used to determine the ratio of required voltage resolution to transducer temperature coefficient for the desired temperature resolution, assuming a thermistor or RTD drawing the maximum test current allowed by the self-heating limitations. Suppose the desired temperature resolution is 0.01°C , transducer resistance is 10 ohms, and the power dissipation constant is $10\text{ mW}/^{\circ}\text{C}$. Choosing the desired temperature resolution band (see right side of graph), draw a line perpendicular to the power dissipation axis from the point corresponding to the specified dissipation constant of the transducer until it intersects the 10-ohm vertical. Then extend a line horizontally from this intersection to the ordinate. This defines the ratio as approximately 3.5×10^{-4} . The required voltage resolution will be this figure multiplied by the specified transducer temperature coefficient.

change, must be measured, a digital instrument may be required. (An analog instrument can only indicate the equivalent of about two digits). Figure 2 shows the minimum necessary number of digits for thermocouples referenced to 0°C . The minimum number of digits is the number required to display both the quantity being measured and a change equal to the desired resolution. This figure is determined by the ratio of the thermocouple output (at the appropriate temperature) to the change in output that corresponds to the temperature resolution desired.

On Fig. 2 find the intersection of operating temperature with the appropriate thermocouple graph. In the section where this point falls is a table that lists the required number of digits next to the desired temperature resolution. For example, a type J thermocouple operating at 300°C with a desired resolution of 0.1°C will re-

quire a 4-digit meter. An additional digit may be necessary for consistency with the decade calibration of most instruments.

RTD instrumentation

Resistive thermal devices frequently do not involve low-level signals. Nonetheless, the above remarks on input isolation, normal-mode rejection, and common-mode rejection apply to instrumentation for RTDs also.

To find the resistance of an RTD, a known current is passed through it and the resultant voltage drop measured. Often a digital resistance meter or digital multimeter will do the whole job. If high accuracy is not required, the interpretation is relatively simple, because RTD resistance is nearly linear with temperature.

However, transducer self-heating or sensor power dissipation can pose problems, particularly when more ac-

5. Required digits for thermistors. Since most thermistors have a beta between 3,000 and 5,000, this graph can be used to directly determine the number of digits required. For a desired temperature resolution of 0.1° C and an operating temperature of -133° C the intersection will lie in the 2-digit band. The ratio of thermistor resistance to necessary resistance resolution is between 400 and 600. Dividing the thermistor resistance by this ratio gives the resistance resolution required of the measuring instrument.

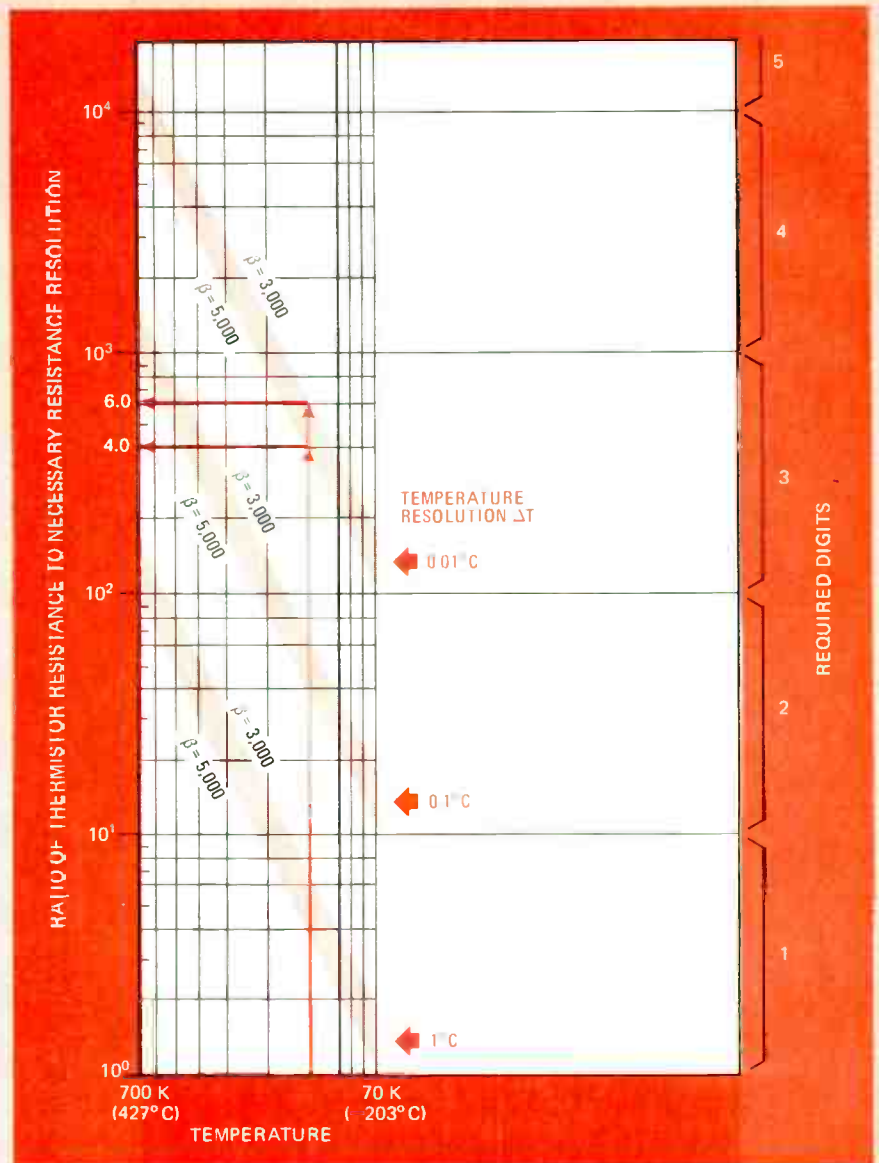

accurate or precise measurements are required. Transducer self-heating determines the amount of power a transducer can dissipate, without its temperature being changed from ambient by more than the temperature resolution desired. This sets limits on the test current.

The smaller the temperature difference to be resolved, the lower the permissible test current. Low test currents, of course, mean low voltages, so microvolt and even nanovolt sensitivity may become necessary.

Most digital multimeters have built-in precision current sources that are switched into the circuit automatically on resistance ranges. Such meters make excellent readouts for RTDs, provided the test current is not excessive for the transducer's rating and for the temperature resolution desired, and provided the instrument has ample digital resolution (number of digits).

For RTDs, first determine whether an available resist-

ance meter can be used or whether a separate current source and voltmeter must be used. To establish if a resistance meter is acceptable, look up self-heating in the RTD's specifications and then multiply this by the temperature resolution desired to obtain the maximum power dissipation. Next go to Fig. 3, which plots maximum test current as a function of transducer resistance for a range of power-dissipation values and temperature differences. Voltage drops for various test currents across the transducer are also indicated.

On Fig. 3 select the transducer power-dissipation-constant and temperature-resolution combination at the right of the graph. The intersection of this line with a vertical line representing the transducer resistance (at the appropriate temperature) determines test current as read at the left of the graph. A check of the manufacturers' specifications will show whether the digital mul-

TRANSDUCER SUMMARY

TRANSDUCER	THERMOCOUPLES	RTD's	THERMISTORS
Temperature range	-270°C to 2865°C	-273°C to 1050°C	-272°C to 315°C typical -90°C to 150°C
Output	50 μV/°C to 80 μV/°C	0.0005 Ω/Ω°C to 0.5 Ω/Ω°C (10 Ω to 3500 Ω at 0°C)	0.1 Ω/Ω to 1 Ω/Ω°C (10 Ω to 10 MΩ at 25°C)
Repeatability and resolution			
Short-term	0.1°C (0.001°C possible)	0.05°C (0.0002°C possible)	0.0001°C
Long-term	0.1°C	0.1°C	0.1°C (0.01°C possible)
Accuracy	0.1°C (0.3°C typical)	0.5°C (0.0002°C possible)	0.1°C to 0.2°C (0.01°C possible)

timer has a resistance range compatible with this maximum test current.

Assuming the resistance range to be compatible, then it is necessary to ensure that the DMM has enough digits. For RTDs, the minimum number of readout digits is determined by the temperature coefficient of resistance (transducer output) and the desired resolution of temperature difference. This number of digits, D, is the smallest integer equal to or greater than N, which can be found from:

$$N = \log(1/tc) + \log(1/\Delta T)$$

where ΔT is the temperature resolution and tc is the temperature coefficient for the RTD. For platinum RTDs, tc = 0.0039 ohms/ohm-°C, so that N = 2.5 + log(1/ΔT). Therefore, the number of digits required for a platinum thermometer is as follows:

ΔT(°C)	D
1.0	3
0.1	4
0.01	5

Similar tables can be constructed for other RTDs. Note that an additional digit may be necessary for consistency with the decade calibration that's found in most instruments.

In some cases, the built-in resistance range of available digital multimeters may use more current than permitted by self-heating limits. If so, a separate low-level current source must be used in combination with a digital or analog micro- or nanovoltmeter.

The current, I, must be set to a value equal to or less than the maximum current as determined from Fig. 3. From the manufacturer's specifications, determine the resistance, R, of the RTD over the appropriate temperature range. Then use V = IR to calculate the full voltage developed by the test current.

If the current used is the maximum test current allowed by self-heating limitations, the required voltage resolution can be found from Fig. 4. Select the temperature-resolution band that applies to the application (see right side of graph). Within the band, find the RTD dissipation constant on the slanting axis. Extend a perpendicular from this axis until it intersects the vertical representing the transducer resistance at the temperature to

be measured. A horizontal from this point to the ordinate gives the required voltage resolution divided by the temperature coefficient of the RTD. This value times the temperature coefficient specified for the RTD is the required voltage resolution.

If less than the maximum allowable current is used, the required voltage resolution must be calculated. First find the necessary resistance resolution from:

$$\Delta R = R(tc)(\Delta T)$$

Then calculate the required voltage resolution:

$$\Delta V = I\Delta R$$

Finally determine the minimum number of digits required for the microvoltmeter. For DMMs, this is the smallest integer that's greater than or equal to N, where, as before,

$$N = \log(1/tc) + \log(1/\Delta T)$$

An extra digit may again be necessary for consistency with the decade calibration of most instruments.

Thermistor instrumentation

Considerations in selecting readouts for thermistors are much the same as for RTDs. However, because the thermistor is extremely nonlinear, there is a great deal more variation with temperature in the number of digits required to read a temperature to a particular resolution. Figure 5 is a selection plot relating the minimum required number of digits to temperature, temperature-difference resolution, and thermistor beta and output.

First select a band on the graph corresponding to the desired temperature resolution. The intersection of the operating temperature with this band gives the ratio of thermistor resistance to the necessary resistance resolution. Dividing the thermistor resistance by this figure determines the resistance measurement resolution required. The minimum required number of digits is read to the right of the graph. As before, an extra digit may be necessary for consistency with the decade calibration of most instruments. The test-current limitations in Fig. 3 also apply to thermistors, and the meter must be checked for resistance range compatibility in the same way as for RTDs. □

Gas and smoke detector uses low-leakage MOS transistor

by Al Pshaenich and Roger Janikowski
Motorola Semiconductor Products Inc., Phoenix, Ariz.

With metal oxide semiconductor field-effect transistors (MOS FETs) that have very low leakage current, combustion gas detectors can now be inexpensively built to run on battery power. This type of detector consists of an ionization chamber and a solid-state amplifier. Besides sounding an alarm in the presence of gas or smoke, the detector warns when the battery is dying.

An ionization chamber consists essentially of a collector electrode extending into a metal chamber, which forms the other electrode. A minute amount of radioactive material in the chamber emits alpha particles that bombard the air molecules and ionize some of them. When an electric potential is placed across the electrodes, the attracted ions produce an extremely small current—in the range of 10 to 30 picoamperes. Combustion-gas molecules that enter the chamber tend to attach themselves to the ions. The enlarged ions move more slowly in the electrical field, reducing the

current across the electrodes of the detector.

If the ionization chamber is placed in series with a high-impedance reference, the pair forms a voltage divider. When the current decreases in the presence of gas or smoke, the voltage across the reference element decreases, and a comparator detects the change.

In the battery-operated detection circuit in the diagram, Q_1 and Q_2 form a MOS-bipolar differential amplifier. Q_1 is a high-impedance buffer, which has an input leakage current of about 1.0 pA—at least one order of magnitude less than the chamber current, so that it doesn't load the circuit. The reference resistor R_1 has an impedance approximately equal to that of the ionization chamber in the absence of smoke, thus setting the voltage at the FET gate to about 6 volts. The FET source current is about 30 microamperes, and the gate-to-source voltage is about 2 V, which places the source—the terminal connected to R_2 —at 8 V. The threshold control, R_3 , is set to back-bias Q_2 , typically at about 500 millivolts.

Tests with smoke levels at 2% and 4% obscuration produced a negative voltage shift at the buffer gate of about 2 V and 3 V, respectively. This is enough to turn off Q_1 and turn on Q_2 and Q_3 , which applies a logic 1 at one input of the NAND gate 1. This gate, together with inverter 2 and the associated discrete components, forms a nonsymmetrical astable multivibrator, which

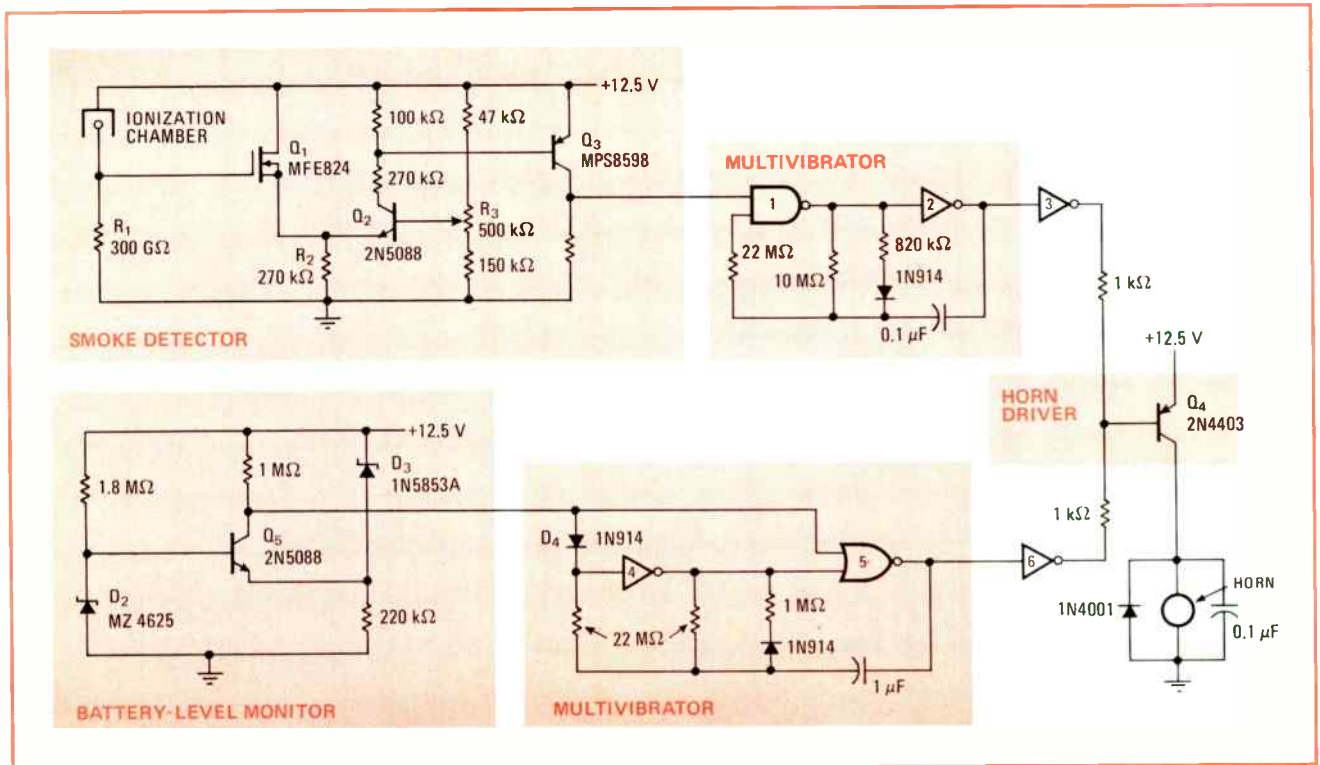

Detector. A MOS FET transistor, Q_1 , with high input impedance monitors the voltage level at a divider, one half of which is an ionization chamber. Differential amplifier Q_1 - Q_2 picks up any decrease in this voltage and triggers a multivibrator that sounds a pulsating alarm. Low battery voltage triggers a second multivibrator that uses the same horn to sound a "beep . . . beep . . . beep" warning.

begins to oscillate when Q_3 turns on. In the multivibrator, the capacitor charges quickly and discharges slowly; while it is discharging, it causes the horn to sound via the inverter 3 and driver transistor Q_4 . The horn blows continuously for 2.5 seconds, then turns off for 0.2 seconds while the capacitor recharges. This pulsating alarm continues as long as smoke is present.

A comparator, consisting of one transistor and two zener diodes, determines when the battery is low. Diode D_2 carries only about $5\mu\text{A}$, so that the base voltage at Q_5 is about 3 v. The other diode, D_3 , couples the full change in battery voltage to the emitter of Q_5 . These diodes, which have zener breakdowns of about 4.5 v and 8.2 v, respectively, turn on and quickly saturate Q_5 when the voltage of the expiring battery sags to approximately 10.5 v. This drops its collector from near the battery voltage, maintained by D_4 at the input of inver-

ter 4, to about 2.5 v, which is below the threshold of NOR gate 5. This is part of another astable multivibrator that also blows the horn via the same driver. But this capacitor is larger, and the network charges it slowly and discharges it quickly, so that the horn makes a 1-second toot every 23 seconds. This alarm is not only distinctly different from the smoke alarm, but it also conserves the energy remaining in the battery.

A single complementary-MOS integrated circuit, MC14572, can be used to build the four inverters, one NAND and one NOR, from which the two multivibrators are assembled. The other components in the multivibrators, and those in the smoke-detection and the battery-monitor circuits, are discrete. □

Engineer's Notebook is a regular feature in Electronics. We invite readers to submit original design shortcuts, calculation aids, measurement and test techniques, and other ideas for saving engineering time or cost. We'll pay \$50 for each item published.

Pocket calculator converts to keyboard entry station

by Fred W. Etcheverry
SWRL Educational Research & Development, Los Alamitos, Calif.

A low-cost data-entry device can be built from a pocket calculator, without disturbing its calculator functions, by connecting a few wires from easily located internal points to a few simple logic circuits.

In a typical calculator, the keyboard is a matrix switch. When power is on, the rows of the keyboard are rapidly and continuously scanned in sequence. Depressing any key makes a connection from one row circuit to one column circuit; the particular combination of row

and column identifies the key and, in the calculator, initiates a function such as entering a digit into a register or executing an arithmetic operation on previously entered numbers.

Bringing the row and column signals outside the calculator to similar external logic circuits permits the key to be similarly identified and can initiate another function.

As shown in Fig. 1, two 1-out-of-N encoders convert the row and column signals into unique combinations of bits. All column signals go through an OR or NOR gate, then through a delay, and finally to a retriggerable one-shot circuit. The delay insures that the column signal is neither a legitimate key depression that has just caught the trailing edge of a scanning pulse, nor a spurious noise pulse. As long as any key is held down, the one-shot is repeatedly retriggered, providing an n-key rollover function to protect against accidental

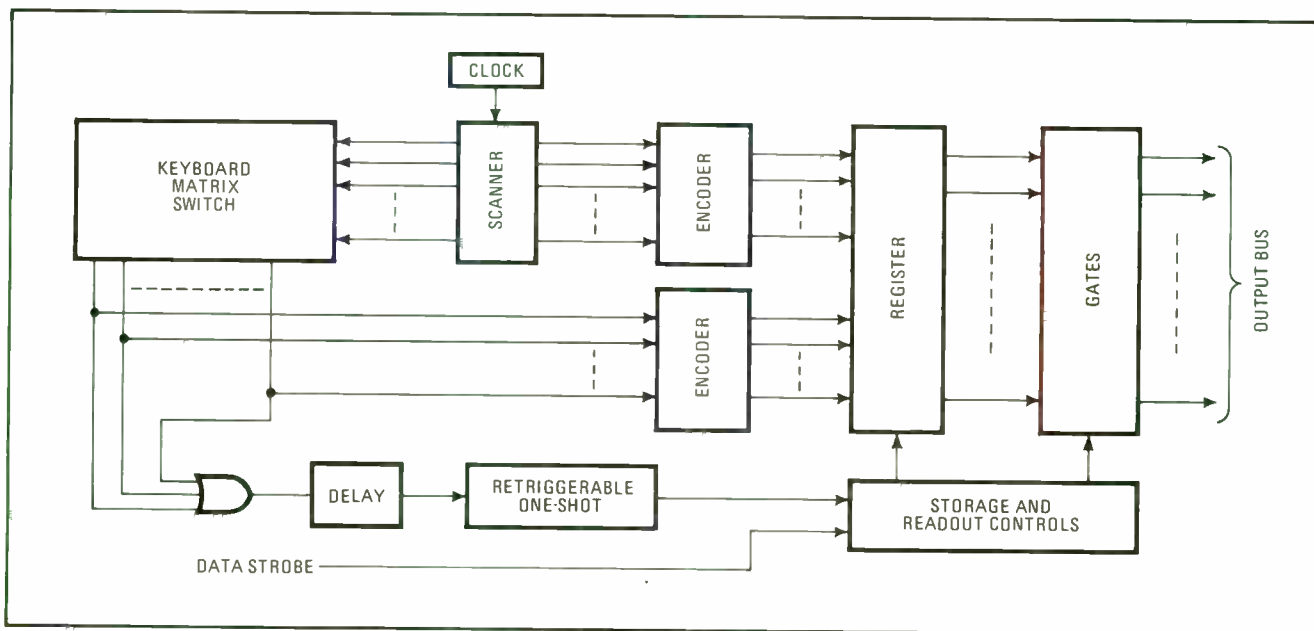

1. Keyboard functions. Standard row-and-column signals from a calculator keyboard can be encoded into a data word and stored in a register for gating onto a bus to any kind of digital system. All added components are standard integrated circuits.

True rms Voltage, Current and Power measurements all at 0.25% accuracy

The YEW Type 2504 Digital AC Meter has been especially developed to solve the complex problems of accurate measurement of non-sinusoidal waves. Type 2504 is packed into a compact modular case and used as a general-purpose digital instrument for the measurement of power and the true rms value of voltage and current. Operation by front panel pushbuttons is extremely simple and negligible instrument loss is featured.

Type 2504 includes our patented feedback time division techniques and pulse width modulation counting method whose excellence have been well proven in the YEW Type 2885 Standard Digital Wattmeter (accuracy of 0.02% at 50 to 60Hz). Type 2504 employs a versatile plug-in module system which permits the selection of a variety of input ranges and functions: single- or multi-range inputs, direct or normalized reading, remote control, analog and BCD outputs, etc.

Main Specifications:

Main Body

- Max. Reading: 11900
- Units Marks: V, mA, A, W and kW
- Dielectric Strength: 2,500V AC between input terminals and case
- Types Available: W, V-A, V-A-W measurements by either direct or normalized (rated input displayed as 1.0000) reading

Plug-in Input Modules

- Types Available: Single-range module: 100V/5A (500W), Multi-range module: 30V/60V/100V/150V/300V, 0.5A/1A/2A 5A/10A (15W to 3,000W)
- Resolution: 10mV/digit, 0.1mA/digit, 10mW/digit
- Accuracy: $\pm 0.25\%$ of range
- Frequency Range: 25Hz to 1kHz

- **Multi-selectable measurements by plug-in module system**
- **Suitable for precision measurement of even distorted waves**



YEW

• For Electronic Measuring, Recording Instruments:

YOKOGAWA ELECTRIC WORKS, LTD.

Yaesu-Mitsui Bldg., 5-7 Yaesu, Chuo-ku, Tokyo 104, Japan Phone: 274-6511 Telex: J28544 YEW TOK

Overseas Offices: • YEWTEC CORPORATION, 1995, Palmer Ave., Larchmont, New York, 10538, U.S.A. Phone: 914-834-3550 Telex: 710-566-1104 • YEW EUROPÄISCHES VERBUNDUNGSBURO, 2000 Hamburg 26, Hammer Landstrasse, 76 I.O.G., Germany. Phone: Hamburg 2191310, Telex: 41211435 YEW D (for domestic call, omit "41")
Representatives in Europe: • Belgium: COMPTOIR COMMERCIAL INTERNATIONAL S.A., (03) 32.78.64 • France: TEKELEC AIRTRONIC, 626-0235 • Finland: FINN METRIC OY, 460 844 • West Germany: NBN ELEKTRONIK, (08151) 13036 • Italy: VIANELLO S.P.A., 5483811 • Norway: AS MAXETA, 53090 • The Netherlands: TECHMATION NV, 020-456955 • Spain: ATAI0 INGENIEROS, 215-35-43 • Sweden: TELEINSTRUMENT A.B., 87-03-45 • Switzerland: OMNI RAY AG, 01-340355 • United Kingdom: MARTRON ASSOCIATES LTD., Marlow (06284) 5071.

multiple key depressions. The rise of the one-shot's output stores the encoded data corresponding to the key depressed—the first, if more than one—into a set of flip-flops. From these the data is available for use in any system requiring the keyboard entry.

A specific interface based on a Bowmar MX-50 calculator is shown in Fig. 2. The keyboard on this calculator has 18 keys in a 5-by-4 matrix, requiring a total of nine external connections to bring out the row and column signals. These are numbered P1 through P9, left to right as seen on the keyboard with the display facing up, after the calculator's cover is removed.

Each of the nine lines is connected to a voltage divider and a transistor to convert the calculator's MOS signal level to TTL. The new levels are inverted and encoded by five NAND gates in two ICs—all of a triple

3-input and half of a quadruple 2-input—and stored by five D-type flip-flops (two per IC package) in such a way that every key turns on at least one flip-flop, as shown by the encoder output listings in Fig. 2.

Meanwhile the four column lines are delayed by an RC network that filters out any spurious or trailing-edge pulses and triggers the one-shot. Its rise stores the data in the five flip-flops, and turns on a sixth flip-flop to indicate that the data word has been stored. An external-data strobe signal repeatedly attempts to set a seventh flip-flop, but is unable to do so until the latter has been conditioned by the sixth one. The seventh flip-flop transfers the data onto an external bus through a set of open-collector gates, and indirectly clears the whole register and, via another one-shot, prepares the data entry station for another key signal. □

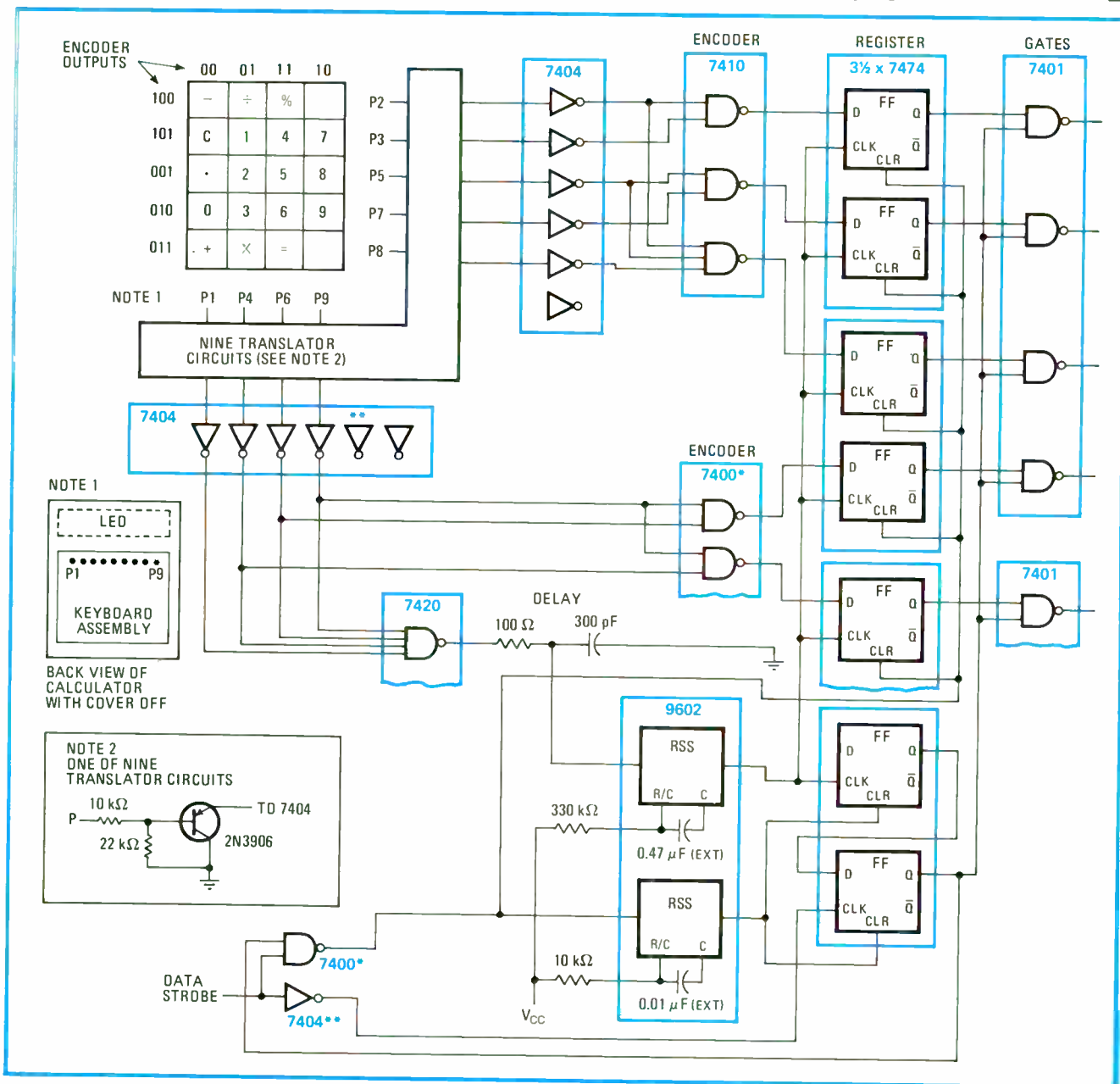

2. Implementation. Parts of 12 integrated circuits packages, plus a few discrete components, bring keyboard signals out to external bus. Only one external signal—the data strobe—is required; it sets the data on the bus and clears the register.

Buy semiconductors now and save

With supplies plentiful in a soft electronic-components market, smart shoppers are finding that it's bargain time once again at the semiconductor supply houses. Some shoppers say **prices are now at rock bottom—both for digital and analog circuits in big and small quantities.** Here are some sample prices being reported around the industry: small-scale TTL, 10 to 15 cents per gate; MSI TTL, 15 cents per gate; **op amps, like the 741, down from 55 to 60 cents to a low 26 cents in a mini-dip package;** voltage regulators selling at \$1.25, down from \$2; 1103s in the \$2-3 range, and **static 1,024-bit RAMs, \$3 to \$4.**

Low-power Schottky TTL gets better and better

It's hard to beat the speed-power product (10 nanoseconds at 2 milliwatts) that's made low-power Schottky TTL today's fastest-growing standard logic family—and now it's getting even harder, as semiconductor suppliers learn how to cut gate delays while keeping power consumption at the same level. Fairchild's 9LS family, for example, which is **specified at 5 ns and 2 mW,** will be joined this month by a 5-ns Schottky family from Raytheon. And TI, too, is now rumored to be considering a 5-ns "A" version of its own.

How really to build a tone-burst generator from a 556 IC timer

You may have discovered that the hookup recommended in the Signetics' applications manual for building a tone-burst generator from the company's ubiquitous 556-type dual IC timer does not work at all. But don't blame the dual timer—the real culprit is a typographical error in the wiring diagram, says William D. Kraengel, Jr., of Ground Systems Engineering in Valley Stream, N.Y.

A tone-burst generator is little more than a gated astable multivibrator. One of the timers is wired as a one-shot, while the other acts as an astable. In response to an input trigger, the one-shot will produce a pulse that turns on the astable, which, in turn, generates a burst of pulses. With the Signetics' setup, **the astable is incorrectly gated through its trigger input. Instead, the astable should be gated through its reset input, and its trigger input should be tied to its threshold input.**

Now there's a kit for bipolar LSI systems

We've seen several MOS microcomputer design kits recently, but Intel's kit for developing Schottky bipolar LSI systems is the first of its kind to come to our attention. **For \$720, Intel says, you get enough computing elements to build a high-performance 16-bit CPU or controller** and enough other devices, device documentation, and design aids to design other systems. The company also promises to **send kit buyers updated documentation and selected new members of the family during 1975.** Intel's address is: 3065 Bowers Ave., Santa Clara, Calif. 95051.

Automotive electronics standards in the works

If you yearn to be a supplier to the automobile industry, better **check out some key standards being proposed by subcommittees of the Society of Automotive Engineers,** 2 Pennsylvania Plaza, New York, N.Y. 10001. They include "Environmental practices for electronic equipment design" and "Electromagnetic susceptibility test procedures for vehicle components."
—Laurence Altman

The Schottky sandwich.

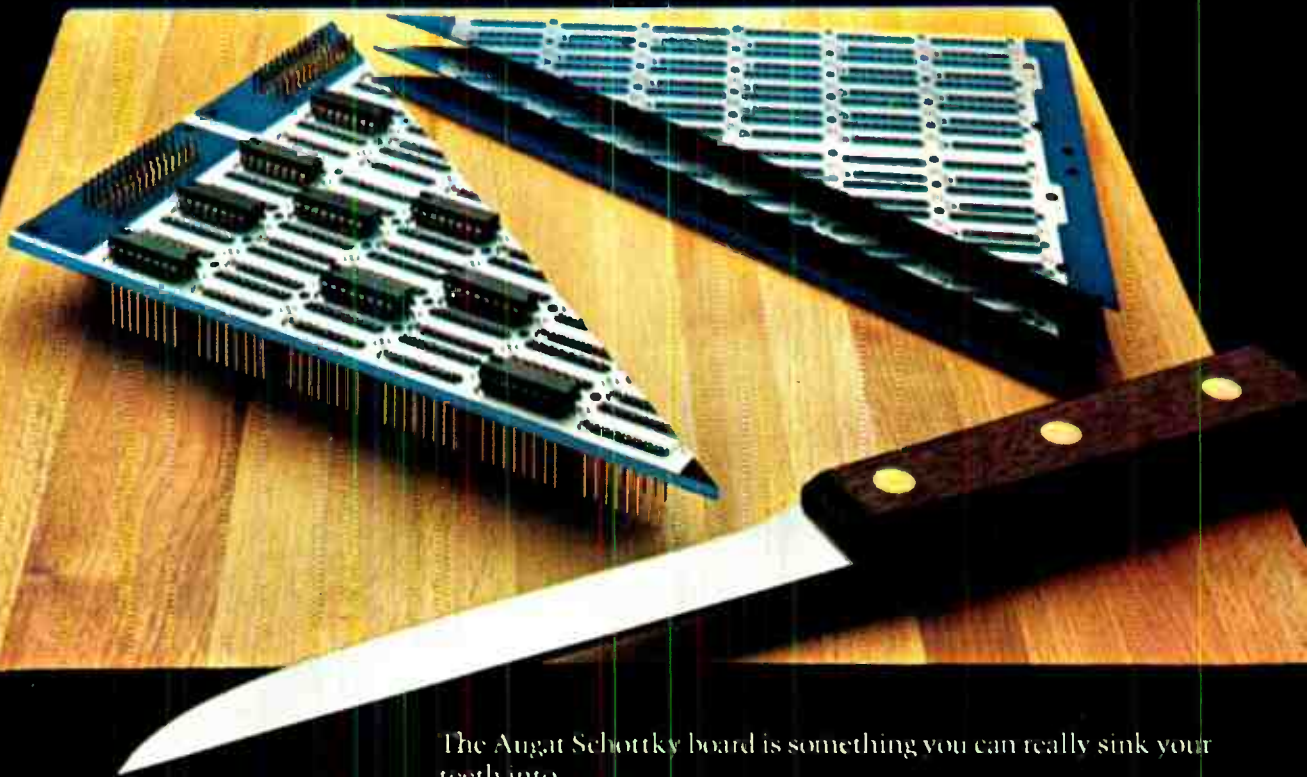

The Augat Schottky board is something you can really sink your teeth into.

On the outside there are two ground planes, top and bottom, instead of just one.

On the inside there's a special voltage plane that's made of a generous slice of copper.

Laminated together, it makes a very neat sandwich that goes perfectly with Schottky TTL design.

For example, it increases distributed capacitance by as much as 400 percent. And at the same time, it greatly reduces high frequency noise.

It has ground embraced socket and I.O. connections that enhance isolation of signal interconnections.

Individual DIP decoupling capacitor zones and electrolytic-type decouplers at every power entry point.

And voltage and ground socket pins that are soldered directly to their planes to drastically lower impedance.

All in all, the Augat Schottky board can save you up to 90 percent in breadboarding and prototyping time. Tens of thousands of dollars in start-up costs. And many expensive hours in field maintenance.

The Augat Schottky boards are standard catalog items available right now in any quantity and in any multiple of patterns, from 30 up to 180.

If you'd like a taste of what it's all about, contact any of our world-wide distributors or Augat, Inc.,

33 Perry Avenue, Attleboro, Mass. 02703.

Tel. 617-222-2202. TWX 710-391-0644.

AUGAT

Circle 129 on reader service card

Europe—Augat N.V., Boulevard A. Reyers 103, 1040 Brussels, Belgium, Tel. (02) 7369399.

Japan—Kyokuto Boeki Kaisha Ltd., New Otemachi Bldg., 2-1, 2-Chome Otemachi, Chiyoda-Ku, Tokyo 100-91, Japan Tel. (03) 244-3788



**This Model 30
portable function generator
goes from
2 Hz to 200 kHz with
sines, squares, triangles,
and linear
or log sweeps.**

**And it goes for
\$149.⁹⁵**

\$149.⁹⁵

WAVETEK

WAVETEK®

P.O. Box 651, San Diego, Calif. 92112
TWX 910-335-2007, Tel. (714) 279-2200

Schottky components are byte-sized

Family of bipolar MSI and LSI devices has 8-bit organization for easy interfacing with 8- and 16-bit microprocessors; many in 20-pin DIPs

by Michael J. Riezenman, New Products Editor

As higher-performing LSI processors became generally available, designers were able to score great advances in control and data-communications systems. But a gap existed between the available interface and control components and those needed to work with the processor chips. This gap has made it necessary to hunt through a catalog of standard TTL devices to find the product that most closely approximated the desired function. Texas Instruments intends to fill this gap with a line of components designed specifically for the desired functions [*Electronics*, Nov. 14, p. 29].

A unique feature of many of the components is that they are organized in byte-size segments (by eights rather than by fours) for easier interfacing with 8-bit and 16-bit microprocessors. Also, they are typically much faster than any of today's microprocessors, making them suitable for high-speed data-communications—an application for

which many of today's devices can't measure up.

The new products break down into two categories: memories and interfacing circuitry. The memories include read-only, programmable read-only, first-in/first-out, and random-access. Among the interfacing circuits are octal latches, universal shift/storage registers, multiplexers, and counters.

One of the most interesting of the new interfacing circuits is the model SN74S299 8-bit universal shift/storage register. Although it has many potential applications, one of the most promising is a temporary storage device. As Richard L. Horton, market development manager for digital circuits at TI's Houston facility points out, "If you have data on a bus and an interrupt comes through, and you don't want to go through a memory cycle to send the data down to memory, you simply open up the register's input ports, and in 10 nanoseconds everything

that was on the bus is stored in the byte register. When the interrupt is over, all you do is activate the tri-state control, and in 10 more nanoseconds you've driven the data back onto the bus and restored all the information."

As Horton emphasizes, all of this temporary data storage can be done within the cycle in which the processor is operating. No extra memory operations are needed. Thus, especially for relatively slow microprocessors, the time savings can be significant.

The shift register spans the frequency range from dc to a minimum of 50 megahertz (70 MHz is typical) making it approximately 10 times faster than the fastest of today's bipolar microprocessors. The device, which draws a typical collector current of 150 milliamperes, is packaged in a new 20-pin plastic dual in-line package with a 0.3-inch row spacing—that's half the width of the older 24-pin packages. Price of

Fast Interface. Asynchronous first-in/first-out memory SN74S225 can handle data rates from dc to approximately 30 MHz (20 MHz minimum), making it an ideal interface between fast processors and slow peripherals. The data outputs can all sink 16 mA and supply -1 mA.

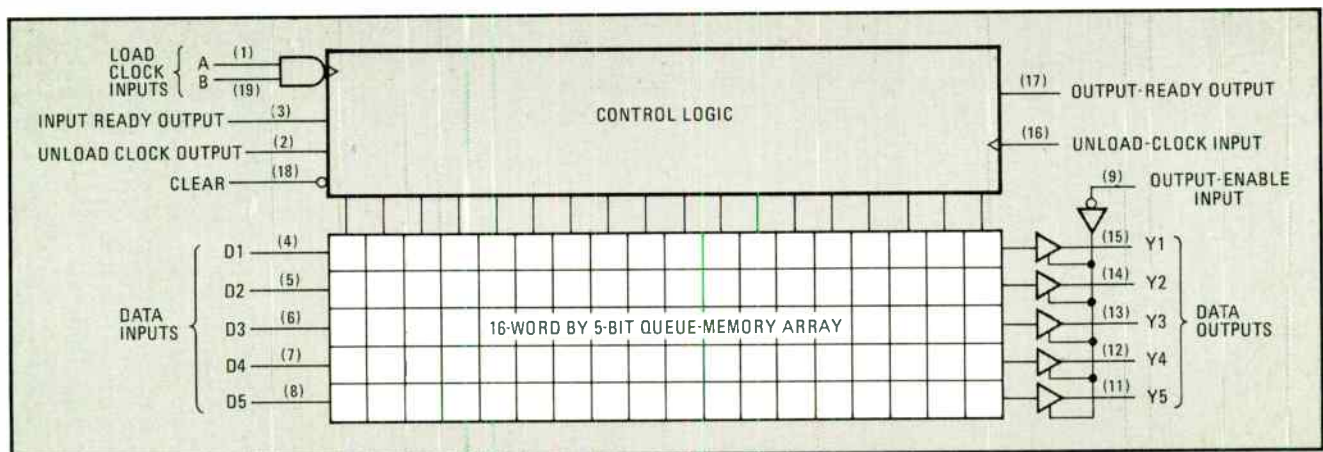

Where can you find a remote controlled cassette tape transport for under \$100?

For years, designers have been waiting for a high quality tape transport at a reasonable cost. Now the Phi Deck has arrived, the first American-made transport with features like complete remote control, quick head engagement, no tape coasting, battery or AC current operation, a capability for digital or analog signal recording and standard or non-standard speeds. But the features don't stop there. It can play a C-120 cassette with ease, has the fastest stop-start speed of any deck of its kind on the market, and because it has four separate motors, can be equipped to electronically sense the status of the tape, preventing any tape damage, ever. And the price is under \$100 even if you buy just one. There are so many uses for a transport with this flexibility, it's a wonder someone didn't think of it before.

HERE!

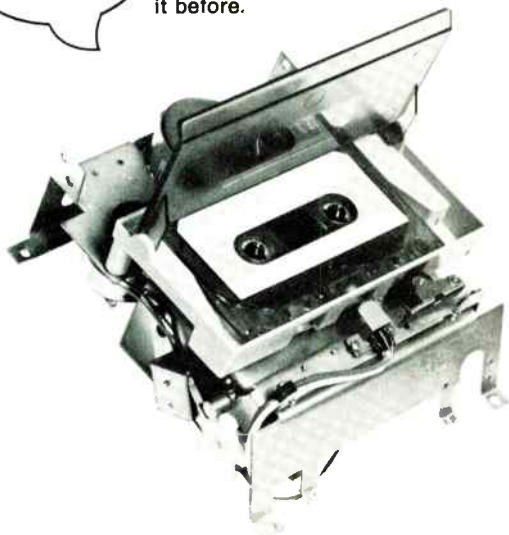

PHI-DECK A PRODUCT OF I.I.I.

An affiliate of The Economy Company, Educational Publishers
Oklahoma City, Oklahoma 73125

Call, write, or send the coupon to:

Individualized Instruction Incorporated
1901 N. Walnut
Oklahoma City, Oklahoma 73105
(405) 528-8444 Ext. 76

Please send me more information about
PHI-DECK.

Name _____

Address _____

City _____ State _____ Zip _____

G

New products

the SN74S299, which is available now, is \$5.60 each in lots of 100 pieces.

Another important device in the new Schottky family, one that will become available in the first quarter of 1975, is the model SN74S373 octal latch. This device, which consists of eight transparent D-type latches in a single package, is nothing less than a byte-size input/output port for a microprocessor. It provides full parallel access for loading and reading, has a Schmitt-trigger clock for high noise immunity, and has three-state bus-driving outputs. Typical propagation delay time is 4.5 ns; and typical collector current is 95 mA.

Among the ROMs and PROMs in the new family, perhaps the most significant is the 2,048-bit model SN74S471 programmable read-only memory, which is organized into 256 8-bit words. Like the universal shift register, the PROM comes in TI's new high-density 20-pin package, has three-state outputs to drive data buses directly, and has high-impedance pnp inputs which reduce the address-buffer-drive requirements. The memory has a typical chip-select access time of 15 ns, and a typical address-select access time of 45 ns. Typical power consumption per bit is 0.25 milliwatt. The ROM versions of this PROM are the models SN74S271 and the SN74S371.

Since a fast interface is needed between slow peripheral devices and ever faster processors, the model SN74S225 asynchronous first-in/first-out memory is expected to prove useful to designers of equipment for applications such as real-time data processing. This 16-word by 5-bit device can handle data rates—both input and output—from dc to 30 MHz. Since even the fastest minicomputers don't transfer data any faster than about 10 MHz, this device has speed to burn in terms of today's requirements, but clearly will continue to be useful with forthcoming generations of bipolar processors.

Texas Instruments Inc., Inquiry Answering Service, P. O. Box 5012, Dallas, Texas 75222 [338]

We put the Guardian Angel TO THE TEST!



“Hey, Angel,” we said, “lots of engineers need a very small relay (like with all terminals on .1” grid for PC boards) but they want it to carry a big load (like up to 50 amps).”

“Easy,” said the Guardian Angel.

“Wait,” we said, “this relay must be very dependable (like for computers and business machines) but must be very low cost (like for the competitive appliance business).”

“Not so easy,” allowed the Angel.

“There’s more,” we told her. “Engineers want this relay in dozens and dozens of variations (like 5 to 50 amps, SPST to DPDT and everything in between). Oh, and AC or DC.”

The Guardian Angel looked at us like we were nuts.

“And while you’re at it,” we went on, “give it a temperature range -45°C to $+70^{\circ}\text{C}$... life span over 10,000,000 operations...and bring it in at about an ounce.”

The poor kid just started to cry.

“Look,” says we, “you’re supposed to be *THE* Guardian Angel of engineers, so let’s see you do your stuff. PASS US A MIRACLE, BABY!”

DID THE GUARDIAN ANGEL SUCCEED?
Or did she fall on her pretty patoot?

SEE NEXT PAGE FOR THE EXCITING ANSWER ▶▶▶

Components

Capacitor has wide range

Layered construction of film-dielectric trimmer broadens capacitance swing

Because of its interleaved construction and film dielectric, a new series of trimmer capacitors provides a wide capacitance swing and tight temperature coefficient at low cost. The film dielectric is basically a pol-

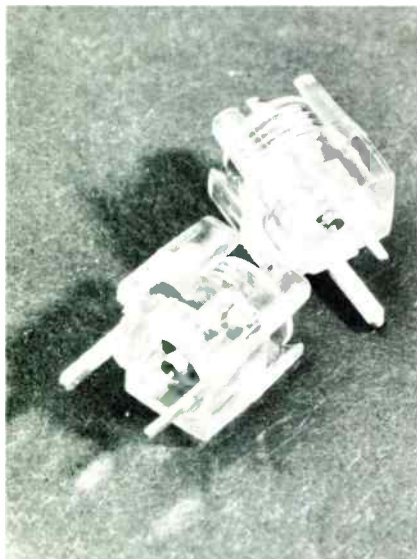

ymide/FEP sandwich, alternately layered with the trimmer's rotor and stator. The number of these alternated layers determines device capacitance.

The series 809-05 trimmers are intended for commercial/industrial applications. They are available in three nominal capacitive ranges: 1 to 3.5 picofarads, 1.8 to 10 pF, and 2 to 18 pF. All have a working voltage rating of 300 v dc, but they are tested to 600 v dc. Their temperature coefficient is $-350 \text{ ppm}/^\circ\text{C}$ $\pm 150 \text{ ppm}/^\circ\text{C}$ over the range of -40°C to $+125^\circ\text{C}$. At 1 megahertz, their Q factor is 1,000.

The new 0.02-ounce trimmers are constructed for pc-board mounting

on a 0.1-inch grid. When seated, they measure 0.292 inch wide by 0.264 in. thick by 0.36 in. high. The outside case is made of polysulfone, and the screwdriver adjustment can be located at the top and/or bottom of the units. The brass rotor has gold-plated contacts, while the stator is silver-plated brass.

The settability of the trimmers is quite good because of their light-torque adjustment. For the 1-to-3.5-pF unit, the required torque ranges between 0.15 and 2.0 ounce-inches. For the 1.8-to-10-pF unit and the 2-to-18-pF unit, it lies between 0.35 and 2.7 oz-in.

Unlike competitive ceramic trimmers, the series 809-05 film-dielectric devices can be dropped without sustaining damage. A trimmer made with a ceramic dielectric, which is brittle by nature, tends to chip or crack when dropped.

The new film trimmers cost 55 to 65 cents in quantities of 10,000 or more. Delivery time varies from stock to six weeks.

Mepco/Electra, Inc., Columbia Rd., Morristown, N.J. 07960 [341]

Aluminum capacitors cost 40% less than tantalums

A line of aluminum solid-electrolytic capacitors resembles tantalum units both electrically and physically, yet costs up to 40% less for a given value of capacitance. The square devices are available in nine capacitance values—ranging from 0.1 to 2.2 microfarads—and in three voltage ratings. The working voltages are 10, 16, and 25 volts, with respective surge voltage ratings of 13, 20, and 32 v. Price of the 0.22-

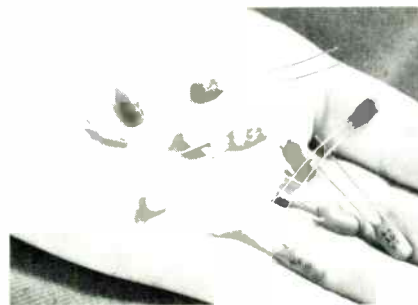

μF , 10-v capacitors is \$59 per thousand in lots of 10,000. Delivery is from stock.

International Importers Inc., 2242 South Western Ave. Chicago, Ill. 60608 [344]

Proximity switch senses only nonferrous metals

The solid-state Tepco 500 series proximity switch is unaffected by ferrous materials, but is sensitive to nonferrous metals. The device, which operates directly from 120 volts ac, will typically sense aluminum at 0.25 inch and will switch up



to 100 watts of power. The sensors are sensitive at their front faces only and are offered with both normally open and normally closed output contacts. Packaged in a steel housing 1 in. in diameter and 3.25 in. long, the switch will accept standard 0.5-in. conduit fittings.

Technical Electronic Products Co., 52500 Southdown Rd., Utica, Mich. 48087 [345]

Mercury-film relay is not position-sensitive

A miniature mercury-film relay provides bounce-free switching of currents from a few picoamperes up to 2 amperes. Unlike conventional wet mercury relays, the film device is not position-sensitive; it provides a contact resistance of less than 150 milliohms regardless of orientation. The relay is mounted in a 16-pin dual in-line package measuring 0.413 inch high by 0.787 in. long by 0.433 in. wide. The model DL is hermetically sealed for long life: it is

We said,
"OK, Angel,

**PASS US
A MIRACLE"**

and she
produced the

**AMAZING
1360
RELAY**



IT'S SMALL... all terminals on .1" grid spacing for standard PC board, weighs about an ounce.

IT'S BIG... carries 5 to 50 AMPS with a life expectancy over TEN MILLION operations.

IT'S HIGH... in quality to meet uncompromising dependability demands.

IT'S LOW... in price to keep your product competitive.

IT'S VERSATILE... DPDT, DPST-NO; DPST-NC, SPDT, SPST-NO; SPST-NC... 5 to 50 amps, AC or DC. Solders right on PC board... or use mating socket.

Way to go, Angel...way to go!

SEND FOR... the complete story on the new 1360... plus all the other miraculous Guardian Relays. Circle the reader service number for your just-off-the-press 1974 RELAY CATALOG.



GUARDIAN[®]

GUARDIAN ELECTRIC MANUFACTURING CO. 1566 West Carroll Ave., Chicago, Illinois 60607

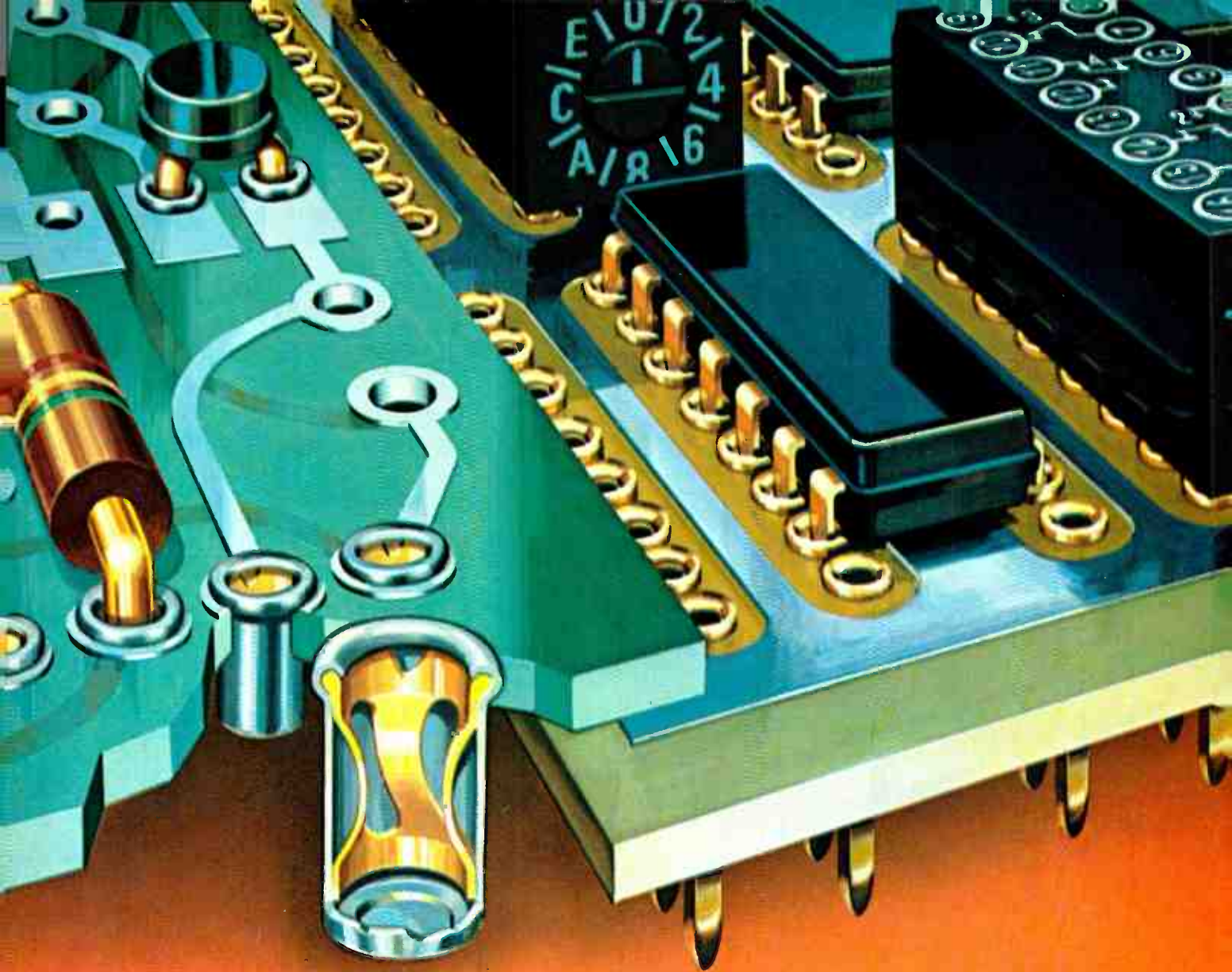

AMP gives you 60 minutes to put 3,000 sockets in their place.

Because that's all the time you need with our high-speed socket applicator. The sockets themselves give you easy pluggability.

And easy mounting of leaded devices such as transistors, crystals, plug-in relays and integrated circuit packages.



AMP sockets have closed or knockout bottoms, plus posted versions. They can take round or rectangular leads. And their low profile offers high packaging density. Gold- and tin-plated sockets are available, and all have excellent solderability.

So if you want quick, reliable loading of miniature spring sockets into dielectric panels, at low applied cost, call (717) 564-0100. Or write AMP Incorporated, Harrisburg, Pa. 17105.

AMP is a trademark of AMP Incorporated.

AMP

INCORPORATED

New products

EUROPE

Austria—AMP Austria. Branch of AMP Deutschland G.m.b.H., Markgraf-Ruediger Str. 6-8, 1150 Vienna. Phone: 924191/92

Belgium—AMP Belgium. Branch of AMP-Holland N.V., Rue de Brabant 62-66, Brussels. Phone: 19.36.07

France—AMP de France. 29, Chaussee Jules-Cesar, Boite Postale No. 39, 95301-Pontoise (Val d'Oise), France. Phone: 464-92-20, 464-92-30

Germany—AMP Deutschland G.m.b.H., Amperstrasse 7-11, 607 Langen, B. FFM., West Germany. Phone: (06103) 7091

Great Britain—AMP of Great Britain Limited, Terminal House, Stanmore, Middlesex, England. Phone: 01-954-2356

Holland—AMP Holland N.V., Papierstraat 2, 's-Hertogenbosch, Holland. Phone: (04100) 25221

Italy—AMP Italia S.p.A., Via Fratelli Cervi 15, 10093 Collegno (Torino), Italy. Phone: 785-656

Spain—AMP Española. S.A., Apartado 5294, Pedro IV, 491, 495, Barcelona 5, Spain. Phone: 307-75-50

Sweden—AMP Scandinavia AB, Datavagen 5, 175 00 Jakobsberg, Sweden. Mailing Address: Fack S-175 20 JARFALLA 1, Sweden. Phone: 0758/10400

Switzerland—AMP A.G., Haldenstrasse 11, 6006 Luzern, Switzerland. Phone: (041) 235421, 235422, 235423

NORTH AMERICA

Canada—AMP OF CANADA LTD., 20 Esna Park Drive, Markham, Ontario. Phone: 416-499-1251

Mexico—AMP de Mexico, S.A., Apartado Postal 179, Naucalpan de Juarez, Edo. de Mexico. Phone: Mexico City 576-41-55

Puerto Rico—AMP OF CANADA LTD., 677 Calle de Diego, Rio Piedras, Puerto Rico 00924. Phone: (809) 766-2346

United States—AMP Incorporated, Harrisburg, Pa. 17105. Phone: 717-564-0100

SOUTH AMERICA

Argentina—AMP S. A. Argentina 4 de Febrero, 76 Villa Zagla—SAN MARTIN, Buenos Aires, Argentina. Phone: 752-4612

Brasil—AMP do Brasil Ltda., Rua 7 de Abril 355, Sao Paulo, Brasil. Phone: 335-204

PACIFIC

Australia—Australian AMP Pty. Limited, 155 Briens Road, Northmead, N.S.W. 2152 Australia. Mailing Address: P.O. Box 194, Baulkham Hills, N.S.W. 2153 Australia. Phone: 630-7377

Japan—AMP (Japan), Ltd., No. 15-14, 7-Chome, Roppongi Minato-Ku, Tokyo, Japan. Phone: 404-7171

For AMP products and services in most other countries, there's a network of official distributors. To get more information about them, please write: AMP International Division, Harrisburg, Pa. 17105, USA.

AMP

INCORPORATED

rated for more than five million operations at 1 A, 24 v dc, and it can go more than 50 million operations at 10 microamperes, 100 millivolts. Both of these figures are for direct current and resistive loads. The model DL is available in four different coil voltages: 5, 6, 12, and 24 v. Corresponding operating powers are 385, 400, 410, and 440 milliwatts.

Arrow-M Corp., 250 Sheffield St., Mountainside, N. J. 07092 [343]



Metal-film resistors

are 100% tested

The MR series of metal-film resistors is 100% screened by means of a proprietary third-harmonic distortion test, at no extra cost to the user. Available in 0.5- and 0.25-watt sizes, the resistors are offered with 1% and 2% tolerance ratings and are supplied either on lead tapes or on reels. Equivalent to the manufacturer's military type R107 and R120 resistors, the new components have

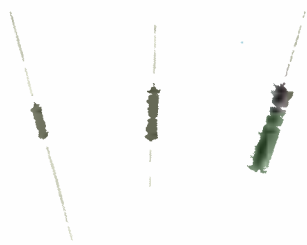

the added advantage of being flame-retardant.

Mepco/Electra Inc., Columbia Rd., Morristown, N. J. 07960 [346]

Low-profile relay permits 0.5-inch board spacing

A lightweight, low-profile relay for use on printed-circuit boards permits board spacings as close as 0.5 inch center to center. The model T10 weighs only 30 grams and measures 0.375 in. high. It is a four-pole Form C device with a contact life expectancy of at least 50 million op-

erations at no load to 50,000 operations at full rated load. Initial contact resistance is 50 milliohms or less. The contacts are made of gold-flashed silver and are rated at 0.1 to 3.0 amperes at 30 v dc resistive. Coil voltage ratings are 6, 12, 24, 36, and 48 v dc. The relay will pull in at 75% of the rated coil voltage and has a power requirement of 800 milliwatts. Pricing of the relay can be as low as \$3.06 in large quantities.

Potter & Brumfield Division, AMF Inc., 1200 E. Broadway, Princeton, Ind. 47670 [347]

Capacitors have strong leads for automatic insertion

A line of conformally coated axial-leaded ceramic capacitors features exceptional lead strength—making the devices suitable for use with automatic insertion equipment. The Blue Dart line is offered in two physical sizes covering the capacitance range from 10 picofarads to 0.12 microfarad. Special attention is given to the application of the conformal coating to prevent the drip-down or "pants leg" commonly found on axial-lead dipped capacitors.

Emcon, A Division of Illinois Tool Works Inc., 11620 Sorrento Valley Rd., San Diego, Calif. 92121 [348]

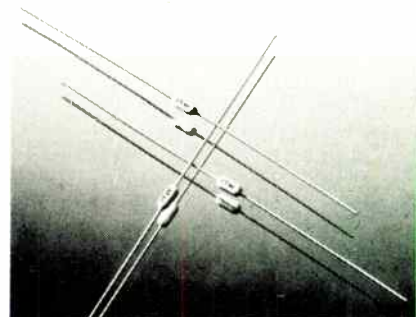

Who will be your top Your Advertising

5 thoughts on why and how the Electronics Technology Marketing burden is shifting from direct selling to advertising.

1. *Nobody can afford market coverage at \$66,680 per thousand.*

The mathematics of selling dictate that we can no longer afford to add market coverage just by adding salesmen. What we have to do is make the salesmen we have a *lot* more effective. The evidence is all around us:

- The average cost of an industrial salesman's call has gone from \$42.92 to \$66.68 in the last six years.

- The potential customer base for electronics technology has more than doubled in the last 10 years, and may very well double again in the next 5. Can we afford to redouble our sales staffs?

- A typical sales engineer calls regularly on fewer than 50 individuals per year. So if you have a big sales force—say 100 people—you are regularly contacting fewer than 5,000 out of

the more than 150,000 people who are making decisions for and against you every day. *In the U.S. alone.*

- A typical sales engineer spends only 3 hours and 53 minutes per day across the desk from a customer. That's the good news. The bad news is *how that time is spent*—explaining again what your company does for a living, why it's a good company to do business with, the products you make, your position in the market, what you can do for the customer, going through the literature, showing the samples, and on and on. Not to mention last night's ball game and the joke every other salesman is telling that week. You can't afford to let this happen—you have too much invested in your sales engineer's time and skill. He must be employed at his *highest* efficiency.

2. *Selling is communicating. The trick is to pick the right media.*

Salesmen are communications media just like publication advertising, trade shows, catalogs, buyers' guides, and direct mail. In some ways they are the most effective media. But they are *by far* the most expensive.

Once we accept the idea of salesmen as just one of many marketing communications media which we can select, we can begin to assign them the proper roles. And then assign the ad manager *his* proper role.

The *primary* role of salesmen as communications media is *selling*: Closing in on and negotiating orders for *known* business potentials at *known* customers. Other good roles for salesmen are: Regular hot-lunch-and-love with key customer personnel, personal follow-up of *well-qualified* sales leads, negotiating *complex* specifications or custo-

mer requirements, providing product demonstrations that have been *requested* by the customer, checking *major* customer and distributor inventory levels to recommend adjustments, and handling major, *serious* complaints.

Other roles for the salesman (not particularly productive but probably unavoidable) are: meeting the sales manager's airplane, call reports, quarterly territorial forecasts, and pigeon at the sales-meeting poker game.

3. *Communications media roles to which your Ad Manager should be assigned include:*

- Identifying new customers. Use your advertising to *help the new customer find you*. Screen the inquiries carefully with letters, reply cards, and the telephone until you find an opportunity worth the investment of \$66.68.

- Disseminating Information. Use your advertising to get the customer to *ask* (under no pressure) for your catalogs, spec sheets, and applications notes.

- Distributing samples. Ditto.
- Lining up demonstrations.

If your product must be demonstrated to be sold, you can use your advertising to motivate the customer to request a demo. Then your salesman can mop up. His batting average will be better than if he arranges the demos on his own.

- Building knowledge about—and preference for—your company. There's just no way your salesmen can do this. They don't have the time. Your advertising manager *can* do it. *Inexpensively*. Do a little survey of your own. Ask your salesmen for a list of questions customers ask about

salesman next year? Manager.

your company. If there are more questions than "What would you like to sell me today?", you have an advertising opportunity.

4. *How your ad manager can sharpen your message and make your advertising more effective with direct-response appeals.*

Whether you make the simplest component or the most complex measurement system, see what you can do to "package" your advertised offering as if it could be sold on a direct-response basis.

This will improve your customer's perceived ratio of benefits to price to risk and ease of purchase. And, your advertising will work harder for your salesmen. Here's where your ad manager can really shine.

For example:

- Direct marketing approach leads to sale (either direct or through distribution) of low-cost instruments and components. A free-trial feature may be the key.
- For higher-priced, more complex equipment and components, the direct-response message can trigger a request for demonstration, applications information, or performance data. A "no-obligation" feature could be useful.
- For complex systems, or state-of-art components, direct-response appeals can motivate the potential new customer with a problem *to find you* (your sales organization probably won't find him) and to do so in the context of a specific solution you can provide. Following up this kind of request is where your salesman is most effective.
- Another winning appeal is "direct marketing benefits"

aimed at high-level technical management with an "over-the-shoulder" approach. ("Tear out this ad and send it to your design chief.")

- An alternate approach is solutions-oriented, designed to hit the technology manager where he's hurting. ("If it would take you more than 20 minutes to design this filter, call us collect.")

5. *Other random thoughts on direct marketing appeals:*

- If your selling proposition is too complicated to be expressed in direct-response advertising, it may be too complicated. Period.
- To be effective, direct-response advertising must be *consistent*.
- In media selection, seek combinations of publications which give you the *broadest* possible coverage consistent with impact and continuity.
- If publications do not perform well in the direct marketing mode, don't use them for this purpose.
- The tools you use to follow up on customers' direct responses (letters, phone calls, design kits, catalogs, etc.) are all expensive. But nowhere near \$66.68 each. So do it right.

Why am I telling you all this?

First, because I'm tired of seeing advertising budgets wasted on vague objectives and messages when they could be invested to do a lot of things our over-committed sales staffs are trying to do now.

Second, because I'm tired of seeing the ad manager having to justify his existence when he should be the key man on your sales team.

Third, because advertising is an important source of revenue for *Electronics*, and we will only succeed long term if electronics companies really take advantage of the economic power of advertising.

Fourth, because *Electronics* is the *premier* direct-marketing medium. The more people who find that out, the better I'll like it.

Daniel A. McMillan III
Publisher

P.S. If you've gotten this far, you should know that you've just read a direct-marketing ad. Why not go all the way and send me the following coupon?

To: Dan McMillan, Publisher
Electronics
1221 Avenue of the Americas
New York, N.Y. 10020

- Please send me a reprint of this ad plus the prior 4 in the series.
 Just send a reprint of this ad—I already got the other 4.
 Maybe there's a grain of truth in what you said. Have someone call me to talk about direct-marketing appeals for my products.

Name _____

Company _____

City/State/Zip _____

Phone _____

Electronics
THE SOURCE

This is the Fifth of a series of editorials on advertising, marketing, and planning in the Electronics Technology Marketplace. Your comments are welcome.

Instruments

Counter carries low price tag

Automatic microwave unit for \$4,000 uses YIG-tuned generator, thin-film circuits

One of the more welcome technological innovations of recent years has been the development of automatic counters to measure microwave frequencies. Manual counters require operator skill to make



the measurement and interpret the display. Now, automatic counters can measure highly complex signals, but these instruments are expensive. Most automatic counters are priced in the \$5,000 to \$6,000 range—about \$1,500 to \$2,000 higher than manual counters.

EIP Inc. of Santa Clara, Calif., is seeking to overcome the price barrier by offering the model 331 microwave counter, which provides fully automatic frequency measurements from 0.825 to 18 gigahertz. The low price of \$4,000 has been previously associated only with manual transfer oscillator counters and heterodyne units for plug-in counters.

The automatic operation of the EIP 331 eliminates the need for manual adjustments to tune a cavity or phase-lock an oscillator. Measurements can be made simply by connecting the unknown frequency to the input and reading the display. The Autohet measurement technique provides unusual fm tolerance plus sensitivity, the result of a system built around a solid-state

YIG-tuned comb generator and thin-film circuitry.

The center frequency of signals with as much as 200 megahertz fm deviation can be measured directly. Modulation from high-density communications channels or electronic-countermeasures circuitry can be operating while measuring carrier frequencies. The counter has a sensitivity range from -15 dbm to -20 dbm. Sensitivity can be extended to -20 dbm to -25 dbm by adding a \$250 option.

To simplify the display and eliminate the need to interpret the legend, decimal point, or a dial setting, a seven-digit display with fixed decimal point is divided into gigahertz, megahertz, and kilohertz sections. Green light-emitting diodes in the display avoid what the company calls "the visual discomfort associated with intense red LEDs."

Remote programing, BCD output, and rear-input options are available for systems applications at \$600, \$100, and \$50 respectively. In the system mode, as many as 800 readings per second can be made.

EIP Inc., 3130 Alfred St., Santa Clara, Calif. 95050 [351]

Portable megohmmeter built for plant, field tests

Designed for measuring insulation resistance, troubleshooting insulation faults, and for preventive maintenance and other testing functions, a line of portable megohmmeters rapidly checks out equipment in the factory and field. Called the series L-17, the megohmmeters consist essentially of an insulation resistance-

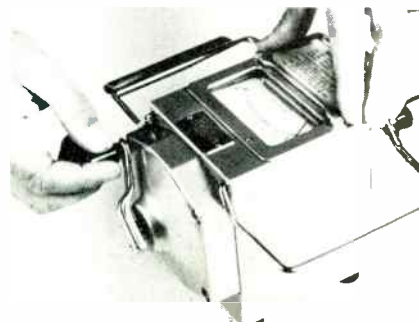

measuring element and a hand-powered generator for current supply. Measurements are made by connecting the terminals of the megohmmeter to those of the lines or wiring under test, and turning the crank. Resistance is read directly on a scale. Different models can apply voltages ranging from 250 to 2,500 volts and can measure resistances from 50 to 10,000 megohms.

Beckman Instruments Inc., Cedar Grove Operations, 89 Commerce Rd., Cedar Grove, N.J. 07009 [353]

Receiver calibrates local frequency standards

Providing output signals that are phase-locked to the National Bureau of Standards station, a WWVB receiver permits calibration of frequency standards, frequency synthesizers, counters, oscillators, and other sources to NBS accuracy. The model 8160 receiver includes a frequency-difference counter with 0.01-hertz resolution, digital readout for making absolute error measure-



ments, and phase-locked outputs at the frequencies most often used in counters and synthesizers. The unit is rack- or bench-mountable. Price is about \$1,300, and delivery time is 90 days.

Spectracom Corp., 87 Wedgewood Dr., Penfield, N.Y. 14526 [354]

System compresses signals onto tape for analysis

A compression/expansion system called the model 3170 interfaces wide-dynamic-range input signals to

New from Zeltex INC.

ADC12QZ and DAC12QZ

A/D CONVERTER

12 Bits/40 μ sec

- Unique Low-Noise Successive-Approximation Design
- Fully Self-Contained with Guaranteed No Missing Codes Over 0° to 70°C
- Pin Configuration Conforms to Popular Industry Standard
- Quantities 1-9 . . . \$129.00

There are several variations of the above models also available featuring:

Resolutions from 8 to 14 Bits
Speeds to 3 μ sec (ADC) and 300 nsec (DAC)
Extended Temperature and Military Performance

All Pin-Interchangeable!

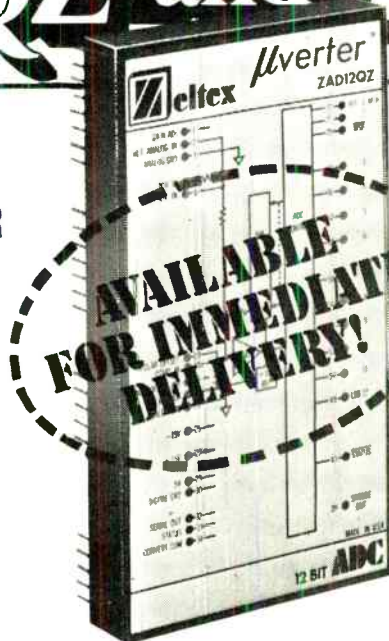

D/A CONVERTER

12 Bits/5 μ sec

- Gain Stability Less Than 10 ppm/°C. Offset Stability 3 ppm/°C
- Fully Monotonic Over 0°C to 70°C
- Pin Configuration Conforms to Popular Industry Standard
- Quantities 1-9 . . . \$ 79.00

To place your order now,
call Gene Lavielle (415) 686-6660 or
TWX 910-481-9477

Zeltex INC. 940 DETROIT AVE. CONCORD, CA 94518
(415) 686-6660 TWX 910-481-9477

Circle 141 on reader service card

The high performance photoreader family

With an eye focused on giving you top price/performance, Tally brings you a family of photoreaders loaded with features. Here's the line-up.

Model R-2050

The new Tally R-2050 delivers 250 characters per second for only \$275. Or \$375 with com-



plete electronics. The compact, super reliable unit features easy, adjustment-free operation.

Model R-2000

For added performance power, the R-2000 comes complete with power supply and bi-directional drive elec-



tronics. Prices start at \$546. Numerous options can be added. Speed is 300 cps continuous and 200 cps asynchronous.

Model R-5000

For those applications that demand the very best, the top of the line R-5000 has



speeds of 500 cps continuous and 1200 cps search. It's the reader with all the extras built-in.

TALLY

Get the full story. Write or call Tally Corporation, 8301 So. 180th St., Kent, Washington 98031. Phone (206) 251-6771.

Circle 182 on reader service card

Ballantine, 3 to 1 in your favor!

New 15MHz Precision Voltmeter replaces three old designs
100 μ V sensitivity
unmatchable performance
from \$385

Call your local Ballantine field engineer



BALLANTINE LABORATORIES, INC.
P.O. Box 97, Boonton, New Jersey 07005
201-335-0900 TWX 710-987-8380

3045A / 3046A



Circle 183 on reader service card 141

DON'T BE TALKED INTO LESS



BUY THE WORLD'S BEST



MX-1. The biggest bargain in the industry becomes an almost incredible buy. Our base price now includes AC, DC and ohms. And we do it without sacrificing NLS quality on any feature. Price includes five voltage ranges from .100000 volt full scale (1 microvolt sensitivity), to 1000.00 volts full scale; plus autoranging and wide-range ratio. Five full digits (with a sixth for 20% over-ranging). Options include BCD outputs and ratio to + 100 VDC reference. (Mil Spec version designated as AN/GSM-64).

\$1295



LX-2. There is no competitive instrument that can match the LX-2's quality. The standard model comes with four full digits—plus a fifth for over-ranging; and measures DC volts, AC volts, resistance, and multi-function ratios—automatic ranging included. Automatic polarity and range selection. Options permit BCD outputs and battery operation. The LX-2 is our fastest selling four plus digit multimeter. Mil Spec (Class II) version is designated as AN/USM-341.

\$645



NON-LINEAR SYSTEMS, INC.

P.O. BOX N, DEL MAR, CALIFORNIA 92014

ORIGINATOR OF THE DIGITAL VOLTMETER

CALL TED JANSEN COLLECT AT 714-755-1139 (TWX 910-322-1132)

Circle 142 on reader service card

NEW NEW NEW

IMC introduces fan for cooling sandwiched areas

IMC's new, high performance FULMAR fan features maximum efficiency for cooling high power density enclosures and rows of printed circuit board arrays. Unique design of this fan allows for convenience of "Side by Side" mountings for maximum airflow distribution and stable motor performance under low voltage (brown out conditions). Fulmar's low noise level is a natural for computer room use.



4-3/4" diameter by 5-29/32"

FEATURES

- A compact 2" in depth
- Meets U.L. recognition requirements
- Automatic reset overload protector is standard
- Capacitor supplied with unit

50/60 HZ AIRMOVER



Circle the "Bingo" for details! For immediate service please call Fred Taylor, Sales Manager at (603) 332-5300 or write:

IMC MAGNETICS CORP.

NEW HAMPSHIRE DIVISION

ROUTE 16B, ROCHESTER, NEW HAMPSHIRE 03867

142 Circle 181 on reader service card

New products

a standard instrumentation tape recorder by compressing ac signals of over 100-dB dynamic range onto magnetic tape. The compressed signal may then be analyzed by a spectrum analyzer, or it may be restored to its original range before analysis. Heart of the system is the model 3171 record amplifier. In the compress mode, a precision detector in



the feedback loop maintains the average value of the amplifier output at a constant level. This level and the gain-analog level are recorded on two tape tracks and played back later on the two tracks for analysis. The 3171 record amplifier has a frequency response from 1 hertz to 100 kilohertz, 80-dB gain range, gain accuracy to within ± 0.25 dB, differential input, and selectable constant-output levels of 0.316 or 0.1 volt. It is priced at \$1,250. The compressed signal can be restored with the model 3172 playback expander, which is priced at \$1,500.

Ithaco Inc., 735 W. Clinton St., Ithaca, N.Y. 14850 [355]

Portable frequency counter covers 30 Hz to 600 MHz

A compact frequency counter designated the model 1680 is suitable for field or laboratory use and operates from either an ac line or internal rechargeable batteries. Intended for mobile land, sea and airborne communications applications, the unit measures over the range from 30 hertz to 600 megahertz. It has a sensitivity of 10-15 millivolts up to 500 MHz, and 20-40 mV from 500 to 600 MHz. The counter has a nine-digit LED display, and the company says it will measure accurately even when the carrier wave contains a

Electronics/November 28, 1974

TESTING SIMPLIFIED.

A while back, Fairchild Systems Technology decided to simplify incoming inspection of semiconductor devices. We established a design concept: "Make it easy for the user." Then we took our ideas a logical step further. It had to be foolproof.

The result? Fairchild's Qualifier 901, a benchtop tester for incoming inspection of CMOS, DTL, and TTL logic ICs.

It's a low cost, high performance IC tester featuring simplicity of operation and maintenance. Designed primarily for incoming inspection, the Qualifier 901 system keeps faulty IC's out of finished products, thus eliminating expensive rework and repair.

OUR NEW BUSINESS CARD

The Qualifier 901 is easily programmed by the "Qual-Card" - a



software entry device, made of plastic and optically coded for each program required. The Qual-Card is virtually indestructible and leaves nothing to chance.

To test a run of devices, an operator merely inserts the appropriate Qual Card for the device to be tested into the optical reader in the Qualifier 901. There are no knobs to turn. No switches to select. No values to choose. The Qual-Card does it all.

It absolutely dictates what is to be measured, to what levels, and to what accuracy. In 60 to 200

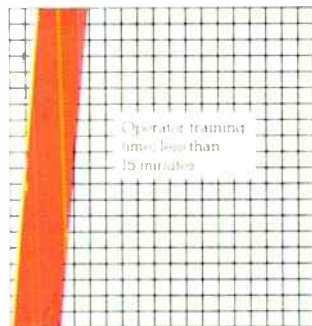

microseconds your 16 to 24-pin IC has been thoroughly tested functionally and parametrically.

A standard device library of several hundred Qual-Cards is available from Fairchild Systems Technology and can be delivered on a turnaround basis. If a custom card is required, it can be written and verified by Fairchild, then delivered by mail for your immediate use.

TWO SELECTIVE PROFIT CHARTS

Both charts in this column tell the same truth: the Qualifier 901's simplicity of programming and operation mean fewer testing costs, more profit.

Operator training: No operator training is required beyond basic equipment familiarization. There's no time lost training technicians to read time consuming data sheets. No programmers to hire or train. Nothing is left to chance.

Programming and testing: Testing with the Qualifier 901 is amazingly simple. There are basically only two things you have to remember: The device to be tested and the appropriate Qual Card. You lose no time studying data sheets. The flexible Qual-Cards eliminate paper tapes and performance boards. Qual-Cards are easily stored for ready access.

To test, only four easy steps are required:

Power. Turn power on. The Qualifier 901 automatically performs a self test sequence which checks out the tester hardware. When this is complete the Qualifier 901 is now ready for programming.

Program. The proper Qual-Card is selected to match the type of device being tested. The card is inserted into the slot on the front of the tester and the Ready light is observed.

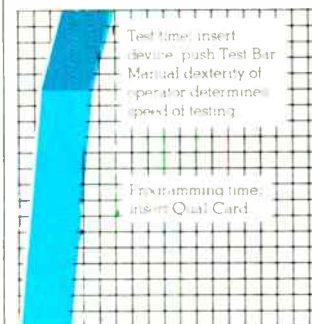

Test. The Qualifier 901 is ready for test and the device is inserted into the test head socket. The "Test Bar" is depressed and the device is tested in 60 to 200 milliseconds.

Observe. The test head indicator lights are observed. Green indicates PASS. Amber indicates FUNCTIONAL PASS. Red indicates FAIL.

Your operator can't miss.

DRO OPTION: FIRST LEVEL ANALYSIS WITHOUT TOP LEVEL COSTS

We've added a new option to the Qualifier 901: A digital readout (DRO) for first level analysis of voltage and current. More than expanded function, there's the true beauty of simplicity in the DRO option. Analysis as simple and foolproof as Qualifier 901 go no-go testing.

Actually, there are two uses for the DRO. One is to monitor voltage levels of the +15 and -15 power supplies - from which analog voltages and currents are derived to be applied to the device. A reading is taken at the reference point of the system to indicate if the supplies are operating and properly adjusted.

The main function of the DRO option is to measure and digitally display the voltage or current of a device on test in a FAIL condition.

Let's pick up the analysis procedure from the last step of go/no-go testing. A red light indicates FAIL condition. The Qualifier 901 is in the STOP and FAIL mode, and on PROTECTIVE OVERRIDE. The operator pushes the START switch.

Qual-Card programming takes over. The program searches out the first failure and stops. An indicator lights opposite the appropriate pin number on a grid display.

The operator turns a pin selector rotary switch until the two digit display matches the pin number lit on the grid display. That's all. The FAIL pin is correctly identified.

Purposefully, there are no pin identification numbers for the

positions of the selector switch. The Qualifier 901 is a universal tester and pin numbers change from device to device, up to the 24-pin capacity. Pin selection - a confusing and error prone task if left to the operator, is processed simply by Qual Card programming.

Once the pin numbers are matched, the operator turns to the function range switch, and selects the appropriate parameter for that should be measured, whether voltage or current.

To emphasize: the DRO option automatically converts from the fixed rotary positions of the pin selector via a microprocessor to actually map the pins of the device. The DRO tells the operator which pin he's on - not vice versa. There is no way to test the wrong pin.



The DRO option: analysis as foolproof as go, no-go testing.

A SIMPLE OFFER

If you'd like more information on the Qualifier 901, now with DRO option, we'll send you a brochure, a list of representatives and a growing library catalog of Qual-Cards now available. Call collect or write today.

Fairchild Systems Technology, A Division of Fairchild Camera and Instrument Corporation, 1725 Technology Drive, San Jose, California 95110. (408) 998-0123, TWX: 910-338-0558.

FAIRCHILD
SYSTEMS TECHNOLOGY
A DIVISION OF FAIRCHILD CAMERA AND INSTRUMENT CORPORATION



**Taking the
delays and
rework out of
wire handling.**



**SEE WHAT
GARDNER-DENVER
IS DOING NOW.**

Speed your wiring work with these tools and machines from Gardner-Denver—the Solderless Systems People. We offer the only complete selection of manual, semi-automatic, and fully automatic equipment for making solderless wrapped connections. Write for Bulletin AC-35 and ask for details on any of the units shown here. Gardner-Denver Company, Grand Haven Division, Grand Haven, Michigan 49417.

Circle 144 on reader service card

*Wire-Wrap is a registered trademark of Gardner-Denver Company.

Portable Wire-Wrap* Tools for production, lab, and pilot work. Air, electric, or battery powered. Also, the most complete selection of wrapping bits and sleeves.



Terminal Locator System for semi-automatic wrapping in medium volume.



Wire Preparation Unit delivers wire cut to length and stripped one end or both. For low or high volume users.



Automatic Wire-Wrap Machine for high production wiring. Makes solderless connections at speeds of 1100 to 1200 wires per hour.



Twisted-Pair Wire Preparation Unit produces twisted wires cut and stripped to length as required.



GARDNER-DENVER

New products

large proportion of a-m. It is 7 inches wide, 10½ in. deep, and 2 in. high. Weight with batteries is 5½ pounds.

Dymar Electronics Ltd., Colonial Way, Radlett Rd., Watford, Herts. WD2 4LA, England [356]

Microwave sources span L through X band

Four modular microwave sources for the L, S, C, and X bands deliver stable, spectrally pure continuous-wave signals in overlapping regions of the spectrum from 800 megahertz to 11.0 gigahertz. Applications include broad- and narrow-band testing of communications equipment. The sources are suited for use as stable local oscillators, the company points out. Stability and freedom



from harmonic outputs are provided by lightly loaded cavity-tuned oscillators. Non-contacting tuning elements eliminate metal-to-metal wear and minimize output noise. Internal modulation facilities include fm and square-wave. Available output power varies from 35 milliwatts to 80 mw, and prices range from \$2,075 to \$2,560. Delivery time is 30 days.

Polarad Electronic Instruments, 5 Delaware Dr., Lake Success, N.Y. 11040 [357]

General-purpose recorder can be used as remote unit

Individual servomechanisms assure precise positioning of chart paper and styli in two general-purpose portable dc recorders, available as single- or dual-pen instruments for field and laboratory applications.



The recorders plot independent variables as analogs of dc voltages against time (model 6006) or against a third analog voltage (model 6002). Recordings are made with overlapping dry styli on 7-inch-wide pressure-sensitive paper—no ink is required. Efficient use of battery power (D cells) allows the recorders to be used in the field and for special tasks as self-contained remote units, the company says. Each instrument is 5 in. in diameter by 15 in. long and weighs 5 pounds. Options are available to the user for interfacing the dc recorders to external equipment.

Instro Co., 3446 Kurtz St., San Diego, Calif. 92110 [358]

Testers use modular high-voltage sections

The five models in the 8060 PL series of portable dc insulation testers are designed to be versatile. Each consists of a control unit, plus one or more identical high-voltage (60 kilovolts) section that are interchangeable and can be expanded from 60 kv to 500 kv in approximately 60-kv increments. The high-voltage circuitry is a cascade system, eliminating the disadvantages of voltage-multiplier circuits. Each air-insulated high-voltage module is a complete voltage doubler with its own epoxy-encapsulated transformer; each transformer has a tertiary winding to feed the succeeding stage. The lightweight, rugged modules feature reversible polarity and high current output for fast charging. Options include a capacitor discharge unit to provide rapid impulsing for fault-location purposes, and a 1% line regulator for low-leakage measurements.

Hipotronics Inc., Brewster, N.Y. 10509 [359]



Psst! It's wrapped.

In less than one second, your operators make permanent, gas-tight electrical connections with Gardner-Denver Wire-Wrap* Tools. Tool weighs only 13½ ounces. Handles 18 through 32 gauge wire. Send for Bulletin 14-1 on Gardner-Denver Wire-Wrap tools, bits, and sleeves. Gardner-Denver Company, Grand Haven Division, Grand Haven, Michigan 49417.

*Wire-Wrap is a registered Trademark of Gardner-Denver Company.

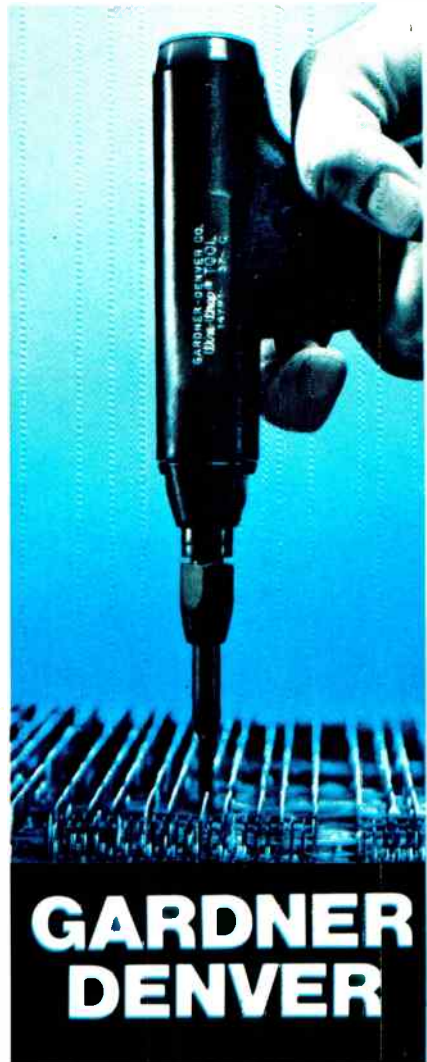

GARDNER DENVER

Domestic or Professional YOUR potentiometer is here

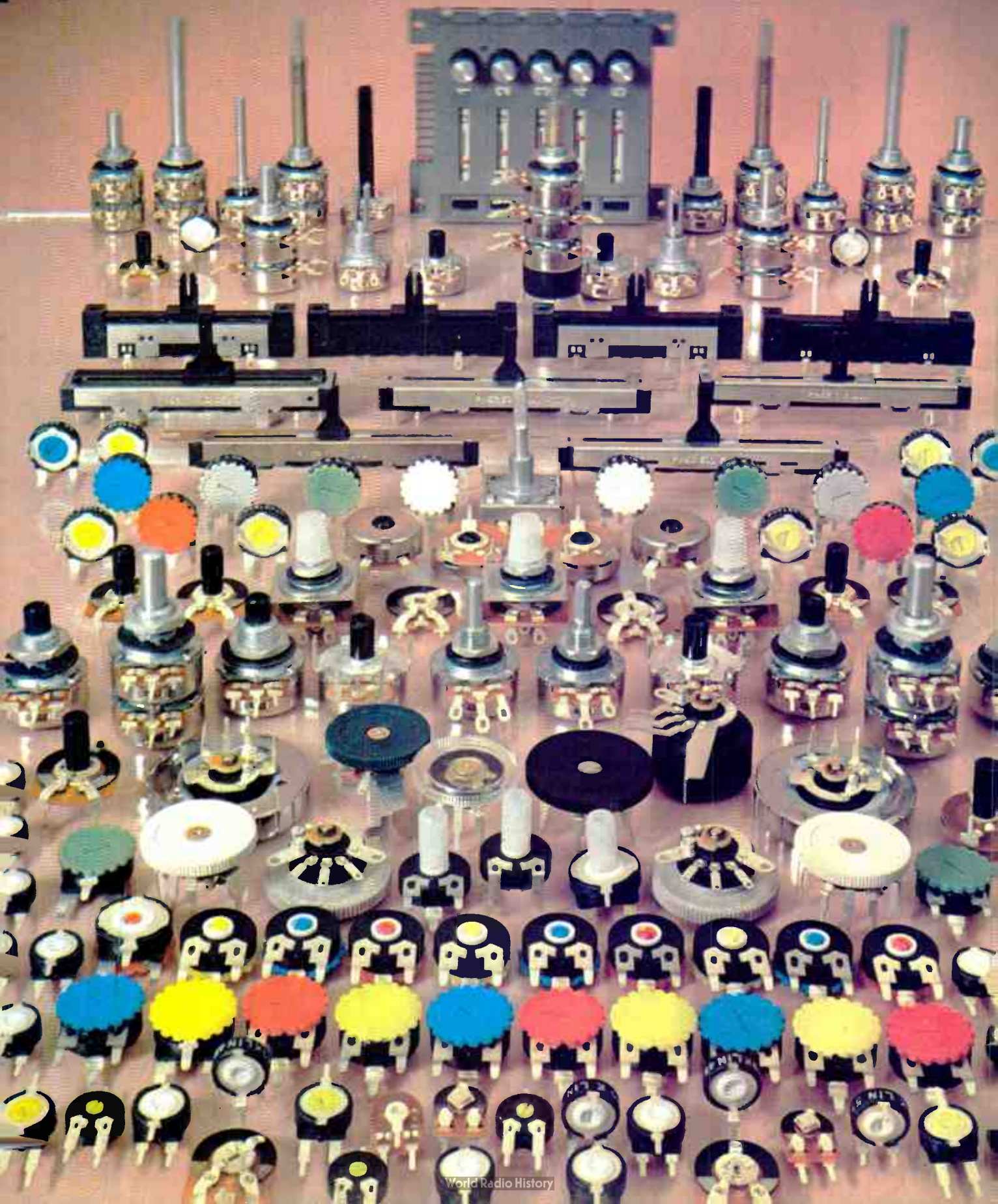

With our range of preset, rotary spindle, slider and rectilinear potentiometers—all designed round the prime requirements of noise-free operation and long life—we have brought new standards of quality and reliability to the potentiometer market for domestic or professional use.

In a technology not normally associated with dramatic breakthroughs we have introduced new ideas to component design and manufacture.

Like our Series PT preset pots which are fully enclosed in flame retardent plastic for protection from environmental factors. And the new PL40 slider pot, with its enclosed track and specially designed wiper movement that eliminates jitter, giving ultra-smooth operation.

Of course we also provide the usual options, like matched pairs for stereo applications, various terminal arrangements, earth screening and mains switches.

There's also the new PL25, a 20-turn rectilinear preset control for radio and tv varicap tuning applications.

In short, in any situation calling for high quality potentiometers, the discerning engineer should turn to PIHER.

Write or ring for full details.

U.K.—PIHER International LTD.,
Romar House, The Causeway,
Staines, Middlesex, England.
Tel: Staines 56157. Telex 934157.

U.S.A.—PIHER International Corp.,
1239 Rand Road, Des Plaines,
Illinois 60016, U.S.A.
Tel: 312 297 1560. Telex 282154.

Germany—PIHER International GmbH,
85 Nurnberg, Tuchergartenstrasse 4,
W.Germany.
Tel: 0911 533 051 Telex 623354.

France—PIHER International SARL,
83, Rue Etienne Dolet, 94230,
Cachan, France.
Tel: 656 26 07. Telex 27107.

Italy—PIHER International S.P.A.,
Via Censio 34, 20154 Milan, Italy.
Tel: 314532/316213.

Head Office—Riera Cañado,
s/n Apartado de Correos 53,
Badalona (Barcelona), Spain.
Tel: 389 03 00. Telex 59521.

 **PIHER**

Circle 146 on reader service card

New products

Semiconductors

PROMs include test bits, words

Design permits factory pretesting—to assure high programming yields

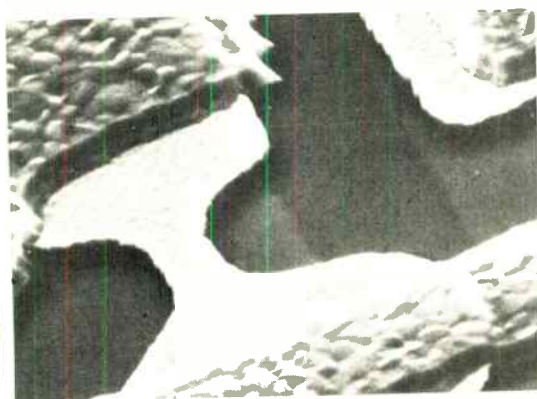

Low yields in the user-programming stage have been a big problem with field-programable read-only memories. In an attempt to solve it, Advanced Micro Devices Inc. adds an extra bit to each word and adds two extra words in one of its latest products, a 256-bit field-programable ROM. The novel technique permits factory pretesting, which in turn is expected to improve yields during user-programming.

The device comes in an open-collector version called the Am27S08 and a three-state-output type, the Am27S09. Both are Schottky-clamped TTL circuits that are organized as 32 words by 8 bits and offer an address-access time of 55 nanoseconds over the commercial temperature range, 75 ns over the full military temperature range of -55°C to 125°C .

The extra or ninth bit on each word plus two extra words are used by engineers at Advanced Micro Devices to make sure that each output can be programmed, that programming one output does not program the one next to it, and that every address-decoder output can handle the programming current.



Also, the design allows testing of ac performance.

The PROMs use polysilicon fuses that are $1/10$ mil wide. This material was selected, AMD says, because it requires lower currents than avalanche-migration or metallic fuses and because it is not subject to metal migration or other potential failure mechanisms characteristic of metals.

The PROMs are shipped with all bits HIGH. As shown in photo (above left), at each bit location there is a narrow link of polysilicon material which is conductive, but which can be opened like a fuse by having a short, high-current, pulse passed through it. The fusing process melts the polysilicon at the center of the link (photo at right, above), and the two melted ends pull away from each other, providing an open circuit that produces a LOW at the memory output.

Both the Am27S08 and -09 are housed in hermetic dual in-line packages. The price for units that operate over the range from 0°C to 75°C is \$8.10 each; from -55°C to 125°C , it is \$16.

Advanced Micro Devices Inc., 901 Thompson Pl., Sunnyvale, Calif. 94086 [411]

16-kilobit ROMs have 450-ns access times

An n-channel, metal-gate, metal-oxide-semiconductor 16-kilobit read-only memory is organized as 2,048 bytes by 8 bits. The mask-program-

**The Gould 6000
Data Acquisition System:
128 fully floating and integrating inputs,
scans to 200 points/sec.**

The portable and rugged Gould 6000 analog to digital data logger-reader is the best way to monitor and precisely record low frequency data. It accepts both analog and digital input signals, converts the data to digital form, displays the data for real-time monitoring and stores up to 500,000 readings on a 3M 1/4" computer grade mag-tape. It offers high noise rejection, high input impedance, programmable gain and much more.

Write Gould Inc., Instrument Systems Division, 3631 Perkins Ave., Cleveland, Ohio 44114. Or Kouterveldstraat Z/N, B.1920 Diegem, Belgium.

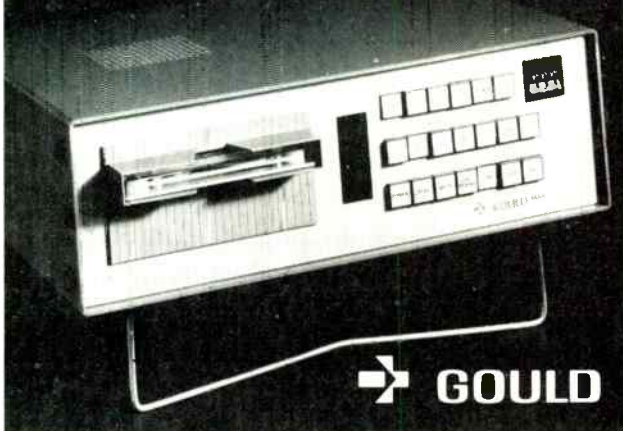

Circle 150 on reader service card

New products

cents each in lots of 1,000.

Signetics, 811 East Arques Ave., Sunnyvale, Calif. 94086

Darlington's have high gain, low saturation voltages

Three Darlington power transistors offer unusually high current gains, good gain holdup, and low saturation voltages. Collector-to-emitter voltages range from 30 to 80 v and current ratings are 2 to 10 amperes. Betas range from 1,000 to 10,000. The model D41K is a 2-A device with a minimum beta of 10,000 at 200 milliamperes. It is a pnp complement to the older D40K. The D44E and D45E are npn and pnp units, respectively; each is a 10-A transistor with a minimum beta of 1,000 at 5A. The devices are intended for such applications as regulators, servo amplifiers, and inverter power supplies. Prices range from 60 cents for the D41K to 80 cents each for the D45E—both in quantities of 1,000 to 9,999. Delivery is from stock.

General Electric Co., Semiconductor Products Department, Building 7, MD49, Electronics Park, Syracuse, N. Y. 13201 [417]

2-GHz transistor puts out 12.5 W with 40% efficiency

The RCA2023-12 microwave transistor delivers a minimum of 12.5 watts across the 2.0-to-2.3-gigahertz band with a gain of 7 dB and a collector efficiency of 40%. Mounted in a stripline package with an internal input-matching network and internal shunt tuning at the collector, the transistor is suitable for large-signal continuous-wave and pulsed applications. Other construction features are integral emitter-site ballasting resistors and low thermal resistance for improved ruggedness and increased overdrive capability. The price of the RCA2023-12 is \$238 in small quantities.

RCA Solid State Division, Box 3200, Somerville, N. J. 06876 [418]

**Do you use
Paper tape punches?**



Type 1133
46 chars/sec

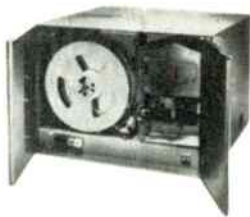

Type 1114
110 chars/sec



Type 1183
80 chars/sec

Other models available.
All models can be supplied with full tape handling and as OEM mechanisms.



Marketing Director
Data Dynamics Ltd, Data House,
Springfield Road, Hayes, Middlesex, England.
Telephone: 01-848 9781. Telex: 935429

023 P115

SIEMENS

Cost-Effective Solutions to Semiconductor Test Problems

APPLICATION:

Verification of semiconductor memory performance from device to system level.

WHAT TO LOOK FOR IN A TESTER:

High speed microprocessor.
Independent X & Y addressing.
Off-the-shelf device interface.



COMPUTEST MODEL 901

Semiconductor testing demands a practical low-cost solution. To check performance of semiconductor memory from the device through the system level requires memory-oriented addressing capability, a stable clock system, performance compatible device interface and real-time error detection. It's all found in the Computest Model 901 benchtop memory tester.

The Computest 901 has an easy-to-use, 10 MHz microprocessor, independent X & Y address generator, and a flexible, multi-channel clock. A complete inventory of RAM/ROM interface modules puts the 901 to work for you immediately.

The Computest 901—flexible, versatile, tailored in price and performance for semiconductor memory testing from device to system level.

FREE!

Send for the Computest catalog of Semiconductor Test Equipment and our Semiconductor Program Library



NAME _____
COMPANY _____
ADDRESS _____
CITY _____
STATE _____ ZIP _____

**For applications assistance, contact:
John Lalley, (609) 424-2400**

Siemens Corporation
Electronic Systems Division
Computest Products

3 Computer Drive, Cherry Hill, N.J. 08002 (609) 424-2400

New products

Data handling

Drive operates up to 4 disks

Master/slave arrangement is less expensive than multiple full drives

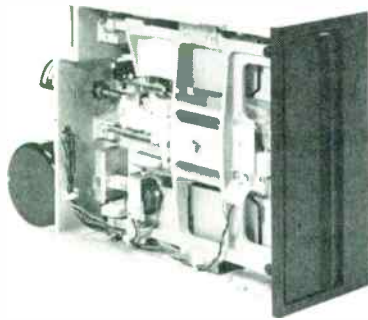

Now that flexible-disk drives are becoming popular in data applications, demand for lower costs is opening a market for dual drives. Dual drives, however, though less expensive than two singles, have disadvantages—notably an interdependence that means complete loss of disk capability if the drive fails.

Orbis Systems Inc. has developed what it calls a compromise, a master/slave system that permits the electronics in one master drive to operate slaves that operate up to four disks. This costs less than multiple full drives, yet provides most of the capability of independent units. It is slightly more expensive than a dual drive of equivalent performance, but less expensive than for three or four systems.

The new Orbis drives are the 74M (master) and 74S (slave), both based on the company's previously announced model 74. Mechanically, the drives are identical, except for the adoption of die-casting in place of the earlier sand-casting. The new casting method not only raises production rates but also permits four drives to be mounted in one 19-inch

rack. Orbis has also added a mechanical interface to prevent the operator from closing the door unless the disk or diskette is fully inserted.

The master drive includes full electronics, providing interface, read/write control, step and direction, data separator and sector generator, plus secondary interface for the slave drive. The slave, though containing minimum electronics, gives identical performance.

John Ring, president of Orbis, says the arrangement is completely transparent to the user. "He doesn't know whether he's on direct interface, as in a star arrangement or daisy chain of master units, or if he is using the slave units."

The drives themselves are IBM-compatible, with an unformatted capacity of 3.1-million bits per disk and a data transfer rate of 250,000 bits per second. Access time is 6 milliseconds from track to track, with 14-ms settling time. Rotational period is 360 ms, and average latency is 83 ms. Addressing of a specific unit is by small internal switches on the unit.

As an option, Orbis offers an enhanced interface that combines the cost savings of the slave unit with a pseudo-star arrangement. This overlapped-seek configuration permits a unit to interrupt when it needs to communicate with the host computer, rather than simply waiting until it is addressed. Also optional is rotational position-sensing.

The 74M is priced at \$695 and the 74S at \$595.

Orbis Systems Inc., 3303 Harbor Blvd., Bldg. K4, Costa Mesa, Calif. 92626 [361]

PROMs tailor calculator to user's application

Many calculators offer special functions and capabilities—for engineering, statistics, metric conversion, even navigation. But sometimes a user in one field needs mathematical functions from another field—an engineer, for example, might sometimes need the functions available on a business/statistics machine.



Sharp Electronics' model PC-1002 calculator is a scientific unit with four extra function keys that the user can define by plugging in the appropriate programmable read-only memory. With different PROMs, the functions of the special keys are changed, converting the calculator to any application the user needs.

The PROM provides 256 steps of programing memory and permits the special-function keys to perform like hard-wired function keys. Standard chips, supplied by National Semiconductor, are now available for statistics, mathematics, metric conversion, and surveying. Still in the preparation stage are designs to cover structural engineering, electrical engineering, financial, and other fields. Sharp can also manufacture special PROM modules to order.

The PC-1002 can be keyboard-programmed with up to 64 steps. Its 15 functions include trigonometric, inverse trigonometric, hyperbolic, exponential, logarithmic, factorial, power, azimuth, and area calculations. Radian or degree mode is switch-selectable. The PC-1002, including one PROM, is priced at \$645. Each additional PROM is \$75, and special plug-ins are \$75 plus a software charge.

Sharp Electronics Corp., 10 Keystone Pl., Paramus, N.J. 07652 [362]

Magnetic-tape formatter mounts inside tape drive

A phase-encoded magnetic-tape formatter is mounted directly inside the tape drive to save rack space

CELCO can make an "Above-Average" Scanner & Printer System for your Image Processing Application.



CELCO's Large-Format Scanner is a unique solution for automating the production of master fonts for a manufacturer of computer typesetting equipment. Scanning a 16-million point area, this system calibrates itself and reduces an artwork master 14 inches x 14 inches to a digital record in 16 seconds.

Our Precision Printer is designed to automatically access the digital records created by the Scanner, and reproduce high-resolution photo-reductions on a master plate.

CELCO has led the field in producing High-Resolution CRT Scanning Systems for applications in Satellite Image Recording, Nuclear and Astronomical Research, Pattern Recognition, Medical Research, high-speed Map-Making, Automatic Inspection Systems, and other "Above-Average" requirements.

This "Above-Average" Scanner and Printer System represents a combination of CELCO's unique in-house

capabilities. From long experience in analog electronics and display engineering, to a broad achievement in both digital hardware and software systems, CELCO can offer a "state-of-the-art" approach to your most unusual problems.

If you have an image processing application, look to CELCO for the "Above-Average" solution.

CONSTANTINE ENGINEERING LABORATORIES COMPANY
1150 E. Eighth Street, Upland, CA 91786

70 Constantine Drive, Mahwah, N J 07430



**Cut your
hot design problems
down to size.**

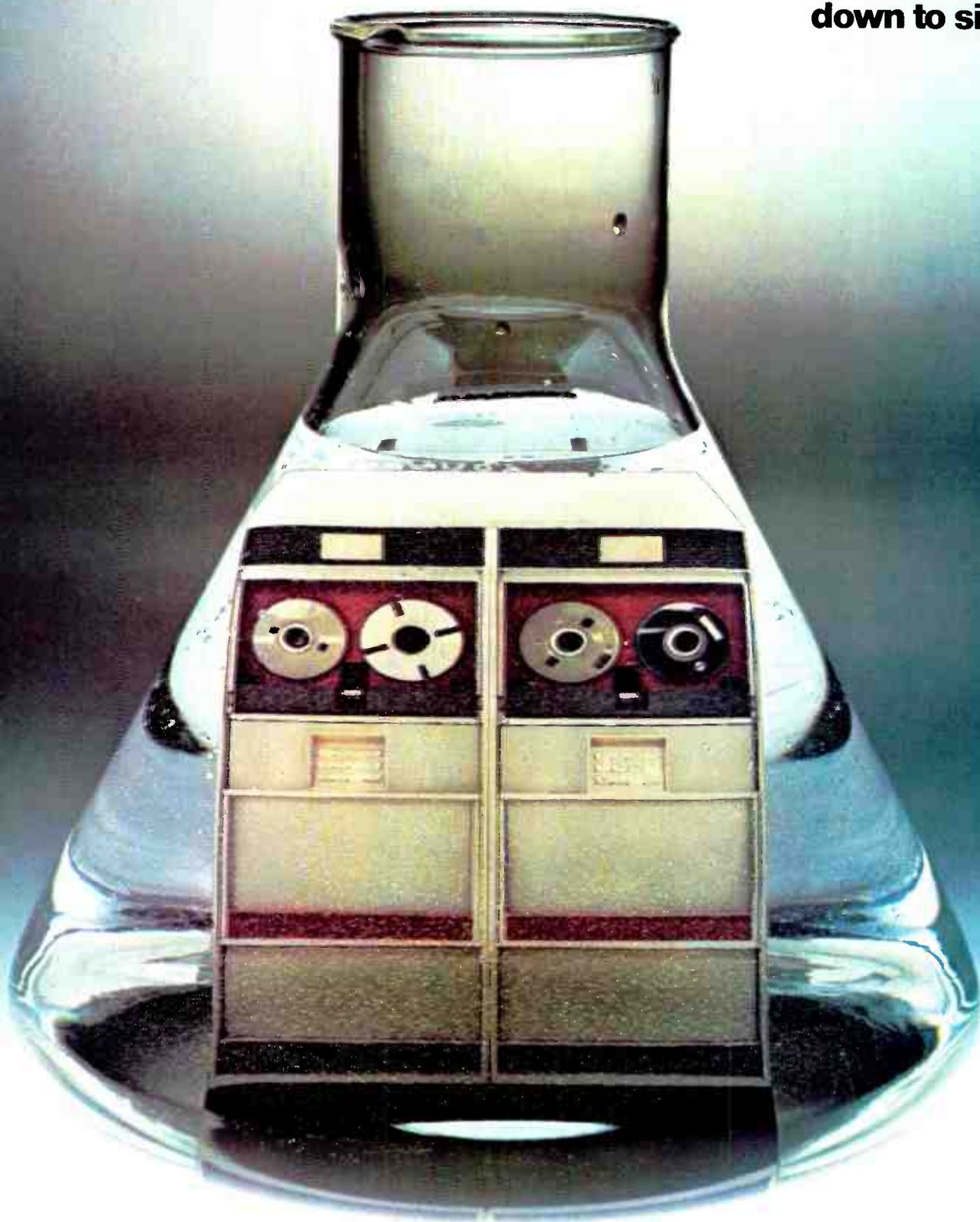

Circle 154 on reader service card

Use Dow Corning dielectric coolants.

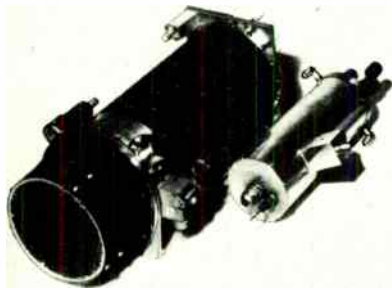

A UHF amplifier, for airborne equipment (right), was reduced in size and weight by using Dow Corning® 200 fluid. Only this unit produced full power over full frequency at an altitude of 100,000 ft.

If you're stuck with a hot electronic apparatus that you want to pack away in a snug place somewhere, relax. Silicone dielectric fluids from Dow Corning could be your answer.

The thermal stability of silicone fluids, combined with excellent physical and dielectric properties, solves the critical problem of high performance in smaller equipment. Specifically, rapid heat dissipation, superior dielectric strength, and low losses over the temperature range —40 to 200 C are primary reasons why closer spacing or size reductions in electronic apparatus are possible. Available in a wide viscosity range, they can be used for cooling power tubes, damping meter indicators, insulating high-voltage power supplies, or filling dashpots.

Non-sludging and essentially non-toxic, silicone fluids deliver long life at a competitive price where conventional organic liquids fail rapidly.

For specific information on our complete line of fluids, write Dow Corning Corporation, Dept. C-3336, Midland, Michigan 48640.

Silicones; simply the best way to protect electronic equipment

DOW CORNING

DOW CORNING

New products

and eliminate the cost of separate rack mounting. The model 6922 permits daisy-chaining of up to four magnetic-tape units (MTUs). And its addressing capability allows the use of one other formatter. The formatter conforms fully to industry standards for the operation and interfacing of 0.5-inch tape, and can handle MTUs with up to two standard speeds from 1.5 to 45 inches per second. Units with single-gap and dual-gap heads may also be mixed. Price in OEM quantities is under \$1,200. Delivery time is 30 days.

Microdata Corp., 17481 Red Hill Ave., Irvine, Calif. 92705 [363]

Disk drive/controller is compatible with System/3

The model BST/45 disk drive and controller is plug-compatible with IBM System/3 computers. Costing less than the IBM model 5445, the new device offers up to four-disk drive capacity for models 10 and 15. Because it uses an electrical voice-coil mechanism for head positioning, the BST/45 is said to have faster access times and improved reliability when compared with the hydraulically actuated IBM system. Average head-movement time, for example, is 35 milliseconds compared with 60 ms for the IBM unit.

Business Systems Technology, Inc., 1215 West Katella Ave., Orange, Calif. [364]

Drive for 3M cartridges reads at 30 or 90 ips

The model 771 tape drive for 3M cartridges can read at either 30 or 90 inches per second, giving it a maximum data-transfer rate of 144 kilobits per second. The unit's maximum speed error is $\pm 0.1\%$, and it has the ability to read-after-write or write-after-read, which makes minor editing fairly simple. For ease of maintenance, the drive has been designed to be serviced without dismantling or using extender boards.

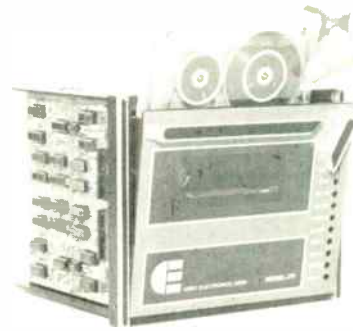

In quantities of 100 pieces, a one-track drive sells for \$360. Indicator lamps are standard with the model 771.

Omni Electronics, Inc., P.O. Box 306, Hauppauge, N. Y. 11789 [365]

Programmer's aid converts data from binary to octal

An accessory for the front panel of any minicomputer or micro-processor converts both the memory address and the data stored there from binary to octal form and displays them on light-emitting-diode readouts. The first available units will operate directly with all Data General Nova 2/4 and 1200 series minicomputers, and with Digital Computer Controls D-116 series minis. Other models for use with other computers can also be supplied. The system consists of a display section that attaches to the computer's front panel with double-sided adhesive tape plus an interconnect logic box. Price of the ADS model 7 is \$399. Delivery time is 60 to 90 days.

Advanced Digital Systems, Inc., 146 West Main St., P.O. Drawer D, Mohawk, N. Y. 13407 [369]

Memory switch allows use of 256k words with Novas

A memory switch that allows the use of up to 256k words of memory with Nova 800 and 1200 (or equivalent) minicomputers is less expen-

New literature

Solder-pin lamps. Performance features and major specifications of the Eldema "C" series of solder-pin lights, which require no sockets, are presented in an illustrated brochure published by Eldema Division, Genisco Technology Corp., 18435 Susana Rd., Compton, Calif. 90221. Circle 421 on reader service card.

Data management. The Information Network division of Computer Sciences Corp., 9841 Airport Blvd., Los Angeles, Calif. 90045, offers a brochure that tells how data-management concepts rectify the problems encountered in traditional program/file approaches [422]

Custom MOS circuitry. Starting with an outline of the operation of a MOS transistor and proceeding to descriptions of silicon-gate, ion-implantation, and other advanced technologies, a booklet entitled "Customized MOS Circuits" is available from AEG-Telefunken Corp., 570 Sylvan Ave., Englewood Cliffs, N. J. 07632. In addition to a technical review, the booklet gives details of Telefunken's capabilities and procedures for the design of customized circuits. [423]

Green lasers. A new line of neodymium-doped yttrium-aluminum-garnet lasers, operating at a wavelength of 0.532 micrometer, is described in a brochure called "The Green Machine." Intended for holographic applications, both the lasers and the free booklet can be obtained from International Laser Systems Inc., 3404 N. Orange Blossom Trail, Orlando, Fla. 32804. [424]

Ceramic capacitors. The complete line of CFI ceramic capacitors is described in catalog put out by Circuit Functions Inc., 1121 Lawrence Drive, Newbury Park, Calif. 91320. The catalog includes data on chip capacitors, four series of standard capacitors, and the latest miniature units. [426]

Elastomeric connectors. Data sheet CEC-011 concerns a family of con-

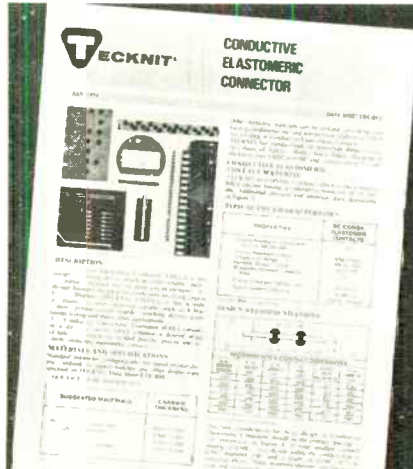

nectors made of a dielectric carrier into which are molded contacts made of a conductive elastomer. The principal application of the connectors is for liquid-crystal displays, but other uses are discussed in the data sheet offered by Technical Wire Products Inc., 129 Dermody St., Cranford, N. J. 07016 [427]

Servo controller. The subject of a bulletin from Moog Inc., Controls Division, Prorer Airport, East Aurora, N.Y. 14052, the model 127-101 motherboard servocontroller frame should be of interest to manufacturers of industrial vehicles and equipment. [428]

Subminiature relay. A pair of completely independent DPDT relays housed in a single 16-pin dual in-line package is described in data sheet 73-125, available from AMP Inc., Harrisburg, Pa. 17105. [429]

Analyzing rubber compounds. A 26-page-booklet from Barnes Engineering Co., Analytical Products Group, 30 Commerce Rd., Stamford, Conn. 06902, suggests effective techniques for obtaining strong infrared spectra of various rubbers and rubber formulations. Included in the booklet are 12 spectra, reproduced full scale. [430]

Additive circuit manufacture. The "A-Plus" approach to making copper-conductor printed-circuit boards is analyzed in a 12-page design

Presenting... Dipped Tantalums from Matsuo

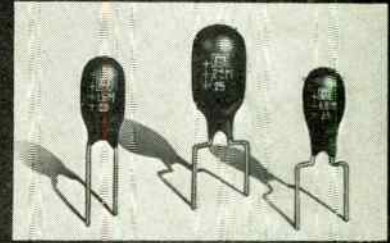

BLUE DT TYPE DTS FEATURES:

- * Price competitive with electrolytics
- * Close tolerance lead spacing for easy insertion into PCB's
- * Hard insulating epoxy resin coating . . . protects against mechanical damage and moisture
- * Excellent electrical performance . . . low leakage, high stability over a wide range of frequency and temperature
- * Readily available

...also from Matsuo

Molded Tantalum Chip Capacitors



TANCHIP TYPE TCA FEATURES:

- * High accuracy lead location
- * Can be face down bonded using the reflow soldering process
- * Ideal for use in hybrid circuits or on printed circuit ceramic substrates
- * Molded case provides mechanical protection and easy handling
- * Unique terminal design offers excellent protection against solder heat
- * Optimizes high capacitance and miniature size
- * Excellent electrical performance . . . low leakage current, highly stable characteristics
- * Readily available

MATSUOELECTRICO, LTD.

Toyonaka, Osaka, Japan
Telex: 523-4184 OSA

**MATSUO ELECTRONICS OF
AMERICA, INC.**

El Segundo, Ca. 90245
Tel. (213)679-0379 TWX:9103257164

NEW!



■ Key Switch

• Features:

- Easy key operation
- Electronic circuits and power supply circuits can be freely selected according to the application.

• Applications:

- Automatic vending machines, data terminals, E.C.R., P.O.S., etc.

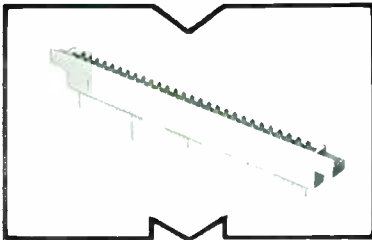

■ P.C. Connectors

The S-400 Series P.C. connectors (through hole or eyelet) are available with various shaped insulators and terminals. Polarization guide is provided.

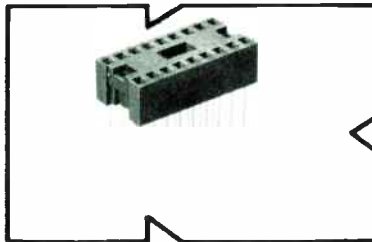

■ IC Sockets (Wrapping type)

Continuous packaging is possible. Socket terminal spacing mates that of the IC itself.

- Number of pins: 14 (SI-2425), 16 (SI-2426), 18 (SI-2427).
- Contacts: Gold-plated.

• SMK MAIN PRODUCTS:

Switches, Connectors, Terminals, Sockets, Plugs, Jacks, Full Keyboard Switches, Fuse Holders, Keyboard Switches, Others.

SMK

SMK ELECTRONICS CORP. OF AMERICA

743, W. Gardena Blvd., Gardena, Calif. 90247, U.S.A.
Phone: (213) 770-8915 Telex: 691144

SMK EUROPE S.A.

361, Rue au Bois, 1150, Bruxelles, BELGIUM
Phone: (02) 762.23.84 Telex: 26278 SMK BRU

SHOWA MUSEN KOGYO CO., LTD.

No.5-5, 6-chome, Togoshi, Shinagawa-ku, Tokyo
142, Japan. Phone: 785-1111
Telex: 2466301 SMK TOK J
Cable: "SHOWAMUSEN" TOKYO

New literature

guide published by Methode Electronics, Inc., 7447 W. Wilson Ave., Chicago, Ill. 60656. Besides a description of the process, the guide presents design criteria for its most effective utilization. [431]

Passivated Darlingtons. A line of power transistors and Darlingtons that use glass passivation for improved stability is covered in a series of nine data sheets from International Rectifier Corp., Semiconductor Division, 233 Kansas St., El Segundo, Calif. 90245. [432]

Microwave synthesizers. A four-page brochure summarizing the company's capabilities and products in the microwave-synthesizer area is obtainable from Watkins-Johnson Co., 3333 Hillview Ave., Palo Alto, Calif. 94304. [433]

Batch-processing control. The PGS program-set station controls sequential-type batch-processing operations by means of curves scribed

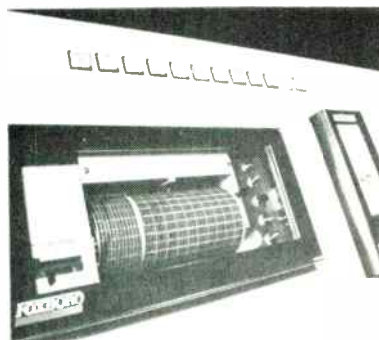

Program Set Station
for programmed batch control

onto a Mylar program sheet. Bulletin L-37 from The Foxboro Co., Foxboro, Mass. 02035, tells how it's done. [425]

Data acquisition. An eight-page brochure available from FX Systems Corp., Mt. Marion Rd., Saugerties, N.Y. 12477, describes the company's Digitem series of data-acquisition systems and a broad range of industrial and scientific applications. [434]

Top Quality

MAGNETIC HEADS



SM-9C
read head for
computer



MSP-6

- 6 in 1
cassette stereo head for
auto reverse
play / record / erase

SAN-E DENKI CO., LTD.

110-1, Minami Kawahori, Tennoji-ku,
OSAKA, JAPAN
PHONES: OSAKA (06) 779-1591
CABLE: SANMAGNETICS OSAKA

Circle 187 on reader service card

Exclusive Economic and Industry Studies

**For Financial Analysts,
Corporate Planners,
Business Economists,
Marketing Executives**

Geared directly to the future, our Department of Economics offers more than 40 forecasting tools to help project the general economy and industrial growth over the short and long run.

EXAMPLES: Do you know that the current operating rate for the chemical industry is 86%? For synthetic materials, the utilization rate is 93%? That construction and mining machinery new orders are expected to be 8% higher in 1974 than in '73? That steel expects a 3% decline in physical volume of sales in 1974? That consumer income after taxes will increase 8% in 1975?

At a modest cost, our various services covering most industrial segments of the economy are available to you.

For more information write for our booklet, "Exclusive Economic Studies," or phone Douglas Greenwald, Chief Economist, (212) 997-2216.

Department of Economics
McGraw-Hill Publications Company
1221 Avenue of the Americas
New York, N.Y. 10020



Electronics/November 28, 1974

Abbott Transistor Labs, Inc. Technical Advertising Agency	6	General Electric Co., Semiconductor Products Department Advertising & Sales Promotion Syracuse Operation	38	RCL Electronics, Inc. Morway Advertising Agency	14
Adret Electronique Psycho Publicite	2E	General Magnetics McCarthy Scelba DeBias Advertising Agency, Inc.	3rd Cover	Reticon Corporation The House Agency	89
Alcatel	20E	General Radio Grad Associates	5E	Rohde & Schwarz	1E
Aluminum Company of America Ketchum, MacLeod & Grove, Inc.	108	Georgia Department of Community Development Gerald Ratshoon Advertising, Inc.	114	RTC Feldman Calleux Associates	67
Ampex Cassy and Hull, Ltd	12E	Gould Instrument Systems Marsteller, Inc.	2	San-E Denki Co., Ltd.	160
AMP Incorporated Aitkin-Kynett Company, Inc.	136-137	Gould, Inc./Instrument Systems Division Carr Liggett Advertising, Inc.	150	Schauer Manufacturing Corp. Nojan, Keelor & Siles	50
Analog Devices, Inc. Schneider Parker, Inc.	56-57	Guardian Electric Manufacturing Company Kolb/Tookey and Associates, Inc.	133, 135	Selmar CPM Studio	11
Anritsu Electric Company, Ltd. Diamond Agency Company, Limited	135	Hewlett-Packard Corporate Marketing Communications	17-26	Sesosem Bazaine Publicite	53
Augat Creamer, Trowbridge, Case & Bastford, Inc.	129	IMC Magnetics Corp. Monad Advertising Design	142	Sharp Electronic Corp. SSC&B Advertising	107
Ballantine Laboratories, Inc. MLF Graphics	141	Individualized Instructions, Inc. Jordan Associates	132	‡ SHELD AHL, INC. Chuck Ruhr Associates Advertising, Inc.	67
Beckman Instruments Limited	7E	Industrie Bitossi s.a.s. Studio Rumi	16E	Shipley Company Ingallas Associates, Inc. Advertising	9
‡ Beckman Instruments, Inc., Heliport Division N W Ayer Jorgensen/MacDonald, Inc.	53	Instrumentation Engineering Inc. Fletcher-Walker-Gessell, Inc.	90	Showa Musen Kogyo Co., Ltd. General Advertising Agency, Ltd	160
Burroughs Corporation Conti Advertising	7	Intel Corp. Regis McKenna, Inc.	28-29	‡ Siemens Corp.—Electronic Systems Division, Computest Products JL Associates	151
CELCO (Constantine Engineering Laboratory Co.) Stano Advertising	153	Intersil, Inc. Tyce-Fultz	70-71	Siemens A.G. Munich Linder Presse Union GmbH	62
Chuo Tsusho Kaisha	48	Interstate Electronics Corp. Chris Art Studio, Inc.	164	Solid State Scientific Inc. Aitkin-Kynett	82
Clairex Corporation Black-Russell-Morns	4th Cover	IPT Corporation Rock Advertising Design	10	Spectrol Electronics Corp. J M R, Inc.	34
Continental Specialties Corp. Robert A. Paul	156	Ithaco, Inc. Webb & Athey, Inc.	58	Sprague Electric Company Harry P. Bridge Company	8
Cramer Division of Conrac McCarthy, Scelba, DeBiasi	30	Keeco, Inc. Weiss Advertising	5	Systron Donner Concord Instruments Fred Schott & Associates	61
CTS Corporation Reincke, Meyer & Finn, Inc.	77	LTT	17E	Tally Corporation Bonfield Associates	141
‡ Dale Electronics, Inc. Swanson, Sinkey, Ellis, Inc.	68-69	Matsuo Electric Co., Ltd. Daiko	159	Tektronix, Inc. Tektronix Advertising	43, 45, 47
Dana Laboratories Dailey & Associates	115, 117	‡ Matsushita Electric Trading Co., Ltd. Hakuhodo, Inc.	18E-19E	Texscan Corporation Bruce Bottum Associates	112
Data Dynamics Rumill-Hoyt, Inc.	150	Micro Switch Division of Honeywell N W Ayer & Son, Inc.	2nd Cover	Thomson CSF/Dumont Ranieri, Saslaw, Mohr and Associates	1
Dataram Corporation Louis Zimmer Communications	55	Microsystems International Limited Peter Barrett and Associates	12-13	Tokyo Electric Co., Ltd. PAL, Inc./Export Advertising	162
Data Translation, Inc. Mark L. Nigberg, Inc.	157	Motorola Semiconductor Graham & Gillies Limited	15	‡ United Chemicon, Inc. Spitz Advertising Agency, Inc.	64
Delta Air Lines Burke Dowling Adams, Inc.	140	Narda Microwave McCarthy, Scelba, De Biasi Advertising Agency, Inc.	85	Unitrode Corporation Culver Advertising, Inc.	37
Digital Equipment Corporation Creamer, Trowbridge, Case & Bastford, Inc.	32-33	National Semiconductors Limited Griener Harnes Maclean Ltd	149	‡ U.S. Instrument Rentals, Inc. of Instrinsics, Inc.	1
Dow Corning Corp.—Fluids, Emulsions, Compounds Division Ketchum, MacLeod & Grove, Inc.	154-155	Non-Linear Systems A & J Associates, Inc.	52, 142	Wavetek San Diego Chapman Michetti Advertising	130
Eratom of California, Inc.	156	Ohtama Industry Co.	164	‡ Weston Instruments, Inc. APCL & K Inc.	68-69
Electro Scientific Industries Commark Group, Inc.	84	Oscilloquartz SA, Neuchatel Publicitas	9E	Wima, Westermann Oliver-Beckman GmbH	16
Elevam Electronic Nihon Keizai Advertising Co., Ltd.	88	Panasonic Ogilvy & Mather, Inc.	110	Winchester Electronics Renaccio Advertising & Marketing, Inc.	72-73
Exact Electronics Hugh Dwight Advertising	49	Philips Elcoma Intermarco nederland	64	Yokogawa Electric Works, Ltd. General Advertising Agency, Inc.	126
Exstron Inc. CTS Advertising	30-31	Philips TMI Broekjes Communication Systems S.A.	74	Zeltex Zeltex Advertising Agency	141
Fairchild Camera & Instrument (Systems Technology Div.) Rose Associates Advertising and Public Relations	143	Pihler International Ltd. Scott Mac Taggart Advertising	146-147		
‡ Ferroxcube Black-Russell-Morns	15	‡ Precision Monolithics, Inc. Marlborough Associates, Inc.	11		
Fluke Manufacturing Co., John Bonfield Associates	57	Primo Co., Ltd. General Advertising Agency, Inc.	157		
Fluke Trendar Lincoln Associates, Inc.	27	Procond S.p.A. Quadrangolo	14E		
John Fluke Mfg. Co., Ltd. Lennox Marketing Limited	164	RCA Ltd. Marsteller, Ltd.	10E-11E		
Gardner-Denver Company Buchen Advertising, Inc.	144-145	RCA—Solid State Division Marsteller, Inc.	80-81		
General Automation Albert, Newhoff & Burr	86				

Classified & Employment Advertising

F. J. Eberle, Manager 212-997-2557

EQUIPMENT (Used or Surplus New) For Sale	
American Used Computer Corporation	158
Fishman Co., Phillip	158
Jensen Tool	158
Mountain West Alarm	158
Radiation Devices Company	158
Radio Research Instrument Co.	158
Tucker Electronics Co.	158

For more information on complete product line see advertisement in the latest Electronics Buyer's Guide
 * Advertisers in Electronics International
 ‡ Advertisers in Electronics domestic edition

New digital dynamics!

Digital Line Printer LP-108B

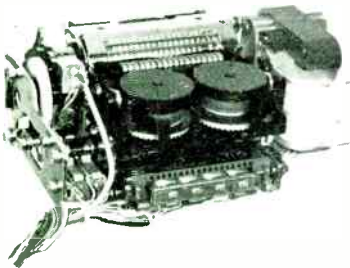

In your machine they mean
a more efficient print system.

TEC has put new digital dynamics into its LP-108B line printer that add up to higher reliability from a more compact unit.

A continuously rotating drum simplifies print hammer actuation, cuts down on energy consumption and introduces fewer wear-prone parts. With the LP-108B you get up to 18-column red/black printing and 13 characters per column—all clean and easily legible.

This is just one of the many high quality units made by TEC to help you make business machines better, more economically.

Try it for size, ask for full spec./characteristic sheets. We'll also send you a catalogue on our new and highly advanced LP-201 digital printer.



TOKYO ELECTRIC CO.,LTD.

14-10, 1-chome, Uchi-Kanda, Chiyoda-ku,
Tokyo, Japan

Advertising Sales Staff

Pierre J. Braudé New York [212] 997-3468
Director of Marketing

Atlanta, Ga. 30309: Joseph Lane
100 Colony Square, 1175 Peachtree St., N.E.
[404] 892-2868

Boston, Mass. 02116: James R. Pierce
607 Boylston St. [617] 262-1160

Chicago, Ill. 60611:
645 North Michigan Avenue
Robert W. Bartlett (312) 751-3739
Paul W. Reiss (312) 751-3738

Cleveland, Ohio 44113: William J. Boyle
[716] 586-5040

Dallas, Texas 75201: Charles G. Hubbard
2001 Bryant Tower, Suite 1070
[214] 742-1747

Denver, Colo. 80202: Harry B. Doyle, Jr.
Tower Bldg., 1700 Broadway
[303] 266-3863

Detroit, Michigan 48202: Robert W. Bartlett
1400 Fisher Bldg.
[313] 873-7410

Houston, Texas 77002: Charles G. Hubbard
Dresser Tower 601 Jefferson St., [713] 224-8381

Los Angeles, Calif. 90010: Robert J. Rielly
Bradley K. Jones, 3200 Wilshire Blvd., South Tower
[213] 487-1160

New York, N.Y. 10020:
1221 Avenue of the Americas
Warren H. Gardner [212] 997-3617
Michael J. Stoller [212] 997-3616

Philadelphia, Pa. 19102: Warren H. Gardner
Three Parkway,
[215] 997-3617

Pittsburgh, Pa. 15222: Warren H. Gardner
4 Gateway Center, [212] 997-3617

Rochester, N.Y. 14534: William J. Boyle
9 Greylock Ridge, Pittsford, N.Y.
[716] 586-5040

San Francisco, Calif. 94111: Don Farns
Robert J. Rielly, 425 Battery Street.
[415] 362-4600

Paris: Alain Offergeld
17 Rue-Georges Bizet, 75 Paris 16, France
Tel: 720-73-01

Geneva: Alain Offergeld
1 rue du Temple, Geneva, Switzerland
Tel: 32-35-63

United Kingdom & Scandinavia: Keith Mantle
Tel: 01-493-1451, 34 Dover Street, London W1

Milan: Robert Saldel
1 via Baracchini, Italy Phone 86-90-656

Brussels: Alain Offergeld
23 Chaussee de Wavre
Brussels 1040, Belgium
Tel: 13-73-95

Frankfurt/Main: Fritz Krusebecker
Liebigstrasse 27c, Germany
Phone 72 01 81

Tokyo: Tatsumi Katagin, McGraw-Hill
Publications Overseas Corporation,
Kasumigaseki Building 2-5, 3-chome,
Kasumigaseki, Chiyoda-Ku, Tokyo, Japan
[581] 9811

Australasia: Warren E. Bail, IPO Box 5106,
Tokyo, Japan

Business Department

Stephen R. Weiss, Manager
[212] 997-2044

Thomas M. Egan,
Production Manager [212] 997-3140

Carol Gallagher
Assistant Production Manager [212] 997-2045

Dorothy Carter, Contracts and Billings
[212] 997-2908

Frances Vallone, Reader Service Manager
[212] 997-6057

Electronics Buyers' Guide

George F. Werner, Associate Publisher
[212] 997-3139

Regina Hera, Directory Manager
[212] 997-2544



Large and medium scale integration: Keep up with this fast changing technology

Now, in one comprehensive volume, a complete working grasp at large and medium scale integration for electronics engineers engaged in the design of electronic systems, equipment and products.

A wealth of practical working data on large and medium scale integration has been culled from the most important articles in Electronics magazine by Samuel Weber, Executive Editor. Emphasis is on design problems at the system or subsystem level, as well as on the economics of today's design.

Whatever the design problem — from partitioning a digital system to working with a semiconductor company in producing the best LSI design, this book covers the full range of today's important technologies on a practical, rather than a theoretical, level.

It's yours for \$15.00. Keep up.

FREE 10-DAY EXAMINATION

McGraw-Hill Book Company
1221 Ave. of the Americas,
New York, N.Y. 10020



Send me a copy of Large and Medium Scale Integration (068815-X) for 10 days on approval. At the end of that time, I will either remit \$15.00, plus tax, postage, and handling, or return book without further obligation. (Remit in full with this coupon, plus any tax, and McGraw-Hill pays all postage and handling costs.)

Name _____

Address _____

City _____

State _____ Zip _____

Offer good only in the U.S. and subject to acceptance by McGraw-Hill. For prices outside U.S., contact McGraw-Hill Book Co.

23 K138-4018-3

FEATURE ARTICLES FROM ELECTRONICS MAGAZINE ARE NOW AVAILABLE IN REPRINT FORM!

Valuable additions to your electronics library are now available thru this exclusive reprint service. Just check the articles you wish to order and enclose check or money order for prompt service.

No. of Copies Wanted		No. of Copies Wanted	
_____	R- 11 Computer-Aided Design	_____	R-310 Penetration Color Tubes are Enhancing Information Displays
_____	R- 15 Special Report on LSI Packaging	_____	R-312 Leadless, Pluggable IC Packages Reduce Costs
_____	R-016 Special Report on The Transistor: Two Decades of Progress	_____	R-316 Hybrid Circuit Technology Solves Tough Design Problems
_____	R- 18 Reshaping the EE for the Seventies	_____	R-318 Buckling Up for the Bumpy Road to Detroit
_____	R-023 Special Report: Tomorrow's Communications	_____	R-320 Planar Interconnection Techniques (Designer Must Plan Early for Flat Cable)
_____	R-027 Consumer Hazards: Why They Happen, How They Can Be Fixed	_____	R-322 Special Report: The New Displays Complement the Old
_____	R-031 Circuit Designer's Casebook (U.S. Only)	_____	R-324 Semiconductor Memories Are Taking Over Data-Storage Applications
_____	R-032 Active Filters	_____	R-326 Optical Spectrum Report and Optical Spectrum Chart
_____	R-033 Infra-Red Detector Chart	_____	R-328 Pervasiveness of Electronics Entire Issue of Electronics
_____	R-101 Special Report: The Right Numeric Readout, a Critical Choice for Designers	_____	R-400 Japanese Forecast 1974
_____	R-104 The New Concept for Memory and Imaging: Charge Coupling	_____	R-402 European Forecast 1974
_____	R-107 Wanted for the '70s: Easier-to-Program Computers	_____	R-404 U.S. Forecast 1974
_____	R-110 Automation for Survival and Profit	_____	R-406 Logics New Design Tools
_____	R-113 Optoelectronics Makes It At Last (3 part series)	_____	R-408 Bringing Sight to the Blind
_____	R-203 East Europe Market Report	_____	R-410 Passive Components
_____	R-205 Bridging the Analog & Digital Worlds with Linear ICs	_____	R-412 Liquid Cooling Semiconductors
_____	R-207 Technology Gap Starts to Close for Computer Peripherals	_____	R-414 Simplified n-Channel Process
_____	R-209 Semiconductor RAMs Land Computer Mainframe Jobs	_____	R-416 Optical Waveguides Look Brighter
_____	R-211 Electromagnetic Spectrum Report and Foldout Chart	_____	R-418 Computer Analyses of RF Circuits
_____	R-213 Electromagnetic Spectrum Chart (rolled in mailing tube)	_____	R-420 Computerized Text-Editing and Typesetting
_____	R-306 Charge Coupling Improves Its Image, Challenging Video Camera	_____	R-422 A Microprogrammable Minicomputer
_____	R-308 Program for Transition from NonLinear to Linear Transistor Model	_____	R-424 Microprocessor Applications
		_____	R-426 Special Issue—Technology Update—1974

Payment must accompany your order... USE THIS PAGE AS YOUR ORDER FORM

Make check or money order payable to Electronics Reprints. All orders shipped prepaid via parcel post. Allow two to three weeks for delivery.

Back Issues Now Available. 1960 to 1969 \$5.00 each. 1970 to 1973 \$3.00 each.

Mail Your Order To
Janice Austin
ELECTRONICS REPRINTS
P.O. Box 669
Hightstown, N.J. 08520

Amount of Order	\$ _____
Plus 10% Handling Charge	\$ _____
TOTAL AMOUNT ENCLOSED	\$ _____

SEND REPRINTS TO

Name _____
Company _____ Dept. _____
Street _____
City _____ State _____ Zip _____

A new autoranging multi-function counter using LSI/MOS from the "Counter House"

\$349

Who else but FLUKE could bring you this new multi-counter at such an attractive price? A multi-counter that measures frequency or period — and totalizes too. Model 1900A from Fluke "The Counter House" has a dynamic range of 5 Hz to 80 MHz . . . advanced LSI/MOS circuitry . . . autoranging . . . and autoreset on all functions, gate times, filter and attenuator. And of course the 1900A incorporates all the traditional Fluke quality, and comes with a full 12-month guarantee plus a 15-day money-back policy.

Phone or write to-day for complete details on the \$349 multi-counter from Fluke — "The Counter House".
Circle 164 on reader service card



FLUKE
COUNTER DIVISION

John Fluke Mfg. Co. Ltd., Counter Division,
P.O. Box 1094, Station "D" Buffalo, N.Y., 14210.
Phone (716) 842-0311. TWX 610-492-3214

instant pulse

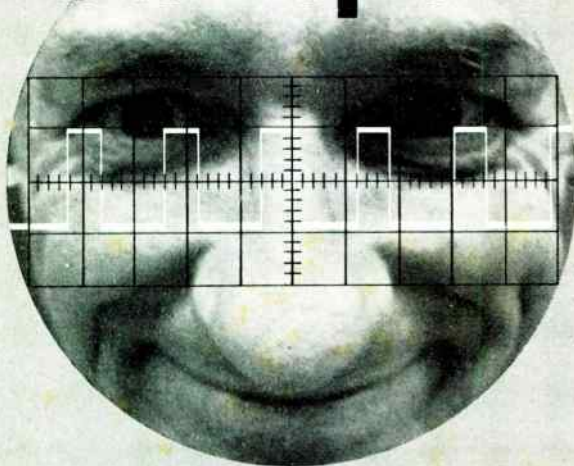

Interstate Pulse Generators have Constant Duty Cycle

Engineers are always surprised when they select the Constant Duty Cycle mode and adjust the width control on an Interstate Series 20 Pulse Generator — they get an instant pulse. It's "countdown-free," too.

For the whole story on Interstate's Instant Pulsers, call John Norburg collect. He'll send you Interstate's Series 20 Pulse Generator catalog — instantly.

Phone (714) 772-2811

IEC INTERSTATE
ELECTRONICS
CORPORATION
Subsidiary of A-T-O Inc.

Dept. 7000, Box 3117, Anaheim, California 92803
TWX U.S.A. 910-591-1197 TELEX U.S.A. 655443 & 655419.

164 Circle 188 on reader service card

"Permalloy"

from Japan's magnetic material specialist

Ohtama is Japan's only specialized permalloy product maker. To assure the highest quality, all processing is done at our own factory. Both mass-production and small lot items. Send your requirements and drawings today.

Main products

Shield cases • Synchroscope • oscilloscope •
electronic watch
Shield cases and head cores VTR • tape re-
corder • audio equipment

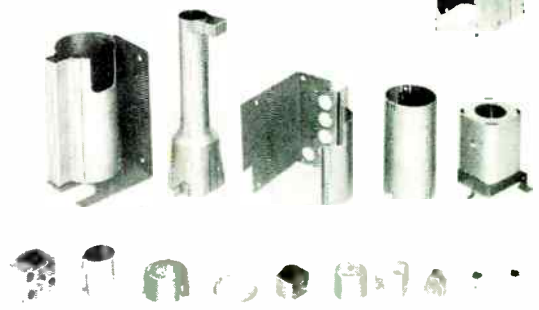

OHTAMA OHTAMA INDUSTRY CO., LTD.

1780, Oshitate, Inagi, Tokyo, 192-02 Japan Phone: 0423-77-4311

Circle 189 on reader service card

3 WIRE SYNCHRO TO LINEAR D.C. CONVERTER

ACCURACY 1/2 %



#MAC 1422-1

Provides a linear conversion of a synchro angle to a DC Voltage

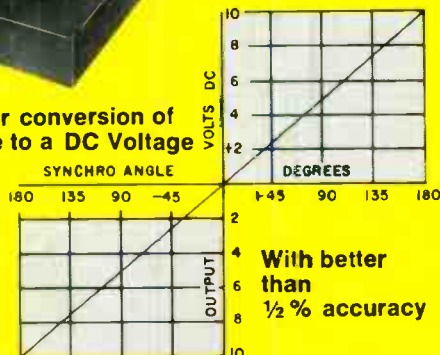

Specifications

Accuracy: $\pm 1\%$ over temperature range
 Input: 11.8V, 400 HZ line to line 3 wire synchro voltage
 Output Impedance: less than 10 Ohms
 Input Impedance: 10K minimum line to line
 Reference: 26V $\pm 10\%$ 400HZ (Unit can be altered to accommodate 115V if available at no extra cost)
 Operating temp. range: -25°C to $+85^{\circ}\text{C}$
 Storage temp. range: -55°C to $+100^{\circ}\text{C}$
 DC power: $\pm 15\text{V} \pm 1\%$ @ 75ma (approx.)
 Case material: High permeability Nickel Alloy
 Weight: 6 Ozs. Size: 3.6" x 2.5" x 0.6"

SOLID STATE SINE-COSINE SYNCHRO CONVERTER - NON VARIANT

This new encapsulated circuit converts a 3 wire synchro input to a pair of dc outputs proportional to the sine and cosine of the synchro angle independent of a-c line fluctuations.

- Complete solid state construction.
- Operates over a wide temperature range.
- Independent of reference line fluctuations.
- Conversion accuracy — 6 minutes.
- Reference and synchro inputs isolated from ground.

Specifications Model DMD 1508-2

Accuracy: Overall conversion accuracy 6 minutes. Absolute value of sine and cosine outputs accurate to $\pm 30\text{mV}$
 Temperature Range:
 Operating -40°C to $+85^{\circ}\text{C}$
 Storage -55°C to $+125^{\circ}\text{C}$
 Synchro Input: 90V RMS $\pm 5\%$ LL 400Hz $\pm 5\%$
 DC Power: $\pm 15\text{V DC} \pm 10\%$ @ 50MA
 Reference: 115VRMS $\pm 5\%$ 400Hz $\pm 5\%$
 Output: 10V DC full scale output on either channel @ 5ma load
 Temperature coefficient of accuracy:
 ± 15 seconds/ $^{\circ}\text{C}$ avg. on conversion accuracy
 ± 1 MV/ $^{\circ}\text{C}$ on absolute output voltages
 Size: 2.0" x 1.5" x 2.5"
 Units are available with wider temperature ranges and 11.8V LL, 26V reference synchro inputs. Information will be supplied upon request.

A.C. LINE REGULATION

A new method has been developed which allows us to provide a low distortion highly regulated AC waveform without using tuned circuits or solid state active filters of any kind.

The result is a frequency independent AC output regulated to 0.1% for line and load with greater than 20% line variations over a wide temperature range.

Features:

- 0.1% total line and load regulation
- Independent of $\pm 20\%$ frequency fluctuation.
- 1 watt output
- Extremely small size
- Isolation between input and output

Specifications: Model MLR 1476-1

AC Line Voltage: 26V $\pm 20\%$ @ 400Hz $\pm 20\%$
 Output: 26V $\pm 1\%$ for set point
 Load: 0 to 40ma
 Total Regulation: $+0.1\%$
 Distortion: 0.5% maximum rms
 Temperature Range: -55°C to $+125^{\circ}\text{C}$
 Size: 2.0" x 1.8" x 0.5"

Other units are available at different power and voltage levels as well as wider temperature ranges. Information will be furnished upon request.

4 QUADRANT MAGNETIC ANALOG MULTIPLIER

DC x DC = DC OUTPUT

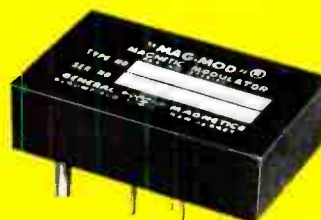

#MCM 1478-1

Specifications Include:

Transfer Equation: $E = XY/10$
 X & Y Input Signal Ranges: 0 to $\pm 10\text{V}$ peak
 Maximum Static and Dynamic Product Error: 1/2% of point or 2MV, whichever is greater, over entire temperature range
 Input Impedance: X = 10K, Y = 10K
 Full Scale Output: $\pm 10\text{V}$ peak
 Minimum Load for Full Scale Output: 2000 ohms
 Output Impedance: Less than 10 ohms
 Bandwidth: 1000Hz
 DC Power: $\pm 15\text{V}$, unless otherwise required, at 20ma
 Size: 1.3" x 1.8" x 0.5"
 Output is short circuit protected

Product Accuracy is $\pm 1/2\%$ of all theoretical product output readings over Full Temperature Range of -55°C to $+125^{\circ}\text{C}$.

Maximum Output Error for Either

X = 0, Y = 10V
 Y = 0, X = 10V
 X = 0, Y = 0

would be ± 2 MV over Entire Temperature Range.

There is No Substitute for Reliability



GENERAL MAGNETICS • INC
 135 Bloomfield Ave. Bloomfield, New Jersey 07003 - Tel. (201) 743-2700

Circle 901 on reader service card

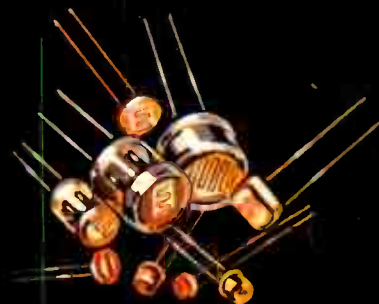

New Photoconductive Material Rock Stable... Less Light Memory

New Type 9 photoconductive material is now available in three photocell packages from Clairex — TO-5, TO-8, TO-18. Type 9 material is more stable at high temperatures and has less light memory than normal CdS materials. Type 9 material also has improved linearity and broader spectral response. Try Type 9 material if you have photocell stability problems.

Call (914) 664-6602 or write Clairex®, 560 South Third Avenue, Mount Vernon, New York 10550.

CLAIREX ELECTRONICS
A DIVISION OF CLAIREX CORPORATION