

Thermal printers making a quiet impact 51  
 The widening world of Impatt diode amplifiers 82  
 Reader survey finds EE disenchantment persists 89

# Electronics®

LIBRARY  
ST. TECHNICAL INST  
AT MEMPHIS



**Special report**  
**Semiconductors**  
**drive on**  
**mainframe**  
**memories**

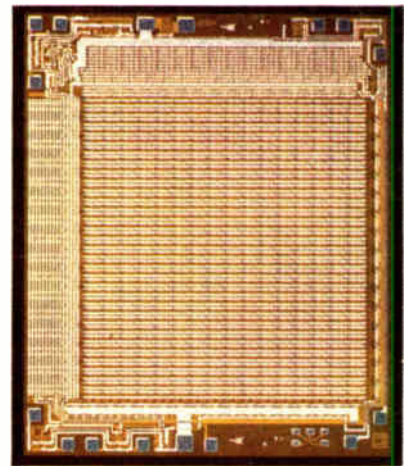

38128

MEMPHIS TN  
 5903 MACON COVE  
 LIBRY  
 ST TECHNICAL INST  
 1420 TCH598 MCSA1 JUN73

# a superior power supply

# FOR YOUR SYSTEM FROM KEPCO

introducing the **PTR** automatic crossover power supply module

PTR is an exceptionally stable power supply module offering the convenience of automatic crossover operation for the stabilization of either voltage or current. It offers fully operational programming control of both channels—with a "flag" to tell your system which mode the combination of control and load has selected. PTR's are well built, in the Kepco tradition. All I-C's and transistors (including the power transistors) are socketed for easy maintenance. The entire circuit is contained on a plug-in printed circuit card.

A compact 13 $\frac{7}{8}$ " x 5" x 3 $\frac{15}{32}$ " convection-cooled package that will deliver its full current in any environment—up to 71°C. There is no derating requirement.

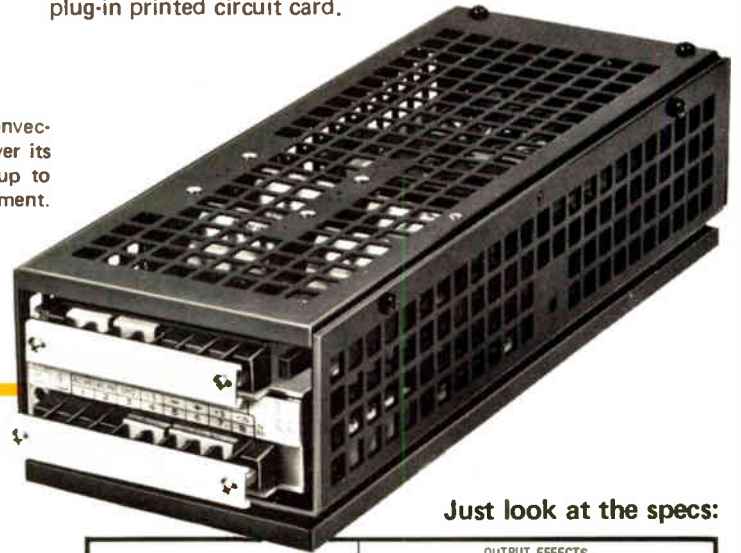

Just look at the specs:

INFLUENCE QUANTITY	OUTPUT EFFECTS	
	VOLTAGE MODE	CURRENT MODE
SOURCE: 105–125/210–250V a-c	<0.001%	<0.005%
LOAD: No load – full load	<0.005% or 0.1 mV <sup>(1)</sup>	<3.0 mA
TIME: 8-hour (drift)	<0.01% or 0.2 mV <sup>(1)</sup>	<0.05% or 0.1 mA <sup>(1)</sup>
TEMPERATURE: Per °C	<0.01%	<0.05% or 0.1 mA <sup>(1)</sup>
RIPPLE: [rms]	<0.1 mV	<0.5 mA
RIPPLE: P-P [20 Hz–10 MHz]	2.0 mV	2.0 mA

<sup>(1)</sup> whichever is greater.

Choose from six compact models:

MODEL	d-c OUTPUT RANGE		PRICE <sup>(2)</sup>	SHIP WGT.	
	VOLTS	AMPS		lbs.	kg.
PTR 7–5.5	0–7	0–5.5	\$225.00	12	5.5
PTR 15–3.3	0–15	0–3.3	225.00	12	5.5
PTR 21–2.5	0–21	0–2.5	225.00	12	5.5
PTR 40–1.4	0–40	0–1.4	225.00	12	5.5
PTR 72–0.8	0–72	0–0.8	225.00	12	5.5
PTR 100–0.6	0–100	0–0.6	225.00	12	5.5

<sup>(2)</sup> Optional overvoltage crowbar: \$25.00.

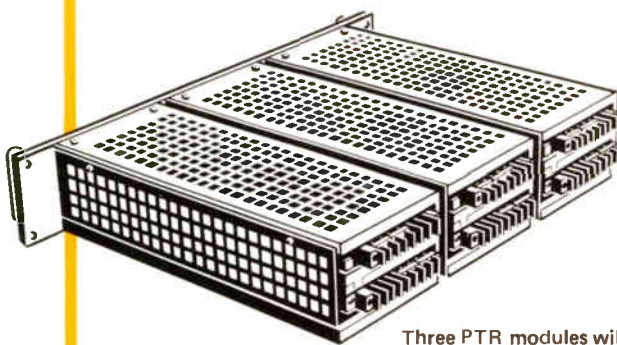

Three PTR modules will mount conveniently behind a 3 $\frac{1}{2}$ " x 19" panel, 4 units behind a 5 $\frac{1}{4}$ " x 19" panel.

all KEPCO  
products are  
backed by a firm  
**5-Year  
Warranty**

For complete specifications and applications notes, write Dept. EL-14

KEPCO, INC. • 131-38 SANFORD AVENUE • FLUSHING, N.Y. 11352 • (212) 461-7000 • TWX #710-582-2631 • Cable: KEPCOPOWER NEWYORK

Circle 900 on reader service card

with **KEPCO**  
*you're in control!*



# One way or the other,



## they're a lot of sweeper for the money.

In solid-state microwave sweep oscillators, our 8620 series will give you more sweeper than you ever thought a modest sum could buy. And the wide selection assures that you can configure the *best* solution for your sweeper needs.

For starters, there's a choice of mainframe: The low-cost 8620B (\$975) has Start-Stop and  $\Delta F$  sweeps, stable CW and versatile modulation. The more "sophisticated" 8620A mainframe provides remarkable latitude in operating modes, exceptional frequency resolution and settability, plus remote programming capability. Its price tag? Just \$1450.

Then there's flexibility in RF coverage: For example, new wideband VHF/UHF plug-ins, 3 to 350 MHz and 10 to 1300 MHz. Plus microwave

units extending to 18 GHz. And for most frequency ranges, you can choose either economical single band plug-ins or get multi-band operation by combining RF modules in a single drawer. Our multi-band approach makes it possible to cover such wide spans as 0.1-6.5 GHz or 5.9-12.4 GHz in a compact unit only 5 inches high.

Any way you do it, you get a sweeper with high sweep linearity, accurate frequency calibration, low residual FM, low spurious and harmonics — and a low price.

Ask your HP field engineer for the new brochure on the 8620 series. It'll give you the complete story on why they're so much sweeper for so little money.

**For new standards in sweepers—  
think HP.**

HEWLETT  PACKARD

HP sales, service and support in 172 cities in 65 countries. For more information write: Hewlett-Packard, 1501 Page Mill Road, Palo Alto, California 94304; Europe: P.O. Box 85, CH-1217 Meyrin 2, Geneva, Switzerland; Japan: YHP, 1-59-1, Yoyogi, Shibuya-Ku, Tokyo, 151.

Circle 1 on reader service card

# Another Exclusive From HP— Self Test!

Examine HP's new low-cost multimeter 3490A. It's a full 5-digit instrument that's priced \$300 less than two other major manufacturer's units—yet its low price includes Self Test.

Self Test is the built-in bonus you get because the circuits within the 3490A perform double-duty. Design scrutiny coupled with unique signal routing let us include Self Test without adding more circuits, and without raising the price.

**Always Ready**—Need to use your DMM? Simply flip the switch and Self Test tells you that 3490A is ready to perform. With a 3490A, you'll never be in doubt concerning your DMM's readiness.

**Programmable**—For systems work, 3490A's Self Test is remotely programmable, which lets your computer determine its operational capability *before* you start to measure data. You'll have assurance that your DMM is ready to tackle its assigned tasks.

**Cuts Equipment Costs**—Because calibration is aided by Self Test, the time needed to calibrate your 3490A is trimmed significantly, while the need for costly calibration equipment is reduced. And, if problems ever should occur in your 3490A, Self Test will assist your technician in isolating the fault.

Price for the 3490A is just \$1650 which includes AC, DC, Ohms, and Self Test functions. (Systems features—isolated BCD output and isolated remote control are low-cost options.) For further information on the 3490A, contact your local HP field engineer, or write Hewlett-Packard, Palo Alto, California 94304. In Europe: 1217 Meyrin-Geneva, Switzerland.

HEWLETT  PACKARD  
DIGITAL MULTIMETERS

AO92/3



## 25 Electronics Review

MILITARY ELECTRONICS: Cost to count as much as performance, 25  
MILITARY ELECTRONICS: Pentagon says 'copters cost too much, 26  
COMMERCIAL ELECTRONICS: Share failure costs, TV makers say, 26  
MEMORIES: Bell sleuths solve bubble mystery, 27  
GOVERNMENT ELECTRONICS: Shear look with acoustic doppler, 28  
CONSUMER ELECTRONICS: Mostek spawns timer family, 29  
AIR TRAFFIC CONTROL: FAA rethinks MLS mess, 29  
AIR TRAFFIC CONTROL: FAA eyes microwave network, 30  
COMPONENTS: Solid state booms in first 5 months, 30  
SATELLITES: GE, cable ask to use Canadian bird, 32  
MANUFACTURING: Distributor programs PROMs by TWX, 34  
COMPUTERS: Virtual memory for minis on horizon, 34  
FOR THE RECORD: 34

## 45 Electronics International

JAPAN: GaP polycrystals lead to segmented display, 45  
JAPAN: Modulating a laser directly, 45

## 51 Probing the News

COMMERCIAL ELECTRONICS: Thermal printers make their mark, 51  
CONSUMER ELECTRONICS: Solid state trips home burglars, 54  
PEOPLE: IEEE critic scores some points, 56  
COMPANIES: ICL cultivates export market, 60

## 63 Technical articles

SPECIAL REPORT: Semiconductor RAMs mature, 63  
DESIGNER'S CASEBOOK: Precision integrator resets as it samples, 78  
Wired-OR DTL gates increase multiplexer input capacity, 78  
Wien bridge in notch filter gives 60-dB rejection, 80  
COMMUNICATIONS: Impatts now compete as microwave amplifiers, 82  
YOU AND YOUR CAREER: EEs still feel insecure, survey shows, 89  
ENGINEER'S NOTEBOOK: Fail-safe font has 7-segment digits, 93  
ECL-compatible logic uses less power from single supply, 94

## 99 New Products

IN THE SPOTLIGHT: Panel meter offers 3 full digits, 99;  
Digital multimeters press analog units, 100  
INSTRUMENTS: Power amp spans 2-500 MHz, 101; Logic probe, 101  
DATA HANDLING: APL-graphics terminal, 104; NC system, 104  
COMPONENTS: Bandpass filters are tunable, 106  
PACKAGING & PRODUCTION: Wire-wrapper sells for \$5,995, 108

## Departments

Publisher's letter, 4  
Readers comment, 6  
Meetings 8  
People, 14  
40 years ago, 16  
Electronics newsletter, 21  
Washington newsletter, 37  
Washington commentary, 38  
International newsletter, 47  
Engineer's newsletter, 96

Title R registered U.S. Patent Office; Copyright 1972 McGraw-Hill Inc. All rights reserved, including the right to reproduce the contents of this publication in whole or in part. Volume 45, Number 18

## Highlights

### Thermal printers get set to go, 51

With their inherent advantages over mechanical printers—virtually noiseless operation, high reliability, and light weight—thermal printheads are appearing in calculators and computer terminals.

### Special Report: Semiconductor RAMs mature, 63

In the past year, new p-channel dynamic random-access memories have come on the scene, challenging the successful 1103. And n-channel devices have come of age, as have the big bipolar RAMs. Here's an in-depth round-up of what's available—and what they offer to memory system designers.

### Impatt diodes work out as microwave amplifiers, 82

Design advances have helped these two-terminal devices get around their big drawback—narrow bandwidth. Now, cascaded for higher gain and power, they are challenging the travelling-wave tube, transistors, and Gunn diodes.

### The EE still feels insecure, study shows, 89

Results of an *Electronics* survey indicate that, while employed engineers are moderately satisfied with their jobs, many EEs continue to be angry and frustrated. What's more, the uneasiness spawned by the business downturn and layoffs persists even though a recovery is at hand.

### And in the next issue . . .

Special report on Wescon . . . digital fuel injection design . . . what computers are doing in aerospace.

### The cover

The core memory is giving up ground to semiconductor random-access memories in some computer mainframe jobs. One reason is their smaller size. For example, the Fairchild 95415 ECL 1,024-bit RAM on the right actually would fit in the space occupied by three dozen bits in the core array.



# Electronics

EDITOR-IN-CHIEF: Kemp Anderson

EXECUTIVE EDITOR: Samuel Weber

MANAGING EDITORS: Lawrence Curran, *News*;  
Arthur Erikson, *International*

SENIOR EDITORS: John Johnsrud,  
H. Thomas Maguire

ART DIRECTOR: Fred Sklenar

ASSOCIATE EDITORS: Richard Gundlach,  
John N. Kessler, Howard Wolff

## DEPARTMENT EDITORS

*Aerospace*: William F. Arnold  
*Circuit Design*: Lucinda Mattera  
*Communications & Microwave*:

Lyman J. Hardeman  
*Computers*: Wallace B. Riley  
*Consumer*: Gerald M. Walker  
*Industrial*: Alfred Rosenblatt  
*Instrumentation*: Michael J. Riezenman  
*Military*: Ray Connolly  
*New Products*: H. Thomas Maguire  
*Solid State*: Laurence Altman  
*Special Issues*: Harry R. Rapp

COPY EDITORS: Margaret Eastman,  
Everett C. Terry

ASSISTANT EDITOR: Marilyn Offenheiser

ART: Charles D. Giatto, *Associate Director*

PRODUCTION EDITORS:  
Patricia Cybulski, Arthur C. Miller

EDITORIAL SECRETARIES: Vickie Green,  
Nancy Baldasare, Julie Gorgoglione

## FIELD EDITORS

*Boston*: James Brinton (Mgr.), Gail Farrell  
*Dallas*: Larry Armstrong (Mgr.)  
*Los Angeles*: Paul Franson (Mgr.)  
*New York*: Alfred Rosenblatt (Mgr.)  
*San Francisco*: Stephen Wm. Fields (Mgr.),  
Judith Curtis  
*Washington*: Ray Connolly (Mgr.),  
William F. Arnold  
*Frankfurt*: John Gosch  
*London*: Michael Payne  
*Paris*: Arthur Erikson  
*Tokyo*: Charles Cohen

## McGRAW-HILL WORLD NEWS

*Director*: Walter A. Stanbury; *Atlanta*: Stan Fisher; *Chicago*: Mike Sheldrick; *Cleveland*: Arthur Zimmerman; *Detroit*: James Wargo; *Houston*: Robert E. Lee; *Los Angeles*: Michael Murphy; *Gerald Parkinson*; *San Francisco*: Margaret Drossel; *Seattle*: Ray Bloomberg; *Washington*: James Canan, Herbert W. Cheshire, Seth Payne, Warren Burkett, William D. Hickman; *Bonn*: Robert Ingersoll; *Brussels*: James Smith; *London*: Marvin Petal; *Milan*: Peter Hoffmann, Andrew Heath; *Moscow*: Axel Krause; *Paris*: Stewart Toy, Michael Johnson; *Stockholm*: Robert Skole; *Tokyo*: Mike Mealey

PUBLISHER: Dan McMillan

ADVERTISING SALES MANAGER: Pierre J. Braudé

ADVERTISING SALES SERVICE MANAGER:  
Wallis Clarke

BUSINESS MANAGER: Stephen R. Weiss

CIRCULATION MANAGER: George F. Werner

RESEARCH MANAGER: David Strasser

MARKETING SERVICES MANAGER:  
Tomlinson Howland

**Semiconductors** are becoming nearly as pervasive in electronic applications as electronics itself has become all across industry. Our special report this issue on semiconductor random-access memories (p. 63) details how the new breed of p-channel and n-channel MOS RAMs, as well as the just-emerging big bipolar RAMs, are taking over some computer mainframe chores.

That's just one of many product areas that are benefitting from the versatility of semiconductors. There's so much going on that our versatile Solid State Editor, Larry Altman, is kept hopping. After wrapping up his special report on the expanding world of linear ICs for the June 5 issue, he contributed half of last issue's two-part report on ICs in consumer applications and then jumped right in to complete the 15-page semiconductor RAM report. His next task? Instead of resting up, he took some vacation days to insulate and panel an old farm house in upstate New York.

**Dissatisfaction**—that's the key word in two career-related articles in this issue. On page 89, you'll find the eyeopening results of our recent questionnaire asking our EE readers about their job status in these uncertain times.

Our Consumer Editor, Jerry Walker, who handled the survey, says: "Reviewing some of the returns was a wrenching experience, as EEs indicated emotions ranging from uneasiness to despair about the future of the profession."

Putting together that story gave Walker a lot of insight into the career problems that caused Irwin Feerst, a consulting engineer and former teacher, to set out to reform the IEEE. Feerst, the subject of the Probing the News story on page

56, failed in his second bid to run for IEEE president. But his ideas are gaining supporters.

"Changes appear to be afoot," says Walker, "as the IEEE has responded to the push to be concerned with professional development. And as the current crop of students grows more active, perhaps there will be no need for an Irwin Feerst to agitate. And I think he's the first person to hope so."

**Burglar alarms** are not used only to protect stores, banks, and other business property. For one thing, they are being installed in more and more homes around the country. Our Probing the News on page 54 covers that growing market. In her reporting, Marilyn Offenheiser, who wrote the story, found a number of offbeat applications indicating that the market for burglar alarms and related sensors may be wider than most people image.

"There's a statue of Buddha in a major American museum that is sitting on a weight sensor," she says. "As long as he is left to sit and contemplate, all is OK. Then there's the waterworks in Portland, Me. It's chlorine mixing apparatus has a special burglar alarm, which was put in after someone broke in trying to poison the water. At least one company installed alarms on the lights at the top of radio towers, to thwart anyone who might like to see a plane plow into the mast. The Smithsonian's moon rock has its own special burglar alarm, as do the specially-bred rabbits at the cancer research labs in Bethesda, Md."



August 28, 1972 Volume 45, Number 18  
89,900 copies of this issue printed

Published every other Monday by McGraw-Hill, Inc. Founder James H. McGraw 1860-1948. Publication office 1221 Avenue of the Americas, N.Y. N.Y. 10020. Second class postage paid at New York, N.Y. and additional mailing offices.

Executive, editorial, circulation and advertising addresses: Electronics, McGraw-Hill Building, 1221 Avenue of the Americas, New York, N.Y. 10020. Telephone (212) 997-1221. Teletype TWX N.Y. 710-581-5234. Cable address: MCGRAW HILL LN Y.

Subscriptions limited to persons with active, professional, functional responsibility in electronics technology. Publisher reserves the right to reject non-qualified requests. No subscriptions accepted without complete identification of subscriber name, title, or job function, company or organization, including product manufactured or services performed. Subscription rates: qualified subscribers in the United States and possessions and Canada, \$8.00 one year, \$12.00 two years, \$16.00 three years, all other countries \$25.00 one year except Japan \$50.00 per year including air freight. Limited quota of subscriptions available at higher-than-basic rate for persons outside of field served as follows: U.S. and possessions and Canada, \$25.00 one year, all other countries \$50.00. Single copies: United States and possessions and Canada, \$1.00, all other countries, \$1.75.

Officers of the McGraw-Hill Publications Company: John R. Emery, President; J. Elton Tuohig, Senior Vice President—Services; Donald B. Gindley, Group Vice President; Vice Presidents: Ralph Blackburn, Circulation; John R. Callahan, Editorial; John B. Hoglund, Controller; David G. Jensen, Manufacturing; Jerome D. Luntz, Planning & Development; Joseph C. Page, Marketing.

Officers of the Corporation: Shelton Fisher, President; Joseph H. Allen, President, Publications and Business Services Group; John J. Cooke, Senior Vice President and Secretary; Ralph J. Webb, Treasurer. Title registered in U.S. Patent Office; Copyright 1972 by McGraw-Hill, Inc. All rights reserved. The contents of this publication may not be reproduced either in whole or in part without the consent of copyright owner.

Subscribers: The publisher, upon written request to our New York office from any subscriber, agrees to refund that part of the subscription price applying to copies not yet mailed. Please send change of address notices or complaints to Fulfillment Manager; subscription orders to Circulation Manager, Electronics, at address below. Change of address notices should provide old as well as new address, including postal zip code number. If possible, attach address label from recent issue. Allow one month for change to become effective.

Postmaster: Please send form 3579 to Fulfillment Manager, Electronics, P.O. Box 430, Hightstown, N.J. 08520.

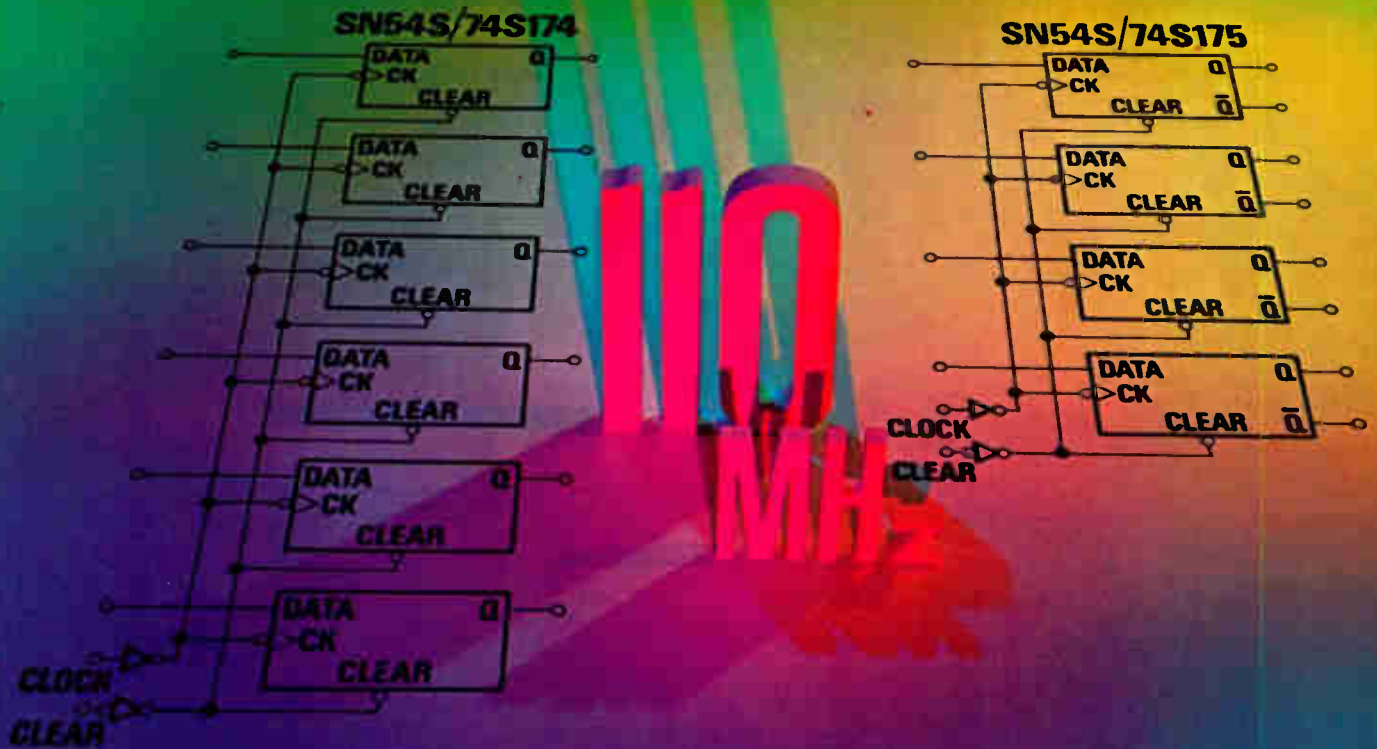

# SCHOTTKY

## Fastest TTL storage registers-- 3 times faster than standard TTL.

With clock frequencies of 110 MHz, these new additions to TI's Series 54S/74S Schottky MSI family are three times faster than the equivalent Series 54/74 TTL storage registers (see table).

The new SN54S/74S174 consists of six D-type flip-flops with single-rail outputs and the new SN54S/74S175 consists of four D-type flip-flops with double-rail outputs. Both are designed for use as buffer-register file memories, high-speed memory address registers, high-speed shift registers/counters and pattern generators.

Delay times are typically 2.5 ns per logic level and both devices have clear inputs. All inputs are buffered for a normalized fan-in of 1 to allow for easier system interconnection.

	Schottky S174/S175	Standard 174/175
Maximum clock frequency (typ)	110 MHz	35 MHz
Propagation delay (clock to output)	10 ns	20 ns
Power dissipation/flip-flop	75 mW	37.5 mW

### Full compatibility

As with all Schottky MSI circuits, these new ICs are fully compatible with all other TTL forms—standard, high-speed, low-power and low-power Schottky.

Not only will new systems benefit from these new storage registers, but also existing system performance can be easily upgraded. Both devices are pin-compatible and functionally identical to their

equivalent Series 54/74 standard TTL circuits.

The new S174 and S175 come in plastic or ceramic dual-in-line packages and in flat packs for use over the  $-55^{\circ}\text{C}$  to  $125^{\circ}\text{C}$  and  $0^{\circ}\text{C}$  to  $70^{\circ}\text{C}$  temperature ranges. They're available now from authorized TI distributors or factory stocks.

### Send for Schottky brochure

For details on the fastest TTL storage registers available—as well as other new Series 54S/74S Schottky TTL functions—get Brochure CC-408. Circle 212 on the Service Card or write Texas Instru-



ments Incorporated, P. O. Box 5012, M/S 308, Dallas, Texas 75222.



TEXAS INSTRUMENTS  
INCORPORATED



# When You Buy a Power Supply, Why Not Get the Best?



28 VDC to DC  
(55,463 Hrs.)  
Model C95D

28 VDC to 400  $\text{A}$   
(61,387 Hrs.)  
Model 53D

400  $\text{A}$  to DC  
(56,148 Hrs.)  
Model W5D

## Abbott's New Hi-Performance Modules

are designed to operate in the stringent environment required by aerospace systems — (per MIL-E-5100K or MIL-E-5272C) and MIL-STD-461 for electromagnetic interference.

**RELIABILITY** — MTBF (mean time between failures) as calculated in the MIL-HDBK-217 handbook can be expected in excess of 50,000 hours at 100°C for all of these power modules. The hours listed under the photos above are the MTBF figures for each of the models shown. Additional information on typical MTBF's for our other models can be obtained by phoning or writing to us at the address below.

**QUALITY CONTROL** — High reliability can only be obtained through high quality control. Only the highest quality components are used in the construction of the Abbott power module. Each unit is tested no less than **41 times** as it passes through our factory during fabrication — tests which include the scru-

tinizing of the power module and all of its component parts by our experienced inspectors.

**NEW CATALOG**—Useful data is contained in the new Abbott Catalog. It includes a discussion of thermal considerations using heat sinks and air convection, a description of optional features, a discussion of environmental testing, electromagnetic interference and operating hints.

**WIDE RANGE OF OUTPUTS** — The Abbott line of power modules includes output voltages from 5.0 volts DC to 3,650 volts DC with output currents from 2 milliamperes to 20 amperes. Over 3000 models are listed *with prices* in the new Abbott Catalog with various inputs:

- 60 $\text{A}$  to DC, Regulated
- 400 $\text{A}$  to DC, Regulated
- 28 VDC to DC, Regulated
- 28 VDC to 400 $\text{A}$ , 1 $\phi$  or 3 $\phi$
- 24 VDC to 60 $\text{A}$ , 1 $\phi$

Please see pages 930 to 949 of your 1970-71 EEM (ELECTRONIC ENGINEERS MASTER Catalog) for complete information on Abbott modules.

Send for our new 68 page FREE catalog.

# abbott transistor

LABORATORIES, INCORPORATED  
5200 W. Jefferson Blvd./Los Angeles 90016  
(213) 936-8185 Cable ABTLA85  
1224 Anderson Ave. Fort Lee, N.J. 07024  
(201) 224-6900

## Readers comment

### The nanofarad—British vote

To the Editor: I have read with interest the "Readers comment" concerning the use of nanofarad [*Electronics*, July 17, p.6]. British standard B.S.1852:1967, "Marking codes for values and tolerances," clearly defines the nanofarad as the preferred unit.

The use of the symbol also replaces the decimal point, as Perr Cardestan, of the University of Hawaii, suggests.

It is to be hoped that engineers will become familiar with this standard, although it's likely to be a slow process.

Ian E. Shepherd  
Electronics & Instruments Group  
Bell & Howell Ltd.  
Basingstoke  
Hants, England

■ *The original proposal for substituting the nanofarad for the picofarad to eliminate leading and trailing zeroes came from Brock Drew, of MIT's Charles Stark Draper Labs [*Electronics*, May 8, p.131].*

### International team

To the Editor: One of the first things I turn to when *Electronics* arrives is "International newsletter." Doing so in the July 31 issue, I was surprised to read in the lead piece that British Aircraft Corp.'s Rapier missile system was licensed to McDonnell Douglas.

As you correctly pointed out [*Electronics*, April 24, p.39], "... The Norden division of United Aircraft Corp., Norwalk, Conn., has obtained a license to build and sell the British-developed Rapier missile system in the U.S."

Your April 24 story went on, correctly, to explain that McDonnell Douglas Astronautics Co., of Huntington Beach, Calif., had teamed with Norden to produce the projectile.

In short, Norden is the licensee with BAC, and as such, is responsible for the entire Rapier program in the United States. McDonnell Douglas Astronautics is part of our team.

Edward R. Cowles  
Norden division  
United Aircraft Corp.  
Norwalk, Conn.



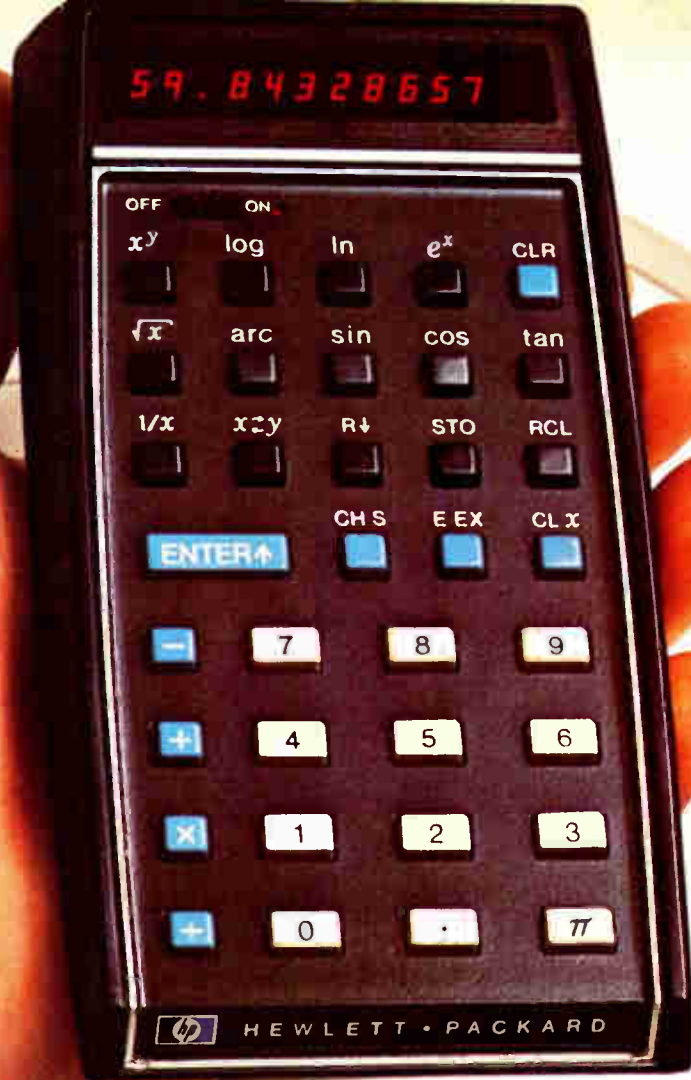

The HP-35 -  
A small tribute  
to great American  
ingenuity. Made in U.S.A.  
Don't settle for less.

# Hewlett-Packard presents the world's first pocket calculator that challenges a computer

Slide-rule portability and computer-like power for just \$395

Hewlett-Packard's HP-35 is a new time-and-work saver that can free you from countless hours of tedious computation. This cordless wonder is just a bit larger than a pack of king-size cigarettes and weighs a mere 9 ounces. Yet it *challenges a computer* in handling complex problems, including log, trig and exponent functions with a single keystroke. Best of all, it solves these problems on the spot—whether in the lab, on a plane, or at a job site. All this highly sophisticated, highly portable calculating power costs a mere \$395.00. So why settle for less? Find out now what the HP-35 can do to make your job a little easier . . . and a lot more productive. Write today for your free Capability Report.

Mail to:

HEWLETT-PACKARD  
Advanced Products, Dept. 205  
10900 Wolfe Road, Cupertino, Calif. 95014

Please mail me a free copy  
of your in-depth Capability Report  
on the HP-35 Pocket Calculator

NAME \_\_\_\_\_

TITLE \_\_\_\_\_

FIRM NAME \_\_\_\_\_

ADDRESS \_\_\_\_\_

CITY \_\_\_\_\_

STATE \_\_\_\_\_

ZIP \_\_\_\_\_

Circle 7 on reader service card

HEWLETT  PACKARD

Dear Gabby:

**"Why is parallel vs serial automatic IC testing like comparing a Ferrari to a Model T Ford?"**



**Datatron's Girl Gabby**

**DEAR GABBY:** My neighbor who works for a large IC user says that comparing Datatron's parallel automatic IC tester to serial testers is like comparing a Ferrari to a Model T Ford. Can this be true?  
CAR BUFF

**DEAR BUFF:** A good analogy indeed! Serial testers apply a stimulus to an IC input and sequentially monitor all outputs. A very slow process. Datatron is a parallel tester with individual electronic cards (PECs) for each pin of the IC under test, making it possible to force and monitor all inputs and outputs simultaneously.

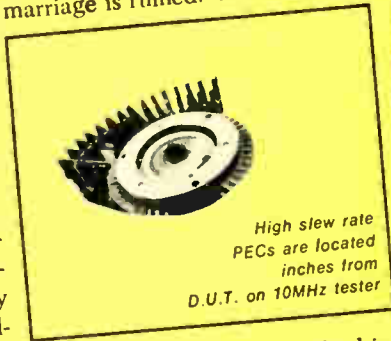

High speed rate  
PECs are located  
inches from  
D.U.T. on 10MHz tester

**DEAR DESPERATE:** Slip him a data sheet on Datatron's Model 4500 test system which will exercise his memory at 10MHz and perform access time measurements in parallel as well! Program generation uses simple English language too. He's sure to come home happy!  
GABBY

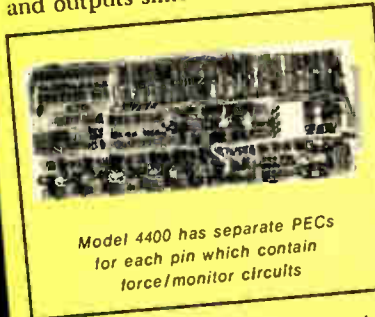

Model 4400 has separate PECs for each pin which contain force/monitor circuits

This drastically reduces test time, simulates actual IC operation, and makes it easy to expand or update the system.  
GABBY

**DEAR GABBY:** My husband is in charge of testing at Integrated Circuits Inc. Lately, he's been grumpy with me and the kids because he can't exercise his memory

★ ★ ★  
Confidential to Weight Lifter from Muscle Beach: Thanks for the snapshot showing your "pecs". However, since the "PECs" we refer to are our exclusive Pin Electronic Cards, I'm afraid we can't use your services.  
GABBY

★ ★ ★  
Send your questions — either straight or humorous — to Gabby. We'll mail a Flair pen for all received and pay \$100 if we use question in future ad.

**datatron inc.**

1562 Reynolds Ave / Santa Ana, Calif. 92711  
(714) 540-9330

**moving up fast in...**



## Meetings

**First National Conference on Remotely Manned Systems:** NASA, Caltech, Ramo Aud., Caltech, Pasadena, Calif., Sept. 13-15.

**Western Electronic Show & Convention (Wescon):** WEMA, Convention Center, Los Angeles, Sept. 19-22.

**Engineering in Medicine and Biology:** IEEE, Americana, Bal Harbour, Fla., Oct. 1-5.

**International Symposium on Remote Sensing of Environment:** U. of Michigan, Willow Run Labs, Ann Arbor, Oct. 2-6.

**U.S.A. & Japan Computer Conf.:** AFIPS, IPSJ, Tokyo, Oct. 3-5.

**Ultrasonics Symposium:** IEEE, Statler Hilton, Boston, Oct. 4-6.

**National Electronics Conf.:** NEC, Regency Hyatt O'Hare, Chicago, Oct. 9-11.

**International Conference on Cybernetics and Society:** IEEE, Sheraton, Washington, D.C. Oct. 9-12.

**Conference on Display Devices:** IEEE, United Engineering Center, New York, Oct. 11-12.

**Eascon:** IEEE, Marriott Twin Bridges, Washington, D.C., Oct. 16-18.

**The Business Equipment Show:** McCormick Place, Chicago, Oct. 16-20

**International Conference on Computer Communications:** IEEE, ACM, Hilton, Washington, D.C., Oct. 24-26.

**Nerem:** IEEE, John B. Hynes Civic Auditorium, Boston, Nov. 1-3.

**International Conference on Magnetism and Magnetic Materials:** AIP, IEEE, et al., Hilton, Denver, Nov. 28-Dec. 1.

**International Electron Devices Meeting:** IEEE, Washington Hilton, Washington, D.C., Dec. 4-6



WHICH COMPANY IN THE WORLD OFFERS THE BROADEST LINE OF

# Trimmer Capacitors?



SUBMINIATURE CERAMIC



CERAMIC

offers the world's broadest variety of styles and capacitance values in its extensive line of Ceramic Trimmers. Style 518 above, for example, is a compact little Monobloc trimmer designed for applications where saving space is vital. Easily mounted ERIE Trimmers are available in terminal arrangements to meet PC board or point-to-point wiring needs. Voltage ratings to 500Vdc. A full 180° min to max range. Designed to meet or exceed applicable requirements of MIL-C-81A

**NEW . . .**  
**TAKE A LOOK AT THIS LITTLE GEM!**  
**VARI-Thin**  
**WORLD'S SMALLEST PRECISION VARIABLE CAPACITOR**

Imagine, our new VARI Thin measures only .221" dia x .080" thin. And it has a capacitance range from 5 to 30 pF. This latest low profile ERIE Trimmer was designed by the foremost capacitor engineers for the burgeoning quartz watch industry, and now its advantages are being utilized in a variety of miniaturized instrument and communication gear. We suggest the advantages of VARI Thin can be applied to your newest packaging schemes. Write TODAY for further data . . . VARI-Thin



**ERIE 515**  
 Shown 5 times actual size

Actual Size



AIR

Performance stability is assured with ERIE Air Trimmers. Rotor and stator plates are precision machined from solid brass extrusions. Erie's unique design provides strong top plate construction. Terminal arrangements to meet every mounting need. Custom designs available such as for LC tuned circuits and for higher voltage applications.

A lot of companies talk about variable capacitors. Some offer ceramic. Others air . . . or glass. Erie manufactures the total line of sophisticated miniature Trimmer Capacitors. In fact, most knowledgeable engineers look to Erie first for the Trimmer Capacitor of their choice. Ceramic. Air. Glass. Quartz. Plastic. Erie has them all . . . 10 different dielectrics . . . more than 1,000 variations . . . and the quality is typically Erie.

Applications for Erie Precision Trimmer Capacitors include avionics apparatus, communications equipment, oscilloscopes, crystal oscillators, crystal filters . . . and now the newest of them all, *electronic quartz watch systems*. Any circuit demanding very precise tuning and stable performance.

So design with Erie in mind. Let us serve as your one-stop source for Trimmer Capacitors. Chances are we have a cataloged trimmer that's just right for your application.



PLASTIC

ERIE Plastic Trimmers are ideal for applications calling for low minimum capacitance and high ratio of min to max capacitance range. These popular trimmers are economical, provide excellent resolution, High Q, stability and high self resonance. Available in both Teflon® and polystyrene dielectrics.



GLASS and QUARTZ

ERIE Glass and Quartz Trimmers are excellent for fine tuning resolution. ERIE Quartz Trimmers are ideal where highest Q possible is essential and for applications requiring higher maximum capacitance. ERIE Hi-K Glass Trimmers provide up to 30% greater capacitance. Hermetically sealed units available. And our 590 series features an embedded electrode, combining very high capacitance with a rugged outer wall . . . perfect for RF circuits requiring maximum stability. Units meet or exceed applicable requirements of MIL-C-14409.

Get your nearby Erie man TODAY . . . write for our complete Trimmer Capacitor catalog — 500.

Circle 9 on reader service card

**ERIE TECHNOLOGICAL PRODUCTS, INC.**  
 Erie, Pennsylvania 16512



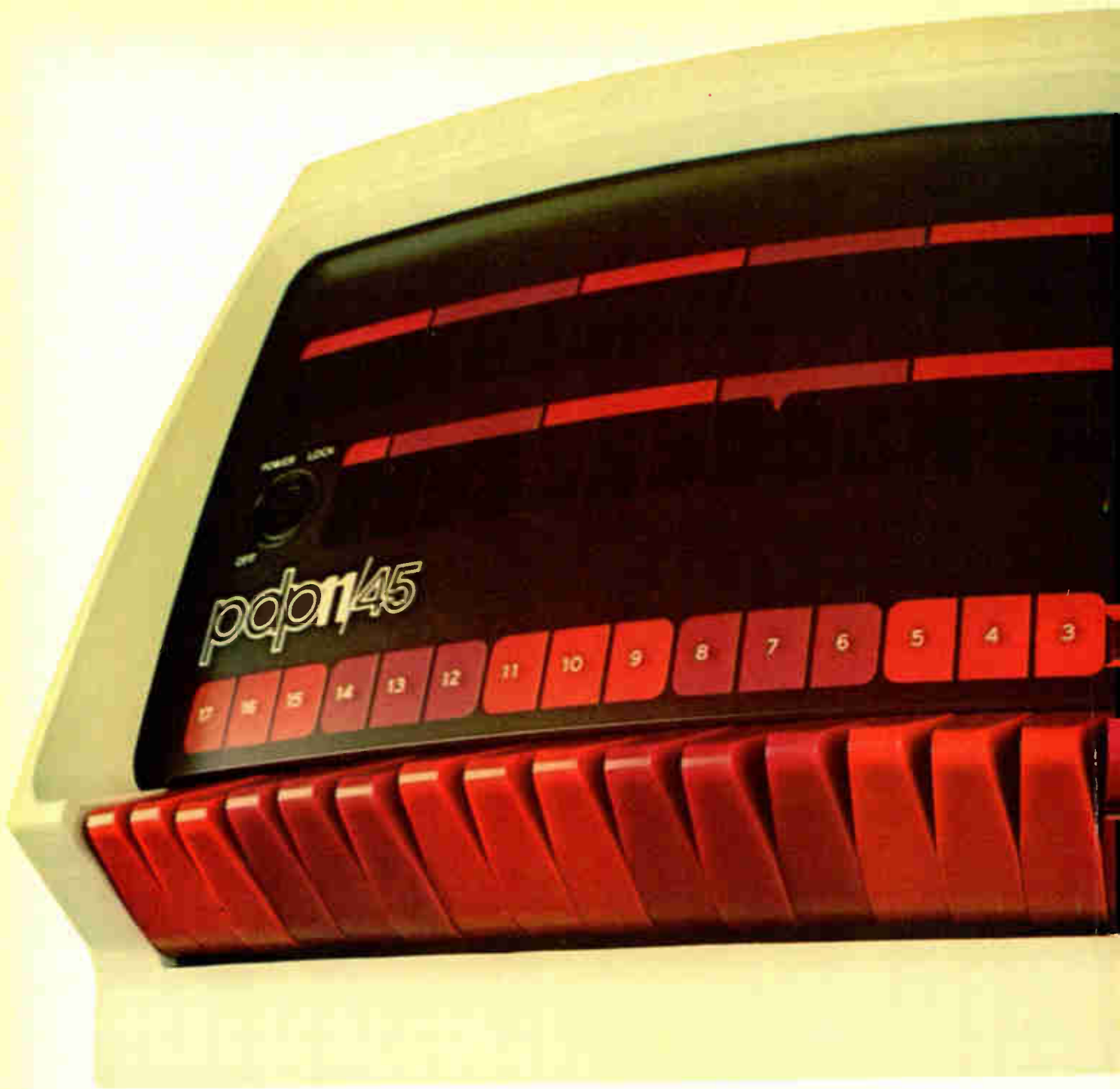

## Once you've seen the PDP-11/45, you'll scale computers

Take a good close look at the new 11/45 and you'll start expecting medium scale computers to have features like 64-bit multi-accumulator floating point

hardware. Memory expansion to 248K bytes. Complete memory management hardware for dynamic relocation and protection. Dual ported memories. Three protected processor environments for multi-programming. 16 general-pur-

pose registers. Stack and double-address operations.

And you'll be looking for speeds like 300 nanosecond instruction execution.





# never be able to look at medium the same way.

Three hundred nanosecond solid-state memories. Fast floating-point. (Single precision 2-word multiply in 6 microseconds. Double precision, 64-bit multiply in 9 microseconds.)

And you'll expect to get it all for around \$19,500. Complete with 8K core

and console terminal. Before quantity discounts.

That's what you'll go looking for. But you won't find it.

Except in the PDP-11/45.

Write for the literature. Digital Equipment Corporation, Maynard, Mass. 01754. (617) 897-5111. European headquarters: 81, route de l'Aire, 1126 Geneva 26, Tel: 42 79 50.

**digital**

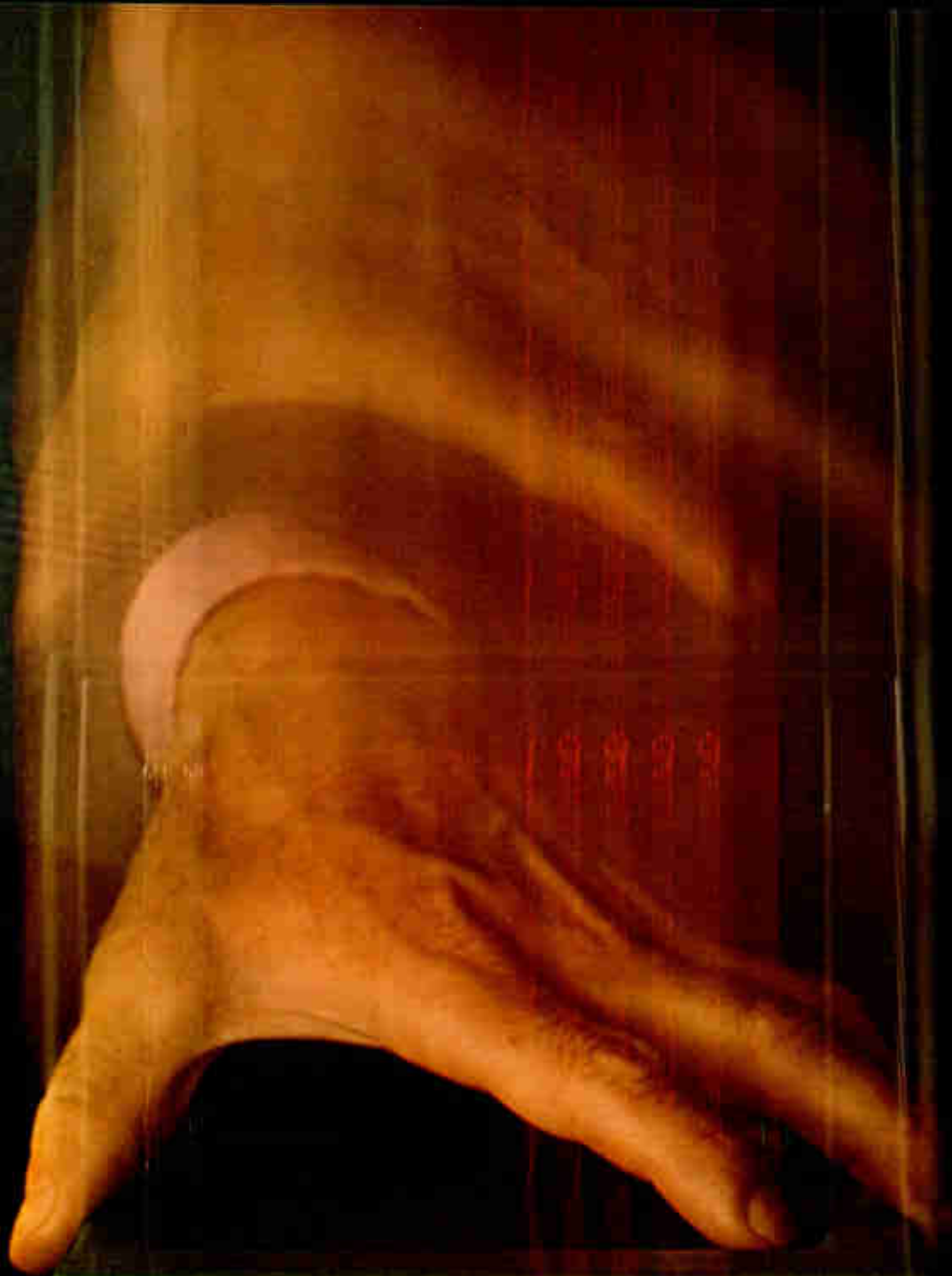

34740 A DISPLAY

OFF ON

19.999

HEWLETT • PACKARD 34702A MULTIMETER

INPUT V HI LO

DCV ACV OHM

100Ω 1 10 100 1000 10MΩ

INPUT Ω 350V MAX 100V MAX

Detailed description of the multimeter face: The device is a Hewlett-Packard 34702A digital multimeter. At the top, a red LED display shows the number '19.999'. To the left of the display is a power switch labeled 'OFF ON' and a label '34740 A DISPLAY'. Below the display, the brand name 'HEWLETT • PACKARD' and model '34702A MULTIMETER' are printed. The front panel features two sets of input terminals on the left, labeled 'HI' and 'LO', with a lightning bolt symbol and the letter 'V' indicating voltage measurement. Between these terminals are three rotary function switches for 'DCV' (Direct Current Voltage), 'ACV' (Alternating Current Voltage), and 'OHM' (Resistance). Below these switches are six range selection buttons labeled '100Ω', '1', '10', '100', '1000', and '10MΩ'. On the right side, there are two more input terminals, also labeled 'HI' and 'LO', with a lightning bolt symbol and the letter 'Ω' indicating resistance measurement. Above these terminals are labels '350V MAX' and '100V MAX'.



# The New Snap-On...



## Low-Cost, 4-Digit Measurement System 3470.

- Bright LED Display section has 100% overranging.
- AC/DC/OHMS snap-on with display. (\$600 complete)
- DC snap-on with display. (\$475 complete)
- Snap-together expandability with sandwich centers—battery pack (\$200); BCD (\$175).
- H-P's exclusive self-test accessory reduces down time (\$50).

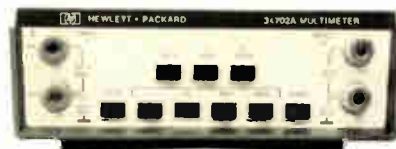
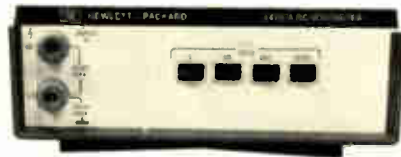

If you need one of these low-cost DMM's, there's no time like the present. Pick up the phone and call your nearest H-P Representative, now. Or, write to Hewlett-Packard, Palo Alto, California 94304; Europe; P.O. Box 85, CH-1217 Meyrin 2, Geneva, Switzerland. In Japan: YHP, 1-59-1, Yoyogi, Shibuya-Ku, Tokyo, 151.

HEWLETT  PACKARD

DIGITAL VOLTMETERS

092/41

Circle 13 on reader service card

# FREE Engineering Handbook on Electromagnetic Delay Lines

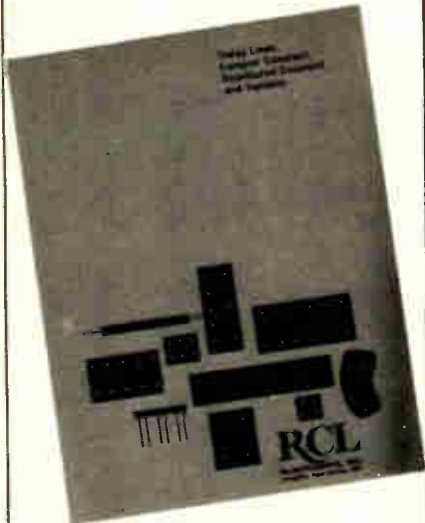

**We've reserved  
a copy  
for your desk . . .**

Terms . . . engineering definitions . . . how to specify delay lines . . . characteristics of various types . . . specifications . . . they're all included in this concise, easy-to-read handbook . . . yours for the asking.

**LUMPED CONSTANT . . .  
DISTRIBUTED CONSTANT  
. . . VARIABLE**  
all three types are covered  
in this reference  
handbook.

# RCL

**RCL ELECTRONICS, Inc.,**

General Sales Office:

Seven Hundred  
South Twenty First Street  
Irvington, New Jersey 07111

## People

Bell, back at DEC,  
generating ideas

Gordon Bell resonates like a bell, though less with sound than with energy and ideas. So now that he's back at Digital Equipment Corp. as vice president for engineering, he's sure to make his presence felt.

Bell, a professor of electrical engineering and computer science, is on leave from Carnegie-Mellon University, Pittsburgh. But he really never left DEC after joining the Maynard, Mass., maker of minicomputers as an MIT graduate student in mid-1960. No one remembers exactly whether he was DEC's first or second engineer, but he has either held corporate office or consulted there for the past 11 years.

**Numbers game.** In his first tour at DEC, Bell worked on logic modules, DEC's first major source of income. Then he was made responsible for the PDP-4, got supervisory responsibility for the PDP-5, and began the PDP-6 effort. "At this point, DEC began to look more interesting than my MIT speech-recognition research, so I went full-time."

"The PDP-6, ancestor of the PDP-10, may have made the minicomputer revolution possible," speculates Bell. "We simply couldn't build the PDP-6 with standard wiring techniques—too many errors—so we ordered wire-wrap equipment. That meant we also were able to use wire-wrap on the PDP-8. If we had not had that low-cost assembly capability, DEC wouldn't have been such a factor in the growth of the mini, and the whole minicomputer business might have been delayed by two years or more."

Since the PDP-6 was the PDP-10's antecedent, Bell feels some pride in the later line, too. And, though more executive than pure engineer by then, he personally worked on logic circuits for the PDP-10. "I like to get my hands on things,"

he says. "It was being an executive that sent me back to school."

In 1966, Bell moved to Carnegie-Mellon. There he concentrated on machine architecture and descriptive languages for digital hardware and machine performance that could give "concise, unambiguous descriptions of the relative merits of various machine/instruction set combinations."

**Lift for user.** When this material, called PMS and ISP (for processor, memory, switch; and instruction-set processor), gets into wide circulation it could trigger shootouts among existing machines, says Bell, giving the often confused user a needed lift. The languages also could act as a powerful design aid, right down to the last gate or data bit, he adds. He figures that it will take four or five years for the techniques to get into general circulation, although he already has used them at DEC.

What sort of effort is Bell going to undertake at DEC? "Among other things, I'd like to attack our problem of large numbers of products selling over broad market lines," he says. "I feel that, though we have to fill the needs of the market, we can do the job with more hardware commonality—say, more common sub-assemblies." This attitude may already be showing in DEC's home-built core memories, which have permitted price cuts.

"I like a common-peripherals approach too," says Bell. And his support now appears to be paying off in

**Stacking DEC.** Gordon Bell, back at DEC as engineering vice president, reverberates with ideas.



machines like the DEC-writer and Digital Equipment's new high-density disk stores.

### Fisher's R&D to move aerospace to consumers

The appointment of Joseph L. Behr to be vice president of research and development for Fisher Radio, Long Island City, N.Y., underlines the intention of Fisher, as well as other consumer-oriented companies, to transfer aerospace and defense technology to civilian uses. Not only is carrying out this concept one of Behr's prime duties, but he is himself an aerospace transferee.

Formerly with the Electronics and Space division of Fisher's parent company, Emerson Electric, Behr was responsible for interdivisional electronic developments. He helped bring digital control techniques developed by the space division to Emerson's industrial operations, and now he's planning to do much the same for the consumer end of the business at Fisher.

Behr entered Fisher as director of quality management, but the firm's need for a broader look at technical developments than was possible through the old organization led to formation of an independent R&D staff free from day-to-day engineering problems and able to look a couple of years ahead.

**Testing.** One of the first direct benefits Fisher gained from Emerson's space programs was computerized testing of stereo components in the production facility. Because the space projects were heavy in digital developments, it's likely that digital controls in tuning and automatic on/off timing features will be among the first transfers to Fisher amplifiers and tuners.

Having worked in both aerospace and industrial electronics since graduation from St. Louis University, Behr comments that many companies give lip service to the transfer of technology to consumer goods, but now he has a chance to show that the idea makes competitive sense.

# FIBEROPTICS



## solving design problems with the light fantastic

EFC combines imagination with electronic, fiber optic and optical skills to solve the problem and build the equipment in every conceivable field... from computers to groceries and surgery to jet engines.

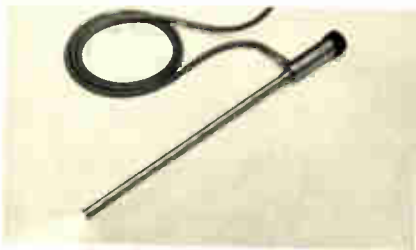

### BETTER LIGHT FOR DOCTORS

In general and dental surgery, there has long been a need for light weight, sterilizable light guides that could withstand constant handling. Previously, sterilizability has been attained only by sealing the fiber optics in a heavy walled, semi-flexible jacket, thus greatly limiting the usefulness of the light guides themselves. EFC has introduced a special, fully sterilizable glass fiber with a diameter of .0005" — giving it superior flexibility and strength and resulting in high resistance to breakage. These fibers need only be encased in a thin walled, flexible sheathing. These tough fibers — combined with a variable light generator — have been used in light guides and instrumentation for a variety of surgical procedures.



### THE SUPER SUPERMARKET

Customers and the big food retailers have at least one thing in common... the strong desire to speed up the check-out process. Fiber optics will be part of a marvelous new "gun" that soon will re-

duce check-out time. All items purchased will carry a coded label or imprint.

The check-out clerk will have an optical scanner or code reader which is passed over the markings on the purchased goods. It reads and decodes the label and prints out the item name and unit cost for customer receipt. This error-free system can be a valuable inventory control or provide any sales information.



### PRINTED LIGHTS AND COLOR MULTIPLEXING FOR VEHICLES

A new tape fabricated from optical fibers can replace the multitude of light bulbs, sockets and wires that currently confuse the back side of vehicle instrument panels. This fiber tape — illuminated by a single bulb — glows at many predetermined points, illuminating all function switches. The advantages: high reliability, lower cost, less power consumption. The same advantages could apply to your vehicle, appliance or multi-point illumination system. Power consumption and wiring complexity continually plague vehicle designers. A new system using a single power buss with individual power requirements programmed through a single color multiplexed optical fiber — has been designed and tested for vehicle application. Exterior lamp monitoring, once an optional extra on luxury vehicles, is now available from EFC under the name LITECHEX.

**Now, you've seen how EFC Fiberoptics solves diverse problems...  
tell us about yours. Call E. F. Scott at 617-835-6276**



## ELECTRO FIBEROPTICS

A Valtec Company

99E Hartwell Street, West Boylston, Mass. 01583



# New types WIMA<sup>®</sup> capacitors for industrial electronics and for exacting requirements

- Metallized polyester capacitors
- Metallized polycarbonate capacitors
- Metallized polypropylene capacitors
- Plastic film capacitors in special capacitance tolerances
- Plastic film capacitors for A.C. and pulse duty
- Miniature capacitors
- Low voltage electrolytic capacitors

WIMA capacitors are quality components for electronic equipment.

Please send for the latest technical catalogue.



## WILHELM WESTERMANN

Spezialfabrik für Kondensatoren  
D-68 Mannheim 1  
Fed. Rep. of Germany

Augusta-Anlage 56  
P.O. Box 2345  
Tel.: (621) 40 80 12  
Telex: 4-62 237  
Cables: Wimakondensator

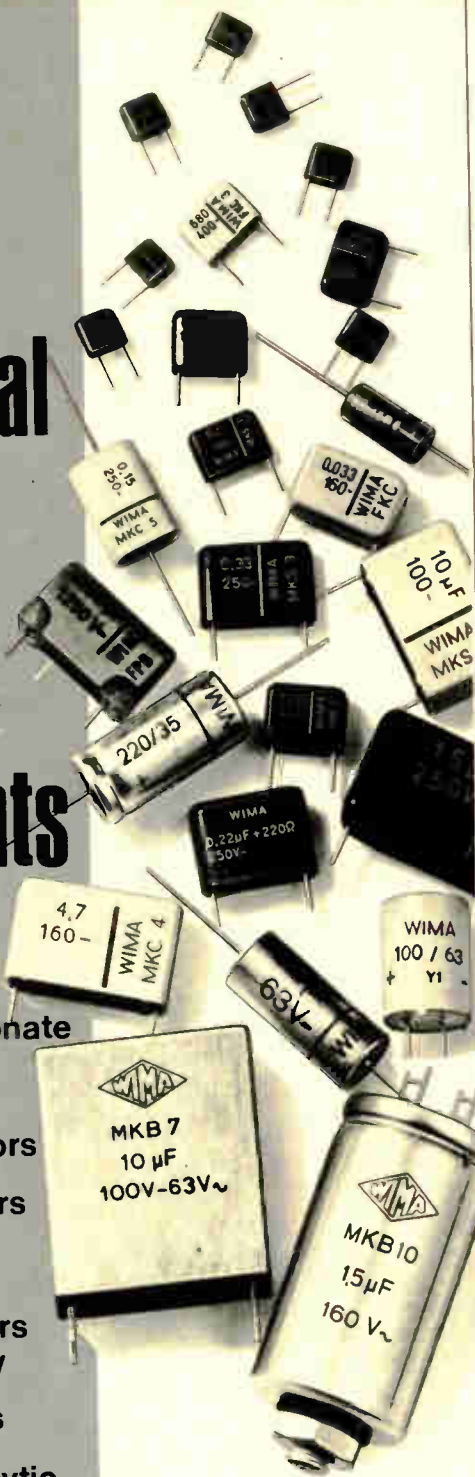

## 40 years ago

From the pages of *Electronics*, August 1932

Dr. Kennelly, radio pioneer and author of the "reflecting layer" theory of radio propagation, to which his name is given in the Kennelly-Heaviside Layer, outlines the phenomena which may be watched for during the coming solar eclipse of August 31. This eclipse will be total throughout a wide band across New England, and will be the last total eclipse to visit the Eastern United States for a generation.

Professor E.V. Appleton, King's College, London, suggests that there exist two distinct ionized layers. The upper layer or F region at about 230 km. altitude is produced by ultraviolet light, the lower or E layer at about 90 km. by electrons or atoms thrown by the sun with speed of 1,000 miles per sec. Professor Appleton calls attention to the opportunity of using the forthcoming eclipse to shed light into this question. In consequence of the motions of the moon and the earth, the stream of supposed particles will be interrupted more than an hour before the ultraviolet light is stopped. There would possibly be two radio eclipses, the particle eclipse affecting the E layer from which the ordinary broadcast waves are turned back and the much shorter optical eclipse affecting the F layer which is reached by 80-m. waves. The particle eclipse covers a belt east of the track of optical totality.

A new gaseous-discharge lamp of extremely high luminous efficiency has just been developed in the laboratories of the Philips Glowlamp-Works at Eindhoven, Holland, by Dr. Gilles Holst and his staff. In this lamp, a low-voltage discharge takes place in a mixture of neon gas and sodium vapor, between an oxide cathode and one or more anodes. The lamps used in the highway lighting installation shown on the front cover of this issue of *Electronics* have a length of about 12 cm. and a diameter of 6 cm., and with an input of 100 watts, give from 500 to 600 international candles. The total flux of light amounts to between 5,000 to 6,000 lumens.



## From The Datacraft DC-38 Building Block Comes A True Planar Design 8K Single Card Memory

Today at Datacraft you can buy an 8K X 18 magnetic core single card memory in a true planar design... all electronic components and core plane array connected to the single plane of a printed circuit card.

This is a design with no compromise. There are no stacked components... no qualifications.

Like our 4K single card memory, the 8K single card is also available two ways. The 8K single card can be expanded up to 64K X 18. Take the two card approach and you can get one timing and control card to drive eight 8K X 18 digital stack boards. Then you can expand even further in banks of 64K.

But a big bonus is that the 4K and 8K digital stack boards are interchangeable in the same chassis with no internal wiring. Both the 4K and 8K DSB use the same timing and control board. Or, if your application calls for it, the 8K single board memory is also interchangeable with the 4K single board memory with no internal wiring.

The 8K single board memory is about 25 per cent less than two 4K printed circuit boards.

Here is truly a memory system you can get in just the right combination of price and performance to match your exact specification.

The 8K single board memory is simply another example of how we use the modular design of the DC-38 as a basic building block.

Just clip the coupon for more information on any Datacraft memory. And if you don't see the configuration you need, then just give us a call... we're probably working on it.

**Datacraft Corporation**  
Post Office Box 23550  
Fort Lauderdale, Fla. 33307

Please send me specifications for the configuration I have checked.

- 4K X 18 Single Card Memory
- 4K X 18 digital stack boards with separate timing and control card
- 8K X 18 Single Card Memory
- 8K X 18 digital stack boards with separate timing and control card
- Call me about another configuration

NAME \_\_\_\_\_  
TITLE \_\_\_\_\_  
COMPANY \_\_\_\_\_  
CITY \_\_\_\_\_ STATE \_\_\_\_\_ ZIP \_\_\_\_\_

# *Datacraft*



# We Stacked

Some time ago we announced our family of everything-on-one-card core memories. Off-the-shelf. Spectacularly low prices. Fully TTL compatible with no analog or critical timing inputs required. And available in a wide range of sizes and performance characteristics.

But since then a few others have been shouting about their card memories. A pair over here. Three-of-a-kind over there.

Okay. Time to reshuffle, cut

the cards—and lay the whole new hand on the table.

First, let's look at those features common to *all* our card memories:

We use 18 mil wide temperature core throughout for top quality performance, high density and great reliability. Our unique 3 wire, 3 Dimensional planar stack design assures high density packaging. It also allows you to plug "piggy-back" style into the

electronic board via an individual pin-and-socket design. This interconnect arrangement offers several advantages. The layouts are easier. The lead lengths are shorter. The interconnections are on an integral basis. Noise is less. And performance is considerably improved.

So much for the advantages of the entire family. Now here are some individual features of the three series:

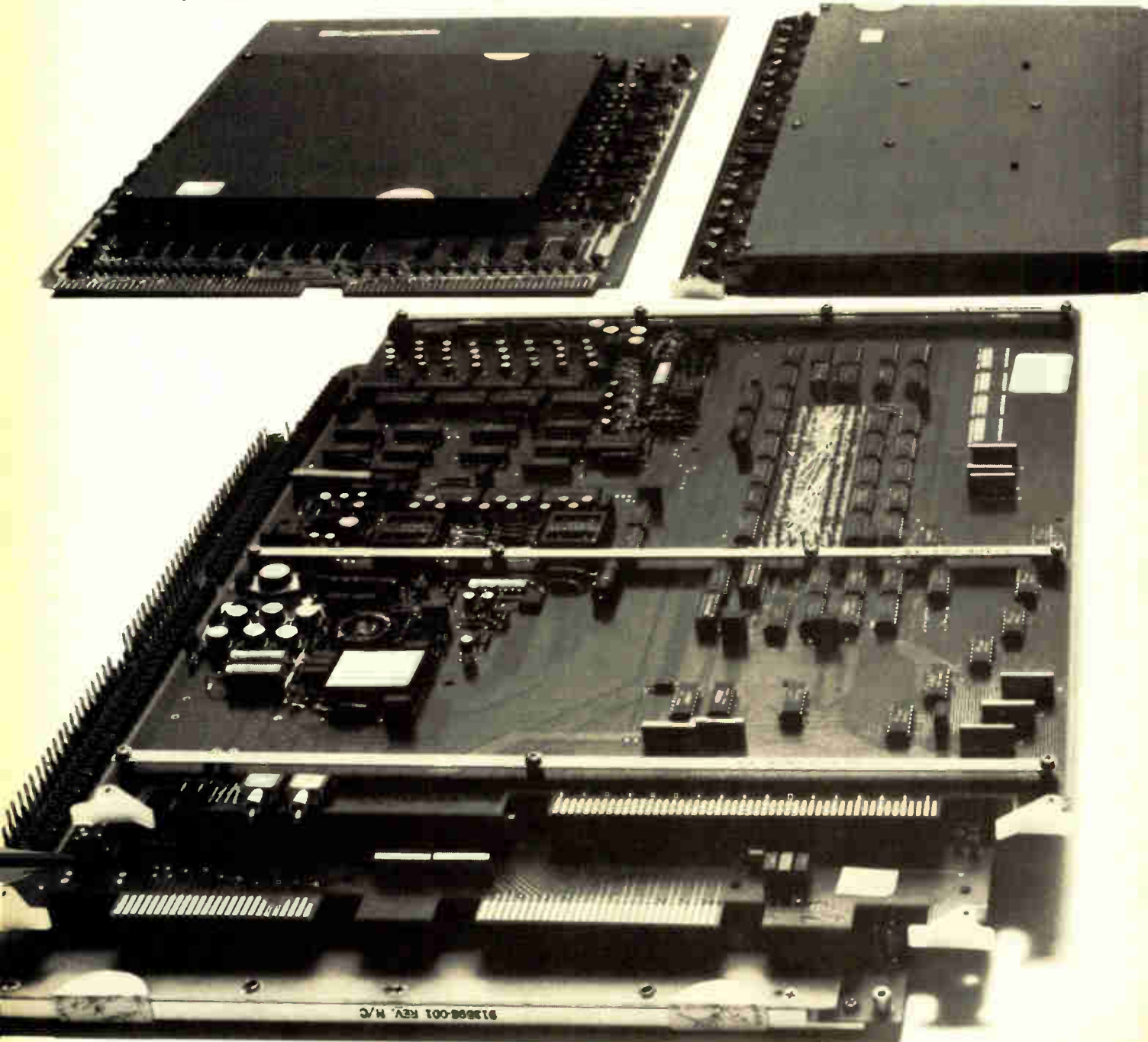



# the Deck.

## Micromemory 2000

Here you have the total system on one card with edge connections that allow the memory to be treated just like a logic circuit. With this series there are no funny voltages. The card operates from plus five volts input only.

## Micromemory 3000

This series is the high performance version of Micromemory 2000. You get high speed: 650 nanosecond



cycle time and 300 nanosecond access time. Byte control and Data Save features are included.

## Micromemory 6000

This is the newest member of the family, and in some ways the most exciting. It is a multiple board module with a 16K sense that offers you a modular concept for large mass memories. In its basic configuration of 16,384 words by 40 or 32,768 by 20, it uses only two boards. The fully expanded unit of 65,536 by 40 or 131,072 by 20 uses five PCBA's including four stack assemblies. Cycle time is 1200 nanoseconds and access time is 500 nanoseconds. Basic PCBA size is only 12.75" x 15.4". The outline width of a 16K x 40 group is only 1.7". Low drive cores are used for low power input requirements.

There you have it. The

broadest range of sizes and performance characteristics, the best list of design features – and the newest modular concept in mass memories. From the outfit that was dealing the cards before the others even learned the rules of the game.

So take another long look at our table of specs. Then give us a chance to bring a smile to your face with price and delivery quotes. It won't take us long to turn you into a card shark. Once we show you how to stack the deck.

**When you're hot, you're hot.**

	MICROMEMORY 2000	MICROMEMORY 3000	MICROMEMORY 6000
Configuration	4,096x9	8,192x18	16Kx40
Alterable to:	–	16,384x9	32Kx20
Full Cycle Time	1.0 $\mu$ s	650ns	1.2 $\mu$ sec
Access Time	400ns	300ns	500ns
Modes	R/R, C/W, R/M/W	R/R, C/W, R/M/W	R/R, C/W, R/M/W
Byte Control	–	X	X
Data Save	X	X	X
Required Voltages	+5V	$\pm$ 15V, +5V	+15V, +5V
# of PCBA's	1	1	1 control card + 1 per 16Kx40
PCB Size	11 $\frac{3}{4}$ x15"	11 $\frac{3}{4}$ x15.4"	12 $\frac{3}{4}$ x15.4"
Allowable PCB Spacing	1"	1"	1"
Expansion in a single chassis to:	16,384x9 8,192x18	65,536x9 32,768x18 16,384x36	65,536x160 131,072x80 262,144x40
Extended Address to:	32,768x9	65,536x18	524,288x40
In increments of:	4,096x9	16,384x9 8,192x18	16,384x40 32,768x20
Stack	3W, 3D	3W, 3D	3W, 3D
TTL Compatible	X	X	X

# electronic memories & magnetics

New solid-state lifetime switches are Magic Dot's contribution to state of the art. They operate on a capacitance principle, have *no moving parts* — and last a lifetime.

Unique design advantages include:

- Will not jam, wear or change characteristics
- Logic compatible with zero bounce
- Completely sealed for continuous performance in hostile environments
- Flexibility in size, shape and output characteristics
- No 'behind panel' space and ¼" to ½" height

New Magic Dot switches can give you the competitive edge by significantly enhancing the performance, reliability and packaging of your product, while they permit the mere touch of a finger to become man-to-electronics interface. Write or call today for detailed technical and applications information.

# these switches don't know that switches fail!

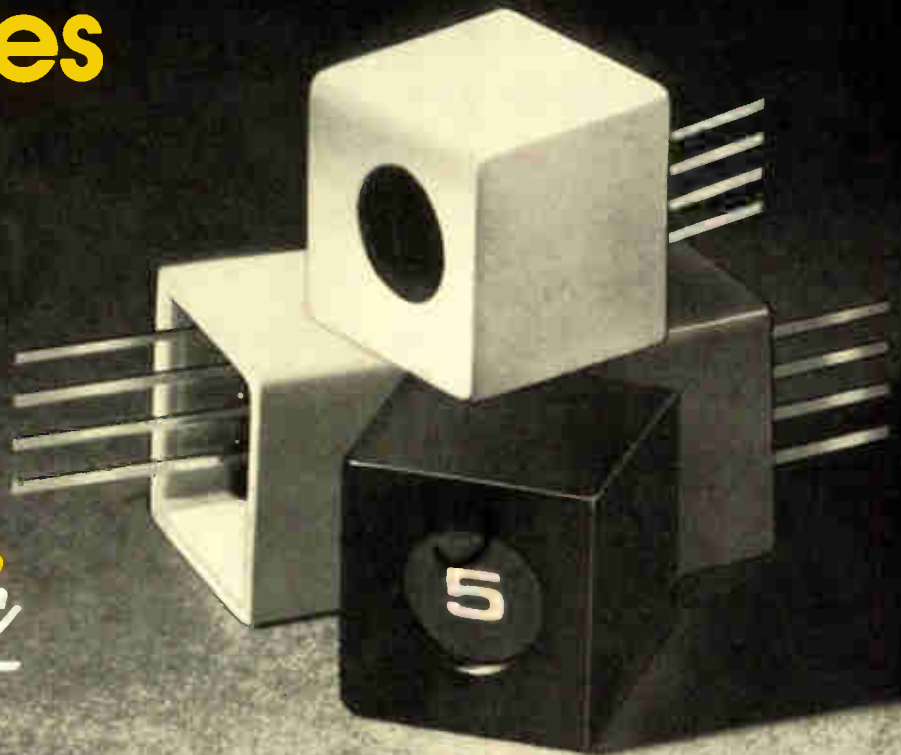

**magic  
dot**

**MAGIC DOT, INC.** 40 Washington Avenue South / Minneapolis, Minnesota 55401 / 612/333-8161

WESCON Booth #2921

## TV frame grabber goes solid-state with MOS memory

The Mitre Corp., a think tank specializing in interactive cable TV research, has developed a solid-state device for holding and refreshing a single television frame on a receiver screen. **Replacing the more expensive videotape recorder and the electronic storage tube previously tried,** the solid-state memory will be used in a two-way CATV educational project.

In the Mitre setup, a computer feeds a vector/character generator, which is multiplexed, to two memories. The memories, in turn, continuously refresh the TV screen until the user calls for a new picture. Color information can also be reproduced.

The refresh memory is composed of two MOS ICs on one printed-circuit board. The first, which contains luminance information, is an 88,000-bit dynamic shift register operating at a rate of about 10 megahertz. The other has color information in a MOS RAM organized as three bits by 1,500 words.

## NRMEC developing 1,024-bit SOS RAM

Silicon-on-sapphire appears to be ready to take its place as the memory technology of the moment. First, Inselek Co. put together a 256-bit static random-access memory and is on the way to a 1,024-bit model [*Electronics*, Aug. 14, p.35]. Now, **North American Rockwell Microelectronics Corp., one of the early entries in MOS technology, is also developing a 1,024-bit SOS RAM.**

SOS fabrication is desirable because it can compete in price and speed with bipolar technology, but has much lower power dissipation. The 65-nanosecond NRMEC parts, which should be ready in prototype by February, will have power dissipation of about 250 milliwatts. Bipolar equivalents dissipate 500 to 1,000 mW.

**The company also is developing a 12,800-bit (256 by 50) SOS-diode ROM with more than twice the capacity of its current ROM part, but at a unit price only 40% to 50% higher than the current \$30 in 100-piece lots.** Prototypes are due in December. NRMEC, which holds basic process patents for the epitaxial deposition of silicon on sapphire, is also discussing licensing with a number of companies.

## LED watches seen poised for takeoff

At least one company that's a major supplier of light-emitting diode displays for watches **expects the market to take off in the same way the calculator market did.** Says a company official: "I'm seeing the same signs now for LED electronic watches that I did a year ago for LED calculators." [*Electronics*, May 22, p. 59]. One of those signs could be a three-way deal in which Elgin will be first on the market with a popular-priced LED watch.

Uranus Watch Co., a small company in New Rochelle, N.Y., will put together the kit for Elgin. In it will be C-MOS from Hughes Aircraft's Newport Beach, Calif., plant, and assembled by a Hughes subsidiary—International Circuits Technology—in Tijuana, Mexico. And the display is expected to be the largest order ever supplied by Fairchild Semiconductor's MOD division.

One of the reasons for the move to LEDs may be problems encountered in developing liquid-crystal displays. What's more, says the display maker's official, "Pushbutton displays may not be acceptable to



95% of the population, but there are still lots of customers among the rest.”

## Communications chip replaces 30 to 40 TTL IC packages

Standard Microsystems Corp., of Hauppauge, N.Y., says it has built the first universal synchronous receiver/transmitter for data communications to be designed on a single silicon chip. An MOS LSI device using p-channel oxide-nitride technology, **the chip performs all receiving and transmitting functions associated with synchronous data communications at rates to 250 kilobaud.** The TTL-compatible chip replaces as many as 30 to 40 TTL IC packages on a printed-circuit board, or 10 to 15 packages when the individual off-the-shelf transmitter and receiver chips are used, asserts the company. The device in quantities from 100 to 999 is priced at \$20.50 each. If designed with TTL, a similar system would cost \$60 to \$80.

## Signal generator by H-P boasts super s/n ratio

The Hewlett-Packard Co. has announced a new signal generator whose noise performance is at least an order of magnitude better than that of other solid-state signal generators. **The unit, which rivals the best tube-type generators, boasts a wideband signal-to-noise ratio of better than 140 decibels/hertz.** Aimed at the receiver testing market, the generator covers from 450 kilohertz to 550 megahertz and comes in two models.

The basic generator costs \$3,100; an additional \$1,350 buys a built-in counter and phase-lock capability for synthesizer accuracy and stability. Fully calibrated a-m and fm modulation capability is standard on both models.

## Retraining bill likely to pass House in 1973

Enactment early next year is forecast for the ambitious \$1.025 billion legislation to retrain jobless aerospace and defense engineers, scientists, and technicians. **Generating the optimism was the easy passage of the bill in the Senate late this month.** House action is unlikely in this session before adjournment for the election.

The bill, sponsored by Sen. Edward M. Kennedy (D., Mass.), authorizes creation of a Civilian Science Systems Administration, patterned after NASA and administered by the National Science Foundation. It also would require modification of Federal procurement regulations to protect benefit and pension rights of professionals who are transferred or laid off because of contract completions or cancellations. Though the White House has been silent, **the Administration is known to oppose the measure on economic grounds,** including the increased cost of defense contracts it predicts would result from the pension-protection clause.

## Addenda

Corning Glass Works has reduced attenuation in glass-fiber optic wave-guides to 4 decibels per kilometer from 16 to 20 dB/km. Tests were performed on a 550-meter length; **Corning's next step is to try to get loss down to 2 dB.** . . . An improved version of the System IV/70 computer is in the works at Four-Phase Systems, Cupertino, Calif. It'll be a byte-oriented machine instead of a purely binary system, as was its predecessor, announced nearly two years ago [*Electronics*, Sept. 14, 1970, p.52].

# C-LINE MICROWAVE PIN DIODES

**Choose the best  
and still pay less for your  
microwave switching needs**

## C-LINE MICROWAVE PIN DIODES — SPECIFICATIONS

Type	Maximum Total Capacitance (0V, 1GHz)	Maximum Series Resistance (100mA, 1GHz)	Minimum Carrier Lifetime ( $I_c = 10\text{mA}$ )
	$C_T$	$R_s$	$\tau$
	pF	$\Omega$	us
UM4001B	3.0	0.5	5.0
UM7001B	0.9	1.0	2.5
UM7101B	1.2	0.6	2.0
UM7201B	2.2	0.2	1.5
UM6001B	0.5	1.7	1.0
UM6101B	0.7	1.0	1.0
UM6201B	1.1	0.4	1.0
UM6601B	0.4	2.5	1.0

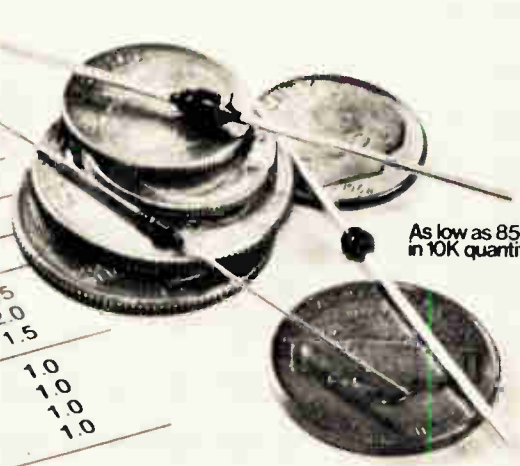

As low as 85¢  
in 10K quantities

You can now select capacitance, resistance and carrier lifetime and get circuit optimization at the industry's lowest prices. These new 100V PIN diodes from Unitrode all feature low distortion and low insertion loss for microwave applications such as TR switches, antenna selectors, receiver channel selectors, switching matrices and attenuators in AGC circuits. They're available off the shelf at your local Unitrode distributor. Samples on request.

For fast action, call Sales Engineering collect at (617) 926-0404, Unitrode Corporation, Dept. 8Y, 580 Pleasant Street, Watertown, Mass. 02172



**UNITRODE** quality takes the worry out of paying less.

**MODEL 99 20 MHz PULSER**

**\$285.00!**



**MODEL 88 20 MHz PULSER  
PLUS 5 volt 1 amp POWER SUPPLY**

**\$395.00!**



■ REPETITION RATES 2 Hz to 20 MHz ■ PULSE WIDTHS 20 nsec to 200 msec ■ RISE AND FALL TIME 5 nsec ■ OUTPUT +1 volt to +5 volts (40 ma sink) ■ POWER SUPPLY (Model 88 Only) 5 volts 1 amp.

# 2 new bargain boxes from Systron-Donner/Datapulse

The Models 88 and 99 both feature the same excellent pulse generating capabilities and, as an added convenience, the Model 88 provides an independent power supply output. TTL designers will really appreciate the exceptional versatility of the Model 88... an extremely compact, light and portable source of high quality TTL driving pulses with a useful +5 volts TTL breadboard power supply built right in. The Model 99 duplicates the 88's pulse generator characteristics precisely, making it an outstanding bench instrument for use

in applications where a power supply is separately available or is not required. Both instruments employ advanced designs and incorporate standard, top quality components, with the emphasis on high grade performance and low end-product prices to meet and beat today's economies and purchase restrictions. Result: Two superbly engineered instruments at prices you can't afford not to afford. For complete specifications, demonstrations etc., call your nearby Scientific Devices man or contact us directly. **Datapulse Div., Systron-Donner Corporation, 10150 West Jefferson Boulevard, Culver City, California 90230. Phone: (213) 836-6100. TLX: 67-3219 TWX: 910-340-6766.**

**The Systron-Donner Instruments Group:**

Alpha Scientific □ Computer Systems □ Concord Instruments □ Datapulse □ Kruse Electronics □ Microwave □ Trygon Electronics





## Weapons cost to count as much as performance

Engineer must consider price a problem under new DOD policy, Foster warns at meeting of industry chiefs

**Responding to** economic and political pressures, senior Pentagon leaders are recommending a new weapons-system procurement policy to fill the void left by the discredited Total-Package-Procurement approach of former Defense Secretary Robert S. McNamara.

Called Design-to-Cost, the recommendations—DOD officials say privately that they're certain to be adopted—will for the first time stress costs at least equally with performance. To cope with the cost dilemma that has led recently to reductions in numbers of weapons procured, Defense Research and Engineering Director John S. Foster Jr. declared earlier this month: "We are willing to take the radical step of ordering into production a less-capable piece of equipment—compared one-for-one with an alternative system—if we can get substantially more numbers and, therefore, increased total combat capability." Another element of the policy, Foster said, includes "reducing radically the size of industry design teams."

**Getting picture.** Foster's hard-hitting presentation was one of two that spelled out the new approach to a mid-August Washington meeting of defense-industry leaders, sponsored by the National Security Industrial Association. In a more detailed briefing, Leonard Sullivan Jr., Foster's principal deputy, indicated that a projected 1980 defense

budget of \$112 billion "will be identical in purchasing power to an \$83 billion budget now" on the premise that personnel expenses and operations and maintenance costs will eat up 40% and 20%, respectively, of future budgets, leaving 40% for procurement, R&D, construction, and foreign military assistance.

"Failures under the design-to-cost approach will result in early terminations," Foster warned, rather than "the desperate efforts to patch up a wrong initial decision" that characterized total-package procurement. The new policy rules out DOD's getting "a little bit pregnant" early in the game and then proceeding inexorably to the birth of some dubious weapon." Corporate management must make individual engineers "believe costs are a problem," said

Foster, in a departure from his prepared remarks. "If individual engineers will believe this is a real problem—a problem they individually must face—then we can hack it."

A new defense systems concept, dubbed a "hi-lo force mix," was described by Sullivan as a more attractive alternative for accommodating future "budget limitations and dwindling technological superiority" than cutting force levels.

**Worst vs largest.** Single-mission systems with technological superiority would be stressed in a small elite force designed to meet "the worst threat," explained the DDR&E deputy, while a larger standard force "would be designed against the largest numerical threat," with multipurpose characteristics where desirable. Other cost-cutting options to

**Mismatch.** Pentagon estimated 1980 procurement budget is \$8.5 billion for eight categories.

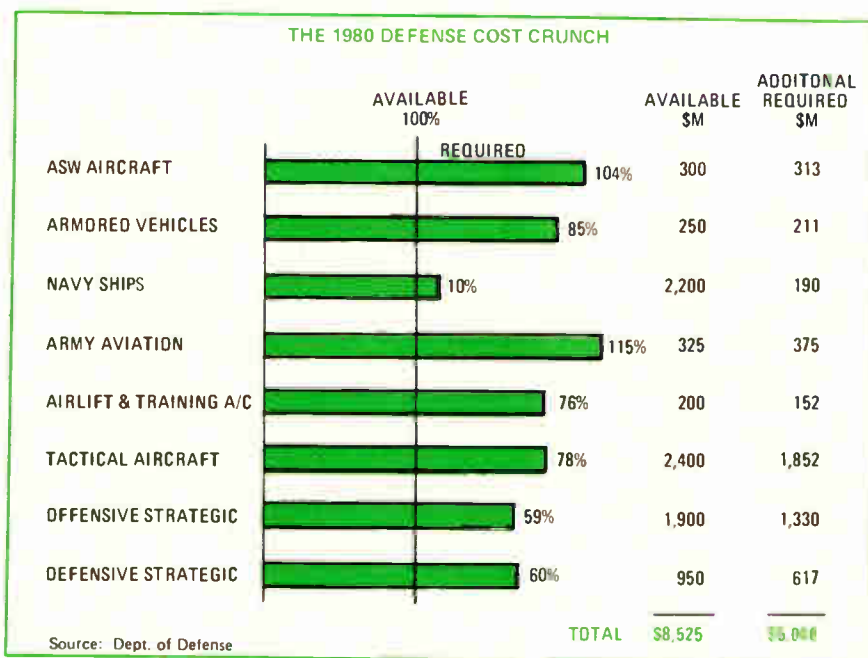

be pursued include "more stress on the continued product improvement of existing systems to avoid expensive start-up of new programs," plus "an all-out attempt to arrest the cost growth associated with continuously expanding requirements" established by the uniformed military for new weapons.

Beyond a new force mixture and constraining military demands, Sullivan also said the Defense Department needs to:

- Formalize the process of designing to a cost.
- "Dispel the myth of bigger defense budgets 'just around the corner'" so that industry and the military will take the problem seriously.
- Revise long-range planning systems to include realistic, authoritative budget forecasts; 10-to-20-year budget and force-level projections, instead of the five- and eight-year cycles now used.
- Revise accounting and reporting for "vastly greater visibility" into operations, maintenance, training, base-support, and manpower costs.
- Undertake special cost-reduction programs in research, development, test, and evaluation "to increase reliability and/or decrease maintenance and to provide standardized components."

Citing avionics as one contributor to soaring aircraft systems costs, Sullivan warned Pentagon suppliers that their customers "must avoid new requirements which are 'nice to have.' New technology for newness' sake has got to go by the boards." □

## Consumer electronics

### Share failure costs, suppliers asked

It worked for the multimillion-dollar space and defense contracts, then for big computer builders. Now television receiver manufacturers are trying to engage their components suppliers in plans to share the costs of field repairs traced to parts failures. So far, the effort has been mostly talk; it's been received with

## Pentagon finds 'copters too costly and puts the blame on avionics

"Still too expensive," says the Pentagon's Leonard Sullivan Jr. of the Army's ceiling price on its new helicopter—UTTAS for Utility Tactical Transport Aircraft System. That kind of remark rattles not only the Army, but three industrial teams that are bidding for selection as one of two builders of competitive prototypes. Defense officials say that selection is scheduled for the end of August between Textron Corp.'s Bell Helicopter Co., Boeing Vertol, and Sikorsky. The ultimate winner of the production award from the two-model competition will be constrained to a \$600,000 unit price for the airframe, to be powered by a Government-furnished GE engine.

How does DOD plan to get the UTTAS cost lower? Put the question to DDR&E director John S. Foster Jr., and the response is blunt: "Avionics. There are things there we are just not going to pay for."

Beyond that, Foster declines elaboration, even though the recent cancellation of the Lockheed AH-56 Cheyenne helicopter gunship program leaves UTTAS as the major Army helicopter effort for the short term. Though the Army withdrew its controversial fiscal 1973 request for

\$35.7 million in development appropriations for Cheyenne, it now wants \$40 million to begin, instead, on a new, smaller, lighter and cheaper version.

Of other upcoming fixed- and rotary-wing aircraft efforts, Sullivan and Foster make these points:

- Heavy-lift helicopter cost projections are underestimated by the Army. The HLH and UTTAS efforts, plus future Army aviation requirements, should constitute about one-quarter of total service purchases in 1980. Yet, "if continued on its current path, it would absorb 50%."
- Tactical aircraft, for which some \$2.4 billion annually is forecast to be available in 1980, will overrun that projection by about \$4.2 billion, largely because of the introduction of the Navy's Grumman F-14 and Air Force's McDonnell-Douglas F-15 fighters. That "situation would be much worse" if DOD had not set a ceiling of \$1.4 million each for the AX experimental attack fighter, for which Northrop Corp.'s A-9A and Fairchild Industries' A-10A are now competing. For another upcoming program, the "lightweight" supersonic fighter, DOD has set a \$3 million unit cost ceiling.

about as much enthusiasm among components firms as a summer re-run.

The problems facing the set makers are twofold. First, TV companies do not have the same clout in dollars with their suppliers that the aerospace firms had. Second, there is no easily administered procedure for identifying the causes of field failures so that repair costs can be bucked back to the original supplier.

**Overweight.** As one color-TV engineer pointed out, "A program to determine the repair cost shares and who's at fault would be so cumbersome that administering it would more than outweigh the gains."

Nevertheless, receiver companies have taken the first steps toward

convincing suppliers that reliability in entertainment products is a vital concern because of the high cost of warranty repairs and the competition from quality-conscious Japanese manufacturers. The effort has been directed toward all parts suppliers, but prime attention recently has focused on semiconductor manufacturers as more ICs make their way into TV chassis. While a long way from practical use of warranty cost-sharing, other steps have been taken to get consumer-product suppliers to tighten reliability. These efforts include:

- Zenith Radio Co., Chicago, has written its own quality-control specifications for semiconductor suppliers that is as tough as any aerospace requirement. One IC supplier,



Sprague Electric's Semiconductor division, Worcester, Mass., has set up a special rack to life-test 100 chroma processing devices at a time for Zenith color receivers. Built in cooperation with Zenith, the rack turns on circuit boards for 25 minutes and off for five minutes to simulate the on/off cycles of the complete television set.

Each chroma processing circuit is on for one minute before it is replaced in the operating circuit by another IC. Fifty boards are on constant load and the other 50 are on 1-minute cycles. Sprague is monitoring with this system the red - Y, the green - Y, and the blue - Y color input-signals. The result is simultaneous testing of the equivalent of 100 TV sets.

■ RCA's Consumer Electronics division, Indianapolis, Ind., kicked off its emphasis on reliability with a series of vendor meetings, a tactic often used by aerospace firms to drum up enthusiasm for quality control among suppliers. Since then, RCA has been working on a computer program to predict reliability of individual parts before the TV set goes on sale. To try out the program, the predicted failure rates of past models have been compared with actual field experience, and the computer program has come quite close.

■ General Electric's Television Receiver Products department, Portsmouth, Va., has negotiated a lot-tolerance-percent-defective (LTPD) type of quality control inspection for parts suppliers, rather than the more common acceptable-quality-level (AQL) approach. LTPD is a statistical sampling plan structured to protect the buyer, whereas the AQL technique tends to work out in favor of the seller.

**Higher prices.** Set makers agree that, to get more quality assurance, parts makers will insist on higher prices, which have to be justified by savings in warranty costs. However, an engineering director explains, "We would be willing to pay twice as much for some parts to get upgraded reliability, but the problem is that the division's performance is rated on production costs. It's a

matter of convincing management that higher costs at the production end mean savings in maintenance. The system is more important than the parts price." □

## Memories

### Bell sleuths solve a bubble mystery

Bell Laboratories engineers working with magnetic-bubble garnet devices say they have solved the problem posed by oversized "super," or hard, bubbles. These bubbles, which had cropped up in the circuits Bell fabricated, would propagate erratically.

**Slowdown.** With lower mobility than normal bubbles and a sharply angled path, the hard bubbles could slow the speed of a shift register—which is the basic memory element of magnetic bubble technology—by a factor of as much as 100, recalls Joseph E. Geusic, head of the Fundamental Memory Components department. "A register with a 100-kilohertz clock rate could be slowed to only 1 kHz," he says.

Uncontrolled, the phenomenon could have "wiped out garnet as an effective material for memory de-

VICES," declares Andrew H. Bobeck, a supervisor in Geusic's department.

When the problem was recognized about two years ago, says Geusic, circuit designers blamed variation in the garnet materials. Later, they blamed faulty measurement techniques. Neither proved to be the cause.

Then, investigating the properties of bubble devices made from multiple layers of garnet epitaxially deposited on a nonmagnetic substrate, Bobeck observed something unusual. With two layers of garnet, hard bubbles formed only in the upper layer.

Concurrently, experiments to see how ion implantation might improve garnet's magnetic properties revealed something equally striking. With an ion-implanted film approximately 0.3  $\mu\text{m}$  thick atop a garnet layer 6 $\mu\text{m}$  thick, no hard bubbles were formed in the bottom layer.

Thus, Bell had at least two ways to prevent the hard bubbles from forming. All that was missing to wrap up the case was to find what the hard bubbles actually were. "It has to do with what goes on in the walls of the bubbles themselves," explains another group supervisor, William A. Tabor. The bubbles are extremely small; their outer diameters range from 3 to 9  $\mu\text{m}$ . But their walls have a finite thickness. Al-

**Parts picture.** Television manufacturer testing incoming circuit boards. TV makers are talking about passing field-repair costs to component suppliers. But problems are complex.

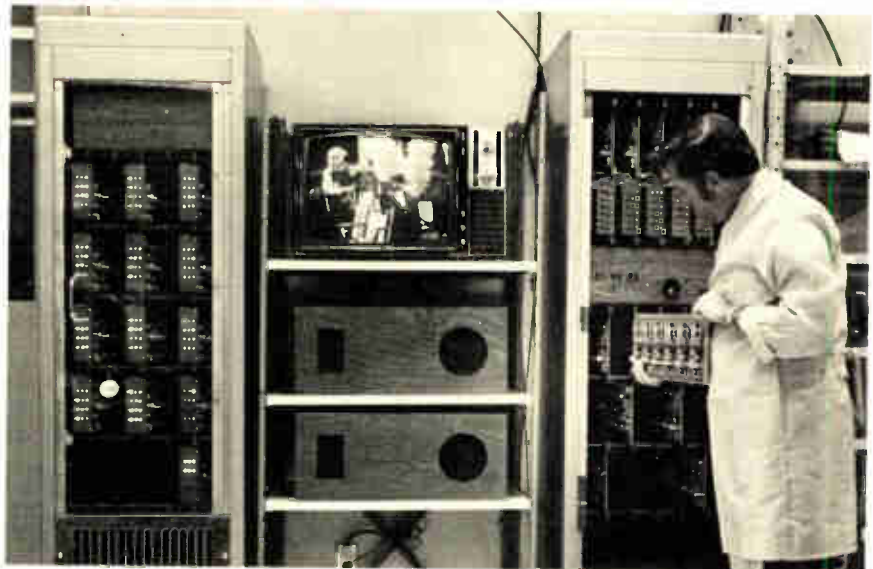



though this is only about  $0.4 \mu\text{m}$ , it's equivalent to hundreds of iron atoms wide.

In a magnetically biased bubble device, the magnetization inside the bubble follows one direction, while the magnetization outside goes in the opposite direction. This affects the spins of the iron atoms in the material. For example, if the atoms spin upward inside the bubble, the atoms outside the bubble spin downward. However, the transition from one spin direction to another within the bubble wall occurs gradually across the hundreds of iron atoms strung across the wall.

**Either way.** In a normal bubble, the spin direction of the iron atoms changes gradually across the wall in a so-called Bloch transition. However, the direction can be either clockwise (CW) or counter-clockwise (CCW). In some bubbles, the entire sense of rotation is CW, and in others, it's CCW. But in one class of bubbles the sense of rotation often varied from CW to CCW. Where a wall section with a CW transition meets one with a CCW, still another transition—a Neel—is needed.

Thus, there are pairs of Bloch-

Neel transitions around the circumference of a bubble wall—upwards of 200 transitions in a hard bubble and only a few for a normal-appearing bubble. Between the two are bubbles that resemble either the normal or hard bubbles.

Fabricating the magnetic bubbles from either a double film of garnet, or with an ion-implanted layer prevents the complicated wall structure, explains Tabor. "The second layer 'caps' the bubble with a continuous domain wall and constrains the Bloch-to-Neel transition to a minimum," he continues. "You end up with only a pair of transitions and a normal bubble." □

### Government electronics

## A shear look with acoustic doppler

At New York's Kennedy International Airport, nine planes in a row miss landing approaches. At nearby La Guardia Airport, a Federal Aviation Administration DC-3

crashes because of near-ground wind turbulence. While no one is hurt in any of those incidents, they graphically illustrate the reason for the concern over maverick wind currents—uneven and unperceived—called wind shear. What bothers the FAA is vertical wind shear below 3,000 feet that could affect a plane's attitude as it comes in to land.

Consequently, the FAA, in cooperation with the National Oceanic and Atmospheric Administration (NOAA), is developing an acoustic pulsed-doppler system that will alert air traffic controllers to wind-shear conditions so that they can warn approaching pilots. After development is completed, the FAA intends to buy an operational model to test. It hopes to purchase 100 or more units for planned category 3 airports—those equipped with all-weather landing instruments.

Similar to broadcasting radar beams, the FAA-NOAA acoustic system uses temperature (which affects sound) and wind differences as the bases for acoustic returns. Unlike electromagnetic waves, however, sound waves depend on air molecules. Correlating the times of the returns can give the various wind levels, explains Kenneth A. Kraus, program manager in the Airport division of FAA R&D.

"There's no question that doppler radar or doppler microwave can do the same job, but they need a lot of power to do it, and that makes them expensive," Kraus says. The FAA-NOAA system uses triangulation with three 4-kilohertz transmit-receive transducers about 200 meters apart, one beaming vertically and the other two intersecting that beam. The results at 100-foot intervals are fed into an 8,192-word-memory Nova computer. "The electronics is fundamentally high-fidelity circuitry," he comments.

The basic idea is to provide a wind profile every 100 feet up to 3,000 feet with an accuracy within 5 knots. But, since "a controller isn't going to look at 30 numbers," toler-

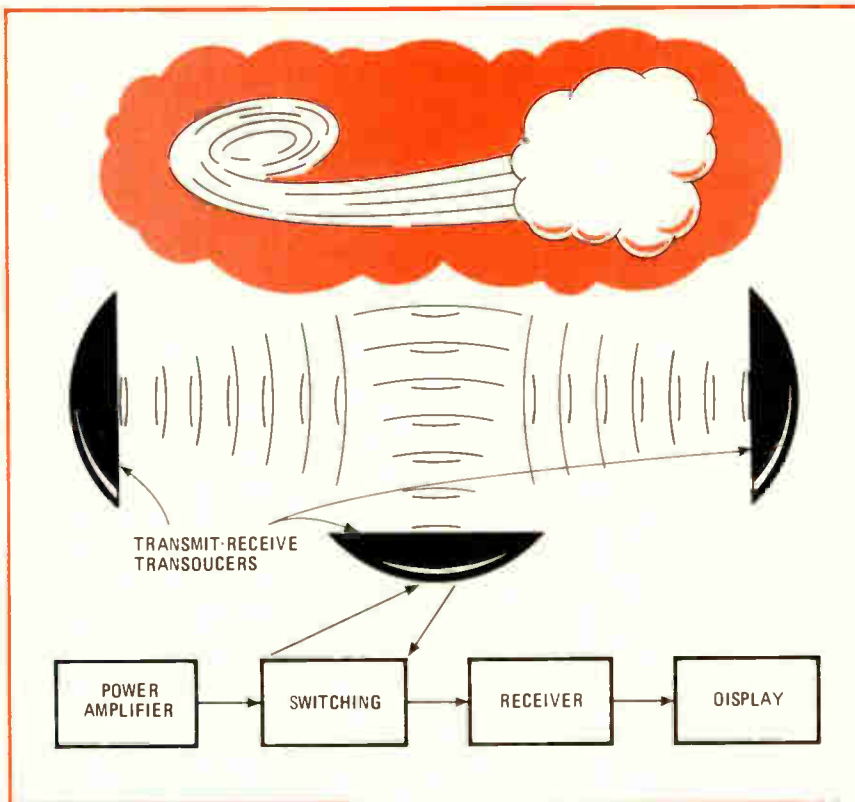

**In a breeze.** FAA's acoustic pulsed-doppler system is designed to detect maverick wind currents that occur below 3,000 feet.

ance levels may be programmed in and "have a red light to tell when the wind is too much," Kraus says. Later, the information may be included in projected automatic data links between air traffic control systems and pilots.

Being developed at NOAA's Wave Propagation Laboratory in Boulder, Colo., a breadboard unit will be tested this winter at Denver Airport, Kraus says. □

---

## Consumer electronics

---

### Mostek 'superclock' spawns timer family

A one-chip clock circuit that can be tailored for a score of specialized timepiece applications is the base for three standard clock products in the works at Mostek Corp., Dallas. And with changes in the chip's final gate mask, users can buy essentially custom timers for only 10% to 20% of the cost of custom development.

"We didn't think our final clock would be as general as it turned out," says Gordon Hoffman, marketing manager, "but our experience was that each manufacturer wanted his product to look a little different." So Mostek designed a flexible microprogrammable circuit that's engineered toward user convenience, keeping in mind the American Micro-systems clock circuit—an alarm clock with snooze option [*Electronics*, Jan. 31, p.66]—that Mostek engineers consider their toughest competition. Mostek began sample sales this month.

"The circuit is totally programmable," Hoffman says. "We can hit any timekeeping market." The clock has several registers that can be programmed through the gate mask to yield such applications as calendar clocks and elapsed-time counters.

**Alarm.** The original p-MOS chip developed for the family is an alarm clock with full clock-radio features. It allows either 12- or 24-hour operation and display, including a-m/fm indication, operation from either 50- or 60-hertz line frequencies, and

separate control of hours, minutes, and tens of minutes for convenient time and alarm setting. The circuit includes a 24-hour alarm with immediate alarm reset and seven-minute snooze features. The alarm tone is generated on the chip, and, with external amplification, it provides loudspeaker drive and a pulsating alarm sound. The clock will alert the user to a power failure or a low-power condition in battery or battery-backup operation by showing all eights until the time is reset.

Clock-radio control features include radio-wake and sleep-delay up to 120 minutes. The chip, 180 by 180 mils, is packaged in a 28-pin dual in-line package and numbered 5017 P-AN. Mostek will also sell the same chip in a cheaper 24-pin DIP, without bonding out the clock radio features, as the 5017 P-AA. The Mostek circuits will directly drive luminescent-anode seven-segment display tubes without interface circuitry. "The clock was developed in conjunction with Ise Electronics of Japan and therefore can drive Ise tubes directly," says Berry Cash, marketing vice president.

The first variation to spring from a gate-mask change is the 5017 P-BB, a combination calendar and digital clock. Mostek engineers sacrificed the alarm register, re-

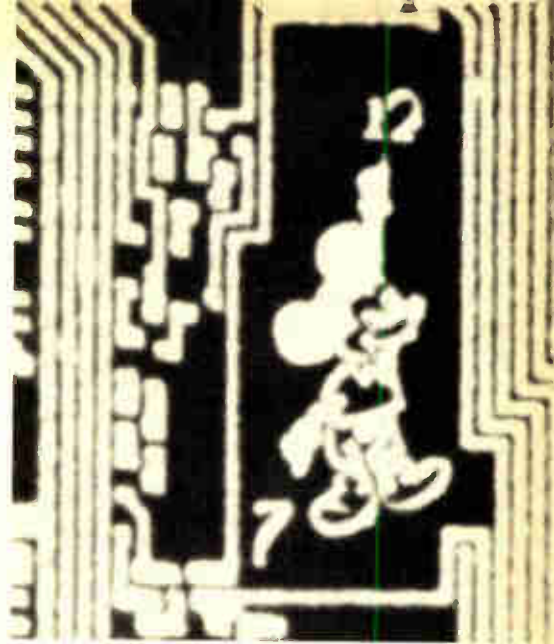

**Hands on time.** Mickey Mouse demonstrates Mostek's one-chip clock circuit that can be used in many timepiece applications.

programming it for the calendar application: time is displayed for 8 seconds, and then month and date in digital form for 2 seconds. Designers also incorporated logic to suppress the display, to allow the circuit to be hooked up to the Mostek one-chip calculator. Two Mostek customers are now developing desktop calculators that will display date and time.

The three clocks will sell for less than \$10 in large quantities as production hits capacity later this year, Cash says. The price for fewer than 25 is \$30 each. □

---

## Air traffic control

---

### FAA trying to rethink its way out of microwave landing mess

The Federal Aviation Administration thought it was doing everyone a good turn when it began to open a market for interim microwave instrument landing systems (MLS) [*Electronics*, July 31, p. 21], but in the last few weeks the agency has been discovering that its good intentions are turning into a nightmare. Buffeted by manufacturers and airport operators, and facing disagreement within, the FAA is now trying to find the least painful way out of its dilemma.

The FAA had originally wanted to

change regulations to enable MLS units to become eligible for matching Federal funds under the Airport Development Aid Program. That way, private airport operators could more easily afford to buy the systems for short-takeoff-and-landing (STOL) and general-aviation operations on an interim basis until a "universal" MLS system is designed and built later this decade.

Also, U.S. manufacturers, such as Singer's Kearfott Division, AIL division of Cutler-Hammer Inc., Tull Aviation Corp., and Boeing Co.



could get into a larger domestic market. And the FAA, after making sure that all the systems were safe to use, could go back to developing the "universal" system.

**Incompatible.** But it isn't working out that way, say FAA and industry sources. None of the competing systems are compatible with each other, a measure of untidiness in the national air system the agency strives to avoid. Some salesmen are telling airport operators that the FAA would maintain the systems for them, which the agency doesn't want to do. But if the systems had been bought with Federal funds, the FAA would have had to.

"They're in turmoil in there trying to figure out what to do," comments one company official who recently visited the FAA to find out what's going on. "We're not just in a dilemma," he says, "we're in the middle of a big fist-fight." Officials of some companies believe a good market exists, but what the FAA winds up doing will determine who competes best.

There is no easy way out. The agency could change its mind and decide not to approve interim MLS for Government funding, but, having attracted manufacturers to the market, it's probably too late to turn back. MLS companies would quickly complain to their congressmen and FAA topsiders that their system should be eligible, as conventional (nonmicrowave) ILS units are. And airport operators would be denied a useful system.

**Other ways.** As an alternative, the agency could approve only one system for Federal funding, but excluded companies would scream. And it might take other firms some time to develop the approved system, since one company wouldn't be able to sole-source the whole market. Or the FAA could go with a so-called "Category 1/2" conventional ILS, but FAA R&D personnel are believed to be against that approach.

Elements of the FAA had warned of these potential problems, but were ignored until the problems actually cropped up. Now FAA administrator John Shaffer wants his crew to recommend some course of ac-

tion by Oct. 15 to help him out. If one MLS technology were to be selected on a technical basis, it would be scanning beam, such as AIL's or Tull's. But a fixed-beam system, such as Singer-Kearfott's, would win on a cost basis, say FAA insiders. They quickly add that other manufacturers will be eager to enter the market when the FAA decides what to do. Another problem with interim MLS units is that none of them seriously consider inclusion of distance-measuring equipment, an expensive must. □

## ... and considers automated network

In its effort to automate and digitize the en-route, terminal, radar and weather-service functions of the Air Traffic Control System, the FAA has largely overlooked the vast communications network linking those elements. Now that control-system upgrading is under way, the agency is planning to design and build a new totally integrated communications system to interconnect the equipment.

**Costs.** Design and cost of the system, now unknown, depend on several things, including what the FAA can afford and what Congress will authorize, but electronic voice-switching alone is estimated to cost more than \$100 million. The program, only surfacing now, isn't included in the agency's latest annual 10-year plan outlining future projects. The FAA in mid-August awarded a \$219,304 contract to Computer Sciences Corp., Falls Church, Va., to assist a new FAA-Transportation Department communications system planning committee to design the network.

The FAA wants an automated digital net to communicate by microwave data links instead of leased telephone lines, high-speed terminals to replace the present low-speed Teletypes, high-capacity computers to direct communications between the processors at various airport and en-route traffic-control

centers, and computerized message switching. The network also would be designed to accommodate further planned sophistication of the air-traffic control system, such as addition of electronic voice-switching and automatic ground-to-air data links. Time- and data-sharing capabilities will be considered, too.

Plans call for the design to be finished during the summer of 1973, with the network's first phase "completely in by January 1976," says the FAA-DOT committee chairman, Daniel J. Hamilton, chief, Air-Ground Communications section, in the FAA's Communications Development division.

The FAA is moving hastily because its "communications resources are quickly becoming, if not already, inadequate for the communications requirements associated with air-traffic control," according to a staff document. "A major problem," reports another, "is the urgent requirement for totally integrated planning. At the present time, there exist no standards for communications service within the FAA. The lack of standards poses a serious problem for maintaining uniform levels of performance and user participation in the national aviation system."

One problem with the lack of an over-all plan is that the FAA spends about \$50 million a year merely to lease telephone lines for its data transmission, plus the cost of its regular phones, Hamilton says. "These are recurring costs. We might be spending too much money. Perhaps we should share lines." □

---

## Components

---

### Solid state booms in first 5 months

Gains in linear devices sales led a ballooning U.S. IC market in the first five months of 1972. There were strong increases in unit factory sales over those for a similar period in the previous year, trailed by smaller dollar-volume gains. And dollar vol-



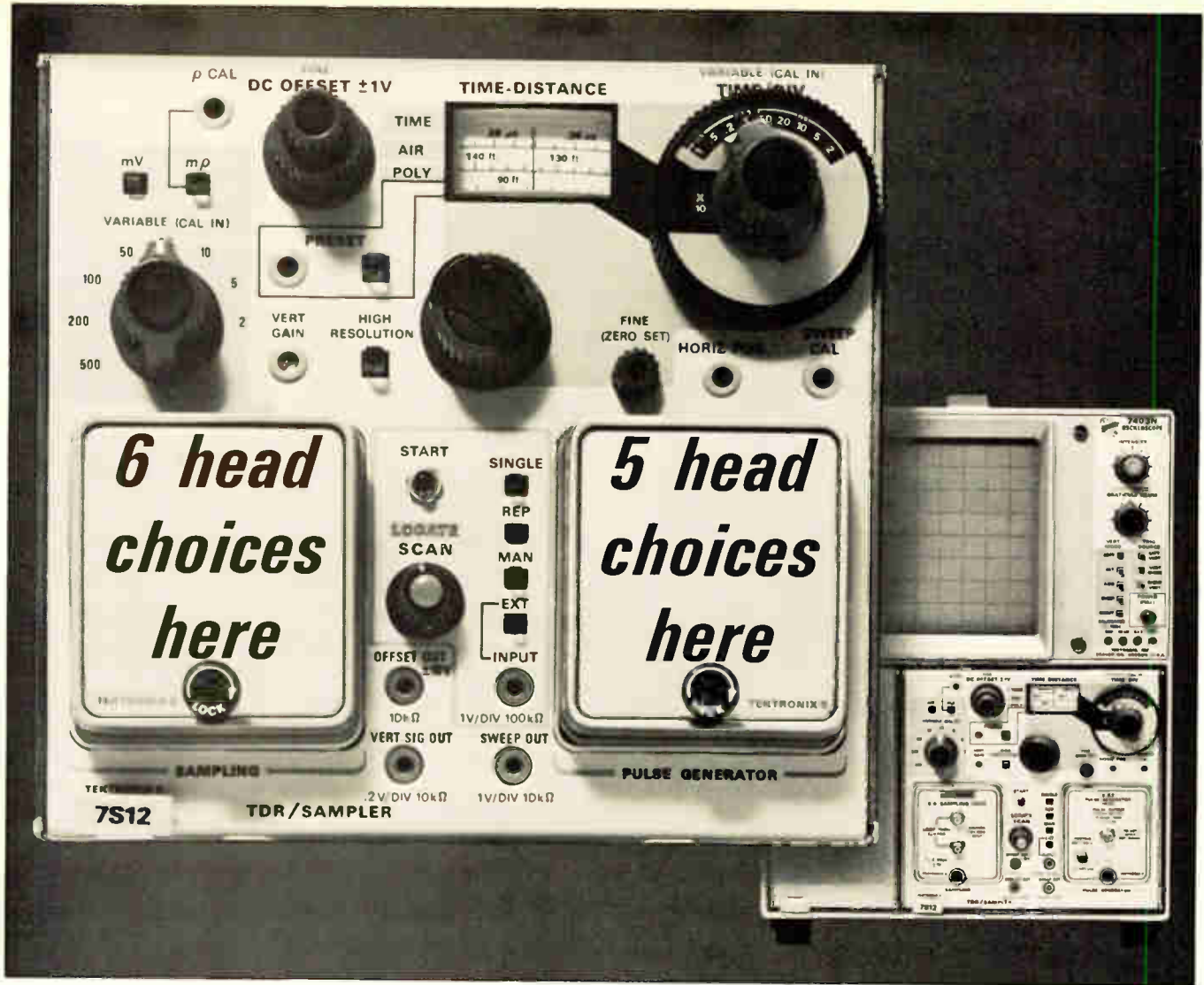

# *2 heads are better than 1 when you have 11 to choose from*

Time Domain Reflectometer or General Purpose Sampling . . . the choice is yours with the TEKTRONIX 7S12 TDR/Sampler, a scope plug-in that uses your choice of plug-in heads to do many sampling jobs well. When installed in a 7000-Series mainframe with your selection of two of the eleven plug-in heads, the 7S12 is ● a general-purpose single-trace Sampler ● or a high-resolution 45-pico-second Sampler/Time-Domain Reflectometer ● or a Sampler/Time-Domain Reflectometer for long lines ● or a Sampler with a Hi-Z probe ● or a Sampler with 30-pico-second response ● or a Sampler with one megohm BNC input ● or a Sampler with 50-ohm feedthrough ● or a Sampler with 11.6-GHz bandwidth ● or with a 7M11 in another scope mainframe compartment, the 7S12 is a Sampler with a delay line.

The 7S12 uses one of six sampling input heads in its left compartment to provide the input characteristics and response you desire. The right compartment uses a pulse generator head for TDR or a trigger recognizer head for general-purpose sam-

pling. There are three pulse generator and two recognizer heads to choose from.

Systems prices start at \$2950 for general purpose applications (7403N/7S12/S-1/S-53). TDR systems start at \$2850 (7403N/7S12/S-5/S-54). Your Field Engineer will be glad to discuss what TEKTRONIX Sampling can do for you. Give him a call.

U.S. Sales Prices FOB Beaverton, Oregon  
Tektronix, Inc., P.O. Box 500-A, Beaverton, Oregon 97005, U.S.A.

## *the 7S12 TDR/Sampler*



**TEKTRONIX®**  
committed to  
technical excellence

ume also chalked up a healthy gain, though less than unit sales.

Total IC sales rose 70% to more than 280 million units, valued at just under \$273 million, a gain of 31.7% over January-May 1971. Linear IC sales of 41 million units reflect a 95.2% rise, and their \$48.7 million value reflects a 51.2% gain, the largest increase for any category.

The figures are part of a total U.S. solid-state market of 1.5 billion devices worth \$571 million for the five months, according to new Electronic Industries Association statistics. They indicate a 34.2% jump in unit sales and a 22.3% rise in dollar value from 1971 levels of 1.1 billion units worth \$467 million.

Semiconductor chips, recorded in the EIA tabulation under the category of "other," was the only area registering a decline. Sales of \$5.1 million were off 38.6% from sales of \$8.3 million reported through May of last year.

**Upward.** Trade association data indicated solid-state sales of \$571 million in the five months. A Commerce Dept. first-quarter estimate of \$1.2 billion for factory shipments of American-made components of all types represents a gain of 12% over 1971's last quarter.

The EIA January-May total of \$272.8 million for IC sales compares

with the Government's January-March tabulation of shipments worth \$231.5 million [*Electronics*, Aug. 14, p.49]. Figures in that published table were in thousands of dollars, rather than in millions, as was indicated in the heading. □

Satellites

GE, cable want to try the ANIK-1

General Electric and the National Cable Television Association have asked the FCC informally about using Canada's upcoming domestic satellite, ANIK-1, for experimental operations in the U.S. Both NCTA and GE stress that they are only testing the water for short-term experiments, but while other applicants for domsat networks wait for FCC action, their queries raise questions about the highly uncertain domsat drama.

Apparently furthest along, the NCTA proposal would mean leasing one of the 12 Canadian channels for a network of a few earth stations, connected by terrestrial microwave link to an urban cable TV system. Such questions as cost, who would

operate it, and who would build it are still under negotiation. If the system were to be permanent, it could be used when a U.S. domsat goes up. Telesat, the Canadian Comsat, reportedly had expressed keen interest in the project.

But there are several hurdles, besides assembling an operational group and getting FCC approval. For one, the enterprise would have to be blessed by both governments. On the technical side, an official with Hughes Aircraft Co., builder of ANIK-1, expresses concern about delivery of possible "substandard signals" throughout most of the U.S.

The GE idea, which is being floated without top corporate approval, is an attempt to determine the feasibility of a private communications network, based on its portable Apollo ground station experience, to link its more than 200 plants in 46 states.

The FCC also will consider Comsat's request to stay the commission's June ruling calling for "multiple entry," with restrictions primarily on Comsat, AT&T, and RCA [*Electronics*, July 3, p. 72]. The commission also must consider their requests for removing these restrictions, with new commissioner Benjamin L. Hooks possibly playing an important tie-breaking role [*Electronics*, July 31, p. 23]. Industry observers speculate that the commission may compromise on Comsat's restrictions by removing the embargo on offshore connections, but keeping the ones involving AT&T.

**WU first.** When the commission finally gets down to processing applications, it will first consider that of Western Union Telegraph Co., first to file. The company plans to issue requests for proposals for an estimated \$12 million worth of earth-station equipment, and it is negotiating with NASA to get 1974 launch dates for its system. Earlier, it announced a \$20.7 million satellite contract with Hughes [*Electronics*, Aug. 14, p. 36], which it can cancel, should it fail to get FCC approval.

Although the FCC has told WU it may proceed at its own risk, pending approval, "we feel pretty confident that we're going to get ap-

SOLID STATE PRODUCTS — U. S. FACTORY SALES

Description	First Five Months 1972		1971		1972 VS. 1971	
	(millions of units and dollars)					
	Jan. — May 1972	Jan. — May 1971	Units	Dollars	Units	Dollars
Digital ICs	174.3	178.4	109.3	139.0	59.5	28.3
Linear ICs	41.0	48.7	21.0	32.2	95.2	51.2
Total monolithic	215.3	227.1	130.3	171.2	65.2	32.7
Hybrid ICs	65.2	45.7	34.7	36.0	87.9	26.9
Total ICs	280.5	272.8	165.0	207.2	70.0	31.7
Discrete devices	1,244.4	293.5	971.5	251.6	28.1	16.7
Other	—	5.1	—	8.3	—	(38.6)
Grand total	1,524.9	571.4	1,136.5	467.1	34.2	22.3

Source: EIA

QIKMATE™, Burndy's new self-mounting rectangular connector block is a real penny pincher. It saves money from the start because it costs less to buy. And its unique, one-piece design saves on installation costs, too.

Install the receptacle with a snap. It quick-locks into a standard punched hole, without screws or nuts. Quick release design lets you remove it with simply a squeeze. The plug and receptacle mate easily and are held together by quick-disconnect latches.

There are no loose pieces to assemble or lose. The quick dis-

connect clasps, pin protection skirt and polarization are all molded into the blocks. And contact hole numbers are molded into both wiring side and mating side for faster, more accurate wiring.

QIKMATE comes in a 6, 12 and 24 circuit model. Consult your Burndy representative for additional configurations. It accommodates the Burndy Trim Trio line. That means it takes coax, machined or strip-formed contacts. Which means it can also cut your costs on stocking and inventory.

# Cutting costs is a snap!

 **BURNDY**  
Norwalk, Connecticut 06856

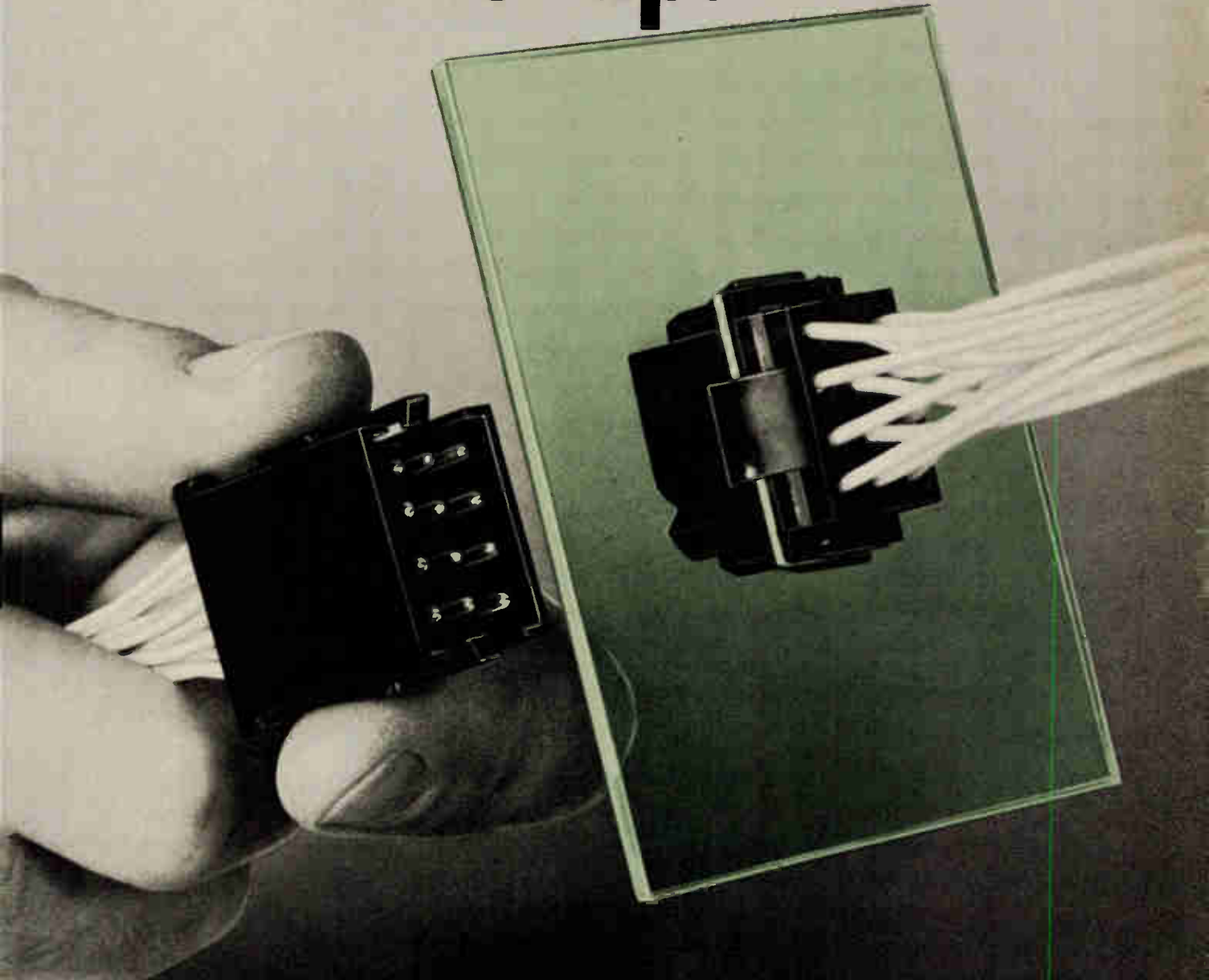

# BURNDY CONNECTS

International Sales Headquarters & Manufacturing Facilities: Canada/England/Belgium/Mexico/Brazil/Australia/Japan/Sales Offices in Major Cities  
Circle 33 on reader service card



proval," says F. William Ziegler, assistant vice president and program manager. He says WU's backers assure company officials that "we've got enough money to proceed" and foresee no problem in raising future funds. Also, Fairchild Industries and Western Union International are teaming to form a domsat corporation. □

## Manufacturing

### Distributor programs PROMs by TWX

Not only are distributors performing some of traditional duties of original-equipment manufacturers, but they're doing it with technological élan. A prime example is Weatherford Electronics, a major Western distributor, which is offering free coding of field-programmable read-only memories (PROMs). That's not unusual [*Electronics*, July 3, p. 74], but Weatherford has added a wrinkle: it will do the job for users who supply simple programming tape by mail or TWX. And to do it, Weatherford had to develop its own automatic equipment.

Until now, manufacturers and distributors have been willing to code PROMs for users, but have a typical setup charge of \$25 to \$50 per pattern, plus often, a minimum-quantity order and charge per device. Though this technique is less expensive than masked ROMs that have typical setup charges of \$500 to \$1,000, it can still significantly affect the price of a part that costs only about 4 cents per bit. Weatherford also claims 24-hour processing—masked ROMs often entail a couple of months.

Weatherford, with home offices in Glendale, Calif., had been programming PROMs manually, but decided that growing use of the devices required increased programming efficiency. Consequently, Jerry R. Allen, Weatherford's product marketing manager, put his background at Texas Instruments' Test Equipment group to work, and the result

was a system that automatically programs ROMs from Weatherford's Harris Semiconductor and Intersil lines. The company is also ready to code PROMs from its prime semiconductor source, TI, when TI brings out these products.

The PROM is programmed by a standard paper tape, punched with a simple coding pattern; for a 64-by-eight ROM, for example, the customer can dial a 24-hour, automatic-reply TWX number for details of the coding format, and transmit his coded tape. Or he can mail in the tape. No charge is made beyond the cost of the parts—so long as the user cuts the tape—and there is no minimum part order.

Weatherford will also make the tape for a one-time charge of \$25, but most users have access to a teletypewriter. As Allen says, "We want to make it so easy that the user wouldn't consider any other way." □

## Computers

### Virtual memory for minis on horizon

Two researchers at the University of Massachusetts in Amherst have brought virtual memory near commercial reality for minicomputers. Robert M. Glorioso and Timothy D. Chase have taken a Digital Equipment Corp., PDP-11/20 with 8,192

words of core and made it appear to be the equivalent of a machine with 32,768 words by swapping "pages" of material in and out of disk memory. And since this is far from the capacity of the disk, they also have made it possible to "bank" other 32-kilobit sections and call these up at user-command.

**Cost, space factors.** There were restrictions. First, since the mainframe was inexpensive, the hardware and software changes had to cost less than the mainframe store that the virtual system would emulate; second, the software operating system had to be compact, taking little space in mainframe memory to leave room for data coming in from disks.

Glorioso, an associate professor, and Chase, a former graduate student, succeeded by using a relatively simple combination of associative memory, simple small-scale logic, and a slightly revised software monitor system.

The package count for the modification adds up to about 150 small ICs, and the men estimate that this number could be cut in half through use of MSI. As for cost, in their opinion, similar hardware could be offered as an inexpensive option with any disk-equipped minicomputer system.

By doing so, minicomputer makers might save some money formerly spent on software support, since many demands of the user would vanish, along with the over-

## For the record

### IEEE brass backs changes

IEEE officials have urged members to adopt a set of constitutional changes that would include a portable-pension plan, guidelines for employment practices, and lobbying for tax-free pension payments by self-employed professionals. However, collective bargaining is ruled out.

### Courts, computers, and MOS

Allen Organ Co. is suing North American Rockwell over MOS devices developed for electronic organs. Among other things, Allen says NR conspired to compel Allen to purchase devices only from NR. . . . New RFPs for 42 computers with options for 12 more are being drafted for the Pentagon's Autodin (automatic digital network). . . . Motorola's first remote MOS design center is due to open Sept. 11, in Boston [*Electronics*, Jan. 3, p. 30].

lays and complex disk-file structures of nonvirtual systems.

Chase and Glorioso were able to implement an operating system in a little less than one-eighth of available mainframe memory. This left about 7,000 words for virtual-memory use. The researchers made each page 1,024 words long; the computer's mainframe core acted like a push-down stacked store, forcing the needed page to the top of the stack, and lowering the others correspondingly.

But the machine must know when not to switch pages, or which page to pick from disk: A failing of some paged memory systems in that they "flail," changing pages unnecessarily and slowing or stopping computation. The key is a single flip-flop circuit that's either enabled or not, depending on the output of an associative memory. In the PDP-11, the first five of its 16 address lines running to the memory-address register are cut, and an electronic switch is inserted. The switch is open in the so-called user mode, enabling the associative memory to compare the five address bits coming from the central processor against its look-up table, and if the wrong bits—indicating nonresidential pages—are present, the associative memory triggers an operation similar to an interrupt, and the necessary page of data or program material is fetched from disk.

**Time to update.** When the flip-flop is set by the associative memory, the central processor is denied access to memory until the proper page has been fetched. This happens each time the central processor performs a "return-from-interrupt" operation, and since these are frequent, the associated memory has time enough to keep the memory's contents updated. Computation is slowed only during disk-fetch, and then only by milliseconds.

The flip-flop remains set until the central processing unit generates an interrupt, and then the core memory is opened to the CPU, making the machine act like a conventional model. This is called the monitor mode. □

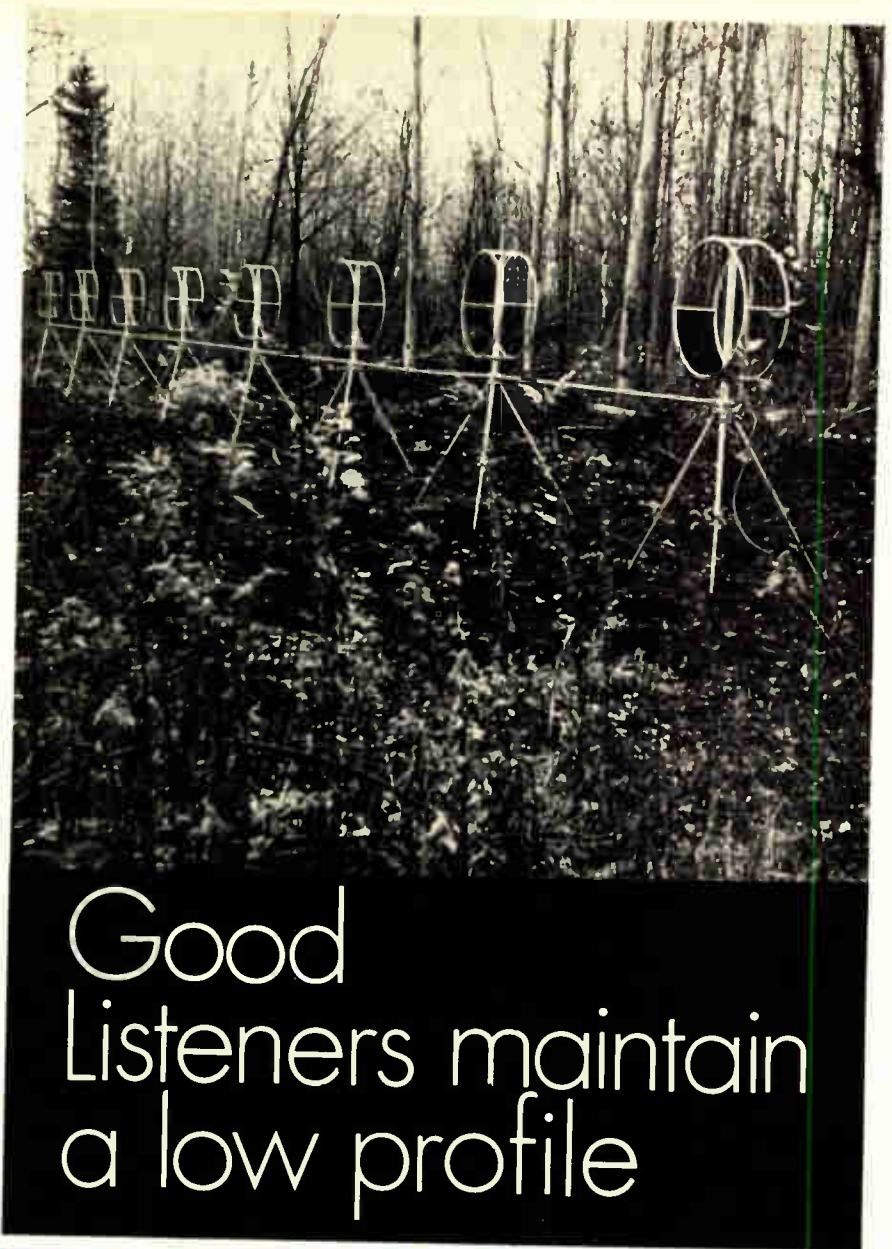

## Good Listeners maintain a low profile

Even in the solitude of the forest depths, from rooftops, arctic tundra, swamps to sweltering tropics, 'neath snow, sand or ice, the Hermes Loop antenna keeps an ear to the sky. The amazing aperiodic antenna does away with vast log periodic and rhombic arrays - those towering antenna farms.

In rosette configuration, the Hermes loop antenna provides an omnidirectional broadband receiving array in space merely 1/100th that of the traditional antenna farm.

More than 53 government agencies around the world have pressed the loop antenna into service.

A new, even more compact version is available. Only Hermes Electronics makes it.

**2-32MHz  
BROADBAND**

**ASK US Send for our Brochure**

Hermes Electronics Limited  
Suite 315  
2020 F Street NW  
Washington, DC 20006 USA  
202-296 2978  
TWX 710 822 1106





# Metal Glaze™ resistors don't crack up under stress and strain.

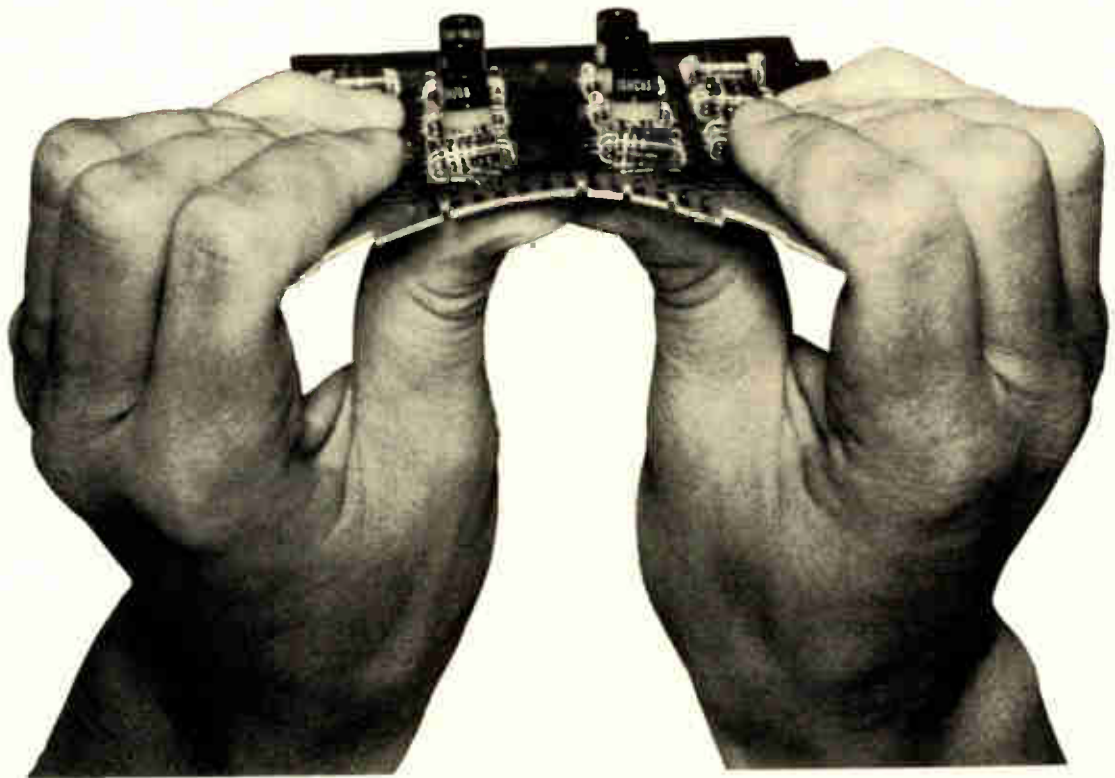

Metal Glaze resistors are made to take stresses and strains that crack up so many other types. Physically and electrically, they're tough customers.

Metal Glaze resistors can take PC card flexing, exposure to solvents, automatic machine insertion, potting—and general knocking around. The glass-hard Metal Glaze film is permanently fused to a solid ceramic core. Lead wires are soldered to the core in a patented process. This makes the resistive element and the terminations one continuous component which, even in its sub-assembly form, is mechanically stronger than many finished resistors. Molded in a tough, environmentally protective envelope, Metal Glaze resistors are practically indestructible.

Metal Glaze resistors can take their share of electrical jolts, too. For power handling they're conservatively rated, and often can be operated at twice rated power without degradation. Short-time overload and high temperature characteristics are excellent.

Competitively-priced Metal Glaze resistors are available in power ratings from 1/8 watt to 5 watts, in  $\pm 1\%$ ,  $\pm 5\%$ , and  $\pm 10\%$  tolerances.

TRW Metal Glaze resistors are available in quantity from your local TRW industrial distributor. Please contact TRW/IRC Fixed Resistors, an Operation of TRW Electronic Components, Boone, North Carolina 28607. Phone (704) 264-8861.

**TRW**  
IRC FIXED RESISTORS



## Navy developing deep ocean array . . .

The Outgrowth Caesar program of the Naval Electronics Systems Command (NavElex) is about to initiate first-phase conceptual studies of a new deep-ocean antisubmarine warfare project. **Tentatively labeled SASS, for suspended-array surveillance system, its ultimate costs are put at billions of dollars.** The secret effort, sources say, is an extension on a grand scale of the successful Caesar underwater listening system, which is mounted on the Atlantic continental shelf and extends by cable from the Carolinas down into the Caribbean. Electronic companies competing for SASS in the Outgrowth Caesar program—whose **funding jumped to \$88.9 million this year for a total of \$807 million since the Caesar program's inception** [*Electronics*, May 22, p. 49]—include Edo Corp., GE, Hughes, IBM, Litton, Lockheed, Raytheon, Sanders Associates, and Sperry Rand.

## . . . able to monitor international straits

Conceived as a series of large ocean-bottom structures, up to 200 feet long, **SASS would be scattered in international waters at depths of up to 18,000 feet near straits and other ocean choke-points through which submarines and surface shipping must pass.** Signals picked up by hydrophones suspended from the structures would be cabled to shore receiving stations. There they could be transmitted, perhaps by satellite, to Ocean Surveillance Information System stations for real-time computer plotting and relay to appropriate Navy vessels [*Electronics* Jan. 3, p. 75]. The Naval Facilities Engineering Command is responsible for structural aspects of SASS. NavElex is overseeing the electronics.

## FAA readies RFPs for oceanic air-traffic control

To automate its transoceanic air-traffic control centers, the Federal Aviation Administration expects to ready specifications and requests for proposals in October and award contracts by spring. Similar to the domestic ATC upgrading, the plan calls for **expanding the present research and development system at Oakland, with options for other units at Miami, New York, San Juan, Honolulu, Anchorage, and the FAA's Atlantic City Research Center.** Cost of the Oakland unit is estimated at \$3-4 million.

## NSF predicts big Federal R&D jump

The Department of Defense, National Aeronautics and Space Administration, and Atomic Energy Commission will **account for over a half of a projected \$900 million rise in Government research and development expenditures for fiscal 1973,** according to the latest National Science Foundation estimates. Most of DOD's \$400 million increase to \$8.8 billion will be for missiles and related equipment. NASA's \$67 million climb to \$3.3 billion will be for the space shuttle, space science and applications, and aeronautical technology.

Other big gainers from 1972's \$16.2 billion total R&D bill are the Department of Health, Education and Welfare, up \$194 million to \$1.9 billion; NSF, \$75 million to \$526 million; and the Commerce Department, \$55 million to \$228 million. The Commerce funds will be mostly for weather and ocean research by the National Oceanic and Atmospheric Administration and for National Bureau of Standards work on computer technology and on stimulating civilian R&D.

## Costs and credibility: DOD's last chance?

The Department of Defense is going on an economy kick. At least it says it is. But in Washington that statement has so far produced just about every possible response but one: belief. There have been, in this election year, knowing nods, sly smiles, occasional winks, and even one "Good Lord, I wonder how long this one will last?" In short, many in Congress and industry want to wait and see.

The suspicions are to be expected. When Deputy Defense Secretary Kenneth Rush paraded the new Design-to-Cost policy before the nation's top contractors at a National Security Industrial Association symposium, he marched in with three of the Pentagon's top civilians to lay it out in open session [see p. 25].

Nevertheless, the gathering followed by just a week DOD's confirmation of plans to scrap Lockheed's Cheyenne helicopter gunship for the Army after an investment of six years and funds variously put at \$350-400 million. But now, after facing up to the Cheyenne fiasco, the Army has withdrawn its request for fiscal 1973 funds that Congress was unlikely to vote anyway [Electronics, May 8, p. 49], and has substituted a larger request so it can go back to the drawing board. If Cheyenne had gone to production, it would have run to more than \$4 million a copy, according to Leonard Sullivan, Deputy Director of Defense Research and Engineering.

### The short wait

But the military aircraft and electronics industries may not have long to wait for their suspicions to be dispelled—that is, for Rush and his colleagues to deliver on their promise to get a better bang for the public buck. The alternative, in the DOD view, could very well wind up being no bang at all. Tactical aircraft, for example, have become so costly, says Rush, that "we will be able to buy only about 50% of the number we need over the next five years to replace our existing force."

Extrapolate current cost increases out 40 years, says Assistant Defense Secretary Barry Shillito, and "the entire Air Force budget would be spent on one plane, the Army budget on one tank, and the Navy budget on one ship." That grotesque result would breathe new life into one of Calvin Coolidge's defense concepts: "Why not buy just one airplane and let the aviators take turns?"

The fact that no one at the Pentagon laughs at the Coolidge line any more is an encouraging sign that the men who specify military "requirements" may be getting the message, along with industry. As DDR&E's Sullivan put it

to manufacturers when explaining the relative austerity that will mark the avionics on the Air Force B-1 bomber: "We can no longer afford to 'require' your favorite gadgets unless we are very sure that the added complexity is absolutely essential—not just cost-effective on one trumped-up scenario."

### Things to come

Some avionics manufacturers blanched at the bad news that such "favorite gadgets" as new terrain-following radars may never get beyond prototyping—if that far—in the new economic crunch. And, though DDR&E's John Foster makes a point of declaring that "the crunch is now," the news is not all bad for avionics and other hardware producers.

There are, for example, definite signs that more aircraft and other weapons will stay in inventory longer if subsystems were upgraded regularly. Rush touched on that when he labeled DOD "guilty" of "not seeking maximum useful growth from existing systems."

Moreover, there is a push to develop weapons subsystems independently of and prior to weapons-production decisions. A technique that Shillito says "is practiced religiously in the USSR," it can produce economies, he argues, by holding down the over-sophistication that, mirrored in so many past decisions, has produced costly, yet only marginal, superiority. And in the case of the Cheyenne, attempts at sophistication produced no weapon at all.

### Getting the fat out

If military electronics and related technologies are going to succeed at what Rush and others have declared will be "a cooperative effort," some companies are going to get buried in the crunch. As Shillito puts it: "Many parts of our defense industry are overbuilt, overmanned, and overmanaged." And there are those in industry who believe the same criticism can validly be made of the defense establishment—civilian and military.

Certainly no one disputes that overhead can be cut on both sides. The question is: Will it? Foster—who has delivered more than one "last chance" economic pep talk to contractors before—now seems to believe it must. "Past mistakes," he warns, "simply cannot continue." Failure of the Design-to-Cost concept would mean the failure of DOD and its contractors to "re-achieve credibility with the Congress." The alternative then is congressional management of defense programs through legislation, a threat that DOD considers as terrifying as any in all of the world's arsenals.

—Ray Connolly

# Sensitivity 10 mV

# Stabilities to $\pm 5$ parts in $10^{10/24}$ hrs.

## Battery option

## \$770 up, delivery 30 days

All models frequency expandable  
Resolution to 9 digits or 0.1 Hz  
Small size, 3½" H, ½ rack W  
BCD output for systems use  
Remote programming



\$770



\$1,050



\$1,395



\$2,295

Now choose from the industry's widest selection of **frequency counters!** For details or a demo, contact your Scientific Devices office or Concord Instrument Division, 10 Systron Dr., Concord, CA 94520. Phone (415) 682-6161. In Europe: Systron-Donner GmbH Munich W-Germany; Systron-Donner Ltd., Leamington Spa UK

SYSTRON  DONNER

The Systron-Donner Instruments Group:

Alpha Scientific  Computer Systems  Concord Instruments  Datapulse  Kruse Electronics  Microwave  Trygon Electronics

Electronics/August 28, 1972

Circle 39 on reader service card 39



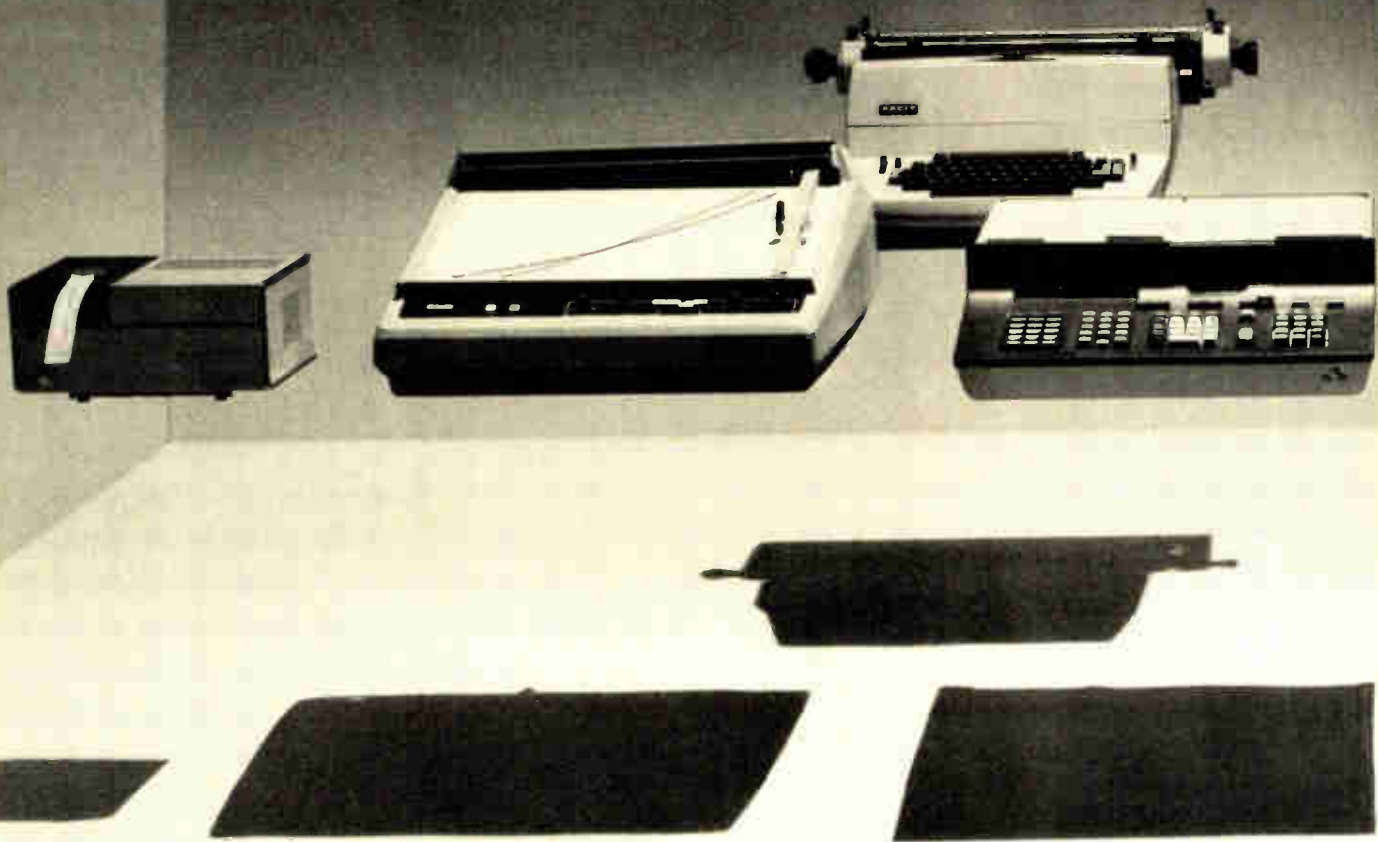

# Hewlett-Packard Series 9800. The Name And Number Mean More Than Calculators.

Computing Power Is One Thing. The most striking example of computing power, that we know about, is our HP-35 Calculator. At nine ounces, this *shirt-pocket powerhouse* marvelously challenges a computer in handling problems from simple arithmetic to complex mathematics. And costs \$395.



If we can package that much power in a shirt-pocket, imagine what our Series 9800 Model 10 and 20 can do:

Model 10. The one for doing repetitive problems (statistics, quality assurance, or surveying, to name a few). It comes with an LED Display, 50 registers *and* 500 program steps of memory. Coming in at under \$3,000, the Model 10 can both perform a complete regression analysis, and solve 10 simultaneous equations. You can add

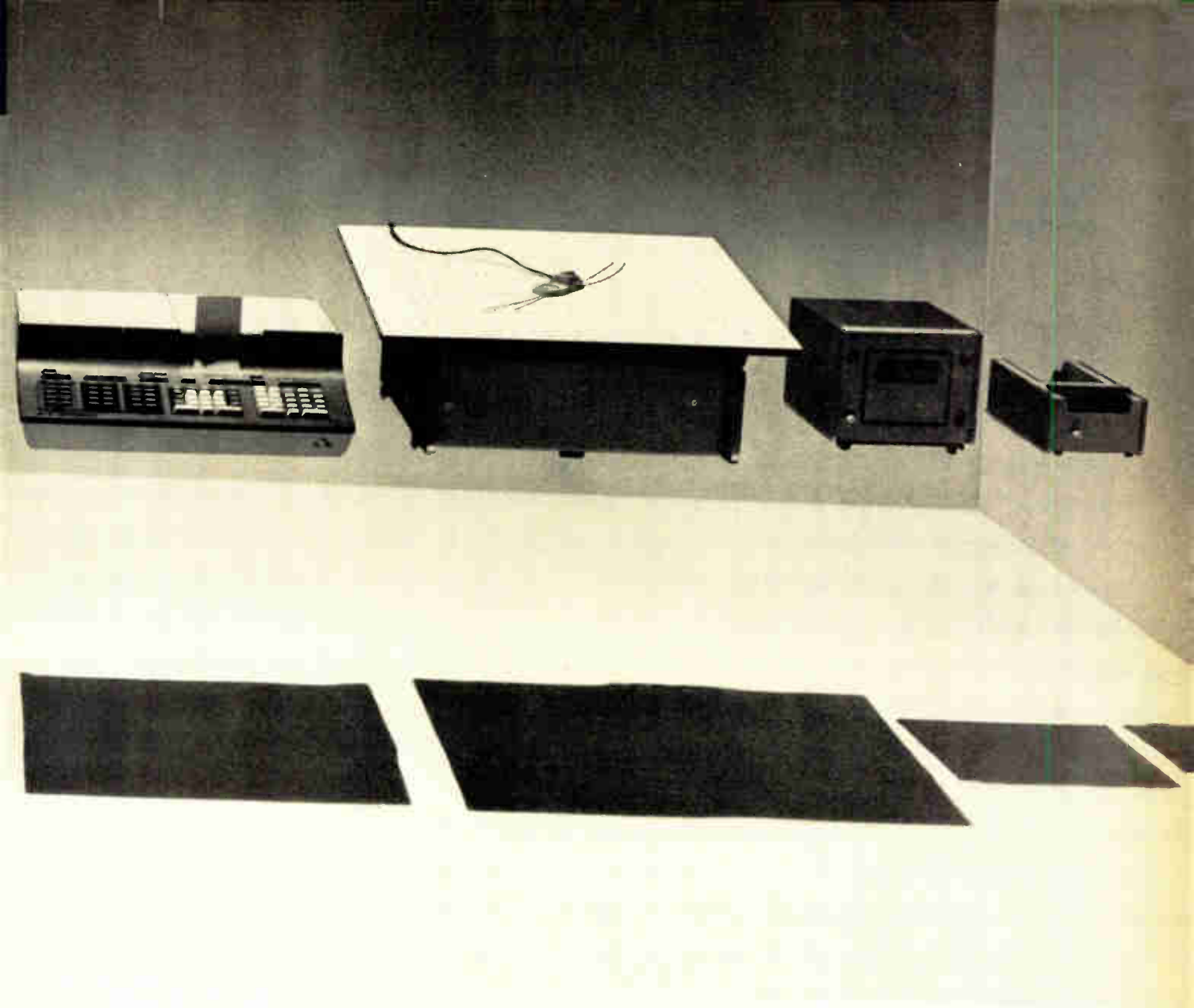

special functions, memory and printer with or without alphanumerics.

**Model 20.** The one for a lot of on-the-spot programming of complex problems. You get the best of both worlds: Very fast operation internally, with direct communication between you and the calculator. You key in your problem just as you'd write it—in Algebra and English. It gives you instructions and labeled solutions that you readily understand through its unique alphanumeric display and printer. Add to this Model 20's extensive error detecting and correcting features and its whopping memory—and you'll quickly find that it'll take you from concept to solution faster than any other system around.

What's more, with the Series 9800, you're not limited to the data formats of the Calculator. For input, you have your choice of Marked Card Reader, Paper Tape Reader, or Digitizer; for storage, the Tape Cassette; and for out-

put, a Typewriter, or our X-Y Plotter that both draws and writes.

**Support Is Another Thing.**

We're in a unique position to help you. It's the aggregate of our experience in virtually every discipline of science and engineering that does it for us. Not just with products but with people. People like your HP Field Engineer. Chances are, he'll bring the solution to your problems with him. If not, he'll put you in touch with someone who will. The point is, he can talk your language. So you do get the most from your investment. Save time in the beginning. And money in the end.

**Service Is A Third.** With over 170 field service centers in 65 countries, service is available regardless of where you are. For most, it takes only a phone call.

**Product Line Is A Fourth.**

You probably already know us as one of the world's leading designers and manu-

facturers of precision electronic measurement equipment. To that end we build over 2,000 products for scientists, engineers, doctors, and businessmen.

Today we're a leader in computing equipment as well. Our line runs from the Model 35 Calculator, right on up to the System 3000, a multi-lingual, multi-programming computer. Between those, and all that goes between, we can help you find the most cost-effective solution to your problems.

For more information or a demonstration of the HP Series 9800, write: Hewlett-Packard, P.O. Box 301, Loveland, Colorado 80537.

**HEWLETT  PACKARD**  
**CALCULATOR PRODUCTS**

HP sales, service and support in 172 cities in 65 countries.

For a demonstration, circle reader service no. 196

For information on the HP-35, circle reader service no. 197

# Announcing PDP-8's going

We're making more of our own PDP-8 peripherals. A new 8K memory unit. And a new 1.6 million word disk. You know what that means. They're costing us a whole lot less now.

So they're going to cost you a whole lot less. As much as 61% less.

And we're bringing down prices everywhere we use those new memory units. PDP-8's with the new 8K core memory unit now cost up to 27% less.

And the price of a typical PDP-8 system drops by an absolutely amazing 47%. Mind you that's before quantity discounts.

Then if that's not enough, we're also introducing a host of brand new

**PDP-8/E (8K)**  
**WAS**  
**\$7,740**  
**NOW**  
**\$5,650**

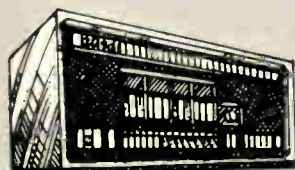

**PDP-8/E (4K)**  
**WAS**  
**\$4,990**  
**NOW**  
**\$4,490**



**PDP-8/F (8K)**  
**WAS**  
**\$6,740**  
**NOW**  
**\$5,150**



**PDP-8/M (8K)**  
**WAS**  
**\$5,990**  
**NOW**  
**\$4,850**



**TYPICAL PDP-8 SYSTEM**  
 (PDP-8/E, 8K core, LA30 DECwriter, highspeed paper tape reader/punch, 1.6M word disk)  
**WAS**  
**\$35,985**  
**NOW**  
**\$19,900**



**MM8-EJ**  
 (8K core memory)  
**NEW**  
**\$3,900**

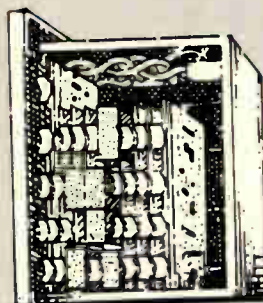

**DISK PACK**  
 (1.6M word disk pack)  
**WAS**  
**\$20,400**  
**NOW**  
**\$7,900**



**LS8-E**  
 (165-character/second line printer)  
**NEW**  
**\$5,000**





# after your business sale.

PDP-8 products. Eight new peripherals, in addition to the 60 we already offer. Six new software packages, in addition to the 250 in our library. All for the 15,000 PDP-8's in use now. And there's more to come.

Don't look so surprised. We've just done what we always do. Make more computer cost less.

Write. Or call. Digital Equipment Corporation, Maynard, Mass. 01754.

(617) 897-5111. European headquarters: 81 route de l'Aire, 1211 Geneva 26, Tel.: 42 79 50.

**digital**

**VR20**  
(two-color oscilloscope plotter display)

**NEW**  
**\$4,000**



**LA30A**  
(receive-only version of the LA30 DECwriter)

**NEW**  
**\$2,500**



**VT8-E**  
(low-cost alphanumeric display)

**NEW**  
**\$1,900**



**LA30-E**  
(DECwriter with EIA interface)

**NEW**  
**\$3,195**

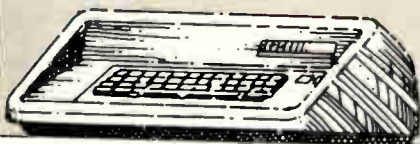

**RT02**  
(data entry terminal with alphanumeric display)

**NEW**  
**\$1,300**

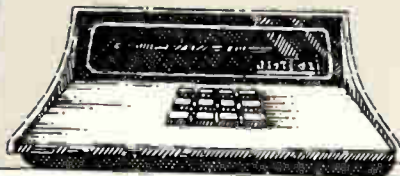

**KL8-F**  
(asynchronous data interfaces)

**NEW**  
**\$425 each**

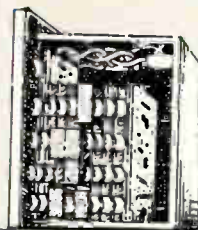

**KL8-M**  
(medium controller)

**NEW**  
**\$250**



**TECO**  
(text editor)

**NEW**  
**\$55**



**BITMAP**  
(core memory management program for absolute binary programs)

**NEW**  
**\$15**



**OS/8 BASIC**  
(operating system program with file and string manipulations)

**NEW**  
**\$150**



**DEC/X8**  
(utility system extender package)

**NEW**  
**\$300**



**TD8-E COPY**  
(file management program for PDP-8 systems using magnetic DECtape storage)

**NEW**  
**\$15**



## De-bug your new ROM designs before you build them.

With the SMS ROM Simulator, you will save thousands of dollars and months of de-bugging and re-masking on every new ROM design. It can simulate as many as 16 4096-bit ROMs at a time. And it simulates in your circuit at operational speeds, identical in function and in performance to the ROM you will use in production.

For sale, lease or rent. Sales price starting at \$4,350 for a minimum of two simulation cables. Short term rentals for approximately 9% per month of purchase price.

Write, TWX or call collect for complete information:  
Dan Scheel, Sales Manager, Signetics Memory Systems,  
740 Kifer Road, Sunnyvale, California 94086.  
(408) 739-7101 TWX: 910-339-9257

**Signetics Memory Systems**  
**sms**

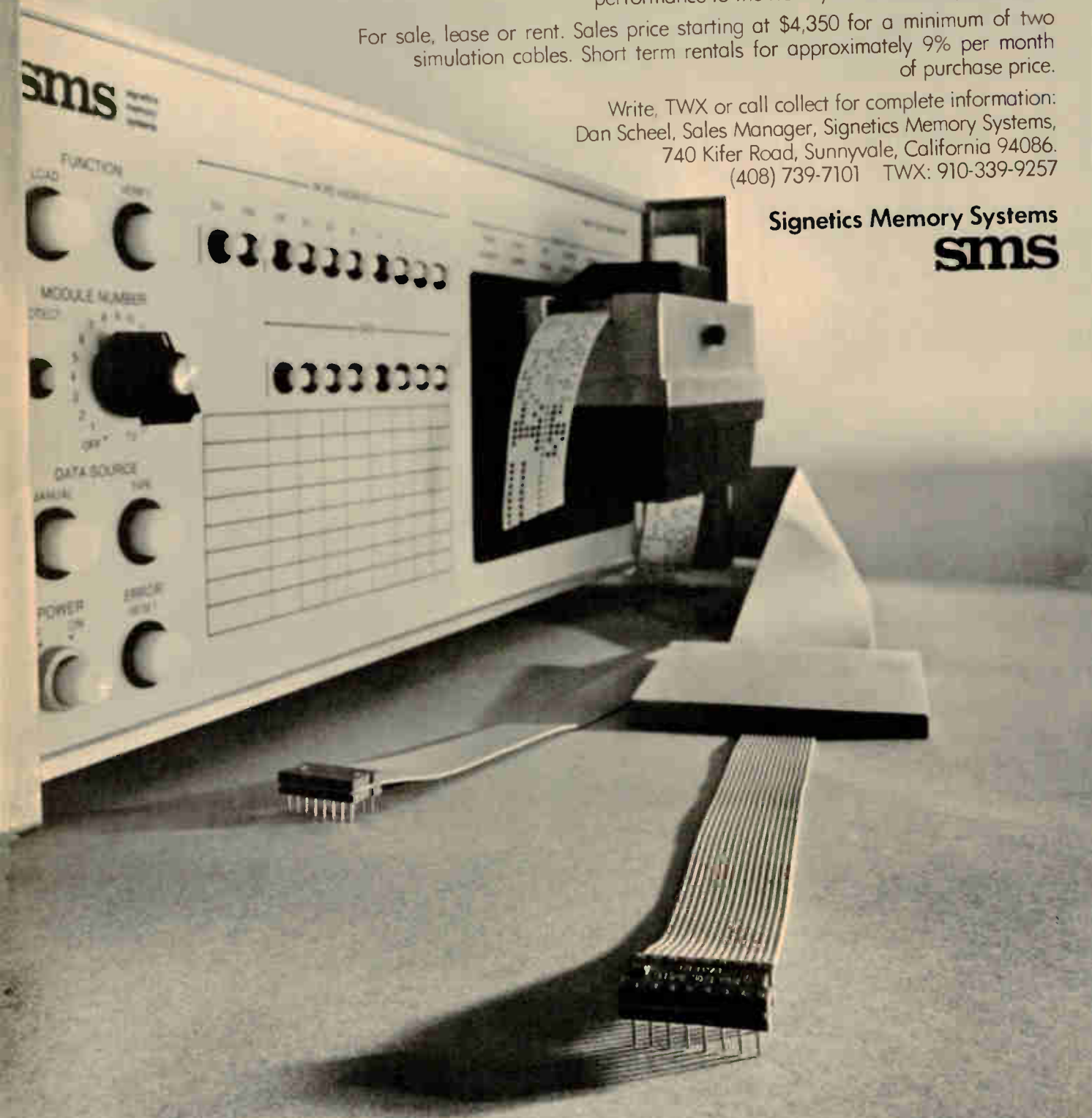



## GaP polycrystals, made by new technique, form LED displays

While others try to grow better single-crystal gallium phosphide material for light-emitting-diode displays, workers at Sony Corp.'s Central Research Lab have found they can get good results much less expensively with polycrystalline material. What's more, they have further cut costs by developing a hybrid numerical display that does not require wire bonding.

Gallium phosphide is one of the most attractive semiconductor materials for displays, but it tends to be expensive because of the difficulty in growing it. The usual process involves temperatures that exceed the 1,469°C melting temperature of GaP and pressures of up to 50 atmospheres. This makes for an expensive piece of equipment that may cost something like \$130,000 and is tricky to use.

**Grains.** Studies by Sony and others show that saucer-type etch-pit defects, which degrade the performance of LEDs, tend to be high in the GaP grown by this method. However, line defects do not cause as much degradation. Thus, Sony scientists reasoned they could use polycrystalline material with fairly large size single-crystal grains, because grain boundaries are a line defect. Sony calls its new method synthesis solute/diffusion.

The equipment used is fairly simple and can be made in Sony's own shops for about \$6,000. It consists of a crucible that initially contains only molten gallium with a temperature gradient—about 1,200°C near the top and 1,000–1,100° at the bottom. This crucible is surrounded by a container that contains phosphorus at a vapor pressure of about 1 atmosphere—which occurs at about 420°.

The phosphorus vapor dissolves in the gallium melt and gradually diffuses toward the cooler regions,

where it becomes supersaturated, and gallium phosphide precipitates. When the process is completed, the crucible contains an ingot of polycrystalline GaP with large single-crystal grains. Characteristics of this material are excellent, Sony says, and there are almost no saucer pits after AB etching. This freedom from pits makes it possible to produce the junction for both high-efficiency green and red LEDs with only one liquid-epitaxy process.

This material is sliced into wafers, an epitaxial layer grown to form the junction, and the wafer lapped. Including the 50–100-micrometer thickness of the epitaxial layer, the completed wafers are about 250 micrometers thick. The wafers are then diced to form chips measuring about 120 micrometers by 2 millimeters.

**Right angles.** Although it is usual for chips in LED displays to be used with the junction parallel to the surface of the display, the Sony chips are used with a perpendicular junction. Thus, the 250-micrometer thickness becomes the width of the individual segments.

Elimination of wire bonding is an important feature of the Sony hybrid displays. Each chip is mounted so that it bridges two metalized regions on the glass substrate. Metalized regions extend to DIP-type leads at the substrate edge. □

## Modulating a laser directly

With a control circuit using only a resistor and a transistor, researchers at Japan's Olympus Optical Co. are doing away with optical modulation of a helium-neon laser. Their approach involves internal modulation

of the laser's output power, rather than manipulation of the beam after it has left the laser. So far, they have achieved pulse rates of several hundred kilohertz and are working on reaching somewhat higher rates.

The power output of the typical helium-neon gas laser reaches a peak at a single value of tube current, with falloff for both larger and smaller values. Modulating the laser by lowering the current causes problems—the gas discharge is extinguished as current is reduced. Operation becomes unstable, and high-speed modulation is not possible because the gas discharge cannot be turned on and off at a very rapid rate.

**Modulation.** Instead, Olympus modulates by increasing the discharge current. Normally, lasers are designed so that falloff in power output is at a minimum over a wide range of currents from the peak value, which makes them relatively unsuitable for operation in this mode. So Olympus built lasers optimized for a rapid falloff in power output for increasing values of current. Present lasers give a peak power output at discharge currents of 5 to 6 milliamperes, with output falling to zero for currents in excess of 15 to 17 mA.

The simple modulation circuit consists of one resistor and one transistor, together with a power supply with a somewhat higher than usual voltage. The supply voltage, about 2.1 kilovolts, is adjusted so that when it is applied in series across the laser tube and the 50-kilohm load resistor, the circuit current is sufficient to prevent laser oscillations. The modulator resistor, connected between the negative terminal of the power supply and the laser tube, is then adjusted so that it reduces circuit current to the level that gives maximum output. □



# Cable-Scan™ System



Model G4D — with 400 circuit adapter chassis.



Model CS-200SR — 200 input encoder with remote readout head.

Cable-Scan users have eliminated costly rework and production delays by verifying the correctness of the work at the point of fabrication. This system combines instant identification and testing in 1/5th the time of present methods.

By touching the end of any wire the operator introduces a low level signal through the finger tips to each circuit. This causes the readout to identify the wire by number.

Write for bulletin on how you save with Cable-Scan—identify, test for continuity, shorts and many other production functions. Cable-Scan Inc., 145 E. Emerson Ave., Orange, California 92665 (714) 998-1961

**Cable-Scan Inc.**  
Division of Thomas & Betts Corporation

508



*identifies and tests wires and cable assemblies by touch while you are fabricating*

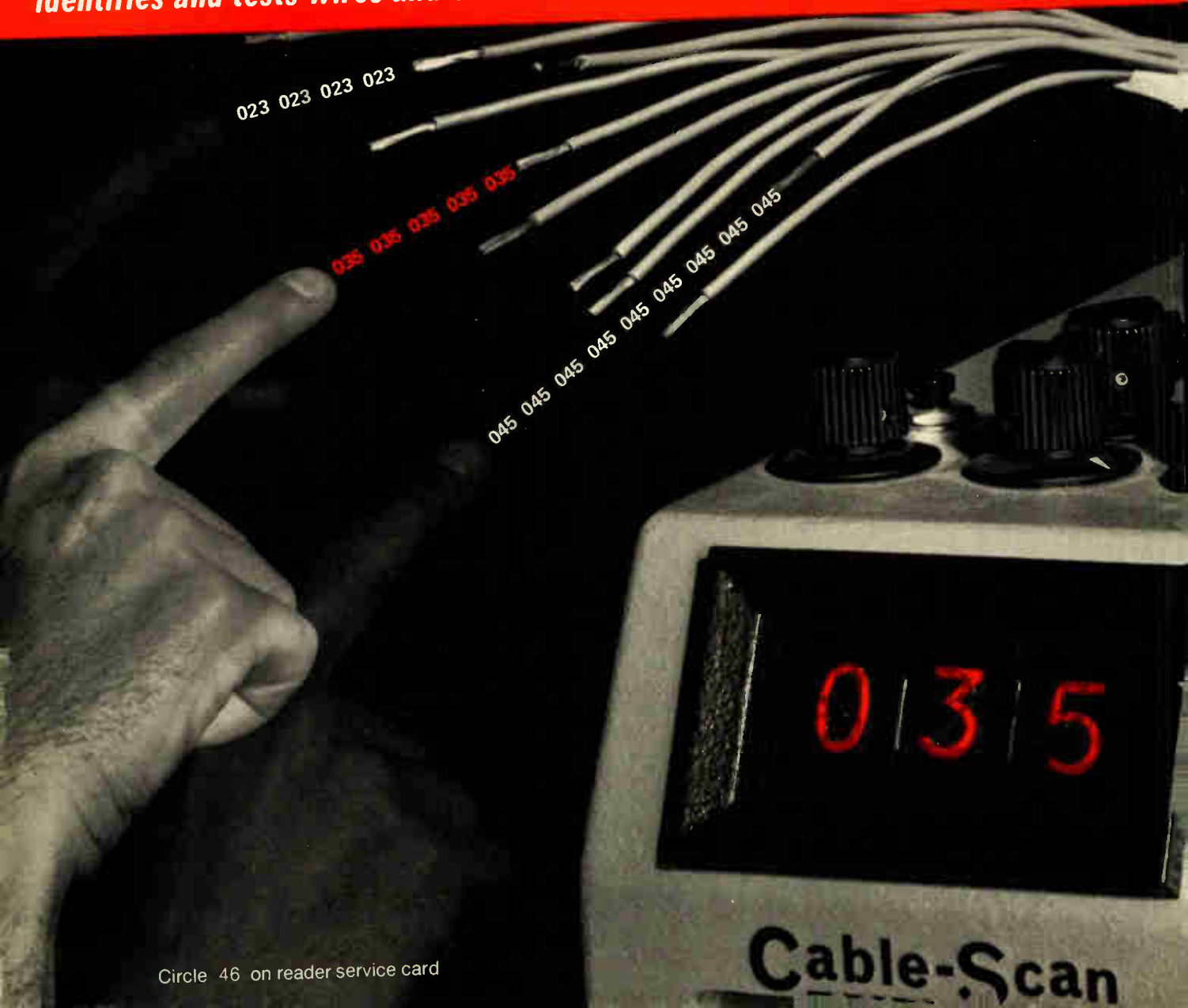

Circle 46 on reader service card

# International newsletter

## What color TV system will Italy choose?

The Italian government, only two months old, may be toppled by the supposedly technical question of whether to broadcast color television using the French Secam or West Germany's PAL system. A month ago, French president Georges Pompidou visited Italy and proposed that "Latin unity" be reflected in Italy's adoption of Secam (which stands for sequential and memory). Since a decision on color TV has been postponed by Italian governments for the last eight years, the immediate reaction to the French proposal was to hedge—by calling for a 60-day test of both systems.

That move raised industry fears that the door was being opened to Secam at a time when all manufacturers are geared up for PAL (for phase-alternation line) because all the other West European countries use it. **Some even say that with the 60-day decision a typical Italian compromise was in the offing—continuing the test indefinitely—which is really a non-decision.**

Now the Republicans, one of the parties making up the current shaky majority, have threatened to withdraw if Secam is chosen. And the Social Democrats, members of the coalition, later joined them in **condemning the choice of any system—on the grounds that Italy has more urgent economic and social problems to solve first.** With the question becoming a political football, no one expects Italy to get color TV for some time to come.

## British LED makers to sell wafers to U.S. buyers

Because the market for light-emitting diodes is developing very slowly in England—and in any case is dominated by U.S.-made products—**British LED makers are looking into new ways of exploiting their materials know-how.** Ferranti Ltd., first in the field with green gallium phosphide numeric and alphanumeric modules [*Electronics*, Electronics International, April 26, 1971], is switching its effort into offering fully processed 1.25-inch slices, which buyers can scribe into dice and mount themselves. Dice size, defined by masking, is 18 mils square. Plessey Co. is considering following suit by selling yellow GaP vapor-epitaxy-processed slices that would need diffusion, application of contacts, dicing, and mounting by the buyer. Both companies plan to sell mostly in the U.S., where they believe there's some dissatisfaction with standard LED red as a display color. In addition, Plessey will shortly offer its yellow GaP as single-diode lamps on a conventional header. These lamps give 1,000 foot lamberts from 40 milliamperes.

## Sweden's IBM computer orders anger Saab

The computer division of Saab-Scania AB has protested to the government that **IBM is getting an unfair advantage in a planned \$40 million state computer purchase.** The company complained that the Statskontoret, the state agency charged with all government computer purchases, has contracted with IBM for computers and peripheral equipment to be used in a lengthy test period for a central real estate registry. **Saab-Scania contends that the central registry will end up locked into using the IBM equipment when it goes in full-scale operation in 1976.**

Instead, it says, the government should scrap the central registry idea and shift to a provincial system. Further, the government should wait until an official study on the future of the Swedish computer industry is

# International newsletter

completed. Saab, incidently, has supplied most of the computers used for provincial data operations.

## Japanese firm to distribute IPL's self-scanned arrays

Integrated Photomatrix Ltd., a British specialist in integrated self-scanned light-sensitive diode arrays, is moving into the Japanese market through an agreement with distributor Rikei Corporation of Tokyo. Rikei will aim at selling IPL's arrays to Japanese optical character-recognition equipment makers. So far, the self-scanned array hasn't attracted Japan's own semiconductor manufacturers. IPL's main sales at present are in the U.S. and Continental Europe.

## Yugoslavs target West Germany for entertainment gear

With the West German market for entertainment electronic products booming, television and radio makers in Yugoslavia are bracing to get in on the action. **One company, Elektronska Industrija of Nis, is planning a sales drive on a broad front, aiming at a 30% sales increase in monochrome TV sets and stereo receivers over last year's figure.** This, says a representative in Germany, would bring its total to 65,000 TV receivers and to 15,000 stereo sets. The company will try to push sales by no longer selling to mail-order houses and manufacturers exclusively, but also through wholesalers and retailers.

## U.S., UK test link kicks off automated cargo net

A world-wide automated cargo-handling system featuring computerized information centers at ports of entry—and ultimately a dedicated satellite network—is the goal of an experimental project coordinated by the Department of Transportation. **The 12-month project will start in November with an automated data link between New York's Kennedy International Airport and London's Heathrow.** Later, the test will be expanded to include exchange from the point of origin through ports to the destination. A similar test is being negotiated with Japan.

Many U.S. ports and companies already have shown strong interest in the idea, says a DOT source. Spurring the plan is the logjam of cargo—which impairs cargo security—due to slow-moving paperwork, even though individual cargo groups are highly automated. “Our goal is to have computers talking to computers and move no paper at all,” the DOT spokesman says. **With the tests, DOT hopes to work out the bugs so that ports and shipping associations can build systems.**

## ITT's British arm designs new TTL products

ITT Semiconductors Ltd., the British branch of ITT's international semiconductor operation and a major producer of 74 TTL within ITT, **will progressively add new integrated functions of its own design to the second-source products that constitute its IC business.** Some new 74 TTL functions are being sampled now, and later this year, some TV ICs, also claimed to be original, will be announced.

The British-designed TTL circuits include some quad two-input power drivers intended for interfacing out of TTL into lamps, relays, and so on. They are rated at 30 volts maximum output nonconducting and 250 milliamperes maximum current output per line at 0.4 V. Also coming out are a low-voltage, low-current input Schmitt trigger for interfacing into TTL and a high-stability self-starting clock generator with pulse widths from 35 nanoseconds to 40 seconds.



# it's all in the family



## 250 AMPS & 600 VOLTS

(SDT 5840) (SDT 5865)

*Solitron has expanded its high power, high current  
NPN Silicon Planar Transistor Line!*

Six individual series of planar power transistors have been developed by Solitron to meet various application requirements for high current switching. These silicon power devices are constructed with the **largest single planar chip** in the industry. They are the most versatile high power, high current, fast switching transistors available today.

**FEATURING:**

- Hi-Rel Construction
- $f_t = 15$  MHz Typical
- Power Dissipation @  $100^\circ\text{C} = 300\text{W}$
- Low Thermal Resistance,  $\theta_{J-C} = 0.33^\circ\text{C/W}$

\*Also available in TO-68 Case

Series No.	$I_c$ (max)	$V_{CE0}$
SDT 5840	250A	100V
SDT 5850	200A	200V
SDT 5860	150A	300V
SDT 5845	75A	400V
SDT 5855	60A	500V
SDT 5865	30A	600V

## FROM THE HOUSE OF POWER

For complete information, prices and engineering application assistance, dial toll-free 1-800-327-3243. Or write:

# Solitron

DEVICES, INC.

1177 BLUE HERON BLVD. / RIVIERA BEACH, FLORIDA / (305) 848-4311  
TWX: (510) 952-7610

SAN DIEGO, CALIF.  
8808 Balboa Ave.  
CMOS, PMOS Circuits  
Diodes, Rectifiers, &  
Zeners  
FET & Dual FET  
Transistors  
High Voltage Assemblies  
Linear & Monolithic IC's

RIVIERA BEACH, FLA.  
1177 Blue Heron Blvd.  
Hi-Rel Power Transistors  
SI & Ge. Power  
Transistors  
Hi-Rel Power Hybrids  
PNP-NPN Industrial  
Transistors

PORT SALERNO, FLA.  
Cove Road  
Microwave Connectors  
Plaxial (R) Cable  
Precision RF Coaxial

JUPITER, FLA.  
1440 W. Indiantown Rd.  
Microwave Stripline  
Components  
Microwave Diodes  
RF and Microwave  
Transistors  
Hi-Rel Power  
Transistors

TAPPAN, N.Y.  
256 Oak Tree Road  
Diodes & Rectifiers  
Ferrite & Ferrite Devices  
High Voltage Assemblies  
Power Rectifiers  
Thick Film  
Hybrid Circuits

KENT, ENGLAND  
Tubbs Hill House  
London Road,  
Sevenoaks  
Solidev, Ltd  
Full line of  
Solitron devices

BEN BARAQ, ISRAEL  
51 Hayarkon Street  
AEL Israel, Ltd.  
Full line of  
Solitron devices

TOKYO 105, JAPAN  
Rm. No. 21,  
Kyodo Bldg.  
No. 4-10, 2 Chome  
Higashi Shinbashi  
Minato-ku  
Full line of  
Solitron devices

NEW FROM HONEYWELL

# A complete graphic data acquisition system, with its own built-in signal conditioning, in a package just 8¾" high!

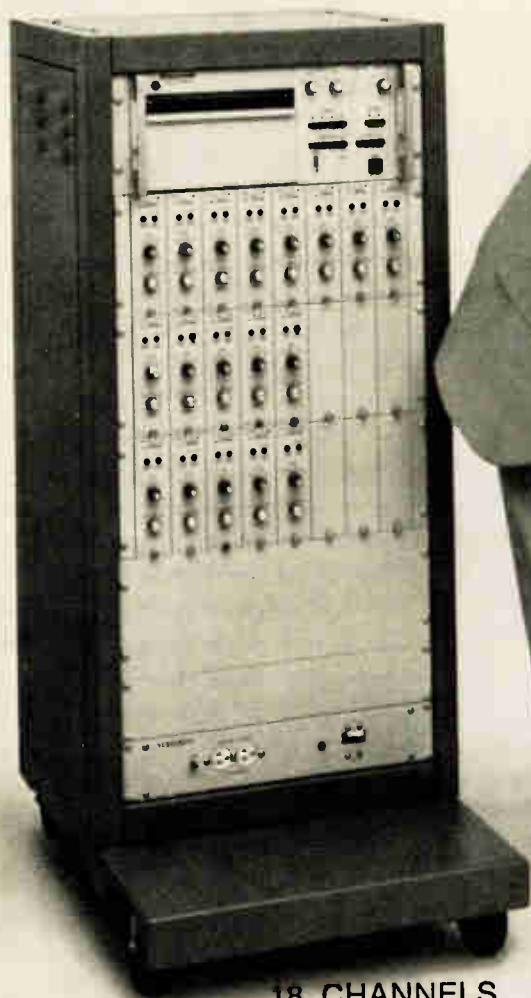

18 CHANNELS  
**THEN**



18 CHANNELS  
**NOW**

Our new one-piece data acquisition system offers benefits that other graphic systems can't, such as:

**Completely self-contained.** Signal conditioning circuitry is built right into the 1858! All you do is select and plug your choice of modules into the front panel.

**Most readable and accurate record available.** Our 1858 allows any trace to be positioned at any point on the record with full record width deflection, plus digital trace identification. In addition, it offers high-frequency response and a super-fast rise time—without trace overshoot—and without high-frequency trace wipe-out . . . for the easiest-reading record, the best resolution ever.

Circle 50 on reader service card

**As easy to use as an oscilloscope.** With the all-electronic, fiber-optic CRT 1858, there are no galvanometers or pens to fuss with. No mathematics or matching networks to fool with. There's simple front panel set-up for calibration, trace position and sensitivity. Just plug in your signal inputs and you're ready to record.

**18-channel recording capability.** This new system records up to 18 channels, each with DC to 5,000 Hz response. You also get a choice of 42 discrete paper speeds up to 120" per second!

**True portability.** Just because our 1858 gives you an 80% reduction in rack space and weight isn't the only reason it's called portable. It's also because *everything* you need is self-contained within that package, including signal conditioning and paper take-up! You

can stick it in a rack, set it on a table, or carry it away.

**A variety of signal conditioning modules.** Your choice includes a high-gain differential amplifier, a low-gain differential amplifier, a medium-gain differential amplifier, an impedance interface module, a strain gage control unit and a thermocouple control unit.

**And this is only part of the story.** For more information, call 303-771-4700. Write Lloyd Moyer, MS 218, Honeywell, Test Instruments Division, P. O. Box 5227, Denver, Colorado 80217.

**Honeywell**  
The Automation Company

# Thermal printers make their mark

Calculator and computer-terminal makers begin adopting this reliable, noiseless technique for fast-growing, economy-conscious market segment

by Larry Armstrong, Dallas bureau manager

The thermal printer is making a quiet impact on the traditionally mechanical terminal and calculator markets. Most of these are all-electronic thermal printhead systems that offer virtually noiseless operation and high reliability. And manufacturers are also promoting their products' light weight and low power needs for the hand-held calculator marketplace. While not without problems—the thermal printer cannot yet produce multiple copies, and printout is sometimes difficult to read—these printers appear to be poised for steady growth.

"Our major thrust, without any doubt, is to open the calculator market to the thermal printhead," says Ian McCrae, optoelectronics marketing manager at Texas Instruments Semiconductor group, Dallas. "That will be the biggest segment."

The total market for thermal printheads, McCrae estimates, is about \$3.5 million, and 85% of that will be spent on printheads for terminals. In 1973, about 35% of a \$5 million market will be for calculator applications. By 1975, the printhead market will top \$10 million—with 60% going for calculators.

The terminal business is also continuing to grow, but it won't have nearly the effect of the "hundreds of thousands of printing calculators" that Ed Ruggiero, president of Dallas-based Displaytek Corp., expects to see sold next year. Shipments of terminals will total about 100,000 this year, and "10% of these are thermal printers—maybe," says William E. Gott, data terminal marketing manager at TI's Digital Systems division, Houston, which builds a line of terminals called the Silent 700. "Two years ago, we had essen-

tially zero percent," he adds. "I expect that it will grow to 25% of the total market in five years, and of course the total market is growing between 20% and 30% annually." And Gerald W. Schoenwald, director of marketing for Anderson Jacobson Inc., Sunnyvale, Calif., arrives at the same percentage figure.

Early inroads in the calculator market have been made already. Canon claims that it is still making small numbers of Pocketronic calculators with the original TI 4-by-5 dot-matrix printhead, but industry insiders say that Canon production is "barely a trickle."

The Canon Pocketronic's ticker-

**Handful.** Displaytek's palm-size thermal printer mechanism weighs 8 ounces with a 100-foot roll of paper. A single solenoid advances the paper and controls printhead pressure.

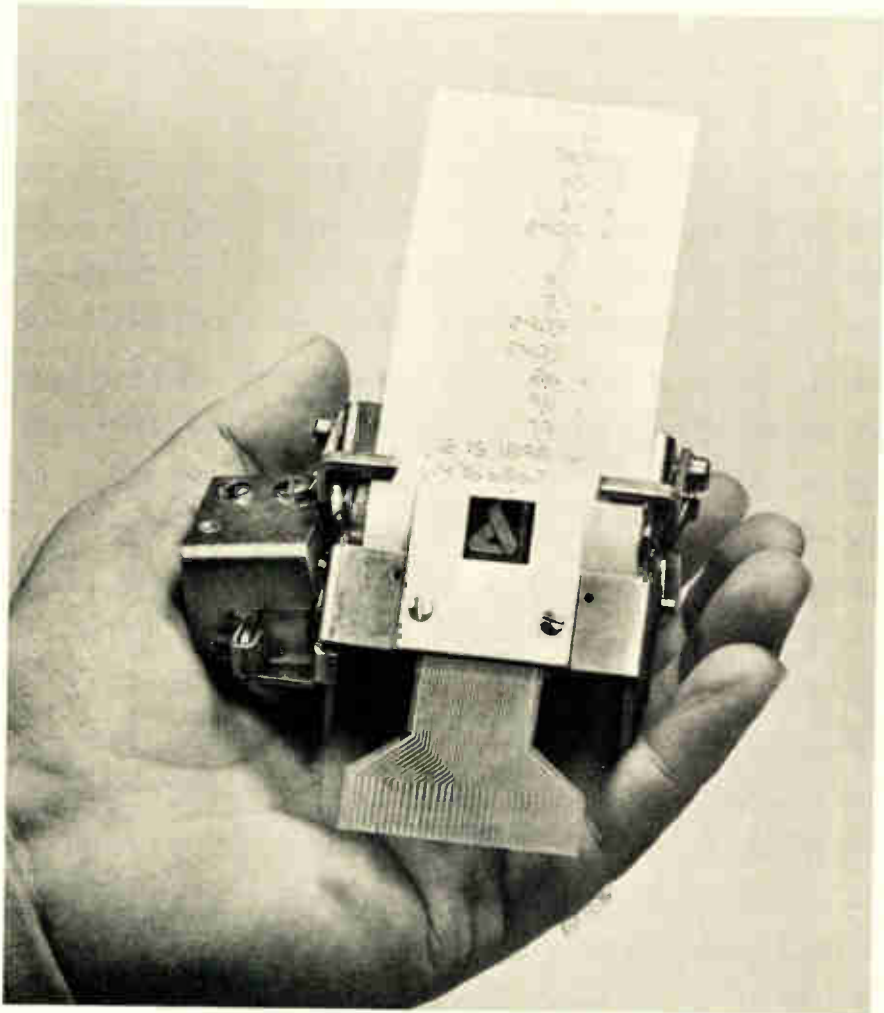



## Probing the news

tape-type printout is not as desirable as the adding-machine-tape printout manufacturers and consumers are demanding now, and although Canon has shown its distributors a desktop calculator that uses a moving TI printhead to obtain a wider tape output, the company has not announced the machine. Several other companies are readying or have shown desktop calculators with printers, but most either rely on the \$50-to-\$75 Seiko electromechanical printers, or like Toshiba, they use impact printers designed in-house.

**How much?** The total cost of a thermal printer—"a Seiko replacement"—is less than \$50, says McCrae. And all the mechanisms needed to drive the head and advance the paper are less than \$10 "in reasonable quantities," he says. The required electronic components include the head, about \$12; a couple of row-column drivers, less than \$4; and a decoder, around \$5, he estimates.

Displaytek takes a different approach than TI. Engineers there have designed a hand-size, nine-character printing mechanism that uses a single solenoid to advance the paper and control printhead pressure. "The multicharacter printhead opens up the possibility of battery-operated, portable calculators with complete accountant format," says Ruggiero.

The Displaytek unit, which

weighs 8 ounces with a 100-foot roll of paper, will debut in the Phoenix P calculator, expected to retail for \$299.

A major obstacle to product acceptance of thermal printheads is inability to produce multiple copies. National Cash Register Co., Dayton, Ohio, is working to eliminate that problem, and has developed two-part paper that relies on higher printhead temperatures to penetrate an almost transparent cover sheet. "We use chemicals on the back of the front sheet and the front of the back sheet," says Don Loving, project manager for NCR's own C-260 thermal print terminal. But he admits that the approach is not yet satisfactory. And there are other disadvantages. "The print quality, since it is a dot-matrix format, is not as good as that of an impact printer," says Schoenwald. "And finally, the cost of the paper is somewhat higher than conventional bond paper."

But Anderson Jacobson went to thermal printing in its AJ-630 keyboard terminal to reduce weight, cut noise, and increase reliability [*Electronics*, May 10, 1971, p. 132]. NCR's Loving guarantees 40 million print cycles—a figure representative for all thermal printheads. Computer Devices Inc., Burlington, Mass., averages about one maintenance call every 14 or 15 months on terminals that incorporate print mechanisms purchased from NCR. This rate compares with three or four per year for mechanical printers, says CDI president William Northfield.

### The thermal techniques

Technically, there are several different types of thermal printers, Hewlett-Packard Co. screens the heater material on its substrate for a thick-film approach. National Cash Register Co. and Anderson Jacobson Inc. use a thin-film technique, whereby a proprietary resistor material, such as tin oxide, is vacuum-deposited on a substrate in the desired dot pattern. The dots are then connected to the external drive circuitry. Anderson Jacobson uses a 5-by-8 dot matrix; NCR uses a 5-by-7 matrix, and also supplies a 5-by-8 version to its subsidiary, Electronic Communications Inc.

Texas Instruments and Displaytek Corp. manufacture monolithic silicon types. Displaytek makes a 5-by-7 dot matrix for a single-character head, and also manufactures seven-bar segment numerals in increments of four per chip. These four-number chips are lined up with an eight-bar function indicator to produce multicharacter printers of four to 13 digits. The Displaytek chips, which are beam-leaded, incorporate all the drive circuitry on the chip [*Electronics*, June 5, p. 48]. TI, which now supplies 4-by-5 and 5-by-7 dot matrixes, plans fast and slow 5-by-5 versions.

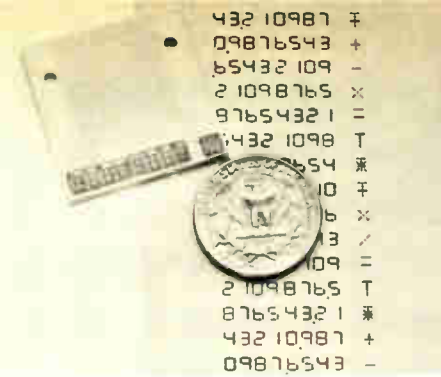

**Monster.** This 175-by-460-mil monolithic chip actuates Displaytek's thermal printer.

Noiseless operation is a major benefit. "Calculators are used in offices, and people in offices put a high priority on noise," says Jack Dunn, factory marketing manager for calculators at Hewlett-Packard Co.'s Loveland, Colo., division. H-P builds a 16-character printer in two programable calculators retailing for \$2,975 and \$5,475, "and there's a good possibility that we'll use thermal printing in some lower-priced calculators, as well," he says. An OEM version of H-P's line-of-dots approach is being used by Custom Electronics, Chanute, Kan., in remote terminals for police cars.

**Printing in katakana.** In Japan, Matsushita Communication Industrial Co. is developing a thermal printer for calculators that uses a 5-by-7 dot matrix semiconductor printhead. Oki Electric Industry Co. is developing its own thermal printhead which should be on the market in a year, if the device doesn't infringe on U. S. patents. Sharp Corp. has a small development effort in thermal printers and says it could probably start production next year, but it, too, is concerned about patent infringement.

But Stateside manufacturers think that their patent positions are stronger, which will enable them to penetrate not only the U.S. market, but the Japanese market as well.

Already many firms are studying Oriental alphabets. H-P, for example, has put a Japanese-alphabet read-only memory in a calculator that Dunn says can print out katakana. Displaytek is working on a printer that will print a 9-by-11 matrix large enough to accommodate both the katakana and hiragana Japanese alphabets, as well as some simple kanji characters used by the Chinese. □

## PROBLEM:

cramming more power distribution cable into less space.



## SOLUTION: a cable that's flat instead of round.

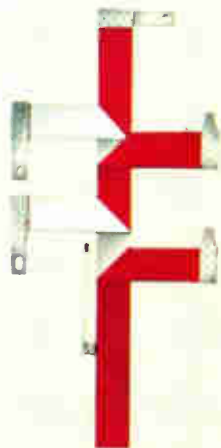

Now you can pack more power distribution cable into less space than you ever thought possible. By using Brand-Rex's new *flat* PVCA cable. A vinyl-insulated aluminum strip you can stack, run in trays or ducts, bend at any angle for branching or to follow any contour.

UL-recognized for 105°C, 100 volt operation, PVCA has passed the UL vertical flame test. And its outer jacket is highly resistant to oil and grease.

Standard terminals, including center tap, are readily available for fast, economical, air-tight, water-tight connections and splices. Yet new PVCA costs *less* than the conventional cable it replaces.

For a fact folder that outlines in detail all the special problems this new concept in flat power distribution can solve, write to Brand-Rex Company, Willimantic, Conn. 06226. Or call: 203/423-7771.

**BRAND-REX**  
4,000 solutions in search of a problem.

Consumer electronics

## Solid state trips home burglars

Manufacturers are adapting industrial protection systems for a new neighborhood network market estimated at \$100 million by 1976

by Marilyn Offenheiser, Assistant Editor

**As home burglaries increase**—one occurs every 15 seconds in the U.S.—the market for more and better alarm systems grows. Until a few years ago, homeowners who wanted reliable burglary protection could only purchase industrial systems. And the prices of these cumbersome systems were prohibitive, except to the affluent.

**Commercial to consumer.** Recently, however, the companies concerned with protecting factories and banks are responding to the demand for home protection. The result has been adaptation and scaling down of commercial alarm systems

for home use. Typical units cost from \$400 up, depending on the technology and system size.

But there have been problems. "There are no systems truly engineered for home use," says Gene Dowd, vice president of security operations at Bourns Inc., Riverside Calif., "so the systems still have hangups." Two major problems, industry spokesmen point out, are the high rate of false alarms and the expense of transmission lines where a central station is used as a buffer between the home and police.

The major companies in the home alarm market include Bourns;

ADT Co., New York; Westinghouse Security Systems Inc., Pittsburgh; Dictagraph Corp., Florham Park, N.J.; AMF Inc., White Plains, N.Y.; Universal Security Instruments Inc., Baltimore; Sentron Inc., Woburn, Mass.; Systron-Donner Security Devices division, Concord, Calif.; Oak Securities Inc., Crystal Lake, Ill.; Magnavox Inc., Fort Wayne, Ind.; and Theta-Com, Los Angeles.

**Sensors.** There are two basic types of home alarms. The most common is the perimeter system, in which pressure-sensitive doormats and magnetic switches or sensors at windows and doors trip the alarms. The second type—activated by ultrasonic, infrared, microwave, or photoelectric devices—is for space or area protection. Most systems have panic buttons so that the user can send an alarm, whether his system is on or off, and most are powered by house current. Systems are turned on by keys, or in ADT's case by a digital code punched in a control panel by the user.

Any alarm system, such as the Magnavox and Universal types, can be connected locally within the home, directly to the police, or to a central station monitored by alarm company personnel. When a central station receives an alarm, usually over leased lines, it is digitally coded with location and type of emergency information (most companies include fire protection in the package), decoded, and printed out at the central station. The receiving station is in turn hooked to the police by hot line or radio. George Held, vice president of planning at ADT, estimates that 50% of his customers are connected to central stations, and the other half have local

**Setting up.** A homeowner activates or deactivates the alarm system by punching a digital code on ADT's control panel. A triggered signal goes to central station, then to police.





alarms. ADT's Houston operation is also the first to be computerized.

Systems that are linked directly to the police can transmit alarms in various ways: Richard Schmidt, Bourns marketing manager, says that about 40% of the systems are hardwired, 20% use telephone dialers with pretaped messages over regular phone lines, and another 10% use digital dialers, with the telephone number of the police station built into logic modules.

**Expensive line.** But leased-line signal transmission is expensive—a line can cost up to \$30 dollars a month. And transmission lines are the easiest part of the system to sabotage. "When regular phone lines are used," says Paul Bert, director of planning and development at Oak, "they can be jammed by burglars calling in from the outside, or cut. Regular phone lines are not supervised, as are leased lines."

As an alternative to leased lines, companies have been exploring other methods of transmission. Raymond Carey, president of ADT, says the company has been studying CATV and microwave transmission, and management has been keeping an eye on the private microwave networks now under construction. In the interim, Carey says that ADT is developing a transmitter to send pulsed messages to the central station over regular telephone lines.

Oak is using CATV cable for transmission in Crystal Lake, Ill., Detroit, Washington, D.C., and Madison, Wis. Oak installs perimeter and ul-

trasonic systems "and the cost," says Bert. "is only \$500 to \$600 for installation, with \$12 to \$15 a month lease. This compares with \$1,000 or \$2,000 installation fees charged by other companies, with \$30 a month maintenance. Also, the cable cannot be easily cut; and to be doubly sure, we sequentially poll each line from the central station every 5 seconds to check its condition."

Theta-Com is one of several cable equipment manufacturers going to burglary protection. The Hughes Aircraft Co. subsidiary is installing 30 new alarm systems in California, a number the company predicts will grow to 1,000 installations by the end of the year. Theta-Com will offer a perimeter system connected either to a central station or to the police.

**Sorry, wrong number.** The high false-alarm rate has prompted a spokesman for Burns Inc., the New York City protection agency, to exclaim: "That's why we are trying to stay out of the home market!" A major reason for false alarms is that home conditions are opposite to those found in industry: a factory is empty when it needs protection, but a home is usually occupied. This has prompted the wider use of perimeter systems, which are least susceptible to false alarms. Area alarms are too sensitive for general home use: an ultrasonic system can be set off by a pet or by a member of the household getting up at night; microwave radar systems are so sensitive that they can penetrate walls—

even as far as street sidewalks; infrared systems are heat-sensitive and can be tripped by slight changes in temperature; and photoelectric systems can be tripped by drapes blowing in the wind.

So far, solutions have been to provide space systems mainly for vacationing families, and to use central stations as buffers. Many systems also provide abort mechanisms for false alarms. ADT, for example, builds in a time delay that can be ranged up to 45 seconds—enough time, the company feels, for a user to abort a false alarm by the push of a button on the control panel. The Westinghouse system has a voice override so that a homeowner can call the central station verbally to negate a signal. And each Westinghouse customer also has a special verbal code to be used in case the call is forced at gunpoint. Westinghouse has also developed what it calls a quadrature detection unit to be used with its ultrasonic system that uses a series of phase-locked loop networks to filter out small disturbances, such as those that might be caused by a dog.

**Better mousetrap.** Although most home systems are characterized by solid-state components and transistor-transistor logic, several companies are working on other techniques. AMF will introduce a system this fall which will also use diode-transistor logic and MOS technology. The Sonoguard division of Sentron Inc. is the only company known to use sonar to deliver the signal via doppler shift from infrared, ultrasonic, or weight-sensing devices to the alarm. An intruder tripping the system sets off 150 watts of oscillating sound at a painful 130 decibels.

Bourns is working on a light-gradient system alarm that will "see" an intruder across a field, but right now the system is so sensitive that it will pick up automobile headlights. Bourns is also two to three years away from a sensing device that will pick up a man's heartbeat to trip an alarm. ADT offers as options a pocket-sized transmitter that will send an alarm from any point near the home, a window screen that looks "safe" to an intruder but is actually threaded with sensors, and a silent alarm, similar to those installed in banks. □

## Sleeping giant awakens

"In five or 10 years, home burglar alarms will be as common as appliances," states Raymond Carey, president of ADT. Carey estimates the market (dubbed a sleeping giant in the industry) will reach \$100 million, a figure New York market researcher Frost & Sullivan Inc. estimates for 1976. Last year, the home burglar-alarm market was \$60 million. However, Dictagraph's vice president of marketing, John Gibson, points out, "the market isn't as simple as it appears. A businessman accepts alarm protection as a definite necessity. The homeowner, on the other hand, really hasn't accepted the need for protection yet. It's a matter of psychology." Bourns's Schmidt, predicts that public acceptance will double in about three years, "with the same technology in use as today."

In Europe, industry insiders agree that the market is virtually untapped. ADT already has subsidiaries in England, France, and Holland. Westinghouse is now negotiating with several European protection firms. Spokesmen for both companies agree that new marketing strategies will have to be devised to reach the European homeowner. "Europeans," they say, "don't get uptight about statistics."



**Erudite needler.** Irwin Feerst says the IEEE isn't doing what it must to meet the career needs of today's engineers.

**The IEEE's gadfly**, 44-year-old engineering consultant Irwin Feerst, has lost a round in his battle to bring the institute "kicking and screaming into the 1950s." In the past year, Feerst has become an ever more vocal critic of the institute and its leadership. Earlier this month, he failed to gather enough signatures to run for the IEEE presidency, but he vows he will continue to be a critic of the IEEE establishment on behalf of what he calls the working EE.

Abrasive, inspired, and single-minded, Feerst has twice attempted to implement his long list of institute reforms by seeking the presidency. He spent 14 months campaigning and about \$1,000 in out-of-pocket expenses. Through his erudite needling of the leadership of the institute, he has become ad-

People

## IEEE critic scores some points

Maverick with a mission, Irwin Feerst, loses presidential bid, but plans to continue his role as advocate for the working EE

by Gerald M. Walker, Consumer Editor

mired by some members and disliked by others. And though Feerst was about 500 names short of the 2,000-plus needed to get on the presidential ballot, some of the proposals he espouses will continue to be important issues. Ironically, the IEEE is moving toward early adoption of at least one of his proposals—the portable pension.

**Pushy.** "The usual comment for a defeated candidate is to say, 'let's join forces', but that's baloney," says the former Adelphi University engineering teacher. "I absolutely plan to keep up the role of militant and irreverent advocate, to open up this organization, and get information to the members. I will keep up the pressure to have the IEEE behave as a professional organization and stop it from teaching trivia."

Statements like these have not made Feerst a favorite around IEEE headquarters, nor with the board of directors, some of whom feel he's way out in left field with his candidacy. Nevertheless, Feerst has raised provocative issues, albeit with an occasionally irritating delivery. He believes that the IEEE, among other things, should:

- Start a portable pension now. While IEEE is currently studying this concept, Feerst would have the organization immediately sign up with a pension program now being set up by the American Chemical Society. IEEE executive director and general manager Donald Fink contends that until the constitution is changed by an amendment recently put before the members, it is not possible to join the chemical society's pension organization. He adds that the IEEE

is preparing its own program to be ready if members vote for the amendment.

- Report on professional salaries. Feerst wants the IEEE to prepare an average-salary report by engineering position for every company hiring EEs. This guide would allow engineers to see how their pay compares with the average for the company. The American Association of University Professors (AAUP) prepares a report of this type from colleges and universities.

- Act as a professional defender. Another policy followed by the AAUP is to investigate reports of "nonprofessional" treatment of its members. If a university is found to have mistreated a professor, the AAUP publishes the results of the investigation and censures the school, thus alerting members of ill treatment at particular institutions. Feerst advocates a similar plan.

- Accredit EE departments. As a means of better matching the number of EEs graduating with the number of jobs available, Feerst would have the IEEE toss out the Engineering Joint Council and take over accrediting of electrical engineering departments. Emulating the American Medical Association's decisive role in controlling medical schools, the IEEE could impose its own standards. He admits, however, that there is a risk in creating a shortage of EEs similar to that of doctors.

- Begin direct election of the board. In order to get more grass-roots members involved directly in IEEE activities, Feerst proposes to expand the board and hold direct elections of all its members. Currently, the



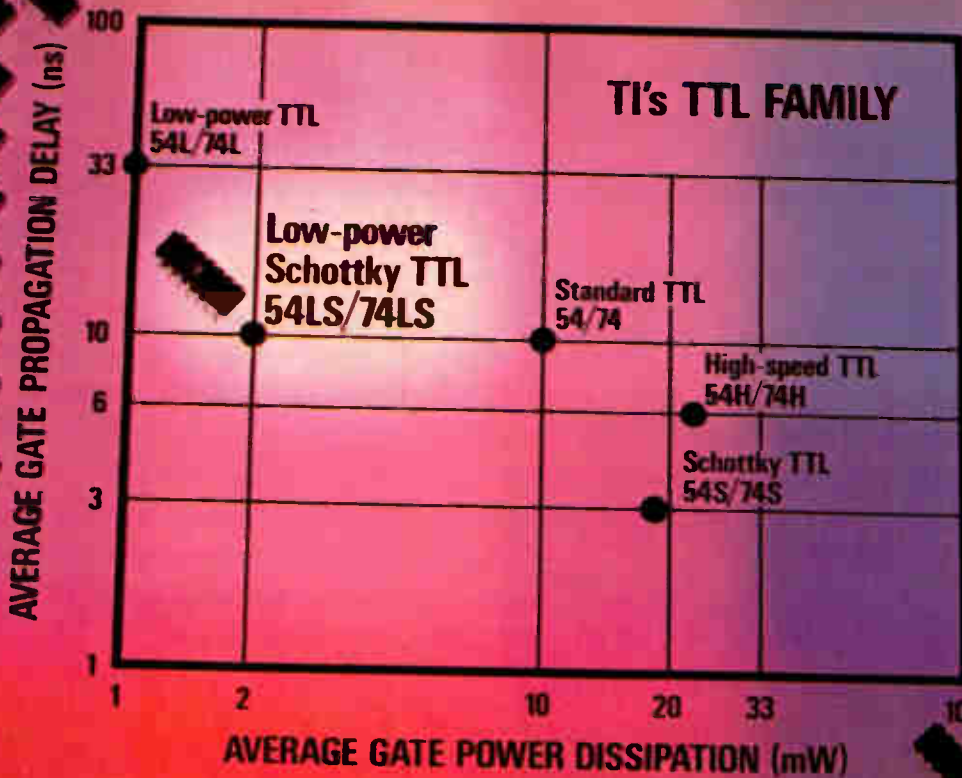

# SCHOTTKY

## Low-power Schottky: 10 ns at < 2 mW.

21 SSI and 13 MSI circuits now available in TI's new low-power Schottky TTL family. They provide all the performance of low-power TTL (Series 54L/74L) with increased speed of 10 ns/gate and power dissipation of less than 2 mW.

Low-power Schottky offers greatly improved speeds in portable or remote systems, or in any application where minimum power is a prime consideration. Compared to low-power TTL circuits, low-power Schottky TTL provides three times the speed with a power increase of less than 1 mW/gate.

Fully compatible, readily available

This new series is compatible with all TTL — standard, high-speed, low-power and Schottky. Evaluation quantities are available now from authorized TI distributors or direct from factory inventories; production quantities four weeks ARO.

Send for complete details

Circle 213 on Service Card for data sheets. Or write Texas Instruments Incorporated, P.O. Box 5012, M/S 308, Dallas, Texas 75222.



### NEW LOW-POWER SCHOTTKY SSI CIRCUITS

	100-999
SN74LS00N Quad 2 NAND gate	\$0.96
SN74LS01N Quad 2 NAND gate, open collector	0.96
SN74LS02N Quad 2 NOR gate	0.96
SN74LS03N Quad 2 NAND gate, open collector	0.96
SN74LS04N Hex inverter	1.14
SN74LS05N Hex inverter, open collector	1.14
SN74LS10N Triple 3 NAND gate	0.96
SN74LS20N Dual 4 NAND gate	0.96
SN74LS22N Dual 4 NAND gate, open collector	0.96
SN74LS30N Single 8 NAND gate	0.96
SN74LS51N Dual 2 AOI gate	0.96
SN74LS54N 4-wide, 2-input AOI gate	0.96
SN74LS55N 2-wide, 4-input AOI gate	0.96
SN74LS73N Dual J-K edge-triggered flip-flop	1.91
SN74LS74N Dual D-type edge-triggered flip-flop	1.91
SN74LS76N Dual J-K flip-flop, preset and clear	1.91
SN74LS78N Dual J-K flip-flop, common clock	1.91
SN74LS112N Dual J-K edge-triggered flip-flop	1.91

SN74LS113N Dual J-K flip-flop, no clear	1.91
SN74LS114N Dual J-K flip-flop, common clock and clear	1.91
SN74LS228N Dual J-K edge-triggered flip-flop	1.91

### NEW LOW-POWER SCHOTTKY MSI CIRCUITS

	100-999
SN74LS83N 4-bit full adder	\$3.51
SN74LS95AN 4-bit left-right shift register	4.78
SN74LS138N 3-to-8-line decoder/1-to-8-line demultiplexer	4.78
SN74LS139N Dual 2-to-4-line decoder/Dual 1-to-4-line demultiplexer	4.78
SN74LS153N Dual 4-to-1 data selector/multiplexer	4.78
SN74LS155N Dual 2-to-4-line decoder	4.78
SN74LS181N Arithmetic logic unit/function generator	25.85
SN74LS194N 4-bit bi-directional universal shift register	4.78
SN74LS195N 4-bit parallel-access shift register	4.78
SN74LS196N Presettable decade counter	4.89
SN74LS197N Presettable binary counter	4.89
SN74LS253N 3-state version of SN74LS153	5.74
SN74LS295N 3-state version of SN74LS95A	5.74

All prices are 100-piece quantities for plastic dual-in-line packages.

TEXAS INSTRUMENTS  
INCORPORATED



elected board members choose another group. Fink says that this two-step approach is the best way to get qualified men for posts requiring financial, technical programming, and academic expertise.

**6-32 screw.** All of these points are aimed at making the EE as good as the 6-32 screw—one of Feerst's oft-repeated parables. He points out that for a company to fulfill a typical Government contract, the 6-32 screws are acquired with a purchase order and the EEs are hired. If the contract is cut back, restitution is made for the 6-32 screws, and they are used elsewhere—but the EEs get laid off. His message: The EE should work under a protective contract.

Though weary and disappointed, Feerst feels that his bid was worth it. He has been a consultant since 1969, and for seven years prior to that, he was an assistant professor. From 1949 to 1962 he worked as an engineer for AIL, CBS, and Sperry, to name a few. Why did he choose to interrupt his on-going consulting business from his quiet suburban New York home to get into institute politics? His reply sounds maudlin in this hard-nosed day, but it was love of the profession—and a conviction that EEs have been abused during the business downturn, while their institute has kept its head in the sand.

"I'd had it up to the eyeballs," he remarks. "I could afford the campaign and wanted to do something, not for personal gain or prestige, but out of a sense of responsibility. I've spent my whole life among EEs and resent their being treated as eunuchs. I also believe in the IEEE as an organization, which is why I wanted to work from within rather than form another organization."

An indication of why Feerst has been both admired and disliked in IEEE is his description of what he would have done if elected president. His first act would have been to fire Donald Fink. "He's a paid representative of everything that's wrong with the IEEE, an emitter that does not produce a signal," Feerst charges. Next, he would have organized committees to reexamine, with an eye toward the best use of

resources, how the IEEE can best serve academic members.

To help pay for these activities, Feerst would cut back on some of the institute's technical publications and move the annual industry show out of the expensive New York Coliseum to less costly arenas in various other cities. Both steps would save funds for use on other projects.

But all of this is conjecture in the light of the petition failure. Feerst reads the mood of the members as "wait and see," now that the leadership has been given a clear mandate to move the organization into socioeconomic activities. This mandate came via a questionnaire, circulated earlier this year, through which members heavily supported a portable pension, political activities, and other career-motivated projects.

**Feerst impact disputed.** Despite the sharpness of Feerst's dissent with the leadership on certain points, Fink feels that Feerst's efforts were beneficial. But he strongly downplays the IEEE maverick's influence on the recent course taken by the board. Instead, Fink says that the membership questionnaire was far more responsible for change than Feerst's campaigning.

Fink states: "He was completely correct and proper in deciding to run for president to get his ideas into the organization. But he was not a prime force. The entire membership was the key, the real source of influence on the leadership, as revealed to everybody by the questionnaire results."

The next important step will be passage of the amendment altering the constitution to permit socioeconomic action, according to Fink.

"There is no chance in 100,000 that this current board will not follow through if the amendment is passed," he asserts. "And remember that two-thirds of this board will carry over into next year."

**The response.** As for the leadership's response to Feerst's proposals, Fink points to the work already begun on a portable pension. He is less certain about how effectively IEEE can get comparative salaries by company, but says it may be possible later. Fink, however, rejects the possibility of direct election of all board members in the near future, but does not preclude the possibility of such a change. He disagrees with Feerst's plan to accredit EE departments, saying that there is no explanation of how it would limit the supply of EEs.

On the other hand, Fink agrees with Feerst that the membership is now waiting to see if the IEEE carries out a socioeconomic plan. "If the amendment passes and the board fails to act, there will be cause for criticism, but I don't see that happening," he states.

Feerst is less sanguine. "I'm willing to give the IEEE a chance, but I don't hold out much hope that there will be real changes, because they will be held back by the board," he muses. "The discouraging thing is that nothing I advocate is new or untried. It's shocking that the IEEE has never thought of these proposals, while sister organizations with members in the same position as EEs have done more. My main goal has been to drag IEEE, kicking and screaming into the 1950s. I resent being called a radical, when all I am doing is copying other efforts." □

### The new amendment

Changes to the IEEE constitution, which members will vote on this November, would alter the purpose of the organization to make it both technical and professional. There is no change in the technical, scientific, and educational objectives, but the amendment adds new professional objectives.

Professional activities, as seen by the board, cover technical, economic, social, legislative, and ethical efforts. With passage of this amendment, the board will be permitted to pursue any and all of these activities. The amendment specifically prevents IEEE from engaging in collective bargaining for members, however.

With a bow toward the public, the amendment adds the intention that the IEEE work for "constructive application of technology in its fields of competence" for the benefit of all men, and to promote "understanding of the influence of such technology on the public welfare."

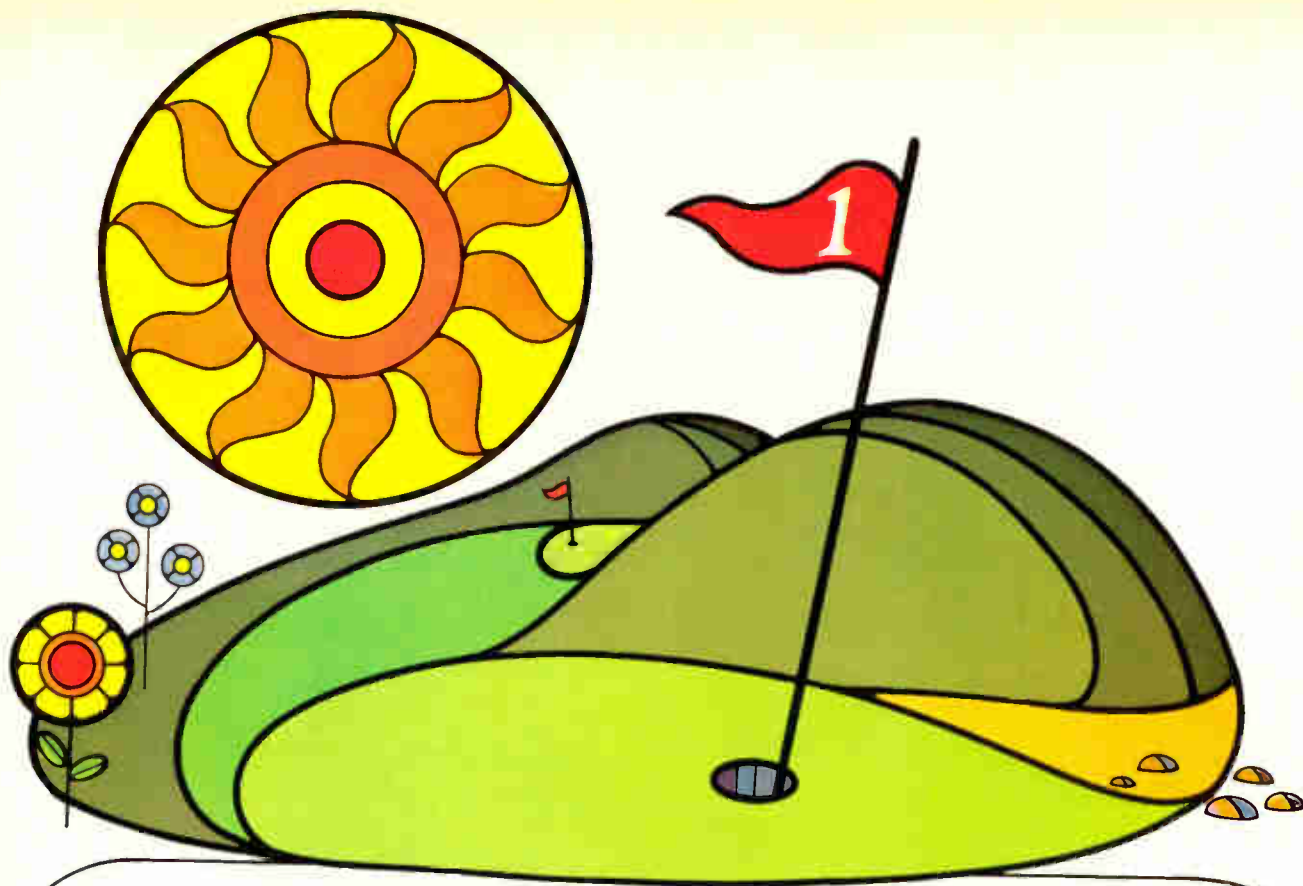

# If you'd rather be golfing

Let SAE solve your packaging problems.

Are the problems of component selection, packaging, and systems assembly interfering with your golf game? Then delegate all that to us. You can concentrate on grooving your swing.

Only SAE provides a complete packaging service in your choice of three systems: Plug-in, Planer, and Dipstik™.

We manufacture all the hardware for plug-in systems, including PC cards, card guides, card files, enclosures, connectors, sockets, mounting and bussing.

Prefer planer? We'll provide the logic panels, mounting hardware, sockets, and all peripheral items.

Or investigate our unique Dipstik. It gives twice the IC density as PC methods, and eliminates lots of hardware.

Whichever method you choose, we can supply the components for you to assemble yourself. Or, we'll pick the parts, do the assembly, and let you do the wiring. Or, we'll provide everything: components, assembly, and Wire-Wrap®. So, just call us in . . . and you go out golfing!

**Free bumper sticker for your desk.** Flaunt your favorite sport. Or, if something else turns you on, tell us. Maybe we can send you a bumper sticker for that, too. We'll also include a brief brochure describing how we can relieve you of systems packaging hang-ups. Write us:

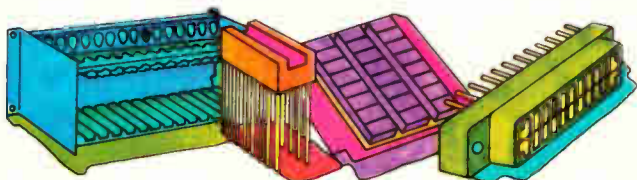

**Stanford Applied Engineering Inc.**

340 Martin Avenue, Santa Clara, California 95050 Telephone (408) 243-9200 — (714) 540-9256 — TWX 910-338-0132

Electronics / August 28, 1972

Circle 59 on reader service card 59



Companies

# ICL cultivates export market

British computer maker readies a new computer line, plans international sales campaign from a strong base at home and in Eastern Europe

by Michael Payne, London bureau manager

**Europe's No. 1 computer company** is trying harder. Britain's International Computers Ltd. is trying to develop a new line of computers and will try to sell the new machines around the world as successfully as it has sold its present series at home and in Eastern Europe.

For its push, ICL can count on strong British government backing—up to a point. The government has promised \$35 million over 18 months to help ICL get its new line on the market sometime within the next two years. The aid is the latest installment in research-and-development money the government has given the company during the past few years. The government aims to keep Britain strong in computer technology, but has made it clear that aid won't go on at that level forever.

ICL, of course, hopes the new line of machines will eventually boost its sales—last year they ran \$375 million—enough to raise an expectation that the company will be eventually free of need for support from the public purse. Otherwise, there's always the risk that a less-friendly future government might abandon ICL to foreign control.

Although the London-based company isn't revealing details about its new machines, it can be expected to offer some technical innovations. But software, in ICL planners' eyes, is even more important. John Pinkerton, responsible for performance evaluation at ICL, says that in developing the new system, software requirements have been put first, and hardware was developed to fit the software—not vice versa.

The new line of machines will have to be compatible with two mu-

tually incompatible series inherited when ICL was formed in 1968 by merging International Computers and Tabulators Ltd. (ICT) and the Computer division of English Electric Co. From ICT came the 1900 series, and from English Electric, the System 4. In insisting that the new series be compatible with its existing machines, ICL acknowledges a principle that most computer makers agree with: if an existing user can't buy a new model without starting again from scratch, then he might as well buy another-make machine. "It would be suicidal for us," says Pinkerton, "to change to a new machine that one lot of established customers couldn't use."

Pinkerton says the new series will have architecture different from either of its predecessors, and compatibility will be obtained by various bridging techniques, many of them quite well known. "We haven't allowed the past to condition the future" he says. "The 1900 series is near the limit of development, and can't go much further. Developing System 4 means following the same path as IBM into 370-

like systems, and we don't see much future for ourselves on that path."

If ICL is to compete with IBM and stay healthy, it must make its products different in some ways so that the company can offer some things that IBM doesn't offer. This difference provides specialist appeal for some buyers that helps sales.

One factor that has and will continue to help ICL is its history of reliable customer service. The company has kept most of the customers inherited from its immediate predecessors. Another plus is the pressure the British government exerts in encouraging domestic purchases of ICL machines.

But ICL hasn't had much of an impact in Western Europe because of IBM's stranglehold there. ICL's foothold in France, albeit tenuous, is mainly due to the fact that one of its distant predecessors, Power-Samas, had strong French connections. ICL has always concentrated on areas where it was able to develop some special advantage over U.S. competitors.

Nonetheless, Ralph Land, manager for Eastern Europe, maintains the company's performance in Rus-

**Testing.** Engineers at ICL's West Gorton plant check a 1906A central processor.





sia and the East Bloc proves that the British computer maker can compete with IBM, even when no favorable conditions are working for it. Says Land: "Many people think we've succeeded in Eastern European countries because the U.S. Government inhibited the sales efforts of our American competitors, or because of anti-American feeling in East Europe. I don't believe there's any substance to their reasons. We succeeded because we have a better marketing strategy for the area than anybody else." Land estimates that the Russians buy 60% of all computer imports from ICL, the Poles 60%, and the Czechs 30%.

**How to succeed.** Land says the key to ICL's strategy is that as soon as it makes a sale in an East European country, it establishes a permanent support office there with systems engineers, programmers, and instructors. On the other hand, people from IBM, Univac, and Honeywell commute from cities in West Europe. ICL has a permanent staff of about 40, mostly Britons, in Moscow. "The Russians are always aware of our presence" says Land, "and it's paid off." Because he made a good start, Land expects to maintain his sales momentum, now that competition is increasing. ICL has sold about 80 machines in Eastern Europe, to IBM's 60 or so, and ICL's systems average rather larger size.

Outside of Eastern Europe and some parts of the British Commonwealth, ICL does not yet have a significant export market. Geoffrey Cross, managing director of ICL and in charge of the day-to-day running of the company, is doing his best to change this situation. Cross came from Univac, where he was in charge of marketing and servicing in North and South America. He is convinced that ICL's prosperity depends on expanding its international operations.

Cross will most likely start in Western Europe, where ICL has made sales in France and Sweden, but few elsewhere. He does not rule out links with American and Japanese companies, if they will usefully expand the company's market. Even the present British Government has said it will allow foreign investment—if control of the company does not pass from Britain. □

# New Eastman 910<sup>®</sup> MHT holds when the heat is on

If you haven't been able to take advantage of cyanoacrylate adhesives because of a high temperature problem, try new Eastman 910<sup>®</sup> MHT adhesive. Bonds made with this adhesive have been found to withstand temperatures above 400°F. Tensile strengths of up to 5000 p.s.i. can be obtained at room temperature.

For further information, call: (615) 247-0411 or write: Eastman Chemical Products, Inc., Industrial Chemicals Division, Kingsport, Tennessee 37662



Circle 61 on reader service card

## Save Cost Enjoy Quality with TOKO INC.

Announcing a new cost saving plan on PCB assembly with transfermolded Dual-In-Line PULSE TRANSFORMERS and DELAY LINES by thick film approach.

Offering a wide range of custom-designed features which meet your requirements.

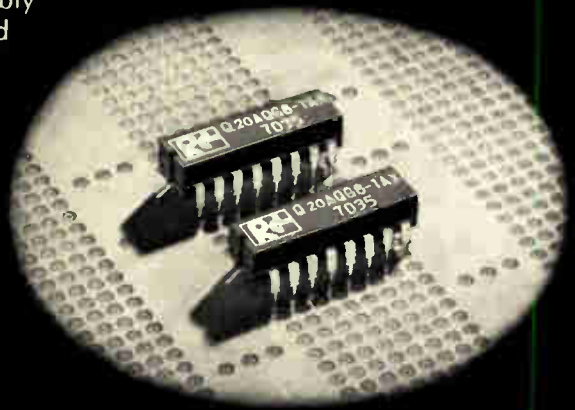

For further information, just call or write:



**TOKO, INC.**

Head Office: 1-17, 2-chome, Higashi Yukigaya, Ohta-ku, Tokyo, Japan

New York: ToKo New York, Inc.

350 Fifth Avenue, New York, N.Y. 10001 U.S.A. Tel: 565-3767

Los Angeles: Toko, Inc. Los Angeles Liaison Office

1830 West Olympic Blvd., Los Angeles, 90006 Cal. U.S.A. Tel: 380-0417

Düsseldorf: Toko Elektronik GmbH:

4 Düsseldorf, Lakronstrasse 77, W. Germany Tel: 0221-284211

# SEVENTY ACTIVE YEARS IN RADIO TELECOMMUNICATIONS

1901 . . . using kites and 500 feet of wire  
Guglielmo Marconi and his assistants,  
Kemp and Paget, receive the first  
transatlantic radio message. Faintly,  
but triumphantly, the three dots, 'S' in  
Morse Code, span three thousand miles  
breaking what was then the major  
communications barrier between  
continents.

1972 . . . seventy years later, Canadian  
Marconi Company has set the pace for  
breaking today's communications barriers  
using another form of code — pulse  
code modulation.

If you are in the business of  
communicating voice or data, find out  
how you can benefit from seventy years  
of telecommunications experience.

Write and ask us about our MCS 6900  
digital microwave communications system  
. . . **the better way to communicate.**

CANADIAN MARCONI COMPANY   
TELECOMMUNICATIONS DIVISION • 2442 TRENTON AVE., MONTREAL 301, P.Q., CANADA  
TEL.: (514) 343-3411, TELEX NO. 05-267563, TWX NO. 610-421-3564, CABLE: ARCON MONTREAL

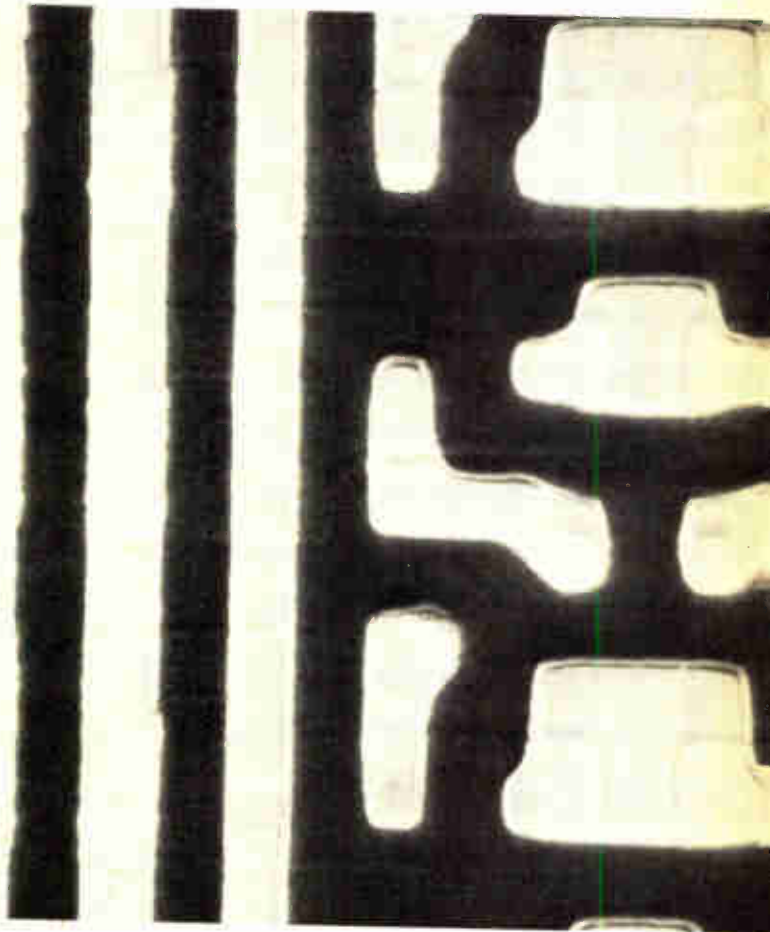
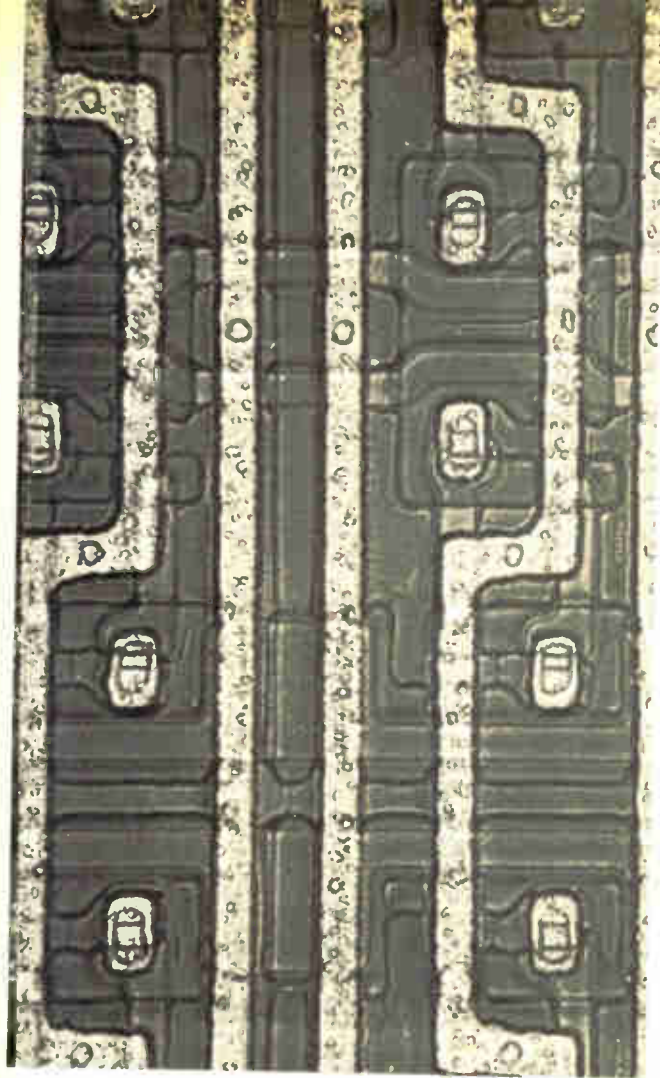

**The latest in memories.** Left: A Signetics ion-implanted n-channel RAM cell; right, Fairchild oxide-isolated bipolar RAM.

# Special Report: Semiconductor RAMs land computer mainframe jobs

Challenging cores in more and more applications, the new random-access memories proliferate as improved p-channel units vie with the successful 1103, n-channel devices come of age, and big bipolar RAMs arrive

by Lawrence Altman, *Solid State Editor*

□ When innovation coincides with demand, there's inevitably an explosion of activity. It's happening this year in semiconductor random-access memories.

Within the last 12 months, at least four circuit versions of the p-channel MOS dynamic random-access memory have emerged to threaten the dominance of the 1103 in medium-performance applications. In addition, the long-awaited n-channel RAMs have arrived—the high-speed 1,024-bit kind, the easy-to-use static kind, and the extra-dense 4,098-bit kind. Finally, more

than a half dozen new ways to build bipolar random-access memories have emerged from the laboratory, permitting the fabrication of arrays containing 1,024 bits and more on a single substrate and ushering in the age of the really fast big RAM. Such an outburst of new technology and new products has been absent from the semiconductor scene since the TTL boom of the 1960s.

What can the memory system designer make of all this "RAM-of-the-month" activity? Table I gives the competitive status of devices presently available in the



## SPECIAL REPORT

three RAM types, along with what are the probable limits to the various technologies.

The lines are clearly drawn. The standard p-MOS memories, because they're cheap and likely to get cheaper, will still be used for the bulk of semiconductor RAM applications, especially in the small mainframe, add-on, and cache situations or wherever moderate speed and power requirements can be traded off for low price.

But the large 4- to 8-kilobit n-RAM, as it begins falling to the same price-per-bit level as the p-RAM, will take over moderate-speed applications. Even today a 4,096-bit, n-channel memory could make an attractive alternate to the standard 1103-type p-RAM. Since it has the same speed plus four times the capacity, it would lower the system part count and interconnect costs at no loss in performance. Also its power per bit requirement is considerably lower.

Moreover, putting yet more pressure on the p-RAMs are the fast n-RAMs with the same bit density plus twice the speed. Surely the territory now controlled by the slower p-MOS technology will gradually diminish, till perhaps ultimately it may be edged out of the main memory field and be relegated largely to logic functions in calculators.

Meantime, an interesting fight is also shaping up between fast n-RAMs and bipolar big RAMs. Presently, fast n-RAMs and the big bipolar RAMs are at the same density level (1,024 bits on a chip), with big bipolar RAMs slightly ahead in speed and n-RAMs holding an edge in price, power dissipation, and availability. However, the big bipolar RAMs are likely to get bigger and faster and their propagation delay-power product smaller and

**1. The RAM—father of them all.** The 1103 from Intel started the stampede to semiconductor memories. It was the first time that more than 1,000 bits of read/write memory could be supplied on a single semiconductor chip in a low-cost MOS configuration.

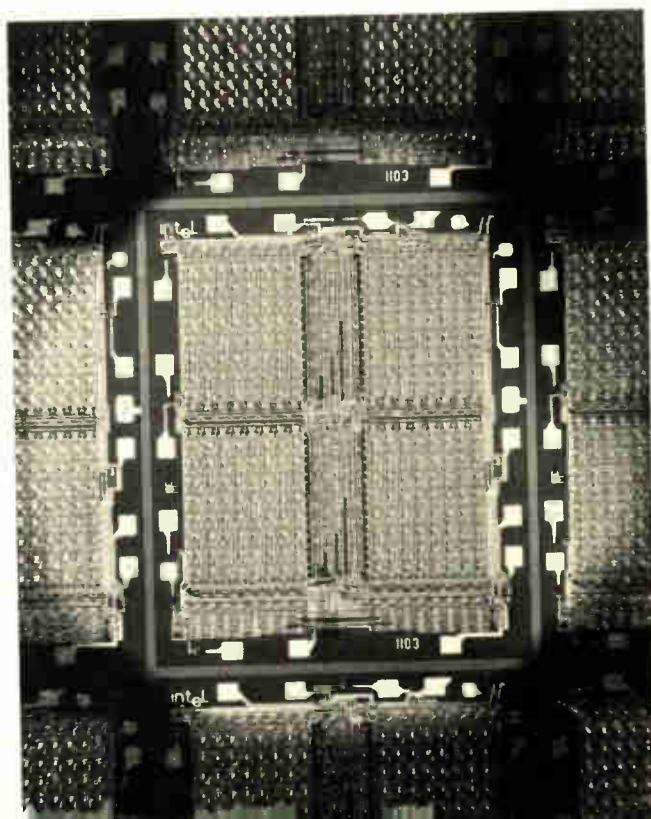

smaller—already it's about 2 picojoules. At the 4,000-bit-per-chip level, with access times in the 30-50-ns range, the bipolars would appear to be untouchable in performance. Add to this the fact that they are TTL-compatible, offering considerably more system flexibility. Indeed, once established in the market place, they could well become the principal mainframe technology.

### The 1103: world traveler

Nevertheless, standard p-channel MOS dynamic RAMs presently are in greater demand than all other RAMs put together. About 200,000 units are used per month, and more than a dozen semiconductor manufacturers are attempting to second-source the basic device—Intel's 1103 (Fig. 1). Introduced in late 1970, this memory has penetrated virtually every computer application area throughout the world.

The reason for its popularity is clear: it was the first chip to contain 1,024 bits of easily accessible memory. And it offered other inducements as well. The fact that all address circuitry is contained on the chip eliminates the external coding circuits required by core memories, as well as by the early semiconductor versions. Power dissipation is low—1 watt per chip during read/write operation and only 1 milliwatt per chip when not enabled (during the retention mode). The inputs are protected against static charge spikes, a constant threat in large-memory environments. The output configuration offers wired-OR capability, eliminating the need for additional transistors and OR circuits following the outputs of the device. Thus, adding on 1103 memories is a simple procedure because the system requires no additional supporting circuits. And the package is the low-cost, standard 18-pin dual in-line.

Since the 1103 is a dynamic memory, it must be refreshed. But the refresh period is short—only 2 milliseconds for 0°C to 70°C ambient—and all 1,024 bits can be refreshed in 32 read cycles.

The 1103 is organized as 32 rows of 32 cells each (Fig. 2). In operation, five address lines, A<sub>0</sub> through A<sub>4</sub>, are decoded to select one row of cells. When accessed, the

**2. Up the organization.** The 1103 organization contains all address circuitry and sense amplifiers. Organized in 32 rows of 32 cells each, it operates from five address lines, A<sub>0</sub> through A<sub>4</sub>, which are decoded to select the row of cells containing the bit to be accessed.

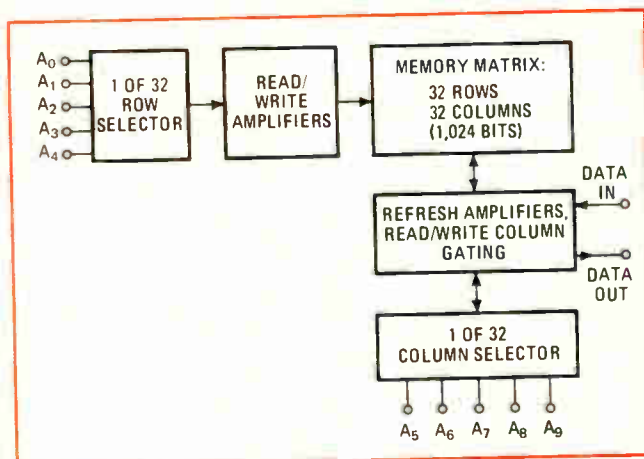

contents of this row are transferred to a row of 32 refresh amplifiers. In the course of one memory cycle, therefore, whether read or write, the data is regenerated and written back into the selected row of cells.

Address bits  $A_5$  through  $A_9$  are decoded to select one refresh amplifier for communication with the data input and output terminals. In this process, data output is sensed as a current. Activation of the write clock effectively disconnects the refresh amplifier outputs from the write data lines, and permits the signal on the data-input line to override the signal at the output of the selected refresh amplifier.

### Time to remember

Figure 3 shows the basic timing of the 1103 memory cycle. The timing values specified for each of the input signals are the ones guaranteed to permit operation over the specified operating temperature range. The cycle timing is established by the three clock signals: precharge, chip enable, and write.

Initially, prior to execution of a memory cycle, all clocks are at their high state, at a voltage approximately equal to the clock supply voltage  $V_{SS}$ . To begin a cycle, precharge is first brought low, to approximately  $V_{DD}$ . This operation activates the row and column decoders, and also charges all read- and write-data lines negatively—that is, to the equivalent of a logic “high” state for p-channel MOS. (In the discussion which follows, clocks, etc., are considered “on” at the  $V_{DD}$  level and “off” at the  $V_{SS}$  level, while “high” and “low” refer to the magnitude of changes with respect to the MOS substrates.)

A key feature of the timing scheme is the fact that the decoder circuitry is rather faster than the line-charging circuitry, so addresses need not be stable until a little after precharge is applied. The system designer may take advantage of this characteristic in several ways, perhaps, for example, to utilize a slower and less expensive address driver. Of course, addresses may be provided before precharge is turned on.

After precharge and addresses have been present long enough for the data lines to charge and decoders to

**3. Careful timing.** Operation of the 1103 involves three timing signals: precharge, chip-enable, and write. Because decode is faster than line charge, address need not be stable until after precharge. But there is a critical precharge and chip-enable overlap time.

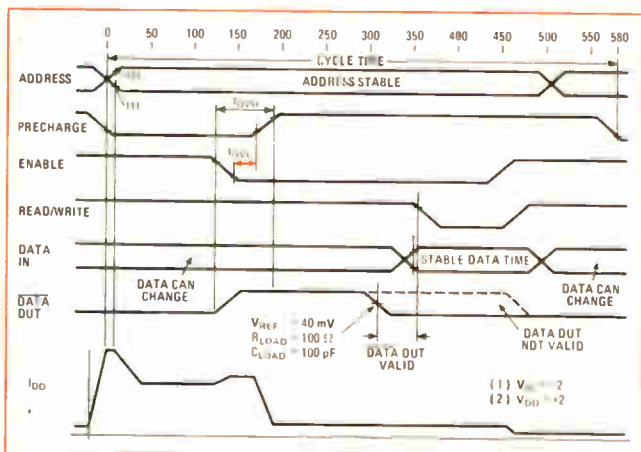

stabilize, the chip-enable clock may be turned on (dropped to its low state). At this point, the desired read-select line is activated, and the circuits for charging the read-data line are disabled.

Next, the read-data lines begin to discharge selectively, with the signals on them approaching values corresponding to the complements of the data stored in the selected row of cells. During the selective discharge, the precharge signal is turned off (raised high to  $V_{SS}$ ). This action removes the charging signal on the write-data lines, and closes a path so that these lines may be selectively discharged. The write-select line corresponding to the chosen read-select line is also activated, so that the cell contents are restored.

It should be pointed out that the signal level on the

**4. Better timing.** The 6002, pioneered by AMS and second-sourced by TI and Motorola, has a straightforward timing cycle (b) that needs no overlapping. Built with a four-transistor cell (a), the p-channel metal-gate RAM is gaining in popularity.

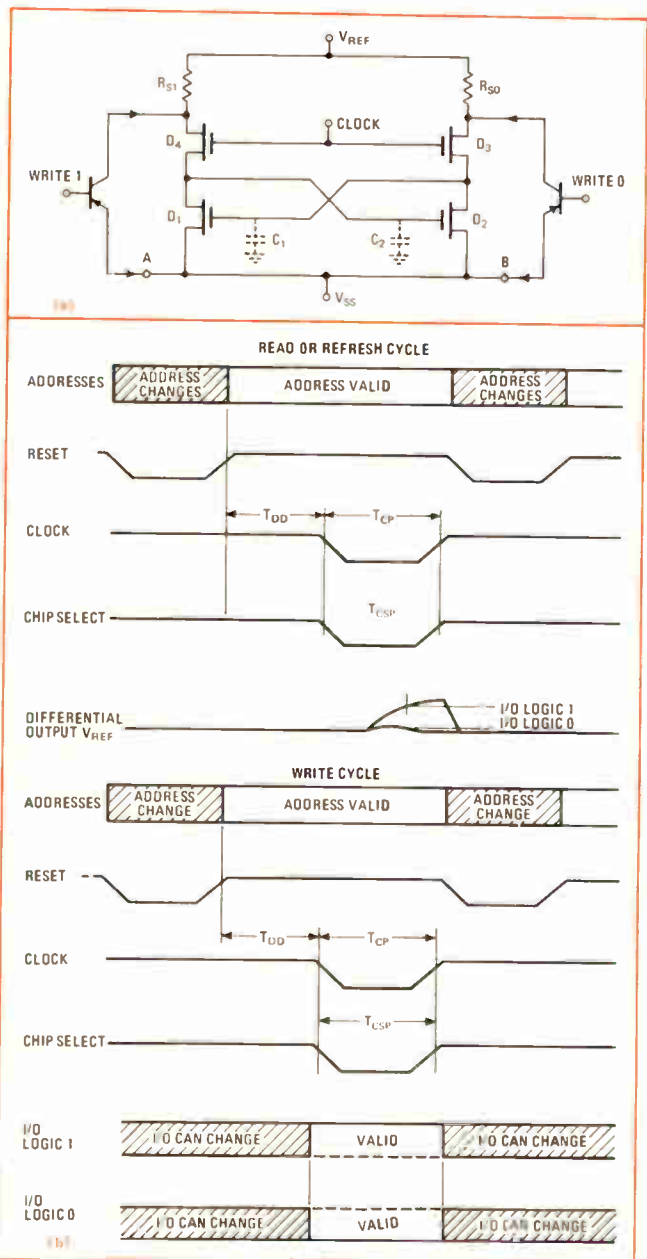



## SPECIAL REPORT

write-data line is a function of the overlap time  $t_{ovl}$  between precharge and chip enable. If this overlap is too short, the read-data lines will not have discharged sufficiently when the discharge path from the refresh amplifiers to the write-data lines is closed. As a result, high (negative) levels written into the cells may be reduced.

If the overlap time is too long, however, weak lows within the cells may result in some discharge of the read lines before closure of the write backpath. Consequently, cells with weak lows have higher levels (that is, even weaker lows) written back into them, eventually resulting in lows changing to highs. Worse still, this problem is aggravated by the small but unavoidable capacitance coupling that occurs between the data and select lines and the cell storage capacitor.

Clearly the critical nature of the 1103's overlap timing presented system designers with some problems. Since the moving window between precharge and chip-enable (shown as  $t_{ovl}$  in Fig. 3) is only about 30 nanoseconds, some carefully designed timing circuits are required with the 1103 to insure fast rise and fall clock times and accurate sequencing. Indeed, this timing requirement dampened (and to some extent still dampens) the enthusiasm of some computer manufacturers for the 1103.

### Enter the 6002

The first device to become popular that does not suffer from the timing problems of the 1103 was the American Microsystems Inc. 6002, a 1,024-bit dynamic random-access memory organized in 32 rows by 32 columns and based on a four-transistor cell that greatly simplifies the timing operation. (Actually the 6002 and an earlier version, the 6001, were developed and on the market before the 1103, but for one reason or another never caught on.)

Figure 4b shows the timing diagram and voltage waveforms of the 6002, and Table 2 compares the timing parameters of the 6002 and the 1103. Note that the critical overlap time  $t_{ovl}$  has been eliminated for the 6002. Because its cell has four transistors, writing data is simply executed by a pair of switches like the write transistors attached at A and B in Fig. 4a. If the write-one transistor is turned on, it will force A to close to  $V_{SS}$ . This cuts off any conduction which may have been occurring in  $Q_2$ . Simultaneously, the capacitor  $C_1$  will be charged, and  $Q_1$  will begin to conduct. When the cell is selected for a subsequent read operation, current will exist in the  $Q_1$ ,  $Q_4$ , and  $R_{S1}$  side of the cell, and a differential amplifier between A and B would sense the voltage difference and detect the presence of a logic 1.

This simplified cell operation, when the cells are put into a 1,024-bit array, turns into a greatly simplified timing scheme. For now the reset input performs two functions in its low state: it precharges the device, and it turns off all the address inverters. On the 6002, the address inputs are the drain of an MOS device, and because they are off during the reset period, input capacitances are very low. This means that no overlap times are needed, because the address inputs can be changed

before reset goes low, provided that the previous cycle is complete.

After the reset input is taken high, a period is required for the row and column decoders to function— $t_{DD}$  in the timing diagrams. The clock and chip-select periods occur next, with the clock input gating the row decoder while the chip-select input enables the column decoders. Information from the selected cell is then transferred to the input/output lines, which are also gated by the chip-select input. After the output data has been sensed, the clock and chip-select are returned to the positive state, and the device is ready for the next cycle.

Besides timing simplicity, the 6002 has another fea-

## Dynamic memory cells; three designs

Basic to the high bit densities of MOS memory chips are memory cell designs that exploit the near-zero input current requirements of an MOS transistor. Such a cell must be periodically accessed to replenish it because the charge it stores decays from junction leakage associated with the access and sense devices.

This refreshing procedure varies with different cell designs, but in most cases occurs approximately every 2 milliseconds at 70°C. At lower temperatures, refresh cycles may not be required for hundreds of milliseconds.

There are three approaches to dynamic memory cell design. The first (shown in a) is a one-transistor cell. A single capacitor is charged to a logic 1 or a 0 level by the column when it is accessed during a write cycle (row-select enabled). During a read cycle, the charge on the capacitor modifies the voltage on the floating column line. This voltage is then sensed by an internal amplifier.

To allow the state of the cell to be sensed externally, the internal amplifier must provide significant power gain. The magnitude of this gain varies directly with the size of the capacitor, which, however, ought to be minimized if high bit densities are to be achieved. The optimum capacitance, in fact, turns out to be smaller than the parasitic capacitance of the column line, so that destructive readout occurs and the cell contents must be rewritten after every read cycle.

To do this, additional peripheral logic and a clock phase have to be added to the memory chip, making the timing requirements more complex at the system level. Moreover, the column parasitics may be large enough to necessitate redundant decoding and a division of the column lines to reduce the number of cells sharing the line. In short, this type of cell does not use the inherent voltage gain capability of an active device to the best advantage, nor does it lend itself to a simplified chip interface.

A three-transistor cell can be designed (b) that does employ the active voltage gain within the cell. Although this cell has more components and access lines than the single-transistor cell, it is about the same size because the storage capacitor can be quite small, thanks to the power gain provided by the active device ( $Q_1$ ). This is the type of cell used in 1103 memory designs.

Information is stored as charge on a capacitor—in this case, the capacitance associated with the gate of the rel-



ture not found on the 1103; because the row-decode output is tied to the clock input of the cell, all 32 cells are in a stable state any time a row is selected. This selection will refresh those 32 cells, regardless of the state of the chip-select input.

Finally, and again because the 6002's cells all have four transistors instead of three, the device can be charged and discharged faster than the 1103, and therefore can be accessed, and the array cycled, more quickly. From Table 3, which gives the key parameter comparison, the access and cycle times of the 6002 are 150 nanoseconds and 290 ns, respectively, compared to 300 ns and 580 ns for the 1103. Average power dissipation is also lower: 180 mW operating for the 6002, 280

mW operating for the 1103; and 2 mW standby for the 6002, against 5 mW for the 1103.

### All is not perfect

However, the 6002 does suffer some drawbacks. Most serious, perhaps, is that, until recently, because it was never very well known, it was not designed into very many systems. Also, because refresh is an external operation, an additional power supply is needed by the 6002, over and above the 1103's requirements. Moreover, the 6002 requires higher input voltages  $V_{SS}$  (20 volts, compared to 15 v), which means a bigger supply.

Next, where the 1103 has a single-ended output, the 6002's is differential. This complicates the tradeoff be-

atively large active device ( $Q_1$ ). To access the cell, columns B and D are first precharged to some negative potential near  $V_{DD}$  at the beginning of a cycle. The read-select line is then enabled, and transmission device  $Q_2$  can conduct. If the voltage on the gate of  $Q_1$  exceeds device threshold,  $Q_1$  conducts and column B discharges to a potential near  $V_{SS}$ . If the potential on the gate of  $Q_1$  (charge on C) is not sufficient to turn  $Q_1$  on, column B remains precharged at the negative potential. The condition of column B is then sensed by an on-chip amplifier.

To refresh this type of cell, information on column B must be inverted and rewritten into the cell. This is achieved by an on-chip "refresh" or "column" amplifier which discharges column D if column B remains precharged. Or if B is discharged, D remains precharged. The write-select line is then enabled, and the gate of  $Q_1$  assumes a potential near that of column D, refreshing the cell. For a write cycle, new information is placed on column D and stored in the cell.

Precise timing is required to perform this operation. In the 1103, the potential of column D is critically related to the overlap time between the precharge and chip-enable controls. The information stored in the cell can be adversely affected if that overlap time violates a minimum or maximum limit.

Figure c illustrates the four-transistor dynamic-memory cell design. The four active devices are interconnected to form a latch similar to the flip-flop circuits used in static memories. The cell is dynamic, however, since no-load devices (resistors) are used.

Information is stored on the gate capacitances of  $Q_1$  and  $Q_2$ . Because two devices are used, both the information and its complement are available to the internal sensing logic. Although the cell area has been increased and another interconnection is required, the amount of on-chip peripheral circuitry is reduced.

This design requires neither special refresh amplifiers nor the timing constraints associated with them. The cell access is regenerative, and the active gain capabilities of the MOS devices are used to full advantage. In addition, the potential on the gate of the conducting device in each cell need not exceed threshold voltage, since accessing the cell refreshes the node charged to the higher potential. This increases the internal safety margin.

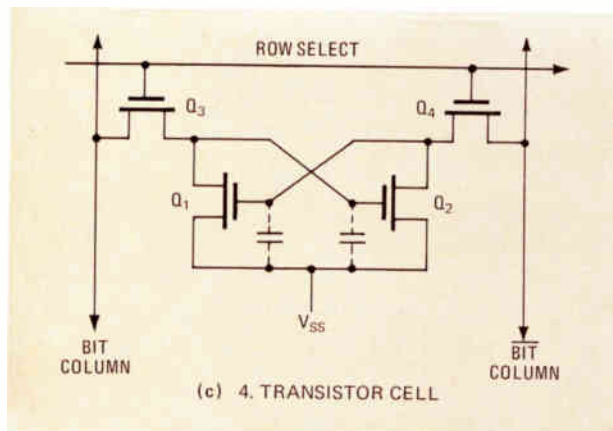
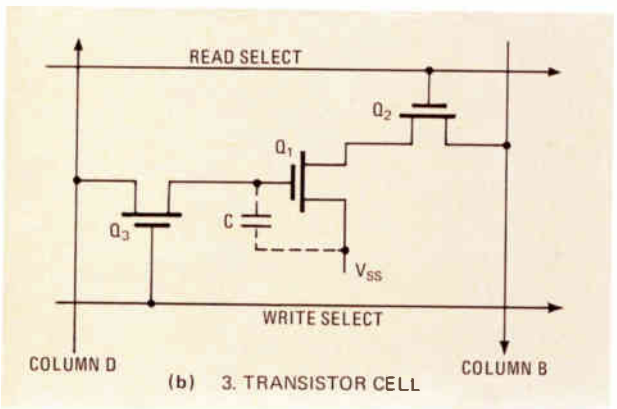
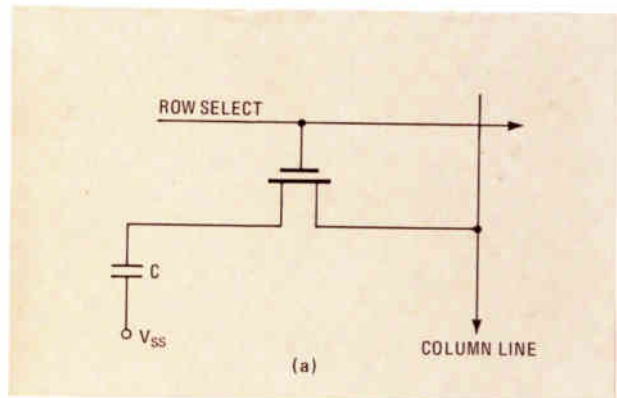

## SPECIAL REPORT

cause, although the differential output offers better noise immunity, it also yields lower output current swings. In fact, the 6002's output current is a mere 100 microamperes, as against the 1103's 700  $\mu\text{A}$ , so that a more sensitive and more expensive sense amplifier is required.

But perhaps the biggest obstacle to the general acceptance of the 6002-type device is its 22-pin package. This larger package size means it occupies more board space than the 1103 does and is not pin-compatible with that device. A way around the difficulty is to tie together the clock and chip-select, so that the 6002 can fit into a standard 18-pin DIP and no longer needs the extra power supply. But some flexibility is lost with this arrangement because now the memory, like the 1103, must be enabled during refresh. Also the power dissipation rises to 1103 levels, and in fact, very little performance advantage remains over the 1103.

Nonetheless, TI, which is second-sourcing the 6002 along with Motorola, is planning just such an 18-pin version in its 4603, and AMS is expected to follow suit. With this modified 6002, since performance is relaxed to standard 1103 levels, price will be the major factor in the competition for customers. At present, the 1103 types now cost generally 25% to 50% less in big buys than the 6002 types.

### The beneficiary, the 3534

In designing one of the latest 1,024-bit MOS RAMs, Fairchild had the advantage of everyone's experience with the 1103 and the 6002, and was able to incorporate major improvements. Unlike the 6002, the Fairchild 3534 is pin-for-pin compatible with the 1103, costs about the same, and can be operated with the identical timing and interface requirements. But it also has another mode of operation which significantly reduces system cost and/or increases system performance in comparison with equivalent system.

The improvement results from circuit design. Precharge and chip-enable overlap requirements are eliminated, so that timing, control, and interface circuitry are simplified, and access and cycle times are shorter.

Output data is referenced to the negative-going edge of chip-enable, not to the positive-going edge of precharge. This permits faster access times, since precharge clock skew is eliminated and level-shifter rise times are

not a factor. Read and write cycle times are equal (480 ns maximum), so that only one timing chain is required for optimum read and write cycle times. Moreover, since read/write is specified as a level, not as a pulse, the timing circuitry and decoder logic associated with the write pulse are not required, resulting in fewer components and faster write cycles. Lastly, standby current is reduced from 4 milliamperes to 100  $\mu\text{A}$ , so that system power is also significantly less.

### Good timing, too.

In addition to the skew of the precharge and chip-enable controls in the 1103, caused by the uncertainty in switching times associated with level-shifting circuits, skew is also associated with the circuitry that generates the discrete timing intervals necessary for device operation. From the system viewpoint, it is very desirable to minimize critical timing intervals and dependence on level-shifter switching characteristics.

The 3534 four-transistor cell design, together with the absence of refresh amplifiers, frees the system designer from many of the 1103-type timing constraints as shown in the timing diagram of Fig. 5.

The 3534 no longer requires the precharge and chip-enable overlap. All it needs is for the precharge pulse to stay low for a minimum of 150 ns and for a delay of at least 125 ns to occur from the start of precharge to the start of chip-enable. The data-out is valid for 165 ns after the chip-enable goes low, but is independent of precharge. There are no other restrictions on the precharge pulse. It can go high immediately, it can stay low throughout the entire cycle, or it can remain low for successive cycles.

Again, the 1103 precharge pulse not only must stay low for a precise precharge interval, but its transition from low to high must occur within a time interval which has a minimum as well as a maximum limit. As a result, the designer must stay within the very tight boundaries of these maximum and minimum values. All control circuitry must be extraordinarily precise, and system costs rise sharply.

With the 3534, the only relationship between precharge and chip-enable is that their leading (negative-going) edges must be separated by the precharge time—here, 125 ns. The overlap requirements having been removed, precharge may return to the high level any time after a minimum of 150 ns. The implication is that precharge can remain low for extended periods, allowing many accesses to the device in rapid succession—a

**5. Unrestricted.** With Fairchild's 1,024-bit 3534 MOS RAM (left), operation only requires that the precharge pulse stay low for a minimum of 150 ns and for a minimum delay of 125 ns from the start of precharge to the start of chip-enable. 1103 timing (right) is shown for comparison.

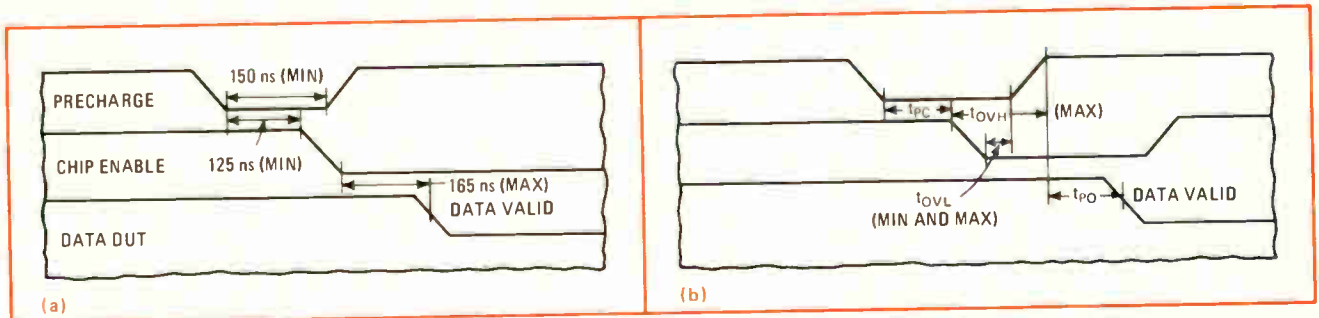



mode of operation that can be useful for transferring data blocks, though at a cost of increased power dissipation.

The elimination of overlap constraints provides another important system benefit, illustrated by the relationship between the leading edge of chip-enable and valid data-out. Data is available for a maximum of 165 ns after chip-enable on the 3534, and is not referenced to the trailing or positive-going edge of precharge, as in the 1103. At the system level, this eliminates the clock skew associated with the rising edge of precharge, providing faster access and cycle times in a worst-case design.

In addition to the timing and speed improvements possible with the 3534, significant power savings can be realized in a system, since the device's standby power is less than 2 mW. Consider a 16-kiloword-by-36-bit memory system organized on 4-by-18 basic storage boards. Also assume that, during a memory cycle, only two of the eight storage boards are selected and only 18 memory devices per board dissipate maximum power, because precharge, chip-enable and read/write are decoded. In this situation, 540 of the 576 memory devices will always be in the standby mode.

Calculated out, the worst-case power dissipated by

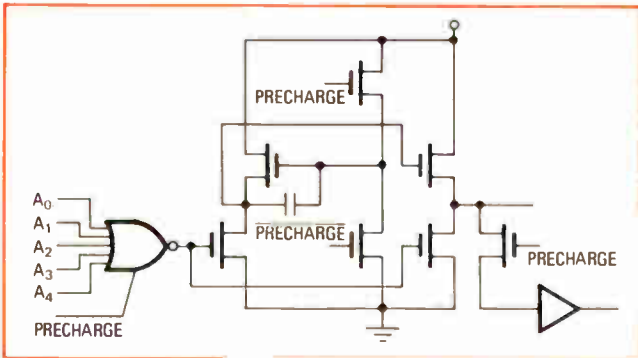

**6. Letting bipolar in.** National's new 1,024-bit 5260 RAM has Tri-State TTL-compatible outputs. Its input stage accepts bipolar signals directly on all lines except precharge and read/write. Level translators are eliminated at inputs.

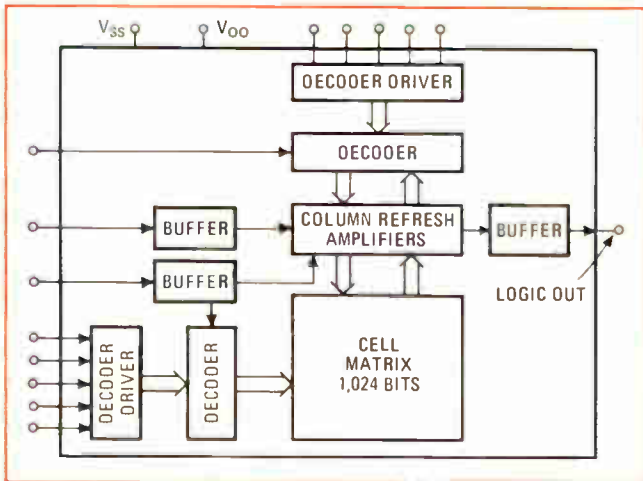

**7. Implant boost.** Mostek's 1,024-bit 4006 RAM, shown here in block diagram, has the ability to perform all internal decoding and sensing statically. Precharging is eliminated, and control and addressing are simplified. Ion implanting boosts RAM performance.

the memory devices in a 3534 system is approximately three times lower than with 1103 type devices. The system implications of this power differential are clear: they include lower-cost power supplies, lower operating temperatures, higher reliability, and minimum cooling requirements.

The question is how much will these new p-RAMs crowd the 1103. As attractive as they are, it is only fair to state that the original 1103, introduced by Intel two years ago, is functioning successfully in virtually every computer application. The requirement for precision in 1103 timing circuits has long since been dealt with by the system designer, and indeed, it was the success of the standard 1103 that prompted the other semiconductor manufacturers to develop their own versions of the device. They had the advantage of hindsight: Intel did not.

Table 4 shows all the 1,024-bit dynamic random-access memory types currently on the market. Besides the 1103, Intel makes a 1103-1 for use primarily where greater speed (150 ns) is worth the tradeoffs of higher power dissipation (up to 500 mW) and higher price (20% more) than the standard 1103.

Two 1,024-bit p-MOS RAMs recently introduced—Mostek's MK4006 and National's MM5260—are unlike most other p-MOS devices in being at least partially TTL-compatible. They do not need buffer level-shifting circuitry to interface with this family of bipolar computer logic, but they reach this goal along two different routes.

### The silicon gate and TTL

In the National MM5260 device, which is a fully decoded dynamic RAM, silicon-gate low-threshold technology is used to achieve the bipolar compatibility on

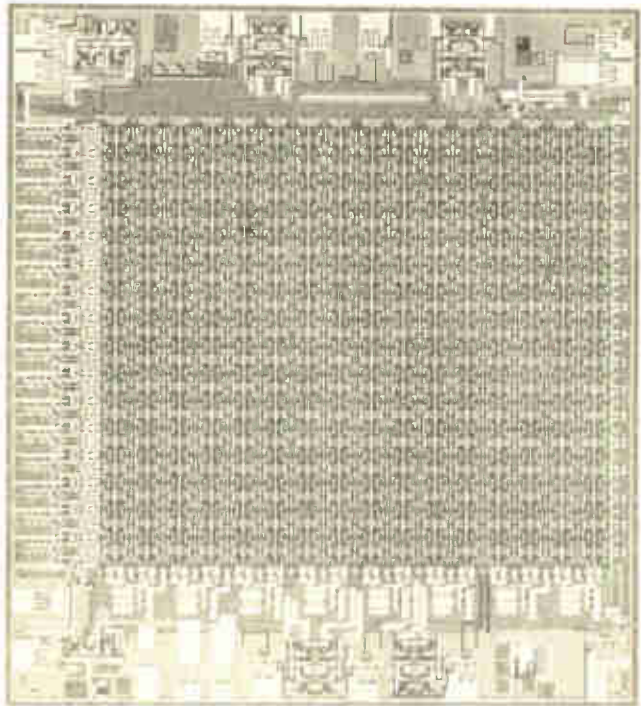

**8. It's fast—it's n-MOS.** The fastest MOS RAMs are made with n channels because electrons propagate faster than holes. This 1,024-bit n-channel RAM from Electronic Arrays (EA1500) has an access time of only 85 ns—the fastest MOS RAM available today.



## SPECIAL REPORT

all input/output lines except the precharge and read/write. In addition, a three-state output allows wired-OR capability and common input/output data busing.

Internally, the design of the MM5260 is fairly standard, with the 1,024 storage cells in a 32-by-32 array. However, all the data and address inputs sense bipolar data levels—5 v—and data is read out at the original data levels. This eliminates external level translators at inputs and sense amplifiers at outputs.

The common I/O terminal on the MM5260 is made possible by the structure shown in Fig. 6. The I/O gating and sensing elements are National's proprietary Tri-State MOS scheme. As the name implies, each element has three operating states. Two are the bipolar-compatible logic 1 and 0 states, while the third is a high-impedance state that disables the element because only a small leakage current flows at no definable logic level.

This third state prevents data transfer, allows one element to look into the other, and permits outputs of several packages to be bus-connected with no significant change in memory cycle time. One pin serves for both input and output because the read output buffer is in the third state when write is enabled, and vice versa. When these outputs are bus-connected, read speed is high because the disabled elements on the bus load the enabled outputs very lightly.

In addition, the National device depends on only two standard supplies (+5 v and -12 v) instead of three high-level and non-standard supplies (+20 v, +16 v

and +5 v). Possibly an additional negative supply (-5 v) would be required if a high-speed sense amp is used.

The MM5260 is easily expandable in a memory system. Having 10 address inputs, it is effectively a memory of 1,024 one-bit words. To add to the number of bits per word merely requires parallel access of, say, nine, devices for 1,024 nine-bit words. A chip-select input, enabled by decoding additional address bits, allows expansion of word capacity.

### Ion implants and TTL

Mostek's way of making its p-MOS RAM compatible with bipolar inputs is to use an ion-implanting process during some of the critical doping stages of cell fabrication. With implanted transistors, better control of the doping levels is possible, and this yields more stable operation from lower TTL/DTL thresholds than is attainable with conventional diffused doping.

The implanting process also allows both enhancement (normally off) and depletion (normally on) MOS transistor to be fabricated on the same MK4006 chip, so that conventional MOS load resistors can be replaced with constant-current depletion transistors. These current loads give the device a faster read cycle time, along with lower standby power, than are characteristic of most other RAMs (see Table 4).

The block diagram of the memory is shown in Fig. 7. A feature of the MK4006 useful to a systems designer is the memory's ability to perform all internal decoding and sensing in a static manner. Here precharging or clocking normally associated with dynamic memories is eliminated, and a user may treat the control and addressing as he would a static memory.

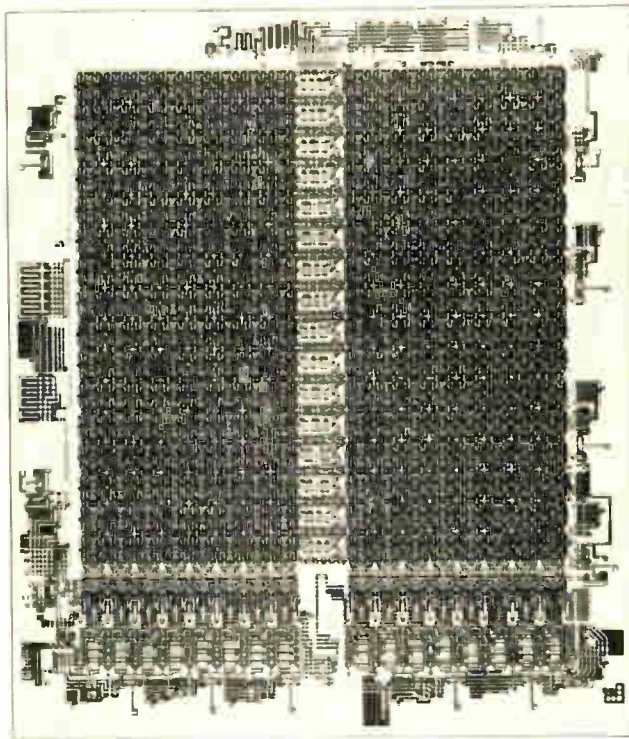

**9. Getting static.** Intel's 2102 n-channel RAM is completely static, requiring no refresh. TTL-compatible in all inputs, it operates off a single 5-volt supply. Built with low-threshold silicon-gate process, it is an early example of the easy-to-use n-RAM variety.

### Enter n-channel

All the MOS dynamic RAMs discussed so far have been p-channel devices with moderate performance. Table 4, however, lists two other devices, both n-channel dynamic RAMs. These n-MOS memories, Electronic Arrays' 1500/1501 and Fujitsu's MB8201, each have considerably faster access times than their p-channel equivalents. It is this boost in access time, with a corresponding drop in standby power dissipation, that is destined to make n-channel RAMs so formidable a competitor.

In general, there are three ways to take advantage of

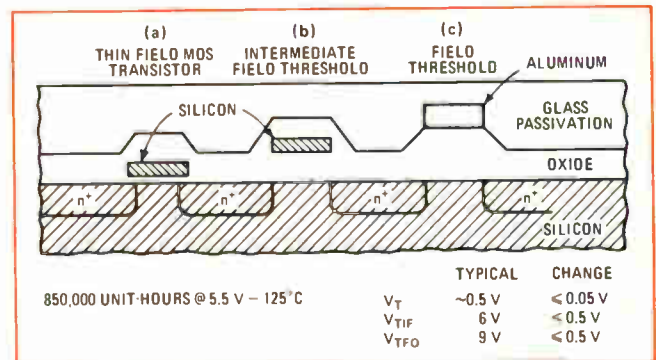

**10. Reliable n-channel.** Reliability in n-channel fabrication comes three ways: region (a) is protected by glass passivation, and (b) and (c) are protected from external contamination by the same process that protects the reliable 1103. Intel developed this Si-gate process.

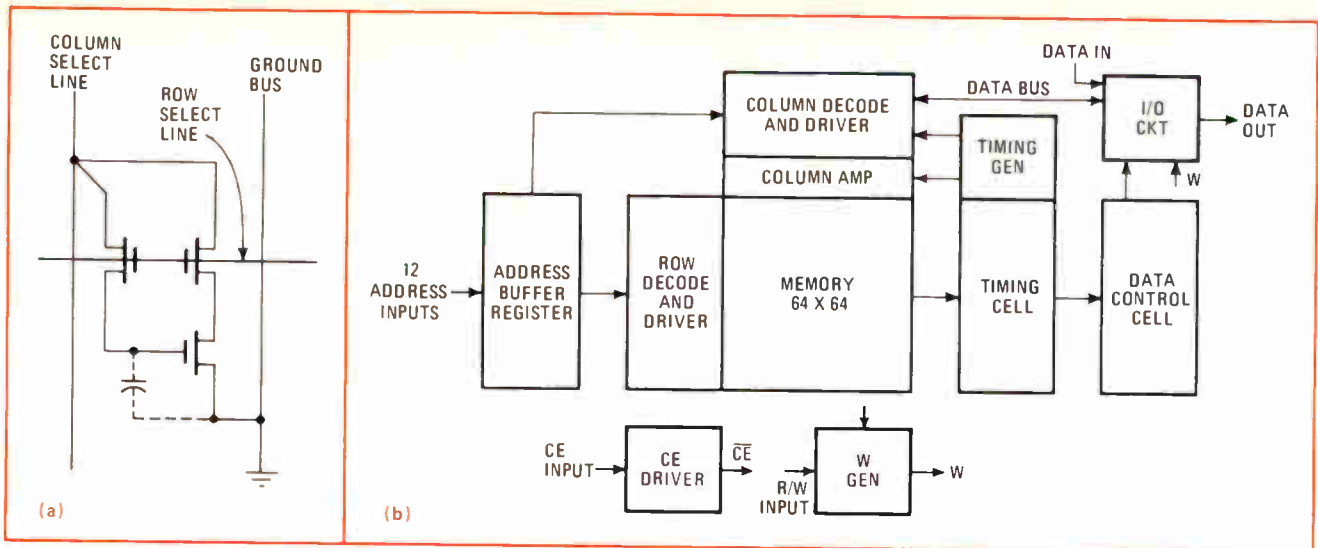

11. The big RAM. Applying a silicon-gate process to an n-channel process yields 4,096-bit RAM. Designed by Intel, it is arranged in a 4,096-words-by-one-bit configuration (b). It benefits from three-line cell design (a). Making its debut shortly, RAM will be largest to date.

the higher performance of n-MOS structures (Table 5). One is to go all out for speed—50 to 80 ns—and settle for just moderate density of 1- to 2-kilobits and moderate power dissipation of 400 to 600 mW, as is done in the Electronic Arrays and Fujitsu devices. The second is to go all out for simplicity of use—static design for only one TTL power supply—and make do with a 300-ns access time and, again, moderate 1- to 2-kilobit density. The third is to put the emphasis on high density and low cost, with moderate speed, moderate power dissipation and a normal three-level power supply requirement: an instance is Intel's soon-to-be-announced 4,096-bit dynamic RAM.

Put more briefly, the new n-channel technology offers either a faster, larger n-MOS device than p-MOS does, or larger, cheaper n-MOS RAM with the same speed and power dissipation as a p-MOS unit, or an easier-to-use one with the same performance.

N-channel devices became practical, once it became possible to apply silicon-gate technology to them. The better device parameters are directly due to the greater carrier mobility, electrical characteristics, and device geometry associated with the silicon-gate n-channel process. Because n carriers have higher mobility than p carriers, n-channel devices are from two to four times

faster, depending on clock voltage. And because of reduced parasitic conduction, the spacing between memory elements, line widths, and contact holes can be made smaller, so that memory elements also become smaller and can be placed closer together—typically 0.2-mil widths and spacings for n-MOS, as against 0.6 mil for p-MOS.

### Fast access

Electronic Arrays' 1,024-bit dynamic RAM, the 1500 (Fig. 8), is an example of the speed available with n-channel processing. Its 85-ns access time—two to four times faster than p-RAMs—makes it the fastest 1-kilobit MOS RAM in production. Moreover, though the device has an external refresh option, accomplished in the usual manner with a single pulse every 2 milliseconds, it can automatically refresh itself during each operation cycle. This unique feature eliminates the need for refresh address circuitry, creating a system saving.

Because all 1,024 storage cells are simultaneously refreshed by any write pulse, one write pulse bussed to all RAMs in the system will refresh the entire system. (In contrast, p-channel RAMs require 32 pulses addressed to columns in the storage array). And because now a write pulse can be applied every system cycle, automatic refresh also eliminates periodic memory busy intervals. During write cycles, RAMs in the memory-board matrix that are not enabled are refreshed without being written into. During read cycles, the write line is pulsed after chip enable, thus never interrupting the normal memory cycle.

In active operation, the 1500 dissipates only 160 mW—35% to 40% of p-channel RAM dissipation. In addition, it can be logically brought to standby between accesses by bringing all inputs to logic 0. This reduces standby power dissipation to 35 mW. Conventional pre-charge is not used to bring the RAM out of standby and into active operation. Any address input to a memory module will update the standby condition and the 1500 then turns on in several nanoseconds.

Finally, as already mentioned, n-channel RAMs, such as the 1500, interface more easily with bipolar logic

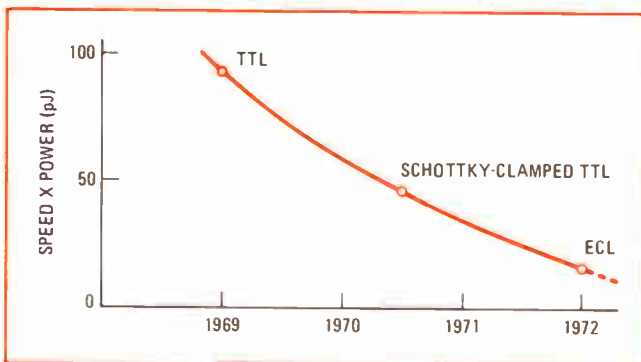

12. As time goes by. The product of delay and power continues downward. Bipolar RAMs use the ECL configuration because it offers the lowest product. Access times of these 1,024-bit devices range from 30 to 60 ns. And higher bit densities are in the offing.



## SPECIAL REPORT

than do p-channel memories. The n-channel silicon-gate process provides positive-logic operation on standard +15-v and -15-v supplies.

### It's compatible

This compatibility with existing bipolar logic, was the dominant aim of Intel's design for its new n-channel 1,024-bit RAM, the 2102, which is static and therefore does not need refreshing. The company's low-threshold silicon-gate process enables the 2102 (Fig. 9) to operate off a single +5-v supply, so that it is TTL-compatible in all respects—inputs, outputs, clock lines, and power supply. Of course, since static RAMs are two to three times slower than their dynamic counterparts, the device will be useful mostly in peripheral systems, where speed is not needed. However, coupled to the new high-speed n-channel shift registers now becoming available (for example, Intel's 2-megahertz 2401), it gives the peripheral system designer a way to match the low power requirements of the RAMs with the higher speed of the shift registers.

The low-voltage n-channel silicon-gate process also affects the size of the chip layout, which is a function of the voltages applied to the various junctions. Since the 2201 requires only a +5-v supply, and since the internal nodes are at even lower voltages, diffusions can be placed close together (0.4 mil) and channels may be short (0.25 mil). Indeed, tighter and smaller layouts can be achieved without tight alignment tolerances, and such a high packing density permits larger arrays at a lower cost per bit.

Table 6 lists the area savings for the 2201 n-RAM compared to p-RAMs. The n-channel array needs a memory cell less than half the size of the one in a comparable p-channel device cell, enabling a chip that could handle only 256 bits as a p-channel RAM to accommodate 1,024 bits as an n-channel RAM.

A third advantage of the low-voltage technology is the reduction of parasitic device interactions, which are

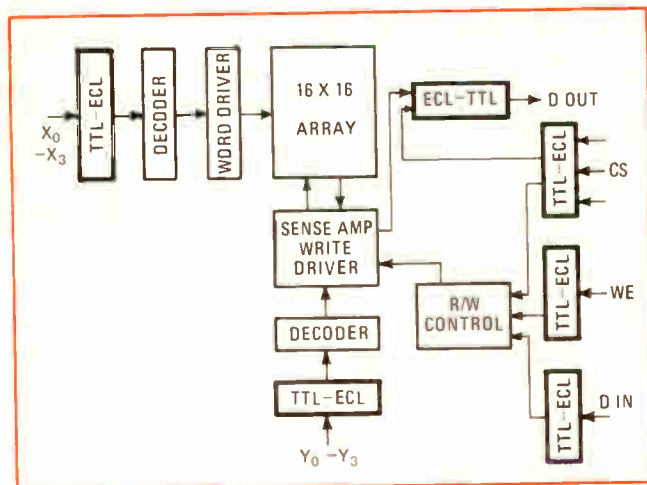

**13. Convertible.** To make a TTL RAM with ECL cells requires a TTL-ECL converter at the inputs and outputs. But since input and output buffers are needed anyway, negligible extra space and power is used. In straight ECL arrays, buffers replace converters.

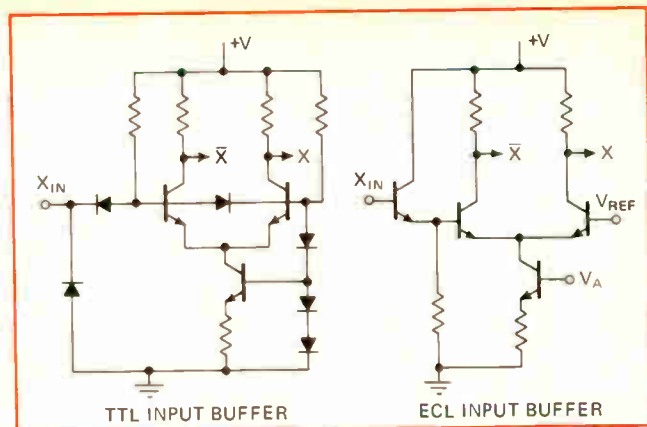

**14. The buffer.** These high-speed input buffer circuits are put on TTL and ECL memory chips to interface with outside world. These buffers would be located near the bonding pads. The TTL circuit includes the converter circuit.

caused by interconnection levels that have higher threshold voltages than the voltages used for the operation of the circuit. The undesirable results were both large leakage paths and high capacitance caused by field inversion—problems that needed solving before high-density n-channel devices could be implemented.

### The constant type

In general, the reliability of n-channel silicon-gate technology is dependent on the stability of the threshold voltages of the MOS transistors and the use of two levels of interconnects in the array. In addition, the stability of dynamic storage circuits will be determined by change in junction leakage, since this leakage determines the retention time of the memory cell.

## The 2,048-bit p-RAM debate

Stirred by a request from Honeywell Information Systems for a 2,048-bit RAM, semiconductor manufacturers two years ago began exploring the possibility of doubling the number of bits on a chip with conventional p-channel processing. The results, available now or due shortly, are standard products from AMS, Signetics, National, Motorola, TI, General Instruments, and probably several others.

The 2,048-bit p-RAM has its points. It is completely TTL-compatible, fully decoded, and accessible in less than 300 ns while cycling in less than 600 ns. Its timing is simple—there's no overlapping—and at less than 100 microwatts per bit, its power dissipation is fairly low.

But whether it offers enough advantage over the 1,024-bit memories to make it worthwhile is not certain. Naturally, it costs more than the 1103 types, because yields are lower with the larger die sizes. And the faster lower-power 4,096-bit n-RAMs are coming along to outperform it at twice the capacity. Its supporters say that the 4,096-bit RAMs are not yet available and meanwhile the 2,048-bit RAM gives the user the only option of getting more memory into smaller spaces with standard products. They also point to the reliability of the process.

While the debate rages, Honeywell is using the 2,048-bit p-RAMs as core replacements, and other users see them as possibilities in buffer stores.



TABLE 1: COMPETITIVE STATUS OF DYNAMIC RANDOM-ACCESS MEMORIES

	p-MOS RAM		n-MOS RAM				Bipolar big RAM	
	Now	Potentially	Fast process		Slow process		Now	Potentially
			Now	Potentially	Now	Potentially		
Number of bits	1,024-2,048	2,048	1,024	2,048	4,096	8,192	1,024	4,096
Access time (ns)	150-300	100-200	85-120	50	300	150	50	15-20
Power dissipation (mW/bit)	0.2	0.2	0.25	0.1	0.1	0.05	0.5	0.25
Average large-quantity price (cents/bit)	0.4	0.10-0.15	25	2-5		0.1-0.2	25-50	5-10

The basis for the inherent high reliability of silicon-gate n-channel devices is the way the layers are arranged. In the cross-section of an n-channel MOS transistor and the interconnects used in the silicon-gate process (Fig. 10), three parts of the device are identified: the thin-field segment (a), the intermediate field with the silicon line interconnects (b), and the thick-field segment with metal line interconnects (c).

In (a), the MOS transistor is well protected from the external environment by a glass passivation barrier. The resistance of this barrier to Na+ contamination has been well established in p-channel technology. The interconnects of (b) and (c) are also fabricated as in the p-channel process, and so are also well protected from external contamination.

Included in Fig. 10 are the results obtained on test devices at Intel after 580,000 unit-hours of a stress of 5.5 V (maximum value for the TTL circuits) at 125°C. It shows that virtually no shifts in any of the threshold voltages were observed. The junction leakages of these devices were also monitored and no increases observed. In addition, the n-channel technology improves gate protection of the input devices, resulting in the lower breakdown voltage of the diodes.

It was applying these silicon-gate techniques for reducing interconnect capacitance and oxide contamination that allowed Intel to proceed to the big n-channel payoff: the super-dense RAM. Already Intel is sampling a 4,096-bit n-channel dynamic random-access memory and claims that ultimately the process is probably good for 8,192 bits on a single chip. Among others close to a 4,096 n-channel RAM are Electronic Arrays, Standard Microsystems, and Philips.

The Intel 1401 memory has impressive specifications. Arranged in a 4,096-words-by-1-bit configuration, it is fully TTL-compatible in inputs and outputs, with the exception of the clock input which is only a 12-v supply. Access time is less than 300 ns, cycle time less than 500 ns, active power is smaller than 100 microwatts per bit with standby less than 1 μW/bit. It requires the conventional three levels of power supply (+12 v, +5 v and -5 v), and comes in a standard 22-pin package. Clearly a chip capable of accessing 4,000 bits in less than 300 ns with a total power dissipation of less than 0.5 w has got to create a stir among designers of mainframe systems.

The combination of the silicon-gate n-channel process with a new cell design (Fig. 11a) made it possible to pack 4,096 bits on a single chip. Although the cell still

TABLE 2

PARAMETER	1103	1103-1	6002	UNIT
Refresh period	2	1	2	ms
Operating temperature range	0-70	0-55	0-70	°C
t <sub>ovL</sub> (Precharge and chip enable overlap)	25-50	5-30	Not applicable	ns
t <sub>cw</sub> (Chip enable to write pulse overlap)	Not specified but necessary	15	Not applicable	ns
t <sub>access</sub> (From address to output)	300	150	150	ns
t <sub>cycle</sub> (Write)	580	340	250	ns
t <sub>cycle</sub> (Read)	580	340	250	ns
I <sub>oo</sub> or I <sub>ss</sub>	Max.	59	68.5	mA
	Avg.	25	23	
Standby power	60	76	2	μW/bit
V <sub>ss</sub>	16	19	20	V
(V <sub>BB</sub> -V <sub>ss</sub> ) or (V <sub>SX</sub> -V <sub>ss</sub> )	3-4	3-4	2.5	V
Compatibility with each other	No	No	No	

TABLE 3: KEY PARAMETER COMPARISON

Parameter	1103	6002	Unit
V <sub>SS</sub>	+15 → +17	+19 → +21**	V
V <sub>DD</sub>	0	0	V
V <sub>BB</sub> or V <sub>SX</sub>	+3 → +4	+2.4 → +2.6*	V
V <sub>REF</sub>	—	+6.65 → +7.35	V
Process	Silicon gate, low V <sub>t</sub>	Standard (111)	
Minimum data out current	700, single-ended	100, differential	μA
Average power operating	280	180	mW
Average power standby	5	2	mW
Typical V <sub>REF</sub> current	—	1	μA
Minimum cycle time	580	290	ns
Address valid to output, max.	300	150	ns
Refresh interval	2	2	ms
Refresh scheme	32 read cycles	32 read cycles	—

\*will operate at +3 → +4      \*\*will operate at +16 → 19

contains the normal three transistors, only three lines pass through it—a column-select, a row-select, and a ground bus. Conventional cells contain as many as five lines and seven connections. Lowering the line count greatly adds to the cell's compactness. Together with the small areas normally associated with the silicon-gate process, it produces a cell only 1.8 square mils, one-third the size of a p-MOS cell.

A block diagram of the memory is shown in Fig. 11b. The 12-bit address buffer register accepts TTL inputs of 2.4 V minimum. The address is then decoded into one of 64 rows and one of 64 columns to select one of the 4,096 cells contained in a 64-by-64 matrix. The decoders use six dynamic NOR input gates, achieving fast address decoding with minimum power dissipation. The address buffers, also built from dynamic circuitry, not only convert the TTL levels to MOS levels, but also serve as a register, thus requiring stable address for only 100 nanoseconds.

Again, the 4,096-bit memory employs a single high-level clock (CE) from which all internal timing signals are triggered. Significantly, the precharge clock input, normally used in dynamic RAMs to precondition all internal nodes, is no longer necessary. Its function is performed instead by the CE driver: so that all dynamic nodes are preconditioned automatically between active memory cycles. As a result, the memory can be driven through read, write, or read-modify-write cycles controlled by a single TTL-level input. To refresh the 4,096-bit array, it is only necessary to perform memory cycles at each of the 64 row addresses.

Taking up a little behind where n-RAM leaves off is the new 1,024-bit bipolar dynamic random-access memory. Access times for these devices—typically 35 to 60 ns—are 1½ to three times faster than those of n-channel devices and about an order of magnitude faster than p-channel speeds.

Clearly then, the 1,024-bit bipolar RAMs are destined to be a significant semiconductor large-mainframe technology. Their access times give the system designer the speed he needs for even the fastest mainframes in use today. And their direct compatibility with TTL and ECL systems frees him from all the problems of interfacing different logic and memory technologies.

Historically, of course, bipolar RAMs were in production as long as five years ago—but with few bits on a chip. The largest on the market had only 64 or 256 bits, until Fairchild's and Raytheon's new 1,024-bit RAMs were announced in June.

Nonetheless, the 256-bit devices manufactured by a host of companies—Texas Instruments, Fairchild, Signetics, Motorola, National, Intel, Raytheon, and others—had such fast (30-ns) access times that they won very wide acceptance in computer memory systems, primarily for fast scratchpad and add-on applications. Large mainframes, however, would require too many 256-bit devices to be economically or technically attractive.

### Narrower isolation the key

Fairchild led the way in the development of the high-density bipolar memories, followed closely by Raytheon, Motorola, Signetics, Intersil, TI, and Intel are all in the running with new bipolar processes. What was required to build the large arrays was a different bipolar process—the earlier method of isolating adjacent memory cells with active p-type diffusions simply took up too much substrate space.

Most of the high-density methods that have evolved, are based on some form of passive isolation. Fairchild uses a ring of thermally grown oxide around each memory cell. Raytheon uses an air notch, and Motorola will use a back-filled poly notch. Admittedly, refinements in standard isolation can also produce a 1,024-bit RAM, such as Signetics thin-epi system, Intersil's gold-doping process, and TI's compose masking. But these push the standard technology to its limit, whereas for passive isolation methods, 1,024 bits on a chip is just the beginning.

### Who's got what

Two companies have 1,024-bit bipolar RAMs presently on the market. Fairchild has a 1,024-bit TTL RAM (93415), sporting a 60-ns access time, and an ECL version (95415) with an access time of 45 ns. Raytheon has a TTL RAM, the RR5502, with an access time of 50 ns. All three devices are available in standard 16-lead hermetic dual in-line package, and include full decoding and sensing on the chip. In each, separate data-in and data-output lines are provided.

Signetics Corp. has also produced a 1,024-bit RAM



TABLE 4

	AMS 6002	INTEL 1103	MOSTEK MK4006	NATIONAL MM5260	INTEL 1103-1	FAIRCHILD 3534	ELECTRONIC ARRAYS 1500/1501	FUJITSU M88201
Organization	1,024 X 1	1,024 X 1	1,024 X 1	1,024 X 1	1,024 X 1	1,024 X 1	1,024 X 1	1,024 X 1
Refresh rate (ms)	2	2	2	2	1	2	5	1
Operating temperature (°C)	0-70	0-70	0-70	0-70	0-55	0-70	0-70	0-70
Power supplies	+7 V, +20 V +22.5 V	+16 V, +20 V	+5 V, -12 V	+5 V, -12 V	+19 V, +22 V	+16 V, +20 V	+15 V (EA 1500) +12 V (EA 1501)	
Substrate bias	Yes	Yes	No	No	Yes	Yes	Yes	
Access time (ns)	150	300	400	350	150	300	85 (EA 1500) 150 (EA 1501)	80
Cycle time:								
Read (ns)	250	480	400	450	340	480	150 (EA 1500) 250 (EA 1501)	160
Write (ns)	250	580	650	600	340	580	250 (EA 1500) 400 (EA 1501)	160
Critical times	No	$t_{OVL}$ (25-50) $t_{EW}$ (15 min)	No	No	$t_{OVL}$ (5-25) $t_{EW}$ (15 min)	No	No	No
Standby power ( $\mu$ W/bit)	2	60	35	75	76	4		
Operating power (mW)	180	400	450	400	500	200	185 (EA 1500) 89 (EA 1501)	
TTL compatibility	No	No	Yes	Yes	No	No	No	
Technology	Hi thresh Al-gate p-channel	Lo thresh Si-gate p-channel	Lo thresh ion-impl p-channel	Lo thresh Si-gate p-channel	Lo thresh Si-gate p-channel	Lo thresh Si-gate p-channel	Lo thresh Si-gate n-channel	Lo thresh Al-gate n-channel
Cell structure	4-trans	3-trans	3-trans	3-trans	3-trans	4-trans	3-trans	
Package	22-pin DIP	18-pin plas	16-pin DIP	16-pin DIP	18-pin plas	18-pin DIP	18-pin DIP	24-pin OIP

jointly with Signetics Memory Systems for an add-on memory, but it is not commercially available. Later this year, however, the company plans to announce a standard 1,024-bit RAM in the 35- to 40-ns range.

About the same time, Intersil also will introduce a 1,024-bit bipolar memory, only with a longer access time of about 100 ns, because a standard 0.1-mil gold-doping process was used. Scheduled for the end of the year is a RAM from TI that is built by using a single nitride mask for all critical alignments. And to go into production early next year at Motorola are TTL and ECL 1,024-bit RAMs, both with more or less the same specifications as the Fairchild and Raytheon parts.

### TTL versus ECL

Since both TTL and ECL versions of the new bipolar RAMs are now available, it is possible to compare their advantages.

Table 7 lists the key performance parameters of Fairchild's ECL and TTL RAMs, both for the 256-bit and 1,024-bit devices. What immediately becomes apparent is that the ECL devices give a 50% advantage in speed while dissipating no more power than the TTL equivalents. In fact, the delay-power product of the 1,024-bit ECL RAM is considerably lower than that of the other devices. Hence, more bits are possible on an ECL chip

without greatly increasing the power dissipation—important considerations when a conventional DIP must be used.

The high performance of an ECL RAM springs directly from its ability to operate at high speeds without resorting to circuit tricks. For instance, Schottky barrier clamp diodes are used to eliminate storage delays in TTL configurations. But ECL is nonsaturating and inherently fast.

Other circuit and logic features of ECL are advantageous in terms of speed, power, and chip area for the design of complex devices. Figure 12, for instance, shows speed-power products of logic gates in a 25-gate array band on three popular circuit technologies. It reveals ECL as the winner in high-speed low-power operation. In addition ECL offers greater flexibility, provides automatic inversion, wired-emitter OR, wired-collector AND, and series gating. And if more than 20 gates are needed, it requires less chip area than TTL. An added advantage of this approach is that, by using buffers, TTL-compatible functions can be obtained from the same basic ECL design.

The TTL elements use TTL-ECL and ECL-TTL high-speed-level converters at all interfaces with the outside world (Fig. 13). Since input and output buffers are necessary for all memory designs, the additional level con-

# SPECIAL REPORT

TABLE 5

Device type	Access time (ns)	Density (kbits)	Power supply (V)
1. High speed	50-85	1-2	-5, +5, +15
2. High density	300	4-8	-5, +5, +15
3. Ease of use	500-1,000	1-4	+5

version consumes negligible incremental chip area of power. In ECL arrays, ECL input and output buffers simply replace the converters. Typical circuits are shown in Fig. 14. On the memory chips the buffers or converters are located near the bonding pads.

### Systems implications

New bipolar RAMs will fill sockets in two main categories of application: updating existing designs, and implementing new system architectures, because memory cycle times are now compatible with the fastest available logic speeds. For example, an important recent trend in computer design has been the transition from instruction programs residing in bulk memory to microprograms stored near the logic. The microprograms are usually stored in braided wire or semiconductor read-only memories (ROMs), in place of which high-density, low-power, read/write memories can now be used in many applications. This eliminates the manufacturing and inventory of large numbers of fixed codes which present a serious logistical problem. Writable control stores also permit easy correction of errors in microprograms and allow frequent changes of the "instruction set" to match different applications.

The most revolutionary aspect of the device is that it represents the break-even point at which semiconductor main memories become feasible in a wide range of systems from a cost and density viewpoint. Moreover, they offer a far more convenient means of achieving cycle times under 200 ns than the relatively expensive and

complex plated-wire and specialized core stacks that have often been used in high-performance main memories. In this context, too, it's an added bonus that semiconductor memories, being static and self-contained and with all decoding and sense amplifiers included on the chip, can be distributed throughout the logic as required. The availability of power-down versions of the 1,024-bit element later this year will further expand the opportunities for economical bipolar bulk storage.

Another widespread application of big bipolar RAMs has been in cache or buffer stores. Inserting a high-speed buffer between the processor and a large, slow core or MOS memory will enhance the performance of the latter at relatively low cost. Used to replace the earlier 256-bit designs, the higher-density 1,024-bit bipolar devices can increase the capacity of the cache with no power or size penalty. In fact, improving the bit ratio will further improve the apparent speed of the main memory. Similarly, buffers which serve as temporary stores for large blocks of data being transferred from a high-speed disk file, can considerably improve the effective performance of the disk as they themselves become larger and faster.

As large, high-speed scratchpads, the bipolar RAMs will simplify many of the problems previously encountered in multiprocessing or in the simulation of long shift registers. A high-speed counter linked to the address inputs of the memory array will allow serial data storage at speeds greater than 15 to 20 MHz. In this area, in fact, the RAMs promise to oust MOS technology. The fastest large MOS scratchpads and shift registers currently projected will yield system cycle times of only about a third to half the speed of the bipolar devices described here. To achieve this speed, moreover, MOS designs require complex timing, multiple power supplies, wide voltage swings, special sense amplifiers, drivers and external clocks—and fairly large memory sizes are needed to amortize the cost of these additional peripheral electronics. Bipolar memories therefore can be expected to dominate in the highest-performance equipment, as well as in small-to-medium and distributed main memory applications.

### What the future holds

Even before the competitive lines have been firmly drawn, several new semiconductor RAM technologies are emerging that may change the picture. These technologies are heading toward two goals: to increase the performance of MOS memories, while maintaining their low price, and to increase the density and lower the price of bipolar memories, while retaining their high performance.

In MOS, for example, developments are afoot to use complementary processing to build memories. Both Motorola and RCA already have small-density C-MOS random-access memories on the market, and Solid State Scientific, Intersil, Harris, and Fairchild are among others known to be working on similar devices.

The C-MOS RAMs are medium-speed memories now used primarily where micropower operation is desirable—for example, in compact remote-memory applications. The Motorola MCM14505, a 64-bit C-MOS RAM with 200-ns access time, is designed for scratchpad and

TABLE 6. COMPARISON OF p- AND n-CHANNEL STATIC RAMs

Product		Process	
		p-channel	n-channel
Static RAM	Device #	1101A	2102*
	Size	256 bits	1,024 bits
	Organization	256 X 1	1,024 X 1
	Cell size	17.2 mil <sup>2</sup>	7.9 mil <sup>2</sup>



TABLE 7: COMPARISON OF KEY DEVICE PARAMETERS

Parameter	TTL		ECL	
	256	1024	256	1024
Power, total (mW)	500	500	500	500
Power/bit (mW)	2	0.5	2	0.5
Read access time (ns)	35 (typ) 50 (max)	60 (typ) 85 (max)	25 (typ) 35 (max)	45 (typ)
Delay power (pJ)	70	30	50	23
Chip select access time (ns)	20 (typ) 30 (max)	30 (typ) 50 (max)	7 (typ) 15 (max)	20 (typ)
Cell size (mil <sup>2</sup> )	14	10	14	10
Die area/bit (mil <sup>2</sup> /bit)	45	19	45	19

buffer memories. The RCA devices—the CD4036A for binary addressing, and the CD4039A for direct word-line addressing—are also intended for ultra-low-power digital uses. Each is a four-word-by-eight-bit RAM in a 24-lead dual in-line package.

Silicon-on-sapphire is another new technology that boosts MOS RAM performance. Inselek is taking the SOS/MOS route in its RAM products, and has lately developed 64-bit and 256-bit RAMs. Both of these devices operate statically, but are undeniably fast. With the new 256-bit RAM, Inselek has achieved a combination of high-speed—35 ns—and low power dissipation—0.4 mw per bit. That combination is better than in any other RAM product—bipolar or MOS. Moreover, the SOS fabrication system yields a packing density four times higher than the old bipolar structures. Significantly, Inselek will soon announce an SOS/MOS 1,024-bit RAM.

The higher performance in static memories that can be built with silicon-on-sapphire is due primarily to the better isolation and lower parasitic capacitance that this substrate system offers. Inselek uses the SOS system in combination with n-channel depletion-mode devices to build its memories—a combination of the highest speed with the lowest power dissipation.

Other new isolation techniques can also produce better MOS memories. For example, Fairchild is known to be working with its Isoplanar oxide-isolation process to build MOS RAMs with the same advantages in packing density that it offers in bipolar memories. MOS RAMs with 8,000 bits—and even 12,000 bits—are in the offing with the potential for reduced cost per bit.

In The Netherlands, Philips has adapted its oxide isolation—called Locos for local oxidation of silicon—to build 4,096-bit developmental RAMs. Significantly, the Philips memories are built with standard p-channel technology, but because of the space-saving feature of Locos, memory cells as small as 2 mil<sup>2</sup> can be achieved.

To save still more space, the Philips approach is to build dynamic memory cells that have only one transistor per cell. Likewise, a single capacitor per cell is used to store the charge. Because the size of this capacitance is also minimized, the logic swings are not as large as

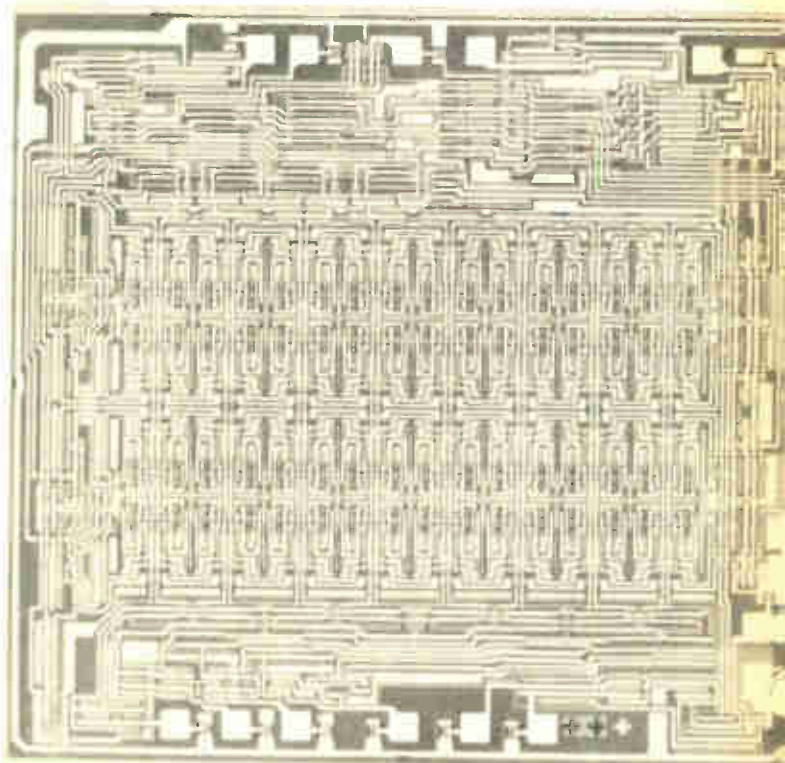

15. What the future may bring. This 64-bit C-MOS RAM from Motorola provides micropower operation at fairly fast speed (200-ns access times). The 14505 RAM can be used in such applications as scratch-pad and buffer memories.

normally experienced. Thus, the Philips device requires a better sense amplifier—a new circuit design that has already been developed.

Circuit design is also being used by bipolar memory makers to increase memory density and cut power dissipation. IBM in Germany has developed a new all-transistor memory cell that eliminates the resistive loads. This saves space, while yielding memory operation that dissipates only submicrowatts per bit. □

Reprints will be available at \$2.00 each. Write to Electronics Reprint Dept., P. O. Box 669, Hightstown, N. J. Copyright 1972 Electronics, a McGraw-Hill publication.

## Wired-OR DTL gates increase multiplexer input capacity

by Eric G. Breeze  
Fairchild Semiconductor, Mountain View, Calif.

A 10-input multiplexer can be built by adding only one diode-transistor-logic gate package to an eight-input multiplexer that has an open-collector output. Decade multiplexers are not currently available as standard integrated circuits because of the lead constraints of conventional dual-in-line packages. Either an eight-input multiplexer in a 16-lead DIP or a 16-input multiplexer in a 24-lead DIP can be purchased. And modifying the 16-input unit is both an expensive and cumbersome way to build a decade multiplexer.

Only three DTL gates are needed to add two input bits to an eight-input multiplexer, provided the multiplexer has an open-collector output that can be wired-OR like all standard DTL gates. The decade multiplexer illustrated makes use of the OR tie facility of the  $\bar{Z}$  output of Fairchild's type 9313 eight-input multiplexer.

The most significant bit of the binary-coded-decimal control input is connected to the ENABLE (active low) input of the multiplexer and to the inputs of gates  $G_1$  and  $G_2$ . When the most significant control bit is low (code value of 0 to 7), the multiplexer operates normally, accepting input bits 0 through 7, and  $G_1$  and  $G_2$  are disabled (their outputs are high).

For BCD input selection codes of 8 or 9, the most significant control bit is high, the multiplexer is disabled, and input bits 8 and 9 can pass to the output, since both  $G_1$  and  $G_2$  are enabled. Gate  $G_3$  performs as an inverter for the least significant control bit into the multi-

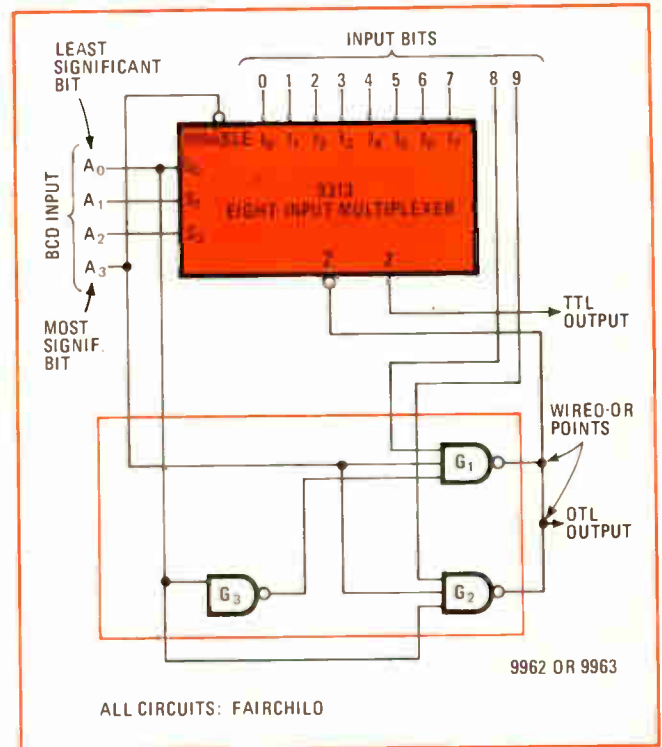

**Two more bits.** Binary-coded-decimal input controls selection of input bits to decade multiplexer. When most significant bit  $A_3$  is low, gates  $G_1$  and  $G_2$  are disabled, and eight-input multiplexer operates normally for input bits 0 through 7. For high  $A_3$  bit, eight-input multiplexer is disabled, but  $G_1$  and  $G_2$  transfer input bits 8 and 9 to output. DTL gates and  $\bar{Z}$  output are wired-OR.

plexer to decode input selection code 8.

The type 9313 multiplexer contains an inverter stage after its  $\bar{Z}$  output, making both TRUE ( $Z$ , TTL-compatible) and ASSERTION ( $\bar{Z}$ , DTL/TTL-compatible) outputs available. □

## Precision integrator resets as it samples

by Dennis J. Knowlton  
University of Wyoming, Laramie, Wyo.

A circuit that continuously samples the integral of an input and resets itself achieves an accuracy of within 0.1%. Other integrators with this tight an accuracy can be expensive and complicated because they do not integrate continuously but rather require some time to sample and reset.

The integrator shown uses two sample-and-hold cir-

cuits—while one is sampling, the other is holding the previous integral value. Reset is also continuous—the previous value of the integral is fed back so that the circuit is continuously reset for the full integration time period. In this way, integration precision is determined primarily by hardware and not by technique. Adding an offset adjustment to each of the operational amplifiers permits accuracy to be improved by at least an order of magnitude.

The integrating section is a simple integrator, composed of an op amp having a low input bias current and a feedback capacitor. The sample-and-hold section contains complementary MOSFETS. One portion of this section holds the integral, while the other follows (samples) the output from the integrating section. When the MOSFETS are switched, these roles are interchanged. The



741-type op amps are used in voltage-follower configurations to isolate the integrating section from the sample-and-hold section.

The integrator is a true feedback system. If the integration period is 1 second, the integral formed during a 1-second period is fed back to the input during the following 1-second period to reset the integrator. Meanwhile, new data is being integrated. The output, then, is the sum of the new integrated data, plus the old data that has been integrated back to zero, which simply

yields the integral of the new data. Two timing diagrams show the circuit's response to a pulse input and to a step input.

Calibration procedure for the integrator is straightforward. After the feedback circuit is unhooked, resistor  $R_1$  is adjusted to obtain the desired slope from the integrating section (for example, 1 volt out per second per volt in). The feedback circuit is then connected again, and resistor  $R_2$  is adjusted so that there is no overshoot or undershoot to a step input. □

**Precision integration.** Simple integrator can provide accuracy within 0.1% because it continuously integrates input. Output from integrating section is sampled by one sample-and-hold circuit, while the other holds previous integral and uses it to reset integrator. Complementary MOSFETs do the switching. Sample-hold roles reverse every integration period.

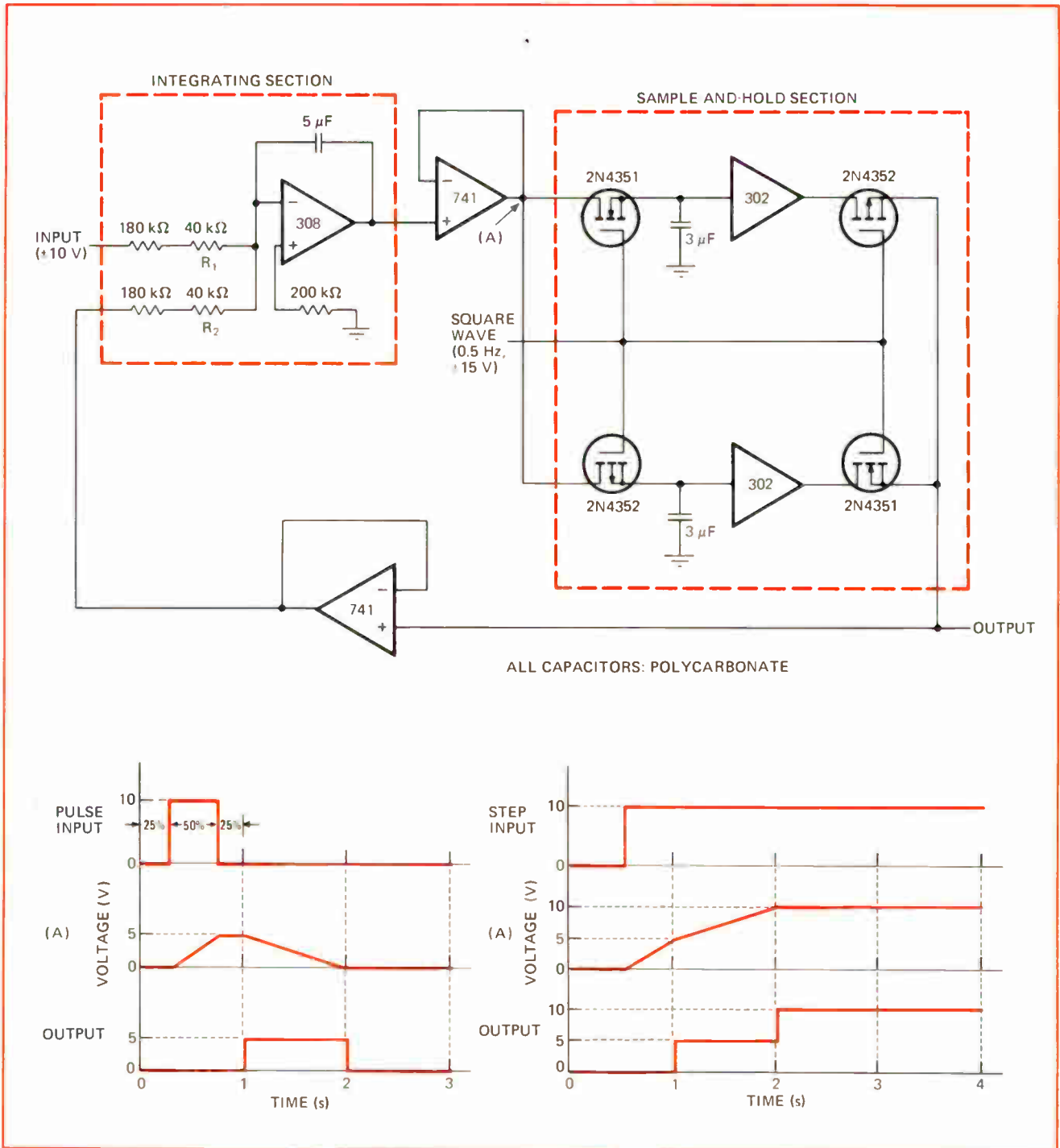

# Wien bridge in notch filter gives 60 dB rejection

by Donald DeKold  
University of Florida, Gainesville, Fla.

A modified phase splitter and Wien bridge network form a notch filter that is capable of providing 60 decibels of signal rejection. The bridge network, which consists of two capacitors and two resistors, makes this high rejection possible and allows the filter to be tuned with ganged capacitors or resistors. The three-capacitor, three-resistor bridge ordinarily used for the twin-T variety of notch filter is not as easy to null because more components must be trimmed, and maximum notch depth is usually about 45 dB.

Because of the wideband frequency response of its modified phase splitter, the filter (a) can operate from subaudio frequencies up to hundreds of kilohertz. For very-low-frequency performance, however, a direct coupling scheme must be worked out.

Unlike a unity-gain phase splitter, the filter's phase splitter has a gain of approximately -2 at its collector. If collector resistance is small with respect to resistor R of the bridge, the ac equivalent circuit of (b) can be drawn.

The voltage transfer function of the equivalent circuit is:

$$H(s) = V_o(s)/V_i(s) = (s^2C^2R^2 + 1)/(s^2C^2R^2 + 3sCR + 1)$$

where  $s = j\omega$ , with  $\omega$  representing frequency.

This transfer function has a transmission zero at  $\omega = 1/RC$ , the center frequency of the notch. At frequencies above and below the notch frequency,  $H(s)$  approaches unity. Since every R is paired with a C in the expression for  $H(s)$ , the shape of the transfer characteristic cannot be changed by varying the ratio of R/C. The filter's Q, therefore, is constant for any value of R or C, or at any frequency for which the notch is designed.

A practical implementation of the filter is shown in (c), along with its frequency response. Instead of a single collector resistor, a potentiometer and a series resistor are used so that the filter can be adjusted for maximum signal rejection.

Employing a standard dual ganged variable capacitor for the bridge capacitors allows the notch to be tuned from 8 to 200 kHz. Notch depth may vary because of imperfect tracking of the capacitors, but will never drop below a minimum of 45 dB. Because the filter operates at a high impedance level, it should be shielded to avoid noise pickup at the output node. □

Designer's casebook is a regular feature in Electronics. We invite readers to submit original and unpublished circuit ideas and solutions to design problems. Explain briefly but thoroughly the circuit's operating principle and purpose. We'll pay \$50 for each item published.

**Effective notch.** Non-unity-gain phase splitter and four-element Wien bridge make up notch filter (a) capable of suppressing unwanted signals by 60 decibels. Ganged variable components can be used for bridge R or C, allowing notch to be tuned over broad frequency range. Filter transfer function can be found from equivalent circuit (b). Practical filter (c) has adjustable collector resistance.

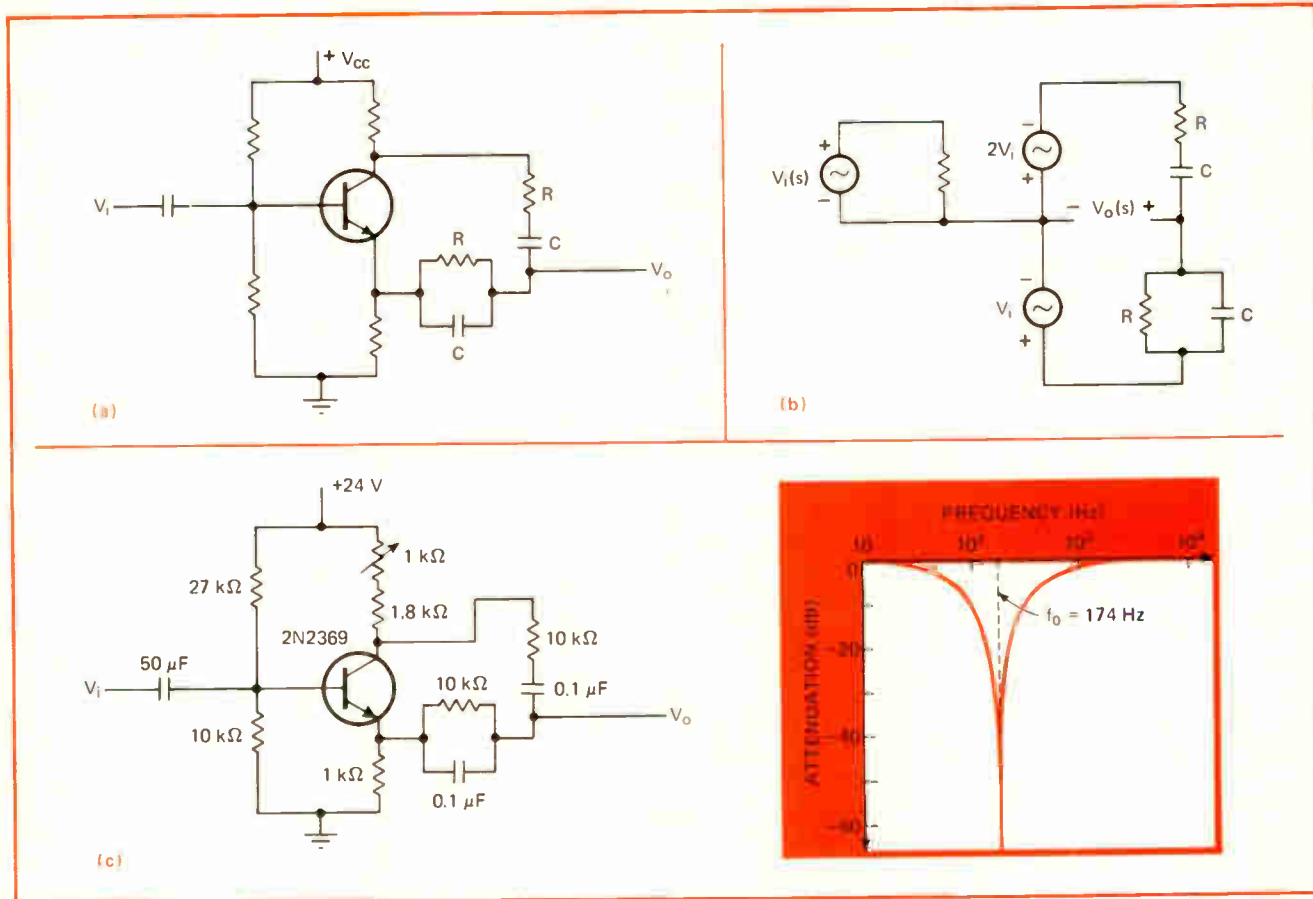





P-channel  
J FET

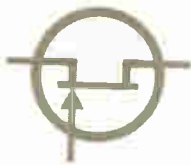

N-channel  
J FET

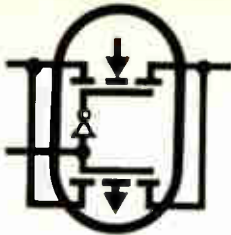

CMOS  
FETs



P-channel  
MOS FET

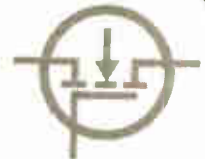

N-channel  
MOS FET

Since 1962, Siliconix has evolved FET technology and applied it to a complete line of singles, duals, arrays, and IC's. So what's new?

# Switch 16 channels with CMOS DG506.

Here is a single-pole 16-channel multiplexer using paired CMOS FETs, with drivers controlled by a 4-bit binary word input plus an Enable-Inhibit input — all on one chip! Check the functional diagram and then refer to the decode truth table to see what binary word input selects which switch.

### The DG506 features:

- $\pm 15$  V Analog signal range
- Break-before-make switches
- ON resistance < 500 ohms
- TTL, DTL, and CMOS direct control interface
- 36 mW standby power

DG506 Function Diagram

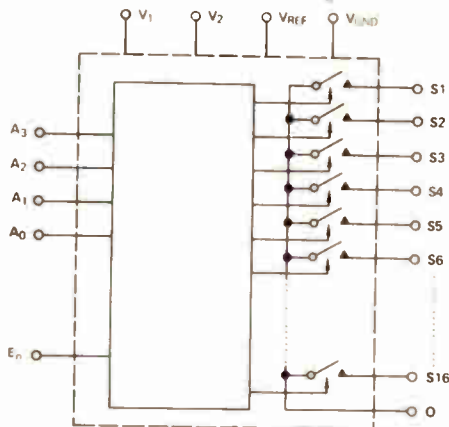

Decode Truth Table

A <sub>3</sub>	A <sub>2</sub>	A <sub>1</sub>	A <sub>0</sub>	E <sub>n</sub>	ON SWITCH
X	X	X	X	0	NONE
0	0	0	0	1	1
0	0	0	1	1	2
0	0	1	0	1	3
0	0	1	1	1	4
0	1	0	0	1	5
0	1	0	1	1	6
0	1	1	0	1	7
0	1	1	1	1	8
1	0	0	0	1	9
1	0	0	1	1	10
1	0	1	0	1	11
1	0	1	1	1	12
1	1	0	0	1	13
1	1	0	1	1	14
1	1	1	0	1	15
1	1	1	1	1	16

Our catalog line of drivers and switches will cover most applications. If your switching problems are unique — and whose aren't — call our applications people. They're eager to help. For complete information,

## write for data

Applications Engineering: (408) 246-8905



Siliconix incorporated

2201 Laurelwood Road, Santa Clara, California 95054

# Impatt diodes start competing as microwave system amplifiers

These reliable devices are being built into equipment now that circuit-design development has overcome the drawback of narrow bandwidth; cascading has increased gain and power outputs

by H.C. BOWERS, *Electron Dynamics division, Hughes Aircraft Co., Torrance, Calif.*

□ Impatt diodes, usually associated with oscillator circuits, are now proving their worth as microwave amplifiers. The two-terminal solid-state devices are competing with conventional amplifier elements, such as traveling-wave tubes and transistors.

Impatt amplifiers are more reliable than TWTs. They produce about the same power as transistors in C-band amplifiers, and they are ahead in the power race at higher frequencies, where transistors have yet to make inroads. And, while the Impatt is noisier than the Gunn diode, it delivers more power at X band and above.

Impatt diode amplifiers are being built in such production equipment as output stages in radar test sets used to check out F-14 and F-15 aircraft and cw amplifiers for X-band and millimeter-wave communications systems. But while Impatt usefulness has been proven in the field, the engineer should be aware of the many tradeoffs and design considerations involved before he accepts them without question or writes them off.

The chief reason for the Impatt's slower acceptance is that, although the single-stage units built in the past were relatively easy to make, they were narrowband and had little gain or output power. These characteristics have been changed.

Multituned matching circuits have been applied to the single-diode amplifier to expand its bandwidth, and interstage circulators are being added to allow the cascading of several diodes to achieve greater gain and higher power output.

To aid the designer in his evaluation of the Impatt for his application, data has also been gathered on such characteristics as intermodulation distortion, amplitude-to-pulse-modulation conversion, and reliability. This article presents an overview of these characteristics, as well as a brief look at the types of circuits used to achieve optimum Impatt performance.

## Reflection amplifier

Two-terminal amplifier circuits are classified into two basic categories: reflection amplifiers, which use a device such as a ferrite circulator to separate input and output signals sharing the same diode port, and transmission amplifiers, where the diode is simply placed in a transmission line with separate input and output ports.

Although the reflection amplifier requires the added signal isolating component, it is the more popular because it is easier to implement and has greater gain.

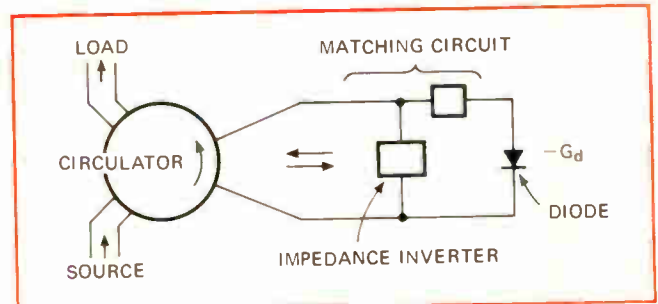

1. **Reflection.** The single-tuned reflection amplifier, which has a circulator to isolate the source from the load, is the most popular amplifier circuit used with two terminal devices.

gain-bandwidth product, and stability for a single stage. Since the diode terminates the transmission line in the reflection circuit (Fig. 1), the amplified signal is reflected back toward the circulator.

A matching resonator circuit is required to obtain the desired gain and center frequency. In general, max-

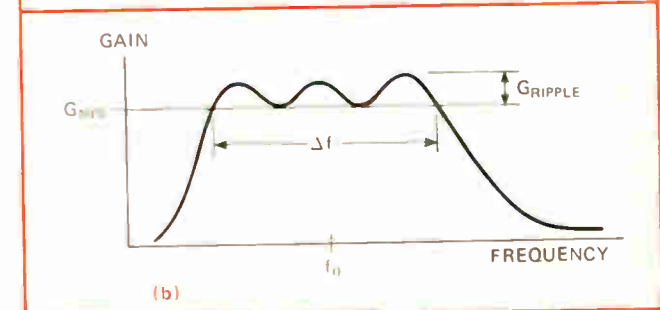
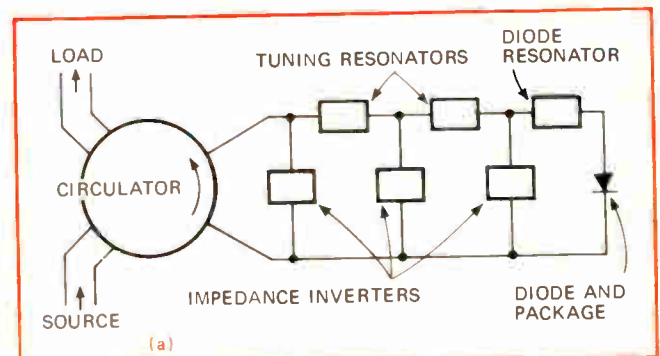

2. **Broader band.** Practical broadband design synthesizes the response (b) with a resonator, then matches each tuning circuit with an impedance inverter. Response is characterized by a specified ripple and minimum gain over a given band.

imum gain occurs at or near the frequency at which the total susceptance (diode plus package plus circuit, referenced back to the diode junction) is zero.

At frequencies below X band, the resonator that determines the center frequency can be a lumped element. At X band and above, a distributed element is used. This resonator can be a shorted length of transmission line in shunt with the diode or a short section of series line between the diode and the impedance inverter.

The impedance inverter is needed to match the diode and resonator to the transmission line and circulator. This matching element determines the center-band gain of the amplifier, and can be a step or taper transformer, a quarter-wavelength section of line, or a lumped capacitance or inductance.<sup>1</sup>

A low Q is desirable for best power, efficiency, and gain-bandwidth product. The ratio of operating frequency to the diode's resonant frequency is of primary importance in fixing this value of Q, but the package and type of matching network are also factors.

Typical unloaded Qs for an unpackaged X-band diode range from as low as 4 to over 7. Addition of a package and good matching circuit can raise the Q to a value of 8 to 12. Poor packaging and bad choice of matching elements can result in Qs of 20 or more because of unnecessary parasitics.

### Broadbanding the amplifier

The gain-bandwidth product of the single tuned amplifier is quite limited, but fortunately there are well known techniques for broadbanding matching circuits.<sup>1,2</sup>

A basic technique (Fig. 2) uses a sequence of resonators, in addition to the element that resonates the diode at the desired center frequency. In theory, these additional circuit elements should be alternately series and shunt resonant structures, all having the same center frequency but with differing susceptance or reactance slopes. In practice, however, it is usually easier to synthesize only one type of resonator, either series or

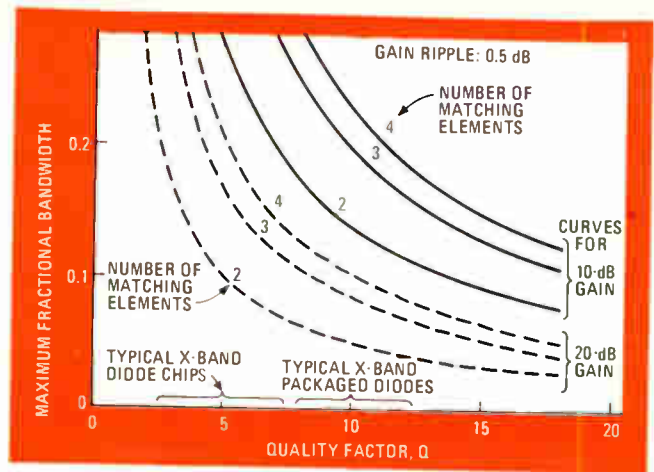

**3. Bandwidth limit.** Design curves help determine maximum theoretical gain-bandwidth limit for a maximum passband ripple of 0.5 dB. Practical circuits, because of mismatches and design approximations, will usually have narrower bandwidths for a given gain.

shunt, and achieve the desired matching with impedance inverters between the elements.<sup>1</sup> The resonators can be lumped elements at the lower frequencies, but are usually half-wavelength series or shunt sections of transmission line at the higher frequencies.

As indicated in the general response curve of the broadband amplifier of Fig. 2b, the gain will have several peaks, depending on the number of matching resonators. The amplifier response is usually characterized by a minimum gain value and a gain ripple over the band.

For an amplifier of given gain, the maximum theoretical bandwidth is a function of the circuit quality  $Q_A$ , and the number of matching elements (Fig. 3). However, the bandwidth will often be substantially less than that predicted by the curves, or the ripple may be considerably more.

While useful as first-order approximations, the broadband matching techniques have their limitations.

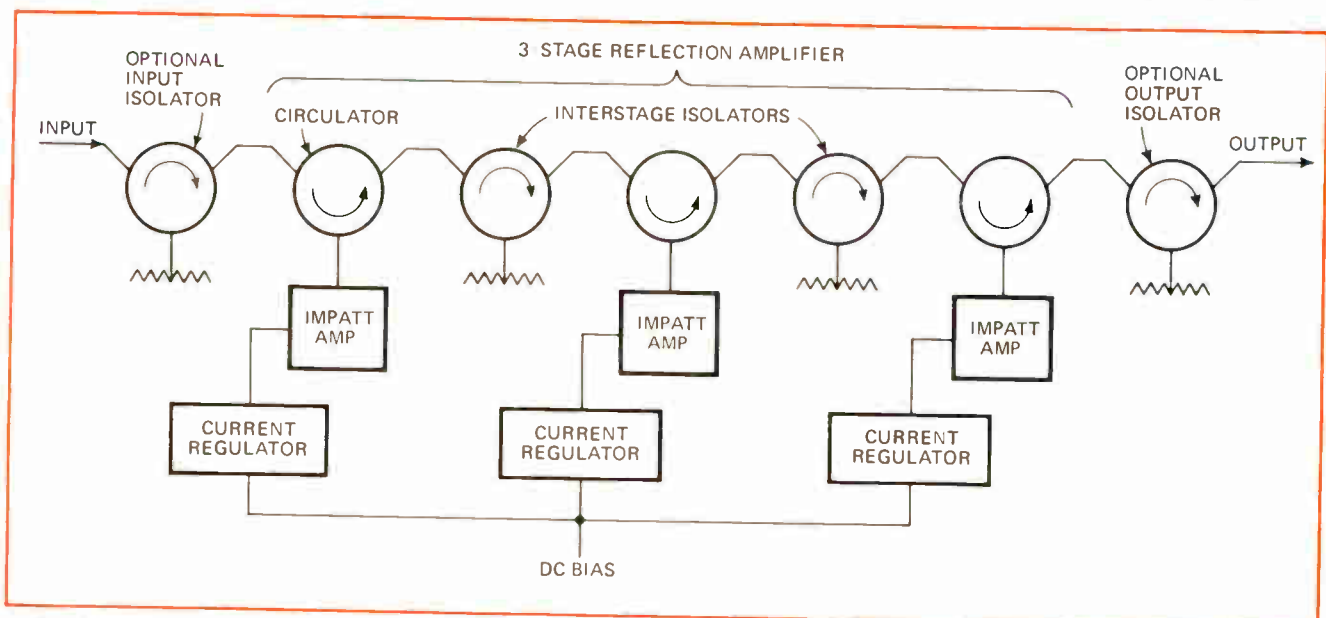

**4. Power pack.** For higher gain-bandwidth products than are available in single-tuned diode stages, reflection amplifiers are placed in tandem. Interstage isolators provide over-all stability.



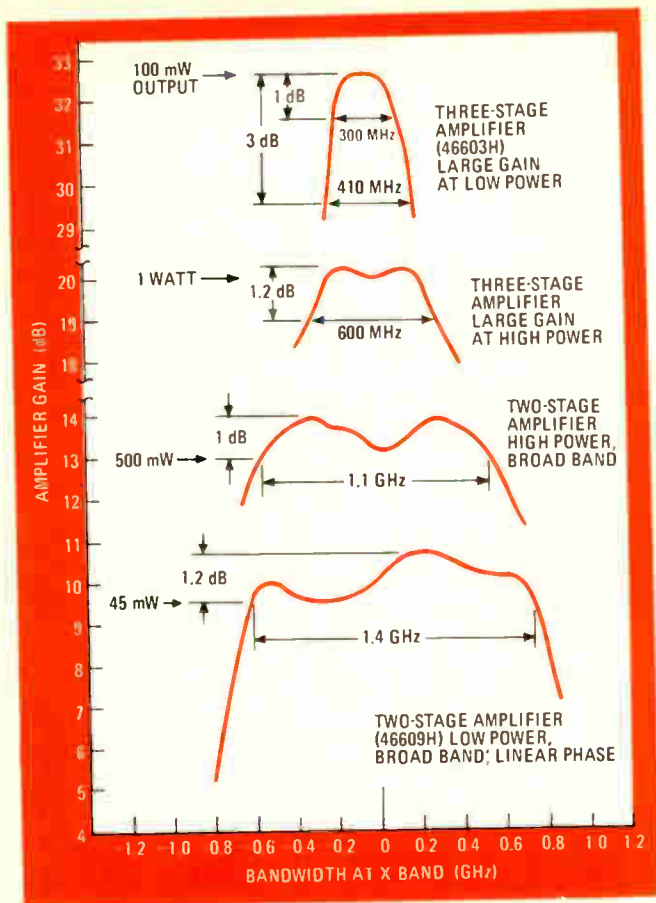

5. **Pick-a-power.** Power output must be considered when gain is traded for bandwidth. Higher power output for a given gain-bandwidth product is achieved by adding amplifier stages.

Generally, theory requires a detailed knowledge of device and circuit parameters, and important parameters such as diode conductance, diode  $Q_s$ , and the component values of the passive matching circuits are only measurable to within 5% to 10%.

Although Impatt reproducibility is now much improved, diode-to-diode variations still prevent interchanging the devices randomly in amplifiers. Therefore, amplifier circuits should have sufficient tuning flexibility to compensate for expected variations in production devices.

### Multistage amplifiers

Several Impatt amplifier stages can be combined to achieve greater gain-bandwidth or gain-power combinations. For the reflection-type amplifier, each stage is coupled to the over-all circuit via a circulator (Fig. 4). An isolator is also generally used between each pair of stages to provide stability and minimize interstage coupling and detuning. An isolator on the input of the multistage amplifier will reduce input VSWR from as high as 2.0 to less than 1.2. An output isolator has a similar effect on output VSWR and protects the output stage from large-load VSWRs.

No simple rule determines the number of stages required or the gain distribution among those stages. The final design of a multistage amplifier usually involves several trials to obtain the proper balance of gain and gain compression among a number of stages.

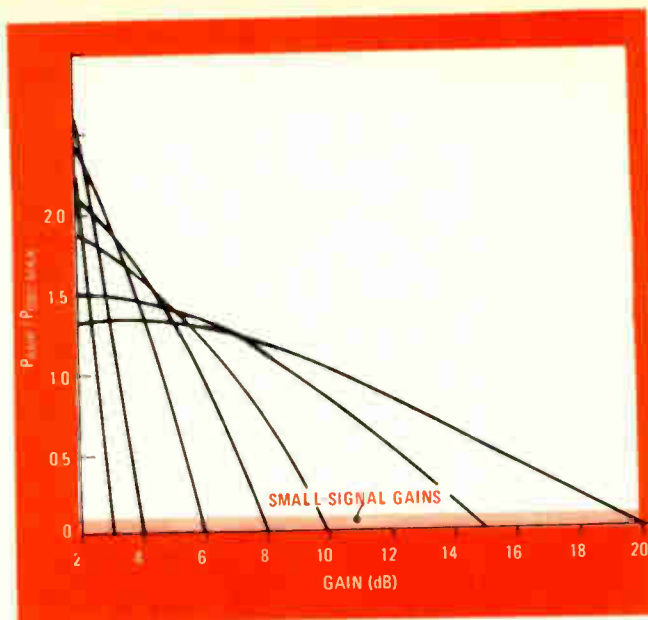

6. **Tradeoffs.** Knowing the small-signal gain for an Impatt diode amplifier and its maximum power capability when used as an oscillator, these design curves show how much amplifier power can be obtained at a desired gain level. Points near the horizontal axis represent the small-signal gain for each curve.

Except for high-performance amplifiers with tight linearity, the input-stage gain is determined by gain-bandwidth product limitations. On the other hand, output-stage gain is determined primarily by power requirements and gain compression limits.

Multistage Impatt amplifiers can be designed to provide numerous combinations of high gain with relatively narrow bandwidths or broader bandwidths at lower gain values. Representative performance of four amplifiers is shown in Fig. 5. Since performance of the two low-power units doesn't approach closely the theoretical limits of Fig. 3, they are relatively easy to manufacture in production quantities. But the half-watt amplifier with 13 dB minimum gain over a 1.1-GHz bandwidth and only two stages of amplification is more difficult to achieve and requires more time in tuning.

A number of amplifiers have been built with 0.5 to 2 w output power, although usually with less gain and bandwidth. At these power levels, gain is limited by gain compression and amplifier stability. Gains of 10 dB in the 0.5- to 1-watt level and 6 dB at 2 w are typical for two-stage amplifiers in X band. The three-stage 1-w amplifier with 20-dB gain shown in Fig. 5 is relatively easy to achieve.

### Large-signal characteristics

As signal level is increased toward saturation, the gain of an amplifier will change because the admittance of the diode is a function of the rf voltage at the diode junction.<sup>3,4</sup> In general, negative conductance decreases and the susceptance increases with increasing signal level.

When near saturation, a single-stage, single-tuned amplifier's gain and center frequency decrease with increased signal level. The design curve in Fig. 6 predicts the amount of gain reduction as signal level goes up. If small-signal gain (close to horizontal axis) and max-

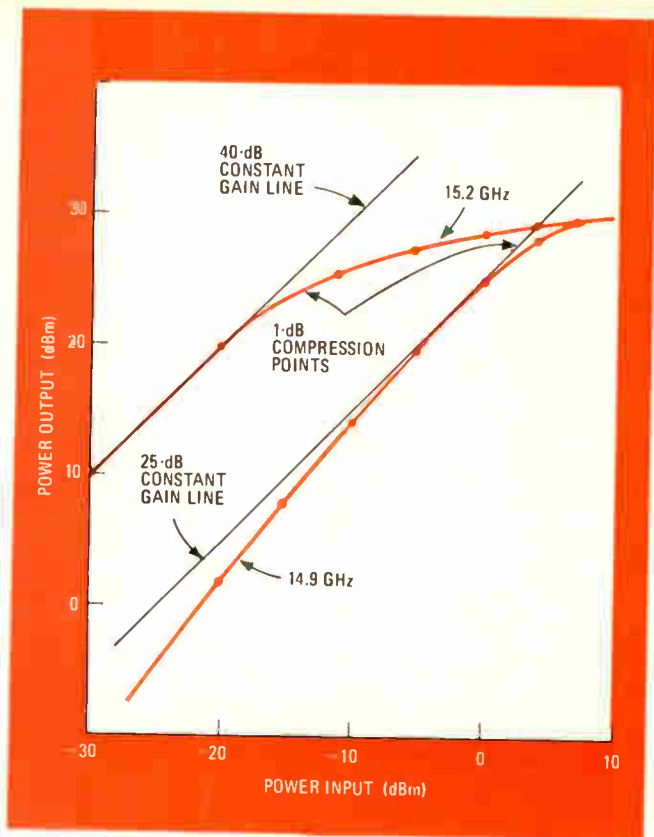

**7. Compressed gain.** The 1-dB gain compression points of a multituned Impatt amplifier are a function of the circuit's operating frequency. Interstage variations in gain over the operating frequency range make production testing of the amplifier difficult.

imum oscillator power of a device are known, amplifier output power can be determined for any desired gain. Note that at the 3-dB gain level it is possible to get twice the power from an amplifier that would be available from the same diode in an oscillator circuit.

The curves of Fig. 6 have proven accurate for all amplifiers constructed at Hughes. Attempts to obtain more gain at a given power level will result in small-signal instabilities.

Large-signal behavior of multituned single-stage amplifiers is more difficult to predict. Because of the matching networks, a simple change in diode characteristics can produce a relatively complicated change in the over-all response. Nevertheless, some general characteristics of the multituned reflection-type amplifier can be predicted.

The decrease in diode conductance tends to lower the over-all gain of the amplifier, whereas a change in the diode's susceptance causes a skewing in the frequency response. The gain will decrease faster on the high-frequency edge of the band than on the low-frequency side. Because of the frequency downshift of device characteristics with increasing drive level, it is even possible to get a gain increase at the lower band edge.

Multistage multituned amplifiers can be even more complex in their large-signal behavior. As indicated by the curvature of the lines in Fig. 6, even small-signal stages exhibit some gain compression. The over-all gain compression of the multistage amplifier is thus dependent on the behavior of each stage. And since each

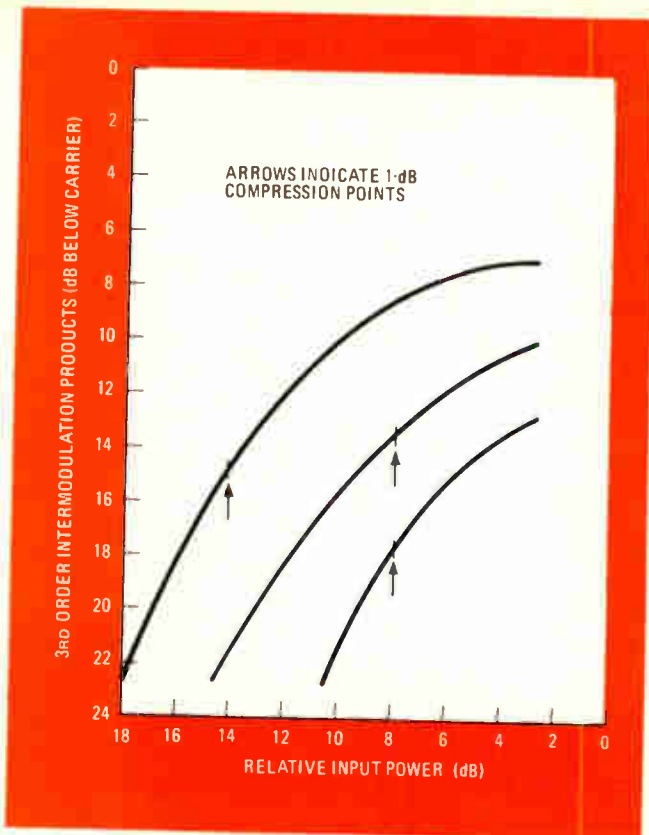

**8. Distortion.** Third-order intermodulation products are typically 10 to 20 dB below the carrier level for a single-tuned reflection-type Impatt amplifier. Input power is normalized to the power required for complete saturation of the amplifier.

stage operates at a different power level, gain variation with frequency at the output is not directly related to the variations of any one stage.

An example of these gain and gain-compression variations is shown in Fig. 7 in the three-stage amplifier. The amplifier is designed to have a constant gain of 20 dB over 300 MHz, with a center frequency of 15.05 GHz. Saturated power output is 1 w. On the high-frequency end of the band, the 1-dB gain compression point occurs at a low-power output. However, at 14.9 GHz, the general lowering of center frequency, caused by susceptance changes partially cancels the decrease in gain that result from diode conductance changes at large-signal levels, and the 1-dB compression point occurs at a much higher power level. At smaller signal levels, there is even over-compensation, and gain increases slightly with signal level over a small range of powers.

Other large-signal amplifier effects include harmonic generation, amplitude-to-phase modulation conversion, intermodulation products generation, and spurious responses.

Harmonic generation is generally not a serious problem. Even at full saturation, the second harmonic is usually more than 40 dB below the carrier level. Simple filters to further reduce harmonic levels can be included as part of the bias circuit at relatively little cost.

Amplitude-to-phase-modulation conversion at the 1-dB compression point is usually about  $1^\circ/\text{dB}$  or less, and at full saturation, about  $3^\circ/\text{dB}$  is typical. In some very narrow-band high-gain amplifiers,  $5^\circ/\text{dB}$  can be ob-



served, especially near the band edges.

Intermodulation products vary considerably from one amplifier to another. They depend not only on the power level, but also on the number of stages, gain, frequency, and gain distribution among stages. At the 1-dB gain-compression point, third-order intermodulation products can be from 10 to 20 dB below the carrier; at full saturation, these modulation products can be from 8 to 15 dB below the carrier. Examples of typical third-order intermodulation behavior are shown in Fig. 8.

Spurious spectral lines at frequencies other than the signal frequency are caused by a general lowering of the device's frequency at large-signal levels and to circuit mismatches at these lower frequencies. Spurious lines, which are quite sensitive to out-of-band VSWR, can occur at frequencies much lower than the operating frequency. Since it's difficult to maintain low VSWR at the circulator junction very far out of band, other techniques, such as stabilizing networks, must sometimes be used to suppress these unwanted signals.

### Stabilizing networks

Impatt diodes exhibit a negative resistance only over a limited frequency range; therefore, amplifiers are often constructed without the need for stabilizing circuits, as such. These Impatts are stabilized by presenting the correct load admittance at center-band resonance. But amplifiers frequently exhibit spurious oscillations at high power levels and require special stabilizing circuits. Basically, these circuits present either a high series impedance or low shunt impedance load to the diode outside of the desired band of operation. This load prevents spurious oscillations, both in and out of band.

To demonstrate the usefulness of stabilizing networks, a diode was tested in a single-stage amplifier with and without a stabilizing circuit. Spurs began to appear in the unstabilized circuit at about the 0.5-watt output level. With the stabilizing circuit, a power output of 2 w was obtained without any spurious lines.

### A noisy device?

The noise figures of Impatt amplifiers are relatively high. Typical noise figures for silicon-diode Impatt am-

plifiers are in the 30-to-35-dB range, although measured values as low as 27 dB have been observed. Nevertheless, if preceded by low-noise amplifiers with sufficient gain, Impatt amplifiers can be used as power-output amplifiers in low-noise systems. Silicon Impatt noise characteristics in a stable X-band system are shown in Fig. 9. The degradation of a-m noise is less than 1 dB, measured 125 dB below carrier.

Although noise data for gallium-arsenide Impatt amplifiers is somewhat less consistent than that for silicon, noise figures are similar—about 30 dB. Perhaps this variation is due to the lag in the state of the art for GaAs materials, but devices with lower noise figures will probably follow GaAs technology advances. However, noise figures as low as 17 dB have been reported for X-band GaAs Impatt amplifiers.<sup>5</sup>

Amplifier phase linearity, related to group delay variations, can be quite good for multituned multistage Impatt amplifiers, as shown in Fig. 10. The maximum deviation from linear phase is  $\pm 7^\circ$  over a bandwidth of more than 1 GHz. This corresponds to a group delay deviation of less than 0.25 nanosecond.

### Injection-locked oscillators

The basic reflection-amplifier circuit may also be operated as an injection-locked oscillator.<sup>6,7,8</sup> In this mode, the Impatt diode is tuned to oscillate at some frequency  $f_0$ . An additional signal at a frequency at or near  $f_0$  is then injected at the input port, and the oscillator locks frequency and phase to the injected signal. The system thus resembles an amplifier, except that an output is present in the absence of an input signal.

Injection locking for amplification of frequency- and phase-modulated signals is attractive because of the increase in single-stage gain. For example, this technique can achieve 20-dB gain in one stage over a limited temperature range, 10 dB more than a stable amplifier configuration produces.

However, injection locking has some drawbacks.

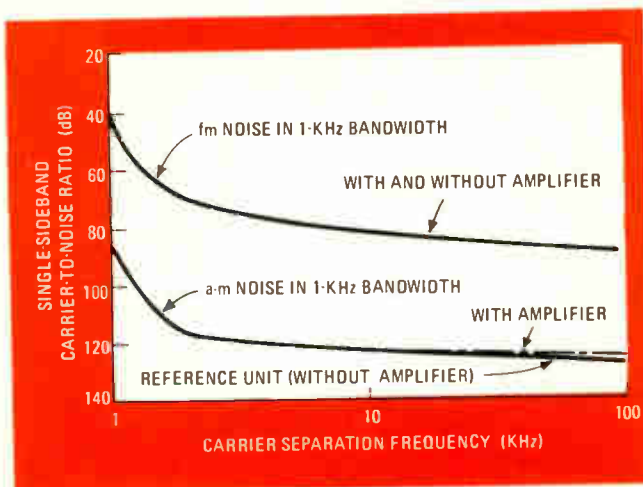

9. Noise. Little a-m noise and no measurable fm noise is added by a typical Impatt amplifier. Here, a 500-milliwatt, 10-dB Impatt amplifier is attached to a crystal-controlled oscillator-multiplier source.

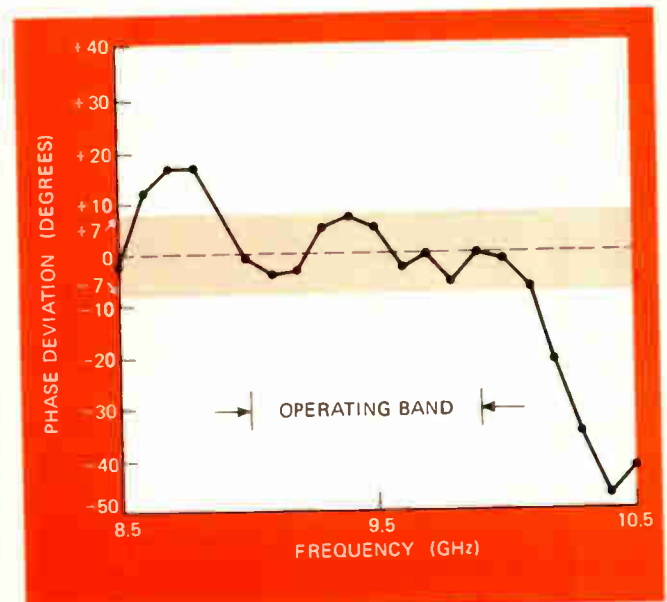

10. Linear phase. Deviation of phase from a linear slope of  $-50$  degrees per 100 MHz is  $\pm 7$  degrees maximum over a 1-GHz band. The two-stage coaxial amplifier has 10 dB of gain and 250 mW output.



Added circuitry is needed to turn the system off if it loses lock. Moreover, additional testing is required to make sure it holds lock with temperature changes.

Injection-locked oscillators have instantaneous bandwidth limits of typically less than 100 MHz in X and Ku bands, but they may be mechanically tuned over several hundred megahertz. The locking bandwidth and relative phase are given by the expressions:

$$\Delta f_{\max}/f_0 = (2/Q_{\text{ext}})(P_1/P_0)^{1/2} \text{ and}$$

$$\Theta \text{ is approximately } \sin^{-1}(\Delta f/\Delta f_{\max})$$

where:  $\Delta f_{\max}$  = the maximum locking bandwidth

$\Delta f$  = the frequency deviation from  $f_0$  within the locking bandwidth

$P_1$  = the incident locking power

$P_0$  = the free-running oscillator power

$Q_{\text{ext}}$  = the external circuit-quality factor

$\Phi$  = the relative phase angle between the injected signal and the output signal.

These expressions are valid for locking gains greater than 10 dB. Under these conditions, the output power of an injection-locked oscillator varies little for several orders of magnitude of the input-signal level.

Injection locking has also been used at millimeter frequencies. At V band (50-75 GHz), locked oscillators have operated with gain-bandwidth products as high as 6 GHz at output powers of greater than 100 mW.

The large-signal behavior of an injection-locked oscillator depends on the nature of the diode nonlinearity and the degree of coupling between the diode and external load.<sup>7</sup> In general, increasing the level of the large-signal locking drive results in a reduction in output power because of increased saturation level, which limits the maximum available output power from the locked oscillator to approximately that of a free-running oscillator. In this mode, amplifier power outputs can't be summed. Also, for some applications of the locked oscillator, amplitude-to-phase modulation conversion is a potential source of fm distortion.

The spectral noise characteristics of injection-locked Impatt oscillators have been analyzed<sup>9</sup> and experimentally verified<sup>10</sup> by a number of laboratories. In general, although the a-m noise level of injection locked oscillator is slightly higher than that of the free-running

oscillator, the f-m noise at frequencies close to the carrier can be reduced by injection-locking an Impatt oscillator with a relatively noise-free low-level signal.

Under these conditions, the noise spectrum (as measured by the fm deviation per unit bandwidth) is equal to that of the injected signal close to the carrier. At increasing divergence from the carrier frequency, the noise level of the locked oscillator asymptotically approaches that of the free-running oscillator. For larger values of locking gain, the increase in noise appears at frequencies closer to the carrier.

### Millimeter-wave amplifiers

Reflection-type Impatt amplifiers can operate at frequencies to 60 GHz and higher. At these frequencies, they require a different circuit form, consisting of a combination of waveguide and coaxial components (Fig. 11). A two-stage commercially available amplifier has a typical gain response shown in Fig. 12.

The 0.5-dB bandwidth of this amplifier is more than 500 MHz, while the 3-dB bandwidth is more than 2.7 GHz. Over a temperature range of 0 to 60°C, the gain variation is less than ±0.2 dB because of temperature compensation in the current regulators that drive each diode. Even when overdriven, spurious outputs from this amplifier are more than 40 dB below the carrier. This amplifier, with its four-junction circulator, had an input VSWR of less than 1.07, and the amplifier would operate without degradation into a load VSWR of 1.3. Millimeter-wave Impatt amplifiers are particularly useful in any frequency or phase-modulator system and can be used at gain levels to about 15 dB.

### Transmission-type amplifiers

The discussion so far has been limited to reflection-type amplifiers, which are most desirable at lower power levels where large gain-bandwidth products are desired. A second basic circuit category for two-terminal devices is the transmission amplifier.<sup>11</sup> Its circuit configuration (Fig. 13) has the basic advantage that it does not require a circulator.

The transmission amplifier circuit is less well developed than the reflection-type circuit. But it has been

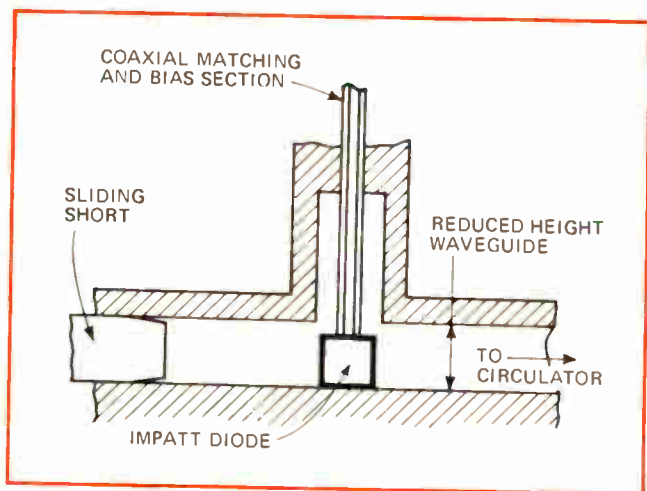

**11. Millimeter wave.** At frequencies to over 60 GHz, the reflection amplifier circuit combines a coaxial bias section with waveguide. Reduced-height waveguide matches to the lower diode impedance.

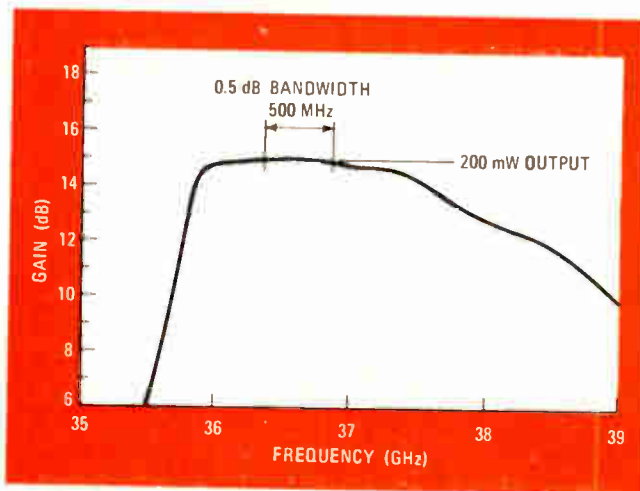

**12. Wideband.** Mm-wave amplifier achieves a 500-MHz, 0.5-dB bandwidth and about 3 GHz bandwidth at the 3-dB points. Input and output VSWR for the amplifier is less than 1.07 and 1.3, respectively.

analyzed for applications where low-gain, high-power output stages are needed. Eliminating the need for a circulator reduces construction costs and leads to less loss per stage; hence, higher efficiency and power output from a multistage amplifier is possible.

Reflected power (from amplifier stages toward the source) is a most critical parameter in the transmission amplifier circuit. To minimize reflected power, the source impedance must precisely match the input impedance of the amplifier (device plus load). In a multistage amplifier, this condition must, of course, be applied to each stage. Matching to these complex conditions is considerably more difficult than achieving the single matching condition that exists for reflection amplifiers.

Both calculated and experimental results for a two-stage transmission amplifier are shown in Fig. 14. The calculated response is based on a mathematical model of the physical circuit structure with diodes in place.<sup>12</sup> The 1-dB compression point occurs at about 0.6 w. At the 1-w output level and a gain of 5-dB, the gain compression is about 2 dB.

### Reliability

Extensive evaluation of the reliability of Impatt diodes is in progress. The most important device parameter affecting reliability, and ultimately device lifetime, is operating junction temperature. Work at Hughes is aimed at statistically correlating mean-time-before-failure with junction temperature, mainly by step-stress testing. In addition, a failure-analysis program has been initiated to provide the basis for tentative device failure models and to aid in improving device processing.

The step-stress testing is to establish operational stress levels that will accelerate predominant failure

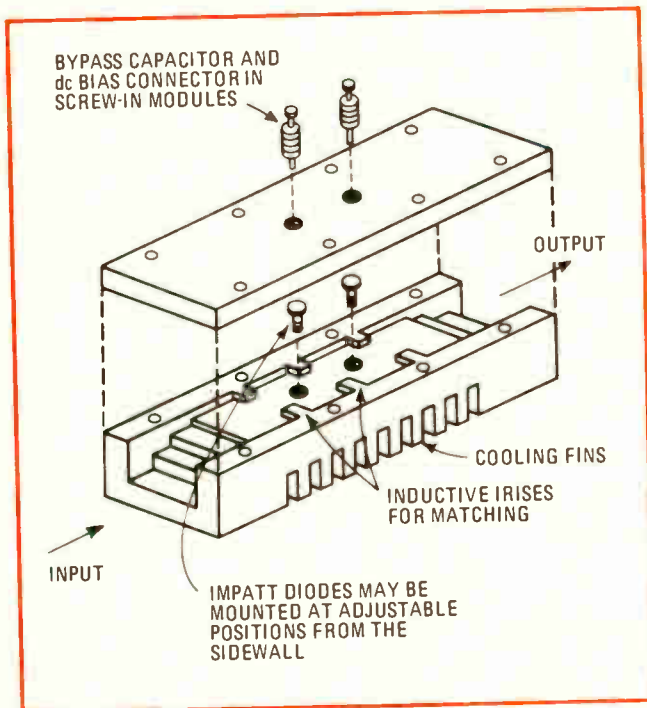

13. No circulator. The waveguide transmission amplifier, which needs no circulator, lends itself to high-power low-gain applications.

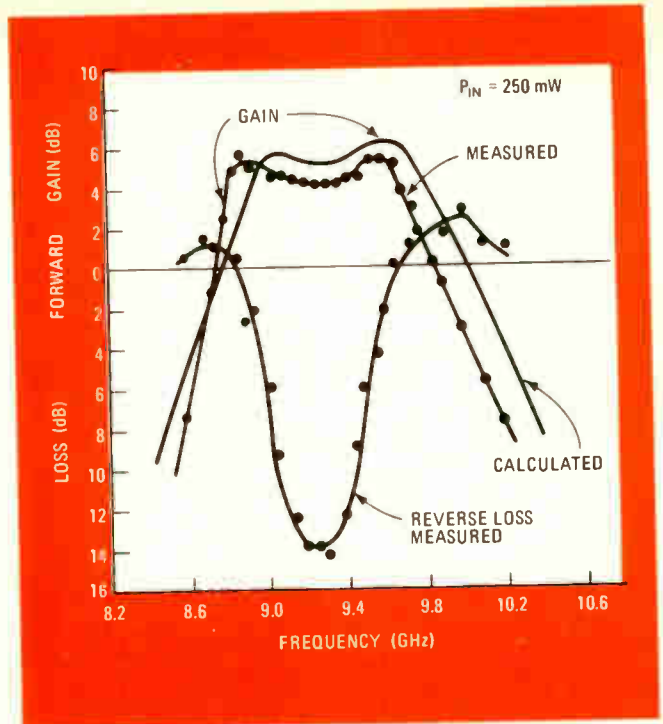

14. Transmission gain. Forward gain for an X-band two-stage transmission amplifier is about 4 to 5 dB with 250 mW input. Gain compression at 1-w output is about 2 dB. Circuit losses per stage are generally lower than in the reflection amplifier.

mechanisms so that meaningful failures can be generated in a relatively short time. High junction temperature resulting from dc power dissipation is used as a stressing agent. Statistical analysis of diode lots subjected to various stress levels thus provides data on MTBF as a function of a particular junction temperature (stress level). This information may in turn be extrapolated to obtain data on MTBF for any junction temperature.

For silicon Impatt devices, typical operating temperatures vary from approximately 150°C to burnout temperatures, which are about 400°C. Preliminary results from the step-stress analysis indicate reliable operating junction temperatures up to 225°C, where the predicted MTBF is on the order of 10<sup>5</sup> hours. At a junction temperature of 350°C, this value is reduced to approximately 10 hours, which is obviously unsatisfactory. □

### REFERENCES

1. G. L. Matthaei, L. Young, and E. M. T. Jones, "Microwave Filters, Impedance-Matching Networks, and Coupling Structures," McGraw-Hill Book Co., 1964.
2. W. J. Getsinger, "Prototype for use in Broadbanding Reflection Amplifiers," IEEE Trans. on Microwave Theory and Tech., pp. 486-497, November 1963.
3. J. L. Blue, "Approximate Large-Signal Analysis of Impatt Oscillators," Bell System Tech. Journal, pp. 383-396, February 1969.
4. D. L. Scharfetter and H. K. Gummel, "Large-Signal Analysis of a Silicon Read Diode Oscillator," IEEE Trans. on Electron Devices, ED-16, pp. 64-77, January 1969.
5. H. J. Kuno et al., "Low-Noise Epitaxial GaAs Avalanche Diode Amplifiers," presented at IEEE International Electron Devices Meeting, October 1968.
6. R. Adler, "A Study of Locking Phenomena in Oscillators," Proc. IEEE, Vol. 34, pp. 351-387, June 1946.
7. M. E. Hines, "Negative-Resistance Diode Power Amplification," IEEE Trans. on Electron Devices, Vol. ED-17, pp. 1-8, January 1970.
8. I. Talsuguchi, N. R. Dutrich and C. Bunko Swan, "Power-Noise Characterization of Impatt Oscillators," IEEE J. of Solid State Circuits, Vol. SC-7, pp. 1-10, February 1972.
9. K. Kurokawa, "Noise in synchronized oscillators," IEEE Trans. on Microwave Theory and Techniques, Vol. MTT-16, pp. 234-240, April 1968.
10. M. E. Hines, J. C. R. Collinet, and J. R. Ordvia, "Fm Noise Suppression of an Injection-Locked Oscillator," IEEE Trans. on Microwave Theory and Techniques, Vol. MTT-16, pp. 738-742, September 1968.
11. T. A. Midford and H. C. Bowers, "Transmission-Type Avalanche Diode Amplifiers," 1972 IEEE International Convention Digest, p. 350.
12. H. C. Bowers, T. A. Midford, S. T. Plants, "Impatt Diode Multistage Transmission Amplifiers," IEEE Trans. on Microwave Theory and Techniques, Vol. 18, No. 11, pp. 943-951.



# Many EEs still feel insecure about their careers, survey shows

Though the industry is projecting confidence and health, engineers continue to be jittery about job security and the opportunity for using their technical skills fully

by Gerald M. Walker, *Consumer Editor*

□ While most employed engineers appear moderately satisfied with their present employment, there are still a good many EEs who are angry, frustrated, or just plain bored. These contrasting moods were discernible in the results of a questionnaire on job status that appeared in *Electronics*, June 19, p. 103.

Intended to sample readers' experience, the survey provided respondents with an opportunity to sound off about being underemployed, shuffled around by employers, harassed with paper work, and abused as a group by economic conditions. However, the returns indicate that the majority were not simply soreheads, but concerned engineers uneasy about the future.

The uneasiness created by the business downturn and widespread layoffs persists, as does the chronic ambivalence about the pleasures and drawbacks of the career apparent a year ago—and this is happening despite what looks to be a recovery year in the industry. For example, there was an almost even split in the responses to three key questions about happiness on the job:

- On pay increases since the end of the so-called wage/price freeze—53% received boosts, 47% did not.
- On feeling underemployed—49% said yes, 50% said no, and 1% did not reply.
- On satisfaction with their present position—16% were completely satisfied, 45% moderately satisfied, 29% moderately dissatisfied, 9% completely dissatisfied, and the remainder gave no reply.

## What's wrong

The most common gripes about job satisfaction concerned having to do menial technicians' jobs, preparing paper work, and not having enough responsibility. Other complaints were added to them in the comments. As one middle-aged senior engineer put it, "Poor pay, poor benefits, no job satisfaction, management complaining about being taken advantage of, doing the same job I was doing 10 years ago—the same way. There is no incentive to use new or advanced methods."

A 34-year-old MEE in aerospace adds, "My position is that when I finish my design job, I have an excellent chance of being laid off. After 22 months in the company, I have not received a raise. Same for my fellow design engineers. The field cries out for 'union.'"

With a serio-comic touch, a 37-year-old EE with 15 years in engineering comments, "I am probably the last happy engineer. At present I am driving a truck. My

salary is approximately the same, but I have a complete list of fringe benefits, an annual raise, and I get paid for overtime. Why am I a happy engineer? Because now it is a hobby and I am not trying to make a living at it."

On the whole, however, responses to the question, "What would you prefer to be doing professionally?" reflected the majority's commitment to engineering, despite its frustrations. A desire for more challenging work was mentioned by far the most frequently. Other preferences included switching from defense/aerospace to commercial/industrial manufacturers, starting their own business, and moving into management. And one in six answering the question was completely content with his present position. "I am the lucky kind who is doing what he most enjoys. I seem to be growing at a good rate and getting more responsibility accordingly," said a 26-year-old EE for a semiconductor firm.

Layoffs may have declined this year, for only 6% reported cutbacks in engineering departments this year, as against 27% last year. Twenty-six percent reported cutbacks for both 1971 and 1972, compared with 38% who said no heads rolled in either year. Of the group that did experience departmental reductions, most

## Who replied

The returns to the job status questionnaire [*Electronics*, June 19, p. 103] represented a cross-section of age, years of experience, salary, company type, and location. Among the employed engineers, the 31-to-35 age group had most representation, five to 10 years of experience was most often cited, and salary ranges of \$11,000 to \$13,999, \$14,000 to \$16,999 and \$17,000 to \$19,999 were most mentioned. Companies represented most heavily were in communications/radar, missiles and space, computer, and electronic components. Design engineers contributed the most returns among job categories.

As for the unemployed, most were 40 to 60 with experience ranging from 16 to 25 years. Most-mentioned company types were missiles and space, electronic components, and computers.

The break-out of states for both employed and unemployed followed an expected order—California, Massachusetts, New Jersey, New York, Pennsylvania, and Texas with the lion's share. There was also a handful of foreign-country respondents—all employed.



stated that they did not have to work longer hours to take up the slack, despite the general complaints about overtime and weekend work.

Responses from unemployed EEs, though too few to be conclusive, were valuable indicators. Most had been out of work for over a year, some for two years. Significantly, well over half were 41 years old or older, and very few had more than a bachelor's degree.

A clue to the plight of the older, unemployed EE is that most of those responding had had just five or fewer engineering job interviews even in long-term jobless situations. Consequently, most have sought employment in nonelectronic industries and have looked for jobs outside of engineering. In addition, most have taken non-engineering graduate courses to convert to other professions. Included in the list of non-engineering jobs were selling insurance, selling real estate, teaching, product sales, selling automobiles, and starting one's own company. Most of the unemployed had been in engineering for 11 to 25 years.

Not unnaturally, comments from the unemployed reflected discouragement with the system and a desire to get out of a technical career. Such was the case with an engineer who had moved through a number of semiconductor firms, growing up with basic processing to become a product manager, only to be scuttled along with the entire product program in July 1970. He writes:

"The purpose of relating this information is to illustrate that I did earn my pay, that I did get good raises, and that with a BS I contributed sufficiently to be able to demand good pay. Now, all of a sudden, I am over-qualified for any professional job; so how do I live, or at least exist, until job opportunities reopen? I became a real-estate salesman and opened a pizza parlor.

"Now what happens if the industry needs engineers? Would I go back to work in an environment where there is no security? I doubt it. What's more important is how many others like me are there? Who is losing? I'm making my way—my net worth has increased at almost \$40,000 per year since I became unemployed. In order for me to consider going back into electronics, the rewards would have to be quite generous. And how much does the U.S. lose with all these technical people pumping gas, laying cement, etc.—not through choice, but of necessity—to put bread on the table?"

### Hurt feelings

Far more discouraged, a former project engineer with 16 years of experience, comments, "I am 38 years old, and have a wife and three children to support. I am receiving food stamps besides unemployment compensation. This is what my years of college and engineering have bought me. I hope to find employment outside the electronics field and never hear the words technology and engineering again."

"The engineer has been treated as a piece worker," he adds. "Once his design, with many hours of unpaid overtime is completed, he is laid off. No wonder electronics is like the garment industry of the 19th century."

An out-of-work director of engineering, aged 52, observes, "I assume my engineering career is finished, just at that age when my earnings should be maximum." A BSEE, 20 years younger, says bitterly, "When I put nine

years in engineering and end up making luggage for \$140 a week, I realize I've been swindled."

About two-fifths of the employed respondents had been laid off or transferred in the preceding two years. On the whole, the laid-off group found new jobs with relative ease, a large proportion within three months. But many suffered penalties in being relocated. Most ended up with lower-paying jobs and lower responsibilities, and a third in this category took completely different positions from those they had formerly held.

Considering the job market, it was not surprising that just 16% changed jobs of their own accord during the last two years. However, one respondent reports, "I left EE work to raise chinchillas. I'm independent and free."

A preponderance of both employed and unemployed agreed that the engineer has not been treated fairly during the downturn in the economy and the cut in Government spending. The same held true concerning efforts by state and national agencies to find jobs for unemployed engineers—a large majority feels these programs are inadequate.

Nevertheless, a strongly worded disagreement with the prevailing attitude came from a Midwestern research engineer, aged 30. He states, "Except for cases of unreasonable age discrimination, any engineer who cannot find a job in his profession is not very competent. I oppose all these pseudo-union attempts to protect incompetent engineers. Every single one of the laid-off guys I know was a bad performer. Good riddance."

### Assistance that isn't

Far more typical, a 41-year-old project engineer argues, "The engineer has been pictured in the news as being responsible for pollution and environmental damage. The implication is that the engineer is now getting his 'just deserts' and is not to be pitied. The engineer's side of the story always seems to end up on the cutting-room floor. There is consequently very little push behind programs to assist the engineer."

Similarly, "technologists will continue being misused and exploited until we get together and form strong professional organizations, or affiliate with the type of union which can back up demands for fair treatment by the private and government developers and users of technology," a West Coast respondent states, adding, "We should also develop our own code of ethics. If these things were done, we might gain some respect."

Concerning placement efforts, this reader charges, "they are ineffective, politically expedient, publicity-generating, paper-shuffling, computerized boondoggles embodying the worst of aerospace practices and governmental bureaucracy. They benefit few of the truly hard-hit (over 40 and laid off from long-term high-paying positions), and some specify racial quotas, while excluding the older technologist (another minority but with no political clout). They do benefit the developers of the programs, typically ex-aerospace management types, and the institutions conducting the training. The federally encouraged but unfunded 'self-help' groups tend to inhibit through policy and fragmentation . . . a real movement by rank and file towards professional organizations dedicated to improving the status of technology as a career. Perhaps this is intentional. The self-help

## Job status of the employed—mixed experiences

Here is a summary of the results on certain key questions that appeared on the June 19 questionnaire in Electronics. Statistics were compiled from forms submitted by readers, and percentages have been rounded.

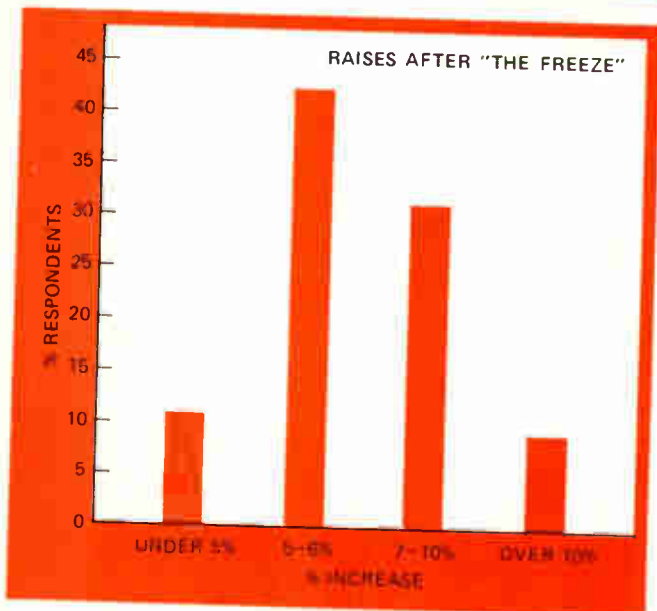
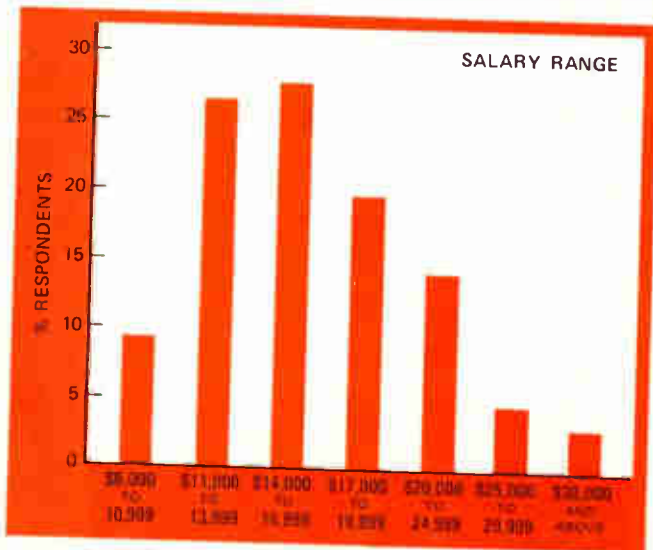
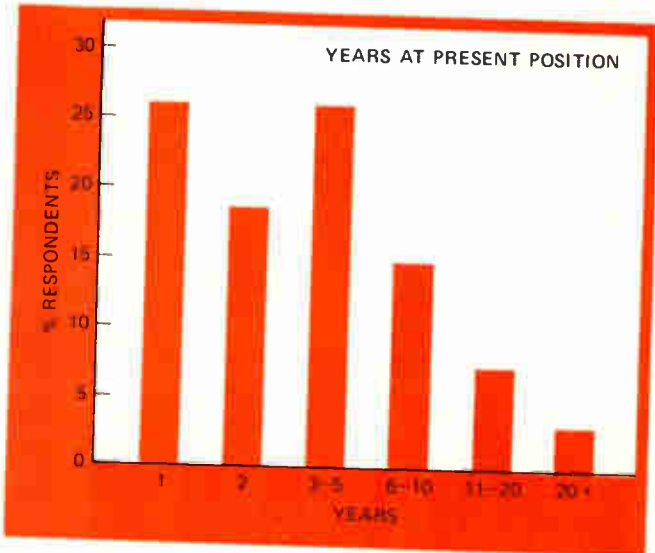

### EXPERIENCE OF THOSE LAID OFF AND REHIRED:

#### NUMBER OF MONTHS OUT OF WORK:

1-3 months:	44%
4-6 months:	26%
7-9 months:	9%
10-12 months:	6%
Over a year:	10%
No answer:	5%

#### SALARY WHEN REHIRED:

Higher:	19%
Lower:	46%
Same:	24%
No answer:	10%

#### LEVEL OF RESPONSIBILITY WHEN REHIRED:

Higher:	23%
Lower:	40%
Same:	23%
No answer:	15%

#### CURRENT ASSIGNMENT VERSUS LAST:

Same:	14%
Related:	41%
Completely different:	33%
No answer:	12%

### JOB SATISFACTION

#### ARE YOU SATISFIED WITH YOUR POSITION?

Completely satisfied:	16%
Moderately satisfied:	45%
Moderately dissatisfied:	29%
Completely dissatisfied:	9%
No answer:	1%

groups have helped individuals within their ranks more than the funded governmental programs, however."

Agreeing that the governmental projects to hire engineers have fallen short, a 40-year-old East Coast EE also contends that the "problem is at least equally due to selfish, shortsighted attitude of corporations that deny responsibility and refuse even moderate risks in marketing, financial, and personnel policies."

"I tried all of their [governmental agencies] approaches," says a 50-year-old engineer in Government contracting. After being out of work for over a year, he took a job at a lower salary, a lower level of responsibility, and on a completely different technical assignment. He reports that over 1,000 résumés were sent out, but the agencies produced no job interviews.

Perhaps a 35-year-old Texan summarized with irony the feelings of many engineers when he remarked, "My father is a plumber, and if he and his fellow workers were treated the way engineers are, every drain in the country would be stopped up." □



## You've just lost your excuse for not using solid-state microwave amplifiers.

Because now there are C, X, Ku, and millimeter wave amplifiers from Hughes at power levels up to 1.5 watts.

And not just experimental models either. These new avalanche diode amplifiers have already proven themselves in the F-14, F-15 and Phoenix programs.

They can replace many TWTs. They're

reliable. They're tough, small, light, and very cheap to buy and maintain.

They perform like gangbusters too. Power outputs in C- and X-bands go to 1.5 watts, minimum. Ku-band—1 watt minimum. 33-40 GHz—200 mW minimum. 50-75 GHz—50 mW minimum. Bandwidths up to 10%, gains to 30 dB.

And we warranty each

amplifier for one year.

So if you'll write or call us about your needs and applications, we'll give you some solid answers. With no excuses. 3100 W. Lomita Blvd., Torrance, CA 90509 (213) 534-2121.

**HUGHES**

HUGHES AIRCRAFT COMPANY  
ELECTRON DYNAMICS DIVISION



## A fail-safe font of seven-segment digits

by Brian Astle  
Optel Corp., Princeton, N.J.

The trouble with most popular seven-segment display fonts is that a failure in a single segment may transform one digit into another. For example, if one segment sticks at "off," a 7 could be interpreted as a 1, or if it sticks at "on," a 0 could appear as an 8. Here is an idea for a font, which, although it has not been widely tested and would require some operator training, is fail-safe and can even be extended to mathematical symbols.

In the odd-parity font, shown in Fig. 1c, each digit contains an odd number of segments and so has odd parity. Thus if one segment either goes off or comes on, the error will be immediately recognized (the common font has both odd and even parity).

In this new font, the formats for digits 0, 1, and 4 require learning. The symbol for zero was made to resemble an imperfectly closed script zero. This is not

likely to be confused with any other numeral, and offers an alternative to the slashed zero now used to distinguish zero from the letter O. The symbol representing one was chosen as the full symbol 1, with the upper left and lower right strokes deleted. Note that the symbol has full height and width, an aesthetic advantage not enjoyed by the common font one. The symbol representing four was derived from the common font symbol by deleting segment B.

The concept also can be extended to mathematical symbols. There are 64 odd-parity seven-segment symbols, 22 of which are shown in Fig. 2. The decimal-point symbol was chosen to be readily distinguishable from the minus symbol and to be similar to the European notation. The symbol for a power is similar to the vertical arrow symbol, and also suggests the conventional positional notation.

The symbol for multiplication, which is needed to represent floating-point numbers, was chosen arbitrarily. Bases other than 10 are indicated by symbols that precede the base numbers. The symbols for 10 and 11 provide the extra two symbols needed for counting in base 12. The symbol for 10 also is useful in representing floating-point decimal numbers.

Complex numbers require the symbols representing

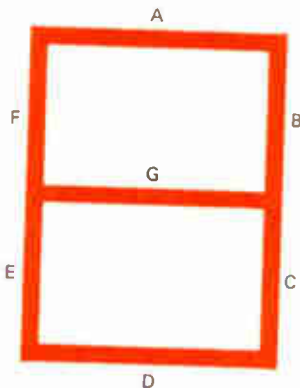

(a)

FONT	SEGMENTS USED	FONT	SEGMENTS USED
0	A B C D E F	0	A B C D E
1	B C	1	B C D
2	A B D E G	2	A B D E G
3	A B C D G	3	A B C D G
4	B C F G	4	C F G
5	A C D F G	5	A C D F G
6	A C D E F G	6	C D E F G
7	A B C	7	A B C
8	A B C D E F G	8	A B C D E F G
9	A B C D F G	9	A B C F G

(b)

(c)

1. Failure in one segment of seven-segment display (a) could produce misinterpreted digits with the font presently used (b). Proposed odd-parity font (c), though it requires relearning, displays meaningless character when one segment fails.

addition, subtraction, and the square root of  $-1$ . It is sometimes desirable to represent complex numbers in  $r\theta$  coordinates, and a symbol for the complex plane angle is reserved to denote the use of these coordinates. When this symbol appears between two numbers, the first number represents the distance from the origin. The second number represents the angle in degrees, unless it is followed by the symbol for radians.

To complete the set of commonly used symbols, those for divide and for equal have been included, although they are not strictly necessary for number representation. Certain important numbers such as  $\pi$  and  $e$  are worthy of representation and are also included.

The author has compiled an additional list of symbols for some of the more common functions, which he will make available to those who are interested.  $\square$

SYMBOL	CONVENTIONAL REPRESENTATION	ODD-PARITY, SEVEN-SEGMENT REPRESENTATION
MINUS	-	- G
DECIMAL POINT	. or ,	C
EXPONENTIAL	Positional	┌ A E F
TIMES	X	└ C D E
BASES OTHER THAN 10	Positional	└ D E F
TEN	10	▯ A C D E G
ELEVEN	11	┌ B C F
PLUS	+	└ B C G
SQUARE ROOT OF $-1$	$\sqrt{-1}$ or $j$	┌ A C D
COMPLEX PLANE ANGLE	$\angle$	┌ A B F
DEGREES	$^\circ$	┌ A B G
RADIANS	rad	└ E F G
LESS THAN	<	└ D E G
LESS THAN OR EQUALS	$\leq$	└ D F G
GREATER THAN	>	┌ C D G
GREATER THAN OR EQUALS	$\geq$	┌ B D G
PLUS OR MINUS	$\pm$	▯ A B D F G
APPROXIMATELY	$\approx$	└ B C D E G
DIVIDE	/ or $\div$	┌ B E G
EQUALS	=	≡ A D G
Pi	$\pi$	┌ A B C E F
BASE OF NATURAL LOGARITHMS	e	E A D E F G

2. Mathematical symbols can be represented in odd-parity, seven-segment font for use in more complex displays.

## New ECL-compatible logic uses less power from a single supply

by Bohumir Sramek,  
International Peripherals & Computer Corp., Santa Ana, Calif

Anyone looking for a logic family that's compatible with conventional emitter-coupled logic, but dissipates less than one-quarter of the power at the same propagation delay should be interested in a new logic family called  $2\frac{1}{2}$ -diode logic. Circuits in the new family require only one power supply voltage, with a potential of only  $2\frac{1}{2}$  times the voltage drop across a diode; hence the name,  $2\frac{1}{2}$ -D.

Other advantages include: fewer components per gate, and therefore less area per gate on a silicon chip; more gates per package within power dissipation limits;

better reliability and lower cost, as a direct result of the lower power dissipation; and the ability to operate with a single standby battery cell during a primary power outage.

The  $2\frac{1}{2}$ -D family does have two disadvantages: it doesn't have an uncomplemented output, and its threshold is temperature-dependent. A temperature-dependent power supply should overcome the latter disadvantage. A supply that changes by  $-3$  millivolts per degree Centigrade change in temperature should keep the threshold in the middle of the logic swing, since the transistor base-emitter voltage changes by approximately  $-2$  mV/ $^\circ$ C.

In emitter-coupled logic—sometimes called current-mode logic—a constant current is steered through one of two paths by a current switch. These circuits are suitable for high-speed applications because no transistor saturates in these circuits, and carrier storage does not occur.

In a typical ECL circuit (Fig. 1) the power dissipation

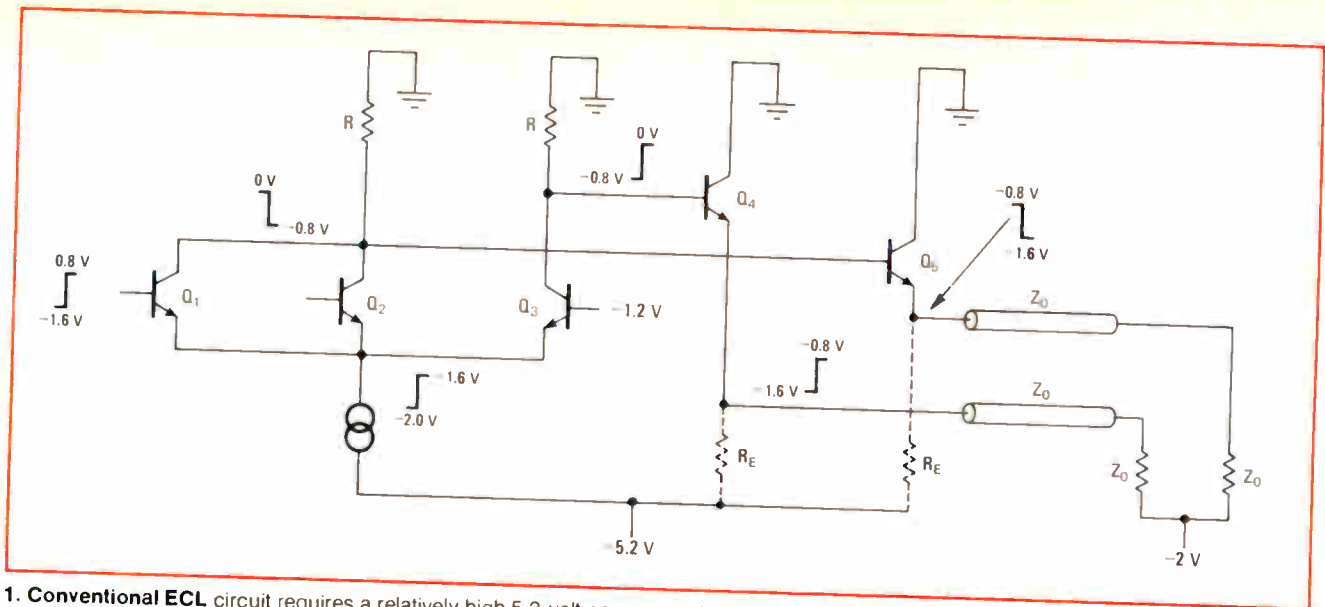

1. Conventional ECL circuit requires a relatively high 5.2-volt power supply, in addition to a 2-volt supply, for output transistors.

is established by the collector resistance  $R$ , the power supply  $V_{EE}$  of  $-5.2$  v, and the value of the emitter resistors, which may be at either the driving end or the receiving end of the transmission line, depending on the application.

A simple  $2\frac{1}{2}$ -D logic current (Fig. 2) needs only one 2-v supply, the same as the termination voltage in the conventional ECL circuit. But with the same value of collector resistance and the same logic levels, the propagation delay is not affected. This reduces the power dissipation per switch by about 60%.

A further power reduction of 50% to 70% below this already low level (to a point 12% to 20% of the original) is possible by eliminating the noninverting output while keeping the same current from the  $V_{EE}$  supply. This is possible by removing the noninverting emitter follower circuit and the reference transistor ( $Q_3$  in Fig. 1).

When circuit elements are removed, the natural properties of the semiconductor material establish the reference, as they do in saturating-logic families such as DTL and TTL. However, the logic capability of the  $2\frac{1}{2}$ -D circuit is only slightly affected—the OR/NOR function of the

original ECL circuit is changed to a NOR function, from which any larger digital function can be assembled.

When the circuit in Fig. 2 has a binary 0 at both inputs, both input transistors  $Q_1$  and  $Q_2$  are non-conducting and the only current path from the power supply is through the output transistor  $Q_3$ . If a binary 1 appears at either input, the corresponding transistor turns on, and current flows through  $R_E$ , having a value such that the sum of the two currents through the two branches with a 1 at the input equals the current through the output branch and  $Q_3$  when both inputs were at logic 0.

In this simple circuit, the diode prevents the input transistors from saturating by clamping the collector at 0.8 v, the drop across the diode. But a more practical circuit (Fig. 3) uses a transistor as a clamp instead of a diode; the proper choice of  $R_{C1}$  and  $R_{C2}$  allows an adjustment of logic levels. Meanwhile, the ratio of  $R_{C1} + R_{C2}$  to  $R_E$  can be varied (as it can in the diode version) to make the transfer characteristic of the gate match that of standard ECL. □

Engineer's Notebook is a regular feature in Electronics. We invite readers to submit original design, applications, and measurement ideas. We'll pay \$50 for each item published.

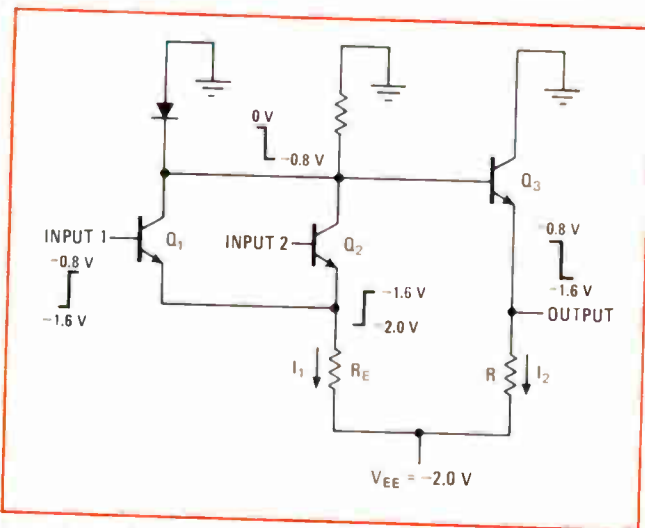

2.  $2\frac{1}{2}$ -D circuit uses only a 2-volt supply and only one of two output circuits; reference transistor cuts power by factor of 5 to 8.

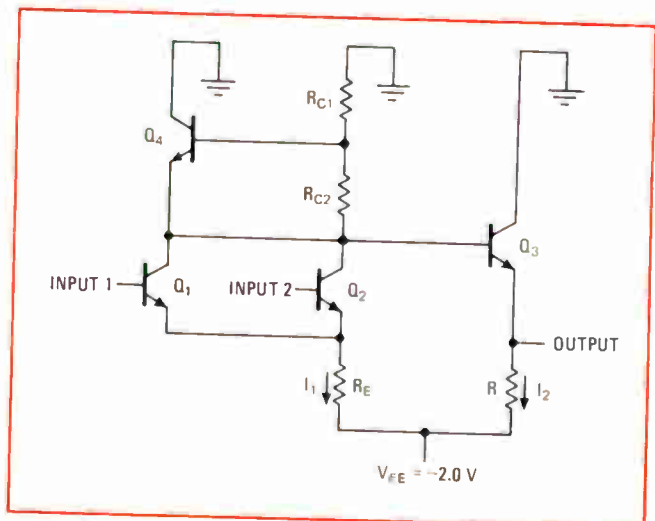

3. For matched performance, transistor clamp  $Q_4$ , instead of diode, assures logic levels and transfer characteristic are the same as ECL.



## Is grass greener across the sea. . .

Ever had the feeling that a year or two of work overseas "someday" might be just the thing to recharge your batteries? Or are you just curious about job opportunities outside this country? **The U.S. Department of Commerce has put out a 150-page guide that can help you zero in on a decision.**

Called "Engineers' Overseas Handbook," the guide examines the picture in 114 countries, arranged alphabetically from Afghanistan to Zambia. **Information is in the form of answers to 12 questions posed by Commerce experts to their foreign counterparts.** A typical question: "Can foreign engineers (specifically, U.S.) work without a license issued by the country? If not, what are the requirements for such a license?"

The book could turn out to be a bargain at \$1.50 per copy. Order it from the Superintendent of Documents, Government Printing Office, Washington, D.C. 20402.

## . . . or is it better to be own boss?

If you're really determined to start your own business and don't happen to be independently wealthy, a \$24.95 investment in a new book entitled "Up Your OWN Organization!" could save you a lot of time, trouble, and cash. Written by Donald M. Dible, who got his BSEE at MIT and his master's at Stanford, **the 372-page work goes into considerable detail about profiles and case histories, entrepreneurial motivation, partners, training, idea conception, establishing a business plan, and—last but not least—where to get money.**

The book is published by Entrepreneur Press—a new business started by Dible—whose mail address is Mission Station, Drawer 2759T, Santa Clara, Calif. 95051.

## Two-day session to examine hospital role of engineer

Coming up is a golden opportunity to get in on one of the hottest new areas for EEs: clinical engineering. The means is a two-day tutorial session called "The Clinical Engineer in Today's Hospital" scheduled for Oct. 27 and 28 at Washington's Sheraton-Park Hotel.

**The program is aimed at applications in the total patient-care environment.** Clinical engineering in a variety of those environments will be emphasized. Information, program, and registration forms are available from the Association for the Advancement of Medical Instrumentation, Suite 417, 1500 Wilson Blvd., Arlington, Va. 22209.

## Addenda

Here's a useful addition to your collection of charts: **Ithaco's phase and amplitude response of variable filters.** The monograph covers four-pole Butterworth high-pass, four-pole Butterworth low-pass, and four-pole Bessel low-pass filters. The booklet number is IAN-101, and Ithaco's address is 735 West Clinton St., Ithaca, N.Y. 14850. . . . Motorola Semiconductor has just published the first edition of the Semiconductor Data Library. The first two volumes of the three-volume set give data-sheet specs of all Motorola discrete semiconductors. **However, the third volume offers a technical description of all EIA-registered devices made by all manufacturers.** Price for the basic set is \$6.50; for \$10, you also get an updating service.

# We made it as a snap-in replacement for your analog meter. And it is.



## Our AD2002 2½-digit DPM. Only \$50.00.

Our panel meter gives you everything.

Right off, it's the smallest high performance 2½-digit DPM you can buy right now. Only eight cubic inches that measures 1.8" H x 3" W x 1.5" D.

Think of it as a component.

It easily snaps into your panel from the front. And has a green filter because we found that green is easier to look at.

For options, you can have our AD2002 with red, blue, or amber colored filters to color-code your readouts.

Plus BCD outputs to provide data processing interfacing capability with a variable reading rate to

let you hold and read on command.

All it lacks is ambiguity.

It's an improvement over any analog meter because it improves the reading of critical signals.

In medical, scientific and industrial instrumentation. And measurement, control and data acquisition systems.

It's accurate to  $0.5\% \pm 1$  digit with 10mV resolution. Accepts unipolar, single ended input signals over a full scale range of 1.99V.

It has automatic overload indication. RCA Numitron tubes. Is 5VDC powered. And even has a seven segment filament test.

To assure reliability, we burn-in each meter for 7 days before shipping.

Like our first digital panel meter, if we couldn't have made it better, we wouldn't have made it.

Or any of the 3½, 4½, and other DPM's we've got on the way.

We can send you an evaluation sample of our AD2002 right now. Along with our 1972 Product Guide which shows all the other things we make to solve more of your problems better than anyone else.

Analog Devices, Inc., Norwood, Mass. 02062.  
(617) 329-4700.



# The FUJITSU quality for sale in Ultra-Mini Relays

## Relays Type 151 and 473 Series

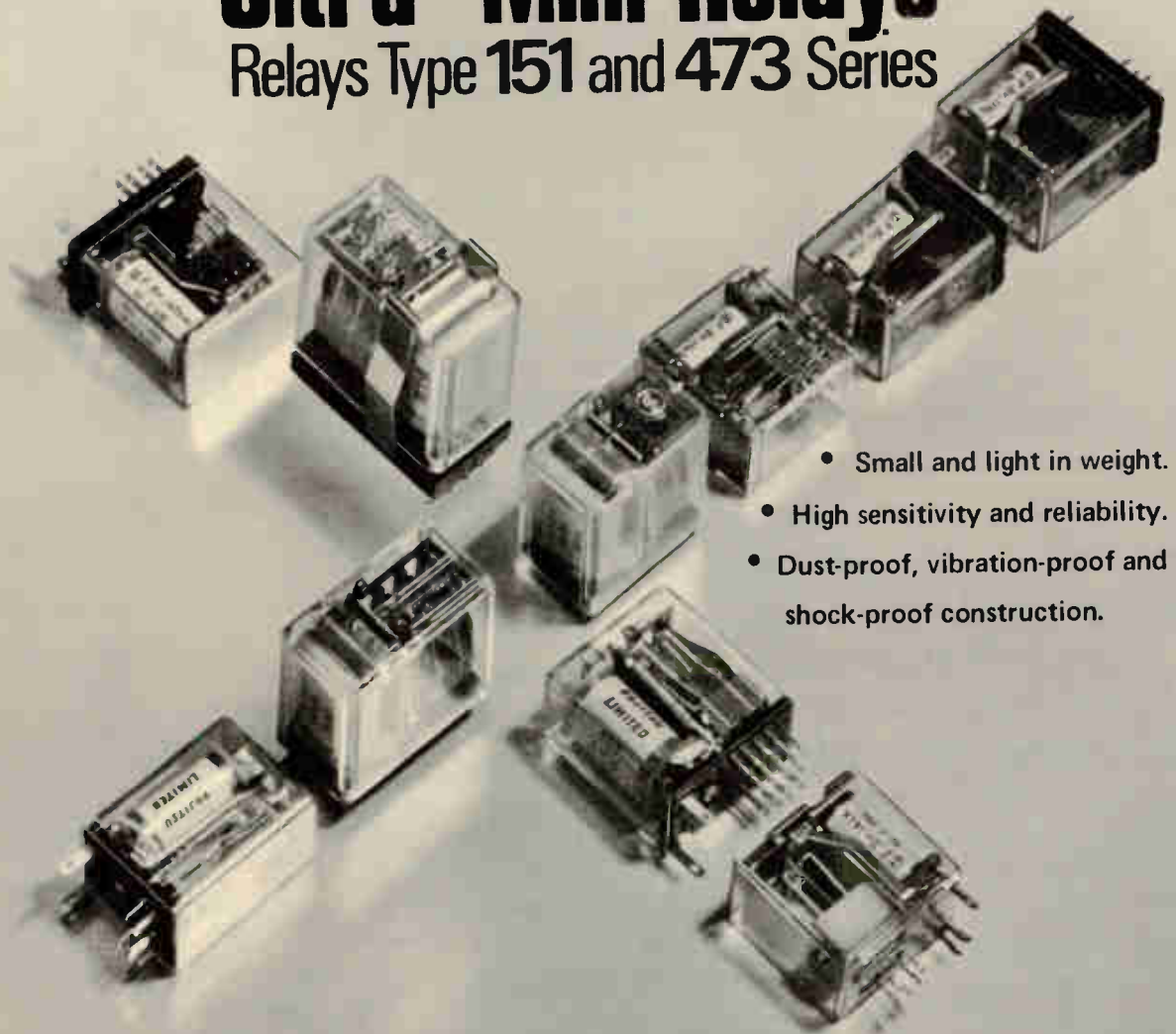

- Small and light in weight.
- High sensitivity and reliability.
- Dust-proof, vibration-proof and shock-proof construction.

	Contact Form	Contact Rating	Voltage Rating	Pick-up Current (Voltage)	Stray Capacity	Pull-in Time	Drop-out Time	Initial Contact Resistance	Dielectric Strength	Shock	Life	Dimensions (mm)	Weight (gr)
151-156 (Single contact)	DPDT 4PDT	100V DC 0.3A 100V AC 1A	6-48V DC	5-58mA DC	-	10mS	8-15mS	Max 50mΩ (Gold plated) Max 150mΩ (Silver, No. 1 alloy)	500V AC for one minute	10G for 11mS duration without relay dam- age	5 x 10 <sup>7</sup>	32.5 x 29.5 x 18.8 (4PDT)	25
151X (Small stray capacity)	DPDT	100V DC 0.1A 100V AC 0.3A		11-58mA DC			Max 1PF	8mS				Max 400mΩ	27.1 x 28.8 x 18.5
473D, 474D (Twin contact)	DPDT 4PDT 8PDT	100V DC 0.3A	6-100V DC	6-130mA DC	-	20mS	6mS	Max 50mΩ (Gold plated) Max 150mΩ (Gold flashed)				32.5 x 35.0 x 18.8 (8PDT)	40
473A, 474A (Twin contact)	DPDT	115V AC 1A	6-115V AC	4.8-92V AC	-			32.5 x 23.7 x 18.8				30	

\* 151 Screw/solder terminal  
153, 473 Plug-in with socket  
156 Stud-screw/solder terminal

154 Printed circuit board (151 relay remodelled)  
155 Printed circuit board (153 relay remodelled)  
474 Printed circuit board (473 relay remodelled)

 **FUJITSU LIMITED**  
Communications and Electronics  
Marunouchi, Tokyo, Japan

MAIN PRODUCTS □ Telephone Exchange Equipment □ Carrier Transmission Equipment □ Radio Communication Equipment □ Space Electronics Systems □ Auto Radios & Car Stereos (TEN) □ Electronic Computers & Peripheral Equipment (FACOM) □ Telegraph & Data Communication Equipment □ Numerical Control Equipment (FANUC) □ Remote Control & Telemetry Equipment □ Electronic Components



# Panel meter offers 3 full digits

Priced under \$50 and featuring a fully floating front end, digital unit is designed to replace precision analog meters

by James Brinton, Boston bureau manager

A digital panel meter that's a direct replacement for analog meters is an engineer's dream. Unfortunately, DPMS traditionally have cost more than galvanometers, need external power, and lack the analog meter's two-terminal input flexibility.

But the dream is fast becoming reality. Analogic Corp., Wakefield, Mass., has introduced what it calls the nearest thing available to a replacement for analog meters, at a price between \$47 and \$49 each in lots of 100, and below \$45 in lots of 1,000.

While the new meter—the model AN2530—does require 3 watts of power, it offers a standard BCD output, a feature nonexistent on analog meters, and standard external blanking, a rare feature on DPMS. A three-digit DPM using incandescent seven-segment displays, the model AN2530 has 1-in-1,000 resolution, in contrast to the 1-in-200 resolution of its nearest competitors—2½-digit devices.

The other specs of the AN2530 look good, too. Linearity is within 0.2% plus or minus one count; input bias current is only 10 nanoamperes—competing units run well above 200 nA; input impedance is a constant 1,000 megohms—many competing meters have only 100 megohms at best, and their impedance can fall as voltage rises above the full scale limit of the meter. What's more, sensitivity at 100 microvolts per count is said to be 100 times that of competing units costing more.

Common-mode rejection is unusually high—120 decibels—made possible by the meter's analog return system. Competing meters usually ground out to the mainframe

digital power supply, but Analogic's system uses a fully floating front end capable of handling multi-hundred-volt swings.

To get this level of performance and three-digit resolution at the price, Analogic's engineers revamped the traditional panel meter so much that the circuitry inside the 6.5-cubic-inch case bears little resemblance to past DPMS. Component count is down from as much as 80 parts for competing 2½-digit DPMS to only about 40 for the AN2530. Analogic designers accomplished this by using transistor-transistor logic instead of MOS LSI devices that, they say, are supposed to reduce parts cost and count, but often don't. The AN2530's entire logic complement consists of a gate package and three counters driving three decoder drivers.

Bernard M. Gordon, Analogic's board chairman, says, "If we had used MOS LSI, we would have had to outboard 25 or so components around the chip to allow display driving. Even a three-year projection of prices showed that the same functions in MOS would have cost at least twice as much as the approach we used."

Analogic has filed for a patent on the circuitry, but to illustrate the

multitask approach to parts use, Gordon cites a transformer that couples a count pulse out of the isolated analog section and into the counter circuitry and also transmits a synchronizing pulse from the time-base generator to eliminate random errors in plus and minus counts. Most other parts do at least double duty: 10 components (three displays, three counters, three decoder drivers, and one gate package) supply all gating control and multiplying functions; of the five components in the time-base generator, only one is active, and out of 15 components in the analog front end, only five are active, and four of these are single transistors.

"We have made every component count," says Gordon. Thus, Analogic also has cut production costs and theoretically has increased reliability. But most importantly, "we have been able to reach prices competitive with so-called high-accuracy (within 0.5% to 1.0%) analog meters, while offering three-digit resolution and higher accuracy than either competing DPMS or analog meters," he adds.

Samples are available from stock at \$75 each.

The Analogic Corp., Audubon Rd., Wakefield, Mass. 01880 [338]



# Digital multimeters press analog units

Fluke instrument features 3½-digit display, full complement of ranges; voltage-to-frequency converter eliminates zero offset error

by Michael J. Riezenman, Instrumentation Editor

The ubiquitous analog multimeter will probably be with us forever. But its position as king of the electronics tools in the laboratory, on the production line, and in the field is being challenged by a number of modern digital multimeters. These new instruments are not only more accurate than their analog counterparts, but they are easier to use, and they feature the unambiguous displays that only digital instruments can provide.

Fluke's new model 8000A is a portable 3½-digit unit with a full complement of ac and dc voltage and current ranges, plus dc resistance ranges. Although the instrument does not have automatic ranging, it does provide automatic polarity detection and display.

The heart of the instrument is a unique voltage-to-frequency converter that determines the polarity of the input signal at the digital, rather than the analog, level. Because this converter is used, the instrument has no zero offset error,

and it doesn't need a separate calibration adjustment for each polarity.

There are five ranges for both ac and dc voltage, starting with  $\pm 100$  millivolts full scale and running up to  $\pm 1,000$  volts. Also, 100% over-ranging is provided on all voltage scales except 1,000 v which goes up to only 1,200 v. Current, like voltage, is measured on five ranges for both ac and dc, starting at  $\pm 200$  microamperes full scale and going up to  $\pm 2$  amperes, including the over-ranging. Six resistance ranges are provided—from 200 ohms full scale to 20 megohms.

Because of its small size (8.5 in. by 1.75 in. by 10 in.) light weight (8 lb with batteries), and ruggedness, the 8000A should prove particularly valuable in field servicing applications such as the maintenance of computer peripherals, in industrial situations, and anywhere that ac power isn't conveniently available.

The single-unit price of the 8000A is \$299, excluding batteries. A set of

rechargeable batteries, good for at least eight hours of continuous operation and complete with an internal battery charger that recharges them during line operation, adds \$50 to the base price. Quantity discounts are available.

John Fluke Manufacturing Co. Inc., P. O. Box 7428, Seattle, Wash. 98133 [339]

## KEY SPECIFICATIONS

(All accuracy specifications are good from 15°C to 35°C)

**Maximum dc voltage error:**  $\pm(0.1\%$  of reading + 1 digit).

**Input resistance on dcV:** 10 megohms.

**Maximum ac voltage error:** 45 Hz to 10 kHz,  $\pm(0.5\%$  of reading + 2 digits); 10 kHz to 20 kHz,  $\pm(0.7\%$  of reading + 2 digits).

**Input impedance on acV:** 10 megohms in parallel with 100 pF.

**Maximum dc current error:**  $\pm(0.3\%$  of reading + 1 digit).

**Maximum ac current error:**  $\pm(1.0\%$  of reading + 2 digits) from 45 Hz to 10 kHz, except for the 2-A range, which has an upper frequency limit of 3 kHz.

**Maximum voltage burden for current measurements:** 0.22 V, to 1 A.

**Maximum resistance error:** 200 ohms to 2 megohms,  $\pm(0.2\%$  of reading + 1 digit); 20-megohm range,  $\pm(0.5\%$  of reading + 1 digit).

**Ohmmeter input characteristics:** Current through unknown is 1 mA on the 200- and 2,000-ohm ranges, 100  $\mu$ A on the 20-kilohm range, 1  $\mu$ A on the 200- and 2,000-kilohm ranges, and 0.1  $\mu$ A on the 20-megohm range. Maximum voltage that can be applied safely to the input terminals is 130 V rms on the 200- and 1,000-ohm ranges, and 250 V rms on the others.

**Display:** 7-segment LED, character height is 0.25 in.

**Calibration interval to maintain listed specs:** 1 year.

**Stable.** Multimeter will retain its specified accuracy for at least one year if stored at a temperature between  $-40^{\circ}\text{C}$  and  $+85^{\circ}\text{C}$ . Operating temperature range is  $-10^{\circ}\text{C}$  to  $+55^{\circ}\text{C}$ , although the specified accuracy is only guaranteed from  $15^{\circ}\text{C}$  to  $35^{\circ}\text{C}$ .



Instruments

## Power amp goes to 500 MHz

Low-priced instrument delivers 300 milliwatts; gain is nominally 27 dB

A common way to boost the output power, and thus the usefulness, of laboratory signal sources is to follow them with a highly linear, broadband power amplifier. To be truly useful, such an instrument must be able to faithfully reproduce complex broadband signals and operate without damage or oscillation into severe impedance mismatches. Such instruments are not inexpensive.

An exception to this rule has just come onto the market: it provides 300 milliwatts of output power over the range from 2 to 500 megahertz and costs only \$295, including power supply. Called the model 500L, the amplifier is made by Electronic Navigation Industries Inc., of Rochester, N.Y. The instrument gain is nominally 27 decibels, and it varies less than  $\pm 1$  dB from its mean over the specified bandwidth. Full power is typically available from 1.7 MHz to 560 MHz, but with increased gain variation.

The amplifier is unconditionally stable. It can work into any load—including open and short circuits—without damage or oscillation. This makes it particularly valuable for driving any device having impedance that is a strong function of applied power and/or frequency. Electro-optical devices, ultrasonic transducers, and some broadband antennas are typical examples.

Central to the amplifier's high performance/price ratio is its thin-film hybrid construction. All of the transistor circuitry, except the wide-band impedance transformers, is bonded to a single 0.5-in.-by-1.0-in. alumina substrate. All of the transistors in the amplifier are bonded to the single substrate through "heat spreaders" that reduce the chip tem-

peratures by as much as 30°C. This reduces the number of transistors needed to produce the rated output, while increasing the over-all reliability of the unit.

The 500L's power supply consists of an IC regulator driving a discrete series-pass transistor—the only discrete transistor in the entire instrument. The power supply can tolerate variations of up to  $\pm 12\%$  around the nominal ac voltages of either 115 v or 230 v rms. Total power consumption is 12 watts at any frequency from 50 to 400 hertz.



The amplifier has a typical noise figure of 8 dB and a maximum VSWR of 2:1 on both input and output. Input and output impedances are both 50 ohms.

Electronic Navigation Industries, Inc., 3000 Winton Road South, Rochester, N.Y. 14623 [351]

### Logic probe checks high-level systems

With the growing use of such high-level logic functions as Teledyne's Hinil—now second-sourced by Texas Instruments—and Motorola's HTL family, the need has been created for a logic probe so that the designer or service man can quickly check out a system.

Hewlett-Packard Co. fills the need with its model 1052H high-level-logic probe that indicates a circuit's state—high, low, or bad—by means of a single lamp. And since the probe can work with power supplies of 12 to 25 volts, it can be used with other types of systems, including MOS and relay logic.

All digital information detected by the probe is displayed on the indicator lamp located near the probe tip. Threshold levels of 9.5 v  $\pm$  1 v

for a logic "high" and 2.5 v or below for a logic "low" are established by a circuit in the probe. At the tip, logic "low" is indicated by lack of glow in the lamp. Logic "high" is indicated by lamp glow at full brightness, and intermediate levels or open circuits are indicated by a medium glow.

Jan Hoffand, designer of the unit, says that in addition to indicating static logic conditions, the probe can detect pulses, whether single or in trains. Single pulses, even those as short as 100 nanoseconds, are captured by the probe and stretched via an internal circuit to 0.05 second, thus providing a clearly visible display. The lamp flashes on momentarily to indicate high-going pulses and blinks off to indicate low-going pulses. The presence of pulse trains up to about 5 megahertz is displayed by lamp flashes at a 10-hertz rate.

Hoffand points out that the user need not worry about loading down his test circuit. "The probe's input impedance is better than 20 kilohms for both high and low signals," he says, "and the input drive requirements are also very low—for a logic 0, the circuit under test has to sink only about 200 microamps or less, and for a logic 1, it has to source less than 100 microamps." The probe is built for the industrial environment. The power supply input is protected against damage for voltages from -400 v to +40 v, and the probe tip is protected from -70 to +70 v continuous and  $\pm 200$  v intermittent. Most of the probe's circuits are contained on a single custom chip, a feature that is expected to enhance reliability.

The model 1052H probe has a tentative price of \$95, and delivery is from stock.

Hewlett-Packard Co., 1501 Page Mill Rd., Palo Alto, Calif. 94304 [352]

### Modulator and leveling loop is for V-band applications

A modulator and leveling loop provides leveling to within  $\pm 1.5$  decibels over any 10-gigahertz band-



## New products



width in V-band, from 50 to 75 gigahertz. The model 44710H is an in-line closed-loop unit that consists of a ferrite variable attenuator, a dc power supply and amplifier, a 10 dB coupler, and a flat detector. It can also be used as an amplitude modulator by utilizing the power supply and ferrite modulator head only. Price of the modulator-leveling loop is \$4,425, and delivery time is 60 days after receipt of order.

Hughes Electron Dynamics Division, 3100 West Lomita Blvd., Torrance, Calif. 90509 [353]

### Operator's panel simplifies oscilloscope controls

The PM3110, a dual-trace oscilloscope, offers a simplified operator's panel with four signal adjustment knobs instead of the usual six or



eight. Level and stability controls for triggering, as well as dc balance controls, have been replaced by automatic internal circuits. Triggering is automatic, and three selector switches control trigger source, trigger polarity, and trigger mode. Sensitivity can be multiplied 10 times to 5 mV/cm by means of the input-control switches; in the high-sensitivity mode, bandwidth is 5 MHz.

Price of the unit is \$550.

Test & Measuring Instruments Inc., 224 Duffy Ave., Hicksville, N.Y. 11802 [354]

### A-m signal generator is accurate to within 0.01%

A range from 50 kilohertz to 80 megahertz is offered by the model 921A a-m signal generator. A three-



digit display uses Nixie tubes. Accuracy varies with frequency, and worst-case error is 1.0%. A 100-times expander on the display provides reduced error calibration points every 100 kHz so that maximum error is then 0.01%. Maximum output power is 200 mW (+23 dBm) into 50 ohms; this corresponds to a maximum loaded output voltage of 3.2 v rms. Price of the model 921A is \$1,730.

Logimetrics Inc., 100 Forest Dr., Greenvale, N.Y. 11548 [355]

### Impulse generator offers flat spectral output to 100 MHz

A variable-repetition-rate impulse generator is intended primarily as a calibrator for substitution-type interface measurements. It features four triggering modes: internal, power-line frequency, external, or manual. Pulse rate can be varied continuously from 50 Hz to 5 MHz or from 0 to 5 MHz by manual or exter-



nal triggering. Spectral output is flat to 100 MHz and is less than 5 dB down at 1 GHz. The model 533X-11 is all-solid-state and is said to deliver a very stable output.

Singer Instrumentation, Los Angeles Operation, 3211 South La Cienega Blvd., Los Angeles, Calif. 90016 [356]

### 1-GHz switch uses p-i-n diodes instead of relays

A solid-state switch for testing both active and passive devices is called the model 255E. It is available in 75- and 50-ohm impedances, and can be used for comparative tests of frequency responses in the range from 5 to 1,000 megahertz. The switch replaces reed relays with



p-i-n diodes and features dual-channel input and output modules, which may be brought from the main unit directly to the point under test. Channels may be selected individually or mixed at the output.

Kay Elemetrics Corp., 23 Maple Ave., Pine Brook, N.J. [357]

### High-resolution chronometer can check electro-optics

The model TSN 630 digital multiple time measurement system provides time-interval measurements for checking physical quantities, such as speed, distance, or position. Applications include electro-optics and telemetry. Resolution is  $\pm 0.1$  nanosecond, and a built-in printer is provided. The unit can also measure nonrepetitive intervals, as well as a great number of intervals simultaneously. Price is \$17,770.

Hadron Inc., 800 Shames Dr., Westbury, N.Y. 11590 [358]

# THE MITE<sup>T.M.</sup>

## NEW HEAT GUN FROM MASTER



Convenient Hanging Loop

Rugged, Anodized, Air Cooled Barrel

Safety Light—Easy to see indicates unit is "on"

One Hand Control—Three way switch operated with simple finger movement

Now bring a new dimension to heat shrinking as well as countless other industrial applications. Easier to handle . . . only two pounds with nozzle . . . perfectly balanced.

Three easily interchangeable color-coded nozzles to speed specific jobs. Silver (standard) . . . used for most shrinkables (475°F). Blue nozzle for Mylar\* (500°F). . . and Black for Teflon\* (800°F.) both optional equipment. Nozzles can be changed in seconds.

Draws only 5.4 amps. High impact housing withstands hard knocks of shop use. For information on the new MITE Heat Gun or the full line of Master Heat tools, contact your distributor or write:

\*Reg Trade Name of DuPont

**MASTER**

Appliance Corporation, Racine, Wisconsin 53403, Phone 414 633-7701

Circle 117 on reader service card

# Standard POWER Supplies at OEM Prices!



Single-Dual-Triple Outputs

**DUAL OUTPUT**  
MODEL SPS 30D 12/15

**ADJUSTABLE RANGE:**  
11 to 16 Vdc @ 0.9 Amps.

**REGULATION:**  
Line . . . . . ± 0.25%  
Load . . . . . ± 0.25%  
Ripple . . . . . 0.1% RMS

**PRICE 1 to 9 \$44**

**DISTRIBUTORS**

Advent Elect., Rosemount, Ill.  
Angus, Inc., Moorestown, N.J.  
Arneson & Co., Minneapolis  
Arrow Elect., Farmingdale, N.Y.  
Cameradio, Pittsburgh, Pa.  
Esco, Inc., Dayton, Ohio

JEM Elect., Rockford, Ill.  
Lykes Elect., Tampa, Florida  
R. S. Electronics, Detroit, Mich.  
Taylor Elect., Mequon, Wisconsin  
Rose Dist., Burlingame, Calif.  
R. V. Weatherford Co., Glendale  
and all Western Branches.

**STANDARD POWER, INC.**, 1140 West Collins, Orange, California 92667 ■ (714) 633-1092

Circle 118 on reader service card

# COMPRESSED VIDEO

- Starts with a standard CCTV camera
- Ends on the screen of a standard CCTV monitor
- Uses "dial up" voice grade telephone circuits in the middle
- Is a highly flexible alternative to facsimile or the Picture Phone

The CVI 200 series Video Converters provide for single frame TV picture transmission over audio bandwidth circuits. Options include multiple image storage, hard copy, computer I/O, and color.

Video instruments for data acquisition, processing, transmission, and display.

**cv**i

Colorado Video, Inc.  
Box 928 Boulder, Colorado 80302  
(303) 444-3972

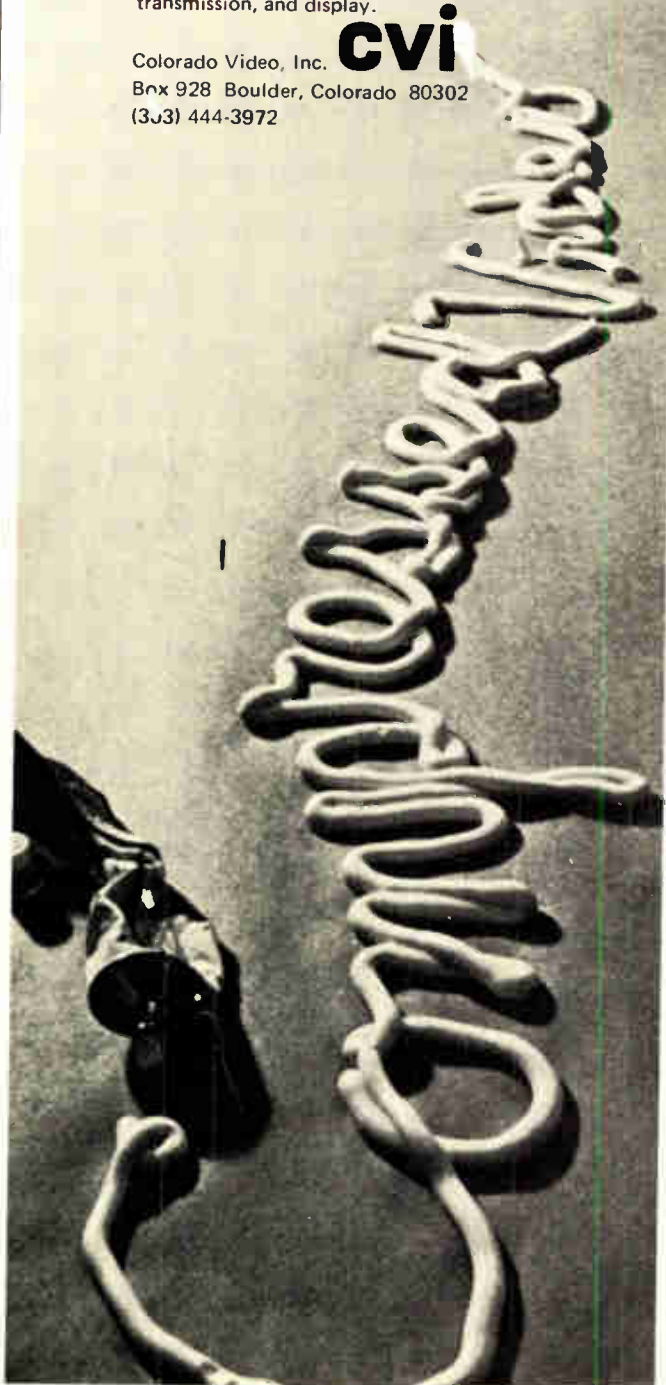

Circle 103 on reader service card 103



Data handling

## Terminal built for APL graphics

---

Low-priced keyboard unit for information systems employs new storage tube

---

Users of APL (a programming language) have found that it is an uncomplicated way to deal with computer graphics, but there has been a hangup with the hardware. APL users have been limited to IBM Selectric terminals like the 2741 that plot data slowly, point-by-point, across the page. Until now the only CRT graphics system has been the IBM 2250, a \$150,000 package.

Now, however, a CRT/keyboard terminal designed for APL and selling for less than \$6,000 is being offered by Tektronix Inc., Beaverton, Ore. [*Electronics* July 3, p. 26]. The new 4013 terminal is similar to the Tek 4010 except that it has a higher-resolution CRT and a new keyboard with upper- and lower-case characters, plus the APL special characters.

"APL was the brainchild of Kenneth Iverson, a Harvard graduate student, in the late 1950s, but the first commercial use of APL as a descriptive language was in 1964 for the IBM System 360," recounts John R. Rowley, marketing supervisor for the Tektronix Information Display Products division. "This early work led to APL/360 for the IBM terminals, and with the advent of APL/360," says Rowley, "the demand grew for a low-cost CRT terminal. Most APL users were involved with graphics and were limited to a Selectric typewriter going plunkety-plunk across the page. And because of some unusual characteristics of APL, a simple refresh CRT terminal could not be used."

In APL, for example, overstrike characters—one character typed over another—creates a new, third instruction for the computer. If a refresh CRT were employed and the keyboard back-spaced, the original

character would be erased and the computer would only see the new character. "But with a storage CRT, such as the one used in the Tek 4010 and now the 4013, the original character remains: thus when a new character is entered over it, a new character results. This, together with the graphics capability of the storage CRT, make the 4013 a very powerful tool," says Rowley.

Technically, the 4013 is similar to the Tektronix model 4010, except for a few significant changes. "We had to go to a higher-resolution CRT," explains Rowley, "so the overstrike characters could be read easily." In a storage CRT, brightness can usually be traded off for resolution. But because APL is becoming popular in business-management information-systems applications, as well as in the scientific community, a new tube was developed to overcome the loss in brightness.

The 4013, along with a complete software package, called APL/Graph will be available in November. The terminal is priced at \$5,450, or will lease for \$275 per month, including maintenance, and APL/Graph sells for \$500.

Tektronix Inc., Information Display Products, Box 500, Beaverton, Ore. 97005 [361]

---

## Computerized NC system runs four machine tools

A minicomputer-based system for controlling two or four machine tools doing different jobs in two or three dimensions has been introduced by the Data General Corporation. Called Contour 1, it's based on the company's Nova 1220 minicomputer.

Two versions are available. For \$17,100, the user gets an open-loop system with 8,192 words of memory that can control two jobs in which the tolerances are no tighter than  $\pm 0.002$  inch. For \$22,600, a closed-loop control that includes a three-axis discriminator and hardware distance departure counters is added. A closed-loop control is usually required for machines capable of tolerances within  $\pm 0.005$  in. To

control four jobs in either version, 4,000 more words of memory are required at a cost of \$2,700 extra. The capacity of the 1220 is 32,768 words. In both open-loop and closed-loop operation, the feed rate is 500 inches per minute and resolution—the smallest increment Contour 1 can generate—is 0.0001 in.

Contour 1 has a control console where the program can be edited on-line. This saves a great deal of time for the programmer, who otherwise would have to make the change in the original system that generates the program, punch a new paper tape, and load the whole new program into Contour 1; this cycle might have to be repeated several times to make one correction. The control console can be located up to 1,000 feet away from the computer system.

Data General Corp., Southboro, Mass., 01772 [374]

---

## Tape transport uses 3M Company cartridge

The model 2021 cartridge tape drive is the first unit of its kind built to handle the 3M Co. model DC300A magnetic-tape cartridge. The drive is available as a desktop console or as a panel-mounted assembly. The 3M cartridge, which contains two reels and 300 feet of  $\frac{1}{4}$ -inch computer tape, requires a single drive motor; the drive has a dual-gap read-while-write head and is available in one-, two-, or four-channel configurations. The 2021 is capable of recording at 800 to 1,600 bits per inch with read, write, and backspace speeds of 30 inches per second. Rewind and fast forward search speeds are 90 inches per second. Data-transfer rate (per channel) is up to 48,000 bits per second. The interface is TTL-compatible. Price in OEM quantities ranges from \$200 for the mechanism to \$500 for the com-





plete unit with electronics.

Mohawk Data Sciences Corp., 781 Third Ave., King of Prussia, Pa. 19406 [363]

### Remote display terminal comes in four screen sizes

Compatibility with IBM Systems 360 and 370 is a feature of the model 7100 Ultronic Videomaster, a stand-alone remote display terminal. The unit can be configured in any of four screen sizes—240, 480, 960, or 1,920 characters—and data transmission speeds are up to 9,600 baud. The format permits construction of fixed and variable fields on the ter-



minal, and the program generates a fill-in-the-blanks type format. Correction of data by insertion and deletion is by line with a large cursor surrounding each character in reverse field. Rental of the 7100 begins at \$125 per month.

GTE Information Systems, 4 Corporate Park Dr., White Plains, N.Y. 10604 [365]

### Caller/modem transmits at speeds up to 300 bits/s

A computer-driven automatic calling unit/modem combination is designated the model 907801-24 for dc pulse output, and the model 907801-34 for dial-tone multiple frequency use. The modems are capable of data transmission at up to 300 bits per second, and meet EIA RS-366 specifications for computer interface and RS-232 specifications for modem interface. The system is



modular, and conversion from dc pulse to dial-tone multiple frequency is accomplished by exchanging one of the modules. Dial-tone detection in pulse and tone models increases reliability in dialing address numbers. Price is from \$920 to \$1,400, depending on the model.

G-V Controls, Division of Sola Basic Industries, 101 Okner Parkway, Livingston, N.J. [366]

### Analyzer identifies problems in communications links

Rapid diagnosis of protocol problems in communications links is provided by the model 810 Bisync line-control analyzer. The unit resolves problem situations by capturing and displaying key control sequences passing through the communications channel, allowing the user to observe the dialog between the two devices. Thus, the instrument can locate and identify system problems caused by violations of line protocol; incompatibility between terminal and computer, terminal and modem, the modems and phone line interface; and in-progress operations or procedures. Price in single quantities is \$2,750

Paradyne Corp., P.O. Box 5144, Clearwater Fla. 33518 [368]

### Printers operate at four lines per second

A line of printers includes the model PR1001, a 16-column unit for a 7-by-9-dot matrix font, and the PR1002, 20-column unit for a 5-by-9-dot matrix font. Using an external

character generator, the mechanisms feature printing of 96 or more alphanumeric symbols per column, thus allowing upper- and lower-case characters. Each mechanism prints four lines per second. Applications include programable calculators, point-of-sale terminals, and data-logging systems. Price is \$359 for a single unit and \$203 in quantities of 1,000.

Elec-Trol Inc., 26477 N. Golden Valley Rd., Saugus, Calif. 91350 [369]

### Disk drive built for small-business configurations

The model 42 disk drive is especially designed for small-business configurations using the Singer System Ten computers. For example, the split disk can be used with a CRT display terminal. The disk provides the System Ten computer with on-line direct-access storage, plus backup storage in one unit, and features two separate removable disk packs. The resident pack is for ma-



nipulation and filing of data, which may be duplicated onto the removable pack and stored for backup. Price is \$15,500, and monthly lease for one year is \$440.

Business Machines Division, The Singer Co., 2350 Washington Ave., San Leandro, Calif. [370]

Components

## Bandpass filters are tunable

Only 4 matched resistors must be connected to get desired center frequency

As active filters find ever wider use, their need for easy tunability has become apparent in such applications as data transmission, frequency analysis, and test instrumentation. So engineers who have been forced to construct such filters almost from scratch will welcome a new line of tunable Butterworth bandpass devices from Frequency Devices Inc., Haverhill, Mass.

With the series 760 filters, the engineer need only select and connect four matched resistors, one for each pole of the two-pole-pair devices, in order to nail down the center frequency ( $f_0$ ) of the passband he desires. And it is a simple matter to use a switching arrangement to add to or subtract from the value of each pole resistance, thus obtaining a switchable  $f_0$ .

The director of engineering at Frequency Devices, Alan E. Schutz, points out that, while it often is difficult to find four matched tracking potentiometers, the effort might be rewarded if the pots were substituted for discrete resistors. The user then would have a filter with infinitely variable  $f_0$  within its bandwidth. Schutz notes that the same function could be performed by four analog multipliers, controlling the filters electronically and opening up a spectrum of uses, including computer control applications.

Three units make up the new line of filters: the model 760, with a maximum  $f_0$  of 50 hertz and a 0.05-Hz-to-500-Hz tuning range; the 762, with a  $f_0$  of 500 Hz and a 0.05-500-Hz range; and the 764, with a maximum  $f_0$  of 20 kilohertz and a range of 20 Hz to 20 kHz. Thus the whole audio band is covered, as well as almost all of the so-called subsonic

frequencies. The product line may be extended to include frequencies above the audible range.

Although set at the factory for unity gain, the filters can be adjusted by the user to supply gain variations of up to 20 decibels. To preserve their output impedance characteristics, the filters are designed with amplifier-attenuator circuitry between the two pole pairs, so impedance remains a low 1 ohm.

The 760 series filters accept  $\pm 10$ -volt inputs and deliver the same voltage range at the output at 2 milliamperes. Noise at the output—specified as all noise over a band of 1 Hz to 100 kHz, an obvious worst-case specification—is 50 microvolts rms, making for a signal-to-noise ratio of about 105 db at rated output.

Tolerance of  $f_0$  is  $\pm 3\%$  when matched 1%, 100-ppm/ $^{\circ}\text{C}$  resistors are used;  $f_0$  is stable within  $\pm 0.03\%$  per degree Celsius. Passband gain at  $f_0$  is rated at  $0 \pm 0.03$  db.

Case size is 2 by 3 by 1 in. for the 760, and 2 by 3 by 0.6 in. for the 762 and 764. Units with Qs of either 5 or 10 are available from stock. The 760 costs \$105 in single units, with prices falling to \$66 in 100-unit lots. The price range for similar quantities of the 762 is from \$95 to \$58, and for the 764, from \$105 each to \$65.

Frequency Devices Inc., 25 Locust Street, Haverhill, Mass. 01830 [341]

## Cooling package dissipates 450 W in a 25°C ambient

A lightweight, forced-air semiconductor heat dissipator measures 3 $\frac{3}{4}$  inches by 5  $\frac{3}{16}$  inches by 4  $\frac{11}{16}$  inches, and weighs 14 ounces. The unit dissipates 450 watts in a 25°C ambient with a semiconductor-case temperature rise of less than 95°C. The series FAHP4 operates with



any standard fan that produces 100 to 115 cubic feet per minute of air, and has mounting holes on 4 $\frac{1}{8}$ -inch centers. Price is \$6.50 each in 1,000-lots.

International Electronic Research Corp., 135 W. Magnolia Blvd., Burbank, Calif. [344]

## Plus-minus regulator is adjustable from -8 to +22 V

A thick-film hybrid plus-minus regulator called the LMR-11 contains a current limiter and two regulator elements. Output voltages are adjustable from -8 volts to +22 v, and stock models are internally set for unregulated input voltages of  $\pm 15$  volts. Line and load regulation is 0.1%, and maximum output current at continuous duty is 1 ampere per side when plus and minus power

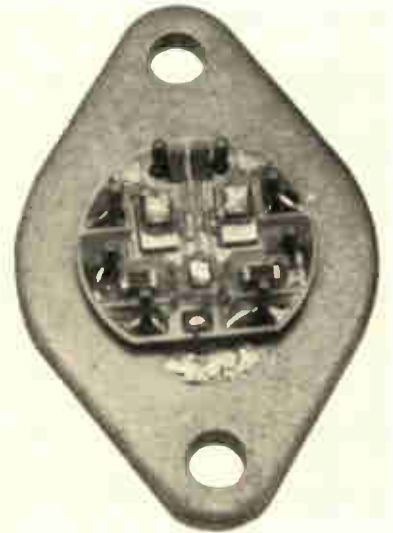

passes are operated simultaneously. Price is \$25 in 1,000-lots.

Ledex Inc., 123 Webster St., Dayton, Ohio 45401 [343]

## 14-pin DIP reed relays can handle 10 watts

Integrated-circuit compatibility is offered by the 0 series of reed relays. The 14-pin dual in-line epoxy-encapsulated Form A units are designed for dense packaging. The contacts are capable of handling up to 10 watts with resistive loads of 0.5

ampere and 50 volts. The relay is available in four coil voltages: the 5-, 6-, and 12-v coils offer resistance of 500 ohms; and the 24-v coil, 1,400 ohms. Pull-in voltage is within 67% of rated coil voltage, and the coil is also available with a suppressor diode. Price is less than \$1.75 each in 1,000-lots.

Micronix, 24248 Crenshaw Blvd., Torrance, Calif. 90505 [347]

### Liquid-level switch has reinforced plastic body

Designed to replace stainless-steel switches, the model L-20 liquid-level switch is made of reinforced



plastic and is aimed at operation in the pressure and temperature area of 150 pounds per square inch and 175°F. The unit, which is able to handle liquids that are corrosive, uses a 10-ampere microswitch that allows direct control of pumps, motors, solenoid valves, and heaters.

Harwil Co., 903 Colorado Ave., Santa Monica, Calif. 90401 [346]

### Circuit overload protector cuts off transients in 1 μs

The model COP circuit-overload protector guards encapsulated circuit modules against excessive voltage surges. Placed in series in a power line, the unit automatically cuts off transients above 18 volts or below 11–12 v. Turnoff time is 2 microseconds if the unit is passing up to 300 mA and 1 microsecond if passing 600 mA or more. The device passes current from 0 to 0.5 ampere of which it requires 25 mA for its own operation. Operation resistance is about 1 ohm, and the unit can

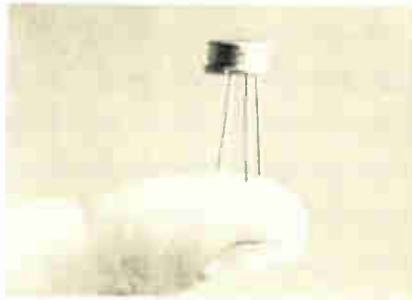

take up to 30 v, or 5 v reverse polarity, without damage. Price is \$25 each in quantities of 1 to 9.

Data Device Corp., 100 Tec St., Hicksville, N.Y. 11801 [345]

### Fixed shielded rf inductor is for pc applications

The Pee Cee Ductor is the designation of a subminiature, shielded, radial-lead rf inductor that is intended for printed-circuit applications. The device has unitized epoxy-molded construction, with values ranging from 0.10 to 100,000 microhenries. Standard inductance tolerance is ±10%, and board



mounting is facilitated by 0.200-inch grid spacing. The unit is available in 73 stock values. Prices range from \$1.55 to \$2.10.

Nytronics Inc., Orange St., Darlington, S.C. 29532 [348]

### Shaft encoder can put out 2,500 pulses per revolution

Designed for high-speed digital control or speed-sensing applications, an optical shaft encoder, designated the Rotaswitch series 880, measures about 2 inches in diameter and is available in many versions. The basic encoder may be specified with pulse rates up to 2,500 per revolu-

tion, and with sine- or square-wave output. Accuracy is to within ±2.5 minutes of arc for all versions. Phototransistors are used for sensing,



and indexing is available. Models with sine-wave outputs may be designated single or quadrature. Price is from \$150, with quantity discounts available.

Disc Instruments Inc., 2701 S. Halladay St., Santa Ana, Calif. 92705 [349]

### Single in-line resistor network saves board space

Greater circuit-configuration flexibility is the key advantage of a line of single in-line resistor networks. The construction allows more room on the substrate, and vertical mounting allows flexibility and



takes up less space on the pc board. The networks are available with up to 15 leads in epoxy conformal coatings. Tolerances are up to 0.1%, and power dissipation is up to 5 watts. Resistors are thick film on an alumina substrate, and nonresistor components may be added.

Mepco/Electra Inc., Columbia Rd., Morristown, N.J. 07960 [350]



CLASSIFIED ADVERTISING  
**SEARCHLIGHT SECTION**  
 BUSINESS OPPORTUNITIES  
 USED OR SURPLUS EQUIPMENT

**Radlatlon Devices Co.**



**BROADBAND AMPLIFIERS**

Our Economical Line of Broadband RF Amplifiers Covers The Frequency Region From 3 MHz. to 800 MHz. With Noise Figures As Low As 3.0 dB. Remotely Powered Versions Are Available. Brochures and Application Notes Are Available Upon Your Request.

RADIATION DEVICES CO., BOX 8450, BALTO., MD. 21234

CIRCLE 951 ON READER SERVICE CARD

**FLASH STRIPPER** For shielded wire braid



Weld groundlead and/or strip braid in one fast operation. Submit sample wire. Ask for data sheets.

**EWALD Instruments Corporation**

Rt. 7E Kent, Ct. 06757 · Tel (203) 927-3278

CIRCLE 952 ON READER SERVICE CARD

RADAR SYSTEMS GROUND AND AIRBORNE. AUTOMATIC TRACKING ANTENNA SYSTEMS. NIKE AJAX. NIKE HERCULES. M-33. MSO-1A. MPS-19. MPS-9. SCR 584. TPS-10. TPS-20. FAA-ASR-2. AIRBORNE SYSTEMS. APN-84. APN-102. APS-20. APS-27. APS-45. DPN-19. DIGITAL COMPUTERS. IBM 650. IBM 704

LARGEST INVENTORY OF RADAR AND MICROWAVE EQUIPMENT IN THE WORLD.

**RADIO RESEARCH INSTRUMENT CO.**  
 3 QUINCY ST., NORWALK, CONN. 06850 (203) 853-2600

CIRCLE 953 ON READER SERVICE CARD

**200 LEACH RELAYS**

End of contract surplus, new in factory cartons. Type 953, 110v AC, 30 amp, 2-pole, doub. T, laminate core. E8306. New cost \$60 ea. Sale \$12.50 ea. Entire lot \$10 ea.

**GENERAL SUPPLY & EQUIP.**

Box 14628, Houston, Tex. 77021.  
 713/748-3350.

CIRCLE 954 ON READER SERVICE CARD

**SURPLUS ELECTRONICS**

URM-7 RFI Meter less tuners \$295  
 HP 410BR VTVM \$55

Write for latest sales bulletin  
**DATA/INSTRUMENTATION ASSOCIATES**  
 208 S. Pulaski St. Balto., Md. 21223

CIRCLE 956 ON READER SERVICE CARD

*Don't forget the*

**BOX NUMBER**

... when answering the classified advertisements in this magazine. It's our only means of identifying the advertisement you are answering.

**New products**

Packaging and production

**Wire-wrapper  
 sells for \$5,995**

Semiautomatic unit has simplified table design, tape reader built in-house

The company that introduced a \$10,000 wire-wrapping machine last year [*Electronics*, July 19, 1971, p. 115] has a new version with much the same capability, but a price tag of only \$5,995. Bruce Billington,

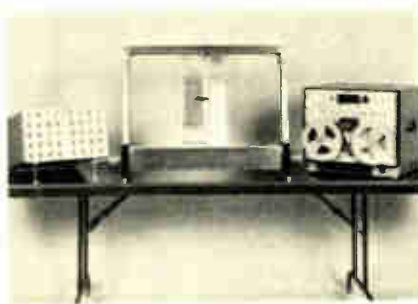

marketing vice president of Standard Logic Inc., Santa Ana, Calif., says the new machine will open up at least two new markets to automated wire-wrapping: the shop employing only a few operators, and the engineering group that has had to depend on slow manual wiring with its attendant errors.

Billington says that the new WWM-600 system offers a typical rate of 200 to 250 wraps per hour, compared to manual rates of 30 to 50 per hour.

The system consists of a fixed positioning table, with a movable pointer that locates the pin for a hand-held wrapping gun. The system also tells the operator what wire length to use. Much of the reduction in price from the earlier machine comes from a simplified X-Y table design, and from its smaller size. It's now only 18 by 24 inches, rather than 24 by 40 inches. The pointing mechanism is also simpler and less expensive, but offers locating accuracy of 0.005 in., sufficient for the 0.100-in. grid used by the connectors. The WWM-600 uses fixed mo-

tors with belt drive, rather than the earlier moving motors and precision screw drive.

Programming of the table is by a paper-tape reader included with the system. The new reader, since it is built by Standard Logic, accounts for part of the reduction price. The system can also be optionally operated from a computer, with as many as five tables controlled by one minicomputer. The company is preparing a number of software options and computer-aided design programs for use with the system. One provides interfaces to a teletypewriter and minicomputer so that the user can simply key in his "from-to" list, and the system will automatically prepare the proper wiring tape. A digitizing program will permit tape production from the jogging controls on the WWM-600's control panel.

Standard Logic Inc., 1630 South Lyon St., Santa Ana, Calif., 92705 [391]

X-Y table can position at 600 inches per minute

A cantilever design is employed on the model XYE-1212 positioning table. The X-Y device, which has 12- by 12-inch travel, is intended for numerically controlled and computer-controlled production operations. The unit is capable of positioning rates in excess of 600 inches per minute; dead-stop to dead-stop time for a 2/10-in. move is 90 milliseconds, and for a 2-in. move, it is 400 ms. Accuracy is to within  $\pm 0.0015$  in. overall, and repeatability is within  $\pm 0.0003$  inch overall.

Icon Corp., 156 Sixth St., Cambridge, Mass. 02142 [394]

Air-abrasive generator is for thick-, thin-film trimming

Engineered especially for thick- and thin-film resistor trimming, an air-abrasive system called Accu-Trim is designed for applications where a precisely controlled uniform mix-



ture of abrasive powder with compressed gas is needed. The operator can vary the powder flow rate and the propellant pressure separately. The machine uses a variety of powders, both abrasive and nonabrasive. Three models are offered: the AT-10 for industrial applications, the AT-20 for use with the company's resistor trimming systems, and the AT-30 to replace air abrasive units on resistor trimmers of other manufacturers.

M.P.M. Corp., 2225 Massachusetts Ave., Cambridge, Mass. 02140 [396]

### Probe system provides fixed and adjustable patterns

The type 60 probe system for hybrid circuits combines the advantages of fixed-pattern probes and adjustable probes. A given pattern, once set, may remain fixed or can be modified as required. Changeover is achieved by changing the probe-

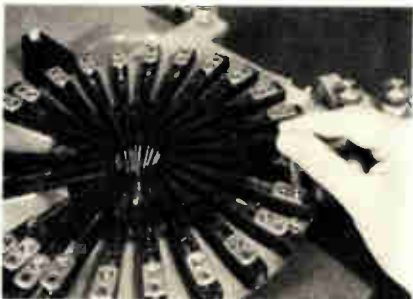

ring assembly. An established probe pattern can be saved as a subassembly, and new patterns are attained by adjusting probes individually. Each probe has a dual-range adjustment, a long range for approximate positioning, and a fine range for final positioning.

Daymarc, 40 Bear Hill Rd., Waltham, Mass. 02154 [397]

## DELIVERED IN 10 DAYS

BANDPASS/BUTTERWORTH/ELLIPTICAL/NOTCH

# PASSIVE FILTERS

- Low-Cost
- Small
- Encapsulated
- Frequency Stable
- Computer Designed
- PC Board Mounting



**BEUKERS LABORATORIES, INC.**

1324 Motor Parkway, Hauppauge, N. Y. 11787

Circle 109 on reader service card



**YOU'RE WHISTLING IN THE DARK...**

if you think that heart disease and stroke hit only the other fellow's family.

**GIVE... so more will live  
HEART FUND**



*Contributed by the Publisher*

**N**ot so long ago, most of us got a good look at the Great Wall of China, in living color. It is quite a sight. Built where it is. But some people would like to build a "Great Wall" around America. And that would be a different sight entirely.

The specifications for the wall are contained in the Burke-Hartke Bill, now before Congress. The key provisions of this bill would:

- Establish permanent quotas on foreign imports into the U.S., at about 60% of current levels.
- Regulate, and severely restrict, the export of U.S. capital and technology.
- Impose a form of double taxation on the foreign earnings of U.S. companies.

The Great Wall of China was built to keep out invaders. The Burke-Hartke Wall goes the Chinese one better. It has *two* sides. One to keep out, and one to keep in. One to shut out foreign competition, and one to shut in *American* competition—in the form of American products, or of American initiative and enterprise.

The clear prospect is that the Burke-Hartke Wall would do far more shutting in than shutting out, at the catastrophic expense of most of U.S. business and industry, most of U.S. labor, and all American consumers and taxpayers.

The even grimmer prospect is that this hostile and defiant act—the United States against the world—would trigger an international trade war. Which would be an economic, political and moral disaster for all concerned.

Why take such an obviously extreme, desperate and dangerous step?

Because, say the supporters of Burke-Hartke, our case is desperate. Foreign com-

petition and the export of U.S. capital and technology have created a "national crisis." We face the "destruction of major industries" and the "loss of one million American jobs."

It is time to set some things straight.

For 77 years, from 1893 through 1970, the U.S. exported more than it imported. The net result was a constant, cumulative increase in U.S. jobs and wages.

In 1971, for the first time in this century, we imported more than we exported—by \$2.9-billion. The net result, at least in theory, was to displace \$2.9-billion worth of domestic goods with foreign imports—and to reduce total U.S. output and employment accordingly.

Total U.S. output in goods in 1971 was well over \$600-billion. The possible loss in output attributable to the \$2.9-billion trading gap was, consequently, 0.5% of the total—and the presumable loss in employment about the same. That is, less than one-half of one percent.

These are the exact dimensions of the "crisis" as it relates to trade.

The facts about the "outflow of U.S. capital and technology" are equally plain.

In 1971, the capital outflow—the additional investment made by U.S. companies in foreign operations—amounted to \$4.5-billion. But the capital inflow—the return on previous investment—reached \$7.3-billion. Leaving a positive balance of \$2.8-billion.

Similarly, the previous export of U.S. technology produced a cash inflow, in the form of royalties and fees, that amounted to \$2.0-billion in 1971.

The idea that the outflow of U.S. capital and technology costs U.S. jobs is quite simply a delusion.

The foreign subsidiaries of U.S. multinational companies are essentially local businesses. 92% of what they produce is sold abroad—and, in most cases, can *only* be made and sold abroad. It *cannot* be made in the U.S., shipped abroad and sold competitively against domestic products.



## Do we need a Chinese Wall around America



Thus, to put it bluntly, the "lost" jobs never existed, and cannot exist. Except in the imagination of those willing to ignore reality to make a case.

**T**he plain truth of the matter is that the "crisis" that has produced the Burke-Hartke Bill is not national, and has nothing to do with exports—of goods, or of capital and technology.

This Bill is the result of the very particular and special problems of certain industries and companies that find themselves unable, for a variety of reasons, to compete effectively against foreign imports.

With all due regard for the reality and seriousness of these problems—and for the industries, companies and people concerned—the Burke-Hartke Bill is *not* the answer.

To protect their interests, it is proposed that we ignore all other interests, all other considerations, and all possible consequences. To (perhaps) save their jobs, it is proposed that we gamble the jobs of another, larger group of Americans.

The trouble is, it won't work—for anybody. It is a bad idea, and a worse gamble.

The Burke-Hartke idea, in brief, is to deliberately demolish the entire delicately balanced structure of international trade and commerce, kick aside the pieces, and declare "a whole new ball game."

The gamble, on which everything rides, is that we can play the game by *our own rules*—with the outcome fixed in advance, in our favor.

The Burke-Hartke rules arbitrarily and unilaterally cut U.S. imports almost in half—from \$47-billion in 1971, to a fixed annual rate of about \$28-billion.

This presents the other nations of the world with an ultimatum—and two equally bleak alternatives.

They can accept an \$18-billion annual loss in sales *to* the U.S., while continuing to buy at the rate of \$40-50-billion *from* the U.S.—thus accepting a *permanent* trading gap on the order of \$20-billion a year.

Or they can cut their purchases of U.S. goods, build their own walls, and let the trade war take its ruinous course.

A hard choice. But can there be any doubt as to the answer? And the results?

**W**alls, in the general experience of mankind, are rooted in fear, built on delusion, and doomed to futility. The Burke-Hartke Wall is no exception.

It is a product of fear, based on the delusion that the answer to competition is to refuse to compete.

It is a symbol of panic and despair—crying, "Stop the world, we want to get off."

But the world won't stop, we can't get off, and we don't need a wall, but a way.

A way, quite simply, to make this country what it can and should be. Strong, productive, and confidently competitive in a competitive world.

This is the way—the *only* way—to really save our jobs.

And our self-respect.

---

*We at McGraw-Hill believe in the interdependence of American society. We believe that, particularly among the major groups—business, professions, labor and government—there is too little recognition of our mutual dependence, and of our respective contributions. And we believe that it is the responsibility of the media to improve this recognition.*

*This is the fourth of a series of editorial messages on a variety of significant subjects that we hope will contribute to a broader understanding.*

*Permission is freely granted to individuals and organizations to reprint or republish these messages.*

*John R. Emery*  
John R. Emery, President  
McGraw-Hill Publications Co.



■ <b>Abbott Transistor Labs., Inc.</b> Technical Adv Agency	6	<b>Magic Dot, Inc.</b> -Division of S. J. Groves, Inc. Fischbein Advertising Inc	20
° <b>Allen Bradley</b> Hoffman York, Inc.	24E	<b>Master Appliance</b> Klau-Van Prietersom-Dunlap, Inc	103
<b>Analog Devices, Inc.</b> Schneider Parker Guy, Inc.	97	° <b>Philips Gad Elcoma</b> 2E, 7E, 19E, 22E-23E Tag-intermarco delaMar	
<b>Beukers Laboratories, Inc.</b> Snow & Depew Advertising, Inc.	109	° <b>Philips N. V. Pit/T &amp; M Division</b> Marsteller International S A	46
<b>Brand-Rex</b> Creamer, Trowbridge, Case & Bastord, Inc.	53	° <b>Philips Power Supplies</b> Marsteller International S A	15E
<b>Burdny Components</b> Van Leeuwen Advertising, Inc.	33	■ <b>RCL Electronics, Inc.</b> Morway Advertising Agency	14
<b>Canadian Marconi Company,</b> <b>Telecommunications Division</b> Telecommunications Advertising	62	° <b>Rohde &amp; Schwarz</b>	1E
■ <b>Clairex Corporation</b> Michel-Cather, Inc.	4th cover	° <b>Schneider R. T.</b> Intermedia	20E
<b>Colorado Video, Inc.</b> O'Connell-Columb, Inc. Creative Business Communications	103	<b>Signetics Corp.,</b> <b>Sub. of Corning Glass Works</b> Hall Butler Blatherwick Inc	44
■ <b>Digital Equipment Corporation</b> 10-11, 42-43 Creamer, Trowbridge, Case & Bastord, Inc.		<b>Siliconix Incorporated</b> Paul Pease Advertising	81
<b>Datacraft Corporation</b> The Communicator	17	<b>Solitron Devices, Inc.,</b> <b>Transistor Division</b> Haselmire Pearson Advertising, Inc	49
<b>Datatron, Inc.</b> Larry Courtney Company	8	<b>Standard Power, Inc.</b> William E. Wilson Company	103
■ <b>Eastman Chemical Products, Inc.</b> <b>Industrial Chemicals</b> J. Walter Thompson Company	61	<b>Stanford Applied Engineering</b> Rose Associates Advertising & Public Relations	59
<b>Electro Fiberoptics Div.</b> Davis Advertising, Inc.	15	■ <b>Systron Donner Concord Instruments</b> Bonfield Associates	39
<b>Electronic Memories, Inc.</b> Gumpertz, Bentley, Fried, Scott	18-19	■ <b>Systron Donner Corp. - Datapulse Div.</b> Bonfield Associates	24
■ <b>Erie Technological Products Co., Inc.</b> Altman Hall Associates Advertising	9	<b>Tektronix, Inc.</b> Dawson, Inc.	31
<b>Fujitsu Limited</b> Asian Advertisers Inc.	98	■ <b>Texas Instruments Incorporated,</b> <b>Components Group</b> Albert Frank Guenther Law, Inc	5, 57
<b>Hermes Electronics Ltd.</b> Public & Industrial Relations Limited	35	‡ <b>Thomas &amp; Betts Company</b> McCarthy, Seelba, DeBasi Advertising Agency, Inc.	46
■ <b>Hewlett-Packard</b> Stone & Adler Incorporated	7	<b>Toko, Inc.</b> Hakuhodo, Inc	61
■ <b>Hewlett-Packard</b> Tallant/Yates Advertising, Inc.	40-41	<b>TRW Electronics, IRC Boone Division</b> Odiorne Industrial Advertising, Inc	36
■ <b>Hewlett-Packard</b> Tallant/Yates Advertising, Inc.	2, 12-13	■ <b>Unitrode Corporation</b> Impact Advertising	23
■ <b>Hewlett-Packard</b> Richardson, Seigle, Rolfs & McCoy, Inc.	1	° <b>V/O Techmashexport</b> V/O Vneshtorgreklama	5E
■ <b>Hewlett-Packard</b> Dorland Advertising Ltd	9E-12E	<b>Wima, Westermann</b>	16
<b>Hitachi Ltd.</b> Dentsu Advertising Ltd.	17E		
■ <b>Honeywell Test Instrument Division</b> Campbell Mithun Inc.	50		
<b>Hughes Aircraft Company</b> Foote, Cone & Belding	92		
■ <b>Kepeco Incorporated</b> Weiss Advertising	2nd cover		
■ <b>Lambda Electronics Corporation</b> Michel-Cather, Inc.	3rd cover		

## Advertising Sales Staff

<b>Pierre J. Braudé</b> [212] 997-3485 Advertising Sales Manager
<b>Atlanta, Ga. 30309:</b> Joseph Lane 100 Colony Square, 1175 Peachtree St., N E [404] 892-2868
<b>Boston, Mass. 02118:</b> James R. Pierce 607 Boylston St. [617] 252-1160
<b>Chicago, Ill. 60611:</b> 645 North Michigan Avenue Robert W. Bartlett (312) 751-3739 Paul L. Reiss (312) 751-3738
<b>Cleveland, Ohio 44113:</b> William J. Boyle [716] 586-5040
<b>Dallas, Texas 75201:</b> Richard P. Poole, Charles G. Hubbard 1340 Republic National Bank Building [214] RI 7-9721
<b>Denver, Colo. 80202:</b> Harry B. Doyle, Jr. Tower Bldg., 1700 Broadway [303] 266-3863
<b>Detroit, Michigan 48226:</b> Robert W. Bartlett 2600 Penobscot Building [313] 962-1793
<b>Houston, Texas 77002:</b> Richard P. Poole, Charles G. Hubbard 2270 Humble Bldg [713] CA 4-8381
<b>Los Angeles, Calif. 90010:</b> Robert J. Rielly Bradley K. Jones, 3200 Wilshire Blvd., South Tower [213] 487-1160
<b>New York, N.Y. 10020</b> 1221 Avenue of the Americas Warren H. Gardner [212] 997-3617 Michael J. Stoller [212] 997-3616
<b>Philadelphia, Pa. 19103:</b> Warren H. Gardner 6 Penn Center Plaza, [212] 971-3617
<b>Pittsburgh, Pa. 15222:</b> Warren H. Gardner 4 Gateway Center, [212-971-3617
<b>Rochester, N.Y. 14534:</b> William J. Boyle 9 Greylock Ridge, Pittsford, N.Y. [716] 586-5040
<b>San Francisco, Calif. 94111:</b> Don Farns Robert J. Rielly, 425 Battery Street, [415] 362-4600
<b>Paris:</b> Alain Offergeld 17 Rue-Georges Bizet, 75 Paris 16, France Tel 720-73-01
<b>Geneva:</b> Alain Offergeld 1 rue du Temple, Geneva, Switzerland Tel 32-35-63
<b>United Kingdom:</b> Keith Mantle Tel 01-493-1451, 34 Dover Street, London W1
<b>Milan:</b> Robert Saidel 1 via Baracchini Phone 86-90-656
<b>Brussels:</b> Alain Offergeld 23 Chaussee de Wavre Brussels 1040, Belgium Tel 13-65-03
<b>Stockholm:</b> Brian Bowes Office 17 Kontor-Center AB, Hagagarten 29, 113 47 Stockholm Tel 24 72 00
<b>Frankfurt/Main:</b> Fritz Krusebecker Liebigstrasse 27c Phone 72 01 81
<b>Tokyo:</b> Masaru Wakeshima, McGraw-Hill Publications Overseas Corporation, Kasumigaseki Building 2-5, 3-chome, Kasumigaseki, Chiyoda-Ku, Tokyo, Japan [581] 9811
<b>Osaka:</b> Ryoji Kobayashi, McGraw-Hill Publications Overseas Corporation, Kondo Bldg., 163, Umegae-cho Kita-ku [362] 8771
<b>Australia:</b> Warren E. Bail, IPO Box 5106, Tokyo, Japan
<b>Business Department</b>
<b>Stephen R. Weiss, Manager</b> [212] 997-2044
<b>Thomas M. Egan,</b> Production Manager [212] 997-3140
<b>Carol Gallagher</b> Assistant Production Manager [212] 997-2045
<b>Dorothy Carter,</b> Contracts and Billings [212] 997-2908
<b>Frances Vallone,</b> Reader Service Manager [212] 997-6057
<b>Electronics Buyers' Guide</b>
<b>George F. Werner,</b> Associate Publisher [212] 997-3139
<b>Regina Hera,</b> Directory Manager [212] 997-2544

## Classified & Employment Advertising

F. J. Eberle, Manager 212-971-2557	
<b>EQUIPMENT (Used or Surplus New) For Sale</b>	
Data Instrumentation Associates	108
Ewald Instruments Corp.	108
General Supply and Equip.	108
Radio Research Instrument Co.	108
Radiation Devices Co.	108

- For more information on complete product line see advertisement in the latest Electronics Buyer's Guide
- ° Advertisers in Electronics International
- ‡ Advertisers in Electronics domestic edition