

Consumers warming to microwave cooking 54
A bipolar LSI approach to low-level logic 80
Designing with the integrated Schmitt trigger 83

Electronics®

SPECIAL REPORT

Peripherals reshape computer systems

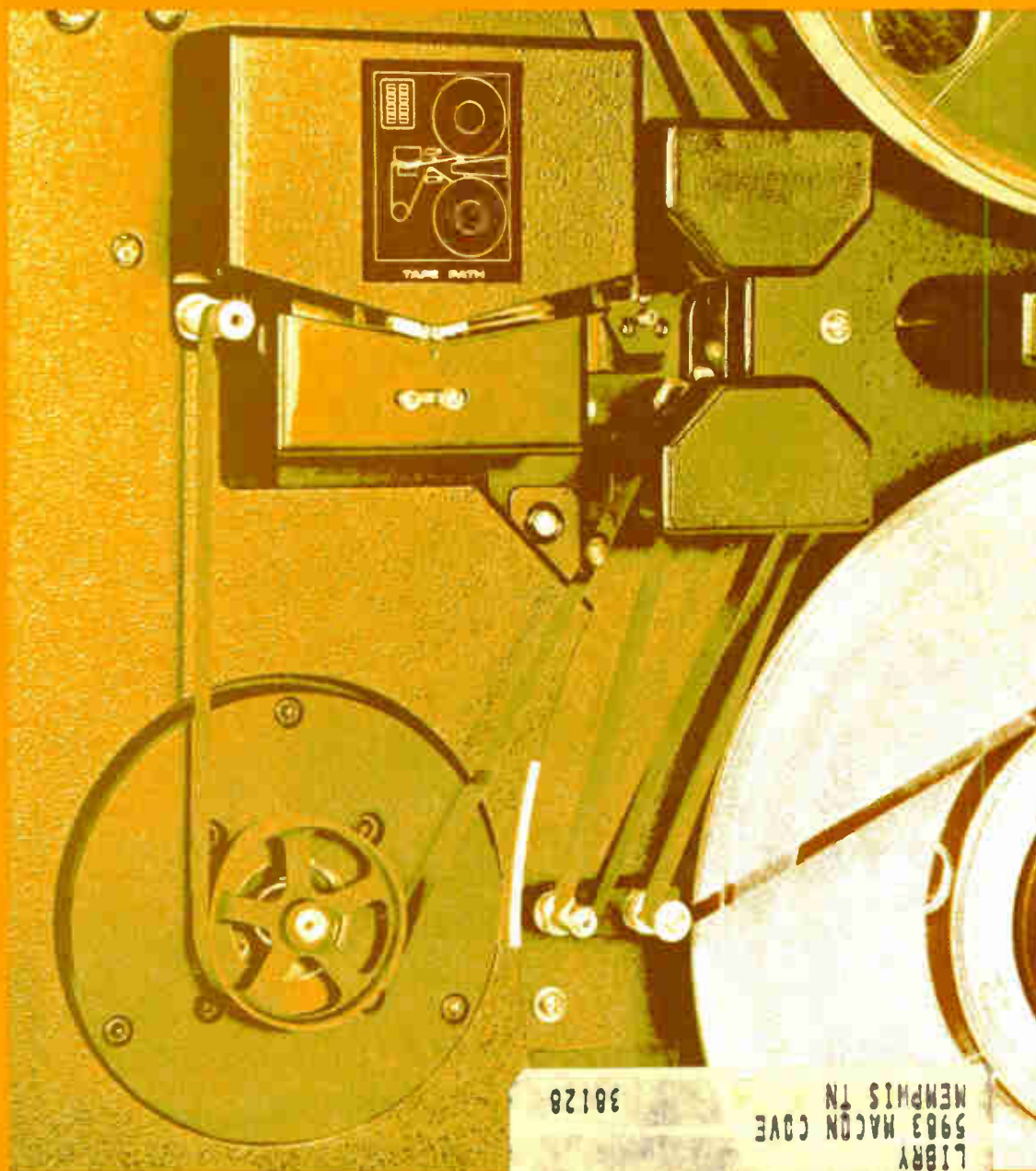

1420 TECHNICAL INST
MEMPHIS TN 38128
LIBRARY
5963 MACON COVE
ST TECHNICAL INST

only from now - logic panels with decoupling capacitor provisions



for standard applications...

Decoupling efficiency of better than 98% is achieved from 1.34 kHz through 50 MHz by using Scanbe's suggested capacitor array.

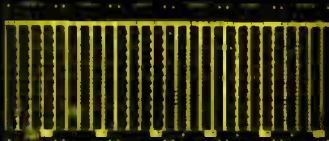

UNIVERSAL MODEL LPU
\$35.50 avg./zone (25 pc. quant.)

- 18, 36 or 54 pin rows
- For 14, 16, 24, 36, 40 LEAD DIPS

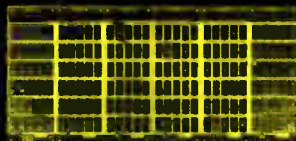

STANDARD MODEL LPS
\$35.00 avg./zone (25 pc. quant.)

- 14 or 16 LEAD DIPS
- 30 to 180 sockets in 30 socket zones

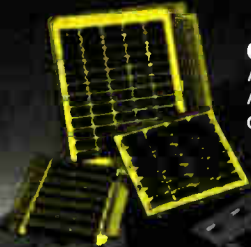

CUSTOM LOGIC PANELS

Available in any shape, size or configuration.
Any number of pins for discretes or decoupling capacitors.

All of our universal, standard and custom series logic panels now incorporate this outstanding advance. All of our models are supported by the best, most complete line of quality accessories (including our ME-2 sockets) to optimize and assure top performance and reliability.

So if your logic panel needs call for quality performance, exclusive features and low price, get the best logic panels... only from Scanbe. Call or write for our latest logic panel brochure.

SCANBE MANUFACTURING CORP.
"The Packaging People"
3445 Fletcher Ave. • El Monte, Calif. 91731
(213) 579-2300 / 686-1202

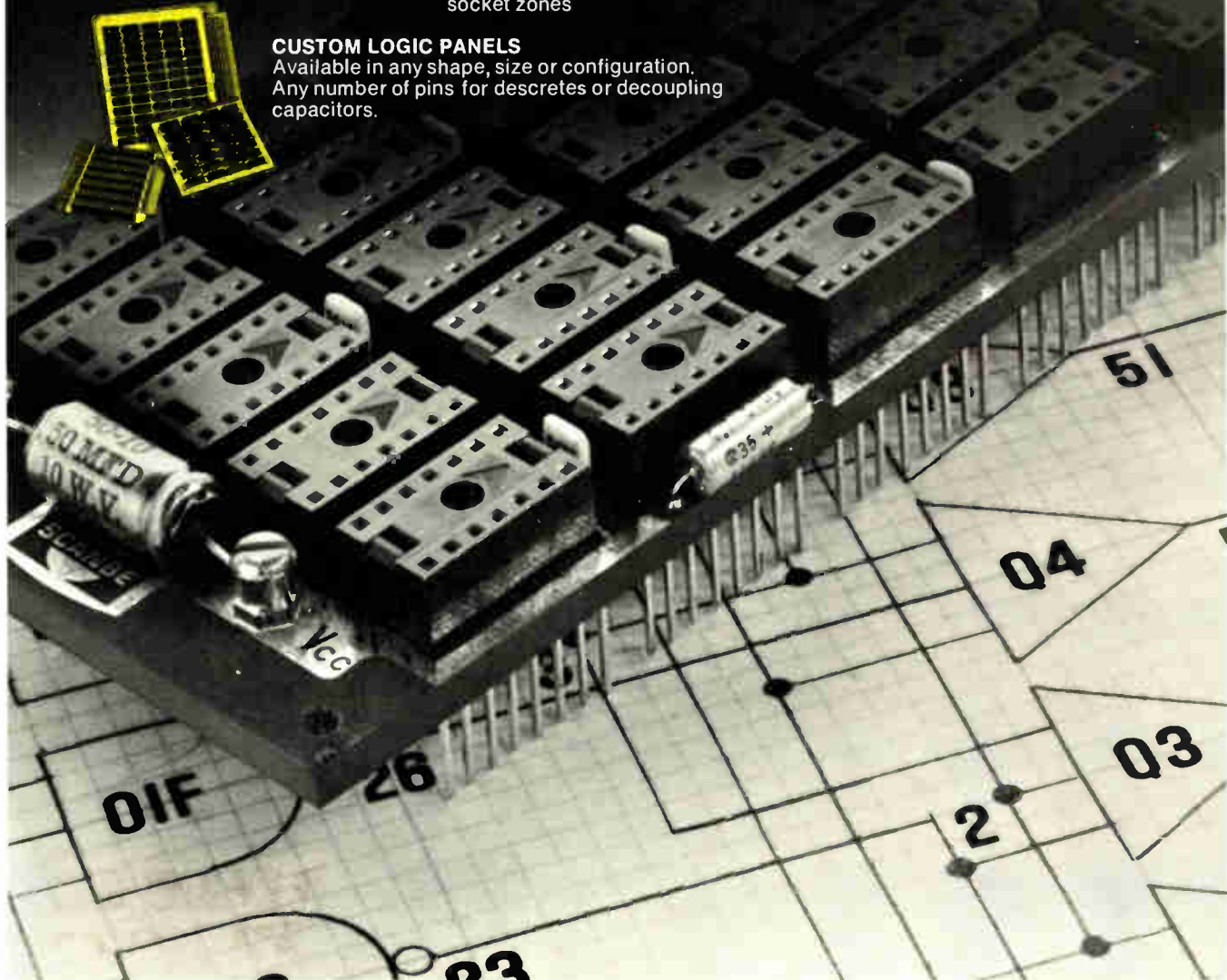

Centralab Trimmer Resistors... in line with your design requirements



Write
Centralab
for
Bulletin
No. 1284PR2

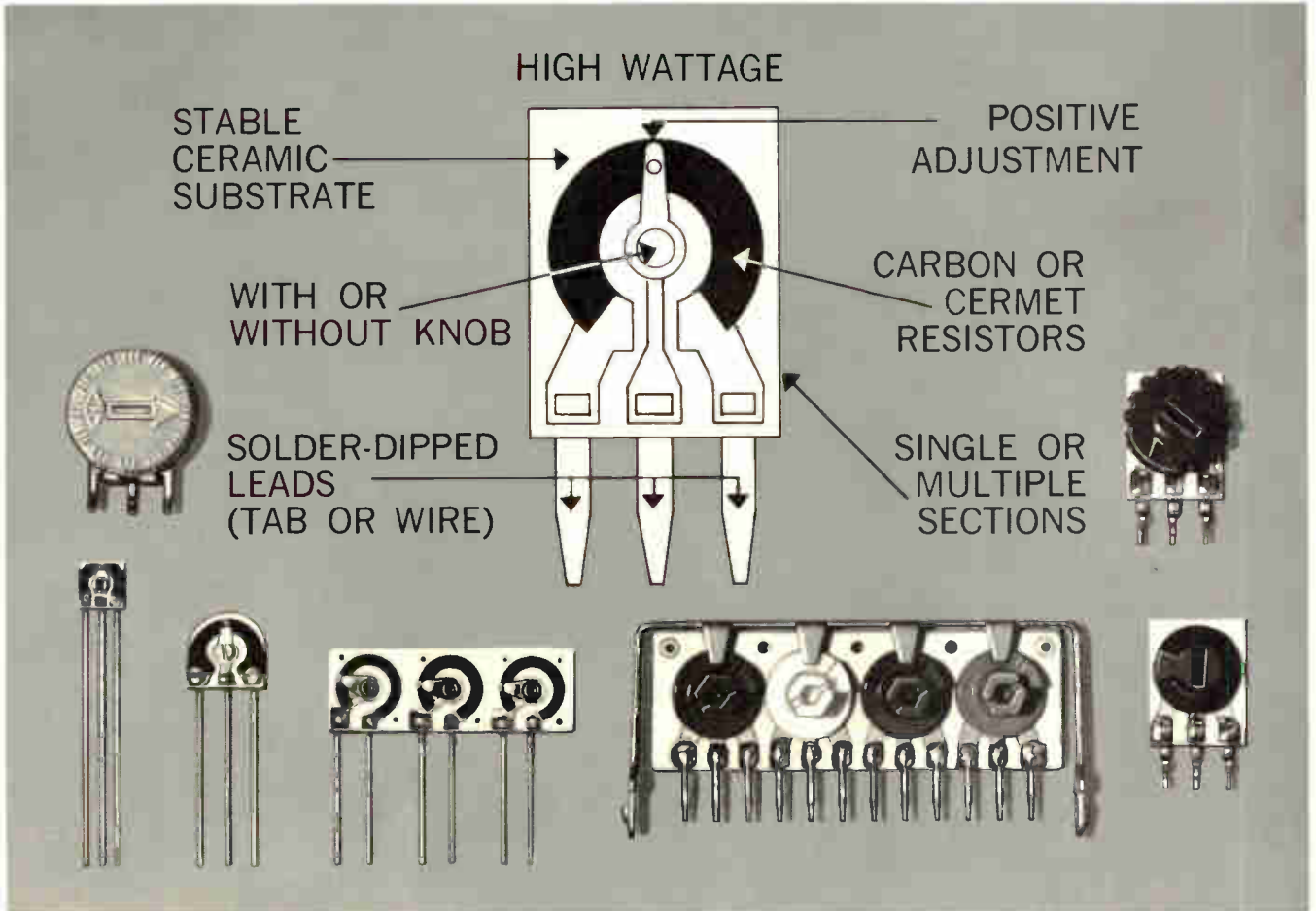

Ceramic—just one reason they're better!

The ceramic substrates of Centralab trimmer resistors—in both carbon and cermet—give them performance unmatched by phenolics. They're conservatively rated at double the wattage capability! You get higher wattage in a smaller space. They'll withstand higher operating temperatures. At 70° C they accept a full wattage load and derate to zero at temperatures of 105° C for carbon and 125° C for cermet.

Ceramic bases give you dimensional stability you can depend on—they won't shrink. They eliminate the problem of flux migration during flow soldering, too, so you can forget catastrophic failures often encountered with conventional trimmers. And—whether

you specify wire leads or one of three tab styles, all are solder-dipped for ease of installation.

Another reason for selecting Centralab trimmer resistors is their smooth, positive adjustment. Their design eliminates the erratic, "slip-stick" effect in setting.

The seven series of Centralab trimmer resistors come in sizes from 1/4" to 3/4", single or multiple sections, in ratings from 1/20 to 3/4 watt, TC as low as 150 PPM, competitively priced with phenolics. They give you more of what you're looking for in a trimmer. If you need more reasons or specifications see EEM, 1972-73 Edition, or write Centralab Electromechanical Sales.

GET CENTRALAB THE "IN" LINE FOR YOUR DESIGN

Hybrid Microcircuits
Pushbutton & Rotary Switches
Capacitors
Potentiometers
Technical Ceramics
Ceramic Packages
Semiconductor Devices
Trimmer Resistors



CENTRALAB

Electronics Division
GLOBE-UNION INC.

5757 NORTH GREEN BAY AVENUE
MILWAUKEE, WISCONSIN 53201



programming interface

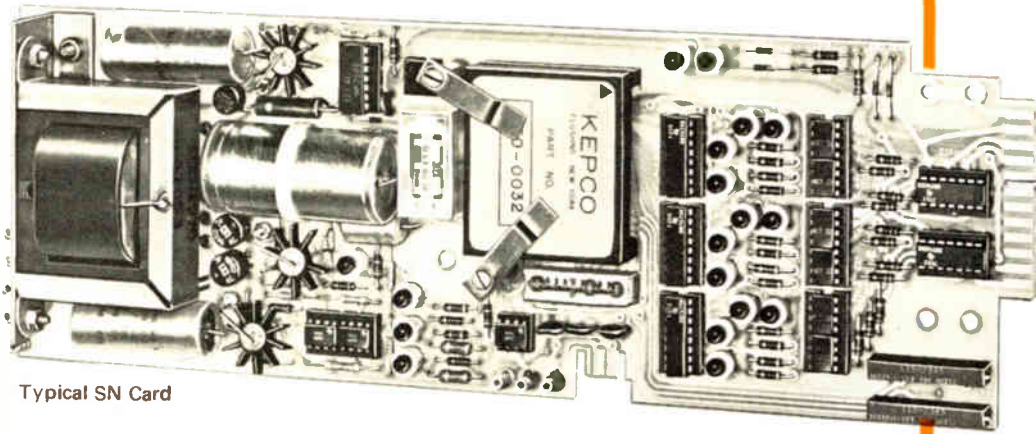

Typical SN Card

The five Kepco SN models offer a selection of DAC's for the digital control of anything that can be programmed by a 10V analog signal. You need no digital experience to use the SN. We've built-in the power—all you need is the 115/230V a-c line. We've built-in the data storage and delayed strobe for glitchless programming. All you need is a 10 microsecond pulse or a switch closure. We've built-in the isolation—so you don't need to worry about grounding. We've built the PC board and a variety of housings—all you need to mount them is a bench top or rack space or a small slot in your equipment.

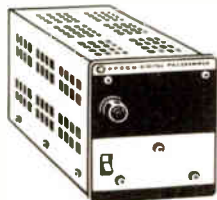

The CA-6 enclosure accommodates 2 SN Cards.

The SN Cards mount up to 6 abreast in a convenient plug-in format.

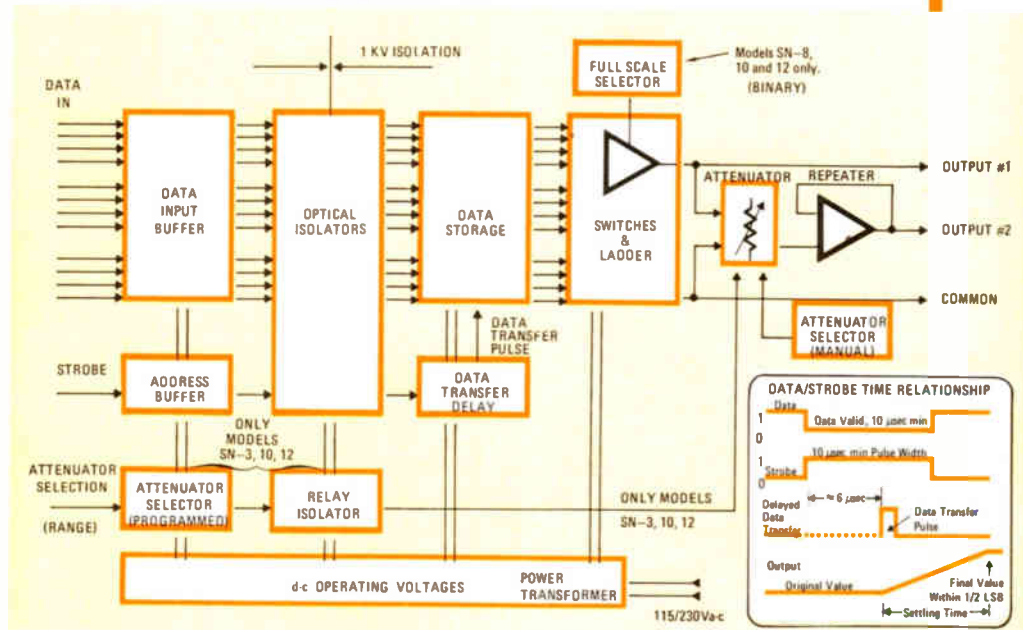

SPECIFICATIONS	MODEL SN-2	MODEL SN-3	MODEL SN-8	MODEL SN-10	MODEL SN-12
RESOLUTION	2-Digit	3-Digit	8-Bit	10-Bit	12-Bit
INPUT DATA CODING	COMPLEMENTARY BINARY CODED DECIMAL 4 LINES PER DIGIT 8-4-2-1		BIPOLAR OUTPUT: COMPLEMENTARY OFFSET BINARY UNIPOLAR OUTPUT: COMPLEMENTARY BINARY		
ACCURACY @ 25°C (% OF FULL SCALE READING) SCALE FACTOR ERROR ⁽¹⁾	±0.2%	±0.1%	±0.1%	±0.1%	±0.05%
ZERO OFFSET	ZEROING TRIMMER IS BUILT-IN.				
LINEARITY	±0.2%	±0.05%	±0.2%	±0.05%	±0.01%
PRICE	\$305.00	\$440.00	\$305.00	\$387.00	\$472.00

(1) May be calibrated with optional trimmer, Option "R"—Price, \$10.00. Add the option letter as a suffix to the model number.

For complete specifications and applications notes, write Dept. EH-14

KEPCO

21 Electronics Review

GOVERNMENT ELECTRONICS: FAA opens market for interim MLS, 21
COMMERCIAL ELECTRONICS: Point of sale: by 1976, \$562 million, 21
MILITARY ELECTRONICS: Inertial platform, Jeep survey land, 22
COMMUNICATIONS: FCC delay keeps domsat grounded, 23
SPACE ELECTRONICS: NASA's gear may upgrade outside tests, 23
AIR-TRAFFIC CONTROL: Lockheed diversifies with FAA award, 24
MEETINGS: AFIPS puts eggs in one basket, 25
CONSUMER ELECTRONICS: Japan slips in trade balance battle, 25
MANUFACTURING: One firing cuts cost of multilayer boards, 26
COMPANIES: Cyanamid shies away from OCR market, 26
MEDICAL ELECTRONICS: X-ray processing without darkroom, 27
FOR THE RECORD: 27

37 Electronics International

GREAT BRITAIN: Radar display uses glowing, moving plate, 37
JAPAN: Device shows channel numbers on color TV screen, 37

49 Probing the News

INDUSTRY: Electronics industries recovering, 49
MILITARY ELECTRONICS: Pilotless planes: big new market? 51
CONSUMER ELECTRONICS: Cooks warm up to microwaves, 54
COMPUTERS: Terminals enter more classrooms, 56

59 Technical Articles

COMPUTERS: Technology gap starts to close for peripherals, 59
DESIGNER'S CASEBOOK: Oscilloscope converter gives 4 channels, 76
Logic probe with LED display checks ECL circuits, 76
Controlling op amp gain with one potentiometer, 78
SOLID STATE: Low-power bipolar technique begets LSI logic, 80
CIRCUIT DESIGN: The versatile integrated Schmitt trigger, 83
ENGINEER'S NOTEBOOK: Varactor pair improves modulation, 86
Summing up the front-release, rear-release debate, 87

90 New Products

IN THE SPOTLIGHT: N-channel MOS bids for mainframes, 90;
Solder or socket: a new approach, 92
COMPONENTS: Active filters use IC op amps, 93
INSTRUMENTS: Ac calibrator is programmable, 95
DATA HANDLING: Static card reader is rugged, 98
SEMICONDUCTORS: 1,024-bit RAM has 35-ns access time, 100
MATERIALS: 102

Departments

Publisher's letter, 4
Readers comment, 6
People, 12
Meetings, 14
Electronics newsletter, 17
Washington newsletter, 33
Washington commentary, 34
International newsletter, 39
Engineer's newsletter, 89
New books, 104
New literature, 104

Title R registered U.S. Patent Office. Copyright 1972 McGraw-Hill Inc. All rights reserved, including the right to reproduce the contents of this publication in whole or in part. Volume 45, Number 16

Highlights

Microwave ovens move into the home, 54

Housewives in Japan, the U.S., and Europe have suddenly become enamored of microwave ovens. New standards on maximum allowable microwave leakage have apparently dispelled fears of radiation hazard, and marketing men have successfully pushed the product's convenience.

Computer peripherals get smarter, 59 (cover)

At last peripheral equipment is profiting from semiconductor advances, says this seven-part Special Report. Microprogrammed controllers are increasing efficiency, and electronic features are reducing cost. Moreover, better electromechanical concepts are in the offing.

An LSI TTL chip that keeps its cool, 80

Paralleling the inputs and outputs of several logic circuits on a chip averts the problem of overheating, because each gate can then function off much less power. Over-all power dissipation of the 350-gate bipolar chip is below 200 mW.

N-channel MOS for mainframe memories, 90

Availability of fast 1,024-bit n-channel MOS memories has already spurred development of a modular memory system that is cheaper than bipolar-based equivalents yet approaches their speed. Eighty DIPs fit on one printed-circuit board.

... and in the next issue

Automatic testing of digital logic boards—how to design them for easy testing and how to generate test patterns ... the growing importance of ICs in consumer electronics.

The cover

Tape drive from Ampex is a member of the upcoming generation of innovative peripheral equipment.

Electronics

EDITOR-IN-CHIEF: Kemp Anderson

EXECUTIVE EDITOR: Samuel Weber

MANAGING EDITORS: Lawrence Curran, *News*;
Arthur Erikson, *International*

SENIOR EDITORS: John Johnsrud,
H. Thomas Maguire, Stephen E. Scrupski

ART DIRECTOR: Fred Sklenar

ASSOCIATE EDITORS: Richard Gundlach,
John N. Kessler, Howard Wolff

DEPARTMENT EDITORS

Aerospace: William F. Arnold
Circuit Design: Lucinda Mattera
Communications & Microwave:

Lyman J. Hardeman
Computers: Wallace B. Riley
Consumer: Gerald M. Walker
Industrial: Alfred Rosenblatt
Instrumentation: Michael J. Riezenman
Military: Ray Connolly
New Products: H. Thomas Maguire
Packaging & Production:
Stephen E. Scrupski
Solid State: Laurence Altman
Special Issues: Harry R. Karp

COPY EDITORS: Margaret Eastman,
Everett C. Terry

ASSISTANT EDITOR: Marilyn Offenheiser

ART: Charles D. Ciatto, *Associate Director*

PRODUCTION EDITORS:
Patricia Cybulski, Arthur C. Miller

EDITORIAL SECRETARIES: Vickie Green,
Nancy Baldasare, Julie Gorgoglione

FIELD EDITORS

Boston: James Brinton (Mgr.), Gail Farrell
Dallas: Larry Armstrong (Mgr.)
Los Angeles: Paul Franson (Mgr.)
New York: Alfred Rosenblatt (Mgr.)
San Francisco: Stephen Wm. Fields (Mgr.),
Roberta Schwartz
Washington: Ray Connolly (Mgr.),
William F. Arnold
Frankfurt: John Gosch
London: Michael Payne
Paris: Arthur Erikson
Tokyo: Charles Cohen

McGRAW-HILL WORLD NEWS

Director: Walter A. Stanbury; *Atlanta*: Stan Fisher; *Chicago*: Mike Sheldrick; *Cleveland*: Arthur Zimmerman; *Detroit*: James Wargo; *Houston*: Robert E. Lee; *Los Angeles*: Michael Murphy; *Gerald Parkinson*; *San Francisco*: Margaret Drossel; *Seattle*: Ray Bloomberg; *Washington*: James Canan, Herbert W. Cheshire, Seth Payne, Warren Burkett, William D. Hickman; *Bonn*: Robert Ingersoll; *Brussels*: James Smith; *London*: Marvin Petal; *Milan*: Peter Hoffmann, Andrew Heath; *Moscow*: Axel Krause; *Paris*: Stewart Toy, Michael Johnson; *Stockholm*: Robert Skole; *Tokyo*: Mike Mealey

PUBLISHER: Dan McMillan

ADVERTISING SALES MANAGER: Pierre J. Braudé

ADVERTISING SALES SERVICE MANAGER:
Wallis Clarke

BUSINESS MANAGER: Stephen R. Weiss

CIRCULATION MANAGER: George F. Werner

RESEARCH MANAGER: David Strassler

MARKETING SERVICES MANAGER:
Tomlinson Howland

Publisher's letter

The equipment—from punched-card readers to sophisticated terminals—that's attached to a computer mainframe may be called peripheral, but is really essential to working with the computer. Over the years, the main thrust of technology has been the upgrading of the mainframe. Now, though, progress in peripherals is catching up—and fast.

That's why our special report in this issue bears the title: "The technology gap starts to close for computer peripherals." With all the activity in the field, we decided it was time to round up the major trends, detail just what the peripheral makers—and users—can expect in the way of progress.

In the 16-page report, which starts on page 59, you'll find sections covering such hot items as remote terminals and printers, as well as magnetic tapes and disks, and those old standbys, the punched-card machines. They all have one big common denominator: their technological development is just not standing still.

For Wallace Riley, our computer editor, putting together the report was, of course, a massive job. "But the hardest job was deciding what not to put in. Compensating for that agony, however, was the excitement of encountering such widely differing views on what's happening in peripherals. When everybody looks at the future the same way, there's not much of a story to tell. But here everybody is looking at a different point on the horizon."

With educators reaching out more and more toward electronics as a tool for improving the quality of

education, it's natural that they should sooner or later tap the computer. And as minicomputers proliferate, the cost of computer-based teaching systems is coming within the reach of more teachers and school officials (see *Probing the News*, p. 56).

Supplied with input from our string of reporters around the country, Roberta Schwartz, editorial assistant in our San Francisco bureau, put together that story. Roberta has many reasons to be intrigued by the subject. Armed with a master's degree in education, she has taught French and music. And, expecting a child in a few months, she is naturally interested in what schools will look like in the next decade.

"Having taught in New Jersey and New York school systems, I was aware of the many problems in education," she says. "As a French teacher, I also realized the great benefits that could be reaped from electronic equipment—such as a language laboratory—provided it was used properly.

"But computers in education, other than as computational aids, was something new and fascinating to me. In interviewing teachers using equipment while doing the story, I found their enthusiasm overwhelming and the range of applications surprising. I became so involved in one program, I began talking to the machine! And it kept smiling at me, via a series of Xs. What it wanted me to do was spell my name, so every time I hit a letter in my name, it smiled."



July 31, 1972 Volume 45 Number 16
93 407 copies of this issue printed

Published every other Monday by McGraw-Hill, Inc. Founder James H. McGraw 1860-1948. Publication office 1221 Avenue of the Americas, N.Y., N.Y. 10020, second class postage paid at New York, N.Y. and additional mailing offices.

Executive, editorial, circulation and advertising addresses: Electronics, McGraw-Hill Building, 1221 Avenue of the Americas, New York, N.Y. 10020. Telephone (212) 967-1221. Teletype TWX N.Y. 710-581-5234. Cable address: MCGRAW HILL N.Y.

Subscriptions limited to persons with active, professional functional responsibility in electronics technology. Publisher reserves the right to reject non-qualified requests. No subscriptions accepted without complete identification of subscriber name, title, or job function company or organization including product manufactured or services performed. Subscription rates: qualified subscribers in the United States and possessions and Canada, \$8.00 one year, \$12.00 two years, \$16.00 three years; all other countries \$25.00 one year except Japan \$50.00 per year including air freight. Limited quota of subscriptions available at higher-than-basic rate for persons outside of field served, as follows: U.S. and possessions and Canada, \$25.00 one year; all other countries \$50.00. Single copies: United States and possessions and Canada, \$1.00; all other countries, \$1.75.

Officers of the McGraw-Hill Publications Company: John R. Emery, President; J. Elton Tuohy, Senior Vice President—Services; Donald B. Gndley, Group Vice President; Vice Presidents: Ralph Blackburn, Circulation; John R. Callahan, Editorial; John B. Hoglund, Controller; David G. Jensen, Manufacturing; Jerome D. Luntz, Planning & Development; Joseph C. Page, Marketing.

Officers of the Corporation: Shelton Fisher, President; Joseph H. Allen, President, Publications and Business Services Group; John J. Cooke, Senior Vice President and Secretary; Ralph J. Webb, Treasurer. Title registered in U.S. Patent Office. Copyright 1972 by McGraw-Hill, Inc. All rights reserved. The contents of this publication may not be reproduced either in whole or in part without the consent of copyright owner.

Subscribers: The publisher, upon written request to our New York office from any subscriber, agrees to refund that part of the subscription price applying to copies not yet mailed. Please send change of address notices or complaints to Fulfillment Manager, subscription orders to Circulation Manager, Electronics, at address below. Change of address notices should provide old as well as new address, including postal zip code number if possible, attach address label from recent issue. Allow one month for change to become effective.

Postmaster: Please send form 3579 to Fulfillment Manager, Electronics, P.O. Box 430, Hightstown, N.J. 08520.

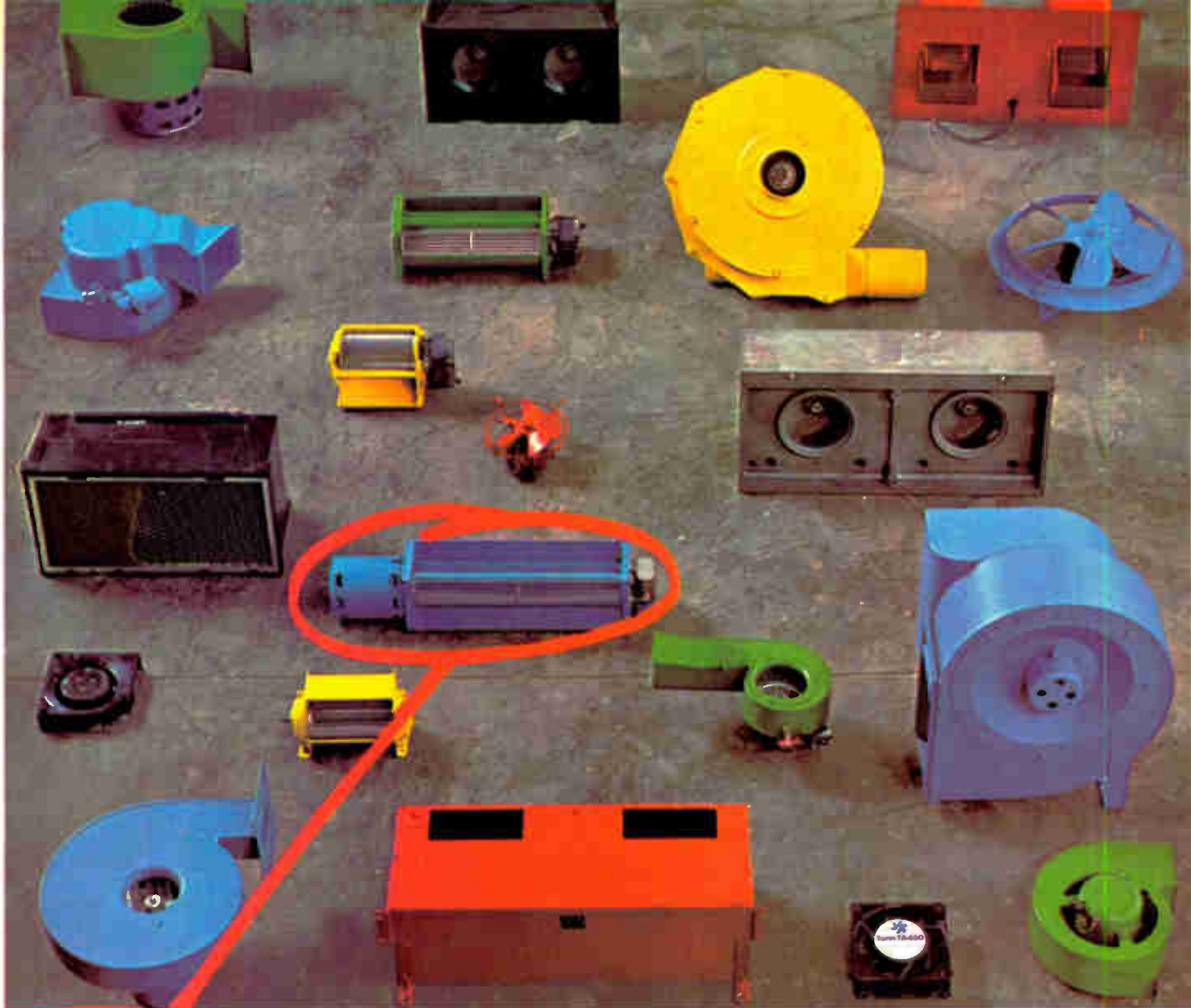

**This one
does a job
for your
competitor.
But it might
not be
for you.**

Torin Flexibility

Problem: A computer manufacturer handed us a knotty air-supply problem. Their new model had a memory and a logic system with gates of 18 cards each. Both systems required an equal air flow for each card, and the rate of flow was different for each system.

Installations would be at a wide range of altitudes, and since their market was foreign as well as domestic, both 50 and 60-cycle motors were called for.

Because of the proximity of the motors to the gates, a high degree of EMI containment was vital. And, finally, guards were required for maintenance protection.

Solution: Our engineers considered the horizontal configuration of the gates and utilized transverse blowers. Impeller length was matched to the width of the gates to provide an equal air flow to each card.

We used shaded-pole motors for altitudes up to 3,000 feet. Both 50 and 60-cycle versions. For altitudes above 3,000 feet we selected a permanent split-capacitor motor.

That makes three motor capacities, each with left and right-hand mounts. Six in all, and all adaptations of one basic blower. Each met the high EMI containment, and the maintenance guards were designed so as not to hinder flow requirements.

See? There's a lot to it, even when you know how.

Your competitor's air-moving problems are his. Yours are yours. And both are firmly dictated by optimum product performance. Often we can produce exactly what you require through modifications of existing units. But if custom design is called for we can turn that out too. More than 500,000 square feet of modern production space results in competitive pricing and realistic deliveries.

You see here just one example of our flexible problem-solving experience. There's so much more to the Torin story. Get it first hand from one of our twenty Technical Sales Representatives. Or, write or phone for our tells-it-all booklet.

Torin Corporation
United States: Torrington, Conn.
 Van Nuys, Calif
 Rochester, Ind., Elgin, Ill.

Canada: Oakville, Ont.

England: Swindon, Wilts.

Belgium: Nivelles

Australia: Sydney

Circle 5 on reader service card



A Smart Way to Beat Your Power Supply Size Problem

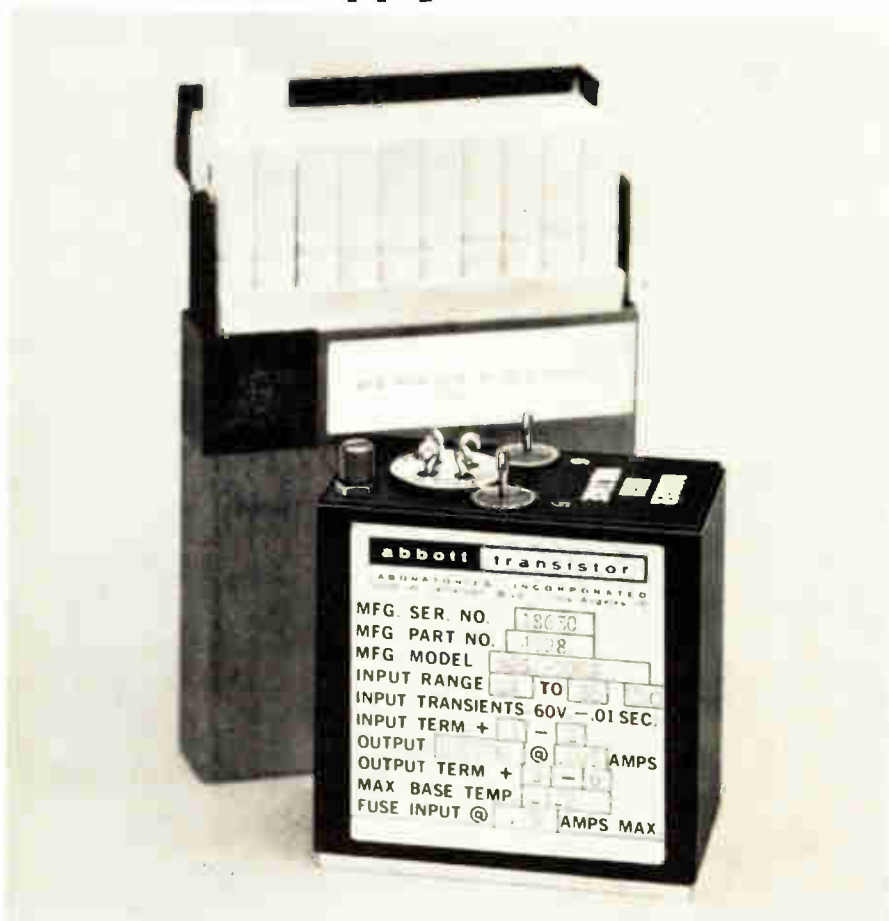

1½" thin, 2¾" narrow, 2¾" short

yet this converter produces 1000 volts DC, regulated, from a battery input of 28 VDC! It weighs less than 15 ounces. This is only one of our wide variety of many small light weight converters, inverters and power supplies — there are over 3000 models listed in our newest catalog, including size, weight and prices. If you have a size problem, why not send for an Abbott catalog?

MIL SPEC ENVIRONMENT — All of the power modules listed in our new catalog have been designed to meet the severe environmental conditions required by modern aerospace systems, including MIL-E-5272C and MIL-E-5400K. They are hermetically sealed and encapsulated in heavy steel containers. New all silicon units will operate at 100°C.

Please see pages 618 to 632 of your 1971-72 EEM (ELECTRONIC ENGINEERS MASTER Catalog) for complete information on Abbott modules

Send for our new 56 page FREE catalog.

abbott transistor

LABORATORIES, INCORPORATED

5200 W. Jefferson Blvd./Los Angeles 90016
(213) 936-8185 Cable ABTLABS

1224 Anderson Ave./Fort Lee, N.J. 07024
(201) 224-6900

Readers comment

Rotating ring design

To the Editor: A most unfortunate and untrue statement appears in the article, "Rotating ring display offers new face for instruments," by H. G. Dill, A. M. Leupp, A. T. Robinson, T. N. Toombs, and R. F. Zurcher [*Electronics*, Jan. 31, p. 52], concerning their ingenious ring display. In two places, it is stated that the horizontal drive configuration may considerably reduce the visibility of the rotor ring surface by the masking effect of the stator poles.

However, I see no reason why the rotor ring could not be made in a C-shape, the lower arm of which would be identical to the structure in Fig. 3. But the rest would be non-magnetic, and the upper arm would provide a fully visible surface capable of taking any markings. The figure below may more clearly indicate what I mean.

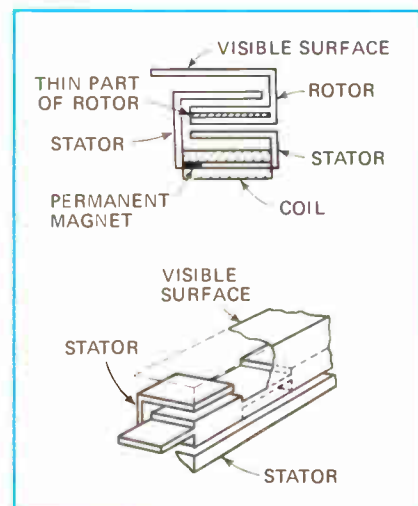

I realize this could only be used in a single-ring configuration and not, for instance, in the three-ring structure of Fig. 4. If the horizontal drive has a strong preference on the basis of simplicity, I should be very interested to know if any other technical problems preclude the use of a C-shape rotor.

T. J. Goldman
Physics Department
Harvard University
Cambridge, Mass.

■ Mr. Dill replies: Mr. Goldman is quite correct with respect to the visibility of the horizontal ring. We have considered the C-shaped rotor with



RT-01. The data entry terminal you didn't think there was the remotest chance you could afford.

An RT-01 with a 16-character keyboard, numeric Nixie* read-out, four status indicators to display non-numeric information from your computer, Teletype and EIA serial line compatibility will only run you from \$600 to \$1000.

Or as little as \$500 without the Nixie display. Chickenfeed.

So now, if you're a big opera-

tion, you can have an RT-01 here, an RT-01 there, an RT-01 everywhere you've ever wanted one.

If you're little, you can have one at last.

We've got a booklet that'll tell you all about it that you can write for.

Or, if you're in as big a hurry as we hope you are, we've got a

good egg who'll be happy to run right over and explain it to you.

We're the Logic Products Group, Digital Equipment Corporation, Maynard, Massachusetts 01754. (617) 897-5111.

digital

*Registered trademark of Burroughs Corporation

Circle 7 on reader service card

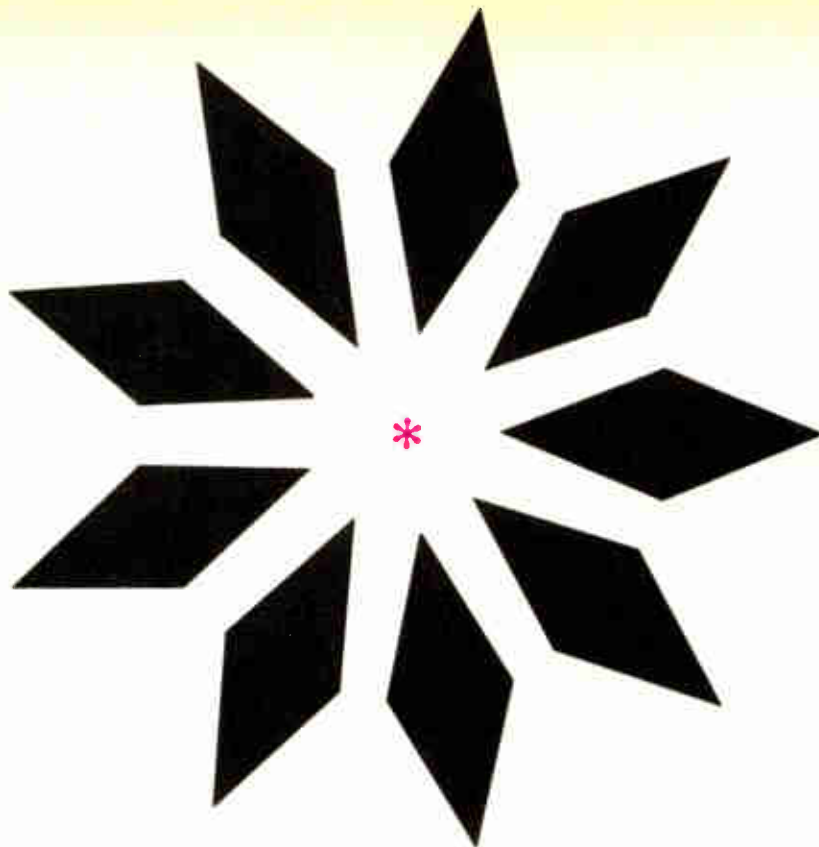

Complete HF Receive Antenna capability in a 50 meter circle

How Hermes did away with vast rhombic or log-periodic antenna farms. Shoed away by a shrewd array:

Take 1 meter diameter loops, 4 meters apart, and get an omni directional broad-band receiving array.

Covers 2 - 32 MHz.

Optimum beam characteristics for both long and short range communications.

Rosette configuration of linear arrays gives a number of overlapping high gain beams - all available simultaneously.

*** Using less than one hundredth of traditional real estate.**

Aperiodic Loop Systems are shrewd enough for restricted space, quick set up, roof mountable, or just below ground level. And portable version now available.

From polar icecap to sweltering tropics.

Installed in more than 52 locations for more than ten governments and more than 32 of their agencies.

Give up the antenna farm. ASK US

Hermes Electronics Limited

Suite 315
2020 F Street N. W.
WASHINGTON
D.C., 20006
Telephone 202 296-2978
TWX 710-822-1106

other solutions. However, there are three problems.

- The increased mass of the C-shaped rotor means less acceleration and less shock stability. The C-shaped rotor is also considerably more difficult to fabricate.

- The larger surface area means higher friction.

- The design and assembly of the display is more difficult, since the stator is embedded in a nonmagnetic (plastic) body.

The problems mentioned are especially valid for small displays with lower power dissipation, such as watches. But there may be applications where the C-shaped rotor is useful. The horizontal and vertical rotor in the Electronics article were intended as examples only.

Semantics: 'acoustical'

To the Editor: In "What else is new?" [*Electronics*, July 3, p. 6], Walter K. Gross states, "... why mechanical signal paths in monolithic crystal filters should be termed 'acoustical' is beyond my comprehension, since they rarely have anything to do with 'hearing.'"

The term "acoustical" stems from the fact that mechanical energy is propagated in longitudinal waves, which are associated in physics with sound.

By the way, any mechanical resonator will "sing" when excited in the audible frequency range. Want to bet?

Edgar G. Knop
Telelift GmbH

Munich, West Germany

Diagram corrections

To the Editor: I'd like to point out a few corrections for the circuit diagram of my Designer's Casebook, "Amplitude modulator is highly linear," [*Electronics*, June 5, p.101].

The pnp transistor, Q₃, should have been a type 2N3672 device; diodes D₁ and D₂ should have been type 1N662 devices; and the output frequency at point E should have been $\omega_r \pm \omega_m$.

Donald DeKold
Santa Fe Junior College
Gainesville, Fla.

Erie Tubular Ceramic Capacitors Help Reduce Circuit Costs 3 Ways!

\$ Economy of the Capacitor Itself

\$ Tubular Shape is Ideal for Automatic Insertion

\$ Low Profile Blends with High Density Packaging Concepts.

CAPACITORS SHOWN
3 TIMES ACTUAL SIZE

If you are involved in engineering, manufacturing or purchasing and finding "a better way" is vital, ERIE Tubular Ceramic Capacitors can help you cut operating costs and boost profits in a number of different ways.

For example, if you have a tuned circuit application needing very precise temperature compensation... specify ERIE Tubular Ceramic Capacitors. Or where nominal capacitance control to $\pm 1\%$ is important. Or where rising production costs dictate components be designed for automatic insertion. Or where you want a low profile capacitor that blends with high density circuit packaging schemes. Specify ERIE Tubular Ceramic Capacitors.

These completely versatile, low cost capacitors are perfect for a wide range of applications... from the competitive entertainment market to sophisticated military and aerospace programs. Reliable? We've made billions of them... for nearly four decades. And they cost only pennies each. Think Tubular... Erie Tubulars.

Talk to your Erie representative... or write for literature — ERIE TUBULAR CERAMIC CAPACITORS

TRY THIS MICRO SIZE
MONOLITHIC CAPACITOR FOR
EQUIPMENT OPERATING
UNDER SEVERE ENVIRONMENTAL
CONDITIONS.

ERIE STYLE 8015
ACTUAL SIZE

012 mfd.
Hermetically Sealed in Glass

We also offer you a whole new world of packaging ideas with our state of the art monolithic ceramic capacitors. Select the capacitance values, voltages and characteristics to suit your circuit needs. Ask your nearest Erie representative... or write for literature about Erie Monobloc® Ceramic Capacitors.

ERIE TECHNOLOGICAL PRODUCTS, INC.
Erie, Pennsylvania 16512

ERIE

Circle 9 on reader service card

Model 980A

\$3,475

Quantities 1 to 100 with hardware multiply and divide and many other built-in standard features

TI continues its leadership in price and performance with the new Model 980A general purpose computer.

The 980A, as with the 960A, is a fast, powerful and flexible 16-bit computer at a low unit price with all the features, built-in and *standard*. Consider these many standard features, compare the price and you'll see why the 980A is the most cost-effective general purpose computer available today.

- Hardware, multiply/divide with 16 or 32-bit add and subtract
- 750-nsec add immediate
- 5.25- μ sec multiply
- 750-nsec, full-memory cycle time
- Bit/byte/word/byte string data addressing
- Memory parity
- Programmable memory protect and privileged instructions
- Power fail/auto restart
- Power supply to support 65K memory
- Memory biasing (dynamic relocatability)
- I/O bus with 4 ports basic (expandable to 14 in basic chassis, 256 overall)

CPU with 4K memory	\$ 3,475
CPU with 8K memory	\$ 4,975
CPU with 16K memory	\$ 7,975
CPU with 32K memory	\$13,975

(prices are FOB Houston and do not include illustrated tabletop cabinet)

- Main chassis semiconductor memory expandable to 32K. (Up to 65K with memory expansion unit: Two weeks memory protect with optional battery)
- Full, lockable front panel with break point and 4 sense switches
- Switch-initiated ROM bootstrap loader
- Auxiliary processor port
- Direct memory access channel (expandable to 8 ports)
- Four priority interrupts standard (expandable to 64)
- 98 basic instructions (16, 32 or 48 bit)
- 9 addressing modes
- 8 working registers plus status register

A pre-generated standard software system is supplied which allows the user to generate custom system software. Additional soft-

ware for the 980A includes:

- Symbolic assemblers and cross-assemblers for IBM 360/370
- FORTRAN IV
- Link and source editors (object and source)
- Modular executive control routine including disc management
- TI Language Translator (TILT) to extend FORTRAN, assembly, or create special application languages
- Service maintenance, debugging and utility programs.

For applications support, TI offers the resources of its experienced Applications Engineering group. Also, training courses on 980A software and hardware are scheduled regularly, and TI service facilities are located throughout the United States and abroad.

Would you like to know more about the new 980A price/performance leader? Write to Computer Products Marketing Manager, Texas Instruments Incorporated, P.O. Box 1444, Houston, Texas 77001. Or call (713) 494-2168 or any of the sales offices listed below.



Arlington, Va (703) 525-1444 • Atlanta, Georgia (404) 237-8666 • Boston, Mass (617) 890-7400 • Chicago, Ill (312) 593-2340 • Cleveland, Ohio (216) 464-1192 • Dallas, Tex (214) 238-3881 • Dayton, Ohio (513) 294-0774 • Denver, Colo (303) 758-5536 • Detroit, Mich (313) 352-5720 • Los Angeles, Calif (714) 547-9221 • Minneapolis, Minnesota (612) 831-5094 • Newark, N J (201) 467-2670 • New York, N Y (212) 233-6890 • Orlando, Fla (305) 644-3535 • Philadelphia, Pa (215) 643-6450 • San Francisco, Calif (408) 732-1840 • St Louis, Mo (314) 993-4546 • Bedford, England 58701 • Clamart, France 6450707 • Frankfurt, Germany 726441 • Bad Godesberg, Germany 65534

TEXAS INSTRUMENTS

INCORPORATED

JUST OFF THE PRESS!



RCL's NEW 1972 RESISTOR ENGINEERING GUIDE

the industry's most extensive and most accurate compilation of engineering information on wire-wound resistors

PRECISION/HI-SPEED POWER/WIRE-WOUND RESISTORS

including: beryllium oxide core power resistors . . . 22 special temperature coefficients from -50 PPM to +6000 PPM . . . sub-miniature precision resistors . . . ladder and summing networks.

Write for your free copy today!

RCL

ELECTRONICS, INC.
700 South 21st Street
Irvington, New Jersey 07111

People

Ampex looks to Slover to solve financial woes

When the Ampex Corp. wound up its last fiscal year with a loss near \$90 million, \$35 million of it charged to the Music division, the corporate brass quickly swept a new boss into that bedeviled division's Elk Grove Village, Ill., headquarters. Ampex was—and is—banking on William L. Slover to solve the division's woes (it accounts for 20% of Ampex's business). He had a good record as marketing manager at the firm's Computer Products division, Culver City, Calif.

In fact, the 50-year-old Slover is primarily a computer man. With an EE from Pratt Institute in Brooklyn, he soon moved into marketing at Monroe Calculator and went to Bryant Computer Products Corp. before moving on to Ampex Computer Products division nine years ago.

"We'd like to transfer techniques we used in computer marketing to the Music division," he explains. The division reproduces tapes from records. One tack will be to stress quality and price as two independent selling points. To accomplish this, two lines will be introduced: a prestige product and a budget product. The prestige line will have classical music as the fulcrum, and will feature dressed-up packaging.

"There has been a gap in quality goods," admits Slover, who is a classical-music buff. "We have not done a good job in marketing classical music, and the result is a vacuum. The industry needs a new sound." The budget tape, on the other hand, will be sold directly to the retailer, who will then sell it for about \$2.

Slover: Sweetening Ampex's Music division.



Slover has decided to revamp distribution channels, expanding through direct-mail campaigns and premium programs with Kraft Foods and Bonus Photos. One of the division's biggest miscalculations was the \$60 million deal with Kinney (now Warner Communications Inc.) for the reproduction of tapes from four record labels. "We renegotiated in March," Slover says, "so we do not distribute tape, which was our original mistake."

Another Slover objective is specialization. "We need experts," he says, "for example, a classical expert to market classical music and a black to handle black music." He has also hired a mathematician to calculate marketing logistics and strategies.

Moreover, he is pushing hard to improve the quality of the master tapes, and also has his engineers working on a two-tune tape to compete with the record industry's biggest seller—the 45-rpm single [*Electronics*, July 3, p.25].

Simultaneously, he is working on the returns problem. Previously, returned unsold tapes were unloaded for about a dollar apiece. Now, cassettes are degaussed and rerecorded at lower speeds than the original recordings, with a computer controlling the time matching. Ampex is also trying to adapt the method for eight-track cartridges but, says Slover, "the process is just not good enough yet."

Prime Computer bases its future on firmware

To those in computers, the start of another small firm must seem strange. The market already is so competitive that some experts predict a shakeout. But the founders of six-month-old Prime Computer Inc. are optimistic.

President and board chairman of the Natick, Mass., firm is Robert C. Baron, 38, former director of engineering and programming at the Computer Control System division of Honeywell Inc. Vice president for engineering is J. William Poduska,

34. His pedigree runs from MIT, through sophisticated data processing research at the NASA Electronics Research Center, and eventually to the Honeywell Information Sciences Center—Honeywell Information Systems' internal think tank—where Poduska was director.

Both men agree that credentials alone do not guarantee success. Any company needs both a top-flight product and an attractive marketing approach to succeed in this field. Baron and Poduska feel that they have both. Baron dislikes calling the forthcoming Prime 200 computer a minicomputer. "While in size and price it will be similar to minicomputers, we feel that the Prime 200 has more in common with machines like the IBM 360/50."

According to Poduska, the still largely secret design makes extensive use of firmware, or micro-programing, so much so that nearly every Prime 200 computer almost could be termed a multiprocessor. Also, he says, the firm is sworn not to ship hardware until a complete software package is ready to go along. Prime's lever in the marketplace is expected to be its commitment to complete hardware/software packages.

Indeed, "in designing the machine, we began with the general capability and software we wanted and worked our way back toward the hardware needed to implement them," says Poduska. This approach is just the reverse of general practice. But Poduska notes that because the cost of digital ICs is already low and getting lower, it makes little sense to skimp on gates at the possible expense of performance.

"Nearly everyone agrees that today the cost of computer systems lies more in the peripheral equipment area than with the central processor," says Poduska. "Unfortunately for most of our potential competitors, this became the case after they had developed their lead products, not before. Now, because we know that the CPU will turn out to be a small part of system costs, we can afford to use as much internal hardware as necessary to meet our performance goals."

What is a *buffered* tape transport?

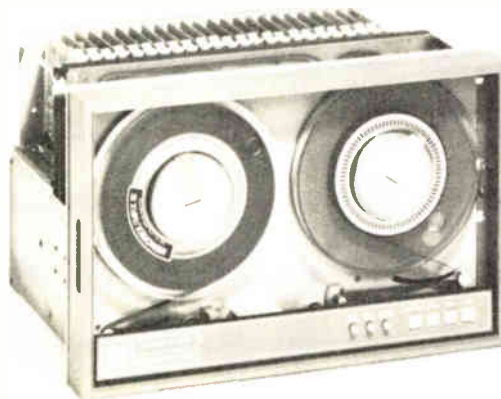

We'll answer that question.

Kennedy Model 1708 series tape transports offer a solution to many recording problems where data rates are too high for incremental recorders but where the interface simplicity of the incremental is desirable.

Model 1708 accepts data asynchronously at high rates until an input buffer is full — then records the data at 15 ips.

Meanwhile data is being stored in a second buffer. At data rates below 5500 characters/second gap time is zero; data flow is uninterrupted. Alternatively data bursts at rates up to 250 KHz can be accepted.

Tapes produced are fully formatted 9-track, 800 cpi. Read-After-Write check and asynchronous read options may be incorporated. Both 8½ and 10½ inch reel versions are available.

We haven't made incrementals obsolete — we have extended their speed and flexibility to new levels.

For complete information on Model 1708 and buffered tape transports, contact Kennedy Co. today. **KENNEDY CO.**

540 W. WOODBURY RD., ALTADENA, CALIF. 91001 • (213) 798-0953

KENNEDY
QUALITY
COUNT ON IT

When Revere

whistles up a

tempest in a

te kettle,

Plenco handles

keep their cool.

The people at Revere Copper and Brass Incorporated, Clinton, Ill., started pleasing tea fanciers over 40,000,000 tea kettles ago.

When you've made so many fine kettles, you know something about heat; where you want it and where you don't.

That's how fast-heating copper bottoms and cool-to-touch molded handles came to be part of the Revere Ware tradition.

Contoured and gleaming, many of the handles are molded of our Plenco 308 Black, a general-purpose phenolic thermoset. Plenco 308 offers excellent heat resistance as well as excellent performance in compression and transfer molding (manual or

automatic) for a very wide variety of applications. The molder: Diemolding Corporation, Canastota, N.Y.

We try to always have something good brewing for you at Plenco in the way of selections, service and ideas. Just whistle and they're yours.



PLASTICS ENGINEERING COMPANY
Sheboygan, Wis. 53081

Through Plenco research . . . a wide range of ready-made or custom-formulated phenolic, melamine, epoxy and alkylid thermoset molding compounds, and industrial resins.

Meetings

Joint Automatic Control Conference: AIAA, IEEE, et al., Stanford University, Palo Alto, Calif., Aug. 16-18.

Western Electronic Show & Convention (Wescon): WEMA, Convention Center, Los Angeles, Sept. 19-22.

Engineering in Medicine and Biology: IEEE, Americana, Bal Harbour, Fla., Oct. 1-5.

International Symposium on Remote Sensing of Environment: U. of Michigan, Willow Run Labs, Ann Arbor, Oct. 2-6.

U.S.A. & Japan Computer Conf.: AFIPS, IPSJ, Tokyo, Oct. 3-5.

Ultrasonics Symposium: IEEE, Statler Hilton, Boston, Oct. 4-6.

National Electronics Conf.: NEC, Regency Hyatt O'Hare, Chicago, Oct. 9-11.

International Conference on Cybernetics and Society: IEEE, Sheraton, Washington, D.C. Oct. 9-12.

Conference on Display Devices: IEEE, United Engineering Center, New York, Oct. 11-12.

Eascon: IEEE, Marriott Twin Bridges, Washington, D.C., Oct. 16-18.

The Business Equipment Show: McCormick Place, Chicago, Oct. 16-20

International Conference on Computer Communications: IEEE, ACM, Hilton, Washington, D.C., Oct. 24-26.

Nerem: IEEE, John B. Hynes Civic Auditorium, Boston, Nov. 1-3.

International Conference on Magnetism and Magnetic Materials: AIP, IEEE, et al., Hilton, Denver, Nov. 28-Dec. 1.

International Electron Devices Meeting: IEEE, Washington Hilton, Washington, D.C., Dec. 4-6

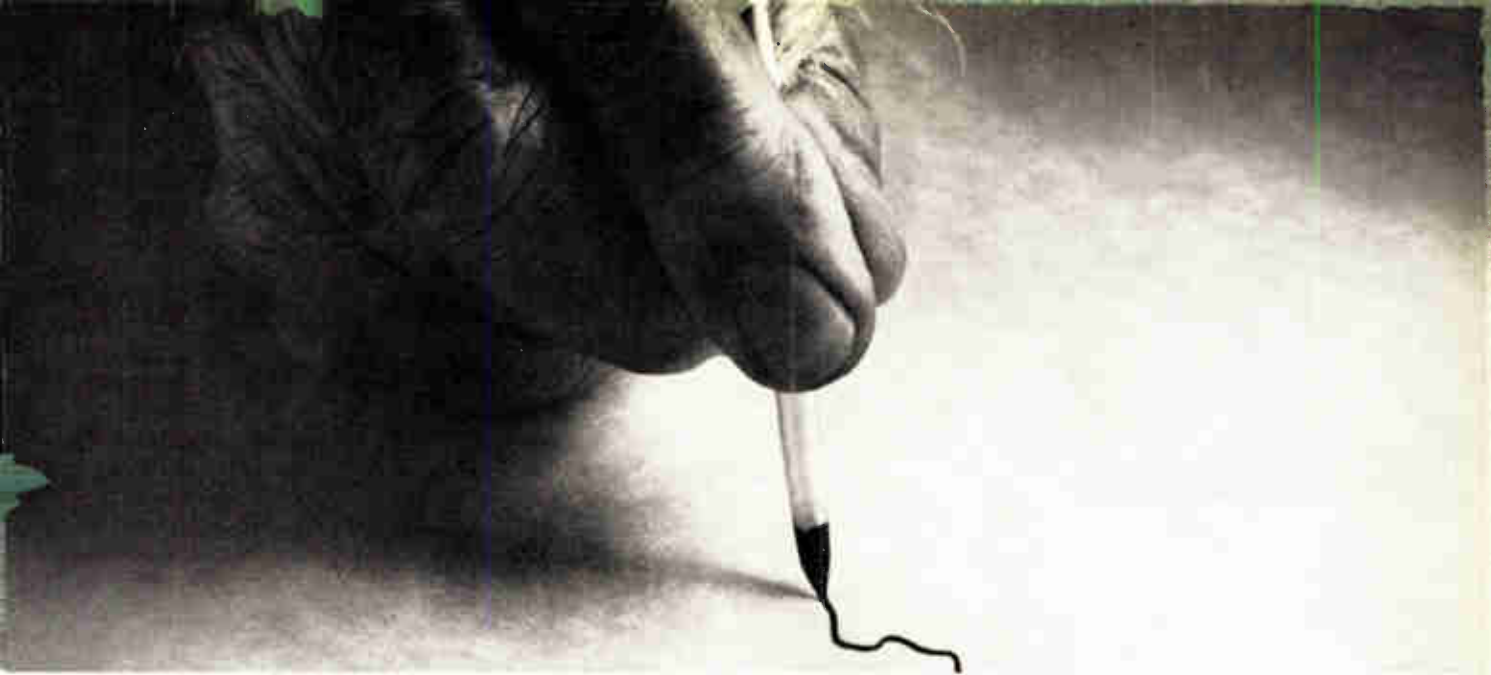

Once maps were made by hand.

But why today?

Once, a man told another of what he'd seen and that man drew a map that all others could follow.

All of that was done by hand. That was then.

Today, a man takes a picture from an airplane of what he sees. And a second man prepares a manuscript from these photos. And then, this manuscript is transferred to film.

And then—incredibly—all of the lines that will make up the map (the rivers, the mountains, roads and streets) are *scribed* onto a negative master. By hand.

Finally, a swivel knife is used to cut outlines of specified areas. By hand. In

the seventies of the twentieth century.

Someone doesn't trust someone.

We, CalComp, have told cartographers that our 745 flatbed plotter will scribe lines equal to the tolerances and standards of the most skilled mapmaker's hand.

Cartographers have told us that they tried plotters once. And the lines were not accurate. And they were uneven. And wiggly.

The CalComp 745 Plotter is accurate to a rate of plus or minus .001 inch. The lines it scribes or cuts are smooth and even. (Their step size is only .0001 inch.)

And our 745 plots at a

speed of 4.2 inches per second. No hand alive can do that accurately.

If you make maps by hand, call us. We'll help you get from here to there.

Write us at California Computer Products, Inc., Dept. EM-M6-72, 2411 West La Palma Avenue, Anaheim, California 92801. Or call (714) 821-2011.



CALCOMP

Sight down the barrel of a Burndy terminal like the Vinylug® shown below. The entrance is carefully funneled so wires can be inserted easily without splaying. That means your production rates will climb because operators can insert wires faster without fumbling. Then, as the crimp is completed the barrel serrations cut the wire oxide for better electrical contact and stronger wire retention.

Variety? Burndy terminals speak with forked tongue, along with ring, rectangular and flanged fork configurations. And the new Burndy Fingrip push-on type terminal

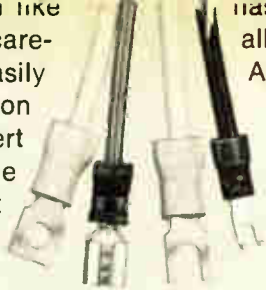

has the same easy entry feature. Burndy terminals all come vinyl insulated, nylon insulated or bare. And in wire ranges from 22 to 10.

There's a Burndy installation tool for every application too, whether you're crimping a few terminals a day or a few thousand an hour. Choose from simple hand tools, strip fed bench presses or a fully automated system which measures, cuts, strips and terminates up to 6,000 an hour.

Put together Burndy quality, variety, tooling and our renowned service and you can see why our customers are so attached to our terminals.

Easy to get attached to.

 **BURNDY**
Norwalk, Connecticut 06856

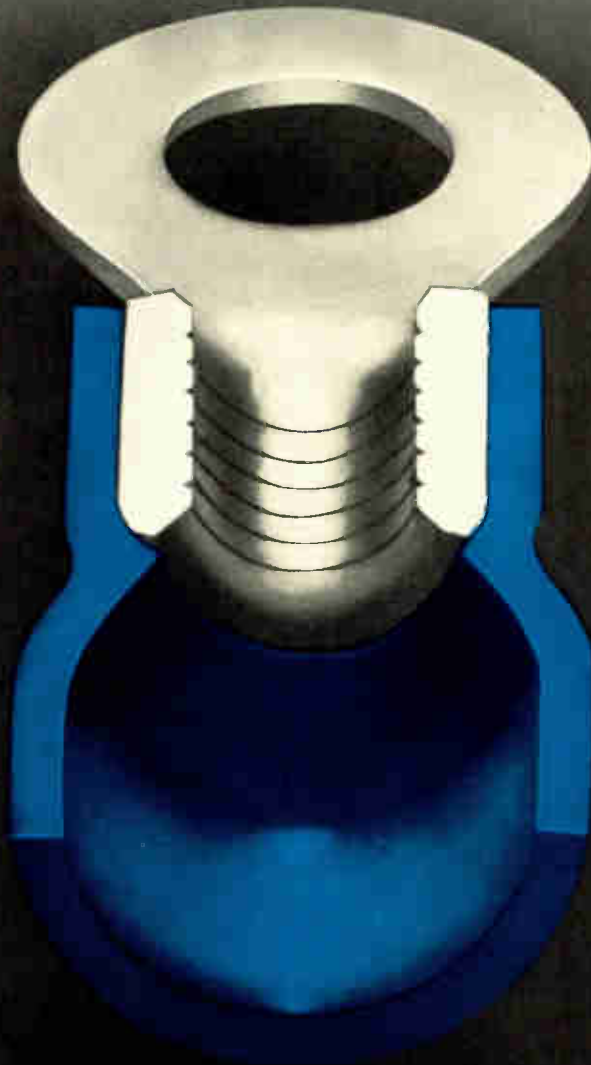

BURNDY CONNECTS

International Sales Headquarters & Manufacturing Facilities: Canada/England/Belgium/Mexico/Brazil/Australia/Japan/Sales Offices in Major Cities

Makers of RAMs try to pin down 1103 business

With an eye on the healthy demand for 1103-type random-access memories, makers of similar devices are adapting their products for compatibility with the 18-pin 1103. Texas Instruments, for one, has converted its 22-pin 4062, a second-source version of Advanced Memory Systems' 6002, into an 18-pin RAM by tying together clock and chip select. This means a smaller package, requiring one less power supply, but some flexibility is lost, since the memory must be enabled during the refresh cycle; and power dissipation is higher than in the 22-pin package. TI is sampling the modified 4062 and hopes to lower the price to be more competitive with the 1103. AMS, originator of the 6002, is expected to come out soon with an 18-pin type.

Smart terminal can grow smarter

Digital Equipment Corp. will announce next month the GT40, a CRT graphics display terminal with a built-in computer. It's a low-priced example of the thrust toward intelligent terminals (see p. 63). The new terminal will operate in stand-alone or remote configurations, but most important are its flexibility and expansion capabilities. Standard items include light pen, full ASCII keyboard and character set, a serial communications interface, and 31 special mathematical and scientific symbols. In addition to its display control processor, each GT40 will include DEC's new PDP-11/10 16-bit computer. Because of its architecture, this computer can be upgraded to performance levels approaching those of medium-scale machines. Added memory, extra processing logic, microprogram packages, and almost all PDP-11 software can be accommodated in expanded versions of the machine. The GT40 terminal will sell for \$12,000 to \$15,000.

H-P redoubles storage scope writing rate

The pace of developments in storage scopes is getting almost as fast as the scopes themselves. At the beginning of the year, a writing rate of 5 centimeters per microsecond was about as good as you could get. Then Hewlett-Packard Co. introduced its 100 cm/ μ s model 184A in March at the IEEE Show. Tektronix Inc. doubled the speed limit with its model 7623 (see p. 95). And now, H-P has redoubled to a high of 400 cm/ μ s. This latest development, to be announced in August, is not incorporated in a new instrument but is a \$500 option for the 184A—a variable-persistence scope with a base price of \$2,200.

Bill to break up communications, computer firms . . .

Communications and computer companies stand near the top of a list of seven industries threatened with being broken up under the "Industrial Reorganization Act," a bill introduced by Sen. Philip A. Hart (D., Mich.), a leading advocate of stronger antitrust legislation.

Under the bill, an Industrial Reorganization Commission with a 15-year life would have powers to break up monopolies or oligopolies if: (1) a corporation's average rate of return after taxes exceeded 15% of net worth for five consecutive years out of the seven preceding a complaint; (2) there had been no "substantial" price competition among two or more corporations in any product line for three consecutive years in the preceding five, and (3) 50% or more of product sales were accounted for by four or fewer corporations in any year of the three

preceding the complaint. A company could retain monopoly power if it could show **its power was due solely to its patent position, or if divestiture would result in a loss of "substantial economies."**

. . . has industry wary but mainly for the long term

Though Sen. Hart, chairman of the antitrust and monopoly subcommittee, concedes his bill has no chance of passage soon, **it has some corporate representatives nervous** because of its long-term implications. Said one computer industry attorney and lobbyist, "With a lot of consumers automatically assuming that big business is bad today, this kind of thing could eventually snowball." The Electronic Industries Association's initial response was that the bill "represents some of the thinking pervading today which assumes that **any problem, real or not, can be solved simply by creating another layer on top of the Federal bureaucracy**" and "could have a dampening effect on the economy."

Package-in-socket cuts MOS/LSI cost

A team approach to cost reductions in packaging of MOS/LSI circuits is credited with developing pluggable packages that will be price-competitive with lead-frame types. American Lava Corp., Chattanooga, Tenn., has designed a **leadless ceramic package with contact pads along the edge of the top surface**, and Amphenol Industrial division, Chicago, has fashioned a **socket with a snap-down lid** that clamps the package in place and makes contact with the gold pads on the ceramic. The American Lava package is a single-plane type; because the die-bonding pad is in the same plane as the contact fingers, it cannot use uphill bonding. However, the company points out that many semiconductor makers can now do downhill bonding without fear of shorting lead wires to the edge of the chips.

Digital autopilot lands commercial jet in test flight

Digital techniques moved into still another part of the analog world with the successful test aboard a Beech-Hawker 125 business jet of a **flight control system guided by a general-purpose digital computer**. According to Bendix Corp.'s Navigation & Control division, the aircraft was flown hands-off through level flight, as well as approach, flare-out, and touchdown, "the first automatic landing to be made with a digital computer in a commercial aircraft." For the flight, Bendix replaced its FGS-70 analog flight guidance system with its BDX-910 airborne digital computer.

Norden to build color ATC displays

Turning to color displays for sharper presentations of radar data to air traffic controllers, the Federal Aviation Administration has awarded a \$432,000 contract to Norden division, United Aircraft Corp., Norwalk, Conn., **to develop four-color 16- and 22-inch cathode ray tubes**. Using techniques developed by Norden, each CRT will have a single electron gun, rather than the three guns used in conventional color tubes. Also, the conventional tube's shadow mask that centers the electron beam onto the proper color phosphor will be eliminated. Instead, a mixture of phosphors is deposited on the tube's face and **each color is stimulated selectively by varying the electron-beam voltage**. Colors will identify different aircraft blips and provide contrast for alphanumeric characters, as well as separate blips from weather and ground clutter.

Microdata gives you a new kind of minicomputer

The Twin Mini doubles throughput for just a few dollars more

Put two microprogrammable CPU's with separate control memories and I/O facilities into a Micro 1600 cabinet where they share a common core memory. That's the idea behind the Twin Mini. And it works wonders. For the first time, core memory is used so efficiently that your throughput rate is more than double that of other CPU's. Applications which normally call for much larger or more expensive computers can now be handled simply and economically by this effective combination of Micro 1600 parts.

You show us your requirements. We'll show you how to build a system with unmatched processing power per dollar. Your system may fit into a single Micro 1600 cabinet or overflow into two. Either way, the performance will match our claims or your money back. Find out how easy it is to do business with Microdata. Write for details.

MicrodataTM

Microdata Corporation
644 East Young Street
Santa Ana, Calif. 92705
(714) 540-6730



TM trademark Microdata Corporation





THE TEKTRONIX S-3260 AUTOMATED TEST SYSTEM

...the result of years of systems experience...

THE S-3260 WILL TEST:

- MOS and Bipolar Shift Registers
- Random Access Memories
- Read-Only Memories
- MOS and Bipolar Random Logic Arrays
- Circuit Boards
- Modules
- Subsystems

S-3260 FEATURES:

- **Advanced Test Fixturing**—Nanosecond Response Characteristics
- **128 Active Pins**—64 Input, 64 Output
- **Functional Tests**—20-MHz Data Rate; Force, Compare, Mask and Store @ 20 MHz; Individual Drive and Compare Levels at Each Pin; Programmable Loads.
- **Parametric (DC) Tests**—Functional Preconditioning, Differential Voltage Measurements; Kelvin Connections; Force V, Measure I; Force I, Measure V.
- **Dynamic (Timing) Tests**—One Shot Time Measurements; Functional Preconditioning; Dual, Strobed Comparators; Active or Passive Loads.
- **Go-No-Go or Analytical Tests**
- **Interactive Program Writing**
- **Device-Oriented Source Language**
- **Graphical Test Result Displays**
- **Data Logging and Data Reduction with Computer Graphics Displays**
- **Optional Hard Copy Output**
- **Modify Tests and Data Logging Options at Run Time**

Your TEKTRONIX Field Engineer can arrange a discussion with a Systems Specialist. Call him or write Tektronix, Inc., P. O. Box 500-A, Beaverton, Oregon 97005.



TEKTRONIX®

committed to
technical excellence

FAA opens market for interim MLS

With a "universal" microwave landing system still a decade away, the agency is taking intermediate steps

Since it will be 10 years before the Federal Aviation Administration completes installing its "universal" microwave instrument landing system (MLS) now under initial development [*Electronics*, Jan. 3, p. 43], the agency is taking two steps which will open up the use of "interim" systems:

- During fiscal 1973, it will issue requests for quotations from industry "to purchase limited quantities" of production units for short take-off and landing (STOL) applications, says Jack W. Edwards, systems development section chief of the Microwave Landing Systems branch. The FAA's current 10-year plan projects a first buy of less than 10 units and a maximum of 75.

- The agency is proposing changes in Federal regulations to let private operators use small, lower cost MLS units at smaller airfields or those with difficult approaches. That "will open up a market, if the systems are approved," says Edward Kaneko, assistant chief, Maintenance Program division in the Airways Facilities Service.

In general, microwave systems offer higher performance at the same cost as conventional instrument landing systems. Operating with narrower beams, they cause less frequency congestion and permit higher glide slopes, an important factor for STOL airports. Thus, the proposed changes would let the

large number of small airport operators and aircraft owners not directly under FAA air-traffic control use microwave technology to cope with local traffic conditions.

The regulation shift would let small MLS units be used at such airports operating under instrument flight rules. This inclusion would sweeten the market because the ground hardware could become eligible for 50% Federal Airport Development Aid grants.

Fast break. Already several companies are actively in the market. First out is Singer's Kearfott division, with its Air Force-derived Talar units. Golden West Airlines uses such a unit at the Fullerton, Calif., airport. Rocky Mountain Airways, which uses one at Eagle, Colo., wants two more for the Steamboat Springs and Aspen ski resorts.

Others in the market are AIL division of Cutler-Hammer Inc., which has sold its Co-Scan unit to the Canadian Ministry of Transport and military versions to the U.S. Army and Navy; Tull Aviation Corp., with a sale to the state of Minnesota; France's Thomson-CSF, which will begin testing a unit this fall; and Britain's MEI Equipment Co., which is now developing a civilian version of its military hardware. Boeing Co. is also completing tests on a unit for possible mass production [*Electronics*, July 17, p. 32].

"We have a conservative market estimate of 500 systems and that's just in the U.S.," says Jefferson Z. Amacker, director of special programs at Singer-Kearfott. "We're getting a lot of inquiries from abroad. In fact, the international part is better right now." He estimates that for every interim MLS

that the FAA buys, about 10 airport operators will buy units.

"Once the FAA makes that buy, they're buying for a lot of airports," Amacker says. Sample prices indicate that ground hardware would cost between \$50,000 and \$100,000 and airborne units from \$4,000 to \$10,000 per plane, although Singer is developing a general aviation unit which will sell for less than \$2,000.

Caution. But, before there's a stampede, FAA's Kaneko cautions, there are several hitches. The agency has to approve all the systems to be installed. Also, although the proposed rule change is expected to go through, it could receive strong opposition when it goes out for public comment soon. The Air Transport Association, the airlines' trade group, already charges that permitting interim MLS jeopardizes the "universal" system.

Compatibility may become another problem. FAA's Edwards points out that the competing interim MLS units "are incompatible with each other and with all microwave ILS systems coming up." □

Commercial electronics

Point of sale: by 1976, \$562 million

One of the most exhaustive studies of the potential market for both point-of-sale terminals and credit-verification devices predicts, among other things, a better than five-fold growth in electronic cash register sales in the next five years. And the study predicts a sharp drop in cash

register prices during that time.

The report, prepared for hardware manufacturers by consultants Creative Strategies Inc., Palo Alto, Calif., points out that electronic cash registers currently sell for \$3,000 to \$7,500 each, depending on the system in which they are used. However, they are expected to repeat the history of electronic calculators, which eventually dropped from \$400 to less than \$100.

Starting from a base of \$74 million for 20,000 units this year, electronic cash registers should reach \$390 million and 94,000 units by 1976. Credit systems hardware, the equipment used to verify and authorize credit-card purchases, is expected to reach \$172 million with 234,000 units by 1976, starting from a 1972 level of only \$17 million and 31,000 units, the report continues.

Creative Strategies estimates that Singer Business Machines, New York, holds 55% of today's electronic cash register market—thanks to an early entry into the field, plus a whopping order from Sears, Roebuck & Co. for 17,000 units—and Singer should retain over 30% by 1976. National Cash Register Co., Dayton, Ohio, will probably account for 25% of the market by 1976, a radical change from its dominant position in electro-mechanical cash register installations. As for credit-card equipment, TRW Data Systems holds over 50% of the present market. However, the report does not project how this industry

segment will be cut up by 1976.

Department stores will account for the major portion of point-of-sale register sales, going from 8,300 units this year to 29,700 by 1976. Department stores will have purchased 91,150 units in that time. Credit cards issued by general merchandise stores dominate the credit-verification equipment market now, mainly on the strength of manual-entry terminals—15,000 in use. However, oil company card verifiers should lead by 1976. □

Military Electronics

Inertial platform on Jeep surveys land

Surveying land is always a time-consuming effort—far too time-consuming for the needs of modern mobile artillery. Army men figure that surveying terrain by simply driving around in a Jeep would save a lot of time. And the Position and Azimuth Determining System (PADS) developed for the Army Combat Development Command, Ft. Sill, Okla., by Litton Guidance and Control Systems division, Woodland Hills, Calif. does just that.

The Litton system, developed under a \$1.8 million contract, is about to begin acceptance tests at the Army Engineering Topographical Laboratory. After that, the system

may go into engineering and field tests. Possible production is many years off, but the concept obviously has many uses outside artillery, including map-making and geological exploration.

Grounded. PADS is an adaptation of a Litton airborne inertial guidance system, but the ground system has a big performance advantage over airborne systems. It offers a typical accuracy of within 10 feet per hour rather than the 6,000 feet of an aircraft system. The major reasons for this accuracy, explains Robert W. Maughmer, program manager, is the ability to stop the Jeep carrier occasionally for a reference check and thereby cancel significant errors. Also contributing to accuracy is the use of a new Singer-Kearfott laser velocity sensor as a reference and highly sophisticated optimal real-time error-correction techniques that use Kalman filtering.

The sensors for the system are mounted on a heavy platform at the front of the jeep. Basic sensors are the gyro and accelerometers, identical to airborne ones. Also mounted on the platform is the three-sensor laser velocimeter and a target used for transferring azimuth data from a reference theodolite.

Also part of the system and taking up the whole rear of the Jeep are the data processing unit, control and display unit, power supplies, and test equipment. All are modified for the job from standard equipment.

Specs. The Army's basic requirements for the system were mission duration of up to six hours, ability to be used anywhere in the world between 75° south and 75° north latitude, and a temperature range of 0° to 125° F. Army representative J. Perrin, of the Engineering Topographical Labs, says that preliminary testing results have been "very impressive," with operation up to 10½ hours. Errors have been small and seem to be of expected type. Using initial optical alignment, PADS provides a horizontal position accuracy within 66 feet circular probability error, an elevation accuracy within 33 feet, and an azimuth accuracy within 0.3 mil.

Contributing significantly to the

Reconnaissance. With inertial platform and laser velocimeter mounted on reference plate, vehicle can survey by simply driving around terrain.

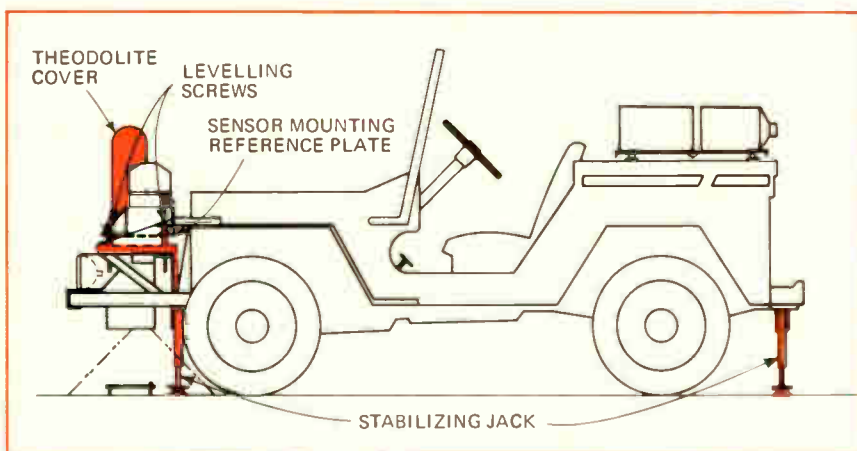

performance of the system, says Maughmer, are sophisticated error-correction techniques, which take into account almost 30 error sources. Some errors are controlled by conventional techniques, such as careful selection of system components. About 15 of the sources, however, are considered in the Kalman model, which greatly reduces the requirements placed on the system computer. □

Communications

FCC delay keeps domsat grounded

It took the Federal Communications Commission almost seven years to mull over what to do about a domestic satellite communications system before deciding in mid-June for "multiple entry" into the potentially lucrative market [*Electronics*, July 3, p.72]. Now, the FCC says it needs more time to consider pleas by AT&T and Communications Satellite Corp. (Comsat), which claim they were unfairly restricted in the commission's attempt to encourage as many viable entrants as possible.

Originally, the FCC decided to clean up the matter by July 25, but, faced with significant pressure from the White House, AT&T, and Comsat, the commission says it intends to consider the pleas in early September, effectively delaying any other applicants from moving ahead until the reconsideration matter is settled. Four applicants, Western Union Telegraph Co., MCI Lockheed Satellite Corp., Hughes Aircraft Co., and Western Telecommunications, Inc., opposed Comsat's request for a stay.

Crucial. Two men hold key roles in any reconsideration decision—chairman Dean Burch, who led the minority in the 4-to-3 decision limiting participation by AT&T and Comsat, and new commissioner Benjamin L. Hooks, who took his seat after the decision, replacing majority member Robert L. Bartley. Burch and Hooks are President

Nixon's appointees, as are the other minority commissioners, Charlotte T. Reid and Richard E. Wiley.

Just how much Burch will be able to influence Hooks is a big industry question these days. If Hooks decides not to vote, and Burch isn't able to swing any of the remaining majority, the resulting tie would let the mid-June decision stand.

The commission's decision restricted AT&T to either operating its own satellite service for message telephone service only or buying such service from someone else. Comsat was forbidden to serve AT&T only, but it, as a wholesaler of services, could service AT&T equally with other companies. Or it could become an end-to-end retailer.

Minority. In a sharp dissent, Burch, joined by Reid and Wiley, campaigned for letting Comsat either put up a satellite for AT&T and let other communications customers have access to it, or put up its own independent system without any restrictions. Charging that Comsat is "the big loser," Burch says the company would have only the choice of becoming an end-to-end carrier under the decision. Pursuing his unrestricted-entry philosophy, he says

Space electronics

NASA's new testing equipment may upgrade outside tests

LSI devices for space hardware will have to pass stiffer incoming inspection and qualification tests, now that new test systems are going on-line at NASA's Marshall Spacecraft Center, Huntsville, Ala.

The Quality Assurance Laboratory there recently received a 64-channel, 2-megahertz Macrodata MD-200 test system for wafer-probing MOS. The system includes a localized temperature control for the -55 to +150°C.

Leon Hamiter, QA manager, says, "We're going to push very hard on temperature-extreme functional testing." What's more, a new Macrodata LSI tester system is on order.

that the commission would penalize success by structuring the marketplace instead of allowing "full and fair competition between new and existing carriers."

Hooks says he hasn't decided whether or not he'll vote in any reconsideration. "If I can prepare myself from the written record, I'll vote," the former judge says. He would have a lot of reading to do but would still have missed the oral presentations made by FCC staff.

Hooks says that the information should be in the written record. But if he votes on that basis, a new problem may arise. "If Hooks votes, it'll go to the courts and drag on for several years," one industry observer predicts.

Says an industry source, "if Burch's position prevails, it will cause the other players to reconsider their positions. It could wind up to be just one system. It makes no sense to make deals, when you don't know the ground rules right now."

As for terminal equipment, one spokesman says it makes no difference who comes out ahead, except for AT&T. "They would build their own earth stations, and that's not good for us." □

The 128-channel system will have 10-MHz capability for testing packaged MOS and bipolar devices [*Electronics*, Apr. 26, 1971, p.18].

Hamiter feels that the functional testing for degradation at temperature extremes is necessary, but the problem is that most parts of the circuit in LSI devices aren't accessible. "Most suppliers won't have the capability we have to do this testing on a production basis," he says. "When we get their parts, we'll give them the thorough testing."

LSI suppliers won't have access to NASA's equipment, but Hamiter obviously thinks that their test procedures could stand a bit of improve-

ment. "I believe that one of the greatest weaknesses in LSI today is that the suppliers aren't properly testing their parts. This is true both in memories and logic."

Experience so far has been good. "We have a better reliability, from the standpoint that you can turn it on and start testing, than any other semiconductor tester we have."

Check-out. NASA bought the system for engineering evaluation and qualification testing of LSI parts made by outside companies, as well as for tests on LSI designed and manufactured in the center's own labs. It also will be used for electrical acceptance tests for products purchased for hardware built at Marshall or by subcontractors.

Up to now, the QA laboratory has used Texas Instruments' test systems for discrete and integrated semiconductors—which were generally standard parts, such as low-power TTL and C-MOS. Little LSI has been used before. But now, to achieve minimum weight and power requirements, NASA is getting into in-house-designed parts, which are made outside. Thus, most circuits will be custom-built, increasing the need for convenient testing.

Ironically, the larger system, with its 128 leads, was selected about a year and a half ago. But even then,

the number of package leads was dropping, and Hamiter thinks that they may have gone a bit overboard. That's good news for suppliers faced with the need to buy an LSI test system, for NASA's cost about \$550,000. Since it is far more complex and customized than most would consider necessary, no supplier need buy an exact duplicate.

Marshall isn't the only NASA center doing something about testing LSI devices. The John F. Kennedy Space Center in Florida has ordered an MOS tester from Tektronix Inc., Beaverton, Ore., for \$250,000. □

Air-traffic control

Lockheed diversifies with FAA award

The block diagram of Kennedy International Airport's air-traffic control system "looked almost exactly" like the one used by the Navy's Mark 86 shipboard gunfire-control system. So, looking for diversification ideas, engineers at Lockheed Electronics Co., Plainfield, N.J., felt that they had found a winner. They figured that the experience gained in the big-computer-

based Navy system could be applied, using its own minicomputer, to the civilian aviation market.

The payoff came earlier this month. The Federal Aviation Administration awarded Lockheed a \$1.5 million contract for the development and test of a minicomputer-based air traffic control system to be used at medium-size airports.

Potential. And the payoff for Lockheed could be handsome, indeed. Lockheed's winning bid was \$21.671 million for 145 systems, in various configurations, and \$29.92 million for the maximum of 208. Including spares, documentation, and the initial \$1.5 million, Lockheed could realize more than \$35 million from the program. And the overseas market will at least equal the U.S. figure, says T.J. Anderson, vice president and general manager of the Products and Systems division.

In winning the contract, the Lockheed Aircraft Corp. subsidiary beat out a team of Sperry Rand Corp's. Univac division, Texas Instruments, and Burroughs Corp.

Lockheed's equipment, designated Tracab/Tracon Alphanumeric System, was designed to meet the requirements of the FAA's programmable ARTS II (Automated Radar Terminal System). Such a system provides air-traffic controllers with a computer-processed alphanumeric display of traffic within a given area, including aircraft identities and altitudes.

Tracab, Terminal Radar Approach Control in Cab, is a system intended for the cab of the airport control tower. Tracon, standing for Terminal Radar Approach Control facility, refers to a system installed in the relative darkness of an instrument flight rules (IFR) room.

In addition to providing terminal area automation, the Lockheed system could act as an en-route control center, processing and distributing flight plans. Price of the system starts at \$100,000 and depends, in Anderson's words, on "what the airport already has on hand."

Mini. The Lockheed system's MAC-16 computer can process up to 256 aircraft simultaneously with as little as 12,000 words of computer

Controlling air traffic

Lockheed Electronic's air traffic control system for the FAA will process altitude and identity data from an aircraft transponder received via an airport's secondary surveillance radar (ASR). It detects and separates transponder replies and converts the data so that an alphanumeric tag is displayed adjacent to the aircraft target on a CRT screen.

There are three major subsystems: data acquisition (DAS), data processing built around a Lockheed 1-microsecond-cycle-time MAC-16 minicomputer, and a data entry and display (DEDS). The data-acquisition system converts transponder and radar return from the radar beacon system into digital form. With inputs from the DAS, the MAC-16 minicomputer performs target declaration, conversion to alphanumeric format, and updating of the real-time display. The DEDS consists of a character generator, 16-inch displays, a position-entry module, and a 32,000-bit memory.

Within five months, Lockheed will deliver, under its \$1.5 million contract, a prototype system that accepts ASR data for test and evaluation at the Wilkes-Barre, Pa., airport. Subsequently, the company will deliver two "partial" and potentially lower-cost systems. One, for Paine Field near Seattle, won't have a DAS because it will accept remote data from the common radar digitizer working with the long-range radar at the FAA's nearby en-route control center. The other system, at Peachtree-Dekalb airport in Georgia will operate similarly, accepting partially processed data from the ARTS-III-type installation at nearby Atlanta airport.

memory, says Matthew S. Tutino, assistant general manager of the division. Moreover, by adding display terminals, input/output channels, and up to 64,000 bits of memory—the MAC-16's limit—the ATC system could accommodate any airport, according to Lockheed.

Lockheed's win of the FAA contract will greatly strengthen its attempts to sell its system overseas. As Anderson puts it: "Foreign prospects are always asking, 'Who is buying it in the U.S.?' Now he has an answer. □

Meetings

AFIPS puts eggs in one basket

Sobered by its first loss on a Joint Computer Conference in several years, which came after continued recent declines in exhibit space sold, the American Federation of Information Processing Societies (AFIPS) has decided to fold one of its tents. Beginning next year, AFIPS will have one national computer exposition instead of the traditional Spring and Fall Joint Computer Conferences.

The 1973 National Computer Conference and Exposition will cover a full five days, beginning next June 4 at the New York Coliseum; the Fall Joint Computer Conference Dec. 5-7 in the Anaheim, Calif., Convention Center will be the last of the joint shows. The deficit from the Spring Joint was just \$10,000, but the federation was faced with the bleak outlook that this trend was likely to continue, even with the economy evidently recovering from the recession of the last few years.

Thus, on the basis of advice from an in-house committee, a group of volunteer advisers from the industry, and a hired consultant, AFIPS decided to reorient the conferences. "The show has to be for users, not strictly for technologists," says AFIPS president Walter Anderson.

But technologist, need not fear they will be left out. "On the con-

trary," Anderson says, "the technical aspects of the joint conferences have been their strong point, and we definitely don't want to lose that. We're actually trying to leave the technical part of the show the way it's always been, and to expand the rest of the show around it. We want technology to be only about 20% of the picture, and users to make up the other 80%."

The Fall Joint will be a preview of future annual conferences, in that it will include four application themes oriented to particular classes of users. These will be in manufacturing, banking and electronic payment methods, information data centers, and medicine and health care. Of the remainder of the sessions, approximately half will be keyed to applications, users, and management.

Plans are being made for conferences in 1974 and subsequent years, but AFIPS hasn't arrived at any final conclusions yet—except one. "The meetings, for the next few years at least, will be in population centers," Anderson says. □

Consumer electronics

Japan slips in trade balance battle

The Japanese-U.S. dispute over the consumer electronics trade balance is getting hotter. Both sides continue to arm themselves with new statistics to prove their positions. Japan, despite a new counterattack on the threat of U.S. countervailing duties on TV receiver imports, appears to be losing ground.

In the top market area of color receivers, U.S. manufacturers' sales to dealers are up 21.1% from a year ago—to more than 3 million in the first half of 1972—according to new Electronic Industries Association figures. At the same time, latest Customs Bureau figures promulgated by EIA show color TV imports in the first five months are down 0.1% from last year to 480,395 sets. Most of the imports are Japanese.

Monochrome set imports are rising, however, although EIA sources point out that many of these are made by U.S. offshore operations in places like Taiwan. Units imported jumped 37.9%, compared to 1971, in this category to more than 2 million sets in the first five months. At the same time, monochrome set sales to dealers in the first six months, says EIA, rose 9.1%.

Not happy. Meanwhile, Japanese manufacturers are still upset. Their trade association has denied to the Treasury Department the charges of Zenith and Magnavox that Japanese consumer electronics makers received substantial export subsidies and should be subject to countervailing duties [*Electronics*, June 19, p.30].

H. William Tanaka, a Washington attorney who represents the Electronic Industries Association of Japan (EIAJ), attacked the "hypocrisy" of the two U.S. complainants. "They, themselves," he says, "have benefited from substantial subsidies and other incentives offered by Taiwan and Mexico on the TV sets that they export to the U.S." In a two-volume legal brief filed with the Treasury, the EIAJ called for dismissal of the action.

Similarly, the U.S.-Japan Trade Council, an organization of 700 U.S. firms supported in part by the Japan Trade Promotion Office, filed a detailed legal brief against the countervailing duty charges.

The council's contention is that countervailing duties invite retaliation by the Japanese. Moreover, the trade promotion group, citing the latest export contract figures by 14 of Japan's leading trading companies, says "a substantial drop in exports appears likely before the end of 1972."

Declines of 20.6% and 22.4% in the yen value of export contracts in April and May compared to a year ago, says the council, indicate that "Japan is already losing much of its competitive edge."

The April-May declines follow a currency revaluation last December. Since that time, the council contends, contracts for all products recorded by the trading companies in

the first quarter of 1972 ran slightly below the year before and then began to drop sharply. □

Manufacturing

One firing cuts cost of multilayer boards

Multilayer ceramic boards can hold a lot of circuit in a small package, but the trade-off is in cost. Continuous strip production of "green," or unfired, ceramic tape can bring that cost down, according to Hitachi Ltd.'s Semiconductor and IC division. Hitachi has set up a production line that can react quickly to customer needs, it says, yet still is economical for small production runs [*Electronics*, July 17, p. 20].

The Hitachi process, which it calls screened multilayer ceramic, is based on the screening and drying of alternate conductor and dielectric layers on the green ceramic tape, followed by a single firing. Working with a continuous strip, the company can avoid the time and costs of firing between every step.

In the process, a 40-mil-thick ceramic tape, 18 inches wide, is cast into a strip with a blading technique at about 20 in. per minute. The tape is slit into six equal strips and reeled up. The tape is then punched with guide holes about 200 mils apart along each edge to assure registration in subsequent screening steps. The needed conductor patterns and dielectric coatings are screened and dried to build up the multilayer structure, and then individual parts are punched out of the strip and fed into the furnace for the single firing.

Roll-out. In Hitachi's "green" ceramic process, perforated strip of ceramic is screened and dried many times before firing.

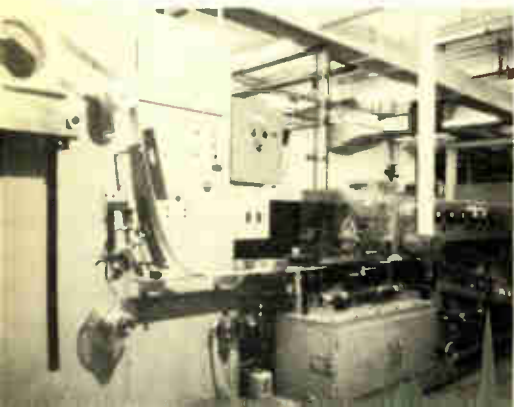

The key to the process was development of the dielectric paste. It had to have a shrinkage rate equal to that of the green ceramic, as well as the metalization. And it had to have a controlled spreadability to assure the accurate placement of the holes that carry interconnections between layers.

Hitachi says that relative location tolerances can be held to within 2 mils at printing rates of 1 to 2 seconds per piece. Standard conductor line widths are 8 to 10 mils, although 4- to 5-mil lines are possible. Via hole diameters can be as small as 8 mils, and substrate size can be as large as 5 by 5 in. □

Companies

Cyanamid shies from OCR market

Despite the best efforts of electronics engineers, potential users of optical character recognition have been turned off by OCR's price, size, speed, or errors. Keyboard-to-tape and keyboard-to-disk systems can dominate the low-cost data-entry field because a human interprets the text.

Even manufacturers are turning off to OCR's elusive appeal. For a time, American Cyanamid Co., Bound Brook, N.J., had a recognition scheme that not only avoided the grotesque characters needed by some OCR machines, but also could transfer typewritten data to magnetic tape at 2,400 characters per second. Prototypes had error rates of only 2-3%—and the goal of one error in 10,000 was within reach.

What's more, Cyanamid executives figured they could sell the system for about \$49,000 or lease it at about \$1,300 per month. Meanwhile, letters of intent were rolling in.

But in April, Cyanamid stopped development of the system, which it had christened Lumiscan 2400, dismantled the design team, and began efforts to sell the technology. The company now is about two weeks

from signing over rights to Lumiscan to a new firm. No one at Cyanamid will name the buyer—SEC rules forbid this—but it is said to be involved in computer typesetting.

Aglow. Lumiscan was based on work dating back to 1960 on luminescent materials and a search for ultraviolet-absorbing compounds that would make plastics less susceptible to sunlight. Work continued from 1965 at the firm's Stanford, Calif., research labs with studies of rare-earth dopants for lasers. Finally, Cyanamid had a set of compounds almost invisible under ordinary light, but which glowed brightly under ultraviolet.

Consultants suggested that Cyanamid use the phosphors in industrial marking applications—or as a variation on OCR. After almost 2 years of development the result was a machine resembling an office duplicator. Single documents or stacks were fed in at one end, read, and dropped into a basket at the other.

Documents were prepared by using an IBM Selectric typewriter with an altered ribbon and a special type ball. It held a clear, sans serif type face and a bar code immediately beneath each letter. The ribbon was half ink, allowing the letters to be read, and half phosphors, which transferred the bar code to the paper. To an untrained eye, a Lumiscan document looked like any other typewritten paper.

Output. Within the 2400, an ultraviolet lamp illuminated the phosphor, and its glow was focused into a photomultiplier through a system of line-scanning lenses. The tube's pulsed output was converted to an IBM-compatible tape format. Indeed, other than proprietary synchronization and timing circuits, the code converter held about all the electronics needed, accounting for the low price.

Thus, from an outside point of view, Cyanamid had a winner in the starting gate. With prototype deliveries scheduled for May and June, why did the company scratch it at post time? Some spokesmen think the company may have missed one boat to catch another. Cyanamid wanted money to buy out Shulton,

For the record

C-MOS from National

Within the next few weeks, National Semiconductor Corp., Santa Clara, Calif., will announce 40-50 C-MOS gate functions as standard products. Most will be part of a new series that National calls 54/74C—devices that are pin compatible with existing 54/74 TTL functions.

Robots get funding

The Office of Naval Research has taken \$1 million from the Pentagon's Advanced Research Projects Agency and contracted with the Massachusetts Institute of Technology to start an artificial intelligence laboratory. Immediate goal of the new lab, directed by Marvin Minsky, is to "endow robot-like devices with human-like learning, viewing and manipulative capabilities."

maker of Old Spice cosmetics, because that line meshes well with the firm's Breck Shampoo. "It was a question of entering the OCR market, where we had little experience, or bolstering our position in a known field," says one man at Cyanamid.

But the shadow of competition also loomed. There are almost 20 firms in the OCR business, about 10 making mark readers. Consolidation of General Electric and Honeywell and the demise of RCA's computer operation may also have played key roles in the decision. □

Medical electronics

X-ray processing without darkroom

Hospitals use a variety of film processors for developing X-ray film. Exposed sheet film is fed in at one end, and in minutes, the developed negative comes out the other. But a darkroom and technician are needed for taking exposed film out of the cassettes used for transporting and exposing it, feeding the film to the processor, and reloading the cassettes with new film.

Now Houston's RADX Corp. is building an automated X-ray cassette handler, conceived by Dr. Nicholas G. Demy, radiology chief at Somerset Hospital, Somerville, N.J. Called Load-a-Mat, the \$18,000 machine does all the handling automatically, even picking

new film from one of four magazines, all in only 16 seconds.

The machine was put together by Demy and an associate, Kenneth G. Catlin, in their spare time over a period of three years, using time delays and other relays to provide sequencing control.

RADX is reluctant to spell out exactly how it redesigned the hardware into a package measuring 5 feet long, 2 ft. wide, and 6 ft. high. M. M. Williams, president, says his company, maker of X-ray and nuclear medical peripheral hardware, has added "all kinds of infrared sensors" to detect malfunctions and prevent unloaded cassettes from being returned to an X-ray technician.

"The electronics package—what we call the brain—probably has in excess of 1,000 parts in it," Williams adds. "It does all the automatic sequential sensing, telling all those pneumatic parts what to do and when to do it."

RADX put one Load-a-Mat into the M.D. Anderson Hospital in Houston for 60 days and has an evaluation model at the University of Florida Medical School, in Gainesville. The radiologist there is Dr. Clyde M. Williams, a part owner of RADX and brother to the president. Another will be tested at the University of Rochester, N.Y., School of Medicine and Dentistry.

What's more, developer Catlin cites another event that could have greater significance for future sales: General Electric Co. has a Load-a-Mat that it is showing its salesmen and may market them. □

FIRST IN



DUAL FET's

We've got all of these DUAL FET's in stock for immediate delivery at the lowest possible prices. Give us a call now and get your quantity discount prices.

Solitron DUAL FET's feature: low noise, low capacity, low output conductance, superior tracking... and they're matched and tested. Check off your needs below:

KH5196	SDF514	2N5452
KH5197	SDF515	2N5453
KH5198	UC2130	2N5454
KH5199	UC2132	2N5515
KH5515	UC2134	2N5516
KH5516	UC2136	2N5517
KH5517	UC2138	2N5524
KH5518	UC2139	2N5561
KH5519	UC2455	2N5562
KH5520	UC2456	2N5563
KH5521	2N3921	2N5564
KH5522	2N3922	2N5565
KH5523	2N3954	2N5566
KH5524	2N3954A	2N5902
SDF500	2N3955	2N5903
SDF501	2N3955A	2N5904
SDF502	2N3956	2N5905
SDF503	2N3957	2N5906
SDF504	2N3958	2N5907
SDF505	2N4083	2N5908
SDF506	2N4084	2N5909
SDF507	2N4085	2N5545
SDF508	2N5045	2N5546
SDF509	2N5046	2N5547
SDF510	2N5196	2N5647
SDF511	2N5197	2N5649
SDF512	2N5198	2N5902
SDF513	2N5199	2N5909

Solitron DEVICES, INC.

Give us a quick call today, and test our productivity. We also excel in CMOS, PMOS, LIC's, and Custom Circuits. Solitron Devices, Inc., P.O. Box 23157, San Diego, California 92123.
Telephone (714) 278-8780 TWX 910-335-1221

The C/MOS pioneer makes more news.

RCA COS/MOS base prices

Here's what the trade press is saying about COS/MOS technology:

“COS/MOS expected to replace TTL as leading logic family”

ELECTRONIC PRODUCTS MAGAZINE—MARCH, 1972

“C/MOS cuts data system's size, power drain”

ELECTRONICS—MARCH 13, 1972

“Solid-state logic that mechanical engineers can use”

PRODUCT ENGINEERING—JUNE, 1972

“C/MOS outlook buoys Pitney Monarch”

ELECTRONIC NEWS—JANUARY 10, 1972

“C/MOS MSI is snowballing”

EDN—JUNE 15, 1972

“Very low power dissipation, exceptional noise immunity, wide power supply operating range (3 to 15 volts) and high dc fanout make COS/MOS a very attractive logic family”

SOLID STATE TECHNOLOGY—MAY, 1972

“plenty of competition for TTL...from an ever broadening line of CMOS circuits”

THE ELECTRONIC ENGINEER—JUNE, 1972

“CMOS is being considered more and more for applications once dominated by TTL or PMOS”

ELECTRONIC DESIGN—APRIL 13, 1972

reduced an average of 25%

Here's what RCA is doing about COS/MOS cost effectiveness:

The swing to RCA COS/MOS keeps growing...for consumer products, for commercial and industrial equipment. Unit volume shipped thus far in 1972 is running at about three times the rate for the comparable period a year ago.

And now — RCA, the pioneer in COS/MOS, is able to offer a general base price reduction averaging approximately 25% over the entire commercial line of more than 180 types of COS/MOS IC's.

These reductions are possible through lower production costs based on improved yields. Through increased volume production leading to a broader base for fixed costs. And through improved engineering and production performance based on experience gained during more than eight years of COS/MOS development and production programs.

Base prices for COS/MOS circuits

in plastic packaging are now reduced by an average of approximately 25%. In ceramic by 20%. In flatpack by 20%. And in chip form by 50%.

New base prices apply to dual-in-line plastic, dual-in-line ceramic, flatpack and chip configurations. Check the table at right for base price reductions on popular circuits (100-999 unit levels).

These lower base prices extend COS/MOS cost effectiveness...open up even broader applications...make COS/MOS more advantageous for engineers designing new systems or redesigning present systems.

To find out how COS/MOS can have a major impact on your products — and their cost effectiveness — contact your RCA Representative or Distributor. Or write RCA Solid State Division, Section 70G 31, Box 3200, Somerville, New Jersey 08876.

Circuit	Description	Previous Price (100-999)	New Price (100-999)	Percent Reduction
Plastic				
CD4001AE	Gate	\$1.18	\$0.78	34%
CD4013AE	Flip-Flop	2.40	1.62	33%
CD4029AE	Counter	6.90	6.35	8%
Chips				
CD4001AH	Gate	2.06	0.68	67%
CD4013AH	Flip-Flop	2.96	1.39	53%
CD4029AH	Counter	8.65	3.79	56%

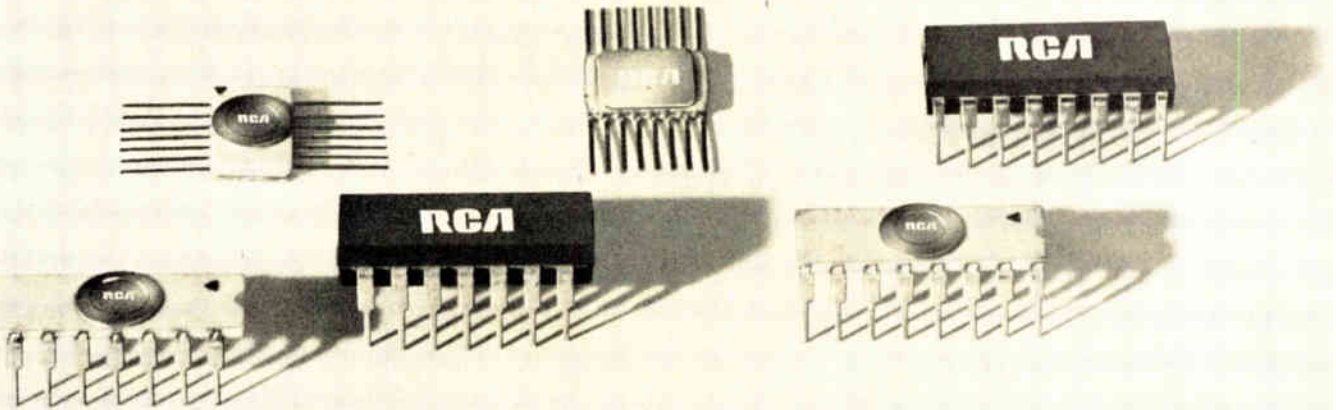

International: RCA, Sunbury-on-Thames, U.K., or Fuji Building, 7-4 Kasumigaseki, 3-Chome, Chiyoda-Ku, Tokyo, Japan. In Canada: RCA Limited, Ste. Anne de Bellevue 810, Canada.

RCA Solid State
products that make products pay off

Announcing PDP-8's going

We're making more of our own PDP-8 peripherals. A new 8K memory unit. And a new 1.6 million word disk. You know what that means. They're costing us a whole lot less now.

So they're going to cost you a whole lot less. As much as 61% less.

And we're bringing down prices everywhere we use those new memory units. PDP-8's with the new 8K core memory unit now cost up to 27% less.

And the price of a typical PDP-8 system drops by an absolutely amazing 47%. Mind you that's before quantity discounts.

Then if that's not enough, we're also introducing a host of brand new

PDP-8/E (8K)
WAS
\$7,740
NOW
\$5,650

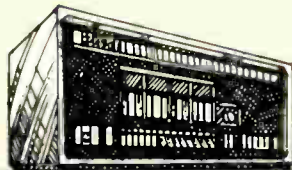

PDP-8/E (4K)
WAS
\$4,990
NOW
\$4,490

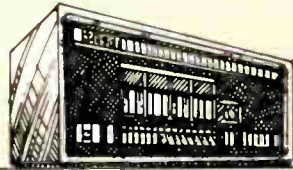

PDP-8/F (8K)
WAS
\$6,740
NOW
\$5,150



PDP-8/M (8K)
WAS
\$5,990
NOW
\$4,850



TYPICAL PDP-8 SYSTEM
 (PDP-8/E, 8K core, LA30 DECwriter, highspeed paper tape reader/punch, 1.6M word disk)
WAS
\$35,985
NOW
\$19,900



MM8-EJ
 (8K core memory)
NEW
\$3,900

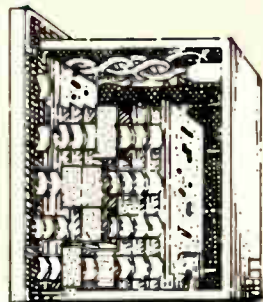

DISK PACK
 (1.6M word disk pack)
WAS
\$20,400
NOW
\$7,900



LS8-E
 (165-character/second line printer)
NEW
\$5,000



after your business sale.

PDP-8 products. Eight new peripherals, in addition to the 60 we already offer. Six new software packages, in addition to the 250 in our library. All for the 15,000 PDP-8's in use now. And there's more to come.

Don't look so surprised. We've just done what we always do. Make more computer cost less.

Write. Or call. Digital Equipment Corporation, Maynard, Mass. 01754.

(617) 897-5111. European headquarters: 81 route de l'Aire, 1211 Geneva 26, Tel.: 42 79 50.

digital

VR20

(two-color oscilloscope plotter display)

NEW
\$4,000



LA30A

(receive-only version of the LA30 DECwriter)

NEW
\$2,500



VT8-E

(low-cost alphanumeric display)

NEW
\$1,900

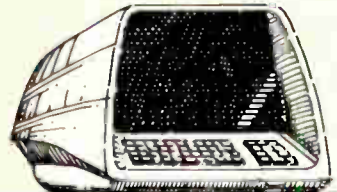

LA30-E

(DECwriter with EIA interface)

NEW
\$3,195



RT02

(data entry terminal with alphanumeric display)

NEW
\$1,300

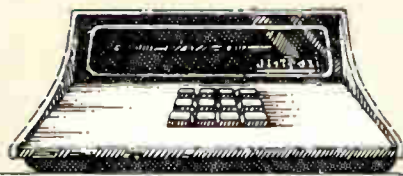

KL8-F

(asynchronous data interfaces)

NEW
\$425 each

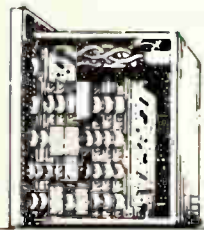

KL8-M

(modem controller)

NEW
\$250



TECO

(text editor)

NEW
\$55



BITMAP

(core memory management program for absolute binary programs)

NEW
\$15



OS/8 BASIC

(operating system program with file and string manipulation)

NEW
\$150



DEC/X8

(utility system exerciser package)

NEW
\$300



TD8-E COPY

(file management program for PDP-8 systems using magnetic DECtape storage)

NEW
\$15



NEW



GOT THE MESSAGE?

Our DigiTec engineers got the message. We told them to take a good multimeter and make it better. We didn't put any restrictions on them, just gave them a free hand. Now instead of an improved meter, we have a new meter, from the inside out!

They started with a new A to D board which gave the meter improved basic accuracy (.05%), greater stability, and a four digit LED display.

Next they tackled the metal case; building it

stronger, more rugged to house and protect. Controls were simplified and redesigned to provide the best possible human engineering factors.

They might have stopped there and been satisfied with an almost-totally new meter, but they had steam up and went on. A new, 8 hour battery pack was incorporated as standard instead of an option at no increase in price. That's right... all these improvements plus the battery pack and still only \$375.

Our model 262C Multimeter carries its own message and DigiTec Representatives carry a model 262C. **HAVE YOU GOT OUR MESSAGE?**

DigiTec by United Systems Corporation 918 Woodley Rd., Dayton, Ohio 45403 (513) 254-6251 Representatives throughout the world. For complete specifications, request new catalog.



DigiTec: precision measurements to count on.

Circle 32 on reader service card

Shuttle award will spread big money

The NASA contract for the development of the space shuttle orbiter is expected to benefit electronics companies and systems houses greatly this year and increasingly for the next several years. The agency's election year plan is **to spread the orbiter's \$3.4 billion around, requiring the winning company to subcontract as much as possible for such systems as data handling, flight control and avionics** [*Electronics*, Jan. 17, p. 36].

Projected funding levels for the orbiter, which will take the lion's share of shuttle development money, are approximately \$355 million for FY 1974, \$700 million for '75, nearly \$1 billion for '76 and '77, and about \$550 million for '78, the final development year. **Cost of the total shuttle program is put at \$8.5 billion over the next two decades.**

GSA moves to expand computer role

Greater control over running the Government's computers is being planned by the General Services Administration, the country's largest civilian computer customer. Following a confidential study by Fry Consultants, Chicago, GSA **foresees enlarging the use of specialized common carriers such as MCI Inc. or Datran**, which it feels will deliver higher-quality data at lower cost than conventional communications do. The Government would **buy fewer medium-sized computers and more mini-computers, which would be fused into networks to communicate with large computers** at regional data centers.

Also, the agency will **begin actively marketing its advance planning, design and engineering functions to other agencies** that now perform their own. First move was GSA's consolidation of its telecommunications and computer operations into the Automated Data Processing and Communications Service [*Electronics*, July 17, p. 34].

Competition sought on control package for AF drones

The Air Force will go the competitive route later this year on designs for a complete control and data retrieval package for remotely piloted vehicles and drone aircraft (see p. 51). The Aeronautical Systems division, Wright-Patterson AFB, signalled its plan to call for **hardware and software development design specifications for separate ground and airborne systems, each able to monitor and control up to 20 drones at a time**. So far the division says only that it will require use of the same frequency band for drone monitor and control as for payload data retrieval, and that these data links must have anti-jam protection.

Compromise Aerosat plan tried out

A new compromise to break the deadlock over the key issue of 50-50 production sharing between U.S. and European companies for the proposed joint Aeronautical Services Satellite is being discussed among the participating government agencies [*Electronics*, April 24, p. 37]. Backed by the Federal Aviation Administration, the new approach would let any qualified bidder pitch for the Aerosat but **leave it to one U.S. and one European representative make the final choice among those offering production sharing and those not.**

The move seeks to placate the White House Office of Telecommunications Policy yet satisfy the Europeans. Reportedly, OTP has tentatively approved, with the State Department yet to okay. The new plan **reduces the number of satellites from six to four, and the cost from about \$140 million to less than \$100 million.**

Family planning.

We planned our new disk drive family to give you unlimited design flexibility. All members are plug compatible (use the same controller). You can add or subtract memory almost at will. Tinier by far, they make your system more compact. Each contains its own power supply for even greater design simplicity and reliability.

And there's a configuration for every need. The low cost Model 103 (top) is only 5¼ inches high, yet provides 24 megabits of fixed

disk storage sealed in a dust-free environment. The 8¾ inch high top loading Model 303 (bottom left) and the front loading cartridge version Model 203 (bottom right), store 24 or 48 megabits. The 48 megabit versions have a second fixed disk right in the package.

Use Caelus family planning to plan your new family of systems. For a demo and happy price news call or write Caelus Memories, Inc., Box 6297, San Jose, California 95150. Phone (408) 298-7080.

Caelus Micro-Mini Disk Memory Systems.

Products of Electronic Memories & Magnetics Corporation

EMM



Radar display uses glowing plate to show moving ships' tracks

In marine radar, there are snags with both relative-motion and true-motion display formats. Relative motion doesn't bring out the true headings of other ships, and in poor visibility the navigator has to watch carefully, making continuous plots of the positions of other vessels to pick out potential collision courses.

In true-motion conversion displays, one's own ship moves across the screen while land remains stationary. But the view ahead progressively decreases. What's worse, unless the ship is heading due north, targets are rotated around the display in proportion to the deviation of the heading from due north.

Test. Now, the Kelvin Hughes division of Smiths Industries Ltd. has a display that it claims will cut out the snags of both formats. It's soon to be demonstrated on the ferry *Princessan Desiree*, which plies between Frederikshaven in Denmark and Gothenburg in Sweden.

The essential component in the system is 15-inch-long plate, made by Thorn Electrical Industries Ltd., which emits orange light when electrically energized and exposed to blue light. The glow persists as long as the charge is maintained.

The substrate, forming the negative electrode, is iron covered with two layers of a special vitreous enamel, a thin layer of manganese-doped zinc cadmium sulphide phosphor, and a transparent layer of tin oxide for the positive electrode.

Operation. First image in the KH system is an ordinary radar relative-motion picture in blue on a 3.5-in. CRT, which uses short-persistence phosphor. This image is projected through lenses and a color-separation filter onto the image-retaining plate. As targets move across the CRT, they build up tracks on the plate, which persist as long as the charge is held. Because the phos-

phor has a short persistence, there's no smear on the CRT for the plate to pick up. These tracks make collision courses immediately obvious.

However, in relative-motion displays, stationary targets also leave tracks on the plate. The main achievement of the KH system is that it retains tracks for moving targets and eliminates them for stationary targets.

This is done by televising the picture on the plate, using an ordinary closed-circuit system and moving the plate backwards relative to the ship's heading. The plate's movement across the CRT and the camera lens is proportional to the ship's speed. As the image moves across the CRT, the stationary targets on it

continue to fall on the same section of plate. They build up no tracks, thus differing from the moving targets, which have an additional component of motion on the CRT.

Because the plate is not infinitely long, it cannot be moved backwards forever. Every so often—normally somewhere between 1.5 and 6 minutes, depending on the range in use—the plate is de-energized, making the image disappear, and is moved forward to the start position.

Readout. For course changes, the plate is rotated under control of the ship's compass. This also keeps the display aimed towards 12 o'clock. He also sees tracks behind moving targets, including the track behind his own ship. □

Japan

LSI device generates channel numbers on color TV screen

An MOS LSI circuit designed to display 6-inch-high channel numbers right on the screen of a color television set is now being made by the Sharp Corp. The new device eases remote TV operation, because the usual channel-selector switch numbers are too small to be seen at a distance.

Coming soon. Sharp will use this display on a new set, which has remote controls for all normal functions, except turning the power supply on and off. Because Japanese standards for remote controls may not be formulated by the time the set goes on sale, Sharp expects to advertise the display feature but refrain from advertising the remote control. Sets will go on sale in Japan in August, and sales in the U.S. will start a bit later.

Sharp says the device is p-channel LSI with about 1,000 elements. A channel-number input signal from extra contacts on the tuner switch is decoded by a discrete circuit, with a diode matrix and about eight transistors.

Display. The chip has a read-only memory and is similar to circuits used in computer-terminal displays. The clock frequency is near 450 kilohertz and synchronized with the horizontal sweep frequency. Numerals are generated as a seven-by-five matrix with each element taking 30 lines of the TV raster. Thus the numerals are about 6 inches high on a 20-in. screen. As the set is tuned, the channel number flashes in white and remains on the screen for about 1.5 seconds after the desired channel is selected. □

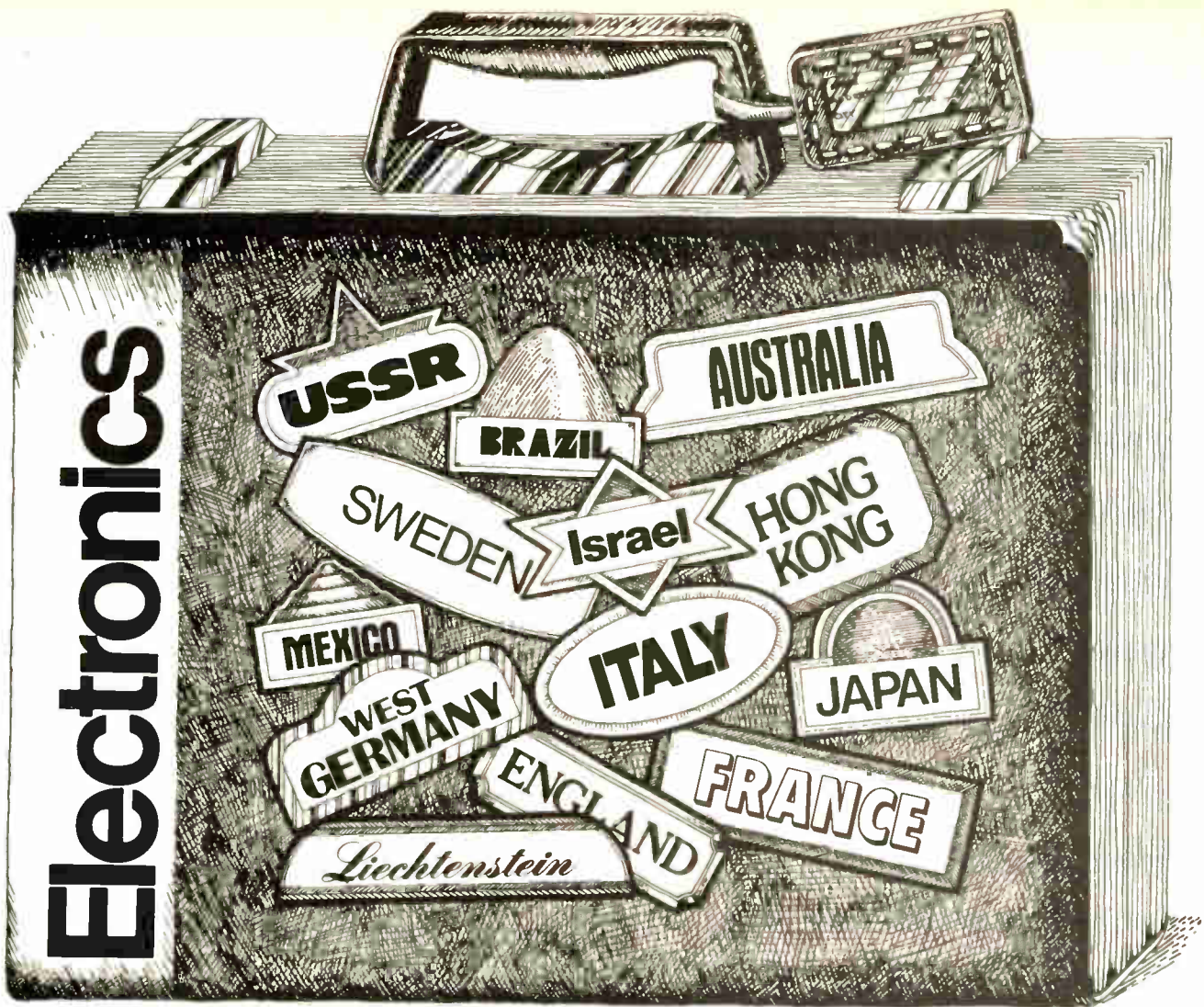

If you're selling your product overseas, sell it first class.

It's no big secret that the biggest growth potential in electronics is overseas. Where there's room to grow, there's room to sell.

But before you sell anything, you have to get your message across the water.

And Electronics Magazine gets it across.

We sell over 21,000 subscriptions to 121 countries outside the U.S. Of those, more than half go to people who never read any of the next five U.S. electronics publications.

And with the high overseas pass-along rate, actual reach is almost five readers per copy.

The international market will be the electronics industries' second childhood. And if you're

advertising anywhere else but Electronics, it'll grow up without you.

Of course, there's more to growth than just reaching a lot of new people. They have to be the right people. And Electronics' international subscribers are right.

All these important customers believe in Electronics. And they'll believe in you when you advertise in Electronics.

With our kind of worldwide readership, you can't afford not to go to
The Source.

Electronics 
THE SOURCE.

U.S. companies vie for Roland license

A U.S. licensee for the Franco-German anti-aircraft missile Roland 2 will be designated within the next few months to bid on an \$800 million U.S. Army contract. Competing for the license are Martin-Marietta, Raytheon, General Electric, a Hughes-Boeing team, and a Westinghouse-Northrop team. The Roland 2 is in advanced stages of development by Aerospatiale of France and MBB of West Germany. The U.S. Army, which is demanding a system that can knock out a low-flying plane within 8 seconds of detection, also is considering two other European systems—the Thomson-CSF-Matra Crotale missile and the British Aircraft Corp. Rapier. North American Rockwell took over the Crotale option from Northrop earlier this month. BAC's Rapier licensee is McDonnell Douglas.

Mullard readies 1,024-bit RAM

By year-end, Mullard Ltd. expects to have ready the first development samples of a 1,024-bit bipolar random-access memory chip. The chip is built using a format called injection logic invented at Philips Eindhoven Research Laboratories. In this technique, the transistor geometry uses a common emitter and multiple collectors, and logic functions are obtained by interconnecting collector outputs instead of emitter inputs. It allows the gates to be built without resistors, which saves power and chip area. The processing incorporates another Philips technique, Locos (for local oxidation of silicon), in which transistors are separated by a thin non-conducting channel, which also raises density.

The processing cycle is one stage longer. Mullard engineers say the RAM will have an access time of about 300 nanoseconds—slower than an MOS RAM—but will be cheaper and have lower dissipation. Packing density of the process is said to be 100 gates per square millimeter and speed/power product to be 1 picojoule per gate. Because the RAM is relatively slow, its main field of application is thought to be as bulk backing memory for large computer systems. The low heat generation will permit large compact memories to be built without forced cooling.

Philips pushes its cassette recording system as standard

With many European firms already having accepted the VCR color recording system as a standard, Philips Gloeilampenfabrieken in The Netherlands, developer of that system, is seeking VCR standardization in countries using the NTSC color transmission norm. Towards that end, the Dutch company has licensed Shiba Electronic Co. in Tokyo to manufacture the cassette system—and wants Shiba to push Japan's Electronic Industry Association to make standard the VCR system's NTSC version. And, in U.S., North American Philips Corp. is trying to get the Society of Motion Picture and Television Engineers to opt for VCR standardization. In Europe, 10 consumer electronics firms in West Germany, England, Switzerland, and Italy have already adopted the VCR system as a standard, and three more are expected to follow suit soon.

West Germany may pull out of Europa-2 program

Europe's chances of securing a place in space are getting dimmer and dimmer. After repeated failures of European-developed launch vehicles, West Germany's minister of science and education Klaus von Dohnanyi hinted at the possibility of discontinuing the Europa-2

launcher development program altogether. **That would also put in jeopardy the follow-up program for the Europa-3 carrier vehicle.** Thus far the countries participating in Europe's launch vehicle development efforts—France, West Germany, England, Italy, The Netherlands, and Belgium, with Australia providing the launch facilities—have put up roughly \$700 million for the Europa-1 and Europa-2 programs. No successful launches have been made to date, however. A withdrawal from these programs by West Germany would mean the loss of a major contributor, what with that country having dished out about \$200 million so far. A West German pullout could well mean Europe's complete abandonment of launch vehicle development.

Brazil buys British ship-to-air TV missile system

The ship-to-air missile television guidance system developed by Marconi-Elliott Avionic Systems Ltd. for the Royal Navy will be used for weapon guidance in the six frigates being built for the Brazilian Navy by the British shipbuilder Vosper Thornycroft Ltd. This will make four national navies using the system. Each Brazilian frigate will have a combat information center and two weapon control systems, for which Ferranti Ltd. is prime contractor. The TV camera is in parallel with a radar that locks onto and tracks the target. Hence the target remains in the middle of the screen. **The waveform created by the flare from the missile is used to bring the missile into the middle of the screen automatically, where it is on target.** For fine control as the missile nears the target, an over-riding joystick controller is provided. The radar is made by Selenia of Italy.

AEG-Telefunken signs trade pact with Soviet Union

Continuing East-West rapprochement keeps brightening the prospects for more cooperative deals between Western electronic firms and Socialist-bloc countries. Now that West Germany's AEG-Telefunken and the Russian State Council for Science and Technology signed in Moscow late this month a preliminary consultation and cooperation agreement, chances are that the two partners will soon enter long-term know-how exchange and licensing arrangements involving specific areas of electronics. It is particularly in data processing, communications, and in the electric energy field that AEG-Telefunken sees such deals being made. The German company also holds out prospects for more equipment deliveries to the Soviet Union. **At present, AEG-Telefunken's trade volume with Russia accounts for only 1% of its total foreign business.**

Japanese cartel to set TV, recorder prices in Europe

A cartel to maintain minimum prices on black-and-white TV sets and tape recorders exported to the three Benelux countries is being set up by the Japan Machinery Exporters Association. **The association hopes to expand the move to cover 13 European nations in the near future.** It had hoped to start with 13 nations in July, but was prevented from doing so by West Germany, which said the cartel would violate its anti-trust laws. The Japanese government will now try to negotiate with the German government. **Color television was not included because of the many unresolved questions concerning the PAL transmission system patents.**



Investigate New Sources of Quality Products at . . .

JAPAN ELECTRONICS SHOW '72

Tokyo
Sept.
21-27

エレクトロニクスショー

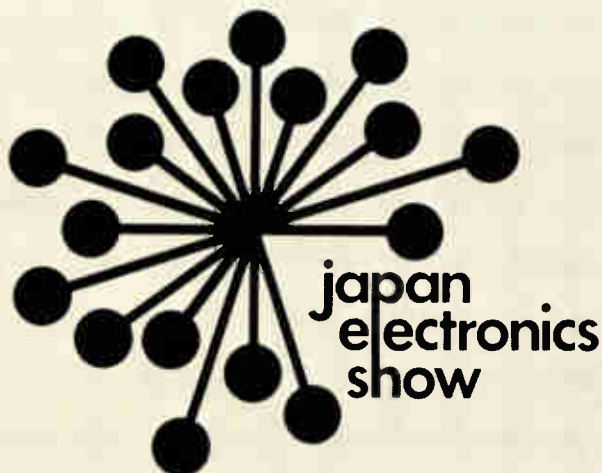

'72 JAPAN ELECTRONICS SHOW

SEPT. 21-27, 1972, TOKYO

We look forward to.....

Your visit and to see you at the Japan Electronics Show '72 in Tokyo. In Asia, this show is an internationally famous exhibition with all electronics including consumer products, industrial equipment, components, etc., displayed in greatest scale.

Many electronic products are also displayed in this show by U.S.A. and the leading countries in Europe and South-east Asia. Last year, many buyers from 64 foreign countries have visited the show for study and observation of Japan's electronics.

For details of the '72 JES (11th), please write to:

JAPAN ELECTRONICS SHOW ASSOCIATION
(Show management for the Electronic Industries Association of Japan)
2-2, Marunouchi 3-chome, Chiyoda-ku, Tokyo, Japan Cable: ELINDASO TOKYO



Investigate New Sources of Quality Products at . . .

JAPAN ELECTRONICS SHOW '72 Tokyo Sept. 21-27

Hitachi high speed thyristors glass passivated to maximize reliability.

In addition to high reliability,
Hitachi CU06V glass passivated high speed thyristors also bring
other major advantages to modern equipment designs.
Mass production assures immediate supply in
any quantity you require at greater cost savings.
And a standardized T066 package means extra ease in usage,
meeting and matching all of your high speed applications now and later.

MAXIMUM ALLOWABLE RATINGS & CHARACTERISTICS

Items	Symbols	Units	CU06VC	CU06VE	CU06VF	CU06VG
Peak Forward Blocking Voltage	V_{DRM}	V	200	400	500	600
Repetitive Peak Reverse Voltage	V_{RRM}	V	5			
Average Forward Current	$I_{T(AV)}$	A	3.0 (Single phase, half-wave 180° conduction, $T_c=60^\circ\text{C}$)			
Peak One cycle Surge Current	I_{TSM}	A	50 (10m sec. conduction, sine half wave 1 cycle)			
Peak Gate Power Dissipation	P_{GM}	W	Forward=20, Reverse=20			
Operating Junction Temperature	T_j	°C	-30 ~ +100			
Weight		g	6			
Turn Off Time	t_q	°S	Max. 4.5 (V_{GK} (bias) = -2.5V, $T_c=70^\circ\text{C}$, 15.75 kHz, see fig. 1)			
Maximum Forward Voltage Drop	V_{TM}	V	3.3 ($T_j=25^\circ\text{C}$, single-phase, half-wave peak value 10A, conduction angle 180°)			
DC. Gate Trigger Voltage	V_{GT}	V	4.0 ($T_j=25^\circ\text{C}$, forward voltage between A-K 6V DC)			
DC. Gate Trigger Current	I_{GT}	mA	40 ($T_j=25^\circ\text{C}$, forward voltage between A-K 6V DC)			
Thermal Resistance	θ_b	°C/W	4.0 (junction to base)			

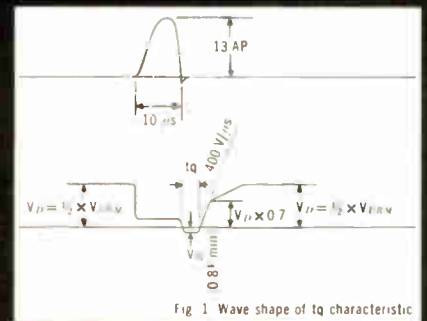

Head Office Section XH-E: 6-2, 2 chome, Otemachi, Chiyoda-ku, Tokyo 100 Argentina: Av. de Mayo 666, Piso 12, Buenos Aires Tel. 33-3201 Brazil: Av. Rio Branco 151, Grupo 1505, Rio de Janeiro-GB Tel. 231-1321 England: 2nd Fl., 11/12 Finsburg Sq., London E.C.2 Tel. 588-3275 West Germany: 4000 Dusseldorf, Graf Adolf Strasse 37 Tel. 10846 Hitachi America, Ltd.: New York: 437 Madison Av., New York, N.Y. 10022 Tel. (212) 758-5420 San Francisco: 100 California St., San Francisco, Calif. 94111 Tel. (415) 981-7871 Nissei Sangyo GmbH Deutschland: 4000 Dusseldorf, Am Wehrhahn 41 Tel. 36 09 03 Nissei Sangyo Co., Ltd., Taipei Office: Nanking Bldg., No. 165, Sec. 2, Nanking East Rd., Taipei 104 Tel. 570704 Nissei Sangyo Co., Ltd., Hong Kong Branch Office: Room No. 904, Realty Bldg., 71 Des Voeux Rd., Central Hong Kong Tel. 227403 Nissei Sangyo Comercio e Representacao Ltda: Edificio Estrela, Av. Rio Branco 211, 9° Andar Salas 96/99 Sao Paulo, Brasil Tel. 221-3011, 3805





Investigate New Sources of Quality Products at...

JAPAN ELECTRONICS SHOW '72

Tokyo
Sept.
21-27

The Panasonic Ultrasonic Ceramic Microphone/Transmitter. There must be applications we haven't even thought of.

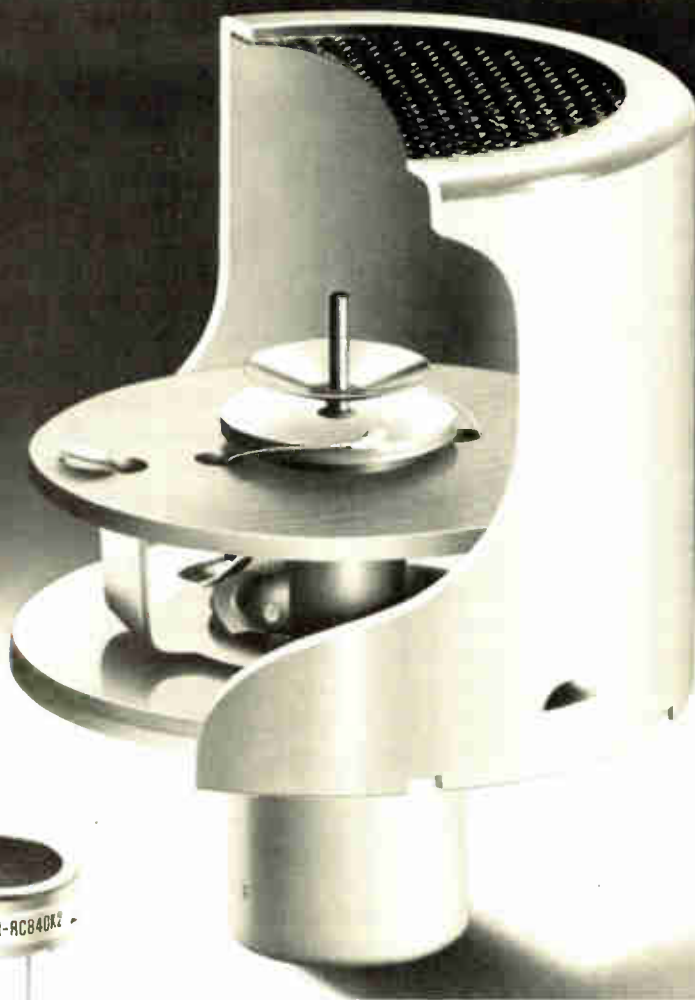

Frequency Characteristics

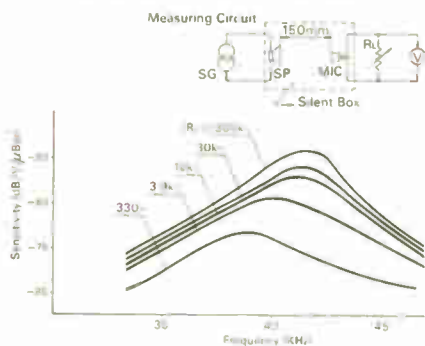

Radically different from previous ultrasonic ceramic microphones, this Panasonic element employs a conical aluminum resonator and the effect of standing waves in the case to obtain higher sensitivity and output voltage. Its sturdy construction pays off in superb durability and stability, regardless of temperature and humidity. Even shocks can't shock it.

Excellent as a receiving microphone,

it is equally suitable as transmitter—we produce special types for either purpose. As a transmitter, sensitivity is especially sharp.

Applications? In remote control units of TV sets and other appliances; in proximity detectors for triggering burglar alarms, automatic doors, etc.

We're sure that you can think of a host of other uses.

Panasonic

just slightly ahead of our time

MATSUSHITA ELECTRIC CORPORATION OF AMERICA

Industrial Division

Pan-Am Building, 200 Park Ave., New York, N.Y. 10017, U.S.A.

TWX 710-581-4158 Tel: 973-5710 Area Code 212



Investigate New Sources of Quality Products at ...

JAPAN ELECTRONICS SHOW '72

Tokyo
Sept.
21-27

Primo *NEW.....* Condenser Microphones

The CMU-506B is a condenser microphone powered from a self-contained 9V battery, a quality microphone offering response found in professional microphones along with high stability, extended serviceability, and a good signal-to-noise ratio. Design provides for the needs of semi-professionals and amateurs alike.

● Frequency response: 20—20,000Hz; ±4dB Voice: -12dB at 100Hz ● Output impedance: 600 ohms (balanced) ● Sensitivity: -72dB (1μ bar, 1kHz) ● Signal-to-noise ratio: More than 50dB.

This microphone designed for the semi-professional is powered by a self-contained 1.5V battery.

Because of excellent response, it is widely used in broadcasting stations and recording studios.

Featured are high stability, ruggedness, and an excellent signal-to-noise ratio.

● Frequency Response: 50—13000Hz ±3dB Voice: -12dB at 100Hz ● Output Impedance: Balanced 600 ohms ● Sensitivity: -72dB ±2dB 1kHz (0dB=1v/μ bar) ● Signal-to-noise ratio: More than 50dB.

● For catalog, write to:

PRIMO COMPANY LTD.

CHICAGO ILLINOIS OFFICE:
111 EAST WACKER DRIVE, SUITE 2207, CHICAGO
ILLINOIS 60601 TEL: (312) 565-0220, 0221
TELEX: 25-4225 PRIMO MUS CGOILLUSA



CMU-506B
Uni-directional
Condenser
Microphone (With wind screen, tone switch)



EM-507
Electret
Condenser
Microphone (With tone switch)

HEAD OFFICE:
25-1, 6-CHOME, MURE, MITAKASHI, TOKYO, JAPAN
TEL: 0422-43-3121~7
CABLE: "PRIMO MUSASHINO MITAKA"
TELEX: 2822-326 PRIMO J

Now
automated
measurement
of
distortion to
0.05%

Programmable Oscillator **MST-840** ▼

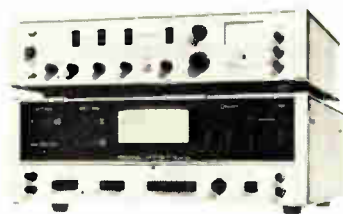

Programmable Automatic
Distortion Meter **MST-851** ▲

This hard-to-beat combination features programmable control of all functions and a fundamental reject band width not found in other distortion measuring sets, along with ample system reliability.

Distortion Measurement: ● Measured frequency range: 10Hz-100kHz (3 ranges) ● Distortion range: 0.1-30% (six ranges) ● Automatic control range (input): 62mV-77.5V ● Automatic control rate (input): Control within 800mmsec.

Level Measurement: ● Measured frequency range: 10Hz-300kHz ● Input impedance: 100kilo-ohms (unbalanced) ● Level range: +40 to -70 dB (twelve ranges).

Signal-to-Noise Ratio Measurement: ● Measured frequency range: 10Hz 60kHz ● Measurement range: (0-70dB) to 0-120dB.

Output: ● Distortion: Ac following elimination of fundamental ● Level: Ac following range selection.

Remote Signal: ● Code level: High state logical "1" (0: 0-1.1V 1: 2-5V) ● Frequency control: BCD, three places plus two bits ● Function: Eight instructions 8 bits.

Frequency Display: ● Displayed frequency: Three decimal places.

Our broad product line includes a Sequence Programmer and Programmable Intermodulation Distortion Meter.

See our products on display at the JES Exhibition



Electronics is The Source for sales leads.

AVERAGE NUMBER OF SALES LEADS PER AD:

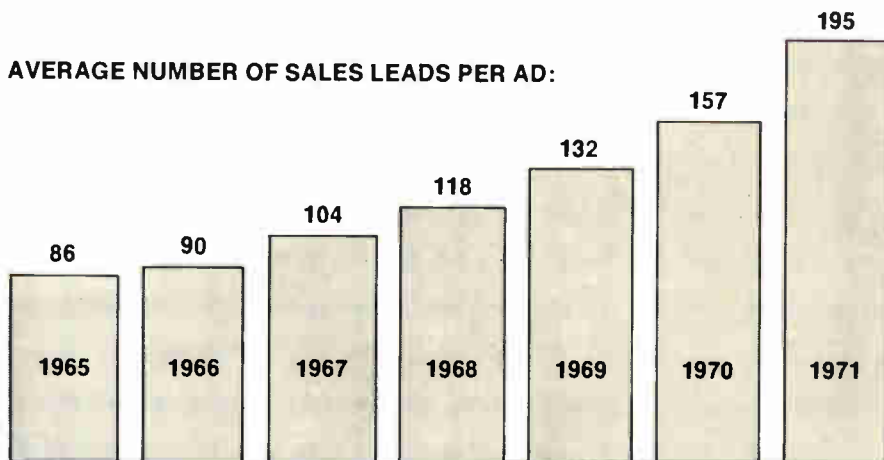

Electronics is The Source for a lot of valuable things.

Editorial excellence, reader loyalty, an audience with buying power.

It's also The Source for reader response. And this response is increasing every year. In fact, it's more than doubled in the last six years.

Last year alone we averaged 195 inquiries for each ad. And remember,

that's just an average.

So if you want response and not just exposure, put yourself in The Source.

With our ever-increasing inquiry rate, you can't afford not to.

Electronics **JES**
THE SOURCE. **GROW**



Investigate New Sources of Quality Products at . . .

JAPAN ELECTRONICS SHOW '72

Tokyo
Sept.
21-27

NOBLE

CONTROLS FOR AUDIO DEVICES



SLIDE VARIABLE RESISTOR:
Stroke sizes available are 30, 45 and 60mm, each available in the gang type. Various shapes of lever are prepared.



V24L5S(MPL)(U74DF):
This is a push-type-switch attached by a UL label, and its switch (SW) rating is available in three types—TV1, TV3 and TV5.



BALANCE VOLUME:
This is a volume which is able to one-touch control four sound sources. The maximum manipulation angle of the lever is 60°. Each of the built-in volumes can be manipulated freely over the full stroke. Measuring 60 x 60mm in outside diameter and 50mm in depth.



V24L5G(4R)N:
This is a continuous variable type volume specially designed for 4-channels, with its mutual deviation of resistance value being made extremely minimal as compared to the conventional versions.



FIXED COMPOSITION CAPACITOR (Small Molded Cap):
This is an extra-small capacity condenser having a static electric capacity ranging from 0.12pF to 4.7pF. Its permissible tolerances are made as small as $\pm 5\%$, $\pm 10\%$ and $\pm 20\%$, thereby gaining wide acceptance both at home and abroad.



STYROL CONDENSER (Heat-Resistant Type):
This is a special condenser using polystyrene films as electric conductors. Excellent in high frequency performances, it is best suited for high frequency syntony circuits, side circuits, coupled circuits and filtered circuits. Patent pending as a new heat-resistant condenser.

MAIN PRODUCTS

Variable Resistor, Electronic Switch, Capacitor Fixed Resistor, Power Resistor, etc.



NOBLE

ALL ROUND ELECTRONIC COMPONENTS MANUFACTURER
TEIKOKU TSUSHIN KOGYO CO., LTD.

335 Kariyado, Nakahara-ku, Kawasaki, Kanagawa, Japan
Tel: (044) 42-3171. Cable: TEITSU-KAWASAKI
Telex: 3842-155

If you're selling your product overseas, sell it first class.

It's no big secret that the biggest growth potential in electronics is overseas. Where there's room to grow, there's room to sell.

But before you sell anything, you have to get your message across the water.

And Electronics Magazine gets it across.

We sell over 21,000 subscriptions to 121 countries outside the U.S. Of those, more than half go to people who never read any of the next five U.S. electronics publications.

And with the high overseas pass-along rate, actual reach is almost five readers per copy.

The international market will be the electronics industries' second childhood. And if you're advertising anywhere else but Electronics, it'll grow up without you.

Of course, there's more to growth than just reaching a lot of new people. They have to be the right people. And Electronics' international subscribers are right.

All these important customers believe in Electronics. And they'll believe in you when you advertise in Electronics.

With our kind of worldwide readership, you can't afford not to go to The Source.

Electronics

THE SOURCE.



Investigate New Sources of Quality Products at . . .

JAPAN ELECTRONICS SHOW '72

Tokyo
Sept.
21-27

SOLID TANTALUM CAPACITORS

MATSUO'S



Unique punch-cut lead wire allows for an ease of attachment to the printed circuit board and labor saving. It is suitable for entertainment as well as industrial uses. The features include wide operating temperatures, superior stability and

Dipped Solid Tantalum Capacitor BLUE DT Type DTS

moisture resistance. Very low leakage (0.02CV or 1 micro ampere). Standard Voltage Rating: 3.15 to 35VDC. Standard Capacitance Value: 0.1 to 100 MFD. Standard Capacitance Tolerance: $\pm 20\%$ (M).



Leadless and dimensionally accurate. Ideally used for HYBRID ICs, withstanding the severe temperature conditions of reflow soldering (220°C, 5 seconds). The electrical performance is improved without increasing cost, resulting in: very low leakage (0.02CV or 1

Tantalum Chip Capacitor TANCHIP Type TCA

micro ampere), excellent stability (ΔC , 5% typical, at 85°C), and low dissipation factor and impedance at high frequency. Standard Voltage Rating: 6.3 to 35VDC. Standard Capacitance Value: 0.1 to 100MFD. Capacitance Tolerance: $\pm 20\%$ (M).

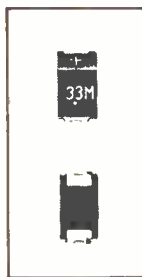

For information, please contact:
MATSUO ELECTRIC CO., LTD.
5-3, 3-chome, Sennari-cho, Toyonaka-city, Osaka, Japan.
Cables: "NCCMATSUO" OSAKA Telex: 523-4164 OSA

Compact Your Line Printing Costs

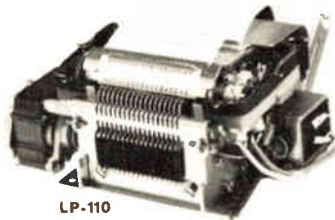

LP-110

This miniaturized line printer from TEC puts a new level of simplicity and efficiency into line printing. The LP-110 has a continuously rotating drum with up to 18 columns at 14 ch/col. The revolutionary drum also brings new speed—5.5 to 6.5 lines per second, and new reliability, as there are fewer wearing parts. Two color, clearly legible digits are printed by hammers actuated directly by magnet. These mechanisms therefore make possible high printing speed. And you get wider adaptability. Contact TEC and see how well the LP-110 fits into your present systems.

SPECIFICATIONS
Printing Speed: 5.5 to 6.5 lines per second
Print Drum: Up to 18 columns.
 14 positions per column
Character Spacing: Column spacing: 2.54mm
 Line spacing: 4.23mm
Ribbon: 2 colors (Black & Red)
Weight: 1.8kg (3.9lbs)
Dimensions: 141mm (W) x 104mm (D) x 70mm (H)
Environment: 0 C to 50 C
Life: 5 million lines



TOKYO ELECTRIC CO., LTD.

14 10, 1 chome, Uchi-Kanda, Chiyoda-ku, Tokyo, Japan

IC's DESERVE SMK SOCKETS!

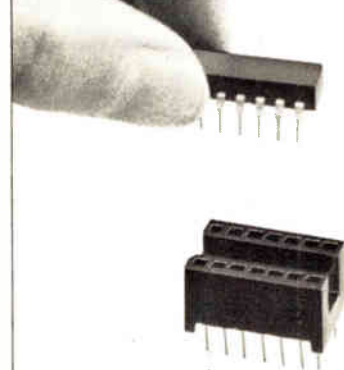

SMK IC sockets are designed and manufactured to satisfy a wide range of requirements, both in consumer products and industrial equipment. Sockets are available in dual in-line (14-, 16-, and 20-pin) and hybrid (7-, 9-, and 10-pin) types.

POWER SWITCHES

Satisfy UL Specifications (TV-3)



SJ-1973 (SPDT)



SJ-4957 (DPDT)

Positive action SMK Power Switches satisfy the stringent specifications of UL. Fifteen types have been approved under TV stipulations. Unique design makes the SMK switch well suited to a variety of applications.



SHOWA MUSEN KOGYO CO., LTD.

No. 5-5, 6-chome, Togoshi, Shinagawa-ku, Tokyo 141, Japan
 Phone: 785-1111
 Cable: "SHOWAMUSEN TOK"
 Telex: 2466301SMKTOK J

24,940 KEY PEOPLE WHO DON'T READ THESE,



READ THIS.

That's a lot of people to be putting all their faith in just one magazine. Especially when there are so many others to choose from.

Yet all these important customers would rather go to The Source than read any of the next five electronics magazines.

That's a lot of readers. And that's a lot of trust.

We get so much unduplicated readership simply because we can't be duplicated.

So once they've read Electronics, they've read it all. And if you're advertising everywhere else, nearly 25,000 prospective buyers will never see it.

These readers are so loyal, they'd rather

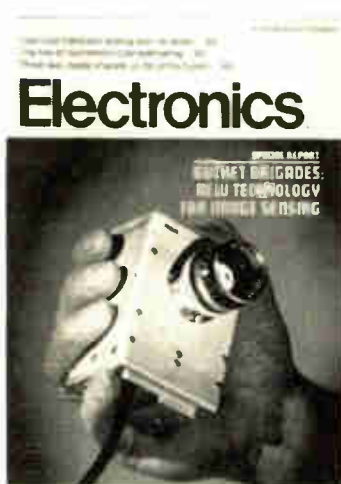

pay from \$8 to \$25 to read our magazine than get all the others free. And their loyalty is just part of our story.

58,000 (67%) Electronics subscribers are managers.
70,000 (81%) have engineering job functions.
74,000 (85%) decide who their companies will buy from. And a third of them decide on purchases of over \$100,000 a year.

These crucial buying influences believe in Electronics. And they'll believe in you when you advertise in Electronics.

With our kind of readership, you can't afford not to go to The Source.

Electronics 
THE SOURCE.

“Scotchflex” Flat Cable Connector System makes 50 connections at a time.



“SCOTCHFLEX” IS A REGISTERED TRADEMARK OF 3M CO.

Build assembly cost savings into your electronics package with “Scotchflex” flat cable and connectors. These fast, simple systems make simultaneous multiple connections in seconds without stripping or soldering. Equipment investment is minimal; there’s no need for special training. The inexpensive assembly press, shown above, crimps connections tightly, operates easily and assures error free wiring.

Reliability is built in, too, with “Scotchflex” interconnects. Inside of connector bodies, unique U-contacts strip through flat cable insulation, grip each conductor for dependable gas-tight connections.

“Scotchflex” offers you design freedom, with a wide choice of cable and connectors. From off-the-shelf stock you can choose: 14 to 50-conductor cables. Connectors to interface with standard DIP sockets, wrap posts on standard grid patterns, printed circuit boards. Headers for de-pluggable connection between cable jumpers and PCB. Custom assemblies are also available on request.

For more information, write Dept. EAH-1, 3M Center, St. Paul, Minn. 55101.



“Scotchflex”.
**Your systems approach
to circuitry.**



Crystalonics has a 4-ohm FET with a 1-volt threshold for \$3.69?*

That's almost right.

The best doesn't cost any more anymore.



Our 2N5066 has a 4-ohm typical (8-ohm maximum) R_{ON} . We have to admit, it does have an offset voltage, but it's only 300 microvolts typical (1 millivolt maximum). The off-current is still 1 nano-amp maximum, and it takes less than 1 volt to turn it on. The device does draw some current in the on state (less than 1 milliamp), but that's OK in most cases, because the signal source impedance is usually less than 1 ohm.

If you're getting suspicious, you're right. We lied... it's an NPN transistor, not a FET... but everything else we've said about it is the truth. Besides, do you really care?

If you're not miffed and are still interested, we have a "P-channel" equivalent (the 2N3677) at an even lower price. Both really warrant your investigation if you are designing analog switching circuits. We'll send you one of each to try if you'll drop us a note. If more data would help, circle the reader service number.

P.S. We also make the real McCoy.
*100-piece price

TELEDYNE CRYSTALONICS

147 Sherman St. • Cambridge, Mass. 02140 • TEL: 617-491-1670
1800 N. Highland Ave. • Suite 616 • Hollywood, Calif. 90028 • TEL: 213-469-5871

Probing the news

Analysis of technology and business developments

Electronics industries recovering

Manufacturers of all types of gear are convalescing with the aid of a general business upturn and expect a Government shot in the arm soon

by Alfred Rosenblatt, New York bureau manager

The electronics industries have begun to flex their muscles and forget the convulsions of the recent recession. As 1972 moves into its second half, a sampling of companies shows business to be good and the belief it will remain strong for the rest of the year. Sales volume generally continues upward.

And as the election bandwagons roll faster, the Administration is working on some tougher trade measures to cope with the job-related problem of increased electronics imports and the soaring trade deficit [*Electronics*, May 8, p. 65]. Governmental aid to exports, insiders suspect, will come in November with a second downward revaluation of the dollar.

Most encouraging, however, is that the business rebound appears to be broadbased. Alfred P. Oliverio, marketing manager at the Hewlett-Packard Co. Electronic Products group, remarks that the strong business picture is expected to hold "across the board." This situation is allowing companies, he says, "to fulfill pent-up requirements and spend for capital and plant equipment."

Not only are instruments reportedly selling well, but so are semiconductors, components, computers, computer-based information systems, and consumer electronics. And this trend is expected to continue through the end of 1972.

On the military and aerospace side, procurement dollars are up—not unexpected in an election year. The 1972 military electronics portion will take about a \$9 billion share of an estimated \$12.8 billion Federal electronics market, reflecting increases in new Air Force and

Navy programs such as avionics, antisubmarine warfare, countermeasures, and communications.

"This is a characteristic trend," says one Pentagon economic analyst. "When hot wars cool down, as Southeast Asia has, the dollar share goes up for heavy electronics areas like reconnaissance, surveillance, and command and control.

Bookings increase. At North American Rockwell Electronics group Anaheim, Calif., maker of the Minuteman missile guidance system, among other military programs, sales are down a little, but bookings are "up about 20% this year over last," president Donn L. Williams reveals. Williams foresees protracted growth over the next few years. "I don't look for any sudden surge," he says. Similarly, A.E. Puckett, executive vice president of Hughes Aircraft Co. Culver City, Calif., with its communications and navigation satellite and weapons systems, predicts a rise to \$880 million level in 1972, up from only \$765 million last year.

Still another military equipment manufacturer doing well is Kearfott division of the Singer Co., Little Falls, N.J., which reports business as "excellent" this year after attaining "record sales levels during the past two years from sales of production navigation systems for the P-3C antisubmarine warfare aircraft and the A-7D/E attack plane.

The general avionics market is also experiencing a strong turnaround, "especially at the higher end of the business aviation market," says Thomas A. Campobasso, marketing vice president at Collins Radio Co., Dallas.

Consumers also seem to have



Semiconductors jumping. Charles Phipps at TI says that semiconductor industry sales are making nearly 10% jumps a quarter.

Double. William C. W. Mow of Macrodata, maker of test systems for semiconductor memories, reports sales almost double '71.



Probing the news

more money to spend for electronics. As many as 8 million color television sets could be sold this year, surmises Richard Kraft, a vice president at Motorola's Consumer Products division, Chicago. This figure would be an increase of about 10% over last year's sales.

Semiconductors, considered a bellwether of the electronics marketplace because they're used everywhere, are doing particularly well. It's been a "dramatic recovery from recession conditions," declares William C. Hittinger, who heads RCA's Solid State division, Somerville, N.J. Beginning with the fourth quarter of last year, "the semiconductor industry—essentially flat the first three quarters of 1971—has been making nearly 10% jumps each quarter," says Charles H. Phipps, manager of strategic planning for the Texas Instruments Semiconductor group in Dallas.

Transistor-transistor-logic sales are especially strong—reaching as much as \$190 million in 1972 from \$126 million last year, he says. Also strong are linear ICs, hitting \$120 million to \$130 million in 1972, from \$91 million in 1971. Business is brisk, observes John R. Welty, assistant general manager at Motorola Semiconductor Products division, Phoenix. The division's first half sales jumped 20% over first half

1971, and Welty says the fourth quarter sales should be "very strong."

Semiconductor memories are also beginning to do better, if sales of memory test systems are any indication. "During the first six months of the year, we've hit 87% of last year's total," says William C.W. Mow, president of test-system manufacturer Macrodata Corp., Chatsworth, Calif. "Our goals for sales and profit have been surpassed, and we're looking for sustained growth."

Accelerating. Discrete components are also selling well. "Business is great, and we think it's going to remain so because the recovery is broad-based," says Clayton Ryder, director of marketing at the Electronics division, Allen-Bradley Co., Milwaukee. Orders during the first six months of 1972 were up 15% to 20% over a comparable period a year ago, Ryder asserts.

A similarly sanguine report comes from Sprague Electric Co., North Adams, Mass. Its business is not only up "satisfactorily," but president Bruce R. Carlson expects an accelerating rate of increase during the second half of 1972.

Distributors, through whose hands pass an ever-increasing portion of electronic components, are also heartened. For example, Cramer Electronics Inc., Waltham, Mass., says it has booked \$42 million in sales during the first half of the year, compared with \$60 million

for all of 1971. And the increased bookings tune is echoed on the West Coast. First-half business at Los Angeles-based Kierulff Electronics is reported 35% higher than in the similar period last year.

In the computer marketplace, IBM's whopping 22.6% increase in first-half revenues—to \$4.7 billion—sets the tone. And minicomputer giant, Digital Equipment Corp., Maynard, Mass., also finds business conditions exhilarating. Sales for the fiscal year, ending in June, are expected to increase by 30%, with machines selling well across the board—including DEC's System 10 general-purpose large-scale system, which sells for upwards of \$400,000.

Hightime. At Interdata Inc., Oceanport, N. J., president Dan Sinnott says first-half sales of the growing minicomputer firm will be close to \$6 million, compared with \$3.6 million last year. The profits picture has turned from a loss to a gain of \$500,000 so far. Sinnott singles out communications-oriented data processing as the greatest area of growth.

If computers are doing well, peripherals to serve them must be prospering also. "Everything looks a hell of a lot better than at this time last year," declares Jack James, president of core memory maker Telex Computer Products, Tulsa, Okla., more specific with sales figures is Jack Ogg, senior vice president of peripheral equipment maker Data Products Inc., Woodland Hills, Calif., which last year had sales in the \$55 million range. "Business has picked up in both the U.S. and Europe, with an order increase of about 25% over what we saw nine months ago," he reports.

When it comes to instrumentation, others besides Hewlett-Packard, with a third quarter ending today 25% ahead of last year's find cause for joy. General Radio's senior vice president, Ivan G. Easton, terms sales "very strong compared to a year ago," and this is in virtually all segments of the Concord, Mass., manufacturer's business.

And at Tektronix Inc., Beaverton, Ore., sales for the fiscal year ending in May rose 12.5% to \$164 million, with the company looking forward to "continued good business," for the rest of the year. □

Bookings bright. Donn L. Williams, president of the North American Rockwell Electronics group, says his company's bookings are up about 20% over last year.



Military electronics

Pilotless planes: big new market?

Development of remotely piloted vehicles is slowed by scattered funding and absence of high-level military leadership

by Ray Connolly, Washington bureau manager

In military electronics, growth markets that promise broad industry participation have become rare, as the Pentagon finds its funds shrunk by Congress and inflation. Now the industry believes it has found such a market in remotely piloted vehicles (RPVs)—the small and potentially low-cost aircraft designed to be flown by pilots using data links and seated at ground-based or airborne consoles.

But there is frustration within segments of the military and the electronics industries that the program is not growing faster, despite the fact that much of the technology is at hand. There is also concern that RPV funding is fragmented among the services and that there is no top-level sponsor shepherding RPV efforts.

The Air Force identifies some \$25 million as directly budgeted for RPV R&D this year, and there is more when other funds in that service, the Army and the Directorate of Defense Research and Engineering (DDR&E) are counted. The best estimate is that some \$60-\$75 million will go out to industry this year in electronic hardware awards.

Proof of broad industry interest was given at a classified three-day symposium early this summer. Sponsored by the Electronic Industries Association and DDR&E, it attracted more than 600 registrants—twice the expected number. The symposium covered sensors, command, control, communication, ground systems and data links.

Since then, the AF Aeronautical Systems division at Wright-Patterson AFB outside Dayton, O., has awarded a \$10.1 million contract for a high-altitude, long-endurance re-

connaisance RPV called Compass Cope to Teledyne Ryan Aeronautical, San Diego. This second Compass Cope award, intended to compete with a Boeing prototype for which the Seattle company received \$5.6 million a year ago, marks the first AF move to develop an RPV able to take off and land on a runway. "All reconnaissance drones now in the inventory are air-launched and are midair-recovered by CH-3 helicopters" using nets, explains Lt. Gen. Otto J. Glasser, AF deputy chief of staff for research and development.

Family. The Compass Cape push puts the Air Force ahead of both Army and Navy in developing a new family of turbojet aircraft for the 1980s. In that time frame, the RPV is expected to grow from its present reconnaissance, jamming and air-to-ground strike roles—missions now being performed on a limited basis over southeast Asia—to an air-to-air interceptor, functioning either as a recoverable tactical aircraft or as an expendable, one-time reconnaissance-strike weapon dub-

bed "an electronic kamikaze" by one AF specialist.

Air Force Under Secretary John L. McLucas estimates that multi-mission, tactical RPVs should be able to be delivered at a unit cost less than \$500,000 in production while the current goal for single-shot vehicles is somewhere between \$25,000 and \$50,000. Either figure is a far cry from the \$12-\$18 million flyaway cost for a contemporary manned reconnaissance-strike fighter. Avoiding those costs in future—as well as the possible loss of pilots' lives—is precisely what the military has in mind with its drive for the RPV.

Pushing that drive is a cadre of aerospace and electronics companies. Teledyne Ryan, with its long experience producing target and reconnaissance drones, is often seen as the leader in the competition, but it faces more than Boeing in the Compass Cope program. It is also competing with Northrop Corp. in two AF multi-mission RPV studies funded at \$300,000 and \$292,000, respectively. Following their deliv-

Drone control. Two drone control panels and telemetry displays, from Motorola's Integrated Target Control System, serve to regulate remotely piloted drones' control surfaces

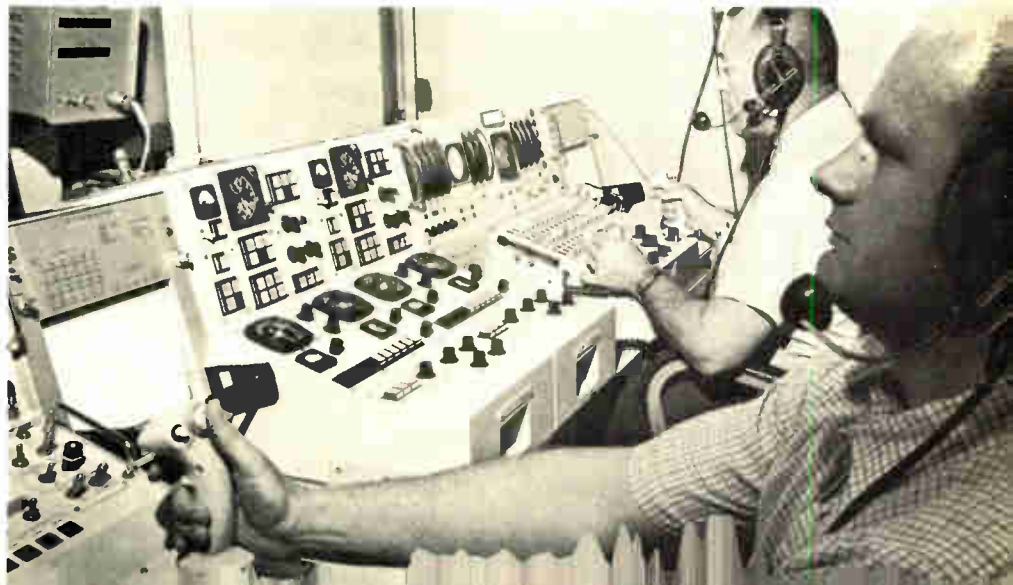

ery to Wright-Patterson in August and subsequent evaluation, the AF Aeronautical Systems division will move to its next step toward development of a strike aircraft. Also in the scramble are E-Systems Inc., formerly LTV/Electrosystems, following its demonstrations of its XQM-93A RPV for the Air Force; Lockheed Missiles and Space Co.; Martin-Marietta's Denver division; General Dynamics Corp.; and McDonnell Douglas Aircraft.

ASD is also pushing for new R&D sources in areas ranging from pulse-laser-gated low-light-level TV systems to low-cost engines and low-cost airframe materials.

At the same time, the AF Rome Air Development Center, Rome, N.Y., is proving a significant source of continuing contracts for RPV command and control technology. One typical effort contributing to that data base was the Range-Only Multiple Aircraft Navigation system (Romans), under which IBM's Electronics Systems Center, Owego, N.Y., successfully used trilateration to demonstrate simultaneous navigation of four aircraft to ranges beyond 80 nautical miles. Circular error probabilities against multiple test points were 20 feet, and precise aircraft steering was achieved.

Meanwhile, before this fiscal year is out, the Army expects that it will award two competitive prototype contracts for a remotely piloted observer/designator aircraft. It will be an integrated television sensor and a laser target designator to identify and then illuminate targets for attack by laser-guided artillery or missiles. Funded out of the \$34.8 million sought for Stano (surveillance, target acquisition and night observation), the low-cost, low-flying vehicle is budgeted for \$7 million this year. Army assistant secretary for R&D Robert L. Johnson describes it as a daytime system now, but says he would not rule out future use of a forward-looking infrared system if an all-weather capability can justify its cost and if an initial TV system proves successful.

As these efforts by the individual services continue, one common industry suspicion is that the problem

with getting RPV programs together is that "they lack a strong single voice at the top" of the Defense establishment—"a sponsor with a star on his shoulder," as one contractor put it. Brig. Gen. Theodore S. Coberly, just departed as Air Force Director of Reconnaissance and Electronic Warfare, was the closest thing to a spokesman for RPVs, but his retirement leaves the chair vacant.

Lt. Gen. Glasser's role as a deputy overseer for all R&D precludes his pushing RPVs at the expense of other efforts. But in testimony before Congress earlier this year, Glasser put RPVs high on the list of Air Force priorities. "We are doing only a very minimal amount of effort in that area and could do much more."

Challenges. If there is a single technological problem facing large-scale usage of RPVs in the future, it is in the broad area of wideband communications between the pilotless planes and the men behind the ground and airborne consoles that will fly them. "A jam-free data link is probably the biggest challenge to RPVs," says one Pentagon electronics warfare specialist. "Another is multiple vehicle control in a combat environment. Apart from enemy jamming, RPVs cannot be jamming each other." The prospect that as many as 40 vehicles might be simultaneously controlled from a single ground station only a few hundred

miles from a target presents many other unresolved questions for military planners. Can you successfully hand off a vehicle from a controller in one center to another? How do you best protect the control center itself from being wiped out? If RPVs on strike missions intended for defense suppression are designed to home, say, on radar signals, how do you counter enemy missiles that home on jamming signals?

For selected strike missions, McLucas says the Air Force is weighing the use of terminal guided bombs such as the Laser Paveway and Walleye. For navigation, the Air Force is interested in low-cost Loran technique.

For the future, McLucas says the Air Force anticipates an "austere experimental hardware and flight program," testing the concept of a mother vehicle. Probably this would take the form of a medium bomber or transport, carrying two RPVs slung under its wings, each equipped with two rockets plus guns for a multiple-pass attack capability against radar-detected enemy aircraft. Though McLucas says the tests would be aimed toward development of key subsystems such as electro-optical sensors, flight control and the communications link, most contractors see a larger market over the short term for R&D on recoverable, ground-based RPVs. □

RPV control systems

What electronics suppliers are particularly looking for is money for development of a control system for RPVs. Although several, including Motorola's Government Electronics division at Scottsdale, Ariz., are looking for a request for proposals for such a development this year, the Air Force is moving uncertainly. Rome Air Development Center, Rome, N.Y., for example, appears to be taking a piecemeal approach with its recent request for industry interest in exploratory development of a C-band phased-array antenna able to handle 10 to 25 RPVs on five video channels at 20 megabits per second, plus digital data streams of kilobits per seconds.

Based on its selection as developer of the triservice Integrated Target Control System by the Navy two years ago, Motorola believes its ITCS hardware for drone electronics is readily adaptable to RPVs. Robert Seitzberg, Motorola's manager for program and product development for drone electronics. Seitzberg sees RPV control requiring a 200-kHz data link for video and/or infrared sensors, a multivehicle control capability, a "worst case" range of "several hundred" nautical miles, and countermeasures to prevent jamming. Motorola's ITCS award, in part, calls for development of six AN/TSW-10 ground control stations able to handle six drones simultaneously. The Air Force, however, is also supporting Sperry Rand's Univac division in its effort to build on its AN/UPO-3 microwave guidance control system and derive from it a computer-controlled system for simultaneous handling of four to six drones.

It's tough to get lipstick to go where it's supposed to go.

But Clare can help. We understand interface technology and we've designed components to meet your requirements. We know how to pluck the right tube of lipstick out of inventory with an automated system. And we've learned a lot about delicate batch processing. And sensitive power control. No matter what you're trying to do, we know how to design and apply components that help you translate computer talk into reliable processing and control.

Clare engineering keeps pace with your interface problems—and your imagination. That's why we refined and developed mercury-wetted, dry and wetted reed relays—then built the most comprehensive lines available in the industry. We make everything,

from the capsule to the completed relay.

Mercury-wetted relays for low-level analog signals. Clarreed® for standard dry reed applications. MicroClarreed® for subminiature, high-speed performance. Picoreed® relays for high-density mounting situations. All give you fast, reliable performance with total input/output isolation characteristics. All are immediately available in a variety of configurations and combinations.

And if we haven't designed what you need yet, we'll get into that too.

The point is, Clare has the capability to participate with you in interface design, no matter how complex the problem.

We've published a free booklet on interface applications. Six minutes of ideas that may trigger some thoughts for you. Send the coupon for your free booklet, or call your Clare representative directly.



a GENERAL INSTRUMENT company

Circle 53 on reader service card

C. P. Clare & Co., 3101 Pratt Blvd., Chicago, Illinois 60641

Name _____
Company _____
Address _____
City _____ State _____ Zip _____

Consumer electronics

Cooks warm up to microwaves

Home oven sales are beginning to boom in the U.S. and Japan, now that radiation leakage standards have been set and costs reduced

by Lyman J. Hardeman, *Communications and Microwave Editor*

Although the microwave oven won't heat up the kitchen like the conventional electric or gas range, it is becoming one of the hottest-selling consumer appliances, with sales expected to grow faster than 30% annually for the next several years.

U.S. home oven sales are now about 175,000 units a year, and in Japan, more than three times that number are being sold annually. Europe is off to a slower start: no more than 15,000 new units are expected to go into European kitchens this year.

The dramatic U.S. and Japanese growth can be attributed to several factors. First, the fear of biological hazards has subsided since the governments of both countries adopted new standards for the maximum microwave radiation leakage allowed from the oven. Furthermore, aggressive marketing efforts have succeeded in convincing housewives of the conveniences afforded by this

electronic-age appliance. Finally, higher sales volume has sent production costs of microwave cookers sliding down the learning curve.

Three manufacturers dominate U.S. home oven sales. Raytheon's Amana division and Litton Industries' Atherton division each holds about 35% of the market, followed by Japan's Sharp Corp. with approximately 20%. Other suppliers to the American market include Magic Chef, Heath, Thermador, Roper, Panasonic, Mitsubishi, and Toshiba.

All manufacturers have been hampered in their sales efforts because of the microwave leakage scare about two years ago and by the lack of definitive Federal standards to be met by microwave oven manufacturers. Now these problems have been solved (see panel).

The price tag for the average 600-

watt home oven is now in the \$350-\$450 range, down about \$50 from the average of the past several years. In general, however, oven pricing is based on the microwave-power rating and the number of extras, and the highest-price units seem to be selling the fastest.

"We have not found that price is a major factor," claims Verle Blaha, director of engineering at Litton's Atherton division in Minneapolis. Blaha points out that the higher-priced units with added conveniences are the sales leaders. Raytheon, with three standard models at the same list-price levels as Litton, has experienced similar pricing patterns. In the American appliance market, microwave ovens are considered luxury items, and the interested customer is said to be buying the top of the line.

Matsushita's line. Matsushita is one of 10 microwave oven manufacturers in Japan, where 900,000 units are expected to be sold next year—more than double remaining world sales.



Cool cooker. The microwave oven from Litton Industries features an intrusion-proof, see-through door and a two-speed timer. Unit is portable and operates on 110 V.



But while high-priced microwave ovens may now be outpacing the less glamorous models, all manufacturers are keenly aware that volume will bring down prices for all versions. With an eye on mass sales for lower-priced models, the makers are considering engineering reviews to determine how to cut costs. As John Osepchuk, principal research engineer at Raytheon, puts it: "If cost-cutting design studies will buy competitive advantages, they will be done."

But while advancing technology may bring new designs in the future, manufacturers have already established some common equipment characteristics. Although frequencies at 915 and 2,450 megahertz have been allocated for microwave ovens in most countries, virtually all ovens operate at 2,450 MHz, mainly because rf energy is more evenly distributed inside the ovens at this frequency.

Typical home ovens deliver about 600 watts of average rf power, and most are pulsed at about 2 kilowatts at peak, or a duty cycle of from 30% to 40%. Magnetrons generate the required power with a typical efficiency of 60% to 70%.

Production costs of the average oven are now distributed fairly evenly between the ac power supply, the microwave source, and the housing. A chief target for lowering over-all costs is the type of microwave source, since its choice can lead to a cut in the cost of the power supply and the housing. A more efficient source operating at lower voltages would significantly reduce costs of the power supply. At the same time, a microwave source easily coupled to the oven cavity, but immune to rf reflections, could simplify the design of the housing.

Progress is being made in reducing the cost of the microwave source. Magnetron life in microwave ovens has increased from 500 hours to roughly 2,000 hours in the past five years, which has significantly affected sales warranties.

Sweden's largest oven producer, Husqvarna AB, will use a ceramic tube as the microwave source in two home ovens to be announced later this year. The company is considering the U.S. as a future market for the new oven. Cost reduction is a

The microwave hibachi

Many Japanese consumers are going straight from their hibachis to microwave ovens. The average Japanese home uses gas hotplates for cooking. If the home has an oven, it is probably a portable enclosure that fits over one of the hotplates.

Whatever the reason, Japanese microwave oven sales are at least double the total market in the rest of the world. And there aren't even the slightest hints of Japanese demand leveling off.

A Sharp Corp. spokesman says that during the 1972 fiscal year, ending next March, more than 600,000 microwave cookers will have been sold. This is more than 100 times the sales volume of only five years ago. He also predicts sales of 900,000 units in fiscal 1973, 1.2 million in 1974, and 1.5 million in 1975.

There are 10 manufacturers of microwave ovens in Japan: Matsushita Electric Industrial Co., Sharp Corp., Tokyo Shibaura Electric Co. (Toshiba), Hitachi Ltd., Mitsubishi Electric Corp., Sanyo Electric Co., The General Corp., New Nippon Electric Co., Riccar Sewing Machine Co., and Fuji Electric Co.

All manufacturers agree that Matsushita is dominant in oven production, in part because it has the largest number of retail outlets. Matsushita claims to have supplied 35% of microwave cookers sold on the Japanese market in 1971, and the company is aiming for 40% of the market this year. Sharp Corp., which was the first Japanese firm to produce electronic ovens in quantity, is now No. 2, followed by Toshiba and Hitachi. Sharp, however, has almost a monopoly on exports to the United States. Total Japanese exports of ovens were over 53,000 last year.

primary goal of the design.

Browning. Because microwaves alone won't brown the surface of foods, devices such as infrared lamps and resistance heating elements are also being incorporated into ovens. Hirst Electric Industries Ltd., Crawley, England, has developed an oven that uses recirculated hot air. But the disadvantage in many of these browning techniques is that the oven cavity must be

heated, negating the cool-cooking feature, a popular selling point. However, Ken Ishino, chief engineer at Japan's TDK Electronics Ltd. reports that his company has developed a ceramic ferrite dish that will brown foods when placed in a microwave oven.

"The next thing they'll have," one observer comments "is a low-Q steak sauce" to aid in browning meat in the electronic oven. □

A regulatory solution

The Federal radiation safety performance standard, which was adopted by the Bureau of Radiological Health in 1970, became effective last year. The standard requires that ovens emit a microwave field strength not to exceed 1 milliwatt per square centimeter at time of manufacture and 5 mW throughout the life of each unit. Both measurements are made a distance of 5 cm from the oven's surface. A standard with these same provisions became effective in Japan in July 1971.

Another important provision of the U.S. standard stipulates that an oven must have a minimum of two safety interlocks to prevent accidental radiation when its door is open.

The interlock issue is still active. "We are considering upgrading the interlock standard to include a feature such that if one of the interlocks fails in an unsafe condition, then the oven is rendered inoperable and would require a service call for repair," says Walter Gundaker, chief of the compliance branch of the bureau's Electronic Products division.

The American Home Appliance Manufacturers Association considers this added redundancy a "reasonable requirement" and has worked with the bureau to draft specific proposals. "I don't expect AHAM or any of the manufacturers to object to this latest regulatory proposal," predicts Jack Wiezeorick, an AHAM official.

Computers

Terminals enter more classrooms

More U.S. schools are starting to use computer systems as teachers' aids, attracted by lower costs and better programming

by Roberta Schwartz, San Francisco bureau

Computers as classroom teaching tools are becoming more popular as advancing technology cuts their cost and enhances their versatility. The low-cost minicomputer, the development of simpler and easier to use computer languages, and more sophisticated and diverse computer programs are attracting increasing numbers of public school systems toward computer-assisted instruction.

Although the first efforts of GE, RCA and Philco-Ford in the 1960s fell by the wayside, and although IBM has scaled down its education operation considerably, the American institute for Research, Silver Spring, Md., projects that "by 1975 about 35% of the nation's high schools will have computers for education." Already 50% of the high schools across the country have access to a computer for administrative chores.

Coming at a time when tradi-

tional education has not been able to cope with bored students, high absenteeism and large drop-out rates, the computer offers many advantages not previously available. Comments Louis Fein, director of instructional technology in the Palo Alto, Calif. school system, "A single student at a terminal can proceed at his own rate." The computer quickly grades the student, letting him know how well he has done, and provides the teacher with guidelines for rating the student. Self-paced lessons, with no stigma attached to working on a lower grade level, allow the student to feel in control.

Confirming this view, George Perry, an administrative official in the Berkeley Calif. Unified School District, says, "Kids enjoy the computer because it is not so browbeating and damaging to the ego." In addition, Art Freier, mathematics specialist for the Los Angeles city schools, points out that computers are sometimes better than teachers: "Each kid can spend 10 minutes a day in intensive practice, and that's better than five days of conventional work. I've taught in classrooms for 18 years and never was able to get kids to do 10 minutes of serious work like this."

Computer-aided instruction systems are already installed in several places. In the Watts area of Los Angeles, for instance, ghetto children have been using six Hewlett-Packard 2000C minicomputers with 32 terminals for practice and drill work in reading and math. A seventh HP-2000 is available throughout the dis-

trict for math problems solving. In suburban Boston, children from affluent families are using a Digital Equipment Corp. PDP-8 time-sharing system with 13 terminals, eight in the high school and five in three junior highs. And in Palo Alto, 60 deaf and hard-of-hearing children in grades 1-12 are using a Control Data Corp. 7000 time-sharing computer, which is linked by phone lines to three Friden terminals at the elementary school center, and one terminal each at the junior and senior high centers.

One computer specialist likened the vast body of available programming to a cafeteria where the child can select a menu from the varied offerings. In fact, programs have been developed in fields as diverse as vocational guidance, French, biology, English, creative writing, nursing, and mathematics.

What's available. The several educational computer systems available vary in size as well as in purpose. Digital Equipment Corp., Maynard, Mass. offers the EduSystem 10 and 20, which are small systems, built around the PDP-8E. The 10 includes one terminal, a basic language processor, a library of sample programs and textbooks, and 4,096 words of memory at a cost of \$250 to \$350 per month. DEC's total system, the EduSystem 80, which can cost as much as \$1,500 a month, uses a PDP-11 computer with 24,576 words of core memory, a 262,000-word high-speed disk, a memory line printer, paper tape, and four DEC tapes, plus a time-shared Basic-Plus processor, 16 terminals, and an optional 1.2 million word disk memory.

Although DEC systems were first



Electronic tools for teaching. In a Los Angeles school, students use calculators for practice in math.



Communicating. The individualized instruction afforded by computers in the classroom speeds learning and develops ability to concentrate.

used in math courses, their application is expanding considerably. According to the company, problem-solving is a DEC system's most vital job. But a fast-growing area is simulations, where the computer aids students to study, for example, the reaction of atoms to X-ray bombardment.

The system 3000 is Hewlett-Packard Co.'s most recent entry in computer education. It is "multi-lingual" (Fortran, Basic, and other processing languages can be handled concurrently) and may be time-shared among 64 terminals. Core memory is expandable from 32-kilobytes to 128-kilobytes. The first systems will be delivered this fall. Forty of the H-P system 2000 series have been sold. The system can handle up to 32 terminals, uses only Basic, and employs a 2100 minicomputer. The H-P 2000B in the Berkeley Unified School District's program serves up to 400 students in grades 4-6. The cost for the 2000E, the largest system in the series, is \$50,000 or \$1,500 a month and for the 3000 system as high as \$500,000 or \$4,200 a month.

Data General Corp., Southboro, Mass., has five computer systems geared to the educational market, ranging in price from \$8,500 to \$50,975 a month. All are designed around the Basic language. A maximum of 16 users can be handled simultaneously. The simplest, the Seminar 1, is made up of a Nova 1220 computer with 8,192 words of core memory, while the Seminar 5 uses the Nova 800 jumbo computer, which has 24,576 words of core memory. Educational Data Systems, Newport Beach, Calif., and MiniComp Systems Inc., Scarsdale,

N.Y., have built their educational computer systems for elementary and secondary school use around the Data General system.

Also, Univac Corp. has a \$2 million computer-aided instructional network, used for remedial instruction in elementary math and English, installed in Chicago. A Univac central processor with 9,800 words of core memory is hooked on line to 14 schools, each of which has 15 of the company's Uniscope CRT terminals. Basic software was developed by Univac in conjunction with Computer Curriculum Corp., using Assembly and Copi languages.

Calculating on education. The market potential looks so good that some programmable calculator makers are offering much of a computer system's capabilities while slashing costs. Computer Design Corp. in Los Angeles, Calif., has just

introduced its Tutor Computer, a preprogrammed calculator for teaching arithmetic and aiding science students. It sells for \$1,175, or \$995 in quantities of 30.

H-P has recently replaced its 9100 series with two new programmable calculators for education, and more than 100 units are now in secondary schools. The new machines, the H-P 9810 (which sells for \$2,975) and the H-P 9820 (which sells for \$5,475), are used largely for problem-solving in math and the sciences.

Wang Laboratories, Tewksbury, Mass., has also just announced a new low-priced series of calculators for education—the 400 series, which ranges in price from \$900 to \$1,200, including software. The company has been selling calculators for instruction since 1967, and has machines in nearly 800 schools throughout the country. □

Less future

With the aim of extending the computer's educational range, two experimental approaches to computer-aided instruction—CAI—will be investigated over a five-year period with a \$9 million grant from the National Science Foundation. One of them concerns the Ticcit (time-shared, interactive, computer-controlled information television) system, which is being developed by the Mitre Corp., a nonprofit Federal contract research center.

Ticcit uses two Data General Nova 800 time-sharing minicomputers, plus 128 color TVs with headphones and keyboards to turn them into terminals. The courseware is geared to the junior college level. The hope is that decreased costs, achieved in part by using minicomputers, will allow CAI's application in small school systems and even in individual homes.

The second major effort included in the NSF project is dubbed Plato, a highly centralized system. Plato IV uses a Control Data 6400 computer for its extended core storage. Eventually, four central processors will serve as many as 4,000 terminals simultaneously in an 800-mile radius. Each terminal includes a plasma display panel, a random-access slide projector, an optional random-access audio device, and an infrared sensor system responsive to the touch of a finger. By this fall more than 100 terminals are expected to be on line.

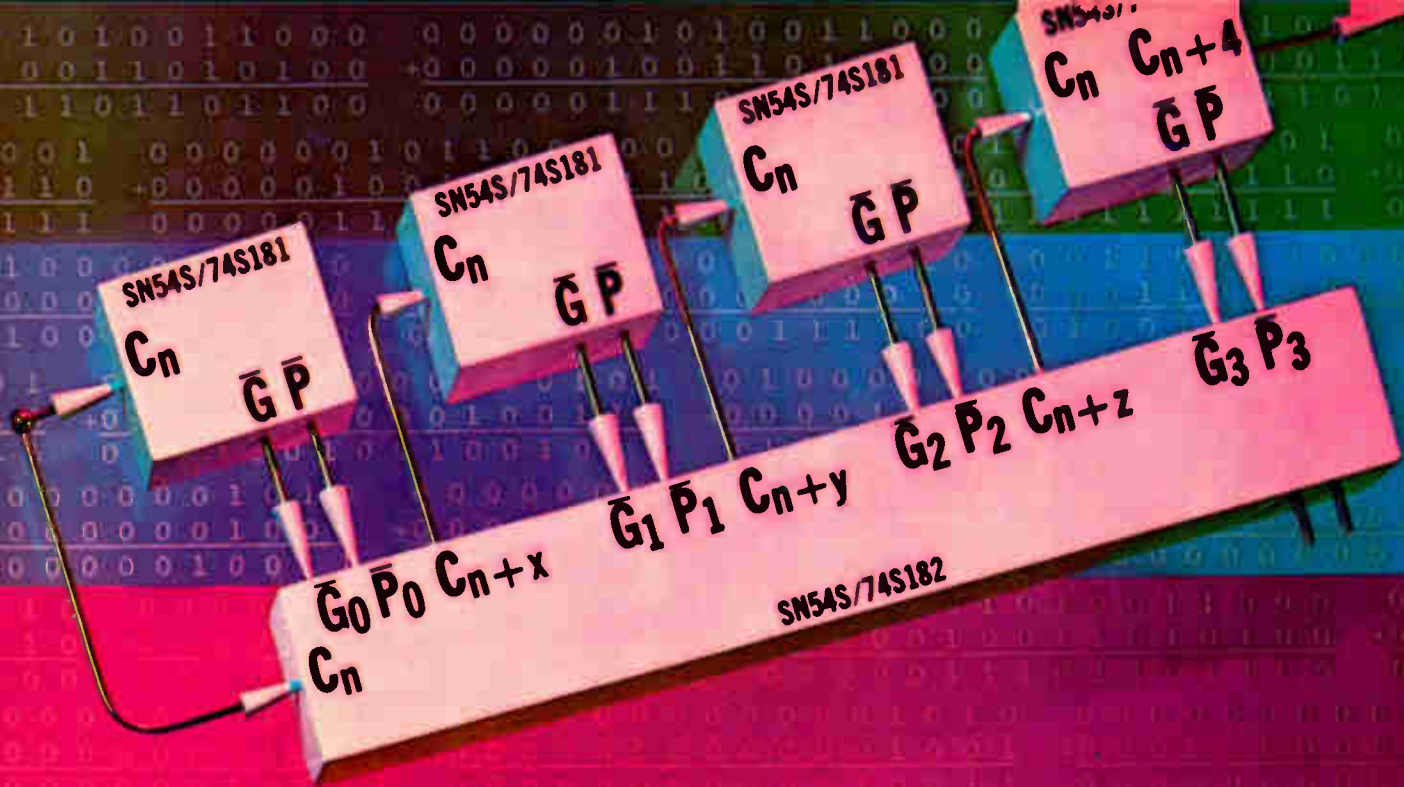

SCHOTTKY

Add 16 bits in 19 ns – with Schottky TTL MSI

The fastest TTL adder/subtractor available is formed by TI's Schottky SN54S/74S181 and SN54S/74S182.

Combined as shown above they add 16 bits in 19 ns.

The S181 arithmetic logic unit, with a complexity of 75 equivalent gates, will perform 16 binary operations on two 4-bit words (or provide 16 logic functions of two Boolean variables). Average internal logic gate performance is 2.0 ns at 8 mW.

The S182 will provide the carry/look-ahead function for up to 16-bit word lengths. Total S182 delay is 4 to 7 ns, depending on logic path.

Upgrade existing designs

The Schottky S181/S182 combination is nearly twice as fast as its standard TTL counterpart (see table). And since they are functionally and mechanically interchangeable, it's easy to upgrade existing system designs.

COMPARATIVE SPEEDS

Bits	Schottky S181/S182	Standard S181/S182	ALU Units	Look- ahead Units
1-4	11 ns	24 ns	1	0
5-8	18 ns	36 ns	2	0
9-16	19 ns	36 ns	3-4	1
17-64	28 ns	60 ns	5-16	2-5

High performance for new designs

For new designs, the Schottky S181/S182 offer speeds comparable to nonsaturating logics (19 ns versus 16 ns, typically, for the same function performed with ECL) – with lower power requirements and much greater design freedom.

Complete compatibility

TI's Schottky line – including the S181/S182, 15 other MSI functions and 19 SSI circuits – is totally compatible with all TTL. Standard, high-speed, low-power, and low-power Schottky. Together,

these TI families offer more than 250 integrated circuit functions with compatible logic levels, voltage swings and noise margins. This enables the designer to optimize the speed/power product of his system.

Full temperature range and package choice

The SN54S/74S181 and SN54S/74S182 are available in both -55° to 125°C and 0° to 70°C temperature ranges...in plastic and ceramic DIPs and flat-packs.

Send for data sheets

For your copy of "New Schottky TTL" which contains data sheets on all of TI's Series 54S/74S Schottky MSI devices, circle 217 on the Service card. Or write Texas



Instruments
Incorporated,
P.O. Box 5012,
M/S 308, Dal-
las, Tex. 75222.



TEXAS INSTRUMENTS
INCORPORATED

The technology gap starts to close for computer peripherals

Semiconductor advances are being combined with new designs to improve the price/performance ratio and operation of gear that has lagged behind the progress in mainframe development

by Wallace B. Riley, *Computers Editor*

□ Mechanical peripheral equipment—bulky, slow, and costly—thus far hasn't benefited appreciably from the onward march of technological improvement that has radically lowered the price/performance ratio of computer mainframes. But a new thrust in the design of peripheral equipment seems to be gathering impetus:

- The advent of low-cost read-only memories has enabled controllers for peripheral devices to be designed around microprograms, thus permitting peripherals to be used more efficiently and economically. In some cases, the capability of controllers has been so enhanced that they are almost comparable to small computers.

- A combination of improved electromechanical and electronic design is now showing up in new low-cost peripherals for minicomputers.

- The first experimental and tentative attempts to replace electromechanical functions by electronic ones are beginning to emerge—while, conversely, new electromechanical concepts are being suggested to overcome the deficiencies of traditional designs.

Microprograms today either provide or are on the verge of providing such diversified services as mixed groups of peripheral devices run by a single controller, sophisticated error-correction schemes, and even limited computation related in some way to data transfer operations.

Meanwhile, new electronics and new mechanics are both heavily involved in such recently announced machines as Data General Corp.'s Novadisc and the series of minicomputer-oriented peripherals that Digital Equipment Corp. has been announcing from time to time.

And many organizations are developing such new memory technologies as magnetic bubbles, charge-coupled devices, and bucket brigades. One or more of these technologies may eventually replace rotating magnetic disks. Meanwhile, other manufacturers are taking a hard look at traditional designs for peripheral equipment—recognizing, for example, that obsolescence is not likely soon to overtake the concept of the unit record, a machine-readable document that can be handled individually, yet machine-processed in bulk.

Peripheral equipment covers a wide range, from the oldest, which seemingly most resists radical improvement, to the newest and most sophisticated:

- Remote terminals, which, with associated data communications facilities, extend the usefulness of high-

speed computation outside the limits of the computer room.

- Printers, which continue to satisfy the desire for permanent human-readable output—sometimes in appalling volume.

- Magnetic tapes, which took over some of the punched card functions, while at the same time serving as an extension of the computer's memory.

- Magnetic disks, which at first overcame the tape's intrinsic disadvantage—serial access. Disks later acquired the major advantage of both tapes and punched cards as storage media—effectively unlimited off-line storage—when they became available in the form of disk packs and cartridges.

- Punched-card machines, which were the first large-scale practical input medium for computers and remain a major one.

This report examines the technological trends that are evident today in these major types of peripheral equipment. Some other types of machines were purposely omitted—for example, paper-tape readers and punches—because although they are useful in some applications, they seem long ago to have reached the limit of substantial technological improvement.

Others, like keypunches, data recorders, and optical character readers, were omitted because they operate wholly or principally off-line. Still others, such as data communications equipment, were omitted because, although they are intimately connected with some aspects of computers and computer peripherals—notably remote terminals—they seem to justify a special report of their own.

Part 1: Bicycle-wheel computers

So many new kinds of peripheral equipment have become available, and so much new capability has been added to them that the computer system's central processing unit today may be likened to the hub of a bicycle wheel. It's there, and it's important, but it doesn't account for much of the system's activity.

In fact, the term "central processing unit" and its synonyms, such as "mainframe," have become misnomers. Many of the tasks formerly reserved for the classic CPU are now likely to be performed by several interconnected processors in a multiprocessing configuration, or network, while other basic housekeeping tasks

are performed routinely by the peripheral devices or their controllers.

Of course, the shift in emphasis has another aspect. It's been made possible by advances in technology that have also vastly increased the capability of the processor, central or otherwise, while reducing its cost. These improvements have resulted in many more instructions per dollar, viewed either as executable instructions per dollar invested or as executed instructions per dollar of operating cost. Either way, the central processor from this viewpoint is more central than ever.

These advances in technology have brought about processors having a wide range of cost and performance; a variety of peripheral equipment is available to serve them. But this variety doesn't span nearly as broad a range in cost and performance as do the processors—which include both giant computers worth mil-

In such configurations, further progress in technology means that controllers can be smaller and less expensive, or alternatively, they can economically take on still more functions from the main processor, leaving it with only the most difficult and broad-based computation tasks.

Functions of a peripheral controller are basically of three types, from the center outward; computation, management, and drive. In some minicomputers, all functions are performed in the central processor, interfering with the processor's main task—processing data. But in larger machines, the driving functions are taken outside—logically, at least, and usually physically, too. These functions translate computer commands, such as READ, WRITE, SEARCH, into specific commands that the particular machine can execute—for example, START, STOP, BACK UP.

In a more sophisticated controller, some management functions may be present. These can begin with error-detecting capability and go on to certain degrees of error correction and even to recognizing certain patterns of errors; from these patterns, the controller may conclude that the electromechanical device being controlled has acquired a serious flaw, and the controller can alert the processor that the device should not be used until the trouble has been repaired. Management also includes organizing blocks of data passed to and from a magnetic drum, buffering a stream of data, and refreshing a cathode-ray tube display.

Finally, some low-level computation, related to the movement of data, can be put in the controller. All this is done to keep the central processor from being tied up by the details of running the peripherals, much as a corporation executive delegates the bulk of his routine detail work to his subordinates.

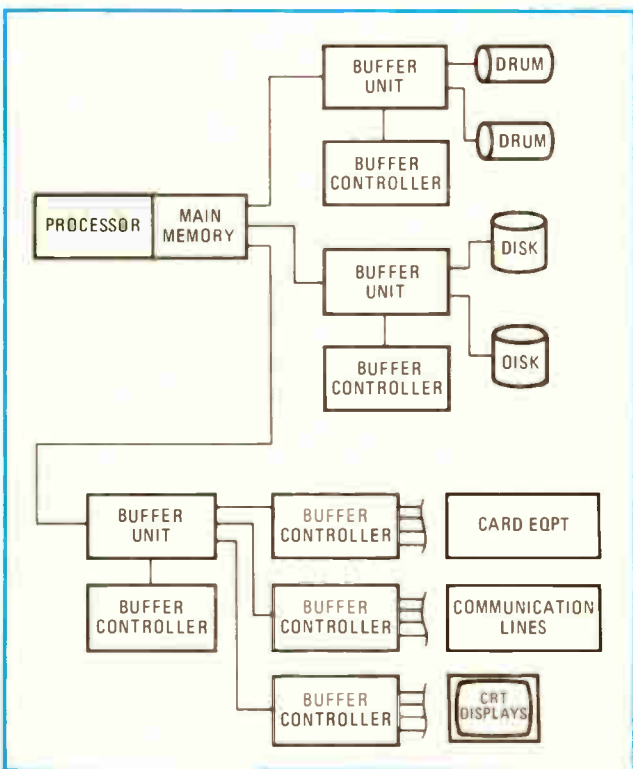

1. Subsidiaries. The most sophisticated example of the use of subsidiary processors to control conventional peripherals is in the giant CDC Star-100, where buffer controllers take over management and low-level computation from central processor. They can process data among themselves, even when main processor is down.

lions of dollars and general-purpose machines selling for less than \$5,000.

Versatility needed

This range presents the problem of how to use essentially the same peripherals at both extremes of processor performance. And most larger systems have subsidiary processors between the central processor—which thereby loses some of its centrality—and the peripheral equipment (Fig. 1).

Part 2: Reliability, cost, performance

Processors, of course, have long since outpaced peripheral equipment, which is still hobbled by electromechanical limitations. The step from cams, relays, and interposers to all-electronic operation—first with vacuum tubes, then with solid-state devices—has opened the door to high-performance computers that could scarcely be imagined as recently as World War II.

But even today's most advanced systems haven't outgrown the need for physical movement of input-output media—a punched card, a reel of tape, a sheet of paper—and this need, as much as anything else, has inhibited the pace of peripheral equipment development.

"This aspect of peripheral equipment will always be present," asserts Robert W. Puffer III, manufacturing engineering manager of Digital Equipment Corp., Maynard, Mass. "So the biggest challenge in design is to do with costs of electromechanical equipment what has been done in the CPU with all-electronic equipment."

While advances in electromechanical design are awaited, large solid-state and magnetic arrays lurk in the wings and may take the place of some present equipment eventually:

- A commercial product based on a completely nonmechanical magnetic technology is on the market now.
- Solid-state random-access chips that will shortly ap-

pear in systems eliminate the need for fast rotating serial-access memories; they've already wiped out an announced solid-state serial-access product.

■ Several organizations are actively engaged in other nonmechanical magnetic and semiconductor technologies with varying degrees of promise.

Cambridge Memories Inc.'s DOTram-4 and DOTram-16 memories [*Electronics*, May 8, p. 141] are based on the company's domain-tip propagation technology (Fig. 2). This nonmechanical magnetic storage scheme has at least the potential of taking the place of magnetic rotating disks, although at projected quantity prices of 0.1 cent to 0.25 cent per bit, it's still many times as expensive as a disk unit.

IBM memory replacement

Today, Advanced Memory Systems offers a 2-million-byte replacement memory for an IBM computer that occupies only a quarter the space of IBM's own core memory for that computer and has an access time about six times as fast. Units like this, using the soon-available 4,096-bit chips, will sell for prices that may wipe out the need for fast drums. Customers are already paying premium prices per bit to get fast transfer rates from such drums, and the random-access capability will eliminate the inherent rotational latency time of the drum. These prospects have eliminated all prospects of reviving the AMS semiconductor storage unit [*Electronics*, Feb. 16, 1970, p. 43], a collection of shift registers that had an access time two orders of magnitude faster than a magnetic drum, but never went beyond pilot production.

Other nonmechanical magnetic and semiconductor technologies being investigated include magnetic bubbles, charge-coupled devices, and bucket-brigade memories; although not yet appearing in commercially available equipment, these technologies have high potential.

"But it'll be a long time before solid-state technology seriously impacts the moving-head disk," says Puffer. "Look at the improvement in performance between IBM's last two major disk storage units, the 2314 and the 3330. What's more, even IBM admits that there is still room for technological improvement in the 3330.

"Storage costs per bit in moving-head disks are still low enough that solid-state technologies won't catch up for many years. They'll cut into fixed-head disks first," concludes Puffer.

Replacement is not imminent

Thus, electrochemical peripheral devices will continue to be with us for some time to come. Within their limitations, low-cost and reliable operation are among the characteristics claiming the attention of peripheral-equipment designers.

For some designers, low cost is the overriding goal—particularly in minicomputers. Users may not balk at paying \$20,000 for a disk memory to use with a million-dollar computer; but they don't like to pay that much when the mainframe costs only \$3,000. The trouble is that, given the present state of electromechanical theory, if the designer is to keep the cost down on any particular piece of equipment, he must be extremely innovative.

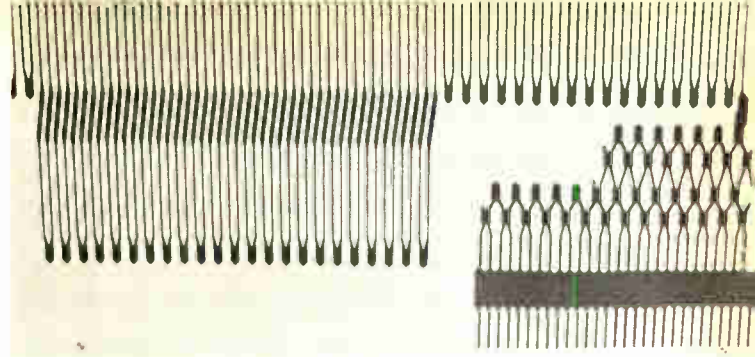

2. Propagation pattern. In Cambridge Memories' DOTram shift register units, magnetic domain tips are driven through serpentine film patterns of magnetic material by an external two-phase field.

But for other designers, reliability is more important than cost; and when working with minicomputers, they rank performance—a combination of capacity, interchangeability, and throughput—in third place. For example, a designer may choose the more expensive of two components or subassemblies if it offers a clear advantage in reliability.

Or, in choosing the data format or storage medium, he may sacrifice capacity and throughput for reliability. Of course, if he knows his job, he won't discount cost as an important factor; he may be able to sacrifice a parameter such as data packing density in favor of a simple mechanism with loose tolerances if it reduces the cost of the machine.

A recent development that increases reliability by an order of magnitude or more is the availability of large-scale integrated circuits with sophisticated error detection and correction circuits. For example, several manufacturers offer a 54/74180 eight-bit odd-even parity checker and generator, and Hamming code generators have also been offered. Circuits like these are inexpensive enough to be used in minicomputers. Previously, such circuits were built only with complex networks of discrete components or smaller ICs, and sometimes they required special software routines, so that they were economically feasible only in the largest computer systems.

Automatic recertification

Another recent development that tends to improve the reliability of peripheral equipment, primarily in larger systems, is automatic recertification. Whenever a unit has been temporarily shut down for the correction of a fault or for incorporating a change, it should be put through its paces before being returned to regular service to make sure that no new bugs were inserted while the work was being done.

In the past, this recertification has had to be done manually by the serviceman. But automatic off-line recertification has been incorporated in some control units for the last couple of years, and in the IBM 3830 control unit for the 3330 disk storage unit, on-line recertification is possible. It notifies the operating system software of any difficulty that it detects when the trouble occurs, and if appropriate, the operating system notifies the human operator. Automatic recertification is part of a routine in the control unit's microprogram. Its operation depends on the fact that the disk unit isn't always busy—that there are short intervals between successive

read and write operations during which the recertification process can be carried out.

There's continuing pressure for higher performance in peripherals, as well as for lower cost. And there's a need to match peripheral equipment performance as nearly as possible to that of the processor that will use it. "A product like the PDP-11/45 computer," says DEC's Puffer, "puts severe demands on the peripherals. You'd degrade system performance seriously if you tried to run a disk having an average 100-millisecond access time on the 11/45; the processor requires something much faster." Normally, with the 11/45, DEC offers a 30-to-50-ms disk cartridge unit for bulk data storage or a 12-ms high-performance fixed-head disk for real-time applications.

Application tailoring

Application tailoring will be the next big step in upgrading peripheral performance. "Today, on channels that normally handle more than one peripheral unit, all the units on a channel must be identical in most systems," says Michael D. Simon, section head, auxiliary storage, at the Honeywell Information Systems Inc. plant in Billerica, Mass. "But not all applications require this. Some could use a mixture of disks of different densities and transfer rates, running on a single controller." Likewise, it would not be difficult to design a single controller to handle a series of tape drives, for example, at different transfer rates.

Today's most popular interface for peripheral equipment includes buffers for absorbing small speed variations and other mismatches between the peripheral and the processor, transmits a whole word or major part of a word at once, as opposed to a bit at a time, and requires an asynchronous "handshaking" between the two sides of the interface. The last term means that every signal transmitted by either the peripheral or the processor is retained at a dc level until the receiving unit acknowledges it with another dc signal—which in turn stays on until the first signal falls at the receiver.

But the trend in the minicomputer industry seems to be toward an interface based on the Electronic Industries Association standard RS-232-C, which defines such criteria as signals and voltage levels for a telephone line connected to a computer. This interface calls for serial transmission, one bit at a time. Because the connection uses only one line pair for half duplex transmission or two pairs for full duplex, "handshaking" is impractical. This interface is already standard for remote connections involving telephone lines and modems; but it's so simple that many designers use it for a local hookup, omitting the modem.

Communications interface

"One reason for the acceptance of the communications interface," says Robert D. Oakley, product manager at Microdata Corp., Santa Ana, Calif., "is that new interface circuits are readily available at low cost. The Western Digital [Corp., Santa Ana, Calif.] TR 1402 seems to be the most popular part for the parallel-to-se-

rial conversion, with buffering and timing, and the Harris [Semiconductor, Melbourne, Fla.] 1488 converts voltages from TTL levels to those called for in the RS-232 standard."

Many of the advances now appearing and soon to appear in peripheral equipment owe their practicality and economic feasibility to microprogrammed controllers. In a processor, just as a program specifies a sequence of operations to be performed, so a microprogram specifies a sequence of steps or machine states required for each operation. Generally speaking, a single microinstruction sets up a route for data along one of several paths within the machine.

Likewise, in a peripheral control unit, a microprogram specifies the sequence of states for the unit's operation, in conjunction with the electromechanical device it controls. In both applications, the advantages are the same—simplified design and operation, a more orderly layout, and less cost.

These advantages are sufficiently recognized today for microprogramming (or "firmware") to have become the rule rather than the exception in processors. And now that the cost of implementation—notably in semiconductor read-only memories—is down, microprogramming is beginning to make sense in more and more kinds of peripheral equipment.

From the user's point of view, microprogramming is valuable because it is the basis of application tailoring—even though, in general, the user himself is denied access to the program. "And from the manufacturer's standpoint, microprogramming permits a simplified common design, around which controllers for a variety of peripheral units can be built at lower cost than if multiple designs were required," says A. B. Ragozzino, director of engineering, Peripheral Devices division, Honeywell Information Systems.

ROMs optimize logic

Microdata's Oakley adds, "Several of our recent controllers use read-only memories for logic optimization. The cost of ROMs has reached a stage where it is the best choice for this job. And our new controller for the IBM Selectric typewriter as an on-line printer uses a ROM for control." Oakley thinks that more of this type of control will appear soon in specialized controllers.

3. Smart terminal. Sycor 340 is a data entry terminal that provides real-time batch processing with a remote computer.



Microdata has led in microprogram control of mini-computers. It's therefore not surprising that the company is improving the cost efficiency of peripheral control through a dual-processor approach. "We've realized that one of the minicomputer's limitations is that it can handle lots of input/output, or fast calculation, but not both at once," says Oakley. So Microdata offers a dual processor system for \$4,995, about \$1,000 less than the price of two separate machines; one of the pair can be dedicated to computation and the other to controlling several complex input-output functions or a large number of medium-speed devices.

Alterable microprograms are beginning to appear also, as the cost of semiconductor read-write memories follows the downward pricing trend of ROMs. However, they are intrinsically more expensive than ROMs and also require a means to prevent accidental or unauthorized alteration.

The usual ROMs are alterable, in a sense, if they are packaged on pluggable cards. They are altered by a serviceman who removes one card and replaces it with a different one. To the objection that this takes time and requires the machine to be shut down, Ragozzino replies, "You don't require this kind of change very often—say once or twice a year. At that rate, changes that take two or three minutes, or even two or three hours on site, are quick."

Part 3: Remote terminals

Perhaps the most remarkable growth in any field of peripheral equipment in recent years has been that of the terminal. It may be a cathode-ray tube display, often with some accessory equipment, and sometimes it's merely a Teletype; however, at the other end of the scale is the remote-batch terminal, which is most likely a small general-purpose computer.

Terminals have benefited enormously through adaptation of semiconductor technology advances, which enables the terminals to perform various degrees of local processing, thereby reducing the time they must be connected to host computers. This partial processing capability is termed "smartness." Microprogramed chips have been of particular value in performing routine repetitive processing tasks at minimal cost.

Through an on-line real-time terminal, the user can interrupt the computer (via one or more stages of line concentrators, buffers, and communications controllers), insert his program or data, and get his reply within a few seconds. Operation can be interactive; that is, the user and the computer can "converse" with one another.

On the other hand, the remote-batch terminal is simply a mechanization of the classic batch-processing computer. The remote batch terminal reduces substantial overhead cost of maintaining interaction with the computer. The user loads his entire program, in the form of a deck of cards, a reel of tape, or other medium, into the terminal, which then transmits the entire program over a telephone line to the processor. There it is buffered on a magnetic drum or disk, loaded into the computer when its turn comes, and executed. The processed output returns to the user, frequently in only a

few minutes, via the reverse route.

In its simplest form, neither the terminal itself, nor its control unit contains any electronic circuitry beyond that required to drive the CRT or other output medium, to refresh a CRT image, and to receive and transmit data over a communications line. Both the terminal and its controller are "dumb."

The dumb terminal

The earliest remote terminals were of this dumb type—like the ubiquitous Teletype machine, which was adapted from its original use in communications networks. Even IBM's 2260 CRT display and its controller—originally designed as a computer terminal—are dumb because the terminal relies on the computer for all processing. Some successors to the 2260, however, have acquired some smartness.

"There remains a place for these terminals," says Guy Mallery, director of sales for Incoterm Corp., Natick, Mass. "Teletypes, for example, are still going strong; they and their successors will probably continue to do so for a long time."

A dumb terminal with a smart control unit is exemplified by what Digital Equipment Corp. has been offering for some years—its PDP-8 computer with one or more terminals, acting as a front end for another system—a larger DEC computer or another type of machine altogether. DEC's recent move into communications equipment as a major part of its business [*Electronics*, June 19, p. 44] indicates how important this kind of terminal can be.

Implicit in interactive operation is the transmission of alphanumeric data only. But the graphic data terminal, with or without interaction, is another important class. For example, Tektronix Inc., Beaverton, Ore., has a series of graphic terminals based on its storage tube. Each model comes with a keyboard that permits interaction by using alphanumeric data; for graphic data input and graphic interaction, a joystick, which controls the position of a cursor on the screen, is optional at extra cost on any model.

None of the Tektronix terminals can be considered smart; because the storage tube contains its own memory, no external memory or associated logic is necessary. "Our terminals can be used with minicomputers as inputs to a time-sharing system," says Morgan Howells, marketing manager for information display products at Tektronix. "But our customers design their own systems; we don't offer them."

The smart terminal

What is a "smart" terminal? Samuel N. Irwin, president of Sycor Inc., defines it as a general-purpose computer with a program, a means to store data, a collection of peripheral equipment—the classic computer as first conceived in the 1940s by John von Neumann, the mathematician. Almost every computer is built around this concept. But the terminal is optimized toward economy and a good man-machine interface.

A smart terminal does less than a total data processing job, but it can at least reformat the data and accumulate it on a cassette or other storage medium. If directions for these simple tasks are wired in, the terminal

SPECIAL REPORT

is a little less than smart. But if they are programed, and therefore easily changed, and if the terminal can also be programed to perform some other routine tasks, the terminal is smart. The more functions it can do under its own program control, the smarter it is.

"Computer people are a little scared of smart terminals," says Herbert E. Schmitz, manager of system development at Sanders Data Systems. "They're worried about a terminal doing something not coordinated with the central processor." Because smart terminals take over jobs formerly done only by the mainframe, such as preparation of data, the natural division of labor between central processor and terminal threatens to disappear. Schmitz admits some of the worries are justified—the terminal could modify a file or program in the mainframe, for example. But it can also take job loads off the mainframe, and therein lies its value.

Schmitz described the Sanders Can Do unit as smart enough to be used as a self-contained business system, maintaining a data base in a disk memory. It can be used off-line during the day, storing data entered, and become a remote batch terminal at night, transmitting the stored data to another computer. In other cases, the terminal can handle both data entry and inquiry. "Both are simple 'put' and 'take' functions, but they are different, from the point of view of the operator," says Schmitz.

Incoterm's stand-alone unit can function entirely by itself, because it contains a small general-purpose computer in the same box that houses the CRT display. Other units on the market also have considerable capability in one box—including the Sycor 340 (Fig. 3) and Computer Terminal Corp.'s Datapoint 2200.

Terminals get smarter

In what way are smart terminals getting smarter? By becoming more and more easily programable, says Irwin. "The user knows his job better than anyone else, so he's in a better position to do the programing," he says.

Programing ease is directly related to the availability of semiconductor memories, in Irwin's opinion; whereas programing wouldn't be feasible with a core memory in a terminal, he says, because a core memory of the proper size is too small to be economically manufactured. He points out, "A core memory's cost is approximately proportional to the square root of its capacity; whereas a semiconductor memory's cost per bit is almost constant, regardless of the size of the array. On the other hand, a semiconductor memory has to have a tape cassette or other backup device handy to restore its contents if power fails."

Incoterm's Mallery disagrees with this viewpoint. "We use a core memory, capacity 4,096 bytes, cycle time 1.6 microseconds," he says. "Semiconductor memories can't match this speed at this price; but it's fast enough for the terminal. Besides, we install our terminals in the uncontrolled business environment, where a spike or momentary outage on the power line can wipe out the contents of a semiconductor memory."

Within this framework, Richard Heiman, director of

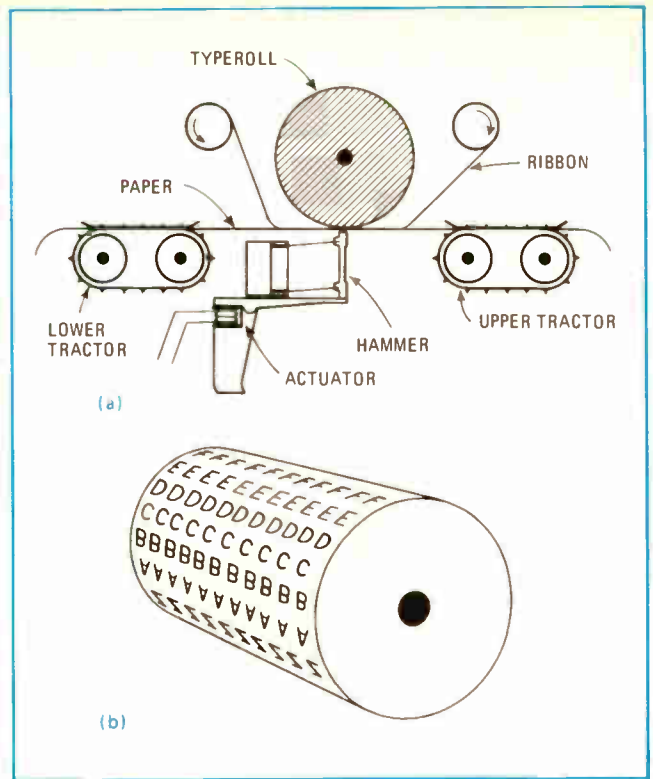

4. Drum printer. One complete alphabet, including numerics and special symbols, is spaced around rotating drum; alphabet is repeated in full for each printing position on the page—often up to 132 character positions per line. To print any given character, the actuator in that printing position pushes the hammer against the paper just as the character is passing on the other side.

product development at Incoterm, sees a different trend: "Distributed processing is the coming thing. We can add a disk storage unit, a tape cassette, and other equipment to our terminal, so that we can work with a local data base. We can't do much manipulation without access to a large machine. But in the long run, as ICs get cheaper, terminals are becoming more and more powerful."

"When we began this company," says Irwin, "we saw very large powerful computers coming into use by 1975, and we saw there would be a need for a way to get into these machines. Remote computation would be common, but users would still need batch processing."

Irwin sees a need to control four problems in obtaining access to a large computer: communications cost, channel cost, human operator discipline, and the input/output medium. "Communications cost is important because one shouldn't spend \$5 on a telephone call to get the answer to a 10¢ question," he says. Channel cost is important in the sense that the number of interrupts to the main computer must be minimized, because each of them takes time out of the main computer's work and impacts its performance. Human operators, although they are a necessity, shouldn't become so much a part of the process that it suffers when an operator isn't feeling well or is tired, or just doesn't show up one morning. And the medium is important as potentially another step in complexity or cost between the problem and its solution.

"We concluded that only a computer can optimize all

four of these problems—that the terminal should itself be a von Neumann machine,” says Irwin.

But he doesn't necessarily see a trend away from batch processing. On the contrary, in some applications he finds the 24-hour turnaround characteristic of batch processing is satisfactory. “When we speak of remote computation,” he says, “we mean organizationally remote.”

For example, with a smart terminal and with a job that can be done overnight, the job can be entered into the terminal in one format, the terminal can repack it and forward it to the central computer in a way that is both more efficient in its use of the communications facilities and better suited for the central computer's processing. Then the terminal can receive the output in the same way, reformat it again, and present it to the user in the morning. A terminal with a tape cassette, either built-in, as Sycor's is, or externally connected, is particularly good for this purpose.

Part 4: Printers

Printers, in general, are of two types—impact and nonimpact. Both kinds come in either serial (character-at-a-time) or line forms; line printers, of course, have a much greater printing capacity, but are also much more expensive.

Impact printers range from the lowly but almost indestructible Teletype machines, chugging across the page at a maximum rate of 10 characters per second, to high-speed chain printers, which churn out up to 2,500 150-character lines per minute.

Many impact printers, particularly the faster ones, are prone to breakdown, and most of them are noisy. But they remain in demand because they can make multiple copies.

For the most part, there remain only two kinds of line printers—the drum printer and the chain or train printer. Today's fastest printers are usually chain printers, but drum printers cost less.

The drum printer contains a horizontal cylinder with rows of printable characters arranged around its circumference—one row for every printable column (Fig. 4). Opposite each row, behind the paper being printed on, is a hammer that momentarily presses the paper against one of the characters as the drum rotates. Electronic control circuitry keeps track of the position of the drum and fires each hammer forward at the proper time to intercept the desired character as it passes the printing position. One line is printed during each revolution of the drum; one printing decision is made for each hammer during the revolution.

The chain printer

The chain printer contains a series of alphabets on a chain or belt, or along an oval track, opposite the printing line (Fig. 5). As with the drum printer, hammers behind the paper momentarily press it against the appropriate characters at the right time. The controls for this printer are more complex than those that are used for the drum because they must make many print/no-print decisions for each hammer during the printing of one line, although no hammer is actuated more than once

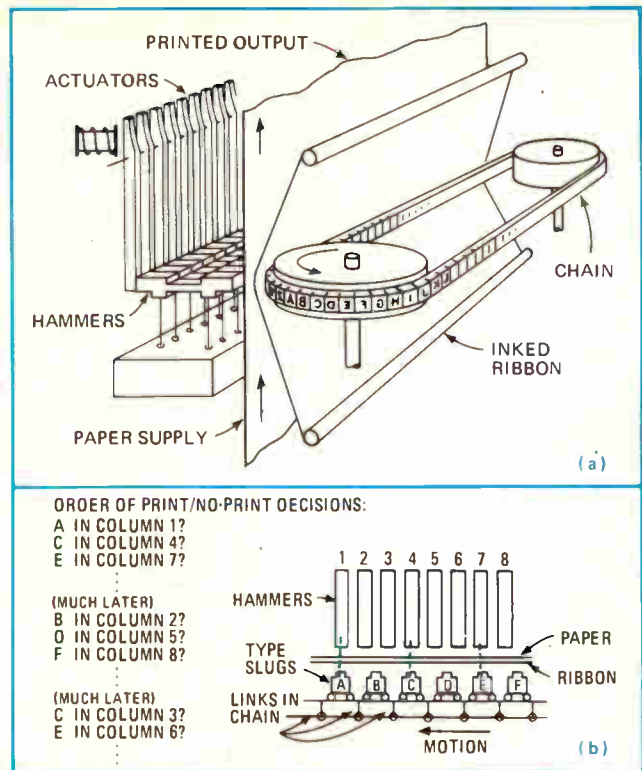

5. Chain printer. Several complete alphabets are repeated along the moving chain; every printing position in a line is presented at least once with every character in the alphabet during a print cycle. Printing a character involves driving the corresponding actuator slightly ahead of time, as in the drum printer; but character slugs are so spaced that no two actuators work simultaneously.

per line. Characters in the chain are spaced slightly farther apart than printing positions, so that no two hammers must fire at exactly the same instant—although in general, two could fire only a few microseconds apart.

There is a distinct performance gap between teletypewriter-like serial printers, with speeds up to about 30 characters per second (Fig. 6), and full-scale line printers, none of which costs less than about \$10,000, even at the slowest speeds, which are around 100 lines per minute.

Pressure to fill this gap is coming from the rapidly growing minicomputer market. Minicomputers are fast enough to be good for many applications, and they're now available for only a few thousand dollars. “They need a faster-output printer, but one that is much less expensive than even a slow line printer,” says Steven Kaczeus, inventor of the 100-character-per-second serial printer, the Printec 100, announced by Printer Technology Inc., last fall.

Another factor pushing the development of faster serial printers is the rapidly growing interest in remote access to computers, with the consequent need for terminal facilities to permit this access. Charles J. Barbagallo, director of engineering at Honeywell Information Systems, Lawrence, Mass., says “Serial printers are proliferating because they are badly needed in conjunction with the present explosion of terminals. Users need devices alongside their terminals to produce low-cost hard copy.”

Most slow printers, like the familiar Teletype, have

SPECIAL REPORT

cylindrical or spherical printing heads that twist, turn, and bob up and down to put the correct character opposite the printing position at the right time. In some, the head moves up against the paper; in others a hammer pushes the paper up against the print head from behind to make the impression.

For speeds above 15 characters per second, printers generally use one of two approaches: a series of pins selectively driven against the paper, or a wheel with the printable characters arranged around it in a helical pattern. The pins print characters in the form of dot matrices; they are mounted in a print head that moves intermittently across the paper.

In the wheel version, as the wheel spins, it travels across the paper, driven by a lead screw that has a pitch equal but opposite to that of the helical pattern of characters on the rim of the wheel. This causes all the characters to remain aligned with a particular print position during a full revolution of the wheel, and then to move abruptly to the next print position as the next revolution begins. There is usually a short angular gap on the wheel between the last character and the first to allow the impacting mechanism to settle when both the last and the first characters are to be printed in those adjacent positions.

Servo operation

Servo control is beginning to appear in various kinds of peripheral equipment; in printers, it promises extremely accurate control of the printing element and of paper feeding. For example, Diablo Systems Inc., a subsidiary of Xerox Corp., uses servo control in the Hytype I printer. The machine (Fig. 7) attains a printing speed of 30 characters per second with only nine moving

6. Fast impact printer. Digital Equipment Corp. DECwriter prints dot-matrix characters at a rate of 30 per second.

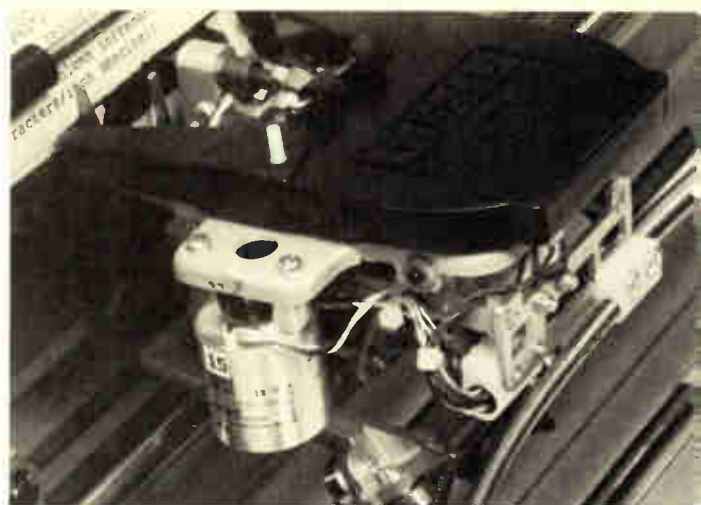

7. Servo-controlled printer. Diablo Hytype model 1200 has 96-character alphabet, prints left-to-right or right-to-left, feeds paper up or down, with variable character or line spacing, to produce a high-quality printout quickly and quietly.

parts. Similar servo controls appear on other types of equipment—such as the head-positioning mechanism in IBM's large 3330 disk storage unit. "The servo unit is fast, and it's accurate," says Honeywell's Barbagallo, "and it's becoming economically feasible, now that the necessary electronic circuitry is inexpensive enough to make the servo pay off." Barbagallo adds that the cost will fall even further when production builds up to sufficient quantities. He concludes that a market of impressive size will appear for such equipment when point-of-sale terminals—electronic on-line cash registers—become generally available.

Sanders Data Systems uses several different types of printers in various models of its CRT terminals. A Sanders spokesman says, "The impact market has been proliferating for the last 18 months—first with a reduction in price, then with attempts to maximize speed without significantly increasing cost. Most importantly, impact printers are getting more reliable and less costly to maintain, but there is still vast room for improvement."

Printing without pounding

Nonimpact printers are generally quieter and potentially faster than impact printers. They include electrostatic, thermal, inkjet, and magnetic types.

An electrostatic printer has needles to deposit electric charges on the paper in the pattern to be printed; these charges attract powdered toner, which is heat-set to form the finished image (see Fig. 8).

A thermal printer uses heat to darken treated paper; the print head usually contains a number of tiny heating elements that have temperature rise and fall times rapid enough to permit printing at reasonable speeds.

An inkjet printer sprays tiny drops of ink toward the paper through a nozzle that places an electric charge on the ink as it passes; the droplets pass deflecting electrodes, charged to vary ink patterns, causing the jet to "paint" alphanumeric characters or other images on the paper.

At least one electromagnetic printer has been designed [*Electronics*, June 5, p. 48] that is the magnetic

analog of the electrostatic printer; however, it has an intermediate stage of magnetic tape on which the image is formed before it is transferred to the paper.

Steve Kaczeus sees a definite market opening up for nonimpact printers—even as his own company is getting underway with a fast impact printer. “In another five years, the nonimpact printer will be the standard machine,” says Kaczeus. “Today, these machines need special paper, or print only dot-matrix characters with their limited legibility, or are limited to single copies. But eventually these drawbacks will be overcome.”

To back up his optimistic outlook on nonimpact printers, Kaczeus cites a recently issued patent for a machine capable of multiple nonimpact copies. It burns dot-matrix characters through the appropriate number of sheets with series of tiny electric sparks.

“The biggest advantage to nonimpact technology is its reliability,” says Kaczeus. “Today’s best impact printers—even including the Printec-100—have a mean time between failures of about 1,000 hours. With almost any nonimpact technology, this could be made 10 times better.”

A frequently cited problem with nonimpact printers is the high cost of treated paper. But this problem has already been licked, in the view of Honeywell’s Barbagallo. “What’ll really bring nonimpact printers into the picture is their enormous output capability,” he says. “That’ll reduce the question of impact versus nonimpact to one of system requirements versus cost.”

“But remember that volume capability of the nonimpact printer doesn’t necessarily improve system performance,” warns Michael Simon, also of Honeywell. “It just gives you more volume on-line if you need it for any reason. It’s a matter of cost. It may often be cheaper to put the data to be printed on magnetic tape, then use a tape-to-printer conversion off-line.”

Part 5: Magnetic tape

Peripheral backup storage devices include magnetic tapes and disk units, plus a few unconventional designs that are not likely to proliferate in the near future.

Magnetic tape devices have a longer history. They were first designed as a way to provide a more compact storage and input-output medium and a faster data transfer rate than punched cards, but they quickly became a convenient means of archival storage. Many computer installations still have vaults full of these old, slow tapes, and read data from some of them perhaps once or twice a year; for that reason, all recent tape drives, except for the highest-performance models, still can be operated at the old 200 character-per-inch, 75 inch-per-second rate when necessary.

But magnetic tape has one serious disadvantage: purely serial access. If a user needs to consult a record that happens to be wound near the center of a reel of tape, he must read the entire length of tape from the outside in before he can read the record he wants. Therefore, jobs to be run on tape-oriented computer systems require the records to be gathered in advance, sorted, and batch-processed, taking related data off the tape in order as the tape unwinds. Jobs requiring random access to previously stored records cannot be run

efficiently when the records are stored solely on tape.

Two forms of magnetic tape are of most interest today: the standard reel that is ½ inch wide and 2,400 feet long, and various forms of cassettes and cartridges intended for use with inexpensive low-speed systems.

The standard tape reel carries nine longitudinal tracks of data recorded at packing densities of 800 bits per inch in NRZI code or 1,600 bits per inch by phase encoding. Data is recorded in parallel on the nine tracks, eight of which carry information and one of which carries parity bits. An older standard reel of the same dimensions, but with only seven tracks, is still in use. Densities are 200, 556, and 800 bits per inch, all NRZI. The most important difference between the two standards, besides density, is the spacing between the tracks, requiring differently built read-write heads; these are not ordinarily interchangeable.

Tape drives move the tape at speeds from 37½ to 250 inches per second. With the two standard nine-track densities, these speeds produce data transfer rates from 30,000 to 400,000 characters per second, read in parallel from the nine tracks.

Phase encoding increases

There has been a substantial increase in recent years in phase-encoded magnetic tape. Before that, however, the practically universal standard was NRZI, which stands for non-return-to-zero.

In NRZI, a binary 0 produces no readback signal: long strings of 0s therefore can create timing problems. Furthermore, a long string of 0s can’t be distinguished from a loss of signal caused by a flaw in the tape. Another difficulty is that, at high densities, the readback signals tend to overlap one another, creating the appearance of variations in timing.

Phase encoding overcomes all of these problems. A

8. Electrostatic printer. Gould 4800 printer/plotter can produce up to 3,000 lines per minute of either alphanumeric or graphic material, with hardly any noise. It can run concurrently with microfilm unit.



SPECIAL REPORT

readback signal is always present, regardless of the data pattern; only a serious tape flaw can make the signal disappear. And because the signal is always present, the overlapping at high density is constant, so that the timing doesn't appear to vary (at least not from this cause).

A number of variations in phase encoding have been proposed at one time or another and sometimes put into use. The alternatives usually reduce the number of intermediate transitions in some way, as a function of the encoded data, or they otherwise simplify the electronic circuitry required to translate the readback signal into a form intelligible to the processor.

Controller functions

Among the specific functions of the tape control unit are the following:

- Translating data to be written from the computer code into a different series of signals; these, when amplified in the drive, send current through the write coils in the head in the proper pattern to create the desired flux changes on the tape.
- Decoding a binary-coded address into a signal on a single line that selects a particular drive from eight or more connected to a controller.
- Translating data read from the tape from its complex recorded waveform into digital signals. (In some newer machines, this is done in the tape drive instead of the control unit.)
- Dynamically correcting the delay that occurs in the signals from some tracks relative to those from other tracks—as the delay and tracks involved are continually changing. These delays occur because it's practically impossible to guide the tape perfectly straight across the read-write head or to correct for all electrical and mechanical irregularities. Overlapping of high-density NRZI signals is also a cause of these delays.
- Detecting, and in some systems correcting, errors in the data as it is read.

Were the drives designed to perform these functions directly, each would effectively require its own control unit—an expensive proposition. Therefore, the functions

are incorporated in the tape control unit as a separate entity.

Tape control units, incorporating more functions and more sophisticated operation in successive designs, have become more and more complex, acquiring increasing capability until now they are virtually small computers themselves. Advances in electronic technology, with corresponding reductions in cost, have made this possible, just as with other peripherals. The use of microprograms in control units is one of the more important of these advances.

Storage Technology Corp., Louisville, Colo., claims it was the first to introduce a tape control unit with a microprogram. Its first control unit, which was compatible with IBM's on both the drive side and the channel side, was nevertheless only half the size of IBM's, thanks in part to the use of microprogramming. "All manufacturers are using microprograms now," says Thomas S. Kavanagh, director of special programs, "although not all of them have delivered microprogramed units yet."

STC matches both of IBM's usual packing densities, which have achieved the status of de facto standards: 800 bits/in., NRZI, and 1,600 bits/in., phase-encoded. STC has also recently introduced a new noncompatible model that records phase-encoded data at 3,200 bits/in. At this high density, with the tape zipping along at 250 in./s, the transfer rate is 800,000 bits/s—comparable to that of IBM's biggest disk storage unit, the 3330. For serially organized files, the new tape actually outperforms the 3330 because it doesn't have to seek data from track to track and it never has to wait out the disk's rotational latency time.

This may be a straw in the wind. Clifford Leath, product manager for tape memory products at Ampex Corp. Computer Products division, Marina del Rey, Calif., says, "3,200 bits/in. density is coming, but there's no market for it now. There's no market in the computer industry until there's a standard for information interchange, and only IBM can set that standard. It doesn't even care what ANSI [American National Standards Institute] does. I think IBM will offer 3,200 bits/in. when it's ready to do so; there are no big problems involved in it." In general, Leath feels that changes in magnetic tape subsystems are evolutionary, gradually

CASSETTE AND CARTRIDGE COMPETITION

	Tape Width	Tape Length	Cartridge Dimension (in.)	How Driven ¹	Encoding ²	Density bits (in.)	Tracks
3M	1/4 in.	300 ft	4 x 6 x 0.665	Band	PE	1,600	4
Digitronics	0.15 in.	190 ft	3 1/4 x 3 5/8 x 1 1/16	Cap	MPE	Up to 1,600	2
IBM	16 mm	35,100 or 120 ft	4.2 x 4.2 x 1	Spr	RB	20	9
Teletype	1/2 in.	100 ft	3 x 3 x 1	Cap	MRB	125	9
Philips	0.15 in.	300 ft	4 x 2 1/2 x 1 1/2	Cap R-R	PE	800	2

¹ Cap = capstan; Spr = sprocket; R-R = reel-to-reel; Band (see text)

² PE = phase encoding; MPE = modified phase encoding; RB = return-to-bias (+saturation = 1, -saturation = 0); MRB = modified return-to-bias (-saturation = 0, demagnetized = 1)

producing better performance for less money and, with features like automatic loading, more convenience.

Drives connect radially

Another innovation now appearing on many tape subsystems is the radial connection between the control unit and a number of tape drives (Fig. 11). The radial connection replaces the traditional "daisy-chain" connection in which the drives are connected in a serial string, with the control unit attached at one end and a special line-terminator block in lieu of additional drives at the other.

Although the change is not itself technologically significant, it indicates a significant change in the way tape subsystems are used (as well as a substantial increase in cost). With the daisy-chain connection, reading or writing on any drive in the chain effectively isolates all the others for the duration of the operation; and if one drive in the chain malfunctions, it cannot be removed from the chain even momentarily without shutting down the entire system long enough to disconnect and reconnect the cables.

But newer systems often provide advanced levels of multiprogramming or serve remote users through teleprocessing, so that even a brief shutdown is intolerable. And with multiprogramming, tapes are often switched from channel to channel on different interconnected processors, which requires an independent path to every drive. The radial connection provides this independent path, and it also permits individual drives to be taken off-line for maintenance without disturbing other drives or the rest of the system.

Controller in mainframe?

It might seem logical for IBM to introduce a new computer having the tape control unit integrated with the processor circuitry instead of in a separate housing; after all, within the past two years the company has integrated a disk control unit and a communications adapter. (Although those moves were almost certainly market-oriented rather than technological—they confounded competitors making IBM-compatible equipment—the integration would not have been possible without improved technology.) But an "integrated tape adapter" isn't likely, because there's a big market for multiple controllers that perform tape switching, and integrating the controller with the processor would hamper the tape switching interconnections.

On the other hand, an integrated controller for tape, as well as more deeply integrated controllers for disk and communications, would enhance the speed of the system as a whole because it would eliminate cable delay. "I see a general trend toward moving the electronics inside the main box and leaving just the mechanical assembly outside," says J. Garrett Fitzgibbons, president of MRX Sales and Service Corp., the marketing and service subsidiary of Memorex Corp., Santa Clara, Calif.

Fitzgibbons believes IBM would be motivated to do this by the encroachment of independent peripheral-equipment manufacturers upon IBM's markets. "So if IBM turns the peripheral device into a strictly mechanical part and moves all the electronics into the main box,

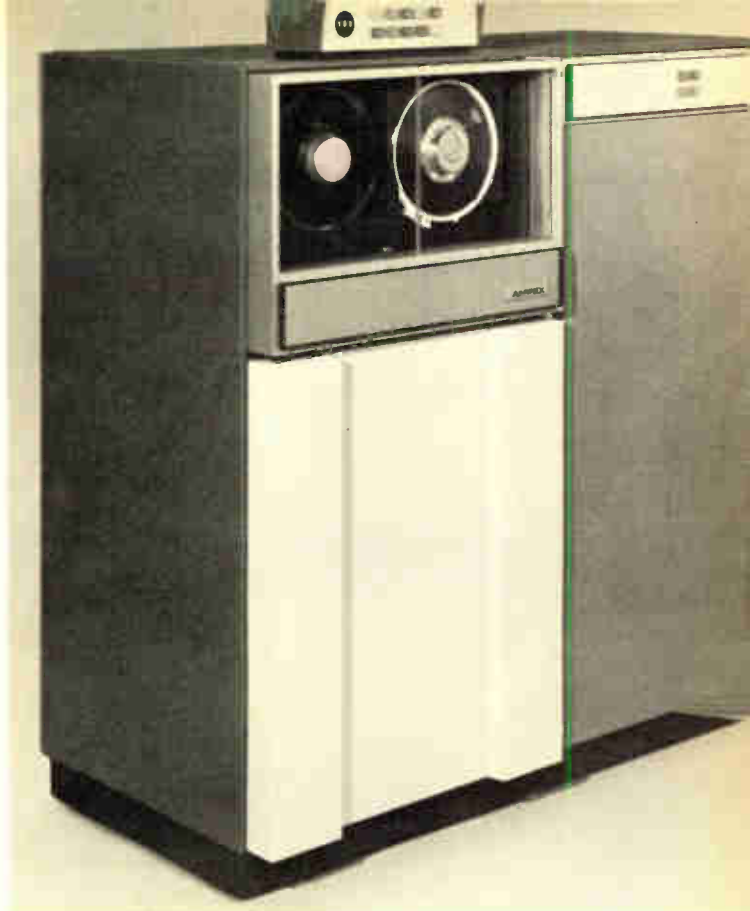

9. Tape drive and controller. These Ampex products, plug-to-plug replacements for IBM equipment, feature easy maintainability through front panel. IBM drives require access from the rear.

it will be tougher for the others to produce the peripherals more cheaply than IBM, because of IBM's ability to tool up for very long production runs."

Fitzgibbons believes that the economics of the entire computer market is to "do it the IBM way," because IBM has such a large share of the market. "Every time someone tries to do something different, he is doing it wrong," says Fitzgibbons.

Cassette data storage

Digital cassettes and cartridges offer low-cost, convenient data storage for minicomputers and remote terminals. But, although there's been a lot of publicity about cassettes in the last couple of years, they're not as widely used as this publicity suggests. If they were, market pressures would oblige their makers to adhere closely to standards: but most makers don't.

The word "cassette" usually implies the unit introduced some eight years ago by Philips Gloeilampenfabrieken for portable audio tape recorders. But digital cassettes are much more precisely and ruggedly constructed than audio units, even though externally, they look quite similar.

Because the cassette was a European invention, the first attempt at standardization was made by the European Computer Manufacturers Association (ECMA), which published a specification some time ago. This specification has been picked up by ANSI, through the International Standards Organization (ISO), with which both ECMA and ANSI are affiliated. ANSI's version isn't

SPECIAL REPORT

yet an official standard, but it's been widely circulated and has the status of a de facto standard, somewhat like the standards that exist because they are IBM specifications.

But people aren't paying much attention to this de facto standard, especially in the United States. Everyone in the digital cassette business is new at it, and for most of the applications that use digital cassettes, interchanging them among machines of different manufacturers isn't a factor in their use. These conditions don't bring pressure on any manufacturer to adhere to any standard, de facto or otherwise. However, most vendors insist they are in the cassette business to stay, and as the use of cassettes increases, pressure for official standardization and adherence to standards will increase.

"Bell and Howell follows the ANSI standard, such as it is," says Kurt R. Peterson, product manager in that company's Electronics and Instruments group in Pasadena, Calif. "But, for example, some of our competitors depart from the density and speed specifications of the standard in order to tighten up their designs in certain ways, and thereby to reduce their own costs.

"Still, standardization will be required in time," Peterson continues. "Big companies will start using cassettes in large quantities; they'll demand standardization because they'll refuse to get stuck with a single manufacturer for their machines."

Other than standardization, most companies in the cassette and cartridge business, striving for improved reliability and lower cost, are finding plenty of room for immediate improvement in both areas. The newer equipment performs many functions electronically rather than mechanically. Since the trend in costs for electronics is consistently downward, transports are sure to become less expensive and more reliable.

Designs vary

Although many of the cassette drives resemble audio recorders in that they use external capstans to drive the tape at a constant speed, some newer designs have gone to direct reel-to-reel drive, with various electronic stratagems to control the speed, tape tension, and other variables. Other designs that use reel-to-reel drive don't try to control the speed; instead, they compensate through sophisticated electronic circuitry for the inevi-

10. Substitute. In this System 360/model 40 installation, Ampex tape drives are connected in place of IBM equipment and provide equivalent performance at a price approximately 20% below IBM's.

table speed variation as one reel increases in size and the other decreases.

If the data is recorded in one of several forms of phase encoding, it'll stand speed variations better than NRZI can. Furthermore, if a phase-locked loop is incorporated in the motor control of an inexpensive mechanical drive, the speed will be nearly constant, and the cost is much less than that of a high-precision drive that has constant speed assured by mechanical means.

"The key to cassette reliability," says Joseph E. Godbout, a systems design engineer at Data General, "is how the tape moves outside the cassette. For that reason, the drive should be a simple device that can compensate for mechanical wear." Reel-to-reel drive is simpler than cassette drive, and the electronic circuitry should be able to compensate for the large speed variations that occur as a result of changing reel sizes as the tape moves. Mechanical simplicity is also likely to produce velocity oscillations during the first few milliseconds after the tape starts moving; electronics can compensate for this also, at lower cost than refining the mechanics, in Godbout's opinion.

Bell and Howell's Peterson agrees with Godbout, in that the cassette itself offers a poor guide for the tape. "The tape should be pulled out of the cassette and guided externally," he says. This, in turn, means that the drive can't be too simple. Peterson cites the Bell and Howell model 240 cassette drive (Fig. 12), which has a pair of fingers that pulls the tape out of the cassette and drops it into a 180° loop around the capstan. The tape is driven only by friction: strain-gage sensors measure the tension in the tape and control the reel motors to keep the tension constant. There are no pinch rollers and no pressure pads, both of which tend to batter the tape and lower its reliability.

Reel-to-reel problems

The reel-to-reel drive has its problems, too. Sycor's Irwin says that his company tried reel-to-reel drive in one of four complete redesigns of its recorder in the five years it's been in business. "We found we couldn't optimize both tension and speed at the same time," he says. Tension tends to increase as the driven reel builds up in size, and thus the winding becomes uneven. (Even though its increasing radius tends to decrease torque, the unwinding reel is accelerating against a frictional retardant, whether the tape speed is constant or the driven reel's speed is constant, so that the tension in the tape increases.)

"Furthermore," says Irwin, "we wanted our cassettes to be usable interchangeably on other machines, and vice versa. To do this, we felt we had to adhere to the



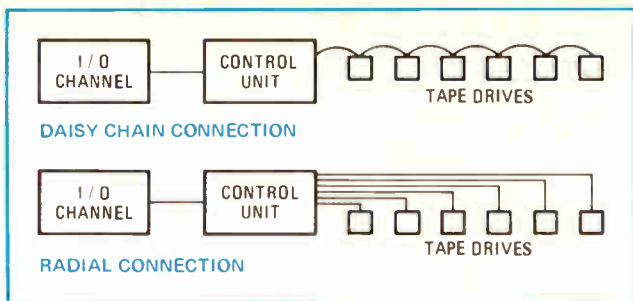

11. New hookup. Unlike traditional daisy-chain connection, radial connection provides direct path from controller to every tape drive.

various proposed standards. We could do all kinds of clever little design tricks if we weren't concerned about the advantages of interchangeability."

"This kind of interchangeability is nice," replies Godbout, "but I wouldn't sacrifice reliability to achieve it. I'd like to see interchangeability among my own company's machines, maybe, but I don't care about anybody else's."

Microdata's Bob Oakley remarks, "We've supplied cassettes with some of our machines, but they have problems: service, reliability, and the fact that the proposed standards haven't been finally approved or enforced. The ECMA standard is questionable because IBM hasn't adopted it. The cassette just doesn't look like a replacement for magnetic tape." Oakley thinks the so-called "floppy disk," used by IBM to reload its writable control stores, and similar products from companies like Memorex and Iomec make more sense than cassettes.

"The cassette market has been an enigma," says Ampex Corp.'s Clifford Leath. "It won't receive the growth that was forecast a few years ago, due to a combination of the recession, hardware problems, and lack of standards. In the interim, alternatives have arisen; the floppy disk is one of them. And IBM threw out a red herring, its 1/4-inch cassette. Yet for terminal applications, the Philips cassette is the only real standard now. The cassette market is beginning to move."

"Even so," Leath continues, "the cassette won't replace standard 1/2-inch tape. The cassette costs about half as much, but it doesn't have anywhere near half the transfer rate or storage capacity. For computer applications, we feel that cassettes will be limited to program loading, not data processing applications."

Among the companies that are unconcerned about interchangeability are Digitronics, Minnesota Mining and Manufacturing Co., IBM, and Teletype. Each of these makes equipment that uses a cartridge of that company's own design. Basic specifications of each cartridge and the Philips cassette, are shown in the table on page 68.

The 3M cartridge is one of the more interesting, particularly since the company also makes Philips cassettes and cassette drives. Its cartridge contains a band of a rubbery substance—its exact composition is proprietary—which winds around both reels, two idler pulleys, and an internal capstan. A simple external drive—a bidirectional motor with a rubber roller on its shaft—turns the capstan by friction, but not on the part of the capstan where the band is. The band picks up the motion and imparts it to the two reels at their surfaces, so



12. Cassette drive. Two Philips cassettes can be used on this drive to provide a million bytes of low-cost sequential mass storage.

that both tension and speed remain constant; as the reels change in size, the band simply follows their surfaces inward or outward.

"This tape performs well over a wide range of performance parameters," says Ed Crosby, marketing supervisor for both the cartridge and the Philips cassette. "Its speed can range from 0 to 90 inches per second, and its specifications approach those of standard 1/2-inch full-size tape drives. Yet its cost is not much more than that of the conventional digital Philips cassette—\$12 each in lots of 1,000, compared to \$5 to \$6 for the cassettes." The 3M tape can be accelerated at up to 2,000 inches per second per second, corresponding to a start time of 23 ms at 30 in./s; this minimizes velocity overshoot because the elastic drive band absorbs most of the shock of starting.

IBM, on the other hand, has designed a low-performance cartridge. Its application, recording characters from a typewriter to simplify letter-writing and editing, doesn't call for high performance, which perhaps justifies its design. A similar but not identical cartridge is used in IBM's model 50 magnetic data inscriber, which came out about the time many companies were introducing new keyboard-to-tape machines two or three years ago. These machines made considerable inroads on IBM's keypunch business, but the magnetic data inscriber cartridge has such a low data rate that it poses no threat whatever to anybody's keypunch.

The Digitronics cartridge, like the Philips cassette, uses 0.15-inch-wide tape wound on coaxial reels. These reels are not motor-driven, but are connected by a spring that keeps the tape pulled tight at all times. A single servo-controlled dc motor in the transport drives a capstan, against which the tape is pressed by a roller inside the cartridge. The unwinding tape from one reel tends to tighten the spring; its tension pulls the winding reel, which takes up the tape driven past the read/write head by the capstan. The spring has enough slack in it to compensate for the varying speeds of the reels as tape moves from one to the other.

The Teletype cartridge is simply a reel of tape in a square container. In use, the tape is wound onto a take-up reel that is a permanent part of the terminal, and rewound into the container when the job is finished.

Part 6: Magnetic disks

To overcome the serial-access disadvantage of magnetic tape, the magnetic disk file was developed. Because a disk's read-write head can move directly to a

SPECIAL REPORT

track containing a desired record, total access time is never more than a matter of milliseconds, as opposed to the several minutes required to go through a reel of tape.

This category can include the rotating drum, which is one of the older forms of bulk storage. But the use of fixed heads is a latter-day development—heads were too expensive to reserve one for every track in early disk and drum units.

Some disk units, however, have a disadvantage not suffered by tape; their disks are permanently fastened to rotating shafts. While these units have large capacities and short access times, the fact that the data has nowhere to go, once it is on the disks, can be a nuisance.

The solution: a storage device that shares the disk's rapid access with the tape's archival storage capability—the disk pack. Although fixed-disk units are still in wide use, disk-pack devices (Fig. 13) represent the most rapidly developing peripheral storage medium today.

But disk packs haven't displaced magnetic tape—for a number of reasons. Among these are tape's entrenched position—thousands of reels already storing archival information, which nobody wants to transfer to disks; the higher cost of disk packs; and the greater bulk and lower density in bits per cubic inch of the disk units.

Fixed-disk storage units come in two varieties: those with fixed heads, or one head per track, and those with moving heads. Disk-pack units are also of two varieties: those with multiple disks per pack and those with only one disk; the latter are usually called disk cartridges.

Interest in disk storage units is high because they stand to enhance system performance with the most cost-effectiveness. "Honeywell is making a maximum effort in this area," says Ragozzino. "Among other things, we're looking into ways of designing controllers to obtain various levels of subsystem performance with a single controller design. Almost certainly, this common controller will use a microprogram to define its functions."

Data is recorded serially on most disks, but is shifted into parallel format in the control unit before being passed on to the processor. The serial recording permits the use of cyclic error-detecting and correcting codes. These codes are easier and less expensive to make now than ever before, and the outlook is for the trend to continue, as downward pressure continues on the cost of integrated circuits.

Coding on disks

Like tapes, disks are usually encoded in NRZI, although some of the newer machines use phase encoding or a variation of it. Because of its lower probability of error, phase encoding will probably come into increased

13. Disk-pack units. Ampex DS-314 disk storage units use interchangeable packs, each capable of storing up to 29 million bytes.



THE IBM 96 COLUMN CARD

1 2 3 4 5 6 7 8 9 10 11 12 13 14 15 16 17 18 19 20 21 22
 ABCDEFGHIJKLMNOPQRSTUVWXYZ 01234
 56789,.-@#*\$/+_:!|=8<>|'~?`"()'
 16 17 18 19 20 21 22 23 24 25 26 27 28 29 30 31 32 33 34 35 36

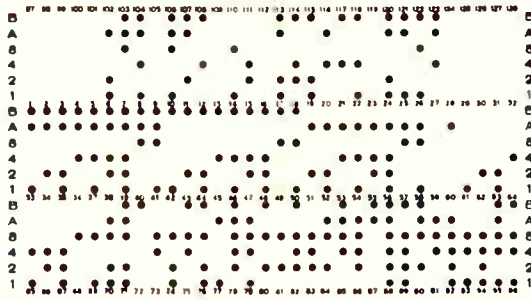

14. Rejuvenator. Decline of standard 80-column IBM card, 3.25 by 7.6 inches, has been offset by popularity of smaller 96-column card.

use in future units. Also, as in tapes, disk control units are growing in complexity, gradually taking functions away from the processor. The continuing increase in the number and kinds of large-scale integrated circuits, continuing developments in read-only memories and microprogramming, and continuing decrease in costs, have contributed to this complexity and undoubtedly will contribute more in future designs.

The fixed-head, fixed-disk unit has the highest performance and the shortest access time. The unit contains one or more disks, which rotate under or between the read-write heads; data can be recorded on both top and bottom surfaces of each disk. The disks typically rotate at 1,800 revolutions per minute, at which speed the average access time is 17 milliseconds. The units come in a variety of formats and speeds, but since the disks are permanently mounted, there is no question of interchangeability and therefore no need for standardization, except possibly at the interface between the disk unit and other equipment.

The movable-head, fixed-disk unit has a considerably longer access time than the fixed-head type because the head must move across the disk from track to track, as well as wait for the disk to rotate to the desired starting point. Average access time under these conditions is likely to be from 50 to more than 100 ms, including both the head travel or "seek" time and the disk rotation time.

Disk drive design

The device may contain either a single disk or a stack of disks rotating as a unit. A single head may move across the top of the single disk, or two heads may be used to read data recorded on both top and bottom surfaces. In the stacked-disk form, heads are mounted on a comb-like structure—one head on the top and one on the bottom of each "tooth." The heads read data recorded on both top and bottom surfaces of the disks. As with the fixed-head disks, formats and exact speeds differ from manufacturer to manufacturer.

More development activity is evident now for storage

units using disk packs and disk cartridges than in either of the other two forms. Both of these—like the fixed disks—have the advantage of pseudorandom access to data, but they also permit the storage medium to be removed from the drive and kept off-line like tape libraries.

Disk packs began to appear about eight years ago with six disks in a pack (10 recording surfaces; the top of the top disk and the bottom of the bottom disk remained unused). These have almost completely given way to larger packs containing 11 disks and 20 surfaces each, which have become the standard of the industry today and were brought in by IBM's 2314 and 2319 disk storage units. These packs are used by many competitive machines (and produced by many competitive media suppliers); but they appear to be approaching or passing their peak usage.

New standard

Their successors: the high-capacity, high-speed units typified by IBM's 3330 disk storage unit. Many other companies have either brought out their own versions of the 3330 or have announced their intention to do so. These units use 12-disk 20-surface packs, hold almost 3½ times as much data each, have half the average access time, and provide more than 2½ times the data rate of the previous standard.

The disk cartridge was introduced as a bulk storage medium for applications where the capacity of even one disk pack was more than a system needed. Many manufacturers produce drives and cartridges today, most of them compatible with the IBM variety, but a few have a different form. Some cartridge systems operate only with one or more cartridges on independent drive mechanisms.

Others include one cartridge drive and one single fixed disk with a movable head on a common mounting in a single enclosure. These are useful in installations where, without the fixed disk, an otherwise removable cartridge would remain in place on the spindle for days or weeks; however, the addition of the fixed disk offers

SPECIAL REPORT

improved performance at lower price.

Sanders Data Systems designs IBM compatibility into as many products as possible. "However," says a spokesman, "it's not always possible. Our disk cartridge drive can't read IBM's cartridges, nor can theirs read ours, although the cartridges themselves are identical."

Part 7: Punched cards

Only a few years ago the annual rate of growth in the use of punched cards was estimated to be 11% per year, tapering off to 2% per year by 1973 [*Electronics*, April 15, 1968, p. 193], as the use of keyboard-to-tape, optical character recognition, and other advanced types of data-entry machines increased. But the decline hasn't been as rapid as predicted; a more recent measurement by International Data Corp. shows that 6% more cards were used in 1971 than in 1970, and the same industry research organization estimates that their use in 1972 will be 7% more than in 1971.

Almost certainly, the life of these cards has been prolonged by the introduction in 1969 of IBM's small System 3/model 10 computer and the later model 6. The

15. Card reader-punch. IBM 2540 is the workhorse of card equipment used with the System 360 and 370 computers. It's too slow to be connected directly to a large computer; therefore, data is normally transferred to a disk or tape when the computer has a little spare time, and the computer utilizes it from that faster medium. This process, called "spooling," is reversed for output data.



16. 96-column machine. Decision Data Corp. 9650 multifunction card unit can read, punch, collate, sort, merge, or reproduce the new small cards introduced with IBM's System 3 computer.

System 3's principal input medium is a 96-column punched card (Fig. 14) that is smaller, but has larger capacity than the previous 80-column standard card [*Electronics*, Aug. 18, 1969, p. 48].

Probably these 96-column cards have stabilized or perhaps even reversed a tapering off in the total use of punched cards. For one thing, the System 3, the parent machine, has turned out to be a runaway seller—with an estimated 10,000 installations so far and another 6,000 unfilled orders. Meanwhile, IBM has introduced equipment that adapts 96-column cards for System 360 and 370 computers. Their squarish shape and small size make them much easier to handle than 80-column cards: so, although originally introduced for small-business applications, they are becoming a popular input medium for these larger machines.

Decision Data Corp. was established in 1970 to make the most of this projected growth in the use of 96-column cards [*Electronics*, Oct. 12, 1970, p. 140]. It's done quite well so far; its latest coup is a contract to supply 96-column card processing equipment to Burroughs Corp. for use with the latter's new B-1700 computer. Decision Data's line now includes 10 different 96-column card machines (Fig. 16). "But we're ready to go into 80-column machines too," says Frank H. McPherson, vice-president for marketing. "There's still plenty of business in the 80-column market."

Catch up with technology

Most of the advances in technology that will be reflected in new and improved peripheral equipment will be evolutionary rather than revolutionary. DEC's Bob Puffer offers one good reason: "Sometimes we have a technology that we don't use right away, even though we know quite a lot about it, because we're not sure of the customer's reaction to it. We can't commit ourselves to an expensive development project based on it and then find it won't sell."

Schmitz, of Sanders, sums it up: "Right now it's apparent that technology is ahead of the user. I have systems in the lab that are capable of wonderful things, but the user hasn't come up to speed on them. From a practical business point of view you can't retrain all your operators; so we have to figure out when and how to market our systems. We have to bet where technology is and bring it together with the reality of modern business practices." □

Reprints will be available at \$3.00 each. Write to Electronics Reprint Dept., P. O. Box 669, Hightstown, N. J. Copyright 1972 Electronics, a McGraw-Hill publication.

Centralab hybrids... in line with your design requirements



Write
Centralab
for
Bulletin
No. 1429H2

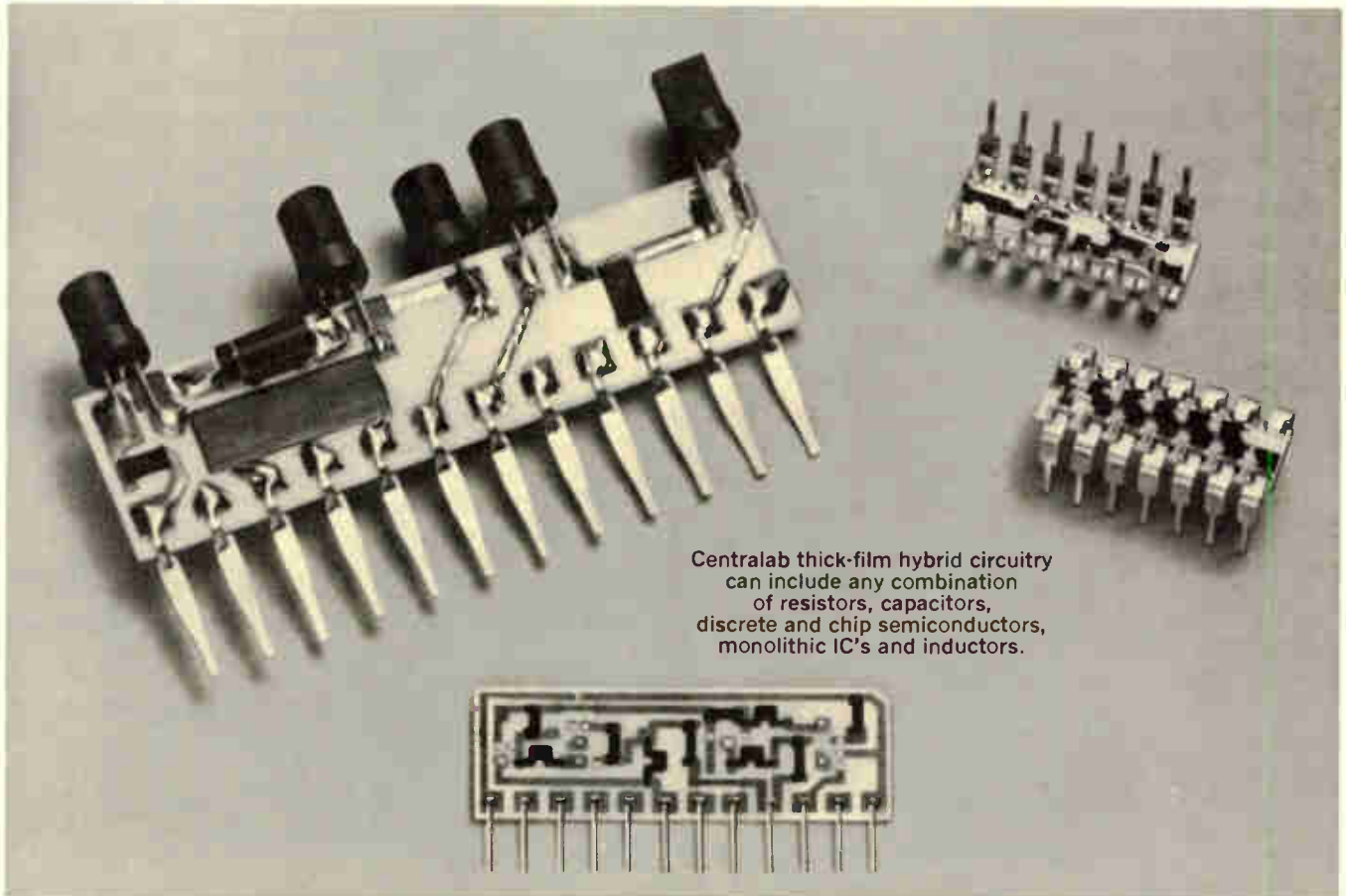

Centralab thick-film hybrid circuitry can include any combination of resistors, capacitors, discrete and chip semiconductors, monolithic IC's and inductors.

Come to us for thick-film capability

When you come to Centralab for custom thick-film hybrid circuits you have the assurance of over 27 years of experience in design and production. As the pioneer in hybrids we have developed over 50,000 custom designs. Today, no other manufacturer can offer you as much flexibility—in packaging, in circuit function and in reliability.

No other 300 mil. DIP, for example, can give you higher package power—up to 3 watts per package. Centralab offers you high density networks with as many as 28 resistors in a 16 lead DIP, 24 in 14 lead configurations. Compare resistor tolerance, as low as .5% and TC of 0 ± 100 ppm and you'll see that our kind of customized circuitry is unmatched anywhere.

Chip hybrids that combine fired-on resistors, capacitors and interconnections with diodes, transistors and IC's

are small in size but big in reliability.

Discrete networks were our first hybrids—in 1945. Our expertise is your assurance you'll get circuits that save space and reduce costs of assembly and provide improved reliability as well.

Custom designs meet the most demanding specifications such as complex functions or power drivers.

Our specialized designs include resistor values to 1 gigohm, voltages to 50 kV and resistor value ranges from 10 ohms per square to 10 megohms per square.

If you've a special application for hybrids, call Centralab. We have the capability to give you the performance and reliability that meet your specs—with delivery that meets your requirements. Write or call, A. R. Wartchow, Marketing Manager, Electroceramic Products, Centralab.

GET CENTRALAB THE "IN" LINE FOR YOUR DESIGN

Hybrid Microcircuits
Pushbutton & Rotary Switches
Capacitors
Potentiometers
Technical Ceramics
Ceramic Packages
Semiconductor Devices



CENTRALAB

Electronics Division
GLOBE-UNION INC.

5757 NDRTH GREEN BAY AVENUE
MILWAUKEE, WISCONSIN 53201

power supplies. This arrangement provides an independent centering control for each channel. Any offset voltage resulting from the large feedback resistors is not a problem, since the centering control provides adequate amplifier adjustment range.

The scope's gate output is divided down by a dual J-K flip-flop to supply binary channel selection signals for the integrated amplifier circuit. This gate signal is synchronized to the scope's sweep, so that there are no timing difficulties. After each trace is completed, the negative-going gate signal selects the next channel. The retrace time allows adequate time for channel selection.

The passive network at the input to the flip-flop—capacitor C_1 and resistors R_1 and R_2 —extracts a trigger

pulse of approximately 5 v from the 30-v waveform obtained at the GATE OUT terminal of a Tektronix type 545 scope. Other scopes may require a different passive network.

Important circuit performance characteristics include: a gain of 1, a bandwidth of dc to 5 megahertz, a slew rate of 15 v/microsecond, a maximum input voltage of ± 10 v, an input impedance of 2 megohms, and a crosstalk figure of 80 decibels.

Circuit voltage range, bandwidth, and input impedance can be increased by adding op amps to buffer each input. Making the gain of each of these buffers independently variable further improves circuit versatility. Approximate parts cost for the entire circuit is \$25. □

Scope converter. Monolithic quad operational amplifier provides inexpensive way to increase display capability of standard oscilloscope. Binary inputs drive IC op amp; dual flip-flop divides scope's gate output to obtain channel selection signals. All channels have centering controls for nulling offset voltage. Negative-going scope gate signal selects next channel after each trace. Circuit operates out to 5 MHz.

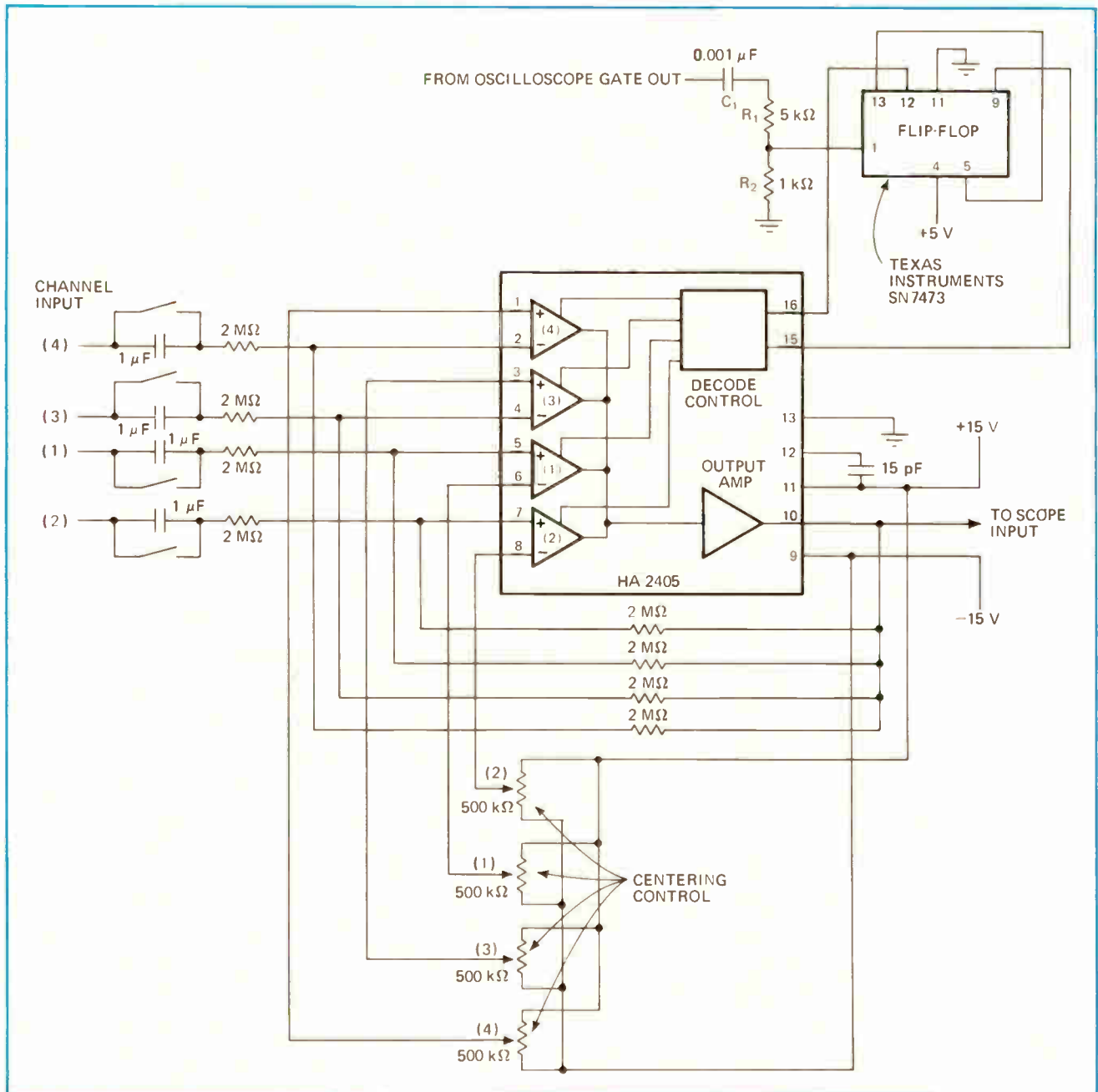

Controlling op amp gain with one potentiometer

by T. Frank Ritter
San Antonio, Texas

A single potentiometer and a few resistors can control the gain of an operational amplifier from a selected negative value, through a null, to its positive open-loop gain. The variable-gain circuit, which is shown in (a), maintains a high input impedance, even at high amplification. It makes a convenient wide-range voltage reference for a voltage regulator because it eliminates the need to switch the op amp's circuit for above- or below-reference operation.

A graph of voltage gain versus potentiometer rotation is also shown in (a). The equation for output voltage can be written as:

$$E_o = [E_i R_F / (R_1 + R_1)] [(R_1 / R_2) - (R_{1+} / R_{1-}) + (R_1 / R_F)]$$

where R_{1+} is the resistor at the op amp's noninverting input, and R_{1-} the resistor at the inverting input. Varying feedback resistor R_F changes the magnitudes of both the positive and negative gains without changing the appearance of the graph; varying resistance ratio R_{1+} / R_{1-} shifts the null point.

As resistor R_{1-} approaches infinity, op amp gain varies from null to positive infinity only, as illustrated in (b). The equation for output voltage becomes:

$$E_o = [E_i R_F / (R_{1+} + R_1)] [(R_1 / R_2) + (R_1 / R_F)]$$

As can be seen from the figure, the gain curve for this circuit is nearly logarithmic.

For a potentiometer rotation of 10% to 90%, amplifier gain can be varied over four decades. The gain at 50% rotation is the ratio $(R_1 + R_2) / (R_{1+} + R_1)$. Any general-purpose differential op amp can be used in the circuit. □

Designer's casebook is a regular feature in Electronics. We invite readers to submit original and unpublished circuit ideas and solutions to design problems. Explain briefly but thoroughly the circuit's operating principle and purpose. We'll pay \$50 for each item published.

Wide-range gain adjustment. Potentiometer varies gain of operational amplifier (a) from chosen negative value to positive open-loop value. Null point can be shifted by changing resistance ratio of noninverting input resistor R_{1+} to inverting input resistor R_{1-} . Removing R_{1+} permits positive gains to be controlled over wide range, as shown in (b). Circuit's input impedance remains high over full gain range.

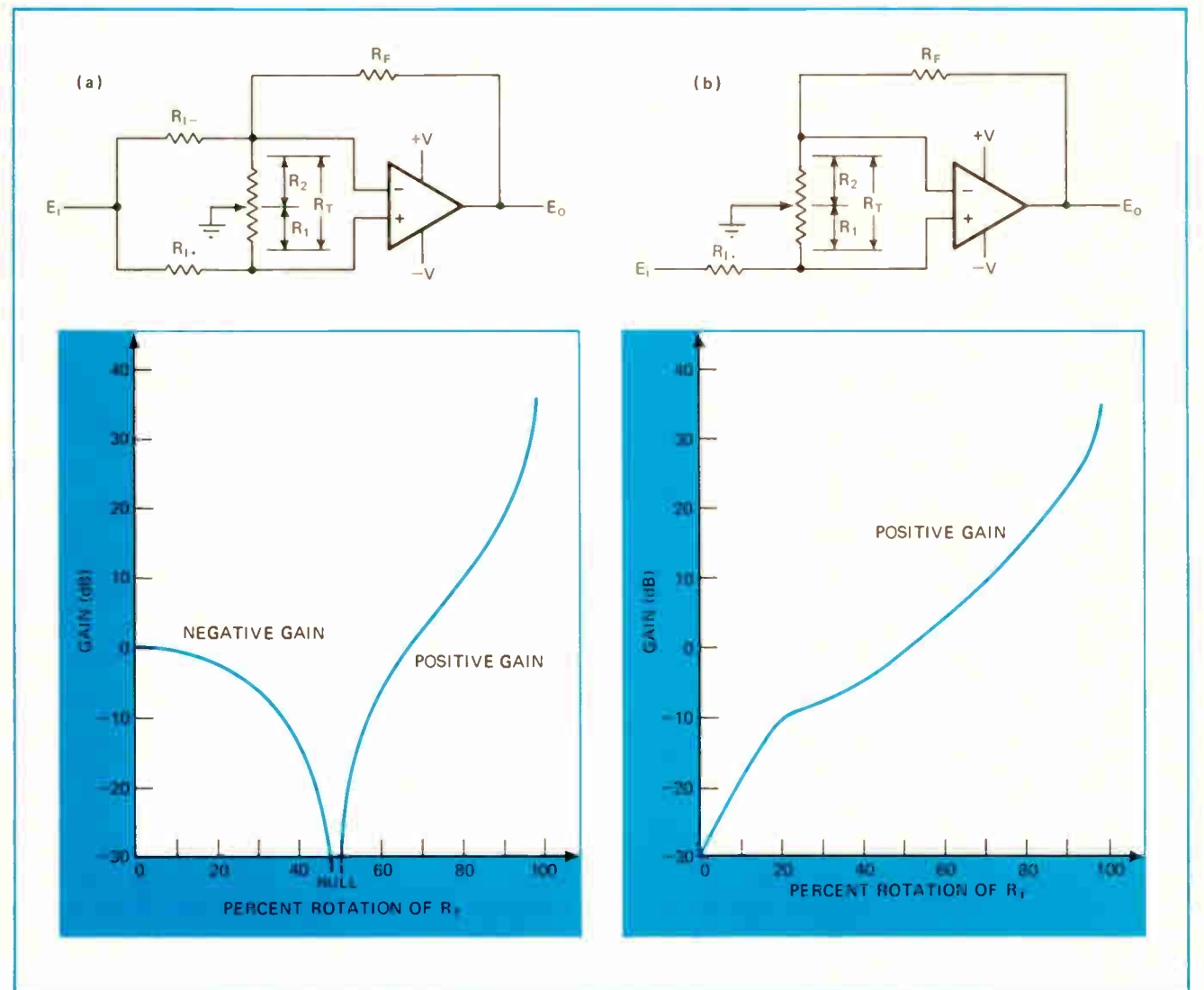

to build a better VHF/UHF FET mixer:

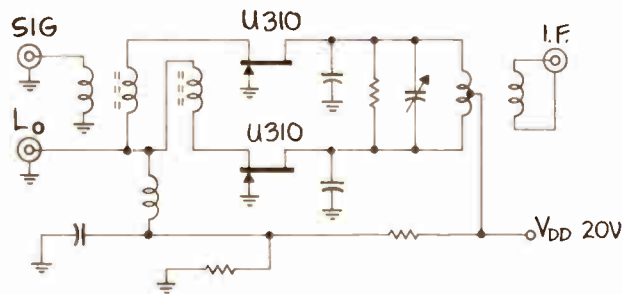

Try our U310 junction FET in this balanced mixer and make your own performance comparison. Our results are below. The inherent square-law transfer characteristic of the FET ensures high intermodulation intercept and signal desensitization. The grounded-gate connection is most stable, while source injection of both the signal and local oscillator make easy impedance matching into the FETs. Also, the balanced configuration reduces l.o. radiation from the signal port and suppresses the generation of even harmonics (which helps reduce intermodulation).

How do you select an optimum JFET for a mixer? Low gate capacitance is needed for wide bandwidth — the Siliconix U310 typically has $C_{gs} = 4.5$ pF and $C_{gd} = 1.9$ pF. Useful conversion gain comes from high transconductance. Our U310 has typical $g_{fs} = 14,000$ μ mhos. Dynamic range is bracketed by the lowest drain current for an acceptable noise figure and the maximum drain current — typically $I_{DSS} = 40$ mA for the U310. For an optimum balance, matched pairs are available.

50-250 MHz Mixer Performance Comparison

Characteristic	JFET	Schottky	Bipolar
Intermodulation Intercept Point	+ 32 dBm	+ 28 dBm	+ 12 dBm [†]
Dynamic Range	100 dB	100 dB	80 dB [†]
Desensitization Level (the level for an unwanted signal when the desired signal first experiences compression)	+ 8.5 dBm	+ 3 dBm	+ 1 dBm [†]
Conversion Gain	+ 3 dB*	- 6 dB	+ 18 dB
Single-sideband Noise Figure	6.5 dB	6.5 dB	6.0 dB

[†] Estimated * Conservative minimum

There's a lot more to this, so

write for data

and get the complete story on VHF/UHF mixing and the Siliconix U310.

Applications Engineering: (408) 246-8905



Siliconix incorporated

2201 Laurelwood Road, Santa Clara, California 95054

Low-power bipolar technique begets low-power LSI logic

A major obstacle to bipolar LSI logic is overheating caused by unevenly distributed power levels; one solution is to revise the circuit layout so that individual gates can function on as little as 0.5 mW each

by M. P. Xylander,* IBM Corp., Endicott, N. Y.

□ Any kind of LSI TTL has to contend with the power dissipation problem. Otherwise, all those hundreds of gates, crowded onto a single chip, will generate a damaging degree of heat. Adding high-value resistors would reduce gate power requirements, but they would occupy too much chip area, and in any case they're unnecessary. A better idea is to rearrange the circuitry so that each gate needs much less power—and that, basically, is what the new low-level-logic (LLL) technique does.

The result is TTL gates with power levels as low as half a milliwatt each—and 350-gate LSI chips that dissipate a total of less than 200 mW. The voltage requirement is a mere 1.2 volts. Computer logic systems built around these chips will therefore need fewer boards and interconnections, will themselves dissipate less power, and on both counts will be more reliable.

What LLL does is to parallel the inputs and outputs of several logic circuits on the same chip, sharing the available power between the drivers and device terminations. The scheme also eliminates the 100-kilohm resistors typically associated with logic configurations, and frees the large areas of chip these resistors would otherwise occupy for the addition of many more logic gates.

True, FET logic designs can also yield low-level-logic circuit because with FETs it is possible to simulate a high value of resistance, and this keeps the current low

and the power dissipation at a minimum. But FETs have another problem: noise. Their high output impedance markedly raises the level of coupled noise, which occurs between printed-circuit lines, discrete wires, and multi-conductor cables, and frequently results in random errors if not kept under control.

The way it works

The low-power gate circuit shown in Fig. 1a is much like a standard TTL circuit. Its component values should be considered representative; other values could be chosen, depending on the application. In this case, 1.2 V was used as the nominal power supply voltage, but 2–3 V could be used if higher speeds were needed.

Figure 1b shows the dc condition when the output of the circuit is at the up level (approximately +1.2 V). To attain this condition, the input of at least one emitter of Q_1 must be at the down level—around +0.1 V. (Actually, since the input voltage is the saturation voltage of the output transistor of the preceding LLL circuit, it will typically be 0.1 V at this point.) Transistor Q_1 is forward-biased and in saturation. Its 20-milliampere base and collector current is supplied through the 2-kilohm resistor, such that about 0.05 mA goes through the base, 0.15 mA is shunted through the 3-kilohm resistor and the collector, and the entire 0.20 mA emerges from the emitter. Since Q_1 is in saturation, the base of Q_2 is approximately 0.2 V, and causes Q_2 to be cut off.

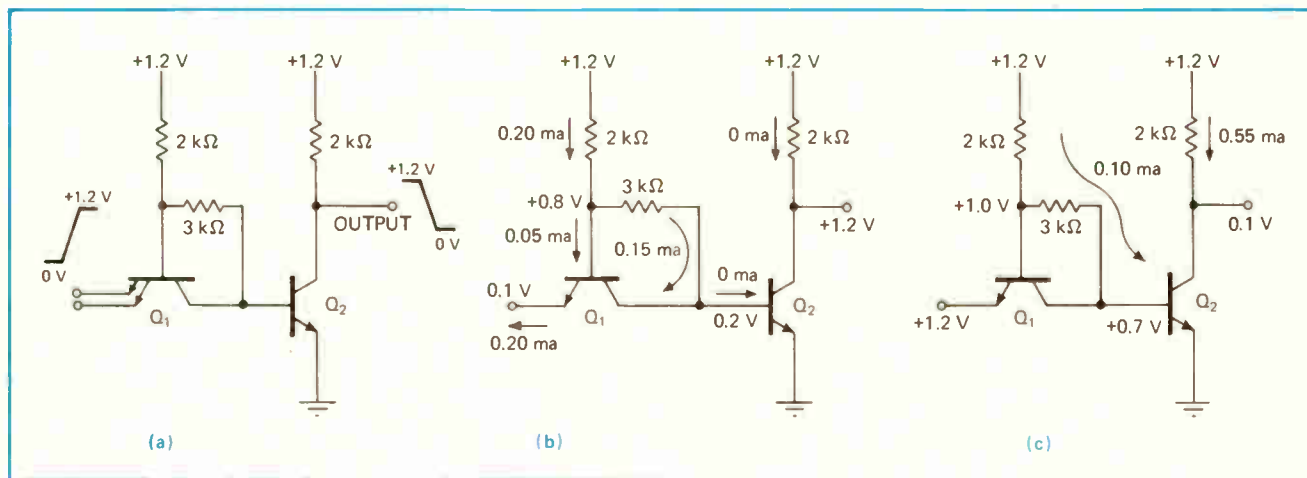

1. Getting down to basics. In the low-level logic gate (a), 1.2 volts is the nominal power-supply voltage and becomes the logic 1 level when the circuit is up. Typical dc conditions in this position are shown in (b), while the down level (approximately 0.1 V) is shown in (c).

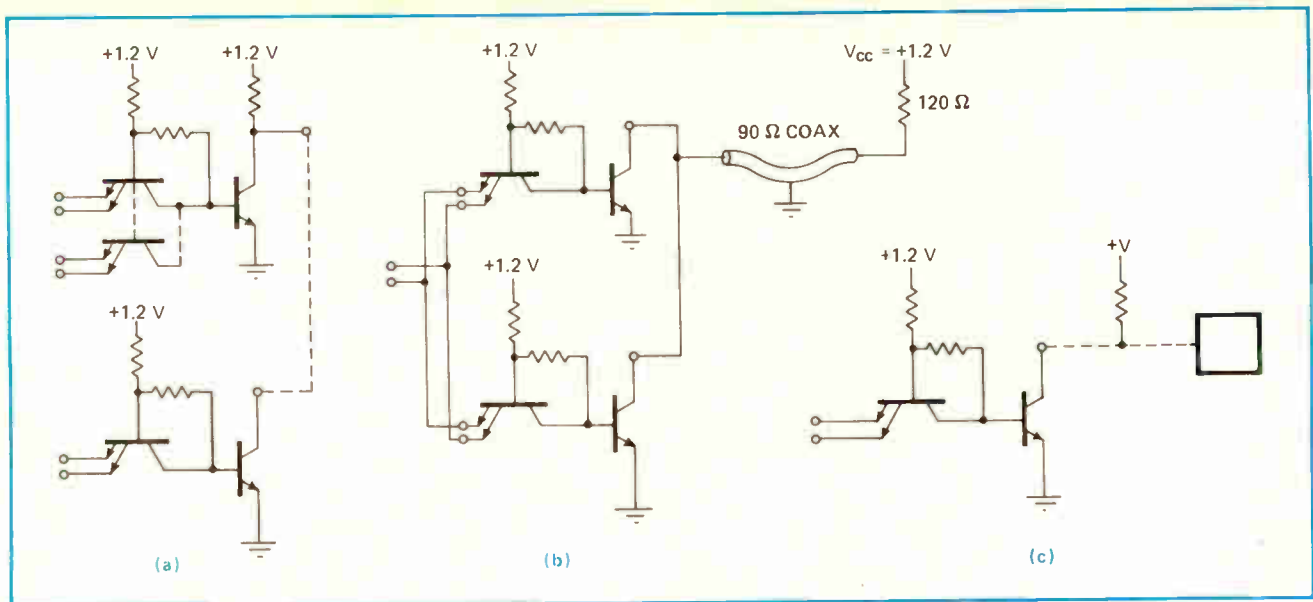

2. Functions. Basic gate structure is a NAND logic function (positive-and-invert). By connecting collectors as shown in (a), the NOR logic function (positive-or-invert) can be performed. Terminated line is driven (b) by paralleling two circuits and terminating the 90-ohm transmission line to V_{cc} with a 120-ohm resistor. An external pull-up resistor (c) can change the output voltage swing to mesh with another circuit.

Figure 1c shows the dc condition when the output of the circuit is at the down level (approximately +0.1 v). To attain this condition, the inputs to all the emitters of Q_1 are assumed to be at the up level of around +1.2 v. Under this condition, Q_1 is reverse-biased and cut off. Q_2 's 0.1-mA base current, which is supplied through the 2 and 3-k Ω resistors, causes Q_2 to be forward-biased and saturated. The output voltage is typically 0.1 v.

Starting from the basic LLL gate, all the conventional logic functions can be performed. The circuit is basically a NAND logic function (positive-and-invert). By dotting the collectors (Fig. 2a), the NOR logic function (positive-or-invert) can be performed. Combined, they perform double-level logic (positive-and-or-invert).

Power drivers can be formed by paralleling the inputs and outputs of several logic circuits on the same chip. Terminated line drivers can be formed (Fig. 2b) by paralleling two circuits and terminating the transmission line with a 120-ohm resistor returned to the operating voltage V_{cc} . (This resistor value is adequate for a 90-ohm transmission line.) Unterminated lines of any reasonable length can also be driven by one or more circuits in parallel. In addition, the number of inputs can be extended simply by adding input transistors with multi-emitters—a method that does not increase power dissipation.

Most important, the LLL circuit is compatible with conventional TTL and DTL circuits. All that is required is an external pull-up resistor to convert to the higher voltage (Fig. 2c). Moreover, a simple diode with shifting network will make the circuit compatible with ECL.

How well it works

The circuit's low power dissipation is borne out by a simple calculation, assuming $V_{cc} = 1.2$ v.

$$\begin{aligned} \text{Down level power} &= 1.2 \times 0.20 \text{ mA} = 0.24 \text{ mW} \\ \text{Up level power} &= 1.2 \times 0.65 \text{ mA} = 0.78 \text{ mW} \\ \text{Average power (50\% duty cycle)} &= \frac{1}{2}(0.24 + 0.78) = \\ &= 0.51 \text{ mW} \end{aligned}$$

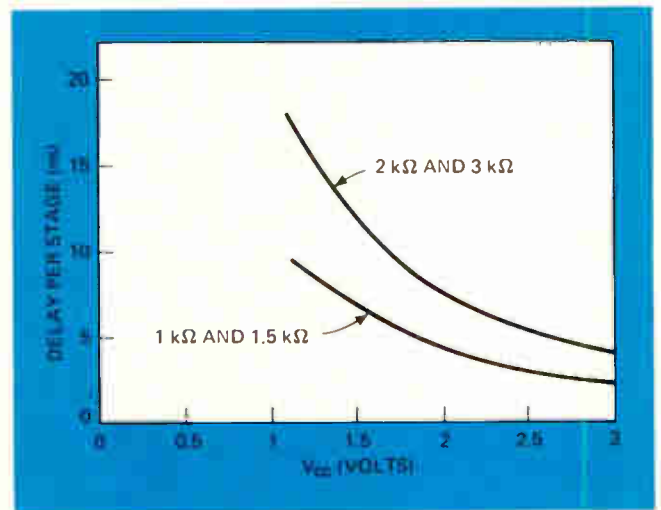

3. Speed-up. As with all logic configurations, increasing the applied voltage V_{cc} will increase the speed (reduce the gate delay). Operation for two sets of circuit resistor values is shown.

With this kind of average power dissipation, a total of 350 circuits on a chip altogether will require less than 200-mW—a power level that is easy to control with cooling fans.

But there's more to the LLL chip's performance than reduced power. The fact that it is an LSI design implies improved performance because the interconnection lengths between gates have been greatly shortened. Typical delay per stage is reduced to the 10–20-nano-second range, with a further significant improvement made by trading off increased power for speed. Figure 3 shows the results of increasing V_{cc} : for a given resistance, the delay per stage becomes shorter as the power increases.

Of course, device design will also have a significant effect on performance. For instance, if speed is not an important factor, gold doping is unnecessary—and its elimination will enhance yield and reliability.

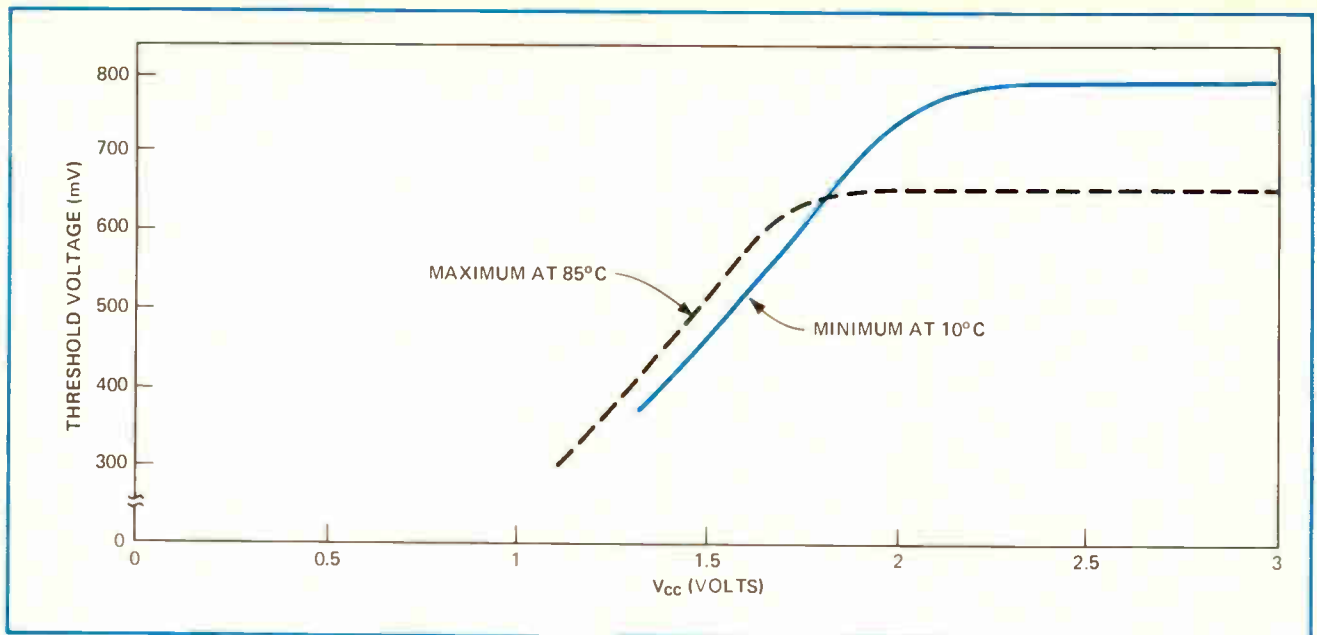

4. Rejecting noise. Because the threshold voltage of the LLL circuit is a function of V_{cc} , thresholds adjust automatically to compensate for any changes that may occur in power-supply voltage. The situation is ideal for optimizing noise rejection.

Noise rejection is also excellent. The threshold voltage of the LLL circuit noise rejection is a function of the power-supply voltage and automatically compensates for any change in that voltage, thus maintaining optimum noise rejection (Fig. 4). This unique and extremely important feature results in greatly improved reliability at the system level.

Also unique is the principle applied to powering the LLL circuits. Instead of a tolerance on the power supply, only the minimum value of supply voltage need be specified, as indicated in Fig. 5a. Actually, any voltage will suffice, provided it is equal to or greater than the minimum value (1.3 v at 10° C and 1.1 v at 85° C). This is worst-case—nominally, the circuit functions with as little as 0.9 v.

Of course, power dissipation increases rapidly as the power supply voltage increases (Fig. 5b). Simultaneously, however, there is an improvement in noise tolerance. Either a battery or a conventional power supply can be used, and its nominal voltage should be selected so that the minimum value is equal to or greater than the minimum specified for LLL. This means that any tolerance on the power supply is acceptable—a feature that reduces power supply costs and also minimizes the number of decoupling capacitors needed. Furthermore, since only a single voltage is required, power distribution problems are minimized.

The most economical power supply is simply two silicon diodes in series, which can be biased through a resistor by any positive voltage supply—+3, +5, +6, or +10 v. The result is a nominal power supply of +1.4 v, which will provide power to hundreds or even thousands of LLL circuits.

This type of power supply is especially useful if the circuits are to be used in an environment of extreme temperature variations because the characteristics of the diodes match the power supply characteristics shown in Fig. 5a. That is, the voltage across the diodes has a negative temperature coefficient that optimizes the supply

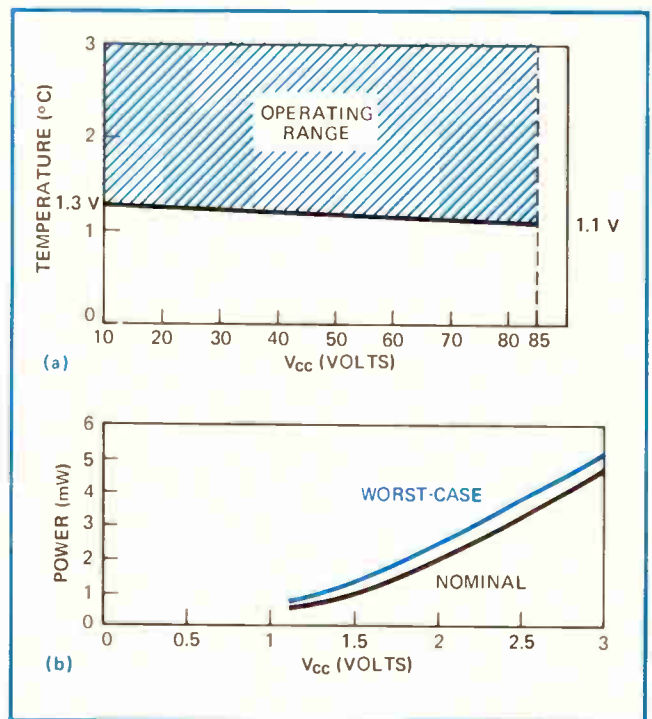

5. Supertolerant. With the LLL circuit, there are almost no restrictions on the power supply. As shown in (a), any value will serve, provided it exceeds a minimum (in this case, 1.3 v at 10° C and 1.1 v at 85° C). But as the supply voltage increases, so does the power dissipation (b). In any case, noise tolerance is always maintained.

and therefore maintains optimum performance and noise rejection.

If possible, all communicating circuits should be powered by the same power source. If that is not possible, and one group of LLL circuits must communicate with a group powered by a different supply, the supplies must be compatible. All that is required for the groups of LLL circuits in that condition is to limit the fanout between them to one or two. □

Q_3 to ground can be found from the Thévenin equivalent circuit:

$$V_E = (460 \Omega)(4.6 \text{ v}) / (750 \Omega + 450 \Omega) = 1.74 \text{ v}$$

Assuming values of $V_{BE1} = 0.7 \text{ v}$ and $V_{\gamma 2} = 0.55 \text{ v}$:

$$V_{T+} = -0.7 \text{ v} + 0.55 \text{ v} + 1.74 \text{ v} = 1.59 \text{ v}$$

Negative-going threshold V_{T-} can be determined by assuming transistor Q_2 is on and saturated. As the input to the Schmitt trigger drops, transistor Q_3 begins to turn on and the circuit conditions of Fig. 2b apply. When Q_3 turns on, transistor Q_2 is in the active state and its collector voltage is:

$$V_{C2} = V_{CC} - I_{C2}R_{C2} \quad (1)$$

Computing Q_2 's collector current:

$$I_{C2} = [\alpha_2(V_1 - V_{BE2})] / R_E \quad (2)$$

where α_2 is the common-base current gain of transistor Q_2 . Substituting Eq. 2 into Eq. 1 and solving for V_1 with $\alpha_2 = 1$ yields:

$$V_1 = V_{BE2} - V_{\gamma 3} + V_{CC} - R_{C2}(V_1 - V_{BE2}) / R_E$$

or:

$$V_1 = V_{BE2} + (V_{CC} - V_{\gamma 3}) / (1 + R_{C2} / R_E) \quad (3)$$

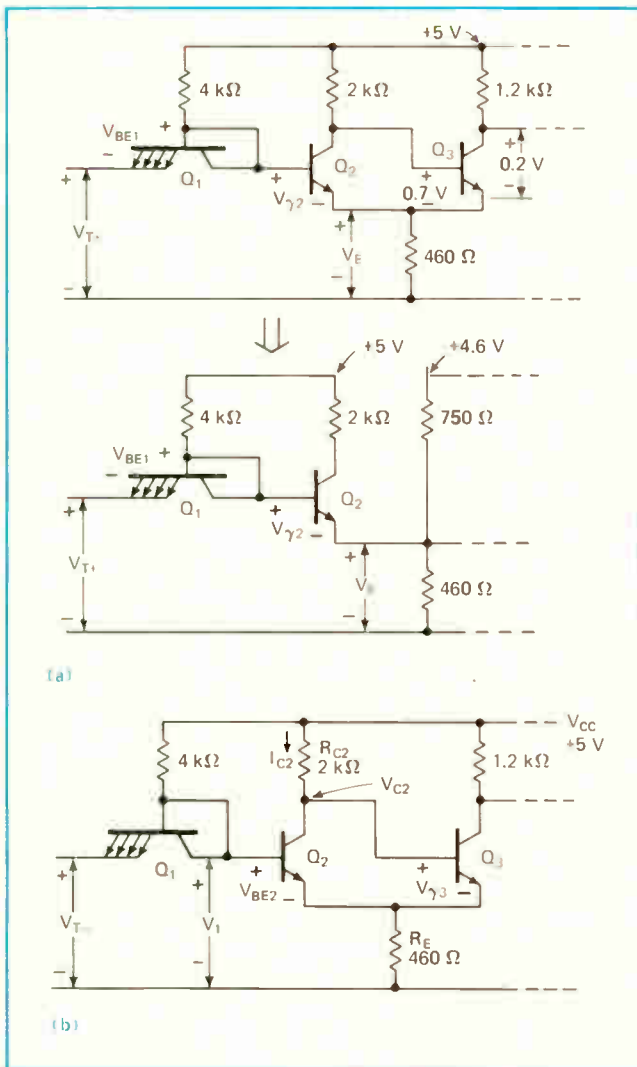

2. Calculating threshold voltages. Positive and negative switching thresholds are the most important Schmitt parameters. Simple way of finding positive-going voltage (V_{T+}) needed to switch from high to low state is to use Thévenin equivalent (right) of circuit (left) in (a), with Q_2 in cutoff and Q_3 in saturation. To compute negative-going threshold (V_{T-}), Q_2 is saturated while Q_3 is cut off, as in (b).

The equation for V_{T-} becomes:

$$V_{T-} = -V_{BE1} + V_{BE2} - V_{\gamma 3} + V_{C2} = -V_{BE1} + V_1$$

Replacing V_1 with Eq. 3:

$$V_{T-} = -V_{BE1} + V_{BE2} + (V_{CC} - V_{\gamma 3}) / (1 + R_{C2} / R_E)$$

Since V_{BE1} approximately equals V_{BE2} , this equation reduces to:

$$V_{T-} = (V_{CC} - V_{\gamma 3}) / (1 + R_{C2} / R_E)$$

With the circuit component values shown and with $V_{\gamma 3} = 0.55 \text{ v}$, the negative-going threshold voltage can be easily evaluated:

$$V_{T-} = (5 \text{ v} - 0.55 \text{ v}) / [1 + (2 \text{ k}\Omega) / (460 \Omega)] = 0.83 \text{ v}$$

Both threshold voltages vary considerably with supply voltage V_{CC} . For example, a 1-v change in V_{CC} will cause a variation of 380 millivolts in positive-going threshold voltage V_{T+} :

$$dV_{T+} / dV_{CC} = 0.38$$

Similarly, for V_{T-} :

$$dV_{T-} / dV_{CC} = 1 / (1 + R_{C2} / R_E) = 0.185$$

The type 7413 Schmitt trigger can operate over a wide temperature range. Positive-going threshold V_{T+} is almost insensitive to temperature changes because its thermal variations either cancel or are negligible. And negative-going threshold V_{T-} is only slightly temperature-dependent:

$$V_{T-} = V_{CC} - V_{\gamma} / (1 + R_{C2} / R_E)$$

Differentiating this equation with respect to temperature (T) yields the negative-going threshold temperature dependence:

$$dV_{T-} / dT = dV_{\gamma} / (1 + R_{C2} / R_E) dT$$

Since $dV_{\gamma} / dT = -2 \text{ mV} / ^\circ\text{C}$, then:

$$dV_{T-} / dT = 0.37 \text{ mV} / ^\circ\text{C}$$

Widely used Schmitt circuits

The integrated Schmitt trigger is useful in a variety of applications. For instance, Fig. 3a shows a simple RC multivibrator that can be implemented with only one-half a type 7413 Schmitt trigger, plus a single resistor and a single capacitor.

Circuit operation is simple. Capacitor C is initially uncharged and has a voltage across it that is less than V_{T+} ; the circuit's output level is high. The capacitor charges through resistor R and through multiple-emitter transistor Q_1 . When the voltage across C reaches V_{T+} (about 1.6 v), the Schmitt changes state so that its output goes low, discharging C through R and saturated output transistor Q_7 . When capacitor voltage drops to V_{T-} (about 0.8 v), the Schmitt switches to its high state and C begins to charge again.

Several dc considerations influence the selection of resistor R . It must not draw excessive current from the output, but its value must be high enough to prevent the loading of subsequent stages. Its maximum value is restricted by the current-sinking capability of output transistor Q_7 . A resistance of 390 ohms is recommended by one manufacturer of the type 7413 Schmitt for a fanout of 2.

With $R = 390 \text{ ohms}$, the equations for output pulse width are:

$$t_H = 0.15C$$

$$t_L = 0.34C$$

where t_H is the period of time (in nanoseconds) during which the multivibrator is high, and t_L , the duration (in nanoseconds) of the low output period. (The units of ca-

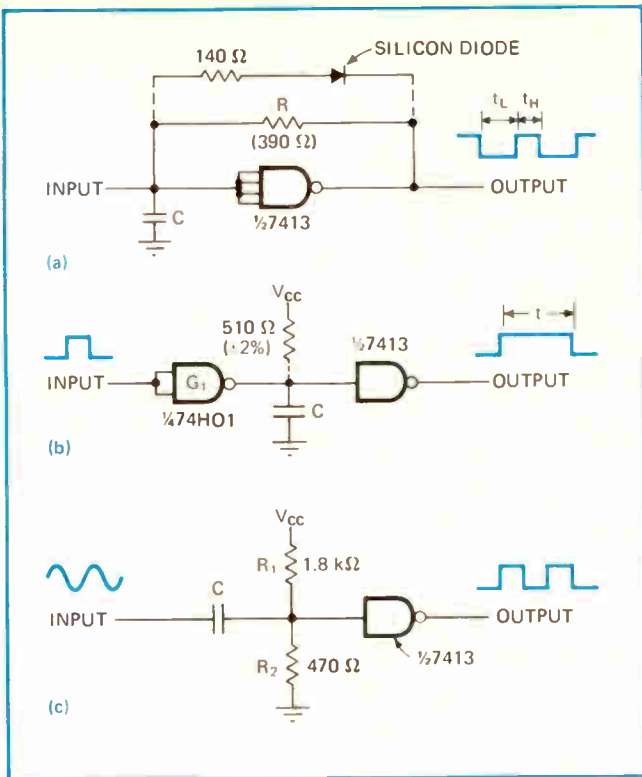

3. Using the Schmitt. Simple multivibrator (a) requires only external resistor and capacitor; adding diode and second resistor achieves 50% duty cycle. For pulse stretcher (b), extra resistor compensates for unit-to-unit processing variations so that output pulse width is more predictable. Biasing Schmitt at its mid-threshold point enables it to convert sine waves to square waves (c).

pacitance are picofarads.) Multivibrator frequency in hertz, therefore, will be:

$$f = (2.02 \times 10^{-3})/C$$

where C is in farads.

As the timing equations indicate, the multivibrator output is low approximately 70% of the time. Adding a resistor and a diode, as shown by the dashed lines, reduces the discharge cycle time, yielding a multivibrator with a duty cycle of 50%. With the values shown, output frequency becomes:

$$f = (3.3 \times 10^{-3})/C$$

Again, C is expressed in farads and f in hertz.

A relatively simple one-shot (or pulse stretcher) can be built with the circuit configuration of Fig. 3b. When an input pulse is applied to NAND gate G₁, its output goes low, but the Schmitt trigger's output remains high. Before the Schmitt can switch to its low output state, capacitor C must charge to V_{T+}. The charging resistor is the base resistor of transistor Q₁. Output pulse width for this circuit is nominally:

$$t = 1.95C$$

where t is in nanoseconds and C in picofarads.

Variations in the charging resistor cause output pulse width to vary from unit to unit. Performance can be improved by inserting a resistor between the supply and the capacitor. Pulse width then becomes:

$$t = 0.26C$$

for t in nanoseconds and C in picofarads. Pulse width is reduced with the additional resistor.

Another useful circuit converts a sine wave to a

The Schmitt trigger reviewed

A variation of the basic Eccles-Jordan bistable multivibrator, the Schmitt trigger is also called an emitter-coupled binary. Unlike the conventional binary, it exhibits hysteresis, switching from one state to another at different threshold voltages, depending on the direction of the triggering input. Additionally, the Schmitt's input terminal is not involved in regenerative switching and so keeps the same potential during and after transition, creating an excellent triggering circuit.

Normally, the Schmitt operates with a loop gain of greater than unity. Circuit hysteresis can be eliminated by making the loop gain equal to unity through resistance adjustment. The positive- and negative-going threshold voltages can also be shifted.

For a more-than-unity loop gain, input voltage v_i must reach positive-going threshold V₁ before the Schmitt can switch to its high output state (v_o = V₁₁). When v_i decreases, it must pass the V₁ threshold level before the transition to the low output state occurs (v_o = V₁). The circuit is unstable in the region between V₁ and V₁₁. For the low output state, Q₁ is off and Q₂ on; for the high state, Q₁ is on and Q₂ off.

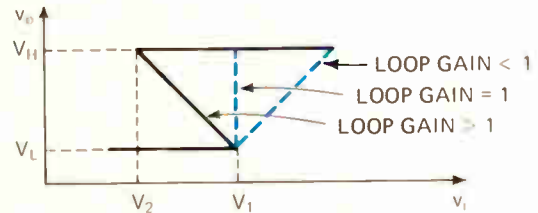
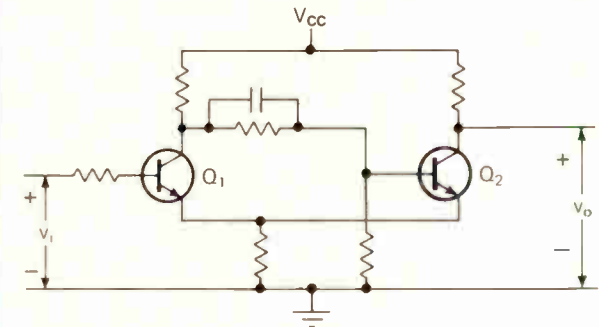

square wave, as shown in Fig. 3c. Resistors R₁ and R₂ bias the Schmitt trigger at the mean value of its threshold voltages to obtain the necessary 50% output duty cycle. To avoid differentiating the input signal, the impedance of capacitor C at the operating frequency of interest should be much less than the parallel resistance of R₁ and R₂:

C approximately equals $(4.3 \times 10^{-3})/f$ where C is in farads and f in hertz.

The converter can be operated at frequencies up to about 8 megahertz. If all four inputs of the Schmitt trigger are tied together, peak input voltage can be as high as 6.5 v. If only one input is used, maximum input voltage becomes 5.5 v peak. The minimum input voltage should be about 1 v peak. □

BIBLIOGRAPHY

"TTL Schmitt Trigger," Texas Instruments Application Report, Bulletin CA-152

Varactor pair in new stripline circuit improves modulation

by Donald Neuf
RHG Electronics Laboratories, Farmingdale, N.Y.

Modulation linearity is a most important consideration for designers of color television transmitters—any variation in the phase or amplitude of the transmitted signal will distort both hue and saturation at the viewer's end. Here is a design approach for modulating an fm transmitter that uses two tandem varactor diodes for improved linearity and a novel stripline design that provides tight radio-frequency coupling and diode bias isolation.

With the more conventional single-varactor lumped-element tuning circuit, the frequency of oscillation normally varies as the fourth root of the tuning voltage—hardly a linear relation. However, if the series inductance of the tuned circuit could be changed without adding stray capacitance, then the frequency could be made to vary as the square root of the tuning voltage. The required variable inductance is easily achieved by adding a varactor diode and an impedance inverter, such as a quarter-wavelength transmission line (the sec-

ond varactor stage in the pi network, Fig. 1).

The stripline design has two center conductors in different planes (one above the other, instead of the two side by side as in conventional coplanar stripline). This arrangement provides the necessary tight coupling without the critical tolerances inherent in the conventional coplanar structure.

The color TV transmitter must supply typically 250 milliwatts at 7 gigahertz, with a maximum frequency deviation of ± 4 megahertz. The transmitter must handle baseband modulating signals from 0.1 hertz to 10 megahertz and hold the differential amplitude and phase variation across the 8-MHz deviation range to within ± 0.5 dB and $\pm 0.5^\circ$, respectively.

The varactor-modulated Impatt transmitter was constructed in a stripline package with a built-in circulator (Fig. 2). In addition to isolating the load and providing an input port for an external locking signal, the circulator simplifies measuring external Q and the optimization of the oscillator first as an amplifier.¹

A gallium-arsenide Impatt diode was chosen for its lower noise qualities.² The Impatt diode has an equivalent Q low enough to provide the desired frequency deviation. In general, oscillation occurs at a frequency at which the net circuit reactance is zero and the negative diode resistance is equal to the positive source resistance. And although oscillation is possible when the diode's negative resistance is greater in magnitude than

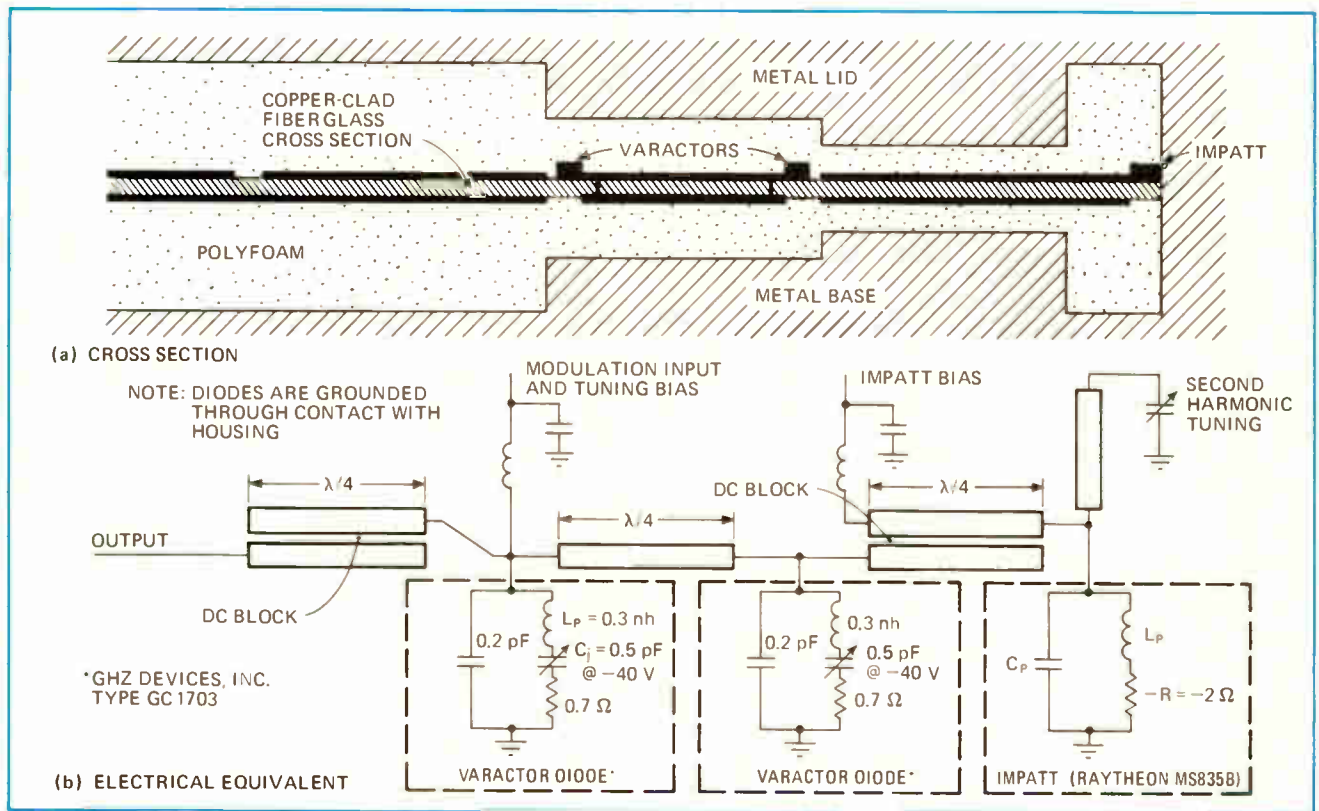

1. A cross-section of the Impatt transmitter (a) details the stripline construction with center conductors in two planes. An equivalent circuit for the varactor-modulated transmitter (b) illustrates the quarter-wavelength coupling techniques with dc blocking.

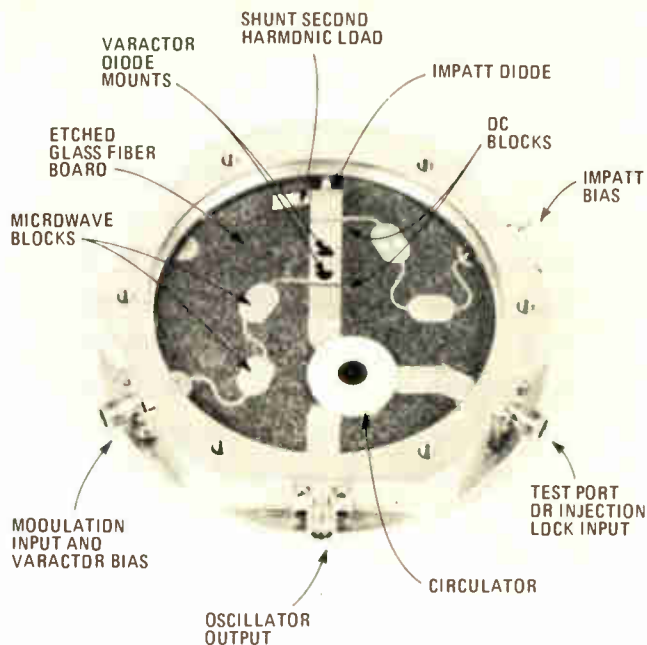

2. A built-in three-port circulator isolates the load from the varactor-modulated Impatt-diode oscillator, provides a convenient test port, and can also serve to inject an external locking signal. The complete fm transmitter is shown without the cover (top ground plane) and the top layer of polyfoam.

the source resistance, an optimum operating point was chosen where the oscillator has the highest efficiency and the lowest noise spectrum.³

The oscillator circuit construction uses both sides of a copper-clad glass fiber board for the stripline dual center conductors (Fig. 1). This stripline design offers more predictable impedance control and higher Q than does microstrip. A polyfoam material (dielectric constant of 1.2) is then used to support the stripline center conductors. The stripline design also provides a means of si-

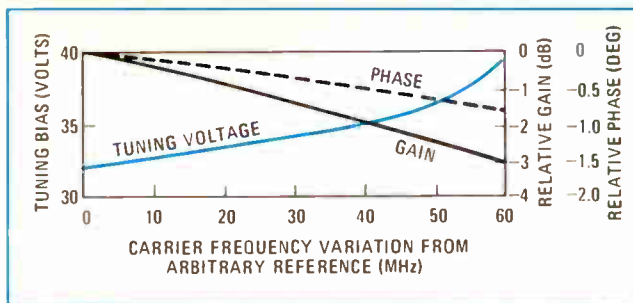

3. Differential gain and phase are held to within ± 0.5 dB and $\pm 0.5^\circ$, respectively, over any 8-MHz segment within the varactor tuning range. A bias of 32 to 40 volts (a compromise between diode breakdown and tuning control) provides about a 60-MHz tuning range.

multaneously filtering the second harmonics and isolating the varactor modulation and dc bias voltages from the avalanche diode. Equivalent characteristic impedances of the quarter-wavelength sections are determined by using "odd" and "even" propagation-mode analyses.⁴

The avalanche diode is also loaded by a separately adjustable half-wavelength line. This circuit controls the second harmonic loading and helps to reduce fundamental noise.⁵

The final package power output, in the 100 to 200 mW range, increases about 1 dB with an increase in tuning voltage. A varactor bias in the 32- to 40-volt range produces an rf frequency variation of some 60 MHz. The total fm noise of the oscillator, measured with a standard EIA TV noise-weighting filter, was 8 kHz rms. □

REFERENCES

1. J. Ashley and F. Palka, "A Modulation Method for the Measurement of Microwave Oscillator Q," PGMTC, November 1970, pp. 1002-1004.
2. M. Gupta, "Noise in Avalanche Transit-Time Devices," Proc. IEEE, December 1971, pp. 1674-1687.
3. A. Cowley et al., "Noise and Power Saturation in Singly Tuned Impatt Oscillators," IEEE Journal of Solid-State Circuits, December 1970, pp. 338-345.
4. G. Matthaei, L. Young and E. M. T. Jones, "Microwave Filters, Impedance-Matching Networks, and Coupling Structures," McGraw-Hill, p. 221.
5. F. Sullivan and W. From, "Second-Harmonic Tuning Effects on Impatt Diode Oscillator Noise Characteristics," 1971, IEEE-GMTT International Microwave Symposium Record.

Summing up the front-release rear-release connector debate

by Terry Leen and John Cameron
Amphenol Connector division, Bunker Ramo Corp., Broadview, Ill.

Historically, the relative merits of front-release and rear-release connectors have been controversial, both among connector manufacturers and within users' plants. Fortunately, the comparative advantages of each system are now becoming clear, and the choice between the two can be made objectively.

In the front-release connectors, the contacts are released from the front and then removed from the back, generally with metal tools. In the rear-release version, the tool is generally plastic, and is applied from the back of the connector—the wire-bundle side.

In both systems, contacts are retained by means of a

shoulder on the contact and a retention clip in the connector. Contact retention mechanisms can be constructed of either metal or dielectric materials.

The design engineer has contended that rear-release connectors are better, since they offer design simplicity and an improvement of mating reliability because of their hard-front socket inserts. Also, the service tool, being plastic, tends not to damage the connector.

The manufacturing manager, however, has generally disliked them; typical comments have been: "Sure they mate nicely, but termination servicing of jacketed bundles of braided wires, which must be pigtailed within 1/4-inch to 1-in. from the rear of the connector, is difficult if not impossible;" "the plastic service tools break constantly;" "I can't remove oversize wire accidentally inserted;" or "I can't crimp two wires to a rear release contact because the tool will not fit over the wire."

Management's viewpoint, of course, is to insist that all factors—initial purchase cost, assembly cost and perhaps most important, life cost—be considered.

The tables will assist all three groups in getting to-

TABLE 1: FRONT- AND REAR-RELEASE CONNECTORS COMPARED

FRONT-RELEASE

ADVANTAGES

- Contact identification easier
- Low life cost of metal tools
- Larger wire diameters possible
- Wire shielding may be close to grommet sealing surface, also is easily serviceable
- No auxiliary tools needed for broken wired contacts

DISADVANTAGES

- Male pins may bend during removal
- High initial cost of metal tools
- Closed-entry hard-front insert design adds parts, complexity
- Contacts not serviceable in mated connector
- Not adaptable to CTJS, Mil-T-81714
- Moderate to high connector life cost

REAR-RELEASE

- Male pins won't bend on removal
- Low initial cost of plastic tools, ready availability for servicing
- Closed-entry hard front insert design less complex
- Contacts serviceable in mated connector
- Adaptable to CTJS, Mil-T-81714
- Low to moderate connector life cost

- Visual contact identification difficult
- High life cost of plastic tools
- Wire diameters restricted
- Wire shielding not very close to grommet sealing service, as tools need clearance
- Auxiliary tools needed for broken wired contacts
- Broken tips of plastic tools may lodge inside contact pockets, preventing contact insertion or removal

TABLE 2: LIFE COST OF PLASTIC VS. METAL TOOLS

Description	Plastic	Metal
Initial cost (insertion and removal set)	0.55¢	\$30
Average tool life (insertions and removals)	100	100,000
Cost / insertion and removal	0.0055¢	0.0003¢

TABLE 3: LIFE COST OF TYPICAL CONNECTORS VS. MATERIAL

Material	Reliable life @ 200°C (hours)	Material cost / lb	Cost / lb / hr
DAP	45	\$0.75	\$0.0167
GFE	1,500	\$1.75	\$0.00117
Astrel 360	70,000	\$25	\$0.00036
Silicone	7,500	\$3	\$0.0004

Note: All connectors are of similar size and employ front and rear plastic and metal retention systems.

TABLE 4: LIFE COST OF CONNECTORS

Connector design	Reliable life @ 200°C (hours)	Connector cost (mated pair)	Cost/pair/hr	Failure mode
Front release Polymer retention MIL-C-81511	7,500	\$55	\$0.00734	Rubber
Front release Metal retention MIL-C-26500	1,500	\$50	\$0.0334	Plastic
Rear release Polymer retention MIL-C-83723	7,500	\$30	\$0.004	Rubber
Rear release Metal retention MIL-C-83723	1,500	\$30	\$0.02	Plastic

gether on the decision. Table 1 summarizes the basic points of comparison. More specific application life-cost considerations must be based on the connector materials and the type of insertion-removal tool.

Insertion-removal tools, normally used with removable-crimp contacts, can be either metal or plastic. Life costs of typical tools are compared in Table 2.

Connector life is determined, not by the type of retention system, but by the connector materials. These are basically metal, rubber, and plastic. The latter two rubber or plastic determine the "reliable life" of a connector operating at 200°C. (The reliable life of a plastic ma-

terial is defined as the time required for it to lose 8% of its original weight; the plastic thus loses its strength, and a contact would be pushed out. The reliable life of silicone rubber is defined as the time required for it to lose 50% of its original elongation; the rubber thus loses its ability to seal).

Table 3 summarizes the life cost of materials used in connectors. Table 4 summarizes the life cost of typical connectors of similar size employing front or rear, plastic or metal retention systems. □

Engineer's Notebook is a regular feature in Electronics. We invite readers to submit original design, applications, and measurement ideas. We'll pay \$50 for each item published.

Analog comparators may facilitate ECL applications

If you've been itching to use new high-speed emitter-coupled-logic circuits in data-acquisition systems, but have been holding back because you couldn't afford complex high-speed analog circuitry to go along with the ECL, help is on the way. **Comparators, for example, are now becoming available with less than 10-nanosecond propagation delays**, which will allow building such circuits as 100-megahertz sample-and-hold units. Advanced Micro-Devices, Sunnyvale, Calif., and Motorola Semiconductor, Phoenix, are among the first to offer the new circuits.

Spinning nylon cuts polyurethane in pc board repair

In replacing components on coated pc boards, do you have trouble removing polyurethane conformal coatings without damaging the copper traces? Engineers at Ampex Corp. Instrumentation division faced this problem in developing a recorder for NASA's Skylab. The NASA-specified coating PR-1538 is rather hard and thick, and while hot-wire and knife techniques can get the top layers off, the material that lies under dual in-line ICs is troublesome. Ampex engineers used **short lengths of nylon filament, as small as 30-mil diameter, in an electric drill** (any hobby type, such as the Dremel Moto-Tool will do). The rotating nylon gets into hard-to-reach places, and is both hard enough to chew out the remaining polyurethane and soft enough to avoid harming the metal traces.

Videotape teaches memory course

Planning to use semiconductor memories? If you can get your management to spring for \$295, **you could attend a new videotape course from Texas Instruments on all kinds of storage elements**—from high-speed ECL to low-speed core, including MOS and cache memories. More than half the course deals with applications. TI is sending the tape on a seminar tour in September to 20 cities, beginning in the Washington-Baltimore area. **TI will also sell a copy of the video tape and printed materials for less than \$4,000** if your company has, say, 15 or 20 engineers to take the course. A one-hour evaluation tape summarizing the memory course and the earlier MOS course is being sold for \$35. Also look for a course on linear ICs, which will be ready in February. And if you live in the Dallas-Fort Worth area, you will be able to see TI's first course—"Understanding Semiconductors"—on the local Public Broadcasting System this fall.

Addenda

Talk about making things easy for the service technician—one of GE's new solid-state color TV chassis has four **dual in-line ICs with small plastic extractors attached to each IC during assembly**. If the TV repairman has to yank the device, he's got a disposable extractor already in place. . . . **If you're considering using flat cable, you'll find useful a revised version of the Institute of Printed Circuits' "Handbook of Flat Cable."** In 34 pages, it gives as good a wrap-up of the subject as we've seen. It goes for \$5. Write to IPC, 1717 Howard St., Evanston, Ill. 60202, and ask for IPC-PC-230A. . . . Another new handbook worthy of attention is the **"Analog Digital Conversion Handbook"** from Analog Devices Inc., Norwood, Mass. 02062. The 3/4-inch-thick paperbound book carries a price tag of \$3.95.

N-channel MOS bids for mainframes

Memory system built around 1,024-bit RAM gives 250-ns access time; 2.7 million bits of storage can be packaged in 19-inch rack-mount chassis

by Laurence Altman, Solid State Editor

Only a few months have passed since a fast 1,024-bit n-channel MOS memory component became available, and already it's the heart of a memory system that offers not only n-channel speed but the capacity, price, and other advantages of MOS.

First to put it all together is Monolithic Systems Corp. with its Monostore VI/Planar, a general-purpose modular memory system using the n-channel 1,024-bit elements made by Electronic Arrays Inc. The basic Monostore VI is built on a single printed-circuit card containing up to 81,920 bits and organized as 4,096 words by 20 bits. It provides an access time of 250 nanoseconds and a cycle time of 500 ns. It is faster than most core systems and approaches bipolar performance at much lower cost.

The Monostore VI cards are packaged on 0.5-inch centers to build a system that can contain up to 2.7 million bits in a 19-inch rack-

mount chassis. The system's access and cycle times, capacity, and size are expected to make it a strong competitor for the mainframes of large computers. Smaller versions of the modular system will be useful for buffering, display refreshment, digital control, minicomputer memories, and extended stores.

In addition to the storage array, the single-board Monostore VI includes timing and control circuits, address register and decoding, and data input and output registers.

The system is organized around Electronic Arrays' 1,024-word-by-one-bit dynamic RAM, the EA 1500 [*Electronics*, March 27, p. 136]. This element is placed in a plug-in socket and, along with the interface circuitry, forms the complete memory. The Monostore, which is compatible with TTL in both input and output, is constructed so that when large systems are desired, a bus arrangement can be used. With this ar-

range, the address is strobed into the addressed module and then onto the bus.

As shown in the block diagram, the address register, 12 bits long, loads the input address upon receipt of the read/write command. The timing and control card provides all the timing pulses to the memory and the return pulses to the interface.

To load a word into the Monostore system requires 500 ns from receipt of the write command. However, since the memory contains an input data register, the input need only be held until the write pulse has returned high. The memory will then continue to write the data into the location addressed.

Another feature of the system is its built-in addressing capability; this allows addressing of up to eight modules. By using eight modules, tied to a common address, data, and command bus, addressing can be arranged to provide 32,000 words. Additional words may be addressed by external decoding logic.

Three modes. The memory has a read-modify-write mode, as well as the standard read and write command capability. The read-modify-write mode is initiated by a read command and performs a read operation in 450 ns; it allows a 50-ns modify time and writes the modified data back into the location addressed. The old data is retained in the memory output register. The modify time may be changed by changing the data pulse width, a process that requires the cycle time to be lengthened.

The memory system accepts TTL or DTL integrated circuits, so buffers are not required. The low logic level

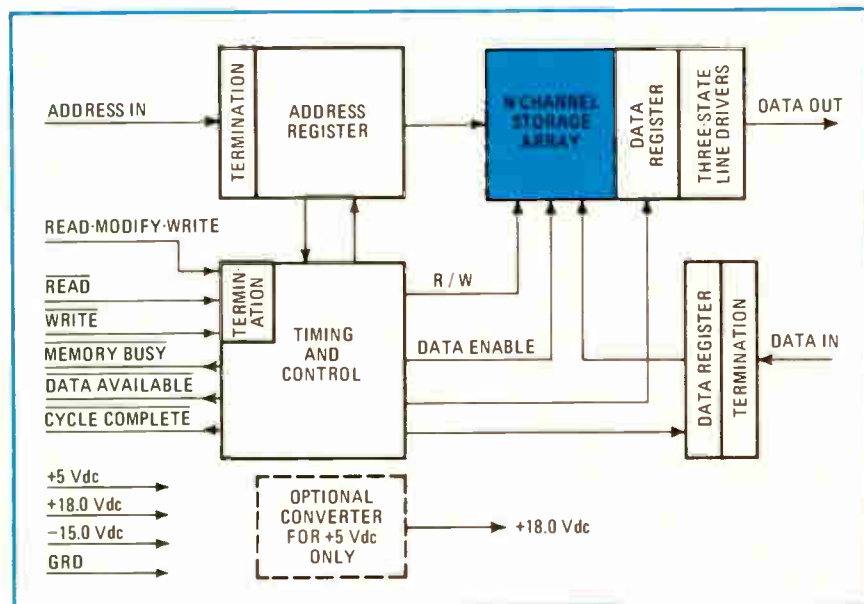

CATV-MATV AMPLIFIERS

is between 0 and 0.5 volt, and the high level is between 2.5 and 5.5 v. All of the input lines are terminated at the memory by a 330-ohm resistor to ground and a 270-ohm resistor to 5 v.

Address input lines, to a maximum of 16, carry address information to the memory. The address input is single-ended and contains the binary input which specifies the memory word to be operated on. The address must be in a stable logic state at the start of the read or write command, and it must remain stable during that command.

The standard outputs are from Tristate TTL circuits and require a terminating resistance at the receiving end of the line. The low level is

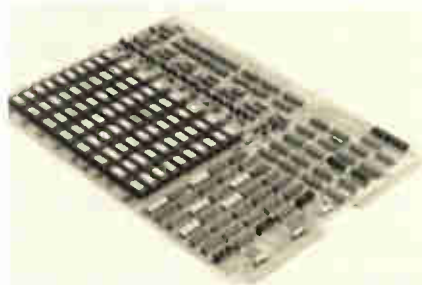

Memory on a card. The basic system consists of 80 n-channel MOS storage elements plus control electronics on one circuit card.

between 0 v and 0.5 v and with a sink capability of 20 milliamperes. All timing relationships are measured between the 50% points. Rise and fall times are measured between the 10% and 90% points.

The data is read out in the form of one line per bit from the register, which is loaded with the proper data during the read operation. The data output is valid at the time of the data-available pulse and remains valid until the next memory operation. Depending on the connection of the data-enable line, the output may be a level or a strobed type.

The system requires +5 vdc, +18 vdc, and -15 vdc. If the external power supply has +5 vdc only, the others can be generated by using a dc-to-dc converter. This converter, offered as an option, attaches to the main circuit board via standoffs.

Monolithic Systems Corp., 2700 So. Shoshone, Englewood, Colo. 80110 [338]

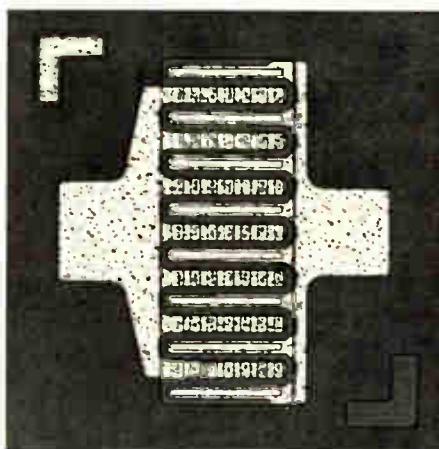

WIDEBAND RF AMPLIFIERS - BFR 36, BFR 38 AND BFR 99

We now have the ideal transistor kit for antenna amplifier applications. It consists of BFR 38 and BFR 99, the only two PNP devices in the market specially developed for MATV (Master Antenna TV) and CATV (Cable Antenna TV) amplifiers, combining high frequency, low noise and high power. The kit is completed by the ultra linear power NPN transistor BFR 36.

- Ultra low noise
- Very high frequency: $f_T = 1.4$ GHz
- Ultra linear high gain
- Very good intermodulation properties

Frequency range (MHz)	Channel 61 to 68	Channel 200 to 207	Channel 510 to 517	Channel 742 to 750
TRANSISTOR USED IN:				
Final stage	BFR 36	BFR 36 BFR 36	BFR 36 BFR 36	BFR 36 BFR 36
Driver stage	—	BFR 99 BFR 99	BFR 99 BFR 99	BFR 99 BFR 99
Third stage	—	—	— BFR 99	— BFR 99
Second stage	—	— BFR 38	BFR 99 BFR 38	BFR 99 BFR 38
First stage	BFR 99	BFR 38 BFR 38	BFR 38 BFR 38	BFR 38 BFR 38
OUTPUT VOLTAGE (V_{rms}) on 75 Ω at $d_{im} = 30$ db				
	3.3	3.3 3.3	2.5 2.5	2.0 2.0
POWER GAIN (dB)				
	50	45 60	45 55	30 45
NOISE FIGURE (dB)				
	4.0	4.0 4.0	4.5 4.5	5.0 5.0
V.S.W.R. over the whole channel:				
for the Input	< 2	< 2 < 2	< 2 < 2	< 2 < 2
for the Output	< 2	< 2 < 2	< 2 < 2	< 2 < 2

SGS-ATES SEMICONDUCTOR CORPORATION
 435 Newtonville Avenue · Newtonville, Mass. 02160
 Phone (617) 9691610

A Member of the SGS/ATES Group of Companies

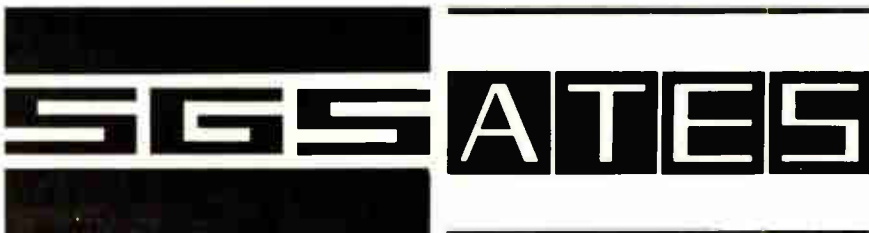

Solder or socket: a new approach

Low-cost DIP carrier assembly allows user to defer decision on solder or plug-in method until system design is complete

by Stephen E. Scrupski, Packaging & Production Editor

Wire-wrapped interconnections for dual in-line integrated circuits have been used increasingly in the past few years. That trend developed because more designers have recognized the importance of remaining flexible to design changes until late in prototype or even in early production stages. However, two major drawbacks to the approach have been the cost of the sockets required to provide the wire-wrapping posts and the potential unreliability of a socketed, rather than a soldered, IC. Now Augat Inc., Attleboro, Mass., has a low-cost approach that will allow users either to solder the ICs or socket them, still preserving the 0.1-inch grid on the posts to meet semiautomatic and automatic wire-wrapping machine needs.

The new interconnection system, designated the 8200 series, is based on a carrier in which the DIP is first inserted and has its leads crimped to hold it in place. The carrier, made of glass-filled nylon, is inserted between spring contacts that press against the sides of the DIP lead frame to make contact. The spring contacts, inserted in the circuit board, provide a wrapping post on the other side.

To fabricate a replaceable, socketed DIP, the carrier can be inserted with the DIP right-side up, with the DIP leads pointing downward (the "alive" position). The DIP can also be extracted if it is inserted with the leads pointing up (the "dead" position), but it would more usually be wave-soldered in place, with the crimped leads soldered to the tips of the spring contacts.

Augat figures that the cost of the new approach will be about 45 cents per IC position, ready for wire-

wrapping. This is about 60% of the cost of other socket wire-wrapping methods. The carriers will cost about 1 to 2 cents each, the company says.

The introduction of a new IC carrier is significant in terms of new test and insertion fixtures. The machines needed to insert the DIPs into the carriers, crimp the leads, and put the loaded carriers back into magazines have gone through a preliminary design phase at Universal Instruments Corp., Binghamton, N.Y., a producer of computer-controlled component-insertion machines. Universal also has modified conventional insertion machinery to handle the loaded carriers, inserting them in either the dead or alive position. Some programming changes would have to be made if the DIPs are to be inserted in the dead position, since the terminals then would appear to be mirror images of the alive position.

The Universal contacts are constructed on one piece and thus are less costly than Augat's two-piece machined contacts. When inserted

in the alive position, the carrier causes the DIP to be about 1/8-inch higher in profile than it would be in present Augat boards, in which the DIP is inserted directly into the socket pins.

However, dead and alive mountings could not be mixed on one board if soldering is to be performed later, since the alive-mounted DIPs would have to be protected from the solder bath. Before soldering, the carrier can be tested in either position.

Augat also has tooled up to produce adapters for flat-cable connectors having pins in the dual in-line format, as well as for empty DIP shells that would hold custom circuitry and mate with the contacts on the circuit board. Panels will be available in a standard format, but special units will also be available without appreciable extra time or expense, according to the company. A test report that shows reliability levels under extreme conditions has been prepared.

Augat Inc., 33 Perry Ave., Attleboro, Mass. 02703 [339]

Dead or alive. In the dead position, the DIP—on its back with legs up in the air—can be either plugged in or soldered. The alive position is for pluggable operation only.

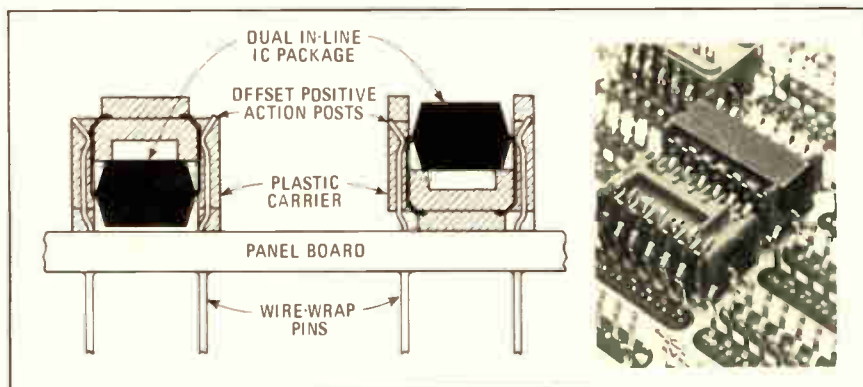

Components

Active filters use IC op amps

Integrated amplifiers tighten frequency tolerances, lower prices of pretuned units

A manufacturer of active filters since 1966, Burr-Brown is now introducing a family of filters that contain integrated operational am-



plifiers, rather than discrete-component op amps like the company's earlier models. This integrated approach provides improved center-frequency accuracy, better temperature stability, less output noise, smaller size, and lower prices.

The series ATF76 filters mark the beginning of Burr-Brown's stepped-up active filter product program. The company is developing a universal active filter for release as a standard product this year. Tunable active filters will also move from custom to standard status before the year's end.

The new filters can operate at center frequencies ranging from 1 hertz to 20 kilohertz. They can perform low-pass, bandpass, or notch (band-reject) filtering functions. The low-pass units provide Butterworth, Bessel, or Chebyshev responses with 2, 4, 6, or 8 holes. The bandpass filters are available either as single-tuned (one pole pair) units with a Q of 2 to 50 or as stagger-tuned (two pole pairs) units with a Q of 2 to 20. Notch models are two-pole units offering Qs of 2 to 10.

All filters are complete circuits; external components are not required for tuning, which is done at the factory. Moreover, they are supplied in encapsulated modular packages that have a low 0.4-inch profile. Two-pole low-pass and notch models are housed in the smallest package, measuring 1.5 by 1.5 inches. Six- and eight-pole low-pass models occupy the largest packages of 2.1 by 3.0 inches.

Center-frequency accuracy is within $\pm 1\%$ for bandpass filters and $\pm 2\%$ for low-pass and notch filters. Frequency drift is as low as $\pm 0.03\%/^{\circ}\text{C}$ over the temperature range of -25° to $+85^{\circ}\text{C}$. All the filters are specified as unity-gain devices having a gain accuracy of within $\pm 0.5\%$. Output noise level is held to 50 microvolts for low-pass units, 100 μV for bandpass units, and 200 μV for notch units.

Series ATF76 filters are available from stock in small quantities. Single-unit prices range from \$35 to \$123, while 100-piece prices drop to between \$21 and \$109.

Burr-Brown Research Corp., International Airport Industrial Park, Tucson, Ariz. 85706 [341]

Film resistors double power capacity in standard package

Eight new metal oxide film resistors double the power capacity available in a standard package. The ROH units offer a range from 3.8 watts to 20W at 220°C , with voltages from 7.5 kilovolts to 40 kV. Resistance is from 100 ohms to 8,000 megohms. The units are designed for power circuit applications requiring high stability, accuracy, and long component life. Typical uses include meter multipliers, bleeders, voltage divi-

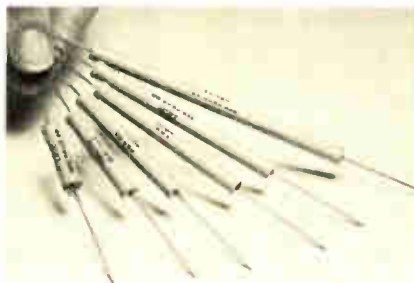

ders, and dropping and filter resistors. They can also be used in many ac applications.

Resistance Products Co., 914 South 13th St., Harrisburg, Pa. 17104 [344]

Keyboard has output code built into each switch

An optical-switch keyboard generates the final output code directly in the keyswitch. Each keyswitch contains a unique code in the form of a light mask, and key depression causes selective masking of collimated light beams in accordance with the specified code. A single incandescent light source and parabolic reflector provide the light for the entire keyboard. Sixteen photodetectors are sufficient for an 85-key unit. Options include parity

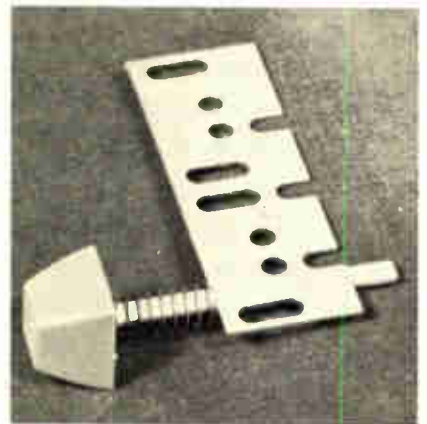

generation, serial or wired-OR output, special codes, and a desktop case. Single price for a 53-key ASCII-coded keyboard is \$150, with quantity prices as low as \$66.

Weston Digital Systems Inc., 7100 Mesa Dr., Austin, Texas 78731 [345]

14-pin DIP delay line is only 0.220 inch high

The series LC-250 lumped-constant delay line is available in a 14-pin dual in-line package measuring 0.220 inch high. The epoxy-molded unit affords the user savings in printed-circuit-board packaging density. Delay times offered are from 5 to 200 nanoseconds, and rise

CLASSIFIED ADVERTISING

SEARCHLIGHT SECTION

BUSINESS OPPORTUNITIES
USED OR SURPLUS EQUIPMENT



RADAR SYSTEMS GROUND AND AIRBORNE, AUTOMATIC TRACKING ANTENNA SYSTEMS, NIKE AJAX, NIKE HERCULES, M-33, MSO-1A, MPS-19, MPS-9, SCR 584, TPS-1D, TPS-28, FAA-ASR-2, AIRBORNE SYSTEMS, APN-84, APN-102, APS-20, APS-27, APS-45, DPN-19, DIGITAL COMPUTERS, IBM 650, IBM 704.



LARGEST INVENTORY OF RADAR AND MICROWAVE EQUIPMENT IN THE WORLD.
RADIO RESEARCH INSTRUMENT CO.
3 QUINCY ST., NORWALK, CONN. 06850 (203) 853-2600

CIRCLE 952 ON READER SERVICE CARD

WELDING HAND TOOL

TW 17 A
\$ 48 00



Replaceable Tip - Adjustable Pressure
AC and Stored Energy Power Sources

EWALD Instruments Corporation
Route 7E, Kent, Conn. 06757

CIRCLE 953 ON READER SERVICE CARD

Somebody— Somewhere

needs your idle equipment! Reach that buyer quickly and economically thru the

“SEARCHLIGHT SECTION”

The meeting place of
Used Equipment Buyers and Sellers

Send new ads to:

ELECTRONICS
P.O. Box 900, N.Y., N.Y. 10020

New products

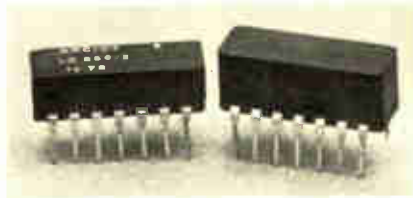

times are from 2 to 40 nanoseconds. Impedances are 50, 100, 200, and 360 ohms, and attenuations range from 3% to 15% minimum, depending on the other values. Each delay has 10 taps at equal timing intervals.

Arcidy Associates, 370 Commercial St., Manchester, N.H. 03101 [346]

Dry reed relay is housed in TO-116 dual in-line case

A dry reed relay offers simplicity of assembly testing and servicing, along with transistor-transistor-logic

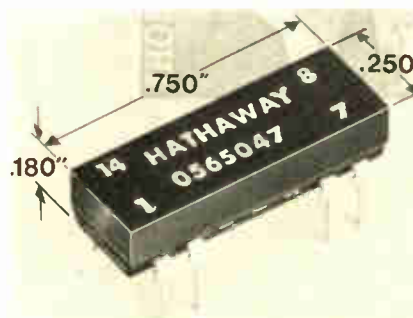

compatibility. In order to facilitate automatic insertion with integrated-circuit production machines, the unit is housed in a TO-116 dual in-line package. Other features include low contact resistance, high packaging density, high dielectric strength, long life, and good environmental capabilities.

Hathaway Instruments Inc., 5250 East Evans Ave., Denver, Colo. 80222 [348]

Thumbwheel switches have board-mounting terminals

A line of rotary thumbwheel switches includes terminals that are compatible with printed-circuit boards. The 1976-series switches measure 0.350 inch wide and are available with 0.090-inch notched

terminals for mounting on 1/16-inch mother boards or 0.160-inch notched terminals for use with 1/8-inch boards.

Electronic Engineering Co. of California, 1601 East Chestnut Ave., Santa Ana, Calif. [347]

Chip inductor is silicone-encapsulated

Providing high-temperature construction, a new chip inductor has a ceramic pad and rigid silicone encapsulation. Tinned edge and bottom connectors permit a visible solder fillet to be formed in applying the device. Compatibility with other chip components is provided by the rectangular shape. Large bonding pads insure adhesion, and the encapsulation provides a low outgassing characteristic.

Piconics Inc., Cummings Rd., Tyngsboro, Mass. 01879 [349]

Slide switch offers 1 1/8-inch mounting centers

The 6600 series of small slide switches has 1 1/8-inch mounting centers. The single-pole units are available in two and three positions with momentary or maintained contacts, in a variety of circuit configurations,



actuator sizes, and colors. Ratings offered in the series are 6 amperes at 125 volts ac, 3 A at 250 V ac, and 1 A at 125 V dc.

Tower Manufacturing Corp., 158 Pine St., Providence, R.I. 02903 [350]

Instruments

Ac calibrator is programable

Separate precision amplifier can boost output to 1,200 V rms at 200 mA

The John Fluke Manufacturing Co., supplier of high-accuracy dc calibration equipment, has started building ac calibration instruments. Its model 5200A is remotely programable in both frequency and amplitude. A companion product, the 5205A power amplifier, can be used with either ac or dc sources.

The basic 5200A ac calibrator is priced at \$3,995, and the remote programming feature is a \$995 option. Fluke says this \$4,990 total compares with prices of \$8,000 and up for equivalent instruments that are programable in frequency and amplitude. The 5205A amplifier is priced at \$2,495.

The instruments are intended for use in calibration laboratories, by makers of digital voltmeters, and in precision gyro work where precise voltages and frequencies are required. Because the oscillator in the 5200A calibrator can be locked to an external source, such as the Fluke 6160 frequency synthesizer, highly accurate frequency and amplitude can be obtained.

The 5200A range extends from 10 hertz to 1.2 megahertz, and frequencies are controlled to four-digit resolution. Amplitude is controlled in seven ranges from 1 millivolt to 1,000 volts. Six-digit resolution is provided in 1-nanovolt steps in the 1-mV range and increases to 1-mV steps in the 1,000-v range; 20% overrange capability is standard for all ranges. The 5200A provides outputs from 100 microvolts rms to 120 v rms at a 50-milliampere current level. The 5205A extends both voltage and current range to 1,200 v rms at 200 mA rms.

Amplitude accuracy for the 5200A is within $\pm(0.02\%$ of setting

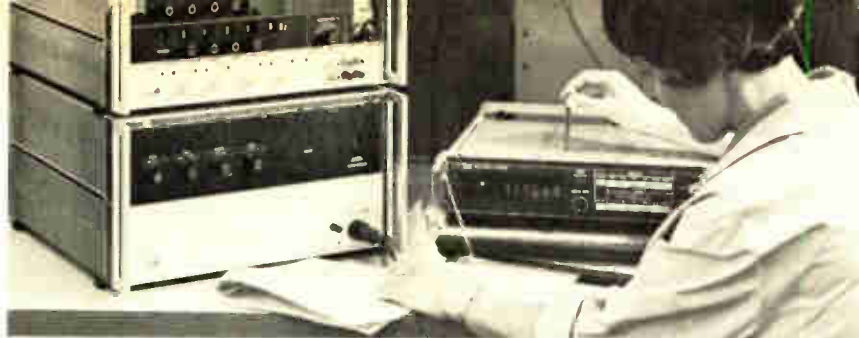

+ 0.002% of range) for midband frequencies from 50 hertz to 20 kilohertz. When coupled with the 5205A amplifier, midband accuracy is within $\pm(0.03\%$ of setting + 0.003% of range) for amplitude levels from 100 v to 1,200 v rms. Frequency accuracy is within $\pm(1\%$ of setting $\pm 0.1\%$ of range).

The 5205A may also be used as a separate amplifier for a wide range of dc, sinusoidal, and complex waveforms generated by a variety of other stimuli from dc to 120 kHz. When it is used with the 5200A, the combination may be controlled manually or remotely as a single instrument.

By itself, the 5205A amplifier is highly flexible. A dc-coupled precision power amplifier with programable gains of 10 and 100, it provides dc output voltages from zero to 1,600 v at current levels of 100 mA. Ac output voltages of 1 mV to 1,200 v rms can be obtained at current levels of 200 mA rms.

One application of the 5205A is generating fast high-voltage pulses for component stress testing. Driving the 5205A amplifier with an appropriate function generator, a typical 700-v pulse would have rise and fall times of about 900 ns.

Delivery of the instruments will begin during the third quarter.

John Fluke Manufacturing Co., Box 7428, Seattle, Wash. 98113 [351]

Storage scope writes at 200 cm per microsecond

For capturing high-speed, one-shot electrical events, the storage oscilloscope is a welcome alternative to the high-speed camera. It permits extended analysis of the trace and, in the case of signals with low repetition rates, provides a constant-light-level display.

A new storage scope from Tektronix increases both the writing speed

and viewing time for these signals far beyond what has been commercially available. The model 7623 offers a stored writing speed of 200 centimeters per microsecond and a viewing time of many tens of hours. In addition, the 7623 can function in a variable-persistence mode (Tektronix' debut in this field), as a bistable storage scope, or as a conventional 100-megahertz instrument.

The 7623 is one of three new Tektronix storage scopes. The others are the 7613, which has a transmission half-tone CRT with a variable-persistence feature and a view time of 7 minutes; and the 7313, which has a bistable CRT with split-screen storage and a view time of 4 hours. Both write at 5 div./ μ s. All three offer Tektronix' alphanumeric display of measurement data along with the waveform on the CRT and, since they are members of the 7000 series, accept all of the 24 plug-ins.

With the top-of-the-line 7623, a vertical display in excess of one centimeter with a 50-MHz single-shot sine wave, for example, can be stored with a sweep speed of 20 nanoseconds per division—0.9 cm per division. Its long viewing time allows the user to locate a specific event and still gives him time enough to find a camera, hunt up a roll of film, and take the picture.

The 7623's mesh-to-mesh transfer storage CRT uses the principles of both a classic halftone transmission CRT and a bistable direct-viewing storage CRT. In its halftone mode, it offers a high-contrast display of slower-speed signals for viewing times of a few minutes. Halftone operation also provides for the variable-persistence feature. The bi-



New products

stable mode is used for slow-speed signals, but has a view time of many hours.

The transfer storage CRT includes a proprietary high-speed target. Essentially, the signal is stored on this target and then is transferred to a long-view-time bistable target.

The 7623, without plug-ins, sells for \$2,850; the 7613 for \$2,500, and the 7313 for \$2,000. All will be available in September.

Tektronix Inc., Box 500, Beaverton, Ore. 97005 [352]

Transient store recorder built for industrial tests

A transient store recorder accepts and stores single-shot transients or recurring analog signals, in single or dual channels, for playback in digital or analog form. The model 512A is designed for operation over the range from dc to 50 kilohertz, and is aimed at industrial testing, structural analysis, and other appli-



cations where high resolution of the captured data is important. Data is stored in a microcircuit memory offering 2,048 samples in a single channel or 1,024 samples in dual channels with 0.1% amplitude resolution. Price of the recorder is \$2,475.

Physical Data Inc., 5160 North Lagoon Ave., Portland, Ore. 97217 [354]

Digital multimeter offers 1-microvolt resolution

A digital multimeter, the model 2540/A1, provides 18-range, four-parameter measuring capability, with ac/dc resolution of 1 microvolt. With a 5½-digit readout, the unit can measure ac and dc voltage from 100 millivolts full scale to 1,000



volts full scale, dc ratio from $\pm 1.00000:1$ to $\pm 100.000:1$, and resistance from 100 ohms full scale to 10 megohms full scale. Overrange of $\pm 20\%$ is provided on all functions. Price is \$1,295.

Data Precision Co., Audubon Rd., Wakefield, Mass. 01880 [355]

Versatile pulse generator covers 20 hertz to 50 MHz

The model 850 pulse generator spans the range of 20 hertz to 50 megahertz, and offers pulse widths from 10 nanoseconds to 50 milliseconds and delays from 10 ns to 50 ms. Frequency, width and delay are each adjustable in 10 coarse ranges, with fine verniers providing continuous variations within each range and overlap to adjacent ranges. Pulse rise and fall times are less than 4 nanoseconds, and duty cycles to within 99% may be obtained.

Dytech Corp., 391 Mathew St., Santa Clara, Calif. 95050 [356]

Pulse generator includes breadboard power supply

A pulse generator designated the model 88 is a source of transistor-transistor-logic driving pulses, and has a built-in 5-volt TTL breadboard power supply. Features include repetition rates to 20 megahertz, 5-nanosecond rise and fall times, current sink capability, and narrow pulse widths. Overload indication is pro-



vided by a pilot light, and a crowbar circuit protects against overvoltages. Price is \$395.

Systron-Donner Corp., Datapulse Div., 10150 West Jefferson Blvd., Culver City, Calif. 90230 [357]

Counter gives autoranging in frequency and time modes

The Autometronic counter 5500A autoranges both time interval and frequency measurements. The autoranging circuitry uses a read-only memory so that measurements with the desired resolution can be made without operator adjustments. The instrument is self-adjusting so that the most significant digit is in the left-most position. Resolution is se-



lectable in 4, 5, 6, or 7 digits, and the unit has 10 operating modes plus a check or test mode. The modes are: count, frequency, period, positive pulse width, negative pulse width, period average, ratio A/NB, time A to B, time interval and remote programming. The unit, in a basic six-digit package, is priced at \$650.

Ballantine Laboratories Inc., P.O. Box 97, Boonton, N.J. 07005 [358]

Picoammeters cover 8 decades on one scale

Logarithmic picoammeters are able to display up to eight decades on a single meter scale without any need for range changing. The 26000 series includes three models, each of which covers a different range within the total span from 10^{-13} to 10^{-3} ampere. Extra-cost options include negative-only input, bipolar

input, internally installed bias supplies, contact meter relays, and electronic trips. Applications include semiconductor and capacitor testing



and leakage-current monitoring. Prices vary from \$875 to \$950 depending on range.

Keithley Instruments Inc., 28775 Aurora Rd., Cleveland, Ohio 44139 [359]

Compact 25-MHz scope provides X-Y capability

A dual-trace, compact 25-megahertz oscilloscope designated the model D66 is priced at \$795. Bright displays are obtained by using 10 kilovolts on the rectangular 5-inch CRT. Sweep rates from 2 seconds/division to 100 nanoseconds/division, X-Y measurement capability, and 14-nanosecond rise time are offered. Accuracy is to within 5%. Deflection

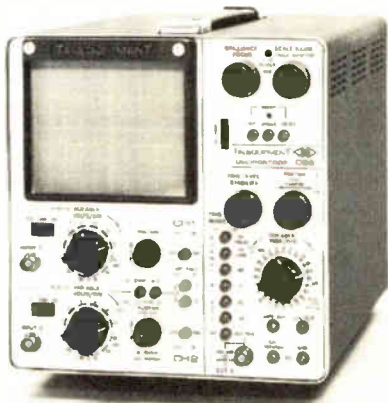

factors extend to 10 mv per centimeter at full bandwidth and to 1 mv/cm at 15 MHz. The unit can also trigger at television field or line rates.

Tektronix Inc., P.O. Box 500, Beaverton, Ore. [360]

Until mini-computers get smart enough to talk to mag. tapes here's a great

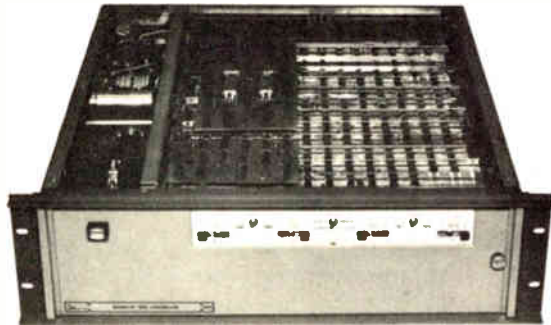

conversation piece

Name just one magnetic tape formatter versatile enough to handle dialogue between most mini-computers and multiple tape units. Seven- and nine-track mix, NRZ and phase-encoded formats, different densities, several speeds. And play software-compatible controller too.

Some clues to put you on the right track: it's new. It generates and reads IBM-compatible NRZ and/or phase-encoded formats. One formatter will handle up to four 7- or 9-track, multiple-density (200,556,800 bpi), multiple-speed (6.25 to 112.5 ips) magnetic tape units. Plug in a computer adapter and you have a complete controller system. Daisy-chain two formatters and control up to four 7- and 9-track NRZ plus one to four 1600 bpi tape units.

DATUM Computer adapters for most mini-computers are off-the-shelf items. Plug these single-board adapters directly into the existing enclosure, or buy blank boards with up to 196 IC sockets already mounted, if you wish, and design your own. DTL/TTL integrated circuit logic is used throughout the formatter design to ensure compatibility. Software compatibility with both computer manufacturers' packages and existing user-developed routines comes from years in the computer-interface business.

Got it? It's DATUM's Series 5091 Magnetic Tape Formatter. Versatile, reliable, economical. A great way to get your mini-computer talking to tape machines. While you strike up more rewarding conversations. Like call us for information:

DATUM

PERIPHERAL EQUIPMENT DIVISION

the mini-peripheral people

170 E. Liberty Ave., Anaheim, Calif. 92801 Telephone: (714) 879-3070.

New products

Data handling

Card reader is rugged

Low-priced static unit for 80-column cards uses continuous-brush technique

Photo-optical techniques have just about taken over dynamic card reading for computer input, but an improved version of an earlier technique—the brush method—has been developed by Hickok Controls Division for a static card reader that sells for under \$500.

Aimed at data collection, automatic inspection, and programing control applications where the user wants access to many bits of information at the same time, the model 960A reads standard 80-column, 12-row tab cards, using a continuous-brush technique. Accurate readings and long-term durability are insured by multi-strand contacts instead of single-point sensing. Through each hole in the card, three to five strands make electrical contact to a metal pad. Readings are insured even if the card holes are slightly off center.

In addition, the brush contact provides a positive double-wiping action, to stop contaminants on the card from obscuring the correct readings.

Hickok also offers a choice of interface electronic packages. The model 80 scanner has two operating modes, sequential and addressable. In the sequential mode, an externally supplied advance pulse steps the scanner to the next column. In the addressable mode, col-

umns may be addressed randomly. Corner sensing insures proper card insertion in the model 960A. Readings will not occur until a card is in the correct position. Remote reset is standard: the reader will retain the card until commanded by the system to eject it and reset.

Price of the 960A is \$495, with quantity discounts ranging up to 45%. Delivery time for volume orders is 90 days.

Instrumentation & Controls Division, The Hickok Electrical Instrument Co., Dupont Ave., Cleveland, Ohio 44198 [361]

Universal format converter built for on-line systems

A self-contained interface unit, for on-line systems with dissimilar code formats, speed differentials and input-output levels, is designated the model 702 universal format converter. The device accepts any 5-, 6-, 7-, or 8-level start-stop code and generates an equivalent output in any other code. The converter handles 1/O speeds from 37.5 to 4,800 baud. Synchronous input circuitry for special synchronous-to-start/stop conversion applications is available at customer request. The model 702 is programed to customer specifications, using a programable read-only memory chip that can be reprogramed at the factory if requirements change.

Frederick Electronics, Hayward Rd., P.O. Box 502, Frederick, Md. 21701 [363]

Printer operates at 36 characters per second

The model 55 printer, which comes in a case with interface and power supply, accepts serial-by-character or full-parallel binary-coded data inputs and is transistor-transistor-logic compatible. Printing speed is up to 3 lines (36 characters) per second, with a 12-column capacity, using numerals or limited alpha characters. Twelve characters are available in each column. The printer operates with a 115-volt, 60-



cycle-ac motor, and has a self-contained re-inking ribbon. Price of the complete unit is from \$44 to \$500, depending on quantity and configuration.

Addressmaster Corp., 416 Junipero Serra Dr., San Gabriel, Calif. 91776 [364]

Mark/hole readers handle punched, hand-marked cards

Two 80-column card readers photo-electrically read punched cards, pencil-marked cards, or cards with both punched and pencil-marked data. The models 8035 and 8045 handle 300 cards per minute and 450 cards per minute, respectively.



They operate by pushbutton control for different reading modes. Price of the model 8035 is \$2,115 in OEM quantities of 100; and the model 8045 is priced at \$2,265.

Bridge Data Products Inc., 738 South 42nd St., Philadelphia, Pa. 19104 [365]

Digitizer provides direct output to peripherals

A semiautomatic digitizer called the MetriGraphic combines integrated-circuit design with a rotary encoding system to provide direct output to an ASR-33 Teletype, punched

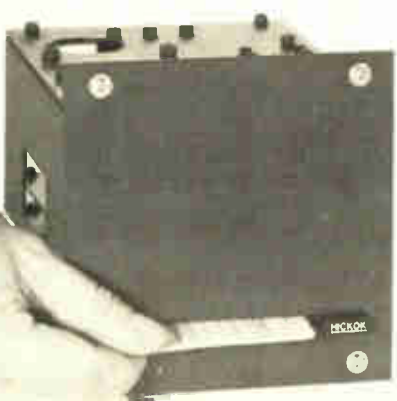

cards, magnetic tape, or automatic digital drafting system. The primary function of the unit is to convert graphs, charts, maps, design drawings, or printed-circuit artwork to digital form. The optical cursor is moved by hand over the surface of the graphic material so that digitizing is accomplished instantaneously, and the resulting signal is fed directly into a digital recorder or any I/O device. Price is under \$10,000.

H. Dell Foster Co., P.O. Box 32581, San Antonio, Texas 78216 [366]



Modem, dialer combined in compact cabinet

A data modem also incorporates an automatic dialer in the same compact cabinet. Consisting of plug-in modules, the modem/dialer is compatible with Bell System 103A (300-baud) or 202C (1,200-baud with or without reverse channel) modems and with Bell 801A (pulse) or 801C (Touch-Tone) automatic calling units. The chassis features complete diagnostics, a front-panel display of all interface leads, and audible monitoring of line signals. The unit

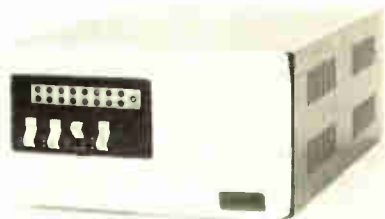

is equipped with a row of eight lights to indicate the status of the dialer interface lines, while another eight lights display the interface

status of the modem. Price is \$700 for 300 baud with dialer, and \$800 for 1,200 baud with dialer.

The Vadic Corp., 916 Commercial St., Palo Alto, Calif. 94303 [367]

Batch terminal verifies data validity at source

Data validation at its source is possible with the model 88-23 remote-batch terminal system. The unit has a built-in programable minicomputer and magnetic-tape storage system that relieves the operator of numerous formatting, information-access, arithmetic and data-input tasks, thus reducing the margin of human error. Descriptions of the source documents are entered into the memory of the terminal, which then controls the data entry and automatically verifies the validity of



certain data entered. This can include customer codes, order number sequences, and operational codes, as well as check digit verification. The 88-23 includes a minicomputer with a memory of 4,000 words, expandable to 8,000 words.

Data 100 Corp., 7725 Washington Ave. South, Minneapolis, Minn. 55435 [368]

80-column-card reader handles 1,000 cards/minute

An 80-column-card reader can handle up to 1,000 cards per minute, and is particularly suited to remote-job-entry terminal operations that typically process 200,000 to 300,000 cards a day. The model 1000 uses a single rotating mechanism to eliminate common picking,



transport, and stacking problems, and a fiber-optic read-head provides error-free performance. The unit can be linked with most existing controllers, and is aimed at users who have programable terminals or run high-speed (9,600-baud) line printers operating at 600 lines per minute or more. OEM prices are \$1,995 for one unit and \$1,735 in quantities of 100.

True Data Corp., 550 Newport Center Dr., Newport Beach, Calif. 92660 [369]

Modems have self-test and remote diagnostics features

A 2,400-bits-per-second modem designated the 24 LSI, and a 2,000-bits/s model called the 20 LSI, incorporate MOS LSI circuitry and offer a remote test feature for error diagnosis in point-to-point or multipoint systems from a single site. A status panel display permits on-line evaluation of the data communi-



cations system. Self-test capability is built-in, and options include automatic answer and reverse or secondary channel. The modems operate over the public dial-up network as well as over dedicated lines. Price is \$1,780 in small quantities, or lease is \$53 per month.

International Communications Corp., 7620 N.W. 36th Ave., Miami, Fla. 33147 [370]

Semiconductors

1,024-bit RAM has 35-ns access

Low speed-power product offered in memory using air-isolation technique

With new bipolar isolation methods showing the way, semiconductor makers are racing to market with both transistor-transistor-logic and emitter-coupled-logic versions of the 1,024-bit random-access memory.

Raytheon Semiconductor has chosen the ECL route for its RR5502, which offers one of the best available speed-power products—a typical access time of 35 nanoseconds at a total dissipation of 400 milliwatts.

The Raytheon device is built with an air-isolation technique [*Electronics*, July 17, p. 65], which the company calls V-A TE, for vertical anisotropic etch. The process permits the memory cells to be 10 times smaller than those of the earlier bipolar memories that have active p-region isolation.

The only other bipolar 1,024-bit RAM currently available is Fairchild's Isoplanar memory, a TTL device with an access time of approximately 60 ns and a power dissipation of 500 mw. Both units are expected to go far toward satisfying the demand for faster semiconductor mainframe memories.

Besides providing fast access, the Raytheon RR5502 has attractive delay characteristics. Orlando Gallegos, memory and digital product manager, points out that, with a 2-ns propagation delay and gate current of only 1 milliamperere, the power-delay product is only 10 picojoules. This is one-quarter that of commercially available ECL devices, which usually need 4 mw per gate

to achieve 2-ns propagation delays.

"This low power-delay product means that the V-A TE process is capable of still higher densities," says Gallegos, who looks for a 4,096-bit RAM in the near future. "Now that the 1k units are in production and higher densities are coming, we're going after the core mainframe memory business," he says.

The Raytheon unit also has a low input requirement. Because of a pnp input, it needs only a 50-micro-ampere input current, so special drivers are not necessary.

Price of the RR5502 is \$100 each for 1-24 units; \$75 for 25-99, and \$57 for 100.

Raytheon Co., Semiconductor Division, 350 Ellis St., Mountain View, Calif. 94040 [411]

MOS FETs aimed at consumer applications

A family of MOS FETs for the consumer market offers television tuner manufacturers lower-noise features. For high-gain, low-noise performance in TV intermediate-frequency strips, Texas Instruments has designed an n-channel, dual-gate MOS FET with integrated back-to-back zener diodes for gate protection. It offers a typical noise figure of 2 decibels and 28-dB power gain at 200 megahertz, 14,000 microhms forward transconductance, and a low feedback capacitance of 0.05 picofarad, permitting high, stable gain without neutralization.

The device was developed for fm and vhf mixers as well as for rf and i-f amplifiers in TV, and can be used in cable-television amplifiers and converters. Designated the type SFC5414, it will sell for 90 cents in 1,000-piece quantities.

Three other new MOS FETs feature noise figures ranging from 2 dB at 200 MHz to 7 dB at 900 MHz. Typical power gains vary from 24 dB at 200 MHz to 12 dB at 900 MHz. Feedback capacitance is 0.03 pF; forward transconductance is 14,000 microhms. The 3N204, priced at 60 cents each for 1,000 pieces, is designed for rf amplifiers in TV and fm tuners, and can be used for uhf ap-

plications. The 3N205, also priced at 60 cents each, is for vhf mixers. The 3N206, priced at 55 cents, is for tuned high-frequency applications, such as i-f amplifiers in television i-f strips.

Texas Instruments, P.O. Box 5012, Dallas, Texas 75222 [412]

LED lamp provides 180° viewing area

A light-emitting diode lamp called the RL-21 provides a full flood viewing red light instead of a small spot in the center of a larger package. The lamp contains a gallium arsenide phosphide diode in a red-diffusive molded package. The viewing area extends 0.140 inch beyond the face of the mounting clip, which allows a 180° viewing area. Price is 65 cents each in 1,000-lots.

Litronix Inc., 19000 Homestead Rd., Cupertino, Calif. 95014 [414]

Differential multiplexer has decoder on same chip

A four-channel differential monolithic analog multiplexer includes a one-out-of-four decoder on the chip.

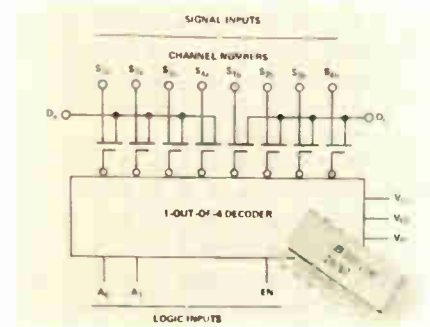

The device employs p-channel enhancement-mode MOS technology. The model DG511 features a ± 10 -volt analog signal range, as well as less than 250-ohms "on" resistance with the analog voltage signal at zero volts. Other features include break-before-make switching action and TTL-compatible log input lines. Price for 1 to 29 units is \$20 each for the industrial model, \$40 each for the military version. The device is

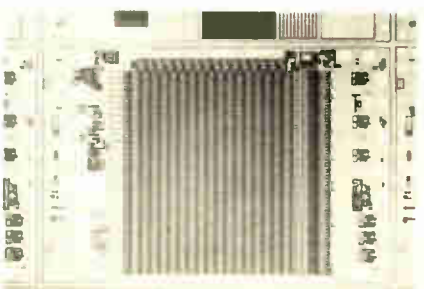

available in a 16-pin dual in-line package.

Siliconix Inc., 2201 Laurelwood Rd., Santa Clara, Calif. 95054 [415]

Kit includes liquid crystal readout and C-MOS circuits

A display kit designed for evaluation purposes uses RCA's low-power, seven-segment liquid crystals coupled with C-MOS integrated circuits. With the kit, the user can build a one-digit up-counter for use in a digital display system. The kit contains a TA8034 reflective-type liquid-crystal numeric 0.6 inch in height, six sockets, and five ICs (two quad exclusive-OR circuits, a decade counter/divider, a ripple-carry binary counter, and NOR gate). The user adds four fixed resistors, a capacitor, and two 9-volt batteries. Price of the kit, including application information, is \$35. Delivery is from stock.

Semiconductor Specialists Inc., P. O. Box 66125, O'Hare International Airport, Chicago, Ill. 60666 [416]

710-ampere SCR offers 10-microsecond turn-off

A 710-ampere-rms inverter SCR with a 10-microsecond turn-off time is available in both ceramic and plastic versions. The PF series units have forward and reverse voltage



ratings from 50 to 500 volts, and are designed for use in low- and medium-voltage motor controls and uninterruptible power supplies. One-cycle nonrepetitive surge cur-

rent rating is 9,000 amperes at maximum load conditions. Prices in 10-99 quantities for 600-volt versions range from \$105.30 to \$117, depending on packaging.

Semiconductor Division, International Rectifier Corp., El Segundo, Calif. 90245 [417]

ROM programed by cutting silicon links in chip matrix

A 1,024-bit bipolar read-only memory is programed by breaking fusible links of silicon embedded in the matrix of the chip. The model 3601 combines two production techniques: the Schottky bipolar process and polycrystalline silicon deposition. Because the PROM is a silicon-fuse type, the width and rise time of

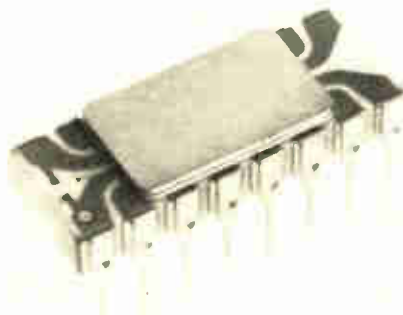

the programing pulse are not critical. The silicon fuse separates cleanly and cannot cure or relink. Using an automatic programmer, typical programing time for each device is one second. Price is \$39 each in 100-lots.

Intel Corp., 3065 Bowers Ave., Santa Clara, Calif. 95051 [418]

Hybrid clock driver supplies pulse rates up to 5 MHz

The model MHP401 clock driver is designed to interface saturated logic to the high capacitive loading of MOS systems. The unit is capable of sourcing and sinking the large peak currents necessary to achieve high clock rates. A hybrid approach is used to provide high current switching transistors and other associated components in a single package without resorting to a costly large-

area monolithic chip. The unit can supply clock pulses at rates of up to 5 MHz while driving a 500-picofarad load operating from a +5-volt and -12-v power supply. The clock rate



may be set at 2 MHz even when driving 2,000 pF, which is equivalent to 60 MC 1160 dual 100-bit shift registers in parallel. Price is \$3.90 each in 100 lots.

Motorola Inc., Semiconductor Products division, Box 20924, Phoenix, Ariz. 85036 [419]

Voltage regulator built for TTL power applications

A 5-volt, 5-ampere voltage regulator is designated the model DPS-2001. The hybrid circuit is designed for transistor-transistor-logic power supply and other 5-volt, high-current applications. It is packaged in a two-lead TO-3 case and requires no external components. Price of single units is \$35, falling to \$16 each in lots of 100.

Dickson Electronics Corp., Box 1390, Scottsdale, Ariz. 85252 [420]



New Eastman 910[®] MHT holds when the heat is on

If you haven't been able to take advantage of cyanoacrylate adhesives because of a high temperature problem, try new Eastman 910[®] MHT adhesive. Bonds made with this adhesive have been found to withstand temperatures above 400°F. Tensile strengths of up to 5000 p.s.i. can be obtained at room temperature.



For further information, call: (615) 247-0411 or write: Eastman Chemical Products, Inc., Industrial Chemicals Division, Kingsport, Tennessee 37662



Circle 102 on readerservice card

New products/materials

Tantalum powder, said to be the highest-capacitance material of its kind that's commercially available, is for use in tantalum capacitors for television, automobile radio, computer, and communications equipment. It permits development of smaller devices, easier fabrication, and lower costs. Designated the SGV series, the new powders are designed for low-voltage devices up to 35 volts. They provide 8,000 microfarad volts per gram, compared to the 6,200 microfarad volts previously available. The lower pressed densities of anodes made from the powders facilitate device fabrication. Prices range from \$27.50 to \$32.50 per pound.

Norton Company, Metals Div., Newton, Mass. 02164 [476]

Thin multilayer laminates called the A33 and B33 are copper-clad, and offer a dimensional stability guaranteed to be within 0.0003 inch per inch from pre-etch to etch condition. Core thickness runs from 0.003 inch to 0.030 inch, with close tolerances available. Copper thickness ranges from 1 ounce to 3 ounces, and other features include high resin content and resistance to solder pot temperatures.

Fortin Laminating Corp., 1323 Truman St., San Fernando, Calif. 91340 [477]

Two glass compositions for use in surface passivation and protection of silicon semiconductor devices are designated codes 7586 and 7723. The glasses have low alkali contents, providing stable coatings over the chip's surface. This improves device performance and isolates the units from electrical and chemical environmental influences.

Corning Glass Works, Corning, N.Y. 14830 [478]

Epoxy adhesive offers a pot life of 20 minutes and a 20-second cure with a heat lamp. The material can be hand-mixed or dispensed from either automatic metering equipment or hand-dispensing units. The material, designated Twenty/twenty, is aimed at bonding applications.

Allaco Products Inc., 130 Wood Rd., Braintree, Mass. 02184 [479]

No moving parts.* No noise. No nonsense.

JUST RELIABLE, TIME-SHARING TERMINALS AND PRINTERS.

That go anywhere, because they weigh only 22 pounds and fit under an airline seat. Terminals that interface with any computer system. Acoustically coupled terminals that work thousands of miles from the nearest computer. Especially terminals and printers that cost so little, you'll think we're kidding. We're not. Fill out the coupon and find out why.



Model
1030
TELETERM[®]

portable time-sharing terminal.



Model
930
TELETERM[®]

TTY-replacement printer.

I BELIEVE YOU'RE NOT KIDDING.

SEND ME ALL THE DETAILS

- Model 1030
TELETERM[®]
 Model 930
TELETERM[®]

Name _____ Title _____

Company _____ Street _____

City _____ State _____ Zip _____

Computer System _____ Phone _____



**COMPUTER
DEVICES INC.**

9 Ray Avenue
Burlington, Ma. 01803
(617) 273-1550

[®] Reg. U.S. Pat. Off. * to break, or wear out, or need adjusting.

COMPRESSED VIDEO

- Starts with a standard CCTV camera
- Ends on the screen of a standard CCTV monitor
- Uses "dial up" voice grade telephone circuits in the middle
- Is a highly flexible alternative to facsimile or the Picture Phone

The CVI 200 series Video Converters provide for single frame TV picture transmission over audio bandwidth circuits. Options include multiple image storage, hard copy, computer I/O, and color.

Video instruments for data acquisition, processing, transmission, and display.

Colorado Video, Inc. **cv**i
Box 928 Boulder, Colorado 80302
(303) 444-3972



Introducing the expensive curve tracer that doesn't cost a lot.

The B&K Model 501A.

It hooks up to any scope, old or new. (Like our Model 1460 triggered-sweep scope.)

And it analyzes all semi-conductors including J-FET's, MOS-FET's, signal and power bipolar transistors, SCR's, UJT's and diodes. Fast and easy.

Constant current and voltage steps with 3% accuracy make the Model 501A an exceptional value. In fact, it performs like \$2,000 units. Yet you can afford one on each engineer's bench. And another for incoming quality control.

Call your B&K distributor. Or write Dynascan Corporation.

In stock at your parts distributor.



\$129⁹⁵



Product of Dynascan Corporation
1801 West Belle Plaine Avenue, Chicago, Illinois 60613

Circle 103 on reader service card

Introducing the expensive dual-trace scope that doesn't cost a lot.

The B&K Precision Model 1470.

The compact 5-inch solid-state 1470 is specially designed to meet 80% of all industrial scope applications.

It has DC to 10 MHz bandwidth with 10 mV/cm sensitivity. Sixteen triggered-sweep speeds range from 1 μ sec/cm to 0.2 sec/cm. Triggers on input signals as low as 5mV.

Sound good? Our prices become even more remarkable once you see our specs.

Call your B&K distributor. Or write Dynascan Corporation.

In stock at your parts distributor.



Product of
Dynascan Corporation
1801 West Belle Plaine Avenue, Chicago, Illinois 60613

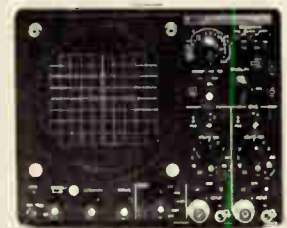

\$499⁹⁵

Circle 117 on reader service card

Circle 160 on reader service card 103

New literature

Reed switching. Hamlin Inc., Lake Mills, Wis. 53551. A compilation of technical information on reed switching includes material on the operation of magnetic reed switches with permanent magnets and electromagnetic actuation. Physical dimension data, information on arc suppression, and explanation of terms are also presented. Circle 421 on reader service card.

LSI test system. A 12-page booklet has been published by Adar Associates Inc., 85 Bolton St., Cambridge, Mass. 02140, detailing the company's Doctor 64 LSI test system. The booklet provides charts and photographs. [422]

Disk memory. A two-page data sheet describes the model L107MA disk memory system and is available from The Singer Co., Librascope division, 833 Sonora Ave., Glendale, Calif. 91201. In addition to technical data and features, the brochure contains specifications and dimensional drawings. [423]

Relays. North American Philips Controls Corp., Cheshire Industrial Park, Cheshire, Conn. 06410. A short-form catalog contains dimensional and electrical data on electronic, electromechanical, and reed relays. Included are latching, industrial general-purpose, and military types. [425]

Transducers. Kulite Semiconductor Products Inc., 1039 Hoyt Ave., Ridgefield, N.J. 07657, has published a four-page bulletin on the application of solid-state transducer technology to the measurement of such physical parameters as pressure, stress, force, acceleration, and temperature. [426]

Thermistors. Fenwal Electronics, 63 Fountain St., Framingham, Mass. 01701. A short-form catalog, L-4A, provides thermistor users with a brief introduction to a variety of thermistor sensors and sensor assemblies. [427]

Magnetic cores. A 24-page design guide describes a family of magnetic

cores specifically manufactured and tested for broadband applications from 0.3 kilohertz to 250 megahertz. The bulletin is available from Indiana General, Valparaiso, Ind. 46383 [428]

Data sets. Bell-compatible 300-, 1,200-, and 2,400-bit-per-second data sets, plus other specialized data communications products, are described in a four-page illustrated catalog offered by Tele-Dynamics division of Ambac Industries, 525 Virginia Dr., Fort Washington, Pa. 19034 [429]

Power transistors. A revised catalog that describes rf power transistors is available from RCA Solid State division, Route 202, Somerville, N.J. 08876. A quick selection guide, charts of frequency allocations, and applications information are provided. [430]

Slide switches. Two bulletins give descriptions, applications, and specifications for enclosed-design slide switches, the model SSR/rocker adapter and the model SSR/flush mount. The bulletins are available from Airpax Electronics Inc., Pacific division, 1836 Floradale Ave., South El Monte, Calif. 91733 [431]

Data coupler. Elgin Electronics Inc., Walnut St., Waterford, Pa. 16441. A two-page illustrated specification sheet provides information on the model EDC-1001B automatic data coupler. [432]

Plotters. Omnigraphic flatbed and Z-fold chart X-Y, strip-chart, and point plotters are described in a short-form catalog and price list available from Houston Instrument division of Bausch and Lomb Inc., 4950 Terminal Ave., Bellaire, Texas 77401 [433]

Power modules. Computer Products Inc., 1400 Gateway Dr., P.O. Box 23849, Fort Lauderdale, Fla. 33307. A four-page brochure features 18 encapsulated printed-circuit-card-mounted power modules for op amp, data conversion, and logic applications. [434]

New books

Modern Control System Theory and Applications, Stanley M. Shinnars, Addison-Wesley Publishing Company, 528 pp., \$14.95

Systems Programming, John J. Donovan, McGraw-Hill Company, 488 pp., \$13.95

Integrated Electronics: Analog and Digital Circuits and Systems, Jacob Millman and Christos C. Halkias, McGraw-Hill Book Company, 911 pp., \$16.50

Materials for Semiconductor Functions, E.G. Bylander, Hayden Book Company, 220 pp., \$13.50

Materials Science and Technology for Design Engineers, Alex E. Javitz, Hayden Book Company, 552 pp., \$23.95

Electronic Analog and Hybrid Computers, Granino A. Korn and Theresa N. Korn, McGraw-Hill Book Company, 421 pp., \$21.50

Digital Computer Fundamentals, Thomas G. Bartee, McGraw-Hill Book Company, 467 pp., \$10.95

Theory and Analysis of Phased-Array Antennas, Noach Amitay, Victor Galindo and Chen Pang Wu, Wiley-Interscience, Division of John Wiley & Sons, 443 pp., \$22.50

Electrical Engineering Fundamentals, Vincent Del Toro, Prentice-Hall, 812 pp., \$13.95

Handbook of Logic Circuits, John D. Lenk, Reston Publishing Company, 307 pp., \$13.95

Fundamentals of Pattern Recognition, Edward Patrick, Prentice-Hall, 504 pp., \$18.00

Computer Networks, Randall Rustin, Prentice-Hall, 205 pp., \$9.95

Systems Networks and Computation: Basic Concepts, Michael L. Dertouzos, Michael Athans, Richard N. Spann and Samuel J. Mason, McGraw-Hill Book Company, 514 pp., \$16.50

How much free time do you have available for reading?



Add up the number of magazines that come across your desk.

Multiply them by an average reading time — minutes to scan, an hour or more to dig in.

Most people can only spend six hours each week on all sources of occupational information.

So how do you fill your professional needs and still keep your reading within reason?

Leaf through this issue again.

Notice how much of its editorial is designed to keep you aware of trends, show you how new technologies are being applied, and give you information on new products.

If you want to keep yourself up to date and cut down on your reading time, do the same thing with every issue of Electronics.

When you make Electronics your regular habit, you'll find you have only occasional need for other electronics magazines.

More information, in less reading time, is one reason it pays you to have your own subscription to Electronics.

Electronics.

It's all you need to read.

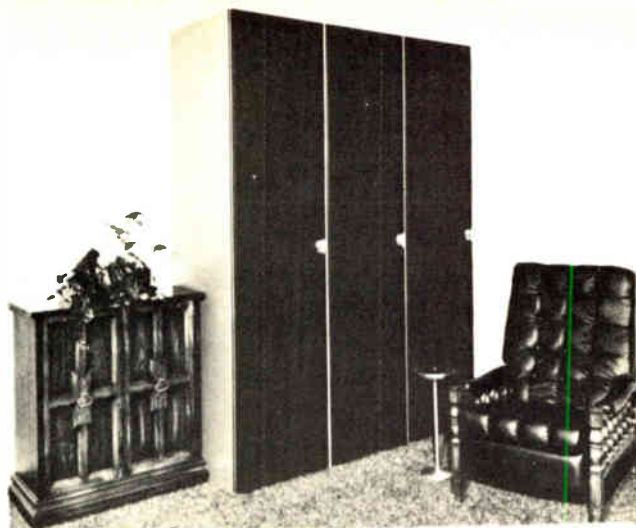

Honeywell Modu-Mount Cabinetry

If you really have a problem in electronic cabinetry and can't find a solution, call on Honeywell.

You see, we don't just sell cabinetry, Honeywell sells solutions to cabinetry problems . . . problems you sometimes didn't realize you had.

For more than just a catalog, for a sure solution to your cabinetry problem, call or write:

Honeywell

Honeywell Inc., 200 Bond Street, Wabash, Indiana 46992

Circle 105 on reader service card

Introducing the expensive digital multimeter that doesn't cost a lot.

The B&K Precision Model 281.

This 2½-digit unit is so versatile, its range covers 99% of your measurements. And its DC accuracy is 1%. The stable 281 also gives you positive over-range and wrong-polarity indications.

It's easy to use (even for semi-skilled people). And easy to read across all 26 ranges, 100mV to 1000V.

Naturally, we're enthused about our Model 281. You will be, too, when you see our complete specs.

Call your B&K distributor. Or write Dynascan Corporation.

In stock at your parts distributor.



\$169⁹⁵



Product of Dynascan Corporation
1801 West Belle Plaine Avenue, Chicago, Illinois 60613

These new additions,

Duals 5 & 10A PNPs 20A NPNs...

New Dual 10A NPN Power Darlingtons give you twice as much in a single package. And double the space efficiency. They're ideal for full wave bridge applications such as stepper motor drivers and converters and desirable as print hammer, servo, relay and lamp drivers, and linear amplifiers. They provide inherently higher reliability through the use of monolithic planar Darlington chips.

The completely new PNP line beginning with 5A and 10A devices and the 20A NPN additions provide design advantages through unsurpassed performance in saturation voltage, current gain, compact packaging and voltage ratings. It adds up. We'll continue to give you more in Darlingtons because our capabilities are still growing.

For complete specifications and prices, call Sales Engineering collect at (617) 926-0404 Unitrode Corporation, Dept. 7 Y, 580 Pleasant Street, Watertown, Mass. 02172



C-LINE DUAL DARLINGTONS

Type	P _O W	V _{CEO} V	h _{FE}	V _{CE (sat)} V	t _{on} μs	t _{off} μs	Package	Price (100- 999)
PIC500	30	100	2000	1.5	0.55	2.0	TO-3 (8-pin)	\$10.00
PIC501	20	100	1000	2.0	0.65	3.6		6.50
PIC502	20	80	750	2.0	0.65	3.6		4.90

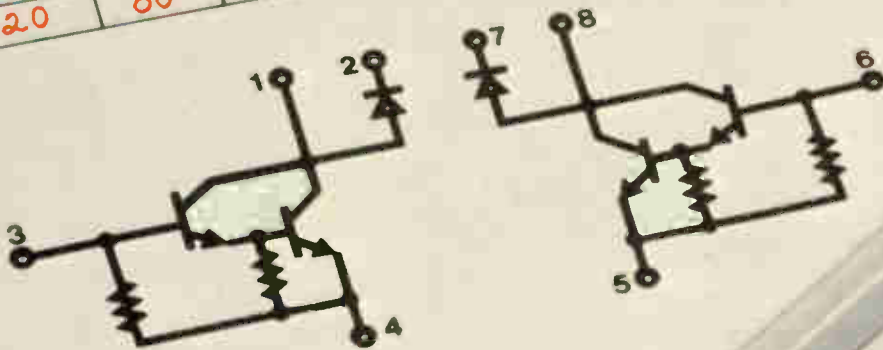

C-LINE

POWER DARLINGTONS

add to our unequalled
Darlington capability.

C-LINE POWER DARLINGTONS

Peak I _c A	Type	Package	V _{CE} V	h _{FE}	V _{CE} (sat) V	I _{on} ns	Price (100- 999)	
5	NPN	U2T301	TO-33	60	1000 @ 2A	15 @ 2A	300	\$1.25
		U2T401	TO-66	60	1000 @ 2A	15 @ 2A	300	1.50
		U2T305	TO-33	150	1000 @ 2A	25 @ 2A	400	1.80
		U2T405	TO-66	150	1000 @ 2A	25 @ 2A	400	2.10
		U2T101	TO-33	80	2000 @ 5A	15 @ 5A	400	2.25
		U2T201	TO-66	80	2000 @ 5A	15 @ 5A	400	2.55
	10	U2T105	TO-33	150	1000 @ 5A	25 @ 5A	500	2.85
		U2T205	TO-66	150	1000 @ 5A	25 @ 5A	500	3.15
		U2T501	TO-66	80	2000 @ 10A	1.5 @ 10A	400	4.30
		U2T601	TO-3	80	2000 @ 10A	1.5 @ 10A	400	4.30
		U2T505	TO-66	150	1000 @ 10A	2.5 @ 10A	500	5.40
		U2T605	TO-3	150	1000 @ 10A	2.5 @ 10A	500	5.40
20	NPN	U2T351	TO-33	60	1000 @ 2A	2.0 @ 2A	250	1.50
		U2T451	TO-66	60	1000 @ 2A	2.0 @ 2A	250	1.80
		U2T355	TO-33	120	1000 @ 2A	2.5 @ 2A	300	2.16
	PNP	U2T455	TO-66	120	1000 @ 2A	2.5 @ 2A	300	2.52
		U2T151	TO-33	80	2000 @ 5A	2.5 @ 5A	300	2.70
		U2T251	TO-66	80	2000 @ 5A	2.5 @ 5A	300	3.06
10	PNP	U2T155	TO-33	120	1000 @ 5A	3.0 @ 5A	400	3.44
		U2T255	TO-66	120	1000 @ 5A	3.0 @ 5A	400	3.78

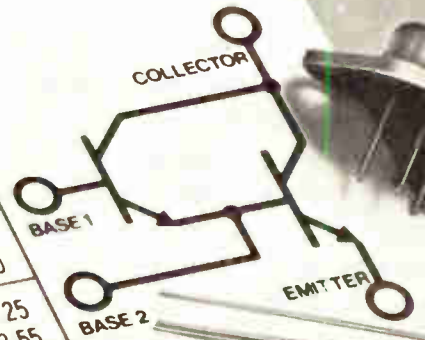

UNITRODE quality takes the worry out of paying less.

Electronics advertisers

July 31, 1972

■ Abbott Transistor Labs., Inc. Technical Adv Agency	6	● Olympus Optical Co. Ltd. FUJI Agency	9E
● Anritsu Electric Co. Ltd. Diamond Agency Co. Ltd.	10E	● Philips Gad Elcoma Tag-Intermarco delaMar	2E,7E,11E
Burndy Components Ketchum, MacLeod & Grove, Inc	16	● Phillips N. V. PIT/T & M Division Marsteller International S. A	38
Caelus Memories, Inc William Cain, Inc	36	■ Plastics Engineering Company Kuttner & Kuttner, Inc	14
California Computer Products Dailey & Associates Advertising	15	■ Primo Company, Inc. General Advertising Agency	45
Centralab Electronics, Div. of Globe Union, Inc. The Brady Co	1,75	■ RCA Solid State Division Al Paul Lefton Company, Inc.	28-29,35
■ Cialrex Corporation Michel-Cather, Inc	4th cover	■ RCL Electronics, Inc. Morvay Advertising Agency	12
■ Colorado Video, Inc. O'Connell-Colburn, Inc. Creative Business Communications	103	● Rohde & Schwarz	1E
Computer Devices The Drumbeater Co	102	■ Scanbe Manufacturing Corp. Warren C. Wilson & Associates	2nd cover
C. P. Clare & Company Buti-Roberts Advertising	53	● Sharp Corp. Dentsu Advertising Ltd	15E
Datum, Inc. Data Advertising	97	■ Showa Musen Kogyo Co., Ltd. General Advertising Agency Ltd	47
■ Digital Equipment Corporation Schneider Parker Guy, Inc	7	■ SGS - ATES STUDIO B Communications	91
■ Digital Equipment Corporation Creamer, Trowbridge, Case & Bastord, Inc	30-31	■ Siliconix Incorporated Paul Pease Advertising	79
● DX Antenna Hakuhodo Incorporated	17E	■ Solitron Devices, Inc. Sol Advertising Agency	27
Dynascan Corporation (Industrial Products Division) Albert Jay Rosenthal & Company Advertising	103,105	■ Teikoku Tsushin Kogyo Co., Ltd. Diamond Agency Co Ltd	46
■ Eastman Chemical Products, Inc., Industrial Chemicals J. Walter Thompson Company	102	■ Tektronix, Inc. Dawson, Inc	20
■ Erie Technological Products Co., Inc. Altman Hall Associates Advertising	9	● Teledyne Crystalonics Gerard K. Gormley Advertising, Inc	18E,48A
Hermes Electronics Ltd. Public & Industrial Relations Limited	8	■ Texas Instruments Incorporated, Components Group Albert Frank Guenther Law, Inc	10-11 58
Hitachi Ltd. Dentsu Advertising	42	■ Toko, Inc. Hakuhodo, Inc	43
Honeywell Corp. Concepts Unlimited, Inc	105	■ Tokyo Electric Co., Inc. PAL Inc Export Advertising	47
Japan Electronics Show Association Asian Advertising, Inc	41	● Tokyo Sokuhan Co., Ltd. Showa Advertising Services, Inc	17E
Kennedy Company R. L. Thompson Advertising	13	■ Torin Corporation Viscom International Inc	5
■ Keppo Incorporated Weiss Advertising	2	■ United Systems Corp. Advertising & Merchandising, Inc	32
Kinsekisha Laboratory Ltd. General Advertising Agency	43	■ Unitrode Corporation Impact Advertising	106-107
■ Lambda Electronics Corporation Michel-Cather, Inc	3rd cover	● Wavetek Chapman Michetti Advertising	19
Matsuo Electric Co. Ltd. Daiko Advertising Inc	47	■ Yokogawa Electric Works Ltd. General Advertising Agency Inc	48B
Matsushita Electric Dentsu Advertising Inc	44		
■ Meguro Denpa Sokki K.K. General Advertising Agency, Inc	45		
‡ Microdata Jim Brunton	19		
Micron Electric Co. Sanko Tsushinsha Ltd.	43		
‡ 3M Electro Products Division Batten, Barton, Durstine & Osborn, Inc	48A		
● Nippon Kogaku K.K. K & L Advertising Agency	16E		
OKI Electric	48A		

Advertising Sales Staff

Pierre J. Braudé [212] 997-3485
Advertising Sales Manager

Atlanta, Ga. 30309: Joseph Lane
100 Colony Square, 1175 Peachtree St., N.E.
[404] 892-2868

Boston, Mass. 02116: James R. Pierce
607 Boylston St. [617] 262-1160

Chicago, Ill. 60611: Robert W. Bartlett
Paul L. Reiss, 645 North Michigan
Avenue, [312] MO 4-5800

Cleveland, Ohio 44113: William J. Boyle
[716] 586-5040

Dallas, Texas 75201: Richard P. Poole,
Charles G. Hubbard
1340 Republic National Bank Building
[214] RI 7-9721

Denver, Colo. 80202: Harry B. Doyle, Jr
Tower Bldg., 1700 Broadway
[303] 266-3863

Detroit, Michigan 48226: Robert W. Bartlett
2600 Penobscot Building
[313] 962-1793

Houston, Texas 77002: Richard P. Poole,
Charles G. Hubbard
2270 Humble Bldg. [713] CA 4-8381

Los Angeles, Calif. 90010: Robert J. Rielly
Bradley K. Jones, 3200 Wilshire Blvd., South Tower
[213] 487-1160

New York, N.Y. 10020
1221 Avenue of the Americas
Warren H. Gardner [212] 997-3617
Michael J. Stoller [212] 997-3616

Philadelphia, Pa. 19103: Warren H. Gardner
6 Penn Center Plaza,
[212] 971-3617

Pittsburgh, Pa. 15222: Warren H. Gardner
4 Gateway Center, [212] 971-3617

Rochester, N.Y. 14534: William J. Boyle
9 Greylock Ridge, Pittsford, N.Y.
[716] 586-5040

San Francisco, Calif. 94111: Don Farris
Robert J. Rielly, 425 Battery Street,
[415] 362-4600

Paris: Alain Offergeld
17 Rue-Georges Bizet, 75 Paris 16, France
Tel 720-73-01

Geneva: Alain Offergeld
1 rue du Temple, Geneva, Switzerland
Tel 32-35-63

United Kingdom: Keith Mantle
Tel: 01-493-1451, 34 Dover Street, London W1

Milan: Robert Sidel
1 via Baracchini Phone 86-90-656

Brussels: Alain Offergeld
23 Chaussee de Wavre
Brussels 1040, Belgium
Tel 13-65-03

Stockholm: Brian Bowes
Office 17, Kontor-Center AB, Hagagarten 29,
113 47 Stockholm Tel 24 72 00

Frankfurt/Main: Fritz Krusebecker
Liebigstrasse 27c
Phone 72 01 81

Tokyo: Masaru Wakeshima, McGraw-Hill
Publications Overseas Corporation,
Kasumigaseki Building 2-5, 3-chome,
Kasumigaseki, Chiyoda-Ku, Tokyo, Japan
[581] 9811

Osaka: Ryji Kobayashi, McGraw-Hill
Publications Overseas Corporation, Kondo
Bldg., 163, Umegae-cho Kita-ku [362] 8771

Australasia: Warren E. Ball, IPO Box 5106,
Tokyo, Japan

Business Department

Stephen R. Weiss, Manager
[212] 997-2044

Thomas M. Egan,
Production Manager [212] 997-3140

Carol Gallagher
Assistant Production Manager [212] 997-2045

Dorothy Carter, Contracts and Billings
[212] 997-2908

Frances Vallone, Reader Service Manager
[212] 997-6057

Electronics Buyers' Guide

George F. Werner, Associate Publisher
[212] 997-3139

Regina Hera, Directory Manager
[212] 997-2544

Classified & Employment Advertising

F. J. Eberle, Manager 212-971-2557

EQUIPMENT (Used or Surplus New) For Sale
Radio Research Instruments Co. 94
Philip Fishman Co. 94

■ For more information on complete product line see advertisement in the latest Electronics Buyer's Guide
* Advertisers in Electronics International
‡ Advertisers in Electronics domestic edition