

Speeding up rms measurements 98  
Correcting character tilt in crt's 108  
Keeping spin-offs in house 127

\$1.00 A McGraw-Hill Publication

September 29, 1969

# Electronics®



*The  
New  
Wave:  
Silicon  
Gate IC's  
Bring on  
A faster  
Generation  
of MOS  
With low  
Thresholds*

142 K55956 44R86 02 71  
R. H. KESTER  
BASIC COMM ELEC  
BOX 956

# COVER-UP TREATMENT

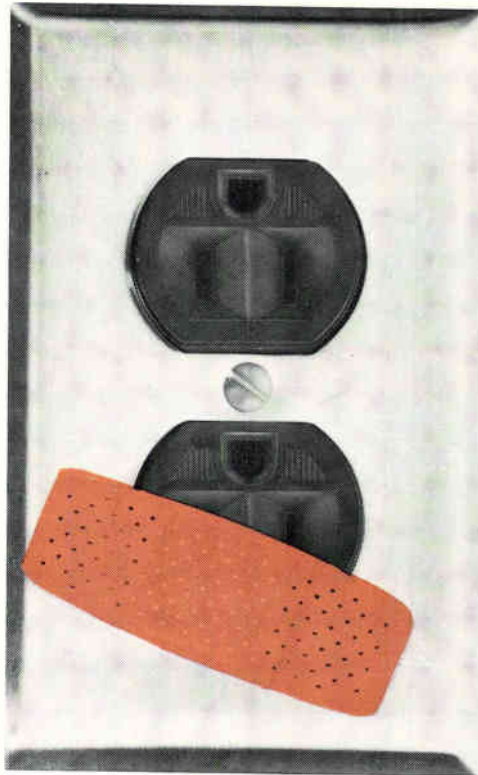

How do you treat line-voltage problems? Certainly not this way, although voltage variations can cause electrical equipment to come down with human-like ailments. You've probably seen it... the motor that suddenly becomes sluggish; the erratic, temperamental instrument; the induction heater that suffers from a "chronic cold", the run-down power supply.

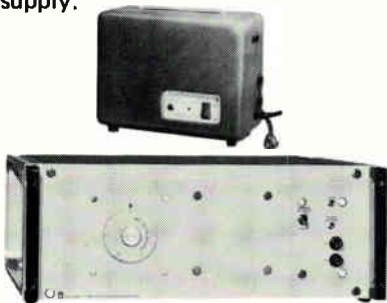

You can return your equipment to good health quickly by treating it

with a steady diet of constant line voltage from a GR Variac® automatic line-voltage regulator. It will provide fast relief to your voltage ills (up to 80 volts/second correction speed) and hold that relief to better than  $\pm 0.5\%$ . There are no side effects with Variac line-voltage regulators; they never distort line waveform or adversely affect power factor. And, they are rugged; overloads as much as 10 times rated current can be handled. All-solid-state circuitry gives them an extra measure of dependability.

There are more than 30 different models of Variac line-voltage regulators from which to choose. They range in capacity from a small 17-lb powerhouse that will handle 1 kVA to large 20-kVA units for heavy-duty industrial applications. Models are

available for line frequencies of 50, 60, and 400 Hz, single-or three-phase, and nominal line voltages of 115, 230, and 460 volts. Prices start at \$310 in U. S. A.

For complete information, write or call General Radio Company, W. Concord, Massachusetts 01781; telephone (617) 369-4400.

GENERAL RADIO



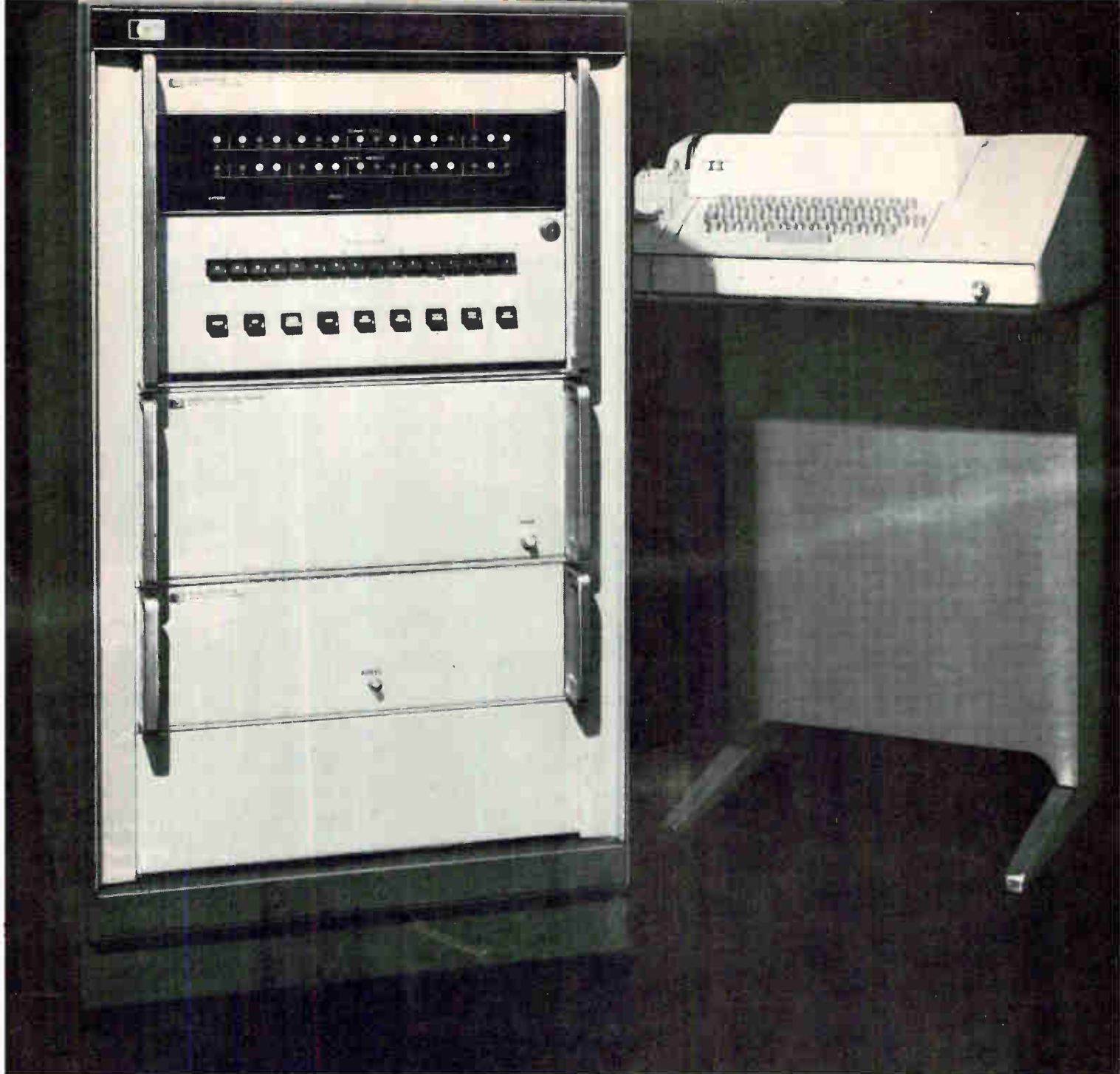

## How low can a high-speed data acquisition system get?

From 10V all the way down to 10mV full scale, at sample rates to 14 kHz. That's how low you can measure with our new high-speed "front-end" subsystem, built from the HP 2930A low-level multiplexer and a 12-bit ADC. And, although you're working in this low range, signal integrity is preserved by CMR better than 120 dB and crosstalk below 100 dB. In addition, there are plug-in filters for optimum noise rejection and band limiting.

With this new subsystem, you can assemble a complete working system around one of our computers and a teleprinter for a low \$29,000. This includes our versatile DACE data acquisition and control executive which gives you real-time operation with minimum programming start-up.

As your needs grow, Hewlett-Packard's modular hardware/software approach lets you expand your system with a wide choice of fully-interfaced peripherals.

To get the real low-down on data acquisition, call your local HP field engineer. Or write to Hewlett-Packard, Palo Alto, California 94304; Europe: 1217 Meyrin-Geneva, Switzerland.

**HEWLETT  PACKARD**  
DATA ACQUISITION SYSTEMS

# We built these tape recorders to play, not to play with!

When you're recording data, you don't want to waste time playing nursemaid to a temperamental tape machine. So we built the HP 3950/3955 Analog Recorders to play tape, not games.

Through simple design and rugged construction, we cut out almost all of the finicky adjustments and maintenance operations required for most recorders.

Routine maintenance on the HP 3950/3955's runs less than one/fifth of that needed for most of the machines you might be considering.

The HP 3950/3955's low initial price, plus the sharply reduced operating costs that come with minimum downtime, make it an attractive buy for a wide variety of scientific, medical and

industrial applications.

If up to five times less tape recorder maintenance and downtime looks good to you, ask your local HP field engineer about our HP Model 3950 and 3955 Analog Recorders. Or write Hewlett-Packard, Palo Alto, California 94304; Europe: 1217 Meyrin-Geneva, Switzerland.

Misalignments that might interrupt your work on other machines are eliminated by a cast aluminum frame, machined to precise dimensions on a numerically controlled milling machine. Tape transport components are mounted to this frame on precisely indexed bosses, and neither shimming or other adjustments are required in the field.

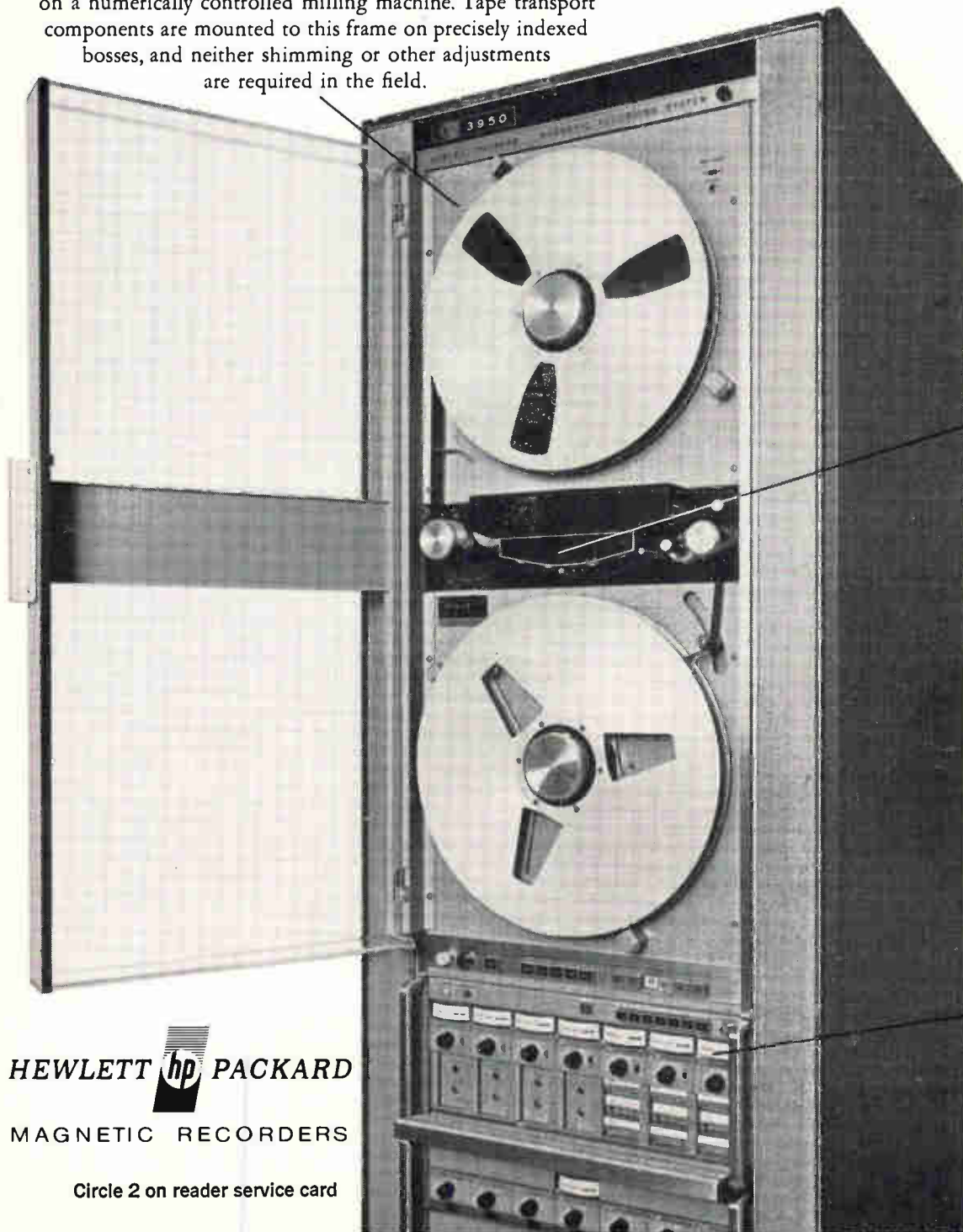

An instrumentation quality, open loop tape drive ends the need for complex servo systems and vacuum or blower buffer chambers. The simple, uncluttered tape path assures easy cleaning and loading. Both IRIG 7 and 14 channel models are available, with the 7 channel model expandable to 14.

Front panel monitor meters, test signal selectors and test I/O connectors for all record and playback electronics are readily accessible.

**HEWLETT  PACKARD**  
MAGNETIC RECORDERS

Circle 2 on reader service card

## News Features

### Probing the News

- 127 **Management:** Keeping spin-offs in house  
133 **Communications:** Help on the way for teleprocessing?

### U.S. Reports

- 47 **Military electronics:** Direct view tube for starlight scope  
48 **Government:** Task Group takes pragmatic view  
49 **Manufacturing:** Speeding semiconductor deliveries  
50 **Integrated electronics:** Switching circuit for d-a converter  
52 **Optoelectronics:** OCR for mixed fonts  
52 **Space:** Ground stations doomed  
54 **Advanced technology:** Speech synthesizer for computers; Silicon sec  
58 **Communications:** Millimeter-wave test goes underground  
58 **Contracts:** Univac looks for more customers for Navy computer  
64 **Lasers:** Measuring the bottom of the sea  
66 **For the record**

### Electronics International

- 199 **Japan:** Array of MOS transistors form tv picture pickup  
200 **Japan:** Company displays three systems for home facsimile  
200 **West Germany:** New twist added to space communications antenna  
201 **West Germany:** Room temperature i-r detector uses InSb/NiSb  
202 **France:** A calculated risk

### New Products

- 141 **In the spotlight**  
141 Monolithic regulator stands alone  
145 **Instruments review**  
145 Correlator does five jobs  
153 **Subassemblies review**  
153 Amplifier offers high isolation  
154 Compact gas laser puts out 1 kw  
157 **Microwave review**  
157 Antenna duplexer is miniaturized  
160 Amplifier produces 10 watts  
162 Spectrum analyzer runs on battery  
165 **Data handling**  
165 OCR reader has low price tag  
166 Terminal does double duty  
171 Tape system can handle 64 stations  
173 **Semiconductor review**  
173 Photodiodes' dark current is low

## Technical Articles

- Solid state** 88 **A faster generation of MOS devices with low thresholds**  
In what may well be the technology's most startling change, highly doped silicon—not aluminum—is used as the gate electrode  
Federico Faggin and Thomas Klein, Fairchild Semiconductor

- Circuit design** 95 **Designer's casebook**  
▪ FET varies Q of tuned circuit by several thousand  
▪ Retriggerable one-shots form delayed-key oscillator  
▪ Single transistor divides frequency in avalanche mode  
▪ Nomograph simplifies finding one-shot's pulse width

- Instrumentation** 98 **Curve fitter aids the measure of rms by overruling square-law slowdowns**  
Eugene Ochs, Dana Laboratories, Inc.  
Peter Richman, Consulting engineer

- Circuit theory** 102 **Feedback sharpens filter response**  
Roland J. Turner, General Atronics Corp.

- 104 **Self-adjustable bandpass filter picks off weak signal despite noise**  
Basil Barber, Sperry Rand Corp.

- Instrumentation** 108 **On the beam for sharp crt character displays**  
James W. Wolf, IBM  
James H. Williams, Lundy Electronics and Systems Inc.

- 113 **Multitraces from single-channel scope?**  
Philip Thompson, Innerspace Technology, Inc.

## Departments

- |    |                          |     |                          |
|----|--------------------------|-----|--------------------------|
| 4  | Readers Comment          | 33  | Electronics Newsletter   |
| 8  | Who's Who in this issue  | 73  | Washington Newsletter    |
| 14 | Who's Who in electronics | 176 | New Books                |
| 22 | Meetings                 | 182 | Technical Abstracts      |
| 31 | Editorial Comment        | 189 | New Literature           |
|    | 197                      |     | International Newsletter |

# Electronics

Editor-in-Chief: Donald Christiansen

## Senior Staff Editors

Technical: Stephen E. Scrupski

News: Robert Henkel

International: Arthur Erikson

Art director: Gerald Ferguson

Senior associate editors: Joseph Mittleman, Harry R. Karp

Assistant managing editors: H. Thomas Maguire, Howard Wolff,

William Bucci, Richard Gundlach, Frederick Corey

Special projects editor: Roger Kenneth Field; Senior staff writer: John Johnsrud

## Department editors

Advanced technology: Laurence Altman

Communications: John Drummond, Leon M. Magill

Computers: Wallace B. Riley, George Weiss

Design theory: Joseph Mittleman

Industrial electronics: Harry R. Karp

Instrumentation: Owen Doyle

Military/Aerospace: Alfred Rosenblatt

New products: William P. O'Brien

Solid state: George Watson, Stephen Wm. Fields

## Field bureaus

Boston: James Brinton, manager; Gail Farrell

Los Angeles: Lawrence Curran, manager; Ralph Selph

New York: Peter Schuyten

San Francisco: Stephen Wm. Fields

Washington: Ray Connolly, manager; Robert Westgate, Lois Vermillion

Bonn: John Gosch

London: Michael Payne

Paris: Arthur Erikson

Tokyo: Charles Cohen

Copy editors: Edward Flinn, William S. Weiss

Assistant art director: Charles Ciatto

Production editors: Susan Hurlburt, Arthur C. Miller

Editorial research: Virginia Mundt

Editorial secretaries: Lorraine Longo, Claire Goodlin, Barbara Razulis, Vickie Green,

Bernice Pawlak, Patricia Bispham

## McGraw-Hill News Service

Director: Arthur L. Moore; Atlanta: Fran Ridgway; Chicago: Robert E. Lee

Cleveland: Arthur Zimmerman; Dallas: Marvin Reid

Detroit: James Wargo; Houston: Barbara LaRoux

Los Angeles: Michael Murphy

San Francisco: Margaret Drossel, Tyler Marshall

Seattle: Ray Bloomberg; Washington: Charles Gardner, James Canan,

Herbert W. Cheshire, Seth Payne, Warren Burkett, William D. Hickman

## McGraw-Hill World News Service

Bonn: Robert Dorang; Brussels: James Smith; Hong Kong: Kate Mattock

London: John Shinn; Mexico City: Gerald Parkinson; Milan: Jack Star

Moscow: Jack Winkler; Paris: Robert E. Farrell, Stewart Toy

Tokyo: Marvin Petal

Reprints: Gail Niles

Circulation: Isaaca Siegel

Publisher: Gordon Jones

Associate Publisher: Dan McMillan

Assistant to the publisher: Wallace C. Carmichael

Electronics: September 29, 1969, Vol. 42, No. 20

Published every other Monday by McGraw-Hill, Inc. Founder: James H. McGraw 1860-1948.

Publication office 99 North Broadway, Albany, N. Y. 12202; second class postage paid at Albany, N. Y. and additional mailing offices.

Executive, editorial, circulation and advertising addresses: Electronics, McGraw-Hill Building, 330 W. 42nd Street, New York, N. Y. 10036. Telephone (212) 971-3333. Teletype TWX, N.Y., 710-581-4235. Cable address: MCGRAW-HILL N.Y.

Subscriptions solicited only from those professionally engaged in electronics technology. Subscription rates: qualified subscribers in the United States and possessions and Canada, \$8.00 one year, \$12.00 two years, \$16.00 three years; all other countries \$25.00 one year. Non-qualified subscribers in the U.S. and possessions and Canada, \$25.00 one year; all other countries \$50.00. Air freight service to Japan \$50.00 one year. Single copies: United States and possessions and Canada, \$1.00; all other countries, \$1.75.

Officers of McGraw-Hill Publications Company: Joseph Allen, President; John R. Emery, J. Elton Tushig, Senior Vice Presidents; Gordon L. Jones, Jr., Group Vice President; Vice Presidents: John R. Callahan, Editorial; Paul F. Cowie, Circulation; John M. Holden, Marketing; David G. Jensen, Manufacturing; Jerome D. Luntz, Planning & Development; Robert F. Marshall, Administration; Robert M. Wilhelm, Finance.

Officers of the Corporation: Shelton Fisher, President and Chief Executive Officer; John L. McGraw, Chairman; Robert E. Slaughter, Executive Vice President; Daniel F. Crowley, Donald C. McGraw, Jr., Bayard E. Sawyer, Senior Vice Presidents; John I. Cooke, Vice President & Secretary; Gordon W. McKinley, Vice President & Treasurer.

Title registered in U.S. Patent Office; © Copyright 1969 by McGraw-Hill, Inc. All rights reserved. The contents of this publication may not be reproduced either in whole or in part without the consent of copyright owner.

Subscribers: The publisher, upon written request to our New York office from any subscriber, agrees to refund that part of the subscription price applying to copies not yet mailed. Please send change of address notices or complaints to Fulfillment Manager; subscription orders to Circulation Manager, Electronics at address below. Change of address notices should provide old as well as new address, including postal zip code number. If possible, attach address label from recent issue. Allow one month for change to become effective.

Postmaster: Please send form 3579 to Fulfillment Manager, Electronics, P.O. Box 430, Hightstown, New Jersey 08520

## Readers Comment

### Clearing the air

To the Editor:

In the article "Viatron—vibrant and probably viable," [June 23, p. 143] a statement regarding Viatron's negotiations with National Semiconductor for development of MOS may be misinterpreted.

To clear up any possible misinterpretations, let me say that I have a great deal of respect for National Semiconductor's competence in MOS design. It was simply a matter of National deciding to concentrate its efforts on standard products, rather than diverge into the design of custom products which we require.

I might add that the reporting was excellent and that this was just one small point I thought should be clarified.

Laurence C. Drew

Vice president

Microelectronics Operations

Viatron Computer Systems Corp.

Bedford, Mass.

### 'Robbery by tariff'

To the Editor:

Your editorial "Japan: Land of rising exports" [Aug. 18, p. 33] implies that if Japan continues its policy of restricting imports, the U.S. might enact counter barriers to trade with Japan. Trade restrictions are the policy tools of mercantilism and should have died out with the 18th Century. Unfortunately such restrictive actions are still advocated by those who promote special interests at the expense of the population in general.

The imposition of restrictions or tariffs on Japanese goods will impose additional and unnecessary expenses on American consumers and will consequently reduce their real income. In 1845 a French economist Frederic Bastiat, called such policies "robbery by tariff." That restrictive tariffs will also hurt the Japanese is of no comfort to Americans who wish to hurt no one and who, most of all, do not wish to be hurt by their own Government.

The action most beneficial for the

**All the advantages of tantalum...at low cost!**

# Type 196D Dipped Solid-Electrolyte Tantalex<sup>®</sup> Capacitors

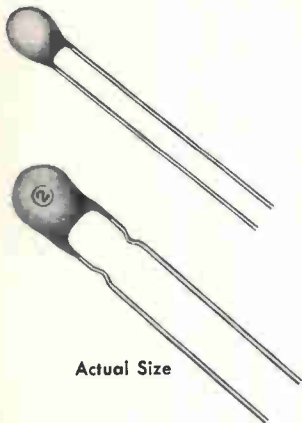

Actual Size

INFORMATION RETRIEVAL NO. 510

Here's a capacitor design that admirably fills the need for low-cost yet dependable solid tantalum capacitors suitable for printed wiring boards. Straight leads as well as crimped leads are readily available to meet your manufacturing needs.

Covering a broad range of capacitance values from .1  $\mu$ F to 330  $\mu$ F, with voltage ratings from 4 to 50 VDC, Type 196D Capacitors are protected by a tough insulating coating which is highly resistant to moisture and mechanical damage.

45C-9124

**Tiny in size...Giants in volume efficiency!**

# Type 160D, 161D Solid-Electrolyte Tantalex<sup>®</sup> Capacitors for hearing aids and ultra-miniature circuits

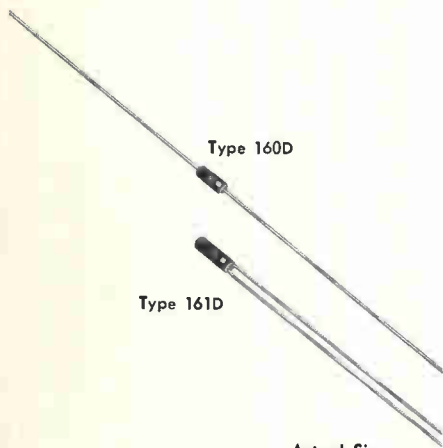

Type 160D

Type 161D

Actual Size

INFORMATION RETRIEVAL NO. 511

Tiny Type 160D/161D Tantalex Capacitors are sealed within a polyester film tube with tightly-bonded epoxy fill, so the assembly is both electrically insulated and highly resistant to moisture. They are available with axial leads as well as in single-ended construction.

Offering extremely high capacitance per unit volume (for example: 0.25  $\mu$ F @ 20 VDC in a case only .065" D. x .125" L.), Tantalex Hearing-aid Capacitors let you select from a broad range of ratings in five different case sizes.

45C-9125

For complete technical data on Type 196D Capacitors, request Engineering Bulletin 3545A. For the full story on Type 160D/161D Capacitors, write for Engineering Bulletin 3515D. Address Technical Literature Service, Sprague Electric Co., 35 Marshall St., North Adams, Mass. 01247.



Sprague<sup>®</sup> and '®' are registered trademarks of the Sprague Electric Co.

**THE BROAD-LINE PRODUCER OF ELECTRONIC PARTS**

# Amperex 'Two-In-One' packaging gives you Plastic IC's with the Reliability you'd expect only from hermetics.

Through a new, double-encapsulation packaging technique which combines the economy of plastic with the reliability of hermetic sealing, Amperex is able to bring you, at regular plastic prices—a line of off-the-shelf, digital IC's...the most reliable line of all-plastic 74N TTL's in the business. The encapsulation approach is unique... here's how it's done:



1. The chip is mounted on a gold-plated grid and is protected with a lacquer coating. The assembly is then packaged in soft epoxy resin which protects the chip against moisture penetration and prevents thermal fatigue of the bonding wires.

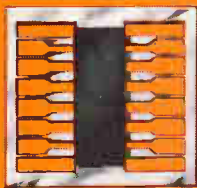

2. This sub-assembly is then welded into the final tin-plated grid structure and packaged in the dual-in-line encapsulation. A special ultra-strong plastic is used for the body of the device to withstand severe bend-pull stresses on the external leads. The leads are specially designed for maximum adhesion to the plastic body. The tin-plating on the leads continues right inside the body of the device, ensuring excellent corrosion-resistance and high quality soldered connections even after storage under tropical conditions.

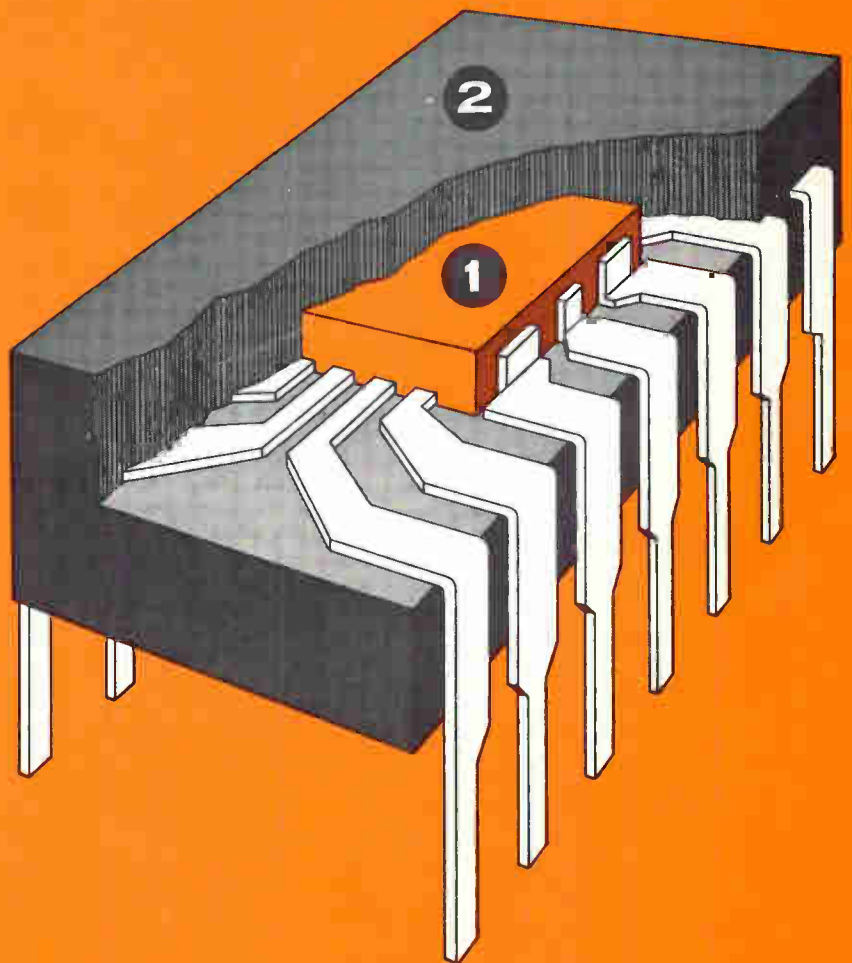

## Amperex®

TOMORROW'S THINKING IN TODAY'S PRODUCTS

A NORTH AMERICAN PHILIPS COMPANY

Circle 6 on reader service card





## HERE'S HOW WE PROVE OUR RELIABILITY:

Apart from stringent quality control during each step of manufacture, batches from each production run are tested for reliability under every conceivable kind of stress... electrical, thermal, mechanical and climatic, including:

- Resistance to thermal fatigue
- Endurance under conditions of intermittent dissipation
- Bond strength
- Bulk leakage
- Degradation of electrical performance under severe thermal stress
- RTR—circuit endurance
- Ability to withstand high and low temperature storage
- Switching capabilities under maximum fan-out and temperature conditions
- Full sequential temperature treatment tests to MIL-specifications
- Solderability
- Shock Resistance, Acceleration and Vibration Step-Stress



A specially prepared Reliability Report, based on three years of constant test procedures, is available. Write for your free copy, on your company letterhead.

**Amperex 74N TTL's are available off-the-shelf from Amperex Distributors listed below.**

SERIES 74N		AMPEREX IDENTICAL TYPE	
<b>GATES</b>			
SN 7400N.....	FJH131	SN 7401N.....	FJH231
SN 7402N.....	FJH221	SN 7410N.....	FJH121
SN 7420N.....	FJH111	SN 7430N.....	FJH101
SN 7440N.....	FJH141	SN 7450N.....	FJH151
SN 7451N.....	FJH161	SN 7453N.....	FJH171
SN 7454N.....	FJH181	SN 7460N.....	FJY101
<b>FLIP-FLOPS</b>			
SN 7470N.....	FJJ101	SN 7472N.....	FJJ111
SN 7473N.....	FJJ121	SN 7474N.....	FJJ131
SN 7476N.....	FJJ191		
<b>HIGHER ORDER FUNCTIONS</b>			
SN 7475N.....	FJJ181	SN 7490N.....	FJJ141
SN 7492N.....	FJJ251	SN 7493N.....	FJJ211

### PACE/AVNET

3961 Pace Court, Schiller Park, Illinois  
Telephone: (312) 678-6310

### ALMO ELECTRONICS

Roosevelt Blvd., at Blue Grass Rd., Phila., Pa.  
Telephone: (215) 676-6000

### INDUSTRIAL ELECTRONICS ASSOCIATES

P.O. Box 12444, Palm Beach Gardens, Florida  
Telephone: (305) 848-8686

### COMPUTER COMPONENTS CORPORATION

P.O. Box 30423, Dallas, Texas  
Telephone: (214) 239-0271

### HOLLYWOOD RADIO & ELECTRONICS, INC.

5250 Hollywood Blvd., Hollywood, Calif.  
Telephone: (213) 446-3181

For data, write:  
Amperex Electronic Corp., Microcircuits Division  
Slatersville, Rhode Island 02876

**Amperex**  
TOMORROW'S THINKING IN TODAY'S PRODUCTS

A NORTH AMERICAN PHILIPS COMPANY

## Readers Comment

American people is always to remove trade restrictions and tariffs; the most damaging is to impose them. It is irrational to react to another's folly by mimicking it.

Ernst F. Germann

Austin, Texas

### For clarity's sake . . .

To the Editor:

Your article, "Acronyms—antic abbreviations," [Sept. 1, p. 111], pointed up a very serious shortcoming of your own magazine. One can hardly turn a page without seeing DTL, FET, IC, LSI, MOS, MSI, SCR, TTL, or some other abbreviation or acronym. Although I am familiar with some of these abbreviations, there is no way to learn the identity of those with which I am not in the pages of *Electronics*. This is particularly perplexing to those who are not electrical engineers.

A simple solution to this problem would be to define each abbreviation the first time it is used in each article e.g., FET (field effect transistor). This would not take up much more space, should not insult the intelligence of those completely familiar with the terms, and should help to clarify some of the articles in your magazine.

L.W. Seiler

Shell Chemical Co.  
Deer Park, Texas

■ If Mr. Seiler would take a closer look at *Electronics*, he would find that before a term is abbrevi-

ated, it is usually spelled out—i.e., it would be metal oxide semiconductor at first mention, but MOS thereafter. However, there are times when the abbreviation is used first, but only when the longer form would either slow or stop the reader—and only when the abbreviation is easily understandable to electrical engineers.

### . . . and then some

To the Editor:

As the compiler of "A Dictionary of Acronyms and Abbreviations in Management, Technology and Information Science" (Shoe String Press, 1968) and as a technical librarian on the staff of the Ministry of Defense, I was extremely interested in your article "Acronyms—antic abbreviations."

I can verify that the coining of acronyms continues to grow rapidly as I have in preparation a second edition of the dictionary, one which will be greatly expanded.

Your article refers to the vast amount of time and painful gestation involved in generating an acronym suitable to the proud parents. More effort should be given to producing acronyms that contain the company's name in some form when it is desired to describe equipment, projects, and the like. Only in this way will a great deal of confusion be avoided and the acronym become truly mnemonic and specific.

Eric Pugh  
Teddington, Middlesex, England

## SUBSCRIPTION SERVICE

Please include an *Electronics Magazine* address label to insure prompt service whenever you write us about your subscription.

Mail to: Fulfillment Manager  
Electronics  
P.O. Box 430  
Hightstown, N.J. 08520

To subscribe mail this form with your payment and check  new subscription  renew my present subscription

Subscription rates: qualified subscribers in the U.S.: 1 year \$8; two years, \$12; three years, \$16. Non-qualified: 1 year \$25. Subscription rates for foreign countries available on request.

## CHANGE OF ADDRESS

ATTACH LABEL HERE

If you are moving, please let us know five weeks before changing your address. Place magazine address label here, print your new address below.

name

address

city

state

zip code

## Who's Who in this issue

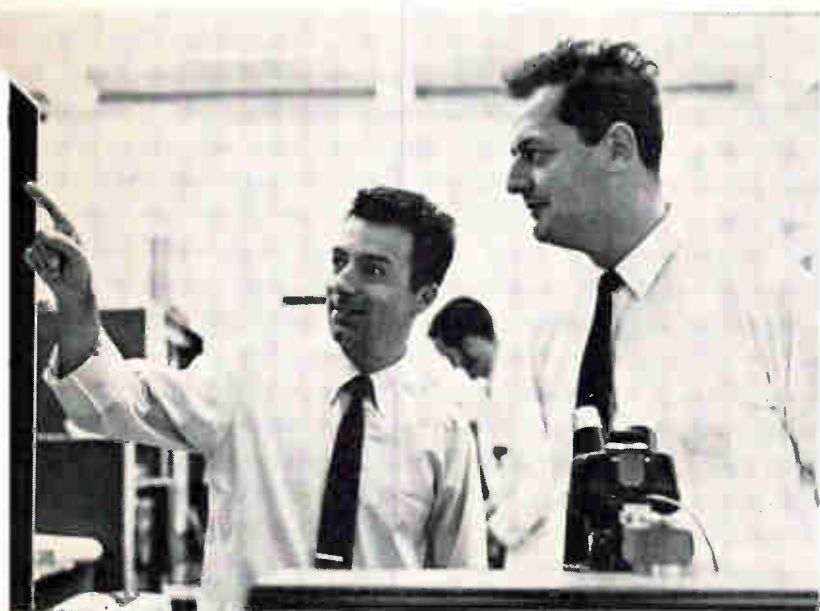

Faggin

Klein

Seeing and helping their pet research project become a new wave of technology has been the rewarding experience of Thomas Klein and Federico Faggin. Their article starting on page 88 explains the advantages of the new wave-silicon-gate technology—over conventional MOS integrated circuit fabrication. A 1960 physics graduate from Aberdeen University, Scotland, Klein worked on IC's at the Mullard Research Laboratories, Redhill, England, until he joined Fairchild in 1966. He now heads MOS IC work at Fairchild's Research and Development Laboratory. Faggin, who graduated from the University of Padua, Italy, in 1965, has been developing silicon-gate technology at Fairchild since early 1968. Previously, he headed their MOS group.

Involved for some time in microelectronic implementation of underwater sonar systems, Basil T. Barber now is researching non-linear smoothing and adaptive techniques. Author of the article starting on page 104, he is research section head in Sperry's advanced sonar systems unit.



Wolf

Alphanumeric displays are a speciality of James Wolf, who helped design most of IBM's computer display line. Wolf is a senior associate engineer at IBM's System Development division, Kingston. James Williams, who joined IBM in 1963, was responsible for deflection circuits in the IBM 2260 and IBM 2265 display stations. Recently, he joined Lundy Electronics & Systems, Charlotte, N.C., where he designs computer peripherals for banks. Their article starts on page 108.

A coast-to-coast effort went into the rms-converter article which begins on page 98. Peter Richman, the designer, is a consulting engineer who works out of Lexington, Mass. Gene Ochs, who helped put the converter into a commercial meter, is a product development manager at California's Dana Laboratories Inc. Before going on his own in 1967, Richman spent 19 years in industry. A founder of the Rotek Instrument Corp., he was chief engineer from 1960 until 1964, when it was acquired by Weston Instruments Inc. From then until 1966 Richman was the Weston-Rotek division's director of advanced development. Like his coauthor, Richman has an MS degree from New York University. Richman's is in mathematics, circa 1951. Gene Ochs earned his in electrical engineering 14 years later. While attending NYU, Ochs worked at the Bell Telephone Laboratories. After graduation he designed spacecraft guidance systems at Hughes Aircraft Co. He joined Dana in 1967.



Turner

Designing bandpass amplifiers for radar and communications equipment is Roland Turner's charter at General Atronics Corp. Author of the article starting on page 102, he has an MSEE degree from Drexel University.



Williams

# Magnetic Flat Pak Modulators, Analog Multipliers, Demodulators mount directly on IC Cards

ACTUAL SIZES

- Hybrid assemblies mount directly on IC cards.
- Space saver design . . . typical dimensions 0.1" thick x 0.5" x 0.75".
- Rugged design, extreme reliability. MTBF design goal 0.25 per million hours.
- Extremely low drift over  $-55^{\circ}$  to  $+125^{\circ}\text{C}$  range.
- Not affected by high intensity nuclear radiation.
- Capable of operating on carrier frequencies as high as five Mhz.
- One or more isolated or floating input signals may be used for modulating, multiplying, dividing, squaring or extracting a root.
- No external nulling or offset adjustments.
- No additional components or compensation required.
- No external operational amplifiers required.
- Standard  $\pm 15\text{ V DC}$  power supplier unless otherwise specified.

## TYPICAL FUNCTION PERFORMED BY THESE COMPACT MODULES

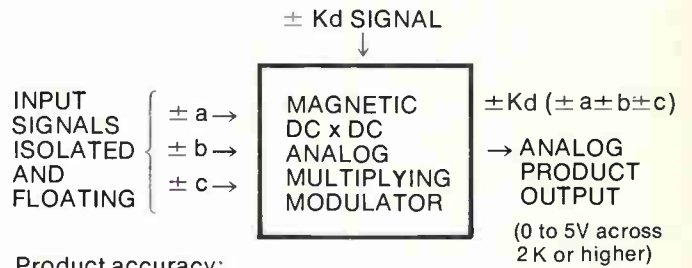

TYPE NUMBER	IMM 1199-1	IMM 1210-1	IMM 1212-1	IMM 1214-1
Reference Carrier Voltage and Frequency	10 V RMS @ 1800 Hz	10 V RMS @ 400 Hz	5 V RMS @ 25 KHz	5 V RMS @ 100 KHz
Input Control Signal Range	0 to $\pm 1.5$ ma DC	0 to $\pm 300$ ma DC	0 to $\pm 5\text{ V DC}$	0 to $\pm 10\text{ V DC}$
DC Resistance of Input DC Signal Winding	8 K ohms	30 K ohms	10 K ohms min	< 5 K
AM Phase Reversing AC Output Range	0 to 5 V RMS @ 1800 Hz	0 to 5 V RMS @ 400 Hz	0 to 5 V RMS @ 25 KHz	0 to 5 V RMS @ 100 KHz
Differential Gain RMS mv. AC Output/ua DC Sig. Input	4 mv RMS/ $\mu$ a DC	16.5 mv RMS/ $\mu$ a DC	1 V RMS/1 V DC	0.5 V RMS/1 V DC
AC Output Null (Noise Level) RMS	$\frac{1}{2}$ % f.s.	$\frac{1}{2}$ % f.s.	0.5 % f.s.	0 to 5 V RMS @ 100 KHz
Output Impedance External Load	< 50 ohms 10 K to 100 K ohms	< 50 ohms 10 K to 100 K ohms	< 50 ohms 10 K to 100 K ohms	< 50 ohms 10 K to 100 K ohms
Excitation (Carrier Winding) Impedance	4 K ohms	25 K ohms	10 K ohms	1 K ohms
Zero Point Drift over Temp. Range Referred to DC Input Terminals	0.25 % f.s.	0.5 % f.s.	0.5 % f.s.	1 % max
Hysteresis in Percent of Max. Input DC Signal	0.2 % f.s.	0.5 % f.s.	0.5 % f.s.	0.5 % f.s.
% Harmonic Distortion in Output Wave	5 %	10 %	< 5 %	< 5 %
Temperature Range	$-55^{\circ}\text{C}$ to $+125^{\circ}\text{C}$	$-55^{\circ}\text{C}$ to $+125^{\circ}\text{C}$	$-55^{\circ}\text{C}$ to $+125^{\circ}\text{C}$	$-55^{\circ}$ to $+100^{\circ}\text{C}$
Frequency Response	DC to 200 Hz	DC to 100 Hz	DC to 2.5 KHz	DC to 10 KHz
Overall Dimensions (in inches)	0.1 x 1.0 x 1.0	0.1 x 1.0 x 1.0	0.1 x .75 x .625	0.1 x .75 x .625
Type of Mounting	Flat Pak Terminals	Flat Pak Terminals	Printed Circuit Flat Pak	Printed Circuit Flat Pak

Magnetic DC x DC Multiplier

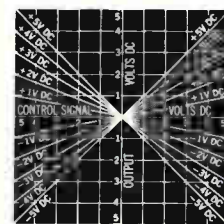

Squaring

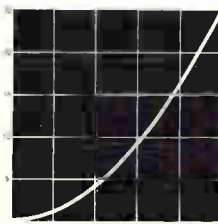

Square Root

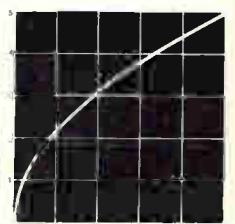

Division



Amplitude Modulation

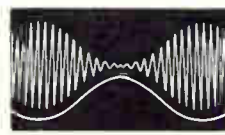

Balanced Modulator



There is No Substitute for Reliability  
**GENERAL MAGNETICS, INC.**  
 135 Bloomfield Avenue,  
 Bloomfield, New Jersey 07003

Circle 9 on reader service card

# We'll go to any length to get into your memory

National's capable of going a long way (or short) to get the right MOS shift registers into your memory. The applications are unlimited.

For starters, you get a variety of bit lengths from our standard line, available immediately. Your National distributor's got them on the shelf and waiting.

If you can't find the register length your application requires, give us a call. We'll program your register length into our standard process. We've been making MOS so long, our memory's capable of anything.

# How's that register?

## DYNAMIC

Dual-25	MM400	-55°C to +125°C
	MM401	-55°C to +125°C (Internal 20K pull-up resistor)
	MM500	-25°C to +70°C
	MM501	-25°C to +70°C (Internal 20K pull-up resistor)
Dual-50	MM402	-55°C to +125°C
	MM403	-55°C to +125°C (Internal 20K pull-up resistor)
	MM502	-25°C to +70°C
	MM503	-25°C to +70°C (Internal 20K pull-up resistor)
Dual-100	MM406	-55°C to +125°C
	MM407	-55°C to +125°C (Internal 20K pull-up resistor)
	MM506	-25°C to +70°C
	MM507	-25°C to +70°C (Internal 20K pull-up resistor)
Dual-64 Accumulator	MM410	-55°C to +125°C
	MM510	-25°C to +70°C
Triple-60+4 Accumulator	MM415	-55°C to +125°C
	MM515	-25°C to +70°C

## STATIC

Dual-16	MM404	-55°C to +125°C
	MM504	-25°C to +70°C
Dual-32	MM405	-55°C to +125°C
	MM505	-25°C to +70°C
8-bit Serial to Parallel	MM408	-55°C to +125°C
	MM508	-25°C to +70°C
8-bit Parallel to Serial	MM409	-55°C to +125°C
	MM509	-25°C to +70°C
Dual-32 Split clock	MM419	-55°C to +125°C
	MM519	-25°C to +70°C

Write or call National Semiconductor, 2975 San Ysidro Way, Santa Clara, California 95051.

(408) 245-4320. TWX: 910-339-9240 Cables: NATSEMICON

**National/MOS**



## Now, ready for you in quantity.

The new Delco Radio DTS-701 and 702 NPN triple-diffused silicon high voltage transistors. They were designed for the tough requirements of off-line deflection in large screen TV.

However, they're built and tested for extra reliability in all high energy circuits. Proved by the surest peak energy capability rating in the business: Pulse Energy Testing.

And right now, they're available in both production and sample quantities.

Why will you want to use the Delco 701 or 702?

For the tough jobs—high inductive load switching or for circuits subject to transients or fault conditions.

For reduction of weight, size and component costs. Circuit complexity and number of components are reduced, so assembly costs go down, too. And fewer components mean higher reliability.

So now you know. The pioneer in high voltage silicon power has done it again.

For prices, samples or complete data, just call us or the nearest Delco Radio distributor listed below.

### SEMICONDUCTOR DISTRIBUTORS

ALA., BIRMINGHAM • Forbes Distributing Company, Inc.  
(205)-251-4104

ARIZ., PHOENIX • Sterling Electronics, Inc. (602)-258-4531

CAL., LOS ANGELES • Kierulff Electronics, Inc. (213)-685-5511  
• Radio Products Sales, Inc. (213)-748-1271

CAL., PALO ALTO • Kierulff Electronics, Inc. (415)-968-6292

CAL., SAN DIEGO • Milo of California, Inc. (714)-232-8951

COLO., COLORADO SPRINGS • L. B. Walker Radio Co. (303)-636-1661

COLO., DENVER • L. B. Walker Radio Co. (303)-935-2406

COLO., ENGLEWOOD • Hyer Electronics Co. (303)-771-5285

FLA., MIAMI • Mountain Electronics, Division of  
Mountain National Co. (305)-634-4556

FLA., WEST PALM BEACH • Mountain Electronics, Division of  
Mountain National Co. (305)-833-5701

ILL., ROSEMONT • F-J-R/Midwest, Inc. (312)-678-8560

ILL., SKOKIE • Merquip Electronics, Inc. (312)-282-5400

IND., INDIANAPOLIS • Graham Electronics Supply, Inc.  
(317)-634-8486

MD., BALTIMORE • Radio Electric Service Co. (301)-539-3835

MASS., NEWTON • The Greene Shaw Co., Inc. (617)-969-8900

MICH., KALAMAZOO • Electronic Supply Corp. (616)-381-4626

MINN., MINNEAPOLIS • Stark Electronics Supply Co. (612)-332-1325

MO., KANSAS CITY • Walters Radio Supply, Inc. (816)-531-7015

MO., ST. LOUIS • Electronic Components for Industry Co.  
(314)-647-5505



**1200V - 3.0A**  
**800V - 0.5A**

<b>DTS-701</b>	
Collector to emitter voltage ( $V_{CE0}$ )	800V
Sustaining voltage ( $V_{CE0}$ (sus))	600V min.
Emitter to base voltage ( $V_{EBO}$ )	5V
Collector current ( $I_C$ )	500mA
Base current ( $I_B$ )	100mA
Power dissipation ( $P_T$ )	25W
<b>DTS-702</b>	
Collector to emitter voltage ( $V_{CEX}$ )	1200V
Collector to emitter voltage ( $V_{CE0}$ )	1000V
Sustaining voltage ( $V_{CE0}$ (sus))	750V min.
Emitter to base voltage ( $V_{EBO}$ )	5V
Collector current ( $I_C$ )	3A
Base current ( $I_B$ )	1A
Power dissipation ( $P_T$ )	50W

Available in solid copper. JEDEC TO-3 package.

#### Kokomoan's Regional Headquarters

Union, New Jersey\* 07083  
Box 1018 Chestnut Station  
(201) 687-3770  
Chicago, Illinois\* 60656  
5151 N. Harlem Avenue  
(312) 775-5411  
Santa Monica, Calif.\* 90401  
726 Santa Monica Blvd.  
(213) 870-8807  
Detroit, Michigan 48202  
57 Harper Avenue  
(313) 873-6560

Kokomo, Ind. 46901  
700 E. Firmin  
(317) 459-2175 Home Office  
\*Office includes field lab  
and resident engineer  
for application assistance.



**THE KOKOMOANS ARE IN POWER**

**DELCO RADIO**  
DIVISION OF GENERAL MOTORS  
KOKOMO, INDIANA

N.J., CLIFTON • Eastern Radio Corporation (201)-471-6600  
N.M., ALBUQUERQUE • Hyer Electronics Company (505)-265-5767  
• Sterling Electronics Inc. (505)-247-2486  
N.Y., BINGHAMTON • Federal Electronics, Inc. (607)-748-8211  
N.Y., NEW YORK • Harvey Radio Co., Inc. (212)-582-2590  
N.Y., WOODBURY, L.I. • Harvey Radio Company, Inc. (516)-921-8700  
OHIO, CINCINNATI • United Radio, Inc. (513)-761-4030  
OHIO, CLEVELAND • The W. M. Pattison Supply Co., Industrial  
Electronics Division (216)-441-3000  
OHIO, DAYTON • F-J-R/Ohio, Inc. (513)-278-9411  
OKLA., OKLAHOMA CITY • Radio, Inc. (405)-235-1551  
OKLA., TULSA • Radio, Inc. (918)-587-9124

PENN., PHILADELPHIA • Almo Electronics, Division of  
Sterling Electronics (215)-676-6000  
PENN., PITTSBURGH • RPC Electronics (412)-782-3770  
TEXAS, DALLAS • Adleta Electronics Company (214)-742-8257  
TEXAS, FORT WORTH • Adleta Electronics Co. (817)-336-7446  
TEXAS, HOUSTON • Harrison Equipment Co., Inc. (713)-224-9131  
UTAH, SALT LAKE CITY • Hyer Electronics Company (801)-487-3681  
VA., RICHMOND • Meridian Electronics, Inc. (703)-353-6648  
WASH., SEATTLE • Kierulff Electronics, Inc. (206)-763-1550  
WASH., TACOMA • C & G Electronics Co. (206)-272-3181  
CANADA, ONT., SCARBOROUGH • Lake Engineering Co., Ltd.  
(416)-751-5980

# Silicon Rectifier for B&W TV applications

Available in production quantities now!



30KV  
LESS \$  
THAN **1.00**

In quantities greater than 50,000 Pcs.

- Diffused silicon.
- Fast recovery.
- Ferrule mounted.
- Available with wire leads.

When you think of Varo Semiconductor products, remember this — we're the company that not only made the first silicon high voltage rectifier ever used in consumer TV sets, but we received the first order for multipliers to be used in consumer TV production, too.



SEMICONDUCTOR DIVISION, 1000 N. SHILOH ROAD, GARLAND, TEXAS 75040 (214) 272-4551

## Who's Who in electronics



Aware. GE's Richard P. Gifford eyes communications as a sociological tool.

In earlier, stuffier times, Richard P. Gifford might never have made it as general manager of the General Electric Co.'s Communications Systems division. For example, he once wrote a paper on what man's technology is doing to the environment while he was chaperoning a 95-decibel teenage dance party. Clearly, Gifford is a man tuned in to today's turned-on and violently changing society.

Internationally recognized as one of the foremost experts on spectrum management, he was instrumental in preparing a 1968 report, "Spectrum Engineering—Key to Progress," that was sent to President Johnson. Gifford was chairman of the Joint Technical Advisory Committee group of the Electronic Industries Association and IEEE that produced it.

**Urbanology.** Though spectrum management still is one of his major interests, Gifford says his attention is focusing on the nation's sociological challenges, and the role of communications in meeting them. First priority, he says, is deurbanizing the city environment which "man has created against his animal instincts." Those violated instincts are a set order of

dominance and a sense of private territory, which man has lost to the street and its crowds. Basically, Gifford thinks, the problems of clean air, transportation, and crowd-handling "might not be worth solving."

Instead, he believes a better answer may be found in broadband communications. With it, says Gifford, city-dwelling professionals who want all the advantages of urban living can be enticed to the countryside where electronic devices will provide him with opera, shopping, and other cultural and economic conveniences. Gifford suggests communities of about 5,000 cable-connected homes, with each community doing its own entertainment and information programming from a central data file. Each community system would be connected with others by microwave or satellite distribution from a central network of data and film libraries.

Gifford says his small, electronically interconnected communities are not the same as Marshall McLuhan's global village, but he does agree that McLuhan's ideas of recorded communications would play a role in his electronic countryside. Gifford says he doesn't want to live in a global village, where he would have to "wake up to the problem of Biafra"—the United States must solve its own problems first, the GE executive asserts.

**Panelist.** Social directions of communications are one part of a study being conducted by a National Academy of Engineering panel on spectrum values in which Gifford is participating. The thrust of the study, to be presented to the White House Office of Telecommunications Management in about a year, is taking it down three general boulevards:

- Dimension the spectrum into units.
- Dimension the economic benefits by measuring productivity of alternate means, such as microwave vs. cable.
- Establish social priorities in distributing the spectrum, such as the needs of defense vs. the need



- Five full digits plus "1" for 20% overranging
- Basic unit measures 0 to 1100 volts dc in three ranges
- Auto ranging and polarity with active 3-pole switchable filter
- 25 millisecond sampling speed
- Full systems capability with timing signals and ready indicator
- Low cost options include ac voltage, millivolt-ohms, external reference (ratio) and fully isolated remote programming and data output.



## The first really new DVM in a decade

**Announcing the Fluke 8300A, a 0.005% digital voltmeter with full systems capability for \$1295**

There are a lot of good DVM's around. All but one share a common set of faults—overwhelming complexity and high cost. And as you might guess, the DVM that beats the others cold is the new Fluke 8300A.

Why?

Because Fluke uses a new A to D technique which reduces componentry by up to 500 percent. Obviously, when components are eliminated, good things happen. Power requirements go down, reliability goes up, circuitry is simplified, troubleshooting is speeded and reduced. Most important to the system

designer, lowered costs mean we can invest some of the savings in features you need in a DVM.

With all its features and accuracy, the Fluke 5-digit DVM sells for less than many 4-digit units. We price the options low, too. A fully loaded Fluke 8300A sells for \$2995. Comparable but not equal competitive instruments cost as much as \$5000.

And when the Fluke name goes on the front you know you're getting quality instrumentation... in keeping with the Fluke philosophy of bringing you standards lab performance in portable instrumentation.

Fluke, Box 7428, Seattle, Washington 98133. Phone: (206) 774-2211. TWX: 910-449-2850. In Europe, address Fluke Nederland (N.V.), P.O. Box 5053, Tilburg, Holland. Phone: (04250) 70130. Telex: 884-50237. In the U.K., address Fluke International Corp., Garnett Close, Watford, WD2 4TT. Phone: Watford, 27769. Telex: 934583.



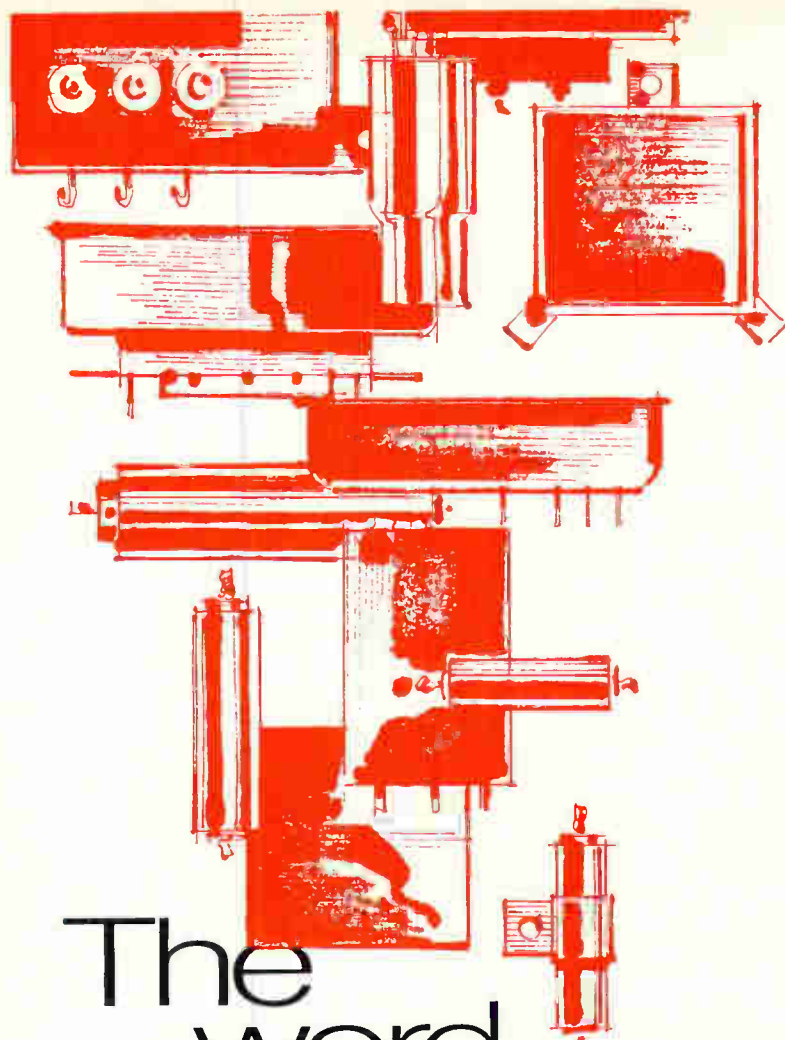

The  
word  
is filtering  
down...

## Captor is capable

Captor is the bright new face in electronic components, particularly filters. Deeply experienced. Imaginative. Capable of producing miniature EMC filters, communications and security filters, custom design filters/assemblies, and other electronic components. Capable too of fast delivery, competitive prices, testing, research. Capable of handling any size RFI/EMC filter order. Has the good word about Captor reached you yet? Write for our capabilities brochure today!

**CAPTOR**  
CORPORATION  
Electronics Division

5040 Dixie Highway, Tipp City, Ohio 45371, Phone: (513) 667-8484

## Who's Who in electronics

and desire for entertainment.

**Make a list.** This last area of the study is the most difficult to define, Gifford says. Through the so-called information revolution, technology can solve the problems it has created, but first man must set his social goals and then use the technology he has to accomplish these ends.

Establishing priorities are part of developing some overall communications authority—such as a Federal Telecommunications Authority to coordinate activities of the Federal Communications Commission, Office of Telecommunications Management, and other agencies now involved in the spectrum [*Electronics*, Sept. 1, p. 16]. Gifford says what is needed is a broad agency, but that getting it really isn't a "crying shame sort of thing."

The problems the OTM and the FCC have now, he says, are meager funding and the added burden of working together "in an era when communications is going to explode."

He thinks that if an FTA is established, power of adjudication should be left with the FCC—with the new organization handling only administration and engineering. Whatever agency is responsible for the spectrum, Gifford believes communications—like all technology—should be used "toward man's end, instead of against them." And though he says he would not like to be a part of the administration of the new agency, he definitely intends to remain involved in the issues that will come before it for resolution.

Of his appointment to head the newly restructured GE division in Lynchburg, Va., Gifford admits to being "very enthused." He sees the formation of the division, which now covers both terminal and transmission equipment, a sign that GE is focusing more on the social and economic aspects of communications. Gifford, 47, was born and raised in New York and moved to Lynchburg 10 years ago where, until his appointment, he managed GE's Communications Products department.

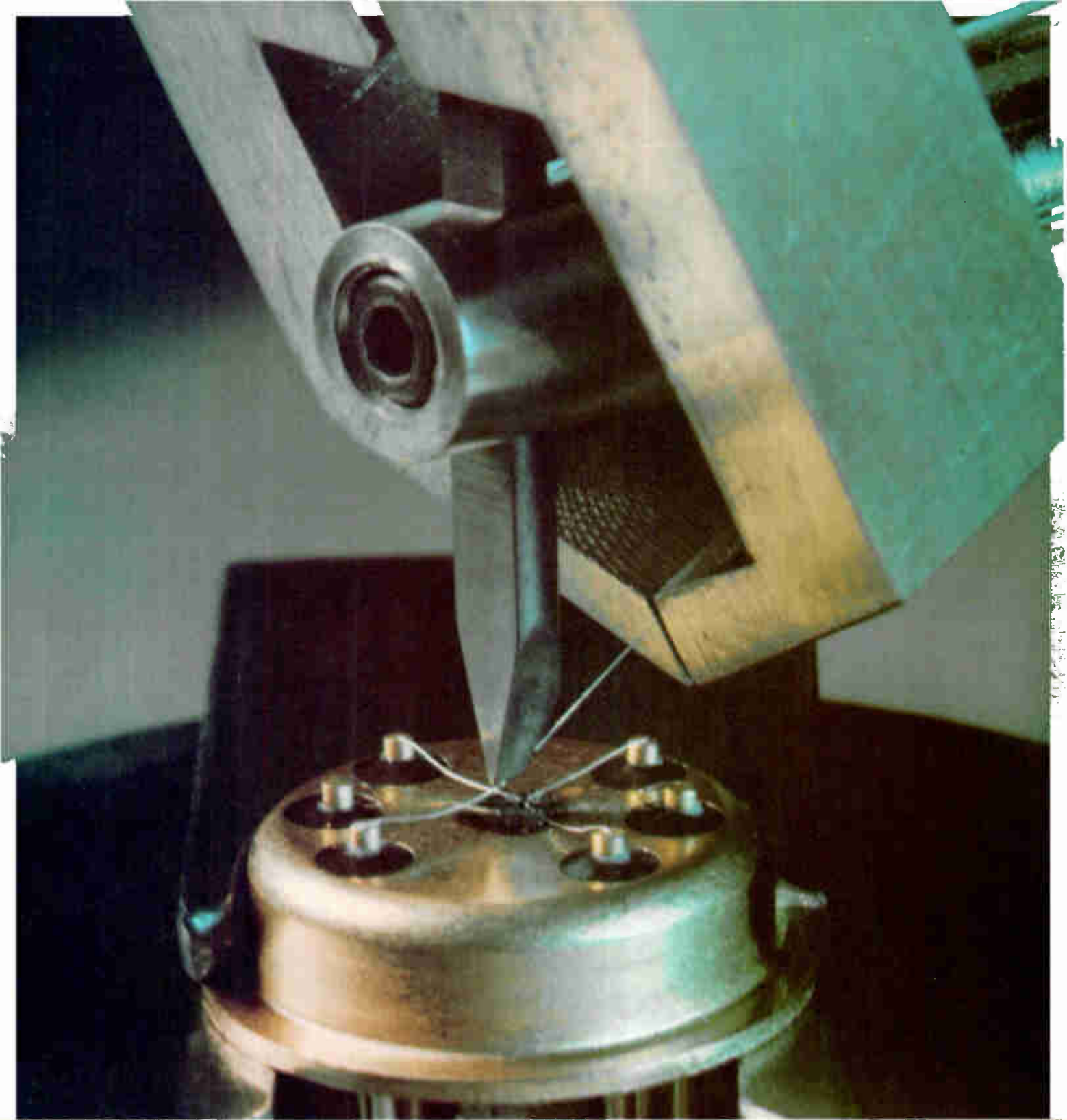

## Craftsmanship in hard materials...an industry standard

HIGH PRECISION TUNGSTEN CARBIDE BONDING TOOLS, SUCH AS THE ONE SHOWN IN THIS 13X MAGNIFICATION OF AN ULTRASONIC LEAD BONDING OPERATION, WERE PIONEERED AND INTRODUCED AS PRODUCTION DEVICES BY TEMPRESS . . . IN 1963, THE TEMPRESS CAPILLARY TUBE, AN INDUSTRY STANDARD . . . IN 1967, THE ULTRASONIC BONDING TOOL, AN INDUSTRY STANDARD. The techniques and the specialized machinery developed to produce such precision products from ultra-hard materials have not been duplicated; quite probably will not be, for they are a result of the unique combination of Tempress people and the

Tempress philosophy. To meet its responsibilities, Tempress maintains a continuing expansion program, limited only by strict adherence to the Tempress Standard of Excellence. (It requires as long as 11 months to train an operator for certain operations.) The same uncompromising standard is applied to Tempress Automatic Scribing Machines and to the entire growing family of Tempress miniature assembly tools and production equipment.



# TEMPRESS

Tempress Industries, Inc., 980 University Ave., Los Gatos, Calif. 95030

Circle 17 on reader service card

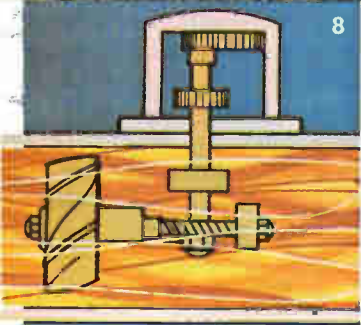

1. As rocket insulation linings for Thiokol Chemical Corporation, Durez® phenolics hold up under firings at 4000° to 6000°F.

2. For the miniature housing of a new digital readout tube, Burroughs Corporation chose a Durez alkyd. The only plastic tested within the specific temperature range that's compatible with the thermoplastic lens, it allows a mere .050" wall thickness and remains free from distortion.

3. In the Cook Electric 600 Fuzed Station Protector, a one-piece Durez phenolic base takes on overloads above 350 amps and tens of thousands of volts, come rain or shine or thunderbolts.

4. Facing up to sparks, flying shards and all the knocks and bangs of the shop floor is a regular shift for the Durez phenolic insulator cap, sleeve and handle on the Martin Wells electrode holder.

5. Out in the midday sun or morning frost, a Durez phenolic motor frame on the Rockwell Green Line hedge trimmer protects the operator with double insulation, helps seal out the elements.

6. Final 'take' in the small hours of a recording session. Durez phenolic parts ensure that Trusonic Wireless Microphone Systems catch the slight shift of mood as it happens. In Trusonic speakers, a .0065" thin-wall phenolic cone wrapped in an edge-wound coil ensures the same live sound reproduction throughout their 10-year guarantee.

7. Durez nonbleeding phenolic closures keep their appearance, hold in the bloom of a perfume.

8. To take continuous submersion in fluids at highs of 400°F, Durez phenolic propellers have replaced stainless steel in Hersey Sparling flowmeters. They don't pit. They don't get out of whack.

9. Slick pavement or thick mire, blistering sands in Arizona or an Alaskan blizzard. These are the everyday crises Durez phenolic parts handle for Bendix power brakes.

10. Inside a Tappan dishwasher, where conditions range from wet and dry cycling to detergents to 200°F, the Durez phenolic spray arm goes on digging the dirt for years on end.

11. Two miles down on the ocean floor, Durez DAP parts insulate each Western Electric transatlantic cable amplifier. They shrug off the pressure, the wear and tear of the tides for twenty years at a time.

**You supply the sparks,  
the blastoff,  
the suds,  
the lightning,  
the surge of the sea.**

**Durez supplies the durability.**

**You've got a 'go' on your new design. Creatively, it's the best thing you've ever done. Now you've got to put it to work, select materials, see how it stands up in the real world. We've spent over forty years putting ideas like yours to work. Clothing them in durability. Making sure the product you've created can face up to all the hazards of time and weather and environment.**

**We know molders and molding compounds.**

**Phenolics. DAP. Alkyds. We know where they've been and what they've done. We know where they can go and what they can do. Think creative. Then think environment. Then have our technical staff supply the durability.**

Durez Division  
Hooker Chemical Corporation  
9009 Walck Road  
North Tonawanda, N.Y. 14120  
Subsidiary of  
Occidental Petroleum Corporation

 **hooker**  
DUREZ DIVISION

# did you know?



General Electric **AC VOLTAGE STABILIZERS** respond instantly\* to give you voltage that is constant... constant, constant, constant, constant, constant, constant, constant, constant...

Send in this coupon for free bulletin giving complete details on GE AC Voltage Stabilizer features, ratings and application data; or see your GE sales representative today.

\* Output voltage is stabilized in less than 2 cycles for transient line drop of 30%.

**GENERAL  ELECTRIC**

Circle 20 on reader service card

.....  
● Section 413-35  
● General Electric Company  
● Schenectady, New York 12305  
● Please send me free bulletin GEA-7376 on AC Line Voltage Stabilizers.  
● NAME \_\_\_\_\_  
● COMPANY \_\_\_\_\_  
● TITLE \_\_\_\_\_  
● ADDRESS \_\_\_\_\_  
● CITY \_\_\_\_\_ STATE \_\_\_\_\_ ZIP \_\_\_\_\_  
.....

# did you know?



General Electric **volt-pac**<sup>®</sup> variable transformers help you vary voltage dependably...year after year,\* after year, after year, after year, after year, after year, after year, after year...

Send in this coupon for free bulletin giving complete details on Volt-Pac transformer features, ratings and application data; or see your GE sales representative today.

\* Laboratory tested for over one million failure-free operations.

GENERAL  ELECTRIC

Circle 21 on reader service card

.....  
Section 413-34  
General Electric Company  
Schenectady, New York 12305

Please send me free bulletin GEA-8110 on Volt-Pac Variable Transformers.

NAME \_\_\_\_\_

COMPANY \_\_\_\_\_

TITLE \_\_\_\_\_

ADDRESS \_\_\_\_\_

CITY \_\_\_\_\_ STATE \_\_\_\_\_ ZIP \_\_\_\_\_

# Introducing PLUSISTOR VECO



## slayer of dragon-size heat regulation problems

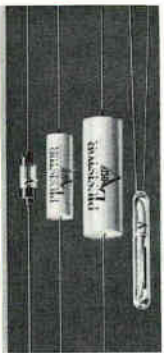

PLUSISTOR is VECO's all-new positive temperature coefficient thermistor for temperature measurement and compensation. A solid state silicon resistor, PLUSISTOR features an average coefficient of  $+0.7\%/^{\circ}\text{C}$  which remains virtually constant through the range of  $-60^{\circ}\text{C}$  to  $+150^{\circ}\text{C}$ . These small-but-stalwart heat defenders are available to you in a variety of designs—

- $\frac{1}{4}$  &  $\frac{1}{2}$  watt axial lead, molded design
- $\frac{1}{4}$  watt, hermetically sealed can
- $\frac{1}{4}$  watt axial lead, glass body adjacent lead, glass probe

Available in decade multiples of E.I.A. standard resistance values from  $10\Omega$  to  $10\text{K}\Omega$ ... 10% standard tolerance or tighter tolerances and special values other than standard where required. PLUSISTOR is just one of a complete line of thermistors from VECO designed to solve the most gigantic of problems.

**VECO**  
**VICTORY  
 ENGINEERING  
 CORPORATION**  
 VICTORY ROAD, SPRINGFIELD,  
 NEW JERSEY 07081  
 (201) 379-5900 • TWX 710-983-4430

## Meetings

### ISA Conference: Texas roundup

Digital sensing of analog measurements has been an on-again, off-again idea for the last decade, starting about the time the digital computer gained a foothold in industrial and avionic control systems. Now digital sensors, or transducers, are being developed again, according to NASA's A.E. Schuler.

At the technologically diversified Instrument Society of America Conference in Houston's Astrohall, Oct. 27-30, Schuler will classify digital transducers, review research and development, and report on the current status of electronic digital transducers being readied by instrument companies under contract to NASA.

In a session on general test measurement, three Texans will give a boost to industrial applications of lasers. As lasers achieved increased power and reliability they become attractive for industrial uses, assert L.N. Peckham, M.O. Hagler, and M. Kristiansen of Texas Technological College. The applications are varied—from extreme-accuracy measuring to nondestructive testing. Continuous lasers have become practical for monitoring and guiding milling machines and tunneling equipment, measuring rate of flow of liquids, and spotting structural weaknesses in materials under stress.

G.G. Vurek of the National Heart Institute, in a session on instrumentation research, will describe a clinical emission photometer that

can detect less than  $10^{-13}$  moles (gram molecules) of sodium or potassium that's found in biological fluids.

For further information contact D.R. Stearn, ISA, 530 William Penn Pl., Pittsburgh, Pa.

### Reflecting the changes

The changing nature of devices—from the traditional, simple general-purpose functions to the newer, highly complex tasks involving different forms of energy—will be reflected at the International Electron Devices Meeting to be held Oct. 29-31 at the Sheraton Park Hotel in Washington. Papers will deal with such topics as the properties of materials and the interaction of materials with light, sound, and electrical energy.

In each session, papers will be grouped according to the type of device—avalanche microwave, imaging and display, high-power traveling wave, integrated electronics, and the like. And there will be sessions on process technology, including the making of integrated-circuit masks. Of special interest is a paper on magnetic-bubble domains and their application by Andrew H. Bobeck of Bell Telephone Laboratories in Murray Hill, N.J. Bobeck is one of the inventors of Bell's magnetic-bubble memory [*Electronics*, Sept. 1, p. 83].

For further information contact J. Sevick, Bell Telephone Laboratories, Murray Hill, N.J.

## Calendar

**Annual Conference of the American Institute of Ultrasound in Medicine;** Winnipeg, Manitoba, Canada; **Oct. 6-10.**

**Engineering Management Conference,** IEEE; Montreal, Quebec, Canada; **Oct. 9-10.**

**IGA Group Annual Meeting, IEEE;** Statler Hilton Hotel, Detroit; **Oct. 12-16.**

**International Symposium on Remote**

**Sensing of Environment, The Center for Remote Sensing Information and Analysis;** University of Michigan, Ann Arbor; **Oct. 14-16.**

**Annual Symposium on Switching and Automata Theory, IEEE;** Waterloo, Ontario, Canada; **Oct. 15-17.**

**Progress into the Sea, Marine**

(Continued on p. 24)



with your  
 reputation at stake,  
 which resistor line would you specify?

take a close look—there'll be no question



Allen-Bradley



Manufacturer X



Manufacturer Y



Manufacturer Z

The above illustrations are from unretouched photomicrographs taken of four  $\frac{1}{2}$ -watt fixed resistors. Compare the anchoring of the leads, the seal provided by the insulating jacket at the ends, the homogeneity of the resistance material, the sharp color code bands—and decide for yourself.

For more details on Allen-Bradley hot-molded resistors, please write for Technical Bulletin 5000: Allen-Bradley Co., 1201 S. Second St., Milwaukee, Wis. 53204. Export Office: 1293 Broad St., Bloomfield, N.J., U.S.A. 07003. In Canada: Allen-Bradley Canada Ltd.

©Allen-Bradley Company 1967

EC69-56

QUALITY ELECTRONIC COMPONENTS



A-B hot-molded fixed resistors are available in all standard resistance values and tolerances, plus values above and below standard limits. **A-B hot-molded resistors meet or exceed all applicable military specifications including the new Established Reliability Specification.** Shown actual size.

TYPE BB 1/8 WATT

TYPE CB 1/4 WATT

TYPE EB 1/2 WATT

TYPE GB 1 WATT

TYPE HB 2 WATTS



**ALLEN - BRADLEY**

Circle 23 on reader service card

**now!**  
**the strongest**  
**power transistor**  
**packages you**  
**can get!**



**New High Reliability...  
 High Strength... Economy Designs!**

A complete line of power transistor packages from Ceramics International. Select from T-060 isolated, T-061 isolated or grounded, T-063 grounded, or The Power Tower. Grounded packages available with gold plating discs. Covers available, too!

Exclusive CI design assures high reliability... high strength performance. Bend leads during mounting... bend 'em back with no fear of losing seal integrity.

All pre-engineered for fast quantity production. In stock for quick prototype delivery. You save engineering and tooling costs.

Think all transistor packages are alike? Compare CI designs. You'll see the difference. Ask for performance data and prices. You'll like our quick response, too!



CERAMICS INTERNATIONAL DIVISION

Mahwah, New Jersey 07430  
 Phone: (201) 529-2800



**Meetings**

(Continued from p. 22)

Technology Society; Washington, Oct. 20-22.

Thermionic Energy Conversion Specialist Conference, IEEE; Carmel, Calif.; Oct. 21-23.

American Astronautical Society National Meeting; New Mexico State University, Las Cruces, Oct. 23-25.

ISA Conference and Exhibit, Instrument Society of America; Astrohall, Houston, Oct. 27-30.

Joint Materials Handling Engineering Conference, IEEE, American Society of Mechanical Engineers; Sheraton Motor Inn, Portland, Ore.; Oct. 27-29.

Joint Conference on Mathematical and Computer Aids to Design, Society for Industrial and Applied Mathematics, Association for Computing Machinery, IEEE; Disneyland Hotel, Anaheim, Calif., Oct. 27-30.

Nuclear Science Symposium, IEEE; Sheraton Palace Hotel, San Francisco; Oct. 29-31.

International Electron Devices Meeting, IEEE; Sheraton Park Hotel, Washington; Oct. 29-31.

Northeast Electronics Research & Engineering Meeting (NEREM), IEEE; Sheraton Boston Hotel, War Memorial Auditorium, Boston; Nov. 5-7.

University Conference on Ceramic Science, Dept. of Metallurgical and Materials Engineering, University of Florida; Nov. 10-14.

Symposium on Adaptive Processes, IEEE; Pennsylvania State University, State College; Nov. 17-19.

Fall Joint Computer Conference, IEEE; Convention Hall, Las Vegas; Nov. 18-20.

Commerce Laser Colloquium, Electronic Industries Association and the U.S. Commerce Department; Paris, France; Nov. 18-20.

Conference on Magnetism and Magnetic Materials, IEEE, American Institute of Physics; Benjamin Franklin Hotel, Philadelphia; Nov. 18-21.

Conference on Image Storage and Transmission for Libraries, U.S. Dept. of Commerce; National Bureau of Standards, Gaithersburg, Md., Dec. 1-3.

Annual Conference, IEEE Group on Vehicular Technology; Columbus, Ohio, Dec. 4-5.

(Continued on p. 26)

# "ALLEN BRADLEY HOT-MOLDED RESISTORS ENHANCE THE QUALITY STANDARD OF OUR DATA-RECORDERS"

Mohawk Data Sciences Corporation

**MDS** The time reduction achieved by the MDS Data-Recorder method of computer input preparation demands continuously reliable operation. And this in turn demands the highest standards of performance from each and every component.

Allen-Bradley fixed composition resistors were a natural selection. Made by an automatic hot-molding technique—developed and used exclusively by Allen-Bradley—A-B resistors afford the ultimate in uniformity. From resistor to resistor—year in and year out—physical and electrical properties are unvarying. Predictable. Always of the highest order.

Performance records are equally excellent. For example, Allen-Bradley hot-molded resistors meet the requirements of the new MIL-R-39008A Established Reliability Specification at the *highest* level—the S level. And this is true for *all* three ratings—the 1 watt, ½ watt, and ¼ watt—and over the *complete* resistance range from 2.7 ohms to 22 megohms.

For complete specifications on this quality line of hot-molded resistors, please write to Henry G. Rosenkranz, and request a copy of Technical Bulletin 5000. Allen-Bradley Co., 1201 S. Second St., Milwaukee, Wis. 53204. Export Office: 1293 Broad St., Bloomfield, N.J., U.S.A. 07003. In Canada: Allen-Bradley Canada Ltd.

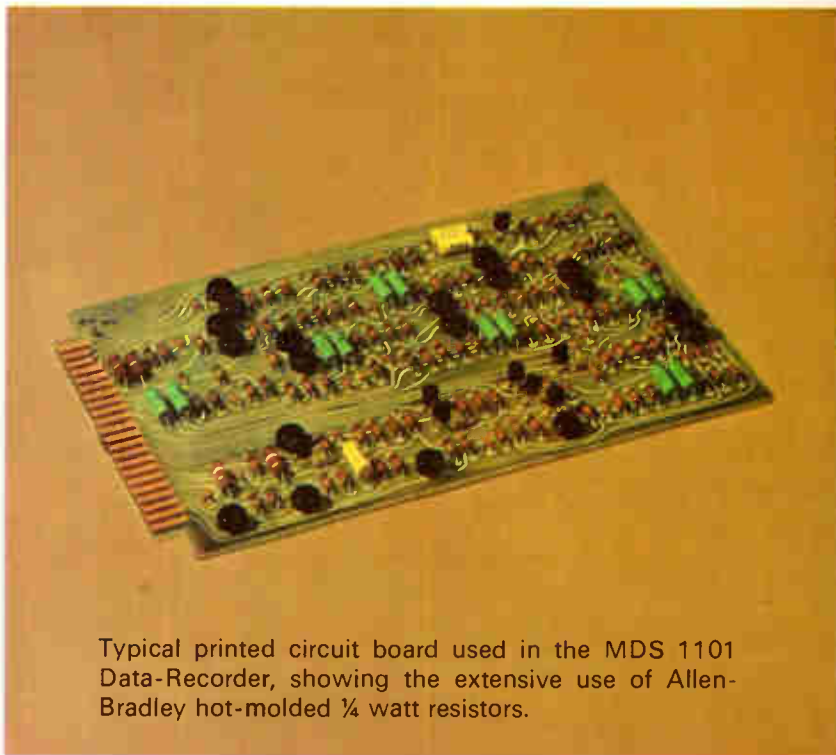

Typical printed circuit board used in the MDS 1101 Data-Recorder, showing the extensive use of Allen-Bradley hot-molded ¼ watt resistors.

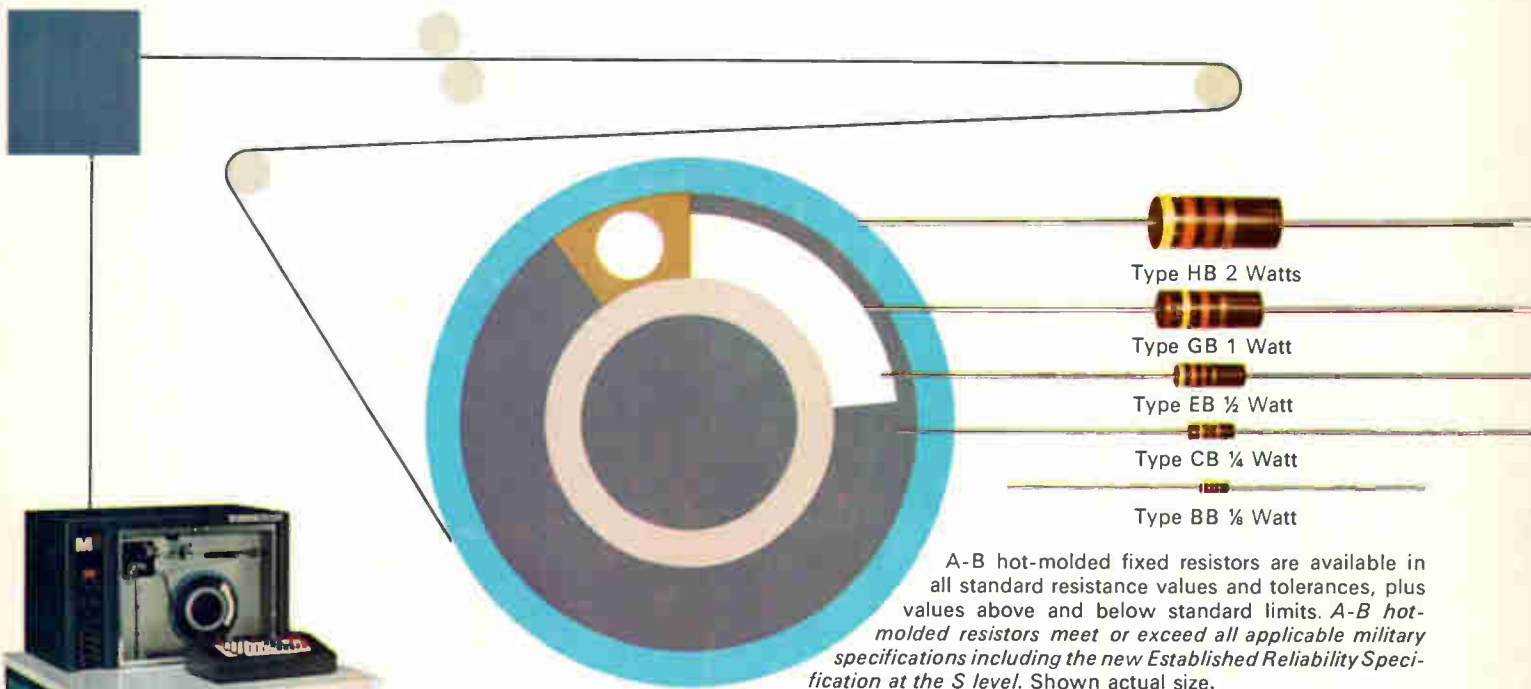

A-B hot-molded fixed resistors are available in all standard resistance values and tolerances, plus values above and below standard limits. *A-B hot-molded resistors meet or exceed all applicable military specifications including the new Established Reliability Specification at the S level.* Shown actual size.

Mohawk 1101 Data-Recorder permits transcribing of data from source documents direct to ½" computer magnetic tape.

©Allen-Bradley Company 1968



**ALLEN - BRADLEY**  
QUALITY ELECTRONIC COMPONENTS

Circle 25 on reader service card

EC69-61

Just as yours is a special kind of electronics, ours is a special kind of electron.

Belonging to a special class of compounds—the *rare earths*. Or (more properly) the lanthanides. Those elements which number from 57 (lanthanum) to 71 (lutetium) in the periodic table. Plus yttrium and thorium.

So what? So *this*. If you're not fully aware that the rare earths are put together in a very special way, which gives them some totally unique properties, learn a little.

In this instance, a little learning is *not* a dangerous thing. We see no reason for you to become a rare-earthologist.

But you should know at least this much: The configuration of the electrons in the rare earths gives them some unusual para- and ferromagnetic properties. Properties which have already been put to use in electronic-circuit components.

# Electronics (Yours)

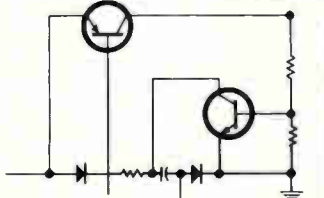

# Electrons (Ours)

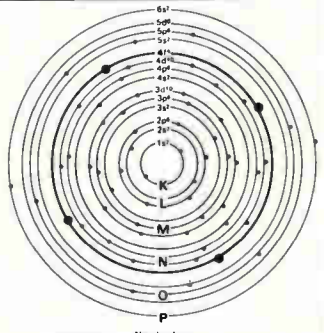

Neodymium

There's also something to be said for the rare-earth compounds as superconductors, as well as semiconductors. As thermoelectrics. As capacitors. As thermoluminescent devices. As CRT and lighting phosphors.

But, frankly, the surface has only been scratched. What would happen if someone with an unheard-of electronic application turned to the rare earths as the answer? Then the sparks would fly.

You may well protest that even if you *wanted* to do something about all of this, you couldn't. Like most of us, you're a specialist. In electronics. To make much headway through the body of knowledge surrounding rare earths, you'd need a chemist.

Aha! Got you *there*. A chemist is exactly what you *do* need. One of your associates. Look him up. Get together.

If your friend the chemist needs more supportive evidence on what the rare earths can do, have him call or write us.

And maybe—just maybe—we can give you hints on how to make electrons do something wild and wonderful. Electronically.

**RARE EARTH DIVISION**  
AMERICAN  
POTASH & CHEMICAL  
CORPORATION

AMERICAN POTASH & CHEMICAL CORPORATION

258 Ann Street; West Chicago, Illinois 60185; Telephone: (312) 231-0760

## Meetings

(Continued from p. 24)

**Symposium on Application of Magnetism in Bioengineering, IEEE, Israel Society for Biomedical Engineering; Rehovot, Israel, Dec. 9-11.**

**Fall USNC/URSI Meeting, IEEE; The University of Texas at Austin, Dec. 8-10.**

**Symposium on Circuit Theory, IEEE; San Francisco, Dec. 8-10.**

**National Electronics Conference, Conrad Hilton Hotel, Chicago, Dec. 8-10.**

## Short courses

**Data Systems Analysis and Design, Association for Computing Machinery; Sheraton Motor Inn, New York, Oct. 9-10. \$165 fee.**

**Modeling of Industrial Processes for Computer Control, Purdue University, Lafayette, Ind.; Oct. 13-22. \$250 fee.**

**Satellite Based Navigation, Traffic Control and Communications to Mobile Terminals, University of California at Los Angeles; Oct. 13-24. \$375 fee.**

## Call for papers

**IEEE Computer Group Conference and Exposition; Washington Hilton Hotel, June 16-18, 1970. Nov. 15 is deadline for submission of papers to Mr. T.C. Foote, IEEE Computer Group Conference, P.O. Box 1727, Rockville, Md., 20850.**

**IEEE - Electromagnetic Compatibility Symposium; Convention Center, Anaheim, Calif., July 14-16, 1970. Nov. 15 is deadline for submission of summaries to P.O. Box 1970, Anaheim, California, 92803, Attn. J.C. Senn, Technical Program Chairman.**

**International Symposium on Submillimeter Waves, Polytechnic Institute of Brooklyn, New York City, March 31-April 2, 1970. Dec. 1 is deadline for submission of abstracts to Polytechnic Institute of Brooklyn, MRI Symposium Committee, 33 Jay Street, Brooklyn, N.Y. 11201, Attn. Jerome Fox, Executive Secretary.**

**Geoscience Electronics Symposium, IEEE; Washington, D.C., April 14-17, 1970. Dec. 1 is deadline for submission of abstracts to Mr. Ralph Bernstein, Chairman, Technical Program Committee, IBM Corp., 18100 Frederick Pike, Gaithersburg, Md. 20760.**

# lev-er-wheel



... so new  
you can't look it up  
in your Funk & Wagnalls

## LEVERWHEEL SWITCH ... a brand new concept ... Thumbwheel Lever-Action by CHERRY

**FASTER SETTING:** A single movement of the Leverwheel setting lever through its 60° arc is all that's necessary for a complete 10-Position cycle. (Compare *that* to plunking through the 360° rotation on conventional thumbwheel!)  
**Instant reset at no extra cost:** A simple sweep with the hand and all levers return to home position with every switch in the bank returned to "zero."

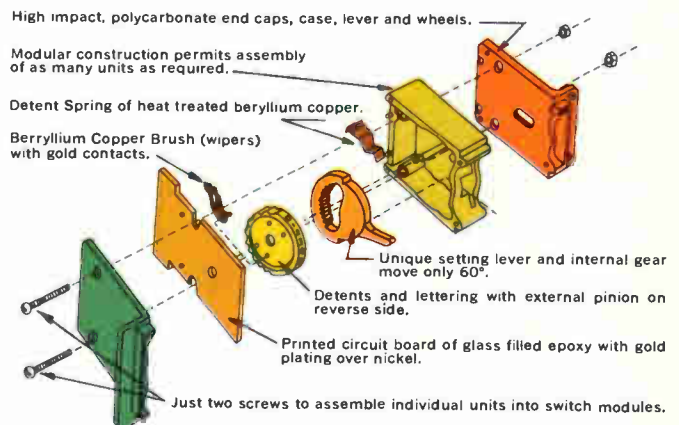
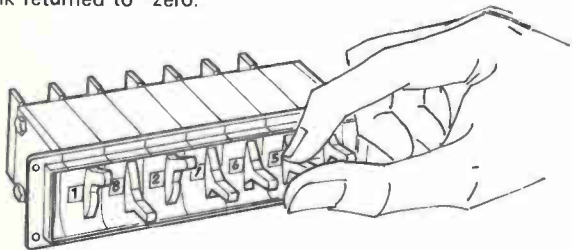

Cherry has new standard thumbwheel switches, too! Like the unique new Leverwheel, Cherry thumbwheel switches are available in miniature and subminiature sizes, totally-interchangeable with other leading thumbwheels.

**SEND TODAY** for a copy of the new brochure describing Cherry Leverwheel and Thumbwheel Switches. *For immediate action phone: 312/831-5024.*

# CHERRY

CHERRY ELECTRICAL PRODUCTS CORPORATION • 1656 Old Deerfield Road, Highland Park, Illinois 60035

Circle 27 on reader service card

# FETTS

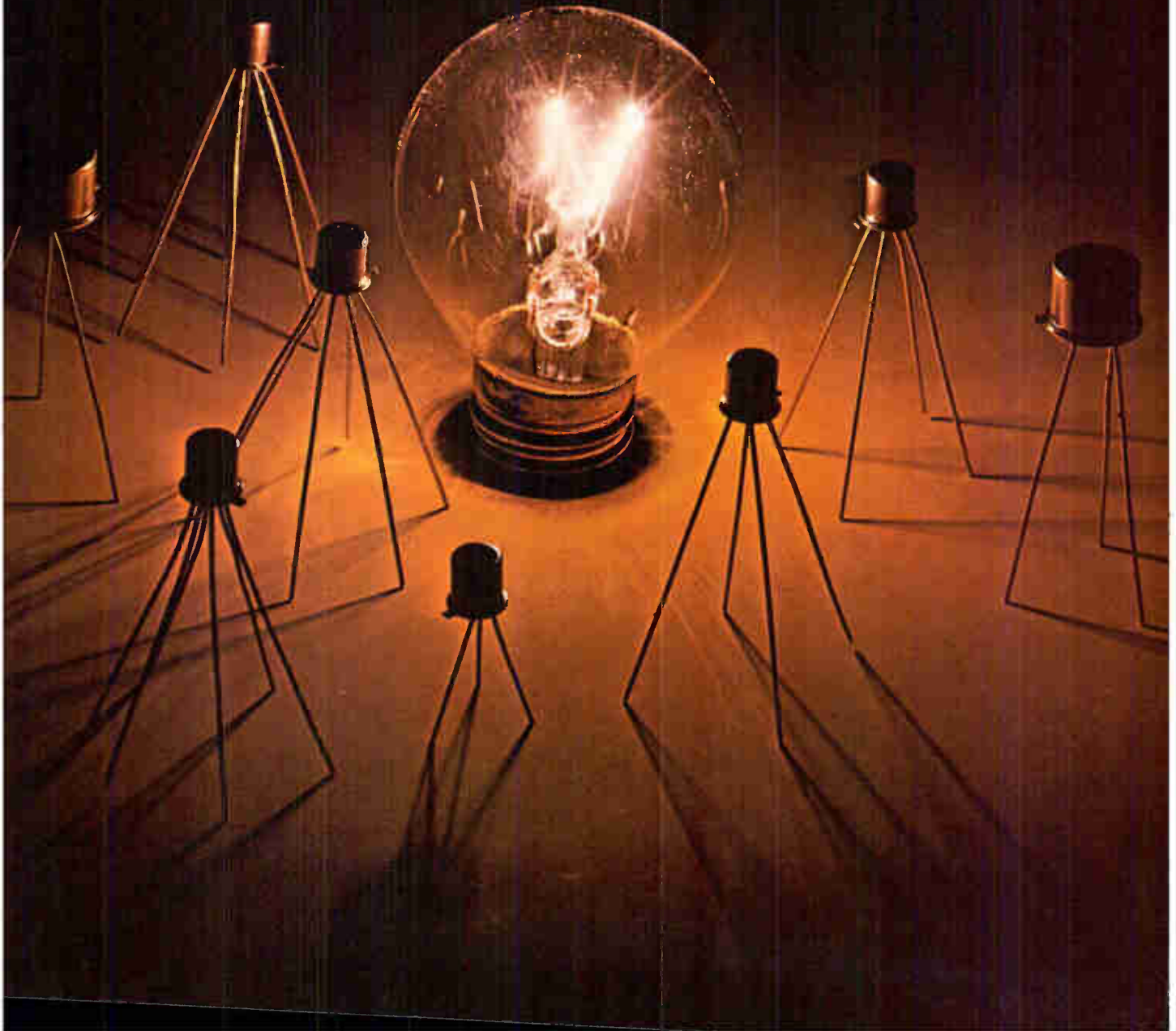

# TI introduces 8 new ones.

## With some new design ideas, too.

Once again, TI extends your circuit design spectrum with new FET products and design ideas.

Here's a variety of eight new field-effect transistors that can spark ideas for your circuits. We have a brand-new design brochure, too, which contains a score of FET circuits you can use.

### 3N160 and 3N161 MOS FETs

If you're interfacing IC logic, you'll want these new 25-volt MOS FETs. Low threshold voltages of 1.5 to 5 V make them ideal for bridging the gap between MOS and TTL or DTL bipolar circuits.

Low leakage and high input impedance keeps drift to a minimum in operational amplifiers and provides high accuracy in electrometer circuits. Use them too for shift-register circuitry, timers, or proximity detectors.

The 3N161 features a zener-protected gate to guard against static-charge damage.

In 100-piece quantities, the 3N160 is \$4.50 and the 3N161 is \$4.70.

For a data sheet circle reader service card number 145.

### 2N5545-47 Dual FETs

Designing operational, general purpose or differential amplifiers? Try TI's new n-channel FET duals:

2N5545, 2N5546, and 2N5547. In 100-999 piece quantities for \$15, \$9 and \$7.50.

They're tightly matched: 5, 10 and 15 mV max gate-source differential. Temperature drift of the 2N5545, for example, is less than  $10 \mu\text{V}/^\circ\text{C}$  and its output admittance is matched within  $1 \mu\text{mho}$  for superior common-mode rejection.

For a data sheet circle reader service card number 146.

### 2N5549 High-Frequency FET

For designers of low-level choppers, logic switches, multiplexers and RF, IF and VHF amplifiers... there's the new n-channel 2N5549 switching FET. Only \$3.30 in 100-piece quantities.

It gives you high gain and low noise—typically 15dB gain and 3.5dB noise at 100 MHz. For three good reasons: high transconductance—greater than 6,000  $\mu\text{mhos}$ . Low feedback capacitance—2pF max. And low on-resistance— $100 \Omega$  max.

For a data sheet circle reader service card number 147.

### 2N5543, 2N5544 High-Voltage FETs

Want to replace a tube with a transistor? Plug in the new 2N5543 or 2N5544 high-voltage n-channel FET. \$3 and \$2.50 in 100-999 piece quantities.

Use them as one-to-one replacements tubes. In high-voltage switching. Large-signal amplifiers. CRT deflection circuits. And line-operated amplifiers in industrial, communications and home-entertainment equipment.

They have high gate-drain breakdown voltages—300 V (2N5543) or 200 V (2N5544). High transconductance—750  $\mu\text{mho}$  min. And low feedback capacitance—2pF.

For a data sheet circle reader service card number 148.

All eight new FETs are available from authorized TI distributors or TI field sales offices.



"FET Design Ideas" is a must for every circuit design engineer's reference file. It contains: 20 circuit diagrams covering a wide range of applications. How to bias field-effect transistors. Applications literature available. And short-form data on all of TI's standard FETs.

To get your copy, write direct to Texas Instruments Incorporated, PO Box 5012, MS308, Dallas, Texas 75222. Or just circle reader service card number 149.



Prices are manufacturer's suggested list; subject to change without notice.

**TEXAS INSTRUMENTS**  
INCORPORATED



# No other multimeter gives you all this

**and no one but Cimron can make a claim like that stick**

Here's the first and only 4-digit instrument that you can take with you and hook up for full multimeter performance anywhere. Cimron, the Customer Concern Company, puts your needs first. That's why this new Cimron 6453 is just one more the competition will have to catch up with.

You get the most advanced MSI and IC construction plus a thin film attenuator . . . which, by the

way, eliminates 75% of the normal calibration requirements. Single plane Digivac readout tubes result in the lowest power consumption of any digital multimeter, and make full-day battery operation possible. The same amplifier used in the most costly instruments provides an input impedance ten times greater than any meter in its class.

The basic instrument gives you 5 ranges of DC voltage measurement with 5th digit overrange, autoranging in all functions, autopolarity, and pushbutton selection. Add remote control, AC,

resistance, print output and the 8-hour battery pack options, and you have full remote program-

ming capability anywhere. And it's computer compatible. The 6453 . . . just 8 pounds and 3½" x 8" x 12", sells for only \$1,125. A full multimeter is less than \$1,600. Call us for a demonstration. Phone (714) 276-3200 or write

Cimron, Dept. D-113, 1152 Morena Blvd., San Diego, Cal. 92110.

**CIMRON**  
first name in measurement

LEAR SIEGLER, INC.



CIMRON DIVISION



---

**Editorial Comment**

---

## Trial balloon—maybe. Hot air—no!

It's no secret that defense spending is down, and projections call for a further decline before Congress is finished marking up the fiscal 1970 budget. However, evidence in Washington indicates that Defense Secretary Melvin R. Laird accurately gauged the sentiments of his former colleagues in Congress when he moved swiftly and effectively, with deputy David Packard, to chop \$3 billion from the budget request inherited from the outgoing Administration.

Beyond stealing some of the thunder from Capital critics of defense costs, Laird chose his own options and bought himself a bit of time as well.

What about next year? With fiscal 1970 defense and space spending effectively pegged at \$77 billion and \$3.8 billion, respectively, industry intelligence is seeking clues to Administration plans for fiscal 1971, the first budget to be entirely formulated by the Republican Administration.

One significant clue comes from Dr. William Niskanen of the think-tank closest to the Pentagon—the Institute for Defense Analysis. Dr. Niskanen planted it before the Military Operations Research Society this June in a hitherto-unpublicized address at West Point. By alleging to his audience that he was reading “a draft copy of the unclassified ‘Annual Posture Statement’ which Secretary Laird will present to Congress next January,” Dr. Niskanen touched off a bomb, because the document proposes “a total obligational authority of \$72.7 billion for FY 1971”—roughly \$5 billion lower than the current budget, reductions included.

His attention-getting device worked all too well. His text, now being circulated in some segments of industry, is labeled “strictly unofficial,” and notes that the views are “solely those of the author.” It advises in a preamble that “the next ‘Annual Posture Statement’ will not be prepared, if at all, until December, and the MORS audience should be expected to know this.” Clearly, most did not, and others remain unconvinced that the Niskanen statement was not a trial balloon. Whatever its nature, the document is recommended reading.

The fiscal premises on which the new \$72.7 billion budget level is based are intriguing.

In the 11-year period after Korea and before Vietnam, Laird is said to observe, “(1) Total U.S. expenditures for major defense programs—including the budgets of the Department of Defense, the Atomic Energy Commission, and other defense-related agencies—were remarkably stable at a level of around \$55 billion in 1968 dollars . . . (2) During this entire period the U.S. faced aggressive Soviet behavior and large Soviet military forces with rapidly improving technology.

(3) Within these budget levels, the U.S. developed a rich array of weapons systems, primarily in the early years, and made major improvements in the active forces, primarily in the later years.” Thus does Laird recommend a \$55.2 billion level for base line forces for FY 1971 and for preparation of the FY 1971-1975 program. Added to this is a \$5 billion hike in costs of “recruitment and retention of military manpower on a strictly volunteer basis,” and, finally, “\$12.5 billion for these expenditures specific to our residual activities in Vietnam.”

Residual activities? The document speaks of a 15,000-man monthly withdrawal of troops from Vietnam designed to get the U.S. out by the fall of 1972—election year—based on this policy posture statement: “In a few nations, such as Vietnam and other nations with which we have carelessly proliferated treaty agreements and military assistance programs, our primary national security interests are not fundamental . . . our obvious policy with respect to these nations should be to reverse our actions to liquidate these commitments as rapidly as possible . . .”

In the Niskanen fable, Secretary Laird bases national security policy on a U.S. outlook that is “internationalist but not interventionist . . . nationalist but not isolationist.”

And what of systems analysis and centralized program-planning? The assessment of IDA's member is that these are “neither necessary nor sufficient to develop an effective defense program.” The Secretary of Defense's stand-in further asserts, “These practices may even be detrimental if they are used as a substitute for providing the correct incentives and guidance for making effective use of the information and management skills at lower echelons.”

Analyst Niskanen's most profound view is that a series of formidable defense studies “suggest that analysis is being used primarily as a language with which to rationalize positions rather than as a procedure to resolve differences.”

Would Melvin Laird say that? Quite probably. So would David Packard.

Would Melvin Laird propose such a budget based on such propositions? If the President told him to, the answer must be yes.

Beyond those answers, it is worth noting that Dr. William Niskanen, a significant figure at IDA, did make just those observations and propositions before a select and influential audience within the military community. Whether or not Dr. Niskanen's exercise in Secretarial secret-sensing is a trial balloon or a paper slider, his thinking about defense trends should not go unnoticed. ■

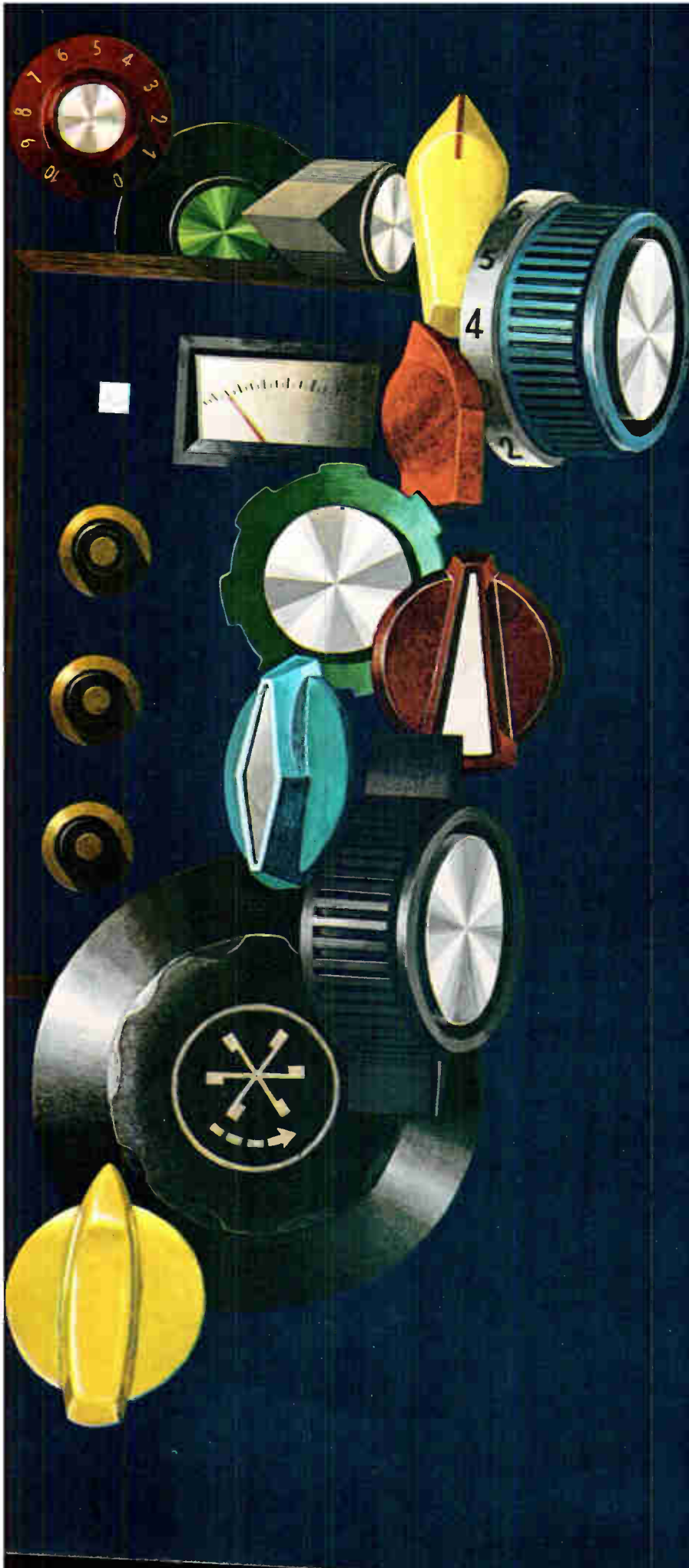

# Rogan Control Knobs For Quality Control

From electronic test equipment to appliances ... from communications equipment to amplifiers ... to almost every type of electrical application required today. Rogan offers the added advantage of *unlimited color* possibilities—molded material, or decorative inlays. It's the Rogan Knob that is selected when quality is the specification—and pricing the consideration. It's the Rogan name that makes the Rogan knob the designers' No. 1 choice in knobs.

Write today for new full color catalog or see us in Sweets or Thomas Micro catalog. Outline your requirements for quotation and free knob sample.

**Rogan**  
BROTHERS, INC.

8019 N. Monticello Ave. Skokie, Illinois 60076  
Phone: (312) 675-1234

# Electronics Newsletter

September 29, 1969

## Litton encounters computer woes

Litton Industries has run into more trouble than it bargained for in developing its so-called block-oriented computer [*Electronics*, July 21, p. 98], which is partially funded by the Air Force Avionics Laboratory. **The Air Force wants an expendable computer for an air-to-surface missile.**

One of the aims of the program, in which Bunker-Ramo's Defense System division is participating with a competitive design, is to build a computer costing \$2,000 to \$3,000 in large production quantities. **Litton's delivery date had been moved back from last spring to mid-1970** [*Electronics*, Nov. 25, 1968, p. 52], and the Guidance and Control Systems division would like to deliver only a paper design and report, rather than prototype hardware. The initial Air Force reaction was to ask Litton to meet its original commitment to deliver hardware, not a paper study.

Avionics Lab officials are withholding comment on the situation until at least mid-October; a Litton spokesman says "contract reorientation" is being discussed with them.

Meanwhile, the lab has accepted delivery of the Bunker-Ramo version of the computer, which uses medium-scale integrated MOS building-block arrays. The Litton approach, admittedly involving high-risk technology, employed a form of discretionary wiring external to an MOS LSI chip.

## Computer data on a 45-rpm disk

Forty-five-rpm records may become a low-cost method of distributing computer data. EG&G Inc. of Bedford, Mass., plans to introduce such a system; it uses slightly modified audio recording and playback techniques to store digital, alphanumeric, and graphic data.

After information is cut onto a master disk, plastic copies would be stamped out cheaply, then mailed to buyers for use as small data bases. The system thus is said to have the economic advantages of audio record production and could be used to store and forward short computer programs, load-up tables, and diagnostic routines. **Its first application may be in "go, no-go" credit verification systems; both an oil company and a chain of private clubs may use it to help clerks spot invalid credit cards by means of keyboard requests.**

The company, reluctant to discuss the innovation, would say only that an unmodulated square wave is recorded and that a slightly modified record player could be used for playback.

## Customized service for MOS lands its first customer

The first customer to sign up for Collins Radio's recently announced customer-controlled design of custom MOS arrays using Collins computers to translate logic diagrams into chip layouts is Viatron Computer Systems Corp. Impressed with Collins' turnaround time of 60 days at most from reception of logic equations to delivered parts [*Electronics*, Sept. 1, p. 33], Viatron, builder of the System 21, will use the Collins system to develop nine chips under terms of an agreement believed to be priced at about \$500,000.

Collins engineers say it took them just two hours to familiarize Viatron management with the simplified logic equations used as the initial input to the Collins automated design facility. **The nine chips in the order include some 1,000 cells, and Collins will have to design only eight new**

---

# Electronics Newsletter

---

ones to implement the functions Viatron wants; the Collins cell library includes more than 300 dynamic MOS cells and 111 static cells.

## Hughes offers first ion-implant MOS

Ion implantation to boost the speed of MOS devices has graduated from R&D to production status at Hughes Aircraft Co.'s Newport Beach, Calif., division. Engineers have built a dual 64-bit dynamic shift register that operates up to 30 megahertz using the so-called IMOS process [*Electronics*, Nov. 11, 1968, p. 55]. The device will be conservatively specified at 20 Mhz—still about 10 Mhz better than shift registers on the market today.

Another new device using IMOS is a 10-channel multiplexer that operates at 15 Mhz. And Radiation Inc. recently announced a 16-channel multiplexer using a combination of bipolar and junction field-effect transistor technology at a top speed of 3 Mhz.

The emphasis in Hughes' MOS work is on custom products, and officials are expecting orders for IMOS parts to be rolling early next year.

## Line printer opens computer market

A line printer little larger than an electric typewriter may help small computers fill business needs for fast hard copies. From Nortec Computer Devices of Ashland, Mass., the new miniprinter fills full-sized 132-column-wide formats at more than 200 lines per minute. Though the device is similar to chain printers, it's said to use parts only one-quarter as costly. Weight and power consumption also are low: 12 pounds vs. 100 pounds and up for other machines; 300 watts vs. a typical 1,500 watts.

The design's weight and power savings make possible the printer's most attractive single feature, a sub-\$7,000 price tag. Its nearest competitor sells for the same price, but fills only an 80-space line. Full-width printers usually sell for at least twice Nortec's price.

## Addenda

Stanford R. Ovshinsky remains bullish about amorphous semiconductors (*Electronics*, Nov. 25, 1968, p. 49). The controversial president of Energy Conversion Devices Inc. says that his company is making alphanumeric displays driven by thin-film amorphous switches. He is unwilling to name his customers, saying only that he's dealing with "selected companies". Ovshinsky adds that Energy Conversion can make read-only memories, and sometime next year will have available a printer that uses amorphous components. He predicts that a three-terminal device will be ready for market by 1972. . . . Honeywell's advanced low-altitude i-r reconnaissance system will be delivered to the Air Force by December. The developmental strip-mapping system, built by the company's Radiation Center in Lexington, Mass., uses a multielement array of mercury cadmium telluride detectors, each fabricated from a single crystal. This permits simplification of the optics. . . . A \$250,000 contract for development and manufacture of infrared radiometers for two Mariner 71 spacecraft has been awarded by NASA to a Hughes Aircraft Co. subsidiary, the Santa Barbara Research Center. Three of the two-channel instruments, similar to those used on two Mariner 69 flights, will sense thermal energy radiated from the Martian surface. Operating life is expected to be about 90 days. The inclined orbit being planned should provide coverage of 70% of the planet's surface. Hughes is also bidding to supply sensors for the Pioneer-series Jupiter probe.

from tel...

**...a new  
concept for  
information  
display!**

..... for the research and development laboratory  
..... in production testing and quality control  
..... for medical diagnosis and patient monitoring  
..... as a teaching aid in classroom demonstration



**tri-color  
display system  
displays up to  
three different  
input signals  
plus horizontal  
and vertical  
reference lines,  
each in a  
separate color  
with high  
resolution and  
sensitivity.**

**THREE-COLOR DISPLAY** The 201 is a large screen, multi-channel, tri-color display unit that provides an entirely new perspective in analog presentations. Three vertical signal channels may be displayed on the 15" CRT simultaneously in red, green and blue with three vertical and three horizontal reference lines in the same colors. This multi-color presentation assures positive identification of each input, regardless of its proximity to the other signals. Even overlapping traces can be easily identified.

**HIGH RESOLUTION, HIGH SENSITIVITY** The unique three-color presentation also enables each signal to be displayed at **full screen height** for high resolution and accurate comparison without sacrificing trace identification. It is not necessary to restrict each signal to a separate segment of the display area.

The 201 System utilizes a separate amplifier for each input channel to provide maximum control of each signal and complete channel-to-channel isolation. Input signal sensitivity range is 100  $\mu$ V/inch to 100 V/inch assuring maximum resolution regardless of input level.

**ELECTRONIC REFERENCE LINES** The tri-color vertical and horizontal reference lines can be adjusted to any position on the screen by individual front panel controls. A vertical reference line may also be externally triggered by a time or frequency marker pulse.

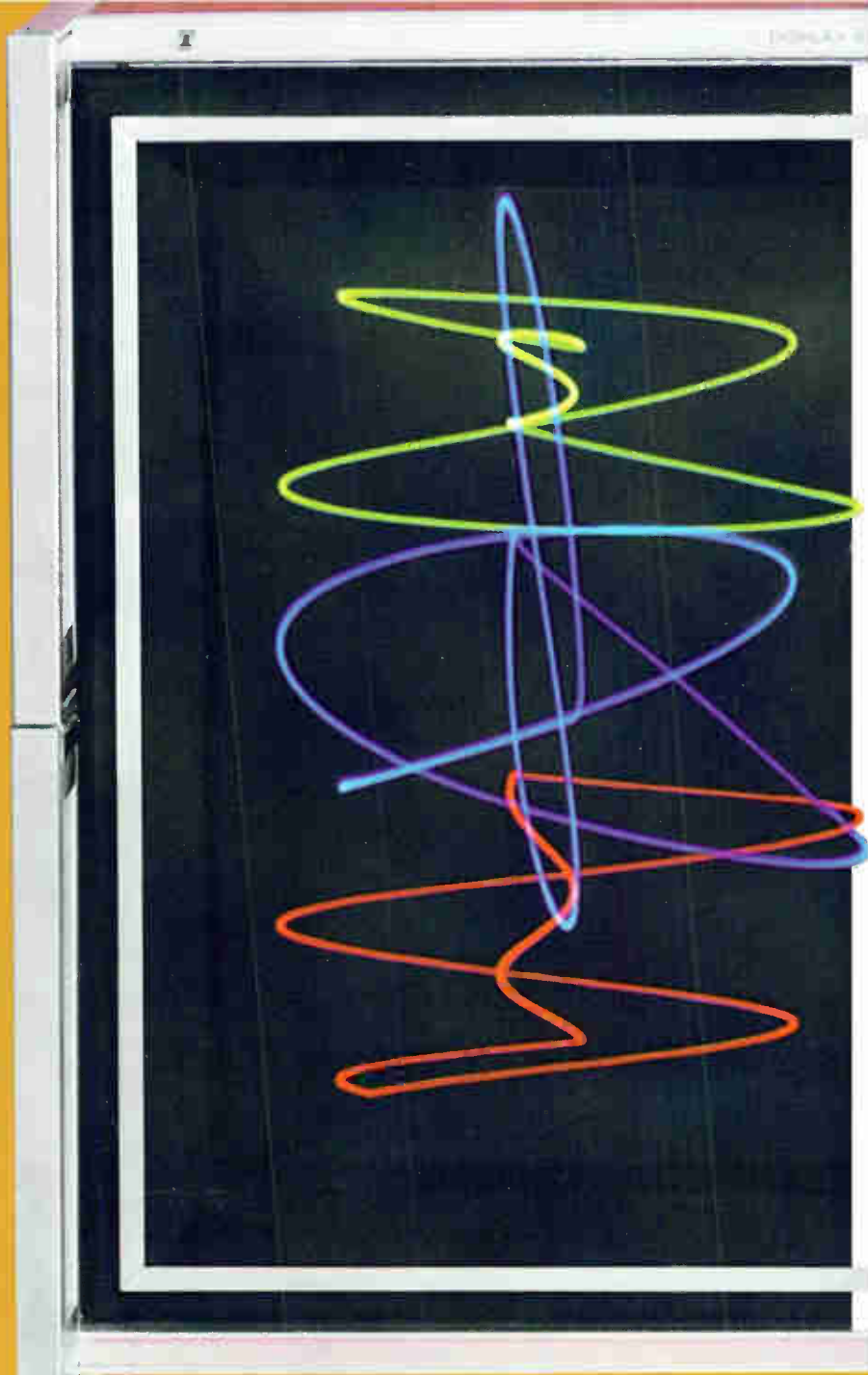

## applications

The high sensitivity, direct coupling, and large screen area of the Model 201 make it an ideal display system for many applications in the fields of electronics, medicine, and education. Applications include any situation in which dc or video information is to be displayed with respect to time or frequency.

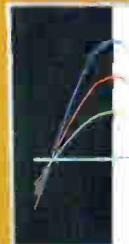

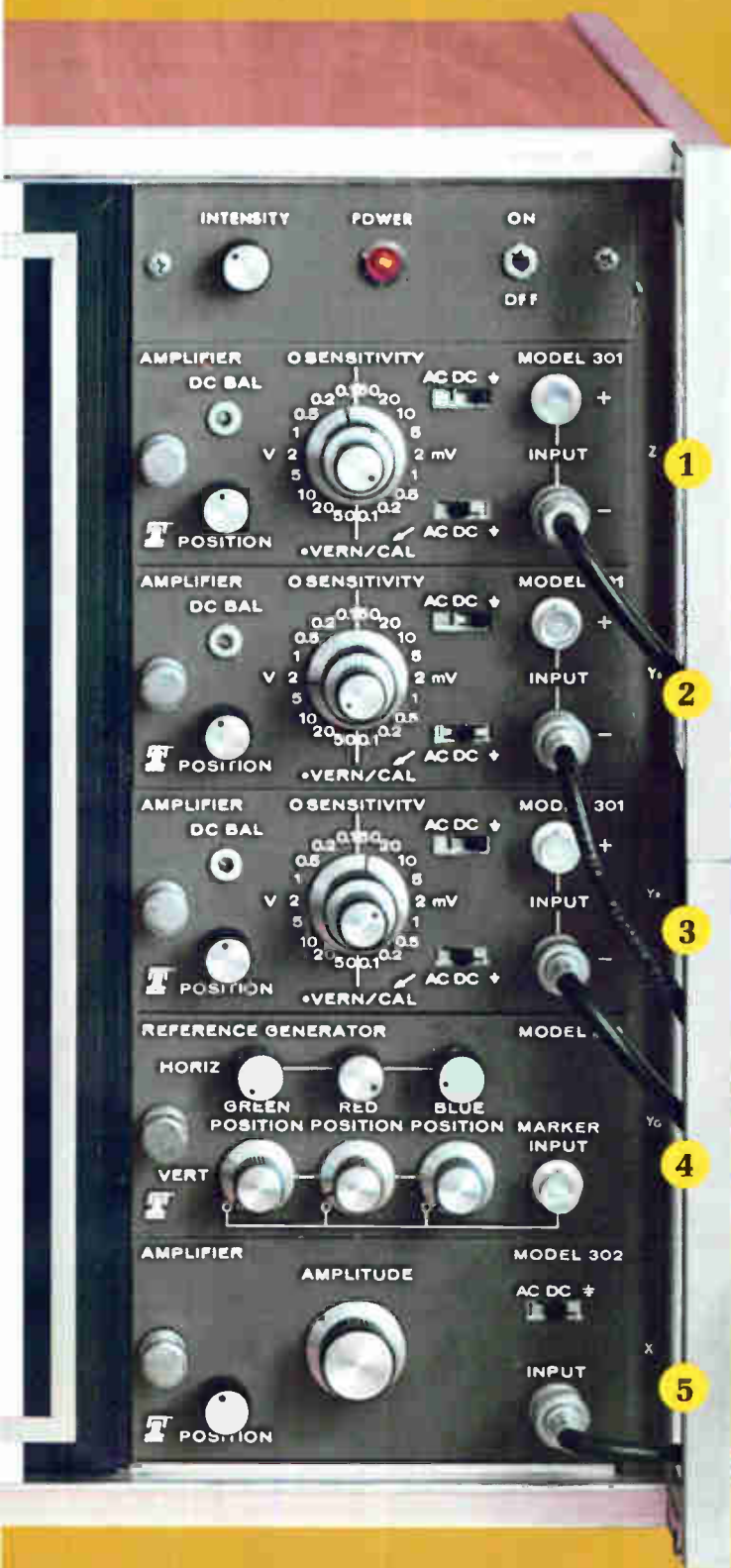

**OPTIONAL TIME BASE** Horizontal deflection in the 201 System is usually obtained from an external sweep signal. A calibrated Time Base is also available as an optional plug-in unit to provide sweep rates from 1 to 1000 milliseconds per inch. A vernier control extends sweep time to 10 seconds per inch.

**SOLID STATE — MODULAR DESIGN** The 201 System is completely solid state with the exception of the CRT. For maximum versatility, the Model 201 consists of a basic display chassis and functional plug-in units. Operating characteristics of the System are determined by the plug-in units selected.

Plug-ins presently available include vertical and horizontal amplifiers, a reference line generator, and a time base. Future units may occupy the entire plug-in area to provide the total signal processing and display functions for multiple parameter measurements.

**VERTICAL AND HORIZONTAL PLUG-IN AMPLIFIERS**

Three vertical amplifier plug-in units 1 2 3 are required for normal operation of the 201 Display System — one for each signal channel. If horizontal deflection is to be obtained from an external signal, an additional amplifier will be required for this channel 5. The Model 320 Time Base plug-in unit can be used in place of the horizontal amplifier to provide a linear calibrated horizontal sweep.

Two amplifiers are available — the Model 301 High Gain Differential unit and the Model 302 Basic Amplifier. Both units are direct coupled, enabling display of dc levels and low frequency signals. Either model may be used for vertical or horizontal channels.

The calibrated deflection factor of the Model 301 differential unit is adjustable from 100  $\mu$ V/inch to 50 V/inch, providing maximum versatility for both low-level and general purpose applications. The vernier control can be used to reduce the deflection factor to 100 V/inch. In differential operation, the common mode rejection is 30 dB.

The Model 302 Basic Amplifier plug-in is a general purpose unit with a continuously variable sensitivity of 100 mV/inch to 10 V/inch.

**TIME BASE PLUG-IN** The Model 320 Time Base plug-in is available for use in the horizontal channel 5 and provides calibrated sweep times of 1 to 1000 msec/inch in four ranges. The vernier control extends the slowest sweep range to 10 seconds/inch. The unit can be triggered by external or internal signals or by the power line. Trigger slope and level adjustments enable triggering at any point on the waveform.

**REFERENCE LINE GENERATOR PLUG-IN**

The Model 310 Reference Generator 4 furnishes three vertical and three horizontal electronic cursors in red, green, and blue which can be positioned anywhere on the screen by independent front panel controls. These reference lines may typically be used to set min/max signal limits for both level and frequency, to compare amplitudes of various input signals, or as a "memory," enabling the user to return the signal amplitude to the original level if desired. Any one of the vertical reference lines may be triggered by an external time or frequency marker pulse.

is illustrated in the display shown in Figure 1. The blue vertical frequency markers were triggered by a sweep generator. The red and blue horizontal reference lines represent the specification limits of the unit under test.

Phase and amplitude relationships of three signals are displayed in Figure 2.

Figure 3 illustrates the variety of data that can be presented to provide maximum information in a single display — the response characteristics of three tuned circuits, vertical frequency markers, and upper and lower limit reference lines.

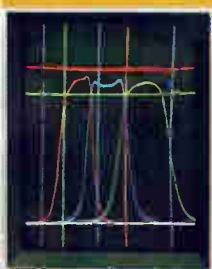
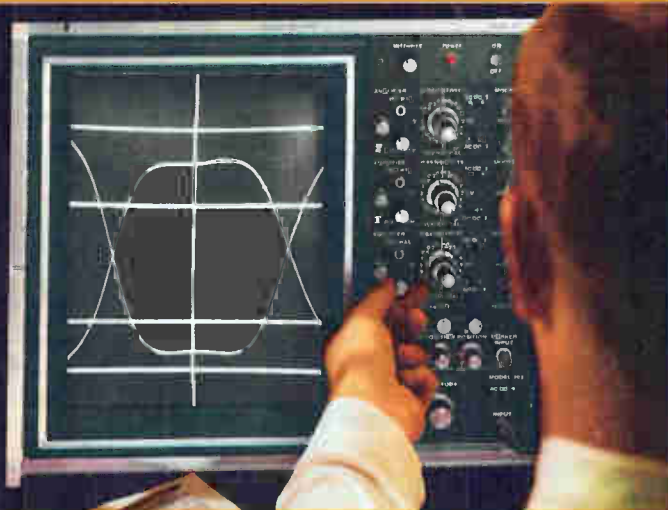

Figure 3

# model 202 monochrome display system

The Telonic Model 202 Monochrome Display System provides all the features of the Model 201 with the exception of color. The advantages of a large screen display system, adjustable reference lines, and plug-in versatility are all available on the Model 202. This monochrome unit is capable of high resolution, low flicker displays with a choice of CRT phosphors. All plug-in units described are applicable to the 202 System.



## specifications

**GENERAL** The vertical sections of the Model 201 and 202 Display Systems utilize a scan/sampling technique. The CRT electron beam is scanned vertically at a 36.2 kHz rate. During down-scan the input signals are sampled producing a dot for each signal. During up-scan the reference lines are displayed. The rapid scan rate provides a high dot density. The highest frequency that can be displayed by the vertical channels is dependent upon both the scan rate and the video bandwidth of the plug-in amplifier being used.

The frequency response of the horizontal channel is dependent upon the small signal bandwidth and the maximum undistorted slew rate. These parameters are primarily a function of the display chassis.

**MODEL 201 TRI-COLOR DISPLAY CHASSIS** A three channel scan/sampling system providing simultaneous display of three input signals in red, green, and blue. The Model 201 has separate facilities for vertical, horizontal, and reference line functions.

**Visible Screen Area** 10.5 inches by 7.9 inches.

**Vertical Scan Rate** 36.2 kHz.

**Horizontal Small Signal Bandwidth (3 dB), 50 kHz. Maximum Undistorted Slew Rate, 10 inches/msec.**

**Accelerating Potential** 20 kV.

**Power** 115/230V, 50/60Hz, 350 watts.

**Dimensions** 17" wide, 14" high, 18½" deep.

**Weight** 50 pounds.

**Price** \$2100

**MODEL 202 MONOCHROME DISPLAY CHASSIS** A three channel sampling system provides simultaneous display of three input signals. Separate facilities for vertical, horizontal, and reference line functions. Optional long persistence cathode-ray tube available.

**Visible Screen Area** 10.5 inches by 7.9 inches.

**Vertical Scan Rate** 36.2 kHz.

**Horizontal Small Signal Bandwidth (3dB), 50 kHz. Maximum Undistorted Slew Rate, 10 inches/msec.**

**Accelerating Tube** P4 phosphor; P7 long persistence phosphor also available.

**Accelerating Potential** 15 kV.

**Power** 115/230V, 50/60 Hz, 300 watts.

**Dimensions** 17" wide, 14" high, 18½" deep.

**Weight** 50 pounds.

**Price** \$1850 (with P4 phosphor) \$1950 (with P7 phosphor)

**MODEL 301 HIGH GAIN DIFFERENTIAL AMPLIFIER**

**Vertical Gain** 0.1 mV/inch to 50 V/inch in 18 calibrated steps, 1-2-5 sequence; accuracy  $\pm 5\%$ ; vernier provides continuous adjustment between steps and extends the 50 V/inch step to at least 100 V/inch.

**Input Impedance** 50  $\mu$ V p-p referred to input at maximum sensitivity.

**Video Bandwidth** DC to 200 kHz; DC to 5 kHz at

0.1 mV/inch; DC to 9 kHz from 0.2 to 0.5 mV/inch. Maximum input frequency dependent upon video bandwidth and system scan rate.

**Common Mode Rejection** 30 dB.

**Input Coupling** AC, DC, or GND.

**Input Impedance** 1 megohm shunted by 47 pF.

**Price** \$350

**MODEL 302 BASIC AMPLIFIER**

**Vertical Gain** Adjustable from 100 mV/inch to 100 V/inch.

**Video Bandwidth** 50 to 200 kHz dependent upon vernier setting. Maximum input frequency dependent upon video bandwidth and system scan rate.

**Input Coupling** AC, DC, or GND.

**Input Impedance** 1 megohm shunted by 47 pF.

**Price** \$150

**MODEL 310 REFERENCE LINE GENERATOR**

**Marking Pulses** 500/1000  $\pm 3V$  pulse, max. rise time 5  $\mu$ secs or birdy type marker.

**Input Impedance** 47 kilohms.

**Price** \$250

**MODEL 320 TIME BASE**

**Step Times** 1, 10, 100, 1,000 msec/inch calibrated to  $\pm 5\%$ . Vernier provides continuous adjustment between steps and extends the 1,000 msec/inch range to 10 sec/inch.

**Trigger Sources** Line, external AC or DC. Internal.

**Trigger Amplitude** Internal, 1-inch deflection. External,  $\pm 0.5 V$  to 20 V peak

**Price** \$300



**BLANK PANELS**

Blank plug-in unit panels are available for Systems not requiring all of the available plug-in units. The panel fits the space taken by one of the plug-ins listed above.

**Price** \$12 Model 315 Blank Panel

**RACK MOUNTING**

Hardware for rack mounting the 201 or 202 Display Systems is included with each chassis

## how to order

1. Select either the Model 201 Tri-Color Display Chassis or the Model 202 Monochrome unit.
2. Choose the vertical amplifiers. For three-channel operation, three separate vertical amplifiers are required; for two-channel, two amplifiers, etc.
3. Order the reference generator or, if this function is not desired, a blank panel may be used in this space.
4. Select either a horizontal amplifier or time base unit for the horizontal channel.

**NOTE:** The Model 201 and 202 Systems must have at least one vertical amplifier and a horizontal plug-in unit installed in order to operate.



A Division of Telonic Industries, Inc.

21282 Laguna Canyon Rd. • Box 277 • Laguna Beach, Calif. 92652

Phone: (714) 494-9401

TWX: 910 596-1320





## DESIGNERS: AVOID SHOTGUN MARRIAGES

For design freedom, 12 sizes, all 550 Mu



### Use Magnetics Inc. 550 Mu Powder Cores

Magnetics Inc. first filled the void between 300 Mu powder cores and nickel laminations with the 550 Mu moly-permalloy powder core. We introduced it in three sizes.

And this perm is still exclusive with us. However, now you can get it in 9 new sizes—an O.D. range of .250" to 1.602". These fixed-gap toroids keep you from being forced into undesirable component marriages, let you tighten design to meet packaging requirements, cut total assembly costs in filters, chokes, transformers, inductors. They also provide: 1. A high inductance-to-size ratio. 2. Reduced d.c. copper resistance. 3. Less distributed capacity. 4.

Greater temperature stability than laminations. Avoid shotgun designing and get more freedom in using magnetic cores for circuit components. Try 550 Mu—we can ship from stock all 12 sizes. For additional information on 550 Mu powder core advantages, write Dept. EL-105 for Bul. FLC-02. Magnetics Inc., Butler, Pa. 16001.



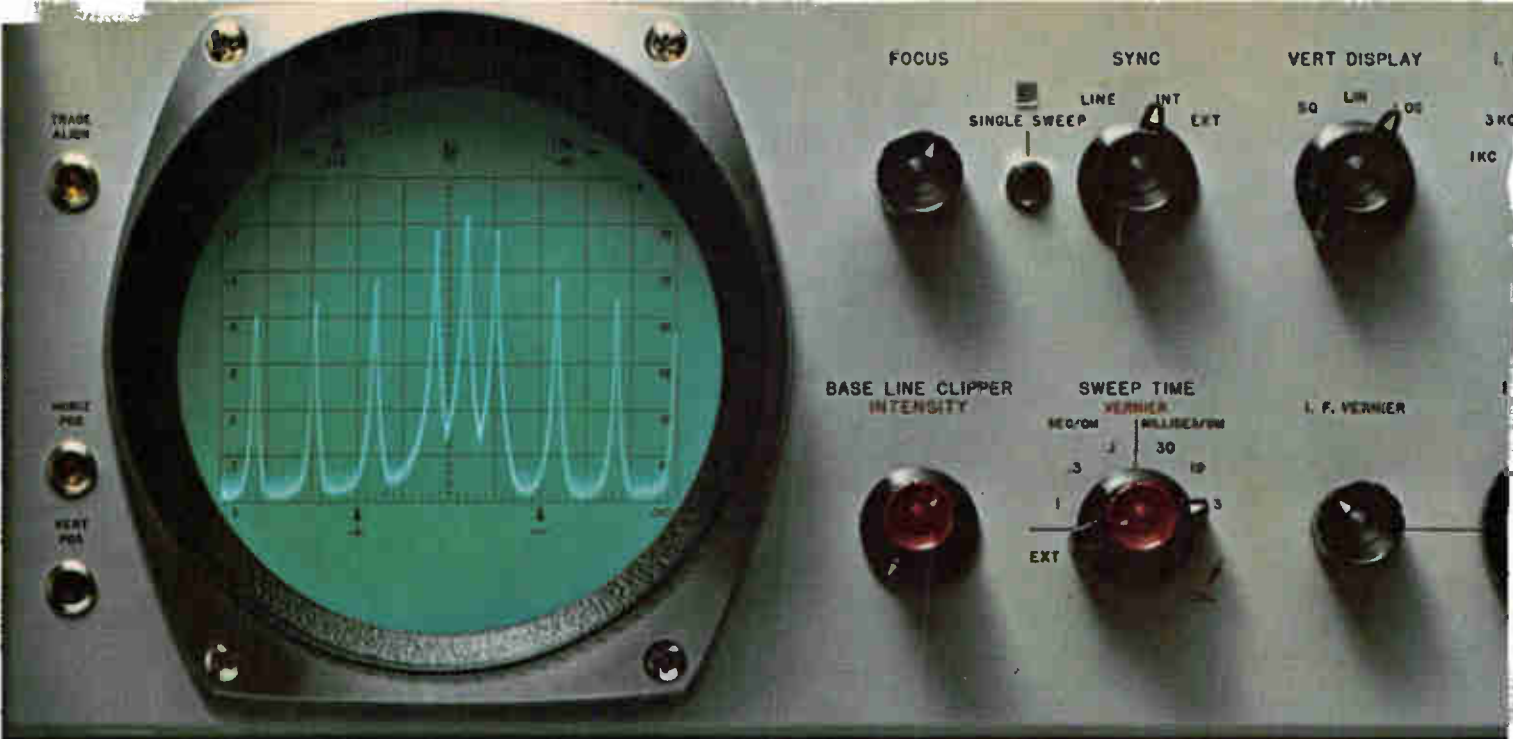

**8551B SPECTRUM ANALYZER - RT SECTION**  
 HEWLETT - PACKARD

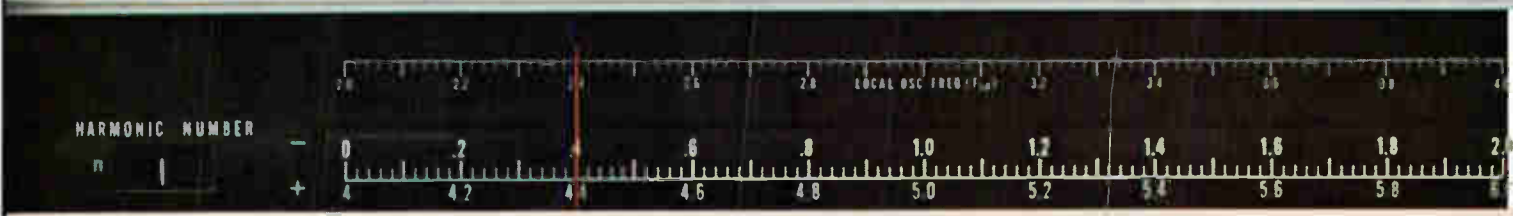



# In the past 5 years, spectrum analyzers have come and gone.

## This is the one that came and stayed.

When the HP 8551B/851B Spectrum Analyzer came on the scene, it turned a theory into technology. This one instrument not only could do more than any spectrum analyzer could do before. It can still do more than any other spectrum analyzer available today.

This spectrum analyzer opened up whole new areas for spectrum measurement—areas like circuit design, systems performance and semi-conductor evaluation. And it continues to be the overwhelming favorite: it's easy to use, accurately calibrated and lets you observe harmonics on broad spectra, modulations on narrow band, or compare low-level signals with high-level carriers.

It has a swept first LO and high frequency first IF that lets you view wide 2 GHz spectra, free from images, spurious and residual responses. It has a calibrated 60 dB display range to give you an accurate comparison of signals vastly different in amplitude. Its RF attenuator permits level setting without overdriving the input. And its wideband mixer provides extremely flat response over the full range from 10.1 MHz to 12 GHz, with  $-100$  to  $-85$  dBm sensitivity.

These and other state-of-the-art advances put our spectrum analyzer in a class by itself. That's why it came and stayed.

Price of the 8551B RF Section is \$7950; the 851B Display Section costs \$2475. An alternate display unit, Model 852A with variable persistence and storage, costs \$3475. Your Hewlett-Packard field engineer will give you all the details on the 8551B/851B's full range of performance. Or write to Hewlett-Packard, Palo Alto, California 94304; Europe: 1217 Meyrin-Geneva, Switzerland.

**HEWLETT**  **PACKARD**

**SIGNAL ANALYZERS**

04904

Circle 41 on reader service card

# Need to sense position, timing, vibration, motion, or random count of anything that moves?

## Then you need an AIRPAX MAGNETIC PICKUP.

Airpax Magnetic Pickups convert mechanical motion to AC voltage **without mechanical linkage or external power**. And they're accurate!

Output voltages are available to 600 volts peak-to-peak in thirty different off-the-shelf configurations. All housings are threaded and come equipped with a mounting nut. All you have to do is drill a hole, tighten the pickup into place and connect two wires to the input of your measuring device.

**The Airpax Pickup** does the rest!  Contact Airpax today for complete information. And if you have a specific problem in mind, let us know.

We'll help you select the proper pickup for the job. **AIRPAX ELECTRONICS**

Seminole Division, P. O. Box 8488

Fort Lauderdale, Florida 33310

Phone: (305) 587-1100

TWX: (510) 955-9866

Telex: 051-4448



# Here's how General Electric's panel meter sales and service army serves you

## UNEXCELLED QUALITY

General Electric's panel meters and meter relays answer the call for faultless performance and high reliability. The quality reputation of your product is sure to be enhanced by using quality engineered instruments from General Electric.

## FAST DELIVERY

You can rely on 150 General Electric distributors, 25 modification centers, and factory stock of more than 30,000 instruments to assure you of prompt and, in many cases, same-day delivery service.

## FULL LINE OF PRODUCTS

General Electric offers you a wide choice of ratings, sizes, and mechanisms for The Big Look® and Horizon Line® panel meters and meter relays, not to mention time meters, edgewise panel meters, meter shunts, and low-voltage current transformers.

## SPECIAL APPLICATION ASSISTANCE

General Electric's trained distributor personnel and your local GE sales engineers are always available for any special application assistance you may require. And, if that's not enough, our factory product specialists are on "ready reserve."

## SPEEDY ORDER FOLLOWING

General Electric's factory communication center provides your local sales office with one-call service regarding the availability, status, and shipment of your order.

## MODIFICATION SERVICE

Available throughout the country, General Electric's modification shops are capable of providing regular and emergency service on specials, prototypes, and standard ratings of panel meters and meter relays to match your requirements.

General Electric stands ready to gain your instrument business with a total value package: quality you can depend on, fast delivery, a full line, local sales representatives, speedy order-following and most important, a progressive "can do" attitude. Our Sales and Service Army is ready. Just give the order. Contact your GE Electronic Components Sales Office or your dependable General Electric panel meter distributor.

592-37

# Any chips off the new IC?

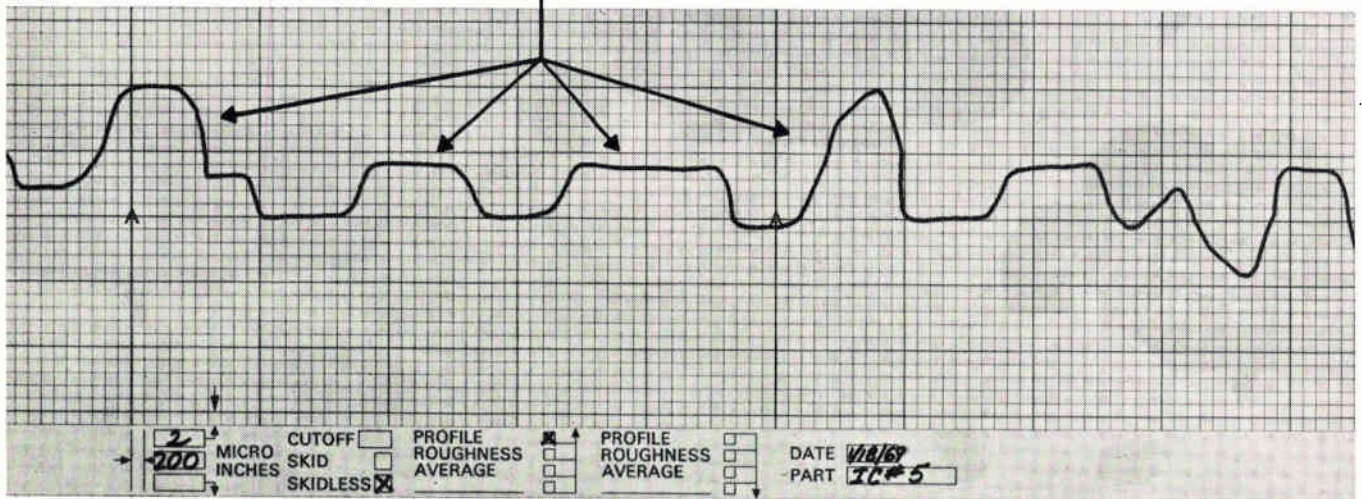
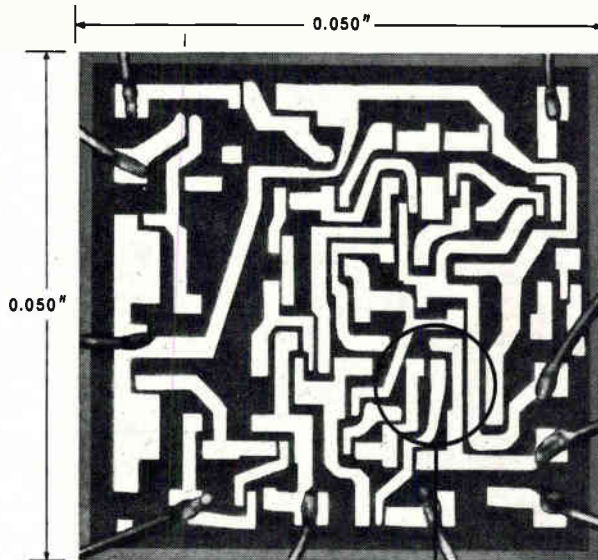

**Non-destructive Clevite Surfalyzer tells you for sure. Shows deposit thickness, steps and true surface profile of a 0.050" diameter IC on a chart 3 feet long! And we haven't scratched the surface!**

Never will either.

The stylus of the Surfalyzer adds the required light touch to surface measurement—glides across delicate circuit deposits at just 0.05 grams. Picks up the slightest imperfection . . . provides an undistorted view of the IC surface.

Note the extra-wide rectilinear channel. And the engineered chart paper that allows actual dimensional measurement of deposit on substrate. And the razor-sharp smudge-

proof trace. It's all part of our plan to provide IC manufacturers and suppliers with the most accurate, easy-to-read, easy-to-use surface recording system.

Have we done it? You be the judge. Write for complete details and the name of your nearest distributor. There's one close by waiting to demonstrate this extraordinary test equipment. Clevite Corporation, Gaging & Control Division, 4601 N. Arden Drive, El Monte, Cal. 91731. Phone: 213-442-7755.

Clevite Surfalyzer 150 Surface Measurement System

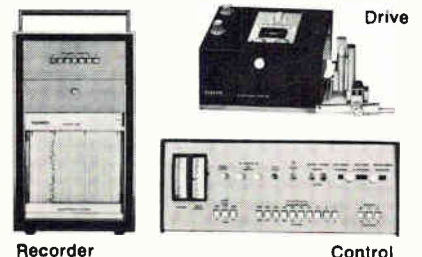

**CLEVITE**

**This is the only instrument to measure precisely return loss, vswr, gain, insertion loss, frequency response, absolute power, and locate faults, too...**

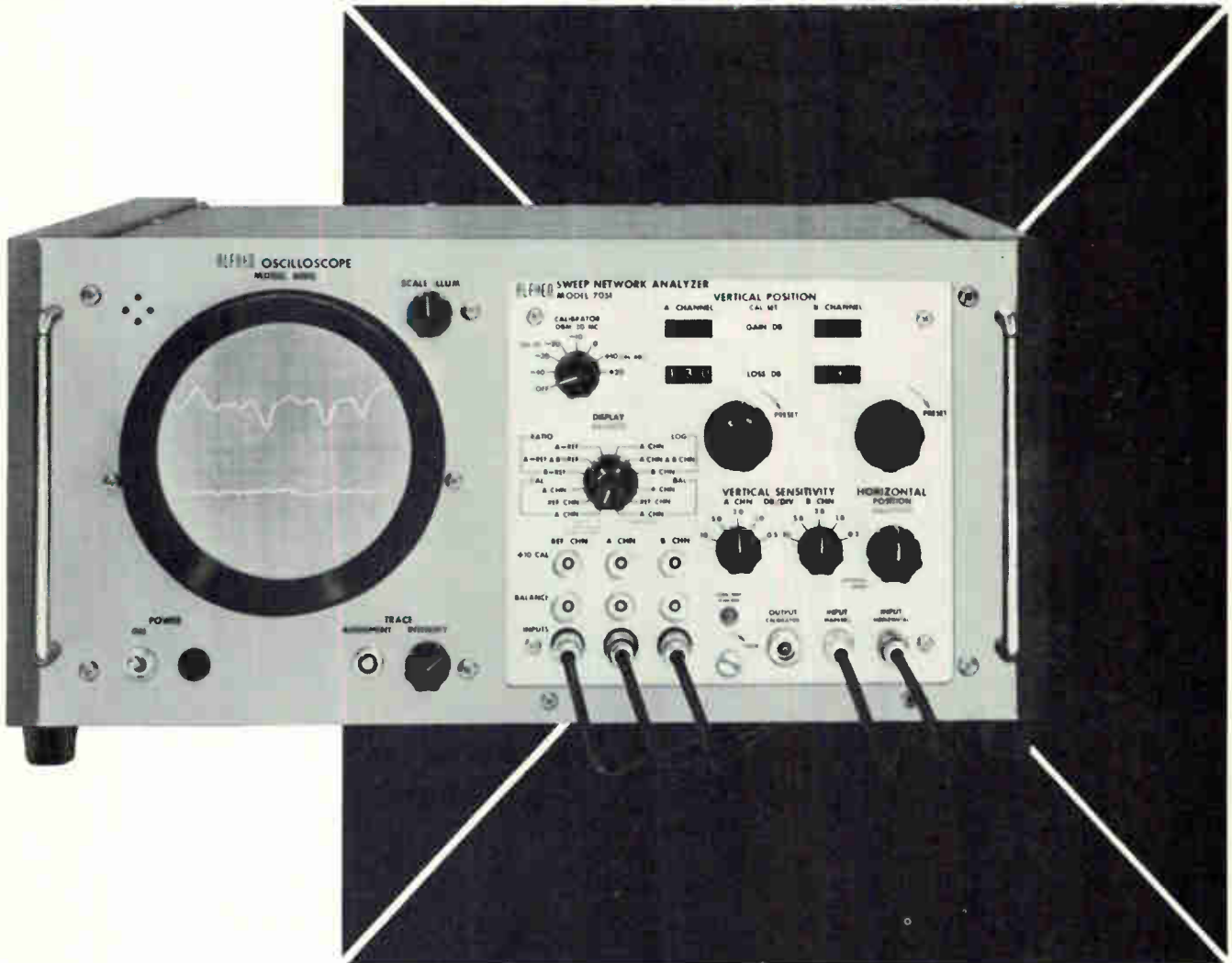

## make it your Alfred Microwave Lab!

For only \$1990, your nearby Alfred sales engineer will put it on your bench. The Alfred 8000/7051 Sweep Network Analyzer is the economical, precise, and convenient way of combining all the functions of an SWR meter, slotted line, power meter, ratiometer, lin log converter, precision attenuator, and oscilloscope. The price includes everything but the directional coupler and crystal detectors. All measurements are made with computer-like accuracy over a 60 db dynamic range with either direct db or dbm readout.

**How to measure transmission systems.** Applications notes 101 and 105 give detailed specifications on the Alfred Sweep Network Analyzer as well as full use data. Note 101 tells you how to make all measurements, including noise. Note 105 offers information on the testing of microwave transmission systems including coaxial cable and waveguide runs. For your free copies, please address Alfred Electronics, 3176 Porter Drive, Palo Alto, California 94304. Phone: (415) 326-6496. TWX: 910-373-1765.



# ALFRED ELECTRONICS

# Now, here it is—The best pulse generator you can buy for \$1225

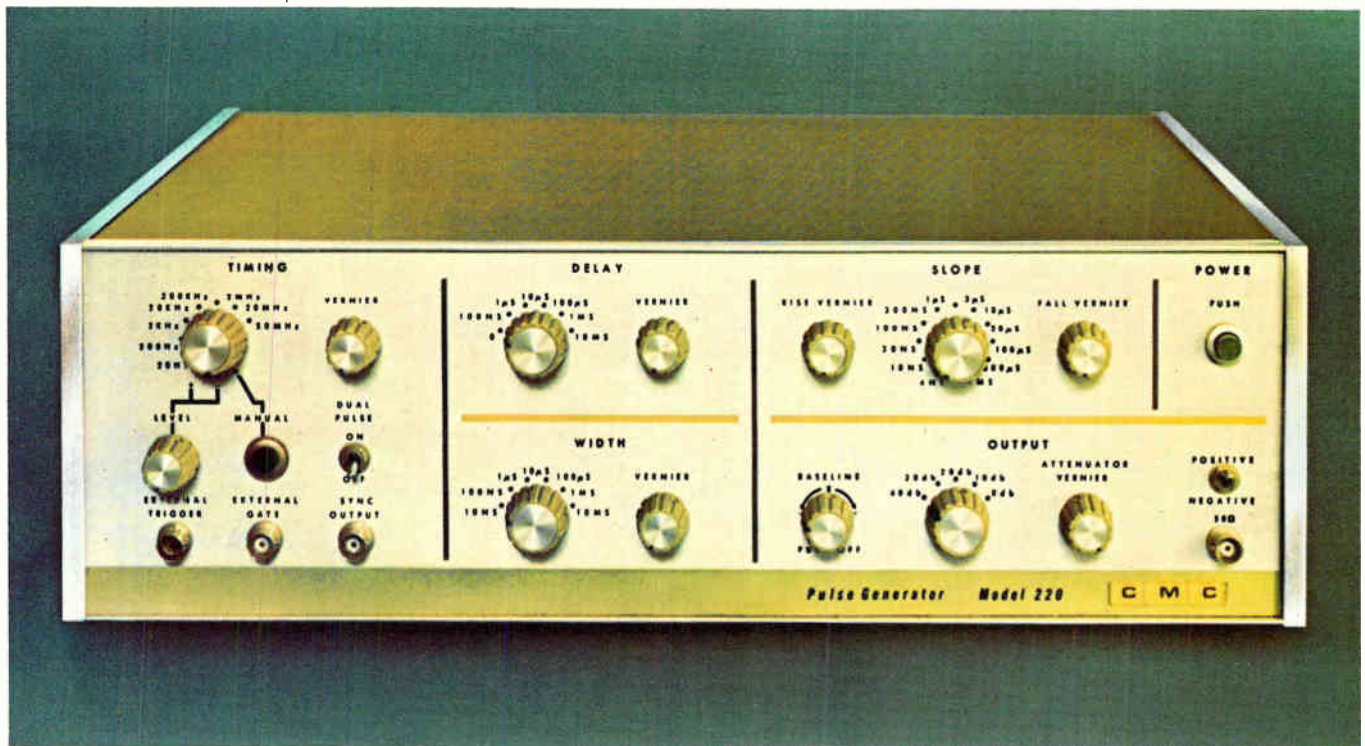

No other pulse generator in the same price range has more going for it than the new CMC Model 220. Just compare its versatility and high performance characteristics with those of any other instrument in its class.

The new Model 220 gives you seven main-pulse frequency ranges from 20 Hz to 50 MHz... offers six ranges of pulse delay from 0 nanoseconds to 10 milliseconds... provides double-pulse-mode operation with pulse separations from 10 nanoseconds to 10 milliseconds... offers output amplitudes up to 10 volts into a 50-ohm load with a  $\pm 5$ -volt offset... and provides eleven ranges of rise-and-fall time from 5 nanoseconds to 1 millisecond at full voltage—a rise-and-fall rate of 500 picoseconds per volt of amplitude! It all adds up to faster, cleaner, fully controllable pulses.

For the rest of the story, just look at the front panel. You'll like the accurate easy operation of this remarkably versatile instrument, which is the result of many months of human-factor engineering. And you'll like the modest \$1225 price, too.

But what else would you expect from CMC with its tradition of providing fine instruments at reasonable prices?

COMPUTER MEASUREMENTS



A DIVISION OF NEWELL INDUSTRIES

12970 Bradley/San Fernando, Calif. 91342/(213) 367-2161/TWX 910-496-1487



# Display tube is easy on the eyes

Image-intensifying triode device unglues the viewer's face from scope and puts the picture on a 125-mm phosphor screen

**Though starlight scopes** do a good job of helping GI's see the enemy at night in the Vietnamese jungles, whoever uses the direct, see-through devices must keep his eye pressed firmly against an eyepiece. This is fine for a soldier in a defense perimeter lying on the ground, but for a sailor bouncing around a fast-moving river patrol boat, or for an airman being jostled in a helicopter, it's no mean feat.

Now, instead of trying to peer through the direct-view scope, that sailor or airman will be able to sit back and see what's happening on what looks like a miniature television set—actually a display tube developed by the Aerojet Delft Corp. of Azusa, Calif. The tube, instead of a man's eye, butts right up against the 25-millimeter-diameter optics of the starlight scope's image intensifiers. It magnifies by five times the picture the soldier would otherwise see and presents an image on a 125-mm-diameter phosphor screen.

**Simpler.** The tube does not have the raster-like scan of ordinary television nor does it have the complex electronics such a scan requires. Instead, its construction resembles a single-stage, electrostatically focused image intensifier, according to P.F. Le Fort, Aerojet Delft's vice president for marketing. It has a triode design—a cathode, focusing electrode, and anode.

Light is coupled through a fiber-optic faceplate onto an S-20 antimony trisulfide photocathode. Electrons from the cathode pass through the focusing coil, which is only about 400 volts above the cathode potential. The electrons then are speeded up by a megaphone-shaped accelerating anode—narrow end at the cathode—and strike the phosphor screen.

Magnification and distortion of the image depends very critically on the shape of the focusing electrode, the spacing—to within .0005 inch—between the anode and cathode, and the accelerating potential

of 20,000 volts. Exact shapes and layout of the elements were determined on a digital computer.

On-axis resolution of the tube is 120 line-pairs per millimeter, corresponding to 3,600 tv lines per picture height for the usual 4-by-3 aspect ratio. Resolution over the full input field can be equalized to 110 line-pairs per millimeter.

**Shrinking.** The tube is about 13 inches long, but Aerojet is developing a six-inch version with two additional grids placed into a break in the anode structure. With these grids, the magnification is achieved—without distorting the image—over a much shorter drift space.

Company president J.J. Van der Sande, who came up with the idea for the tubes, which are being developed with the company funds, says that basically the grid nearest the cathode slows the beam, but at the same time the beam appears to flare out, effectively magnifying the image. A voltage on the second grid then accelerates the beam onto the phosphor screen, with the kinetic energy in the electron converted to light in the image. The new tube will couple onto 40-mm-diameter image intensifiers and produce an output picture with a diameter of some 200 millimeters.

Aerojet Delft has sent one of its 25-to-125-mm tubes to the Air Force and one to the Navy for evaluation. The Air Force is testing it for a night-viewing system in a helicopter, and the Navy wants it for its river patrol craft. Le Fort also sees commercial applications, including night surveillance systems in factories and in police work. Furthermore, clamped to the far end of a fiber-optics light pipe whose front-end is mounted on the rear bumper, the tube could give



**Picture this.** Aerojet Delft's direct-vision display tube will enable soldier, sailor, or airman to use starlight scope without pressing his eye to it.

## U.S. Reports

drivers of big trailer trucks a picture of what's behind their vehicle when they're backing up.

The price of the tube at this developmental stage is high—\$6,000 without electronics. But in high-volume production, the price could drop drastically—to about the cost of a portable tv set, says Le Fort.

## Government

### Picking a path

Pragmatism prevails in the report of the President's Space Task Group delivered to the White House by its chairman, Vice President Spiro T. Agnew. The group proposed a series of "national goals"—rather than the "commitments" of President Kennedy—recommending, in order:

- "An expanded space applications program" with projects like the Earth Resources Satellite.

- Exploitation of space "for accomplishment of military missions" such as surveillance, reconnaissance, and communications "to support the broader objective of peace and security for the world."

- Emphasis on "commonality, reusability and economy" in new systems such as the space shuttle and space station modules that can be interconnected or used separately.

- "Broad international participation and cooperation."

**Three routes.** As to timing and program costs, the President was presented with three possible options in each case by the four-man team that also included NASA administrator Thomas Paine, Air Force Secretary Robert Seamans, and Presidential science adviser Lee DuBridge.

In specific terms, the group predictably recommended a go-ahead on the reusable space shuttle, the six- to 12-man space station module, and the nuclear engine for rocket vehicle applications (Nerva) required for interplanetary transportation [*Electronics*, Sept. 15, p. 91]. In addition, the advisers proposed development of a chem-

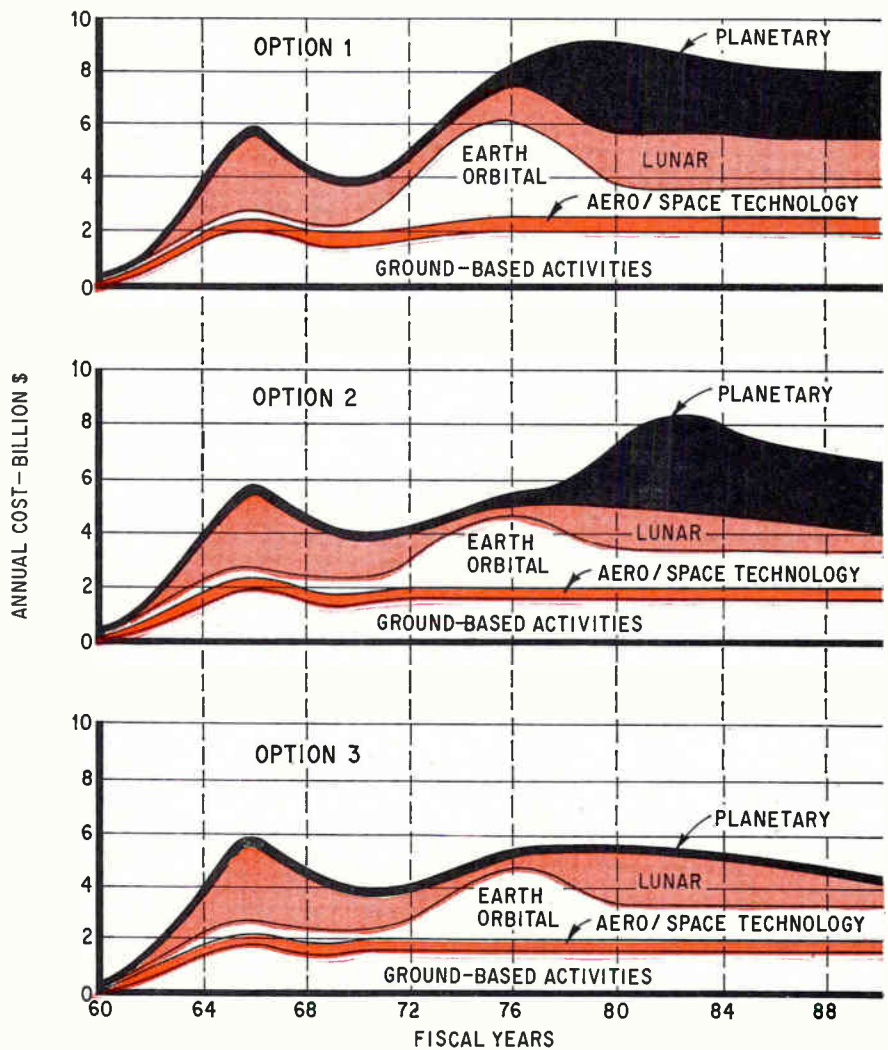

**Waves of the future.** The President's Space Task Group has outlined three time-and-money options for national goals.

ically-fueled "space tug" for moving other spacecraft in earth orbits and for movement between lunar orbits and a lunar base.

The group also recommended a manned Mars mission "before the end of this century." Options presented to the President ranged from 1981—when a landing could take place if "a maximum pace" is pursued—to 1983 under Option 1, up to 1986 under Option 2, and an open date under Option 3. The President was left a nice option of his own with the notation that a Mars decision "would not be required before fiscal year 1974" at the earliest, and could be postponed until fiscal 1978 if the second or third option were elected.

**Still to vote.** Excepting the Vice President, who likes the 1983-86 time frame, none of the group ex-

pressed a Mars mission preference at a White House briefing. NASA's Paine said the agency would state its preference within a few weeks.

The group's strongest recommendations centered on its applications and scientific program, leaving the President fewer choices. It recommends proceeding with the Earth Resources Technology Satellite (ERTS) between 1975 and 1976 [*Electronics*, May 12, p. 34]. Additionally, it is firm for the 1977-79 time frame for multiple outer planet "tours" by unmanned spacecraft [*Electronics*, Aug. 4, p. 47].

Two other applications demonstration satellites for navigation air traffic control and direct broadcast also have been firmly positioned for launching in 1974 and 1978, respectively.

For a trio of other segments of

a national program, the group recommended the following timetable to the White House:

- Manned systems: 1975-77 for the six- to 12-man earth orbiting space station, rising to a 50-man capacity in 1980-84 and 100 in 1985-89. A lunar orbiting station could be launched between 1976 and 1981, with a lunar surface base established two years later.

- Transport systems: an earth-to-orbit shuttle between 1975 and '77, a Nerva vehicle between '78 and '81, and the tug in 1976-'81.

- Scientific systems: a large orbiting observatory is urged for 1979 or 1980; a high-energy astronomical capability between 1973 and 1981; an out-of-ecliptic survey in 1975-'78; high-resolution mapping of Mars between 1977 and 1981; increased Venus atmospheric probes between 1976 and the mid-80's, plus an asteroid belt survey by satellite in 1975-'81 in addition to Grand Tour missions.

**The costs.** Should the President make the unlikely decision to proceed with the advisers' most costly options, NASA funding would rise from the present \$4 billion level to \$8-10 billion in 1980. This would include a mid-1980 manned Mars launch; an orbiting lunar station, lunar surface base, plus a 50-man earth-orbit space station—programs requiring use of Nerva and the chemically-fueled space shuttle and tug.

The more likely Nixon choice, observers say now, would be Options 2 and 3, which the group says would allow funding to be kept at recent levels initially and then increased gradually. The options are identical except that Mars would be deferred in the latter choice while the mission would go in 1986 under Option 2.

NASA funding under either choice would hold at around \$4 billion a year "for the next two fiscal years," says the group, "and then would rise to a peak of \$5.7 billion in 1976—this increase reflecting simultaneous peak resource requirements of space station and space shuttle developments." However, the report notes that developing the two vehicles in series, rather than in parallel, would cost only \$4 billion

to \$5 billion. Option 2 would have a later peak of nearly \$8 billion in the early 1980's, resulting from the manned Mars landing.

For defense space programs, three options could escalate Pentagon budgets from the present level of slightly more than \$2 billion a year to approximately \$2.3 billion in fiscal 1974 under the lowest budget option, to a maximum of about \$3.8 billion about 1980 with a maximum effort. The middle course would push Pentagon space spending up to a 1974 peak of about \$2.8 billion.

## Manufacturing

### Leave the storing to us

One of the chronic problems in the semiconductor industry is delivery. Not only is demand growing constantly, so that device suppliers' capacity is subject to pressure, but there's still some "black magic" in technology—even established production lines can turn out unpredictable batches of defective units. The result: customers often must wait several weeks for delivery.

To combat the problem—and to give itself a competitive edge—

Westinghouse Semiconductor has adopted what it calls a "fusion bank" concept for marketing its products. Silicon-controlled rectifiers are being sold under the new concept, transistors are coming on stream, and rectifiers will be included by Nov. 1.

**In advance.** Here's how the fusion bank works. Westinghouse estimates needs by asking the customer how many devices of a particular type he will require per month, and how many months ahead he would like to be. Westinghouse then stores the total number needed as "fusions"—silicon chips that are complete except for final assembly in a package. On call from the customer, Westinghouse will deliver assembled devices within six days, or two days for rectifiers.

In effect, Westinghouse is relieving customers of the trouble—and expense—of maintaining a large inventory to protect against supplier vagaries, according to John C. Marous, general manager of the division.

There are three reasons the company can do this, all proprietary:

- With a computer program, the final device characteristics can be predicted as soon as the junctions have been diffused in the chip. This means that the subsequent operations can be avoided if the final device won't measure up; often, the chip can be rediffused to give it the desired properties. It also means that the manufacturer knows its own inventory position several days in advance. The program takes 22 variables into account, including parameters like resistivity and carrier lifetime. Moreover, the program continuously upgrades itself by comparing results with predictions and by making appropriate changes in the mathematical model.

- After fabrication (and before sealing) the silicon chip is coated with a resin. Westinghouse won't disclose the nature of the coating materials, but claims that it permits the unpackaged chips to be stored indefinitely.

- The device is packaged by compression bonding. This technique, which employs a spring to



Banker. Westinghouse employee examines chips stored in firm's new "fusion bank."

## U.S. Reports

hold the silicon chip in place, scarcely affects the devices' characteristics—unlike the more conventional solder attachment method. Rejects after packaging, therefore, are minimal.

**Price rise.** Westinghouse's assumption of inventory maintenance for its customers will be reflected in increased prices. But since computer prediction, resin coating, and compression packaging all tend to increase yields, the increase will be modest. The customer still will realize net savings, according to Marous, in addition to the convenience of guaranteed almost-immediate delivery.

## Integrated electronics

### Off with the on

MOS field effect transistors have relatively high "on" resistances and temperature coefficients that go up as temperature rises, making them incompatible with high-accuracy digital-to-analog converters. But engineers at the Guidance and Control Systems division of Litton Industries have come up with what they believe is a unique metal oxide semiconductor switching circuit that gets around the problem of on resistance and is relatively insensitive to changing temperature coefficients.

Their prize development is a hybrid 12-bit d-a converter, consisting of three MOS switch chips, a linear integrated circuit operational amplifier, and a thin-film resistor ladder network. They say it is the smallest unit available; it's all housed in a 1-by-0.75-by-0.1-inch flatpack. Each MOS switch contains four flip-flops and four ladder switches. Curtis Brudos, manager of the electronic design section in the division's digital computer laboratory, says incorporation of flip-flops in the MOS switches to allow storage in the chip, combined with the switching circuit, is particularly novel.

**Civilian use.** The d-a converter will be used in the Cains (carrier aircraft inertial navigation system) computer. Litton officials are con-

sidering marketing it as a component (switches, ladder, and amplifier) and a subsystem (including reference voltage sources). Brudos estimates the component price would be less than \$500.

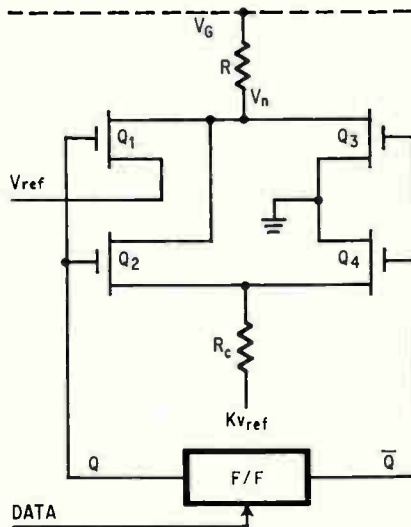

**Switch.** Litton calls use of 12-volt constant-current source unique.

There are two current-bit switches on each MOS chip, and two voltage-bit switches. The current-bit switches circumvent the usual high on resistance of the transistors, by using a switching technique that cuts the effective impedance of transistor  $Q_1$  in the accompanying schematic by two orders of magnitude, Brudos says. Brudos knows of no other firm that has used such a constant-current source in an MOS switch to eliminate voltage drop across such a transistor when that transistor is closed; this was Litton's aim in obtaining a ladder switch-error voltage of zero.

**Vital.** The most significant bits in the converter are for current-summing. Their switches function as a combined current source and precision node-voltage clamp. The point labeled  $v_n$  acts as the ladder's summing node and is held at a virtual ground potential. When transistors  $Q_1$  and  $Q_2$  are turned on, the input node to the ladder ( $v_n$ , with 150 ohms resistance) is switched from ground to the 12-volt constant-current voltage ( $kv_{ref}$ ).

It can be seen that the current

through the ladder resistor ( $R$ ) is constant, and not dependent on the states of the other bits in the ladder. Therefore, if the constant-current resistor  $R_c$  has a voltage supply  $kv_{ref}$  value that is three times the precision voltage reference source  $v_{ref}$ , current flows from the node  $v_n$  to  $kv_{ref}$ . Ideally, when the current at  $R$  equals that at  $R_c$ , there would be no current flow in  $Q_1$ , and the points  $v_n$  and  $v_{ref}$  would be exactly equal, giving the zero drop across  $Q_1$  and the desired zero ladder switch-error voltage.

But because the on resistance of the transistor  $Q_2$  can't be predicted exactly, there is an error in the current source. To overcome it, the values of  $R$  and  $R_{on}$  are specified so that less than 0.6% of the ladder current gets through  $Q_1$ , putting the drop across the transistor at just 0.6% of what it would be if  $Q_2$ , the current source transistor, were not used.

The technique leads to an effective impedance for  $Q_1$  that is reduced by  $1/0.006$ , a factor of 167. With a maximum specified on resistance of 150 ohms, the effective on resistance is less than 1 ohm, and a voltage drop of virtually zero is achieved. But that low 150-ohm on resistance didn't come easy—it took three tries before a manufacturer could produce an interdigitated source-and-drain design that cut it to 150 ohms.

**The usual.** More conventional switching is used for the seven least significant bits. This complementary driven voltage-bit switch connects either ground or the reference voltage into a segment of the ladder network. A binary weighting of the errors caused by the individual switches allows the simpler voltage bit switch to be used without degrading the converter's accuracy.

The converter's accuracy is  $\pm 120$  parts per million from  $-55^\circ\text{C}$  to  $+125^\circ\text{C}$ , a maximum output of +12 volts to -12 volts, reference levels of +4 volts and -4 volts, and a load time of 5 microseconds. Load time is the time required to enter digital data and get an analog signal out. Brudos says speed is compatible with avionics applications in which the unit has to

# Use COS/MOS more ways in more places

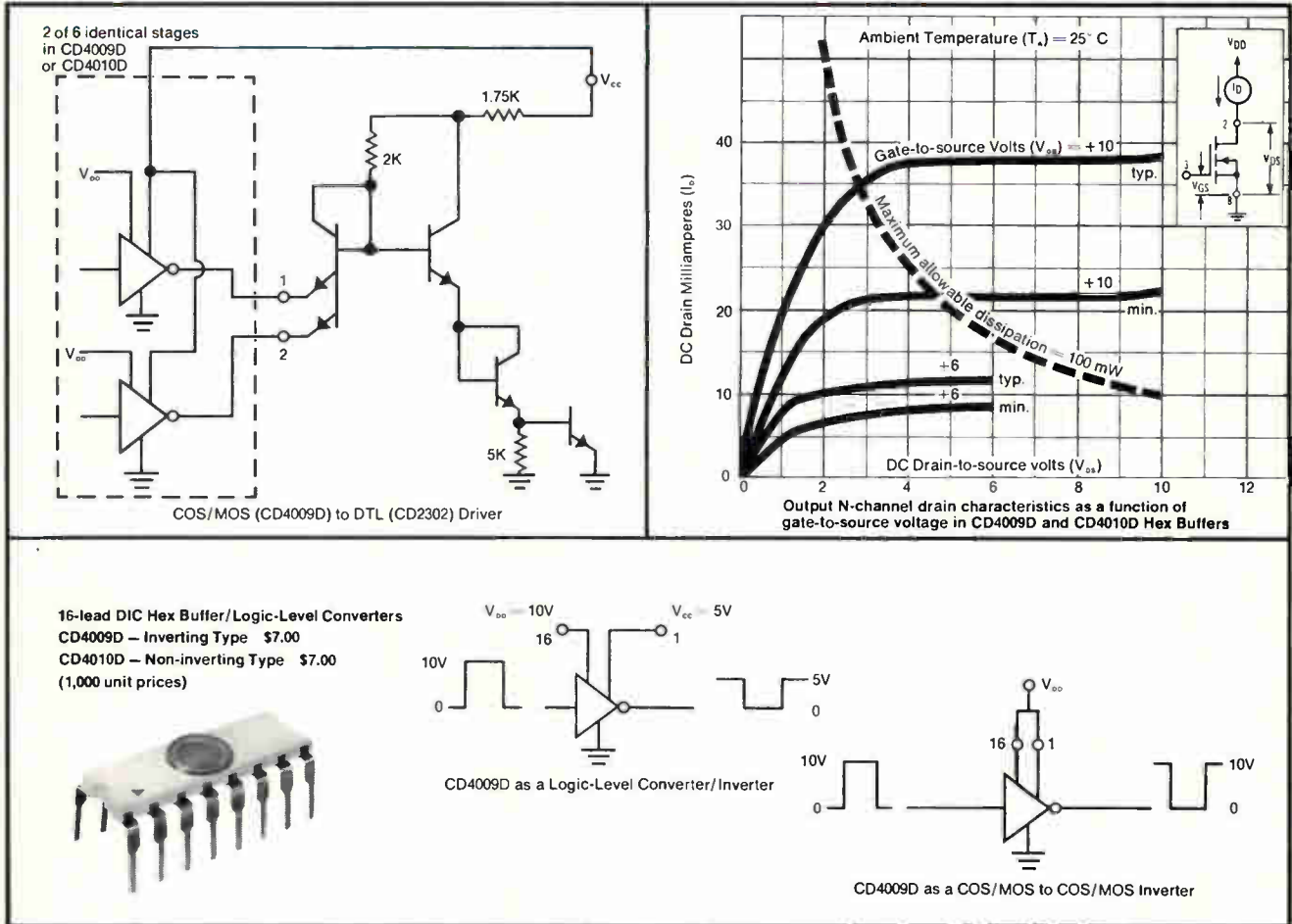

## RCA-CD4009D and CD4010D COS/MOS Hex Buffers bring more flexibility to your logic circuits

Now you have many more opportunities to take advantage of the known capabilities of COS/MOS—RCA's Complementary Symmetry MOS digital integrated circuits. Use the new CD4009D (inverting) and CD4010D (non-inverting) hex buffers for:

- greater driving capability, and wider current flexibility in COS/MOS systems
- greater latitude for interfacing COS/MOS with DTL and/or TTL devices.

A most important feature of these new hex buffers in such applications is their low "1" and "0" output impedances which result in excellent dynamic noise margins.

For more information on the COS/MOS Hex Buffers and the rest of RCA's growing line of COS/MOS Integrated Circuits, get in touch with your local RCA Representative or your RCA Distributor. For specific technical information, write RCA Electronic Components, Commercial Engineering, Section ICN9-3, Harrison N.J. 07029.

**RCA** Integrated Circuits

## U.S. Reports

handle five to 10 channels of information, such as roll, pitch, heading, and possibly magnetic heading, in an inertial navigation system computer.

## Optoelectronics

### Mix 'n' match

In data processing, the bird in the bush has always been the universal optical-character recognizer—an elusive unit that theoretically could take ordinary printed or typed material and convert it at a high rate to machine-digestible form. The two main obstacles: different type styles or fonts that are usually intermixed in printed matter and the handling of the paper being scanned.

Now, CompuScan Inc., a small company in Leonia, N.J., has neatly sidestepped the obstacles with an OCR system in which a small computer stores and identifies multiple type faces, and a flying-spot scanner that reads only microfilm. The latter puts the responsibility for turning pages squarely on machines that put text on microfilm.

**Soft touch.** Unlike most other OCR systems in which a few fonts, at best, are wired into their recognition sections, the CompuScan system is keyed to software. Its speed varies from 20 to 2,000 characters a second, depending upon the quality of the text. Speed in other systems is generally in the 1,000-character range—but there are wide variations among the 31 on the market.

But if the CompuScan system does more than other OCR systems,

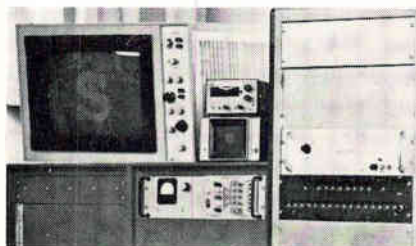

Letter up. OCR that can "read" variety of type fonts.

it does so at a much higher price—about \$900,000 for CompuScan, including a small computer like the SDS Sigma 2, compared to about \$100,000 for other systems. And the \$900,000 price tag does not include a microfilmer.

Recognition is relatively simple: a flying spot scans the microfilm, which is stepped past the scanner by a small motor. The scanner checks for brightness the points of an imaginary 24-by-24-dot matrix for each letter, then compares the points with data stored in the computer's memory. For a match, the scanned letter must have a pre-selected number of points in common with the stored letter. The system automatically goes through five routines if it fails to recognize a letter for these reasons:

- The letter is unusually wide and might actually be two touching characters.

- Two characters in sequence are confusing; they may, in fact, be a single broken character.

- A letter is found to be one of a pair of highly similar letters; in this case, the system detects subtle differences.

- The point population of the matrix is too low or too high. Here, the video sensitivity is increased or reduced for a rescan.

And if all else fails, the following line is displayed for evaluation by an operator, or a confusion symbol is placed in the text where the character should appear.

## Space electronics

### Off the ground

If NASA has its way, America's space program of the 1980's will have to get along without Carnarvon, Toowoomba, and the rest of the ground stations, ships, and planes that have collected tracking and telemetry data from orbiting spacecraft. The space agency says it hopes to save hundreds of millions of dollars a year and obtain more precise data by switching to synchronous satellites to relay information to mission control.

Robert H. Pickard, chief of the

application experiments branch at Goddard Space Flight Center, points out that many of these stations have specialized capabilities that limit their use. Therefore, despite the large number of such stations—the U.S. alone runs more than 100—relatively short observations limit coverage.

**Bit by bit.** This has meant orbit computations based on sequential tracking by multiple ground stations, "dumping" of on-board data at opportune times, and (with manned spacecraft) augmenting stations with ships and planes equipped with r-f.

NASA and the Air Force have made studies of the TDRS concept (for tracking data relay satellite) showing that a properly instrumented synchronous TDRS network can provide complete coverage. However, these parametric studies have had little impact on the design of next-generation low-orbiting satellite missions, the designated users of a TDRS. The system will get its first test as limited incidental support for the Nimbus-E mission in 1972.

Paul Schmid and Paul Hefferman, who worked with Pickard on the project, claim that, as its name suggests, the ATS-F S-band, telemetry, tracking, and command experiment will enable NASA to learn to what extent it can command a near-earth orbiting spacecraft and determine the spacecraft's orbit using tracking data received via synchronous satellite.

**No deals.** Other advantages include elimination of politically sensitive agreements with other countries for stations on foreign soil, and the availability of continuous, immediate, or real-time tracking, telemetry, and command data at master control. But there are problems: for a starter, how do you repair equipment in a satellite? Communications between Nimbus-E and ATS-F will be via scanned 30-foot parabolic reflector on the applications technology satellite and via mechanically-steered (programed or command) antenna on Nimbus. The transmitter power and antenna gain available on Nimbus determine the capacity of the link. Communications between



**NOW**  
**FROM STEWART-WARNER**  
**28 HIGH-SPEED ECL II**  
**MILITARY CIRCUITS**  
**COMPLETELY INTERCHANGEABLE**  
**WITH**  
**MOTOROLA MECL II**

**FAST...RELIABLE...INEXPENSIVE...AVAILABLE !**

**Fast**—Stewart-Warner ECL II military circuits have typical times of only 4 nanoseconds.

**Reliable**—These ECL II's offer the designer the same reliability and design freedom he has with the slower logics, and they will be tested to the tough Class A level of the new MIL-STD-883.

**Inexpensive**—Stewart-Warner ECL II's are priced competitively with TTL's.

**Available**—These 28 high-speed ECL II military circuits are available now from your local Stewart-Warner Microcircuits Distributor in both ceramic flat-pack and dual in-line packages.

For more information, send for our ECL data sheets. And, for off-the-shelf delivery, call your local Stewart-Warner Microcircuits Distributor.

**STEWART-WARNER** SYMBOL OF  
**COMPANIES** **SW**  
EXCELLENCE

STEWART-WARNER MICROCIRCUITS, INC.  
730 EAST EVELYN AVENUE, SUNNYVALE, CALIFORNIA 94086  
PHONE 408/245-9200 TWX 910-339-9210

Circle 53 on reader service card

# TACTICAL RADAR

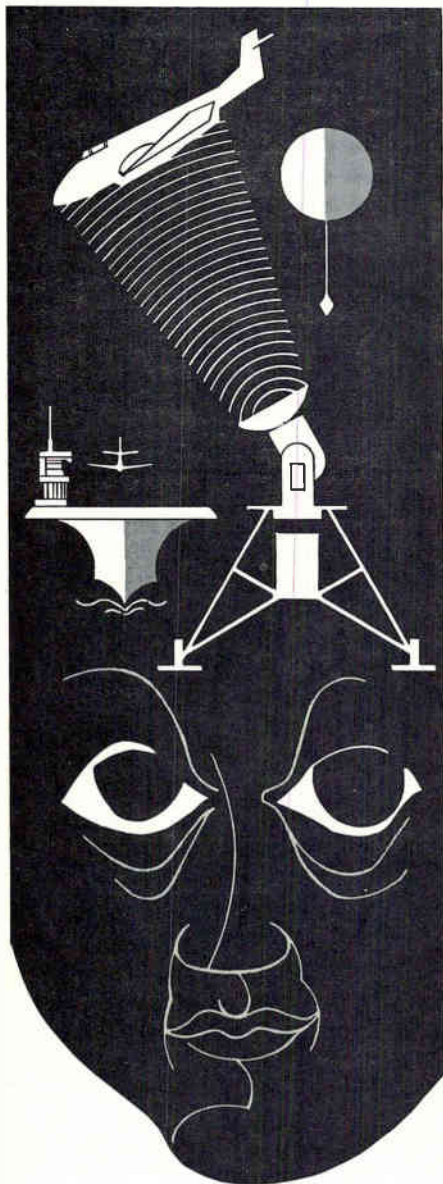

**TOTAL ELECTRONIC  
SYSTEMS CAPABILITY.  
SPECIALISTS IN  
TIME/FREQUENCY,  
RADAR AND  
DATA SYSTEMS  
OFFERING RAPID  
GROWTH.**

**SIERRA**

RESEARCH CORPORATION  
an equal opportunity employer

P.O. BOX 222, BUFFALO, N.Y. 14225

## U.S. Reports

the ATS-F and its ground station will involve a moderately directive spacecraft antenna and a high-gain ground antenna. The capability of this link will normally exceed that of the satellite-to-satellite link, so that the overall data capacity of the combined links will be determined by Nimbus's effective isotropic radiated power.

The repeater on ATS-F will have to have the 8 gigahertz earth-to-relay link cross-strapped to the 1.8 Ghz relay-to-mission link, and the 2.3 Ghz mission-to-relay link cross-strapped to the 7.3 Ghz relay-to-earth link. Measuring the range rate will require a phase-locked local oscillator on the ATS-F. System bandwidths will be a nominal 600 kilohertz (3 decibels) in the earth-relay-mission link, and will be nominally 8 megahertz (3 db) in the return mission-relay-earth link.

NASA anticipates that all these requirements can be met within the framework of the integrated communications subsystem concept presently under consideration for ATS-F. Most of the equipment will be built in-house by NASA to save money. The total cost is expected to be several million.

## Advanced technology

### How's that again?

Remember HAL 9000, the not-so-friendly talking computer in the motion picture "2001: a Space Odyssey?" Well, the Culler-Harrison Co. of Santa Barbara, Calif., has developed a voice synthesizer called HAL I that really lets your computer talk back—with no malice aforesought.

A number of attempts at speech synthesis have been made using Fourier analysis, trigonometry, and averaging techniques to reconstruct the voice. While workable, these methods tend to smear the data together, because they usually only look at a voice waveform through a 10-millisecond averaging window. Smearing causes distortion of vowel sounds and failure to record consonants, resulting in a mechanical-sounding, imperfectly synthesized voice.

Glen J. Culler, cofounder of Culler-Harrison, has devised a differential equation which he says "gives a more precise and succinct look at the waveform." Similarity analysis is performed to derive

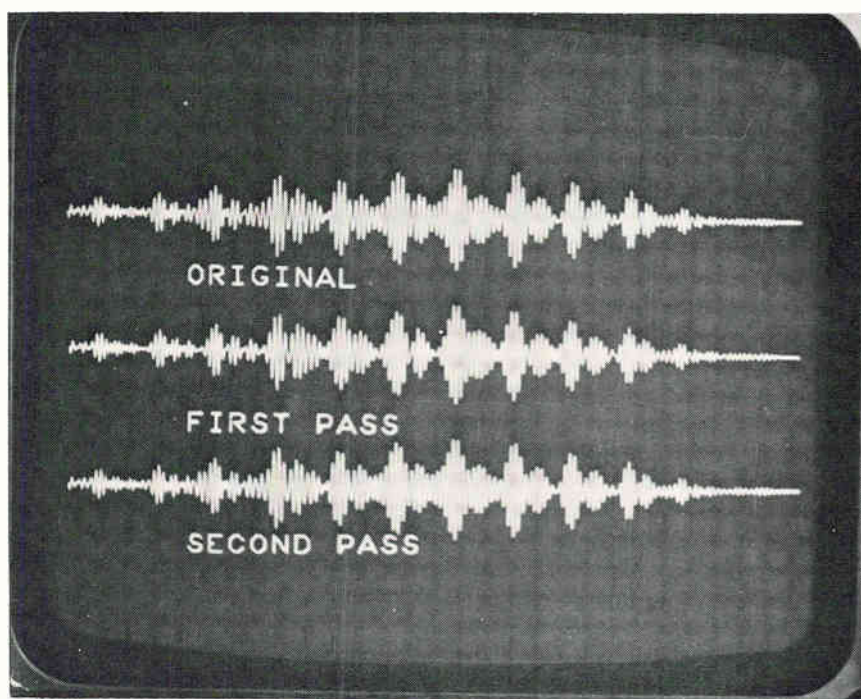

**Small talk.** Top waveform is 600 to 1,800 hertz midrange of the voice. Center, after going through differential equation solver. Bottom, first pass plus what's left after it's subtracted from original.



# RELAYS

## NEW MIL-R-6106

- One-Inch Cube
- 4PDT-10 Amps
- 28VDC-115VAC
- All Welded

## IT'S BABCOCK'S BR30

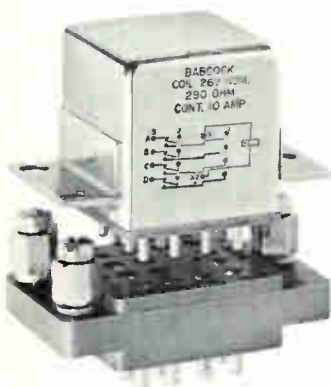

Babcock's new Model BR30 is a miniature, all-welded, 4PDT relay ... designed specifically to meet the requirements of MIL-R-6106 (MS-27400)—and to be completely interchangeable with other models of this type. Characterized by reliable op-

eration in environmental extremes, this new relay is the first developed by Babcock to meet the needs of airframe applications. Performance is outstanding ... to 200g's shock, 30g's vibration, over a temperature range of  $-70^{\circ}\text{C}$  to  $+125^{\circ}\text{C}$ , for a minimum of 100,000 operations. All welded construction, inside and out, assures a contaminant-free unit. Plug-in and solder-hook versions are offered; qualified relay sockets also available.

The Model BR30 is a new relay for new applications ... and it carries the same mark of proven Babcock dependability. Your assurance that it's better because it's Babcock.

The Babcock Model BR30 is a brand new MIL-R-6106 relay ... featuring a new symmetrical magnetic circuit. Utilizing two permanent magnets, this system provides a positive holding force, undisturbed by shock and vibration extremes ... and

dependable switching action throughout the life of the relay.

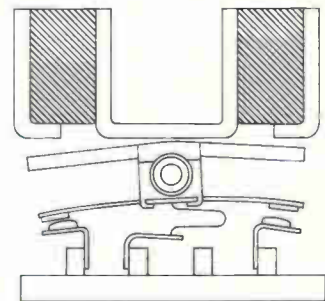

Coil design has also undergone some innovation. AC versions have been fabricated such that coil frequency is operational from 60 Hz to 400Hz, without degradation of ratings.

### SPECIFICATIONS

<b>Contact Rating</b> (@28VDC, 115/208VAC 400Hz)	Resistive: 10 amps. Inductive: 8 amps.
<b>Overload</b>	D.C. 40 amps. A.C. 60 amps.
<b>Rupture</b>	D.C. 50 amps. A.C. 80 amps.
<b>Coil Voltages</b>	6, 12 and 28VDC, 115VAC
<b>Shock</b>	200g's (6ms.)
<b>Vibration</b>	30g's, 70-3000Hz
<b>Operation Temp.</b>	$-70^{\circ}\text{C}$ to $+125^{\circ}\text{C}$
<b>Pull-In Power</b>	600mw
<b>Operate/Release Time</b>	15ms, max.
<b>Bounce Time</b>	1ms, max.
<b>Life</b>	100,000 operation, min.

Get complete information on the new Model BR30 ... contact Babcock Electronics Corp., Relays Division, Subsidiary of Esterline Corp., 3501 Harbor Blvd., Costa Mesa, Calif. 92626. CALL COLLECT (714) 540-1234 or TWX 910-595-1517.

Challenging opportunities for relay-switch engineers.



# Why Design Around Fat Stacks?

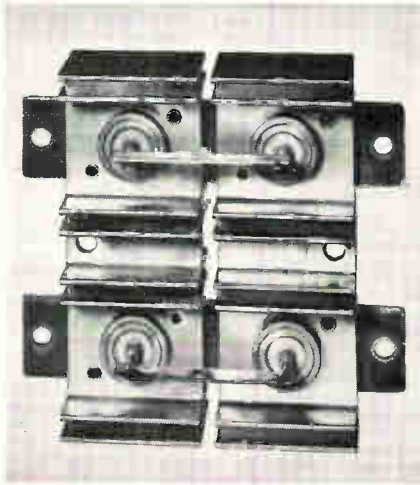

Exclusive configuration of ultra-compact Tung-Sol silicon rectifier stack.

## Tung-Sol low current assemblies slip into a fraction of the space

Tung-Sol's modular assemblies for low current silicon rectifier stacks employ an exclusive mounting technique that trims non-functional ounces and inches. Use of pressure-fit diodes of both polarities eliminates the washers, spacers, and other "fat" hardware of stud-mounted, plate-type units.

For applications requiring three amps or more in the low-current range, Tung-Sol silicon stacks really stack up cost-wise, too. They're available for three standard rectifier circuits: single phase center tap, single phase full wave bridge, and three phase full wave bridge.

Catalog CT-17A describes standard assemblies with surge ratings of 400 amps. Write for your free copy today. Tung-Sol Division, Wagner Electric Corporation, 630 W. Mt. Pleasant Ave., Livingston, N. J. 07039. TWX: 710-994-4865. Phone: (201) 992-1100.

# TUNG-SOL®

HELPS YOU DO MORE  
...WITH LESS

©Reg. T. M. Wagner Electric Corporation

## U.S. Reports

families of wave functions corresponding to the phonemes—members of the set of the smallest units of speech that distinguish one utterance from another—and their related subclusters.

**Chatterbox.** The speech synthesizer is a fast microprocessor that can be linked directly with a 40-byte-per-second computer data channel, converting the bit stream into human speech at 120 to 180 words per minute with any desired voice, pitch, inflection, and style, according to Culler. A key difference between HAL 1 and earlier synthesizers is it doesn't use pre-recorded voice segments, is programmable, and has an unlimited vocabulary and a 4,000-word core memory.

To program speech, the operator, using an on-line keyboard, indicates whether a male, female, or child's voice is to be used. Format statements of two types are used. One duplicates the characteristics of the voice to be used, with each voice is broken into three frequency ranges and the different parts emphasized through use of brass, midrange, and treble controls. In addition, there are other voice parameters. The second format statement forms a phonetic string. Keyboard characters are utilized in various combinations to represent a phonetic table of 41 different sounds, together with volume and pitch increases and decreases, and lengthening of either one or variants of the same phoneme.

All the eight voice control parameters are multipliers of parameters used to define a male voice set up as a standard in the speech synthesis. The standard consists of mathematical parameters that provide the basis for construction of the necessary voicewave functions; the synthesizer uses the standard to determine from each bit what waveform to use.

The microprocessor utilizes transistor-transistor logic, and a high-level programming language that Culler says is richer in logical capacity than most compiler languages. Most instructions are completed in 125 nanoseconds, though a few of the more complex ones take as long as 375 nsec.

**Orders.** Culler says the instructions are a disorganized set, with each instruction containing the data necessary to locate its successor. The instructions are ordered by their successors, not by address. Output from the synthesizer goes through a digital-to-analog converter and is amplified to produce the programmed voice. A display scope also can be connected to the output for playback and comparison of the synthesized voice.

The synthesizer could be used by phone company information services or for airline reservations and information, and to update aircraft weather reports, inventory, and sales reports, Culler says. It also can be used in computer time-shared services to supply additional information to the user without disturbing his information display. In a batch data-processing system with a large number of users, it could give information on how problems were run and make reports. The unit measures 2-by-3-by-1 foot, and is expected to sell for about \$40,000, including the 4,000-word memory.

Although HAL 1 will be marketed immediately, it is only half of a combined synthesizer-analyzer still under development at Culler-Harrison, for early 1970 completion.

## Silicon sec

Name a company supplying television camera tubes and the chances are it's redesigning them drastically—replacing the light- or photoelectron-sensing elements with rugged, more sensitive arrays of silicon diodes.

Texas Instruments and RCA are already sampling silicon-array vidicons. And at the Electro-Optical Systems Design Conference, the Amperex Electronic Corp. announced it is preparing to make one [*Electronics*, Sept. 1, p. 64].

But at the same conference, RCA showed it was even further along in perfecting the new technology when it unveiled a silicon-target version of a secondary electron conduction (sec) vidicon. Designated the RCA-C21117B, the tube substitutes the silicon array for the



# Damon's got 'em!

## Monolithic Crystal Filters.

IMMEDIATE DELIVERY ON "STANDARDS"





Custom designs take a little longer.

If one of the 4 "standards" in the accompanying chart meets the requirements of your communications system, you can forget the delivery problem. Damon is making immediate off-the-shelf delivery of evaluation quantities. In addition, you get all these extra advantages over conventional, multi-component filters: much smaller size, significantly lower price and practically zero failure rate.

Damon also offers a wide variety of computer-assisted custom designs but these take a little longer — 3 weeks from date of order.

For detailed technical brochure on Damon Monolithic Crystal Filters, write Electronics Division, Damon Engineering, Inc., 115 Fourth Ave., Needham, Mass. 02194. Or call (617) 449-0800.

"STANDARD" 4 POLE MONOLITHIC CRYSTAL FILTERS

				
MODEL NO.	6347 MA	6347 MB	6348 MA	6348 MB
Center Frequency	10.7 MHz $\pm$ .5 KHz	10.7 MHz $\pm$ 1 KHz	21.4 MHz $\pm$ .5 KHz	21.4 MHz $\pm$ 1 KHz
Bandwidth, 3 dB	6 KHz min	15 KHz min	6 KHz min	15 KHz min
Bandwidth, 40 dB	24 KHz max	50 KHz max	24 KHz max	55 KHz max
Ripple, Max	1 dB	1 dB	1 dB	0.5 dB
Insertion Loss, Max	3 dB	2 dB	3 dB	2 dB
Spurious Returns	> 40 dB down	> 30 dB down	> 30 dB down	> 20 dB down
Terminations (Resistive)	1.5 kilohms	3.9 kilohms	0.38 kilohms	1.3 kilohms
Ultimate Atten.	55 dB	50 dB	50 dB	45 dB
Op. Temp Range	0°-60° C	0°-60° C	0°-60° C	0°-60° C
Case	T0-8	T0-8	T0-8	T0-5





# ACOPIAN DUALS...

# 2

# POWER SUPPLIES IN THE SPACE OF

# 1

Where your equipment or system requires more than one regulated DC output, consider Acopian duals. They consist of two independent regulated power supplies housed in a single module. You can select two like outputs (such as for op amps) or any of 80,000 combinations of different outputs.

Acopian duals cut mounting space requirements roughly in half, cost less than two individual modules and, like all Acopian power supplies save you time because they're shipped three days after receipt of your order.

For information on the complete line of 82,000 different Acopian power supplies, including singles and duals, regulated and unregulated, and rack mounted assemblies, ask for our new catalog. Write Acopian Corp., Easton, Pa. 18042 call (215) 258-5441.



## U.S. Reports

photoelectron-sensing sec target, not for the photocathode. The result is a tube with the sensitivity of an intensifier/sec combination—600 tv lines resolution at  $2 \times 10^{-5}$  foot candles.

**More efficient.** The greater sensitivity is due to the ability of silicon to convert light or photoelectrons to electronics much more efficiently than the materials used for photocathodes or sec targets. And putting an intensifier high voltage section in front of the silicon results in a target gain of 2,500; this is at least an order of magnitude greater than the target gain in a sec. The new tube—available in sample quantities during the second quarter of next year—has a 40-millimeter, fiber-optic faceplate. It's  $9\frac{1}{4}$  inches long, weighs 9 ounces, and can accommodate a light level range of 1,000:1 with negligible blooming, RCA says.

### Communications

#### Digging in

The much-talked-about field tests of underground millimeter-wave communications will start in New Jersey in 1973. AT&T disclosed its plans in closed hearings before the Federal Communications Commission earlier this month in answer to questions about its apparently ineffective planning for future communications needs.

The company told the Federal

agency that it will spend \$50 million to develop buried waveguides capable of handling 250,000 channels per pipe. In the Jersey installation, waveguides will be 1.5 inches in diameter and frequencies will be 40 to 100 gigahertz. Five miles of pipe will be laid. Immediate objectives will be to determine precisely what waveguide dimensions prevent signal distortion, what curvature the pipes can stand, and what effect earth movement will have on wave propagation.

The idea, says the giant utility, is that if demand for millimeter-wave service materializes as expected by the late 1970's, each waveguide would have a quarter of a million channels. "Someday," said a spokesman, "we may be able to put a million channels on one" waveguide. This compares with the current maximum of 30,000 channels in a coaxial cable buried between Washington, D.C., and Florida.

### Contracts

#### Package with potential

Univac, with a \$9.7 million preproduction contract from the Navy tucked away, is looking for additional buyers of its new computer developed for the Naval Tactical Data System. According to Donald F. Fagan, director of Univac's defense systems operation in Washington, the fixed-price award for



**Dropout.** SRAM, the Air Force's new short-range attack missile, has been successfully dropped from both wing and weapons bay positions by the FB-111 bomber. The supersonic air-to-ground missile passed its first powered launch test in July when it was fired from a B-52. Boeing is contractor for the missile.

# new

## 16 CHANNEL ANALOG MULTIPLEXER

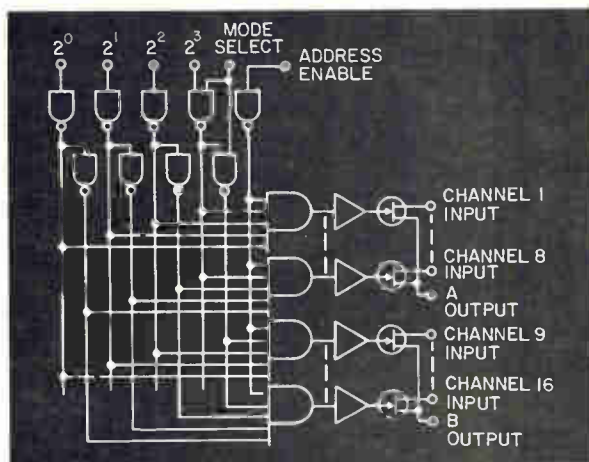

The first LSI subsystem employing NPN's, PNP's and J-FET's in a monolithic structure.

- Bipolar signal handling range in excess of 20 volts
- Full military temperature range
- Lowest input leakage current
- Most versatile multiplexer with random access capability
  - 16 channel
  - Dual 8 channel
  - Differential 8 channel
  - Enable input for all channel blanking or address expansion
- TTL address decoding logic for TTL or DTL compatibility
- Complies with MIL-STD-883
- Off-the-shelf delivery

You get the BEST IC for the job from Radiation's fast expanding linear line.

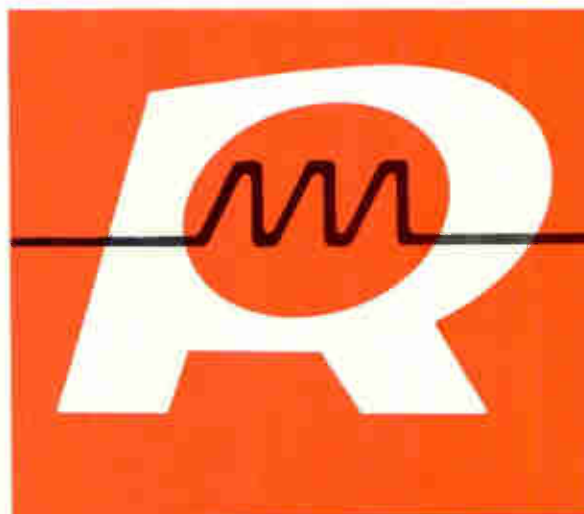

**RADIATION**  
INCORPORATED  
SUBSIDIARY OF HARRIS-INTERTYPE CORPORATION  
MICROELECTRONICS DIVISION

P. O. Box 476, Lexington, Massachusetts 02173  
Area Code 617, 862-1055

600 Old Country Road, Garden City, New York 11530  
Area Code 516, 747-3730

2600 Virginia Avenue, N.W., Washington, D.C. 20037  
Area Code 202, 337-4914

P. O. Box 30667, Dallas, Texas 75230  
Area Code 214, 231-9031

6151 West Century Boulevard, Los Angeles,  
California 90045 • Area Code 213, 670 5432

260 Shendan, Palo Alto, California 94306  
Area Code 415, 321-2280

P. O. Box 37, Melbourne, Florida 32901  
Area Code 305, 727-5430

# Masters of Self Control

(Barnstead's automatically-controlled demineralizers guarantee water of consistently high quality, even regenerate themselves.)

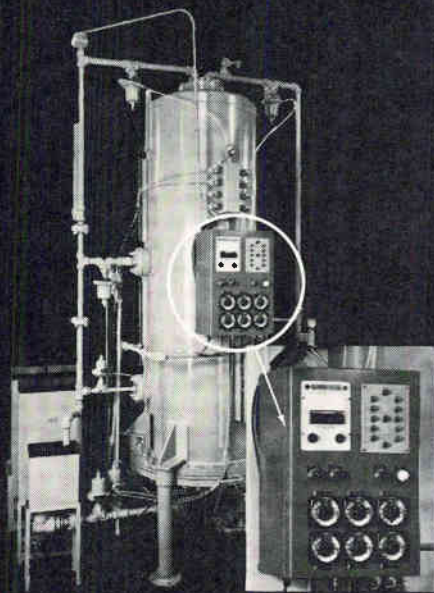

When you want a water purification system that will virtually run itself, and won't get cranky and make mistakes . . . you can't do better than one of Barnstead's demineralizers with Automatic Regeneration Controls.

You just turn them ON! You get assurance that only water of specified purity will reach your product or process, regardless of human frailties. Your people get more time for other work.

Barnstead makes demineralizers up to 3,000 gph and larger . . . with or without automatic controls. And if you need a still? We make them, too.

Write for details. The Barnstead Company, Division of Ritter Pfaudler Corp., 222 Rivermoor Street, Boston, Massachusetts 02132.

**Barnstead**  
A DIVISION OF RITTER PFAUDLER CORPORATION

## U.S. Reports

the first 26 Navy systems could add up to \$17 million.

Beyond that, Fagan sees an even greater potential for the high-speed, modular central processor and core memory package now tagged the AN/UYK-7. With applications in command and control, fire control, and navigation, the computer is being aimed at the Advanced Surface Missile System (ASMS), the planned DD-963 (formerly DX) destroyer program, and the SSN-688 class of high-speed attack submarines. Possible sales: 1,000 systems over a period of five to seven years.

**IC's used.** Developed in two years with \$1 million to \$1.5 million in Navy R&D cash, the UYK-7 uses integrated circuitry throughout, with core memory modules of 48,000 words each, expandable to a maximum of 260,000 words.

Cycle time of the new system is 1.5 microseconds, says Fagan, compared to 2 to 4  $\mu$ secs for its predecessor, the Univac 642B—a computer with the military nomenclature of AN/USQ-20B. Though the cores offer all nondestruct readout capability and the system is compatible with any kind of peripheral hardware, Fagan says Univac is exploring the potential of "mated film memories" for destruct readout capability. [*Electronics*, April 1, 1968, p. 31.]

Univac says the UYK-7 achieves savings of 5-to-1 in volume and 5-to-1 or 6-to-1 in weight compared to its earlier system. Memory modules, for example, occupy about 10 cubic feet and weigh about 500 pounds against the 35 cubic feet and much greater weight required for its predecessor's smaller 32,000-word core packages.

**Not for ASW.** Will Univac slate the UYK-7 for Lockheed's new, carrier-based anti-submarine (ASW) aircraft? "Negative," replies Fagan. "But we will bid a computer the 1832 model electronically compatible with the UYK-7 for S-3A." Univac, a member of the winning ASW aircraft team, along with LTV, is responsible for weapons system integration on the new Lockheed plane.

Though Univac is the sole source on the computer at present, Fagan concedes the package is a Navy

# new

## HIGH SLEW RATE AMPLIFIER

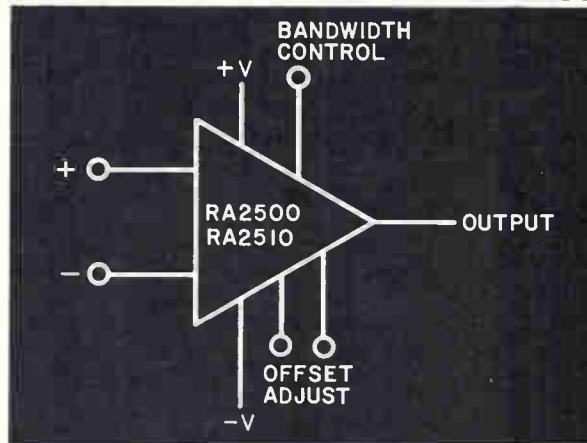

- The highest speed fully compensated-stable at unity gain-Op Amp available today
- Full military temperature range
- Complies with MIL-STD-883
- Off-the-shelf delivery

	RA-2510	RA-2500
• Slew Rate (at unity gain)	$\pm 50\text{v}/\mu\text{s}$ min.	$\pm 25\text{v}/\mu\text{s}$ min.
• Gain	15000	35000
• Large Signal Bandwidth	500 KHz	200 KHz
• Gain Bandwidth	15 mHz	15 mHz
• Offset Current	20 nA	20 nA
• Offset Voltage	2 mV	2 mV
• Output Current	$\pm 20\text{mA}$	$\pm 20\text{mA}$
• Input Impedance	50 megohms	25 megohms

You get the BEST IC for the job from Radiation's fast expanding linear line.

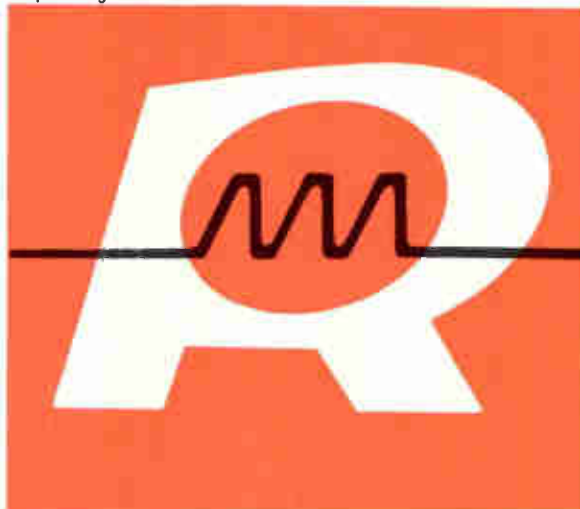

**RADIATION**  
INCORPORATED

SUBSIDIARY OF HARRIS-INTERTYPE CORPORATION  
MICROELECTRONICS DIVISION

P. O. Box 476, Lexington, Massachusetts 02173  
Area Code 617, 862-1055

600 Old Country Road, Garden City, New York 11530  
Area Code 516, 747-3730

2600 Virginia Avenue, N.W., Washington, D.C. 20037  
Area Code 202, 337-4914

P. O. Box 30667, Dallas, Texas 75230  
Area Code 214, 231-9031

6151 West Century Boulevard, Los Angeles,  
California 90045 • Area Code 213, 670-5432

260 Sheridan, Palo Alto, California 94306  
Area Code 415, 321-2280

P. O. Box 37, Melbourne, Florida 32901  
Area Code 305, 727-5430

# Making Testers?

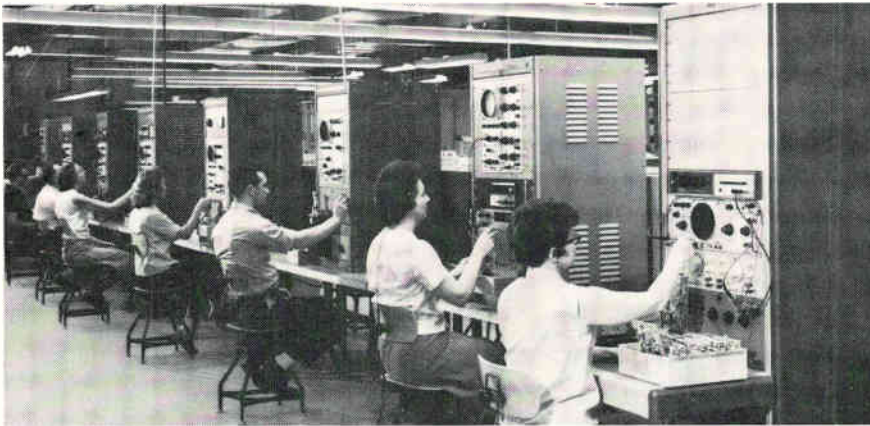

**It's just one way to use Elgin's Integrid® Cards and power supplies to solve a design problem.**

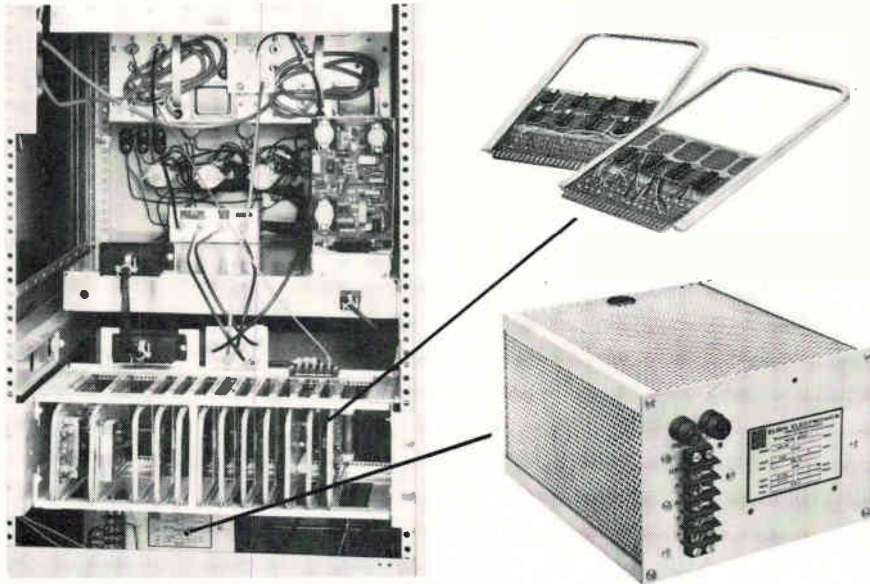

The custom test equipment pictured above demonstrates another use for these Elgin off-the-shelf products when you are faced with a job requiring reliable, low cost components.

Elgin's 5V power supplies in each tester feature exclusive over-voltage and over-current protection. They are available in three basic sizes with output currents of 4, 8 or 16 amps, at low cost with **GUARANTEED PROMPT DELIVERY**—on the way to you within 48 hours after receiving your order.

Inside each tester are 12 circuits assembled on our Integrid Card elements (dual-in-line's above). Integrid Cards are available in multiple patterns, permitting modular use of precisely the type and number of boards required.

The PC Assemblies being checked in the test equipment were made by us, including the printed circuit boards manufactured at our new PC board plant. Circle the reader Service Card for our new Integrid Card and Power Supplies folders.

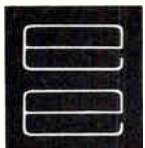

**ELGIN ELECTRONICS**  
**INCORPORATED**

Subsidiary of Basic Incorporated  
P. O. Box 1318 • Erie, Pa. 16512

## U.S. Reports

system developed with Navy money and could be put up for competitive bids as the market expands.

Such was the case with the USQ-20B, for which Univac got nearly \$25 million in Navy money but lost out on the last production award of \$11.8 million to Sylvania Electric's Systems Division.

## Lasers

### How deep is the ocean?

Mapping harbor basins can be almost as trying a task as predicting the weather. In many harbors, strong currents constantly cause bottom formations to shift, building up, for example, new sandbars where none existed before, and eroding others that might have stood as channel markers. Almost as soon as one survey is finished, another is needed.

These harbor surveys are conducted mainly by sonar-equipped vessels that take readings laboriously chugging back and forth across a harbor. However, Holobeam Inc. of Paramus, N.J., is using a different method—examining the surface waves of the vicinity—which until now was considered impractical.

By determining the shape and height of a wave, it's easy to put together its energy profile. Once this factor is determined, and if enough waves are scanned, the wind pattern for an entire area of several hundred or even thousand square miles can be determined. And because of its wind-analysis capabilities, the method can also be applied to collecting data for large-area weather pictures.

**Airborne.** Holobeam's approach utilizes a yag laser at an altitude of 20,000 feet. The system, called Suede (for surface environment definition), consists of an airborne 100-watt continuous-wave laser, complete with a proprietary receiver, power supply, and cooling apparatus. Weighing in at just about 100 pounds, Suede is essentially a distance, measuring, or ranging system. The yttrium aluminum



# new

## HIGH INPUT IMPEDANCE OP AMP

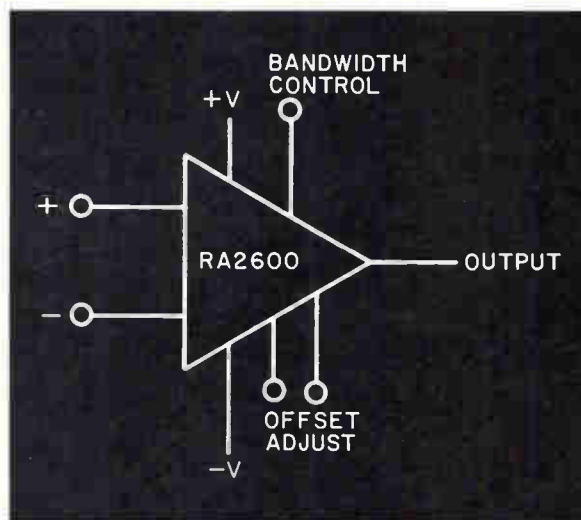

- Input Current = 3 nA
- Input Impedance = 50 megohms
- Slew Rate (at unity gain) =  $\pm 5\text{v}/\mu\text{s}$
- Gain = 200,000
- Gain Bandwidth = 12 MHz
- Short Circuit Protected
- Fully compensated (stable at unity gain)
- Full military temperature range
- Complies with MIL-STD-883
- Off-the-shelf delivery

You get the BEST IC for the job from Radiation's fast expanding linear line.

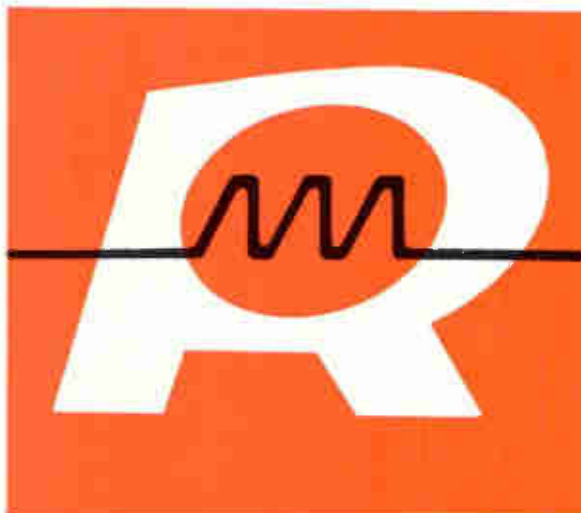

P. O. Box 476, Lexington, Massachusetts 02173  
Area Code 617, 862-1055

600 Old Country Road, Garden City, New York 11530  
Area Code 516, 747-3730

2600 Virginia Avenue, N.W., Washington, D.C. 20037  
Area Code 202, 337-4914

P. O. Box 30667, Dallas, Texas 75230  
Area Code 214, 231-9031

6151 West Century Boulevard, Los Angeles,  
California 90045 • Area Code 213, 670-5432

260 Shendan, Palo Alto, California 94306  
Area Code 415, 321-2280

P. O. Box 37, Melbourne, Florida 32901  
Area Code 305, 727-5430

**RADIATION**  
INCORPORATED  
SUBSIDIARY OF HARRIS-INTERTYPE CORPORATION  
MICROELECTRONICS DIVISION

# A simple dip'll do it



## Application of the new HYSOL Epoxy DRI-KOTE® Powder DK9 BLUE couldn't be easier

Coating of sensitive parts can be accomplished at relatively low temperatures by spraying or dipping in aerated bed or even in a cup as shown in the illustration. HYSOL DRI-KOTE® DK9 fuses as low as 250° where other coating powders demand temperatures in the 400° range. Many small parts like Mylar, tantalum or disc capacitors that do not have enough heat retention for normal powder coating are being coated with new HYSOL DRI-KOTE®. Final cure can be accelerated from two hours in the 250° range to five minutes at 400° if desired.

The low temperature gel characteristics and high build rate from 5 to 100 mils make DRI-KOTE® ideal for coating motor end turns, coils, capacitors and transformers. Excellent moisture resistance, dielectric strength 800 volts per mil.

For further information on low temperature fusing DRI-KOTE® Powder DK9 Blue, write, wire or call HYSOL, Dept. EM-969, Olean, New York 14760.



**HYSOL DIVISION**  
THE DEXTER CORPORATION

## U.S. Reports

garnet laser comprises two 3-kilowatt arc discharge krypton lamps and, according to Suede project manager Ron Kirk, operates at an efficiency of about 1.7%.

It was developed under contract from the Naval Research Laboratory, and although the system has its most immediate application in oceanography and meteorology, Kirk says that a number of avionics firms have been evaluating the airborne laser with thoughts of including it in large military systems on helicopter gunships and tactical aircraft, or for target illumination and acquisition.

## For the record

**Lengthening line.** With about 100 production models of its System 21 consoles on the way to customers, the Viatron Computer Systems Corp. plans to add, among other products, two general-purpose computers to its line. One, the Model 2140, would lease for \$99 a month; the other, the 2150, would go for \$199. Both will be 16-bit machines and use MOS LSI. The 2140 will have a 4,096-bit core memory, while the 2150 will have an 8,192-bit stack. Viatron says the low lease price is made possible, as with the \$39-a-month-and-up consoles, by LSI and high-volume production.

**Teamwork.** Apparently operating on the theory that too many cooks don't necessarily spoil the broth, the Lockheed-California Co. has selected four companies to help develop a modular navigation system for the L-1011 TriStar. The Arma division of Ambac Industries will develop the area system with support from Decca Navigator, and will supply a miniaturized general-purpose digital computer, a flight-data storage unit, and a pilot control and display unit. The inertial module will come from Collins Radio, using a platform made by the Kearfott division of General Precision. Initial Collins portions can be used with or without the Arma area system. Choice of modules rests with the buyer of the plane.

# new

## PARTY-LINE RECEIVER

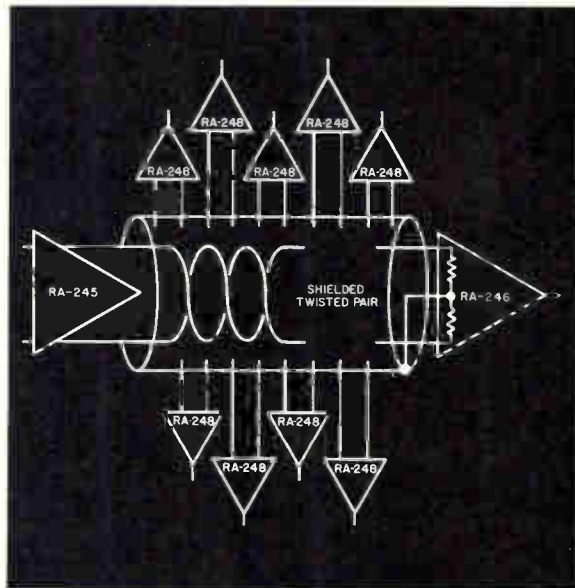

- 10 Party-Line Receivers driven by a line transmitter
- Balanced current mode eliminates switching transients
- Extremely low power consumption
- 3 circuits per package
- No standby power required for idle circuits
- Compatible with TTL and DTL
- Full military temperature range
- Complies with MIL-STD-883
- Off-the-shelf delivery

You get the BEST IC for the job from Radiation's fast expanding linear line.

P. O. Box 476, Lexington, Massachusetts 02173  
Area Code 617, 862-1055

600 Old Country Road, Garden City, New York 11530  
Area Code 516, 747-3730

2600 Virginia Avenue, N.W., Washington, D.C. 20037  
Area Code 202, 337-4914

P. O. Box 30667, Dallas, Texas 75230  
Area Code 214, 231-9031

6151 West Century Boulevard, Los Angeles,  
California 90045 - Area Code 213, 670-5432

260 Sheridan, Palo Alto, California 94306  
Area Code 415, 321-2280

P. O. Box 37, Melbourne, Florida 32901  
Area Code 305, 727-5430

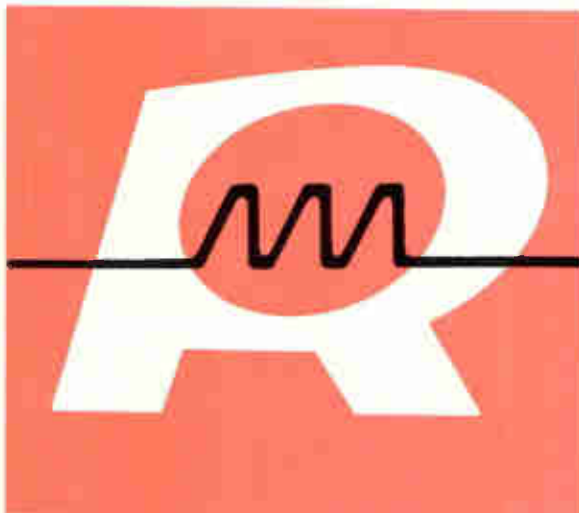

**RADIATION**  
INCORPORATED  
SUBSIDIARY OF HARRIS-INTERTYPE CORPORATION  
MICROELECTRONICS DIVISION

# You don't need a degree to test op amps.

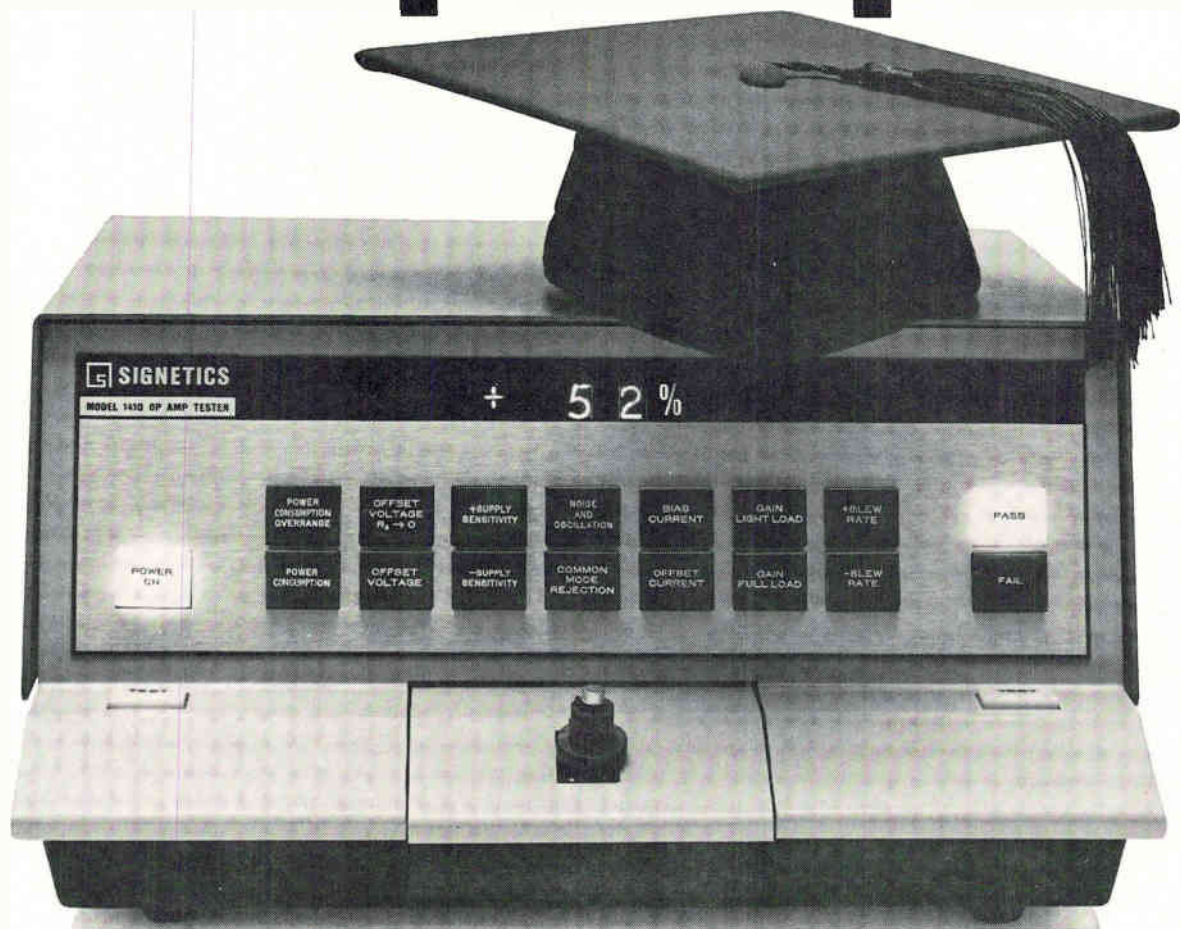

Signetics' new Model 1410 is the most comprehensive, definitive, easy-to-use op amp tester on the market. And we can prove it.

Rather than shout about its many features, let us just tell you how it works and what it does:

First, you simply insert a program board (manufacturer's spec or your own) for the op amp to be tested. Plug in the device. All operations are now performed by pushing illuminated test buttons. Push the top left button and the lights immediately indicate what tests will be performed. Next, push the "Test" button. If all tests are passed all button lights go out and the "PASS" indicator lights up. If any test is failed, the button corresponding to that test stays lit and the fail light comes on.

Now, if you want to know to what degree a given parameter passed or failed its test, just push the button corresponding to that specific test. The

answer is read out immediately as a percentage of the specified test limit.

We call this real "decision language."

There are fourteen tests: power consumption overrange (greater than 200%), power consumption (less than 200%), offset voltage (source resistance zero ohms), offset voltage (source resistance programmed), + supply sensitivity, - supply sensitivity, common mode rejection, bias current, offset current, gain (programmed light load), gain (programmed heavy load), noise and oscillation. And for the first time there are tests you won't find on testers selling for ten times our price: + slew rate, - slew rate.

The Model 1410 has no knobs to turn or meters to interpret. Your secretary could learn to use it in about one minute. Optional input/output boards allow you print-out or data log complete

parameter measurement.

And there's more. But suffice it to say for now that we believe the 1410 represents a major breakthrough in linear testing. Many who have wanted to test op amps can now afford to do so because the 1410 makes op amp testing practical and cost-efficient.

We know that there are some prospects out there who could profit by paying eighty or ninety thousand for this tester.

We're happy to say that the price will not be more than a tenth of that. Plus tax.

**SIGNETICS CORPORATION**  
MEASUREMENT/DATA  
A subsidiary of Corning Glass Works

For detailed information or a demonstration write Signetics, Measurement/Data, 811 E. Arques Ave., Sunnyvale, Calif. 94086, or contact one of the following:

AUTHORIZED SIGNETICS REPRESENTATIVES (Measurement/Data) □ Alabama and Tennessee Col-Ins.-Co., Inc., Huntsville (205) 539-1771 □ California L and M Engineering, Inc., Inglewood (213) 678-5409; Santa Clara (408) 243-6661 □ Connecticut Datch Associates, Inc., New Haven (203) 624-7291 □ District of Columbia (see Silver Spring, Maryland) □ Florida Col-Ins.-Co., Inc., Orlando (305) 423-7615 □ Georgia Col-Ins.-Co., Inc., Marietta (404) 422-8327 □ Illinois Carter Electronics, Inc., Chicago (312) 776-1601 □ Indiana Carter Electronics, Inc., Indianapolis (317) 293-0696 □ Maryland OED Electronics, Inc., Silver Spring (301) 588-8134 □ Massachusetts Datch Associates, Inc., Newtonville (617) 969-9710 □ Minnesota Carter Electronics, Inc., Minneapolis (612) 869-3261 □ Mississippi/Louisiana Col-Ins.-Co., Inc., St. Louis (504) 833-1116 □ New Jersey OED Electronics, Inc., Camden (215) 925-8711 □ New York OED Electronics, Inc., Mt. Vernon (914) 664-0080 □ J. A. Reagan Co., Inc., Albany (518) 489-4777; Binghamton (607) 723-9661; Newburgh (914) 561-4510; Syracuse (315) 471-7274; Utica (315) 732-3775; Rochester (716) 473-2115 □ North Carolina Col-Ins.-Co., Inc., Winston-Salem (919) 765-3650 □ Ohio WKM Associates, Inc., Cleveland (216) 885-5616; Dayton (513) 434-7500 □ Pennsylvania WKM Associates, Inc., Pittsburgh (412) 892-2953 □ Michigan WKM Associates, Inc., Detroit (313) 892-2500

# new

## HARDENED SERIES 54H CIRCUITS



- Dual type D Flip-Flop
- Quad 2-Input NAND Gate
- Dual 2-Input AND-OR INVERT Gate
- Dual 4-Input NAND Gate
- Quad 2-Input AND-OR INVERT Gate
- Two orders of magnitude more resistant to radiation environment
- Dielectrically isolated
- Thin film resistors
- Optimized device geometries
- Low Z mono-metallic metalization system
  - Aluminum interconnect
  - Aluminum die attach
  - Aluminum wire bond
  - Aluminum package posts
- Compatible with 930 Hardened DTL product line
- Full military temperature range
- Complies with MIL-STD-883
- Off-the-shelf delivery

You get the BEST IC for the job from Radiation's fast expanding hardened circuit line.

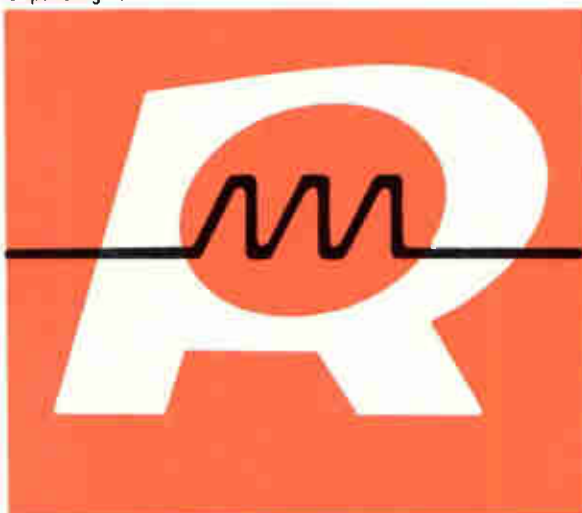

P. O. Box 476, Lexington, Massachusetts 02173  
Area Code 617, 862-1055

600 Old Country Road, Garden City, New York 11530  
Area Code 516, 747-3730

2600 Virginia Avenue, N.W., Washington, D.C. 20037  
Area Code 202, 337-4914

P. O. Box 30667, Dallas, Texas 75230  
Area Code 214, 231-9031

6151 West Century Boulevard, Los Angeles,  
California 90045 • Area Code 213, 670-5432

260 Shendan, Palo Alto, California 94306  
Area Code 415, 321-2280

P. O. Box 37, Melbourne, Florida 32901  
Area Code 305, 727-5430

**RADIATION**  
INCORPORATED  
SUBSIDIARY OF HARRIS-INTERTYPE CORPORATION  
MICROELECTRONICS DIVISION

# SO WHO NEEDS 8 WATTS OF LEVELED RF?

Anyone involved with varactors, transmitters, amplifiers, high-loss devices or non linear networks, that's who. Eight watts of swept RF enables you to test frequency response of high-power components, circuits, or black boxes at, or close to their actual operating levels. There are four Telonic Sweep Generators (Series PD-B) that will provide a **minimum** of 8 watts leveled, swept RF output and up to 40 watts at certain frequencies, available right from the front panel. There's no need to extrapolate test results obtained with low power instrumentation.

The PD-B sweepers also feature automatic overload protection to prevent damage to the power oscillator and a facility for leveling the output externally.

Other specs—  
Frequency range: 20 MHz-1000 MHz  
(varies with model)  
Sweep Width: 0.2-15%  
Modes: Swept and modulated RF  
CW and modulated CW

**FREE—CATALOG 70A CONTAINS ALL SPECIFICATIONS AND A USEFUL SECTION ON SWEEP GENERATOR APPLICATIONS. SEND FOR YOURS.**

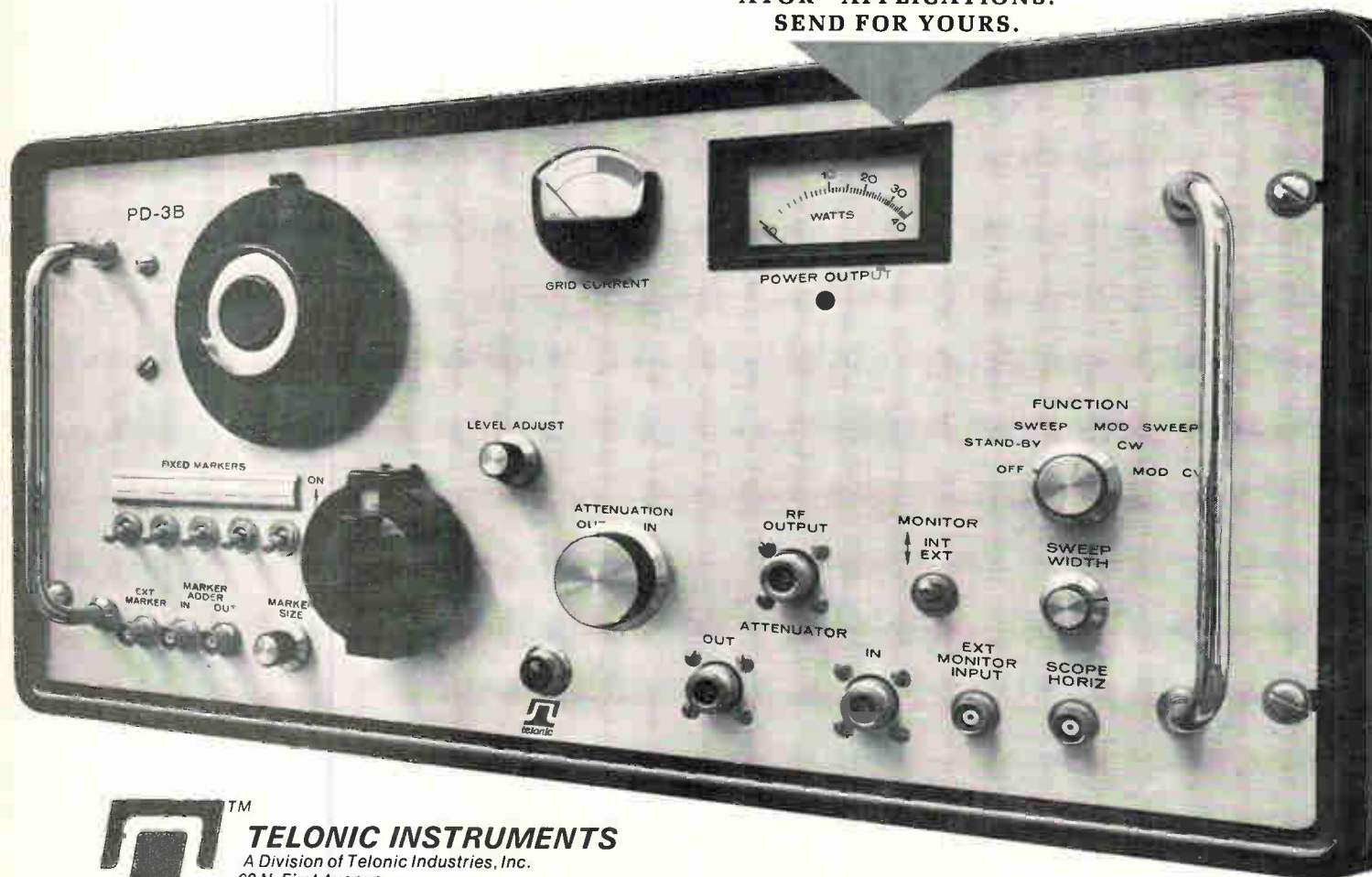

**TELONIC INSTRUMENTS**

A Division of Telonic Industries, Inc.  
60 N. First Avenue  
Beech Grove, Indiana 46107  
Tel: 317 787-3231 • TWX 810 341-3202

Circle 70 on reader service card

# new

## PLATED-WIRE, HARDENED SENSE AMP

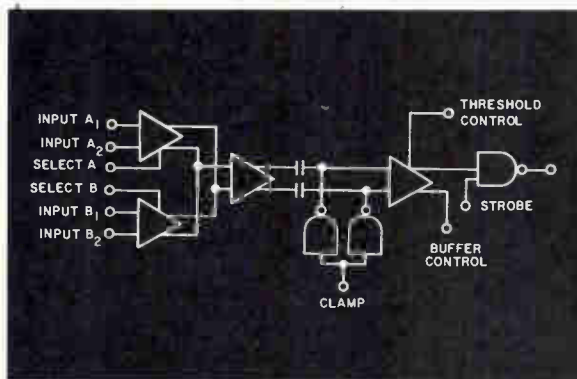

- The first application of linear and digital technology in one monolithic subsystem
- The RA-2540 system in a single chip performs the functions of a hardened differential amplifier and a hardened voltage comparator
- 1 mv signal sensitivity in high noise environment
- 10 ns access time
- Internal D.C. restoration
- Selectable dual channel
- Hardened
  - Photo current compensation
  - Dielectric isolation
  - Thin film resistors
  - Advanced device design
- Complies with MIL-STD-883
- Off-the-shelf delivery

You get the BEST IC for the job from Radiation's fast expanding hardened digital line.

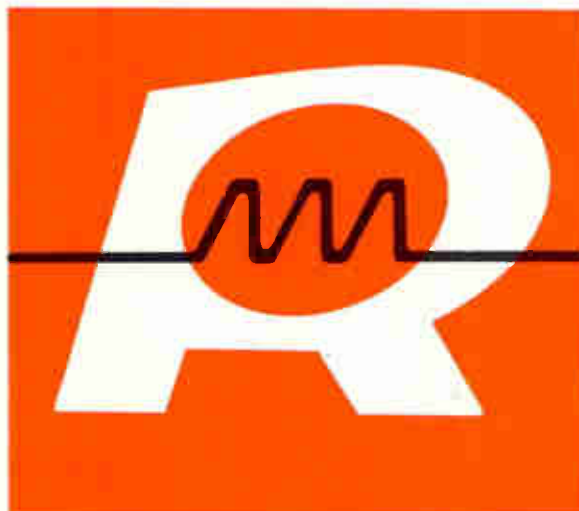

P. O. Box 476, Lexington, Massachusetts 02173  
Area Code 617, 862-1055

600 Old Country Road, Garden City, New York 11530  
Area Code 516, 747-3730

2600 Virginia Avenue, N.W., Washington, D.C. 20037  
Area Code 202, 337-4914

P. O. Box 30667, Dallas, Texas 75230  
Area Code 214, 231-9031

6151 West Century Boulevard, Los Angeles,  
California 90045 - Area Code 213, 670-5432

260 Sheridan, Palo Alto, California 94306  
Area Code 415, 321-2280

P. O. Box 37, Melbourne, Florida 32901  
Area Code 305, 727-5430

**RADIATION**  
INCORPORATED  
SUBSIDIARY OF HARRIS-INTERTYPE CORPORATION  
MICROELECTRONICS DIVISION

# HELIAX ELLIPTICAL WAVEGUIDE

twelve  
ways  
to  
beat  
the  
clock...

by eliminating planning and installation complications of rigid waveguide . . .

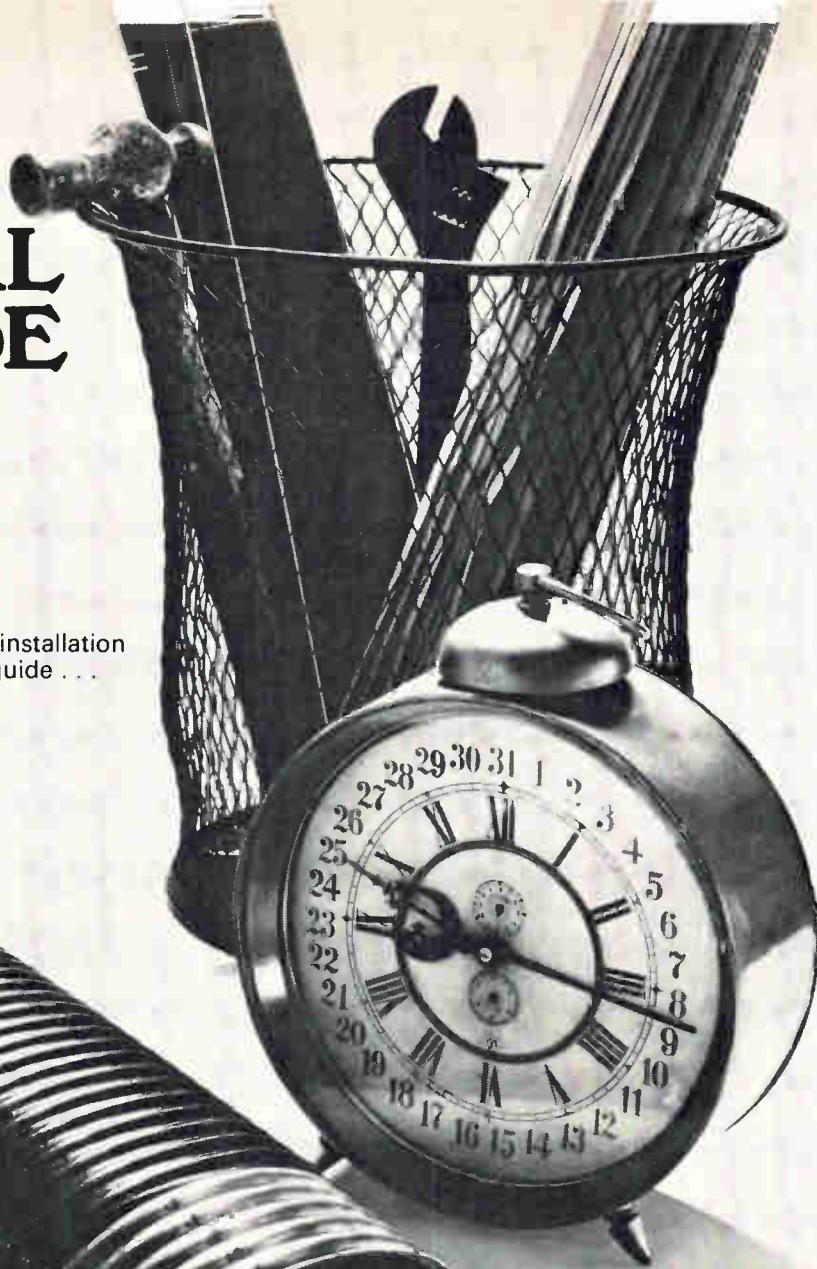

Yes, we have twelve sizes of HELIAX® elliptical waveguide for the microwave spectrum: 10 in stock, 2 more soon. Coverage from 1.7 to 15.2 GHz.

Andrew's unique corrugated construction makes the difference.

Makes HELIAX copper waveguide stronger, more flexible. Long continuous lengths are easily fitted to your layout. You save time and money all down the line. Wouldn't you like to know more? Communicate with Andrew.

10-68

 **ANDREW**

CONTACT THE NEAREST ANDREW OFFICE OR ANDREW CORPORATION, 10500 W. 153rd STREET, ORLAND PARK, ILLINOIS 60462



# Washington Newsletter

September 29, 1969

## First RFP due on Navy computer . . .

A request for proposals to make functional design studies for the arithmetic and control portions of the Advanced Avionic Digital Computer (AADC) is coming from the Naval Air Systems Command. The move is the first formal step toward development of a single, programable, modular computer for all Navy aircraft by 1980-85 [*Electronics*, July 21, p. 53]. The push for "a single computer design meeting all foreseeable airborne processing and control requirements" evolved after the command found it had 300 computer systems in various R&D stages during the past two years. A packed pre-bid briefing was held Sept. 15th in Washington, however, that a firm fiscal 1971 commitment to proceed with the estimated 5-year, \$10 million R&D effort is still pending even though the program has received strong support from the Chief of Naval Operations.

In the upcoming RFP, the Navy will ask, among other things, for built-in test and performance monitoring; interprocessor communications to permit memory sharing, fixed and variable microprogramming, and more than 100 instructions in the control area. Operation time goals range from 1 microsecond for fixed add to 6  $\mu$ sec for floating point divide. The contractor is to provide his best estimate—i.e. gate count—for each defined functional block using a representative semiconductor technology. The greatest risk areas in the program will be in LSI technology cost and yields and in software.

## . . . suggests that industry may have a better idea

The possibility that industry may have a better idea for the Advanced Airborne Digital Computer design will be covered in the upcoming RFP. It will state that a contractor can propose an alternative approach provided it represents "a significant improvement" over the Navy's minimum system and that the firm would grant the Government "an exclusive, royalty free license" to all concepts and designs. The minimum Navy design, using LSI and functional modularity, calls for reducing system size by a factor of five and costs by a factor of 20 over present systems while increasing mean time between failure by a factor of 10.

Navy project officials now lean toward the use of a multiprocessor with floating executive control and a yet-to-be-determined number of task memories.

Hughes Aircraft may have a leg up on potential competitors for the proposed system with an advanced wafer technology it plans to disclose later this fall. With 3-inch diameter wafers, double the size of existing industry slices, Hughes has interested AADC project officials in the idea of developing modules 4-inches square and 1-inch thick, each containing 5,000 gates.

## Medical electronics standards face slow going

Industry obviously would rather write its own standards for medical electronics equipment than get them from the Government. But despite the hue and cry over the need for such guidelines, neither the industry nor the Nixon Administration is breaking any speed records in this area.

Some 15 different bills covering premarket device testing and controls are pending before Congress but Capitol Hill observers don't feel any of these bills are likely to pass in this session. The Administration hasn't taken a position despite the loud noises from Presidential consumer affairs advisor Virginia Knauer. The EIA maintains it is mounting a "substantial" effort to set safety, performance and compatibility standards for medical devices with its new health care electronics section. But

---

# Washington Newsletter

---

there's an apparent general lack of concern by the industry, which feels there is plenty of time and no immediate threat of tough standards being forced on them by Government.

One bill, however, is drawing the industry's close attention—Sen. Mark Hatfield's (R.-Ore.) S-1801, which would create an independent Federal Medical Evaluations Board to set standards and require premarket testing of such equipment as diathermy machines, lasers, defibrillators, pace-makers and electroshock instrumentation.

## Emission standards set on the safe side

Look for microwave oven makers to complain about HEW's proposed emission standard of 1 milliwatt per square centimeter as measured five centimeters from the oven's external surface for three seconds. Industry's present guide is 10 mw/cm<sup>2</sup>.

Scientists at the Symposium on Biological Effects and Health Implications of Microwave Radiation at Richmond, Va., maintained that such a standard is necessary because not enough is yet known about the effects of microwaves on humans. The joint Government-industry committee which must approve HEW's standards also leans toward the safer standard, but would like to get more data not only on microwave hazards but also on what oven design changes would be needed for compliance and how long they would take.

Meanwhile, cold cathode tubes used in high schools and universities will be put under the Radiation Control for Health and Safety Act of 1968 before the end of the year. The tube standards will probably fix the maximum X radiation dosage at 10 milliroentgens per hour at 30 cm.

## Outlook uncertain for "quiet" spy craft

The Advanced Research Projects Agency's "quiet" airplane program, being developed primarily for the Vietnam war, appears to be in trouble and may be headed for the scrap heap. Word is the Lockheed-built YO-3A is suffering heavy cost overruns. Adding to its problems is the likelihood that production versions of the craft won't be ready in time if the U.S. pulls most of its force out of Vietnam in the next two years.

Two prototypes are now flying in Vietnam. Like the U-2, it climbs to cruise altitude, shuts off its engines, and then glides to avoid detection. The craft, whose mission is to detect enemy movements at night, carries a heavy load of electronics, including side-looking radar, infrared detectors, and possibly low-light-level television. Electro-Optical Systems holds the sensor contract, which is said to be where the cost overruns are.

Originally conceived as a tri-service program, the YO-3A lost support of the Air Force because the services couldn't agree on the sensor package. The Air Force went to Cessna for a "quiet" version of its model 128 commercial craft, but Congress has demanded that the contract go out for competitive bidding. How this will be resolved is now unclear.

## Justice expands technology symposium

The Justice Department's third annual symposium on law enforcement science and technology will be larger than ever and represents the Nixon Administration's first big move to boost the use of electronics and other advanced technology in law enforcement. The question now is whether the White House will follow in the same manner with the money to support such work.

More than 100 technical papers will be presented at the three day affair beginning March 31 in Chicago. To be run by Illinois Institute of Technology's Research Institute, the meeting will cover operations research, surveillance and detection, sensors and security-intrusion systems, and information systems for use against organized crime.

# High efficiency / High reliability industrial and lab power supplies

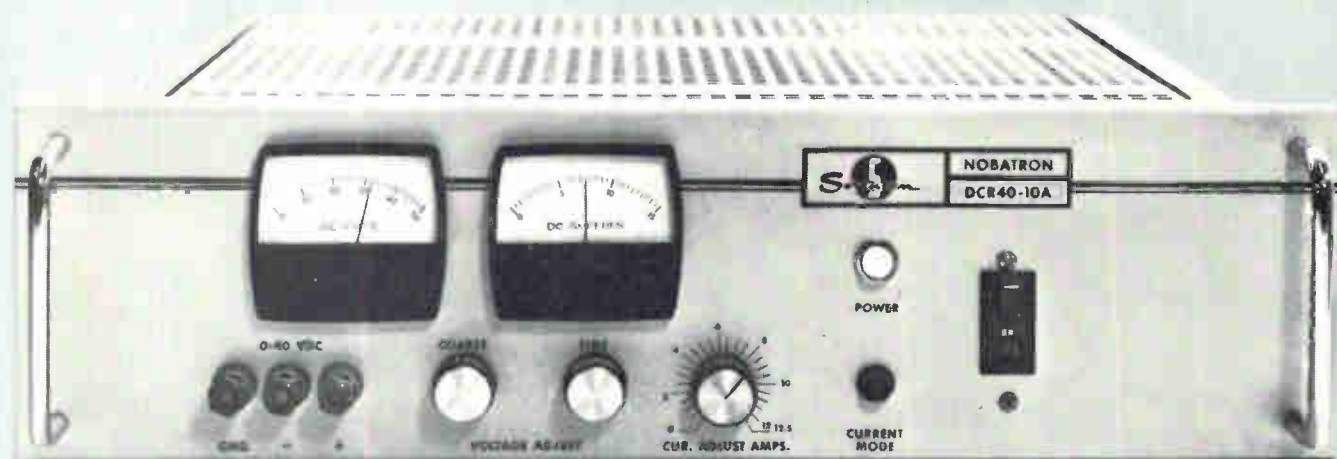

The DCR Series is composed of 34 models — 9 models with power levels of 400 and 800 watts are available, from stock, at 0-40, 0-60, 0-80, 0-150 and 0-300 Vdc in the 5¼" high package utilized by the model DCR 40-10A.

Other features include: ■ compliance with RFI specifications MIL-I-26600 and MIL-I-6181D ■  $\pm 0.075\%$  voltage regulation for line and load changes combined ■ voltage and current regulation with auto-

matic crossover ■ adjustable current limiting with automatic recovery ■ optional overvoltage protection ■ remote sensing and remote programming.

For more information contact your local Sorensen representative or; Raytheon Company, Sorensen Operation, Richards Avenue, Norwalk, Connecticut 06856.

Tel: 203-838-6571;  
TWX: 710-468-2940;  
TELEX: 96-5953

**RAYTHEON**



Circle 200 on Inquiry Card

On the left you see the HP 5323A Automatic Counter at work in a system. On the right is our HP 5325B Universal Counter, making a hard test easy.

The counters could easily be reversed. Because both are programmable and with either of them you can count up to 20 MHz in a system or on your bench. The one you choose depends on what you need.

The Automatic Counter has automatic range selection from 0.125 Hz to 20 MHz. And it needs no switching from frequency measuring mode for high frequency measurements to period measuring mode for accurate low frequency measurements. That's because all measurements are made in the period mode, and internal

computing circuits invert the period measurements to frequency. Thus you get the speed and accuracy benefits of period measurements at low frequencies coupled with the convenience of direct readout in frequency at all frequencies. There's no accuracy penalty at any frequency. The 5323A has a score of other advantages built in. For instance, it can automatically measure the carrier frequency of pulsed signals. Some people buy the 5323A for bench and production line use because its simple, automatic operation and direct readout in frequency reduce errors, even with untrained users. It even keeps tabs on the user by refusing to display more digits than it should for a given measurement speed. For easy use in systems, it's programmable, of course.

## These two counters make systems run smoother.

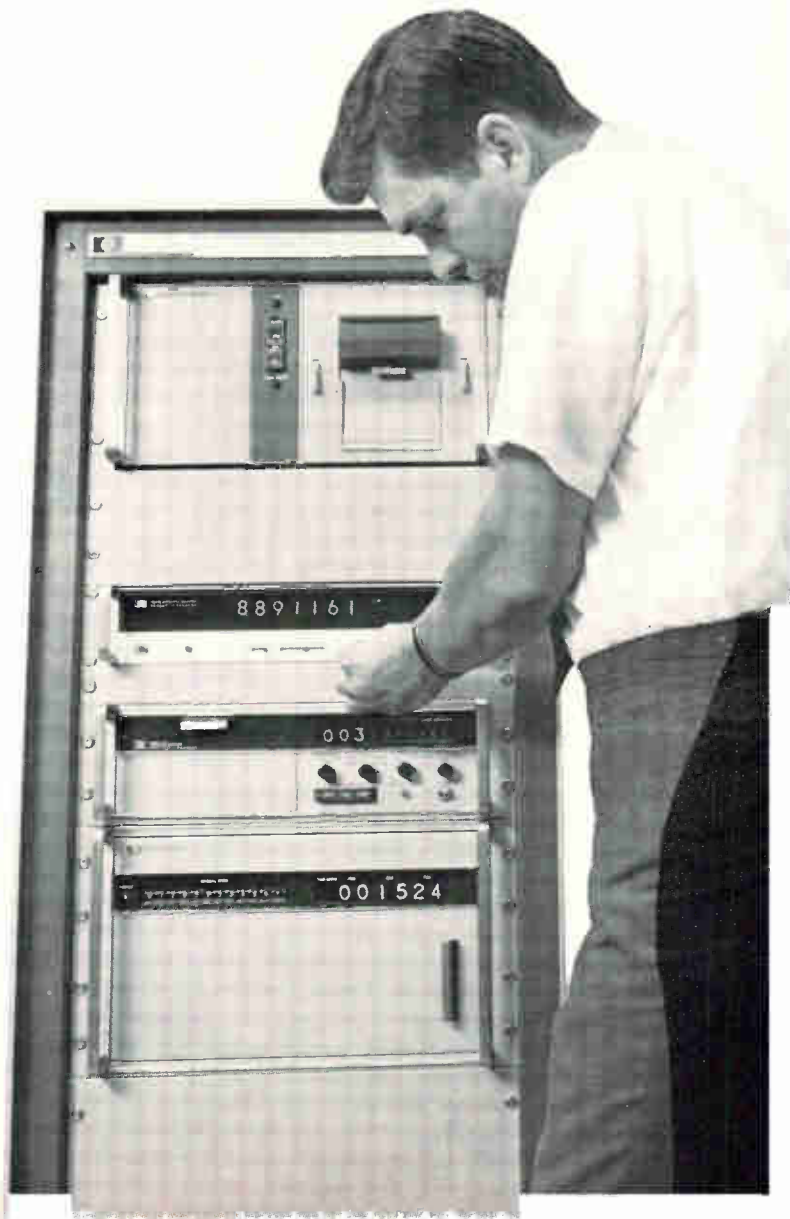

The Universal Counter is even more versatile but is less automatic. It will measure frequency to 20 MHz, time intervals from 100 ns to 10's, and period, multiple period, ratio and multiple ratio. It will totalize input events or scale an input frequency. Time interval stop and start signals can be from common or separate inputs, with separate trigger-level, slope and polarity controls for each. And its very narrow trigger-level threshold band, less than 1.0 mV, prevents false counts when the trigger level setting is marginal. In addition, the Universal Counter generates two types of oscilloscope markers. These not only mark the start and stop points of a measured interval, but can also intensify the entire measured segment. For easy use in systems, it's

programmable, of course. The cost of this versatility for either system or bench use is \$2150 for the 5323A and \$1300 for the 5325B. Your local HP field engineer has all the details. So give him a call. Or write to Hewlett-Packard, Palo Alto, California 94304; Europe: 1217 Meyrin-Geneva, Switzerland.

**HEWLETT**  **PACKARD**  
ELECTRONIC COUNTERS

Circle 77 on reader service card

## And tests run faster.



**Now we're in the memory business.  
And here's a bipolar scratch pad**

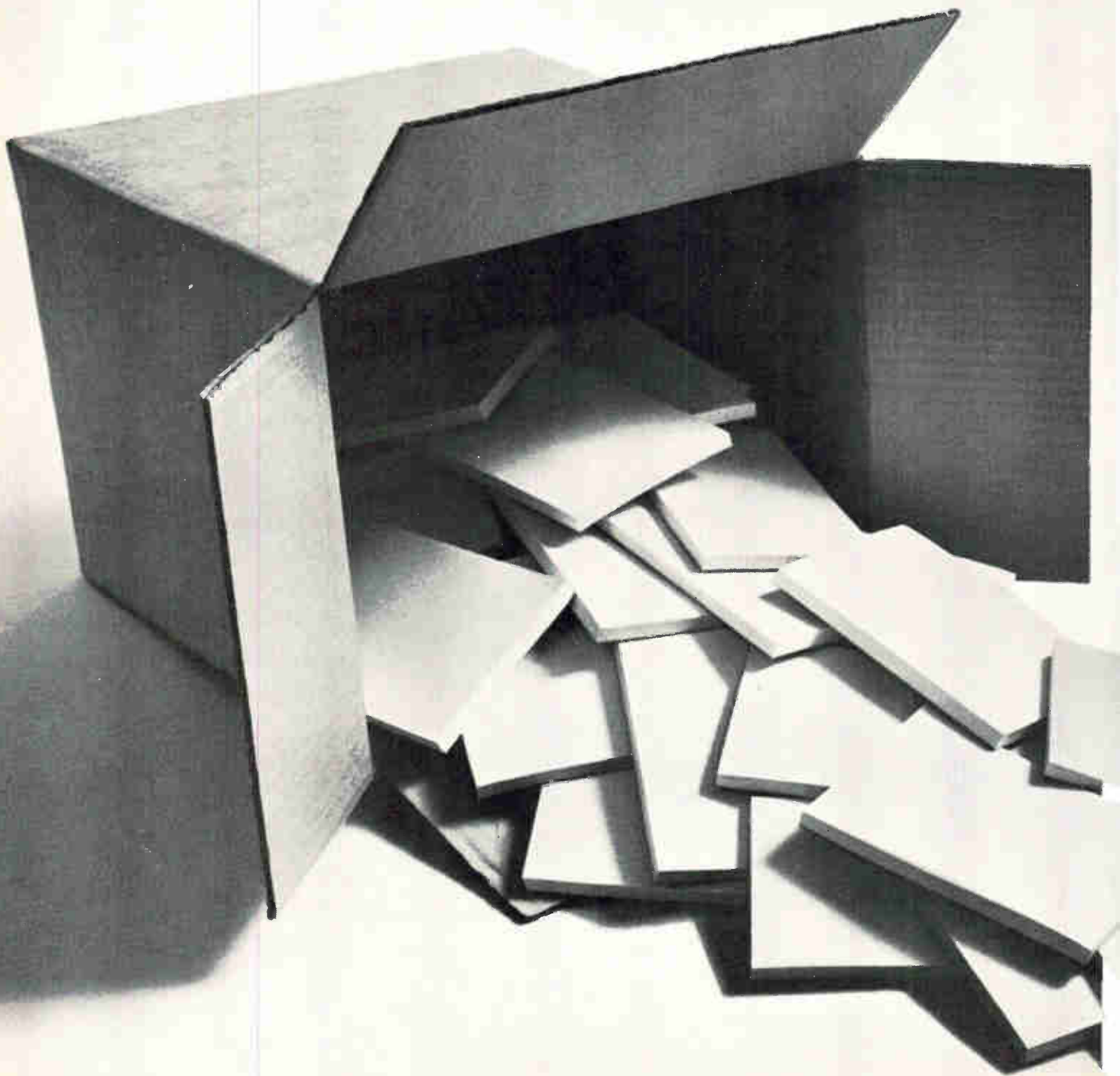

# to help you remember.

Anyone with half an eye can see the bright future of the semiconductor memory business. And for months Raytheon's been deploying to nab a lion's slice of that action. We herded up all the processing niceties of our high-rel military components. All the 10th-mil-tolerance magic of our Ray III TTL. All our way-out beam-lead technologies. And now we're in the business.

Leading off with our spanking new 64 bit bipolar RAM. We guarantee a 45 nanosecond read time, but it usually coughs up a word in under 35 ns. And the entire chip, including on-chip address decoding, write and sense circuitry, perks along on only 350 mW. Cost per 100-999 is \$51.50 ( $-55^{\circ}$  to  $+125^{\circ}\text{C}$  version) and \$38.00 ( $0^{\circ}$  to  $+70^{\circ}\text{C}$ ). Available now, off distributors shelves, in a 16-lead DIP. Flatpacks coming up.

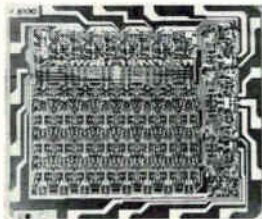

What else? Before the end of the year, look for beam-lead 256-bit and 512-bit multi-chip arrays in 24 pin DIP packages.

And by next June, a monolithic beam-lead 256-bit bipolar scratch pad in a 16-pin DIP. With super-quick access times, thanks to far tighter tolerances and new cell designs. Plus Schottky barrier diodes, washed emitters and like that.

Then in 1970 we'll be unveiling a line of IC read-only memories. And after that it's just a little time until we're mainly in the mainframe memory business.

All of which proves you better keep us in mind when you're in the memory market. The company that gets the ideas and delivers the goods. Raytheon Semiconductor, Mountain View, California. (415) 968-9211.



Circle 79 on reader service card

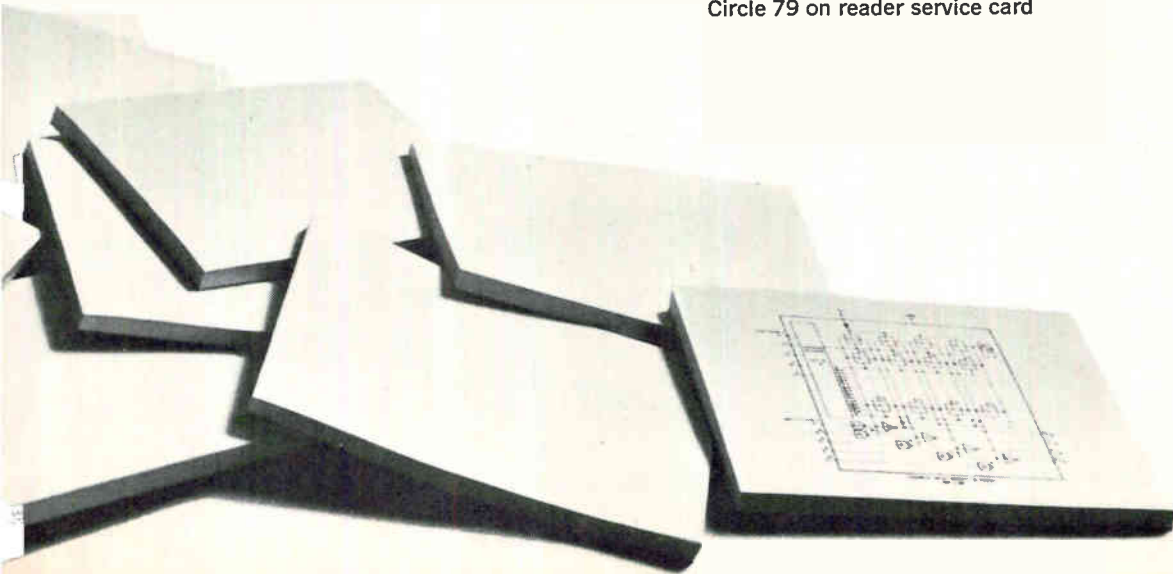

# Maintainability<sup>3</sup>

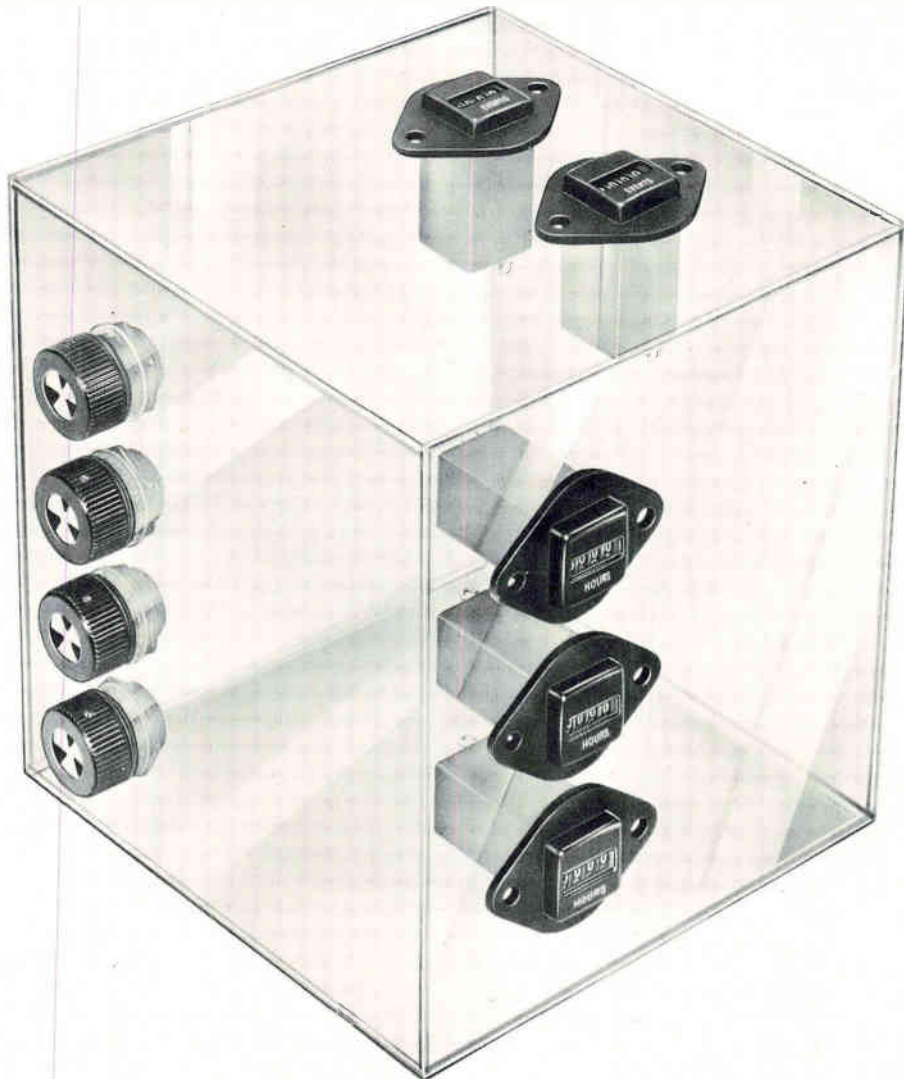

Systems maintainability is assured by Minelco's power of 3: BITE (Built in test equipment) indicators that pinpoint circuit faults, say GO or NO GO. Elapsed Time indicators that tell you how long things have been going on. Events Counters that tell you how often they've happened. And Minelco is the exponent of the maintainability component. Miniature and subminiature—in a size, configuration, and type for every requirement—for *your* requirement. Minimize downtime... get up with the Big Time.



## MINELCO®

SPACE AND SYSTEMS DIVISION



GENERAL TIME

High Ridge Park, Stamford, Connecticut 06904

For information and specifications, contact our local representative:

Huntsville, Ala. (205) 883-0244 / Phoenix, Ariz. (602) 267-3916 / Palo Alto, Calif. (415) 326-4186 / San Diego, Calif. (714) 298-1121 / Orlando, Fla. (305) 851-1210 / Marietta, Ga. (404) 422-8242 / Berkeley, Ill. (312) 544-7400 / Indianapolis, Ind. (317) 925-3528 / Santa Monica, Calif. (213) 451-5711 / Wichita, Kans. (316) 683-7518 / Waltham, Mass. (617) 894-9165 / Bridgeton, Mo. (314) 731-3011 / Plainview, N.Y. (516) 681-8710 / Utica, N.Y. (315) 735-8341 / Columbus, Ohio (614) 231-4571 / Dayton, Ohio (531) 224-0728 / Devon, Pa. (215) 688-5157 / Fort Worth, Tex. (817) 335-4541 / Arlington, Va. (703) 525-1191 / Bellevue, Wash. (206) 454-7922.

**BITE INDICATORS • ELAPSED TIME INDICATORS • EVENTS COUNTERS • ROTARY SWITCHES • TRIMMER POTENTIOMETERS**





Applications Power\*

# HF DUAL FETs for wideband diff amps, and balanced RF circuits

**Wideband Differential Amplifier** Ideal for a preamplifier where high input impedance and low noise over a wide frequency range is desired. At 25 MHz the input impedance is approximately 250K in parallel with 3 pF.

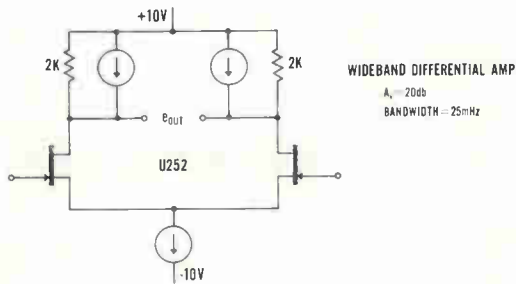

CHARACTERISTIC	SYMBOL	MIN	MAX	CONDITIONS
Transconductance	$g_{fs}$	5,000 $\mu$ mho		$V_{DG} = 10V$ $I_D = 5 mA$
Input Capacitance	$C_{iss}$		5 pF	
Offset Voltage	$ V_{GS1} - V_{GS2} $		10 mV*	
Differential Voltage Drift	$ V_{GS1} - V_{GS2} /\Delta T$		20 $\mu V/^\circ C$ *	

\* The U253 has an offset of 20 mV and a differential drift of 40  $\mu V/^\circ C$  Max.

**Balanced Mixer** The FET's square law characteristic allows this mixer to handle large dynamic signal power while producing low spurious products. Oscillator power drive requirements are extremely low, thanks to the FET's high input impedance.

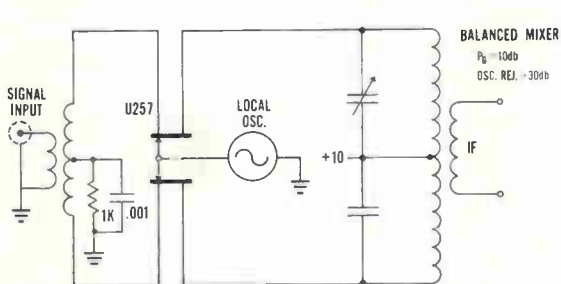

CHARACTERISTIC	SYMBOL	MIN	MAX	CONDITIONS
Transconductance	$g_{fs}$	5,000 $\mu$ mho		$V_{DG} = 10V$ $I_D = 5 mA$
Input Capacitance	$C_{iss}$		5 pF	
Offset Voltage	$ V_{GS1} - V_{GS2} $		100 mV	

These high frequency duals may be used up to 450 MHz depending upon the application and performance desired. If your present design situation is VHF or UHF, if you want instant applications information, call the number below. It's a direct line to our applications group. \*That's applications power.

... in Europe Siliconix Ltd.  
Siliconix House  
Stetty Park  
Saunders Way  
Swansea, U.K.



Our new address . . .

**Siliconix incorporated**

2201 Laurelwood Road • Santa Clara, Calif. 95054  
Phone (408) 246-8000 Ext. 201 • TWX: 910-338-0227

Announcing Digitest 500,  
the \$250 digital multimeter  
from Honeywell.

**No kidding. \$250**

This world's smallest multimeter may be inexpensive to buy, but that's the only thing cheap about it.

Take capability. Our Digitest 500 gives you five functions (resistance, AC and DC voltages, AC and DC currents), plus 17 ranges to choose from. And it can be operated from 117V 50-60Hz line or an external 12V source. Or consider accuracy: Digitest 500 is five times as accurate as the conventional VOM.

As you can see, we've made it both compact and lightweight (2½ lbs.) by using a large-scale integrated circuit. So the Digitest 500 is just 2¾" x 5" x 9", but has polarity indication, a moving decimal point, an overload indicator and built-in calibration check. Plus overrange up to 100% (on all ranges except 300VAC).

For more details, write Don Anderson, M.S. 206,  
Honeywell Test Instruments Division, P.O. Box.  
5227, Denver, Colorado 80217.

**Honeywell**

Circle 82 on reader service card



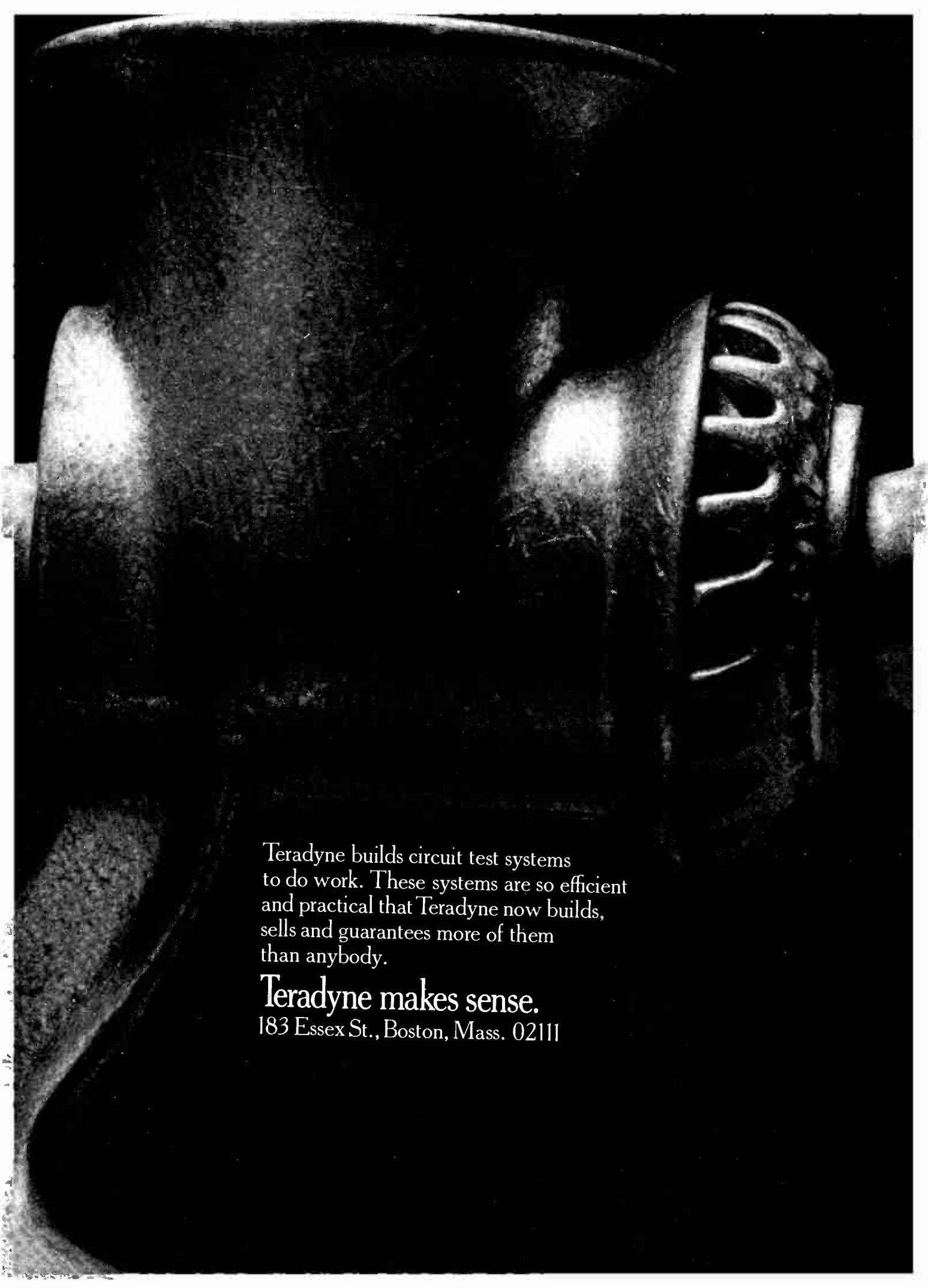

Teradyne builds circuit test systems  
to do work. These systems are so efficient  
and practical that Teradyne now builds,  
sells and guarantees more of them  
than anybody.

**Teradyne makes sense.**  
183 Essex St., Boston, Mass. 02111

# $\pm 50 \text{ ppm}/^\circ\text{C}$ in all Helipot Cermet Trimmers

This significant advance in Helipot's cermet technology is now available at only a dime/unit more . . . 100 ohms thru 2 megohms. In addition, you get essentially infinite resolution, environmental stability, reliability, no catastrophic failures — all superior to wirewound trimmers. We'll also deliver off-the-shelf, locally stocked trimmers with a standard tempco of  $\pm 100 \text{ ppm}/^\circ\text{C}$  in the 100 ohm thru 2 megohm range.

**Beckman**

INSTRUMENTS, INC.  
HELIPOT DIVISION  
FULLERTON, CALIFORNIA • 92634

INTERNATIONAL SUBSIDIARIES: AMSTERDAM; CAPE TOWN; GENEVA; GLENROTHES, SCOTLAND; LONDON; MEXICO CITY; MUNICH; PARIS; STOCKHOLM; TOKYO; VIENNA

# Technical Articles

---

**A faster generation of MOS devices with low thresholds is riding the crest of the new wave, silicon-gate IC's**  
page 88



Substituting highly doped polycrystalline silicon for the conventional gate's aluminum electrode cuts the MOS IC's threshold voltage to 0.4 volts, triples switching speed, and halves chip surface. Besides, the silicon technology is on a par and also is compatible with bipolar IC processing. IC manufacturers, tempted by these advantages, are looking into the process, and commercial products are emerging. The new-wave circuit on the cover is Fairchild's 3708 multiplexer; it's a silicon-gate version of a standard MOS IC and was built to demonstrate the superior performance achievable with silicon-gate technology.

**Curve fitter aids measure of rms by overruling square-law slowdowns**  
page 98

Making rms measurements both quickly and accurately can be done using an rms converter. This device, built with operational amplifiers, calculates the rms value of a signal in less than 300 milliseconds. It does so by first rectifying the input signal, squaring it with the help of a curve fitter, and finally averaging the square with an active filter.

**Feedback sharpens filter response**  
page 102

An op amp with positive and negative feedback results in a filter with good low-frequency skirt selectivity without using the large inductors and capacitors usually required to accomplish this at frequencies as low as 0.3 hertz.

**Self-adjustable bandpass filter picks off weak signal despite noise**  
page 104

Detecting weak signals in noisy environments is often quite difficult to achieve. Noise, whether man-made or caused by the elements, can mask a signal, making its detection difficult. But an active filter whose frequency response automatically adapts to the noise environment makes it easier to pick out signals.

**On the beam for sharp crt character displays**  
page 108

The usual methods for correcting character distortion in crt's are based either on a rigorous mathematical approach or on modifying the deflection yoke windings. However, a new method that empirically derives the necessary waveshape of the correction voltage requires little more than a function generator to approximate this sawtooth waveform.

---

## Coming

**How large a role for computers in MOS design?**

Computers are indispensable in cutting turnaround time on custom circuits from the logic equation stage to mask generation. That's the consensus of several firms whose views will be aired in a special staff report on EDP's role in designing complex MOS arrays.

# A faster generation of MOS devices with low thresholds is riding the crest of the new wave, silicon-gate IC's

In what may well be the technology's most startling change, highly doped silicon — not aluminum — is used as the gate electrode; the new technique lends itself to bipolar processing, say [Federico Faggin](#) and [Thomas Klein](#), engineers at Fairchild Semiconductor

● Unquestionably, the silicon gate is the new wave in MOS technology. And it's no secret that silicon-gate integrated circuits have lived up to their promise of great speed and low threshold voltages, with the latter making them compatible with bipolar IC's. Just how well this promise has been fulfilled is evidenced by the commitment both the Intel Corp. and Fairchild Semiconductor have made to the silicon-gate technique [*Electronics*, Sept. 15, p. 67]. In fact, Fairchild plans to use the technique in just about all of the company's new metal-oxide-semiconductor circuits.

Why is Fairchild so enamored with the silicon-gate technique? The answer, obviously, stems from several factors. But they all add up to this. The technique has already reduced threshold voltages to a mere 0.4 volt, it has tripled speed, and it has cut circuit area by as much as a half—thus more functions can be packed into a given chip area.

Aside from both present and future digital applications, the technique will be useful in making analog circuits for low-level input signals. But the most important application more than likely will be the marriage of MOS and bipolar transistors on the same chip. This marriage will come about because silicon-gate devices, with their protected gate oxide, can be exposed to high diffusion temperatures at almost any step in the process without risk of deterioration.

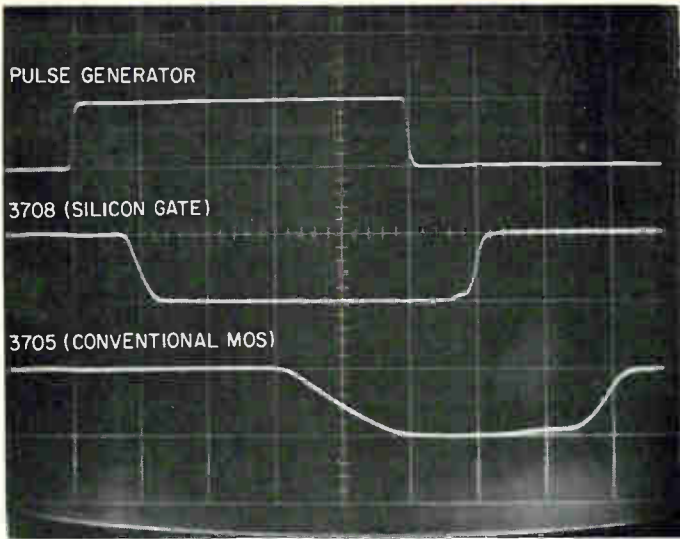

Waveforms: Control signal from the pulse generator causes the eight-channel multiplexer to switch channels. Switching occurs much more rapidly in the silicon-gate version of the multiplexer (3708) than in the conventional version (3705). Here, the IC's are switched from channel 7 to channel 8. Horizontal scale is 200 nsec per division; vertical scale is 5 volts per division. Test circuit is shown below.

In essence, the technique differs from the conventional approach in that the MOS IC is fabricated with polycrystalline silicon, rather than aluminum, as the gate electrode [*Electronics*, May 26, p. 49]. Both techniques are equal in terms of complexity—the number of masking steps are the same. Just why the silicon-gate technique hadn't been thought of earlier can be attributed largely to the fact that aluminum has always been the least troublesome part of MOS structures. Advances in the technology stemmed in large part from work on the dielectric and the semiconductor-dielectric interface, rather than on the aluminum. Moreover, poly silicon can't be wire bonded, and this probably contributed to the delay in considering the material. Researchers reasoned that an aluminum interconnection layer would still be needed.

Even when the first silicon-gate MOS devices were successfully fabricated, J. C. Sarace and his coworkers at Bell Telephone Laboratories who were doing the research apparently failed to recognize some of the most significant advantages of the structure. This was particularly true of the reduced threshold voltage and the higher component density. Fairchild entered the picture late in 1967, when it launched its silicon-gate research-and-development effort. And now, less than two years later, the company is going all out with the new technique.

### A rose by any other name . . .

Metal oxide semiconductors they're called, but metal oxide semiconductors they're not—at least, the newer "MOS" devices are not.

When the term first was coined, no one foretold the proliferation of surface-controlled devices and IC's that were to depart from the traditional structure of a semiconductor in which a metallic oxide serves as an insulating layer. These changes have been so radical that MOS no longer is exactly accurate. First, silicon nitride entered the picture as an alternative to silicon dioxide. Now, highly doped silicon has come along as a replacement for the aluminum-gate electrode.

A far more descriptive term would be conductor-insulator-semiconductor, or CIS. Though such a term comes closer to the mark, its chances of being picked up and popularized are so slim as to be almost non-existent. So entrenched is the term MOS in engineering parlance that it would be virtually impossible for it to be dropped. And as if adding insult to injury, silicon-gate circuits can be described mathematically with the same physical and electrical models as MOS circuits. Little wonder the term MOS will be around for a while.

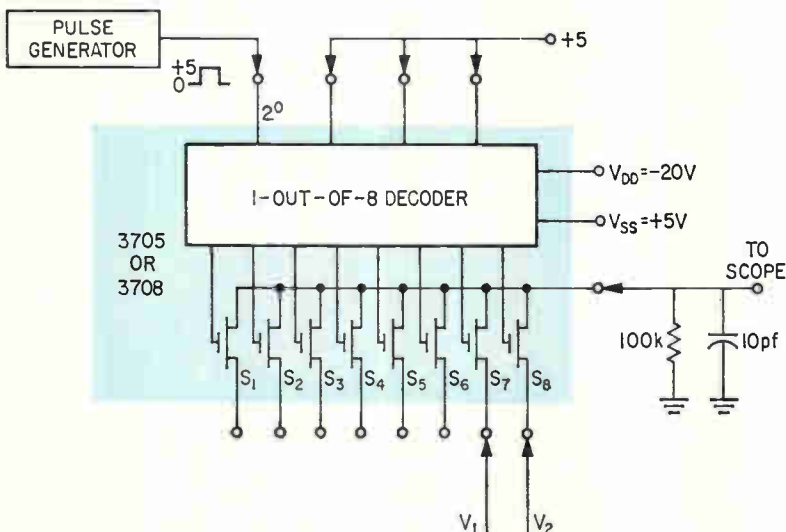

**... Another factor contributing to the small size is that separate masks are used to deposit the gate and the metalization in silicon-gate IC's ...**

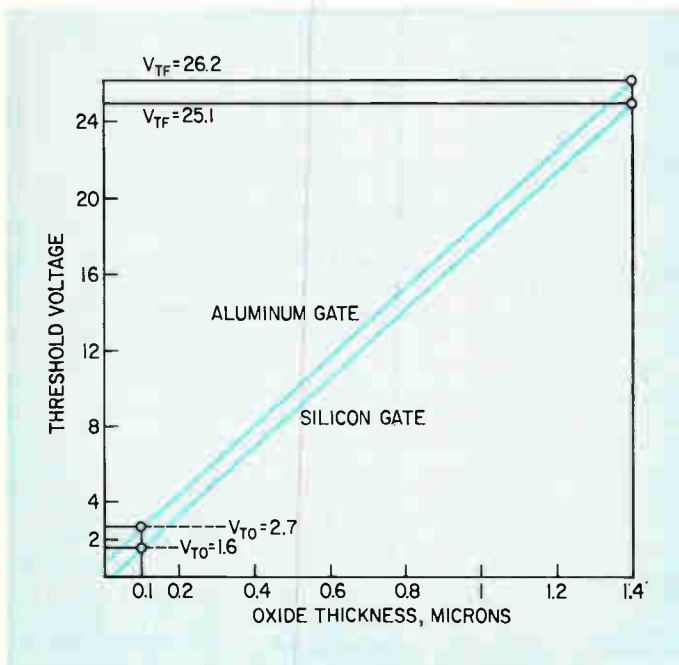

**Improvement.** Silicon gate gives lower threshold voltage for any oxide thickness: Moreover, it gives a higher ratio of parasitic threshold to device threshold ( $V_{TF}/V_{T0}$ ).

Strangely enough, what at first appeared to be major problems—obtaining a thin, smooth film of poly silicon so that contact could be made with the aluminum metalization, and preventing oxygen contamination of the gate during the boron diffusion that would prevent good contact with the aluminum metalization—proved, in the long run, not to be serious at all.

The low threshold voltage is traced to the silicon itself. It has a lower work function than aluminum, and it reduces the fixed surface-state charge,  $Q_{ss}$ —both of which strongly influence the threshold voltage,  $V_{T0} = (Q_{ss} + Q_B)/C_o - \Phi_{MS} - 2\phi_f$ , where  $Q_B$  is the bulk charge of the silicon,  $C_o$  is the dielectric capacitance (which is equal to  $k/x_o$ , the ratio of dielectric constant to the thickness of the dielectric),  $\Phi_{MS}$  is the work-function difference between the metal and semiconductor, and  $2\phi_f$  is the difference in Fermi potential between the inverted surface and the bulk of the semiconductor.

All other things being equal, the use of p-doped silicon for the gate will reduce  $V_{T0}$  by 1.1 volts from that of an aluminum gate.

The advantage of the silicon gate becomes even more apparent when the equation is simplified to a linear function of oxide thickness alone:  $V_{T0} = A_1 + A_2x_o$ , where  $A_1$  and  $A_2$  are constants for any given MOS structure.

With the conventional aluminum-silicon dioxide-silicon

**Shrinkage.** Conventional gate masks must allow for misalignment and therefore produce a transistor that's 50% wider than the self-aligning silicon-gate device.



## Comparison of basic parameters

	1-1-1 Si gate	1-1-1 conventional	1-0-0 Si gate	1-0-0 conventional
$V_{TO}$ , active device threshold voltage	1.5-2.0	3.5-5.0	0.4-1.2	2.0-3.0
$V_{TF}$ , parasitic device threshold voltage	25-40	25-40	10-17	10-17
$BV_D$ , drain breakdown voltage with gate grounded	29-33	35-45	29-33	35-45

structure,  $A_1$  is about 0.9 volt. But with the silicon-gate structure (silicon-SiO<sub>2</sub>-silicon),  $A_1$  is 1.1 volts lower or -0.2 volt. This means that with a typical gate-oxide thickness of 0.1 micron,  $V_{TO}$  is 2.7 volts for the conventional structure and only 1.6 volts for the silicon-gate structure as shown on opposite page.

Even more important is the effect of lower  $A_1$  on the ratio of thick-oxide to thin-oxide threshold voltages. Over the rest of the MOS chip, the oxide is made many times thicker than the gate oxide to minimize chances for parasitic MOS transistors. Typically, the thickness in this region is about 1.4 microns. With conventional MOS structures, the ratio of parasitic threshold to device threshold is 9.7. For the silicon gate structure, the ratio is 15.2. Thus, silicon-gate structures provide margins for operating voltages that are far more comfortable than what conventional structures provide. The figures given here are for 1-1-1 oriented silicon crystals. For 1-0-0 material, the difference is greater, as shown in the table above. The threshold voltage for resistance can be made as low as 0.4 volt.

How does silicon-gate technology result in more compact circuits and faster switching? Consider, first, the conventional process. Here, allowance has to be made for possible misalignment of the three masks used for the source-drain diffusion, gate dielectric growth, and gate-metal deposition. The cumulative alignment toler-

ances and sideways diffusion during gate oxidation create large source- and drain-junction areas, and—far more serious—create a large capacitance between gate and drain. This capacitance, caused by the necessary overlapping of the gate metal and the diffused regions, limits switching speed and is particularly evident when a high-dielectric-constant material (silicon nitride) is used as the gate insulator to obtain low threshold voltage.

Unlike the conventional structure, the silicon-gate structure aligns itself so that there's no need to allow extra area for misalignment. Source and drain regions are diffused after gate oxidation, so there's negligible sideways diffusion. The result is a device whose gate-drain feedback capacitance is negligible. Thus the device can be placed in an area only 2 mils wide, not 3 mils, illustrated below.

Another factor contributing to the small size is that separate masks are used to deposit the gate and the metalization in silicon-gate circuits, whereas the same mask is used in the conventional MOS process. In conventional circuits, there is a minimum spacing between gate and contact metal lines which is dictated by the resolution of the photolithographic process. This factor does not enter the silicon-gate picture.

The compactness afforded by the silicon-gate technology is clearly illustrated by the two-phase, dynamic

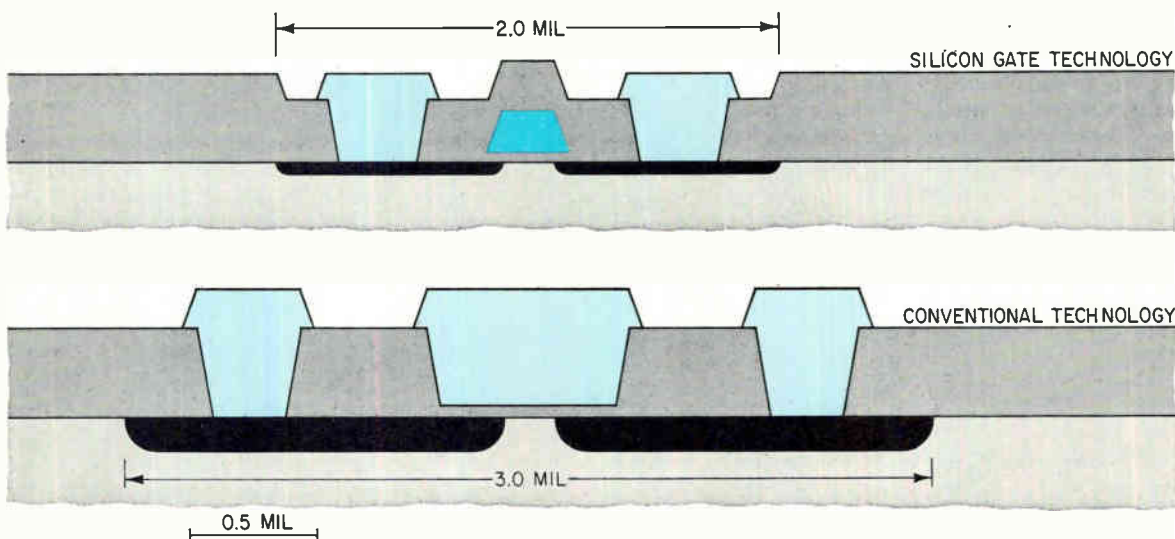

## So similar, yet so different

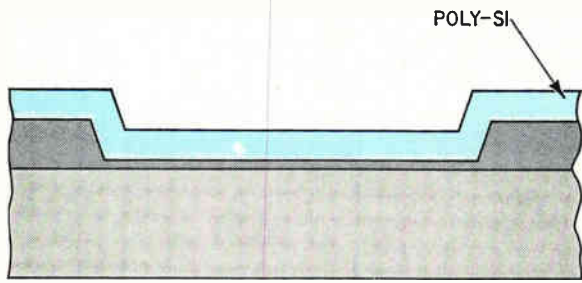

Oxide is grown and poly silicon is deposited.

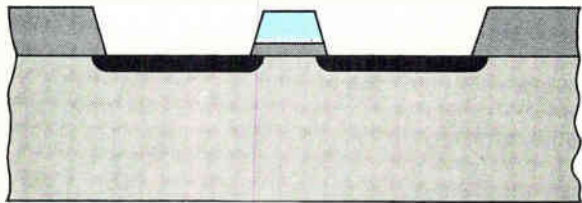

Boron is diffused, forming source and drain junctions.

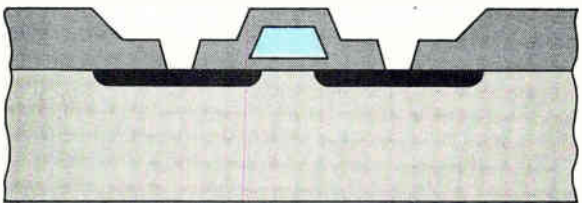

SiO<sub>2</sub> is deposited, windows for contacts are masked and etched.

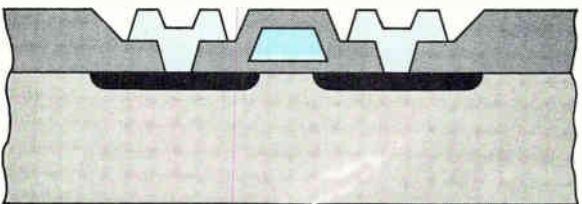

Aluminum is deposited, second interconnection plane is defined.

CROSS-SECTION

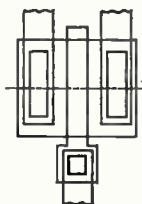
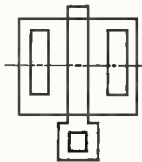
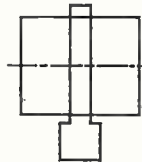
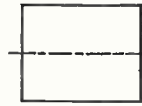

MASK

The conventional method of making MOS IC's starts with growing an oxide on the silicon wafer, and continues with diffusion of boron into the source, drain, and interconnection regions; removal of the thick oxide from regions where the gates are to be formed; growth of a thin thermal oxide in the gate regions under controlled conditions; opening holes in the contact areas; and metalizing the interconnection pattern.

Using silicon-gate technology, p-channel MOS IC's can be fabricated in four masking steps—the same number required in the conventional technology. The starting material, as shown at left, is an n-type silicon wafer; it is oxidized, and a window is etched for each MOS transistor. After this first masking step, the gate oxide is grown and a layer of polycrystalline silicon is deposited over the wafer (A).

The poly silicon layer is masked and etched to define the gate and the first interconnection plane. The gate oxide over the future source and drain is etched away. This is where the self-aligning feature of the silicon gate comes into play: it acts as a mask, preventing the gate oxide from being etched.

Next boron is diffused to form the source and drain junctions (B). Simultaneously, the silicon gate is doped p-type by the boron to give it low resistivity and provide the correct work-function difference.

Another layer of silicon dioxide is deposited, and windows for the source and drain contacts are masked and etched (C). Aluminum is then deposited over the entire surface, which is masked and etched to define the second interconnection plane (D).

The silicon gate process is much more flexible than the conventional one—because it is protected by the silicon and by more SiO<sub>2</sub>, the delicate gate oxide can be exposed to high temperatures after it is formed.

This brings out a major advantage of the silicon-gate process: It's more compatible with bipolar processes. Suppose MOS and bipolar transistors are to be fabricated on the same chip with the conventional process. If it's not to be destroyed or seriously deteriorated, the gate oxide must be grown as the last high-temperature step. This requirement severely limits the performance that can be obtained from the bipolar devices.

In silicon-gate circuits, however, subsequent processing won't affect the gate oxide. Shallow-diffused structures can be formed, as can bipolar transistors for driving current-sinking logic circuits. LSI will have the packing density of MOS and the speed of bipolar circuits.

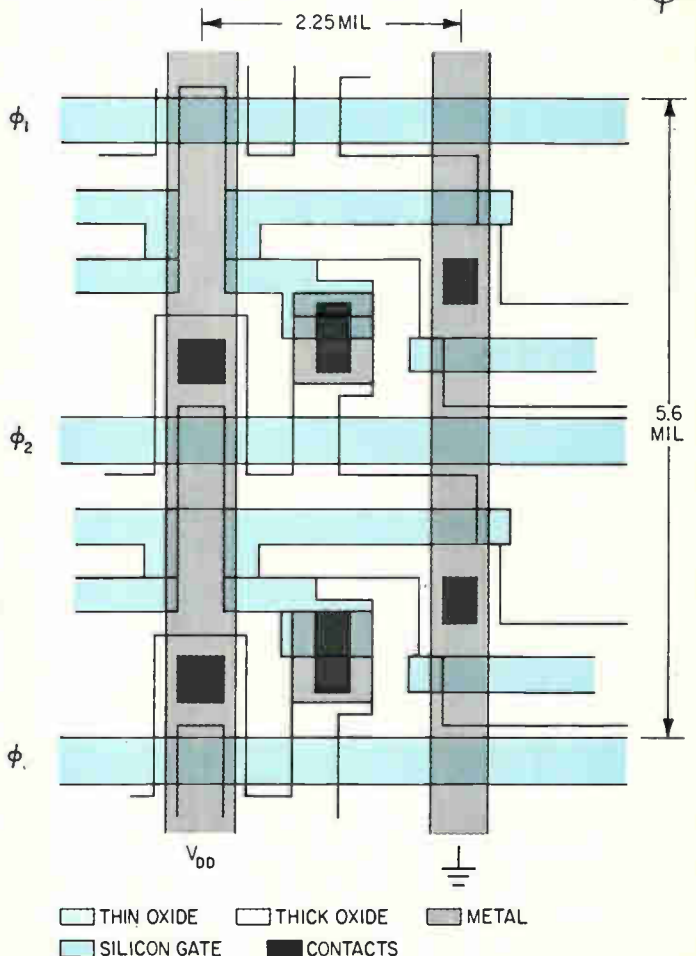
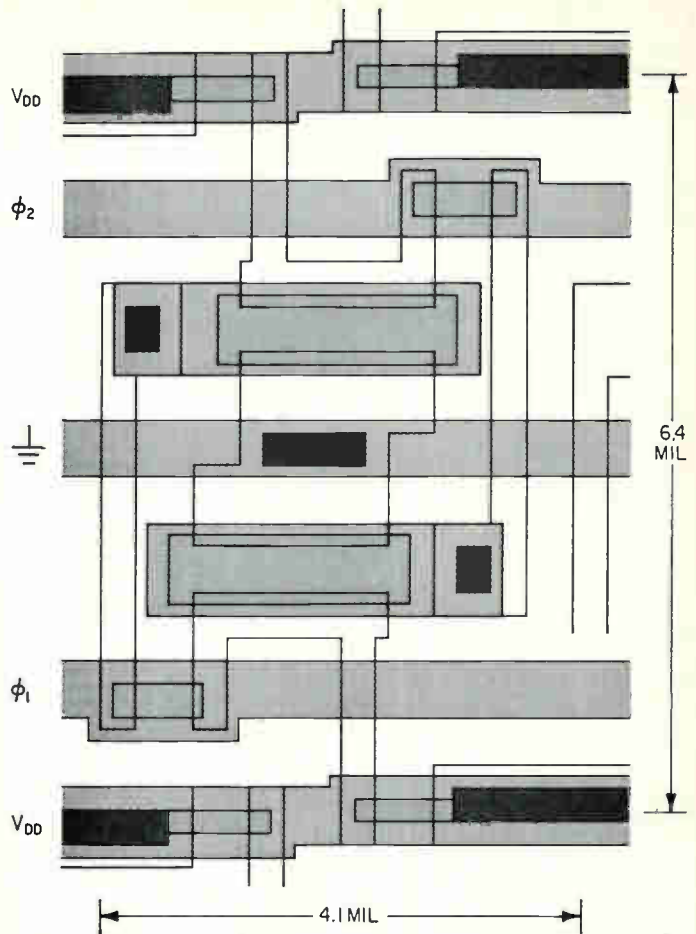
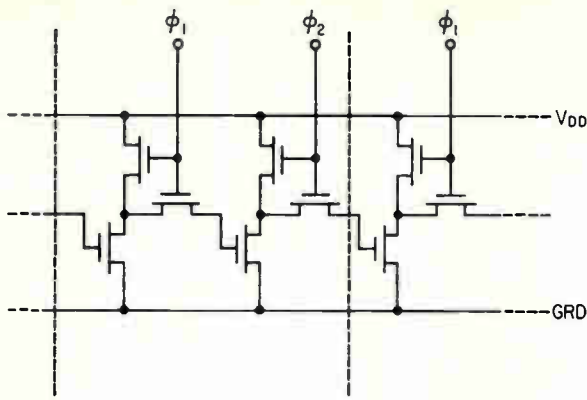

shift register circuit at right. With silicon-gate technology, the register requires an area measuring 2.25 by 5.6 mils. With conventional technology, which must take into account the typical 0.2-mil tolerance for misalignment, the circuit requires an area 4.1 by 6.4 mils. Obviously, the conventional layout is severely metal-limited, which isn't true with the new technology. The silicon-gate layout is enhanced by the two available conductive planes.

From a user's viewpoint, the silicon-gate circuit's lower-threshold and higher-speed advantages are obvious. But the size advantage isn't quite as clear. In the long run, the small area will mean lower costs. This saving stems from the fact that more circuits can be packed onto a wafer and processed simultaneously, and because for a given number of defects per wafer, proportionately fewer circuits are affected.

Contributing to this higher yield is a significant difference in the process sequence. With the new techniques, the gate oxide is well protected by the silicon gate and by a deposited  $\text{SiO}_2$  layer, so there is considerable freedom to use subsequent diffusion or other heat-treatment steps. In conventional MOS, on the other hand, the gate oxide is exposed until the final metalization. Because the gate oxide is thin and is critically located, the heat it can tolerate is severely limited and poor bipolar performance has to be accepted.

**Real estate:** Extra conductive plane provided by silicon-gate technique results in space saving over and above that given by the self-aligning feature. Conventional version of shift-register cell (top) occupies more area than the silicon-gate version (bottom) because more surface is needed for aluminum metalization.

## Comparison of multiplexer characteristics

	3705 (conventional)	3708 (Si gate)
Data channel on resistance, ohms	190	80
Maximum output leakage current, na	10	2
Data input leakage current, na	2	0.2
Output capacitance, pf	40	25.5
Data input capacitance, pf	7.5	4.5
Logic input capacitance, pf	5.5	2.5
Absolute maximum voltage at any pin	-35	-30

Fairchild has observed much higher yields in silicon gate circuits than in conventional MOS circuits whose function is identical, even when no attempt was made to exploit the smaller geometry of the silicon gate.

The circuits used for this comparison were the 3705, an eight-channel multiplexer switch with decoding logic and the 3708, a silicon-gate version of the same circuit with essentially the same geometry. The comparison of electrical characteristics in the table above is revealing; in almost every parameter, the silicon-gate version is superior.

The data-output channel on resistance, for example, is less than half that of the standard-gate IC because lower sheet resistivity in the p-diffused layers can be obtained with silicon-gate technology. This is because the boron-doped layers are not depleted by a subsequent reoxidation. In the interdigitated output buffers (eight are used in the circuit), the source and drain fingers therefore have less series resistance, and the output buffers therefore are more efficient.

The smaller input and output capacitances for the silicon-gate circuit are a direct result of the self-aligning gate.

And when it comes to switching speed, the silicon-gate version really shines. The silicon-gate 3708 responds to an output-enable control signal about three times faster than the standard-gate 3705. And the high

level is about 10% greater in the 3708 because of its lower on resistance. In channel-to-channel switching, too, the silicon-gate IC out-performs the 3705, as shown by the waveforms on page 89.

**As for reliability,** silicon-gate IC's present no problem. Breakdown voltage, for example, showed a slight downward trend in some silicon-gate units in a 200-hour life test of 20 units at 150°C at a bias of -25 volts. In no case, however, did breakdown voltage go below the lowest pre-test value (32 volts), and it was always well above the minimum rating of 25 volts. Under accelerated life testing at 300°C for five minutes with -15 volts reverse bias applied at input and output, the silicon-gate circuits have proven to be exceptionally stable with no failure on the six runs tested. On resistance and leakage current showed similar behavior. After the 200-hour operating life test, for example, on resistance exhibited a negligible change in distribution. ●

### Bibliography

J.C. Sarace, R.E. Kerwin, D.L. Klein, and R. Edwards, "Metal-Nitride-Oxide Field-Effect Transistors with Self-Aligned Gates," *Solid-State Electronics*, Vol. 11, 1968, p. 653.

F. Faggin, T. Klein, and L. Vadasz, "Insulated Gate Field Effect Transistor Circuits with Silicon Gates," presented at International Electron Devices Meeting, Washington, October 1968.

# Designer's casebook

*Designer's casebook is a regular feature in Electronics. Readers are invited to submit novel circuit ideas and unusual solutions to design problems. Descriptions should be short. We'll pay \$50 for each item published.*

## FET varies Q of tuned circuit by several thousand

By Gary A. Vander Haagen

Jodon Engineering Associates, Ann Arbor, Mich.

Many filters require a variable bandpass characteristic. This may be accomplished by adding a field effect transistor to the feedback loop of a tuned amplifier circuit—the FET acts as a variable resistance controlling the amount of feedback to the amplifier. Since the input resistance of the

amplifier is the load resistance of the tuned network, any change in this resistance will change the Q of the network.

The center frequency is set by the 100-kilohm potentiometer, and suitable varactor diodes are selected for the desired frequency range. Varying the 10-k pot changes the bias to the FET which controls the amount of positive feedback to the amplifier. The positive feedback voltage causes the amplifier's negative input resistance to change, thus altering the Q of the resonant circuit.

The integrated circuit wideband amplifier provides 25 decibels of voltage gain for frequencies to about 11 megahertz. For higher frequency ranges, an RCA CA3023 or equivalent IC amplifier can be used to extend the range to 30 Mhz.

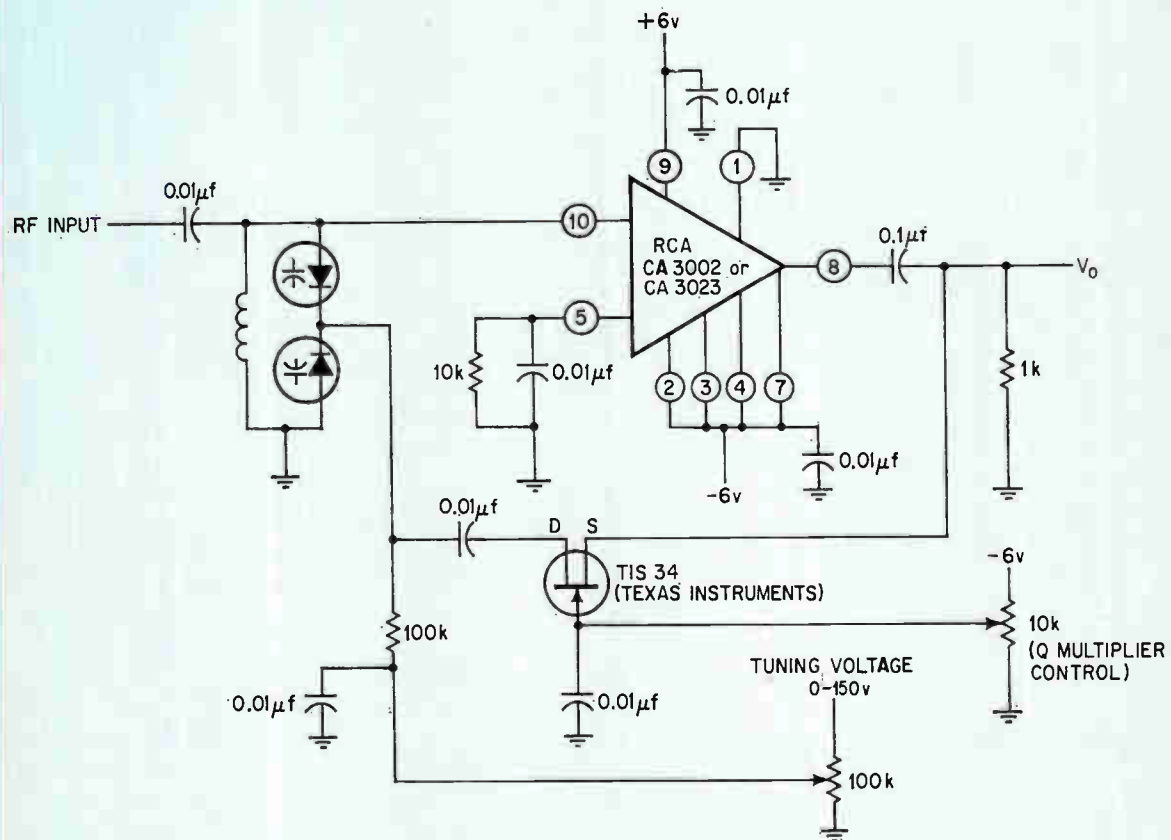

**Variable Q.** The field effect transistor provides a variable change in the negative resistance to the input of the amplifier, thus providing a varying degree of Q multiplication at frequencies in the megahertz range. The circuit, useful in r-f and i-f stages, offers Q's of several thousands.

## Retriggerable one-shots form delayed-key oscillator

By Alexander Liu

Fairchild Semiconductor, Mountainview, Calif.

In cathode-ray tube alpha-numeric display systems, it is desirable to have an oscillator that starts at a preset time after the arrival of a trigger pulse, then generates a predetermined number of clock pulses, and then shuts down until the next trigger. One such circuit, known as a delayed-key oscillator, accomplishes this with several integrated components: retriggerable one-shots, a binary counter, a flip-flop, inverters, and NAND gates.

A master reset pulse resets both the binary

counter and the flip-flop and triggers the first one-shot multivibrator. The output of the multivibrator is delayed by amount  $t$ , which is determined from the equation:  $t = 0.32R_1C_1(+0.7/R_1)$ , where  $R_1$  is in kilohms,  $C_1$  is in picofarads and greater than  $10^3$ pf, and  $t$  is in nanoseconds. The inverted output,  $\bar{A}$ , of the one-shot sets the latch made up of two dual-input NAND gates, while the A output triggers the second one-shot.

Since a sample of the output from the second one-shot is fed back to its input, the one-shot becomes a free-running oscillator with a frequency given by  $f = 10/(t+50)$  hz, where  $t = 0.32R_2C_2$  ( $1+0.7/R_2$ ) and  $C_3$  provides a variable duty cycle for the oscillator. The output of the oscillator is connected to a binary counter that, after the 15th pulse, furnishes an output at the TC terminal as indicated by waveform C. The falling edge of the pulse resets the latch, which then gates the oscillator off.

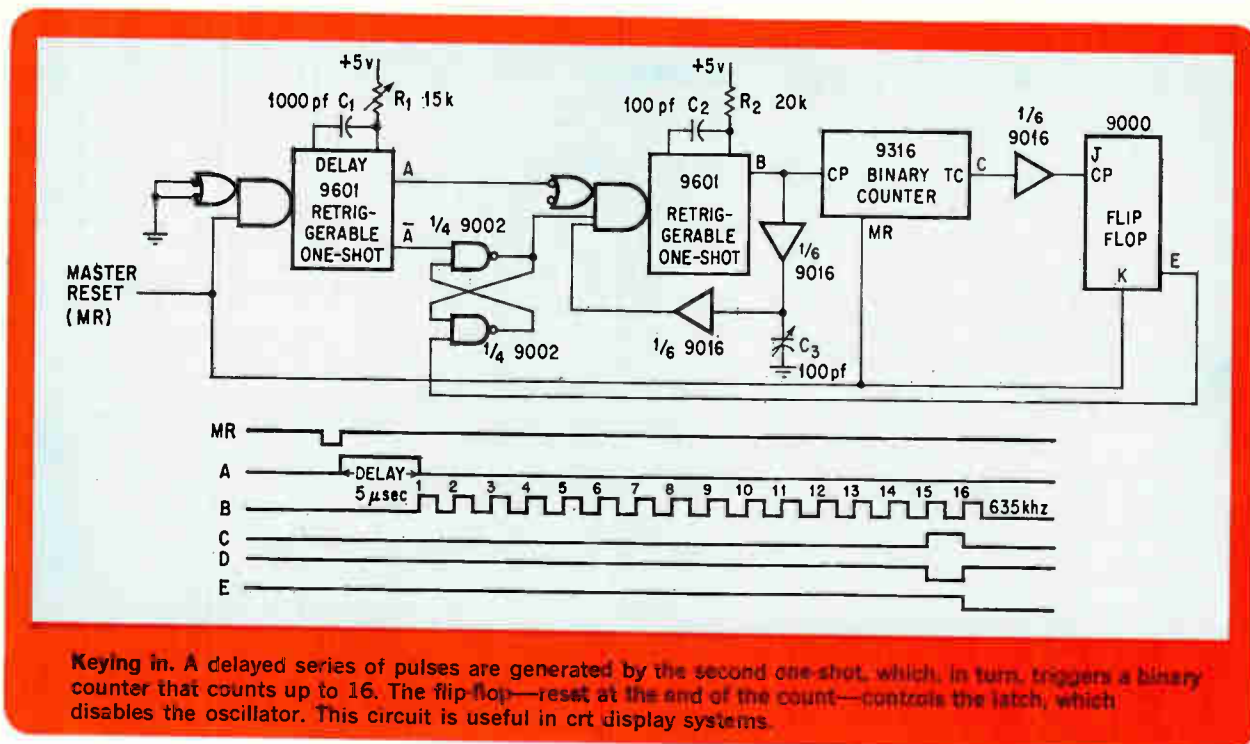

## Single transistor divides frequency in avalanche mode

By Alessandro Moiraghi

University of Milan, Italy

Though rarely used in transistor circuits, the transistor avalanche mode of operation can often lead to much simpler circuit designs: for example a relaxation oscillator which operates with small supply voltages. The oscillator can be built to operate as either a frequency divider or a low-output impedance voltage generator.

The supply voltage charges the capacitor to the

transistor's breakdown voltage with a time constant RC. The avalanche is triggered by positive pulses delivered to the transistor's base which allows the capacitor to discharge rapidly through the transistor and resistor R<sub>2</sub>. A fast-rising pulse is generated at the output and can be coupled to the transistor of the next stage through a resistor.

The division ratio depends upon RC and the input-pulse amplitude.

The period of the divider can be adjusted by changing the input amplitude and the value of the coupling resistor from the preceding stage.

The thermal stability of the divider is affected by the value of r. The circuit is stable between -35°C and +60°C for r=10 ohms as long as each stage's division ratio is not greater than 6.

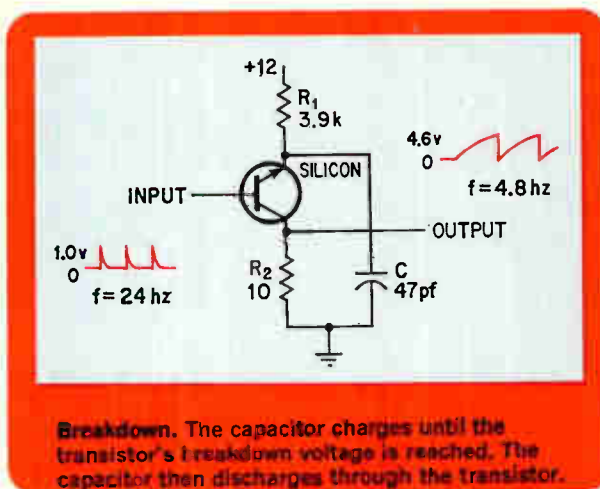

## Nomograph simplifies finding one-shot's pulse width

By Marvin W. Walczak

Westinghouse Defense and Space Center, Baltimore, Md.

There are times when only a nomograph will do for obtaining the pulse width of a one-shot multivibrator's output. Most engineers are familiar with the equation,  $t = 0.65R_T C_T$ , for pulse width where R<sub>T</sub> and C<sub>T</sub> are the timing resistor and capacitor in ohms and farads, respectively. But the relation becomes considerably more complicated if an additional component must be inserted in series with one of these, and the nomograph shown here can save the large amount of time needed to calculate the new time constant.

If the one-shot isn't sufficiently decoupled from the power supply, large negative voltage spikes can be introduced into the supply bus during transitions—as much as 4 volts in a 6-volt supply. By inserting, for example, about a 1-kilohm resistor in series with the timing capacitor, the circuit can be effectively isolated from the supply bus with little effect on the one-shot's recovery time.

The timing equation now becomes:

$$t = -(R_1 + R_2) C_T \ln \left( 0.52 + 0.52 \frac{R_2}{R_1} \right)$$

where R<sub>2</sub> is the additional resistor, and R<sub>1</sub> is the main timing resistor ( $R_1 + R_2 = R_T$ ).

Instead of solving the lengthy equation for t, the nomograph can be used in the following way. Align the desired pulse width t on the left-most ordinate. With a selected value for C<sub>T</sub>, the appropriate

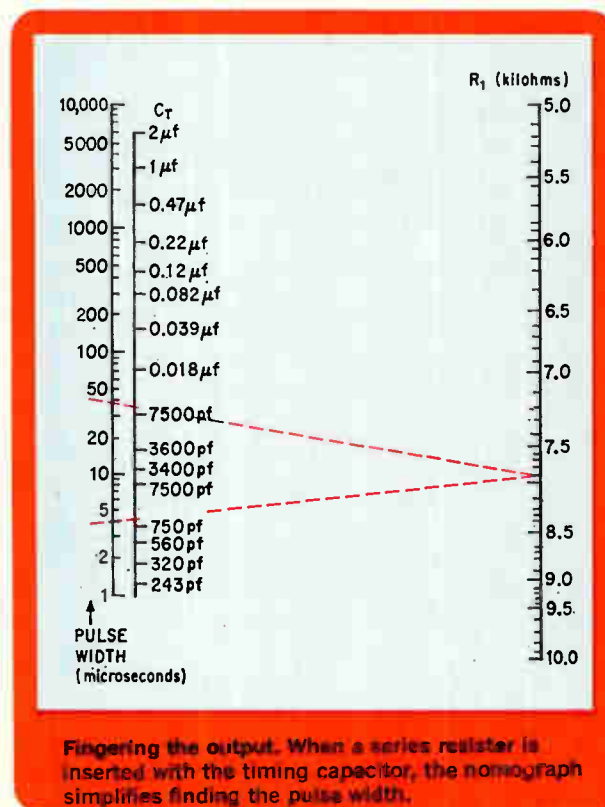

value for R<sub>1</sub> then can be read off from the scale on the right from the line formed by the intersections of t and C<sub>T</sub>.

Since C<sub>T</sub> is directly proportional to the multivibrator's pulse width, any pulse width can be selected, even values outside the range of the nomograph, simply by multiplying C<sub>T</sub> by a suitable factor. To extend the nomograph below the C<sub>T</sub> values given for the same R<sub>1</sub> and R<sub>2</sub>, divide t by the appropriate factor.

# Curve fitter aids the measure of rms by overruling square-law slowdowns

Taking accurate rms readings usually means using a slow thermocouple device; a new converter built with operational amplifiers does the job in 300 msec; its secret: making a rectifier's input-output curve look like a square-law curve

By Gene Ochs

Dana Laboratories Inc., Irvine, Calif.

and Peter Richman

Consulting electronics engineer, Lexington, Mass.

**"Champagne"** and "rms volts" are in the same boat; each once had a very specific meaning, a sparkling wine from a certain part of France in one case and the square root of the average of the square of a voltage in the other. Nowadays any white wine with bubbles is called "champagne", just as almost any reading of an a-c voltage is labeled "rms" regardless of how it was made.

Because it's proportional to the power an a-c signal dissipates, a signal's rms value is a useful parameter for defining the signal. However it's an expensive and slow job to take a true rms reading, i.e. to continuously square a voltage, average it, and then find its square root. For this reason, scaling is often used; it's a cheaper, faster, but less reliable way to find a voltage's rms value.

Now there's a way to have the best of both worlds—the speed of the scaling method along with the reliability of true-rms techniques. A new rms converter that squares a signal with a curve fitter instead of with the traditional but snail-like thermocouple network works quickly and reliably.

Built with operational amplifiers, the converter first rectifies the unknown a-c signal and then feeds it to a filter. The curve fitter controls the rectifier's output in such a way that the rectifier's input-output curve is a segmented-line approximation of a square-law curve. The result is that the filter's output is a d-c signal equal to the unknown signal's rms value.

And the converter's accuracy isn't affected by a decrease in the unknown signal; because of the way the filter's output is fed back to the curve fitter, the

segmented portions of the input-output curve grow smaller when the unknown signal lessens.

From its mathematical definition, a signal's rms voltage is equal to the d-c voltage that would dissipate the same amount of power as the signal dissipates. The most accurate way to find rms values is to measure, with thermocouples, the power spent by the signal in a standard resistor and then find out what d-c voltage dissipates the same amount. However, this process calls for a lot of adjusting, calibrating, and interpreting; and the equipment needed is rather expensive because of the costly circuits that protect the thermocouples and that compensate for their limited dynamic range.

The faster but less reliable scaling method involves measuring a signal's peak or its average value and then scaling this reading to the rms value. For example, when a sine wave's amplitude is multiplied by 0.707 or its average value by 1.11, the product is the rms value. This approach is fine as long as the signal's wave shape, and hence the scaling factor, is known; if it isn't known precisely, the reading will be wrong. For example, if an average-responding voltmeter is used to look at a sine wave that has a 3% third-harmonic distortion, the meter's reading is off by more than 1%, even though the meter's specified accuracy may be 0.1%.

Within the last two years digital voltmeters capable of measuring rms values have appeared. What the makers of these meters have done is automate the old thermocouple-comparison technique. But when matched with the measurement rates of other digital meters, the 2 or 3 seconds that



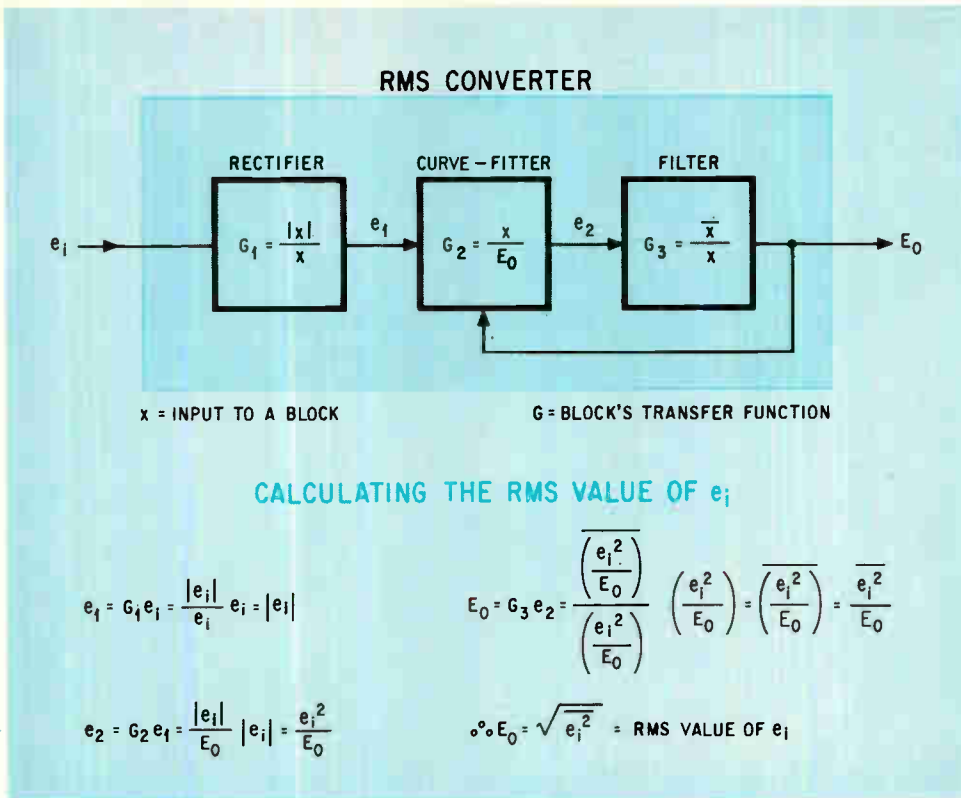

**Step by step.** The converter calculates a voltage's rms value in three steps. First it finds  $e_i$ 's absolute value, then squares the absolute value, and finally averages the square.  $E_0$  then is the rms value of  $e_i$ .

these true-rms dvm's take is still glacially slow.

The new rms converter makes a reading every 300 milliseconds, which is fast enough to keep up with most measurement systems. It's a bit more expensive to make than a peak- or average-responding converter, but still less costly than a thermocouple system. And for a-c signals whose frequency is 100 kilohertz or less, the converter's accuracy is around 0.1%. However, where higher accuracy is needed, the engineer must still resort to thermocouple systems.

Mathematically, the converter calculates rms values in three steps. It first finds the absolute value of the unknown signal,  $e_i$ , then squares the absolute value, and finally averages the square. A separate step for taking a square root isn't needed because the converter's output,  $E_0$ , is fed back in such a way that  $E_0$  itself is the square root of the average of the square of  $e_i$ .

The converter can be visualized as three black boxes connected in series with the output of the third box fed back to the second. The boxes' transfer functions are

$$G_1(x) = |x|/x$$

$$G_2(x) = x/E_0$$

$$G_3(x) = \bar{x}/x$$

where  $x$  is the input to a box. If the input to the first box is  $e_i$ , the output of the third is

$$E_0 = e_i^2/E_0$$

Therefore, the final equation becomes

$$E_0 = \sqrt{e_i^2}$$

A full-wave rectifier in the converter synthesizes  $G_1$ . The rectifier's key component is an operational amplifier, labeled  $A_1$  on the next page, whose gain is high and negative (about  $-10,000$ ). The rectifier also has an input resistor,  $R_1$ ; two output resistors,  $R_4$  and  $R_5$ ; and two feedback loops around  $A_1$ ; one of the loops, with a diode and a resistor,  $D_1$  and  $R_2$ , handles  $A_1$ 's positive outputs, while the other, with  $R_3$  and  $D_2$ , takes care of the negative outputs.

An active filter synthesizes  $G_3$ . This filter comprises an operational amplifier,  $A_2$ , that's in parallel with a capacitor and a resistor,  $C$  and  $R_6$ .  $A_2$ , as is the case with  $A_1$ , has both a high gain and an inverted output.  $C$  and  $R_6$  together remove the d-c ripple from  $E_0$ .

### Making breaks

When  $e_i$  is sinusoidal, for example, the signal at the junction of  $D_2$  and  $R_3$  is a negative half-wave rectified version of  $e_i$ . This signal passes through  $R_4$  to the filter, while  $e_i$  is routed to the filter via  $R_5$ . The value for  $R_5$  is set equal to twice the resistance of  $R_4$ , and  $R_1$  is set equal to  $R_3$ . In this way the amplitude of the half-wave rectified signal in  $R_4$  is twice the amplitude of the sinusoidal signal in  $R_5$ . Therefore the sum of the two signals is a negative full-wave rectified sine wave.

If there were no circuitry other than the rectifier and the filter, the input,  $i_1$ , to the filter would be

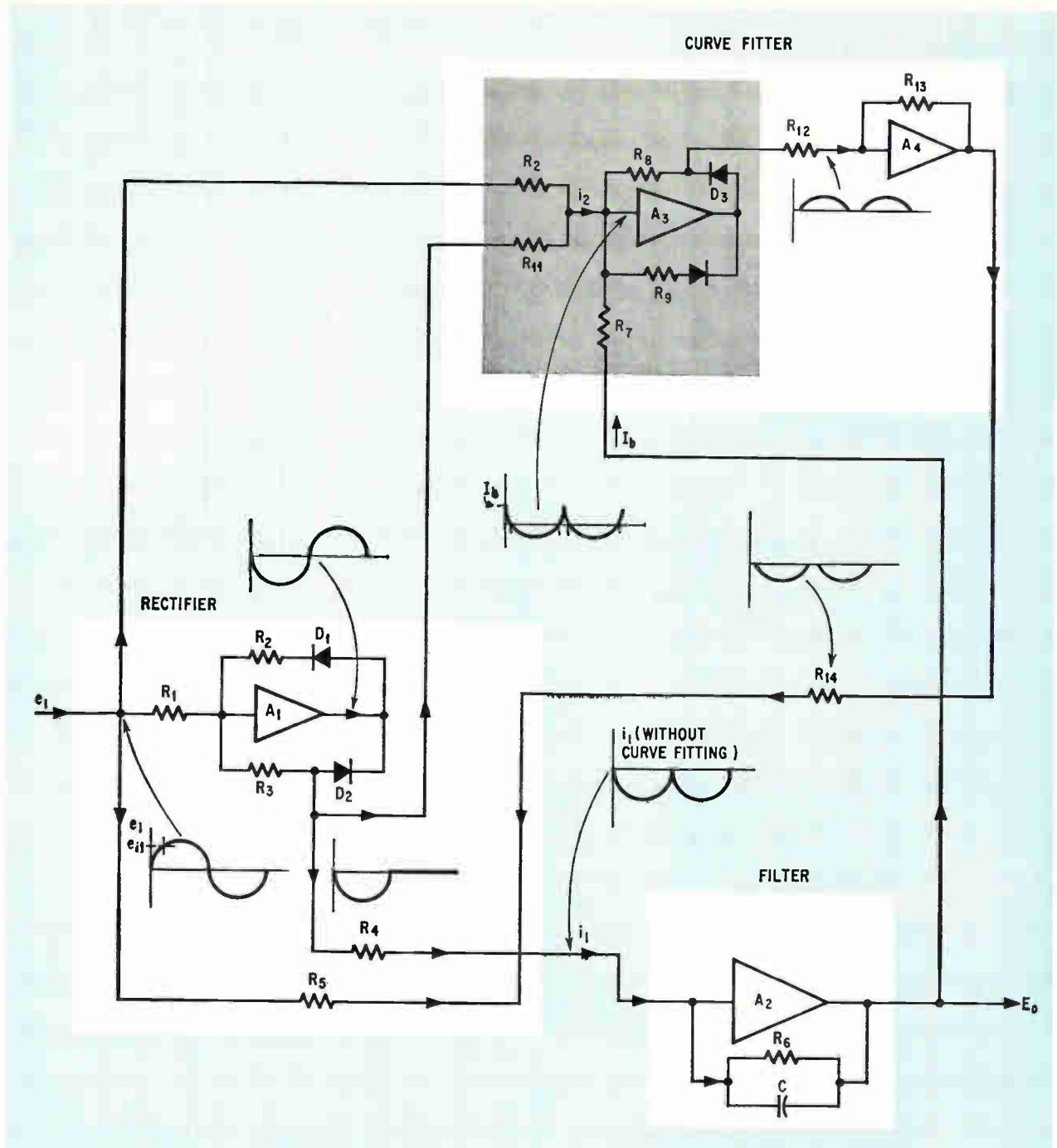

Filling the blocks. A rectifier, a curve fitter, and a filter synthesize  $G_1$ ,  $G_2$ , and  $G_3$ , the transfer functions shown on page 99. Without the curve fitter, the rectifier's input-output plot is a pair of lines coming off the origin, and not the square-law curve needed for computations. The fitter changes the slopes of these lines at certain values of  $e_1$  so that the input-output curve looks more like a square-law curve.  $R_7$  determines where the breakpoints are, and the new slope is determined by  $R_8$  and  $R_9$ . The rectifier in this circuit has one set ( $e_{11}$  and  $-e_{11}$ ) of breakpoints in its input-output curve; but it could have more. Each parallel addition of a rectifier circuit (grey area) adds another set.

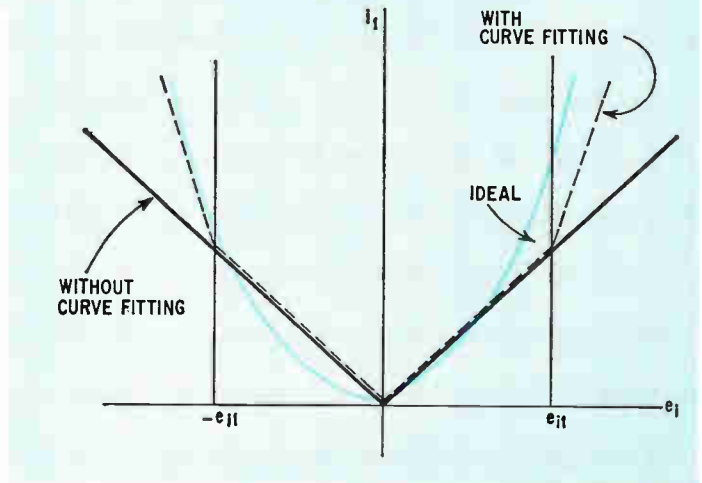

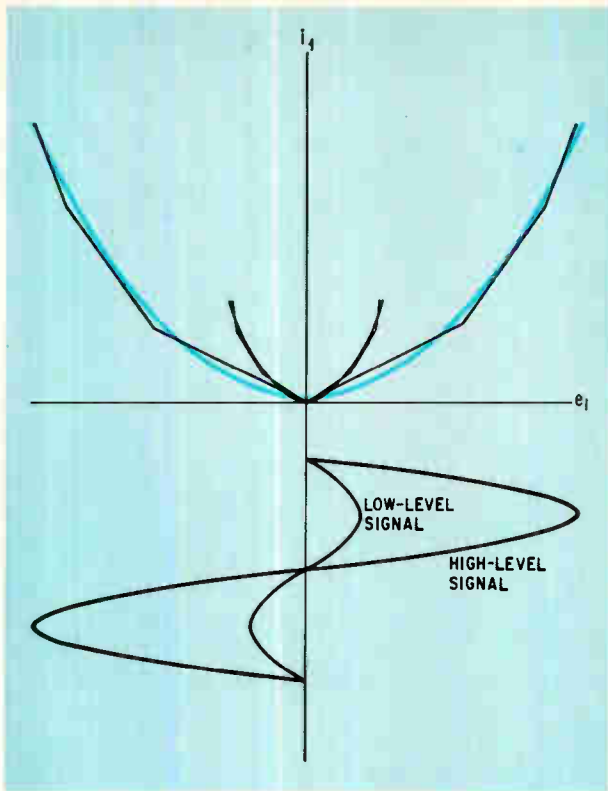

**Low or high.** As  $e_1$  gets smaller, the breakpoints move closer to the origin because when  $e_1$  falls,  $E_o$  naturally falls and with it the bias current. Because the position of the breakpoints does depend on the magnitude of  $e_1$ , the converter's accuracy is independent of  $e_1$ .

this full-wave rectified signal, and  $E_o$  would just be the average of  $e_1$ . In this case the rectifier's input-output curve,  $i_1$  versus  $e_1$ , would be the normal input-output curve of a full-wave rectifier, a V-shaped curve sitting on the origin.

The curve fitter synthesizes  $G_2$  by turning the input-output curve into a segmented-line approximation of a square-law curve. When  $e_1$  reaches some preset value,  $e_{11}$ , the curve fitter changes the slope of the curve, making it look more like a square-law curve.

Part of the fitter is a rectifier, identical in layout to the input rectifier. The difference is that the amplifier,  $A_3$ , in the fitter is biased positively by  $E_o$  through a resistor,  $R_7$ . The magnitude of  $R_7$  determines  $e_{11}$ 's value. The magnitudes of  $R_8$  and  $R_9$ , which are  $A_3$ 's feedback resistors, determine the slope of the  $i_1 - e_1$  curve for  $e_1$  greater than  $e_{11}$ .

At the fitter's input are two resistors,  $R_{10}$  and  $R_{11}$ , which connect the fitter to the converter's input and to the junction of  $D_2$  and  $R_3$ . Therefore when  $R_{10}$  is twice the resistance of  $R_{11}$ , the signals in  $R_{10}$  and  $R_{11}$  add to form  $i_2$ , a negative full-wave rectified version of  $e_1$ .

The bias current,  $I_b$ , shifts  $i_2$  in a positive direction, and  $A_3$  inverts it. The result is that  $A_3$ 's output is a positive full-wave rectified signal displaced from the zero-current baseline by  $-I_b$ . The signal

in  $A_3$ 's positive feedback loop then consists of the clipped-off tops of  $A_3$ 's output. In other words, current flows in the positive loop only when  $i_2$  is higher than  $I_b$ .

Connected to the junction of  $R_8$  and  $D_3$ , the positive-feedback loop's resistor and diode, is another operational amplifier,  $A_4$ , whose gain is  $-1$ .  $A_4$ 's output therefore is the negative of the positive portion of  $A_3$ 's output. This negative signal goes through a resistor,  $R_{14}$ , to the filter's input where it's added to  $i_1$ . This addition changes the slope of the  $i_1$ -versus- $e_1$  curve.

### Getting steeper

The fitter shown on page 100 generates one set of breakpoints,  $e_{11}$  and  $-e_{11}$ . However, if more rectifiers along with their input and bias resistors are added to the fitter the number of breakpoints would increase. And the more breakpoints the  $i_1 - e_1$  curve has, the better it approximates a square-law curve. Each rectifier and its associated resistors connected in parallel to the fitter's other rectifiers and input and bias resistors adds one more set of breakpoints.

Just a few breakpoints are needed to assure adequate accuracy. For example, if its curve fitter generates two sets of breakpoints, a converter can have an accuracy of 0.1%.

One reason for this good accuracy with few circuits is that the breakpoints can be positioned and the slopes chosen to optimize accuracy. When this is done, the segmented curve at a few points will slice through the square-law curve it's trying to approximate. And because the segmented curve will then lie both above and below the square-law curve the approximate error, i.e. the space between the two curves, will tend to average out.

Another benefit that comes from properly picking the slopes and breakpoints is that the converter can be set up to have its best accuracy for particular waveforms. Theoretically the converter can handle inputs of any form, but for a given collection of slopes and breakpoints, accuracy depends somewhat on the input's shape. Normally the converter is set up to handle sine, square and triangular waves.

Furthermore, the converter changes the slope of the square-law curve being approximated as  $e_1$  changes. If this isn't done, as  $e_1$ 's amplitude decreases, so also does the converter's accuracy. Suppose that  $e_{11}$  is set at 1 volt and doesn't change. Whenever  $e_1$  drops below 1 volt, no square-law approximation takes place; as far as  $e_1$  is concerned, the  $i_1 - e_1$  curve is just a straight line.

Feeding back  $E_o$ , besides providing the square-root function, also solves this low-level problem.  $E_o$  controls the bias current, which means it determines where the breakpoints are. The smaller  $E_o$  is, the lower the voltages at which the curve will break. The result of this is that for low values of  $E_o$  the square-law curve being approximated is steep, and that for larger values, not so steep. ■

# Feedback sharpens filter response

Cascading a low-pass network with high-pass sections eliminates bulky inductors and capacitors, making integrated-circuit format possible

By Roland J. Turner

General Atronics Corp., Philadelphia

**Although it's possible** to cascade several LC networks to obtain sharp responses at low frequencies, it is impractical—particularly at frequencies as low as 0.3 hertz. To do this would require large inductors and capacitors.

A far more practical method is to utilize an active filter, which takes advantage of feedback, together with an operational amplifier. By cascading a low-pass network with two high-pass sections, the designer may achieve upper and lower cutoff frequencies of 10 hz and 0.3 hz, respectively. Increasing the positive feedback will steepen the slope of the filter's low-frequency end in the vicinity of 0.3 hz. This active filter arrangement eliminates the need for any inductors and minimizes the capacitor requirement, thus making it possible to build the network in integrated-circuit form.

Such a filter can be put to good use in radar-tracking of slow-moving targets, such as a man or an animal. To avoid misinterpreting the target's true position the equipment must separate the doppler signals from the clutter return of stationary targets; because most of the clutter occurs at frequencies below 0.3 hz, the operator requires a bandpass filter with very sharp low-end skirt selectivity as a characteristic.

The filter achieves its bandpass characteristic by cascading a passive low-pass network that consists of  $R_5$  and  $C_3$  with an active high-pass section in which two poles  $C_1$ ,  $R_1$ , and  $C_2$  and  $R_2$  are imbedded. The operational amplifier provides gain and isolation as do the transistors. The active high-pass section permits signals above 0.3 hz to pass, whereas the low-pass section passes signals that fall below 10 hz of frequency.

Two important features of this active filter are:

- In the region below 0.3 hz the filter's response falls faster than it does in a two-section, passive high-pass filter.

- Low-frequency boost is available and may be chosen by selecting the proper value for both

positive and negative feedback signals by adjusting  $R_3$ ,  $R_4$ ,  $R_N$ , and  $R_p$ .

The transfer function of the active high-pass section is derived from the following relationships:

$$\alpha_1 = \frac{1}{(R_1 + R_3)C_1}$$

$$\alpha_2 = \frac{1}{R_2C_2}$$

$$\alpha_3 = \frac{1}{R_5C_3}$$

$$\beta = R_3/R_p$$

$$K = R_N/R_4$$

$$e_0 = \frac{R_2C_2se_2}{(1 + R_2C_2s)} = \frac{s}{(s + \alpha_2)} e_2$$

$$= \frac{s}{(s + \alpha_2)} Ke_1$$

$$e_1 = \frac{(R_1 + R_3)e_s}{R_1 + R_3 + 1/sC_1} + \frac{\beta e_0/sC_1}{R_1 + R_3 + 1/sC_1}$$

$$= \frac{se_s}{(s + \alpha_1)} + \frac{\beta e_0}{(R_1 + R_3)C_1(s + \alpha_1)}$$

$$e_0/e_s = \frac{Ks^2}{s^2 + [\alpha_1(1 - \beta K) + \alpha_2]s + \alpha_1\alpha_2}$$

The overall transfer function of the bandpass filter becomes

$$A(s) = e_0/e_{IN}$$

$$= \frac{\alpha_3 K s^2}{\{s^2 + [\alpha_1(1 - \beta K) + \alpha_2]s + \alpha_1\alpha_2\}(s + \alpha_3)}$$

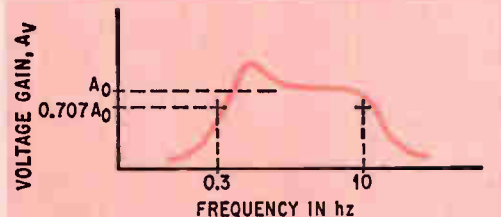
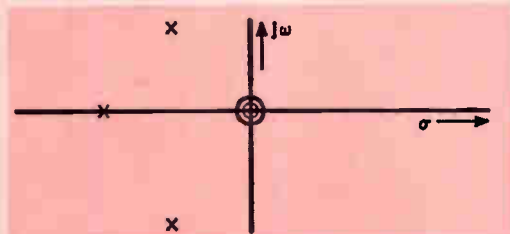
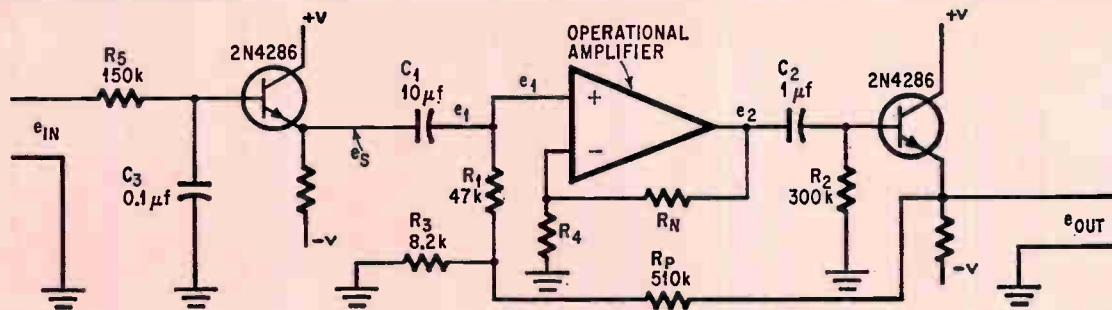

**Active filters.** Two high-pass networks,  $R_1, C_1$ , and  $C_2, R_2$ , are coupled to an operational amplifier and a low-pass circuit,  $R_N, C_3$ . Positive feedback sharpens low-frequency response, eliminating the need for bulky LC networks. Pole-zero pattern for the filter appears at lower left; frequency response is at lower right.

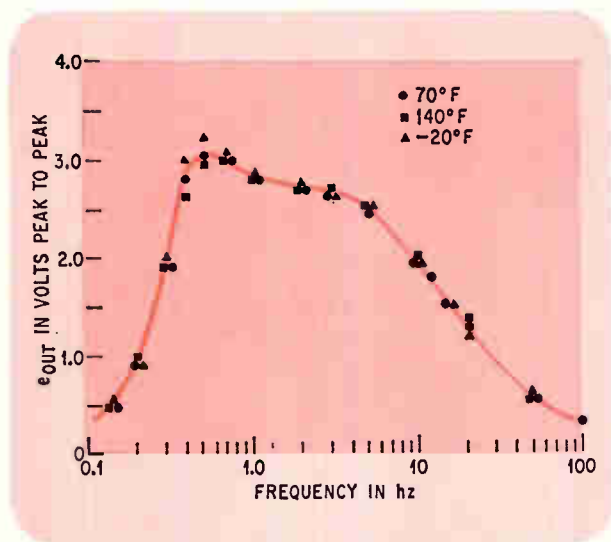

**Temperature variation.** Response curve for the active bandpass filter is plotted as a function of three temperatures. The 3-dB bandwidth points occur at the 0.3 and 11 hertz locations.

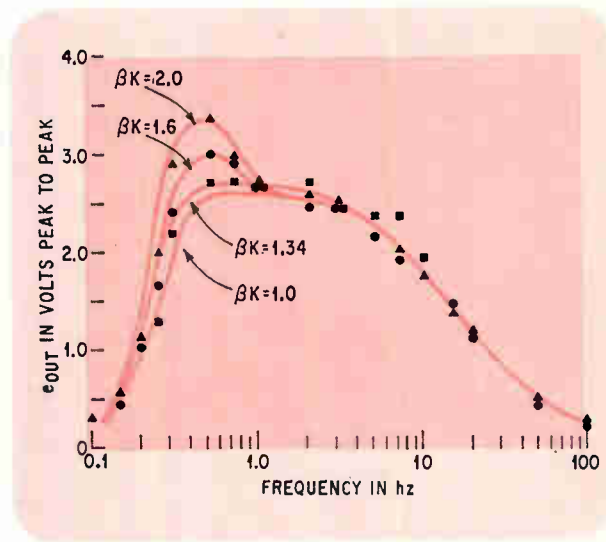

**Frequency response.** Output voltage is plotted for four values of feedback signal,  $\beta K$ . The larger the feedback signal, the sharper the low-frequency response. Low values of feedback cause a flat response.

Inserting the parameter values shown on the schematic into the equation for the transfer function,  $A(s)$ , leads to the expression

$$A(s) = \frac{100s^2}{s^2 + 2.17s + 6}$$

The temperature performance of the active filter was evaluated over a range of  $-20^\circ\text{F}$  to  $+140^\circ\text{F}$ . Experimental results are as shown directly above.

Deviations from the room temperature response are less than 1 db through this temperature range—a good value for radar applications—and since the transfer function remains stable across these temperatures, a stable doppler signal return will be available for detection independent of temperature.

To indicate the measure of low-frequency boost, or slope steepness, and its dependency of  $\beta K$ , experimental  $\beta K$  curves were generated by varying resistor  $R_3$  ■

# A self-adjustable bandpass filter picks off weak signal despite noise

Active device's damping factor is related only to the overall loop gain and not to the time constant as is the case with most conventional filters

By Basil Barber

Sperry Rand Corp., Great Neck, N.Y.

**Detecting a weak signal** transmitted from a noisy environment is difficult if the noise level is strong. Such a signal might be sent from a submarine moving under the sea. Background noise can mask the true signal, and atmospheric conditions—lightning or shifts in the ionosphere, for instance—can cause further errors.

However, an active filter built in integrated-circuit form can detect the desired signal. The filter's damping factor is independent of the system's time constants and directly related to only the overall loop gain of the filter. Thus, the cut-off frequency can be modified without affecting the damping factor. This is particularly valuable in systems that have a limited dynamic range and cannot tolerate large overshoots. Because the filter's time constant  $R_a C_a$  and  $R_b C_b$ , are variable the network automatically adapts to some of the characteristics of the noise's frequency spectrum, increasing the system's dynamic range by 20 decibels. Unlike other schemes that require manual control for setting the frequency response of the system, the response of this device varies electronically, making the filter quite versatile.

The filter is aimed at applications involving frequencies between 20 hertz and 5,000 hz. Typically, it would be used in low-frequency preamplifiers that have continuously variable high-pass filters whose time constants are determined by a particular sea-noise condition; or it could be used in dynamic noise suppressors that use low-pass filters controlled by the weighted integral of the noise's bandwidth and level. Such applications are found in optical trackers, infrared detectors, squelch circuits, and hydrophones.

The block-diagram makeup of a low-pass filter is outlined on page 105. The output frequency

response is determined by some easily integrated input parameter such as a signal level, signal-to-noise ratio, or the power-frequency integral of the noise present. Thus, the output becomes a weighted function of the integral of the input.

A quadratic of the form  $s^2/\omega_n^2 + 2\delta s/\omega_n + 1$  with a damping factor,  $\delta = 1/2$ , is a good compromise between amplitude peaking and overall time delay. This is based on automatic control theory. The engineer thus is faced with the problem of designing his system to implement a damped quadratic of constant amplitude and continuously variable cut-off frequency.

The frequency response of such a filter is expressed mathematically by

$$\frac{e_o}{e_{in}} = \frac{K_1/(\tau s + 1)^2}{1 + K_1 K_2/(\tau s + 1)^2} = \frac{K_1}{\left(\frac{\tau^2}{1 + K_1 K_2}\right) s^2 + \frac{2\tau}{(1 + K_1 K_2)} s + 1} \quad (1)$$

The cut-off frequency is given by

$$\omega_n = \frac{\sqrt{1 + K_1 K_2}}{\tau} \quad (2)$$

and the damping factor is

$$\delta = \frac{\omega_n \tau}{1 + K_1 K_2} = \frac{1}{\sqrt{1 + K_1 K_2}} \quad (3)$$

Since  $\delta = 1/2$ , the product of  $K_1 K_2$  must be 3. The damping factor is independent of the filter's time constant.

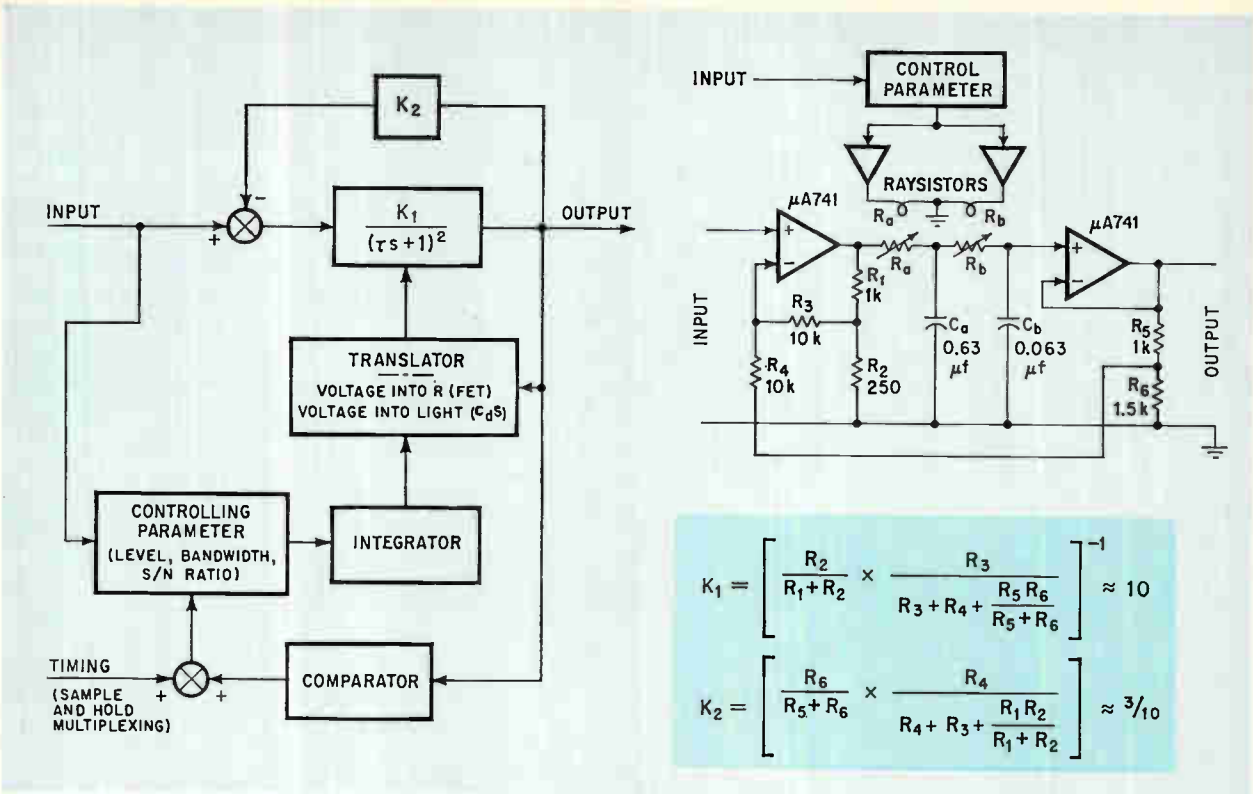

Adaptive filter. Stages for low-pass network reveal mode of interconnection. Output response is dependent on signal level or signal-to-noise ratio. Electrical connection for the filter is indicated at right. The gain for  $K_1$  and  $K_2$  is fixed by the resistors to assure that  $K_1 K_2 = 3$ .

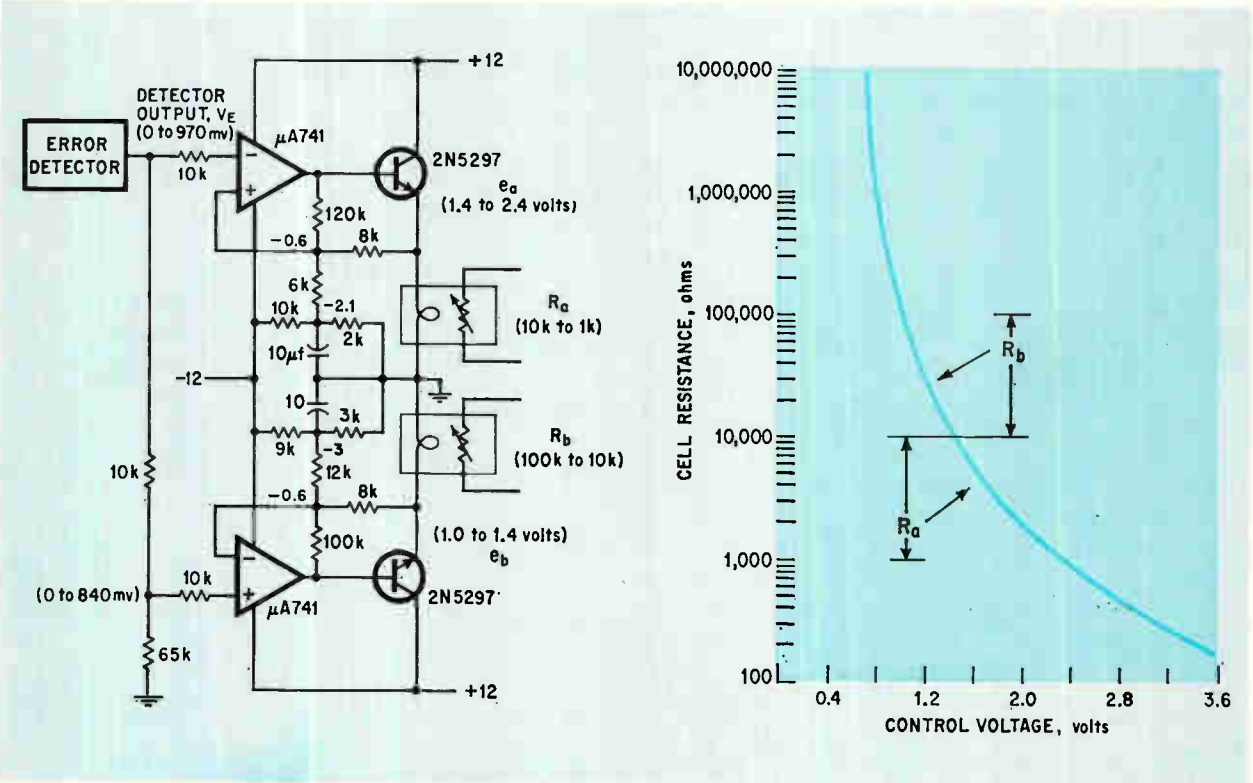

Setting a bias. Schematic depicts the circuit needed for the amplifier that controls the RAYSISTORS' bias levels hence, their resistance. Impedance levels and changes for the component are shown in the graph. Light striking the RAYSISTORS varies the voltage across each element.

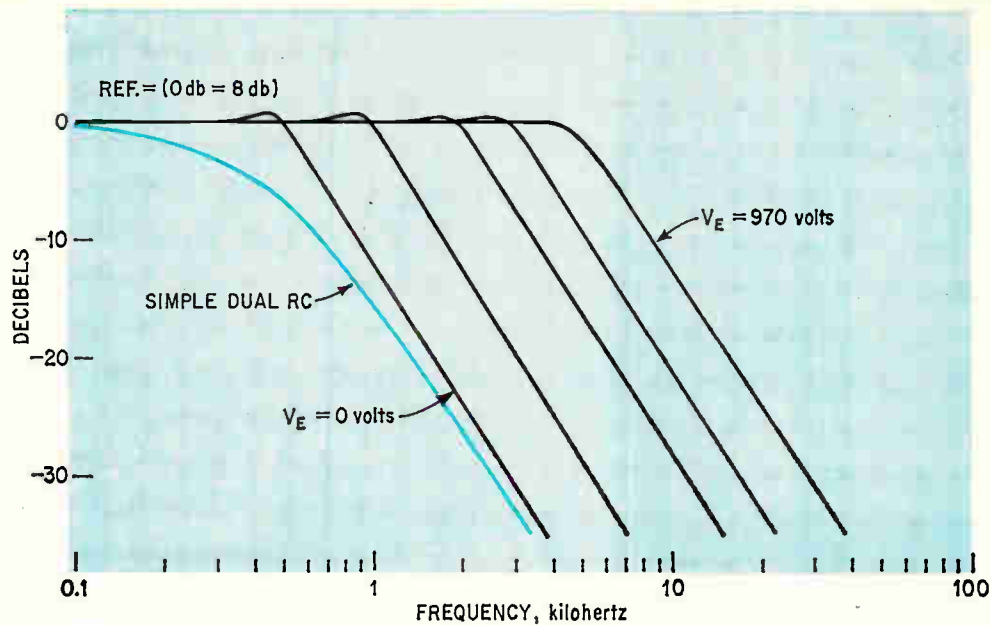

**Response.** Overall frequency response for the low-pass filter is plotted as a function of error detector output,  $V_E$ . As  $V_E$  is increased the cut-off frequency also increases.

From equation 2, the resonant frequency,  $f_n$ , is

$$f_n = \frac{\omega_n}{2\pi} = \frac{\sqrt{1 + K_1 K_2}}{2\pi\tau} = \frac{1}{\pi RC} \quad (4)$$

The complete active filter, covering the 0.5 kilohertz to 5.0 khz band is shown at top, page 105. Because several feedback loops are needed to implement the loop gains, the phase response of the amplifiers must assume a critical role to prevent oscillation at the zero-db level. A model 741 operational amplifier is particularly adaptable to this task since its stability is guaranteed. It is unconditionally stable with substantial amounts of negative feedback and doesn't require external compensation. Resistors  $R_1$  through  $R_6$  form the feedback networks that determine the values of  $K_1$  and  $K_2$ . For  $K_1 K_2 = 3$ ,  $K_1 = 10$ , and  $K_2 = 0.3$ .

The components of the main time constants  $R_a C_a$  and  $R_b C_b$  are implemented with cadmium-selenide Raysistors—optical elements whose resistance varies with changes in light. Although these time constants do vary, their time-rate of change is considerably lower than the operating carrier and their modulation frequency. For all practical purposes, the time constants can be considered unvarying and can be analyzed mathematically with Laplace transforms.

The control amplifier that establishes the proper voltage bias for the Raysistors appears in the bottom drawing at the left of page 105. Impedance levels and variations of the device are also shown at the bottom right of page 105 with the filter's overall frequency response plotted as a function of the error detector output,  $V_E$ , in the graph at the top of this page.

The effects of resistance variations on the cut-off frequency and damping factor may be derived by differentiating equation 3. Thus

$$\frac{d\delta}{dK_1} = -K_2 \frac{(1 + K_1 K_2)^{-3/2}}{2} = \frac{-\delta K_2}{2(1 + K_1 K_2)}$$

$$\text{or } \frac{d\delta}{\delta} = \frac{-K_2 dK_1}{2(1 + K_1 K_2)} \quad (5)$$

Since the value of  $K_1$  is determined by a closed negative feedback loop around a high-gain amplifier,  $dK_1$  variations are small and have an insignificant effect on the system's damping factor.

Similarly, changes in the feedback ratio,  $K_2$ , are reflected as variations of the damping factor since

$$\frac{d\delta}{\delta} = \frac{-K_1 dK_2}{2(1 + K_1 K_2)} \quad (6)$$

A resistor ratio sets the value for  $K_2$ . Therefore, keeping the ratio small minimizes  $K_2$ 's effect on the damping factor's accuracy. Differentiating equation 2 with respect to the time constant, yields

$$\frac{d\omega_n}{d\tau} = \frac{\sqrt{1 + K_1 K_2}}{-\tau^2} = \frac{-\omega_n}{\tau}$$

and therefore,

$$\frac{d\omega_n}{\omega_n} = -\frac{d\tau}{\tau} = -C \frac{dR}{RC} = -\frac{dR}{R} \quad (7)$$

Variations of the cut-off frequency  $\omega_n$  are, therefore, directly proportional to the variations of the time constant  $\tau$ . To keep the impedances from loading each other  $R_b = mR_a$ , where  $m > 5$ . If it is



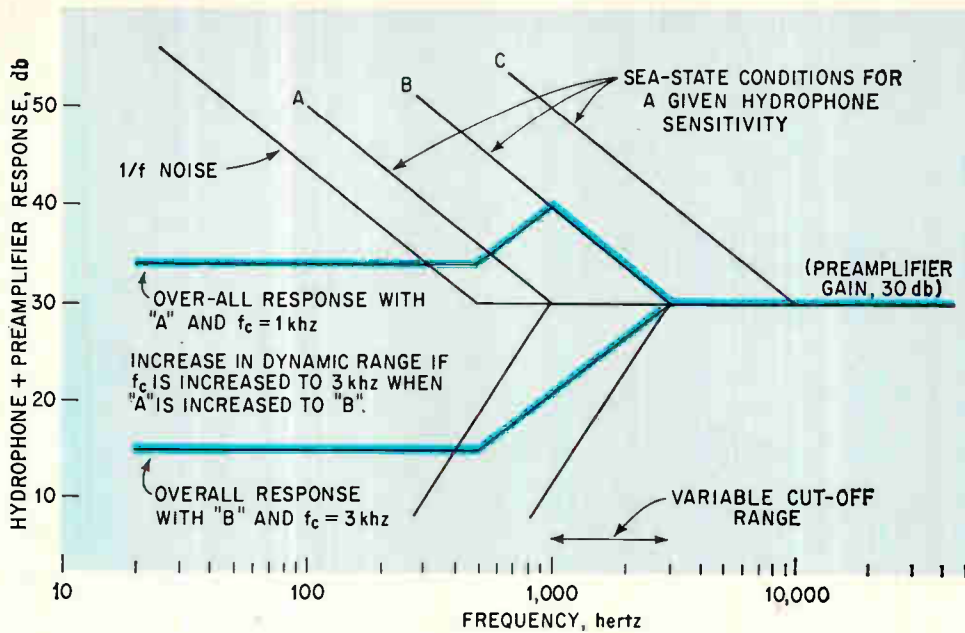

**Applying the filter.**  
Curves reveal the performance of a hydrophone preamplifier with its low-frequency response controlled by a given sea-state condition.

assumed that  $R_b$  tracks by an error of  $\pm \gamma\%$  of  $R_a$ , then, since  $R_b = mR_a$ , its actual value will be

$$R_b = mR_a \pm m\gamma R_a = mR_a (1 \pm \gamma)$$

and 
$$\frac{e_o}{e_i} = \frac{1}{(\tau s + 1) [\tau (1 \pm \gamma) s + 1]}$$

$$= \frac{1}{(1 \pm \gamma) \tau^2 s^2 + (2 \pm \gamma) \tau s + 1} \quad (8)$$

After feedback is introduced equation 8 becomes

$$\frac{e_o}{e_{in}} = \frac{1}{\frac{1 \pm \gamma}{1 + K_1 K_2} \tau^2 s^2 + \frac{2 \pm \gamma}{1 + K_1 K_2} \tau s + 1}$$

from which

$$\omega_n' = \frac{\sqrt{1 + K_1 K_2}}{\tau \sqrt{1 \pm \gamma}} = \frac{\omega_n}{\sqrt{1 \pm \gamma}}$$

and

$$\delta' = \frac{\omega_n (2 \pm \gamma)}{2(1 + K_1 K_2)}$$

$$= \frac{2 \pm \gamma}{2\sqrt{1 \pm \gamma}} \delta \quad (9)$$

where  $\omega_n$  and  $\delta$  are the values previously determined from equation 2 and 3.

Equation 9 can be approximated as

$$\frac{\delta}{\delta'} = \frac{2 \pm \gamma}{2\sqrt{1 \pm \gamma}} \approx 1 + \frac{\gamma^2}{8} \quad (10)$$

Any damping factor deviation created by off

tracking of  $R_a$  and  $R_b$  is, therefore, lessened by  $\gamma^2/8$ , which represents a substantial reduction.

A high pass filter, if required, is produced in a low-pass filter by substituting resistors for capacitors and capacitors for resistors. Thus, equation 1 becomes

$$\frac{e_o}{e_{in}} = \frac{K_1 (\tau s + 1)^2}{1 + K_1 K_2 (\tau s + 1)^2} =$$

$$= \frac{K_1 (\tau s + 1)^2}{\tau^2 K_1 K_2 s^2 + \frac{2 K_1 K_2 \tau}{1 + K_1 K_2} s + 1} \quad (11)$$

and

$$\omega_n = \frac{1}{\tau} \sqrt{\frac{1 + K_1 K_2}{K_1 K_2}} \quad (12)$$

$$\text{and } \delta = \frac{\omega_n K_1 K_2 \tau}{1 + K_1 K_2} = \sqrt{\frac{K_1 K_2}{1 + K_1 K_2}} \quad (13)$$

Since  $\delta = 1/2$ , the product of  $K_1 K_2$  must, therefore, be  $1/3$ . The damping factor is again independent of the filter's time constants  $R_a C_a$  and  $R_b C_b$ . The implementation and error analysis is similar to that presented for the low-pass filter.

A performance curve shown directly above demonstrates a typical application of a hydrophone preamplifier with its low-frequency response controlled by a given weather condition. The sea-state conditions and the  $1/f$  noise characteristics of the solid-state amplifiers particularly aggravate low frequency application; both curves approach a slope of 6 db per octave.

The shaded area represents the improvement in dynamic range possible if the technique of adaptive high-pass filtering is employed. ■

# On the beam for sharp crt character displays

The spherical geometry of crt's causes tilt distortion in alphanumeric displays; a circuit that generates a complex waveform corrects it simply and effectively

By James W. Wolf

International Business Machines Corp., Kingston, N.Y.

and James H. Williams

Lundy Electronics and Systems Inc., Charlotte, N.C.

**Eliminate the tilt** and you'll eliminate a major contributing factor to character distortion in alphanumeric displays. This, as it turned out, was far easier said than done—but no longer. Turning the trick is a function generator that delivers a complex sawtooth waveform to a cathode-ray tube's character-deflection yoke. By correcting the tilt as each character is generated, the waveform effectively eliminates this distortion factor.

Previous solutions employed to correct character tilt and misalignment centered on modifying the yoke windings; building a complicated function generator derived from a second order equation containing square roots; or keeping the angle of deflection of the electron beam to less than 50°. Each proved to be deficient—and costly.

Modifying the yoke windings produces nonuniform magnetic fields which interfere with the beam's scan, resulting in poor focus. The mathematics were too involved to build a function generator as an economical circuit for use in low-cost crt displays. And small deflection beam angles require longer crt's, when most customers of computer peripherals want compact displays.

Basically, an empirical solution was effected by identifying the types of distortion, and their sources; deriving the approximate waveform to be applied to the character yoke, and then designing an appropriate function generator. Considerable savings in complexity were realized by avoiding a rigorous mathematical approach.

Characters tend to be broader at the sides of the crt and shorter at the top and bottom, and also tend

to be tilted and reverse their slope as they are scanned from one quadrant to the next.

These distortions are due mainly to the tube's geometry. Spherical-faced crt's have a larger radius of curvature than the radius of deflection of the electron beam (shown on top of p. 109) giving rise to a pincushion effect. Additionally, the character yoke has a low inductance and fast rise time, and generates certain incremental distortions that are too complicated to analyze here by formulas.

By observing the tilt of the characters as they are scanned across the screen, it's not difficult to figure out the waveform required for correction. Characters in the upper-left quadrant of the screen tilt in the same direction as those in the lower right and consequently require the same correction. The same applies to the upper-right and lower-left quadrants. Also, the tilt is maximal in the corners and decreases in those characters that are displayed nearer to the center of the screen.

Along the top line, maximum correction must be applied to the left edge; it decreases as the center is approached, and then increases again in moving toward the right edge. Travelling down the screen, maximum correction is needed along the top line and decreases as the center is approached; then it increases again until maximum correction is applied to the bottom line. The angle of the tilt reverses direction from top to bottom and from right to left.

Thus the correction voltage must be a parabolic sawtooth wave. Each ramp of the wave must apply a correction voltage from maximum negative to

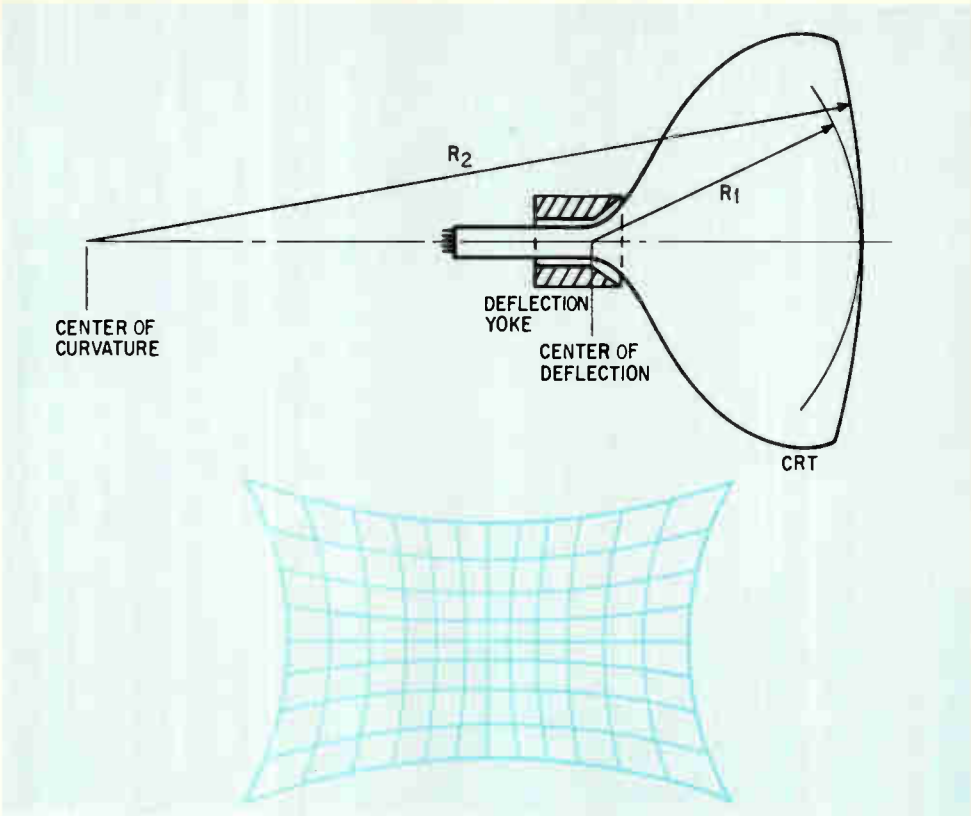

**A matter of geometry.** In a spherical-faced cathode-ray tube, the radius of curvature of the faceplate,  $R_2$ , is larger than the radius of deflection of the beam,  $R_1$ . This causes the pincushion distortion shown below.

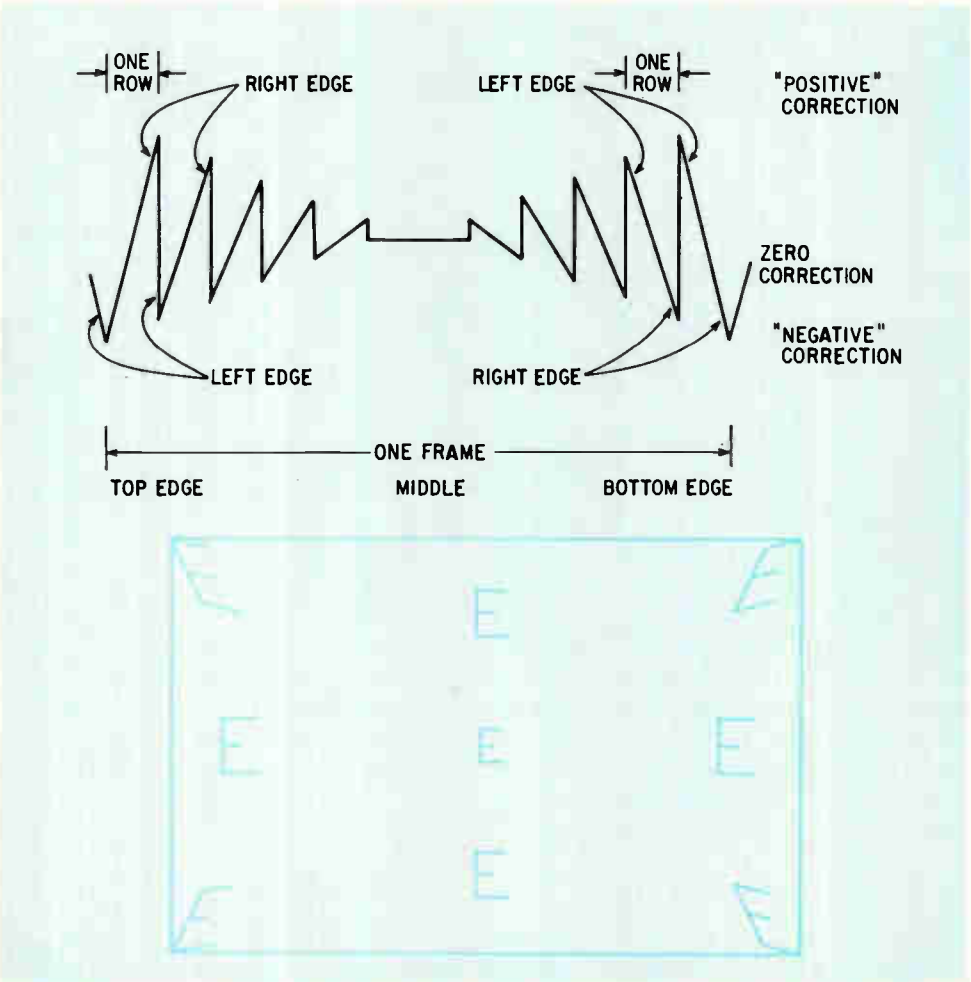

**The slant.** The sawtooth waveform is fed into the character deflection yoke and applies a correction voltage, either positive or negative, depending on the character's location on the screen. Shown below is typical character distortion on a crt.

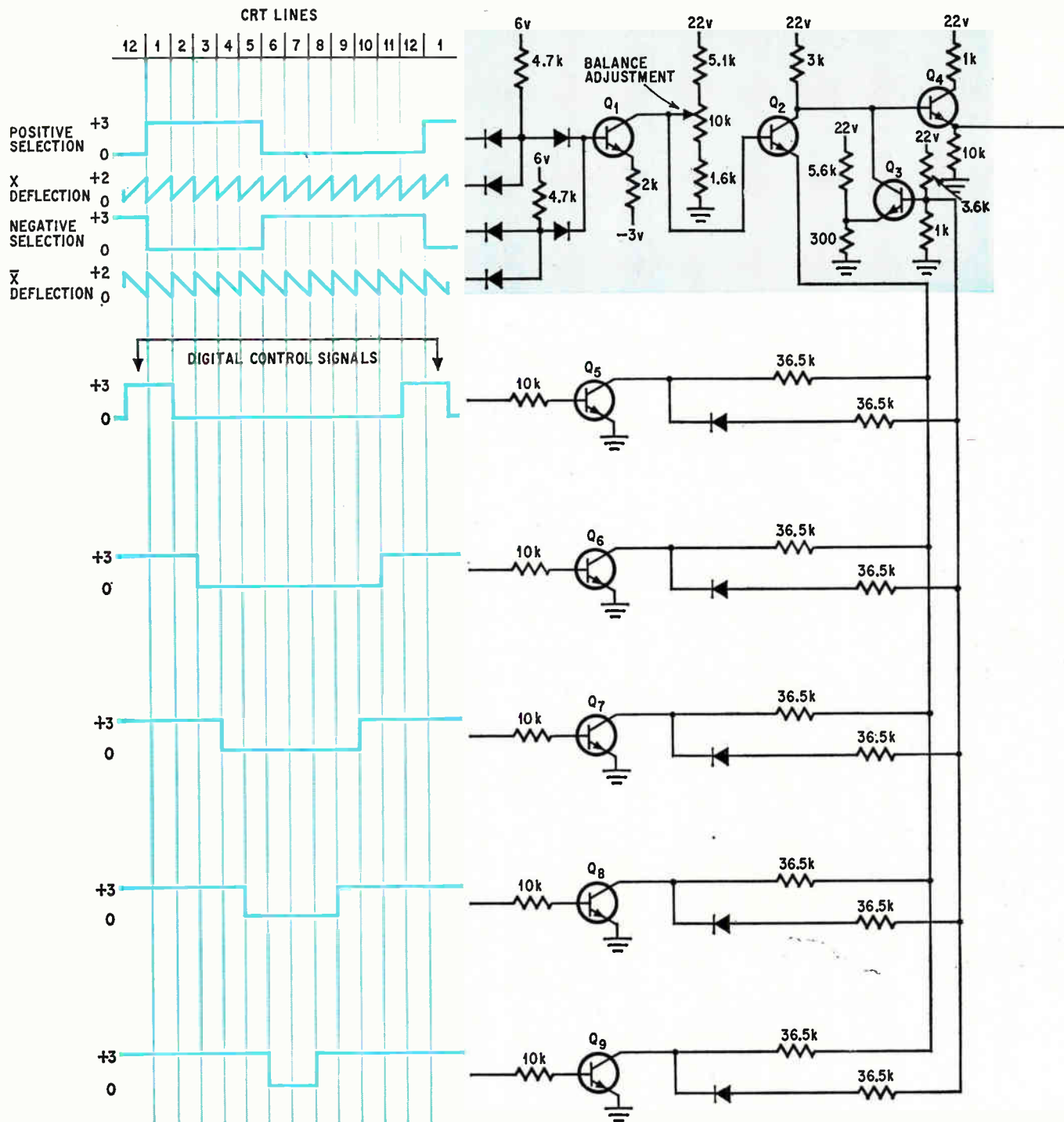

maximum positive across each row in the top half display and opposite in direction for the bottom, and its peak amplitudes must decrease toward the center of the screen (bottom p. 109).

There are two segments to the sawtooth wave-shape. The left has positive slopes that decrease in amplitude as each row scanned on the screen comes closer to the middle. The segment on the right has negative slopes whose amplitudes increase as rows of characters come closer to the bottom.

Each ramp of the sawtooth applies a correction voltage for just one row scanned on the screen,

starting with the topmost row. The peaks represent the maximum positive and negative correction voltages that must be applied to the characters along that particular row. (Positive and negative refer to the currents applied to the  $\bar{x}$  and  $\bar{y}$  deflection yokes and the  $\bar{x}$  and  $\bar{y}$  yokes, respectively.)

### Making waves

Having ascertained the correction current to be delivered to the character yoke, a suitable function generator must be designed to yield a close approximation of the desired waveshape.

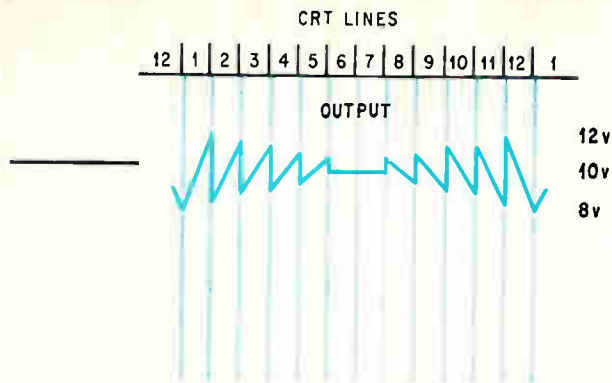

From simple to complex. Transistor  $Q_1$  and associated input diodes form an analog gate that combines the  $x$  and  $\bar{x}$  deflection signals. The digital control signals open and close the transistor gates  $Q_5$  through  $Q_9$  and are effectively multiplied by  $Q_2$ , since  $Q_2$ 's gain changes with its emitter impedance.  $Q_3$ , in conjunction with  $Q_4$ , compensate for the extra d-c component multiplied into the wave by the digital control signals.

The function generator shown on the opposite page (called an analog/digital multiplier because it combines analog signals with digital control signals to produce a complex output) comprises an analog gate of input diodes, five switching transistors controlled by the digital signals, and a d-c adjustment to compensate for any extra d-c component added in when the signals are combined.

The screen, for reference purposes, is divided into 12 segments, or lines. Lines 1 through 5 scan the top half of the screen and generate a positive selection signal, which gates a positive sawtooth into the analog gate. The sawtooth actually originates from the  $x$  deflection yoke.

Lines 8 through 12 gate the negative sawtooth, or the  $\bar{x}$  deflection signal. The two middle segments, 6 and 7, inhibit either sawtooth from being gated into the circuit.

Transistor  $Q_1$  amplifies the gated signal and delivers it to the base of  $Q_2$ .  $Q_2$ 's emitter resistance is determined by the collector resistors of  $Q_5$  through  $Q_9$  in parallel.  $Q_5$  through  $Q_9$  are switched on and off by the digital control signals, thus varying  $Q_2$ 's emitter resistance. As more resistors are switched in by the digital signals,  $Q_2$ 's effective emitter resistance decreases while its gain increases. Thus the sawtooth deflection voltages are combined with the digital control signals to generate a sawtooth with a parabolic shape at the circuit's output.

In combining the analog and digital inputs an unwanted d-c component is added that, unless cancelled out, shifts the correction voltage to too high a level. To compensate for this added voltage a current generated by  $Q_3$  that is inversely proportional to the number of digital input stages turned on biases the output transistor,  $Q_4$ , which then reshifts the d-c bias.

The amount of current generated by  $Q_3$  depends on the voltage ratio at  $Q_3$ 's base and its emitter

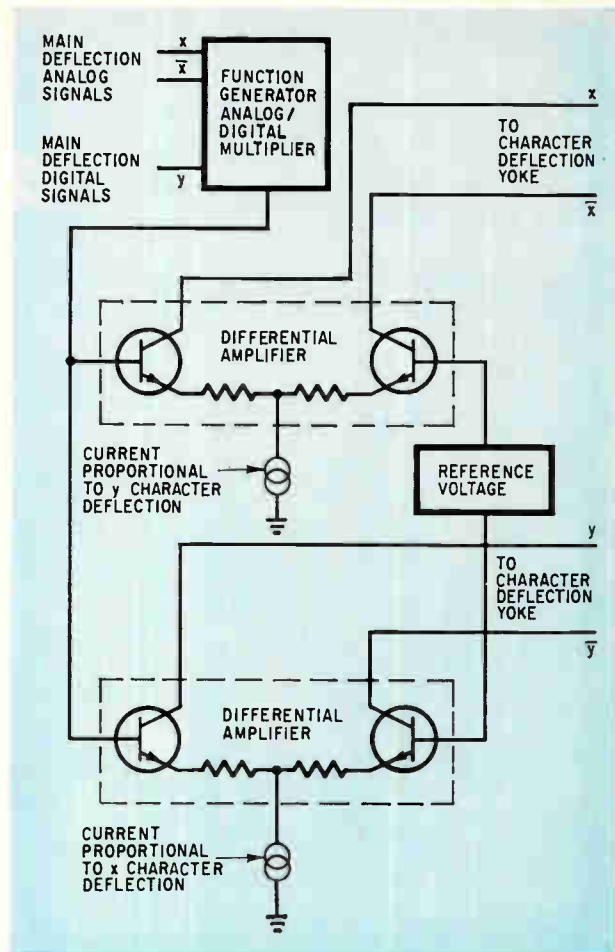

**Making a difference.** After the correction function is obtained from multiplying the  $x$  and  $y$  main deflection signals in the analog/digital multiplier, it is fed into a differential amplifier together with the character deflection current. Characters not in the center of the screen get a slight correction current delivered to the character deflection yoke from the amplifier.

resistance, both of which are controlled by the number of digital input stages turned on. As more digital stages are activated, the ratio of the voltage divider at  $Q_3$ 's base is driven more negative, decreasing the current through  $Q_3$ , thus driving  $Q_4$ 's output voltage higher. The net effect is that each sawtooth is centered at 10 volts—the value of correction voltage at the center of the screen.

The character deflection yoke gets the correction signal from a differential amplifier circuit. One of the transistors in the amplifier is biased at 10 volts—if the voltage from the function generator is 10v, no correction current is delivered to the yoke. Positive and negative signals above and below the 10-v level are delivered to the yoke by the differential amplifier.

The correction voltage could be set by means of a single potentiometer, but if extreme power supply and temperature variations are expected, a sample-and-hold circuit, gated on during the middle lines of the display, should be used. ■

# There's no substitute for a quality zener diode to protect your complex-function circuit designs.

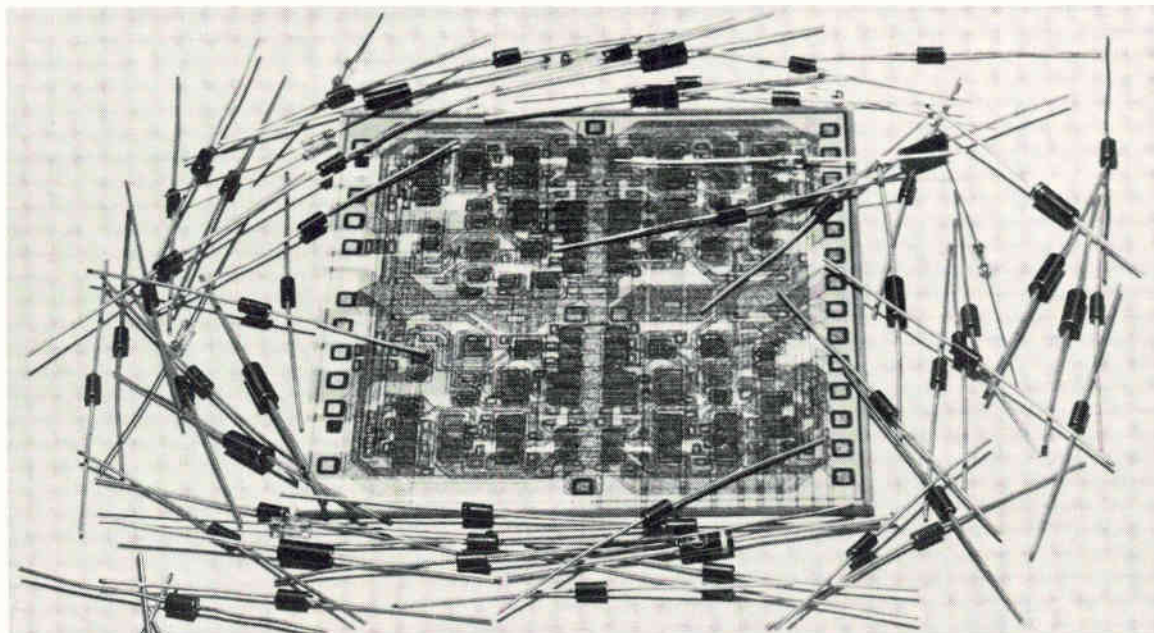

**If there is,  
you'll soon  
know what  
it's worth.**

We've always strived to provide you with the best in zener and reference diodes . . . because we recognize the direct relationship between component reliability and system reliability . . . more important than ever today when so much depends on the instant, consistent ability of a single device to suppress spurious voltage transients.

You can depend on inherent Motorola Zener Diode advantages like:

- Unique, oxide-passivated junctions ensuring low-leakage, bulk breakdown at all reference voltages on all plastic, glass and metal types to 350 W.

- Ramrod\* construction providing safe, sure, lead-to-die contact on all 250 to 400 mW glass units.
- Less than 5 ppm/1,000-hour voltage deviation that locks in voltage reference stability and equilibrium in ultra-critical applications with ZERO-TC/Precision Reference Diodes.
- Better-than-metal, plastic zener diode performance, including higher surge ratings, through rugged, reliable and reasonably-priced Surmetic\* devices.
- Documented test results that show Motorola zener diodes capable of sustained operation *above twice* their maximum power rating.



Send for our new, "no-substitute" design brochure with new Selector and Cross-Reference Guides and Designers\* Data Sheets for a better look at our total commitment to quality that provides you an extra measure of confidence at no extra cost.

Show this to the lowest bidder.

\*Trademark Motorola Inc.

*-where the priceless ingredient is care!*



**MOTOROLA**  
Zener and Reference Diodes

Motorola Semiconductor Products Inc. • P. O. Box 20912 • Phoenix, Arizona 85036

# A single-channel 'multitrace' scope

Multiplexing is the key to expanding capability at relatively low cost; IC monostable multivibrators control FET switches, thus allowing the use of a simple instrument rather than a multichannel scope

By Philip Thompson

Innerspace Technology Inc., Waldwick, N.J.

**Displaying** three or more signals in rapid sequence on an oscilloscope usually requires the services of an expensive multichannel scope. However, by using monostable multivibrators to control field effect transistor switches, a small, economical multiplexing unit, capable of displaying three or more signals on an inexpensive single-channel scope, can be constructed. The output from each switch is then displayed on a cathode-ray tube.

The timing circuit consists of a series of monostable multivibrators—one for each input signal—

connected so that each one drives the next in a closed-loop arrangement. The output of the first one-shot is coupled to the input of the second so that the end of the timed output of the first is used to trigger the second. Similarly, the second triggers the third, which in turn retriggers the first.

The one-shot multivibrators used in this circuit can be triggered by either a positive- or negative-going transition. The first one-shot is initially triggered by a negative-going transition and subsequently by positive-going transitions. The

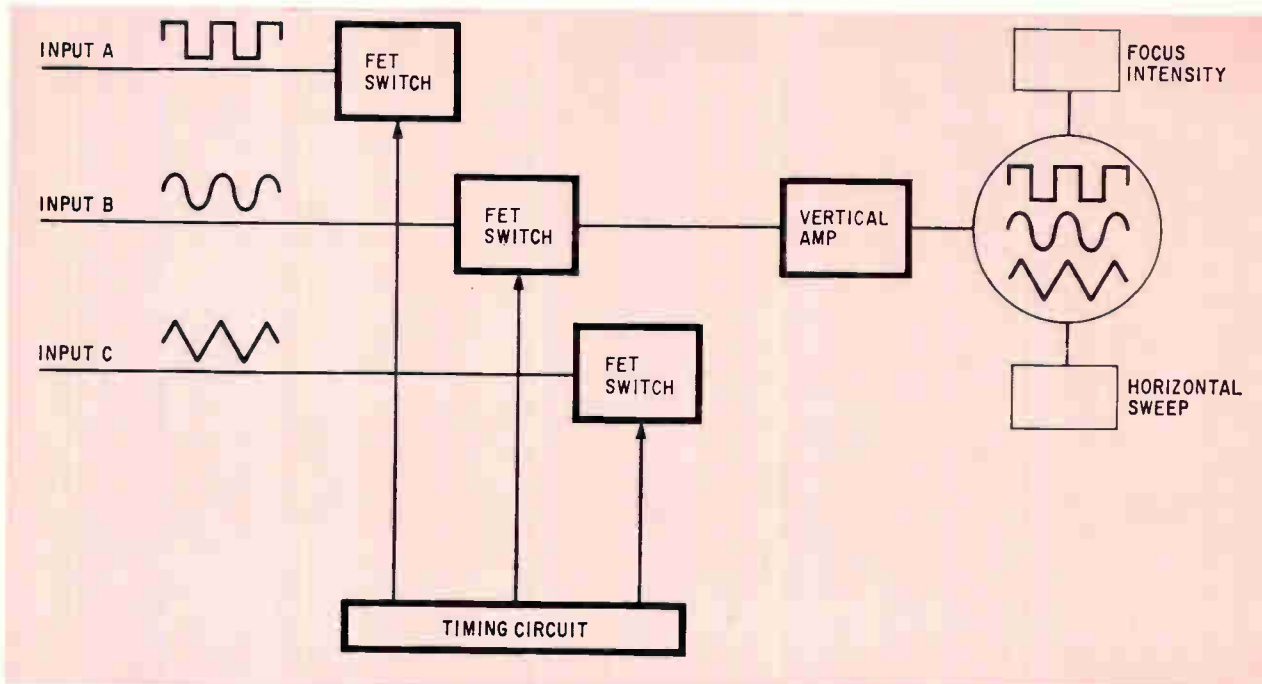

**Multiple trace.** A timing circuit composed of three IC monostable multivibrators and three FET switches combine to form an inexpensive circuit capable of displaying three separate input signals on a single trace oscilloscope. The switch outputs are amplified and applied to the crt.

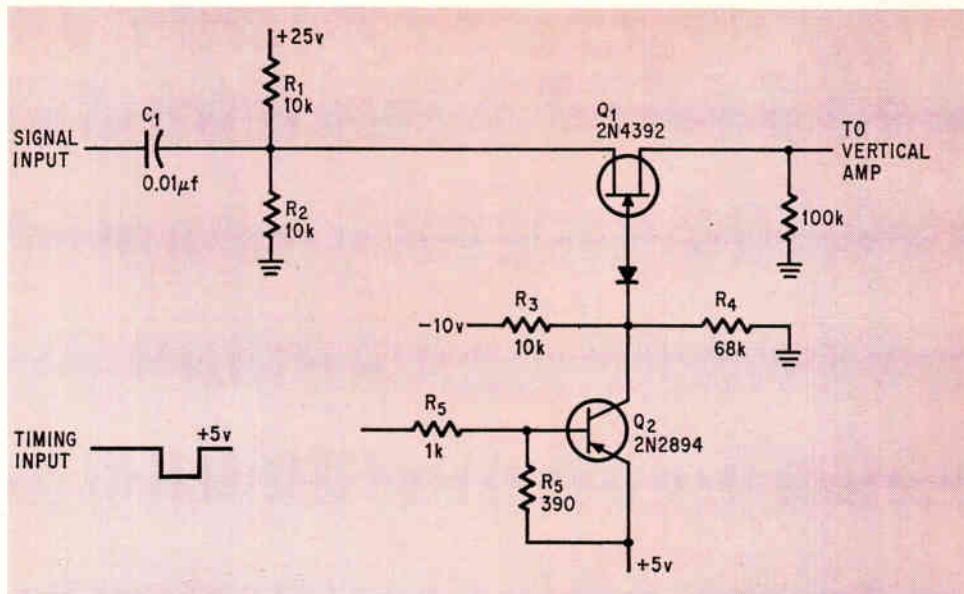

**Chop.** Three mono-stables connected in a closed loop arrangement provide the chop frequency for the FET switches. Pulse duration is controlled by C.

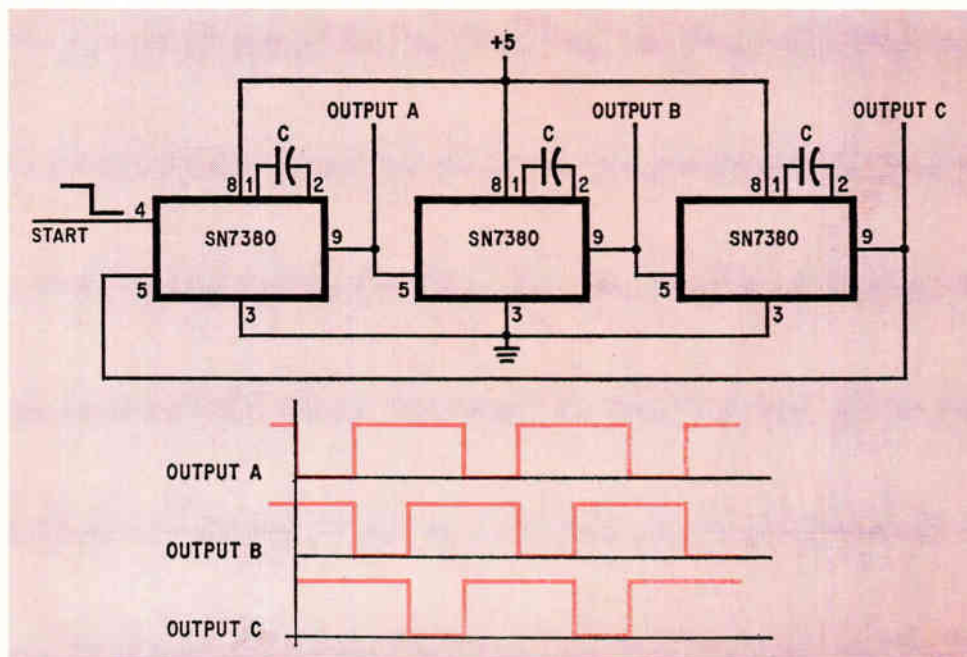

**A switch in time.** A timing signal turns  $Q_2$  on and off, regulating diode bias and thus controlling the FET switch.  $R_1$  and  $R_2$  determine vertical positioning.

remaining one-shots are triggered by the positive-going transitions of the preceding multivibrator. This causes the loop to run continuously and provide independent, equally separated output pulses.

The pulse duration is set by the external capacitor C. A value of 0.01 microfarad gives a pulse duration of approximately 10 microseconds, which is equivalent to a chop frequency of 100 kilohertz. The maximum chop frequency, 100 khz, determines the maximum signal frequency which may be displayed and is limited only by the speed of the one-shots and the switching transistors used.

$Q_1$  and  $Q_2$  form a conventional analog chopper. When the timing signal is +5 volts,  $Q_2$  is off, and its collector is negatively biased. This causes the

diode to conduct and the FET to block. When the timing signal is 0 volt,  $Q_2$  conducts. This back-biases the diode, which opens the gate of the FET and allows it to conduct.

The input to the FET switch is capacitively coupled, and vertical positioning is controlled by the ratio of  $R_1$  and  $R_2$ , which is different for each channel. If desired,  $R_1$  and  $R_2$  can be replaced by a potentiometer so that the vertical position can easily be changed. This method of biasing, however, results in a vertical retrace line on the crt. The retrace may be eliminated by differentiating the positive-going transitions of the timing pulses, summing and amplifying them, and using the result to blank the intensity grid of the crt. ■



# These guys have Utilogic II.

## SIGNETICS STOCKING DISTRIBUTORS

### ALABAMA

Huntsville 35801: *Compar Corp.*, 904 Bob Wallace Ave., Room 114  
Phone: (205) 539-8476

### ARIZONA

Scottsdale 85251: *Compar Corp.*, 84 West 1st Street  
Phone: (602) 947-4336 TWX: (910) 950-1293

### CALIFORNIA

Burlingame 94010: *Compar Corp.*, 828 Airport Blvd.  
Phone: (415) 347-9501

Culver City 90230: *Hamilton Electro Sales*, 10912 W. Washington  
Phone: (213) 870-7171

Burbank 91504: *Compar Corp.*, 2908 Naomi Avenue  
Phone: (213) 843-1772

Los Angeles 90022: *Wesco Electronics, Inc.*, 5650 Jillson Street  
Phone: (213) 685-9525 TWX: (910) 580-1980

Palo Alto 94303: *Wesco Electronics, Inc.*, 3973 E. Bayshore Road  
Phone: (415) 968-3475

San Diego 92111: *G. S. Marshall*, 7990 Engineer Road, Suite 1  
Phone: (714) 278-6350

El Monte 91731: *G. S. Marshall*, 9674 Telstar Avenue  
Phone: (213) 579-1500 TWX: (910) 587-1565

### CANADA

Downsview, Ontario: *Cesco Electronics, Ltd.*,  
24 Martin Ross Avenue

Phone: (416) 638-5250

Montreal, Quebec: *Cesco Electronics, Ltd.*, 4050 Jean Talon West  
Phone: (514) 735-5511

Ottawa, Ontario: *Cesco Electronics, Ltd.*, 1300 Carling Avenue  
Phone: (613) 729-5118

Quebec: *Cesco Electronics, Ltd.*, 128 West Ballier Street  
Phone: (418) 524-3518

### COLORADO

Denver 80110: *Compar Corp.*, 300 East Hampden Avenue  
Phone: (303) 781-0912 TWX: (910) 933-0183

Denver 80216: *Hamilton Electro Sales*, 1400 West 46th Street  
Phone: (303) 931-0580

### CONNECTICUT

Hamden 06500: *Compar Corp.*, 2357 Whitney Avenue  
Phone: (203) 288-9276 TWX: (203) 772-0439

### FLORIDA

Orlando 32805: *Hammond Electronics*, 911 W. Central Blvd.  
Phone: (305) 241-6601

### ILLINOIS

Elmhurst 60126: *Semiconductor Specialist, Inc.*,  
195 Spangler Ave., Elmhurst Industrial Park

Phone: (312) 279-1000 TWX: (910) 254-0169

Addison 60101: *Compar Corp.*, 315 Laura Drive  
Phone: (312) 543-8833

### MARYLAND

Baltimore 21208: *Compar Corp.*, Pikesville Professional Bldg.,  
7 Church Lane

Phone: (301) 484-5400 TWX: (710) 862-0860

Rockville 20850: *Pioneer Washington Electronics, Inc.*, 1037 Taft St.  
Phone: (301) 427-3300

### MASSACHUSETTS

Burlington 01803: *Avnet Electronics Corp. of Mass.*,  
207 Cambridge Street

Phone: (617) 272-3060

Newton Highlands 02161: *Compar Corp.*, 88 Needham Street  
Phone: (617) 969-7140 TWX: (710) 335-1686

Watertown 02172: *Sobley Electronics Corp.*, 36 Arlington Street  
Phone: (617) 926-0235

### MICHIGAN

Southfield 48075: *Compar Corp.*, 21250 10½ Mile Road  
Phone: (313) 357-5369

Detroit 48240: *Semiconductor Specialists Inc.*,  
25127 West Six Mile Road

Phone: (313) 255-0300

### MINNESOTA

Minneapolis 55416: *Compar Corp.*, 3925 Monterey Avenue,  
P. O. Box 16095

Phone: (612) 922-7011

Minneapolis 55423: *Semiconductor Specialists Inc.*,  
7742 Morgan Avenue South

Phone: (612) 866-3434

### MISSOURI

St. Louis 63141: *Compar Corp.*, 11734 Lackland Industrial Drive  
Phone: (314) 542-3399

### NEW JERSEY

Cherry Hill 08034: *Hamilton Electro Sales*,  
1608-10 West Marlton Pike

Phone: (609) 662-9337

Haddonfield 08033: *Compar Corp.*, 15 Potter Street  
Phone: (609) 429-1526

### NEW MEXICO

Albuquerque 87110: *Compar Corp.*, 2129 San Mateo, N.E.  
Phone: (505) 265-1020 TWX: (910) 989-1659

### NEW YORK

Albany 12205: *Compar Corp.*, 6 Highland Avenue  
Phone: (518) 489-7408 TWX: (710) 441-8224

Buffalo 14202: *Summit Distributors Inc.*, 916 Main Street  
Phone: (716) 884-3450

New York 10011: *Terminal-Hudson Electronics*, 236 W. 17th St.  
Phone: (212) 243-5200 TWX: (710) 581-3962

Woodbury 11797: *Compar Corp.*, 335 Crossways Park Drive  
Phone: (516) 921-9393 TWX: (510) 221-2170

### NORTH CAROLINA

Winston-Salem 27101: *Compar Corp.*, 1106 Burke Street  
Phone: (919) 723-1002 TWX: (510) 931-3101

### OHIO

Cleveland 44103: *Pioneer Standard Electronics*,  
5403 Prospect Avenue

Phone: (216) 432-0010

Fairborn 45324: *Compar Corp.*, 16 South Broad Street  
Phone: (513) 878-2631

Fairview Park 44126: *Compar Corp.*, 19500 Center Ridge,  
Rocky River, or P. O. Box 4791

Phone: (216) 333-4120

### PENNSYLVANIA

Philadelphia 19132: *Milgray-Delaware Valley, Inc.*,  
2532 North Broad Street

Phone: (215) 228-2000 TWX: (710) 670-3400

### TEXAS

Dallas 75207: *Hamilton Electro Sales*, 2344 Irving Blvd.  
Phone: (214) 638-0900

Dallas 75241: *Compar Corp.*, 8609 N.W. Plaza Blvd., Suite 222  
Phone: (214) 947-4336

Houston 77019: *Hamilton Electro Sales*, 1216 West Clay Street  
Phone: (713) 526-4661 TWX: (910) 881-3721

Houston 77036: *Universal Electronics*, 5723 Savoy  
Phone: (713) 781-0421

### WASHINGTON

Kirkland 98033: *Compar Corp.*, 12610 N.E. 104th Street  
Phone: (206) 822-4191

Seattle 98108: *Kierulff Electronics*, 5940 6th Avenue, South  
Phone: (206) 763-1550

# Now you can get it II.

What's more, they've got a great big handbook, II—on Utilogic II! Descriptions, specs, usage rules, how-to's, design ideas on the only integrated circuit logic family that gives you I) lowest cost per gate function, II) choice of AND, OR, NAND and NOR logic, and III) silicone DIP's. XXXII pages in all! See any of the guys above—and you can get it II!

# Signetics

Signetics Corporation / 811 E. Arques Ave., Sunnyvale, California 94086 / A subsidiary of Corning Glass Works

# *circuit problems?*

***Signalite Glow Lamps have  
solved problems in these areas:***

- Voltage Regulation & References • Photo-Cell Drivers • SCR Triggering
- Timing • Photo Choppers • Oscillators • Indicator Lights • Counters
- Voltage Dividers • Surge Protectors • Logic Circuits • Flip-Flops
- Memory • Switching • Digital Readouts

Signalite glow lamps combine long life, close tolerance and economy, and are manufactured with a broad range of characteristics to meet individual application requirements. For a creative approach to your design problem . . . contact Signalite's Application Engineering Department.



**ULTRA HIGH LEAKAGE RESISTANCE.** Devices with leakage resistance in excess of  $10^{12}$  ohms are available for circuits requiring this property. Such applications would include sample and hold for A to D conversion, and capacitor memory systems.

**SEE Signalite Application News for TYPICAL APPLICATIONS**



#### **PHOTO-CELL APPLICATIONS**

The A074 and A083 have been designed for use with Cadmium Sulfide or Cadmium Selenide photocells. Applications include photo choppers, modulators, demodulators, low noise switching devices, isolated overload protector circuits, etc. Speed of operation is limited only by the photo-cells.

**SEE Signalite Application News for TYPICAL APPLICATIONS**

#### **SIGNALITE APPLICATION NEWS**



is used to communicate new and proven techniques and applications of Signalite's neon lamps and gas discharge tubes. Signalite Application News provides a forum for an exchange of ideas to keep the design engineer aware of the versatility of neon lamps and their many applications. Copies are available from your Signalite representative or by contacting Signalite.

Circle 334 on reader service card



**VOLTAGE REGULATORS BETTER THAN 1% ACCURACY** These subminiature voltage regulators are used in regulated power supplies, as reference sources, photomultiplier regulators, oscilloscopes calibrators, etc. They are available in voltages from 82 to 143 V. They are used in multiples as regulators in KV ranges.

**See Signalite Application News for TYPICAL APPLICATIONS.**



**NEON TIMERS** The bi-stable characteristics and high leakage resistance of Signalite's special glow lamps make them ideal as a component for timing circuits. The basic circuit resembles a relaxation oscillator network.

**SEE Signalite Application News for TYPICAL APPLICATIONS**

# Signalite

**INCORPORATED**  
NEPTUNE, NEW JERSEY 07753  
(201) 775-2490



A General Instrument Company

313

# GET

## a new source of reliable epoxy case replacements for TO-18 transistors

The General Electric GET transistor series is your new answer to circuit design problems. GET is the most recent member of GE's proved epoxy encapsulated transistor family dating back to 1962 . . . over 6 years of epoxy experience.

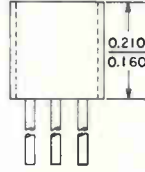

GET's package design conforms to TO-18 mounting patterns in existing PC boards. It's the ideal epoxy replacement for "hermetic devices" . . . no expensive redesign necessary.



These new units use the same industry proved production methods and quality epoxy that made our TO-98 (D16) series so successful. GE epoxy plastic forms a true chemical bond with metal to curb moisture permeation, eliminate internal wire lead fatigue failures, and vibration destruction. Low profile package design means smaller circuits and lower cost.

General Electric epoxy has the ability to contend successfully with a wide range of environmental conditions as shown in the extensive Reliability Evaluation Program described in Pub. 95.36A. Failures experienced with hermetic devices under these levels of shock, acceleration and stress have been eliminated with GE's solid epoxy encapsulant.

Standard NPN and PNP devices are available now through GE distributors. Five family groups representing GE's new epoxy transistor lines are shown below. Additional family types are being added. For more information on GET's for all applications, plus GE's "specials" capability, call or write your GE sales representative or distributor, or write General Electric Company, Section 220-69, 1 River Road, Schenectady, N.Y. 12305. In Canada: Canadian General Electric, 189 Dufferin Street, Toronto, Ont. Export: Electronic Component Sales, IGE Export Division, 159 Madison Avenue, New York, N.Y. 10016.

**GENERAL  ELECTRIC**

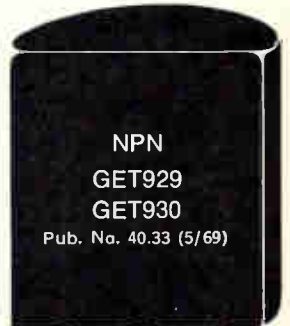
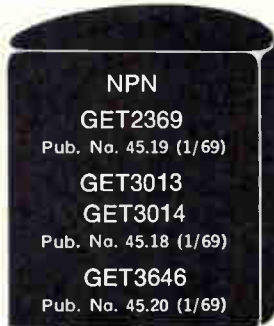
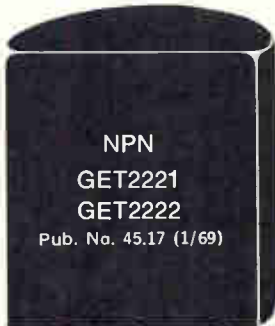
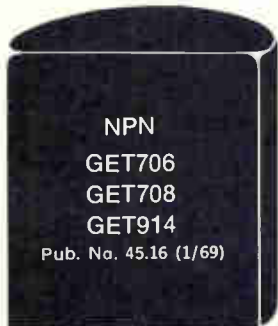

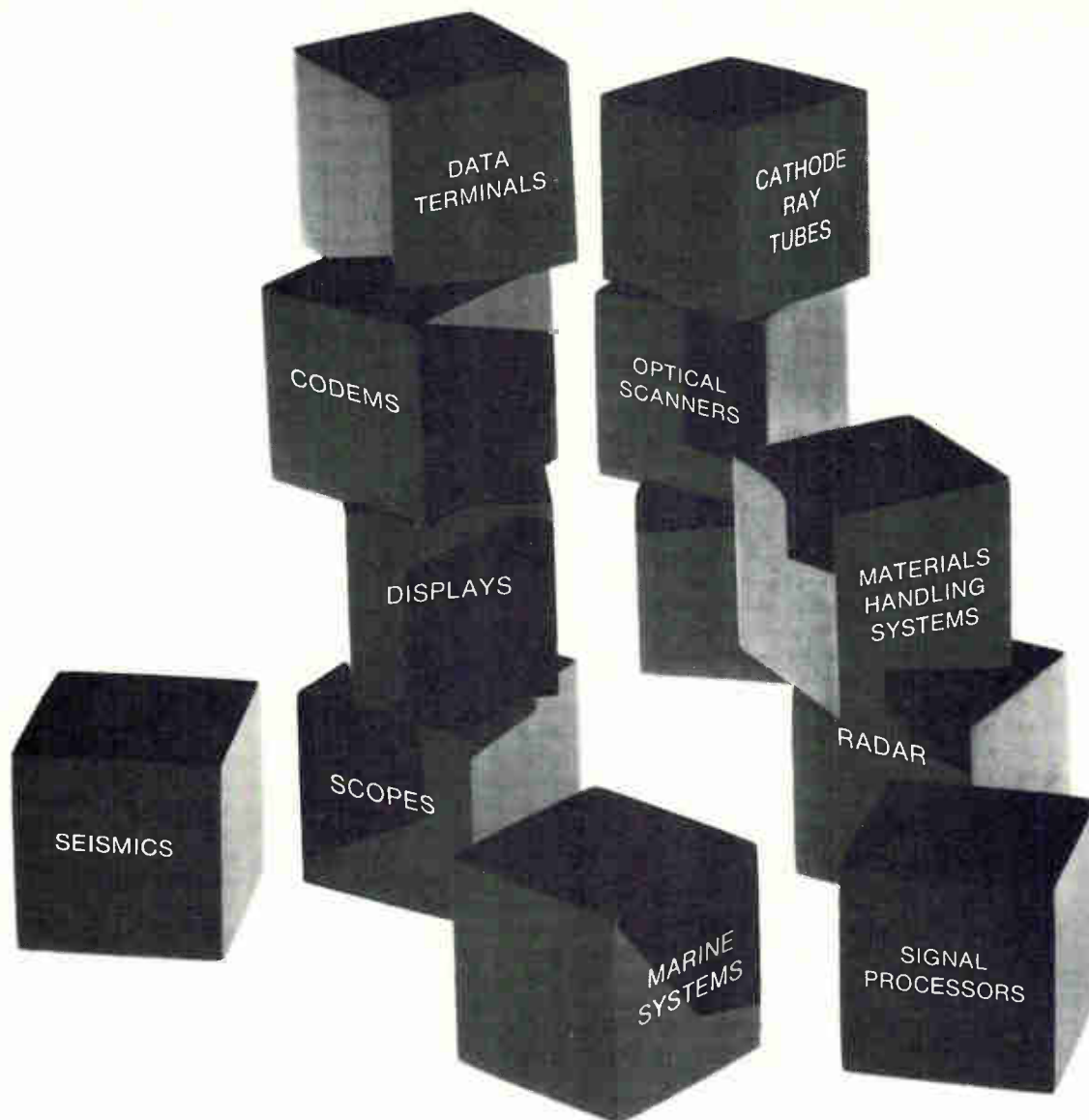

## What more can you get from General Atronics? Plenty. Now that we're a part of Magnavox.

Starting with expanded production facilities and manufacturing know-how . . . especially important for volume electronic requirements in government and industry.

World-wide sales and service facilities.

Economies derived from volume purchase of materials and components.

Extension of qualifications for military contracts.  
Intensified activity in research and development.

And increased ability to contribute to a wider range of markets and customer needs.

Add these to our recognized abilities to generate and implement new ideas in electronic devices and systems for both industry and the military and you've got a meaningful marriage. Now—General Atronics is everything it ever was—plus!

And everything we are is available to you. Write: General Atronics, Philadelphia, Pennsylvania 19118.

**GENERAL ATRONICS**  
a subsidiary of **Magnavox**

# Talk oscillators with Varian. Get a choice in solid state.

Everyone knows Varian sells the widest possible range of thermionic oscillators. But not so well known is the variety we sell in solid state, too.

Consider our line of electronically tuned Gunn effect oscillators. They employ GaAs diodes, operating directly at the frequency you need, with no chains or multipliers. They all compare in cost to thermionic oscillators, with all the system-simplifying advantages only solid state offers. Plus the same guaranteed performance you've come to expect from Varian.

**For wideband tuning** we have an X band YIG-tuned oscillator that provides current-controlled frequency adjustment from 8.0 through 12.4 GHz. Only 2½ inches per side, it weighs less than 24 ounces. And its noise figure is significantly below that of a BWO. C and Ku band oscillators soon to come.

**For rapid, continuous narrowband tuning**, our varactor-tuned X and Ku band oscillators offer up to 1% frequency adjustment at tuning rates comparable to those of a reflex klystron.  $F_C$  can be set mechanically anywhere in the entire frequency band. X band units weigh 4 ounces, measure 1⅔ by 1⅔ by 1⅓ inches.

**And for millisecond discrete frequency switching**, our PIN-diode tuned oscillators are by far the smallest switch-tuning devices you can get. These S band microstrip midgets measure only 1 by 1 by ¼ inches, weigh a fraction of an ounce, and offer options of 2, 4, or even 8 step-frequency changes across their entire range. Other frequency bands can be readily developed. Let's talk. The man who gives you the choice you really need in electronic tuned oscillators is at our more than 30 Electron Tube and Device Group Sales Offices throughout the world.

Or contact our Solid State  
Microwave Division,  
611 Hansen Way,  
Palo Alto, California 94303.

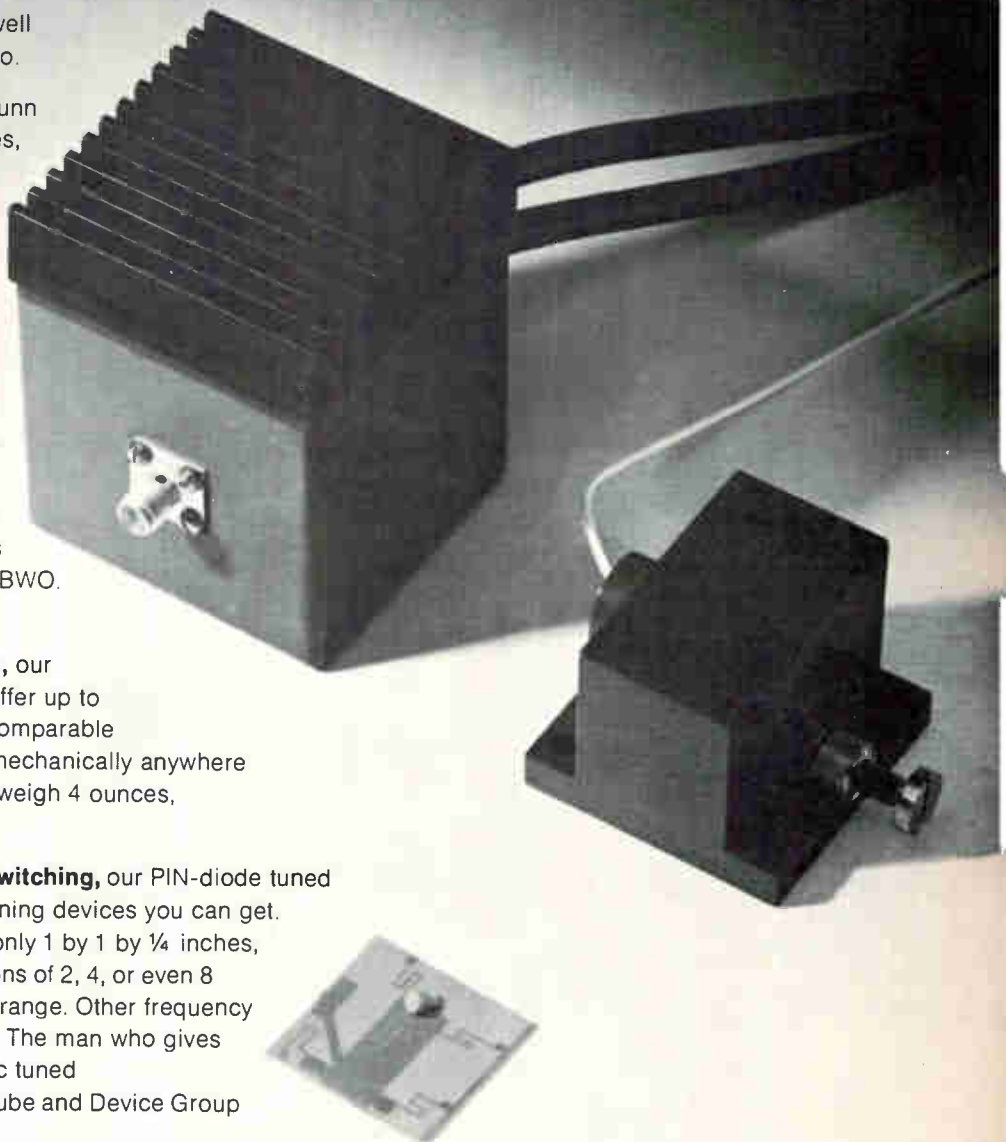

If the communications system  
doesn't track after the big move,  
you know who's going to hear about it.

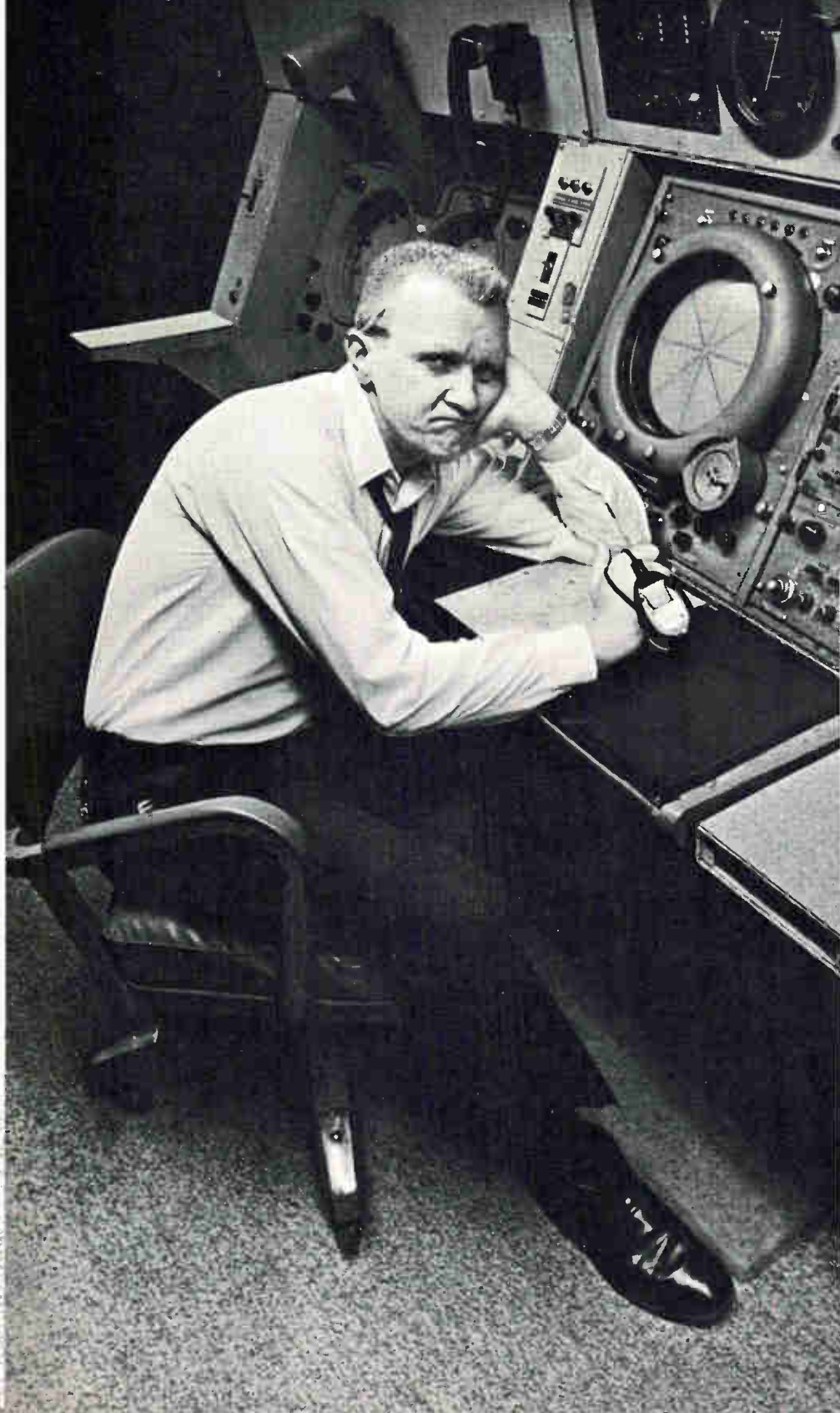

You might receive a few communications that would be banned in Boston (or anywhere else) if the sensitive electronic components go on the blink.

So maybe you'd better communicate with a highly-professional mover who knows how to do the job—Allied Van Lines.

Our Electronic Vans are just as good as our personnel. They have a special bracing that keeps your equipment from slipping . . . an air suspension system that soaks up jolts and bumps along the way.

Call the highly-trained Allied Agent in your area.



**ALLIED VAN LINES®**

**We make the kind of moves  
you never hear about**

When you need data  
about something too hot to handle  
or too fast to see,



call Kodak

Call (716) 325-2000, Ext. 3257. When you face a data collection problem that seems beyond solution, talk to one of our people about a possible *photographic* solution.

Combustion studies, explosion studies, impact studies are familiar disciplines. Photographic procedures, equipment, and materials to evaluate them are readily available. Phenom-

ena in inner space and outer space are also being studied photographically with materials and methods developed by Kodak. Ballistic studies, computer output, and similar high-speed matters are being handled photographically, too.

The large staff of photographic engineers at Kodak is at your disposal. As are many photographic

products for engineering and scientific data photography using computers and/or photographic imaging devices. Let us work with you. Call.

Or, if you wish, write:

Instrumentation Sales,  
Eastman Kodak Company,  
Rochester, N. Y.  
14650.

**Kodak**

# SWITCH CRAFT FORUM



## on Jacks and Plugs

**Jacks and plugs, yet! How can I get excited about them, considering their relative cost in the overall equipment package?**

One sure way to get excited is to suffer costly downtime and repairs on an expensive piece of equipment due to jack or plug failures. While jacks or plugs seldom play the "glamour" roles, you'll find plenty of engineering considerations in their design and application worth looking into from a reliability standpoint.

**I'm willing to be convinced. What should our engineers be most concerned about in specifying dependable plugs and jacks?**

First of all, they should think "total connection" rather than just plugs or jacks. A good percentage of reliability problems stem from mating plugs and jacks from differ-

ent manufacturers. A case in point is the concentricity of the plug tip. (See Fig. 1.) On the smaller jack designs, where contact gaps are minimal, it is possible to open or close the circuit by rotating the plug if the tip is not perfectly concentric. Most cases of erratic operation may be traced directly to these manufacturing or tolerance differences. Other basic design and manufacturing techniques are involved, too. For instance, on plugs, Switchcraft uses a one-piece tip rod machined to close tolerances instead of the less-reliable threaded shank and screw-on tip. Also, certain jack designs employ notched insulating washers that positively interlock with the springs to prevent shifting and possible shorts. These are quality design considerations that the specifying engineer should be looking for.

threat to reliable performance. Spring forming and flexure characteristics with respect to contact pressures are also critical. Solutions to these problems are found in the proper selection of materials and strict adherence to specifications.

Contact resistance is another area. Certain jacks are designed for lighter insertion and withdrawal forces. This creates a problem in maintaining sufficient spring forces for minimal contact resistance. Switchcraft solves this by utilizing silver plated contact springs to compensate for the relative decrease in contact pressures.

The point is, Switchcraft pays strict attention to every design characteristic which is why we have the most extensive, highest quality jack and plug line on the market . . . and that's a plug, Jack!

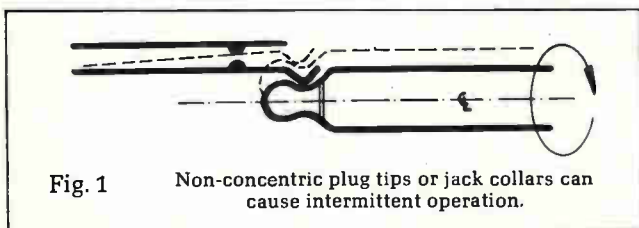
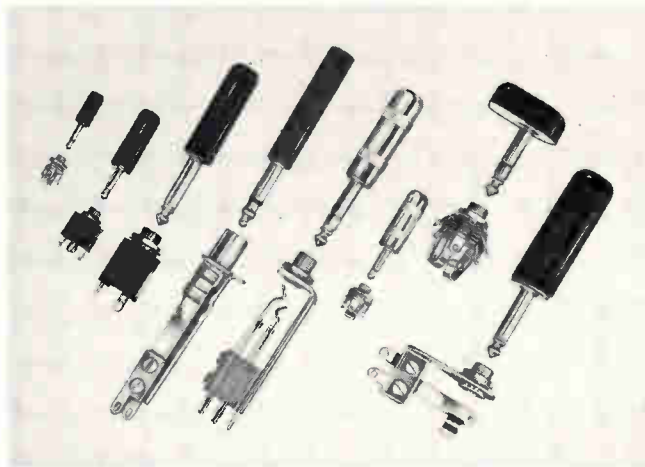

Fig. 1 Non-concentric plug tips or jack collars can cause intermittent operation.

ent manufacturers. A case in point is the concentricity of the plug tip. (See Fig. 1.) On the smaller jack designs, where contact gaps are minimal, it is possible to open or close the circuit by rotating the plug if the tip is not perfectly concentric. Most cases of erratic operation may be traced directly to these manufacturing or tolerance differences. Other basic design and manufacturing techniques are involved, too. For instance, on plugs, Switchcraft uses a one-piece tip rod machined to close tolerances instead of the less-reliable threaded shank and screw-on tip. Also, certain jack designs employ notched insulating washers that positively interlock with the springs to prevent shifting and possible shorts. These are quality design considerations that the specifying engineer should be looking for.

**That covers the mechanical side, but how about some of the electrical design features that make a difference in reliability?**

Surface contamination of contacts is another major



**Surrender! Just tell me how my circuit designers can get all the Switchcraft jack and plug information they'll need.**

All we need is their request on your company letterhead for our "FORUM FACTS on Jacks and Plugs" handbook. We'll also add their name to our TECH-TOPICS mailing list. 10,000 design engineers find these technically oriented application stories on switches and related products extremely valuable.

**SWITCHCRAFT**

5529 N. Elston Ave.  
Chicago, Ill. 60630

Electronics | September 29, 1969



New **GLASKYD 7100 FR**  
an alkyd molding compound  
with the best  
wet electrical properties,  
flame, heat and arc resistance,  
both flexural and  
impact strength,  
dimensional stability,  
a fast molding cycle  
and economy.

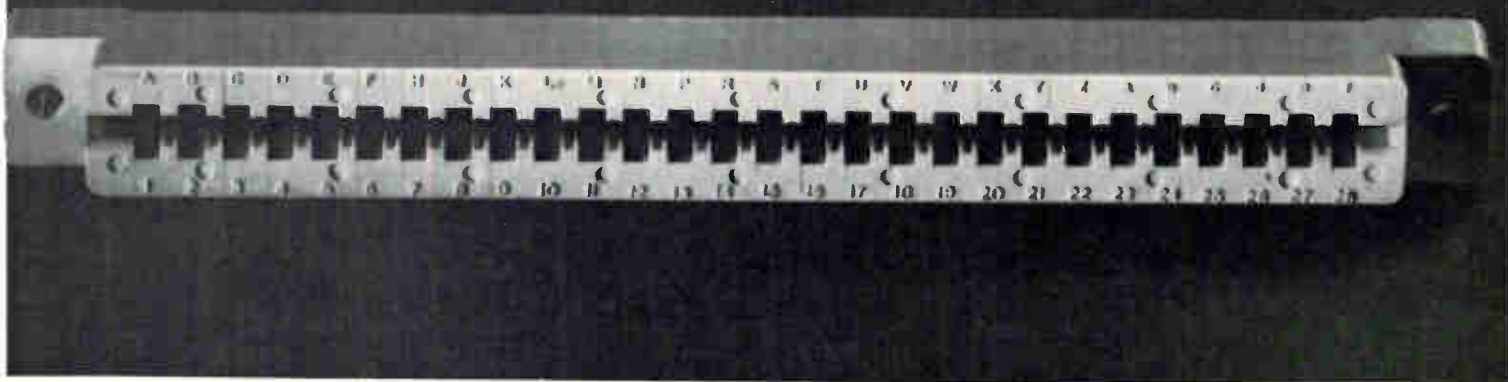

all things considered, it's the  
best connector material you can buy!

For additional information about this circuit  
saver, write American Cyanamid Company,  
Plastics Division, Wallingford, Connecticut 06492.

# 5 GE silicone problem solvers.



**Invisible seal against moisture.** Translucent GE RTV-615 silicone rubber used on this underwater connector assures clear identification of terminals, and improved dielectric strength under high voltage. RTV has excellent electrical properties.



**Mold life doubled.** New RTV-630 silicone molds last twice as long as conventional silicones in molding epoxy parts for electronic modules. Tear strength of 100 lb/in (die B) makes "630" the toughest RTV yet... without sacrificing flexibility.

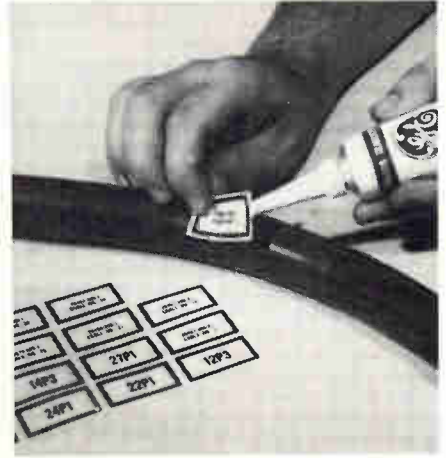

**Durable marking labels** made of GE silicone rubber withstand temperature extremes, aging, moisture, chemicals, fire. RTV adhesive/sealant keeps flexible labels in place permanently on cable, industrial equipment.



**Beats heat and cold.** Electrical heating strip on pipes keeps temperatures constant, indoors and out. GE silicone rubber "jacket," sealed with RTV, has high dielectric strength, resists aging, corona, from  $-65^{\circ}$  to  $600^{\circ}$ F.



**Cheaper than gaskets.** GE RTV-109 silicone rubber seals plate assemblies of food slicer to keep juices out. Non-toxic, inert RTV-109 is applied easily, forms permanent, moisture-proof bond. Contact GE for FDA data on RTV-109.



## And 500 others waiting in the wings.

Chances are you're wrestling with a design problem that could be solved with a GE silicone.

But *which* GE silicone? We have over 500 varieties to choose from. And thousands of success stories to back them up.

Let's make a deal. You tell us what your problem is, and we'll help you solve it.

Without fail.

Write to Section N9311R1, Silicone Products Department, General Electric Company, Waterford, New York 12188.

**GENERAL  ELECTRIC**



product report  
dual-beam

## A NEW Dual-Beam Oscilloscope

### The Viewing Area

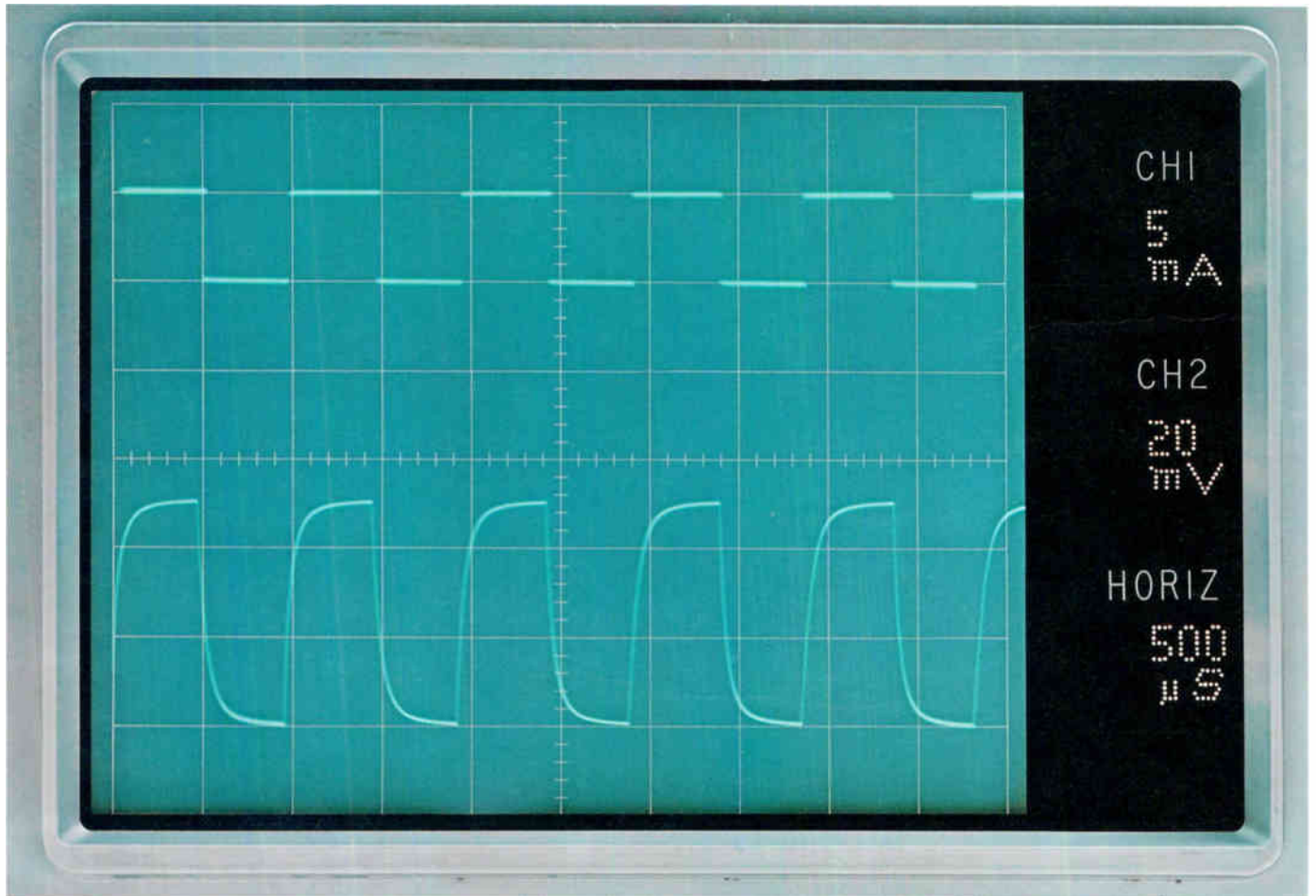

ACTUAL SIZE

**Put a 6-1/2" CRT in your 5-1/4" rack . . .**

**. . . or on your bench!**

With the Type R5030, all the data required to make your measurement is where you need it . . . in the viewing area.

Scale-factors are read out immediately to the right of the 8 x 10 div CRT. Scaled in divisions equal to 1.27 cm, the CRT provides 50% more viewing area than a standard 8 x 10 cm CRT. Each beam has a full 8 x 10 div scan, separate intensity control and push-button beamfinder.



*please turn page for additional information* →

# The Control Panel

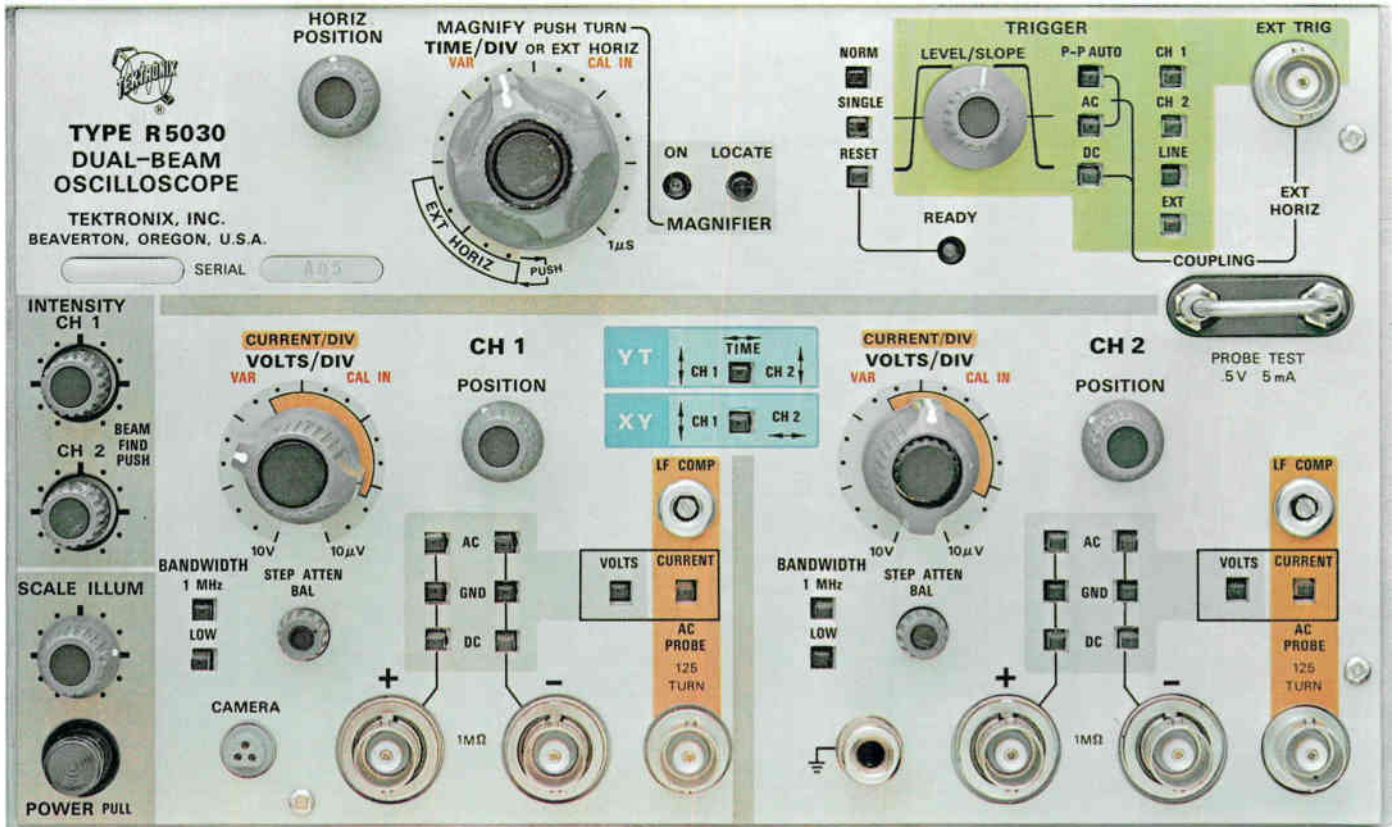

TEKTRONIX PRODUCT REPORT — DUAL-BEAM OSCILLOSCOPE

## easy to use

The complementary color scheme of the control panel of the Type R5030 aids the user in readily distinguishing various control functions.

Current probe inputs for each beam with deflection factors from 1 mA to 200 mA/div are outlined in a salmon color. The bandwidth of the current inputs is from 10 Hz to 1 MHz.

Differential or single-ended voltage inputs are provided with 19 calibrated deflection factors from 10  $\mu$ V to 10 V/div. The scale-factor readouts are corrected automatically when an attenuation probe is attached to the input. Bandwidth is DC to 1 MHz at all deflection factors. However, bandwidth may be limited to  $\approx$  5 kHz to eliminate wide-band noise.

A greatly simplified trigger circuit is outlined in green. With the addition of a peak-to-peak auto mode and a combined level/slope control, the operator will find it difficult, if not impossible, to obtain a nontriggerable condition.

Mode switching has been set aside in a blue panel area where switching from a dual beam Y vs T display to an X vs Y display is as simple as pressing a button.

Rackmount, order Type R5030 ..... \$1850  
 Low-Profile Cabinet, order Type R5030,  
 Option 4 ..... \$1850

U.S. Sales Prices, FOB Beaverton, Oregon

For a demonstration, call your local Tektronix Field Engineer or write:  
 Tektronix, Inc., P.O. Box 500, Beaverton, Oregon 97005



## *Tektronix, Inc.*

*committed to progress in waveform measurement*

# Keeping spin-offs in-house: a new approach to an old problem

By giving creative engineers a degree of freedom and a piece of their own action, one firm expects to cut down on the number who strike out on their own

By Peter J. Schuyten

Associate editor

**Major electronics companies**, confronted by a veritable onslaught of itchy-footed engineers leaving the secure corporate slot to start their own firms, have largely been content to sit back and scratch their heads. But General Electric's Space division has started an innovative experiment in leading its entrepreneurially inclined creative people out of the folds of temptation and back into its own fold—by providing them with almost everything they'd want if they were out on their own.

More and more bright and ambitious engineers and middle-management types are pulling up their stakes and going off to start their own firms. Most of their bosses are just watching in dismay—they feel there is no way to halt this mass exodus; once the creative engineer gets it into his head that his pet project deserves to see the light of day, that's it. Off he goes.

This was why Daniel J. Fink, General Electric's Space division general manager, was so receptive to Jack Guy's idea of starting the Space Technology Products group. For Guy, then manager of technology and subsystem marketing, had a plan which he felt would go a long way toward satisfying the creative engineer while keeping him in-house, and Fink was flexible enough to realize its potential.

**Almost left.** The story started about six months ago. GE physicist Gerald Huth and electrical engineer Robert Locker appeared to be

heading in the same direction as so many other creative types who felt the frustration of not seeing their ideas translated into products—out the door. Their idea was to incorporate the contoured silicon diode which Huth developed about eight years ago, and now holds a patent on, into a product line. (Basically, the diode is a planar device of p-doped n material that has the internal characteristics of an avalanche diode.) It didn't seem possible at the time that management would give them the go-ahead to develop their products—a pair of instruments that detect radiation throughout the entire spectrum of

light and X rays [See panel on p. 128].

Then along came Jack Guy, and the idea for Space Technology Products (STP) was born. In effect, STP was to fulfill the double role of turning space technology into products while keeping the Huths and the Lockers in the GE family.

As Guy tells it, "For a long time I'd been convinced that there was a need for a system or technique to utilize technology that evolves from large companies like GE. Technologists often have a whole pocketful of ideas, but large companies have problems promoting products that don't bring in large

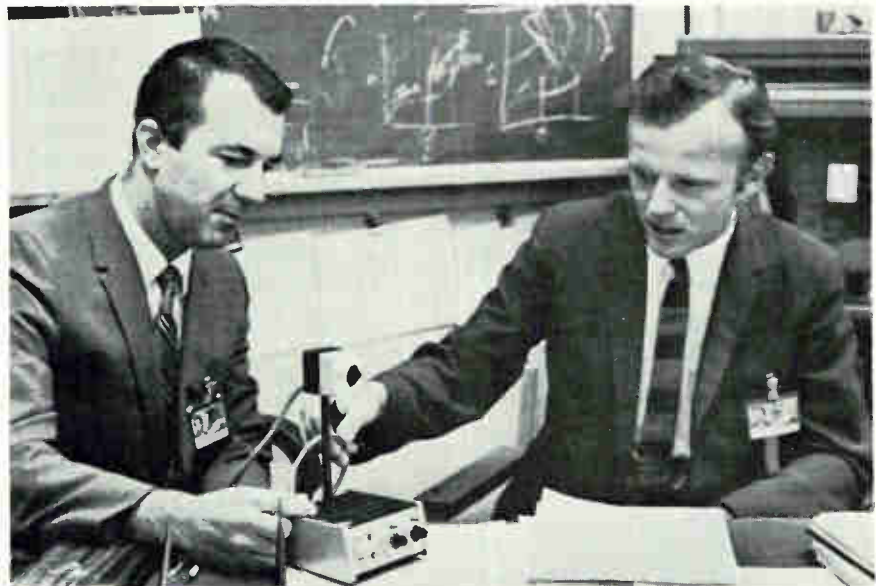

**Rewarding.** GE's STP, experiment has already started paying dividends by keeping creative talent like Gerald Huth (right) and Robert Locker (left) in-house.

dollar volumes; their systems aren't geared for it, so the inventor usually has to go it alone."

**Profit-sharing.** Basically, Guy's idea was for GE to bankroll a group "to exploit contoured silicon diode technology, give them a good deal of freedom, and, if successful, let them share in the profits that they generate."

Guy was allowed to form a 20-man group that included Huth and Locker and to establish his own *modus operandi*. Soon STP will have its own facilities within the Space division complex. "In fact," Guy points out proudly, "we will even have our own entrance. People will come to visit us just like they would any small, independent company."

As Guy explains it, STP comprises three departments: research, which Huth heads; manufacturing, for which Locker is responsible; and marketing and administration, the province of William Granat, who formerly was the division's manager of technologies market development. Guy, of course, is manager of STP.

Like any other Space division group, STP is under the corporate umbrella in the sense that it utilizes the division's legal, financial, publicity, and benefits departments. "In fact, we operate like any other group here—just our goals are different," says Guy. Those goals include doing between \$1.5 million to \$2 million worth of business in the next 18 months. Once that level is reached the profit-sharing plan goes into operation, Guy says, although he won't say how the plan is supposed to work.



**His baby.** Were it not for Jack Guy, STP might never have been a reality.

## Detection, not defection

Formed as much to capitalize on technological fallout from the space program as to keep Gerald Huth and Robert Locker from leaving GE, Space Technology Products is readying two items for the marketplace.

The first is a light detector intended for use in the receiver portion of gallium arsenide and neodymium laser ranging and communication systems. The other is a radiation detector that is, as Huth puts it, "the solid state equivalent of a proportional radiation counter." For use in the medical field, the instrument can detect, or count, low-energy isotopes at body temperatures.

Both products were built around Huth's contoured silicon diode, a planar device of p-doped n material that can operate in the avalanche mode. The contouring controls the electric field at the surface

of the silicon p-n junction, keeping it low enough so that the internal field can be raised sufficiently to cause avalanche.

The silicon avalanche diode detects light from a visible 0.7 micron to 1.1 microns in the near-infrared region, and because of its avalanche characteristics amplifies it an average of 200 times. In this way it is analogous to the photomultiplier tube. For detecting energy in the X ray region the device has a range of from 500 electronvolts to 20,000 ev.

The light detector will sell for about \$900 without a recording or display device. The radiation detector comes in two versions: one, a battery powered portable unit that gives a 10 kilohertz readout, will sell for \$1,900; the other, a laboratory version that counts at a rate of 10 megahertz, will sell for about \$3,000.

**Midwife.** Along with Guy, Locker, Granat, and Huth, there's another person to whom STP owes its existence—Donald E. Mullen, the Space center's manager of division planning. "My ma'n task," says Mullen "was helping Jack Guy devise a strategy to win his idea divisional approval. I guess you could say my role was more midwifery than anything else."

Mullen became aware of Jack Guy's desire to set up something like STP several years ago when the two of them worked together on another project. So it was to Mullen that Guy turned when he wanted help in selling the STP idea to Fink.

Guy now reports directly to Mullen, and in the process skips several steps in the GE pecking order, which no doubt spurs envy in other sections at the division—when Guy wants something, he's got Mullen to run interference for him. Furthermore, section managers usually handle \$10 million to \$20 million in programs and have anywhere from 500 to 1,000 people working for them, not 20-man groups with 18-month marketing goals of \$1.5 million, like STP.

How much has the STP experiment cost? No one at GE will spell it out exactly, but Mullen says it's

been comparatively cheap. "So far STP has cost us a market survey, some floor space, and some key people—people we would have lost altogether if there'd never been an STP."

As far as Mullen's concerned, STP's benefits will far outweigh the investment. "For one thing it will prove to our creative people that creativity is encouraged here," he points out. And apparently the word has gotten around, "for since the STP thing started other creative types are starting to come out of the woodwork and asking us about getting a piece of the action instead of quietly arranging financing elsewhere and then resigning," he adds.

**Out of the fry pan.** "The space program can also use some fallout, Mullen asserts. "So far, the only thing most people see emerging from the program is Teflon frying pans."

One potential fallout item is a bacteria counter that GE developed for NASA. Although Mullen won't spell it out in detail, he says that it can do an analysis in four hours instead of the 24 that other counters usually require. "If we can get it working on a real-time basis, there are a lot of municipal governments that would love to buy it,"

## The yeoman engineer

While GE's STP formula may cause many creative engineers to at least think twice before going out on their own, there are still those, like Thomas (Stoney) Edwards, who just won't sit still until they are running their own shop.

"I've always had the ambition to set up a system of my own," says Edwards, one of the founders of Siliconix and former general manager of the company's Equipment division. Edwards left Siliconix last fall, with the blessing of company president Dick Lee, to found his own firm, International Production Technology (IPT). "While my ambition was partly fulfilled when I helped found Siliconix, this is the real thing," he says of the new firm.

IPT, as Edwards explains, essentially is Siliconix's equipment division set up, or spun off, as an independent company. Siliconix originally got into the equipment business back in 1962. Shortly after the company was formed, "we found that the equipment available just wasn't mature enough to service the semiconductor industry. So we decided to build our own," he relates. At first the products were used only in-house, but later—around 1967—Siliconix found itself with a full-scale commercial operation on its hands.

From all appearances Edwards, while still at Siliconix, had everything an entrepreneurial-type engineer would want: head of his own group; freedom to design and develop his own products; a separate sales force—in effect, his own company. So why did he make a complete break?

Besides his old ambition to strike out on his own, Edwards lists some problems the Equipment division had while under the Siliconix wing. "While the business was successful, it suffered from being an equipment group in a semiconductor industry. We had trouble attracting the right kind of people for equipment manufacturing. Also, with everything we did, there were, of course, strings with Siliconix; for instance, we had to serve Siliconix first and the rest of the industry second."

So, Edwards went to Lee last fall and an agreement was worked out to split the Equipment division away as a separate company. And while relations between spin-off and spin-ee are excellent, they are also strictly businesslike. In fact, Edwards made a point of arranging his own financing from outside sources to insure that IPT would have no obligation of any kind, explicit or implicit, to Siliconix. Currently, Siliconix absorbs about 20% of IPT's volume and has two out of seven spots on IPT's board.

Mullen says with assurance.

Along with STP's structural approach Guy has other ideas for turning technology into products while retaining creative men. One is to subcontract "an idea package," as Guy calls it, to a company which has a similar product line. The key people instrumental in developing the technology act as a program office, managing the subcontract. Unlike a licensing agreement, the subcontract idea would allow the inventor to retain complete control over his idea from beginning to end, which, according to Guy, is essential to keeping the creative mind happy. "Separating the invention from the inventor is like separating the child from its mother," he declares.

Suprisingly, at least according to Guy and Mullen, there have been very few problems so far in the STP experiment. "The most

trouble I've had," says Guy, "is with the legal and financial boys in the Space division. They are just too negative. They sort of overplay their roles as devil's advocates."

**Giant killer.** As for Mullen, his only problem is "keeping Jack Guy confined to one idea. Jack wanted to kill the whole giant at once. My idea was to make Jack stick to one product and one approach. STP's got to be a success before we'll try anything else." It's Mullen's view that STP, if successful, will be an enabler for other kinds of similar ventures, some of which already are being closely scrutinized by Mullen and other GE executives. "If it screws up, it'll shut the gate on this kind of thing at GE for a long time," he adds quickly.

What are STP's chances of success? According to Guy, "If anything like this will succeed, it's going to be STP. We've got all the

**RX Bridge  
spans the  
500 kHz  
to 250 MHz  
range  
...precisely**



### oscillator, bridge and null detector all-in-one

The 250B RX Meter is a self-contained RF bridge that reads impedance in terms of  $R_p$  and  $X_p$  from 500 kHz to 250 MHz. It consists of an accurate, continuously tuned oscillator, Schering bridge, amplifier-detector and null indicating meter.

Ruggedly constructed, the 250B bridge assures the user of the stability necessary for precise measurements. A front panel control adjusts the RF excitation signal to as low as 20 mV, permitting measurement of input and output "Y" parameters of transistors with the accessory 13510A Transistor Test Jig, and use of the bridge for other low-level measurements. Another accessory, the 00515A Coax Adapter Kit, provides a convenient means for adapting the bridge terminals to type "N" connectors for measuring devices with coaxial connections.

The 250B RX Meter is especially useful in determining electrical characteristics of devices and circuits such as inductors, capacitors, transformers; and filters. Price: \$2050.

For complete information and a copy of the 250B Technical Data Sheet, contact your Hewlett-Packard field engineer or write: Hewlett-Packard, Green Pond Road, Rockaway, New Jersey 07866. In Europe: 1217 Meyrin-Geneva, Switzerland.

**HEWLETT  PACKARD**

IMPEDANCE INSTRUMENTS

10908

# You'll love this Red-Head! GE's Newest SSL lamp.

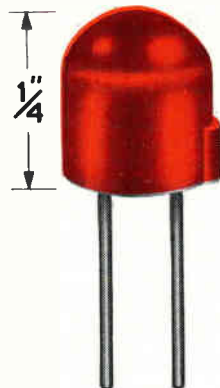

SSL-22's tiny red light has an end-on candle power of 1.5 milli-candela. It is easily visible through a full 180 degrees across the room. No wonder our newest solid state lamp makes such an exceptional indicator or photocell driver.

Efficiency? How's 150 microwatts at 10mA. Current drain? A low 10mA at 2.1 volts. Little SSL-22 (less than a quarter inch tall) shrugs off shock and vibration, keeps lighting brightly for years.

It can be switched at frequencies up to 0.5MHz. With no inrush current. And like the 9 other GE SSL lamps, it's happily compatible with integrated circuits.

SSL-22 and other visible SSL's have hundreds of ap-

plications, as indicators and photocell drivers, in computers, missiles, telephone equipment and aircraft. Infrared SSL's operate in counting devices, machine controls, card and tape readers and many other photoelectric applications.

Free technical bulletins are available for each lamp. Just order by the numbers shown below.

For the whole spectrum of GE SSL applications, together with complete data on all lamps, send for our 64-page Solid State Lamp

Manual. Included are over 80 diagrams, illustrations and graphs. Copies are \$2. Write: General Electric Co., Miniature Lamp Department, M9-4, Nela Park, Cleveland, Ohio 44112.



## Here's the latest picture of the family.

GE Lamp No.	Color	Output	Operating Voltage	Operating Current	Bulletin No.
SSL-1	Yellow	25-65 Ft. L.	2.5-5.1V	50mA	3-8011
SSL-3	Green	100 Ft. L.	1.1-1.7V	100mA	3-8273R
SSL-4	Infrared	0.3mW	1.1-1.5V	100mA	3-8268R
SSL-5A	Infrared	1.4mW	1.1-1.7V	100mA	3-8268R
SSL-5B	Infrared	1.9mW	1.1-1.7V	100mA	3-8268R
SSL-5C	Infrared	2.4mW	1.1-1.7V	100mA	3-8268R
SSL-6	Yellow	25-65 Ft. L.	2.5-5.1V	50mA	3-8011
SSL-15	Infrared	0.5mW	1.1-1.8V	20mA	3-8274
SSL-22	Red	0.15mW	2.1V	10mA	3-9207
SSL-25	Infrared	1.5mW	1.1-1.8V	20mA	3-8274

Miniature Lamp Department

**GENERAL**  **ELECTRIC**



**Heavyweight.** Donald Mullen paved STP's way at divisional level.

advantages of a big corporation behind us, all the flexibility of a small, aggressive company, and a product that looks pretty good." Backing Guy up, Mullen adds that "GE management is very cautious about anything new or unorthodox. This one is a real winner."

If successful, STP may well provide the formula for a wide range of similar ventures. GE appears to be the only one of some 30 large firms to go far enough toward implementing such a venturesome plan that it's willing to talk about it.

At present a very few companies, including Texas Instruments, National Semiconductor, Sylvania, and Xerox's Electro-Optical Systems division, appear to be cautiously moving in the same direction. TI, for instance, has a program called IDEA (for identify, develop, expose, and action), which makes venture capital available for "talented innovators." However, at TI the innovator does not share in any profits. J. Fred Bucy, TI's components group vice president, does say, though, that the company is "currently studying this idea in the hope of arriving at some arrangement in the future."

Spokesmen for both Sylvania and National Semiconductor admit to working on programs of their own, but beg off talking about them, asserting that they're too new to discuss right now. And finally, at Xerox Electro-Optical Systems, there is another program, which, while not allowing the innovator any real independence or management responsibility, does at least have provisions for compensating the engineer who develops the idea.





## Solid-State Sweep Oscillator

**New 1.0 to 4.0 GHz RF Plug-in** covers entire range in one continuous sweep.

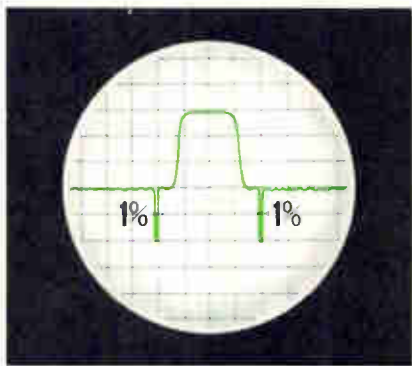

ALL Type 210 Sweep Oscillator is the only one whose markers are always 1% of swept width. You get superior performance and operating simplicity over broad range of 0.25 to 40 GHz. Main Frame price less cabinet: \$1525.

Why switch bands and miss information at crossover points when this new solid-state plug-in gives you full two-octave band coverage in one continuous sweep—with over 30 mW of leveled power?

Why buy different sweep oscillators for various portions of the microwave frequency range when the Type 210 offers a full selection of interchangeable solid-state and BWO plug-ins covering from 250 MHz to 40 GHz?

Why be satisfied with markers that "blow out" and become useless on narrow sweeps when we provide markers that are always 1% of the swept band?

All this and extra features as well—two independent sweeps

fully interchangeable—15 calibrated symmetrical sweeps about four separate CW frequencies—PIN leveling from 250 MHz to 18 GHz.

Fact is, the Type 210 makes other sweepers old fashioned. Try it for yourself. Call our "hot line" to arrange a demonstration. Dial 516-595-3216 during East Coast business hours.



Or write for our new catalog covering ALL's full line of Microwave Instruments.

**AIL** a division of **CUTLER-HAMMER** CONTROL

DEER PARK, LONG ISLAND, NEW YORK 11729

Characters  
per second

500 to  
1000

150

120

60

30

25

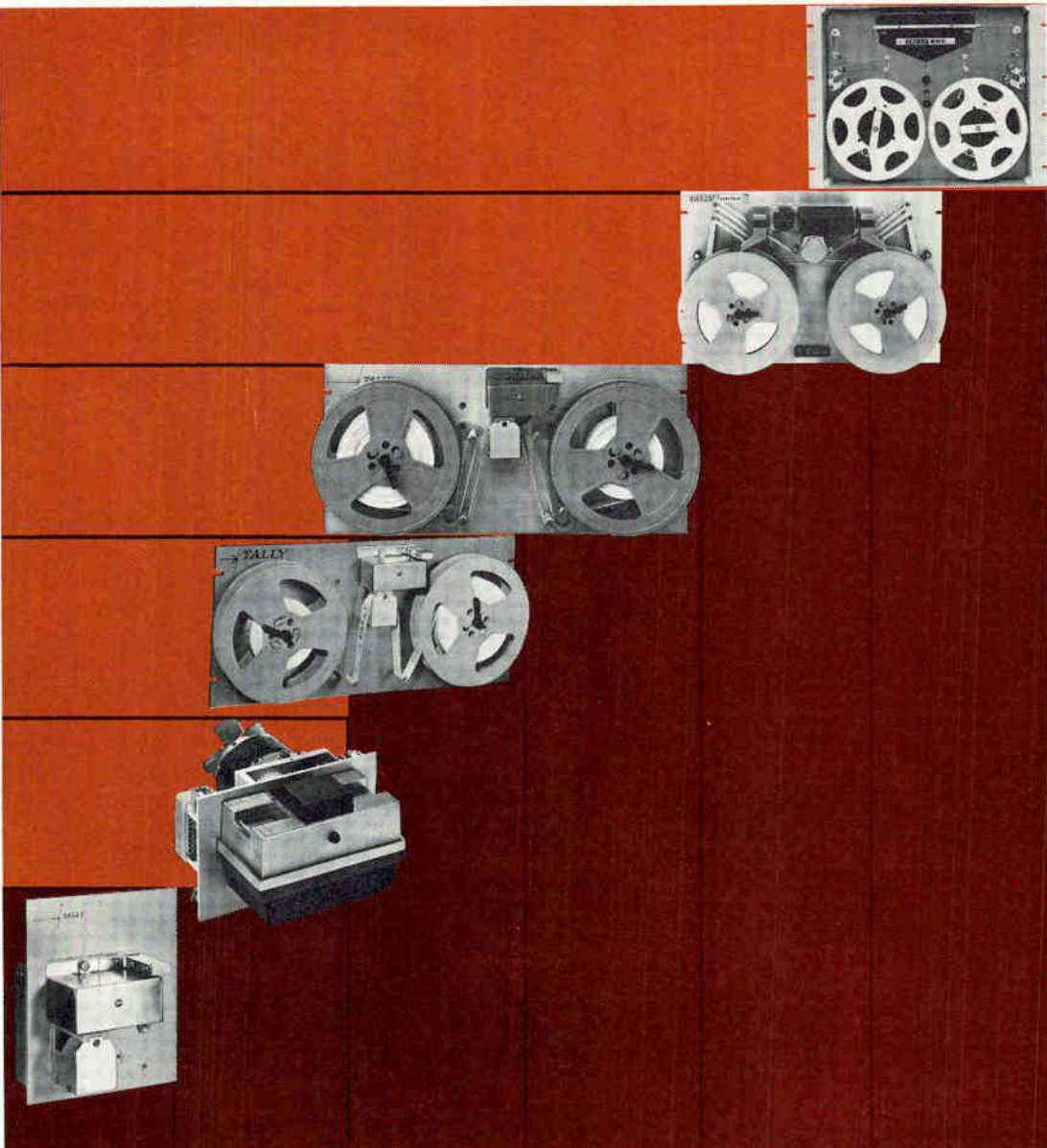

Model  
Number 625

R-30

424

464

HR-150

500 R

# What a line

**...of perforated tape readers!** Tally not only offers the most complete line of perforated tape readers (for paper, foil, or plastic tape), but the broadest and best performing line of perforators too. So whatever your needs in the field of perforated tape technology, write or call us today. Please address Tally Corporation, 8301 South 180th Street, Kent, Washington 98031. Phone: (206) 251-5500. TWX: 910-423-0895. In Europe and the U.K., address Tally Ltd., 6a George Street, Croydon, Surrey, England. Phone: (01) 686-6836.

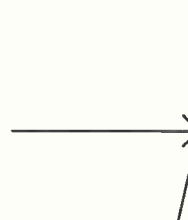
 **TALLY**

# Help on the way for teleprocessing?

Low-cost microwave nets for data, besides competing with Ma Bell, are expected to generate new equipment markets and boost time-sharing

By Ray Connolly

Associate editor

The growing complaint by computer time-sharers that it costs more to get to the computer than it does to actually use it has been voiced by many. Dartmouth professor John Kemeny, computer center specialist, says: "It is not at all uncommon for users who are more than 100 miles away from the Dartmouth campus to pay more for the cost of communications than for the cost of computing." And he adds, "Phone companies are imposing rate structures that discriminate against computers." With Presidential science adviser Lee DuBridge presiding, the Kemeny complaint kicked off a series of eight lectures and discussion titled "computers, communications, and the public interest." Sponsored by the prestigious Brookings Institution and Johns Hopkins University, the first of the Washington-based monthly series drew a computer-oriented audience to whom the problem was all too familiar.

Citing New York City's well-publicized telephone hangup as an example professor Kemeny says, "In many parts of our country our communications network is already being overloaded."

To find an answer Kemney says: "We must consider some drastic solutions including possibly the development of a separate communications network for teleprocessing—hopefully interlinked with the ordinary telephone network—which might provide special and less expensive capabilities for computers."

And an answer could be on the way. As Kemeny delivered his proposal at Johns Hopkins School

of Advanced International Studies in downtown Washington, a small staff not far away in the Offices of Microwave Communications of America Inc., (Micom) was busy preparing a series of filings for the Federal Communications Commission to interconnect most of the nation with just such a network. The filings differ from the Kemeny proposal, however, in that they do not propose to be "interlinked with the ordinary telephone network."

**A revolution.** The Micom proposals represent a communications revolution in several respects. Headed by President John D. Goeken and board chairman William McGowan, Micom is aiming to do for real-time, time-sharing data processing what the American Telephone & Telegraph Co. has done for voice communications—and do it at rates which Goeken says will be "from 56 to

94% cheaper than Bell." [*Electronics*, Sept. 1, pp. 14, 40.]

Goeken, a former General Electric Co. mobile communications equipment representative, also heads Microwave Communications Inc. (MCI), the company which seems to have finally sprung the AT&T lock on national common carrier communications by last month's 4-3 decision by the FCC in MCI's favor to set up a commercial microwave net between Chicago and St. Louis. Though AT&T and Western Union do not appear to have given up with the MCI decision, Goeken and his colleagues are similarly undaunted. "It's taken us six years so far," says Goeken of his fight with the carriers.

Ironically, Goeken's first thought when he and a handful of other GE reps petitioned the FCC for the Chicago-St. Louis link in 1963 was



**Wide coverage.** In addition to MCI's approved Chicago-St. Louis microwave link, other affiliates of Microwave Communications of America Inc., are filing for routes that will almost complete a truly national network.

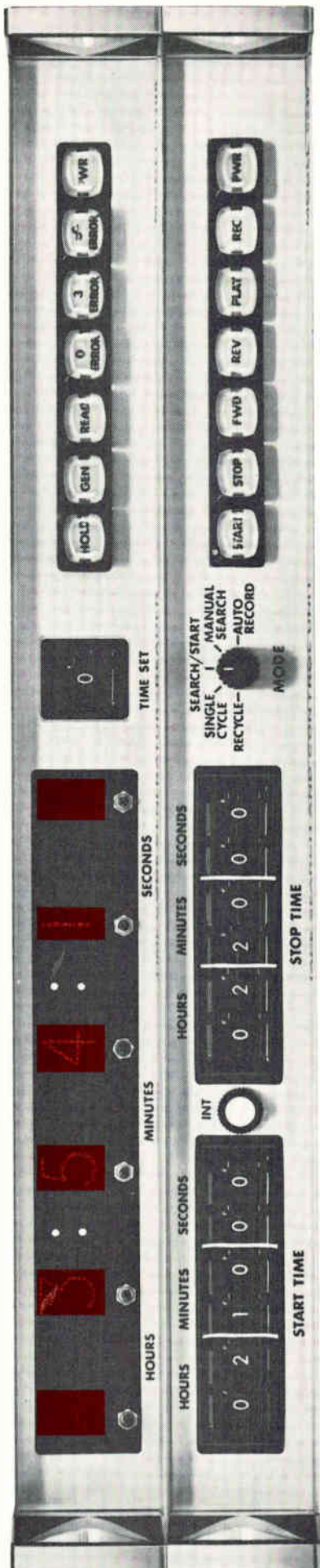

Now: A **True**  
**Tape Search**  
**and Control**  
**System in**  
**3½ Inches.**  
**\$3695**  
**FOB Anaheim.**  
**Delivery: Two Weeks**  
**(or sooner)**

Automatic tape search in *both* directions with this new time code generator and tape search and control system from Datum.

This complete system provides time generation for data acquisition, time reading for data playback, and fully automatic tape search for automatic data reduction — all in 3½ inches.

Modular IC construction permits many optional features, such as slow-code outputs, remote display, remote manual control, and high-accuracy time base.

For complete information about the Datum 9300/9420 Tape Search/Control System, or other timing instrumentation, circle the reader service number below, or write: DATUM, INC., Timing Division, 170 E. Liberty Avenue, Anaheim, California 92801. Telephone Number (714) 879-3070. TWX Number (910) 592-1289.



**Key figure.** Future FCC action on the MCI case could hinge on Commissioner Kenneth Cox, who favored the 4-3 decision and whose term expires next June.

of the money to be made from transportation—with truckers able to communicate with drivers on the busy industrial route, directing deliveries and pickups along the way. Computer-to-computer communication seems to have been the farthest thing from his mind. Now it is uppermost, along with facsimile transmission and voice communications. And so is the formation of a national network of his new class of “special service common carriers,” as they are now labeled, with Micom bearing much the same relationship to these new independents as the Bell System affiliates do to AT&T.

The analogy between Micom and Ma Bell is one that Goeken doesn't like. “AT&T owns a controlling interest in its companies,” contends Goeken. “Micom has only a minority interest in its affiliates; in some of them it will have no interest at all.”

Micom's role, according to Goeken, will be that of a service company tailored to the needs of these independently operating carriers. It would handle such tasks as “national marketing, setting technical standards, maintenance responsibility of interconnected circuits, centralized tariff quoting



... micon aims to do for time-sharing data processing what AT&T did for voice communications—and do it at cheaper rates . . .

and billing of major communications users."

**Great expectations.** First to file with the FCC was MCI New York West for the Chicago-New York run—Goeken says that 66 drop-off points are planned along the link to interconnect such large and small industrial markets as Detroit and Cleveland, Allentown and Johnstown, Pa. Also in varying states of readiness are filings for New York-Boston by MCI New England; Chicago and Minneapolis by MCI North Central; and San Diego and Seattle by MCI Pacific. Considering that each license request will include multiple drop-offs for interconnection with local telephone companies, the MCI-Pacific routing through the Los Angeles and San Francisco areas holds as much monetary promise as does the New York-Chicago hookup. As for New York-Washington, that interconnection is already pending before the FCC in a filing by Interdata—a company in which Goeken and his associates recently acquired a minority interest.

The MCI chief executive has already spoken of plans for other market areas: St. Louis to Kansas City and St. Louis to New Orleans. And there are rumblings of a future Miami-Washington link.

**Impact on EDP.** Bernard Strassburg, the FCC's common carrier bureau chief, opened the Pandora's Box of communications and computer interrelationships when he began his crucial inquiry into the misty area more than three years ago. Computers and communications, he said then, "are like the yolk and the white of an egg. I think we should look at them both before we wind up with an omelet." Since that time, the FCC record shows that Strassburg was not the only concerned chef. The number of cooks flavoring the pot includes virtually every company and industry association with an interest in either field as well as several government agencies.

Criticism from the General

Services Administration—a major computer user—was typical: "The cost at this time of a single full-period circuit with 40,800 baud transmission capabilities is prohibitive for most agency applications."

Communications costs, GSA added, "may be the determining factor in the choice between small computers and central processor-remote terminal systems."

Only the largest users require the 3-kilohertz band lines and can use them effectively. One major computer maker says, "it is unfair that this economy of operation should be available to large business while not to smaller businesses."

The biggest of them all, International Business Machines Corp., sees the problem in a different light. "The nature of data traffic is fundamentally different from voice traffic, and the requirements of data users have been met by adaptations of a network that was essentially designed for voice communications."

None of this should have come as a surprise to AT&T, for its November 1957, Bell System Technical Journal contains this comment: "The telephone network was developed for speech transmission, and its characteristics were designed to fit that objective. Hence, it is recognized that the use of it for a distinctly different purpose, such as data transmission, may impose compromises both in the medium and in the special service contemplated." Even though the statement returned to haunt the company, it must be regarded as a tribute to the foresight of Bell engineers in those relatively early days of modern computer science—days when time-sharing was barely conceived.

With time-sharing a reality and Micom and its independent affiliates offering an inexpensive communications medium, significant changes in the nature of the computer industry are being forecast. One prediction is the integra-



## mite-size relays with macro-size contacts

Couch 2X relays are true 1/2-size, yet the contacts are as large or larger than many full and half-size crystal can units.

Couch 2X relays meet MIL-R-5757D/19 and /30 specs in 1/25th of a cu. in. Design simplicity and oversize contacts assure the ultimate in performance. Each relay is fully tested. Ideal for missile and aerospace switching applications or wherever reliability in small space is of prime importance. Available in many terminal styles and a wide choice of mountings.



Write for Data Sheets No. 9 and No. 10 today.

	2X (DPDT)	1X (SPDT)
Size	0.2" x 0.4" x 0.5"	same
Weight	0.1 oz. max.	same
Coil		
Operating Power	100 mw or 150 mw	70 mw or 100 mw
Coil		
Resistance	60 to 4000 ohms	125 to 4000 ohms
Temperature	-65°C to 125°C	same
Vibration	20G	same
Shock	75G	same

RUGGED ROTARY RELAYS  Dynamically and Statically Balanced



**S. H. COUCH DIVISION**  
**ESB INCORPORATED**  
 3 Arlington St., North Quincy, Mass. 02171

# Control/alarm shortcut.

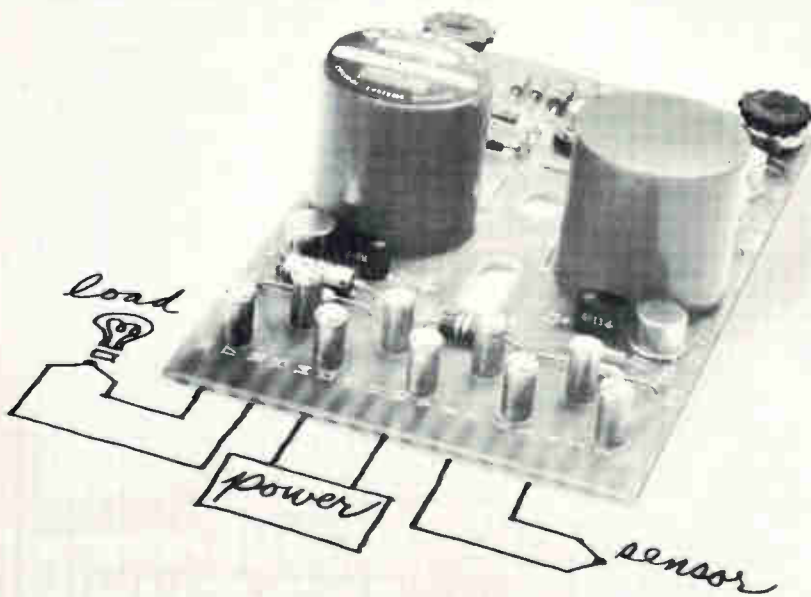

## MAGSENSE

control/alarm for temperature, pressure, speed, flow

Here's the fast, low-cost way to solve control/alarm problems. Hook up sensor, load and power source to a MAGSENSE® module and adjust the setpoint (or dual setpoints). That's it. No time and money wasted designing and debugging a circuit. And you've got proven-in-service performance and reliability.

**Capabilities.** MAGSENSE modules offer 100-billion power gain, accept inputs as low as 10 microvolts or 1 microamp directly *without* preamplification. Completely isolated inputs are *unaffected* by common mode voltages as high as 110vac, 60 Hz or overloads as large as 1000-times full scale. And they operate from a *single* 28v or 12v power source.

**Flexibility.** Standard models offer a wide range of options including single, dual and remote setpoints, adjustable hysteresis, choice of output action, transducer excitation voltage, and cold junction and copper compensation on thermocouple models. And, in the off-chance a standard model won't fit your precise application, we can custom-build one quickly, inexpensively.

**Take the short cut.** Write or call for your free copy of the MAGSENSE Application Manual. It has all the specifications and prices. And all the shortcuts.



**CONTROL DATA**  
CORPORATION

Magnetic Products Operation, Dept. 303  
Control Data Corporation  
775 Colorado Avenue So.  
Minneapolis, Minnesota 55416  
Phone 612/544-8851

tion of corporate EDP systems with massive, time-shared, centrally located systems with smaller, peripheral computers tied in. Expansion of computer service companies for such professions as medicine and law is another.

Moreover, credit card companies, hotels, banks, airlines, and brokerage houses are also looking for economical ways to expand interchange of data between branches.

For the electronics industry itself, the Business Equipment Manufacturers Association (BEMA) forecasts: "The future growth in the use of on-line computer systems will require specialized application terminals which, in turn, may require special modems. Providing these unique modems may become a burden to common carriers. On the other hand, small manufacturers of data processing and data communications equipment often specialize in application terminals for which demand may be too low to justify development by larger companies. These small companies could provide users with economical, specialized terminal/modem devices."

**How big?** Computer utilities and time-sharing service companies are well above the \$100 million mark in total annual volume. And the industry is about doubling in size every year even though communications are estimated at 30% to 50% of their costs. Nevertheless, an Arthur D. Little study shows that growth of data communications channel demand is doubling every two years.

Goeken's MCI hopes to be on the air by July barring further litigation with AT&T and other carriers. However, he could still run into trouble at the state level with Illinois Bell. (The Illinois Commerce Commission, the state regulatory agency, will have to grant MCI the nine drop-offs planned within the state on the way to St. Louis). When MCI is able to proceed, the demand for channels should accelerate beyond the A.D. Little projection.

While eventually channels with bandwidths anywhere in the 200 hz to 4 Mhz range will be available, Goeken plans initially to offer 200 hz, 150 bits-per-second, channels "at five cents a mile" on a one-way



**TRW**  
**Metallized**  
**Mylar Capacitors**

**are different**

**The little things set them apart.**

Things like superior electrical properties. Better environmental properties, too.

Things like variety. Tape-wrap, epoxy or hermetically sealed. Axial or radial leads. Voltages from 50 volts to 600 volts. Values from .001 mfd. to 10.0 mfd. And

tolerances to 1%.

And not so little things like unequalled experience in metallized mylar\*. And the technical know-how to meet special requirements. They all add up to a big difference!

Contact any TRW distributor, or TRW Capacitors, Box 1000

Ogallala, Nebraska. Phone (308) 284-3611. TWX 910-620-0321.

*TRW Capacitors is a Division of TRW INC.* \*DU PONT REGISTERED TRADEMARK

**TRW**<sup>®</sup>

# See where you can't be with COHU TV.

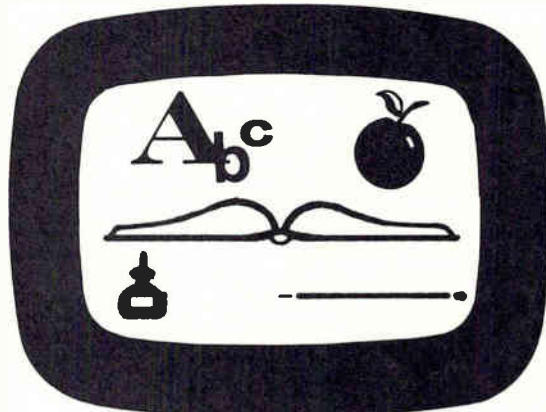

CLASSROOM INSTRUCTION



SPORTING EVENTS

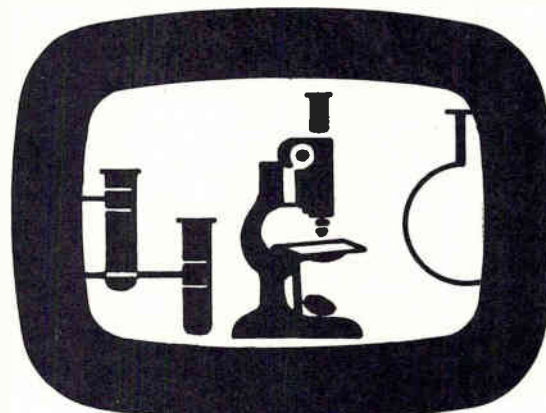

MICROSCOPIC EXAMINATION

For more details contact your nearest Cohu representative or the TV Product Line Manager direct at 714-277-6700, Box 623, San Diego, Calif. 92112, TWX 910-335-1244.

**COHU**  
ELECTRONICS, INC.  
SAN DIEGO DIVISION

basis. Termination charges at each end, exclusive of local loop telephone connection, will be four dollars, Goeken says, "or 50% cheaper than what we told the FCC."

Envisioning links longer than the 275 miles between Chicago and St. Louis, Goeken notes that the one-way mileage charge over a 1,000-mile route would be \$50 a month for a 200-hz bandwidth. If, for example, five users shared that same line over 20 working days, it would cost each user only 50 cents a day.

Becoming more specific, Goeken cites this example for MCI's service on the 275-mile Chicago to St. Louis route someone may want a one-way, 200-hz bandwidth channel. At 5 cents a mile, that's \$13.50 a month for the 275-mile route plus the two-termination charge of \$8. Then if they want a 10-khz channel coming back for a crt display, that's an additional \$351 plus a \$20 termination charge. Regardless of distance, everyone pays a flat \$25 monthly service charge. The total cost is \$417.50 and the customer's own terminal equipment costs and local telephone interconnection charges must be added to that.

According to Goeken, the maximum capacity of MCI's Chicago-St. Louis link will be about 432,000 data channels each having a 200-hz bandwidth—each guaranteeing no more than one error in 10 million bits sent.

The potential of a domestic satellite communications system now proposed by the Communications Satellite Corp. doesn't worry MCI's 36-year-old founder at all. "We feel that land line transmission is best for local communications channels; that microwave is best for medium to long distances, and that domestic satellite would be the most efficient carrier for very long haul transmissions."

For the MCI pilot operation, Goeken has his license. Now he must make it fly. Actually, whether he does or not is now beside the point since the concept of the special service common carrier has been accepted. His list of customers signed and waiting is impressive—including Time-Life for wideband transmission of copy to regional printing plants. ■



# *You say you want a*

low-profile snap-in mounting push button switch or matching indicator that is interchangeable with most 4-lamp displays . . . available in a full range of cap colors . . . with a choice of bezels with or without barriers in black, gray, dark gray or white.



## *and a*

legend presentation that's positive (like this one) or negative (like the one below) or just plain (like the one above) . . . one that's white when "off" and red, green, yellow (amber), blue or light yellow when "on" . . . or colored both "on" and "off."



## *and a*

highly reliable switch proven in thousands of installations . . . available in momentary or alternate action . . . N.O., N.C. or two circuit (one N.O., one N.C.) . . . that accommodates a T-1 $\frac{3}{4}$  bulb with mid-gate flanged base, incandescent, in a range of voltages from 6-28V.



*etc.  
etc.  
etc.*

# *Now, Dialight gives you custom panel designing with a standard line of push-button switches and matching indicators*

Dialight offers a broader range of switch and indicator possibilities than you'll find anywhere in a standard single-lamp line. Sizes:  $\frac{3}{4}$ ", 1",  $\frac{5}{8}$ " square and round. Send today for our new full-color catalog L-209.

## **DIALIGHT**

Dialight Corporation, 60 Stewart Ave., Brooklyn, N. Y. 11237

DT-124



**ML SERIES**



**SR SERIES**

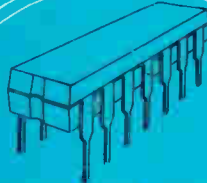

**COMPLETE LINE OF 5 VOLT  
POWER SUPPLIES  
FOR I. C.  
APPLICATIONS**



**FC SERIES**



**HP SERIES**



**GR SERIES**

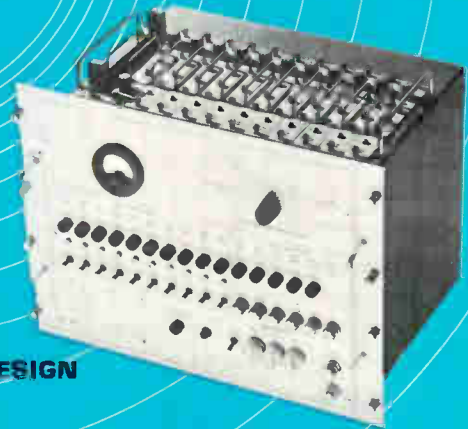

**CUSTOM DESIGN**

# LOGIC POWER

A FEW EXAMPLES OF POWERTEC'S BROAD LINE OF POWER SUPPLIES

## **GR SERIES 5V-2.5A \$ 49**

• 31 STANDARD MODELS • FULL RATING TO 71°C  
• 47 TO 440 HZ INPUT • COMPUTER GRADE COMPONENTS

## **SR SERIES 5V-35A \$249**

• 64 MODELS AVAILABLE • OPTIONAL OVP • REMOTE SENSE CAPABILITY • HIGH EFFICIENCY

## **ML SERIES 5V-20A \$379**

• 100% MILITARY • MEETS MIL-E-16400, MIL-T-21200 • ±.00075% REGULATION • DOCUMENTATION PACKAGE

## **HP SERIES 5V-30A \$789**

• MILITARY AIRBORNE TO MIL-E-5400 • 400 HZ, 3 PHASE INPUT • 24 MODELS AVAILABLE  
• 2 WATTS PER CUBIC INCH

## **FC SERIES 5V-5A \$179**

• 1/5 THE SIZE OF CONVENTIONAL SUPPLIES • HIGH FREQUENCY SWITCHING APPROACH • 20 STANDARD MODELS • OPTIONAL OVP

## **CUSTOM DESIGN**

POWERTEC HAS A COMPLETE FAMILY OF BASIC BUILDING BLOCK CIRCUITS THAT ARE READILY ADAPTABLE TO YOUR CUSTOM SYSTEM SPECIFICATIONS



**AERTRONICS  
CORPORATED**

**POWERTEC DIVISION**

9168 DESOTO AVE., CHATSWORTH, CALIF. 91311 • Phone (213) 882-0004

# Monolithic regulator stands alone

Intended for on-card applications in logic systems, self-contained 5-volt device is almost blowout-proof, has low-voltage, temperature-compensated reference

By Stephen Wm. Fields

Associate editor

"Now that we've finished up with the op-amp people, we're starting on the discrete regulator people," asserts Bob Widlar, linear IC designer at National Semiconductor Corp.—and he means what he says. National's new LM 109 monolithic five-volt regulator is self-contained, and will sell for \$6.50 in quantities of 100 in a three-lead TO-3 power package.

According to Widlar, there's a high-volume market for the 109—on-card regulation for transistor-transistor-logic systems. Widlar says that single-point regulation—one large, central regulator—creates many problems because of the relatively high current requirements of digital systems. "Heavy power busses must be used to distribute the regulated voltage," says Widlar, "and because voltage is low and current is high, the voltage drop across connectors and conductors can cause an appreciable change in the voltage delivered to the load." This problem is aggravated with TTL circuits because, when they switch, they draw transient currents that are many times their steady-state current. False operation will result unless large bypass capacitors are used on the supply lines.

These problems have generated considerable interest in on-card regulation. Rough pre-regulation can be used, and the power distributed without excessive concern for line drops. The local regulators then smooth out the voltage variations due to the line drops and absorb any transients.

The 109 is available in two common transistor packages: in the



Local regulation. Designer Bob Widlar shows his on-card IC voltage regulator, mounted on a heat sink.

solid-Kovar TO-5, it delivers up to 200 milliamps if adequate heat sinking is provided; in the TO-3 power package, the available output current is one to two amps depending on the heat sink.

One of the most important features of the 109, according to Widlar, is that it is essentially blowout-proof. Output current limiting is included, and thermal limiting shuts down the chip to prevent overheating which would destroy the device eventually.

Another feature of the 109 is that it does not use a zener diode for internal reference—instead, the reference is developed from the highly predictable emitter-base voltage of transistors on the chip. With this low-voltage reference, the regulator can operate with input voltages below 6.5 volts.

And, says Widlar, "production tolerances are tight enough so that individual adjustment is unnecessary. It's easy to guarantee worst-case output voltages under all conditions, including variations in temperature, input voltage, and load, as well as long-term stability; and they are within the operating range of logic circuits."

The internal reference developed for the LM 109 also advances the state of the art for regulators, according to Widlar. Not only does it provide, for the first time, a low-voltage, temperature-compensated reference, but it also can be expected to show much better long-term stability than conventional zener references. "The breakdown mechanism of zener diodes is not well understood," says Widlar, "and precision references are obtained only by individual selection and extensive testing." But the emitter-base characteristics of transistors are very well understood; they are as well, among the most stable and predictable characteristics of solid state circuits. Preliminary measurements show that a long-term stability of better than 10 microvolts can be realized.

**Inside.** The internal voltage reference for the LM 109 probably represents the most significant departure from standard design techniques. In its simplest form, the reference developed is equal to the energy-band-gap voltage of the semiconductor material. For silicon, this is 1.218 volts, so the reference need not impose minimum input voltage limitations on the regulator.

To obtain a temperature-com-

# When the chips are down, they ought to be on our IC packages.

It's not just because we want to sell our products (which we do).

Or because we're proud of them (which we are).

We think you should buy our IC packages for a number of reasons.

First of all, we make all our own parts. (Many of our competitors must buy frames and ceramics for assembly.)

We assemble the packages ourselves.

We test our packages for insulation, thermal shock resistance, hermeticity, lack of internal shorts, excess glass-ceramic flow.

And if one of our growing line of packages

doesn't fit your requirements, we'll design one that will.

One more thing. Just because you're getting the best IC package money can buy, don't think it takes a lot of money. In fact, ours probably costs less than any others.

Isn't that where you should put your chips?

Sylvania Metals & Chemicals, Parts Division,  
Warren, Pennsylvania 16365.

**SYLVANIA**  
GENERAL TELEPHONE & ELECTRONICS

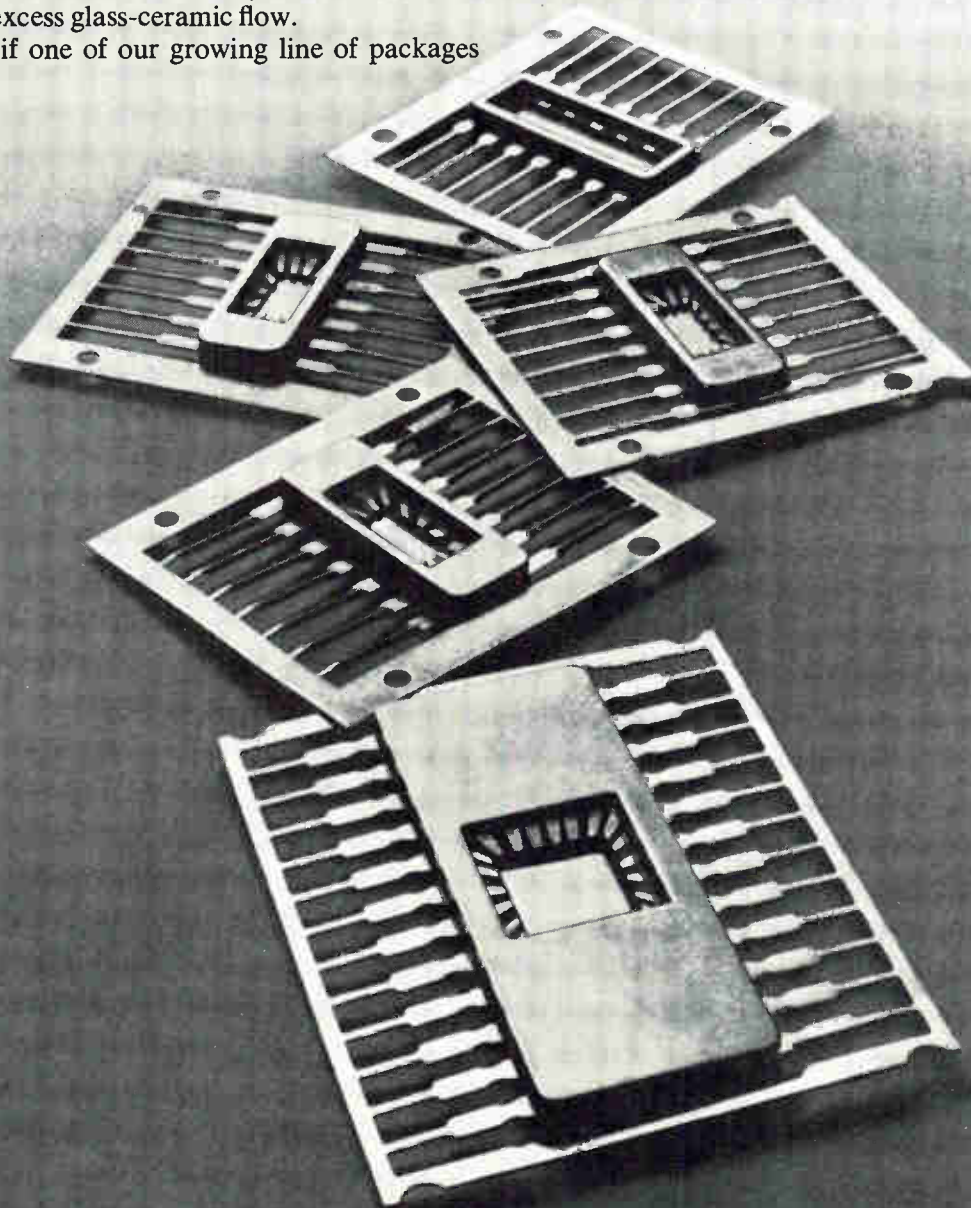

compensated output voltage, the reference uses the positive temperature coefficient of the emitter-base voltage differential between two transistors operated at different current densities. This is done to compensate for the inherent negative temperature coefficient of the emitter-base voltage. The resulting reference voltage is 5 volts.

**Finding answers.** A useful on-card regulator must combine everything in one package—including the series-pass transistor. Widlar has said previously that the pass transistor should not be included in an IC regulator because there are no standard multilead power packages, because IC's necessarily have a lower maximum operating temperature due to their low-level circuitry, necessitating a more massive heat sink, and because the gross variations in chip temperature due to dissipation in the pass transistor worsen load and line regulation.

However, in the case of the logic card regulator, Widlar says, these problems can be met effectively. For one thing, he asserts, if the series-pass transistor is put on the chip, the IC needs only three terminals; hence an ordinary transistor power package can be used. But the most important reason for including the pass transistor on the chip is that it is possible to incorporate thermal overload protection which, according to Widlar, is considerably more effective than other methods of protection.

Thermal protection limits the maximum junction temperature and provides a constant power limit that protects the regulator regardless of input voltage, type of overload, or degree of heat-sinking. But with an external-pass transistor, there is no convenient way to sense junction temperature, so it is much more difficult to provide thermal limiting.

**Absolute protection.** "When a regulator is protected by current limiting alone," Widlar declares, "it is necessary to limit the output current to a value substantially lower than is dictated by dissipation under normal operating conditions. This is done to prevent excessive heating when a fault occurs." Thermal limiting provides

virtually absolute protection for any overload condition, so, says Widlar, "the maximum output current under normal operating conditions can be increased. This tends to make up for the fact that an IC has a lower maximum junction temperature than discrete transistors."

Widlar adds that because the five-volt regulator works with relatively low voltage across it, the internal-pass transistor can operate at comparatively high currents without causing excessive dissipation.

As a final argument, Widlar says that the variations in chip temperature caused by the dissipation in the pass transistor do not cause serious problems for a logic-card regulator. "The tolerance in the output voltage is loose enough so that it is not a serious problem to design an internal reference that has a comparatively small output voltage change for temperature variations as large as 150°C."

Overload protection is provided by two transistors. If the output current rises instantaneously to a point where the output transistor is threatened by secondary breakdown, the current through the output-series resistor increases sufficiently to develop a voltage that is high enough to turn on one of the two protective transistors. This removes the base drive from the output driver transistor, and current limiting is initiated. If the overload persists and chip temperature becomes excessive, the other protective transistor will turn on because its emitter-base voltage is lower at high temperatures. This also will remove the base drive and limiting will occur.

This thermal limiting occurs at junction temperatures of about 175°C; when the condition causing the overload is removed, and the chip cools down to about 160°C, the limiting is removed and the regulator is operational.

The TO-5 can unit costs \$5.50 for the commercial version and \$20 for the military version (-55 to 125°C). For the TO-3 unit, the prices are \$6.50 and \$25, respectively. All prices are for quantities of 100 units. Delivery will be from stock after Oct. 1.

National Semiconductor Corp., San Ysidro Way, Santa Clara, Calif. [338]



INTER-COMPUTER ELECTRONICS  
IS DELIVERING  
**ULTRA-HIGH SPEED  
A TO D CONVERTERS**  
with



data conversion rates up to 320 megabits  
aperture time on the order of tenths of nanoseconds  
word sizes ranging from 4 to 10 bits

PLUS

A MODULAR DESIGN THAT PERMITS A WIDE  
VARIETY OF OPTIONAL MECHANICAL  
ARRANGEMENTS



1213 Walnut Street, Lansdale, Pa. 19446  
(215) 855-0922



No other manufacturer offers as large a selection: hundreds of standard types of control knobs, more than 2,000 "specials". Almost every type, style and color combination is promptly available to you from local distributors and large factory stocks.

Turn to color with the new PANELRAMA knobs shown below...mix or match caps and body colors in almost any combination...to harmonize or contrast with every panel decor.

Or, you can choose elegantly-

styled Designer Series knobs with spun-aluminum caps on body colors of black; light, medium, or dark grays; and off-white. When you need a solid color, select from the nine decorative colors in our 400 series.

For military applications, specify Standard Series control knobs—thousands of quality knobs that meet MS91528. Or, specify the new self-locking push-to-turn knobs and Microverniers...for accurate, precision control settings. And when you need custom-

made knobs, call Raytheon first...to get the advantages of Raytheon quality and fast delivery.

For a catalog, call your distributor or nearest Raytheon regional sales office. Or send the reader service card. *Raytheon Company, Industrial Components Operation, Quincy, Massachusetts 02169.*



## Here's why Raytheon knobs control more settings than any other brand.

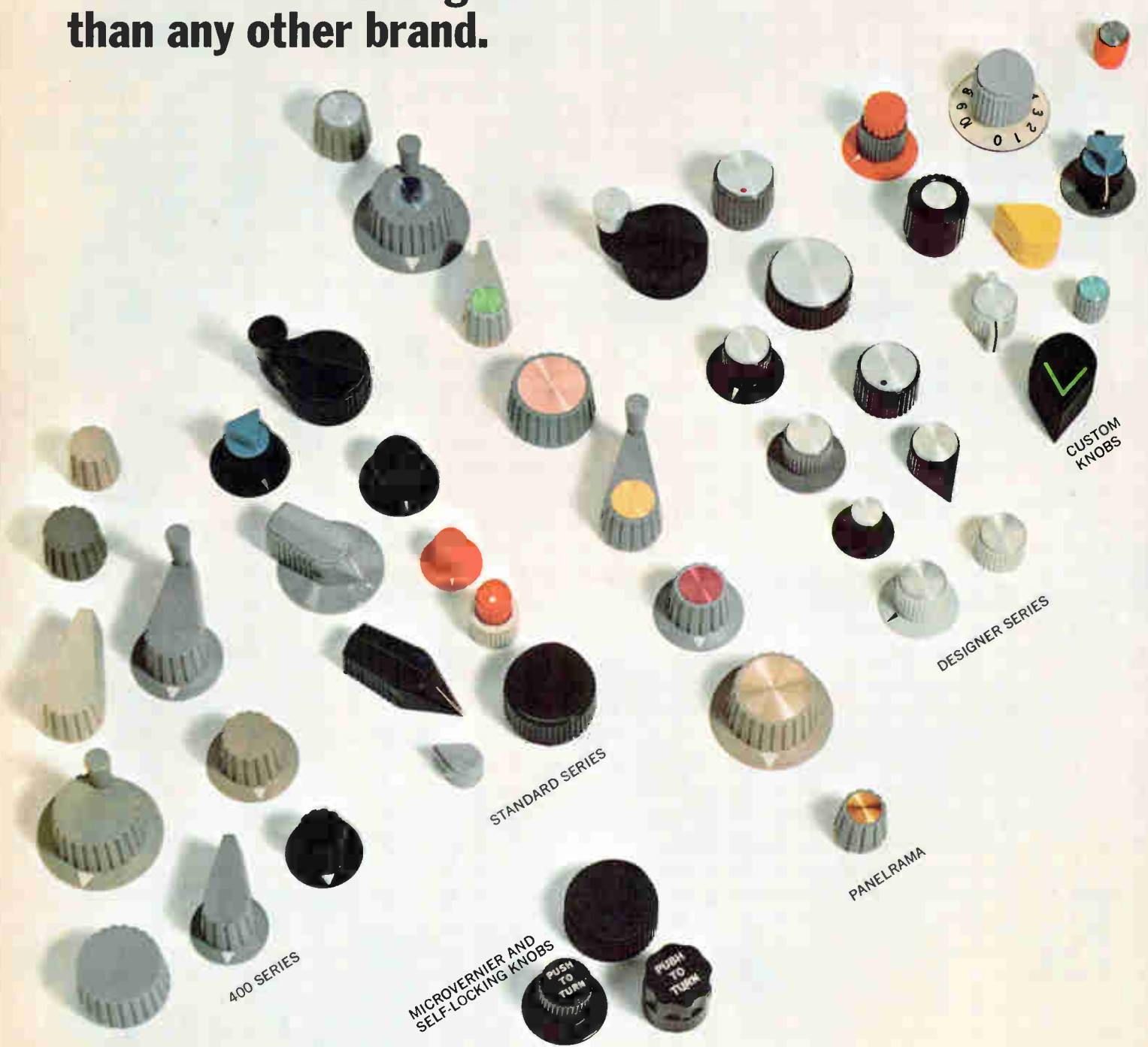

400 SERIES

MICROVERNIER AND SELF-LOCKING KNOBS  
PUSH TO TURN  
PUSH TO TURN

STANDARD SERIES

DESIGNER SERIES

PANELRAMA

CUSTOM KNOBS

# Correlation comes to Everyman

Easy-to-use instrument, priced at \$8,350, calculates and plots correlation and probability functions and signal averages

**Correlation is a word** that scares more than a few people. It conjures images of elaborate test systems, and of pages filled with the most esoteric statistical equations. As a result, it's used only when there's no other way to test a system or to find a signal lost in a haystack of noise.

But the fright-wig may be coming off. "There's a big boom coming

in correlation," predicts Gordon Roberts, engineering manager at Hewlett-Packard Ltd., H-P's division in Scotland. "It has been hard to do statistical analysis of any kind because the equipment needed has been difficult to use, and not very portable. Now the hardware is becoming available."

The hardware Roberts specifically has in mind is the Model

3721A correlator, which was designed and is being built, by his division. Priced at \$8,350, the 3721A calculates and displays autocorrelation and crosscorrelation functions, the probability density function and its integral, and a signal's average value on a point-by-point basis. It measures 17 by 11 by 19 inches, weighs 45 pounds, and operates on line power.



Portable digital multimeter model 6453 uses advanced MSI and IC design and construction techniques. The four-digit instrument has a fifth-digit, 20% overrange. The basic unit measures d-c in five ranges from 100mv to 1,000 v with an accuracy of 0.01%. It weighs eight pounds and is priced at \$1,125. Delivery is 30 days. Lear Slegler Inc., 1152 Morena Blvd., San Diego, Calif. [361]



Dual-readout memory voltmeter model 5201CR has a built-in strip chart recorder. It is for use where a permanent record of transient or spike occurrences is desired. It also records peak voltage pulses as short as 50 nsec in duration. Applications include monitoring power stations and computerized equipment. Micro Instrument Co., 12901 Crenshaw Blvd., Hawthorne, Calif. [362]

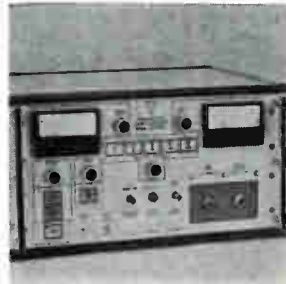

Solid state, high voltage gate generator model RS-03FL is for use in testing image intensifier tubes. It supplies grid-to-cathode pulses of up to 3 kv at rates as high as 10 khz and with rise times of 55 nsec. Pulse rate, pulse amplitude, pulse width, and delay time are all adjustable. The output pulse can be floated. Venus Scientific Inc., 399 Smith St., Farmingdale, N.Y. [363]



Digital panel meter model TPM-200 has a basic voltage range of 0 through 100 mv with 100% overrange. Accuracy is 1% reading  $\pm 1$  digit over a temperature range of  $\pm 10^{\circ}\text{C}$  to  $40^{\circ}\text{C}$ . Display is 2 digits, with long life display tubes offering in-line  $\frac{3}{8}$  in. character height. Resolution is 1 mv with 100 mv full scale range. Tyco Laboratories Inc., Hickory Dr., Waltham, Mass. [364]

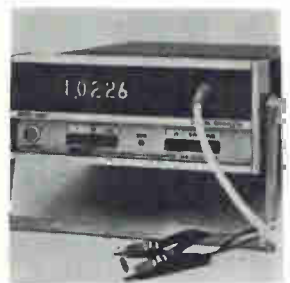

Digital ohmmeter 8303 offers pushbutton operation allowing selection of 9 ranges from 1 ohm full-scale to 100 megohms full-scale. Accuracies are  $\pm 0.02\%$  of reading and  $\pm 0.01\%$  of full scale. The non-blinking readout presentation features 5 Nixie digits, including overrange, with true electronic storage. California Instruments Corp., 3511 Midway Dr., San Diego, Calif. [365]



Differential voltmeter model TDV-1000/1 provides 50 ppm d-c accuracy, 0.1% a-c accuracy, stability of better than 0.005%/60 days, and ranges to 1,000 v. Input impedance on the higher ranges is 10 megohms and on all a-c ranges is 1 megohm, shunted by 40 pf. Price is \$1,385; delivery, within 45 days. Julie Research Laboratories Inc., 211 W. 61st St., New York 10023 [366]



IC tester model 721A is designed for high-volume testing of digital IC's with up to 16 leads. Operation is either manual, or fully automatic when the instrument is interfaced with a mechanical test handler. The unit makes up to 1,024 sequential d-c and functional measurements in less than 100 msec. Microdyne Instruments Inc., 203 Middlesex Turnpike, Burlington, Mass. [367]



Digital panel meter model TPM-ures d-c voltage with an accuracy of 0.05%  $\pm \frac{1}{2}$  count and with 4,000 count resolution. It offers 8 voltage ranges (200 mv to 400 v) and the decimal point position is internally selectable. Behind panel space required is only 2.5 x 3 x 4.2 in. Price (1-3) is \$328; (4-9), \$267. Computer Products, 2709 N. Dixie Highway, Ft. Lauderdale, Fla. [368]

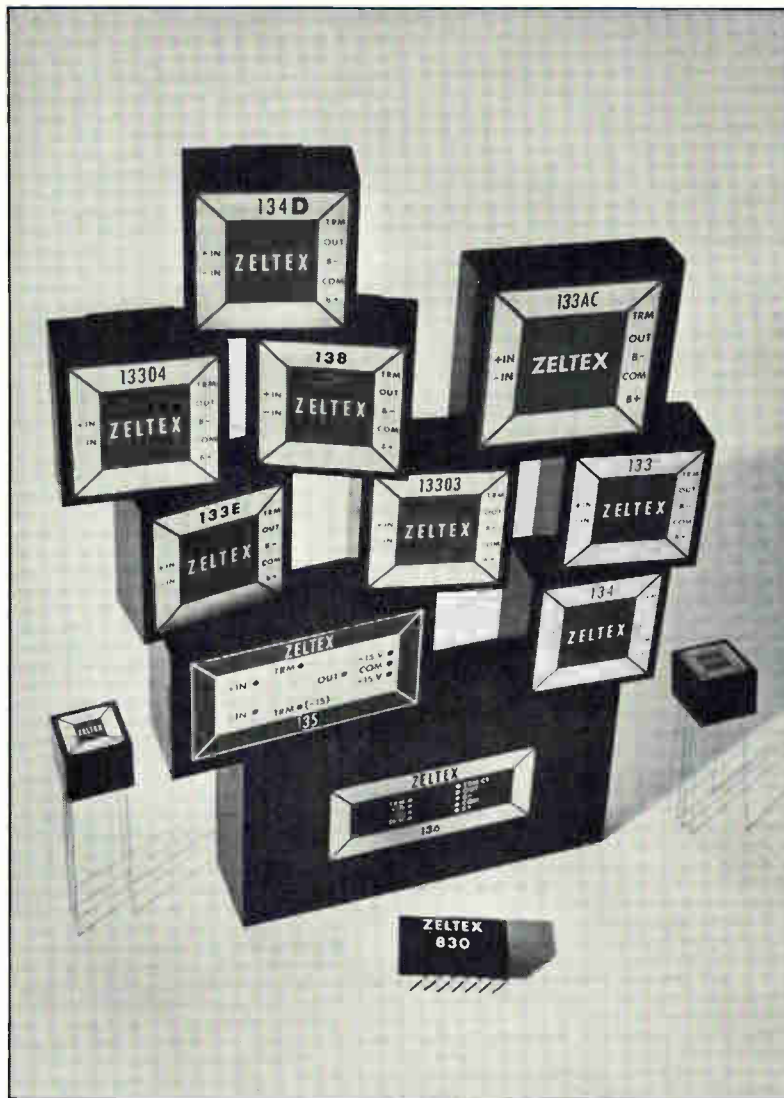

## Here are 13 solutions to your FET OP AMP problems

Thirteen FET-input op amps to solve just about any problem you have—whether it's drift, slew rate, package size, CMRR, settling time, input bias current, common-mode input voltage or cost.

But we didn't stop there. We've developed another five-dozen specials tailored to our customers' individual needs.

Get the point? If you're looking for a FET-input op amp, you should be looking at our data sheet. The one with all the answers.

### **ZELTEX, INC.**

A subsidiary of REDCOR CORP.

1000 Chalomar Road, Concord, Calif. 94520  
(415) 686-6660

Correlation is a method of comparing two signals statistically. First, the correlator samples the signals at a fixed rate for a fixed period, multiplying together the two values measured at each sampling point. At the end of the sampling period, the correlator totals the products, divides the sum by the number of sampling points, and stores the quotient—the average product of the two signals. Next, it changes the phase of one signal relative to the other, and repeats the sampling and averaging processes. Over and over the calculator shifts, samples, calculates, and stores. The correlation function of the two signals defines how the average product changes as one signal is shifted relative to the other. And the correlator displays on a



Work on. The correlator can continuously update its display.

cathode-ray tube the function, a plot of the average points against the amount one signal is shifted. If the two signals being compared are different, the comparison process is called crosscorrelation, and if the signals are identical, it's autocorrelation.

The 3721A, acting as a correlator, samples at a rate that can be set from 1 hertz to 1 megahertz, and displays a 100-point correlation function. The vertical-axis sensitivity has a range of  $5 \times 10^{-6}$  volt squared per centimeter to  $5v^2/cm$ , and the horizontal axis can be scaled between 1 microsecond and 1 second per millimeter.

The instrument can be set to either take a fixed number of samples and stop, or continuously update the correlation curve.

One important use of correlation is in measuring a system's frequency response. Traditionally, engineers apply an impulse to a system and measure output; because the impulse approximates a broad-



# CROWBAR...?

## The One Inside is FREE

Not so many years ago, the prudent transmitter engineer discharged a high voltage capacitor bank by dropping a shorting "crowbar" across its terminals. Today's "crowbar" is a protective overvoltage circuit found on DC power supplies — usually at extra cost. Now HP includes a crowbar as standard on its recently updated series of low-voltage rack supplies . . . at no change in price.

Long established as preferred system supplies for component aging, production testing, and special applications, these supplies have now been redesigned and expanded to meet the stringent demands of today's power supply user. Advantages include low ripple (peak-to-peak as well as rms), well-regulated constant voltage/constant current DC with outputs to 60 volts and 100 amps.

Where loads are critical and expensive, the extra pro-

tection — say, against inadvertent knob-twiddling — from a crowbar is invaluable. On all internal crowbars in this series, the trip voltage margin is set by screw-driver at the front-panel.

Pertinent specifications are: triggering margins are settable at 1V plus 7% of operating level; voltage ripple and noise is 200  $\mu$ V rms/10mV peak-to-peak (DC to 20 MHz); current ripple is 5 mA rms or less depending on output rating; voltage regulation is 0.01%; resolution, 0.25% or better; remote programming, RFI conformance to MIL-I-6181D.

Prices start from \$350. For complete specifications and prices, contact your local HP Sales Office or write: Hewlett-Packard, New Jersey Division, 100 Locust Avenue, Berkeley Heights, New Jersey 07922 or call (201) 464-1234 . . . In Europe, 1217 Meyrin, Geneva.

**HEWLETT**  **PACKARD**  
POWER SUPPLIES

*Additional data sheets available upon request*

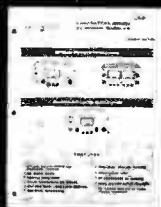

**LAB SERIES**  
smaller package,  
lower power,  
optional crowbar





**CROWBARS**  
A Technical  
Discussion

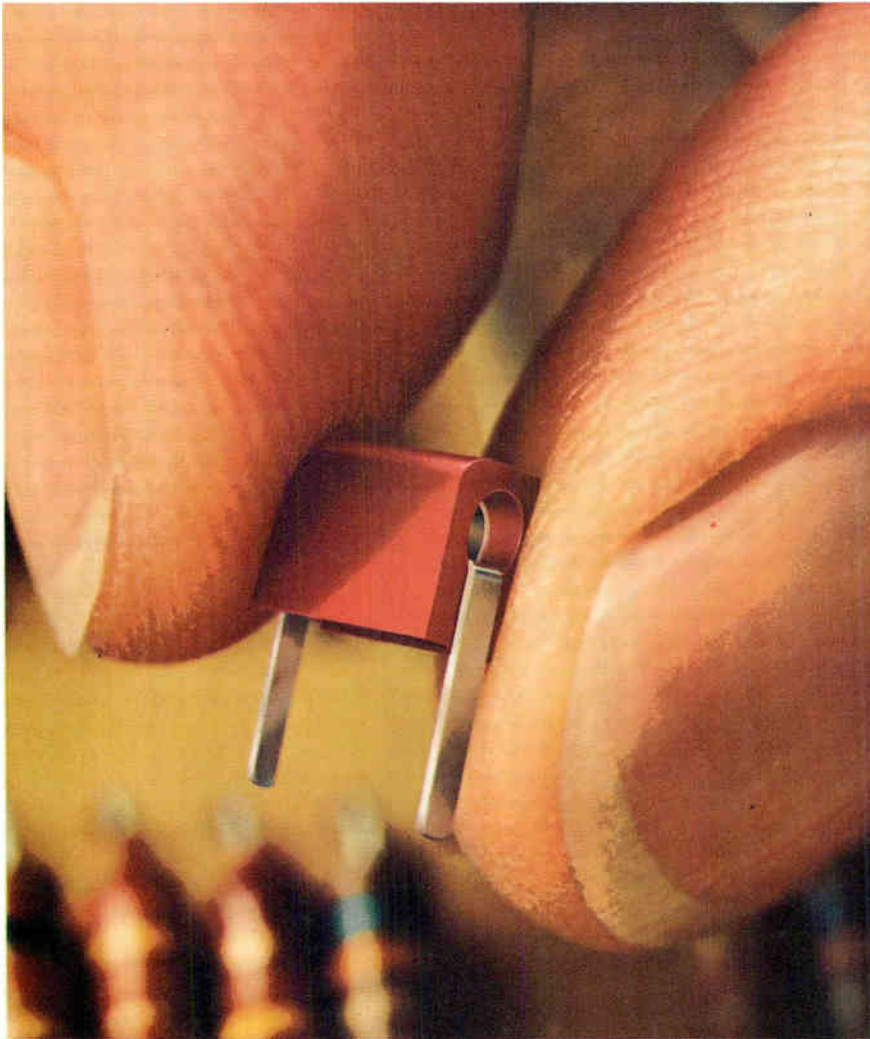

**1969 Power  
Supply Catalog**  
— includes total  
HP power supply line.



Looking for a little jack? (  )  
 How's this for size? (  )  
Actual Size

We've been making miniature jacks for over 10 years. But this new one is half again as small as any horizontal mounting type we've offered before. It accepts a 0.080" diameter tip plug on either end and has a maximum current capacity of 5 amperes. Operating voltage is 1500 volts RMS at sea level, 350 at 50,000 feet. Contact resistance is less than 2 milliohms. Capacitance between adjacent jacks is less than 1 pF at 1 MHz. Comes in 10 colors meeting Federal Standard #595.

Johnson makes hundreds of different jacks and plugs . . . and carries most of them in stock for immediate delivery. Or perhaps you have a unique need. Our engineers will work it out for you. Just give us a call. Meanwhile, return the coupon.

E. F. JOHNSON COMPANY/3010 Tenth Ave. S.W./Waseca, Minnesota 56093

- Send me a sample of your new miniature jack and complete design details.
- Send me information on your complete connector line and other Johnson components.

NAME \_\_\_\_\_ TITLE \_\_\_\_\_

FIRM \_\_\_\_\_ ADDRESS \_\_\_\_\_

 CITY \_\_\_\_\_ STATE \_\_\_\_\_ ZIP \_\_\_\_\_

**E. F. JOHNSON COMPANY**

band input, point-by-point measurements at discrete frequencies are unnecessary. However, in many cases a conflict occurs: the impulse has to be large because if it's not, noise buries the output; on the other hand a large impulse may overload the system. In either case, it's often necessary to shut down the system to run the test.

The crosscorrelation approach has neither of these drawbacks. White noise applied to the system's input is correlated with the system's output; the correlation function is an approximation of the system's response to an impulse, assuming the system is linear. A very low level of noise is all that's needed, and this test can be made even when the system is running.

**Probability.** The probability density function, whose curve is a plot of probability against amplitude, tells what proportion of time a signal spends at various amplitudes. And the area under a portion of the curve is the probability that at a given time the signal's amplitude will be between the two amplitudes that border the area.

Averaging is used to extract a periodic signal from random noise. The correlator measures its input's amplitude at a fixed number of sampling points; on command from a synch pulse, the correlator measures the amplitude again and computes the average amplitude at each point.

The random noise has an average value of zero. Eventually, after enough samples have been taken, the noise averages out.

The 3721's vital components are two analog-to-digital converters, a shift register, and a small, specialized computer for averaging. When the instrument is correlating, its two inputs first are digitized. One signal then goes to a 100-stage 3-bit shift register, made with MOS integrated circuits.

The two signals then go to the computer, which is made with transistor-transistor-logic IC's, and the computed average is stored in a glass delay line. After the delay line collects 100 values, it sends them to the display. Basically the same circuitry calculates the probability density function and averages a signal.



Hewlett-Packard Co., 1501 Page Mill Rd., Palo Alto, Calif. 94304 [369]

# NEW

from

# Soliton

## INDUSTRIAL PNP Silicon Power Transistors!

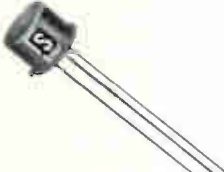
	1 AMP	2 AMP	5 AMP	10 AMP	20 AMP
 <b>TO-3</b>	<i>Special devices and packages not indicated are available to customer requirements.</i>	2N3021-6 2N3171-4 2N3789-92 2N4901-3 SDT 3750-1 SDT 3752-6	2N3183-6 2N3195-8 2N4904-6 SDT 3757-61 SDT 3762-5	2N5737-8 SDT 3825-7	2N5741-2 SDT 3875-7
 <b>TO-66</b>	2N3740-1 2N4898-4900 SDT 3575-7 SDT 3578-9	SDT 3701-2 SDT 3703-5 SDT 3706-11 SDT 3712-15 SDT 3716-20 SDT 3801-4	SDT 3721-5 SDT 3726-8 SDT 3729-32	2N5739-40 SDT 3805-7	2N5743-4 SDT 3850-2
 <b>TO-5</b>	2N3660-1 2N3774-82 2N4234-6 SDT 3550-1 SDT 3552-4	2N3202-4 2N3719-20 SDT 3775-8	<i>For additional information and specification data sheets, contact us today.</i>		

# Soliton

 DEVICES, INC.

1177 BLUE HERON BLVD. / RIVIERA BEACH, FLA. 33403 / (305) 848-4311 / TWX: (510) 952-6676

# Clare announces a new treat in General Purpose Relays

## *It's called the GP1.*

If you haven't heard the name before, it's because we haven't made it before.

You see, we didn't want to make just another general purpose relay. We wanted to make the best. Now we have it.

The new GP1 gives you everything standard 4 PDT, 3 amp relays do. Plus a lot more. Contacts rated at 1/10 horsepower, 240 volts AC. Opposite polarity capability.

Largest selection of contact types:

And you can buy it at a price competitive enough to make you the company hero.

With every order of Clare General Purpose Relays, you get something no other company can offer. The Clare guarantee of outstanding service. The new GP1. Only from Clare.

The first of a complete line of Clare General Purpose Relays—all fully interchangeable with existing types.

For full information, circle Reader Service number, call your Clare Sales Engineer or local Clare Distributor. Or write C. P. Clare & Co., Chicago, Illinois 60645... and worldwide.



### **FREE SAMPLE**

A free sample of the new Clare GP1 General Purpose Relay is available to qualifying purchasing agents and engineers. For details, see reply card insert above.

LOOK FOR  **CLARE** ON GENERAL PURPOSE RELAYS  
a GENERAL INSTRUMENT company

# Amplifier offers $10^{12}$ ohms isolation

Unity-gain device for instruments whose outputs are as much as 1,500 volts above ground has 3 millivolts linearity

"Our customers have been cussin' us out for years, telling us to make an isolating amplifier," says Alan Peabody, market planning manager at Keithley Instruments Inc. The flak should be stopping now because Keithley is offering the Model 399, a unity-gain amplifier that accepts an input whose low side can be as much as 1,500 volts above ground, and converts this

floating signal into one whose low side is either at ground potential or 100 volts above.

Many of Keithley's customers need an isolating amplifier because a good part of the company's instruments have floating outputs, which are useful to the engineer who is feeding them to another floating system. But if he just wants to record the output, he's in trouble

because the recorders in his laboratory are likely to have grounded inputs. Before the 399 became available, he had to either build the isolation circuitry himself or buy an amplifier not specifically designed to work with Keithley's instruments.

Peabody emphasizes that Keithley's customers won't be the only people interested in the 399. "The



Vibra-Larm detectors series IVA-100 provide automatic warning or shutdown due to excessive vibration. They feature a built-in time delay, an on-off trigger output, and an adjustable alarm-set-level. Frequency response is from 5 to 1,000 hz with a temperature range from  $-40^{\circ}$  to  $+170^{\circ}$ F. Repeatability is within 1% of setting. Columbia Research Laboratories, Woodlyn, Pa. [381]



Programmable filters series 1500 are dual high/low units for automatic systems application. They may be controlled by computers, punched cards, tape or contact closures. They are for automatic data-acquisition systems, computer-controlled data reduction and analysis, and for use as automated production standards. Rockland Laboratories Inc., Blauvelt, N.Y. [382]



Hybrid linear circuit multiplier model M-4030 measures  $1.12 \times 1.12 \times 0.4$  in. It has a total accuracy of 1%, including errors due to linearity, scale factor and offset. Bandwidth is 1.5 Mhz with a slewing rate of 15 v per  $\mu$ sec. Feedthrough is less than 30 mv peak-to-peak at 50 khz. Output noise is below 1 mv rms. GPS Instrument Co., 14 Burr St., Framingham, Mass. 01701 [383]



Video amplifier model VA-21 provides a slewing rate of 750 v/ $\mu$ sec with a 12 Mhz frequency for full output. Its ultrastable 6 db/octave roll-off characteristic insures a useful gain-bandwidth product of 80 Mhz minimum. It offers an output of  $\pm 20$  ma at  $\pm 10$  v, 20  $\mu$ v/ $^{\circ}$ C voltage drift and 0.5 na/ $^{\circ}$ C current drift. Data Device Corp., 100 Tec St., Hicksville, N. Y. 11801 [384]



Potentiometer-microswitch module features 7 amp, 250 v snap-action microswitches, phased to the  $7/8$ -in. diameter precision potentiometer contact at arbitrarily prescribed angles. The potentiometer features rugged construction and provides linearities as close as 0.25% with a resistance range of 500 ohms to 150 kilohms. New England Instrument Co., Natick, Mass. [385]



YAG laser YG-2 incorporates a  $2 \times 1/4$  in. crystal that is water cooled, filtered, and deionized. It operates on a conventional 110 v plug-in circuit, and has an output on the order of 30 w. The head is about 12 in. long and 5 x 5 in. in cross section. Unit is designed for resistor trimming and IC balancing. Price is \$3,968. Laser Nucleonics Inc., 123 Moody St., Waltham, Mass. [386]

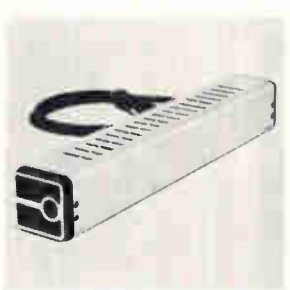

Helium-neon gas laser model 301 comes in kit form or fully professionally assembled. It produces 1 mw of uniphase optical energy at 6,328 angstroms, features an isotopic gas-filled plasma tube that utilizes a long-life cold cathode and prealigned, integral mirror mounts. Price in kit form is \$170; assembled, \$225. Quantum Physics Inc., Forgewood Dr., Sunnyvale, Calif. [387]

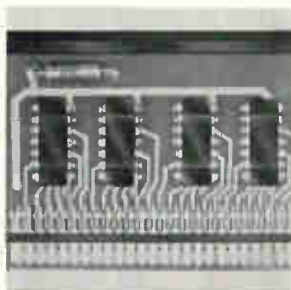

Four-bit digital comparator module model T-218 contains four circuits which are used to compare the numerical values of two four-bit binary numbers. Numerical comparisons of words longer than four bits may be made by cascading additional circuits. Maximum fan-out is 10; input loading factor, 2. Information Control Corp., 1320 E. Franklin Ave., El Segundo, Calif. [388]

# look at the tips of these blades



Here's uniformity that's readily apparent and undeniable. Here's precision . . . achieved only through modern production methods, skilled workmanship, close quality control.

All Xcelite screwdrivers are made this way . . . slotted, Phillips, Allen type, Frearson, Bristol, Scrulox . . . fixed handle or interchangeable blade types . . . to fit precisely, preventing damage to fastener or tool.

That's why they're first choice of manufacturers who seek zero defects on the assembly line, of technicians who take pride in their handiwork.

If you service or assemble precision products, look for screwdrivers, nutdrivers, and other precision tools you need in the extensive Xcelite line.



XCELITE, INC., 130 Bank St., Orchard Park, N. Y. 14127  
In Canada contact Charles W. Pointon, Ltd.

specs are a lot better than we expected when we started designing it," says Peabody. And he feels that engineers working with photosensitive detectors, semiconductor and power-supply testers, or servo systems will be particularly attracted to the new amplifier.

An impedance of  $10^{12}$  ohms and 100 picofarads isolates the 399's input from both the output and the case;  $10^8$  ohms and 1,000 pf isolate the output from the case.

The input range is 0 to 1 volt; a screwdriver-adjustable potentiometer controls the gain. If the gain is 1, the output always is within 3 millivolts of the input.

For a 1-volt input, the 399's temperature stability is 1 mv/°C; common-mode rejection ratio is 120 decibels.

A front-panel switch selects the frequency range. If the 0.01-to-0.35 hertz range is chosen, the maximum output noise is 0.5 mv peak-to-peak. If the range is d-c to 100 hz, the noise rating then becomes 5 mv peak-to-peak.

The 399 isolates the input from the output with a transformer. The input signal, after passing through a buffer amplifier, mixes with a 10-kilohertz signal; the sum and the difference signals go to one side of the transformer; the signal coming out the other side is demodulated and passed through another buffer amplifier to the amplifier's output terminals.

The 399 is priced at \$175. Delivery time is 30 days.

Keithley Instruments Inc., 28775 Aurora Road, Cleveland, Ohio 44139 [389]



## New subassemblies

### Compact laser puts out 1 kw

Active length of CO<sub>2</sub> unit is only 1 meter; cooling makes gas reusable

The prevailing rule of thumb for output of a gas laser has been about 50 watts per meter of active length—until now. Sylvania Electric Products Inc. is getting ready to market a carbon-dioxide laser, the model 970, that generates 1 kilowatt of continuous power from only 1 meter of active length.

The 970 is one of several units, called gas transport lasers, that will be available within five months. The compactness of the complete 970 system, which is 48 inches high, 60 inches wide, and 40 inches deep, is made possible by a closed-cycle gas-cooling system.

The GTL is suited for cutting, drilling, and welding of such difficult materials as ceramics, titanium, and stainless steel.

In conventional, CO<sub>2</sub> lasers, the hot gas is cooled by random diffusion to the walls of the laser tube. They are extended in length to handle large amounts of power and to provide the cooling surface required.

In Sylvania's laser, the hot gas is removed by rapid flow across the active laser area. The gas mixture—carbon dioxide, nitrogen, and helium—is excited by an electrical discharge at the laser region. The flowing gas is cooled to its original temperature in a self-contained heat exchanger, and then is re-cycled to the active region.

Since the gas is reused rather than exhausted into the atmosphere, the laser requires neither a continuous gas supply nor bulky vacuum pumps, and is therefore compact and economical in operation.

The GTL will sell for approximately \$50,000.

Sylvania Electro-Optics Organization,  
P.O. Box 188, Mountain View, Calif.  
94040 [390]

For over 20 years, wire insulations of Du Pont TEFLON fluorocarbon resins have provided maximum performance and reliability under extremes of temperature and adverse environments. But did you know there are composite constructions of TEFLON and polyimides

**TEFLON: all by itself  
the most  
thoroughly proven,  
high-reliability  
insulation**

**Now consider  
the additional  
advantages  
of TEFLON plus  
polyimides**

which offer you extra performance benefits for all wiring applications? TEFLON plus polyimide constructions guard against installation damage because of their toughness and abrasion resistance. They are made in two forms: a polyimide enamel over a primary insulation of TEFLON or a polyimide tape wrapped around the TEFLON.

Both these "TEFLON plus..." constructions are rated for use over a wide temperature range—up to 260°C. They are easily printed and potted, nonflammable, chemical-resistant, lightweight and have a small diameter. They provide the optimum dielectric quality which you expect from insulations made with TEFLON.

If you'd like additional information on composites of TEFLON plus polyimides (or composites using mineral fillers or polyvinylidene fluorides with TEFLON), write us and let us know about the specific application you have in mind.

Write: Du Pont Company, Room 7297G, Wilmington, Del. 19898.



**DU PONT**  
REG. U.S. PAT. OFF.  
**TEFLON**<sup>®</sup>  
fluorocarbon resins

If this  
new  
plus  
doesn't  
grab you,

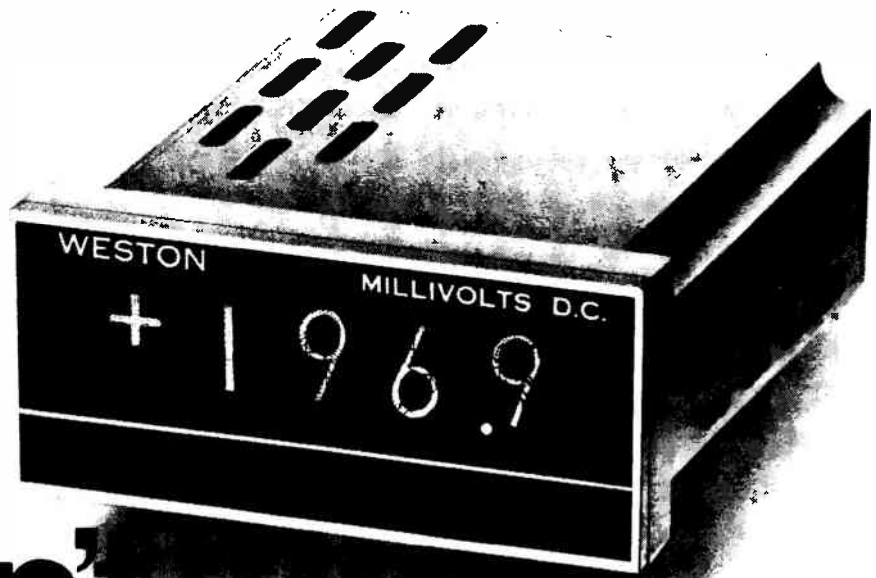

the others will.

As you can see, our latest Model 1292 DPM\* is bi-polar. It's a 3½-digit compact with 100% over-range, plug-in Nixie\*\* tubes, front panel serviceability, and 0.1%  $\pm 1$  digit accuracy. Full BCD output, non-blinking storage display and Weston's patented dual slope integration are standard, of course.

What you can't see are several other new plus features designed to broaden your applications for the Model 1292. Input impedance, for example, is greater than 100 megohms on a 100 MV range, greater than 1,000 megohms on 1 volt, and 10

megohms on all other voltage ranges.

Independent references for positive and negative measurements provide extremely good stability at near zero input levels—difficult to obtain with conventional circuits.

Decimal points are "wired out" for remote control positioning.

Finally, a new range has been added to the standard ranges available—1  $\mu$ a full scale giving 1 nanoamp resolution.

Add them up and we think you'll agree that the Weston bi-polar Model 1292 DPM is the world's

most advanced unit. Yet it costs only a few dollars more than our 3½-digit mono-polar Model 1290 and is fully compatible also with our economy Model 1260. Get complete specifications now on this big new plus in the fastest growing line of digital panel meters.

WESTON INSTRUMENTS DIVISION  
Weston Instruments, Inc., Newark, N.J. 07114.  
a Schlumberger company

**WESTON®**

\*U.S. Pat. No. 3,051,839 and patents pending.  
\*\*Registered trademark, Burroughs Corp.



# Antenna duplexer is miniaturized

Hybrid, thick-film unit for land-mobile communications systems handles up to 30 watts; insertion loss is only 0.1 db at 460 Mhz

**Coaxial relays**, probably the most widely used switching devices for allowing radio antennas to perform the dual functions of transmission and reception, have two notable drawbacks: they are bulky, and their moving parts make them more subject to wear and tear than solid state units. Until now, no solid state part was commercially available for this application, but

Motorola's Semiconductor Products division this month introduced what is believed to be the first miniaturized off-the-shelf duplexer on the market.

Called the MCH 5890, the microwave hybrid integrated circuit antenna duplexer is designed to operate from 400 to 500 megahertz. The thick-film unit can handle 30 watts of input power, with a typical

insertion loss from the transmitter port to the antenna port of just 0.1 decibel at 460 Mhz. It dissipates less than one watt with a 30-watt input.

Craig Marshall, product planner for microwave IC's, says the unit consists of two p-i-n diodes and a quarter-wave transmission line of deposited copper—all on an alumina substrate that is one inch



Solid state microwave signal source model 503537 delivers as much as 0.250 w at Ku-band. It is for use in radiometric systems, as well as a local oscillator pump source for parametric amplifier front ends. It offers 5 coherent outputs at a fundamental frequency of 1347.5 Mhz and 2nd, 4th, 6th and 12th harmonics. Applied Research Inc., Port Washington, N.Y. [401]



Coaxial magnetron SFD-377A delivers a peak output of at least 70 kw at a frequency between 9.355 and 9.395 Ghz. It is designed to meet difficult pulse applications. Pulse-duration capability ranges from 0.3 to 5.1  $\mu$ sec, and the range of the rate of voltage rise extends from 90 to 160 kv per  $\mu$ sec. S-F-D Laboratories, 800 Rahway Ave., Union, N.J. 07083 [402]



Dual 2-stage YIG filter model C2202 is for use at C-band frequencies. It operates from 4 to 8 Ghz. Guaranteed r-f performance, per 2-stage channel, includes 2.5 db insertion loss, 3 db-bandwidth points within 30 to 50 Mhz, and off-resonance isolation greater than 60 db. Unit measures 1.2 cu in. Advanced Microwave Labs, 611 Vaqueros Ave., Sunnyvale, Calif. 94086 [403]

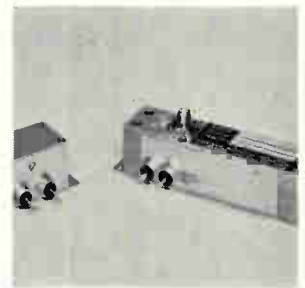

Miniature solid state microwave oscillator has an output power in excess of 10 mw in the 5-Ghz region. The unit is mechanically tunable over  $\pm 50$  Mhz of center frequency with  $\pm 1\%$  electronic tunability. Frequency stability is 0.1% over a temperature range of 0° to +60°C, or 0.4% over a range of -30° to +70°C. Englemann Microwave Co., Skyline Dr., Montville, N.J. [404]



Fixed coaxial attenuators have values of 3, 6, 10, and 20 db. The 3- and 6-db values are flat to within  $\pm 0.2$  db throughout the frequency range from d-c to 12.4 Ghz. The 10- and 20-db values hold to within  $\pm 0.2$  db from d-c to 6 Ghz, and to within  $\pm 0.3$  db from 6 to 12.4 Ghz. Vswr is 1.15 from d-c to 6 Ghz, 1.20 above that. Narda Microwave Corp., Plainville, N.Y. [405]



Voltage and frequency monitor 35-73-01840 operates within the band 380 hz to 420 hz  $\pm 5$  hz. It senses voltage and frequency of the power source and, if they remain within proper values, holds an internal relay energized to provide a fail-safe operation. Frequency sense is 40 to 2,000 hz; voltage sense, 20 to 500 v. Electronic Resources Inc., 4561 Colorado Blvd., Los Angeles [406]



Four-stage, current-tuned YIG filter operates over the 12.4 to 18 Ghz spectrum. Features include a 3 db nominal bandwidth of 275 Mhz, 4 db insertion loss, 1.5:1 vswr, and rejection of 24 db per octave. Additional parameters include cold isolation 60 db, passband ripple (including spurious) 1 db maximum. Frequency Engineering Laboratories, Farmingdale, N.J. 07727 [407]



Transmission-line bandpass filters series FB cover frequencies from 750 Mhz to 10 Ghz. Standard filters are available with bandwidths ranging from 1 to 70% of center frequency. On special order, the company can supply filters with maximal flat amplitude, constant time delay, and elliptic function. Marrimac Research & Development Inc., Fairfield Place, West Caldwell, N. J. [408]

# NOW

Hamilton precision metals has added facilities...and is in the Photoformed® Parts business...



# BIG!

Hamilton has added a new plant—just to produce precision, Photoformed® parts!

This new facility is equipped with the most modern photo-etching machinery on the market. The new equipment will produce precision parts in large quantities to the highest standard of dimensional accuracy.

Now, you can get from the Precision Metals Division, finished parts to the same degree of precision as world wide metal users have come to expect in Hamilton's strip and foil.

Hamilton offers the Total Capabilities of a completely integrated facility controlling every step from melt to finished strip or foil—and now to finished parts. This means that you get the same adherence to metallurgical standards and dimensional accuracy that has become the hallmark of Hamilton.

For the complete story on the capabilities of Precision Metals Division and what it can do for you, write for your copy of the new Photoforming brochure. It's yours for the asking—write today!

PRECISION METALS DIVISION  
**HAMILTON**  
WATCH COMPANY • LANCASTER, PA. 17604  
• PHONE (717) 394-7161

... size is suitable  
for land-mobile radios ...

long, a half-inch wide, and just 25 mils thick. Motorola engineers say the MCH 5890 can be considered a single-pole, double-throw switch that isolates the receiver when it's in the transmit mode by connecting the antenna to the transmitter; it disconnects the transmitter when switched to the receive mode. At 460 Mhz, typical isolation between transmitter and receiver ports is 25 db.

Marshall says coaxial relays are capable of better electrical characteristics, but the tradeoff lies in size. Relays, he asserts, usually weigh 50 to 100 times more than the Motorola hybrid. Because of the Motorola unit's small size, it's ideal for land-mobile and hand-held two-way radios, such as police transceivers, Marshall points out. The Semiconductor Products division could have a ready-made market if the device is designed into the two-way radios made by Motorola's Communications division.

In the transmit mode, the diodes are forward-biased by an external, 10-milliampere to 20-milliampere bias source, lowering the diodes' impedances. The transmitter is connected to the antenna by the low impedance of one of the diodes, while the other diode disconnects the receiver, appearing as a high impedance when it is transformed a quarter-wavelength to the junction of all three arms (transmitter port, receiver port, antenna port) in a parallel-wire representation of the duplexer. The second diode is shunted across the receiver arm in this mode.

In a similar representation for receiving, the diodes' bias is zero and they appear as high-capacitive reactances in series with resistors. The effect in this mode is to disconnect the transmitter, Marshall says, because with both diodes appearing as large capacitive reactances, the diode at the transmitter port disconnects that arm while the second diode does not appreciably load the receiver arm of the circuit.

The MCH 5890 is priced at \$15 in quantities of 1-9, and \$13.50 each for 10-99. It is available from stock.

Motorola Semiconductor Products Inc.,  
Box 20912, Phoenix, Ariz., 85036 [409]

**Film-Met  
is not a  
wirewound...**

**not a  
cermet.**

**Film-Met is a  
whole new trimmer.**

It has an exclusive Amphenol resistance element\* completely different from wirewounds and cermets.

Film-Met™ is a 100% metal element, not a cermet material. The process is different, too. We use a vacuum deposition chamber and our patented process to evaporate metal alloys onto an insulating substrate. The resistive track is then protected by a noble metal overlay.

But the big Film-Met difference is performance.

Film-Met offers both infinite resolution and a low temperature coefficient of 100 ppm/°C maximum. 50 ppm/°C is available on request.

It also provides excellent high frequency and pulse characteristics, and low current noise. In addition, Film-Met has extremely low contact resistance variation.

We're not knocking wirewound and cermet trimmers. We make them too. In many applications, their characteristics fit perfectly. But when they don't you needn't compromise. You can now use Film-Met trimmers.

Film-Met trimmers are available in 3/4" rectangular commercial—3811 series; 1/2" square military—2901 series; and 1 1/4" rectangular military—2851 series.

We'd like you to evaluate this new type of trimmer and compare it to wirewound and cermet. Then tell us if Film-Met isn't a whole new trimmer.

You'll find them at the Amphenol distributor nearest you. Or write to us for complete specs. Amphenol Controls Division, Janesville, Wisconsin 53545.

**Film-Met™ by Amphenol**



**AMPHENOL**  
THE BUNKER-RAMO CORPORATION

\*U.S. Patent No. 3,353,134; also foreign patents.

# What happened when doctors and engineers got together.

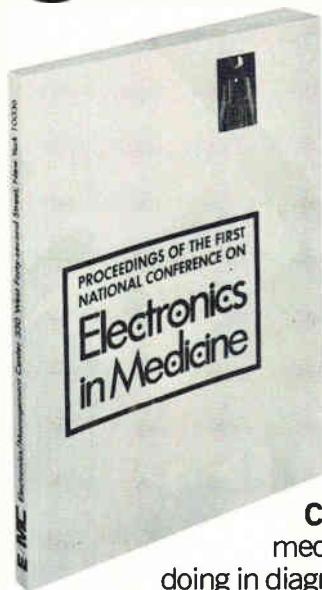

Doctors told engineers how they were using electronics and revealed their most urgent needs. Engineers described and demonstrated their newest equipment for diagnosis, treatment, and prevention. And hinted at things to come.

Their complete dialogue, with illustrations, makes pretty informative reading on a vital and growing market.

Here are some of the things it contains:

**Computers:** How they're joining the medical team. What computers are doing in diagnosis. In communications. The small computer as a paramedical aid.

**Instrumentation:** What's needed. What's available. Patient management. Protection. Standards and safety.

**Electronics in the Hospital:** The surgeon, the hospital, the instruments. What the administrator wants. Prescription for large-scale health care. The surgery department.

Electronics/Management Center  
330 West 42nd Street, New York, N.Y. 10036

Enclosed is \$12 for a copy of the Proceedings of the First National Conference on Electronics in Medicine.

Send the Proceedings and bill me later. P.O. # \_\_\_\_\_

Name \_\_\_\_\_

Company \_\_\_\_\_

Address \_\_\_\_\_

City \_\_\_\_\_ State \_\_\_\_\_ Zip \_\_\_\_\_

New microwave

## Amplifiers put out 10 watts

Solid state modules are designed to oust twt's in telemetry, radar systems

It's hardly a stampede, but solid state modules continue to move into microwave tube jobs, among the latest being a series of amplifiers that can replace traveling wave tube assemblies in medium-power telemetry and radar.

Each of the three units developed by TRW Semiconductors is rated at 10 watts minimum output across its band. The PA-3940 operates from 1.0 to 1.5 gigahertz with 6-decibel gain; the PA-3941, 1.5 to 2 Ghz with 5-db gain; and the PA-3942, 2.0 to 2.3 Ghz with 4-db gain.

The amplifiers operate at 28 volts and efficiency is 25%. The maximum vswr is 2:1 for either the input or the output of each type. Silicon nitride passivation of the transistor chips gives added protection against the environment.

**Challenger.** The PA-3940 is expected to challenge twt's in such applications as L-band telemetry and distance measuring equipment. The other two types, covering the 1.5-to-2.3-Ghz range, will be suitable for S-band phased-array radar and collision avoidance radar.

The units are priced at \$1,285.

TRW Semiconductors Inc., 14520 S. Aviation Boulevard, Lawndale, Calif. 90260 [410]

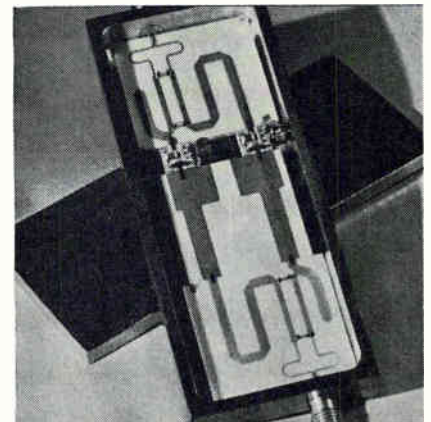

# JUST ADD LIGHT

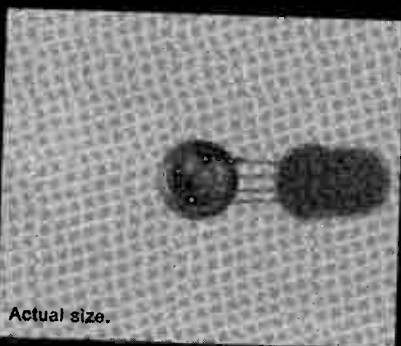

PhotoSchmitt has behind its window a 0.1 mm<sup>2</sup> eye that gets things going for you.

A production line.

A data system.

Your own garage door.

Or stops things going for you.

Or controls whatever you want it to control.

In more accurate words -

PhotoSchmitt is a light sensitive switch with a built-in amplifier enabling direct operation of relays, counters, lamps, solenoids etc. PhotoSchmitt is an

inestimable contribution to position control.

Advanced thin film hybrid technique ensures high reliability.

All it needs to work is light.

And light you've got.

Such a modest little thing should not cost more than ten dollars.

It doesn't.

\$ 9.80.

Got a one-dollar-problem or a million dollar-problem?

We may help you solve it. Send us a letter for further information.



AKERS ELECTRONICS

Address: 3191 Horten, Norway - Telephone: 47 33 42 651 - Telex: Oslo 16 527 - Telegrams: Micro

# WE'VE GOT A BETTER WAY TO MAKE PRINTED CIRCUITS!

*Here's some Industrial History you should know!*

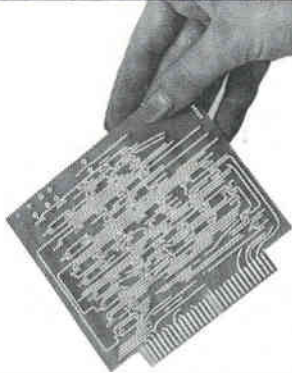

F-104

Developed new technique to produce circuit boards with more reliable plated-thru holes.



PHOENIX

Required new techniques for manufacturing heat sinks and insulation by chemical milling.

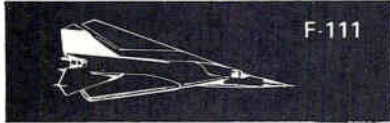

F-111

New industry technique was used to produce multilayer circuit boards with an internal heat sink.



POSEIDON

Developed new technology for sequential laminating multilayer circuit boards with aluminum backbone.



707

Reliable circuit boards in high volume at low cost were produced for this project.



MERCURY

Our company used a unique etch-back method for plated-thru holes in large quantities.



C5

We introduced circuit boards that had the highest density circuitry ever used before on a production basis.



GEMINI

Again, top reliability was required and delivery on-time was made to the customer.



OTHERS

Hundreds of projects use our circuit boards in all phases of civilian and military equipment. We've got a better way to make printed circuitry.



APOLLO

Our circuit boards were on Apollo, LEM, and seis. experiment. Sequential laminating, extra-fine line width and spacing, plated slots and edges.



***This design & production experience can give you a BIG JUMP on your next project. CALL US NOW!***

New microwave

## Spectrum analyzer operates on batt

Lightweight instrument for field measurements covers 10 Mhz to 6.5 Gh

**Light weight** and portability among primary design requirements when the Microwave Division of Systron-Donner developed the model 751, a self-contained spectrum analyzer for field borne measurements.

Covering the range of 10 hertz to 6.5 gigahertz in six it is fully calibrated and can operate for up to eight hours on internal rechargeable battery. battery, it weighs 30 pounds.

The instrument was designed to meet the relatively narrow bandwidth requirements of scope presentations thus reducing the cathode-ray circuit complexity and power consumption. All other circuitry is low-voltage, low-power and self-contained for battery operation.

Scan width is selectable from 1 kilohertz to 500 Mhz, with a resolution from 1 kHz to 10 Mhz. A phaselock circuit stabilizes the first local oscillator, resulting in low drift and spectral purity over the narrowest scan width range. The range of sweep speeds is programmable from 10 sec/cm to  $3 \times 10^{-3}$  sec/cm as well as a manual sweep.

The company says that to meet the power dissipation of 15 watts and the light weight of the model 751, they made it useful for field applications such as spectrum surveillance, antenna pattern measurements, interference and field strength measurements, and CATV monitoring. It also is expected to be used in airborne applications requiring high-performance microwave spectrum analysis.

The rack-mountable unit is 16 3/4 inches high, 16 1/2 inches wide and 14 inches deep. It is priced at \$950 without a battery pack. Mean time between failures is 60 days.

Microwave Division, Systron-Donner Corp., 14844 Oxnard St., Van Nuys, Calif. 91409 [411]

**CONTROL DATA CORPORATION**

**CONTROL DATA CORPORATION**

PRINTED CIRCUITS OPERATION  
7800 COMPUTER AVENUE  
MINNEAPOLIS, MINN. 55435  
PHONE: (612) 920-8600

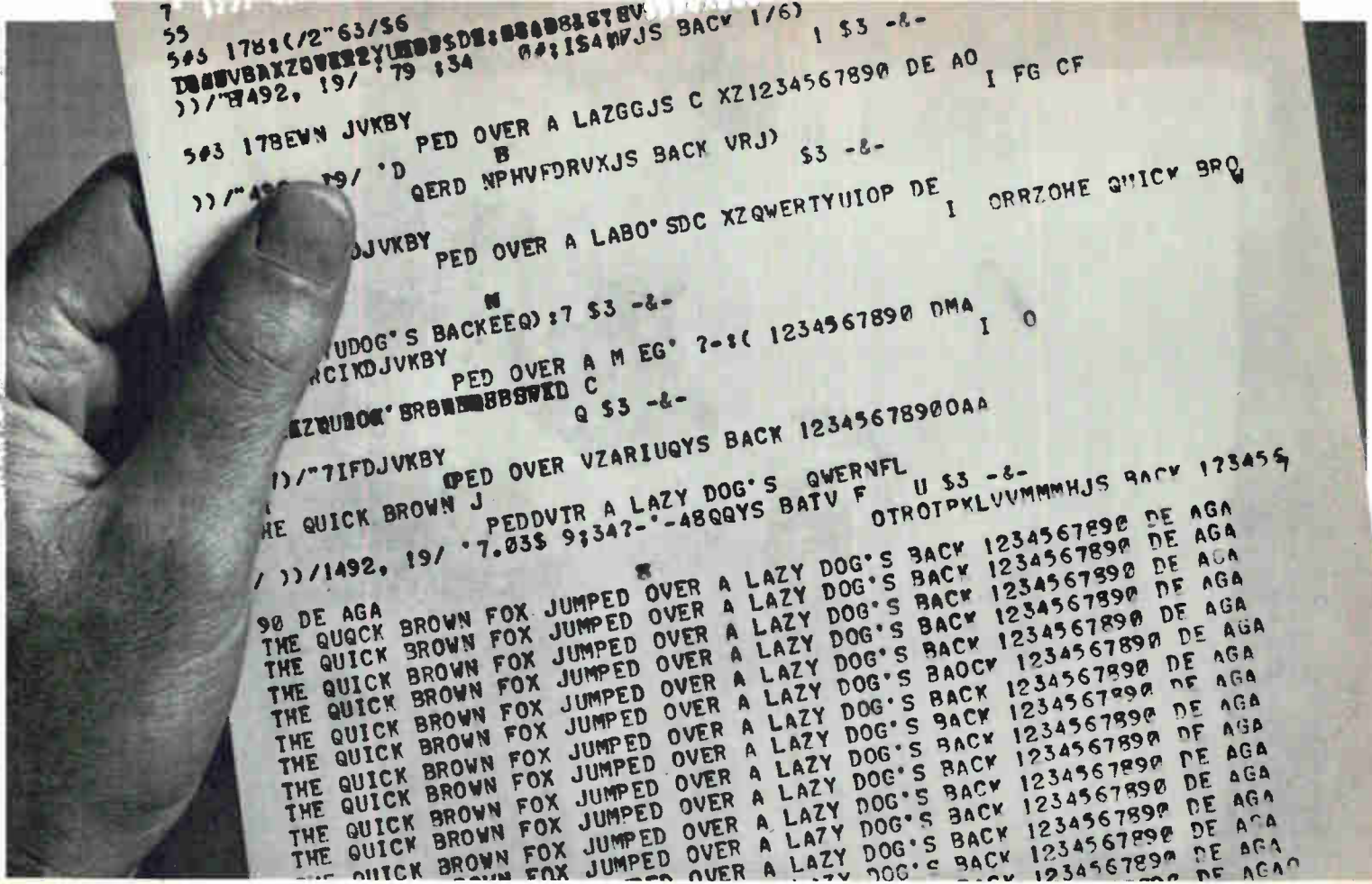

# Look what IBM did for the quick brown fox.

The next time a poor communications channel garbles your message, don't change the channel. Clean it up with IBM's new forward error corrector. And help stamp out inefficient, time-consuming retransmissions.

Custom built for military applications, the IBM forward error corrector is qualified for use in ground, airborne and seaborne applications. It is currently on duty with the USAF Eastern Test Range for down-range tracking.

Catalog number: AN USA-29. Random correction: three bits in any 24 or three bits in any 16, depending on the correction setting you select on the front panel. Burst correction: six to 62 consecutive bits depending upon delay selected. Interface: MIL-STD-188B. Channel data rate: up to 19,200 Bps. Encoder delay: one-bit time.

You may not think of IBM as communications people, but we are. Not only with error correction devices, but with capability in modems, multiplexers, automatic routing equipment, and complete network systems analysis.

Write us about our communications capability. Maybe we can upgrade your quick brown fox.

IBM, Federal Systems Division,  
Gaithersburg, Md. 20760.



IBM Marketing Information, 18100 Frederick Pike  
Gaithersburg, Maryland 20760

Please rush me the facts on the IBM forward error corrector.

Name \_\_\_\_\_  
please print

Title \_\_\_\_\_

Company \_\_\_\_\_

Address \_\_\_\_\_

City \_\_\_\_\_ State \_\_\_\_\_ Zip \_\_\_\_\_



# Everyone's placing orders for immediate delivery on our 500-1000 MHz solid state oscillators!

(well almost everyone)



IN STOCK . . . \$250  
IMMEDIATE DELIVERY

We're featuring *off-the-shelf* delivery on  
MPG Model No . . . . . ETS 375 1-2  
Minimum Tuning Range . 500-1000 MHz  
Minimum Output Power . . . . . 150 mW  
MTBF . . . . . 500,000 hours

Phone, TWX, or write Bob Pizzutiello for quantity discounts.

We also have 15 other standard fundamental oscillators covering octave-band tuning ranges from 30 to 2000 MHz. (Manual and voltage tuning are available in each range.)

Harmonic models are also available. Phone, TWX, or write Herb Bass for applications engineering assistance.



have a catalog describing our amplifiers, oscillators, and front end assemblies.

**Microwave Products Group • Inc.**  
A SUBSIDIARY OF SAGE LABORATORIES • INC.

100 EXPRESS STREET • PLAINVIEW • LONG ISLAND • N.Y. 11803 • TEL.: (516) 938-8200 • TWX: (510) 221-1826





# OCR reader weighs in at modest price

Scanner challenges punched-card reader as on-line computer input device; high-speed unit can handle up to 36,000 turnaround documents per hour

**Optical character** recognition devices, which operate at much higher speeds than the familiar punched-card readers, have been coming on strong as input equipment for processing and storing documentary data for digital computers. In fact, only the high price tag on OCR units has prevented truly widespread usage. Now the Univac division of Sperry Rand is

offering an optical reader which—at \$42,000—carries the lowest price in its class for turnaround document applications.

The 2703 Optical Document Reader scans documents from 3 to 8.75 inches wide and 2.75 to 4.25 inches high. It recognizes numerics from 0 to 9, plus four special symbols, hand-printed vertical marks, or holes in punched cards.

The unit's basic speed is 1,500 characters per second, or 300 6-inch documents per minute. As an optional feature speed can be increased to 600 documents per minute.

The cards enter the unit through an input hopper which holds about 2,000 items. On a command from the central processor, they leave the hopper, are aligned by canted



Drum printer 691 is a three-line-per-second unit expandable from 4 to 21 columns. Nineteen columns contain the digital characters 0 through 9 and 6 symbols. A "floating" decimal point may be programmed in any of these columns. Two columns may be used to print 38 symbols which represent the most often-used engineering units. United Systems Corp., Dayton, Ohio. [421]



Panel-mounted digital comparator model 4310 provides on/off control by comparing BCD input data to a preselected limit. It will compare on command, with comparison to input data being transferred to the output when a compare command pulse is received, or can compare continuously. Price for adjustable limit models is \$165. API Instruments Co., Chesterland, Ohio. 44026 [422]



Solid state alphanumeric keyboard features a Neverwear non-contacting key switch. Coded capacitance keys provide improved reliability and an output compatible with TTL or DTL. The keyboard needs no anti-bounce circuitry, and any popular code may be used. The flexible, modular unit is priced at \$100. Data Term Inc., 1611 Manning Blvd., Levittown, Pa. 19057 [423]

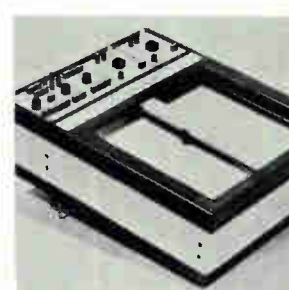

Graphic recorder model 1024 is designed to interface with computers, computer peripherals, data terminals, and a variety of other digital and analog data sources. It gains its versatility by plug-in signal conditioning modules that adapt the recorder to the type of signal to be processed. Data is recorded on a 10.24-in. square plot. Valtec Corp., Box BT, Irvine, Calif. [424]



Digital data logger for simultaneous readout and printout of pressure, temperature, flow, load, and speed parameters—up to 1,000 points or more—is particularly suited to automatic test and process control instrumentation systems. The instrument consists of a digital indicator, an integral scanner, and printer. Consolidated Controls Corp., Bethel, Conn. 06801 [425]



Digital-to-analog converter model D/A 011 is based on the principle of vernier auto transformer windings and MOS FET IC's. It has resolution of 11 bits and accuracy is  $\pm 1/2$  bit. Input voltage is 3.5 v rms, 400 hz with input impedance of 90 kilohms minimum. Output impedance without amplifier is 2 kilohms maximum. Perkin-Elmer Corp., 131 Danbury Rd., Wilton, Conn. [426]

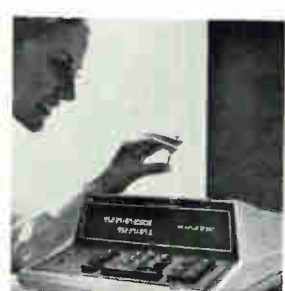

Crt calculator model 820 shows entries and answers for any business calculation in  $1/4$ -in. numerals on a large two-line display panel. Heart of the machine is two memory units,  $1/4$  in. in diameter and  $1/8$  in. high, which store all numbers entered. The calculator is 11 x 17 in. and weighs 14 lbs. Price is \$895. Litton Industries Inc., 550 Central Ave., Orange, N.J. 07051 [427]



Calculator printer model 9120A prints at 180 lines per minute with about as much noise as the ticking of a clock. It has an assembly consisting of 7 tungsten print fingers which sweep across the width of the paper in a vertical array. Characters are written by sending short bursts of very low current through the proper stylus fingers. Hewlett-Packard Co., Palo Alto, Calif. [428]

# LOWEST COST . . . FULL WAVE BRIDGE RECTIFIERS & ASSEMBLIES

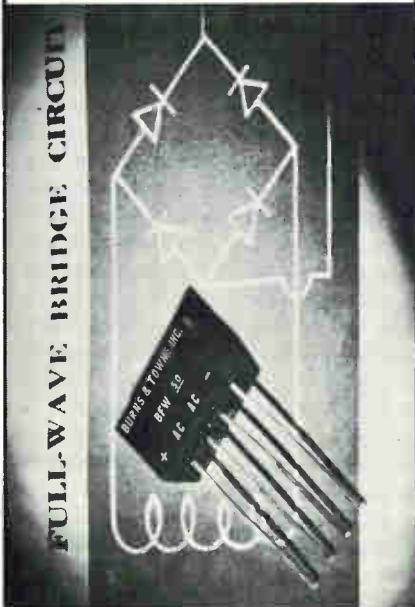

Burns & Towne pre-packaged rectifier circuits represent a significant cost savings over individual components used in multi-rectifier units. Yet, you are always assured of quality and reliability. The low cost BFW family of single phase full wave bridges . . . features high current capability of up to 2.0 amps.

Part No.	Max. PRV (volts)
BFW-50	50
BFW-100	100
BFW-200	200
BFW-300	300
BFW-400	400
BFW-500	500
BFW-600	600
BFW-800	800
BFW-1000	1000

Call or write for full specifications and price data.

Contact FRED SIEGEL  
**BURNS & TOWNE INC.**  
 550 Old Country Road  
 Hicksville, L.I., N.Y., Tel. (516) 935-0522

. . . pencil marks and punches can be read,  
 in addition to printed characters . . .

revolving brushes, and are accelerated to a velocity of 150 inches per second. As the documents travel past the read station, a high-resolution photoelectric scanning system converts the OCR characters into a series of electrical pulses. A recognition logic section determines the character and translates it into digital code for transmission to the central processing unit.

The document then passes a Mark Read/Punch Card Read station where a solar-cell sensing head reads up to 12 pencilled marks per column; this is in addition to the character recognition. This station also can read punched cards.

Documents are routed to any of three output stackers. Stacker

is recognized by a grid of summing amplifiers and resistors attached to the outputs of the register. For a particular character in the register, 13 summing amplifiers will be saturated with large input currents while one amplifier has little or no current at its input and operates a threshold detector in its linear region setting. The threshold detector (one for each summing amplifier) triggers one of 14 flip-flops which delivers a signal to an encoder; the encoder assembles the character in byte form for transmission to the computer.

The Univac 2703 was designed especially for turnaround (return-stub) documents, commonly used as utility bills, insurance premium notices, retail billings, mortgage and loan payments, and payroll checks. The optical character reader functions as an on-line input device to the Univac 9000 series computer which controls the reader's operation, and processes and stores the data received from the documents.

The reader comes with built-in hardware for on-line or off-line diagnosis, and with software test routines for writing and checking recognition patterns.

The 2703 is priced at \$42,000. It can be rented for \$1,050 per month.

Sperry Rand, Univac Division, P.O. Box 8100, Philadelphia, Pa. [429]



Data gatherer. Optical character reader takes information from small cards for input to computer.

selection is controlled by hardware logic from within the OCR, and by software. Each stacker has a capacity of 1,000 documents.

**Scanning.** In the character recognition logic section, characters 16 cells high by 12 cells wide are scanned by a vertical column of 40 photocells, thus enabling the device to read characters that are slightly out of position. Each photocell has an amplifier connected to its output. If the cell detects a black spot the amplifier delivers a logic 1 output. For a white spot, the output is logic 0. All 40 bits are scanned sequentially and delivered to a 240-bit shift register. About 15 scans are made per character.

The character in the shift register

Data handling

## Terminal does double duty

Low-cost input system  
 can also prepare data  
 off-line for processing

It's the extras that count, in buying a car or a data input system; at least, that's usually the case. But not so with the GTU-1, a portable, desk-top terminal developed by the

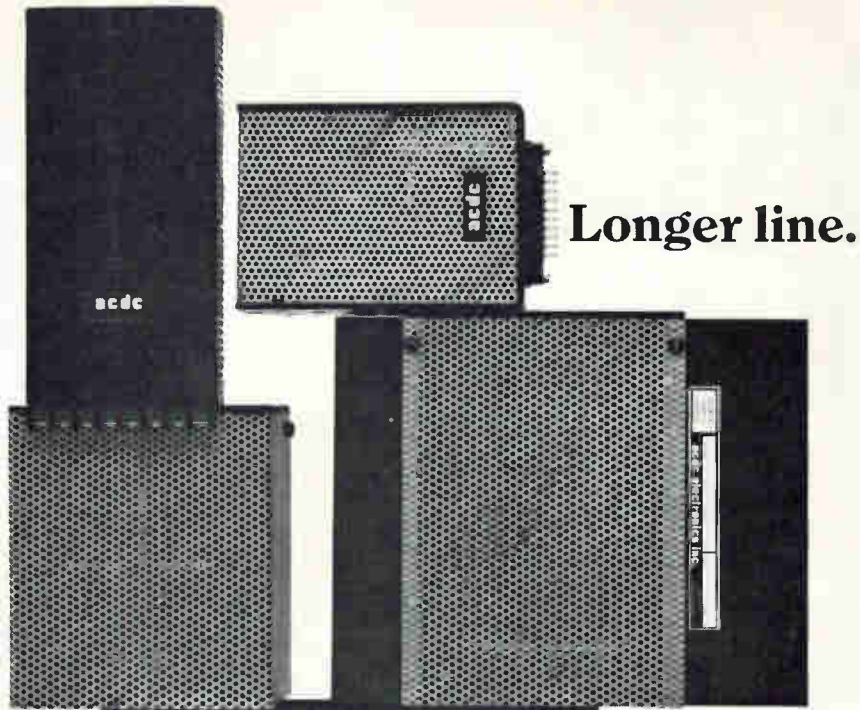

**Longer line.**

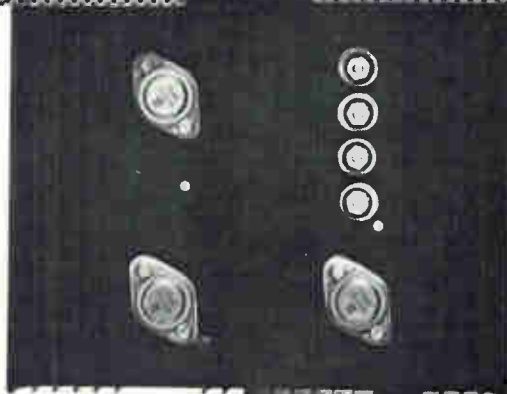

**Shorter delivery.**



We've added more power supplies. And put more of them on the shelf. So now you get a wider selection and faster delivery. Write for our complete catalog. (It includes the new miniaturized JR.) **acdc electronics, inc.** 2979 N. Ontario St., Burbank, Calif. 91504.

# WHILE YOU'RE MAKING UP YOUR MIND TO MOVE TO SOUTH CAROLINA, SOUTH CAROLINA HAS ALREADY TRAINED YOUR LABOR FORCE.

Free.

In state-sponsored technical schools. The same schools that graduated over 42,146 highly skilled workers last year for South Carolina industry.

Do you have special jobs? You'll get specially trained workers. Ready to go on opening day.

But the savings begin even before you open your plant, starting with the finest plant sites available. You'll get acres for the price of square yards almost

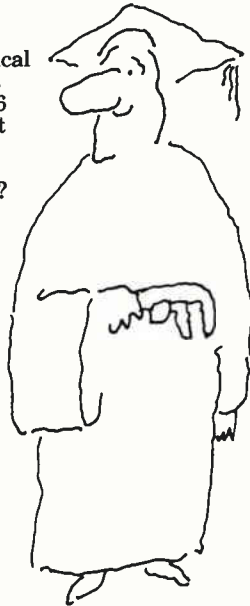

anywhere else. And construction costs will be surprisingly small. You'll have quick, economical transportation by road, rail and air. Taxes are in your favor. And plenty of electricity and natural gas is available at rates well below the national average.

Over 682 industries have made up their minds to move to South Carolina in the last 10 years. We'll help you make up yours.

Mail the coupon today.

Ask Mr. R. H. Kennedy,  
Vice President, Area Development  
South Carolina Electric & Gas Co.  
Box 764, Dept. E  
Columbia, South Carolina 29202

He's got the facts.

Name \_\_\_\_\_

Address \_\_\_\_\_

City \_\_\_\_\_ State \_\_\_\_\_ Zip \_\_\_\_\_

**SOUTH CAROLINA ELECTRIC & GAS COMPANY**

We try to make life easier.

Hypertech Corp. as an interactive data input system for both on-line and off-line data entry and retrieval.

Like Viatron's System 21 (*Electronics*, June 23, p. 141), it uses a great deal of MOS LSI circuitry. But unlike Viatron's, says Hypertech president Eugene D. Spertus, "the GTU-1 does not depend on addition of accessories to get data processing power." Everything is built into the basic system, which will sell for \$5,000 and which consists of a microprocessor, a video display system, an alphanumeric keyboard, and two magnetic tape cassette recorders.

Designed as an economical replacement for currently used data entry systems, the GTU-1 will be marketed as a significant advance over the keypunch-verifier and keyboard-to-tape equipment. Normally, two operators and two machines are required for the preparation of punched cards.

**Two-way check.** With the GTU-1, a single operator enters and verifies data, using only one machine. The information can be checked either by continuously comparing the original with what appears on the cathode-ray tube, or by transferring the data on the crt to one of the built-in tape recorders and then re-typing the data. Then, by pressing a special key, the operator initiates an electronic comparison of the first and second typing. If there is any discrepancy, an alarm sounds.

The Hypertech unit permits an operator to enter programs in the same way that data is entered. And like data, the program information appears on the video screen, can be verified visually or electronically, and can then be stored in either an internal memory or on the machine's magnetic tape recorders. In addition, an interface feature allows the program and data to appear at the same time.

**Flick of the switch.** Furthermore, by throwing a single switch, the GTU-1 can be used as an on-line device in the same way as currently available computer terminals. Its built-in memory eliminates the need to rely on the computers memory for data on the cathode-ray tube.

Hypertech Corp., 7343 W. Wilson Ave.,  
Harwood Heights, Ill. 60656 [430]



Unretouched photo of U.S. dime and Data Products' 18-mil cores.

Memory cores, greatly magnified. To show that they are precision-cut. And to show their uniformity. Not shown is the price, recently minified to as little as \$2.50/K. Our secret? Technology. In this case a new process developed by our Core Memories Inc. subsidiary. It cookie-cuts cores from continuous ferro-plastic tape. Assures consistent density and size; unvarying electrical and mechanical characteristics. Produces a 90% yield, even on 18-mil cores. Permits off-the-shelf delivery. Let Data Products technology minify your core costs.

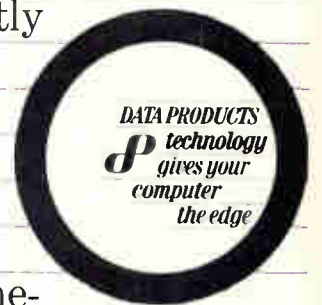

## **DATA PRODUCTS**

6219 De Soto Avenue/Woodland Hills, California 91364

Los Angeles, 213/887-8000 Minneapolis, 612/338-4717 Dallas, 214/239-9641 Acton, Mass., 617/263-3961 Bethesda, Md., 301/652-8120  
Melbourne, Fla., 305/262-4773 Amsterdam, The Netherlands 020/156-297 London, England (1) 579-3116

Circle 169 on reader service card

The  
Choice  
is TTL.

# TI's new MSI arithmetic element. Add it to your adder...

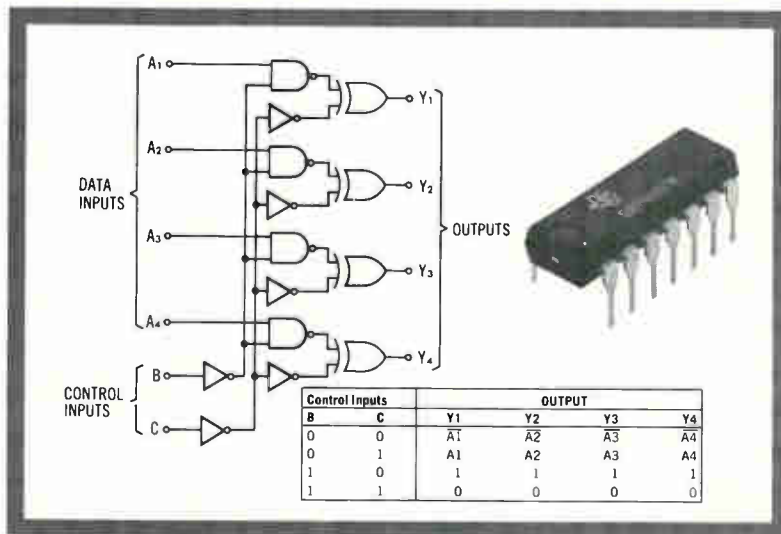

## and subtract four.

TI's new 4-bit true/complement element (SN54H87/SN74H87) replaces five IC packages usually necessary for arithmetic operations—a net saving of four packages or 40% of component costs.

This versatile MSI circuit allows you to perform arithmetic operations when used with a binary full adder. You can add, subtract, direct transfer (do nothing), or decrement (subtract) by manipulating the two control lines. And it's fast—typical propagation delay of 13 ns from data input to output.

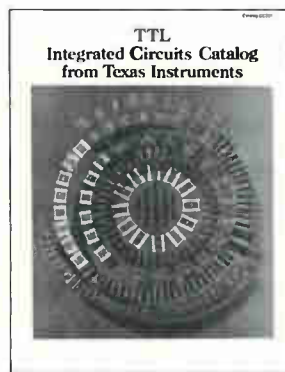

The 74H87 in plastic dual-in-line sells for \$5.12 (100-999 quantities) and is ready for immediate delivery.

We've summed up the SN54H87/SN74H87 in a data sheet. To which we'll add a copy of our new 424-page TTL catalog containing data sheets on all Series 54/74 circuits. Circle 119 on the Reader Service Card, or write Texas Instruments Incorporated, P.O. Box 5012, M.S. 308, Dallas, Texas 75222. Or call your authorized TI Distributor.



**TEXAS INSTRUMENTS**  
INCORPORATED

Data handling

## Key-to-tape unit to KO cards?

System includes desk file  
and computer for editing;  
can handle 64 terminals

Will the parade of keyboard-to-tape machines never end? Yes, says Anthony J. Penta, president of Penta Computer Associates Inc., it's ending right now, with the KeyLogic machine. KeyLogic, he says, wipes out any advantage that punched cards ever had.

Penta's new system includes a data entry terminal, a computer, a disk storage unit, and a tape drive. Up to 64 terminals can be connected to the computer, and their operators can enter data in essentially the same way they would with a keypunch machine. Up to 44 different formats can be used simultaneously. Data is stored in the computer's memory, and the computer—a Redcor—sorts it and stores it temporarily on the disk, which is a Burroughs unit. When the disk accumulates a complete file, it is transferred by the computer to magnetic tape.

Rather than having a keyboard comparable with the IBM keypunch, as do many recently introduced machines, the KeyLogic terminal uses a real keypunch keyboard that Penta buys from IBM. And as do most other systems, the KeyLogic machine has a panel full of signal lights designed to be intelligible even to the least skilled operator.

**Tall order.** Penta sees the new system as a potential replacement of present installations in which there are large numbers of key-punches clattering away all at once. The same, he says, holds true for keyboard-to-tape installations in which the keyboards record on their own tape.

Prices range from \$126,000 for a 12-terminal installation to \$345,000 for 64 terminals—both include one computer, one disk unit.

Penta Computer Associates Inc., 445 Park Ave., New York, N.Y. 10022 [431]

# The innovators.

In coils and transformers, Delevan has been leading the pack for years. How? By innovating. Cramping high values into the smallest configurations takes talent... the highest degree of engineering talent. And, you'll find it only at Delevan. Isn't that really what you want?

Call us. Make us innovate for you!

**Delevan Electronics**  
Division



AMERICAN  
PRECISION  
INDUSTRIES INC.

270 QUAKER ROAD EAST AURORA, NEW YORK 14052 716 652-3600  
OTHER DIVISIONS OF AMERICAN PRECISION INDUSTRIES INC. - BASCO - DUSTEX - ELECTRO MECHANICAL PRODUCTS - MOELLER INSTRUMENT CO. - OXFORD CORP.

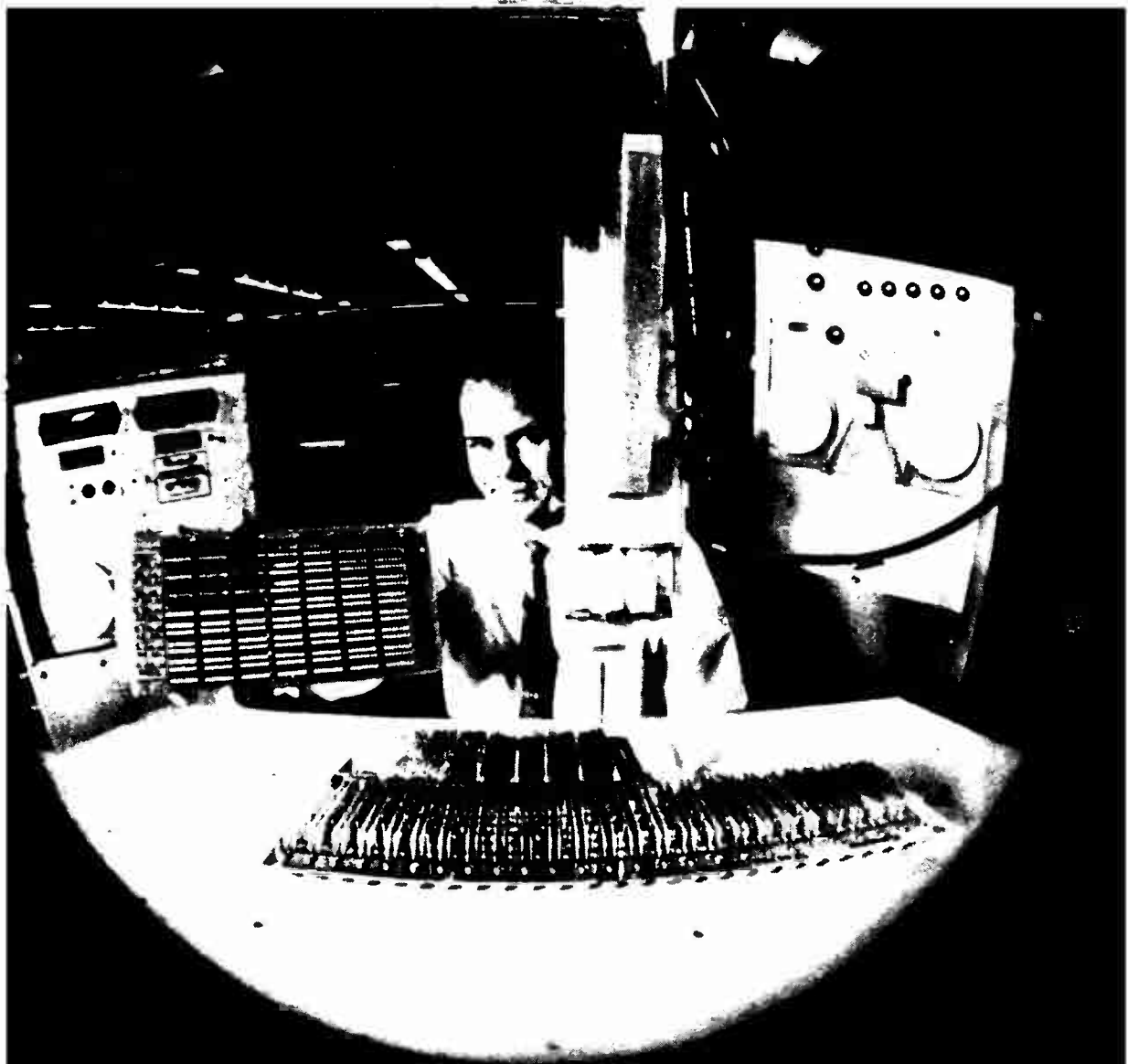

## Do you or don't you?

Whether you're a budget-minded do-it-yourselfer or a guy who needs to save time, CAMBION's high density Wire-Wrap\* system components let you have it your way. Quality 14, 16, 24 or 36-pin Wire-Wrap sockets, cards, card files, power planes . . . you save time and money when you build your systems with the new CAMBION line.

Whether you're building a sub-system or a full logic complex, with CAMBION Wire-Wrap components, you'll have a modular technique that provides maximum flexibility of design, high density packaging and noise immunity.

Is our automated production facility working for you? If not, let's get together!

If you want to start your design further along, we will wire-wrap our cards and package sub-systems for you.

To get the big picture of what CAMBION can do for **you**, ask for our latest literature on CAMBION Wire-Wrap products and facilities. We'll include your Logic Manual as well. They're both fact-packed to save you time and money. Free, to Cambridge Thermionic Corporation, 457 Concord Avenue, Cambridge, Massachusetts 02138. Phone: (617) 491-5400. In Los Angeles, 8703 La Tijera Boulevard 90045. Phone: (213) 776-0472.

Standardize on

**CAMBION**  
the guaranteed electronic component

\*Registered Trademark of Gardner-Denver Co.



# Photodiodes' dark current is lightened

Reverse leakage current is kept to 2 na, response time to less than 1 nsec;  
Light detectors aimed at laser, encoder, switching circuit markets

Perhaps even more crucial than speed and sensitivity in optoelectronic systems detection devices is dark-current level—the maximum reverse leakage current through the device, measured under dark conditions. Motorola's Semiconductor Products division stresses low dark-current level in its first silicon p-i-n photodiodes, designated the MRD 500 and

the MRD 510 models.

Dark current shows up in performance as noise, therefore it must be minimized to obtain a high signal-to-noise ratio. "While we specify 2.0 nanoamperes at 25°C," says Arnold London, section manager for optoelectronic devices, "we have data that show the dark-current level at less than 0.1 na at that temperature, and with a

reverse voltage of more than 40 volts."

Some users may find the speed of the devices is the most important feature, adds Peter Polgar, operations manager for optoelectronics and power varactors. The diodes have a typical response time of less than 1 nanosecond. The MRD 500, with a convex lens, has greater sensitivity (minimum



Axial lead, low reverse-leakage rectifiers series F927 feature a piv range of 5,000 to 25,000 v. Reverse leakage is 1  $\mu$ a at 25°C with average rectifying currents of 0.5 amp at 55°C free air. Units are designed for industrial and military applications where small size, light weight and high reliability are specified. Solitron Devices Inc., 256 Oak Tree Rd., Tappan, N.Y. [436]

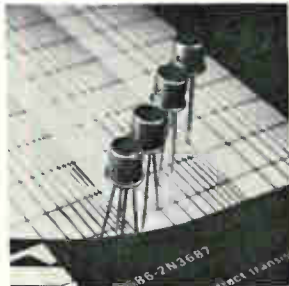

FET amplifiers 2N3684, 2N3685, 2N3686 and 2N3687 provide a 0.1 db typical and 0.5 db maximum noise figure. They offer a low leakage of 100 pa maximum and low pinch-off of 1.2 v. They are useful as high-gain and low-noise amplifiers in various d-c, audio, video, and r-f applications, and low-level choppers. National Semiconductor Corp., San Ysidro Way, Santa Clara, Calif. [437]

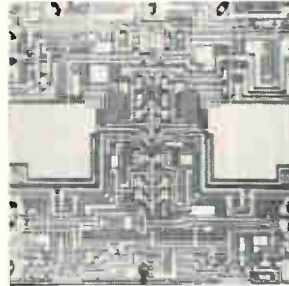

Dual channel, plated wire sense amplifier RA-2540R is a radiation-hardened monolithic IC. It offers a 1 mv signal sensitivity in a high noise environment, and a 10 nsec access time. It is packaged in an all aluminum 14-lead TO-86 flatpack. Price is \$85 each in quantities of 100 to 999; delivery, from shelf stock. Microelectronics Division, Radiation Inc., Melbourne, Fla. [438]

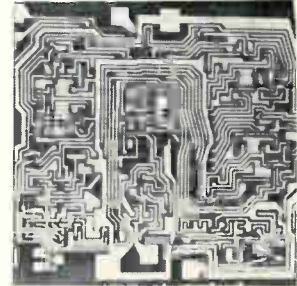

Monolithic digital functional arrays SM143 and SM153 function as programmable frequency dividers. They are rated for operation over the industrial temperature range of 0° to +75°C and are available in a choice of 14-lead, hermetic flatpack or plug-in packages. Devices are priced at \$8.80 each in quantities of 100 to 999. Sylvania Electric Products Inc., Woburn, Mass. [439]

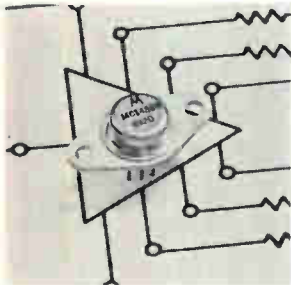

Power booster IC type MC1438 permits load currents of monolithic operational amplifiers to be increased up to  $\pm 300$  ma d-c. Applications include audio and isolation amplifiers, unipolar or bipolar line drivers for either analog or digital systems, and voltage-programable power source. Price (100-999) is \$6.50 each. Motorola Semiconductor Products Inc., Phoenix. [440]

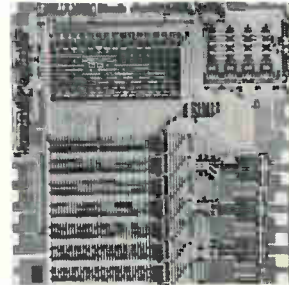

Static read-only memory ROM1K is available in four different word and bit organizations made possible by an on-chip 3-dimensional decoder. The organizations include 128 words x 8 bits, 256 words x 4 bits, 512 words x 2 bits, and 1024 words x 1 bit. It features bipolar compatible outputs and chip inhibit capability. Union Carbide Corp., 8888 Balboa Ave., San Diego, Calif. [441]



One-amp, half-wave silicon rectifiers in the KVO series are 5,000 to 12,000 piv devices for use in lasers, photocopying machines, and Xenon flash power supplies. The KVO features a transfer molded block with fast-on terminals for UL approval as well as the avoidance of corona and simplification of mounting. Electronic Devices Inc., 21 Gray Oaks Ave., Yonkers, N.Y. 10710 [442]



Hybrid diode permits characteristics testing prior to bonding into the circuit, as well as high-reliability processing and stress testing. It has characteristics of fast logic switches, core drivers—2 nsec, 2 pf and voltages up to 1 kv. Prices start at 22 cents each at the 1,000-piece quantity level. Micro Semiconductor Corp., 11250 Playa Court, Culver City, Calif. [443]

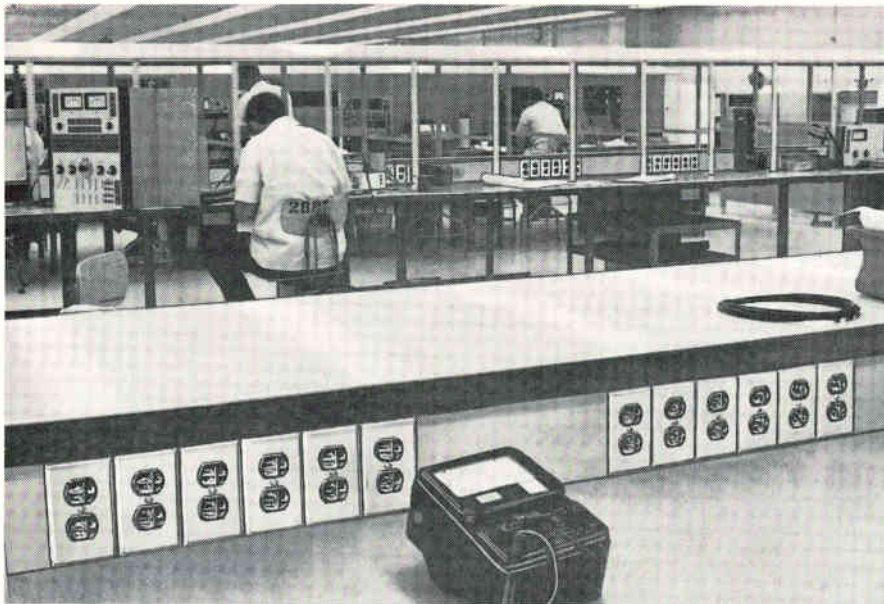

## Electrical convenience for electronic equipment

Whether you make, use or test electronic equipment, the power you need can be delivered neatly in a Wiremold® surface wiring system. All necessary electrical

services and devices are housed in a single raceway, properly sized for present and future needs. Send for literature on the entire line of Wiremold systems.



THE WIREMOLD COMPANY / HARTFORD, CONNECTICUT 06110  
Circle 215 on reader service card

## ... speed could be useful in laser systems ...

1.2 microamperes per milliwatt per square centimeter), than the MRD 510 (minimum  $0.3\mu\text{a}/\text{mw}/\text{cm}^2$ ), which has a flat glass window; both are housed in TO-18-type packages.

These parameters—speed and sensitivity, plus the rated minimum breakdown voltage of 100 volts—are comparable to those of devices already on the market, although Polgar stresses that the devices will operate at 200 volts or more.

The Motorola photodiodes can be applied in laser detection, light demodulation, detection of visible and near-infrared light-emitting diodes, shaft or position encoder detection, or in switching and logic circuitry.

Polgar maintains that the speed of the units could make them useful to the military as, for example, detectors in laser range-finders or laser communications systems. They also will find their way into new industrial instrumentation, he believes.

The MRD 500, with its convex lens, will be used when light levels are lower and fields of view narrower than those compatible with the flat-window MRD 510—the MRD 500's lens gives it five to 10 times higher sensitivity. The MRD 510's window will allow light from the source to be more precisely directed at a specific location on the silicon diode. The flat window makes it ideal as a detector for a light source directed at it through a fiber-optic tube; the light pipe can be precisely located over the detector. The MRD 510 also has a wider viewing angle than the MRD 500.

Both devices are sensitive over a range of about 0.4 micron to 1.1 microns.

Other maximum electrical characteristics for both devices include a forward voltage of 1.0 volt, series resistance of 10 ohms, and a junction capacitance of 4 picofarads. Both the MRD 500 and MRD 510 are priced at \$7.50 each in quantities of 100 or more.

Motorola Semiconductor Products, Inc.,  
Box 20912, Phoenix, Ariz. 85036 [444]

# child's play!

**UNSKILLED OPERATORS  
MOVE MOUNTAINS  
OF INCOMING IC'S  
WITH MICRODYNE'S  
IC TESTER!**



Stuck with a mountain of incoming IC's to test? Unskilled operators use Model 711 for fast, accurate, thorough D.C. and functional measurements of any digital or linear device. Plug-in program modules simplify testing, eliminate errors. From Microdyne . . . the line with the right IC tester for the right job . . . at the right price! Send for information.

**MICRODYNE**  
Please send me Model 711 Bulletin.

NAME \_\_\_\_\_

TITLE \_\_\_\_\_

COMPANY \_\_\_\_\_

ADDRESS \_\_\_\_\_

CITY \_\_\_\_\_ STATE/ZIP \_\_\_\_\_

EL-83

SUBSIDIARY OF COMPUTEST CORP.  
**MICRODYNE**  
 MICRODYNE INSTRUMENTS, INC.  
 203 Middlesex Tpk. • Burlington, Mass. 01803  
 Phone: 617/272-5691

# Mini-est mfd's for $\mu$ spaces

## or: our next series may be invisible

You can still see our new Minitan<sup>®</sup> W-Series tantalum capacitors . . . but just barely. These extraordinary little solid-electrolyte devices — the industry's smallest — pack up to .47 mfd. into a case about the size of a pin head.

What's more, they do it with a maximum DC leakage (at 25°C) of only 0.5 $\mu$ A, standard tolerances to  $\pm 5\%$  and a 130% surge voltage rating. Gold-plated solid nickel leads and an operating temperature range of -55°C to +85°C help make this the finest series of microminiature modular capacitors available for hybrid and thick film circuit use.

Considerably smaller than comparably rated CS13 and epoxy filled devices, Minitan<sup>®</sup> W's have also out-shrunk monolithic ceramics. For example, a typical .22 mfd. ceramic measures .350 x .095 x .070; the Minitan<sup>®</sup> W case is only .100 x .050 x .040.

Of course, if you like capacitors you can see with scarcely a second glance, Components also has the broadest line of CS13, CSR13, CSR09, sub-miniature, and microminiature modular, cordwood, and non-polars around. Send for our new general catalog and get the small picture.

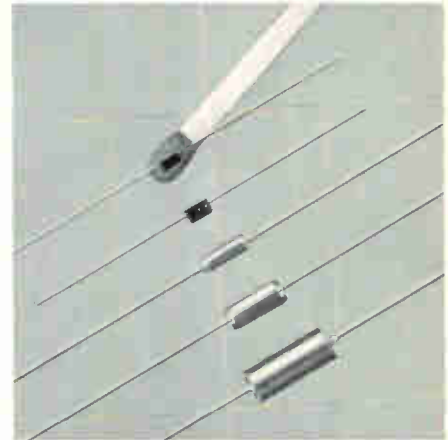

WHAT COMES AFTER MICROMINIATURE? — Looming large in comparison with C.I.'s new "W Series" capacitor (on matchhead) are the following tantalum units: Standard TR Series (CSR13), Miniature TY Series (CSR09), Subminiature Econotan (CT), and Microminiature Minitan<sup>®</sup> (U case).

PART NUMBER		CAP. IN MFD @ 25°C. 120 Hz	WVDC @ 85°C
AXIAL	RADIAL		
W472A	W472R	.0047	20
W682A	W682R	.0068	20
W103A	W103R	.010	20
W153A	W153R	.015	20
W223A	W223R	.022	20
W333A	W333R	.033	20
W473A	W473R	.047	20
W683A	W683R	.068	20
W104A	W104R	.10	15
W154A	W154R	.15	10
W224A	W224R	.22	6
W334A	W334R	.33	4
W474A	W474R	.47	2

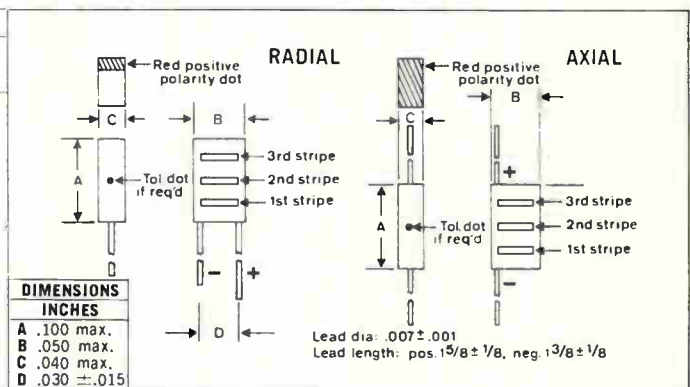

### MINITAN<sup>®</sup> MODULAR

(Also available with axial leads)

	U
	F
	M
	L
	S
	J

068 MFD @ 20 VDC to 220 MFD @ 3 VDC  
(Cordwood Series available from 01 MFD @ 50 VDC)

(ACTUAL SIZE)

### MINITAN<sup>®</sup> CORDWOOD

	Y
	P
	B
	A
	G

01 MFD @ 50 VDC to 47 MFD @ 3 VDC  
(Modular Series available to 220 MFD)

(ACTUAL SIZE)



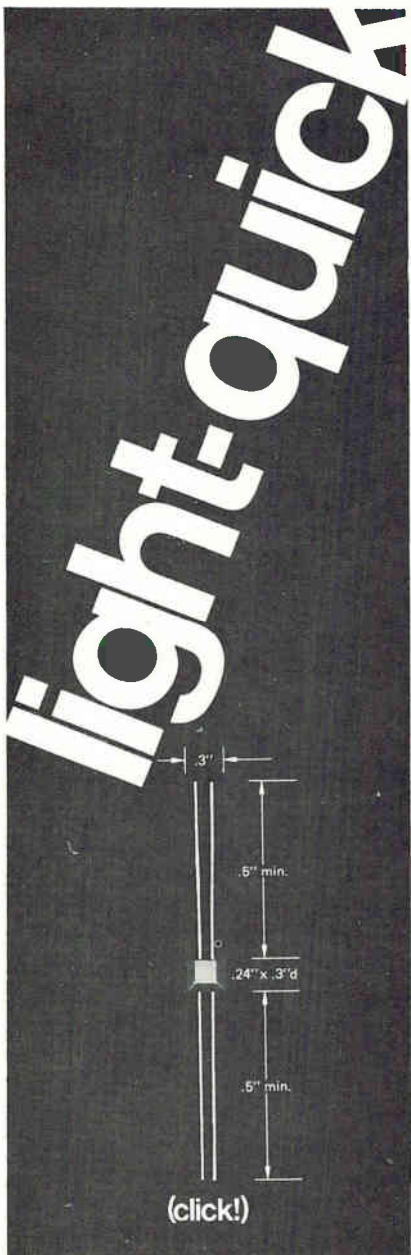

If you're looking for a swift (and noiseless!) electronic switch that offers high voltage isolation of  $10^{11}\Omega$  I/O, consider our MCT 1 coupled GaAs/LED phototransistor pair.

- 2500 volts isolation
- current transfer ratio of 35%
- isolating capacitance: 3pf
- input/output IC-compatible
  - light, rugged, reliable
- analog or digital applications

Call your orders to Semiconductor Specialists, K-Tronics, Kierulff or Schweber. Want more details? Write us at 10131 Bubb Road, Cupertino, California 95014 Phone (408) 257-2140

**Monsanto**

## New Books

### ABC's of logic

Electronic Switching Circuits, Boolean Algebra, and Mapping  
Matthew Mandl  
Prentice-Hall Inc., 229 pp., \$12.50

This book is fairly good, as far as it goes. The trouble is that it doesn't go far enough. For the novice who knows a little something about electronics and wants to pick up some information about switching circuits and logic in a weekend of almost casual reading, this book is just the thing. But for someone who is seeking an in-depth treatment of either or both subjects, other books are available that are much more thorough.

As a text, the book would be more suitable for students not majoring in this field. It contains chapters on the correspondence of switching networks to logic, the implementation of simple switching circuits with transistors, the basics of Boolean algebra and function simplification. There is also a chapter entitled "Numbers, Adders, and Codes," and another describing simple functional units such as counters and registers; two chapters cover sequential circuits.

### Unscrambling Babel

Programming Languages: History and Fundamentals  
Jean E. Sammet  
Prentice-Hall, Inc., 785 pp., \$13.50 paper, \$18.00 cloth

"And the Lord said, 'Behold, they are one people, and they have all one language; and this is only the beginning of what they will do; and nothing that they propose to do will now be impossible for them. Come, let us go down, and there confuse their language, and they may not understand one another's speech.' So the Lord scattered them abroad from there over the face of all the earth, and they left off building the city. Therefore its name was called Babel, because there the Lord confused the language of all the earth; and from there the Lord scattered them abroad over the face of all the earth."

This quotation from Genesis, in a different translation, appears on



Our visible solid state light sources are being delivered in commercial quantities.

Very bright, typically 1000 ft/L @ 50 mA.

Long life: our tests indicate over 1,000,000 hours.\*

Happily compatible with your IC circuitry.

Needs only 10 mW for 50 ft/L @ 6300-7000Å.

Instantly available in package shown or TO-18 header.

Ask Kierulff, Schweber, K-Tronics, or Semiconductor Specialists for our data sheets on the MV-10 series.

Monsanto ESP, 10131 Bubb Road, Cupertino, California 95014. Phone (408) 257-2140

\* $T_A = 25^\circ C$ ,  $I_F = 50$  mA. Result of step-stress testing with end of life projections.

**Monsanto**

# Announcing the "Freon" Solvent Drying System.

## Dries water-wet parts spot-free at 118°F...in 3 easy steps.

1. Lower the parts into the drying sump containing FREON® T-DA 35 solvent boiling at 118°F. Low-temperature boiling eliminates water spotting caused by the evaporation of water. (This system, using the high density of FREON, works by the displacement of water, rather than its evaporation.) No spotting of parts means fewer rejects. And the low-temperature operation also helps to protect delicate parts. The system is compatible with most plastics, elastomers and metals.

2. Remove the parts and allow the excess solvent to drain back into the drying sump. (The solvent is re-usable—no need to discard the solvent because it is saturated with water.) After draining, lower the parts into the first rinse sump containing FREON TF.

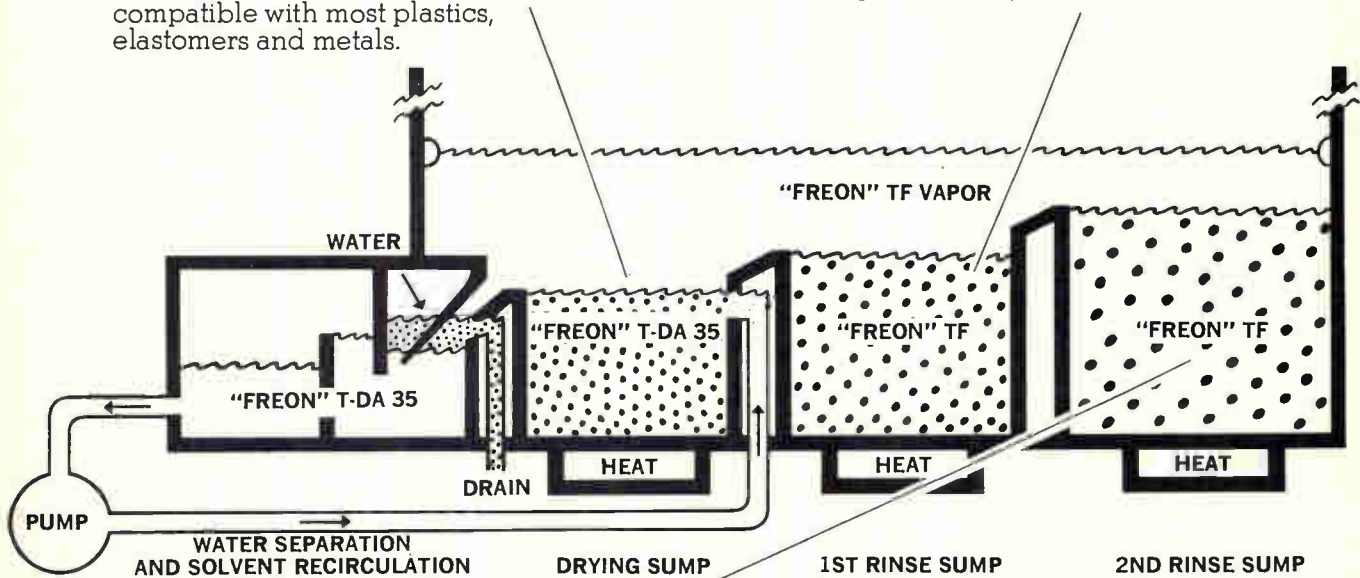

3. Remove the parts from the first rinse sump. Allow to drain and then place in the second rinse sump. Remove the parts and hold them in the vapor zone above the sump. When the dripping stops, remove the parts from the drying system. Parts will be completely dry, spot-free and immediately ready for further processing.

The whole, remarkably simple operation takes only a few short minutes. Furthermore, it is completely safe. FREON solvents are nonflammable, nonexplosive, nonirritating and low in toxicity. For further information on the efficient, economical FREON Solvent Drying System, write: Du Pont Company, Room 7304-J Wilmington, Delaware 19898.



©Du Pont registered trademark for its fluorocarbon cleaning agent.

# Convert any X-Y scope into a curve tracer: \$655\*

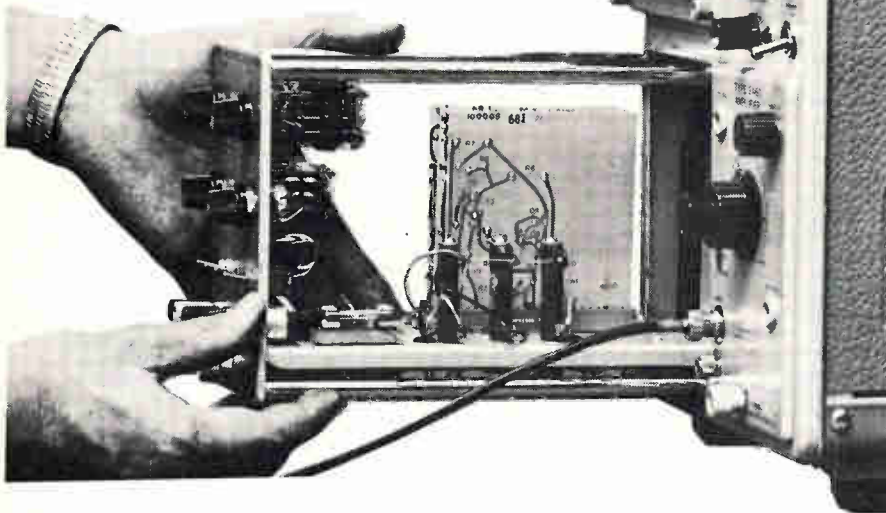

Now U-Tech's plug in and console units are all your oscilloscope needs to become a curve tracer. Save 1/2 to 1/3 the cost!

For the price of one curve tracer, you can now buy two to three of these U-Tech units that use the facilities of your present scope to display the dynamic characteristics of both NPN and PNP transistors, N Channel and P Channel junctions, FETs, MOS-FETs, bipolars, uni-junctions, diodes, tunnel diodes and SCRs.

Ask your distributor about these U-Tech curve tracer units or order direct from:

\* Prices apply to purchase and shipments within U.S.A. fob Salt Lake City, Utah  
 † Registered Trademark Tektronix Inc.

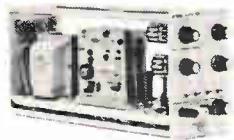

U-Tech plug-in Model 681: \$655.00\*. For use with Tektronix† 560 series Oscilloscopes.

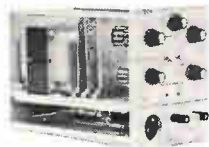

U-Tech plug-in Model 682: \$675.00\*. For use with Tektronix† 530, 540, 550, 580 series Oscilloscopes.



U-Tech Console Model 683: \$685.00\* For use with any X-Y Oscilloscope.

## U-TECH

A Division of Industrial Physics and Electronics Company

4190 South State Street, Salt Lake City, Utah 84107 Tel. (801) 262-2663

Yes, send me curve tracer model.....

Enclosed is:  Check  P.O.  Bill me  Send literature

NAME \_\_\_\_\_ TITLE \_\_\_\_\_

COMPANY NAME \_\_\_\_\_

COMPANY ADDRESS \_\_\_\_\_ PHONE \_\_\_\_\_

CITY \_\_\_\_\_ STATE \_\_\_\_\_

## New Books

the flyleaf of Miss Sammet's book, and is credited to the Association for Computing Machinery. A more apt context for a book on this subject would be hard to imagine—one is surprised that no language called Babel has yet been proposed.

The book is a reference for over 100 different languages, together with their history and general characteristics. It's necessarily somewhat dated, as the author admits in the preface; its cutoff date was the fall of 1967, but it wasn't published until the spring of 1969, and during this time new languages of greater or lesser importance were introduced literally every day.

In some ways the first three chapters are the most important and interesting. Here Miss Sammet describes the history of programming languages, the characteristics that they all must have (at least in her opinion), and basic terminology. She lists some of the factors that a potential user must consider in choosing a language. Chapter 2 describes the functional or nontechnical characteristics of programming languages, and Chapter 3 goes into their technical characteristics.

Following chapters describe languages for scientific problems, for business data processing, for list processing, and for algebraic manipulation. There are also chapters on multipurpose languages, specialized languages, and significant unimplemented concepts—such as a universal language, English as a programming language, and hardware that works directly with higher-level languages without the need for a software computer. The concluding chapter contains the author's opinions on the future directions of programming language technology.

Of what importance is a book on this topic to electronic engineers? Perhaps not very much. But when computers are so much a part of technical and nontechnical life, it behooves persons with more than a casual exposure to them—including probably 90% of this magazine's readers—to become acquainted with the means of using them. Such a person may feel he knows all he needs to know about the language



# Four big reasons why you need

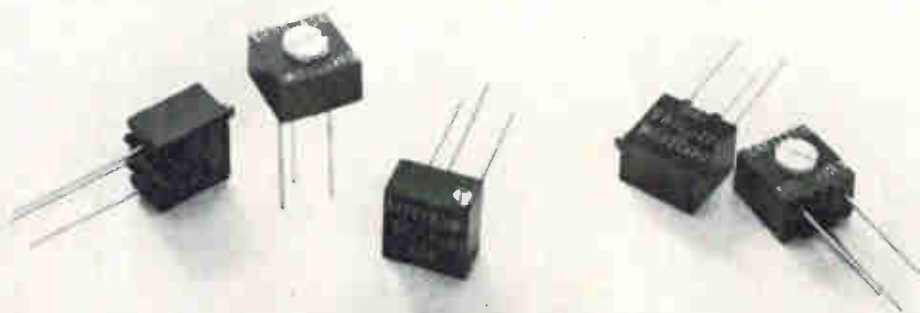

# The Immersibles.

There are many reasons why our Daystrom 501 thru 505 series industrial potentiometers have become a favorite of design engineers. Their space-saving  $\frac{5}{16}$ " size, for one. Weston's patented wire-in-the-groove construction, 5% standard tolerance, superior resolution, low noise and low cost, to name a few others. Now, with the option of total immersibility, we're offering you four more

—complete protection against water, cleaning solvents, flux, and encapsulating compounds. All five configurations are available O-ring sealed to meet MIL-STD-202, Method 106, moisture resistance requirements. And at a price you'd expect to pay for unprotected pots. Play it safe and specify The Immersibles. Your choice of 15-turn or single turn types, top or side adjustable,

in our standard 10 ohm to 20K range are in stock now at selected distributors. Higher values on request. Write today for data sheets and evaluation samples. WESTON COMPONENTS DIVISION, Archbald, Pennsylvania 18403, Weston Instruments, Inc.

a Schlumberger company

**WESTON®**

# We're not interested in next year's callawumpus.

*Our display terminals are priced and programmed for today.*

*No blue sky over-engineering.  
No payments for loafing parts.*

*We offer a complete line, starting under \$1500.*

*And every unit is ready for immediate employment.*

*For further details, call (617) 272-6660 collect.  
Or see us at the following:*

**NEREM '69, November 5-7.**  
Booth 1A73.  
War Memorial Auditorium.

**FALL JOINT COMPUTER CONFERENCE,**  
November 18-20.  
Booth 21010.  
Sahara Hotel.



## Infoton

INFOTON INCORPORATED  
SECOND AVENUE, BURLINGTON, MASSACHUSETTS 01803.  
*Incorporating Information Research Associates, Inc.*

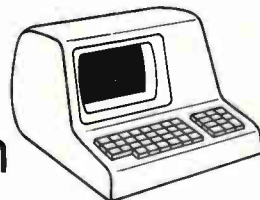

Circle 180 on reader service card

## ***Make your own break.***

You can take a lot of the chance out of your future by including yourself in the Electronics Manpower Register.

When you do, your experience and talents become part of a nationwide computerized placement service.

Our computer is programmed to give every registrant the same

look for every opening. With your prior approval, you'll be considered for every opportunity that matches your resume.

All you have to do is send one to:

Electronics Manpower Register  
**Electronics**  
330 West 42nd Street  
New York, N.Y. 10036

## New Books

he may be using. But what about other similar languages that may or may not be better suited to his purposes?

The book has one minor but disagreeable characteristic. A different type face is used to distinguish phrases in a programming language from the running text. Apparently, the different face was set separately and dropped into place by hand. Unfortunately, the handset type doesn't line up perfectly with the rest; the misalignment, though slight, is unnecessary, and it's just enough to be annoying when encountered repeatedly.

Miss Sammet assumes that the reader knows something about programming, and states this assumption in the preface. She also assumes, without specifically stating it, that the reader knows something about various commercially available computers; for example, she mentions the 7094 and the I103 in passing without saying that the former was IBM's largest computer before 1964 and the latter is an elderly Univac product. A just slightly more specific designation for particular machines would have been better.

## Recently Published

**Zenith Color TV Service Manual, Robert L. Goodman, Tab Books, 160 pp., \$7.95**

A wealth of service data including schematic diagrams for 28 Zenith color chassis is contained in this one reference handbook. General information applicable to all chassis, such as IF and chrome alignment and tuner setup techniques is presented, along with many discussions of troubleshooting case histories. A separate chassis series is covered in each of the last 12 chapters, complete with a full-size schematic diagram for each.

**Structure and Application of Galvanomagnetic Devices, H. Weiss, Pergamon Press, 362 pp., \$18.00**

Geared to solid state physicists and electronics engineers, this book discusses galvanomagnetic devices: their design, applications, and related circuit problems. It covers the basic physical concepts and properties of the devices, then progresses into the application of the Hall and the magnetoresistance effects.



Another large scale MOS array from Philco.



# 16-channel MOS multiplexer adds new versatility in time-division systems.

The pL4S16C is a different kind of switch that can up-date multiplexing functions in your telemetry, data sampling or communication system. Offset voltage is zero. Leakage current is less than 10 nanoamps. And it is voltage-driven . . . needs no complicated drive network.

As a 16-channel multiplexer, the pL4S16C gives you a choice of random access switching, or sequential sampling of all 16 channels, or of simultaneous sampling of two banks of 8 channels . . . just by changing external wiring. Stack them up, and you can get switching in sequential or random access modes, in multiples of 16 channels. Or, if you like, you can use it to switch 2 to 16 channels.

For complete data, write MOS Marketing, Philco-Ford Corporation, Microelectronics Division, Blue Bell, Pa. 19422. Or call Bob Simon at 215-646-9100.

### Typical Specifications

Offset voltage:	0 volts
Signal voltage swing:	10 volts max.
Channel leakage:	<10 nA
"ON" resistance:	<1000 ohms
Power dissipation:	150 mW max.
Input capacitance:	5 pF
Max. clock (sequential mode):	100 KHz
Package:	34-lead flat pack

*the better idea people in MOS*

**PHILCO**



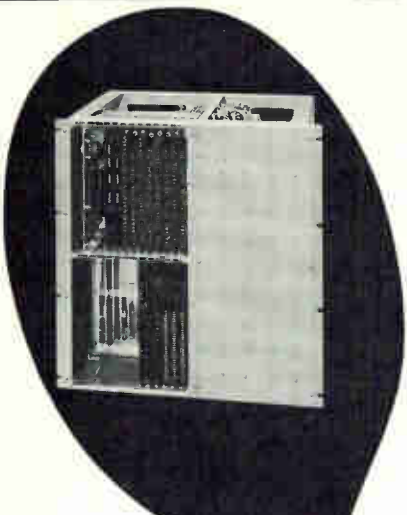

If  
cycle time  
is  
the name of  
your  
computer game,  
read  
the good news:

### Toko Woven Plated-Wire Memory System HS-500 is now available.

Toko's woven plated-wire memory planes and stacks are already well known for their low-cost, high-performance characteristics. Now to be marketed for the first time is Toko's complete memory system, with a capacity of 4096 words by 16 bits expandable to 8192 words and 20 bits. Cycle time is a remarkable 500 ns. Other characteristics are 2D organization, destructive read-out operation, and TTL logic level interface. Cost of the system is remarkably low, and fast delivery can be guaranteed.

Besides this standard woven plated-wire memory system, Toko can undertake the manufacture of custom-made systems according to your specifications. Complete technical details from our New York office.

**RC TOKO, INC.**

Head Office: 1-17, 2-chome, Higashi-Yukigaya, Ohta-ku, Tokyo, Japan

TOKO N.Y., INC.  
350 Fifth Avenue, New York, New York 10001

## Technical Abstracts

### Selecting an MOS design

MOS integrated circuits—the designer's dilemma  
Glen R. Madland  
Integrated Circuit Engineering Corp.  
Phoenix, Ariz.

Which integrated circuit structure—metal oxide semiconductor or bipolar—should a designer employ? There will be extensive equipment applications for both techniques far into the future. But MOS technology is becoming increasingly important and there are tradeoffs the designer must make if he's to choose the IC structure that's best for his needs.

MOS circuitry, generally, can offer much greater complexity in a given area than bipolar circuits. This promises lower costs and higher yields, but MOS circuit functions are limited in speed relative to bipolar circuitry. Because of this, the more complex MOS circuits will be used primarily for lower speed electronic equipment, including computer peripheral and input circuitry.

Bipolar large-scale integration is destined for higher-speed applications, particularly in computer central processors, as well as in large-volume linear uses. And a number of systems are being devised in which both bipolar and MOS structures can be used.

Yields of simple MOS integrated circuits, which require fewer masking and diffusion processing steps, appear equivalent to those of bipolar units—ranging from 5% to 50% for typical configurations. However, the usual MOS circuit is considerably more complicated than the average bipolar circuit.

In bipolar form, a digital counter might cost approximately \$10; in MOS form, about \$2.50; the cost of a complete MOS system could be as little as a tenth of the cost of a comparable bipolar design.

Because of the relatively small size of MOS devices, overall system considerations, involving partitioning and interconnection schemes, are much more important than in a bipolar IC design. In addition, because the MOS device is a new and relatively unexplored circuit ele-

ment, all of its useful properties have not yet been discovered and developed.

MOS circuits have evolved into three basic categories:

- Resistor pull-up circuits, which include d-c, two-phase and three-phase techniques.

- Push-pull switching circuits, including circuits made with p-channel enhancement mode transistors using four-phase clocking techniques, and circuits using n- and p-channel complementary MOS transistors without any additional clocking signals.

- Capacitor pull-up circuits, using two-, three-, and four-phase techniques.

In general, the d-c circuit with the MOS load is the simplest to use and the easiest to fabricate, although speed is low and power dissipation is high. Care must be taken in layout to obtain the proper ratio of sizes for the devices. Complementary MOS, on the other hand, is easy to use in designing, has lower power consumption, and features fast switching speed, but it is difficult to fabricate.

Presented at Wescon, San Francisco, Aug. 19-22.

### Avionics to come

Converging Design Trends in Avionic and Space Electronics Equipment  
J.R. Goodykoontz and V.A. Karpenko  
Electronic Systems Division, TRW Inc.  
Redondo Beach, Calif.

The techniques for designing avionic and space electronics systems are converging rapidly. In the next decade, a unified systems engineering and management approach will be applied to both types of systems. The result will be the development of flexible equipment building blocks used interchangeably in both aircraft and space applications.

Design similarity will prevail because both types of systems will have common conceptual and organizational forms, be based on identical systems disciplines, and be built around the same hardware—primarily large scale IC's.

The early 1970's will see the emergence of a new generation of avionic equipment that will include

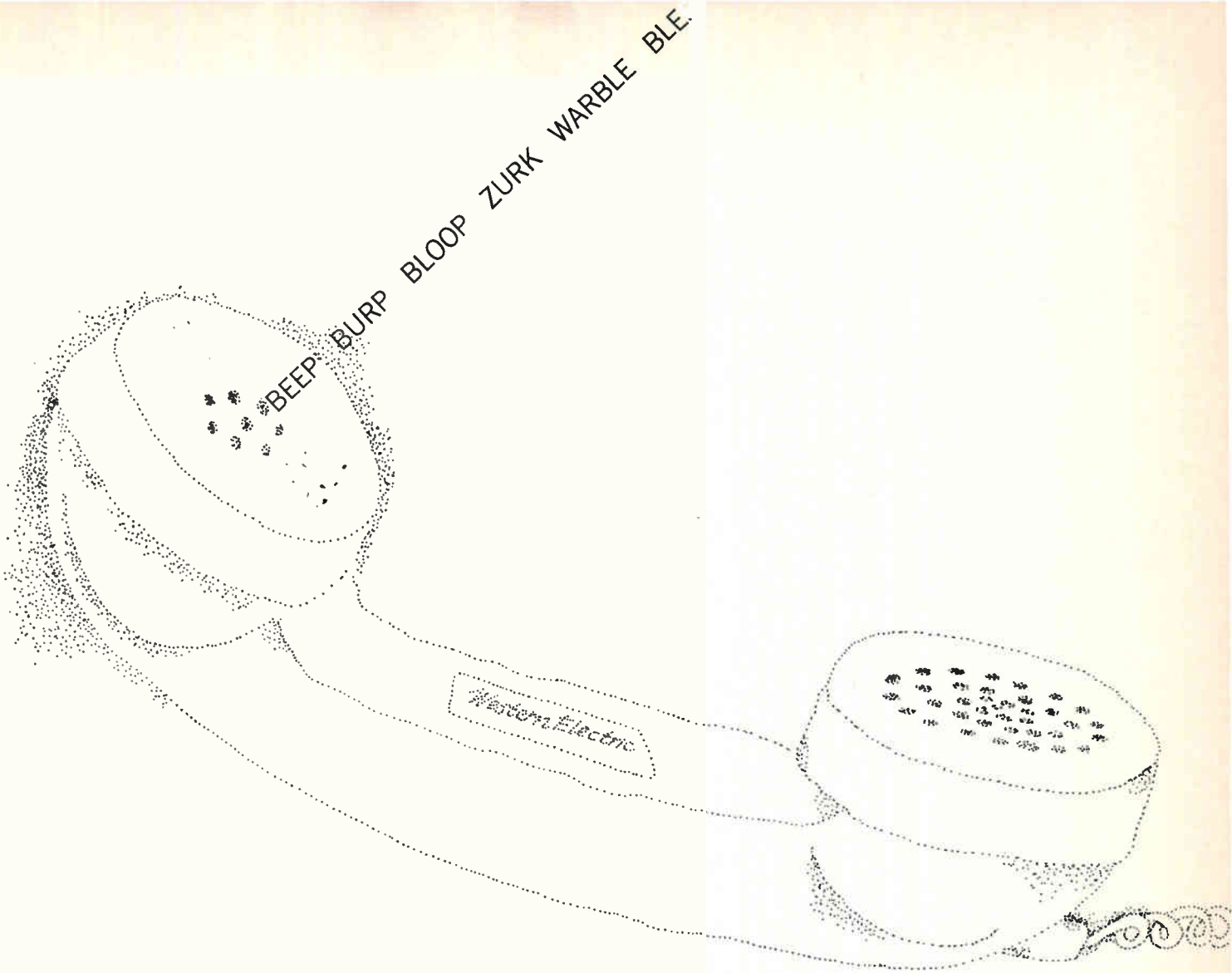

## MONOTHERM® UNDERSTANDS

If you want the output of a computer fed directly into another business machine 3,000 miles away, Western Electric's Data-Phone® Data Communications Set can make the connection. Over ordinary telephone lines.

Data bits from the computer are converted to tones by a Data-Phone data set. At the receiving end a similar set changes the tones back into the signals required by the business machine.

The key component in many Data-Phone data sets is a Western Electric 3A2 Data Unit. And at the heart of the Data Unit is a Riegel

Monotherm® flexible laminate of copper and Type H Kapton® used for the printed circuits.

Why Monotherm? Because it's an extremely flexible laminate which folds like a book to compact size, thus saving valuable space. Because it eliminates the need for a color-coded wiring maze. Because it possesses high dimensional stability. Because it can be automatically (and repeatedly) soldered. Because its uniquely high heat resistance makes it easily repairable in the field.

If automated mass production, high reliability, low cost, im-

proved serviceability and small size are design requirements of your circuits, why not make a connection with Monotherm? The coupon will do it.

Synthane · Taylor Corporation  
Valley Forge, Pennsylvania 19481

Please send me Kapton®/copper data sheets and the Conductor and Dielectric Guide for Riegel Monotherm.

Name \_\_\_\_\_

Company \_\_\_\_\_

Street \_\_\_\_\_ City \_\_\_\_\_

State \_\_\_\_\_ Zip \_\_\_\_\_



**synthane·taylor**

EXCLUSIVE U.S. DISTRIBUTOR OF RIEGEL MONOTHERM IN SHEETS AND ROLLS

Monotherm®—registered trademark of Riegel Paper Corporation for its laminations of conductive and dielectric materials.  
Kapton®—registered DuPont trademark for its polyimide film. Data-Phone®—registered trademark of Western Electric Co.

Circle 183 on reader service card

# YOU ASKED FOR IT.....

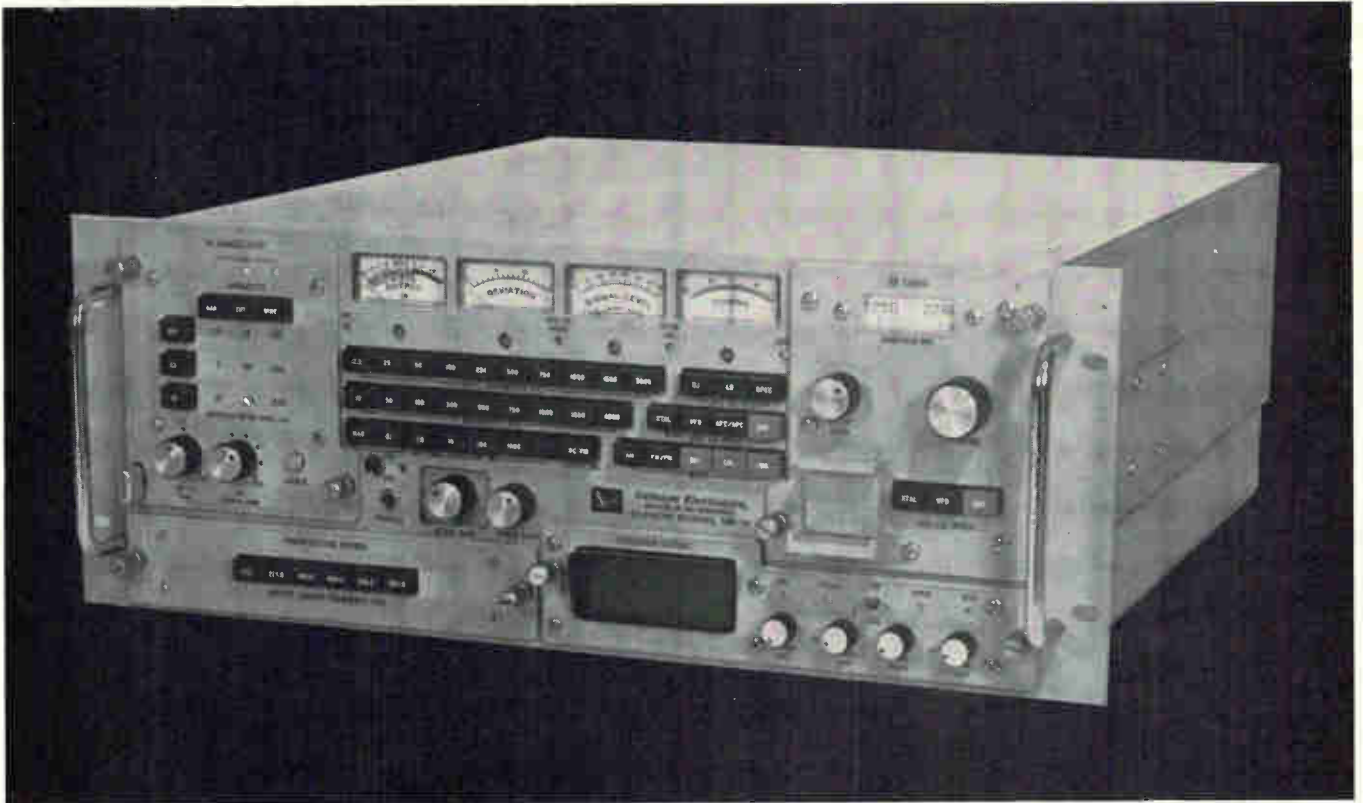

## MODEL TMR-74—THE FIRST “OFF-THE-SHELF” TELEMETRY RECEIVER TO BE ACTUALLY SPECIFIED BY YOU... THE USER.

- PUSHBUTTON SELECTABLE OR COMPUTER PROGRAMMABLE LINEAR PHASE IF FILTERS AND COMPATIBLE BANDWIDTH DEMODULATORS—YOUR nine integral linear phase IF filters from 10 kHz to 6.0 MHz and four integral demodulators including AM, narrowband FM, Standard FM and wideband FM are all selectable by computer or front panel pushbuttons. Extra wide (3 MHz linear phase baseband video response) and wide angle phase demodulators also available.
  - IMPROVED AFC CIRCUITRY—YOUR drift reduction factor of 5,000:1, virtually eliminates tuning and frequency errors.
  - INDEPENDENT AND/OR COHERENT LOCAL OSCILLATORS—YOU can now use two or more standard receivers with pre-detection diversity combiners.
  - ELECTROMAGNETIC INTERFERENCE—YOUR receiver is certified to MIL-STD-461.
  - IF PHASE LINEARITY TO  $\pm 3^\circ$  AND REDUCED 3RD ORDER INTERMODULATION—Assures YOU of minimum data error and distortion for All modulation formats.
  - IMPROVED ADJACENT CHANNEL RF/1ST IF SELECTIVITY—Provides YOU with increased immunity to desensitization.
  - FUTURE EXPANSION—YOUR receiver will be less susceptible to obsolescence since the standard 5½ inch panel can be replaced by a 7 or even an 8¾ inch compatible panel to accommodate additional modules.
- If YOU wish to learn how many of YOUR other ideas such as IC's and FET's were incorporated, write or call Defense Electronics, Division of DEI Industries.

***Defense Electronics***

PRODUCERS OF  
DEI AND NEMS-CLARKE  
EQUIPMENT



A DIVISION OF  
**DEI**  
INDUSTRIES

ROCKVILLE, MARYLAND 20854; (301) 762-5700; TWX: 710-828-9783; TELEX: 089602 • LOS ANGELES, CALIFORNIA 90045; (213) 670-4815  
INTERNATIONAL: ROCKVILLE, MARYLAND, USA CABLE: DEI USA; INTELEX: 64102

*Sales representatives in major cities throughout the world.*

integrated information processors, self diagnostics, self-maintenance, and even system reconfiguration in the event of failures. Perhaps the biggest advance will be the true integration of the avionic system equipment into an information type system. LSI in chips, rather than in flatpacks, will be applied broadly, although improvements in weight will be offset by the circuitry added for increased redundancy, self-diagnostics, and automatic maintenance.

Chief among the concepts that space electronics design will bring to the design of avionics is a higher degree of systems engineering. Although both space and aircraft programs have made use of systems engineering and analytic techniques, the space designers have had to deal with more severe interactions among many tightly packed subsystems. Spacecraft design margins are always less than those for aircraft and, therefore, space problems demand overall systems solutions. Aircraft avionics problems generally do not.

For example, in an aircraft, an electronics thermal problem tends to remain a straightforward thermal problem. But within the close confines of a spacecraft, excessive heat from an electronic circuit also involves problems in structures, dynamics, materials and manufacturing processes, as well as orbital mechanics, trajectory analysis, and attitude stabilization errors.

In general, space designers have emphasized reliability much more than the aircraft designers have. And because of limited boosters, weight and size of space electronics have had to be kept low. Size reduction has also led to lower power requirements. At the same time, designers were forced to build very complex power conditioning equipment, analogous to large regional electric power systems, to supply many different experiments and sensors.

Data management—which involves formatting, modulation, data compression, secure communications, and extraction schemes—has also received more attention in space than in aircraft. After all,

# Lectrohm knows Resistors...

## We should, they're our only business!

Fixed or Adjustable  
Standard or Custom

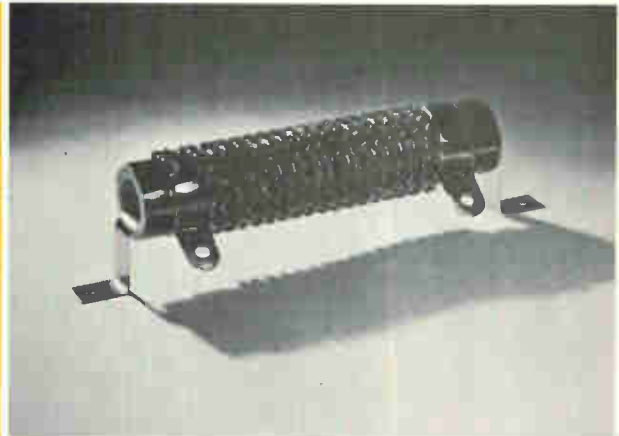

Specialization in the design and production of wire-wound resistors has established LECTROHM'S leadership in the resistor field.

For example, "Rib-on-Edge" resistors are made to order for high wattage service where low resistances from a fraction of an ohm to several ohms are required. They are also used for intermittent duty where relatively small size resistors must dissipate high wattages. Due to its greater heat dissipation and ability to operate at higher temperature, the "Rib-on-Edge" resistor is almost one-half the physical size of the equivalent standard round wire style resistor. It can be furnished in fixed, adjustable or tapped style to afford greater flexibility in equipment design.

Check your resistor needs today . . . send specifications, prints or requirements, no obligation . . . you can trust LECTROHM to match those needs quickly and economically.



**FREE!**  
Full line  
LECTROHM  
catalog.  
Send for your  
copy today!



**Lectrohm, Inc.**

*a subsidiary of*



**COOK ELECTRIC**

5562 Northwest Highway, Chicago, Ill. 60630



Bring Your Measuring Problems To Tokyo

October 11-15, 1969

# 13TH JAPAN ELECTRIC MEASURING INSTRUMENTS—AUTOMATION EXHIBITION

## 13TH JAPAN ELECTRIC MEASURING INSTRUMENT-AUTOMATION EXHIBITION



### OUTLINE OF THE EXHIBITION

1. Name: 13th Japan Electric Measuring Instrument-Automation Exhibition
2. Sponsored by: Japan Electric Measuring Instrument Manufacturers' Association
3. Term: 11 (Saturday) — 15 (Wednesday) October 1969 (for 5 days)
4. Place: Tokyo International Trade Center, Harumi, Tokyo
5. Exhibits: Electric Measuring Instruments
6. Exhibitors Approximately 80 Leading Japanese Manufactures of Electric Measuring Instruments

### 13th Japan Electric Measuring Instrument-Automation Exhibition

Please cut off this invitation and bring it to the Exhibition send it by mail to the following address and you will have an illustrated catalog of Japanese electric measuring instruments:



NAME: \_\_\_\_\_

FIRM: \_\_\_\_\_

ADDRESS: \_\_\_\_\_



**JAPAN ELECTRIC MEASURING INSTRUMENTS MANUFACTURERS' ASSOCIATION**

Keisoku Kaikan Bldg 20 Shiba-Kotohira-cho Minato-ku Tokyo Japan

Circle 217 on reader service card

The chairman company of JEMIMA

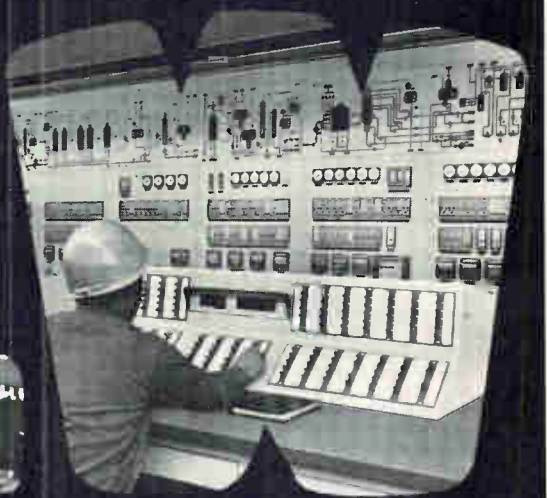
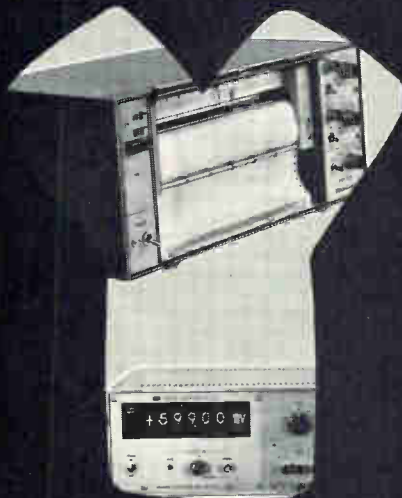

## FOR COMPLETE INSTRUMENTATION ...ASSOCIATES OF **FOXBORO** AND **HEWLETT PACKARD**

Yokogawa Electric offers complete laboratory and industrial process instrumentation from portable meters to process automation. Proven technology and half a century's experience in instrument manufacture are the basis upon which YEW's worldwide fame and association with Hewlett-Packard (partner of a joint-concern) and Foxboro (partner of mutual technological assistance since 1955) are established.

# YEW

## YOKOGAWA ELECTRIC

YOKOGAWA ELECTRIC WORKS, LTD.  
2-9 Nakacho, Musashino-shi, Tokyo, 180 Japan  
YEW EUROPAISCHES VERBUNDUNGSBÜRO Hamburg, Germany

## Technical Abstracts

data is the sole justification for spacecraft. And because a spacecraft must work perfectly the first time, elaborate test procedures were designed into all equipment levels. All of these spacecraft developments will be applied to the requirements of aircraft avionics.

Presented at Wescon, San Francisco, Aug. 19-22.

### Bonding with cones

Flip-chip bonding with formed projections

J.W. Slemmons, S. Salmassy, and M.H. Bester  
Autonetics  
Anaheim, Calif.

Bonding flip-chips by using ultrasonically formed cones of aluminum is low in cost, produces reliable connections, and lends itself to automation. With cones, it is possible to use chips from as many as five or six different suppliers whose devices ordinarily would require several different, possibly incompatible, joining processes. In addition, this method eliminates the problem of getting all contacts on the same plane.

The size and height of each cone is determined by the cavity of the forming tool and the thickness of the foil used. When the proper foil is selected, the entire cavity of the tool is filled, resulting in a slightly domed projection; consistency of size, height, and metallurgy is easily attained.

Cones can be made higher than other types of projections and thus permit the chip to be self-leveling during bonding. The leveling is accomplished by flattening the point of the cone so that all contacts are on the same plane. This compensates for any lack of parallelism between chip and substrate. Another advantage of cone-projection bonding is that any conventional ultrasonic wire bonder or flip-chip bonder that is capable of holding a capillary tip can be used to make projections.

Where high-speed production is desired, the process can be automated. The need for an operator to position the foil and align the tip can be eliminated by securing the

foil over the bonding surface and using a tape-controlled table to position the tip and operate the bonder.

Presented at Wescon, San Francisco, Aug. 19-22

### Crack performer

Nondestructive evaluation of printed wiring boards by means of microhm resistance measurements  
B. Stiefeld  
Sandia Laboratories  
Albuquerque, N. Mex.

Resistive evaluation of the plating thickness or defects of plated-through holes in printed circuit boards turns out to be a simple and relatively accurate method of non-destructive testing. Using an alternating-current, four-wire measurement method, the resistance of holes can be read directly on a meter.

Plated holes have resistances that range from 50 to 500 microhms. To detect such small values, a 60-hertz, constant-current source sends 100 milliamps through the plated hole. The resulting voltage drop between the top and the bottom annular rings of the plated hole is coupled through a 1:100 turns-ratio transformer to a high impedance voltmeter. Since the current is fixed, the voltmeter can be calibrated in microhms.

Because the probes and annular rings of the plated holes can't assure uniform current density, the readings aren't necessarily electrically accurate, but they are repeatable. Thus, results of the electrical method correlate well with mechanical sectioning and thickness determination of the plating.

Voids, cracks, and other defects register abnormally high readings, so the operator needn't be very skilled to determine the defect. As examples, a crack half-way around the circumference registered 320 microhms, compared with 180 microhms for a good-quality 0.001 plating thickness in a 0.050-inch diameter hole. When the crack went completely around, the reading jumped to 620 microhms.

Presented at the International Electronic Circuit Packaging Symposium, San Francisco, Aug. 20 and 21.

# the twisters

The twist of the fingertips tells user that he is handling quality.

A lot of effort has gone into making these aluminum knobs the best you can buy. ALCOKNOBS have been painstakingly machined and anodized to a high satin finish. A wide choice of stock knobs are now available to complement your equipment design. All are available at a reasonable cost and competitive to plastics.

Send for the new ALCOKNOB catalog describing a wide variety of stock knobs and with particulars whereby ALCO can customize knobs to create your own individual image.



# ALCO

ELECTRONIC PRODUCTS, INC.

Lawrence, Massachusetts 01843

Circle 187 on reader service card

# Need a reversible AC hysteresis synchronous motor

to fit this space?



## Dale has one for less than \$2

Dale reversible AC hysteresis synchronous motors give you the industry's best combination of miniature size and low price. Length 1.85"... diameter 1.250"...price, under \$2 in quantity. Designed for long life in continuous use, they're finding wide application in low power driving mechanisms, timing controls, blowers, etc. Output shaft and mounting to your specification.

### SPECIFICATIONS

- Operating Voltage:** 6, 12, 24, 117 VAC or any specified
- Power Input:** 7.5 Volt Amperes
- Output:** 1800 RPM no load
- Torque:** 0.125 oz./in.

### CIRCUIT DIAGRAM

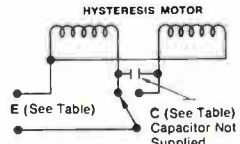

E - VOLTAGE	NOMINAL C - CAPACITANCE	C - VOLTAGE
6	170 MFD	20
12	50 MFD	25
24	16 MFD	50
117	0.68 MFD	300

Want to try one?...Phone 605-665-9301



**DALE ELECTRONICS, INC.**  
**SIoux DIVISION** Dept. ES  
 Yankton, South Dakota 57078  
 A subsidiary of The Lionel Corporation



## NEW FROM McGRAW-HILL

### HANDBOOK OF ELECTRONIC PACKAGING

*Charles Harper.* An outstanding array of experts from leading electronics firms give you all the background material you need on every aspect of electronic packaging in a practical, authoritative handbook that combines all basic elements and principles. \$29.50

### DIGITAL COMPUTER METHODS IN ENGINEERING

*S. A. Hovanessian and Louis A. Pipes.* Numerical methods in solving problems by digital computers. Written primarily for practicing engineers who want a working knowledge of computer calculations as applied to particular fields and the basics as applied to all fields. \$14.50

### MANAGEMENT GUIDE FOR ENGINEERS AND TECHNICAL ADMINISTRATORS

*Edited by Nicholas P. Chironis.* Some 100 key articles drawn from a wide variety of publications and dealing with engineering office practices and management techniques useful to engineers in any field. Articles selected to give the widest coverage to administrators' needs. \$11.50

### DIGITAL MAGNETIC LOGIC

*David R. Bennion, Hewitt D. Crane and David Nitzan.* Discusses digital magnetic-core circuits that offer very high reliability, long life, and adaptability to special environments, emphasizing the physics of core-wire devices, engineering models for use in circuit analysis, and development of circuit-design methods. \$15.00

### APPLIED STATISTICS FOR ENGINEERS, Second Edition

*William Volk.* A thorough revision of a highly regarded book, retains the applications approach, but incorporates much new material on fractional factorials, optimization in experimental design, and computer applications. \$15.50

### EFFECTIVE TECHNICAL SPEECHES AND SESSIONS

#### A Guide for Speakers and Program Chairmen

*Howard H. Manko.* Practical how-to-do-it guidance for all professional men called upon to deliver a paper or chair a program—but unprepared for it and unaware of how a manuscript differs from oral presentation. Technical meetings do not have to be dull! \$7.95

At your bookstore or direct from publisher for 10 days' free examination.

**McGRAW-HILL BOOK COMPANY**  
 330 West 42nd Street  
 New York, N.Y. 10036

Please send me the books checked for 10 days on approval. In ten days I will remit for the books I keep, plus a few cents for delivery costs and local tax (if any) and return the others postpaid.

- 266718 Handbook of Electronic Packaging
  - 304907 Digital Computer Methods in Engineering
  - 109946 Management Guide for Engineers and Technical Administrators
  - 046995 Digital Magnetic Logic
  - 675512 Applied Statistics for Engineers
  - 398966 Effective Technical Speeches and Sessions
- Name \_\_\_\_\_  
 Address \_\_\_\_\_  
 City \_\_\_\_\_  
 State \_\_\_\_\_ Zip \_\_\_\_\_

23-L-969



## New Literature

**Power supplies.** Acopian Corp., Easton, Pa. 18042. A catalog supplement describes the UBT series of modular unregulated power supplies. Circle 446 on reader service card.

**Operational amplifier sockets.** Barnes Corp., 24 N. Landsdowne Ave., Lansdowne, Pa. 19050. Two-page product bulletin PB-1011 covers a line of low profile sockets for module-type operational amplifier packages. [447]

**Step recovery multipliers.** Hewlett-Packard Co., 1501 Page Mill Road, Palo Alto, Calif. 94304. Application note 928 gives a detailed design for a practical times-8, single-stage, step-recovery diode frequency multiplier with typical maximum output power of 75 mw at 16 Ghz. [448]

**Lever switches.** Guardian Electric Mfg. Co., 1550 W. Carroll Ave., Chicago 60607, has available a brochure on lever switches with snap-in cam inserts that permit changing actuator switching positions at any time. [449]

**Laser accessories.** Baird-Atomic Inc., 125 Middlesex Turnpike, Bedford, Mass. 01730, has published a 20-page comprehensive catalog covering a line of laser accessories. [450]

**Quartz transducers.** PCB Piezotronics Inc., P.O. Box 33, Buffalo, N.Y. 14225. Summary sheet 955669 contains complete specifications and pricing on a line of integrated-circuit-piezoelectric quartz pressure transducers. [451]

**Phase-shift circulators.** Raytheon Co., 130 Second Ave., Waltham, Mass. 02154. A 12-page catalog describes more than 100 high-power differential phase-shift circulators. [452]

**Digital system analyzer.** Data Display Systems Inc., 142 Terwood Rd., Willow Grove, Pa. 19090, has available a technical bulletin on a digital system analyzer that is capable of displaying four signals simultaneously in different colors. [453]

**Low-pass filters.** Microwave Filter Co., 135 W. Manlius St., East Syracuse, N.Y. 13057, offers a brochure on vhf-uhf low-pass filters in the 100 to 400 Mhz range. [454]

**Printed-circuit coatings.** Hysol Division, Dexter Corp., 211 Franklin St., Olean, N.Y. 14760, has released form E4-100, a selector guide for printed-circuit coatings. [455]

**Automatic plotting.** Electronic Associates Inc., West Long Branch, N.J. 07740. Bulletin 951504 is a 12-page brochure describing the 430 Data-plotter, a dynamic concept in automatic X-Y plotting. [456]

**Relays and solenoids.** Liberty Controls Division of Liberty Leasing Co., RFD 5, Joliet, Ill. 60431, has available a catalog of its entire line of relays and solenoids. [457]

**Information display.** Metra Instruments Inc., 2257 Old Middlefield Way, Mountain View, Calif. 94040. Brochures and a series of technical notes illustrate and describe the Metrascope, a multichannel bargraph information display instrument employing a crt presentation. [458]

**Ceramic filters.** Clevite Corp., 232 Forbes Rd., Bedford, Ohio 44146. A two-page technical bulletin describes the series TCF hybrid ceramic filters. [459]

**Ceramic-to-metal seals.** Vernitron Electrical Components, 272 Main Ave., Norwalk, Conn. 06852. Data on ceramic-to-metal seal products for electronic applications is shown in four-page bulletin 10-01. [460]

**Indicating controllers.** Barber-Colman Co., Rockford, Ill. 61101. Catalog information on solid state indicating controllers is found in bulletins 1252 DB 6-2 and 7-2. [461]

**Components and instruments.** Weinschel Engineering, Gaithersburg, Md. 20760. Short form catalog No. 5 provides general descriptions and pertinent specifications of the company's components and instruments. [462]

**Interface circuits.** Cermetek Inc., 660 National Ave., Mountain View, Calif. 94040. Complete specifications for the CH1100 series data communications interface circuits, that conform to all EIA Standard RS2328 specifications, are featured in a six-page brochure. [463]

**R-f connectors.** AVA Electronics & Machine Corp., 416 Long Lane, Upper Darby, Pa. 19082. Catalog sheet PIC-669 describes two matching 75 ohm, r-f push-in coaxial connectors. [464]

**Laser production equipment.** Spacerays Inc., Northwest Industrial Park, Burlington, Mass. 01830, has available a four-page brochure describing commercial laser production equipment. [465]

**Toroidal inductors.** Solid State Electronics Corp., 15321 Rayen St., Sepulveda, Calif. 91343. A four-page bulletin describes and illustrates the series L miniature toroidal inductor coils and toroidal inductor decade substitution boxes. [466]

**Converter.** North Atlantic Industries Inc., Terminal Drive, Plainview, N.Y. 11803. A data sheet presents technical specifications and application informa-

# push with ALCOSWITCH

These miniature push button switches control heavy currents with outstanding reliability and consistent performance. Snap-action mechanism allows quick make-and-break along with solid silver contacts for efficient switching operations.

## LIGHTED MODELS

The illuminated push button Series MSPN have over 50 varied colored buttons and sizes to fit your specific applications. Versatile DPDT model with isolated lamp terminals.

## WATERPROOF

The "E" Series is made to rigid specifications exceeding industry standards. Miniature in size, but exceptional in performance. Available as momentary, or Push-ON or Push-OFF, in one, two and 4PDT models.

Whether you need one or one thousand switches you have a greater variety to choose from when you specify an ALCOSWITCH.



SEND FOR COMPLETE  
ALCOSWITCH CATALOG

# ALCO

ELECTRONIC PRODUCTS, INC.

Lawrence, Massachusetts 01843

# Still using LC's? This might change your mind:

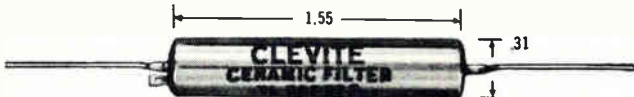

**Clevite's ceramic ladder filters deliver 80 db rejection in 0.1 cu.in.!**

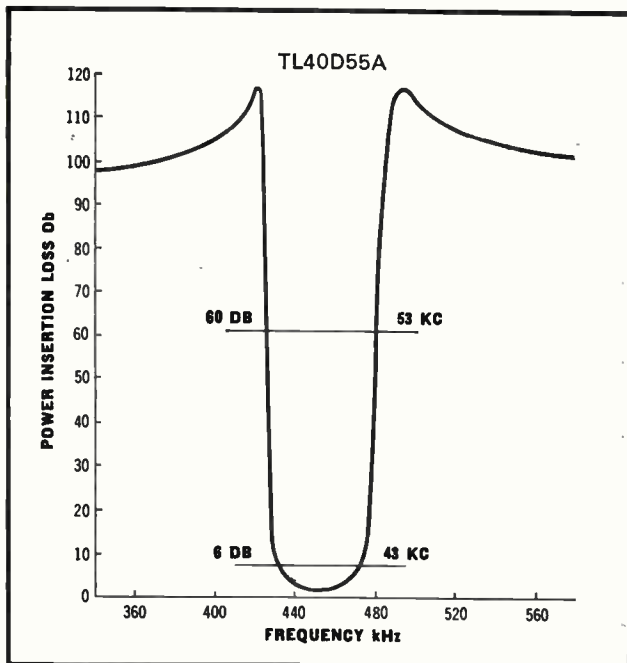

Here's a fixed-tuned filter that offers more selectivity for its size than any conventional i-f filter on the market! Clevite's non-magnetic, non-microphonic, 17-disc ceramic ladder filter is ideal for i-f stages of high quality superheterodyne radio receivers used in airborne or ground AM and FM communications equipment. Stop band rejection: 60 or 80 db. Center frequency tolerance:  $\pm 1$  kHz for 20 kHz B/W and below;  $\pm 2$  kHz for 30 kHz B/W and above. Stability: within  $\pm 0.2\%$  for 5 years; within 0.2% from  $-40^{\circ}\text{C}$  to  $+85^{\circ}\text{C}$ . Impedance (in and out) 2500 ohms for 12 kHz bandwidth and below; 1500 ohms for 13 kHz to 29 kHz B/W; 1200 ohms for 30 kHz bandwidth and above.

Following models standard at 455 kHz (A) or 500 kHz (C) (custom models on special order):

Model Number	B/W		Model Number	B/W	
	Min. @ 6db	Max. @ 60db		Min. @ 6db	Max. @ 60db
TL-2D5 (A)	2 kHz	5 kHz	TL-20D32 (A)	20 kHz	32 kHz
TL-4D8 (A)	4 kHz	8 kHz	TL-30D45 (A)	30 kHz	45 kHz
TL-6D11 (A)	6 kHz	11 kHz	TL-40D55 (A)	40 kHz	55 kHz
TL-8D14 (A)	8 kHz	14 kHz	TL-45D65 (A)	45 kHz	65 kHz
TL-10D16 (A)	10 kHz	16 kHz	TL-50D75 (C)	50 kHz	75 kHz
TL-16D25 (A)	16 kHz	25 kHz			

**PRICES:** 1 — \$52.50; 25 — \$42.00 ea; 100 — \$36.75 ea; 500 — \$31.50 ea; 2000 — \$26.00 ea.

(Prices subject to change without notice.)

Send order or request for Bulletin 94017 to: Clevite Corporation, Piezoelectric Div., 232 Forbes Rd., Bedford, Ohio 44014, U.S.A. Or: Brush Clevite Company, Limited, Southampton, England.

## CLEVITE

# Fast? Fast!

# Nanosecond fast? Faster!

No question about it.

Computer Labs HS Series A/D converters are fast.

Aperture time as short as 0.2 nanosecond!

Word rates vary from

4 bits at 25 MHz

to 9 bits at 5 MHz.

Even delivery is fast!

## COMPUTER LABS

for tomorrow's technology today

(919) 292-6427 • 1109 S. Chapman St.  
Greensboro, N. C. 27403

Circle 219 on reader service card



Every year, ELECTRONICS attracts requests for over 125,000 editorial reprints.

They're like interest payments on our million-dollars-a-year editorial principles.

That's how much we spend annually to produce timely, authentic, and useful articles like those listed on the reader service card as reprints currently available.

Investment and interest make both ELECTRONICS and its readers more meaningful to its advertisers.

# Cut Circuit Costs

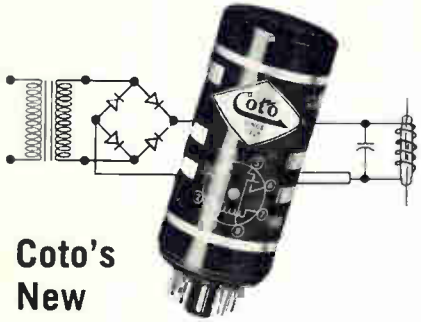

Coto's  
New

## A.C. Reed Relay

**Replaces Costly AC/DC Circuits!**

**Contacts:** Forms A or C with single or multiple poles.

**Ratings:** to 3 amperes or up to 5000 volts D.C.

**Inputs:** 60-800 Hz voltages available.

**Physical:** Available in 8 and 11 pin plug-in housings with electromagnetic shielding. Electrostatic shielding available on order.

*Write for complete specifications. For special requirements, give complete details for quotation.*

**Coto-Coil COMPANY, INC.**  
61 Pavilion Avenue  
Providence, R. I. 02905  
Phone (401) 941-3355

Circle 220 on reader service card

## Want to be unique in our memory?

It's easy. Enter the Electronics Manpower Register.

We'll feed your professional background into the talent memory of our nationwide computerized recruitment service.

Our computer will match your unique profile against every opening being programmed into it by a long list of electronics companies. You'll automatically be qualified for every logical career opportunity. But we'll only release your availability to those companies you approve.

To enter, send us your resume.

Electronics Manpower Register  
**Electronics**  
330 West 42nd Street  
New York, N.Y. 10036

## New Literature

tion for a shoebox-sized model 538/30 digital-to-resolver synchro converter. [467]

**Decoding and counting assemblies.** Burroughs Corp., P.O. Box 1226, Plainfield, N.J. 07061. Detailed engineering information on the C2500 decoding and counting assemblies is available in 12-page brochure 1160. [468]

**Plug-in relays.** Guardian Electric Mfg. Co., 1550 W. Carroll Ave., Chicago 60607, has released a bulletin describing the 1350 series dpdt plug-in relays with all terminals on 0.1 grid spacing for standard p-c boards. [469]

**Motor damping generator.** Weston-Transicoil, Worcester, Pa. 19490, has published a data sheet giving specifications for a new, size 15 motor damping generator. [470]

**Power controllers.** Halmar Electronics Inc., 1544 W. Mound St., Columbus, Ohio 43223. An applications, description and specifications sheet describes the PA-3 three-phase closed/open loop scr power controllers for precision industrial and laboratory processes. [471]

**Environmental chambers.** Tenney Engineering Inc., 1090 Springfield Rd., Union, N.J. 07083, has issued bulletin R24 on a series of Tenneystrat chambers for simulation of altitude, temperature, and humidity. [472]

**Temperature controllers.** Gulton Industries Inc., 3860 North River Rd., Schiller Park, Ill. 60176. Bulletin 300 covers a new series of solid state temperature controllers. [473]

**Reed switches.** Hamlin Inc., Lake & Grove Sts., Lake Mills, Wis. 53551. A condensed catalog includes an application guide and specifications for selection from a complete line of reed switches. [474]

**Crossed-field amplifier.** Warnecke Electron Tubes Inc., 175 W. Oakton St., Des Plaines, Ill. 60018. A four-page technical data bulletin features the electrical and mechanical characteristics of the RW-617 gridded crossed-field amplifier tube. [475]

**Circular connectors.** Bunker-Ramo Corp., Amphenol Connector Division, 2801 S. 25th Ave., Broadview, Ill. 60153, offers a 36-page catalog covering a broad selection of intermediate size miniature circular connectors. [476]

**Telemetry receiver.** Defense Electronics Inc., Rockville, Md. 20854. A 20-page bulletin describes the TMR-74 push-button telemetry receiver. [477]

**Ultrasonic cleaner.** Branson Instruments Co., 76 Progress Dr., Stamford,

# your best move



The world's first ultra-miniature 1/2" rotary switch with the invaluable feature of an adjustable stop. The MRA Series is available as 1, 2, 3, or 4 poles on a single deck with a maximum of 10 or 12 positions. You can choose the universal 1/8" diameter shaft, or a switch with its own specially mated knob. Ideal for installations where size and space limitations are a factor. Conservatively rated at 500 mA @ 125 VAC.

The MSRE waterproof rotary switch series is similar to the MRA Series, but built to meet the highest reliability standards required under any environmental condition.



### LOCKING TOGGLE

World's first totally miniature toggle switches capable of being locked to safeguard against accidents. Full line available in 1-2-3-4 poles. 6 amps @ 125 VAC.

### SLIDE SWITCH

The world's best mini-slide switch with a compact 1/2" case and new anti-tease design. Available in one and two pole, double throw models; 2 amps @ 120 VAC.



# ALCO

**ELECTRONIC PRODUCTS, INC.**

Lawrence, Massachusetts 01843

Circle 191 on reader service card

# ELGENCO 603A NOISE GENERATOR \$545

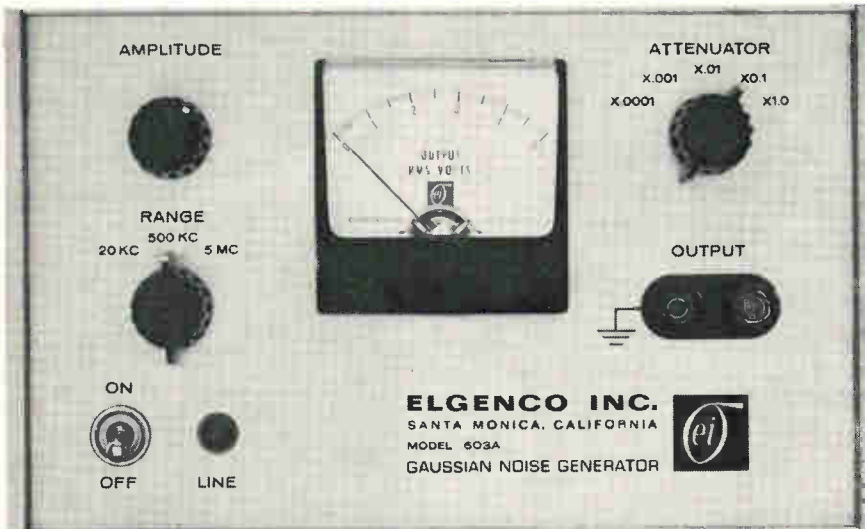

Many obsolete vacuum tube noise generators can be replaced/updated with this solid state 5 Hz to 20 kHz/500 kHz/5 mHz Random Noise Generator with greatly improved characteristics. Very useful where previous equipment is not adequate for present needs. Other Models covering the range of DC to 30 mHz are available. For name of nearest Sales Rep see EEM or contact Elgenco, Inc., 1550 Euclid, Santa Monica, Calif. 90404, Ph. 213-451-1635.

Circle 221 on reader service card

## Up-date your film resistor library.

With our new literature on Mallory film resistors. A complete line. Made by the company with total capability in film resistors. Write, today.

Mallory Controls Company, a division of P. R. Mallory & Co. Inc., Box 327, Frankfort, Ind. 46401.

### GENERAL SPECIFICATIONS

MALLORY TYPE	MILITARY TYPE	TEMPERATURE RATING	POWER RATING (WATTS)	RESISTANCE RANGE (OHMS)
<b>Precision Resistors</b>				
MAC 55	RN55	70°C & 125°C	1/8 & 1/10	10Ω-100K
MAC 60	RN60	70°C & 125°C	1/4 & 1/8	10Ω-499K
MAC 65	RN65	70°C & 125°C	1/2 & 1/4	10Ω-1 meg
MAF 55	RN55	70°C & 125°C	1/8 & 1/10	10Ω-100K
MAF 60	RN60	70°C & 125°C	1/4 & 1/8	10Ω-499K
MAF 65	RN65	70°C & 125°C	1/2 & 1/4	10Ω-1 meg
<b>Semiprecision Resistors</b>				
MAL 07	RL-07	70°C	1/4	10Ω-100K
MAL 20	RL-20	70°C	1/2	10Ω-470K
MAL 32	RL-32	70°C	1	10Ω-1 meg
<b>Power Resistors</b>				
2MOL		70°C	2	30Ω-125K
3MOL		70°C	3	40Ω-125K
4MOL		70°C	4	85Ω-125K
5MOL		70°C	5	95Ω-125K
7MOL		70°C	7	125Ω-125K

# MALLORY

## New Literature

Conn. 06904. Bulletin S-901 gives an in-depth look at the new DUS-TW ultrasonic cleaner. [478]

**Microwave catalog.** RHG Electronics Laboratory Inc., 94 Milbar Blvd., Farmingdale, N.Y. 11735. Twelve-page catalog 70A describes a line of microwave transmitters, receivers and components. [479]

**Indicator lights.** Shelly Associates Inc., 111 Eucalyptus Dr., El Segundo, Calif. 90246, has published a technical data sheet on the Trans-Eye transistorized microminiature indicator lights. [480]

**Motors brochure.** Cramer Division, Conrac Corp., Mill Rock Rd., Old Saybrook, Conn. 06475. A six-page fold-out catalog describes five series of instrument and timing motors. [481]

**Semiconductor insulators.** Thermalloy Co., 8717 Diplomacy Row, Dallas 75247, offers catalog 69-C-3 describing Thermo-Film, beryllium oxide, and anodized aluminum insulators. [482]

**Data conversion devices.** Analog Devices Inc., Pastoriza Division, 221 Fifth St., Cambridge, Mass. 02142. A 24-page handbook covers a line of a-d converters, d-a converters, sample/hold amplifiers, multiplexers, instrumentation amplifiers, buffer modules, encapsulated power supplies, and related digital building blocks. [483]

**Trimmer potentiometers.** Minelco, 600 South St., Holbrook, Mass. 02343, has issued technical bulletin P-67 describing a line of microminiature trimmer potentiometers. [484]

**Packaging panels.** Augat Inc., 39 Perry Ave., Attleboro, Mass. 02703. Catalog 266 covers high density dual-in-line packaging panels designed for automatic wire-wrapping. [485]

**Rental catalog.** Rentronix, division of Inmark Inc., 11501 Huff Court, Kensington, Md. 20795. A 48-page catalog covers a wide variety of instrumentation and small computers available for short-term rental. [486]

**Casting resins.** Emerson & Cuming Inc., Canton, Mass. 02021, offers a six-page folder describing its line of Stycast casting resins. [487]

**Digital voltmeter.** Dana Laboratories Inc., 2401 Campus Dr., Irvine, Calif. 92664. Eight-page data sheet 959 describes the model 5740 five-digit systems digital voltmeter. [488]

**Energy discharge capacitors.** Aerovox Corp., New Bedford, Mass. 02741, has available a four-page technical bulletin on its expanded line of energy discharge capacitors. [489]

# THE SEARCH FOR SOMETHING BETTER...

has been going on at Zenith for 50 years. And the search goes on, into increasingly diverse and stimulating areas. The scope of research and engineering activities, from micro-electronics and biomedical electronics to laser technology and ultrasonics, may surprise some of you—we hope it does.

If we've stirred your curiosity and you're looking for something better too, you'll want to explore the possibility of joining us. We have senior and junior level professional positions for Bachelor through Doctorate in the following areas:

**BIOMEDICAL ELECTRONICS:** Investigation and development of electronic instruments for diagnostic and therapeutic applications as patient monitoring, pacemakers, ultrasonic scanning, etc.

**ULTRASONICS:** Investigation of semiconductors and piezoelectric substances leading to acoustic amplifier and filter elements.

**IC APPLICATIONS:** Establish circuit design principles for thick and thin film and monolithic integrated circuits.

**CIRCUIT RESEARCH:** Design and development of digital communications systems with initial emphasis on digital audio systems.

**ADVANCED ENGINEERING:** Exploration and development of advanced concepts for television and FM stereo receivers utilizing thin film, monolithic and hybrid integrated circuits.

**SYSTEMS ENGINEERING:** Analysis and design of advanced communications systems covering HF to UHF voice and data systems.

Additional opportunities are available in luminescence research, recombination light sources, ultra micro-chemistry, and electro-chemistry, and optical systems.

The location of present and planned facilities offer a wide choice of living areas, ranging from Metropolitan Chicago to northern Illinois rural communities.

Please send your resume, or write for our booklet "Career Opportunities in Engineering and Research."

Donald N. Leon, Technical Recruitment Manager, Engineering Research Division



ZENITH RADIO CORPORATION, 6001 West Dickens Ave., Chicago, Illinois 60639

An Equal Opportunity Employer

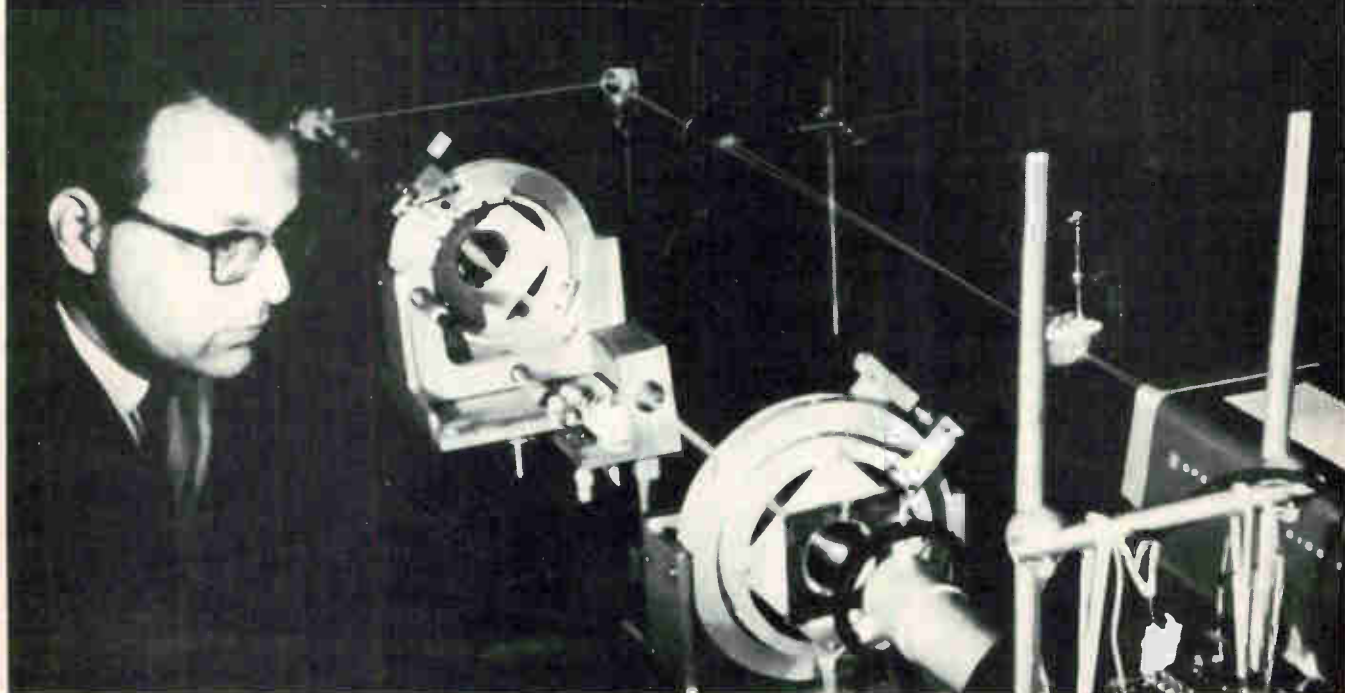

CIRCLE 966 ON READER SERVICE CARD

# INNOVATION

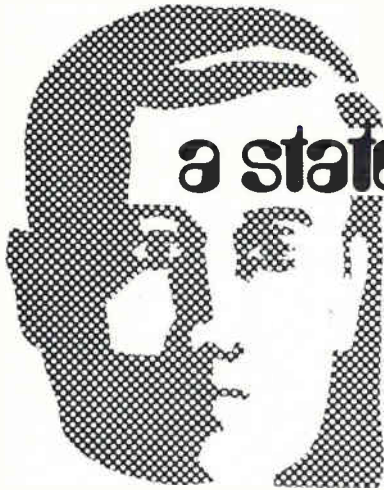

## a state of mind

Tomorrow's better mousetrap—a creative solution to the challenge of change—begins with a curious mind open to the ever expanding horizons of technical innovation. We need EE's with an insatiable desire to venture into the realm of these possibilities in an environment of encouragement and challenge.

Hallicrafters isn't satisfied with yesterday's electronic progress—past innovations that have fostered our reputation as the leader of the electronic communications and countermeasure industry. Instead, we are constantly striving to make the best even better.

In pursuit of electronic excellence, Hallicrafters needs graduate electronic engineers who thrive on challenging assignments offered in an atmosphere of intellectual and creative freedom—who prosper in an environment of curiosity, controversy and commitment.

Specifically we have openings for EE's in ECM Systems, Solid State, Microwave, Antennas, Communications and Electronics Packaging.

Consider the satisfaction of working for Hallicrafters, a company where pride in electronic expertise is the basis of progress. Consider becoming an integral part of a company that regards thinking highly and rewards it accordingly.

Please submit your resume, in complete confidence, to: Professional Placement Director, The Hallicrafters Co., 600 Hicks Road, Rolling Meadows, Illinois 60008.

An Equal Opportunity Employer.

*the hallicrafters co.*

A Subsidiary of Northrop Corporation



CIRCLE 967 ON READER SERVICE CARD

## ***Want to be unique in our memory?***

It's easy. Enter the Electronics Manpower Register.

We'll feed your professional background into the talent memory of our nationwide computerized recruitment service.

Our computer will match your unique profile against every opening being programmed into it by a long list of electronics

companies. You'll automatically be qualified for every logical career opportunity. But we'll only release your availability to those companies you approve.

To enter, send us your resume.

Electronics Manpower Register

**Electronics**  
330 West 42nd Street  
New York, N.Y. 10036

### EMPLOYMENT SERVICE

Southeast/Nationwide EEs. Send resume Tech Div. Brodeur Personnel Services Inc. 3947 Blvd Center Dr. Jax., Fla. 32207.

### SPECIAL SERVICE

Capital Contacts—Before you try Public or Private Placements to Underwriters, Investment Banking Houses, write for free helpful information to Confidential Consultant 817 51st St., Brooklyn N. Y.

## EMPLOYMENT — RATES —

**DISPLAYED:** The advertising rate is \$79.00 per inch for all advertising appearing on other than a contract basis. Contract rates quoted on request.

Subject to Agency Commission.

An advertising inch is measured  $\frac{7}{8}$ " vertically on a column—3 columns—30 inches to a page.

**UNDISPLAYED: \$3.60 per line, minimum 3 lines. To figure advance payment count 5 average words as a line. Box numbers—count as 1 line.**

**Discount of 10%** if full payment is made in advance for 4 consecutive insertions.

Not subject to Agency Commission.

Send new ads to:

## ELECTRONICS

Class. Adv. Dept.,

P. O. Box 12, N. Y., N. Y. 10036

# In electronics it's Electronics magazine to sell used equipment!

Your advertisement will produce Results in Electronics. Engineers turn to Electronics magazine for the latest technical developments — and for the latest buying information. You can reach them inexpensively in Electronics Searchlight Section.

For information:  
Searchlight Section  
Classified Advertising Dept.  
Post Office Box 12  
New York 10036



## Looking For A Challenge?

If you don't feel your experience or advanced educational level is being utilized to the fullest, consider **BRYANT**.

The sky's the limit for you (and for us with you). Bryant Computer Products, a Division of Ex-Cell-O Corporation, is the leading independent supplier of rotating mass memory systems for the digital computer industry. As well as advancing our well-established drum and disc file storage systems,

we are actively engaged in research into applications of laser technology and photo-chemical compounds to computer bulk storage systems. Other computer associated peripherals are also in the mill.

If you want challenge, how about these technologies?

- Precision mechanisms and rotating machinery
- Magnetic materials, plating and coatings
- Magnetic recording and recording head development
- Laser instrumentation
- Photo-chemical compounds and applications
- High frequency electronics and circuits including magnetic and inductive components
- Logic systems and computer systems
- Information theory and communications theory related to storage and retrieval systems

If your PhD, MS, or BS Degree is "going crying", the decision is yours. Contact us today.

### BRYANT COMPUTER PRODUCTS

Division of Ex-Cell-O Corporation  
850 Ladd Road

Walled Lake, Michigan 48088  
Attention: Mr. E. B. Rieckhoff  
Personnel Manager

Laser Technology



Chemical Analysis



An Equal Opportunity Employer

CIRCLE 968 ON READER SERVICE CARD



## SEARCHLIGHT SECTION

- CLASSIFIED ADVERTISING • BUSINESS OPPORTUNITIES
- USED OR SURPLUS EQUIPMENT

### free catalog

#### POTTING APPLICATORS MANUAL AND DISPOSABLE

6cc 12cc 30cc

FOR POTTING, ENCAPSULATING, AND  
SEALING OF MINIATURE COMPONENTS

PHILIP FISHMAN COMPANY  
7 CAMERON ST., WELLESLEY 81, MASSACHUSETTS

CIRCLE 969 ON READER SERVICE CARD

RADAR SYSTEMS GROUND AND AIRBORNE, AUTOMATIC TRACKING ANTENNA SYSTEMS, NIKE AJAX, NIKE HERCULES, M-33, MSO-1A, MPS-19, MPS-9, SCR 584, TPS-1D, TPS-28, FAA-ASR-2, AIRBORNE SYSTEMS, APN-84, APN-102, APS-20, APS-27, APS-45, DPN-19, DIGITAL COMPUTERS, IBM 650, IBM 704.

LARGEST INVENTORY OF RADAR AND MICROWAVE EQUIPMENT IN THE WORLD.

**RADIO RESEARCH INSTRUMENT CO.**  
45 WEST 45TH ST. N. Y. 10036 212-JU 6-4691

CIRCLE 970 ON READER SERVICE CARD

## Mr. Used Equipment Dealer:

When you advertise in the Searchlight Section . . . You have hired your most persuasive salesman:

He's efficient . . . He thrives on long hours . . . His territory is the entire nation . . . and overseas . . . He doesn't see buyers of used and new surplus equipment: They see him—regularly. They depend on him.

He is Searchlight—The section of this publication where wise dealers advertise and list their stocks for sale.

### SEARCHLIGHT SECTION

Classified Advertising Dept. • Post Office Box 12 • New York, N. Y. 10036



Until recently, the world of ultrasonics was better known to bats than men. Branson has changed that.

We've been in ultrasonics for more than 20 years. Solely ultrasonics.

You can accomplish a lot with that kind of concentration.

We have. Branson Ultrasonic Cleaning . . . with advances like our new

solid-state Powerpack generator with exclusive load compensation. What does this mean to you? For the first time, you can power a series of cleaning tanks . . . each with a different load . . . and with maximum efficiency, using only one power source.

If your cleaning problem calls for an ultrasonic solution, don't wander

into the world of working sound with a stranger. Roam it with Branson.

Branson Instruments Co., a subsidiary of Smith Kline & French Laboratories, Progress Drive, Stamford, Connecticut 06904

**BRANSON**

For sound ideas in cleaning, testing and measuring

**The silent world of working sound.**



# International Newsletter

September 29, 1969

**Need computer time?  
The number to call is  
Moscow 2617208**

"For sale. Machine time on Minsk 22 computer (evening and night hours)." So read an ad last week in a Moscow general newspaper, raising not a few eyebrows in Russian computer circles. While most officials of computing centers and users of advanced machines are lamenting the shortage of computers, the computing center of the central mail order cooperative has found time on its hands and, surprisingly, no interested government customers. Just last April, Guri I. Marchuk, director of the huge Novosibirsk computing center, one of the Soviet's three largest, complained publicly of a computer shortage that amounted to "computer starvation" and said a rapid expansion of time sharing would help. One big difficulty that Marchuk cited was that the range of Russian computers was too small for the demand. Maybe he should call Moscow 2617208.

**West Germans line up  
Eastern trade deals**

Watch for more licensing and know-how exchange agreements between East Bloc countries and West Germany. Coming hard on the heels of preliminary trade talks in Bucharest between West Germany's Economics Minister Karl Schiller and Rumanian officials is the arrival of Polish trade delegations in Bonn and West Berlin.

The Poles visited about 20 West Berlin firms, both in electronics and in other growth industries. They are said to be interested in more licensing deals such as already exist with Grundig Werke GmbH and AEG-Telefunken in the consumer electronics field—primarily tape recorders. The Germans, on the other hand, would like to shift the production of certain parts to Poland because of their acute labor shortage.

The Rumanians, too, are eager for increased cooperation and trade with German firms. At official talks in November—that could lead to a five-year agreement—the Rumanians are likely to press for more technical cooperation, particularly for West German support in developing new technical processes. Their interest in German electronic data processing equipment already runs high. Siemens AG, for example, is installing four process-control computers in a steel plant being constructed at Galatz on the Danube. A Siemens 305 computer has just been installed at a Rumanian rubber processing and manufacturing plant, and a Siemens 4004 machine is handling freight movement for the rail network.

**Australia will buy  
F-111—at cut-rate**

While the U.S. Air Force struggles to hold F-111 fly-away costs down to \$8 million, Australia finally will buy 24 planes at the previously agreed ceiling of \$6 million. The deal was completed after the U.S. said it would strengthen the swing-wing, and absorb the extra cost incurred—some \$75,000 per plane. The total Australian payment probably will touch \$300 million, including spare parts and ground equipment.

**Japanese freeze  
home vtr standards**

Sales of home video tape recorders are set to surge forward now that producing companies have agreed to tape format and reel standards. Big stumbling block to mass markets so far has been lack of interchangeability of taped programs from one machine to another. This has not only stalled the development of the pre-recorded tape business, but also has slowed the school and educational market to a trickle.

This week half-a-dozen of the 17 companies that are parties to the

---

# International Newsletter

---

new standards are showing compatible sets at the broadcasters convention in Sendai, Japan, with some commercial sales expected before the end of the year. These new machines use the same 1/2-inch video tape and 7-inch reels used in most other home-type machines. The tape follows an omega-shaped path around a rotating double-recording head assembly, which is 115.82 millimeters in diameter—much smaller than in present machines. Tape speed is 7.5 inches/second; pitch between tracks is 173 microns, and the angle of the tracks is 3 degrees, 11 minutes. A 0.8-mm-wide control track and a 1-mm wide audio track run the length of the tape. Specifications call for a signal-to-noise ratio of better than 40 db and horizontal resolution of 240-250 lines.

## Color-tv tube, sans shadow-mask, closer to market in France

Commercial prospects for France's maskless "grill" color-tv tube are brightening. Development is being taken over by electronics giant Thomson-Brandt, which will buy a majority interest in Societe France-Couleur, the tube's developer up to now. Since Thomson-Brandt is France's major tv set maker, the tube will now have a guaranteed outlet provided it can be mass produced economically.

Both Thomson-Brandt and France's other major set maker, Philips Gloeilampenfabrieken's subsidiary, la Radiotechnique, are understood to have tried in the past to buy up rights to the flat-screen, ultrabright tube, an invention announced in 1965 by engineer Henri de France, inventor of the Secam color-tv system [*Electronics*, May 5, 1965 p. 157]. But French entrepreneur Sylvain Floirat won development rights in 1967, due to strong government backing, according to a Thomson-Brandt official. Floirat has owned 90% of France-Couleur stock.

Apparently because development has lagged under Floirat, the government has now pressured him to step aside for Thomson-Brandt and a group of French banks which will put up \$6 million to get the tube—an important Gaullist symbol of French technical independence—into production.

## ICL gains USSR door to put its foot in

Britain's International Computers Ltd. is the first electronics-only company to be granted accreditation by the Soviet government. Joining 16 other foreign firms with this official status—11 of which are Japanese—ICL stands to gain some long-term benefits from the USSR's action, perhaps some follow-up contracts after it completes its computerizing of the Russian steel industry's distribution system. The first fallout of accreditation: permanent office and living space in government quarters, rather than the constant shift from hotel room to hotel room that most Soviet-trade seekers have to put up with.

## Addenda

Japan's three leading color-tv makers—Hitachi, Matsushita, and Toshiba—are expected to come out this year with all-transistor color sets. Hitachi is going the whole way; all its new color sets, from 13 inch to 19 inch, will be completely transistorized. . . . Olivetti, after three years preparatory work, had high hopes of landing a \$90 million contract for an accounting machine plant near Moscow by the end of this year. Now, without giving a reason, the Russians have scrapped the whole idea, leaving Olivetti without a penny and the Russians with mountains of detailed machine specifications.

# Array of dual-gate MOS transistors successfully generates tv picture

Japanese experiment with solid state picture pickup device that could yield smaller, easier-to-make image-to-signal converter

**Solid state conversion** of subject material into tv signals may be a long way from making obsolete the old reliable vidicon tube, but researchers at Japan's Nippon Electric Co. have moved a step in that direction—with a matrix of MOS transistors—and their approach promises small devices and simple fabrication.

At first glance, Nippon Electric's experimental array looks like anything but a picture pickup device—it consists of a matrix of enhancement-type twin-gate metal oxide semiconductor transistors. Yet this array performs the required functions of light-to-electrical conversion, storage, switching, and addressing. The last two jobs are performed by the dual gates, which together interact to form an AND circuit.

The dual-gate transistors are fabricated on an n-type silicon wafer, into which have been diffused the source, island and drain, all p-type. Over the source-to-island and island-to-drain channels are two gates, insulated from the channels by a layer of silicon dioxide.

**Look, no hands.** The big departure from conventional MOS transistors, though, is that the source has no contact metalization and is, in fact, not connected to anything. The p source region and the n substrate form a photodiode that acts as input transducer and storage unit for each picture element of the matrix.

When negative voltages are applied to the two gates of the transistor selecting that element, current flows through the transistor and charges the source-to-substrate diode until the voltage across it

essentially equals the supply voltage.

Light falling on the matrix penetrates the transparent oxide layer above the source and generates carriers in the source, which diffuse to the junction and discharge the diode.

The frame repetition rate is 60 hertz, so intervals between each transistor selection is exactly 1/60th of a second. For average scene illumination, the voltage across the source-to-substrate diode will rise part of the way toward zero during that period. Since the

diode is reset at power supply voltage during this selection, the current flowing through the load resistor, and output voltage, is proportional to the rise of diode voltage during the one-frame interval. Thus output voltage is proportional to the illumination falling on the transistor source.

As with most photosensitive devices, sensitivity is roughly proportional to the area of the photodiode, in this case the area of the source. To maximize sensitivity, most of the area of each matrix element is occupied by the source—the remainder of the transistor fits in one corner. If bipolar phototransistors were used instead of MOS units, isolation regions would have

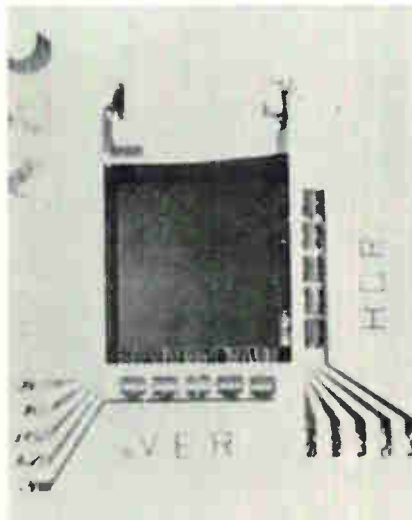

**Building an image.** Nippon Electric's solid state image converter is made as an array of MOS transistors with large source areas. The dual gates that are used to address each transistor in the array and the drain are kept to one corner. With no contact metalization, the source interacts with the substrate to form a photodiode. A 50-by-50 matrix and 10 10-step shift registers make up the prototype unit.

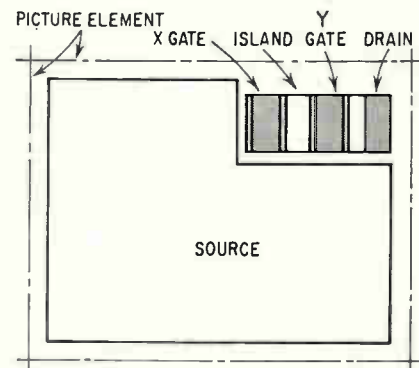
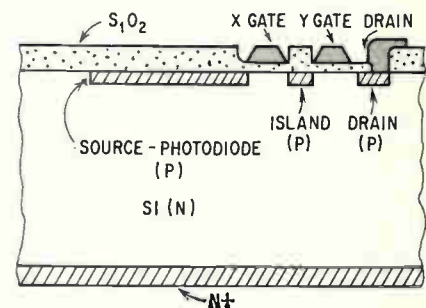

been required, taking up a larger share of available chip surface. In addition, bipolar fabrication requires more diffusion steps than the single diffusion required for the MOS matrix.

Other electronic firms, such as Westinghouse, with a bipolar approach, and Britain's Plessey, with MOS transistors [*Electronics*, March 18, 1968 p. 253], are working on solid state image converters. Nippon officials feel that their new device has an advantage over the others because it's extremely simple to fabricate.

**Checkerboard.** Nippon Electric's device consists of a 50-by-50 monolithic array of MOS transistors, measuring 12.5 by 12.5 millimeters overall. Sweep switching is provided by MOS transistor shift registers. Experimental shift registers have 10 steps on one silicon chip, with an output at each step. Ten shift registers, five each for horizontal and vertical sweep, and the MOS transistor matrix are assembled into a single unit.

Selection time of each of the 2,500 picture elements during sweep is 5.34 microseconds each. Selection times total about 80% of

the 1/60th second frame period; the remainder is used for vertical and horizontal blanking intervals. Although there is no delay in the image pickup device, the blanking intervals are needed to allow for beam retrace in the standard picture tube monitor used for displaying the array's output.

**Gray scale.** The matrix has a dynamic range from about 2 to 7 lux—a nominal order of magnitude—and a gradation of four or five shades of gray. Photocurrents of the individual photodiodes are linear down to lower values of illumination, but switching noise caused by differentiation of matrix selection voltage masks output voltages for lower illumination values. Switching noise, or spikes, are caused by capacitive coupling at the crossover between the X lines of the matrix and output lines—which are connected between the drains of the individual MOS transistors and the common output terminal. Present plans call for change in methods of fabrication to reduce capacitance between these lines.

Many storage-type image devices suffer from an after-image effect that seriously degrades perform-

ance on moving images. With this new device, the time required to charge individual picture elements is a function only of the photodiode capacitance and MOS transistor transconductance—and for samples fabricated is about 100 nanoseconds. Since selection time is set at 5.34 microseconds, charging is completed during individual selection interval, and no after-image effect has been observed.

### West Germany

#### Dishing it up

For space communications stations, the standard rotating-pedestal cassegrain antenna is just not the West German designers' dish. As in other countries, antenna engineers there are trying to overcome two inherent disadvantages in the classic dish design: a tiny cabin for electronic equipment that rides with the antenna and the aperture-blocking subreflector that cuts down on total antenna efficiency.

Now, designers at AEG-Telefunken's Backnang plant have come up with an antenna concept that overcomes both these problems. A sophisticated folded beam path allows the receiving and transmitting gear to be installed in the pedestal. Furthermore, there's no aperture blocking because the subreflector is offset from the main dish axis.

Some antennas now under construction already incorporate one or the other of these two features. For example, an off-center subreflector solves the problem of aperture blocking in an antenna designed at Britain's Birmingham University [*Electronics*, June 10, 1968, p. 255]. And, a large rotating antenna that West Germany's Siemens AG is currently building at Raisting, Bavaria, has the receiving and transmitting gear installed in the pedestal [*Electronics*, Oct. 30, 1967, p. 169].

**Structured.** In addition to both features, AEG-Telefunken says its antenna's unique structural design makes it much more compact and



**Stay at home.** Japan's Matsushita, to drum up interest in consumer facsimile, has developed three systems for home reception. One (above) puts signals in the tv vertical retrace period to generate two pages a minute. The second builds up a fax line from short signals at the end of horizontal lines. The third uses empty space in f-m signals.

rugged—and hence more resistant to wind and weather—than conventional types. Another design plus is that the subreflector is less prone to deformations or warping because it is solidly supported on a massive steel structure. Despite all this, the antenna's energy feed system has no bends, making for a low-loss transmission path between the electronic equipment and the antenna's reflecting surfaces.

Called the SAFE antenna, the new design is intended for satellite communications ground terminals operating with centimeter and decimeter wavelengths. SAFE is the acronym for Satellite communications Antenna with Fixed Equipment room. The design work and antenna characteristic studies, partly financed by West Germany's Ministry for Scientific Research, were carried out on a model one third the size of the actual antenna.

**Fold.** The antenna resembles a truncated cone that's bent in the middle, with the main dish at the bend. The subreflector is mounted at the back end of the cone on a plane offset from that of the main dish by about 45° and thus well outside the main beam path.

The hyperbolic subreflector is illuminated by a bend-less energy feed system through a hole in the main dish. It consists essentially of a long horn topped by a small reflector. The absence of bends reduces the feed system length—and hence the total system loss.

Radio frequency energy sent through the feed horn bounces off three surfaces before it hits free space. It is first reflected from the small ellipsoidal reflector atop the horn. Passing through the feeder aperture the beam hits the subreflector, which focuses the energy onto the main dish.

Depending on the figure of merit at which the antenna is designed to operate, the diameter of the main dish can be anywhere between 12 and 30 meters. The diameter of the subreflector is generally about 25% less than that of the main dish.

AEG-Telefunken says both European and U.S. communications

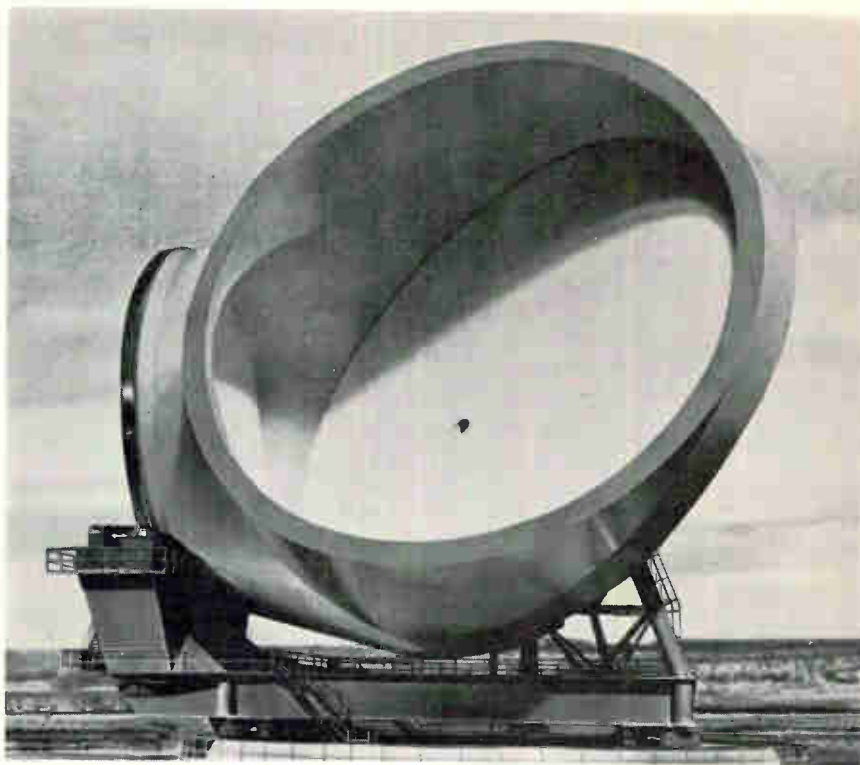

**Folded horn.** Offset subreflector and horizontal feed opening in main reflector eliminate dish-mounted equipment room and give wider effective aperture.

authorities have shown strong interest. Once orders are received, the firm as prime contractor may get a bonus—and become the main supplier of electronics equipment required in the system.

### Infrared indium

Researchers at West Germany's Siemens AC didn't stop researching when they found that indium antimonide doped with nickel antimonide made dandy magnetically controllable resistive components, such as wiperless potentiometers [*Electronics*, May 15, 1967, p. 233]. Now they have found that the same combination makes dandy—and reasonably priced—room temperature infrared detectors.

Other i-r detectors based on indium antimonide (InSb) with another semiconductor crystal dispersed within it have needed cryogenic equipment to maintain the low temperatures essential for detector sensitivity. In the Siemens combination, no cooling is required. The nickel antimonide

(NiSb) imbedded as parallel needle-like structures in the InSb increases the detector's absorption of i-r radiation by so much that the device can operate at room temperatures. The new material is especially suitable for detecting the long-wave components in the infrared spectrum.

**Double barreled.** The company has developed two types of detectors using the new material. One is called the OEN version, because it is based on an optically-induced Ettinghaus-Nernst effect. The other is a photobolometer-type detector.

In OEN detectors, the semiconductor material is cut into a thin slab a few tenths of a millimeter wide and from 1 to 2 mm long. This sliver is placed between the poles of a permanent magnet with the parallel NiSb needles perpendicular to the crystal surface. Infrared rays hitting this surface produce a thermal flow within the material. The thermal flow, in turn, sets up an electric potential whose field lines are perpendicular to both the magnetic field and to the direction of the incident radiation.

The generated voltage, usually in the order of microvolts, is amplified and used to drive a meter.

Siemens' OEN detectors operate at i-r wavelengths above 7 microns with a response speed of about 200 microseconds. At wavelengths below 7 microns the response speed is around 10  $\mu$ sec. They can be used at ambient temperatures from  $-20^{\circ}$  to  $+75^{\circ}$ C.

OEN detectors are about to hit the market and, depending on model, will sell for between \$75 and \$125 in Germany, significantly less expensive than conventional detectors using cooling equipment.

**Bridged.** Siemens' other detector, the photomolometer, has a far slower response speed but is simpler because it doesn't require a magnetic field. Instead, it's based on the simple resistance change that occurs when i-r radiation hits the InSb/NiSb material. The parallel NiSb needles must also be oriented perpendicularly to the radiation-exposed crystal surface.

The photobolometer, still in the development stage, is a Wheatstone bridge consisting of four InSb/NiSb resistors, each with an effective area of about one square millimeter. Two opposite branches of the bridge make up the detector's radiation-sensitive portion, while the other two branches—the reference branches—are shielded from the radiation. The four resistors are produced by photo-etching on a crystal chip to form a fully monolithic detector bridge. The temperature of the measured object can be anywhere between  $-40^{\circ}$ C and  $+200^{\circ}$ C.

### France

#### Calculated risk

Few electronics companies in Europe care to tangle with the Japanese when it comes to price competition in mass-produced products. But one French firm has decided to do just that in the fast-growing market for desk calculators.

This month at the annual Paris office equipment show, Schneider Radio-Television unveiled a new

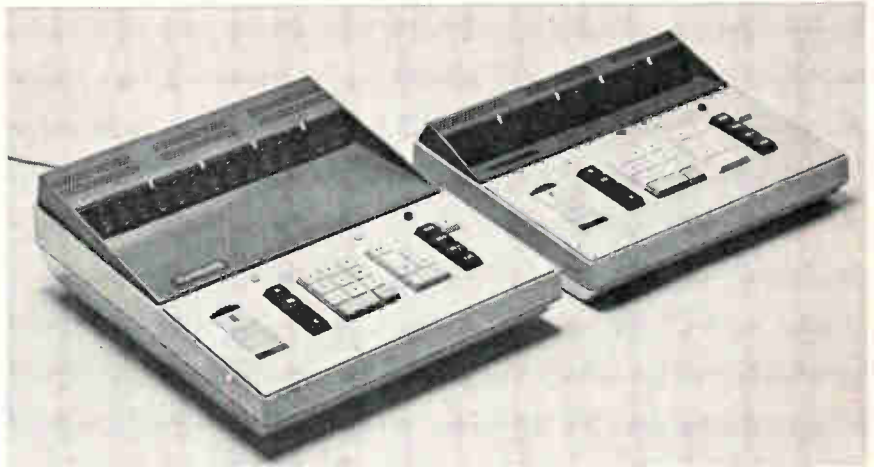

**New entry.** The Exactronique, by France's Schneider, aims at undercutting Japanese calculators. Cost cutting design features remote keyboard units.

line of electronic calculators that offer high flexibility and low price-tags. Schneider's basic model—a four-operation, 16-digit machine called the Exactronique—will retail in both Europe and the U.S. for about \$600, a good \$300 dollars less than the cheapest comparable Japanese model.

**Marketplace.** Electronic desk calculators were launched by the Japanese in 1965 and have remained a profitable Japanese monopoly ever since. In Europe and the U.S. the machines still cost more than double the price of top quality electro-mechanical units, but their lightning-quick reaction time and total silence have made them one of the hottest selling new electronic products of the decade. More than 300,000 of them will be sold this year, with something like 90% made in Japan—though a big slice is marketed abroad under foreign brand names. The world market is expected to grow by 35% annually over the next several years.

It was only last year that Schneider—a consumer products and measuring instrument maker—decided the electronic calculator market was too attractive to pass up. Schneider decided to build a calculator that would offer different features and a dramatically lower price than the Japanese machines. "Otherwise, who would buy it?" asks Martin Birnbaum, chief of Schneider's Professional Electronics division.

Birnbaum says that although most Westerners assume Japan's calculator monopoly is due to lower labor costs, Schneider found that labor accounts for only a minor share of a calculator's price. "Design simplicity was the best way to cut costs," Birnbaum says.

**Shavings.** The low pricetag on Schneider's calculators results from a string of technical wrinkles and cost economies, none very striking alone but all adding up to major savings for the customer. The most dramatic technical cost paring measure was building the calculator's 256-bit memory around a glass delay line identical to those Schneider uses to build its Secam color-tv sets.

The entire memory cost the firm less than \$20, compared with between \$100 and \$150 that, Birnbaum says, Japanese firms generally pay for their core or delay-line memories.

Schneider was also able to make do with 80 integrated circuit packages in its Exactronique, versus 120 or more in most Japanese calculators. Schneider uses 20 IC's in the input section, 50 in the calculating logic circuitry and 10 in the visual display. The secret: custom-design sextuple inverters—made by La Radiotechnique, French subsidiary of Philips Gloeilampenfabrieken—instead of using standard quadruple inverters. Other IC economies came from ultra-tight micro-programming in the calculator's different functions.

Accutronics, Inc.	59, 60	Dialight Corp.	139	McGraw Hill Book Co.	188
Marketing Associates		Michel Cather, Inc.		■ Magnetics Incorporated	39
ACDC Electronics	167	DuPont de Nemours & Co., Freon Div.	177	Lando Adv. Agcy., Inc.	
Chiat/Day, Inc.		N.W. Ayer & Son, Inc.		■ Mallory & Co., P.R., Mfg. Div.	192
■ Acopian Corp.	58	DuPont de Nemours Co., Teflon Div.	155	■ Aitkin-Kynett Co.	
Mort Barish Associates		Batten, Barton, Durstine & Osborn, Inc.		Markem Corp.	3rd Cover
Airborne Instruments Laboratory	131			■ Creamer Trowbridge Case & Basford, Inc.	
Campbell-Mithun, Inc.				Microdyne Instruments, Inc.	174
Airpax Electronics, Inc.	42	Eastman Kodak Co.,		Industrial Public Relations, Inc.	
Tech Communicators, Inc.		PCIM Market Development	121	Minelco, a Subsidiary of General Time	80
Akers Electronics, Horten, Norway	161	Rumrill Hoyt, Inc.		Alden Adv. Agcy., Inc.	
Foote, Cone & Belding International		□ Ebauches SA	17E	Monsanto Co.	176
Alcatel	5E	Claude Langel		Michel Cather, Inc.	
Agence Rene Sicard		Elgenco Incorporated	192	Motorola Semiconductor Products, Inc.	112
Alco Electronic		Wesco Advertising		Lane & Bird Adv., Inc.	
Products, Inc.	187, 189, 191	Elgin Electronics, Inc.	64		
Marketronics Advertising		Carr Liggett Adv., Inc.			
Alfred Electronics	45	E/MC Electronics/Management Center	160		
Bonfield Associates		Ries Cappiello Colwell, Inc.			
Allen-Bradley Co.	23, 25			National Semiconductor Corp.	10, 11
Fensholt Adv. Agcy.				Hall Butler Blatherwick, Inc.	
Allied Van Lines, Inc.	120				
Young & Rubicam, Inc.		Fansteel, Inc.	24		
American Cyanamid Co.,		Reincke, Meyer & Finn, Inc.	15	Philco Ford Co., Microelectronics Div.	181
Plastic & Resins Div.	123	■ Fluke Manufacturing Co., John		The Aitkin-Kynett Co., Inc.	
Wilson, Haight & Welch, Inc.		Bonfield Associates		■ Power Designs, Inc.	206
American Potash and Chemical Corp.,				Samuel H. Goldstein	
Rare Earth Div.	26			Powertec Division of Airtronics	140
Sidney Clayton Assoc., Inc.				Cordova Associates	
■ Amperex Electronics Corp.,		General Atronics Corp.	118		
North American Phillips Co. Div.	6, 7	Garceau Hallahan & McCullough, Inc.			
Sam Groden, Inc.		General Electric Co.,			
Anconra Corp./Neumuller and Co.	204	Instrument Department	43		
Wilhelm Bacher Werbung		Robert S. Cragin, Inc.		Radiation, Inc.	61, 63, 65, 67, 69, 71
Andrew Corp.	72	General Electric Co.,		W.M. Zemp & Assoc., Inc.	
Fensholt Adv., Inc.		Miniature Lamp Div.	130	Radio Corporation	
□ Ates Componenti Elettronici, S.P.A.	14E	Batten, Barton, Durstine & Osborn, Inc.		of America	4th Cover, 51
Publicitas		General Electric Co.,		Al Paul Lefton Co.	
		Silicone Products Div.	124	Raytheon Co., Components Div.	144
		Ross Roy of New York, Inc.		Fuller & Smith & Ross, Inc.	
		General Electric Co.,		Raytheon Semiconductor	78, 79
		Specialty Control Div.	20, 21	Botsford, Constantine & McCarty, Inc.	
		Robert S. Cragin, Inc.		■ Rogan Brothers, Inc.	32
		■ General Instrument Corp.,		Christopher Adv., Inc.	
		Semiconductor Products Div.	117		
		Norman Allen Associates			
		□ General Instrument Europe S.P.A.	10E		
		Studio Cigiemme			
		General Magnetics	9	Sage Laboratories,	
		McCarthy/Scelba/DeBiasi Adv. Agcy., Inc.		Microwave Products Group	164
		General Radio Co.	2nd Cover	Impact Adv., Inc.	
		Horton Church & Goff, Inc.		□ Schlumberger Ltd. EMD	2E
				□ Schlumberger SIS	3E
				Sodipa	
				□ Schneider R.T.	19E
				Noirclerc Publicite	
				S.H. Couch Division, ESB Incorporated	135
				Culver Advertising, Inc.	
				Sierra Research Corp.	54
				B.P. Byer Associates, Inc.	
				■ Signalite Inc., Subsidiary of	
				General Instrument Corp.	116
				McCarthy, Scelba, DeBiasi Adv. Agcy., Inc.	
				Signalite Corp. Sub.	
				Corning Glass Works	68, 115
				Cunningham & Walsh, Inc.	
				Siliconix, Inc.	81
				Robertson West, Inc.	
				□ SODECO	16E
				Publicite Polliand	4E
				□ Sodie	
				Etudes et Creations Publicitaire	
				Soliton Devices Inc., Transistor Div.	149
				Haselmire Pearson Adv., Inc.	
				■ Sorensen Operation Raytheon Co.	75
				South Carolina Electric & Gas Co.	168
				Cargill, Wilson & Acree, Inc. Adv.	
				Sprague Electric Co.	5
				The Harry P. Bridge Co.	
				Stewart Warner Microcircuits, Inc.	53
				Jones, Maher, Roberts Inc.	
				Switchcraft, Inc.	122
				Buti-Roberts Advertising	
				Sylvania Electric Products, Inc.,	
				Parts Div.	142
				Doyle Dane Bernbach Inc.	
				Synthane-Taylor Corp.	183
				Gray & Rogers, Inc.	
				Tally Corp.	132
				Bonfield Assoc., Inc.	
				■ Tektronix, Inc.	125, 126
				Dawson, Turner & Jenkins, Inc.	
				Telonic Instruments	70
				Jansen Assoc., Inc.	
				Telonic Systems Div. of	
				Telonic Industries, Inc.	35 to 38
				Jansen Assoc., Inc.	
				Tempress Industries, Inc.	17
				Hal Lawrence, Inc.	
				Teradyne, Inc.	85
				Quinn & Johnson Adv., Inc.	
				Texas Instruments Incorporated,	
				Components Group	28, 29, 170
				Albert Frank-Guenther Law, Inc.	
				□ Texas Instruments France	12E, 13E
				Dumesnil Publicite	
				Toko, Inc.	182
				Hakuhodo Incorporated	



**ANCRONA**

**3N163  
MOSFET  
Transistors**

P-CHANNEL ENHANCEMENT MODE ·  
ULTRA HIGH INPUT IMPEDANCE AND  
LOW LEAKAGE · FAST SWITCHING ·  
LOW CAPACITANCE

Static Gate to Source and Body	$V_{GS}$	$\pm 40$ V
Transient Gate to Source and Body	$V_{OX}$	$\pm 125$ V
Drain to Source and Body	$V_{DS}$	$-40$ V
Source to Drain and Body	$V_{SDS}$	$-40$ V
Drain to Gate	$V_{DGO}$	$-40$ V
Drain Current	$I_{D(on)}$	$-50$ mA
Continuous Device Dissipation at Free Air Temperature	$P_D$	$375$ mW $25^\circ$ C
Operating Junction Temperature	$T_j$	$-55$ to $+150^\circ$ C

**PRICES**

	1-24	25 up	100 up
\$	5.-	4.40	2.75

**ANCRONA CORP.**

65 East 55th Street · New York, N. Y. 10022  
(212) 688-6285 · Telex 223 117 · TWX (710581 / 4513)

TRW Electronics, Capacitors Div. Fuller & Smith & Ross, Inc. 137  
■ Tung-Sol Division, Wagner Electric Corp. Feeley & Wheeler, Inc. 56

U-Tech, A Division of Industrial Physics and Electronics Co. Ross Clay Advertising 178

Varian Associates Electron Tube & Device Group Botsford, Constantine & McCarty, Inc. 119  
■ Varo, Inc. Tracy-Locke, Inc. 14  
■ Victory Engineering Corp. A.D. Adams Advertising, Inc. 22

Weston Instruments Inc., Archbald Div. Arndt, Preston, Chapin, Lamb & Keen, Inc. 179  
Weston Instruments Inc., Newark Div. Arndt, Preston, Chapin, Lamb & Keen, Inc. 156  
Wiremold Company, The Charles Brunelle Co. 174

Xcelite, Inc. Harold Warner Adv., Inc. 154

Yokogawa Electric Works Ltd. General Adv. Agcy., Inc. 186

Zeltex, Inc. Helme Assoc., Inc. 146

**Classified & Employment Advertising**  
F.J. Eberle, Manager  
212-971-2557

**EMPLOYMENT OPPORTUNITIES** ..... 193-195  
Bryant Computers ..... 195  
Hallcrafters ..... 194  
Zenith Radio Corp. .... 193

**EQUIPMENT**  
(Used or Surplus New)  
For Sale

Fishman, Philip Co. .... 195  
Radio Research Instrument Co. .... 195

■ For more information on complete product line see advertisement in the latest Electronics Buyer's Guide

□ Advertisers In Electronics International

**Electronics Buyers' Guide**

George F. Werner, Associate Publisher  
[212] 971-2310

Robert M. Denmead,  
Midwest Regional Manager  
[312] MO 4-5800

William A. Capuzzi,  
New York, New England District Manager  
[212] 971-3793

Regina Hera, Directory Manager  
[212] 971-2544

Thomas M. Egan, Production Manager  
[212] 971-3140

Carol Gallagher,  
Assistant Production Manager [212] 971-2045

**Circulation Department**

Isaaca Siegel, Manager [212] 971-6057

**Research Department**

David Strassler, Manager [212] 971-6058

**Advertising Sales Staff**

Dan McMillan III [212] 971-3468  
Associate Publisher

Wallis Clarke [212] 971-2187  
Advertising Sales Service Manager

Warren H. Gardner [215] LO 8-6161  
Eastern Advertising Sales Manager

Atlanta, Ga. 30309: Michael H. Miller, 1375  
Peachtree St., N.E.  
[404] 892-2868

Boston, Mass. 02116: William S. Hodgkinson  
McGraw-Hill Building, Copley Square  
[617] CO 2-1160

Cleveland, Ohio 44113: William J. Boyle, 55  
Public Square, [216] SU 1-7000

New York, N.Y. 10036  
500 Fifth Avenue  
James R. Pierce [212] 971-3615  
John A. Garland [212] 971-3617  
Michael J. Stoffer [212] 971-3616

Philadelphia, Pa. 19103:  
Jeffrey M. Preston  
Warren H. Gardner,  
6 Penn Center Plaza,  
[215] LO 8-6161

Pittsburgh, Pa. 15222: Jeffrey M. Preston,  
4 Gateway Center, [412] 391-1314  
Rochester, N.Y. 14534: William J. Boyle,  
9 Greylock Ridge, Pittsford, N.Y.  
[716] 586-5040

Donald R. Furth [312] MO 4-5800  
Midwest Advertising Sales Manager  
Chicago, Ill. 60611: Kenneth E. Nicklas  
Ralph Hanning 645 North Michigan Avenue,  
[312] MO 4-5800

Dallas, Texas 75201: Richard P. Poole, 1800  
Republic National Bank Tower,  
[214] RI 7-9721

Houston, Texas 77002: Robert Wallin,  
2270 Humble Bldg. [713] CA 4-8381

Detroit, Michigan 48226: Ralph Hanning,  
856 Penobscot Building  
[313] 962-1793

Minneapolis, Minn. 55402: 1104 Northstar  
Center [612] 332-7425

St. Louis, Mo. 63105: Kenneth E. Nicklas,  
The Clayton Tower, 7751 Carondelet Ave.  
[314] PA 5-7285

James T. Hauptli [415] DO 2-4600  
Western Advertising Sales Manager

Denver, Colo. 80202: David M. Watson,  
Tower Bldg., 1700 Broadway  
[303] 266-3863

Los Angeles, Calif. 90017: Ian C. Hill,  
Bradley K. Jones, 1125 W. 6th St.,  
[213] HU 2-5450

Portland, Ore. 97204: James T. Hauptli,  
Don Farris, 218 Mohawk Building,  
222 S.W. Morrison Street,  
Phone [503] 223-5118

San Francisco, Calif. 94111: James T. Hauptli,  
Don Farris, 255 California Street,  
[415] DO 2-4600

Pierre Braude Tel: 225 85 88: Paris

European Director  
Paris: Denis Jacob  
88-90 Avenue Des Champs-Elysees, Paris 8  
United Kingdom and Scandinavia

London: Oliver Ball, Tel: Hyde Park 1451  
34 Dover Street, London W1

Milan: Robert Saidel, Roberto Laureri Jr.  
1 via Baracchini Phone 86-90-656

Brussels: Denis Jacob  
27 Rue Ducale Tel: 136503

Frankfurt/Main: Hans Haller  
Elsa-Brandstroem Str. 2  
Phone 72 01 81

Geneva: Denis Jacob  
1 rue du Temple Phone: 31 95 60

Tokyo: McGraw-Hill  
Publications Overseas Corporation,  
Kasumigaseki Building 2-5, 3-chome,  
Kasumigaseki, Chiyoda-Ku, Tokyo, Japan  
[581] 9811

Osaka: Akihiko Kamesaka, McGraw-Hill  
Publications Overseas Corporation, Kondo  
Bldg., 163, Umegae-cho Kita-ku [362] 8771  
Australasia: Warren E. Ball, IPO Box 5106,  
Tokyo, Japan

**Business Department**

Stephen R. Weiss, Manager  
[212] 971-2044

Thomas M. Egan,  
Production Manager [212] 971-3140

Maury D'Gongora,  
Assistant Production Manager [212] 971-2045

Dorothy Carmesin, Contracts and Billings  
[212] 971-2908

Frances Vallone, Reader Service Manager  
[212] 971-2865



# New IRC rectangular trim circuit space and cost

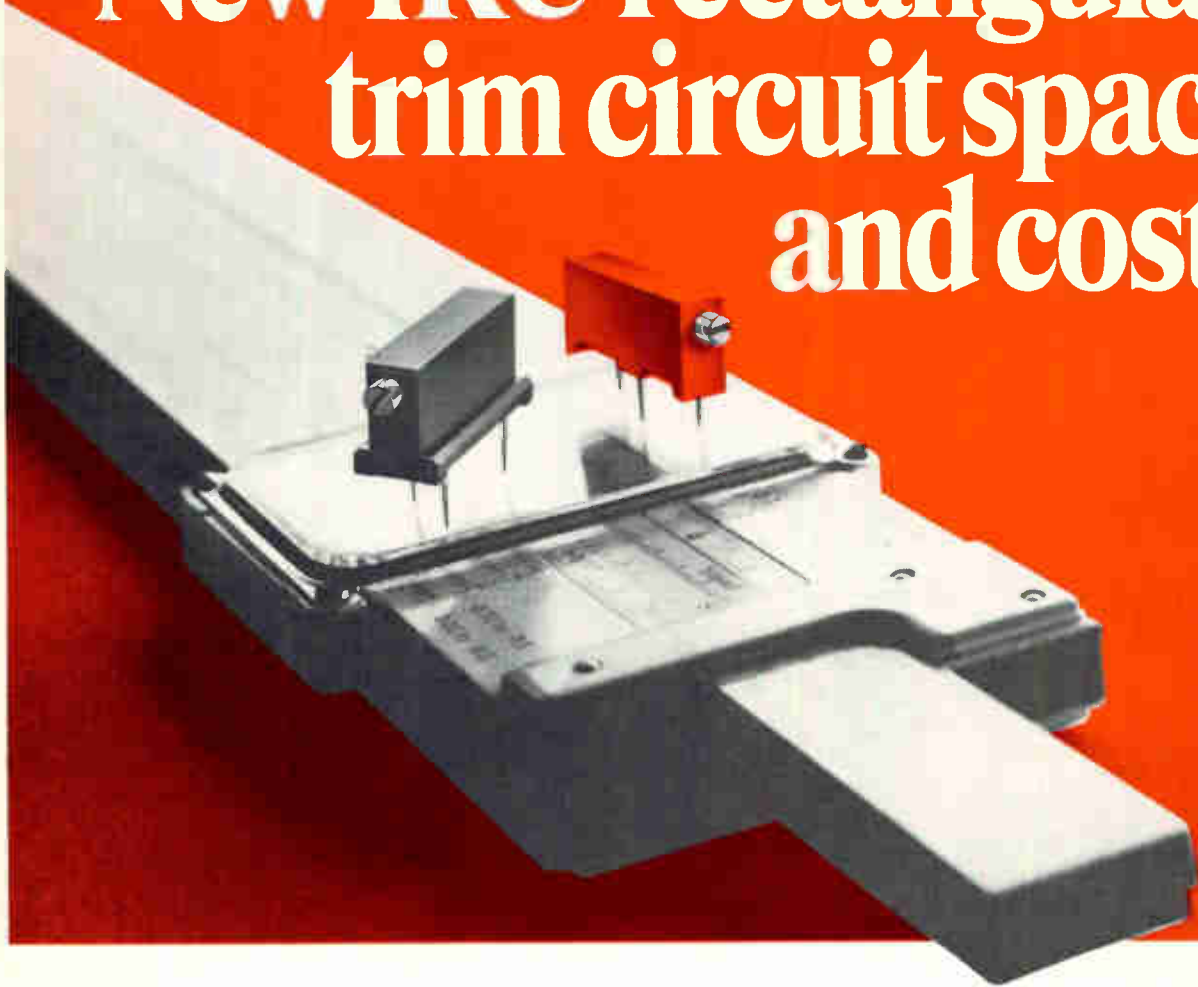

## Metal Glaze and Wirewound types

These 3/4-inch-long rectangular trimmers are made and perform like bigger, more costly units. Only IRC offers a miniature general-purpose unit with these features:

- All-metal adjustment shaft that eliminates breakage or distortion, even under repeated use.
- Silver brazed terminations on Metal Glaze and Wirewound types end resistance buildup associated with pressure connections.
- Ultrasonic bonding of the housing into a one-piece unit that is free of seams or laps.
- Resistance to normal board washing. Units sealed to MIL-R-27208 are also available.

Metal Glaze Type 950 has a rugged, thick-film element that provides excellent high-frequency characteristics and infinite resolution over the entire resistance range of 100Ω to 1 megohm. 3/4-watt @ 25°C. ±10% tolerance.

Precision Wirewound Type 900 has a long-wearing precious metal wiper spring that reduces noise and contact resistance. 1 watt @ 40°C. 100Ω to 20K. ±10% tolerance.

### PIN CONFIGURATIONS

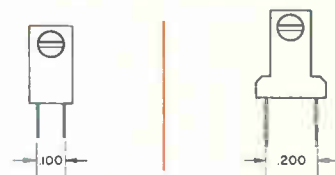

WIREWOUND	METAL GLAZE	WIREWOUND	METAL GLAZE
900-20 Std.	950-20 Std.	920-20 Std.	970-20 Std.
910-20 Sealed	960-20 Sealed	930-20 Sealed	980-20 Sealed

Immediate delivery from stock or from IRC Industrial Distributors. For information and prices write:

IRC St. Petersburg Division of TRW INC.  
2801 72nd St., North, St. Petersburg, Fla. 33733



**DIVISION OF TRW INC.**

# meet uniply\*

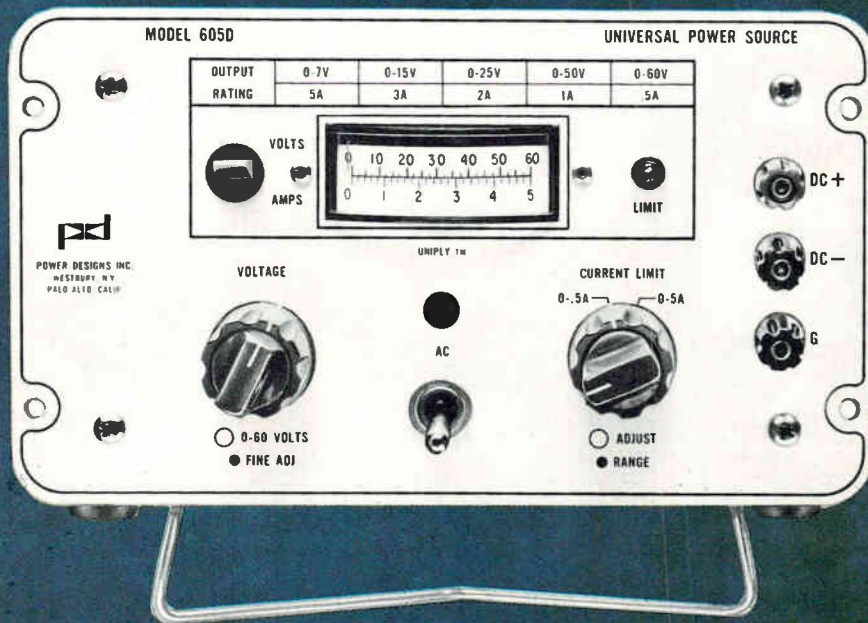

## the one that gets you five.

The Power Designs Model 6050 Uniply\* replaces five laboratory bench power supplies:

- 0-7V at 5A
- 0-15V at 3A
- 0-25V at 2A
- 0-50V at 1A
- 0-60V at 0.5A

- Continuously adjustable over 0-60VDC with 3mV resolution
- Control circuit automatically limits supply to maximum output ratings.
- Flashing light signals current limiter operation. Load in excess of output ratings, or AC line voltage inadequacy.
- Dual-range current limiter with automatic meter range shift.
- All the utility and performance of a high quality regulated power source: 0.01% regulation, 1mV PK to PK ripple and noise to 50 MHz, etc.

Write or call for detailed specifications. \*TM



**power designs, inc.**

Power Designs, Inc.  
1700 Shames Drive, Westbury, New York 11590  
Tel: 516-333-6200 • TWX: 910-373-1251

for only **\$195**

Power Designs Pacific, Inc.  
3381 Miranda Avenue, Palo Alto, California 34304  
Tel: 415-321-6111 • TWX: 910-373-1251

# Electronics reader service

Warning: The Post Office now requires your ZIP CODE on all mail. Please include your ZIP CODE number when filling out your reply card.

Use these handy post cards for more detailed information on: products advertised, new products, new literature.

Circle the number on the Reader Service post card that corresponds to the number at the bottom of the advertisement, new product item, or new literature in which you are interested.

Please print clearly. All written information must be legible to be efficiently processed.

If someone has beaten you to the post cards, you may obtain the needed information by writing directly to the manufacturer, or by sending your name and address, plus the Reader Service number, to Electronics Reader Service department.

All inquiries from outside the U.S. that cannot reach Electronics before the expiration dates noted on the Reader Service post card, must be mailed directly to the manufacturer. The manufacturer assumes all responsibilities for responding to inquiries. Electronics merely provides and clears requests for information from inquirer to manufacturer.

Correct amount of postage must be affixed for all mailings from outside the U.S.

## To subscribe to or to renew Electronics

Fill in the "For Subscriptions" area on the card if you desire to subscribe to or renew your present subscription to Electronics. Send no money. Electronics will bill you at the address indicated on the Reader Service post card.

## Multi-product advertisements

For information on specific items in multi-product advertisements which do not have a specific Reader Service number indicated write directly to manufacturer for information on precise product in which you are interested.

**20** \*For employment inquiries fill in home address. September 29, 1969 Card Expires November 29, 1969 14

Name \_\_\_\_\_ title \_\_\_\_\_

Company\* \_\_\_\_\_

Address \_\_\_\_\_

City \_\_\_\_\_ State \_\_\_\_\_ Zip Code \_\_\_\_\_

1	20	39	58	77	96	115	134	153	172	191	210	229	248	267	286	305	324	343	362	381	400	419	438	457	476	495	514	962
2	21	40	59	78	97	116	135	154	173	192	211	230	249	268	287	306	325	344	363	382	401	420	439	458	477	496	515	963
3	22	41	60	79	98	117	136	155	174	193	212	231	250	269	288	307	326	345	364	383	402	421	440	459	478	497	516	964
4	23	42	61	80	99	118	137	156	175	194	213	232	251	270	289	308	327	346	365	384	403	422	441	460	479	498	517	965
5	24	43	62	81	100	119	138	157	176	195	214	233	252	271	290	309	328	347	366	385	404	423	442	461	480	499	518	966
6	25	44	63	82	101	120	139	158	177	196	215	234	253	272	291	310	329	348	367	386	405	424	443	462	481	500	900	967
7	26	45	64	83	102	121	140	159	178	197	216	235	254	273	292	311	330	349	368	387	406	425	444	463	482	501	901	968
8	27	46	65	84	103	122	141	160	179	198	217	236	255	274	293	312	331	350	369	388	407	426	445	464	483	502	902	969
9	28	47	66	85	104	123	142	161	180	199	218	237	256	275	294	313	332	351	370	389	408	427	446	465	484	503	951	970
10	29	48	67	86	105	124	143	162	181	200	219	238	257	276	295	314	333	352	371	390	409	428	447	466	485	504	952	971
11	30	49	68	87	106	125	144	163	182	201	220	239	258	277	296	315	334	353	372	391	410	429	448	467	486	505	953	972
12	31	50	69	88	107	126	145	164	183	202	221	240	259	278	297	316	335	354	373	392	411	430	449	468	487	506	954	973
13	32	51	70	89	108	127	146	165	184	203	222	241	260	279	298	317	336	355	374	393	412	431	450	469	488	507	955	974
14	33	52	71	90	109	128	147	166	185	204	223	242	261	280	299	318	337	356	375	394	413	432	451	470	489	508	956	975
15	34	53	72	91	110	129	148	167	186	205	224	243	262	281	300	319	338	357	376	395	414	433	452	471	490	509	957	976
16	35	54	73	92	111	130	149	168	187	206	225	244	263	282	301	320	339	358	377	396	415	434	453	472	491	510	958	977
17	36	55	74	93	112	131	150	169	188	207	226	245	264	283	302	321	340	359	378	397	416	435	454	473	492	511	959	978
18	37	56	75	94	113	132	151	170	189	208	227	246	265	284	303	322	341	360	379	398	417	436	455	474	493	512	960	979
19	38	57	76	95	114	133	152	171	190	209	228	247	266	285	304	323	342	361	380	399	418	437	456	475	494	513	961	980

**20** \*For employment inquiries fill in home address. September 29, 1969 Card Expires November 29, 1969 14

Name \_\_\_\_\_ title \_\_\_\_\_

Company\* \_\_\_\_\_

Address \_\_\_\_\_

City \_\_\_\_\_ State \_\_\_\_\_ Zip Code \_\_\_\_\_

1	20	39	58	77	96	115	134	153	172	191	210	229	248	267	286	305	324	343	362	381	400	419	438	457	476	495	514	962
2	21	40	59	78	97	116	135	154	173	192	211	230	249	268	287	306	325	344	363	382	401	420	439	458	477	496	515	963
3	22	41	60	79	98	117	136	155	174	193	212	231	250	269	288	307	326	345	364	383	402	421	440	459	478	497	516	964
4	23	42	61	80	99	118	137	156	175	194	213	232	251	270	289	308	327	346	365	384	403	422	441	460	479	498	517	965
5	24	43	62	81	100	119	138	157	176	195	214	233	252	271	290	309	328	347	366	385	404	423	442	461	480	499	518	966
6	25	44	63	82	101	120	139	158	177	196	215	234	253	272	291	310	329	348	367	386	405	424	443	462	481	500	900	967
7	26	45	64	83	102	121	140	159	178	197	216	235	254	273	292	311	330	349	368	387	406	425	444	463	482	501	901	968
8	27	46	65	84	103	122	141	160	179	198	217	236	255	274	293	312	331	350	369	388	407	426	445	464	483	502	902	969
9	28	47	66	85	104	123	142	161	180	199	218	237	256	275	294	313	332	351	370	389	408	427	446	465	484	503	951	970
10	29	48	67	86	105	124	143	162	181	200	219	238	257	276	295	314	333	352	371	390	409	428	447	466	485	504	952	971
11	30	49	68	87	106	125	144	163	182	201	220	239	258	277	296	315	334	353	372	391	410	429	448	467	486	505	953	972
12	31	50	69	88	107	126	145	164	183	202	221	240	259	278	297	316	335	354	373	392	411	430	449	468	487	506	954	973
13	32	51	70	89	108	127	146	165	184	203	222	241	260	279	298	317	336	355	374	393	412	431	450	469	488	507	955	974
14	33	52	71	90	109	128	147	166	185	204	223	242	261	280	299	318	337	356	375	394	413	432	451	470	489	508	956	975
15	34	53	72	91	110	129	148	167	186	205	224	243	262	281	300	319	338	357	376	395	414	433	452	471	490	509	957	976
16	35	54	73	92	111	130	149	168	187	206	225	244	263	282	301	320	339	358	377	396	415	434	453	472	491	510	958	977
17	36	55	74	93	112	131	150	169	188	207	226	245	264	283	302	321	340	359	378	397	416	435	454	473	492	511	959	978
18	37	56	75	94	113	132	151	170	189	208	227	246	265	284	303	322	341	360	379	398	417	436	455	474	493	512	960	979
19	38	57	76	95	114	133	152	171	190	209	228	247	266	285	304	323	342	361	380	399	418	437	456	475	494	513	961	980

**20** \*For employment inquiries fill in home address. September 29, 1969 Card Expires November 29, 1969 14

Name \_\_\_\_\_ title \_\_\_\_\_

Company\* \_\_\_\_\_

Address \_\_\_\_\_

City \_\_\_\_\_ State \_\_\_\_\_ Zip Code \_\_\_\_\_

1	20	39	58	77	96	115	134	153	172	191	210	229	248	267	286	305	324	343	362	381	400	419	438	457	476	495	514	962
2	21	40	59	78	97	116	135	154	173	192	211	230	249	268	287	306	325	344	363	382	401	420	439	458	477	496	515	963
3	22	41	60	79	98	117	136	155	174	193	212	231	250	269	288	307	326	345	364	383	402	421	440	459	478	497	516	964
4	23	42	61	80	99	118	137	156	175	194	213	232	251	270	289	308	327	346	365	384	403	422	441	460	479	498	517	965
5	24	43	62	81	100	119	138	157	176	195	214	233	252	271	290	309	328	347	366	385	404	423	442	461	480	499	518	966
6	25	44	63	82	101	120	139	158	177	196	215	234	253	272	291	310	329	348	367	386	405	424	443	462	481	500	900	967
7	26	45	64	83	102	121	140	159	178	197	216	235	254	273	292	311	330	349	368	387	406	425	444	463	482	501	901	968
8	27	46	65	84	103	122	141	160	179	198	217	236	255	274	293	312	331	350	369	388	407	426	445	464	483	502	902	969
9	28	47	66	85	104	123	142	161	180	199	218	237	256	275	294	313	332	351	370	389	408	427	446	465	484	503	951	970
10	29	48	67	86	105	124	143	162	181	200	219	238	257	276	295	314	333	352	371	390	409	428	447	466	485	504	952	971
11	30	49	68	87	106	125	144	163	182	201	220	239	258	277	296													

# Reprint service

All Electronics editorial matter available in reprint form:

For reprints of special reports and feature articles see list on right side of this page. Send your order to Electronics Reprint Department at the address indicated. To expedite mailing of your order for single reprints please send cash, check or money order with your order. Allow 3-4 weeks for delivery.

Bulk reprints of editorial matter can be ordered from current or past issues. The minimum quantity is 100 copies. Price quoted on request: call 212-971-2274, or write to address below.

Warning: The Post Office now requires your ZIP CODE on all mail. Please include your ZIP CODE number when filling out your reply card.

3

## Business reply mail

No postage stamp necessary if mailed in the United States

Postage will be paid by

Electronics  
Reader service department  
Box 444  
Hightstown, N. J. 08520

First class  
Permit no. 42  
Hightstown, N. J.



2

## Business reply mail

No postage stamp necessary if mailed in the United States

Postage will be paid by

Electronics  
Reader service department  
Box 444  
Hightstown, N.J. 08520

First class  
Permit no. 42  
Hightstown, N. J.



1

## Business reply mail

No postage stamp necessary if mailed in the United States

Postage will be paid by

Electronics  
Reader service department  
Box 444  
Hightstown, N.J. 08520

First class  
Permit no. 42  
Hightstown, N. J.



To order reprints or for further information, please write to: **Electronics Reprint Department, 330 West 42nd Street, New York, N.Y. 10036.**

To expedite mailing of your order for single reprints please enclose payment with your order.

You may order any of the below listed reprints by key number. Discounts on quantities over 10.

- Key no. R-01 Computer-aided Design: Part I, The Man-machine Merger. 16 pages. \$1.25.
- Key no. R-04 Multilayer Circuit Boards: Sharpening An Imperfect Art. 7 pages. 50¢.
- Key no. R-05 Topology Cuts Design Drudgery. 12 pages. 50¢.
- Key no. R-06 Report on Japanese Technology: Sony. 20 pages. 50¢.
- Key no. R-010 Special Report on Large Scale Integration. 54 pages. \$1.50.
- Key no. R-011 Medical Electronics (1967). 8 part series, 44 pages. \$1.25.
- Key no. R-012 Special Report on Gallium Arsenide 17 parts. 32 pages. \$2.00
- Key no. R-016 Special Report on The Transistor: Two Decades of Progress. 48 pages. \$1.50.
- Key no. R-017 Special Report on Ferrites. 16 pages. \$1.00.
- Key no. R-018 European Electronics Markets 1969 20 page forecast report with a 6 page foldout. \$1.00
- Key no. R-019 U.S. Electronics Markets 1969 32 page forecast report with 4 page foldout. \$1.00
- Key no. R-020 1968 Electronics Index to Technical Articles and Authors Free.
- Key no. R-021 Infrared Detector Characteristics. 23 x 11 inch fold-out chart. 50¢
- Key no. R-022 Active Filters: Part II, Varying the Approach. 8 pages \$1.00
- Key no. R-79 MOS Integrated Circuits. 12 pages. 50¢.
- Key no. R-78 The Overlay Transistor. 15 pages. 50¢.
- Key no. R-75 Biotelemetry. 2 part series, 16 pages. 50¢.
- Key no. R-64 Field Effect Transistors. Parts I, II, and III. 64 pages. \$1.00.

**Would the engineer who asked us to design a marking system to color band electronic peanuts, please call (603) 352-1130.**

**It's ready.**

**If for some strange reason you're not making electronic peanuts, how about your transistors, IC's, SCR's, diodes, thyristors or whatever. We can handle those, too.**

**We've got the systems, typefaces, inks, supplies and services to mark whatever you make, and mark it right.**

**Our problem-solver booklet will tell you more about us.**

**Write for it now.**

**(before you go nuts)**

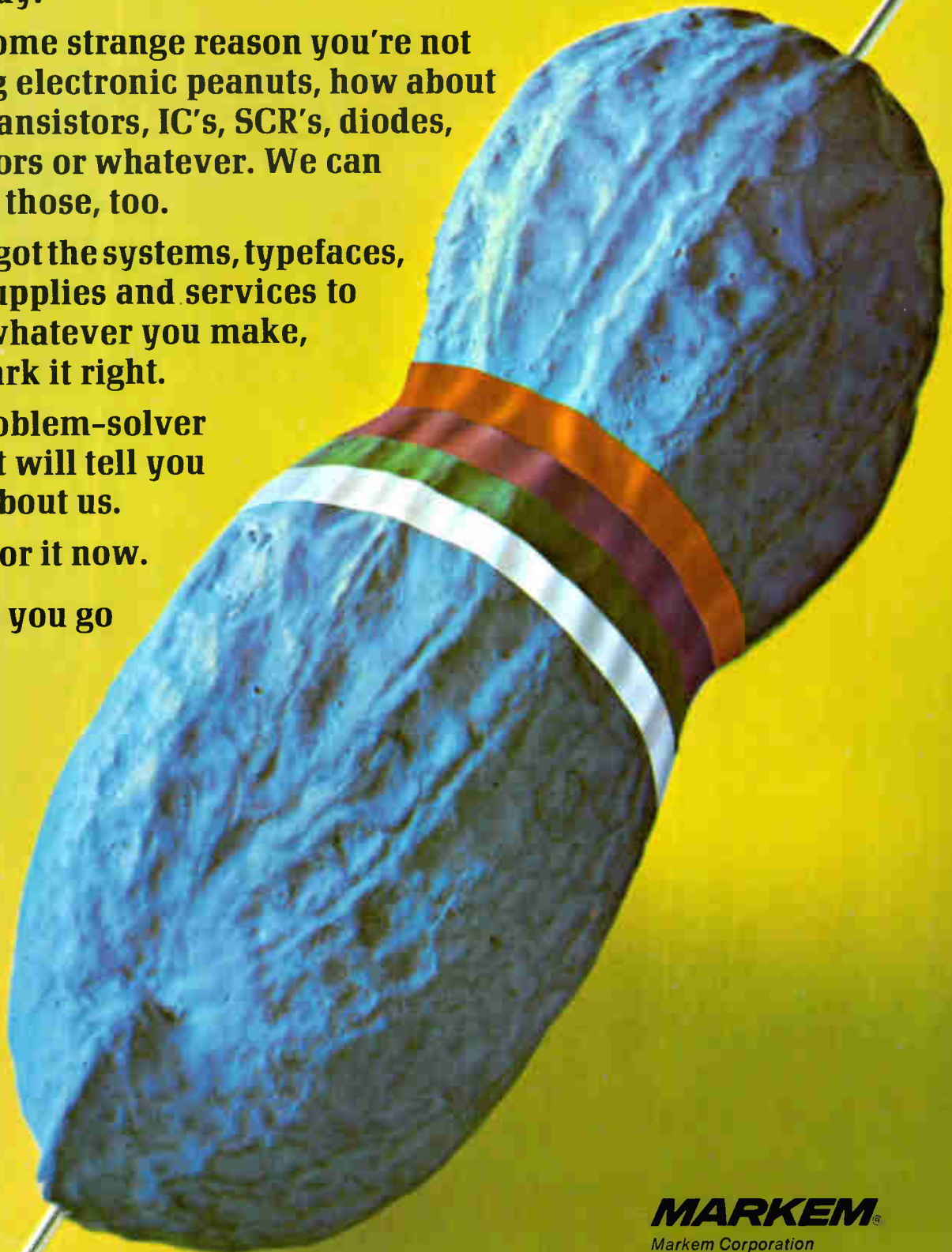

**MARKEM®**

*Markem Corporation  
305 Congress Street  
Keene, N. H. 03431*

International Offices: Markem Europa N.V. Schiphol Oost, Holland; Markem U.K. Ltd. Rugby, Warwickshire, England

Circle 901 on reader service card

RCA ISOCON CAMERA TUBES ARE

**available**

right now to meet your low-light-level TV-system mission requirements—and your production schedules

**tough**

enough to stand up under intense bursts of light

**thrifty**

—significantly lower in price than other camera tubes for low-light TV

**simple**

to set up and stable in operation

**top performers**

—75% response at 400 lines—over 1,000 TV lines limiting resolution—maintained on low-contrast scenes—high resolution pictures right into the corners (RCA supplies the magnetics, too)

**modern designed**

—bred in the David Sarnoff Research Center where they were conceived as promising low-noise pickup devices years ago. Now they're really delivering on that promise.

For more information, call your local RCA Representative. For technical data, write: RCA Electronic Components, Commercial Engineering, Section I-19Q-5, Harrison, New Jersey 07029.

**RCA**