

Electronics®

Bipolar circuits speed up shift registers: page 54

How they'll televise the Olympics: page 60

A new scr ignition system for autos: page 68

October 5, 1964

75 cents

A McGraw-Hill Publication

Below: integrated circuits in industrial computer systems, page 73

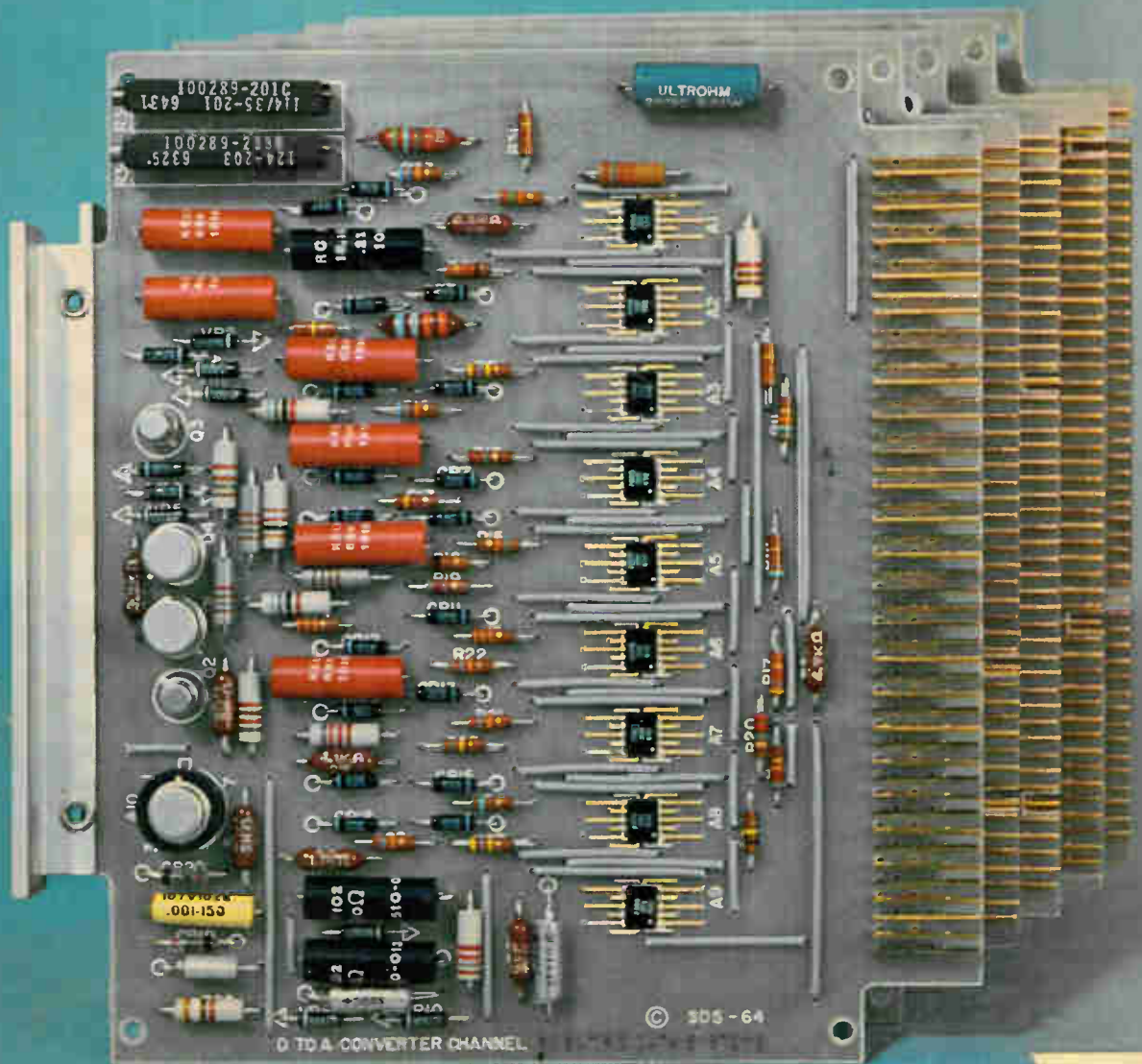

NEW



Engineers at Raytheon's Submarine Signal Division, Portsmouth, Rhode Island, have found the Tone-Burst Generator and 1308-A Audio Oscillator and Power Amplifier an extremely useful combination for driving sonar projectors in test tanks. The oscillator section of the 1308-A is fed into the Tone-Burst Generator, whose output in turn drives the 1308-A power amplifier stage. Range of the 1308-A is from 20c to 20 kc; it can deliver up to 200 volt amperes, and works equally well as a voltage source or as a current source (price is \$1150 in U.S.A.).

Burst Generator

... For Simulating Sonar Signals

... For Amplifier and Transducer Testing

The new Type 1396-A Tone-Burst Generator is the only commercial instrument of its kind. It is basically an electronic gate that alternately passes and blocks a selected number of cycles of any input wave form (dc to 500 kc). The number of cycles in each burst is adjustable from 1 to 128. The interval between bursts is adjustable from 1 cycle to a maximum of 128 cycles or to 10 seconds.

A most important feature of the bursts produced by the 1396-A is that they are coherent; that is, every burst starts and stops at the same point in the cycle. The frequency spectrum of a series of these bursts depends on the number of cycles in the burst, on cycles between bursts, and on the starting and stopping point, all of which are adjustable. Thus the frequency content is exactly defined — measurements are consistently reproducible.

Burst timing is accomplished with a binary scaler instead of a complex phase-locked timing system. The use of digital techniques together with all-solid-state design results in an instrument that is drift-free, easy to operate, compact, and economical.

Typical waveform produced by the 1396/1308 combination, a 15-kc signal turned on for 16 cycles and off for one-half second. Upper trace shows input to sonar projector. Lower trace shows output from projector and subsequent echo return from wall of test tank.

Write for complete information

**Type 1396-A
Tone-Burst Generator**
... \$490 in U.S.A.

INPUT SIGNAL: Range: dc to 500 kc.

EXTERNAL TIMING SIGNAL:

Frequency Range: dc to 500 kc.

Triggering: positive- or negative-going slope, level adjustable from -7v to +7v.

GATE TIMING: Open and closed intervals can be independently set to 2, 4, 8, 16, 32, 64, or 128 cycles of timing signal. With MINUS ONE switch, intervals can be set to 1, 3, 7, 15, 31, 63, or 127 cycles. Gate-closed interval can also be set in one-period increments over a 1-millisecond to 10-second range.

OUTPUT:

Gate Open: Maximum level is ≈ 7 volts.

Gate Closed: Feedthrough less than 140 millivolts, peak-to-peak, with maximum signal input. DC potential difference between open and closed conditions (pedestal) can be nulled out with panel adjustment.

Switching Transients: Less than 140 mv.

Output Impedance: 600 ohms.

Gating Voltage Output: Rectangular wave-form (≈ 12 volts) supplied for triggering oscilloscopes.

Write for complete information

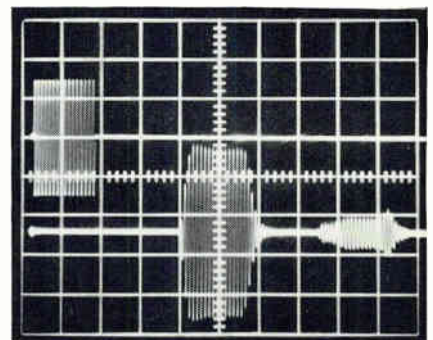

GENERAL RADIO COMPANY

WEST CONCORD, MASSACHUSETTS

IN CANADA: Toronto 247-2171, Montreal (Mt. Royal) 737-3673
IN EUROPE: Zurich, Switzerland — London, England

NEW YORK, N. Y., 964-2722
(Ridgefield, N. J.) 943-3140

CHICAGO
(Oak Park) 848-9400

PHILADELPHIA
(Ft. Washington) 646-8030

WASHINGTON, D. C.
(Rockville, Md.) 946-1600

SYRACUSE
454-9323

DALLAS
FL 7-4031

SAN FRANCISCO
(Los Altos) 948-8233

LOS ANGELES
469-6201

ORLANDO, FLA.
425-4671

CLEVELAND
886-0150

Circle 900 on reader service card

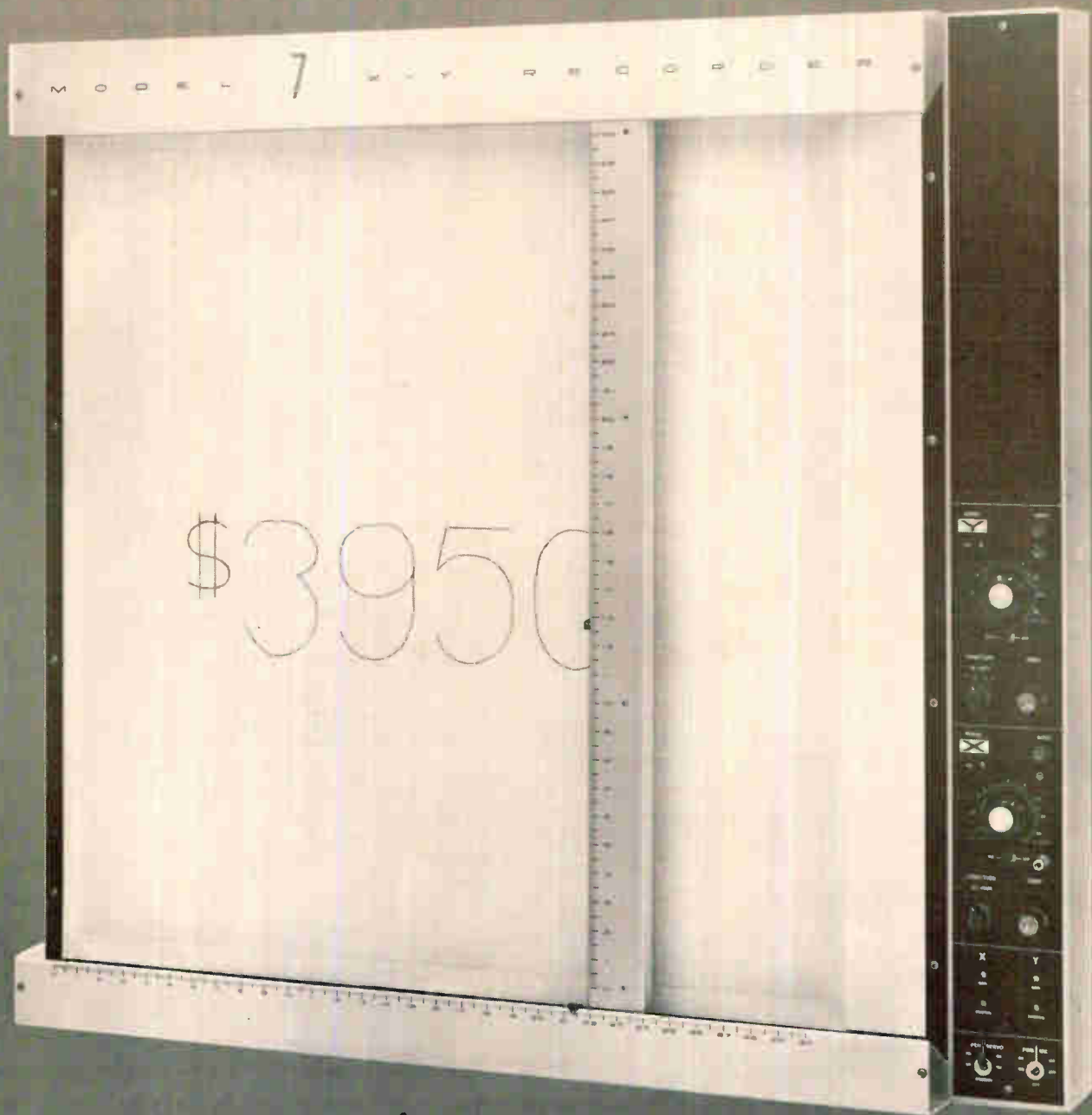

**MOSELEY MODEL 7
X-Y RECORDER
NOW ONLY \$3950**

MOSELEY 
an affiliate of Hewlett-Packard

- 30" x 30" recording area
- 13 calibrated input ranges and stepless range control from 1 mv/in to 10 v/in
- 20 inches per second pen speed
- Table top, console or vertical mounting; modular construction adapts to versatile accessories

50 other x-y models available...from an economy \$975 model, 8½" x 11" to today's most versatile recorders...1- and 2-pen models, table or rack mounting, centimeter or inch scaling, roll chart options.

Call your Moseley/Hewlett-Packard field engineer or write F. L. Moseley Co., 433 N. Fair Oaks Ave., Pasadena, Calif. 91102.

Circle 1 on reader service card

Compare for yourself: Select the performance you need—check the price, adding one vertical plug-in and one horizontal to the \$1325 price of the 175A main frame.

Vertical plug-in	Performance	Price
1750B Dual-Trace Amplifier	50 mc bandwidth (7 nsec rise time), 50 mv/cm max sensitivity (each channel), B channel out available for trigger	\$325
1751A Single-Channel Amplifier	Low-cost performance: sensitivity 50 mv/cm to 20 v/cm, dc to 50 mc (7 nsec rise time)	\$160
1752A Differential Amplifier	5 mv/cm to 20 v/cm sensitivity; dc to 18 mc bandwidth at 5 mv/cm; differential input with 40 db common mode rejection on four most sensitive ranges	\$225
1752B High Gain Amplifier	5 mv/cm to 20 v/cm; dc to 30 mc at 5 mv/cm; 40 mc at 50 mv/cm; differential input on all ranges	\$285
1754A Four-Channel Amplifier*	40 mc bandwidth, sensitivity 50 mv/cm to 20 v/cm; triggering possible from any of the 4 channels; 9 nsec rise time, ideal for computer logic applications	\$595
1755A Dual-Channel High-Performance Amplifier*	1 mv/cm sensitivity with 20 mc bandwidth, 50 mc bandwidth at 10 mv/cm and above, dc coupled; B channel available for trigger	\$575
Horizontal plug-in	Performance	Price
1780A Auxiliary Plug-in	Allows standard functions of scope, 10 nsec/cm to 5 sec/cm sweep; normal or single sweeps	\$25
1781B Sweep Delay Generator	Permits detailed analysis of complex signals or pulses; 0.5 μ sec to 10 sec delay; mixed sweep for simultaneous picture of total and expanded portion of signal; jitter less than 1 part in 50,000	\$325
1782A Display Scanner*	Permits recordings on external x-y recorder of waveforms displayed on crt	\$425
1783A Time Mark Generator*	Provides synchronized intensity-modulated markers, 10, 1 and 0.1 μ sec, $\pm 0.5\%$ accuracy, for simplifying rise time and pulse duration measurement	\$130
1784A Recorder*	Pushbutton strip-chart recording of repetitive traces on crt, complete with graticule marks; 1/20th the price of a photograph; recording paper 5 cm (6 graticule divisions) approximately same size as photo	\$775

*Features available only with the hp 175A, regardless of cost

comparison proves

no scope beats the hp 175A for your requirements: performance versatility—value!

With its six vertical plug-ins, five horizontal plug-ins and high-capability basic main frame, no oscilloscope available today gives you better performance for your dollar than the Hewlett-Packard 175A 50 MC Scope.

The 175A main frame, \$1325, permits bandwidth to 50 mc and offers dual plug-in capability that permits unprecedented versatility. Look at these unique plug-in features: The 1784A Recorder plug-in permits permanent records of waveforms, simply and at a fraction of the cost of a photograph. Other horizontal plug-ins include a scanner for large trace recordings on an external re-

order, sweep-delay operation, and time markers.

A wide selection of vertical plug-ins assures complete measurement coverage. The new 1755A, for example, features dual-channel sensitivity of 1 mv/cm at 20 mc bandwidth and 10 mv/cm at 50 mc. Even on the four-channel plug-in the bandwidth is 40 mc.

Once you've acquired the main frame, the flexibility and value of the 175A are yours. Compare plug-in capabilities and compare price-for-performance. Compare the number of scopes you need to do

all the jobs done as well by the 175A. Then call your hp field engineer for a demonstration; or write for complete technical data. Hewlett-Packard, Palo Alto, California 94304, Tel. (415) 326-7000; Europe: 54 Route des Acacias, Geneva; Canada: 8270 Mayrand Street, Montreal.

Data subject to change without notice. Prices f.o.b. factory.

**HEWLETT
PACKARD** 

An extra measure of quality

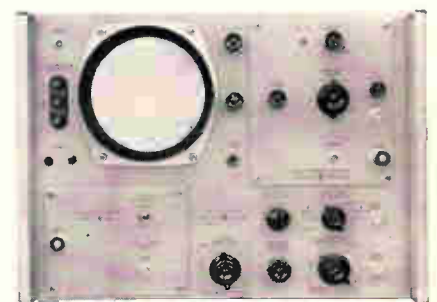

*The buyer who checks performance against price
will make the best scope buy today...tomorrow...*

and from Hewlett-Packard

Electronics

Page 4	Readers Comment
8	People
10	Meetings
15	Editorial
17	Electronics newsletter
39	Washington newsletter
121	New products
155	New literature
159	New books
160	Technical abstracts

In this issue

Title R registered
U.S. Patent Office;
© copyright 1964
by McGraw-Hill, Inc.
All rights reserved,
including the right to
reproduce the contents
of this publication,
in whole or in part.

Electronics review

Page 27	Thin films for all	30	Ultrasonic success
27	Finer foams	32	Excitement in lasers
28	Computer fallout	32	Brighter image
29	Nimbus aftermath	34	Remote-controlled glider
30	Shifting sites		

Probing the news

Page 101	Over-the-horizon radar goes operational
102	Fine Italian hand at the Pentagon
110	The big dish is almost ready
114	Controlling fighter planes from a jeep

Technical articles

Computers	54	Balanced bipolar circuits for shift registers A simple approach to shift registers gets rid of errors that rise from amplifying noise E.E. Newhall, Bell Telephone Laboratories
Microwaves	60	Televising the Olympics New maser amplifier and some inspired engineering make it possible Laurence D. Shergalis, regional editor
Circuit design	64	Designer's casebook Complementary shaper replaces Schmitt trigger; variable r-f resistance attained with photocell; noise-figure nomograph for multistage systems; thermostat operates with 0.01 deg. C. differential; pushbutton plus scr equals fast pulse
Consumer electronics	68	A new ignition system for cars New, capacitive scr ignition system is inexpensive and easy to install R. Van Houten and John C. Schweitzer, Delta Products, Inc.
Special report	73	Inside industrial computers for direct digital control Unique circuit design, logic organization and packaging in seven process control computers Louis S. Gomolak, industrial electronics editor
	75	Scientific Data System's 92: integrated circuits in the digital-to-analog converter
	77	Computer Control Co.'s DDP-116: fastest computer of its type
	78	E-A Industrial Corp.'s 101: programed by printed circuit card to cut costs
	80	Westinghouse's P-50: time sharing logic to keep costs down
	83	3M's Digitele 2201/2018: electrochemical cells and a drum memory
	87	GE's 4040: folds out like pages in a book for easy maintenance
	90	Foxboro's M97000 series: 3 different systems for different needs
	95	New digital valve positioners designed to work with electronic computers in control

Electronics

Editor: Lewis H. Young

Senior editors

Technical: Samuel Weber

News: Kemp Anderson, Jr.

Senior associate editors: John F. Mason, George Sideris

Department editors

Advanced technology: George V. Novotny

Avionics: W.J. Evezia

Circuit design: Michael Elia

Communications: Alexander A. McKenzie

Components: Michael F. Tomaino

Computers: Stephen B. Gray

Industrial electronics: Louis S. Gomolak

Instrumentation: George J. Flynn

Manufacturing: George Sideris

Military electronics: John F. Mason

New products: William P. O'Brien

Solid state: Jerome Eimbinder, G.G. Tirellis

Space electronics: Joel A. Strasser

Staff writers: Leon H. Dulberger, Peggy Jackson

Regional editors

Boston: Thomas Maguire, editor; Susan Turner

Chicago: Cletus M. Wiley, editor; Leslie Krimston

Los Angeles: Harold C. Hood, editor

San Francisco: Laurence D. Shergalis, editor; Mary Jo Jadin

London: Derek Barlow, editor

Copy editors

Howard Rausch, Sally Powell

Graphic design

Art director: Saul Sussman

Assistant art director: John C. Wright, Jr.

Editorial production: Ann Mella, Sandra A. Le Mond

Editorial secretaries: Claire Benell, Mary D'Angelo, Lynn Emery, Kay Fontana, Carolyn Michnowicz, Lorraine Rossi, Lorraine Werner

McGraw-Hill news service

Director: John Wilhelm; Atlanta: Fran Ridgeway; Chicago: Bruce Cross;

Cleveland: Arthur Zimmerman; Dallas: Marvin Reid;

Detroit: Donald MacDonald; Los Angeles: Michael Murphy,

Ron Lovell; San Francisco: Margaret Ralston, Ed. Addeo;

Seattle: Ray Bloomberg; Washington: George Bryant Jr., Glen Bayless,

Charles Gardner

McGraw-Hill world news service

Bonn: Richard Mikton; Brussels: Arthur Erikson; London: John Shinn;

Mexico City: Wesley Perry; Milan: Bruce Bendow;

Moscow: Donald Winston; Paris: Dan Smith;

Rio de Janeiro: Leslie Warren; Tokyo: Marvin Petal, Charles Cohen

Circulation manager: Hugh Quinn

Reprints: T.M. Egan

Publisher: C.C. Randolph

Electronics: October 5, 1964, Vol. 37, No. 26

Printed at 99 North Broadway, Albany, N.Y.

Second class postage paid at Albany, N.Y.

Subscriptions are solicited only from those actively engaged in the field of the publication. Position and company connection must be indicated on orders. Subscription prices: United States and Possessions and Canada, \$6.00 one year, \$9.00 two years, \$12.00 three years. All other countries \$20.00 one year. Single copies, United States and Possessions and Canada 75¢. Single copies all other countries \$1.50.

Published every other Monday by McGraw-Hill Inc. 330 West 42nd Street, New York, N.Y. 10036. Founder: James H. McGraw, 1860-1948.

Subscribers: The Publisher, upon written request to our New York office from any subscriber, agrees to refund that part of the subscription price applying to copies not yet mailed. Please send change of address notices, subscription orders or complaints to Fulfillment Manager, Electronics, at the address below. Change of address notices should provide old as well as new address, including postal zone number if any. If possible, attach address label from recent issue. Allow one month for change to become effective.

Postmaster: Please send Form 3579 to Fulfillment Manager, Electronics, P.O. Box 430, Hightstown New Jersey 08520

Readers Comment

Ceramic Shmoo

Your article on the "Electronic Shmoo" [a multipurpose component, Sept. 7, p. 38] was interesting since we too ran across similar characteristics in a material back in 1956. I believe the material that we were using would be better named the ceramic Shmoo.

We were constructing small reaction furnaces that were controlled by thyratrons using the usual resistance element as a temperature sensor. To permit reasonable control, the sensing element was embedded in an Alundum cement that was molded around the heating grid.







Although the construction of the furnaces met all control requirements, the outer surface had a tendency to chip and crumble. This problem was overcome by using sodium silicate instead of water to prepare the Alundum cement. The furnace turned out fine, but the thyatron would not control, being held in the "off" state even though the furnace was cold. A check for shorts gave negative ohms and a sharp rap against the meter peg. Switching to d-c volts, we found that a potential of about one-half volt d-c had developed across the heater and control-element terminals.

To better understand the reasons for the existing potential, several cells of aluminum oxide (Alundum) and sodium silicate were constructed. The cement was poured into small one-inch-cube plastic boxes with two small copper wires inserted in opposite ends but not in contact with each other. The two terminals were then connected to a 10-millivolt Varian recorder and left to dry. In about one hour the voltage climbed to 300 millivolts whereupon it was disconnected from the recorder and used to power a transistor oscillator. The oscillator ran for 18 minutes, then quit. Further checks proved that a sunbeam from a window had turned the cell off.

A number of terminals may be placed in the same cell and each charged with a d-c pulse of any polarity. The cell will remember

All from Sprague!

Make the right move... specify Sprague SOLID TANTALUM CAPACITORS!

 <p>TYPE 150D Metal-Encased Hermetically-Sealed TANTALEX[®] CAPACITORS (polarized)</p>	 <p>TYPE 151D Metal-Encased Hermetically-Sealed TANTALEX[®] CAPACITORS (non-polarized)</p>	 <p>STYLE CS12 Metal-Encased TANTALEX[®] CAPACITORS to MIL-C-26655A (uninsulated case)</p>	 <p>STYLE CS13 Metal-Encased TANTALEX[®] CAPACITORS to MIL-C-26655A (insulated case)</p>	 <p>TYPE 155D Metal-Encased Hermetically-Sealed TANTALEX[®] CAPACITORS (for high vibration)</p>
 <p>TYPE 172D Metal-Encased Hermetically-Sealed TANTALEX[®] CAPACITORS (for 'cordwood' modules)</p>	 <p>TYPE 250D Metal-Encased Hermetically-Sealed HYREL[®] ST CAPACITORS (for Minuteman Program)</p>	 <p>TYPE 350D Metal-Encased Hermetically-Sealed HYREL[®] ST CAPACITORS (polarized)</p>	 <p>TYPE 351D Metal-Encased Hermetically-Sealed HYREL[®] ST CAPACITORS (non-polarized)</p>	 <p>STYLE CSR12 Metal-Encased TANTALEX[®] CAPACITORS to MIL-C-39003 (uninsulated case)</p>
 <p>STYLE CSR13 Metal-Encased TANTALEX[®] CAPACITORS to MIL-C-39003 (insulated case)</p>	 <p>TYPE 180D Metal-Encased Hermetically-Sealed TANTALEX[®] Feed-Thru CAPACITORS</p>	 <p>TYPE 164D Metal-Tube Axial-Lead RED-TOP[®] TANTALEX[®] CAPACITORS (polarized)</p>	 <p>TYPE 166D Metal-Tube Axial-Lead RED-TOP[®] TANTALEX[®] CAPACITORS (non-polarized)</p>	 <p>TYPE 167D Metal-Tube Single-ended RED-TOP[®] TANTALEX[®] CAPACITORS (polarized)</p>
 <p>TYPE 168D Metal-Tube Single-ended RED-TOP[®] TANTALEX[®] CAPACITORS (non-polarized)</p>	 <p>TYPE 165D Film-Jacketed TANTALEX[®] CAPACITORS (for 'cordwood' modules)</p>	 <p>TYPE 154D Molded-Case Bullet-nose[®] TANTALEX[®] CAPACITORS</p>	 <p>TYPE 190D Molded-Case Rectangular-Shaped TANTALEX[®] CAPACITORS (for printed boards)</p>	 <p>TYPE 160D Film-Jacketed Axial-Lead TANTALEX[®] CAPACITORS (Hearing Aid Type)</p>
 <p>TYPE 161D Film-Jacketed Single-ended TANTALEX[®] CAPACITORS (Hearing Aid Type)</p>				

Number 1 in Solid Tantalum Capacitors Across the Board!

Pioneer in the development of tantalum capacitors, Sprague has the largest and most complete research and production facilities in the capacitor industry. That's why Sprague, with its unmatched experience, is

your *dependable* source of supply!

For additional information, write Technical Literature Service, Sprague Electric Company, 35 Marshall St., North Adams, Mass., indicating the types in which you are interested.

*Trademark

SPRAGUE COMPONENTS

CAPACITORS
TRANSISTORS
RESISTORS
INTEGRATED CIRCUITS
THIN-FILM MICROCIRCUITS

PULSE TRANSFORMERS
INTERFERENCE FILTERS
PULSE-FORMING NETWORKS
TOROIDAL INDUCTORS
ELECTRIC WAVE FILTERS

CERAMIC-BASE PRINTED NETWORKS
PACKAGED COMPONENT ASSEMBLIES
BOBBIN and TAPE WOUND MAGNETIC CORES
SILICON RECTIFIER GATE CONTROLS
FUNCTIONAL DIGITAL CIRCUITS

SPRAGUE[®]
THE MARK OF RELIABILITY

*Sprague and ® are registered trademarks of the Sprague Electric Co.

Only from Sprague!

DOUBLE FEATURE!

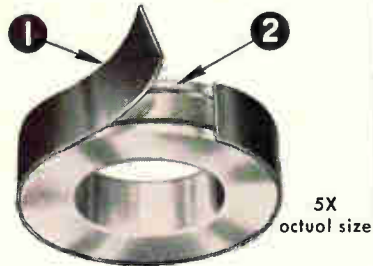

Dynacor® Bobbin Cores have 2 built-in reasons for long operating life without degradation...

1 TOUGH ARMAG® JACKET. Withstands ambient temperatures to 180 C and is compatible with poured potting compounds, permitting Dynacor Cores to be used with normal encapsulation techniques.

2 JET-SMOOTH BOBBIN. Finely-polished stainless steel, completely eliminating sharp protrusions, square corners, or other abrasive action on copper wire windings. Improved manufacturing process results in a bobbin with a more uniform radius than that of an ordinary machined bobbin.

Dynacor Bobbin Cores are also available with ceramic bobbins where needed.

A large stock of popular sizes and flux values insures prompt delivery.

Special cores to customer specifications are quickly and accurately processed.

For complete technical data, write for Engineering Bulletins on Dynacor Bobbin Cores to Technical Literature Service, Sprague Electric Company, 35 Marshall St., North Adams, Mass.



Sprague and ® are registered trademarks of the Sprague Electric Co.

455P-170-63

the polarities of the pulses even though the terminals are side by side. The cells have been used as a three-terminal amplifier with a gain of 14.5; they may also be used as a temperature-sensing element with a very large output per degree temperature rise. They are very sensitive to pressure, can be charged by a light beam and, as previously mentioned, if used as a power supply, they may be shut off by a light beam.

You may notice that the materials can be purchased almost anywhere.

Victor Jackman

Mellon Institute
Pittsburgh

Finding parachuted supplies

With reference to your article "Electronics in the Mekong Delta" [Sept. 7, p. 114], I would like to offer a possible solution to the problem experienced by ground troops in locating supplies dropped by parachutes.

The location of these supplies could be determined by aerial photographs. These photographs could be taken by the ground troops, if supplied with collapsible gun-fired cameras (see drawing), each containing one sheet of Polaroid color film. Such a camera, if developed, could probably be fired from a Very-light pistol.

Paratroops could possibly find this type of camera useful in assisting them to determine their immediate surroundings.

W. F. Slaght

Defence Research Board
Department of National Defence
Quebec, Canada

Alarm receivers

Your comments [Aug. 24, p. 6] to my suggestion of using telephone lines for an alarm system imply that the use of a receiver is expensive. All alarm systems (NEAR and Conelrad) require receivers, and the system I proposed would not require one more expensive than in other systems.

In addition, your proposal for battery-powered receivers, rather than those requiring no batteries, sounds unsafe to me. Further, in densely populated areas, only block receivers are required, not one to every household. For far-flung farm communities, on the other hand, a receiver bought for every household would not be expensive if purchased on installment.

I have tried my system out on a small PAX of 300 lines using a 30-watt oscillator. Thus, for small exchanges serving rural areas, it is certainly practical.

P. Hirschmann

Haifa, Israel

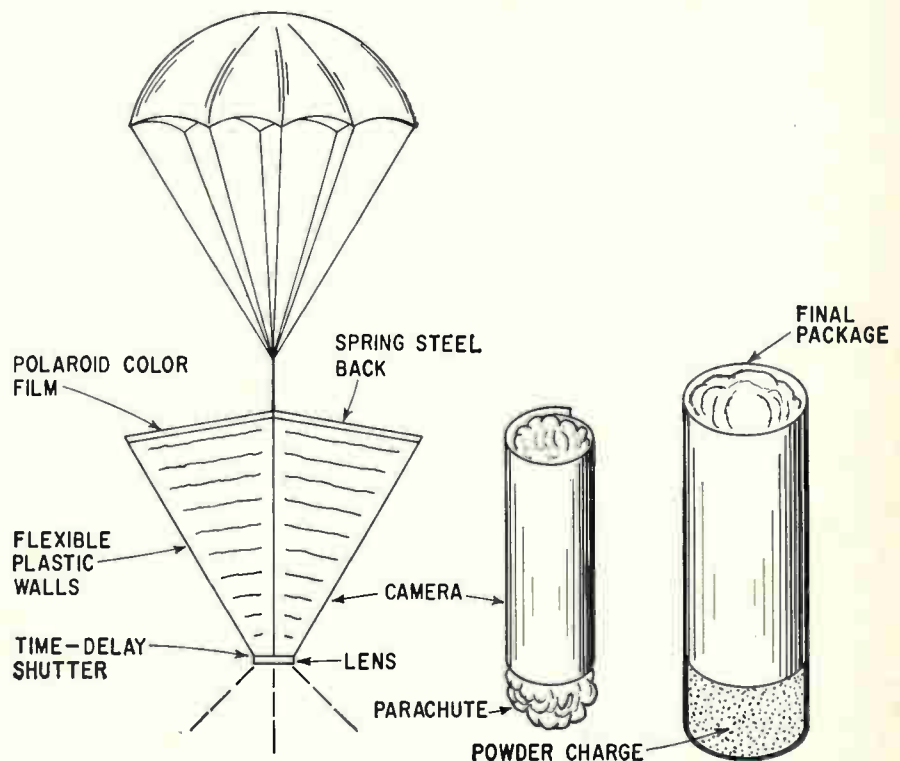

When computers need a cold, cold heart...

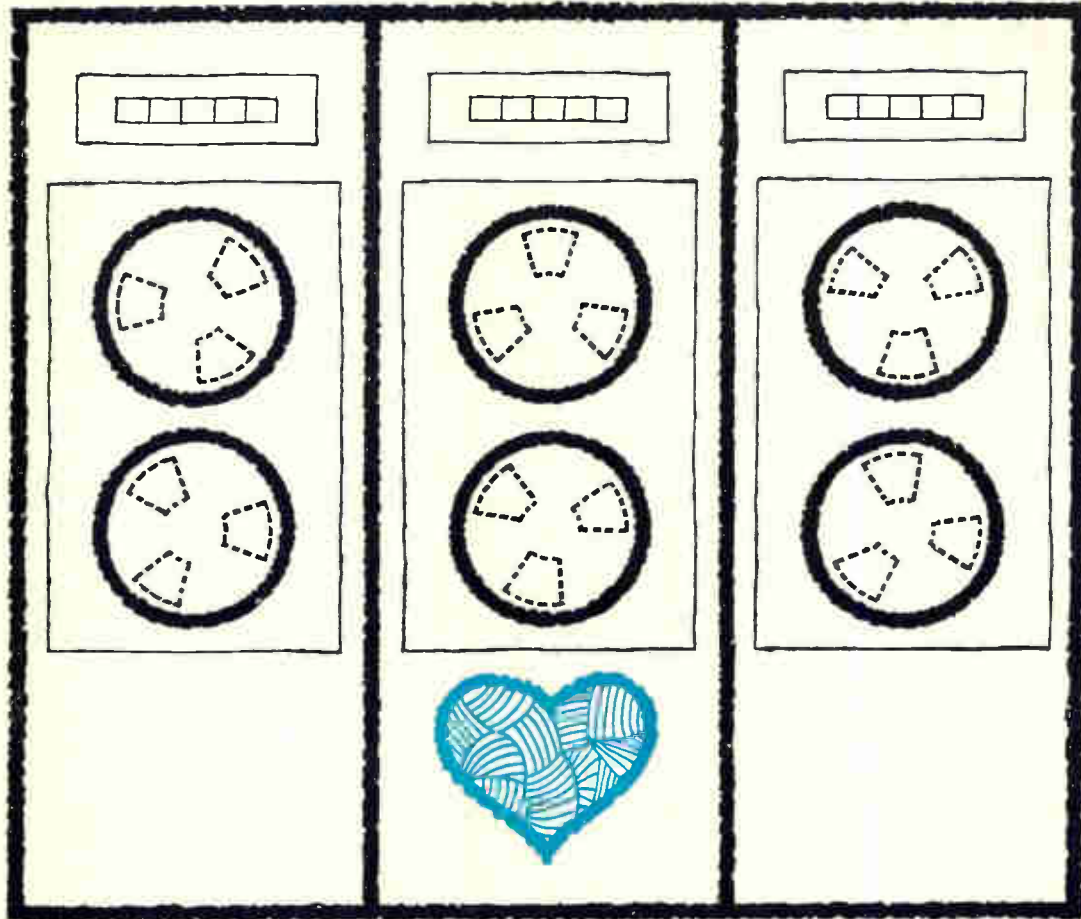

Airco helium creates a minus 452°F bloodstream

Research into "superconductivity" promises exciting new electronics advances, including major reductions in the size of computers. This is possible through the use of smaller components, such as cryotrons, which become superconductive when immersed in a -452°F. bath of liquid helium and operate on very low power sources in this state.

Other electronic uses for helium include the production of gaseous discharge tubes and voltage regulator tubes, and the protective shielding of silicon and germanium crystals during growth. To meet these

expanding uses, Airco has developed the first large-scale liquid helium distribution system, comprising special cryogenic shipping containers, over-the-road liquid tank trucks, and three liquid-to-gas conversion plants.

Airco serves many industries with dependable supplies of liquid and gaseous helium. You can also rely on Airco for oxygen, nitrogen, hydrogen and argon, in both liquid and gaseous forms. Write for more details to: *Air Reduction Sales Company, 150 East 42nd Street, New York, N.Y. 10017.*



AIR REDUCTION

[TETRODES]

NEW from MACHLETT an expanding line of tetrodes

Tube Type	Power Level RF Amplifier or Oscillator	Type of Cooling
ML-8170/4CX5000A	15 kw	Forced-Air
ML-8281/4CX15000A	35 kw	Forced-Air
ML-8545	300 kw	Vapor
ML-8546	300 kw	Water

For details, write: The Machlett Laboratories, Inc.,
Springdale, Connecticut. An affiliate of Raytheon Company.



People

Milton Sanders has been named to the new post of general manager of the Bunker-Ramo Corp.'s Stamford, Conn., Operations — formerly the Tele-register Corp. It's the first major personnel shift at Teleregister since it was combined with Bunker-Ramo in



July by the Martin-Marietta Corp., which controlled both companies.

Sanders was brought to Teleregister in 1957 to take charge of the design and production of a \$16-million, on-line data processing system to handle reservations for United Air Lines. He will now take charge of all engineering, manufacturing, systems work and administration at the Stamford plant.

After the United job, he had major responsibilities in similar systems for nine other airlines, as well as for Teleregister's data-processing systems for banks and hotels. He advanced from assistant to vice president of engineering at Teleregister.

Described by his associates as dynamic, well-read and well-informed—"he hasn't just stuck his nose in engineering books," says one—Sanders, 45 years old, shares some of his information with 20 students at the University of Connecticut, where he's teaching a course in network synthesis.

Percy Halpert, who has been with the Sperry Gyroscope Co. since 1937, has been named a vice president, responsible for the Sperry divisions concerned with guidance, navigation, avionics and missile systems. Sperry Gyroscope is a division of the Sperry Rand Corp.



He succeeds M. D. Lockwood, who remains a vice president.

Halpert, 51 years old, formerly managed Sperry's Phoenix division.

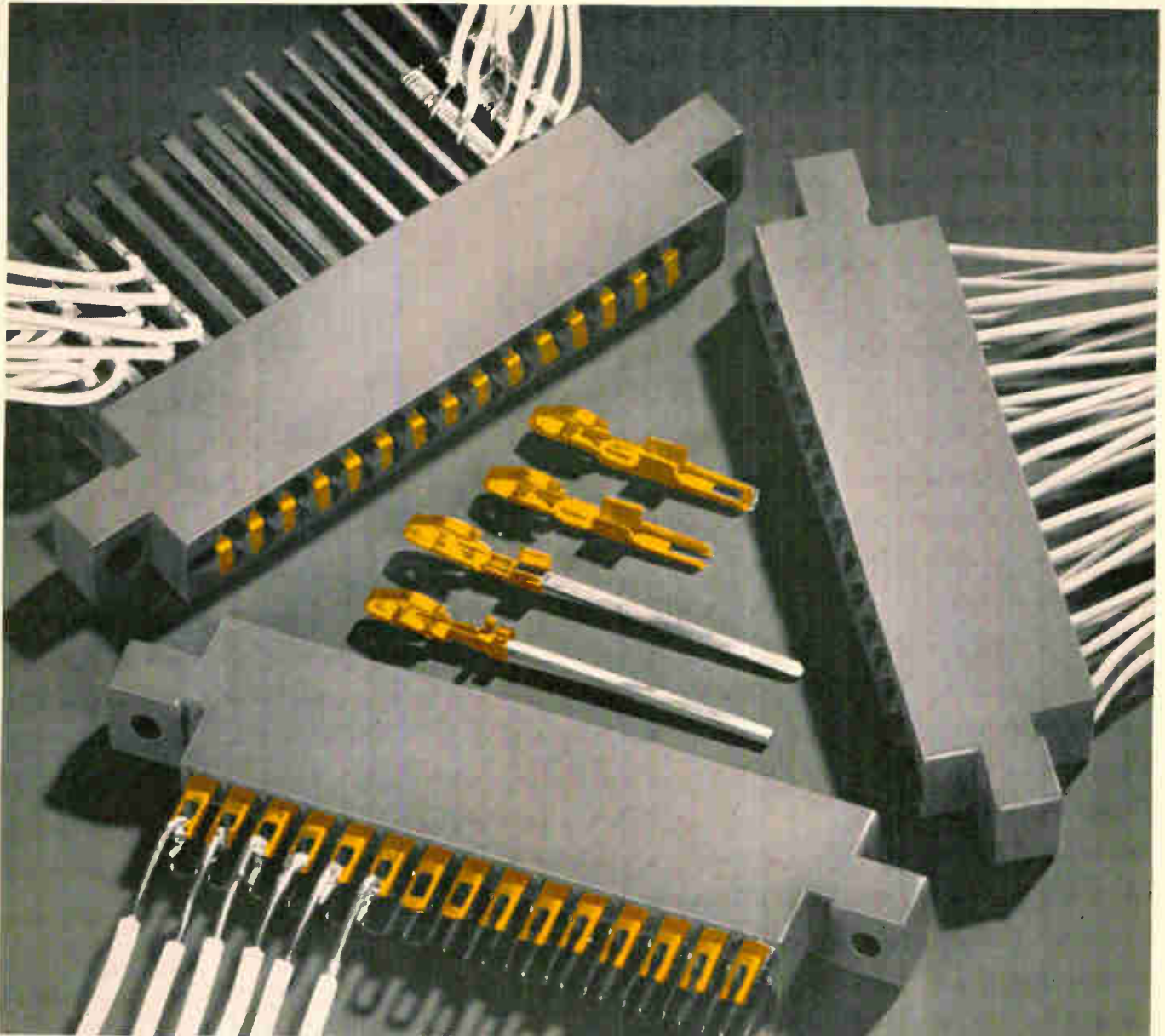

Five-way termination choice

Choose our A-MP* Printed Circuit Connectors for their superior performance features. Then, use any one of five ways to terminate the circuit contacts.

You can crimp and snap-in contact and conductor . . . loading only those positions you need.

Solder them.

Weld, if you like.

Wrap, if that's the way you've always done it.

And finally, a new way—clip-on terminations! This is done with our TERMI-POINT* point-to-point wiring devices, which make a reliable, gas-tight connection by merely pushing a spring-clip and wire onto the contact post. You can use any one of a variety of wires—stranded, solid, tinsel, enamel and printed . . . TERMI-POINT devices accept all of them.

No matter which method you choose, you get all these important advantages in our one-piece printed circuit connector:

- finest quality-controlled construction

- gold over nickel plated contacts to prevent oxide creep
- precisely controlled contact pressures for longer contact life and less wear on circuit paths
- alpha-numerical coded housings
- available in 8, 15, 22, 30 and 32 positions

Write today for the full story on the big choice in printed circuit connectors. You'll get complete information on printed circuit connectors with crimp type contacts or with special post and tab adaptations—plus details on our new TERMI-POINT terminals and tools.

*Trademark of AMP INCORPORATED



A-MP* products and engineering assistance are available through subsidiary companies in: Australia • Canada • England • France • Holland • Italy • Japan • Mexico • West Germany

END GREASE-PENCIL GUESSWORK IN PRODUCTION MEASUREMENTS

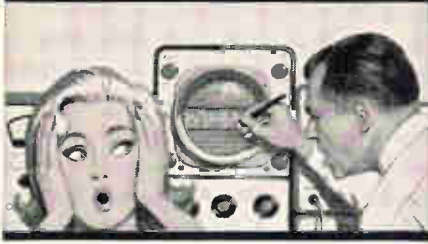

NEW JERROLD 890 Sweep Generator and TC-3 Coaxial Switcher

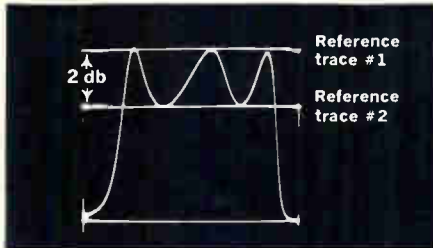

Typical network rf loss displayed with minimum and maximum references by Jerrold 890 Sweep Generator and TC-3 Solid-State Coaxial Three-Way Switcher.

Model 890 Sweep Generator: freq. range 500 kc-1,100 mc; sweep widths 100 kc-200 mc; extreme stability.

Solid-State TC-3 Coax Switcher: freq. range 0-1,200 mc; 3-position operation enables insertion through variable attenuators of 2 reference traces in addition to test trace.

Free brochure explains this and other uses of comparative sweep techniques. Ask for demonstration.



Model 890 Wide-Band Sweep Generator. Price \$845.



Model TC-3 Solid-State 3-Position Coax Switcher. Price \$295.

JERROLD
ELECTRONICS

JERROLD ELECTRONICS
Industrial Products Division
Philadelphia, Pa. 19132

In Canada: Jerrold Electronics, 60 Wingold Ave., Toronto 19, Ont.
Export: Roche International, 13 E. 40th St., New York 10016

**SWEEP GENERATORS • PRECISION ATTENUATORS
AMPLIFIERS • COMPARATORS**

Meetings

American Documentation Institute Annual Meeting, ADI; Sheraton Hotel, Philadelphia. Oct. 4-8.

Air Traffic Control Association National Meeting, ATCA; Chalfonte-Haddon Hall, Atlantic City, N.J., Oct. 5-7.

National Communications Symposium, PTGCT/IEEE; Utica, N.Y., Oct. 5-7.

Institute of Printed Circuits Fall Meeting, IPC, Inc.; Pick-Congress Hotel, Chicago, Oct. 6-7.

Industrial and Commercial Power Systems Annual Conference, ICPC/IEEE, Philadelphia Section IEEE; Marriott Motor Hotel, Philadelphia, Oct. 6-8.

Electronic Information Handling Conference, University of Pittsburgh, Goodyear Aerospace Corp., and Western Michigan University, Webster Hall Hotel, Pittsburgh, Oct. 7-9.

Fall URSI Meeting, PTG/IEEE; University of Illinois, Urbana, Ill., Oct. 11-14.

Electrochemical Society Meeting, Electrochemical Society; Sheraton-Park Hotel and Motor Inn, Washington, Oct. 11-15.

Energy Conversion and Storage Conference, Oklahoma State University, Stillwater, Okla., Oct. 12-13.

AIAA Entry Technology Conference, AIAA Technical Committees for Atmospheric Flight Mechanics and for Entry Vehicles; Williamsburgh and NASA-Langley Research Center, Va., Oct. 12-14.

Protection Against Space Radiations Symposium, NASA, USAEC, USAF; Civic Auditorium, Gatlinburg, Tenn., Oct. 12-14.

Aerospace Nuclear Propulsion Conference, ANS, AIAA; Naval Postgraduate School, Monterey, Calif., Oct. 12-15.

ISA Instrument-Automation Annual Conference and Exhibit, ISA, Park-Sheraton and New Yorker Hotels and Coliseum, New York, Oct. 12-15.

Audio Engineering Society Annual Fall Convention and Exhibit, AES; Barbizon-Plaza Hotel, New York, Oct. 12-16.

Bureau of Naval Weapons Annual Symposium on Advanced Techniques for Aircraft Electric Systems, BuWeeps; Departmental Auditorium, Washington, Oct. 13-14.

Association of Data Processing Service Organizations Fall Symposium,

ADAPSO, Inc.; Statler-Hilton Hotel, New York, Oct. 14-15.

Remote Sensing of Environment Symposium, Office of Naval Research; The University of Michigan, Ann Arbor, Mich., Oct. 14-16.

Sonics and Ultrasonics Symposium, PTGSU/IEEE; The Miramar Hotel in Santa Monica-by-the-Sea, Santa Monica, Calif., Oct. 14-16.

The Road to Commercial Electronics: A Conference on Converting Military Capabilities to Civilian Markets, Electronics Magazine, IIT Research Institute; Grover M. Hermann Hall, Chicago, Dec. 1-2.

Call for papers

Symposium on Microwave Theory and Techniques, G-MTT/IEEE; Jack Tar Harrison Hotel, Clearwater, Fla., May 5-7. **Nov. 15** is deadline for submitting ten copies of a two to four page typewritten, double-spaced, abstract to John E. Pippin, Chairman, Technical Program Committee, 1965 G-MTT Symposium, Sperry Microwave Electronics Co., P.O. Box 1823, Clearwater, Fla. Papers are solicited in areas of microwave acoustics, microwave components for phased arrays and for space applications, active and passive microwave solid-state devices, components and techniques for millimeter through optical wavelengths.

Particle Accelerator Conference, AIP, NSG/IEEE, National Bureau of Standards, USAEC; Shoreham Hotel, Washington, March 10-12. **Dec. 1** is deadline for submitting a 100-300 word abstract to R. S. Livingston, Chairman, Particle Accelerator Conference, Oak Ridge National Lab., P.O. Box X, Oak Ridge, Tenn. 37831. Topics include ion sources, injection, injectors; high power RF sources, systems; accelerating structures; beam interactions; accelerator magnets, power supplies; high voltage breakdown; accelerator operation and automation systems; accelerator alignment; handling of high intensity beams; induced radioactivity and remote handling.

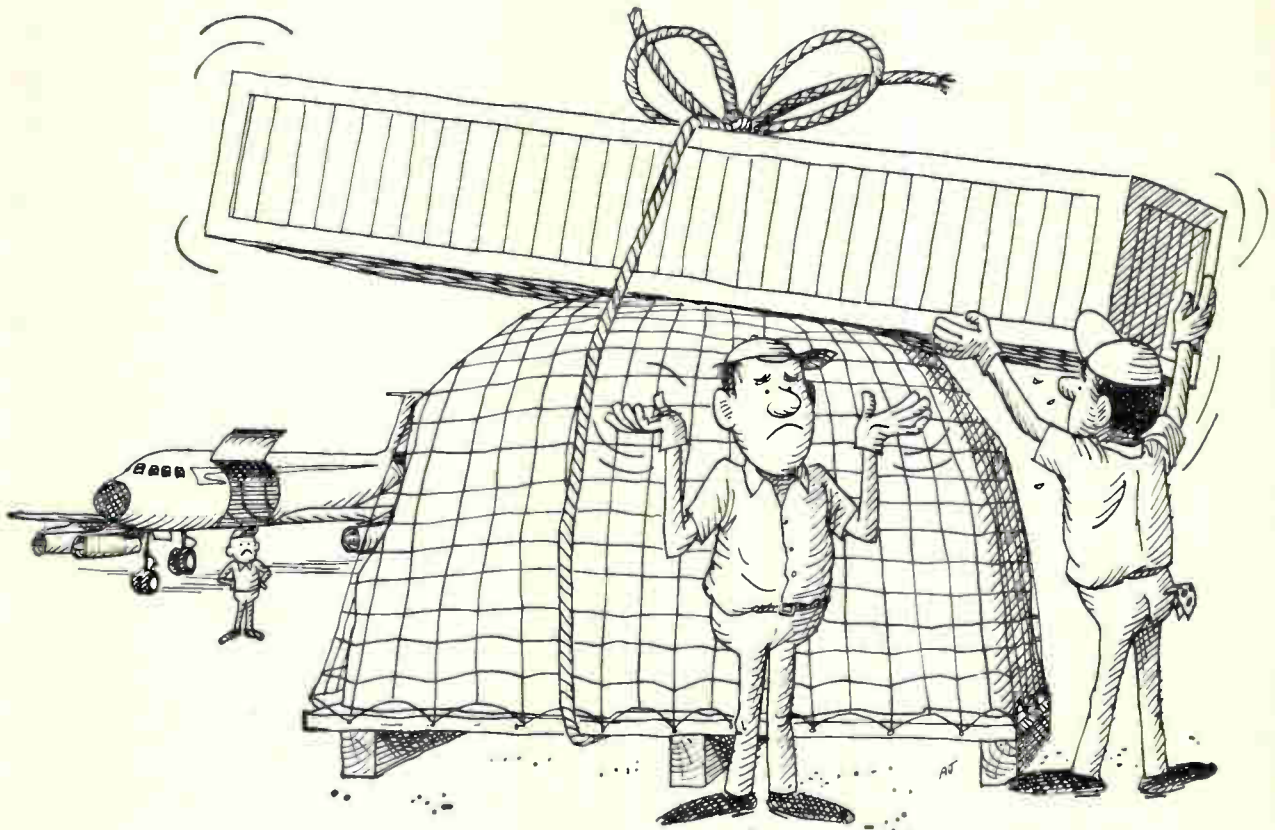

Unpalletable sizes for jet freighters fit and fly easily on Flying Tigers!

Pre-palletizing may work okay for those beautiful little packages that fit the pallet.

But if your cargo is over 7 feet wide or 10 feet long, it won't fit the pallet for a jet freighter—and if it won't fit the pallet, it won't be accepted.

So regardless of the size of your shipment, the easiest thing to do is call Flying Tigers right at the

beginning, before a turn-down.

We'll pick up the cargo at your door. We'll put it straight in a Tiger Swingtail-44. We'll keep track of it all the way through our exclusive advance manifest data system.

We'll fly it to major points East, West, and Midwest in just a few short hours. And we'll deliver it to the door at the other end. It's as easy for you as the nearest phone.

the airfreight specialist

FLYING TIGER LINE





New General Electric components



New G-E 7911 ceramic tube Size and weight reduced, Performance increased

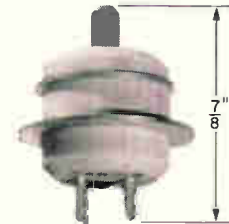

General Electric's new 7911 miniature planar ceramic microwave triode offers advantages in size, weight and performance over previous types. Weight is slashed at least 75%, height reduced to only $\frac{7}{8}$ ". You get up to 3 times greater tube gain-bandwidth product and transconductance/ma. It is ideally suited for beacons and radar altimeters, and new broadband concepts for DME-TACAN-IFF equipment.

A comparison of the 7911 with two other popular types is shown below. For specific application information, contact your G-E sales representative, or write to TIPS for more information.

New G-E compactrons and miniature tubes provide added design flexibility for color TV sets

General Electric's new compactron and miniature tubes now offer expanded design capability for color television receivers, and other electronic applications. Four new types with added functions are available, specifically designed to meet demanding color TV needs:

6JS6A—Pentode Compactron

With improved anti-sneet control, this horizontal output amplifier can eliminate special circuitry and voltage needs. Its space-saving, low-cost design offers more usable output, expanded application possibilities in all-channel color television receivers.

6BH11—Twin-triode Pentode Compactron

This new general-purpose, twin-triode pentode combination gives you the same quality and reliability as the popular miniature type 6GH8A tube. Its pentode and triode characteristics are identical to the 6GH8A.

6HB6—Low-cost High-gain Pentode Miniature

Low-cost video amplifier, with special grid construction, matches the performance of its type 6KR8 companion. This general-purpose miniature with test-proved, high-gain performance is ideally suited for economical color circuitry.

6KR8—High-gain Pentode Triode

This tube will deliver 27,000 μmho in practical video circuitry. It features a high-quality, 3-strap frame grid, and general-purpose high-gain triode. Its rugged construction and high performance make it particularly suitable for color TV.

General Electric compactrons and miniature tubes lower design and manufacturing costs, increase reliability and performance. Compare for yourself the many advantages they offer. Your G-E Sales Engineer has the details and can provide application or prototype assistance.

Characteristic	New miniature ceramic 7911	Standard lighthouse planar types	
		6442	7815
G_m	27,000 μmhos	16,500 μmhos	25,000 μmhos
G_m/ma	1,080	470	360
Tube gain-bandwidth	2,900 mc	1,150 mc	2,000 mc
W_h	3.3 W	5.7 W	6.3 W
Cath. area	0.34 cm^2	0.32 cm^2	0.50 cm^2
Length	$\frac{7}{8}$ in.	$2\frac{3}{8}$ in.	$2\frac{5}{8}$ in.
Max. diam.	$\frac{3}{4}$ in.	$1\frac{1}{8}$ in.	$1\frac{1}{4}$ in.
F_{max}	6,000+ mcs.	5,000 mcs.	3,000 mcs.
Eff. @ 4 Gc.	33%	25%	10%
Outline	Grounded cathode	Grounded grid	Grounded plate
C_{g-k}	5.0 pf	5.0 pf	6.3 pf
C_{g-p}	1.5 pf	2.3 pf	2.0 pf
C_{k-p}	0.05 pf	0.045 pf	0.035 pf
T_{max}	250 C	175 C	250 C
Solderable	Yes	No	No
Weight	$\frac{1}{4}$ oz.	1 oz.	$2\frac{1}{2}$ oz.
W_p	6.5 W	7.5 W	10 W
W_p/area	9.7 W	17.8 W	12.6 W
$E_p \text{ max.}$	3.0 Kv	3.0 Kv	3.5 Kv
I_k	8.2 a/cm	10.8 a/cm	6.6 a/cm

expand design opportunities

G.E. expands reed-switch line: Adds high-voltage and miniature types for design flexibility

When your application requirements call for *higher voltages*, check the rating of General Electric's new type 2VR15 reed switch.

At 5,000 volts (rms), this vacuum reed switch opens new design possibilities. It requires only 113 (± 20) ampere-turns for operate, 55 (± 10) ampere-turns release. Maximum carrying current is 3 amps, contact rating is 15 volt-amps, and contact resistance is 0.05 ohms.

ACTUAL SIZE

2VR15

Y1292

1DR04

When it is *small size* you need, new G-E miniature reed switches, measuring only 2 inches over-all (glass capsule 0.78 in.), offer field-proved reliability and performance.

The type 1DR04, with diffused gold contacts, is ideally suited for either inductive or resistive loads. Full load (160 ma, 25V d-c) life is estimated to 25 million operations.

Type Y1292 miniature switches, with rhodium-plate contacts, have higher dissipation and current ratings. In life tests by one major manufacturer at 60 milliamps, 15 vdc, no failures occurred after 1.75 billion operations.

Compare for yourself the advantages and operating characteristics of General Electric vacuum reed switches. Some 20 different types are available in a variety of sizes, ratings, sensitivity and speeds. Ask your G-E sales representative for prototype samples, or write to TIPS for full details.

Circle 202 on reader service card

New cadmium-selenide photoconductive cells

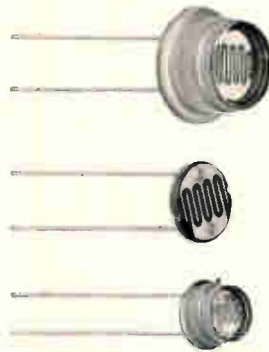

You can now get increased photocell performance and longer life with General Electric's new cadmium-selenide hermetically sealed or plastic-encapsulated photoconductive cells.

Available hermetically sealed in $\frac{1}{2}$ " or $\frac{3}{8}$ " diameters, with encapsulated equivalents, these new cadmium-selenide photocells are ideally suited for applications requiring fast response time and high sensitivity. They react to longer light wave lengths, matching incandescent and some other infrared light sources—even a small change in light level produces high resistance change. See table for specification details of present designs.

Response Time							
Approx. 1000 to 1 resistance change in 10 millisecc. with 25 fc applied in darkness							
Photocell Description							
$\frac{1}{2}$ " hermetic Type Y1206	$\frac{1}{2}$ " plastic Type C425P1	$\frac{3}{8}$ " hermetic Type Y1332	$\frac{3}{8}$ " plastic custom-built				
Operating Voltage							
250 volts	250 volts	30 volts	30 volts				
Sensitivity							
darkness	2 fc	darkness	2 fc	darkness	2 fc	darkness	2 fc
2.5 meg-ohms or more	1500 Ω	5 meg-ohms or more	10000 Ω	2 meg-ohms or more	1000 Ω	2 meg-ohms or more	1000 Ω
Dissipation							
250 milli-watts (500 milli-watts with heat sink)	200 milli-watts	75 milli-watts	50 milli-watts				

See your G-E sales representative, or write to TIPS for more information. Samples for prototype work are available immediately.

G-E vidicon tube offers high performance and light weight

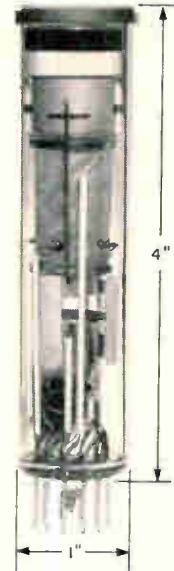

General Electric's new type Z-7845 vidicon tube combines the high resolution performance of all-magnetic vidicons with compact size and light weight.

Operating on a new electron-optical principle, Focus Projection and Scanning (FPS), this new vidicon provides a resolution of 800 TV lines with 750-volts beam acceleration.

The new Z-7845 is especially designed for applications where space and weight are critical, such as, TV missile guidance, star trackers and battlefield surveillance equipment.

General Specifications (Approx.)

Length (exclu. pins) . . . 4 in.

Diameter

Body 1 in.

Target ring 1 $\frac{1}{8}$ in.

Weight

Tube 80 grams

Magnet 120 grams

Heater power 3 to 5 watts

Spectral response S-18

Focusing method magnetic

Deflection method electrostatic

Usable target dia. 0.84 in. max.

Progress Is Our Most Important Product

GENERAL ELECTRIC

For more information, write G-E Tube Dept., Technical Information and Product Service (TIPS), Room A27002, Owensboro, Kentucky. Please specify product(s).

Circle 203 on reader service card
Circle 13 on reader service card 13



NOW-A COMPLETELY INTEGRATED OPERATIONAL AMPLIFIER

New Silicon Planar μ A702 features low offset, high gain

- Low input offset voltage – 2mV
- Low Thermal Drift – $5\mu\text{V}/^\circ\text{C}$
- High voltage gain – 2800
- Large Output Swing – $\pm 5.5\text{V}$
- Operation over a wide range of supply voltages

OPEN LOOP FREQUENCY RESPONSE

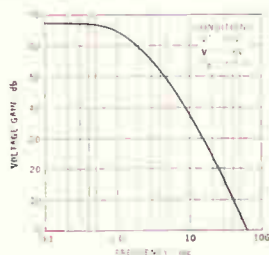

OPEN LOOP VOLTAGE GAIN AS A FUNCTION OF TEMPERATURE

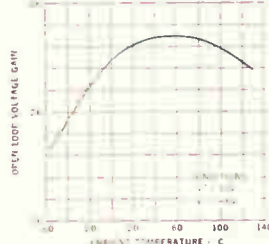

VOLTAGE TRANSFER CHARACTERISTIC

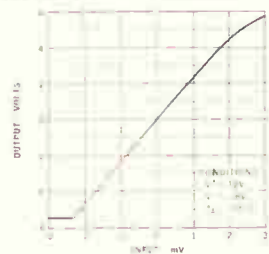

Built into a single chip of silicon using Fairchild's Planar Epitaxial process, the new μ A702 is a complete operational amplifier useful from d-c through 10 mc. It was specifically designed for applications requiring a feedback amplifier, such as miniaturized analog computers and precision instrumentation. It is mounted in 8-lead TO-5 or Fairchild's CERPAK flat package (10 leads with 8 active). The μ A702 features the same high reliability as Fairchild Micrologic. Prices (TO-5 package): 1-24, \$50; 25-99, \$40; 100-999, \$31. For complete specifications, write for data sheet.

AVAILABLE DIRECTLY FROM DISTRIBUTOR STOCKS

FAIRCHILD

SEMICONDUCTOR

DISTRIBUTORS/STOCKING REPRESENTATIVES

AVNET Toronto, Canada 765-2629 BISHMAN Orlando, Fla. 425-8611 CRAMER ELECTRONICS Newton, Mass. WO 9-7700 DART SALES Clarence, N.Y. 874-1212 SYRACUSE, N.Y. GL 4-9257 DENNY-HAMILTON San Diego, Cal. 279-2421 EASTERN SEMICONDUCTOR Syracuse, N.Y. 454-9247 F. C. ELECTRONIC SALES Minneapolis, Minn. 888-0102 ENSCO Cedar Rapids, Ia. 366-1591 Kansas City, Mo. EM 3-6000 St. Louis, Mo. PA 6-2233 HAMILTON Phoenix, Ariz. 312-2601 Culver City, Cal. 870-0236 Palo Alto, Cal. 321-7541 Seattle, Wash. 282-3836 HYER Englewood, Colo. 761-0754 Albuquerque, N. Mex. 268-6744 Salt Lake City, Utah. 322-5849 MARSHALL Scottsdale, Ariz. 946-6576 San Marino, Cal. MU 1-3292 San Diego, Cal. BR 8-6350 Redwood City, Cal. EM 6-8214 NORVELL Dallas, Tex. FL 7-6451 Houston, Tex. MO 5-0558 POWELL Beltsville, Md. 474-1030 Philadelphia, Pa. 724-1978 SCHLEY Watertown, Mass. WA 6-0235 SCHWEBER Westbury, L.I., N.Y. ED 4-7474 SEMICONDUCTOR SPECIALISTS Chicago, Ill. 622-8860 Minneapolis, Minn. UN 6-3435 SHERIDAN Cincinnati, Ohio 562-5932 Cleveland, Ohio 884-2001 Dayton, Ohio 277-8911 SOLID STATE Chicago, Ill. 889-8033 STANDARO Buffalo, N.Y. TT 3-5000 TAYLOR Baldwin, L.I., N.Y. BA 3-8000 TEC SEL Huntsville, Ala. 564-7404 WALKLEY Winter Park, Fla. 647-1216 Baltimore, Md. NO 8-4900 Cherry Hill, N.J. NO 2-9337

FACTORY SALES OFFICES

HUNTSVILLE, ALA 536-4428 4429 SCOTTSDALE, ARIZ 946-6583 PALO ALTO, CAL 321-8780 SHERMAN OAKS, CAL TR 2-1380 ST 8-8701 ENGLEWOOD, COLO 761-1735 ORLANDO, FLA CH 1-2596 OAK PARK, ILL. VI 8-5985 COLLEGE PARK, MD 779-6666 BEDFORD, MASS 275-8450 MINNEAPOLIS, MINN UN 6-3301 ENOWELL, N.Y. 754-2600 JERICHO, L.I., N.Y. ED 4-8500 Poughkeepsie, N.Y. 454-7320 SYRACUSE, N.Y. GR 2-3391 DAYTON, OHIO VCB 1211 KENKINTOWN, PENN TU 6-6623 SEATTLE, WASH AT 2-5344 CANADA OFFICE: TORONTO, ONTARIO 782-9230

FAIRCHILD IS A PATENTED TRADEMARK OF FAIRCHILD SEMICONDUCTOR, A DIVISION OF FAIRCHILD CAMERA AND INSTRUMENT CORPORATION, 113 FAIRCHILD BLVD., MIDDLETOWN, N.J. 08042

Editorial

Starting at the beginning

Once upon a time, an electronics engineer would design a circuit and then hope somebody, somewhere, could use the product of his creation.

Today designing isn't enough. The engineer must start with an understanding of the problem he has to solve. He needs application information as well as design knowledge.

Nowhere has this need—and the perils of ignoring it—been better demonstrated than in the area that engineers have called “computing control.” In 1957, this was looked upon as the promised land. When computing control exploded onto the industrial scene, enthusiastic experts predicted that every chemical, metallurgical and electric generating plant would be run by electronic computers—and soon.

Seven years later, we can scoff at such predictions. By and large, industrial companies didn't go for control computers the way the experts expected. Some of those that did returned the machines to their manufacturers.

There was nothing wrong with the concept of computing control. But most of the hardware designed to do the job was wrong. Based on their experience designing machines to solve scientific problems or to handle business data, engineers designed process-control computers that had wondrous arithmetic capability, high speeds, broad flexibility and huge price tags—generally around \$300,000. The machines also needed extensive programing.

Users, however, needed simple computers that could do repetitive operations, that could be programed easily, and that could be bought for around \$50,000.

Failure to understand the technical and marketing problems blasted many companies' hopes. RCA went into the computer-control business, but didn't stay long. So did Philco. Even Honeywell, which has a wealth of experience in designing, manufacturing and selling process-control instruments and controls, now uses somebody else's machine as often as its own. And earlier this year Thompson-Ramo-Wooldridge, which had introduced the first digital computer for process control, turned over all but 10% of its interest in the business to the Bunker-Ramo Corp., which it set up with Martin Marietta.

Now computer control seems ready for a rebirth—but with a big difference. The new equipment is based on specifications prepared by users. These machines for direct digital control are simple in organization and programing, and are priced as low as \$27,000.

They were designed, packaged and built with the application requirements constantly in mind. Engineers even remembered that industrial maintenance procedures are different than those followed by military users or by data-processing centers. For example, circuits cards were kept big enough so a maintenance man can get at them easily, even when the designer could have used a much smaller board. One designer told us, “We made the cards big so when a maintenance man drops one, he'll be able to find it easily on the most cluttered industrial floor.”

These machines are amazingly reliable. Almost all the suppliers say their machines can run 99.95% of the time.

To do all these things and keep the price down, engineers have introduced some ingenious circuit design, logic organization and packaging. One company has made judicious use of integrated circuits.

Equally important, these new designs (see special report, p. 73) are winning approval from buyers. Computing control may yet be an unqualified triumph for electronics suppliers.

Companies that hope to diversify into new areas—military, consumer or industrial—should heed the lessons learned by computer makers. To succeed in today's competitive market takes more than a brilliant technical proposal. The proposal has to solve a real problem. And the engineer has to start by understanding the application thoroughly.

1000 Volts

High Potential Test

Clifton Precision Synchros

— Leakage less than 300 μ a

THE advent of the ultra high altitude airplane has made necessary synchros with better than ordinary insulation characteristics.

It has also made necessary repeated high potential testing of synchros at RMS voltages of 900 and 1000 across the windings and the case.

Stated simply, we believe that CPPC synchros have the best insulation available. Our Quality Control department has for years insisted that we be able to high potential test 100%, repeatedly. This we can do and maintain current leakage levels three times better than the industry standard.

We have made numerous test runs at

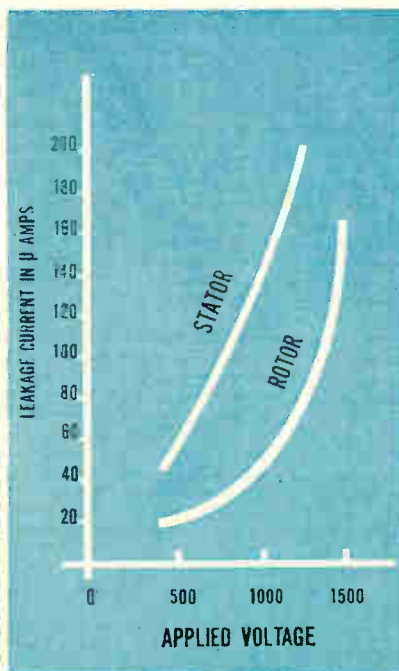

voltages much higher than specification just to make sure that we can, if necessary, accept specifications as high as 1000 volts on even the smallest synchros. If you have high voltage or leakage problems, see us.

CLIFTON PRECISION PRODUCTS

Division of Litton Industries

CLIFTON HEIGHTS, PA. COLORADO SPRINGS, COLO.

cppc

Electronics Newsletter

October 5, 1964

Navy steps up antisub programs

Increased development of antisubmarine warfare techniques and systems is in the works. Nearly \$400 million, or more than one-quarter of the Defense Department's Research, Development, Test and Evaluation budget for fiscal 1965, has been earmarked for the project. Systems-management experts, mostly with experience in air-defense systems, are being gathered by the Navy in an effort to get a new approach to the problem of tracking and destroying enemy submarines.

Capt. Donald G. Dockum, director of the Navy's Undersea Development division, listed these areas of stepped-up emphasis: underwater acoustic warfare, analagous to electronic countermeasures in the air; underwater surveillance systems, also styled after air-defense networks; the Seahawk program, a surface ship designed specifically for antisub warfare; and acoustic intercept techniques as a defense against torpedoes.

Pacific defense system mulled

A tactical air defense system may be built in the Pacific. The Pentagon promises a decision by month's end on a 412L Command and Control System, often called "Baby Sage," which has already been installed in Europe with its focal point a hardened, survivable command center near Weisbaden, West Germany. The system includes search radars, communications, data-processing and weapons-control display equipment. Okinawa is being mentioned as a probable location.

Civilian version of Transit is dropped

A plan to let merchant ships use the Navy's Transit satellite system to obtain navigation fixes has apparently been dropped. The Navy says the responsibility for civilian use of Transit rests with the National Aeronautics and Space Administration, but the agency claims no knowledge of the matter. NASA is pursuing its own navigation satellite project and is expected to announce a development program soon. The NASA satellite would be used by aircraft as well as ships. The Federal Aviation Agency and the Maritime Administration are reported to be strongly interested in the project. Feasibility studies have already been made.

In the early days of Transit's development, the Navy openly supported use of the system by merchant ships. The Navy, however, has slapped a security lid on the Transit program and has even dropped the name Transit. The system is now operational, with four nuclear-powered satellites in orbit.

A prime use of Transit presumably is providing fixes for the inertial navigation systems aboard Polaris submarines.

Ion-beam doping emerges from lab

Soon, ion implantation will no longer be just another promising technique for forming p-n junctions in semiconductor crystals.

The Ion Physics Corp. is about to go into commercial production of solar cells with ion-beam-doped junctions. W. J. King, who heads the research program, says conversion efficiencies of 13%—the amount of solar energy converted to electrical energy—have been achieved. This makes the solar cells competitive with those made by conventional diffusion methods, he says.

The company is starting to make other semiconductor devices. It has already produced more than 400 diodes by dicing solar cells and photo-

Electronics Newsletter

etching a mesa structure on the dice. King says the diodes work well. He and his coworkers are now making field-effect transistors. The process is still being worked on, however. The first approach was to implant boron to get a p-on-n structure, then implanting phosphorous to form the pnp structure. But it is difficult to implant phosphorus on top of boron, so the reverse procedure is being tried. Ion Physics Corp. has been researching the technique for about three years under Air Force sponsorship [Electronics, Apr. 19, 1963, p. 26].

NASA changes patent policy

The National Aeronautics and Space Administration put into effect new regulations on patent waivers on Sept. 28. NASA will allow its contractors to retain patent rights to inventions resulting from government contracts, providing certain conditions are met.

Basically, the conditions are that the inventions aren't the primary purpose of the contract, don't stem entirely from government research and aren't directly related to public health and welfare. Once a waiver is granted, the contractor must actively exploit the invention to retain patent rights.

The policy is in line with regulations already adopted by the Defense Department. The Atomic Energy Commission is taking similar steps. The changes are in keeping with a request made by President Kennedy last October, calling for a uniform policy on patent waivers.

Industry is waiting to see how NASA's new policy will work in practice. Even NASA isn't sure that the change will result in many more waivers being granted.

Marriage begets better circuits

Experimental integrated circuits being made by Motorola, Inc., demonstrate what solid-state researchers have been contending for some time: A marriage of thin-film and diffusion techniques produces superior circuits.

Motorola's Semiconductor Products division is making circuits that withstand 500° C. Conventional circuits fail at temperatures beyond 300° C. Motorola researchers say a circuit that can survive at high temperatures is more likely to operate reliably at normal temperatures.

The gold plating and gold wire normally used in integrated circuits to make interconnection easier is eliminated. Gold causes formation of brittle compounds at 300° C. and at higher temperatures gold-silicon alloys melt. Only bare aluminum and nickel-iron alloy is used. Both can take the heat.

Resistors and capacitors are deposited as thin films of metal and oxides on top of a silicon-oxide layer formed after the transistors and diodes are diffused in the silicon substrate. Unlike diffused components, the thin-film components are relatively insensitive to temperature changes, operate almost independently of the diffused devices and provide a wider range of circuit values.

Motorola isn't making the circuits for sale, but to solve a test dilemma: If circuits are tested at normal temperatures, it may take a year or more for temperature effects in the silicon to show up clearly. By that time, the circuit may be out of production. Stress tests at extreme temperature quickly reveal the effects, but the results are confused if the connectors and passive devices can't stand the heat. The new circuits solve this problem.



Proven two-way communication to Venus and beyond



Apollo lunar explorers' primary link with Earth



For moving targets, instant recognition and recording

MOTOROLA'S DEEP IN ELECTRONICS OPPORTUNITIES

...from deep space to deep sea

Tactical ground/air communications
... air-delivered



Private radio telephones for future ground forces



An added dimension for anti-submarine warfare





RUGGED, LIGHTWEIGHT BUILDING-BLOCKS. Every Motorola component, module, subsystem and system is designed, tested and retested toward the goal of total reliability. The payoff . . . Mariner II Venus probe signals were successfully received from over 50 million miles in space, under extreme environmental conditions exceeding specified parameters. For deeper NASA/JPL pioneering into outer space, similar equipment provides even greater command capability.

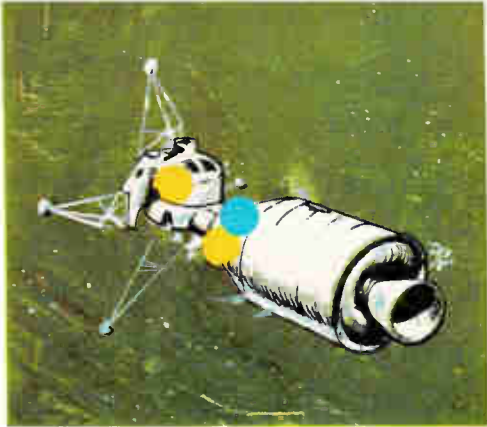

COMMUNICATIONS FOR APOLLO/LEM. Motorola is providing the up-data link and vital communications transponder for the Apollo Spacecraft as well as the transponder for the Lunar Excursion Module. Critical electronic circuitry is assembled in the special, controlled environment of Motorola clean rooms to meet rigid NASA quality assurance specifications.

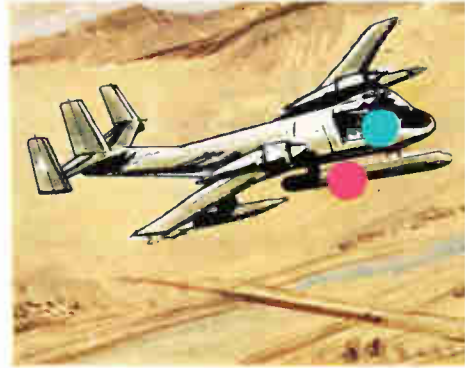

UNIQUE AIRBORNE RADAR CAPABILITIES. Operationally proven for detecting and recording moving targets, at night and under all weather conditions, Motorola side-looking radar is in use on the Army's Mohawk surveillance aircraft overseas. Another of several Motorola radar systems concepts, used in automatically guiding low-flying, high-speed aircraft over and around topographical obstacles, includes a unique electronic scanning method with a narrow synthe beam. This system combines the functions of terrain avoidance, terrain following, ground mapping and station keeping. Employment of new integrated electronics application techniques in the heart of the system has made this advanced concept physically practical in size, weight and performance.

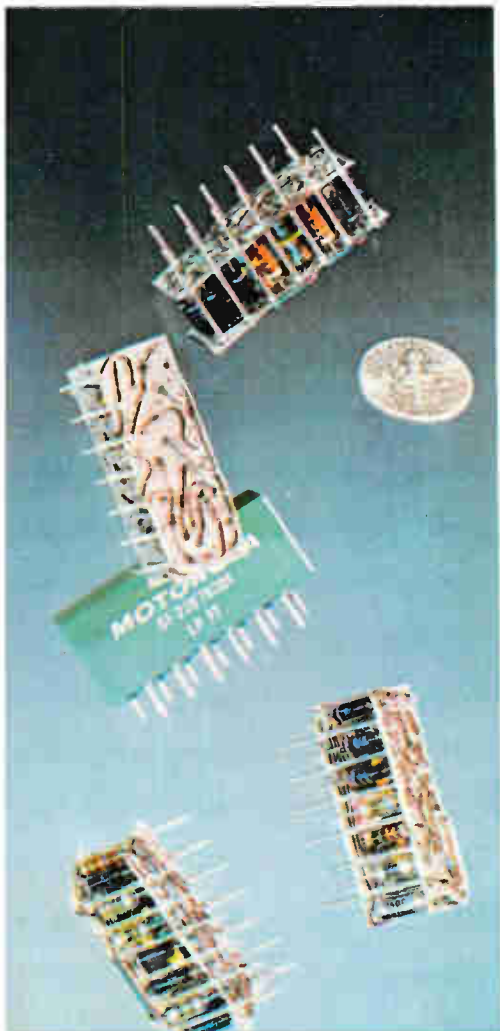

OPPORTUNITIES IN DEPTH... AT MOTOROLA

The projects and technologies described here typify the broad scope of truly creative engineering opportunities at Motorola's Military Electronics Division . . . literally from deep space to deep sea.

SCIENTISTS AND ENGINEERS

will find challenge and stimulation in this vital part of a large corporation whose sole business is electronics. The Division provides well over a half-million square feet of the most modern electronic research laboratories and supporting development facilities including electrical and mechanical engineering laboratories, model shops, pilot production lines and well stocked technical libraries. Of the division's nearly 3,500 people, about 1,000 are professional engineers or scientists.

If you are interested in joining a dynamic company with versatile interests unbounded by narrow specialization, write today describing your background in:

APPLIED SYSTEMS RESEARCH . . .

communications theory, coding theory, logic systems, adaptive communications systems, phase lock and correlation techniques, optimum time-bandwidth utilization, advanced signal processing, redundant systems organization, thermal and structural design, analysis and synthesis of complete systems.

SYSTEMS AND SUBSYSTEMS

DESIGN . . . electronically scanned antennas and phased arrays, integrated circuit applications, digital and voice communications, command and control, telemetry and tracking, data processing and display, radar, missile guidance and fusing.

EQUIPMENT DESIGN . . . solid state transmitters and receivers, high-speed non-impact teleprinters, radar and C-W transponders, command receivers and decoders, microwave solid state devices, oceanographic instrumentation.

continued next page



ROUGH AND READY FOR THE NORTH POLE OR THE TROPICS.

Ambient temperatures of -76° to $+158^{\circ}\text{F}$; saturated humidities, sand and dust, salt spray, rain, wind, snow & ice, shock, vibration, bounce and air-drop are taken in stride by the Air Force AN/TRC-87. This easily maintainable, solid state, ground/air VHF communications system, supplied by Motorola, operates unattended in its own shelter hut and can be remotely controlled.

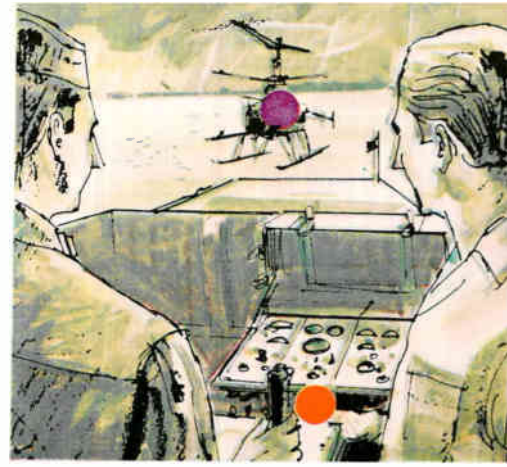
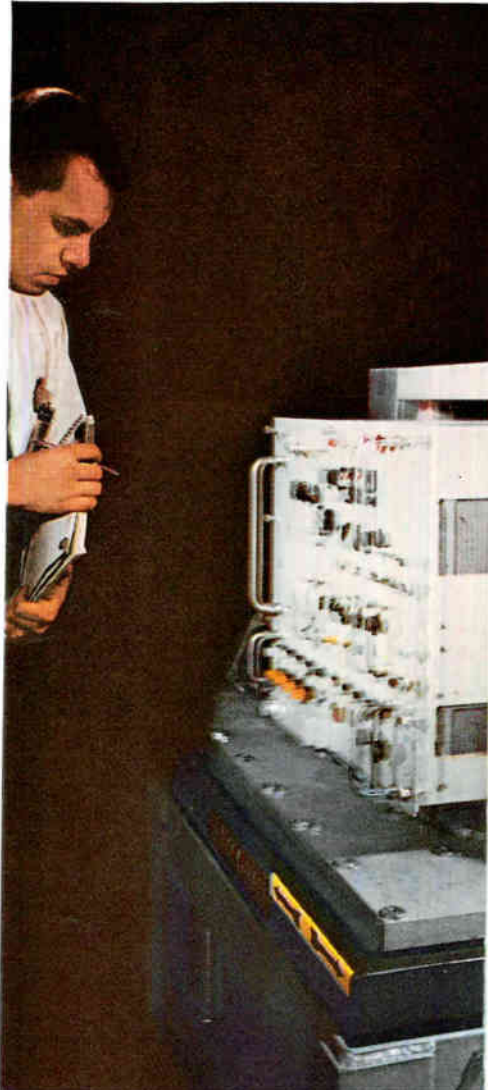

ASW AND UNDERSEA

SENSORS.

For the Navy's DASH (Drone Anti-Submarine Helicopter) program, Motorola provided the heart of the command guidance system—shipboard transmitter controls & coders, and airborne, decoders—to guide weapons-carrying drone helicopters to precise target locations. And, Motorola's capabilities extend well into the ocean depths; e.g., advanced air-dropped sonobuoys extend the range of underwater sonic detection systems. For undersea navigation, the new Motorola-developed all-electronic Solid State Compass, with no moving parts, provides an accurate and dependable direction reference at extreme depths, even under violent shock or vibration.





continued

We are particularly interested in programs on which your experience was obtained and the extent of your technical responsibility. Write our Manager of Engineering for immediate and confidential attention.

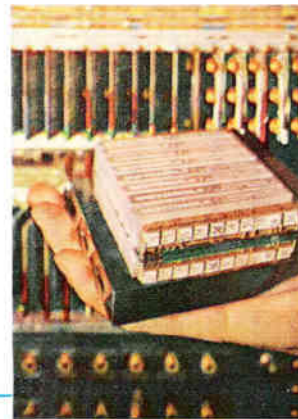

ADVANCED COMMUNICATIONS STUDY.

RADEM (Random Access Delta Modulation) is a continuing study program at Motorola to develop a digitally modulated voice and data communications system permitting person-to-person direct-dialing for many users on a common frequency channel. Operational in areas of high interference, the RADEM concept requires no central exchange or fixed nets and is ideal for random access, discrete addresses, high mobility and message security. Extensive application of integrated electronics offers significant advantages in terms of size, weight, reliability and cost.

FORCING THE STATE-OF-THE-ART

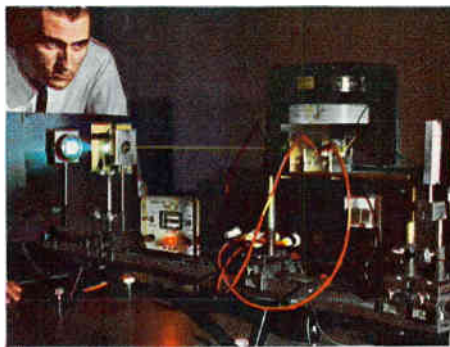

INTEGRATED CIRCUIT APPLICATIONS LEADERSHIP

Motorola has demonstrated the fundamental compatibility of semiconductor and thin-film integrated circuit technologies in this Air Force sponsored, air-ground, digital communications system. The result is a new concept in modular assembly for high-density integrated circuit packages.

POLARIZED ELECTRO-OPTICS

Motorola has developed one of the first truly efficient techniques for high-speed deflection of linearly polarized monochromatic light beams. First applications include translating electric signals into optical patterns—such as alpha-numeric data—which may be presented for visual display, hard-copy read-out or further processing.

LOW-PROFILE, INTEGRATED ANTENNA

This figure-8 UHF antenna study for the Air Force provides omnidirectional, vertically polarized radiation pattern of a conventional 1/4-wave monopole, yet rises only a few electrical degrees above the ground plane. Miniature transistor oscillator, integrated with the radiating structure, provides a complete antenna-transmitter ("Antennamitter") assembly.



ULTRA-PORTABLE RADAR

This solid-state FM-CW design uniquely combines integrated circuitry, molecular components and circuit commonality. Result: a lightweight, highly portable, ultra-reliable tactical radar system for hand-held field use.

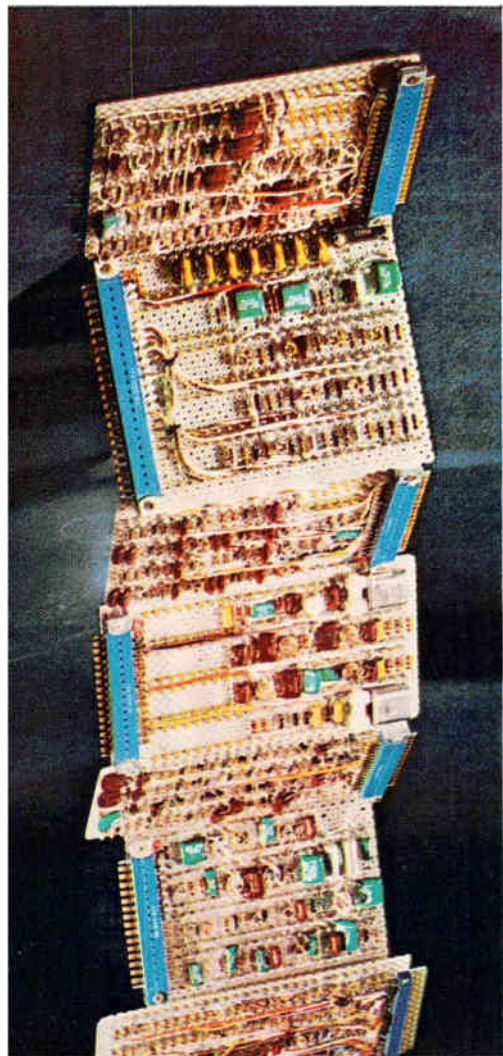

MOTOROLA  **Military Electronics Division**
An equal opportunity employer

SCOTTSDALE, Arizona, 8201 E. McDowell Road / CHICAGO 51, Illinois, 1450 No. Cicero Ave

Report from

BELL LABORATORIES

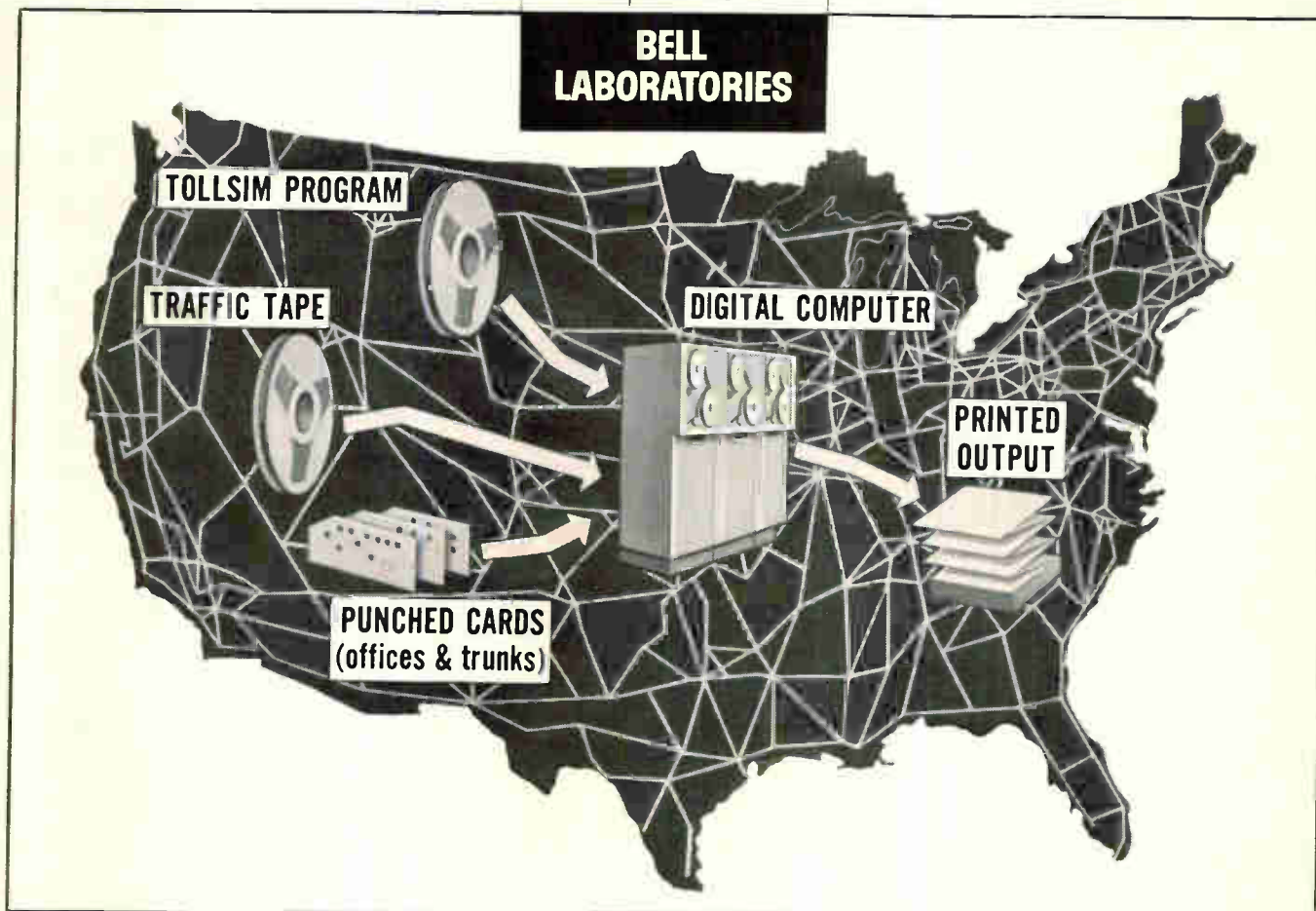

Many functions of the Bell System communications toll network are simulated by a digital computer using the TOLLSIM program along with a traffic tape and punched cards. The traffic tape, which may be used for a number of traffic studies, specifies times, originating and terminating points, numbers, and durations of simulated telephone calls. The punched cards specify characteristics of real or theoretical offices and trunks.

The printed output, by recording and summarizing re-attempts, abandoned calls, and other "real life" traffic data, both for the entire network and for its component parts, enables engineers to judge performance under various operating conditions. Many variations are possible. The effect of rearranging switching equipment in an office, for example, can be studied by using a different punched card for that office.

TRAFFIC ANALYSIS

Mathematics for good telephone service

At Bell Laboratories simulated telephone calls are placed through a computer programmed to represent the Bell System nationwide Direct Distance Dialing network. The computer program, known as TOLLSIM for "Toll Network Simulator," is one of many tools used by traffic specialists in studying how well traffic is handled by the network and how certain design changes might improve telephone service.

For example, a long-standing problem within the telephone industry is that of coping with heavy overload

conditions during relatively short periods. These overloads can occur because of storms or other disasters that result in unusually heavy telephone calling. Such conditions also occur during the Christmas season and on Mother's Day.

In conjunction with earlier theoretical work, a TOLLSIM simulation indicated that, during overload conditions, a greater number of customers could be served if the pattern of automatic alternate routing of telephone calls were changed. The change involved making fewer at-

tempts to route the calls over long, roundabout alternate routes when shorter direct trunks were busy. The results were then confirmed by field tests performed during the 1963 Christmas period.

This work is an example of the way Bell Laboratories people advance traffic theory and practical applications. The goal: to tailor facilities closely to the needs of telephone customers.

BELL TELEPHONE LABORATORIES...
Research and Development Unit
of the Bell System.



2×10^{-11} accuracy

from this new compact solid state atomic standard:

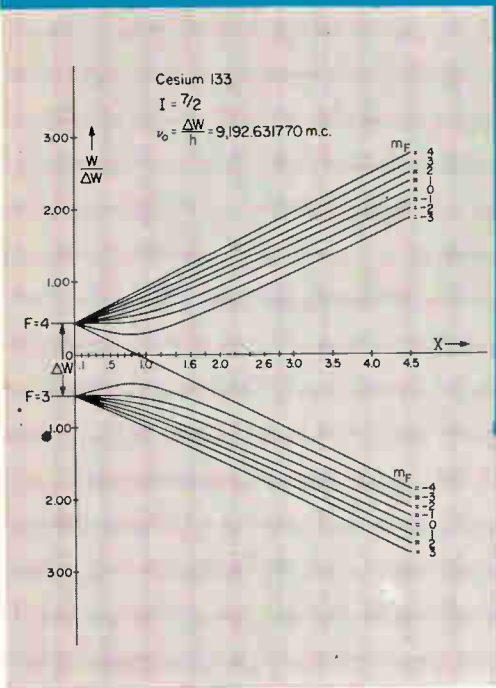

New long-life Cesium 133 resonator plus these unique features:

- Reference to A_1 or UT_2 time scales
- Closed-loop self-checking control circuitry
- Highly stable quartz oscillator
- Only $8\frac{3}{4}$ " high, 65 lbs.

Introducing the Hewlett-Packard 5060A, a new primary frequency standard offering unprecedented features in an easily portable package. Reliability is assured with guaranteed resonator operating life of 10,000 hours, automatic continuous output monitoring, and a rugged, low-drift atomic-controlled quartz crystal oscillator. The oscillator gives superior performance even when not controlled by the atomic resonator, thus providing a means to extend resonator life even longer.

Within the compact resonator, especially designed for the 5060A, Cesium 133 atoms change from one hyperfine energy level to another. These atoms are detected by a hot wire ionizer and electron multiplier and used to control the frequency of the oscillator output.

The block diagram illustrates the electronic techniques.

Outputs provided by the 5060A include 5 mc, 1 mc, 100 kc sine and 100 kc clock control. Specifications include extremely low noise-to-signal ratio and low harmonic distortion.

A feature of the instrument is the provision for re-adjustment of the output for periodic changes of the time scale itself. For example, internationally-agreed UT_2 adjustments may be made with a simple component change.

The new instrument fills a need for a small, reliable primary standard for many military, industrial and scientific applications. It makes practical, for example, microsecond time-of-day synchronization between remote sites, and it is particularly useful for portable applications where precise frequency is desired without direct comparison reference either between locations or to a common standard. Operation is from the ac line or on 22-30 v dc.

Other important features of the 5060A are indicated in the specifications. Compare them with specs of other standards now available. Then call your Hewlett-Packard field engineer for complete data or write Hewlett-Packard, Palo Alto, California 94304, telephone (415) 326-7000; Europe: 54 Route des Acacias, Geneva; Canada: 8270 Mayrand Street, Montreal.

SYSTEM BLOCK DIAGRAM

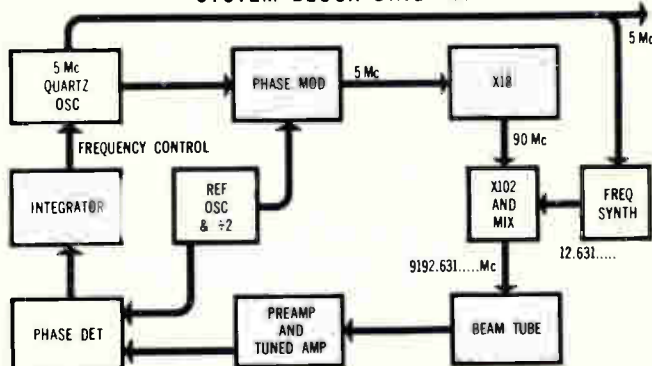

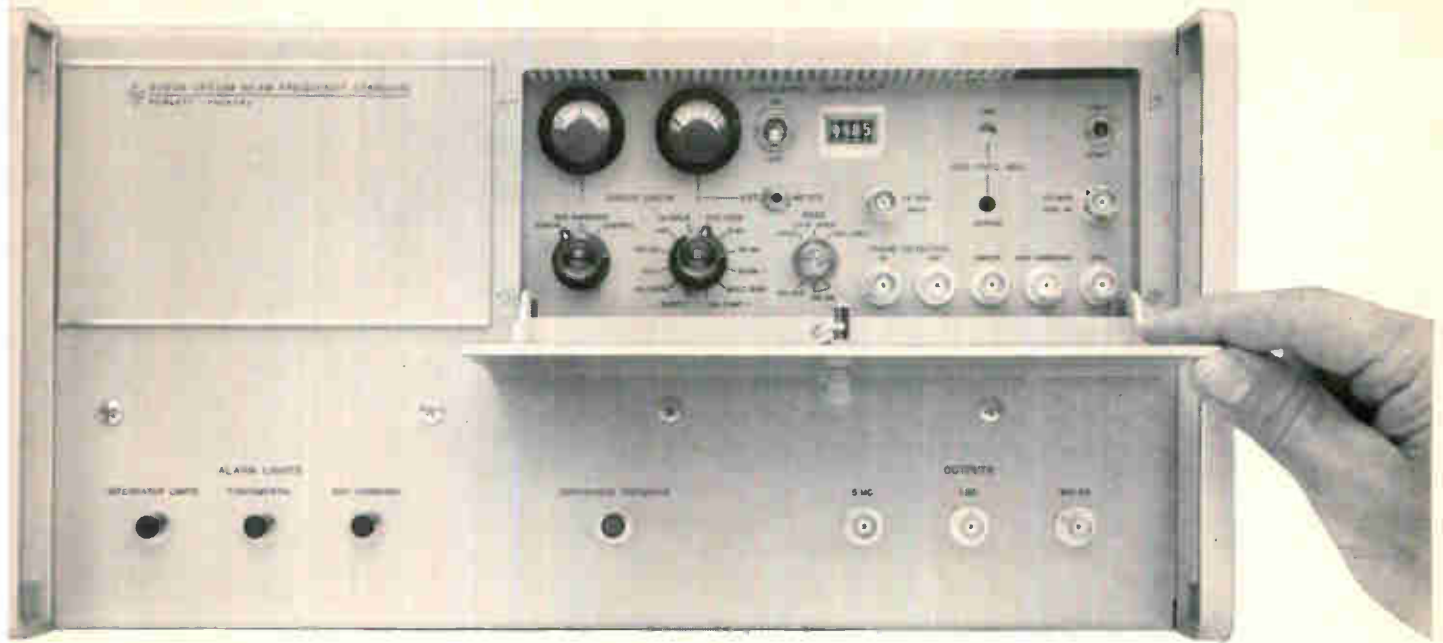

Specifications

- Accuracy:** $\pm 2 \times 10^{-11}$
- Long-term stability:** $\pm 1 \times 10^{-11}$
- Short-term stability:** rms fractional frequency deviation for 1 second averaging:

$$\frac{\Delta f_{rms}}{f} \leq 1 \times 10^{-10}$$
- Warm-up time:** 1 hour (time to reach specified accuracy if oscillator already warmed up);
 4 hours (cold start)
- Noise-to-signal ratio (5 mc):** At least 87 db below rated output; output filter bandwidth approximately 125 cps
- Harmonic distortion (5 mc, 1 mc and 100 kc):** Down more than 40 db from rated output
- Output frequencies:** 5 mc, 1 mc, 100 kc sinusoidal, 100 kc clock drive
- Output voltages:** 1 v rms into 50 ohms, clock drive suitable for hp frequency divider and clocks
- Time scale adjustments:** Adjustable in increments of 10×10^{-10} by changing a component in the frequency synthesizer; automatic logic circuitry provides indication of proper operation; A₁ or UT₂ time scale supplied to order
- Cesium beam tube life:** 10,000 hours guaranteed (operating)
- Power:** 115 or 230 v ac $\pm 10\%$, 50 to 1000 cps, or 22 to 30 v dc; approx. 50 watts operating
- Dimensions:** 16 $\frac{3}{4}$ " wide, 8 $\frac{3}{4}$ " high, 16 $\frac{1}{2}$ " deep, 65 lbs.
- Quartz oscillator only (with cesium beam tube switched off):** Aging rate: $< \pm 5$ parts in 10^{10} per 24 hours
 Stability: As a function of ambient temperature, $< \pm 1 \times 10^{-10}$, 0° to +50°C
 As a function of load $< \pm 2 \times 10^{-11}$ for any resistive load change
 As a function of supply voltage, $< \pm 5 \times 10^{-11}$ for 22 to 30 v dc
- Price:** hp 5060A Cesium Beam Standard, \$15,500
- Data subject to change without notice. Prices f.o.b. factory*

**HEWLETT
PACKARD**



An extra measure of quality

9607

COMPLETELY
GNU



MINCOM'S NEW TIDAX 1.5-mc RECORDER/REPRODUCER

The new TIDAX is a head-on approach to your problems in telemetry and general instrumentation. This high-performance Recorder/Reproducer provides a full fourteen 1.5-mc tracks in one rack — with fully automatic equalization at all speeds. Wideband FM (DC to 500 kc) is available without modification. Signal-to-noise ratio (RMS/RMS) is 25 db at all speeds. TIDAX telemetry capabilities include simultaneous post- and pre-detection recording in PCM, PCM/FM, PAM/FM, PACM and FM-type carrier systems. Mincom's exclusive DC Top Plate is rugged, simple and reliable — full dynamic braking, instant push-button speed control, tape change from 1/2" to 1" in less than ten minutes. Write today for details and complete specifications.

Mincom Division **3M**
COMPANY

300 South Lewis Road, Camarillo, California • 320 Shaw Road, South San Francisco, California • 529 Pennsylvania Building, 425 13th Street, N. W., Washington, D. C. • 135 West 50th Street, New York, New York • Post Office Box 272, Fairborn, Ohio • 1230 Orange Avenue, Winter Park, Florida • 2121 Santa Anna Avenue, Dallas, Texas • Eltron Engineering Sales, Inc., 246 Walnut Street, Newtonville, Massachusetts

Manufacturing

Thin films for all

Dozens of vacuum-deposition machines are being set up by the Mallory-Xerox Corp. in a new plant in Burlington, Mass., to exploit the trend toward the subtractive method of producing thin-film circuits—etching them from standard blanks [Electronics, June 15, p. 94]. The company, recently formed by P. R. Mallory & Co. and the Xerox Corp., will sell wafers coated with resistive, capacitive and conductive material; the buyers will make the circuits.

The company hopes the new product will trigger use of thin-film circuits by every type of assembler of electronic equipment. Most assemblers don't have the facilities or know-how to deposit thin-film circuits, but any company that can etch printed-wiring boards can convert the blanks to circuits.

At present, Mallory-Xerox is test-marketing the blanks to some good customer prospects, but it plans to begin sales early in 1965. Stanley M. Stuhlberg, marketing manager, says he'll spread the word at the National Communications Symposium in Utica, N. Y., on Oct. 5.

Do-it-yourself. Mallory-Xerox makes two kinds of blanks, one for resistor networks and one for resistor-capacitor networks.

Resistor blanks consist of a substrate with a deposited coating of chromium that is plated with copper. A resistor-capacitor blank is made by placing a square of resist on the substrate. The resist is removed after the chromium and copper coats are made. Silicon-monoxide dielectric is deposited on the bare area, overlapping the copper. Then the wafer is plated again with copper.

The purchaser etches the blanks twice, once to form the component electrodes and conductors, and



Resist pattern is transferred from selenium plate (plates look like a mirror) to circuit blanks mounted on sheet of stable film. Etching will leave copper conductor and electrode pattern on the blanks and expose the chromium that will be etched to form resistors.

then to form the resistors from the chromium, using selective chemical etches. Resistor values are set by the area of chromium left on the wafer; capacitor values are determined by the size of the copper electrode left on top of the silicon monoxide.

The process requires only one deposition mask at Mallory-Xerox, a simple aperture through which the dielectric is deposited. The customer prepares only two etching patterns. In contrast, conventional thin-film circuits require four precision masks and deposition cycles: for the resistors, conductors, dielectric and capacitor electrode.

Xerographic resist. While conventional photo-resist or silk screening can be used for etching, Mallory-Xerox will recommend xerographic resist applicators like those now used to make printed-circuit boards [Electronics, Sept. 27, 1963, p. 50]. Xerographic techniques for etching the blanks were developed in 1960 by Xerox, one of the owners of Mallory-Xerox.

The Xerox machines are similar to xerographic office duplicators. A selenium plate is charged to duplicate a pattern. Plastic resist powder adheres to the charged area. The powder is transferred to the blanks by pressing them against the plate, and the resist is

fused to the blanks by solvent vapor.

To speed the process, groups of blanks are mounted on a stable film. The sheet of film also serves as a carrier during etching.

Finer foams

Recipe for lighter, finer, bouncier foam plastic: Add a pinch of metal to polymers while they are molten in an extrusion press. Developed by Ralph Hansen of Bell Telephone Laboratories, this easily-controlled technique may broaden the uses for foams such as polyethylene, polypropylene, polystyrene and fluorocarbons.

These have better dielectric properties than solid polymers because foams are filled with bubbles of gas and gas is a better dielectric than solid plastic. Foaming also cuts material costs, because gas is cheaper than plastics. This isn't too important in the case of polyethylene, which at 30 cents a pound for wire grade is the least expensive. But the fluorocarbon Hansen used, Teflon FEP, costs \$6 a pound—more in small quantities—a price that may prohibit its use even when its superior physical properties make it attractive.

Perhaps potting, too. The new process is aimed primarily at wire and cable insulation and other dielectric coatings. Foamed, or cellular, polyethylene is used as a spacer type dielectric in coaxial cable or to make multiconductor cable smaller and lighter, or floatable. There are other specialty uses, such as gaskets and mechanical or acoustical dampers.

At present, the only widely used application for foam in electronics is potting, packaging or filling components and modules with resins that foam in a mold because of a chemical reaction. Hansen's process permits compression-molding with polymer foams—he's done it with plasticized materials. While

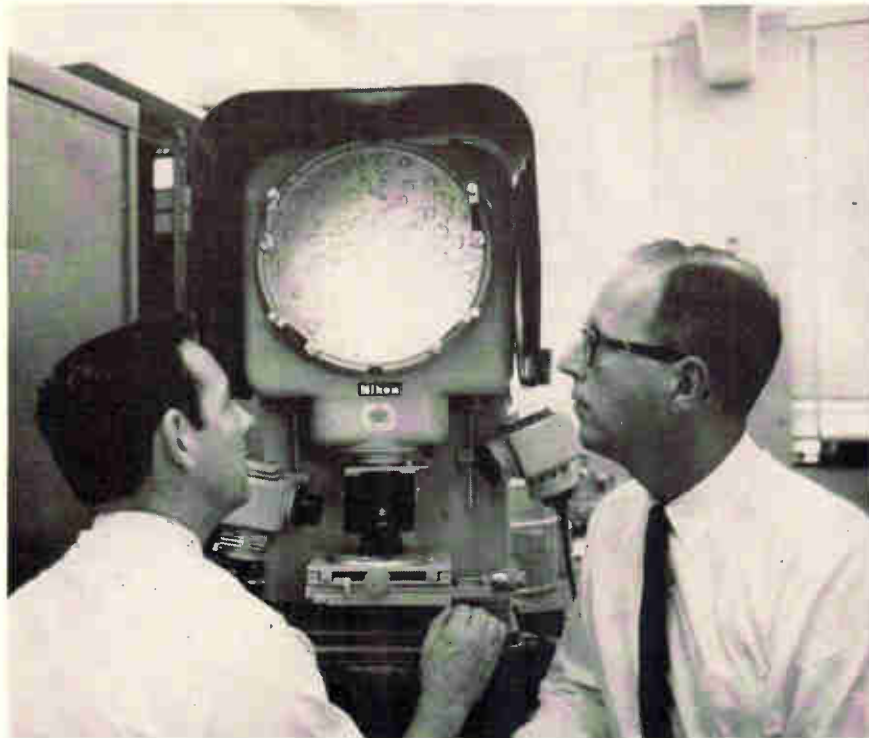

Bubble structure of polymer is examined on projection microscope by W.M. Martin and Ralph H. Hansen, of Bell Telephone Laboratories.

he hasn't checked out potting applications, the process may provide a new family of molding and encapsulation techniques and materials.

Nucleating process. The significance of Hansen's process is twofold: it is easily controlled, and the cells in the foam are up to a thousand times smaller than cells produced by conventional methods.

One way extruded foams are made now is to inject gas into the molten polymer. But when the extruded surface is large compared to volume, as in wire insulation, the gas bubbles readily escape, leaving the entrapped gas volume as little as 5%. Chemicals called blowing agents produce good foams, but leave undesirable residues. Unless the chemical process is carefully controlled, results may be no better than gas injection.

Hansen dissolves a gas such as argon, nitrogen or carbon dioxide in the molten polymer while it is under pressure. He also adds about 1% by weight of metal particles—tin, lead or zinc dust coated on the granules before they are melted. Or, he dissolves right in

the melt a fusible alloy such as wood's metal or a salt such as mercurous chloride, which then decomposes. None of these additives causes any detectable change in the foam's dielectric properties, nor do they require close control of timing and temperature.

As the polymer-gas-metal solution leaves the extruder, the pressure drops, causing the gas to come out of solution. The gas collects in tiny bubbles around the metal particles. The particles act as nucleating agents—just as raindrops form around chemical particles used in cloud seeding.

E. I. duPont de Nemours & Co. worked out a nucleating method for Teflon about two years ago, using materials such as boron nitride. But industry hasn't adopted it. There are apparently no chemical blowing agents for Teflon.

Foam properties. The lab extruder has made foams with up to 75% expansion. Polyethylene, for example, was made in densities of 55 pounds per cubic foot to as light as about 10 lb/cu ft. Teflon FEB was expanded 25% to 35%, but could probably be expanded more

with higher temperatures and pressures than the lab extruder permitted. Hansen says he didn't want to take a chance on getting splattered by pushing the process.

Polyethylene makes a soft foam; polypropylene is medium-soft; Teflon FEP is firm, but resilient, and polystyrene foam is hard.

Computer fallout

Another big electronic-systems company is going into the production-equipment business with items originally developed for its own use. This time it is the International Business Machines Corp.

Early this year, IBM's Industrial Products division tested the reaction of buyers to a hand-gun type of percussive welder—a tool used to weld the ends of wires to terminals. The response was so favorable that the newly-formed division, which had sold only components, firmed up plans to branch out with other equipment.

On Sept. 14, it introduced a "fly's eye" camera for making multiple photo-resist and semiconductor diffusion masks. Two days later, a high-speed component tester went into the catalog. On Sept. 18, an automatic component inserter for printed-circuit-board assembly was added to the line.

The latter two machines are a fraction of the equipment developed by IBM to produce conventional printed-circuit cards. The decision to sell them was undoubtedly influenced by the company's switch to microcircuits in its new System 360 commercial computers, a move away from the printed-circuit cards that are still state-of-the-art in most electronics plants.

Shades of Sage. The testing machine can perform up to 35 tests on resistors, capacitors, resistor-capacitor modules or diodes. Diodes can go through at a rate of 7,200 an hour. But speed isn't the main feature. Test results can be fed into an on-line computer that will show how well each part meets specifications, correlate test results and perform other chores. The component inserter uses a computer

that is programed by punched tape, and will randomly select and insert 24 different-valued ¼-watt resistors in printed-circuit boards, at a rate of 4,500 an hour. Components are fed from magazines that can be loaded by another machine.

Both the tester and component inserter are updated versions of machines that IBM developed in the 1950's to test and assemble components of the Sage (semi-automatic ground environment) air-defense computers and other big data-processing systems. With those testers—as with the new ones—each component got a serial number and a punched-card history of factory and field use. Quality control and reliability studies of the parts and the circuits in which they were used could be made at any time by letting a computer rummage through the card files. But the old component inserter [Electronics, Oct. 24, 1958, p. 82] didn't use punched tape. It was programed by selector switches that placed any of 14 different axial-lead components in any of 24 standard positions on a board.

In a fly's eye. The new camera gets its name from its lens, which is multifaceted like a fly's eye. It was used in development and prototype production of the micro-circuits in the System 360 computers [Electronics, Apr. 20, p. 100, 103].

The camera can take a single

master pattern—as large as 18 inches square—and reproduce it 1,250 times on a 4-by-5-inch film in one operation. The usual technique for making such films is to use a step-and-repeat camera that photographs the pattern over and over again.

While the fly's eye camera is much faster, it does have some drawbacks. Periodicity—or pattern to pattern spacing—is fixed at 0.032 inch. Resolution drops off at the edges of each image. For example, at a magnification of 1/500 (using a master 500 times larger than the image), the resolution on the optical axis of each facet is 400 lines per millimeter; resolution 0.010 inch away from the axis is 200 lines per mm.

But if this can be tolerated, the camera can be used to make masks for such production applications as etching many small printed circuits on a large sheet of board material. The 4-by-5-inch negative can be enlarged to sheet size.

Space electronics

Nimbus aftermath

Failure of the attitude control system on the Nimbus I weather satellite may hasten the use of integrated circuits in the control systems of future Nimbus spacecraft.

Although the failure was mechanical rather than electronic, with attention being focused on the attitude control system, project engineers are now giving thought to improving the electronics as well. More reliable integrated circuits are being considered for the control circuits on Nimbus A1 if they can be ready in time for the August, 1965, launch. They will almost certainly be a part of the Nimbus B control system—the spacecraft that will follow Nimbus A1. No speedup in development of Nimbus A1 is expected despite the failure of Nimbus I.

Warned of Cleo. Nimbus I, launched Aug. 28, sent the first warning of Hurricane Cleo. Its final picture transmission, on Sept. 22, showed early signs of Hurricane Gladys. Then the giant solar-cell paddles locked and could not be rotated into position to pick up the sun's rays. Deprived of solar power, the battery-power supply could not be recharged, the attitude-control system failed and the satellite began to tumble.

Prelaunch testing eliminated practically any chance that the error could have been in the electronics. Semiconductor electronics in the power and control systems were test-operated for 300 hours at 100° C for silicon and 50° C for germanium with junction temperatures brought to 80% of their rated values.

Semiconductor circuits in the camera systems consisted of baked parts—parts that were stored for 1,000 hours at 100° C for silicon and 80° C for germanium.

2 cloud detectors. The next Nimbus will carry two kinds of infrared cloud-detection systems, both medium-resolution and high-resolution. Nimbus I had only the high-resolution infrared system. The infrared systems permit scientists to obtain cloud data at night because the television cameras can only supply useful data in daylight.

In Nimbus A1 the high-resolution infrared system will be linked to the Automatic Picture Transmission (APT) slow-scan television system. This will permit small APT ground-receiving stations to re-

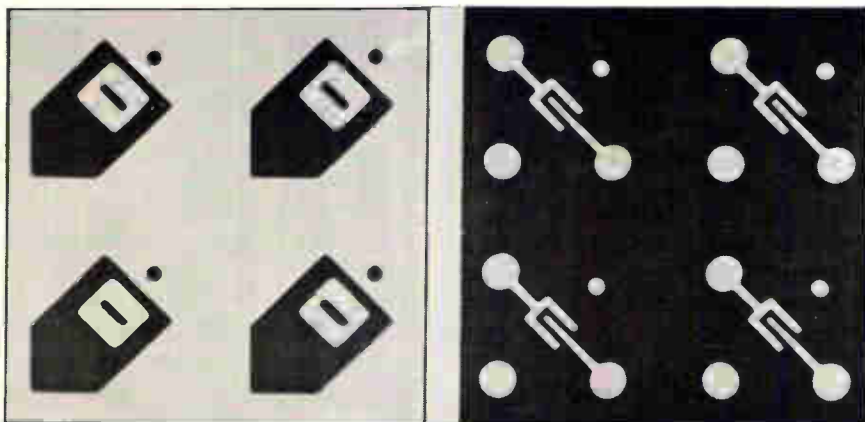

Fly's eye camera puts up to 1,250 patterns like these on a single negative. Pattern at left is for semiconductor-device emitter diffusion. At right is a contact etching mask, like those used to develop circuits in IBM's System 360 computer.

ceive television pictures in the daytime and infrared readouts at night. Nimbus AI, like Nimbus I, will also carry the advanced vidicon camera system—a system that takes pictures and stores them for readout and transmission over one central receiving facility. APT, on the other hand, sends back local area weather pictures in real time to the ground-receiving stations.

The medium-resolution infrared and pulsed-code modulation systems will be linked and assembled using integrated circuits supplied by Texas Instruments, Inc. The digital tape recorder on Nimbus AI will have a thin-film circuit as a preamplifier, manufactured by CBS Laboratories, a division of the Columbia Broadcasting System, Inc.

Government

Shifting sites

The National Aeronautics and Space Administration made a lot of congressmen from other bailiwicks unhappy when it selected the Boston suburb of Cambridge, Mass., as the site of its \$60-million Electronics Research Center. Now the agency is hearing grumbling from an unexpected quarter—Cambridge itself.

The 29 acres selected by NASA for the center are in the heavily congested Kendall Square area of Cambridge and are part of a 43-acre tract marked years ago for urban renewal. The hordes of small businessmen operating in the area, who couldn't afford to relocate, have fought the renewal program up to now; but NASA, which is anxious to get its center into operation, said that the Cambridge site was selected on the condition that the city of Cambridge provide cleared land "without unreasonable delay."

NASA won't admit that it is looking for another site but there is widespread speculation, both in Boston and Washington, that it may have to. James E. Webb, the space agency administrator, wants

the research facility to be near the Massachusetts Institute of Technology, Harvard University and other academic centers in the Boston area. There are at least two other sites near Cambridge that would meet this criterion: the Watertown Arsenal, which the Department of Defense is gradually phasing out, and 24 acres owned by the Massachusetts Turnpike Authority across the Charles River from Harvard.

Get out of town. Arthur Metcalf, president of the Electronics Corp. of America, said 94 companies in Cambridge would have to move out if NASA moved in. He also complained that the city was top-heavy with tax-exempt institutions and governmentally supported activities.

The Associated Industries of Massachusetts is less than enthusiastic about Cambridge as the site of the new center. "We want NASA in Massachusetts," says a spokesman, "but it happens they picked a spot with a maximum impact on jobs. There are other sites where a minimum of dislocation would result."

It seems likely, especially if threatened litigation is initiated, that Webb may have to take another look at those other sites but, because of the political overtones in the situation, it is unlikely that anything will be done about the other sites until after Election Day in November.

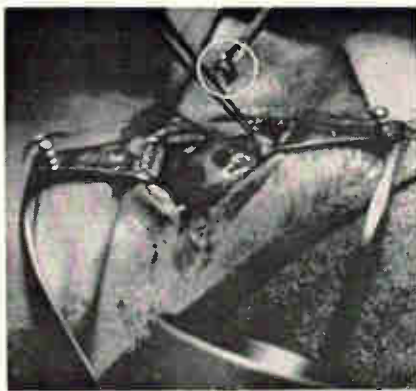

The brass fragment is shown gripped by the miniature ultrasonic-guided forceps, as it is being removed from the eye. The probe was developed by the Smith Kline Instrument Co. at the request of Dr. Nathaniel R. Bronson, who performed the operation.

Medical electronics

Ultrasonic success

A fragment of brass from a .22 caliber shell casing had pierced 11-year old James Cassidy's eye. Now it was firmly lodged near the retina. Even a powerful electromagnet, often used to extract particles from an eye, wouldn't be able to budge the alloy.

At the Walter Reed Army Hospital in Washington (Jimmy is the son of an Air Force staff colonel at the Pentagon) Dr. Jack W. Passmore, head of the hospital's eye clinic and ophthalmologist Dr. Nathaniel R. Bronson got busy.

In 39 seconds. After 1½ hours of preparation by Passmore, all was ready. Dr. Bronson placed a special ultrasound eye probe into the boy's blood-filled eye after a conventional ultrasound eye probe had fixed the rough location of the shell fragment.

Carefully he followed the sonar-like echoes displayed on a cathode-ray tube. Thirty-nine seconds later the operation was over—the brass particle had been removed and Jimmy's eye had been saved.

First time. It was the first time an ultrasound instrument had been used to remove a foreign body from a human eye. Electronic technology had made a notable contribution to medicine.

The instrument, developed by Smith Kline Instrument Co., a division of Smith, Kline and French Laboratories, is a diagnostic device using ultrasound over the range of 1 to 10 megacycles, at a pulse rate of 200 a second. Power levels produced by the diagnostic instrument may be adjusted from .1 to 10 milliwatts. These levels impart an average energy density to human tissue in the millijoule range, precluding damage to the eye.

The ultrasonic retrieval probe consists of a one millimeter diameter, ceramic, crystal transducer mounted behind the tips of miniature eye forceps. The probe is 2 millimeters across and 12 millimeters long, with the transducer installed a known distance from the

**Only
Lambda
offers**

**¼
4 rack
power supplies
with multiple current ratings**

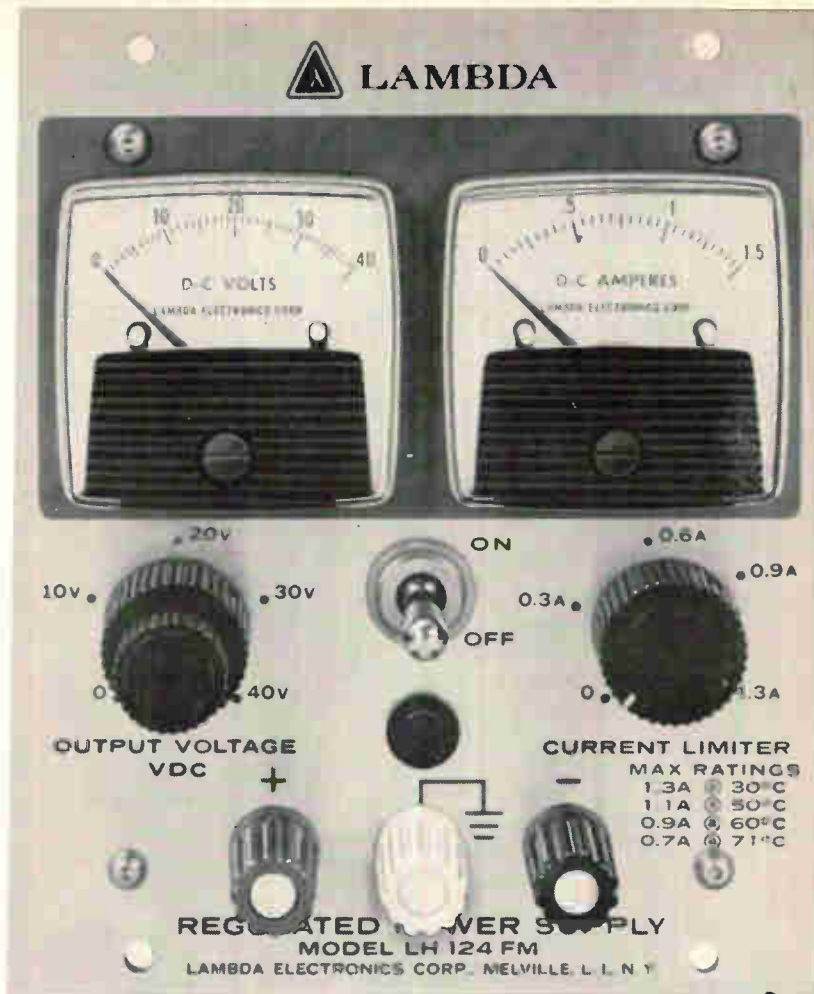

PATENTS PENDING



- Now LH Series is available in 0-10 VDC as well as 20, 40, 60 VDC ¼ and ½ rack models.
- Multi-Current-Rated™ up to 71°C.
- Modular-Subrack design for bench, chassis and rack use.

- Regulation—.015% or 1 MV (line or load)
- Ripple—250 microvolts rms, 1MV P-P
- AC Input — 105-135 VAC, 45-480 CPS.
- Size: LH 118, 121, 124, 127 — 5³/₁₆" x 4³/₁₆" x 15⁵/₁₆"
LH 119, 122, 125, 128 — 5³/₁₆" x 8³/₈" x 15⁵/₁₆"

Model	Voltage Range	CURRENT RANGE AT AMBIENT OF: (1)				Price (2)
		30°C	50°C	60°C	71°C	
LH 118	0-10VDC	0-4.0A	0-3.5A	0-2.9A	0-2.3A	\$175.00
LH 119	0-10VDC	0-9.0A	0-8.0A	0-6.9A	0-5.8A	\$289.00
LH 121	0-20VDC	0-2.4A	0-2.2A	0-1.8A	0-1.5A	\$159.00
LH 122	0-20VDC	0-5.7A	0-4.7A	0-4.0A	0-3.3A	\$260.00
LH 124	0-40-VDC	0-1.3A	0-1.1A	0-0.9A	0-0.7A	\$154.00
LH 125	0-40-VDC	0-3.0A	0-2.7A	0-2.3A	0-1.9A	\$269.00
LH 127	0-60VDC	0-0.9A	0-0.7A	0-0.6A	0-0.5A	\$184.00
LH 128	0-60VDC	0-2.4A	0-2.1A	0-1.8A	0-1.5A	\$315.00

(1) Current rating applies over entire voltage range. DC OUTPUT Voltage regulated for line and load.

(2) Prices are for non-metered models. For metered models and front panel controls, add suffix (FM) to model number and add \$25.00 to the price. For non-metered chassis mounting models, add suffix (S) to model number and subtract \$5.00 from the non-metered price.

LAMBDA ELECTRONICS CORP.
 515 BROAD HOLLOW ROAD • MELVILLE, L. I., NEW YORK • 516 MYRTLE 4-4200
 SEND FOR LAMBDA CATALOG
 SALES OFFICES AND REPRESENTATIVES CONVENIENTLY LOCATED IN MAJOR CITIES

LA155

Circle 31 on reader service card

forcep tips. After the forcep-probe is introduced into the eye, the eye surgeon monitors his progress on a one-inch cathode ray tube as he approaches the object. The display is an "A" scan much like that used in submarine sonar work. When the position of the transducer to the object is reduced to a known distance, 6mm, the forceps are closed and the object removed.

The one-inch cathode ray tube which displays the ultrasound echo has been designed to permit sterilization by gas methods so that it may be placed adjacent to local operating area. The locator and extractor probes may also be sterilized.

Sense of awe. Commenting on the operation, Donald J. Hart, biomedical research engineer, who aided in the development of the

special probe and electronics for the instrument at Smith Kline says, "The ease with which Dr. Bronson manipulated the extractor in removing the large foreign object from the boy's eye made the hours of research and planning to develop these techniques more than worthwhile. It left me with a sense of awe at the possible and still untapped contributions of electronics technology to medicine."

Safety factor. The diagnostic ultrasound instrument, with other probes, also has applications in neurological examinations of the human brain (echoencephalography), without the risks of x-ray techniques; and in fetal head-diameter measurements of infants before delivery to indicate head size in relation to pelvic opening without radiation dangers.

Ultrasound-guided forceps remove a piece of brass from a boy's eye. The surgeon was able to remove the foreign object without random surgical probing in the blood-clouded eye. A cathode ray screen display told him when the transducer-forcep probe was at the correct distance from the object.



Advanced technology

Excitement in lasers

Every laser ever made works on the same principle: in order to get laser emission, it is necessary first to produce a "population inversion," that is, the ratio of highly excited atoms to less excited atoms has to be greatly increased.

Now, Michael Seman and Walter Roth, scientists at the Xerox Corp., propose a new method of achieving the population-inversion effect. Instead of adding to the number of highly excited atoms in the laser material, they propose to reduce the number of unexcited atoms. This would provide the necessary unstable state that triggers laser action.

Chemical selection. This reverse technique is expected to work in gaseous systems with chemical reactions that involve only the low-energy atoms and do not affect the high-energy atoms at all. Chemical transformation would remove the low-energy particles thus providing the necessary ratio.

The subtraction approach could produce laser action from new materials and get more efficient laser action, since no high-energy triggering device need be used. Other possibilities, say the Xerox researchers, are the operation of an ultraviolet laser and a continuous-wave system.

Experiments now underway with a sodium-chlorine system will show whether the new method works.

Brighter image

New horizons for electron microscopes have been opened by the first use of a two-stage intensifier and television monitor with the microscope.

The intensifier, developed by the Radio Corp. of America, amplifies the electron image by magnetically accelerating its electrons between two pairs of screens, and increases the brightness of the image 2,500 times.

From the intensifier, the image is picked up optically by a sensi-

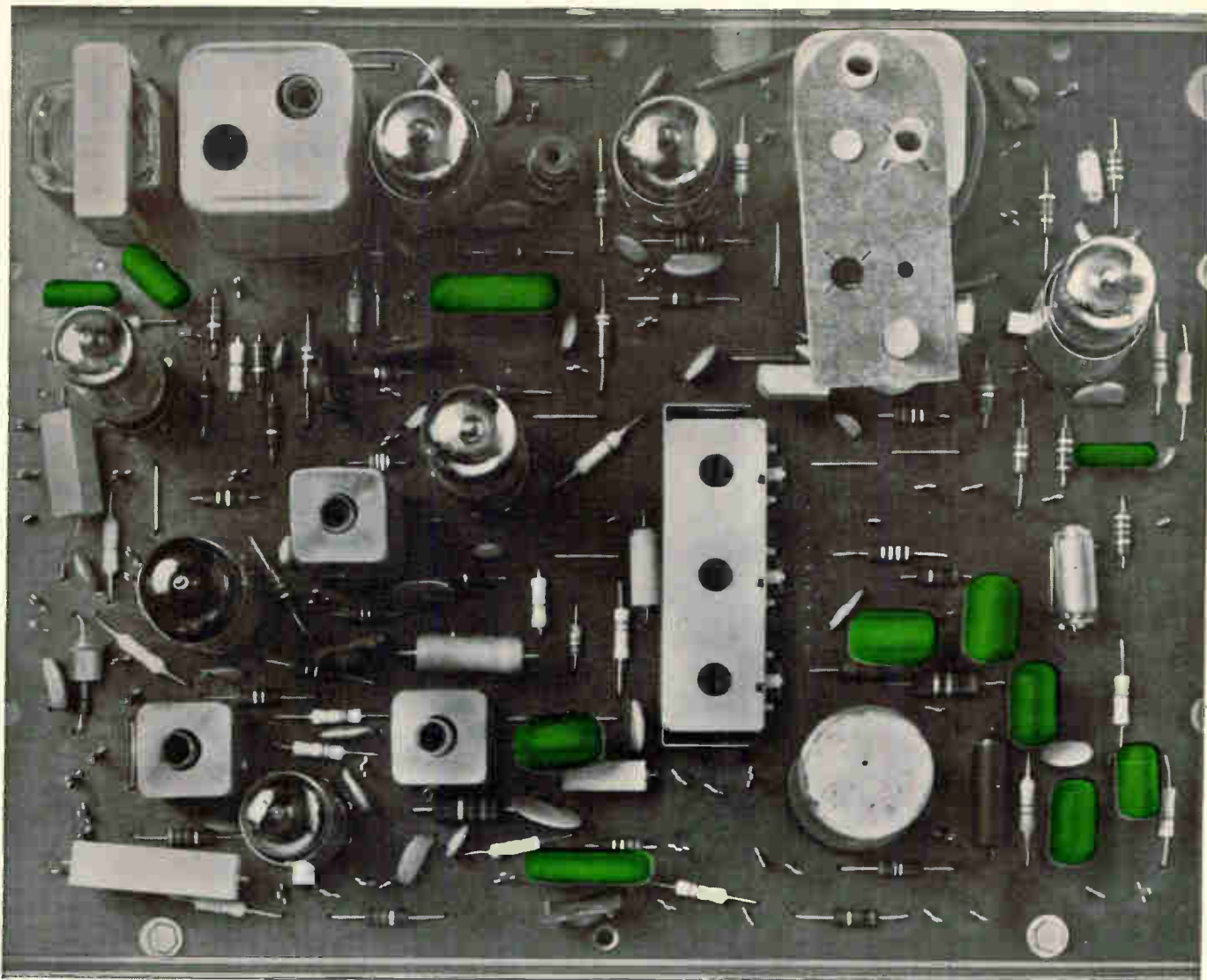

In Westinghouse TV, capacitors of "Mylar"® replaced those of molded paper-

Bob Tesno, TV Engineering Supervisor, tells why:

1. Reliability

"We ran extensive tests comparing capacitors with a dielectric of 'Mylar'* with ones of paper, molded paper and dual dielectric. We found that the capacitors of 'Mylar' came out on top—with virtually no temperature, humidity or leakage problems. In the four years since their adoption, the reliability of capacitors of 'Mylar' in the field has been nearly perfect."

2. Size

"Actually, we first adopted capacitors of 'Mylar' for all Westinghouse TV receivers when printed circuit boards became important factors in production. Capacitors of 'Mylar' are considerably smaller than molded-paper ones of equivalent value. This avoids crowding of components on the board."

*Du Pont's registered trademark for its polyester film.

3. Price

"As a clincher," adds Tesno, "in most cases* capacitors with a dielectric of 'Mylar' cost no more, and, in fact, often cost less than molded-paper or dual dielectric capacitors."*(Note: This applies to capacitors that are up to .1mfd 400v in size.) Can your designs benefit from the many advantages of capacitors of "Mylar"? For complete data, write Du Pont Film Dept., N10452 B-22, Wilmington, Delaware 19898.



Better Things for Better Living
...through Chemistry



tive image-orthicon tube and fed into a special television system where it can be displayed, electronically processed, reversed into a negative with improved contrast, or be recorded in real time on film or on video tape.

The intensifier system can pick up a very faint image and provide further magnification; the electron microscope thus produces a total magnification of about two million; that would magnify a paper clip so it would appear to be 32 miles long.

The magnification possible in an electron microscope has been limited up to now by the problem of brightness. Since the image brightness drops by a factor of four each time magnification is doubled, users have kept their instruments in the dark and tried to make out the faintest possible image on the microscope viewing screen in order to squeeze out all the magnification possible. Often, photographs are made and the image seen for the first time only after the photographs were developed. Increasing the source brightness hasn't helped because the great concentration of energy, especially in organic studies, destroyed the specimen before it could be examined.

Now with the intensifier, the operator can continuously see the image, even while it is being recorded or photographed. The image brightness on the television monitor is high enough for viewing in a lighted room, and can easily be viewed by a large number of people. Previously only two or three persons could squeeze close enough to the electron microscope to see what was going on.

Real-time recording is valuable for studying irreversible one-time events such as metal failures, temperature reactions and other transient phenomena. Now these images can be put on tape or film, and watched over and over again. This is also the first time tapes or movies can be taken directly from an electron microscope.

Another advantage is that specimens likely to be damaged by the intense radiation of an electron microscope can be seen for the first time. Still photographs can be

taken in a fraction of a second instead of several seconds as before.

The image intensifier used is very similar to one being manufactured for the Army for nighttime warfare, but simpler and cheaper.

The television system, which can be added to almost all RCA electron microscopes, adds about \$25,000 to the microscope's price.

Remote-controlled glider

A silent, unmanned glider, controlled by electronically created sound, is being tested for delivering supplies to American troops in Thailand's jungles.

The inflatable glider uses manually controlled guidance by day and an automatic homing system at night. It is manufactured by the Ryan Aeronautical Co.

The glider, in a parachute-type package, is already electrically energized when it is dropped out of a plane. After a six-second delay, the glider opens into a modified parachute and compressed air is released into its inflatable wing and keel. The glider then decelerates, stabilizes and completes the transition from parachute mode of operation to glider mode.

For daytime operation, two audio-tone generators, one at 312 cycles per second and the other at 525 cycles per second, control the

glider. One frequency turns the glider to the left; another frequency governs a right turn.

Electronic pilot. At night, a 977-cycle-per-second tone is generated from a remote ground station and transmitted to two receiving antennas on the glider. If one antenna receives a stronger signal than the other, the glider will turn toward the stronger signal until the strengths become equal. It will continue along this path until another unbalanced signal condition forces another change in direction.

When the glider is in sight, the operator of the remote station can override the automatic homing signal and bring the glider down within a radius of 200 feet of the transmitter.

The transmitter and receiver are completely solid-state and powered by separate battery packs. Very little radiated power is needed for guidance—one-half watt at 133 megacycles—so the electronic gear is compact and portable.

The receiver consists of two identical superheterodyne receivers with a common local oscillator, summed automatic gain control and a control logic system. Signals received at two receiving antennas are amplified, demodulated and fed to logic relays through selective band-pass filters. These signals in turn actuate a reversible servo control motor that causes a differential displacement of the left and right suspension lines connected to the rear end of the wing's leading edges. This causes the glider to turn either left or right.

Simple structure. The glider wing consists of three inflatable structural members, a flexible membrane and an inflation system. The structural members—two leading edges and a keel—join at the apex to form a triangular wing platform. The keel runs longitudinally aft from the apex along the center line of the wing. The three are bonded together and form an inflatable air chamber.

The control platform and cargo container are suspended beneath the wing and attached by lines and control cables.



Audio-controlled glider makes a delivery.



When your operation calls for a reliable digital transport

Just call for CEC's DR-2700 Recorder/Reproducer

Reason: The DR-2700 has set completely new standards of reliability and efficiency for digital recorders. It's so durably constructed and simple to maintain, it's a virtual stranger to off-the-line servicing.

The DR-2700 is a consistent choice for both commercial and military use. These basic advantages will explain why:

- Solid state electronics throughout.
- No programming restrictions at command rates to 200 per second at 150 ips.

- Interlocked command circuits to prevent response to contradictory commands.
- Start/stop time less than 3.0 milliseconds.
- 7 through 16-channel capability in a 72-inch-high cabinet.
- IBM 729 IV compatible.
- ½" or 1" tape configuration.
- Densities up to 555.5 bits per inch.
- Vacuum-buffered tape storage for gentler tape handling.

Of course, those are just some of the reasons why the DR-2700 has become the obvious choice. You will find all its specifications and features equally significant.

For all the facts about the DR-2700, call or write for Bulletin CEC 2700-X15.

CEC

Data Recorders Division

CONSOLIDATED ELECTRODYNAMICS

A SUBSIDIARY OF BELL & HOWELL/PASADENA, CALIF. 91109

INTERNATIONAL SUBSIDIARIES: WOKING, SURREY, ENGLAND

AND FRANKFURT/MAIN, GERMANY

Circle 35 on reader service card

RAYTHEON DIGITAL PRODUCTS

EQUIPMENT/SYSTEMS

for today's needs and tomorrow's speeds

Application

Note #2

This is the second in a series of helpful application engineering tips from Raytheon . . . leader in impulse instrumentation for the high-speed data processing field.

PROBLEM: To digitize multiple inputs (200) in a very short period of time or within close time correlation (1 millisecond).

SOLUTION: The system illustrated in the block diagram sequentially samples 200 input signals in 1 millisecond in the Raytheon Model DM-120 Multiplexer. Used with the associated analog-to-digital converter, Raytheon Model AD-10B, the system is capable of digitizing the signals to a 10 bit accuracy at a 200 KC rate or a 2 MC bit rate.

This system overcomes, for the first time, the economic disadvantage of using a number of A-to-D converters which run at a slower conversion rate and require additional buffering at their output.

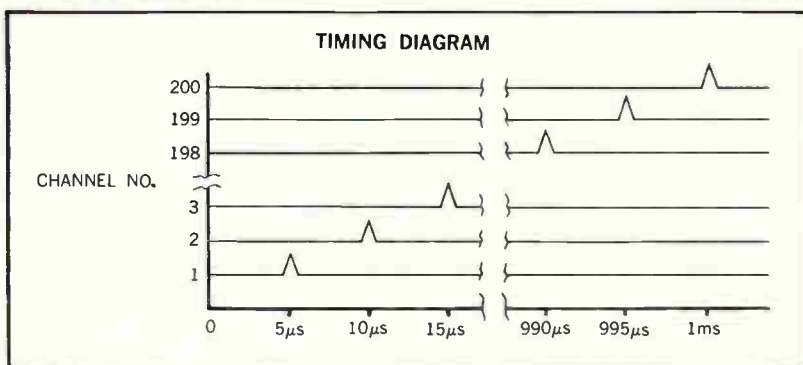
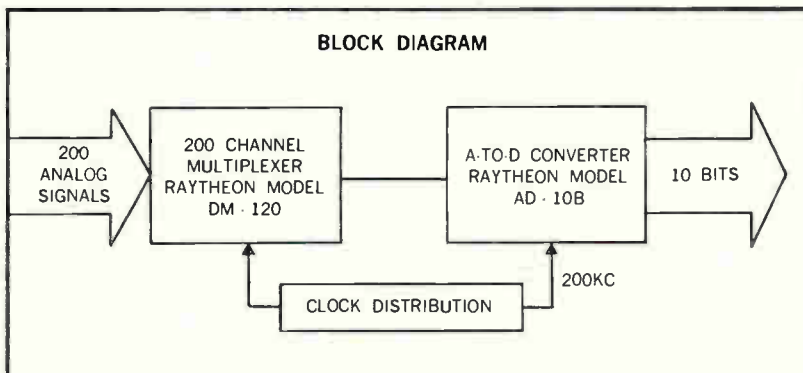

For complete application notes covering this system write (on company letterhead) to: Dept. E-1064

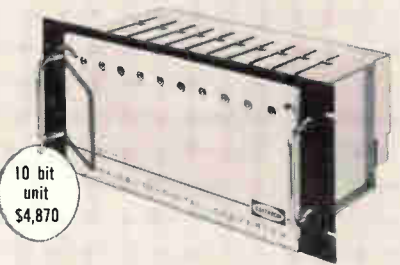

10 bit unit
\$4,870

AD-10B

Ultra High Speed A/D Converter

Raytheon's Model AD-10B is a solid-state, high speed unit capable of up to 250,000 complete 10 bit conversions per second at 0.1 percent accuracies. Its combined speed and accuracy are ideal for applications requiring burst data acquisition.

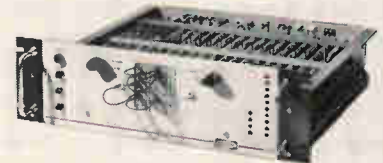

DM-120

Multiplexer

The Raytheon Model DM-120 Multiplexer provides 24 analog switches per unit (expandable to 576 channels in multiple arrays) plus addressing and sequencing logic. The switches are used to connect many analog signals into one A-to-D converter at multiplexing rates up to 1 million channels per second. The unit is capable of super commutating as well as de-multiplexing.

FREE TRIAL OFFER!

Evaluate a Raytheon AD-10B Converter in your own facility at our expense. Contact your Raytheon representative or call collect: Ron Eisenhauer, Area Code 617, 762-6700, extension 406. Raytheon Company, CADPO, 1415 Providence Turnpike, Norwood, Massachusetts.



Bourns Micro-Components: Complete Selection, Highest Ratio of Performance to Size!

Who but Bourns can offer you a resistor with $\pm 5\%$ tolerance in a package just 0.10" long? Or an 85mw transformer in a 0.250" cube? Or a capacitor combining a dissipation factor of 2.5%, max., with a body length of .150"? That's just the start of the Bourns micro-component story.

Take your choice: discrete components (for hybrid circuitry and conventional micro-packaging) or custom film circuits on ceramic substrates. Either way, you get the highest available ratio of performance to size. Bourns micro-components meet applicable MIL-Specs, they're competitively priced and they're available now!

In addition, they're the most thoroughly inspected and tested in the industry. They undergo 100% in-process and final inspections, and are subjected to the relentless double-check of the

Bourns Reliability Assurance Program. And to back them up further, there's the Bourns record of reliability—16 years of participation in the most important programs of our time. Get full details by writing for our free 4-page micro-component technical bulletin now.

Units shown actual size



Micro-Resistors
10 Ω to 1 Meg.



Micro-Inductors
0.1 Hy to 66 Hy



Micro-Transformers
up to 85mw at 1 KC



Micro-Capacitors
10 pf to 0.12 mf

CUSTOM FILM CIRCUITS ON CERAMIC SUBSTRATES ALSO AVAILABLE

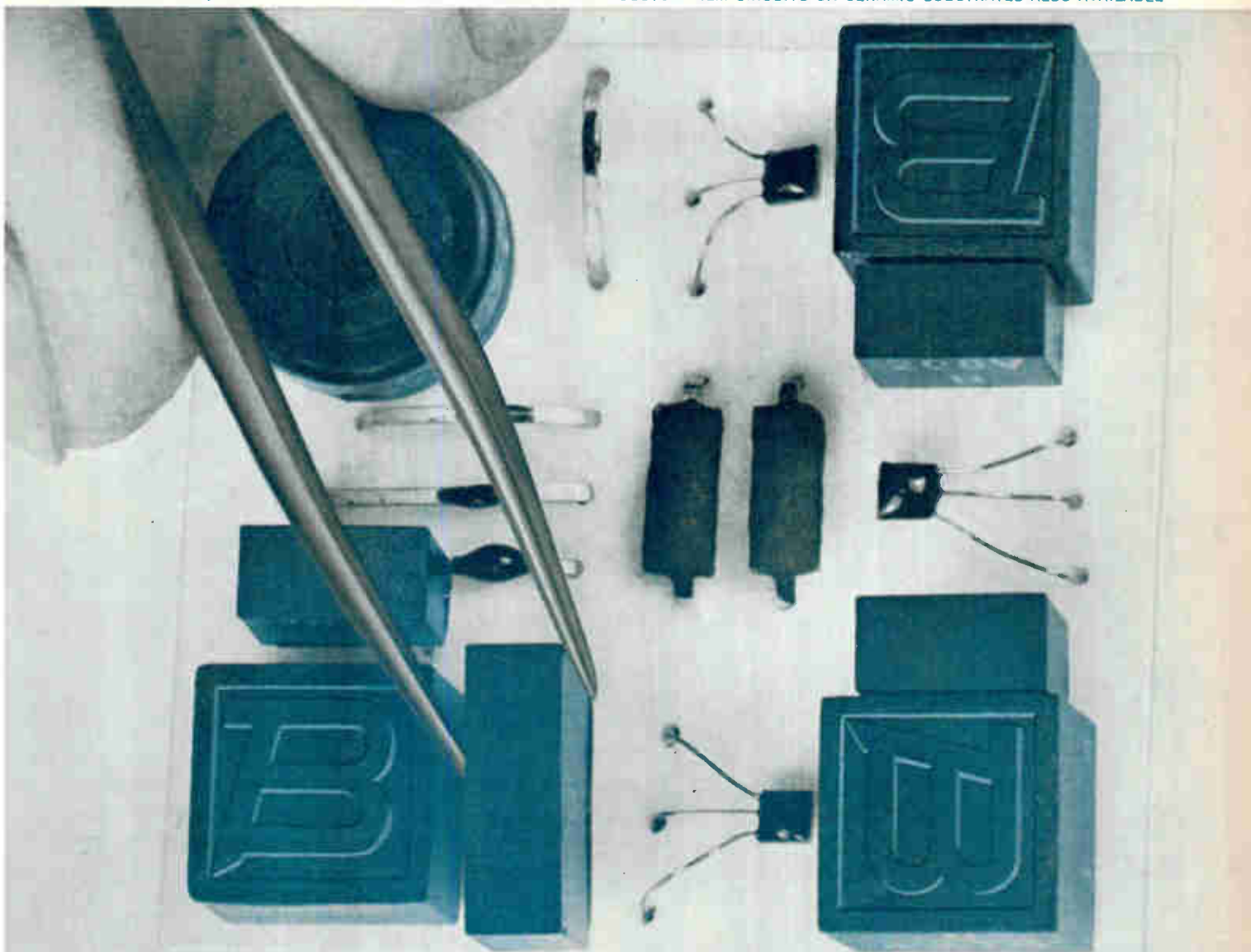

BOURNS

BOURNS, INC., TRIMPOT DIVISION
1200 COLUMBIA AVE., RIVERSIDE, CALIF.
PHONE 684-1700 · TWX: 714-682 9582
CABLE: BOURNSINC.

Honeywell
uses **CTC** memory
test systems

and so do its
core and stack
suppliers

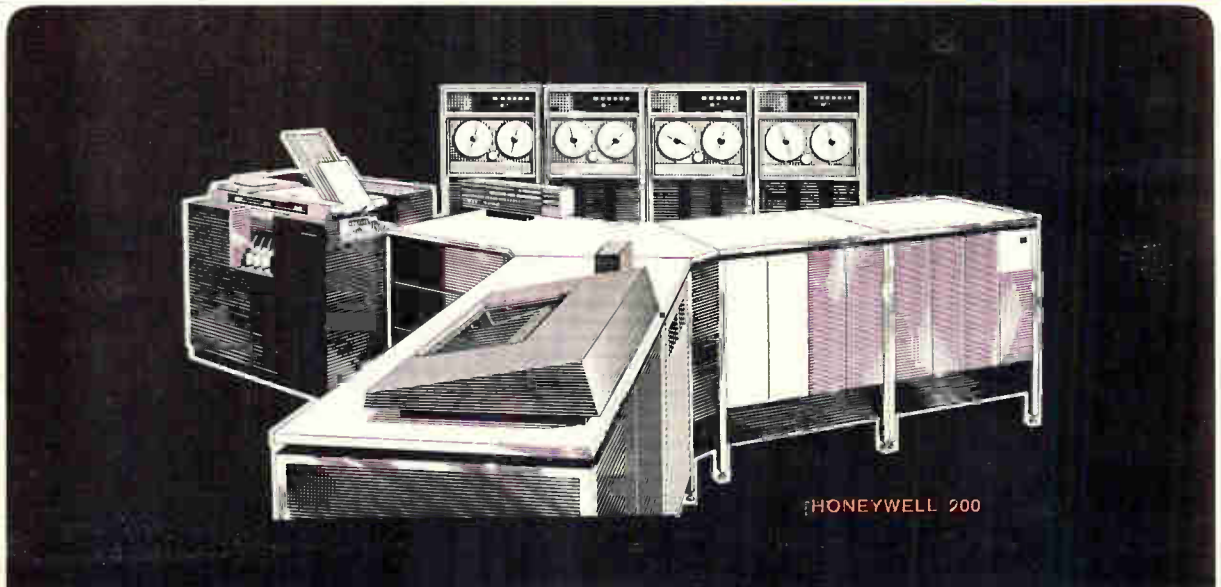

HONEYWELL 900

...those who build the
most reliable digital systems
standardize on
CTC test equipment

**COMPUTER TEST
CORPORATION**
CHERRY HILL, NEW JERSEY



Washington Newsletter

October 5, 1964

Live Olympic tv passes first tests

First test results of the Syncom III relay system makes engineers optimistic about live television coverage of the Olympic Games (p. 60). Commercial-quality TV pictures were attained. The tests were made on wide-band equipment, and engineers predict even better results when narrow-banding equipment is installed at the Japanese transmitter.

When the first signals went on the air, screens were black, with signals being received at a carrier-to-signal ratio of only one decibel, but engineers found that their initial calculations of polarization of signal were incorrect. They readjusted the waveguide twist designed for that purpose, and pictures were so good that Japanese and American engineers celebrated with sake and champagne.

Better rewards for R&D weighed

The Defense Department considers a more liberal policy of reimbursing contractors for independent research and development efforts. A subcommittee of the Defense Industry Advisory Council, which is gathering data from several contractors, plans to assess the data soon. A new policy, long sought by defense contractors, is expected to be drafted and debated in the Pentagon by January.

The issue boils down to this: To what extent should the government finance R&D that the Defense Department doesn't initiate but that industry carries out on its own with the hope of developing items and information for sale to the military?

Johnson stresses weapon advances

President Johnson is reaping all the political advantage he can out of military hardware developments. To counter Sen. Goldwater's charge that Democrats have been letting weapons development lag, Johnson has been announcing piecemeal a series of advances. Over-the-horizon radar and a system for shooting down bomb-carrying satellites are the latest examples (story on p. 101).

There is widespread speculation that before Election Day the President will announce the Administration's readiness to receive proposals from contractors for a manned orbital laboratory. And without specifically committing himself to a development program, he may also indicate stepped-up study of a new manned bomber. Nothing has yet been said about how the Pentagon will use the \$47 million that Congress voted to complete studies on the new plane and to start work on components with long lead times. The Administration had requested only \$5 million.

Military-civilian friction may ease

Some of the conflict between civilian experts of the nonprofit "think tank" and the military weapons analysts in the Pentagon is expected to be eased with the appointment of Jack P. Ruina as president of the Institute for Defense Analysis. Ruina, experienced in working on defense projects with the military, succeeds Richard M. Bissell Jr.

Friction between the civilians and the military developed when Bissell, under orders from the Defense Department, revamped the relationship between the institute and the Pentagon's Weapons Systems Evalua-

Washington Newsletter

tion Group, gaining more freedom for institute experts from the military. The Pentagon's object was for more thorough and objective analyses. The Bissell reforms so irked the military that two three-star generals retired early from the weapons group.

Easing controls on risky projects

Defense officials are considering an easing of controls on contractors who accept high risks. The Pentagon is studying a concept known as "contractor weighted average share," under which a contractor would have a risk score, obtained by evaluating the type of contracts—cost-plus, incentive, fixed fee—he has with the government.

The theory is that if a contractor has a substantial ratio of preferred incentive contracts, and through these contracts is accepting substantial risk, he is sufficiently motivated to control his own costs so that government controls can be eased or eliminated.

The relaxation of controls would extend to government approval of purchasing systems and overtime payments, permission to subcontract, supervision of make or buy decisions, and other aspects. The Defense Industry Advisory Council is working with defense procurement officials to develop the concept.

New Nike-X funds

The Army has given the Western Electric Co. funds for another year's development work on the controversial Nike-X anti-missile missile defense system. Western Electric is the manufacturing arm of the American Telephone & Telegraph Corp. The award of \$309.6 million is added to the \$2 billion already spent to develop the system, although Defense Secretary Robert S. McNamara has said that he hasn't yet decided whether to give the go-ahead on producing and deploying the missile defense system.

Fight brewing over Telpak

If the Federal Communications Commission rules against the Bell System's Telpak service, the issue may be carried to court. Strong support for the bulk microwave communication service was voiced last month by 18 major users, including the government's General Service Administration, the International Business Machines Corp., the Xerox Corp., Eastern Air Lines, Inc., the American Trucking Association and U.S. Steel Corp.

Opposition comes from the Western Union Telegraph Co., Motorola, Inc., and some other microwave equipment manufacturers. They argue that Telpak is unduly competitive. The American Telephone & Telegraph Co. and some of its Telpak customers contend that the service is needed to meet competition and to fill industry's need for bulk communications.

Last March, the FCC tentatively ruled against the Telpak's A and B service that offers the equivalent of 12- and 24-voice channels respectively. It gave limited approval to the C service, with 60 channels, and the D, with 240 channels, if rates are increased. However the agency rules, the issue is certain to spark strong protests.

IUE to step up drive for members

Beefed-up organizing drives to recruit mostly white-collar workers at electronics and instrumentation firms are mapped by the International Union of Electrical Workers, although IUE members at their recent convention failed to provide the additional funds necessary for such a drive.

FORMICA® is our trademark for various products, including our brand of industrial plastics.



FORMICA®
FR-200

• **Flame retardant • High strength • No premium price**

FORMICA FR-200 paper-phenolic laminate . . . for flame retardant printed circuitry. NEMA grade FR-2. Meets properties of MIL-P-3115C. Burn time: 4 sec. (ASTM D635-65 test modified to show burn time after 1st ignition.) High flexural strength (flatwise average value: 21,500 psi lengthwise, 17,500 psi crosswise.) Excellent insulation resistance. High solder blister resistance . . . in excess of 15 sec. at 500°F. Good solvent resistance: 10 min. in trichloroethylene. Can be punched cold up to and including $\frac{1}{16}$ " , warm (140° to 180°F) up to and including $\frac{3}{32}$ ". Available copper clad or unclad. And you pay no more for FORMICA FR-200 than you would for a top-quality XXXP grade.

WRITE FOR DATA ON:

- Electrical /electronic grades
- Copper clad laminates
- Mechanical grades
- Engraving stock

FORMICA CORPORATION
DEPARTMENT-426, CINCINNATI 32, OHIO
subsidiary of 

FORMICA®
industrial plastics

See The Formica World's Fair House at New York for the newest and best in carefree contemporary living.

DEPENDABILITY TO BUILD A NAME ON

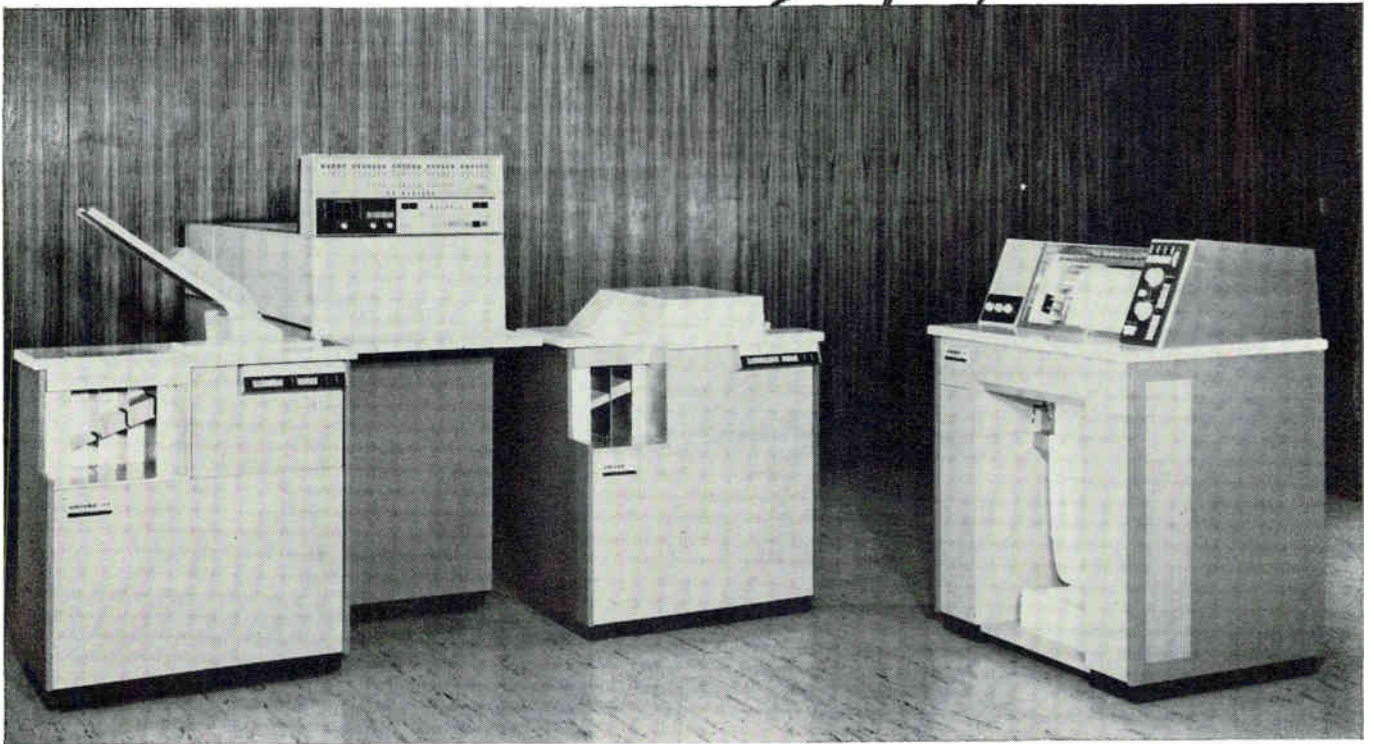
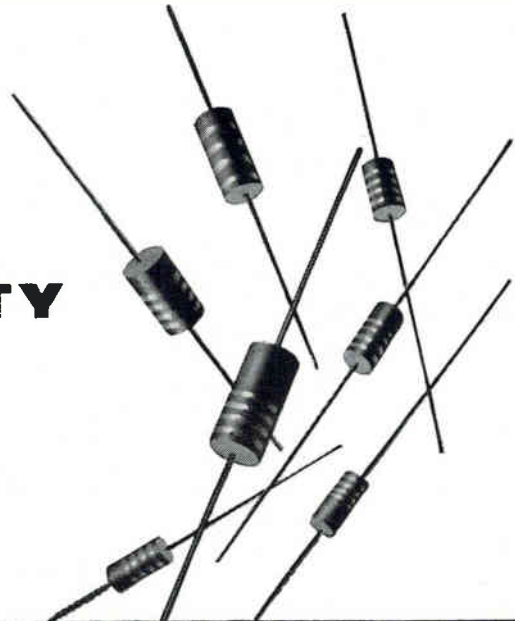

When you build precision computer systems like the UNIVAC 1050, exacting standards are a must. This new computer series developed by the UNIVAC Division of Sperry Rand Corporation brings quality, plus flexibility and economy to medium and small computing applications. Faultless performance of each component must support what has come to be expected of the whole. Reputation . . . of equipment . . . of company, rests upon accuracy and reliability. Such responsibility demands the best . . . Stackpole.

Stackpole resistors are 100% tested. Constant checks on solderability, load life and humidity-temperature characteristics insure highest quality. And each failure-proof resistor order gets to you on time, with "same day" shipment. Let us tell you more about them, write: Stackpole Carbon Company, Electric Components Division, Kane, Pa. Phone: 814-837-7000. TWX: 814-826-4808.



STACKPOLE
ELECTRONIC COMPONENTS DIVISION

ticklish signals?

PUT THEM ON PAPER WITH EASE WITH THIS NEW SOLID STATE OSCILLOGRAPH

Now you can precisely measure and record a greater variety of AC and DC variables — over wider dynamic ranges and with more signal-conditioning capabilities at your command — with this new Sanborn 7700 Series 6- and 8-channel oscillograph. A choice of highly developed plug-in preamplifiers (eight in 7" x 19" of panel space) gives you recording capabilities such as: 1 $\mu\text{V}/\text{div.}$ to 250 volts full scale in a single preamp, which also has multi-range, calibrated zero suppression built in . . . phase-sensitive demodulation of in-phase or 180° out-of-phase floating signals, 60 cps to 40 KC, with calibrated or uncalibrated adjustable phase shifting . . . carrier signal recording from 10 $\mu\text{V}/\text{div.}$ and with calibrated zero suppression and cal. factor.

The all-solid-state circuits in this new system also mean cooler operation with less power than tube circuits . . . easy servicing of modular circuits on accessible plug-in cards . . . simpler, smaller power supplies with integral AC excitation . . . and generally improved drift, gain stability, noise and linearity characteristics. Combine these advantages with the proven and widely-used Sanborn *heated stylus-Permapaper*® recording method: true rectangular coordinate writing with *higher* resolution at slow chart speeds, *no* spills or smears, *greater* environmental immunity, *no* priming or constant attention needed. Call your HP field engineering office for complete specs — or write Sanborn Company, Industrial Division, Waltham, Mass. 02154

SANBORN 
A DIVISION OF HEWLETT-PACKARD

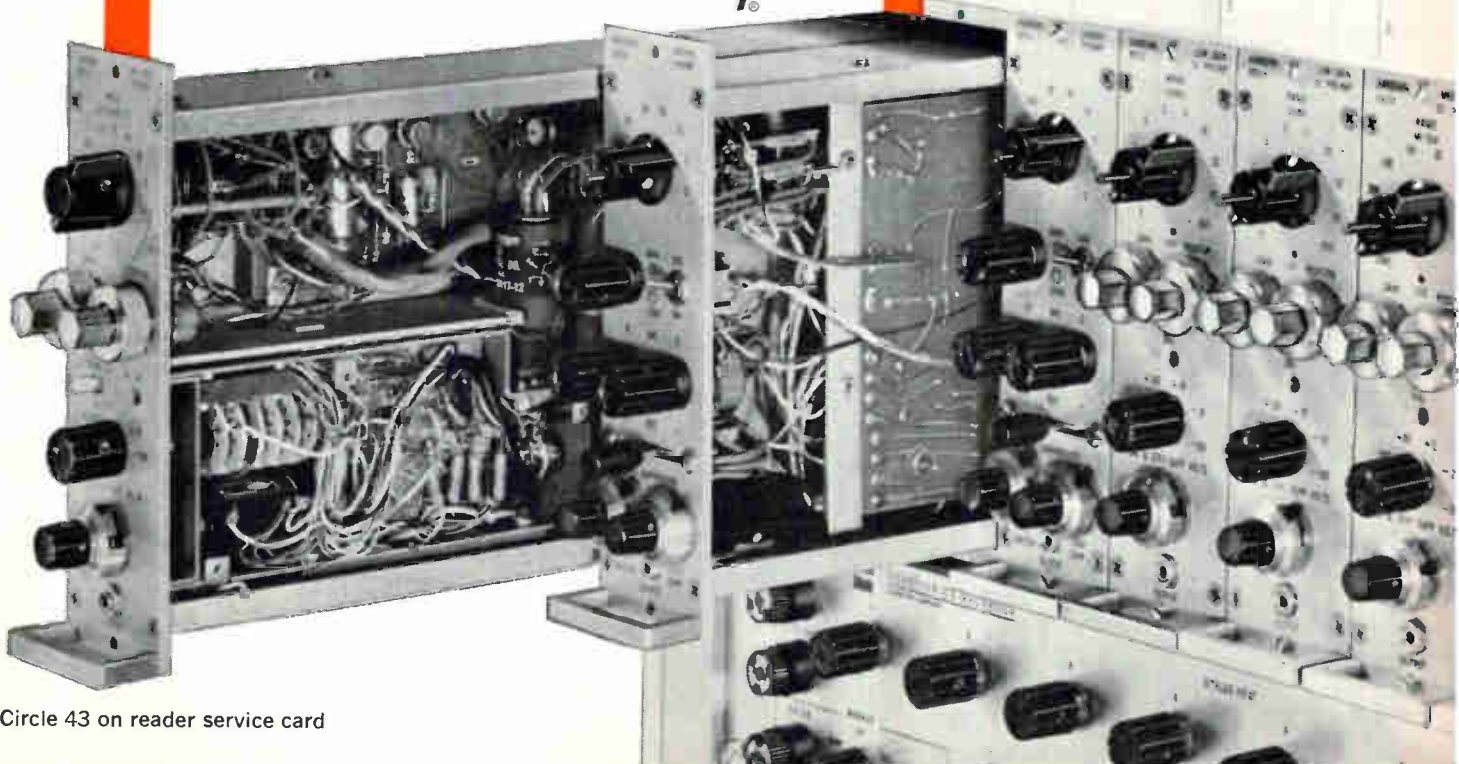
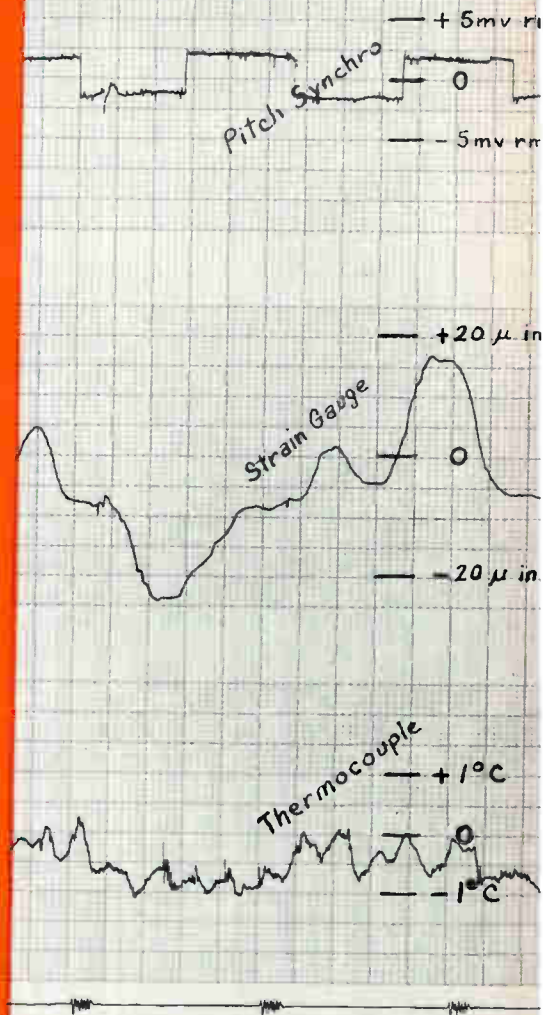

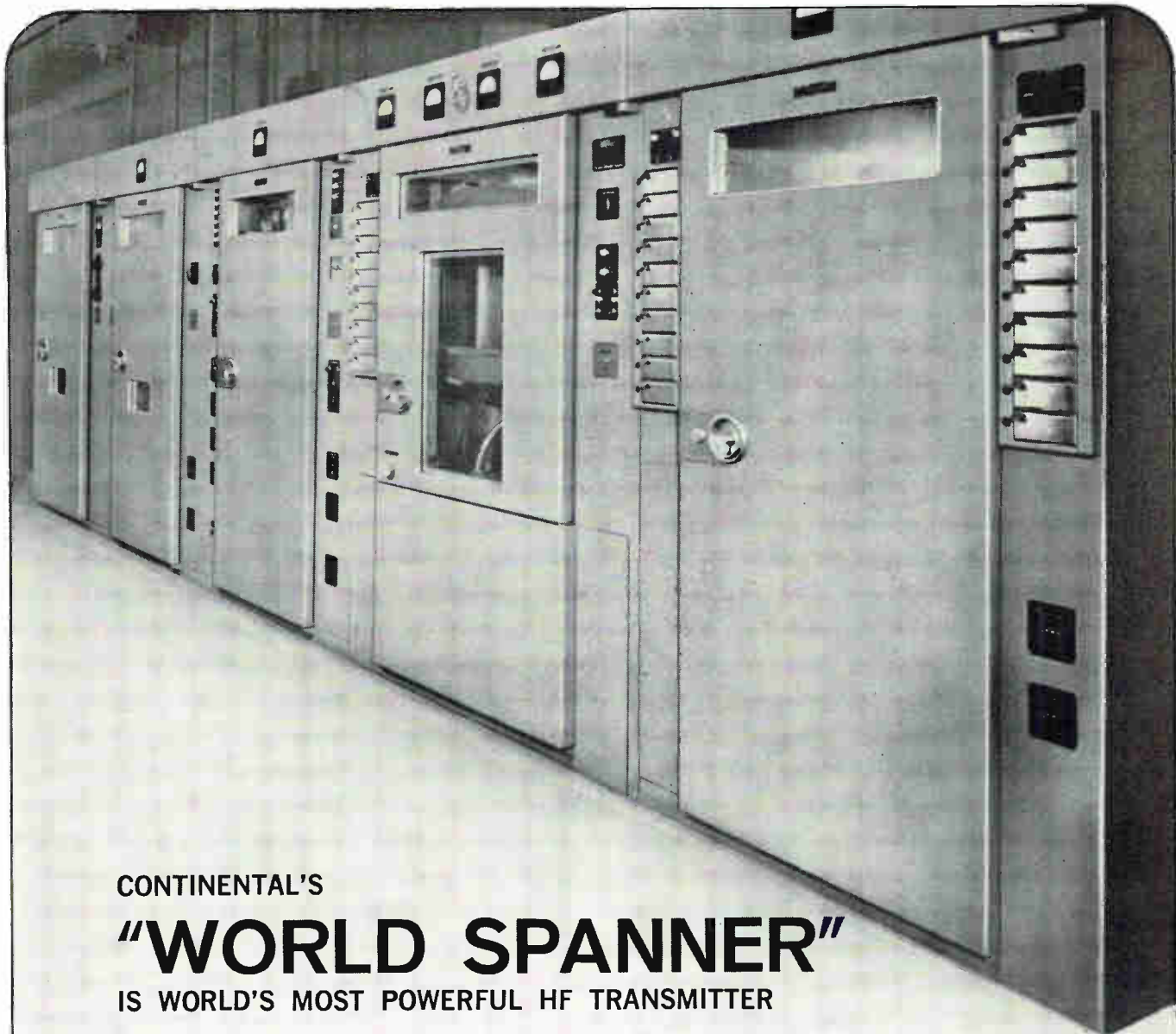

CONTINENTAL'S

"WORLD SPANNER"

IS WORLD'S MOST POWERFUL HF TRANSMITTER

Generating 600,000 watts peak, 300,000 watts average RF power, Continental's Type 621A Amplifier Group is currently being used by the U. S. Air Force, Army, and Navy in communication and research applications. Powerful enough to override natural disturbances and enemy jamming attempts, it beams messages anywhere on earth. Originally developed under an Army Signal Corps contract, and installed for operation as part of the AN/FRT-33 in

1958, it provides continuous range servo tuning of all circuit elements between 4 and 30 megacycles with the capability of presetting 10 channels. A linear amplifier, it can be used for various modes of output such as AM, FM, SSB, ISB, FSK, pulse or any other complex wave shape within the average and peak power capabilities of the equipment. Continental's AN/FRT-32 provides identical capabilities in the 20 to 65 megacycle range.

for information on this and other super power communication/radar and system experience, write Department 35, Continental Electronics Manufacturing Co., P. O. Box 17040, Dallas, Texas 75217

LTV *Continental Electronics*
A DIVISION OF LING-TEMCO-VOUGHT, INC.

New MTPH Miniature Wet Slug Capacitors

Proven In 1,430,000 Hours of Life Testing

Type MTPH capacitors were developed by Mallory as a result of experience gained producing a similar line for use in the Minuteman II missile system made by Autonetics Division of North American Aviation, Inc.

The MTPH style of capacitors are produced in the same "white room" manufacturing facility and by the same highly trained operators used for Minuteman II parts. The materials, production processes and quality controls are also the same; thereby assuring the highest degree of reliability.

MTPH capacitors have higher capacity-voltage product per unit volume than any conventional wet slug, foil or solid tantalum line. This size factor makes these capacitors very desirable for applications with thin

STANDARD RATINGS

MTPH NO.	Rated Cap Mfd.	Rated Voltage D.C.	DCL μa		DF% +25°C	% of +25°C Cap at -55°C	120 CPS Z at -55°C	DF% +85°C	Case Size
			+25°C	+85°C					
MTPH1	6.8	50	3	10	20	70	400	10	A
MTPH2	30	50	8	25	20	70	120	15	B
MTPH3	78	50	10	30	20	60	55	18	C
MTPH4	10	30	3	10	20	65	290	10	A
MTPH5	45	30	8	25	25	60	100	20	B
MTPH6	120	30	10	30	30	55	48	25	C
MTPH7	60	20	7	20	25	55	90	20	B
MTPH8	80	15	6	18	30	55	82	25	B
MTPH9	200	15	8	25	30	50	44	25	C
MTPH10	120	10	5	15	35	50	66	25	B
MTPH11	300	10	7	20	35	40	35	28	C
MTPH12	180	6	5	15	37	50	40	25	B
MTPH13	450	6	6	18	50	40	33	40	C

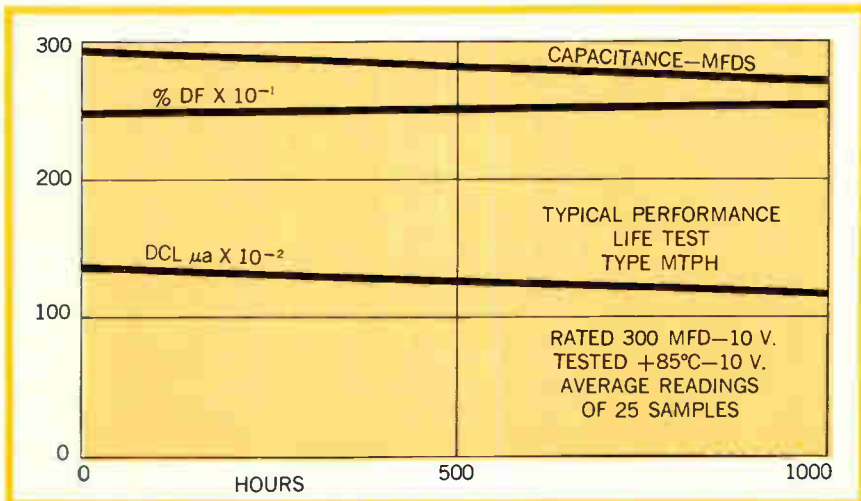
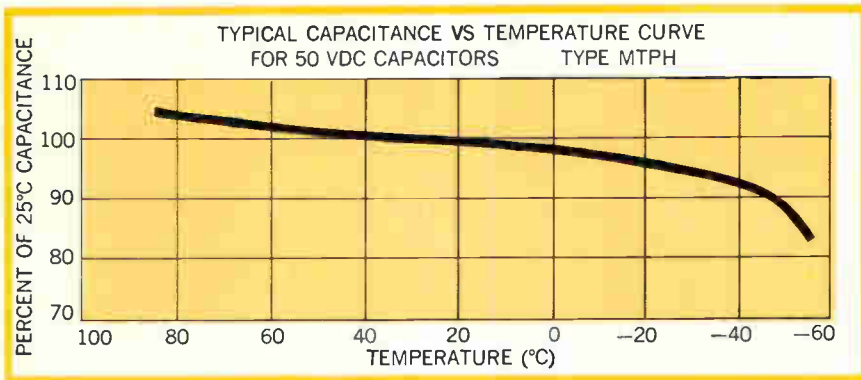

film, integrated and other micro-electronic circuits. An additional advantage of the wet slug construction is the absence of the familiar catastrophic failure mode of solid tantalum devices. After 1,430,000 unit hours of life test at 85°C, at full rated voltage, using a low impedance power source, not one MTPH has failed through short circuiting or excessive DC leakage current.

For complete data and prices, write or call Mallory Capacitor Company, Indianapolis, Indiana 46206—a division of P. R. Mallory & Co. Inc.



MALLORY

... AT LAST — THE FIRST TRUE HYBRID COMPUTER

A completely new kind of signal processor, the Adage AMBILOG™ 200 computer is designed from the ground up to exploit the best of both analog and digital techniques. It combines parallel hybrid arithmetic with stored-program sequential operation.

High processing speeds (often ten times faster than comparably-priced conventional machines) and extensive input/output for both analog and digital data make AMBILOG 200 ideal for data acquisition, simulation, and information display.

PARALLEL HYBRID ARITHMETIC

AMBILOG 200 achieves high processing speeds through parallel organization of hybrid computing elements all operating simultaneously on analog and digital operands. Word length of digital operands is 15 bits; analog accuracy is .01%. A fast 30-bit digital accumulator augments the 15-bit hybrid arithmetic.

A typical configuration performs 12 additions, 2 multiplications and 1 division in ten microseconds.

Hybrid arithmetic, A/D and D/A conversion, comparison, and signal routing and conditioning are all carried out under direct control of the stored program.

SEQUENTIAL STORED-PROGRAM OPERATION

Fifteen and 30-bit data words are transferred at high speeds to and from memory and all other parts of the AMBILOG 200 under flexible stored-program control. Core memory word length is 30 bits; cycle time is 2 microseconds. Memory sizes up to 32,768 words are available, all directly addressable. Digital I/O devices include punched tape, typewriter, magnetic tape, and direct data channels. A unique multiple priority interrupt system permits complete servicing of interrupts in as little as 3 microseconds, and facilitates interconnection for multi-processor installations.

PROGRAMMING

Instruction word length is 30 bits, permitting simultaneous control of memory, source and destination selection, word rotation, and Boolean logical operations. The order structure includes provision for recursive indirect addressing and indexing, a number of conditional and unconditional jumps, and program traps.

The AMBILOG 200 Symbolic Translator permits programming in symbolic source language and is easily extended to accept any problem-oriented source language.

Software support includes programmer and maintenance training, installation and maintenance services, system programs, standard sub-routines, and complete documentation.

BROAD APPLICATION

Flexibility, economy, and real-time processing power make AMBILOG 200 a "natural" for

- Biomedical monitoring
- Seismic data processing
- Sonar and radar signal enhancement
- Test stand instrumentation
- Programmed automatic checkout
- Factory test and inspection
- Communications research
- Process control
- Space-vehicle simulation
- Simulator trainers
- Telemetry receiving stations
- Visual display systems

For more facts, contact I. R. Schwartz, Vice President 617-UN 4-6620.



SEE AMBILOG 200 IN ACTION . . . FJCC, BOOTHS 345-349.

Adage
INC.
292 Main Street
Cambridge, Massachusetts 02142

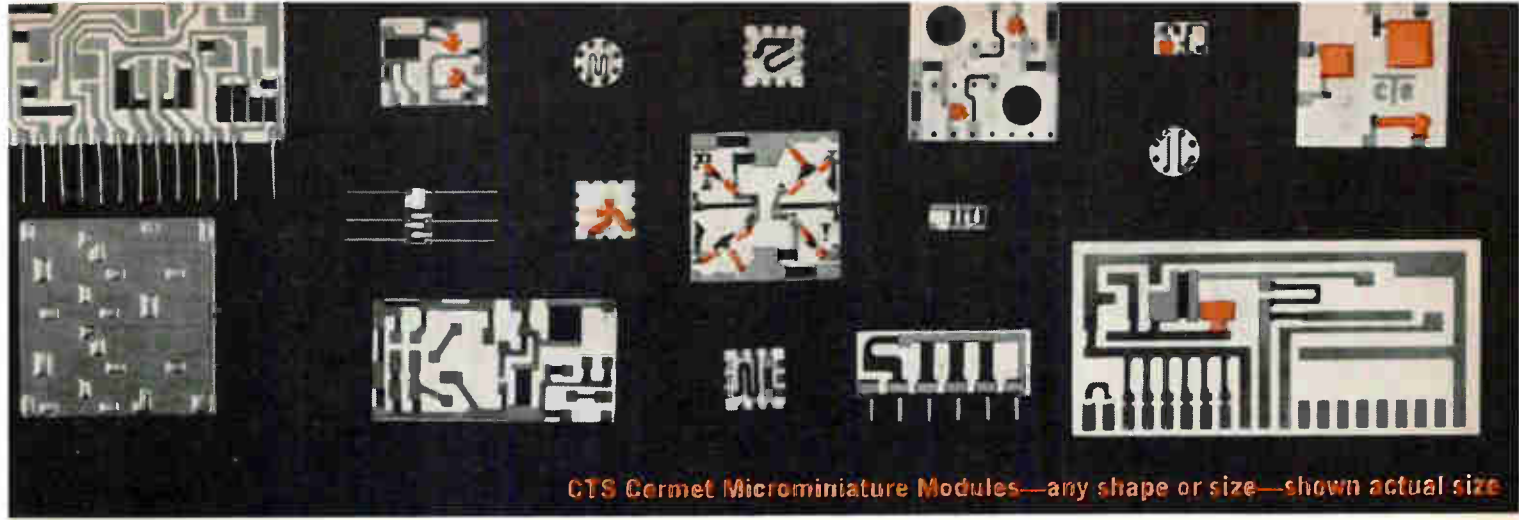

CTS Cermet Microminiature Modules—any shape or size—shown actual size

Born reliable at 650° C. CTS Cermet Microminiature Modules

- **Unusually stable** and substantially unaffected by the most severe environmental extremes due to the virtually indestructible combination of a matrix of inorganic material and precious metal alloys after firing.
- **Built-in heat sink** because the alumina substrates have high thermal conduction.
- **Unaffected by solder.** Modules can be immersed in solder to tin selected conductive tabs or solder discrete components without effect on the cermet resistors and capacitors.
- **Elements can't separate from substrate** during varying environmental conditions. Cermet resistors and capacitors are thermally bonded.
- **Perfect termination** due to similarity of compositions. Pt-Au conductor composition diffuses with the cermet compositions and becomes part of the substrate after firing.
- **Migration dangers eliminated** because no silver is used.
- **No cermet resistance element failures** after 36,000,000 element hours of extended load life reliability tests. Only 0.172% average resistance change at full rated load.
- **Extremely tight quality control** in purchased materials inspection, in-process control of production procedures, step-by-step product inspection, and quality assurance program on completed product.
- **Fired at temperatures exceeding 650°C** so cermet resistors, capacitors and conductive circuit take excessive overloads without failure. Cermet resistors and capacitors operate continuously at 275°C; take short periods of 500°C.

How you can benefit from our design and development experience: We'll evaluate your circuit for incorporation into the new CTS cermet resistor-capacitor module microminiaturized packaging system. Interconnecting circuitry for maximum reliability will be "designed in." Our design engineering group will propose circuit layouts on one or both sides of alumina substrates including positioning of discrete active components using "fired-on" conductive circuits and "fired-on" cermet resistors and capacitors.

CTS Cermet Resistors meet MIL-R-10509

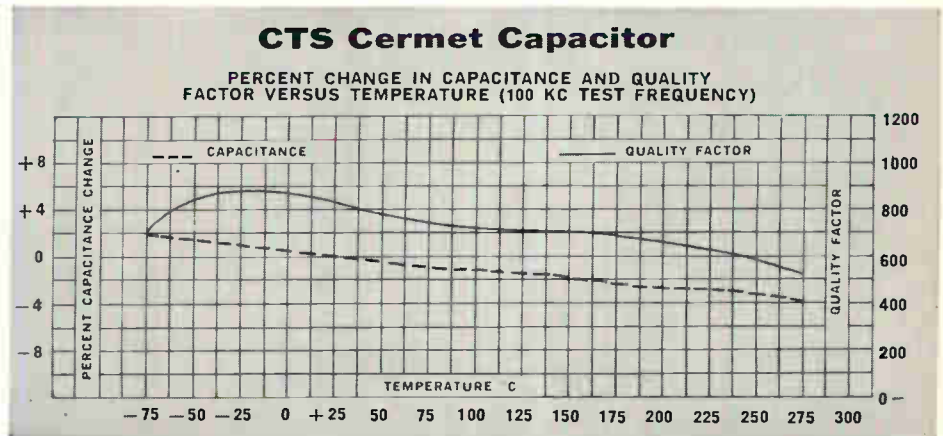

Now in large quantity production

Request complete specifications and information.



Founded 1896

CTS CORPORATION
Elkhart, Indiana

Sales Offices and Representatives conveniently located throughout the world.

Principal Products

Variable Resistors
Selector Switches
Loudspeakers
Trimming Potentiometers
Microminiature Components
& Circuit Packages

Subsidiaries

CTS of Asheville, Inc., Skyland, N. C.
CTS of Berne, Inc., Berne, Indiana
CTS of Paducah, Inc., Paducah, Kentucky
Chicago Telephone of California, Inc.,
South Pasadena, Calif.
CTS of Canada, Ltd., Streetsville, Ontario



MICRO SWITCH Precision Switches

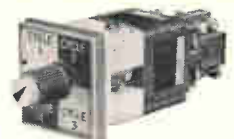

"1SX," Smallest Subminiature Switches available: Long-life, high electrical capacity. Size: .35" x .50" x .20". Variety of auxiliary actuators. SPDT. Rating: 7 amps, 115 or 230 vac; 4 amps ind. and 7 amps res., 28 vdc. Available with gold contacts for dry circuits.



"SM" Subminiature Switches: Small, light weight. 5 or 10 amp versions. Auxiliary actuators available. Size: .78" x .52" x .25". SPDT. Ratings: 5 amp "SM"—5 amps, 125 or 250 vac; 3 amps ind. and 5 amps res., 28 vdc. 10 amp "41SM"—10 amps, 125 or 250 vac; 1/2 hp, 125 or 250 vac. 5 amp version available with gold contacts.



"HM" Hermetically-sealed, Subminiature Switches: Sealed metal-to-metal and glass-to-metal. Interchangeable with other subminiature switches. High-temperature and corrosion resistant. Temperature range, -300° to +500° F. SPDT. .49" x .79" x .25". Rating: 3 amps ind. and 5 amps. res., 28 vdc.



"SE" Environment-proof Subminiature Switches: Small, sealed. Temperature range, -65° to +212° F. Size: .81" x .88" x .34". Auxiliary actuators available. SPDT. Rating: 5 amps, 125 or 250 vac; 3 amps ind. and 5 amps res., 28 vdc.



1CS1 Reed Switch: For dry circuit applications requiring long life, low power actuation. Consists of low reluctance metal reeds, hermetically sealed in inert gas filled glass tube. Actuated by permanent magnet or magnetic coil. Size: .105" diameter x 1.5". Rating: .100 amp, 120 vac; .125 amp, 32 vdc.



"V3" Miniature Switches: Small, high capacity. Screw, solder or quick connect terminals. Can be gang-mounted. Integral actuators (shown) or auxiliary actuators. SPDT or SPST. Size: .74" x 1.09" x .40" (without terminals or actuator). Rating: 15 amp, 125 or 250 vac; 1/2 amp, 125 vdc; 1/4 amp, 250 vdc. Gold contact versions available.



"Z" General Purpose Basic Switches: Rigid lever ideal for slow cams and slides having low operating force. Size: 1.33" x 1.94" x .69". Variety of terminals and actuators. Rating: 15 amps, 125, 250 or 480 vac; 1/2 amp, 125 vdc; 1/4 amp, 250 vdc.



"BZ-2RDS" Basic Switches: Elastomer boot and cover seal protect against dust and moisture. Large diameter plunger and 1/8 inch over-travel. Variety of circuitry and terminals. Size: 1.94" x 1.64" x .69". Rating: 15 amps, 125, 250 or 480 vac; 1/2 amp, 125 vdc; 1/4 amp, 250 vdc.



12 MA Actuators: Fit on pin-plunger switches for pushbutton applications. Attractive black, red, and green plastic buttons in 1/2" and 1" sizes. Anodized mounting hardware.



"AC" Interlock Switches: Used on electrical or electronic equipment to cut power safely when doors or drawers are opened for servicing. Automatic reset. Size: 1.18" x 1.10" x .34".



"DM" Pushbutton Switches: Attractive, rugged snap-in panel mount. SPDT or DPDT circuitry. Three button styles, 1/2" to 1" diameter, red or black. Rating: 10 amps, 125 or 250 vac; 1/2 hp, 125 or 250 vac. Size shown: 1.85" x 1.25" x .68".



"PB" Pushbutton Switches: Snap-action button mechanism with subminiature basic switches. 2, 3 or 4 poles. SPDT. Compact. Size shown: 1.54" x .78" x .91".



"302PB" Miniature Lighted Pushbutton Switches: Occupies less than one cubic inch of space. Alternate action, momentary action, or indicator units. Long lamp life. 15 screen color combinations. Size: 1.3" x .99" x .81".



3MN Basic Switches: Two-circuit double-break for limit or control functions. Integral terminals permit gang-mounting without separate insulating barriers. Combined width of three switches, only 2.03". Rating: 15 amps, 120, 240, 480 or 600 vac; 0.8 amp, 115 vdc; 0.4 amp, 230 vdc. Size: 2.50" x 1.20" x .68".



"Series 2" Modular Lighted Pushbutton Switches: Round or rectangular operator units. Maintained, momentary or magnetic pull-in action. Variety of color screens. 20 switch modules. Size: 3" x 1 1/4" x 1".



"TS" Bushing-mounted Toggle Switches: Sealed lever and keyed bushing. Multi-circuit switching, 1 and 2 pole. Size: 2.24" x 1.13" x .63". Rating: 15 amps ind., 25 amps res., 30 vdc; 10 amps ind. and 15 amps res., 125 vac.



"1RM" Multi-pole Rotary Switches: 15 amp. capacity, up to eight switching units. Two-position switches are standard—up to eight positions available. Gold-contact and hermetically-sealed assemblies available. Size: shown: 2.5" x 1.6" x 1.5".



Mercury Switches: Offer reliability in contaminated atmospheres. Many sizes, capacities, and operating characteristics. Hermetically sealed glass tube. Enclosed switch shown: 1.88" x .53" diameter.



Pre-engineered Electronic Switch-circuit Packages: Eliminate need for custom circuits. Size shown: 3.22" x 1.04" x .75".

Variety gives you the best chance to avoid compromise

A quick glance into the MICRO SWITCH line helps you find an economical off-the-shelf answer to most any switch problem—whether it involves space or weight limitations, circuitry, actuation, environment, indication, reliability, or any of the other countless switch requirements. Most every time you avoid the special you may have thought necessary. The MICRO SWITCH line is that extensive and is continually expanding with new developments. A few of the hundreds available are shown above.

For information on the switches shown or any others, call a MICRO SWITCH Distributor or a Branch Office (See Yellow Pages). Or, write for catalogs.



MICRO SWITCH
FREEPORT, ILLINOIS 61033
A DIVISION OF HONEYWELL
IN CANADA: HONEYWELL CONTROLS LIMITED, TORONTO 17, ONTARIO

HONEYWELL INTERNATIONAL—SALES AND SERVICE OFFICES IN ALL PRINCIPAL CITIES OF THE WORLD. MANUFACTURING IN UNITED STATES, UNITED KINGDOM, CANADA, NETHERLANDS, GERMANY, FRANCE, JAPAN.

Another Sangamo First

8 AUTOMATICALLY SELECTED SPEEDS

(FOR BOTH TRANSPORT AND ELECTRONICS)

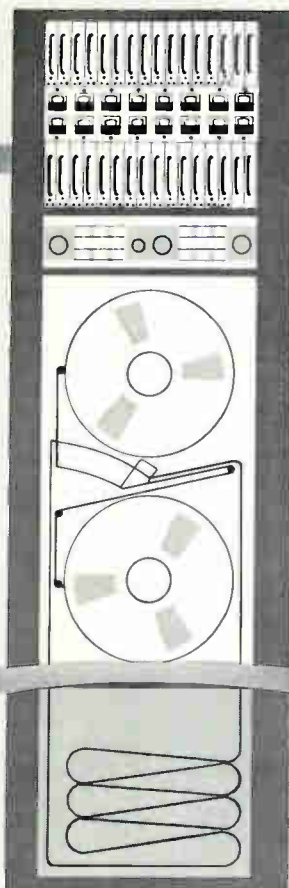

**ONLY THE NEW SANGAMO 4784 8-SPEED SYSTEM
OFFERS SUCH UNIQUE FLEXIBILITY**

Sangamo's automatically switched magnetic tape instrumentation system provides a time base expansion or contraction range of 128:1 . . . 4 times greater than any other system, over an FM bandwidth of 40KC \pm 40% deviation and a direct bandwidth of 600KC at 120 ips.

**Only the Sangamo 4700 Series Makes
All These Features Available**

Choice of from 1 to 8 automatically switched record/reproduce electronics

for economy and system expansion • Optional VU meters for each channel • High torque/low mass transport system • Industry's most precise servo • 1 inch and 1/2 inch tape simultaneously or interchangeably with no mechanical changes • Reel-to-reel or loop at the flick of a switch • The industry's only 1 year guarantee on parts and service.

**Compare Sangamo's Drift, Linearity,
and Signal/Noise Ratio. For a Personal
Demonstration... Write, Wire or Phone.**

SANGAMO

ELECTRIC COMPANY

P.O. Box 359
SPRINGFIELD, ILLINOIS 62705
Phone: 217 544-6411 • TWX: 217 546-0947



ES64-3

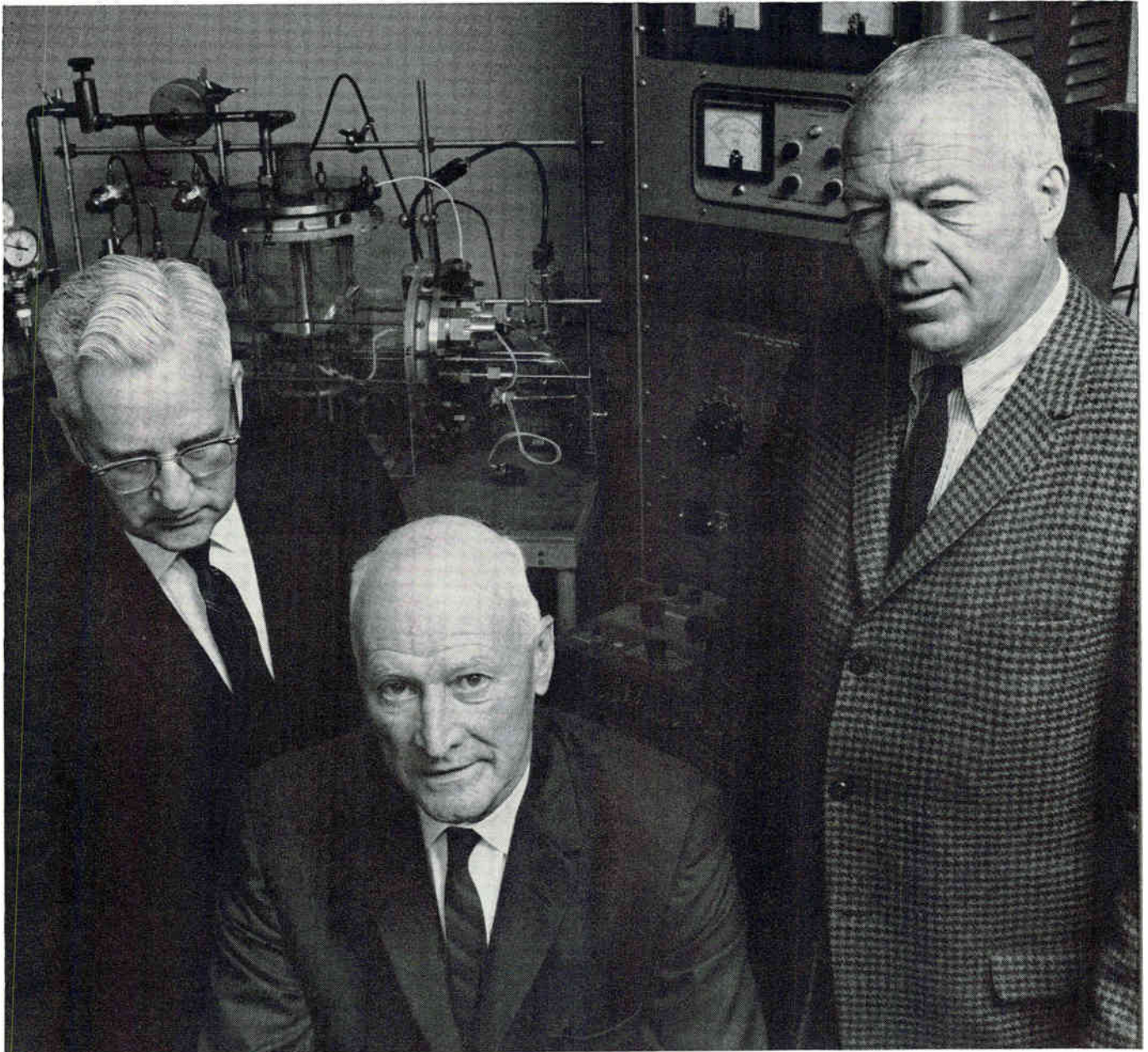

L. to r. Edwin M. Conroy, American Mutual Branch Sales Manager in Springfield with Hollis R. Wagstaff, Vice President, and John Washburn, Corporate Director of Industrial Relations, Sprague Electric Company, North Adams, Mass.

“It took a form of genius to help us cut Workmen’s Compensation costs 58%”

Hollis Wagstaff, Vice President of Sprague Electric Company, says, “Our business demands a special kind of creative ability, and I believe Ed Conroy and his American Mutual team brought their own brand of genius to bear in helping us with our insurance problems. At any rate, today we have better protection and our Workmen’s Compensation costs are down 58% below industry average over the last 6 years.”

American Mutual believes experience plus hard work produces this “form of genius”. If you could use some of it to help reduce your insurance costs please give us

a call. The American Mutual office near you is listed in the Yellow Pages.

AMERICAN MUTUAL

LIABILITY INSURANCE COMPANY

©1964, American Mutual Liability Insurance Company, Wakefield, Massachusetts

A leading writer of Workmen’s Compensation, all forms of Liability, Crime, Accident and Health Insurance

Where is United Air Lines using heat-shrinkable tubing of Kynar®? On the Caravelle, as a jacket over tachometer power cables. Why? Because Kynar provides excellent protection under conditions of flex, vibration, temperature (300°F). Irradiated, expanded tubing of Kynar shrinks 50%—twice as much as other thermoplastics. Its lower heat-shrink temperature (350°F) prevents damage to cabling and solder connections. It costs less...and has almost twice the cut-through resistance of conventional heat-shrinkable fluorocarbon tubing; affords greater strain relief.

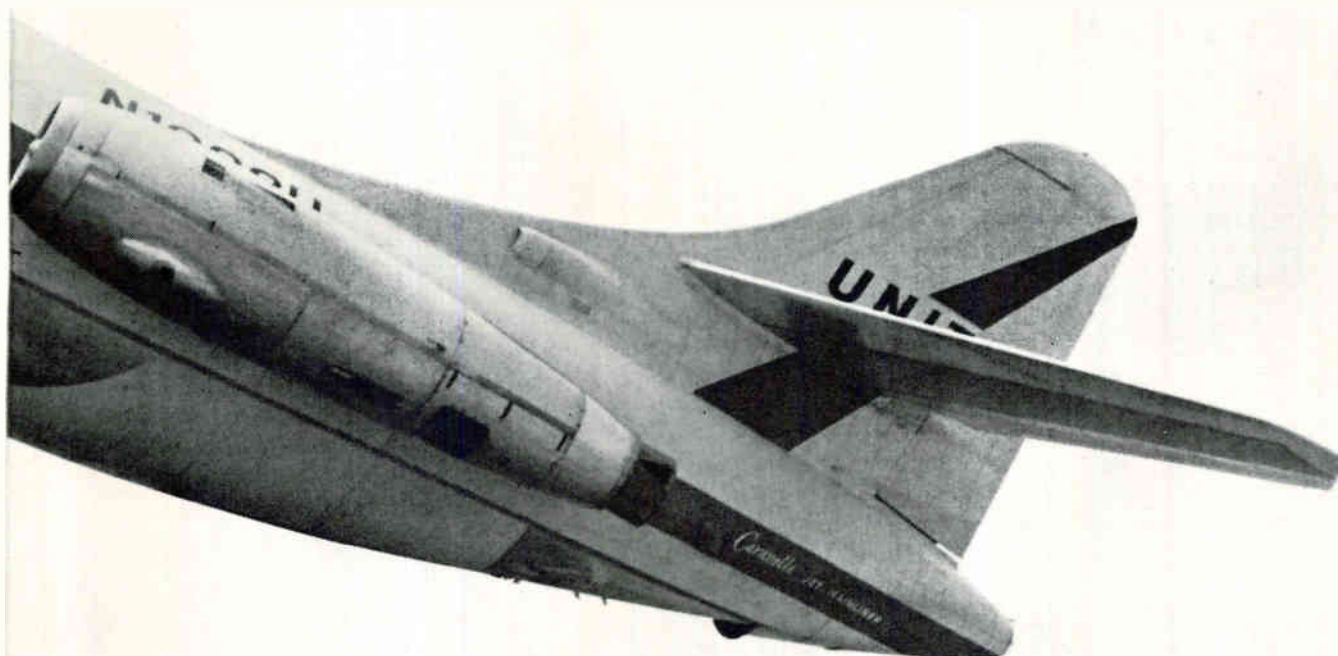
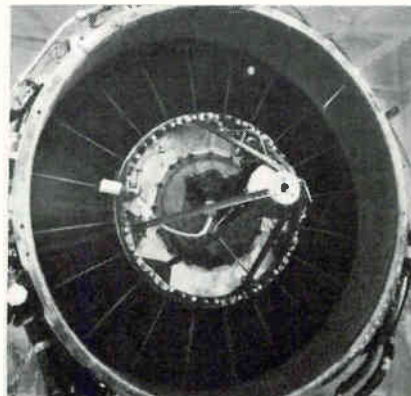

Thermofit* Kynar tubing is made by Rayclad Tubes Incorporated. For information, write: Plastics Department, Pennsalt Chemicals Corporation, 3 Penn Center, Philadelphia, Pa. 19102

Kynar... a fluoroplastic that's tough!

*"Thermofit" is a Registered Trademark of Rayclad Tubes Incorporated.



MINIATURE AND SUBMINIATURE ROUND CONNECTORS

Compact, light, mechanically strong, electrically reliable—Winchester Electronics' small, round connectors are all of these things, making them ideal for industrial and military projects where severe space and weight limitations prevail. And the line is comprehensive enough to cover almost every connector requirement for airborne, portable equipment, communications, photoflash, aerospace and medical instrumentation, telemetering, and many other applications.

Conforming to or exceeding all applicable industry and military specifications, the line includes 4-to-12 contact panel or cable types with or without hoods, and 1, 2, or 3-contact subminiatures. All have been thoroughly proven through years of successful service on operational equipment.

Winchester Electronics also offers equally complete lines of other connector types. These include removable-crimp contact, miniature and subminiature rectangular, printed circuit, quick-disconnect/heavy duty, environmental and special application connectors. All carry assurance of prompt delivery and engineering assistance by a nationwide network of distributors, regional offices and representatives. To obtain complete description of connectors, accessories and tools, write for Catalog No. 364 to: Winchester Electronics, Main Street and Hillside Avenue, Oakville, Connecticut.

WINCHESTER ELECTRONICS

A DIVISION OF LITTON INDUSTRIES



PHOTOGRAPHED ACTUAL SIZE

Technical articles

Highlights

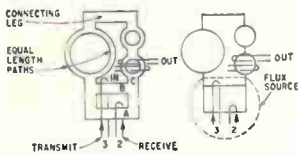

Balanced bipolar circuits improve shift registers: page 54

In most schemes for designing shift registers, the small pulse that represents a zero can be amplified unwittingly to become a one. In a bipolar or symmetric arrangement, however, the sense of the signal determines whether it is a one or a zero. The result is far more accuracy in handling information.

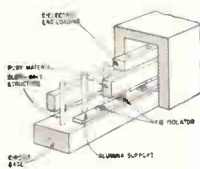

How they'll televise the Olympics: page 60

Opening day of the Olympics will be seen in the United States via satellite. To make it possible, engineers had to redesign antennas and design some interesting new microwave components. The Olympic telecasts may set the pattern for future international television.



A new electronic ignition system for autos: page 68

Transistorized ignition systems were a disappointment. Now a new electronic system, built around the silicon controlled rectifier, looks more promising because it is inexpensive and easy to install.



Inside industrial computers: page 73

Direct digital control of industrial processes needs a particular kind of computer. This special report examines the circuit design, logic organization and packaging of seven new computers, emphasizing some unique features. The builders have made them compact, inexpensive and reliable. In addition, there are descriptions of two digitally actuated flow-valves that can be used with the computers.

Coming
October 19

- Electronic switching in communications
- Easy breadboarding of analog microcircuits
- Analyzing cathode-follower design
- Digital transducer measures variables of liquids

Balanced bipolar circuits improve magnetic shift-register performance

A 200-Kc shift register has been built with gains as high as 30. There's no buildup of zeros or loss of ones. It's done with only ferrites and wire

By E.E. Newhall

Bell Telephone Laboratories, Inc., Murray Hill, N.J.

Magnetic shift-register circuits in which zeros and ones are treated in a symmetric or bipolar fashion, instead of signal or no signal, prevent an undesirable buildup of zeros or degeneration of ones. As a result, the registers can handle information with greater accuracy.¹⁻²

One of the advantages of digital magnetic systems using square-loop materials is the simplicity with which small signals can be amplified. But it has not been easy to exploit this property. In almost all the schemes for designing magnetic shift registers—whether they use cores and diodes, cores and resistors, or transfluxors and resistors—errors can occur because the small pulses that represent zeros are often amplified and become ones; the ones, represented by large positive pulses, often degenerate to the point where they are misread as zeros. To retain correct information in the system, therefore, careful control of pulse rise-time and amplitude is necessary.

In the bipolar arrangement described, small signals are amplified, maintaining the sense of the signals. The amplification is greatest for small signals and decreases for larger signals until the gain per transfer phase is unity. The resultant level is propagated through the system. Satisfactory operation has been realized when the drive currents have been varied from a pulse to a ramp and the transfer time varied over a 5:1 range. With the pulsers available, no upper bound has been established on the drive currents.

In a balanced arrangement, there is no phase corresponding to the usual slow-amplitude-limited phase required in unipolar resistance-coupled systems,³⁻⁵ hence, limitations due to that phase are not present. Gains as high as 30 can be achieved

in one bit time as compared to gains of 4 to 6 in resistance-coupled systems. Speeds of 200 kilocycles have been achieved; the present speed limit being determined by heating. At low speeds, slow transfer times are possible as no resistance is required in the coupling loops. Consequently, the back-voltage and energy requirements of the drive source can be lower than for resistance-coupled systems. Because balanced arrangements are used, the circuits are not particularly sensitive to variations in coercive force or temperature. Using low Curie temperature material (120°C), satisfactory operation has been achieved from 0°C to 50°C without any adjustment of the driving currents. (Using Mn, Mg, Cd, ferrite operation from 0 to 75°C has been readily achieved. Operating characteristics outside this range have not been measured.)

Square-loop magnetic circuit

In the square-loop magnetic circuit shown on top at the right, energization of the transmit winding will cause saturation of the legs forming the big circle, as well as the legs forming the two small circles. This follows because the flux-carrying capacity of

The author



In 1955 Edmund E. Newhall was awarded a National Research Council Fellowship to continue his research in signal theory. He received his doctorate from the University of Toronto in 1958. That same year he joined the Bell Telephone Laboratories where he now does research on ferrite devices for memory and logic circuits. He has written a number of technical articles.

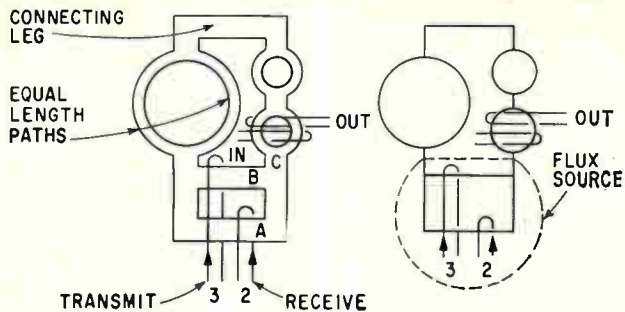
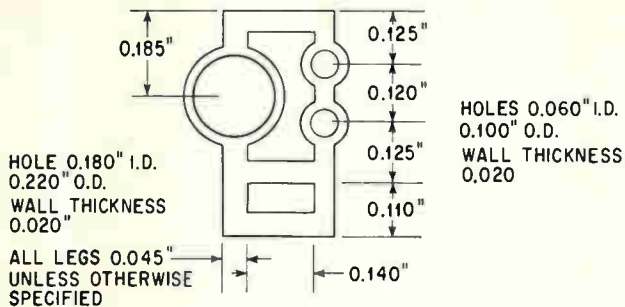

Flux source (bottom rectangle) and three balanced circuits (left); wiring of a balanced circuit (center) and its line diagram (right)

the equal-length parallel paths is less than leg C, which in turn is less than the flux capacity of the sum of legs A and B. If leg C were 0.040 inch wide, and this leg were saturated, it could supply just enough flux to saturate the two parallel paths forming the small hole, as each of these paths is 0.020 inch wide. By making leg C 0.045 inch wide, saturation of the two parallel paths is insured.

If the receive winding is energized, in the sense shown, leg A will be saturated from left to right, and leg B from right to left. Thus there cannot be any net flux into or out of leg C. So the term "neutral" is used to describe the flux condition of leg C. Therefore, drive on the receive winding causes switching of leg C from saturation to neutral. Subsequent application of a transmit pulse, in the sense shown, will drive leg B in the direction in which it is saturated and very little switching will occur; however, it will switch leg A from saturation almost

to neutral, saturating the equal-length parallel paths. It should be clear that after the first cycle, leg B never switches but merely acts as a flux closure path.

The end appendage with the transmit and receive windings is solely for the purpose of driving leg C from saturation to neutral and return. Many other appendages of this kind are possible. The details of the so-called flux source can then be disregarded as long as the source sends leg C from saturation to neutral and return. Now, whenever leg C goes from saturation to neutral, it will be clear, from symmetry, that flux will split equally between the equal-length parallel paths, neutralizing them. However, if a signal is applied on the input winding at the time leg C is going to neutral, the signal will aid switching on one side of the hole and inhibit switching on the other. Again leg C will go to neutral, but the net magnetization around the hole will be clock-

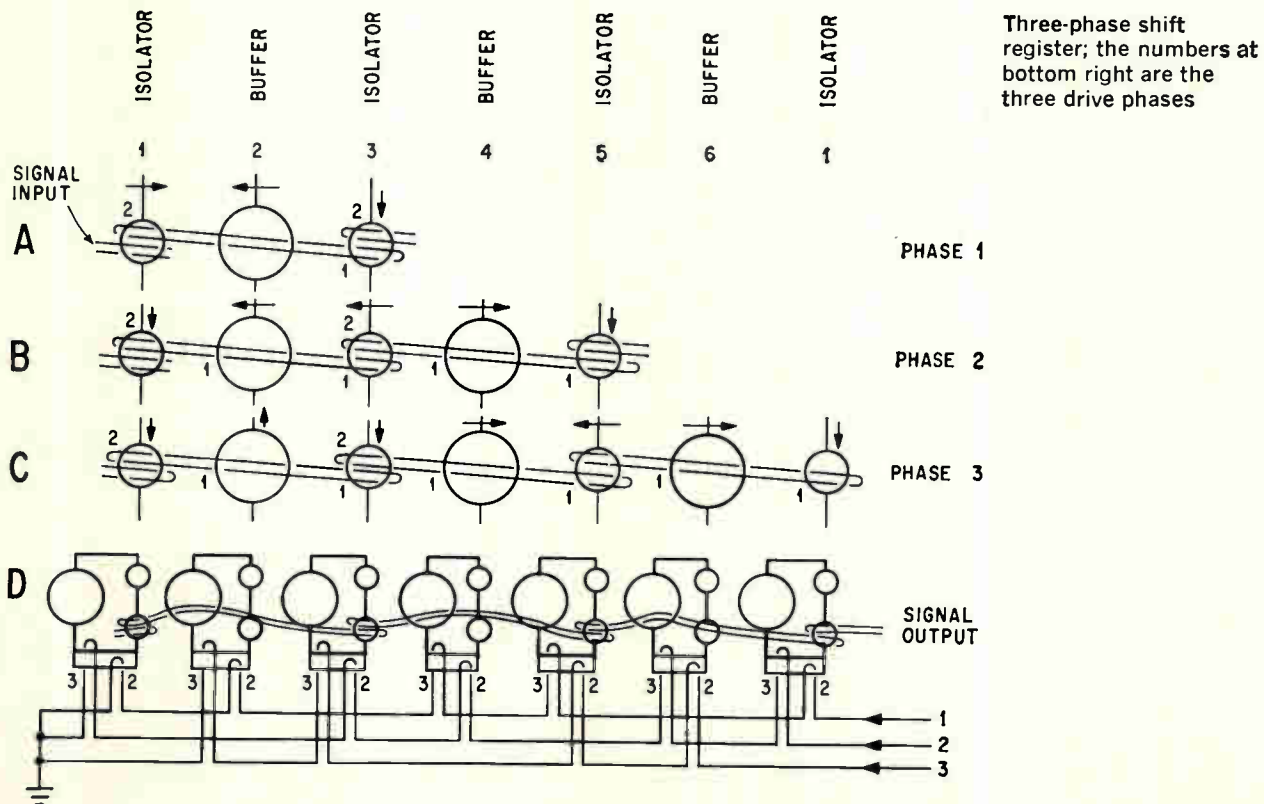

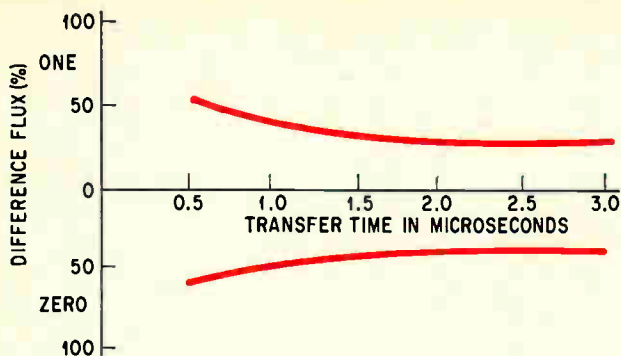

Variation of stable operating level with transfer time

wise or counterclockwise from neutral, depending upon the sense of the input current. In this instance, very small currents can act to store information by tipping the balance of the circuit that has been carefully balanced in the no-signal case. (It should be clearly pointed out that this has been possible for some time in a two-core-per-bit memory scheme. The logic described here goes logically with such a scheme.)

With the dimensions shown, the holes act independently. Thus, a signal or tip in one location does not significantly influence the sense of a tip in another one. Therefore the three sets of equal-length parallel paths may be regarded as three independent series-connected balanced circuits all energized from a common flux source. It should be clear that the energy source and information paths are separated. For purposes of discussion only the information paths are represented, just as in a vacuum-tube equivalent circuit only the signal path is shown, leaving out the d-c supply.

Element characteristics

The following element characteristics should be noted:

1. Whenever a balanced circuit is receiving, no voltage is generated in the input or output leads in the absence of a signal, since flux splits equally between the parallel paths. On the other hand, if a voltage is present on the input winding, then, since the output winding links the same flux as the input, input and output voltages are related by the turns ratio.

2. Once information has been stored in a balanced element, subsequent currents applied to the input winding will tend to destroy the stored information. These disturb currents must be sufficient to switch around the periphery of the hole if the stored information is to be disturbed. On the other hand, only small currents are required to store information, if applied in coincidence with the receiving pulse.

3. Whenever the transmit winding is energized, any stored information will be read out, as both parallel paths terminate in the saturated condition. The sense of the output is determined by the sense of the original tip.

Three drive phases

A shift register is shown in D of the lower figure, p. 55. The first drive phase is applied to the receive winding of elements 1 and 2 and the send or transmit winding of elements 4 and 5 (see upper figure, p. 55). Thus, during this phase, elements 1 and 2 receive information, and elements 4 and 5 transmit their stored information to adjacent elements. During this phase element 3 remains saturated so there is no coupling between input and output. It acts as an isolator. It should be noted that element 7 is connected to the phase lines in the same manner as element 1, and thus has the same time behavior. In this case six balanced elements are required to construct one bit of the shift register. The second phase is wound on the elements in a manner similar to the first phase but displaced two element positions. Thus it causes 3 and 4 to receive and elements 6 and 7 to send. The third phase is similar to the first and second but is displaced two element positions from the second phase.

The operation is readily understood by considering the first three balanced circuits in the signal path. These elements are shown in A of the figure on page 55, without the associated flux sources. Suppose the first element, referred to as an isolator in the figure, is initially saturated by flux which enters at the top and leaves at the bottom. This is consistent with the reset pattern which will have been established by the phase 2 winding shown in D of the figure. If the first phase is now applied in coincidence with a signal pulse of the sense shown, the left side of element 1 will be preferred over the right side. The balanced element will be left with a perturbation from neutral in a clockwise sense. This is indicated by the arrow from left to right above the first element. The tipping of element 1 will generate a coupling-loop current, and, with the winding directions shown, the buffer element, which is also energized by the first phase, will be tipped and left in a counterclockwise sense, indicated by the arrow from right to left. The third element is not energized and remains saturated down. Independent currents can then flow in its input and output windings. The arrow beside element 3 indicates its state at the termination of phase 1. The primary purpose of element 2 is to prevent excessive coupling-loop current during the setting of element 1, hence the name buffer. Note that if no input current is present, the signal currents will not flow in the coupling loop.

The behavior during phase 2 is illustrated in B of the figure on page 55. During this phase, element 1 transmits, element 3 and element 4 receive, element 5 isolates. The information previously stored as a tip in element 1 is read out by saturating element 1. Reading out of this information causes a current to flow, which tips elements 3 and 4, just as elements 1 and 2 were previously set. During this phase, element 2 is not energized and, as long as the coupling loop current is less than the threshold

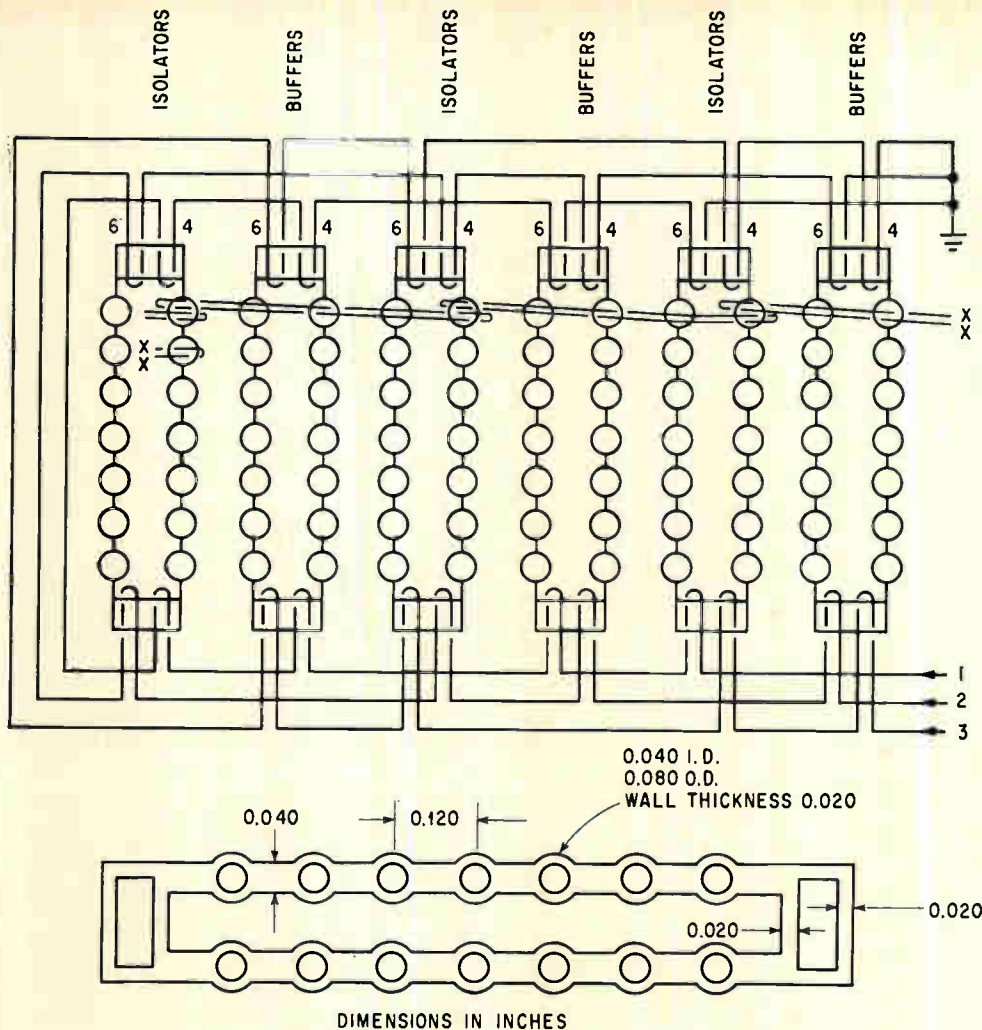

for switching around the periphery of the hole, no switching will occur. The final condition is shown by the arrows in B of the figure. Since no coupling-loop current flows if no information has been stored, it is not unreasonable to expect small tips to cause small currents to flow, and this is indeed the case. These currents are significantly less than the threshold for switching around element 2. With this in mind, it should be clear that the set in element 3 will be almost twice the set in element 1 as the elements are coupled by a 2:1 turns ratio. Here the coupling-loop loss is neglected for all practical purposes, because it is small as long as the coupling-loop currents are small.

The element behavior during phase 3 is shown in C of the figure and is similar to that which occurs during phase 1 and phase 2. Elements 5 and 6 receive and element 3 sends; element 4 is not energized. The elements to the right of element 3 behave exactly as before. The gain will again be 2 if the set is small. Consider the elements to the left. Element 1 has been saturated during phase 2 and will act as an isolator, so only elements 2 and 3 need be considered. With the winding directions shown, it is apparent that if element 2 goes to saturation at the same time element 3 transmits, the voltages will cancel in the coupling loop, as both the elements

were previously set with the same tip to the same flux level. All the operations that take place during phase 3 have been described. Phase 1 and phase 2 are identical to phase 3 except that the operations take place in different locations.

As a tip progresses through the chain, its sense is maintained, but its amplitude grows, as a consequence of the 2:1 turns ratio. This results in larger coupling-loop currents until these currents are sufficient to switch around a nonenergized hole; for example, element 2 during phase 2. Switching around the periphery of a hole causes a flux loss, and the gain per transfer diminishes. When the signal level reaches a point where the flux gain per transfer is unity, the buildup ceases.

Timing

The way in which timing is achieved is shown in D of the figure on page 55. For example, consider the application of phase 3, which will cause elements 2 and 3 to transmit and elements 5 and 6 to receive. The transmit and receive windings have a different number of turns. Thus, with a particular current waveshape applied, the receiving elements all take slightly longer to switch than the transmitting elements. This insures that the receiving element is able to receive information at least as long

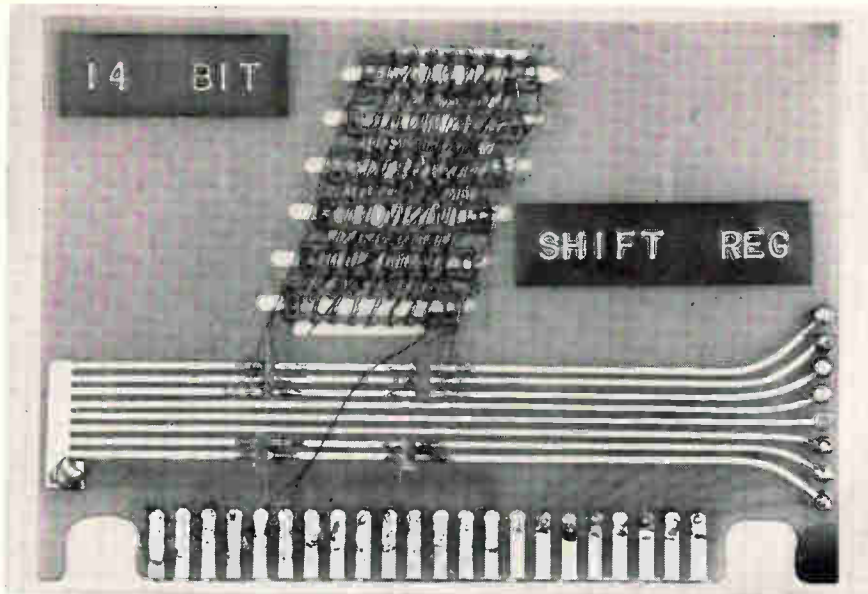

as the transmitting element is producing a tipping current. The receiving element will respond to the coupling-loop current as long as such a current exists. However, once the transmitting element reaches saturation, the shorted turn presented to the receiving element will tend to cause equal flux splitting in that element. As long as timing of this type exists the transfer will be satisfactory. In addition to the 3:2 transmit-receive ratios, ratios of 1:1 and 2:1 have also been found to produce satisfactory timing. Proper timing can be easily achieved in this manner and the applied wave shapes have very little effect on the circuit operation. For example, a ramp of current will cause satisfactory operation as well as a step of current. The fact that the timing can be varied also suggests that the circuit is relatively insensitive to variations in coercive force.

The register shown in D of the figure was connected with the output from element 6 fed back into the input with a polarity reversal so that a one-zero pattern circulated. The flux input into element 2 was measured as a function of transfer time and the results plotted in the figure on page 56. The transfer time was varied from 3 microseconds to 500 nanoseconds by varying the drives. The stable operating level was determined by sensing the flux on a figure-eight winding around the balanced circuit in the second buffer. The difference flux is 100% if all the flux switched goes down one leg. If the difference flux is 50%, for example, this means that 75% of the flux goes down one leg and 25% goes down the other. The figure shows that at 500 nanoseconds transfer time more than 75% of the flux switched goes down one leg in the buffer. At this transfer time most of the switching was occurring in the pulser rise time.

Shift register

A shift register is shown in the figure on page 57, in which all the balanced circuits are the

same size. The top row of balanced circuits is wound in the same manner as the row in C of the figure on page 55. It should be observed that the element following the sixth balanced circuit has the same time behavior as element 1. Therefore, it could be energized from the same flux source; this is done in figure on page 57. The seventh balanced circuit is placed in the first structure. Information then travels across the first row, then the second row, and so forth. There are 14 rows, so a 14-bit shift register can be constructed using 6 of these elements (see photograph above). The structure is driven at both ends to reduce leakage effects. Whenever the structure becomes too long or the coercive force too high, leakage makes it difficult to saturate the balanced circuits in the center portion. The gain of the center stages then decreases. This can be reduced by disturbing the transmit winding and placing one figure-eight turn around the center of the structure.

An open-loop characteristic is shown at top in the figure on page 59. Here the difference flux in the first balanced circuit in the first row is plotted as an abscissa, and the difference flux in the first element in the second row is plotted as an ordinate. The slope at the origin is in the gain for small signals. The offset at the origin is due to natural unbalances in the balanced circuits themselves. When the shift register is connected with output to input, the stable operating level is about 18% of a full set for one polarity and 23% for the other. The stable level maintained in the buffers is roughly twice as great. It will be clear that the shift register of D of the figure on page 55 has a higher stable operating level than that shown in the figure on page 57. Some detailed reflection shows that whenever the buffers are made large, compared to the isolators, the stable operating level will increase. The 14-bit shift register shown required a drive current of about 400 ma per phase with a back voltage of

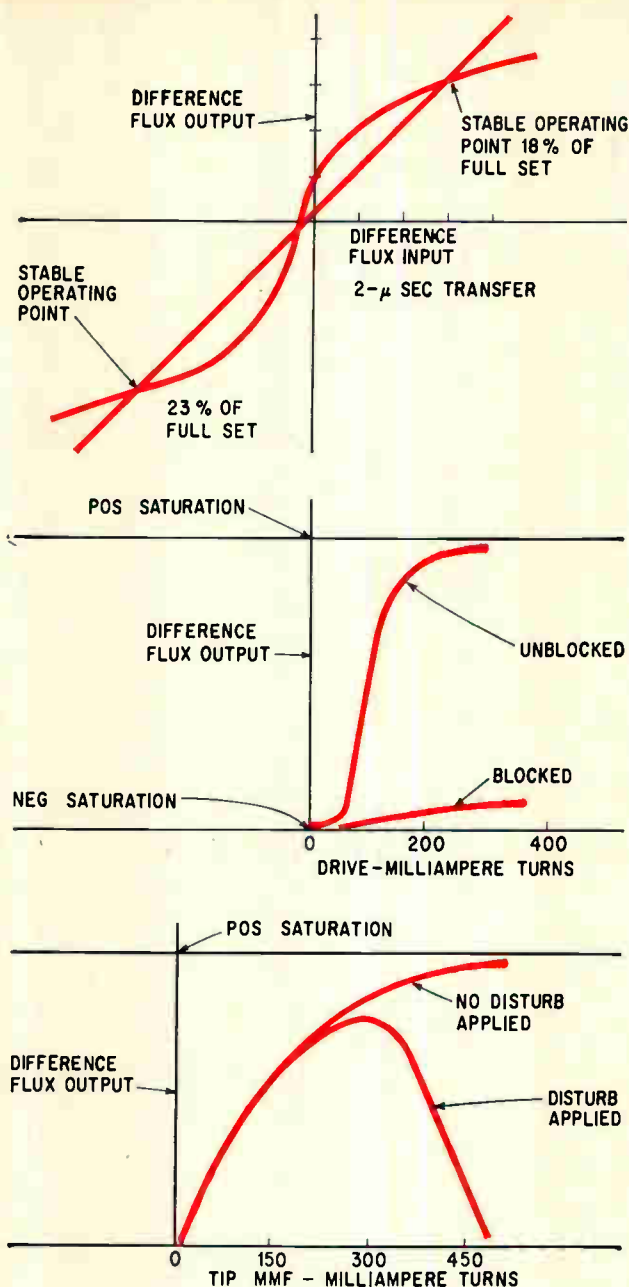

Input-output characteristics of a 14-bit register (top); test to determine characteristics of isolator (center) and of buffer (bottom)

about 3 volts. The structure shown has been pressed from Mn, Mg, Zn ferrite with a coercive force of 0.15 to 0.25 oersteds. A double action press was necessary to avoid excessive warpage on firing. In an improved structure the holes are 0.060 inch inside diameter, 0.110 inch outside diameter, and 0.180 inch center-to-center. The width of the region between holes is 0.055 inch; this insures that the equal length paths will saturate before the region between holes.

Further characteristics

The element characteristics of importance are shown at the center and bottom of the figure just above. These measurements were taken on the bal-

anced circuit shown in the upper figure, p. 55. The blocked and unblocked characteristics in the center figure at the left were taken on a small hole. The transmit winding was first energized, saturating the small hole. A drive was then applied to the small hole and the flux change around the small hole measured. This is the so-called blocked characteristic. The unblocked characteristic was taken in the same manner, except that leg C was neutralized by energizing the receive winding. Measurements of this characteristic determine whether the areas are such that all the stored information will be taken from the element when it is saturated.

The other characteristic of interest is shown in the bottom figure at the left. This is a measurement made on a large hole in the upper figure, p. 55. The magnetomotive force (mmf) acting to tip the balance of the circuit is plotted against the difference flux measured at the time of transmit. The tipping current was a square pulse and the tipping mmf in milliamperes turns is the total mmf acting around the periphery of the balanced element. First, the tipping mmf was applied in conjunction with the receive current, with the tipping current arranged to terminate when the flux source had completed switching. The difference flux at the time of transmit was then recorded. In the second test a disturb mmf of amplitude and duration equal to the tip mmf but of opposite sign was applied between the receive and transmit periods; this tends to destroy the stored information. The difference flux remaining at the time of transmit was then recorded. This characteristic gives some estimate of the control mmf required, as well as the disturb current that can exist before a significant amount of information is lost. The amount of control current required depends linearly on the dimensions of the balanced circuit, up to the point where leakage begins to dominate.

The three-phase balanced bipolar system described here is one of many possible balanced bipolar systems. By direct substitution of balanced circuits in many existing unipolar arrangements, circuits result in which biases are no longer required and the margins improve dramatically.

Acknowledgment

The author thanks W.D. Lewis, H.E. Vaughan, E.B. Ferrell, J.A. Young, J.E. Schwenker, J.R. Perucca, J.N. Brown, J.C. Stuart, F.J. Schnettler, F.R. Monforte and W.W. Rhodes for their assistance.

References

1. E.E. Newhall and J.R. Perucca, "Energy Gain and Directivity Achieved Using Balanced Magnetic Circuits," Solid State Circuits Conference Proceedings, 1963.
2. E.E. Newhall, "The Use of Balanced Magnetic Circuits to Construct Digital Controllers," Intermag Conference Proceedings, 1963.
3. L.A. Russell, "Diodeless Magnetic Core Logic Circuits," IRE National Convention Record, 1957.
4. U.F. Gianola, "Integrated Magnetic Circuits for Synchronous Sequential Logic Machines," Bell System Technical Journal, March, 1960.
5. D.R. Bennion, "MAD—Resistance Type Magnetic Shift Registers," Nonlinear Magnetics and Magnetic Amplifiers Conference Proceedings, 1960, Philadelphia.

Comsat comes on strong with a really big show: The Olympics

Live television coverage, relayed from Tokyo by Syncom III, is credited to a new maser amplifier and some inspired engineering

By Laurence D. Shergalis

Regional Editor

Comsat's television debut should be a smash hit. For its first show, the Communications Satellite Corp. will present the Olympics, live from Tokyo, on Oct. 10, by relay from Syncom III. Comsat will pull off this coup by modifying an antenna formerly used for automatic satellite-tracking and using a low-noise ruby maser amplifier in a newly designed receiver. It took a rush engineering job to ready a system in time for the Olympics this month.

While Syncom III doesn't have the bandwidth for the high-quality television pictures anticipated from later satellites, it is expected to give a dramatic demonstration of worldwide live television. Additionally, the synchronous satellite will provide an elaborate test vehicle to determine which of several systems offers the most promise for future tv relays.

Through the cooperation of the National Aeronautics and Space Administration, the Department of Defense, the Federal Communications Commission, the Government of Japan, and the Japanese Broadcasting Corp. (NHK), the television signal will be beamed from a ground station at Kashima, 50 miles northeast of Tokyo, to Syncom III positioned 22,300 miles above the Pacific Ocean, down the modified antenna at Point Mugu, Calif., and into the Bell Telephone Co.'s network for distribution to the United States and Canada.

The National Broadcasting Co. has an arrangement with NHK for exclusive rights to the televised Olympics but it is offering the opening day program, free of charge, to all other United States networks and stations for simultaneous broadcast. The Canadian Broadcasting Corp. will check incoming signals at Point Mugu and transmit them by microwave to Buffalo, N. Y., then to Montreal where they will be taped. The videotapes will be flown to Europe by jet and immediately broadcast by the European Broadcasting Union. They will

beat the time of videotapes flown from Japan by 12 hours and European viewers will be able to see the Olympics the same day. The European and Canadian broadcasting companies will pay \$150 for each minute of coverage they use. This will help NBC and NHK recoup an investment estimated at \$300,000.

Modification

The prime contractor for the \$250,000 modification project is the Hughes Aircraft Corp. Hughes was assisted by Radiation Inc., Melbourne, Fla., in modifying the 85-foot antenna at Point Mugu, and by the Microwave Electronics Corp., of Palo Alto, Calif., in designing the receiver—the heart of which is a low-noise maser amplifier.

The special design of the antenna, originally intended for very broadband automatic tracking, has been modified to obtain the lowest possible noise-temperature when receiving the narrower band Syncom III signal in a nonautomatic-tracking mode. Among other modifications, choke rings are mounted around the horn to suppress side lobes and to restrict the amount of high-temperature noise from the ground.

A large cone-shaped enclosure at the focal point of the antenna houses the traveling-wave maser, Eimac klystron pumps, Hughes parametric amplifiers, the first 70-Mc amplifier stages, power-supplies, an excess-noise generator for system checks, and associated monitoring equipment.

Designing the amplifier

Although the Hughes system specifications for

▶
Traveling-wave maser amplifier is attached to its low temperature extension head and then placed in an open-cycle liquid helium dewar before being mounted at the feed point of the antenna.

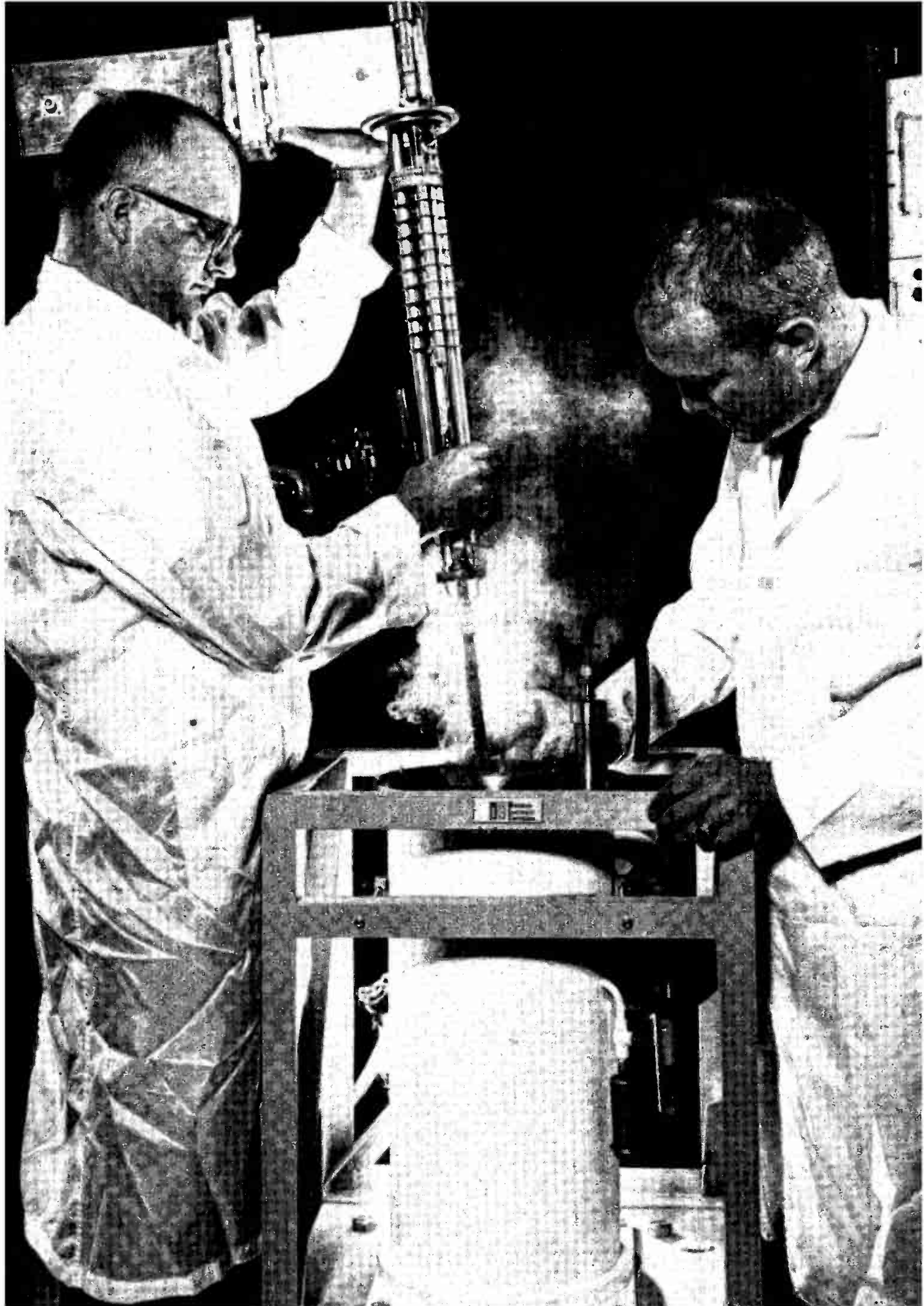

the amplifier called for only 20 decibel gain, final tests on the traveling-wave maser—designed and built in about 90 days by the Microwave Electronics Corp.—showed a gain of between 25 and 26 db at 1,814 Mc. Furthermore, the maser has a high critical temperature (the theoretical temperature at which amplifier electronic gain equals the loss; that is, there is zero insertion gain and infinite noise temperature). This high critical temperature allows the maser to operate in an open-cycle 4.2°K liquid helium dewar assembly. It also permits continuous operation in a closed-cycle liquid-helium refrigerator system. Dewar running time between refills is in excess of 24 hours. Previous systems have had to operate in closed vacuum-pumped dewar operation at bath temperatures of 1.8°K to 1.6°K to achieve similar gain and bandwidth.

The maser's high critical temperature is obtained from a higher quality ruby material and better structural precision. The components which make up the traveling-wave maser, shown below, are the comb-like slow-wave structure, the ruby material, and the yttrium iron garnet isolator. High critical temperature requires tolerances of ± 0.0003 inch in constructing the slow-wave structure and its housing.

The specific requirements on the high-quality ruby material, made by the Linde division of the Union Carbide Corp., were minimum banding (constant concentration of chromium along the length of the boule) and good lineage quality (minimum wandering of the crystalline axis).

Amplifier operating-frequency selection is simple. It requires the adjustment of only two parameters—magnet current and pump frequency.

Because of the Olympic deadline, an external magnet design was chosen over a superconducting one to produce the $2,150 \pm 3$ -gauss homogeneous field required for the maser. The Arnold Engineering Co., Marengo, Ill. was asked to come up with a set of four Alnico-5 magnets in 10 days instead of the usual four to six weeks. The time gained permitted testing of the system well in advance of

the October broadcasts.

In designing the magnets, one of the most critical production steps is the heat treatment of the Alnico-5 castings at 1,675°F in a magnetic field of 1,000 oersteds. The field is applied by current flow through a water-cooled winding around the magnet; this shapes the field to the magnet's configuration. When assembled, the magnets and their pole pieces weigh about 180 pounds.

In the feed house

The maser-dewar assembly is mounted at the antenna feed point directly behind a cross-guide coupler used for noise-temperature measurement. The signal is received from Syncom III at -102.2 decibels above one milliwatt and goes into a waveguide twist. This is a corrective twist to rotate the incident linear polarization of the received signal to the plane of the amplifier. The waveguide twist is adjusted during initial setup tests. Because of the synchronous orbit of the satellite no readjustment should be needed for the duration of the program.

Two Eimac klystron radio-frequency pumps have a switching arrangement that assures a 2,000 hour continuous-run time. Nothing in the maser is subject to wear or degradation, but other critical items in the system have been duplicated or paralleled to ensure system reliability. This explains the two klystrons and the two power supplies and other duplications.

Following the maser are two parametric amplifiers. These are connected to a coaxial switching arrangement. If one of the paramps fails, signal reception will continue. Each paramp has its own power supply.

Traveling-wave tubes were considered, but the paramps were chosen because of their lower noise temperature. The noise figure for a typical twt was between 2 and 3 db as compared with a noise figure of 1.1 db for the paramps. The anticipated signal from one paramp is about -50 dbm at 35°K noise temperature.

The Mark IV

From here on, the receiver system is adapted from the Hughes Mark IV tactical terminal, a portable ground station developed for the Army and designed for use with the Syncom satellite at a frequency of 1,814 Mc. This terminal uses an uncooled parametric amplifier as the first stage. Mark IV participated successfully in the Army's Desert Strike operations, providing the most reliable and continuous communication available. Thus, Hughes had available a great deal of hardware easily adaptable to the 1,814 Mc operating frequency selected for the Olympic project.

The Japanese would like to change the frequency to 1,812.217 Mc. But Hughes feels that operating that close to the band edge of the satellite beacon could result in distortion of the signal. A compromise at 1,813.5 Mc is expected.

Following the paramps, the 1,814 Mc signal is

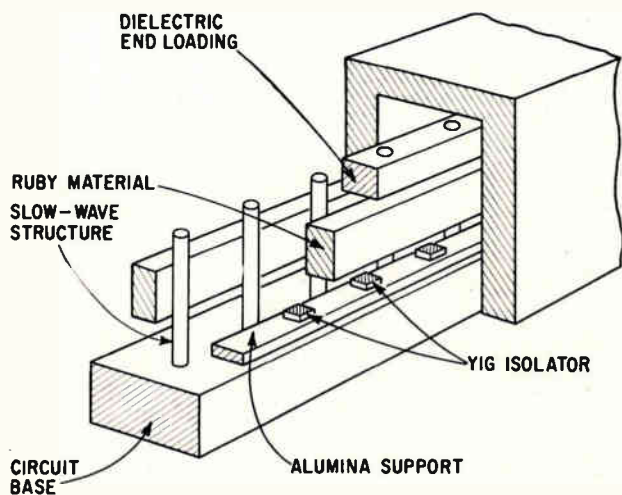

Cross-section of L-band traveling-wave maser

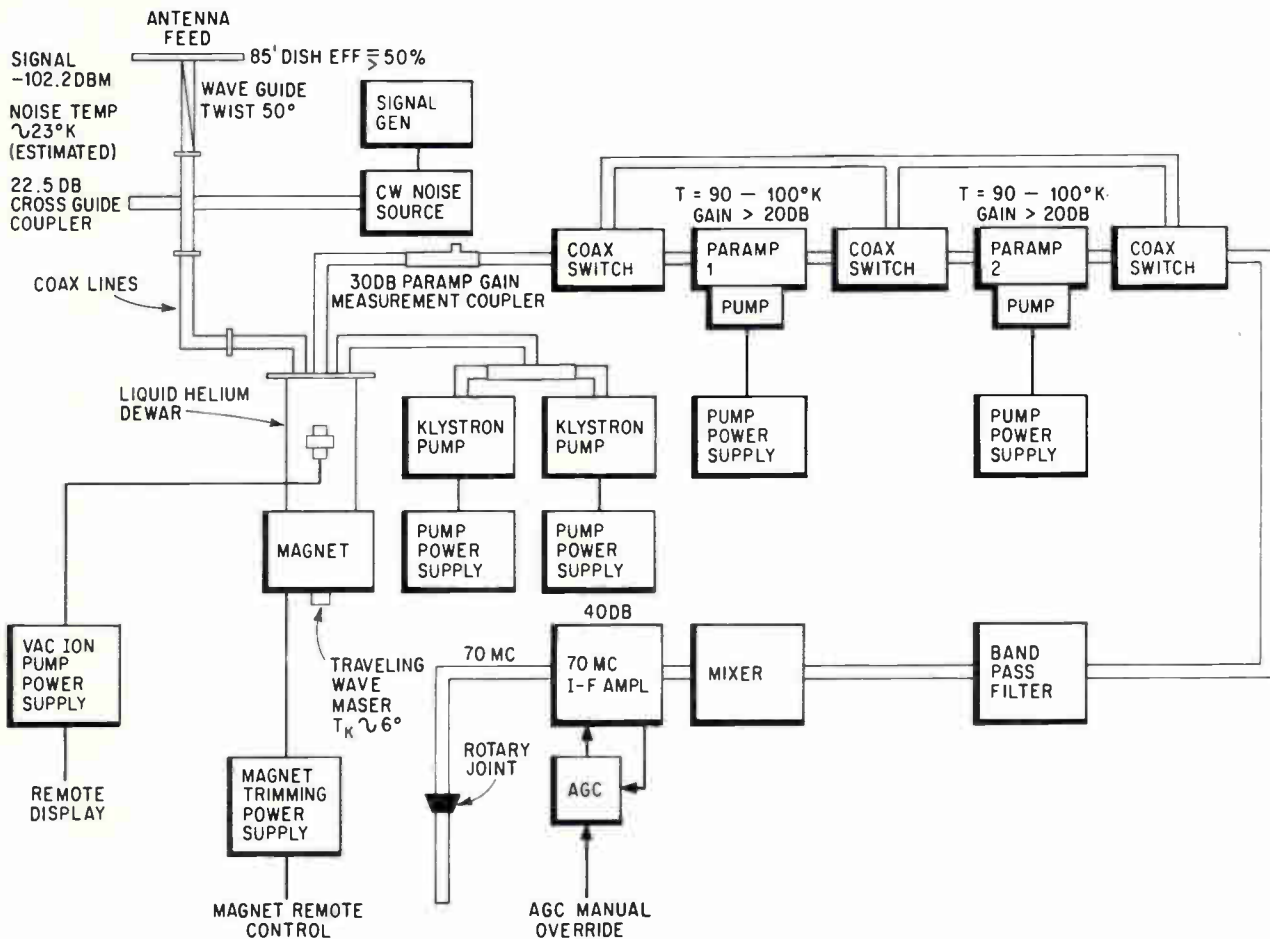

Schematic of equipment in feed house of antenna.

converted to an intermediate frequency of 70 Mc. After one stage of amplification, the signal leaves the feed house, through a rotary joint, goes to the telemetry shack on the ground and then into the rest of the equipment.

Alternative choices

Here, four options for selection of the best possible pictures will be available to the system operators. The signal can go into either of the two Hughes wideband discriminators at 70 Mc. One is a phase-locked detector type that at very low signal levels, or signal-to-noise ratios of zero dbm, will continue to perform, while a conventional discriminator will exhibit noise. The other is a standard wideband discriminator.

The signal from the feed house can also be converted to 120 Mc to accommodate two discriminators from the Space Technology Laboratories. One of these is also a phase-locked detector type. No prediction can yet be made as to the best system, so all four methods will be available for test and use in the Olympic broadcast.

If the bandwidth limitations of Syncom III prove too great to relay an acceptable picture, still another possibility—slow scan—is available to the broadcasters. With slow scan the Japanese Broadcasting Corp. can transmit every other frame at half the standard frame frequency. The received information is then recorded and played back

at the normal scanning and frame frequencies.

Because of the limited bandwidth of Syncom III, the audio portion of the telecast will be sent via Pacific telephone cable and resynchronized at Point Mugu. As an alternative, with a technique developed by Bell Laboratories for use with Telstar, the audio modulation can be carried by the last half (back porch) of the synchronizing pulse.

One of the most serious problems in setting up the system is proving the low noise temperature. This is essential in making initial adjustments for optimum performance and daily operational checks. The problem has been solved with an argon gas tube mounted at the antenna feed. The tube is calibrated to introduce a measured amount of excess noise into the system. With precision measuring equipment located on the ground, and standard ratio techniques, a system noise temperature to an accuracy of 20% can be obtained.

Monitors, video recorders and equipment to tie the Point Mugu signals to U. S. television networks complete the system.

Plans now are to restore the antenna to its original condition within a month after the end of the Olympics, but if the telecasts are successful the system may be used for other projects. There have been inquiries about the station's capability at higher frequencies, even in the four- or six-gigacycle range, and interest in its possible use with other NASA satellites.

Designer's casebook

Noise-figure nomograph for multistage systems

By Karl R. Tipple

LTV Temco Aerosystems, Greenville, Tex.

Analysis of communication systems frequently requires that the noise figure be evaluated from the following expression:

$$NF_{\text{system}} = NF_1 + \frac{NF_2 - 1}{G_1} + \frac{NF_3 - 1}{G_1 G_2} + \dots$$

where NF is the noise figure and G is the gain for each stage contributing to the total system noise figure.

If the system involves just a preamplifier and a receiver, only the first two terms are needed, and solutions to the resulting relation are available by graphic methods. However, if more complicated systems are to be analyzed, the noise figure can be obtained by successive use of two-stage noise figure nomographs, or by actual calculations from the noise figure equation.

With the first method, errors may occur from failure to apply the proper portion of the total system to the second stage of the nomograph. The other method requires much work with the slide rule since the noise figure and gain must be expressed as a numeric ratio for use in the equation.

To obtain the total system noise figure, it is necessary to evaluate a number of terms of the form, $(NF - 1)/G$. These terms are obtained as a numeric ratio from the nomograph above. The individual terms are added and the result is the system noise figure, also a numeric ratio, which can easily be converted to decibels, if required. Since the noise figure and gain are normally expressed in decibels, the nomograph has been arranged to perform the necessary conversion which gives $(NF - 1)/G$ as a numeric ratio.

The noise figure equation for the system shown in the block diagram on page 65, top, is:

$$NF_{\text{system}} = NF_p + \frac{NF_c - 1}{G_p} + \frac{NF_m - 1}{G_p G_c} + \frac{NF_r - 1}{G_p G_c G_m}$$

Note that the noise figure for the cable is equal

Designer's casebook is a regular feature in Electronics. Readers are invited to submit novel circuit ideas, packaging schemes, or other unusual solutions to design problems. Descriptions should be short. We'll pay \$50 for each item published.

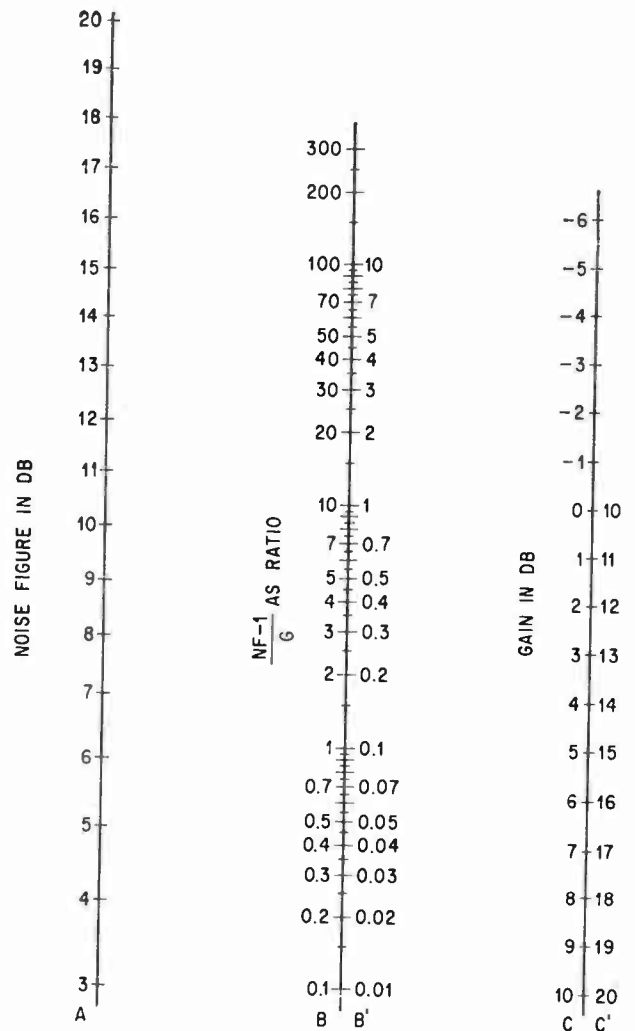

Noise figure nomograph. When the gain G falls on scale C, read results on scale B. When gain G falls on scale C', read results on scale B'.

to its loss in db, and that the gain is negative because the cable introduces a loss.

To determine the total system noise figure, express the first term of the above equation, NF_p , as a numeric ratio, then evaluate the remaining terms using the nomograph.

$NF_p = 7 \text{ db} = \text{antilog } 7/10 = 5$ as a ratio

$\frac{NF_c - 1}{G_p}$: Locate cable noise figure, 5 db, on scale A and preamplifier gain, 11 db, on scale C'. Line through these points intersects scale B' which gives $\frac{NF_c - 1}{G_p} = 0.17$ as a ratio.

$\frac{NF_m - 1}{G_p G_c}$: Locate multicoupler noise figure, 12 db, on scale A and combined gain of preamplifier and cable, 11 db - 5 db = 6 db, on scale C. (The combined gain is algebraically added because the gains are expressed in db). Line through these points intersects scale B which gives

$$\frac{NF_m - 1}{G_p G_c} = 3.7 \text{ as a ratio.}$$

$\frac{NF_r - 1}{G_p G_c G_m}$: Locate receiver noise figure, 8 db, on scale A and combined gain of preamplifier, cable and multicoupler, 11 db - 5 db + 2 db = 8 db, on scale C. Line through these points intersects scale B

which gives $\frac{NF_r - 1}{G_p G_c G_m} = 0.84$ as a ratio.

Inserting the above values in the noise figure equation and adding gives:

$$NF_{\text{system}} \text{ (as ratio)} = 5 + 0.17 + 3.7 + 0.84 = 9.6$$

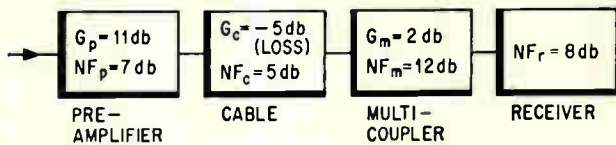

Block diagram for multistage system.

Expressing the result in db:

$$NF_{\text{system}} \text{ (as db)} = 10 \log 9.6 = 9.8 \text{ db}$$

Since the noise figure of a cable is equal to its loss in db, cables with less than 3 db loss produce terms in the noise figure equation which cannot be evaluated with the nomograph because the minimum noise figure on the nomograph is 3 db. However, if the loss of a cable segment is less than 3 db and the gain of the preceding system is greater than 3 db, the error introduced by eliminating the cable $(NF - 1)/G$ term from the equation will be negligible, unless very low noise systems are being analyzed.

Thermostat operates with 0.01°C differential

By Ronald G. Ferrie

Communications & Controls Co., Pittsburgh

An electronic thermostat that operates with an extremely small temperature differential is shown in the circuit at the right. A thermostat will turn on at one temperature, T_1 and turn off at another temperature, T_2 . The difference, $T_2 - T_1$, is the temperature differential of the thermostat.

The circuit consists of a simple unijunction oscillator driving the gate of a silicon controlled rectifier. Resistor R_T is a thermistor that is thermally coupled to the component whose temperature is being regulated. Since the thermistor in the circuit has a negative temperature coefficient of resistance, its resistance decreases as the temperature rises. The controlled temperature is determined by the voltage divider formed by resistors R_1 and R_T . As temperature rises, R_T decreases, and the voltage at the emitter of the unijunction transistor decreases. When the emitter voltage is less than the peak-point voltage, oscillations cease. As the temperature decreases, R_T increases, the emitter voltage rises beyond the peak point voltage, the unijunction again oscillates and fires the scr. In this manner, the circuit supplies the power required to maintain the heater at the desired temperature.

The measured temperature differential of the

electronic thermostat shown, was less than 0.01°C with tight thermal coupling between R_T and H_1 .

The resistance of a thermistor as a function of temperature is

$$R_T = R_0 \epsilon^{B(1/T - 1/T_0)}$$

For a given scr and R_T , the value of R_1 required to maintain temperature, T , is

$$R_1 = \frac{R_0 \epsilon^{B(1/T - 1/T_0)} [E_0 - V_p]}{[V_p - I_p R_0 \epsilon^{B(1/T - 1/T_0)}]}$$

where

R_0 = thermistor resistance at T_0 degrees Kelvin

T_0 = reference temperature in degrees Kelvin

T = desired temperature in degrees Kelvin

B = thermistor constant in degrees Kelvin

E_1 = d-c supply voltage

V_p = unijunction peak-point voltage

I_p = unijunction peak-point current

Assuming tight thermal coupling, the tempera-

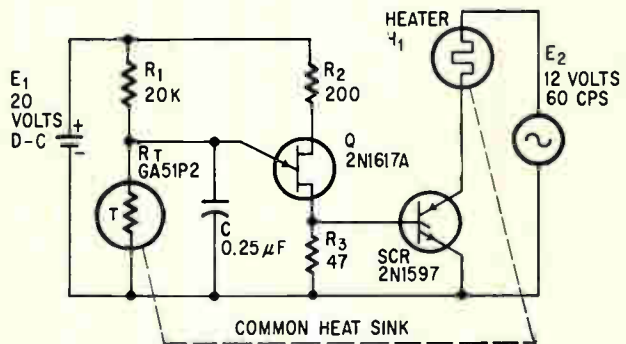

The scr conducts until the heater reaches the desired temperature, then the thermistor turns off the unijunction oscillator.

Designer's casebook

ture regulation is a function of the circuit parameters. Deviation from the desired temperature can be calculated from:

$$\Delta T = -\frac{T^2}{B} \left[\frac{\Delta V_p}{V_p \left(1 - \frac{V_p}{E_1 - I_p R_1} \right)} + \frac{R_1 \Delta I_p}{(E_1 - V_p - I_p R_1)} \right]$$

where ΔV_p and ΔI_p are the incremental differences in peak-point voltage and current which cause the unijunction to oscillate. The minus sign indicates that ΔT will change in a positive or negative direction when both ΔV_p and ΔI_p are negative or positive, respectively.

Complementary shaper replaces Schmitt trigger

By L.L. Kleinberg

Goddard Space Flight Center
National Aeronautics and Space Administration
Greenbelt, Md.

This simple circuit can be designed in little time, and replaces the standard Schmitt trigger. Unlike the Schmitt trigger, the complementary shaping circuit turns itself off when the input is removed.

Initially, both transistors of the complementary shaping circuit are in the off state. The standard Schmitt trigger keeps one of the transistors conducting at all times.

An input signal is applied to the base of Q_1 , turning on Q_1 and Q_2 . Transistor Q_2 will be driven into saturation if:

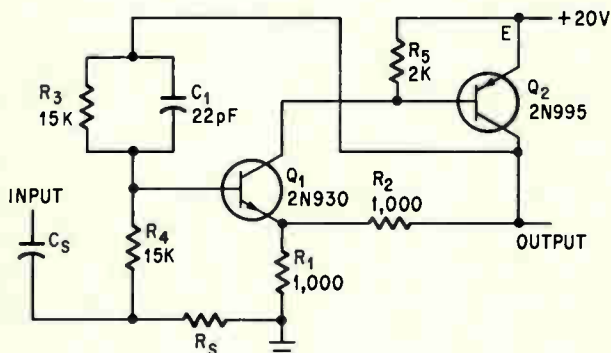

Unlike the Schmitt trigger, both transistors in the complementary shaping circuit conduct during generation of the square-wave output.

$$[1 + (R_2/R_1)][(R_4 + R_S)/(R_3 + R_4 + R_S)] > 1 \quad (1)$$

The circuit will turn off if:

$$[1 + (R_2/R_1)][R_4'/(R_3 + R_4')] < 1 \quad (2)$$

The value of R_4' may be obtained by using the following formula:

$$R_4' = \frac{(R_4 + R_S)(\beta_1 R_{12})}{R_4 + R_S + \beta_1 R_{12}}$$

where $\beta_1 =$ beta of Q_1 (300 maximum for this transistor type) and $R_{12} = R_1 R_2 / (R_1 + R_2)$.

It is the loading of $(R_4 + R_S)$ by the input impedance of Q_1 that insures turn-off when the input signal is removed.

The voltage at the collector of Q_2 as the circuit turns on is given by the following expression:

$$E_{C2} = E_o / (G - \alpha)$$

$$\text{where } G = \frac{R_4 + R_S}{R_3 + R_4 + R_S}$$

$$\alpha = \frac{1}{1 + (R_2/R_1)}$$

$E_o =$ base-to-emitter voltage of Q_1 at turn-on of both Q_1 and Q_2 . The value of E_o is larger than the minimum voltage required to turn on Q_1 . It is smaller than the steady-state base-to-emitter voltage that occurs after Q_2 goes into saturation (E_o is approximately 0.6 volts).

Provided the source impedance is small, the voltage E_{B1} required to turn on the transistors is:

$$E_{B1} = \frac{G E_o}{(G - \alpha)}$$

The turn-off process begins when the emitter voltage drops to the value given by the expression below. This removes Q_2 from saturation:

$$E_{E1(\text{off})} = \alpha E_{C'} \\ \text{where } E_{C'} = E_C - E_{CE2(\text{SAT})}$$

$$E_C = \text{supply voltage} \\ E_{CE2(\text{SAT})} = \text{collector-to-emitter saturation voltage for } Q_2$$

The voltage at the base of Q_1 at turn-off is

$$E_{B1(\text{off})} = E_{E1(\text{off})} + E_{BE} \\ = \alpha E_{C'} + E_{BE}$$

If it is desired that the turn-on and turn-off voltages at the base of Q_1 be equal (zero hysteresis) then:

$$E_{C'} = [(G E_o) / (G - \alpha)] - E_{BE}$$

where $E_{BE} =$ base-to-emitter voltage of either Q_1 or Q_2 during steady-state conduction (approximately 0.7 volts).

It will also be necessary to adjust R_5 to obtain zero hysteresis. For a typical application, $E_o = 0.6$ volts, $G = \alpha \approx 1/2$, $G - \alpha \approx 1/2$, using the equation, $E_{C'}$ turns out to be 5.8 volts. In actual practice it is unlikely that the designer will adjust the supply voltage to obtain zero hysteresis.

For the typical application mentioned:

$$R_4 + R_o = 15.4K \text{ ohms}$$

where $R_o = (R_{SG})(R_S)/(R_{SG} + R_S)$
 R_{SG} = signal generator impedance
 = 600 ohms

and $R_S = 1K$ ohm

$R_4' = (300)(0.5 \times 10^3)(15.4)/[15.4 + (300)(0.5 \times 10^3)]$
 = 14K ohms

Equations 1 and 2 may be rewritten as:

$$(R_4 + R_S)/(R_3 + R_4 + R_S) > \alpha > R_4'/(R_3 + R_4') \quad (3)$$

Substituting in (3):

$$0.507 > \alpha > 0.483 \quad \text{or} \quad \alpha \cong 0.495$$

Since $\alpha \approx \frac{1}{2}$, $R_1 = R_2$

Resistor R_3 was bypassed by a 22-picofarad capacitor to improve high-frequency response. This circuit was used successfully for generating square-waveforms with sine-wave input signals ranging in frequency from 5 Kc to 600 Kc.

Variable r-f resistor attained with photocell

By Richard H. Wagner

Bendix Corp., Southfield, Mich.

A stable, nonreactive resistance element, variable over a two-decade range (100 to 10,000 ohms), was needed for an r-f bridge circuit.

Wirewound potentiometers satisfy the stability and precision requirements but the inherently high and variable inductance makes them unusable at radio frequencies. Precision carbon or metal film resistors exhibit good frequency characteristics but are not recommended for use as rheostats where specific resistance values are required, because of their high temperature coefficients and uncertain contact resistances. Switching arrangements incorporating fixed-film resistors require special turret-type switches to minimize the stray inductance and capacitance, and they are limited in resolution.

A solution to this problem was obtained by using a photoconductive cell as the variable resistance element. The photocell in the diagram at the right is illuminated by a filament-type lamp in series with a wirewound potentiometer, both across a constant-voltage power supply. The potentiometer controls the brightness of the lamp which, in turn, controls the resistance of the photoconductor. With this arrangement, the resistance of the photoconductor approximates a logarithmic function of the potentiometer resistance, as shown in the semi-log graph.

The resistance of a photocell is generally independent of frequency up to 100 megacycles. This upper level depends on the cell's geometry and on the intensity of incident light. Shunt capacitances from 1 to 10 picofarads are typical. Photocells are available in a variety of packaging that permit the use of very short leads to minimize inductance. The isolation between the photoconductor and the control circuit permits remote location of the control potentiometer.

However, several precautions should be observed where stable, reproducible resistance values are required.

- Use a well-regulated power supply because the light output varies as the $7/2$ power of the filament voltage.

- Use long-life, low-voltage lamps with filaments supported at the ends. Filament hangers can vary the light output of a lamp for a given current by a factor of two, because the hanger-to-filament contact varies with lamp position and vibration or shock.

- Provide rigid mechanical support between the photocell and the lamp to maintain stability of cell resistance versus lamp excitation characteristics.

- Set the operating resistance range of the photocell to the region between 1 and 100-foot-candles where the temperature coefficient, previous light history and frequency dependence are all minimized.

- Provide adequate lamp ventilation to insure long life.

- Select the power rating of the photocell conservatively.

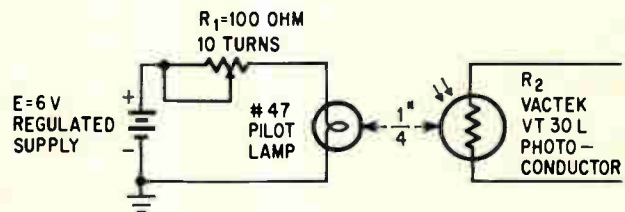

Intensity of lamp illumination controls resistance of photoconductor

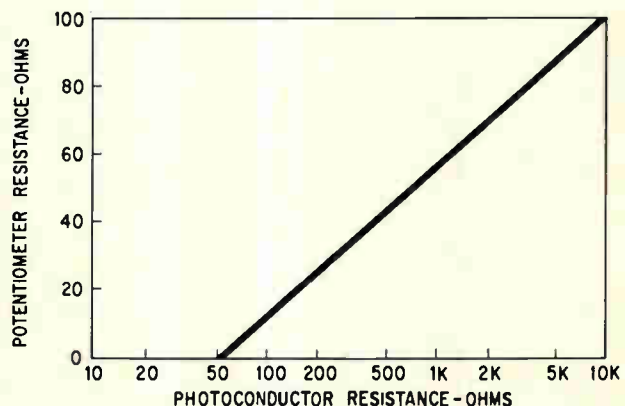

Photoconductor resistance is a log function of potentiometer resistance.

A new ignition system for cars

A silicon controlled rectifier system, inexpensive and easy to install, is on the market now. If it passes automobile industry tests it may become standard equipment

By R. Van Houten and John C. Schweitzer

Delta Products, Inc., Grand Junction, Colo.

Nearly four years ago, the first electronic ignition system was tested by United States automakers. It flopped. The system, in which transistors, instead of distributor points, performed switching was too expensive and did not improve engine performance enough to justify the higher cost. Now automakers are testing a new electronic approach, a capacitive ignition system with a silicon controlled rectifier. The new system looks far more promising.

One reason the silicon controlled rectifier system looks so attractive is that it embraces what engineers feel is a more efficient method of supplying energy. The voltage to fire the spark plug is stored in a capacitor until it is needed, rather than being built up by an induction coil, the approach of the tried-and-true Kettering system.

Since 1914, automakers have used the Kettering or inductive ignition system—a battery, transformer coil and a cam-driven mechanical switch (distributor points). Most of the 8 million autos sold in the U. S. this year will have it. But auto engines have changed radically since those early days. Today the demand for higher speed of rotation, higher compression ratios, and higher horsepowers threaten to obsolete the old electrical kind of ignition system. An electronic system can supply a fatter, more uniform spark than the Kettering system, and will not skip generating a spark even at the highest engine speeds.

Capacitive discharge

Although engineers favor the capacitive discharge system, feasible and practical design has eluded them until recently. With conventional components, such a system becomes too complex and expensive for wide use.

A thyatron gas tube has been used in some designs of capacitive discharge ignition systems, but

tubes are fragile and comparatively shortlived.

At reasonable temperatures the silicon controlled rectifier is an ideal switch for a capacitive discharge system. But for car ignition, scr's must operate from about -65° to more than $+200^{\circ}$ Fahrenheit. Circuit design has to meet this wide temperature range.

Now, a capacitive discharge system that meets the design criteria and eliminates the switching and temperature problems has been developed.

Scr ignition system

The basic design of an scr capacitive discharge ignition system has been known ever since the development of the silicon controlled rectifier. The system consists of a d-c to d-c converter (to change the battery voltage to a higher voltage for storage), a storage element (capacitor), the switching silicon controlled rectifier, and a high-voltage output transformer (coil) to transform the low-voltage stored d-c to a level that will fire the sparkplugs.

The applied battery voltage (top, page 70) is converted from a nominal 12 volts to approximately 400 volts by the converter circuitry (transistors Q_1 , Q_2 , and transformer T_1). This converter operates as follows: the battery voltage applied to the center tap of transformer T_1 causes current to flow through resistors R_1 , R_2 , R_3 , and R_4 and simultaneously through transistors Q_1 and Q_2 to ground. Since it is impossible for these two paths to be equal in resistance, one half of the primary winding will have a higher current flow.

Assuming that the upper half of the primary winding carries slightly higher current than the lower, the voltages developed in the two feedback windings (the ends connected to R_3 and R_4) tend to turn Q_1 on and Q_2 off. This increases the current through the upper half of the transformer winding. The increase in current further drives

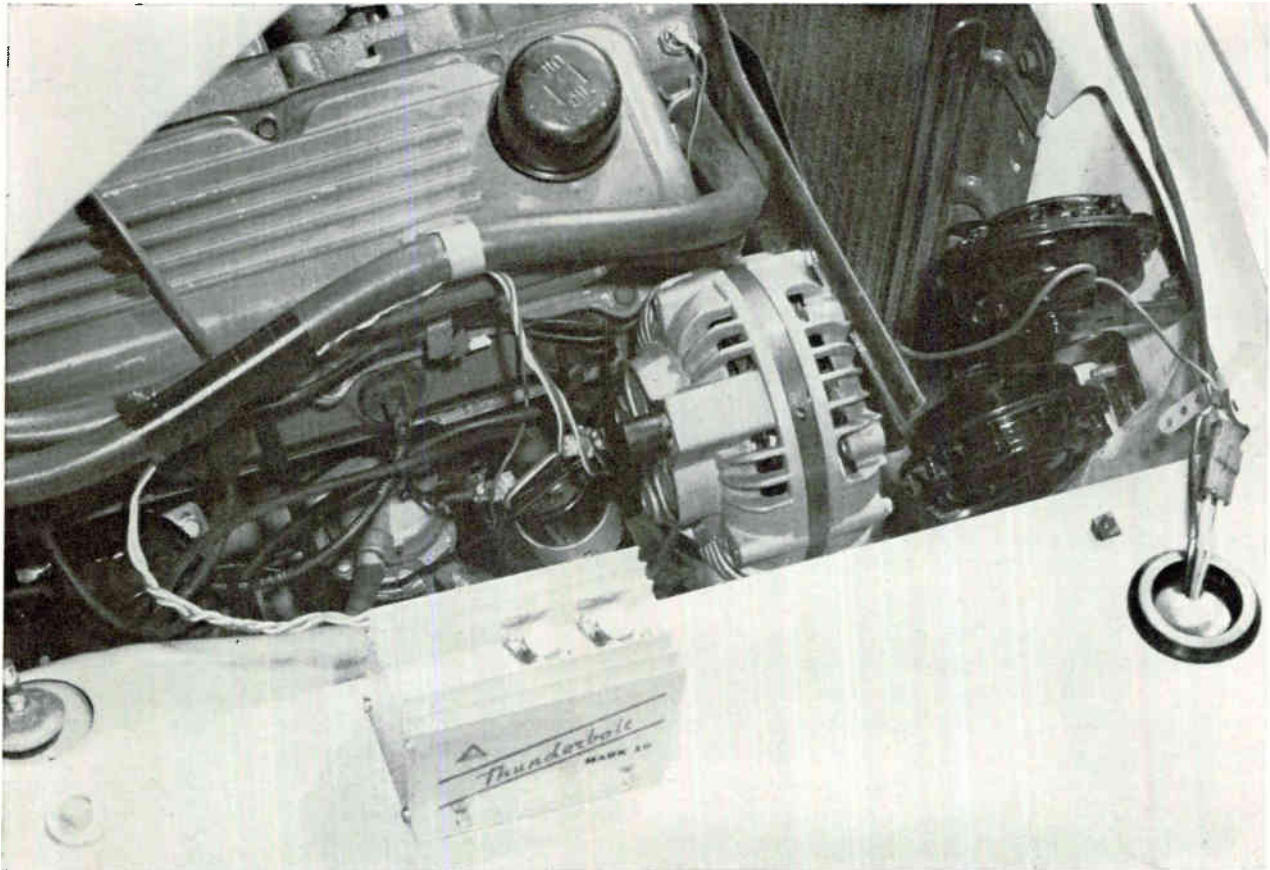

Do it yourself: installation time is 10 minutes, without additional components or rewiring needed. Procedure: remove the wires connected to the ignition coil, attach two terminal blocks and reattach the coil wires.

Q_1 into conduction and Q_2 into cutoff, simultaneously transferring energy to the secondary of T_1 that is rectified by the diode bridge (D_1 - D_4).

When the current through the upper half of the primary of T_1 reaches a point where it can no longer increase, due to resistance in the primary circuit and/or transformer core saturation, the signal applied to the transistor from the feedback winding decreases. Since Q_1 immediately turns off, the current in this winding decreases. The magnetic field developed by this current starts to collapse. This collapsing field, cutting across all the windings in the transformer, develops voltages in the transformer opposite in polarity to the voltage developed by the expanding field. This voltage now drives Q_1 into cutoff and Q_2 into conduction and simultaneously delivers power to the diode bridge. Once started, this action alternates, without load, at approximately 50 cycles per second.

The voltage applied to the diode bridge is rectified to a d-c potential of about 400 volts, charging capacitor C_3 , through the coil, connected through the minus and plus coil terminals to the negative terminal of the diode bridge. This action takes place as soon as power is applied by turning on the ignition key. Simultaneously, voltage is applied from the battery through diode D_5 to capacitor C_1 (serving as a filter to reduce any voltage ripple present on the battery supply). This filtered voltage then flows through resistor R_7 to ground,

if the distributor point is closed, or through C_2 and the silicon controlled rectifier gate if the point is open.

Delivering the energy

Assume that the point is closed and the ignition

Design criteria

The Kettering system is limited in energy-output-per-spark to the 15 to 30 milliwatt-second range. Any new ignition system must meet the following requirements:

- Output energy levels should exceed present levels by substantial margins. A new system should be able to develop energies of 40 milliwatt-seconds minimum, and be easily controlled to set this level higher if necessary. The energy output and voltage levels should remain constant, over an rpm range of 8,000 to 10,000 on eight-cylinder engines.
- As rapid a voltage rise time as possible. With a rapid voltage rise time, ignition system can fire partially-fouled spark plugs more easily.
- A new ignition system should be more reliable than systems currently in use. Reliability must include the time and cost of maintenance—ignition maintenance is often a major part of service costs.
- It should be possible to install the new system easily in existing vehicles with a minimum change in components or wiring.
- It should be low cost and designed for high-volume production.
- Low input power would be an additional advantage since it would reduce the engine load.

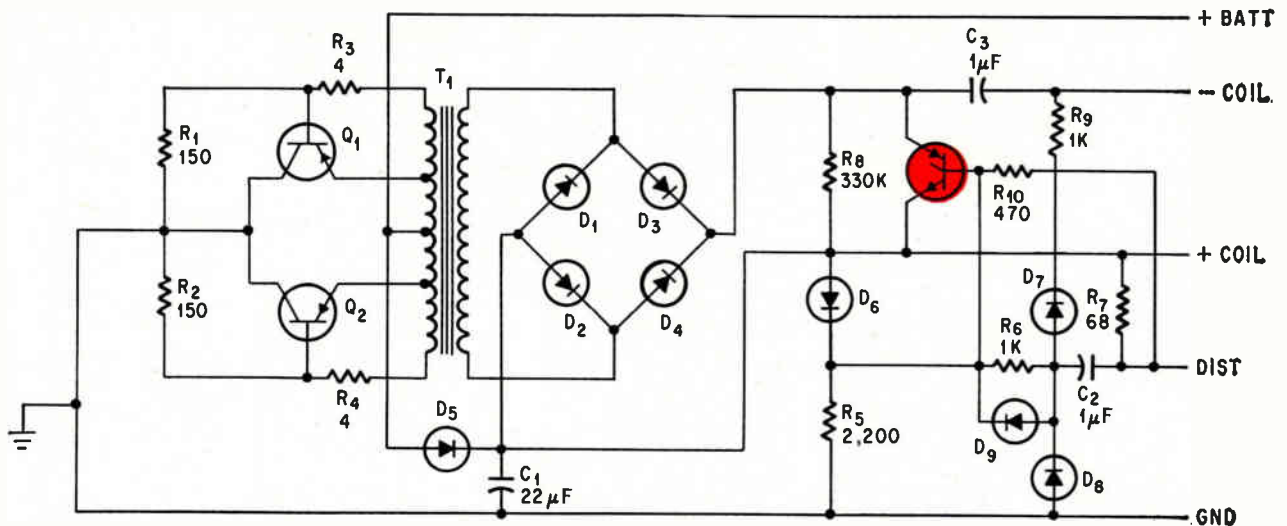

A silicon controlled rectifier (color) is the switch in this capacitive-discharge ignition system. The transistors are the d-c to d-c converter with capacitor C_1 the storage element. The transformer (ignition coil) is not shown.

key is turned—as the first cylinder comes up on compression and reaches the position where the spark plug should be fired, the point opens. The current available at the junction of D_5 and C_1 now flows through R_7 , C_2 , and D_9 to the gate of the silicon controlled rectifier. This current switches the scr on.

When the scr turns on, two things happen simultaneously. The silicon controlled rectifier short-circuits the power supply (the energy is absorbed in the transformer) and the effect of the short reflected to the primary of T_1 removes the drive from transistors Q_1 and Q_2 stopping converter operation. The scr also connects the positive side of C_3 to the plus coil terminal. This forms a closed circuit consisting of the capacitor, silicon controlled rectifier, and coil primary. The energy stored in the capacitor is now delivered to the ignition coil. The coil primary voltage rises from zero to 400 volts in approximately two microseconds (top graph, page 71).

The rise time of a standard ignition coil secondary is slower than the rise time of its primary because of reflected secondary capacitance and primary leakage inductances. A typical secondary rise time is approximately 15 microseconds.

In the circuit made up of the silicon controlled rectifier, capacitor, and coil, a resonant circuit is formed between the primary coil inductance and capacitor C_3 . The flywheel effect of this circuit restores unused energy to the capacitor, the capacitor discharge-current flows through the scr and coil primary creating a magnetic field in the coil. Current produced by the coil's magnetic field continues to flow in the circuit until the capacitor is charged in a reverse direction to approximately 300 volts.

At this point the current attempts to reverse through the scr causing the scr to return to its off condition. The direction of current and voltages causes the diode bridge to conduct as a short circuit (all diodes simultaneously in a conduction

mode). This current flow discharges the capacitor to zero from its reverse direction and recharges the capacitor toward its normal state. The remaining energy is stored in the circuit. When the current supplied by the coil inductance drops to zero, the bridge returns to a normal state, the load is removed from transformer T_1 and normal converter operation resumes.

Short-circuit stability

As designed, the power supply of the scr ignition system meets two important requirements: it is stable when short-circuited by the scr, and it is resistant to parasitic oscillations under those conditions. High-frequency or parasitic oscillations could destroy the inverter transistors by feeding power to the diode-bridge. The scr would continue to conduct, causing losses in the transformer and associated circuitry. The inverter transistors are rated at seven amperes each. They normally carry a maximum of two amperes. Parasitic oscillations would cause the power supply to draw currents of 15 to 20 amperes.

Spark repetition rate

The normal operating frequency of the power supply, without spark load, is in the 50 to 60 cps range. Since the spark repetition rate of an eight cylinder engine at 6,000 rpm is 400 pulses per second, a frequency of 50 cycles will not supply the energy needed. As a result, the power supply changes its repetition rate, as the transformer is reset to a zero flux condition, by the signal coupled back through the diode bridge during the spark cycle. This restarting of the oscillator to follow its load frequency causes the input power to the unit to increase in direct ratio to engine speed (middle graph page 71).

The power supply will deliver full energy to the capacitor at engine speeds over 8,000 rpm. Between spark pulses the converter has plenty of time to recharge the capacitor. Since its current drain is

low, the ignition system operates normally using the ballast-dropping resistor already in most vehicles. This eliminates, in contrast to transistor systems, rewiring the vehicle and/or adding an ignition relay.

No point problem

As the engine continues to turn off compression, the converter recharges the capacitor for the next compression cycle. This enables the scr ignition system to deliver much higher energies during the starting cycle than would be possible if the energy were to be stored during the compression cycle when battery voltage is lowest.

This removes the major handicap of scr capacitive discharge systems—the inability of the silicon controlled rectifier to turn off. Since the scr will always turn off when voltages are removed, and the converter cannot restart due to the reflected load until the scr is off, it is impossible for this system to refuse to reset between spark pulses. Thus a primary problem in previous designs of scr ignitions has been solved.

Since silicon controlled rectifiers radically change gate sensitivity with temperature, something must be done to supply trigger, or gate, current to fire the scr over a low temperature range of -50° to 65°F . Resistor R_7 and capacitor C_2 deliberately overdrive the scr (in current) at the lowest operating temperature and voltage. High temperatures could cause multiple firing of the scr—this is detrimental to spark-plug life and engine operation. Resistor R_9 and diodes D_7 and D_8 couple a negative pulse from the ignition coil, completely charging C_2 as soon as the silicon controlled rectifier switches on. This removes the gate pulse and assures that only one complete cycle will be delivered to the coil each time the points open. Diode D_8 and resistors R_5 and R_{10} apply a normal reverse-gate voltage to the scr so that any ripple voltage still in the gate circuit will not cause the scr to fire except from a definite breaker-point signal.

Silicon controlled rectifiers have another important characteristic in electronic ignition systems. The gate firing characteristic of the scr is primarily a function of time, as long as the supplied current is above the minimum required to fire. The modulation characteristic of the transistor is not present. Dirty or contaminated points do not degrade the spark energy. This system will operate excellently with points that couldn't be used in either a Kettering or a transistor ignition.

Since silicon controlled rectifiers may be triggered by a current pulse of very short duration, it is necessary to prevent point bounce on closure. Point-bounce problems are one of the inherent limitations to high-speed point operation in hot rods, dragster, and other fast cars. To remove the possibility of re-firing by point bounce, diode D_9 and resistor R_6 introduce a known delay of approximately one millisecond in discharging capacitor C_2 when the points close. The spark plugs are properly fired in speed ranges much in excess of

How the system performs . . .

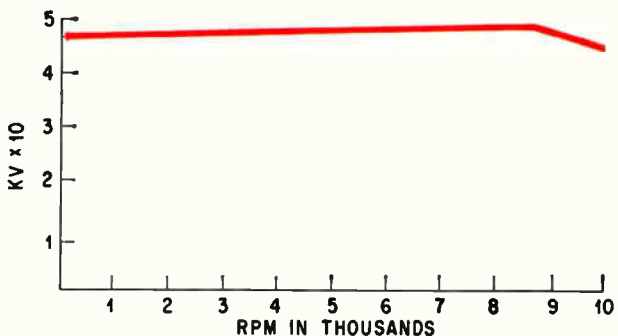
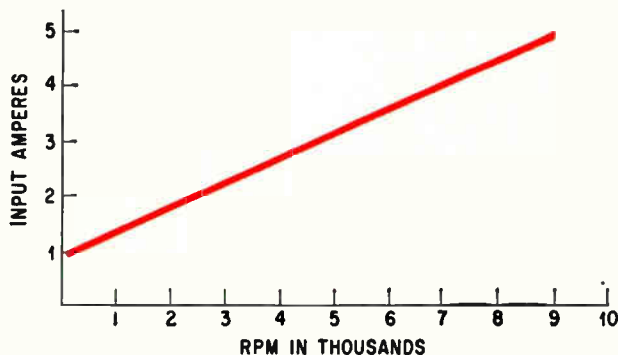
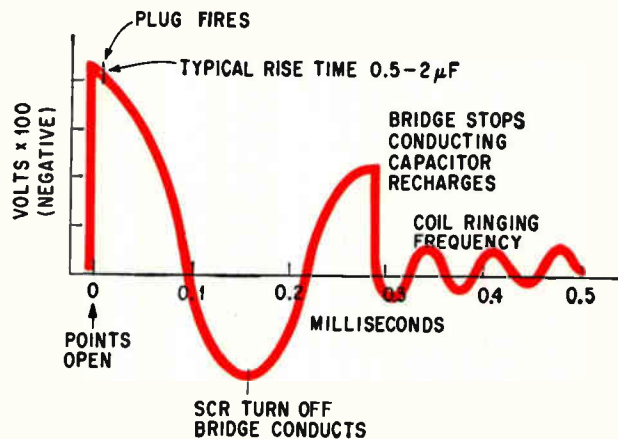

Closed circuit of C_3 , the scr and the ignition coil primary deliver the energy stored in C_3 . Rise time, from 0 to 400 volts, is about 2 microseconds (top). The start-stop operation of the transistor oscillator (dc to d-c converter), following load frequency, causes the input power to the ignition to increase in direct ratio with the engine speed (middle). Accurate ignition control of timing of fire, with sufficient energy to fire even fouled spark plugs, can be obtained at motor speeds in excess of 10,000 revolutions per minute (bottom graph).

those of either a standard ignition system or transistor system.

Analysis of high-speed operation of the scr ignition shows that accurate ignition control of timing may be obtained in excess of 10,000 rpm with minor care being used in point adjustment (bottom graph above).

Resistor R_8 is present to discharge capacitor C_3 when the ignition switch is turned off. This pre-

vents any shock hazard during servicing of the ignition system. Resistors R_3 and R_4 are base-current limiting resistors (to the transistor) controlling the drive currents supplied, and resistors R_1 and R_2 forward-bias transistor Q_1 and Q_2 to assure starting at low temperatures.

Transistor ignition systems, in general, require the removal of the capacitor installed in the distributor. The scr system operates either with or without this distributor capacitor. The only effect of the distributor capacitor is to reduce the scr firing current, since resistor R_7 must supply charge current to it as well as C_2 . Resistor R_7 , however, is sufficiently low in value to supply over two times the maximum required current to the scr even with the distributor capacitor installed.

Coils and rise time

Ignition systems with rapid rise time provide better performance in firing fouled plugs—as less total energy is wasted in the fouling resistance. If the secondary of the ignition coil is considered to consist of an air gap shunted by resistance, then the energy dissipated in the shunting resistance is directly dependent upon the time required to reach the ionization potential of the air gap. Silicon controlled rectifier systems are capable of very rapid rise times and have the ability to fire spark plugs with low shunting resistance.

The rise time of the scr system is dependent, to a large extent, on coil characteristics. However, its rise time to fire is more rapid than a Kettering system with the same coil. The scr ignition unit has been designed to fit existing vehicles without modification but even more rapid rise times—in the two microsecond range—could be supplied with a special coil.

Transformer T_1 is wound on a standard EI stamped lamination core like those used in high quality audio transformers. Although efficiency could be improved slightly with a tape wound or toroid, core using the EI core saves \$6.00 per unit.

The energies delivered by this scr system to the spark plug are easily controlled by the capacitance value of C_3 , but may be raised by increasing the value of this capacitor. As designed, it is capable of delivering 80 milliwatt-seconds of energy to the coil primary. Assuming a coil efficiency of 50%, total spark energy delivered would be 40 milliwatt-seconds, or a substantial increase over the energy of standard systems.

If much higher energies should be needed in the future, system redesign would consist of either increasing the value of capacitor C_3 or increasing the voltage supplied by the power supply. The new energy level increases directly with the capacitance, or, with the square of the voltage.

To meet the requirement for low cost and ease of assembly, printed circuit wiring is used. An aluminum extrusion was designed so that it supports the transformer, circuit board, and scr heat sink in grooves that are part of the extrusion. The bottom cover plate also slides into grooves and the

unit is closed with two end plates, attached with self-threading screws into holes that are also a part of the extrusion. The only secondary operation required in assembly is that of cutting to length, anodizing, and punching a limited number of mounting holes for the converter transistors—these are mounted directly on the extrusion.

Meeting the design criteria

At this point it is possible to compare the system described in this article—the Mark 10 Thunderbolt scr ignition system—with the criteria on page 69.

- Energy levels substantially exceed those of any present ignition system and are readily controlled.

- Voltage rise time using the same coil is much more rapid than in the Kettering system. With special coils, rise times of approximately one-twentieth of standard systems are possible.

- Since point current is low (250 milliamperes maximum) and voltage applied is limited to battery-supply voltage, point life is limited only by mechanical wear. Point condition is relatively unimportant, as is dwell time. Thus, the system has higher reliability than others now being used.

- This scr ignition may be installed on any vehicle without change in components or wiring. Procedure: remove the wires connected to the original coil, attach two small terminal blocks to the coil terminals, and reattach the coil wires. Average installation time: about 10 minutes.

- It can be produced in high volume, and is comparatively inexpensive in production and material costs—all components are commercially available. Current retail price is less than \$50.

- Current load on the automobile battery and charging system is substantially less than in the Kettering system and only about 20% that of most transistor systems.

Acknowledgment

The authors thank the Triad Transformer Co., Sarkes Tarzian, Inc., Extruded Alloys, Inc., and A. Johnson for their assistance.

The authors



During the last two years Robert G. Van Houten has piloted his Twin Comanche over 200,000 miles. After leaving Motorola, Inc., in 1952, Van Houten became vice president and chief engineer of General Meters, Inc. From there he went to Delta Products, as president. He likes flying, reading and fishing. . .



Missiles, planes, resistors . . . John C. Schweitzer has run the gamut in electronics. While at the Boeing Co., he supervised a design group that produced one of the first phase-locked receivers for radio telemetry. Schweitzer was chief engineer for Ultronix, Inc., until 1963. Now he's vice president and chief engineer at Delta.



Direct digital control in industry

DDC seems, at last, to have gained a bridgehead in the processing field. Here's how seven computer makers are coming to grips with the problems peculiar to these industries

By Louis S. Gomolak

Industrial Electronics Editor

- **Scientific Data System's 92:** with the only analog-to-digital converter that uses integrated circuits
- **Computer Control Co.'s DDP-116:** fastest computer of its type with memory-cycle time of only 1.7 microseconds
- **E-A Industrial Corp.'s 101:** cheapest conventional computer, with programming by printed-circuit cards
- **Westinghouse's P-50:** time-sharing of logic circuits permits reliability and economy
- **3M's Digitele 2201/2018:** uses electrochemical cells and a drum memory
- **GE's 4040:** flips out like pages in a book, for easy maintenance
- **Foxboro's M97000 series:** 3 different systems for different needs
- **Plus:** new digital valve positioners

Coming of age

When the Institute of Electrical and Electronics Engineers holds its annual show in New York next March, a good deal of attention will focus on a section that didn't exist in 1963, one whose title would have been meaningless to most engineers a couple of years ago: "Computer equipment for DDC."

DDC—for direct digital control—is time-sharing, or multiplexing, of a computer among many controlled loops. It uses a small, fast, efficient computer that uses a complicated formula in a shortened form, or algorithm, to control a process plant. Its programming is short and simple.

At three sessions of the IEEE show, 16 manufacturers will talk about their DDC systems. The presentation promises to be one of the most exciting ever given at the annual show.

It will herald the fact that computers have finally gained a foothold in one of their biggest potential markets: the process industries.

The story of process-control computers is not one of undiluted success. They had been anticipated eagerly in such industries as petroleum, chemicals, steel, cement, metalworking and electric utility—industries looking for real automatic control. But the first systems, offered in the mid-1950s, were unsatisfactory. They were overdesigned and consequently too big, slow and costly. Their arithmetic capabilities were much too large, requiring complicated programming for process control.

Their complicated hardware had been designed in the same way as electronic data-processing systems, the kind that banks use for accounting. The minimum price was \$300,000.

In the early 1960s, the concept of direct digital control began to take form; its suitability for the process industries was apparent. Here was a technique that could use reliable, inexpensive, flexible control computers. But where were such computers?

In April, 1963, a group of process-industry representatives met in sedate Princeton, N.J. In two days they hammered out guidelines to the kind of computers they needed for process control.

Computer makers took careful note. In a few months they had designers busy at drafting boards and in laboratories. Some computers were modified. New systems began to take shape. "Inexpensive" and "reliable" became the bywords.

Late last year the first DDC system was announced—Digitele, by the Minnesota Mining and Manufacturing Co. Since then, seven computers have been programed for DDC. Some of the known installation include the Monsanto Co. plant in Alvin, Tex., with a Westinghouse Electric Co. computer; the Standard Oil Co. (New Jersey) refinery at Aruba, Venezuela, with a Foxboro Co. computer; Imperial Chemical Industries, Ltd., of Britain, uses computers by Ferranti, Ltd., another British concern; and the Shell Chemical Co. plant in the Netherlands, using a computer by an undisclosed supplier.

This report analyzes the seven computers that are specifically aimed at direct digital control. The prices range from \$5,800 to \$320,000. The reliability, while not part of contracts, is rated unofficially at 99.95% or better.

The potential effects of these DDC computers on a chemical process have been spelled out by Monsanto's senior engineering supervisor, Theodore Williams.

- Consolidating a control system for a multi-million-dollar plant to the equivalent of three file cabinets and a large desk.

- Cutting the costs of this equipment by at least one-third.

- Positive fail-safe transferring from automatic-computer to manual-operator control.

- Assuring control systems that would be out of action less than four hours a year.

- Substantially reducing the number of operating personnel.

- Eliminating the two departments that calculate a plant's yield and costs.

- Installing preassembled, prewired and pre-checked systems simply and quickly.

- Taking advantage of a computer's flexibility by programing to use advanced control concepts such as feed-forward, cascade and adaptive control, at no extra cost or equipment.

- Using either one master computer plus satellite computers, or one large-capacity computer system to supervise an entire plant, keeping it going at peak efficiency, at a cost only one-half to one-third that of present supervisory control systems.

The following articles cover the vanguard computers that have formed the electronic base for the third generation in computer development.



System uses integrated circuits

Scientific Data Systems, Inc., rejects NAND logic in favor of the more-reliable, less-expensive AND/OR approach

By its novelty, DDC is future-looking. The computer with perhaps the most futuristic design is the SDS-92, made by Scientific Data Systems, Inc. It's the first industrial process-control system to use off-the-shelf integrated circuits (cover).

Edmond Pelta, director of circuit design, says Scientific Data used integrated circuits in its analog-to-digital and digital-to-analog converters for greater packing density, speed, accuracy, economy and reliability. The company is also convinced that integrated circuits will play an increasingly important role in computers of the future, and it wants to get started with them as soon as possible.

In designing the SDS-92, Scientific Data altered several company policies of long standing. One was a rule that every SDS system must be interchangeable with every other. Another was the use of AND/OR logic instead of the more widely used—but more costly and less reliable—NAND approach.

Its 1.75-microsecond memory cycle makes the SDS-92 the second-fastest computer covered in this report. Add time is 3.5 microseconds. The magnetic ferrite-core memory, with silicon driver circuitry, is offered in 2,000, 4,000 or 8,000 words of storage space, with possible expansion to 32,000. Word length is 12 bits plus a parity, or checking, bit.

The manufacturer hopes the 92's speed will suffice well into the future. "We wanted a computer so fast that it wouldn't need to be modified for at least three years, no matter what the process application," explains William Kamsler, manager of advanced systems design.

To hold the cost down, Scientific Data hit on the 12-bit word that company studies had shown to be adequate for the calculating accuracy needed for DDC. To cut costs further, the company used a memory from the SDS-9300, one of its scientific machines. The basic price of the SDS-92, with 2,000 words of memory, is \$29,000. This includes a cabinet-mounted programmer's console and an input-output teletype printer.

For small process plants a 4,000-word memory is considered enough. For medium-size plants, or for processes that mix different types of control such as conventional plus feed-forward or cascade,

or for customers that want at least a simple type of process optimization, 8,000 words is considered the minimum necessary memory.

The choice of AND/OR logic circuits was made for reasons of reliability and economy. Diodes cost less than transistors and required simple circuitry.

Integrated-circuit pigeon-holes

The input signal and output signal subsystems use integrated circuits as the storage registers, or pigeon-holes, for incoming or outgoing data in the analog-to-digital and digital-to-analog converters. A DDC system for an oil company in the Midwest that SDS has bid on will serve as a good system's example.

A low-level multiplexer, or time-shared switching device, is connected to five differential thermocouple transducers. The high-level multiplexer is connected to various conventional processes transducers.

The commutating, or switching, devices are Uni-Mod relays made by James Electronics, Inc. Each logic card has four input channels, or relays, along with their transistor drivers and control gates. The Uni-Mods are used for their low leakage, 6×10^{-4} picofarads. The system's common-mode noise rejection is 140 decibels.

The analog-to-digital converter receives the multiplexed signals and feeds them to a junction box. The junction box isolates the computer main frame (the logic, arithmetic and control sections) from the power and ground systems of the process plant. It also couples signals in and out of the main frame, to and from the process.

The digital-to-analog converters, one for each output control signal, use flat-packaged, 14-lead integrated circuits similar to the DTL-931 made by

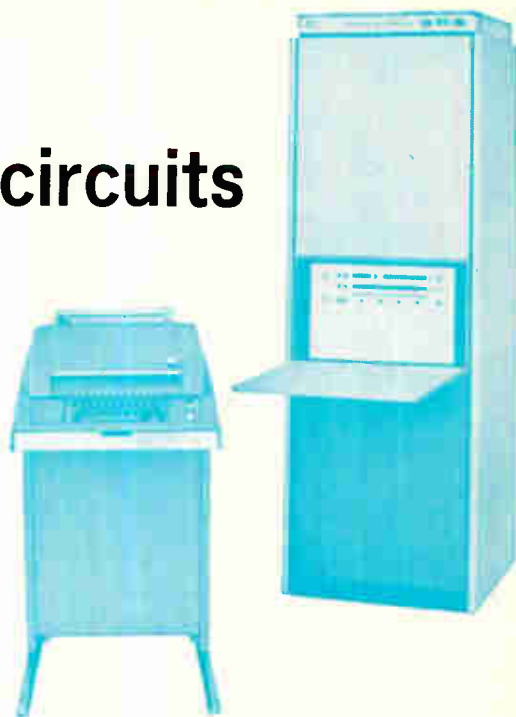

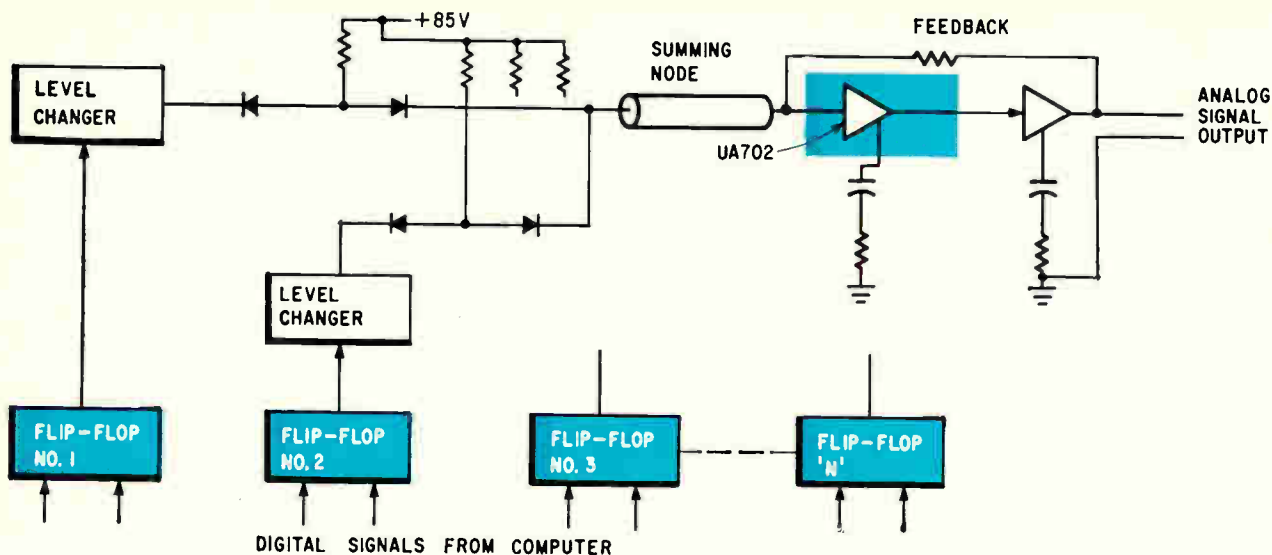

Digital-to-analog converter uses integrated circuits in all input registers and in the input circuit to the operational amplifier. The registers are double-rank flip-flops.

Fairchild Semiconductor a division of the Fairchild Camera & Instrument Corp., as the input storage registers. A Fairchild UA-702 is the input to the operational amplifier shown in the diagram at the top of this page. Here's where real savings in over-all system costs are expected.

Why integrated circuits?

Pelta gives five main reasons for using integrated circuits.

- The analog-to-digital and digital-to-analog converters were due to be redesigned—a small but perfect place to start using integrated circuits.
- Because of a need for simultaneous output signaling to the final process controlled-valves, integrated circuits provided an inexpensive way to get simultaneous storage.
- Savings could be obtained. Four circuit cards

were formerly needed to hold eight flip-flops, one digital-to-analog resistor network, eight inverters and an operational amplifier, when all used discrete components. Now the same design, using integrated circuits, requires only one printed-circuit card. This reduces card costs by 75%. It also reduces by 50% the computer cabinet space needed for each converter.

- The cost for discrete components for the two input storage registers, 4 transistors, 12 diodes, 16 resistors and 4 capacitors—plus the circuit cards is higher than for equivalent integrated circuits and their single circuit card.
- With integrated circuits, analog and digital sub-units can now be mounted on the same size card, measuring 5 by 5.4 inches. This cuts circuit wiring cost 50%.

Here's how integrated circuits are used in a digital-to-analog converter.

The input storage registers, in the diagram above, are double-rank, or two-stage, flip-flops. When the clock, or the system time control, goes from 0 to +4 volts, a digital signal at the input terminal of an integrated-circuit register is transferred into the first stage. There is no output signal yet from the converter.

When the clock goes from +4 volts back to 0, the signal in the first rank transfers into the second rank; a voltage goes to the level changer and a conventional digital-to-analog signal conversion occurs. This happens simultaneously for all input registers.

Integrated circuits eliminate an extra storage register at each input, and probably increase the reliability of the converters.

Reliability of the integrated-circuit package is probably the same as that of just one transistor in the old design, Kamsler maintains.

This increase in reliability and reduction of manufacturing costs, added to the simpler design and higher reliability obtained by using AND/OR logic, account for the SDS-92's low price and high

Drawback: packaging of integrated circuits

While Scientific Data is sold on the performance capabilities of integrated circuits, it isn't completely happy with the packages available.

Edmond Pelta, director of circuit design, says: "We're using both flat-packs and TO-5 can types of integrated circuits. The packs have all the leads we need; but they're hard to handle, hard to test and hard to insert on the circuit cards. The leads are too close and bend too easily.

"There's only one reason integrated circuits are packaged this way: the military backed their development and order the largest quantities.

"The TO-5 cans are easier to handle, test and insert, but they don't have enough leads. You have to use more to do the job.

"What we'd like to see is a flat-pack embedded in a plastic cube, or similar design. The leads could be self-supporting and could come out of the cube in a design that made for easy insertion. We could really lower manufacturing, testing and handling costs with this type of packaging."

speed. Converters using integrated circuits will be recommended by Scientific Data for each direct-digital control system. Scientific Data also plans to use integrated circuits in the redesign of its multiplexers, and tentatively for a third-generation computer that is still in the idea stage. The first generation consisted of tube-using computers; the second, transistorized machines.

Software for control

The SDS-92, when used in a complete system, will be able to perform the two-mode and three-mode control algorithms, or conventional process

control, plus feed-forward, cascade and adaptive, or optimizing control.

A complete array of peripheral devices, from magnetic tape to display oscilloscopes and auxiliary drum memories and disk files, is available, but at added cost.

Scientific Data, like other companies covered later in this report, prefers to sell its main frame plus input-output teleprinter to a systems builder. Several systems companies, such as Fischer & Porter Co., Leeds & Northrup Co. and possibly the Allis-Chalmers Mfg. Co. and Bunker-Ramo Corp. are reported discussing quantity prices for the 92.



Fastest computer?

Variation on pedestal circuit, added to high-speed memory cycle, produces a fast, inexpensive machine for Computer Control Co.

The fastest computer in this report is the Computer Control Co.'s DDP-116 with a memory-cycle time of 1.7 microseconds. The price for a main frame, cabinet-mounted programming console and input-output typewriter is \$28,500. Computer Control considers its machine a direct competitor of the SDS-92.

The diode-gate input to the transistorized NAND logic circuit that forms the base of the DDP-116 is basically a pedestal gate. Computer Control has used this circuit as the basis for all its computers.

Because of automated production, 3C has greatly lowered the cost per circuit.

The gate, comprised of a capacitor-resistor-and-diode, is the input to the basic flip-flop. This circuit is repeatedly used for accumulators, the program counter, memory information and memory-address registers.

How it works

The logic arrangement of the computer requires only two memory cycles for most operations. This is another economy factor.

A typical add operation takes a total of 3.4 microseconds (two memory cycles at 1.7 μ secs. each). During the first cycle (see block diagram) the program counter transfers its data to the memory-address register, causing the required instruction to be transferred into the memory information register. Then the address is transferred into the memory address, the operating code into the operating-code register (block not shown). The second cycle causes the data to transfer into the memory-information register and the contents of the accum-

ulator and of the memory-address register to be fed into the adder. The result is transferred back into the accumulator.

If more data is to be combined, the first computation is put into the B accumulator and the process begins again for the new incoming data.

The DDP-116 has a word length of 16 bits and operates as a parallel machine, both at the input and internally. The capacity of the core memory

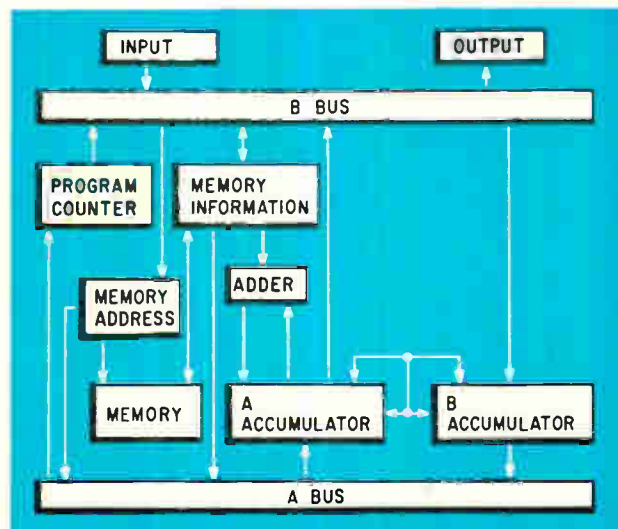

In 3.4 microseconds the computer can carry out a complete addition. Most internal operations are performed in this time—including instruction access and execution.

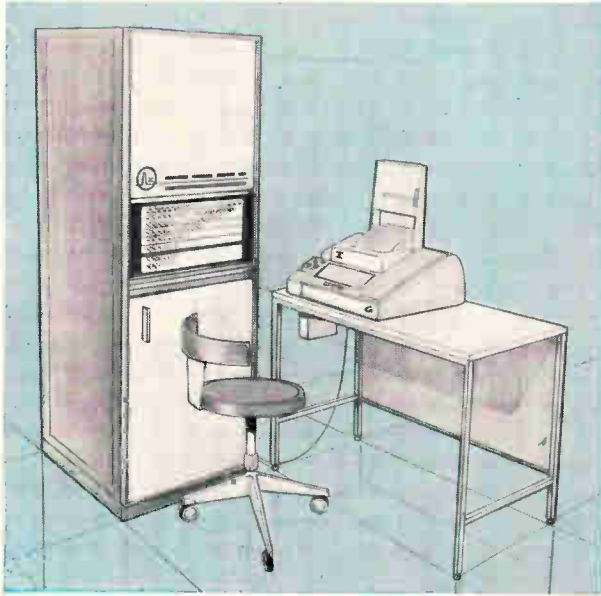

matrix is basically 4,096 words; other basic memory modules of 1,024 or 8,192 words are available. The memory can be expanded to 32,768 words. "Direct digital control needs at least an 8,000 word memory to really do the job that's needed," says Gardner Hendrie, a group leader in 3C's computer systems division. Until March, Hendrie was in charge of the Foxboro Co.'s DDC project, the only such intensive study known.

Like Scientific Data, 3C prefers to serve as a main-frame supplier. Makers of computer systems have already approached 3C about the 116. Hendrie says, "We've also bid on complete systems—we'll go either way."

◀The DDP-116 needs no special installation procedures. Everything is contained in the one cabinet, except the keyboard input-output paper-tape punch and reader at the right.



Technical help from the past

While competitors devise novel circuits and programming, E-A Industrial uses wired programming and satellite control

The smallest computer system comes from the youngest computer manufacturer, the one-year old E-A Industrial Corp. Ralph Benghiat, manager of computer systems, admits: "We've gone back to fundamentals to build this machine. To get the reliability and the low price, we've made it a simple wired-program unit.

With programming reduced to pulling out one plug-in card and replacing it with another, the 101 is in the bargain basement of DDC, selling for between \$20,000 and \$30,000.

Satellite control

Most of the computers described in this report are offered as self-sufficient machines. But E-A's 101 was built for a different purpose. "The only realistic way to keep the low cost and high reliability of any DDC controller is to use it as a satellite computer—two or three small machines controlled by one larger one," Benghiat says.

E-A Industrial designed the 101 so that its entire memory is accessible to an optimizing computer. By running it as a satellite machine, "You

don't have to put all your eggs in one basket," says Benghiat. "The optimum equation on any process changes continually as the engineers learn more about the process. Such things as quality control, plant and process economics, product mix—they all change with time. The basic control principles stay the same, but the optimum equation doesn't. A satellite system lets a user solve both the "eggs" and optimization problems.

Unlike the Computer Control Co., which considers the trend toward silicon transistors as a "fad," E-A uses silicon semiconductors throughout its system. Benghiat says this is because of silicon's stability at high temperatures.

The 101's memory consists of ferrite cores. The basic logic circuits are conventional NAND gates.

The basic 101 calculates the two-mode algorithm, proportional-plus-reset action. Other algorithm circuit cards are being designed.

The 101 is a User's Conference Type 1 machine. It has a wired program, suitable for the simplest DDC applications, with data logging at extra cost. When placed in a process, the 101's basic scan

Silicon vs. germanium

While its machine is the fastest, 3C won't go to the supposedly faster silicon transistors; it plans to stick with germanium. A spokesman explains: "The temperature ranges in which control computers operate aren't high—not over 120°F in the control room where there's always a human operator. The speeds of the computers aren't high either, unless it would be a serial machine with a high cycle time. Then silicon might be needed. Germanium transistors and diodes can do the job DDC specifies if the circuit design is right."

The only silicon used in the 116 is for the core memory drivers, for temperature-control characteristics. Everything else is germanium.

The features of the 116 include: the input-output signal-transfer bus, indexing and indirect addressing (a programmer's aid), and priority interrupt.

The programming package includes, for the \$28,500

price, a symbolic assembler and computer diagnostic, and use, or basic operation, routines.

Options include memory parity (or checking), a high-speed arithmetic option (microseconds), and a real-time clock. By the end of the year, a full line of peripheral equipment will be available, such as input-output analog and digital modules and high-speed printers.

The basic DDP-116 is housed in a single rack, with the computer-control console on the cabinet. No special wiring or subflooring is needed.

The operating temperature is from 10° to 45°C. Humidity range is to 90%. Input power is single-phase, 115 volts, ± 10 volts, at 60 cycles per second.

Other than the displays on the computer itself, graphic panels and the operator's process-control console will cost extra. Manual data entry and display are made through the 10-cps keyboard paper-tape punch and reader. But, this only takes care of the principal computer registers.

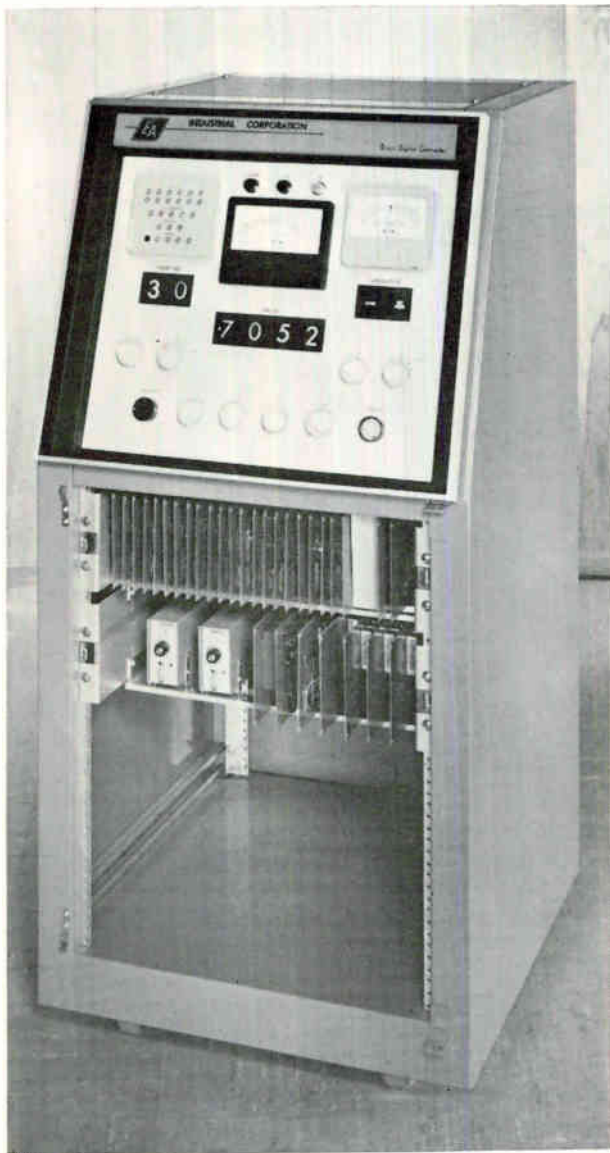

rate will be 100 inputs per second. Because of the satellite concept, three or four 101's would be used for large processes, under over-all direction of a central computer.

This means that each 101 could look at something less than 100 inputs, and scan rate per input would increase. Certain inputs would be scanned repeatedly in a single cycle.

The computer's internal word-length is 24 bits, in addition to plus- or minus-signs, input-word length is 12 bits. There is only one signal gain, but this can be changed by replacing that particular circuit card with another. Common-mode noise rejection at 60 cycles per second is 110 decibels.

Output signal accuracy is 1/4096, standard for all the machines discussed. The computing sequence is also conventional: The input signal from the process transducer is converted from analog to digital form, alarm limits are compared, set point value is compared, any error is integrated, and proportional and reset signals are added for the output-control signal.

The output signals sent to the flow-valves are transmitted through mercury-wetted relays. Reed relays could have been used, but reliable types are slightly more noisy than reliable mercury-wetted relays.

Three forms of output signals

Output signals are available in the three standard forms. One is a pulse count, for positioning stepping-motor digital positioners such as the one announced last year by Honeywell, Inc., at the Instrument Society of America Show or the Robertshaw Controls Co. and Conoflow Corp. devices discussed on pages 95 and 96 to be shown next week at the 1964 ISA's show in New York City.

Another signal is a pulse rate for velocity actuation of valves. The last form of signal is the time-

tested 4- to 20-milliamperere d-c signals for conventional analog valve-actuators.

The standard 101 provides only one of these output types. A mix of all three in one controller involves extra cost.

The system diagram on page 81 shows the output connected to the operator's display, an alarm display, a maintenance panel or any optional display a user might want. But, the 101 of the photograph on page 79 is the entire system.

Operator and alarm displays are shown in the top panel. Additional displays are available at extra cost. Digital voltmeters are used to show loop parameters. The conventional meters are used for percent readings because process personnel are familiar with this type of display.

The 101's front door has been removed in the photo on page 79 to show the setup for a four-loop system. The top row of cards is the computer

section, including the wired-program cards. These 24 cards, plus the seven analog-to-digital converter and input-output cards in the second row, comprise the entire system. The two small oblong boxes on the left end of the bottom row are amplifiers that are now being replaced by cards similar to the rest of the computer.

Besides the two-mode algorithm, other control schemes such as feed-forward are being put into printed circuit, wired-program form. As the 101 now stands, the proportional band—the percentage of input signal used to produce a 100% output signal—is adjustable over a range of 0.1% to 1,000%, and the reset rate from 0.0001 to 1 repeat per second. If one input transducer should malfunction and the control algorithm become unworkable, the operator could take that particular input off-line and the last control signal would continue to be repeated to the final actuator.



Double duty for components

Besides time-sharing of controlled loops, Westinghouse's Prodac-50 computer time-shares its own operation

"If each flip-flop isn't used at least once during each instruction execution—redesign," says Frank G. Willard, the man behind the Westinghouse Electric Co.'s Prodac-50 computer.

"We want everything working all the time," he continues. "Constant operation never destroyed an electronic component. Time-sharing computer circuits, like DDC itself, give an efficient system."

Willard is advisory engineer in the company's computer systems division. His dogma is one reason that Westinghouse attained a low price of \$21,500 for the main frame of the P-50, with 16 external interrupts and a 4,096-word memory. With an input-output teletypewriter, it costs \$26,000.

The memory matrix consists of magnetic ferrite cores; the rest of the machine uses silicon semiconductors for high temperature operation, 32° to 120°F, without external cooling. Memory-cycle time is 4.5 microseconds; add time, with two 14-bit words, is 18 microseconds. The machine is a parallel (external and internal) type with single

addressing of the memory. Indirect addressing of memory locations is also available at extra cost.

Double duty for flip-flops

The basic building block in this machine is a cordwood-constructed dual-NAND gate with diode input. Switching time is about 25 nanoseconds, with a maximum of 50 nanoseconds. By making the flip-flops do double duty—as memory locations and storage registers—Westinghouse was able to reduce the total number of components. Time-sharing of circuits and components reduced component count and increased reliability.

But Willard's philosophy does have a disadvantage: slower over-all speed compared with say, the Prodac-500. Still, the simple arithmetic and logic operations in the Prodac-50 require no more time than do the large computer-control systems.

For example, adding two words takes 18 microseconds. The memory-cycle time is 4.5 microseconds—four memory cycles per addition. One cycle

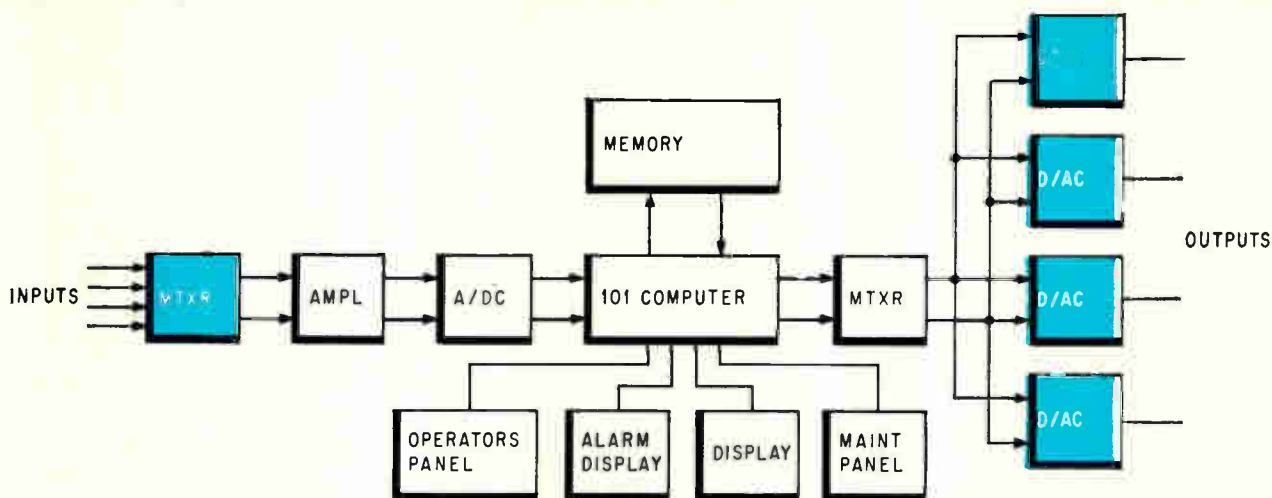

Expanding the 101 digital computer consists of adding one input card to the multiplexer and one digital-to-analog converter card at the computer output.

updates the program counter located in the memory. The second selects the address of the needed word. The third reads the address location, transferring the word to the adder. The fourth transfers the second word to be added from its location in the accumulator.

This double-duty design, used throughout the P-50, has reduced the number of transistors to about 800 from about 10,000 for the P-500.

Compactness deemphasized

While reliability is a major design objective, so is maintainability. When something fails, how long does it take to fix it? Here Westinghouse made a 180° turn. While nearly everybody else was emphasizing small size, the P-50's electronics are comfortably spread out.

The P-50 uses big printed-circuit cards—10 inches long and 6 inches wide. The circuit layout is roomy (photo at right). Card mounting is on one-inch centers for natural cooling.

The cards—there are 25 in the system, 14 in the main frame—also have some notable features. By grouping on one card all the components pertaining to a single bit, Westinghouse concentrated all the circuit requirements for logic and control in the main frame into 14 cards. Each identical card holds the read-write circuits, logic and control flip-flops and even the indicator lights for just one bit.

“When a computer manufacturer plays the miniaturization game,” says Bates Murphy, director of computer systems training, “a maintenance man is pinned to the wall. Normally he not only has to isolate a trouble to a logic function, but that function might actually be a sub-sub-sub-function in the over-all system.”

“With this one-bit-one-card design, with every bit being processed through its own channel, or

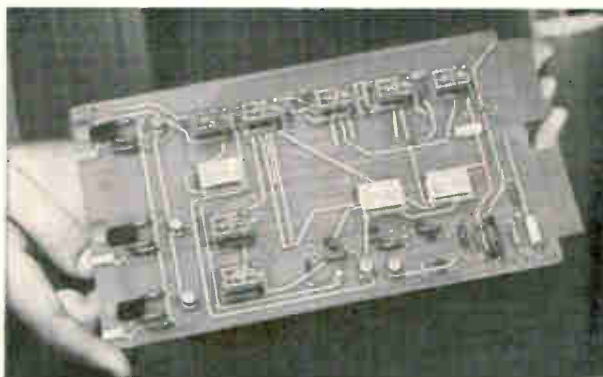

Circuit cards 10 inches long by 6 inches wide are used in the P-50, despite an industry trend to smaller cards. The dual-NAND gates of the cordwood type are widely spaced, and plug-in connectors are large for easy insertion.

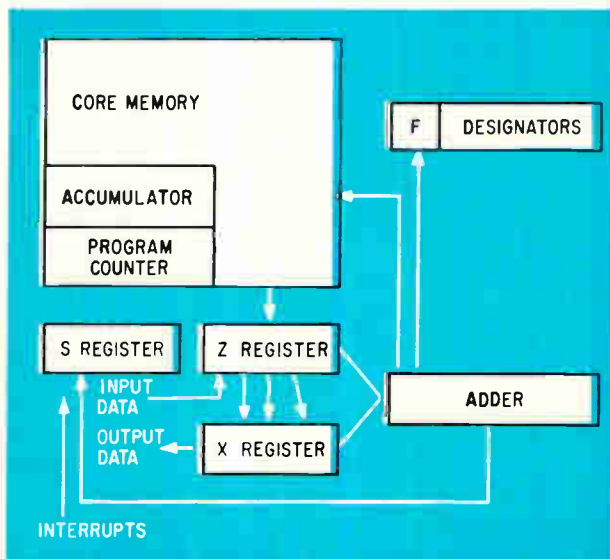

Accumulator and program counter are both memory locations. This eliminates two extra registers. What's left is time-shared.

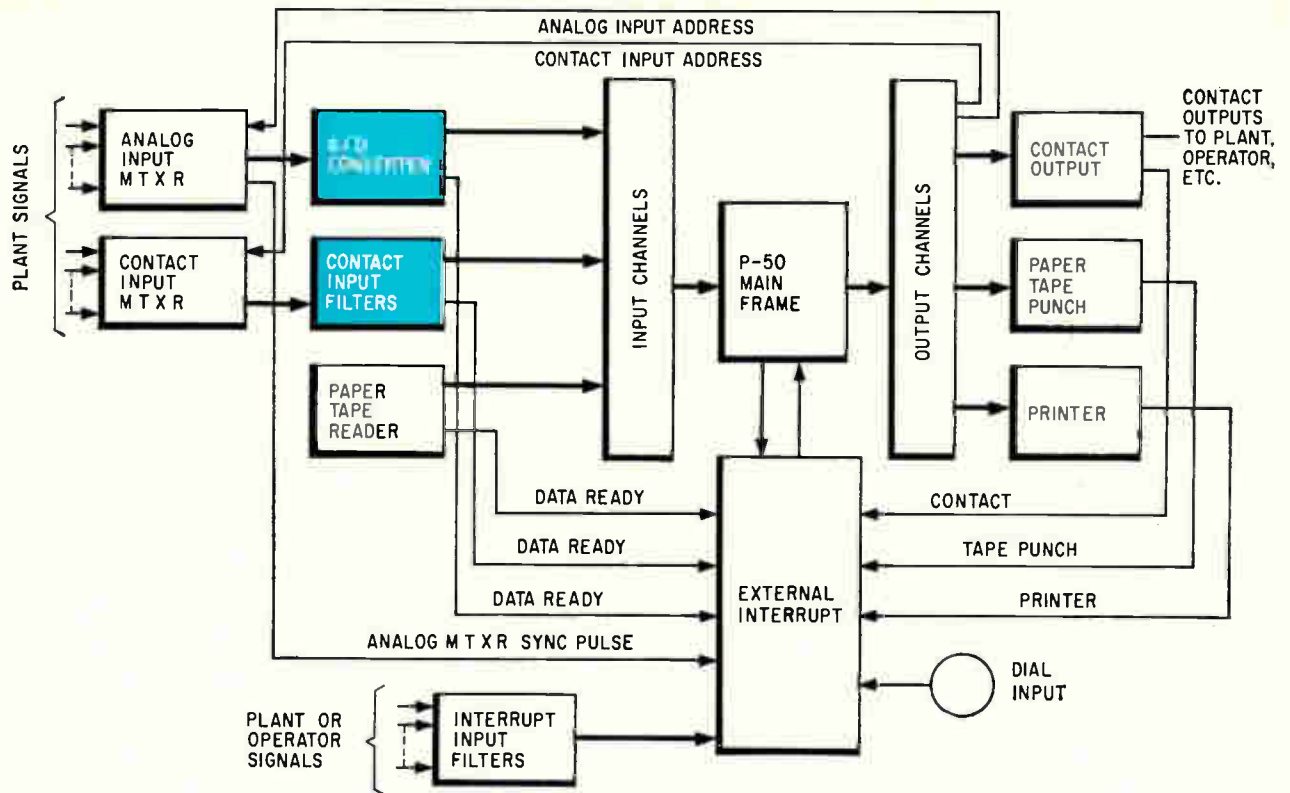

In analog-to-digital converter (color) and in the contact input (color), each bit has its own buffer-gating transformer. The contact output is through mercury-wetted relays, two relays for each stepping motor. The motors are standard types, 50 steps per revolution.

circuit card, we think 85% to 90% of system failures can be repaired in 10 to 15 minutes," Murphy explains. "Just find which bit is faulty in the data word and pull that bit's card."

All input signals from the process, digital or analog, are transferred into the P-50 through individual transformers. In the analog-to-digital converter and the contact-input subsystems (diagram above), there is a separate transformer for each bit of the 14-bit word. These transformers—there are about 100 in the system—serve two functions. They are both buffers (isolating the process from the computer) and control gates.

Patents on the associated circuitry are pending and Westinghouse is reluctant to describe it. But basically, the transformer's gating circuits will not let the transformer pass an incoming signal until a control signal from the computer also arrives at the same time.

Analog-to-digital conversion is accomplished with a conventional voltage-to-frequency converter and a counter. The incoming signal is integrated in the counter for one cycle of the a-c line frequency to cancel line-induced noise. Common-mode noise rejection is 120 decibels. The conversion rate is 40 input signals per second for each converter, to an accuracy of 0.1% with 50 millivolts as full scale.

To eliminate noise, all digital inputs are also fed through a filter system, then to the input channels and into the computer's main frame.

The P-50's output signals, sent through two mercury-wetted relays rated at 100 volt-amperes, are used

to run stepping motors. One relay is for A-phase pulses, the other for B-phase. The sequence of A and B determines which way the motor steps—50 steps per revolution is standard. The motor's output shaft can drive slide-wire potentiometers, position the movable cores in differential transformers, act as the flapper valve control in pneumatic regulators, or drive small process flow-valves directly.

The Monsanto Co. is planning to use two P-50's in the manufacture of raw materials for low-suds soaps. It is reliably reported that the contact pulses will be fed to new panel-mounted digital pneumatic valve positioners made by Honeywell, Inc.

The P-50 needs a maximum of 500 watts, single-phase, 120 volts, 60 cps a-c, plus or minus 10%. The ferrite-core memory is fully protected in case power fails; battery power for emergency operation is offered at extra cost.

To reduce the cost of a complete system Westinghouse has attempted to develop "fill-in-the-blank" type software, or programs. According to Robert Kirby, a vice president, the cost of an entire P-50 system will average between \$50,000 and \$100,000. Standard programs, included for the basic price of \$26,000 include such standbys as the trigonometric functions, exponential functions and square root. Also a complete executive package, programmer's console program, operator's console routine, the two- or three-mode algorithm, standard data logging, feed-forward and cascade routines, plus a simple optimizing program.

Departures by 3M's Digitele

It uses electrochemical cells to develop output signals; analog-to-digital converters detect errors

"You're losing money by using a computer to calculate signal error or generate output-control signals," says a spokesman for the Minnesota Mining and Manufacturing Co.'s instrument department. "You're saving money and time only when the computer does complex operations such as data logging, algorithms or alarm programing."

This is the reasoning behind an approach to direct digital control that's at complete odds with that of the other six companies in this report.

3M spent two years developing its Digitele control system which was introduced last year at the Instrument Society of America show. Two Digiteles are scheduled for installation this year, one on the West Coast, the other in the East.

What's so different?

According to Earl Bullock, a senior development engineer, the output-module for reset-plus-propor-

tional, or two mode, control uses the Solion cell as both a memory device and an amplifier.

The Solion is an electrochemical device that produces a continuous output current proportional to the integral of its input current [Electronics, Feb. 27, 1959, p 53].

The Digitele 2201 Direct Digital Controller, pictured and diagramed below, is a User's Conference Type 1 machine, or wired-program computer. When combined with the 2018 computer, with a 4,096-word drum memory, the 2201/2018 system is a User's Type II system, can be used for direct substitution in place of conventional analog controller systems and for special computerized functions such as data reduction, control algorithms and alarm programing. It also provides its own back-up.

All these features are for the basic system's price of \$37,000. This includes 56 inputs controlling 28 loops with reset and proportional type control, plus

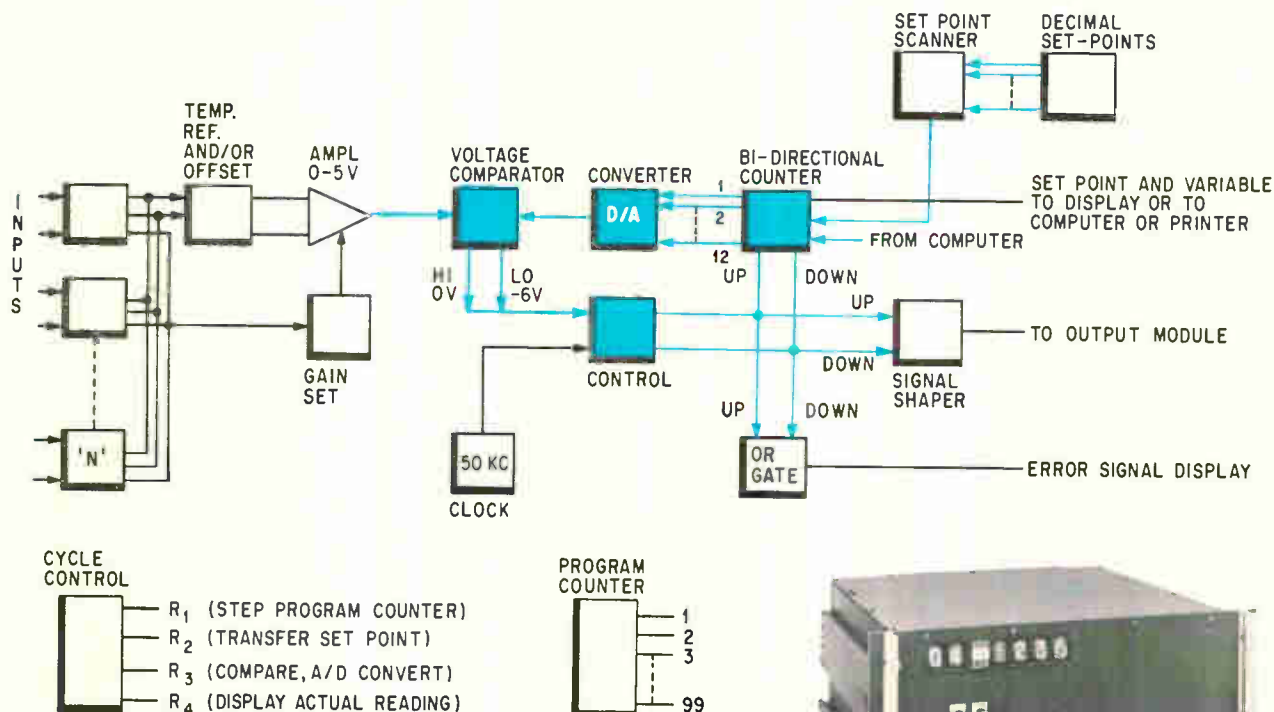

Master controller detects the digital error as it converts analog to digital using the voltage comparator, D/A converter and bi-directional counter (color). By itself, the controller on the right can handle proportional-plus-reset or two-mode controlled processes.



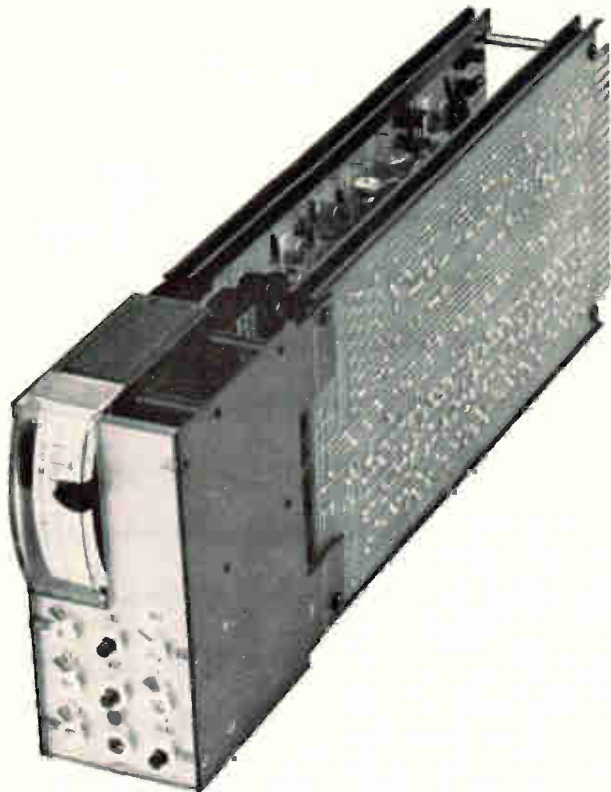

Electrochemical Solions (color below) are used in proportional and reset circuits as memories and current-to-current amplifiers. The output module above can hold just the reset or both circuits for two-mode control of one loop.

some special control functions and readout in engineering units.

Beating the drum

The two reasons behind the low cost of the 3M control computer are the use of a drum memory and time-sharing of the serial logic and control circuitry. Time-sharing, as in the Westinghouse P-50, permitted simpler circuit design. Cycle time of the drum is 10 microseconds—slow compared with the other computers in this report. Add time is 312 microseconds. But high speed, according to the 3M official, isn't needed. The repetitive error-detection and output-signal generating functions are not done in the computer. Error-detection is done in the master controller. Then the digital error signal from the master controller goes to individual output modules. Each of these develops its own reset-plus-proportional signal.

Bullock gives four reasons for this approach.

- The computer doesn't enter into the control and error-detecting picture at all. It only calculates and stores data.
- There's a direct tie between input and output signals.
- If the computer fails, the signal is still processed, thanks to the built-in back-up.
- If plant power fails you can use either battery-back-up or manually adjusted output control modes.

How the master controller works

Operation of the master controller and the out-

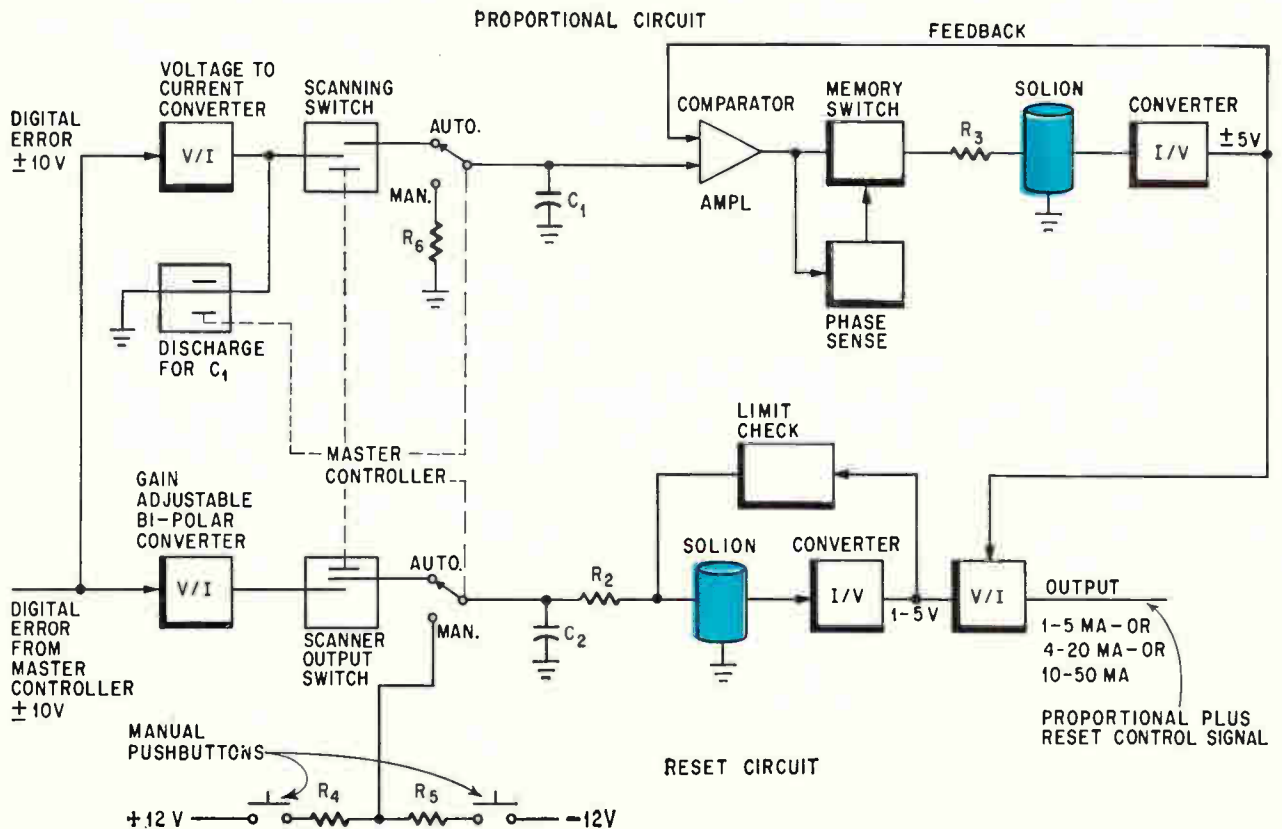

put modules is the same whether they're tied in to the computer or controlling a process on their own.

In the diagram on page 83, the input circuit selects the gain and connects the signal to the amplifier. The amplifier linearizes the signal to some value within 0 to -5 volts. The analog-to-digital conversion that follows gives a digital error signal at the same time as the conversion by starting the conversion at the set-point value, not from zero.

The two-direction counter and the digital-to-analog converter form an electronic potentiometer. They produce an analog signal proportional to the set-point, and send it to the comparator for matching with the unknown input voltage. Until a match is made, the difference is sensed by the control circuit, which pulses the two-direction counter up or down to get a match. The number and direction of the pulses tells error magnitude and polarity. The two-direction counter sends its signal to the set-point and variable display, to the printer or to the computer if one is used. The signal shaper receiving say a series of up pulses, puts out a 10-volt signal whose time duration is the total time of the error pulses, each 20 microseconds long. A down signal is one of -10 volts. The OR gate sends the

digital error to its display on the front of the master controller.

Reset first

Reset control is a short name for proportional-speed, floating-point control. Reset action is best used on slow-response processes, and is easier to produce electronically than proportional-type control.

The bottom circuit in the diagram on page 84 is the reset portion of the output module. If this is the only type of control needed, the module pictured at the left, will only have this circuit in it.

The voltage-to-current converter uses common-base connected transistors because of their constant-current characteristics. This circuit converts the error-voltage into an exact amount of current to charge capacitor C_2 after the scanner-output switch is closed.

This switch, part of the output multiplexer, isolates the integrator circuit that follows. It also selects the right output module.

Capacitor C^2 is a high-speed integrating device. It takes the high rate error current and passes the accumulated charge on C_2 at a slow rate, through R_2 , to the Solion cell. The Solion output current

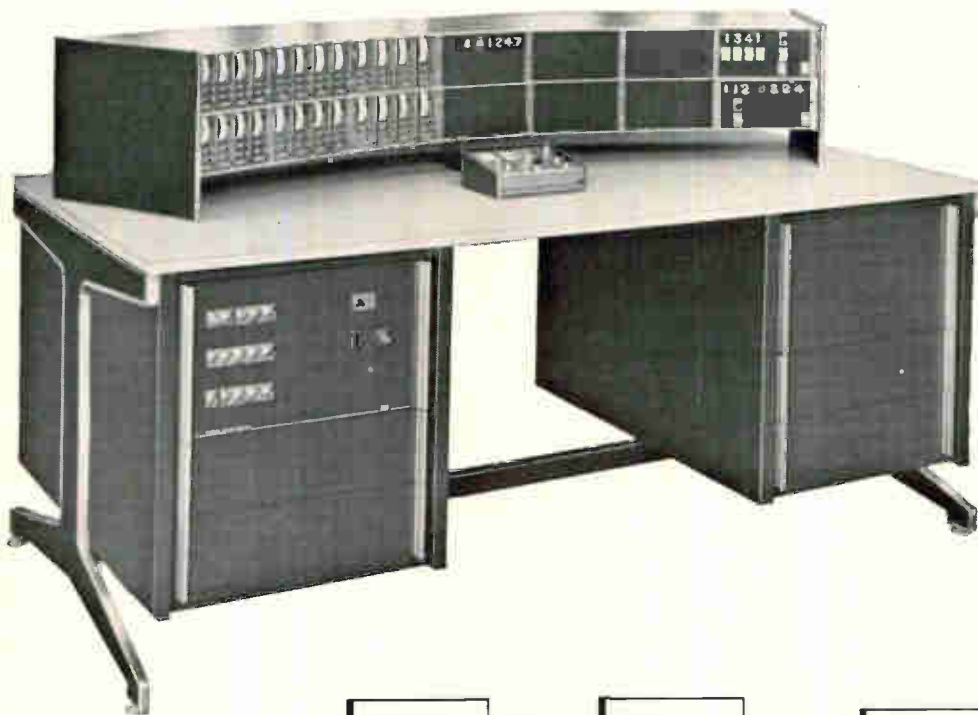

Built-in back-up is provided by the master controller-computer combination system. If the computer fails (drawer, left side of desk), since it is not detecting or outputting signals, the process is still under control using the master controller (at left of curving console). Control signals (color at right) can also be fed directly from the computer.

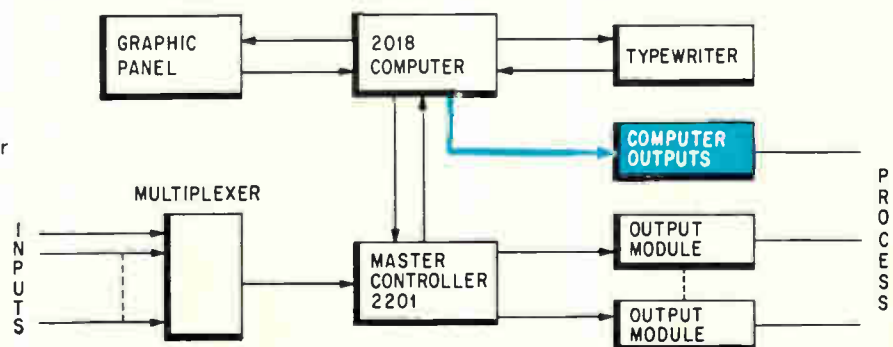

changes in direct proportion to its input charge. The polarity of the incoming charge from C_2 determines how the Solion output changes, more for a negative input and less for a positive input.

The output current is converted to a 1- to 5-volt signal. The voltage drives the limit-sensing circuit that sets the range of output current for a 1-to-5, 4-to-20 or 10-to-50-milliampere signal output. The voltage can also be used on its own, if voltage-actuated flow-valves are used in the process.

The Solion, besides being an accurate integrator, is also used as a memory. The Solion circuit can change output currents in increments much smaller than 1 part in 1,000, and "remember," for hours if necessary, the exact value to within 1% of the output-signal range. When switched to manual, each output module sends out the last signal that the Solion integrated. Under manual control, each loop can be controlled by the operator using the +12 volt or -12-volt buttons.

Proportional for 2-mode control

After integrating capacitor C_1 in the proportional circuit on page 84 has been discharged, a new digital error signal—the same one that is being processed through the reset circuit—is applied to C_1 . The voltage-to-current converter produces an analog current that charges C_1 to an analog voltage that is proportional to the digital input-error signal. The memory switch is closed at the end of the error signal.

If the comparator amplifier detects a difference between Solion output voltage and the new input voltage, the memory switch stays closed. The comparator amplifier produces a new current for the Solion until its output, the converted current-to-voltage signal, is the same as that on the C_1 integrator. This is detected by the zero-sensing circuit, which opens the memory switch; the Solion now retains the last signal received.

The proportional and reset circuit voltages are then combined for the output two-mode control current for that loop $I_o = K(I_i + I_p)$. I_o is the output current with K equaling 1 for 1 to 5 ma, 4 for 4 to 20 ma or 10 for 10 to 50 ma outputs. I_i is integral, or reset, current and I_p is the proportional current.

In the computer

The computer communicates with the master controller through special transistorized registers. When the computer does send a new set-point, it is stored in a register and then fed to the two-direction counter.

The data word in the 2018 computer contains 24 bits, including sign. The basic number of commands is 24, but this can be expanded to 32 when needed. There are four levels of programmed priority interrupt. Rate, or other complex control functions such as feed-forward or cascade, are available on a limited number of loops—five or six per second.

Construction of printed-circuit boards is of two

types: individual components on a 4- by 9-inch board with an aluminum frame, and submodule wafers mounted in sets on a 3½- by 9-inch mother-board.

The software, or programing, in the basic \$37,000 computer system includes program load, diagnostic, multiply, divide and square-root routines.

Random notes

Proportional band is adjustable from 1% to 200%, and reset is from 5 to 100 percent-minutes for full-scale change—to reduce errors to within 0.1%.

Common-mode noise rejection is 110 db minimum at 60 cps. The scanning rate is 60 points per second.

Analog-to-digital conversion accuracy is $\pm 0.25\%$ of full scale, and data indication is to three decimal places—0 to 99.9% full scale for the master controller, 0 to 99.9% full scale with the computer.

The power required is 115 volts, 60 cycles per second $\pm 10\%$ at 75 watts for the controller and 210 watts for the computer-controller system.

A basic master controller for an eight-loop system costs \$5,800; this includes reset action only, and readout in percent of full scale or engineering units. The controller has room for 16 input modules. Using a selective 12-prong plug, each module automatically selects the amplifier gain and, if needed, bias for that specific input. The controller measures 19 by 10½ by 20 inches. The computer system can be included in the left side of the operator's desk-console that is three feet wide by six feet long. For rack-mounting, a space 42 inches high by 19 inches wide is needed for a complete computer-controller system.

Control techniques

Conventional process control uses analog controllers that operate in the two- or three-mode control technique. Two-mode control combines an output signal (proportional) that is proportional to the error signal from the process with a second signal (reset) proportional to the time-integral of the error, between the set-point and the measured signal. Three-mode control is combination of proportional and reset, plus a third signal (rate), proportional to the rate at which the error is changing.

The formula for proportional, reset and rate is compactly contained in an algorithm for faster and simpler computer operation.

Feed-forward is a control technique that detects process changes before they affect the process output, and provides an anticipating correction signal to the process. Feed-forward information comes from the process input, whereas conventional control information comes from the process output.

Cascade control uses the output signal from one process function, or loop, as the set-point for a second loop.

Optimization involves use of a computer to determine the best set-point to improve the process toward the various goals of best product, highest efficiency, least amount of substandard product, the widest range of products from one plant at lowest operating costs, and so on.

Adaptive control involves use of a computer to continuously adapt the control algorithm to changing process conditions.

GE spurns arithmetic for logic

Its 4040, designed partly by another computer, opens up in three hinged sections for easy maintenance

“Only 20% to 30% of a computer’s operating time is used for arithmetic manipulations,” says Raymond Berendsen, general manager of the General Electric Co.’s process computer section, “so we put the emphasis on faster logic in the GE/PAC-4040.”

Even so, the 4040 has a five-microsecond memory cycle, a 16-microsecond add time and a 24-bit product multiplication that is rated at 320 microseconds maximum.

For easy maintenance, the computer opens in three hinged sections, like a book.

All silicon components are used for high temperature range. GE believes that the circuit card and complete system packaging is tighter and more efficient because “We get more performance with fewer components—for example, using memory locations as working registers,” Berendsen contends.

The GE/PAC-4040 (Process Automation Computer) uses a word of 24-bits plus parity, or checking, bit with parallel input and serial internal operation. The output is parallel.

The 4040 performs two or three-mode control algorithms, plus cascade, feed-forward and other complex control functions. With a basic core-matrix memory size of 4,000, 8,000 or 16,000 words, the system can work a two-mode algorithm in 750 microseconds.

It automatically scans up to 256 inputs, analog and digital, at 150 per second, checking for high or low limits and alarming off-limits. It can start manual or automatic control, output a pulse-control signal, and tell the process operator—through one or more graphic panels—what’s going on.

The input subsystem uses a 12-bit analog-to-digital converter of the successive-approximation, bipolar type, with an accuracy of 0.1%. The selectable range amplifier is rated at 10, 20, 40 and 80 millivolt ranges, full scale selected by the program. The signal-conditioning unit, following the input multiplexer, converts the milliampere input signals to a nominal 62.5-millivolt signal that is then fed into the computer’s main frame for processing.

Common-mode a-c noise rejection is 10^6 with a line unbalance of up to 100 ohms.

The main frame

The memory is single-address with direct or rela-

tive addressing as an aid to programers. “We use seven memory locations as indexing registers,” says Berendsen.

The registers—in the arithmetic and control unit—are used in the following sequence: A, B, I, P and J (diagram on p. 89). The A register consists of 24 high-speed flip-flops with a bit configuration of 0 to 23. A acts as a temporary storage for the data coming from, or going to, the input-output equipment connected to the process. It is also the

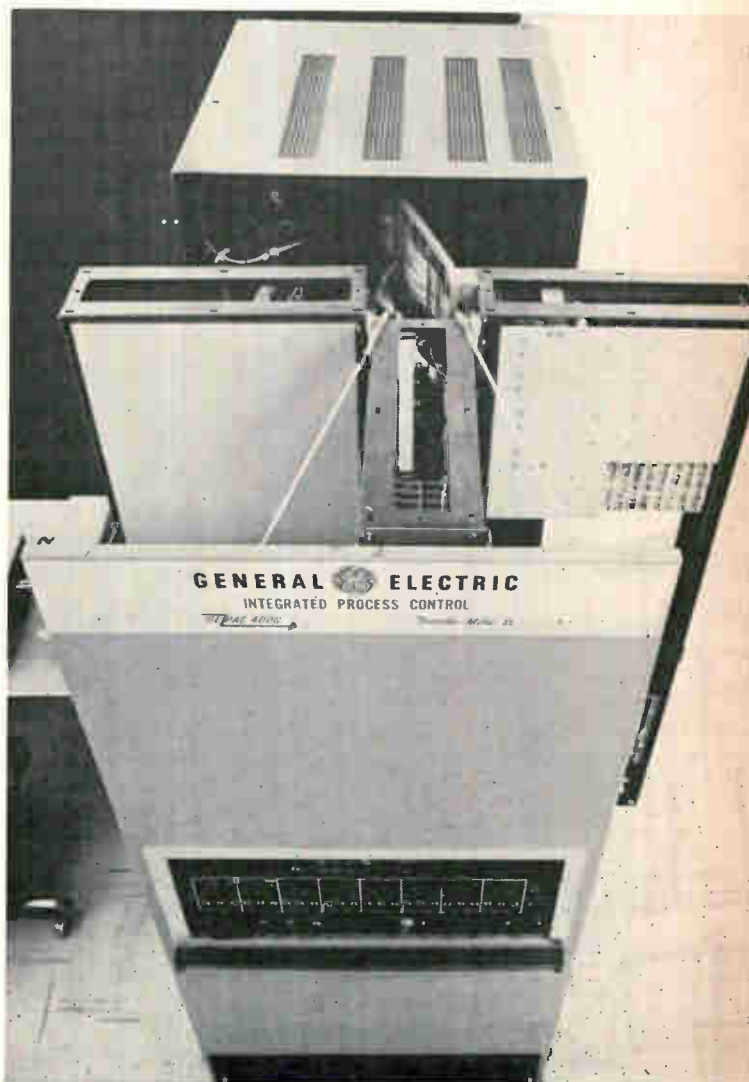

accumulator during arithmetic and bit-manipulation operations.

Register B is the parallel-entry buffer between the core memory and the arithmetic unit. It's the link between the memory and the A, I and P registers.

Register I, also a 24-bit register, is the temporary storage for the arithmetic unit's controlling bits.

The data register and address register are both memory locations.

To pull data out of memory, the needed data's general address is transferred by P to the memory-located address register. The specific address, or pigeon-hole, is found in the memory. It is transferred in parallel, via the memory-located data register, to B. B is parallel-transferred to the first instruction register I_1 , and also in serial form through the Full Adder B to the I_2 register. In I_1 the decoded instruction from memory, whether modified or not, will now address the specific memory location and bring out the needed data for arithmetic and logical operations. The new data will then be transferred to the memory, or to the input-output equipment, or used to select specific modules and other devices within the input-output equipment.

The logical choice

The 4040's basic logic circuit was designed using another computer, according to Richard Berling, one of the circuit designers of the 4040. He says the circuit operates in temperatures from 0° to 70°C, and that the machine's temperature range is 0° to 50°C.

The basic logic circuit is a diode-coupled NAND, slightly modified. Component data from other GE divisions was also used to program the computer-designer.

"Every circuit and every component is based on military designs," Berling says. "If they can hold up for the military they'll sure make it in industry."

"As an example," he continues, "the derating factors from one of the Air Force's communications systems are used for carbon resistors. We go them one better. Our resistors are bought with $\pm 5\%$, and we figure $\pm 10\%$ end-of-life operation. The Air Force only specs $\pm 8\%$. With worst-case design throughout the system, this allows us to operate within the user's specifications even if all components are at the end of their life-ratings. Also, we derate needed operating power to 50% of the component maker's specification before the circuit will fail."

To the diode-coupled NAND gate, GE has added two 1N914 diodes for noise rejection instead of the usual one diode. Also, to decrease the number of components needed for any one function, expansion terminals have been installed on each circuit card (circuit at right).

D_3 provides the OR function and D_4 - D_5 (color) give the extra noise rejection described by Berling.

A' is one of the expansion terminals, used to expand the AND function if an operation should

need, say, one to seven functions all to happen simultaneously for a specific output signal. O' expands the OR function of the circuit if it should be needed.

"Another reason we picked mil-spec components is that they're low-cost because of large military orders," Berling says. "Because the component vendor is already set up for high-volume production we get a good price on a highly reliable component."

"When we started on this machine, we wanted a low price tag. So we used a computer to do the circuit selection, design and optimization."

The computer, a GE-225, analyzed what design would be best for all the high-volume circuits such as the logic elements and flip-flops. It was programed to pick the best design for the highest efficiency.

Several kinds of logic were evaluated: resistor-transistor, diode-transistor, diode-resistor-transistor, resistor-capacitor-transistor, and direct-coupled-transistor. Diode-transistor logic was the over-all winner.

What ordinarily would have taken six months of engineering only took one month (for programming) and six hours of computer running time.

The computer was then used to optimize the design of the circuit chosen. The machine determined the best resistor tolerances, power-supply levels and tolerances, and circuit fan-out. "The computer also told us the effects the other circuits would have on the driving circuit gain and speed," Berlin recalls. "After this, all our new computers will be computer-designed."

This design work allows the 4040's circuits to perform to rated accuracy even with all circuit components operating at their extreme limits. The next GE/PAC is said to be a system one-half the size of the 4040, so designed that it can be completely built with integrated circuits.

Like pages in a book

The basic 4040 uses 40 types of circuit boards. Each is coated for resistance to moisture and industrial contamination.

Each receptacle, used in the book-page frames is made of molded plastic, probably the only use of

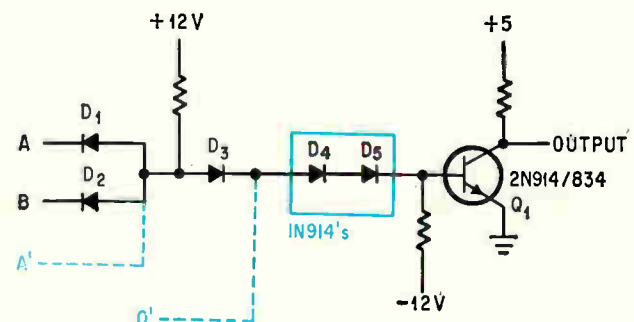

The diodes in color block are added to this basic diode-coupled NAND gate for extra noise rejection.

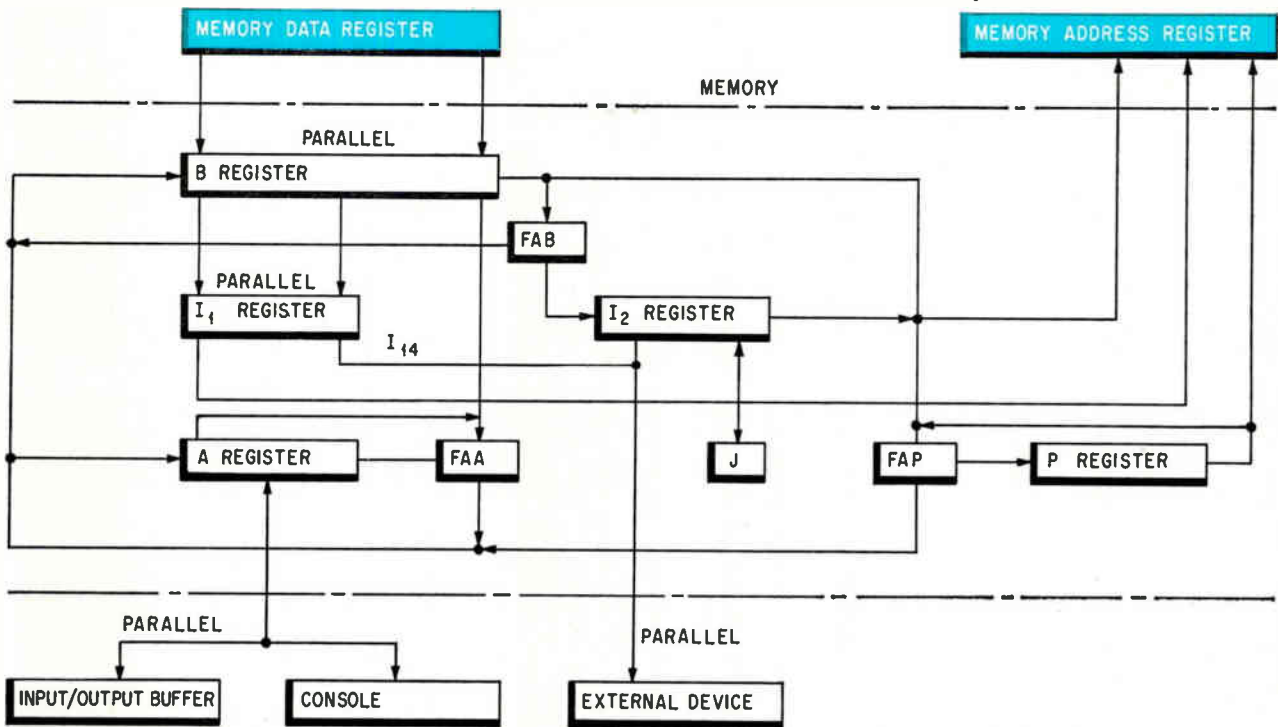

Memory locations are used as indexing registers (color) to reduce components as shown in this simplified diagram of the arithmetic and control unit.

plastic in any of the computers discussed in this report. Each receptacle holds 17 cards, spaced on one-inch centers.

The book-page frames are on a roll-out base, each frame holding 10 card receptacles.

The two outer pages are hinged to the stationary inner page. This allows maintenance men to get at all sides of the electronics; it also allows walk-in access to the input process-signal terminations and to the power supplies that are mounted inside the back of the stand-up cabinet (photo, p. 87). This approach also cut production cost by 20%.

Basic system size is configured in 50, 80, 120

and 160 loops, with modular field expansion features built in.

Operator panels permit entry or display of set-points, control constants, high-low limits, display of measured-variable value and loop identification. A key-switch is included, at extra cost, to eliminate unauthorized changing of process parameters.

Software includes assembling, compiling, debugging and hardware diagnostic routines. The process assembler language accepts coded instructions such as those of Fortran II or TASC (Tabular Sequence Control), and translates them into computer instructions for the 4040.

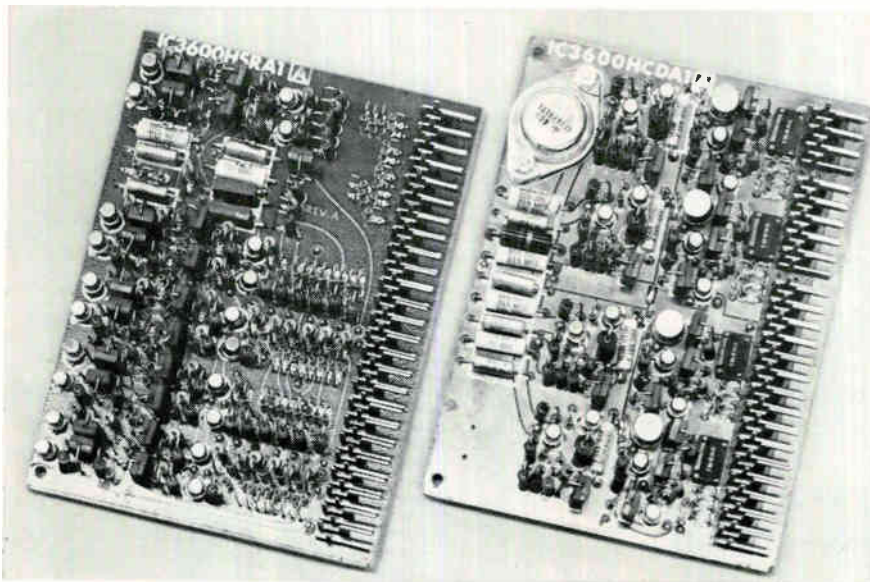

Two typical circuit cards. Component density averages 200 per card or 15 per inch.

Foxboro: a successful skeptic

It installs conventional process-control systems while planning what it calls the first 'true' DDC computer

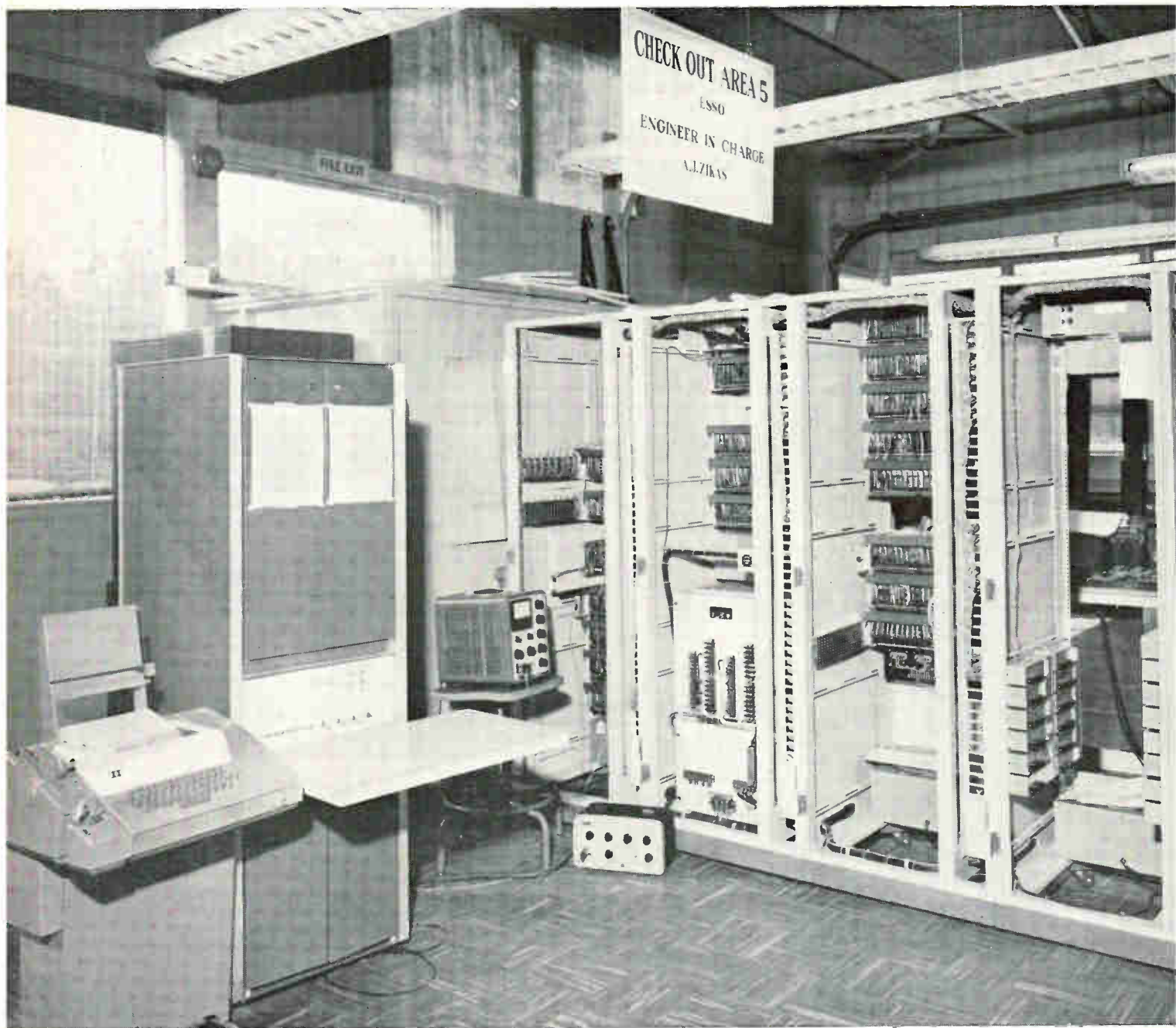

The company with the most success in DDC is also the one with the least confidence in present specialized computers for direct digital control.

"There are now no true special-purpose DDC computers," says Thomas Nourse, marketing manager of the Digital Systems division of the Foxboro Co. "In most cases these so-called DDC computers are stripped-down general-purpose machines with reserve capacity for uses other than DDC."

Foxboro insists there isn't enough test data to design a special-purpose DDC computer. It is generating its own data at a test laboratory in Foxboro, Mass. Meanwhile, it is selling to industry its M97000 series of conventional computers—the 97400 for basic DDC and some simple optimization; the 97600 for advanced DDC and both process optimization and supervisory control of satellite computers; and the 97600-A for high-speed control of entire processing complexes.

These systems are complete; the prices include graphic panels, operator consoles and even the computer control room. The prices, detailed later in this article, are the highest in this report but also probably the most realistic.

Foxboro's systems may be the most conventional in design, but the company speaks with the most authority about DDC. It has won two of the three DDC contracts awarded to United States companies—the Standard Oil Co. (New Jersey) plant in Venezuela and the Dow Chemical Co. unit in Midland, Mich.

One computer controls another

For two years, Foxboro has been conducting an in-company DDC test. At its Massachusetts laboratory, an analog computer is used to simulate different process parameters, and a Foxboro M97600 computer acts as the DDC controller. The Foxboro machine controls a 17-loop heat-exchanger. Results of this study have already affected the design of Foxboro's operator console and are expected to help determine the design of the company's "true" DDC computer.

The experiment was begun by Gardner Hendrie, who left Foxboro in March to become group leader in the computer systems department of the Computer Control Co. The study is now under the direction of William Vannah, former editor of Control Engineering magazine.

To date, this is the only known test setup of its kind in the electronics industry.

Digital vs. analog

Foxboro maintains that it's futile to compare the price of DDC (as a direct substitute) with that of conventional analog controller systems. Nourse explains: "Against pneumatic systems a DDC computer will never break even. And against electronic

Little brother. To check out the modified M97400 DDC computer system (center-right) going to Standard Oil Co.'s refinery in Venezuela, Foxboro uses a conventional M97400 (left) to put the larger machine through its paces.

analog control, the cross-over point is at 220 loops." The cross-over point is the one where the cost of DDC computer control, as a direct substitute, equals that of analog control systems.

"Previous claims of 50 loops as the cross-over point can't be proved," Nourse continues. "These figures are for a main frame, minimum memory and an input-output typewriter—a control system without eyes or hands." It's like saying a three-year-old can run any process plant.

However, Foxboro says today's systems make up in capability, flexibility and compactness what they lack in economy.

The table at the top of page 92 gives the basic specifications for Foxboro's three systems.

Foxboro's prices for a complete 50-loop setup with the M97400 is \$150,000; for 100 loops, \$210,000; and for a 200-loop complex, \$320,000. The 97400 is equivalent to the Digital Equipment Corp.'s PDP-5, the 97600 to Digital Equipment's PDP-4, and the 97600-A, a new version soon to be produced, equivalent to the PDP-7.

The Foxboro system's memory, arithmetic and control sections are made by Digital Equipment to specification drawn up by Foxboro. Foxboro builds the input-output subsystems and provides the peripheral devices.

Each system shown in the table has already, according to Foxboro, been quoted for a DDC application. The 97400 is going to Aruba, Venezuela, for the Standard Oil Co. (New Jersey); a 97600 is going to the Dow Chemical Co. The photo at the left is of the Standard Oil machine.

Availability — the big question

"There is no such thing as 99.95% proven availability," says Richard Sonnenfeldt, general manager of Foxboro's Digital Systems division. "It'll be at least another year before anyone can statistically state if 99.95% is realistic or not. To prove 99.95% means an operating time of 8,000 hours per year with less than four hours down-time. To mathematically prove 99.95% means recording data on operation for 160,000 hours. No one has a system with that much operating time yet."

The 97000 series uses standard direct-coupled transistor logic, with no frills. Redundancy is used where experience with previous on-line systems has shown that it was needed. The 97400 and 97600 use mostly germanium components, with silicon in spots such as the memory core drivers. The 97600-A will be nearly all silicon, with the high-speed circuits using a 10-megacycle clock rate for timing.

The magnetic ferrite-core memory, with silicon driver circuitry, is rated at 1.75 microseconds with an add time of 3.5 microseconds, using 18-bit words.

All three computers use both core memory and a drum memory for mass storage of optimization and supervisory-control data.

Measuring reliability

Basic reliability for an industrial computer system is rated two ways—component-failure rate and

The Foxboro M97000 computers

	M97400	M97600	M97600-A
Operation	Fully parallel all models		
Word length	12 bits	18 bits	18 bits
Memory type	magnetic ferite-core and drum storage		
Memory size: core (maximum)	8,192	32,678	32,638
drum (maximum)	262,144	131,072	131,072
Memory cycle time (core)	6 microseconds	8 μ sec.	1.75 μ sec.
(drum)	8.3 milliseconds	all models	
Add time	18 μ sec.	16 μ sec.	3.5 μ sec.
Multiply time	186 μ sec.	170 μ sec.	4.4 μ sec.

data-signal error rate.

The component-failure rate determines whether components such as connectors and cables are working according to specification. The error rate is concerned with errors in data transmission. It is not, according to Sonnenfeldt, as closely tied to component-failure rate as some people think. An accumulation of error margins can degrade waveforms sufficiently to cause erroneous signals to be calculated or sent out to the flow-valves.

The design and construction of the circuits are the primary determinants of the component-failure rate. In industrial environments, the failure rate of semiconductors predominate by several orders of magnitude over those of resistors, capacitors, wiring and soldering. If the transistors and diodes are selected carefully, the failure rate will be low.

Foxboro uses no commercial grade of semiconductors. All transistors and diodes are built by the manufacturer according to Foxboro specifications. They are tested entirely by an analytical method, rather than on a go-no-go basis, after a baking period of 24 hours at 190°F for both germanium and silicon.

Double-decker circuit board

Most input-output subsystems use printed-circuit boards made in two layers (photo right). The reasons for the double-deck approach are: Wider spacing is possible between connections; the boards are thicker and therefore less apt to bend or warp; and repair is easier because a submodule can be removed and another put in its place without having to tear apart the entire circuit. Cordwood-type construction is a similar approach in other systems.

This double-deck board is more expensive than the usual single-layer board, but Foxboro figures it's better to spend an extra dollar in construction than a thousand if the computer fails and a process is shut down.

Germanium vs. silicon

"The intrinsically greater reliability of silicon at very high temperatures," says Sonnenfeldt, "unfortunately doesn't always show up in industrial environments. When the choice is between low-production-volume silicon and a high production volume germanium transistor, such as that used in the Minuteman missile, the germanium proves out best."

"Too many people conclude that silicon is superior just because it's been used in space," he continues. "That superiority doesn't automatically carry over into the industrial area. Only when a silicon device is the best one for the job do we use it." Foxboro's 97400 and 97600 are germanium-using machines; the 97600-A uses almost all silicon "because of circuit speed, not proven superior reliability."

Failure rates, according to Sonnenfeldt, are not substantially lower with silicon than with germanium. But the failures are often due to different causes. "Because we are using silicon we have reliability," some engineers say. "This may be an innocent naivetè," says Sonnenfeldt, "but it's still false."

Making a connection

There's no question, Sonnenfeldt says, that inadequate printed-circuit connectors increase failure

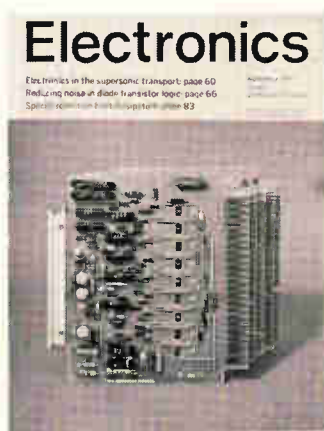

The cover

Integrated circuits, the vertical row of black boxes at right, are input registers for one channel in a digital-to-analog converter. The circuit card is part of the SDS-92 process-control computer system made by Scientific Data Systems, Inc.

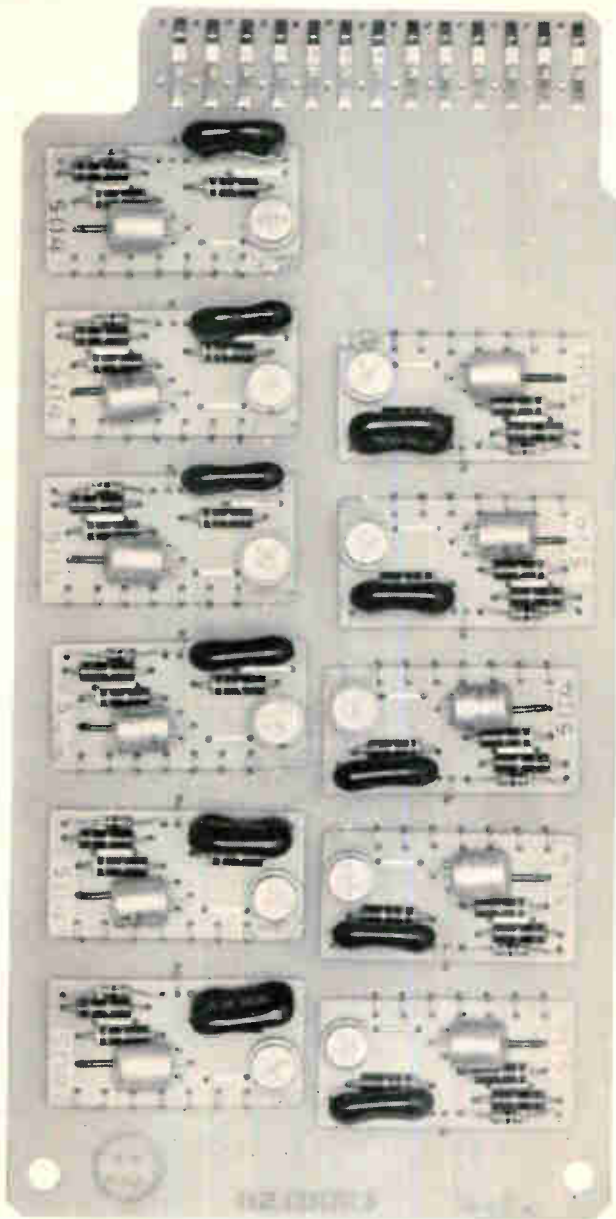

Double-decker approach to circuit-card design gives this card a hand-sewn look. The small second decks give added rigidity and make replacement and repair of subcircuits easy.

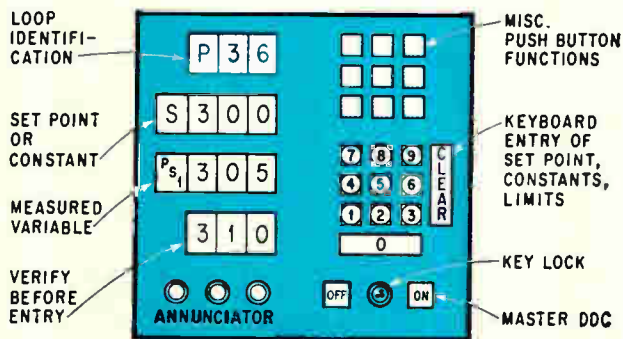

Operator display is one of the major unsettled questions in direct digital control. Here is Foxboro's answer, one very similar to the display to be used for the Standard Oil Co.'s DDC installation.

rate. Inadequacy of connector construction, not number of connectors, is the real deterrent to high reliability, he insists.

Foxboro completely avoids plated or printed-on contacts on the ground that they are worn down easily, even though they cost less. The company uses a spring-type connector.

Input signals

The analog input subsystem has scanning rates of 20, 40 or 200 points per second, depending on system configuration. Four program-controlled input-signal gains are available. Over-all system accuracy, including signal conversion, is guaranteed at 0.1%.

Contact, or digital input signals, are available in groups of six up to a total of 1,026; and priority interrupts, or signals that have a priority over all others, are arranged in groups of six up to a total of 108.

Pulse inputs, from transducers such as turbine flowmeters, can be scanned at high or low speeds at from 6 to 39 inputs per scan.

Output signals

The 97000 series gives contact, or pulse, output signals in groups of six up to a total of 324. The pulses are rated at two amperes at 250 volts maximum, and output speed can be as high as 1,500 outputs a second.

Digital-to-analog converter outputs in the 0- to 10-volt d-c or 10-to-50-milliamper d-c ranges are offered, from either 8- or 10-bit conversions. Each subsystem module can have a maximum of 39 outputs, expandable in increments of one. Separate power supplies, as back-ups for individual modules, are provided at no extra cost.

The display dilemma

The operator's console is a combination of functions. Here is one of the big problems facing DDC users. The Standard Oil, Monsanto and Dow applications each required a custom-designed display. At the Users' Second Conference in May, operator display was the big question, and it remained unsolved. The DuPont Co., Standard Oil and Monsanto each offered a recommendation. But the choice of a standard version—and one that will be cheapest because of volume production—is still open.

The Foxboro DDC display for the operator's console is shown at the left. This setup is almost identical with that going into Standard Oil's refinery at Aruba, and also is a result of Foxboro's in-company DDC studies.

The display combines data entry and set-point display with value changes—all digital readouts—along with an annunciator system and keylock against "illegal entry" of process-control constants. It also includes manual control and transfer switches—the push-buttons in the upper right-hand corner.

Control algorithms can be solved for velocity,

full speed and position flow-valve actuation. DDC outputs can be either contact closures, pulse or analog signals. If only contact outputs are used, a solid-state multiplexer is used in the system to switch as many as 100 output process-signal points per second. Higher speeds are available at extra cost.

Actual pulse, or duration time, is determined by the algorithm solution value used to load a count-down register. Output selection is synchronized with analog scan and with retrieval of set-point and control parameters from memory locations.

The pulse outputs can be used to drive stepping-motor devices or to adjust analog-type back-up or set-point controllers.

All DDC outputs revert to manual (or optional analog controller) back-up when the computer fails or loses control. An option is also offered for fail-safe shut-down of the process by forcing certain flow-valves in the control system open or closed when the computer fails.

Software for on-line operation

Three types of software are provided for on-line operation: input, output and executive routines. Each of these divides into either interrupt or basic loop routines. Interrupt is performed in real time based on signal priority; basic routines, when computer time is available.

The input routines include analog, alarm and contact scanning, along with console display and tape or card-conversion programs.

The output routines are binary-coded-decimal and vice versa for display, print-out format and engineering units conversion routines, arithmetic and function control, contact output control and DDC multiplexing control.

In addition to assembler and Fortran II com-

piler programs, on-line assembling, compiling and debugging programs will be available for use in early 1965.

Foxboro also offers a "fill-in-the-blanks" type of DDC control program. It solves a selected algorithm when the set-points and constants have been inserted by the user.

For its third-generation process-control computer, to be designed especially for DDC, Foxboro is seeking answers to six questions. It expects to get those answers from the Standard Oil and Dow installations. The questions are:

- How many controlled loops can a DDC computer handle without overburdening the computer input-output subsystems?

- Will computing speed of present machines restrict the number of loops in the previous question? Or will highly specialized machines be needed to give the user unrestricted flexibility?

- Will the conventional algorithm for two- and three-mode feedback control be adequate? Or will it need modification to give better control than conventional analog controllers?

- Will advanced concepts, such as adaptive and feed-forward techniques, increase control while decreasing equipment needs? And if they do, will DDC systems be economically justified compared with existing analog controllers?

- Can today's DDC system shift reliably to an analog back-up system in case of failure? Or will the DDC systems prove so reliable that analog back-up won't be needed?

- What are the best operator-DDC system communications for start-up, normal operation and emergencies? And what happens to maintenance men when they don't get to keep up repair skills because of the system's high reliability and infrequent down-time?

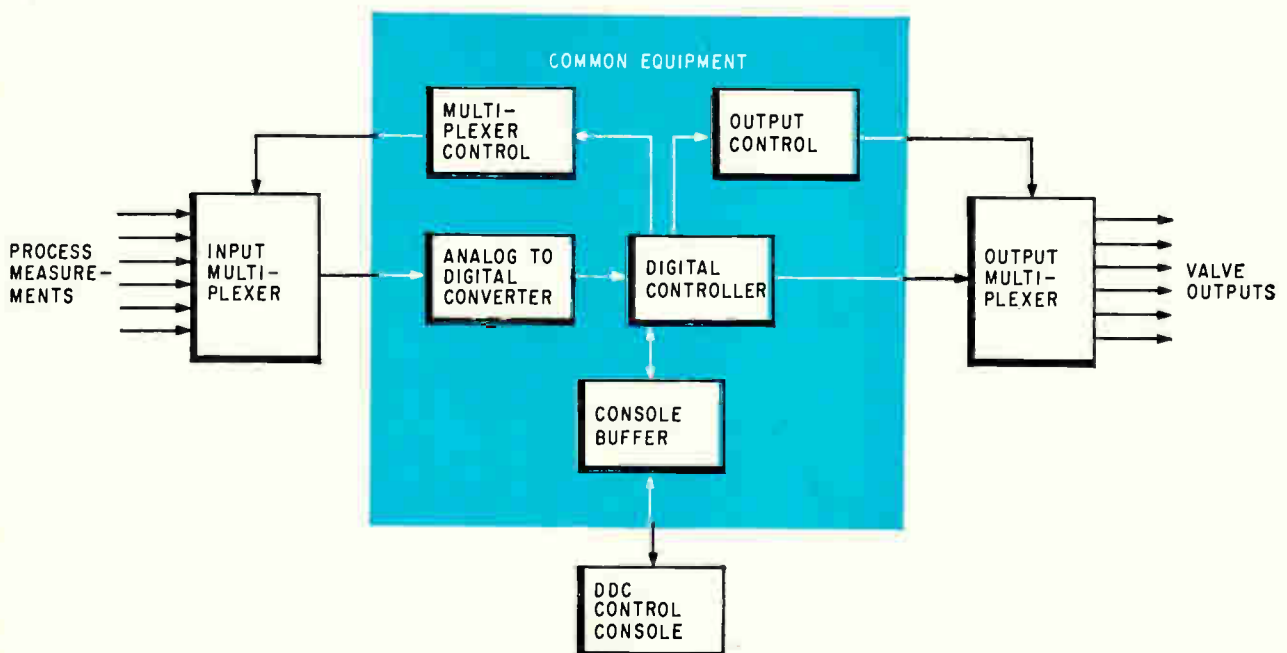

Essential elements in a DDC system. Foxboro is waiting until it gets test results before it puts its ideas into hardware.

Controlling industry's 'faucets' digitally

Now digital-to-analog conversion can be performed at the flow-valve instead of inside the computer

All seven computers mentioned so far in this report have achieved simple designs and relatively low costs. But all do basically the same thing: They generate digital signals, convert them to analog, and use these analog signals to control flow-valves in process industries.

If digital signals could be used directly by process controllers, this complex conversion step could be eliminated in the computer. Computers could be smaller, simpler, and as much as 25% cheaper.

The simplest way to do this is to put the conversion equipment on the valve itself. The first practical step in this direction was taken by the valve division of Honeywell, Inc. At last year's show of the Instrument Society of America, the company exhibited a valve positioner that uses a digital signal to control a pneumatic power supply that positions conventional flow-valves.

Next week, at the 1964 ISA show, two other manufacturers—the Conoflow Corp. and Robertshaw Controls Co.—will demonstrate their competitive digital-pneumatic transducers-positioners. Both use stepping motors to control pneumatic power supplies. The motor used by both Conoflow and Honeywell is the Slo-Syn, made by the Superior Electric Co. Robertshaw, on the other hand, designed its own stepping motor.

How Conoflow does it

Any digital transducer-valve-positioner is a stepping motor driven by pulse signals from a DDC computer. The motor controls a lever or shaft which, in turn, controls an air- or pneumatic-positioning system that opens or closes a flow-valve.

The motor in the Conoflow device converts the computer's digital signal to a proportional pneumatic signal with a range of 3 to 15 pounds per square inch. This signal feeds into a conventional pneumatic valve-positioner.

The motor is a two-winding stepping motor that can be moved at 200 steps per revolution. Metal-stops limit the motor to five revolutions, a total of 1,000 steps, for an accuracy of one part in 1,000. Maximum speed is 400 steps per second. It takes

2.5 seconds to go from 0 to 1,000 steps.

Two units—one for low-pressure valves, the other for high pressure—operate over a temperature range of -40° to $+150^{\circ}$ F. The transducers can be mounted either on the valve or in a remote location. The price is \$150.

Another way—with scr's

Conoflow's digital transducer is driven by a series of pulses. But to take advantage of signaling systems already in use, Conoflow has a two-



Digital-pneumatic transducer with its cover removed. The stepping motor changes digital signals from the control computer into pneumatic signals of 3 to 15 pounds per square inch by controlling an air nozzle.

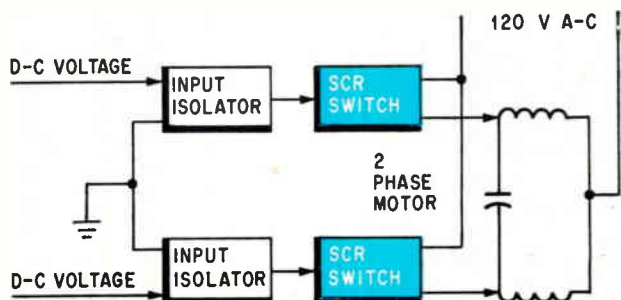

Two-direction solid-state switch controls 110-volt a-c motors that can either control pneumatic power supplies or directly drive flow-valves. The silicon controlled rectifiers (color) are controlled by low-level d-c voltages from the DDC computer.

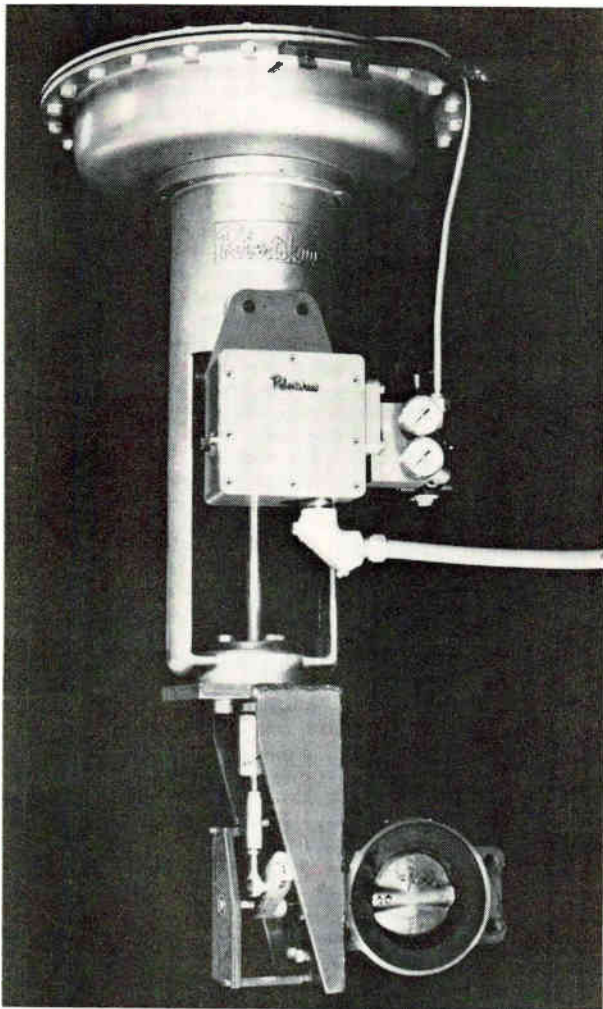

Digital-pneumatic valve-positioner is mounted directly on a process flow-valve. The stepping motor (in the box) is driven at 2 to 240 steps per second by pulse signals from the control computer.

direction solid-state switch that operates from pulse-duration output signals. The switching device uses two silicon controlled rectifiers.

The pulse-duration type of output signal is already used in systems where a computer calculates the set-points for conventional analog controllers. This is a basic form of satellite process control.

When a pulse-duration signal is used with an a-c motor that starts and reverses nearly instantaneously, very short pulse durations cause the motor to move in very small increments, in a manner approaching that of a stepping motor but at less cost.

The computer maker also can avoid installing expensive relay-output signal devices to drive 110-volt a-c motors. The low voltage already found in computers—5 to 18 volts—can be used to control the scr switch.

The two-direction switch has an input of low-level d-c voltage. The switch controls a 110-volt a-c motor that, in turn, can control a pneumatic power supply or directly drive a flow-valve.

Two switches, in parallel, are in each package. Each device has its own input-output circuits. The diagram on page 95 shows the input as three-wire,

one acting as ground, with the scr's as the output switches. A built-in transformer eliminates any signal interference.

Minimum input is 150 millivolts d-c with an input impedance of 430 ohms. Input signal power is 53 microwatts. With a series resistor added to the input circuit, the Conoflow switch will operate from low voltage—say five volts—that is common to most digital computers. Switch-on time is 0.1 millisecond, maximum switch off-time 9 milliseconds. Maximum output power is 100 watts. The amplifier can run continuously in a temperature range of -40° to $+150^{\circ}$ F.

Robertshaw's approach

The Robertshaw Controls Co. contends its stepping motor is as accurate as the Slo-Syn, but cheaper.

Kenneth Kreuter, manager of Robertshaw's Midwest Research Center, further insists that the accuracy of 0.1% specified by the Users' Conference is attainable with today's flow-valves.

However, Robertshaw's stepping motor—for which nine patents have been applied for—has demonstrated an accuracy of 1 part in 3,000.

In the model 663, the bifilar stepping motor (right) with an encapsulated stator operates from square-wave d-c pulses. Operating speed is 240 steps per second. To fully open or close, the valve takes less than four seconds at an accuracy of 0.25%. Price is about \$200.

The digital valve-positioner also has a valve-stroke attachment that allows it to be mounted on any manufacturer's flow-valve without special hardware. A manual-automatic switch is included for emergencies.

The design also includes a potentiometer to give remote position-indication.

Byproducts of the stepping motor

After Robertshaw showed its digital positioner to engineers at Westinghouse's Computer Systems division, the Westinghouse people suggested two byproducts. Each sells for about \$200.

One is a digital potentiometer for use as a set-point device. It uses either the bifilar stepping motor or a low-voltage a-c synchronous motor. The standard model, the 662, uses the stepping motor and a precision potentiometer with a manual override switch in case the computer malfunctions. The set-point unit is a panel-mounting type for operator-control panels. High and low indicators, and a 1-to-5 or 4-to-20-milliamper current generator are also available as options.

The other byproduct is a set-point device for use with pneumatically actuated control systems. It is powered by the d-c stepping motor or the a-c synchronous motor. The device will give an output-control pressure range of 3 to 15 pounds per square inch, accurate to within 0.5%.

Reprints of this report are available. Use the reader service card at the back of this issue.

© copyright 1964 Electronics © A McGraw-Hill Publication

Fluke offers YOU proven quality in calibrated high voltage supplies

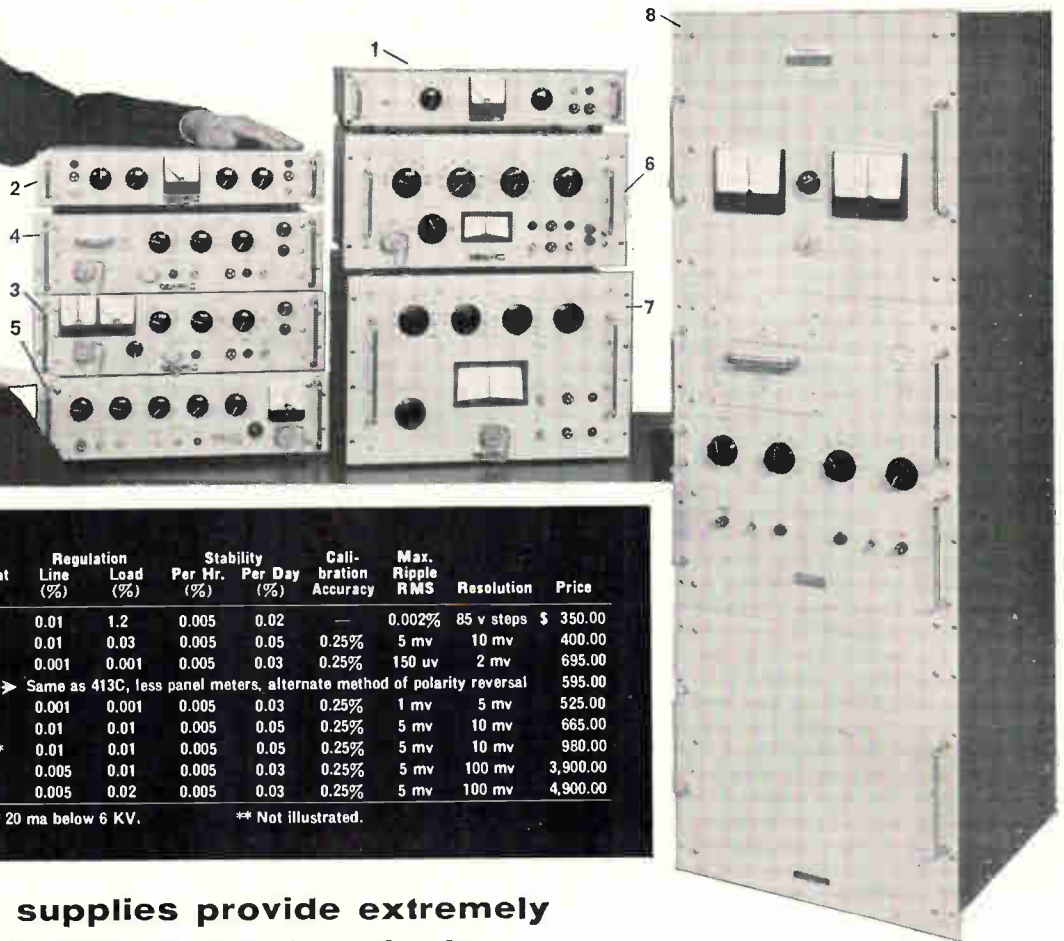
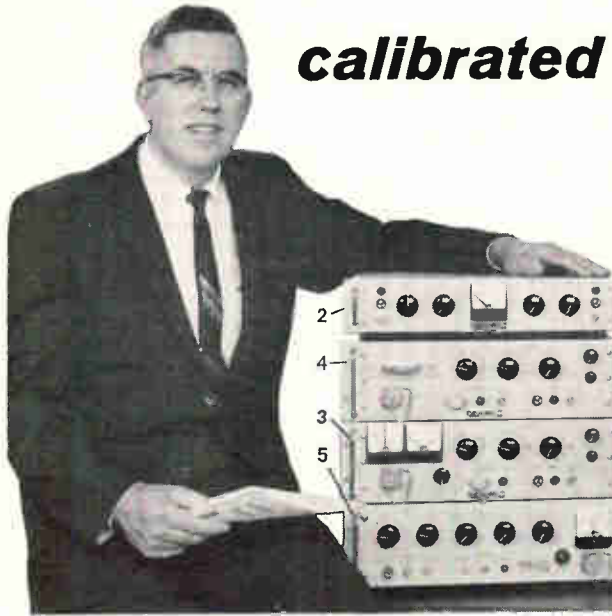

Model	Voltage	Current (ma)	Regulation Line (%)	Regulation Load (%)	Stability Per Hr. (%)	Stability Per Day (%)	Calibration Accuracy	Max. Ripple RMS	Resolution	Price
(1) 409A	170-1530 v	0-3	0.01	1.2	0.005	0.02	—	0.002%	85 v steps	\$ 350.00
(2) 412A	500-2010 v	0-15	0.01	0.03	0.005	0.05	0.25%	5 mv	10 mv	400.00
(3) 413C	0-3111 v	0-20	0.001	0.001	0.005	0.03	0.25%	150 uv	2 mv	695.00
(4) 413D	Same as 413C, less panel meters, alternate method of polarity reversal									
(5) 405B	0-3100 v	0-30	0.001	0.001	0.005	0.03	0.25%	1 mv	5 mv	525.00
(6) 408A	500-6010 v	0-20	0.01	0.01	0.005	0.05	0.25%	5 mv	10 mv	665.00
(7) 410A	1000-10,000 v	0-10*	0.01	0.01	0.005	0.05	0.25%	5 mv	10 mv	980.00
** 430A	10,000-30,220 v	0-10	0.005	0.01	0.005	0.03	0.25%	5 mv	100 mv	3,900.00
(8) 430B	10,000-30,220 v	0-50	0.005	0.02	0.005	0.03	0.25%	5 mv	100 mv	4,900.00

* 20 ma below 6 KV. ** Not illustrated.

These power supplies provide extremely well regulated, ultra stable, low ripple potentials for use in the most exacting applications.

In more than 5,000 installations where quality is essential, Fluke power supplies are on the job, providing unexcelled performance and reliability through electrical and mechanical excellence of design. With the addition of the new 430 series, the Fluke spectrum is now 0 to 30,000 VDC. Every specification parameter is conservative; customers have found this to be true without exception, and show their confidence by specifying Fluke when their voltage demands increase.

Certain applications demand high calibration accuracy, while others require high stability and a low ripple component. Excellent line and load regulation are always a must. Across the specification board, Fluke high voltage supplies meet or beat virtually *all* system requirements.

Volume-production techniques and maintenance of a large stock keep Fluke supplies attractively priced.

What is *your* high voltage application?

Technical data on all nine instruments will be sent to you upon request. Prices are f.o.b. factory, Mountlake Terrace, Washington. Prices and data subject to change without notice.



JOHN FLUKE MFG. CO., INC., Box 7428, Seattle, Wash. 98133.
Telephone 206-776-1171; TWX 910-449-2850; Cable: FLUKE.



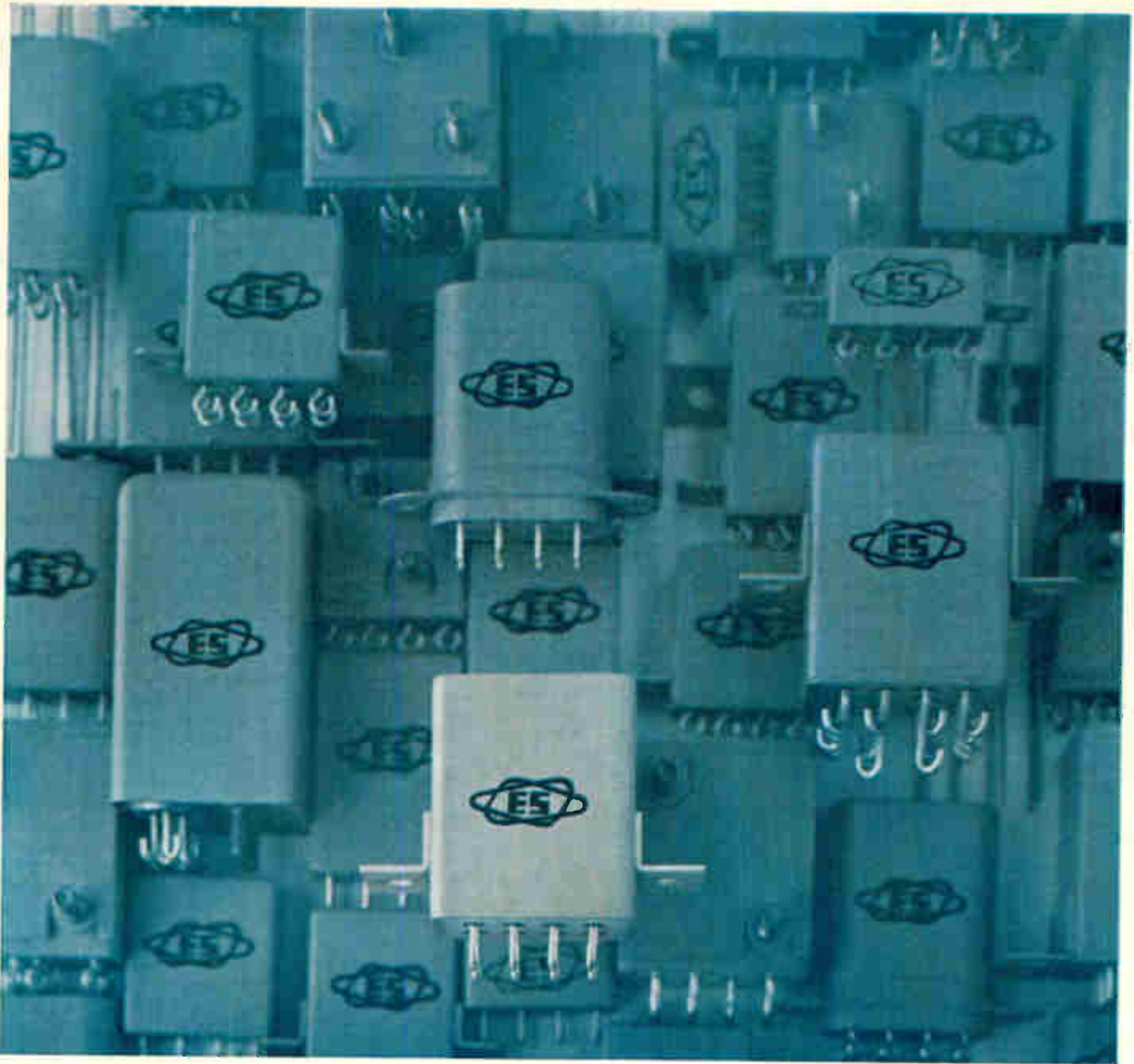

Off-the-shelf MIL-Spec relays: 9000 in stock—100 different kinds!

We have the nation's widest selection of hermetically sealed military relays—and we guarantee shipment in less than five days! We can also quickly supply you with many other, less common, relays because of our large stock of subassemblies and parts.

Whether you need a few or many relays, quantity is no problem for Electronic Specialty Co. In the first three months of our warehouse-stocking program, we shipped more than 6700 relays of all types, including latching and nonlatching, dry-circuit to 10-amp,

multiple-pole, miniature and microminiature sensitive.

Whatever you need in a MIL-Spec relay, chances are we have it on our shelves. For the illustrated brochure "Inventory Relays," containing listings, technical data, and minimum-quantity prices of Electronic Specialty's dependable relays, write to ES Literature Center, 4561 Colorado Boulevard, Los Angeles, California.

ES is a diversified organization providing defense and industry with systems, subsystems, and components for controls, communications, power, and space conditioning.



ELECTRONIC SPECIALTY CO./ELECTRONICS DIVISION—Portland/18900 N.E. Sandy Blvd., Portland, Ore. (Formerly Iron Fireman Mfg. Co.)
Los Angeles, Calif./Anniston, Ala./Ft. Madison, Ia./Harrisonburg, Va./Hurst, Tex./Pomona, Calif./Portland, Ore./Thomaston, Conn./Toronto, Ont.

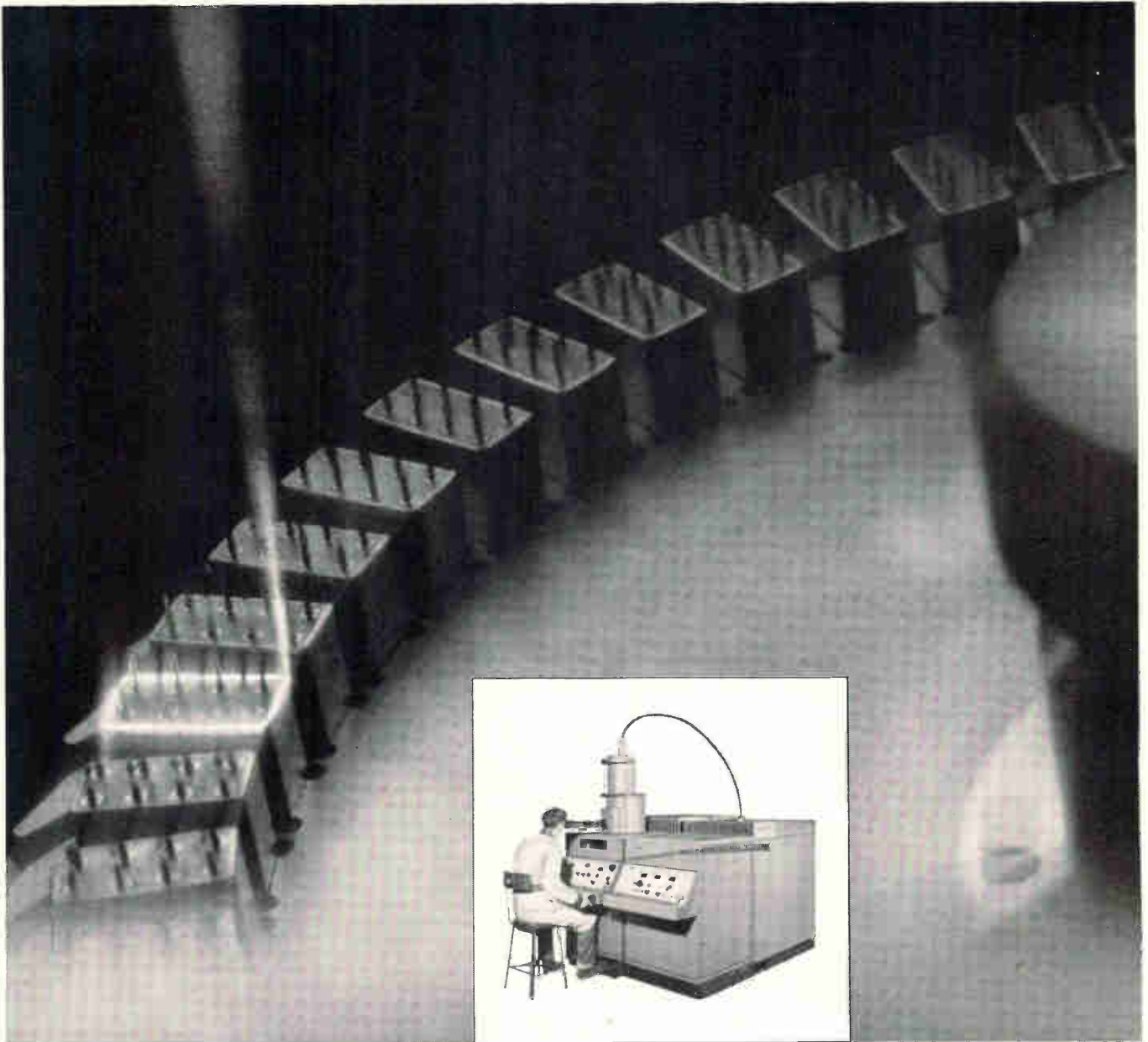

Why three leading relay manufacturers use the Hamilton Standard Electron Beam Welder to seal subminiature relays

The Hamilton Standard Electron Beam Welder can be programmed precisely enough to seal a crystal case type relay in a few seconds, with production rates up to 250 units an hour. It allows engineers to design for lowest weight and highest reliability, because the high energy density of the beam concentrates all the heat in a remark-

ably small area. Contamination is eliminated because electron beam welding takes place in a vacuum. Physical and electrical properties remain unchanged because electron beam welding involves very low heat input.

Filtors, Inc., General Electric (Waynesboro), and the Leach Relay Division have all found the Hamilton

Standard Electron Beam machine an important tool in crystal case relay manufacture. Other companies have discovered its value in many different problems of microelectronic production. To find out how it can help **you**, send for bulletin. Write: Manager, Electron Beam Systems, Hamilton Standard, Windsor Locks, Connecticut.

Hamilton Standard DIVISION OF UNITED AIRCRAFT CORPORATION • WINDSOR LOCKS, CONNECTICUT

U
A

Probing the News

Military electronics

Over-the-horizon radar is in business

President announces that production will start on techniques under development since late '40s

Over-the-horizon radar is not news to engineers, but President Johnson tried to pass it off as news as he campaigned for election.

When the President announced that the United States has an operational radar that can "look" beyond the horizon, it was clearly a political move. But to the electronics industry the gambit had great import. Johnson's announcement meant that a family of over-the-horizon radars was going into production after having been in development since the late 1940s.

Some industry experts had feared that over-the-horizon radar had been stalled because of the Air Force's huge investment in line-of-sight radar such as is used in the Ballistic Missile Early Warning System. The argument for using both BMEWS and over-the-horizon radar, however, is that while the new radar will pick up the missile sooner than BMEWS can, it will probably not be as accurate.

To provide this quicker reaction, the Defense Department is ready to plunk down nearly \$50 million next year after having spent the same amount on perfecting the new system during the past two years.

I. Good news for Raytheon

The Raytheon Corp. was the only company that Defense Secretary Robert S. McNamara could remember as working in the field when he called a hurry-up press conference to expand on the President's announcement. Although McNamara was shy on technical details, it's no secret that Raytheon has been pursuing for almost 20 years a method of "bouncing" beams off the ionosphere to attain over-the-horizon radar returns.

Because of military secrecy, Raytheon has never been able to disclose details of its long-range ionospheric radar work. The company has, however, discussed a related system called COZI (communication zone indicator), an oblique ionospheric sounding system for determining propagation characteristics of the ionosphere at any instant. The technique is applicable to radar.

COZI transmits a fairly short pulse that is reflected from the ionosphere and returns to earth at some distant point. Backscatter from the earth's imperfect reflection characteristics causes some of the energy to return to the transmitter site. If the height of the ionosphere is known, and an accurate time base is used at the receiver, the backscatter return time can be related to distance along the earth's surface.

To spot missiles, COZI would detect backscatter or other electromagnetic perturbations from missile plumes.

Correlations. Because the backscatter returns would be highly attenuated and masked by noise, a correlation technique is necessary to get range and velocity data from them. One method would be to store the transmitted pulse in a memory so it can be compared with the returning backscatter signal.

Additional signals, based on knowledge of the effects of missile launchings on backscatter, could also be stored in the memory and correlated with the returns to identify a missile.

II. Two Navy techniques

Raytheon and the Air Force are not the only ones that have been

working on over-the-horizon radar.

The Naval Research Laboratory, which pioneered radar before World War II, has developed two techniques of its own. One, called Madre (for magnetic drum receiving equipment), bounces a short wave (in the upper portion of the high-frequency band) off the ionosphere to the target to detect aircraft and missiles.

The other is called Tepee because the electromagnetic wave follows a path that looks like a row of Indian tents. It is a high-frequency, backscatter system. An electromagnetic pulse is transmitted so it ricochets between the earth and the ionosphere several times. As it bounces, it can detect the ionized gas created by a missile or nuclear explosion.

In field tests, this system detected targets successfully at 4,000 miles. Later the radar picked up targets 5,000 miles away.

Civilians, too. Madre uses a drum correlator to separate targets from noise. The General Electric Co. developed the hardware and a random-sampling process to work with a drum recorder.

Both the Airborne Instruments Laboratory, a division of Cutler-Hammer, Inc., and the Erco division of ACF Industries, Inc., are suppliers for Tepee. But a wall of security closed on over-the-horizon radar after the President's announcement and the companies won't talk.

For those who like previews, the over-the-horizon announcement was really made last January when McNamara told a Senate committee that the Pentagon had an operational prototype. But few people read the long tedious testimony.



Fine Italian hand at the Pentagon

It belongs to Eugene G. Fubini, assistant Secretary of defense. His influence and power are reshaping electronics research and development

After the dedication ceremonies for the Arecibo Ionospheric Observatory in Puerto Rico last fall, a horde of eager public relations men moved toward the speaker's platform. In tow were their individual celebrities, Air Force generals and industry big-wigs, who wanted to shake hands with the assistant secretary of defense, who is also deputy director for defense research and engineering.

But Eugene Ghiron Fubini had disappeared. He was sighted a few moments later on a 700-foot-long catwalk, the only way to get to the antenna-feed system that is suspended 500 feet above the reflector mesh of the world's largest radio-astronomy dish.

I. At McNamara's side

It's becoming increasingly evident that Fubini has a hand in everything of consequence in military electronics and communications. When Robert S. McNamara called a press conference recently to elaborate on President Johnson's announcement that "now we have produced, and we are installing, our first facilities of operational over-the-horizon radar," Fubini was at the Defense Secretary's side. The assistant secretary had run the program, organized the tests, chosen the systems to be developed, and decided on the programs that were to bring over-the-horizon radar to operational status.

Fubini ranks high on the Defense Department totem pole. His influence has grown steadily since 1963 when President Kennedy appointed him assistant secretary. One high official who has seen Fubini in action at the Defense Secretary's staff conferences says,

"He doesn't even stand in awe of McNamara." Another says, "The office was always important but Fubini is trying to make it essential."

'Through the wringer'. Fubini tries to stay close to Washington. He often visits military installations but prefers to see industry officials in his office rather than at their plants. He has been known to visit a company to check personally on the progress of a research and engineering project.

Apparently he knows what he's looking for. Marlin Kroger, an official at the Autonetics division of North American Aviation, Inc., describes one of those visits.

"Fubini is one of the few people to come into Autonetics with the breadth of technology to understand everything we do," says Kroger. "He recently spent 14 hours here and he really put people through the wringer from one end to the other, right down to the technical detail. When you propose something to him, he immediately goes into the mathematics and physics of it to see if what you say makes sense. This is why engineers like to deal with him. If they show him something good, he's thrilled. They feel it's unusual to reach someone at Fubini's level who understands what they're doing."

II. Decision maker

Because Fubini is an acknowledged authority in electronics and communications, Harold Brown, who directs defense research and engineering at the Defense Department, relies on him to guide and monitor programs in these areas. Fubini's decisions are crucial to

the electronics industry because defense research and development accounts for 60% of the total—estimated at nearly \$4 billion—spent nationally in electronics research.

One defense-industry official put it this way: "I don't know whether it's McNamara or Brown who makes the bullets. I do know that Fubini does the shooting."

And Fubini has shot down many a project. He says it's part of the McNamara-Brown-Fubini attempt to halt the tendency to invest in every idea that gives hope of producing a superweapon. He asserts that costly developments have been dropped when it appeared that they wouldn't pan out. But McNamara's critics say that political reasons often outweigh technological considerations. They say that's why the Skybolt missile was abandoned and why the General Dynamics Corp. won the controversial contract for the TFX plane.

Man in charge. Fubini is in full control of the military communications satellite program. He acted as McNamara's agent in negotiations with the Communications Satellite Corp. for a shared commercial-military system. Now that the shared-satellite idea has been abandoned, the Italian-born assistant secretary is closely directing the program to develop an independent communications system for the military.

Another program over which Fubini exercises close control is the expansion of the national military command system. This is a top-priority effort whose goal is a vastly improved command system that will enable the White House to monitor and directly control, if it wishes, nearly all types of military operations down to a very small unit level.

The idea is to make sure that civilian authorities will be able to

Written by Sally Powell with reporting by Herbert Cheshire in Washington, Ron Lovell in Los Angeles, Thomas Maguire in Boston, Ed. Addeo in San Francisco and Cletus M. Wiley in Chicago.

control a military situation in a world where a small conflict might lead to nuclear war. A giant, closely knit system of sensors, communications gear and computers will tie together the military, diplomatic and intelligence branches of the government and give a constantly updated assessment of the worldwide political and military situation. It will provide a picture of all immediate threats to peace and of the means available to the United States for responding to them.



'Keep it simple'

III. In the War Room

While Fubini is considered Brown's alter ego, his importance to the electronics industry extends beyond that role. One of his most important assignments is to review in behalf of McNamara and Cyrus Vance, deputy secretary of defense, the over-all budgets (not just the R&D portions) for communications equipment and command-and-control items. He also oversees the supersecret National Security Agency—not to be confused with the National Security Council or the Central Intelligence Agency—that is under McNamara's direction and control.

Fubini spends half of his time keeping a close eye on the agency for McNamara. He recommends electronic and mechanical means of gathering and transmitting intelligence. In crises such as the incidents in the Gulf of Tonkin off North Vietnam, Fubini is one of the top Pentagon officials who meet in the War Room.

Fubini's background has made him especially valuable in the area of intelligence. In 1943 and 1944 he was a scientific consultant and technical observer to the U.S. Army and Navy in Europe. He helped to

establish electronic reconnaissance and jamming capabilities for the invasions of Italy and southern France. For the next two years he was in Britain with the U.S. Eighth Air Force, in charge of electronic reconnaissance and countermeasures. He also worked on electronic countermeasures as a consultant to the Air Communications Office of what was then the War Department and is today the Department of Defense.

'You remember him'. A former assistant secretary of defense who knew Fubini during the war years says, "If you meet him you remember him. He's a unique kind of person, very ebullient, small and dynamic. He's always jumping out of chairs. He is not like any other guy you meet."

When Fubini joined the Defense Department at the start of the McNamara regime, as deputy director of defense research and engineering systems, his wartime friend had become an assistant secretary in the department. The friend says admiringly, "Gene has extraordinary physical energy. He is able to go to bed late and get up early. He shows up at the Pentagon between 7:15 and 7:30 in the morning and stays there sometimes until 8 or 9:30 at night.

"I don't know how he does it really. I mean he has six kids at home, a big place on the Potomac, and he has horses, dogs, cats, lawns and orchards. He always goes home with a briefcase stuffed with work."

IV. Devil's advocate

John Moore, president of Auto-netics, believes that Fubini's influence has grown steadily. He credits this to the assistant secretary's intelligence, courage and



'Do you have to do it?'



'Director of marketing for defense contractors'

objectivity, all attributes that McNamara appreciates. "He has made his office very powerful, but often he's in the unfortunate position of being the devil's advocate," the company official explains. "He'll take sides just to bring out the flaws in a system and show people where they're wrong."

Fubini, like many other top aides under Brown and like most of the key civilians around McNamara, is forceful and somewhat abrasive. An officer of a big electronics company says Fubini is "brilliant but exceedingly rude." It's evident that the volatile assistant secretary enjoys heated arguments over issues; he likes to ask difficult questions and he demands full answers.

There are complaints from industry spokesmen who are bitter about what they consider to be Fubini's lack of concern for the future of the defense-aerospace companies. Last spring Fubini refused to attend a conference on diversification of industry from military to civilian pursuits. At an armed-services technical conference shortly after that, he criticized the reports of trouble in the defense-aerospace industry. He said in part, "I'm tired of these gloomy stories."

Singleminded. This parochial thinking is attributed to Fubini's singleminded concern with the military. He's worried that industry may start slighting military business and make it difficult for the department to find the kinds of suppliers it wants. His refusal to participate in the diversification talks may have stemmed from a fear that once industry diversifies into civilian pursuits, it will not give military contracting a high priority. That would make Fubini's job a lot tougher. Right now he's in the catbird seat, with many companies

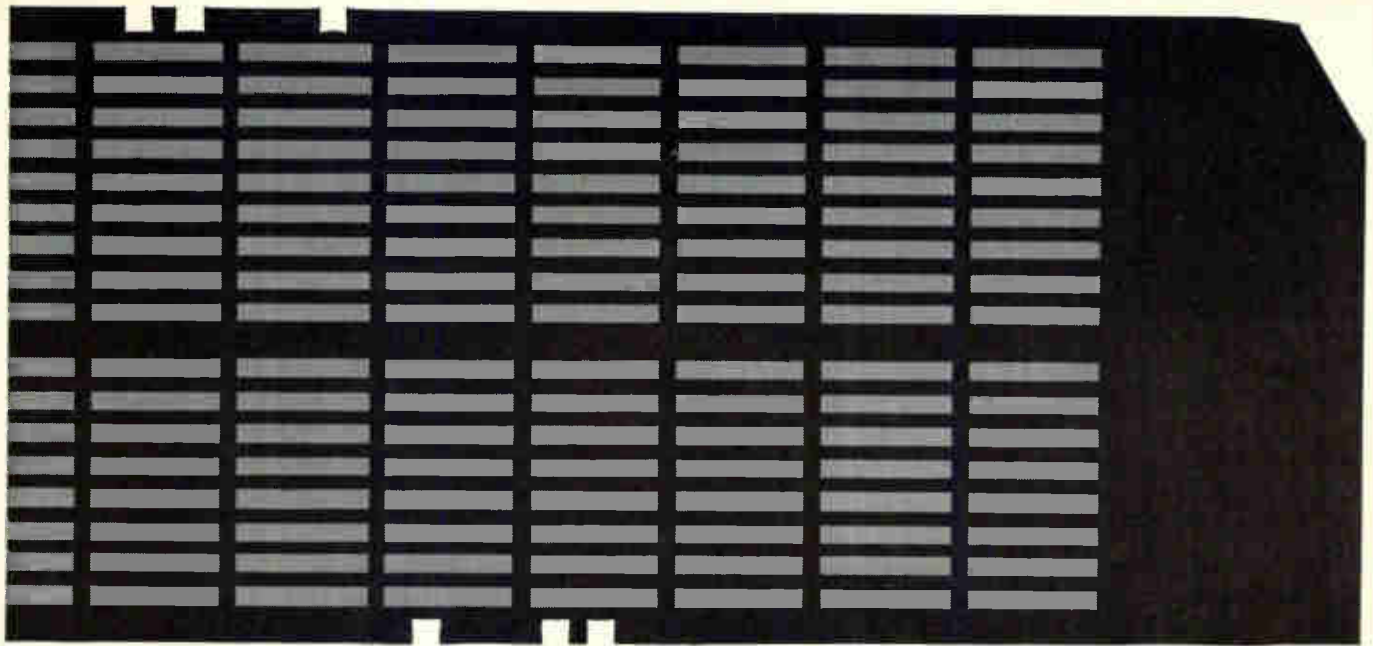

The Long Awaited Breakthrough In EDP

Via Magnetic Iron Oxides The rapidly developing science of Electronic Data Processing has received an impetus of explosive significance through the stepped-up use of magnetic iron oxide coated cards.

Handling mass storage and retrieval of voluminous data and utilizing advanced random access techniques, in some cases the cost per 10,000 alpha-numerical characters has been driven down to as low as one-tenth of their former costs!

Engineering the 'packing density' of the data into radically tighter units on the cards has brought EDP within the pocketbook range of scores of companies not previously in the 'live prospect' class.

Williams, as a major supplier of magnetic iron oxides congratulates the EDP industry for its enterprise. Williams for its part will continue to provide the chemical purity and uniform magnetic properties that make their product a standard of reliability.

Yes — Williams stands ready and willing to dispense all pertinent, technical information. Write Department 30

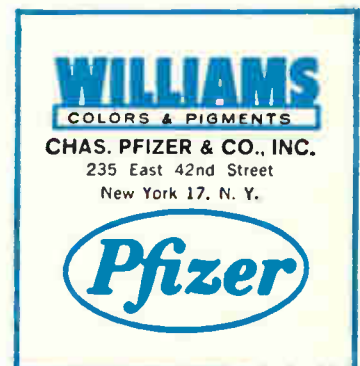

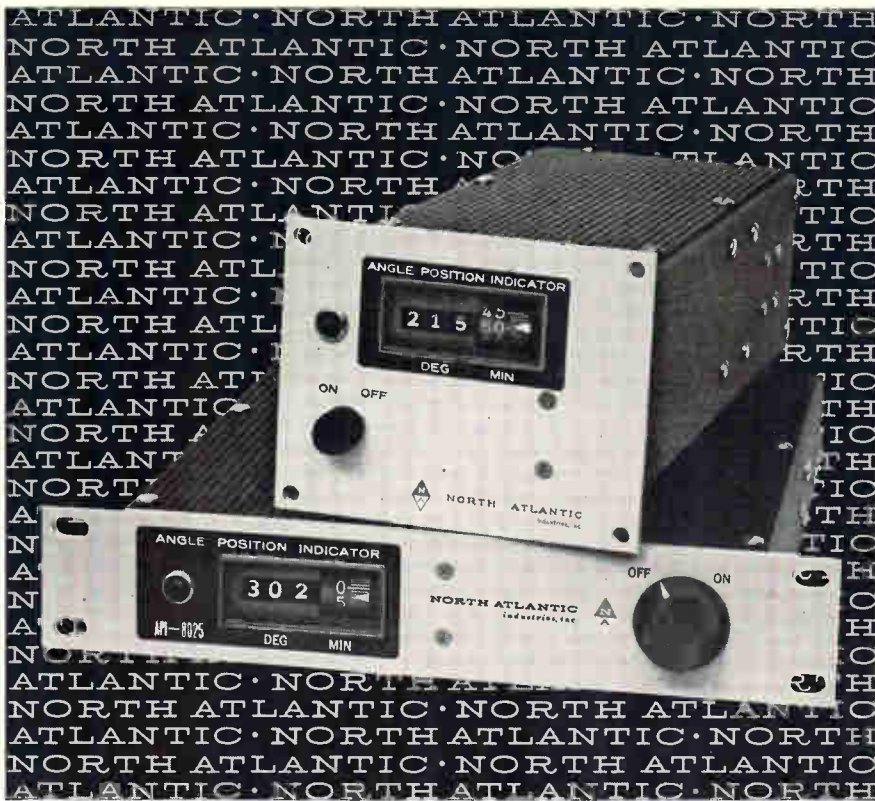

how to measure resolver or synchro position with 30 second repeatability

In both production test and ground checkout systems, North Atlantic's high performance Angle Position Indicators provide exceptional operator ease and precision in the measurement of synchro and resolver position. Features include digital readout in degrees and minutes, 30 second resolution, continuous rotation, plug-in solid-state amplifier and power supply modules. Due to the design flexibility of these units, they can be readily provided with a variety of features for specific requirements. Typical units in this line incorporate combinations of the following features:

- Single Synchro or Resolver Input
- Dual Synchro or Resolver Inputs
- Retransmit Synchro, Resolver, Potentiometer, or Encoder
- 2-Speed Synchro Input
- Multi-frequency Inputs
- DC Input
- 0-999 Counter

BASIC SPECIFICATIONS

Range	0°-360° continuous rotation
Accuracy	6 minutes (standard)
Repeatability	30 seconds
Slew Speed	25°/second
Power	115 volts, 400 cps
Size	1¾" h x 9½" w x 9" d
API-8025	1¾" h x 9½" w x 9" d
API-8027	3½" h x 4¾" w x 9¾" d



Your local North Atlantic representative has complete data on the API line. Call him today or write direct for technical literature.

NORTH ATLANTIC industries, inc.
TERMINAL DRIVE, PLAINVIEW, L. I., NEW YORK • Overbrook 1-8600

fighting for defense contracts. He doesn't want that situation to change. If it does, the department will have to go out and search for companies instead of being able to choose among them.

V. Blackboard sessions

Fubini's office is in the outer ring of offices at the Pentagon. There the top civilian officials of the Defense Department oversee the nation's \$52-billion-a-year military effort. Next to Fubini's desk is a large blackboard that he uses for two-way communication.

The president of a large electronics corporation was accompanied by a group of experts when he called on Fubini. He said later, "Fubini was always at that damned blackboard or asking one of us to prove something on it."

An official outside the Defense Department finds Fubini's tendency to lecture irritating. "When we were arguing over whether the military should use the commercial communications-satellite system or build one of its own," he complains, "Fubini would lecture aeronautics and space experts on technical matters they knew as much or more about than he did."

The vice president of an electronics company on the West Coast agrees that Fubini is tough. "I don't like having any of our proposals turned down, but I don't blame Fubini when our presenters try to give him a snow job," he concedes. "He's tough and he's knowledgeable and we know that we've got to be prepared before we see him."

Twitting the general. There is criticism from the military on the delays in getting a go-ahead signal on projects they consider essential. They don't like Fubini's habit of twitting them on projects that bogged down even when some of the fault might be laid at McNamara's door.

One general, frustrated by Fubini's refusal to approve a new project, is said to have commented, "That doesn't leave many projects I can start this year." Fubini, recalling belated deliveries, overruns and over-budget schedules on some of the general's other projects, retorted, "That'll give you a chance to finish the projects you started last year."

VI. Procurement policy

When McNamara took over the Pentagon he was appalled to find that of the 10 to 15 systems recently procured, none had a final cost less than triple the original estimate. Several had final costs approximately 10 times that estimate. Fubini now handles most of the management of defense R&D programs and concentrates on procurement policy, an area to which McNamara has given much personal attention.

Fubini shares the Defense Secretary's distaste for something Fubini calls "the American syndrome" and defines as "If you can do it, do it, no matter how costly or how complicated." Fubini calls this a national sickness. To him, the first questions that should be asked are, "Do you have to do it?" and "Is it really needed?"

Program definition. Today proposals get close scrutiny from the Pentagon. Long, detailed justifications are demanded by Fubini. Before a full-scale development is approved, more time is spent than ever. Proposals must first go through a program-definition phase. Fubini is an ardent proponent of this concept, formulated by his predecessor, John Rubel, who is now vice president and director of technical planning at Litton Industries, Inc.

In essence, this is how Fubini sees the program-definition phase:

- Getting a clear concept of what is needed.
- Exploring in depth as many possible of the unknowns present in any new effort.
- Accomplishing the over-all system design.
- Designing the subsystems and major components.
- Establishing management procedures.
- Obtaining realistic cost estimates.

The program has ruffled some military feathers. Many high-echelon armed-services officials complain that not enough weapons possibilities are being explored. They consider Fubini's insistence on a clearly defined need or mission, before a new program is begun, a dangerous tendency.

Republican presidential candidate Barry Goldwater has repeated

DURANT

**DIGITAL
READOUT COUNTERS
for
PRECISION
CONTROLS**



Model "D" SERIES
Wheel diameter: 1"
Figures: 1/4" high

**HI-SPEED
QUIETEST
LONG LIFE**



Model "Y" SERIES
Wheel diameter: 3/4"
Figures: 3/16" high

BOTH SERIES AVAILABLE WITH HI-SPEED GENEVA INDEX (AS ILLUSTRATED IN "Y" ABOVE)

Exclusive TRANSFER MECHANISM — Hi-Speed GENEVA INDEX — does it!

Much higher speeds — "Y" Series 3000 RPM intermittent — "D" Series 2500 RPM intermittent. Yet these high speeds are accomplished with approximately 50% lower noise level. The smooth transfer eliminates "chatter" and excessive wear for much longer, dependable life expectancy. Applications are in navigational instruments, tracking devices, radar equipment, digital voltmeters, business machines, machine tools, position indicators, and many other digital presentations from rotary motion. Meets military specifications.

DURANT INSTRUMENT COUNTERS

The largest "family" of digital readout indicators ever offered to designers in standard models. The "Y", "D" and "S" Series offer almost infinite selection of choices as to number of figures, rotation, side of drive, type of wheel imprint. This feature alone serves virtually all design requirements, saving time developing prototypes and saving money on special tooling and short runs. Catalog 400 on hand at the design stage will help speed your research work.

Remember — Ask for Catalog 400

DURANT MANUFACTURING CO.

612 North Cass Street
Milwaukee, Wis. 53201



MODEL 4-Y-9994
BEARING DEGREE COUNTER



MODEL "Y" 8831
DUAL BANK SERIES

DURANT

COUNTING INSTRUMENTS

Accurately Count Everything . . . EVERYWHERE



MODEL "YE"
ELECTRIC
HIGH SPEED
QUICK RESET



COUNTER
FOR TRUE
AIRSPEED
INDICATOR



INSTRUMENT
COUNTER WITH
LUMINESCENT
FIGURES



HIGH SPEED
COUNTER FOR
NAVIGATING
INSTRUMENT



DEGREES AND
MINUTES
INSTRUMENT
COUNTER



INSTRUMENT
COUNTER FOR
INCREMENTAL
OSCILLATOR

REPRESENTATIVES IN ALL PRINCIPAL CITIES

that charge in his campaign speeches. He accuses McNamara of creating a deterrence gap by not pushing development of a new manned bomber and space weapons.

Battleground. Fubini turns a deaf ear to such criticism and continues to execute the McNamara policy. The program-definition phase, he believes, eliminates the need for numerous program changes and subsequent increased costs once the program is begun.

Most of the battles are fought out in the Brown-Fubini shop. Research-and-development proposals flow from the military services to the service secretaries through their assistants for R&D. That's when they're reviewed, challenged, perhaps redirected, and eventually approved or disapproved.

Fubini defends the rigorous examination against the charge that there is too much questioning and delay before the go-ahead is given. Decisions simply can't be made quickly or superficially, he insists, in these days when almost no new major weapons system can be developed for less than \$1 billion. He

seconds McNamara's view that, because of the technical complexity of modern weapons, a sound choice of major weapons systems is essential. He insists, despite some heavy evidence to the contrary, that political considerations have no weight.

Changing needs. Another point that Fubini hammers home at every opportunity is that defense contractors have to adjust to the department's changing needs. No longer are strategic weapons the critical concern. He concedes that there is a need to improve the existing weapons and to work on counter weapons—counter missiles, counter submarines, counter radars—but he adds, "Our very existence is no longer immediately dependent, as it used to be, on the development of weapons for nuclear war."

VII. New direction

The view of the Defense Department, expressed by Fubini, is that increasing effort should be devoted to nonstrategic or peripheral wars. "New, unmatched challenges appear in this area; we find that

we have a lot of things to do," he says. "In some areas we even need to recover some ground because we have retrogressed from where we were in World War II."

Fubini says the military is now faced with an entirely new situation. Strategic wars can be aimed and centrally controlled; for these wars, a few very expensive, very sophisticated systems were and are more than justified, Fubini believes. He emphasizes, however, that for peripheral wars there is an urgent need for hundreds or thousands of items of lower cost and complication.

Old-fashioned engineering. The assistant secretary is urging the electronics industry to understand that the Defense Department wants a multiplicity of small and medium-size new systems. A crying need in these developments is for simplicity, he says.

"Old-fashioned engineering may come back in vogue because one cannot have simplicity without good engineering," he declares. "To make things simple takes a lot of ability, and this is going to be the most important and most diffi-

PAKTRON'S NEW 50-volt capacitors are

cult challenge facing us."

New procurement methods. Fubini appeals to the industry to come forward with ideas that can be sold to the Pentagon, instead of waiting for proposals to come out of Washington. He notes that the department is trying to avoid rigid adherence to conventional methods of procurement that require competition in cases where a new idea or product is offered by a contractor. To take advantage of industry initiative, Fubini believes in direct negotiations and contracting. He says formality, delay and red tape will be eliminated in the effort to encourage the electronics industry to come up with new ideas.

No empty phrase. Fubini confers with industry representatives frequently "to find out what is on their minds and to make sure that the government-industry partnership in defense is not an empty phrase." He sees his role as "almost a director of marketing" for defense contractors, and believes it's important that they understand what the government wants.

There have been persistent rumors that Fubini might leave his

government post soon. He says he'll be on the job at least until Dec. 31. He has made no commitments beyond then, and says he won't until he knows the outcome of the election.

VIII. Turin to Washington

A first encounter with the assistant secretary produces some surprises. Fubini's speech and manner still bear heavy traces of his native Italy. He was born in Turin and received his doctorate in physics from the University of Rome in 1933. Shortly before World War II, he left Italy with his parents. His father, a professor, was invited to lecture at the Institute for Advanced Studies at Princeton University and Fubini took a job as an engineer at the Columbia Broadcasting System in New York. Fubini became a citizen in 1945. Mrs. Fubini, the former Jane Elizabeth Machmer of Amherst, Mass., is a daughter of the late William Lawson Machmer, who was dean of the University of Massachusetts.

The six Fubini children—five girls and a boy—range in age from 7 to 18 years. The oldest girl is a

sophomore at Smith College. The other Fubini children attend the Sidwell Friends School, a private school at which Mrs. Fubini teaches kindergarten.

Fubini is an inveterate do-it-yourselfer. He's repaired everything from his lawn mower to a broken desk drawer for a stenographer at the Pentagon. He has an aversion to seeing things fall into disrepair.

Diplomat. Fubini has managed to avoid any organized personal attack. It is no secret that he wields a tremendous amount of power and that many of his decisions are unpopular. Nonetheless he has managed to maintain a high level of popularity.

In a recent speech to electronics company employees he said, in effect, "Don't give up, we need your ideas." This created some optimism in an industry that has suffered severe body blows at the hands of the Defense Department.

But the industry has seen too many shifts in policy to buy this new attitude of cordiality. It is still making up its mind whether it has a friend or foe in Eugene Fubini.



New miniature high performing Mylar* film/foil capacitor for quality transistorized circuits. Epoxy coated for excellent moisture resistance. Uniform size. Capacitance value to 0.47 mfd with tolerance to $\pm 5\%$.

The "white" series has an internal design to protect the high performance Polyester film and an external design to satisfy any circuit construction system.

Detailed information available on request.

*DuPont

Working Voltage: 50v DC

Tolerance: $\pm 5\%$, $\pm 10\%$, $\pm 20\%$

Dissipation Factor: 4×10^{-3} max. @ 25° C, at 1 KC

Temperature Stability: 4% max. deviation from 25° C value in range of 0° C to 85° C, at 1 KC

i t PAKTRON
DIVISION ILLINOIS TOOL WORKS INC.
1321 LESLIE AVENUE • ALEXANDRIA, VIRGINIA



SPACE-SAVING MINIATURE EDGEWISE PANEL METER

new slim profile for 1½" edgewise meters... no barrel... easy stacking

International Instruments' new Model 1122 edgewise meter is completely flat, from scale to terminals. There's no back-of-panel barrel projection. Saves you precious space on the panel and behind it. You have complete freedom of component placement.

A new shielded movement makes possible unlimited stacking — side-by-side or one on top of another. The shielding eliminates magnetic interaction between meters and allows interchangeable installation on either magnetic or non-magnetic panels (with or without flange).

The new movement also gives you improved performance. Its single through-pivot provides better coil alignment. Torque-to-weight ratio is exceptionally high, too.

The compact Model 1122 is available in vertical- and horizontal-reading models. In 27 standard AC and DC voltage and current ranges.

If you have a tight-space problem or need comparative readout, have a look at our new data sheet. Just ask for Bulletin 385.

 **international
instruments inc.**
8703 Marsh Hill Road, Orange, Connecticut 06477
SA-3044

Advanced technology

Big dish is almost ready

With techniques learned from Project Haystack, engineers are cooking up new plans for a 600-foot diameter dish

By Thomas Maguire

Regional editor

Engineers on project Haystack, a giant antenna erected by the Air Force for more powerful radar and communications systems, knew there would be no second time around. The trial-and-error approach was out. There could be no prototype. With \$15 million and further development of bigger antennas at stake, they had to be right the first time.

This month, after nearly five years of design and construction, Haystack—a marvel of versatility and a stunning example of creative mechanical and electronic design—was dedicated.

The huge structure, a 120-ft. paraboloid, uses a minimum of metal; its electronic transmitting gear is packaged in room-sized modules permitting a different application to be performed by merely replacing one module with another; and its digital computer control can move the 180-ton structure a distance as small as a millimeter without jolting. The radome-housed antenna will nearly triple the limits of transmission power frequency.

As a radio telescope, Haystack will compare with the best in the world in the 1,000-Mc range; it will be unrivaled in the 10-Gc range.

Boost for telescopes. Astronomers have long waited for more powerful radio telescopes to probe the cosmos. Until now they have been stymied by the difficulty of constructing the big antennas needed.

When the Navy's plan to build a huge telescope at Sugar Grove, W. Va. collapsed, the telescope at Jodrell Bank, England, was left as the world's biggest, operating at frequencies to about 600 Mc. The beamwidth from Haystack (so-named because it is located on Haystack Hill in Massachusetts)

will be narrower to provide higher resolution and more sensitivity. It will operate at frequencies to 30 Gc, almost 50 times Jodrell Bank's.

I. Boosting the art

At the Massachusetts Institute of Technology's Lincoln Laboratories, where the design was carried out for the Air Force's Electronic System's division, engineers claim they avoided the approach that may have helped fell the Navy's 600-foot Sugar Grove project. They didn't try to modify existing hardware; instead, they concentrated on solving fundamental problems.

Computer analysis. First, they developed a computer program for analyzing the precision metal structure in three dimensions. Usually, this kind of antenna design is reduced to a simple two-dimensional problem so the mathematics can be handled more easily. Then, one of Lincoln Laboratories' contractors, the North American Aviation Corp., developed a second program that served as a check on the MIT calculations. Their engineers considered effects of gravity, temperature changes, and errors in manufacture and erection—in three dimensions.

The approach worked so well that the same programs have been okayed for the design of even bigger dishes. Backed up by Haystack know-how, scientists at Harvard University and MIT are already considering building another huge radio astronomy antenna, perhaps as big as the 600-foot-diameter planned for the Sugar Grove antenna.

Until now communication engineers have been reluctant to build bigger antennas. They too want antennas of larger effective apertures (to improve detection sensitivity,

increase bandwidth and beam resolution) and are watching Haystack closely.

II. Room-like modules

The Haystack station is unequaled in versatility. It can be used as a space and communications ground terminal, a tracking and measurement radar, a radio telescope, or a test bed to evaluate new components. It has this flexibility because the electronic equipment for generating signals is packaged in room-sized modules, hoisted to the antenna and easily plugged in and removed.

The first module built is a high-power X-band radar. Its first job will be to bounce signals off Venus. The package includes a 100-kilowatt transmitter to generate pulses at 7,750 Mc, a feed system, and special low-noise receivers.

Huge amplifier. The final amplifier, developed by Varian Associates demonstrates the impact of Haystack's power on components. Initially, engineers planned to use four 25 kw klystrons in series. Then they changed to two 50 kw klystrons. Finally they settled for a single 100 kw, five-cavity klystron tube with a gain greater than 50 db, a bandwidth of about 40 Mc, and an overall efficiency of 40%.

Noise was even a more vexing problem. Engineers developed special low-noise receivers with two-stage, diode, parametric amplifiers cooled by liquid nitrogen or helium to reduce the electron motion that contributes to noise. At first, dewar vacuum jars filled with liquified gas will be used. However, engineers are now evaluating a closed-cycle helium refrigerator to replace the dewar vessels.

III. Smooth control

One key specification for the antenna is that its narrow beam be pointed with an uncertainty of less than one-tenth the bandwidth. Some experiments need accuracy within one-one hundredth of beamwidth.

To accomplish such precision, Haystack has a real-time control system run by a Univac 490 digital computer. Basic nautical almanac data is stored in the computer's memory, along with basic data that compensates for system errors in construction and refrac-

NEW!

MINIATURE COAX PATCHING

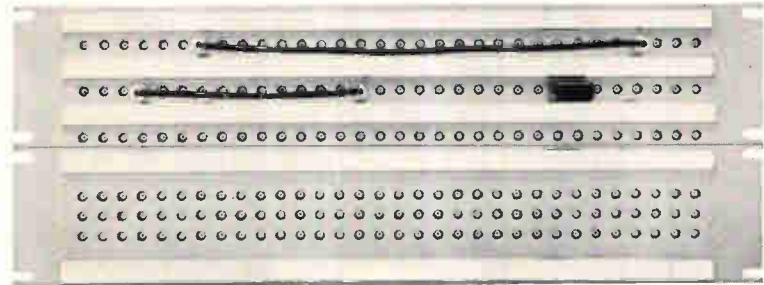

THIS RACK SPACE SAVED BY USING A
TROMPETER MINIATURIZED PATCHING SYSTEM
(192 JACKS CONDENSED IN 7" OF RACK SPACE)

- MAXIMUM PATCHING DENSITY — ONE HALF NORMAL RACK SPACE
- USABLE WITH BOTH STANDARD & MINIATURE COAXIAL CABLE SYSTEMS
- QUICK DISCONNECT FOR MAXIMUM FLEXIBILITY
- COMPLETE LINE OF PARALLELING ACCESSORIES

Where maximum patching density is required our miniaturized patching system provides twice the number of jacks in a standard 19" panel, requiring only half the rack space of a standard patch panel.

The miniature patch panels and accessories are designed for utilization with small cable systems of RG-122 (50 ohm), Amphenol 21-597 (75 ohm), RG-180 and RG-195 (95 ohm). Standard RG-58, 59 and 62 cables can also be used through our special cable terminations.

Special paralleling accessories are available to provide 2, 3 or 4 parallel circuits in front or back of the panel.

Manufacturers of Coax and Twinax Patching Systems and Switching Matrices.
Write for our catalog showing complete line of equipment and accessories.

TROMPETER ELECTRONICS INC.

7238 ETON AVE., CANOGA PARK, CALIFORNIA 91303
Phone 213/346-1550

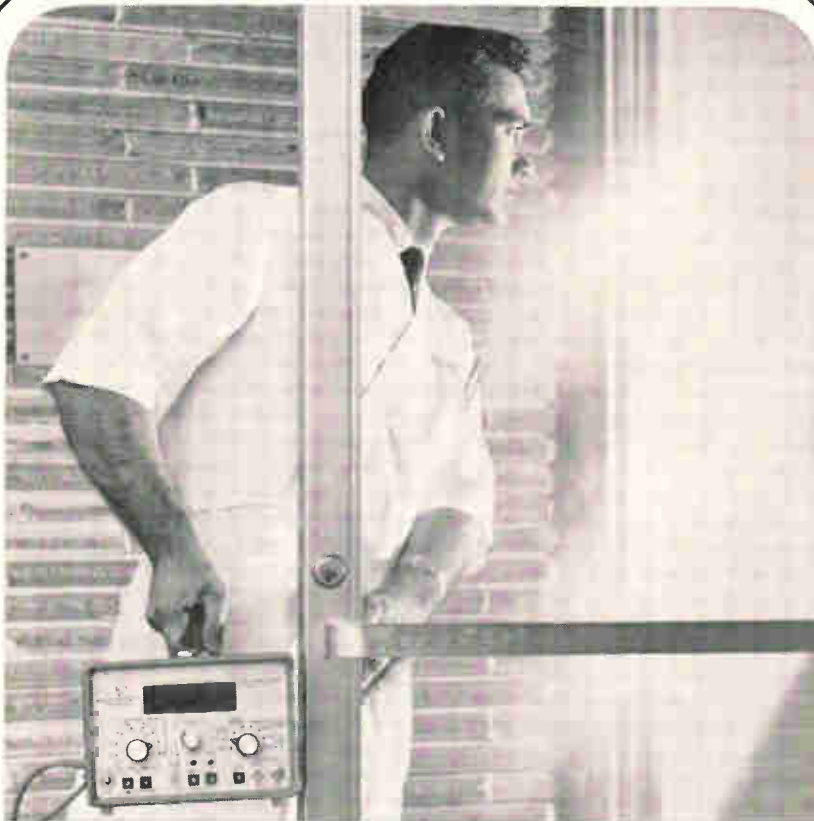

**new!
portable
universal
1 Mc
timer
counter**



The TC-2A measures frequency, period, multiple period, single or dual channel time intervals and ratios.

Six digit resolution

is achieved with a four digit, in-line readout by switching the most significant digits to the left, out of the readout. When displaying any four digits of the six digit reading, five switch-selectable gate times allow the rapid identification of the most significant digits.

The time base is derived from a 1 mcps oven controlled crystal oscillator.

AC coupled, sensitivity is 200 mv to 250 v rms; input impedance is 100 K shunted by 30 pf. DC sensitivity is 2 v to 10 v with 5 K input impedance. Frequency range is 0 to 1 Mc. Price: \$995. F.O.B. Houston, Texas. Availability: 30 days ARO.



houston instrument corporation

4950 Terminal Avenue / Bellaire, Texas 77401 / MOhawk 7-7403
Cable: HOINCO / TWX 713-571-2063

tion of the atmosphere.

When an operator types the name of a planet into the almanac, the computer will find the planet's location and point the antenna at it.

Precision pointing. For positioning, the antenna has two data systems. One is a conventional one-speed synchro loop that positions the antenna grossly. Then a precision shaft encoder takes over for accurate pointing, converting angle into electrical phase difference.

This device, developed by the Whitaker Corp., has two electrostatically coupled, eight-inch-diameter glass discs. One rotates with the antenna; the other is fixed.

Three sets of conductive patterns have been painted on one disc; each set has a pair of sine waves, displaced by 90°. With this electrostatic resolver, every time the antenna shaft rotates once, 256 fine phase vector rotations and eight medium phase vector rotations are produced.

Jolt insurance. Even such a precision positioning system wasn't enough. To insure against jolting, particularly for short movements, engineers had to design new bearings and ways to lubricate them. Smooth-running hydraulic servomotors—rotated by the movement of radially placed pistons against a lobed cam—drive the antenna.

IV. Applications ahead

After Haystack gets its final check-out, experiments will proceed to study the planets, the moon, the earth's atmosphere, interstellar gas clouds and external galaxies.

The mammoth antenna will also be used to speed the development of some special devices. Herbert G. Weiss, MIT project engineer, sees a rebirth for the tunnel diode. "Because tunnel diodes don't need cryogenic cooling," he said, "and because they are stable and reliable, they are attractive for wide-band amplifiers. A tunnel-diode receiver with a 1,000° system temperature and 1,000 Mc bandwidth is equivalent to a maser or parametric amplifier with a system temperature of 100° and a bandwidth of only 10 Mc."

But the men of MIT and the Air Force aren't in a rush. Nor did the engineers hurry to build Haystack. The completion date is nearly two years behind schedule.

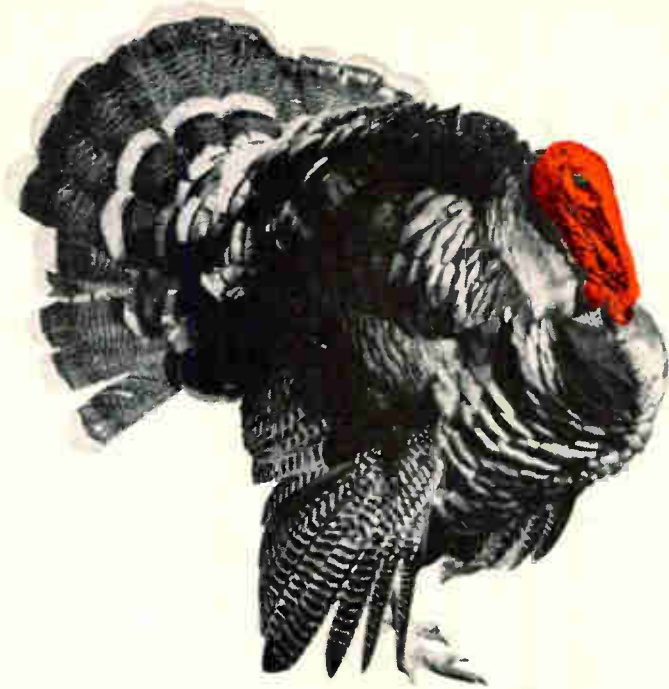

**If you ship from
5 to 50 pounds anywhere in the U. S.
you're missing a bet**

...unless you check Air Express.

There are many reasons why. For example, you can actually ship a 20 pound package from New York to Chicago by Air Express for less than motor carrier (\$6.20 vs. \$6.82) ... and at a sizable saving in time.

Among air cargo services, Air Express is often cheapest *and* quickest too.

Another point. Air Express rates are figured door-to-door. You only

have one call, one waybill.

And there's more. Air Express can deliver by sunset tomorrow to any one of 21,000 U.S. cities.

Pickup is made within 2 hours of your call. Your packages get top priority on every scheduled airline after air mail.

On the ground, 10,500 delivery trucks speed deliveries between you, the airports and your customers. Compare this with any other

service available.

There is only one Air Express ... it's a joint venture of all 39 scheduled airlines and R E A Express. No wonder it gives you the best service in the air and on the ground.

Next time you ship from 5 to 50 pounds, try Air Express. Simply call your local R E A Express office for detailed information.

Air Express outdelivers them all ... anywhere in the U.S.A.

Air Express
Division of REA Express



147,357*

IMAGE ORTHICON

HOURS

WITH

NO

DOWN

TIME

*accumulated operating hours
in medical fluoroscopy,
broadcast, underwater and
industrial applications.

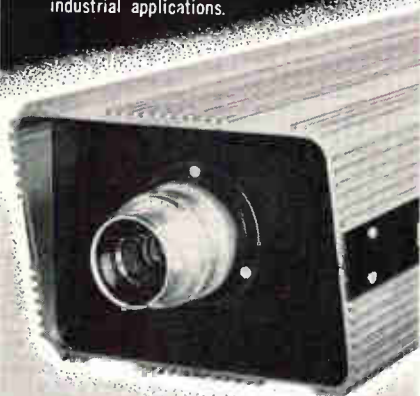

TV CAMERA PERFECTION!

MTI's new ORTH III Image Orthicon television camera doesn't know how to quit. Where high resolution under low light level conditions is needed the ORTH III does the job . . . and keeps doing it. ORTH III is setting a new standard for reliability and excellence among broadcasters, industrial engineers, underwater experts and medical men. The ORTH III will meet your specifications and application and there is an MTI man ready to help.

- Fully transistorized • Low Noise Cascade Nuistor preamp
- Fully regulated all solid state power supply • Modular sub-systems • Rugged extruded aluminum camera case
- 945-875-675-525 line options

World's largest manufacturer of low light level Image Orthicon cameras.

mti

MARYLAND
TELECOMMUNICATIONS, INC.

VIDEO INSTRUMENTATION

York & Video Roads, Cockeysville, Md.
301-666-2727

Military electronics

Controlling fighter planes from a jeep in battle area

Air Force shopping for first equipment in \$100 million program to bolster air support in brushfire encounters

By Thomas Maguire

Regional Editor



The Air Force is ready to buy equipment that can be flown anywhere in the world to provide tactical air support for military ground actions.

The Electronic Systems division at Hanscom Field, Mass., is sending out technical proposals for 325 jeep-mounted communications units, the first hardware in a \$100-million program designed to bolster the Air Force's effectiveness in fighting brushfire wars.

The six-month-old program also involves command communications over a battlefield, control of air traffic, and detection and interception of hostile planes. The effort is part of the Air Force's newest air-control system, designated 407L, which encompasses all mobile electronic systems needed for tactical warfare.

I. Sense of urgency

Nobody talks about a crash program at the 407L center, but a sense of urgency is apparent. Col. George A. Guy, director of the program, explains: "We're not out to develop new equipment. Our job is to get a system into the field as soon as possible. Research and development will come later."

Guy says this will be the first time that all the electronics needed for tactical warfare have been packaged into one air-transportable system.

Some of the equipment for the 407L system was developed under earlier Air Force programs, and some was built for specific Army and Marine Corps needs. A big chunk of the system is the setup for air-traffic control at combat airfields, which 407L took over when it absorbed the 428L program in August. Other gear, if it's light enough, will come from the 412L "Baby Sage" program [Electronics, Apr. 17, 1959, p. 29]. Other parts will be put together by industry.

There's no prime contractor on 407L. There will be various types of equipment packages, each suited to a specific need.

Each jeep-mounted unit will con-

Airfield control tower, built by the Radio Corp. of America, is typical of portable equipment to be used in 407L. The tower was developed for the 482L program, now a part of 407L.

Ballantine Sensitive True-RMS RF Millivoltmeter

Model 340

Price: \$760
(with all accessories*)

Measures True-Rms
regardless
of Waveform
and Voltage

High, Uniform Accuracy
and Resolution over
entire 5-inch scale

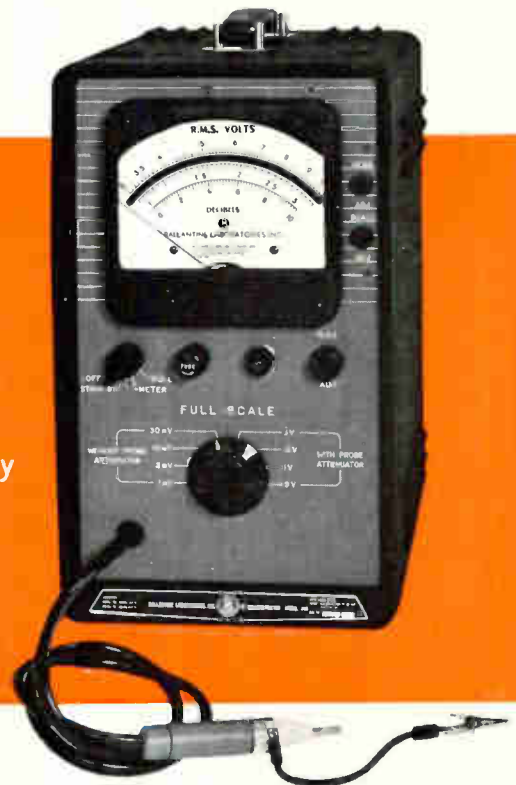

Measures 300 μ V to 3 V from 0.1 Mc to 1,000 Mc

Ballantine's Model 340 is a sensitive, wideband, rms-responding voltmeter with a basic accuracy of better than 4%. Its 5-inch voltage scales spread out the readings logarithmically. Thus you can make measurements to the same high resolution and accuracy at the bottom of the scale as you can at full scale.

Outstanding is the Model 340's rms-response to distorted sine wave voltages, regardless of their levels. This is most important at high frequencies since all known calibrating standards are based on rms-responding devices.

SPECIFICATIONS

Voltage Range 300 μ V to 3 V	Crest Factor 100 to 3 depending on voltage range
Frequency Range 0.1 Mc to >1,000 Mc; calibrated to 700 Mc	Scales Two logarithmic voltage scales, 0.95 to 3.3 and 3.0 to 10.6. One decibel scale, 0 to 10
Indication True-RMS on all ranges, all voltages	Mean Square DC Output ... 0.1 V to 1.0 V dc. Internal resistance 20 kilohms. (For connection to recorder.)
Accuracy ...% of Reading	
0.1 Mc — 100 Mc, 4%;	
100 Mc — 700 Mc, 10%;	
above 700 Mc as sensitive indicator	

*Accessories include a probe tip for in-circuit measurements, an adapter for connection to N or BNC, a T adapter for connection to a 50 ohm line, and a 40 db attenuator

Member Scientific Apparatus Makers Association



— Since 1932 —
BALLANTINE LABORATORIES INC.
Boonton, New Jersey

CHECK WITH BALLANTINE FIRST FOR LABORATORY VACUUM TUBE VOLTMETERS, REGARDLESS OF YOUR REQUIREMENTS FOR AMPLITUDE, FREQUENCY, OR WAVEFORM. WE HAVE A LARGE LINE, WITH ADDITIONS EACH YEAR. ALSO AC/DC LINEAR CONVERTERS, CALIBRATORS, WIDE BAND AMPLIFIERS, DIRECT-READING CAPACITANCE METERS, AND A LINE OF LABORATORY VOLTAGE STANDARDS 0 TO 1,000 MC.

NEW

from HEINEMANN...

REMOTE-OPERATED CIRCUIT BREAKER ...FOR INACCESSIBLE LOCATIONS

Now there's a simple, low cost way to remote-switch our circuit breakers. With a Heinemann Re-Cirk-It® Series 100 remote-operated circuit breaker.

It's ideal for hard-to-get-to factory installations. Or in confined quarters on board aircraft. Or at unattended utility or pipeline stations.

In some applications, where frequent switching is not required, it might economically replace a contactor. And with the Heinemann remote-operated breaker, you also get built-in overload and short-circuit protection, as well as higher interrupting capacity.

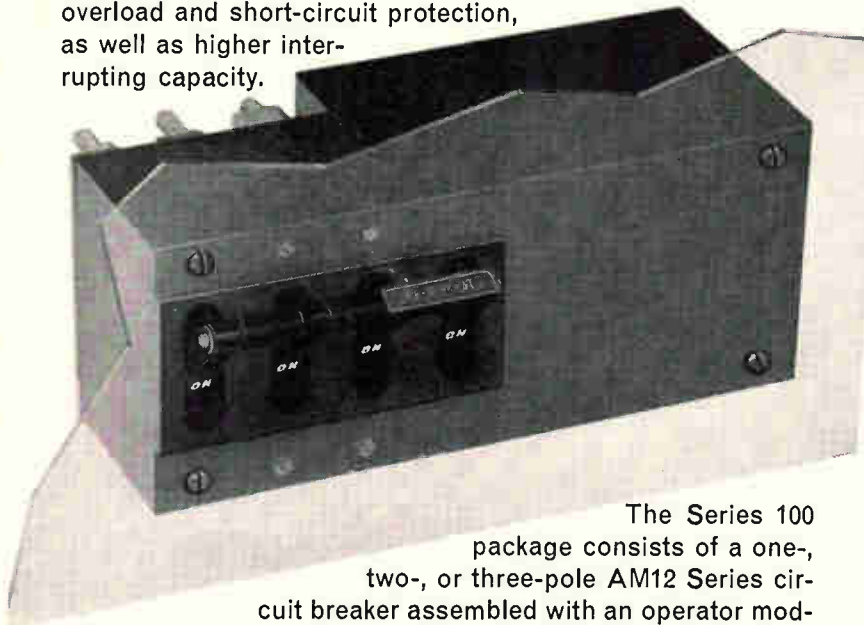

The Series 100 package consists of a one-, two-, or three-pole AM12 Series circuit breaker assembled with an operator module. The operator is powered by a rugged electric-motor drive, which can be controlled by any type of SPDT maintained-contact switch.

The package is compact and easy to install. A three-pole model measures 6" x 2-1/2" x 3-5/16" deep. Panel mounting requires just one cutout, plus four mounting-screw holes. And only the breaker handles and handle boss extend in front of the panel.

The breaker itself is hydraulic-magnetic. It has no thermal tripping elements. Trip points and current-carrying capacity are temperature stable.

We offer the breakers in our remote-operated series with all of Heinemann's special internal circuit arrangements: relay-trip, shunt-trip, auxiliary switch, etc. A variety of control modes is therefore possible.

Bulletin 601 has complete details. Write for a copy.

HEINEMANN ELECTRIC COMPANY

2600 Brunswick Pike, Trenton, N. J. 08602

SA-3033

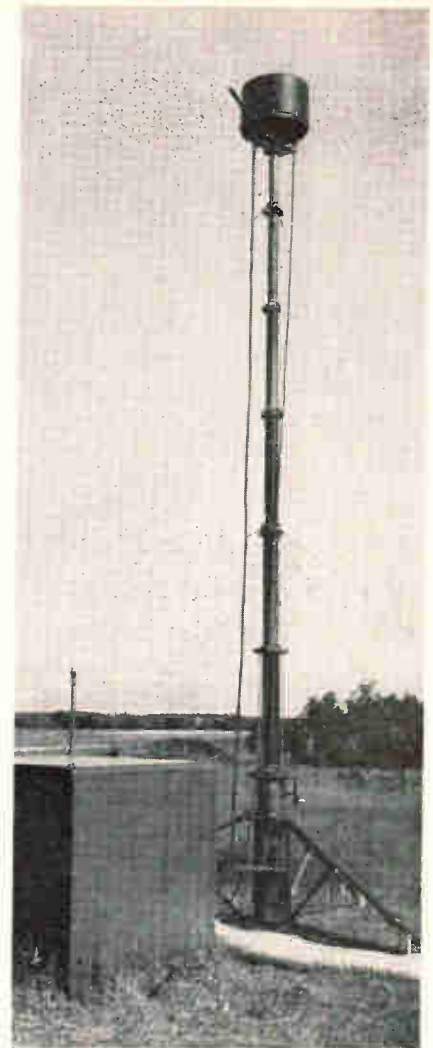

AN/TRN-17 beacon-transponder was developed in the 482L program and will be used in the 407L system. It provides the primary navigational aid for the system. It continually transmits azimuth and range information to as many as 100 properly equipped aircraft within its line-of-sight coverage area.

sist of high-frequency single-side-band transmitters and receivers, and amplitude-modulated uhf and vhf transceivers. Auxiliary equipment, to be carried in a trailer, will include a 1½-kilowatt generator and remote-control antennas. The Air Force will buy 52 additional uhf receivers and 70 additional vhf receivers.

The equipment will be used by air liaison officers who, as forward air controllers, will work in the battle area with the Army or Marines to provide coordinated air support.

II. Packaged airfields

Battlefield control of air traffic will be provided by "packaged air-

fields" built under 482L, now a part of the tactical air-control system. Three complete systems have been purchased from the Radio Corp. of America. The system is being tested at the air proving ground at Eglin Air Force Base, Fla.

Industry officials recall that the Air Force expected the 482L to do more than necessary for air-traffic control.

Design of the 482L equipment began when the "25 bare bases" concept was advocated at the Pentagon, they explain. Under this plan, the Air Force picked 25 locations from which limited warfare could be waged anywhere in the world. At that time the Air Force was to build 25 of the 482L emergency mission-support systems.

Between design and procurement, the sense of crisis had eased, and it was decided that 10 systems or less would be needed. Furthermore, some officers in the Tactical Air Command have always believed that some parts of the system won't have to be used in every combat situation. One officer said: "Under some conditions, all you need is the tower TSW-6 and the approach radar. You can get pilots in without the rest of the equipment."

III. Battlefield support

For detecting and intercepting hostile aircraft, the 407L program will use some of the transportable equipment, built for 412L, the overseas tactical air-control and warning system nicknamed Quickdraw, or Baby Sage. A fixed, hard-core survivable version has been installed in West Germany.

The 412L equipment that is too big and heavy for airlift will not be used in the 407L system. The Tactical Air Command considers most of the 412L radar equipment to be good, but too big and complex. Some of the communications gear is expected to be usable as 407L components.

The Air Force will buy the AN/TRC-97 troposcatter microwave communications equipment now used by the Marine Corps. The TRC-90 has also been approved for procurement by the Defense Department. These two systems will replace the TRC-66 that was developed for the 412L system. Be-

MICROWAVE-RELAY-LINK NEWS

from **POLARAD**

*world leader
in Microwave
Instrumentation*

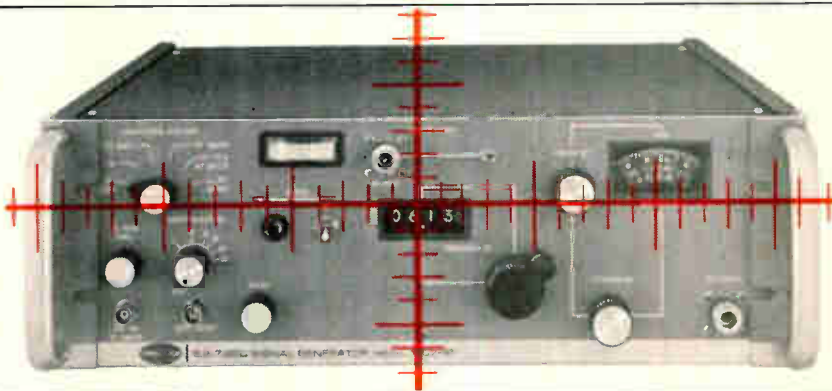

HOW TO KEEP THEM ON THE AIR ...and RIGHT ON THE BUTTON

Know why more and more leading microwave-link manufacturers and operators are standardizing on the new P.E.I. modular test sets?

Take a look at the Model 1307-1P—one of 13 standards—for the answer. It is a *complete, precise, microwave test facility* in one highly portable cubic foot. It is light, strong, stable, and **very** easy to use.

It's a $\pm 1\%$ accurate signal generator from 5.2-7.2 GC, with error-free **digital** readout. It has high (+3 dbm) output controlled by a superb wide-range precision attenuator. It's packed with every kind of modulation facility you'll ever need—including a **really flat** 0-50 MC sweep. Note the ± 1 db accurate power meter... **very** handy.

Use it from the receiver input right through the transmitter—to measure receiver threshold sensitivity and noise-muting level, pre-selector and filter alignment, transmitter power level, modulator gain, and transmitter linearity. Use it for receiver IF and discriminator alignment, TWT alignment, and measurement of TWT saturation characteristics. Use it as a sweeper for checking microwave bandpass networks. Use it for frequency dial calibration, and to check image rejection, sensitivity, power, power gain, VSWR. You can even use it as a receiver local oscillator, modulated transmitter, or system microwave reference in checkout equipment.

Like all the units in this new series, it is modular and fully compatible, electrically and mechanically. (The matching doubler, for checking dual-diversity systems, is the Model 1509.)

Write, or circle the inquiry card for full data. Better still, **call** us. We'll bring one over. Bet we sell it to you!



POLARAD ELECTRONIC INSTRUMENTS

A Division of Polarad Electronics Corporation
World Leader in Microwave Instrumentation

34-02 Queens Blvd., Long Island City, New York 11101

For precise temperature testing from -300°F to $+525^{\circ}\text{F}$

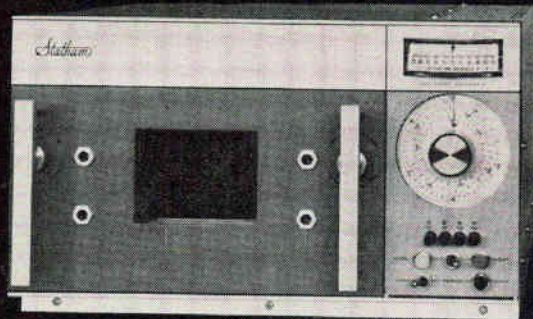

STATHAM MODELS SD6 AND SD3 ARE 700 CU. IN. CAPACITY CHAMBERS FEATURING $\pm\frac{1}{4}^{\circ}\text{F}$ CONTROL ACCURACY

Designed for precise temperature testing of electronic components, Statham Models SD6 and SD3 chambers feature true proportional control of heater power by all solid-state circuitry. The design advances in these chambers eliminate the conventional heater power relay and cycling about the control point.

Model SD6 has a range of -100°F to $+525^{\circ}\text{F}$. For high performance and convenience, liquid CO_2 is used for cooling. Developed especially for low temperature requirements, Model SD3 operates from -300°F to $+400^{\circ}\text{F}$ and utilizes liquid nitrogen for cooling.

CONVENIENT TEMPERATURE CONTROL



24 Inch Dial Control

Models SD6 and SD3 feature 24 lineal inches of calibrated set-point scale. Temperature readout is obtained by a deviation meter calibrated in one-degree increments. This expanded scale approach provides a level of accuracy and readability not attainable in conventional chambers.



Optional Push-Button Control

Frequently repeated temperature settings can be made faster and more accurately with Statham's *push-button* temperature selection control. The buttons, which may be set at any desired temperature, provide precise repeatability.

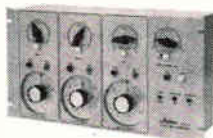

Cycle Time Controller

Statham cycle time controllers permit programming the chambers in any required sequence of hot-ambient-cold-ambient, etc.



Statham Instruments, Inc.
Environmental Products Division
2221 Statham Blvd., Oxnard, Calif.
HUnter 6-1080 (Area Code 805)

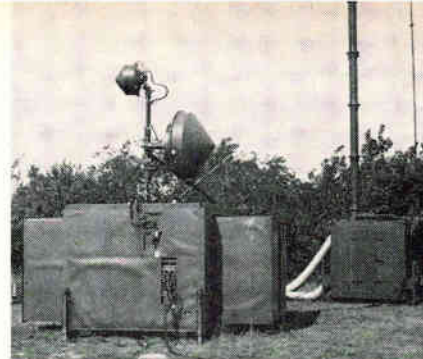

AN/TSW-5 radar will be the radar-approach control central for all air traffic in the terminal area of the airfield. The radar was developed for the 482L program.



Long-range search radar (AN/TPS-35) which detects and identifies aircraft by displaying range and bearing information on remote scopes. Developed for the 482L system, it will be used in the 407L.

cause of its weight, the TRC-66 was obsolete before it was tested.

The Tactical Air Command has also asked the Air Force for a 3-D radar that won't exceed 6,000 pounds and can be housed in two shelters that are capable of being airlifted by helicopter.

The command communications subsystems of 407L will provide equipment for the Air Force's command post that will work with Army commanders at battle headquarters.

The first battlefield communications system will be manually operated. Controllers will watch the aircraft on display scopes and control the pilots directly with voice-communication links. Eventually the system is expected to use lightweight computers, automatic display equipment and data links.

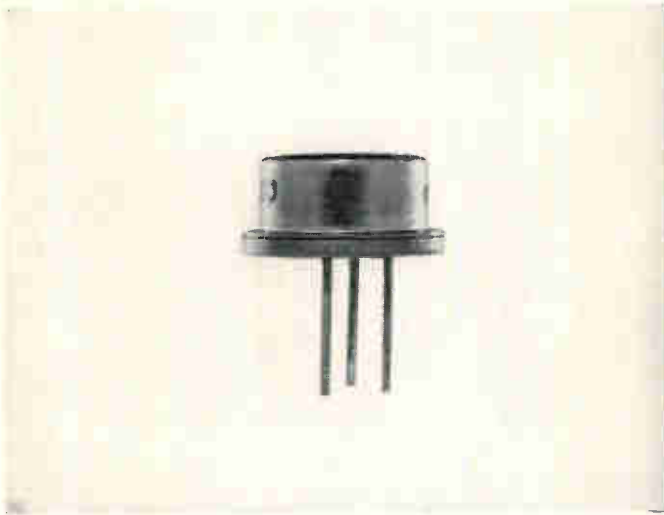

Meeting MIL specs?

***AnSCO lets you see
the reliability***

If you've invested millions in an in-plant reliability program, you should include Superay® 'H-D' Industrial X-ray film. Why? Because it can show up best the tiniest imperfection in your electronic components. This ultra-fine grain Class I film has very high contrast and microscopic definition throughout the entire KvP range. It's designed for high definition radiography and the ultimate in image quality.

For the X-ray "reliability" your components deserve, ask your AnSCO Representative about AnSCO Superay 'H-D' Industrial X-ray films. Or write:

gaf

ANSCO

X-RAY PRODUCTS OF
GENERAL ANILINE & FILM CORPORATION
140 WEST 51 STREET · NEW YORK 10020

A new pattern for power

Let's say $\circ = 1/20$ of a watt.
Stored in a dry cell battery,
($1/20$ th watt) will operate
a portable radio.



It takes 20 \circ s (1 watt)
to operate a flashlight.

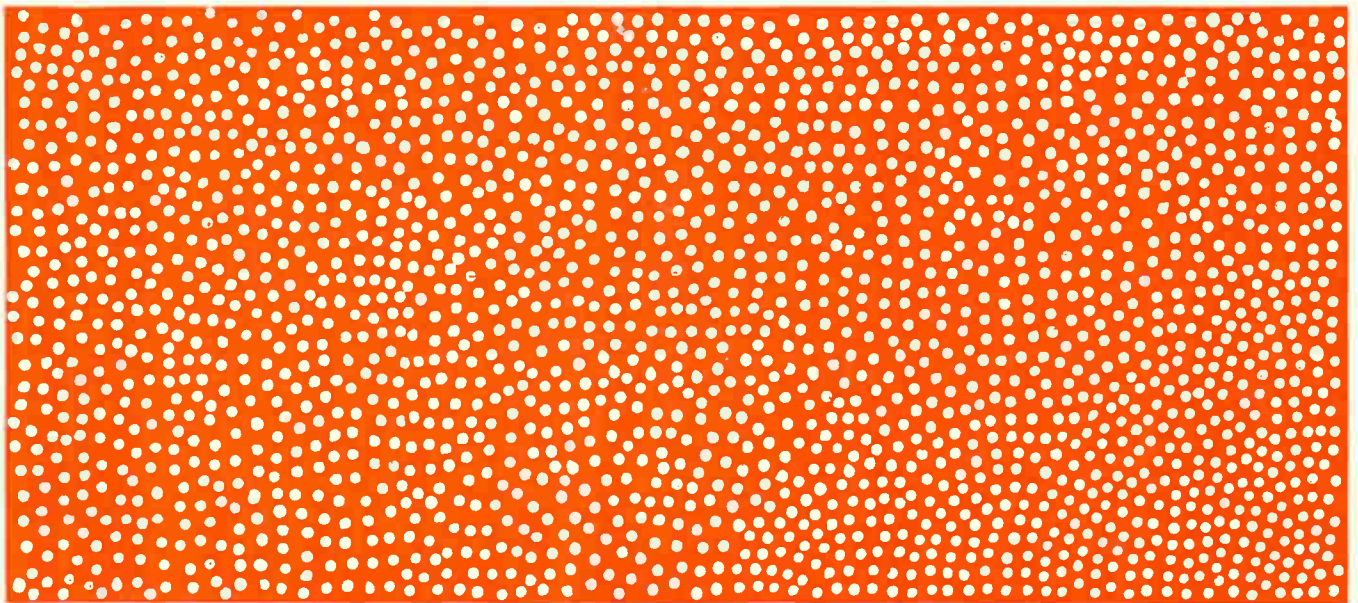

A single "Eveready" nickel-cadmium rechargeable battery can deliver from 1 to 100 watts (2,000 times the wattage required to power a transistor radio). It creates a new pattern for power.

If portable power were limited to low wattage devices like radios and flashlights, there would be no need for a battery capable of packing more power in a small storage chamber. But there is a need. The demand for heavy-duty cordless products has created it.

This market is constantly increasing as people discover cord-free, carefree living. It's time to design for the future. That's why Union Carbide's Technical Center in Cleveland, Ohio has developed the new "Eveready" nickel-cadmium rechargeable battery. This is Union Carbide's latest contribution to the growth of cordless products.

The message for you in this pattern: New incentive, new freedom in electronic design. Designs you may have dismissed as impossible or impractical

just a few years ago are now possible *and* practical.

For help in working out the proper power combination for your product, get in touch with one of Union Carbide's Battery Engineers. He's highly trained and experienced. If your product requires a rechargeable battery, he can supply you with the "Eveready" B/M/C (Battery/Motor/Charger) POWER PACKAGE you need to make your product "go". In this unique POWER PACKAGE, you'll get the proper combinations of an "Eveready" rechargeable battery, a high quality, long life electric motor that operates at 75% to 80% efficiency . . . and the correct battery charger.

Contact: Battery Engineering Dept., Union Carbide Corporation, Consumer Products Division, 270 Park Ave., New York, N. Y. 10017.



Look to the Leader in Cordless Power—
"Eveready" Batteries with "Power to Spare".

"Eveready" is a registered trade mark of Union Carbide Corporation



Compact instrument combines six functions

This a-c/d-c differential voltmeter can be used to calibrate with laboratory-standards accuracy

Designed to measure a-c or d-c voltages so accurately that it can be used to calibrate other laboratory-quality voltmeters, model 741A a-c/d-c differential voltmeter/d-c standard combines six functions in a single, compact, solid-state instrument. It is a d-c differential voltmeter of 0.03% accuracy and it may also be used directly as an electronic d-c voltmeter. The input impedance is constant, and greater than 1,000 megohms, regardless of null condition. It is a 0.03%-accurate digital-setting source for d-c voltages from 0 to 1,000, with regulated current to 20 ma. Resolution is 1 part per million. Stability is better than 0.003% a day; 0.005% a month. Line regulation is less than 0.002% for 10% line-voltage change.

As an a-c measuring instrument, model 741A introduces a shunt capacitance of less than 5 pf at the "touch and read" point in the measured circuit. The shunt resistance is 1 megohm. As an a-c differential voltmeter, its specified accuracy is 0.1% of reading $\pm 0.01%$ of full scale, from 0.1 v to 1,000 v.

A built-in recorder output is driven by a d-c amplifier which may be used separately, with a maximum gain of 60 db and output of 1 v into 2,000 ohms or more.

According to the manufacturer, the new instrument was designed to exploit, more fully than ever before, the differential voltmeter principle, which is to attain high accuracy by measuring only the difference between a known and an unknown voltage. Model 741A incorporates newly-developed circuitry which maintains constant high input impedance, unchanging with null condition. The meter thus continuously presents accurate difference readings, without constant null chasing, as the measured circuit drifts. Many typical d-c differ-

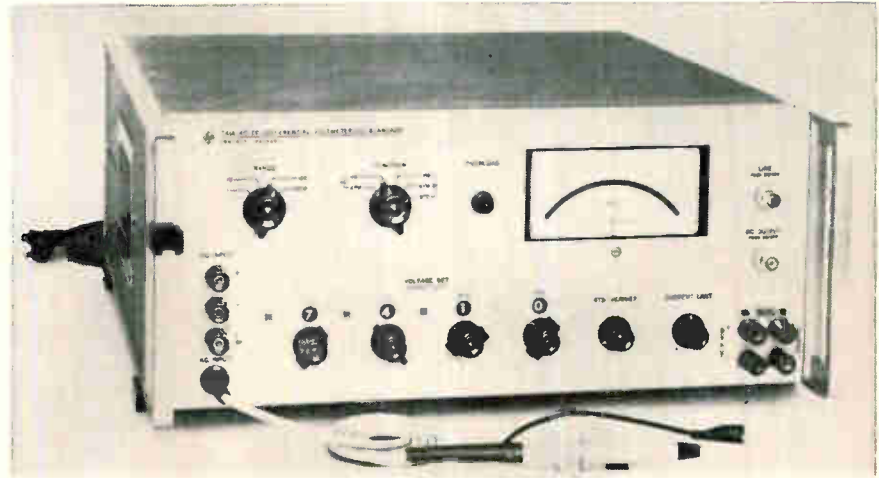

ential measurements are thus made conveniently; long-term drift in regulated power supplies, precision transducers, and attenuators will be steadily and accurately indicated. The built-in recorder output provides means for automatic plotting.

A-c performance. Entirely new with model 741A is the same capability for a-c differential measurements. Not only does the input resistance remain high and constant regardless of null condition, the complex input impedance remains high through a broad frequency range because of the low shunt input capacitance. This avoids introducing high reactive losses into the measured circuit, and preserves accuracy. High a-c voltages may be measured without drawing high current. A-c power sources or oscillators can be measured to a new degree of accuracy and resolution with the a-c differential technique. The same input characteristics are maintained when the instrument is used directly as an electronic a-c voltmeter.

End-scale resolution of 0.005% is readily attained, either in a-c or d-c readings. Where less resolution and

greater speed are desirable the use of fewer digits will not affect the device under test and it is not necessary to complete the nulling operation every time a measurement is made. Null sensitivity is determined by the range switch, so it is always appropriate to the decade in use, and off-scale meter deflections are avoided.

The d-c voltage standard source is adjustable with 0.001% resolution. The output current limit is vernier adjusted; active current limiting circuitry provides transient-free adjustment.

An overload indicator is included. It functions whenever excessive voltage is applied or whenever excessive current is drawn from the d-c standard, warning the user that his measurement may be in error for this reason.

Model 741A measures 6 $\frac{7}{8}$ in. high, 16 $\frac{3}{4}$ in. wide and 18 $\frac{1}{4}$ in. deep; and weighs approximately 40 lb. Price is under \$1,500. This is less than the combination of units it replaces. Deliveries are to begin in December this year.

Hewlett-Packard Co., 1501 Page Mill Rd., Palo Alto, Calif.
Circle 301 reader service card

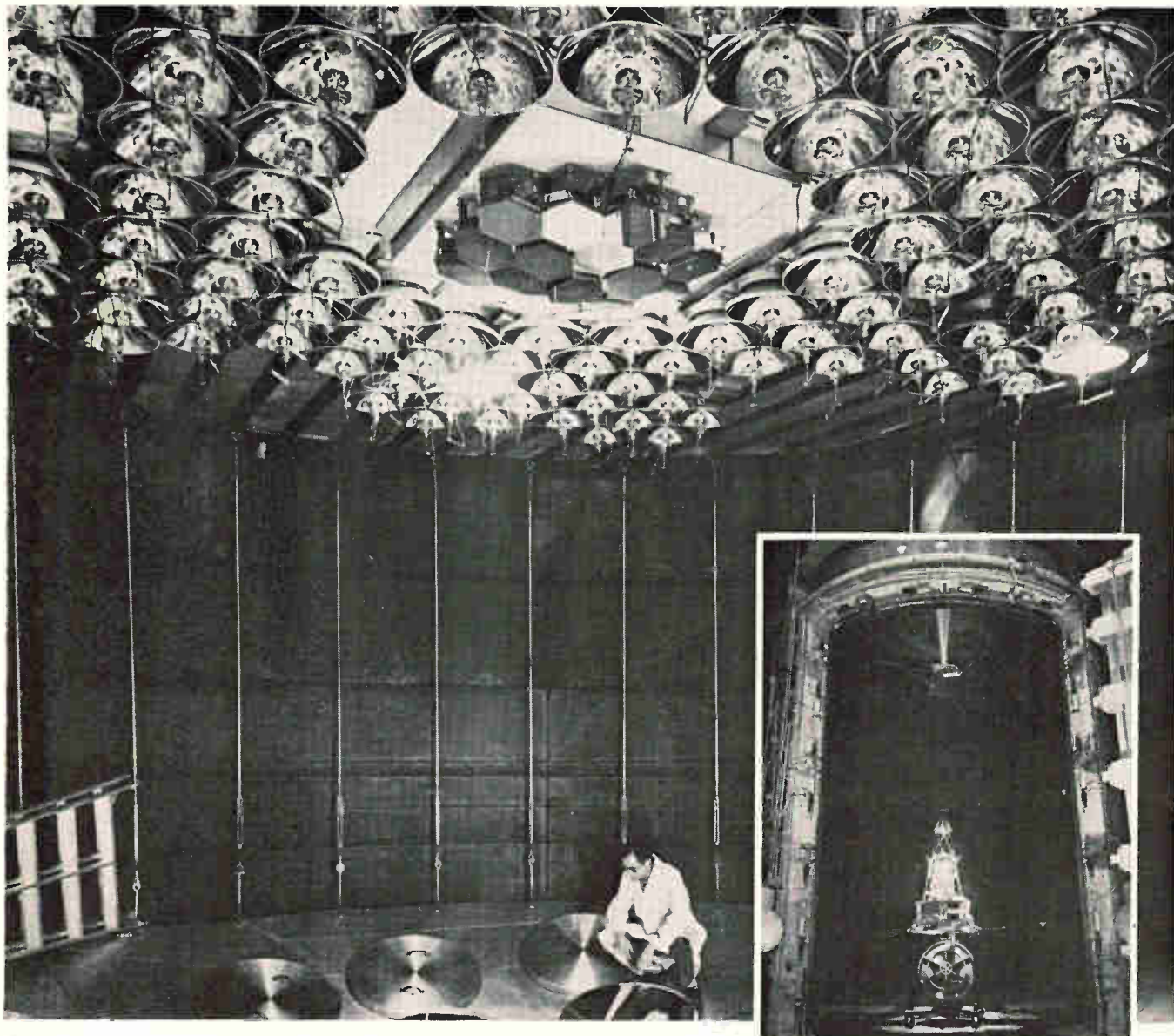

ENGELHARD optical fused quartz assures highest light transmission in JPL's interplanetary space simulator

In Pasadena, California, at the California Institute of Technology Jet Propulsion Laboratory, stands a giant new environmental chamber for testing reactions of spacecraft on extended journeys to other planets.

Here, JPL is conducting tests for the National Aeronautics and Space Administration to determine how a space vehicle's color, finish, material, shape and orientation to the sun determine the effects of solar heat on its surface.

These effects can best be tested by building a lighting system which duplicates all the visible and invisible rays of the sun in a collimated beam. To achieve this, an intricate optical system was designed for JPL's simulator — and fused quartz was used for its lens and lamps.

The simulator is a cylindrical tower 80 feet high and 27 feet in diameter, with a steel vacuum chamber in the lower part. In the upper part, which houses the solar simulation unit, a battery of mercury-xenon lamps

shines down on a parabolic mirror which reflects a concentrated light beam upward to a hyperbolic mirror. From this mirror the light is again reflected downward through a 3-foot diameter lens and into the vacuum chamber. Inside the chamber the light is converted to a collimated beam which shines down on the spacecraft as would sunlight in space.

The quartz used in JPL's simulator must be of the highest quality — isotropic in all directions and free of all bubbles, striae and strains in order to transmit light efficiently. Quartz was chosen because it met all these important requirements and achieved the highest transmission possible in the ultraviolet and infrared ranges.

Engelhard produces high quality quartz for many applications, and it is daily proving its worth in the many therapeutic and technical apparatus used in the chemical, electronic and metallurgical industries. Write to our Technical Service Dept. for detailed data on Amersil Fused Quartz.

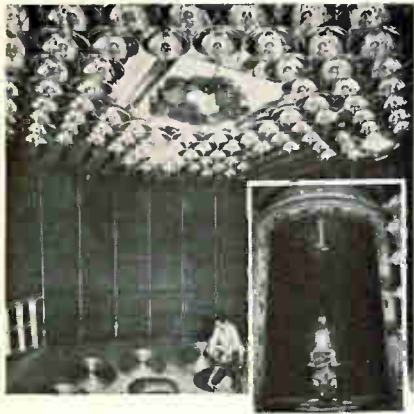

Some other

ENGELHARD

products

LAMINATED CONTACT MATERIALS are produced in virtually any combination of precious metals and alloys with base metals and alloys. Types include edge, strip, inlay, spot, single or double-face laminations. Supplied in flat lengths, in strip, coil or fabricated forms.

THIN WIRE AND FOIL are produced by Engelhard's Baker Platinum Division to meet rigid electronic design requirements. Both extruded and Taylor Process thin wire are available in diameters as small as .001". Thin-gauge foil is supplied in sheets up to 8" x 18".

TEMPERATURE-SENSITIVE METALS are available in a complete line for applications requiring temperature response from -100° to $+1,000^{\circ}$ F. Wilco Thermometals® are supplied in a wide range of resistivity in rolls and strips or tempered and formed to specification.

PRECIOUS METAL CONTACTS in pure or alloyed forms of silver, platinum, palladium and gold provide unmatched resistance to atmospheric corrosion and electrical pitting. Engelhard will manufacture to specification or provide material in wire, rod or sheet form.

SLIP RINGS — all types and sizes are available for design and manufacture of assemblies to the most critical tolerances. Engelhard maintains complete facilities, metallurgical and engineering services to satisfy your most critical requirements.



New Components and Hardware

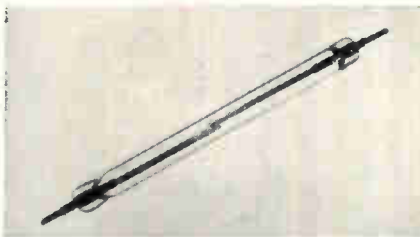

Computer-type dry reed switch

The life expectancy claimed for this dry reed switch is more than one billion (10^9) contacts at no load before the first failure. It can be operated either electromechanically or by a permanent magnet, or by a combination of the two, and is designed primarily for use in electronic computers, calculating machines and telephone exchanges. Internal atmosphere of the gas-tight reed capsule is a mixture of nitrogen and hydrogen. Both spst and dpst type contacts are available. The switch may be obtained with either rhodium or gold-plated contacts. The Ericsson Corp., 100 Park Ave., New York. [311]

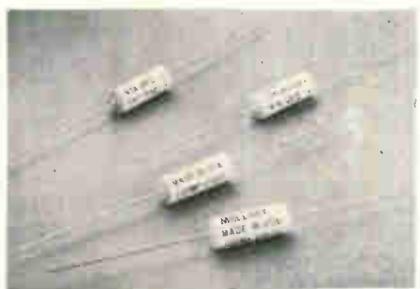

Molded aluminum tubular capacitors

Aluminum electrolytic capacitors, designated type MTA, are fully molded, using a new plastic material and a new molding technique, according to the manufacturer. Samples are immediately available in the $\frac{3}{8}$ in. by $1\frac{1}{8}$ in. axial lead sizes. Operating temperature range is -20°C to $+65^{\circ}\text{C}$. Working voltage range is 3 wvdc through 50 wvdc. Capacitance range is 175 μf

at 3 v to 20 μf at 50 wvdc, with a standard capacitance tolerance of -10% to $+100\%$. The d-c leakage is less than 0.03 μa per μf volt. Non-polar units have a capacitance range from 100 μf at 3 wvdc to 10 μf at 50 wvdc.

Mallory Capacitor Co., a division of P.R. Mallory & Co. Inc., Indianapolis, Ind. [312]



Wirewound trimmers rated 1 w at 70° C

Low-cost, wirewound trimmer potentiometers now being produced have all-welded internal construction. Power rating of the 2200 series is 1 w at 70°C , derating to zero power at 125°C . Resistance range is from 10 to 30,000 ohms. Models are offered with a standard tolerance of $\pm 10\%$, with lower tolerances available. The 2200 series is available with three standard configurations: model 2280 has 22 AWG gold-plated printed-circuit pins; model 2292 has 26 AWG gold-plated solid wire terminals; model 2297 has 28 AWG stranded vinyl insulated leads. Case dimensions of all are 1 in. long by 0.30 in. high by 0.18 in. wide. Dale Electronics, Inc., P.O. Box 488, Columbus, Nebr. [313]

Power contactor is small and light

A small, lightweight, 20-amp power contactor features rugged construction and contact barriers capable of handling 3-phase a-c ratings. Available in three models—28 v d-c; 115 v a-c, 60 cps; and 115 v

How do you produce and assemble parts too small to be measured with a micrometer?



Engineer StereoZoom into your product as a component, or use the complete microscope . . . for quality-control inspection, for production-line fabrication and assembly . . . of micro-miniature parts and products.

UNIVAC® uses Bausch & Lomb StereoZoom®

The UNIVAC Microelectronic Aerospace Computer contains 1,952 parts but is a mere 6" square by 7" high and weighs less than 17 pounds. Using less power than a small table radio, it can in a single second perform 125,000 additions or subtractions, multiply 30,000 times, divide 15,000 times, or compute 8,000 square roots. To assemble this microminiature marvel, UNIVAC technicians use a StereoZoom Microscope, which lets them see tiny circuits that measure $\frac{1}{4} \times \frac{1}{8}$ inch and are only $\frac{35}{1,000}$ of an inch thick. Guided by StereoZoom's big, sharp *three-dimensional* image, the operator easily inserts 1,243 of these microelectronic circuits by hand with an ordinary pair of tweezers.

If you need to assemble or inspect parts that are too small even to be measured with a micrometer, StereoZoom can help you. Bausch & Lomb has 24 models with magnification ranges from 3.5× to 120×. Call your dealer, or write Bausch & Lomb Incorporated, 61410 Bausch Street, Rochester, New York 14602.

Univac is a registered trademark of Univac Division of Sperry Rand Corporation.

BAUSCH & LOMB 

1964 MASTER DESIGN AWARD WINNER—Microscopes for Science Teaching and Flexiscope

New Components



a-c, 400 cps—the hermetically sealed unit's balanced armature design provides reliable, trouble-free performance in meeting specifications outlined in MIL-R-6106C. It can operate in a temperature range of -70°C to $+120^{\circ}\text{C}$, withstanding severe environments. The compact (2.4 in. by 2.5 in. by 1.465 in.), lightweight (0.6 lb) unit is offered in numerous mounting and terminal styles. The company reports it is ideally suited for airborne, ground support and industrial electronic applications where reliable performance is needed to handle switching of heavy resistive and inductive loads.

Leach Corp., 1123 Wilshire Blvd., Los Angeles 17, Calif. [314]



Display storage tube with high resolution

A rugged-construction display storage tube gives air-to-air radar and air-to-ground capability. Type WX-5047 is designed for use in systems that require controllable persistence, signal integration, high writing speed, or display brightness greater than that available from conventional crt's. Such applications might include electrical transient studies, fire control, navigation and terrain avoidance radar, weather radar and general oscilloscope displays. At a writing speed

of 100,000 inches per sec, the tube has stored resolution of 90 lines per inch when saturated brightness is 50% as measured by the shrinking raster method. Minimum saturation brightness is 1,200 foot-lamberts. High resolution is obtained without sacrificing writing speed. The electrostatically focused and deflected tube has a single writing gun. The over-all length is 14 $\frac{7}{8}$ in. and useful viewing diameter is 4-in.

Westinghouse Electronic Tube Division, Elmira, N.Y. [315]

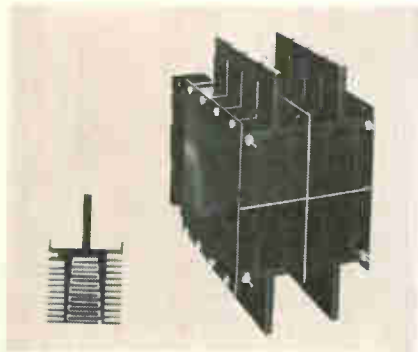

Forced convection heat dissipator

A new heat sink, model 2403, utilizing the flexible modular building-block concept, maintains minimum temperatures of power transistors, diodes and resistors even under conditions of high heat load. Each 2403 module is extruded aluminum, designed to permit the greatest total surface area possible while still maintaining optimum laminar flow characteristics. These heat sinks may be ordered anodized, clear or colored finish, and are available with or without blower.

Astro Dynamics, Inc., Second Ave., Northwest Industrial Park, Burlington, Mass. [316]

Trimming pot is nonwirewound

A new nonwirewound rectangular trimming potentiometer is announced. It is available in all popular terminal and mounting configurations including insulated stranded leads, solder hooks, printed-circuit pins and panel mount. High-frequency operation

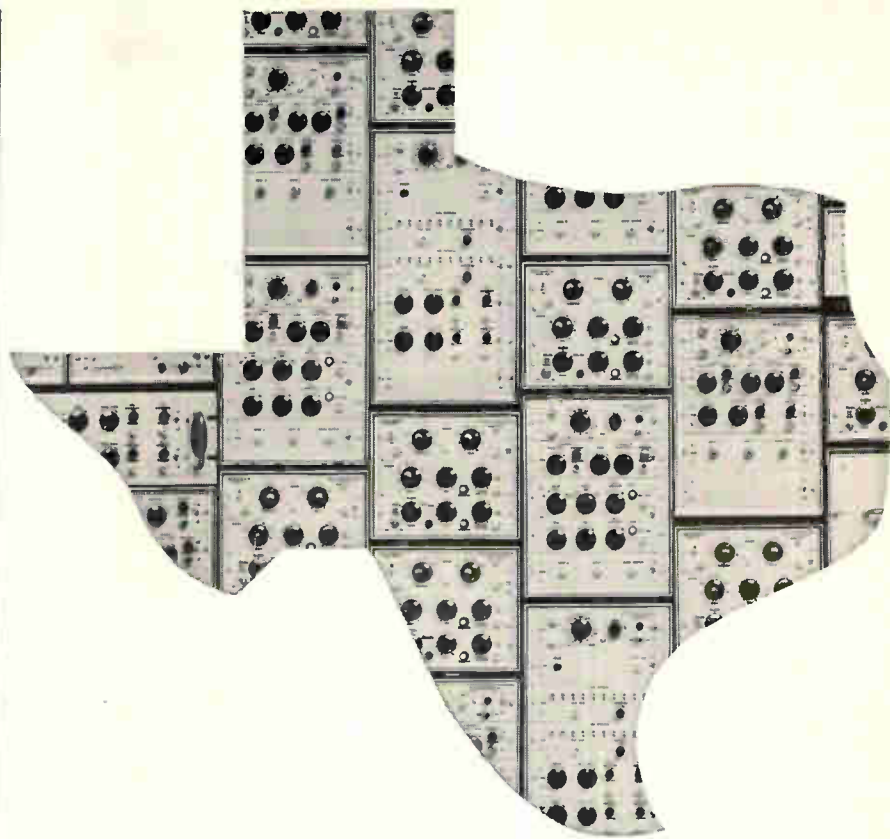

Texas Instruments Makes 247 Pulse Generators

(one must meet your requirement)

- Repetition Rates to 100 MC
- Rise and Fall Times from .3 nanosecond
- Pulse Shaping and Programming
- Solid-State Construction
- Easy to Use, Easy to Expand
- Prices from \$950

TI's complete line of flexible, high performance signal generating equipment offers units to satisfy any test or design application. Fixed, fast or variable rise and fall times; standard special or mixed waveforms; variable amplitude, width and delay . . . all with characteristic, stable, clean waveforms. Available as portable or rack-mounting instruments, TI Pulse Generators are lightweight, compact and extremely easy to use.

Write for information, wire for demonstration, call collect to order.

INDUSTRIAL
PRODUCTS
GROUP



TEXAS INSTRUMENTS
INCORPORATED
P. O. BOX 66027 HOUSTON, TEXAS 77006
7 RUE VERSONNEX GENEVA, SWITZERLAND

691

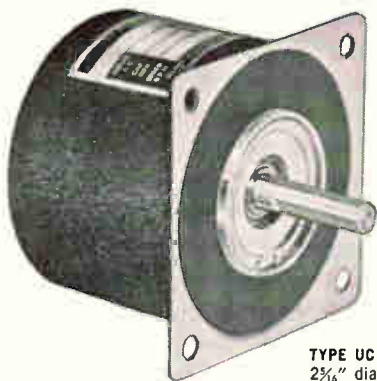

TYPE UC & UH MOTORS
2½" dia. x 3¾" max. length



TYPE UC & UH GEARMOTORS
2¾" dia. x 3¾"

NEW 2¼" A.C. GEARMOTORS SYNCHRONOUS & INDUCTION

Get torques from 1.2 oz. in. to 10 lb. in. from Globe's new Type UC & UH commercially priced a.c. motor family. Induction capacitor motor is available in three stack lengths rated at 1, 3 or 6 oz. in. torque at 3,000 rpm. Standard windings available for 115 or 230 v.a.c., 1 or 3-phase, 2, 4 or 6 poles, 60 cps. Encapsulated stator seals out dirt and moisture. Motors have ball bearings, stainless steel bearing seats and shafts. Motors are available with choice of 13 life-lubed spur gearheads with ratios from 6:1 to 1800:1, continuous output torques from .4 to 10 lb. in., speeds from 3,000 down to .56 rpm. Each gear cluster has separate mounting shaft for maximum support. Hysteresis synchronous versions can be stalled without damage. Mounting is interchangeable with traditional type 2½" motors. Request Bulletin UCH.

Globe Industries, Inc., 1784 Stanley Avenue,
Dayton, Ohio 45404. Tel.: 513 222-3741.



GLOBE

New Components

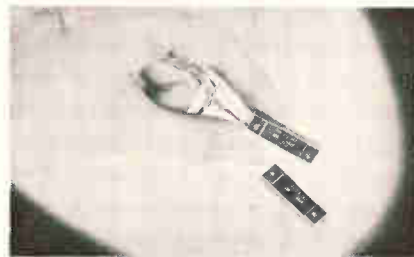

without inductive or reactive shift is insured by the uniform continuous film element. Resolution is virtually infinite due to the uniformity of the film. A new method of simultaneously firing the track resistance material and the terminating material is said to provide extremely low end resistance and high reliability. The 25-turn model 749 is available in standard resistances from 10 ohms to 1 megohm with a power rating of 1w at 70°C and a temperature coefficient of ± 400 ppm/°C. It is designed to withstand shock of 100 g for 11 millisecc and vibration of 30 g to 2,000 cps. Price in unit quantity is \$6.45. Spectrol Electronics Corp., 1704 S. Del Mar Ave., San Gabriel, Calif. [317]

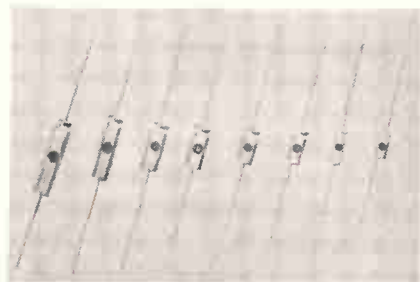

Preferred number capacitor line

Miniature aluminum electrolytic capacitors have been developed to coincide with the international preferred number series. The 77F line has been designed with a ± 20 percent capacitance tolerance to fit this numbering series and is available in eight case sizes. In the preferred number series, each nominal capacitance value is selected so that the maximum allowed by its tolerance coincides with the minimum capacitance allowed for the next higher rating. Thus, the

range is covered by a minimum number of capacitors. This eliminates multiple ratings and simplifies the circuit designer's job of selecting the proper capacitor. Operating over a temperature range of -40°C to $+85^{\circ}\text{C}$, the new capacitors are expected to find a ready market in communications equipment where low operating temperatures are required. The line boasts an elastomer seal, allowing less weight loss, and all-welded tab-to-foil construction, eliminating high resistance contact. Low leakage current and long life make the line suitable for applications in computers, instruments and industrial controls where high quality and stable characteristics are important. Units are rated from 1 to $330\ \mu\text{f}$ and up to 160 v. General Electric Co., Irmo, S.C. [318]

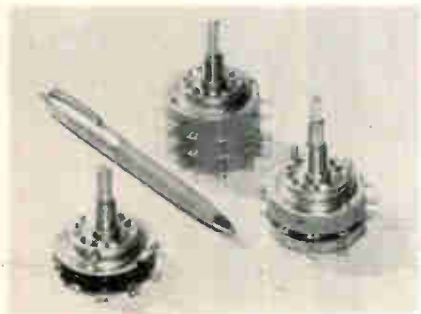

Sealing switch in oil boosts current, voltage

A new rotary switch design makes possible a hermetically sealed enclosure. Filling the enclosure with oil upgrades current and voltage ratings tenfold, according to the manufacturer. A wiper contact action starts at a high-performance level and improves throughout the life of the switch. Switches have exceeded 250,000 test operations. Through-contact resistance from terminal to terminal runs 5 milliohms or less. Terminal leakage resistance with high-performance materials is 800,000 megohms. Shorting and nonshorting functions can be mixed on the same pole in any order. Design permits up to 24 positions per pole. Electronic components may be wired into the modular circuit construction of the switch. Switches are available in a wide range of dielectric materials. Stackpole Carbon Co., Johnsonburg, Pa. 15845. [319]

LIGHTWEIGHT CHAMPION OF THE T-R RELAYS



Actual Size

TYPE RJ1A
2KV PK (16 MC)
7 AMPS RMS (16 MC)
 $1\frac{3}{16}$ " LONG
ONE OZ.

Ounce for ounce the RJ1A controls more power than any other relay in the world. It will handle 2 KW average power into a 50 ohm load at VSWR 1:1 at 2 to 32 megacycles. And since it was designed for high volume production it offers the utmost economy.

The high strength vacuum dielectric guarantees a tremendous internal overvoltage safety factor — more than double the rated peak test voltage. Resistance is low (.010 ohms) and remains low and stable for the life of the relay.

The RJ1A is ideally suited for such applications as airborne, mobile, or marine communications systems for switching between antennas, antenna couplers or transmitters, or between transmitters and receivers. In sonar equipment they are being used as long life relays to switch 25 amp, 100 milliseconds pulses to transducers.

For higher power applications Jennings offers a complete line of vacuum transfer relays not much larger than the RJ1A. These relays are available in peak test voltages up to 38 KV Peak and continuous current ratings up to 75 amps RMS.

Write for more detailed information on the RJ1A and Jennings complete line of vacuum transfer relays.

RELIABILITY MEANS VACUUM | VACUUM MEANS

Jennings

JENNINGS RADIO MFG. CORP., 970 McLAUGHLIN AVE., SAN JOSE 8, CALIF., PHONE Cypress 2-4025

The Hughes/NASA Syncom stands still at 6875 mph to talk to a billion people.



CIRCUIT DESIGNERS... **is your appointment in space with Hughes?**

Today, Hughes is one of the nation's most active aerospace/electronics firms. Projects include: F-111B PHOENIX Guided Missile System, TOW Anti-Tank Missile, SURVEYOR Lunar Spacecraft, SYNCOM, VATE, ARPAT, POLARIS, Hard Point Defense and others.

This vigor will assist the qualified engineers and scientists towards more and better opportunities for both professional and personal growth.

Many immediate openings exist. The engineers selected for these positions will be assigned to the following design tasks: the development of high power airborne radar transmitters, the design of which involves use

of the most advanced components; the design of low noise radar receivers using parametric amplifiers; solid state masers and other advanced microwave components; radar data processing circuit design, including range and speed trackers, crystal filter circuitry and a variety of display circuits; high efficiency power supplies for airborne and space electronic systems; telemetering and command circuits for space vehicles, timing, control and display circuits for the Hughes COLIDAR (Coherent Light Detection and Ranging).

If you are interested and believe that you can contribute, make your appointment today.

For immediate consideration, please airmail your resume to:

Mr. Robert A. Martin
Head of Employment
Hughes Aerospace Divisions
11940 W. Jefferson Blvd.
Culver City 49, California

Creating a new world with electronics

HUGHES

HUGHES AIRCRAFT COMPANY
AEROSPACE DIVISIONS

An equal opportunity employer.

U. S. CITIZENSHIP REQUIRED

New Instruments



Voltage calibrators in five models

A series of solid-state a-c voltage calibrators is available in five models, each with varying capabilities. Voltage ranges from 1 mv to 1,000 v, and frequencies from 60 cps to 5 kc. Accuracy is 0.25% of dial setting for 6 months. The unit is designed for portable operation for rapid a-c calibration. Price is \$980 to \$1,990.

Holt Instrument Laboratories, Oconto, Wisc. [351]



Digital oscillator for lab and factory

A precise, solid-state digital oscillator has been introduced for general laboratory and production-line use. Model 820, with calibrated amplitude control, eliminates the need for an electronic counter and an rms voltmeter for applications requiring an accurate, calibrated frequency source. Key features and specifications include four-digit frequency settability to 0.005%. Range is 10 cps to 200 kc. Automatic sweep throughout the range is an instrument option. Frequency response is flat within 1% from 10 cps to 200 kc. Controls consist of inline rotary switches with line readout to set frequency and an

amplitude control which combines a step-attenuator and calibrated vernier providing $\pm 1\%$ output voltages over the range of 1 mv to 10 v. The rack-cabinet housing is 3½ in. high, 10¾ in. deep and 19 in. wide. Price is approximately \$945.

Vidar Corp., 77 Ortega Ave., Mountain View, Calif. [352]



Three-mode controller offers high stability

This solid-state, 3-mode controller receives command from internal or external sources which can vary in ranges from 0 to 10 mv to 0 to 10 v d-c. Output is 0 to ± 10 v into a 5,000-ohm load or 4 to 20 ma into a 500-ohm load if requested. Accuracy is 0.05% linearity conformance between process and command to reduce controller error to zero. Stability is 0.05% based on 10-v process signal. Additional features are bumpless transfer between internal and external command, and between automatic and manual control, complete set of front-of-panel test points, noninteractive continuity adjustable variables, excitation for external set point expandability for lead, lags, rate and filtering.

CompuDyne Corp., Hatboro, Pa. [353]

Frequency standard in compact package

A solid-state frequency standard, model 10, employs a precision quartz crystal vibrating at a frequency of 5 Mc. The basic frequency is divided by fail-safe regenerative dividers that provide outputs of 1 Mc and 100 kc as well as the basic 5-Mc output. Long-



Super-Colossal Director

Call it a director, monitor, controller, or traffic cop—the API contactless meter-relay takes charge of practically every control situation, either in OEM equipment or on a production line.

It operates on a direct unamplified signal from any variable, and gives you more sophistication with less complication than any other control device.

Straightforward, simplified design means reliability and ease of application. It's inherently fail-safe.

You don't have to be an engineer to use it—but engineers appreciate it most.

Features that make it easy to use

1. **Indicates continuously**—You always read the true signal, either side of adjustable set point.
2. **Acts fast at set point**—Control action either way at set point is almost instantaneous (10 to 20 milliseconds).
3. **Near-perfect repeatability**—Frictionless taut-band movement responds uniformly, unaffected by line voltage.
4. **True proportioning (optional)**—Analog action near set point, in band up to 5 per cent of full scale.
5. **Pre-packaged circuits**—Modules mount anywhere, for greatest convenience.

API contactless (optical) meter-relays are offered in all popular current and voltage ranges, including AC, and as temperature controllers. Three case styles, three sizes, double or single set point. Many available off-the-shelf from stock.

ISA Booth No. 1418
NEC Booth No. 514

Ask for Bulletins 33-D (Prices)
and 35-C (Circuits)



Assembly Products, Inc.
CHESTERLAND, OHIO • AREA CODE 216 • HA 3-3131

Gold Immersion Solution by Sigmund Cohn

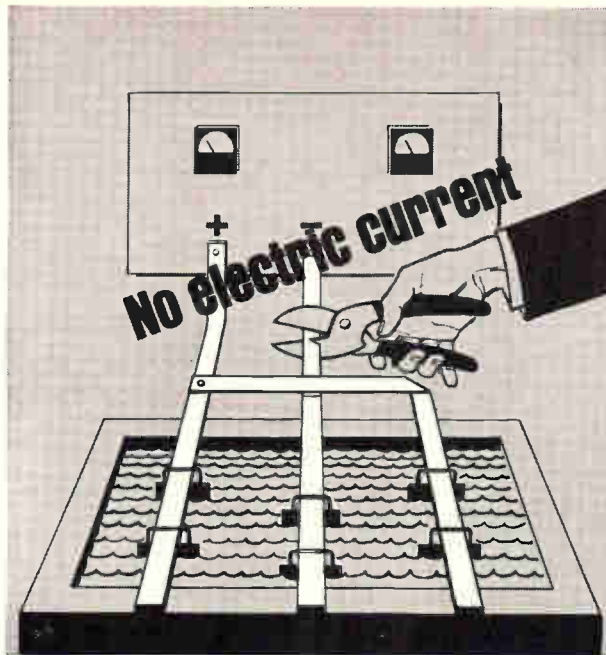

- Greater throwing power . . . ■ Uniformity of Deposit . . .
- Gold is readily applied onto Copper, Nickel and alloys; also Brass, Silver and Silicon—simply by immersing the cleaned part in the solution . . .
- Consult us about application to your products.

SIGMUND COHN CORP.

121 South Columbus Ave., Mt. Vernon, New York

since 1901



SIGMUND COHN CORP. OF CALIFORNIA, Burbank, Cal. / SIGMUND COHN-PYROFUZE, INC., Dallas, Texas

Circle 221 on reader service card

POSITIVE SAFETY FACTORS provided by patented PRESS-TO-TEST INDICATOR LIGHTS

MEET REQUIREMENTS OF MIL-L-7961B

Checks lamps—instantly—without removal from the assembly. Light pressure on the lens cap assembly breaks the normal circuit and makes a test circuit. If the lamp lights when pressed in, it is proven satisfactory . . . If the lamp fails to light when pressed in, it is defective; (lamps can be quickly replaced from the front of panel). Release of finger pressure restores the lens cap assembly to operating position.

Press-to-Test Indicator Lights mount from back of panel in a 15/32", 5/8", or 1" clearance hole, and are available in a wide range of lens styles and colors. Many of the units are offered with or without dimmer caps.



(Units shown approx. 75% actual size)

U.S. Patent Nos. 2,424,574-5; 2,697,719

Every assembly is available complete with lamp. For complete data, request Catalog L-161C. SAMPLES ON REQUEST—AT ONCE—NO CHARGE.

DIALCO

Foremost Manufacturer of Pilot Lights

DIALIGHT CORPORATION

60 Stewart Ave., Brooklyn 37, N.Y. • (212) HYacinth 7-7600

New Instruments

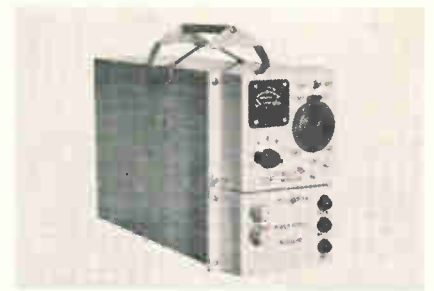

term stability of all output frequencies is better than 5 parts per billion per day after 11 days of continuous operation. The unit is of modular construction and is complete with power supply and standby batteries good for 8 hrs of continuous operation in case of power failure. Weight is approximately 20 lb.

Geo Space Corp., 7725 New Haven Ave., Melbourne, Fla. 32901. [354]

Servo tester yields variety of data

This versatile instrument generates the special waveshapes necessary to measure both the frequency and transient response of servo loops and their components. With a cathode-ray oscillograph, the 100-C quickly yields data such as damped natural frequency, damping factor, amplitude and phase as functions of frequency and system resonance levels. It uses transistor circuitry, and operation is directly from the 117 v, 60 or 400 cps line. Data frequency range is 0.02 to 60 cps. The three carrier frequencies used are 60, 400 and 2,500 cps. Outputs include a linear sweep and phase reference (for cro X-axis deflection), carrier and d-c sine for frequency response tests, and carrier and d-c step for transient tests.



A precision demodulator with separate panel terminals is included. The 100-C can be used for servo component and system development, in final production test and alignment, and for field depot calibration of autopilot components and indicator servos.

Industrial Control Co., Central Ave., at Pinelawn, Farmingdale, L.I., N.Y. [355]

Bar-graph oscilloscope for telemetry displays

A solid-state, bar-graph oscilloscope, model KB-703, displays up to 100 channels of data presented as calibrated vertical bars on a 17-in. cathode-ray tube. The instrument has a maximum input sensitivity of 1 v for full-scale deflection. High-speed electronic commutation allows unusual reliability and complete absence of flicker, even when standard tube phosphors are used, according to the manufacturer. The instrument can be used with telemetry systems, for monitoring flow rates, for process control, and, generally, wherever the rapid assimilation of much data is involved.

ITT Industrial Products Division, 15191 Bledsoe St., San Fernando, Calif. [356]

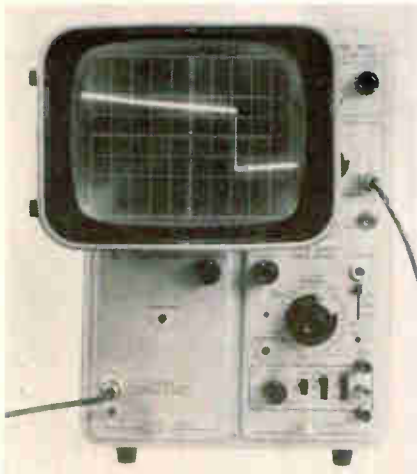

Scope image expander attaches easily

The Stereoramic oscilloscope-image expander eliminates any problems in visual and subjective interpretation, either close-up or for group viewing, in reading of oscilloscope images. The instrument increases

CONQUERING

CAPACITANCE CURVATURE

... or, the
HAPPILY
HARMLESS
HYPERBOLA

[a drama in one masterful act]

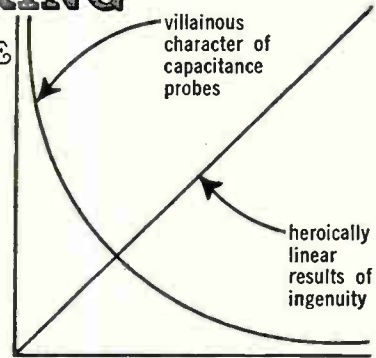

PROLOGUE: After high accuracy and stability, the greatest virtue one can hope for in transducer instrumentation is linearity. If a transducer is *absolutely linear*, initial "offset" in a test set-up just doesn't matter... the sensitivity is *constant*.

THE PROTAGONISTS: Now, then — in our Models DM-100 and B-731-A Distance, Motion, and Vibration-analysis instruments of boundless versatility and unbelievable accuracy, stability, and resolution) we employ as a non-contacting probe, a *capacitance transducer*. (So do our esteemed competitors.)

THE PLOT: Capacitance, however, is not a linear function of distance (plate-spacing, that is)—it is an inverse function... inherently messy. The competition (poor old chaps!) are apparently content with this hyperbolic state of affairs. Not us. Never.

THE PLOT RESOLVED: We (cleverly!) introduce the probe capacitance into a feedback circuit in such a way that the current fed back is itself inversely proportional to the capacitance. Result? *Linearity Regained. Absolutely Constant Sensitivity. Virtue triumphant.*

EPILOGUE: Do you test things that spin? vibrate? writhe or creep? ... barely breathe? You need a DM-100 (measures down to 1 micro-inch with external CRO) or the B-731-A (same, plus direct-reading P-P vibration amplitude, 50-500,000 micro-inches) ... to "straighten you out", so to speak. *Anywhere* you position the probe, the sensitivity will hold true to the range setting you have selected. Recorder/scope drive outputs on both. Ultra-sensible prices, too. Ask us to introduce you to its whole family of companion instruments and accessories. They are, literally,



THE END



WAYNE KERR CORPORATION

14-22 FRINK ST., MONTCLAIR, N. J. (201) 746-2438

INNOVATIONS in INSTRUMENTATION



EDGERTON, GERMESHAUSEN & GRIER, INC.

**NOW
CUSTOMIZED
TO YOUR SPECS**



**THE SD-100
PHOTODIODE**

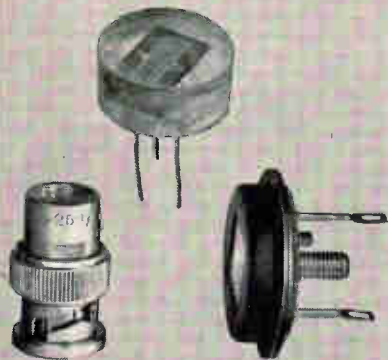

Wide spectral range. Nanosecond response. High sensitivity. Low noise. Linearity of response. Circuit design simplicity. These proven parameters, collectively unavailable in any other light detecting unit, characterize the versatile EG&G silicon surface barrier SD-100.

This EG&G photodiode has broad applications in laser and guidance systems, and for pulsed light, light intensity and waveform measurements. It can now be modified by EG&G into special cell and package configurations to meet your exact requirements: larger or smaller area photodiodes, bi-cells, quadrature cells, matrix arrays, radiation detectors. Each is hermetically sealed in standard JEDEC package or to custom configuration, and can be integrated with fibre optic cables or light pipes for optimal coupling.

RISE TIME:..... 4×10^{-9} sec. @ 90v
FALL TIME:..... 15×10^{-9} sec. @ 90v
SPECTRUM:..... 0.35 to 1.13 microns
SENSITIVITY:..... $0.25 \mu A/\mu W$ @ 0.9u
LOW NOISE:..... 1×10^{-12} watts
LINEARITY OF RESPONSE:..... Over 7 decades

For complete information, write Products Division, 176 Brookline Avenue, Boston, Massachusetts 02215.

EDGERTON, GERMESHAUSEN & GRIER, INC.



New Instruments

the crt traces and grids to approximately four times the image area with precise resolution and without distortion of the total viewing area. For remote viewing with the use of extra long probes, crt images are amplified with clear and sharp resolution at distances of over 20 feet. The new expander attaches simply and can be swiveled in or out of position. The oscilloscope controls are left clear for adjustment. The instrument is available for all popular brand scopes. Price is \$129.

Ednalite Research Corp., 210 N. Water St., Peekskill, N.Y. [357]

One-man portable leak detector

An easy-to-operate, portable leak detector has been developed for use on high- and ultra-high vacuum systems. The battery-operated, audible leak detector can be clipped to the operator's belt and enables one man to check for leaks on even the largest vacuum systems. Other available detectors are said to be many times larger and heavier, and usually must be attended by two men. The detector can be plugged in to the recorder output of any pressure measuring device or ion pump control with an output between 0.1 v and 1 v. Leak detection does not require interruption of system operation and the device can be used on either ion-pumped or diffusion-pumped systems. The

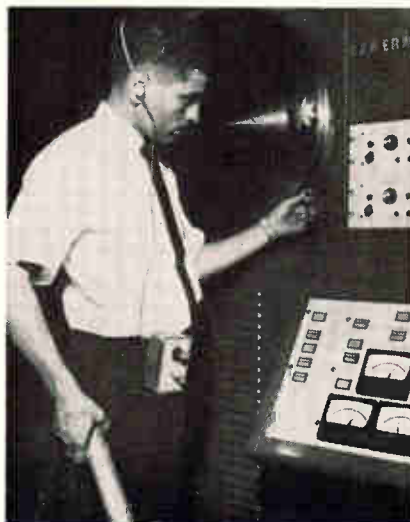

EDGERTON, GERMESHAUSEN & GRIER, INC.

**QUANTITATIVE
LIGHT
MEASUREMENT**



\$375

**WITH THE EG&G
LITE-MIKE**

Nanosecond response. Wide spectral and dynamic range. Meter measures average power. Permits scope display of wave shape, rise and fall time, duration, amplitude, and integrated light pulse energy in the visible and near infrared range (0.35 to 1.13 microns). All for \$375.

Provides light source evaluation in CW and pulsed lasers; flash photolysis; flash tubes and equipment; exploding bridge wires; material fluorescence; gallium arsenide signals. Also provides standard for light instrumentation.

Ten inches high; light in weight; built-in controls for sensitivity and ambient light balancing; swivel-mounted head aligns with source. Order direct from Products Division, 176 Brookline Avenue, Boston, Massachusetts 02215.



EDGERTON, GERMESHAUSEN & GRIER, INC.

new device operates by amplifying the difference between the pressure response of a probe gas sprayed over the leak and the characteristic pressure response of air. The difference is indicated to the leak detector operator by a change in audible tone transmitted through a set of earphones. Sensitivity is comparable with that of larger and more elaborate detectors. When used with the proper pressure gage under ultra-high vacuum conditions, leaks as small as 10^{-14} torr liters per sec may be detected. Sensitivity of the instrument is such that a change in pressure of one part in 100 can be immediately and unmistakably detected. Price of the unit is \$350.

General Electric Vacuum Products Operation, Schenectady, N.Y. [358]

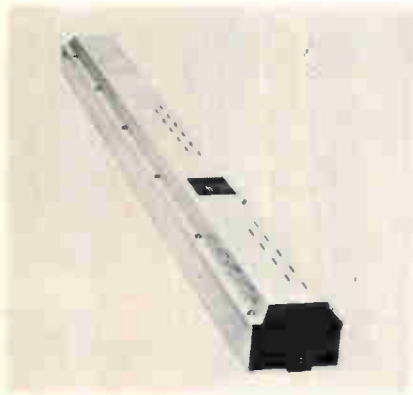

Helium-neon gas laser with extreme stability

An angular adjustment mechanism that is insensitive to mechanical vibration yet allows fine adjustment to achieve parallelism with resolution of less than 1 sec of arc is featured on the LG9 laser. D-c excitation of the helium-neon gas laser contributes to its extreme stability. The LG9 produces a 50-mw output multimode wavefront at 6,328 angstroms. Hemispherical and large radius operation is achieved with only three reflectors and a Brewster's angle discharge tube. Reflectors may be added or interchanged quickly and easily with little or no adjustment. The 20-lb laser measures 59.5 in. long with a 3.5 by 4-in. cross section. Price is \$8,150.

Raytheon Co., Laser Advanced Development Center, 130 Second Ave., Waltham, Mass. 02154. [359]

RMC

HIGH STABILITY, TYPE JE

DISCAPS

are Practically Immune to Severe Temperature Change

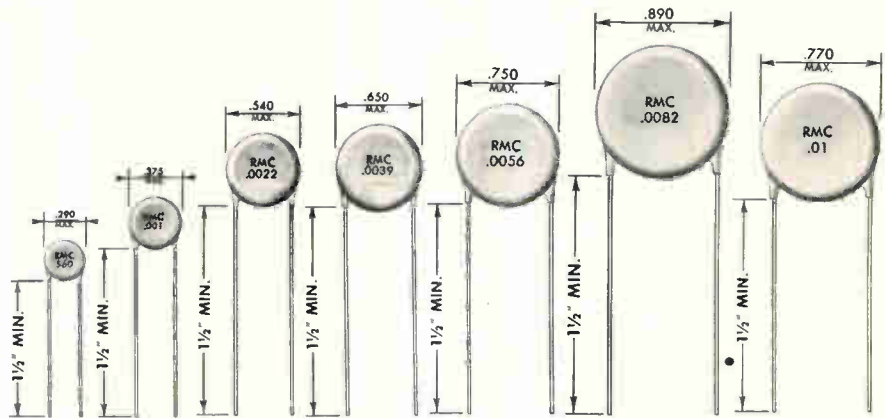

150	330	680	.0012	.0027	.0047	.0068	.01*
180	390	820	.0015	.0033	.0056	.0082	
220	470	.001	.0018	.0039			
270	560		.0022				

*Dual Disc construction—long leads only.
Disc sizes under 1/2" diameter have lead spacing of .250".
Disc 1/2" diameter and over have .375" spacing.

Specifications

CAPACITANCE: Within tolerance @ 1KC and 25°C.

CAPACITANCE TOLERANCES: +10%, +20% or +80 - 20%

WORKING VOLTAGE: 500 VDC

POWER FACTOR: 2.0% @ 1KC

INSULATION RESISTANCE: Greater than 7500 Megohms @ 500 VDC

TEMPERATURE COEFFICIENT: Z5E, Y5E

FLASH TEST: 1250 VDC for one second

LIFE TEST: Per EIA RS-198 Class II

POWER FACTOR AFTER HUMIDITY: 3.0% @ 1KC

INSULATION RESISTANCE AFTER HUMIDITY: Greater than 1000 Megohms @ 500 VDC

BODY INSULATION: Durez phenolic -- vacuum wax impregnated

LEAD STYLES AVAILABLE: Long lead - #22 tinned copper -, fin-lock, kinked lead plug-in and pin type plug-in

RMC Type JE Discaps exhibit only $\pm 4.7\%$ capacitance change over the extended -30° to $+85^\circ\text{C}$ temperature range. These capacitors are especially suited for use in mobile communication and like equipment. Typical usage in R-C response shaping networks and feedback loops, in addition to conventional applications, is indicated.

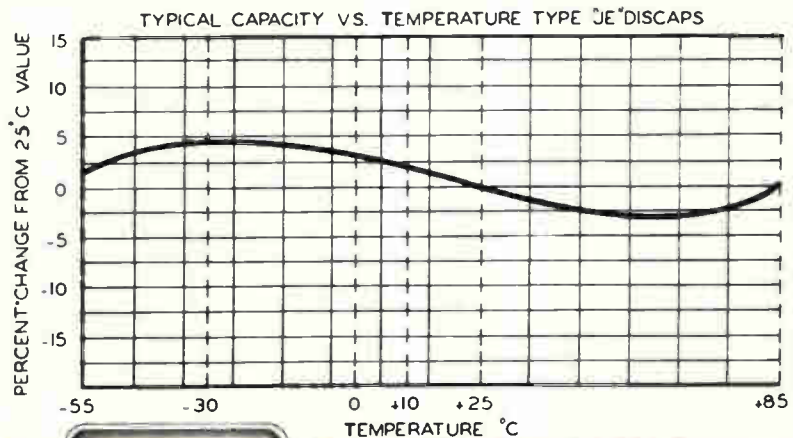

DISCAP CERAMIC CAPACITORS

RMC

RADIO MATERIALS COMPANY

A DIVISION OF P. R. MALLORY & CO., INC.

GENERAL OFFICE: 4242 W. Bryn Mawr Ave., Chicago 46, Ill.

Two RMC Plants Devoted Exclusively to Ceramic Capacitors

FACTORIES AT CHICAGO, ILL. AND ATTICA, IND.

KAY ELECTRIC COMPANY

Maple Avenue, Pine Brook, Morris County, New Jersey

Frequency Range: 100 cps to 2 mc.
Output: 1 volt rms into 50 or 70 ohms.
Flatness: ± 0.5 db.
Sweep Width: 400 cps to 2.0 mc in one range, or continuously variable in 3 bands with full range 10 kc or 2.0 mc.
Price: \$275.

NEW!
KAY
P-130E

100 cps to 2.0 mc Sweep Generator Head



**Plug-in
Sweep
Generator**

New Semiconductors

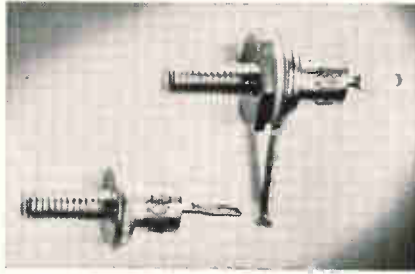

Silicon rectifiers are extremely rapid

A series of high-speed, diffused-junction silicon rectifiers have been introduced. They are said to have more than ten times the frequency capability of conventional rectifiers. Described as ideal for such uses as h-f power supplies, high-speed switching, and multiphase rectifier applications, the devices are registered as 1N3884-3893. They are rated from 50 to 400 v, 12 amps, and are available in the JEDEC DO-10 isolated top-hat stud package as well as the DO-4 standard top-hat stud. Electrical characteristics include very low recovery time (70 nsec typical, 200 nsec maximum), high current capability (15 amps d-c, 12 amps average to 100°C, derated linearly to zero at 150°C) and extremely high rectification efficiency to 150 kc. Prices range from \$11.25 to \$18 in the 100-999 quantity.

Texas Instruments Inc., 13500 North Central Expressway, Dallas, Texas. [331]

Solid-state reference has standard cell stability

Silicon voltage-reference diodes—1N3580 through 1N3584B—are available in the standard one-watt package. Nominal voltage is 11.7 when measured at 7.5 ma at 25°C. With stability comparable to that of a standard cell, they have even less variation with temperature and are virtually unaffected by environmental conditions, according to the manufacturer. These hermetically-welded, subminiature devices match the positive temperature co-

efficient of a precisely controlled Zener with the negative coefficient of three similarly controlled rectifiers in one tiny package to achieve extremely low variations in reference voltage over temperature changes as wide as -55 to $+150^\circ\text{C}$. All units in the series meet or exceed applicable military and/or commercial and industrial standards.

U.S. Semcor, 3540 W. Osborn Rd., Phoenix, Ariz. 85019. [332]

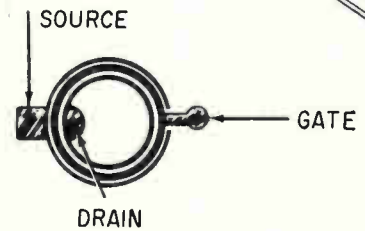
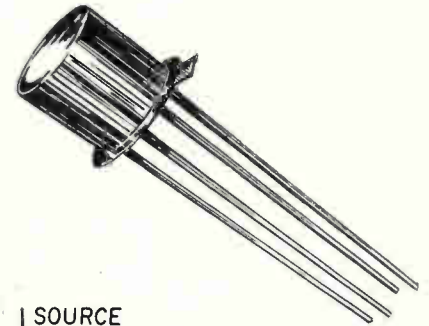

Low-noise FET with insulated gate

An insulated-gate field effect transistor, model K1001, has been announced. The MOS (metal-oxide-silicon) transistor is said to utilize an improved fabrication method. Typical noise figures of 4 db and power gains of 13 db are measured now at 200 Mc, whereas, according to the manufacturer, the best prior qualifications for a FET were only offered at 1 kc. Assembled into a TO-18 package, the K1001 has three leads, with a fourth planned for substrate connections. It was designed for vhf small-signal, low-noise amplifications. One of the benefits of tight parameter control is the very low variation in feedback capacitance. Electrical parameters of this MOS type of structure can be easily adjusted for many circuit configurations. The K1001 is an N-channel depletion

device that behaves like a vacuum tube when bias voltage is applied. Many vacuum tubes such as the cascode amplifier can be replaced with these field effect transistors, or used as amplifier-mixers by injecting the local oscillator into the gate, in the second half of the stage. With temperature stability now comparable to planar types, and linear transfer function characteristics in portions of its operating area, this new transistor type is said to open new vistas for solid-state receiver design, uhf tuners, choppers and low-frequency, low-noise circuitry.

Kmc Semiconductor Corp., Parker Road, R.D. 2, Long Valley, N.J. [333]

High-Q varactors feature ribbon leads

Low-cost, high-Q varactors are being marketed. The PV1400 series diodes offer minimum capacitance swing of 10 from zero to 120 v and series resistance values of less than 2 ohms in units with 7 pf capacitance at -6 v. Capacitance voltage sensitivity is approximately square-law up to breakdown voltage. The diode features gold-plated ribbon leads for low inductance and easy mounting in strip transmission line. Body dimensions are 0.070 in. by 0.150 in. maximum. Price is \$10 to \$30 depending on type and quantity.

Parametric Industries, Inc., 63 Swanton St., Winchester, Mass. 01890. [334]

Four-layer diode carries 300 amps

A new four-layer diode, the 4TP001, is useful in radar modulators and pulse generators where peak currents of 300 amps or more must be carried. Depending upon

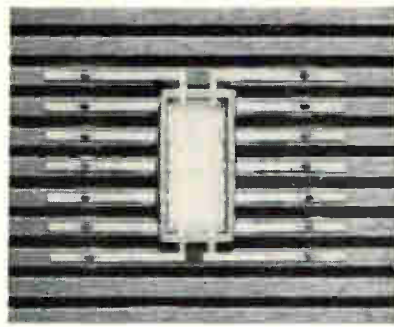

FLAT PACKS...

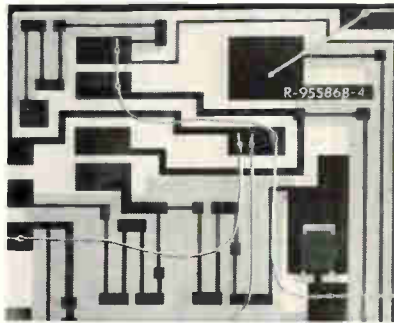

THIN FILMS...



THE NEW MICROWELDER MARK II WELDS BOTH!

Literally two welders for the price of one—the advanced Microwelder Mark II offers unprecedented microelectronic welding versatility. The Mark II welds large external flat pack leads to printed circuit boards, and fine wires onto thin films. It can perform such "exotic" tasks as welding .009" steel balls to the rim of a cone, or .001" thick foil to a .00003" film on mylar...as well as the more conventional welds. • A few of its features: automatic high speed weld cycle • single tip with .002" working end • dead weight system for uniform force from 10-1600 grams • ultra precise AC weld energy • all solid state power supply with plug-in boards. • Price: \$5250—F.O.B. Azusa, California. • Write for further information and/or a personal demonstration of the versatile Mark II by our electronic representative in your area: Commercial Products, Dept. E, P. O. Box H, Azusa, California



COMMERCIAL PRODUCTS, Azusa, California

**transmitter
oscillator
meets
every FAA
transponder
requirement**

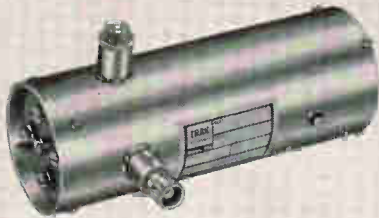

9506-1000

Trak Microwave Corporation has developed the first transponder-transmitter oscillator to meet every requirement of the Federal Aviation Authority (ARINC No. 532D). Most important, it is the first oscillator, commercially available to meet critical requirements of frequency stability and altitude.

As a triode oscillator, (Part No. 9506-1000) its advantages over other types include smaller size and operating economy. The replaceable triode means that the oscillator, at end of tube life can be brought back to optimum performance by replacement of the triode at nominal cost.

TYPICAL SPECIFICATIONS

Frequency: 1090 Mc. ± 10 Mc.
Power Output: 500 watt minimum
Power Input Requirements: 1500 VDC plate at 2.5 amp. peak plate current, -50 VDC grid bias with 80 V peak grid pulse, 6.0 VDC Efil at 1.25 amp. nominal.

Altitude: 55,000 ft.

TYPICAL FREQUENCY STABILITY CHARACTERISTICS ARE:

Efil vs. frequency ± 0.20 Mc. for 6.3 V. @ $\pm 3\%$ regulation

EB vs. frequency ± 0.25 Mc. for 1500 V @ $\pm 3\%$ regulation

VSWR vs. frequency ± 1.60 Mc. for 1.5: 1 all phase angles

Duty vs. frequency ± 0.15 Mc. for .001 to .002 duty (.01 duty max.)

Temp. vs. frequency ± 0.50 Mc. for -54 to +90°C

Total typical frequency stability characteristics are ± 2.70 Mc.

Physical: 2 in. diameter by 5 5/16 in. long, excluding projections. Weight 13 ounces in aluminum, 30 ounces in brass.

Trak manufacturing facilities are geared to produce these oscillators in quantity orders to meet production schedules and Trak engineers will meet with you either at TRAK or in your facility for demonstration and consultation. Arrange a conference now. Phone COLLECT Tampa 877-6735.



TRAK MICROWAVE CORPORATION

5006 N. Coaldge Ave. Tampa, Florida 33614

New Semiconductors

the circuit used, the diffused silicon device can switch voltages between 400 and 700 v in 0.1 to 0.4 μ sec. The diode is mounted in a hexagonal stud package, with the anode of the device connected to the stud. A new flat-top V-I characteristic makes it easy to string the devices in series while providing for current biasing rather than voltage biasing. The 4TP001 is priced at \$300 in quantities of 1 to 9; \$275 in lots of 10 to 24.

Clevite Semiconductor, 1801 Page Mill Rd., Palo Alto, Calif. [335]

Molded zener diodes in compact design

A series of compact, 2-w, molded zener diodes is announced. Designated LMZ-8.2A through LMZ-100A, they are suitable for almost any application where cost and space are paramount considerations. Contained in a non-conducting epoxy resin capable of withstanding most Mil-S-19500 environmental requirements, the new zeners have a full 2-watt rating in a package smaller than that which houses the conventional 400 mw glass diode. All units are taken, through temperature cycling from -55°C directly to 200°C before they are electrically tested. Voltages are available in 5% standard tolerance in single units for 8.2 through 100 v.

U.S. Semcor, 3540 Osborn Rd., Phoenix, Ariz. 85019. [336]



Silicon rectifiers for high-voltage use

An economy line of high-voltage silicon rectifiers has been announced. They are suitable for power transmitters and receivers, motor controls, speed regulation,

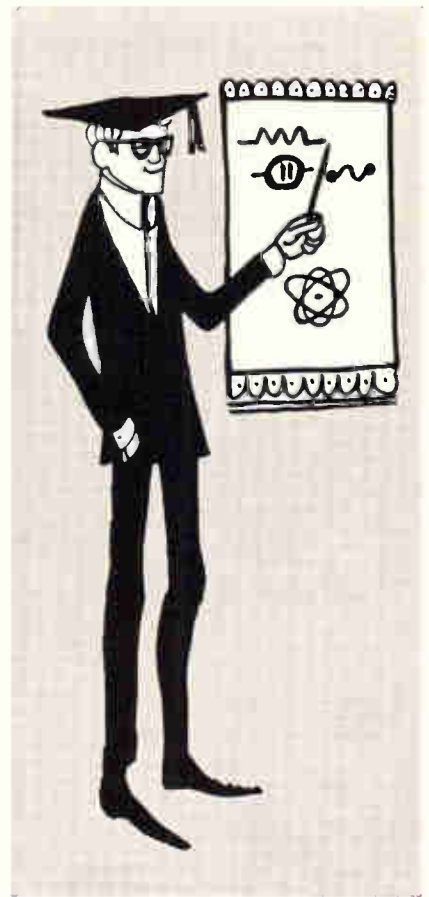

workability

(pre-production training)

WESTern PENNSylvania has a time-tested and proved-in-use plan by which employees—adaptable, productive people with a variety of industrial aptitudes—will be trained in advance for whatever skills are needed for YOUR particular operation at no cost to you. For details on this ability... and for complete information on financing plans for plant, machinery and equipment, and working capital... and WESTern PENNSylvania's favorable tax climate, mail coupon, wire or call collect.

WEST PENN POWER

an operating unit of ALLEGHENY POWER SYSTEM



INDUSTRIAL SHELL BUILDINGS available at \$2.95 to \$3.25 a sq. ft. completed to your specs in 60-90 days.

Area Development Department Phone: 412-TE 7-3000
WEST PENN POWER
Greensburg, Pa. 15602

Please send me information on: Pre-production Training
 Favorable Tax Climate Financing Plans Industrial Properties
ADA4-8E

Name _____

Title _____

Company _____

Address _____

City _____ State _____

Zip _____

Code _____ Phone _____

Circle 223 on reader service card
Electronics | October 5, 1964

replacement of high-voltage gas and vacuum rectifier tubes and other h-v power supply applications. The stud-mounted units come in two series: 800 to 1,200 piv, 1 amp at 100°C; and 800 to 1,200 piv, 3.5 amps at 100°C. The double diffused rectifiers are glass-to-metal hermetically sealed in a DO-4 package. Typical of the units is the EDD103, rated at 1,000 piv, 3.5 amps at 100°C case temperature. It is priced at \$1.80 in quantities of 1 to 99.

Electronic Devices, Inc., 21 Gray Oaks Ave., Yonkers, N.Y. 10710. [337]

Rectifier diodes offer high reliability

High-power silicon rectifier diodes are available. With proper cooling, type 400, Jedec series 1N3288 can provide forward currents up to 125 amps with maximum reverse voltage ratings up to 1,000 v peak. They were designed for high-current,



high-voltage industrial and military applications. The diodes are hermetically sealed, eliminating moisture penetration. The glazed ceramic body provides a long surface-creepage path, reducing the possibility of leakage and arc-over because of moisture and surface contamination. Hard-solder construction and welded cases provide high reliability under severe operating conditions. Type 400 has a maximum half-cycle surge current under load of 3,000 amps peak. The diodes are available with either forward or reverse polarity. In operation, the allowable temperature range for the junction is -65° to +200°C. Prices start at \$5.50 in quantities of 25 to 99.

Westinghouse Semiconductor Division, Youngwood, Pa. [338]

MAGSENSE®

METER MONITOR

Now in lower-cost board form for mounting into your equipment



Model 70—\$60. Single Set Point



Model 77—\$99. Dual Set Point

The only solid-state comparators with

- 100 ms response
- 1 μ a sensitivity
- 100 billion power gain
- "no contact" reliability

Here in lower-cost circuit board form are the same basic MAGSENSE units that have proved themselves in the extremes of polar cold, desert heat and space. The magnetic sensing devices detect and compare electrical currents less than 1 μ a—thereby accepting the output of thermocouples and strain gages directly *without amplifiers*.

Both the Model 70 with single set point and Model 77 with dual set points for detecting high and low limits are normally supplied with non-latching outputs for DC inputs with ranges of 100 μ a, 1 ma, 10 ma, or 100 ma. The Model 70 can also be supplied with latching or pulse outputs.

BRIEF SPECIFICATIONS

Response Time: 100 ms max., 50 ms typical.

Power Required: 10 to 14 VDC at approx. 30 ma (70) and 50 ma (77) exclusive of load current.

Output Load: Up to 50 ma for Model 70, up to 100 ma for Model 77. 500 ma optional.

Size: 3" x 3.35" x 1.25".

Weight: Approx. 4 ounces.

Mounting: Chassis mounted or connector mounted. Holes for rear terminal mounting on meters.

Electrical Connections: Terminal wiring and plug-in edge connector similar to Elco 6007-18.

Price and Delivery: Model 70—\$60. Model 77—\$99. From stock.

CONTACT THESE DISTRIBUTORS FOR COMPLETE INFORMATION OR DELIVERY FROM STOCK . . .

WEST	ELECTRONIC ENTERPRISES 1900 Washington St., N. E. Albuquerque, N. M. (505) 256-1585	No. Illinois, N.W. Indiana and Central Wisconsin A & M INSTRUMENT* 4801 North Ridgeway Chicago, Illinois (312) 539-4460	2651 East Main St. Columbus, O. (614) 237-8615	Maryland, No. Virginia THOMAS H. CLOSS 21 W. Pennsylvania Ave. Towson, Md. (201) 825-4455
So. California & Arizona	Miss. Arkansas, Louisiana & Texas (Except Six West Co.)	Minnesota, Dakotas, N. W. Wisconsin	SREPCO DIVISION* 314 Leo St. Dayton, O. (513) 224-0871	SOUTH
PERLMUTH ELECTRONICS* 5057 W. Washington Blvd. Los Angeles, Calif. (213) 931-1041	BUTLER & LAND 5538 Dyer Street Dallas, Texas (214) 361-6631	PINKNEY & ASSOCIATES 1925 Nicollet Ave. Minneapolis, Minn. (612) 338-0523	Six New England States	North & South Carolina
8068 Engineer Road San Diego, Calif. (714) 278-6230	1845 Line Avenue Shreveport, La. (318) 422-0697	INSTRUMENTATION SERVICES, INC.* 917 Plymouth Avenue Minneapolis 11, Minn. (612) 521-6267	ALVIN S. MANCIB COMPANY* 365 Walden St. Cambridge, Mass. (617) 864-2494	SYSTEMS SERVICE CORPORATION P. O. Box 17525 3748 Monroe Ave. Charlotte 7, N. C. (704) 377-3407
2859 E. Thomas Rd. Phoenix, Ariz. (602) 264-4934	1034 Constance Street New Orleans, La. (504) 524-0688	Michigan & Indiana (Except Counties Lake, La Porte & Porter)	Randolph & Coe Roads P. O. Box 467 Middletown, Conn. (203) 347-5629	Georgia
No. California & Nevada	Oklahoma	THE SATULLO COMPANY* 4514 North Woodward Royal Oak, Mich. (313) 566-2375	Metropolitan New York, Long Island, & N. New Jersey	ELECTRO-TECH, INCORPORATED* 690 Murphy Ave. S.W. P. O. Box 10857 Atlanta, Ga. (404) 753-4128
HELD & MOLLARD, INC.* 1125 Marshall Street Redwood City, Calif. (415) 365-1700	RIDDLE & HUBBELL 302 S. Cheyenne Tulsa, Okla. (918) 585-5624	618 Cincinnati-Batavia Rd. Cincinnati, O. (513) 752-6683	A & M INSTRUMENT COMPANY* 48-01 31st Ave. Long Island City, N. Y. (212) 726-4343	3107 Cullman Ave. Charlotte, N. C. (704) 333-0326
Washington, Oregon & No. Idaho	MIOWEST	Eastern Wisconsin	E. Pennsylvania, Delaware & Southern New Jersey	307 27th Street Orlando, Florida (305) 423-5589
EICHER & COMPANY 5 W. Harrison Seattle, Wash. (206) 284-1811	Neb., Iowa, Kansas, Missouri & So. Illinois	TAYLOR ELECTRIC* 4080 Northport- Washington Rd. Milwaukee, Wis. (414) 964-4321	ROBERT K. NYE ASSOCIATES P. O. Box 611 Berwyn, Pa. (215) 644-8479	Florida (Except Counties west of Gadsden, Liberty, Franklin)
Colorado, Utah, Wyoming, Montana and So. Idaho	IMPALA, INC. 7540 Lowell Street Overland Park, Kansas (913) 648-6901	OHIO, East Kentucky, W. Pa. and W. Virginia	ELECTRIC METER SERVICE* 5013 Vine St. Philadelphia 7, Pa. (215) 424-3422	THE JAMES SPAOER CO. 512 North 18th St. Birmingham, Ala. (205) 252-7419
PETERSON COMPANY 4949 Colorado Denver, Colo. (303) 333-5434	247 South Pinecrest Wichita, Kans. (316) 682-3593	PIONEER STANOARD ELECTRONICS* 5403 Prospect Cleveland, O. (216) 432-0010		THE D. E. GRANT COMPANY 2513 Catalina Dr. Orlando, Fla. (305) 424-4057
521 W. 4th North Salt Lake City, Utah (801) 355-7464	1011 Clifton, N. E. Cedar Rapids, Ia. (319) 362-2125			*Stocking Representative
New Mexico, Six W. Texas Counties	7049 Laupher Hazelwood, Mo. 63042 (314) 522-1600			

CONTROL DATA CORPORATION

CONTROL SYSTEMS DIVISION
4455 MIRAMAR ROAD, LA JOLLA, CALIFORNIA



POTENTIOMETERS · POTENZIOMETRI · POTENTIOMETER
 POTENTIOMETRES · POTENCIOMETROS

- CHOOSE FROM HUNDREDS OF FACTORY MODELS
- CUSTOM MADE TO YOUR SPECIFICATIONS
- WORLD RENOWNED RELIABILITY

OTHER LESA PRODUCTS:

- automatic record changers
- manual record players a.c. & d.c.
- portable phonographs
- tape recorders
- fractional power motors

LESA COSTRUZIONI ELETTROMECCANICHE S. p. A. — VIA BERGAMO, 21 — MILANO — ITALY
 LESA OF AMERICA CORPORATION — 32-17 61st St., Woodside 77, New York. (212) YE 2-9330
 LESA DEUTSCHLAND GMBH — Wiesentalstrasse 1 — Freiburg i Br. — Deutschland

Circle 204 on reader service card

Specify "WELLS" for Precision Molded Parts...

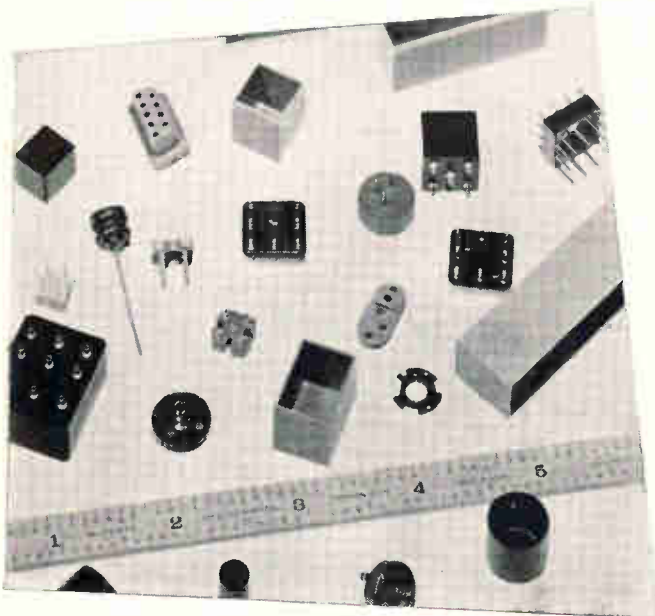

Wells is a specialist in molding intricate, miniature parts out of thermo-set plastic compounds—the tougher the job the better! Complete compression and transfer molding facilities. Short runs or long runs. Sample cavities at nominal cost. Top quality guaranteed.

WELLS ELECTRONICS COMPANY
 1701 S. MAIN STREET, SOUTH BEND 23, IND.

138 Circle 138 on reader service card

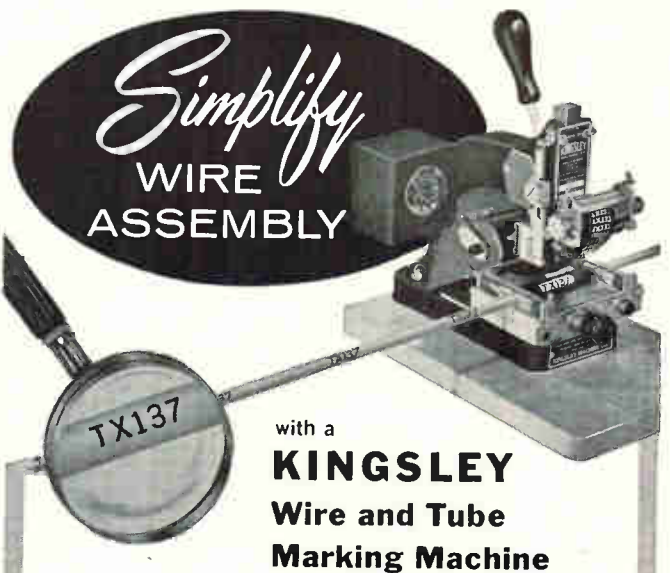

with a
KINGSLEY
 Wire and Tube
 Marking Machine

Now you can mark each wire or piece of plastic tubing with its own individual circuit number.. quickly.. economically — right in your own plant!

Cut costs and speed production with the same machine that has proved so successful in the aircraft/missile field.

Write for details.

KINGSLEY MACHINES
 850 Cahuenga • Hollywood 38, Calif.

Circle 205 on reader service card

New Subassemblies and Systems

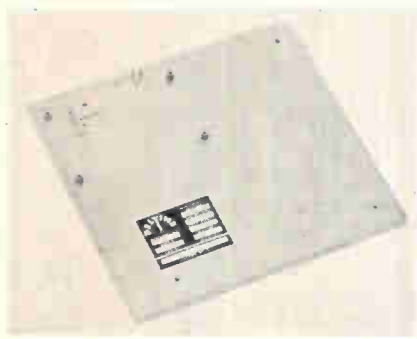

Delay line in compact case

New sonic wire packaging techniques have led to the development of the model 214A, a case model permitting up to 10 millisecon of delay time and 10,000 bits of data storage capacity. The unit has been designed for magnetostrictive delay line applications requiring relatively long delays in smaller volumes than existing models without compromising performance or reliability. Model 214A is compatible with all of the company's standard circuit modules.

Deltime Inc., 225 Hoyt St., Mamaroneck, N.Y. [371]



Solid-state preamps cover 2 to 1,000 Mc

Solid-state preamplifiers covering 2 to 1,000 Mc are available in a completely self-contained laboratory or weather-proof enclosure with an integral power supply. The series provides octave coverage in the vhf and uhf ranges with guaranteed noise figures of 4 db in the 100 to 400-Mc region and 6 to 8 db in the 500 to 1,000-Mc range. A wide variety of commercial and militarized preamplifiers permit

considerable design flexibility. Special versions are available to meet unique requirements. The laboratory enclosure for these units includes a front panel switch and pilot light, and a fused power supply that operates from 105 to 125 v a-c. The weatherproof enclosure is suitable for remote mast mounting in tropical or marine environments and includes an integral power supply that operates from 105 to 125 v a-c, 50 to 400 cycles. Applied Technology Inc., 3410 Hillview Ave., Stanford Industrial Park, Palo Alto, Calif. [372]

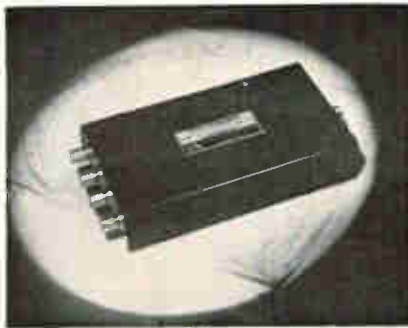

Signal distributors are all-solid-state

Two models of a 2 to 32-Mc antenna multicoupler unit embody a new concept in passive h-f signal distribution. Signal distributor model SD-4 has four outputs; model SD-8 has eight. The compact, all-solid-state units are intended for use where a number of receivers with their input circuits tuned to different frequencies are to be fed from one antenna. Insertion loss is less than 1 db. When receivers are tuned to different frequencies, the SD unit delivers to each receiver almost the same signal as if it alone were connected to the antenna. Thus, performance is comparable to that of active multicouplers but with vastly decreased intermodulation distortion. With input signals of up to 10 v, intermodulation distortion is negligible. In operation, an SD unit effectively puts the receiver input circuits in series. As a result, antenna signal power at each frequency is developed across the

PROCEDYNE PRECISION PHASE METER

*with Outstanding
Specifications*

Model PM-200

- Frequency Range 10 cps. to 500 kcps.
- Direct plus automatic readout 0-360°
- Wide scales for good resolution over full range of phase angles
- Minimum controls, rapid accurate phase measurement
- Hybrid circuitry for maximum performance



The Procedyne Model PM-200 is a direct reading precision phase angle meter designed for the dynamic analysis of physical systems. This unit measures the phase angle difference between two periodic voltage signals of equal frequency over a frequency range of 20 cps. to 500,000 cps. This unit is a low cost general purpose meter with excellent performance characteristics. It is a highly reliable, extremely precise, convenient tool for phase angle measurement. Write for product catalogue of phase meters, frequency response analyzers and calibration equipment.

PROCEDYNE
ASSOCIATES INC.

221 SOMERSET STREET
NEW BRUNSWICK, NEW JERSEY
201-CH 9-8347

SEE US AT '64 ISA SHOW, OCTOBER 12-16
NEW YORK COLISEUM, BOOTH NO. 1328

CEI's New LF Receiver Is on Top



...and its VLF twin is just below

CEI's new LF-VLF twins provide highly sensitive AM and CW reception over the entire 3-300 kc frequency range. The Model 301A (that's the one on the bottom) covers 3-30 kc while the 302 covers 30-300 kc. Each has a band switch to select among three bands within the frequency range.

On AM, they offer a choice between manual or AGC with fast or slow response. Both the 301A and 302 have internal BFO's, which are activated in the CW mode, and each receiver

has an image rejection of 70 db minimum with equally excellent sensitivity.

Solid state components reduce heat and cut power requirements for each receiver to only 2½ watts. Compact construction means they can be stacked, as shown, in only 7" of rack space.

For complete details on these and other CEI products, please write:



COMMUNICATION ELECTRONICS INCORPORATED

6006 Executive Boulevard, Rockville, Maryland 20852, Phone (301) 933-2800

Circle 206 on reader service card

New Subassemblies

input of the receiver tuned to that frequency. Short cable runs are required between the signal distributor and the receivers. The passive units are especially valuable in strong-signal environments where they greatly increase the dynamic range of a receiving system over that obtained with active distribution units.

Anzac Electronics, Inc., Moody's Lane, Norwalk, Conn. [373]

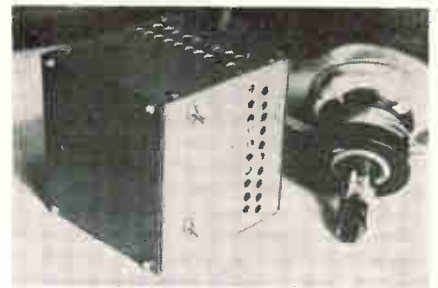

Video amplifier for crt drive

Type IT-284 provides 20 Mc video for high-resolution tv, computer displays and the like. An input of 0.25 v peak-to-peak provides 50 v peak-to-peak output for crt grid or cathode drive. Single-ended or balanced input with excellent common mode rejection is provided. This all-solid-state design uses Mil-Spec transistors, and will operate at 60° C ambient. Furnished without power supply, the amplifier dissipates less than 12 w. Single unit price is \$400.

ITI Electronics, Inc., 369 Lexington Ave., Clifton, N.J. [374]

Shaft angle encoding system

A newly developed encoding system can measure and digitally encode angles with accuracies as high as one part in one million. The system consists of a precision dual-speed magnetic transducer (DSMT) and a display counter, and meets the most exacting requirements for a variety of applications ranging from large antenna installations to small components in space ve-

America's largest designer and manufacturer of crystal and component ovens

NOW OFFERS A COMPLETE LINE OF

PACKAGED OSCILLATORS

OVENAIRE has developed a complete line of standard oscillators covering the frequency range from 10 KC to 100 MC with stabilities up to .0001%/DAY.



OSC-11



OSC-10

OSC-11
1 MEGACYCLE
Short Term Stability
 $\pm 5 \times 10^{-9}/10$ sec. interval
Long Term Stability
 $5 \times 10^{-8}/\text{DAY}$

OSC-10
1 MEGACYCLE
Short Term Stability
 $\pm 5 \times 10^{-10}/10$ sec. interval
Long Term Stability
 $\pm 3 \times 10^{-9}/\text{DAY}$

ILLUSTRATED ABOVE ARE 2 VERSIONS OF A 1 MEGACYCLE OSCILLATOR WHICH ARE PART OF OUR STANDARD LINE.

ovenaire Inc.

706 FORREST STREET CHARLOTTESVILLE, VA.

AMERICA'S LARGEST DESIGNER/MANUFACTURER OF CRYSTAL AND COMPONENT OVENS

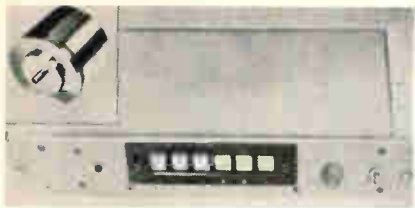

hicles. The DSMT transduces shaft angles into analog a-c signals; the simple solid-state electronics of the system converts the angles into the phase time domain where clock pulses are counted to give a digital measurement of the angle. The system features zero velocity error. Interrogation is possible at any instant. It is completely gearless, making the problem of backlash, wear, and alignment non-existent. Eclipse-Pioneer Division, The Bendix Corp., Teterboro, N.J. [375]

Semiconductor laser delivers up to 1/2 w

This compact c-w semiconductor laser weighs only 45 lb and has its own closed-cycle cooling system. The RSL4 delivers an output of up to 1/2 w of continuous power at a wavelength of 8400 angstroms in the infrared region. Electrical efficiency is 30%. Operating temperature of 30° K is achieved with a closed-cycle Norelco cooler driven by a 1/2 h-p electric motor. Ordinary tap water is employed in the heat exchanger for the cooler. The gallium arsenide laser can be used as an infrared illuminator, for communications, or for other applications requiring continuous

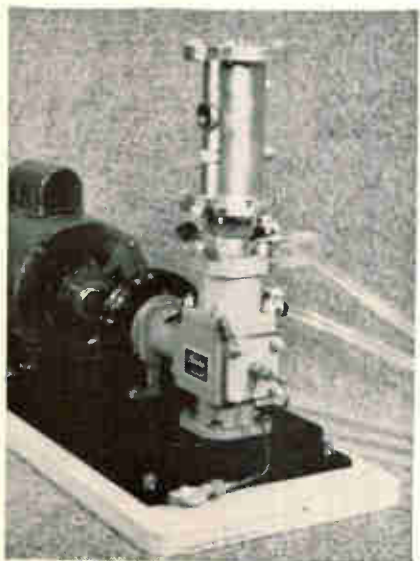

WHAT'S THE LATEST IN DISC CATHODES? ASK SUPERIOR.



Standard ED 1-2. (.121" OD shank, .490" ceramic). Most widely used cathode. Standard length, .312".

Narrow neck ED 1-5. (.121" OD shank, .365" ceramic). For 110° deflection tubes. Standard length, .312".

Miniature ED 1-33. (.100" OD shank, .365" ceramic). For 110° deflection tubes. Standard length, .280".



Miniature ED 1-11. (.090" OD shank, .365" ceramic). Save up to 50% heater power. Standard length, .280".

Shielded EX 271. Permits better temperature uniformity and control of grid-cathode spacing.

Shielded EX 270. Permits operation with small power consumption and hence low heat generation.

Widest choice of disc cathode designs

There are three basic types of Superior disc cathodes. Each has its own advantages. All feature close control of the E-dimension (distance between top of cap and top of ceramic), flare at the shank opening to facilitate assembly, shadow groove in the ceramic to inhibit electrical leakage and are available in wide choice of both cap and shank materials. Available in 0.121", 0.100" and 0.090" outside diameter shanks. Ceramic diameters can be either 0.490" or 0.365", with either round or triangular center hole.

New shielded disc cathodes—EX 271 and EX 270

In the EX 271 design, the emitter is shielded from the ceramic and isolated by an exceptionally long heat-conducting path. In the EX 270 design, the slender shank, thermal shield and thin ceramic permit low heater power consumption. The shield also acts to eliminate leakage if sublimation takes place.

Widest choice of disc cathode materials

Superior's disc cathodes feature separate nickel cap and shank alloys. Hence you may choose the most suitable material for each. The Cathaloy® series, developed and controlled by Superior Tube Co., offers alloys with high strength, high activity, low sublimation, freedom from interface impedance, or any desired combination.

Cathaloy A-31. Approximately twice as strong as tungsten-free alloys at high temperatures.

Cathaloy A-33. Combines the high emission of active alloys with freedom from sublimation and interface impedance.

Cathaloy P-51. More than 100% stronger than X-3014 at high temperatures.

X-3014. Powder metallurgy pure nickel for resistance to sublimation. Suggested for shanks.

X-3015. Special shank alloy for strength with resistance to sublimation and for non-emitting characteristics.

Nickel 220, Nickel 225, Nickel 230 and Nickel 233. Suggested for caps requiring normal emission with rapid activation.

Driver Harris 599 and 799. Provide rapid activation plus high level d-c emission. For caps only.

For your copy of our Catalog 51, write Superior Tube Company, 2500 Germantown Ave., Norristown, Pa.

Superior Tube

The big name in small tubing

NORRISTOWN, PA. 19404

West Coast: Pacific Tube Company, Los Angeles, California

Johnson & Hoffman Mfg. Corp., Carle Place, N.Y.—an affiliated company making precision metal stampings and deep-drawn parts

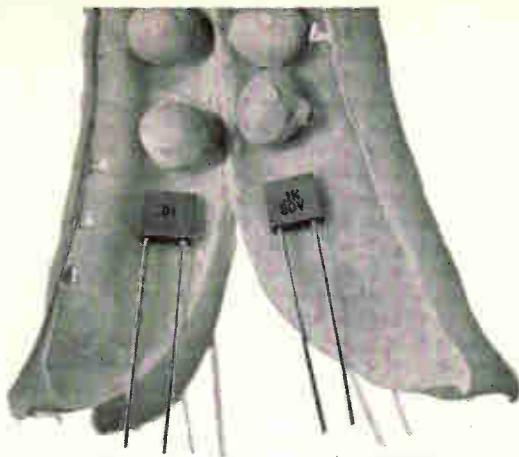

CK06
Values to 10,000 pf

VK 30BX
Values to 100,000 pf
BX Characteristic

LOOK ALIKES... with a dramatic difference!

Our VK 30BX units look like the familiar CK06 capacitor — but inside there's a dramatic difference! The new units have 10 times the capacitance. Their exclusive monolithic construction gives them extraordinary reliability over a capacitance range of 12,000 pf to 100,000 pf. Tolerances: 10% and 20%; IR: greater than 5,000 megohms at 25°C; Voltage Rating: 50 vdc; Operating Temperature: -55°C to 125°C. Meets or exceeds environmental tests in MIL-C-11015. Ask for Data Sheet C 10.

© Vitramon, Inc., 1964

Vitramon
INCORPORATED
Box 544 Bridgeport, Connecticut 06601

In United Kingdom contact:
Vitramon Laboratories Limited
Marlow Road
Bourne End, Bucks
England

Circle 207 on reader service card

**TWO
NEW
MAGNELINE®
INDICATORS
FROM PATWIN**

Subminiature (7/32" character) Series 12000 and large (9/16" character) Series 16000 indicators now broaden both ends of Patwin's line. Both of the new series feature the famous Magneline principle for reliability and long life. Like to know more?

*Write, or phone 203-756-3636
for free literature*



SERIES 12000



SERIES 16000

PATWIN® ELECTRONICS
A DIVISION OF THE PATENT BUTTON COMPANY
WATERBURY, CONNECTICUT • 06720

New Subassemblies

laser output. Even more compact custom units are available for airborne applications. Price of the standard RSL4 is \$7,725.

Raytheon Co., Laser Advanced Development Center, 130 Second Ave., Waltham, Mass. 02154. [376]

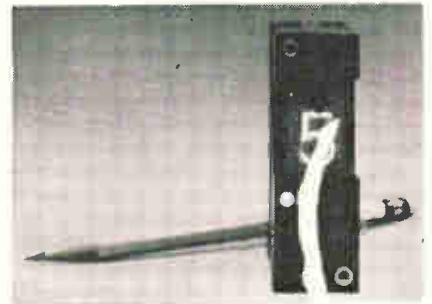

**Numerical display
offered in two models**

The Transindicator numerical display is a completely packaged readout with a wide temperature range and bright display. It is available in two models. The ND-100 is designed especially for use as a dependable building block module in timing, industrial control and computer systems, as well as all other applications where an exceptionally clear display and wide angle of vision are desired. The ND-200 incorporates a latching storage feature enabling sampling, storing, and statically displaying BCD data presented to its input during a dynamic high-speed operation. Transiron Electronic Corp., Wakefield, Mass. [377]

**Compact EL readout
and translator**

A four-digit, multi-numeric electro-luminescent readout and translator has been developed. Originally constructed as the display portion of a portable laser range finder for use with infantry and field artillery, the SD-176 readout translator is 4 in. long, 2 in. high and 1/2 in. wide. This packaging technique, however, can be applied to any military or commercial need that requires extreme ruggedness of design, low

power and high reliability, coupled with compactness. The electroluminescent readout translator consists of six separate functional units: EL lamp (readout), two transfer panels, printed-circuit plate, switching matrix and connection panel. The unit provides for four, nine-segment numerical digits with integral translation from binary coded decimal (1-2-4-8) for each digit, the symbols O and X indicating system operating information, and the word meters illuminated signifying units of measure. The SD-176 was designed for operation at 200 v rms sine wave and 1,600 cps to minimize size of the power supply. When all four digits are illuminated, total current required is less than 3 ma. The readout produces a light output of 15 foot-lamberts which can be reduced for nighttime applications.

Sylvania Electric Products Inc., 730 Third Ave., New York, N.Y. [378]



Miniature filters cover 3 kc to 1 Mc

A wide range of miniature filters is available featuring low loss, small size, and light weight. Three low-pass series, designated type ML, and three high-pass series, designated type MH, provide 40 db, 50 db, and 60 db minimum stop band attenuation at cutoff ratios of 1.3 F_c , 1.6 F_c , and 1.9 F_c respectively. Minimum-pass band ripple is 0.25 db and insertion loss is 1 db maximum. Impedance levels are 500 ohms to 10,000 ohms, while frequency range is 3 kc to 1 Mc. Their light weight is due to the use of foam impregnation in a molded epoxy case. Size of the standard filters is 1 in. by 0.75 in. by 0.62 in.

ESC Electronics Corp., 534 Bergen Blvd., Palisades Park, N.J. [379]

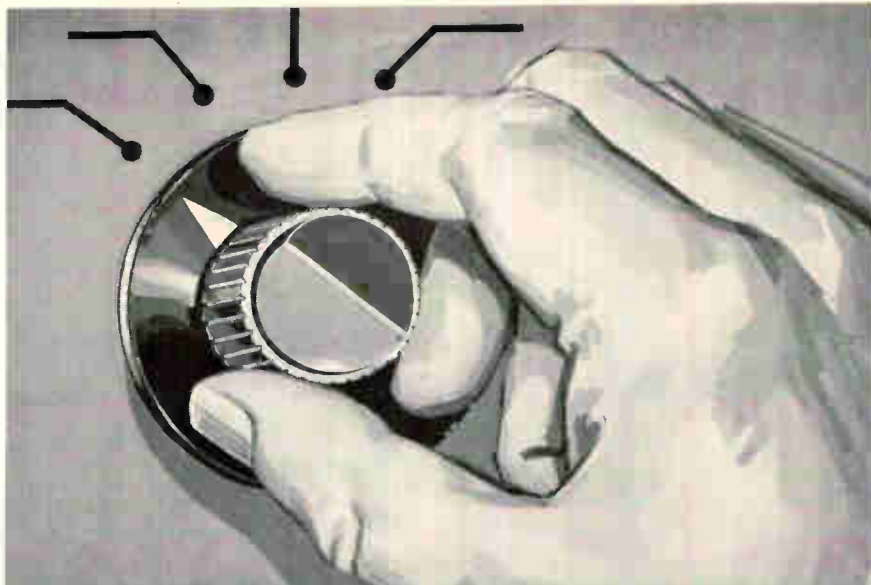

ON YOUR COMMAND

Hyperion

FOR FAST, RELIABLE, CONVENIENT, DATA RETRIEVAL

Precision Time Indexing and Automatic
Search Equipment for Rapid Data
Acquisition and Processing Systems

The Model HI-215 Universal Tape Search Unit is truly a Universal Time Display Decode and Search Unit that accepts any range time code format . . . Searches at uncontrolled speeds with millisecond resolution . . . Automatically controls any instrumentation tape transport . . . Compensates for input signal variations of better than 40 db. . . Employs only passive code plugs for reliability and is extremely economical to expand to other code formats.

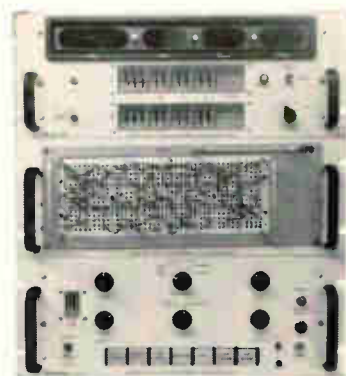

Model HI-215 ABC
Universal Tape Search Unit



Model HI-138



Model
HI-188

Hyperion furnishes precision time indexing equipment for generating time code formats suitable for recording on magnetic tape, oscillographs, data recording cameras and strip chart recorders for both ground and airborne environments.

Hyperion

 INDUSTRIES, INC.

• DIGITAL PRODUCTS DIVISION

134 COOLIDGE AVENUE, WATERTOWN, MASSACHUSETTS, 02172
TWXN: WTWN MASS - 860 TEL. WA 6-0140

NON-STOP COOLING



McLEAN PACKAGED BLOWERS

GO STEADY FOR
**THOUSANDS
OF HOURS**

THAT'S TOTAL RELIABILITY!

**RFI SHIELDED
MIL-SPEC
COMMERCIAL**

McLean's new "Computer Age" line of blowers offers striking good looks that won't wear off, won't wear out and won't need replacement. That's the ultimate in packaged cooling.



SEND TODAY
FOR
1964 CATALOG

**McLEAN ENGINEERING
LABORATORIES**
P.O. Box 228, Princeton, New Jersey
Phone 609-799-0100 • TWX 609-799-0245
The Originator and Leader in Packaged Cooling

New Microwave

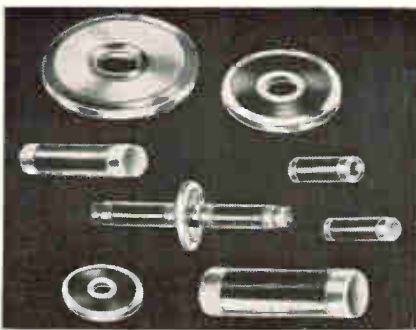

Microwave resistors in thin-film design

Carbon thin-film resistors have been designed for use in microwave attenuators, precision coaxial terminations, dummy loads, coupling loops, and many other special applications. They offer excellent high-frequency characteristics and stability plus superior performance under pulse applications. Pyrolytically deposited films on selected substrates are completely protected with special high-temperature epoxy resins. Extremely thin films and lack of spiralling result in minimum inductances. They provide tight tolerances ($\pm 1\%$ standard), high reliability and economy in standard or special rod and disk types. Rod and disk resistors are available singly or in sets to assemble attenuator pads from 1 to 30 db. Also available are rods and disks for 50, 75 or 100-ohm terminations. Frequency range is d-c to 10 Gc; resistance range, 0.001 ohm to 1,500 ohms; temperature range, -55°C to $+150^{\circ}\text{C}$, and humidity range, 0 to 100% rh.

Film Components Division, Ring Industries, Inc., 80 Kings Road, Madison, N.J. [391]

Reflex klystron with fixed frequency

A new, fixed-frequency, reflex-klystron amplifier will deliver at least 15 mw at 16.5 Gc with excellent frequency stability under severe environmental conditions. The VA-276A is especially designed for use in airborne radars. Each tube can

be trimmed easily ± 100 Mc by adjusting the trimming screw with an Allen wrench. Conduction cooling through the output flange is usually adequate without auxiliary cooling. Other advantages include very small frequency deviation under shock and vibration, low operating voltages, and high-altitude operation without pressurization. Beam voltage is 300 v d-c; beam current at 300 v, 30 ma d-c; dimensions, $1\frac{5}{16}$ by $1\frac{1}{8}$ by $2\frac{1}{4}$ in.; maximum weight, 5 oz.

Varian Associates, 611 Hansen Way, Palo Alto, Calif. [392]

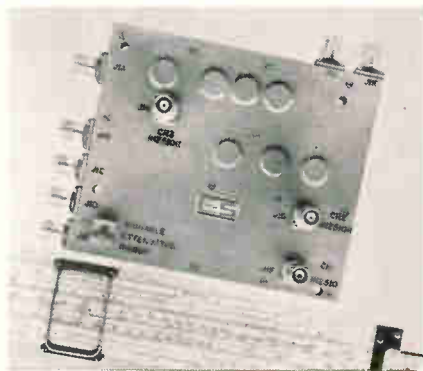

Stripline saves space and weight

An air-dielectric strip transmission line with integrated components permits savings in space and weight. The microwave subsystem, called Air-Line, includes attenuators, duplexers, mixers, couplers, ferrite devices, detectors, and stub tuners. Initial studies indicate that a complete system for 50-kw X-band weather radar microwave transmission can be produced in a module 3 by 3 by $\frac{1}{2}$ in., occupying about 85% less space than the waveguide equivalent. The manufacturer is currently achieving bandwidths from d-c to K band, and is working on multi-octave operation. Present designs handle 4 kv peak power at Ku band, with insertion loss of less than 0.7 db per foot. Applications for Air-Line include duplexers, radar front ends, mixers, test sets, and plug-in microwave modules.

Electronic Specialty Co., 5121 San Fernando Rd., Los Angeles 90039. [393]

Ferrite circulators cover 3.7 to 4.2 Gc

New ferrite Y circulators have typical characteristics of 25 db isolation and 0.2 db insertion loss over a 10% frequency band. They are temperature compensated to maintain their characteristics over wide temperature ranges. Circulators find application as duplexers, as inputs to parametric amplifiers and as compact isolators when one port is terminated. By substituting an electromagnet for the permanent magnet, the circulator becomes an extremely useful high-speed switch. This is particularly valuable in communication links to switch in standby equipment without loss of information. Model 813 measures 5 in. by 4¾ in. by 2 in. Frequency is 3.7 to 4.2 Gc; isolation, 25 db minimum; insertion loss, 0.2 db max; vswr, 1.08 max; power capability, 3 kw peak, 30 w average. Portchester Instrument Corp., 114 Wilkins Ave., Port Chester, N.Y. [394]

Coax termination dissipates 5 kw peak

This compact, high-power coaxial termination operates from 1 to 2 Gc. Model 9800F has a peak power rating of 5 kw. Average power rating is 300 w. Maximum vswr over the entire frequency range is 1.2. The water-cooled unit has a body length of 5¾ in. Over-all length, including the type N female connector, is 6½ in. Body diameter is 1½ in. Weight, with water connectors, is only 26 oz. The unit meets

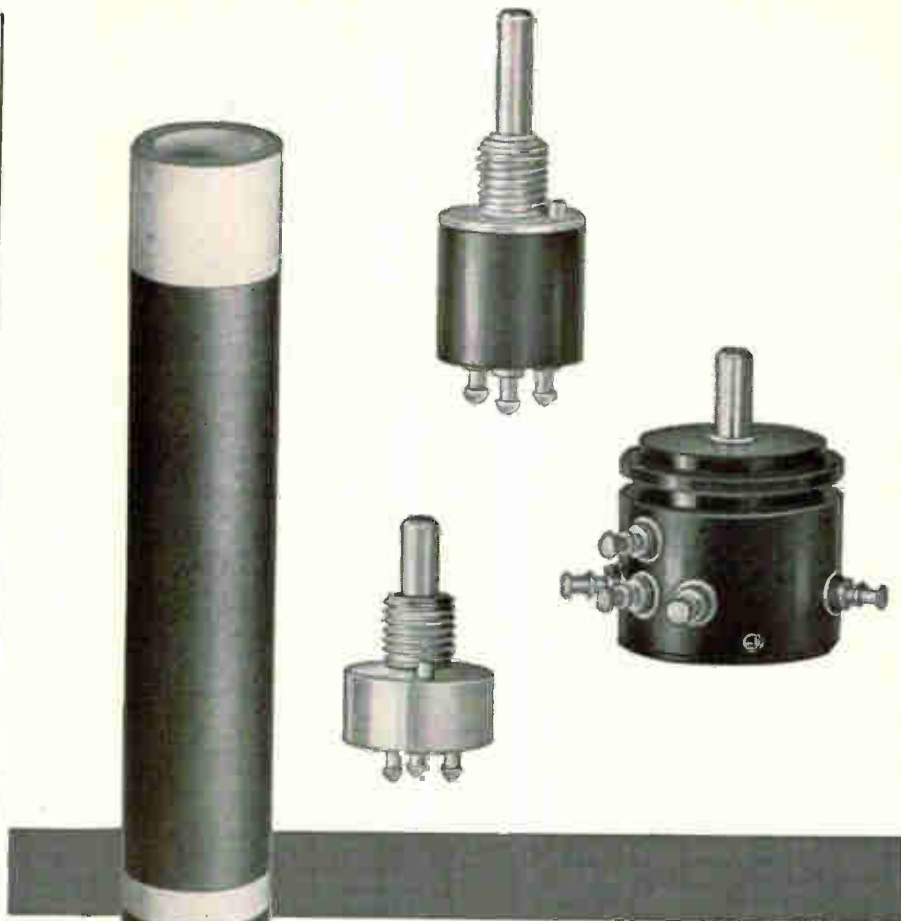
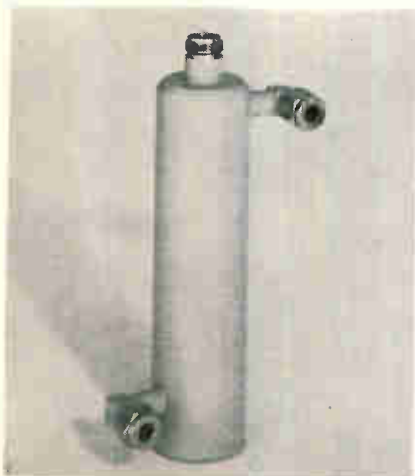

MystR™

RESISTANCE ELEMENT

Did you know that the potentiometers and fixed resistor illustrated use MystR as the resistance element?

MystR (mist-r) is a totally new and versatile thin-film resistance material—features: ■ high stability ■ infinite resolution ■ low contact resistance ■ is non-inductive at high frequencies ■ low contact noise ■ and long life. This flexible thin-film resistance material is resistant to high temperature, shock, and vibration, and has effective heat dissipation.

Can these resistance devices fit into your design? Why not check their individual specifications. MystR may simplify the solution of your problem.

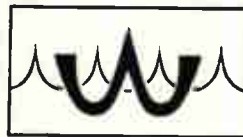

Specifications available on request.

WATERS
MANUFACTURING INC.
WAYLAND, MASSACHUSETTS

**Manufacturing
Quality Resistors
under Rigid
Reliability
Control**



Rohm

METAL FILM RESISTOR
CARBON

**TOYO
ELECTRONICS
INDUSTRY
CORPORATION**

P. O. BOX 103 CENTRAL
KYOTO, JAPAN

New Microwave

the environmental requirements of MIL-E-5400 CL II.
Sage Laboratories, Inc., 3 Huron Dr., East Natick, Mass. [395]



**Miniature X-band
comblin filter**

The use of coaxial techniques at X-band frequencies allows the construction of bandpass filters which are much smaller than their waveguide equivalents. Miniature X-band combline and interdigital filters can be supplied with either connectors (OSM) or waveguide flanges. An example of a miniature X-band combline filter is seen in the F-4015. This unit measures only 2½ by ½ by ½ in., plus OSM connectors, and has insertion loss of less than 1 db at 11,320 Mc and more than 25 db at 11,200 Mc. It is designed for use in rugged environments over wide temperature ranges. Drift is less than 20 ppm per degree C. A temperature-compensated version is available with drift of less than 5 ppm per degree C.

Melabs, 3300 Hillview Ave., Stanford Industrial Park, Palo Alto, Calif. [396]

**Solid-state switch
operates from 1 to 4 Gc**

A broadband, solid-state, spdt switch has been added to the Tri-Plate line. Model DS508 has a 50-nsec rise time and operates from 1.0 to 4.0 Gc. It provides an inexpensive, compact switch for use in multiplexing, r-f signal suppression, transmit-receive switching, broad pulse modulation and signal

DC POWER SUPPLIES



CONTINUOUS VOLTAGE COVERAGE — 4.7 to 60 vdc

Input: 105-125 vdc, 50-400 cps
Regulation: From $\pm 0.05\%$
Ripple: From .002% or 1 mv, rms
Temp. Coeff.: From $\pm 0.01\%/^{\circ}\text{C}$
Voltage Adjustment: $\pm 5\%$
Max. Temp. of Base: 65°C

- WIDE VARIETY OF CURRENT RATINGS
- ELECTRONIC SHORT CIRCUIT PROTECTION
- FULLY REPAIRABLE
- 7 STANDARD SIZES (OVER 450 MODELS)
- PRICE RANGE **\$45-\$225**



INSTRUMENTS: EEM ('63-64 Pg. 902)
EBG (1964 Pg. 462)

POWER SUPPLIES: EEM ('64-65 Pg. 1341)
EBG (1963 Pg. 307)

VOLTAGE STANDARDS: EEM ('64-65 Pg. 929)



390 CAPITOL AVE., HARTFORD, CONN.
Circle 208 on reader service card

NEW

Packed with more important data than ever before... the 1964-65 issue of **Electronics Buyers' Guide**. Four great major sections: Product Listings; Product Advertising; Index of Electronics Manufacturers; Government, Other Agencies and Technical Services.

USED

Week in, week out, EBG is the industry's standard catalog-directory... a necessary working tool for the men who buy and the men who sell components, equipment, systems, materials and services.

Electronics Buyers' Guide
A McGraw-Hill Publication
330 West 42nd Street,
New York, N.Y. 10036



steering. It can be used to switch a single input to either of two outputs or either of two inputs into a single output. The high speed unit measures only $1\frac{1}{8}$ in. by $\frac{3}{8}$ in. by $3\frac{3}{4}$ in. Operating temperature range is -55°C to $+75^{\circ}\text{C}$. Isolation is 30 db minimum. Insertion loss is 2.5 db max with 1.5 db typical; vswr, 2.0:1 max. Average quantity price is \$285.

Sanders Associates, Inc., 95 Canal St., Nashua, N.H. [397]

Microwave generator uses thin GaAs slab

A gallium arsenide microwave generator has been developed to produce peak power of 1 w at 800 Mc. This power source consists of a thin slab of gallium arsenide mounted on a heat sink. When d-c is passed through the slab, it produces coherent oscillations at microwave frequencies. Minimum mean output power is 50 mw at a

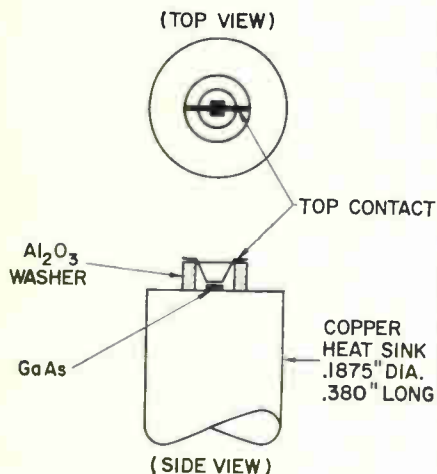

duty cycle of 5%. Power conversion efficiency is 2.5% or greater. The device is available for experimental purposes as an accommodation to research scientists in other laboratories. Price is \$200.

International Business Machines Corp., Research Division, Box 218, Yorktown Heights, N.Y. [398]

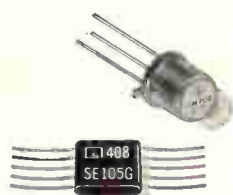

Need to say a lot
in a little space?

(or make markings
more durable...or
more economical...
or at higher rates?)

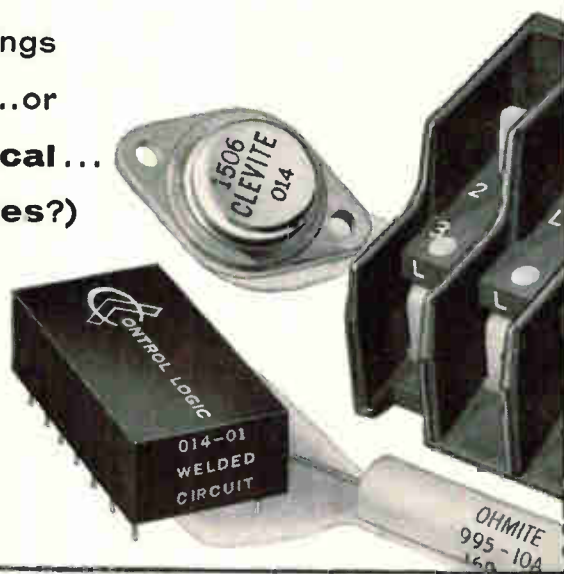

We can show you how

We can show you how to identify products so they will resist extreme amounts of handling, abrasion, many solvents and other atmospheric conditions... or how to sequentially number and identify components with savings of more than \$50 per 1000... or how to print trademark, type number, value and date code on 90 units a minute... or how to produce an imprint that remains readable after 1000 hours at 200°C ... or get 10 digits and 2 letters in a micro-circuit area of $0.090''$ — or 21 characters on a TO-5 case with interchangeable type number and date code... or save 75 cents of every dollar you now spend on buying, applying, inventorying and discarding obsolete preprinted labels.

The answers are in proven Markem machines, type and specialty inks, which daily produce better product or package identification by reducing costs, smoothing production control and increasing customer acceptance. And while Markem machines, type and inks are helping to produce better products through more complete and lasting identification, they frequently pay for themselves in the savings they make possible. Tell us what you make, what it must say, and for how long: we'll give you a specific recommendation and cost estimate right away. Write Electrical Division, Markem Machine Co., 305 Congress St., Keene, New Hampshire 03431.

MARKEM

new

from BURR-BROWN



TWO, SOLID-STATE HIGH VOLTAGE OPERATIONAL AMPLIFIERS

MODELS PROVIDE: 1641 1642

High Voltage @ 10ma	$\pm 50v$	$\pm 100v$
High DC Gain	110db	110db
Wide Bandwidth	0.4Mcps	0.4Mcps
High Stability	$\pm 25\mu v/^{\circ}C$	$\pm 25\mu v/^{\circ}C$

Burr-Brown's new differential input DC operational amplifiers are ideal for integrator and amplifier applications requiring high voltage with solid-state stability. Current stability of the 1641 is better than $\pm 2na/^{\circ}C$ while the 1642 holds $\pm 20na$ from $-20^{\circ}C$ to $+60^{\circ}C$. Both all-silicon units feature less than $10\mu v$, rms noise and internal zero control. Mount up to 16 units per $3\frac{1}{2}'' \times 19''$ rack. Priced at \$175 and \$195, respectively, in unit quantity. For complete information or applications assistance, write, wire, or phone today.

OPERATIONAL AMPLIFIER HANDBOOK
96 pages of valuable theory and circuits.

A note on your letterhead will get you a free copy.



BURR-BROWN

RESEARCH CORPORATION
Box 6444 TUCSON, ARIZONA
Telephone: 602-623-0328 • TWX: 602-792-2681

New Production Equipment

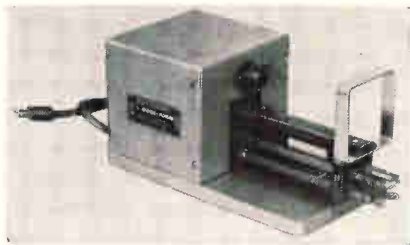

Thermal wire-stripper is safe and fast

A thermal wire-stripper is available for bench-type uniform high production, precision stripping of most types of thermoplastic insulations. It safely and quickly removes insulations from all types of thermoplastic-insulated wire, including Teflon. Multilevel temperature control provides choice of temperature for fast, clean insulation removal. Temperature is selected by a five-position control knob on the panel. A fingertip lever controls the stripping element contact pressure to permit stripping even the most delicate standard wires. A positive mechanical stop gives easily adjustable, precision control of uniform stripping length or may be withdrawn for center stripping. Rush Wire Stripper Division, The Eraser Co., Inc., 1068 S. Clinton St., Syracuse, N.Y. [421]

Vacuum tweezer system handles tiny parts

A miniature parts handling system utilizes a light-weight aluminum vacuum pencil and electromagnetic type vacuum generator. Model CV-100 vacuum tweezer system will pick up a wide variety of

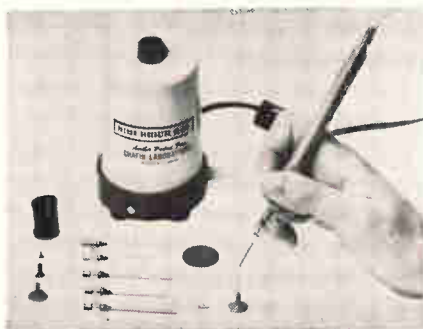

small parts without pressure or damage. Applications include semiconductor assembly, where small silicon and germanium wafers and circuits must be handled with speed and care, microelectronic fabrication, and other industrial or laboratory requirements where precision handling of very small and fragile components is required. Model CV-100 consists of a continuous operating vacuum generator, five stainless steel vacuum tips of various diameters, three polyvinylchloride acid and solvent resistant vacuum suction cups, a plastic vacuum filter, vacuum grease and 40 inches of tygon vacuum tubing. Selling price of the entire system is \$39.95 in single units. Chafin Laboratories, 909 N. First St., Phoenix, Ariz. 85004. [422]



Water-cooled laser for industrial use

A high-repetition-rate laser has been developed for industrial applications. Model LE-1 laser can drill holes smaller than 0.0002 in. in rapid succession. Typical applications include balancing gyros and trimming resistors. The water-cooled device employs a $6\frac{5}{8}$ -in.-by- $\frac{5}{8}$ -in. ruby rod and is capable of producing more than 10 joules of energy per pulse at a rate of one a second. Pulse width is variable from 1 to 10 milliseconds. When

operated in a short pulse mode and fitted with a Q-switch, the new laser can also serve as a transmitter for ranging and optical radar systems. Price is approximately \$12,500.

Raytheon Co., 130 Second Ave., Waltham, Mass. 02154. [423]



Solid carbide drills for circuit boards

A series of drills has been announced that are specially designed for the materials and structures of circuit boards. A double relief design of the drill point cleanly shears the metal plating of the circuit panel, drilling a hole totally free of burrs. The drill flutes are specially designed to carry chips out of the hole during the drilling operation so that hole diameter accuracy can be dependably maintained and drill breakage absolutely minimized. These drills are manufactured in a complete range of drill sizes from No. 1 to No. 80 and include all fractional inch and decimal sizes up to 0.250 in. The Metal Removal Co., 1801 W. Columbia Ave., Chicago, Ill. [424]

Proportioning machine dispenses liquid resin

The Portionator is a liquid-resin proportioning and dispensing machine with a ratio range of 1:1 to 100:1. It will deliver the exact pre-set ratio of both resin and hardener at a constant accuracy—less than 1% variation—whether a full stroke or a partial stroke is pulled. Both resin and hardener are dispensed from individual jets so there is no internal mixing to cause machine damage, work stoppage or production loss. There is one simple ratio adjustment and a calibrated scale to eliminate all weighing, measuring and delicate epoxy handling

NEW 1/2 INCH TWO WATT PHOTOCELLS



AVAILABLE NOW!

Additional data plus new 16 page photo-cell manual for design engineers free on request.

Clairex now offers a new "5M" Series of photoconductive cells with two watts power dissipation in a rugged, hermetically sealed metal case only .490" in diameter. Available in all standard Clairex CdS and CdSe photosensitive materials offering numerous combinations of response time, sensitivity and spectral response. Suitable for direct relay operation and many other applications.

CLAIREX

"The LIGHT Touch in Automation and Control"

8 West 30 Street, New York, N. Y. 10001, 212 MU 4-0940

Circle 149 on reader service card

Planning to change your address?

Use the form below to indicate a change of address. Because our issues are addressed in advance, please try to allow at least 5 weeks for change of address to become effective. Attach the address label from your most recent issue in the space provided below.

[Please print the following information for proper service]

Title or position

Name

Chief job responsibility

Company and Div

Product or Service Approx. No. of employees

Address

City Zone State or Prov.

Mail to: Fulfillment Manager, Electronics
P.O. Box 430, Hightstown, N.J. 08520

***Paste present mailing label or address from wrapper or envelope here.**

**new from
holt**

**solid state
AC voltage**

**for low cost,
fast AC
calibration**



Holt's new 613 AC Voltage Calibrator is the latest model of a series of five instruments designed for inexpensive, rapid AC calibration.

The Models 610, 610A, 611, 612 and 613 are particularly suited for portable operation in the calibration laboratory, production areas, shipboard and remote sites. The long-term calibration, solid state design, low price and light weight make each instrument in this series a versatile source for AC voltage calibration.

MODEL 613 SPECIFICATIONS

Voltage: 1 mv to 1000 VAC
Frequency: Internal Oscillator - 50, 400 & 1000 cps
 External Oscillator - 50 cps to 5 KC
Voltage Calibration: \pm .25% for six months
Price: \$1990.

Other models in this series are as low as \$980. Write Holt for complete details, NEC Booth 754.

HOLT

INSTRUMENT LABORATORIES
 OCONTO, WISCONSIN

New Production Equipment

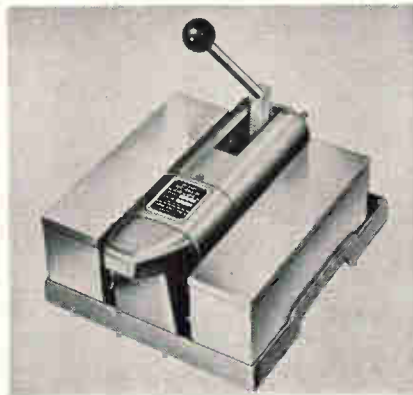

problems. The machine has a no-drip feature using special valves. It is adaptable to most two-component, self-leveling liquid resin systems. Base area is 12 by 14 in. The tank capacity is 2 quarts on each side and the cylinder capacity 1.1 fluid oz each side, with a maximum delivery capacity of up to 8 gallons per hour.
 Glenmarc Mfg. Co., Northfield, Ill. [425]

**Monitor controls
vapor deposition**

A new monitor accurately controls the vapor deposition of thin films. Versatile in application, it is useful in semiconductor manufacturing and other processes. Model VDM-1 is equipped with meters to measure three parameters: film thickness to 500, 2000 and 5000 angstroms full scale; rate of deposition to 10, 50 and 100 angstroms per second; and temperature of the substrate during vaporization. Meter indication accuracy is 2% of full scale. Up to



McGRAW-HILL

Book Notes

ELECTRONIC ANALOG AND HYBRID COMPUTERS

Just Out. Covers "classical" electronic analog computation and tested programming and scaling procedures, as well as actual design of analog computing elements. By G. Korn, Univ. of Arizona; and T. Korn. 400 pp., illus., \$17.50. Payable on terms; see coupon

HANDBOOK OF MATHEMATICAL TABLES AND FORMULAS

Just Out—4th Ed. Offers up-to-date reference on the most frequently needed formulas, theorems, and tables. Sets, logic, relations, functions, Boolean algebra, and many other aspects are covered. By R. Burington, 4th Ed., 448 pp., \$4.50

ELECTRONICS ASSEMBLY METHODS

Just Out. Provides the technical background necessary for the fabrication of today's complex electronic equipment. Electricity and modern electrical and mechanical hardware are described and explained. By S. Duarte and R. Duarte, both of Compton Coll. 344 pp., 270 illus., \$5.95

INTRODUCTION TO MICROWAVE THEORY AND MEASUREMENTS

Just Out. Combines microwave theory with practical measurement techniques. Transmission lines, waveguides and components, active microwave devices, and microwave measurements are covered. By A. Lance, Hughes Aircraft Co. 308 pp., \$8.50

SEMICONDUCTOR DEVICES

Just Out. Explains the operation, structure, and characteristics of the most important semiconductor devices. Approach is based on properties of semiconducting materials and is completely non-mathematical. By J. Brophy, IIT Research Instit. 144 pp., illus., \$5.95

10 DAYS' FREE EXAMINATION
 Convenient Mail Service
 Direct from McGRAW-HILL

McGraw-Hill Book Co., L105X
 327 W. 41st St., New York, N. Y. 10036

Send me book(s) checked below for 10 days' examination on approval. In 10 days I will remit for book(s) I keep plus few cents for delivery costs, and return unwanted book(s) postpaid. (If you remit with coupon, plus local tax, we pay delivery costs—full refund and return privilege.)

Korn & Korn—Elec. Analog & Hybrid Comp., \$17.50
 Payable \$7.50 in 10 days, \$10 in 1 month

Burington—Hdbk. of Math. Tables & Formulas, \$4.50

Duarte & Duarte—Elec. Assem. Methods, \$5.95

Lance—Intro. to Microwave Theo. & Meas., \$8.50

Brophy—Semiconductor Devices, \$5.95

Name

Address

City State Code Zip

Company

Position

For price and terms outside U.S. write McGraw-Hill Int'l., N. Y. 10036 L105X

six measurements can be accommodated simultaneously and a six-position switch facilitates channel selection. The miniature film-monitoring sensor is housed in a copper cylinder $\frac{5}{8}$ in. long by $\frac{3}{4}$ in. diameter, open at one end to expose a face of the sensor. It is mounted with the exposed face contiguous to, or in an opening in, the substrate on which the film is deposited. The sensor element is easily replaced when necessary. The temperature sensor, similarly housed, is placed with the flat face against the rear of the substrate to avoid hot spots.

Gulton Industries, Inc., 212 Durham Ave., Metuchen, N.J. [426]

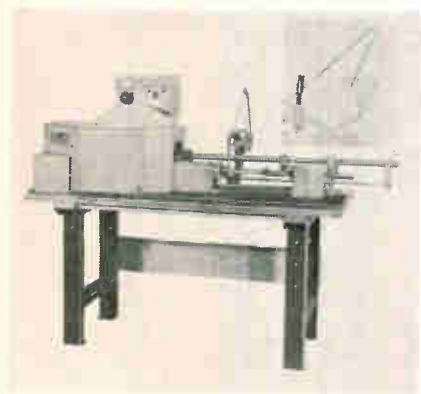

Linear and nonlinear resistor-strip winder

A new machine with driven tail-stock winds nonlinear (variable pitch) or linear wound resistor or potentiometer strips without flexing or twisting during winding. Model 931 winds strip up to $7\frac{3}{4}$ in. overall winding length that can be drawn through a $\frac{3}{4}$ in. i-d spindle, using wire sizes 18 to 42. A time-saving holder keeps the wire within easy reach of the operator after the finish lead has been severed. Winding speeds are variable up to 2,500 rpm depending on coil configuration. Set-up time is only 5 to 10 minutes for complete job change-over. Slight toe pressure begins the winding cycle. The machine stops automatically at winding cycle end. Dimensions of the machine are 63 in. long by 30 in. wide by 48 in. high including 32 in. bench height. Basic price is approximately \$2,800. Geo. Stevens Mfg. Co., Inc., 6001 North Keystone Ave., Chicago, Ill. 60646. [427]

JOHANSON VARIABLE AIR CAPACITORS ARE DESIGNED TO EXCEED MIL-C-92/MIL-C-14409



JMC 2950 "Miniature" Series

- Low Temp Coef & Capacity Drift
- Exceeds MIL Vibration & Shock requirements
- Fungus, Salt Spray, & Humidity protection

CAPACITANCE RANGE: 1.0-10.0 μf

OPERATING TEMP RANGE: -55°C to $+125^{\circ}\text{C}$

DIELECTRIC BREAKDOWN: > 500 VDC (sea level to 150,000 ft)

INSULATION RESISTANCE: $> 1,000,000$ megohms @ 50% RH

Q: > 2000 @ 100 MC

Write for complete information

Johanson

MANUFACTURING CORP

Rockaway Valley Road • Boonton, New Jersey

Circle 210 on reader service card

Telrex

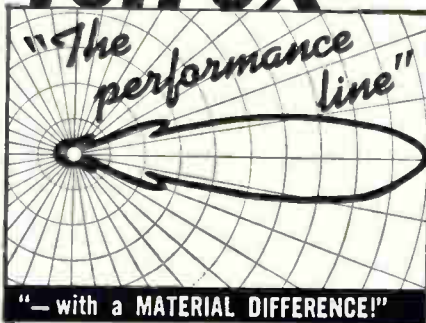

The Choice of the Discriminating Communication Engineer . . . the Man who Never Settles for Anything Less than THE-VERY-BEST!

telrex "BEAMED-POWER" ANTENNAS and ANTENNA SYSTEMS

Provide optimum performance and reliability per element, per dollar. Antennas from 500 Kc to 1500 Mc. Free PL88 condensed data and pricing catalog, describes military and commercial antennas, systems, accessories, Towers, Masts, Rotators, "Baluns" and transmission line data.

ANTENNAS Communication and TV Antennas
SINCE 1921 **telrex**
LABORATORIES

Asbury Park 41, New Jersey, U.S.A.
Circle 211 on reader service card

More torque, Less weight



APT-1; 1 cu. in., 3.15 oz. (actual size)

in moving coil mechanism

Stable, linear, accurate mechanism for indicating, control or recording systems. 1% linearity over $18.0-18^{\circ}$ and greater accuracy assured by coil design with over 75% of winding "working" in high energy, uniform field air gap. Coil system weighs 0.85 gm, develops 26.4 mmg of torque; 3:1 T/W. Vibration resonance negligible; acceleration errors sharply attenuated. Standard pivots and jewels—custom damping—wide range of sensitivities.

AMMON

AMMON INSTRUMENTS, INC.
345 Kelley Street, Manchester, N. H. 03105

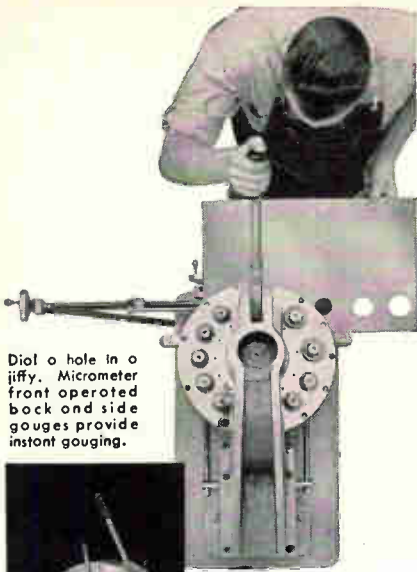

Diol o hole in o jiffy. Micrometer front operated back and side gauges provide instant gouging.



new **Di-Acro turret punch press**

Accurate Burr-Free Punching at 12 Rotating Stations

The new Di-Acro 4 Ton Turret Punch Press provides rapid, close tolerance punching of round, square, oval and rectangular holes from $\frac{1}{16}$ " to 2".

Rotating turrets provide rapid indexing for single or sequence punching. Precision hole location quickly obtained with Micro-twin gauges. Punches sheet metals up to 16 gauge mild steel, fibreboard, asbestos, paper, cork, leather, rubber, plastic and other sheet materials.

Dies are mounted in turrets—always handy. Standard clearance between punch and die is .002". Choice of 6 other clearances at no charge. The Di-Acro Turret Punch Press is safe, simple to operate—requires little maintenance.



Consult the Yellow Pages of your phone book under Machinery, Machine Tools for the name of your Di-Acro distributor or write us for catalog describing this and other Di-Acro machines.

pronounced die-ack-ro



**DI-ACRO
CORPORATION**

4310 Eighth Ave. • Lake City, Minn.

New Materials

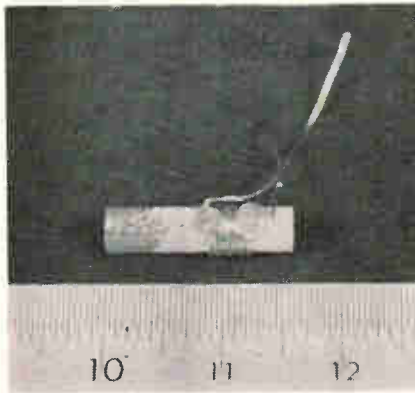

Epoxy resin adhesive is thixotropic

A new epoxy resin adhesive, A-31, is shown in a typical application, the sealing of terminals. One of the primary advantages of the adhesive is its thixotropy, even at elevated temperatures, which contributes greatly to ease in handling. The material remains a creamy or buttery consistency making it extremely workable, easy to apply and resistant to motion during cure. Elevated temperatures, if anything, tend to inhibit flow even further. The adhesive is said to have excellent electrical properties and should prove valuable for assembly of components, conformal coating, sealing and bonding. It also has very good resistance to moisture and general solvents. A-31 has a relatively quick cure, reaching 70% to 80% of its ultimate strength within 16 to 20 hours at room temperature.

Armstrong Products Co., Inc., Warsaw, Ind. [411]

Polyurethane system for printed circuits

A single-component polyurethane system has been developed for the protection of assembled and soldered printed circuits. The product, Metex conformal coating, can be applied by spray, dip or brush, and it cures at room temperature. It is said to have excellent gloss, a Shore D hardness of 82 and excellent flexibility, abrasion resist-

ance and impact resistance. The coating withstands thermal shocks from -80°F to 200°F . It has a dielectric strength of 800 v/mil (160 sec), a surface resistivity of 1.2×10^{14} ohms, and a volume resistivity of 2.4×10^{15} ohm-cm. It can be soldered through for component removal and repair work.

Macdermid Inc., Waterbury, Conn. [412]

Pressure-sensitive adhesive tape

A pressure-sensitive adhesive tape has been developed that meets many special physical property requirements necessary in some electronic applications. Designated PD473, it has a DuPont "H" film backing of 0.001 in. and a high-temperature silicone adhesive. Its temperature range (-110° to 550°F) and dielectric strength of 6,400 v are suitable for insulation applications where temperature extremes are to be encountered. The film backing affords a great deal of conformability, which is desirable when used for miniature and sub-miniature electronic component applications.

Mystik Tape, Inc., 1700 Winnetka Ave., Northfield, Ill. 60094. [413]

Solder cream speeds micromodule work

A new solder cream has been especially formulated for micromodule work, including component and substrate soldering. A combination of prealloyed solder and rosin flux, it can be applied through silk screens, etched masks and other similar devices in thicknesses up to 0.025 in. After screening, the cream is easily cured to form a dry, nontacky, nonflaking coat, ready for use any time after curing. Tests show no deterioration of coatings stored for over six months. Soldering of cured coats is easily affected by any heat application such as hot air blasts, continuous or batch-type ovens, and the like, at normal soldering temperatures. The new solder cream can be applied to

printed-circuit, ceramic substrates, and special configurations on such metals as copper, tin-lead, silver, gold and similar solderable surfaces. The company reports that the cream serves to protect base materials from deleterious oxidation effects.

Alpha Metals, Inc., 56 Water St., Jersey City, N.J. [414]

Low-temperature potting compound

A new two-component potting compound has been introduced. HumiSeal type 2A6L, a 100% solids system, is based on a polyurethane formulation. Its outstanding characteristics are its flexibility and its ability to withstand the stresses of low-temperature applications. Classified AIEE Temperature Class A (105°C), its recommended lowest temperature use is -73°C (-100°F). The compound possesses a combination of physical and electrical properties that make it ideal as an impregnant and casting resin for electronic components and assemblies. It can also be used as a direct substitute for silicone rubbers for protection of sensitive components before potting.

Columbia Technical Corp., Woodside, N.Y. 11377. [415]

Conductive compound repairs printed wiring

A one-component conductive compound, Shurbond 112, is designed for quick but lasting repairs of printed wire circuits. The resinous silver paint, when applied in thin layers, hardens in five minutes. Highly flexible, it can be wound around a mandrel 1/8 in. in diameter without cracking. In addition to reliable, easy repairs of printed circuits, tests have shown that Shurbond 112 can be applied effectively for grounding capacitors to steel chassis, connections made to heat-sensitive diodes and transistors, and electric shielding. The compound is available in several weight sizes, each packaged with hypo applicators, and retails at \$7.50 for 6 cc.

Anchor Alloys, Inc., 966 Meeker Ave., Brooklyn 22, N.Y. [416]

These ALITE[®] POWER TUBE CERAMICS

Not only
LOOK ALIKE

They are IDENTICAL

- Physically
- Electrically

Envelopes . . . spacers . . . windows . . . insulators — whatever your requirements for high alumina ceramic power tube components, you can rely on Alite for exact duplication of properties, part after part, order after order.

This repeatability is assured by Alite's rigid Quality Control procedures. For example, accompanying each group of parts through production is a card on which is kept a record of material lot code numbers, process times and temperatures, etc. In-process and final inspections are detailed and thorough.

As a result, Alite high alumina ceramics are perfectly homogeneous. Dimensional tolerances are strictly held. Several Alite formulations, with differing Al₂O₃ content, are available which meet or exceed the specifications of our most demanding customers.

Alite parts can be supplied unmetallized, metallized, or as vacuum-tight ceramic-to-metal sub-assemblies.

* * * * *

Let us review your specific requirements — without obligation: send us prints and other pertinent data. Or, write for free bulletins giving complete information about Alite.

ALITE
DIVISION

U. S. STONEWARE

BOX 119

ORRVILLE, O. 44667

5-J

Circle 153 on reader service card

**WANT TO
DO BUSINESS
WITH THE
GOVERNMENT ????????**

Then check the Military and Government Procurement Guide in the orange section of your **ELECTRONICS BUYERS' GUIDE**.



*Remember How Great
LEL Mixer Preamps used to Work?*

THEY STILL DO...

and NOW You

Can Get 'em in ONE WEEK!*

**(at a new low price too)*



Know why so many mixer preamp purchasers have always looked to LEL? Reliability...it's a factor LEL units have proved over and over with long, trouble-free performance. Selection's a big reason too...LEL offers the widest choice of matched assemblies (over 1,000) ever produced for the microwave field.

Add to all this a new ONE WEEK DELIVERY SCHEDULE on most models, and a new LOW PRICE. It's easy to see why, more than ever, LEL Mixer Preamps are your best buy!



New...

LEL Catalog '64

FREE...send for it today!

LEL INC. AKRON ST., COPIAGUE, L. I., NEW YORK 11726
(516) AMityville 4-2200 • (516) PYramid 9-8200 • TWX Code 516-691-5085

High Performance ...Minimum Size!



*Learn about the
new line of **solid
state oscillators**
from Sanders!*

First . . . from Sanders! An entirely *new* line of solid state oscillators with an input power requirement of only 16 volts nominal. Advanced Sanders engineering capabilities offer the circuit engineer an exceptional new line of highly developed components with superior operating characteristics.

Sanders UHF solid state oscillators combine high performance and low cost with minimum size of about 2 1/4" x 1 3/4" x 1 1/4". Eight new oscillator models are now available, each covering wide tuning ranges for applications between 50 and 600 MC.

These new reliable units from Sanders offer exceptional frequency stability at operating temperatures between -30°C and ±60°C. For full details, write Sanders Associates, Inc., Microwave Products Dept., 95 Canal Street, Nashua, New Hampshire.

CREATING NEW DIRECTIONS IN ELECTRONICS
SANDERS ASSOCIATES, INC. 

Circle 212 on reader service card

Another Arm-The NO. 40 CIRCLE TEMPLATE

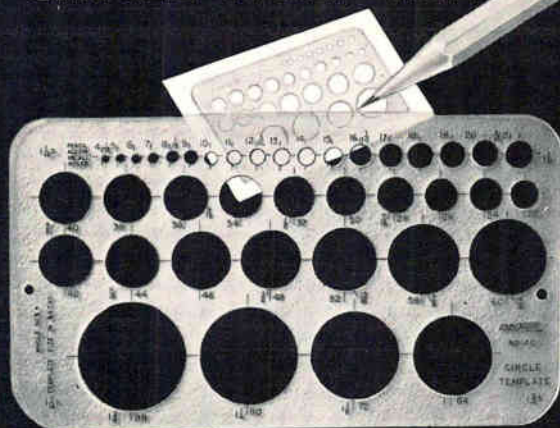

\$1.00 AT YOUR LOCAL DEALER

.030 MATTE FINISH MATHEMATICAL QUALITY DOUBLE-CURED PLASTIC.
ALL HOLES SMOOTH-MILLED TO ENGRAVING MACHINE ACCURACY.

ONE OF MORE THAN 30 RAPIDESIGN TIME-SAVER TEMPLATES—ALL
OF WHICH ARE BETTER MADE, MORE USEFUL AND LESSER PRICED.

CATALOGUE NO. 49 AVAILABLE UPON REQUEST

RAPIDESIGN INC.
P. O. BOX 592 GLENDALE, CALIF.

New Literature

Glass substrates. Corning Glass Works, Corning, N.Y. Properties of Pyrex brand substrates for thin-film circuits are listed in an 8-page illustrated brochure. Circle 451 on reader service card

Mass spectrometer. Consolidated Electro-dynamics Corp., 360 Sierra Madre Villa, Pasadena, Calif., has available a 12-page bulletin on the 21-130 laboratory mass spectrometer. [452]

Silicon power transistors. Silicon Transistor Corp., Carle Place, N.Y. An 8-page brochure contains data on series 2N3232 through 2N3240 silicon power transistors for industrial uses. [453]

Rubidium standard. Varian Associates, Palo Alto, Calif. Reliability data on V-4700 rubidium vapor frequency standards are given in a bulletin. [454]

Potentiometer recorder. Barber-Colman Co., Rockford, Ill. Bulletin DB 1221.3-3 describes the VASAR II potentiometer recorders. [455]

Encoders. Baldwin Electronics, Inc., 1101 McAlmont St., Little Rock, Ark. Bulletin O11A covers encoders that provide angular position data in the form of a cyclic binary code. [456]

Sweep oscillators. PRD Electronics, Inc., 202 Tillary St., Brooklyn, N.Y. 11201, is offering a 2-page data sheet describing its new 720 series of sweep oscillators. [457]

Printing systems. Potter Instrument Co., 151 Sunnyside Blvd., Plainview, L.I., has available technical literature on an off-line printing system and a multifunction printing system having the capabilities of a high-speed alphanumeric printer and a high-speed graphic plotter, with multiple copy output in either mode. [458]

Heat sinks. Astro Dynamics, Inc., Second Ave., Northwest Industrial Park, Burlington, Mass., has made available an 18-page manual containing information on fin design of heat sinks. [459]

Tantalum capacitors. Cornell-Dubilier Electronics, 50 Paris St., Newark, N.J. 07101, offers a 4-page brochure on its broad line of tantalum capacitors that exceed military specifications. [460]

R-f connectors. Sealectro Corp., Mamaroneck, N.Y. A 52-page catalog contains complete electrical and mechanical specifications for over 300 standard ConheX connectors. [461]

Wire stripper. Ideal Industries, Inc., 5180 Becker Place, Sycamore, Ill. 60178. A hand instrument designed for the precision stripping of Fiberglas insulated wire is described in bulletin N-211. [462]

Microwave tubes and components. Amperex Electronic Corp., Hicksville, L.I. 11802, announces publication of its new condensed microwave tubes and components catalog. [463]

Spectrum analysis. Hewlett-Packard Co., 1501 Page Mill Road, Palo Alto, Calif. 94304. Application Note No. 63, a 41-page booklet on spectrum analysis, is now available. [464]

Piezoelectric accelerometer. Consolidated Electro-dynamics Corp., 360 Sierra Madre Villa, Pasadena, Calif. Bulletin 4273 describes a piezoelectric accelerometer with a compression design that virtually eliminates the problems of acoustic bombardment, cable whip, and thermal transients. [465]

Capacitance standards. Boonton Electronics Corp., Parsippany, N.J. A data sheet outlines the model CS- precision capacitance standards which are intended for calibrating and standardizing three-terminal bridges. [466]

Rotary solenoids. Ledex Inc., 123 Webster St., Dayton, Ohio 45402. Catalog C-264 contains 32 pages of latest technical data on 10 basic rotary solenoid designs. [467]

Power modules. Electronic Research Associates, Inc., 67 Sand Park Road, Cedar Grove, N.J. A 2-page catalog sheet describes the company's complete line of low-cost, nonregulated, silicon power supplies. [468]

Circuit protectors. Airpax Electronics Inc., Cambridge, Md. Bulletin 16E-2 provides detailed information on a new line of circuit protectors for single and multiphase circuits. [469]

Encapsulation forms. Stevens Tubing Corp., 86-88 Main St., East Orange, N.J. 07019. Over 1,000 sizes of fiber glass epoxy potting forms and header plates for components encapsulation are detailed in a new data sheet. [470]

Magnetic shielding foils. Magnetic Shield Division, Perfection Mica Co., 1322 No. Elston Ave., Chicago, Ill., 60622. Data sheet 172 describes and illustrates new adhesive-backed Netic and Co-Netic magnetic shielding foils offered for experimental laboratory and design applications and for small production runs. [471]

Cable connector. Connector Corp., 6025 No. Keystone Ave., Chicago, Ill., 60646, offers data sheet 30A on a new 12-pin cable connector for commercial and industrial interchassis, rack and panel connector applications. [472]

Custom manufactured transformers. Electronic Devices Inc., P.O. Box 87, Race Road, North Ridgeville, O., has



NEW IDEAS in COMPONENT PACKAGING

by
Paul F. Bruins, Ph. D.

DuPont's new H-Film offers big new advance in component insulation and protection

● Not since Mylar appeared on the scene has a packaging film offered such exciting potentialities for electrical/electronic product protection as does Dupont's H-Film.

Brand new on the market, H-Film — a polyimide material — has nevertheless been fully tested in severe applications which prove its remarkable properties. It has the general characteristics of Mylar at room temperature, but at temperatures that cause Mylar to degrade or fail, H-Film maintains its properties virtually intact!

SALIENT PROPERTIES

● H-Film has been successfully used in applications where the temperatures have been cryogenic (-269°C), and in others where temperatures reached 400°C . It is flame resistant; does not char until 800°C is exceeded. It won't melt. It is infusible. It has no known organic solvent. It has exceptional resistance to radiation and abrasion.

APPLICATIONS

● Spiral-wound H-Film tubing is excellent for insulating capacitors, resistors, relays, transformers, motors and the like. It is ideal for use with components, instrumentation or appliances where maximum protection in severe environments or long, reliable service is desired. Therefore, it is exceptionally well suited to aircraft or space vehicle applications. H-Film will cut production rejects, too, since soldering iron heat won't burn or even char the insulation.

Niemand Bros. specializes in high quality, accurately formed spiral tubing and fabricated parts of many different fibre and film combinations, including electrical grade kraft, fishpaper, acetate, Mylar, heat shrinkable Mylar, Teflon, polystyrene and polyethylene — as well as the new H-Film. We will gladly explore possible applications with you. For details — or for our Technical Products folder — write or call.

• • •

"Niemand Notes" is a newsletter loaded with practical ideas on component packaging. To receive each issue, just send us your name and address.



NIEMAND BROS. INC.



Technical Products Division

45-13 94th Street

Elmhurst, L. I., N. Y. 11373

Tel. 212-898-1616 TWX 212-672-1346

exclusively
for
industry

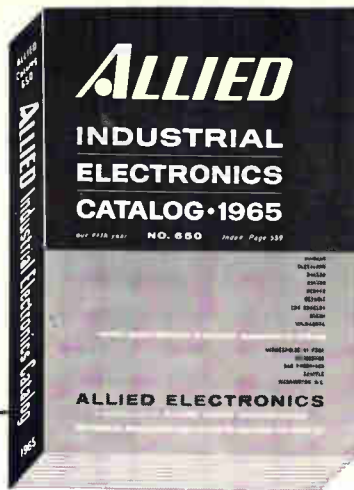

free

ask for
your 1965 **ALLIED**
INDUSTRIAL CATALOG NO. 650

576 PAGES • COMPLETE INDUSTRIAL ELECTRONICS CATALOG
FOR THE SPECIAL USE OF PURCHASING AGENTS AND ENGINEERS

- World's Largest Stocks of Electronic Components
- Same Day Shipment • Factory OEM Prices

for **FREE** copy, check reader service card or write direct

ALLIED ELECTRONICS

subsidiary of ALLIED RADIO CORPORATION

100 N. Western Ave., Dept. 80-K, Chicago, Illinois 60680

Circle 214 on reader service card

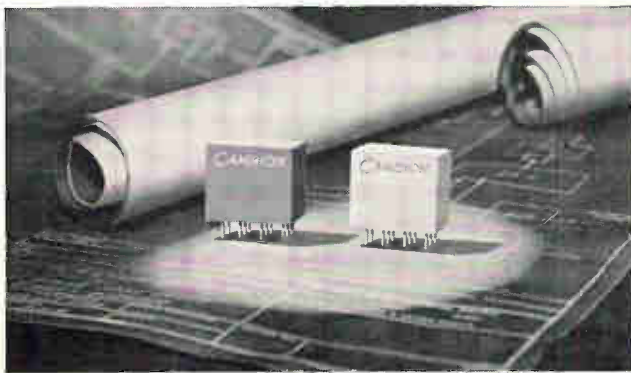

Build only the logic you need
with these low-cost
100 KC digital modules

Avoid paying heavily for computer capacity you can't use . . . CAMBION® modules — in all necessary types, including multiple versions of diode and transistor logic functions — enable you to easily hook up any combinational or sequential logic pattern, positive or negative. These miniature (less than 1 in. sq.) modules feature 12-pin configuration for greater function density, straightforward circuitry, easy mounting in printed circuits or sockets, simplified interconnection. Epoxy-encapsulated, they operate at voltages varied from -6V to -12V, within temperature range from -35°C to +65°C. Write for complete new catalog or design engineering aid to Cambridge Thermionic Corporation, Systems, Logic and Digital Modules Dept., 210 Concord Ave., Cambridge, Mass. 02138.

CAMBION®

Standardize on CAMBION...The Guaranteed Electronic Components

156 Circle 156 on reader service card

A BRIGHT
FUTURE for **EL**

and ZEP AERO leads in custom design
and manufacture of ELECTROLUMIN-
ESCENT panels and devices for . . .

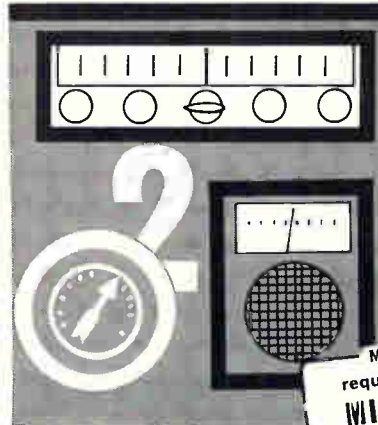
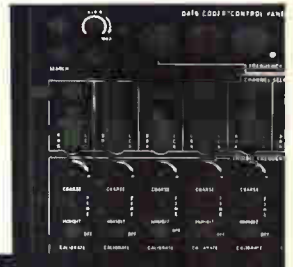

- AIRCRAFT CONTROL & COCKPIT LIGHTING
- SHIPBOARD AND UNDERSEA SYSTEMS
- GROUND SUPPORT SYSTEMS
- ALPHA-NUMERIC SYSTEMS DISPLAYS

MANUFACTURED TO MEET
requirements of Specification
MIL-P-23817 (WE-P)

Available in a variety of colors for an evenly diffused, glare-free, lasting, cold light on lightweight plastic . . . a material inherently ideal for its strength, and ease of fabrication.

Zep Aero Design Engineers specialize in adapting EL to your individual requirements.



Write on Company letterhead or call . . .
ZEP AERO, EL Division, 111 Penn St.,
EL Segundo, Calif. (213) SPring 2-4151.

Circle 215 on reader service card

UPGRADE YOUR EQUIPMENT QUALITY

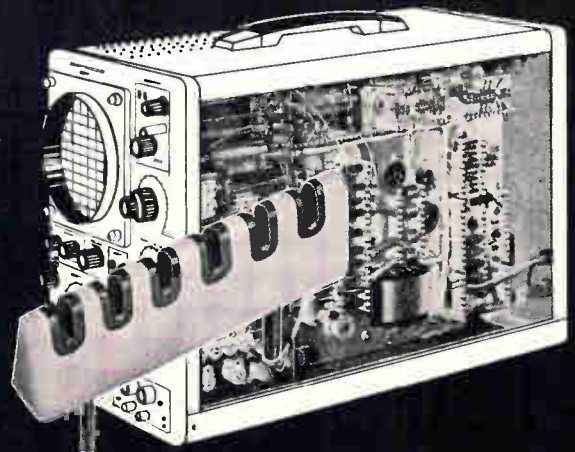

**CERAMIC
TERMINAL STRIPS**

Features a permanent bond between metal and ceramic, not just an adhesion. Fired copperplate on ceramic is silverplated and tinned which facilitates soldering and resoldering of components and leads. Superior to temperature afflicted plastic. Withstands excessive heat.



ALCOSWITCH

Lawrence, Mass. Dept. J-50

Circle 216 on reader service card

announced a technical brochure on custom manufactured transformers for industrial electronics, missiles, aircraft and military electronics. [473]

Semiautomatic tube tester. Westinghouse Defense and Space Center, Box 153, Baltimore 21203. A 4-page illustrated publication gives specifications and special features of a semiautomatic electronic tube tester. [474]

Integrating galvanometer. Consolidated Electro-dynamics Corp., 360 Sierra Madre Villa, Pasadena, Calif. Bulletin 7353 describes an integrating galvanometer that is especially useful for recording vibration amplitudes. [475]

Analog-to-digital converter. General Micro-electronics, Inc., 2920 San Ysidro Way, Santa Clara, Calif. 95051. A technical data sheet gives tentative specifications for the model ADC, an analog-to-digital converter that features use of silicon semiconductor integral circuits throughout. [476]

Circuit-card extracting tools. Hewson-Waltz Corp., 3851 Sepulveda Blvd., Culver City, Calif., has published a catalog illustrating extractor models said to combine the best of many unique features for ease and proper handling of costly circuit cards. [477]

Hybrid tee mixer. Microwave Development Laboratories, Inc., 87 Crescent Rd., Needham Heights, Mass. A series of folded H-plane hybrid tee mixers covering 13.325 to 17.5 Gc are tabulated in bulletin MS64-5. [478]

Dielectric plastic material. The Polymer Corp., Reading, Pa. Technical bulletin BR-20 contains property and availability data on Z-tron thermoplastic, developed for strip transmission lines and microwave frequency applications. [479]

Ferrite components. Melabs, 3300 Hillview Ave., Stanford Industrial Park, Palo Alto, Calif. A 16-page catalog describes ferrite components for use between 30 Mc and 72 Gc. [480]

Piezoelectric accelerometer. Consolidated Electro-dynamics Corp., 360 Sierra Madre Villa, Pasadena, Calif. Bulletin 4280 describes a low-impedance piezoelectric accelerometer that combines a piezoelectric sensing element and an all-solid-state source follower in one small package. [481]

Connector selector. Deutsch Co., Electronic Components Division, Municipal Airport, Banning, Calif. A wall chart provides an immediate visual method for determining specifications on the DM, DS, MDS, DD, MDR, DA, DTK, BTK and hermetic connectors. [482]

Data acquisition system. Ampex Corp., 401 Broadway, Redwood City, Calif. A complete list of specifications for the DAS-100 data-acquisition system for general or medical use is included in a six-page fold-out bulletin. [483]

new!

A free guide book to the profit potential available in Florida's electronics industry.

Write for your free copy today! Full, factual and detailed information about your future as a Florida industrialist. A partial list of subjects covered: the fantastic "Space-Age Market"; the solid growth of the industry in Florida; the markets for electronic components... instrumentation... and general manufacturing; the welcome climate that offers a tax structure so favorable, you'll want to investigate; the unlimited R&D facilities available to you; the ease of recruitment of engineers and technicians, and the solid growth environment Florida offers you.

But write today! Investigate Florida—the growth state! Discover what a Florida plant can mean to you and your company's profit picture! Write today for your free copy of "OPPORTUNITIES IN ELECTRONICS."

INDUSTRIAL Florida

opportunities
in
electronics

Mr. Wendell Jarrard
Chairman
Florida Development
Commission, Dept. 4447A
Tallahassee, Florida 32304
Please send me free copy of
"OPPORTUNITIES
IN ELECTRONICS"

NAME.....
FIRM NAME.....
ADDRESS.....
CITY.....STATE.....ZIP.....

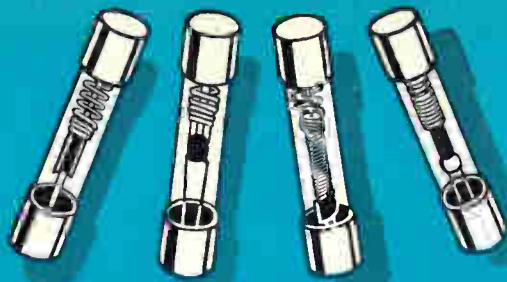

FUSETRON

dual-element Fuses
time-delay type

"Slow blowing" fuses that prevent needless outages by not opening on motor starting currents or other harmless overloads—yet provide safe protection against short-circuits or dangerous overloads.

BUSS

Write for BUSS
Bulletin SFB

BUSSMANN MFG. DIVISION, McGraw-Edison Co., St. Louis, Mo. 63107



All Types Available

for Every
Application

BLOCKS

for BUSS FUSES

Single pole, multiple pole, small base, full base, molded base, laminated base, porcelain base for fuses from 1/4 x 5/8 inches up. Also signal fuse blocks and special blocks of all types.

Tell us what you need or . . .

BUSS

Write for BUSS
Bulletin SFB

BUSSMANN MFG. DIVISION, McGraw-Edison Co., St. Louis, Mo. 63107

BUSS: 1914-1964, Fifty years of Pioneering

Circle 159 on reader service card

Circle 159 on reader service card



Find the manufacturer... Fast!

It's just a matter of seconds to get the valuable information you need about electronic manufacturers and suppliers in the Electronics Buyers' Guide. The EBG has over 200 pages listing the names, addresses, phone numbers and key individuals of manufacturers of electronics equipment, related components and materials. All this plus vital company statistics. At a glance you know important facts about the company, exactly what each company makes, and where to find the manufacturers' representatives in your area. No wonder the EBG is the industry's standard catalog-directory!

Electronics Buyers' Guide

A McGraw-Hill Publication

330 West 42nd Street, New York, N. Y. 10036

New Books

Space electronics

Progress in Astronautics and Aeronautics—Vol. 13, Guidance and Control II
Edited by Robert C. Langford and Charles G. Mundo
Academic Press, New York, 1964
997 pp., \$14.25 (AIAA member \$10.75)

This is the 13th of a series of books sponsored by the American Institute of Aeronautics and Astronautics. It is a follow-up to Vol. 8, of this series, which was published in 1962 and compiled by a different set of editors.

The new book is an outgrowth of a specialist conference organized by the institute and held at Massachusetts Institute of Technology in August, 1963. It is not the proceedings of the conference, but is intended as a reference guide to, and a report on, the field.

The result is a wide-ranging collection of papers on such diverse subjects as lifting-body re-entry problems, deep-space navigation and guidance, manned control of space vehicles, rendezvous guidance, and a section on inertial guidance. The sections vary in their approach and organization.

The attitude-control section leads off with a survey paper highlighting the 10 papers that follow. Other sections consist of papers tied together only by general subject grouping.

Mathematical background required of the reader is generally of graduate level, although several excellent papers require far less education on the part of the reader.

The bibliographies, graphical and tabular data, and the illustrations and photos accompanying

these papers add up to an awesome collection of reference material. Unfortunately, reference to any desired bit of information is difficult because of the lack of an index, coupled with the inevitable overlap of closely associated papers. The lack of an index would have been excusable had not the editors professed their intent for the book to serve as a reference guide.

Another point of minor irritation is the placement of all tabular, graphical and illustrative material in a single grouping at the end of each paper.

The book is an excellent reference for those working at the conceptual or advanced design level on space systems.

Norman Roulston Jr.
Martin Co., Canaveral Division
Cocoa Beach, Fla.

New Developments in Electrical Protection



BUSS quick-acting Fuses

"Fast Acting" fuses for protection of sensitive instruments or delicate apparatus;—or normal acting fuses for protection where circuit is not subject to starting currents or surges.

BUSS

Write for BUSS
Bulletin SFB

BUSSMANN MFG. DIVISION, McGraw-Edison Co., St. Louis, Mo. 63107

Circle 159 on reader service card

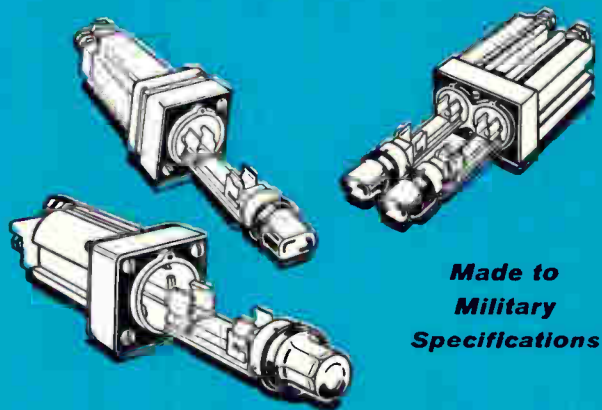

Made to
Military
Specifications

BUSS FUSEHOLDERS • LAMP INDICATING SERIES HG

Quick, positive, visual identification of faulted circuit. Transparent knob permits indicating light to be readily seen.

Fuses held in clips on fuse carrier which slides into holder and locks in place with bayonet type knob.

Holder designed for panels up to 1/8 inch thick.

BUSS

Write for BUSS
Bulletin SFB

BUSSMANN MFG. DIVISION, McGraw-Edison Co., St. Louis, Mo. 63107

Circle 159 on reader service card

SAVE

with

Midwest

BRASS



quality brass nuts

Value analysis engineers in many leading manufacturing companies have switched to Midwest Sintered Brass Nuts to lower fastening costs. Write today for more information on this modern concept in quality fastener manufacture.

- anti-corrosive
- strong
- economical
- precision made

Send for free literature and price list.



Midwest

BRASS

MIDWEST SINTERED PRODUCTS CORPORATION

13605 South Halsted Street
Riverdale, Illinois 60627
Phone: Viking 9-5290

Let us quote on your requirements today.

Technical Abstracts

Torque from light

Brushless d-c motor.* R.D. Kincer and R.G. Rakes, Sperry Farragut division of Sperry Rand Corp., Bristol, Tenn.

An electronic commutator takes the place of the brush in a d-c motor. The switching system eliminates the friction, arcing and wear of sliding-contact brushes. Radio-frequency interference is eliminated, and the brushless motor works with a high efficiency-to-weight ratio.

The electronic motor was developed in conjunction with the National Aeronautics and Space Administration's Goddard Space Flight Center. The motor is desirable for applications where the source of energy is a battery and where size, weight, maintenance, explosion hazard and power consumption must be a minimum.

The brushless motor has a permanent-magnet rotor that carries a cylindrical shield. A small incandescent lamp is inside the shield. Photocells are arranged around the lamp. As the rotor turns, the photocells are scanned in sequence by a light beam from the lamp. The beam passes through an aperture in the cylindrical shield; the photocell outputs drive an electronic switching network, causing a flow of armature stator current in a direction to develop maximum torque.

Performance characteristics of the first motor produced suggest its practical capabilities. Power output is 3 watts at 24 volts d-c, torque is 0.67 in.-oz. at 3,000 rpm, stall torque is 2.7 in.-oz. at 10.2 watts, no-load speed is 3,800 rpm, and peak efficiency of the motor is 50% at 3,000 rpm. The initial design can be improved by hermetically sealing the entire motor (excluding bearings and rotor), reducing weight and size, and improving performance and reliability.

The brushless d-c motor has been suggested for use in servo systems, motor drives for space systems, wheel systems for the orientation of space vehicles, and one-half-horsepower drives for circulating a coolant system in a space vehicle.

Applications suggested include

use for large sound-movie cameras where radio-frequency interference and acoustical noise must be at a minimum, time-base generators, oscillographs and wheel drives for dynamic braking.

Present limitations of the brushless d-c motor are its inability to withstand extreme temperatures and its high production costs. Temperature limits are set by the characteristics of semiconductors now available. The cost of the motors is expected to drop when production rises and when their special transistors are mass-produced.

Pattern recognition

Computer recognition of handwritten first names.* F.N. Marzocco, System Development Corp., Santa Monica, Calif.

To determine how much preprocessing would be needed for a computer to recognize handwriting, 20 signatures from each of 10 people were collected during two sessions of 10 signatures each. Each signature was then projected on a 20-by-48 grid, and any grid cell containing part of the signature was filled in. The filled-in grids were treated as keypunch manuscripts, one grid row per card and one hole for each filled cell. Other card fields contained sequence and identifying information.

There was considerable difference in signatures between the two sessions; the signatures served as inputs to study the effects of parameter changes in a learning program using stimulus-sampling theory, as performed on a digital computer.

Ten cards of a signature group were read into the computer, and the grid information stored in counters; one set of counters was for filled cells for each signature, another set for empty cells, for a total of $960 \times 10 \times 2$, or 19,200 counters. Under one condition the computer examined only the filled cells; under the second, each of the 960 cells was examined for a single

Presented at the 1964 Western Electronic Show and Convention (Wescon), Aug. 25-28, Los Angeles.

Find the manufacturer... Fast!

It's just a matter of seconds to get the valuable information you need about electronic manufacturers and suppliers in the Electronics Buyers' Guide. The EBG has over 200 pages listing the names, addresses, phone numbers and key individuals of manufacturers of electronics equipment, related components and materials. All this plus vital company statistics. At a glance you know important facts about the company, exactly what each company makes, and where to find the manufacturers' representatives in your area. No wonder the EBG is the industry's standard catalog-directory!

Electronics Buyers' Guide

A McGraw-Hill Publication

330 West 42nd Street, New York, N. Y. 10036

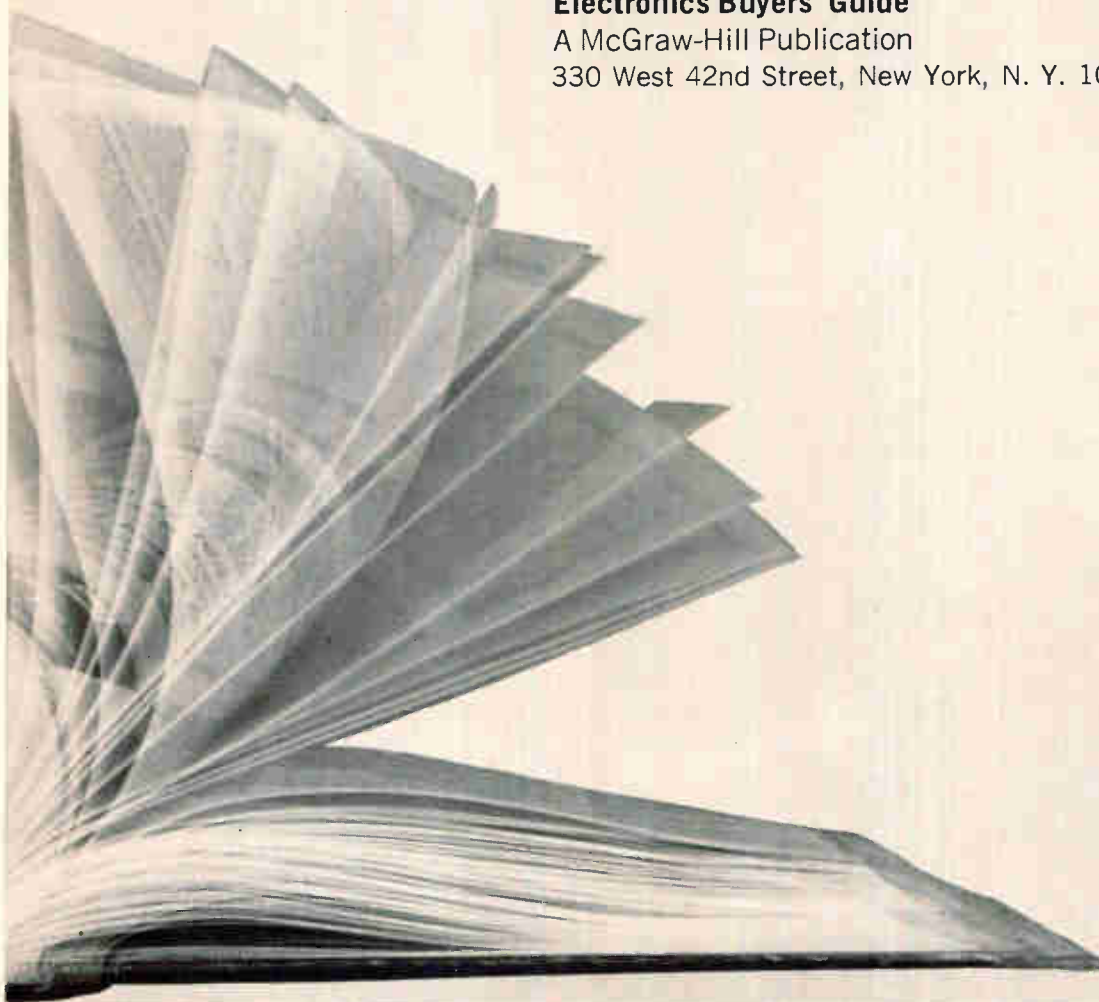

CALIFORNIA
WATER
PROJECT

CHIEF ENGINEERING COMPUTATIONS BRANCH

New Position in the California State Department of Water Resources.

The California Water Project (now under construction by the Department of Water Resources) envisions a system of reservoirs, aqueducts, pumping plants, and other hydraulic facilities throughout the state.

This newly established position in a rapidly growing organization is for an engineering or scientifically trained individual with knowledge of engineering programs. He must have sufficient experience in the use of digital and analog computers and their application to the solution of engineering problems of this nature.

The Chief, Engineering Computations Branch, will plan, organize, direct, and promote a centralized program of electronic computing and data processing for use in relation to engineering design, construction, and utility operations, including automation of State Water facilities.

Requires more than five years of broad and extensive professional engineering experience, at least two of which must have included responsibility for directing the application of digital and analog computer methods to the solution of major engineering problems; and a college degree in science, preferably in engineering.

The position is in Sacramento, in smog-free Central California. Interviews held in California only.

**SALARY RANGE: \$1,111
TO \$1,351 PER MONTH**

For details please contact

C. S. Warner

Engineering Personnel Services, State Personnel Board,

801 Capitol Mall, Sacramento, California 95814

Phone (916) 445-3033

signature.

One purpose of the study was to determine the amount of preprocessing needed to obtain effective recognition of handwritten words. The author now believes that less preprocessing is required than had been assumed, because some of the items believed essential for preprocessing (such as isolation into the number of loops or number of times the loops cross a horizontal line) are implicit in the binary coding used, and no special techniques are needed to isolate these characteristics.

Low-noise twt's

Investigation of improved magnetic materials for ppm-focused low-noise traveling-wave tubes.* D.A. Schrupf, General Electric Co., Palo Alto, Calif.

A substantial reduction in the noise figures of periodic permanent magnet-focused traveling-wave tubes is achieved by improved magnetic materials and focusing circuits.

The new twt's have a reduction of four decibels in noise and an increase of five decibels in small-signal gain. In a 4.9-pound package, the tube obtains a maximum noise figure of 7.9 decibels from 6.4 to 12 gigacycles. Noise figures of 6.7 to 6.9 db have been achieved over the 9.2- to 10.2-Gc band. These figures were obtained previously only by much heavier and bulkier traveling-wave tubes focused by uniform or single-reversal permanent-magnet fields [Electronics, June 28, 1963, p 80].

The magnetic circuit design was improved by using Alnico 8 and Alnico 5 magnets having consistently high and uniform magnetic properties. Alnico 8 was used for the axially magnetized field, and Alnico 5 for the radial field.

Tubes were constructed by standard metal-ceramic techniques. Improvements in the design increased the tubes' operating temperature range, to -65° to -100° C, from -50° to 75° C, with less than 2 db change in noise figure and small signal gain. The new tubes meet the vibration specifications required in military applications, and pass the 30-G shock and 100,000-foot altitude tests.

Presented at the 1964 Western Electronic Show and Convention (Wescon), Aug. 25-28, Los Angeles.

The use of radially oriented and magnetized Alnico 5 magnets provides a way to produce optimum field strength and period length; this results in lower noise in twt's. It is feasible to use solid-disk radially magnetized Alnico 5 gun and stack magnets as a periodic-permanent-magnet (ppm) focusing circuit for low-noise twt's.

Improvements in magnetic circuit design, by reducing other problems, have given added evidence that the effects of electrical and magnetic lenses degrade the noise figures of ppm-focused tubes. The electrical lens effect was reduced by extending the length of the uniform gun, so that at least 3 db gain occurs in this region.

Steering phased arrays

The use of grating lobe techniques in phased-array design.* W.A. Berze, Martin Co., Orlando, Fla.

In phased-array applications requiring high angular resolution, and consequently large aperture, it is sometimes desirable to use an antenna configuration employing fewer elements than in a conventional array of the same dimensions and resolution. One such configuration, which has found use in passive applications, is called the multi-element interferometer, or grating lobe array. Although the discussion in this paper is of linear array systems, it can be extended to planar arrays.

For a linear array having uniformly spaced, isotropically radiating elements with identical coefficients, the far-field voltage pattern is given by

$$\begin{aligned} \text{Sin}(\theta, \lambda) &= \frac{\text{Sin} \frac{N\phi}{2}}{\text{Sin} \frac{\phi}{2}} \\ &= \frac{\text{Sin} \left(N \frac{\pi d}{\lambda} \text{Sin} \theta \right)}{\text{Sin} \left(\frac{\pi d}{2} \text{Sin} \theta \right)} \end{aligned}$$

which indicates a major lobe occurring whenever the denominator goes to zero; that is, for all values of θ for

$$\text{Sin} \theta = \pm \frac{k\lambda}{d}$$

To employ the grating-lobe an-

tenna in an active radar, it is necessary to suppress the two-way response of the antenna to all but one lobe at any given time; that is, to eliminate grating-lobe ambiguities. The two-way amplitude response, S_p , of an antenna configuration is given by

$$S_p = (\theta) = S_t(\theta) \times S_r(\theta)$$

where $S_T(\theta)$ is the far-field transmitting-amplitude pattern and $S_R(\theta)$ is the receiving amplitude pattern.

One practical technique for the removal of grating-lobe ambiguity is the vernier array. In this method, two arrays of approximately equal over-all length and slightly different element separation are employed to produce, transmit and receive patterns having lobe separations differing by one or more null beamwidths.

If corresponding lobes of each pattern are brought into alignment, then the remaining lobes of each pattern will fall on side-lobe zeroes of the other pattern, producing a product pattern that has a single, unambiguous lobe. This product lobe may be steered in increments of θ_{SR} across a coverage sector θ_C by shifting one pattern with respect to the other, causing successive pairs of transmit and receive lobes to fall into alignment. Methods of beam steering, lobe registration and tracking are explored for the vernier technique.

Another grating-lobe approach that is discussed in detail and evaluated employs a grating-lobe array for the receiver aperture and uses a shorter filled-in transmit array to resolve the lobe ambiguities.

Integrated circuits

Design of semiconductor integrated circuits for low-cost electromechanical control systems.*
W.F. DeBoice and N.D. Salman
Autonetics division, North American Aviation, Inc., Anaheim, Calif.

A logical next step in the increasing application of semiconductor integrated circuits is their use in electromechanical control system. The requirements of electromechanical systems seem at first to discourage the use of standard type of integrated circuits. How

Reprints Available from Electronics

Special Reprint Offer: For your reference file—a complete set of Special Reports reprinted from the pages of Electronics in the past year. A total of 155 pages of valuable and informative articles combined in an attractive folder. The reports are individually bound. The special discount price for the reports is \$2.50 which includes both handling and shipping costs. Order now using the coupon at the bottom of this page. The following reprints are included in this offer:

Oceanography—A survey of the growing electronics technology associated with underseas exploration. 15 pages.

Magnetics—An Electronics special report on what's new in today's magnetic technology. 24 pages.

Digital Instrumentation—A look at some new techniques in instrumentation. 16 pages.

Modern Electronic Packaging—How to locate, connect and afford protection for electronic devices and components. 16 pages.

Electronic Markets New Directions 1963-64-67—Surveys present markets and forecasts future electronics marketing opportunities. Includes marketing statistics and projections. 20 pages.

Today's Semiconductors—Survey of the newest semiconductor devices available to circuit designers. Tells how and where to use them to the greatest advantage. 24 pages.

Materials for Space Age Electronics—A comprehensive survey of a materials technology that is now shaping the course of the Electronics industry. 16 pages.

Radio Frequency Interference—Causes, effects and cures. How RFI has grown in the electronics industry making what was once a nuisance to a few an industry wide problem. 24 pages.

Remember to refer to this special offer when you order. Price is \$2.50 for the complete set or you may order them individually at 50¢ per copy.

Send your order to:
Electronics Reprint Dept. 330 West 42nd Street
New York, N.Y. 10036

Reprint order form

To help expedite mailing of your reprints please send cash, check or money order with your order.

For reprints of the latest special report:

Direct Digital Control in Industry

Send me reprints of key no. R-61 & R-60 at 50¢ each.

For reprints of previous feature articles or special reports fill in below:

Send me reprints of key no(s) at ¢ each.

For prices and listing see the reader service card

For complete set of special reports (See special offer above)

Send me complete set(s) of special reports offered for \$2.50 per set.

Name

Number & Street

City, State

Zip Code

* Presented at the IEEE MIL-E-CON-8 International Convention on Military Electronics, Sept. 14-16, Washington.

Pioneer manufacturer of ceramics

Kyocera

for the electronic industry
& BETTER PERFORMANCE



Widest choice of advanced ceramics.

Forsterite, Alumina, Steatite,
Zircon, Mullite, Cordierite,
Magnesia, Titania, Beryllia,
Multiform Glass, etc.

KYOTO CERAMIC CO., LTD.

11, Haramachi, Nishinokyo, Nakagyo-ku,
Kyoto, Japan.

Circle 217 on reader service card

SHIZUKI CAPACITORS

Injection Polypropylene Resin
Molded Metallized Lacquer Film
Capacitors (-30°C +85°C)

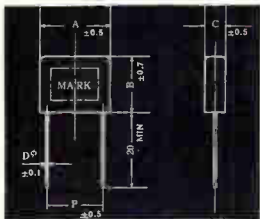

50 volts D.C. Working unit: mm

TYPE	CAP	A	B	C	D	P
PML-0.47/50	*0.47 μ F	14.0	14.0	5.0	0.6	10.0
PML-0.5/50	0.5 μ F	14.0	14.0	5.0	0.6	10.0
PML-0.68/50	*0.68 μ F	19.5	16.0	5.5	0.6	15.0
PML-1.0/50	*1.0 μ F	19.5	16.0	5.5	0.6	15.0
PML-1.5/50	*1.5 μ F	24.0	19.0	6.5	0.7	19.0
PML-2.0/50	2.0 μ F	24.0	19.0	6.5	0.7	19.0
PML-2.2/50	*2.2 μ F	24.0	19.0	6.5	0.7	19.0
PML-3.3/50	*3.3 μ F	30.0	20.0	7.0	0.7	25.0
PML-6.8/50	*6.8 μ F	31.0	23.0	10.0	0.8	25.0

*STANDARD

- ◇ Lacquer Film Capacitors ◇ Mylar Capacitors
- ◇ Metallized Paper Capacitors for Motor running, fluorescent ballasts ◇ Noise Suppression Capacitors
- ◇ Ignition Capacitors ◇ Miniature Electrolytic Capacitors



SHIZUKI ELECTRICAL MFG. CO., LTD.
HEAD OFFICE: TAISHA-CHO, NISHINOMIYA, JAPAN
CABLE ADDRESS: "CAPACITOR" NISHINOMIYA
TOKYO FACTORY: 10-7, ARAIYUKU, OTA-KU, TOKYO

Circle 164 on reader service card

ever, the use of adapting circuits with standard amplifying integrated circuits overcomes this problem.

The adapting circuits contain the elements needed for versatility; they also contain whatever remaining circuitry which cannot be designed into the semiconductor integrated circuits.

The standard integrated circuits accomplish most of the required functions. For small-signal amplification, standard integrated circuits are: a differential voltage amplifier for providing input signal return isolation and driving push-pull loads; a differential current amplifier for use with high-impedance pickoff bridge circuits in sensors; a high-gain a-c amplifier; a decade amplifier with a voltage gain of 10; a d-c operational amplifier; and a wide-band amplifier with high gain-bandwidth product.

One complication in the use of integrated circuits in electromechanical control systems is the absence of transformers in microelectronic form. Other means are required to provide isolation between signal return lines and the common ground bus. This is why differential amplifiers with high common-mode signal-rejection are used.

Another problem is that the circuit designer seldom can combine pnp and npn transistors in complementary circuitry. All the elements of the semiconductor integrated circuit are produced by the same process; to combine npn and pnp transistors would require a very complex production process. Usually npn transistors, which are easier to produce than pnp transistors, are used.

Circuit design isn't the only problem. The most severe causes of rejects are the random surface and internal defects that occur in the semiconductor material. When a semiconductor integrated circuit contains one of these defects, it generally cannot be used. Since the defects are distributed at random over a slice of material, the probability of defect-free semiconductor integrated circuits increases as the area of the integrated circuit decreases. In general, the die size should not exceed 50 by 50 mils. Passive elements generally require larger areas than do transistors or diodes.

Find
the
product...
Fast!



It's quick and easy to locate any of the thousands of electronic and allied products in your **Electronics Buyers' Guide**. All are listed clearly and unmistakably, cross-indexed with end use terms, synonyms and newly devised terms. And, all advertisers in the EBG are carefully cross-referenced to their catalog-advertisement. Top this off with 6,000 trade names indexed alphabetically and you have the most complete, accurate and authentic product listings in the industry!

Electronics Buyers' Guide
A McGraw-Hill Publication
330 West 42nd Street,
New York, N.Y. 10036

PINPOINT

your

RECRUITMENT ADVERTISING

**to the Engineers
and Technical
Management men
in the
Electronics
Industry . . .**

When you need Engineers—remember this fact: **Electronics** serves thousands of engineers with the latest engineering developments and news of the electronics industry. Engineers read **Electronics** because its high calibre editorial content is *specially designed for them* . . . that's why your Employment advertising in **Electronics** can pinpoint a most concentrated source of experienced engineers. Your **MOST DIRECT LINK** to these qualified men is in the **EMPLOYMENT OPPORTUNITIES** section. For more facts, of placement of your ad,

For Rates and Information Write:

Electronics

**A McGraw-Hill Publication
Classified Advertising
Division
P.O. Box 12, New York
10036**

SENIOR STAFF EXPANSION: SCIENTISTS AND ENGINEERS

room for
achievement
at **IBM**®

Opportunities: At all technical staff levels to work on aircraft, missile and aerospace projects, and studies connected with lunar logistics vehicles, computer concepts, reconnaissance/surveillance techniques, tactical systems, TITAN II and III, MOL, MORL, OSSS, GEMINI, and SATURN I, IB and V.

Expansion of the senior staff at the IBM Space Guidance Center* in Owego, N. Y., with groups also located at Huntsville, Ala., and Los Angeles, Calif., requires people skilled in the advanced technologies implicit in these R&D areas:

Creative Mathematics

Operations research and analysis
Space navigation (trajectory and orbital analyses)
Systems synthesis

Advanced Systems Design

Inertial guidance and navigation
Reconnaissance data acquisition and processing
Flight control systems
Communications systems

Advanced Equipment Design

Electronic sensors (radar processors)

Optical/infrared sensors

Laser systems

Advanced computers:

- Organization
- Design automation
- Logic design
- Thin film circuits
- Input/Output devices
- Integrated circuits (semiconductor physics)

Qualifications: A scientific or engineering degree in any one of a broad range of disciplines, with related experience in one or more of the areas listed above. IBM is an Equal Opportunity Employer.

Please write, outlining your qualifications and interests, to: **R. R. Hayden, Manager of Employment, IBM Space Guidance Center, Dept. 554-1, Owego, New York 13827.**

*The Space Guidance Center was built on a 700-acre site in 1957 to contain IBM's defense and space efforts. Current projects include TITAN II and III, MOL, MORL, OSSS, GEMINI, and SATURN I, IB and V.

ENGINEERS WANTED THE CANADIAN BROADCASTING CORPORATION

is seeking Engineers interested in the following fields

1. Television Broadcast Studio System and Equipment Design and Installation.
2. Television and Radio Broadcast Transmitter Installation and Design.

Positions to be filled are permanent and carry pension, sickness and other benefits including generous leave allowances.

Salary Range: up to \$10,000 per annum depending on qualifications and experience.

Base location will be Montreal but some travelling will be required.

It is desirable that applicants hold a degree in Electrical Engineering from a recognized University or have equivalent professional qualifications and have at least five years directly applicable experience. However applicants with other qualifications may be considered.

Arrangements will be made to interview suitable applicants. Applications, complete with resume of education and experience should be mailed to:

Personnel Office,
Canadian Broadcasting Corp.,
7925 Cote St. Luc Road,
Montreal 29, Quebec, CANADA.



E. E.'s
for FEE-PAID Positions
WRITE US FIRST!
Use our confidential application for professional, individualized service . . . a complete national technical employment agency.
ATOMIC PERSONNEL, INC.
Suite 1207L, 1518 Walnut St., Phila. 2, Pa.

RESUMES

Job Resume Writing Instructions & Samples.
Everything needed to effectively sell yourself —Only \$1.95. Resume Consultants, 418 N. 63rd Street, Phila., Pa. Editing & Printing Service available. Write for free details.

An employment advertisement in this **EMPLOYMENT OPPORTUNITIES** section will help you find the engineers you need. It's an inexpensive, time saving method of selecting competent personnel for every engineering job.

SEARCHLIGHT SECTION

STEPPING SWITCHES SIGMA HERMETICALLY KURMAN
SENSITROLS WARD LEONARD
STRUTHERS M. AUTOMATIC
DUNN ELECTRIC
ROTARY RACHET LEACH CLARE
ALLIED LEVENS NOLD
LEDEX CLARE
CLARE ANCE
LEACH ALLIED
MINIA CRAFT
SIGMA LEDEX
NORTH KEYING
ELECTRIC PHILLIPS
DORMEYER CONTROLS
TELEPHONE AMPERITE
TYPE
KURMAN PRODUCTION WESTERN
QUANTITIES ELECTRIC
STEVENS MOST MAKES CUTLER
ARNOLD IN STOCK HAMMER
CONTACT Send for GENERAL
MERCURY Latest ELECTRIC
SOLENOIDS Catalog GUARDIAN
ADVANCE E CONTACTORS
ALLEN BRADLEY PRICE ELECTRIC
POTTER SQUARE D WESTON
BRUMFIELD MINIATURE AIRCRAFT

LARGEST STOCK OF RELAYS IN THE WORLD

Universal RELAY CORP.

42 WHITE ST. NEW YORK 13, N. Y. WALKER 5-6900

CIRCLE 951 ON READER SERVICE CARD

V-I-S* SERVICE



FASTEST TO BOTH COASTS

FOR YOUR VERY IMPORTANT SHIPMENTS

2nd DAY between Chicago—Milwaukee and Eastern Terminals

4th DAY between Chicago—Milwaukee and West Coast.

LIFSCHULTZ FAST FREIGHT

NEW YORK — CHICAGO — PHILADELPHIA — BOSTON
HOLYoke — BALTIMORE — BLOOMFIELD, N. J.
NEW HAVEN — PROVIDENCE — MILWAUKEE
LOS ANGELES — SAN FRANCISCO

CIRCLE 950 ON READER SERVICE CARD

ELECTRON TUBES

KLYSTRONS • ATR & TR • MAGNETRONS
SUBMINIATURES • C.R.T. • T.W.T. • 5000-6000 SERIES

• SEND FOR NEW CATALOG A2 •
A & A ELECTRONICS CORP.
1063 PERRY ANNEX
WHITTIER, CALIF.
AN 92865 OR 696-7544

CIRCLE 952 ON READER SERVICE CARD

★ WRITE FOR NEW **KEYSTONE free catalog** ★

★ BATTERY HOLDERS, TERMINALS, ★
★ TERMINAL BOARDS & HARDWARE ★

KEYSTONE ELECTRONICS CORP.
49 BLEECKER ST., NEW YORK 12, N. Y.

CIRCLE 953 ON READER SERVICE CARD

TUBES & COMPONENT FREE...CATALOG BARRY ELECTRONICS

512 BROADWAY NEW YORK 12, N.Y. 212-WALKER 5-7000 TWX-571-0484

CIRCLE 954 ON READER SERVICE CARD



U.S. ARMY EE-8
Telephone fully reconditioned at 2 for \$35.00. Any number can be used on same line. Wire 2c per ft. or \$65.00 per mile. Write for complete telephone list.

TELEPHONE ENGINEERING CO.
Dept. E-8241
Simpson, Pa.

CIRCLE 955 ON READER SERVICE CARD

SMALL AD but BIG STOCK
of choice test equipment and surplus electronics
Higher Quality—Lower Costs
Get our advice on your problem

ENGINEERING ASSOCIATES
434 Potterson Road — Doyton 19, Ohio

CIRCLE 956 ON READER SERVICE CARD

free catalog POTTING APPLICATORS MANUAL AND DISPOSABLE

6cc 12cc 30cc

FOR POTTING, ENCAPSULATING, AND SEALING OF MINIATURE COMPONENTS

PHILIP FISHMAN COMPANY
7 CAMERON ST., WELLESLEY 81, MASSACHUSETTS

CIRCLE 957 ON READER SERVICE CARD

RADAR AUTO-TRACK & TELEMETRY ANTENNA PEDESTALS
3 & 10 CM. SCR 584 AUTOTRACK RADARS. M-33 RADAR
TPS-1D SEARCH. APS-45 TPS-10D HT. FINDERS. WX RADARS.
FPN-32GCA. APS-10 APS-15B APS-27 (AMTI) SEARCH. ■
APN-102 DOPPLER. DOZENS MORE. GARGINDRONS. PFFVS.
25-51-23-6 MEGAWATT PULSE MODULATORS. CAVITIES.
PULSE TRANSFORMERS. IF STRIPS. WAVEGUIDE. BENDS
200 MC. 1 KMC. 3 KMC. 6 KMC. 9 KMC. 24 KMC. RF PKGS.

RADIO RESEARCH INSTRUMENT CO.
550 5TH AVE., NEW YORK 36, N. Y. JU 6-4691

CIRCLE 958 ON READER SERVICE CARD

COMINCO

HIGH PURITY METALS
AVAILABLE FORMS

clip and save

Product	ALUMINUM	ANTIMONY	ARSENIC	BISMUTH	CADMIUM	GOLD	INDIUM	LEAD	SILVER	TIN	ZINC
BARS	✓	✓	✓	✓	✓	✓	✓	✓	✓	✓	✓
SHEETS	✓				✓	✓	✓	✓	✓	✓	✓
WIRE	✓				✓		✓			✓	✓
POWDER		✓	✓	✓	✓	✓	✓	✓	✓	✓	✓
SHOT		✓		✓	✓	✓	✓	✓	✓	✓	✓
ROD	✓			✓	✓		✓	✓	✓	✓	✓
RIBBON							✓	✓			
PRE-FORMS	✓				✓	✓	✓	✓	✓	✓	✓
SALTS					✓		✓				

COMINCO PRODUCTS, INC.

electronic materials division

818 West Riverside Avenue, Spokane, Washington 99201

Phone Area Code 509 RI 7-6111 • TWX 509 328-1464

Circle 218 on reader service card

3602



Advertising sales staff

Gordon Jones: [212] 971-2210
Advertising sales manager

Atlanta, Ga. 30309: Gus H. Krimsier,
Michael H. Miller, 1375 Peachtree St. N.E.,
[404] TR 5-0523

Boston, Mass. 02116: William S. Hodgkinson,
McGraw-Hill Building, Copley Square,
[617] CO 2-1160

Chicago, Ill. 60611: Robert M. Denmead,
Daniel E. Shea, Jr., 645 North Michigan
Avenue, [312] MO 4-5800

Cleveland, Ohio 44113: Paul T. Fegley, 55
Public Square, [216] SU 1-7000

Dallas, Texas 75201: Richard P. Poole, The
Vaughn Building, 1712 Commerce Street,
[214] RI 7-9721

Denver, Colo. 80202: John W. Patten, David
M. Watson, Tower Bldg., 1700 Broadway,
[303] AL 5-2981

Houston, Texas 77025: Kenneth George,
Prudential Bldg., Halcombe Blvd.,
[713] RI 8-1280

Los Angeles, Calif. 90017: Ashley P.
Hartman, John G. Zisch, 1125 W. 6th St.,
[213] HU 2-5450

New York, N.Y. 10036:
Donald R. Furth [212] 971-3616
Frank LeBeau [212] 971-3615
George F. Werner [212] 971-3617
500 Fifth Avenue

Philadelphia, Pa. 19103: William J. Boyle,
Warren H. Gardner, 6 Penn Center Plaza,
[215] LO 8-6161

San Francisco, Calif. 94111:
James T. Hauptli, 255 California Street,
[415] DO 2-4600

London W1: Edward E. Schirmer, 34 Dover
Street, Hyde Park 1451

Frankfurt/Main: Matthee Herfurth, 85
Westendstrasse Phone: 77 26 65 and
77 30 59

Geneva: Michael R. Zeynel,
2 Place du Port 244275

Paris VIII: Denis Jacob, 17 Avenue
Matignon ALMA-0452

Tokyo: Nobuyuki Sato, 1, Kotohiracho,
Shiba, Minato-ku (502) 0656

Osaka: Kazutaka Miura, 163, Umegae-cho,
Kita-ku [362] 8771

Nagoya: International Media Representa-
tives, Yamagishi Bldg., 13,2-Chome,
Oike-cho Naka-ku

Hugh J. Quinn: [212] 971-2335
Manager Electronics Buyers' Guide

David M. Tempest: [212] 971-3139
Promotion manager

Milton Drake: [212] 971-3485
Market research manager

Richard J. Tomlinson: [212] 971-3191
Business manager

Theodore R. Geipel: [212] 971-2044
Production manager

See GRC at NEC Booth #352

Primo MICROPHONES

A complete line of
microphone cartridges
and units for
the OE market

Types :

* Velocity	* Uni-Directional	* Crystal	* Magnetic
* Dynamic	* Condenser	* etc.	

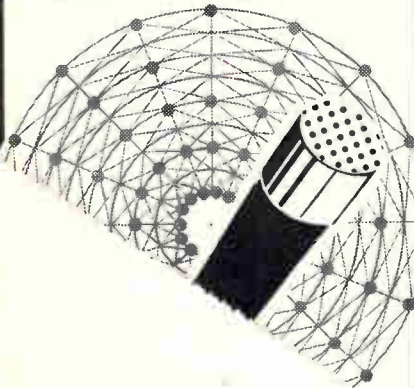

LTD.
KASHI,
JAPAN



**NYLON
COIL BOBBINS**

WIDE RANGE OF STOCK SIZES
—from 1/4" diam. x 11/64" long,
to 1-1/16" diam. and 1-1/16" long.
Round, square, rectangular to your
specs. Any thermoplastic, any
shape, any size. (No minimum size.
Maximum to 1-1/16" x 1-1/16".)

YOU SAVE thru GRC's exclusive
mass production methods—single
cavity techniques—on fully auto-
matic, patented machines. GRC's
one-piece nylon molded bobbins
are highly uniform-accurate. Speed
winding, make the most out of
nylon's outstanding properties.

When you need bobbins, you want
GRC. Send for standard stock sheet
or quotes on sizes, shapes, and
materials to your order.

Write now for
prices and new
GRC Fastener
Catalog



GRIES REPRODUCER CORP.
World's Foremost Producer of Small Die Castings
151 Beechwood Avenue • New Rochelle, N. Y.
Phone: (914) NEW Rochelle 3-8600

Circle 219 on reader service card

on reader service card

Reprint service

All Electronics editorial matter available in reprint form:

For reprints of special reports and feature articles see list on right side of this page. Send your order to Electronics Reprint Department at the address indicated. To expedite mailing of your order for single reprints please send cash, check or money order with your order.

Bulk reprints of editorial matter can be ordered from current or past issues. The minimum quantity is 100 copies. The higher the quantity ordered, the more economical the cost per copy. Prices quoted on request.

To order reprints or for further information, please write to: Electronics Reprint Department, 330 West 42nd Street, New York, N.Y. 10036. Telephone: Area code 212 971-3140.

Business reply mail

No postage stamp necessary if mailed in the United States

Postage will be paid by

First class
Permit no. 42
Hightstown, N. J.



Electronics
Reader service department
Box 444
Hightstown, N. J. 08520

26 Please give complete information

Name _____ title _____

Company _____

Address _____

14

Oct 5, 1964

Card Expires

Dec. 5, 1964

1 19 37 55 73 91 109 127 145 163 181 199 217 235 253 271 289 307 325 343 361 379 397 415 433 451 469 487 963
 2 20 38 56 74 92 110 128 146 164 182 200 218 236 254 272 290 308 326 344 362 380 398 416 434 452 470 488 964
 3 21 39 57 75 93 111 129 147 165 183 201 219 237 255 273 291 309 327 345 363 381 399 417 435 453 471 489 965
 4 22 40 58 76 94 112 130 148 166 184 202 220 238 256 274 292 310 328 346 364 382 400 418 436 454 472 900 966
 5 23 41 59 77 95 113 131 149 167 185 203 221 239 257 275 293 311 329 347 365 383 401 419 437 455 473 901 967
 6 24 42 60 78 96 114 132 150 168 186 204 222 240 258 276 294 312 330 348 366 384 402 420 438 456 474 902 968
 7 25 43 61 79 97 115 133 151 169 187 205 223 241 259 277 295 313 331 349 367 385 403 421 439 457 475 951 969
 8 26 44 62 80 98 116 134 152 170 188 206 224 242 260 278 296 314 332 350 368 386 404 422 440 458 476 952 970
 9 27 45 63 81 99 117 135 153 171 189 207 225 243 261 279 297 315 333 351 369 387 405 423 441 459 477 953 971
 10 28 46 64 82 100 118 136 154 172 190 208 226 244 262 280 298 316 334 352 370 388 406 424 442 460 478 954 972
 11 29 47 65 83 101 119 137 155 173 191 209 227 245 263 281 299 317 335 353 371 389 407 425 443 461 479 955 973
 12 30 48 66 84 102 120 138 156 174 192 210 228 246 264 282 300 318 336 354 372 390 408 426 444 462 480 956 974
 13 31 49 67 85 103 121 139 157 175 193 211 229 247 265 283 301 319 337 355 373 391 409 427 445 463 481 957 975
 14 32 50 68 86 104 122 140 158 176 194 212 230 248 266 284 302 320 338 356 374 392 410 428 446 464 482 958 976
 15 33 51 69 87 105 123 141 159 177 195 213 231 249 267 285 303 321 339 357 375 393 411 429 447 465 483 959 977
 16 34 52 70 88 106 124 142 160 178 196 214 232 250 268 286 304 322 340 358 376 394 412 430 448 466 484 960 978
 17 35 53 71 89 107 125 143 161 179 197 215 233 251 269 287 305 323 341 359 377 395 413 431 449 467 485 961 979
 18 36 54 72 90 108 126 144 162 180 198 216 234 252 270 288 306 324 342 360 378 396 414 432 450 468 486 962 980

For Subscriptions: New Renewal, [check one box] Domestic and Canada, 3 years \$12.00, 1 year \$6.00

You may order the following reprints by key number using order form on page 163

Prices for the below listed reprints unless otherwise specified are 1-10 copies 50¢ each; 11-24 copies 35¢ each; 25-99 copies 25¢ each; for price on 100 or more copies please request quote.

Key no. R-61 Direct Digital Control In Industry, 24 pages.

Key no. R-60 Transistor Heat Dissipators, Part II, 8 pages 25¢

Key no. R-59 Transistor Heat Dissipators, Part I, 24 pages.

Key no. R-58 Oceanography, 15 pages.

Key no. R-57 Magnetics, 24 pages.

Key no. R-56 The Case For Magnetic Logic, 8 pages. 35¢

Key no. R-55 Voltage Variable Capacitors Used For Electronic Tuning, 9 pages. 35¢

Key no. R-53 Digital Instrumentation, 16 pages.

Key no. R-49 Injection Laser Systems, [2 part series] 12 pages. 35¢

Key no. R-48 Modern Electronic Packaging, 16 pages.

Key no. R-47 Electronic Markets New Directions 1963-64-67, 20 pages.

Key no. R-45 Today's Semiconductors, 24 pages.

Key no. R-42 Materials for Space Age Electronics, 16 pages.

Key no. R-41 Telemetry Today, 7 pages. 25¢

Key no. R-40 Tunnel Diodes, [4 part series] 26 pages.

Key no. R-39 Radio Frequency Interference, 24 pages.

Key no. R-38 Family Tree of Semiconductors, [22" x 11" foldout chart].

Key no. R-31 1962 Electromagnetic Spectrum Chart, [22" x 30" foldout chart]. \$1.00

Key no. R-30 Graphical Symbols For Electronic Diagrams, [29" x 11" foldout chart].

Key no. R-26 Lasers Devices and Systems, [1961 4 part series] 23 pages. \$1.00

Key no. R-19 Medical Electronics, [1961 7 part series] 42 pages. \$1.50

Business reply mail

No postage stamp necessary if mailed in the United States

Postage will be paid by

First class
Permit no. 42
Hightstown, N. J.



Electronics
Reader service department
Box 444
Hightstown, N.J. 08520

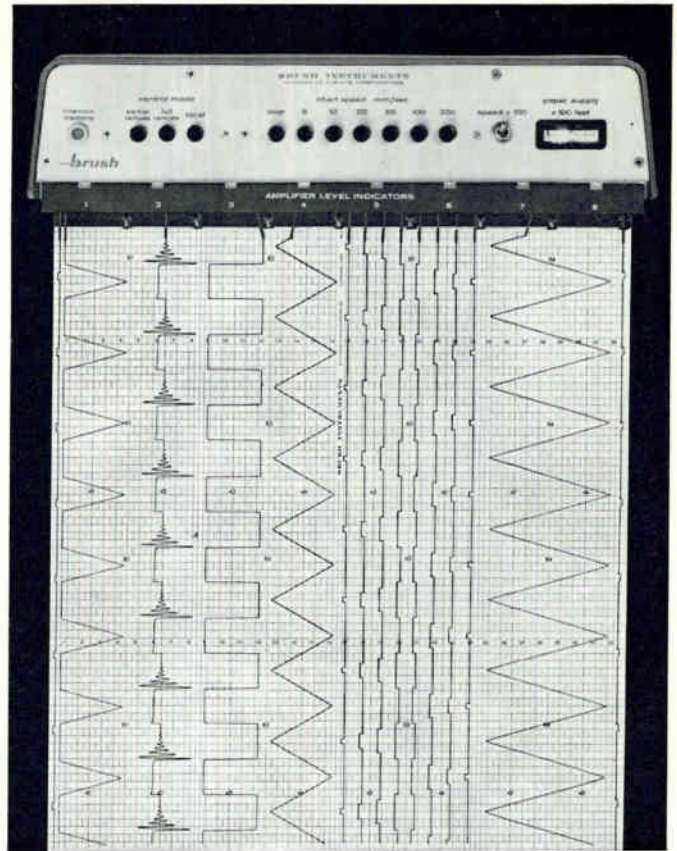
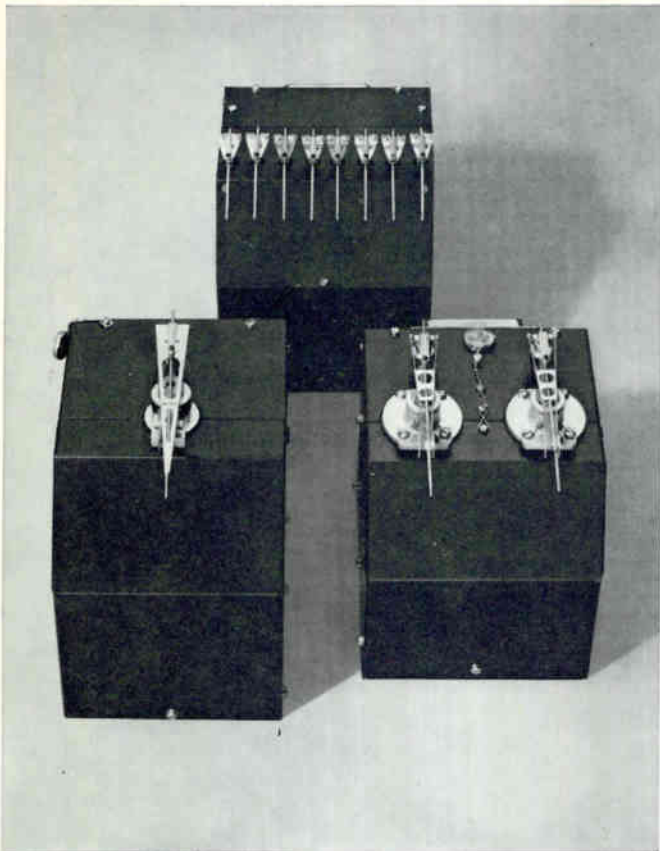

These are Optional Penmotors for the Brush Mark 200 Series 1707 Recorders

You should see the information they give ...in combination!

(modern oscillography will never be the same)

Optional penmotors are the newest of several Brush innovations that change previous notions about today's direct writing recording. The pace-setting Mark 200 now gives you any combination of variables . . . 80mm channels for extreme resolution in absolute measurement . . . 40mm channels for coordination of dynamic information . . . "yes-no" information from time-codes, relays, actuators, etc. *One recorder presents them all . . . in any combination . . . on the same chart . . . on a common time base!* The choice is yours! And, a pressurized inking system with over 10,000 channels of performance produces traces so accurate and crisp that you can't mis-read the signal. *True* rectilinear motion results from a unique linkage that creates a straight line 99.9% accurate. A super-sensor called the Metrisite "polices" the pen position for instant self-correction without mechanical restraint. The rule book of oscillography is changed. Check Brush for *new* standards. Your letterhead request will bring the complete story.



brush INSTRUMENTS
DIVISION OF **CLEVITE** 37TH AND PERKINS, CLEVELAND 14, OHIO

Circle 901 on reader service card

Here is an excellent core driver

... One that's been popular
for two years

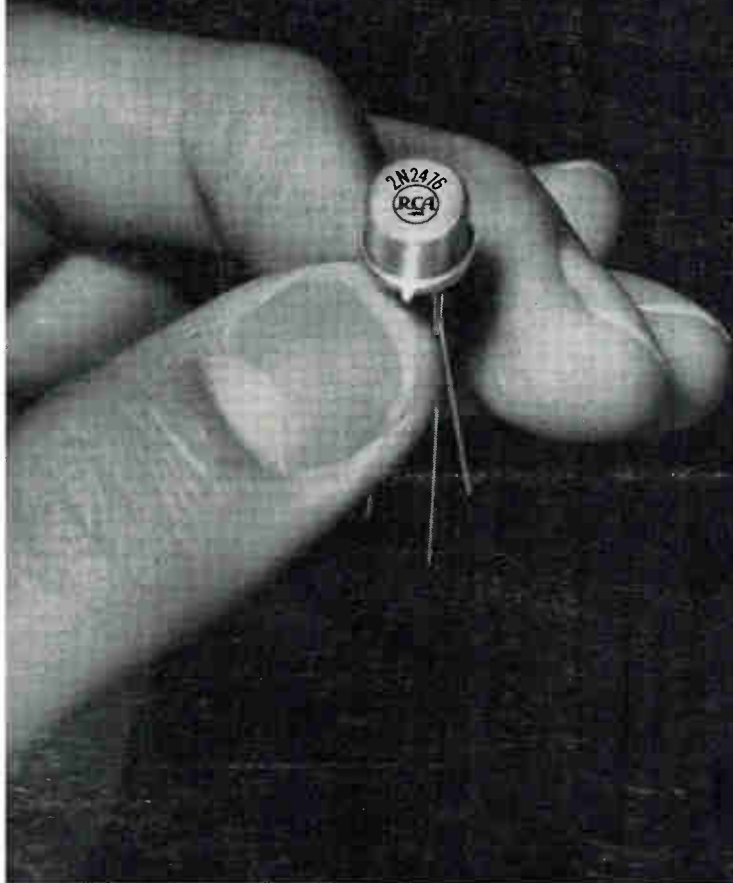

Here's an even better one

... Delivers 75% more driving
voltage without sacrificing speed
(at only slightly higher cost)

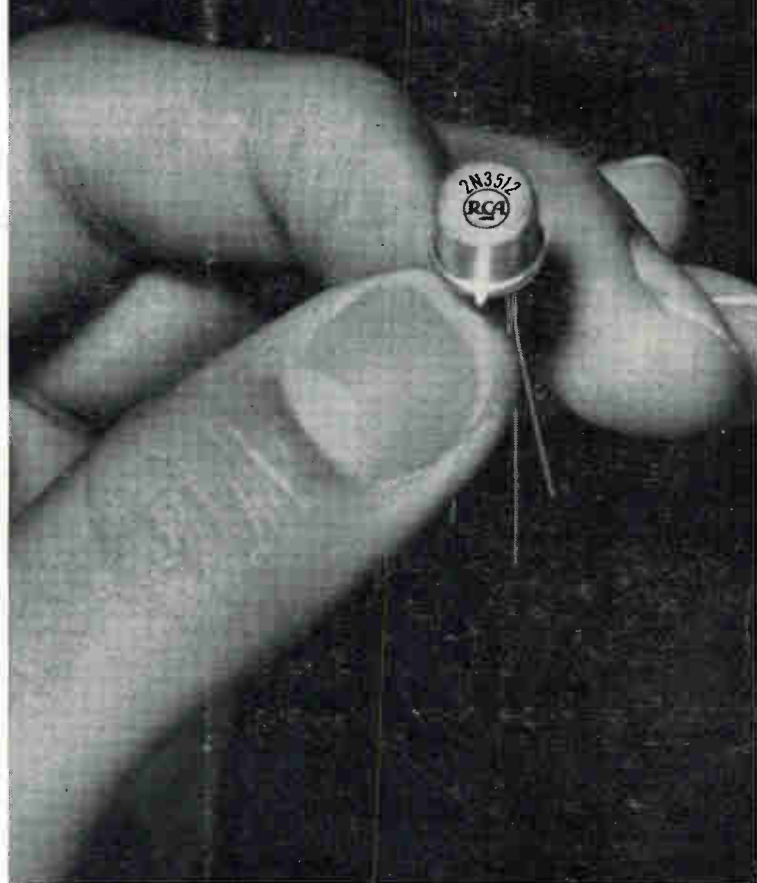

That's right! A 75% boost in collector-to-emitter voltage capability ($BV_{CE0} = 35$ volts as compared with 20 volts for the popular 2N2476, 2N2477) makes the new RCA 2N3512 ideal for high-voltage, high-speed, high-current switching applications.

Current capability is the same: 500 ma.

Because of its high voltage capability, the 2N3512 is particularly useful in large, modern computers where memories are both faster and larger... with higher inductive voltages. The high-speed, high-voltage capabilities of the 2N3512 make it applicable not only to large-scale commercial computers, but also to special-purpose digital test and communications equipment.

RCA ELECTRONIC COMPONENTS AND DEVICES, HARRISON, N. J.

Other outstanding features of the 2N3512:

- Turn-on time: 16 nsec typical, at $I_C = 150$ ma
- Turn-off time: 27 nsec typical at $I_C = 150$ ma
- Storage time: 17 nsec typical at $I_C = 150$ ma
- Gain-bandwidth product: 375 Mc typical
- $V_{CE}(\text{sat})$: 1.0 volt maximum, 0.45 volts typical at $I_C = 500$ ma, $I_B = 50$ ma

For full technical information call your RCA Field Representative. Or write: Commercial Engineering, Section C-N-10-1, RCA Electronic Components and Devices, Harrison, N. J.

AVAILABLE THROUGH YOUR RCA DISTRIBUTOR



The Most Trusted Name in Electronics

Circle 902 on reader service card