

MAY 8, 1959

# electronics

A MCGRAW-HILL PUBLICATION

VOL. 32, No. 19

PRICE SEVENTY-FIVE CENTS

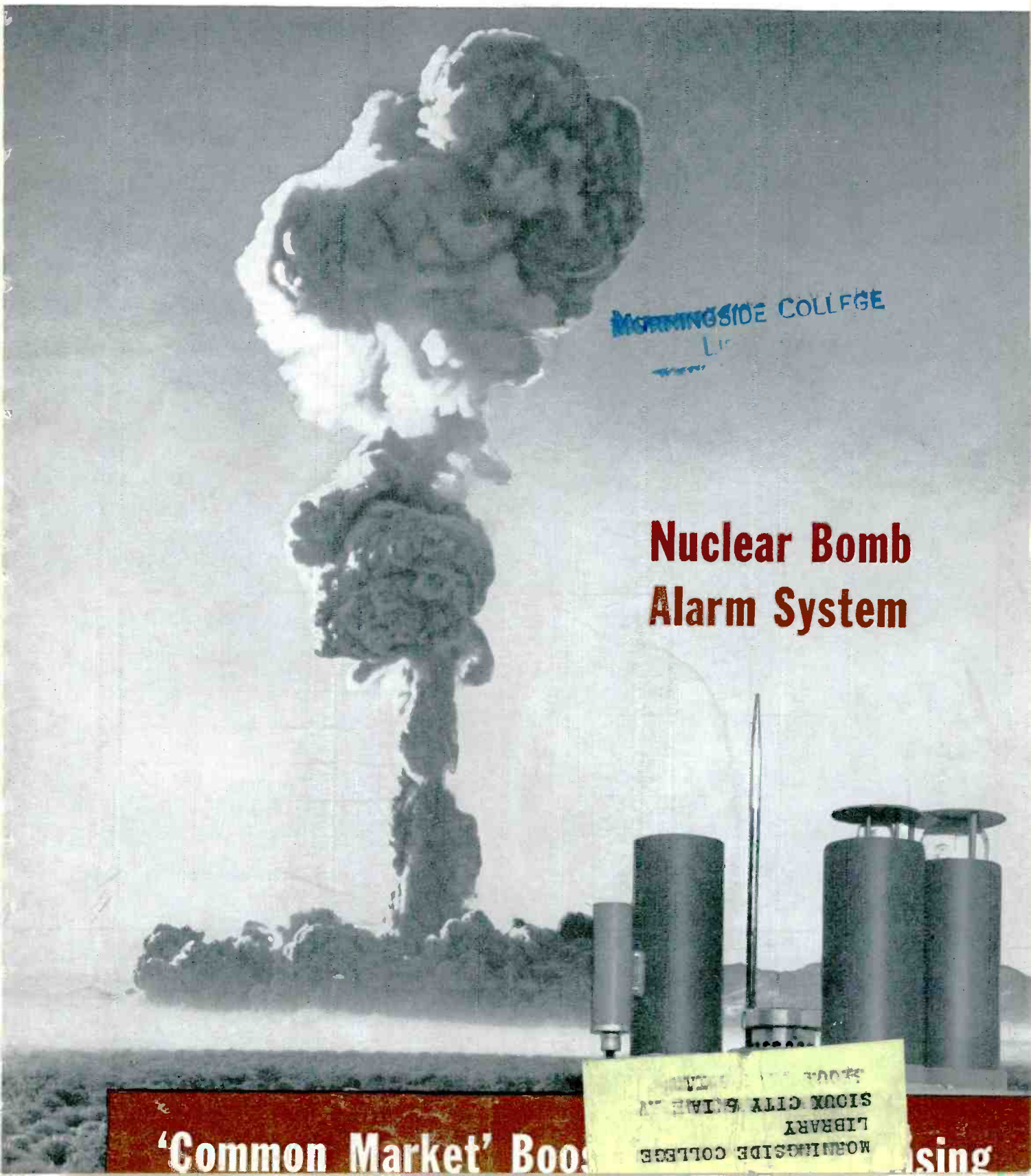

MORRINGSIDE COLLEGE  
LIBRARY

## Nuclear Bomb Alarm System

'Common Market' Boost

MORRINGSIDE COLLEGE  
LIBRARY  
ST. JOSEPH CITY, MISSOURI

ing

# Creative Microwave Technology

Published by Microwave and Power Tube Division, Raytheon Manufacturing Company, Waltham 54, Mass., Vol. 1, No. 4

## NEW KILO-LINE RECORDING STORAGE TUBES SPECIALLY DESIGNED FOR SCAN CONVERSION

To meet the need for low-noise, high-resolution devices for frequency and scan conversion, Raytheon scientists and engineers have developed two new storage tubes: the single-gun QK-685 and the dual-gun QK-703. These tubes are now available in production quantities.

Both types incorporate a specially designed tetrode electron gun for higher resolutions — 1,000 TV lines at 50% modulation — and better control over beam cut-off than conventional triode guns. A new multiple collimating lens improves background uniformity and results in shading-to-signal ratios of less than 10%.

The ability of the dual-gun type to read and write simultaneously makes this tube particularly applicable to slow-down video and conversion from PPI to TV scan patterns for "Bright Display."

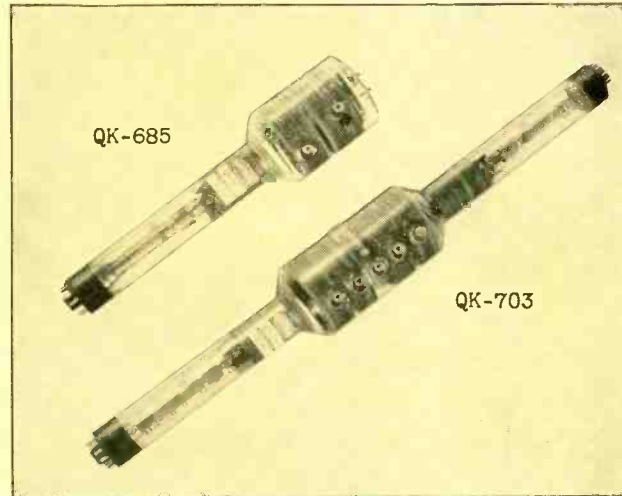

Typical Operating Characteristics

QK-685 and QK-703	
Anode Voltage	4,000 Vdc (Max.)
Resolving Power	1,000 Lines (Nom.)
Magnetic Focus	700 Lines (Nom.)
Electrostatic Focus	QK-685—10 $\mu\text{f}$ (Nom.)
Output Capacitance	QK-703—20 $\mu\text{f}$ (Nom.)
Maximum Deflection Angle	30°

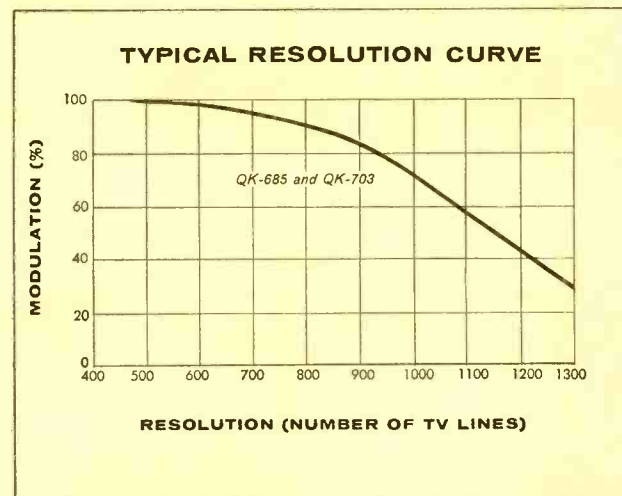
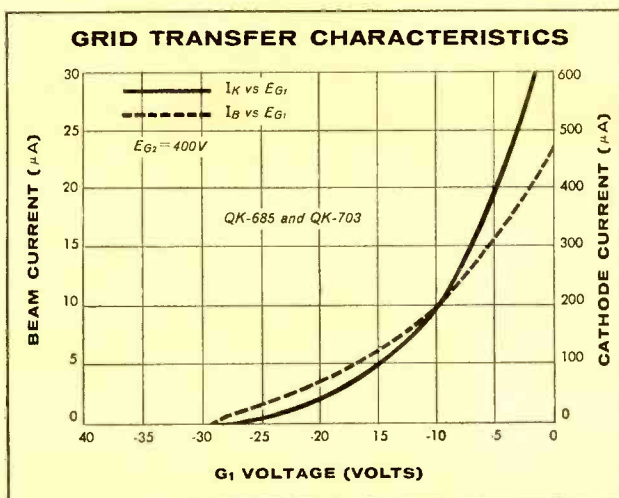

Excellence in Electronics



You can obtain detailed application information and special development services by contacting: Microwave and Power Tube Division, Raytheon Manufacturing Company, Waltham 54, Massachusetts

A LEADER IN CREATIVE MICROWAVE TECHNOLOGY

## Issue at a Glance

A McGRAW-HILL PUBLICATION  
Vol. 32 No. 19

JAMES GIRDWOOD, *Publisher*

W. W. MacDONALD, *Editor*

JOHN M. CARROLL, *Managing Editor*

*Associate Editors:* Frank Leary, Michael F. Tomaino, Howard K. Janis, Sylvester P. Carter, Haig A. Manoogian, Roland J. Charest, William P. O'Brien, George Sideris, John F. Mason, William E. Bushor, Ronald K. Jurgen, Thomas Emma, Samuel Weber, Sy Vogel.

*Pacific Coast Editor (Los Angeles)* Harold C. Hood; *Midwestern Editor (Chicago)* Harold Harris; *New England Editor (Boston)* Thomas Maguire.

*Art Director*, Harry Phillips, Roy Thompsen.

*Production Editor*, John C. Wright, Jr., Bernice Duffy, Jean L. Matin.

*Market Research*, Edward DeJongh, Marilyn Koren.

*Editorial Assistants*, Gloria J. Filippone, Arlene Schilp, Patricia Landers, Catherine McDermott, Eleanor Schaefer, Carol Weaver.

**BRUCE A. WINNER**, *Advertising Sales Manager*. R. S. Quint, *Assistant Advertising Sales Manager and Buyers' Guide Manager*. Fred Stewart, *Promotion Manager*. Frank H. Ward, *Business Manager*. George E. Pomeroy, *Classified Manager*. Hugh J. Quinn, *Circulation Manager*.

*New York:* Donald H. Miller, Henry M. Shaw, William J. Boyle. *Boston:* Wm. S. Hodgkinson. *Philadelphia:* Warren H. Gardner. *Chicago:* Harvey W. Wernecke, Martin J. Gally. *Cleveland:* P. T. Fegley. *San Francisco:* T. H. Carmody, R. C. Alcorn. *Los Angeles:* Carl W. Dysinger, D. A. McMillan. *Denver:* J. Patten. *Atlanta:* M. Miller. *Dallas:* Gordon L. Jones, Robert T. Wood. *London:* E. E. Schirmer. *Frankfurt:* Michael R. Zeynel.

### Business

European Licensing Grows. What U.S. firms are doing—and why . . .	30
Air Force Updates Network. More business for our industry . . . . .	35
Infrared Spots Air Pollution. New systems fight smog . . . . .	38
Computers Going Underground. Miniaturization is the key . . . . .	45
Shoptalk . . . . .	4
Electronics Newsletter . . . . .	11
Washington Outlook . . . . .	14
Financial Roundup . . . . .	19
Over The Counter . . . . .	19
Market Research . . . . .	24
Current Figures . . . . .	24
Meetings Ahead . . . . .	46

### Engineering

Tower-mounted nuclear blast detectors activate warning alarms, blast doors and air filter systems in underground installations. See p 53 . . . . .	COVER
Nuclear Bomb Alarm Systems. Electronic sentry activates protective measures . . . . . By J. C. Champeny, T. E. Petriken and S. Siciliano	53
Compatible Stereo Radio Using A-M/F-M Multiplex. Stereo for the standard broadcast band . . . . . By H. E. Sweeney	56
Transistor Dual Conversion for Marker-Beacon Receivers. Marker-beacon receiver is transistorized . . . . . By R. G. Erdmann	59
Dopplar Radar Navigation. Characteristics are tabulated for 11 radars . . . . . By F. B. Berger	62
Zero-Crossing Technique Syncs Wavetrain Outputs. Output starts a zero crossing of sine wave . . . . . By J. A. Werek, Jr.	64
Using Tv Techniques in Astronomy. Electronics serves as an astronomical tool . . . . . By J. Borgman	66
High-Temperature Cables. Tabulation of information on coaxial cables that employ Teflon dielectrics . . . . . By E. T. Pfund, Jr.	69
How to Design Reflexed Transistor Receivers. Proper design avoids motorboating . . . . . By J. Waring	70
Microwave Measurements. Microwave equipment calibration time reduced . . . . . By J. H. Corn	74

### Departments

Research and Development. Tracer Displays Zener Curves . . . . .	76
Components and Materials. Graphite Becomes Available as a Fabric . .	80
Production Techniques. Air Cylinders Operate Assembler . . . . .	84
On the Market . . . . .	88
Literature of the Week . . . . .	116
Plants and People . . . . .	120
News of Reps . . . . .	123
Comment . . . . .	124
Index to Advertisers . . . . .	134



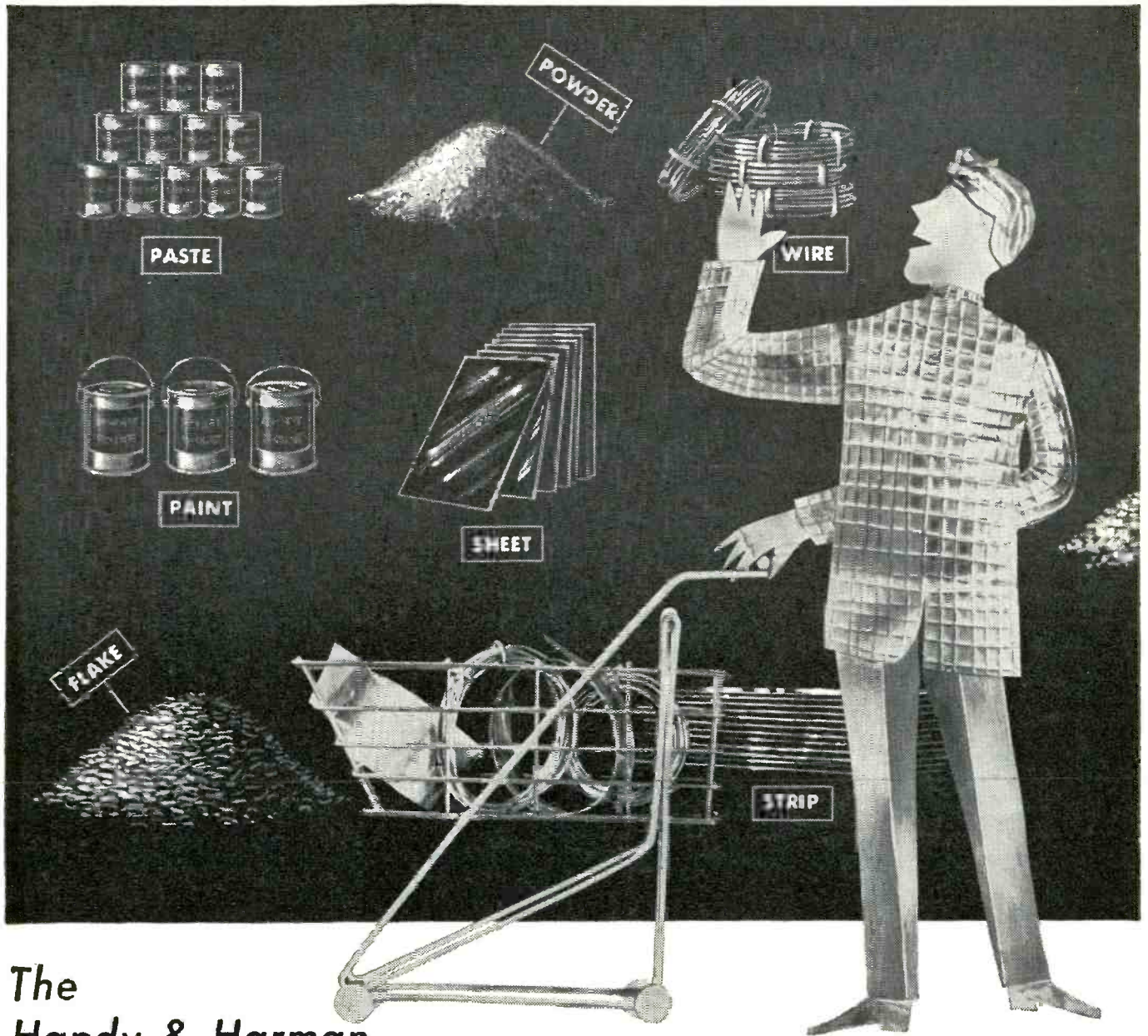

The  
Handy & Harman

# Silver Supermarket

Has every form of silver for your electronics applications

Silver, in many forms and alloys, is a necessity in the electronics and electrical industries. To meet this need on a high quality level, Handy & Harman manufactures powder, flake, paint, paste, sheet, strip, wire, etc., for printed circuits, wiring, resistors, condensers, thermistors, contacts, printed terminal strips on glass, ceramics, plastic laminates, etc.

Another "At Your Service" Division of the Handy & Harman Silver Supermarket is our Research and Engineering Department. Always ready to help you with any problem or project you may have involving silver for *any* application.

#### VISIT OUR BOOK DEPARTMENT

We have five Technical Bulletins giving engineering data on the properties and forms of Handy & Harman Silver Alloys. We would like you to have any or all of those that

particularly interest you. Your request, by number, will receive prompt attention.

- Fine Silver ..... Bulletin A-1
- Silver-Copper Alloys ..... Bulletin A-2
- Silver-Magnesium-Nickel ..... Bulletin A-3
- Silver Conductive Coatings ..... Bulletin A-4
- Silver Powder and Flake ..... Bulletin A-5

Your No. 1 Source of Supply and Authority  
on Precious Metal Alloys



## HANDY & HARMAN

General Offices: 82 Fulton St., New York 38, N. Y.



# Specific reasons why engineers specify Lambda Power Supplies



*The only power supplies guaranteed for 5 years*

This unprecedented five-year guarantee is the strongest proof of consistent trouble-free power supply performance ever offered. It is bolstered even further by a series of independent surveys which prove that Lambda equipment is preferred by more than 50% of the engineers who specify power supplies.

## CHECK LIST: LAMBDA REGULATED DC POWER SUPPLIES

Model	Style	Voltage Range (VAC)	Current Range (MA DC)	Regulation Impedance Ripple (Table I)	6.3 VAC Output (Amps)	Meters	Output Voltage Control	Output Terminals	Size (Table I)	Price (U.S. and Canada) F.O.B. Factory College Pt., N. Y.
<b>REGULATED POWER SUPPLIES—RACK MOUNTING</b>										
<b>TRANSISTORIZED</b>										
LT-1095	Rack	0-32	0-1000	A	—	None	Rear	Rear	S-1	285.00
LT-1095M	Rack	0-32	0-1000	A	—	2 1/2" rect	Rear	Rear	S-1	315.00
LT-2095	Rack	0-32	0-2000	B	—	None	Rear	Rear	S-1	365.00
LT-2095M	Rack	0-32	0-2000	B	—	2 1/2" rect	Rear	Rear	S-1	395.00
<b>TUBE REGULATED</b>										
C-280	Rack	0-200	0-200	C	10A	None	Rear	Rear	S-2	184.50
C-280M	Rack	0-200	0-200	C	10A	3 1/2" rect	Rear	Rear	S-2	214.50
C-281	Rack	125-325	0-200	C	10A	None	Rear	Rear	S-2	159.50
C-281M	Rack	125-325	0-200	C	10A	3 1/2" rect	Rear	Rear	S-2	189.50
C-282	Rack	325-525	0-200	C	10A	None	Rear	Rear	S-2	169.50
C-282M	Rack	325-525	0-200	C	10A	3 1/2" rect	Rear	Rear	S-2	199.50
C-480	Rack	0-200	0-400	O	15A	None	Rear	Rear	S-2	259.50
C-480M	Rack	0-200	0-400	O	15A	3 1/2" rect	Rear	Rear	S-2	289.50
C-481	Rack	125-325	0-400	O	15A	None	Rear	Rear	S-2	244.50
C-481M	Rack	125-325	0-400	O	15A	3 1/2" rect	Rear	Rear	S-2	274.50
C-482	Rack	325-525	0-400	O	15A	None	Rear	Rear	S-2	259.50
C-482M	Rack	325-525	0-400	O	15A	3 1/2" rect	Rear	Rear	S-2	289.50
C-880	Rack	0-200	0-800	E	20A	None	Rear	Rear	S-3	340.00
C-880M	Rack	0-200	0-800	E	20A	3 1/2" rect	Rear	Rear	S-3	370.00
C-881	Rack	125-325	0-800	E	20A	None	Rear	Rear	S-3	315.00
C-881M	Rack	125-325	0-800	E	20A	3 1/2" rect	Rear	Rear	S-3	345.00
C-882	Rack	325-525	0-800	E	20A	None	Rear	Rear	S-3	360.00
C-882M	Rack	325-525	0-800	E	20A	3 1/2" rect	Rear	Rear	S-3	390.00
C-1580	Rack	0-200	0-1500	F	30A	None	Rear	Rear	S-4	550.00
C-1580M	Rack	0-200	0-1500	F	30A	3 1/2" rect	Rear	Rear	S-4	580.00
C-1581	Rack	125-325	0-1500	F	30A	None	Rear	Rear	S-4	575.00
C-1581M	Rack	125-325	0-1500	F	30A	3 1/2" rect	Rear	Rear	S-4	605.00
C-1582	Rack	325-525	0-1500	F	30A	None	Rear	Rear	S-4	650.00
C-1582M	Rack	325-525	0-1500	F	30A	3 1/2" rect	Rear	Rear	S-4	680.00
28	Rack	200-325	0-100	G	3A	None	Rear	Rear	S-5	59.50
28M	Rack	200-325	0-100	G	3A	3 1/2" rect	Rear	Rear	S-5	89.50
29	Rack	100-200	0-100	H	3A	None	Rear	Rear	S-5	69.50
29M	Rack	100-200	0-100	H	3A	3 1/2" rect	Rear	Rear	S-5	99.50
32	Rack	200-325	0-300	J	2 @ 5A	None	Rear	Rear	S-6	139.50
32M	Rack	200-325	0-300	J	2 @ 5A	3 1/2" rect	Rear	Rear	S-6	169.50
33	Rack	100-200	0-300	J	2 @ 5A	None	Rear	Rear	S-6	154.50
33M	Rack	100-200	0-300	J	2 @ 5A	3 1/2" rect	Rear	Rear	S-6	184.50
50R	Rack	0-500	0-500	K	2 @ 5A	4 1/2" rect	Front	Fr & rear	S-7	420.00
		0-50	0-50	L						
		0-200	0-200	M						
<b>REGULATED POWER SUPPLIES—PORTABLE AND BENCH</b>										
25	Bench	200-325	0-100	G	3A	None	Front	Front	S-8	69.50
26	Bench	100-200	0-100	H	3A	None	Front	Front	S-8	79.50
50	Bench								S-9	440.00
										See Model 50R above
71	Portable	0-500	0-200	N	2 @ 5A	3 1/2" rect	Front	Front	S-10	310.00
		0-50	0-50	P						
		0-200	0-200	Q						

**TABLE I**  
DC OUTPUT VOLTAGE REGULATION, IMPEDANCE, RIPPLE

REGULATION		Internal Impedance (ohms)	Ripple, rms (millivolts or %)
Line (105-125 VAC)	Load (min to max)		
Less than	Less than	Less than	Less than
A 0.15% or 20MV	0.15% or 20MV	0.50	1 mv
B 0.15% or 20MV	0.15% or 20MV	0.025	1 mv
C 0.15% or 0.3V	0.25% or 0.5V	6	3 mv
D 0.15% or 0.3V	0.25% or 0.5V	3	3 mv
E 0.15% or 0.3V	0.25% or 0.5V	1.5	3 mv
F 0.15% or 0.3V	0.25% or 0.5V	0.75	3 mv
G 1%	1%	10	10 mv
H 1%	1%	10	5 mv
J 1%	1%	4	10 mv
K 0.15% or 0.1V	0.5% or 0.3V	2	8 mv
L 0.1%	unregulated	3,300	2 mv
M 0.1%	unregulated	17,500	5 mv
N 0.15% or 0.3V	0.15% or 0.3V	4	5 mv
P 0.1%	unregulated	5,500	2 mv
Q 0.1%	unregulated	25,000	5 mv

**TABLE II**  
SIZES AND WEIGHTS

Size	M x W x D (inches)	WEIGHT	
		Net (lbs)	Shipping (lbs)
S-1	3 1/2 x 19 x 14 1/4	35	65
S-2	5 1/4 x 19 x 14 1/4	53	80
S-3	7 x 19 x 14 1/4	84	100
S-4	8 3/4 x 19 x 14 1/4	120	140
S-5	5 1/4 x 19 x 8	19	23
S-6	10 1/2 x 19 x 9 1/4	42	52
S-7	10 1/2 x 19 x 14 1/4	89	140
S-8	8 x 14 x 6	19	23
S-9	12 1/2 x 22 x 15	110	158
S-10	13 x 8 3/4 x 14 1/2	49	85

### GENERAL SPECIFICATIONS

Sufficient tolerance is incorporated in the specifications to allow for normal commercial component and tube deviations. Tube replacements may be made with any equivalent tubes meeting E.I.A. specifications.

**INPUT** 105-125 VAC, 50-400 CPS, single phase. Exceptions: Models 50, 50R and 71 — 105-125 VAC, 50-60 CPS.

**DC OUTPUT Voltage Range:** Continuously variable over ranges specified, except where otherwise noted.

**Current Range:** The current ranges given apply to the entire DC output voltage range, and for input voltages from 105 to 125 VAC. No "de-rating" is necessary.

**Polarity:** Either positive or negative terminal may be grounded.

**AC OUTPUT** The AC output is unregulated, isolated and ungrounded. It has a value of slightly higher than 6.3 V

(when fully loaded) at an input of 115 VAC. This value allows for voltage drop in connecting leads. Dual outputs may be connected in series or parallel.

**DUTY CYCLE** Continuous duty at full load.

**METERS** Where meters are indicated, a separate voltmeter and milliammeter are provided.

**OVERLOAD PROTECTION** Ample protection is provided against external overload and internal failure conditions by means of fuses.

Circuit breakers of the magnetic, "trip-free" type are employed in Models 50, 50R, 71 and LT series as protection against external overloads. And in the LT series, the transistor complement is independently protected by special transistor circuitry.

**STYLE** Rack Models are designed for mounting on standard 19" relay racks.

Bench Models are provided with compact, specially-designed, ventilated cabinets equipped with carrying handles. The power supply units may be removed from their cabinets for mounting in standard relay racks (except Models 25, 26 and 71).

**RATINGS AND COMPONENTS** All components used are of the highest quality and are operated well within manufacturers' ratings. Hermetically-sealed, oil-filled capacitors are used exclusively, except in LT series, where special high purity foil, long-life electrolytics are used. "C" and "LT" series power supplies use hermetically-sealed magnetic components exclusively. Ample safety factors are provided in the design to insure the long life, and the dependable, trouble-free operation so desirable in industrial and laboratory applications.

*All specifications and prices subject to change without notice.*



**LAMBDA ELECTRONICS CORP.**

11-11 131 STREET • COLLEGE POINT 56, NEW YORK

INDEPENDENCE 1-8500 CABLE ADDRESS: LAMBDA TRON, NEW YORK

Send for latest catalog

## electronics

May 8, 1959 Vol. 32, No. 19

Published weekly, with an additional annual BUYERS' GUIDE and REFERENCE Issue in mid-June, by McGraw-Hill Publishing Company, Inc., James H. McGraw (1860-1948) Founder.

Executive, Editorial, Circulation and Advertising Offices: McGraw-Hill Building, 330 W. 42 St., New York 36, N. Y. Longacre 4-3000. Publication Office: 99-129 North Broadway, Albany 1, N. Y.

See panel below for directions regarding subscriptions or change of address. Donald C. McGraw, President; Joseph A. Gerardi, Executive Vice President; L. Keith Goodrich, Vice President and Treasurer; John J. Cooke, Secretary; Nelson L. Bond, President, Publications Division; Shelton Fisher, Senior Vice President; Ralph B. Smith, Vice President and Editorial Director; Joseph H. Allen, Vice President and Director of Advertising Sales; A. R. Venezian, Vice President and Circulation Coordinator.

Single copies in the United States, U. S. possessions & Canada 75¢; \$1.50 for all other foreign countries. Buyers' Guide in the United States, U. S. possessions & Canada \$3.00; all other foreign \$10.00. Subscription rates—United States and possessions, \$6.00 a year; \$9.00 for two years; \$12.00 for three years. Canada, \$10.00 a year; \$16.00 for two years; \$20.00 for three years. All other countries, \$20.00 a year; \$30.00 for two years; \$40.00 for three years. Second class postage paid at Albany, N. Y. Printed in U.S.A. Copyright 1959 by McGraw-Hill Publishing Co., Inc.—All Rights Reserved. Title registered in U. S. Patent Office. BRANCH OFFICES: 520 North Michigan Avenue, Chicago 11; 68 Post Street, San Francisco 4; McGraw-Hill House, London E. C. 4; 85, Westendstrasse, Frankfurt/Main; National Press Bldg., Washington 4, D. C.; Six Penn Center Plaza, Philadelphia 3; 1111 Henry W. Oliver Bldg., Pittsburgh 22; 55 Public Square, Cleveland 13; 856 Penobscot Bldg., Detroit 26; 3615 Olive St., St. Louis 8; 350 Park Square Bldg., Boston 16; 1301 Rhodes-Haverty Bldg., Atlanta 3; 1125 West Sixth St., Los Angeles 17; 1740 Broadway, Denver 2; 901 Vaughn Bldg., Dallas 1. ELECTRONICS is indexed regularly in The Engineering Index.

Subscription: Address correspondence to: Fulfillment Manager, Electronics, 330 W. 42nd St., New York 36, N. Y. Allow one month for change of address, stating old as well as new address. Subscriptions are solicited only from persons engaged in theory, research, design, production, management, maintenance and use of electronics and industrial control components, parts and products. Position and company connection must be indicated on subscription orders.

Postmaster: please send form 3579 to Electronics, 330 W. 42nd St., New York 36, N. Y.



Member ABP and ABC

**COMMON MARKET.** A steadily rising market for electronic products has been growing in Europe through the post-war recovery years. Also growing have been European manufacturing facilities in search of customers. One answer for the overseas manufacturer has been found in the "common market" concept. Under this plan, six European nations are lowering trade barriers, reducing tariffs and permitting favorable exchange of each other's currency.

U. S. manufacturers feel they too can cash in on the benefits of the European common market. One way to do this is to license European firms to make their products and, in some cases, distribute them under the licensor's brand.

Associate Editor Emma has been talking to exporters and manufacturers, as well as consulting industry export records. For details on what he has learned, see p 30.

**ELECTRONICS NEWSLETTER.** In daily newspaper jargon a "hell box" is a column or two on the front page left open until the last minute for the latest news. Our hell box is called Electronics Newsletter.

Here you will read first about developments such as the Raser quantum mechanical amplifier, the plasma thermocouple, or electrostatic halftone printing. To get these items, ELECTRONICS' New York and field editors are backed up by McGraw-Hill domestic and foreign news bureaus and correspondents.

Associate Editor Janis constantly receives such reports, taps other news sources, and edits the most significant items for the newsletter. He holds an A.B. from Kenyon College, an M.S. from Columbia's Graduate School of Journalism, sharpened his news sense as a wire service war correspondent in Korea, learned the inside of the electronics industry working for Bell Telephone Laboratories.

### Coming In Our May 15 Issue . . .

**ULTRASONIC SURGERY.** The use of electronics in medicine has made possible some remarkable progress in diagnosis and treatment of human illness in the last few years. Applications in surgery are now increasing. Recent investigations have shown that precisely controlled bursts of intense ultrasonic energy focused at specific points in the brain may be of great value in both experimental and clinical neurosurgery.

B. J. Cosman of Radionics, Inc., T. F. Hueter of Massachusetts General Hospital next week describe an instrument which uses ultrasonic techniques to produce changes ranging from circumscribed destruction of deep-seated ganglia in the brain to subtle alterations of the central nervous system. Device produces required 1,000 watts/cm<sup>2</sup> at accurately micropositioned points, focused in a manner that minimizes effect on surrounding tissues.

**LOW-JITTER THYRATRON SWITCH.** Thyratrons are often ruled out for switching applications requiring precisely repeatable firing delays because of time jitter problems. This is despite the high current capabilities and low dissipation of the thyatron.

R. L. Forgacs of the Ford Motor Company in Dearborn, Mich., has devised a method of minimizing jitter in small thyratrons. He applies it to sound velocity measurements in metals to determine elastic constants. Forgacs used a trigger pulse with a very short rise time and an amplitude much larger than the minimum required pulse, among other precautions. Results are a pulse-to-pulse time jitter of only 0.2 millimicrosec.



# SPRAGUE® RELIABILITY in these two dependable wirewound resistors

MINIATURE

**Blue Jacket®**  
VITREOUS-ENAMEL POWER RESISTORS

Sprague's new improved construction gives even greater reliability and higher wattage ratings to famous Blue Jacket miniature axial lead resistors.

A look at the small *actual sizes* illustrated, emphasizes how ideal they are for use in miniature

NEW SMALLER SIZE

**KOOLOHM®**

INSULATED-SHELL POWER RESISTORS

New Koolohm construction features include welded leads and winding terminations—Ceron ceramic-

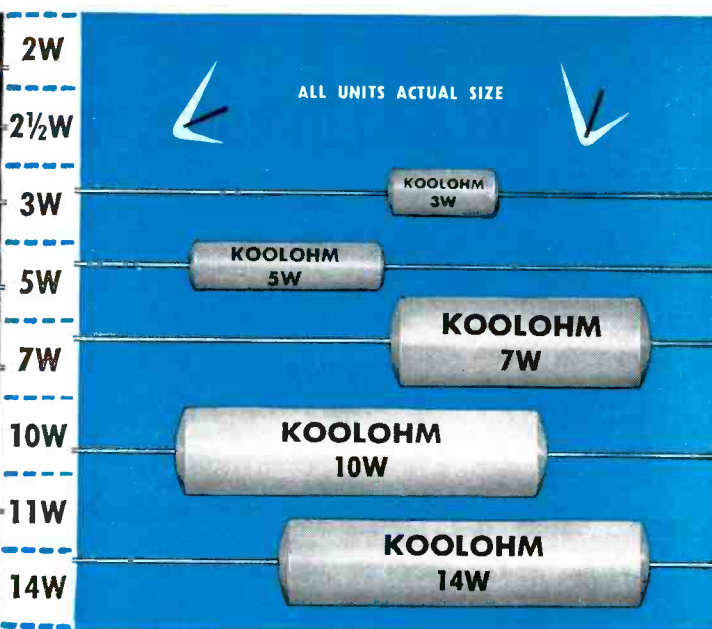
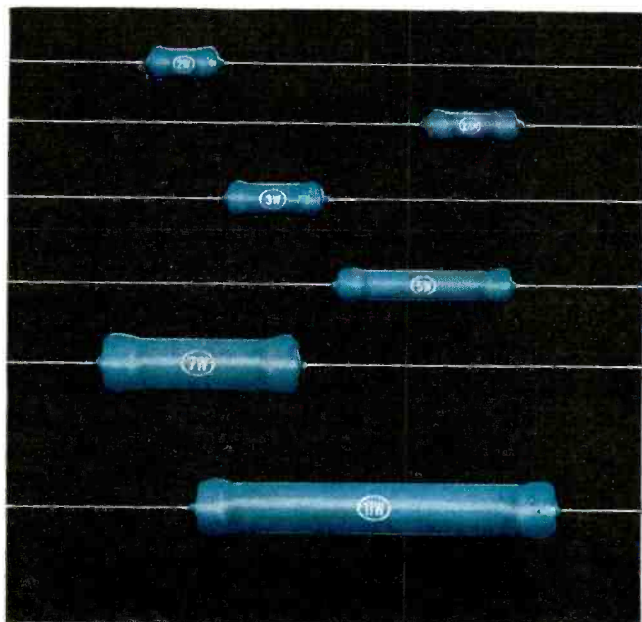

electronic equipment with either conventional wiring or printed wiring boards.

Get complete data on these dependable minified resistors, write for **Engineering Bulletin 7410**.

**TAB-TYPE BLUE JACKETS:** For industrial applications, a wide selection of wattage ratings from 5 to 218 watts are available in Sprague's famous Tab-Type Blue Jacket close-tolerance, power-type wirewound resistors. Ideal for use in radio transmitters, electronic and industrial equipment, etc. For complete data, send for **Engineering Bulletin 7400A**.

insulated resistance wire, wound on special ceramic core—multi-layer non-inductive windings or high resistance value conventional windings—sealed, insulated, non-porous ceramic outer shells—aged-on-load to stabilize resistance value.

*You can depend upon them to carry maximum rated load for any given physical size.*

Send for **Engineering Bulletin 7300** for complete technical data.

**SPRAGUE ELECTRIC COMPANY**

35 MARSHALL STREET • NORTH ADAMS, MASS.

**SPRAGUE®**

THE MARK OF RELIABILITY

SPRAGUE COMPONENTS: RESISTORS • CAPACITORS • MAGNETIC COMPONENTS • TRANSISTORS  
INTERFERENCE FILTERS • PULSE NETWORKS • HIGH TEMPERATURE MAGNET WIRE • PRINTED CIRCUITS

**NEW!**  
**KAY**  
*Magna-Sweep*

Cat No. 3500

- See 5-1000 mc or 2200-3800 mc Displayed at One Time
- Built-in Precision Wavemeter with  $\pm 0.1\%$  Accuracy, Covers Complete Range
- Digital Counter for Direct In-line Read Out
- Output Voltage Held Flat by AGC Circuit
- Continuously Variable Center Frequency and Sweep Width

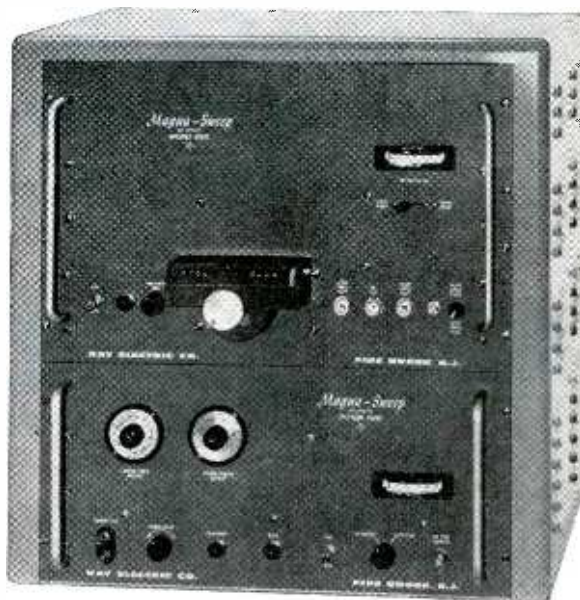

## ALL-ELECTRONIC SWEEPING OSCILLATOR

### SPECIFICATIONS

**Frequency Range:** Low band, 5-1000 mc; high band, approximately 2200-3800 mc.

**Sweep Width:** 25 mc minimum to at least 1000 mc, continuously variable.

**RF Output:** Low band, 0.1 volt rms into 50 ohms, flat within  $\pm 0.75$  db; high band, 1.5 volts rms into 50 ohms, flat within  $\pm 1.0$  db; AGC controlled. Powers up to 0.5 watt available on S-band by internal modification.

**Spurious Output:** Up to 500 mc, more than 40 db down; above 500 mc, more than 30 db down.

**Frequency Indicators:** Precision wavemeter,  $\pm 0.1\%$  accuracy, with direct-reading in-line digital counter for each band.

**Built-in Detector:** Facilitates wide-band studies.

**Sweep Output:** Regular sawtooth synchronized with sweeping oscillator. Amplitude 7 V approx.

**Power Supply:** Input approx. 300 watts, 117-V ( $\pm 10\%$ ), 50-60 cps ac, B+ electronically regulated.

**Dimensions:** 22" x 22" x 15" in cabinet; standard 19" rack panels.

**Weight:** 150 lbs.

**Price:** \$4950.00, f.o.b. factory.

### DESCRIPTION

The *Magna-Sweep* is an all-electronic sweeping oscillator with two broadband outputs at 5-1000 mc and 2200-3800 mc.

Employing the latest in high frequency techniques, this beat-frequency device also incorporates a precision wavemeter for accurate measurement of output frequency as read on a direct-reading in-line digital counter.

By internal modification, the output power on the S-band portion of the frequency range may be increased up to 0.5 watt. The RF output throughout the entire frequency range covered by the *Magna-Sweep* is held flat by a fast-acting AGC circuit to within  $\pm 0.75$  db on the low band and within  $\pm 1.0$  db on the high band. Both the sweep width and center frequency are continuously variable. Since the source of frequency sweep is sawtooth voltage, no phasing adjustments are needed. On the retrace of the sawtooth voltage the signal source is blanked providing a zero reference base line on an oscilloscopic display. The *Magna-Sweep* is extremely useful in standard frequency alignment procedures for television, radar, or communications systems where very wide band coverage is needed. It may also be used as a wide-band spectrum analyzer or as a transistor alpha tester, as well as in wide-band filter and traveling wave tube investigations. With a suitable cable and detector, a wide-band Mega-Match for the measurement of standing waves may be made.

WRITE FOR NEW KAY CATALOG

# KAY ELECTRIC COMPANY

Dept. E-5

Maple Avenue

Pine Brook, New Jersey

Capital 6-4000





***"Virtually Jamproof***

***against either enemy or nature..."***

NEW YORK TIMES

## **THE U.S. NAVY'S COMMUNICATIONS MOON RELAY**

This project, the design, development and installation of an operational anti-jam communications system—the first to use an astronomical body as a passive relay station—was undertaken by us just 36 months ago. Described by Rear Admiral Rawson Bennett, Chief of Naval Research, as "one of the most significant advances in radio communications in many years," Communications Moon Relay is designed to link Washington and Pearl Harbor by way of the moon.

In addition to providing communications that are virtually jam-proof against either enemy or nature, Communications Moon Relay opens up a whole new spectrum of radio frequencies for long range communication.

A system such as this Moon Relay—designed, developed and installed by us for the U. S. Navy—is the type for which our experience and our creative and imaginative approach to challenging communications problems are particularly suited.

*It is just one of the many "out of this world" problems we have solved, or are now solving, for the military services and other Government agencies with exacting communications requirements.*

**DECO**

**DEVELOPMENTAL  
ENGINEERING CORPORATION**

COMMUNICATIONS SYSTEMS RESEARCH, DESIGN AND DEVELOPMENT

1000 Connecticut Avenue, N. W. • Washington 6, D. C.  
Fort Evans Laboratory, Leesburg, Virginia

# 100 CPS X-Y RECORDING

with immediate  
readout

THE NEW SANBORN  
MODEL 670 OPTICAL  
X-Y RECORDER HAS

- ★ 1% linearity
- ★ frequency response  
3 db down at 130 cps  
independent of amplitude
- ★ writing speeds to  
2500 in/sec.
- ★ 8" x 8" direct print  
paper chart
- ★ trace monitoring on  
phosphorescent screen

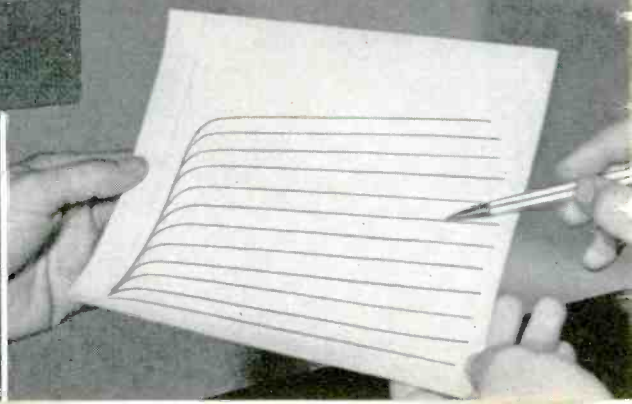
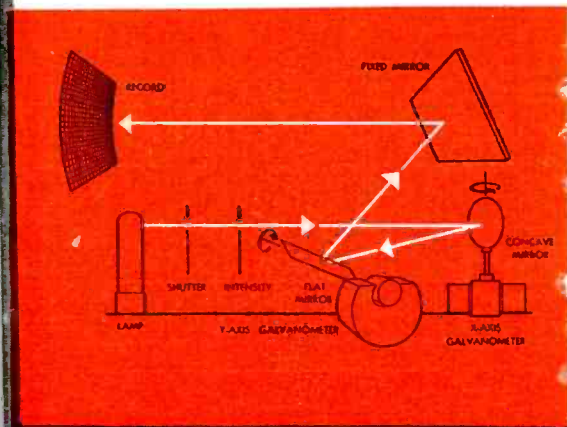
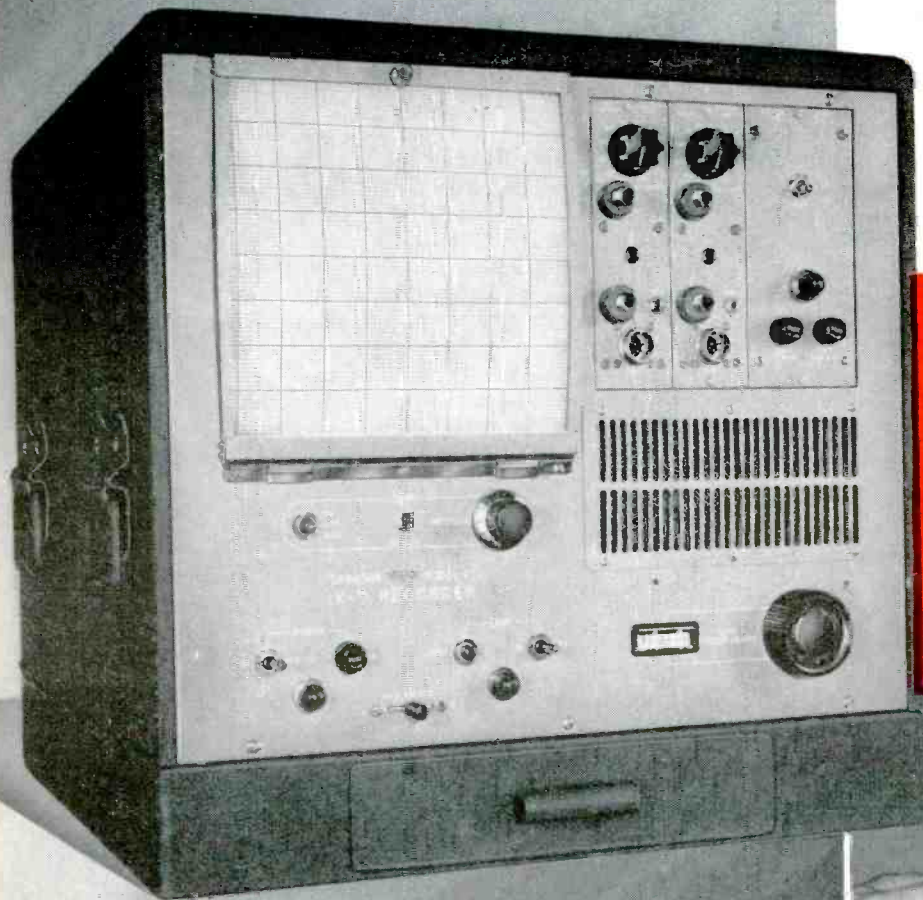



**X-Y** RECORDING never before possible with electromechanical instruments can now be done with the new Sanborn Model 670 X-Y Recorder. Direct writing on ultraviolet-sensitive recording paper by a beam deflected by optical galvanometers makes possible the combination of fast writing speed and 130 cps frequency response not found in any other X-Y recorder. Transistor characteristics, acceleration and vibration of mechanical parts and events of similar short duration can be recorded with linearity of 1% of full-scale and at trace speeds as fast as 2500 inches per second. Square wave response exhibits no greater than 1/2% overshoot at any amplitude; sensitivities as high as 62.5 uv/inch (depending on preamplifier used).

**PLOTS OCCUPY AN 8" x 8" RECORDING AREA** and can be previewed or monitored on the instrument's phosphorescent screen. An Axis Record switch to print X and Y axes on the record, and a Beam Intensity Control to assure maximum trace clarity, are among the front panel controls provided. An 8" x 8" sheet of the ultraviolet-sensitive chart paper (stored in drawer at base of cabinet) is easily placed on the back of the hinged screen. Brief post exposure in normal room light is the only developing process.

**OPTIONAL INTERCHANGEABLE PREAMPLIFIERS** for each axis presently include the Model 850-1300B DC Coupling and Model 850-1200 Phase Sensitive Demodulator; a Carrier Preamplifier, High Gain Preamplifier and a time base generator are now in development. Driver Amplifiers are compact, fully transistorized plug-in units with single-ended input and output. Galvanometers are low resistance, low voltage units of rugged, enclosed construction; sensitivity and damping are independent of coil temperature. Accessible, unitized circuitry also extends to the power supplies—a front-panel plug-in for both preamplifiers and a second supply for both driver amplifiers. A built-in blower provides constant, forced filtered air cooling. The Recorder can be rack mounted in 15 1/4" of panel space, or housed in its own 20" x 20" x 21 1/4" optional portable cabinet.

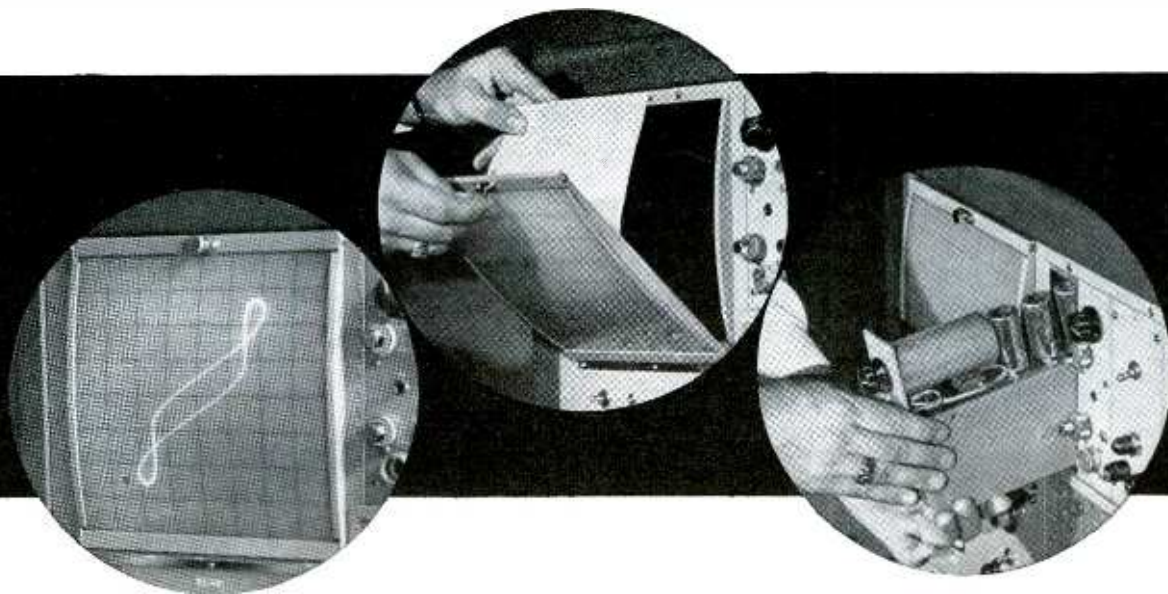

Ask your local Sanborn Sales-Engineering Representative for complete information on the Model 670 X-Y Recorder, or write the Industrial Division in Waltham, Mass.

**SANBORN COMPANY**

INDUSTRIAL DIVISION • 175 Wyman Street, Waltham 54, Massachusetts



**EIMAC TUBES**  
**NOW IN PRODUCTION**  
**IN AMERICA'S NEWEST,**  
**MOST MODERN TUBE PLANT**

In San Carlos, California, Eimac's third and largest plant is nearing full production to meet the great demand for many popular Eimac electron tube families. Never before have so many advanced techniques and processes been applied to vacuum tube manufacture. Eimac's leadership in new processing methods has brought a new era of quality to electron tubes.



Ready for shipment, these Eimac ceramic tetrodes are just one of more than a hundred different tube types manufactured by Eitel-McCullough, Inc., including negative grid tubes, power amplifier klystrons, reflex klystrons and traveling wave tubes.

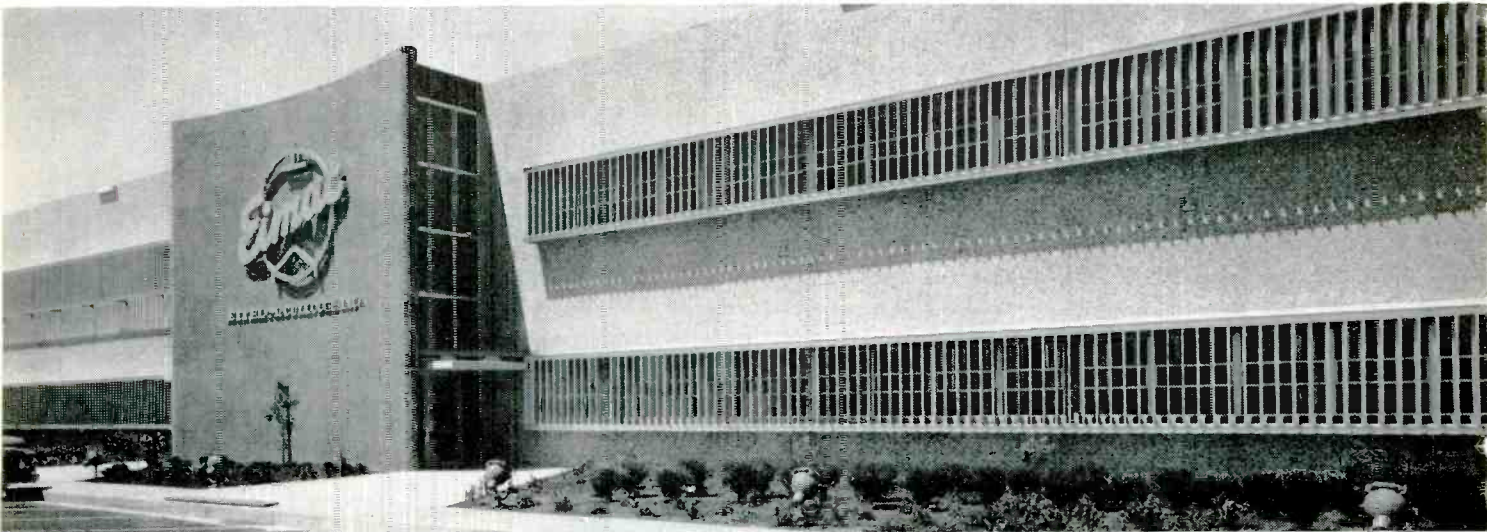

mac, San Carlos, greatly increasing production capacity, joins San Bruno and Salt Lake City facilities as Eimac's newest plant.



nal tube assembly in near-sterile "clean rooms" assures exceptional tube reliability. These rooms are pressurized with filtered, conditioned air to prevent the tiniest dust particles from entering. Even shoes are automatically vacuum cleaned as personnel enter the room through double-door air locks.

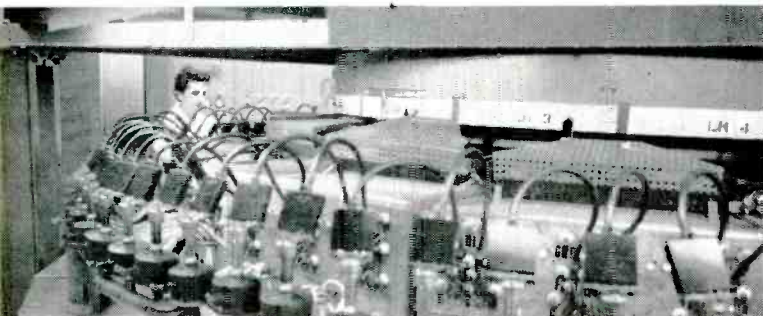

mac designed rotary vacuum pumps speed production, achieve hard, clean tube vacuums. Pumping Eimac tubes at high voltages and ambient temperatures assures long life and reliability. These giant rotary pumps are typical of production equipment custom designed by Eimac for transmitting tube manufacture.



Every tube meets rigid Eimac specifications before shipment. On test consoles like this, dozens of electrical characteristics are patiently tested and recorded for each Eimac tube produced. Environmental testing equipment is also available for testing for severe applications.



**EITEL-McCULLOUGH, INC.**  
 SAN CARLOS, CALIFORNIA



## **ELECTRONICS NEWSLETTER**

**SMALL BUSINESS** share of hard goods procurement by defense agencies in 1958 dropped 36 percent below the 1957 level. So said Dwight D. Guilfoil, Jr., president of Paraplegics Manufacturing Co., Franklin Park, Ill. to subcommittee of the Senate Select Committee on Small Business. Only 10.3 percent of negotiated contracts in the year ending May 1958 went to small business, he reported. Of \$20 billion spent, negotiated contracts accounted for \$15 billion.

**PORTABLE RADIATION DOSE-RATE METER** for emergency use at home is called for by the Office of Civil and Defense Mobilization, Battle Creek, Mich. Electronics firms are invited to seek specifications and technical guidance from OCDM, which expects to award development contracts. Instrument must operate on ordinary dry cell batteries and be able to check them. Direct reading must show gamma radiation in range from one to 100 roentgens per hour.

**CESIUM BEAM TUBE**, used as frequency standard for ICBM guidance, is being miniaturized by National Company, Malden, Mass., which calls the device an Atomichron. USAF has awarded the firm a \$1 million contract. Two Atomichrons will be produced, one weighing 25 lb and occupying 0.8 cu ft and the other weighing 30 lb and occupying 1.2 cu ft. Firm says the precise, unvarying resonance of the cesium atom is compared with the output of a crystal oscillator and results in stability surpassing other frequency generators.

**DESK-TOP ANALOG COMPUTER** may become as familiar an engineer's tool as the slide rule. New transistorized model, about the size of a standard electric typewriter and weighing only 80 lbs, was shown last month by Electronic Associates. The basic analog computer has 10 operational amplifiers, can handle five second-order differential equations simultaneously with an accuracy of 0.1 percent. Price of the new computer, PACE TR-10, starts below \$4,000.

*International Electrotechnical Commission, which meets in Madrid June 30 to July 10, will discuss semiconductor devices and other electronic topics. U.S. participates through a committee of the American Standards Association.*

**SHILLELAGH**, an Army surface-to-surface missile for close-in support of troops, is expected to be operational in the mid-1960's under a \$23 million development program awarded to Aeronutronic Systems, West Coast subsidiary of Ford Motor Co. Raytheon has been selected as subcontractor for development of the fire control subsystem. Electronic computer will be used in guidance.

**HIGHWAY COMMUNICATIONS SYSTEM** consist-

ing of low-frequency transmitters spaced along a highway, and transistorized receivers in cars, has been demonstrated by General Motors Research Laboratories and Delco Radio division. Receiver may be a separate unit or combined with the car radio, but would operate whether the car radio was on or off. Car radio would be muted during voice message from roadside transmitter or, if the radio was turned off, a signal would operate its transistor output stage and put the message through the loudspeaker. Electromagnetic induction system operates at 10 to 20 kc by means of a highly controlled signal and can be detected only near the transmitter antenna.

**FLATNESS GAGE FOR TESTING MICA** has been developed for the General Services Administration by American Research and Manufacturing Corp., Rockville, Md. Firm says visual examination to determine flatness of mica is often inaccurate, cites smoothness of mica as important for reliability in mica capacitors and tv-type tubes. GSA, which is interested in grading mica for stockpile purposes, is now testing prototype machine.

*Braille printing plate may now be made in minutes by means of an IBM 704 which translates English text, already punched on cards, into coded symbols. These are reproduced as Braille dot-pattern symbols above the English printout. If the English is correct, an embossing machine then makes plates of the corresponding Braille patterns.*

**THREE-SIDED** fixed antenna 150 ft high and 60 ft on each side is the key element of a radar system to be developed by W. L. Maxson Corp. under a \$1.7 million Federal Aviation Agency contract. Antenna will receive radar energy reflected from aircraft in any one of 100 elevation beams. FAA says gear will give air traffic controllers accurate height data on planes up to 50 nautical mi range. Prototype is scheduled for October 1960 completion.

**ACE HIGH**, NATO's forward scatter antenna system stretching from northern Norway to eastern Turkey, is making use of a new arc-welded aluminum waveguide with a conductive protective finish. I-T-E Circuit Breaker Co. used the waveguide in more than 130 antennas built under a \$5 million contract. Firm says new fabrication technique lowers cost. Steel dishes 30 to 60 ft in diameter were fabricated in Europe by Krupp as subcontractor to I-T-E.

**MICROPHONE**, apparently using a piezoelectric crystal, is reported by the Soviets for detecting and measuring the sounds of internal tension in concrete. Oscillations from microscopic cracks are said to be picked up by the microphone, amplified and recorded on tape and oscillograph.

# VERSATILE

Multi-channel—telegraph A1 or telephone A3

# STABLE

High stability (.003%) under normal operating conditions

# RUGGED

Components conservatively rated. Completely tropicalized



FROM GROUND TO AIR OR POINT TO POINT

Here's the ideal general-purpose high frequency transmitter! Model 446, suitable for point-to-point or ground-to-air communication. Can be remotely located from operating position. Coaxial fittings to accept frequency shift signals.

This transmitter operates on 4 crystal-controlled frequencies (plus 2 closely spaced frequencies) in the band 2.5-24.0 Mcs (1.6-2.5 Mcs available). Operates on one frequency at a time; channeling time 2 seconds. Carrier power 350 watts, A1 or A3. Stability .003%. Nominal 220 volt, 50/60 cycle supply. Conservatively rated, sturdily constructed. Complete technical data on request.

Now! Complete-package, 192 channel, H.F., 75 lb. airborne communications equipment by Aer-O-Com! Write us today for details!



3090 S. W. 37th AVENUE

MIAMI 33, FLORIDA

A-131



It could  
happen...

with

**El-Menco**  
CAPACITORS!

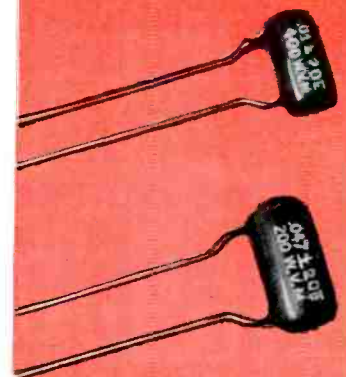
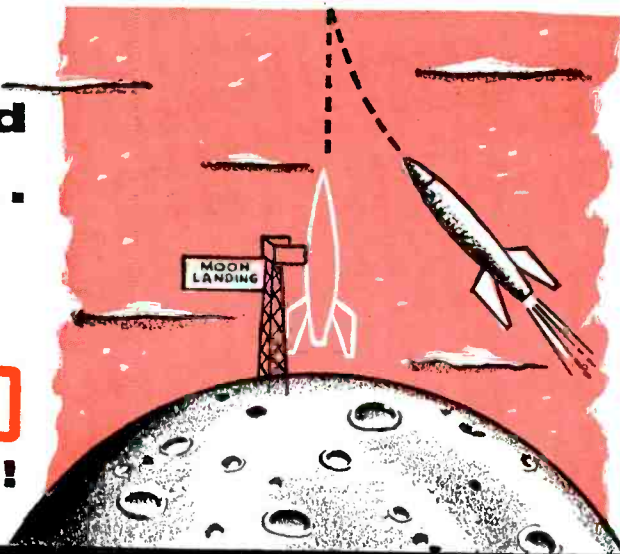

**NEW**

*Mylar-Paper Dipped*

**CAPACITORS**

**TYPE  
MPD**

**INSURE FAILURE-PROOF PERFORMANCE!**

Only 1 Failure In 7,168,000 Unit-Hours for 0.1 MFD Capacitors\*

**Setting a new standard of reliability!**

\*Life tests have proved that El-Menco Mylar-Paper Dipped Capacitors — tested at 100°C with rated voltage applied — have yielded a failure rate of only 1 per 716,800 unit-hours for 1 MFD. Since the number of unit-hours of these capacitors is inversely proportional to the capacitance, 0.1 MFD El-Menco Mylar-Paper Dipped Capacitors will yield ONLY 1 FAILURE IN 7,168,000 UNIT-HOURS.

**SUPERIOR FEATURES!**

• Five case sizes in working voltages and ranges:

200 WVDC —	.018 to .5 MFD
400 WVDC —	.0082 to .33 MFD
600 WVDC —	.0018 to .25 MFD
1000 WVDC —	.001 to .1 MMF
1600 WVDC —	.001 to .05 MFD

**SPECIFICATIONS**

- **TOLERANCES:**  $\pm 10\%$  and  $\pm 20\%$ . Closer tolerances available on request.
- **INSULATION:** Durez phenolic resin impregnated.
- **LEADS:** No. 20 B & S (.032") annealed copper-weld crimped leads for printed circuit application.
- **DIELECTRIC STRENGTH:** 2 or 2½ times rated voltage, depending upon working voltage.
- **INSULATION RESISTANCE AT 25°C:** For .05MFD or less, 100,000 megohms minimum. Greater than .05 MFD, 5000 megohm-microfarads.
- **INSULATION RESISTANCE AT 100°C:** For .05MFD or less, 1400 megohms minimum. Greater than .05MFD, 70 megohm-microfarads.
- **POWER FACTOR AT 25°C:** 1.0% maximum at 1 KC.

Write for Technical Brochure Giving Complete Information on the El-Menco Tubular Dur-Paper Line.

THESE CAPACITORS WILL EXCEED ALL THE ELECTRICAL REQUIREMENTS OF E.I.A. SPECIFICATION RS-164 AND MILITARY SPECIFICATIONS #MIL-C-91A AND MIL-C-25A.

FOR FAILURE-PROOF PERFORMANCE... COUNT ON EL-MENCO MYLAR-PAPER DIPPED CAPACITORS... FROM MISSILE GUIDANCE SYSTEMS TO DATA PROCESSING EQUIPMENT!

\*Registered Trade Mark of DuPont Co.



**El-Menco**  
*Capacitors*

**THE ELECTRO MOTIVE MFG. CO., INC.**

WILLIMANTIC CONNECTICUT

Manufacturers of El-Menco Capacitors

- molded mica • dipped mica • mica trimmer • dipped paper
- tubular paper • ceramic • silvered mica films • ceramic discs

Arco Electronics, Inc., 64 White St., New York 13, N. Y.  
Exclusive Supplier To Jobbers and Distributors in the U.S. and Canada

# WASHINGTON OUTLOOK

THE LONG-AWAITED House Armed Services subcommittee probe into weapons system procurement—under direction of Rep. F. E. Hebert (D., La.)—has begun. Hebert is listening to the aircraft industry's top echelon argue the merits of the scheme. But he and other Democrats on the committee have already voiced their ideas: they feel present procurement system concentrates defense business among fewer firms. When all the furor is over, best guess is that the Air Force will promise new curbs on weapons system prices to stress more subcontracting—a policy that was started even before Hebert's probe.

In the course of his testimony, North American Aviation president J. L. Atwood disclosed major electronic subcontractors on his company's B-70 and F-108 projects, argued that weapons system contracting has not restricted the volume of subcontracting.

On the B-70, Sperry Gyroscope is working on the auxiliary gyro platform; IBM, bombing-navigation. On the F-108, Electronic Specialty Co., antenna system; ITT, mission and traffic controls; Hughes, fire controls; Garrett, central air data system. On both projects, NAA's own Autonetics division is developing the automatic flight control system.

- A wide-ranging Pentagon study of U.S. retaliatory-deterrent policy is now under way. It could result in a revamping of long-range production schedules for manned bombers, ballistic missiles, and other key weapons systems in which electronics plays a major role.

The policy review was spurred by the argument of Army and Navy strategists that the U.S. is maintaining an over-kill capability in the Strategic Air Command, that the size of this country's retaliatory striking force does not have to be increased as SAC planners would like. Indeed, the critics claim, the force can be trimmed in size since we now have the capability to destroy any potential enemy several times over.

As things stand now, as potential targets increase in number, SAC targeting plans are accordingly broadened. But hostile ICBM development—and the assumption that the new missiles will be placed in widely dispersed, underground, and highly secret sites—has compounded SAC's target problems to such an extent that many experts now feel an overhaul in strategic planning is needed.

As the critics see it, less than maximum deterrence is adequate. For one thing, our deterrence is weakened by readying our bombers and missiles to destroy enemy missile and bomber bases after an attack has been launched on us.

They argue it would make more sense to aim our retaliatory force at the enemy's more vulnerable big cities. The size of such a force, of course, could be smaller than the so-called maximum force. It would still threaten an enemy with utter devastation.

- Behind the Army-Navy demand for a policy revision is this: The military planners are reconciled to the fact that the total defense budget will not be boosted more than 3 percent a year in the immediate future; they want to divert money from SAC for their own forces.

The Army wants a bigger slice of the military pie to bolster fire-power and mobility of its tactical forces. The Navy wants more for antisubmarine forces, tactical planes, fleet modernization—and for its Polaris IRBM submarine force, which it considers a less vulnerable, more effective nuclear strike force than Air Force land-based missiles.

## MEASURE ATTENUATION

DIRECTLY  
up to 30 db

# WEINSCHEL

single channel  
INSERTION LOSS

## TEST SET

Maximum systems error: .1 db  
Resolution about .02 db  
Frequency Range: 20 MCS to  
90,000 MCS

KEY  
INSTRUMENTS



### Bolometer Preamplifier, Model BA-1B

Features wide dynamic linear range, extremely low noise level, cannot burn out barretter.

### AF Substitution Attenuator for RF Square Law Detector, Model CF-1

Calibrated directly in rf power ratios; has high input impedance, low output impedance.

### Audio Level Indicator, Model IN-1

Precharging circuit reduces required observation time. Has adjustable indicator time constant, low noise level.

### Double Stub Tuner, DS-109

For theory, method, required instruments and recommended accessories, request Application Notes #1.

Weinschel Fixed Coaxial Attenuators cover the frequency range of DC to 12 KMC.

Write for complete catalog,

specifying frequency range of interest.



**Weinschel Engineering**  
KENSINGTON, MARYLAND



Now from **CLEVITE** . . .

# HIGH POWER TRANSISTORS



*Clevite offers new types with improved reliability and power handling capacity.*

**EIA REGISTERED TYPES WITH:**

- Improved seal for long life.
- Saturation voltage less than 1 Volt at increased maximum rated current of 15 amperes.
- Average thermal resistance 0.7°C per watt.
- Current gain controls: 60-150 at 5 amperes.
- 100% test for resistance to transient burn out.
- Either standard pins or solder lugs.

**TECHNICAL DATA**

Typical Electrical Characteristics at 25°C

	2N1147 2N1146	2N1147A 2N1146A	2N1147B 2N1146B	2N1147C 2N1146C
Collector to Emitter Voltage Shorted Base (I <sub>C</sub> = 1 amp)	30V (Min)	40V (Min)	60V (Min)	75V (Min)
Saturation Voltage (I <sub>C</sub> = 15 amps)	1.0V (Max)	1.0V (Max)	1.0V (Max)	1.0V (Max)
DC Current Gain (I <sub>C</sub> = 5 amps)	60-150	60-150	60-150	60-150
DC Current Gain (I <sub>C</sub> = 15 amps)	35	35	35	35
<b>Absolute Maximum Ratings</b>				
Collector Current	15 amps	15 amps	15 amps	15 amps
Collector to Base Voltage	40V	60V	80V	100V
Collector to Emitter Voltage	40V	60V	80V	100V
Power Dissipation at 70°C Case Temperature	25W	25W	25W	25W
Junction Temperature	95°C	95°C	95°C	95°C

**OTHER CLEVITE DIVISIONS:**

- Cleveland Graphite Bronze • Brush Instruments
- Clevite Electronic Components • Clevite Harris Products
- Clevite Ltd • Clevite Ordnance • Clevite Research Center
- Intermetall G.m.b.H. • Texas Division

## CLEVITE

### TRANSISTOR PRODUCTS

241 Crescent St., Waltham 54, Mass. TWinbrook 4-9330

A DIVISION OF



*Lint-free uniforms of "Dacron" are available through these leading manufacturers:*

**ANGELICA • FASHION-SEAL • HOLLYWOOD UNIFORM CO. • MILBURN MFG. CO. • WORKLON**

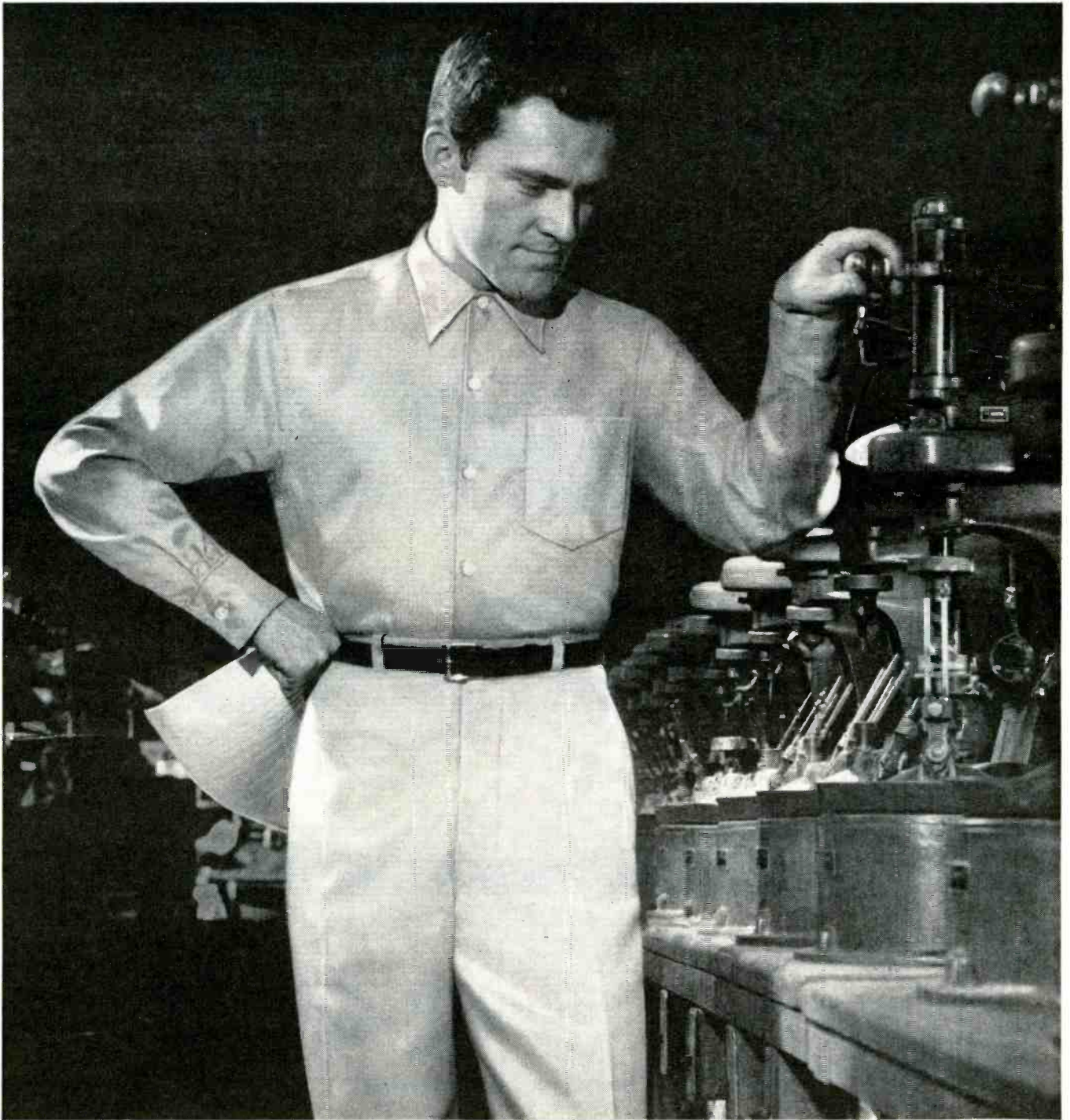

## LINT-FREE UNIFORMS

New uniforms made with filament yarn of 100% "Dacron"\* polyester fiber are amazingly lint-free. The smooth surface of "Dacron" yarns does not pick up lint that can interfere with precise laboratory testing procedures. Because of "Dacron", these uniforms wear ex-

tra-long, resist acids and chemical corrosion . . . save you money on replacement costs. And, they are wash 'n' wear . . . hold their creases, stay neat wearing after wearing. Ask about uniforms of "Dacron" today. (Laboratory coats and coveralls also available.)

**DU PONT BETTER LIVING FIBERS GIVE YOU SO MUCH MORE**

*\*Du Pont's trademark. Du Pont makes fibers, not the fabric or uniform shown.*

**DACRON®**  
POLYESTER FIBER



BETTER THINGS FOR BETTER LIVING  
... THROUGH CHEMISTRY



# CANNON PLUGS

The assembling of highly-flexible electronic systems and sub-systems into a modular package . . . for fast inspection, testing, service, and replacement of components . . . calls for standardized-type plugs throughout the system. Reliability and optimum flexibility in shell designs and types of layouts are the design criteria for the more than 18 different basic Cannon Modular and Rack/Panel Plug Series. This Series is available in standard, miniature, or subminiature sizes . . . for standard or printed circuitry. Up to 180 contacts and a varied combination of contacts for control, audio, thermocouple, co-ax, twin-ax, and pneumatic connections. Single or double-gang. With or without shells. The Rack/Panel Series ranges from the tiny "D" subminiature to the heavy-duty DPD Rack/Panel Plug. For further information on Cannon Modular and Rack/Panel Plugs write for Cannon DP Catalog, Cannon Electric Co., 3208 Humboldt St., Los Angeles 31. Please refer to Dept. 00. Factories in Los Angeles, Santa Ana, Salem, Toronto, London, Paris, Melbourne, Tokyo. Distributors and Representatives in the principal cities of the world.

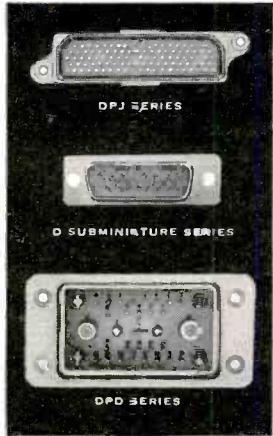

## Maximum Flexibility for Modular and Rack/Panel Applications

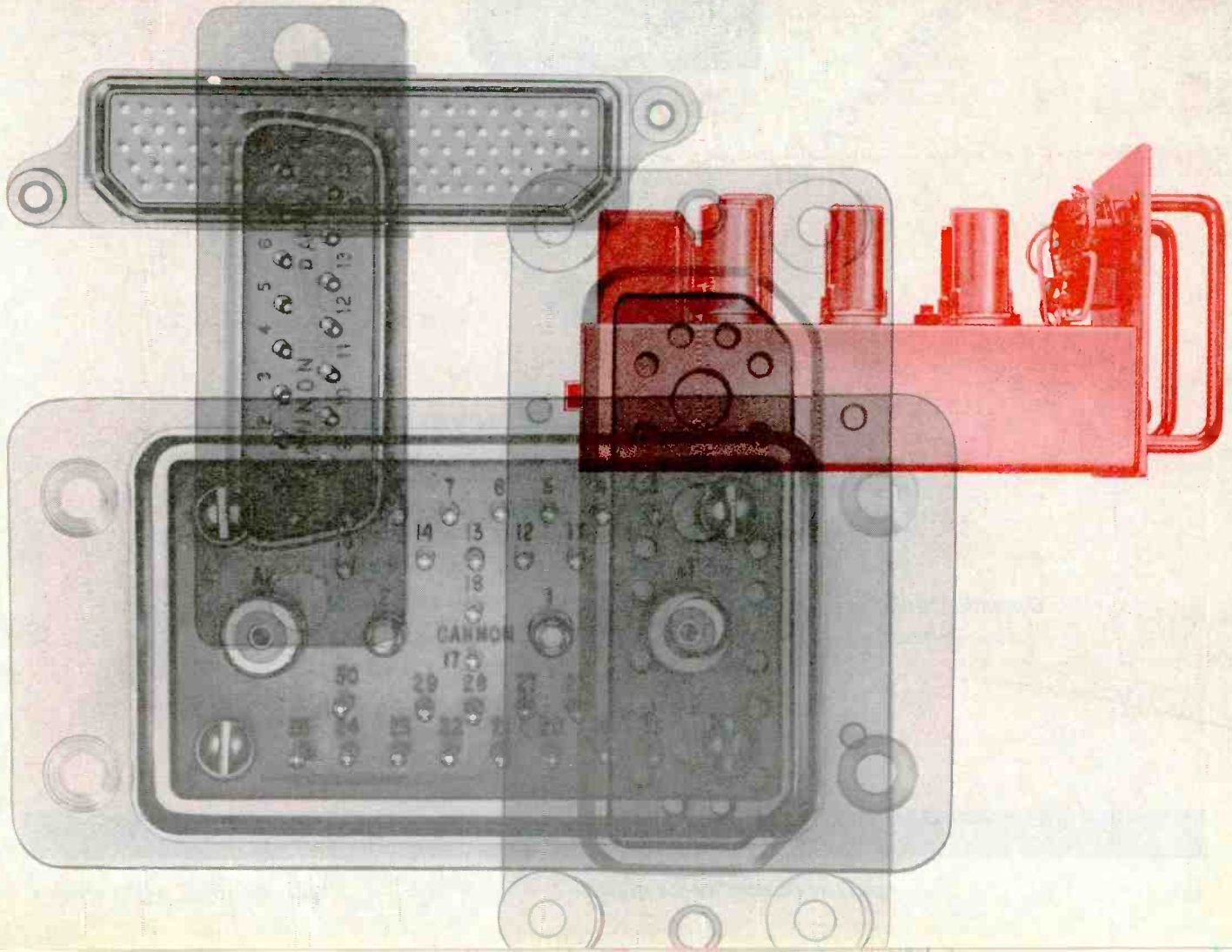

# NEW AIRPAX "500 SERIES" CIRCUIT BREAKER



## POSITIVE PROTECTION

This new improved miniature magnetic circuit breaker has an inverse time delay mechanism providing a trip level which is unaffected by ambient or operating temperature. Available in 50 volt DC ratings from 50 MA to 10 AMPERES; 120 RMS volts at 60 or 400 CPS with ratings from 1 to 10 AMPERES.

- ◆ Operation unaffected by severe shock and vibration. ◆ Long or Short time delay.
- ◆ Hermetically sealed—Explosion proof. ◆ Toggle is trip free.



CAMBRIDGE DIVISION

CAMBRIDGE, MARYLAND

5M110



# New Acquisitions Announced

ACQUISITIONS reported this Spring are showing some additional facets of the growth pattern of our industry.

• **Anaconda Wire & Cable Co.**, New York, has begun negotiations for purchase of 100 percent of the stock of **Sequoia Wire & Cable**, Redwood City, Calif., from **Mandrel Industries, Inc.**, Burbank, Calif. AWC will operate its new property as a wholly-owned subsidiary for making small-gage wire for aircraft, missiles and control equipment. Final arrangements for the stock purchase are now underway.

• **Electronic Specialty Corp.**, Los Angeles, has purchased **Electrical Engineering & Manufacturing Corp.** in the same city. No purchase price has been quoted. The purchased firm employs 150 people who manufacture motors and actuators for the aircraft and missile industries. Combined sales of the newly-joined firms are running at \$7 million. This represents a 40-percent increase in gross sales for **Electronic Specialty**. The parent firm says the addition of the motor manufacturing facility is part of a planned expansion program aimed at increasing total systems capability.

• **Ling Electronics** has acquired **Altec Companies, Inc.**, by a vote of approval of 80 percent of Altec's stockholders. Combined stockholders at the next meeting will be asked to approve a plan to call the new corporate entity **Ling-Altec Electronics, Inc.** No changes are planned in the operations, management or policies of Altec.

• A two-stage arrangement has been announced by **Raytheon Manufacturing Corp.**, which reveals that its wholly-owned subsidiary, **Applied Electronics Corp.**, has purchased the assets of **Webster Manufacturing Company**, Mill Valley, Calif. Webster Mfg. produces radiotelephone antennas for marine use and amateur radio antennas. **Apelco**, which is located in south Los Angeles, says no

changes are contemplated in plant location or personnel of its new installation. The Webster products will continue to be distributed through existing channels, as well as through newly available channels used by **Apelco**.

• **Technical Operations Inc.**, Burlington, Mass., has announced acquisition of major control of **Power Sources Inc.** PS, partly owned by **Microwave Associates**, makes power supplies.

## OVER THE COUNTER

1958	BIDS	COMMON	WEEK ENDING	April 17	April 24
LOW	HIGH	STOCKS	BID	BID	ASKED
33 1/2	20 1/2	Acoustica Assocs	34	33	37 1/2
1 5/8	3	Advance Industries	3 1/2	3 3/8	4 1/8
3 1/8	6 5/8	Aerovox	7 3/8	8 3/4	10
5 1/2	15	Appl'd Sci Princet	9	10	12 1/4
1 1/8	8 7/8	Avien, A	8 1/4	8 1/4	10 1/2
6 3/4	24	Baird-Atomic	28 3/4	28 3/4	32
9 3/4	13 3/8	Burndy	16	15 1/2	18 7/8
6 3/4	9	Cohu Electronics	7 3/4	7 7/8	8 7/8
11	22 1/2	Collins Radio	33 1/2	36 1/2	41 5/8
32 1/2	49	Cook Electric	47	46 1/2	52 1/2
4	7	Craig Systems	9 5/8	9 5/8	11 3/8
17 5/8	25 3/8	Eastern Industries	18 3/4	17 3/4	20 1/8
1 1/4	8 3/8	Elco Corp	7 3/4	7 5/8	8 3/4
10 1/2	21	Electro Instr	26	30	33 3/4
34	49	Electronic Assocs	42	45 1/2	56 1/2
5	11	Electronic Res'rch	17 1/2	17 1/2	19 5/8
8 1/2	12 3/4	Electronic Spec Co	15	16	19 1/8
15 1/4	49 1/2	Epsco, Inc	43	38 1/2	47 1/4
5 1/2	9 3/8	Erie Resistor	9 1/4	9	10 1/8
10	17 1/2	Fischer & Porter	14	12 3/4	15 1/8
5 1/2	10 1/2	G-L Electronics	12 3/4	12 1/2	14 3/8
12	27	Giannini	29 1/2	32	35 1/8
...	...	Haydu Elec Prod	5 1/4	5	6 5/8
30	39 1/2	Hewlett-Packard	44 1/2	45	54
23 1/4	48	High Voltage Eng	56 1/2	61	70
1 3/4	3	Hyon Mfg	3 5/8	3 3/8	4
1 1/8	5 1/8	Industro Trans'tor	4 3/8	5 1/4	6 5/8
...	...	Internat'l Rec'f'r	24 1/2	26 1/4	29 1/8
...	...	Interstate Engin'g	34	36 1/2	41 3/8
1 1/2	4 1/4	Jerrold	6 5/8	6 1/4	7
21	30	D. S. Kennedy	30	28	33
3 3/4	29	Lab For El'tronics	31	33	38 1/4
19 1/4	28	Leeds & Northrup	28 3/4	28 1/2	30 7/8
2	3 1/8	Leetronics	3 1/4	3 1/2	4 1/4
5	18 3/4	Ling Electronics	26 1/4	25 1/2	28 1/4
3 1/4	8 1/4	Magnetic Amplifiers	8 1/2	8	9 1/8
27 5/8	41 1/2	Magnetics, Inc	5	5 1/8	5 3/4
4 5/8	12	W. L. Maxson	14 5/8	14 1/2	16 7/8
10 5/8	29	Microwave Assocs	40	46	51 3/8
5 1/4	11 3/4	Midwestern Instr	12 3/4	12 5/8	14 3/8
1 1/8	7	Monogram Preci's'n	10 1/2	11 3/8	12 5/8
3 1/2	7 1/4	Narda Microwave	10 1/4	10 1/4	11 1/2
...	...	Narda Ultrasonics	9 3/8	9 3/8	10 5/8
9 3/4	16	National Company	22	24 1/2	26 3/4
14 1/4	56	Nuclear Chicago	33	33	41 3/4
4 1/2	7 3/8	Pacific Mercury, A	13 1/4	13	14 5/8
10 1/8	27 1/2	Packard-Bell	37	38 1/2	44 5/8
4 1/4	9 3/8	Panellit, Inc	7 3/4	7 1/2	8 5/8
21	53 1/4	Perkin-Elmer	42 1/2	48	54 1/2
11 3/8	19 1/2	Radiation, A	19 1/2	19 1/2	22 1/2
2 1/8	7 3/8	Reeves Soundcraft	6 1/8	6	7 7/8
13	32 1/2	Sanders Associates	27 1/2	29 1/2	36 1/8
...	...	Silicon Transistor	9	7 1/4	9 1/2
7	12	SoundScriber	17 1/2	17 1/4	18 7/8
22 3/4	40	Sprague Electric	50	45	52 1/2
26	35	Taylor Instruments	33 1/2	33 3/4	37
5 1/2	15	Technical Operat'ns	20	20 1/2	25 1/4
5 1/2	15 3/4	Telechrome Mfg	25	24 1/2	29 7/8
3 1/4	7 3/4	Teletcomputing	10 1/2	11 7/8	13
1 1/8	2 3/4	Topp Industries	2 3/4	2 3/4	3
8 3/4	16 1/4	Tracerlab	13 1/4	13 1/8	14 5/8
3 3/4	10 3/4	Tracerlab	11 1/2	10 1/4	12 5/8
1 1/4	3 3/8	Universal Trans'tor	1 3/8	1 1/4	1 5/8
14 1/4	40	Varian Associates	59 3/4	60	64 3/4

The above "bid" and "asked" prices prepared by the NATIONAL ASSOCIATION OF SECURITIES DEALERS, INC., do not represent actual transactions. They are a guide to the range within which these securities could have been sold (the "BID" price) or bought (the "ASKED" price) during preceding week.

★★★★★

IN EVERY FIELD, THERE IS ONE  
FOREMOST NAME . . . IN SONIC  
ENERGY, THAT NAME IS BENDIX

## FACTS YOU MAY NOT KNOW ABOUT SONIC ENERGY CLEANING—

You probably know that Bendix Sonic Energy Cleaning is in truth a *production tool*—a practical method for (1) lowering cleaning costs while (2) improving product performance and (3) reducing the number of rejects. But perhaps you don't know the where-why-who needed to justify investment in equipment.

WHERE applicable (it isn't always), Bendix Sonic Energy Cleaning has set some new records for efficiency and economy (we'll show you case histories to back this up).

WHY Bendix® is today's top authority on this system can be answered in one word—*experience*. Bendix has lead since the early days, pioneering Sonic Energy Cleaning.

WHO can use it? Who cannot? That's easy to determine—Bendix maintains an Applications Laboratory where production experience is teamed with the latest facilities in finding the answer.

If you can use it to real advantage, Bendix has a complete line so that the best equipment for your particular needs can be selected quickly.

GET THE AUTHORITATIVE FACTS . . .  
SEND FOR THIS FREE REPORT



The principles and workings of Sonic Energy Cleaning are illustrated, described and analyzed in detail. A five-step plan is outlined to help you determine feasibility of Sonic Energy Cleaning for you. To get your

copy, write PIONEER-CENTRAL DIVISION, BENDIX AVIATION CORPORATION, 2719 HICKORY GROVE ROAD, DAVENPORT, IOWA.



SONIC ENERGY CLEANING

CIRCLE 19 READERS SERVICE CARD  
CIRCLE 20 READERS SERVICE CARD →

# HIGH-POWER FILTERS TO SUPPRESS HARMONIC AND BEING DEVELOPED AT GENERAL ELECTRIC MICRO-

**T**HE equipment designer's requirement for freedom from harmonic and spurious signals in microwave radars is the subject of a continuing, large-scale project at the Microwave Laboratory of the General Electric Power Tube Department.

Result of this work is significant progress toward development of a line of microwave filters suitable for eliminating such signals from high-power magnetrons, klystrons and traveling-wave tubes. These filters are intended for use in the waveguide line between tube and antenna. Low insertion loss in the pass band and high attenuation in the stop band of these filters as-

sure efficient systems operation. Low VSWR over both the pass band and the stop band allows these filters to be used without danger of tube damage.

Filter development is only one of a broad range of activities now being conducted at the G-E Microwave Laboratory. Applied research, advanced development, and prototype design are conducted in all areas of microwave tubes and microwave techniques (see list on opposite page). Technical inquiries pertaining to advanced microwave development are invited. *Power Tube Department, General Electric Company, Schenectady, New York.*

\* \* \*

Professional opportunities available for electron tube production, engineering, and scientific personnel. Inquiries are invited.

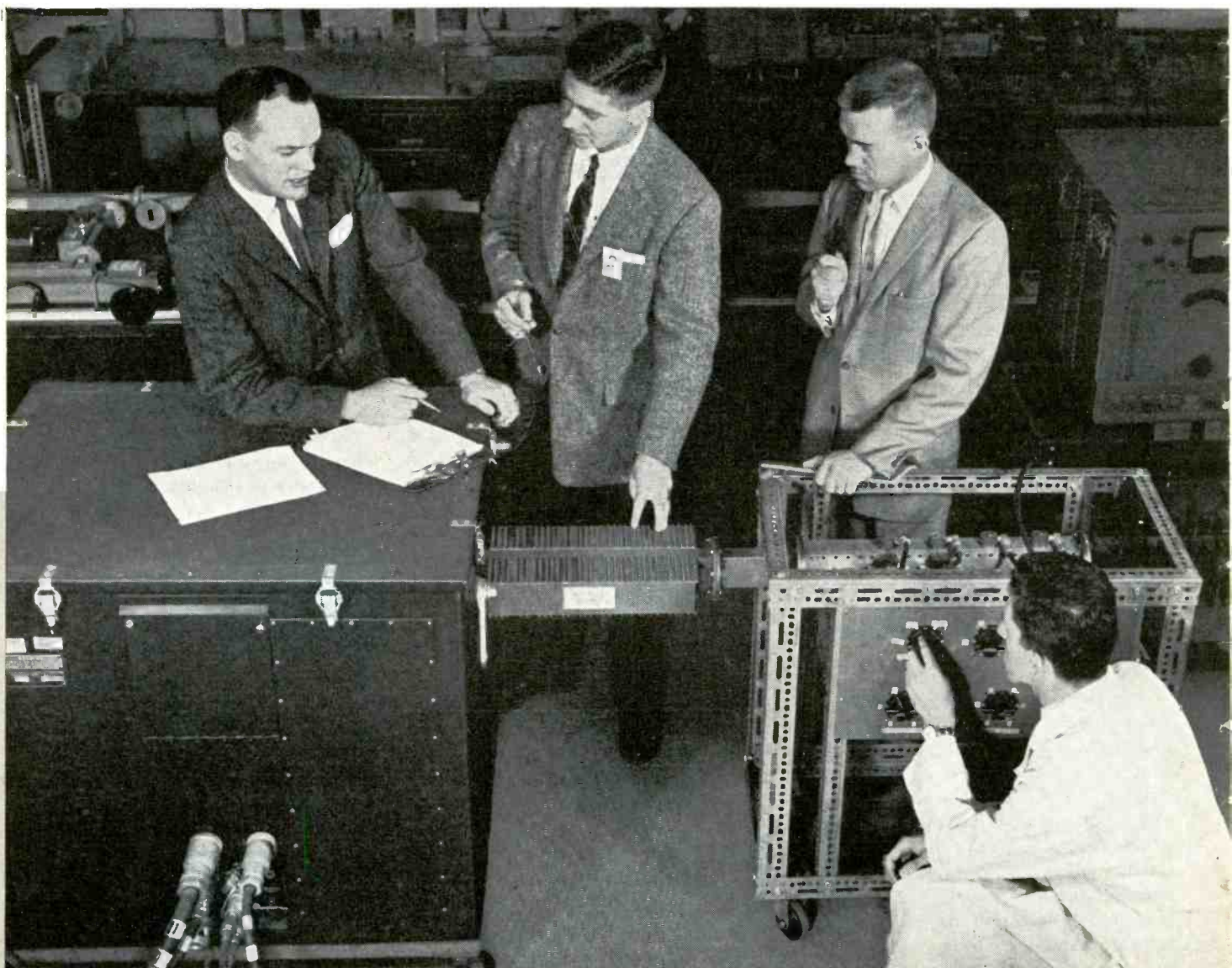

Precise measurement of filter characteristics being made with special harmonic probe section developed at the General Electric Microwave Laboratory. *Left to Right: Project Engineer Vernon G. Price, John P. Rooney, Richard H. Stone, Robert N. Spong (foreground).*



# SPURIOUS SIGNALS WAVE LABORATORY

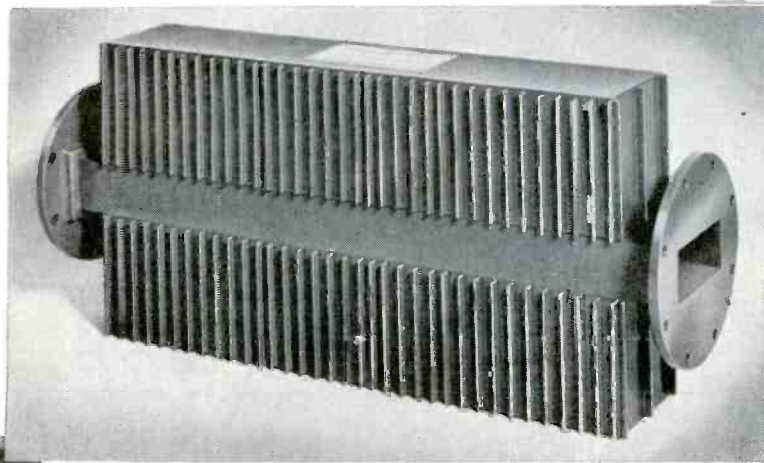

▲ Typical of a family of high-power harmonic suppression filters under development is this unit which has an insertion loss in excess of 25 db for all signals from 5400 mc to 10,000 mc. It is capable of power levels up to 5 megawatts and has an insertion loss below 0.2 db throughout the pass band from 2700 to 3100 mc. The VSWR across both pass and stop bands is less than 1.8. Two or more filters can be joined in cascade to increase harmonic rejection. Other developmental filters operating in the L and S bands have been designed to meet specific operating conditions. All filters of this family are of rugged construction to meet performance standards of military applications.



▲ The General Electric Power Tube Microwave Laboratory is located at Stanford Industrial Park, Palo Alto, California where it was one of the Park's pioneer installations. Its scientists and engineers have the advantage of technical exchange with the faculty and research staff of Stanford University, as well as extensive opportunities for graduate training. Constant technical liaison is also maintained with General Electric's own Research and General Engineering Laboratories, Schenectady, New York.

The extensive program of the General Electric Microwave Laboratory on advanced microwave components and techniques includes the following:

CW Klystron Amplifiers	Pulse Klystron Power Amplifiers
Super-Power Klystrons	High-Power Pulsed TWT Amplifiers
Voltage-Tunable Oscillators	Low- and Medium-Power CW TWT Amplifiers
High-Power Duplexers	Low-Noise, Broad-Band TWT Amplifiers
Microwave Filters	Frequency Multiplier TWT Amplifiers

*Progress Is Our Most Important Product*

**GENERAL**  **ELECTRIC**

# CAN "MATCHED" SERVO COMPONENTS

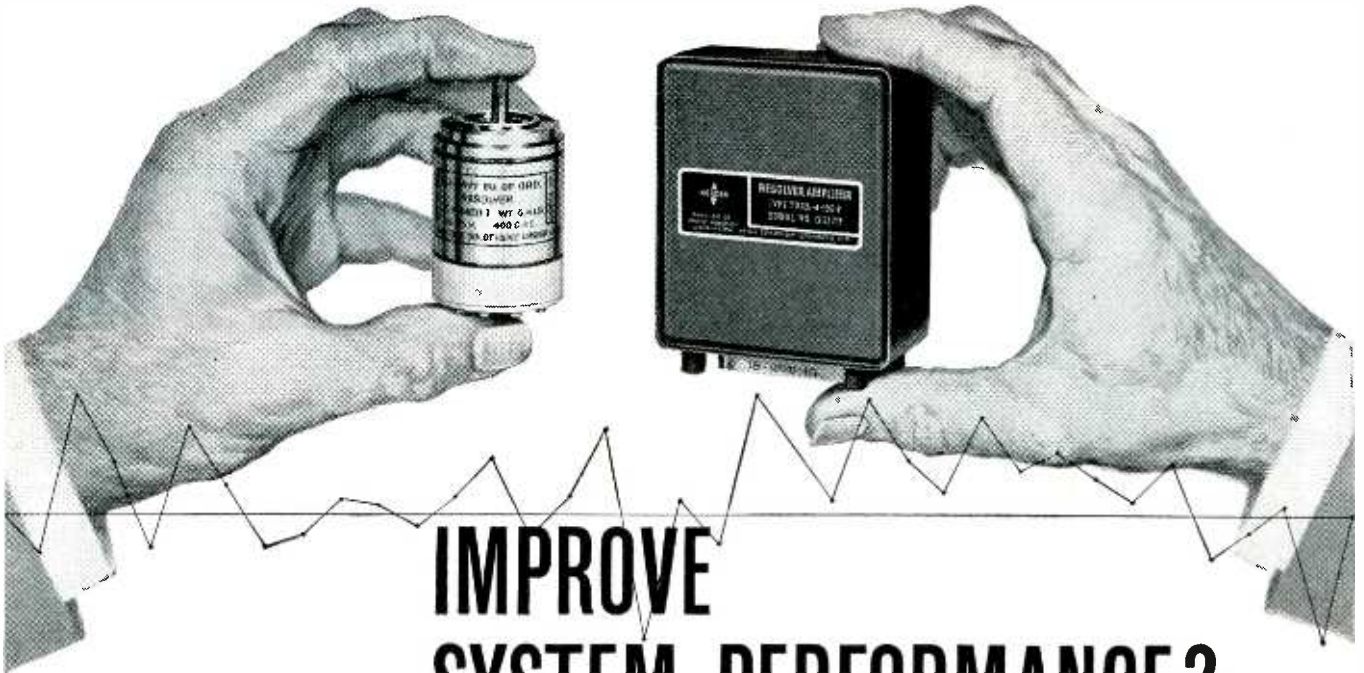

## IMPROVE SYSTEM PERFORMANCE?

They certainly can! And if performance in your servo system is important, you owe it to yourself to check out the advantages "matched" servo components by Ketay can give you.

For example, Ketay's 105D2V Resolver (designated by the Bureau of Ordnance as Mark 4 Mod 1) trimmed to the TREA 4-100-2 Amplifier gives you a bonus of high performance and interchangeability:

1. The system will be trimmed to  $\pm 0.02\%$  transformation ratio, with a phase shift tolerance of  $\pm 1'$ .
2. The amplifier will hold linearity to  $\pm 0.02\%$  from  $-55^\circ$  to  $+100^\circ\text{C}$ .
3. The receiver will achieve  $.05\%$  conformity to the sine wave, and  $\pm 3'$  interaxis error.

Similar benefits in matched performance can be obtained with system combinations using Ketay synchro transmitters, transformers, receivers, differentials, transistorized servo amplifiers, and servo motors.

But performance is not all you gain. When all or most of your components are from Ketay, broadest technical assistance is assured, and service and spares problems are simplified.

Ketay engineers are working on many advanced environmental and accuracy problems in developing prototype systems. Why not call or write for help in solving your servo component problems?

*Ketay matched components:*

SYNCHROS  
RESOLVERS  
POTENTIOMETERS  
SERVO MOTORS  
TACHOMETERS  
SERVO AMPLIFIERS  
GYROSCOPES

*Catalogues available*



Division of United Aircraft Corporation

KETAY DEPARTMENT, Commack, Long Island, N.Y.



**without E-W  
cooling units,  
electronic gear  
in this hut  
would  
burn out  
in minutes!**

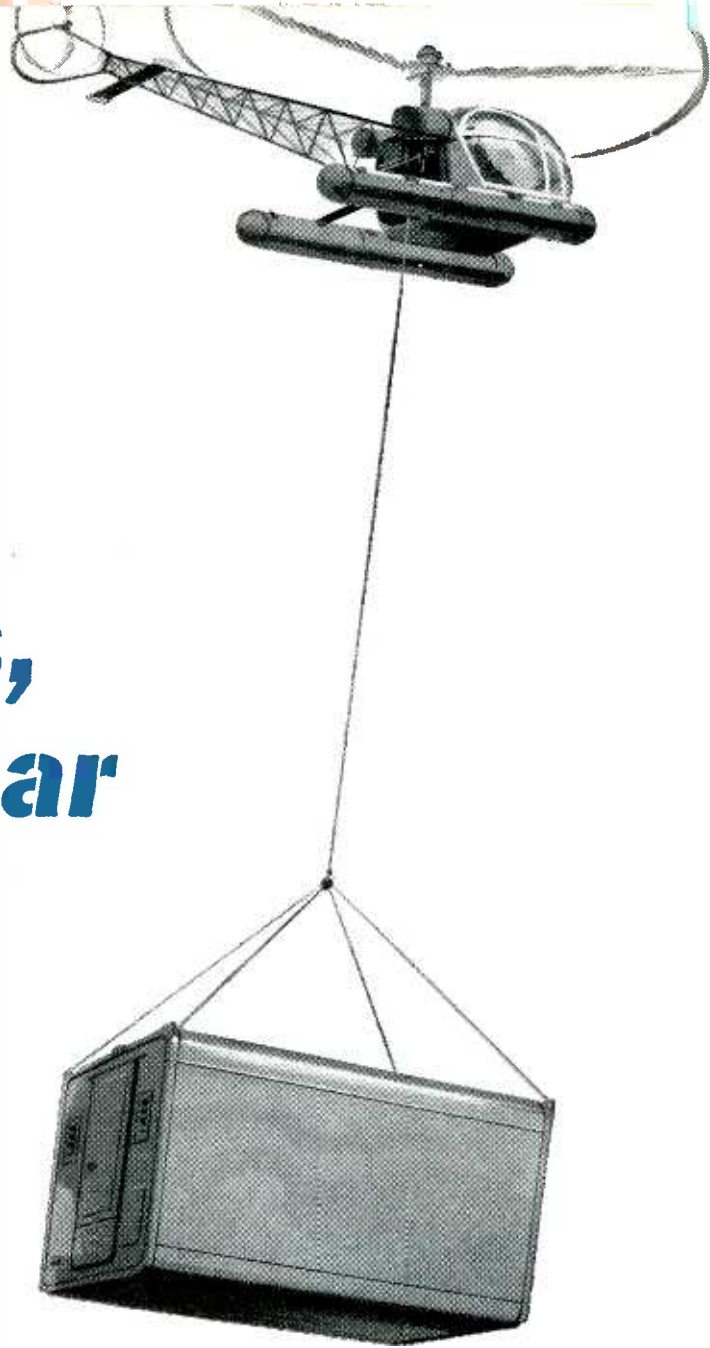

The Ellis and Watts Model A-9 Unit that keeps this critical electronic gear cool has a cooling capacity of 9000 BTU's per hour. Without this vital cooling capacity the electronic equipment would burn itself out in a matter of minutes! Wherever electronic gear is used, it creates heat problems. And, in compact airborne huts these problems are especially serious.

Designing and building specialized units to keep electronic gear cool is our business at Ellis and Watts. Units of any capacity, configuration, control requirements or functions can be designed and built to any applicable military or commercial specifications. E-W Units will function perfectly in any climate conditions on earth.

For additional information on Ellis and Watts Model A-9 Unit for cooling electronic gear in airborne huts or similar installations, write for Bulletin #130-E.

*Compact, Model A-9 Unit, developed especially to provide cooling in airborne huts, measures only 27 1/4" x 26 1/8" x 16 1/4" high—leaves maximum space for vital electronic equipment.*



**ELLIS AND WATTS PRODUCTS, INC.**  
P. O. Box 33-E, Cincinnati 36, Ohio

## Total Re-Design for Freas Laboratory Ovens

Freas laboratory ovens have recently undergone a complete design change and now offer such innovations as an electronic control system, higher operating temperatures and advanced styling features which combine to provide greater operating dependability and convenience.



### New Control Dependability

The most interesting feature of the new oven line is the electronic control system which utilizes a resistance thermostat acting through an electronic tube and sealed mercury relay. Moving parts—usually the cause of oven control failures in hydraulic thermostat systems—are completely eliminated. The simple circuitry of the new system is shown below.

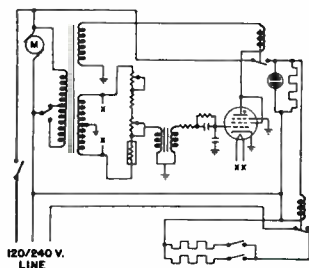

### Higher Operating Temperatures

Increased insulation, internal reinforcing and generally improved construction coupled with the electronic control now allow operating temperatures up to 325°C setting a new high in the laboratory oven field.

### New Operating Convenience

The functionally grouped controls offer new ease of operation. The control dial is calibrated for direct temperature selection. The modern exteriors are easy to clean and maintain. Work load capacity and temperature uniformity in gravity convection models has been greatly increased by a unique airflow system.

Whether your needs are for standard ovens, vacuum, incubators, sterilizers, low temperatures, high temperatures (1000°F.) or special purpose models, you will find them all fully described in Bulletin #302—contact your Distributor or PRECISION.

Since 1920

The Finest in Quality Laboratory Apparatus



3739 WEST CORTLAND STREET  
CHICAGO 47, ILLINOIS  
CIRCLE 24 READERS SERVICE CARD

## MARKET RESEARCH

# Two New Surveys Underway

ONE MAJOR PROBLEM of electronics industry market planners has been to obtain a detailed breakdown of military and industrial end-equipment sales. Until now, most of the figures available pertained only to broad categories and were based on rough estimates.

The Business and Defense Services Administration of the Department of Commerce aims to crack open these relatively undeveloped statistical areas of the electronics industry through a new end-equipment survey which was recently mailed to 550 electronics firms.

Survey questionnaire asks for 1958 unit and dollar sales of 60 equipment items in six major equipment categories, with separate data for military and industrial sales. Data on unfilled orders is being picked up for military equipment, while inventory backlogs are being acquired for a few industrial items.

The six major equipment categories are: navigation aids; search detection, surveillance and tracking; sonar and underwater sound; communications; missiles and test equipment.

Simultaneously, BDSA is surveying 150 component manufacturers to obtain reliable information on the growing microwave components market, currently estimated to total some \$200 million.

Survey seeks unit and dollar sales information on nearly 50 different types of microwave components, exclusive of microwave tubes.

Overall results of both surveys will be made available to industry, probably sometime in the Fall.

• **Role of market research** in new-product development is to minimize the risks of failure, Charles S. Roberts told a recent meeting of New York Chapter of IRE Professional Group on Engineering Management. He heads a New York market consulting firm bearing his name. The electronics firm which wishes to survive in today's competitive market should anticipate its customers' future needs by committing important resources to product development.

• **McGraw-Hill's 12th Annual Survey of Business' Plans for New Plants and Equipment, 1959-1962**, spells good news for manufacturers of electronic industrial and commercial equipment, which is widely sold to the new plant and plant modernization market.

U.S. business has revised upwards its plans for investment in new plants and equipment. It now expects to increase capital spending seven percent in 1959. Preliminary and incomplete plans for 1960 are already slightly above those for 1959. Similar plans for 1961 and 1962 are only four percent below the high level of spending estimated for 1959-1960.

Plans call for expenditure of \$34 billion on new plants and equipment in 1959, an increase of \$2 billion over last year. Manufacturing companies alone expect to spend \$10.472 billion in the current year, a seven-percent increase over actual expenditures in 1958.

Of special interest to the electronics industry is the fact business will make intensive efforts to modernize obsolete plants and equipment in the years, 1959-1962. Two-thirds of the expenditures planned for this period will be for modernization. Electronics industry usually gets a larger share of modernization spending. Much new plant spending goes for non-electronic items.

## FIGURES OF THE WEEK

### LATEST WEEKLY PRODUCTION FIGURES

(Source: EIA)	Apr. 17, 1959	Mar. 20, 1959	Change From One Year Ago
Television sets	95,023	94,648	+24.8%
Radio sets (ex. auto)	270,658	269,051	+70.7%
Auto sets	98,141	100,804	+130.4%

### STOCK PRICE AVERAGES

(Standard & Poor's)	Apr. 22, 1959	Mar. 25, 1959	Change From One Year Ago
Electronics mfrs.	88.80	80.63	+74.5%
Radio & tv mfrs.	101.46	95.96	+123.0%
Broadcasters	96.88	94.30	+65.0%

### LATEST MONTHLY SALES TOTALS

(Add 000)	Feb. 1959	Jan. 1959	Change From One Year Ago
Transistors, value	\$14,550	\$13,627	+113.8%
Transistors, units	5,393	5,195	+73.6%
Rec. tubes, value	\$28,630	\$26,808	+11.6%
Rec. tubes, units	33,155	31,150	+11.8%
Pic. tubes, value	\$14,085	\$15,210	+25.6%
Pic. tubes, units	738	785	+32.8%





## Technological Competition

*Continual demands are being made* for more effective—and more *complex* electronic weapons systems. These demands have multiplied the problems of reliability to a point where some scientists have resorted to mystical methods to “hex” competitive systems—even to the point of sticking pins in voodoo dolls.

With Hughes systems and components you have no such reliability problems. Hughes “hardware” is backed by the brain power of over 5000 reliability-oriented Hughes engineers and scientists—who have designed and developed well over two billion dollars worth of reliable electronic systems and components. When you specify HUGHES you insure against breakdowns—even under the most severe environmental conditions.

On the three following pages you’ll find specific examples of Hughes reliable components — semiconductor devices, TONOTRON\* Storage Tubes, and MEMO-SCOPE® recorders.

In addition to these, other Hughes Products devices which offer you this “built-in” reliability include: precision crystal filters for selective tuning... rotary switches... thermal relays... MEMOTRON® and TYPOTRON® storage tubes... microwave tubes... diodes, transistors and rectifiers... and industrial systems which operate a complete and integrated line of machine tools.

\*Trademark of H.A.C.

*For additional information regarding any component or system please write: Hughes Products, Marketing Dept., International Airport Station, Los Angeles 45, California.*

Creating a new world with **ELECTRONICS**

**HUGHES PRODUCTS**

© 1959. HUGHES AIRCRAFT COMPANY

SEMICONDUCTOR DEVICES • STORAGE AND MICROWAVE TUBES • CRYSTAL FILTERS • OSCILLOSCOPES • RELAYS • SWITCHES • INDUSTRIAL CONTROL SYSTEMS

# How to get ultra- uniformity

in a Silicon

## PNP fused alloy transistor

Through precise manufacturing techniques, Hughes PNP fused-junction silicon transistors give you extreme uniformity of parameters by type. Result: circuit interchangeability no longer is a problem.

Designed for switching and amplifying applications at low and medium current levels, these Hughes transistors offer you a number of advantages:

- useful Beta at extremely low collector currents
- $BV_{EBO}$  and  $BV_{CBO}$  are similar
- high punch-thru voltage ( $BV_{CBO}$  in excess of 100 volts in types 2N1244 and 2N1234)
- low saturation resistance

These E.I.A. registered devices, now available in production quantities, are housed in TO-5 (single ended) and coaxial packages (double ended). Engineered for extreme reliability, several types meet MIL-T-19500A specifications.

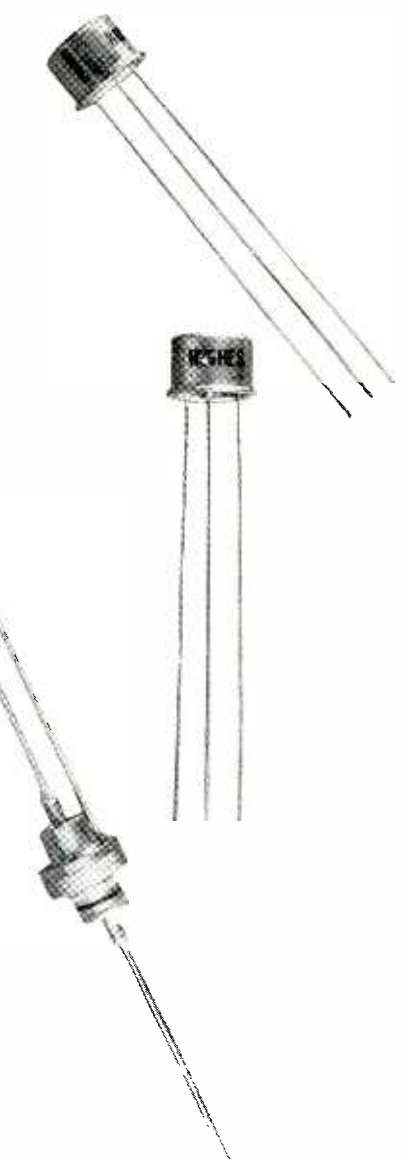

Coaxial Package Type:	2N1238	2N1239	2N1240	2N1241	2N1242	2N1243	2N1244
TO-5 (formerly JETEC-30) Package Type:	2N1228	2N1229	2N1230	2N1231	2N1232	2N1233	2N1234
Collector to Emitter Voltage ( $BV_{CEO}$ ) ( $I_{CEO} = 100\mu A$ )	15V	15V	35V	35V	65V	65V	110V
Collector to Base Voltage ( $BV_{CBO}$ ) ( $I_{CBO} = 100\mu A$ )	15V	15V	35V	35V	65V	65V	110V
Emitter to Base Voltage ( $BV_{EBO}$ ) ( $I_{EBO} = 100\mu A$ )	15V	15V	35V	35V	65V	65V	110V
Coaxial Package: Power dissipation . . .	1 watt in free air (derate 7.4 mw/°C)						
	5 watts with heat sink (derate 37 mw/°C)						
TO-5 Package: Power dissipation . . .	250 mw (derate 1.8 mw/°C)						
Collector current limited by power dissipation. Operating and storage temperature range	-65°C to +160°C						

Your inquiry regarding these transistors will be given prompt attention. Just write or call the Hughes sales office nearest you. They are located in Boston (phone WO 2-4824), Newark (phone MA 3-3520), San Francisco (phone DA 6-7780), Syracuse (phone GR 1-0163), Philadelphia (phone MO 4-8365), Chicago (phone NA 2-0283), and Los Angeles (phone OR 8-6125). Or write Marketing Department, SEMICONDUCTOR DIVISION, NEWPORT BEACH, CALIFORNIA

Creating a new world with *ELECTRONICS*

**HUGHES PRODUCTS**

© 1959, HUGHES AIRCRAFT COMPANY



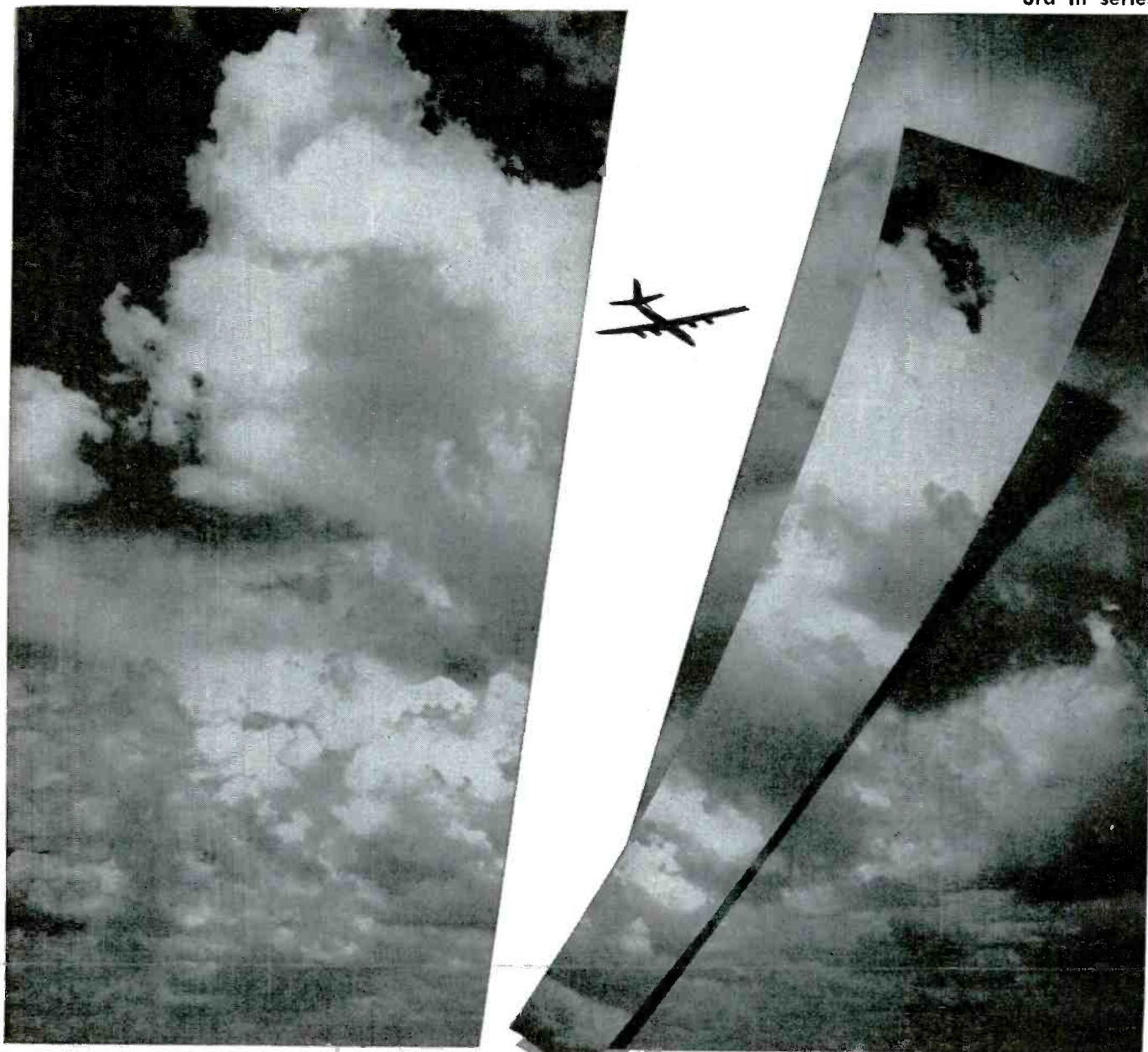

## taking "whether" out of the weather

With the Hughes TONOTRON\* tube in your airborne weather radar system you can provide smoother, more dependable air miles.

Ideally suited to weather radar, the Hughes TONOTRON tube gives you:

**Full Gray Scale**—Seven different shades of gray.

**High Picture Brightness**—In excess of 1500 foot-lamberts with full half-tone range. Even in full sunlight no viewing hood is required—thereby providing maximum safety.

**Controllable Persistence**—Gives you flexibility in analyzing the complete weather problem.

These same characteristics make the Hughes TONOTRON tube equally adaptable to many other military, scientific and commercial applications, such as: sector scanning, ground mapping, "B" scan radar, oscillography, armament control radar, optical projection systems and miniature radar indicators. TONOTRON tubes are available in a range of sizes...from 3 inches to 21 inches in diameter.

You can obtain additional information concerning Hughes Tonotron tubes by simply writing: Hughes Products, Electron Tube Sales, International Airport Station, Los Angeles 45, California.

\*TRADE-MARK OF H. A. C.

Creating a new world



with ELECTRONICS

**HUGHES PRODUCTS**

© 1959, HUGHES AIRCRAFT COMPANY

SEMICONDUCTOR DEVICES • STORAGE AND MICROWAVE TUBES • CRYSTAL FILTERS • OSCILLOSCOPES • RELAYS • SWITCHES • INDUSTRIAL CONTROL SYSTEMS

# SHOCK TEST PROBLEMS SOLVED

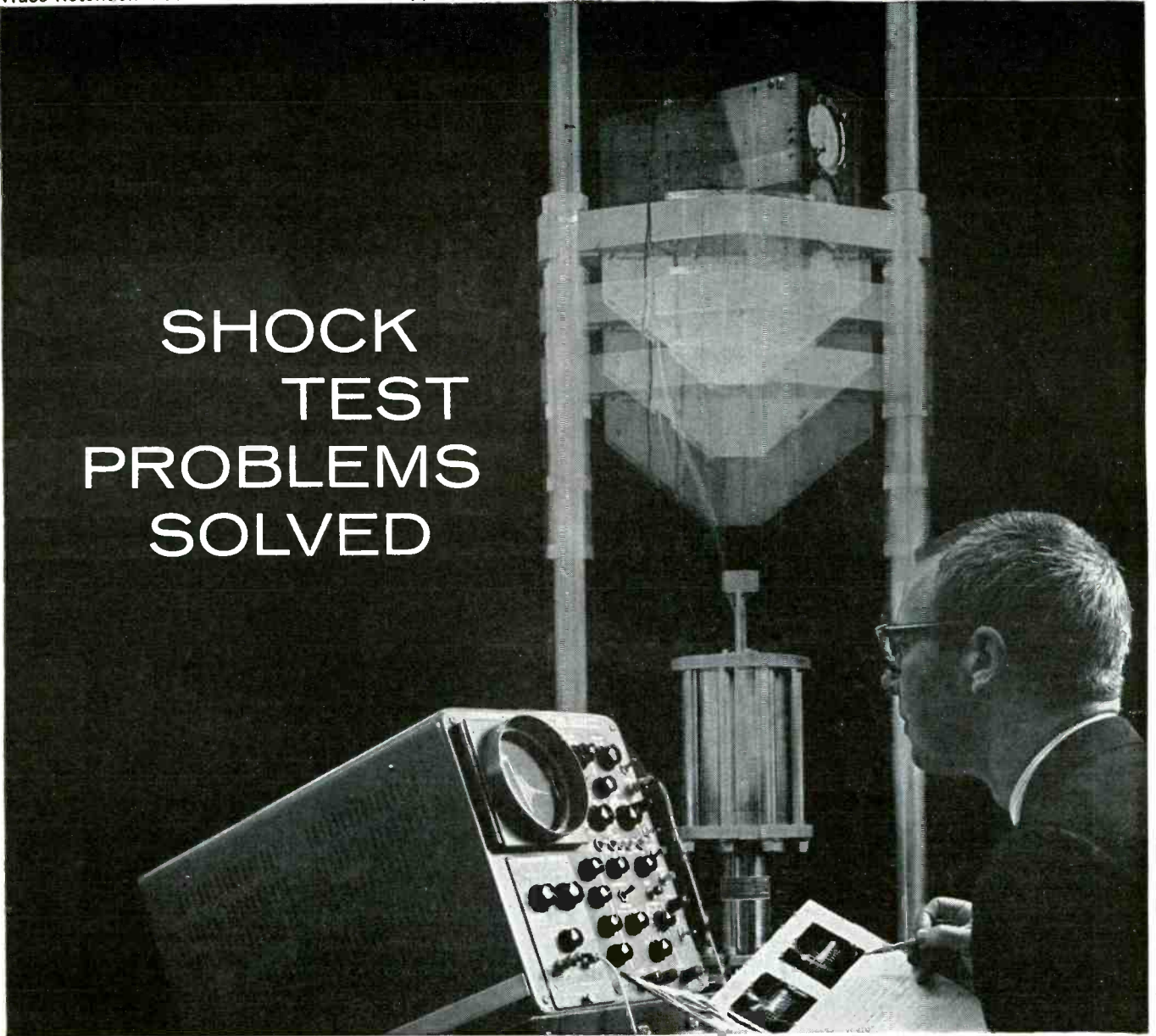

Now with the Hughes MEMO-SCOPE® oscilloscopic recorder you can instantly freeze wave forms which record shock and other environmental tests. In association with the Hyge Shock Test Unit, manufactured by Consolidated Electrodynamics, you can produce predictable, repeatable acceleration shock thrusts. The information can be stored on the face of the MEMO-SCOPE recorder for hours—or even days if necessary—until intentionally erased. Successive wave forms may be written above, below or directly over the

*Many unique problems have been solved with the MEMO-SCOPE recorder through trace retention. Refer your problems to us by writing: Hughes MEMO-SCOPE recorder, Hughes Products, International Airport Station, Los Angeles 45, California.*

original information. This ability to freeze transients for study saves you time and money in transient analysis.

In addition to physical testing (shock, stress, and strain) the MEMO-SCOPE recorder makes it possible for you to solve problems associated with:

- Ultrasonic flaw testing
- Drift measurements
- Ballistics, explosives research
- Switch, relay contact studies
- Transducer testing
- XY plotters
- Medical diagnosis problems
- Trouble shooting

#### SPECIFICATIONS:

Sweep Speed for Storage: 10 microseconds per division (0.33").

Frequency Response: DC to 250 KC down 3 db.

Sensitivity: 10 millivolts to 50 volts per division or with optional high sensitivity preamplifier 1 millivolt to 50 volts per division.

Creating a new world with *ELECTRONICS*

## HUGHES PRODUCTS

© 1959, HUGHES AIRCRAFT COMPANY

SEMICONDUCTOR DEVICES • STORAGE AND MICROWAVE TUBES • CRYSTAL FILTERS • OSCILLOSCOPES • RELAYS • SWITCHES • INDUSTRIAL CONTROL SYSTEMS



ECONOMICAL

# STEREO

WITH ONLY TWO TUBES

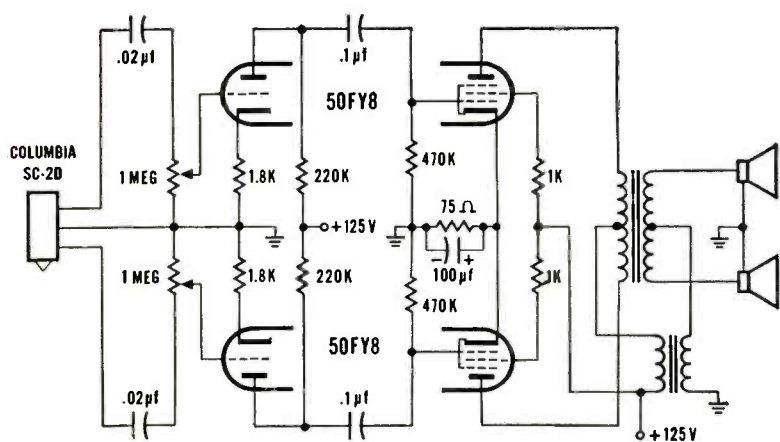

**CBS SIMPLEX STEREO:** A modified simplex amplifier by CBS Laboratories . . . a special cartridge by Columbia Records . . . and the new 50FY8 triode-pentode by CBS-Hytron unite to make possible truly economical stereo.

The CBS-Hytron 50FY8 combines a triode voltage amplifier and a pentode power output tube in a T-6½, nine-pin miniature bulb. Operating from the popular Columbia CD stereo cartridge, the triode section drives the beam pentode to 3.5 watts output.

The compact new tube (same outline as 6BQ5) is available in four heater versions: 6FY8, 12FY8, 25FY8 and 50FY8. Designed for stereo, this versatile tube has other potential applications. Check the characteristics. Write for technical bulletin E-334.

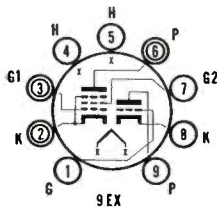

*More reliable products through  
Advanced-Engineering*

**CBS-HYTRON**, Danvers, Massachusetts  
A Division of Columbia Broadcasting System, Inc.



### TYPICAL CLASS A OPERATION OF 50FY8

CHARACTERISTIC	TRIODE	PENTODE
Heater	50 volts at 150 ma	
Plate voltage (volts)	125	125
Grid 2 voltage (volts)	—	125
Grid 1 voltage (volts)	—1.5	—13.5
Plate current (ma)	2.5	50
Grid 2 current (ma)	—	10
Transconductance (μmhos)	2000	7500
A-c load resistance (ohms)	—	2000
A-f input voltage (vrms)	0.3	—
Max. power output (watts)	—	3.5
Distortion	Approx. 10%	

Important max. ratings for pentode section are: Plate and grid 2 voltages, 150 volts. Plate and grid 2 dissipations, 8 and 2 watts respectively. Heater-cathode voltage (heater negative or positive to cathode), 200 volts.

### Electronic Component Exports to European Common Market Nations\*

	Electron Tubes (receiving)	Electron Tube Parts	Inductors	Crystal Diodes, Transistors	Capacitors	Resistors
<b>1954</b>						
Netherlands.....	\$68,046	\$29,481	\$23,107	\$16,076	\$60,852	\$17,173
Belgium.....	236,291	5,886	27,911	38,052	53,719	33,244
France.....	562,854	40,147	74,145	58,932	112,622	224,539
West Germany.....	174,815	64,078	14,463	23,740	32,012	10,856
Italy.....	287,798	77,784	61,721	6,669	39,995	42,619
	<hr/>	<hr/>	<hr/>	<hr/>	<hr/>	<hr/>
<b>\$2,519,627</b>	<b>\$1,329,804</b>	<b>\$217,376</b>	<b>\$201,347</b>	<b>\$143,169</b>	<b>\$299,200</b>	<b>\$328,131</b>
<b>1957</b>						
Netherlands.....	\$74,610	\$28,992	\$15,429	\$154,834	\$76,388	\$42,644
Belgium.....	184,045	1,077	128,049	194,806	142,258	51,699
France.....	446,523	250,248	163,569	723,866	156,391	244,658
West Germany.....	321,908	78,307	20,402	153,694	70,361	80,398
Italy.....	818,928	202,427	547,594	413,104	79,154	152,834
	<hr/>	<hr/>	<hr/>	<hr/>	<hr/>	<hr/>
<b>\$6,026,197</b>	<b>\$1,846,014</b>	<b>\$561,051</b>	<b>\$875,043</b>	<b>\$1,640,304</b>	<b>\$531,552</b>	<b>\$572,233</b>
<b>1958</b>						
Netherlands.....	\$40,810	\$205,582	\$16,310	\$672,372	\$21,547	\$105,122
Belgium.....	162,793	6,964	37,252	77,609	87,431	64,469
France.....	359,598	249,709	170,316	1,207,073	203,625	248,179
West Germany.....	989,190	128,188	57,508	168,043	37,952	87,421
Italy.....	298,280	444,610	623,783	708,761	102,361	190,174
	<hr/>	<hr/>	<hr/>	<hr/>	<hr/>	<hr/>
<b>\$7,773,032</b>	<b>\$1,850,671</b>	<b>\$1,035,053</b>	<b>\$905,169</b>	<b>\$2,833,858</b>	<b>\$452,916</b>	<b>\$695,365</b>

\* Figures not available on Luxembourg

# European Licensing Grows

## U.S. electronics firms are turning to licensing as a means of offsetting to-day's spreading competition of European Common Market

THE EUROPEAN COMMON MARKET, in operation on a six-nation scale since January, is causing many U. S. electronics firms to start development of some new working concepts.

At the outset, the competitive edge for C-M member nations, (France, Belgium, Netherlands, Italy, Luxembourg and West Germany) over American exporters seems formidable. Some factors favoring the European suppliers are: relaxed trade barriers, loosened customs regulations, freer currency exchange and close geographic proximity to each other.

A growing number of U. S. firms, however, have been finding increased comfort in the knowledge that this seemingly uphill situation can be turned to advantage if the right approach is taken.

### Licenseses

In many cases, this approach is the overseas licensee who will manufacture the product in a local factory using local workers and distribution channels. In return for

technical information and advisory personnel, the licensee will make the product and return a profit to the licensor in the form of royalty per unit, percentage of gross profit, flat annual fee or some other method.

In terms of required capital outlay and general risk, the licensee method is generally considered most suitable for small or moderate-sized firms.

### Brand Names

Actual manufacture of the product, in many cases, means that the U. S. firm's trademark goes on it. American manufacturers usually leave this to the overseas firm to decide. In cases where a familiar European trademark is of value in selling a new product, the U. S. brand name goes by the board. When a known trademark, backed by international advertising, seems to be the best bet, it stays on the product with a credit line to the local manufacturer. The licensee's judgment is usually the final deciding factor.

Figures derived by the U. S. De-

partment of Commerce give some indication of the rate of growth of Common Market purchases of electronic components (see chart). The monthly average for 1954 shipments totaled \$209,969, with a yearly total slightly in excess of \$2½ million. In 1957, the monthly average came to \$502,183 representing a yearly total of more than \$6 million. Last year's figures show the size of the market for the components indicated more than trebled the 1954 shipments. The monthly average for 1958 was \$647,753. The year's total was \$7,773,032.

In terms of population, the Common Market area is growing at a good rate. One French publication predicts that the next decade may see figures matching those of the U. S.

### How It's Done

An example of how licensing works may be seen in plans shaping up at International Electronic Research Corp., Burbank, Calif. This firm is planning to market heat-dissipating shields for electron



tubes through the licensee method. A plant is being built in Paris to house manufacturing and distribution facilities. The French licensee will distribute throughout the six-nation common market as well as Switzerland. IERC also has licensing agreements within the British Commonwealth.

International Resistance Company, Philadelphia, has been reaching overseas markets for some time through licensees in West Germany, Italy, Great Britain, Denmark, Australia, and Latin America. The firm gives no indication of worry over Common Market competition. Most IRC products made in Europe carry the trademark of the local manufacturer. A recently concluded agreement with Chicago Telephone Supply Corp., Elkhart, Ind., provides for sharing of the IRC facilities here and, if CTS desires, abroad as well. A spokesman for International Resistance says CTS will probably make use of the foreign establishments.

A number of segments of the electronics industry feel that the growth of the European market is linked to the growth of television, hi-fi and other forms of entertainment electronics. Increased numbers of tv sets and hi-fi rigs mean more tubes, more components and increased numbers of service establishments.

One firm planning to act on this concept, Harold Radio and Electronics Corp., Mt. Vernon, N. Y., has recently announced plans to sell its line of Steelman tape recorders, radios and phonographs through an overseas export representative. A close watch will be kept on consumer acceptance of the products. If conditions indicate, the firm may set up manufacturing facilities abroad at some future date to sell products which will by then have established their trade name in European markets.

The American firms who manufacture military goods, aeronautical electronic gear and specialized test equipment will probably be less interested in foreign licensing than those making equipment and components for industrial and commercial applications. Most gear in the former category is contracted for and purchased in the U. S. at federal level rather than sold abroad.

## THE MOSELEY

# AUTOGRAF

trade mark

## X - Y - (T)\* RECORDER

A direct writing, low frequency oscillograph for:

- X-Y RECORDING
- PLOTTING ONE VARIABLE VS TIME

With appropriate accessories will:

- PLOT IDENTIFIED POINTS FROM TAPE OR CARDS
- READ OUT CONDUCTING CURVES
- AUTOMATICALLY PRODUCE GAIN-FREQUENCY RECORDS

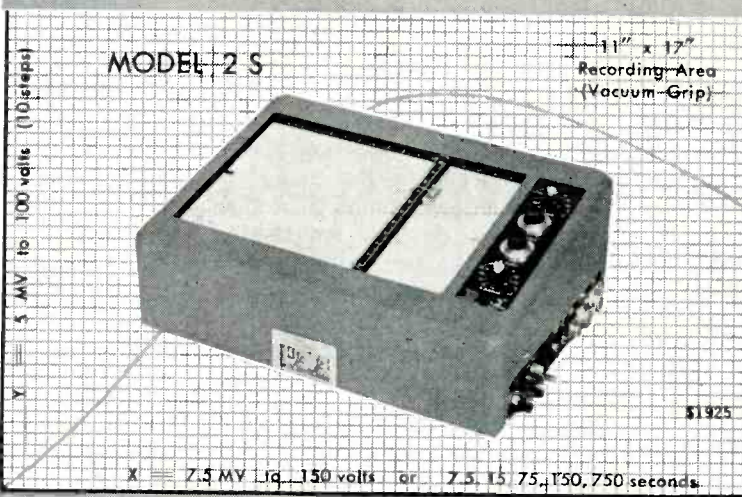
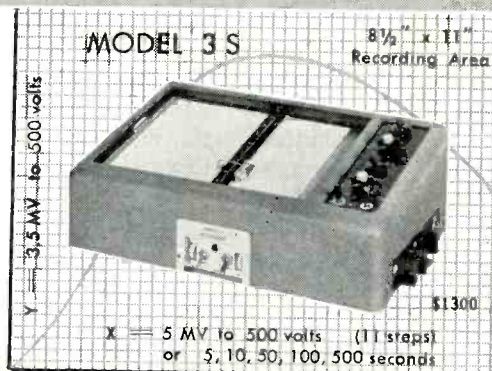

\* with TIME BASE

All models illustrated feature:

- Isolated servo-actuated drives for each axis
- Full range zero set and zero suppression
- Input filters and stepless range controls
- 200,000 ohms/volt input resistance
- One second or less for full scale deflection
- Better than 0.25% accuracy with 0.1% resetability

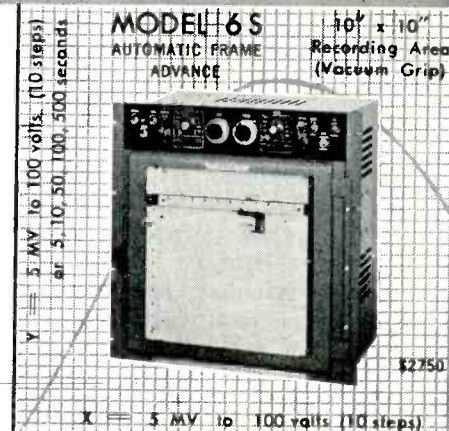

All prices f. o. b. factory. Prices and specifications subject to change without notice.

Call our sales representative in your area or write direct for additional information.

## F. L. MOSELEY CO.

409 N. FAIR OAKS AVE., PASADENA, CALIFORNIA

# ELECTRONICS ENGINEERS

and other professional graduates with related experience —  
for positions in DESIGN, DEVELOPMENT and SALES

It will pay you to look into the many fine opportunities in the large and rapidly expanding Curtiss-Wright Electronics Division at Carlstadt, N.J., E. Rutherford, N.J., and Caldwell, N. J.

If you are capable of earning up to \$15,000 a year on work that requires imagination and the ability to think beyond conventional barriers, Curtiss-Wright offers you unlimited opportunity. There are openings in the following diversified fields:

## RADAR SYSTEMS

To design and develop unique circuitry for utilizing radar signals from stationary and moving targets. Strong theoretical knowledge required with experience in the design of radar and communications circuits, as well as electro-optical devices. Systems engineering capabilities desired in the area of fire control radar and associated weapons systems.

## INDUSTRIAL INSTRUMENTATION

Opportunities in systems design and application with an established multi-product line for control of paper, rubber, plastic and metal processes. Expansion program based on current backlog. Must be graduate electrical engineer or physicist with automatic control, instrumentation, or servo-loop experience.

## NUCLEAR REACTOR CONTROLS

Excellent opportunities for engineers with experience on: research & training reactors, military and commercial power reactors, and nuclear propulsion systems, with particular emphasis on applications and systems engineering, and application of solid state devices to nuclear reactor instrumentation.

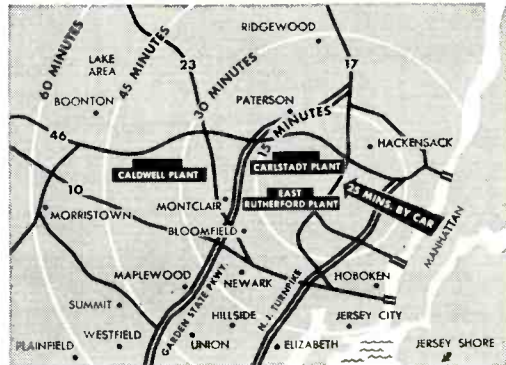

New turnpikes, parkways and superhighways make driving a pleasure in the Northern New Jersey area. Electronics Division plants are only a short drive from a wide choice of residential communities.

## SERVO SYSTEMS

Electrical engineering degree with 3-5 years experience in analog computer and/or servo-mechanism design and development.

## DIGITAL COMPUTER

Minimum 5 years technical experience beyond engineering or allied degree. Minimum 3 years in digital computer techniques with special ability in systems design.

**GROWTH AND DIVERSIFICATION —**  
The Electronics Division has enjoyed steady growth over the years, with heavy emphasis on commercial business in addition to the many new projects in the military and space fields. This calls for an equally steady increase in qualified personnel, and creates constant opportunities for advancement along many lines.

Send detailed resume to: Mr. T. W. Cozine, Mgr., Executive & Technical Placement,  
Curtiss-Wright Corporation, Dept. ED-57, Wood-Ridge, N. J.

ALL REPLIES CONFIDENTIAL

**CURTISS-WRIGHT**   
CORPORATION • WOOD-RIDGE, N. J.



# NEW MONITOR OSCILLOSCOPES

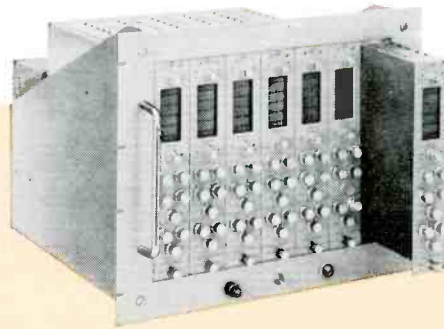

View up to  
7 circuits simultaneously!

New Sierra Model 218 Monitor Oscilloscopes provide, in the smallest possible package, a convenient and practical means for viewing and evaluating complex voltages. Up to seven oscilloscopes can be mounted side by side in a standard relay rack—units measure only 10½" high x 2½" wide (front panel). Thus seven circuits can be monitored simultaneously.

Designed primarily for tape recording and data handling systems, the Monitor Oscilloscopes are particularly suited for measuring and analyzing mechanical quantities through a transducer. Such quantities include stress, strain and vibration, pressure, displacement and acceleration.

Unusual design features include printed circuitry, broad bandwidth, smooth high frequency rolloff without overshoot and minimum heating (only 20 watts dissipation per scope unit, including filaments!) Request bulletin and demonstration.

## SIERRA ELECTRONIC CORPORATION

A Subsidiary of Philco Corporation

5444A Bohannon Drive • Davenport 6-2060 • Menlo Park, California, U.S.A.

*Sales representatives in all major cities*

Canada: Atlas Instrument Corporation, Ltd., Toronto, Montreal, Vancouver, Winnipeg  
Export: Frazer & Hansen, Ltd., San Francisco,

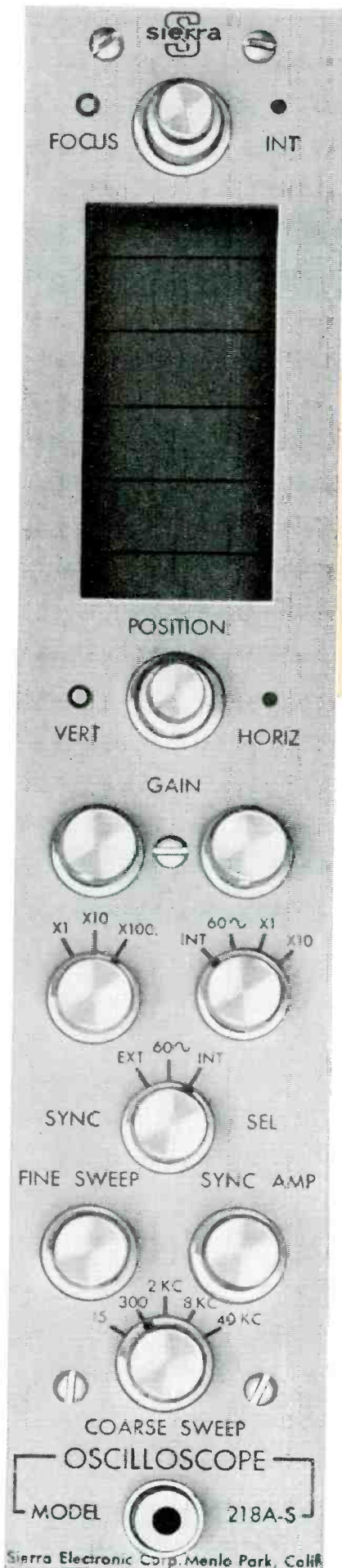

# Doing Pulsed or "Fast" Circuit Work?

## Square Wave Generator



1 cps to 1 MC; 0.02  $\mu$ sec rise time

**hp 211A Square Wave Generator.** Versatile, wide range instrument for testing oscilloscopes, networks, video and audio amplifier performance, modulating signal generators, measuring time constants. Offers simple control of electronic switchers; is also convenient for indicating phase shift, frequency response and transient effects.

Special features include two separate outputs — a 7 volt, 75 ohm circuit for television work and a 55 volt, 600 ohm output for high level work. Both outputs offer full amplitude variation. May be operated free-running or externally synchronized with positive going pulse or sine wave signal of 5 volts minimum amplitude. Compact, weighs only 25 lbs. Cabinet model, \$300.00; rack mount model, \$305.00.



## Pulse Generator

0.07 to 10  $\mu$ sec pulses, 0.02  $\mu$ sec rise time



**hp 212A Pulse Generator.** Time saving basic instrument for radar, television and other "fast" circuit work, including testing rf amplifiers, filters, band pass circuits; oscilloscopes and peak measuring equipment, pulse modulating uhf signal generators. Offers positive or negative pulses of 50 watts amplitude, delay and advance sync out circuits for synchronizing to other circuits, direct-reading pulse length control, high quality pulses with 0.02 rise and decay, flat top and minimum overshoot. Jitter less than 0.01  $\mu$ sec. Permits delivery of accurate pulses to end of long transmission lines; if line is correctly terminated, pulse shape is independent of line length, sync conditions, input voltage or output attenuator setting. Internal impedance 50 ohms or less, either polarity. Repetition rate, internal sync 50 to 5,000 pps, external sync approximately 2 to 5,000 pps. Cabinet model \$585.00; rack mount model, \$570.00.

Call your -hp- representative for details or write direct. *Data subject to change without notice. Prices f.o.b. factory.*

### HEWLETT-PACKARD COMPANY

1009A Page Mill Road • Palo Alto, California, U. S. A.

Cable "HEWPACK" • DAvenport 5-4451

Field Representatives in all Principal Areas

4653R



also offers new 120A Oscilloscope—dc to 200KC—\$435



# Air Force Updates Network

World-wide communications planning calls for updating, modernizing and, in next decade, integrating into a three-service network

ACTIVITY CURRENTLY under way on USAF's world-wide communication system means big business for our industry.

Total cost of keeping USAF's global communications system up to date during fiscal years 1959-1960 will be about \$45 million. This work, known as Project Quickfix, includes buying and installing new equipment to replace the 1950-1953 model gear now in use, extending the present network and changing over transmitting equipment to single sideband.

## Long-Range Plans

Meanwhile a study is being made under contract (project 480-L) by ITT, RCA, Hughes and Hoffman for additional modernization of the present system to cover needs of the 1960-1970 period. This long-range plan will enable direct user-to-user hookup irrespective of what kind of traffic is to be passed. The system will provide for sending control signals to both manned and unmanned weapons, graphical communications such as facsimile, high-speed teleprinter and improved air-to-ground communications all over the world.

Project 480-L will be part of a common Defense Department world-wide communications system that will tie all three services' networks together. Tri-service integration will be run by the Communications-Electronics Directorate of the Joint Staff and will be done over the next ten years.

## Project Quickfix

Admittedly Project Quickfix is a patch-up job. But it is a wide-ranging one. Almost all Air Force communications systems will be overhauled. The only major exceptions are: weapon-system control channels within the Sage system, temporary tactical communications networks, research and development facilities and local base communications. In all, six major systems will be worked over.

The common long-haul communications system is the point-to-point and air-ground-air communications system required to support USAF weapons systems, air operations, and related air activities.

The USAF communications network is a world-wide, integrated, teleprinter tape-relay network of landline channels designed to carry USAF administrative message traffic. This system uses Air Force-owned and operated facilities as well as leased commercial facilities and circuits of the Army and Navy.

The USAF air operations network is a rapid-service landline teleprinter network handling operational type traffic. In the U. S., all flight service centers are connected with all Air Force bases and all other air operations activities by leased teleprinter facilities.

The USAF weather teleprinter and weather facsimile network provides weather and facsimile service between forecasting stations and agencies requiring current weather data. In the U. S. leased circuits are used. Overseas, both leased landline and Air Force-owned radio

circuits are employed.

The global weather broadcast and intercept system provides for reception of blind transmissions of weather information to Air Force activities throughout the world.

And theater communications networks have been provided for each Air Force overseas theater to support special operational requirements. These networks consist of leased landlines, both military-owned and leased microwave systems. Both voice and teleprinter channels are available. In some areas, tropospheric scatter is used.

## Equipment Requirements

Quickfix will involve updating existing Air Force communications equipment. Here is some of the gear currently being used:

High-frequency a-m transmitters range from 3 to 50 kw. Tropospheric scatter transmitters deliver 50 kw. In general, the long-haul intercontinental circuits are equipped with 50 kw ssb transmitters and high-gain receivers. Usually the high-frequency transmitters are used in the temperate zones while tropospheric systems are used in the Arctic. However, improved performance gained by use of tropospheric scatter has led to its installation in other areas where high diversity, reliable communications are needed.

Receivers range from commercial a-m sets to special military h-f ssb units such as the AN-FRR41. Multiplex equipment at the Communications Centers ranges from four to 16 channel units, depending on circuit requirements.

Teleprinter equipment varies from the single teleprinter through the semiautomatic Western Union Plan 51.3 to the fully automatic Western Union Plan 55, with capacity for handling and storing input from approximately 100 lines.

The teleprinter system consists of about 20 major relay stations and some 60 minor and tributary stations throughout the free world.

## Jet Age Batteries



Prime ignition batteries for jet airliners were developed by Sonotone. Firm's president, I. I. Schachtel, inspects unit which weighs only 10 lb, is 2½ in. wide, 4½ in. deep, 14 in. long. Other battery weighs 12 lb, is 4½ in. wide, 4½ in. deep and 10 in. long

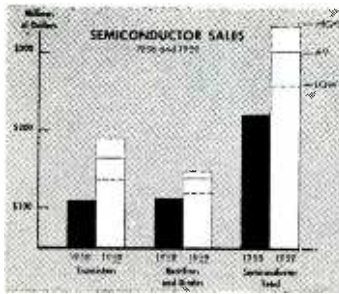

Paul Petrack takes the

stand for **electronics**

ITT (International Telephone & Telegraph Corp.), Components Division, Clifton, New Jersey is a leading electronics manufacturer of electron tubes, fixed capacitors, silicon power diodes, selenium rectifiers, hermetic seals, miniature switches, and other component parts.

Former Chief Engineer, and present Product Manager for silicon products, Paul Petrack is a market expert for electronics components. His functions require him to determine what products will be in greatest demand (according to the industry's latest technical developments) and what products will be the most profitable to market.

According to the subscription records, electronics is sent to your home. Why?

*Because I have more time to read it and more time to digest it.*

Does electronics help you create new business for ITT?

*Yes, by keeping me aware of new developments in industry, the state of the art, and market potentials for existing products, we are better able to direct our efforts toward meeting our product goals.*

What "product image" has electronics conveyed to you over the years?... or, How would you define electronics' position in the electronics industry?

*I consider electronics required reading...it is clear, concise and complete.*

If it's about electronics, it's advertised and read in electronics

# electronics

Published WEEKLY plus the mid-year electronics BUYERS' GUIDE  
A McGraw-Hill Publication • 330 West 42nd Street, New York 36, N. Y.





# FIRST SILICON TRANSISTORS WITH 150 Mc Alpha Cutoff PLUS POWER

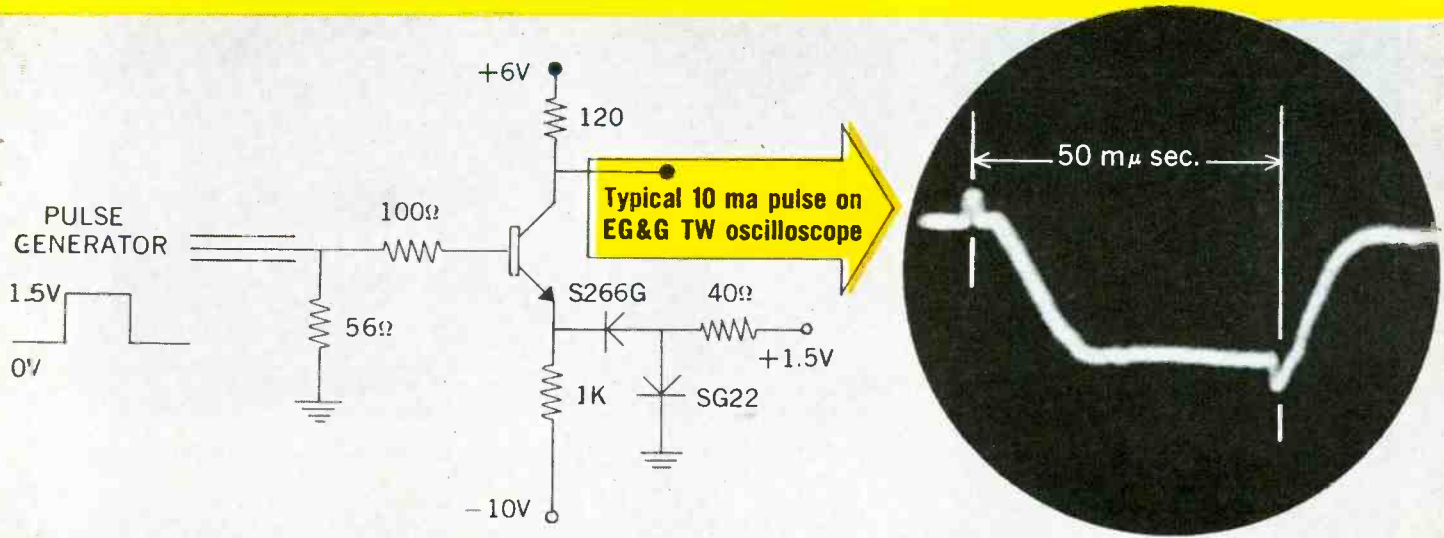

## ABSOLUTE MAXIMUM RATINGS

Collector to Emitter Voltage — $V_{CE}$	15 Volts
Collector to Base Voltage — $V_{CB}$	15 Volts
Emitter to Base Voltage — $V_{EB}$	3 Volts
Total Power Dissipation: at 125°C Case Temperature	.5 Watts
at 100°C Amb. Temperature	0.5 Watts

## SPECIFICATIONS AND TYPICAL CHARACTERISTICS AT 25°C

	Min.	Typical	Max.	Test Conditions	
D.C. Current Gain	$h_{FE}$	10	20	—	$I_C = 10\text{ma}$ , $V_{CE} = 6\text{V}$
D.C. Collector Saturation Voltage	$V_{CE}$	—	.5	0.6V	$I_C = 10\text{ma}$ , $I_B = 2\text{ma}$
Collector Cutoff Current	$I_{CO}$	—	2	$5\mu\text{a}$	$V_{CB} = \text{Rating}$
Output Capacitance	$C_{ob}$	—	8	$12\mu\text{mf}$	$V_{CB} = 6\text{V}$ , $I_E = 0\text{mA}$
High Frequency Current Gain	$h_{fe}$	5	7.5	—	$F = 20\text{mc}$ , $V_{CE} = 6\text{V}$ , $I_E = 10\text{mA}$
Delay Time	$t_d$	—	6	$m\mu\text{sec.}$	
Rise Time	$t_r$	—	12	$m\mu\text{sec.}$	
Fall Time	$t_f$	—	10	$m\mu\text{sec.}$	

Here's a silicon logic transistor with the speed of the fastest germanium types . . . **PLUS POWER HANDLING ABILITY!** Transitron's 2N1139 represents a giant step forward in transistor technology, augmenting the industry's most complete line of silicon transistors. Typical total switching times average less than 30 milli-microseconds.

Transitron's fast switching types now cover the entire current range up to 5 amperes — offer a rugged silicon transistor for every *switching* application.

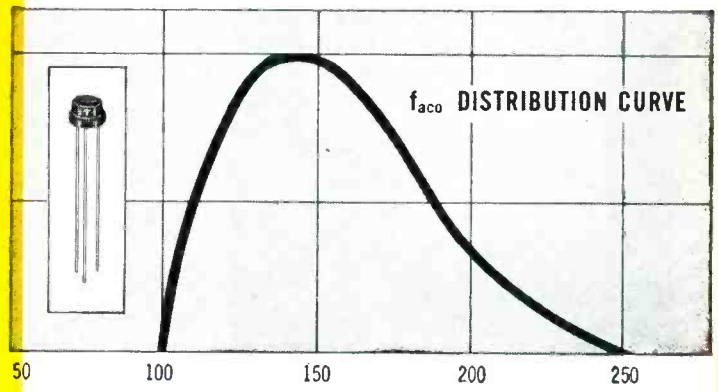

TRANSISTORS • RECTIFIERS • DIODES • REGULATORS • VOLTAGE REFERENCES



# Transitron

electronic corporation • wakefield, massachusetts



# NEW VIBRATING CAPACITOR



A vibrating-reed type capacitance modulator for use in measuring currents as low as  $10^{-16}$  amperes.

Long term stability for process control. Drift  $\pm 0.2$  millivolts per day, non-cumulative.

Write for  
Catalog 523.

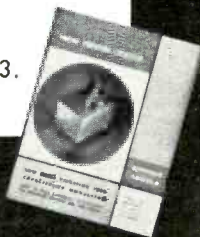

## STEVENS INCORPORATED ARNOLD

7 ELKINS STREET  
SOUTH BOSTON 27, MASS.

S/A-15

CIRCLE 38 READERS SERVICE CARD

# Infrared Spots Air

Electronic equipment samples street air as new detection systems help pinpoint trouble spots in big cities' growing smog problems



Infrared detection equipment shown here can spot and record concentrations of harmful fumes as low as one part per million

INFRARED DETECTION of carbon monoxide and other air pollutants can now be made continuously and quantitatively with a newly designed electronic system.

Successful street-site tests conducted by the Department of Air Pollution Control in New York indicate the infrared system can detect carbon monoxide in concentrations as low as one part per million.

The system relies on dual infrared beams. One passes through a chamber having a continuous stream of street air pumped through it under pressure. The other beam passes through a sealed

reference chamber containing a controlled air sample.

Deviations in the amount of infrared absorption of each chamber are measured electronically and indicated on a continuous graph.

The instrument, called the LIRA, was developed by Mine Safety Appliances, Pittsburgh, Pa. It can be modified to detect a variety of methane gases and other harmful substances found in major cities throughout the country.

Applications in other cities are planned during the year. Among interested municipal authorities are those responsible for tunnel operations and bus terminals.

## Space Equipment Highlight of Show

DALLAS — COMPONENTS and instruments for missiles and space vehicles held the spotlight at the 11th annual Southwestern IRE Conference and Electronics Show held here late last month. An estimated 3,500 attended. Exhibits numbered 153.

SWIRECO tried something new in handling technical papers. Each speaker was required to submit a 1-page summary of his talk. These

were reproduced, bound and sold at the meeting so visitors could select papers they most wanted to hear.

Of the technical sessions, one on solid-state electronics drew attention. Papers included a discussion of solid-state devices and phenomena of current interest, maser developments, magnetoabsorption, thermal impedance measurements of silicon diodes and rectifiers and a semiconductor diode parametric am-



# Pollution

plifier at microwave frequency.

Another session which drew attention was one on new components. Papers were presented on micro-circuitry and applications of solions, including a low-frequency solion amplifier, acoustic definition meter using solion integrators and use of solions in automation.

In other sessions of interest, P. B. Montgomery and William A. Bonner of the University of Texas Southwestern Medical School described a new tool for the investigation of living cell processes.

The ultraviolet flying spot television microscope has made it possible to obtain lengthy motion pictures of the chemical images of undamaged living cells as revealed by their ultraviolet absorption patterns, they stated.

S. M. Zimmerman, president of Electron Corporation of Dallas, gave a paper on ultrasimplification of vidicon television camera design. He described as a logical approach design of a circuit that will conform to the minimum requirements of a video monitor or television receiver.

## Signal Corps Lists Top Contractors

ARMY SIGNAL CORPS' top 15 contractors for R&D and missile procurement, as of Jan. 31, were mainly electronics firms.

Latest list shows:

Collins	\$161,249,461.
Martin	103,468,747.
Hughes	103,332,963.
General Electric	85,969,144.
Western Electric	83,107,182.
Motorola	72,415,800.
Philco	69,911,684.
RCA Victor	67,262,701.
Sperry Rand	58,910,337.
Fairchild Engine & Airplane	52,035,821.
Sylvania	48,729,709.
University of Michigan	36,529,616.
Kleinschmidt	31,281,351.
Republic Aviation	30,285,361.
Raytheon	29,929,699.

## LAPP

### GAS-FILLED CONDENSERS



for duty at

**High Voltage**

**High Current**

**High Frequency**



Lapp's experience of 18 years of design and manufacture of gas-filled condensers is back of this precision-made unit and its promise of years of trouble-free duty. It is small in size and low in loss, offers high voltage and current ratings, high frequency limits, safety, puncture-proof operation and constant capacitance under temperature variation.

The entire electrical and mechanical assembly of the Lapp gas-filled condenser is supported by a top aluminum ring, the steel tank serving only as a support for this ring and as a leak-proof gas container. High-potential plates are carried on a rigid center stud which is supported by a top ceramic bowl. Grounded rotor plates are carried on ball bearings nearly the full tank diameter. This construction provides a grounded tuning shaft on variable models and makes possible efficient and complete water cooling for high current operation.

Models in four tank diameters, 7" to 18", are available, in variable or fixed capacitances, for duty up to 30,000mmf; in current ratings to 400 amps at 1mc; operating voltages to 80Kv peak. Write for Bulletin 302, with complete description and characteristics data. Lapp Insulator Co., Inc., Radio Specialties Division, 152 Sumner Street, Le Roy, N. Y.

# Lapp

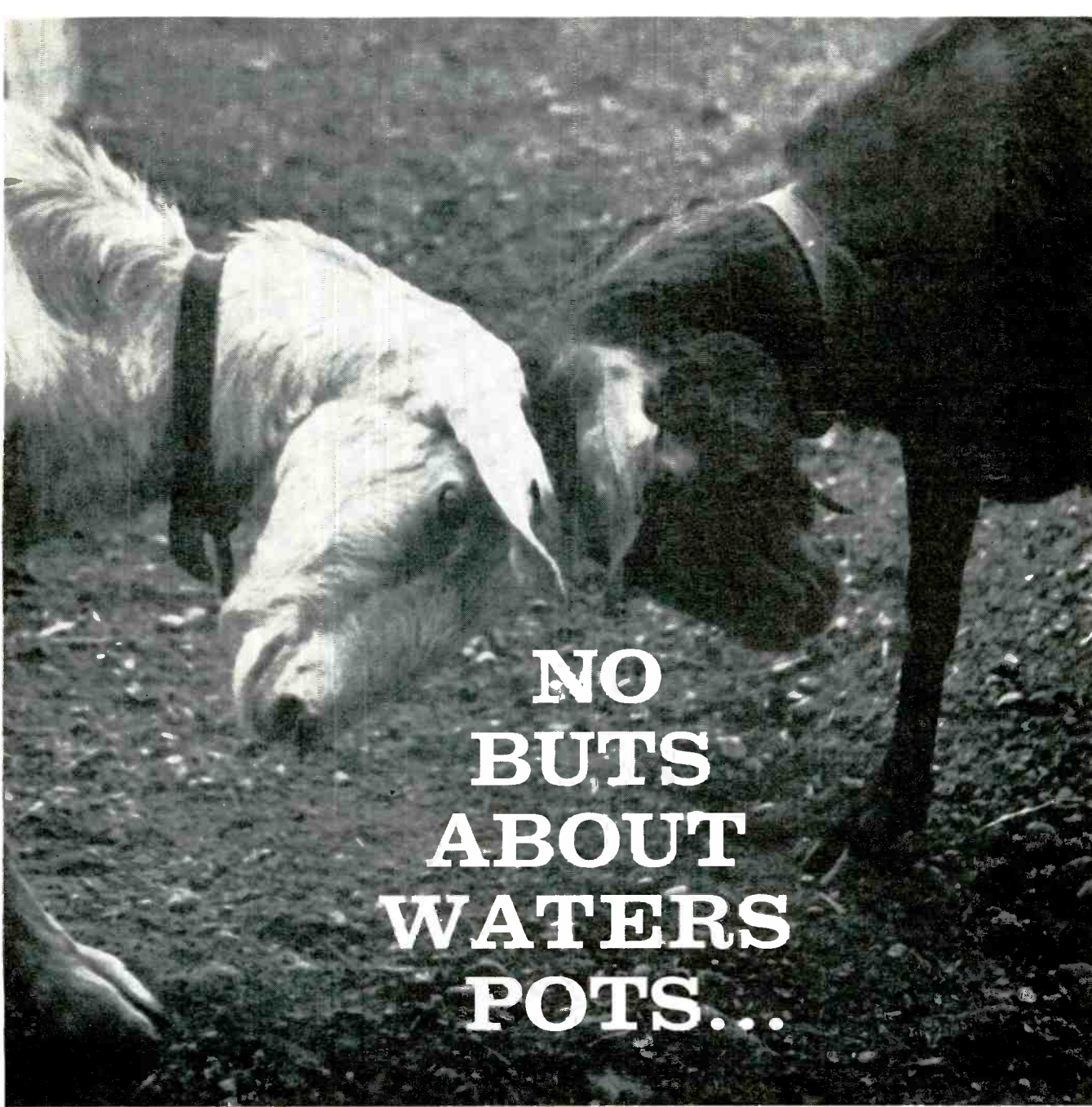

# NO BUTS ABOUT WATERS POTS...

Waters miniature precision potentiometers, exhaustively tested by an independent testing laboratory, must meet or exceed every applicable specification by a comfortable margin before a single potentiometer is shipped. Waters takes the speculation out of specs! Tests include operation with power, total immersion, salt spray, high humidity, temperatures from  $-65^{\circ}\text{C}$  to  $+150^{\circ}\text{C}$ , high altitude, extreme vibration, and high shock. There is a reliable Waters miniature potentiometer for almost every precision application. Write for Catalog PF 1258.

**New Waters sine-cosine pot takes almost 2/3 less space!**

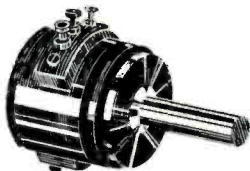

With the accuracy of a 3" pot in 1 1/4" diameter, the WPS-C 1 1/2 provides two separate 360° sinusoidal voltages displaced 90° in phase, representing the sine and cosine of the angle of shaft rotation. Particularly useful in radar PPI displays and various types of computers. Terminal conformity is  $\pm 1\%$  of sine-wave amplitude  $\pm 0.5\%$  peak-to-peak. Resistance range is  $20\text{K} \pm 5\%$  standard, 500 ohms to 50K as requested. Servo-type or tapped hole mountings, phosphor bronze bushing or ball bearings, "O" ring shaft seal if required, ganging up to 4 cups. Meets MIL-E-5272A, MIL-R-19A and other environmental specifications when sealed with "O" ring.



POTENTIOMETERS • SLUG TUNED COIL FORMS • RF COILS • CHOKES • POT HOOK® PANEL MOUNTS • TORQUE WATCH® GAUGES • C'TROL METER/CONTROLLER • INSTRUMENTS



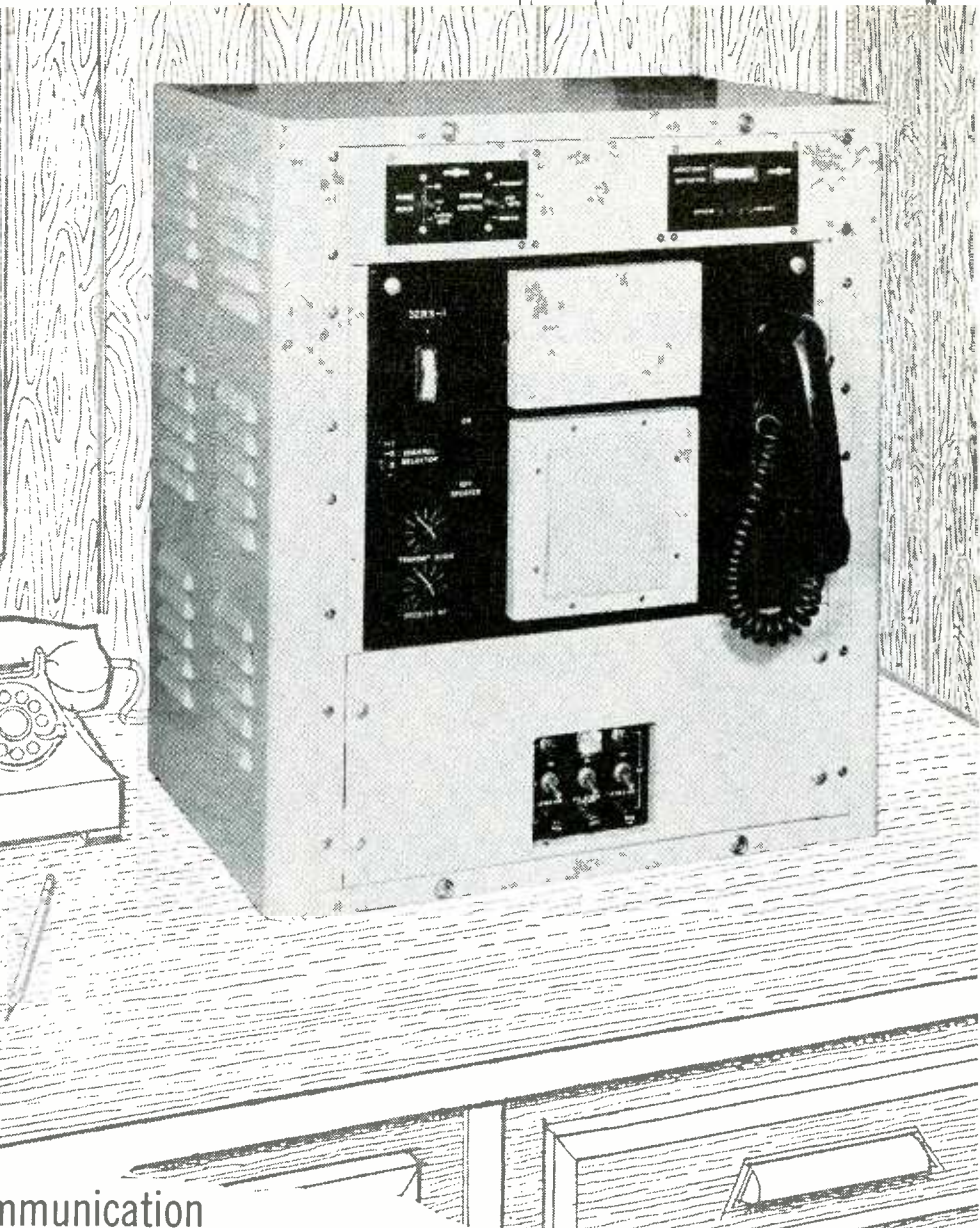
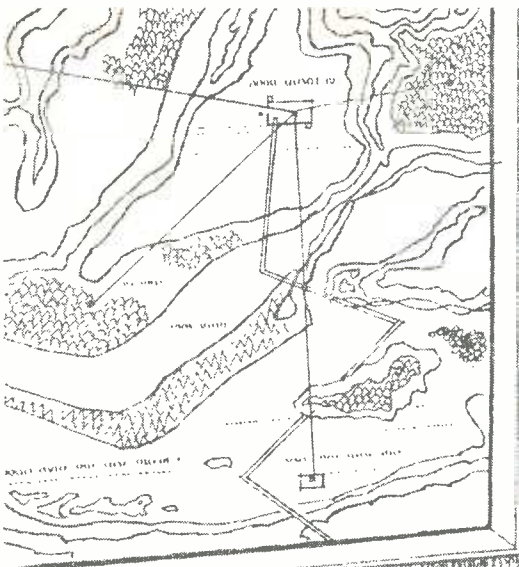

improved communication  
simplified operation  
with **COLLINS SSB** HF transceiver

The compact Collins 32RS-1 offers the full advantages of Single Sideband: more talking power, less bandwidth, and immunity to selective fading. True simplification for even non-technical operators has been achieved by design excellence, not compromise. Highly stable circuits assure "on frequency" operation without an additional manual adjustment control. Simplified, improved design gives long, reliable service.

The 32RS-1 can provide up to 4 crystal-controlled frequencies in the 1.6 to 15 mc range, selected by a flick of a selector switch. In transmission it provides 100 watts peak envelope power

output — Single Sideband "talking power" 3 db higher under normal conditions, 9 db higher under severe fading, than that of AM equipment with equivalent rating. A balanced modulator and Mechanical Filter sideband generator, multiple tuned circuits and linear amplifier assure a clean signal in transmission, while automatic load control maintains a high level of "talking power" by compensating for changes in voice level. In reception the Mechanical Filter provides excellent selectivity for the desired signal and rejection of off-channel interference.

A special feature of the 32RS-1 is VOX control, with the transmitter ac-

tuated by the voice of the person speaking over the circuit. This makes it possible to operate the transceiver through telephone extensions or switchboards without extra push-to-talk switches.

The 32RS-1 also simplifies the maintenance technician's task, with components and maintenance adjustment controls readily accessible, and test meter and transmitter alignment generator built-in.

Contact your nearest Collins distributor or write for literature on the 32RS-1 and complete station accessories — antennas, antenna couplers, directional wattmeters and phone patches.





# WANTED:

## Engineers who can top these stories

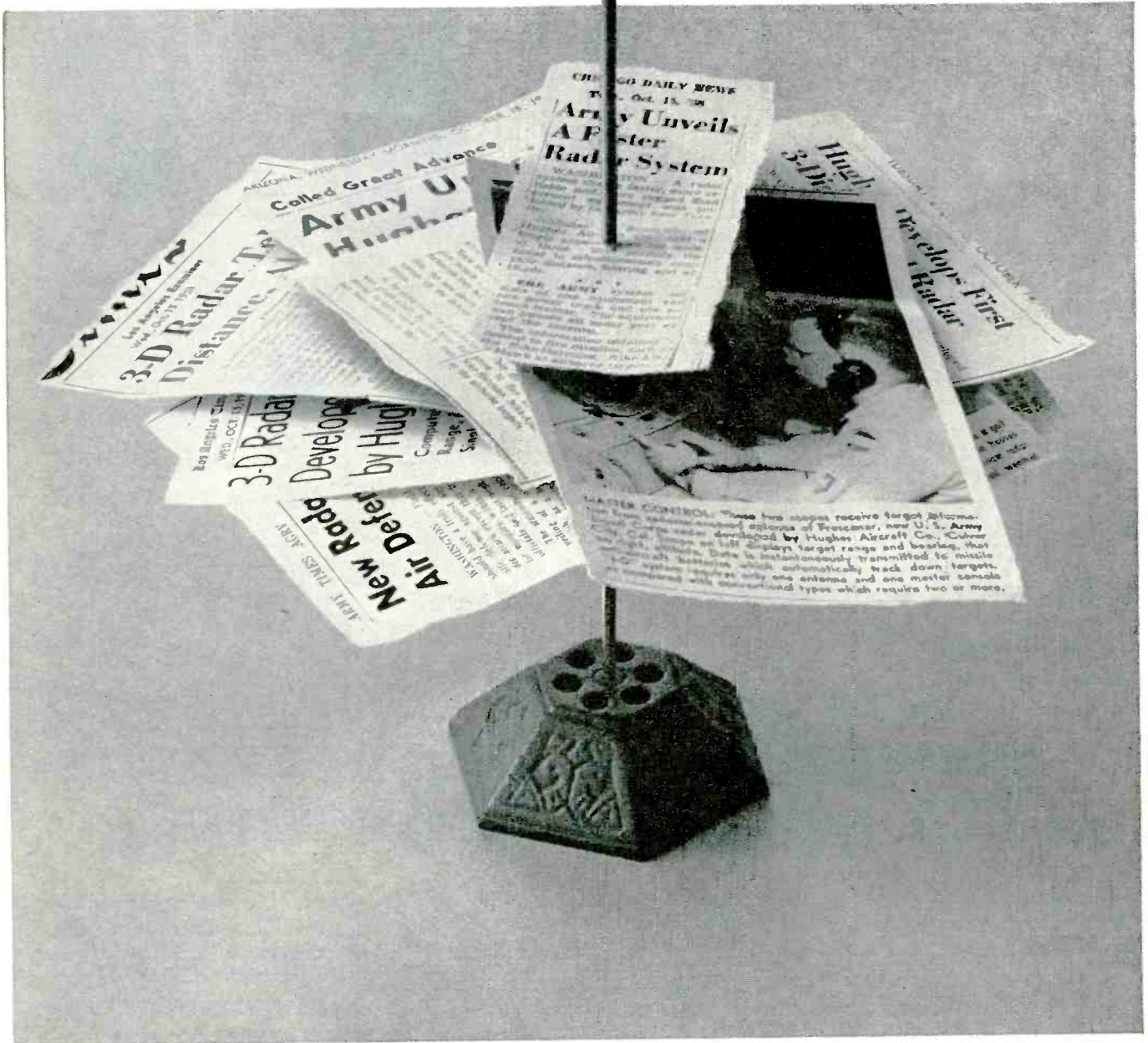

Hughes new frequency scanning radar has been called the most important new development in the art since radar itself was conceived. Mechanical antenna movement has been largely eliminated. The radar beam is positioned in space by varying the frequency of the electromagnetic energy applied to the antenna.

Already, this new principle has proved its mettle. The Army's new Frescanar radar handles a large number of targets with great accuracy and presents all information with three-dimensional realism.

Obviously this is but one step in the evolution of this new radar principle. Hughes Fullerton needs engineers who can exploit this breakthrough and go on to discover new commercial and military applications as yet undreamed of.

Hughes Fullerton is now rapidly expanding. While the main emphasis is on advanced Research and development work, there are positions open in a variety of engineering activities.

If you are the engineer interested in truly stimulating work, with an eye for

solid opportunity and personal and professional growth, we invite your inquiry. Please contact Mr. L. V. Wike.

*the West's leader in electronics*

### HUGHES

©1959 H. A. C.

GROUND SYSTEMS  
Personnel Selection & Placement  
Hughes Aircraft Company  
Fullerton 4, Orange County, California



# The "Inside Story" of Power Wire Wound Resistors

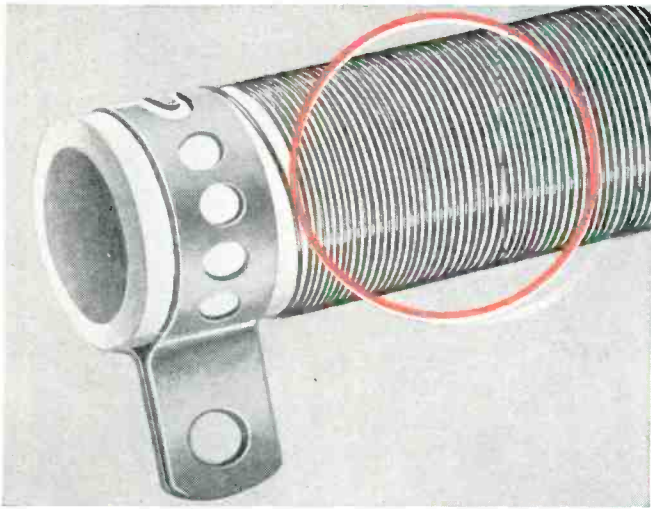

**IRC RESISTEG RESISTOR BEFORE COATING.** Note the precision winding of heavier gauge wire . . . no uneven spacing . . . no chance for arcing-over.

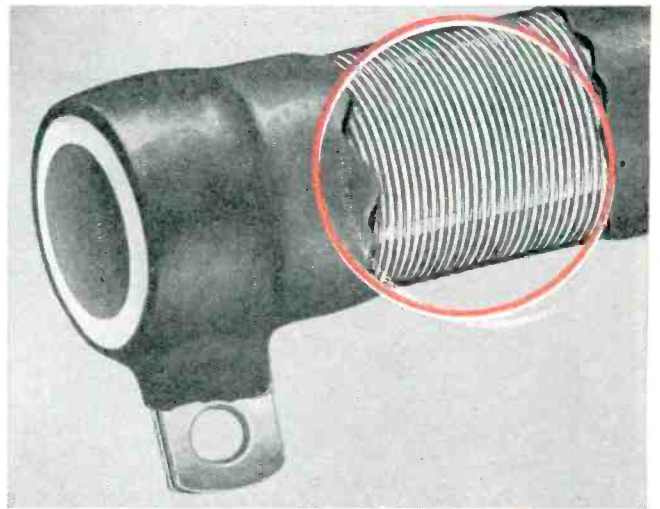

**IRC RESISTEG RESISTOR CURED AT 205°F.** No shifting together or change in position of wires . . . no "work-hardened" after-effect.

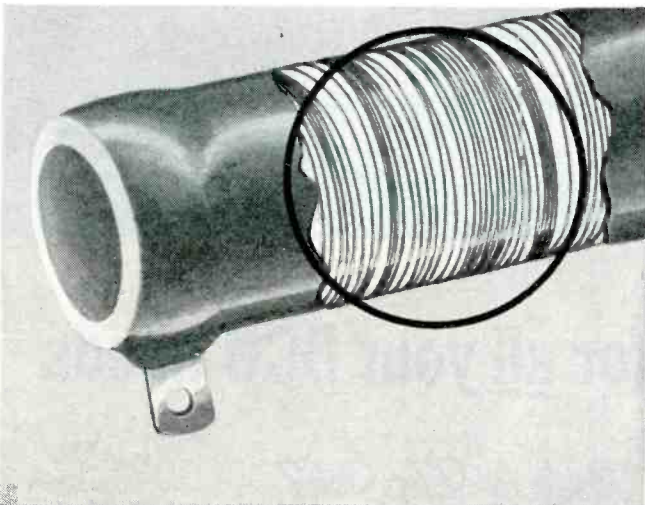

**VITREOUS ENAMEL RESISTOR CURED AT 1200°F.** Note the shifting together and uneven spacing of lighter gauge wire that results during high temperature curing.

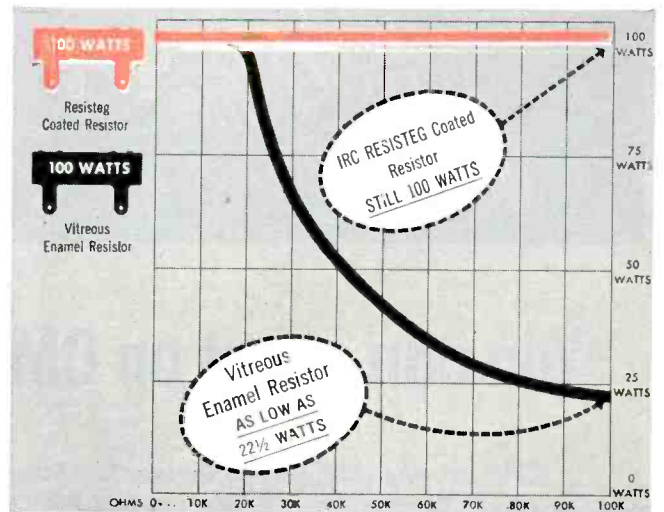

**COMPARISON OF AFTER-CURING RATINGS.** IRC Resistor with RESISTEG Coating still rates 100 watts. Vitreous enamel resistor rates as low as 22½ watts.

## HOW LOW TEMPERATURE CURING OF IRC RESISTEG COATING PROTECTS YOUR EQUIPMENT

Because IRC's exclusive RESISTEG Coating can be cured at temperatures as low as 205°F—nearly 1000° lower than vitreous enamelled resistors—your equipment is protected by resistors that maintain their *full rating*. No shifting together of winding turns during curing . . . no changes in wire positioning . . . no "work-hardened" wires due to compensating for expected shifting . . . no hot spots from arcing-over. Just *quality* resistors that need no derating—even at high values—and are more stable over longer life. Write for Catalog C-1!



INTERNATIONAL RESISTANCE COMPANY • Dept. 376, 401 N. Broad Street, Philadelphia 8, Pa.



*The industry's  
most complete  
DCU line-*

## You can count on CMC for all your DCU needs

CMC now offers original equipment makers no less than 28 standard DCU models, including the new transistorized Model 100T. That's the most complete line available from one source. In most cases, you're supplied from stock in a matter of days.

### *Price Important?*

CMC gives you a double price break. First, you pay less for CMC equipment to start with. Second, you get a special OEM discount on quantity orders. Prices on request.

### *Quality a Must*

There's no excuse for making an inferior DCU. We don't. Your local CMC engineering representative has the facts to prove it.

### *Applications Almost Endless*

CMC DCU's fill almost every conceivable circuit requirement for digital data handling systems, counters, scalars, frequency and time interval meters and preset counter-controllers. CMC's units are interchangeable with most existing counting equipment. Including our own.

### *Ready for Solid State?*

CMC is now in production on transistorized DCU's. These compact units incorporate decade readout and coded output matrix. No separate cards and plugs required. Available with vertical number panel or Nixie readout.

### *Concise Catalog Available*



Our new DCU catalog gives you prices and key specs at a glance. If you don't have it, write, wire or call and we will mail it to you free.

*CMC can supply you with better DCU's at lower prices, plus off the shelf delivery. It will pay you to check with us first.*

## **Computer Measurements Company**

*A Division of  
Pacific Industries, Inc.*

5528 Vineland Avenue, North Hollywood, Calif.  
Dept. 185 • Phone STanley 7-0401 • TWX: N HOL 8290



# Computers Going Underground

New solid-state computers spur Pentagon decision to build subterranean Sage centers

INTRODUCTION of new high-capacity solid-state computers into the Air Force's multibillion dollar Sage (Semi-Automatic Ground Environment) air defense control system has spurred a new Pentagon decision to build all future Sage installations underground.

As a result, design work has been halted on six bases originally scheduled to be built above ground. The construction freeze affects facilities planned for Seymour Johnson AFB, N. C.; Webb AFB, Tex.; Ft. Knox, Ky.; Robins AFB, Ga.; England AFB, La.; and Scott AFB, Ill.

The new solid-state computers use transistors rather than conventional electron tubes. The result has been a dramatic miniaturization of Sage apparatus.

The bulk of the system is still under construction. It will consist of a network of giant digital computers housed at 29 U. S. bases and two in Canada. When completed the Sage system will bring together and evaluate radar warnings and tracking, and direct fighter-interceptor planes and Nike and Bomarc missiles to destroy enemy aircraft.

Major Sage electronic contractors are IBM, which designed and is producing AN/FSQ-7 digital computers; Burroughs Corp., manufacturing smaller but similar computers for outlying stations; AT&T, in charge of interconnecting land lines and radio-communication circuits; Bendix and Hazeltine, subcontractors to IBM for radar scope display consoles and other controls; and Western Electric, which is installing and servicing the system.

The new policy on Sage reflects the Air Force's intensified plan to build key facilities underground or in hardened configurations. Plans were recently approved to build a new air defense command combat control center underground in Colorado. This is the base which coordinates operations at regional Sage centers.

Air Force also plans to place later Atlas ICBM launching facilities underground. These missiles will be geared to an inertial guidance system which doesn't require conventional radio facilities as do the earlier radio-guided Atlas units.

Titan and Minuteman sites will also be built underground.

## Controls Missile Launchings

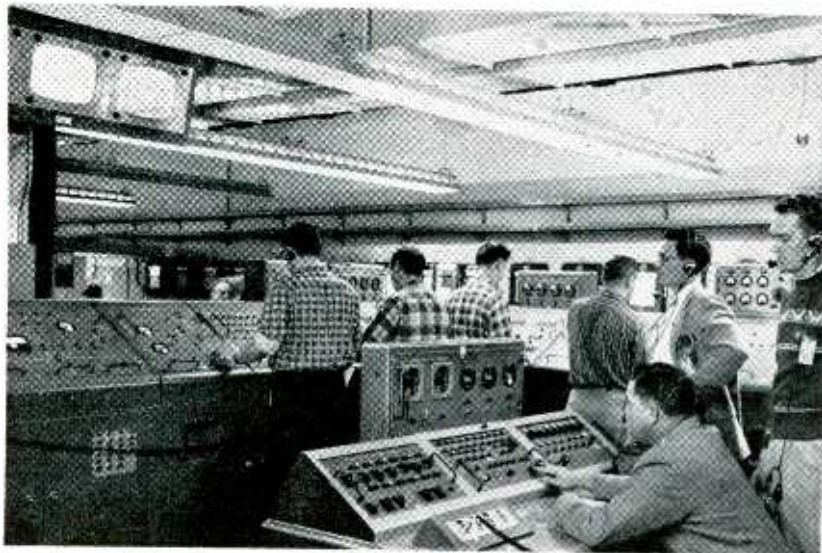

Blockhouse control for launching Convair Atlas intercontinental ballistic missiles

# CIRCUIT DESIGN ENGINEERS



SONAR

MISSILE  
GUIDANCE

TELEMETERING

AIRBORNE  
RADAR

there  
are  
important positions  
available at

*Bendix-Pacific*

TELEMETERING... SONAR...

MISSILE GUIDANCE... AIRBORNE RADAR

If you have had two or more years experience in Circuit Design in Telemetering, Sonar, Missile Guidance or Airborne Radar . . . and are interested in moving to a permanent, well paying position in Southern California—

Please write W. C. Walker your qualifications or fill in the coupon and mail today.

W. C. Walker, Engineering Employment Manager  
Bendix-Pacific, Bendix Aviation Corporation  
11604 Sherman Way, North Hollywood, Calif.

I am interested in \_\_\_\_\_ Engineering.  
I am a graduate engineer with \_\_\_\_\_  
degree and \_\_\_\_\_ years experience.

Name \_\_\_\_\_

Address \_\_\_\_\_

City \_\_\_\_\_ Zone \_\_\_\_\_ State \_\_\_\_\_

# You can only stretch a spec sheet so far!

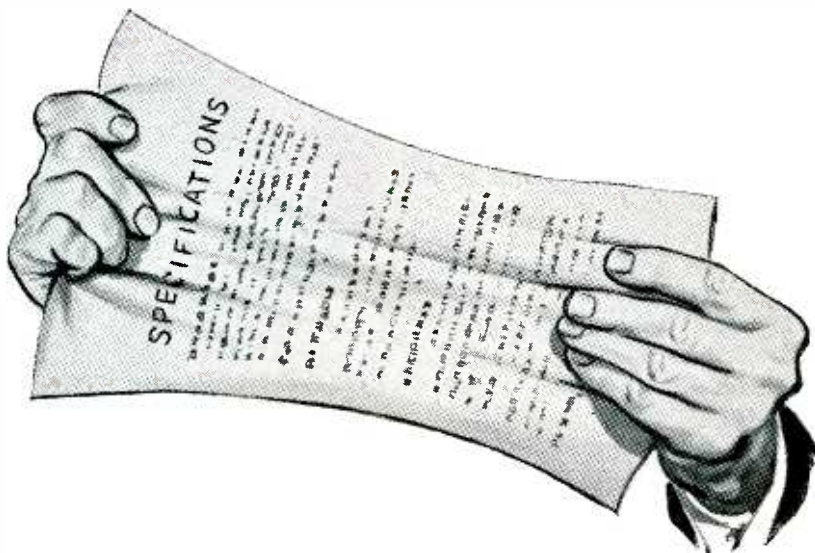

*In a stereo cartridge, it's what you hear that counts. And Sonotone's ceramic cartridge gives you brilliant performance and nothing less.*

More phono makers have specified Sonotone for the top of their line than any other cartridge...because only Sonotone gives true sound without distortion...high-frequency response with less record wear. Sonotone stereo gives a performance so superior you can truly hear the difference. The secret? Sonotone's four exclusive operating features listed below.

1. Extremely high compliance...also means good tracking, longer record life.
2. Amazingly clean wide-range frequency response.
3. First quality jewel styli tips—correctly cut and optically ground for minimum record wear.
4. Rumble suppressor greatly reduces vertical turntable noise.

Prices start at \$6.45 (including mounting brackets).

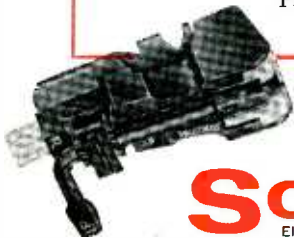

Get details on converting to stereo. Send for free booklet: "Stereo Simplified," Sonotone Corp., Dept. CRR-59, Elmsford, N. Y.

**Sonotone**®  
Electronic Applications Division, Dept. CRR-59

**ELMSFORD, NEW YORK**

In Canada, contact Atlas Radio Corp., Ltd., Toronto

Leading makers of fine ceramic cartridges, speakers, microphones, electronic tubes.

## MEETINGS AHEAD

May 6-8: Electronic Components Conference, AIEE, EIA, IRE, WCEMA, Benjamin Franklin Hotel, Phila.

May 6-8: Seventh Region of IRE, Technical Conf. & Trade Show, Univ. of New Mexico, Albuquerque, N. M.

May 11-13: Power Instrumentation, National Symposium, ISA, Kansas City, Mo.

May 11-13: Automatic Techniques, Joint Conf., PGIE of IRE, AIEE, ASME, Pick-Congress Hotel, Chicago.

May 12-14: Assoc. of American Railroads, Communications Meeting, Netherland-Hilton Hotel, Cincinnati, O.

May 18-20: Instrumental Methods of Analysis, ISA, Shamrock-Hilton Hotel, Houston, Tex.

May 18-20: Electronic Parts Distributors Show, EISC, Conrad-Hilton Hotel, Chicago.

May 21-27: Transistors and Assoc. Semiconductor Devices, International Convention, Institution of Electrical Engineers, Earls Court, London.

May 25-27: National Telemetry Conference, ARS, IAS, AIEE, ISA, Brown Palace & Cosmopolitan Hotel, Denver.

June 1-3: Microwave Theory and Techniques, National Symposium, PGMTT of IRE, Paine Hall, Harvard Univ., Cambridge, Mass.

June 4-5: Production Techniques, National Conference, PGPT of IRE, Villa Hotel, San Mateo, Calif.

June 7-11: Microwave Tubes, International Congress, Verband Deutscher Elektrotechniker, VDE, Briener Strasse, Munich, Germany.

June 8-11: American Rocket Society, Semi-Annual Meeting, El Cortez Hotel, San Diego, Calif.

June 15-20: Information Processing, International Conf., UNESCO, PGEC of IRE, AIEE, ACM, UNESCO House & Palais de Exhibition, Paris.

June 15-20: Electromagnetic Theory Symposium, USSI, PGAP and PGMTT of IRE, Univ. of Toronto, Ontario, Canada.

There's more news in ON the MARKET, PLANTS and PEOPLE and other departments beginning on p 88.



# New!

## Fibrous Silicone Rubber

- *high permeability*
- *excellent compression-deflection*
  - *excellent compression set*
  - *-65°F to 500°F temperature range*
  - *good tensile and tear strength*

COHRLastic FSR is a new and unique silicone rubber product developed by the Connecticut Hard Rubber Company. It possesses many useful properties superior to silicone sponge and foam, and should be extremely suitable for such applications as shock and vibration isolators, thermal insulators, high temperature press pads, pressure moldings, etc.

The unusual and random orientation of silicone rubber fibers as shown in the background gives COHRLastic FSR good tensile and tear strength, high permeability, very low density, excellent compression-deflection characteristics, extremely good compression set, and a useful temperature range of -65°F to 500°F.

COHRLastic FSR is being introduced in sheets 1/4" thick, 9" wide, 6' long, and in a density of 20 lbs./cu. ft. As applications develop, COHRLastic FSR will be made in continuous lengths, larger widths, different thicknesses and various densities in the range of 15-25 lbs./cu. ft.

FREE SAMPLE and data — Write, phone or use inquiry service.

**CHR**

*Leader in fabrication of silicone rubber.*

**CONNECTICUT HARD RUBBER CO.**

407 EAST STREET NEW HAVEN 9, CONNECTICUT



# NERVE CENTER

*for teleprinted messages*

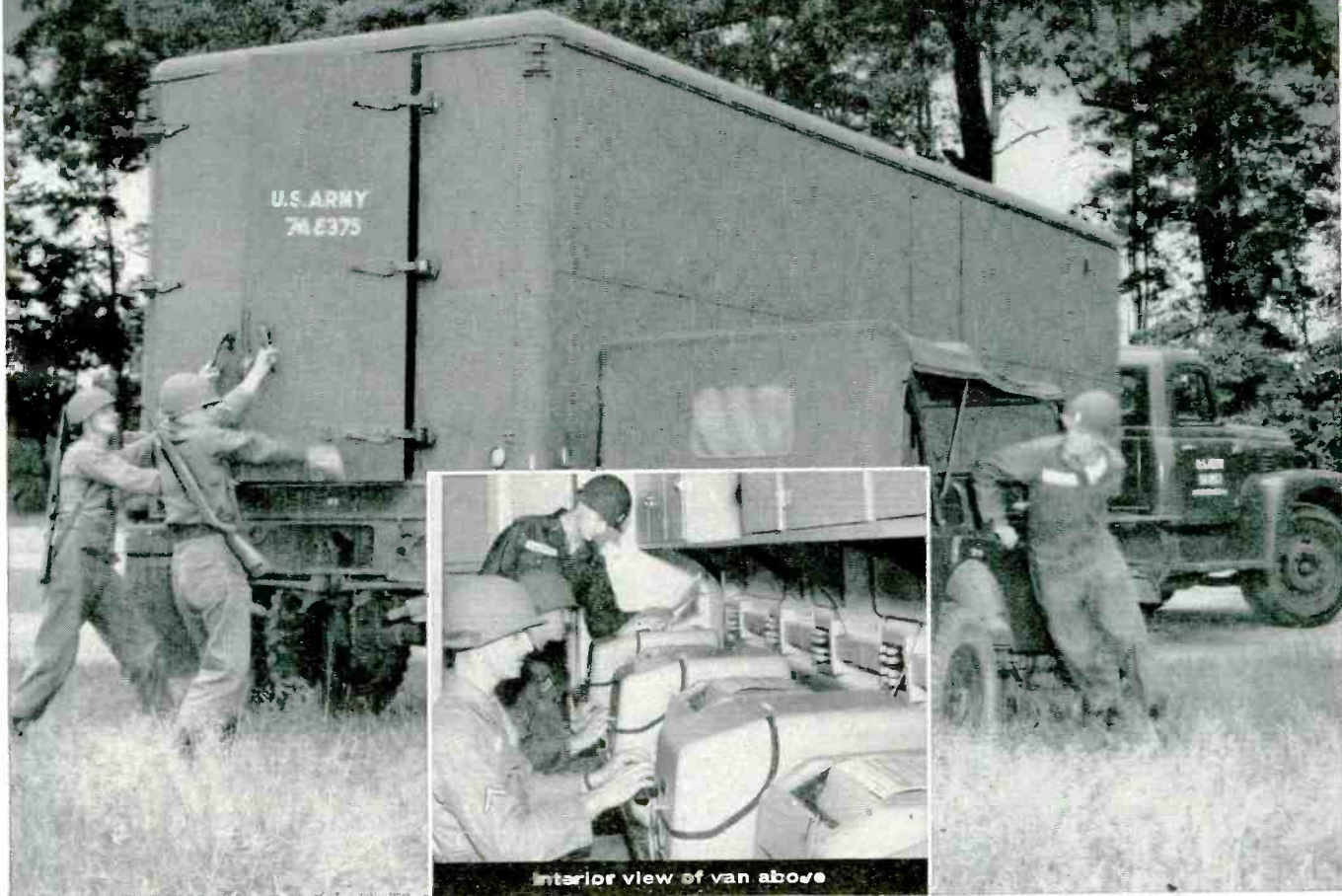

***Kleinschmidt teletypewriters move up with the U. S. Army,  
operating without interruption under combat conditions***

Constant contact, *in print*, between combat headquarters and widely-dispersed field units! Developed in cooperation with the U. S. Army Signal Corps, Kleinschmidt teletypewriters in this mobile communications center are capable of sending and receiving thousands of teleprinted messages a day. Operation is fast, accurate, dependable, simple. In

recognition of proved performance, Kleinschmidt equipment for the U. S. Army is manufactured under the Reduced Inspection Quality Assurance Plan. Now Kleinschmidt experience points toward new accomplishments in electronic communications for business and industry. The new concepts, new applications are virtually unlimited.

# KLEINSCHMIDT



**DIVISION OF SMITH-CORONA MARCHANT INC., DEERFIELD, ILLINOIS**  
Pioneer in teleprinted communications systems and equipment since 1911



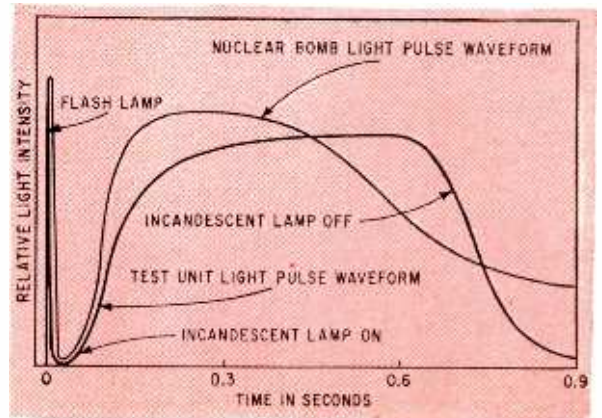

FIG. 1—Output of test unit simulates initial fast rise and subsequent sustained pulse of light flash from nuclear bomb

Installations are protected by new warning system which detects nuclear detonations. Shown here are thermal radiation detector and accompanying test unit

# Nuclear Bomb Alarm Systems

Key underground military installations are protected from surprise nuclear attack damage by detection and warning system that recognizes nuclear explosion and activates automatic equipment

By **JOHN C. CHAMPENY\***, Physicist, **THOMAS E. PETRIKEN**, Physicist, and

**SEBASTIAN SICILIANO**, Engineering Technician, Applied Physics Division, U. S. Army Signal Research and Development Laboratory, Fort Monmouth, N. J.

IN MANY UNDERGROUND nuclear bomb shelter installations it is necessary to take last minute button-up precautions to prevent damage from near-miss explosions. Blast doors must be closed, air filters must be activated and critical utility circuits must be protected from damage.

Normally, these protective measures may be taken on receiving warning of an expected attack, but in case of a surprise attack the first warning may be the bomb explosion itself. The explosion must be detected and identified and warning devices actuated within a fraction of a second to give blast protection devices a chance to operate. The short warning time available means that an automatic system must be used to eliminate human delay that could spell the difference between survival and disaster. An automatic alarm system has been developed to give this

necessary warning in case of a surprise attack. The system operates if a nuclear detonation occurs in the immediate vicinity but does not give location or direction information.

**BASIC SYSTEM**—The basic system comprises a group of detectors, the control panel, interconnecting cables and test units. The detectors are mounted in groups on steel towers above the shelter area to be protected. Three types are used to avoid any chance of failure and to provide for reliable operation. A thermal radiation detector detects and identifies the flash of thermal radiation light from a nuclear detonation. The second unit, a gamma ray detector, detects the pulse of nuclear radiation accompanying the detonation. Gamma radiation is not seriously af-

\* Now with Edgerton, Germeshausen & Grier, Inc., Boston, Mass.

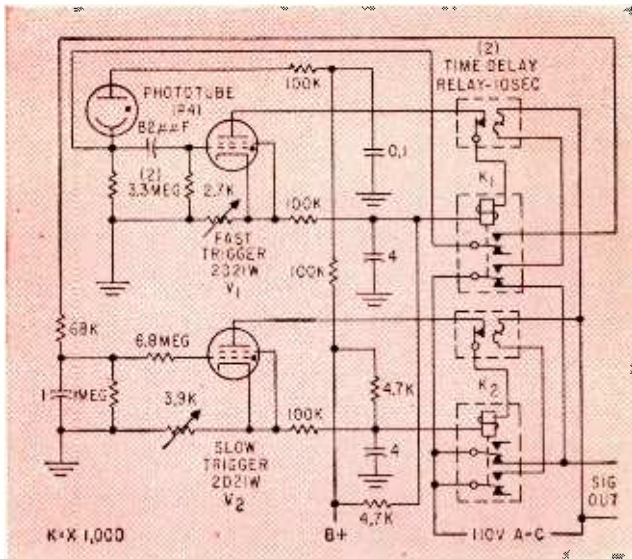

FIG. 2—Circuit diagram of the thermal radiation detector

ected by fog or rain which may impair the sensitivity of the thermal radiation detector. Under normal conditions however, the thermal radiation detector is more sensitive.

The third unit, the blast detector, is actuated by the blast wave itself as it passes over the detector tower. A warning signal is sent even if the tower and wiring are destroyed by the blast wave.

The system control panel is located in a protected area of the underground shelter. Activation of any detector flashes a warning light and rings an alarm bell. Relays in the panel unit actuate the shelter "but-ton-up" measures preset by the system operator.

The detectors and the control panel are connected together by conventional multiconductor cable installed on poles or in conduit. Both the thermal radiation and gamma ray detectors are provided with test units which supply simulated bomb signals. The operator at the control panel may check the system for satisfactory operation at any time by use of these test units.

System power is normally obtained from the 110-v 60-cycle lines through a power control panel. In case of power failure a battery-powered motor generator is automatically switched in by control relays. In most cases, several towers are used for greater protection.

**THERMAL RADIATION DETECTOR**—The thermal radiation detector serves to detect and identify the light flash from a nuclear explosion. The waveform of this flash is usually made up of an initial fast-rising pulse of a few milliseconds duration followed by a longer sustained pulse lasting for one or more seconds. This waveform is unique to nuclear explosions and a typical example is shown in Fig. 1.<sup>1</sup>

The thermal radiation detector responds only to this type of pulse and discriminates against short flashes from lightning and shell bursts, and long slowly rising pulses caused by vehicle headlights and sunlight reflections. The circuit, shown in Fig. 2, triggers only on a fast rising pulse followed by a sustained pulse. A 1P41 red-sensitive photocell re-

ceives the light flash. Rapidly rising light intensity applies a positive electrical pulse through a high pass filter to the grid of fast-trigger thyatron  $V_1$ . This thyatron, normally cut off, fires and energizes relay  $K_1$  in its plate circuit. If no further light signal is received the thyatron is extinguished 10 seconds later by a time delay relay.

However, if a sustained light pulse is received after a fast rising pulse fires  $V_1$ , the signal from the sustained pulse passes through the contacts of relay  $K_1$  and a low-pass filter to the grid of the slow-triggering thyatron  $V_2$ . Firing of this thyatron actuates relay  $K_2$  in its plate circuit, opening the normally closed signal circuit. Opening of the signal circuit operates a warning relay at the control panel. The warning relay rings an alarm bell, lights an indicator light and operates the protective systems. The normally closed-circuit mode of operation provides a fail-safe signal if the detector or cable is destroyed.

The thermal radiation detector is enclosed in a waterproof cylindrical aluminum housing which is mounted to have a clear view in all directions. A Fresnel lens under a glass dome receives the light flash and transmits it to the photocell. Omnidirectional coverage is used and a metal sunshade disk keeps out the direct rays of the sun. Detection sensitivity is good under all weather conditions except dense fog or smoke. Exact bomb detection range depends on atmospheric conditions, ambient light level and bomb size.

**TEST UNIT**—A test unit which supplies a simulated nuclear flash is mounted near the thermal radiation detector to allow remote checking of its operation. A high-voltage transformer and rectifier charge a 0.5- $\mu$ f capacitor to 2,000 v. When a switch is depressed at the control panel a relay discharges the capacitor into a xenon flash lamp. At the same time, 110 v is applied to an incandescent projection lamp connected across the relay coil.

The flash lamp provides a fast-rising light pulse while the incandescent lamp gives a slow-rising sus-

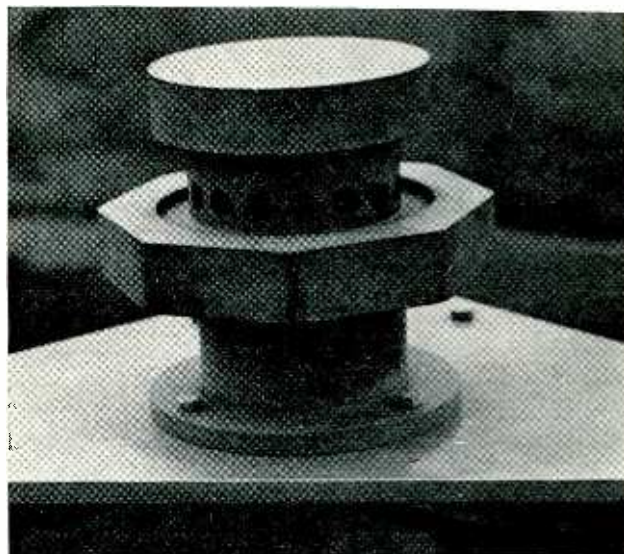

Blast detector encloses a diaphragm-operated pressure switch



# Tested and certified!

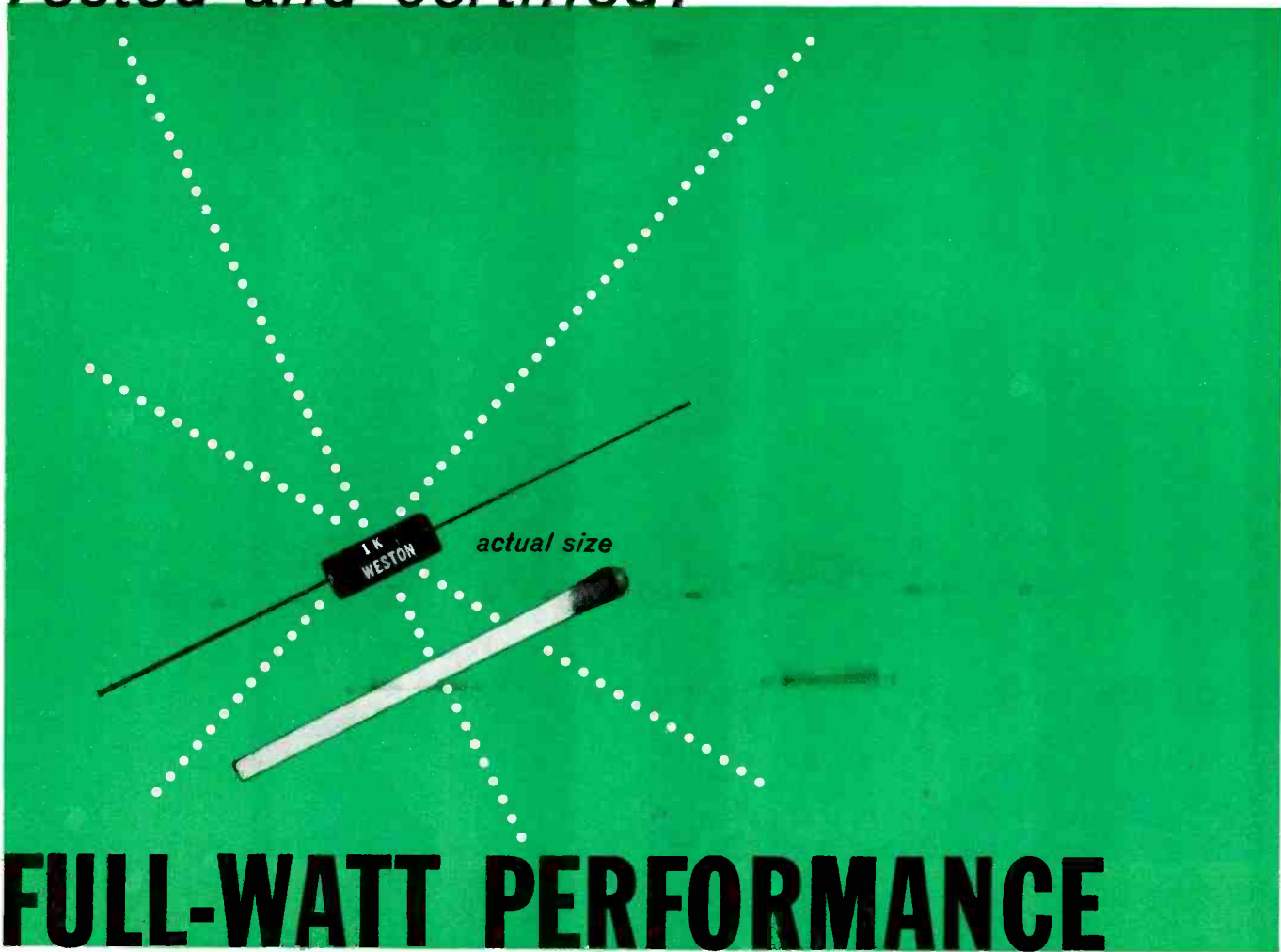

## FULL-WATT PERFORMANCE

### at 100C in the new, miniaturized 1/4-watt Metal-Film Resistor

Does this performance chart suggest anything to you? Hundreds of electronic, missile, and aircraft design engineers have already taken advantage of this latest Vamistor's extraordinary operating characteristics. Model 9855-4 precision metal-film resistor—another Weston exclusive—may be just the answer to *your* stability, temperature or miniaturization problem.

For example, this resistor, available in values from 50 ohms through 1.5 megohms, has (1) maximum continuous working voltage of 350v . . . (2) temperature coefficient of 25 or 50 ppm . . . (3) tolerances of 1%, .5%, .25%, .1%.

For full information . . . or for the address of your nearest distributor, contact your local Weston representative. Or write direct to Weston Instruments, Division of Daystrom, Inc., Newark 12, N. J. In Canada: Daystrom Ltd., 840 Caledonia Rd., Toronto 19, Ont. Export: Daystrom Int'l., 100 Empire St., Newark 12, N. J.

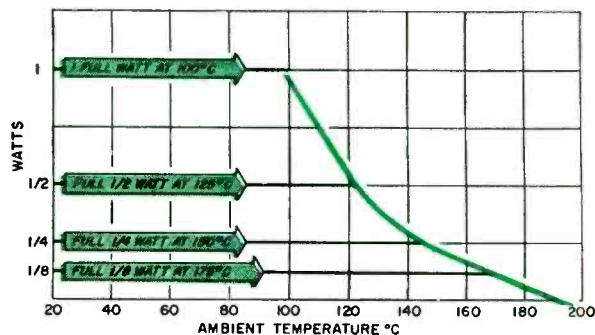

# WESTON

*Metal-film Resistors*

WORLD LEADER IN MEASUREMENT AND CONTROL

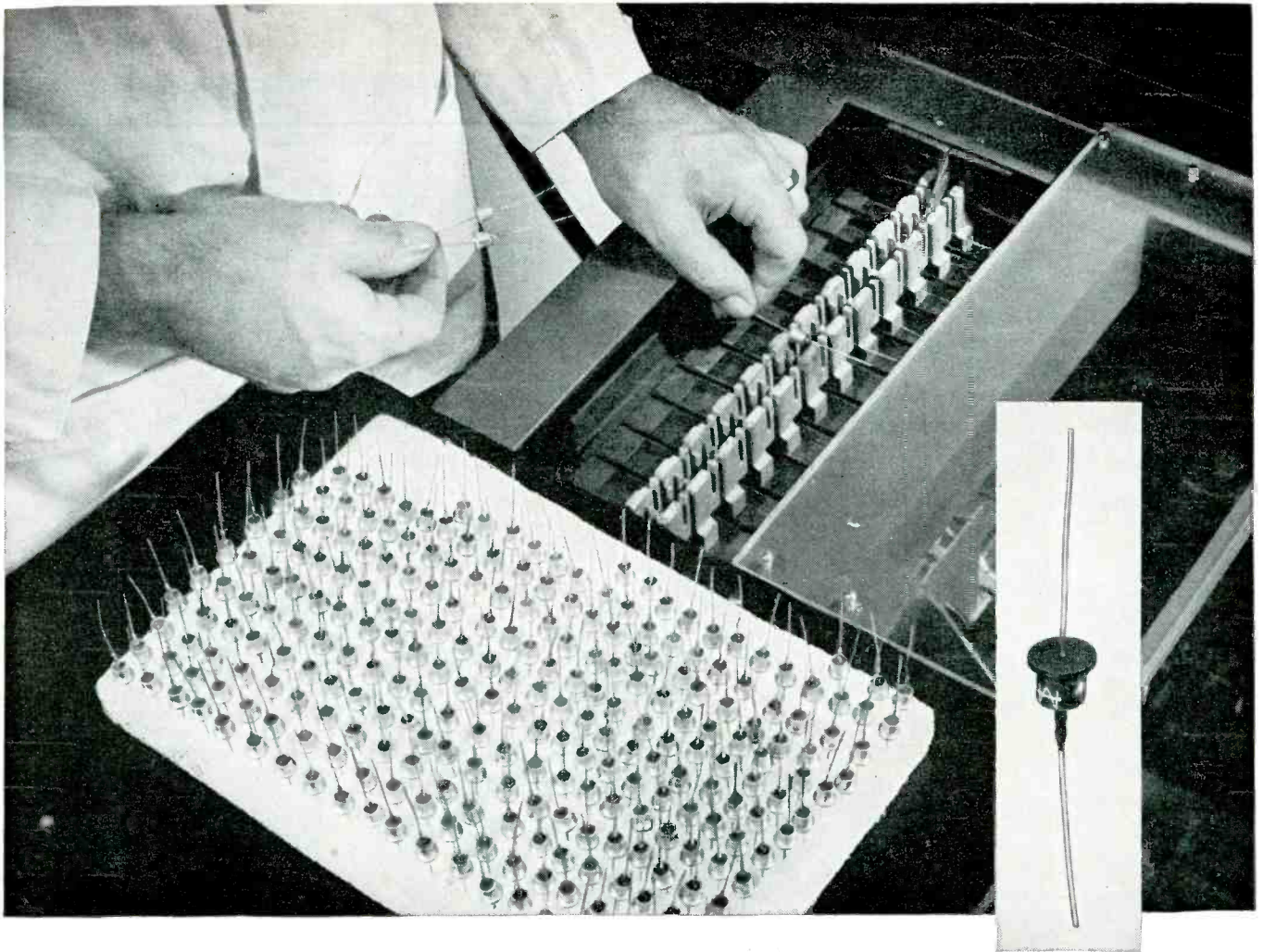

## 100% High Temperature Testing Eliminates Premature Failure of Type E Silicon Rectifiers

How can you make sure a "top hat" silicon rectifier won't fail during the critical first few hundred hours of use? Here's one of the tests we perform on every Mallory Type E silicon rectifier to protect against early failure.

After final assembly, all Type E rectifiers are heated 30% above maximum rated temperature in oven shown. Each one is checked for reverse leakage current at rated voltage. Any rectifier that exceeds 0.5 milliamperes reverse leakage at this high temperature is automatically rejected.

Mallory Type E silicon rectifiers are designed for industrial applications requiring operation in severe environmental conditions. Hermetically sealed, they're ideal for jobs requiring minimum forward voltage drop and minimum reverse leakage current. When only the best is good enough, use Mallory Type E silicon rectifiers.

### RATINGS—(60 CPS Resistive or Inductive Loading)

Catalog Number	Maximum PIV	Maximum RMS Voltage	Maximum Cont. Reverse DC V.	Max. DC Output	
				100° C. Amb.	50° C. Amb.
E 50	50V	35V	50V	500MA	750MA
E 100	100V	70V	100V	500MA	750MA
E 200	200V	140V	200V	500MA	750MA
E 300	300V	210V	300V	500MA	750MA
E 400	400V	280V	400V	500MA	750MA
E 500	500V	350V	500V	425MA	750MA
E 600	600V	420V	600V	400MA	750MA

### SPECIFICATIONS

Maximum One Cycle Surge Current.....	15 Amps
Maximum Full-Load Forward Drop (Full Cycle Avg. @ 100° C.).....	.5 Volts
Maximum Leakage Current (Full Cycle Avg. @ 100° C.).....	.5 MA
Ambient Operating Temperature.....	-65° C. to +100° C.
Storage Temperature.....	-65° C. to +150° C.

**P. R. MALLORY & CO. INC.**  
ELKON DIVISION  
Semiconductor Department  
DU QUOIN, ILL.

**P. R. MALLORY & CO. Inc**  
**MALLORY**



**TYPE T**  
encapsulated silicon rectifiers for high quality and reliability at commercial prices.



**TYPE P**  
for fuse clip mounting where simplified replacement is required.



**Three  
Allied Control  
Miniature**

**10  
amp**

**Relays**

Type  
MHY

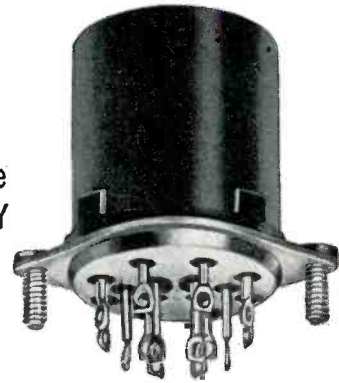

Type  
CH

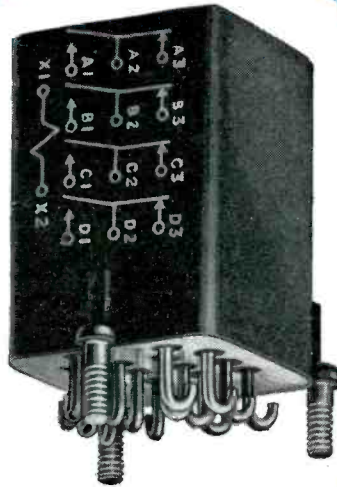

These relays are designed to meet the rigid requirements of missile, aircraft and ground support equipment.

For complete information write for CH, MHY, or PBH Bulletin

Type  
PBH



**GENERAL SPECIFICATIONS**

	Type CH	Type MHY	Type PBH
Contact Form	4 PDT	4 PDT	2, 3 and 4 PDT
Contact Rating	10 amps resistive 8 amps inductive at 29 v d-c or 115 v a-c	10 amps resistive at 29 v d-c or 115 v a-c	10 amps resistive at 29 v d-c or 115 v a-c
Shock	100g	75g	50g
Vibration	30g up to 2000 cps	20g up to 500 cps	10g up to 500 cps
Temp. Range	-65°C to +125°C	-65°C to +125°C	-55°C to +85°C
Weight	5 oz.	4.2 oz.	6.5 oz.
Overall Dimens.	1 <sup>7</sup> / <sub>16</sub> x 1 <sup>1</sup> / <sub>2</sub> x 2 <sup>3</sup> / <sub>16</sub>	1 <sup>1</sup> / <sub>16</sub> x 1 <sup>1</sup> / <sub>16</sub> x 1 <sup>6</sup> / <sub>16</sub>	1 <sup>4</sup> / <sub>16</sub> x 1 <sup>5</sup> / <sub>16</sub> x 2 <sup>13</sup> / <sub>16</sub>

**ALLIED CONTROL**

ALLIED CONTROL COMPANY, INC., 2 EAST END AVENUE, NEW YORK 21, N. Y.

## Unique combination of performance, size and price

**OVER 1000 TIMES AS SENSITIVE** as galvanometer recorders. . . and Varian's null-balance potentiometer needs no power from the source being measured. Rugged, stable mechanism allows ink or inkless recording — easy-to-read rectilinear chart — source impedances of up to 100,000 ohms.

**LESS THAN HALF AS WIDE** as a standard 19-inch rack. Two Varian G-11A's mount side by side on a rack panel 10 $\frac{3}{8}$  inches high. Or as a portable, the G-11A is an easy-to-handle 15 pounds. The G-10 sits on less than one square foot; its horizontal chart is handy for jotting notes.

**MORE VERSATILE AND ADAPTABLE** than any similar recorder — adjustable zero, adjustable span (from 9 to 100 mv on the G-11A), multiple chart speeds (up to four on the G-11A), and plug-in input chassis for different recording requirements.

**PRICES THAT BEGIN AT \$365** for the G-10 and \$470 for the G-11A. Because unneeded performance costs money, Varian has intentionally designed for 1% limit of error and 1-second balancing time. Thus, Varian provides needed ruggedness, dependability and operating features at moderate cost.

# VARIAN STRIP CHART RECORDERS



Varian G-11A for panel, rack or portable use for laboratory or equipment builder.

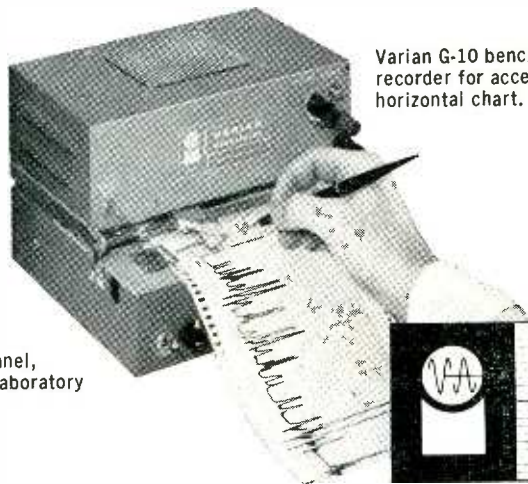

Varian G-10 bench-top recorder for accessible, horizontal chart.

WRITE TODAY FOR COMPLETE SPECIFICATIONS AND STANDARD OPTIONS



**VARIAN associates**

INSTRUMENT DIVISION

PALO ALTO 1, CALIFORNIA



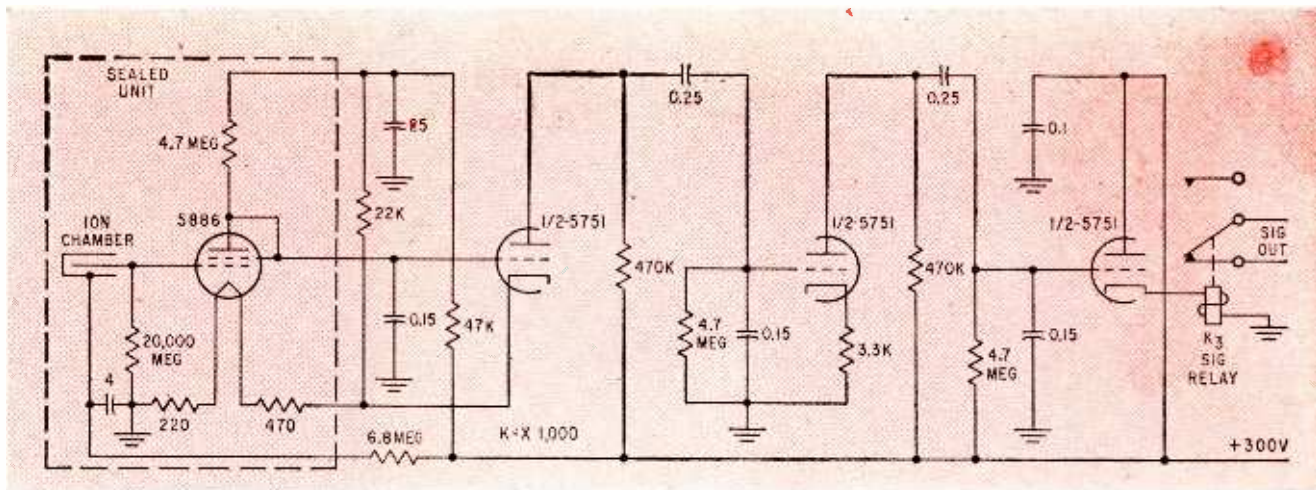

FIG. 3—Gamma-ray detector uses a-c coupled ion chamber to detect pulses of gamma radiation

tained pulse. The combined waveform shown in Fig. 1 is picked up by the thermal radiation detector and triggering of the detector indicates operation.

**GAMMA-RAY DETECTOR**—The gamma-ray detector triggers on the gamma ray pulse produced by a nuclear detonation. An a-c coupled ionization chamber circuit shown in Fig. 3 detects the radiation. The cylindrical ion chamber is operated with 300 v applied to the outer shell. When gamma radiation passes through this chamber a voltage drop is produced across a 20,000-megohm load resistor. The voltage drop is amplified by a direct-coupled 5886 electrometer tube and three 5751 triode stages. The last stage is connected as a cathode follower with a sensitive relay in the output circuit.

When a nuclear explosion occurs in the vicinity of the detector a sudden increase of gamma-ray intensity is picked up by the ion chamber. The voltage developed across the 20-kilomegohm load resistor is amplified and causes a decrease of plate current in the last 5751 stage which deenergizes signal relay  $K_3$  if the amplified signal is large enough. Operation of the signal relay opens a signal line to the control panel and actuates the warning system.

Discrimination against false triggers from cosmic ray showers is provided by keeping ion chamber sensitivity low. An alternating-current coupling makes the detector insensitive to slow increases in gamma-ray intensity as might be received from the fallout of a distant nuclear explosion.

The gamma ray detector is mounted in a waterproof aluminum housing placed near the thermal radiation detector. No window is used as the gamma rays can penetrate the aluminum case walls with little attenuation. Detection range is less than that of the thermal radiation detector under good atmospheric conditions but is not seriously reduced by rain, fog or smoke.

**GAMMA-RAY TEST UNIT**—A solenoid-operated pulsed gamma-ray source is used for remote checking of the detector. A 4-millicurie Cobalt<sup>60</sup> pellet is held in one end of a solenoid plunger. The solenoid is normally unenergized with the active end of the plunger enclosed in a lead shield. When the control panel op-

erator applies voltage to the solenoid coil the plunger is pulled out of the lead shield and allowed to radiate gamma rays through the aluminum case walls.

The gamma ray pulse has a rise time of about 0.01 sec and the intensity is sufficient to trigger the detector in less than 0.1 sec. The test unit is enclosed in a small cylindrical case fastened to the outside of the gamma-ray detector.

**BLAST DETECTOR**—The blast detector<sup>2</sup> is made up of a 2½-in. aluminum bronze diaphragm held in a machined aluminum housing. The center of the diaphragm rests on the plunger of a small pressure-sensitive switch. Slow changes in air pressure on the face of the diaphragm are equalized through small holes in the housing but rapid transients deflect the diaphragm and cause the switch to open. For typical shock waves this occurs if the peak pressure is greater than 0.8 psi.

Opening of the switch actuates the warning relay at the control panel. The blast detector operates only when the blast wave reaches the detector itself. The only warning time is that time necessary for the blast wave to travel from the detector to the shelter to be protected. It therefore gives less opportunity for actuation of protective systems than the detectors which operate immediately after bomb detonation. The blast detector does provide an excellent last-ditch protection because of its simplicity and reliability. No test unit is used with this detector but periodic inspection insures satisfactory operation.

**CONTROL PANEL**—The control panel, located in the underground shelter, includes conventional signal relay circuits. The signal relays are operated by opening of normally-closed relay contacts at the detectors. The relays hold until reset by switches. Disable switches allow individual detectors to be removed for servicing as necessary.

The front panel has an indicator light display which indicates which specific detector has operated. Test switches allow remote checks of detector operation without actuation of the warning circuits.

#### REFERENCES

- (1) Los Alamos Scientific Laboratory, "The Effects of Atomic Weapons," McGraw-Hill Book Company, Inc., New York, 1950.
- (2) W. C. Stange, "A Rugged Blast-Sensitive Switch," Ballistic Research Laboratories Technical Note 950, Aberdeen Proving Ground, Md., 1954.

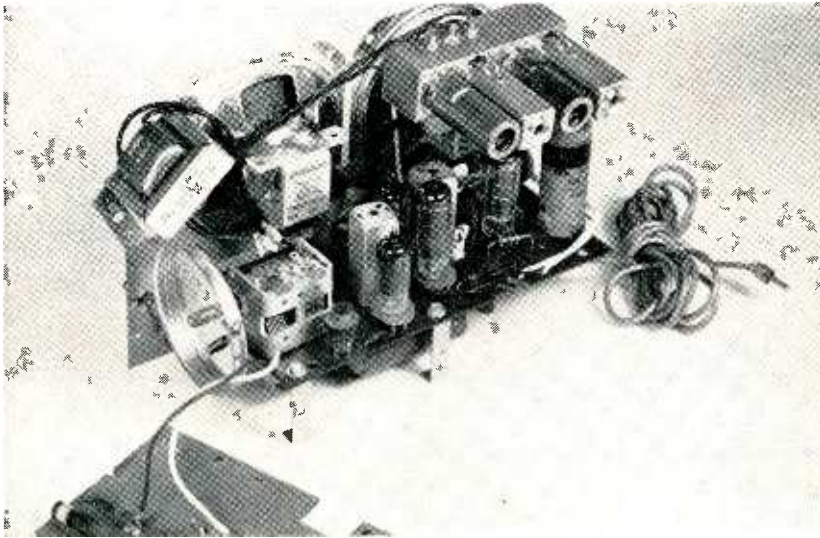

Conventional a-m receiver modified for a-m stereo. Subchassis at upper right is f-m portion

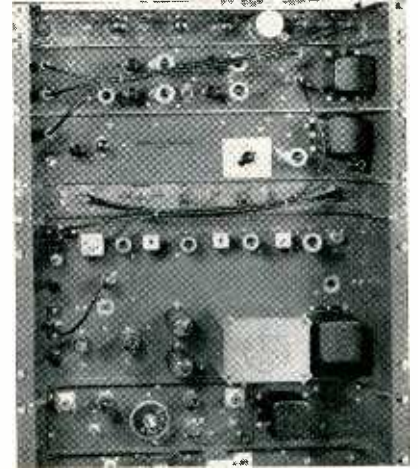

Experimental stereo transmitter. Center chassis is main modulator-transmitter with precompensator below. Top chassis are audio preamplifier, matrix and delay line

# Compatible Stereo Radio

SEVERAL SYSTEMS have been proposed for transmitting stereophonic sound in the standard broadcast band. Most of these systems use a combination of amplitude modulation and some form of angle modulation.

The Westinghouse broadcast-band stereo system uses simultaneous amplitude modulation and narrow-band frequency modulation of the same carrier. The carrier is amplitude modulated with the sum of the signals from the left (*A*) and right (*B*) microphones producing a balanced monophonic signal (*A + B*) similar to that from a single centrally located microphone. The carrier is narrow-band frequency modulated by the stereophonic difference between the right and left microphones (*A - B*).

A conventional broadcast receiver tuned to the center of the transmitted signal will receive the program in ordinary monophonic fashion.

## Transmission

Tests have indicated that most stereophonic information is in the frequency range between 300 and

3,000 cps. This range of frequencies is used therefore to frequency modulate the transmitter. The deviation is low enough so that generated sidebands will not fall outside the allotted a-m channel. A filter designed to pass only this band of frequencies is in Fig. 1.

Certain defects exist in the simple system described thus far. If, for example, there is no

a-m signal but only an f-m signal such as would occur when *A* and *B* are equal and out of phase, the frequency-selective circuits in the receiver will modulate the signal amplitude which will show up as a false a-m signal at the envelope detector. An illustration of this effect is shown in Fig. 2.

As there is no amplitude modulation at the transmitter, this signal

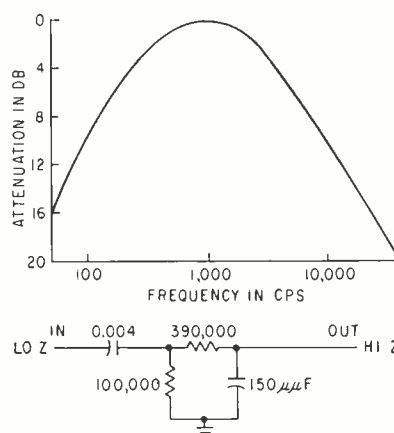

FIG. 1—Bandpass filter for 300 to 3,000 cps used to extract stereophonic information for narrow-band frequency modulation of carrier

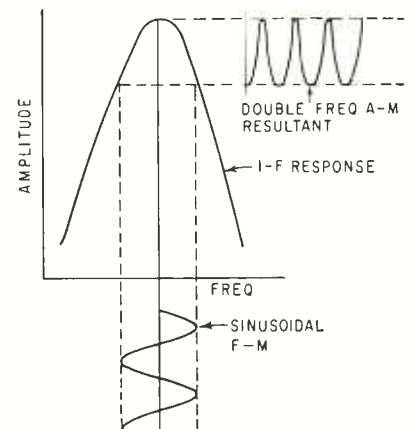

FIG. 2—Generation of double-frequency a-m signal from f-m signal in frequency-selective circuit introduces harmonic distortion during reception





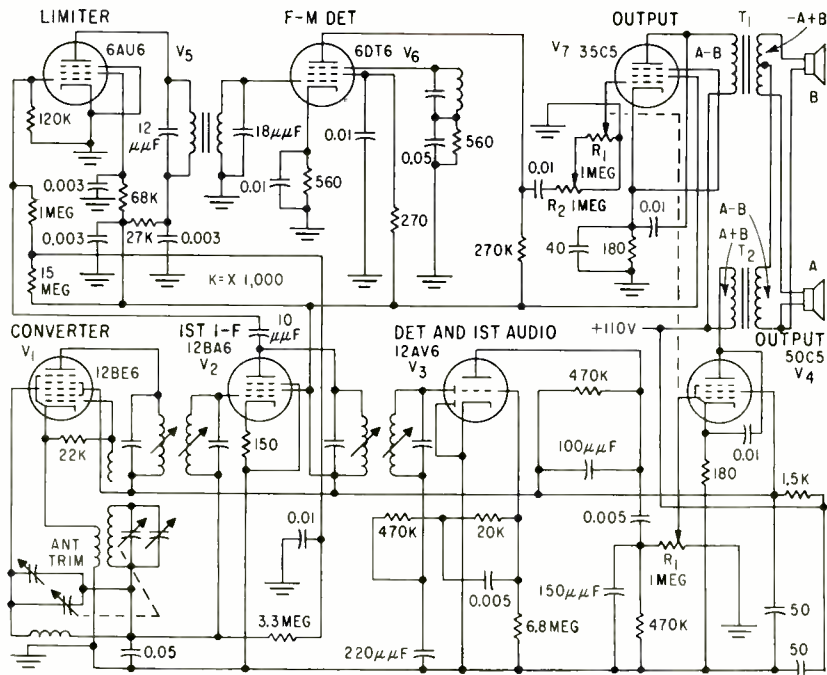

FIG. 5—Conventional a-m receiver adapted for stereo by addition of limiter, f-m detector and audio stage. Matrixing is done in audio output transformers

audio stage. High-amplitude modulation requires high gain and good limiting in the f-m channel. To not have too much gain at the i-f frequency with the accompanying danger of regeneration, a harmonic of the i-f frequency is selected for amplification. Harmonics of the i-f frequency are generated at limiter  $V_5$  during limiting.

The fourth harmonic of the i-f is chosen for the f-m detection because it is well outside the broad-

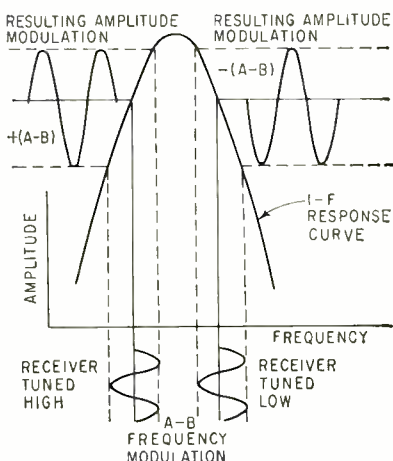

FIG. 6—With f-m signal input to frequency-selective circuit, opposite polarity outputs are generated when receiver is tuned to high or low side of carrier

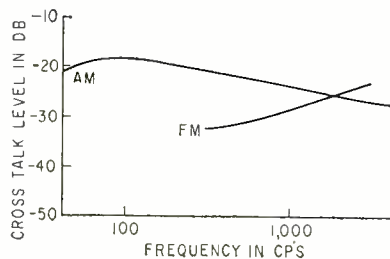

FIG. 7—Crosstalk level is below 20 db down giving sufficient separation

cast band preventing r-f feedback into the receiver front end.

### Matrixing

The matrixing is done in the audio output transformers. The  $(A - B)$  transformer  $T_1$  has a center-tapped secondary. One half is tied to  $(A + B)$  transformer  $T_2$  and the result is  $(A + B) + (A - B) = 2A$ . The other half is inverted and the result is  $(A + B) - (A - B) = 2B$ . These are the signals supplied to the loudspeakers.

Master gain control  $R_1$  is a ganged pair of potentiometers, one for each channel. Balance control  $R_2$  is in the  $(A - B)$  channel.

When this control is set at zero there is no  $(A - B)$  signal and therefore no stereo. As  $R_2$  is varied, the amount of  $(A - B)$  is increased

and the separation of the two channels is increased. Too much  $(A - B)$  signal will result in improper matrixing and less effective separation.

### AGC

To maintain proper matrixing for all signal levels, a tight agc system is required, as changes in signal level will result in changes of  $(A + B)$  but essentially no changes in the  $(A - B)$  signal. This will result in improper matrixing. The agc bias is therefore taken from the grid of limiter  $V_5$  to get a more sensitive agc signal.

### Two-Receiver Method

Another feature of this system is the ability to receive a stereophonic program using two conventional broadcast receivers.

When a conventional a-m receiver is tuned to the center of the transmitted signal, it will receive a balanced or  $(A + B)$  signal; tuned slightly off the signal, slope detection of the f-m component also takes place.

If the receiver is tuned to the high side, Fig. 6 shows that a certain amount of  $(A - B)$  signal will be slope detected and when added to the  $(A + B)$  signal due to normal a-m detection will yield a signal predominantly  $A$ . The other receiver is tuned to the low side and yields  $-(A - B)$  because of the opposite sign of the slope.

When the  $-(A - B)$  signal is added to the  $(A + B)$  signal the predominant signal is  $B$ .

Using this technique, good quality stereophonic sound can be heard using two conventional broadcast receivers.

Measurement of the crosstalk of amplitude modulation into the f-m channel and measurement of the crosstalk of the frequency modulation into the a-m channel is shown in Fig. 7.

It is generally felt that crosstalk of about 20 db down is sufficient separation for stereophonic purposes where the signals of the two channels are not completely distinct.

The author acknowledges the work of Charles W. Baugh, Jr., and Richard W. Cook in this development.





Three-indicator-light adapter is mounted on one-indicator-light receiver to form small, light package

# Transistor Dual Conversion for Marker-Beacon Receivers

Airborne marker beacon receiver has high first i-f for good image rejection and lower second i-f for stable gain. With same sized transistorized adapter, one-indicator-light receiver is converted to three-indicator-light receiver weighing about two pounds

By **RICHARD G. ERDMANN**, Airborne Communications Engineer, Radio Corporation of America, Camden, N. J.

**J**UNCTION TRANSISTORS and diodes completely replace vacuum tubes and relays in a dual-conversion superheterodyne marker beacon receiver. The one-indicator-light receiver with transistorized adapter converts to a three-indicator-light marker beacon receiver that weighs less than two pounds and draws less than two watts.

The transmitted 75-mc carrier in marker beacon systems is amplitude modulated to denote marker function (airways, 3,000 cps; outer runway, 400 cps; middle runway, 1,300 cps). Two receiving system types are in general use. The one-light receiver responds to any of three modulating frequencies with

identification being aural. The three-light receiver separates the frequencies to operate three color-coded lights.

When the aircraft passes over a marker beacon transmitter, the tone is heard. At a predetermined signal level, an indicator lights to establish aircraft position.

## One-Light Receiver

The dual-conversion receiver in Fig. 1 has a high-frequency first i-f for good image rejection and a low-frequency second i-f to provide stable gain. The first i-f circuits include only passive tuned circuits.

With dual conversion, the number of i-f stages could be reduced be-

cause of the increased gain per stage. A single-conversion receiver with a high i-f would have required that the i-f transistors operate at a frequency where gain would not be high. Tests of the dual-conversion receiver showed a signal-to-noise ratio of 20 db or more. Input to the receiver during these tests was 500  $\mu$ v at 75 mc modulated 30 percent.

The 75-mc filter in Fig. 1 consists of four tuned circuits. The tuned circuits feed a mixer whose output is fed to a triple-tuned filter tuned to the first i-f of 4.2 mc. This signal is converted to the second i-f of 520 kc by a 4.72-mc converter.

The broadband second i-f stages

feed a diode that detects the audio and agc signals. Part of the output is rectified and turns on the indicator light when the received signal exceeds a predetermined level.

Stray ground-current coupling between the preselector tuned circuits was encountered at 75 mc. This coupling, resulting from lack of a good ground plane with the printed circuit, made the receiver susceptible to spurious responses. Therefore, a one-can assembly was made that includes  $T_1$  through  $T_4$ , first i-f coil  $T_5$  and oscillator coil  $T_6$ .

Zero-temperature-coefficient ceramic capacitors are used in the tuned circuits of  $T_1$  through  $T_4$  and in  $T_5$  for stable preselector performance. Near critical coupling allows maximum nose bandwidth with good skirt selectivity. It also simplifies tuning of the filter.

### First I-F

A drift transistor,  $Q_1$ , is used in the oscillator in a grounded-base configuration with a fifth-overtone crystal. The circuit is stabilized in relation to d-c operating point by a large emitter resistor and a relatively low d-c impedance provided by base-biasing network  $R_1$  and  $R_2$ .

Frequency stability is better than  $\pm 10$  kc. Using a transistor and a permeability-tuned oscillator coil make the oscillator much less susceptible to vibration and shock.

Diode  $D_1$  is supplied with injection power from  $Q_1$ . Forward bias on  $D_1$  minimizes variations in diode impedance caused by supply-voltage and temperature changes and their effect on oscillator power and receiver gain. Since frequency output is a fundamental rather than a harmonic, spurious responses through the receiver preselector fall at 70.8-mc intervals and are easier to control.

### I-F Selectivity

Near-critical coupling is used in the first i-f filter  $T_5$ ,  $T_6$  and  $T_7$  for the same reason as in the preselector. This i-f selectivity also contributes to the skirt selectivity of the receiver passband.

The first i-f is fed to crystal-controlled converter  $Q_2$  which oscillates at 4.72 mc producing a 520-kc second i-f. Frequency error contributed to the receiver by this conversion is only a few hundred cycles maximum, and conversion gain variations with temperature and

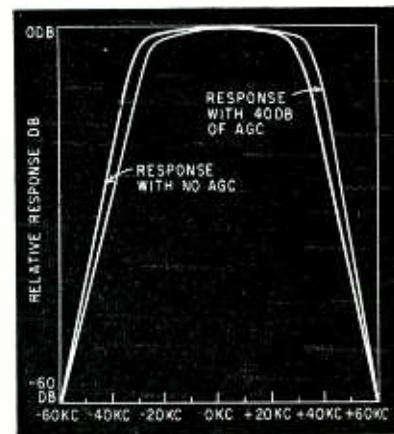

FIG. 2—Composite selectivity of first and second i-f filters is influenced only slightly by parameter shift of the transistors

supply-voltage changes are comparable to a straight i-f amplifier.

The drift transistor (2N247) produces enough power gain at the oscillator frequency to eliminate need for a separate oscillator inductance, eliminating one tuned circuit.

Output impedance of the converter is high enough to permit coupling the converter collector directly to the top of the second i-f filter  $T_8$  through  $T_{11}$ . The filter is used rather than distributed selectivity to eliminate effects of transistor parameter variations with temperature and supply-voltage changes, transistor replacement and agc action. The filter is critically coupled and operates at medium  $Q$ , yielding the required broad-nose selectivity of 80 kc to the 6-db points.

Composite selectivity of the first and second i-f filters shown in Fig. 2 is influenced only slightly by parameter shift of the transistors.

The second i-f amplifier  $Q_3$ ,  $Q_4$ ,  $Q_5$  and  $T_{12}$ ,  $T_{13}$ ,  $T_{14}$  is completely broadbanded and requires no tuning adjustments. Since all receiver selectivity is before these circuits, broadbanding does not have some of the usual undesirable effects such as susceptibility to cross modulation. Power gain of the second i-f stages is better than 20 db including conversion loss. The drift transistors in the second i-f amplifier operate well inside the flat gain region of the power-gain versus frequency curve and have high d-c betas for good agc action.

These transistors are stabilized

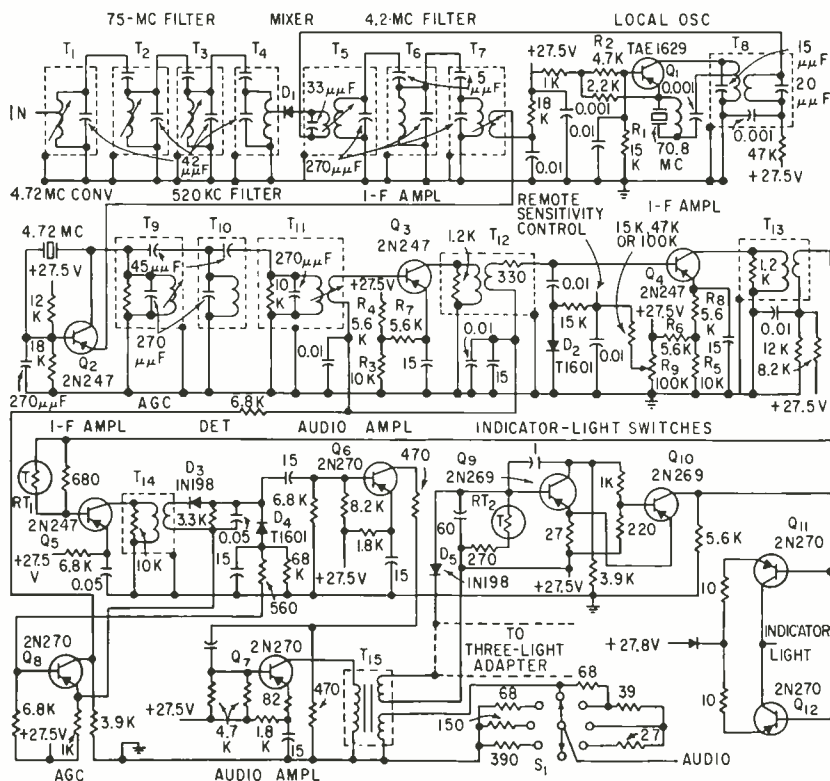

FIG. 1—Schematic of one-indicator-light receiver shows first i-f filter circuits which consist of only passive tuned elements. Second i-f stages use three drift transistors



in relation to operating point and interchangeability by large emitter resistances and a relatively low d-c impedance base-bias network. Emitter resistors of  $Q_3$  and  $Q_1$  are tied to a voltage divider network ( $R_3$  and  $R_1$  for  $Q_3$ ,  $R_2$  and  $R_4$  for  $Q_1$ ). These networks provide fixed emitter potentials that cut off collector current rapidly when base voltage approaches agc threshold. Below agc threshold, resistors  $R_7$  and  $R_8$  serve as emitter-stabilizing resistors for  $Q_3$  and  $Q_1$ , respectively.

Thermistor  $RT_1$  compensates all gain variation with temperature incurred in the receiver from antenna to audio output.

The circuit between  $T_{12}$  and  $Q_1$  forms an r-f voltage divider for remotely adjusting receiver sensitivity. Since agc lowers collector current and power gain of this stage, the network permits changing gain without disturbing d-c parameters.

Radio-frequency impedance through diode  $D_2$  is inversely proportional to d-c through it. Since  $R_6$  controls d-c through  $D_2$ , it controls r-f impedance of the diode. Remote control of current through  $D_2$  is easily accomplished, since it involves a d-c of 1 ma or less. Gain adjustment of approximately 20 db can be provided in this manner.

The third i-f amplifier,  $Q_7$ , must be stabilized at a high output level to prevent i-f clipping and provide sufficient power for detection.

### AGC

Agc amplification is necessary because available d-c power from detector  $D_3$  is low. Agc amplifier  $Q_4$  receives rectified power from  $D_3$  and reduces forward bias on  $Q_3$  and  $Q_1$  as signal strength increases.

The base of  $Q_3$  is isolated from second detector  $D_3$  by  $D_1$ , so that  $Q_3$  can be stabilized for temperature

when developed bias on  $D_3$  is below the agc threshold level. The agc is delayed for maximum receiver sensitivity with  $D_1$  providing the delay. No coupling between detector  $D_3$  and the agc line occurs until forward voltage across  $D_1$  reaches about 0.5 volt. The receiver agc curve is shown in Fig. 3.

First audio amplifier  $Q_6$  provides audio gain and serves as an impedance-matching stage between

Diode  $D_5$  rectifies audio and supplies forward bias directly to the base of  $Q_6$ . Transistor  $Q_6$  is normally cut off and  $Q_{10}$  is normally conducting. Transistor  $Q_6$  conducts when a rectified signal from  $D_5$  places forward bias on its base. Transistor  $Q_{10}$  is cut off and the potential on its collector drops. This drop appears on the bases of  $Q_{11}$  and  $Q_{12}$ , permitting collector current to flow out to the light circuit.

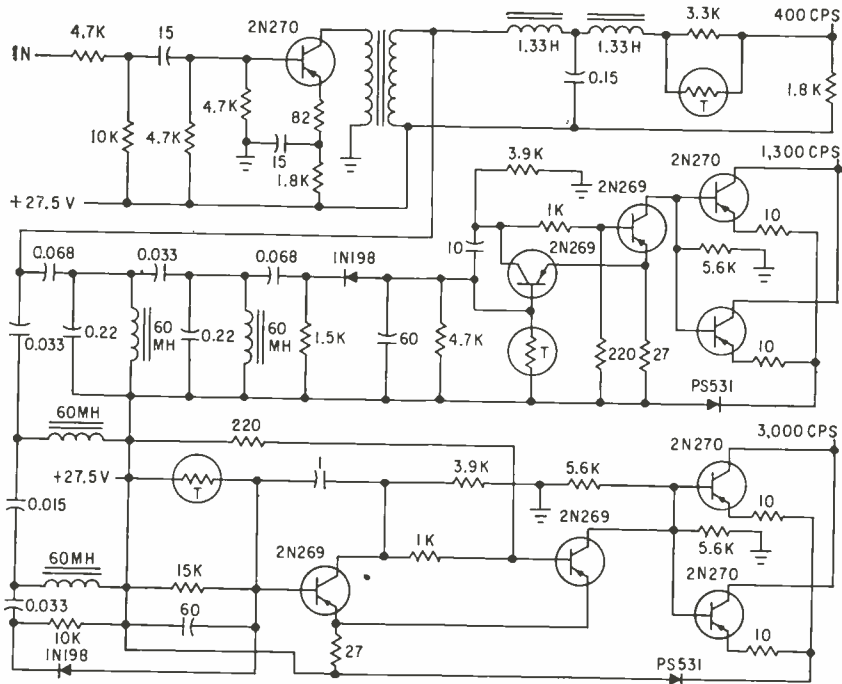

FIG. 4—The 1,300-cps band-pass filter is the only one in the three-indicator-light adapter that requires a high degree of stability

detector and audio amplifier  $Q_7$ . Output from  $Q_7$  is passed to the audio output terminals from a secondary winding of  $T_{15}$  through attenuator  $S_1$ .

Attenuator  $S_1$  maintains constant load on the output winding while permitting four steps of audio attenuation. A constant load is required to keep a-c gain of  $Q_7$  constant. Failure to do so would result in variation of the indicator-light threshold not only with audio output level but with r-f input signal level.

### Indicator-Light Circuits

The indicator-light circuits provide relay-type switching when receiver input exceeds a threshold level. Transistors rated in milliwatts of collector dissipation control almost three watts of indicator-light power.

The switching action of  $Q_{11}$  and  $Q_{12}$  occurs suddenly, causing the switching of  $Q_{11}$  and  $Q_{12}$  to occur in microseconds. Since this time is much less than the thermal time constant of the base-collector junction of  $Q_{11}$  and  $Q_{12}$ , time of peak-power dissipation is so short that it does not cause unsafe transistor junction temperatures.

### Three-Light Adapter

The transistorized three-light adapter requires only two more electronic switches, in addition to a loss amplifier and filters. The schematic in Fig. 4 shows the filter network, which consists of low-pass, band-pass and high-pass filters. Component tolerances and temperature stabilization of the filters are not critical. The 1,300-cps band-pass filter is the only one that requires a high degree of stability.

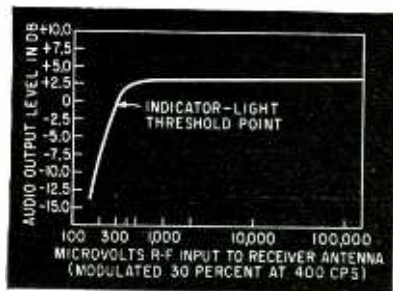

FIG. 3—Automatic-gain-control characteristics of receiver at 25 C

# Doppler Radar Navigation

Design features of Doppler radar navigation systems are summarized in table of major characteristics

By **F. B. BERGER**, General Precision Laboratory, Inc., Pleasantville, New York

**Table I—Characteristics of Airborne Automatic Navigation Systems**

System	Manufacturer	Weight (lb)	Volume (cu ft)	Input Power	Temperature Range (deg C)	Antennas	Number of Beams	Stabilization	Transmission Frequency (mc)
APN-66	General Precision Laboratory, Inc.	725	34.7	2,500 v-a 350 w d-c	-55 to 55	Four linear arrays	4	Horizontal and ground track	8,800
APN-67	Ryan Aeronautical Co.	175	8	900 w d-c		Paraboloid (split to form two antennas)	2 <sup>b</sup>	Data (antenna fixed)	13,500
APN-78	Laboratory For Electronics	150	6	600 w d-c		Lens	3	Data (antenna fixed)	9,799
APN-79	General Electric Co.	266	5.6	1,400 w		Combination lens and reflector	3	Data (antenna fixed)	
APN-81	General Precision Laboratory, Inc.	389	22.3	989 v-a 1 $\phi$ 1,700 v-a 3 $\phi$ 100 w d-c	-55 to 55	Four linear arrays	4	Horizontal and ground track	8,800
APN-82	General Precision Laboratory, Inc. and Ford Instrument Co.	436	23.4	1,173 v-a 1 $\phi$ 1,946 v-a 3 $\phi$ 100 w d-c	-55 to 55	Four linear arrays	4	Horizontal and ground track	8,800
APN-89	General Precision Laboratory, Inc.	323	20.5	440 v-a 1 $\phi$ 1,050 v-a 3 $\phi$ 75 w d-c	-55 to 55	Four linear arrays	4	Horizontal and ground track	8,800
APN-96	General Precision Laboratory, Inc.	112	5.2 to 14 <sup>c</sup>	900 v-a 100 w d-c	-55 to 90	One planar array	4	Horizontal and ground track	8,800
APN-102 RADAN <sup>d</sup> 212	General Precision Laboratory, Inc.	91	4.5	430 v-a 20 w d-c	-55 to 71	One planar array	4	Pitch and ground track	8,800
APN-105	Laboratory For Electronics	215	7	850 w d-c		Two lenses	3	Data (antenna fixed)	13,500

(a) averaged over 10 mi of travel (b) one of three Doppler frequencies is replaced by rate of climb signal (c) depends on optional



DOPPLER NAVIGATION SYSTEMS determine change in vehicle position from a known starting point by integrating velocity with respect to time. Velocity is obtained by combining known parameters with measured Doppler frequency shift of an electromagnetic signal back-scattered from the earth's surface. Table I lists major characteristics of Doppler navigation systems now in production in the United States.

Systems using data stabilization have antennas fixed with respect to the aircraft, and a computer for operating on input Doppler and vertical data to yield

desired velocity components. Systems using antenna stabilization have an antenna assembly which is stabilized to a horizontal plane with roll and/or pitch data, and rotated in azimuth to align the axis of symmetry of the assembly in the direction of ground track. Both methods develop equivalent information.

The term Janus is restricted to systems in which echoes received from more than one beam are mixed prior to final detection. By this definition, therefore, coherent pulsed or c-w systems are considered Janus if direct signal mixing techniques are used.

Type of Transmission	Coherence	Altitude Limits (ft)	Speed (knots)	Basic Outputs	Accuracy <sup>a</sup>
Pulsed Janus 4.5% duty ratio	Self-coherent <sup>c</sup>	below 500 to above 70,000	70 to 700 ground speed 0 to 240 wind speed	Present latitude and longitude, ground speed, drift angle, wind speed and direction, and others	Ground speed better than 0.2%, drift angle better than 0.2 deg.
c-w	Coherent	0 to 70,000	80 to 800 ground speed	Present position, remotes for miles travelled north-south and east-west, magnetic variation, true heading, heading and drift miles, and autopilot signal	Present position within 0.5% for 0.1 deg heading reference (neglecting non-systematic sea effects)
Pulsed Janus 50% duty ratio	Coherent		-50 to 300 horizontal, ±3,000 fpm vertical	Visual displays of present position, course and distance to destination, ground speed, vertical velocity, hovering. Also other remotes	
c-w Janus	Self-coherent <sup>c</sup>	0 to 70,000	120 to 1,200	Visual display of present position, course and distance to destination, and ground track. Others available for remotes	
Pulsed Janus 4.5% duty ratio	Self-coherent <sup>c</sup>	below 500 to above 70,000	70 to 700 ground speed 0 to 240 wind speed	Visual display of drift angle and ground speed. Remote ground speed, drift angle, wind speed, and wind direction	Ground speed better than 0.2%, drift angle better than 0.2 deg, wind speed ±3 knots, wind direction ±0.2 deg
Pulsed Janus 4.5% duty ratio	Self-coherent <sup>c</sup>	below 500 to above 70,000	70 to 700 ground speed	Present latitude, longitude, ground speed, drift angle, wind speed and wind direction	Ground speed better than 0.2%, wind speed ±3 knots, wind direction ±0.2 deg
Pulsed Janus 4.5% duty ratio	Self-coherent <sup>c</sup>	below 500 to above 70,000	70 to 700 ground speed	Visual display of ground speed, drift angle with external reference heading; 3-wire, 2-speed synchro output of track angle	Ground speed better than 0.2%
Pulsed Janus 25% duty ratio	Self-coherent <sup>c</sup>	below 500 to above 70,000	70 to 700 ground speed	Various analogs of ground speed and drift angle, wind speed and wind direction	Ground speed 0.1%, drift angle 0.15 deg
Pulsed Janus	Self-coherent <sup>c</sup>	200 to above 70,000	70 to 1,000 ground speed	Visual displays and analogs of ground speed and drift angle	Better than 1% of actual track, better than 0.5% of drift angle
Pulsed Janus 50% duty ratio	Coherent	0 to 70,000	0 to 1,500	Present position	Present position within 0.67% (probable), 1.55% (maximum)

units (d) registered trademark of General Precision Laboratory, Inc. (e) compares front and rear pointing echoes

# Zero-Crossing Technique

Sinusoidal wavetrain output starting at the zero crossing of a sine wave is produced by a gating circuit. This wavetrain generator is used to determine characteristics of ultrasonic delay lines and other ultrasonic equipment

By JOHN A. WEREB JR., \* Staff Member, MIT, Lincoln Laboratory, Lexington, Mass.

EVALUATION and testing of ultrasonic equipment requires a variable frequency sinusoid wavetrain generator whose output is synchronized with the zero crossing of the sine wave. The generator is used to determine the attenuation and velocity characteristics of sound and ultrasound in wire type delay lines using magnetostriction transducers.

Gated oscillators, usually used in these applications, may be undesirable as the first few cycles of output may be unstable and the output wave may contain a d-c component. The unstable cycles cause trouble when a test requires only a few cycles. The d-c component generates unwanted transients in the system being tested.

## Synchronizer

A continuous sine wave is fed into the wavetrain generator or synchronizer and the output shown in Fig. 1 is produced. The output wavetrain starts at the zero crossing of the sine wave. This gives a stable presentation on a cathode-ray oscilloscope and greatly reduces input harmonics.

Gate length  $t$  is variable from a fraction of a cycle to many cycles. Gate length is limited only by the relationship  $(T-t) = 5t$ , where  $T$  is the repetition period.

Two synchronizers are used to cover the frequency range from 20 cps to 2.5 mc. One operates from 20 cps to 300 kc while the second covers from 300 kc to 2.5 mc. Two units are required because the large components required at low fre-

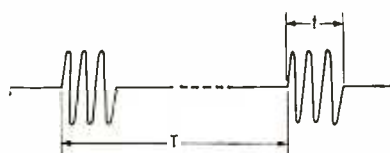

FIG. 1—Output wave starts at zero crossing of sine wave

quencies do not perform well at the higher frequencies.

Up to 120 kc the gating effectiveness is approximately 50 db and decreases with increasing frequency due to diode capacitance. Cascading of two or more switches gives larger gating values at upper and lower frequencies.

## Circuits

A block diagram of the synchronizer is shown in Fig. 2. An oscillator capable of providing 4 mw at 2 v is connected to the electronic switch and the slicer. The slicer is a Schmitt trigger with a level control in front which causes ON action at the zero crossing.

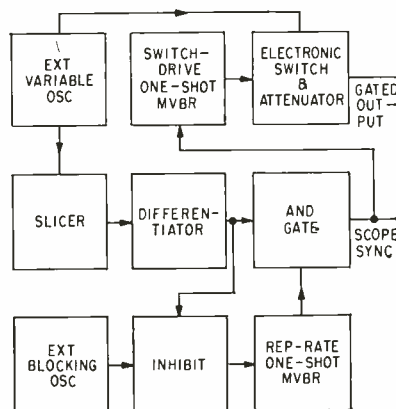

FIG. 2—Inhibit circuit eliminates jitter

The output of the slicer is fed to a differentiator then to an AND circuit. The AND circuit delivers one pulse per cycle. One or more pulses pass through the AND whenever the repetition-rate one-shot multivibrator is on. The first pulse triggers the switch-drive one-shot multivibrator and opens the electronic switch for the time  $t$ . This operation repeats at the time  $T$ .

By adjusting the period of the repetition-rate one-shot multivibrator to be greater than the period of the sine wave,  $T$  will hold to within one cycle of the sine wave.

## Jitter

Without the inhibit circuit a wavetrain could, at high frequencies, be out of synchronism with the zero crossing. The number of degrees from zero at which synchronization occurs is called jitter.

The pulse from the AND gate is slightly wider than necessary to trigger the switch-drive one-shot multivibrator. If the repetition-rate one-shot multivibrator is turned on while the pulses from the differentiator are imposed on the AND gate, the rep-rate multivibrator output may be sufficient to turn on the switch-drive one-shot multivibrator. Since only the front end of the pulse is synchronous a slight jitter will occur.

## Inhibit Circuit

The simple inhibit circuit eliminates jitter completely. For negative pulses coming from the blocking oscillator shown in Fig. 3 diode  $D_1$  is an open circuit and the rep-rate one-shot multivibrator will not trigger. If the positive pulse from

\* Now with Sanders Assoc., Nashua, N. H.



# Syncs Wavetrain Outputs

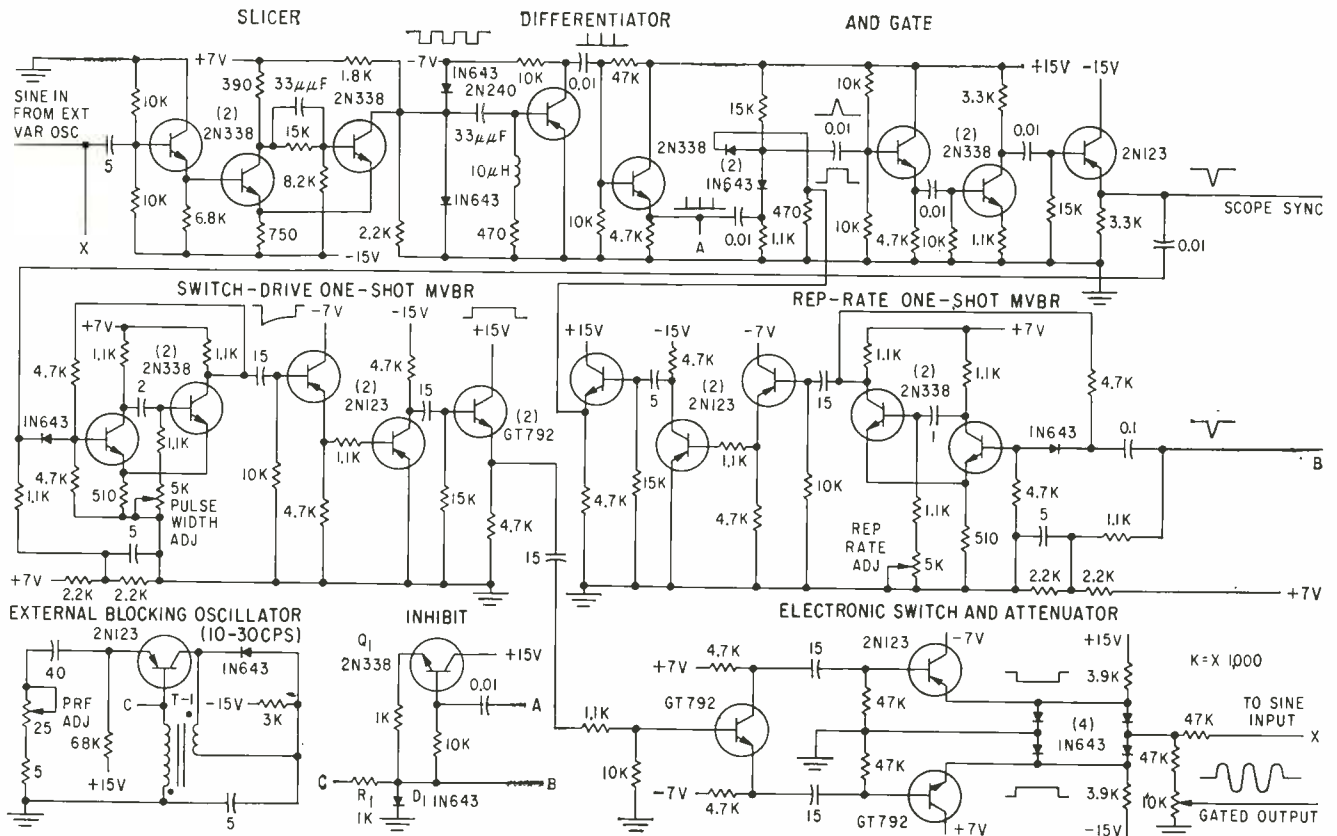

FIG. 3—Detailed circuit of a synchronizer covering the frequency range from 20 cps to 300 kc. External blocking oscillator allows use of alternative repetition-rate generator when required

the differentiator is imposed on the AND gate the pulse turns on the transistor  $Q_1$  in the inhibit circuit, causing  $D_1$  to conduct. Diode  $D_1$  will then be a short circuit to the pulse from the blocking oscillator and the rep-rate one-shot multivibrator will not trigger, eliminating jitter. For this reason pulses of opposite polarity are chosen to drive the rep-rate one-shot multivibrator and the AND circuit.

Resistor  $R_1$  produces an internal resistance in the blocking oscillator so that  $D_1$  looks like a short circuit when conducting.

Germanium transistors type 2N388 can be directly substituted for the silicon transistors used in this instrument if temperature conditions allow.

## Application

The synchronizer may be used to determine the characteristics of

ultrasonic delay lines. Figure 4A is a block diagram of a system for locating inhomogeneities in a delay line. An artificial flaw is created on the line by clamping it at a point between the receiving transducer and the end, setting up a region of inhomogeneous stress which produces a reflection.

Details of the delay line are shown in Fig. 4B. For the input signal shown in Fig. 4C the output of Fig. 4D is produced. Location and extent of the flaw can be determined by examining the output waveform.

Acknowledgement is made to Vincent Sferrino, of Lincoln Laboratory, for his contribution to parts of the circuit design. The work reported here was supported jointly by the Army, the Navy and the Air Force under contract with the Massachusetts Institute of Technology.

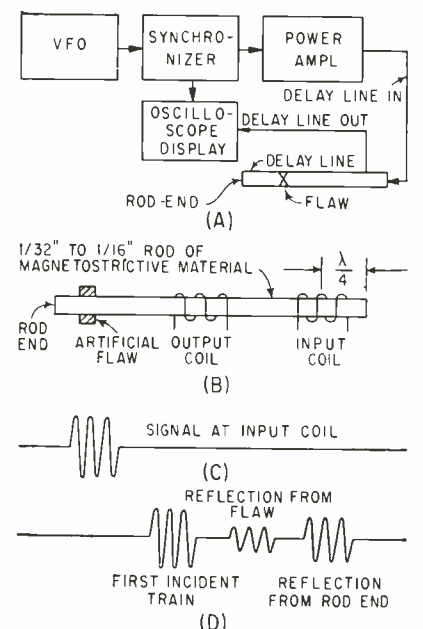

FIG. 4—Delay line test setup (A) with details of delay line (B) and input (C) and output (D) signals. Output wave shows location and extent of flaw

# Using Tv Techniques

Modern electronic techniques aid astronomers in locating variable stars. Unique flying-spot-type closed-circuit television system compares two photographs and displays any difference between them. Several nonastronomical uses are also suggested

By J. BORGMAN, Assistant Professor of Astronomy, Univ. of Groningen, Holland

OF THE VAST NUMBER of stars visible on a clear night, certain types are known as variable stars. This means the amount of light that they radiate is variable. Some of these stars show irregular variation, but most are of a certain periodic type that have periods of a day or more. This periodic type of star has become an important tool in astronomy as the mean energy radiated in a certain band of wavelengths can be derived from the period of light variation. The apparent mean brightness, measured by the observer on earth, will give the distance to the star. Hence, variable stars are important distance markers especially at large distances where no other method of equal dependability exists.

## Detecting Variable Stars

An astronomical telescope such as the 48-in. aperture Schmidt telescope at Mt. Palomar can photograph several millions of stars in the Milky Way in a few minutes on a single plate. The process of detecting the variable stars in this enormous quantity is laborious and time consuming. Several methods of variable star detection have been used all based on the principle of comparing two photographs of the same region of the sky taken at different times. The variable stars that have changed sufficiently in the time between two exposures show detectable differences between the sizes of the two images on the photographs. In principle, all optical star images have the same size due to the extremely small angular di-

ameter of the stars. The photographic plate shows an increased image diameter for an increased brightness due to aperture and exposure effects.

A comparison or blink micro-

and shrink. The probability of detection using the microscope is small.

Approximately 75-percent of detectable variable stars are overlooked. It is often necessary to re-examine the plates several times before any variation in the image is noticed. An estimation of this incompleteness can be seen from the number of rediscoveries made when searching the same pair of plates more than once.

## System Operation

A new variable-star detection instrument based on the principle of flying-spot scanning is shown in Fig. 1. This instrument compares two photographic plates taken with a telescope aimed at the same region of the sky at different times. The raster from a flying-spot scanner is beamed to a semitransparent mirror where the light splits into two paths. One path is reflected by a conventional mirror. It then goes through a lens and through one of the photographic plates to another multiplier phototube. The other path is reflected by two conventional mirrors through a lens and the other photographic plate to another multiplier phototube.

When the photographic plates are correctly positioned using the optical-mechanical arrangement, the same region of the two photographs are scanned by the raster of the flying-spot tube. Each of the multiplier phototube tubes generates a video signal consisting of: (1) signals caused by images of stars on each of the photographic plates; (2) irregularities caused by

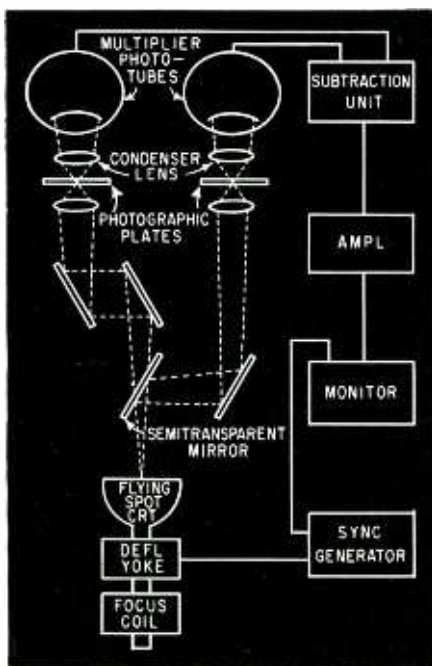
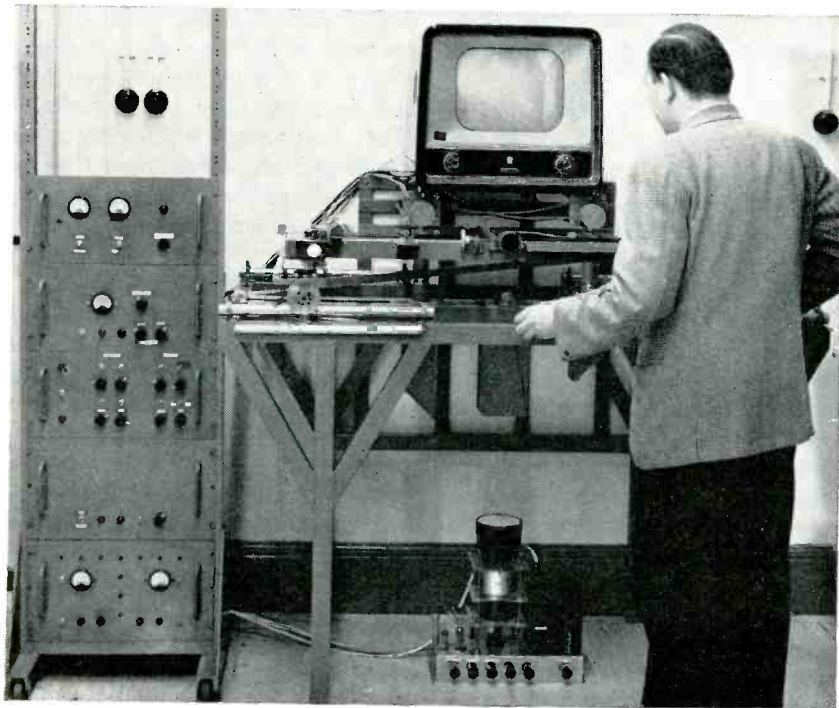

FIG. 1—Semitransparent mirror splits beam into two paths. One goes through each photograph to associated multiplier phototube. Video signals are subtracted and difference signal processed for use by monitor

scope equipped with an optical-mechanical arrangement enables alternate viewing of the same region of both plates. Using this instrument, no change is seen in stars having constant brightness but variable stars appear to grow



# in Astronomy



Operator adjusts two photographic plates simultaneously while observing tv monitor. Rack, left, contains video amplifier, sync generator, and power supplies. Two containers under tv monitor hold multiplier phototubes. Scanning unit is on the floor

the plate grains between the star images; (3) signals caused by impurity spots on each plate; and (4) noise generated by the multiplier phototubes.

If the scanned portions of the two plates are identical and geometrically matched, then both multiplier phototube video signals contain the star image signals simultaneously. If one multiplier phototube signal is reversed in polarity and subtracted from the other multiplier phototube signal, then all equal and matching signals will cancel thus making all nonvariable star image signal components disappear.

If a variable star is present on the photographic plates, then the subtraction of one star image signal component from the other brighter star image component will result in some residual signal that will appear as an output of the subtraction unit.

The output of the subtraction unit also contains the noncorrelated signals such as multiplier photo-

tube noise and phosphor grain impurities.

These signals appear as a slight snow in the background of the picture monitor. After amplification the star image difference signal is used to intensity modulate a television-type monitor. The monitor raster is synchronized with the flying-spot scanner raster.

The screen of the monitor will show the combined image of the noise and the star image difference signal between the two photographic plates scanned. All stars with the same brightness on the two plates disappear while the difference between the two images of a variable star remains. Figure 2 shows an example of the detection of a variable star on the monitor screen.

### Scanning and Optics

The scanning unit is a standard flying-spot scanner with a high degree of resolution and a short persistence. The optics were cut from selected plate glass whose reflecting

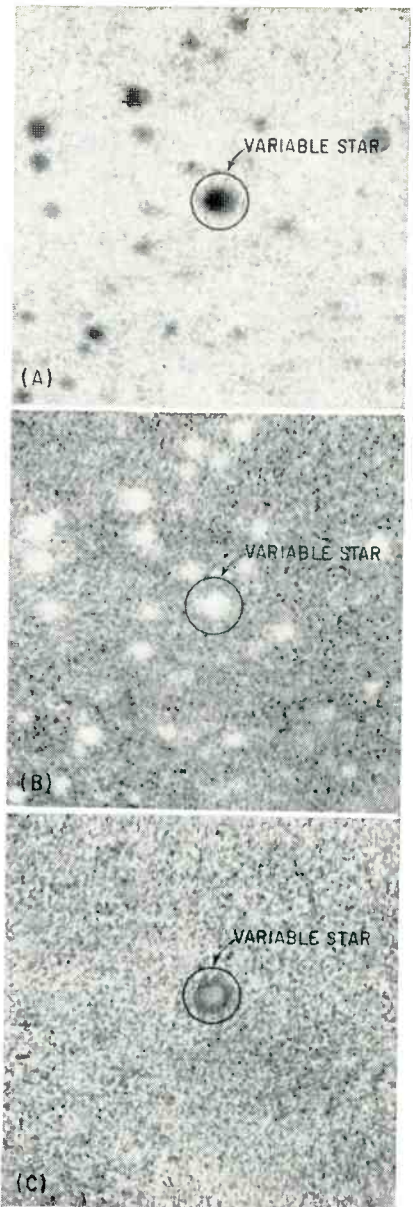

FIG. 2—Photos of tv screen taken during variable star search; A is the negative image of one plate and B is the positive image of the other plate. The difference between the two images is shown in C. The variable star is circled

surfaces are aluminized. The two lenses are standard 8-mm telephoto types  $f$  1.5 with a focal length of  $1\frac{1}{2}$  in.

The large focal ratio of these lenses is necessary to maintain good signal-to-noise ratio of the video signal. The demagnification of the raster to the photographic plates is about  $30\times$  allowing the





# High-Temperature Cables

Tabulation gives physical and electrical properties of Teflon coaxial radio-frequency cables that are suitable for high-temperature environments

By E. T. PFUND, JR., United ElectroDynamics, Pasadena, California

IN THE FIELD of high-temperature components, one of the most difficult problems to be solved is the development of suitable insulated wire. Teflon provides low loss and permits high operating temperature. The tabulation presented here gives information available to date on high-temperature coaxial cables of various designs employing Teflon dielectrics of air-spaced construction. Air-spaced, filament, threaded or taped Teflon cables are suitable in high

temperature environments because sufficient voids exist within these cable designs to compensate for thermal expansion. In the future, Teflon may be widely used with fillers such as quartz or glass which can extend its heat distortion characteristics.

Research and testing of these cables was sponsored by the Electronic Components Laboratory, Wright Air Development Center, under Contracts AF-33 (616)-3607 and AF-33 (616)-5189.

## 300 C Resistant 50-Ohm Coaxial Cables

Conductors	Teflon Dielectric	Flexibility	Attenuation- 400 mc		Freq. Limit (up to)	Capacitance		Drawbacks	Advantages
			db/ 100 ft	deg. C		$\mu\text{f}/$ ft	deg. C		
Cable o-d = 0.415 in. Double-braid, Silver- covered-copper outer cond o-d = 0.325 in.	Tape (RG-115A/U) <sup>1</sup>	Flexible	4.75	315	5,000 mc	28	315	Affected by nuclear radiation	Withstands high voltage
			4.65	205		29.4	205		
			4.35	25		29.6	25		
			2.50	-184					
Silver-covered-copper stranded inner cond o-d = 0.084 in.									
Nickel-clad-copper outer cond o-d = 0.250 in. Silver- plated inner cond o-d = 0.082 in.	Helical filament <sup>2</sup>	Semi- flexible	5.2	500*	10,000 mc	22.5	500	Affected by nuclear radiation and thermal shock	Low-loss
			5	300**		21.9	300		
			3.33	25		21.9	25		
3003 soft aluminum outer cond o-d = 0.445 in. Aluminum tubing inner cond o-d = 0.147 in.	Braided threads <sup>3</sup>	Semi- flexible	2.92	25	5,000 mc	24.4	25	Affected by nuclear radiation and thermal shock	Low-loss Withstands high voltage
			3.25	300					
Aluminum outer cond o-d = 0.529 in. Silver-plated Aluminum inner cond o-d = 0.164 in.	Parallel tubes <sup>5</sup> (six)	Semi- flexible	3.8	360*	10,000 mc	23.7	300	Affected by thermal shock and nuclear radiation	Low-loss Withstands high voltage
			3.8	300**		23.6	25		
			1.3	25					

1—available from Amphenol—Borg Electronics Corp., Chicago

2—available from Phelps-Dodge Copper Products Corp., Yonkers, N. Y. under the name SPIRAFIL—HT

3—available from Rockbestos Products Corp., New Haven, Conn., as type NA

4—available from Rockbestos and from Boston Insulated Wire and Cable Company

5—available as a special, SPIR-O-LINE, cable from Prodelin Inc., Kearny, New Jersey

\*—after 5 minutes

\*\*—after 360 hours

# How to Design Reflexed

Reflex circuits in which i-f and a-f gain are achieved in the same transistor stage have recently been incorporated into economy broadcast receivers. Careful design is required to avoid motorboating

By JOHN WARING, Philco Corporation, Philadelphia, Pa.

CIRCUITS WHICH USE a single transistor for simultaneous amplification at intermediate and audio frequencies have been adopted recently for use in economy broadcast receivers. The reflexing circuit, normally used as a second i-f amplifier and first audio amplifier, can provide gain from a single transistor only a few db less than the gain obtained from two transistors in conventional circuits. It is not accomplished without sacrifice in distortion and power handling capabilities. Furthermore, care must be exercised in designing such circuits to avoid instabilities, particularly at high signal levels. The design of the reflex stage is also conditioned by system functions such as agc and overload level.

## Fundamental Aim

In the design of a reflex stage the fundamental aim is to provide high gain and sufficient undistorted output power to drive the audio output transistor to its rated output level without permitting regeneration in the form of motorboating to occur. This can be accomplished by choosing the proper i-f and audio load resistances, selecting sufficiently high operating collector current and voltage to prevent audio and r-f clipping, and maintaining reasonable phase characteristics in the feedback loop.

A reflex circuit used in a portable broadcast receiver is shown in Fig. 1. In this circuit, transistor  $Q_1$  amplifies a modulated i-f signal introduced at  $A$  and drives diode detector  $D_1$ , which produces an audio signal at the transistor base terminal. The transistor now amplifies

at audio frequencies and delivers signal power to the audio load at  $B$ . The 450-ohm resistor across the output terminals represents the audio load presented by the audio output transistor and its biasing network.

## Major Requirements

There are three major demands on the reflex stage during its operation. First, it must deliver sufficient undistorted audio power to drive the audio output stage to its rated level. Second, it must supply enough i-f power to the second detector to provide linear detection and agc voltage. A third requirement is stable operation throughout the range of signal levels which the stage is expected to handle.

Assume that for rated power output the audio output transistor requires a drive of 0.125 v peak across its input resistance of 450 ohms, that the d-c audio load is 560 ohms, and that the second detector requires a zero modulation i-f drive

of 0.7 v peak across its effective resistance of 1,500 ohms to provide for linear operation and sufficient agc voltage. Assume that the reflex stage of Fig. 1 uses a linear transistor with an i-f output impedance of 30,000 ohms and a supply of 6 v.

If the transistor is assumed to be driven at audio frequencies only, the audio load line of 250 ohms (450 ohms in parallel with 560 ohms) can be drawn on the collector characteristic curves, as shown in Fig. 2, for a quiescent operating point of 4.9 v and 2 ma. The latter value is selected to provide adequate signal handling capabilities in the collector characteristic. The peak audio current swing on this line is  $I = 0.125/250 = 0.5$  ma for rated audio drive.

Assume that the transistor is matched to the effective resistance of the detector. This matching requires an impedance transformation of 20/1 or a voltage transformation of 4.5/1. Thus, to obtain

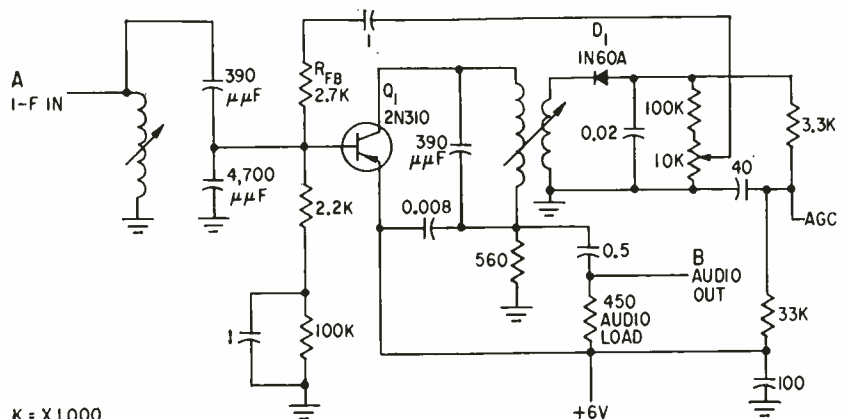

FIG. 1—Schematic of reflex circuit used in a portable broadcast receiver



# Transistor Receivers

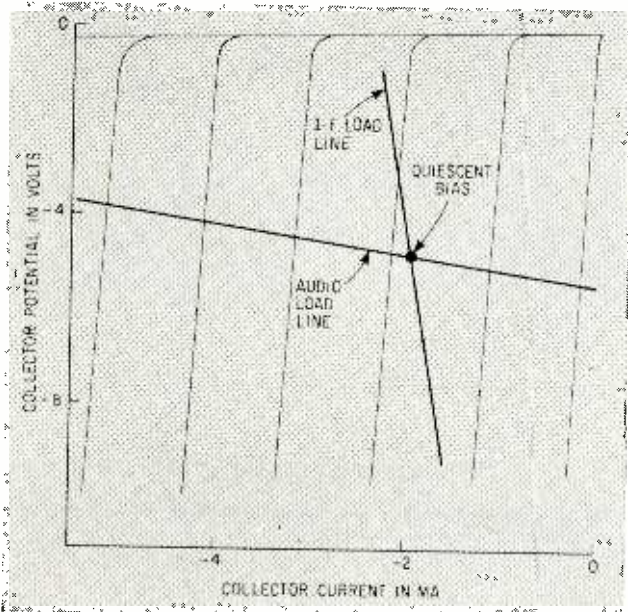

FIG. 2—Audio and i-f load lines drawn on collector characteristic

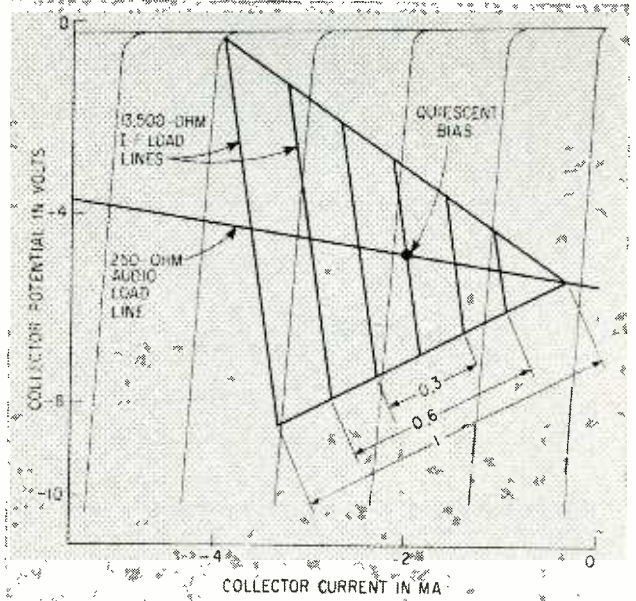

FIG. 3—Envelope of i-f carrier shown for various modulation indices

the 0.7-v i-f signal required to operate the detector, the zero-modulation peak collector swing would be 3.1 v, and at 100-percent modulation, peak collector swing would approach 6.2 v, causing clipping of the modulation. A choice of 3:1 as the voltage transformation ratio results in a peak collector swing of 4.2 v for a 100-percent modulated signal to give the desired detector drive. Assume that modulation is sinusoidal. The effective resistance of the detector is transformed to 13,500 ohms at the collector-emitter terminals of the transistor. If the transistor is assumed to be driven at intermediate frequencies only, the i-f load line can be drawn as shown in Fig. 2.

## Combined Signals

In normal operation of the circuit, the transistor is driven through an appreciable portion of its collector characteristics by simultaneous audio and i-f signals. This operation can be described as a shift in the quiescent bias point of the i-f load line along the audio load line at an audio rate. Since the audio information is derived

from the modulation on the i-f signal, the envelope of the excursions of voltage and current on the collector characteristics forms a definite pattern which aids in describing the behavior of the reflexed transistor.

## Envelope Detector

It can be seen in Fig. 1 that the envelope detector produces a peak negative output at a time corresponding to the peak amplitude of the modulated i-f carrier. The detected envelope is fed to the base of the transistor, so the transistor is driven to maximum current on the audio load line at the same time. This assumes there is no phase shift in the feedback circuit. The transistor likewise is driven to minimum current on the audio load line at a time corresponding to minimum amplitude of the modulated i-f carrier. The envelope of the i-f carrier is shown in Fig. 3 for modulation indices of 0.3, 0.6 and 1, where it is assumed the i-f carrier drive to the reflex stage is held constant while the modulation index is varied. Since it is normal practice to specify the rated output power of a broadcast receiver for a

30-percent modulated signal, the 0.5-ma swing shown in Fig. 3 for a 30-percent modulated signal, is just sufficient for proper system operation. It is assumed here that the feedback resistance  $R_{FB}$  of Fig. 1 has been adjusted to provide this 0.5-ma audio swing with the volume control set at maximum output, when the second detector is driven with a 0.7-v, 30-percent modulated i-f signal.

This reflex stage used in a receiver capable of holding the i-f voltage at the detector to 0.7 peak by use of agc constitutes a working system. However, in an economy receiver the agc is seldom capable of holding the i-f level at the second detector constant, particularly at levels near overload. Figure 3 shows that failure to hold this level will cause clipping in saturation as well as cutoff. Clipping in saturation leads to the usual system faults near overload but clipping in cutoff can cause serious regeneration in the form of motorboating.

## Motorboating Process

To visualize the regeneration process in the reflex amplifier, assume the i-f load line of the stage

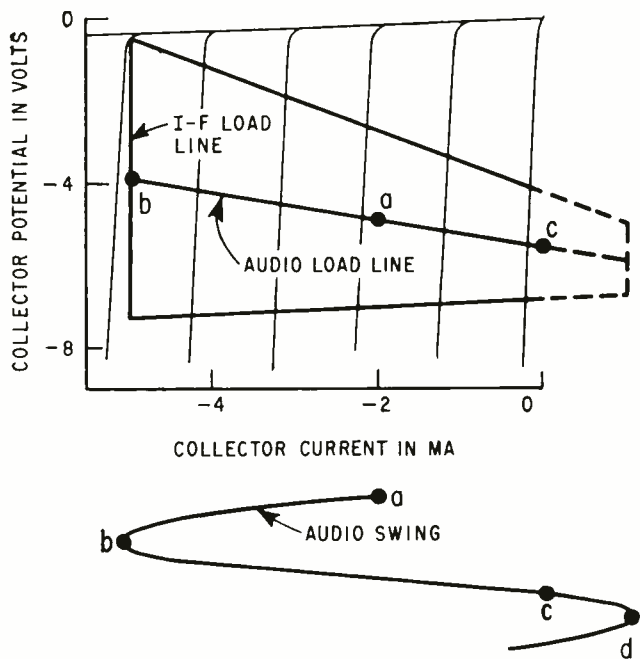

FIG. 4—Motorboating takes place as positive audio swing extends past point c

is vertical and that both the value of the audio feedback resistor  $R_{FB}$  and the volume control setting are selected to give a peak audio swing of 3 ma. Then the envelope of a 60-percent modulated i-f signal on the collector characteristic is as shown in Fig. 4, if no regeneration occurs. The behavior of the amplifier may be analyzed by starting from the quiescent point *a* and by assuming the amplitude of the i-f signal is increasing sinusoidally. Since the envelope detector is polarized for negative output, the transistor is driven further into conduction along the audio load line to point *b* which represents the peak envelope amplitude.

The amplitude of the i-f signal then drops to reduce the output from the detector driving the transistor toward cutoff at point *c*. The operation has been normal to this point and would proceed, as in normal overload, to clip off one third of the positive audio swing if it were not for the feedback characteristics of the reflex circuit. Actually, as the audio swing progresses more positive than *c*, the transistor is cut off and the i-f signal delivered to the detector becomes zero. Thus, the envelope detector develops a positive step which drives the transistor further into cutoff, and the latter remains cut off until the time

constant of the detector and feedback circuit permits the transistor to return to conduction. At that time i-f signal abruptly appears at the detector which drives the transistor well into conduction.

When motorboating is severe, this drive into conduction is limited by driving into saturation and clipping of the i-f signal. The oscillation is similar to the behavior of a multivibrator which is stable only at saturation and cutoff. The motorboat waveform is largely a function of the modulation frequency, feedback circuit time constant and the strength of oscillation.

#### Positive Envelope Detection

In the circuit of Fig. 1 the detector diode is polarized to produce a negative output which will provide agc voltage for an *nnp* transistor. When the polarity of this diode is reversed to provide agc voltage for a *pnnp* transistor, the operation of the reflex stage is modified, because the maximum i-f signal is now associated with positive audio drive instead of negative audio drive. The envelope of the i-f signal on the collector characteristic is shown in Fig. 5 for modulation indices of 0.3, 0.6, and 1. Notice that the quiescent bias current has been increased from 2 ma to 2.5 ma to prevent clipping of the

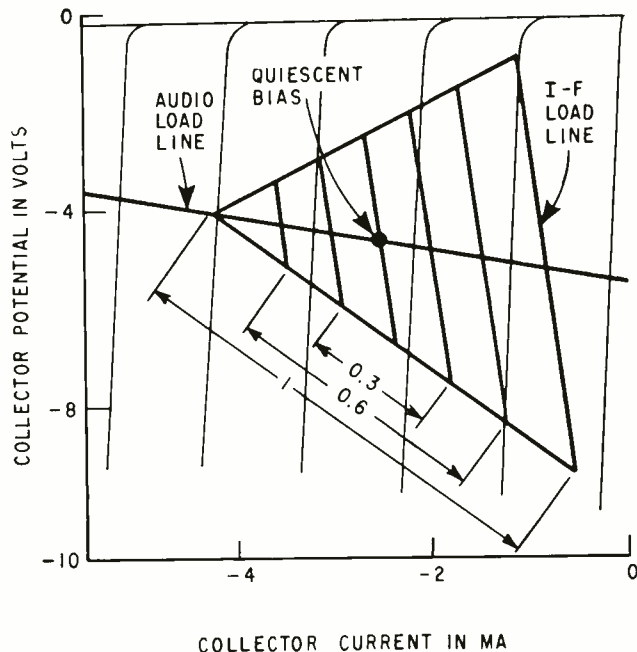

FIG. 5—Intermediate-frequency signal envelope when detector is polarized for positive output

i-f signal in cutoff. The conditions which caused motorboating in the circuit of Fig. 1 are considerably alleviated, because regenerative clipping now occurs in saturation. When the transistor has good saturation characteristics, motorboating is improbable at high-modulation indices and is only moderately serious at low modulation indices. A disadvantage in this mode of operation is the cutoff clipping of the peak i-f signal which occurs at excessive audio drive. This condition can cause low overload level and loss of agc.

#### Other Considerations

The best transistor for reflex circuits is one which has collector characteristics showing excellent linearity and sharp knees. The transistor should have the qualifications normally expected of the i-f and audio amplifier including good gain and stability.

When the transistor is used in a low-voltage reflex circuit, its saturation voltage should not exceed a few tenths of a volt or system overload level may suffer. When  $I_{co}$  becomes an important transistor parameter, cold temperatures can cause motorboating while high temperatures can cause reduction in overload level, the sensitivity and the output power.



# CINCH HEAT DISSIPATING TUBE SHIELDS

★ **NOW AVAILABLE—**

from CINCH—the complete line of  
HEAT DISSIPATING TUBE SHIELDS, for  
Miniature, Subminiature, Octal and  
Power Tubes.



T5 and T6



TR5 and TR6

The 7 and 9 pin Miniature Series, T, TR  
and NW Series are variously covered by  
Military Specifications:

- MIL-S-9372B (USAF)
- MIL-S-242A (Ships)
- MIL-S-19786A (Navy)
- SCL-6307/2 (Signal Corps)

In the Octal and Power Series, the shields  
are covered by Redstone Arsenal and Sig-  
nal Corps approval.

Where shields are required blackened,  
Henderlube is supplied as the Standard  
finish.

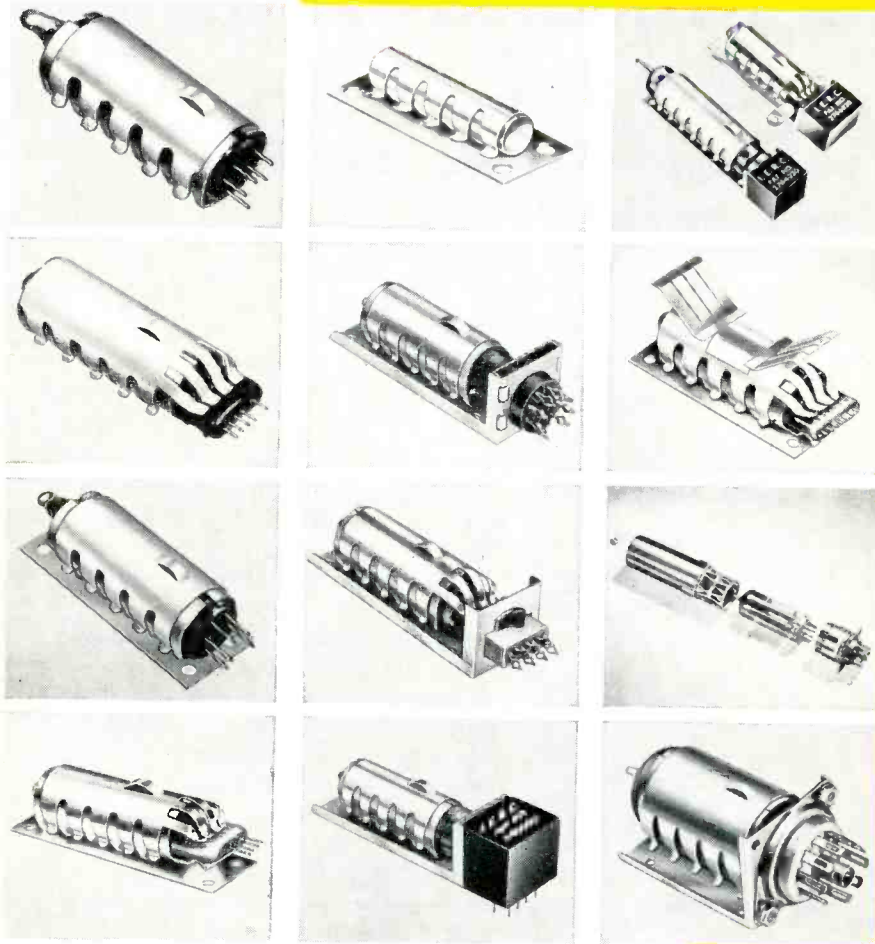

SUBMINIATURE AND MINIATURE SHIELDS



OCTAL and POWER SHIELDS



**Cinch**  
ELECTRONIC  
COMPONENTS



Under license arrangement with  
International Electronic Research  
Corporation.

**CINCH MANUFACTURING COMPANY**

Centrally located plants at  
Chicago, Illinois, Shelbyville,  
Indiana, La Puente, California  
and St. Louis, Missouri.

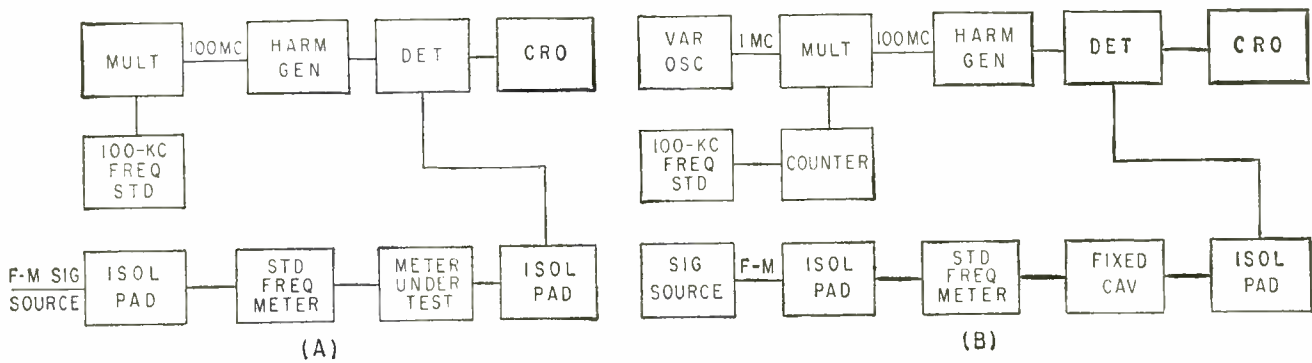

FIG. 2—Harmonics of frequency standard produce markers on bell curve produced by f-m signal in (A). Variable oscillator is used for calibration of fixed cavities (B)

# Microwave Measurements

Increased accuracy and reduced calibration time are gained using comparison method of microwave frequency determination

By J. H. CORN, Engineer, Headquarters Engineering, Western Electric Co., Winston-Salem, N. C.

**T**HIS METHOD of microwave frequency measurement uses direct comparison between the unknown frequency and a primary frequency standard.

Accuracy of frequency comparison is limited by the readability of the equipment.

## Signal Source Calibration

Figure 1 shows the method of calibrating a signal generator. The output of the 100-kc frequency standard is multiplied to 100 mc and passed through a harmonic generator to a crystal detector where it is mixed with the signal source.

The detected signal is applied to the vertical input of an oscilloscope. The oscilloscope displays a straight trace until the signal source frequency is adjusted to a harmonic of the 100-mc frequency standard and a zero beat appears.

By referring to the rough calibration made by conventional means the harmonic of the marker can be identified.

For absorption-type wavemeters,

a frequency-modulated signal source is used as shown in Fig. 2A.

## Wavemeter Calibration

When a klystron is used as a signal source, the mode spectrum appears

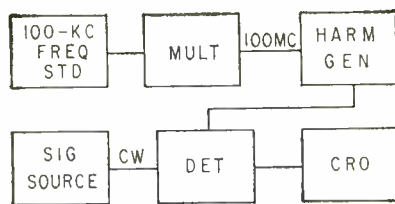

FIG. 1—Harmonics of frequency standard are mixed with signal source to produce visible zero beat

as a bell curve on the oscilloscope trace.

As the klystron center frequency is varied, markers appear on the curve. The most prominent markers appear where the klystron frequency and harmonics of the 100-mc frequency standard zero beat.

When an absorption wavemeter is tuned into the bell curve fre-

quency, a dip appears at the point in the spectrum corresponding to the wavemeter frequency. By aligning the center of the dip with one of the prominent markers, 100-mc points can be calibrated.

Usable markers can be obtained every 10 mc in S-band and every 20 mc in X-band. When the frequency of a wavemeter or cavity is not a harmonic of either 10 mc in S-band or 20 mc in X-band, a variable oscillator is used as shown in Fig. 2B. The variable oscillator's calibration is compared with a 100-kc frequency standard to an accuracy limited by the counter.

## Aligning Marker

By varying the oscillator frequency, the marker can be precisely aligned with the dip caused by the wavemeter or cavity.

As the approximate wavemeter or cavity frequency is known, the harmonic order of the marker is multiplied by the fundamental frequency indicated by the counter to give the exact marker frequency.



# SQUEEZING HIGH POWER

INTO

small packages

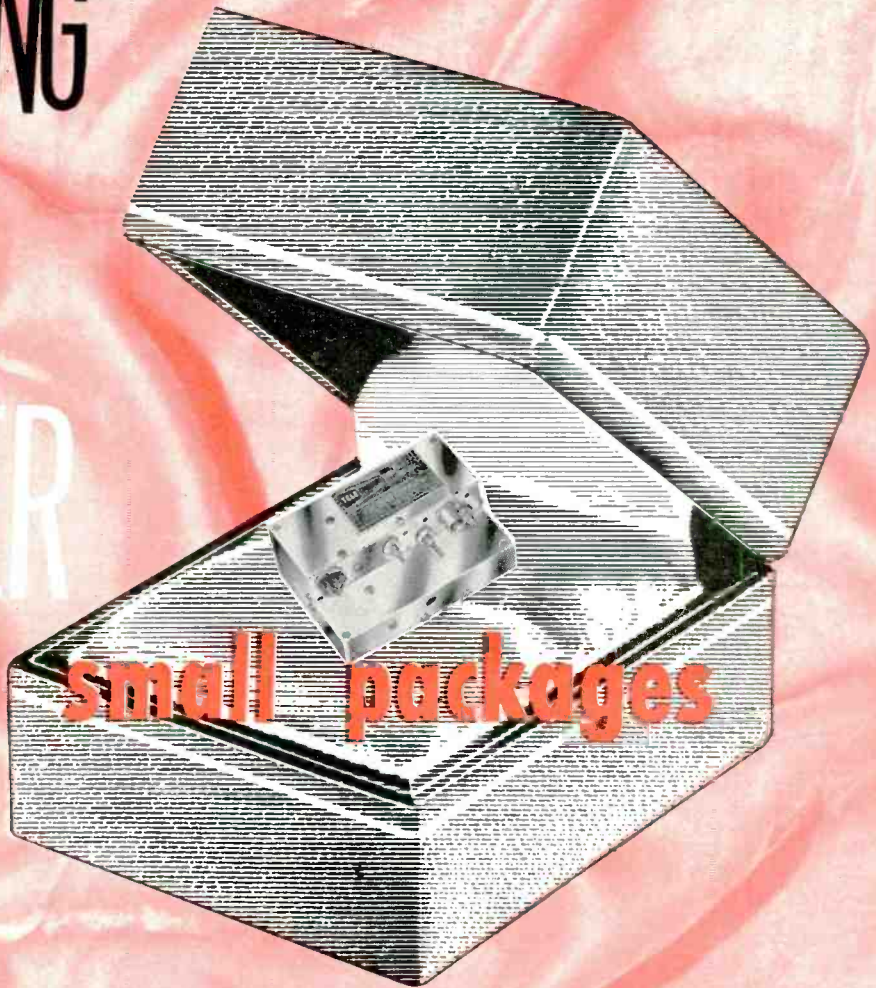

Unhampered by traditional thinking, TELECHROME engineers have developed an entirely new concept in telemetering equipment — unequalled in compactness, ruggedness and dependability.

## TELEMETERING TRANSMITTERS

FM/FM or PDM/FM Crystal Controlled  
215 to 260 Megacycles

SUB-CARRIER OSCILLATOR,  
Model 800C — 1.5" x 1.9" x 2.45"

Model 1472



4" x 1.5" x 2.7"  
2 Watts

Model 1463



5 1/2" x 3 1/4" x 4"  
15 to 30 Watts

Model 1462

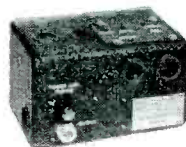

6" x 4 1/4" x 3 3/4"  
50 to 80 Watts

Model 1466A



6.5" x 4" x 3.25" RF Amplifier  
2 watts in — 100 watts out



Deviation stability  $\pm 1\%$   
of band width. Deviation  
linearity less than 1% of  
band width under all con-  
ditions measured from a  
straight line drawn be-  
tween end points.

COLOR TV • INDUSTRIAL INSTRUMENTATION • TELEMETRY

# TELECHROME

MANUFACTURING CORP.

FOR MESSAGES FROM OUTER SPACE

28 RANICK DRIVE AMITYVILLE, N. Y. LINCOLN 1-3600

Cable Address: COLORTV TWX: AMITYVILLE NY2314

Midwest Engineering Division—106 W. St. Charles Rd.,  
Lombard, Ill., MAYfair 7-6026

Western Engineering Division—13635 Victory Blvd.,  
Van Nuys, Calif., State 2-7479

# Tracer Displays Zener Curves

By V. A. CORDI AND C. C. PACKARD

International Business Machines Corp., Owego, N. Y.

WIDESPREAD use of Zener diodes requires reliable information concerning their characteristics. The Zener diode curve tracer to be described determines Zener diode characteristics more accurately and faster than previous methods. It may be used to determine dynamic impedance, detect low-level noise, define temperature coefficient and make production-line tests.

Magnitude of test diode reverse bias  $E_1$  in Fig. 1 is controlled by  $R_1$ . Superimposed on the d-c bias is an a-c signal,  $E_2$  generated by an oscillator. Voltage swing about the d-c operating point determines the extent of the Zener characteristic to be investigated and is controlled by adjustment of oscillator output.

Transformer  $T_1$  matches impedance and provides d-c isolation. Capacitor  $C_1$  prevents d-c saturation of the transformer. Resistor  $R_2$  limits test diode current and serves as a standard for current calibration of the oscilloscope.

The Zener diode characteristics

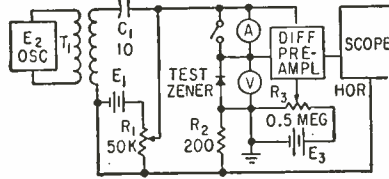

FIG. 1—Test setup uses differential pre-amplifier to permit close investigation of significant portions of curves

are displayed on a Tektronix type 531 oscilloscope. Zener voltage across the diode provides vertical scope deflection and Zener current, measured in terms of voltage drop across calibration resistor  $R_2$ , provides horizontal scope deflection.

### Differential Preamplifier

The differential preamplifier, used in conjunction with a known reference voltage, determines the increment of the Zener curve to be investigated. In Fig. 1, adjustment of reference voltage  $E_3$  permits any portion of the Zener characteristic curve to be centered on the scope.

The desired portion can then be expanded for detailed investigation by increasing amplifier gain. Increments can be displayed at a sensitivity as precise as 1 mv/cm.

Curve A in Fig. 2 shows the entire reverse characteristic of a 10-volt Zener diode using a low-gain preamplifier. The horizontal scale is 2 ma/cm and the vertical is 2 v/cm. Dynamic impedance and sharpness of the Zener knee cannot be accurately determined, and an increase in scope gain will remove the Zener region of the curve from the display.

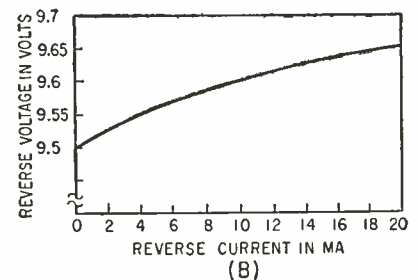
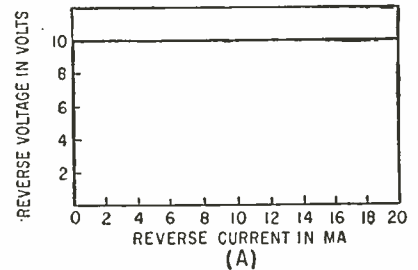

FIG. 2—Characteristic curve made with low-gain preamplifier at (A) is compared with curve at (B) made with high-gain differential preamplifier

Curve B, using a high-gain differential preamplifier, shows only the Zener region of the same characteristic curve. Scope calibrations are 50 mv/cm on the vertical and 2 ma/cm on the horizontal.

### Diode Tests

For this report, Zener dynamic impedance is defined as incremental Zener voltage divided by corresponding incremental Zener current or  $\Delta E_z / \Delta I_z$ . Since dynamic imped-

## Analyzing Wind-Tunnel Data



Transonic wind tunnel at Boeing Airplane Co. uses variety of electronic gear to control tests and gather data. At left is analog computer; at center are Leeds & Northrup recorders for recording transducer signals; and at right is automatic programmer to control data gathering, tunnel operation and model position



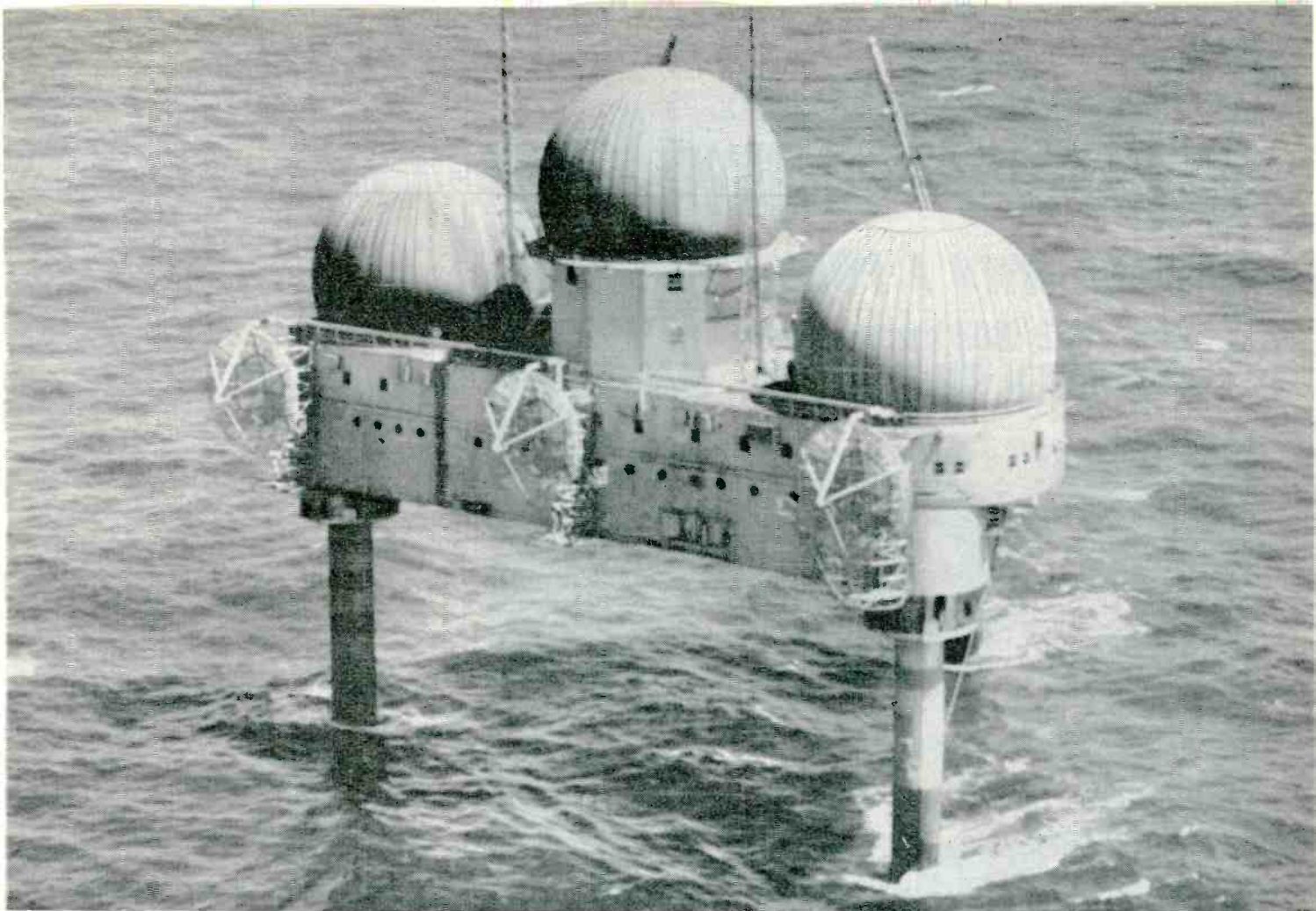

PHOTO COURTESY US AIR FORCE

**OFFSHORE INSTALLATION** of the Texas Tower Defense System—radar network that helps safeguard the nation's shorelines. Each of the three domes houses radar antennas that constantly sweep the horizon to detect, identify and

plot approaching aircraft. Electronic instrumentation in the center dome includes the Bendix AN/FPS-20 radar unit with Tung-Sol/Chatham's VC1257 hydrogen thyratron tube, Tung-Sol/Chatham development.

## Tung-Sol/Chatham VC1257 replaces four tubes in *Bendix* Texas Tower radar set!

The Texas Tower and other key defense systems have required more and more powerful radar equipment. Bendix Radio, to keep pace with this need, replaced four bulky modulator tubes in its AN/FPS-20 radar unit with a single Tung-Sol/Chatham hydrogen thyratron.

Tung-Sol/Chatham's VC1257 features vastly superior power-handling ability, up to 33MW. An internal hydrogen reservoir promotes long life and permits optimum pressure adjustment for a variety of operating conditions. In Bendix

AN/FPS-20, the VC1257 provides 7.7 microsecond pulses of 13,500 volts and 700 amperes at a pulse repetition rate of 360 pps. Output pulses need no synchronization as with multiple tube operation.

Hydrogen thyratrons, exclusive Tung-Sol/Chatham development, are available to designers for a variety of pulse modulator applications—1KW (miniature) to 50 MW. All offer benefits in operating efficiency like those gained by Bendix. For complete data, contact: *Tung-Sol Electric Inc., Newark 4, N. J.*

Engineer points out Tung-Sol/Chatham VC1257 installed in Bendix AN/FPS-20 radar equipment.



**ts TUNG-SOL®**



## "POWER WITH A PUNCH"

### EG&G's 7322/1802 ceramic-metal HYDROGEN THYRATRON



## BIG TUBE PERFORMANCE

in compact modulator circuit design for: End of Line Clipper • Switch • Crowbar

The EG&G 7322/1802 weighs 2.07 pounds, has a height of 5¼ inches and a diameter of 3¾ inches. It can be mounted in any position and is designed to operate at high power levels, high repetition rates and high temperatures.

It also features low cathode input power, low trigger drive requirements, fast warmup and low jitter. Rapid recovery allows operation at repetition rates above 50,000 pulses per second.

The 1802 has withstood 500g shock and 2000 cps vibration at 10g. Ceramic-metal construction permits envelope temperatures to 400° C, ambient temperatures to 125° C.

#### MIL-ACCEPTANCE TESTING:

Peak Anode Voltage (epy)	25KV	Peak Anode Current (ib)	1000 amps
Average Anode Current (Ib)	1.5 amps	RMS Current (I <sub>rms</sub> )	40 amps
Pb Factor, (epy x ib x prr)	20 x 10 <sup>9</sup>		

Individual ratings can be exceeded by derating other conditions. Thus the EG&G 1802 has been operated at 30KV anode voltage, or at 2000 amperes anode current, or at a Pb factor of 50 x 10<sup>9</sup>.

## PRODUCTION QUANTITIES AVAILABLE



For additional technical data or other information, please write to:

**EDGERTON, GERMESHAUSEN & GRIER, INC.**

160 BROOKLINE AVENUE, BOSTON 15, MASS. • 1622 SOUTH "A" STREET, LAS VEGAS, NEV.

ance is a function of d-c operating point, the bias current at which impedance is measured must be specified. Accuracy gained measuring dynamic impedance with the curve tracer rather than by static measurements is shown in Table I.

Table I—Dynamic Impedance Measured Staticly and with Curve Tracer

Bias Current (ma)	Dynamic Impedance	
	Static Measurements (ohms)	Scope Trace (ohms)
5-10	14	10
20-25	10.8	3
25-30	11.8	5

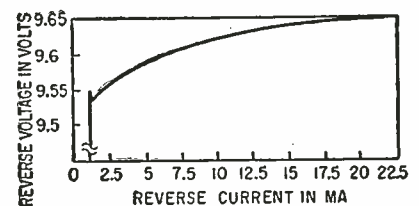

FIG. 3—Curve tracer displays avalanche noise at Zener knee

Avalanche noise level in Zener diodes may be as high as 0.04 percent of breakdown voltage. Detection of noise levels in the millivolt range may be made with the curve tracer, as shown in Fig. 3.

Temperature coefficient is defined as the percent change of Zener voltage/deg C or  $[(\Delta E_z/E_z) \times 100]/\Delta T$ , where  $\Delta E_z$  is change in Zener voltage,  $E_z$  is absolute voltage and  $\Delta T$  is change in temperature (deg C).

The characteristic curves of a 6-volt Zener in Fig. 4 were taken at 25 C and 140 C (case temperature). At the 5-ma point, change in Zener voltage with respect to the two curves is 0.4 volt. Substituting in the above equation, temperature coefficient is 0.052 percent/deg C. Generalized manufacturers' ratings for a 6-volt Zener are about 0.05 percent/deg C.

For production testing a given type, upper and lower limit traces on the scope may be used to find diodes whose characteristics are within predetermined limits. Per-



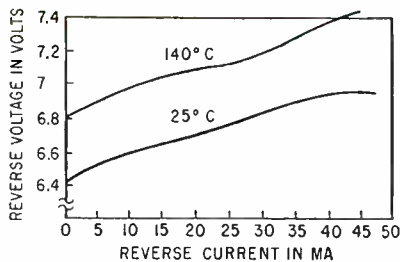

FIG. 4—Characteristic curves of 6-volt Zener diode were made at 25 and 140 C

manent recordings of Zener characteristics can be obtained by photographing the scope trace.

## Nuclear Propulsion Studied for Space Use

PROPULSION of a large space platform by controlled nuclear explosions is under investigation by General Atomic division of General Dynamics. This is one of a series of investigations involving new means of propulsion for space applications.

The study, which was proposed by General Atomic, differs from other proposals under consideration in that it looks to employment of a series of controlled detonations within the atmosphere and beyond. Initial commitment for this study calls for the expenditure of \$1 million during the fiscal year 1959. Continuation of the project will be based upon the results of the study during the initial phase.

Project Orion, recently revealed by the Advanced Research Projects Agency, has been underway for the past nine months at General Atomic.

## Nerve Impulses Control Artificial Hand

MODEL HAND controlled by biological currents is reported from Russia. It is based on studies of the relationship between electrical potentials in the human organism and nervous activity.

Biological currents passing through the stump reportedly set the artificial hand in motion. It is hoped that further study of the characteristics of nerve impulses will increase the use of nerve impulses to control artificial members.

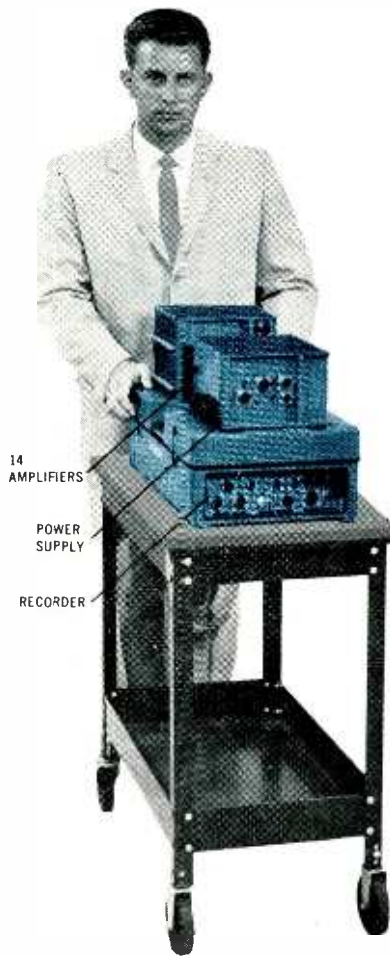

*New recording accuracy and portability with miniaturized electronics*

## 14-channel magnetic tape recording system in **LESS THAN TWO CUBIC FEET**

DataTape's mobile recorder simultaneously records and monitors test data on 14 separate tape tracks in Direct, FM, and PDM modes. PCM (digital) data is handled with equal facility when the recorder is fitted with digital magnetic heads. Full IRIG range of tape speeds from 17½ to 60 ips is available. Rigid cast magnesium case with dust-proof cover assures unyielding precision in tape drive and tracking under severe environmental stresses. CEC all-metal-surface magnetic head stacks have track spacing, width, and nomenclature in accordance with IRIG specifications for perfect compatibility with other systems. Power supplies for the recorder are contained within the cast case.

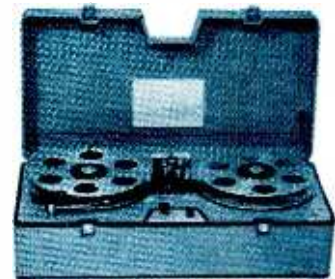

Plug-in miniaturized amplifiers are of modular design and are completely interchangeable regardless of mode selected. Wide range of input voltages (1 to 10 volts) and frequency response from d-c to 10 kc satisfy practically any data recording requirement. CEC's new FM amplifier provides ultra-linear, low-drift operation. FM center frequency is determined by precision internal plug-in units. Power supply and amplifiers are contained in extremely rugged but lightweight cast magnesium cases and do not require shock mounting. Complete 14-channel system, including recorder, weighs only 122 lbs. For complete information, call your nearby CEC sales and service office or write for Bulletins CEC 1578-X2 and 1592-X1.

DataTape Division **CEC**

CONSOLIDATED ELECTRODYNAMICS / 360 sierra madre villa, pasadena, california

FOR EMPLOYMENT OPPORTUNITIES WITH THIS PROGRESSIVE COMPANY, WRITE DIRECTOR OF PERSONNEL

# Graphite Becomes Available as a Fabric

BY ELECTRICALLY HEATING a fiber or fabric such as rayon to a temperature approaching 5,400 F, National Carbon Co., Div. of Union Carbide Corp., has succeeded in producing graphite fibers and fabrics. In the thermo-chemical conversion, the crystalline structure of the material is changed to that of graphite similar to manufactured graphite used for such applications as furnace electrodes.

## Electronic Applications

The unique new form of graphite holds promise for innumerable applications in the electronics industry. Some applications that have already been suggested include thermoelectric elements doped with boron; vacuum-tube grids; infrared emitters and static eliminators.

Properties of the fabrics or fibers are the same as those of ordinary graphite. At ordinary pressures, graphite has no melting point and goes directly from the solid to vapor state at temperatures of about

6,600 F. It gets stronger at higher temperatures. For example, its tensile strength at 4,500 F is about twice that at room temperature.

## Acid Resistance

Graphite textiles are resistant to attack by acids, alkalis, and organic compounds except for those of a high oxidizing nature. The textiles are unreactive with many molten metals and have excellent electrical

and thermal conductivity.

National Carbon is producing experimental quantities of graphite fibers and fabrics for test and evaluation. An example is a cloth of square weave, 28 by 28 construction. It is being made in a 40-in. width up to seven ft long with an average thickness of 0.024 in. Initial quantities of this particular fabric are available at \$1.50 per sq ft.

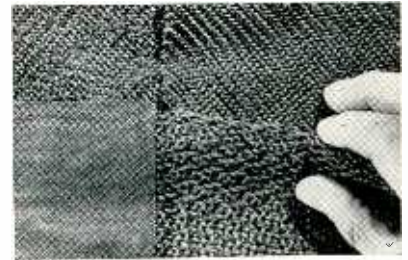

Four weaves of graphite cloth are some of those being produced experimentally

One-in. strip of graphite cloth, 40 in. long, wrapped around beaker of water brings water to boil rapidly when connected to a 110-v circuit

# New Motor Design Boosts Efficiency



Desired air gap (pencil) is predetermined and motor is built around this dimension

DESIRED AIR GAP is predetermined and then the motor is built around the air-gap dimension in a new approach to motor design by General Electric. Called Unitized motors, the new rotary units feature permanent alignment of each bearing on the motor shaft to hold the

rotor centered in the stator even against side loading.

First motors available in the new series are 4-pole, KSM 59-frame shaded-pole and permanent-split capacitor units with ratings up through 1/15 hp. Two-pole units with shaded-pole ratings through 20 millihp and universal series motors of various ratings will be available soon.

## Advantages

The new motors, relative to conventional motor design, give either higher output for the same size, input and temperature rise; or lower current input for the same size, output and temperature rise; or lower temperature rise for the same size, input and output.

New developments in the bearings, lubrication system and insulation contribute to over-all life and

performance characteristics.

A continuous hydrodynamic oil film supports the motor shaft in all of the new motors. A capillary retention system prevents excess loss of oil from the lubrication system.

Retention capabilities of the motor's lubrication system are such that only annual reoiling is recommended as compared to every three to six months.

The entire stator core is coated by a specially developed resin with high mechanical and dielectric strength. Core laminations are then fused into a complete and integrated unit. The new core insulation is not affected by humidity.

## Insulation

Additional protection is afforded by further processing of the stator in epoxy varnish. This added processing provides for additional in-



after routing,  
clip and save

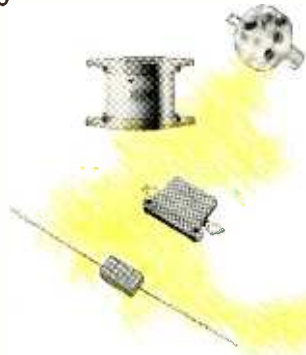

a continuing series on technical topics of specific interest to engineers

## What makes mica the unique dielectric?

Mica is as old as the earth itself. Ancient Hindu writings show that mica was thought to be the remains of lightning flashes from which sparks had emanated and had become preserved in the earth. It was therefore regarded as being endowed with extraordinary properties, and was used in medical ritual. The replacement of such charming stories with modern technical knowledge has, however, not altered the fact that mica is endowed with extraordinary properties.

Mica is found in pegmatite rock, formed in the early stages of the cooling of the earth's mass. Crystals of mica were formed under high heat and pressure, and in the presence of moisture vapor and magnetic fields. The physical and chemical changes during this period served to impart a unique stability in physical, chemical and electrical properties. The chemical structure of mica is represented as  $H_2KAl_3(SiO_4)_3$  which is Muscovite; India Ruby is one of the grades of exceptional quality and is used in most mica capacitors. Other types of mica, to name a few, are Phlogopite, Lepidolite and Biotite, of which only Phlogopite is of limited interest in experimental capacitors for very high temperature operation.

Mica is found in varying degrees of purity, some with less mineral or vegetable constituent, or stain, and some with more nearly perfect physical integrity—that is, free from cracks or air inclusions. As a result, raw mica must undergo careful physical examination and be graded according to quality and size. Sangamo has had over 35 years experience in the selection and processing of mica, together with a knowledge of mica capacitor production. Capacitor grades of mica film are generally obtained from the Bihar, Bengal, or Madras provinces of India. Mica for other purposes may be found in Canada, Brazil, Argentina, Madagascar, Africa, Russia, New Hampshire, South Carolina and South Dakota. This list is by no means complete. An idea of the magnitude of the task of selecting suitable mica can be obtained from the fact that only an estimated ten per cent of all the world's mica deposits are suitable for use in mica capacitors.

The earliest mica capacitor was probably made by Matteucci, a contemporary of Faraday's, about 1845. However, capacitors did not become commercially interesting until the advent of radio in the early years of this century, as a result of the growth of electrical technology. Both the electrical and electronics industries have depended significantly upon mica. Mica insulation between commutator segments in rotating machinery and the mica spacers in vacuum tubes are still vital to these industries.

In capacitors, the choice of dielectric material is as important as the method of construction. Mica, because of its sheet form, lends itself to stacked construction, resulting in a lower inductance assembly than can be obtained in wound capacitors. Mica capacitors are therefore suitable for very high frequency operation.

The mechanical or dimensional stability of mica allows blanking or die-cutting of dielectric plates to a desired size with only a very few thousandths of an inch variation. Precise assemblies may therefore be obtained and result in a greater ability to achieve accurate miniaturization. Electrodes may be permanently bonded to the mica dielectric plates by screening on conducting silver paste. This process has been refined to a high degree of accuracy, and results in superior electrical stability when compared to laying foil between mica plates to form the electrodes. Silvered mica

capacitors exhibit exceptional stability in extremes of temperature.

The Q and dielectric constant (therefore, the capacitance) of mica change very little over wide ranges of frequency and temperature. Such small changes are due to the fact that the molecular structure of mica is essentially non-polar—that is, the molecules of mica do not have an unbalanced electrical charge. Thus they are not free to swing freely as magnets do (mica is practically non-magnetic) when in the presence of an electric field. Such fields are present when the capacitor is charged. Movement of the molecules would result in heating by the friction of their motion. Poor dielectrics exhibit considerable heating, as is shown by the heat developed in wood and glue in the process of laminating plywood in dielectric heating devices.

Heating effects may become very pronounced when high frequency alternating voltages are applied. The rapid changes in the direction of current flow cause polar molecules to literally vibrate about their rest position. The low heating of mica under such conditions is evidenced by the fact that certain types for transmitting applications will carry apparent currents to 50 amperes, at a few megacycles, resulting in only few degrees temperature rise.

Minimum dielectric heating is very essential since it has been shown that the life expectancy of a capacitor is reduced by a factor of approximately one-half for each ten degree centigrade rise in temperature.

All mica capacitors do not possess the ultimate characteristics of natural mica, since designs and manufacturing procedures differ according to original intent and application. However, the characteristics shown in the table could be realized under ideal conditions.

Characteristic	Approximate or Ideal Value
Dielectric Constant	7 (resulting in a moderate degree of miniaturization)
Q	3000 or greater
Power Factor	0.05% or less
Self Resonant Frequency	Up to 500 megacycles
Insulation Resistance	100,000 megohms or greater
Operating Temperatures	Up to 230°C. (85°C standard for commercial types)
Temperature Coefficient of Capacitance	0 to +70 parts per million per degree centigrade
Capacitance Drift or Capacitance Retrace	0.05% or less

At Sangamo all mica capacitors are designed and manufactured to exceed the physical and electrical requirements of applicable military specifications. The wide variety of Sangamo mica capacitor types allow flexibility of design and superior products for the most critical applications to meet individual specification requirements. Engineering catalog and bulletin giving full information on types and characteristics are available upon request for your examination.

SC59-3

**SANGAMO ELECTRIC COMPANY, Springfield, Illinois**

--designing towards the promise of tomorrow

**we're not sure** (yet)



- ✓ WHAT YOU CAN USE THIS RELAY FOR
- ✓ HOW MUCH IT WILL COST
- ✓ EXACTLY WHAT THE STANDARD OPERATE & RELEASE VALUES WILL BE
- ✓ THAT THE SPECS, SIZE AND SHAPE WON'T CHANGE
- ✓ THAT IT WILL EVER GET INTO PRODUCTION

**we are sure**



- ✓ THAT THIS IS A DC VOLTAGE OPERATED, SPDT, HIGH RELEASE, DEVELOPMENTAL RELAY
- ✓ RELEASE CAN BE ADJUSTED UP TO 95% OF SPECIFIED OPERATE VOLTAGE (FROM 6 TO 24 VOLTS)
- ✓ IT WILL SWITCH 2 AMPERE RESISTIVE LOADS AT 28 VDC/120 VAC ON LESS THAN 500 MW. OF SIGNAL
- ✓ IT WOULD BE DANDY FOR MONITORING & CONTROLLING VOLTAGES IN AUTOMATIC BATTERY CHARGERS, POWER SUPPLIES, FILAMENT CIRCUITS, BATTERY-OPERATED TV SETS
- ✓ THAT CONTACT PRESSURE IS NOT DEPENDENT ON COIL SIGNAL
- ✓ THAT IT IS NOT SUITABLE FOR MILITARY ENVIRONMENT APPLICATIONS
- ✓ THAT IT'S KNOWN AS THE SERIES 111 RELAY AND THAT A SAMPLE IS AVAILABLE AT A PRICE



Maybe you twiddled the knob on the display of this relay in our booth at the last Old Campground meeting. If so, we hope you noticed on the meter just how close operate and release values can be. If you think you might be able to use such a relay, we'll gladly send additional particulars, with sure and not so sure portions clearly marked.

**SIGMA**

SIGMA INSTRUMENTS, INC.  
62 Pearl St., So. Braintree 85, Mass.

AN AFFILIATE OF THE FISHER-PIERCE CO. (SINCE 1939)

sultation and mechanical strength of the windings and for anticorrosion protection.

## Low-Melting Glasses Useful for Potting

VARYING PROPORTIONS of sulfur or selenium and the heavy metals arsenic and thallium are used in a new group of low-melting glasses. Developed at Bell Telephone Laboratories, the glass compositions become fluid at temperatures between 125 and 350 C. In this range, viscosities are about equal to that of castor oil at room temperature. Viscosities of this order make it possible to coat devices by a simple dipping procedure.

Electrically, the glasses range from semiconductors to insulators with a minimum resistivity of  $10^9$  ohm-cm and a maximum of over  $10^{11}$  ohm-cm. Chemically, they are insoluble in water, dilute alkalis, acids including hydrofluoric and organic solvents. But they are attacked by concentrated alkalis.

The compositions exhibit extremely low permeability to both water and helium and possess good wetting characteristics with respect to most metals. Thermal expansion coefficients range from 20 to  $50 \times 10^{-6}$  per deg C. Thermal conductivities are about 0.0007 cal/(sec) (cm<sup>2</sup>) (deg C/cm).

The possibility of using the glasses for encapsulating semiconductors, capacitors, resistors and printed-circuit boards appears promising.

## Polyvinyl Chloride Conductive Compound

COMMERCIALY AVAILABLE for extrusion, calendering and injection molding, a new electrically conductive polyvinyl chloride compound has an electrical volume resistivity of 11 ohms/cm<sup>3</sup>. Known as Abbey 100, the material is compounded from Opalon vinyl resin supplied by Monsanto Chemical Co. The material itself is available from Abbey Plastics Corp., Hudson, Mass.

Applications being investigated of interest to the electronics field include replacement for copper



braid in wire, electrical tape shielding on microphone cable, ignition-wire conductors and shielded wire for use on coaxial cables.

## Stereo Cartridge Uses Rubber Adhesive

ONE of the problems in design of a stereo cartridge is to obtain high compliance and low moving mass simultaneously so that tracking force can be kept to a minimum.

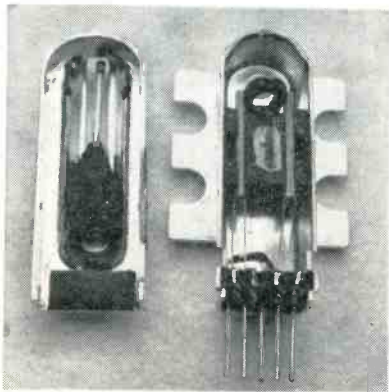

In the Weathers C501 ceramic stereo cartridge, this is accomplished by using a neoprene-based adhesive, Bondmaster G580, a product of Rubber and Asbestos Corp. Within a space of  $\frac{1}{4}$  in., a special rubber, metal and ceramic elements are bonded. The adhesive used had to have properties in between the limits of great flexibility which would not give sufficient bond strength and great rigidity which would destroy stereo lateral motion.

## ARDC Digs Into Molecular Electronics

As forecast in *ELECTRONICS* (p 38, April 24), the Air Force has contracted with Westinghouse for a \$2-million program for development in molecular electronics.

Westinghouse scientists have succeeded in growing germanium crystals as thin, uniformly flat ribbons or dendrites. This form of the semiconductor material makes easier the fabrication of integrated devices combining both active and passive circuit functions in single units.

The dendrites are grown in the proper thickness for direct use.

Because **HIGH RELIABILITY** Is A "Must" ...

Missile Engineers Specify

**Vitramon**

**CAPACITORS**

"Vitramon" Capacitors for high reliability applications are tested to meet the most stringent requirements for performance. Every capacitor ordered under the new High Reliability Specification S-1002 undergoes tests encompassing 300,000 UNIT HOURS OF LIFE AT 125° C to assure an A. Q. L. 12 times higher than Mil Specifications — and every shipment against an S-1002 order is accompanied by tabulated results to verify extreme reliability.

Inherent characteristics are built into "Vitramon" Capacitors through the fusing of quality porcelain enamel and fine silver to produce a dense, homogenous, truly monolithic unit that requires no case or hermetic seal. If you have capacitor applications requiring high reliability, write for High Reliability Specification S-1002, describing materials used, manufacturing process, as well as all tests and failure rates.



**"VITRAMON" CAPACITORS OF PROVEN QUALITY ARE USED IN THESE MISSILES:**

JUPITER	TALOS
LACROSSE	TARTAR
NIKE-ZEUS	ATLAS
BULLPUP	BOMARC
CORVUS	FALCON
POLARIS	MACE
REGULUS II	SNARK
SPARROW II	TITAN
SPARROW III	VANGUARD
	EXPLORER

**Vitramon**

INCORPORATED

BOX 544E • BRIDGEPORT, 1, CONNECTICUT

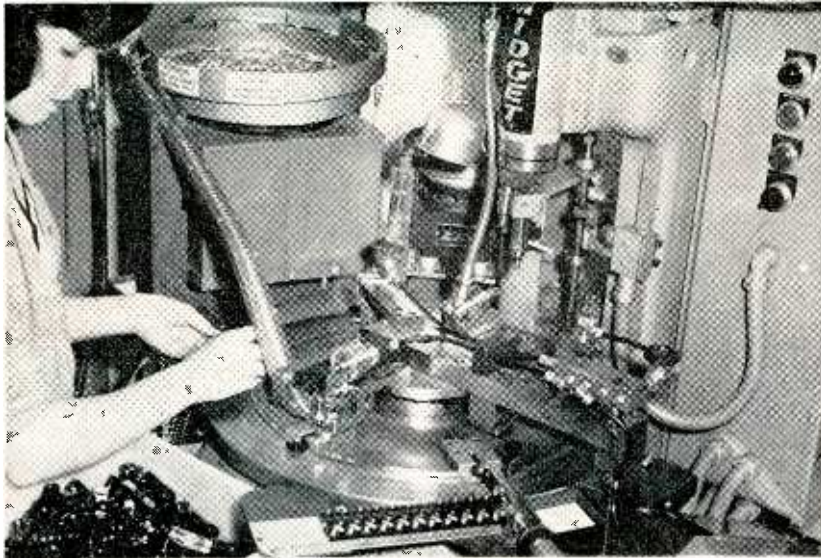

Pace of spring assembly machine is controlled by operator through main ram. Ram, in turn, controls operation of air cylinders at other stations.



Loading station. Ejection plunger (left) moves out of nest when workpiece enters



After escapement places pivot, operator adds spring by hand

## Air Cylinders Operate Assembler

MECHANICAL LINKAGE between machine stations is avoided by use of small air cylinders on a semiautomatic snap-action switch spring assembler. The operator controls the main ram of the machine. The ram, in turn, controls the other air cylinders.

A primary reason for use of the machine, by Unimax Switch Division, W. L. Maxson Corp., Wallingford, Conn., is uniformity of switch characteristics. Pivots and contact springs (Fig. 1) are positioned, staked and stressed on bases previously provided with pivot posts and stationary contacts. Rate is 600 an hour and up, depending on delicacy of parts.

The machine's base is a 1-ton

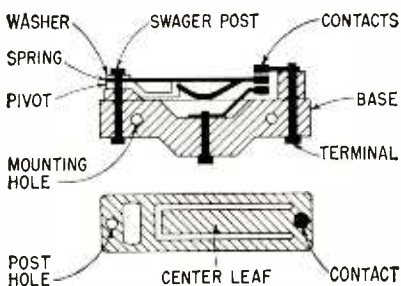
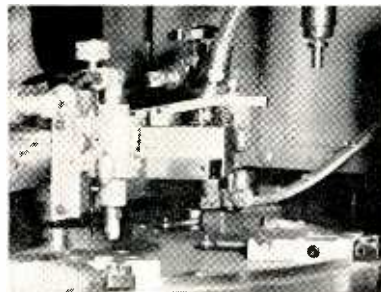

FIG. 1—Cross section of typical switch assembly and top view of spring



Main ram (upper right), spring depressing roller and ejection cam (left)

Denison Multipress with a rotary table indexing clockwise. There are 7 stations, 2 manually loaded.

First, the operator lines up bases on a feed track. As each base is added in line, the base at the head of the line is pushed into alignment with the nest. The base is driven into the nest by an air cylinder. Second, a pivot is placed on the post. The pivots are oriented in a vibratory feeder and drop onto the post through an air-driven escapement. Third, the operator places a beryllium copper spring on the post.

Springs are supplied in strips of stampings. The stampings are not quite separated so that the operator can break off each spring as she is

ready to place it. An advantage is that the operator does not have to orient each spring individually.

At the fourth station, another vibratory feeder supplies washers which are dropped through an escapement onto the post atop the spring. Fifth, the main ram swages the hollow post over the washer, fixing the spring on top of the pivot.

The main ram is actuated by a foot pedal which the operator presses after loading stations 1 and 3. As the ram comes down, it trips the electrical circuits which actuate and time the air cylinders at stations 1, 2, 4 and 6. The ram also hits a counting switch and the table is automatically indexed.

Sixth, the center leaf of the spring is depressed by a roller and snaps into place in a notch in the pivot. After the roller retracts, the switch is ejected into a discharge chute.

To eject, a plunger is pushed into the nest. The plunger rides on a cam set at table top height. The plunger has a roller on the end which contacts the cam. The plunger was originally pushed out of the nest as the base entered the nest at station 1.

Bases are kept positioned in the



Experience—the added alloy in **A-L Electrical Steels**

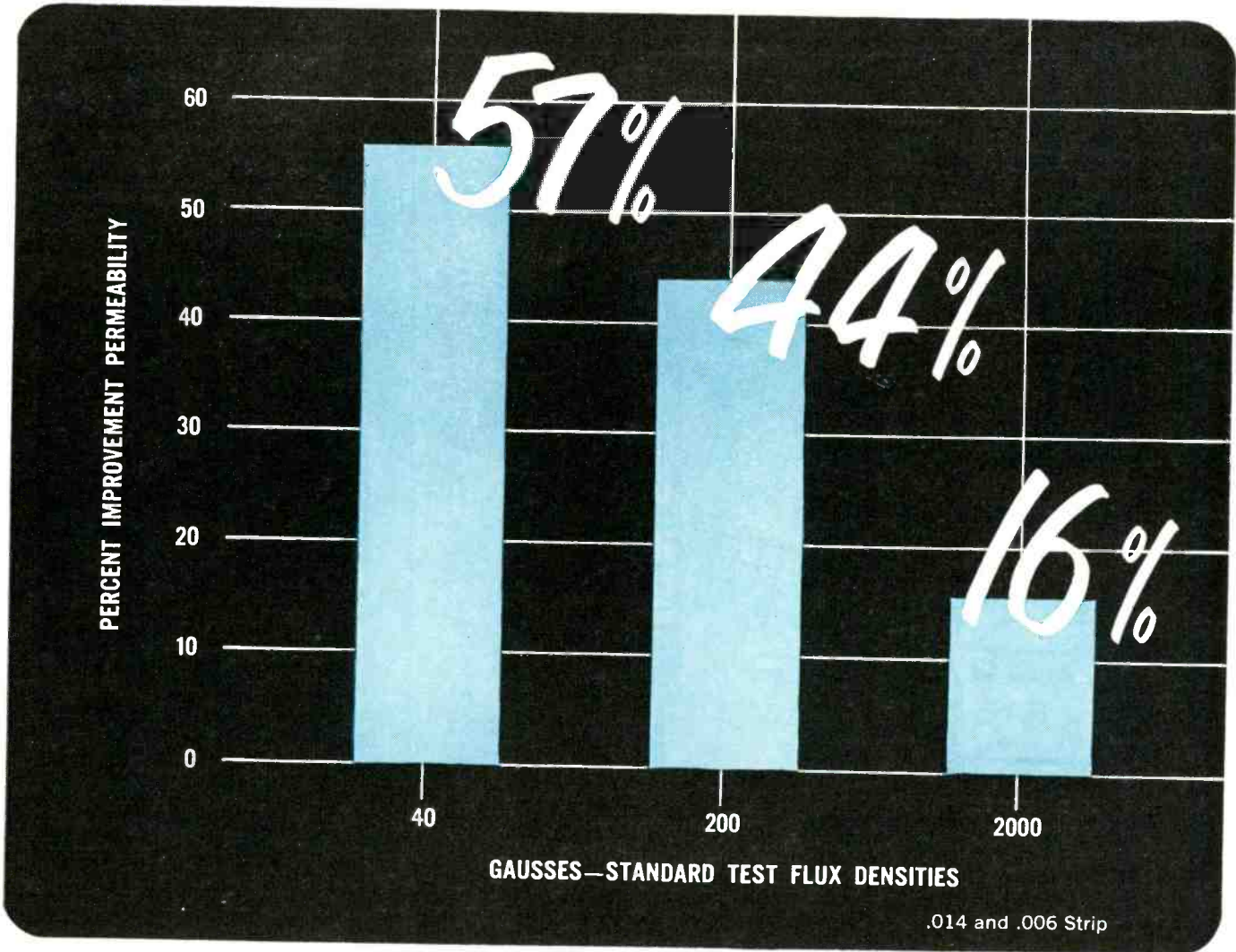

## Greater permeability for Allegheny Ludlum's AL-4750...and it's *guaranteed*

**promises more consistency, higher predictability for magnetic cores**

AL-4750 nickel-iron strip now has higher *guaranteed* permeability values than ever before. For example, at 40 induction gaussses AL-4750 now has 57% higher permeability than in the past, using the standard flux density test.

This greater permeability means better consistency and predictability for magnetic core users . . . and allows careful, high performance design.

This improvement in AL-4750 is the result of Allegheny Ludlum's continuing research on electrical alloys and

nickel-bearing steels. Moly Permalloy has been similarly improved in permeability. A-L constantly researches silicon steels, including A-L's well-known grain-oriented silicon, Silectron, and other magnetic alloys.

Complete facilities for the fabrication and heat treatment of laminations are available at Allegheny Ludlum. And A-L's technical know-how guarantees you close gage tolerance, uniformity of gage throughout the coil and minimum spread of gage across the coil-width.

If you have a problem on electrical steels, laminations or magnetic material, call A-L for prompt technical assistance. Write for blue sheet EM-16 for complete data on AL-4750. *Allegheny Ludlum Steel Corporation, Oliver Building, Pittsburgh 22, Pa. Address Dept. E-17.*

WSW 7491

# ALLEGHENY LUDLUM

STEELMAKERS TO THE ELECTRICAL INDUSTRY

Export distribution, Electrical Materials: AIRCO INTERNATIONAL INC., NYC 17

Export distribution, Laminations: AD. AURIEMA, NYC 4



foremost  
designers  
and  
manufacturers  
of  
telemetry  
receivers

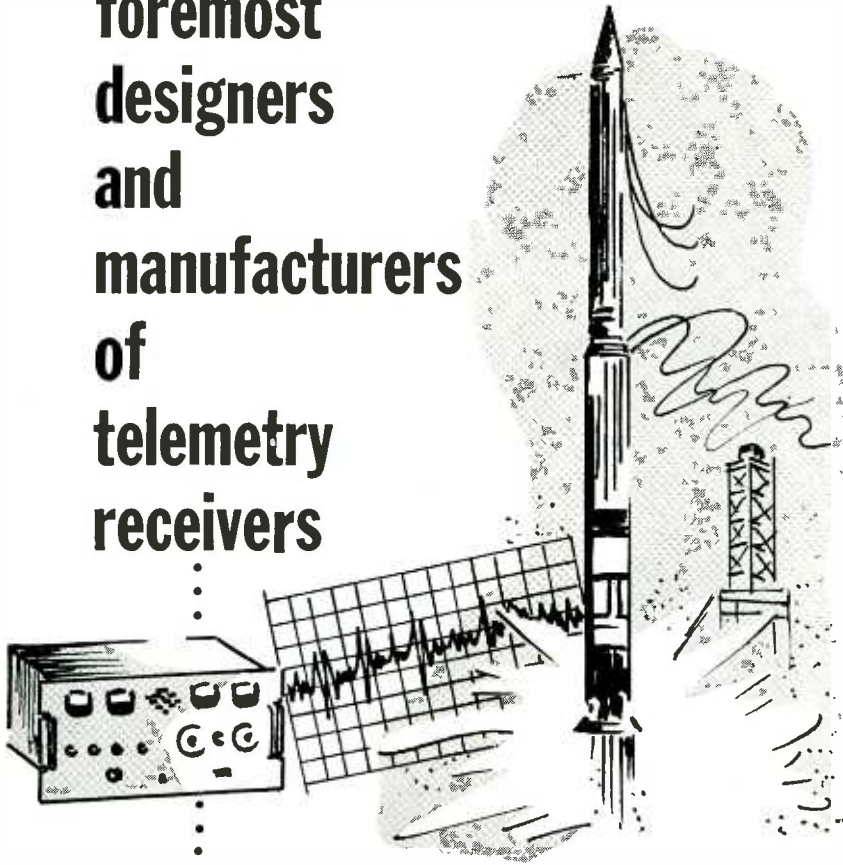

**NEMS • CLARKE**

has been designing and manufacturing precision electronic equipment since 1909 when it first produced communications devices for the United States Government. This half-century of experience is recognized by government and industry alike. Today more than 95% of the telemetry receivers in use at United States missile test stations and ranges were designed and built by Nems-Clarke. Among many installations now using this equipment are:

- PATRICK AIR FORCE BASE**
- VANDENBERG AIR FORCE BASE**
- WHITE SANDS MISSILE RANGE**
- EGLIN AIR FORCE BASE**
- ARMY BALLISTIC MISSILE AGENCY**

We welcome inquiries on  
problems in the telemetry field

**NEMS • CLARKE COMPANY**

A DIVISION OF VITRO CORPORATION OF AMERICA  
919 JESUP-BLAIR DRIVE • SILVER SPRING, MARYLAND • JUNIPER 5-1000

necks by spring-loaded ball bearings which fit into the mounting holes in the bases.

**Freon Protects Epoxy In Ultrasonic Cleaner**

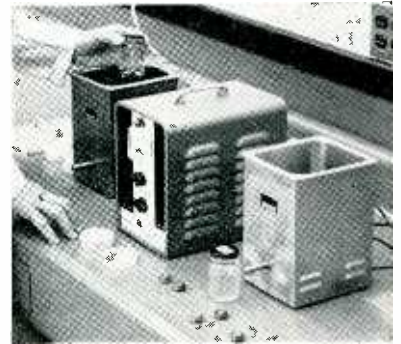

Parts are bottled in liquid freon for cleaning

FREON is used as an ultrasonic cleaning medium by Reeves Instrument Corp., Garden City, N. Y. The liquid freon is used when an inert medium is required for protection of epoxies and other insulating materials.

Parts shown are small motor stators. Since freon evaporates in air, the freon and parts are placed in a half-filled capped glass jar. The jar is immersed in the liquid in the cleaning tank. One jar of freon is used for rough cleaning and a second jar handles fine cleaning.

The setup shown is used to prepare gyro and resolver parts before assembly in a white room. Cleaned parts are kept in desiccators until used. The cleaning equipment, made by Acoustica Associates, has an average output of 50 watts. One generator drives both rough and fine cleaning tanks.

**Air Press Prevents P-C Board Warping**

WARPING OF TEFLON base printed wiring boards during exposure of the sensitized copper plating is avoided at Ford Instrument Co., Long Island, N. Y., with a simple press built over the light table.

The table top is a 1/2 inch plate of glass set into a 3/4 inch steel plate as shown in Fig. 1. Pattern, board blank and black art paper are laid



on the glass. An air cylinder, mounted in a frame above the glass, drives a  $\frac{3}{8}$  inch steel plate down onto the board. The light is turned on and the press is retracted a few seconds after the board is printed.

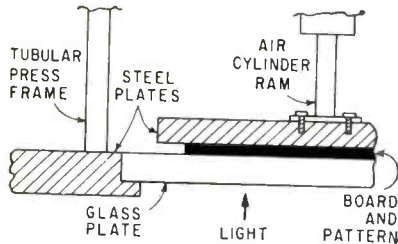
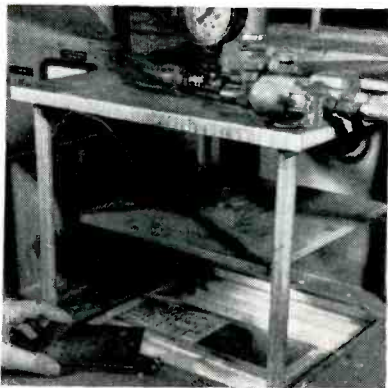

FIG. 1—Cross-sectional view of press in printing position



Heavy steel plate drops to table after board blanks are loaded



Epoxy board strips around 3 edges of pattern form frame for board blank. Pattern is being checked on light table

The pattern is made into a frame for the board blanks by glueing straight edge strips of thin epoxy board along 3 sides of the pattern. For double-sided boards, the frame looks like an "H". The same setup can subsequently be used on a light table after resist is developed to check the registry of lands and holes on predrilled double-sided boards. Pin pricks centered in the hole patterns are references.

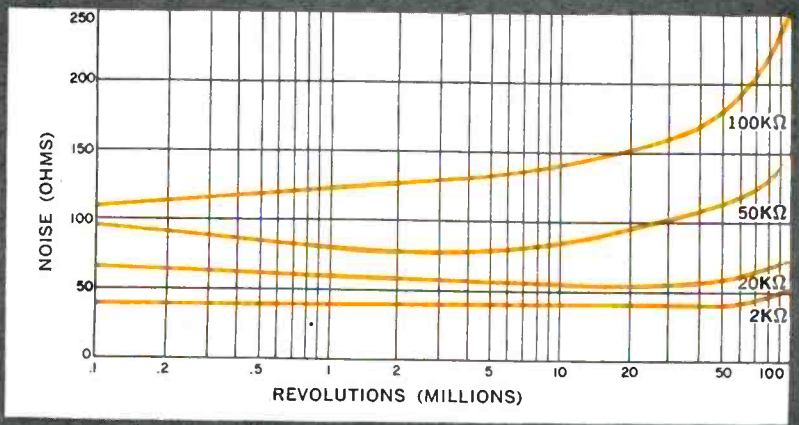

# 50 MILLION REVOLUTIONS



The capability of maintaining low noise operation for millions of cycles is inherent in the design of Markite Conductive Plastic Potentiometers. The noise curves above are typical of the reliability and performance that can be expected of all Markite potentiometers.

In addition to reliable and predictable performance, Markite Conductive Plastic Potentiometers also provide:

- Infinite resolution.
- Independent linearity to 0.05% in  $1\frac{5}{16}$  inch dia. units.
- Operation in ambient temperatures up to 200°C.
- Shock and acceleration resistance in excess of 100g.
- Vibration resistance in excess of 70g.
- Rotational speeds up to 1,000 rpm and beyond.
- Operation under applicable Military Specifications.

Write for Design Data and Catalog for Rotary and Rectilinear Potentiometers

**MARKITE PRODUCTS CORPORATION**  
155 Waverly Place • New York 14, N. Y.

# ON THE MARKET

## Binding Posts plunger type

GRAYHILL, INC., 561 Hillgrove Ave., LaGrange, Ill., has added two new binding posts to its line. The 29-100 (with threaded stud) and the 29-104 (with molded phenolic in-



ulating washers), designed to provide fast positive contact, are operated by depressing the plunger, inserting the lead, and releasing the plunger. Post extends only  $\frac{3}{8}$  in. above mounting surface. Circle 200 on Reader Service Card.

## Panel Light subminiature

THE SLOAN CO., 4029 Burbank Blvd., Burbank, Calif. A new, sub-miniature ColorLite, model 855S-E, that produces more light than is required by military specifications,

is now in production. The tiny,  $\frac{3}{8}$  in. diameter incandescent indicating light for all edge-lighting applications has a  $\frac{1}{2}$  in. opaque cap for flush mounting. It permits the design and manufacture of smaller, more compact edge-lighted panels. Circle 201 on Reader Service Card.

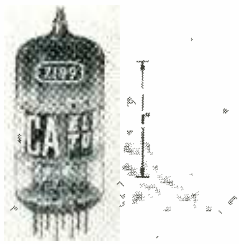

## Triode/Pentode for audio use

RADIO CORP. OF AMERICA, Harrison, N. J. The 7199 is a medium-mu triode—sharp-cutoff pentode of the 9-pin miniature type especially designed for use in audio equipment

where low hum and reduced noise are necessary design requirements. It is useful in tone-control circuits, phase-splitter and high-gain voltage amplifier circuits, and in preamplifier circuits if the input-signal level is 100 mv or more. Circle 202 on Reader Service Card.

## P-C Laminate flame-resistant

NATIONAL VULCANIZED FIBRE CO., 1059 Beech St., Wilmington 99, Delaware, announces a new flame-resistant laminated plastic, primarily for p-c applications. Designated Phenolite grade XXXP-475, it of-

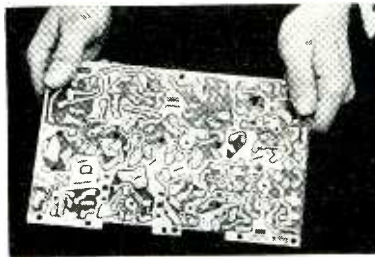

fers excellent electrical properties, very high insulation resistance, low moisture absorption—exceeding all NEMA required values for grade XXXP by wide margins. It yields excellent punching results with a minimum of heating in the range of 130 to 150 F. Circle 203 on Reader Service Card.

## Keyboard Switch 6-pole unit

PENDAR, INC., 14744 Arminia St., Van Nuys, Calif. A new switch available in either push on-push off or momentary is designed for light-action keyboard type installations where additional switching circuits are required. Need for costly relay

banks is eliminated along with space and weight problems. The 6 independent poles can be supplied in any combination of normally open or closed contacts, such as 5 open, 1 closed or 3 pole double throw-double break. The switch is manufactured with 1 to 2 lb operating pressure,  $\frac{1}{2}$  in. mounting thread,  $\frac{3}{8}$  in. case diameter,  $\frac{1}{8}$  in.





# A Logical Deduction

- Because** ordinary magnetically-regulated power supplies are *too sluggish* to handle load and line transients,
- Because** NJE refused to be satisfied with such performance, and developed, back in 1956, a *fundamentally superior circuit*,
- Because** this thoroughly proven circuit uses the speed and power-gain of a transistor amplifier to force rapid response from the magnetic amplifier,
- Because** the transistors are never in the power path, but handle low-level signals only,
- Because** this transistor-magnetic —“TRM”— circuit retains the reliability and economy of magnetically-regulated supplies, but greatly improves speed of response (15 millise. typical), widens operating range (8:1 typical) and tightens regulation (0.1% typical),
- Because** TRM supplies can be “zero-lagged” against line and load transients,
- It follows that** NJE TRM is your *best buy* in a magnetically-regulated power supply!

## QED...choose NJE



**TRM-40-30**  
5-40 volts  
0-30 amperes

*Write for complete catalog*

MODEL NUMBER	OUTPUT RANGE	
	VOLTS	AMPERES
TRM-28-30	24-32	0-30
TRM-28-60	24-32	0-60
TRM-28-120	24-32	0-120
TRM-40-15	5-40	0-15
TRM-40-30	5-40	0-30
TRM-40-60	5-40	0-60
TRM-40-120	5-40	0-120
TRM-80-7.5	10-80	0-7.5
TRM-80-15	10-80	0-15
TRM-80-30	10-80	0-30
TRM-80-60	10-80	0-60
TRM-160-7.5	20-160	0-7.5
TRM-160-15	20-160	0-15
TRM-160-30	20-160	0-30



**NJE CORPORATION**

345 Carnegie Avenue, Kenilworth, New Jersey

CH 1-1500 TWX - ROSELLE, N. J. 51 FAX - FFP



**marion**  
 advancement  
 in instrument  
 design

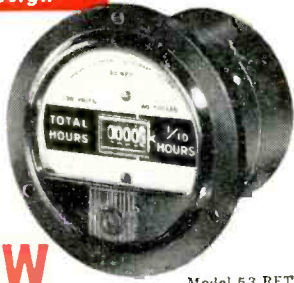

Model 53 RET

**NEW**  
**LOW COST**  
**ELAPSED TIME INDICATOR**

Unsealed, bakelite case design provides low cost. Self-starting synchronous motor drives 5-digit counter; records hours to 99999 or hours and tenths to 9999.9. Square Model 53 SET 3 1/2" also available. For 110 or 220 volt, 60 cycle AC. Standard ASA/MIL 3 1/2" mounting. Data on request. Marion Instrument Division, Minneapolis-Honeywell Regulator Co., Manchester, New Hampshire, U.S.A.

Copyright © 1959, Marion

**marion**  
 "WHERE ELECTRONICS MEETS THE EYE"  
**meters**



CIRCLE 185 READERS SERVICE CARD

**MICO** Precision Apparatus

**NEW HEAVY DUTY 2 & 3 DIMENSIONAL ENGRAVER**

FOR Engraving Nameplates Fine Routing Work Profiling Small Objects Making Small Dies and Molds



**UHF COAXIAL WAVEMENTERS**

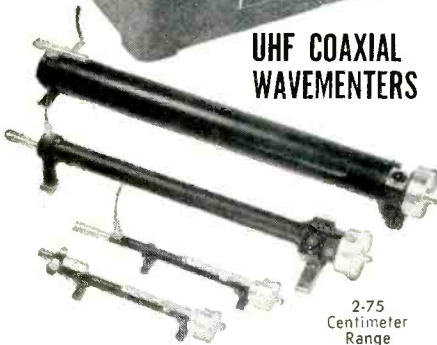

2-75 Centimeter Range

Send for Illustrated Catalogs  
**MICO INSTRUMENT CO.**

76 Trowbridge St. Cambridge 38, Mass.  
 CIRCLE 186 READERS SERVICE CARD

travel and 1/2 ampere inductive contacts at 28 v d-c. Circle 204 on Reader Service Card.

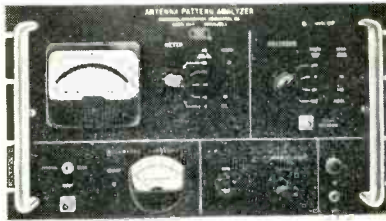

**Analyzer**  
 antenna pattern

WEINSCHEL ENGINEERING, 10503 Metropolitan Ave., Kensington, Md. Designed primarily to utilize r-f crystals in a video detector system because crystals have a high r-f detection efficiency and are cheaper and less subject to burnout than barretters, the model BA-7 antenna pattern analyzer requires a maximum of only 1 μw r-f power to achieve a maximum range of measurement of 45 db (r-f) in one step. For greater versatility, a d-c biasing circuit is included to permit the use of conventional barretters, requiring a d-c bias between 0 and 10 ma. Circle 205 on Reader Service Card.



**Tv Camera Mount**  
 heavy-duty

KIN-TEL, a division of Cohu Electronics, Inc., 5725 Kearny Villa Rd., San Diego 12, Calif. A new tv camera mount has greatly broadened the area that can be continuously monitored by a single closed-circuit tv system. Model ARC-11B camera mount was designed specifically to support heavy acoustical or weatherproof housings such as

**FLIGHT DATA and CONTROL ENGINEERS**

Cross new frontiers in system electronics at The Garrett Corporation.

High-level assignments in the design and development of system electronics are available for engineers in the following specialties:

**1. ELECTRONIC AND FLIGHT DATA SYSTEMS AND CONTROLS** A wide choice of opportunities exists for creative R & D engineers having specialized experience with control devices such as: transducers, flight data computers, Mach sensors, servo-mechanisms, circuit and analog computer designs utilizing transistors, magamps and vacuum tubes.

**2. SERVO-MECHANISMS AND ELECTRO-MAGNETICS** Requires engineers with experience or academic training in the advanced design, development and application of magamp inductors and transformers.

**3. FLIGHT INSTRUMENTS AND TRANSDUCERS**

1) DESIGN ANALYSIS Requires engineers capable of performance analysis throughout preliminary design with ability to prepare and coordinate related proposals.

2) DEVELOPMENT Requires engineers skilled with the analysis and synthesis of dynamic systems including design of miniature mechanisms in which low friction freedom from vibration effects and compensation of thermo expansion are important.

**4. PROPOSAL AND QUALTEST ENGINEER**

For specification review, proposal and qualtest analysis and report writing assignments. Three years electronic, electrical or mechanical experience required.

Forward resume to:  
 Mr. G. D. Bradley

**THE GARRETT CORPORATION**

9851 S. Sepulveda Blvd.  
 Los Angeles 45, Calif.

DIVISIONS:  
 AiResearch Manufacturing—Los Angeles  
 AiResearch Manufacturing—Phoenix  
 AiResearch Industrial  
 Air Cruisers • Airsupply  
 Aero Engineering  
 AiResearch Aviation Service

CIRCLE 90 READERS SERVICE CARD

May 8, 1959 — ELECTRONICS



# LIGHTWEIGHT

## airborne electronic cooling package

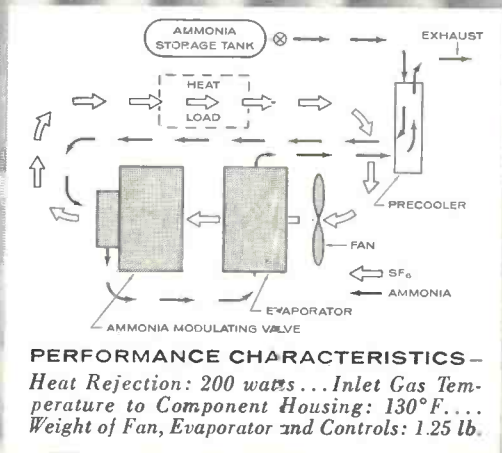
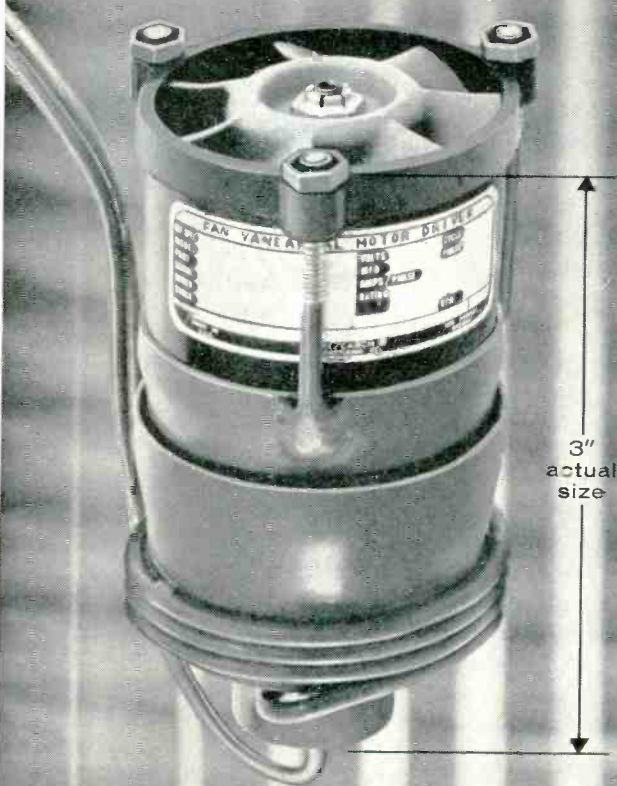

## Spans the gap between direct ambient cooling and closed cycle systems

• This AiResearch open-cycle cooling unit is designed for environmental conditioning of electronic and electro-mechanical equipment in problems of low total heat dissipation aboard aircraft and missiles.

Much lighter and less complex in operation than closed cycle systems, this compact package is recommended when required total heat dissipation is low...large heat loads

for short periods of time, or small heat loads for long periods of time. It also replaces direct ambient cooling systems when ambient sink is not low enough or not easily available.

Ammonia in this expendable evaporative system cools sulfur hexafluoride ( $\text{SF}_6$ ) which passes over the hot electronic components. The  $\text{SF}_6$  then recirculates for cooling, and the ammonia is dumped overboard.

Applications of this system include: inertial guidance system cooling, missile transient cooling, and spot cooling where ambient sink is not available.

AiResearch has designed and manufactured cooling systems of all types... direct ambient, closed and open-cycle systems handling all magnitudes of cooling loads and utilizing various working fluids. We invite you to send us details of your problem.

**THE GARRETT CORPORATION**  
AiResearch Manufacturing Divisions

Los Angeles 45, California • Phoenix, Arizona

Systems, Packages and Components for: AIRCRAFT, MISSILE, ELECTRONIC, NUCLEAR AND INDUSTRIAL APPLICATIONS



# HOW CERAMIC MAGNETS ENERGIZE NEW IDEAS

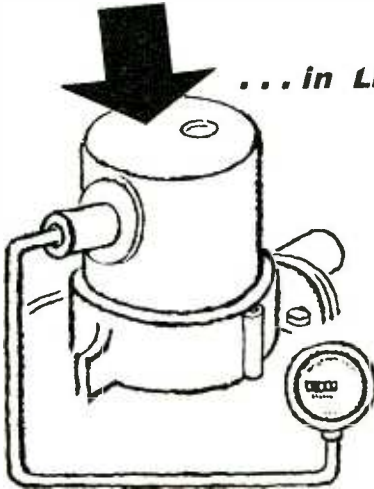

**... in Liquid Flow Registers** • Water and liquid meters of all kinds can be read at a distance with the remote-indicating "Read-O-Matic" Register developed by the Badger Meter Mfg. Co., of Milwaukee. Heart of the "Read-O-Matic's" self-contained generator is an inexpensive 6-pole ring magnet of Stackpole Ceramagnet. The quick release of the magnet under spring tension induces a 3-volt pulse in 6 coils. This is accurately transmitted to a remote totalizing counter.



**... in Appliances** • Powerful, low cost Ceramagnet ceramic permanent magnets open, close and hold doors; put *snap* into snap-action switches and thermostats; catch lids from can openers; increase lint catcher efficiency . . . make dozens of other magnet uses commercially practical for the first time. Ceramagnet magnets require no keepers; retain magnetism indefinitely, can be molded in practically any shape.

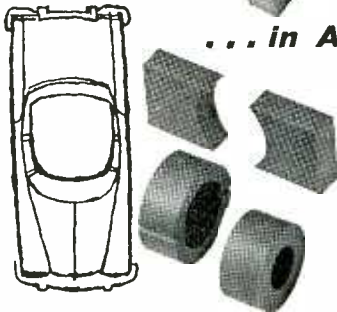

**... in Automotive Equipment** • High coercive force and high electrical resistivity make Ceramagnet ideal as field magnets in small dc motors. In addition, these ceramic magnets are likewise being investigated for use on fuel-pump drives, speedometers, ammeters, carburetors, and other devices.

Where can YOU use Ceramagnet? For practical suggestions, and engineering details, write for Stackpole Bulletin, RC-11A. STACKPOLE CARBON COMPANY, St. Marys, Pa.



Ceramag<sup>®</sup> ferromagnetic cores  
Slide & Snap Switches • Electrical  
contacts • Coldite 70+ fixed composition  
resistors • Variable composition  
resistors • Brushes for  
all rotating electrical equipment  
Graphite bearings, seal rings &  
anodes . . . and many other carbon,  
graphite and electronic  
components.

those used near outdoor test stands or in conjunction with industrial surveillance systems. It circles from side to side in a continuous back-and-forth action, panning the tv camera over an adjustable sector. Built-in speed controls allow the scanning cycle to be varied over a wide range. Circle 206 on Reader Service Card.

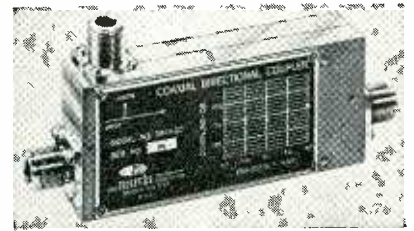

## Coaxial Coupler extremely flat

NARDA MICROWAVE CORP., 118-160 Herricks Rd., Mineola, N. Y., announces a series of extremely flat coax couplers. Limiting frequency response variation to only 0.2 db over a full octave, the units also present a deviation of mean value from nominal of only  $\pm 0.3$  db. Six models cover frequency bands from 240 to 11,000 mc with a nominal coupling value of 20 db; four models are available with 10 db values, covering 500 to 8,000 mc. Primary vswr is 1.1 to 1.25, and secondary vswr is 1.2 to 1.3, depending on the model. All are priced at \$200. Circle 207 on Reader Service Card.



## Nuclear Batteries utilize Krypton

RADIATION RESEARCH CORP., 1114 First Ave., New York 21, N. Y., announces availability of Krypton batteries producing output potentials greater than 5 kv in a volume less than  $\frac{1}{4}$  cu in. and free from radio-



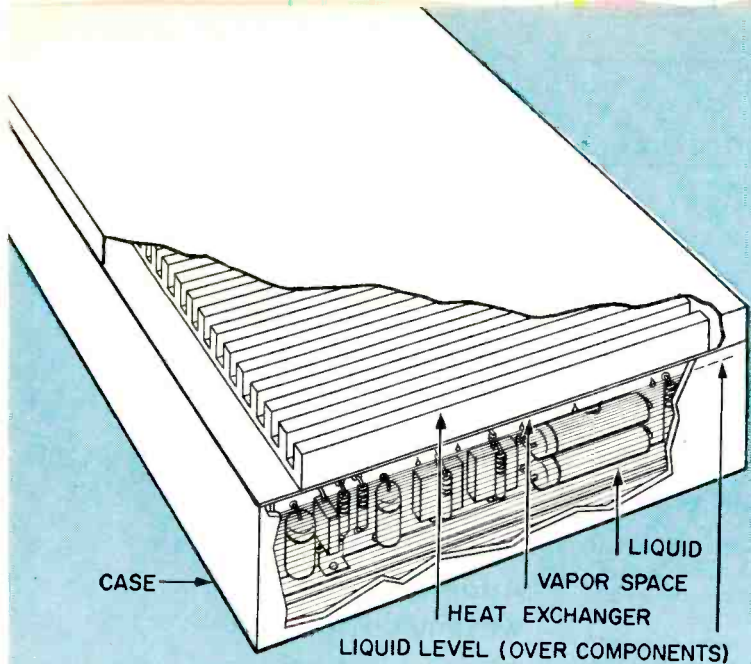

In Raytheon's "EV-GRAV" system, liquid refrigerant boils off the surfaces of the individual electronic components, rises as vapor, condenses on the heat exchanger, and drops as liquid to repeat the cycle.

## "EV-GRAV" COOLING

### IN THE DESIGN OF HIGH HEAT-DENSITY ELECTRONIC EQUIPMENT

Performance requirements for electronic equipment in supersonic aircraft and missiles place particular emphasis on the need for more efficient heat transfer techniques.

The use of fluorochemical refrigerants in an "evaporative-gravity" cooling system is a novel method of removing heat from electronic components. The refrigerant boils at the surfaces of submerged heat-dissipating components and condenses on the surface of a heat exchanger at the top of the package.

This technique has proved more efficient than free convection in oil dielectrics or forced convection with gas dielectrics. The high dielectric strength of the fluorochemicals permits the achievement of higher density packaging.

Contributions such as this are typical of the Heat Transfer Group in Raytheon's Government Equipment Division . . . assisting design engineers in developing the complex weapons systems of tomorrow.

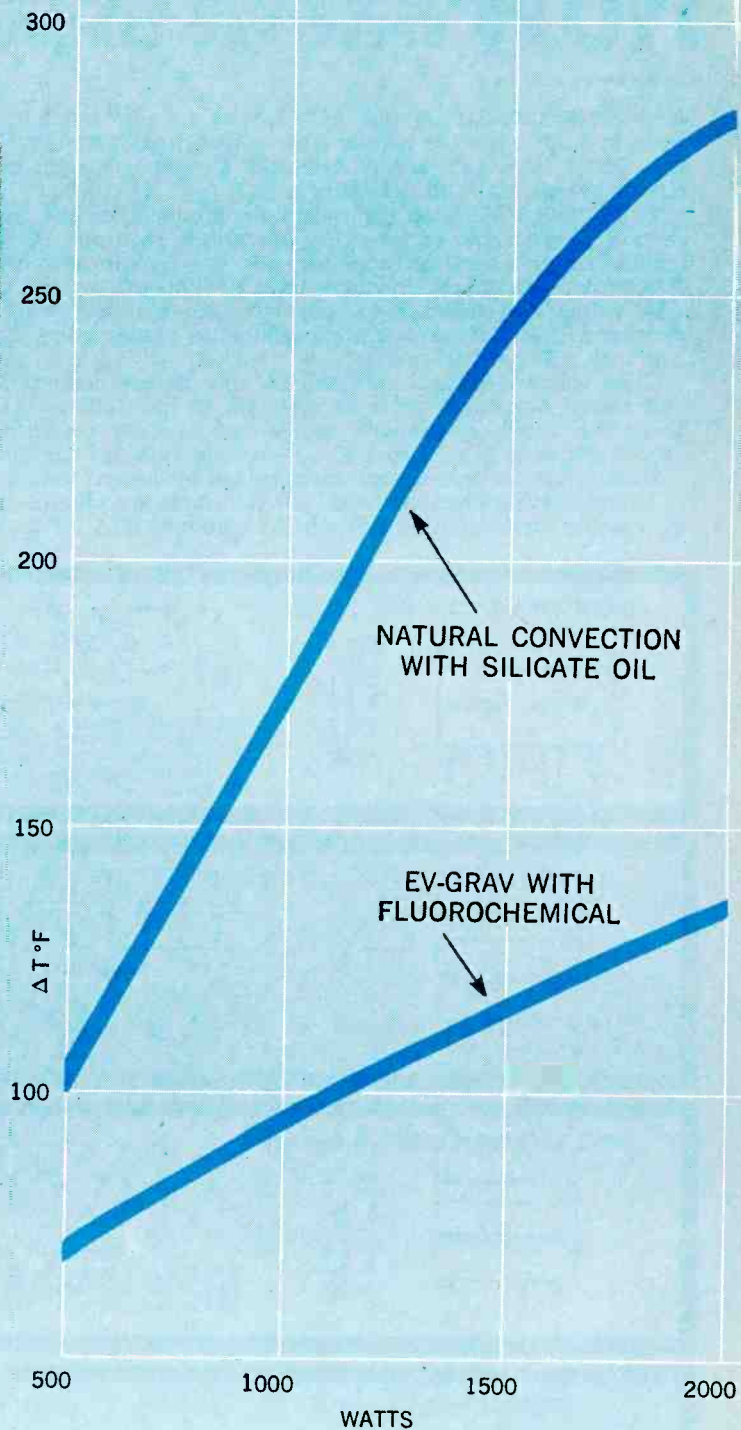

### PROFESSIONAL ASSOCIATION WITH A FUTURE

Qualified engineers and physical scientists with BS or advanced degrees interested in systems, development, design or manufacturing engineering of complex electronic equipments are invited to write Donald H. Sweet, Government Equipment Division, Raytheon Manufacturing Company, Wayland, Massachusetts.

Engineering Laboratories: *Wayland, Maynard, Sudbury, Mass.; Santa Barbara, Calif.*  
 Manufacturing Facilities: *Waltham, North Dighton, Mass.*



GOVERNMENT EQUIPMENT DIVISION



# NOW all the advantages of the Speer PAC System in standardized SPEER PAC CIRCUITS!

New STANDARDIZED SPEER PAC Circuits are now available right off the shelf, in addition to the regular custom-designed SPEER PAC. Either way, the SPEER PAC (Packaged Assembly Circuit) lets you design printed circuit boards with full flexibility.

The SPEER PAC with its multiple component circuit package greatly reduces the number of insertion operations required. PAC components include tubular ceramic capacitors and fixed composition resistors. PAC RESISTORS are available in values from 10 ohms to 20 megohms in standard EIA values and tolerances—they offer one-half watt rating in a 40° C ambient. PAC CAPACITORS are available in values from 10  $\mu\text{f}$  to 10,000  $\mu\text{f}$  with a 500 volt rating.

Close tolerances can be offered because all components are fabricated and tested separately prior to insertion in the SPEER PAC. The use of these individual components results in low stray capacitances between circuit elements (i. e., 1 to 1.5  $\mu\text{f}$  between adjacent components).

Excellent moisture resistance is provided by the wax impregnated coating of thermosetting phenolic resin. All terminals are plug-in type with .200 in. spacing for compatibility with the standard EIA 0.1 in. grid system.

**DIODE TRIODE COUPLING CIRCUIT**

COMPONENT VALUES

C1=2000uuf	+80-20%	R1=6.8M $\Omega$	$\pm 20\%$
C2=220 uuf	+50-30%	R2=470K $\Omega$	$\pm 20\%$
C3=250 uuf	+50-30%	R3=470K $\Omega$	$\pm 20\%$
C4=5000uuf	+80-20%		
C5=250 uuf	+50-30%		

**DIODE PENTODE COUPLING CIRCUIT**

COMPONENT VALUES

C1=2000uuf	+80-20%	R1=4.7M $\Omega$	$\pm 20\%$
C2=150 uuf	+50-20%	R2=1. M $\Omega$	$\pm 20\%$
C3=.01 ufd	+80-20%	R3=3.3M $\Omega$	$\pm 20\%$
C4=150 uuf	+50-30%	R4=10 M $\Omega$	$\pm 20\%$
C5=5000uuf	+80-20%		

**SYNC TAKE-OFF COUPLING CIRCUIT**

COMPONENT VALUES

C1=270uuf	$\pm 20\%$	R1=10 K $\Omega$	$\pm 20\%$
C2=.01 ufd	+50-20%	R2=330K $\Omega$	$\pm 20\%$
C3=25 uuf	$\pm 30\%$	R3=2.2M $\Omega$	$\pm 20\%$

**VERTICAL INTEGRATOR**

COMPONENT VALUES

C1=.01 ufd	+80-20%	R1=22 K $\Omega$	$\pm 20\%$
C2=2000uuf	+50-20%	R2=8200 $\Omega$	$\pm 20\%$
C3=5000uuf	+50-20%	R3=8200 $\Omega$	$\pm 20\%$
C4=5000uuf	+50-20%	R4=22 K $\Omega$	$\pm 20\%$

Contact our Technical Service Department for further information on these and other STANDARDIZED PAC Circuits, or a custom designed PAC, to meet your own particular requirements.

**JEFFERS ELECTRONICS DIVISION**  
SPEER CARBON COMPANY  
Du Bois, Pennsylvania



logical ingestion hazard. Minimum current is 100  $\mu\text{A}$  at no load; capacity, less than 30  $\mu\text{f}$ ; temperature range, -175 to +165 F. Circle 208 on Reader Service Card.

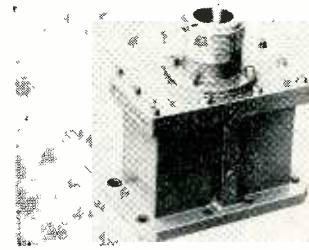

## Adapter waveguide to coax

TAMAR ELECTRONICS, INC., 2339 Cotner Ave., Los Angeles 64, Calif. Part No. 2500 waveguide to coax adapter has the following specifications: frequency range, 2,350-3,600 mc; power handling, 500 w; vswr, 1.2 to 1 maximum; insertion loss 0.1 db maximum; weight, 15 oz. Circle 209 on Reader Service Card.

## Isolation Relay many applications

KLANN ORGAN SUPPLY Co., P. O. Box 2398, Waynesboro, Va. A new isolation relay makes the coil readily available for wiring purposes while providing the distinct advantage of suitable contacts within the shielding of the chassis near the critical circuits they will control. All coil voltages and contact arrangements are available to meet customer's requirements. Circle 210 on Reader Service Card.

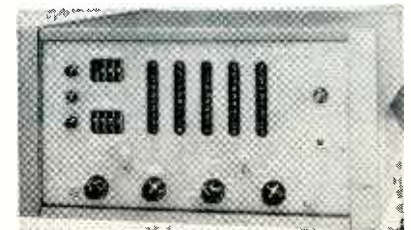

## EPUT Meter dual limit

BERKELEY DIVISION of Beckman Instruments, Inc., 2200 Wright Ave., Richmond 3, Calif. Model 7153 EPUT meter indicates whether metered frequency is below, within or above two selected limits by light-



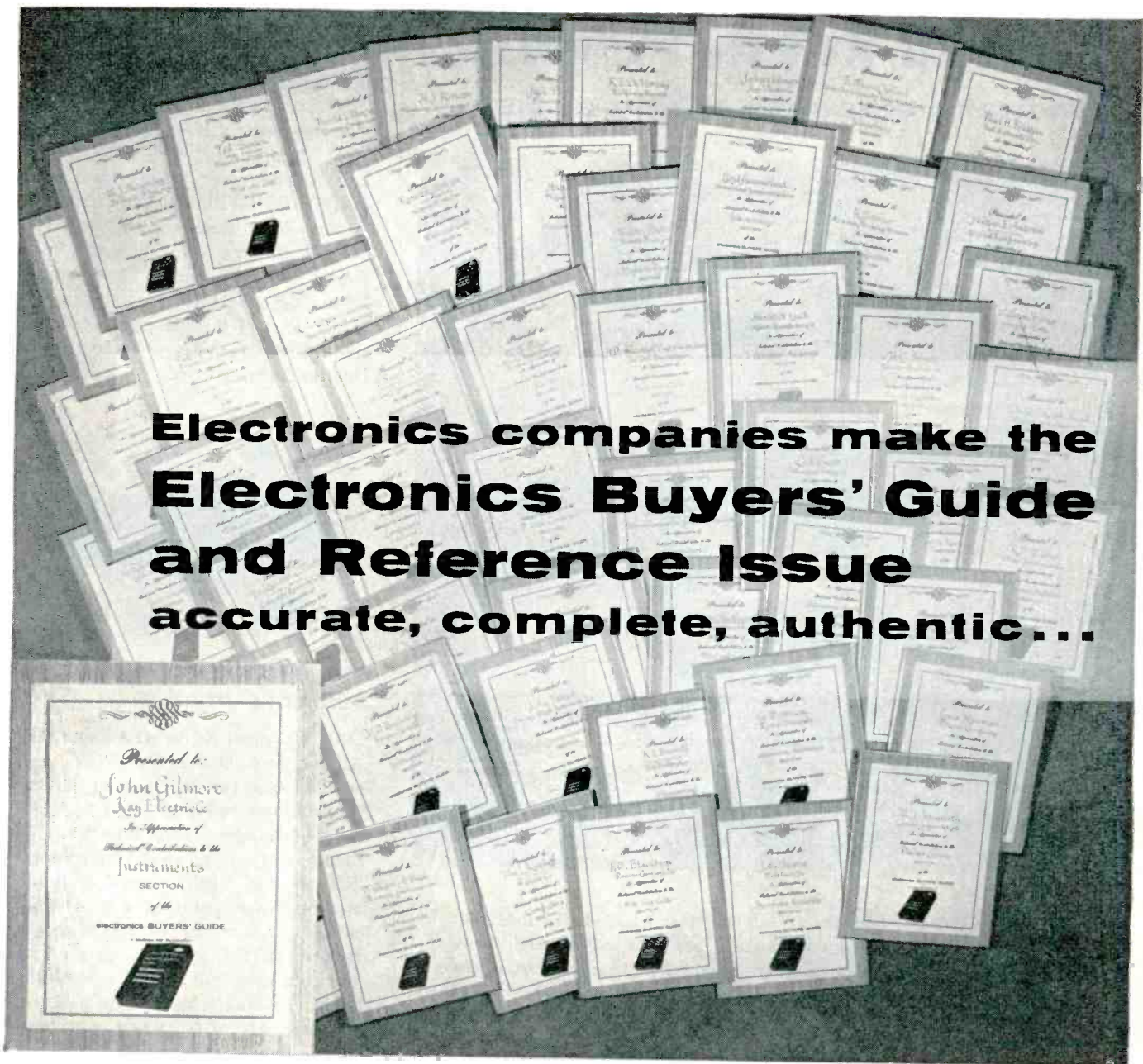

**Electronics companies make the  
Electronics Buyers' Guide  
and Reference Issue  
accurate, complete, authentic...**



For nineteen years, firms in the electronics industry have made direct contributions to the accuracy, completeness and authenticity of the BUYERS' GUIDE.

Recently, the staff of the BUYERS' GUIDE decided to award plaques to express appreciation to those in the industry who had made direct contributions to improve the product listings. The photograph above represents a few of the awards that have been made.

The awarding of the plaques is but one indication of how the BUYERS' GUIDE evolved over the years... a cooperative effort between the publication and the industry it serves.

Only through years of experience can a buyers' guide reflect the needs of an industry as complex and dynamic as electronics... one more reason why the BUYERS' GUIDE is the ONE accepted product and data book in the field.

Published mid-year as the 53rd issue of **electronics**

A McGRAW-HILL PUBLICATION

330 WEST 42ND STREET, NEW YORK 36, N. Y.

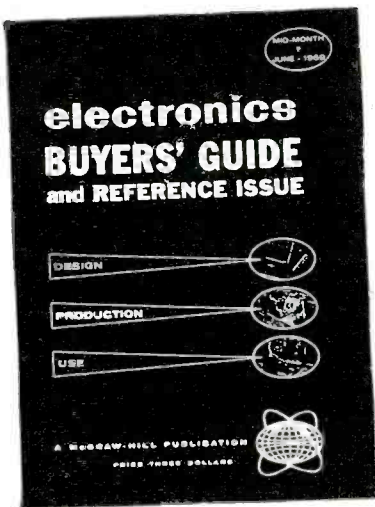



# THREE KLEIN PLIERS

## to make electrical wiring easier

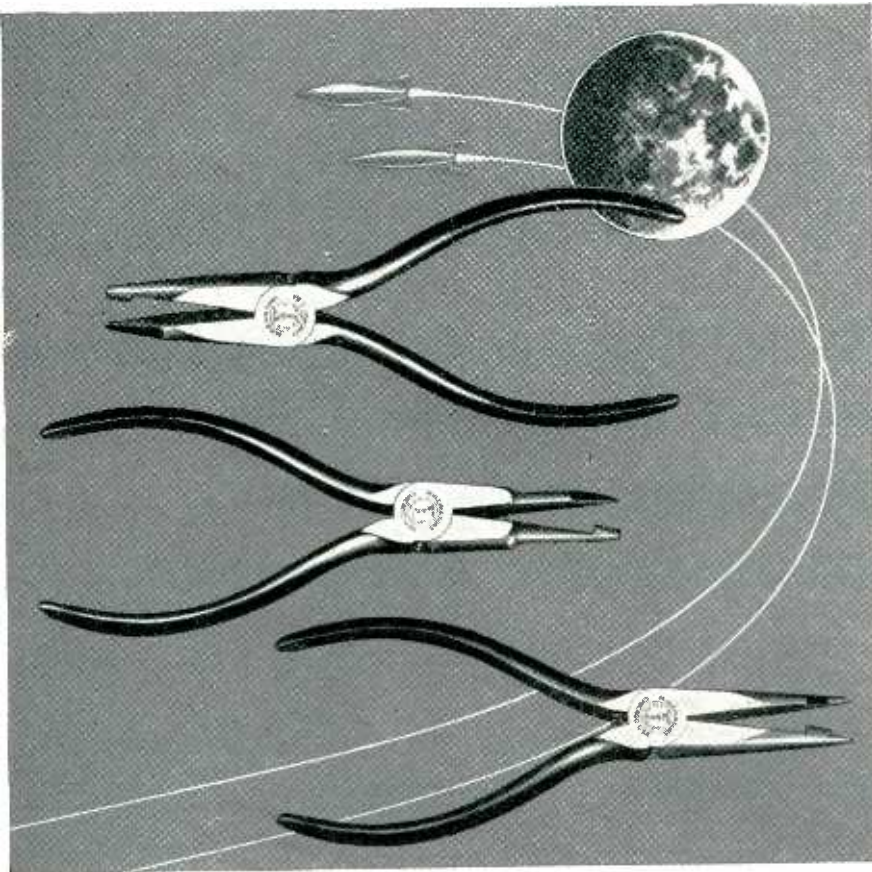

Here are three newly engineered Klein Pliers which will solve difficult problems in the wiring of electronic assemblies. Catalog 101-A describes these and scores of other pliers in the complete Klein line. If you wire electronic assemblies, write for a copy.

### ALL-PURPOSE ELECTRONIC PLIER

Patent pending

Shear blade cuts flush and holds clipped end of wire

Requires no sharpening; will cut hard or soft wire. Smooth, continuous action prevents shock which may damage resistors. For bare wire up to 18 gauge.

No. 260-6—length 6 $\frac{3}{8}$ "

No. 260-6C—with coil spring that holds jaws open

### NEEDLE-NOSE PLIER

Patent pending

Similar to No. 260-6 but nose has been slimmed down to permit use in confined areas.

No. 261-6—length 6 $\frac{3}{8}$ "

No. 261-6C—with coil spring to hold jaws open

### LONG-NOSE PLIER—KNIFE AT TIP

Pat. No. 2,848,724

Jaws behind blade hold clipped wire end firmly

A shear-cutting plier that will cut hard or soft wire. Blade is at the tip of the plier. Supplied with coil spring to keep jaws apart.

No. 208-6PC—length 6 $\frac{3}{8}$ "

Write for Catalog 101-A, which shows the complete line of Klein Pliers, including 20 pliers recently developed.



ing one of three panel lamps—"LO", "IN" or "HI". The frequency limits are selected by positioning two 4-digit decade switches. Relay contact closures, occurring simultaneously with the illumination of panel lamps, may be used to actuate audible alarms or to control the source of the input frequency. Meter has a frequency range of d-c to 100 kc and a sensitivity of 0.1 v rms into 10 megohms. **Circle 211 on Reader Service Card.**

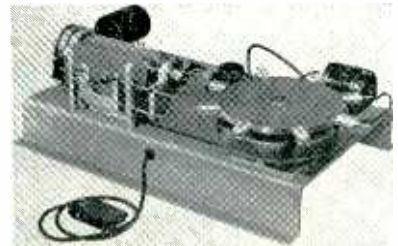

### Coil Winder

#### automatic transfer

COIL WINDING EQUIPMENT CO., 109 Audrey Ave., Oyster Bay, N. Y., has developed a turret transfer device that allows adding—only as required—hopper feed for the coil forms, stripping, cementing, taping and cutting attachments, without any need for creating special machines. This automatic transfer is a feature of the model CK, a winding machine that will produce complete bobbin or single layer coils without operator attention when equipped with a hopper or magazine feed for the coil forms and appropriate standard attachments. **Circle 212 on Reader Service Card.**

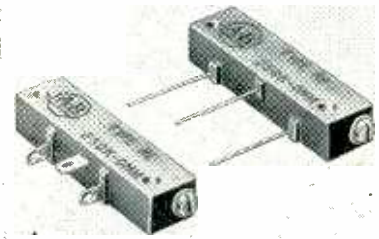

### Fixed Resistor

#### adjustable type

ALLEN-BRADLEY Co., 136 W. Greenfield Ave., Milwaukee 4, Wisc. The compact type R adjustable fixed resistor has a solid hot molded resistance element and a molded car-



**Mathias KLEIN & Sons**  
 Established 1857  
 Chicago, Ill., U.S.A.  
 7200 McCORMICK ROAD • CHICAGO 45, ILLINOIS



bon brush to provide long life and reliable performance. Operation is said to be exceptionally smooth, and no abrupt resistance changes occur during setting. The moving element is self-locking to assure stable settings, and it is adjustable through a 25-turn range. The adjustment screw has a free wheeling clutch to prevent damage from overtravel. Circle 213 on Reader Service Card.

### TWT Amplifier 55 lb total weight

MENLO PARK ENGINEERING, 711 Hamilton Ave., Menlo Park, Calif. A twt amplifier which provides a 30 db power gain from 12.0 to 16.0 kmc has been introduced. Equipment uses a permanent magnet twt, weighing less than 5 lb. No electromagnet is needed for focusing. Power supply regulation is better than 0.1 percent. Maximum ripple is 10 mv. Circle 214 on Reader Service Card.

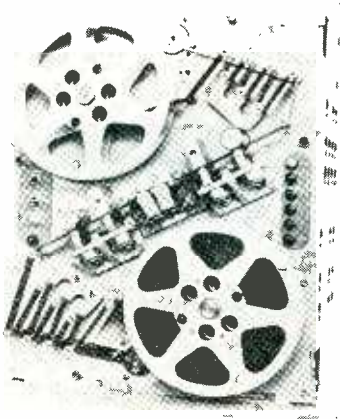

### Tape Recorder high speed

COOK ELECTRIC Co., 2700 Southport Ave., Chicago 14, Ill. Model 750-7300 high speed digital magnetic tape recorder provides extremely high reliability, a maximum storage capacity in a small volume, and remote operation from computer generated command signals. Only solid state or magnetic amplifier active electronic circuit components are used in the device. Thirty-two channels of information are recorded on the 1-in. wide magnetic tape. The normal data format consists of 8 channels of information recorded

# 26 NEW TYPES ADDED TO BENDIX NOISE SOURCE TUBE LINE!

Freq. Range KMC	Band	Waveguide Number	Bendix Type Number	RETMA Type No.	Mount Type	Recommended Mode of Operation (Note 2)	Anode Current Ma (Note 1)	Tube Drop Volts (Note 1)	Tube Excess Noise Ratio DB (Note 3)
1.12-1.70	L	RG-69/U	RXB103085	6881 7101	10°E 90°H 90°H 90°H	D.C.	250	130	15.2
			TD-21			D.C.	250	65	15.2
			TD-29			A.C. and D.C.	250	130	18.0
			TD-33			A.C. and D.C.	250	75	15.2
2.6-3.95	S	RG-48/U	TD-12	6358 6782	10°E	D.C.	250	80	15.2
			TD-22		90°H	A.C. and D.C.	250	45	15.2
			TD-31		10°E	A.C. and D.C.	250	85	15.2
			TD-32		10°E	A.C. and D.C.	250	140	18.0
			TD-34		10°E	D.C.	250	155	18.0
			TD-35		90°H	A.C. and D.C.	250	80	18.0
			TD-38		10°E	PULSE*	(250)	(90)	15.2
			3.30-4.90		S	WR-229	TD-24 TD-30	6852	10°E 10°E
3.95-5.85	C	RG-49/U	TD-10 TD-39 RXB103422	6356	10°E 10°E 10°E	D.C. PULSE* D.C.	250 (250) 250	70 (80) (110)	15.2 15.2 18.0
5.85-8.20	X	RG-50/U	TD-10 TD-39 RXB103422	6356	10°E 10°E 10°E	D.C. PULSE* D.C.	250 (250) 250	70 (80) (110)	15.2 15.2 18.0
8.20-12.40	X	RG-52/U	TD-11	6357 6882	10°E	D.C.	200	75	15.2
			TD-23		10°E	D.C.	200	115	18.0
			TD-40		10°E	PULSE*	(200)	(85)	15.2
			RXB103093		90°H	D.C.	200	(35)	15.2
			RXB103394		90°H	A.C. and D.C.	(100)	(50)	15.2
12.4-18.00	K	RG-91/U	TD-18	6684	10°E	D.C.	200	70	15.2
			RXB103399		10°E	D.C.	200	(110)	18.0
			RXB103409		10°E	A.C. and D.C.	(100)	(65)	15.2
			TD-41		10°E	PULSE*	200	(80)	15.2
			RXB103411		90°H	A.C. and D.C.	(100)	(50)	15.2
			RXB103254		90°H	D.C.	200	(40)	15.2
18.0-26.5	K	RG-53/U	TD-13	6359	10°E	D.C.	200	65	15.2
			RXB103423		10°E	D.C.	200	(100)	18.0
			TD-42		10°E	PULSE*	(200)	(75)	15.2
			RXB103411		90°H	A.C. and D.C.	(100)	(50)	15.2
26.5-40.0	K	RG-96/U	RXB103251		10°E	D.C.	(150)	(120)	15.2

NOTE 1: Anode current and tube drop are D.C. values. Values in parentheses are tentative.

NOTE 2: D.C. operation—Cathode at one end only.

A.C. and D.C. operation—Cathodes at both ends.

Pulse operation—Cathode at one end specially designed for pulse operation.

NOTE 3: The Excess Noise Ratio in DB is  $10 \log \left( \frac{T_{eff}}{290} - 1 \right)$

\*If the anode current during the "on time" of a square pulse (of greater than 100 micro sec. duration) is nominally the same as the rated D.C. anode current, the tube drop during this period will be approximately the same as the rated D.C. tube drop.

Expanding its line from 9 types to 35 types, Bendix Red Bank now offers a great variety of noise source tubes.

But great variety is only one advantage. Noise source tubes that are free from ambient temperature corrections are the result of making tubes so that no correction in noise figures is necessary from  $-55^{\circ}\text{C.}$  to  $+85^{\circ}\text{C.}$  What's more, long life and unusual stability result from precise quality control—far beyond the usually accepted tolerances for such products.

Whatever your applications, whether for  $10^{\circ}$  or  $90^{\circ}$  angle mounting, check with our specialists for the most efficient solution. Write RED BANK DIVISION, BENDIX AVIATION CORPORATION, EATONTOWN, NEW JERSEY.

West Coast Sales & Service: 117 E. Providencia Ave., Burbank, Calif.

Export Sales & Service: Bendix International Division, 205 E. 42nd St., New York 17, N. Y.

Canadian Distributor: Computing Devices of Canada, Ltd., P. O. Box 508, Ottawa 4, Ontario

**Red Bank** Division



BUILD ON . . .

# **Eastern**

**CLIMATE CONTROL EXPERIENCE:**

## **PRESSURIZATION and DEHYDRATION**

Look to Eastern Industries for the advanced pressurization/dehydration packs required by the avionic and ground support systems of tomorrow. Whenever a precisely controlled flow of dehydrated air is required, Eastern design and production experience team up to create compact, lightweight, reliable subsystems. Characteristics and performance range of existing units:

Characteristics and performance range of existing units:

capacities: up to 1.5 FT<sup>3</sup>/Min. free air  
operating temperatures: from -67°F to +150°F, 100% R.H.

operating altitudes: from 10,000 ft. to 50,000 ft.

weights: from 8 lbs. to 115 lbs. complete

Smaller packs feature replaceable chemical dehydrator elements—the larger subsystems are available with automatic reactivating dehydrators.

Let us quote on your next pressurization/dehydration requirement. In the meantime, write for full information on the entire line of Eastern aviation products. Send for Bulletin 360.

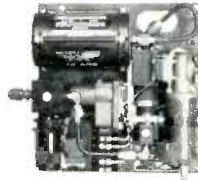
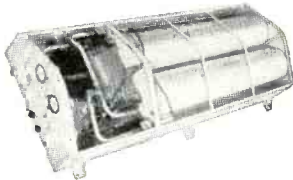
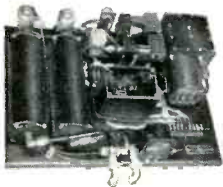

**a wide range of units for specialized air control**

**EASTERN  
INDUSTRIES  
INCORPORATED**  
100 SKIFF STREET  
HAMDEN 14, CONN.



in parallel. Four sequential passes of the tape are made which results in an effective tape length of 4 × 2,400 ft, or 9,600 ft. Circle 215 on Reader Service Card.



### **Audio Oscillator stable output**

BARKER & WILLIAMSON, INC., Bristol, Pa. An audio oscillator with self-contained power supply is recommended for use where a stable, accurately calibrated source of frequencies between 30 and 30,000 cps is desired. Model 200 generates a 10 v output into a 500 ohm load and has a convenient power attenuator for lower values. At 5 v output, distortion is less than 0.2 percent. Circle 216 on Reader Service Card.



### **Silicon Rectifier replaces 6X4 tubes**

SARKES TARZIAN, INC., 415 N. College Ave., Bloomington, Ind. Rated at 1,600 v peak inverse and 500 ma d-c the type S-5207 silicon rectifier will replace up to 5 type 6X4 tubes in parallel. Pin connections are identical so the units are interchangeable. Rugged construction and long life makes it an ideal replacement or original equipment item. Circle 217 on Reader Service Card.

### **Transformers four new models**

TRIAD TRANSFORMER CORP., 4055 Redwood Ave., Venice, Calif. Four new transformers in the T $\bar{Y}$  series



## MEET ROLLY CHAREST

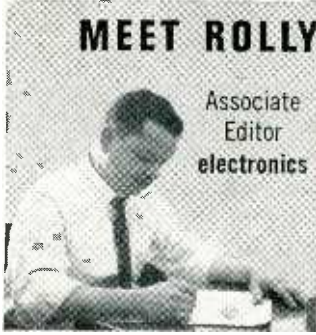

Associate Editor  
**electronics**

### RESUME:

Charest, Roland J., Boston University, BS in Journalism. Formerly New England editor for electronics. Navy sonarman. Writer, reporter, editor for Lynn Item, Boston Globe, Boston Traveler. Won a New England Associated

Press (AP) award in 1955 for writing feature articles in the major city newspaper class.

### PRESENT OCCUPATION:

Rolly Charest supports Managing Editor Jack Carroll for editorial content accuracy and expediting putting each weekly issue to bed. Rolly reworks headlines for greater readability, is involved in makeup, and helps polish editorial content. Rolly's across-the-board background assures you accuracy in the face of journalistic pressures; articles in this week's issue that could be held over to the next deadline, but are not. The readers' interests come first!

### REFERENCES:

"If you're not a subscriber, if your subscription is expiring, if you will miss exciting features "in-the-works" by electronics 26-man staff, fill in box on Reader Service Card. Easy to use. Postage is free.

**electronics**

A McGraw-Hill Publication • 330 W. 42nd St., New York 36

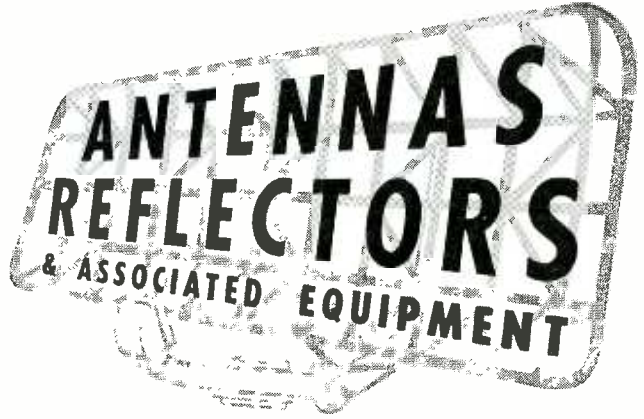

## FROM DESIGN TO PRODUCTION

**Stock Reflectors** — solid spun, 4 in. to 10 ft. in diameter • mesh, 4 ft. to 18 ft. in diameter • larger sizes or special shapes on request.

**Antennas** — up to 10,000 mc

**Large Waveguide Components**

Prompt Delivery of any type antenna or reflector  
— precision built to your specifications.  
Write for technical data.

# Ainslie

CORPORATION

312 Quincy Ave., Quincy, Massachusetts

CIRCLE 99 READERS SERVICE CARD

theory \* design \* performance  
of electronic circuits

## ELECTRONIC SEMICONDUCTORS

**Just Published.** A rigorous and systematic introduction to semiconductor physics, developing the subject logically from simple concepts and giving clear pictures of the conduction mechanism of electronic semiconductors within the framework of the band model. Among the book's outstanding features are the treatment of acceleration of electrons, the Zener effect, etc. Book is a translation of the 2nd German edition of *Elektronische Halbleiter* by Eberhard Spenke. Translated by D. Jenny, H. Kroemer, E. G. Ramberg, and A. H. Sommer, RCA Laboratories. 430 pp., 163 illus., \$11.00

## RANDOM SIGNALS AND NOISE

**Just Published.** An introduction to the statistical theory underlying the study of signals and noises in communications systems. Contains an introduction to probability theory and statistics, a discussion of the statistical properties of the Gaussian random process, a study of the results of passing random signals and noises through linear and nonlinear systems, and an introduction to the statistical theory of the detection of signals in presence of noise. By **William B. Davenport, Jr.**, and **William L. Root**, Lincoln Laboratory, M.I.T. 393 pp., illus., \$10.00

## NUMERICAL ANALYSIS

**Just Published.** Covers the topics most directly needed for a clear understanding of methods used in numerical solution of differential equations, both ordinary and partial, and in the solution of integral equations. Clearly explains the use of finite-difference methods in obtaining numerical solutions to problems—emphasizing procedures which can be most readily programmed for an electronic digital computer. Many helpful techniques such as the use of lozenge diagrams for numerical differentiation and integration are supplied. By **Kaiser S. Kunz**, Ridgefield Research Lab. 381 pp., 40 illus., \$8.00



## ELECTRON TUBE CIRCUITS

**New 2nd Edition Just Published.** Discusses and evaluates the fundamental properties of electron tubes and their circuit operations—analyzes tuned and untuned amplifiers—and takes up in detail circuits essential to modern electronic systems such as voltage, video, and power amplifiers; waveform generators; oscillators; modulators, etc. Scores of practical examples show you best applications of theory. By **Samuel Seely**, Case Inst. of Technology. 2nd Ed. 695 pp., 739 illus., \$10.50

## BASIC FEEDBACK CONTROL SYSTEM DESIGN

**Just Published.** Bases the study of feedback control system design on complex frequency plane analysis—the root-locus. A wide range of servo transducers and components are covered. Recent advances covered include a section of gyroscopes and force-balance transducers, inertial navigation; analysis of nonlinear systems such as the describing function technique and phase plane analysis. Frequency methods, such as Nyquist and Bode, are included. By **C. C. Savant, Jr.**, U. of Southern Cal. 418 pp., illus., \$9.50

SEE ANY BOOK 10 DAYS FREE

McGraw-Hill Book Co., Dept. FL-5-8 327 W 41st St., New York 36  
Send me book(s) checked below for 10 days' examination on approval. In 10 days I will remit for book(s) I keep plus few cents for delivery costs, and return unwanted book(s) postpaid. (We pay delivery costs if you remit with this coupon—same return privilege.)

- Spenke—Elect. Semiconductors, \$11.00  Kunz—Numerical Analysis, \$8.00  
 Davenport & Root—Random Signals, \$10.00  Seely—Elect. Tube Circ., \$10.50  
 Savant—Feedback Cont. System Design, \$9.50

Name ..... Address .....

City ..... Zone .... State .....

Position ..... Company .....

For price and terms outside U.S., write McGraw-Hill Int'l., N. Y. C. FL-5-8

you can  
make it  
**BETTER**  
with...

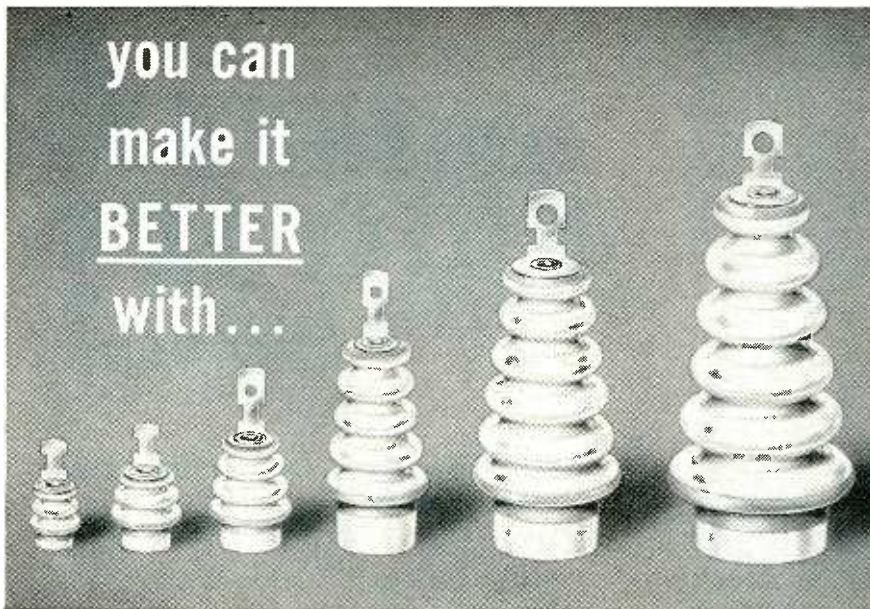

## ... NICOTE® Metallized Hermetic Terminals

Whenever your plans call for the use of terminals in controls, relays, transformers, capacitors, motors, or heater units, take a tip from satisfied engineers everywhere and investigate the plus-values of NICOTE Metallized Hermetic Terminals.

Custom-engineered of HIGH ALUMINA CERAMICS and metallized with Frenchtown's exclusive NICOTE, these terminals offer you definite advantages:

- Will withstand continuous immersion in lead-tin solder at 260° C. (500° F.).
- Reduce tracking through superior external shape, so important in smaller size terminals.
- Provide easier threading of wire through the terminal because of improved tapered bore design.

- Effect a permanent, positive seal that is resistant to high thermal and mechanical shock.

NICOTE Metallized Hermetic Terminals are available in six varying sizes with a choice of terminal hardware to fit any exacting application.

Write today for Engineering Data Sheet 1055 which provides complete terminal specifications plus engineering details on a wide selection of terminal hardware.



**frenchtown** PORCELAIN COMPANY  
FRENCHTOWN, NEW JERSEY

for transistor power supplies are introduced. Operating from 12.6 v d-c supply, they are designated TY-78, TY-79, TY-80 and TY-81; and are rated 250 v at 100 ma, 300 v at 200 ma, 325 v at 150 ma and 375 v at 200 ma respectively. They may be stacked on a mounting bolt with series parallel connections easily made to the peripherally located terminals producing an output equal to the sum of the combined units at only a slight loss in efficiency. Circle 218 on Reader Service Card.



## Magnetic Recorders wide band

MINCOM DIVISION of Minnesota Mining & Mfg. Co., 2049 So. Barrington Ave., Los Angeles 25, Calif. The new CV-100 series of precision tape recording equipment is designed to provide instrumentation video engineers with production units that can simultaneously record, for example, seven complete channels of video information, each of which requires 1-mc bandwidth. This can be done for a 15 minute period, on one reel of half-inch tape. Circle 219 on Reader Service Card.

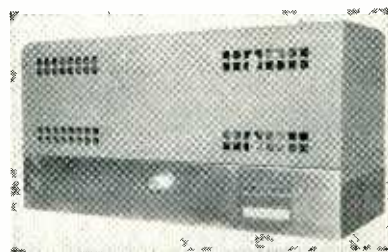

## Amplifiers single channel

SEG ELECTRONICS Co., INC., 1778 Flatbush Ave., Brooklyn, N. Y., is producing a new series of super-powered single channel amplifiers





# *“Higher Education ... Our Greatest Tool”*

OSCAR G. MAYER  
Chairman, Oscar Mayer & Co.

“During the last twenty years we have had dramatic evidence of what massive research can accomplish. Every thinking American today is acutely aware that our future welfare depends upon this vital activity.

“But sound higher education is the prerequisite of good research; it is vitally important that our higher education be constantly improved, beginning with our secondary schools. Higher education is the only means with which we can mine our most valuable natural resource: the creativity of the human mind in all fields, social and cultural as well as scientific.

“By supporting the college of your choice in its efforts to provide the best possible faculty and physical facilities, you are investing in the one tool with which to shape favorably the future of America.”

If you want more information on the problems faced by higher education, write to:  
Council for Financial Aid to Education, Inc., 6 E. 45th Street, New York 17, N. Y.

*Sponsored as a public service, in cooperation with the  
Council for Financial Aid to Education*

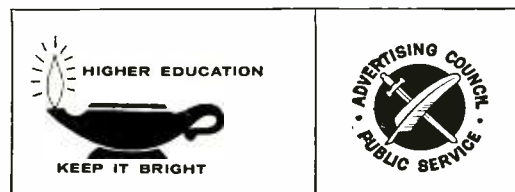

# chemistry

At Los Alamos, chemistry means research in such fascinating fields as radiochemistry, radiation chemistry, biochemistry, reaction kinetics, cryogenics and the chemistry of uranium, plutonium, deuterium and tritium. It means too, the availability of some of the world's finest research facilities. And chemistry is only one of the scientific activities in which trained men and women with imagination find challenge at Los Alamos.

Employment inquiries are invited. Write to:

Personnel Director  
Division 59-43

**los alamos**  
scientific laboratory  
OF THE UNIVERSITY OF CALIFORNIA  
LOS ALAMOS, NEW MEXICO

for the vhf television field. They deliver at least 20 v into a 75 ohm load, which is in excess of 5 w. They are designed to follow the usual 1 v output final amplifier used in the community tv field and deliver an additional 26 db gain to enable the signal to be driven over long distances. Circuit consists of a grounded-grid amplifier which drives a push-pull twin triode transmitting tube. The final amplifier is double-shielded to eliminate stray radiation. **Circle 220 on Reader Service Card.**

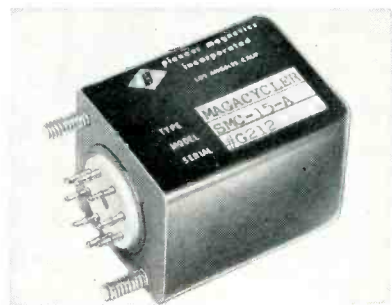

## Transducers two new ratings

PIONEER MAGNETICS INC., 5858 Wilshire Blvd., Los Angeles 36, Calif. The SMC line of Magacycler precision frequency to voltage transducers now has two new ratings, the SMC-15 and SMC-5000. The SMC-15 is designed to meet a demand for the conversion of l-f pulse rates to a directly proportional d-c voltage or current. The SMC-5000 covers the high audio frequency range by converting signals of 0 to 1,250 cps up to 0 to 5,000 cps to the desired linear d-c output. **Circle 221 on Reader Service Card.**

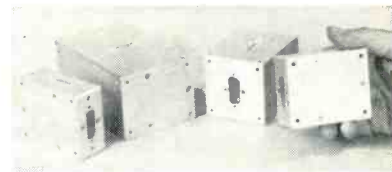

## Telemetering Units modular style

APPLIED SCIENCE CORP. OF PRINCETON, P.O. Box 44, Princeton, N. J., has in production new modular, transistorized airborne or ground-



based telemetering equipment for data acquisition, that offers exceptional environmental performance and long-term versatility. Known as K-Series equipment, the first group of these new modules is designed principally for multiplexing and coding (multicoding) data in pulse width (pdm) form in airborne and ground-based systems. The building block modules have a standard dimension of 3½ in. high by 2½ in. wide. The package lengths are normally in multiples of ½ in. Circle 222 on Reader Service Card.

**20  
TO  
200 D.P.**

**SEND YOUR  
PRINTS FOR  
QUOTATION**

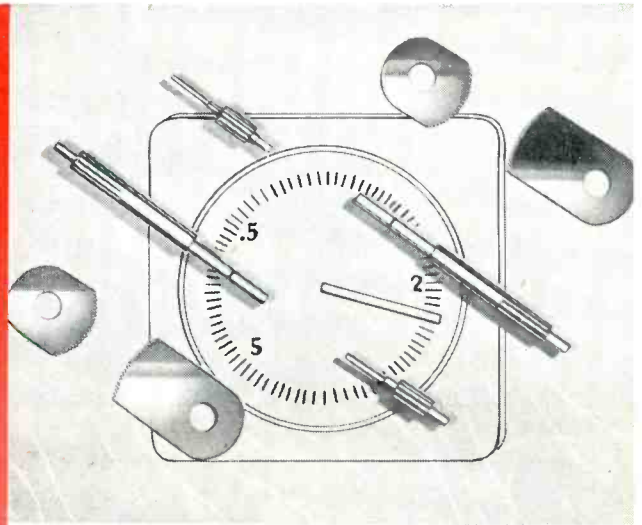

SPURS • HELICALS • WORM AND WORM GEARS • STRAIGHT BEVELS  
LEAD SCREWS • RATCHETS • CLUSTER GEARS • RACKS • INTERNALS • ODD SHAPES

THE *Finest*  IN GEARS™

**Beaver Gear Works Inc.**

1021 PARMELE STREET, ROCKFORD, ILLINOIS

CIRCLE 153 READERS SERVICE CARD

**Transistors  
high power**

CLEVITE TRANSISTOR PRODUCTS, 241 Crescent St., Waltham 54, Mass. The 2N1146 and 2N1147 series of germanium *pn-p* high power transistors feature ring emitter construction and large junction area for conservative current and power ratings. Low thermal resistance, low base input voltage, low saturation voltage, and superior current gain up to high values of collector current make them ideal for use in high current switching circuits, d-c to d-c converters, high power audio amplifiers and voltage regulated power supplies. Circle 223 on Reader Service Card.

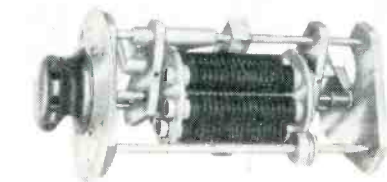

**Step Attenuators  
high power**

EMPIRE DEVICES PRODUCTS CORP., Amsterdam, N. Y., has developed two new high power microwave step attenuators. Units are conservatively rated at 4 w continuous, 2 kw peak, and can be obtained with steps of six positions (model AT-108) or 12 positions (AT-109). Intended for incorporation into narrow band or broad band devices and systems where reliable and accurate attenuation of r-f voltage is desired, these attenuators include a

**VERSATILE TOOLS FOR**  
*Electronics and Research*

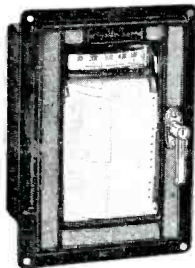

**FOR USE IN**

- Trouble Shooting
- Performance Tests
- Life Tests
- Electronic Gages
- Nuclear Studies
- Tracer Element Studies
- Scintillometers
- Air Samplers
- Photronic Devices
- Audiometers

**DC MILLIAMMETERS:** having the simplicity and ruggedness found only in direct-writing recorders. No linkages. No servo-motors.

Range	Coil Resistance	Critical Damping Resistance	Swinging Time (Critically Damped)
0-1 MA	1400 Ohms	50,000 Ohms	0.5 second
0-5 MA	70 Ohms	4,000 Ohms	0.5 second

**The ESTERLINE-ANGUS Company, Inc.**  
*Pioneers in the Manufacture of Graphic Instruments*  
Dept. E • P. O. Box 596,  
INDIANAPOLIS 6, INDIANA

Please send me a copy of Catalog Sec. 42

NAME \_\_\_\_\_  
ADDRESS \_\_\_\_\_  
CITY \_\_\_\_\_

**HIGH SPEED,**

# Sensitive Polarized RELAYS

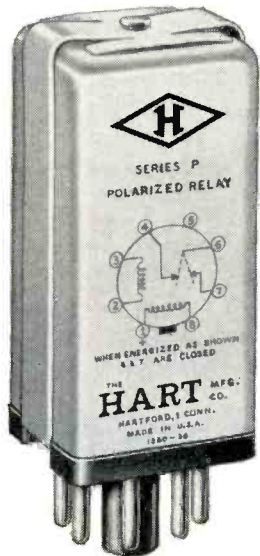

**"DIAMOND H"**



**SERIES P  
Relays**

**FOR ELECTRONIC AND  
COMMUNICATIONS APPLICATIONS**

Engineered to provide extremely fast action with high sensitivity, freedom from bounce and excellent stability, "Diamond H" Series P Polarized Relays give consistent performance with low distortion. Under some conditions they will handle over 1,000 pulses per second.

Magnetically latched SPDT, with two independent coils, Series P Relays are available with various coil resistances from 10 to 4,000 ohms each coil. Contact ratings will vary with switching speeds desired, but range from 60 milliamperes to 2 amperes.

Extremely compact, to save space and weight, they fit standard octal sockets. Their impact and vibration resistance is excellent for relays of this type, thanks to extra-rugged construction.

"Diamond H" engineers are prepared to work out a variation to meet your specific requirements. Write or phone us your needs.

**THE  
HART MANUFACTURING  
COMPANY**

**202 Bartholomew Ave., Hartford, Conn.  
Phone Jackson 5-3491**

self-contained coaxial switch for changing insertion loss values. Circle 224 on Reader Service Card.

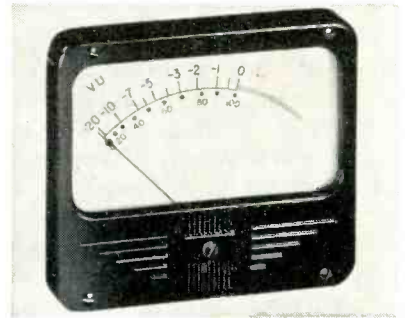

**Panel Meter  
self-illuminated**

HOYT ELECTRICAL INSTRUMENT WORKS, INC., 42 Carleton St., Cambridge 42, Mass. Model 647 self-illuminated VU panel meter features convenient front opening to facilitate light bulb replacement. Only a 2 1/4 in. diameter aperture is required for installation. The arrowhead pointer positions instantly on the easy-to-read, 3-in., black, red and buff "A" scale. The meter is specifically designed for accurately measuring levels of sound or noise in wire line monitoring. Circle 225 on Reader Service Card.



**Rectangular Sockets  
tube and transistor**

FLUOROCARBON PRODUCTS INC., Camden 1, N. J. New rectangular subminiature low-loss tube and transistor sockets are designed to conserve space in wired or p-c applications. The Chemelec sockets have a Teflon insulator body which is press fitted into mounting receptacle. The compression mounting feature eliminates additional fastening hardware or operations since plastic memory characteristics of Teflon causes the portion of the socket which has been forced through the mounting hole to return to its original dimension, lock-



send for this

**FREE**

**EICO  
Electronics  
Catalog**



you save 50% on Top-Quality  
**Test Instruments**  
**Hi-Fi • Ham Gear**  
**KITS AND WIRED**  
for professional and home use

**TEST INSTRUMENTS**

battery eliminators  
battery testers  
bridges  
decade boxes  
electronic switch  
flyback tester  
oscilloscopes  
probes  
signal and  
sweep generators  
tube testers  
transistor tester  
vacuum tube  
voltmeters  
volt-ohm-  
milliammeters

**HI-FI**

stereo and monaural  
tuners  
preamplifiers  
power amplifiers  
integrated amplifiers  
speaker systems

**HAM GEAR**

cw transmitter  
modulator-driver  
grid dip meter

OVER 1½ MILLION  
EICO instruments in  
use throughout  
the world.

LIFETIME service and calibration guarantee.  
IN STOCK at your neighborhood EICO dealer.  
Send now for FREE catalog E-5



33-00 N. Blvd., L. I. C. 1, N. Y.

... praised by the experts  
as **BEST BUYS IN ELECTRONICS**

© 1958 ELECTRONIC INSTR. CO., INC.

CIRCLE 152 READERS SERVICE CARD

**ILLINOIS CAPACITORS KNOWN THE WORLD OVER  
for their TIME TESTED QUALITY!**



there is an Illinois Electrolytic Capacitor  
for every Electronic Requirement!

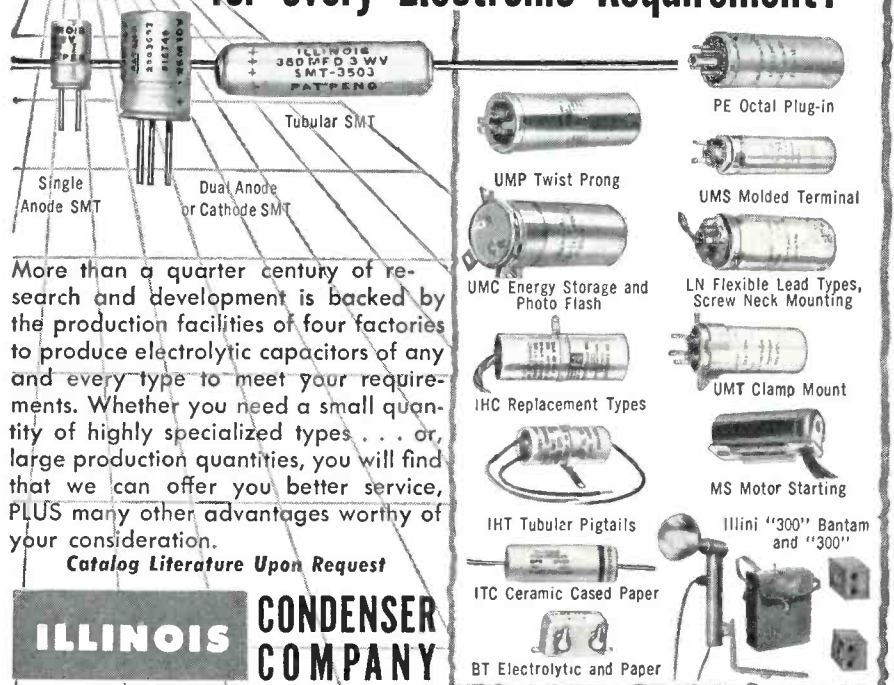

More than a quarter century of re-  
search and development is backed by  
the production facilities of four factories  
to produce electrolytic capacitors of any  
and every type to meet your require-  
ments. Whether you need a small quan-  
tity of highly specialized types . . . or,  
large production quantities, you will find  
that we can offer you better service,  
PLUS many other advantages worthy of  
your consideration.

Catalog Literature Upon Request

**ILLINOIS CONDENSER  
COMPANY**

1616 N. Throop Street • Chicago 22, Illinois • phone: EVERglide 4-1300 • TWX: CG3149

Export Department, 15 Moore Street, New York City, New York; Cable, Minthorne, New York

CIRCLE 157 READERS SERVICE CARD



**FOREMOST**  
in  
**AIRBORNE  
LORAN**

**EDO CORPORATION**  
College Point, L.J., N.Y.  
Since 1925

**Special Purpose Wire**

**titanium**

**phosphor bronze**

**BERYLLIUM  
COPPER**  
Silvercote ®

**ALUMINUM**

**ni-clad-ti**

NICKEL CLAD (not plated) TITANIUM WIRE

FOR  
CERAMIC-TO-METAL  
BRAZING

● OTHER NON-FERROUS

Consider WIRE and the importance of its function  
in your product. Whether a highly engineered appli-  
cation or a simple stapling purpose, your choice of  
the proper alloy or composition, temper and type of  
wire could mean success or failure during crucial  
test.

round • flat — square ■ half-round ▲

Precision gauges from 1/8 to .002. Close tolerances held.

**SPRING WIRE — WIRE FOR INSTRUMENTS  
ELECTRONICS — STRAND FOR WIRE ROPE AND  
BRAIDED APPLICATIONS — MANDREL WIRE  
WIRE FOR FORMS — RIVETS — STAPLING**

Send for descriptive folder.

**LITTLE FALLS ALLOYS  
INCORPORATED**

186 Caldwell Avenue • Paterson 1, N. J.



CIRCLE 156 READERS SERVICE CARD  
ELECTRONICS — May 8, 1959

CIRCLE 158 READERS SERVICE CARD

# EXPANDED RESEARCH

to advance new concepts of  
SPACE FLIGHT

⊕ Expanded Research programs to meet the most complex technological requirements of the Space Age are only one of the far-reaching objectives of the new multi-million-dollar Lockheed Research Center, near Los Angeles. Destined to become one of the nation's major research installations, its programs are broad in scope and designed to investigate new frontiers of space flight.

⊕ A primary consideration in planning the new Research Center was to provide environment for scientific freedom and ideal research conditions—using the most advanced equipment available. This modern, integrated research facility will touch almost every aspect of aviation and transportation—leading toward exploration into completely new or relatively undeveloped fields of science and industry.

⊕ On completion, most of Lockheed's California Division's research facilities will be located in this single area. The Center will provide complete research facilities in all fields related to both atmospheric and space flight—including propulsion, physiology, aerodynamics and space dynamics; advanced electronics in microwave propagation and infrared; acoustics; mechanical and chemical engineering and plasma/magneto-hydrodynamics; thermal electricity; optics; data communications; test and servo-mechanisms.

⊕ The first phase of the advanced research building program has already begun—with initial construction of a \$5,000,000 supersonic wind tunnel and high-altitude environmental test facilities.

⊕ Scientists and engineers of high caliber are invited to take advantage of outstanding career opportunities in this new Lockheed Research Center. Openings now exist for thoroughly qualified personnel in: Electronics; aero and thermo dynamics; propulsion; servo-mechanisms; materials and processes; structures and stress; operations research; research in optics, infrared, acoustics, magneto-hydrodynamics, instrumentation, mechanics and hydraulics; mathematics and in all phases of design.

⊕ Write today to: Mr. E. W. Des Lauriers, Manager Professional Placement Staff, Dept. 15052, 1708 Empire Avenue, Burbank, California.

# LOCKHEED

## CALIFORNIA DIVISION

BURBANK, CALIFORNIA

ing the unit permanently into place and preventing loosening by shock and vibration. Circle 226 on Reader Service Card.

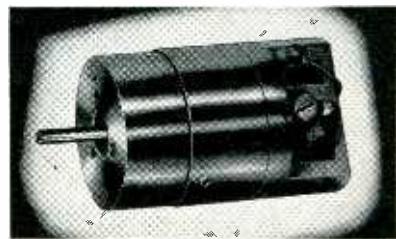

### Reversible Motor small size

CARTER MOTOR Co., 2762 A W. George St., Chicago 18, Ill., announces the M-105 d-c/a-c series reversible motor. It is available in several models, ranging from 6 to 48 v d-c or a-c input, and is rated at 1/75 hp in intermittent duty, or 1/125 hp continuous duty. Overall dimensions are approximately 1 3/4 in. diameter by 3 in. long, plus the 3/4 to 1 in. shaft extension. Circle 227 on Reader Service Card.

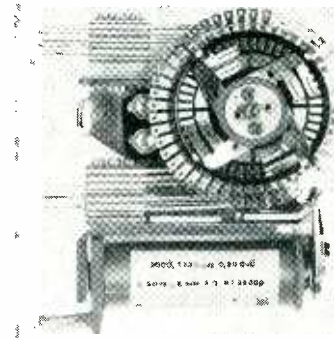

### Relay/Rotary Switch versatile unit

SCHRACK ELECTRIC, 1100 Madison Ave., New York 28, N. Y. A new component, slightly larger than a telephone relay, consists of a pawl-and-ratchet-driven rotary switch and four 12-point banks. It is available in many combinations of interrupter, off-normal, or cam-operated contacts (make or break) up to a total of 16 springs. It is ideal for sequencing, counting, programming or remote control. Bifurcated springs with double contacts are used throughout. Circle 228 on Reader Service Card.



## Logging System single-channel

DATEX CORP., 1307 So. Myrtle Ave., Monrovia, Calif., announces the K-120 single-channel digital logging system. It provides fully automatic or on demand digital recording on adding machine tape from many types of recorders or from a shaft input. It incorporates a Datex encoder, a control unit, and a Datex-Monroe printer. System assures greater accuracy and lower data reduction costs. It is supplied as a complete ready-to-operate unit. Normal installation takes less than an hour. Circle 229 on Reader Service Card.

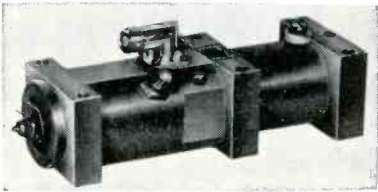

## Pulse Oscillator for radar systems

AVION DIVISION of ACF Industries, Inc., 11 Park Place, Paramus, N. J., has announced a 20-oz S-band pulse oscillator for radar and microwave systems. Model 306 has a power output of 1.5 kw peak minimum at 0.001 duty cycle, 1  $\mu$ sec pulsewidth 1,000 pps. Vibration is listed at 20 g, 20-2,000 cps. It operates at temperatures from -50 to 100 C. Overall dimensions are: 6 $\frac{1}{2}$  in. long, 2 in. wide, and 1 $\frac{1}{8}$  in. high, excluding connector. Circle 230 on Reader Service Card.

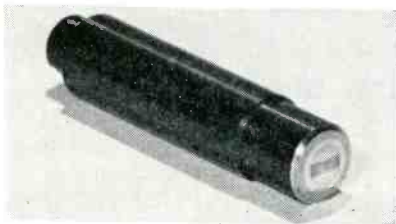

## Memory Drum Head low inductance

J. B. REA CO., INC., 2202 Broadway, Santa Monica, Calif. This single track, low inductance, head will read and record information on

# NEW\* WESTINGHOUSE PROXIMITY LIMIT SWITCH

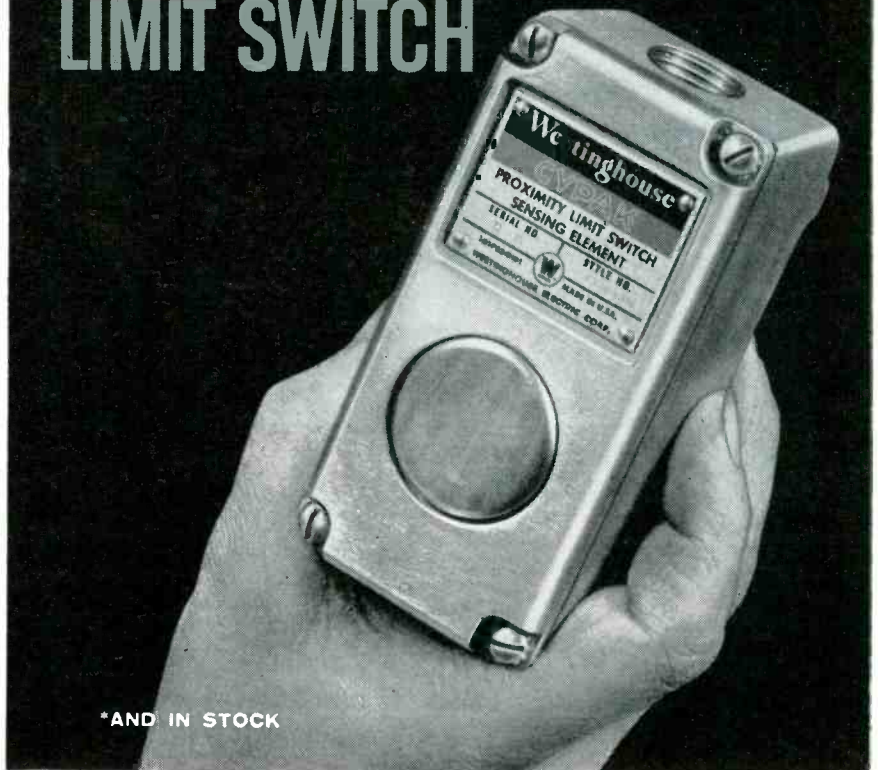

\*AND IN STOCK

## ...WON'T WEAR OUT... NEVER NEEDS REPLACEMENT

No tubes . . . no moving parts to weaken and fail from wear . . . not affected by dust, dirt, oil mist or iron filings . . . will even operate under water . . . sensing heads available for distances of  $\frac{1}{2}$  inch and 2 inches . . . also for explosion-proof applications . . . corrosion and vibration resistant . . . won't spark, pit or wear, because there are no contacts.

Sure, they cost a little more initially. But we haven't seen the application yet where the new Westinghouse proximity limit switch can't pay for itself time and again through eliminated replacements and machine down time.

GET ALL THE FACTS about new Westinghouse proximity limit switches . . . see how and where they can benefit you. Write to Westinghouse Electric Corporation, Director Systems Department, 356 Collins Avenue, Pittsburgh 6, Pennsylvania. J-01011

YOU CAN BE SURE...IF IT'S **Westinghouse**

WATCH "WESTINGHOUSE LUCILLE BALL-DESI ARNAZ SHOWS" CBS TV MONDAYS

**Mr. ENGINEER**

**Why Not Consider  
FIELD ENGINEERING**

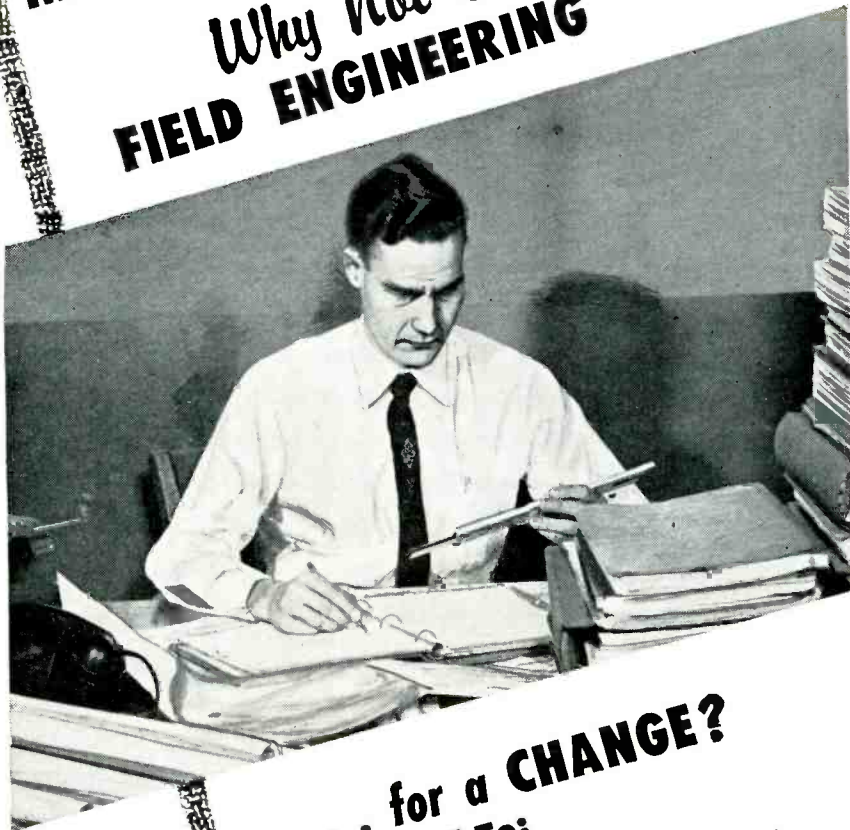

**Have YOU Ever Desired To:**

**EXPAND** your experience to include World Wide Communications Systems . . .  
**BECOME** fully experienced in the world's most advanced electronic systems and equipment . . .  
**ENJOY** the freedom of locating anywhere in the world . . .  
**INCREASE** your earning potential and provide greater security for your family . . .

• If you find yourself answering yes to any of these questions, let us send you our new, full color, illustrated employment brochure which explains the challenge as well as the positions now open for PHILCO Field Engineers. Write NOW . . . get the facts on . . .

**"PHILCO . . . First IN EMPLOYMENT OPPORTUNITIES"**

**PHILCO TECHREP DIVISION**

DEPT. 39, 22nd & Lehigh Avenue,  
Philadelphia, Pa.

magnetic memory drum systems at high frequencies. The HD-9 allows a 2½ to 4 mil spacing between head and recording medium with negligible loss in definition. A locking four conductor polarized plug is used for ease and speed in changing to any desired wiring arrangement. Overall dimensions: length, 2.186 in.; diameter, 0.5 in. Circle 231 on Reader Service Card.

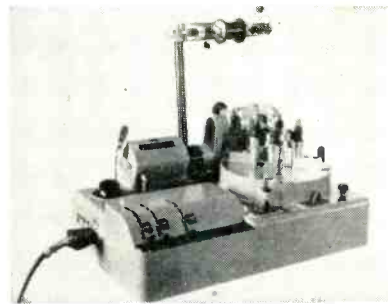

### **Toroidal Winder for precision pots**

CARL HIRSCHMANN CO., INC., 30 Park Ave., Manhasset, L. I., N. Y., has available the Micafil RWP toroidal winder for high precision potentiometers. Some of its features include: automatic shut-off when a preset number of turns has been reached, adjustable wire tensions, automatic direct reading winding speed, and provisions for both continuous and sector windings of one or more layers. Sectors can be wound up to a maximum of 300 deg. Circle 232 on Reader Service Card.

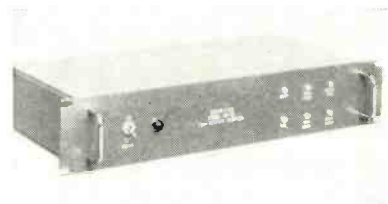

### **PDM Display Adapter 3½ in. rack space**

KAUKE AND Co., 1632 Euclid St., Santa Monica, Calif. Model AD-2S pdm display adapter makes it possible to present standard pdm telemetry data in convenient bar graph form on any standard laboratory-type oscilloscope. Unit features silicon transistor circuitry and missing channel correction. It contains a precision slicer-amplifier for clean-



- NOW AVAILABLE
- OFF-THE-SHELF DELIVERY
- FACTORY PRICES



**WINCHESTER  
ELECTRONICS**  
INCORPORATED

- CONNECTORS
- TERMINALS
- ACCESSORIES

AUTHORIZED DISTRIBUTOR

**GREENE SHAW**  
COMPANY, INC.

341 WATERTOWN ST., NEWTON 58, MASS.  
DEcatur 2-9300 — DEcatur 2-6500

CIRCLE 162 READERS SERVICE CARD

No quicker, more accurate way to get information on PRODUCTS and SERVICES than . . . .

**electronics  
BUYERS'  
GUIDE**

keep it  
at your  
fingertips!



**electronics  
BUYERS' GUIDE**

A MCGRAW-HILL PUBLICATION  
330 WEST 42nd ST. NEW YORK 36, N. Y.

# BEEDA-E-25 EDGEWISE METER

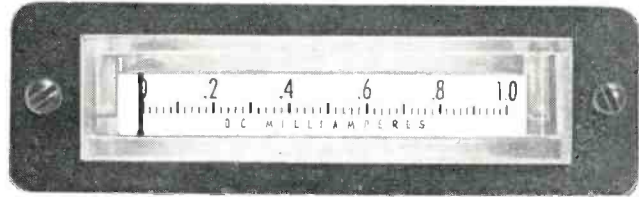

ACTUAL  
SIZE

• • • can be used in either Horizontal or Vertical position — may be paired for comparative reading.

Conserves Space where panel area is limited

Contains the Magcentric Self Shielding Movement

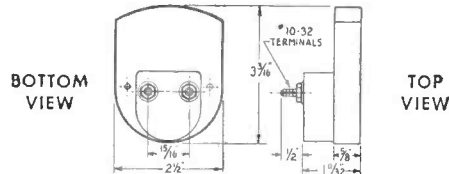

**BEEDE** ELECTRICAL INSTRUMENT CO., INC.  
PENACOOK, N. H.



CIRCLE 164 READERS SERVICE CARD

# RIBBONS • STRIPS

- of —
- ★ PURE TUNGSTEN
  - ★ THORIATED TUNGSTEN
  - ★ MOLYBDENUM
  - ★ SPECIAL ALLOYS

and OTHER METALS

IN

**ULTRA THIN SIZES**

to

TOLERANCES CLOSER THAN COMMERCIAL STANDARDS

by

**OUR SPECIAL ROLLING TECHNIQUE**

Note: for highly engineered applications—strips of TUNGSTEN and some other metals can be supplied

**ROLLED DOWN TO .0003 THICKNESS**

- Finish: Roll Finish—Black or Cleaned
- Ribbons may be supplied in Mg. weights if required

**For HIGHLY ENGINEERED APPLICATIONS**

DEVELOPED AND MANUFACTURED BY

**H. CROSS CO.**

15 BEEKMAN ST., N. Y. 38, N. Y.  
TELEPHONE: WOrth 2-2044  
COrtlandt 7-0470

CIRCLE 165 READERS SERVICE CARD

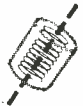

# tough

\*Solves  
Hi-temp  
Problem

# now

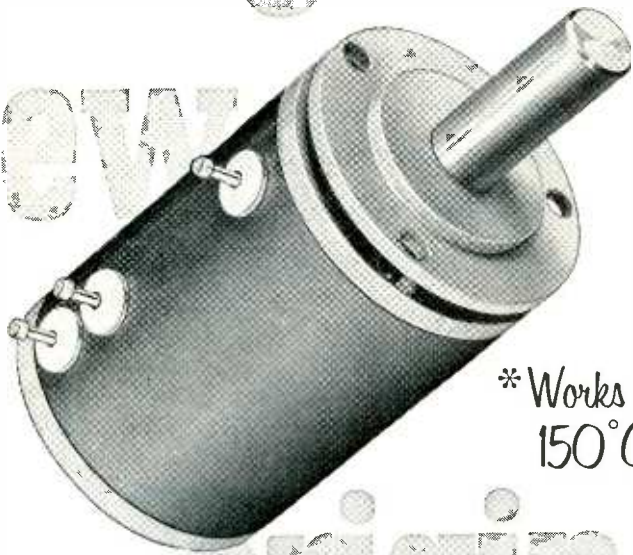

\*Works to  
150°C!

# original

## INTRODUCING THE SPECTROL METAL MULTI-TURN PRECISION POT

Another example of creative engineering from Spectrol, the new Model 590 10-turn pot features machined aluminum construction with the helical coil placed directly against the case for maximum heat dissipation. You can expect a longer operating life at higher ambient from the Model 590.

### **Non-hygroscopic aluminum case furnishes excellent dimensional stability**

The new pot operates in a relative humidity of 95% over a temperature range of -65 to +150°C. It functions above 20g vibration from 55 to 2000 cps, withstands a 30g shock, and meets all specifications to an altitude of 30,000 feet.

Now in production, the new 590 is available in ranges from 25 to 120,000 ohms. Standard linearity tolerance is  $\pm 0.3\%$  with 0.025% on special order. Featuring fused-glass sealed terminals flashed with precious metal, the unit can be supplied with as many as 48 terminals. Both ends of the shaft are supported by ball bearings. The 1" diameter unit is also available with non-linear functions.

Your nearby Spectrol sales engineering representative will be glad to provide complete technical information or you may write directly to Dept. 185



**ELECTRONICS  
CORPORATION**

*"precision electronic components"*

1704 South Del Mar Avenue, San Gabriel, Calif.

ing up raw signals at the output of receivers. Accessories include a marker pulse generator and an adjustable gate for gating an individual channel to a counter or other display device. Circle 233 on Reader Service Card.

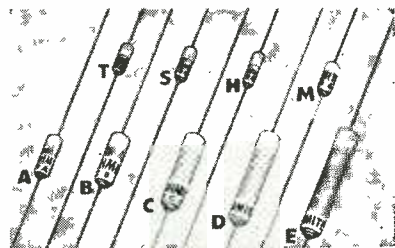

## Capacitors expanded line

OHMITE MFG. CO., 3672 Howard St., Skokie, Ill. A new case size, H, has been added to the line of series TW tantalum wire electrolytic capacitors. New unit has overall body dimensions of 0.075 in. diameter by 0.255 in. It offers the same capacitance range (0.01 to 8  $\mu\text{f}$ ) as existing size S, which has slightly different dimensions. The new size increases the line to 9 physical sizes, the smallest measuring 0.080 in. diameter by 0.203 in. and the largest, 0.134 in. diameter by 0.812 in., including insulation. Circle 234 on Reader Service Card.



## Silicon Rectifiers 50 to 600 piv

ARCO ELECTRONICS, INC., 64 White St., New York 13, N. Y., announces type SR silicon rectifier series in peak inverse voltage values from 50 to 600 v with 500 ma output current rating. Hermetically sealed in triple plated top-hat enclosure, they are conservatively rated for high long term reliability. In addition to the usual life, moisture resistance, and military environmental tests, they are 100-percent tested for static and dynamic characteristics, both forward and reverse, at elevated temperature. Circle 235 on Reader Service Card.



## Rotator-Indicator precision machined

TELREX, INC., Asbury Park, N. J., announces model R-360C custom-built rotator-indicator system used in military and commercial applications. The 2-in. o-d antenna support mast mounts through the rotator and through a precision machined pinned and keyed 2-in. i-d heavy-wall, high-tensile, seamless mechanical tube, thus the support masting can be lowered and raised through the rotator without having to move the rotator to one side. This eases the installation or take down of antenna and/or rotator while reducing installation hazards. Circle 236 on Reader Service Card.



## H-F Generator low inertia

D&R LTD., 402 East Gutierrez, Santa Barbara, Calif. Model D-1309 generator is a reliable power supply for missiles. At 6,000 cps with shaft speeds up to 60,000 rpm it develops 300 w and can be driven by a hot-gas turbine or other suitable means. Featured in the design are low inertia and short circuit protection. Unit weighs 8.5 oz and its measurements are 1.5 in. in diameter and 1.67 in. long. Circle 237 on Reader Service Card.

## Tiny Capacitor molded mica

GENERAL INSTRUMENT CORP., 65 Gouverneur St., Newark 4, N. J. Claimed to be the smallest molded mica capacitor ever produced, the Missilmite measures 0.0077 cu in. and weighs 1/2 gram. Designed to make smaller, lighter guided missiles possible, the device meets or exceeds critical military specifications. It will withstand operating

# DISTORTION ANALYSIS 20 cps to 600 kc

Two Marconi Wave Analyzers for evaluating the individual components of complex waveforms.

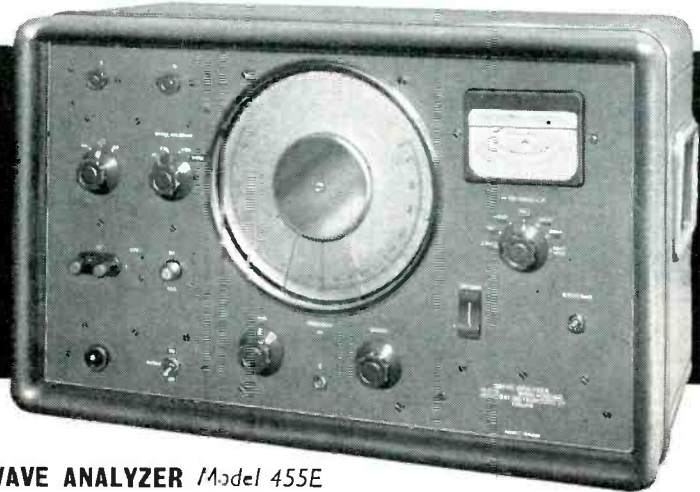

### WAVE ANALYZER Model 455E

Measures harmonics, intermodulation and noise in audio signals and also in modulation envelopes of rf carriers up to 500 mc.

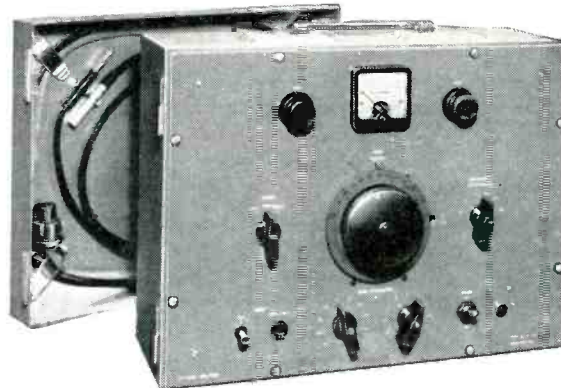

### HF WAVE ANALYZER Model 1270

Covers ultrasonic frequencies up to 600 kc. Particularly suitable for use on wide-band-modulation systems such as multi-channel links.

### SPECIFICATIONS

#### Model 455E

Frequency Range: 20 cps to 16 kc.  
Input Range: 30  $\mu$ v to 300 volts.  
Input Impedance: 0.1 to 2.5 megohms.  
Crystal filter gives 4-cps selectivity.  
RF Inputs: 100 kc to 500 mc, 1 to 4 volts.  
Power-line or battery operation.

#### Model 1270

Frequency Range: 10 to 600 kc.  
Input Range: 20  $\mu$ v to 2 volts.  
Input Impedance: 75, 600 & 10,000 ohms.  
Fundamental rejection filters for distortion measurement down to -90 db.

Send for leaflets B153

## MARCONI INSTRUMENTS

AM & FM SIGNAL GENERATORS  
AUDIO & VIDEO OSCILLATORS  
FREQUENCY METERS  
VOLTMETERS · POWER METERS  
DISTORTION METERS  
FIELD STRENGTH METERS  
TRANSMISSION MONITORS  
DEVIATION METERS  
OSCILLOSCOPES, SPECTRUM &  
RESPONSE ANALYZERS  
C. METERS & BRIDGES

111 CEDAR LANE · ENGLEWOOD · NEW JERSEY

TELEPHONE: LOWell 7-0607

Canada: Canadian Marconi Co · Marconi Building 2442 Trenton Ave · Montreal 16  
Marconi Instruments · St. Albans · Herts · England

# REGATRAN SEMICONDUCTOR POWER SUPPLIES

Transistorized  
for Reliability  
Short Circuit Proof  
for Dependability

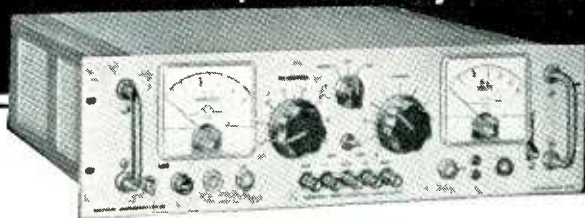

The exceptional reliability of transistorized power supplies is only available when the transistors are fully protected. That's why Regatran Power Supplies employ an exclusive all-electronic circuit breaker. In the event of a short circuit, transistor current is instantaneously cut off, output voltage drops to near zero. Power is restored by simply operating a reset switch located on the front panel.

There are many other features too: 0.1% regulation, less than one millivolt ripple, low output impedance, remote sensing, three-way circuit protection.

Wide range models cover a complete range starting at zero with maximum outputs up to 60 V dc. Narrow range models are available in every popular voltage rating up to 36 V dc. Request complete data from factory.

## WIDE RANGE MODELS

D-C OUTPUT		MODEL NO.	DIMENSIONS IN INCHES			APPROX. WEIGHT IN LBS.
VOLTS	AMPS		H	W	D	
0-7	0-15	TO7-15	8¾	19	15	40
0-7	0-5	TO7-5	5¼	19	15	30
0-14	0-10	TO14-10	8¾	19	15	40
0-14	0-5	TO14-5	5¼	19	15	30
0-32	0-15	TO32-15	8¾	19	15	70
0-32	0-5	TO32-5	5¼	19	15	40
0-36	0-15	TO36-15	8¾	19	15	70
0-36	0-5	TO36-5	5¼	19	15	40
0-60	0-7.5	TO60-7.5	8¾	19	15	70
0-60	0-2.5	TO60-2.5	5¼	19	15	40

## BRIEF SPECIFICATIONS

REGULATION: 0.1% or 0.01 volt, no load to full load, 105- to 125-volt line.

RIPPLE: Less than 1 millivolt rms.

CIRCUIT PROTECTION: Short circuit proof.

OUTPUT POLARITY: Positive, negative, or floating ground.

REMOTE SENSING: Eliminates effect of voltage drop in power leads.

® Registered U. S. Patent Office. Patents pending.

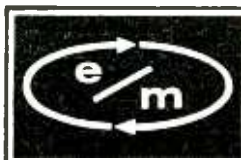

**ELECTRONIC  
MEASUREMENTS**  
COMPANY OF RED BANK  
EATONTOWN • NEW JERSEY

temperatures of  $-55^{\circ}\text{C}$  to  $+125^{\circ}\text{C}$ . Capacitance range is from  $5\ \mu\mu\text{f}$  through  $240\ \mu\mu\text{f}$ . Circle 238 on Reader Service Card.

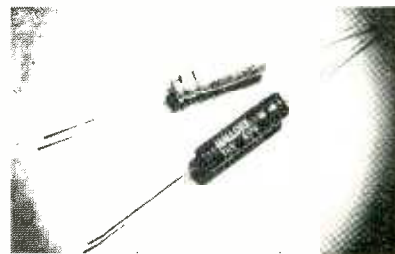

## Capacitors computer grade

P. R. MALLORY & Co., INC., Indianapolis 6, Ind., announces the THR miniature computer grade electrolytic capacitors. They are especially applicable to transistorized low voltage power supplies and to airborne uses requiring extreme reliability. A series of ratings from  $75\ \mu\text{f}\ 3\ \text{v d-c}$  to  $100\ \mu\text{f}\ 25\ \text{v d-c}$  is available in  $\frac{3}{8}$  in. diameter cases from  $\frac{3}{8}$  in. to  $1\frac{1}{2}$  in. long, fitted with No. 20 tinned axial leads. Capacity tolerance is  $-10$  percent to  $+100$  percent; temperature range,  $-40^{\circ}\text{C}$  to  $+85^{\circ}\text{C}$ . Circle 239 on Reader Service Card.

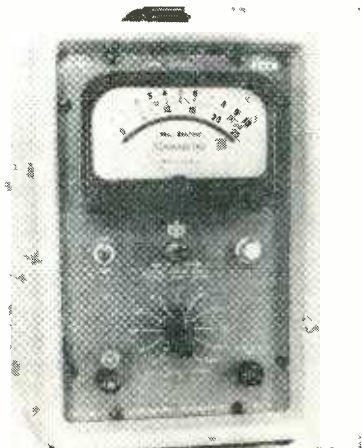

## Ohmmeter linear scale

MILLIVAC INSTRUMENTS DIVISION of Cohu Electronics, Inc., Box 997, Schenectady, N. Y. Model MV-279A direct-reading, linear-scale ohmmeter reverses previous resistance measuring techniques. Instead of measuring the current supplied to an unknown resistance by a fixed supply voltage, it meas-



ures the voltage drop produced across the unknown resistor by a constant current source. The direct-reading ohmmeter is accurate to 0.25 percent of full scale on its 11 measuring ranges from 1 ohm to 1 megohm. The linear scale reduces the danger of misinterpreting readings to a minimum. **Circle 240 on Reader Service Card.**



### Signal Generator 50 kc to 65 mc

HEWLETT-PACKARD Co., 275 Page Mill Road, Palo Alto, Calif. Model 606A signal generator covers the 50 kc to 65 mc range. It is particularly useful in driving bridges, antennas and filters, and measuring gain, selectivity and image rejection of receivers and i-f circuits. Output is constant within  $\pm 1$  db over the full frequency range, and is adjustable from +20 dbm (3 v rms) to -110 db (0.1  $\mu$ v rms). **Circle 241 on Reader Service Card.**

### Bench Punch highly versatile

WHITNEY METAL TOOL Co., 724 Forbes St., Rockford, Ill. The No. 118 punch is said to fulfill a big need in the electronic industry for a compact bench punch that has much capacity (2 in. hole through 14 gage), low price and extreme versatility. With an overall height (less the 24 in. handle) of 15 $\frac{1}{2}$  in. and a length of 14 $\frac{1}{2}$  in., this tool has a 7 in. throat depth and a 4 $\frac{1}{2}$  in. throat height. Other features are an adjustable ram, durability, removable ram cap, work table with gages, and a wide range of punch applications using readily available standard punches. Complete data are available from the manufacturer. **Circle 242 on Reader Service Card.**



## ...and now for the sealing test!

If the pots you need *must* function in a dust or sand environment, you *could* build 'em yourself to make *sure* they stay clean! But before you move heaven and earth while testing your creation, exactly what have you planned, to give you a tight seal, yet low torque? And if that isn't enough of a problem, how do you keep foreign matter out of the bearings?

But why move heaven and earth, mostly earth, to test your own dirt-free pot, when Ace has the pots with the dust-free features? Special O-rings seal sand, dust and other foreign matter eliminating abrasion damage. Our wound nylon packing delivers excellent sealing with *lowest* torque. Also, a special silicone-type grease, located in shaft pockets, captures foreign particles before they ever get a chance to do any damage. So if grit's a problem for you, come to Ace for the answer. See your ACErep!



*This 3" AIA Acepot (shown 1/3-scale), meeting all MIL spec's on sealing, incorporates these exclusive anti-dirt and dirt-trapping features. Mandrels are also fungicide-varnished, to insure long life.*

**ACE** ELECTRONICS ASSOCIATES, INC.  
99 Dover Street, Somerville 44, Mass.  
SOMerset 6-5130 TMX SMVL 181 West. Union WUX

Acepot® Acetrim® Aceset® Aceohm® \*Reg. Appl. for

# NOW

## A Silicon Rectifier to Replace Type 6X4 Tubes



### Tarzian

## TUBE REPLACEMENT TYPE S-5207 FULL WAVE SILICON RECTIFIER

Direct plug-in replacement for type 6X4 vacuum tube rectifiers . . . allows replacement of up to 5 6X4 tubes in parallel.

- Small Size
- Directly Interchangeable
- High Efficiency
- No Filament Power
- 500 ma dc, 1600 piv
- Rugged Construction
- Hermetically Sealed

#### DIMENSIONS

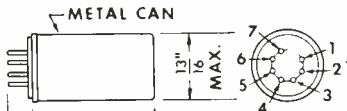

PIN CONNECTION  
PINS #1 AND #6 ARE A.C. (ANODE)  
PIN #7 IS POS. (CATHODE)

SEVEN PIN  
MINIATURE BASE

#### MAXIMUM RATINGS FOR S-5207 FULL WAVE SILICON RECTIFIER

PEAK INVERSE VOLTAGE.....	1600 V. MAX. PER SECTION
PEAK RECTIFIER CURRENT.....	5000 MA MAX. PER SECTION
D.C. OUTPUT CURRENT.....	500 MA MAX.
AMBIENT TEMPERATURE.....	100°C MAX.
REPLACES .....	TYPE 6X4

Write for Design Note #37

**SARKES TARZIAN, INC., Rectifier Division**  
DEPT. D-2 415 NORTH COLLEGE AVE., BLOOMINGTON, INDIANA

IN CANADA: 700 WESTON RD., TORONTO 9, TEL. ROGER 2-7535 EXPORT: AD AURIEMA, INC., NEW YORK CITY

## Literature of

### MATERIALS

**Rare Earth Metals.** Nuclear Corp. of America, 170 W. Proviencia St., Burbank, Calif. A new data sheet on rare earth metals, containing a price list of twelve of them, has been prepared. Circle 250 on Reader Service Card.

### COMPONENTS

**High Temperature Synchros.** Kearfott Co., Inc., 1500 Main Ave., Clifton, N. J., has published a bulletin describing a line of high performance synchros which operate effectively over a temperature range of -54 C to +200 C. Circle 251 on Reader Service Card.

**Power Packs.** Electronic Research Associates, Inc., 67 Factory Place, Cedar Grove, N. J., has available a two-color catalog sheet covering descriptive data on a new line of miniaturized magnetic-transistor regulated power packs. Circle 252 on Reader Service Card.

**Pressure Cutoff.** Datex Corp., 1307 S. Myrtle Ave., Monrovia, Calif. Bulletin 103 describes the PE-103 pressure cutoff which is specifically engineered for the simultaneous control of pressure data from a multiplicity of pressure channels. Circle 253 on Reader Service Card.

**Multiplexers.** Rantec Corp., 23999 Ventura Blvd., Calabasas, Calif. A 4-page folder describes a line of multiplexers which consist of coupled high Q coaxial band pass filters. Circle 254 on Reader Service Card.

**Components and Instruments.** Weinschel Engineering, 10503 Metropolitan Ave., Kensington, Md. A new short form brochure covers step attenuators, modulated rf sources, terminations and insertion-loss measuring equipment. Circle 255 on Reader Service Card.

**Transistor Products.** Ferrotran Electronics Co., Inc., 693 Broad-



## the Week

way, New York 12, N. Y., has available its 12-page, 1959 catalog of transistor equipment and components. Circle 256 on Reader Service Card.

### EQUIPMENT

**Glass Diode Sealer.** Kahle Engineering Co., 3322 Hudson Ave., Union City, N. J., has a descriptive catalog sheet of its automatic glass diode sealing machine which seals up to 1,500 glass diodes per hr. Circle 257 on Reader Service Card.

**Eddy-Current Equipment.** Dynamic Division, Eaton Mfg. Co., Kenosha, Wisc., has released a comprehensive illustrated bulletin describing its complete line of adjustable speed drive equipment for industrial applications. Circle 258 on Reader Service Card.

**Coil Winding Machine.** Carl Hirschmann Co., 30 Park Ave., Manhasset, L. I., N. Y., has available a 6-page brochure in color on the Micafil coil winding machines. Circle 259 on Reader Service Card.

**DRD Meters.** Kay Electric Co., Maple Ave., Pine Brook, N. J. A recent mailing piece contains description, features and specifications for a line of direct-reading digital frequency meters. Circle 260 on Reader Service Card.

**Instruments.** Bourns Laboratories, Inc., P. O. Box 2112, Riverside, Calif. An illustrated 8-page brochure summarizes key information on a line of linear motion potentiometers, pressure transducers, accelerometers and angular position transducers. Circle 261 on Reader Service Card.

### FACILITIES

**Radiation Facilities.** Radiation Dynamics, Inc., Westbury, L. I., N. Y., offers a 4-page bulletin describing the facilities, services, and potential applications of the new irradiation center located at its plant. Circle 262 on Reader Service Card.

# Wave Analyzer

## Type FRA2

- ★ BANDWIDTHS: 2, 25, and 125 cps
- ★ 3 microvolts to 400 volts
- ★ 0 to 16 kc
- ★ SIMPLIFIED AND STABLE INITIAL ADJUSTMENT AND BALANCING

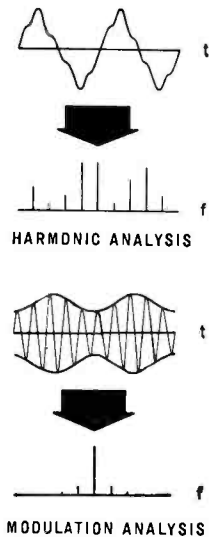

A new, improved Wave Analyzer with outstanding features:

- Spurious responses and harmonics are suppressed by 80 dB
- 1500 cps output available for a recorder (provisions for mechanical coupling as well)
- Type FRA2T, a special design with built-in Tone Generator (0 to 16 kc), simplifies selective measurement of frequency responses and recording of intermodulation phenomena. Remote control of output.

**ACCURACY: 0.5 dB**

**HUM: Below 5  $\mu$ volts**

**NOISE: Below 2  $\mu$ volts**

**MAIN DIAL: 0 to 16 kc, accurate within 1% + 1 cps**

**INCREMENTAL DIAL: 0 to  $\pm$  60 cps, direct reading**

WRITE FOR COMPLETE INFORMATION

Radiometer, a leading Scandinavian instrument manufacturer with a world wide service organization, offers a line of 50 different instruments such as:



AF-OSCILLATORS

R-L-C BRIDGES

STANDARD-SIGNAL GENERATORS

VACUUM-TUBE VOLTMETERS

ELECTROCHEMICAL INSTRUMENTS

# RADIOMETER

72 EMDRUPVEJ, COPENHAGEN NV, DENMARK

Representatives:

United States: **WELWYN INT. INC.**  
3355 Edgecliff Terrace  
Cleveland 11, Ohio

Canada: **BACH-SIMPSON LTD.**  
London  
Ontario

# How Long Does It Take



## to find the electronic test instrument you need?

... how can you be sure it's the best available for your needs?

Did you know that there are 4,500 different electronic test instruments manufactured by some 400 different companies?

Think of how many catalogs, spec sheets, and how much bombastic advertising you have to go through to find the instrument best suited to your needs!

Imagine the volume of correspondence and follow-up, the size of your filing system, the many telephone calls and interviews... the hours, days, weeks of valuable time involved!

And when you're all through, you still can't be sure you haven't missed something important—haven't compromised your needs somewhere along the way—or purchased something unnecessarily more elaborate and costly.

A SERVICE THAT PAYS FOR ITSELF MONTH AFTER MONTH, YEAR AFTER YEAR

All the headaches, uncertainty, and costly investment of time can be eliminated in *one stroke* through TECHNICAL INFORMATION SERVICE. The FREE brochure describes in detail how TIS works to make electronic test instrument selection swift, easy, and wise! If you don't have the problem, someone in your company does. Get a copy of the brochure for that man. He will be delighted to receive it. Use this convenient coupon. Do it NOW!... it's FREE and there's no obligation.

**ti TECHNICAL INFORMATION CORPORATION**

41 Union Square, New York 3, N.Y.  
WAtkins 4-2111

.....  
 GENTLEMEN: Code: 605  
 Send me the free TIS brochure, at no obligation.  
 NAME \_\_\_\_\_ TITLE \_\_\_\_\_  
 DEPT. \_\_\_\_\_ COMPANY \_\_\_\_\_  
 ADDRESS \_\_\_\_\_  
 CITY \_\_\_\_\_ ZONE \_\_\_\_\_ STATE \_\_\_\_\_  
 .....  
 CIRCLE 172 READERS SERVICE CARD

## NEW BOOKS

### Introduction to Nonlinear Analysis

By W. J. CUNNINGHAM.  
 McGraw-Hill Book Co., New York,  
 1958, 349 p., \$9.50.

FACED with the necessity of solving a mathematical problem arising in practice, an engineer is often disheartened when he discovers that it is nonlinear. The superposition principle is then no longer valid and the door is open to a bewildering variety of possible types of behavior.

The text under review is devoted to the exposition of some of the basic techniques that engineers can use in solving nonlinear differential equations in a single independent variable. It has been developed from courses that the author has offered to graduate students at Yale University. The background assumed consists of undergraduate engineering mathematics, electric circuit theory and mechanics. Numerical, graphical, and analytical methods of solving nonlinear problems are explained. The availability of elaborate computing machinery is not assumed and the discussion is limited to those methods and problems that can be handled with a slide rule or a desk calculator.

The book shows the hand and mind of a skilled teacher in its organization and exposition. Apart from its merits as a text for a formal course, the book is also suited for self-instruction, as it features throughout numerous completely worked examples. These range over many fields of application—for the most part electrical and mechanical, but occasionally also thermal and biological.

The book concludes with problems for the student and a bibliography.—C. F. REHBERG, *College of Engineering, New York University, Bronx, N. Y.*

### The Junction Transistor and Its Applications

By E. WOLFENDALE.  
 Macmillan Co., New York, 1958,  
 394 p., \$7.50.

THIS clear and useful introduction to junction transistor circuits is

A Message to Executives Seeking a New Plant Site



Check these 3 Important Plant Location Advantages in

## PENNSYLVANIA

100% financing for your new plant

Complete financing on lease-purchase plan—low interest rate—deferred amortization. Plant "shells" now being readied for completion. Inspection welcomed.

Improved "tax climate"

No capital stock and franchise taxes—no machinery and equipment taxes—no stock transfer tax—no state personal income tax—reduced manufacturer's sales tax.

Plant location services

Staff specialists available to serve industry, engineering firms, management consultants, industrial realtors and others with fully detailed plant location data.



For free copy of pamphlets on these Pennsylvania Plant Location Advantages, write or call:

PENNSYLVANIA DEPARTMENT OF COMMERCE

Main Capitol Building  
 407 State Street, Harrisburg, Pa.  
 Phone: CEdar 4-2912

CIRCLE 173 READERS SERVICE CARD

May 8, 1959 — ELECTRONICS



aimed principally at the newcomer to the field. The material is well organized, to the point and presents some basic techniques of practical transistor circuit design.

After developing the necessary background material, specific circuit configurations are discussed with a design objective, the techniques being illustrated by practical examples. Unfortunately, some of these examples may be misleading, since transistors currently available in the United States have greater capabilities than the book indicates.

Although the usual subjects are treated, several aspects of the coverage deserve comment. The inclusion of a chapter on class C amplification is worthy of special note. This mode of operation, particularly suited to the characteristics of the junction transistor, has been insufficiently emphasized in previous books.

The material on sinusoidal oscillators and amplitude modulation and detection is sketchy; fuller discussion of these subjects is definitely warranted.

The chapter on transistor d-c converters is probably the highlight of the book. Two conversion principles are extensively treated, the one based on the transformer, the other on the ringing choke. Although there are slight differences between British and American conversion methods, the material presented in this chapter should be found extremely useful. An outstanding feature of this book is its readability. The authors have kept analytic detail to a minimum and relegated derivations involving tedious algebra to appropriate appendices. This results in a book that is both an easy to use reference and a painless introduction to the junction transistor and its applications.—S. SCHENKERMAN, *Missile Development Div., Ford Instrument Co., Long Island City, N. Y.*

### THUMBNAIL REVIEW

Hanbuch Fur Hochfrequenz-Und Elektro-Techniker, V Band. Verlag Fur Radio-Foto-Kinotechnik GmbH, Berlin, Borsigwalde, Germany, 809 p, DM26.80. About 7000 terms with definitions of devices and techniques in the field of electronics.

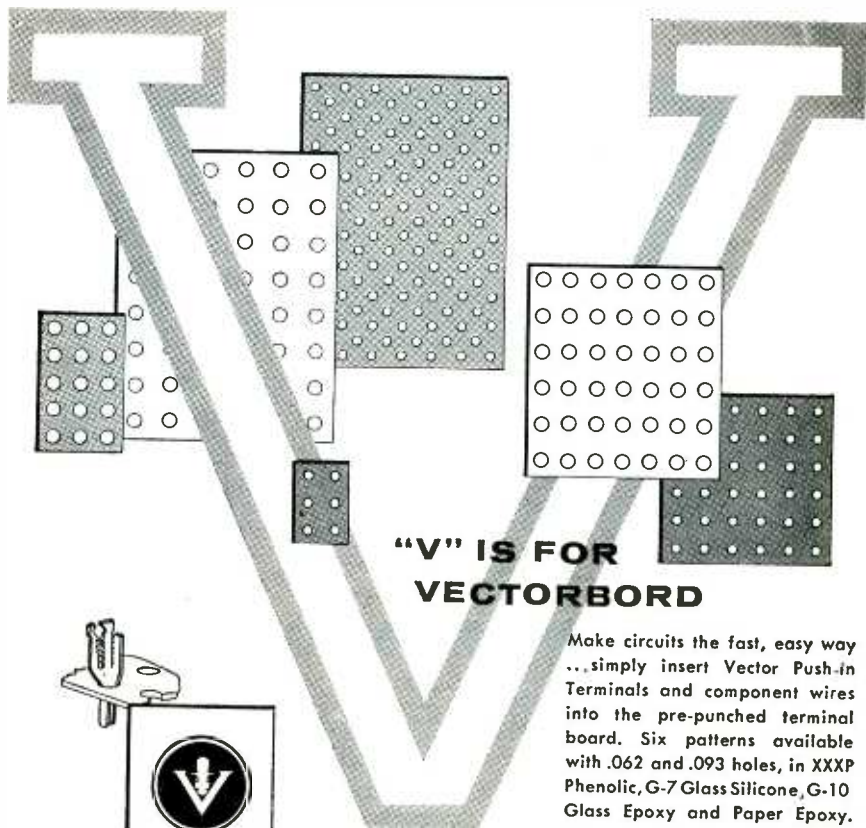

## "V" IS FOR VECTORBORD

Make circuits the fast, easy way .. simply insert Vector Push-in Terminals and component wires into the pre-punched terminal board. Six patterns available with .062 and .093 holes, in XXXP Phenolic, G-7 Glass Silicone, G-10 Glass Epoxy and Paper Epoxy.



Write for complete information to

### VECTOR ELECTRONIC COMPANY

1100 FLOWER STREET, GLENDALE 1, CALIFORNIA

TELEPHONE: CHapman 5-1076

CIRCLE 174 READERS SERVICE CARD



Pictured above: Western Electric employees, wearing Worklon uniforms of lint-free 100% Orlon, work on military electronic equipment in the dust-free Gyro manufacturing area at the Western Electric Company's Lexington Road plant, Winston-Salem, N. C.

## WESTERN ELECTRIC Combats Dust Contamination With WORKLON Uniforms Of Lint-Free 100% ORLON

When lint-free conditions are essential, leading plants and laboratories rely on lint-free 100% Orlon or 100% Dacron uniforms by Worklon. Savings are many times the low cost thanks to far longer wear, reduced product contamination, proved resistance to acids, other chemicals. Complete facts are furnished in Worklon's informative new catalog — yours for the asking!

**WORKLON**  
LINT-FREE  
Acid-Resistant Industrial Apparel

SEND FOR FREE CATALOG TODAY!

Worklon, Inc., Dept. E-59  
253 West 28th St.,  
New York 1, N. Y.

Kindly send new Worklon catalog FREE.

name \_\_\_\_\_  
co. name \_\_\_\_\_  
address \_\_\_\_\_  
city \_\_\_\_\_ zone \_\_\_\_\_ state \_\_\_\_\_





## Resistor Manufacturer Moves

ULTRONIX, INC., San Mateo, Calif., maker of precision wirewound resistors, has moved into a new \$100,000 plant in that city.

The new building is a two-story structure with 10,000 sq ft of manufacturing area. Features of the facility are high density lighting, vinyl tile flooring, precast tilt-up construction and an air-conditioned engineering production area. The building contains complete facilities for environmental testing to military specifications.

Ultronix, which was founded two and one-half years ago, by three of the present group of five stockholders, has grown from three to 90 employees in that time. Only a year ago the company ranked 25th in the manufacture of precision wirewound resistors. Now the firm claims to be one of the largest suppliers in the country, serving such organizations as Douglas, Lockheed, Ampex, MIT, and Sperry-Rand. Sales last year were \$1,100,000.



## Elect Ridenour To EIA Board

LOUIS N. RIDENOUR, vice president and general manager of Lockheed Aircraft Corp.'s newly formed electronics and avionics division, was

recently elected a member of the EIA board of directors. He replaces L. E. Root, vice president and general manager, missiles and space division, Lockheed Aircraft.

## Kulite Appoints Senior Engineer

SEYMOUR ROSENBAUM recently joined the engineering and development staff of Kulite Tungsten Corp., Ridgefield, N. J., as senior engineer. He will be in charge of development of refractory metals and alloys for high temperature and other applications by vacuum casting and/or powder metallurgical means.

Prior to joining Kulite, Rosenbaum was senior metallurgist of the research and advanced development division of Avco Mfg. Corp., Wilmington, Mass.

## John Fluke Co. Erecting Plant

CONSTRUCTION has begun on a new plant for John Fluke Manufacturing Co., Seattle, Wash. The new facility will have approximately 18,000 sq ft of space. Its location is just north of Seattle in the town of Mountlake Terrace, Wash.

The Fluke Co. is a manufacturer of precision electronic instruments and employs approximately 70 people. Occupation of the plant is expected late in July.



## Name Kimball TRG Director

ELECTION of Dan A. Kimball, president of Aerojet-General Corp of Azusa and Sacramento, Calif., as a director of the Technical Research Group, Inc., Syosset, L. I., N. Y., was recently announced.

At the same time it was revealed that Aerojet-General has purchased a minority interest in TRG, Inc., and that the two companies will work jointly on advanced optical detection systems of interest to the national defense.

## Clairex Opens In Puerto Rico

PHOTOCONDUCTIVE cells utilized in many industrial and military applications will soon be produced in Puerto Rico as the Clairex Corp. of Puerto Rico announced the opening of its plant there. The principals of the new organization are the



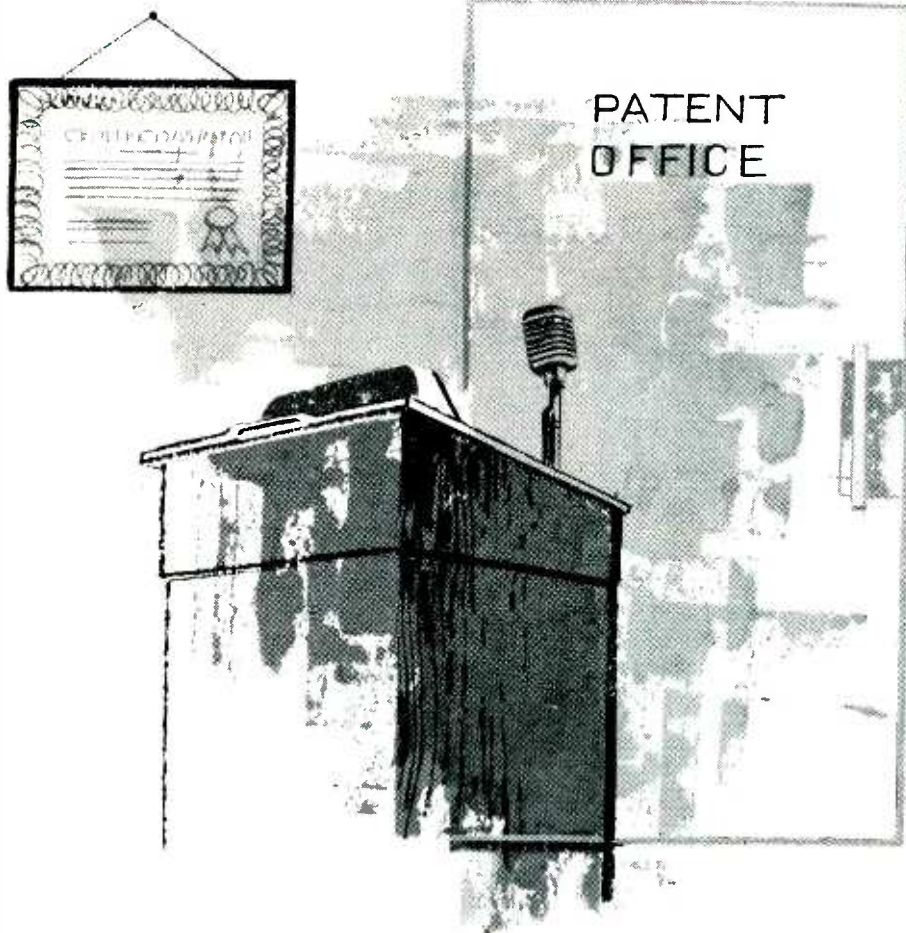

## How far can an engineer go at AC?

- Inertial Guidance Systems
- Afterburner Fuel Controls
- Bombing Navigational Computers
- Gun-Bomb-Rocket Sights
- Gyro-Accelerometers
- Gyroscopes
- Speed Sensitive Switches
- Speed Sensors
- Torquemeters
- Vibacall
- Skyphone



If you are a graduate engineer in the electronics, electrical or mechanical fields, you are recognized as a *professional* when you work in AC's instrumentation business.

AC encourages you to write and present papers at professional society meetings. What's more, if your original research and experimentation leads to new inventions, AC will assist you in obtaining patents.



You can also enhance your status through advanced training. AC offers three special "in house" programs—for recent graduate engineers, for experienced engineers and for engineering supervisors. These practical courses constitute AC educational "extras" and are second to none in the country. They're offered in addition to the AC and General Motors educational assistance programs for men who wish to take advanced studies in nearby universities.

These are just a few of the advantages you'll enjoy while you work on AC's famous AChiever inertial guidance system or a wide variety of other electro-mechanical, optical and infra-red devices . . . for today and the "space age."

Step into the "space age" with the greatest name in industry . . . General Motors. Just write the Director of Scientific and Professional Employment: Mr. Robert Allen, Oak Creek Plant, Box 746, South Milwaukee, Wisconsin.



SPARK PLUG ⚡ THE ELECTRONICS DIVISION OF GENERAL MOTORS

# AMCI AUTOMATIC IMPEDANCE PLOTTERS

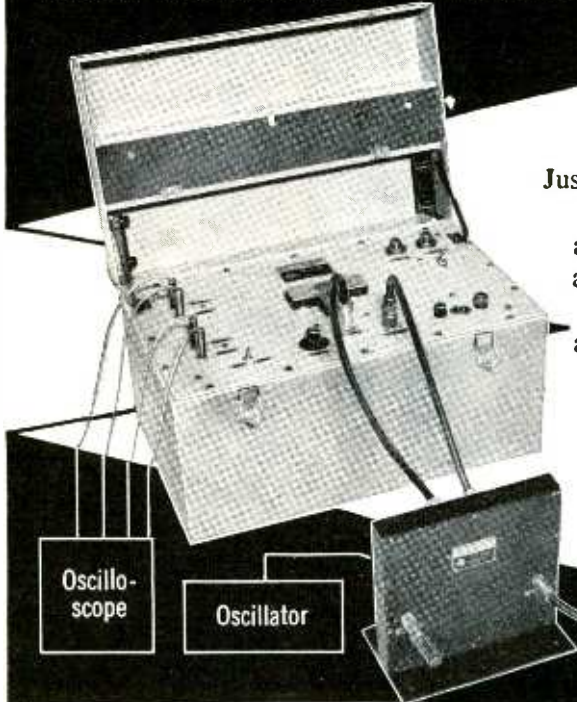

## For Lab or Production Testing

Just turn the oscillator dial, manually or by a motorized sweep drive, and the impedance curve of load Z is traced on a regular or an expanded Smith chart.

Either an oscilloscope or a two-axis recorder can be used.

Write for catalog.

Oscilloscope

Oscillator

Load "Z" to be measured



**ALFORD**  
Manufacturing Co.  
299 ATLANTIC AVE., BOSTON, MASS.

Model 12 ..... 2.5 mc.-250 mc.  
Model 11-Q ..... 30 mc.-400 mc.  
Model 11-PS ..... 180 mc.-1100 mc.

INSTRUMENTS - ANTENNA SYSTEMS - COMPONENTS - AIR NAVIGATION AIDS

CIRCLE 176 READERS SERVICE CARD

same as those for Clairex Corp., New York, which for the last six years has devoted itself exclusively to the development and manufacture of photoconductive cells.

Immediate purpose of the Puerto Rican enterprise is to provide expansion for the manufacture of these cells for the new automobile and photographic markets. The decision to expand in P.R. was determined by considerations of climate, availability of competent personnel, and the advantages of the tax structure.

## Bright Joins Denver Labs

JAMES A. BRIGHT has joined the technical staff of Denver Laboratories of Ramo-Wooldrige, a division of Thompson Ramo Wooldrige Inc. He was formerly with McDonnell Aircraft Corp. where he was a development engineer in the electronics department of the airplane engineering division.

*This is not an offer of these Securities for sale. The offer is made only by the Prospectus.*

## 130,000 Shares Moog Servocontrols, Inc. Common Stock

(\$1 Par Value)

Price \$15 per Share

*Copies of the Prospectus may be obtained in any State in which this announcement is circulated from only such of the underwriters, including the undersigned, as may lawfully offer these securities in such State.*

Kidder, Peabody & Co.

Blunt Ellis & Simmons

A. G. Becker & Co.  
Incorporated

Paine, Webber, Jackson & Curtis

F. S. Moseley & Co.

Shearson, Hammill & Co.

G. H. Walker & Co.

April 28, 1959.



## Filtors Names J. J. Carlin

APPOINTMENT of James J. Carlin to the position of production engineer at Filtors Inc., Port Washington, N. Y., is announced. Improved relay reliability, the development of new production methods, and the acceleration of present production procedures are among his main duties.

Before coming to Filtors, Carlin



spent five years with United Aircraft, Norden-Ketay Division, Com-mack, N. Y., where he was responsible for setting new production records as superintendent of the potentiometer plant.

Prior to that he was with Fairchild Camera and Instrument Corp. where he spent two years working on their electromechanical installations.

## News of Reps

Cashin-Tipton and Associates of San Diego, Calif., has been selected to represent Fairchild Controls Corp., Hicksville, N. Y., in San Diego County.

Scientific Sales Engineering Co., manufacturers reps for the southeastern United States, has been named to represent Ultronix, Inc., San Mateo, Calif., manufacturer of precision wire wound resistors and trimming potentiometers.

A new sales engineering organization, Dyna Sales Co. of Los Angeles, Calif., will represent several major manufacturers of instrumentation and control systems and related components in the southern California area. Company is now representing Allegany Instrument Co., Inc. of Cumberland, Md., and Moran Instrument Corp. of Pasadena, Calif.

Appointment of Barry E. Houser of Perth Amboy, N. J., as sales rep for the territory consisting of Delaware, Maryland, Washington, D. C., eastern Pennsylvania, New Jersey and parts of Virginia, is announced by Delttime, Inc., Mamaroneck, N. Y.

Contacts, Inc., Wethersfield, Conn., recently appointed two new reps. John W. Shannon of Arlington Heights, Ill., will cover the Chicago area; Gordon Fixman of St. Louis, Mo., the St. Louis area.

Sterling Transformer Corp., Brooklyn, N. Y., has appointed Naudain & Bohaker of Philadelphia, Pa., as sales reps in the Philadelphia, south Jersey, Maryland and Virginia areas.



Scylla



Naval Research Lab's  
Condenser Battery



Columbus II

Of particular interest to the thousands of international visitors to the historic Geneva Atoms-For-Peace Conference, was the display of thermonuclear fusion research equipment which the U. S. Government set up. Significantly, several of these devices use low-inductance condensers made by Tobe. Three of the machines are shown here.

Even now—long after the conference—Tobe receives inquiries and orders from every corner of the globe. The postmarks read like a roll call at the United Nations: Great Britain, Japan, Italy, U. S. S. R., France,

Brazil, The Netherlands, Sweden and many others.

Scientists and engineers of these countries are in perfect accord in their recognition of Tobe's achievements in thermonuclear condensers. For the fact is that when controlled, power-producing fusion is a reality, Tobe will have had a hand in it.

But why wait till then for Tobe's aid? Tobe's "creative engineering in action" will help you solve your present condenser problems. Talk to Tobe today. Tobe Deutschmann Corporation, Norwood, Mass.

specify  
**TOBE**  
PRODUCTS

**TOBE DEUTSCHMANN • CONDENSER PIONEERS SINCE 1922**

# RUGGED and RELIABLE New! TRANSISTORIZED

The  
**A. W. HAYDON COMPANY'S  
TRANSISTORIZED SUB-MINIATURE  
ELECTRONIC TIME DELAY RELAYS!**

**SAVE SPACE AND WEIGHT!**

	Miniature Series	Sub-Miniature Series
Cross Section	1 7/16" x 1 1/2"	3 1/2" x 1 3/16"
Length	2 1/4" long	2" long
Weight	6 ounces	3 ounces
WRITE FOR:	Bulletin AWH TD-503	Bulletin AWH TD-504

**TEST-PROVED PERFORMANCE!**

High Temperature: 125°C (250°F)  
Vibration: 2000 CPS of 15 g.  
Contact arrangements up to 4 pole double throw.  
Unique transistorized R.C. time constant network.  
Time Delays from 50 MS to 120 seconds. Longer Delays available.  
Hermetically sealed housings.

MEET  
REQUIREMENTS  
OF MIL-E-5272A.



The  
**A.W. HAYDON Company**

235 NORTH ELM STREET, WATERBURY 20, CONNECTICUT  
Design and Manufacture of Electro-Mechanical Timing Devices



CIRCLE 179 READERS SERVICE CARD

## COMMENT

### No Wonder Missile Signals Fail!

(In "Why Missile Signals Fail," p 42, Apr. 10) you show Palo Alto about half way down the west coast of the peninsula of Baja California.

Perhaps your draftsman should repeat Geography I or stand with his face in the corner.

Palo Alto is about half way down the San Francisco peninsula, one day's journey on horseback south of Mission San Francisco de Assis, on the Camino Real, in the ancient province of Alta California, and has so been since 1774.

This ancient province has now become the state of California, a part of the United States of America; the mission is now within the confines of the city of San Francisco; the Camino Real is still an important highway; the Palo Alto, from which the city takes its name, is still standing.

RONALD L. IVES

PALO ALTO, CALIF.

Reader Ives is right, and our apologies to Palo Alto. Our cartographer is also still standing—in the corner.

### More for Standards

I found the plea for standardization in Mr. Jump's letter (Comment, p 96, Apr. 3) quite interesting. I have thought that the use of standard terms and drawing symbols would make the reading and understanding of electronic literature a great deal easier for the reader.

This could be accomplished by following the military standards that have been established and are in the files of most concerns, especially those doing prime or sub-contract work for the government.

Use of the military standards would cover component and part nomenclature such as the rectifiers Mr. Jump mentioned, but not such general terms as commercial or industrial. In the latter case, I would venture to say that the electronics field is divided into consumer, industrial (preferable to commercial) and military markets.

As to the choice between diode

## Electrical Coil Windings

For 40 years . . . specializing in all types of coils to customers' specifications. Design or engineering assistance available on request.

# COTO-COIL CO., INC.

SINCE 1917

65 Pavilion Avenue Providence 5, Rhode Island

CIRCLE 180 READERS SERVICE CARD

### MEET ED DeJONGH

Associate Editor, electronics  
MARKET RESEARCH EXPERT



A graduate of Oberlin, BA, and Harvard Business School, MBA, Ed DeJongh is the researcher and analyst who is responsible for "Market Research", "Figures of the Week", sales estimates, sales forecasts, marketing news, and developments in marketing. Ed is constantly preparing for a year-end statistical issue and forecast for the following year. If you're not a subscriber, if your subscription is expiring, if you need market data in your work, fill in box on Reader Service Card. Easy to use. Postage free.



**electronics**



A McGraw-Hill Publication  
330 West 42nd Street, New York 36, N. Y.



## Meet Bill O'Brien

Associate Editor, **electronics**  
New Products, Plants, People...



### Resumé:

O'Brien, William P., St. Joseph's College, A.B. 4 years, Army Signal Corps. Radio Operator's school, Ft. Monmouth. Radar and radio operator. Expedited government contract awards, Gibbs and Cox, Inc., naval architects. More than 13 years on **electronics** editorial staff; 10 years as editor for new products, plants and people.

### References:

Bill's job of keeping track of the products, plants and people in the electronics field provides readers with the kind of information that keeps them abreast of the latest happenings... the kind of editorial that makes **electronics** 26-man staff unique. Only with a large staff of specialists is it possible to fill the readers' needs in this fast-moving, fast-growing industry.

If you're not a subscriber, if your subscription is expiring, if you will miss important news, exciting features planned in coming issues, fill in the box on the Reader Service Card. Easy to use. Postage is free.

**electronics**  
A McGraw-Hill Publication  
330 W. 42nd St., New York 36, N.Y.

and rectifier, the Federal Cataloging Handbook H6-1 defines a metallic rectifier as an electrical item of which the working element is constructed essentially of metallic substances which changes alternating current by the rectifying action occurring at the junction interface between a metallic conductor and a semiconductor. A semiconductor diode is defined as a two-electrode semiconductor device containing germanium or silicon and having an asymmetrical current-voltage characteristic.

Most people in the electronic field have been exposed to military standards to a considerable degree either in military service or in work done for the government, and thus have a fair knowledge of what they encompass. This, in addition to the close cooperation between the Department of Defense and industry groups such as the American Standards Association and the Electronic Industries Association, provides a means of establishing a universal standard by common usage. Where military standards do not exist, those adopted by the American Standards Association could be used.

HAROLD M. HONIG  
TUNG-SOL ELECTRIC  
LIVINGSTON, N. J.

It seems to us that if a diode (as the name indicates) is a device with two active elements, then a rectifier is only a special class of diode, whether it's solid, gas-filled or operating in a vacuum. The word "rectifier" seems more clearly to describe a function than a device.

### Radiation Charts

Unfortunately there were two errors in ("Radiation Charts for Paraboloidal Antennas," p 104, Sept. 12 '58). You may find it desirable to print a brief correction notice.

The second paragraph contains a statement which should read:  $u = \frac{2a\pi}{\lambda} \sin \theta \dots$  etc.

The third paragraph should not have contained the final exponential; rather just:  $F(r) = e^{-kr^2}$ .

LAWRENCE LECHTRECK  
CREVE COEUR, MO.

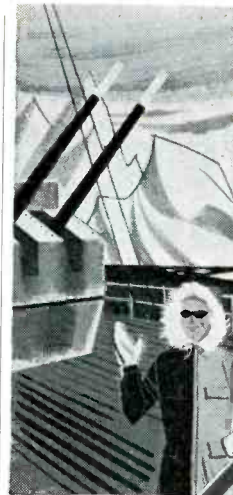

### Anywhere...

At sea, in the icy cold of the antarctic  
S.S. WHITE Molded Resistors in values up to 50,000 megohms retain their characteristics.

### in Any Weather

Airborne, in the steaming heat of the tropics!  
S.S. WHITE Molded Resistors are made of coated, non-hygroscopic material that resists moisture.



*S.S. White*

**"ALL-WEATHER"**

Molded Resistors  
Withstand Temperature  
and Humidity

FIXED RESISTANCE VALUES RANGE  
FROM 1000 OHMS TO 10,000,000  
MEGOHMS!

65X Molded Resistor — 1 watt  
80X Molded Resistor — 3 watts

While bargain buys in resistors are wearing out and being replaced, durable S.S. WHITE "All-Weather" Molded Resistors are still giving top performance in hundreds of commercial, industrial and scientific applications.

Our resistors are characterized by low noise level... precision... stability... have negative temperature and voltage coefficients. Compact... excellent stability and mechanical strength... values do not deteriorate due to age.

We'll be glad to cooperate with you in applying these high-quality resistors to your product. For our Bulletin 5409, just drop a line to Dept. R.

*S.S. White*  
**INDUSTRIAL DIVISION**

10 East 40th Street  
New York 16, New York  
CIRCLE 183 READERS SERVICE CARD

# ENGINEERS ERCO

a pioneer and one of the leading producers of electronic flight simulators, is increasing its engineering activity to include volume engineering programs in the fields of analog and digital computer techniques, telemetry, transistor applications and light/optical scanners.

Challenging and diversified assignments in Product Design are offered by this constantly growing organization to the career-minded engineer who wishes to combine stability with the latitude necessary for rapid professional and financial growth. Immediate opening exists for qualified, professional personnel whose areas of experience coincide with the following requirements:

## CIRCUIT DESIGN JUNIORS, INTERMEDIATE AND SENIOR.

B S E E for transistor circuitry, application, analog and digital computer techniques, DC amplifiers, simulation, telemetry and design of systems and components.

B S in physics, plus experience in one or more of the following: optics, hydraulic instrumentation, human engineering, numerical analysis, computer techniques.

## HUMAN FACTORS

PhD degree in experimental, physiological or industrial psychology with 3 to 5 years' industrial experience as engineering psychologist or comparable years of experience with military as training and/or proficiency measurement specialist. Will head 3-man team conducting plant-wide human factors efforts, including human engineering of high fidelity weapon system simulators and trainers.

## TECHNICAL WRITERS

B S in E E or Physics, or equivalent, plus 2 years' experience in the preparation of operational and maintenance manuals & engineering reports concerning electronic systems & components.

## EXCELLENT SALARIES

*Commensurate with Education and Experience*

**Modern Company Benefits  
including Educational Assistance Plan**

**Relocation Assistance**

**Ideal Living Conditions in suburban Washington, D. C.**

Send resume To:

Mr. R. J. Reid, Technical Employment Manager

## ERCO PLANT

Nuclear Products—Erco

DIVISION OF ACF INDUSTRIES INCORPORATED  
RIVERDALE, MARYLAND      WARFIELD 7-4444

## OPPORTUNITIES CONTROL CIRCUIT ENGINEERS

For systems and control circuit design work—as well as definition of basic techniques for improving performance characteristics — utilizing transistors, magnetic devices and servomechanisms.

Qualifications: B.S.E.E. with up to eight years' experience is required. June 1959 B.S.E.E. graduates are also desired.

At IBM you'll have unusual professional freedom, work with specialists of diverse backgrounds, have access to a wealth of systems know-how.

Whether you're a man who likes to work independently or as a member of a small team, your contributions and achievements will be quickly recognized.

You may participate in a wide range of educational programs. In addition, you enjoy all the other advantages of IBM employment: job stability, liberal company benefits, excellent salaries.

Write, outlining your qualifications and experience to:

Mr. W. R. Berg,  
Dept. 554E2  
IBM Corporation  
Endicott, New York

# IBM<sup>®</sup>

INTERNATIONAL BUSINESS  
MACHINES CORPORATION



# 20-second quiz for electronics engineers:

*(the prize could be the most important step forward of your entire career)*

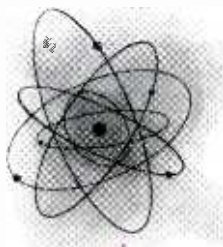

**1** Have you worked in electronics for 3 to 5 years?

YES  NO

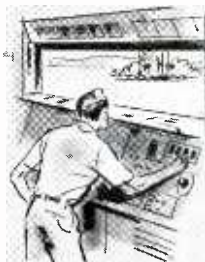

**2** Experienced in telemetering, microwave antennas, servomechanisms, systems engineering, reliability evaluation and analysis?

YES  NO

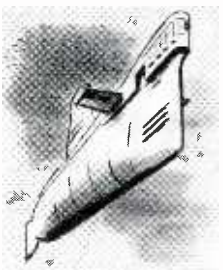

**3** Interested in projects like Subroc, new underwater-to-underwater missile? Or Pinpoint Guidance—designed to steer interplanetary vehicles unerringly through space, advanced aircraft and missiles straight to target?

YES  NO

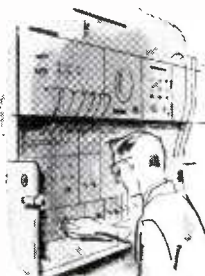

**4** Would you prefer a position of specific responsibility, but with plenty of creative elbowroom?

YES  NO

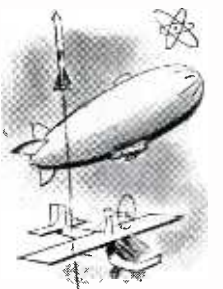

**5** How about job security? Would you rather work for an established company with a high degree of diversification—and a proved record of success in many fields?

YES  NO

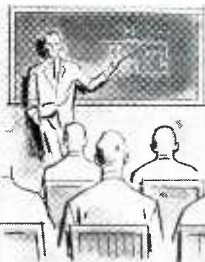

**6** Do you feel that you're ready for the big move of your career—the move that will enable you to grow professionally and increase your income at the fastest possible rate over the long haul?

YES  NO

*IF YOU'VE ANSWERED "YES" to these six questions, it will pay you to investigate the select engineering opportunities which exist for you at Goodyear Aircraft—prime contractor of Subroc—America's largest producer of rocket-engine cases—pioneer of Pinpoint Guidance—builder of the largest acquisition radar structures in history and creator of ground-support structures of unparalleled mobility.*

*Write today—in complete confidence—to: Mr. C. G. Jones, Manager, Personnel, Goodyear Aircraft Corporation, Akron 15, Ohio*

# GOODYEAR AIRCRAFT

Laboratories in Akron, Ohio, and Litchfield Park, Arizona

Pinpoint—T. M. Goodyear Aircraft Corporation, Akron 15, Ohio

## PERSONNEL MANAGERS

### LOOKING FOR Experienced Engineers . . . Technical Personnel?

Write for a free copy of:

#### **"How You Can Reach The Experienced Engineer . . ."**



The top-flight engineers and technical personnel you want are at a premium...as this twelve page booklet points out. How you can reach and influence these men is the story told.

The booklet tells where to find the experienced engineer. It explains how you can make contact . . . channel and concentrate your employment advertising to just the men with the job qualifications you want. Included are testimonials from personnel men who use technical publications successfully . . . sample advertisements that got results . . . helpful hints to consider and pitfalls to avoid when you prepare your copy and layout for an Employment Opportunity advertisement.

Write for your free copy to:

Mr. Thomas Bender  
Classified Advertising Division  
McGraw-Hill Publishing Co., Inc.  
P.O. Box 12  
New York 36, New York

#### Fellow Engineers and Scientists:

My company has asked me to tell you of the unusual opportunities in operations research at System Development Corporation. These range from positions for engineers and scientists who would like to develop their skills working in a team under an experienced leader to opportunities for those who are looking for positions of leadership. I hope that the following account of our work will lead you to inquire for further information.

Briefly, SDC's business is automated decision-making systems. More fully, we develop large scale, computer-based information processing systems in which the computer is used as an on-line, centralized control element for a system operating in real-time. At this stage of the art these systems are semi-automatic, the man-machine type in which man shares the repetitive control function with the computer. Our work is concept-oriented, rather than hardware-oriented, and deals with problems of over-all system design, data processing development, and man-machine system training.

The most fully developed large-scale semi-automatic system is the SAGE (Semi-Automatic Ground Environment) Air Defense System. We have a major responsibility in the development of SAGE. Our experience and unique team skills have led to diversification of our activities; we now have important contracts for other major military and government systems vital to our country. The demand for our services is reflected in our growth from 70 to more than 2,700 employees since 1955, and the intriguing possibilities of automated decision-making are only beginning to be realized.

In this brief message, I can only suggest the variety of operations research problems at SDC. Perhaps the most important point is that this variety is limited only by the imagination and initiative of our scientists.

Some examples of areas of work are: (1) allocation of decision-making functions between man and machine for optimal system performance; (2) measures of system capacity and system performance; (3) exploration and evaluation of design changes by operational gaming; (4) quality control and testing of operational computer programs; (5) allocation of computer capacity among several system functions; (6) scheduling and costing of production of operational computer programs; (7) optimal assignment of mixed weapons to targets.

SDC recognizes the importance of a well planned research program for the vitality and future of the company, and we are carefully organized to carry out such a program. The following are some areas our operations research people are involved in: (1) simulation and operational gaming techniques in problems of control systems; (2) information retrieval and theory of information processing; (3) medical data processing; (4) universal language for computer programming; (5) logistics. We have unusual facilities for research at SDC—these include one of the largest computer facilities in the world and outstanding simulation laboratories.

We have given considerable thought to organizing the activities at SDC to provide for professional development and self-expression. Operations research professionals are carefully assigned so that their individual talents are matched with company needs. These assignments are reviewed regularly to make sure that developing talents are directed into new company opportunities. We regard the publication of research articles and participation in professional societies as activities important to the company. We encourage new ideas and provide the time and means to explore them.

SDC is one of the leaders in a field which will have a remarkable technological and scientific development. It is a new and vigorous company with a bright future. I encourage you to join us.

Please write Mr. R. W. Frost at the address below if you wish to pursue this invitation.

*William Kaush*





William Karush  
Assistant Director for Research  
Operations and Management Research  
System Development Corporation

## GENERAL DYNAMICS ELECTRIC BOAT DIVISION

Designers & Builders of Nuclear Submarines

### *Invites Inquiries From* **ENGINEERS**

Interested in Unique Problems

This division of General Dynamics is currently working on 7 nuclear powered submarines (including the Polaris missile firing A Subs) as well as advanced research and development in a variety of fields. The design and construction of nuclear powered submarines and their attendant systems pose unique and intricate problems to challenge the imagination.

#### IMMEDIATE OPENINGS IN:

**MISSILE CONTROL SYSTEMS**—BS or MS degree in EE. For technical direction and coordination of installation and testing of Polaris weapons systems on nuclear powered submarines. 2 to 5 years experience desired in fire control, navigation, guidance or launching systems.

**CIRCUITS & EQUIPMENT**—Development of circuits and equipment in conjunction with missile and navigation systems installations aboard submarines. Requires EE degree with advanced courses and experience in servomechanisms.

**ELECTRICAL SYSTEMS**—1, 5 years experience on shipboard electrical systems design. For design of electrical power and control systems for prototype nuclear propulsion systems for a marine gas cooled reactor plant.  
2. EE, ME or Physics degree required. Responsible for conceptual engineering and systems analysis of large complex devices employing a combination of electrical, electronic, electromechanical, hydraulic and pneumatic systems. Should be familiar with servomechanisms theory, experienced in use of analog or digital computers as a design tool, and have a good grasp of mathematics. Will work on proposal preparations, feasibility studies and execution of hardware contracts.

**SERVOMECHANISMS**—For engineering design of servomechanisms in both the instrument and multiple horsepower class. Will interpret performance specifications and be responsible for design of a system in accordance with the specifications, including stability studies, and the calculation of other performance criteria.

**COMPUTERS**—Responsible for conceptual engineering and programming of special purpose digital and analog computers. Should be familiar with system engineering, experienced in programming and check systems for both analog and digital computers, with good grasp of simulation techniques. Requires EE, Physics or Mathematics degree.

**CIRCUITS**—Responsible for conceptual and production engineering of electronic equipment. Familiar with servomechanisms and analog computer theory. Experienced in use of semiconductors, magnetic amplifiers and vacuum tube circuit elements; good grasp of mathematics; EE or Physics degree.

.....

Electric Boat Division's location—just half way between New York and Boston on the Connecticut shore near New London—provides excellent living and working conditions. To arrange convenient interview appointment at General Dynamics headquarters in New York, or at Electric Boat Division in Groton, send your resume, in confidence to James P. O'Brien, Technical Employment Supervisor.

## GENERAL DYNAMICS ELECTRIC BOAT DIVISION

GROTON

CONNECTICUT



## job too confining?

Sometimes circumstances place a good engineer in a small assignment that cramps his design capabilities. Gilfillan has a number of openings that would be especially appealing to the professional engineer who requires a position offering diversified technical challenge. Vacancies now exist for electronic engineers with a minimum of 2 years experience in missile systems, microwave, radar receivers, digital computers, and countermeasures.

You owe it to  
yourself to write to

**Gilfillan** 

DIR. SCIENTIFIC PERSONNEL, DEPT. 54  
1815 VENICE BLVD., LOS ANGELES, CALIF.



complete tracking systems

a basic pursuit of

PHILCO

# WESTERN DEVELOPMENT LABORATORIES

PALO ALTO

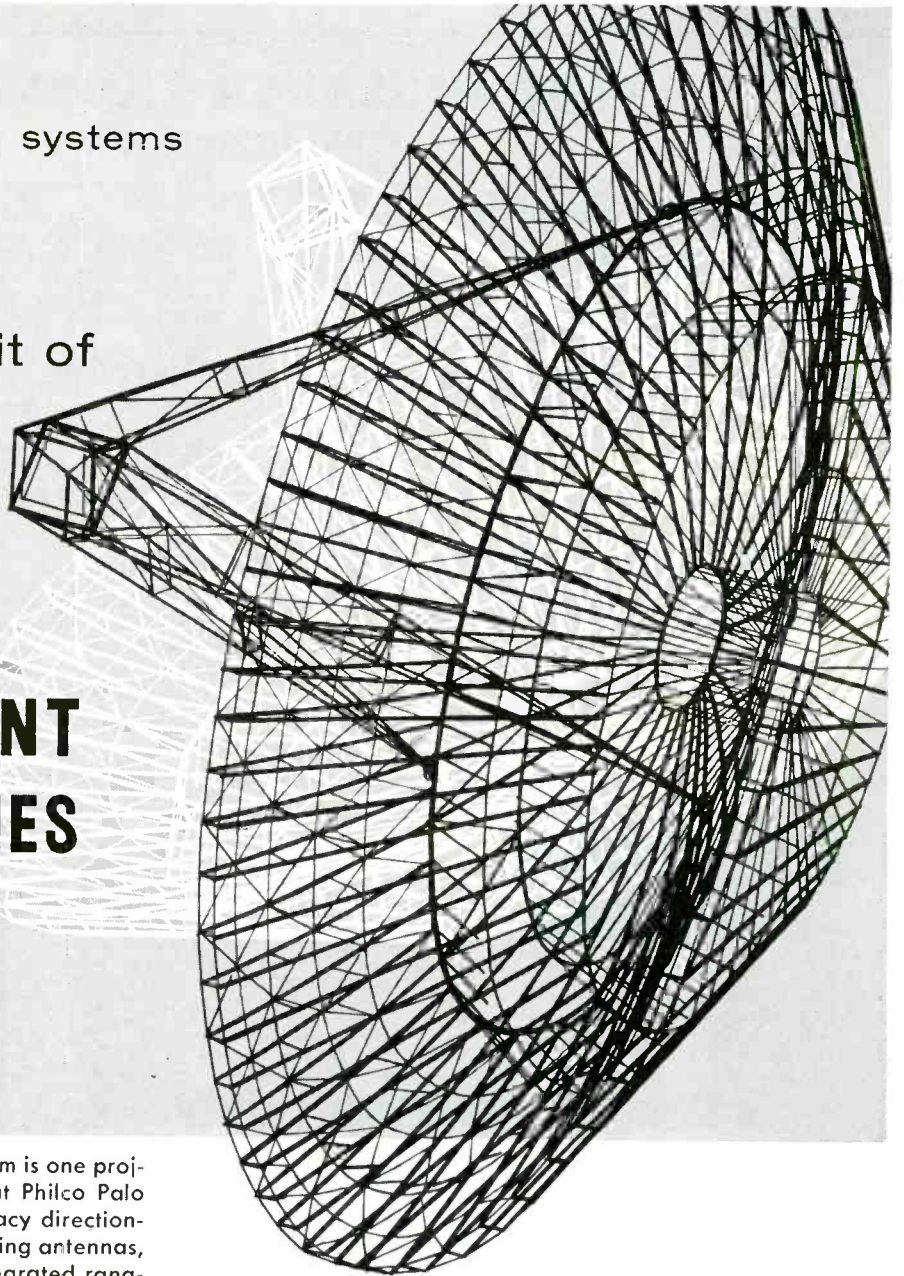

An all-new, complete Space Tracking System is one project now under design and construction at Philco Palo Alto. The project encompasses high-accuracy direction-finding antennas, large passive slave-tracking antennas, high power transmitting antennas and integrated ranging equipment.

Pioneering in the precision tracking field, Philco Palo Alto needs alert, creative, enthusiastic Engineers and scientists of all levels who are qualified in structural, RF and servo design.

*Your confidential inquiry is invited; please write H. C. Horsley, Dept. E*

## PHILCO WESTERN DEVELOPMENT LABORATORIES

3875 Fabian Way, Palo Alto, California

A part of the Government and Industrial Division of Philco Corporation

5510

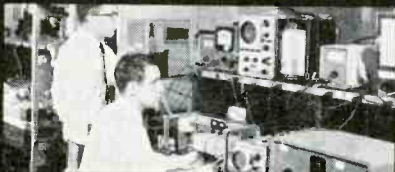

Measuring phase stability vs. temperature during prototype equipment development

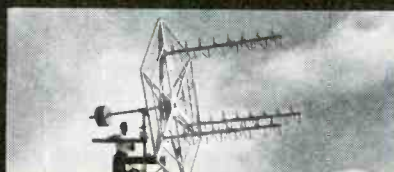

Developmental helical antenna, part of sophisticated new direction finder system



Pattern measurements—vital to development of a microwave dish antenna

# ESSO RESEARCH LABORATORIES

BATON ROUGE, LA.

An Engineer Skilled In  
**ELECTRONICS**  
**MATHEMATICS**  
**INSTRUMENTATION**

**SALARY COMMENSURATE  
 WITH QUALIFICATIONS**

**For:**

Challenging work in a promising field with an organization interested in process simulation and high speed plant measurements by electronic means. Large digital and analog computers available. This growth field offers a variety of opportunities for advancement.

**Job Description:**

- Application of special electronic equipment to pilot plant studies.
- Integration of process and instruments for more advanced control systems.
- Cooperative work with other engineers on more fundamental approach to process control.

**Qualifications:**

- Knowledge of Process Control Theory and Problems.
- Sound mathematics background for dealing with process simulation.
- Three to four years of industrial experience desirable.
- Interest centered in process applications of electronics.
- Personality suitable to cooperative work with others, and to training others in electronics.

## ELECTRONIC ENGINEER

**SENIOR**

B.S. in E.E. or Physics  
 Advanced degree preferred

Excellent living conditions—Liberal co benefits  
 Unsurpassed professional growth potential.  
 Send resume in confidence; **Mr. TOM DALTON**

### STANLEY AVIATION CORP

2501 Dallas Street

Denver, Colorado

Heavy experience and proven ability in Systems design & development of Instrumentation, Automatic Control, Computation & Communication systems, in areas of AVIONICS, GUIDED MISSILE flight & ground support or related fields.

Desirability to create and sell development ideas to military and commercial customers and to supervise small electronics group in execution of resultant engineering projects.

## FOR ADDITIONAL INFORMATION About Classified Advertising

Contact The McGraw-Hill  
 Office Nearest You

- ATLANTA, 3  
 1301 Rhodes Haverly Bldg. JACkson 3-6951  
 M. MILLER
- BOSTON, 16  
 350 Park Square HUBbard 2-7160  
 D. J. CASSIDY
- CHICAGO, 11  
 520 No. Michigan Ave. MOhawk 4-5800  
 W. HIGGINS
- CLEVELAND, 13  
 1164 Illumination Bldg. SUperior 1-7000  
 W. B. SULLIVAN T. H. HUNTER
- DALLAS, 2  
 1712 Commerce St., Vaughn Bldg.  
 Riverside 7-5117  
 GORDON JONES F. E. HOLLAND
- DETROIT, 26  
 856 Penobscot Bldg. WOodward 2-1793  
 D. M. WATSON
- LOS ANGELES, 17  
 1125 W. 6 St. HUnTley 2-5450  
 P. M. BUTTS
- NEW YORK, 36  
 500 Fifth Ave. OXFord 5-5959  
 H. T. BUCHANAN R. P. LAWLESS
- PHILADELPHIA, 3  
 Six Penn Center Plaza LOcust 8-4330  
 H. W. BOZARTH T. W. McCLURE
- ST. LOUIS, 8  
 3615 Olive St. JEFFerson 5-4867
- SAN FRANCISCO, 4  
 68 Post St. DOuglas 2-4600  
 S. HUBBARD

## ELECTRONIC ENGINEERS

### MANSON LABORATORIES

Has several openings at project level for men with experience in the following or closely related fields.  
**HIGH POWER PULSE MODULATOR DESIGN**  
 Radar and Microwave systems, as well as Tube and Components testing  
**HIGH VOLTAGE POWER SUPPLY DESIGN**  
 To meet modern demands for TWT, Klystron, Carcinotron and backward wave Oscillator applications  
**COMMUNICATIONS INSTRUMENTATION**  
 Crystal saver circuits (Crystal synthesizers), high stability Oscillators, Transistor Circuitry, Transmitters and Receivers.  
 Excellent salaries. Liberal benefits. Ideal location combining city and country life, travel time to NYC 47 min.  
 Call, Write or Apply in Person

MR. DONALD M. GERBER, PERSONNEL DIRECTOR  
**MANSON LABORATORIES, Inc.**  
 375 FAIRFIELD AVE. STAMFORD, CONN., DAVIS 5-1391

## ONE SOLUTION TO MANPOWER PROBLEMS . . .

through the EMPLOYMENT OPPORTUNITIES Section of this publication. The market place for those offering or wanting the services of men on engineering, technical and executive level.

This section offers an effective solution to your manpower problems, because its readership is confined to just the type of men you need . . . Waste circulation is avoided . . . You reach only the men you want.

**ELECTRONICS, P. O. Box 12, New York 36, N. Y.**



## SPECIALIZED PLACEMENT SERVICE

Engineering and Professional Personnel, Fee Paid Openings in:

Missile Guidance Systems, Circuitry Design, Technical Writing, Research and Development, Logical Design, Flight Control Systems, Digital Computer Design, Communications, Radar, Telemetry, Packaging and Instrumentation.

Forward resume for prompt and confidential attention to:

STEWART K. FOGG Personnel Consultant  
225 Haverford Ave. Narberth, Penna.  
(Suburban Philadelphia)

### POSITIONS!

To satisfy your objectives and use your best talents! S.E.E. helps many distinguished companies and organizations to obtain able men at all levels. No placement fees to you. Send resume for appraisal & full information.

Scientists, Engineers & Executives, Inc.  
1026-17th St., N. W., Washington 6, D. C.

## PROFESSIONAL SERVICES

### YARDNEY LABORATORIES, Inc.

"Pioneers in Compact Power" \*  
Electro-Chemical Generators of Energy  
"from milliwatts to megawatts" \*

40-48 Leonard Street Worth 6-3100  
New York 13, N. Y. \* T.M.

## RADIO RESEARCH INSTRUMENT CO.

550 FIFTH AVE.  
NEW YORK  
JUDSON  
6-4691

### F-28/APN-19 FILTER CAVITY

Jan. spec: Tuneable 2700-2900mc, 1.5db max. loss at ctr, freq. over band. New, \$37.50 each.

### SCR 584-SKYSWEEP ANTENNA PEDESTAL

Full azimuth and elevation sweeps, 360 degree azimuth, 205 degree elevation. Accuracy  $\pm$  one mill or better in angle, 6 ft. dish, fully desc MIT, Radiation Lab series Vol. 1 pg 281 and 209, Vol. 26, pg 233. For full tracking response. Includes pedestal drives, selsyns, etc. Excellent use condition. First time these pedestals have been available for purchase. Control consoles also in stock.

### COMPLETE RADAR SYSTEMS

SCR-584 30 ft. trailer Skysweep antenna system PPI indicator + RHI 10 cm. High power for airway control missile-satellite tracking, radio astronomy R & D. As new. Complete.

SCR 784 Complete 10 cm. Sky Sweep System.

AN/APS-10 Complete airborne Radar Mfg. by G.E. 3cm. using 2142 Magnetron for Navigation, Mapping, Weather, Collision Avoidance. Like New.

AN/MPN-1A (GCA) Ground Control Approach Radar, 30 ft. trailer with 3cm precision and 10cm Search Radars as used by CAA. Full desc. Vol. 11 MIT Rad Lab Series Sec. 8.13.

WEATHER RADAR 275 kw, 10 cm. Compact wt. 488 lbs. rotating yoke PPI 4, 20, 80 mile ranges, ideal for weather forecasting. Lab. Brand new. FCC approved \$950.

Super pro BC779 absolutely guaranteed to perform, \$74.50. Power supply separately available, \$24.50. Interconnecting cable, \$2.50. This is a high performance 16 tube general purpose super heterodyne, truly a bargain. Limited number remain.

GIZMOS & SUCH, Still River, Massachusetts

# ENGINEERS

## RESEARCH-DESIGN-DEVELOPMENT

FOR CREATIVE ASSIGNMENTS WITH  
ADVANCED DEVELOPMENT GROUPS

CHALLENGING TASKS, LONG TERM EMPLOYMENT, INTERESTING PROGRAMS

"Let's deal with specifics!" Assignments at Daystrom require the performance of original work involving studies, design, and development of systems typical of those listed below.

### NUCLEAR INSTRUMENTATION

Reactor control systems for atomic powered vessels and aircraft; Reactor protection and alarm systems.

### AIRCRAFT AND MISSILE ELECTRONICS

Nose Cone checkout systems; Bombing and Navigational subsystems tester.

### DIGITAL COMPUTERS

Solid State Display Generators; 20,000 word (67 bits per word) solid state memory system; Transistorized tactical data communications systems; Data collection and reduction system.

### COMMUNICATIONS and TELEMETERING

Frequency synthesizers; Single sideband transmitters; Digital data translator; High stability receivers; Automatic direction finder; SSB telemetering system.

### TRAINERS and SIMULATORS

Large tactical training system. 30 combat information center positions; Multiple target simulator for Monopulse Radar system; Pulse doppler radar simulator.

### RADAR SYSTEMS

High performance search radar; Missile tracking and guidance radar; Monitoring beacons; Doppler navigator; Low level radar altimeter; Countermeasures systems.

Can you make a major contribution, are you interested in challenging problems rather than routine tasks? If so, we are interested in you. Work with others of equal ability and interests in an atmosphere stimulating to your professional growth.

For interviewed consideration, send complete resume in strict confidence to:

Mr. JOHN E. THOMAS, Director of Research & Development

## DAYSTROM INSTRUMENT

Division of Daystrom Incorporated

Archbald, Penna.

# SEARCHLIGHT SECTION

(Classified Advertising)

BUSINESS OPPORTUNITIES

EQUIPMENT - USED or RESALE

## YOUR PRODUCT DEVELOPMENT NEEDS COMPLETE ENVIRONMENTAL TESTING—NOW YOU CAN FILL THE GAP

Dale Products now offers its environmental testing facilities and personnel to serve you in the development and testing of your new products. You have at your command a complete testing laboratory service.

Your inquiries will receive our prompt attention. If interested, please contact Glenn Carter at

### DALE PRODUCTS, INC.

COLUMBUS, NEBRASKA  
Telephone: 4-3131

### 400 CYCLE GENERATORS also variable frequency

Large stock on hand

Write for catalogs

RELIABLE ELECTRIC MOTOR REPAIR CO.  
19 California Ave. Paterson, N. J.

### All Brand RESISTORS

Type J Potentiometers Single-Duals-Triples  
Type G Miniature Potentiometers  
By Return Mail . . . From Stock

LEGRI S COMPANY  
391 Riverdale Ave. Yonkers 5, N. Y.

## Poor Aladdin . . .

The best service at Aladdin's command was rubbing a lamp and WISHING for what he wanted. YOU have "Searchlight" to help you find what you want!

CAN "SEARCHLIGHT" SERVE YOU?

If you produce  
**FERRITES**  
**ELECTRONIC CORES**  
**MAGNETIC RECORDING**  
**MEDIA**

... then let WILLIAMS  
 help by supplying you  
 with latest, authoritative  
 technical data on

**PURE FERRIC  
 OXIDES**  
**MAGNETIC IRON  
 OXIDES**  
**MAGNETIC IRON  
 POWDERS**

Since final quality of your production of ferrites, electronic cores, and magnetic recording media depends on proper use of 3 specialized groups of magnetic materials... you'll find it mighty helpful to have all the latest, authoritative technical data describing the physical and chemical characteristics of each. This information is available to you just for the asking. So send today. Meanwhile, here are highlights of each product group.

**Pure Ferric Oxides:** For the production of ferrite bodies, we manufacture a complete range of high purity ferric oxide powders. These are available in both the spheroidal and acicular shapes, with average particle diameters from 0.2 to 0.8 microns. Impurities such as soluble salts, silica, alumina and calcium are at a minimum.

**Magnetic Iron Oxides:** For magnetic recording—audio, video, instrumentation etc.—we produce a group of special magnetic oxides with a range of controlled magnetic properties. Both the black ferrous-ferric and brown gamma ferric oxides are available.

**Magnetic Iron Powders:** For the fabrication of magnetic cores in high-frequency, tele-communication, and other magnetic applications, we make a series of high purity iron powders.

*These materials are products of Williams research facilities. For your convenience, we maintain fully equipped laboratories for the development of new and better inorganic materials. We also investigate new fields of application. Please write, stating your problem. We'll be glad to cooperate. Address Dept. 25, C. K. Williams & Co., 640 N. 13th St., Easton, Pa.*

**WILLIAMS**  
**COLORS & PIGMENTS**

**C. K. WILLIAMS & CO.**  
 East St. Louis, Ill.  
 Easton, Penna. • Emeryville, Calif.

CIRCLE 184 READERS SERVICE CARD

# INDEX TO ADVERTISERS

● AC Electronics Division.....	121	Pennsylvania Dept. of Commerce.....	118
● Ace Electronics Associates, Inc.....	115	Philco Techrep Division.....	108
Aeronautical Communications Co.....	12	Precision Scientific Co.....	24
● Ainslie Corporation.....	99	● Radio Corporation of America..4th Cover	
● Airpax Electronics Incorporated.....	18	● Radiometer.....	117
● Alford Mfg. Co.....	122	● Raytheon Mfg., Co.....	93, 2nd Cover
● Allegheny Ludlum Steel Corporation..	85	● Sauborn Company.....	8
● Allied Control Company, Inc.....	49	● Saugamo Electric Company.....	81
Beaver Gear Works, Inc.....	103	● Sarkes Tarzian, Inc.....	116
● Beede Electrical Instrument Co, Inc..	109	● Sierra Electronic Corporation.....	33
● Bendix Aviation Corp.		● Sigma Instruments, Inc.....	82
Red Bank Division.....	97	● Sonotone Corp.....	46
Pioneer Central Division.....	19	● Spectrol Electronics Corporation....	110
● Bendix-Pacific.....	45	● Speer Carbon Company.....	94
CBS-Hytron A Division of Columbia		● Sprague Electric Company.....	5
Broadcasting System, Inc.....	29	● Stackpole Carbon Company.....	92
● Cannon Electric Company.....	17	● Stevens Arnold, Inc.....	38
● Cinch Mfg. Corp.....	73	Technical Information Corporation... 118	
● Clevite Transistor Products, A Division		● Telechrome Mfg., Corp.....	75
of Clevite Corporation.....	15	● Texas Instruments Incorporated, 3rd Cover	
Collins Radio Company.....	41	● Toke Deutschmann Corp.....	123
Computer Measurements Company....	44	● Transitron Electronic Corporation....	37
Connecticut Hard Rubber Co.....	47	● Tung-Sol Electric Inc.....	77
Consolidated Electrodynamics.....	79	● Varian Associates.....	50
● Coto-Coll Co., Inc.....	124	● Vector Electronic Co.....	119
● Cross Co., H.....	109	● Vitramon Inc.....	83
● Curtiss-Wright Corporation.....	32	● Waters Manufacturing, Inc.....	40
● Developmental Engineering Corpora-		● Weinschel Engineering.....	14
tion.....	7	● Westinghouse Electric Corp.....	107
duPont de Nemours & Co. (Inc.) I.E.	16	Weston Instruments, Division of Day-	
● Eastern Industries Incorporated.....	98	strom Inc.....	51
Edgerton, Germeshausen & Grier, Inc.	78	● White Mfg. Co., S. S.....	125
Edo Corporation.....	105	● Williams & Co., C. K.....	134
● Eitel-McCullough, Inc.....	10	Worklon, Inc.....	119
● Electro Motive Mfg., Co., Inc., The... 13			
● Electronic Instrument Co. (EICO)....	105		
Electronic Measurements Co.....	112		
Ellis & Watts Products, Inc.....	23		
Esterline-Angus Company, Inc.....	103		
Frenchtown Porcelain Company.....	100		
Garrett Corporation, The.....	90, 91		
● General Electric Co.			
Tube Department.....	20, 21		
Greene Shaw Co., Inc.....	109		
Handy & Harman.....	2		
● Hart Manufacturing Co.....	104		
● Haydon Co., A. W.....	124		
● Hewlett-Packard Company.....	34		
● Hughes Aircraft Company.....	25, 26, 27, 28, 42		
● Illinois Condenser Co.....	105		
● International Resistance Company....	43		
Jeffers Electronics Div. of Speer			
Carbon Co.....	94		
● Kay Electric Company.....	6		
Kidder, Peabody & Co.....	122		
Klein & Sons, Mathias.....	96		
Kleinschmidt-Division of Smith-Corona			
Marchant Inc.....	48		
● Lambda Electronics Corp.....	3		
● Lapp Insulator Co., Inc.....	39		
● Little Falls Alloys, Inc.....	105		
Lockheed Aircraft Corp.....	106		
Los Alamos Scientific Laboratory....	102		
Mallory & Co., Inc., P. R.....	52		
● Marconi Instruments.....	111		
Marion Instrument Div, Minneapolis-			
Honeywell Regulator Co.....	90		
Markite Products Corporation.....	87		
● Mico Instrument Co.....	90		
● Moseley Co., F. L.....	31		
Nems-Clarke Company.....	86		
● NJE Corporation.....	89		
Norden Division of United Aircraft			
Corporation.....	22		
Professional Services.....	133		
CLASSIFIED ADVERTISING			
F. J. Eberle, Business Mgr.			
EMPLOYMENT			
OPPORTUNITIES.....	126-133		
SPECIAL SERVICES.....	133		
EQUIPMENT			
(Used or Surplus New)			
For Sale.....	133		
ADVERTISERS INDEX			
Dale Products, Inc.....	133		
Daystrom Instrument Div., of			
Daystrom Inc.....	133		
Electronic Laboratory Supply Co.....	133		
Erco Div. of ACF Industries Co.....	126		
Esso Research Laboratories.....	132		
Fogg, Stewart K., Mr.....	133		
General Dynamics—Electric Boat Div....	130		
Gilfillan Brothers Inc.....	130		
Gizmos & Such.....	133		
Goodyear Aircraft Company.....	127		
International Business Machines Corp....	126		
Legri S. Company.....	133		
Manson Laboratories, Inc.....	132		
Philco Western Development Laboratory	131		
Radio Research Instrument Company....	133		
Reliable Electric Motor Repair Co.....	133		
Scientists Engineers & Executives Inc....	133		
Stanley Aviation Corporation.....	132		
System Development Corporation.....	128-129		
● See advertisement in the June, 1958 Mid-Month			
ELECTRONICS BUYERS' GUIDE for complete line			
of products or services.			
This index is published as a service. Every care is taken			
to make it accurate, but ELECTRONICS assumes no			
responsibilities for errors or omissions.			



# NEW HIGH-RELIABILITY TANTALUM CAPACITOR SERIES



ACTUAL SIZE CASE STYLES



**125°C operation • standard  $\pm 10\%$  tolerance**

*Now, premium performance solid tantalum capacitors to fill your highest reliability requirements!*

**134 ratings from 1-330  $\mu\text{f}$ , 6-35 v**

Exceeding all existing MIL specs over a full range of industry-standard ratings and case sizes, the subminiature SRM series features . . . new low dc leakage limits and long operating and storage life . . . standard  $\pm 10\%$  tolerance . . . operation from  $-80^\circ\text{C}$  to  $+125^\circ\text{C}$  . . . ruggedized construction . . . reverse voltage capability . . . nominal voltage derating required at  $125^\circ\text{C}$ . TI's advanced processing techniques and 100% testing of pre-aged units assure SRM capacitors to the most exacting reliability standards.

\*Trademark of Texas Instruments Incorporated

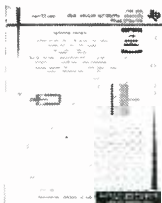

Contact your nearest TI sales office today for delivery information and your copy of the 12-page bulletin listing specifications of all 134 ratings.

**DC LEAKAGE vs WORKING VOLTAGE AND TEMPERATURE**

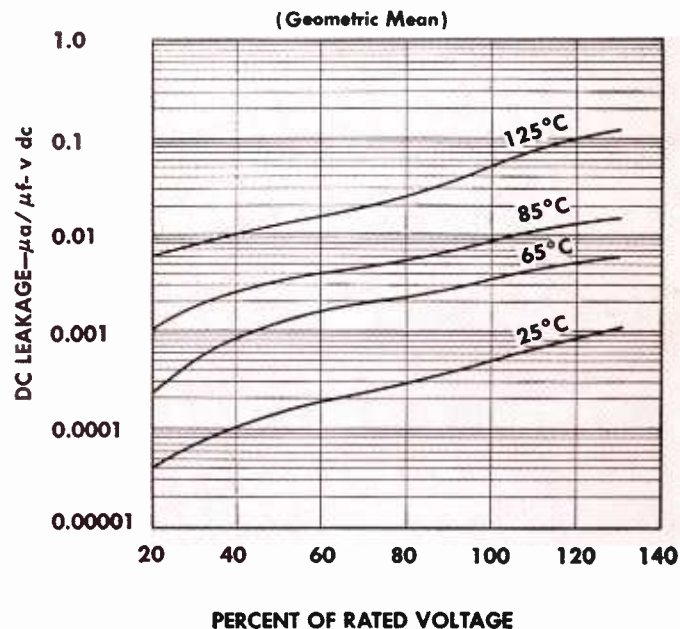

from THE WORLD'S LARGEST SEMICONDUCTOR PLANT



**TEXAS INSTRUMENTS**  
 INCORPORATED  
 SEMICONDUCTOR-COMPONENTS DIVISION  
 POST OFFICE BOX 312 • 13500 N. CENTRAL EXPRESSWAY  
 DALLAS, TEXAS



# RCA

# PHOTOCONDUCTIVE CELLS AND PHOTOJUNCTION CELLS

## FOR INDUSTRIAL APPLICATIONS

- High Sensitivity
- Small Size
- Reliable Performance



7223



7224

If your control problems involve a light source, look to RCA for the solution. RCA-designed Photoconductive and Photojunction Cells are manufactured under the strictest quality controls to assure dependability and long life. So for applications ranging from street-lighting control to high-speed

computers, contact your RCA Field Representative for complete information about RCA Photoconductive Cells and RCA Photojunction Cells. Or for technical data on specific types, write RCA Commercial Engineering, Section E-19-Q-2, Harrison, N. J.

RCA Type	Description	Spectral Response	Wave-length of Max. Spectral Response angstroms	Maximum Ratings Abs.—Max. Values			Characteristics at 25°C				
				Voltage Between Terminals volts	Power Dissipation mw	Ambient Temperature Range °C	Voltage Between Terminals volts	Radiant Sensitivity $\mu\text{a}/\mu\text{w}$	Luminous Sensitivity ma./lumen	Illumination $\mu\text{a}/\text{fc}$	Max. Dark Current $\mu\text{a}$
6957	Cadmium-sulfide, head on photoconductive cell for street-lighting control and other light-operated relay applications.	S-15	5800	250	500	-75 to +60	50	580	1640	4000	20
7163	Compact, cadmium-sulfide, head on photoconductive cell for street-lighting control and other light-operated relay applications.	S-15	5800	250	300	-75 to +60	50	290	820	2000	40
7223	Very tiny photojunction cell of the head on type. Employs germanium p-n alloy junction. For computer and sound-pickup-from-film applications. Infrared sensitive.	S-14	15000	50	25	+50 Max.	2.5	0.68*	—	0.2	35
7224	Very small photojunction cell of the side-on type. Employs germanium p-n alloy junction. For sound-pickup-from-film and computer applications. Infrared sensitive.	S-14	15000	50	30	-40 to +50	45	0.52	14	0.7	35
7412	Small cadmium-sulfide, head on photoconductive cell. For industrial light-operated relay applications.	S-15	5800	200	50	+60 Max.	12	1580	4500	300	0.1
7467	Very small, photojunction cell of the side-on type. Employs germanium p-n alloy junction. For sound-pickup-from-film and computer applications.	S-14	15000	50	30	-42 to +50	45	0.52	14	0.7	35

S-14 Spectral Response

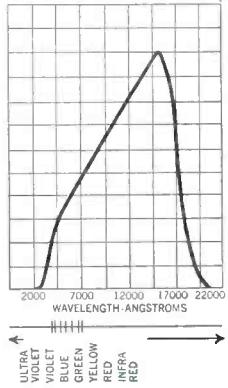

S-15 Spectral Response

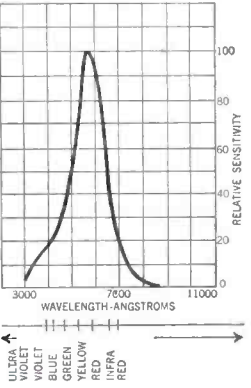

**RADIO CORPORATION OF AMERICA**  
Electron Tube Division  
Harrison, N. J.

- RCA FIELD OFFICES**
- 744 Broad St., Newark 2, N. J., HUmboldt 5-3900
  - 6355 E. Washington Blvd., Los Angeles 22, Calif., RAymond 3-8361
  - Suite 1154, Merchandise Mart Plaza, Chicago 54, Ill., WHitehall 4-2900
  - 714 New Center Bldg., Detroit 2, Mich., TRinity 5-5600

- GOVERNMENT SALES**
- 744 Broad St., Newark 2, N. J., HUmboldt 5-3900
  - 244 N. Wilkinson St., Dayton 2, Ohio, BAldwin 6-2366
  - 1625 "K" Street, N. W., Washington 6, D. C., DIstrict 7-1260