

JANUARY 9, 1959

# electronics

A MCGRAW-HILL PUBLICATION

VOL. 32, No. 2

PRICE SEVENTY-FIVE CENTS

Automatic  
Voice Data Link

*SPECIAL*  
Our Market for 1959



# DIGITAL VOLTMETER, \$825



## Automatic range and polarity selection. Just apply the probe and read voltage directly!

**hp 405AR DC DIGITAL VOLTMETER** is a completely new instrument providing, literally, "touch-and-read" voltage measurements between 1 and 1,000 volts. *Range, even polarity, are automatically selected.* Readout is in-line, in bright, steady numerals. *New, novel circuitry provides a stability of readings virtually eliminating jitter in the last digit. This reduces operator fatigue and avoids uncertainty.*

Special features include a floating input, electronic analog-to-digital conversion, digital recorder output and front-panel "hold" control permitting manual positioning of decimal. Voltage sampling rate is variable from 1 reading every 5 seconds to 5 per second; or can be controlled externally by a 20 v positive pulse.

### BRIEF SPECIFICATIONS

**Range:** 0.001 to 999 v dc; 4 ranges.  
**Presentation:** 3 significant figures, polarity indicator  
**Accuracy:**  $\pm 0.2\%$  full scale  $\pm 1$  count  
**Ranging time:**  $\frac{1}{2}$  sec to 2 sec  
**Input impedance:** 11 megohms to dc, all ranges  
**Response time:** Less than 1 sec  
**AC rejection:** 3 db at 0.7 cps; min. 50 db at 60 cps  
**Price:** \$825.00

Data subject to change without notice. Price f.o.b. factory.



## HEWLETT-PACKARD COMPANY

5100A PAGE MILL ROAD • PALO ALTO, CALIFORNIA, U.S.A.  
CABLE "HEWPACK" • DAVENPORT 5-4451

FIELD REPRESENTATIVES IN ALL PRINCIPAL AREAS

A MCGRAW-HILL PUBLICATION  
Vol. 32 No. 2

H. W. MATEER, *Publisher*

JAMES GIRDWOOD, *Associate  
Publisher*

W. W. MacDONALD, *Editor*

*Managing Editor*, John M. Carroll.

*Feature Editor*, John Markus.

*Associate Editors*: John M. Kinn, Jr., Frank Leary, Michael F. Tomaino, Howard K. Janis, Sylvester P. Carter, Haig A. Manoogian, Roland J. Charest, William P. O'Brien, George Sideris, John F. Mason, William E. Bushor, Ronald K. Jurgen, Thomas Emma, Samuel Weber.

*Pacific Coast Editor* (Los Angeles) Harold C. Hood; *Midwestern Editor* (Chicago) Harold Harris; *New England Editor* (Boston) Thomas McGuire.

*Art Director*, Harry Phillips, Roy Thompson.

*Production Editor*, John C. Wright, Jr., Bernice Duffy, Jean L. Matin.

*Market Research*, Edward DeJongh, Marilyn Koren.

*Editorial Assistants*: Gloria J. Filippone, Arlene Schilp, Patricia Landers, Catherine McDermott, Eleanor Schaefer, Carol Weaver.

JAMES GIRDWOOD, *Advertising Sales Manager*, R. S. Quint, *Assistant Advertising Sales Manager and Buyers' Guide Manager*, Fred Stewart, *Promotion Manager*, Frank H. Ward, *Business Manager*, George E. Pomeroy, *Classified Manager*, Hugh J. Quinn, *Acting Circulation Manager*.

*New York*: Donald H. Miller, Henry M. Shaw, Martin J. Gallay. *Boston*: Wm. S. Hodgkinson. *Philadelphia*: James T. Hauptli. *Chicago*: Bruce Winner, Harvey W. Warnecke. *Cleveland*: Warren H. Gardner. *San Francisco*: T. H. Carmody, R. C. Alcorn. *Los Angeles*: Carl W. Dysinger, D. A. McMillan. *Denver*: J. Patten. *Atlanta*: M. Miller. *Dallas*: Gordon L. Jones, Robert T. Wood. *London*: E. E. Schirmer. *Frankfurt*: Michael R. Zeynel.

## Issue at a Glance

### BUSINESS

Remote Computers Guide Missiles. Inside story on interceptors....	26
USSR: Plan for Electronics. Technology gets an economic role....	31
Washington Forecast for 1959. More buying in our field.....	34
What's Inside the Atlas. Two milestones for electronics industry...	37
Shoptalk .....	4
Electronics Newsletter .....	9
Washington Outlook .....	12
Financial Roundup .....	17
Over the Counter.....	17
Market Research .....	20
Current Figures .....	20
Meetings Ahead .....	38

**Our Market for 1959. An ELECTRONICS Special Report..... 41**

### ENGINEERING

Automatic Voice Data Link. Steel and plastic igloos stand guard ready to vector fighter pilots in on possible enemies. See p 47, COVER	
How Robot Voices Vector Fighter Pilots. Flight-path data are converted to verbal instructions.....By C. W. Poppe and P. J. Suhr	47
Detector Pin Points Magnetic Tape Flaws. Automatic tape tester checks recorded tape for broadcast use.....By N. J. Thompson	50
Function Generator for Radar Simulator. Open-loop photoelectric function generator has accuracy better than one percent. By Barbara Silverberg	52
Special Circuits for Transistor Receivers. Design information on four stages for transistor portable receivers. By Wm. E. Sheehan & Wm. H. Ryer	56
Multiplying Circuit Uses Magnetic Amplifiers. Square-law circuits replace thermal-converters in four-quadrant analog device. By W. A. Geyger	58
Portable Multiplexer for Telephone Communications. Microwave radio system is pulse position modulated. By Paul W. Kiesling, Jr.	60
Hard Magnets for 500 C. With proper design permanent magnet materials are usable at high temperature....By George Sideris	63
Dynamic Trap Captures Weak F-M Signals. Circuit tracks and attenuates undesired signal.....By Elie J. Baghdady and George J. Rubissow	64
Easing Transistor Loads. Design techniques limit power dissipation in d-c transistor amplifiers.....By William F. Saunders, III	68

### DEPARTMENTS

Research and Development. Square-Loop Core Logic Circuits, Electronic System Cancels Stamps.....	70
Components and Materials. Flexible Conductor Operates to 250C, Shift Resistor Uses Single-Wire Memory.....	74
Production Techniques. Photos Assist Drafting Assembly, Motorized Fixture Simplifies Fluxing.....	78
On the Market.....	84
Plants and People.....	106
Comment .....	110
Literature of the Week....	104
News of Reps.....	109
Index to Advertisers.....	116

Dr. Wright takes the



stand for **electronics**

What is your present work in electronics, Dr. Wright?

*Vice President In-Charge-of-Operations-and-Engineering at Tung-Sol Electric Inc., a leading manufacturer of electron tubes, semiconductors, tv tubes, lamps, power supplies, flashers, selenium and silicon rectifiers.*

How many people are at Tung-Sol?

*Approximately 6,000.*

Briefly, what is your background in electronics?

*Twenty-two years with Tung-Sol.*

How many years have you been reading electronics?

*It goes back over twenty years..*

Why have you continued to read it?

*After all, this is a very technical and rapidly changing industry. I don't know which is more important, the editorial or advertising. They both help us to keep up with what's going on in the world of electronics.*

It has been said that leading publications build a "personality" for themselves. This is a quality that cannot be measured with facts and statistics. How would you characterize the "personality" of electronics magazine?

*It's not too highbrow, yet it's not a gossip sheet. It's an excellent middle-of-the-road job of reporting technical and business developments. electronics does a down-to-earth reporting job.*

If it's about electronics, read it in **electronics**.

## **electronics**

Published WEEKLY plus the mid-year electronics BUYERS' GUIDE  
A McGraw-Hill Publication • 330 West 42nd Street, New York 36, N. Y.



# and now... SOLAR FURNACES!

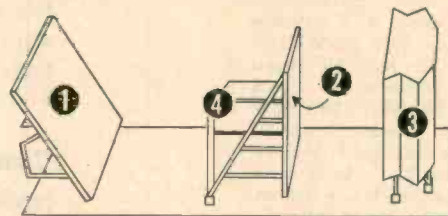

**FROM SUNBEAM TO SUNBOMB:** Sunlight is reflected from 355-mirror heliostat ①, through shuttered attenuator ②, strikes 180-mirror concentrator ③. Concentrator focuses a 4" dia. image of approx. 5,000°F within test chamber ④.

This mighty complex of mirrors can convert a dancing sunbeam into a devastating "sunbomb" — a pulse of concentrated energy hot enough to make tungsten boil.

Such is the new solar furnace of the U. S. Army Quartermaster Research and Development Command just installed at Natick, Mass. It is designed to simulate the intense heat radiation of atom bomb blasts in order to test Army protective materials before actual field trials.

There's more to the furnace than mirrors, of course. The intricate solar tracking mechanisms, capable of following the sun in both elevation and azimuth — as well as the rugged construction which enables the furnace to withstand hurricane winds — these are by Kennedy, a long-time tamer of "out-of-this-world" problems.

CHALLENGING POSITIONS OPEN FOR ENGINEERS IN THIS FAST-GROWING ORGANIZATION



ANTENNA EQUIPMENT

**D. S. KENNEDY & CO.**

COHASSET, MASS. Evergreen 3-1200

*West Coast Affiliate...*

**SATELLITE-KENNEDY, INC. of CALIFORNIA**

P.O. Box 1711, Monterey, California - FRontier 3-2461

Published weekly, with a BUYERS' GUIDE and REFERENCE issue in mid-June, by McGraw-Hill Publishing Company, Inc., James H. McGraw (1860-1948) Founder.

Executive, Editorial, Circulation and Advertising Offices: McGraw-Hill Building, 330 W. 42 St., New York 36, N. Y. Longacre 4-3000. Publication Office: 99-129 North Broadway, Albany 1, N. Y.

See panel below for directions regarding subscriptions or change of address. Donald C. McGraw, President; Joseph A. Gerardi, Executive Vice President; L. Keith Goodrich, Vice President and Treasurer; John J. Cooke, Secretary; Nelson L. Bond, President, Publications Division; Shelton Fisher, Senior Vice President; Ralph B. Smith, Vice President and Editorial Director; Joseph H. Allen, Vice President and Director of Advertising Sales; A. R. Venezian, Vice President and Circulation Coordinator.

Single copies 75¢ in the United States and possessions, and Canada: \$1.50 for all other foreign countries. Buyers' Guide \$3.00. Subscription rates—United States and possessions, \$6.00 a year; \$9.00 for two years; \$12.00 for three years. Canada, \$10.00 a year; \$16.00 for two years; \$20.00 for three years. All other countries \$20.00 a year; \$30.00 for two years; \$40.00 for three years. Second class postage paid at Albany, N. Y. Printed in U.S.A. Copyright 1959 by McGraw-Hill Publishing Co., Inc.—All Rights Reserved. Title registered in U. S. Patent Office. BRANCH OFFICES: 520 North Michigan Avenue, Chicago 11; 68 Post Street, San Francisco 4; McGraw-Hill House, London E. C. 4; 15 Landgrat-Wilhelm, Frankfurt/Main; National Press Bldg., Washington 4, D. C.; Six Penn Center Plaza, Philadelphia 3; 1111 Henry W. Oliver Bldg., Pittsburgh 22; 55 Public Square, Cleveland 33; 856 Penobscot Bldg., Detroit 26; 3615 Olive St., St. Louis 8; 350 Park Square Bldg., Boston 16; 1321 Rhodes-Haverty Bldg., Atlanta 3; 1125 West Sixth St., Los Angeles 17; 1740 Broadway, Denver 2; 901 Vaughn Bldg., Dallas, 1. ELECTRONICS is indexed regularly in The Engineering Index.

Subscription: Address correspondence to: Fulfillment Manager, Electronics, 330 W. 42nd St., New York 36, N. Y. Allow one month for change of address, stating old as well as new address. Subscriptions are solicited only from persons engaged in theory, research, design, production, management, maintenance and use of electronics and industrial control components, parts and products. Position and company connection must be indicated on subscription orders.

Postmaster: please send form 3579 to Electronics, 330 W. 42nd St., New York 36, N. Y.



Member ABP and ABC

## Shoptalk . . .

**CONTINENTAL DEFENSE**—Three weeks ago a supersonic Bomarc missile launched from Cape Canaveral brought down a drone flying off the coast of Florida. Intercept data was relayed to the missile by way of a Sage system computer in Kingston, N. Y. Thus ended the testing phase of the Bomarc project. Future firings will be by operational crews training to handle the missile. On p 26, Associate Editor Mason tells how the radar-to-computer-to-missile triple play of our continental air defense works and who's who in the project.

Another aspect of continental air defense is vectoring manned interceptors in on hostile bombers. On p 47, C. W. Poppe of Fairchild Camera and Instrument describes an automatic voice data link that helps reduce human error in passing the word.

Rounding out the picture, the cover photograph of this issue shows one of our DEW line stations operated by Federal Electric Corp. These long-range radars are the far-seeing eye of continental air defenders.

**OUR MARKET FOR 1959**—Next year will be a good one for the electronics industry. Government spending for electronics is big and getting bigger both by actual volume and percentagewise for our industry. Things look good for the home entertainment market and for sales of industrial and commercial electronic equipment.

These are the conclusions of members of ELECTRONICS research staff, whose statistical look ahead for the electronics business is the subject of a Special Report beginning on p 41. The report is based upon three months of intensive study of the industry, during which our research staff contacted producers and consumers of electronic equipment and components from coast to coast; compared the findings and predictions of all public and private fact-gathering groups.

### Coming in Our January 16 Issue . . .

**RANGE INSTRUMENTATION**—Each time a missile leaves the launching pad at Cape Canaveral, the Caribbean airwaves hum with data as hundreds of millions of dollars worth of electronic gear goes to work. From launch to terminal flight to final impact, precision electronic and optical systems follow the huge birds and relay vital data to scientists on the ground.

Next week Associate Editor Leary brings you the complete story of how range instrumentation has become an extensive new field of applied technology in a few short years. It's a story that has been a year in the gathering. Leary traveled extensively, talked to Air Force people responsible for missile range instrumentation at Patrick AFB and other installations.

You'll learn details of the incredibly complex telemetry, tracking and computing facilities now in existence.

**FERROELECTRIC DEVICES**—Electric tuning techniques using the nonlinear characteristics of dielectric materials such as barium strontium titanates are finding increasing use in electronic circuit design.

According to T. W. Butler of the University of Michigan's Electronic Defense Group, voltage tunable ferroelectric capacitors are being applied to a variety of practical circuits such as f-m oscillators, panoramic receivers and afc systems. Butler's article describes how these new devices are made and what problems are involved in using them as circuit elements.

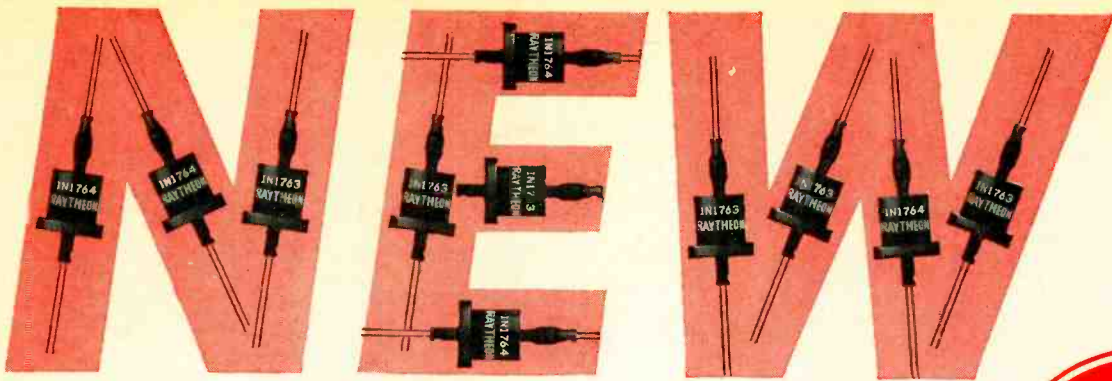

**1N1763 and 1N1764 DIFFUSED JUNCTION**

# SILICON RECTIFIERS

**PRICED FOR COMMERCIAL AND INDUSTRIAL POWER SUPPLY APPLICATIONS**

**FEATURES:**

**Economical** — now, silicon rectifiers at entertainment field prices.

**Uniform** — the Raytheon Solid State Diffusion Process permits flat junctions and assures uniform characteristics and uniformly high quality.

**Hermetically Sealed — Welded**

**Reliable**

**SPECIFICATIONS:**

PARAMETER (25°C)	TYPE		UNITS
	1N1763*	1N1764†	
PIV	400	500	V
RMS Voltage	140	175	V
DC Load Current	500	500	mA
Surge Current for 0.1 sec	15	15	A
Max. Reverse Current at PIV	100	100	μA

\*for operation direct from power line  
†for operation from step-up transformer

**TYPICAL CIRCUIT APPLICATIONS**

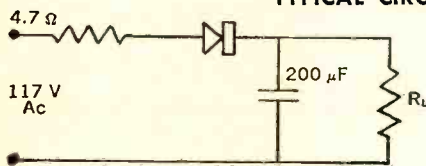

Half wave rectifier, capacitive load

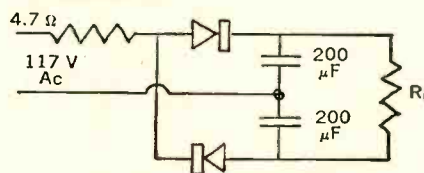

Full wave doubler circuit



**SEMICONDUCTOR DIVISION**

Needham Heights, Massachusetts

SILICON AND GERMANIUM DIODES AND TRANSISTORS • SILICON RECTIFIERS

**NEW YORK:**.....589 Fifth Ave., Plaza 9-3900

**CHICAGO:** 9501 Grand Ave., Franklin Park, National 5-4000

**LOS ANGELES:** 5236 Santa Monica Blvd., NOrmandy 5-4221

# GENERAL PLATE

## Copper Cored Glass Sealing Wire Features a Sound Metallurgical Bond

... And Gives You These Advantages ...

GLASS SEALING ALLOY

COPPER CORE

- Leakproof Seal between Alloy and Core
- High Electrical Conductivity
- Increased Thermal Conductivity
- Coefficient of Expansion Matches Glass
- Facilitates Miniaturization
- Cuts Costs

General Plate Copper Cored Alloy Wire (33% copper clad core, 67% glass sealing alloy) gives you three times greater electrical conductivity than solid #52 alloy wire of equal diameter.

This means you can substantially increase the current carrying capacity of your solid sealed leads without going to larger diameters — or, if you have a miniaturization problem, you can reduce sealing wire diameters correspondingly. The sound metallurgical bond between the copper core and outer shell eliminates any air or gas leaks in the wire.

General Plate Copper Cored Glass Sealing Wires are used for better performance in glass-to-metal seals in hermetically sealed devices such as switches, relays, coils, controls, vacuum tubes and semiconductors.

They are available in #52 alloy, Type 446 stainless, low carbon steel, Kovar\* and other glass sealing alloys. Write for Bulletin IND-15.

For details on the complete line of General Plate Clad Metals, ask for a free copy of GP-1 Catalog.

\*T.M. Registered Carborundum Co.

*You Can Profit by using  
General Plate Clad Metals*

**METALS & CONTROLS CORPORATION**

General Plate Division



1301 Forest Street, Attleboro, Mass.

FIELD OFFICES: NEW YORK • CHICAGO • DETROIT • INDIANAPOLIS • MILWAUKEE • PASADENA





## RECTIFIER NEWS

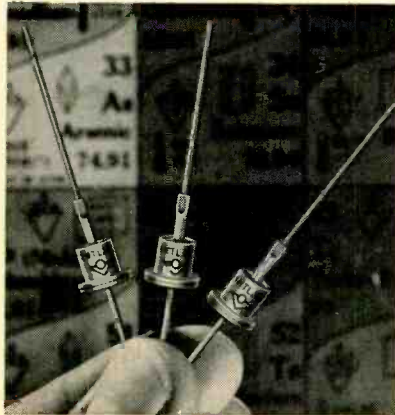

### Military Type High Temperature Silicon Power Diodes Operate to 165°C

For military or industrial applications where high temperature operation is a must, International Rectifier offers two series of axial lead, hermetically sealed power diodes. Both supply full rated power under convection cooling without a heat sink.

JETEC series 1N536-1N540 and 1N1095-96 operates at -65°C to +165°C with output currents to 750ma. PIV ratings from 50 to 600v. Bulletin SR-202A describes them.

For power supply or magnetic amplifier use, 16 JETEC types are listed in Bulletin SR-132E. Ratings: 50 to 600v PIV at 300ma. Temperature range: -65°C to +150°C.

The high forward conductance and extremely low leakage of these diodes permits rectification efficiencies to 99% at power frequencies; up to 70% at 50kc.

CIRCLE READER SERVICE CARD NO. 115



Ratings: 100 to 500 PIV, up to 500ma

Miniaturized Silicon Diodes For Military and Commercial Use.

Write for Bulletin SR-205

### Hermetically Sealed Industrial Silicon Diodes Provide 750ma Output Without Heat Sink

Diodes in this series have been designed to provide optimum reliability and efficiency to your industrial or commercial equipment circuits. By eliminating the space consuming heat sink, you can also realize economies in equipment size as well as assembly time and costs.

Rectified dc output current ratings to 750ma at 50°C can be obtained with PIV voltages ranging from 100 to 500v.

The diode junction is hermetically sealed in an all-welded, shock-proof housing . . . a mechanical construction assuring physical strength and a positive safeguard against contaminants. This adds up to the really important feature - long term reliability! For complete specifications . . .

CIRCLE READER SERVICE CARD NO. 116

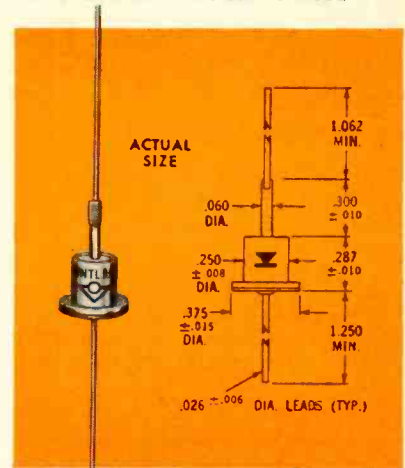

#### Absolute Maximum Ratings (at 60 cps. Resistive or Inductive Load)

DIODE TYPES	SD-91	SD-92	SD-93	SD-94	SD-95	SD-91A	SD-92A	SD-93A	SD-94A	SD-95A
Peak Inverse Voltage, Volts	100	200	300	400	500	100	200	300	400	500
RMS Input Voltage, Volts	70	140	210	280	350	70	140	210	280	350
Continuous D.C. Voltage, Volts	100	200	300	400	500	100	200	300	400	500
Rectified D.C. Output Current, ma.										
at 50° C Ambient	550	550	550	550	550	750	750	750	750	750
at 100° C Ambient	300	300	300	300	300	500	500	500	500	400
Max. Surge Current (1 cycle), Amps.	10	10	10	10	10	15	15	15	15	15
Max. Operating Frequency, Kilocycles	50	50	50	50	50	50	50	50	50	50
Ambient Operating Temperature, °C	-65°C to +125°C					-65°C to +125°C				
<b>ELECTRICAL CHARACTERISTICS</b>										
Max. D.C. Forward Voltage Drop at 25°C	1.5 volts @ 550 ma dc (all types)					1.3 volts @ 750 ma dc (all types)				
Min. Series Resistance (Capacitive Load) (ohms)	6.8	6.8	6.8	6.8	€ 8	4.7	4.7	4.7	4.7	4.7
Max. Leakage Current (mA) at Rated Continuous D.C. Voltage at 100°C	1.0	1.0	1.0	.80	.65	0.5	0.5	0.5	0.4	0.3

### High Temperature Stud Mounted Silicon Diode Series Includes Nineteen JETEC and JAN Types.

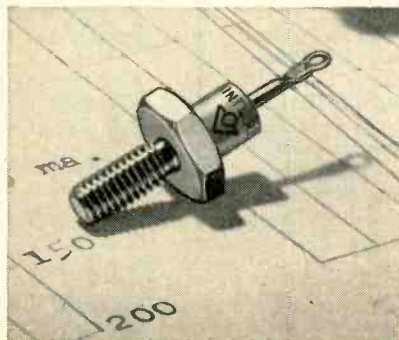

These silicon power rectifiers are designed for conduction cooling by mounting directly onto the chassis. Ratings from 400ma to one amp. are possible at PIV ratings of from 50 to 630 volts.

Power supply types 1N627 thru 1N614 and magnetic amplifier types featuring low leakage current and high forward conductance are included in Bulletin SR-135C.

JAN types 1N253, 1N254, 1N255 for the military are in full production.

CIRCLE READER SERVICE CARD NO. 117

FOR SAME DAY SERVICE ON PRODUCT INFORMATION DESCRIBED ABOVE, SEND REQUEST ON YOUR COMPANY'S LETTERHEAD



# MICRO SWITCH Precision Switches

## Five switches of special interest to Electronic Engineers

### Three of them are

# NEW

#### NEW

*ultra-small*

*super-sensitive*

*mercury switch AS603A1*

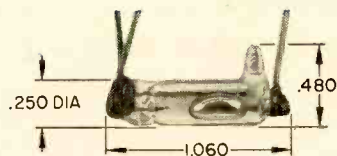

This new switch, designed for vertical gyros, stable platforms, missiles and rockets, is the most precise mercury switch available. Differential angle—.150° max. Mass shift—.085 gm. cm. SPDT. It operates reliably at temperatures as low as -65° F. Hermetically sealed contacts. Switch is unaffected by water vapor, dust, dirt, fungus and corrosive fumes. It is rated at .225 amps., 30 vac, 400 cps resistive load. Weight—3.5 grams (including leads). Ask for data sheet No. 153.

#### NEW

*"SX" series*

*sub-subminiature switches*

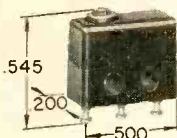

These all-new switches combine extremely small size with "regular size" electrical capacity and excellent reliability. They present a new set of possibilities to the designer of compact devices. 5 amps. 250 vac, 30 vdc. Two mounting holes accept No. 2 screws. Weight—1/28 oz. Ask for data sheet No. 148.

#### *Subminiature door interlock switch 7AC1-T*

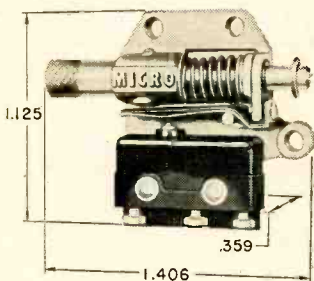

Cuts off power in equipment cabinets when service door is opened. Manually pulling the rod actuator to maintained contact position closes circuit for checking. When door is next closed, switch returns to normal . . . re-sets itself to safety position. Ask for data sheet No. 108.

#### NEW

*"1PB600" series*

*"One Shot" switches*

These new switch assemblies produce a one-and-only-one pulse output. Miniature package includes push-button switch and potted one-shot circuit. Eliminates need for designing special pulse input circuits for high speed electronic devices. The square wave pulse width is factory adjustable from .5 to 2.5 micro seconds, and the amplitude from 3 to 60 volts. Both width and amplitude are independent of speed of operation of switch. Ask for data sheet No. 150.

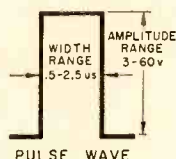
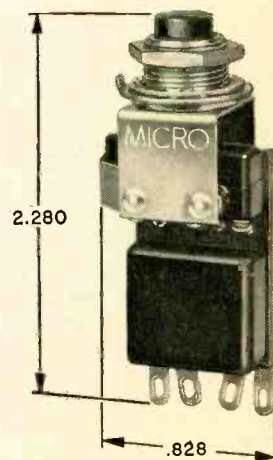

#### *"SE" series environment-free subminiature switches*

"SE" Series switches are the smallest and lightest environment-free switches available. Construction is completely sealed. Operate reliably from -65° to +350°F. Pin plunger actuation. Choice of contact arrangements. Rating 5amps. 125 or 250 vac. 28 vdc—15 amps. inrush; 4 amps. resistive; 3 amps. inductive. Weight—.24 oz. (without leads). Ask for Catalog 77.



Engineering assistance in switch applications is available from the MICRO SWITCH branch office near you. Consult the yellow pages of your telephone book.

MICRO SWITCH . . . FREEPORT, ILLINOIS

A division of Honeywell

In Canada: Honeywell Controls, Ltd., Toronto 17, Ontario



# Honeywell

MICRO SWITCH PRECISION SWITCHES

## **ELECTRONICS NEWSLETTER**

**ATLAS RADIO COMMAND GUIDANCE** is getting new push. GE announces assignment of 150 engineers and technicians to Warren AFB, Cheyenne, Wyo., in connection with installation and check-out of Atlas radio command guidance system. GE expects personnel buildup there will reach peak in 1960.

**CANADA** may embark on a Bomarc missile program as part of the overall North American air defense scheme. This was reported in Montreal following announcement that Boeing had awarded a contract to Canadair Ltd. for engineering services. Canadian firm is sending 150 missile experts to the U. S. for 12 months to take part in engineering of the Bomarc weapon system.

**SNARK**, USAF's 6,000-mi-range supersonic missile, gets a \$50-million contract boost that will extend production through Dec. 1960. Prime contractor Northrop also produces Snark's stellar-inertial guidance system and airframe.

**AIRBORNE TV SURVEILLANCE** system called "Alpha" is being evaluated by the Navy, says Temco Aircraft Corp., the developer. Firm says system was designed under Navy contract as a means of terminal guidance for missiles, but is also being evaluated for reconnaissance use.

**TRANSISTORIZED DATA-PROCESSING** system is announced by RCA. 501 system uses transistorized auxiliary input and output gear, fits into a 15 by 20-ft room. Basic unit costs \$675,000, or is leased at rate of \$13,000 for a 40-hour week.

**JAMES B. FISK** this month moved up to the presidency of Bell Telephone Laboratories, while president Mervin J. Kelly became chairman of the board of directors. Fisk last summer was chairman of the Western delegation at Geneva which studied ways of detecting nuclear tests in the event an agreement on their suspension could be reached.

*Atlas computer components are plated with 24-karat gold, assembled in building blocks and soldered automatically in an infrared induction furnace at Burroughs Corp. Detroit-area plant.*

**RUSSIANS** are making production use of numerically controlled machine tools operating from punched tape or magnetic tape. So says Harry W. Mergler, assistant professor of mechanical engineering at Case Institute of Technology, who recently visited Soviet factories. Mergler also noted that in the automatic controls field the Soviets have a tendency to put a system into full-scale production line use as soon as it's in reasonably good working state.

**SWALLOW**, Republic's surveillance drone system, (ELECTRONICS, p 14, May 30, 1958), has been given a \$25-million contract boost by Army Signal Corps. The small SD-4 jet pilotless aircraft will be equipped with radar, infrared and photographic cameras. Guidance is accomplished by preprogrammed automatic guidance or by ground or air control.

**DOPPLER RADAR** tornado warning system has been proved practical. That's the report from Cornell Aeronautical Laboratory which developed the system for the U. S. Weather Bureau. CAL says development brings "hope for mitigating some of the severe damage caused by tornadoes."

*Infrared pyrometer that detects overheating of airplane engines between 300 and 700 C was recently unveiled by the Nippon Electric Co. in Tokyo.*

**NAVY CONTRACT** of about \$2 million has been awarded to Collins Radio Co. for a high-density microwave system for the Pacific missile range. System will connect Point Mugu control center and subsidiary centers at San Nicholas Island and Point Arguello, distance of about 150 mi.

**ATLAS MISSILE SATELLITE** and its communications relay system may have economic implications for the future. Army missile scientist Wernher von Braun envisioned a satellite receiving the texts of letters or telegrams by radio, storing them on tape and transmitting them on command to ground stations at their destination. That might go far towards defraying the cost of space research and exploration.

**SPECIAL ADVISORY COMMITTEE** headed by Mervin J. Kelly, new board chairman of Bell Labs, will study the scientific programs of the Department of Commerce. Kelly told ELECTRONICS his group would recommend to Secretary Lewis L. Strauss next June steps that would gear the department to the changing needs of science and industry. Kelly's personal area of study is the possibility of mechanizing the Patent Office. Other agencies to be studied: Bureau of Public Roads, Maritime Administration, Weather Bureau, Coast and Geodetic Service, National Bureau of Standards and Office of Technical Services.

**NAVY's** Oakland, Calif. supply center, which provides 90 percent of the supply and logistic support to ships and shore stations in the Pacific area, is installing Philco's transistorized digital data-processing system, Transac S-2000.

**ALL-TRANSISTOR WIREPHOTO TRANSMITTER** is announced by Japanese firm Toho Electronics. due out next spring. Factory price: \$1,250.

# How CDF Di-Clad® can solve your printed-circuit problems

The CDF line of copper-clad laminates in all grades is now known by a new name—Di-Clad. Di-Clad grades meet the varying needs of design, production, and operation of electronic equipment. Grades other than those described are also available.

**Di-Clad 28E.** For high mechanical strength, low moisture-absorption, and good insulation resistance, CDF Di-Clad laminates of epoxy resin laminated with glass fabric offer the designer a strong, reliable combination.

**Di-Clad 112T.** A Teflon\* glass-fabric laminate offering the best dielectric properties over a wide temperature and frequency range.

Send us your requirements and let our engineers help you select the right grade for your application.

\*Du Pont trademark for its tetrafluoroethylene resin.



## CONTINENTAL-DIAMOND FIBRE

A SUBSIDIARY OF THE *Bull* COMPANY • NEWARK 16, DEL.

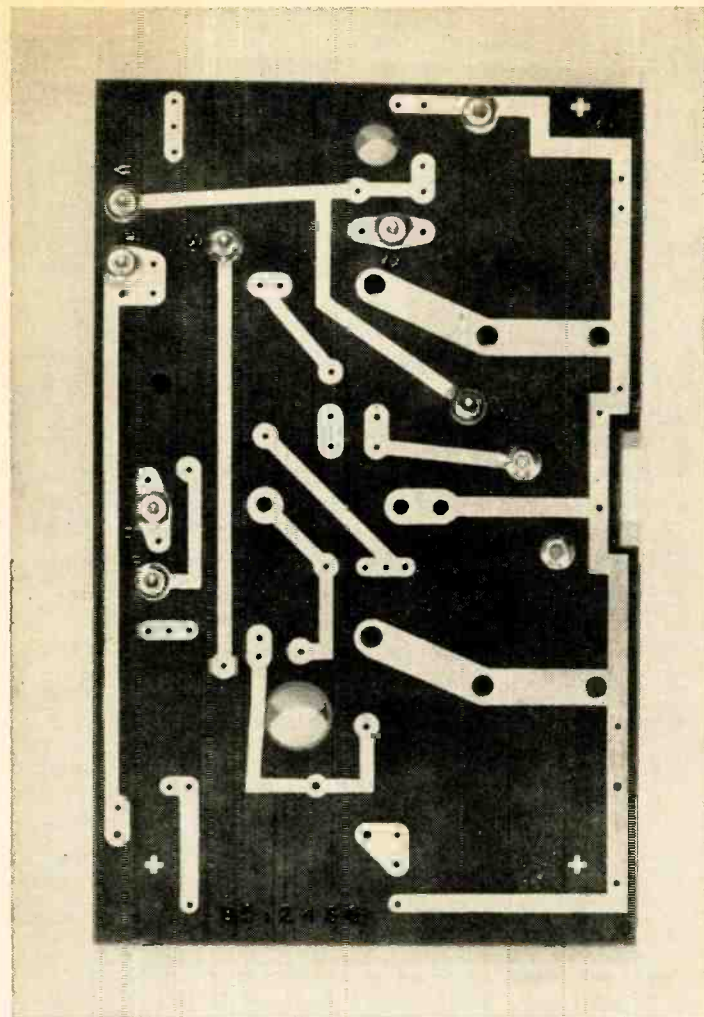

**Di-Clad 2350.** An economy paper-base phenolic grade having good tensile, flexural, compressive, and impact strength. Adequate for most non-critical printed-circuit applications. Can be cold punched and sheared up to 5/64 of an inch in thickness.

### TYPICAL Di-Clad PROPERTY VALUES

	Di-Clad 2350	Di-Clad 26 (NEMA XXXP)	Di-Clad 28 (NEMA XXXP)	Di-Clad 28E (NEMA G-10)	Di-Clad 112T Teflon*
BOND STRENGTH—0.0014" foil (lbs. reqd. to separate 1" width of foil from laminate)	6 to 10	6 to 10	6 to 10	8 to 12	4 to 8
MAXIMUM CONTINUOUS OPERATING TEMPERATURE (Deg. C.)	120	120	120	150	200
DIELECTRIC STRENGTH (Maximum voltage per mil for 1/16" thickness)	800	900	850	650	700
INSULATION RESISTANCE (Megohms) 96 hrs. at 35°C. & 90% RH (ASTM D257, Fig. 3)	500	150,000	600,000	100,000	75,000
DIELECTRIC CONSTANT 10 <sup>6</sup> Cycles	4.5	4.0	3.6	4.9	2.6
DISSIPATION FACTOR 10 <sup>6</sup> Cycles	0.040	0.026	0.027	0.019	0.0015
ARC-RESISTANCE (Seconds)	5	10	10	130	180
TENSILE STRENGTH (psi.)	18,000	16,000	12,000	48,000	23,000
FLEXURAL STRENGTH (psi.)	27,000	21,000	18,000	70,000	13,000
IZOD IMPACT STRENGTH edgewise (ft. lbs. per inch of notch)	0.80	0.45	0.42	12.0	6.0
COMPRESSIVE STRENGTH flatwise (psi.)	32,000	28,000	25,000	62,000	20,000
BASE MATERIAL OF LAMINATE	Paper	Paper	Paper	Medium-weave, medium-weight glass cloth	Fine-weave, medium-weight glass cloth
COLOR OF UNCLAD LAMINATE	Natural	Natural greenish	Natural	Natural	Natural

All these standard grades are available with 0.0014" and 0.0028" or thicker electrolytic or rolled copper foil on one or both surfaces. Other metal foils and other resin-and-base combinations can be supplied on special order.

\*Du Pont Trademark

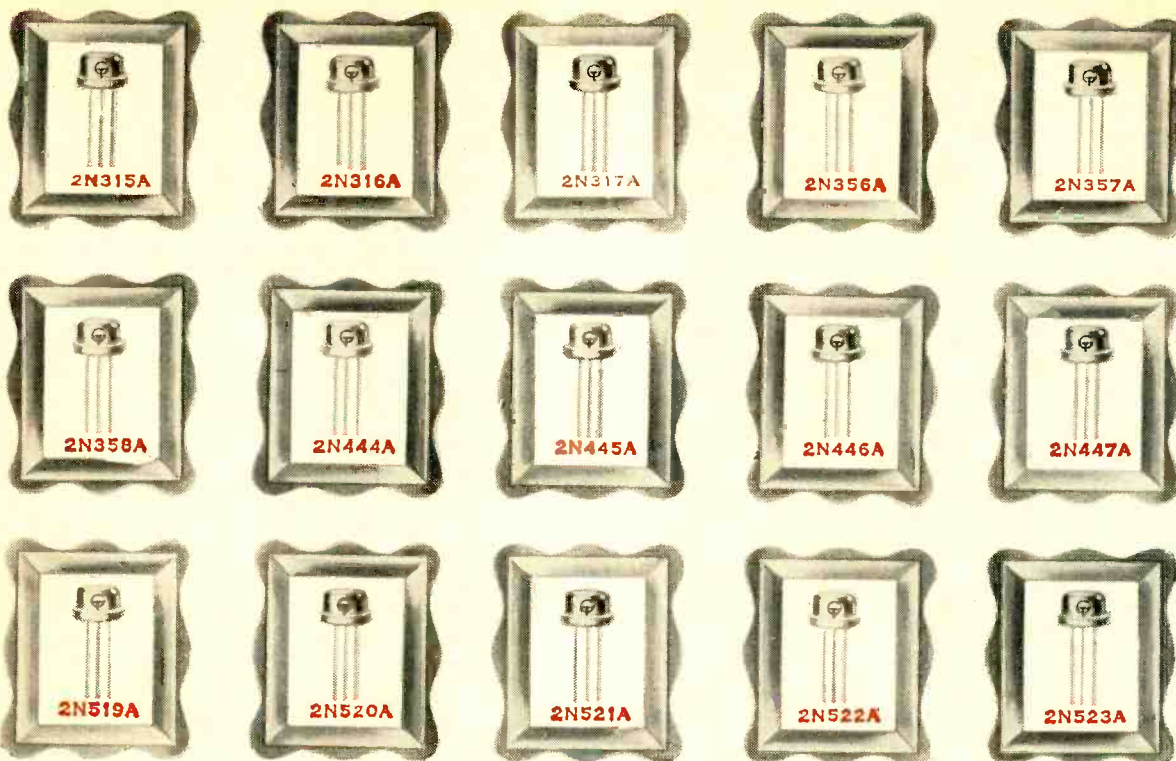

# New "Custom Quality" Family By GENERAL TRANSISTOR

## RESEARCH ACTIVITIES APPROACH IDEALIZED TRANSISTOR RELIABILITY

A bright new chapter in transistor history is being recorded at GT's research laboratories, resulting in progressive transistor design of unprecedented reliability, performance and stability. Advanced production control techniques have made possible the New "A-Types" with specification refinements providing . . .

New process controls highlighted by high sensitivity hermetic seal testing, pre-tinning of internal parts, automatic welding of the hermetic seal case and individual handling of units in process insure improved reliability, uniformity of electrical properties, high mechanical strength and superior hermetic seal. All transistors are pre-aged for 100 hours at 100°C.

TIGHTER PARAMETER CONTROL  
HIGHER OPERATING VOLTAGES

HIGHER SWITCHING SPEEDS  
WIDER APPLICATION RANGES

SPECIFICATIONS: POWER DISSIPATION: 150MW @ 25°C STORAGE TEMPERATURE: -65°C TO -100°C

TRANSISTOR TYPE (EIA)	POLARITY	CUT-OFF STATE		CONDUCTING STATE (SATURATED)		TYPICAL SWITCHING CHARACTERISTICS WITH CIRCUIT GAIN OF 20 AT I <sub>c</sub> LISTED UNDER CURRENT GAIN		ALPHA CUT-OFF f <sub>α</sub> MC Typical
		Collector-Base Rating BVCB0	Oper. Volt V <sub>CE</sub> min. I <sub>C</sub> MAX = 10μA V <sub>BB</sub> = 1.5V R <sub>BB</sub> = 62K	h <sub>FE</sub>	Conditions	Delay + Rise Time t <sub>d</sub> + t <sub>r</sub> μSEC	Storage + Fall Time t <sub>s</sub> + t <sub>f</sub> μSEC	
2N317A	PNP	25V	12V	20 - 60	I <sub>c</sub> = 400ma, V <sub>CE</sub> = .25V	0.3	0.7	20
2N316A	PNP	30V	18V	20 - 50	I <sub>c</sub> = 200ma, V <sub>CE</sub> = .2V	0.4	0.9	12
2N358A	NPN	30V	20V	25 - 75	I <sub>c</sub> = 300ma, V <sub>CE</sub> = .25V	0.4	0.9	9
2N357A	NPN	30V	25V	25 - 75	I <sub>c</sub> = 200ma, V <sub>CE</sub> = .25V	0.5	0.9	6
								Minimum
2N523A	PNP	20V	10V	100 - 400	I <sub>c</sub> = 20ma, V <sub>CE</sub> = .25V	0.2	0.6	21
2N522A	PNP	25V	12V	80 - 300	I <sub>c</sub> = 20ma, V <sub>CE</sub> = .25V	0.3	0.8	15
2N521A	PNP	25V	15V	60 - 250	I <sub>c</sub> = 20ma, V <sub>CE</sub> = .25V	0.4	0.9	8
2N447A	NPN	30V	15V	80 - 300	I <sub>c</sub> = 20ma, V <sub>CE</sub> = .25V	0.4	0.7	9
2N446A	NPN	30V	18V	60 - 250	I <sub>c</sub> = 20ma, V <sub>CE</sub> = .25V	0.7	1.0	5
2N445A	NPN	30V	20V	40 - 150	I <sub>c</sub> = 20ma, V <sub>CE</sub> = .25V	1.0	1.3	2

WRITE FOR BROCHURES G-140A AND G-150A

Popular computer types 2N311, 2N312, 2N404, 2N426, 2N427, 2N428, 2N439 and 2N440 are also available.

You grow fastest with the products that serve you best. Prove it to yourself today with GT.



## GENERAL TRANSISTOR

C O R P O R A T I O N

91-27 138TH PLACE • JAMAICA 35, NEW YORK

"YEARS AHEAD  
IN RELIABILITY"

# BARNSTEAD NEW TRANSISTOR WASHER

FOR WASHING and RINSING TRANSISTORS, DIODES, RECTIFIERS, TUBE PARTS and MATERIALS SUCH AS SILICON AND GERMANIUM



Maintains 15,000,000 OHM ultra-pure water while conserving make-up water through special re-purification cycle.

Best results with faster rinsing and fewer rejects are obtained when ultra-pure, hot water is employed in washing and rinsing of transistors, diodes, and other electronic components. The Barnstead Transistor Washer conserves thousands of gallons of water each day as it repurifies the pure, hot water keeping it free of organic impurities, and submicroscopic particles to 0.45 microns. Completely factory-assembled, ready for operation.

## EVERYTHING IN PURE WATER EQUIPMENT

Write for Catalog

- WATER STILLS, steam, gas and electric with capacities from 1/2 to 1000 g.p.h.
- REGENERATIVE TYPE DEMINERALIZERS, 50 to 2,500 or more g.p.h.
- SUBMICRON FILTERS, 400 or more g.p.h. Submicroscopic filtration to 0.45 microns

**Barnstead**  
STILL & STERILIZER CO. Inc.

BOSTON  
Jamaica  
4-3100

CHICAGO  
Mulberry  
5-8180

NEW YORK  
Kingsbridge  
8-1557

PHILADELPHIA  
Locust  
8-1796

SAN FRANCISCO  
Templebar  
2-5391

CLEVELAND  
Academy  
6-6622

LOS ANGELES  
RYan  
1-6663

84 Lanesville Terrace, Boston 31, Mass.

FIRST IN PURE WATER SINCE 1878

CIRCLE 8 READERS SERVICE CARD

12

# WASHINGTON OUTLOOK

ELECTRONICS PRODUCTION in 1959 will reach "a new all-time high," according to the government's official outlook report on the new calendar year. The report, prepared by the Commerce Dept.'s Business & Defense Services Administration, estimates factory output of electronic equipment and components valued at about \$7.9 billion. This is about 14 percent more than last year's volume of slightly under \$7 billion.

The BDSA forecast excludes research and development expenditures, thus falls short of the Electronic Industries Assn.'s \$8.3 billion estimate of industry sales in 1959. (For ELECTRONICS' views, see p 41.)

On the consumer product side, the government outlook anticipates a boost of some 10 percent over 1958 output—to a total of \$1.5 billion.

This is based on a hike in black-and-white tv receiver production from about 5 million sets to about 6 million; also, an increase in radio receiver output from about 12 million sets last year to about 13.5 million in 1959. Government forecasters see no "substantial permanent increase in the size of the consumer market" until color tv sales reach annual rates of at least 500,000 units.

The forecast is for a hike of some 16 percent in military electronic output—not counting R&D spending. But the government warns against possible cancellations, cutbacks, contract revisions and reductions in size of the military establishment.

The outlook is for a continued rise in shipments. One big factor: The increasing numbers of long lead-time missiles becoming operational during 1959. In addition to missiles, BDSA stresses that defense electronic output will be pushed by communications modernization, including the increased use of single sideband and scatter techniques, and the growing electronic content of just about all other weapon systems.

BDSA predicts an 18-percent hike in output of commercial and industrial electronic equipment.

- In components, BDSA estimates a 12-percent increase in electron tube production. The forecast comes in the face of admittedly increasing substitution of semiconductors for tubes. The increase is predicted across the board for transmitting and special-purpose tubes, tv picture tubes, receiving tubes, and rebuilt tubes.

A 25-percent increase is forecast in production of semiconductor devices. Total volume this year of transistors and crystal diodes is estimated at \$250 million. Production of electronic components other than tubes and semiconductors will rise about 12 percent over 1958 levels.

- Uhf tv spectrum is slated for close scrutiny during 1959 if FCC commissioners Craven and Ford keep at projects now in the talking stage. The Craven plan, outlined last summer, calls for a study to determine whether a block of 25 continuous channels can be set up at the upper end of the present vhf spectrum.

Then, in a pre-Christmas talk, Commissioner Ford warned that the future looks shaky for uhf stations if things follow their present course. Like Craven, Ford stressed the need to move slowly in order to minimize risk of loss by tv manufacturers and stations.

Electronics industry is keeping an eye open for space that may become available if the tv spectrum is changed. Officials of the Bell System, for example, hope for the day when the uhf spectrum may be used in part to supply telephone service on a nationwide basis for automobiles, busses and airplanes.

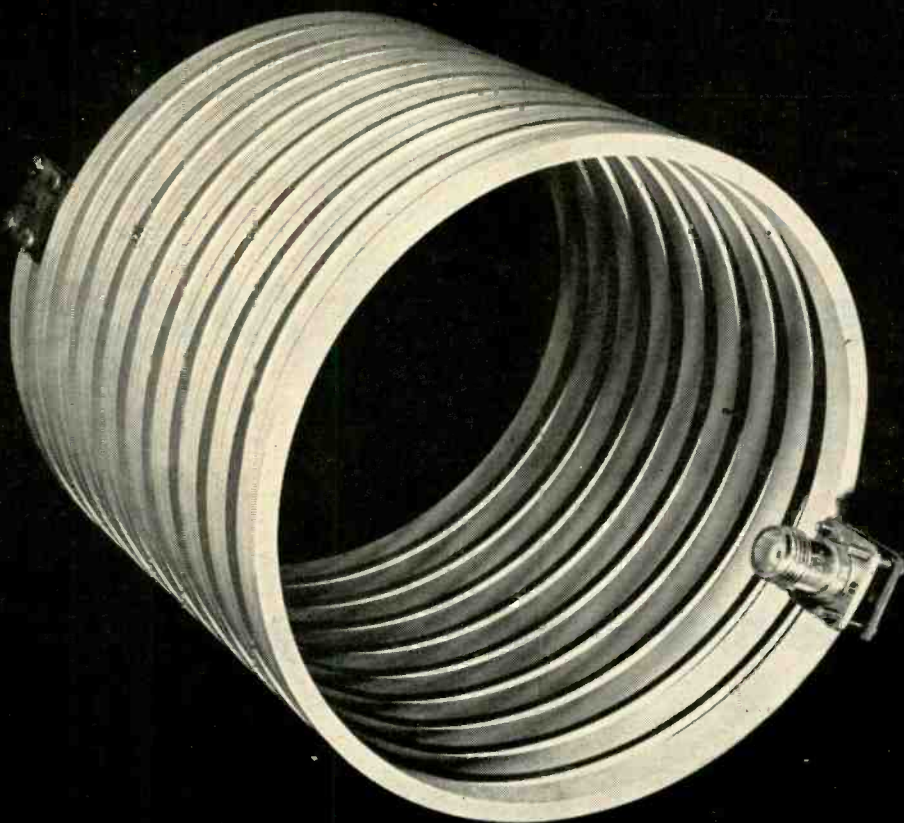

Microwave delay line for use in airborne equipment.

## MICROWAVE RESEARCH

The expanding role of electronic equipment in modern military operations has given high priority to microwave research. No field today offers greater challenge to the scientist and engineer.

In support of current electronic countermeasures programs and in anticipation of future systems requirements, Ramo-Wooldridge Division is engaged in microwave research to develop new techniques and to refine conventional components.

Research is under way at Ramo-Wooldridge for new methods and new designs to reduce substantially the over-all size, weight and complexity of electronic equipment for both airborne and ground-based uses.

For example, the low-loss delay line in the photograph above was designed, developed and manufactured by Ramo-Wooldridge for use in airborne equipment. Packaged for use in the system for which it was designed, this miniature

ceramic unit weighs less than two pounds. It replaces a component which weighed more than twenty pounds and occupied more than five times as much volume.

Special opportunities exist for those with qualified experience in microwave research—in technique evaluation, component development, and design of such systems equipment—at Ramo-Wooldridge.

*Engineers and scientists are invited to explore openings at Ramo-Wooldridge in:*

- Electronic Reconnaissance and Countermeasure Systems
- Infrared Systems
- Analog and Digital Computers
- Air Navigation and Traffic Control
- Antisubmarine Warfare
- Electronic Language Translation
- Information Processing Systems
- Advanced Radio and Wireline Communications
- Missile Electronics Systems



**RAMO-WOOLDRIDGE**

P. O. BOX 90534, AIRPORT STATION • LOS ANGELES 45, CALIFORNIA

a division of *Thompson Ramo Wooldridge Inc.*

# Industry Moves Ahead with Plan '59 . . .

## *To modernize now for growth and profits*

**The most expensive task to be performed in America, in this new year of 1959, is the modernization of our industrial plant and equipment.** This is true despite the huge expenditures on new facilities made in the past decade.

Contrary to popular opinion, and even to much learned opinion, our industrial facilities are not up to date. In a special survey conducted in August 1958, and supplemented by further interviews since that time, the McGraw-Hill Department of Economics found that it would take \$95 billion to bring all our plant and equipment up to the best modern standards. This is over \$15 billion more than the record budget of the U.S. government for the coming year.

**How did we get so far behind?** It is true that business has made record capital expenditures in recent years, but most of this investment has been to expand capacity. And in concentrating on new capacity, industry has fallen behind on the modernization of older facilities. Meanwhile, the \$8 billion a year surge of research and development has brought forth new machines and new processes, at a rate that

makes prewar and even early postwar equipment badly obsolete.

The lag between what research has promised—especially in more efficient tools of production—and what has actually been accomplished up to now shows clearly in the AMERICAN MACHINIST inventory of metalworking equipment for 1958. This new study, covering 167 types of equipment in 5,800 metalworking plants, shows that three out of five metalworking machines are over ten years old. This is a startling indication of how obsolete many plants have become. A 1958 machine tool is 54% more productive than one purchased in 1948. Many of the tools industry now uses are actually of 1939, or earlier, design.

### **Investment Starts Up**

**Now industry's plans for 1959 show a new awareness of the need to modernize.** In its surveys, conducted during the last part of 1958, the McGraw-Hill Department of Economics discovered these facts:

**(1) Companies generally believe that a larger investment in modernization will**



**mean more profits—soon.** Most of the manufacturing companies in the surveys expect their current modernization expenditures to pay off in less than five years. With labor costs rising steadily, it is only with better, more modern equipment that most companies can hope to make these profit gains.

**(2) Industry's plans for modernization have been revised upward.** Total plans for 1959 investment, in new plant and equipment, now come to \$33 billion—compared with \$31 billion reported earlier. And most of these new plans are directed toward modernization—installing new processes or making ready for new products, developed out of the most recent scientific advances.

It therefore seems clear that modernization expenditures in 1959 will rise enough to make an impressive start on the job of updating our plant and equipment. But it will be no more than a start. Research also is moving ahead with giant strides. Plant expenditures must increase rapidly, from 1958's low level, to win the battle against obsolescence.

### **How Can We Modernize Faster?**

What can we do to accelerate industry's new drive for more modern plant and equipment? One aid will be an improved flow of technical information on how, and where, to modernize. With this purpose, the McGraw-Hill Publishing Company several months ago inaugurated PLAN '59, a joint effort by all its magazines to spotlight the best opportunities for modernization. During 1959, McGraw-Hill publications will continue this effort by putting special emphasis on new developments in plant and equipment.

On the key problem of financing modernization—the question “Where's the money coming from?”—the McGraw-Hill Department of Economics plans several new studies in the months ahead. The first of these will deal with the number one problem in financing: the need for adequate depreciation allowances. Such studies

are a small, but we hope a helpful, part of the total effort that is needed to modernize American industry.

### **An Individual Effort**

**The really vital steps in modernizing must be taken by individual companies.** The backlog of obsolete plant and equipment is widely dispersed, among firms of all sizes and in all areas. It cannot be wiped out by dynamic equipment policies on the part of a few leading firms. Not just a few, but thousands of industrial companies must take inventory of their respective equipment and compare it, case by case, with the best new machines available.

Finally, there is need for increased public recognition of the modernization problem, and for federal tax policies appropriate to a period of rapid technical change in business.

**The most important point is that the modernization drive has begun. This start can accelerate, with intelligent business and public policies, to give us truly modern industrial facilities. Plant and equipment expenditures are finally beginning to reflect the stepped-up pace of research and development. This can be a major factor in renewed economic growth and prosperity as we move into 1959.**

*This message was prepared by the McGraw-Hill Department of Economics as part of our company-wide effort to report on opportunities for modernization in industry. Permission is freely extended to newspapers, groups or individuals to quote or reprint all or part of the text.*

  
PRESIDENT

**McGRAW-HILL PUBLISHING COMPANY, INC.**

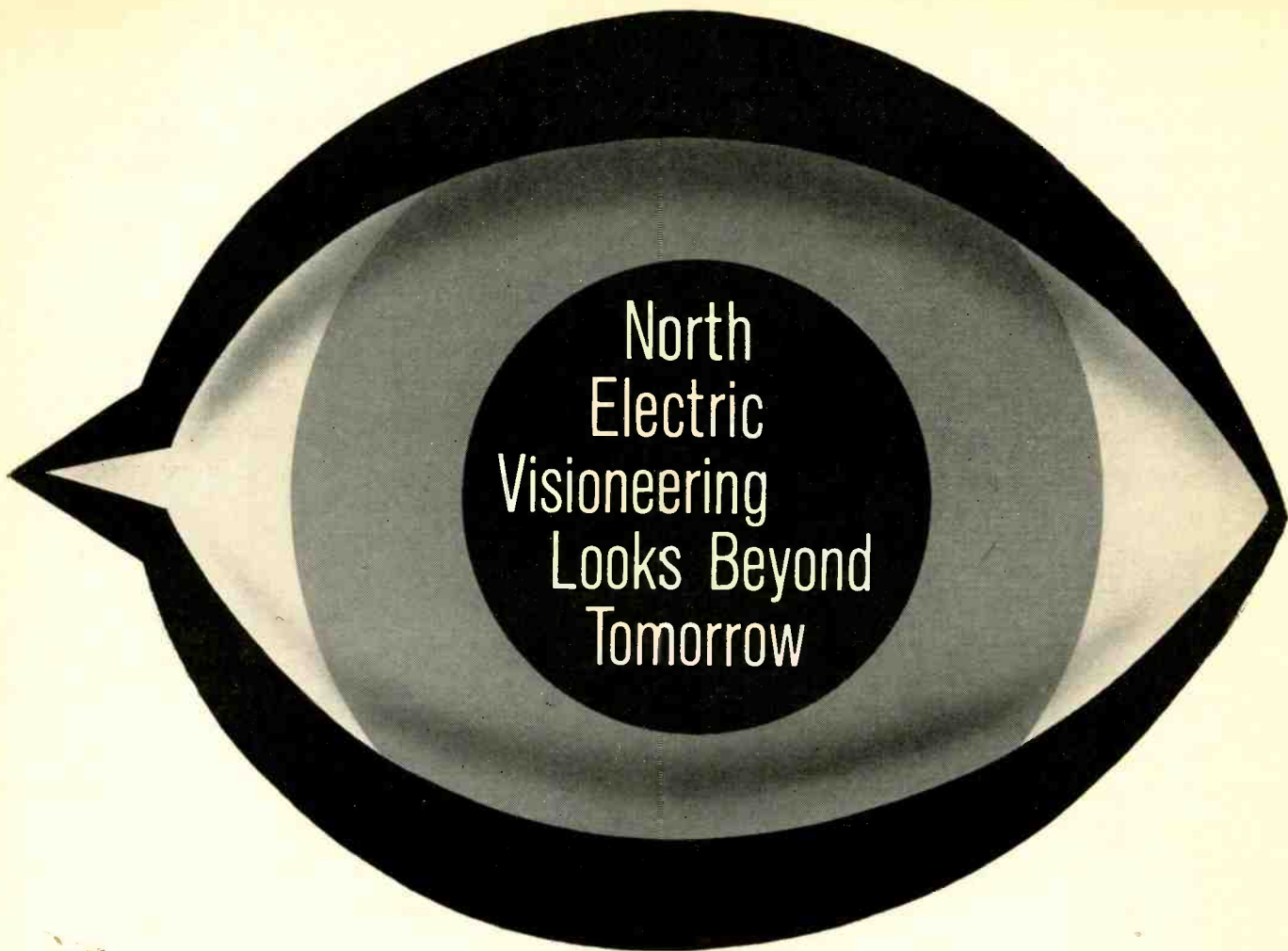

North "visioneering" is an engineering concept that couples the accumulated experience of 75 years with vision that looks beyond the immediate future in developing systems to increase man's productivity, make man's life more comfortable and add immeasurably to the security of man's present and future.

The dramatic story of significant North Electric Company contributions to system development and engineering will open whole new areas of thought on how North "visioneering" can be applied to extend the scope of your capabilities beyond today's boundaries.

A copy of "North Electric System Concepts" booklet is yours for the asking—write Dept. IB, North Electric Company, Galion, Ohio.

Control Systems • Communications • Electronics

INDUSTRIAL DIVISION

**NORTH ELECTRIC COMPANY**

491 SOUTH MARKET STREET • GALION, OHIO



## FINANCIAL ROUNDUP

# Sees Tax Aid on Way

INCOME TAX DEDUCTION on a portion of earnings reinvested in new plant and equipment has good chance to pass in Congress in 1960, says Senator John Sparkman (D-Ala.), chairman of Senate Small Business Committee. Problem of financing electronics firm growth would be eased if bigger slice of profits before taxes could be retained. As legislators are thinking of allowing deductions un-

market facilities available for Tele-Signal products. T-S will retain design and engineering responsibilities for its equipment and will continue present sales and pilot manufacturing efforts.

## Need Lint-Free Acid-Resistant Synthetic Uniforms?



*Angelica "engineers"  
your uniform problems*





# Get Quality *AND* Performance Value with Mallory Capacitors . . .

*for Military • for Industrial • for Entertainment Equipment*

Choose a capacitor to meet your exact requirements from the broad line of dependable Mallory electrolytics. (Many types and variations not shown, including all MIL-C-62 types, are available.)

*Mallory offers a complete range of Tantalum Capacitors.* Mallory pioneered the sintered-pellet anode which made possible the first 200°C capacitors to meet critical military vibration requirements. Ratings range from the newest type HAT—the smallest tantalum capacitor ever made—to the XTV high capacity units . . . with a broad selection in between.

*Mallory Premium and Computer Grade Capacitors* offer extra-service life and reliability. Extra precautions in the selection of materials and in the manufacturing processes assure highest quality and exceptional stability.

*Mallory FP and WP Capacitors* have been accepted industry standards for many years. This original 85°C electrolytic is stable and dependable, even at high temperatures. These capacitors feature the famous fabricated plate anode and etched cathode construction, or etched anodes for lower voltages. New spring-clip mounting of the capacitor element within the can means lighter weight—improved resistance to shock and vibration—assurance against electrolyte leakage.

*Mallory Cardboard-cased Capacitors* offer maximum service at low initial cost. Built to rigid quality control standards, these popular priced components meet a wide variety of initial equipment and service needs.

To assist in selecting and applying the best capacitor to your exact requirements, Mallory offers the services of trained circuit application engineers. Call on them whenever you need help. Mallory will also be glad to supply you with complete technical specifications and application data.

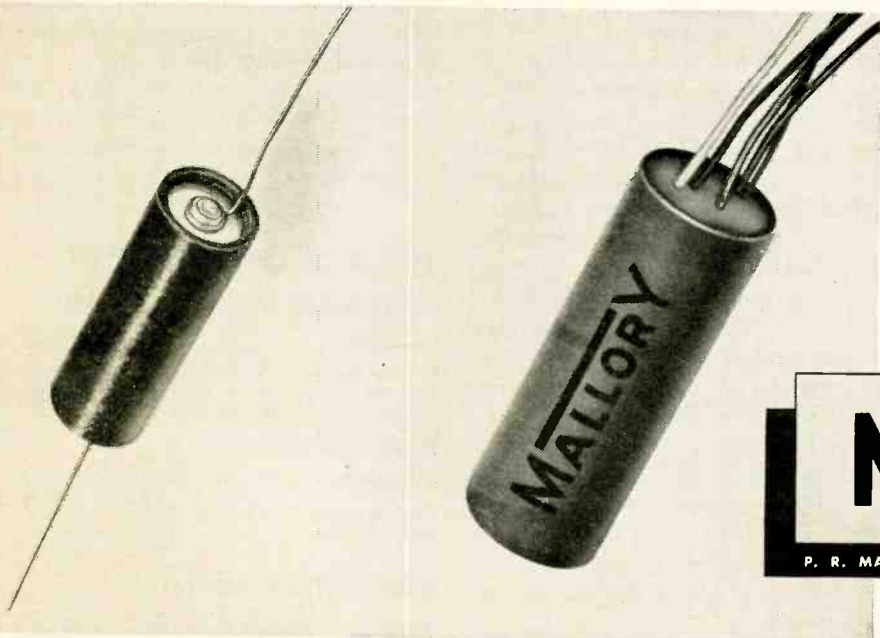

**TC—Standard of quality.** Mallory TC capacitors have long been a standard for coupling and bypass application—proven performance—backed by years of experience. Also special TCX type for -55°C.

**Economy and performance.** Mallory cardboard-cased capacitors can't be beat in entertainment equipment where economy is paramount. Choose from a wide variety of ratings and mountings.

P. R. MALLORY & CO. Inc.  
**MALLORY**  
P. R. MALLORY & CO. Inc., INDIANAPOLIS 6, INDIANA

# friend or foe?

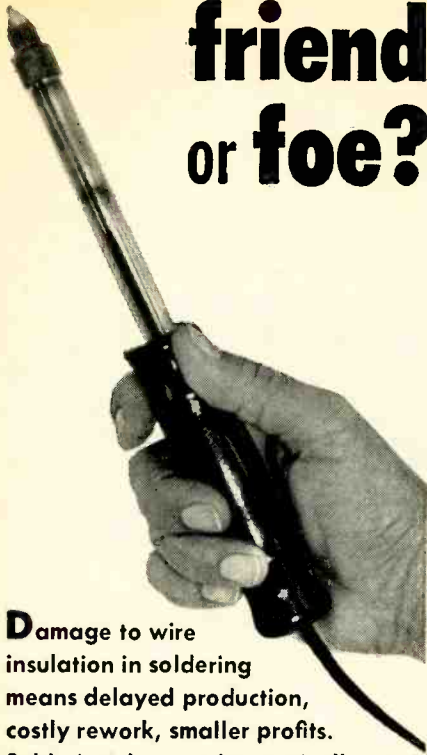

Damage to wire insulation in soldering means delayed production, costly rework, smaller profits. Soldering damage is practically eliminated by the use of Markel's

## FLEXLEAD

### TEFLON\* LEAD WIRE

Markel FLEXLEAD, the precision lead wire with Teflon insulation, is unaffected by soldering temperatures.

FLEXLEAD also is impervious to solvents, corrosive chemicals, lubricants and moisture—and is noted for its excellent flexibility and superior electrical properties over the widest ranges of temperature and frequency.

Markel FLEXLEAD is available from stock in standard sizes and colors to MIL-W-16878-C specifications.

For the same characteristics in insulating tubing, specify Markel FLEXITE in Teflon.

\* (Du Pont Registered Trademark)

HYGRADE

Sample of FLEXLEAD or FLEXITE Teflon free on request.

FLEXITE

L. FRANK MARKEL & SONS  
SINCE 1922

INSULATING TUBINGS AND LEAD WIRE  
NORRISTOWN, PENNSYLVANIA

CIRCLE 16 READERS SERVICE CARD

## MARKET RESEARCH

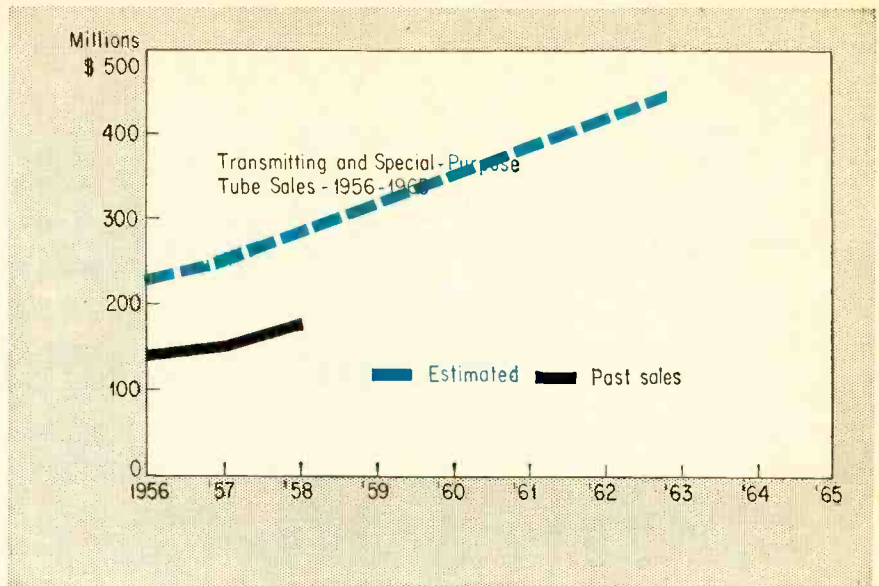

## Special-Tube Sales Rising

FACTORY SALES of transmitting, microwave, power and other special-purpose nonreceiving tubes were about \$180 million at factory prices in 1958. The market for 1959 looks like about \$210 million. At present rate of expansion this should pass the \$300-million mark about 1962, nearing \$400 million around 1965.

Uses of power tubes in industry, and military increases in microwave applications of magnetrons, switching tubes, klystrons and traveling wave tubes will account for much of the rise.

In addition to the steadily growing total sales volume of these tubes, the variety of types is increasing rapidly as technological advances cross new frontiers.

The breakdowns shown here are a composite of industry estimates, since reporting groups prefer to keep their official figures confidential. One difficulty the groups face is that precise categories are complicated by growing number of small specialist manufacturers who are not members of reporting associations. Problems arise also where one or two makers do most of the business in one category. In these cases production figures are reflected only in totals, not for specific categories.

The overall picture is one of steady growth, with some types fluctuating, others climbing rapidly. In the latter group are storage

tubes. They now have annual volume of well over a million dollars; cost \$1,000 to \$1,500 per unit. X-ray tube market appears relatively stable but growing slowly. Sales in 1958 were around \$8 million.

There are a few relatively soft spots, such as ignitrons, which sold over \$3 million in 1956, were down to \$2.6 million in 1957 and even lower in 1958. Harold Vance, chairman of NEMA-RETMA joint committee on these tubes, and presently manager—sales engineering, RCA Electron Tube Div., points out this is a direct result of last year's poor automobile business. The car industry, which buys ignitrons to weld chassis together, has been the largest market for these tubes.

## FIGURES OF THE WEEK

### LATEST WEEKLY PRODUCTION FIGURES

(Source: EIA)	Dec. 19, 1958	Nov. 21, 1958	Change From One Year Ago
Television sets	110,021	116,530	+13.8%
Radio sets (ex. auto)	319,478	390,019	+ 3.4%
Auto sets	124,976	137,678	+28.7%

### STOCK PRICE AVERAGES

(Standard & Poor's)	Dec. 23, 1958	Nov. 26, 1958	Change From One Year Ago
Electronics mfrs.	72.24	64.90	+44.0%
Radio & tv mfrs.	76.19	68.96	+86.7%
Broadcasters	78.07	73.77	+52.4%

### LATEST MONTHLY SALES TOTALS

(Add 000)	Oct. 1958	Sept. 1958	Change From One Year Ago
Transistors, value	\$13,462	\$10,811	+90.3%
Transistors, units	5,595	5,076	+57.9%
Rec. tubes, value	\$34,362	\$33,951	-10.6%
Rec. tubes, units	41,540	40,061	-11.8%
Pic. tubes, value	\$19,352	\$17,704	- 0.7%
Pic. tubes, units	957	892	- 3.9%

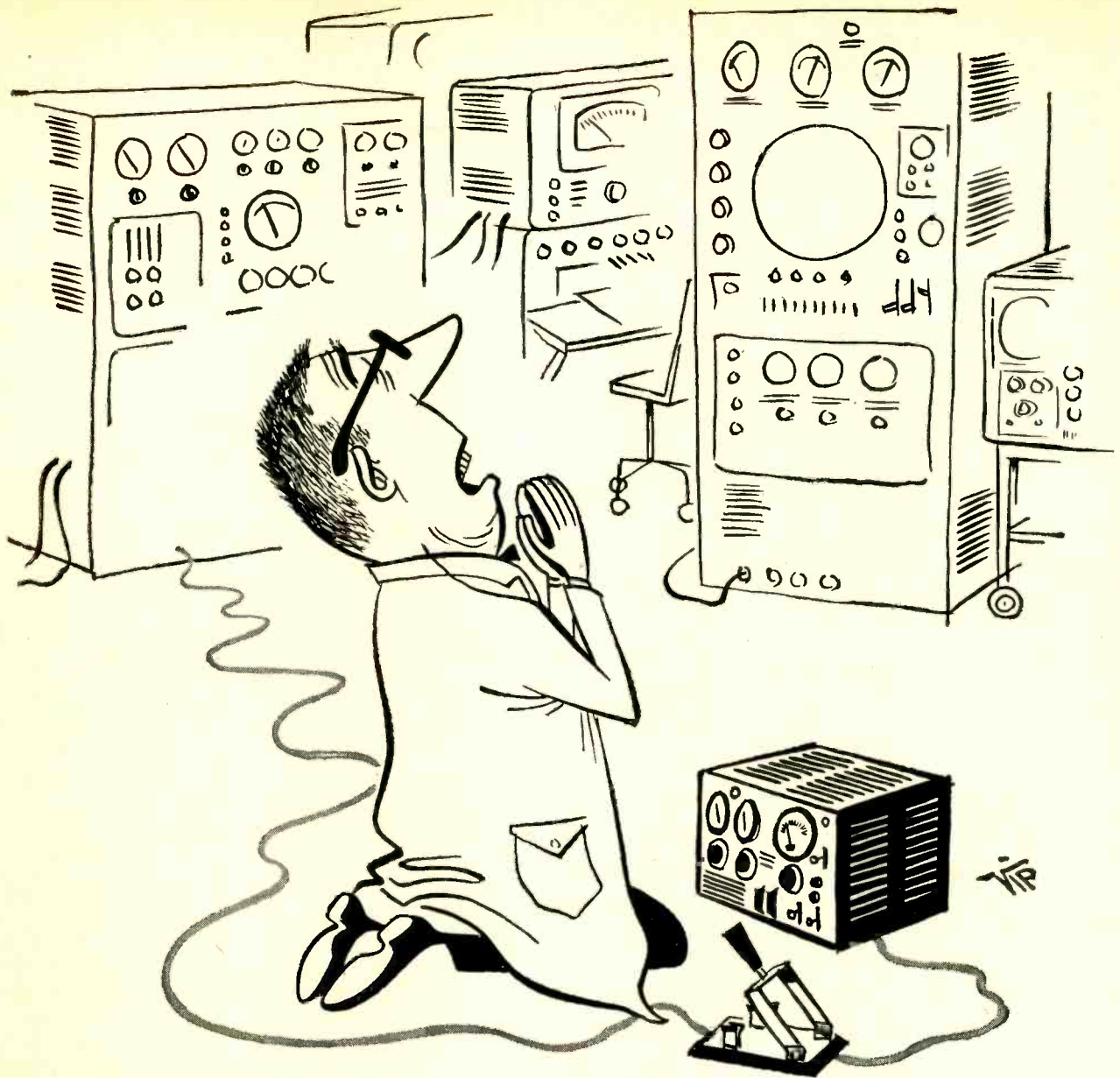

## Quality Control: *state of the art*

*It has been rumored* that some engineers rely upon supernatural means to insure proper quality control. When all else fails, there is something to be said for this method. At Hughes Products, however, we try to take a more scientific approach to quality control. That's why Hughes Products systems and components have established such an outstanding record of reliability.

On the following three pages are specific examples of reliable Hughes components—Quick Recovery Diodes, TONOTRON\* Storage Tubes, and MEMO-SCOPE® Oscilloscopes.

In addition to these, other Hughes Products devices with this “built-in” reliability include: Precision Crystal Filters for selective tuning... Rotary Switches... Thermal Relays... MEMOTRON® and TYPOTRON® storage tubes... Diodes, Transistors and Rectifiers with uniform performance... and Industrial Systems which automate a complete and integrated line of machine tools.

\*Trademark of H. A. C.

*For additional information regarding any component or system please write: Hughes Products, Marketing Dept., International Airport Station, Los Angeles 45, California.*

*Creating a new world with ELECTRONICS*

**HUGHES PRODUCTS**

© 1958. HUGHES AIRCRAFT COMPANY

SEMICONDUCTOR DEVICES • STORAGE AND MICROWAVE TUBES • CRYSTAL FILTERS • OSCILLOSCOPES • RELAYS • SWITCHES • INDUSTRIAL CONTROL SYSTEMS



**quick  
recovery!**

## Reliable Hughes Silicon Junction Diodes

With recovery to 400 K ohms (minimum) in 1 microsecond... Hughes high-speed silicon diodes reliably meet the quick recovery requirements of most germanium types, and in addition, stand up under high voltages at high temperatures. In fact, the breakdown voltages increase with temperature... thereby providing maximum protection when temperatures reach unexpected levels. With this order of reliability, Hughes quick recovery silicon diodes assure dependability under the most severe operating temperatures.

Typical performance levels:

Breakdown voltages at current of 0.1 mA from 30-200 volts.

Ambient operating temp.  $-80^{\circ}\text{C}$  to  $+150^{\circ}\text{C}$   
Reverse current—as low as  $1\ \mu\text{A}$  at  $-175$  volts and  $25^{\circ}\text{C}$   
—as low as  $30\ \mu\text{A}$  at  $-175$  volts and  $100^{\circ}\text{C}$

Special high conductance types in the quick recovery series are available in all voltage classes. No matter what your problem, chances are that there is a Hughes diode to meet your need. Write today for a complete data sheet on the Hughes quick recovery silicon diode—or any other Hughes semiconductor device.

Address: HUGHES PRODUCTS, Marketing Department, International Airport Station, Los Angeles 45, Calif.

*Creating a new world with ELECTRONICS*

**HUGHES PRODUCTS**

© 1958. HUGHES AIRCRAFT COMPANY

SEMICONDUCTOR DEVICES • STORAGE AND MICROWAVE TUBES • CRYSTAL FILTERS • OSCILLOSCOPES • RELAYS • SWITCHES • INDUSTRIAL CONTROL SYSTEMS



*Constantin* GLASS-TO-METAL SEALS PROVIDE...

# captive weather

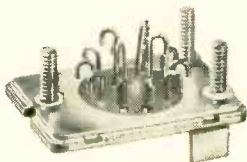
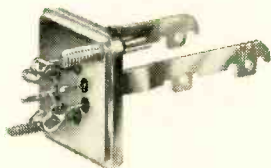
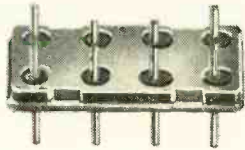

The operational bugs which are nourished on moisture and humidity never grow beyond the incubator stage when Constantin Glass-To-Metal Seals protect your —

- Relays
- Transistors
- Capacitors
- Crystals
- Rectifiers
- Transformers

For standard, miniature, and subminiature components alike, the atmosphere is maintained unchanged from the controlled conditions that existed at the moment of sealing.

**Captive weather . . . by CONSTANTIN . . .** permits today's complex equipment to retain its functional punch I-o-n-g after conventional glass-to-metal seals surrender to oxidation and corrosion.

Your airborne, shipboard, and ground support equipment needs "captive weather" . . . the prime parameter of trouble-free longevity. Write Constantin today . . . your problems, your needs, your applications . . . are sincerely invited.

"QUALITY WITH CONFIDENCE"



## *L. L. Constantin & Co.*

**MANUFACTURING  
ENGINEERS**

GENERAL OFFICES: ROUTE 46  
LODI, NEW JERSEY

PLANTS: 187 SARGENT AVE.  
CLIFTON, N. J.

ROUTE 46,  
LODI, N. J.

5TH AND CAPITOL STS.  
SADDLE BROOK, N. J.

# Remote Computers Guide

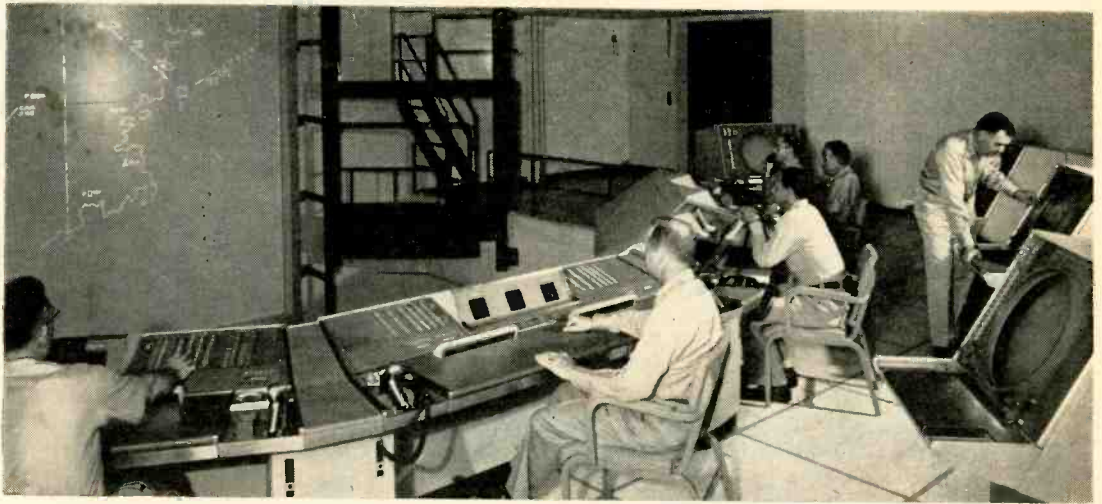

Monitored and directed in Kingston, N. Y.'s IBM Sage Center, Bomarc knocks down a drone near Canaveral, Fla.

While controversy continues over relative merits of Army's Nike-Hercules and USAF's Bomarc for air defense, both surface-to-air interceptors are successfully speeding toward operational readiness

DESPITE CURRENT controversy over actual need in our air defense system for both Army's Nike-Hercules and USAF's Bomarc ground-to-air missiles, today both interceptor weapon systems are moving ahead toward operational readiness with good speed.

Proponents of economy cuts on missiles with similar missions are countered by strategists who point out that Army's Nike-Hercules is a 100-mi-range point defense weapon, while USAF's Bomarc A and the super Bomarc B are area defense interceptors going out to about 200 and 400 miles respectively.

Both Nike-Hercules and Bomarc A have been test fired successfully a number of times. Bomarc's final launch from Cape Canaveral, controlled via leased lines by IBM's Kingston, N. Y., Sage facilities, took place three weeks ago (photo above), thus ending Kingston's experimental Bomarc launchings.

## New Site Opens

Future Bomarc firings will be for training operational crews at Santa Rosa Island, just off the northwest Florida coast. First operational testing and training site for Bomarc crews was activated last

month at nearby Eglin AFB, Florida's Auxiliary Field No. 9.

First of the four operational Bomarc launching sites now under construction will be ready before the end of this year. Work on the remaining 10 scheduled sites has not yet begun.

Nike-Hercules is now moving into ready-made Nike-Ajax launching sites where, after some modification, both missiles can be operated with the same equipment.

Construction appropriations for Nike and Bomarc sites, written into Public Law 85-685, on Aug. 20, 1958, include \$173,678,000 for the Army and \$269,100,000 for USAF. Prior to utilization of the funds, however, the Defense Secretary must determine, with respect to each defended area, which missile or combination of missiles will be used. He has authority to transfer these funds between services.

Both Nikes and Bomarc are controlled by automatic ground guidance radio command systems: Nike-Ajax and Nike-Hercules by Martin's Missile Master system and Bomarc directly by the continental network of IBM Sage centers. Bomarc's terminal guidance system is active radar homing, produced by

Westinghouse. Firm's total for this gear to date is \$60 million.

Nike sites, located in areas covered by Sage operations, are an integral part of the North American Air Defense system. The Sage Direction Center computer automatically provides each Army Air Defense Command post with information concerning approaching aircraft and identification.

## Assigns Targets

Army defenses correlate this data furnished by Sage with their own local radar displays. Target assignments are made by the NORAD commander in the Sage Direction Center for engagements by the Army's defenses.

The Sage/Bomarc firing sequence begins when an AN/FPS-20 long-range search radar, produced by Bendix, detects a flying object. This return is passed along to an AN/FST-2 coordinate data transmitter (Burroughs) located on the radar site. The data transmitter converts the radar return to polar coordinates—range and azimuth—for transmission in digital form over leased lines to an AN/FSQ-7 computer (IBM) in the Sage Direction Center (each center uses two

# Missiles

of these \$27-million computers).

Digital information on the object's range and azimuth is stored in "Long Range Input" magnetic drums of the computer, compared with programmed data and converted into Cartesian coordinates, referenced to the appropriate Bomarc launch pad.

## Missile Gets Orders

At the instant the fire button is pressed at the weapons console in the Sage center, prelaunch computations are initiated and transmitted to the guidance unit in the Bomarc. These commands are fed directly to the missile during the brief period between flight initiation and take-off. After launch, they go by land-line to the transmitter at the launch site and from there by radio to the missile.

Midcourse commands are calculated and transmitted as required to maintain an intercept course.

Tracks made by the target and by Bomarc are distinguishable on the ground radar scope by turning on a beacon in the missile. Flight path of the target appears on the scope as a line of tiny crosses; the missile appears as slants or slashes.

When the missile is guided to within striking distance of the target, the computer tips missile into a steep dive. The computer cuts off, the missile's active radar homing transmitter goes on, following its echo returns to the kill.



Up to 100,000 instructions per second go from this IBM computer to guide missile in flight to interception. Scope and FIRE button adjacent to it are parts of computer

*New Speed...Versatility...Reliability...*

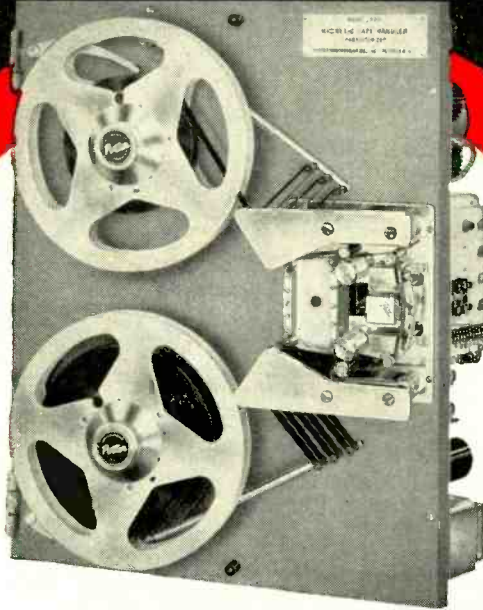

## TRANSISTORIZED DIGITAL MAGNETIC TAPE HANDLER MODEL 906

### ● Check these new standards of reliability and performance

- Completely transistorized for maximum reliability
- Trouble free brushless motors
- Over 50,000 passes of tape without signal degradation
- Linear servo system
- Life expectancy of pinchroll mechanism: over 100,000,000 operations
- Skew  $\pm 3 \mu\text{sec}$ .  $1/2''$  tape, center clock at 100 i.p.s.
- Vacuum loop buffer
- Continuous flutter free cycling 0 to 200 cps
- Normal speed up to 100 i.p.s.
- Rewind or search speed constant at 300 i.p.s.
- Six speeds forward or reverse up to 150 i.p.s.
- Better than 3 milliseconds start, 1.5 millisecc stop
- Front panel accessibility
- In line threading
- End of tape and tape break sensing
- All functions remotely controllable
- Tape widths to  $1\frac{1}{4}''$

The 906 is usually supplied with the Potter 921 transistorized Record-Playback Amplifier; a unit that features:

Pulse or level outputs

Output gating  
1 i.p.s. to 150 i.p.s.

Manual, relay, or  
electronic function switching  
Dual read-write operation

Potter also manufactures a complete line of Perforated Tape Readers, High Speed Printers and Record-Playback Heads.

Contact your Potter representative or call  
or write direct for further information.



The mark of  
Engineering Quality

### POTTER INSTRUMENT COMPANY, INC.

Sunnyside Boulevard, Plainview, N. Y.  
OVERBROOK 1-3200

Potter has career opportunities for qualified engineers who like a challenge, and the freedom to meet it.

# SOLAR SAILING



EXPANDING THE FRONTIERS OF SPACE



## TECHNOLOGY

**SOLAR SAILING:** Space travel with the aid of solar radiation pressure—an area of advanced research at Lockheed. Vehicle would employ a sail that would be raised and lowered in flight. The artist has depicted Magellan's ship "Trinidad" to symbolize man's great voyages of discovery.

**Lockheed Missile Systems Division** is engaged in all fields of missile and space technology—from concept to operation. Advanced research and development programs include—man in space; space communications; electronics; ionic propulsion; nuclear and solar propulsion; magnetohydrodynamics; computer development; oceanography; flight sciences; materials and processes; human engineering; electromagnetic wave propagation and radiation; and operations research and analysis.

The successful completion of programs such as these not only encompasses the sum of man's knowledge in many fields, but requires a bold and imaginative approach in areas where only theory now exists.

The Missile Systems Division programs reach far into the future. It is a rewarding future which men of outstanding talent and inquiring mind are invited to share. Write: Research and Development Staff, Dept. A-22, 962 W. El Camino Real, Sunnyvale, California, or 7701 Woodley Avenue, Van Nuys, California. For the convenience of those living in the East or Midwest, offices are maintained at Suite 745, 405 Lexington Avenue, New York 17, and at Suite 300, 840 N. Michigan Avenue, Chicago 11.

*"The organization that contributed most in the past year to the advancement of the art of missiles and astronautics."*

NATIONAL MISSILE INDUSTRY CONFERENCE AWARD

**Lockheed** / **MISSILE SYSTEMS DIVISION**

SUNNYVALE, PALO ALTO, VAN NUYS, SANTA CRUZ, SANTA MARIA, CALIFORNIA  
CAPE CANAVERAL, FLORIDA • ALAMOGORDO, NEW MEXICO

*ahimoto*

# Improved Metal-To-Glass Alloy Holds Seals Tight Against Hydrogen at 250 Pounds Pressure

Development of Clare† Mercury-Wetted Contact Relays  
aided by special gas-free Driver-Harris #152 Alloy



Driver-Harris Alloys at work in Product Advancement

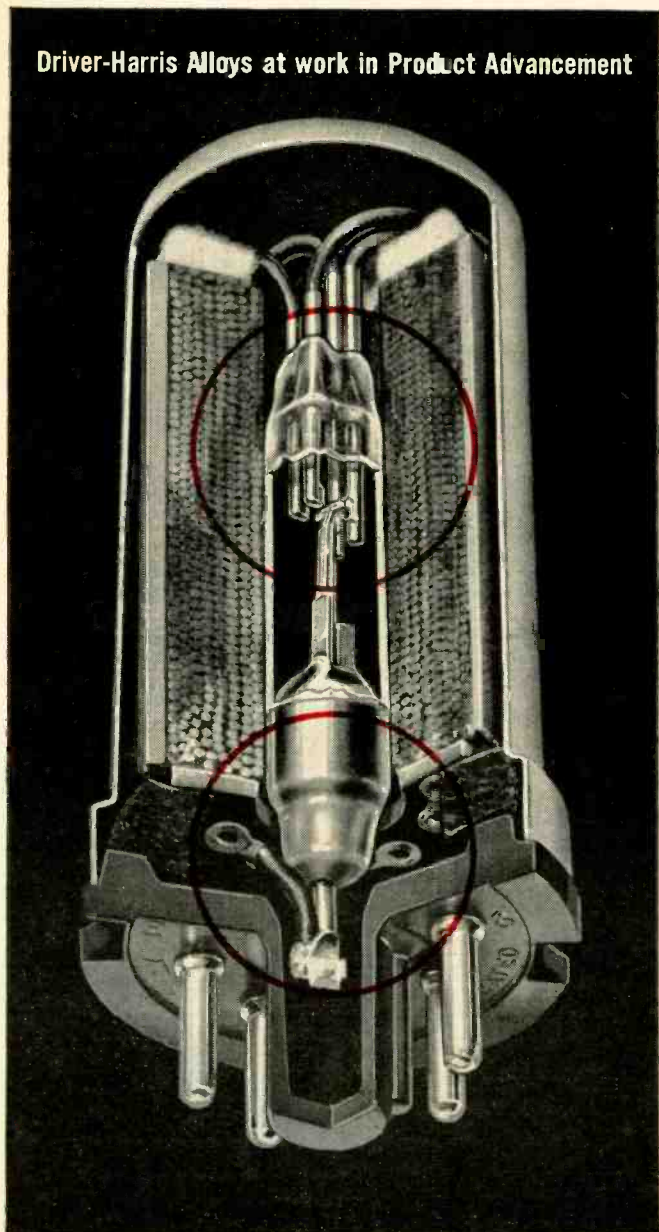

For all kinds of high-speed switching machines and devices which demand accuracy and dependability of the highest order, this new Clare Type HG Relay offers a combination of high speed, high current-and-voltage capacity with remarkably uniform long-life performance. It has a conservative life expectancy of more than a *billion operations* when operated within its ratings and can be driven at speeds up to *100 operations per second*.

In this cutaway view ( $2\frac{3}{4} \times$ ) a magnetic switch, hermetically sealed in a high-pressure hydrogen filled glass capsule, and a coil, are enclosed in a steel vacuum tube type envelope. The switch forms the core of the coil which provides the magnetomotive force for operating it.

The glass enclosed switch is very compact and small ( $5/16''$  diameter x 2" long) yet its handling capacities of 5 amperes and 500 volts maximum are truly remarkable.

These features of its construction make this possible. In the switch segment, the platinum contact surfaces are wetted and protected from electrical and mechanical erosion with mercury by means of a capillary connection to a mercury reservoir below the contacts. In addition, the high hydrogen pressure enables the contact gap to withstand a high voltage gradient without breakdown.

Keeping the gas from leaking posed a production problem. The specifications for the lead wires at the top of the switch and the tubular vacuum stem at the bottom were stiff. 1. Gas-tight seal against hydrogen at 250 PSI. This was difficult. 2. Perfect match to thermal expansion characteristics of the glass. 3. Good ferromagnetic properties. 4. Exceptional surface bonding properties since the permissible maximum 5 ampere 500 volt limits are dictated rather by factors relating to heating of the metal-to-glass seal than the current handling capacities of the contacts.

Driver-Harris was called upon to produce such an alloy and succeeded in developing a special gas-free nickel-iron alloy No. 152 which meets all these requirements to the complete satisfaction of Clare Engineers.

Do your engineering and product development plans hinge upon a special alloy — why not discuss it with Driver-Harris. We have, since 1899, produced 132 special purpose alloys in just this fashion — in answer to a particular problem and extraordinary specifications. We have a special bulletin on Sealing Alloys if you care to have one. Your inquiry is awaited.

†C. P. Clare & Co., Chicago, Ill.  
\*T.M. Reg. U.S. Pat. Off.

## DRIVER-HARRIS\* COMPANY

HARRISON, NEW JERSEY • BRANCHES: Chicago, Detroit, Cleveland, Louisville

Distributor: ANGUS-CAMPBELL, INC., Los Angeles, San Francisco • In Canada: The B. GREENING WIRE COMPANY, Ltd., Hamilton, Ontario

MAKERS OF THE MOST COMPLETE LINE OF ALLOYS FOR THE ELECTRICAL, ELECTRONIC, AND HEAT-TREATING INDUSTRIES



# USSR: Plan for Electronics

Soviets pin much hope for success of new seven-year economic plan on electronics developments. Though expecting control devices to flow quickly from lab to plant, Reds continue to stress basic research

SOVIET electronics development is slated to play an important role in the success or failure of the new seven-year economic plan.

In recent months Soviet leaders have emphasized the importance of electronic control devices in achieving automation. Since announcement of the new economic plan, there have been more signs that Communist hopes for eventually surpassing the United States economically lie in industrial instrumentation and scientific advances.

Aleksander Nesmeyanov, president of the USSR Academy of Sciences, in a recent article in Pravda discussing the role of science in the seven-year economic plan, singled out these fields of investigation:

- Basic research in nuclear physics in general, and studies of controlled thermonuclear reactions in particular.

- Astronomy, by means of powerful optical and radio instruments and also rockets and earth satellites carrying electronic instruments.

- Solid-state physics, tabbed for "a leading place in the scientific development program."

"Great tasks of technical progress face the country in creating a material-technical basis of communism," wrote Nesmeyanov.

"This includes work on the foundations of computing technique and the development of new, more rapid electronic computing machines which, in the next seven years, will find wide application in the most diverse spheres."

## Setting Up Model Plants

Nesmeyanov sees "integrated mechanization" and automatic production controls as "the key factors assuring continued technical progress." To this end, and apparently because of the urgency imposed on the scientists by the seven-year plan, research institutes will bear

the responsibility for setting up the model plants from which later automatic factories will evolve.

Development of artificial materials with special properties also "opens vast prospects," declared the Academy of Sciences president. Specifically mentioned: superhard alloys, synthetic fibers, organic and nonorganic synthetic polymers and rare elements.

## Program in Gear

To lay the groundwork for Soviet Communism's dream of eventual economic domination of the world, a tremendous program of research expansion is already underway (ELECTRONICS, p 21, Dec. 12, 1958).

Much of the building of laboratories and institutes is going on outside of European Russia. So-called "scientific towns" are springing up in widely scattered places, often with a specialty such as physics-electronics.

Apparently this idea of technical specialization ties in with the role of a research institute as a fountain of new manufacturing processes. And with the spread of electrification in the central and eastern parts of the USSR, more plants will be needed.

Accelerated development and modernization of existing research institutes, maintained by the separate science academies in all of the Soviet republics, was also called for by Nesmeyanov.

What Nesmeyanov wrote in Pravda underscores the "crash" nature of the Soviet production-oriented research and development program. As chairman of the Academy of Sciences, he reports directly to the USSR Council of Ministers. His voice is the dominant one in Soviet scientific circles. It surely will remain so only if he successfully implements Khrushchev's ambitious plan by advancing electronic

technology from the laboratory to the automatic factory.

However, outside the domain of the Academy of Sciences other electronic work goes on in the Ministry of the Radio Industry (largely responsible for production of radio and tv sets and components) and the Ministry of Communications (largely responsible for construction of transmission facilities).

Each of these ministries has its own quotas for production and installation of electronic equipment.

Last month a three-day conference on tv was held in Moscow which included research scientists, representatives of plants manufacturing tv gear and heads of stores that sell sets. A Soviet report said it discussed the outlook for tv in the light of the new economic plan.

## Soviet Growth

One official said that about 100 new tv transmitting centers and stations are to be built during the next seven years.

He reported that there are now some 60 transmitters operating in the Soviet Union, along with about 70 relay stations. Area reached, he said, is inhabited by more than 50 million people.

Next year alone, 26 tv stations are slated to begin broadcasting. As relay lines are extended, the official stated, it will be possible to "re-broadcast programs from tv stations abroad."

Meanwhile, Boris Stepanov, deputy chairman of the radio and tv committee attached to the USSR Council of Ministers, said:

- By 1965, tv "will embrace all densely populated areas."

- Number of tv sets will increase during the period by 12.5 million and radio receivers by 17 to 18 million. (He said the USSR now had 15 to 18 million radio sets and 2.6 million tv sets.)

# Which of these McGraw-Hill HANDBOOKS will help you most . . . ?

AVAILABLE ON  
**EASY  
TERMS**

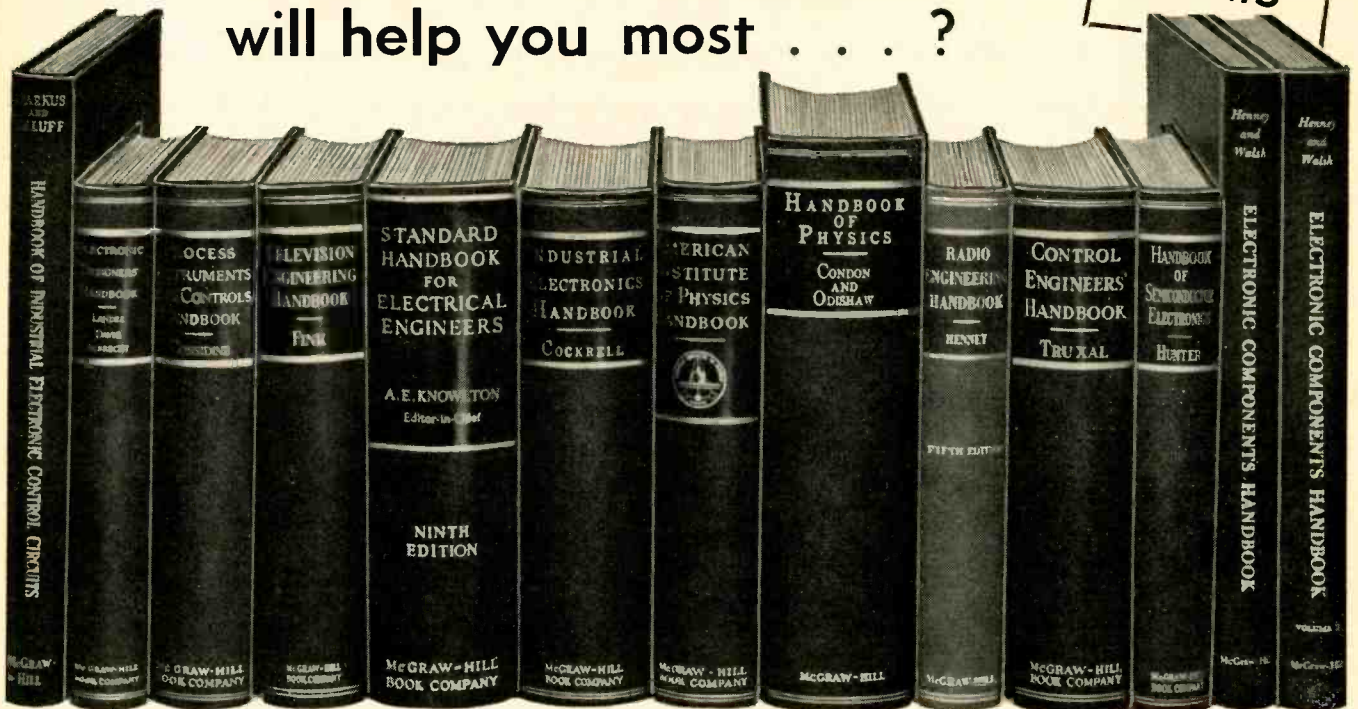

## HANDBOOK OF INDUSTRIAL ELECTRONIC CONTROL CIRCUITS

Brings you over 300 tested industrial electronic control circuits. For each application you have a circuit diagram, component values, performance characteristics, etc. By John Markus and Vin Zeluff. 352 pp., 326 illus., \$8.75

## ELECTRONIC DESIGNERS' HANDBOOK

Gives fundamentals and needed data for the design of all types of electronic equipment, together with technical discussions, design examples, etc. Surveys the field from vacuum tubes to waveform and network analysis. By Robert W. Landee, Donovan C. Davis, and Albert P. Albrecht. 1152 pp., 984 illus., \$16.50

## PROCESS INSTRUMENTS AND CONTROLS HANDBOOK

A thorough treatment of the operating and design fundamentals of measurement and automatic control systems used in the process fields. Provides formulas, critical data, mathematics, etc. Ed. by Douglas M. Considine. 1383 pp., 1137 illus., \$19.50

## TELEVISION ENGINEERING HANDBOOK

Covers the entire subject of television technology, including basic fundamentals as well as practical design data for transmitters, receivers, and networks. Gives detailed coverage on color and foreign TV systems and includes latest material on many other subjects. Ed. by Donald Fink. 1483 pp., 1159 illus., \$18.00

## STANDARD HANDBOOK FOR ELECTRICAL ENGINEERS

The up-dated encyclopedia of facts, figures, definitions, conversion factors, principles, accepted formulas, experimental data, etc., covering every major area of electrical engineering. Ed. by Archer E. Knowlton, assisted by R. M. Shoop. 9th Ed. 2230 pp., illus., \$21.00

## INDUSTRIAL ELECTRONICS HANDBOOK

Just Out! Authoritative descriptive and reference material on all phases of industrial electronics and control. Covers basic engineering, physical laws, circuits, etc. Components are described from standpoint of users' needs. Ed. by W. D. Cockrell. 1408 pp., illus., \$22.50

## AMERICAN INSTITUTE OF PHYSICS HANDBOOK

Gives a wide range of tables, graphs, summaries of formulas, and other factual data

from all fields of physics. Sponsored by Amer. Inst. of Physics. Coordinating Ed. Dwight E. Gray. 1535 pp., illus., \$17.50

## HANDBOOK OF PHYSICS

Just Out! A comprehensive guide to basic physics covering important principles, basic ideas and concepts, and mathematical formulations of all branches of classical and modern physics. Helps you in a better understanding of problems, methods, and equations. Ed. by E. U. Condon and Hugh Odishaw. 1504 pp., 784 illus., \$25.00

## RADIO ENGINEERING HANDBOOK

Just Out! Helps you solve all your radio engineering problems quickly, easily, and accurately. Hundreds of pages of charts, selected design data, tables, circuits, diagrams, and formulas. Revised coverage includes material on transistors, high-frequency measurements, non-linear circuits, transmitters, and much more. Ed. by Keith Henney. 5th Ed. 1775 pp., over 1500 illus., \$25.00

## CONTROL ENGINEERS' HANDBOOK

An authoritative source of information on components and techniques for use in design of feedback control systems. Covers

electromechanical, mechanical, hydraulic, pneumatic, electronic, and magnetic systems. Describes their use, operating characteristics, etc. Ed. by John G. Truxal. 1048 pp., 1114 illus., \$18.50

## HANDBOOK OF SEMICONDUCTOR ELECTRONICS

A comprehensive guide and reference concerned with the design and application of transistors, diodes, and photocells. Describes how they work, how they are made, and how they are used in many circuit applications. Ed. by Lloyd P. Hunter. 604 pp., 484 illus., \$14.00

## ELECTRONIC COMPONENTS HANDBOOK

Facts, data, and engineering information on components that meet tri-service military and industry specifications, and how they are used for maximum reliability. Ed. by Keith Henney and Craig Walsh.

VOL. I—Resistors, Relays, Capacitors, Switches. 244 pp., 164 illus., \$9.00

VOL. II—Power Sources and Converters, Fuses and Circuit Breakers, Electrical Indicating Instruments, Printed Wiring Boards, Solder and Fluxes, Choppers, Blowers, RF Transmission Lines. 359 pp., 283 illus., \$12.50

### 10 Days' FREE Examination • Mail Coupon Today

McGraw-Hill Book Co. 327 W. 41st St. New York 36, N. Y. Dept. L-1-9

Send me book(s) checked at right for 10 days' examination on approval. In 10 days, I will remit for book(s) I keep, plus few cents for delivery costs, and return unwanted book(s) postpaid. **SAVE:** We pay all delivery costs if you remit with this coupon; same return privilege.

Check here if convenient monthly terms are desired.

Print Name.....

Address.....

City.....Zone.....State.....

Company.....

Position.....

Markus & Zeluff—Hdbk. of Indus. Elec. Control Cir.—\$8.75

Landee et al.—Elec. Designers' Hdbk.—\$16.50

Considine—Proc. Instr. Cont. Hdbk.—\$19.50

Fink—Television Engrg. Hdbk.—\$18.00

Knowlton—Std. Hdbk. Elec. Engrs.—\$21.00

Cockrell—Ind. Elec. Hdbk.—\$22.50

AIP—Amer. Inst. Physics Hdbk.—\$17.50

Condon & Odishaw—Hdbk. of Physics.—\$25.00

Henney—Radio Engrg. Hdbk.—\$25.00

Truxal—Control Engrs. Hdbk.—\$18.50

Hunter—Hdbk. of Semicon. Elec.—\$14.00

Henny & Walsh—Elec. Comp. Hdbk.

Vol. I—\$9.00

Vol. II—\$12.50

For price and terms outside U. S., write McGraw-Hill Int'l., N. Y. C. 36

L-1-9



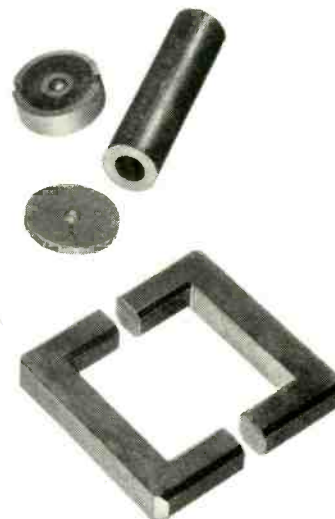
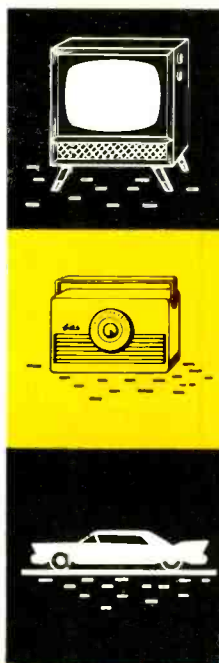
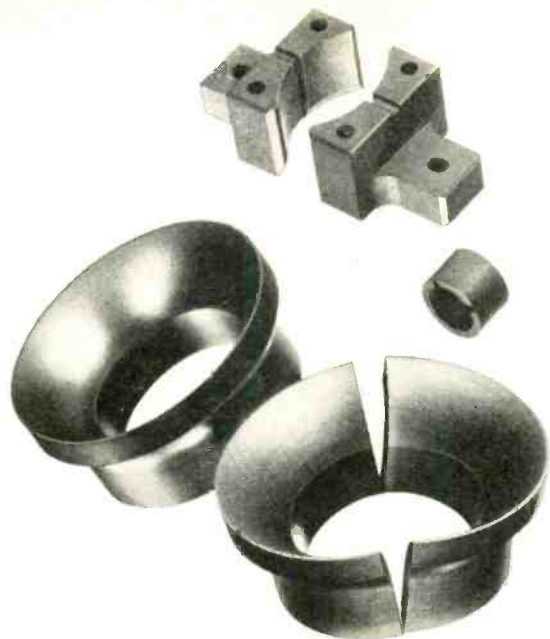

The ferrites MOST electronic manufacturers DEPEND UPON

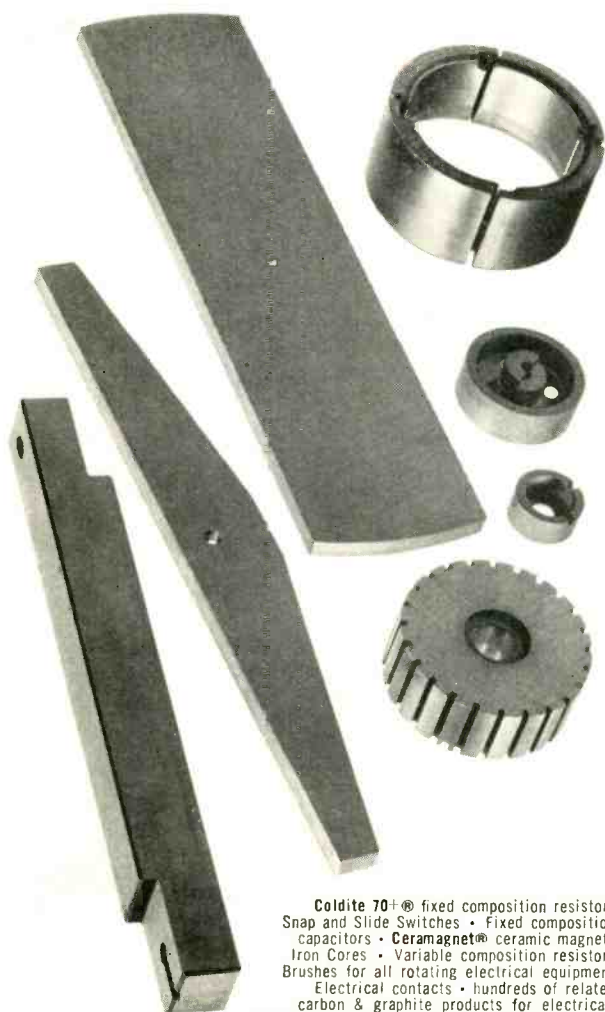

Coldite 70+® fixed composition resistors  
 Snap and Slide Switches • Fixed composition  
 capacitors • Ceramagnet® ceramic magnets  
 Iron Cores • Variable composition resistors  
 Brushes for all rotating electrical equipment  
 Electrical contacts • hundreds of related  
 carbon & graphite products for electrical,  
 mechanical, chemical and refractory applications.



**...FOR UNIFORMITY**  
 of electrical and mechanical  
 characteristics from one unit  
 to another, and from one  
 order to the next.



**...FOR PERFORMANCE**  
 that matches special physical  
 and electrical requirements  
 "on the nose".



**...FOR "ON TIME" DELIVERIES**  
 to meet Production deadlines.

Electronic Components Division  
 STACKPOLE CARBON COMPANY, St. Marys, Pa.



## TWO OUTSTANDING HIGH-TEMPERATURE MAGNET WIRES

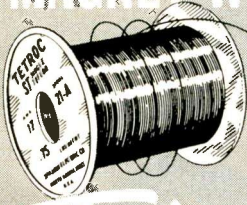

# Tetroc

FOR CONTINUOUS OPERATION AT  
HOTTEST SPOT TEMPERATURES  
UP TO 200°C

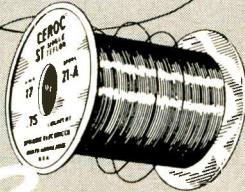

# Ceroc

FOR CONTINUOUS OPERATION AT  
HOTTEST SPOT TEMPERATURES  
UP TO 250°C

For continuous operation at hottest spot temperatures up to 200°C (392°F) and up to 250°C (482°F) for short periods of time—depend upon TETROC—an all Teflon-insulated wire available in both single and heavy coatings.

CEROC is Sprague's recommendation for continuous operation at hottest spot temperatures up to 250°C (482°F) and up to 300°C (572°F) for short periods of time. Ceroc has a flexible ceramic base insulation with either single silicone or single or heavy Teflon overlays. The ceramic base stops "cut-through" sometimes found in windings of all-fluorocarbon wire. Both Tetroc and Ceroc magnet wires provide extremely high space factors.

Write for Engineering Bulletins 405 (Tetroc Wires) and 400A (Ceroc Wires).

SPRAGUE ELECTRIC COMPANY  
35 Marshall Street, North Adams, Mass.

# SPRAGUE®

THE MARK OF RELIABILITY

CIRCLE 28 READERS SERVICE CARD

# Washington Forecast

Capital observers predict: more military and civilian government spending for electronics, hassle over procurement policies

THE ROLE of Washington in the electronics industry will grow even larger in 1959 than it has been in the past.

The Federal government will become an even bigger market for electronics industry output. The increase will be both in dollar volume and in proportionate share of the industry's factory output.

While the lion's share of government buying in electronics will be by the military services, civilian agencies will also step up their procurement of electronic products. Some factors are: more civilian-directed scientific space exploration, modernization of the nation's civil airways system and the growing use of electronic data-processing machines.

Military spending for research, development and production of electronic hard goods will increase despite the administration's firm intent to pull the reins on overall government outlays.

A top-level Defense Dept. official estimates that about 28 percent of the military hard-goods dollar goes for electronic equipment. He forecasts that electronics' share will increase to one-third of the defense procurement dollar within two or three years.

### Defense Budget

Overall military spending in fiscal 1960, starting July 1, 1959, is expected to run to \$42 billion—about \$1.2 billion over the current rate of expenditure. Missile production expenditures will rise by at least \$1 billion over the current \$3.4 billion rate—with at least 40 percent spent on electronic gear. The electronics slice of the missile dollar will probably remain stable.

Aircraft production expenditures will dip well under \$7 billion in fiscal 1960 for the first time in eight years. Current rate of expenditure is \$7.2 billion; next

year's volume is likely to show a reduction of some \$1 billion, reflecting a rapid transition to missiles. But the electronic slice of the aircraft production dollar, now averaging 25 percent, will increase with the growing stress on automatic fire control, guidance and navigation.

Military research and development spending, estimated at \$2.4 billion this year, will rise slightly. Electronic projects take up at least one-quarter of the defense R&D dollar now, are certain to comprise an even larger slice next year.

### Defense Strategy

The new defense budget reflects the Administration's intent to stress strategic bomber and missile forces as a deterrent to aggression. The official view is that we have sufficient tactical forces to fight a limited war.

### Contract Renegotiation

The Renegotiation Act, under which so-called excessive profits are recaptured from defense contractors, will be extended—probably for two more years. The law expires June 30, 1959. No major changes are likely.

### Defense Procurement

Congress is pushing in opposite directions on military buying regulations. Sen. Saltonstall, ranking Republican on the Senate Armed Services Committee, plans to introduce a bill to step up the use of weapon-system management—with increased powers for the prime contractor.

But Rep. Herbert's House Armed Services Investigations Subcommittee, however, plans to probe the increasing use of the weapon-system procurement method. Herbert thinks this buying scheme hurts small business, wants to reduce the volume of contracts now being

# for 1959

awarded in this manner.

The Pentagon, meantime, is putting finishing touches on a new set of procurement rules spelling out the types of costs the government will allow on defense contracts.

## Minimum Wage Rates

The Labor Dept. will take action this year on the aircraft industry's petition that electronics companies in missile work be required to pay the same Walsh-Healey minimum wage rates as aircraft firms do. In general, there's now a wage differential of some 20 percent.

Electronic companies are opposing the aircraft industry's petition, warn of an across-the-board boost in defense costs.

The Labor Dept. has proposed putting electronics firms with end-item prime missile contracts under aircraft industry rate while exempting subsystem producers.

## Taxes

The tax outlook for 1959 is tougher. Tax rates are not likely to be raised. Chairman Wilbur Mills of the House Ways and Means Committee says revenue can be increased by closing loopholes and taxing income that now is exempt.

Corporate income tax rates will be extended beyond their June 30, 1959, expiration date at present 52 percent rate. There are plans to cut back on kinds of income entitled to the 25-percent capital-gains tax rate.

## Radome Tests



Electrical characteristics of high-strength radome walls are being determined by Stanford Research Institute engineers. Equipment permits use of a narrow strip of the radome to simulate a large, flat radome panel

Where  
nothing else  
fits!

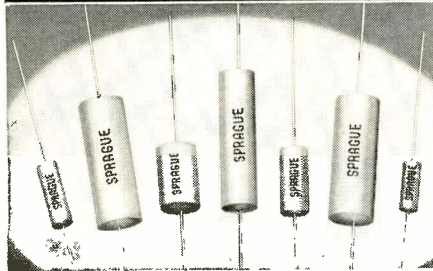

## YELLOW-JACKET\* Filmite® 'E' CAPACITORS

- for transistor circuits
- for auto radios
- for miniature portables
- for many other miniature applications

The smallest of Sprague's film capacitors, new YELLOW-JACKET Filmite "E" Capacitors are ideal for a variety of transistor and low-voltage electron tube circuits. Rated at 200 volts d-c, these miniature units have been thoroughly design tested for use at ambient temperatures up to 85°C.

### Check these important features:

- special polyester film and thin gauge foil
- excellent service life under severe heat and humidity
- available in ratings from .01 to 1.0 MF
- extended foil "non-inductive" design

Get these YELLOW-JACKET miniatures from your distributor without delay. Or, write for Engineering Bulletin No. 2063A to Technical Literature Section, Sprague Electric Company, 35 Marshall Street, North Adams, Massachusetts.

## SPRAGUE TANTALEX® CAPACITORS



for miniaturized  
transistor circuits

Sprague Solid-Electrolyte Type 150D Tantalum Capacitors combine true miniaturization with electrical stability previously unobtainable in an electrolytic capacitor of any type.

Type 150D Capacitors are impregnated with a solid, non-corrosive, semi-conductor material which cannot leak under any circumstance.

Sprague, the first company to manufacture solid tantalum capacitors commercially, has far more experience in making a stable low-leakage yet physically small capacitor than any other source.

Sprague has by far the largest production capacity and can offer you excellent delivery at competitive prices!

Write for Engineering Bulletin 350C to Technical Literature Section, Sprague Electric Company, 35 Marshall St., North Adams, Mass.

# SPRAGUE® SPRAGUE®

the mark of reliability

the mark of reliability

# RI·tran

## I. F. TRANSFORMERS

### for **FM** application

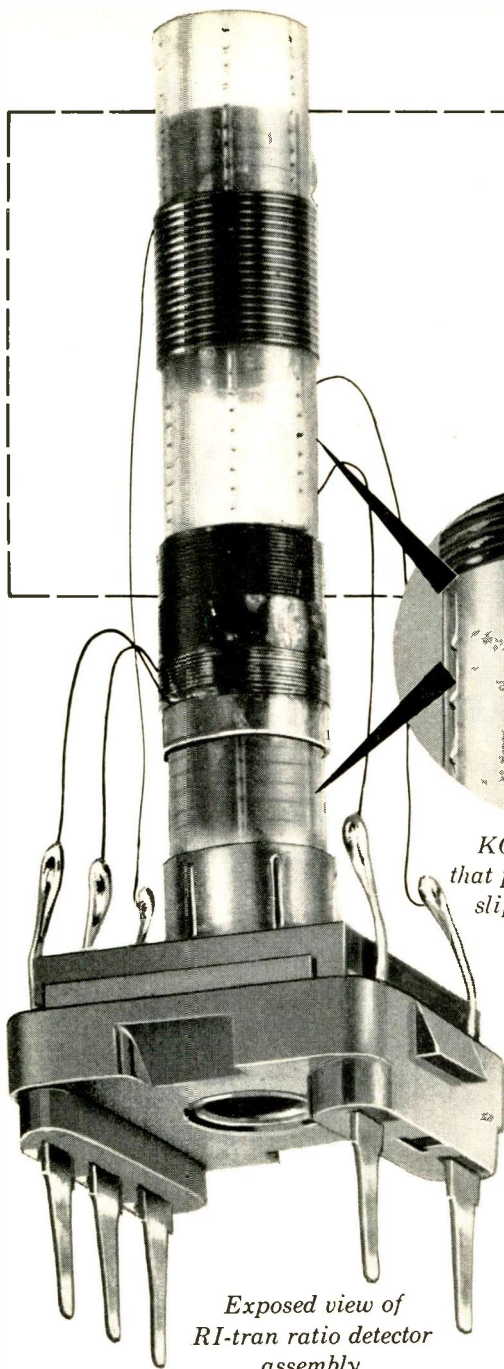

*Exposed view of  
RI-tran ratio detector  
assembly*

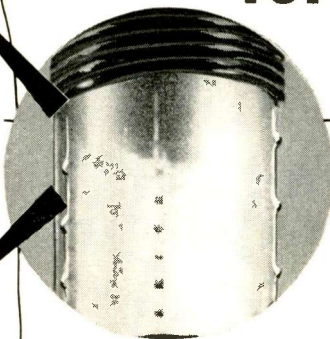

*KOILOCK teeth  
that prevent coil from  
slipping on form*



CHASSIS DETAIL

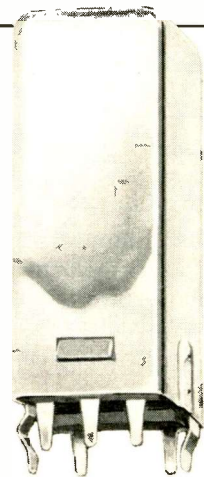
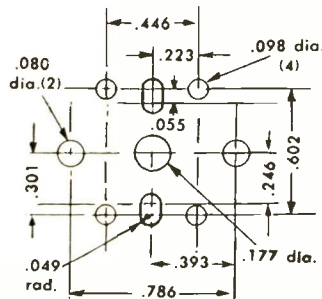

CHASSIS DETAIL

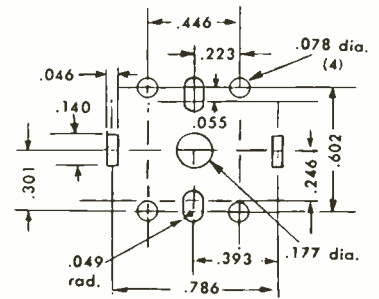

The many successful applications of RI-trans in *discriminator, ratio detector, and other FM applications* are further evidence of the electrical efficiency of the RI-tran design. Greatly simplified with low torque nylon coil forms, the RI design also makes mechanized production possible, resulting in top quality transformers at lower cost. All wiring attachments are made ABOVE the base, preventing lead breakage and break-downs from lug bending.

In addition to FM applications, millions of RI-trans are now in use in a variety of AM applications. RI-trans for transistorized circuits are available in  $\frac{3}{4}$ ",  $\frac{1}{2}$ ", and  $\frac{3}{8}$ " sizes to cover ranges of unloaded "Q" from 45 to 200 with shunt capacities from 65 to 470.

Complete data, including core and lug details, suggested layouts, test and circuit diagrams as well as performance data, is shown in the RI Catalog.

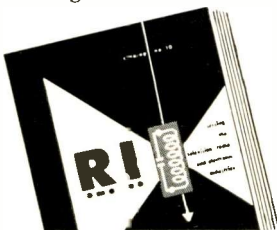

*write for your copy of Catalog no. 10*

## **RADIO INDUSTRIES, INC.**

also manufacturers of ceramic disc capacitors, feed-thrus, coils and selenium disc rectifiers

666 Garland Place • Des Plaines, Illinois

# What's Inside the Atlas

Electronics firms are playing major roles in this nation's history-making space feats

ORBITING last month of the Atlas missile satellite represents two milestones for the U. S. electronics industry:

- Use of a radio-inertial system to guide the 4½ ton, 185-ft Atlas hull into orbit.

- Operation of a satellite communications system which received transmissions from the ground and later relayed them to earth directly or from storage on command.

Guidance used to put Atlas in orbit was GE-Burroughs' radio-inertial system. GE reports that it has received \$83 million worth of contracts so far for the same kind of equipment that took care of the Atlas' tracking, measuring and ground-to-missile data transmission. Atlas is built by Convair-Astronautics.

Burroughs is responsible for the ground-based computer which figures missile trajectory and determines guidance commands for steering the vehicle into orbit. Last month two contracts totaling almost \$22.5 million brought Burroughs' total for Atlas ground equipment to about \$68 million.

American Bosch Arma's pure inertial system, originally designed for Titan, will be tested in Atlas some time this year.

## Developed Secretly

Communications system, which relayed teletypewriter and voice messages of President Eisenhower around the world, was developed secretly by the U. S. Army Signal Research and Development Laboratory, Ft. Monmouth, N. J. RCA's Astroelectronics division and Convair-Astronautics division reportedly contributed to the development.

One voice or seven teletypewriter messages can be transmitted with a power of 8 watts on 132.435 and 132.905 mc. Two beacon transmitters on 107.938 and 107.97 mc are used for tracking.

Communications payload weighs about 150 pounds. This includes two separate 35-pound communications packages, each of which contains:

1½ by 5-in beacon transmitter; 4½ by 3½ by 1¾-in control unit; 6¼ by 4¼ by 4½-in communications transmitter; 3½ by 4½ by 1-in receiver; 4½ by 9¼ by 2-in d-c to d-c converter and an irregular-shaped zinc-silver battery approximately 13 by 6 by 5¼-in. Each 35-pound unit is about 24 by 10 by 10-in.

Army Signal engineers say the remaining 80 pounds of gear consists largely of coaxial cables, the antenna system, duplexers, r-f cables and other system components. System uses printed circuitry and more than 50 transistors, and a few tubes. Control unit provides circuitry for various switching functions.

Secret Atlas firing had code name Score—for signal, communications, orbit, relay experiment. Accuracy of the guidance and success of the communications system open up possibilities for other electronics-carrying satellites, such as for tv relay, tv reconnaissance and upper atmosphere studies in preparation for putting a man into space.

## Jamming Problem

Though enemy jamming is a possibility in radio command guidance systems, GE says: "In all tests to date we have been unable to jam our own radio-inertial guidance system. Jamming requirements can be made so difficult that the enemy finds it a most ineffective and undependable mode of defense." (ELECTRONICS, p 14, Apr. 24, 1958.)

Major subcontractors for the Atlas system, according to government sources, include: Aircraft Armaments Inc., simulator cabinet; Ampex, tape recorders; Dalmo-Victor, antennas; Electronic Engineering, recorders; General Bronze, antenna; Goodyear Aircraft, radomes, antenna assemblies; Machlett Laboratories, tubes; National Co., measuring sets; Nuclear Products, ACF Industries Erco div., training, simulation equipment; Riverside Plastics; radomes; Stromberg-Carlson, test equipment; and Varian Associates, klystron tubes.

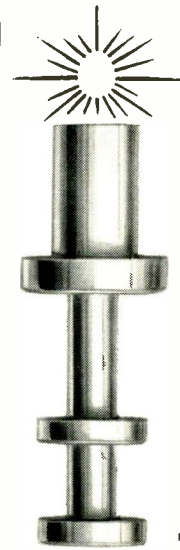

## LOOKING FOR THE IDEAL TERMINAL SETTER?

STOP. You've found it. A Black & Webster Electropunch or full automatic Electroset can solve your terminal setting problems **\$135<sup>00</sup>** — for as little as

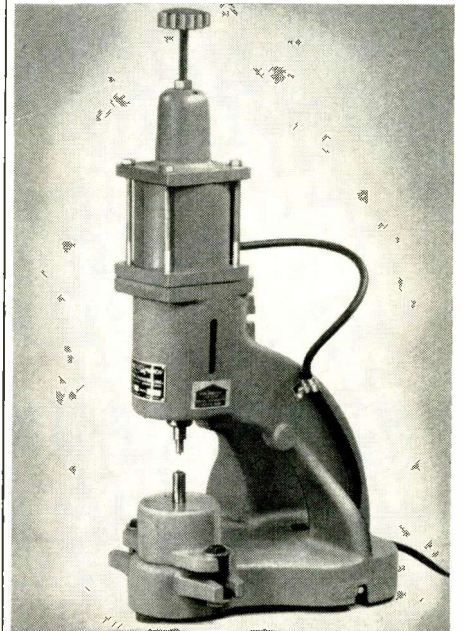

**SHORT RUNS: Electropunch** — sets hand fed terminals twice as fast as conventional methods. All electric. Foot switch operated.

**LONG RUNS: Electroset** — automatically feeds and sets terminals up to 3600 per hour. All electric. Customized to your needs.



### WHAT'S YOUR PROBLEM?

Black & Webster can help. Send sample terminal and requirements.

Write today for free 12-page catalog describing our complete line of production tools.

**BLACK & WEBSTER, INC.**

Dept. E, 445 Watertown Street  
Newton, Massachusetts

# RUGGED

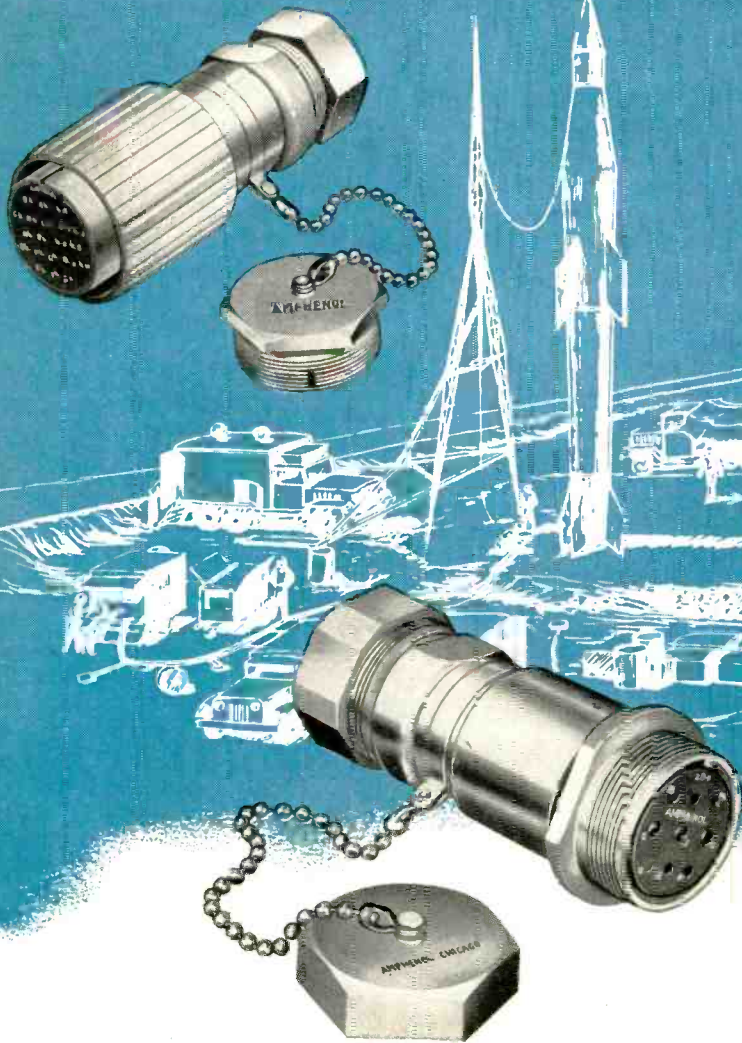

## GSE CONNECTORS

Connectors employed in Ground Support Equipment must be rugged and reliable—and easy to handle under any conditions. Fully meeting these particulars, AMPHENOL's popular 89 series GSE connectors are being used in many top missile projects.

GSE connectors are completely waterproof and provide dependable service even when submerged in mud, ice or water. An internal rubber gasket in the cable clamp, a type "W" washer at the mating faces and another washer used with panel mounting receptacles provide assured protection.

To facilitate handling in rough weather, coupling rings are extra-long and heavily grooved. Flats are conveniently located for field-servicing with standard open-end wrenches. Caps & chains are provided for all connectors.

AMPHENOL GSE connectors are available in a large number of standard "MS" inserts. Complete catalog data is available upon request.

AMPHENOL ELECTRONICS CORPORATION

chicago 50, illinois

**AMPHENOL**

## MEETINGS AHEAD

Jan. 12: Medical Electronics Meeting, Detecting Unseen Cancer Cells, PGME of IRE, Inst. for Cancer Research, Philadelphia.

Jan. 12-14: Reliability and Quality Control, Nat. Symp., PGRQC of IRE, ASQC, EIA, Bellevue-Stratford Hotel, Philadelphia.

Jan. 13-14: Cathode Ray Tube Recording, Systems Development Corp., Engineers Club, Dayton, O.

Jan. 14: Computers and Medical Diagnosis, Rockefeller Institute, N. Y. C.

Jan. 21-23: Southwest Electronic Exhibit, Arizona State Fairgrounds, Phoenix, Ariz.

Jan. 29-30: Long Distance Transmission by Waveguides, Institution of Electrical Engineers, London, England.

Feb. 1-6: American Institute of Electrical Engineers, Winter General Meeting, Statler Hotel, N. Y. C.

Feb. 12-13: Transistor & Solid-State Circuit Conf., AIEE, PGCT of IRE, Univ. of Penn., Philadelphia.

Feb. 12-13: Electronics Conference AIEE, IRE, ISA, CPS, Eng. Soc. Bldg., Cleveland.

Feb. 17-20: Western Audio Convention, Audio Eng. Soc., Biltmore Hotel, Los Angeles.

Mar. 3-5: Western Joint Computer Conf., AIEE, ACM, IRE, Fairmont Hotel, Los Angeles.

Mar. 5-7: Western Space Age Conf. and Exhibit, L. A. Chamber of Commerce, Great Western Exhibit Center, Los Angeles.

Mar. 15-18: National Assoc. of Broadcasters, Annual Convention, Conrad Hilton Hotel, Chicago.

Mar. 23-26: Institute of Radio Engineers, IRE National Convention, Coliseum & Waldorf-Astoria Hotel, New York City.

Mar. 31-Apr. 2: Millimeter Waves, Symposium, Polytechnic Inst. of Brooklyn, USAF, ONR, IRE, USA Signal Research, Engineering Societies Bldg., N. Y. C.

Apr. 5-10: Nuclear Congress, sponsored by over 25 major engineering and scientific societies, Public Auditorium, Cleveland.

Apr. 13-15: Protective Relay Conf., A & M College of Texas, College Station, Texas.

January 9, 1959 — ELECTRONICS

# Temperature Compensated PRECISION TACHOMETER

- .16% Linearity 0-3600 RPM
- .05% Output Voltage Tolerance at 3,000 RPM
- 2V per thousand RPM voltage gradient
- 15°C to 75°C temperature range
- 0° ± 6 minutes 3000 RPM phase shift
- 10 mv max. null voltage
- 3 mv max. in phase axis error
- 115V 400 cycle input, 8 watts
- Size 20 illustrated (Type 20TG-6777-01.) Other sizes with similar or greater accuracies can be designed to your requirements. Write or call your nearest Oster office for further information today.



**actual size**  
Type 20TG-6777-01

**Oster**®

Precision Tachometer  
Production Testing

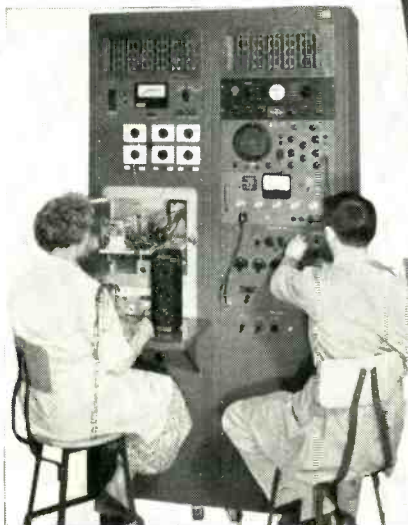

Burton Browne Advertising

Other products include servos, synchros, resolvers, motor-gear-trains, AC drive motors, DC motors, servo mechanism assemblies, reference and tachometer generators, servo torque units, actuators and motor driven blower and fan assemblies.

*John Oster*

**MANUFACTURING CO.**  
*Yo & Potting Equipment Specialist*  
**Avionic Division**  
Racine, Wisconsin

**NEW YORK  
OFFICE**

237 North Main Street  
Hempstead, L.I., New York  
Phone: IVanhoe 3-4653  
TWX Hempstead N. Y. 705

**NEW JERSEY  
OFFICE**

517 Lyons Avenue  
Irvington, New Jersey  
Phone: Essex 3-2361

**WESTERN  
OFFICE**

5333 So. Sepulveda Blvd.  
Culver City, California  
Phones: EXmont 1-5742  
TEXas 0-1194  
TWX S. Mon 7671

**Engineers For Advanced Projects:**

Interesting, varied work on designing transistor circuits and servo mechanisms. Contact Mr. Robert Burns, Personnel Manager, in confidence.

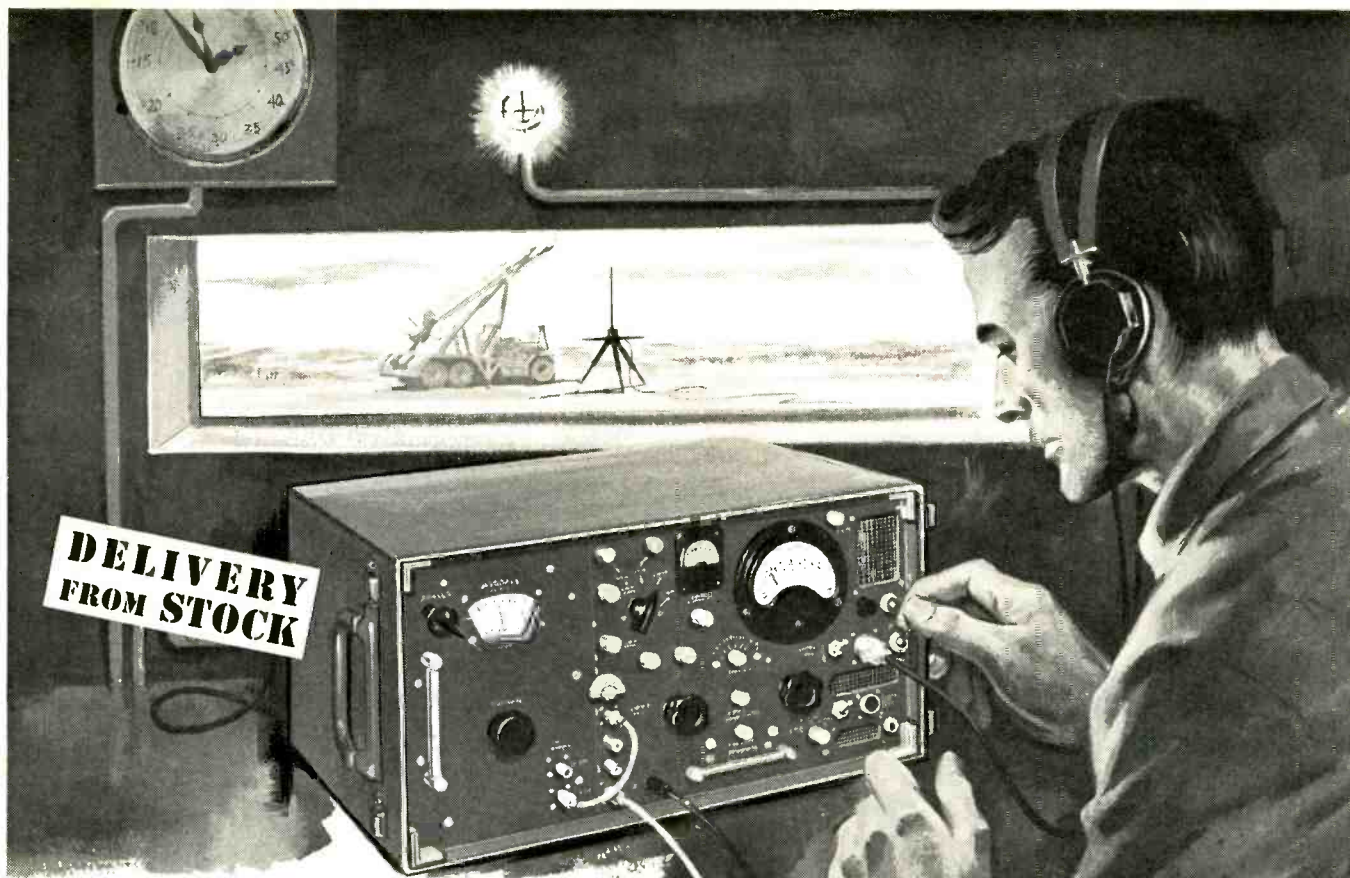

**DELIVERY  
FROM STOCK**

**FLEXIBILITY IN THE FIELD...**

just one of the many useful features of

**EMPIRE'S  
NOISE & FIELD INTENSITY METER  
MODEL NF-105**

Model NF-105 remotely located from its antenna, for personnel safety.

- Measures 150 kilocycles to 1000 megacycles accurately and quickly with only one meter.
- Approval status: MIL-I-6181B, Class 1, MIL-I-6181C, Category A; MIL-I-26600 (USAF).
- Direct substitution measurements by means of broad-band impulse calibrator, without charts, assure repeatability.
- Self-calibrating, for reliability and speed of operation.
- True peak indication by direct meter reading or aural slideback.
- Four interchangeable plug-in tuning units for extreme flexibility.
- Economical . . . avoids duplication.
- Safeguards personnel . . . ALL antennas can be remotely located from the instrument without affecting performance.
- Compact, built-in regulated A and B power supply, for stability.
- Minimum of maintenance required, proven by years of field experience.



Only the Model NF-105 is so simple to operate that one technician can take readings over the entire frequency range in less time than required by three engineers manning any other three separate instruments.

Send for our Catalog No. N-357

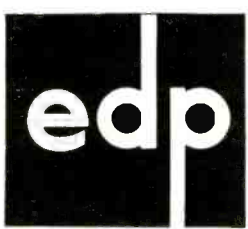

**EMPIRE DEVICES PRODUCTS CORP.**  
AMSTERDAM, NEW YORK VICTOR 2-8400

MANUFACTURERS OF:  
FIELD INTENSITY METERS • DISTORTION ANALYZERS • IMPULSE GENERATORS • COAXIAL ATTENUATORS • CRYSTAL MIXERS



**SPECIAL:**

# Our Market for 1959

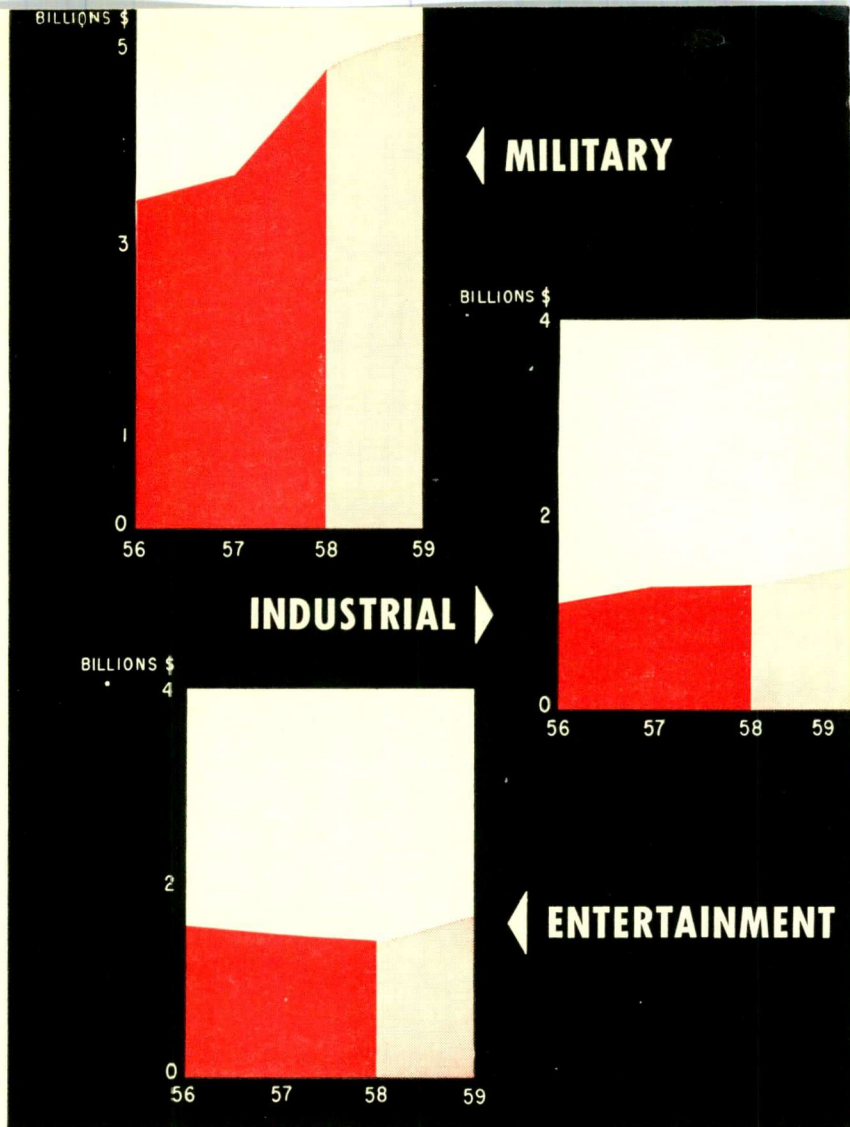

Increased military spending and renewed confidence of both consumers and businessmen foretell a substantial rise in factory sales of electronic equipment and replacement parts

ANOTHER RECORD YEAR for the electronics industry is indicated. Factory sales of electronic equipment and replacement parts in 1959 will total over \$9 billion, may go even higher.

Total revenue from all electronics sales and services reached \$13.2 billion in 1958, up slightly from 1957's \$13 billion. Comparable figure for 1959 is \$14.6 billion.

Despite lingering effects of last year's military cutbacks and the recession, industry sales last year reached \$8.2 billion, topping 1957's high of \$8 billion at the factory.

The year ahead will be a good one for our industry, with sales rising once again more than those of industry at large. (See "Electronics' Growth Tops Nation's Pace," p 14, Oct. 7, 1958.) Signposts are to be found both in our industry and elsewhere pointing

to a steadily improving general economic picture. Some of the basic trends and indicators are:

Big backlog of military orders; no letup visible ahead.

Industrial bank loans to business starting back up.

Consumers' time payment obligation at new low, while real income and disposable income are rising rapidly.

**MILITARY ELECTRONICS**—The U. S. Government, our industry's biggest customer, will take more than \$5 billion worth of electronics in 1959. This compares with \$4.5 in 1958 and \$4.3 in 1957. This year, likely to be the best for sales to the military, will see increase largely due to the substantially increased production of many missiles, combined with continued high sales of manned aircraft. This year's

## MILITARY ELECTRONICS



business will be up despite some cutbacks in some missile and aircraft contracts.

Conservative estimates point to a missile tab of about \$4.7 billion for 1959. Of this, at least \$1.9 billion will go for missile electronics. Although many missiles will be in production in 1959, the full impact of the missile increase won't be translated into production until 1960 or later. Increased allotments for research and development in 1959 for guidance and control will also lead to more production in the years ahead.

Recent information from the Department of De-

fense and investigation by *ELECTRONICS* editors (See "The Missile Market," p 13, Nov. 28, 1958) has raised estimates of electronics' share of missile funds. Previously electronics' dollar share of average missile contract was estimated at 35 percent. Revised estimate is 40 percent.

Military aircraft will have a good production year, with about \$6.8 billion total expenditures. Of this, electronics' slice will amount to \$1.7 billion or more. The aircraft-missile dollar ratio was three to one in 1957, is less than two to one now, and may be down to 50-50 or 40-60 in 1960. But while defense armament

## A QUICK LOOK AT THE ELECTRONICS BUSINESS

	1958	1959
GOVERNMENT ELECTRONICS.....	\$4.54 Billion	\$5.3 Billion
Aircraft.....	1.9	1.7
Missiles.....	1.22	1.9
All Other.....	1.42	1.7
ENTERTAINMENT.....	1.343	1.555
TV Sets.....	.682	.750
Radio Sets.....	.273	.345
Other.....	.388	.460
INDUSTRIAL—COMMERCIAL.....	1.378	1.572
REPLACEMENT PARTS.....	.960	1.0
BROADCAST, DISTRIBUTION, SERVICE	5.0	5.2
<b>TOTAL, ELECTRONICS SALES &amp; SERVICE.....</b>	<b>\$13.221 Billions</b>	<b>\$14.627 Billions</b>

## FACTORY SALES OF INDUSTRIAL ELECTRONIC EQUIPMENT

	1958	1959
Broadcast.....	\$53 Million	<b>\$55 Million</b>
Mobile Radio.....	85	95
Microwave.....	35	40
Marine.....	14	15
Aviation.....	70	150
Other Communications.....	37	42
Data Processing.....	258	310
Test Instruments.....	220	235
Industrial Control.....	160	170
X-Ray.....	90	95
Atomic Instrumentation.....	42	50
Electronic Heating.....	25	30
Industrial Television.....	7	8
Commercial Sound.....	125	135
Theater Equipment.....	40	42
Miscellaneous.....	90	100
<b>TOTALS.....</b>	<b>\$1,378 Millions</b>	<b>\$1,572 Millions</b>

shifts and guided missiles take on more and more of the job previously handled by piloted aircraft, jet aircraft will become increasingly a part of everyday life. Shrinking military aircraft electronics needs, therefore, will be offset in part by increased requirements for nonmilitary air navigation, communication and traffic control.

Spending on military communications, radar and associated hardware will amount to about \$740 million in 1959. Military R&D will take at least \$600 million. This figure will be upped if some prototype and tooling money now in missile and aircraft allotments is subtracted from them and reflected directly in defense figures for R&D. Other smaller military categories will push the final figure over \$5.0 billion.

**INDUSTRIAL ELECTRONICS** — Industrial and commercial electronics is on the brink of a new growth period. Total sales of this equipment during the coming year should pass the \$1.5-billion mark, could go as high as \$1.6 billion, exclusive of distribution and maintenance. Last year's figure was \$1.37 billion, up from 1957's \$1.24 billion. Gains will come in part from modernization programs in all industries, including our own.

McGraw-Hill's Economics Department finds in its late 1958 survey that plans for 1959 capital spending in certain industries are already higher than expenditures for 1958. These plans involve more money for modernization and replacement of obsolete facilities than for expansion. With one exception, the industries planning most capital spending are also the ones who make most use of industrial electronics.

These industries include the railroads, which spent

only half as much for capital expenditures in 1958 as in 1957. They also include other transportation and communications companies such as airlines, trucking and shipping companies. Electric and gas utilities plan slight cuts for 1959 in this capital spending. But they were the only industries to spend more in 1958 than in 1957, so their expenditures will remain high. The petroleum industry also plans to spend more for capital goods this year than in 1958.

Businessmen will spend more money on electronics than ever before. Much of it will go for mobile radio communications.

There is the possibility of a good-sized market opening up in the increased use of electronics in automobiles for other than radio applications. (See "Autos Enter Electronics Era," p 73, Nov. 21, 1958.) If these uses start in 1960 cars, there will be heavier buying of components in 1959.

**ENTERTAINMENT ELECTRONICS** — Consumers are expected to purchase over \$1.6 billion (factory value) worth of electronic gear for home entertainment. This contrasts with the \$1.38 billion bought last year and 1957's mark of \$1.53 billion.

Television receiver sales will reach nearly \$750 million, about six million units, compared to 1958's 5.3 million receivers, worth about \$682 million. Color tv is still not slated for a major breakthrough. Set sales will probably be about 150,000 units as compared with 1958's 125,000 sets. The boom in record playing equipment will continue, with packaged phonographs and high fidelity components getting an extra push from stereo. Tape recorders will sell well over 600,000 units.

Radio receivers will enjoy increased sales, with a

## FACTORY SALES OF ELECTRONIC ENTERTAINMENT EQUIPMENT

	1958	1959
TELEVISION RECEIVERS (B&W).....	\$682 Million	<b>\$750 Million</b>
TELEVISION RECEIVERS, (COLOR)...	37	<b>50</b>
Home Radios.....	64	<b>73</b>
Clock Radios.....	45	<b>52</b>
Portables.....	63	<b>70</b>
Auto Radios.....	101	<b>150</b>
RADIO RECEIVERS, ALL TYPES.....	273	<b>345</b>
PHONOGRAPHS.....	143	<b>155</b>
HIGH FIDELITY.....	95	<b>130</b>
TAPE RECORDERS.....	150	<b>175</b>
<hr style="border: 0.5px solid black;"/>		
<b>TOTAL FACTORY SALES.....</b>	<b>\$1,380 Millions</b>	<b>\$1,605 Millions</b>

big increase in sales of auto radios. New automobile sales were down 30 percent to only 4.3 million in 1958, but will increase greatly in 1959. Automobile radios in 1957 accounted for more than 35 percent of all radio receiver production. Conservative estimates for this year run from 5.5 million autos to beyond seven million. Estimate of at least 6.3 million comes from Prof. Hans Brems, who predicted the car boom of '55. The anticipated increase of 30-40 percent in next year's automobile sales will mean increased sales of auto radios.

McGraw-Hill's Economics Department has compiled information on consumer spending potential for the months ahead. Durables purchases are seen increasing because: (1) Consumers now have more money than during the past year, except for Christmas debts that will be largely paid off in 2-3 months. (2) Disposable income which has shown little increase since early 1956 is now going up rapidly. Disposable income is measured after taxes and adjustment for increased cost of food, rent and other basics. (3) There is evidence of increased buyer confidence. (4) There are more average radio and tv receivers in use than ever before. (5) More households will be formed next year than ever before. More than two million tv sets will be bought by these new householders alone.

There are now tv receivers in 84 percent of all homes in this country.

Enough of the ingredients exist to suggest that the year 1959 will be a good one for entertainment electronics.

**COMPONENTS**—Replacement parts for 1958 are estimated to have reached \$960 million sales and will near the billion dollar mark in 1959.

Counting both intraindustry sales and sales of replacement parts, semiconductors had their best year, selling about \$240 million. They should reach \$310-million worth at the factory in '59. Electron tubes are expected to reach about \$950 million in 1959, after sales totaling \$910 million in 1958. Cathode-ray tubes brought in \$170 million last year and should sell about

\$185-million worth in 1959. Other circuit components: resistors, capacitors, transformers and chokes and miscellaneous totaled about \$2.3 billion in 1958, are expected to reach about \$2.5 this year.

The tube industry will see slightly increased sales of replacement tubes while crt's for tv sets will rise. Greatest growth areas in electron tubes will be in sales of power and transmitting and other special-purpose tubes.

While sales of conventional components for replacement are continuing at an increasing rate, there is much growth in specialized components for missiles, data-processing equipment and other gear requiring reliability and precision. High sales levels are expected in all types of components as equipment manufacturers build up inventories that were seriously depleted during last year's extra-cautious buying.

**NONMANUFACTURING INCOME**—Broadcast revenue has remained fairly constant around \$2 billion and is not expected to rise greatly this year. Distribution of consumer and commercial electronics totals another \$2 billion. Maintenance and service will reach about \$1 billion in 1959, rising gradually with the amount of electronic equipment in use.

**FOREIGN TRADE**—Moderate increases in electronics foreign trade are expected as part of a general increase in world trade. Among reasons for this is the expectation of higher and long-term spending for consumer goods in Europe. Also contributing will be the settling of raw materials prices on the world market and a record flow of intragovernment development capital to both expanding market areas and underdeveloped countries.

One example of a growing market: according to a U. S. Information Agency official, sales of tv sets overseas will grow from the present 21 million to 50 million by 1962. How much of this market U. S. manufacturers take will depend on whether they will adapt production to foreign systems and on how well they can compete in price.

increasing  
component  
density . . . . .



**MODEL 1**

Component Density 9 per cu. in. \*  
Diameter 0.625"; Depth 0.371"  
Rating 1/10 watt



**MODEL 6**

Component Density 18 per cu. in. \*  
Diameter 0.502"; Depth 0.155" ± 10%  
Rating 1/10 watt



**MODEL 8**

Component Density 158 per cu. in. \*  
Diameter 0.286"; Depth 0.110 ± 5%  
Rating 1/10 watt

. your job . . and **Centralab's**

**for military, commercial,  
transistor, and  
communication applications**

Here is a graphic illustration of how Centralab has met your needs for greater and greater miniaturization. Pictured (actual size) are three ultra-miniature Centralab Radiohms.® When introduced, each was the smallest variable resistor on the market—and was superseded in that position only by the introduction of the next smaller Centralab unit.

These variable resistors are available in a variety of mounting styles, to meet the most stringent space requirements—further testimony of Centralab leadership in the development of ultra-miniature components. Increasing component density is your job . . . and Centralab's.



**SPECIFICATIONS:**

**Model 8 Radiohm®:** 500 ohms to 10 megohms at 1/10 watt, wide range of tapers, 250° rotation, minimum rotational life 25,000 cycles.

**Model 6 Radiohm®:** 500 ohms to 10 megohms at 1/10 watt, wide range of tapers, 250° rotation, minimum rotational life 25,000 cycles. Also available with SPST switch.

**Model 1 Radiohm®:** 500 ohms to 10 megohms at 1/10 watt, wide range of tapers, 260° rotation, minimum rotational life 25,000 cycles. Also available with SPST switch.

Detailed specifications are available in Centralab Technical Bulletins. Write for your free copies. Model 1 and Model 6 Radiohms® are stocked by your Centralab distributor, available as the B16 and SM control series respectively.

**\*Cubic inch, rather than cubic foot, is used to provide a more realistic and more readily visualized standard of comparison.**

A DIVISION OF GLOBE-UNION INC.  
914A EAST KEEFE AVE. • MILWAUKEE 1, WIS.  
In Canada: 804 Mt. Pleasant Rd., Toronto 12, Ont.



VARIABLE RESISTORS • ELECTRONIC SWITCHES • CERAMIC CAPACITORS • PACKAGED ELECTRONIC CIRCUITS • ENGINEERED CERAMICS

*These features of*  
**new Brush**  
**ultralinear**  
**recording**  
**systems...**



**... give you more application versatility!**

Simplified Chart Re-loading.

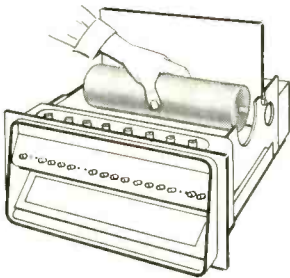

Interchangeable, plug-in signal conditioners.

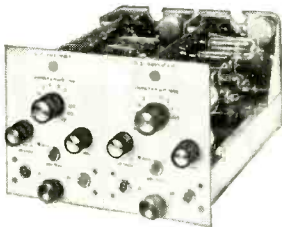

Positive Chart Take-up Drive.

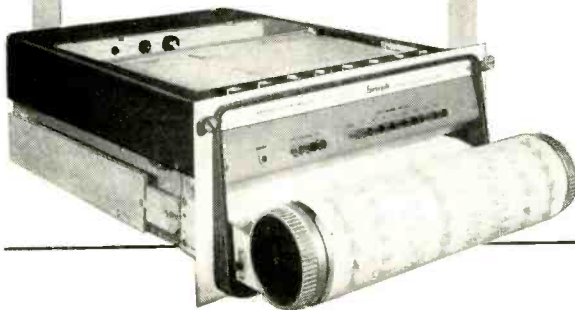

In the fields of telemetry, ground support systems, analog computing and laboratory testing, Brush recording systems have incorporated features which have consistently kept ahead of engineering requirements. Here are a few that show why—

**INTERCHANGEABLE PLUG-IN SIGNAL CONDITIONERS.** You get your choice of sensitivities—you get high input impedance—zero suppression.

**SIMPLIFIED FAST CHART RE-LOADING.** Loaded from the top—features automatic alignment and tracking.

**ACCURATE, EASILY REPRODUCIBLE RECORDINGS.** Your choice of rectilinear or curvilinear charts—rugged “throw-proof” pens.

Illustrated above is a Brush RD-1684 rectilinear, 8 channel recording system. Sensitivity of 10 millivolts per chart line—input impedance, 10 megs balanced or 5 megs grounded. Complete system includes mobile cabinet, oscillograph and 8 signal conditioners. No additional preamplifiers required. Available from stock.

**brush INSTRUMENTS**

DIVISION OF

**CLEVITE CORPORATION**

37th & PERKINS

CLEVELAND 14, OHIO

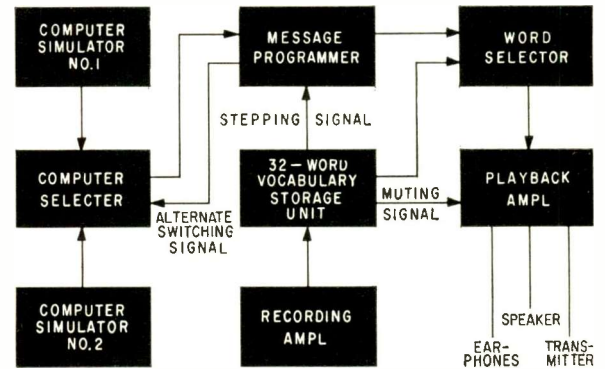
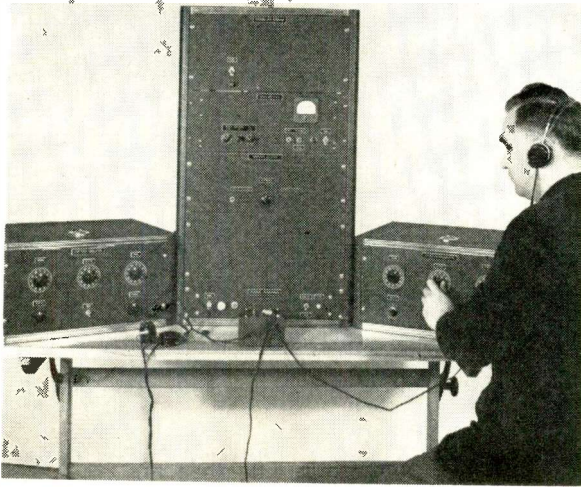

FIG. 1—Automatic voice link handles multiple intercept operations by sequentially transmitting data from several computers

Errors resulting from operator fatigue and poor announcement are eliminated by automatic voice link

# How Robot Voices Vector Fighter Pilots

Experimental automatic voice link converts data describing position of enemy aircraft into verbal instructions for transmission to fighter-interceptors. Words are represented by a five-bit code and are arranged according to desired message format. Binary bits select prerecorded spoken words

By C. W. POPPE and P. J. SUHR\*,

Defense Products Division, Fairchild Camera and Instrument Co., Syossett, New York

MODERN FIGHTER-INTERCEPTOR operations require automatic processing of radar information defining positions of enemy and interceptor aircraft. The voice link described here is capable of accepting outputs from several data processing equipments and automatically converting these electrical signals into a verbal message for radio transmission to intercept aircraft.

**MESSAGE STRUCTURE**—A typical message sent to an interceptor pilot might be: TONE BAKER 2 STEER 185 DEGREES ENEMY ALTITUDE 32 THOUSAND FEET DISTANCE TO CONTACT 19 MILES. Variable address words BAKER 2 and the seven variable numerical words are continuously generated by intercept computers to provide up-to-minute flight-path data for various interceptor aircraft. The alerting signal, represented

by the word TONE, and command words STEER, DEGREES, ENEMY, ALTITUDE, THOUSAND, FEET, DISTANCE, TO, CONTACT and MILES are selected on the automatic voice link equipment and arranged into a predetermined message structure by the operator of the station.

Each word is assigned a unique binary code made up of five bits. The state of each bit is determined by grounding or opening the associated circuit.

**EXPERIMENTAL SYSTEM** — A working laboratory model of the automatic voice link using two computer simulators in place of intercept computers has been built. A block diagram of the system is shown in Fig. 1.

Binary information required to select the two ad-

\* Now with Marine Div., Sperry Gyroscope Co., New York.

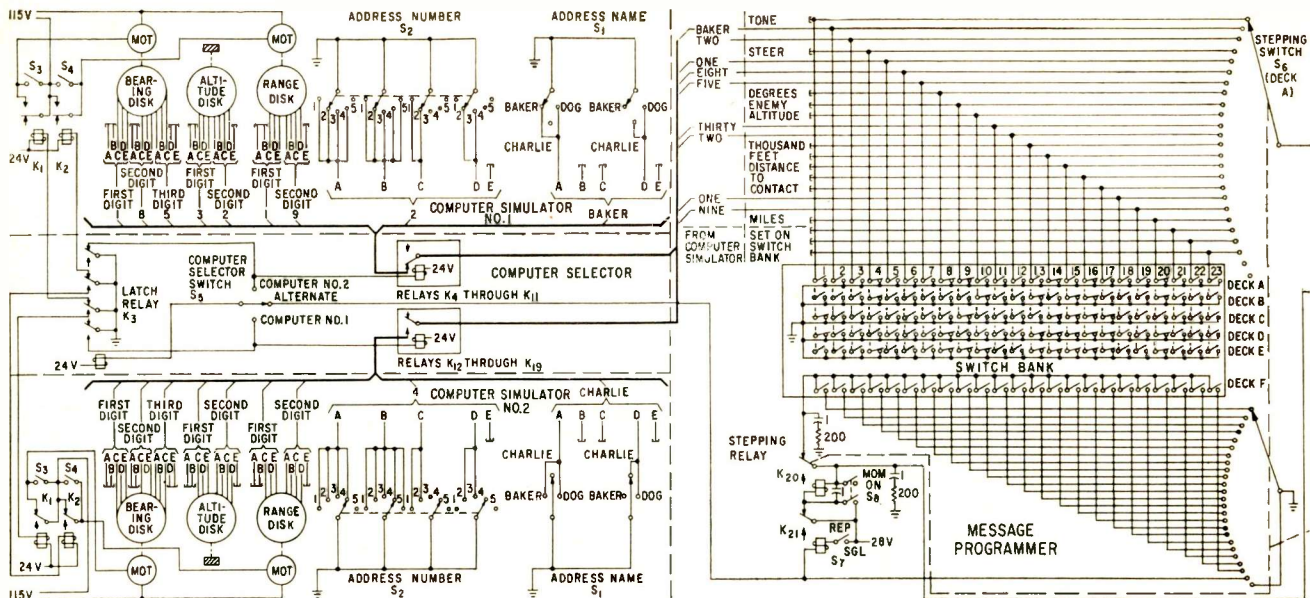

FIG. 2—Each word transmitted by automatic voice link takes 1/2 sec to generate. Muting microswitch  $S_6$  closes 25 millisecc after start of next

addresses and seven numerical words of the example message are generated in each computer simulator. Either simulator can be switched in manually on the computer selector, or the simulators can be selected alternately by a signal sent to the computer selector by the message programmer at the end of each message. The message programmer arranges the message into a preselected format and applies each word sequentially to the word selector. The binary code selects the magnetically prerecorded spoken word from the vocabulary storage unit. The selected audio signal is then fed through the word selector and playback amplifier to a monitoring speaker or earphones, or to a radio transmitter. A recording amplifier is provided to erase words and record new ones as desired.

Stepping signals necessary to advance from word to word are generated by the vocabulary storage unit. This unit also supplies a muting signal to the playback amplifier during the transient-producing switching periods. A schematic diagram of the automatic voice data link model is shown in Fig. 2.

**COMPUTER SIMULATOR**—Two selector switches in the simulator provide means for setting in address information. Switch  $S_1$  generates the two controllable bits of binary information used to select any one of three address names. Switch  $S_2$  generates the four controllable bits of binary information used to select any one of five address numbers.

Three coded disk assemblies generate the variable numerical words. Both bearing and range disks are normally motor driven, but can be positioned manually when necessary. The altitude disk can only be positioned manually. The bearing disk produces steering commands from 5 to 360 deg in 5-deg increments; the altitude disk produces altitudes from 1,000 to 36,000 ft in 1,000-ft increments; and the range disk produces distances-to-target from 1 to 36 miles in 1-mile increments.

Correct information is obtained from bearing and

range disks only when they have stopped rotating. A circuit consisting of switches  $S_8$  and  $S_9$  and relays  $K_1$  and  $K_2$  is used to stop the driving motors. The switches are actuated by 72 indentations spaced evenly around the circumference of the bearing and range disks.

If a computer simulator is feeding information to the rest of the system, relays  $K_1$  and  $K_2$  are energized and one leg of the parallel power circuit supplying the motors is opened. When the switch contact arms fall into a detent, the other leg of the motor power circuit is opened and the disks stop rotating.

**SIMULATOR SELECTOR** — Computer selector switch  $S_5$  controls application of the outputs from the computer simulators to the message programmer. If  $S_5$  is used to select one of the computers and the contacts of latch relay  $K_3$  are already properly positioned, nothing happens. However, if the contacts of  $K_3$  are oppositely positioned, the ground return for the coil of  $K_3$  is made energizing the relay and flipping its contacts to the proper position. This action also energizes relays  $K_1$  and  $K_2$  in the computer simulator and the simulator output feed-through relays  $K_4$  through  $K_{11}$  or  $K_{12}$  through  $K_{19}$  depending on the computer simulator selected. If  $S_5$  is in the ALTERNATE position as shown in Fig. 2, the arms of latch relay  $K_3$  change position each time a message completion signal is received from the message programmer.

**MESSAGE PROGRAMMER**—Six-deck, twenty-five position stepping switch  $S_6$  selects each word of the message sequentially and applies its five-bit binary code to the word selector. The binary code is applied to corresponding positions of decks A through E by one of two means. Variable address and numerical words are supplied by the computer simulator; the warning tone and the command words are supplied by the switch bank. Deck F is used to advance  $S_6$  rapidly to the starting position at the end of a mes-



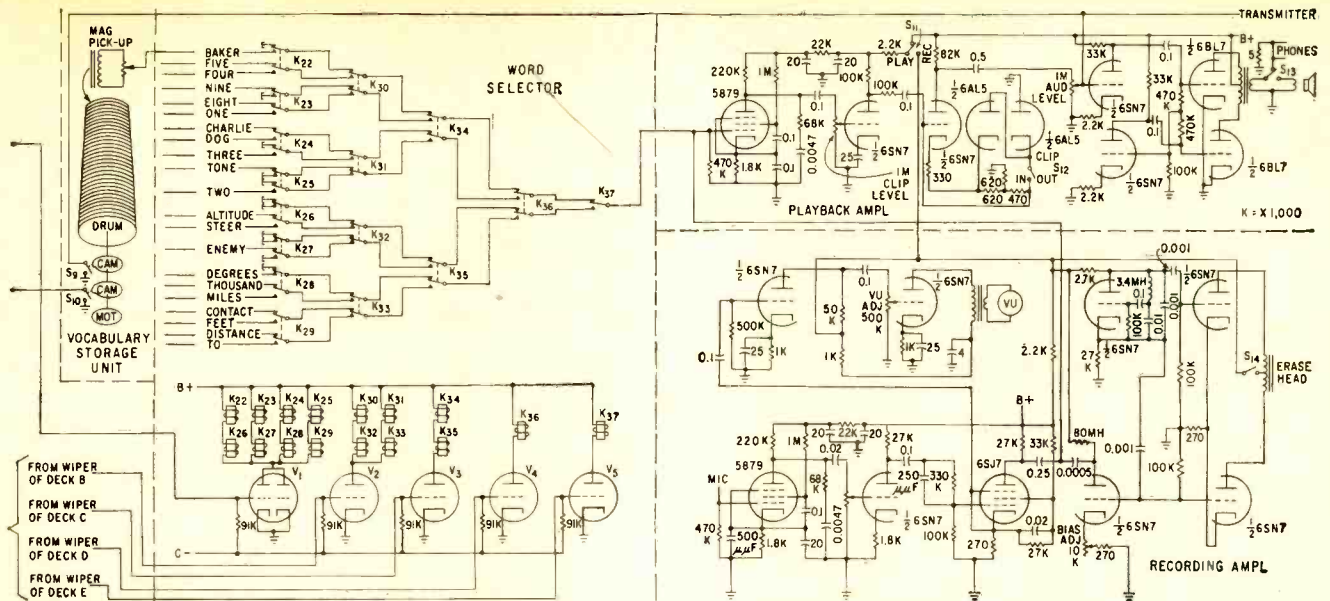

word interval. Stepping microswitch  $S_{10}$  closes 5 millisecc after and opens 5 millisecc before  $S_9$

sage less than 23 words long, to stop the rotation of  $S_9$  at the end of a message sent only once and to provide the message completion signal necessary to switch computer simulators alternately.

Each of the first 23 positions on decks A through F is connected to a single-pole toggle switch. Switches associated with decks A through E are used to set in the binary codes corresponding to the words in the message. The setting of these switches determines which word on the magnetic drum in the vocabulary unit will be chosen by the word selector as  $S_9$  moves to each position.

All toggle switches associated with input lines from the computer simulator are left in the open position; those associated with tone or command words are closed or open depending on the five-digit binary code; and those associated with lines not used for the message are left open.

The switches associated with deck F are used to establish a rapid advance mode after the last word in a message. If a 23-word message is set in, all deck F toggle switches are left open. If a repeated message of less than 23 words is set in, however, all switches associated with positions following the message are closed thereby causing stepping relay  $K_{20}$  to actuate with each step of  $S_{10}$ .

Switch  $S_7$  actuates relay  $K_{21}$  which sets in singular or repetitive modes of message transmission. Momentary ON pushbutton switch  $S_8$  starts the message transmission for a single cycle if  $S_7$  is at SINGLE.

**WORD SELECTOR**—The word selector consists of a relay pyramid and five associated electron tube controllers. The five binary digits used to select a particular word in the message format are applied to tubes  $V_1$  through  $V_5$  which are normally biased to cutoff by negative voltages. Bits representing ungrounded conditions have no effect on the tubes. Grounded bits, however, raise the grid potential of the tubes causing them to conduct and to pull in the associated relays. The audio signal for each chosen

word is fed from one of the 32 pickup heads in the vocabulary storage unit through relay contacts to the playback amplifier.

**VOCABULARY STORAGE UNIT**—A magnetic recording drum 2 $\frac{3}{4}$ -in. in diameter and 7-in. long is used to store the 32-word vocabulary. The drum surface is coated with a layer of red oxide 0.0008-in. thick having a coercivity of 200 oersteds and a remanence of 750 gauss.

Each word is recorded on a track 0.04-in. wide and is spaced  $\frac{1}{2}$  in. from adjacent tracks to minimize crosstalk. The 32 playback heads are arranged in 4 groups of 8 heads. Each group is located at a different point around the drum. The drum rotates at 120 rpm and has a surface speed of 15 in./sec. Frequency response is  $\pm 2$  db over 100-4,000 cps.

Each word recorded on the drum begins 25 millisecc after the start of drum rotation and is completed within 450 millisecc. The overlap of 50 millisecc is the dead time required for the word selector to choose the next word in the message. During the deadtime, microswitches  $S_9$  and  $S_{10}$  are actuated by cams coupled to the shaft of the drum. Switch  $S_{10}$  advances the stepping switch in the message programmer to the next word. Switch  $S_9$  grounds the audio signal to the output stages in the playback amplifier thereby suppressing switching transients.

Automatic voice links can be used in air traffic control applications where voice communication is necessary and where transmission must originate at a remote site. Since commands transmitted digitally from a command center could be converted to verbal messages after reaching a remote transmitter site, fewer land lines and voice channels would be required.

In areas where several languages are used in air traffic control, the vocabulary could be made up in each language and stored on separate drums. The operator could then select the desired transmission language by positioning a selector switch.

# Detector Pin-Points

Transistor oscillator provides test tone. High-speed polarized relay follows transients as tape plays back. Machine stops when deviation in recorded and reproduced level indicates a flaw which would make the tape unsuitable for broadcast use

By **N. J. THOMPSON**, Supervisor of Radio and Tv Studio Maintenance, Wisconsin State Broadcasting Service, Madison, Wisconsin

**C**HECKING OUT recorded magnetic tape is made easy by using this tape-flaw detector. The tester automatically stops tape-transport motion whenever a splice, bad warp or void in magnetic coating cause transient changes in the reproduced level of a tone.

The block diagram, Fig. 1, shows how the unit works. A reel of tape is threaded into the transport mechanism. Switching to TAPE-TEST position removes power from the transport motors, allowing the transport forward switch to be operated without reaction. When a test is started, the start button, pushed and held, supplies 110 v a-c to the transport motors and to the 28-v supply. This starts the transistor oscillator, which records a tone on the tape. The operator adjusts playback gain at a desired level within limits of the sensitive relay. The relay is adjusted with magnetic bias, and closes one contact when the level is 2 db above reference, and closes its other contact when the level is 2 db below reference.

Within this four db range, neither contact is closed, both time-storage capacitors drop, and the power relay is energized. The operator notes the extinguishing of the LOW and HIGH indicator lights and may release the start button. Tape transport continues until the recorded and reproduced level deviates momentarily, at which time the machine stops.

The operator then checks the tape in the vicinity of the heads for flaws. Splices are inspected and remade if necessary, or the reel is

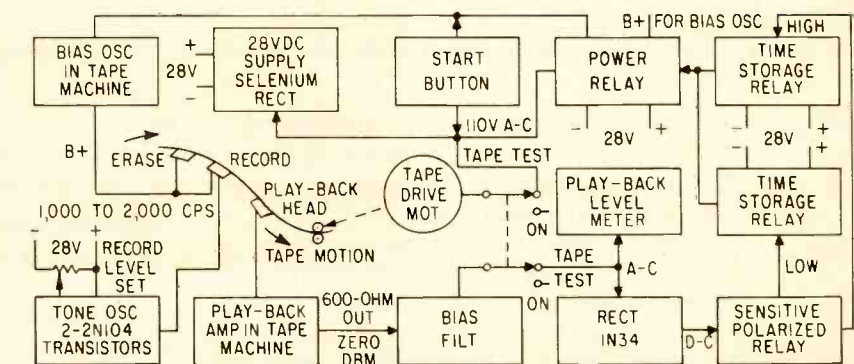

FIG. 1—Block diagram of tape tester. Outlet connection to a clock permits timing of tapes as they are checked in spite of stops and starts

discarded if excessive splices are noted.

## Response To Transients

A transient due to a perpendicular splice may last only a few milliseconds at tape speeds of fifteen inches per second or more. The detector uses a high-speed polarized relay to follow such transients. Tone from the playback head is amplified through the original tape playback amplifier. Output at zero dbm is rectified, filtered and fed to the coil of the polarized relay. To insure fast response, a short-time-constant filter is used on this rectifier.

To prevent limiting response time by slower relays following the polarized relay, the polarized relay charges a memory capacitor as it responds to a transient. This capacitor discharges into the coil of a slower relay, which in turn stops the transport. The polarized relay used will follow as much as 200 cps.

The two heads of the commercial

tape recorder used were replaced with a three-head assembly. The transistor tone oscillator drives the record head directly so a second amplifier is not required for the record channel. Erase and bias are supplied by the bias oscillator on the transport mechanism with no changes. Plate voltage is removed from the bias oscillator by a relay contact in the tester chassis, to prevent the bias oscillator from running during periods when the transport is in the forward position and the motors are stopped by the tester. Running the oscillator without the cooling effect of moving tape heats the heads.

An outlet is provided on the tape tester for connection to a clock. This permits timing of tapes as they are checked in spite of stops and starts.

No internal connections are made in the tape transport or amplifier. All connections are made by intercepting Jones plugs between amplifier and transport with a pair of

# Magnetic Tape Flaws

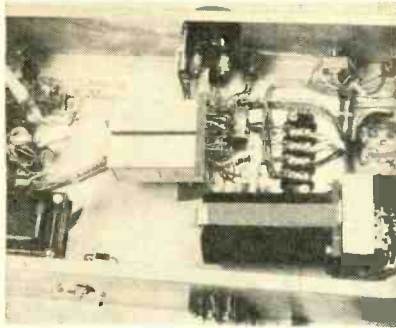

Top view of chassis shows transistor oscillator at upper left, above the 28-v power supply. Polarized relay is located in cam, lower right. Telephone-type up and down relays are mounted horizontally at center



Author demonstrates one-finger operation of automatic tape-flow detector. Sensitivity of limit settings may require a stop for each splice

cable-type Jones plugs. Wires not intercepted are jumped from plug to plug.

The oscillator frequency, 1 to 2 kc, is chosen high enough to be

easily filtered in the playback rectifier, and low enough to be unaffected by minor head misalignment or by head response problems.

Referring to the schematic of Fig.

2,  $C_1$  removes recording bias from the reproduced signal. Capacitor  $C_2$  should not be too large, to maintain adequate speed of response. The memory capacitors are  $C_3$  and  $C_4$ . The primary of  $T_1$  is tuned to frequency by  $C_5$  which is chosen experimentally. The relay contacts are protected from arcing into their capacitive load by  $R_1$ . Resistor  $R_2$  is chosen to bleed the power supply to the same voltage in the operating position as is available at the starting-but-not-at-the-correct-level condition. This is necessary because the oscillator is sensitive to supply variations, and it was deemed cheaper to use this method rather than incorporate a well-regulated supply. Variable resistor  $R_3$ , once set for proper recording level, is never changed. Surprisingly small output, about 0.1 volt at the 3-ohm tap, is required of this oscillator.

The unit may be altered for 6-v relays by changing  $C_3$  and  $C_4$  to 200  $\mu\text{f}$ ,  $R_1$  to 10 ohms, the output tap on  $T_2$  to 8 ohms and  $T_2$  to a 6-v, 1-amp filament transformer. The selenium rectifier must also be changed to a 500-ma unit.

Cooperation of A. F. Puariea in the design is acknowledged.

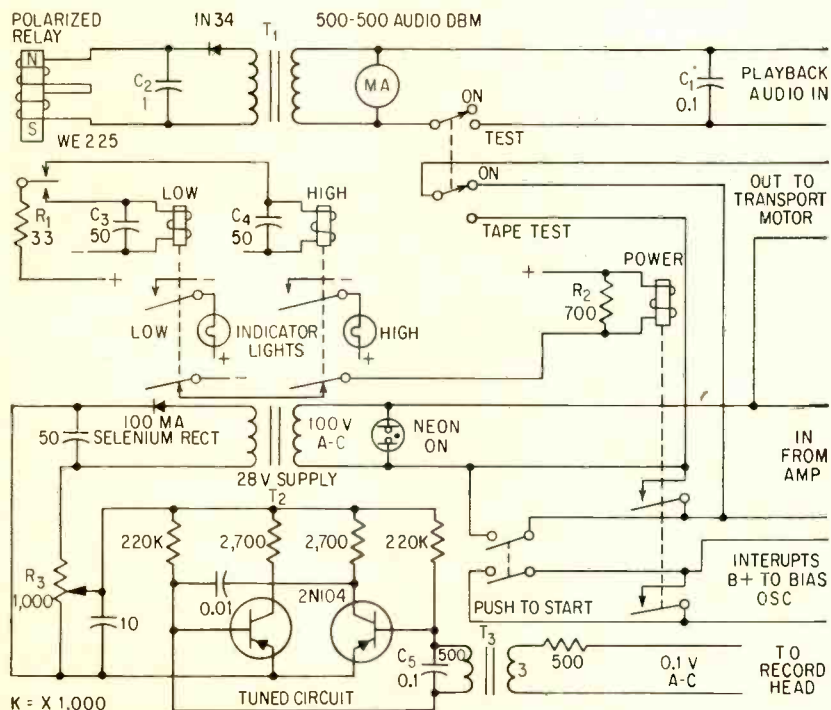

FIG. 2—Tape-flaw detector schematic. Polarized relay charges a memory capacitor as it responds to a transient. This capacitor discharges into the coil of a slower relay, which in turn stops the transport

Open-loop photoelectric function generator can generate any single-valued function with an accuracy of better than one percent. Functions of a function can be produced with slight operating modifications. Many of the problems common to closed-loop operation have been eliminated

By **BARBARA SILVERBERG**, Columbia University, Electronics Research Laboratory, N. Y., N. Y.

# Function Generator for

**A**N INTEGRAL PART of a radar simulator is a function generator to produce the antenna beam pattern. A closed-loop MacNee type function generator used for this purpose was inadequate in its accuracy and frequency response, susceptible to drift, and plagued by

parallax errors, halo effect of the screen and changes in spot size and intensity of the cathode-ray beam.

The general-purpose photoelectric function generator discussed in this article permits the generation of any single-valued function with an accuracy of better than 1 percent,

and in addition, allows the generation of a function of function if it should be desired. With proper choice of vertical scan rate, up to 100 kc, the device has a flat frequency response up to 150 cps for the independent variable, and can reproduce functions with frequency



Bench setup illustrates use of component parts that make up photoelectric function generator

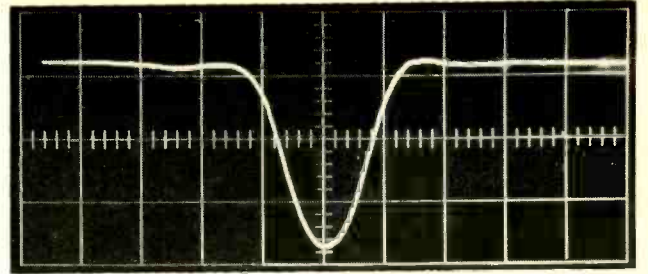
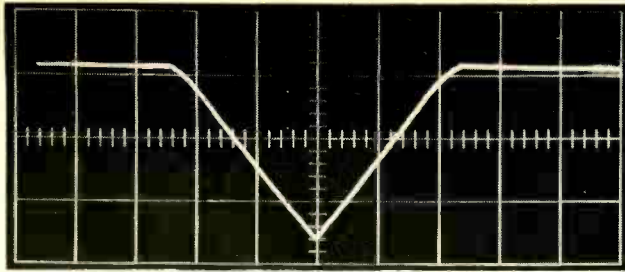

Signals were generated with open-loop photoelectric function generator

# Radar Simulator

components in the kilocycle range. The interval of time in which the function is to be generated, as well as its repetition frequency, may be chosen arbitrarily.

## Open-loop Operation

Unlike earlier methods of function generation, this photoelectric function generator uses an open-loop method of operation. A mask is prepared which is opaque except for the area between the dependent function and an arbitrary reference line, as shown in Fig. 1A. The mask is placed against the face of a flat-faced crt, with the reference line uppermost, and the electron beam is quiescently positioned along a line which is below the lowest point of transparency on the mask. A raster made up of a low-frequency horizontal sweep and a high-frequency vertical sweep is applied to the deflection plates of the crt, and the beam scans the mask at the high

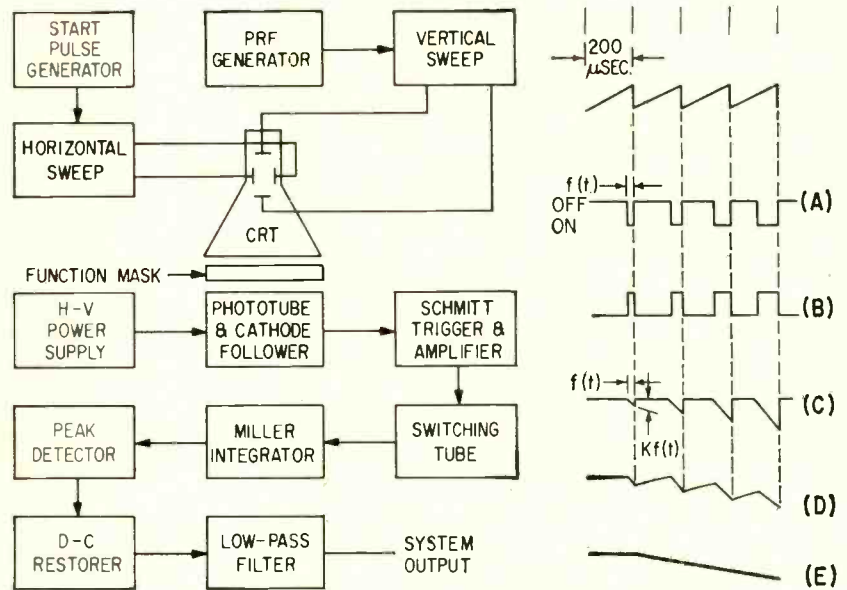

FIG. 2—System block diagram with waveforms for each stage.

sweep rate, as shown in Fig. 1B. Each time the beam moves into the transparent area the phototube viewing the mask saturates and re-

mains saturated until the beam moves across the reference line and back into the opaque area.

Thus for each vertical sweep of the beam, the phototube produces a square wave of duration proportional to the ordinate between the function line and the reference line at the particular horizontal position being scanned.

The amplitude of the square waves is constant, and their fundamental frequency is the repetition rate of the vertical sweep.

The resultant series of duration modulated square waves is amplified, integrated and filtered to produce a varying d-c voltage proportional to the height of the function plus the pedestal between the base of the function and the reference line at the point being scanned. If

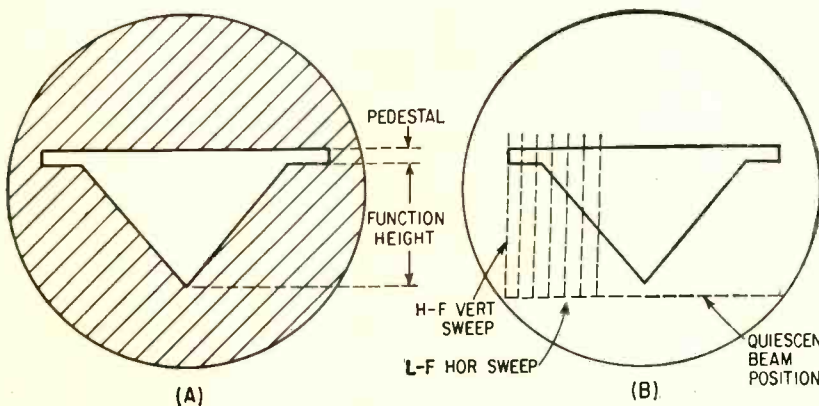

FIG. 1—Opaque mask (left) placed against the cathode-ray-tube face produces the desired function. Raster made up of a low-frequency horizontal sweep and a high-frequency vertical sweep is applied to the crt deflection plates (right)

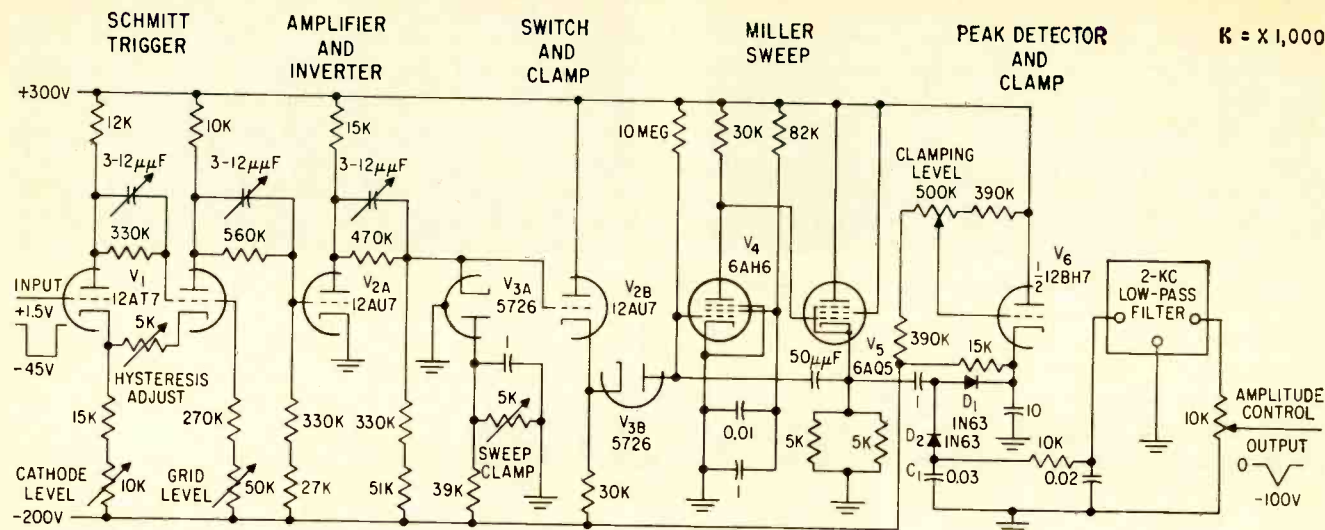

FIG. 3—Function generator which uses a horizontal sweep of ten milliseconds or 100 cps and a vertical sweep of 5 kc

the horizontal position of the beam is a linear function of time, the voltage produced at the output is an electrical replica of the function mask.

The slant of the high-frequency sweeps relative to the vertical causes a small error, which can be eliminated by positioning the cathode-ray tube at a slight angle relative to the reference line on the function mask. This will make the high-frequency sweeps vertical with respect to the function, without affecting the operation of the system in any way.

#### Time Interval

For a function to be generated accurately, it is necessary that the time interval between the completion of the integration of successive duration modulated square waves be constant. This is accomplished by placing the function mask with the reference line uppermost. Consequently the beam enters the transparent area at an arbitrary time depending on the height of the function at the horizontal position being scanned, but crosses back into the opaque region of the mask at a constant repetition rate. This action causes the square waves at the output of the phototube to commence at arbitrary time intervals, but to terminate at a constant repetition rate, and the above requirement is satisfied.

If a sampled output rather than a continuous output is desired, the

vertical sweep trigger pulse can be delayed in time and used to sample the output of either the integrator or the filter.

As an interesting extension of this system, a function of a function can be generated either by varying the vertical sweep speed in a non-linear manner, or by varying some parameter in the integrator circuit, for instance, the time constant or the integrator voltage.

Placing the function on a small pedestal, as shown in Fig. 1A, removes certain inaccuracies from the system. The most basic inaccuracy is due to the time it takes the phototube to saturate, about five  $\mu$ sec. Without the pedestal, any portion of the function which could be traversed by the beam in less than five  $\mu$ sec would not be reproduced linearly. The pedestal absorbs this nonlinearity and also the nonlinear portion which commonly occurs at the beginning of each integration cycle. The time it takes for the response of the phosphor and the phototube to decay effectively adds a small but constant amount to the height of the pedestal. This composite pedestal can be removed easily just prior to filtering the signal at the output of the system, without otherwise altering the function.

#### System Description

A block diagram of the function generator together with its waveforms, is shown in Fig. 2. The choice of the horizontal sweep time

is arbitrary, depending on the requirements of the system in which the function generator is used. Once this has been established, a Fourier analysis of the function will determine the lowest repetition rate for the vertical sweep which will allow the function to be generated to the accuracy required by the system.

Any increase either in the repetition rate of the vertical sweep or in the horizontal sweep time will serve to further improve the accuracy of the generated function. A schematic diagram of a system using a horizontal sweep time of ten milliseconds and a vertical sweep repetition rate of five kc, is shown in Fig. 3.

The deflection system of the Hewlett-Packard 130 A oscilloscope is used with a 5AQP15 cathode-ray tube; the P15 phosphor has an S-4 response (blue-violet portion of the spectrum) of short persistence. The photosensitive device is a Dumont 931-A multiplier-phototube with high gain and an S-4 response, operated from a -1,000-v supply.

The sweep circuit provided in the oscilloscope is used as the horizontal sweep for the system. The 5-kc vertical sweep is supplied externally by a bootstrap sweep circuit which, when the clock pulses come in, first discharges and then allows the sweep to form. This permits these same clock pulses to be applied to the Z input of the scope to blank the vertical sweep retrace. The scope

provides its own blanking signal for the retrace of the horizontal sweeps.

### Circuit Operation

Duration modulated square waves produced by the phototube are fed through a Schmitt trigger which amplifies the signal and eliminates any noise resulting from variations in light intensity. The square waves are further amplified and fed to a cathode follower which opens and closes a diode switch to control integration time of a Miller sweep tube. The most negative excursion of the input to the cathode follower is limited by another diode such that, when the switching diode conducts, it holds the grid of the Miller sweep tube at a fixed low level in its grid base. Only when the switching diode is nonconducting, that is, when the phototube is in its saturated state, is the sweep able to form. To maintain the best possible rise time for the square waves it is advisable to use d-c coupling in this first section of the system.

Because the Miller sweep tube integrates only when the phototube conducts, the amplitude of each sweep is directly proportional to the duration of the corresponding square wave. The square wave in turn is proportional to the height of the function at the abscissa being scanned.

The cathode follower interposed between the feedback capacitor and the output of the Miller sweep tube reduces the recovery time of the integrator to 4  $\mu$ sec. In addition,

this cathode follower drives a d-c restorer and peak detector. Any pedestal present on the function is removed at this point in the circuit by restoring the base of the pedestal to whatever positive voltage is necessary to position the baseline of the function exactly at the zero level. Since the peak detector which follows is designed to pass only that portion of the signal below ground, the pedestal will not come through to the output. The setting of the d-c restorer is the only adjustment in this system which must be checked daily, since drift at this point will determine the amount of the function that appears at the output of the system.

The charge and discharge time constants of the peak detector are chosen to allow the amplitude of the voltage at its output to follow the maximum positive and negative slopes of the function being generated. Following detection, the function is passed through a low-pass filter which has sufficient bandwidth to pass all those frequency components Fourier analysis has proved necessary for accurate reproduction of the function. The filter also cuts off sharply enough to remove the high-frequency ripple.

### Synchronization

For the function to be generated with the best possible accuracy, it is necessary for the horizontal sweep to be synchronized with the vertical sweep each time the raster scans the crt. In many cases, the

trigger pulse which establishes the horizontal repetition rate is generated elsewhere in the system, completely independent of the vertical prf. From this pulse, a trigger pulse is derived that is synchronized to the vertical prf. One method of accomplishing this is shown in the block diagram of Fig. 4. The independently generated trigger pulse (waveform A) switches a bistable multivibrator from the ZERO to the ONE state. The output of the multivibrator, together with the vertical prf clock pulses, is fed to an AND gate; this gate passes the clock pulses only when the multivibrator is in the ONE state (waveform D). Thus the AND gate passes the first clock pulse which occurs after the independent trigger pulse comes in. It is this pulse which is used to trigger the horizontal sweep of the scope. In addition, it switches the multivibrator back to the zero state (waveform B) so that no further clock pulses are passed by the AND gate until the next independent trigger pulse comes in.

### Performance

The function generator is able to generate any single-valued function to an accuracy of better than 1 percent of full scale. The main sources of error which prevail in other function generators of a similar type, such as persistence of the phosphor, delay time of the phototube and amplifier, variation of deflection sensitivity, changes in spot size and intensity, inaccuracies in some optical system which may be used, have, to a large extent, been eliminated. Of the errors which remain, the greatest is due to the small drift in most oscilloscopes.

This research was sponsored by the Electronics Research Directorate at AFCRC, ARDC, under contract No. AF 19(604)-1572.

### BIBLIOGRAPHY

- W. H. Bliss and C. J. Young, Facsimile Scanning by CRT, *RCA Rev*, Sept. 1954.
- D. S. Bond and V. J. Duke, Ultrafax, *RCA Rev*, March, 1949.
- A. A. Gerlach, C. N. Pederson and R. E. Zenger, A Precise Electronic Function Generator, *Proc NEC*, 8.
- E. J. Hancock, Photoformer Design and Performance, *Proc NEC*, 7, p 228, 1951.
- L. G. Polimerou, A New Method of Generating Functions, *Trans IRE*, EC-3, Sept. 1954.
- D. E. Sunstein, Photoelectric Waveform Generator, *ELECTRONICS*, 22, Feb. 1949.

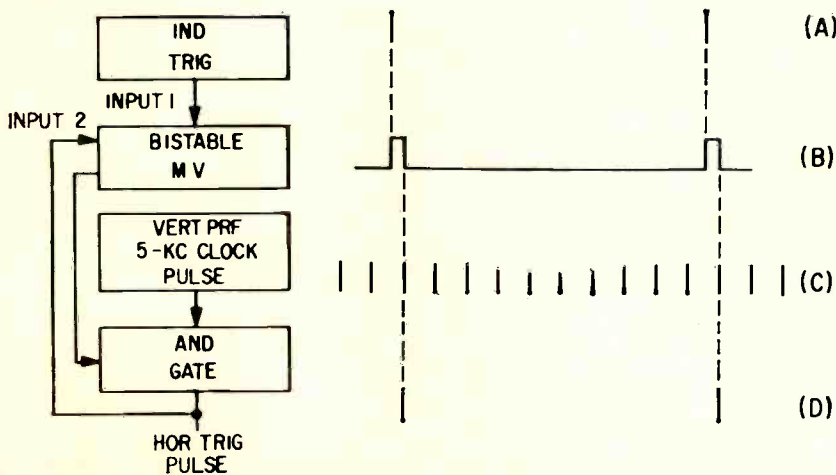

FIG. 4—Synchronization of horizontal and vertical sweep when each signal is generated independently

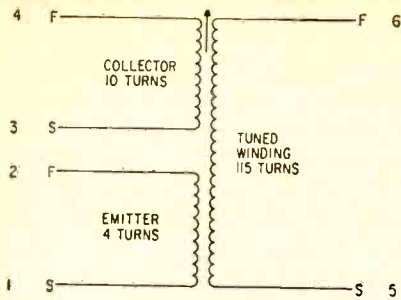

FIG. 1—Typical oscillator coil designed for emitter injection. Single pie gives less variation in coupling than double pie

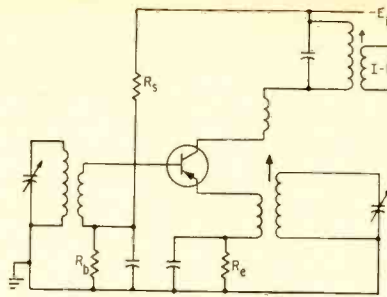

FIG. 2—Emitter-driven converter. Optimum injection voltage for direct emitter current of 0.5 ma is 0.1 to 0.15 v

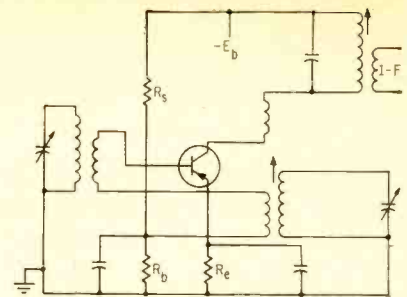

FIG. 3—Base-driven converter. Optimum injection voltage for direct emitter current of 0.5 ma is 0.2 to 0.3 v

# Special Circuits for

Four portable transistor receiver circuits—autodyne converter, reflex circuit, avc overload diode and untuned r-f stage—are summarized in tabular form. Introductory text covers general design procedures for the entire receiver

By **WILLIAM E. SHEEHAN** and **WILLIAM H. RYER**,

Transistor Applications Laboratory, Semiconductor Div., Raytheon Manufacturing Co., Newton, Mass.

Circuit	Description and Design Hints	Problems and Solutions
<b>Autodyne Converter (See Figs. 1, 2 and 3)</b>	<p>Used rather than separate mixer and oscillator. Basically an oscillator with special design considerations. Amplitude of oscillations must be limited by nonlinearity of emitter-base diode and not by any other form of nonlinearity such as collector bottoming. Impedance in collector circuit to oscillator frequency must be small enough so that peak-to-peak oscillator voltage does not approach battery supply voltage closely. Cost is about one-half that of separate mixer-oscillator circuit. Gain is about 30 db.</p> <p>Characteristics of transistor types generally used: input impedance to signal frequency, 500-1,500 ohms; conversion gain, 25-32 db; output impedance at 455 kc, 50,000-100,000 ohms.</p> <p>General design procedure:</p> <ol style="list-style-type: none"> <li>1. Select oscillator coil design</li> <li>2. Determine tuned-circuit parameters (oscillator and signal). Usually determined by convenient gang capacitor size</li> <li>3. Select bias resistor values to give proper operating point and good temperature stability</li> <li>4. Make necessary corrections to oscillator coil to give proper injection voltage across band. For more injection, increase number of turns on collector feedback winding by 10 to 20 percent and decrease turns similarly to lower injection voltage</li> <li>5. Adjust number of turns on secondary of antenna to give fairly even sensitivity across band. Make set track by individual capacitor adjustments at each frequency</li> <li>6. Adjust oscillator-coil and antenna inductances to make set track evenly across band</li> </ol>	<p>Greatest improvement in signal-to-noise ratio can be made by increasing size of antenna.</p> <p>Audio rate squegging may be eliminated by redesigning oscillator feedback circuit or changing values of coupling and/or blocking capacitors.</p> <p>Oscillation at i-f or some multiple may be corrected by relocating parts or revising tuned circuit to remove parasitic resonances.</p> <p>Spurious oscillation, apparent mis-tracking or oscillator pulling and worsened signal-to-noise ratio may be eliminated by removing oscillator feed-through in gang capacitor. Shield r-f section from oscillation section or reverse antenna secondary connections.</p>



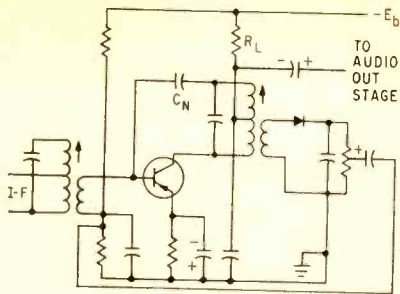

FIG. 4—Typical reflex circuit as used in portable transistor receivers. Transistor is used both as an i-f and audio amplifier

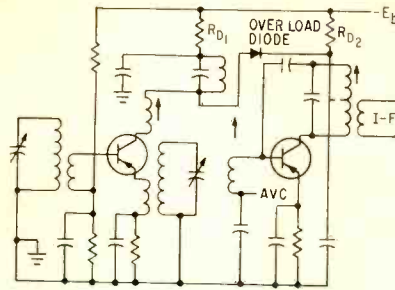

FIG. 5—Avc overload diode circuitry. Operates in conjunction with normal avc applied to the first i-f stage

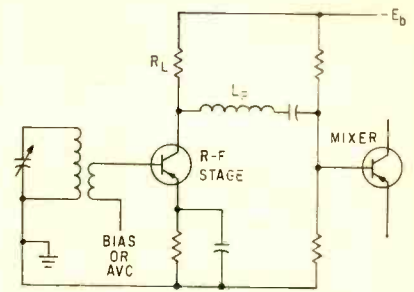

FIG. 6—Untuned r-f stage generally works into a mixer but could also work into a converter stage

# Transistor Receivers

OUTPUT STAGE gains of transistor superheterodyne receivers are about 25 to 40 db depending upon power level, supply voltage and circuitry.

The audio driver stage may be expected to contribute about 40 db of power gain. Overall gain should be about 60 to 80 db. For low distortion, negative feedback (3 to 7 db) may be added, reducing overall gain correspondingly. Knowing overall audio-system gain and input impedance, the second detector may be designed for optimum performance at its level. Diode detector losses are about 12 to 18 db. The avc circuits are usually designed after the i-f stages and make some adjustments in the detector necessary at a later time.

Preliminary design of the converter circuit is made to determine its output impedance. This, together with input impedance of the detector, is necessary for proper i-f system design. Generally, one or two i-f stages will be used. Selectivity requirements will determine whether single- or double-tuned i-f transformers must be used. The transistor type must be determined. Then, knowing transistor parameters and performance requirements, the i-f transformers can be designed by use of proper design equations. If there is to be avc on the first i-f stage only, bias and avc circuits for the i-f stages can be designed and the second detector circuit optimized. Final step is design of the autodyne converter.

Circuit	Description and Design Hints	Problems and Solutions
Reflex (See Fig. 4)	Transistor is used as both an i-f amplifier and as an audio amplifier concurrently. Audio may be capacitance-coupled into next stage as shown or, if audio portion of circuit is used as driver for a class-B output stage, transformer coupling is used. Circuit can contribute 25-30 db i-f gain and 25-35 db audio gain. Its use enables elimination of an audio driver stage from overall circuit without decreasing performance.	Close attention must be paid to avc to prevent overload in the reflexed stage. Reflexed stage itself must be designed carefully to minimize overloading and cross-coupling. Special care must be taken to insure that operation is always in the linear region.
Avc Overload Diode (See Fig. 5)	Overload diode circuit operates in conjunction with normal avc applied to the first i-f stage. Its operation depends upon change in d-c conditions in this stage with changes in bias due to avc. Normally, an avc figure of merit of 30-35 db is obtainable in a set with two i-f stages with avc applied to the first i-f stage only. Addition of overload diode increases this to about 60 db and raises overload from 50,000 to 500,000 $\mu\text{v}/\text{m}$ . Similar improvement can be noted in a set with only one i-f stage. Here, typical figure of merit without diode is 20-25 db; with diode, 50 db. Overload point is raised to about one v/m; without diode, about 200,000 $\mu\text{v}/\text{m}$ . These figures are for 30-percent modulation.	Diode is connected for a-c across the converter to i-f transformer tuned circuit. D-c circuit is arranged so that diode is reverse-biased under weak signal conditions presenting a high impedance to i-f. Under these conditions, there is negligible shunting effect across the tuned circuit. Under strong signal conditions, d-c bias across the diode becomes a low impedance to i-f, loading down the converter to i-f transformer.
Untuned-R-f Stage (See Fig. 6)	Generally works into a mixer but probably could work into a converter as well. Inexpensive way of adding gain. Does not improve selectivity or image-rejection characteristics. Only makes slight improvement in noise characteristics. Adds 10-14 db more gain. Since circuit can use avc, avc figure of merit and overload point are improved considerably. Using untuned r-f stage, typical set with 300 $\mu\text{v}/\text{m}$ sensitivity for 50-mw output can be improved to 50 $\mu\text{v}/\text{m}$ at a 10-db signal-to-noise ratio with an avc figure of merit of 70 db.	Largest problem is to obtain a flat gain characteristic across the band. A small peaking coil may be added to the collector circuit to peak up at the high end of the band. Oscillator voltage must be prevented from feeding into the r-f stage by having a grounded shield plate between the oscillator and antenna sections of gang capacitor.

# Multiplying Circuit Uses

High-speed magnetic-amplifier square-law circuits containing nickel-iron tape cores, silicon diodes and resistors replace slow-response thermal converters in four-quadrant analog multiplying device. Reversible-polarity output operates common ink oscillographs

W. A. GEYGER, U. S. Naval Ordnance Laboratory, Silver Spring, Maryland

**F**OUR-QUADRANT MULTIPLICATION of signal voltages or signal currents may be achieved by applying a multiplication method which corresponds to the fundamental principle of thermal wattmeters:  $(A + B)^2 - (A - B)^2 = 4 AB$ .<sup>1</sup> Two thermocouples or thermoconverters usually provide the square terms; one is heated by the algebraic sum of two derived currents and the other, by their difference.

Recently, the two thermal converters have been replaced with a special form of magnetic-amplifier multiplying circuit, which acts as square-law device; when employed in two channels it provides the required sum and difference terms.<sup>2</sup>

Given two independent polarity-reversible d-c input voltages,  $\pm E_1$  and  $\pm E_2$ , these voltages are multiplied and a product obtained in the form of a polarity-reversible d-c output voltage that operates a standard ink oscillograph.

## Basic Multiplying Circuit

The basic circuit shown in Fig. 1A is a two-stage arrangement that contains the converter (input stage

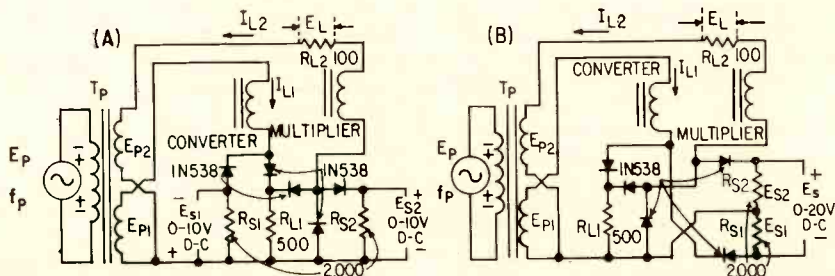

FIG. 1—Basic circuit (A) multiplies d-c voltages  $E_{S1}$  and  $E_{S2}$ ; modified circuit (B) multiplies components,  $E_{S1} = E_{S2} = 0.5E_S$ , of d-c voltage  $E_S$  and provides square terms of signal voltages and currents

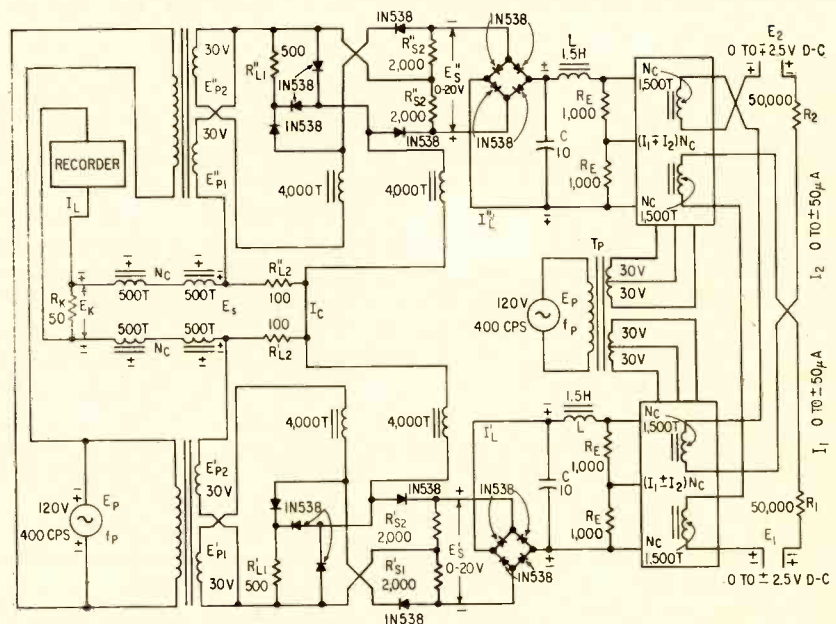

FIG. 2—Polarity-reversible signal currents  $I_1$  and  $I_2$  are multiplied with two square-law and two push-pull magnetic amplifier circuits

controlled by the first signal voltage  $E_{S1}$ ) and the multiplier (output stage controlled by the second signal voltage  $E_{S2}$ ).<sup>8</sup> Resistors  $R_{S1}$  and  $R_{S2}$  provide the necessary path for the presetting magnetizing cur-

rents flowing against the signal voltages.

Circuit operation is described by  $E_L = I_{L2}R_{L2} = (\text{constant}) (E_{S1} E_{S2} / E_{P1})$  where  $E_{S1}$  and  $E_{S2}$  represent average values and  $E_{P1}$  is the rms value of supply voltage  $E_{P1}$  derived from power-supply transformer  $T_P$  with two separate secondary windings. With  $E_{P1}$  equal to a constant, the simplified relationship  $E_L = (\text{constant}) (E_{S1} E_{S2})$  results.

In each stage, the gate voltage ( $E_{P1}$  and  $E_{P2}$ , respectively) must satisfy the condition  $E_{Pmax} < 2\pi f_P N \Phi_{sat}$ , where  $f_P$  is the power-supply frequency,  $N$  is the number of turns of the cores and  $\Phi_{sat}$  is the saturation flux density of the rectangular-hysteresis-loop core.

Certain limitations with regard

# Magnetic Amplifiers

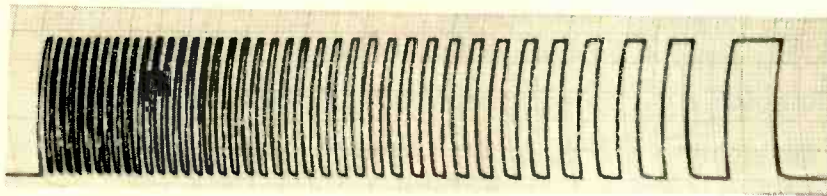

FIG. 3—Output of circuit of Fig. 2 with square-wave input varying from 30 to 0 cps. Frequency variation was obtained by deenergizing a motor-driven switch to obtain the continuously decreasing signal frequency

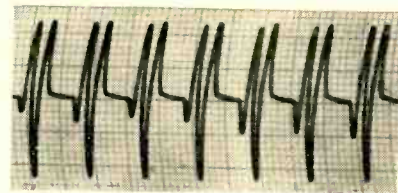

FIG. 4—Output with 60-cps sinusoidal carrier synchronously modulated with 30-cps square wave as the input signal

to the relationship between the instantaneous values of signal voltages  $E_{s1}$ ,  $E_{s2}$  and gate voltages  $E_{p1}$ ,  $E_{p2}$  require that  $E_{p1}$  and  $E_{p2}$  must be square waves symmetrical about zero if  $E_{s1}$  and  $E_{s2}$  are pure d-c signal voltages as derived from a battery or a filter circuit.

In both stages, the magnetizing currents must be minimized by proper design of the high-permeability cores.

## Square-Law Circuit

Each of the two d-c signal voltages,  $E_{s1}$  and  $E_{s2}$  has a certain unchanging polarity with regard to the half-wave rectifier elements series-connected with  $R_{s1}$  and  $R_{s2}$ . One of the basic requirements in many problems concerning multiplication of d-c signals, however, is that each signal may change its polarity.

To fulfill this requirement, the basic circuit is modified as shown in Fig. 1B by supplying the two signal circuits from a center-tapped input resistor ( $R_{s1} + R_{s2}$ ) so that  $E_{s1} = E_{s2} = 0.5 E_s$ . In this case the signal voltage  $E_s$  must also have a certain polarity, as indicated in Fig. 1B.

This circuit provides the unidirectional output voltage  $E_L = (\text{constant}) (E_s)^2$ .

## Complete Circuit

Two square-law circuits have been employed in a four-quadrant analog multiplying device in Fig. 2, using only magnetic cores, silicon diodes and resistors.

Two magnetic-amplifier square-law circuits, similar to that in

Fig. 1B, provide the first square term of the algebraic sum of the currents  $I_1 = E_1/R_1$ ,  $I_2 = E_2/R_2$  and the second square term of difference of these currents  $E_L' = (\text{constant}) (I_1')^2 = (\text{constant}) (I_1 \pm I_2)^2$ ,  $E_L'' = (\text{constant}) (I_1'')^2 = (\text{constant}) (I_1 \mp I_2)^2$ .

Filter circuits ( $L$ ,  $C$ ), and full-wave rectifiers across mixing resistors  $R_x$  convert the polarity-reversible output currents  $I_L' = (\text{constant}) (I_1 \pm I_2)$  and  $I_L'' = (\text{constant}) (I_1 \mp I_2)$  of the two magnetic-amplifier push-pull circuits into substantially pure d-c which does not change in polarity.

The resulting d-c signal voltage  $E_s$  across series-mixing resistors  $R_{L1}'$  and  $R_{L2}''$  is balanced by voltage drop  $E_K = I_L R_K$  across negative-feedback resistor  $R_K$  of the self-balancing magnetic-amplifier push-pull circuit.<sup>2</sup> There is a linear relationship between  $E_s = E_K$  and the average value of the polarity-reversible load current  $I_L$  flowing through the ink recorder; it can be expressed by  $I_L = (\text{constant}) I_1 I_2 = (\text{constant}) (E_1 E_2)$ .

## Practical Application

The arrangement of Fig. 2 has been used in conjunction with a Brush recorder to make a permanent record of the product of currents  $I_1 = 0$  to  $\pm 50 \mu\text{a}$  and  $I_2 = 0$  to  $\pm 50 \mu\text{a}$  ( $R_1 = R_2 = 50,000$  ohms). When supplying the two square-law circuits of Fig. 1B from a ferroresonant magnetic-switch circuit with rectangular-hysteresis-loop core material, the gate voltages ( $E_p$ ) are square waves symmetrical about zero; pure d-c signal

voltages,  $E_{s1}$  and  $E_{s2}$ , can be applied in this case without disturbing proper operation of these circuits.

Supermalloy 2-mil tape cores, with 1-in. inside dia, 1½-in. outside dia and ¼-in. tape width, minimize the magnetizing currents.

Accuracy of measurements obtained with this arrangement is about  $\pm 2$  to 3 percent of full-scale deflection of the ink oscillograph. The response time is about 5 mil-sec, about two cycles of the power-supply frequency.

Figure 3 illustrates the dynamic performance of the circuit of Fig. 2. A 60-cps synchronous motor driven switch provided a 30-cps square-wave input at full rotational speed. The motor was then deenergized and permitted to slow down to a stop to obtain a continuously decreasing signal frequency.

Figure 4 shows the output with a 60-cps sinusoidal input periodically interrupted with the motor-operated switch in such a way that the input was turned on and off during alternating cycles. The resultant input was a 60-cps carrier synchronously modulated with a 30-cps square wave. The phase relationship between the 60-cps carrier and the 30-cps modulation was continually changed by varying the angular position between the switch and the motor shaft.

## REFERENCES

- (1) J. H. Miller, A New High-Speed Thermal Wattmeter, *AIEE Trans.* 60, p 37.
- (2) W. A. Geyger, Magnetic-Amplifier-Operated Ink Recorders, *AIEE Trans* Paper No. 58-541, *AIEE Middle Eastern District Meeting*, Wash., D. C., April 1958.
- (3) L. A. Finzi and R. A. Mathias, An Application of Magnetic Amplifier Circuits to Perform Multiplication and Other Analytical Operations, *AIEE Trans.* 72, Part I, p 455.

# Portable Multiplexer for

Stabilized transistor circuits enable four-channel ppm multiplex unit to operate from  $-54$  to  $+65^{\circ}\text{C}$ . Amplitude modulation of a microwave radio system is pulse position modulated by the multiplexer. Circuit operation of the modulator sweep generator, video pulse shaper, demultiplexer synchronizer and the demodulator flip-flop are described

By PAUL W. KIESLING, JR.,

Communications Department, Raytheon Manufacturing Company, Wayland, Massachusetts

INVESTIGATION of the applicability of transistors to pulse-position communications equipment for military use resulted in the development of a portable four-channel all-transistor multiplexer. The equipment has circuits for four channels of modulation and demodulation, the multiplexing and demultiplexing of these channels, line terminal facilities for both two

and four-wire operation, and low-frequency signaling facilities. It is packaged in a watertight aluminum case that can be carried on a packboard, and weighs 55 pounds.

## Operation

The audio or ringing signal to a modulator is sampled at an 8-kc rate or every  $125 \mu\text{sec}$ . Amplitude of the signal at the instant of sampling alters the position of the channel pulse from its normal position by an amount proportional to the amplitude, or a maximum of  $\pm 1 \mu\text{sec}$  which is 100-percent modulation. The sampling signal originates at an 8-kc oscillator but passes through a pulse shaper to a large delay line before sampling each channel. The delay line provides timing pulses for the four voice channels and the synchronizing channel.

After transmission by a microwave radio link, the video signal, consisting of pulses which have a rise and fall time of  $0.1 \mu\text{sec}$  and a width of  $0.5 \mu\text{sec}$ , is sliced of noise at the top and bottom, amplified and each channel individually demodulated. Synchronization of the receiving circuits to the video signal is provided by the output of a circuit that detects the presence of the closely spaced pair of synchronizing pulses. A large delay line similar to that used in the multiplexing circuits provides the timing pulse to gate the proper video pulse to each channel and to convert the pulse-position modulation

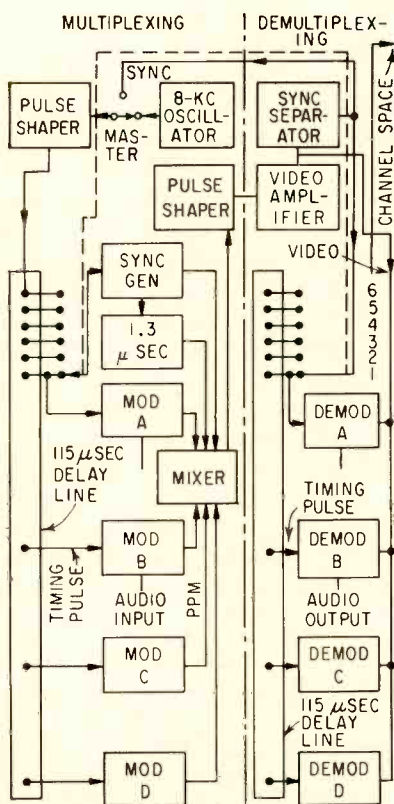

FIG. 1—Terminal equipment block diagram of multiplexer

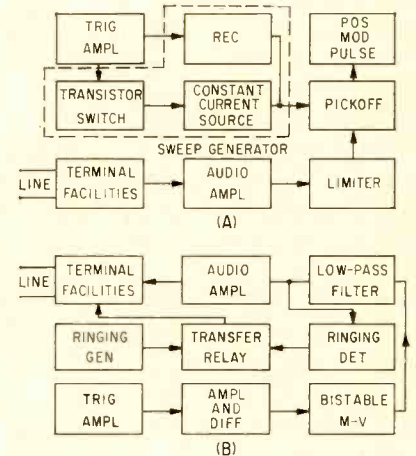

FIG. 2—Basic functions of the modulator (A) and demodulator (B)

to pulse-width modulation. Complete demodulation is obtained by passing the ppm signal to a low-pass, 3.5-kc filter and amplifying the signal output.

Additional circuits convert the four-wire unbalanced circuits to

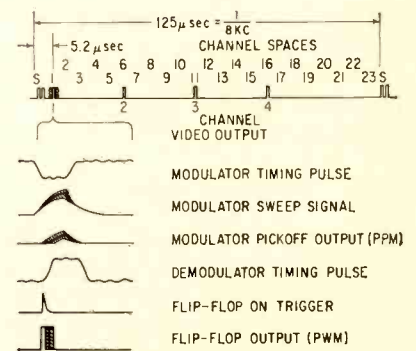

FIG. 3—Video output and modulator and demodulator waveforms for channel one

# Telephone Communications

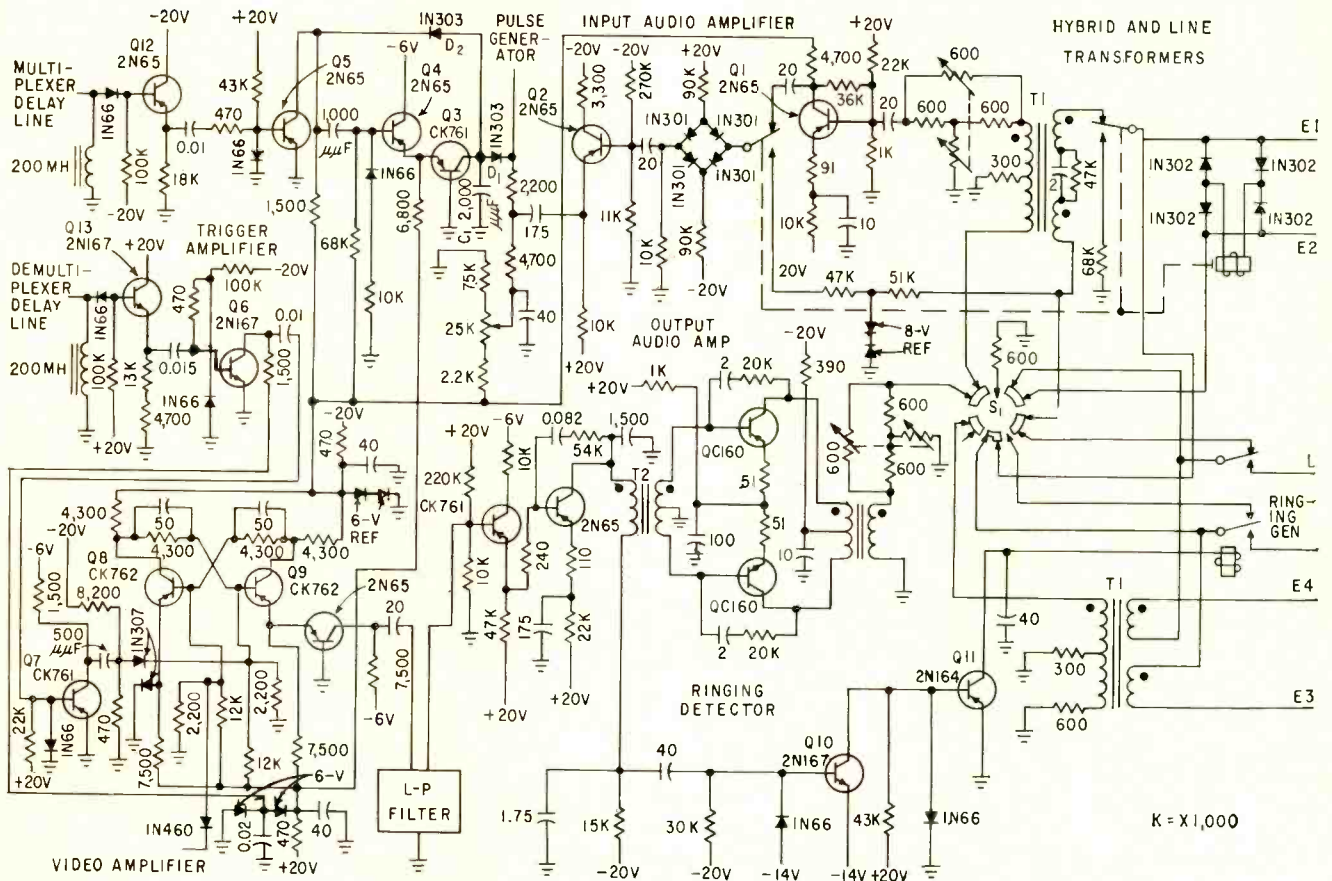

FIG. 4—Modulator-demodulator circuit handles 300 to 3,500-cps voice signals with amplitudes from -20 to +10 dbm

either two- or four-wire balanced circuits and detect low-frequency modulation for signaling. The block diagram of Fig. 1 shows the basic multiplexing and demultiplexing functions and the diagram of Fig. 2 shows the basic functions of a modulator-demodulator. The waveforms of Fig. 3 illustrate the video output and the more important modulator and demodulator waveforms for channel one.

## Modulator

The modulator - demodulator shown in Fig. 4 handles 300- to 3,500-cps voice signals with amplitudes from -20 to +10 dbm and provides output audio signals with the same range of level. In addition, a two-position rotary switch makes it possible to instantly convert from two- to four-wire operation. Additional circuits limit and transfer a high-voltage 20- to 30-cps ringing signal to the modulator

and detect the same frequency signal in the demodulator to transfer the output of a common ringing generator to the line terminals.

The upper half of the schematic is the modulator which uses six transistors: two are used to isolate the sweep circuit from the delay line and to trigger the sweep; two are used in the sweep circuit; and two are used in the audio circuits to terminate the bridge-T attenuator, provide gain and isolate the bridge limiter from the pickoff.

Delay-line isolation is provided by transistor  $Q_{12}$  which is normally cut off. The R-C components in the emitter circuit were chosen to cause  $Q_{12}$  to conduct and  $Q_5$  to conduct and saturate when the negative delay-line trigger reached 50-percent amplitude.

The 10- to 15- $\mu$ sec pulse at the collector of  $Q_5$  cuts off sweep recovery diode  $D_2$  and emitter follower  $Q_4$ . Grounded-base sweep

transistor  $Q_3$  acts as a constant-current source of 2 ma to charge capacitor  $C_1$  at 1 v/ $\mu$ sec. The normal pickoff voltage at the cathode of diode  $D_1$  is about 5 v so the normal unmodulated position of the channel pulse is about 5 $\mu$ sec after the sweep is triggered. Precise adjustment of the pulse position is made by a centering control that adjusts the d-c pickoff voltage. An audio signal of 1-v peak at the pickoff gives 100-percent modulation of  $\pm 1 \mu$ sec.

Amplifier  $Q_1$  drives the limiter and terminates the bridge-T attenuator in 600 ohms. Proper operation of the limiter depends on the high back impedance of the four diodes. High-voltage ringing signals bypass the attenuator, are injected into a limiter and fed into the audio limiter. The ppm output of the modulator has poor rise time and large audio content.

The pulse shaper removes the

audio component from the modulator output to prevent crosstalk and shapes the pulse to the required rise and fall time and width. A typical pulse shaper is shown in Fig. 5. The first stage acts as a high-pass filter and second stage  $Q_{14}$  saturates providing a fast rise time pulse 5- $\mu$ sec wide. This pulse is differentiated and triggers amplifier  $Q_{15}$ . The output of this stage triggers a blocking oscillator.

A shorted delay line of 0.5- $\mu$ sec round-trip length in the base of the 6-0 transistor gives an inverted pulse to turn the oscillator off. This determines the pulse width. The oscillator transformer is wound on a ferrite core. Changes in permeability with temperature do not affect the pulse width since the natural width of the oscillator is always greater than that determined by the delay line. A third winding on the transformer provides drive for output transistor  $Q_{16}$ . The collector of this and similar transistors in the other four shaper circuits in a multiplexer are tied together and act as mixers to provide the video train shown in Fig. 3.

### Synchronizer Detector

After slicing and amplification, the video pulses in the demultiplexer go to the synchronizer or sync separator shown in Fig. 6. The open-circuited 0.65- $\mu$ sec delay line in the collector of  $Q_{17}$  causes a reinforcement of the second synchronizing pulse which is 1.3  $\mu$ sec from the first synchronizing pulse.

A slicing circuit in the base of the second stage,  $Q_{18}$ , is adjusted to permit only the reinforced pulse to fire this stage. This action provides a pulse every 125  $\mu$ sec that is synchronized to the incoming video signal.

Transistor  $Q_{19}$  keeps the slicing voltage constant by compensating for the saturation current of transistor  $Q_{18}$ . This enabled the sync separator to operate from -60 to +70 degrees centigrade. The output of  $Q_{18}$  drives a blocking oscillator that provides the drive for the demultiplexing delay line. This delay line is tapped at appropriate points to provide the demodulator with timing signals that gate the individual video pulses to each demodulator and convert to pulse-width modulation.

### Demodulator

The demodulator (Fig. 4) uses 12 transistors: six in the demodulating circuits and six in the audio amplifier and ringing detector cir-

cuits. Flip-flop  $Q_8$  and  $Q_9$  converts the pulse-position signal to pulse-width modulation. The flip-flop is turned on by the delay-line timing trigger and turned off by the video pulse following the delay-line trigger. The delay line is isolated from the flip-flop by emitter follower  $Q_{13}$  which operates similarly to stage  $Q_{12}$  in the modulator. Transistor  $Q_6$  provides gain and  $Q_7$  provides a pulse with a sharp rise time that is differentiated before turning the flip-flop on.

The output of the nonsaturating flip-flop is width modulated on the trailing edge and has an unmodulated width of 2.5  $\mu$ sec. When transistor  $Q_8$  is turned on, its base is slightly negative, thus holding off the diode on its emitter. The collector is not quite at saturation voltage and the base of transistor  $Q_9$  is positive by about 1 v. The diode in the emitter of  $Q_9$  is conducting, clamping the emitter slightly above 0 v.

In operation, this second emitter diode was replaced by a grounded-base transistor stage to drive the low-pass filter. The collector voltage of an ON transistor is determined by its emitter bias circuit and by the voltage divider to the base of the OFF transistor. The voltage divider is adjusted to keep that base more positive than the conducting diode in the emitter.

### Filter

The low-pass filter, in addition to demodulating the pwm, has an 8-kc notch so that the sampling frequency level is at least 50 db below the audio level in the output. The audio amplifier consists of an emitter follower to properly terminate the filter, one single-ended amplifier and a class-A push-pull amplifier capable of delivering 30 mw of audio power with less than 3-percent harmonic distortion to 600 ohms. The first stage of amplification amplifies a ringing signal of 20 to 30 cps as well as audio. The coupling transformer acts as part of a low-pass filter to pass the ringing signal to ringing detector  $Q_{10}$  and  $Q_{11}$ . Transistor  $Q_{11}$  operates a double-pole double-throw relay to transfer the output of a local ringing generator to the line terminals.

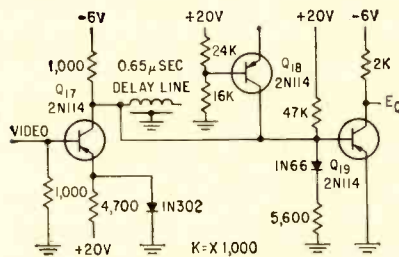

FIG. 6—Pulse synchronized to the incoming video is provided every 125  $\mu$ sec. Transistor ppm equipment operates over a wide temperature range

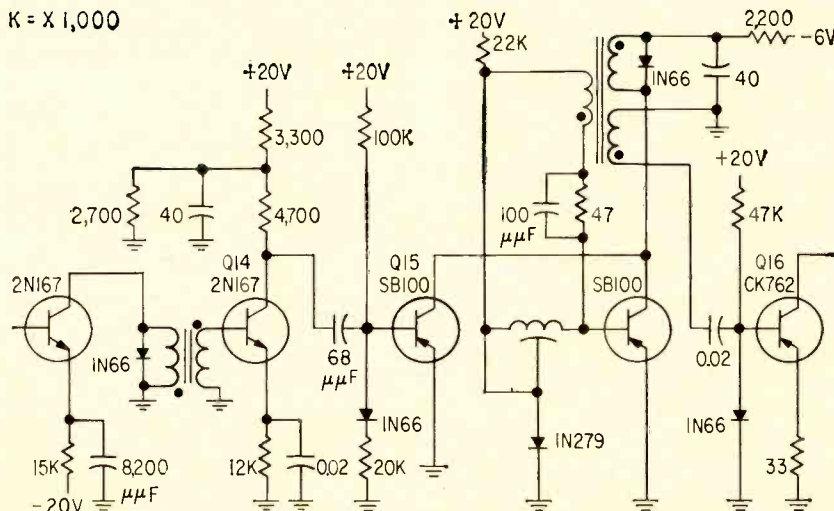

FIG. 5—Pulse shaper removes audio from modulator output to prevent crosstalk

Table I—Properties of 12 Permanent Magnet Materials

Alloy	Residual Flux Density (Gauss)	Coercive Force Oersteds	Max. Energy Product (BH) <sub>max</sub>	Gauss at (BH) <sub>max</sub>	Curie Temp. (°C)	Permanent Change (°C)	Magnetic Losses at 500 C
Alnico I	7,100	400	1,300,000	4,000	870	535	Retain 75% (Alnico I) to 90% (Alnico V) of magnetization
Alnico II	7,500	560	1,600,000	4,600	800	535	
Alnico III	7,000	470	1,350,000	4,500	725	480	(BH) <sub>max</sub> and coercive force decrease 10–20%
Alnico IV	5,500	730	1,250,000	3,100	880	535	
Alnico V	12,700	650	5,500,000	10,400	880	535	Alnico V and VI usable to 700 C with 20% loss
Alnico VI	10,100	750	3,800,000	7,000	880	535	
Alnico VII	7,000	1,050	2,500,000	3,700	870	535	Degrades, but usable
Alnico XII	6,100	1,000	1,650,000	3,200	...	480	
Indalloy	9,000	240	9,000,000	...	...	...	10–20% loss of remanence
Remalloy	10,000	230	1,100,000	6,900	900	...	
Carbon steel	10,000	50	200,000	6,200	770	...	May be used, but loses remanence
Tungsten steel	10,300	70	300,000	6,800	760	...	

# Hard Magnets for 500 C

Magnetic materials with high Curie points and satisfactory metallurgical properties retain enough magnetization for use at high temperatures

By **GEORGE SIDERIS**, Associate Editor

**P**ERMANENT MAGNETS able to retain a substantial portion of their magnetic properties at 500 C are needed in electronic components expected to operate in a nuclear environment. Within 5 to 10 years, new military aircraft and missiles will have temperatures over 500 C throughout most of the aircraft.

Components which require permanent magnets and which are likely to feel the effects of this advance in

operating temperature include transducers, traveling-wave tubes, magnetrons plus servo components and other small motors.

Investigations by Armour Research Foundation and Stanford Research Institute on temperature effects on typical permanent magnet materials are summarized in Table I and Fig. 1. The data is also useful in designing below and above 500 C.

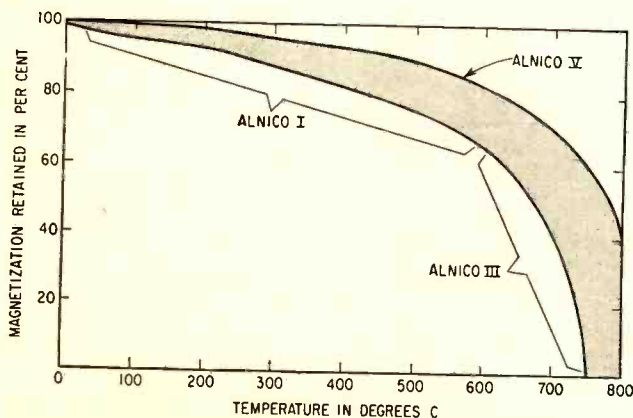

FIG. 1—Magnetic remanence plotted against temperature for Alnico IV

**DESIGN CONSIDERATIONS**—The Alnicos produced by several manufacturers are generally considered usable at 500 C. Except for Alnico III and the steels, however, the materials contain cobalt. The fact that cobalt will become radioactive in a nuclear environment should be considered in overall system design.

Loss of remanence may be compensated or by overdesign or by preaging the material at the operating temperature to offset irreversible magnetic changes due to temperature rise. Coefficients of thermal expansion for these materials are similar. The Alnicos being hard and brittle, are cast and finished by such methods as grinding, while the steels are ductile and machinable.

# Dynamic Trap Captures

In conventional f-m reception, the weaker of two signals is normally suppressed, while the stronger signal is demodulated. In some instances the weaker signal may be the desired one and by using a high-Q trap in a reactance tube circuit, the undesired signal is tracked and attenuated

By **ELIE J. BAGHDADY**, Asst. Professor of Electrical Engineering, and **GEORGE J. RUBISSOW**, Staff Engineer, Instrumentation Laboratory, Massachusetts Institute of Technology, Cambridge, Mass.

**W**ELL-DESIGNED conventional f-m receivers process the sum of two cochannel signals in such a way as to suppress the effect of the weaker signal and deliver a substantially undistorted replica of the message carried by the stronger signal. This channel-capture effect is a well-known characteristic of wide-band f-m systems. It is a boon to high-fidelity transmission when there is some assurance that the desired signal is the stronger of the two competing signals.

But in many important applications such an assurance cannot be made and the desired signal is likely to be the weaker of the two. In applications such as police, military and telemetering systems, the desired signal may be suppressed irretrievably by a stronger undesired signal. Systems that can capture the weaker of two cochannel f-m signals, when desired, not only facilitate reliable communication, but also hold promise for more efficient use of the spectrum.

The system to be described in this article makes use of a trap that tracks and attenuates the stronger of two signals. Because this signal

is frequency modulated, a knowledge of its frequency behavior is needed to guide the trap. This knowledge can be derived with a conventional f-m demodulator such as a limiter-discriminator from the sum of the two input signals.

After appropriate filtering, the output voltage of the demodulator varies essentially with the frequency of the stronger of two input signals.

If this voltage is impressed upon the control grid of a reactance-tube circuit that forms a part of a high-Q tuned trap, the tuning of the trap is varied so that its center frequency follows the instantaneous frequency of the stronger signal. In this way, the trap attenuates the undesired signal below the level of the desired but initially weaker signal. A second conventional f-m demodulator that follows the trap extracts the desired message.

## Variable Trap

A possible embodiment of the variable-trap technique is illustrated in Fig. 1. The i-f amplifier provides the usual i-f selectivity and gain in the f-m receiver. If two signal carriers are passed simul-

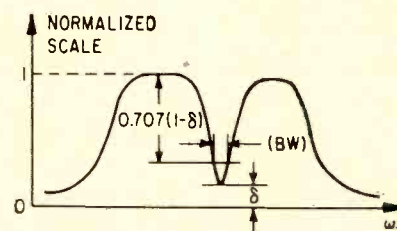

FIG. 2—Graphic illustration of the trap parameters

taneously by this amplifier, the average output voltage of f-m demodulator No. 1 is made to vary directly with the instantaneous frequency of the stronger signal. After appropriate low-frequency filtering the output is impressed directly upon the input of a reactance tube to vary the tuning of a high-Q trap.

The trap introduces a depression in the frequency response characteristic of i-f amplifier No. 3 which is centered approximately about the frequency of the stronger signal. The resulting attenuation decreases the amplitude of the stronger signal by a sufficient amount to enable the initially weaker signal to predominate. The average voltage at the output of the second demodulator then varies directly with the instantaneous frequency of the weaker signal, except when the frequencies of both signals fall within the heavy-attenuation band of the trap.

In this case, if the undesired signal is not cancelled out completely by the trap, the signal amplitudes go through equality at least twice as the weaker signal sweeps across the trap attenuation band. The resulting transitions in capture from

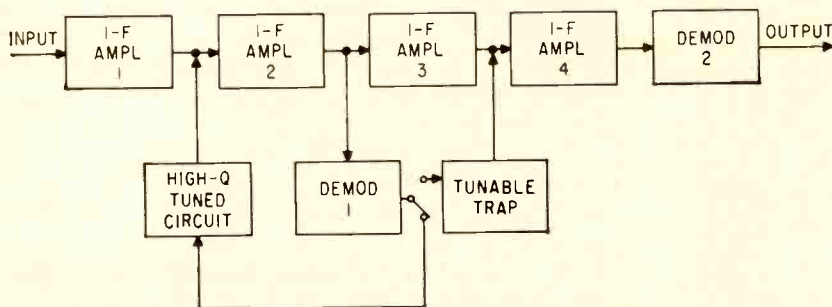

FIG. 1—Block diagram of dynamic trap and booster circuit. In absence of cochannel interference, the switch disconnects the dynamic trap from demodulator 1



# Weak F-M Signals



Authors adjust dynamic trap. Device has applications in police, military communications and telemetering

one signal to the other are accompanied by corresponding bursts of distortion in the detected output waveform. The duration of these distortion bursts can be decreased by designing the demodulator to handle weaker-to-stronger signal amplitude ratios close to unity.

If the  $Q$  of the trap is sufficiently high, the attenuated band covers a small fraction of the i-f bandwidth. Thus, when the two signals fall simultaneously within the trap attenuation band, their frequency difference is small and the deviation of the resultant signal from the frequency of either signal is small.

A high- $Q$  trap can cause noticeable f-m transients when swept by an f-m signal. Fortunately, investigation shows that weaker-signal capture performance of the system is not materially affected by trap bandwidth if the second f-m demodulator is sufficiently well designed.

If the stronger signal is the signal that is wanted, its amplitude may be boosted by introducing a high- $Q$  variable-tuned circuit whose center frequency is controlled by a reactance tube. This dynamic-selector arrangement helps decrease

the random-noise bandwidth and improves the predominance of the stronger signal over interference.

## Trap Techniques

A trap may be characterized by the bandwidth and the depth of the depression it introduces in the steady-state frequency response characteristic of the i-f amplifier. Figure 2 graphically defines these parameters. The trap attenuation factor,  $\delta$ , is by definition the mini-

mum normalized gain within the passband—the normalization being made with respect to the maximum amplitude response in the passband. The trap bandwidth,  $BW$ , is by definition the difference between the frequencies at which the gain within the passband is decreased (by the action of the trap) 0.707 ( $1-\delta$ ) of its maximum value.

A schematic of the trap system is shown in Fig. 3. The trap circuit was designed on the basis of flexi-

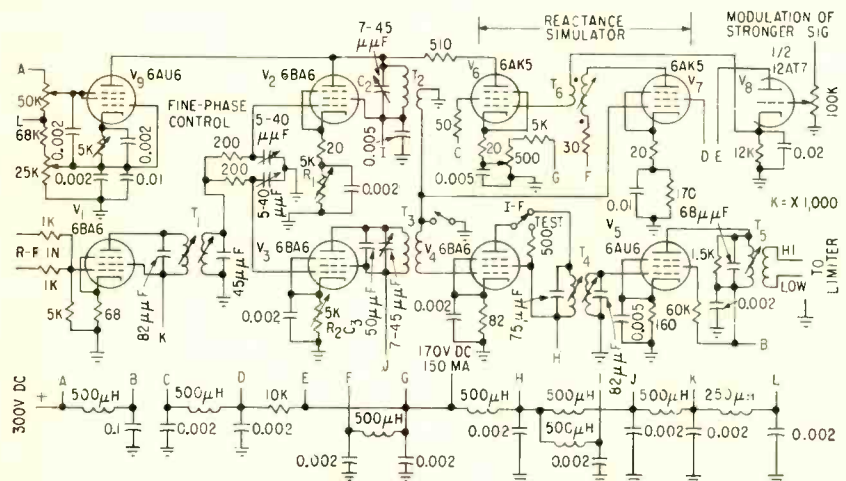

FIG. 3—Schematic diagram of the dynamic trap system. Reactive component of admittance presented at plate of  $V_6$  is varied as a function of stronger signal

bility and ease of variation of the important trap parameters.

The trap circuit consists of two voltage amplifiers  $V_2$  and  $V_3$  with single-tuned plate loads whose circuit Q's have widely different values.

The low-Q circuit consisting of  $C_3$  and the primary of  $T_3$  is fixed-tuned. The higher-Q circuit consisting of  $C_2$  and the primary of  $T_2$  has its center frequency dictated in part by the controllable reactance circuit of  $V_6$ ,  $V_7$  and  $V_8$ , and its bandwidth varied by the value of dynamic negative resistance that is injected by dynatron circuit  $V_6$ . Each resonant circuit is closely coupled to an untuned secondary, and the secondaries are connected with opposite polarities. The choice of low Q for the fixed-tuned circuit enables the signal at the center of the trap response to be superimposed upon the corresponding signal across the secondary of  $T_3$  essentially in phase opposition over the entire range of expected trap center frequencies.

Potentiometers  $R_1$  and  $R_2$  provide direct control over the value of the trap attenuation factor  $\delta$ . Fine adjustment of the phasing between the secondary voltages is provided by a phase-shifting network in the secondary of  $T_3$ .

#### Reactance Simulator

The center frequency of the dynamic trap is determined by the resonant frequency of the tuned primary of  $T_3$ . The position of the trap attenuation band can therefore be changed by varying one of the tuning elements. The circuit shown in Fig. 3 was developed especially to provide the desired variable reactance without any attendant variation in the resistive component that the circuit imposes across the tank of the high-Q trap.

In this circuit tube  $V_7$  is driven through step-down transformer  $T_2$  to avoid overdriving its grid. The output of  $V_7$  undergoes a 90-degree phase shift in the low-loss inductive load  $T_6$ . The voltage across the secondary of  $T_6$  drives amplifier  $V_8$ , this stage acts as a current source feeding the high-Q tank circuit of the trap. It can be shown that the susceptible component of the admittance formed by the plate circuit of  $V_8$  across the tank circuit of the trap can be varied by vary-

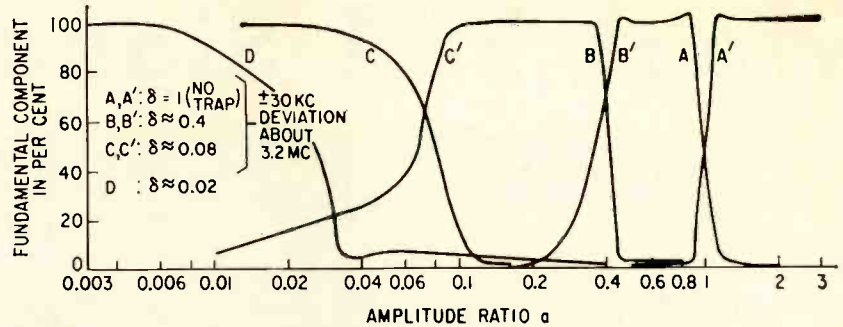

FIG. 4—Effect of trap attenuation factor  $\delta$  on capture performance. Curves A, B, C and D show output from stronger (400-cps) signal

ing the  $g_m$  of tubes  $V_6$  and  $V_7$ .

In this circuit the modulation of the stronger signal varies the  $g_m$  of  $V_6$ . This modulation is applied in series with the secondary of  $T_6$ , and its proper phasing is vitally important to the successful tracking of the stronger-signal frequency by the resonance frequency of the trap.

#### Limiter-Discriminator

In an f-m receiver, the limiter section plays two important roles: it renders the output of the f-m demodulator independent of the amplitude variations of the resultant signal at the input and, with appropriate design, it minimizes the f-m disturbance that the weaker of the two signals at its input causes in the message of the stronger signal at the receiver output.<sup>2</sup>

The limited-discriminator circuit used here has a low output time constant and a detection characteristic that is linear over twice the i-f bandwidth. Three stages of narrow-band limiting precede the discriminator. To avoid time-constant problems, 6BN6 limiters are used. Since no grid-leak bias is required for this tube, sharp changes of amplitude can be well handled.

#### Performance

The capture performance of an f-m receiver is brought out in a test procedure that simulates cochannel interference by the superposition of two carriers whose modulations can be easily identified and separated. A suitable choice of modulation for easy measurements is a sinusoidal message of known frequency. The receiver performance is then evaluated quantitatively in terms of an amplitude plot of the fundamental component of stronger-(or weaker-) signal modulation frequency as a

function of the weaker-to-stronger signal amplitude ratio,  $a$ . Generally, a more complete presentation involves both weaker- and stronger-signal characteristics plotted on the same coordinates, as well as a plot of the total distortion as a function of  $a$ .

The capture characteristics of the dynamic-trap receiver are determined largely by the two parameters that are defined in Fig 2. The more important of the two is the trap attenuation factor  $\delta$ . In essence,  $\delta$  represents the factor by which the amplitude of the undesired (but initially stronger) signal is ideally multiplied.

In Fig. 4, curve A shows the measured capture characteristics of the receiver without the trap. The weaker- and stronger-signal curves are symmetric about the  $a = 1$  line. The capture-transition region is relatively narrow and is centered at  $a = 1$ . Curves B, C and D demonstrate the effect of introducing a dynamic trap of fixed 15-kc bandwidth but with  $\delta$  given the three values indicated on the plots.

These curves show that the introduction of a trap with some assigned value of  $\delta$  shifts the capture-transition region from the neighborhood of  $a = 1$  to the neighborhood of  $a = \delta$ . The weaker signal is thus captured for all values of  $a$  that are slightly greater than  $\delta$  on the one hand and less than or equal to the capture ratio of the f-m demodulator that guides the trap on the other. Curve D represents the best measured performance.

#### REFERENCES

- (1) E. J. Baghdady, Capture of the Weaker of Two Cochannel F-M Signals, (to be published). Also, Quarterly Progress Reports, p 52, Oct. 15, 1957, Research Laboratory of Electronics, MIT.
- (2) E. J. Baghdady, Theory of Stronger-Signal Capture in F-M Reception, *Proc IRE*, 46, p 728, Apr. 1958.

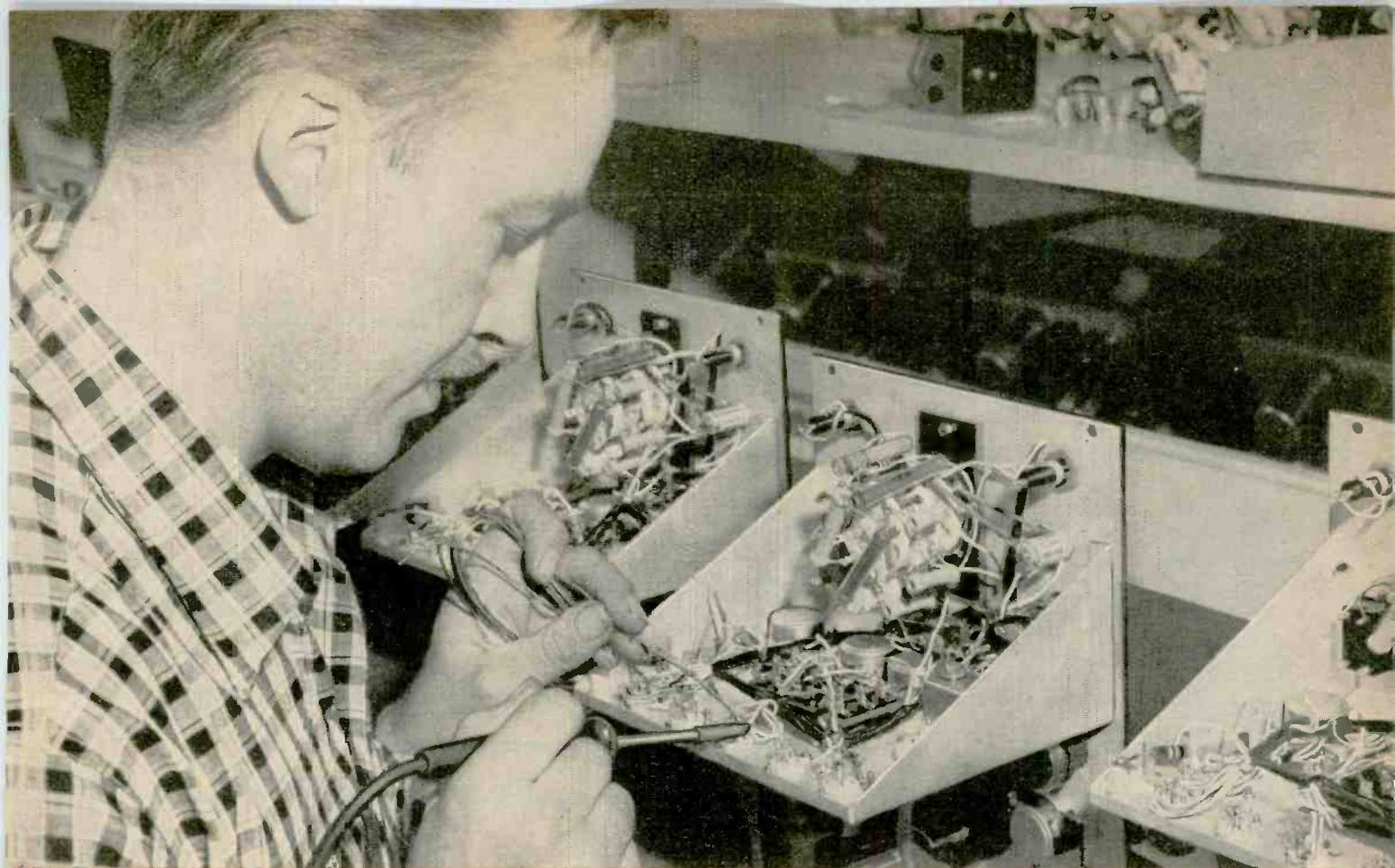

"BEST IRON WE'VE HAD in the plant," says William Fish, a production supervisor of General Radio, Cambridge, Mass. This company has switched to G-E Midget irons for soldering both

delicate and heavy joints in their Type 1862-B Megohmmeters—jobs which formerly required both a heavy and a light iron. G-E Midget iron's light weight also helps reduce fatigue.

## 50 G-E Midget irons do work of 100 former irons at General Radio Co., boost production 25%

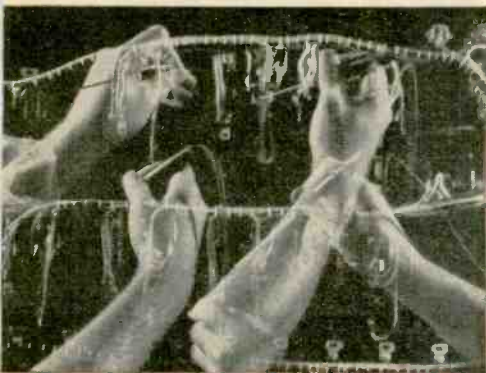

**FASTER HEAT RECOVERY** and lower maintenance of G-E soldering irons have been proved by many manufacturers under their own production conditions—along with competitive soldering irons. If you would like to compare General Electric irons with the irons you are now using, call your G-E distributor.

**DELIVERY TODAY** is now possible on popular soldering irons and other General Electric heaters and devices from a local distributor near your plant. Your replacement inventory may be reduced. For the name of your nearest stocking distributor for G-E heaters and devices, call your General Electric Apparatus Sales Office.

**SAVINGS ACHIEVED** by several users and information about the construction features of General Electric soldering irons are included in a new bulletin, "Save While You Solder," GED-3553. For a copy, call your G-E distributor or write Section 724-3, General Electric Company, Schenectady 5, New York.

**GENERAL**  **ELECTRIC**

CIRCLE 37 READERS SERVICE CARD

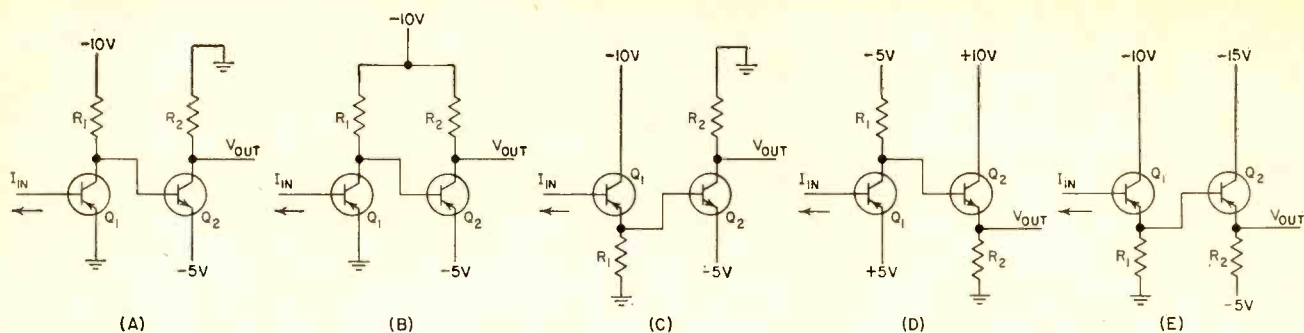

FIG. 1—Typical d-c transistor amplifiers. In (A), large values of  $I_{in}$  can burn out  $Q_2$ . Other circuits effectively limit current

# Easing Transistor Loads

Direct-coupled transistor amplifiers are often driven to overload during normal operation. Some simple design rules presented here limit the current and power dissipation to safe limits when the input stage is overloaded

By **WILLIAM F. SAUNDERS, III** General Engineer, Link Aviation, Inc., Hillcrest, N. Y.

**D**ESIGN OF DIRECT-COUPLED transistor amplifiers must include a means for limiting power dissipation in the transistors during amplifier overloads when every stage may be cut off or saturated with large currents. Considering current and power dissipation of each transistor, with the preceding stage in both extreme conditions, produces a direct-coupled amplifier that will always operate within the ratings of the transistors.

Figure 1A shows a possible two-stage, direct-coupled transistor amplifier. Assume that  $Q_1$  can be driven either to cutoff or to saturation by  $I_{in}$  and examine the base current of  $Q_2$  under these conditions. When  $I_{in}$  is so small that  $Q_1$  is cut off, then  $Q_2$  is also cut off and the ratings of  $Q_2$  are not exceeded. For normal operation with  $V_{out}$  between 0 and -5 volts, the collector voltage of  $Q_1$  is fixed at approximately -5 volts and the collector current divides between  $R_1$  and the base of  $Q_2$ . Any increase in  $I_{in}$  appears in the collector of  $Q_1$ , multiplied by the current gain of  $Q_1$ . This increase in current flows directly into the base of  $Q_2$  since the current through  $R_1$  remains con-

stant. Thus, the base current and power dissipation of  $Q_2$  can reach large values which may cause the destruction of  $Q_2$ . This configuration would be satisfactory only if  $I_{in}$  were limited.

## Other Methods

Another two-stage transistor amplifier is considered in Fig. 1B. If  $I_{in}$  is large, the increased collector current of  $Q_1$  flows through  $R_1$ , making the collector voltage of  $Q_1$  more positive, cutting off  $Q_2$ . For an  $I_{in}$  so small that  $Q_1$  is cut off, the base current of  $Q_2$  is limited by the current through  $R_1$ . This current is approximately equal to the normal collector current of  $Q_1$ , and usually other design requirements such as amplification and normal operating currents result in an  $R_1$  large enough so the maximum ratings of  $Q_2$  are not exceeded when  $Q_1$  is cut off, even though  $Q_2$  is saturated. Thus, the maximum current in  $Q_2$  is independent of the maximum  $I_{in}$  and  $Q_2$  is protected from the effects of extremely large input signals. A common-collector circuit shown in Fig. 1C, has no excessive current or power dissipation in  $Q_2$  when  $Q_1$  is overloaded, provided  $R_1$  is large.

The criteria for either configuration can be written as two rules relating the configuration and transistor type (*pn*p, *np*n). First, a common-emitter stage must be followed by a similar transistor.

Second, a common-collector stage must be followed by a transistor of the complementary type. These two rules are completely general and always provide protection provided  $R_1$  is large.

The low current gain of common-base stages will usually eliminate any saturation problems. For the same reason, it is not normally advantageous to use common-base stages in direct-coupled amplifiers.

Another design procedure restricts the operation of a critical stage to only one of the overloaded conditions. This may be accomplished in an operational amplifier by limiting the input signal to only one polarity. In Fig. 1D and 1E the maximum available base voltage of  $Q_2$  is insufficient to cause large currents in  $Q_2$  even when  $Q_1$  is overloaded. This is not true if the +5 and +10 volt supplies are interchanged in Fig. 1D or if the -10 and -15 volt supplies are interchanged in Fig. 1E.



## Our trees grow faster than our new plant can use them!

Furniture, wood pulp and lumber manufacturing have all grown fast in Southside Virginia. Yet in many parts of the area, tree growth still outstrips tree use. For in this favorable climate and soil, hard and soft woods mature from 50% to 100% faster than further north.

Another growing resource for your plant in Southside Virginia is the abundant electric power supplied by Veeco's modern, interconnected network. Over 1,700,000 kilowatts of generating capability now . . . due to exceed 2,000,000 kilowatts by 1961.

Interested? Ask Veeco for more facts and confidential site-finding help in this land of mild climate and pleasant living . . . where you get Southern advantages within overnight range of top Northeast and Mid-west markets.



Write or phone, Clark P. Spellman, Manager—Area Development  
**VIRGINIA ELECTRIC and POWER COMPANY**  
 Electric Building, Richmond 9, Virginia • MILton 9-1411

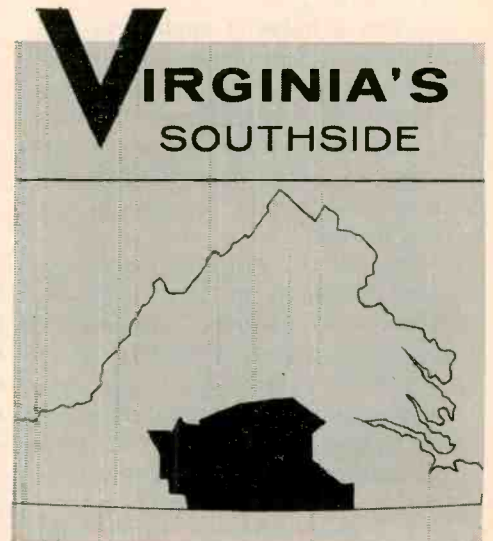

# Square-Loop Cores for Logic-Circuits

By A. L. FREEDMAN, Stevenouge, Herbs, England

CURRENT WEIGHTING is often used to perform logical operations with square hysteresis-loop magnetic cores. For example, the AND gating operation is performed by applying to a core a current pulse equal in magnitude to the input current pulse but opposite in direction. The current pulse is applied simultaneously with the inputs.

Assuming that the direction of the input current pulse is such as to change the state of the core, the change will occur only if both input signals are present. This arrangement suffers from two drawbacks. All inputs must be available during the same input phase. Also, there is the difficulty that the inputs (including the counterbalancing or dummy inputs) have to be precisely standardized, and their durations must coincide exactly.

These drawbacks can be eliminated by using a separate core for each input. Input cores are used for both storage and standardization of the input pulses. An AND gate using this method is shown in Fig. 1.

Inputs  $X_1$  and  $X_2$  and dummy input  $X_3$  (which is always ONE) may be applied at any time. The output winding is wound on cores  $C_1$  and  $C_2$  in one direction and on core  $C_3$  in the opposite direction. The same number of turns are used on all the cores.

## Operation

When a pulse is applied to this winding, simultaneous outputs of the same magnitude are produced. The output from  $C_3$  opposes the outputs from the other two cores. An output of appropriate polarity will result only when  $X_1$  and  $X_2$  are both present.

Most of the common logical operations such as OR (but not the exclusive OR), INHIBIT, combined OR and INHIBIT, and at least  $n$  out of  $m'$  can be carried out in one step.

The method obviously relies on the uniformity of the cores. In a particular application, circuits employing up to four cores were required and with the cores used

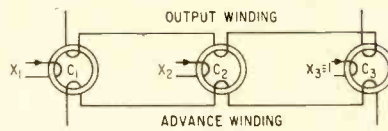

FIG. 1—Output winding on  $C_1$  and  $C_2$  is wound in one direction and in the opposite direction on  $C_3$ .

(Mullard 3mm D3) proved entirely satisfactory.

The proposed method requires more cores than does balancing currents applied to one core during the input phase. This is to some extent offset, since all cores are identically wound, and logical circuits can be built up from one standard element.

The method described is not suitable for use in shift-register type

logic when diodes are used to prevent cores from loading preceding ones. This is because the output winding is wound on cores in opposing directions. Thus, for instance, when core  $C_3$  in Fig. 1 is set, a voltage will appear on the output winding. Assume that a diode is on the output winding directed so that it will allow current to flow to the next stage when cores  $C_1$  and  $C_2$  are reset, but not when these cores are set. It will not prevent the following stage from loading core  $C_3$  when  $C_3$  is set.

The author is indebted to the directors of Ericsson Telephones Ltd. for permission to publish this article.

## Electronic System Cancels Stamps

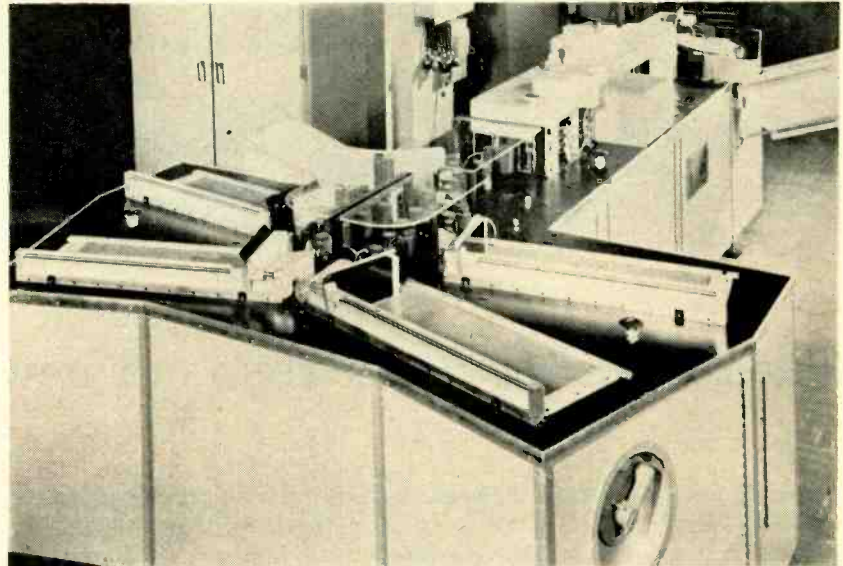

Flying-spot scanners detect presence and position of stamps and actuate appropriate cancelling head at rate of 30,000 letters an hour

AUTOMATIC mail-cancelling and facing machine processes 30,000 letters an hour. Circuitry used is all standard computer and control circuitry. A flying-spot scanner is used to detect presence and position of stamp.

The new machine can accept a pile of mail randomly fed into it, process it one at a time and stack

cancelled mail in four groups. It dispatches for hand cancelling all letters and parcels that are too high or too long for machine handling.

First, the letters are fed one at a time at high speed to the scanner that determines the presence and position of a stamp. Then the stamp is cancelled and the position of the cancellation indicated to the

\*  
VRS  
PS

**Kepeco**

for the most complete line of POWER SUPPLIES

**REGULATION and STABILITY 0.1%**

**VOLTAGE REGULATED POWER SUPPLIES**

MODEL	OUTPUT VOLTS DC	OUTPUT AMPERES DC	OUTPUT IMPEDANCE		SIZE		
			DC-1KC	1KC-100KC	W	H	D
SC-18-0.5	0-18	0-0.5	.04	.4	8 1/4"	4 3/32"	13 5/8"
SC-18-1	0-18	0-1	.02	.2	8 1/4"	4 3/32"	13 5/8"
SC-18-2	0-18	0-2	.01	.1	8 1/4"	4 3/32"	13 5/8"
SC-18-4	0-18	0-4	.005	.05	19"	3 1/2"	13"
SC-36-0.5	0-36	0-0.5	.08	.8	8 1/4"	4 3/32"	13 5/8"
SC-36-1	0-36	0-1	.04	.4	8 1/4"	4 3/32"	13 5/8"
SC-36-2	0-36	0-2	.02	.2	19"	3 1/2"	13"
SC-3672-0.5	36-72	0-0.5	.15	1.0	8 1/4"	4 3/32"	13 5/8"
SC-3672-1	36-72	0-1	.08	.8	19"	3 1/2"	13"

Patent Pending

(TUBELESS)  
**TRANSISTORIZED**  
SHORT CIRCUIT PROTECTED

- **REGULATION:** 0.1% for line changes 105-125 volts at any output voltage in the range minimum to maximum.  
0.1% or 0.003 volt for load changes 0 to maximum (whichever is greater) at any output voltage in the range minimum to maximum.
- **RIPPLE:** 1 mv. RMS.
- **RECOVERY TIME:** 50 microseconds.
- **STABILITY:** (for 8 hours) 0.1% or 0.003 volt (whichever is greater).
- **AMBIENT OPERATING TEMPERATURE:** 50°C maximum. Over-temperature protection provided. Unit turns off when over-temperature occurs. Power-on-off switch on front panel resets unit.
- **TEMPERATURE COEFFICIENT:** Output voltage changes less than 0.05% per °C.
- **SHORT CIRCUIT PROTECTION:** No fuses, circuit breakers or relays! Designed to operate continuously into a short circuit. Returns instantly to operating voltage when overload is removed. Ideal for lighting lamps and charging capacitive loads.
- **OVER-CURRENT CONTROL:** Can be set from 0 to 120% of full load. Current is limited to preset value for any load including short circuit.

**KEPCO**  
**LABORATORIES, INC.**

131-38 SANFORD AVENUE • FLUSHING 55, N.Y.

INDEPENDENCE 1-7000



Model SC-18-2-M

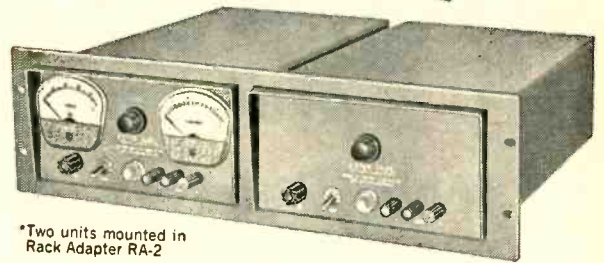

\*Two units mounted in Rack Adapter RA-2



Model SC-18-4-M

- **REMOTE PROGRAMMING** at 1000 ohms per volt is provided. Remote programming allows mounting a voltage control at a remote point.
- **REMOTE ERROR SIGNAL SENSING** is provided to maintain stated regulation directly at load.
- **CONSTANT CURRENT OPERATION:** These units can be set up for constant current operation without internal modification.
- **POWER REQUIREMENTS:** 105-125 volts, 50-65 cycles. 400 cycle units available.
- **OUTPUT TERMINATIONS:** DC terminals are clearly marked on the front panel. All terminals are isolated from the chassis. Either positive or negative terminal of each DC output may be grounded. A terminal is provided for connecting to the chassis. The DC terminals, the remote programming terminals and the remote error signal sensing terminals are brought out at the rear of the unit.
- **CONTROLS:** Power-on-off switch, one turn voltage control, on front panel. Over-current control on rear of unit. Ten turn voltage control available on special order.
- Continuously Variable Output Voltage. No voltage switching.
- Suitable for square wave pulsed loading.
- Either positive or negative can be grounded.
- Units can be series connected.
- High efficiency
- Low heat dissipation.
- Compact, light weight
- For bench or rack use.
- Color: Gray hammertone. (Special finishes available).

**ORDERING INFORMATION:**

Units without meters use model numbers indicated in table. To include meters add M to the Model No. (e.g. SC-18-1-M).

\*Rack adapter for mounting any two 8 1/4" x 4 3/32" units is available. Model No. RA2 is 5 1/4" high 19" wide.

\*Rack adapter for mounting any one 8 1/4" x 4 3/32" unit is available. Model No. RA3 is 5 1/4" high 19" wide.

**AN 0.01% SERIES IS AVAILABLE IN 13 NEW MODELS**  
KEPCO OFFERS MORE THAN 120 STANDARD VOLTAGE REGULATED POWER SUPPLIES COVERING A WIDE RANGE OF MAGNETIC, TUBE AND TRANSISTOR TYPES. MOST MODELS AVAILABLE FROM STOCK. SEND FOR BROCHURE B-587



# SLEEVINGS

are coming  
from Bentley, Harris

In braided electrical insulating sleeveings, Bentley, Harris "firsts" are legion — first in use of glass fibers; first in heat-treated, non-fraying glass fiber sleeveings; first in vinyl-coated fiberglass sleeveings; first with silicone rubber coatings.

In 1959, Bentley, Harris will announce two radically new Class H electrical sleeveings — both designed to give you added product protection with no increase in insulation cost. The truly amazing physical and electrical properties of these new sleeveings will change your thinking about insulation performance standards.

An advance announcement of the first of these new developments is now being prepared. May we send it to you — write us today.

**BENTLEY, HARRIS  
FLEXIBLE SLEEVINGS**

**BENTLEY, HARRIS MANUFACTURING CO.**  
100 BARCLAY STREET  
CONSHOHOCKEN 4, PA. Telephone, Norristown, Pa.: TAYlor 8-7600

orienting device. This device directs the letter to one of four terminal letter collection stackers. All letters are uniformly faced so that stamps—and therefore addresses—are oriented in the same manner.

The machine's special scanning and sensing devices can almost instantaneously make positive identification of a postage stamp. It can differentiate a stamp from envelope windows, trade marks, advertising, Christmas and Easter seals, and other markings on envelopes.

The machine, developed by the Government Electronics division of Emerson Radio & Phonograph Corp., will be installed with Emerson's culling machine. The culling machine is undergoing evaluation tests in the Main Post Office in Washington, D. C. It separates letters from other objects, such as packages, keys, large envelopes.

## More Sound from Transistor Amplifier

By E. F. KEIRNAN, Los Angeles, Calif.

TRANSISTORIZED broadcast receivers with six transistors often use three of the transistors as audio amplifiers. Vacuum-tube receivers having about the same performance capabilities generally have not more than two tubes acting as audio amplifiers. One of these is usually a detector as well.

Theoretically, efficiency of the class A amplifier is 50 percent. In practice, class A vacuum-tube amplifiers range in efficiency from 20 to 25 percent. Transistor class A efficiencies range from 35 to 49 percent.

With these efficiencies, it does not seem necessary to use half again as many transistors for audio amplification.

### Experimental Receiver

The writer assembled an experimental four-transistor superheterodyne receiver. The usual arrangements for coupling the audio output amplifier directly to a hearing-aid unit were used.

Sensitivity and selectivity of the receiver were completely satisfactory. However, audio output was



not. Various changes were made with little improvement. Finally, each of two old vibrating-armature loudspeakers were substituted. Acceptable quality sound output was greatly increased. However, a 2½-in. dynamic speaker and matching transformer produced negligible output.

The dynamic speaker is not a very efficient converter of electrical to acoustic energy. At 400 cycles, when mounted on a large baffle, efficiency falls between 2 and 10 percent, with 3 percent a nominal average. However, this low figure did not account for the almost complete lack of output in the present case, since the vibrating-armature speakers use cone radiators similar to those used in dynamic types.

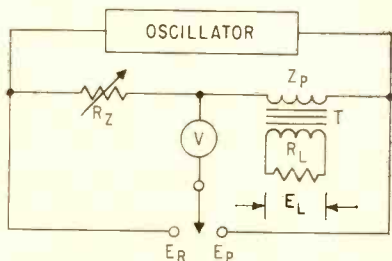

FIG. 1—Simple test setup permits determination of efficiencies of audio transformers for transistor receivers

However, a dynamic speaker requires a matching transformer, while the vibrating-armature speaker does not. To determine the influence of the transformer, tests of a collection of inexpensive miniature and subminiature output transformers were made. For reference purposes, a larger transformer was also tested.

The test setup is shown in Fig. 1. Variable resistor  $R_z$  was connected in series with the primary of transformer  $T$ . Resistor  $R_L$ , equal to the nominal load impedance, was connected across the secondary.

The oscillator was adjusted to 400 cycles and the value of resistor  $R_z$  adjusted until  $E_R$  equalled  $E_P$ . Voltage  $E_L$  across the load resistor was then measured.

Primary watts  $W_p = E_p^2/R_z$ . Secondary watts  $W_L = E_L^2/R_L$ . Transfer efficiency is  $W_L/W_p \times 100$ .

Transfer efficiencies of the small transformers varied between 13 and 17 percent. Efficiency of the larger transformer was 85 percent.

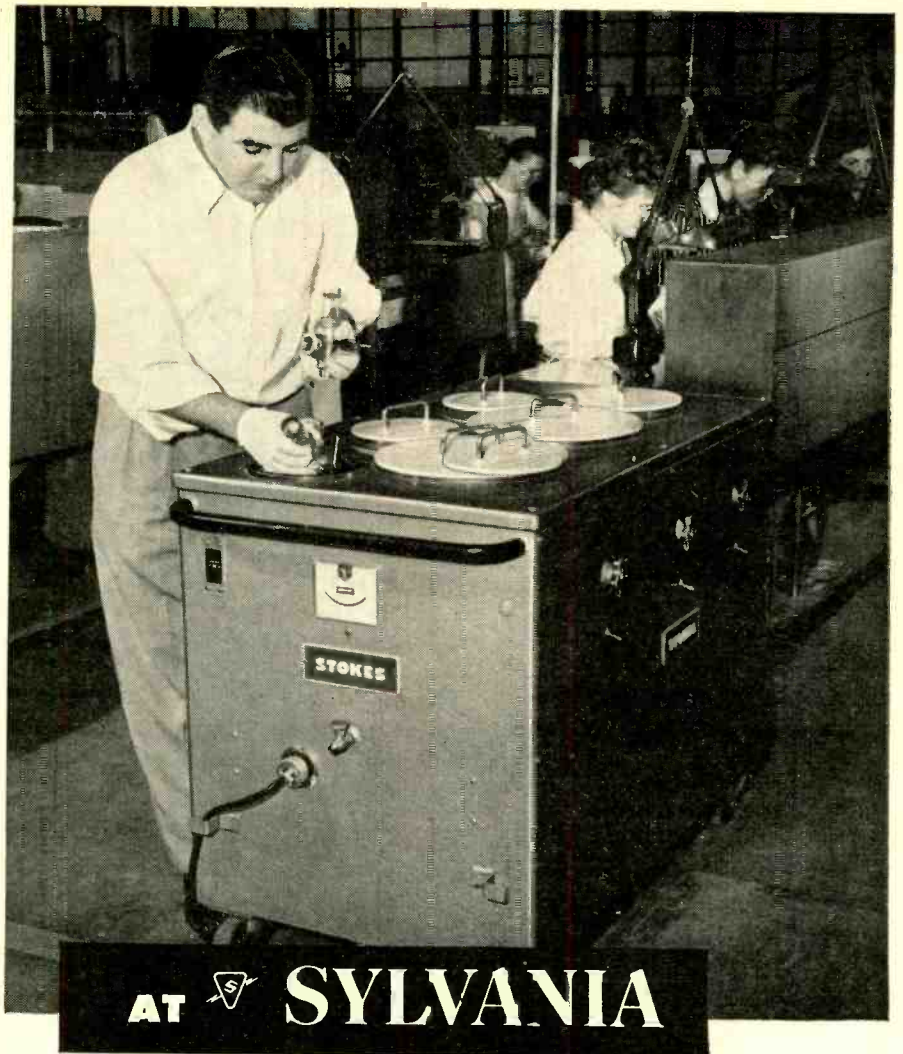

AT  SYLVANIA

... new vacuum storage carts by Stokes play an important part in their program of precision and cleanliness. These carts are used to store precision parts for the complex microwave tubes, counter tubes, duplexers, and other electronic components being produced in the Special Tube Plant of Sylvania Electric Products Inc. at Williamsport, Pa. Vacuum storage keeps these parts clean and dry while awaiting assembly.

Sylvania engineers credit the vacuum storage technique with improved product quality, reduction of rejects, prevention of surface and adsorption contamination, and improved plant cleanliness. Full-time use has proved vacuum storage to be a real step forward in this industry.

The Stokes Vacuum Cart has a self-contained pumping system, connected by manifold to six individual chambers. Each chamber may be separately valved off and opened without breaking the vacuum on the remainder of the cart. The entire assembly is mounted on large rubber-tired wheels to enable easy moving about the plant.

Additional information on this and other Stokes vacuum systems is available on request. Ask Stokes' Engineering Advisory Service for application assistance.

Vacuum Equipment Division  
F. J. STOKES CORPORATION  
5500 Tabor Road, Philadelphia 20, Pa.

**STOKES**

# Flexible Conductor Operates to 250 C

By CHARLES J. BERAN, Chief Project Engineer, Tensolite Insulated Wire Co., Inc., Tarrytown, N. Y.

AS THE TREND towards miniaturization in electronic equipment continues, the need for obtaining the greatest possible mechanical strength in any particular wire size used becomes more and more important. The conductor to be described was developed with this need in mind. It has better tensile strength and flex life than copper and is suitable for use in Teflon-insulated hookup wire for operation to 250 C. Table I shows approximate breaking strengths of some strandings used in fine hookup wires.

### Other Considerations

Another important consideration for a conductor of the type developed is its performance when subjected to repeated stresses of a magnitude less than its ultimate strength. The highest unit stress at which a material can be subjected to a large number of repetitions of loading and still show no evidence of failure is called the endurance limit.

Finally, the selected conductor

material must perform as an electrical conductor and its resistance must not be appreciably higher than that of copper.

### Material Selected

The material selected to give the most favorable combination of conductivity, flex life and mechanical strength is a chrome-copper alloy. Its composition is: copper, 99.05 percent; chromium, 0.85 percent and silicon, 0.05 percent. The alloy is treated to be oxygen-free. It takes nickel and silver plate with the same ease as copper. The plated, annealed alloy has a tensile strength of 49,000 to 52,000 psi as compared to about 35,000 to 40,000

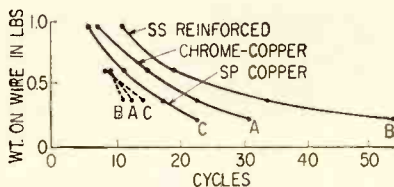

FIG. 1—Comparative flex-life values with bar flex test A. Dotted lines are cycles for first strand to break.

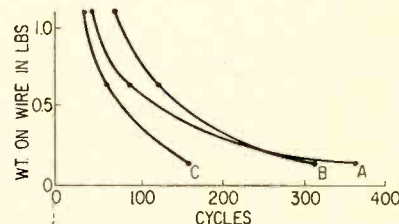

FIG. 2—Comparative flex lives for bar flex test B

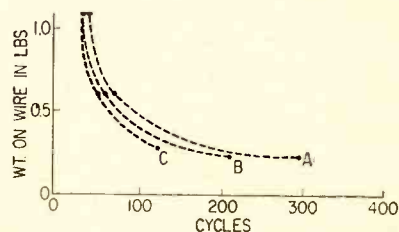

FIG. 3—Flexing for first-strand break for bar flex test B

psi for annealed, silver-plated copper. Conductivity of the new conductor is 90- to 93-percent that of annealed copper. The new conductor meets or exceeds conductor requirements of Type E and EE of Mil-W-16878.

The previous approach to the problem of higher strength conductors has been substitution of a high-strength member for one or more of the silver-plated copper strands. This approach has the following disadvantages: First, increased resistance is brought about generally at the upper limit of or outside the requirements of the appropriate military and commercial specifications. Second, the difference in tensile and elongation between the copper and steel can result in premature failure of the copper strands when flexed. Third, in most flex life testing, the copper conductors fail first, leaving only the reinforcing member or members.

Table II shows a comparison of the physical and electrical properties of chrome-copper alloy, copper and reinforced construction. All wires used for the table were AWG 26, 7/34 concentric. All strands, with the exception of the

Table I—Breaking Strength of Silver-Plated Annealed-Copper Conductors

Wire Size	Stranding	Approximate breaking strength in lb
AWG 24	7/32	15.5
AWG 26	7/34	10.2
AWG 28	7/36	6.6
AWG 30	7/38	4.7
AWG 32	7/40	2.8

Table II—Comparison of Physical and Electrical Properties

	Chrome-Copper Alloy	Copper	Reinforced Strands
Elongation in percent	19	17	18
Tensile strength in psi	50,800	38,000	51,000
Resistance in ohms/M ft	37.0	35.9	42.3

# "We grew too fast for our bank"



When he was fourteen years old, Jim McClain earned pocket money by rewinding motors and transformers. Thirteen years later James Ernest McClain, with very little capital but lots of know-how and drive, started his own business, specializing in the repair of distribution transformers.

In its first year, ESCO Manufacturing Company, of Greenville, Texas, consisting of 27 years old McClain and a hired mechanic, grossed \$35,000, netted \$7,000. Last year, gross was several millions, and net profit, correspondingly substantial.

In the early years the local bank was able and willing to supply all the credit that Esco needed. But the growth

was so rapid and the matching need for working capital so great, the local bank wasn't quite able to go along. So Mr. James Ernest McClain, then head of a company grossing better than a half million dollars, and not willing to dilute his equity or surrender any voice in management, turned to Textile Banking Company for financing cooperation and advice.

Mr. McClain says: "In addition to the advantages we enjoy in using TBC's funds as equity capital, and the savings we effect in eliminating credit losses and the cost of a credit department, there is perhaps an even greater advantage. Though we are far away from the industrial and financial centers, we have the privilege of being able to call on TBC's experienced executives for advice in solving many problems, financial and otherwise. Their experience, their contacts, their ability to supply us with nation-wide credit information usually give us the right solution."

At TBC, we don't work miracles. We help growing companies, whose sales exceed \$500,000 annually, meet all the capital needs of rapid expansion, without surrendering any management control, or without any dilution of profits. If you want to know more about how we do it, write for a free copy of our new booklet, "How to get the cash to keep your business growing."

How to get the *CASH*  
to keep your business growing!



## Textile Banking Company, Inc.

55 Madison Ave., Dept. E, New York 10, N. Y.

Subsidiaries:

T. B. C. Associates, Inc., New York, N. Y.  
Southwest Texbanc, Inc., St. Louis, Missouri

# MORE BIG NEWS

FROM

# FANSTEEL

**NOW...125°C.**  
OPERATING TEMPERATURES

in units rated from 6 to 35 volts<sub>dc</sub>—55°C. to 85°C. operation for units rated 60 and 50 and 60 volts<sub>dc</sub>.

*Plus*

## TWICE THE CAPACITY

Capacity has been increased as much as 100% without increasing case size. Four convenient case sizes cover the broadest and most complete list of ratings available.

# THE NEW FANSTEEL S-T-A Solid Tantalum Capacitor

It's another step by Fansteel to provide a *complete* range of Solid Tantalum Capacitors designed to meet the ever-increasing needs for greater capacity in sub-miniature sizes.

It's available in capacity ranges of .0047 to 330 mfd ... from 6 to 60 volts (wvdc).

Assures unfailing reliability where extremely small size, higher capacitance and extended operating temperatures are required.

S-T-A CASE SIZE

Series	Length	Dia.
5	.250	.125
6	.438	.175
7	.650	.279
8	.750	.341



Write for Latest Information

RELIABILITY

C591A

FANSTEEL METALLURGICAL CORPORATION North Chicago, Ill., U. S. A.

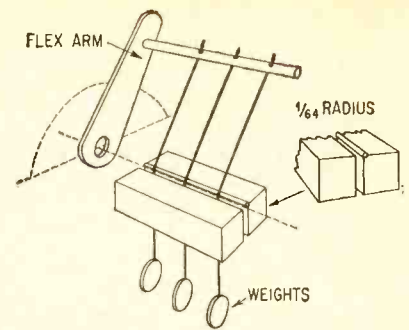

FIG. 4—Bar flex test A with flex cycles of 24/min

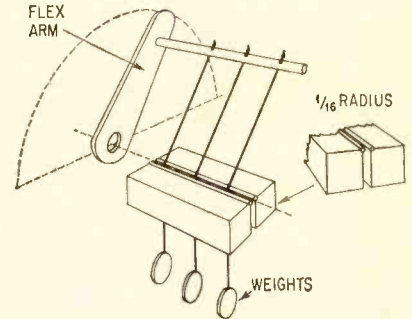

FIG. 5—Bar flex test B with flex cycles of 12/min

reinforcing member, had 40 micro-in. silver plate. Insulation was removed before the conductors were tested. Resistance values can vary slightly from lot to lot of wire because of the tolerance on individual strands.

Figures 1, 2 and 3 show comparative flex-life values for the different conductors. All wires were AWG 26, seven-strand concentric. Figures 4 and 5 show the two different test setups used.

## Shift Register Uses Single-Wire Memory

UNDER DEVELOPMENT at Bell Telephone Laboratories is a reversible, diodeless shift register using a single magnetic wire as the memory element. The wire is twisted and is magnetized most easily in a spiral direction. When a suitable magnetic field is applied, the wire can store pulses. Amount of twist regulates the magnetic interactions between magnetized zones.

Information bits are written in and slid along by means of tiny eight-turn solenoids wound on a ceramic tube. The 0.002-in. diam Permalloy wire is stretched through

the center of the tube.

To insert a magnetized zone into the register, simultaneous pulsing of three adjacent coils is necessary. Two coils must be pulsed to slide this zone along the wire. For example, if a bit is stored by pulsing coils 1, 2 and 3, it can be moved along one space by proper pulsing of coils 1 and 4. After a bit has been advanced, the wire can be cleared by pulsing the erase coil with about 240 ma.

For readout at the end of the register, a 170-ma pulse is passed through three special readout coils. A voltage pulse appears across the magnetic wire if a bit is present. (See *ELECTRONICS*, p 7, Dec. 57.)

## Transducer Package Includes Demodulator

BOTH A DIFFERENTIAL transformer and a phase-sensitive demodulator are combined in a single lightweight package known as the Dirpot and manufactured by Pneuma-Serve Ltd., Toronto.

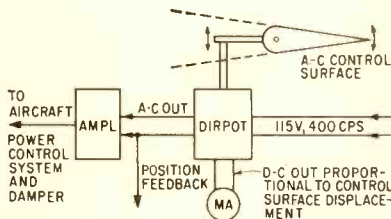

FIG. 1—Dual-output unit used in an aircraft control surface position indicator

Displacement of the armature modifies the flux paths in an E core. The alternating voltage output from the differential transformer is demodulated by the phase-sensitive demodulator. Polarity of the output voltage determines on which side of neutral the armature is positioned.

### Outputs

The 115-v, 400-cps unit has an output of up to  $\pm 3$  ma into a 2,000-ohm load for an armature displacement of  $\pm 0.030$  in. It can also be supplied with an a-c/d-c output for use in such applications as the aircraft control surface position indicator shown in Fig. 1.

# ANOTHER NEW Silicon Rectifier FROM FANSTEEL

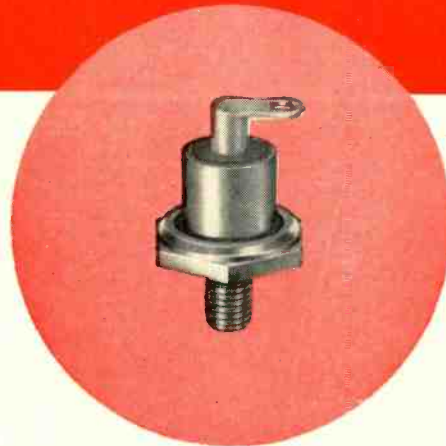

## 35 AMP. Silicon Power Rectifier

Here's the newest addition to Fansteel's growing line of reliable silicon rectifiers. The 4A carries a full 35-amp. load—up to 100 amps in bridge circuits—with rated peak inverse voltages from 50 to 400 V. in 50-volt multiples. And it's built to withstand junction temperatures up to 165°C., storage temperatures from -65°C. to 200°C.

This new low-loss unit mounts snugly in any position. Entire unit is hermetically sealed, with heavy-duty construction to give long trouble-free performance and maximum dependability in high load circuits.

Write for Latest Information



FANSTEEL METALLURGICAL CORPORATION North Chicago, Ill., U. S. A.

E591A

# Photos Assist Drafting, Assembly

By J. C. ISBISTER, R. T. HARDING, S. GANGI and F. J. KIRCH Arma Div., American Bosch Arma Corp., Garden City, N. Y.

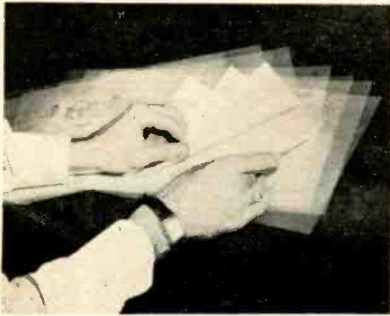

Overlays of translucent detail drawings are built up and photographed to produce drawings with desired amount of detail



First step is preparing vellum pasteup of repetitious detail cut from an expanded drawing

UNUSUAL PROCEDURE for preparing detailed drawings from design layouts has been developed by Arma. Photographic techniques replace hand detailing. "Fotogram" is the word coined to describe it.

It is estimated that Fotogram will eventually relieve the draftsman of 50 per cent of uninteresting and uncreative details. Cost reductions are in proportion and time will be available for more useful,

rewarding work.

The Fotogram process will also reduce the need for preparation of assembly drawings by manual methods. For example, the "exploded" layout can be used for assembly of prototype equipments.

As assembly progresses on the initial products, photographs are made corresponding to the views of a conventional subassembly drawing. When the photos are re-

produced by Fotogram techniques with notes and identifying nomenclature, they become assembly "drawings", eliminating need for manually-prepared drawings. Aside from cost savings, assembly Fotograms facilitate manufacture.

An exploded or expanded method of layout represents unassembled components in their proper spatial relationship and coded to permit assembly. Principal dimensions only are shown. To prepare details, views of the elements to be detailed are cut from a copy of the original layout and are mounted on a standard drawing format or a transparent reusable format, depending on the reproduction method to be used. Additional dimensions and notes are added. The pasteup is reproduced on any desired method.

## Overlays Prepared

An overlay method produces the design layout by building up a series of component elements on translucent material. As the layout progresses, the elements are tiered one on the other until all the elements have been assembled to complete the layout. To detail it, it is necessary only to remove the elements in succession, treating each in the manner described to produce the original Fotogram for normal use.

Variations may be introduced to meet specific requirements by an additive method. A layout produced by conventional or Fotogram methods is detailed by placing a special photographic film over the area desired. Areas required are roughly delineated by tracing over the film with a stylus or brush containing developing solution. The film is exposed to controlled light, to burn out undeveloped areas. The film is exposed with a transparent format overlay to make the master.

In a subtractive method, a paper photo positive of the layout is prepared. Areas to be eliminated from the detail are brushed out with a reducing solution or white paint,

## Fixture Simplifies Fluxing



Shaped parts rotate between brushes loaded with flux

FLUXING OF PARTS with awkward contours is speeded up at Fenwal, Inc., Ashland, Mass., with a motorized fixture. The fixture holds the part and rotates it between a pair of flux brushes.

The part shown is a stainless steel aircraft fire detector, which has a triangular flange mounted on a cylindrical shell. Dipping was im-

practical because the assembly has an open end and hand brushing proved tedious.

In the fixture, the part is held horizontally in a collet mounted on the shaft of a fractional horsepower motor. The collet inside diameter is about  $\frac{1}{8}$  inch oversize to permit the shells to be slipped in and out freely. The collet holds about  $\frac{2}{3}$  the length of the shell.

Rotation is kept slow, about 45 rpm, to prevent the flux from spraying off. Fluxing brushes are held in the ends of a  $\frac{1}{4}$  inch tube bent to straddle the flange. The holder pivots on an axle and is heavier at the brush ends so that it dips into a flux trough when the operator releases the holder. This action also clears the way for loading the fixture.

Fluxing rate of the setup is about 8 seconds per piece. The flange and shell are subsequently torch brazed.

# Sylvania NPN and PNP Transistors...

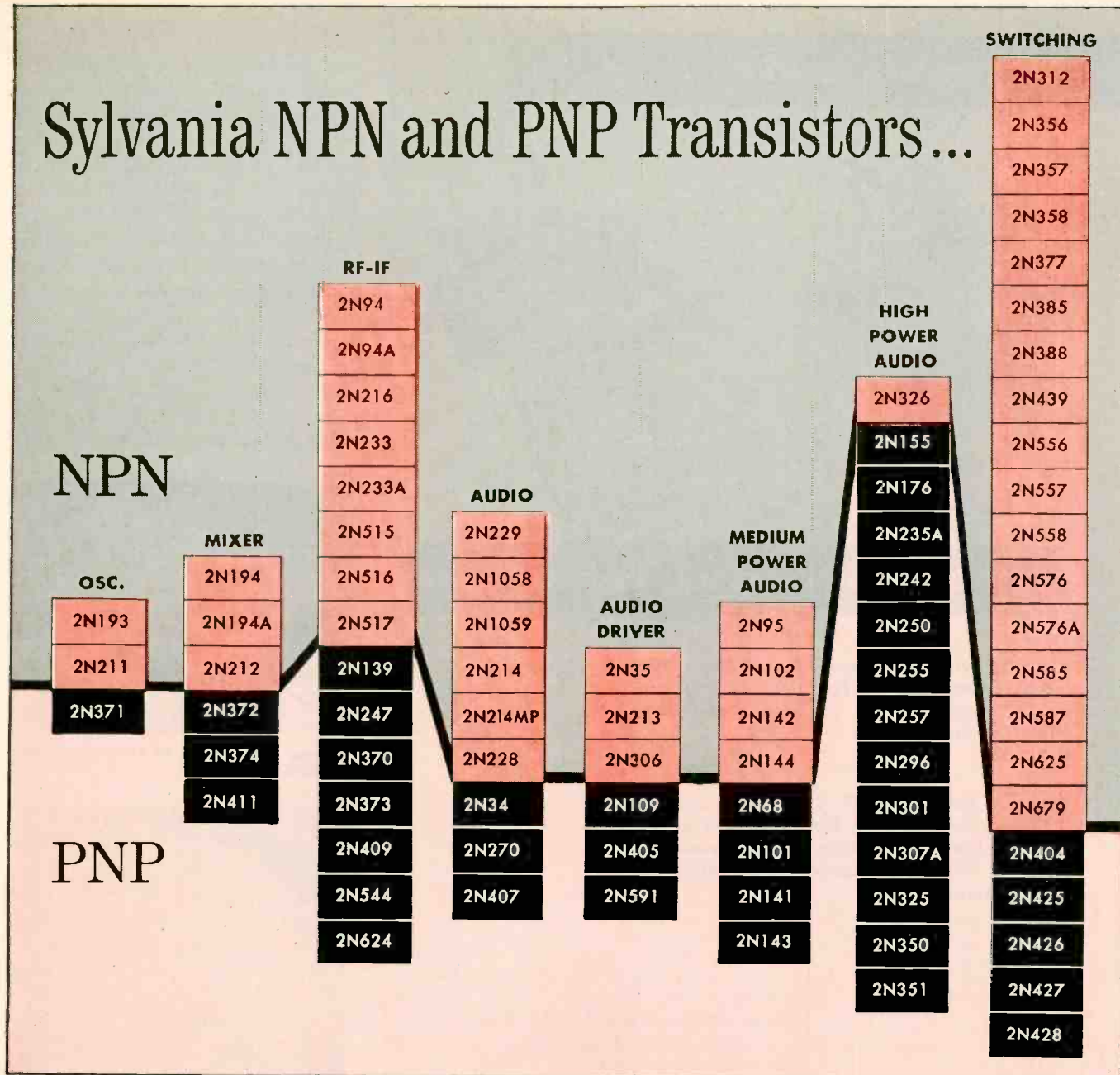

## A planning chart for designers who need both

From high-power audio types to high-stability switching types, both NPN and PNP germanium transistors are now available from Sylvania. With this wide range of types, electronic design engineers can take full advantage of the complementary aspects of NPN and PNP in every major circuit application.

Sylvania NPN and PNP transistors for switching applications exhibit the high Beta stability and fast rise time so important for data processing. NPN and PNP types for RF-IF applications feature high output resistance for increased gain. For your audio needs Sylvania offers one of the industry's most complete lines.

The entire Sylvania line of NPN and PNP types incorporates hermetic seal construction for maximum protection against humidity and other environmental conditions that can affect performance. For complete information on NPN and PNP transistors, contact your Sylvania representative or write Sylvania directly.



# SYLVANIA

SYLVANIA ELECTRIC PRODUCTS INC.  
1740 Broadway, New York 19, N.Y.  
In Canada: P.O. Box 1190, Station "O"  
Montreal 9

LIGHTING • TELEVISION • RADIO • ELECTRONICS • PHOTOGRAPHY • ATOMIC ENERGY • CHEMISTRY-METALLURGY

**a prize pair...**

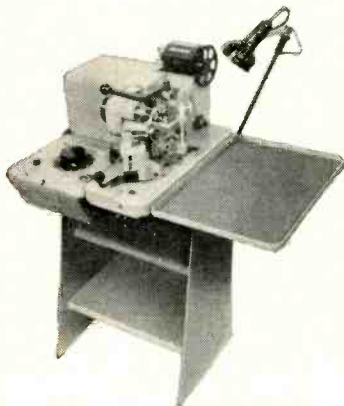

The TW 251

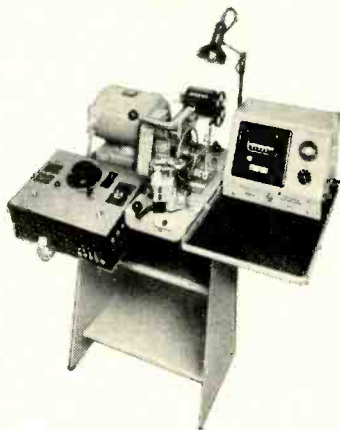

The TW 201

**... of toroidal winders**

The TW 201 . . . economical production winder with minimum manual operation. Efficient, easy to set up and operate . . . absolute dependability built into each machine.

The TW 251 . . . NEW . . . low-cost packaged unit, complete and ready for operation. A slower-winding laboratory machine, usable in production like the TW 201 by addition of pre-determined turns counter.

**TW 201 . . .**  
Semi-automatic toroidal coil winder . . . core oscillated manually . . . clamped mechanically . . . winds standard size coils without additional attachments . . . interchangeable shuttle heads.

**TW 251 . . .**  
Semi-automatic toroidal coil winder . . . similar to TW 201 but has built-in non-predetermined turns counter . . . AC drive variable up to 1000 rpm . . . can use all accessories available for TW 201.



You get the **BEST** from **BOESCH**

**Boesch Manufacturing Co., Inc. Danbury, Conn.**

notes and dimensions are added as required. The Fotogram is then prepared using a reproduction method.

An overlay method of detailing consists of placing a transparent drawing format over the area to be detailed. Notes and additional information are added as required and the combination is reproduced to form the Fotogram.

As part of the program, the preparation of schematic diagrams by the Fotosetter process (ELECTRONICS, p 122, Dec. 5) was evaluated. Studies of its application to military projects indicates that



Pasteup is reproduced by Xerography and Multilith

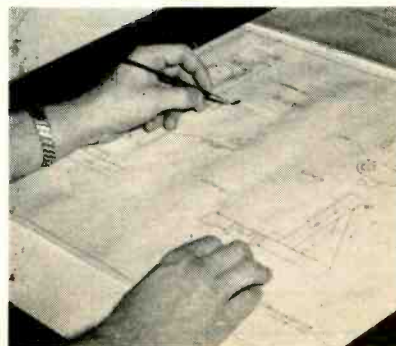

Areas to be eliminated from drawing are bleached out or hidden with white paint

wiring diagrams may be produced in half the time required by manual methods.

## Ultrasonics Cleans Delicate Stampings

METAL STAMPINGS too delicate for mechanical or manual washing may be ultrasonically cleaned in large batches. Such a process is used by Sergeant & Wilbur Heat Treating Corp., Powtucket, R. I., before and after heat treating mu-metal laminations.

The laminations, supplied by Allegheny Ludlum Steel Corp., are



# NOW - IN 1959

## ALL-IN-ONE WEEKLY ISSUES

### SPECIAL ISSUES FOR 1959

**Electronics in Space**  
**Design for Reliability**  
**Transistor Electronic Equipment**  
**Electronics Instruments for Design and Production**  
**Sophisticated Communications Methods**  
**Materials for Environmental Extremes**  
**Electronics Statistics**  
**I R E Show Issue**  
**WESCON Show Issue**

### **PRESENT SUBSCRIBERS**

This subscription card is for NEW subscribers. It is not intended as a renewal notice. If you are already personally subscribing, we shall appreciate your passing the form to one of your associates. Thank you.

L 1/9/59

ELECTRONICS for '59 brings you . . .

. . . latest ENGINEERING and TECHNICAL data and what it means to the Electronics Industry — and to you!

Every Friday, your personal subscription to ELECTRONICS delivers to you an ALL-IN-ONE fact-packed manual — the easy, practical way to make sure you're among the best informed electronic engineers and managers.

Specifically, each issue will cover Design, Research, Engineering, and Manufacturing . . . plus the Trends, Economic Developments, Markets, and Production Figures which interrelate with the Technical Breakthroughs and Economic Pressures.

**YOUR PERSONAL SUBSCRIPTION TO "ELECTRONICS" TOTALLY INFORMS YOU.**

**SAME RATES AS BEFORE**—despite expense of augmented editorial staff and greatly increased production costs. **GET UTMOST VALUE FROM THIS EXPANDED ELECTRONICS SERVICE**—place your personal subscription by means of the card below.

### **NEW** subscription ORDER FORM

**O.K. — put me down for a personal subscription to "electronics" . . . giving me benefit of your weekly editorial service . . .**

Check here  for 1 year \$6     for 2 years, \$9     for 3 years, \$12

Name \_\_\_\_\_ Position \_\_\_\_\_ Dept. \_\_\_\_\_

Company Name \_\_\_\_\_

Street \_\_\_\_\_ City \_\_\_\_\_ Zone \_\_\_\_\_ State \_\_\_\_\_

Products Mfrd. \_\_\_\_\_ Number of  
Or Service \_\_\_\_\_ Employees \_\_\_\_\_

Check here if you want Publication sent to your home \_\_\_\_\_

Street \_\_\_\_\_ City \_\_\_\_\_ Zone \_\_\_\_\_ State \_\_\_\_\_

L 1/9/59

**(Foreign Rates (1 year) Canada \$10, Other Foreign: \$20**

Please  One

Send bill to home address

Send bill to company address

Payment Attached

L-

M-

Please fill out card completely for best service

# NOW - IN 1959

## electronics

.. ISSUED WEEKLY .. EVERY FRIDAY  
**ENGINEERING  
TECHNICAL DATA**  
EVERY ISSUE

This expanded service of ELECTRONICS provides the most comprehensive and fastest aid for the executive and engineer vitally *concerned with every phase of the electronics industry* . . .

New Ideas! . . . New Circuits! . . . New Engineering Techniques!

Improved Manufacturing Methods! . . . New Design! . . . Advances in Research!

Prompt word about New Electronic Equipment, Parts and Components!

Latest Word on New Industrial, Scientific and Military Applications!

Sales and Production Figures! . . . Economic Trends to help you make sounder Investment Decisions!

. . . All the Vital News!

*All subscribers get copies of the GIANT BUYER'S GUIDE*

**SUBSCRIBE PERSONALLY** *for top-value in IDEAS and NEWS*  
**electronics** *Established 1930 — Pioneer Publication in the Field*

Postage  
Will be Paid  
by  
McGraw-Hill  
Pub. Co.

No  
Postage Stamp  
Necessary  
if Mailed in the  
United States

**BUSINESS REPLY MAIL**

First Class Permit No. 64, New York, N. Y.

McGRAW-HILL PUBLISHING CO., Inc.

## electronics

330 WEST 42nd STREET

NEW YORK 36, N. Y.

**Use this  
handy  
order card..**

**to profit by  
ELECTRONICS  
weekly  
editorial service**

0.004 inch thick. As received from cold stamping, they require degreasing. This is done by immersing them for 5 minutes in a chlorinated solvent bath in an ultrasonic cleaner.

The parts are then covered with



Operator removes 1,000 laminations from cleaner

an aluminum oxide powder, Alundum, made by the Norton Co. The powder prevents them from sticking on jigs which hold 1,000 laminations during heat treating and final cleaning.

They are heat treated in a protective atmosphere of cracked city gas and anhydrous ammonia. The parts emerge from the furnace free of scale or discoloration, but are covered with powder partly cooked onto the jugged pieces.

The powder is removed by 20 minutes immersion in an ultrasonically agitated bath of detergent and warm water. The cleaning unit used is a 1 gallon model, Series 600-3, manufactured by Nard Ultrasonics Corp., Westbury, N. Y.

The tank will hold 4 jigs at once, yielding a rate of 12,000 laminations an hour if necessary. S & W reports rejects are virtually nil. The assembled stacks of laminations must meet tolerances of a few ten-thousandths of an inch.

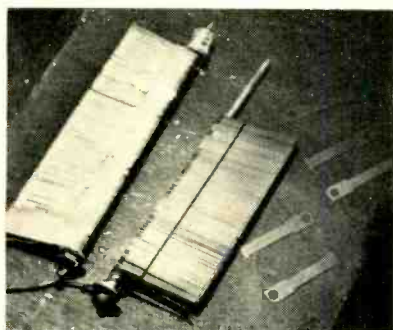

Jig at right shows how stack of laminations has shrunk after removal of powder required in heat treating

**CELCO** *Specialized*

# YOKES

FOR CHARACTER DISPLAYS

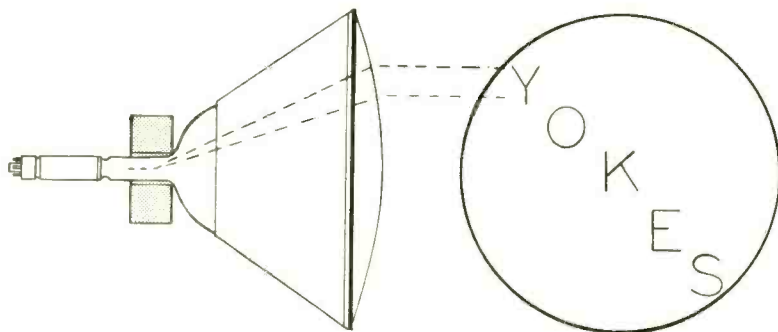

**YEARS AHEAD IN DESIGN PERFORMANCE**

For critical applications, many of our customers have saved years of trial and error in YOKE selection by specifying Celco YOKES.

The construction of our yokes makes it possible to achieve **sensitivities, linearities, responses and distortion-free deflecting fields** not possible with the usual types of yoke.

For precision military and commercial displays, Celco also offers standard yokes in 7/8", 1", 1 1/8", 2", & 2 1/2" CRT neck diameters.

Write for CELCO DEFLECTION YOKE Catalogue & Design Sheets or for immediate engineering assistance Call your nearest CELCO Plant:

**Celco**

*Constantine Engineering Laboratories Co.*

Mahwah, N. J.  
Davis 7-1123

Miami, Fla.  
Plaza 1-9083

Cucamonga, Calif.  
Yukon 2-2688



# ON THE MARKET

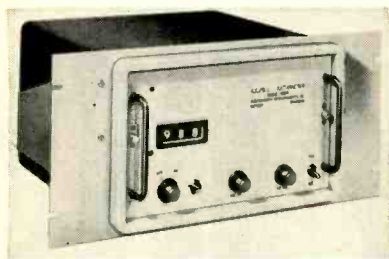

## Digital Ratiometer for a-c, d-c input

PERFORMANCE MEASUREMENTS Co., 15301 W. McNichols, Detroit 35, Mich., announces model 1594 a-c/d-c digital ratiometer for computers and control system applications. Range of ratios that can be

measured directly in numerical values is 0 to 1,000. Input voltages range from 0 to 6.3 v a-c and 0 to 6 v d-c. With a high impedance input, this instrument measures a-c and d-c voltage ratios with a rated accuracy of  $\pm 0.10$  percent full scale. **Circle 200 on Reader Service Card.**

## Frequency Meter high accuracy

JONES-PORTER INSTRUMENT CO., Box 302, Millburn, N. J. Featuring 14 ranges through 80 kc and 7 ranges through 80,000 rpm, all direct reading, the model T-2 frequency meter achieves extreme readability, accuracy, and freedom

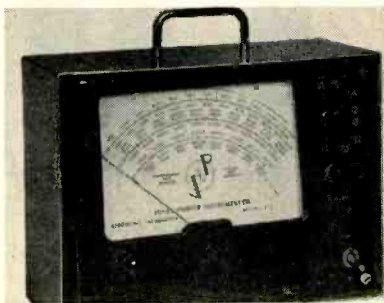

from drift through the use of saturable core circuitry throughout. An internal calibration standard permits the use of any power supply frequency, since it is not related to the 60 cps system. It will accept any input voltage from 10 mv to 300 v and give equal accuracy on any repetitive function. **Circle 201 on Reader Service Card.**

## Silicon Zener Diodes two new types

MOTOROLA INC., 4545 W. Augusta Blvd., Chicago 51, Ill., announces silicon zener regulator diodes with voltage ranges up to 200 v. The 10 MZ series, rated for 10 w at 55 C, is housed in the Jetec, standard

10-32 stud package; while the 50 MZ (50 w) series uses the TO-3 package with either plug-in or solder-in features as well as series interlock construction for protection against overvoltage on load. Both are available with either anode or cathode connected to case. **Circle 202 on Reader Service Card.**

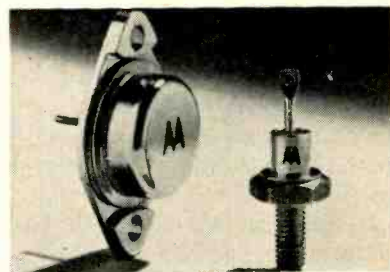

## Plug and Jack for p-c boards

CAMBRIDGE THERMIONIC CORP., 445 Concord Ave., Cambridge 38, Mass., announces a plug and jack, designed for mounting one printed circuit form perpendicular to another. Using this combination, any number of p-c boards may be

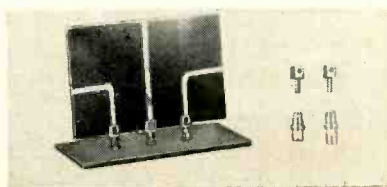

plugged to the master boards. The new plug, designated 2319, has a 0.0635 in. bore running through

the rectangular shank. The end of the shank is slotted to a depth of 0.125 in. to accommodate boards 1/32 in. thick. The plug has a 0.062 in. pin diameter. Its corresponding jack, designated 2320, is available in four different shank lengths for use with circuit boards from 1/16 in. to 3/16 in. thick. **Circle 203 on Reader Service Card.**

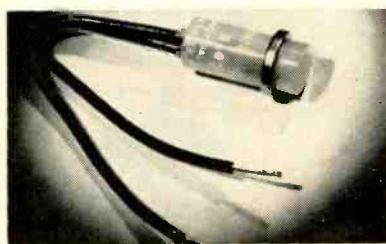

## Pilot Light miniaturized

INDUSTRIAL DEVICES, INC., 982 River Road, Edgewater, N. J., announces a new type miniaturized neon pilot light, the Omni-Glow. Completely assembled by the manu-

facturer and ready for installation and operation, this unit extends for less than  $\frac{7}{8}$  in. behind the panel. It mounts in a single  $\frac{1}{2}$  in. hole and attaches with a push-on nut that is supplied. The unit is U/L and CSA approved. **Circle 204 on Reader Service Card.**

## Power Supply all-transistor

DRESSEN-BARNES CORP., 250 No. Vinado Ave., Pasadena, Calif.



Model 62-124 all-transistor power supply is free from line transients and overshoot in the output. Unit provides full 2-ampere current over (Continued on p 86)



# 50-Volt SUBMINIATURES for Transistor Circuitry



METAL ENCLOSED • MYLAR DIELECTRIC • HERMETICALLY SEALED

Six rugged new capacitor types designed SPECIFICALLY to SAVE SPACE in compact, transistorized assemblies. Two temperature ranges to choose from. All types rated for 500-hours accelerated life testing.

**Full Rated to 85°C**

Types **626G - 627G** (Extended foil)  
 Types **628G - 629G** (Inserted tab)

**Temperature Range**—Full rating at 85°C — to 125°C with 50% derating.  
**Life Test**—500 hours at 85°C and 125% of rated voltage.  
**Capacity Tolerance**—All tolerances to ± 1%.  
**Insulation Resistance**—40,000 meg. x mfd. at 25°C but need not exceed 70,000 megohms.  
**Case Styles**—Available in all case style variations in MIL-C-25A.

**Full rated to 125°C**

Type **616G** (Extended foil)  
 Type **617G** (Extended foil)

**Temperature Range**—Full rating to 125°C - to 150°C with 50% derating.  
**Life Test**—500 hours at 125°C and 125% of rated voltage.  
**Capacity Tolerance**—All tolerances to ± 1%.  
**Insulation Resistance**—50,000 meg. x mfd. at 25°C but need not exceed 100,000 megohms.  
**Case Styles**—Available in all case style variations in MIL-C-25A.

**50-VOLT DIMENSIONS**

Capacitance in Mfd.	626G*		627C		628C*		629C		616G*†		617C†	
	D	L	D	L	D	L	D	L	D	L	D	L
.001	.173 x 3/32	.173 x 3/32	.173 x 3/32	.173 x 3/32	.173 x 3/32	.173 x 3/32	.173 x 3/32	.173 x 3/32	.173 x 1/4	.173 x 1/4	.173 x 3/4	.173 x 3/4
.0022	.173 x 3/32	.173 x 3/32	.173 x 3/32	.173 x 3/32	.173 x 3/32	.173 x 3/32	.173 x 3/32	.173 x 3/32	.173 x 1/4	.173 x 1/4	.173 x 3/4	.173 x 3/4
.0047	.173 x 3/32	.173 x 3/32	.173 x 3/32	.173 x 3/32	.173 x 3/32	.173 x 3/32	.173 x 3/32	.173 x 3/32	.193 x 3/32	.193 x 3/32	.193 x 3/4	.193 x 3/4
.01	.173 x 3/32	.173 x 3/32	.173 x 3/32	.173 x 3/32	.173 x 3/32	.173 x 3/32	.173 x 3/32	.173 x 3/32	.193 x 3/32	.193 x 3/32	.193 x 3/4	.193 x 3/4
.022	.233 x 3/32	.233 x 3/32	.233 x 3/32	.233 x 3/32	.193 x 3/32	.193 x 3/32	.193 x 3/32	.193 x 3/32	.233 x 3/4	.233 x 3/4	.233 x 3/4	.233 x 3/4
.047	.312 x 3/32	.312 x 3/32	.312 x 3/32	.312 x 3/32	.233 x 3/32	.233 x 3/32	.233 x 3/32	.233 x 3/32	.312 x 3/4	.312 x 3/4	.312 x 3/4	.312 x 3/4
.1	.312 x 3/32	.312 x 3/32	.312 x 3/32	.312 x 3/32	.312 x 3/32	.312 x 3/32	.312 x 3/32	.312 x 3/32	.400 x 3/4	.400 x 3/4	.400 x 3/4	.400 x 3/4
.22	.400 x 1	.400 x 1	.400 x 1 1/4	.400 x 1 1/4	.400 x 3/4	.400 x 3/4	.400 x 3/4	.400 x 3/4	.500 x 1	.500 x 1	.500 x 1 1/4	.500 x 1 1/4
.47	.500 x 1 1/4	.500 x 1 1/4	.500 x 1 1/4	.500 x 1 1/4	.500 x 1	.500 x 1	.500 x 1	.500 x 1	.562 x 1 1/4	.562 x 1 1/4	.562 x 1 1/4	.562 x 1 1/4
1.0	.560 x 1 1/4	.560 x 1 1/4	.560 x 1 1/4	.560 x 1 1/4	.560 x 1 1/4	.560 x 1 1/4	.560 x 1 1/4	.560 x 1 1/4				

\*These types have one lead grounded to the case. Others have both leads insulated.

†Also available in 150V, 400V & 600V ranges.

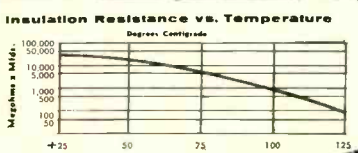
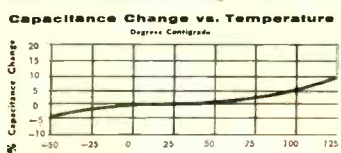

Write for literature on these new types.

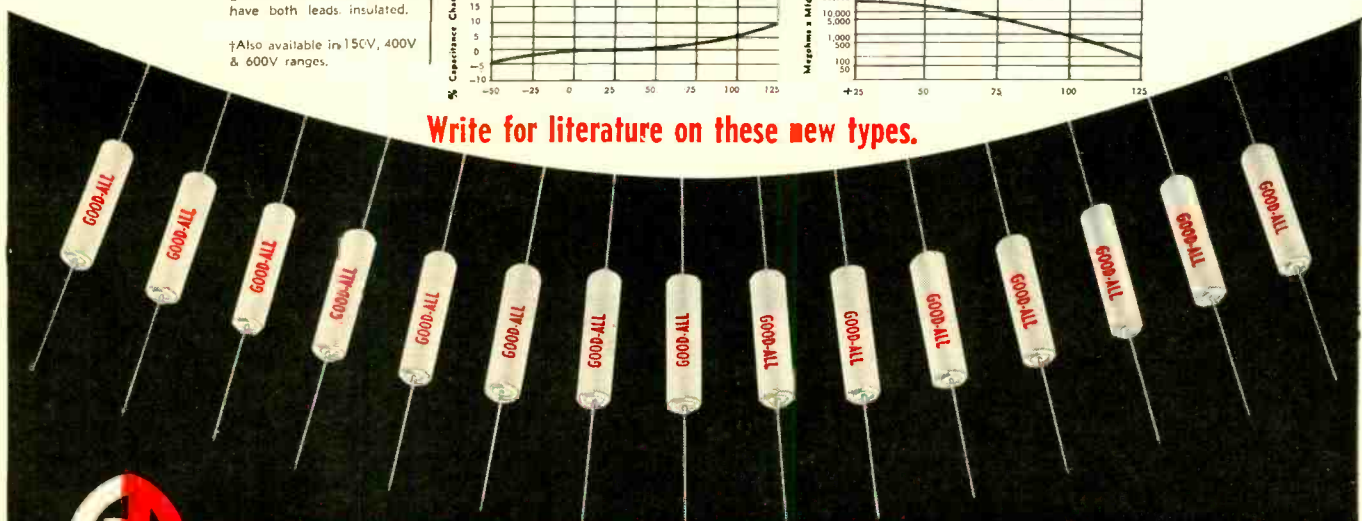

**GOOD-ALL ELECTRIC MFG. CO. • OGALLALA, NEBRASKA**

GOOD-ALL CAPACITORS NOW AVAILABLE AT YOUR LOCAL DISTRIBUTOR

A LEADING MANUFACTURER OF TUBULAR, SUBMINIATURE ELECTROLYTIC AND CERAMIC DISC CAPACITORS

voltage range of 0.5 to 36 v d-c. There is no derating for continuous operation. Regulation is 0.05 percent for a line voltage change from

105 to 125 v; and 0.05 percent from no load to full load. The supply maintains regulation despite rapid switching of full output current.

Unit is short-circuit proof, and has special fusing to prevent damage to transistors. Price is \$640. Circle 205 on Reader Service Card.

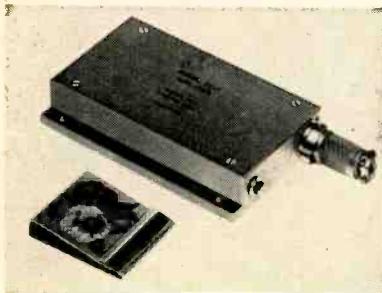

### Telemetry Amplifier subminiature

ENDEVCO CORP., 161 E. California St., Pasadena, Calif., offers a new airborne subminiature amplifier, model 2617, to be used with high impedance transducers such as piezoelectric and capacitive devices. It is protected against humidity

(potted). Subminiature MIL type output connectors are supplied. A selectable fixed gain of 10, 30 or 100 is preset at the factory. Unit offers 1,000 megohm input impedance with less than 50 mv residual noise (shorted input), broad range of 2 cps to 20 kc and low current requirement (5.0 ma). Circle 206 on Reader Service Card.

### Tantalum Capacitor sintered anode

P. R. MALLORY & CO. INC., 3029 E. Washington St., Indianapolis 6, Ind. The new type HAT sintered anode electrolytic capacitor has a case size less than  $\frac{1}{16}$  in. in diameter and only slightly longer than  $\frac{1}{8}$  in. in length, with d-c leakage current

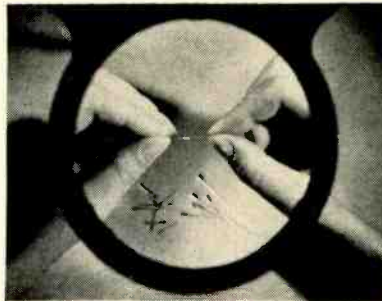

less than  $1 \mu\text{a}$ . It was designed to replace tantalum wire anode capacitors of comparable ratings. Units are ideally suited for by-pass coupling and filter applications requiring relatively high capacitance in a minimum of space. They are available in ratings of 1 to  $10 \mu\text{f}$  and ratings of 1 to 10 v. Circle 207 on Reader Service Card.

### Transistor Tester for lab, production

BAIRD-ATOMIC, INC., 33 University Rd., Cambridge 38, Mass. The KP-2 series of transistor test sets feature extended testing ranges for analyzing transistors at frequencies from 100 cps to 200 kc. They offer

ranges up to 2 amperes, 200 v with two regulated semiconductor power supplies for bias voltages and currents. The direct measurements obtained on the test sets are based on "h" parameters using basic simple and straight forward circuitry for optimum dependability. Circle 208 on Reader Service Card.



### D-C Amplifier recorder accessory

TEXAS INSTRUMENTS INC., 3609 Buffalo Speedway, Houston 6, Texas. Model 301 d-c amplifier converts d-c voltages to 1 ma d-c recorder signals with minimum bur-

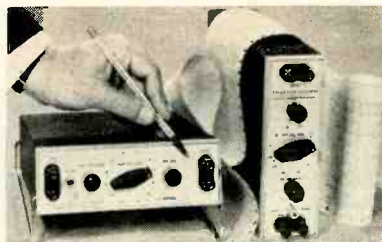

den. It gives d-c amplification with a-c stability. Unit covers range from 10 mv d-c full scale to 100 v d-c full scale in 12-step selection. At the lower limit, indicating sensitivity is 2.22 mv/in. when used on the "recti-riter" recorder. Circle 209 on Reader Service Card.

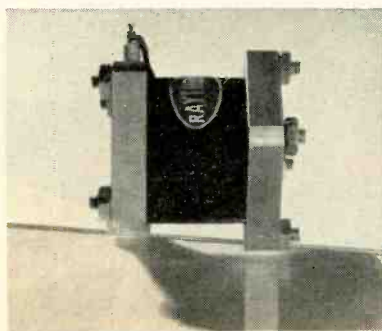

### Ferrite Switch low-power, X-band

RAYTHEON MFG. CO., Waltham 54, Mass., has introduced a low-power X-band ferrite switch for on-off applications. Model SXL1 provides a minimum isolation of 25 db with an insertion loss of 0.5 db (maximum). Multiples of this isolation can be obtained by connecting

several SXL1's in series. Weight is only 15 oz; overall length, 1.7 in. Circle 210 on Reader Service Card.

### Power Supply metallic rectifier

OPAD ELECTRIC CO., 69 Murray St., New York 7, N. Y. Model KM87B aircraft battery substitute

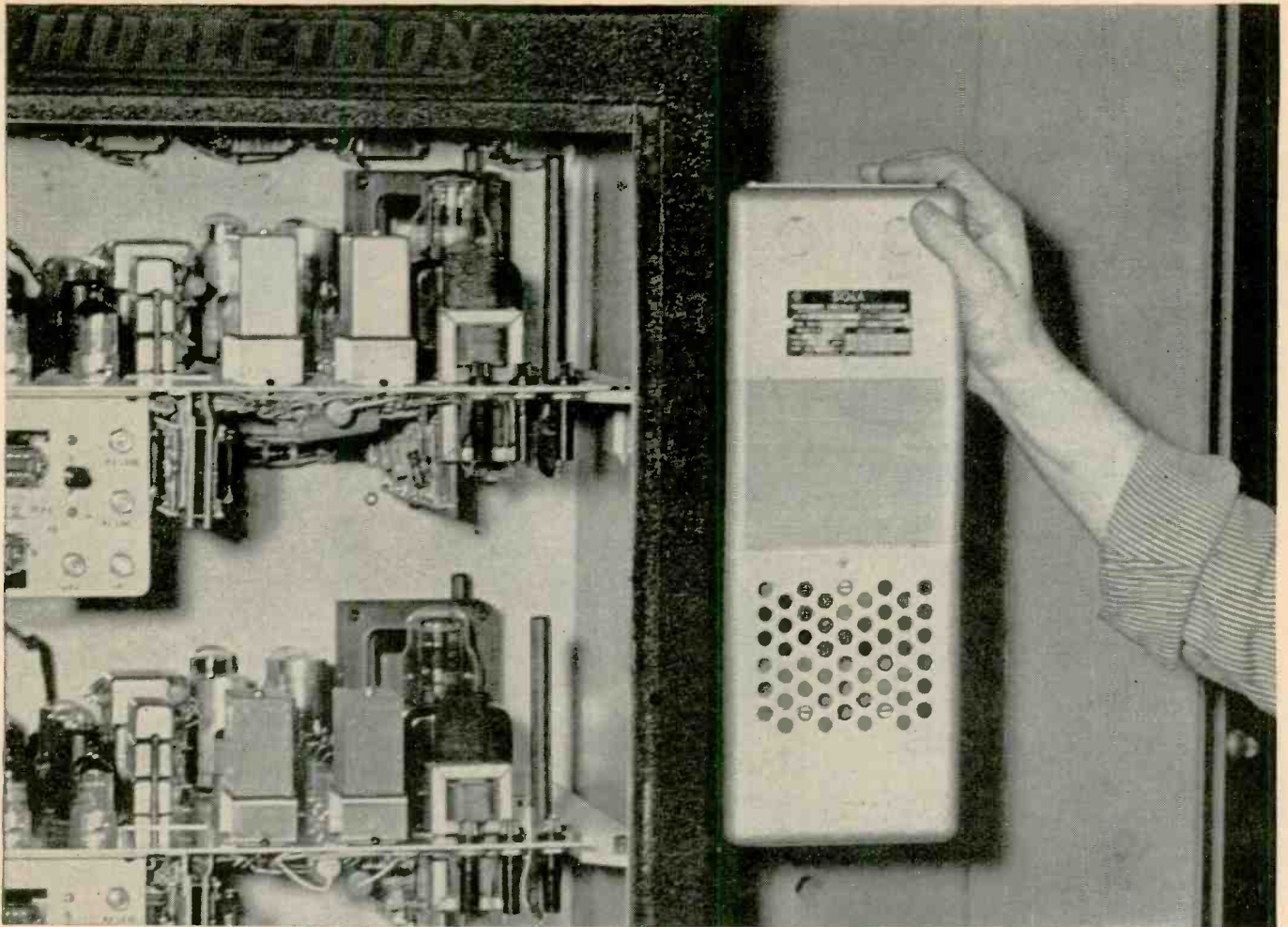

*Sola's Standard-type Constant Voltage Transformer, mounted at right of control cabinet, supplies regulated input voltage for dependable operation of Hurlertron printing register control.*

## Equipment delivers full-efficiency performance with input voltage Sola-regulated within $\pm 1\%$

Built in or added as an accessory, Sola Constant Voltage Transformers permit voltage-sensitive equipment to operate at full efficiency. Variations in line voltage as great as  $\pm 15\%$  are stabilized to within  $\pm 1\%$  of equipment nameplate voltage. This eliminates performance variations and failures caused by irregular voltage—highs, lows, or most transients. Sola-regulated input voltage also gives tubes and other components the correct electrical environment for full life.

The Sola Constant Voltage Transformer is a static-magnetic regulator whose action is automatic and virtually instantaneous—it responds to variations in input

voltage within 1.5 cycles. It has no tubes or moving parts and requires no manual adjustments or maintenance.

The Standard-type CV illustrated is only one of a complete line of Sola voltage regulators having wide application in electrical and electronic devices. Such special types as harmonic-free, filament, plate-filament, and adjustable harmonic-free transformers all provide the benefits of regulated input voltage. More than 40 models of these economical, compact regulators are available from stock. Sola also manufactures custom-designed units (in production quantities) to meet special needs.

**For complete data write for Bulletin CV-170.**

Sola Electric Co., 4633 W. 16th St., Chicago 50, Ill., Blshop 2-1414 • Offices in principal cities • In Canada, Sola Electric (Canada) Ltd., 24 Canmotor Ave., Toronto 18, Ont.



**A DIVISION OF BASIC PRODUCTS CORPORATION**



## THE INDIVIDUAL MAKES HIS MARK AT BURROUGHS

Engineering responsibility is a dynamic concept at ElectroData Division of Burroughs Corporation in Pasadena, California — the West Coast's largest manufacturer of electronic data processing systems. Outstanding opportunity for individual professional contribution here — each ElectroData Engineer has one of the most creative and important of all engineering assignments: the commercial electronic computers of the future. Equally important are the recognition, advancement and compensation for meeting this competitive challenge. Positions with major responsibility and corresponding opportunity are now open for creative, professionally qualified computer engineers. Logical Designer, Circuit Designers, Computer Systems Engineers, Product Engineers and others interested in the digital computer field are invited to investigate these openings. Write to the Professional Personnel Director in Pasadena, address below.

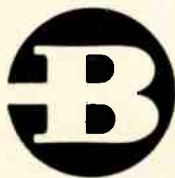

**Burroughs Corporation**  
ELECTRODATA DIVISION  
PASADENA, CALIFORNIA  
"NEW DIMENSIONS in electronics and data processing systems"

is a metallic rectifier type power supply which provides a stepless controllable output of from zero to 32 v d-c with a continuous duty load current rating of 20 amperes. Ripple is held to within  $\frac{1}{2}$  of 1 percent throughout the range of the equipment. Cooling is by convection. Voltage regulation from 1/10 load to full load does not exceed 12 percent at 32 v output. Circle 211 on Reader Service Card.

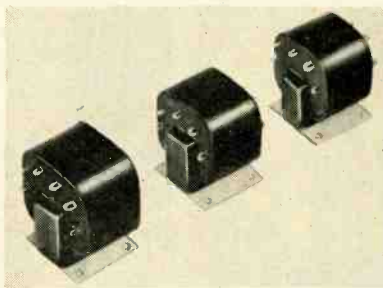

### Transformers filament type

UNITED TRANSFORMER CORP., 150 Varick St., New York 13, N. Y., announces a new stock series of 400 cycle filament transformers designed to provide maximum reliability with small size and weight. They are suited to ground or airborne applications. Circle 212 on Reader Service Card.

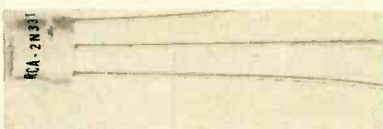

### Junction Transistor pnp type

RADIO CORP. OF AMERICA, Somerville, N. J. The 2N331 is a new, germanium alloy-junction transistor of the pnp type especially designed for use as a low-power a-f amplifier in critical industrial and military applications. It has a current transfer ratio characteristic which is essentially constant over the useful operating current range of the device. The transistor features low collector and emitter cutoff currents, low base resistance, a typical power gain of 44 db, and a typical noise factor of 9 db. Circle 213 on Reader Service Card.

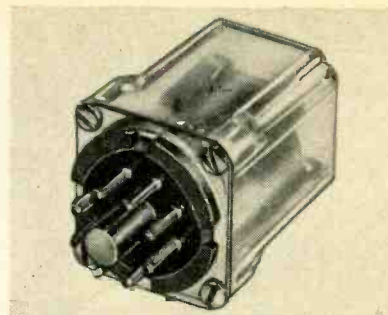

### Midget Relay dust-protected

KURMAN ELECTRIC CO., 191 Newel St., Brooklyn 22, N. Y., offers the series 23D dust-protected, midget sensitive relay. The light weight relay is ideal for all plate circuit, photoelectric, and remote control applications, where space economy and current drain are chief design features. Series 23D has a sensitivity as low as 6 mw, spdt, with a maximum coil dissipation of  $2\frac{1}{4}$  w. Circle 214 on Reader Service Card.

### F-M Transmitter for telemetering

DORSETT LABORATORIES, INC., 401 E. Boyd St., Norman, Oklahoma. Model TR-12 telemetering transmitter features true f-m operation and is crystal stabilized. Frequency tuning range is from 225 to 260 mc. Power output is up to 4 w with a plate supply of 250 v. Filament supply is 28 v a-c/d-c at 400 ma. The true f-m design permits a full 125-ke deviation over a modulation range of from 300 cps to 80 kc with only 1-percent distortion. Circle 215 on Reader Service Card.

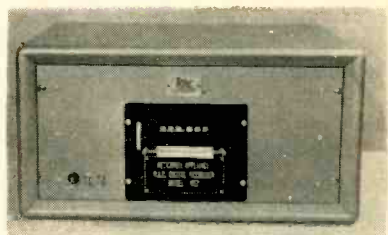

### Digital Recorder versatile unit

RESEARCH APPLIANCE CO., Route 8 at Craighcad Rd., Allison Park, Pa. Model 457 digital recorder is a ver-



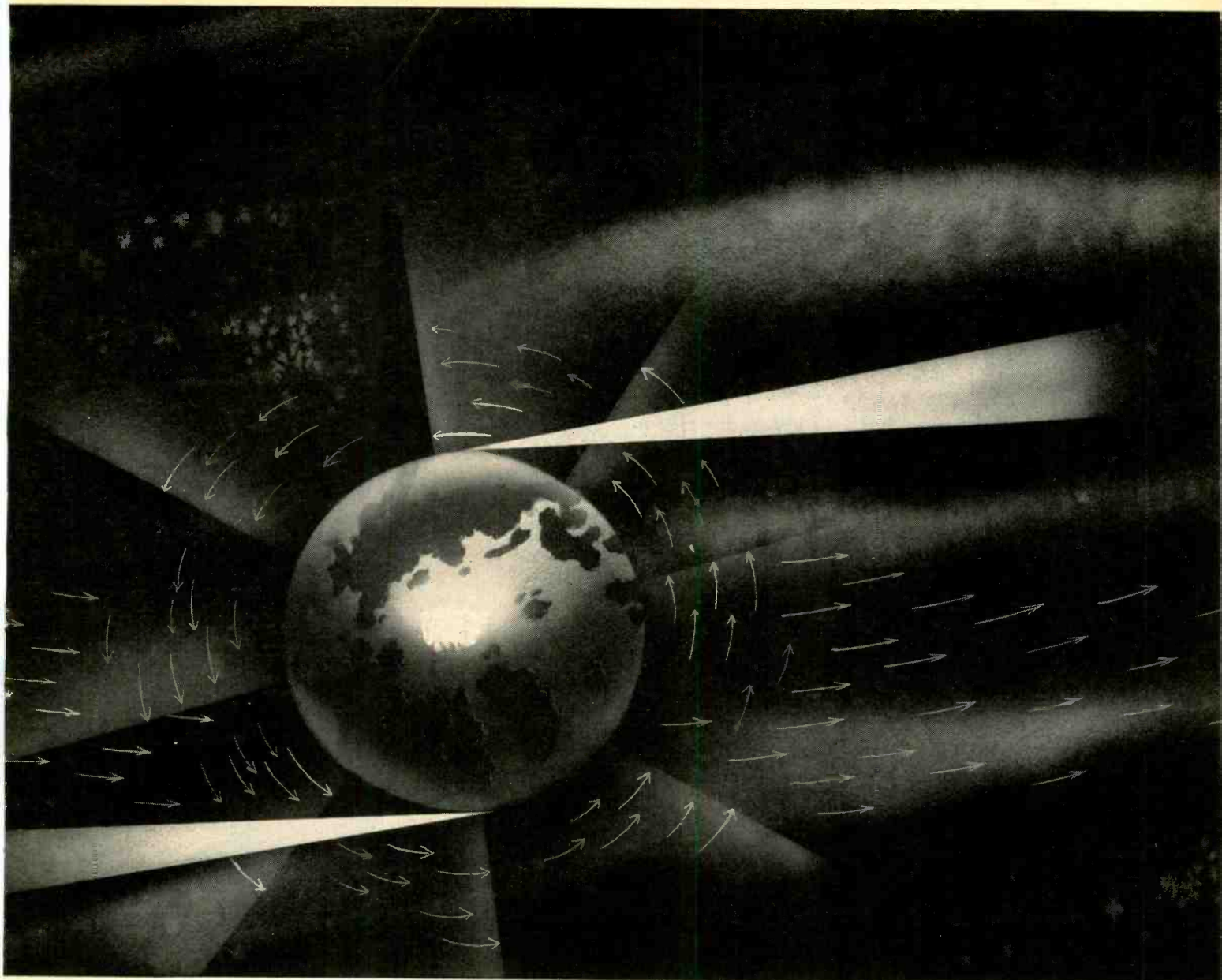

## A further confirmation of special relativity

An extremely high-precision experiment, giving added evidence of the correctness of Einstein's Special Theory of Relativity, has recently been conducted by a joint team of scientists from the IBM Watson Research Laboratory and Columbia University. These tests are perhaps the most precise in the history of measurement.

According to Einstein, light is propagated in a way which does not depend on the frame to which it is referred nor on the motion of the light source. In this unique experiment, the scientists measured the variation in frequency of radio waves radiating from a beam of "excited" molecules in an ammonia MASER. These changes in frequency of radio waves correspond to variations in the

direction of light propagation. The experiment compared wave frequencies to an accuracy of one in one million million—and demonstrated within extremely narrow limits that wave frequency changes do not occur upon reversal of the beam of molecules initially travelling in the same direction as the earth in its orbit.

This research was made possible by the knowledge of microwaves accumulated at the IBM Watson Research Laboratory in New York City. The diverse scientific interests and the computing facilities at this Laboratory have helped scientists of five continents solve problems in basic research in such fields as engineering, astronomy, chemistry, physics and psychology.

*Investigate the many career opportunities available in exciting new fields at IBM.*

*International Business Machines Corporation, Dept 55442, 590 Madison Avenue, New York 22, New York*

CIRCLE 51 READERS SERVICE CARD

**IBM****RESEARCH**

# PRESENT SUBSCRIBERS

## — Please Note!

This subscription coupon is for NEW subscribers. It is not intended as a renewal notice. If you are already personally subscribing, we shall appreciate your passing the form to one of your associates. Thank you.

**Mail Reply to:** McGraw-Hill Pub. Co., Electronics, 330 W. 42nd St., N. Y. 36, N. Y.



### NEW Subscription ORDER FORM

O.K. — put me down for a personal subscription to "electronics" . . . giving me benefit of your weekly editorial service . . .

Check here  for 1 year, \$6     for 2 years, \$9     for three years, \$12

Please  One

- Send bill to home address
- Send bill to Company address
- Payment Attached

Name \_\_\_\_\_ Position \_\_\_\_\_ Dept. \_\_\_\_\_

Please fill out card completely for best service

Company Name \_\_\_\_\_

Street \_\_\_\_\_ City \_\_\_\_\_ Zone \_\_\_\_\_ State \_\_\_\_\_

Products Mfrd. Or Service \_\_\_\_\_ Number of Employees \_\_\_\_\_

Check here if you want Publication sent to your home

Street \_\_\_\_\_ City \_\_\_\_\_ Zone \_\_\_\_\_ State \_\_\_\_\_

Foreign Rates (1 year) Canada \$10, Other Foreign \$20

satile instrument suitable for analog to digital conversion, indication, recording, and controlling. It is available with provisions for connecting to, and controlling a card punch machine for subsequent use in computing and data processing equipment. Printing cycle is 3 sec and longer. Accuracy is  $\pm \frac{1}{2}$  percent. Circle 216 on Reader Service Card.

### Vibration Exciter simple to operate

ELECTRODYNAMICS DIVISION, L. C. MILLER CO., 5005 E. Slauson Ave., Los Angeles 22, Calif. The LCM-100 is a new type of vibration exciter which features a horizontal, air supported, push-pull driven table. Although primarily designed for the production testing of components and small subassemblies, the unit's wide frequency range (5 to 15,000 cps) and high force output will make it an ideal research tool for the product design engineer. Circle 217 on Reader Service Card.

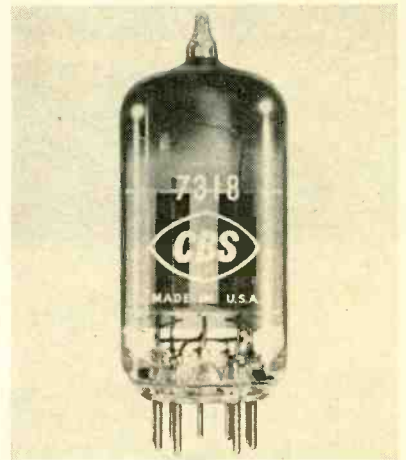

### Pulse Tube fast warm-up

CBS-HYTRON, Parker St., Newburyport, Mass. The high pulse-emission 7318, a new reliable miniature twin-triode, provides two amperes of peak current in 10- $\mu$ sec pulses. The compact tube features fast operational warm-up. Its major uses include industrial, computer, missile and airborne applications. It is ideally suited for blocking oscillators, square wave modulators and multivibrators. It will operate in

**NEW!**

# **KAY** *Vari-Vox*

CATALOG NO. 615-A

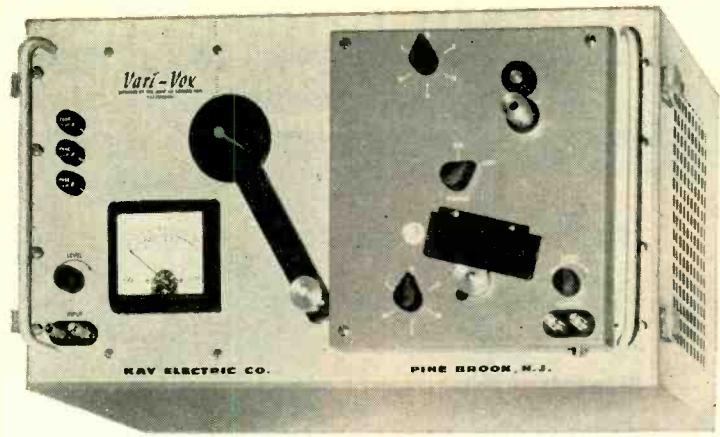

**SPEEDS SPEECH TO TWICE NORMAL RATE . . .**  
**or SLOWS SPEECH TO ONE-THIRD NORMAL RATE**  
*and Still Retains Intelligibility*

## **DOUBLES INFORMATION TRANSMITTED FOR SAME TIME AND BANDWIDTH**

The Kay *Vari-Vox* is a speech-time compressor and expander. During expansion or compression, it repeats or discards parts of audio signals—such as vowels, consonants, pauses in speech—and retransmits the complex signal so that complete intelligibility is retained.

Intelligence fed into the *Vari-Vox* may be speeded up and then compressed, or slowed down and then expanded by a known factor to restore the original meaning. Information fed into the *Vari-Vox* may be transmitted at 18 different speeds between twice the original rate down to one-third the original rate. The degree of compression or expansion versus the speed of the input recording determines intelligibility.

## **SPECIFICATIONS**

- Frequency Response:** 500-8,000 cps  $\pm$  2.0 db (max).
- Input Impedance:** 600 ohms.
- Input Signal Recommended:** 0.2 V rms.
- Sensitivity:** 0.10 V rms for full-scale operation.
- Output Impedance:** 600 ohms.
- Output Signal:** 0.20 V rms.
- Information Rate:** Compression up to 2 times normal rate in 9 steps.  
Expansion down to one-third normal rate in 9 steps.
- Recording Indicator:** Standard V. U. Meter.
- Power Supply:** Self-contained.
- Power Requirements:** 100 watts, 117 V ( $\pm$  10%, 50-60 cps ac).
- Dimensions:** 10½" x 19" x 9" rack panel.
- Weight:** 45 lbs.
- Price:** \$1,495.00, f.o.b. factory. (Add 10% for export.)

## *Vari-Vox* APPLICATIONS (Partial List)

### **Compression**

- Speed up Data Read-out
- Cut Monitoring Time and Tape Storage
- Faster Analysis of Complex Signals
- Reduce Time, Material and Storage in Talking Books or Speech Records
- Increase Information Rate for Signal Monitoring
- Frequency Multiplication of Read-out Signal

### **Expansion**

- Better Interpretation of Foreign Language Monitoring
- Stenographic Transcription of "Difficult" Subject Matter
- Phonetics and Voice Studies
- Foreign Language Studies
- Greater Intelligibility in the Presence of Noise
- Frequency Division of Read-out Signal

Write for New Kay Catalog

## **KAY ELECTRIC COMPANY**

Dept. E-1

Maple Avenue

Pine Brook, N. J.

Capital 6-4000

# NWL TRANSFORMERS

Outstanding in their fields for continuous research, development and design

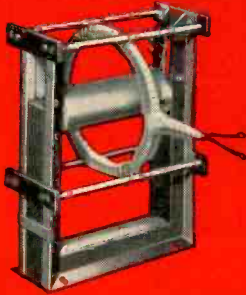

Filament transformer for insulation up to 80 KV AC Test. Low secondary capacitance from 6 to 30 mmfd.

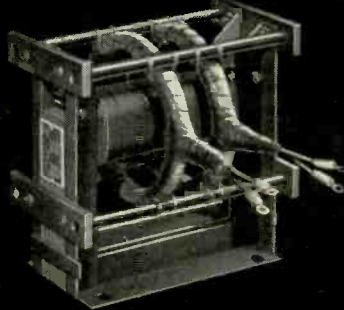

Same as opposite except with 2 or more secondary windings.

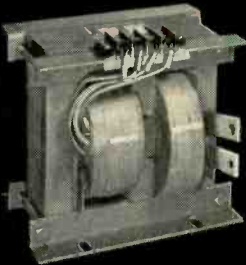

High impedance type transformer from 0.01 to 50 KVA and up to 10 KV. This unit is used for applications where short circuit current must be limited.



High voltage plate transformers up to 30 KV for floating secondary and up to 50 KV with start of secondary c.t. at or near ground. Sizes to 300 KVA.

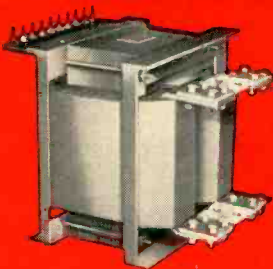

This transformer features low voltage high current secondary windings up to 4000 amps., and up to 300 KVA. Taps on the primary windings afford a wide range secondary current.



Through type instrument current transformer. Available in ranges from 1000 to 10,000 amperes.

NWL custom-built Transformers are made to fit the particular needs of the user. Each Nothelfer transformer is individually tested for core loss, polarity, voltage, corona, insulation breakdown and aging characteristics and must meet all customer's requirements before shipment. We shall be glad to receive your specifications and quote you accordingly.



ESTABLISHED 1920



*Nothelfer*

SAY: NO-TEL-FER

NOTHELFER WINDING LABORATORIES, INC., P. O. Box 455, Dept. E-61 Trenton, N. J.  
Specialists in Custom-Building

an ambient temperature range of -62 to +100 C. Circle 218 on Reader Service Card.



## Accelerometer hermetically sealed

LIND CORP., Research Park, Princeton, N. J. Type TA2 linear accelerometer is a seismic mass system which possesses low cross sensitivity by virtue of the high transverse stiffness of the self-compensating E springs. It is totally immersed in a silicone fluid with a viscosity selected to provide a damping ratio of 0.65. Volumetric changes in the oil with temperature rise are compensated by incorporating expansion chambers in the case. This allows an operating temperature range from -40 C to +100 C. Dual pots are provided for high level, redundant output. Circle 219 on Reader Service Card.



## Instrument Housings corrosion-proof

WARMINSTER FIBERGLASS CO., Box 254, Warminster and County Line Roads, Hatboro, Pa., has introduced new fiber glass reinforced instrument housings which are light,



Actual Size

## TI 2N559 ULTRA-HIGH SPEED GERMANIUM SWITCHING TRANSISTORS

Now TI 2N559 diffused-base germanium transistors give you ultra-high frequency/high temperature operation. Precision manufacture makes possible . . . switching times of 275 millimicroseconds and lower in saturating circuitry . . . minimum of 150 mW at 25°C . . . operation to 100°C . . . meets or exceeds MIL-T-19500A specifications. All units stabilized at well over rated temperatures for utmost reliability.

CHARACTERISTICS†	Conditions	Sym	Min	Max	Units	MAXIMUM RATINGS						
						$V_{CB}^*$	$V_{EB}^*$	$V_{CE}^*$	$T_{STG}$	$I_E$	$I_C$	$T_{jt}$
Emitter Breakdown Voltage	$I_E = -100 \mu\text{Adc}$ $I_C = 0$	$BV_{EBO}$	-3.5	—	Vdc	Vdc	Vdc	Vdc	°C	mAdc	mAdc	°C
Collector Breakdown Voltage	$I_C = -100 \mu\text{Adc}$ $I_E = 0$	$BV_{CBO}$	-15.0	—	Vdc	-15	-3.5	-15	-65 to +100	50	-50	100
Static Forward—Current Transfer Ratio	$I_C = -10 \text{ mAdc}$ $V_{CE} = -0.3 \text{ Vdc}$	$h_{FE}$	25	—	—	* These voltages may be exceeded (without permanently impairing the transistor) provided the current is limited to 100 $\mu\text{a}$ .						
Base Voltage	$I_C = -10 \text{ mAdc}$ $I_B = -0.4 \text{ mAdc}$	$V_{BE}$	0.34	0.44	Vdc							
Collector Cut-Off Current	$V_{CB} = -4.5 \text{ Vdc}$ $T_{\text{ambient}} = 65^\circ\text{C}$	$I_{CBO}$	—	-50	$\mu\text{Adc}$	† Derate at 0.5°C/mw. This is equivalent to a maximum power rating of 150 mw at 25°C ambient.						
Delay and Rise Time	$V_{BE}(0) = -0.5 \text{ Vdc}$ $I_B(1) = -1.0 \text{ mAdc}$ $V_{CC} = -3.5 \text{ Vdc}$ $R_L = 300 \text{ ohms}$	$(t_d + t_r)$	—	75	m $\mu\text{sec}$							
Storage Time	$I_B(1) = -1 \text{ mAdc}$ $I_B(2) = -0.25 \text{ mAdc}$ $V_{CC} = -3.5 \text{ Vdc}$ $R_L = 300 \text{ ohms}$	$t_s$	—	100	m $\mu\text{sec}$	‡ This specification covers the detail requirements for a transistor having the following characteristics at a case temperature of 25±3°C, unless otherwise specified.						
Fall Time	$I_B(1) = -1 \text{ mAdc}$ $I_B(2) = -0.25 \text{ mAdc}$ $V_{CC} = -3.5 \text{ Vdc}$ $R_L = 300 \text{ ohms}$	$t_f$	—	100	m $\mu\text{sec}$							



WORLD'S LARGEST SEMICONDUCTOR PLANT

TEXAS



INSTRUMENTS

INCORPORATED  
SEMICONDUCTOR-COMPONENTS DIVISION  
13500 N. CENTRAL EXPRESSWAY  
POST OFFICE BOX 312 · DALLAS, TEXAS

*This can't be FIREBAN...*



## New Taylor FIREBAN 321 Laminated Plastic is self-extinguishing in only 3 seconds

Electrical faults in appliances, TV sets, radios, motors and other electrical devices frequently lead to fires—and these fires lead to complete destruction of the equipment, sometimes extensive damage to the facilities surrounding it. Taylor FIREBAN 321 is designed to retard fire. Self-extinguishing in only 3 seconds—it is an effective barrier against the spread of flame. In addition, this flame-retardant laminated plastic has excellent moisture resistance, excellent electrical resistance after exposure to high humidity, and good mechanical properties; also offers low dielectric losses. These properties help prevent the electrical faults that lead to fires. Write TAYLOR FIBRE CO., Norristown 40, Pa., for complete details.

# Taylor

LAMINATED PLASTICS VULCANIZED FIBRE

strong, and corrosion-proof. They are ideal for use in the chemical and allied industries where corrosion is a problem. Housings can be any color desired with color an integral part of the housing itself. Circle 220 on Reader Service Card.



### Simulation Table single-axis

GENISCO, Inc., 2233 Federal Ave., Los Angeles 64, Calif., has available the highly versatile and accurate A916 single-axis flight simulation table for testing airborne components under simulated pitch, yaw and roll maneuvers. It may be used with an analog computer, function generator, tape recorder, and digital-to-analog converter to evaluate autopilot systems and to determine the dynamic characteristics of high performance gyros and accelerometers. Circle 221 on Reader Service Card.



### D-C Power Supplies intermediate range

UNIVERSAL ELECTRONICS CO., 1720 Twenty-Second St., Santa Monica, Calif., announces a new line of intermediate range transistorized regulated d-c power supplies, designated as the Q series. They provide output voltages ranging from 5-8 v to from 26-30 v, at currents of 1, 2, 4, 6, 10, 15 and 25 amperes. Regu-

lation of 0.05 v, 0 to full load and 0.05 v per 10-percent line change is provided. Circle 222 on Reader Service Card.

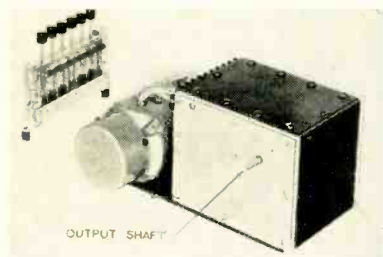

### Transmission Unit multipurpose

HATHAWAY DIVISION, The Hamilton Watch Co., 5800 E. Jewell Ave., Denver 22, Col. A new multipurpose, Class 3 commercial type transmission unit is announced. The 6½-lb package containing five gear sections, is designed for speed, variability and smooth operation. Instantaneous speed changing requires no gear change. Circle 223 on Reader Service Card.

### Gyro Drift Recorder highly accurate

METROLOG CORP., 169 N. Halstead St., Pasadena, Calif., announces a sensitive instrument with better than 1 percent accuracy for measuring and recording drift and random disturbances of gyroscopes, platforms and similar devices. A unique pen makes it impossible for trace to go off-scale, and it will operate unattended for extended periods. It ignores periodic vibration and cyclic inputs which recur at rates in excess of 1 cpm regardless of amplitude of these inputs. It provides a permanent, accurate record which may be attached to the device under test. It has a chart width of 2 in. and a speed of 12 in. per hr. Circle 224 on Reader Service Card.

### Transformers voltage stabilizing

CHICAGO STANDARD TRANSFORMER CORP., 3501 Addison St., Chicago, Ill., has available transformers for use with any type of equipment

precision measurement demands

# WAVELINE MICROWAVE

## instruments

- ATTENUATORS
- SLOTTED LINES
- WAVEGUIDE COUPLERS
- TERMINATIONS
- FREQUENCY METERS
- PHASE SHIFTERS
- DETECTOR MOUNTS
- PRECISION TUNERS

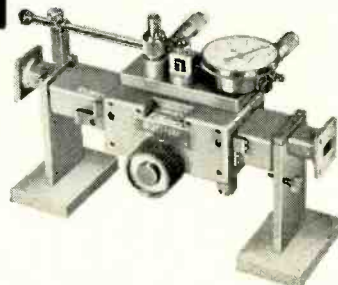

## and components

- MIXERS
- FILTERS
- ANTENNAS
- ROTARY JOINTS
- DIRECTIONAL COUPLERS
- WAVEGUIDE TEES
- DETECTOR MOUNTS
- WAVEGUIDE SWITCHES

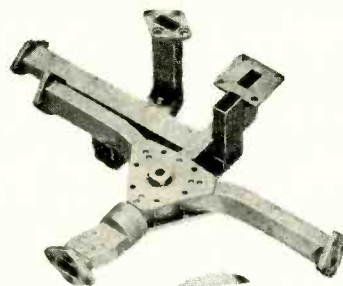

The ninety page Waveline catalog describing over 600 instruments, includes complete technical data, charts, illustrations and engineering reports.

**WAVELINE**  
INC.  
CALDWELL, NEW JERSEY

Phone CApital 6-9100  
TWX Caldwell, N. J. 703



## make all your marking clear... complete... lasting...

WITH A JOB-PROVED METHOD AND MACHINE FROM **MARKEM**

If new products present unusual marking problems, or you'd like to improve your regular day-to-day marking operations, Markem can give you just the help you need. For example, Markem can show you how to automatically feed and imprint both the periphery and top of JETEC 30 case units... maintain high production with frequent imprint changes... position "hard-to-hold" components for exact marking... achieve sharp, readable imprints in small areas or on uneven surfaces... color band at high speed with close registration... assure durability in pre-assembly marking. These - along with hundreds of "standard" jobs - are being done by Markem machines every day.



Markem equipment in your plant provides the marking clarity, durability and speed you need - and often at considerable savings. Get specific help now with *your* requirement, based on nearly 50 years of Markem experience in industrial marking. And ask for a copy of the "Electrical/Electronics" catalog describing 24 Markem machines for marking cylindrical, flat and irregular shapes; tubing, wire, tapes and labels. Write Markem Machine Co., Keene 5, New Hampshire.

# MARKEM

EVERYTHING INDUSTRY NEEDS... FOR PROFITABLE MARKING... SINCE 1911

that requires continuous, automatic voltage regulation. They can be built into the equipment, or can operate as a separate device. Circle 225 on Reader Service Card.

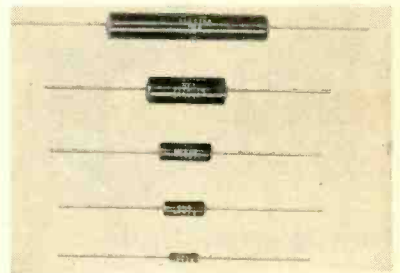

### Metal Film Resistor small, low in cost

ELECTRA MFG. Co., 4051 Broadway, Kansas City, Mo., announces a new molded precision metal film resistor featuring low controlled temperature coefficient, low noise level and high stability under severe humidity conditions. It is claimed to equal or surpass a precision wire wound resistor, yet is smaller, lower in cost, also gives better r-f performance, plus uniformity in size over wide resistance ranges. Circle 226 on Reader Service Card.

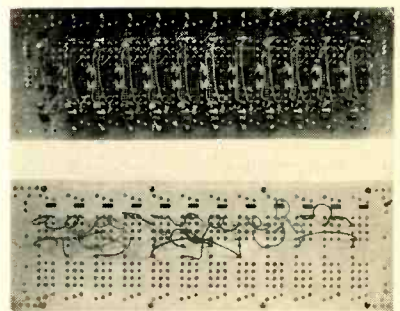

### Logic Unit Board versatile array

GENERAL MILLS, INC., 1620 Central Ave., Minneapolis 13, Minn. This logic unit board is a transistorized digital component from which computers and data handling systems can be assembled simply and at low cost. It is a highly versatile array of basic computer elements which can be rapidly connected to serve complete logic and control functions of complex digital computers. Circle 227 on Reader Service Card.



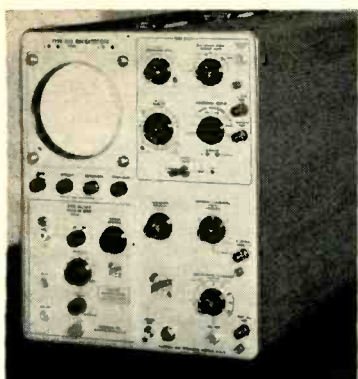

### Oscilloscope d-c to 30 mc

TEKTRONIX, INC., P. O. Box 831, Portland 7, Ore. Type 543 is a fast rise oscilloscope with the plug-in feature. Nine plug-in preamplifiers are available for signal-handling versatility. Sweep range is 0.02  $\mu$ sec/cm to 15 sec/cm, accelerating potential is 10 kv, built-in voltage calibrator has 18 outputs from 0.2 mv to 100 v peak-to-peak. Circle 228 on Reader Service Card.

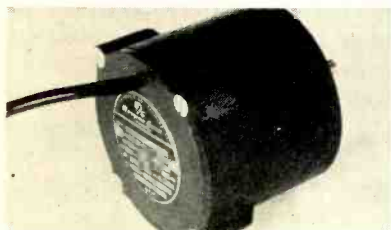

### A-C Motor miniature device

WESTERN GEAR CORP., P. O. Box 182, Lynwood, Calif., announces a new 200 v, 400 cycle, miniature 3 phase a-c motor, model 35YH37. It develops 1/20 hp at 6,500 rpm. Unit was originally designed as a fan motor to circulate air in an aircraft deep freeze compartment. It develops 1/20 hp at 6,500 rpm. 2½ in. in diameter and 2½ in. in length. Circle 229 on Reader Service Card.

### Test Oscillator for 3,950-11,000 mc

FXR, INC., 26-12 Borough Place, Woodside 77, N. Y. The C772A and X772A test oscillators provide self-contained, versatile power sources for the 3,950-11,000 mc frequency range. Maximum output

# NEMS · CLARKE RECEIVERS

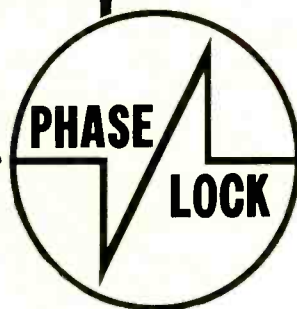

As part of an over-all program to provide the ultimate in telemetry receivers commensurate with the state of the art, Nems-Clarke now offers the 1400 Series Receivers employing phase-lock detection.

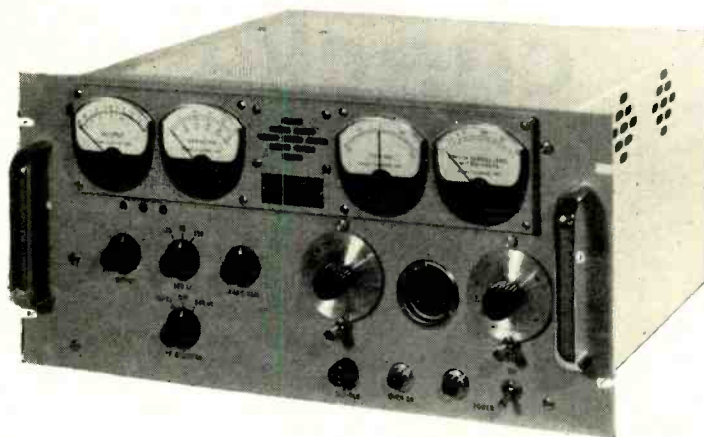

### TYPE 1432 SPECIFICATIONS

<b>Frequency range</b> (determined by plug-in crystals)	215 to 260 mc
<b>Noise figure</b>	less than 8 db
<b>Video output</b>	Sensitivity: 0.16v peak-to-peak per kc of deviation. Frequency response within 3db. AC coupled, 10 cps to 100 kc per second. Adjustable output control on front panel.
<b>VU Meter in Video Output Circuit</b>	Frequency response: flat over frequency range of 400 cycles to 80,000 cycles. Provided with front panel adjustable reference level control.
<b>Frequency Monitor Output</b>	30 mc
<b>Signal Strength Recorder Output</b>	High impedance, 0-15v
<b>Spectrum Display Output</b>	30 mc
<b>Input Impedance</b>	50 ohms nominal
<b>IF Rejection</b>	Greater than 60 db
<b>Image Rejection</b>	Greater than 48 db
<b>IF Bandwidths</b>	500 kc and 100 kc
<b>Power Input</b>	117v AC, 60 cycles, approximately 150 watts
<b>Size</b>	8¾" x 19" x 16½"
<b>Weight</b>	Approximately 40 pounds
<b>Finish</b>	Gray enamel

*We reserve the right to make changes in specifications.*

**NEMS · CLARKE COMPANY**

A DIVISION OF VITRO CORPORATION OF AMERICA

919 JESUP-BLAIR DRIVE • SILVER SPRING, MARYLAND • JUNIPER 5-1000

expecting  
a  
check?

You'll get it quicker if you gave your postal delivery zone number with your address.

The Post Office has divided 106 cities into postal delivery zones to speed mail delivery.

Be sure to include zone number when writing to these cities; be sure to include *your* zone number in *your* return address—after the city, before the state.

of 10-100 mw provides considerably more power than signal generators operating in the same frequency range. Features include an integral power supply and modulator, single knob direct-reading frequency control, automatic reflector voltage tracking and an r-f attenuator. Internal pulse, square wave, and provision for external pulse or frequency modulation are available. Circle 230 on Reader Service Card.

**Laminated Tape Head for four-track use**

THE NORTRONICS Co., Inc., 1015 S. Sixth St., Minneapolis 4, Minn., announces the new model TLD-L laminated stereophonic in-line record/playback magnetic tape head. The laminated pole-piece construction reduces core losses, and, as a result, model TLD-L will record and reproduce frequencies between 30 and 15,000 cps at a tape speed of  $3\frac{3}{4}$  ips. The gap thickness is less than 100-millionths of an in. and its depth is unusually large to promote long life. Track width of each section is 0.043 in. Center-to-center spacing between sections is 0.136 in. Circle 231 on Reader Service Card.

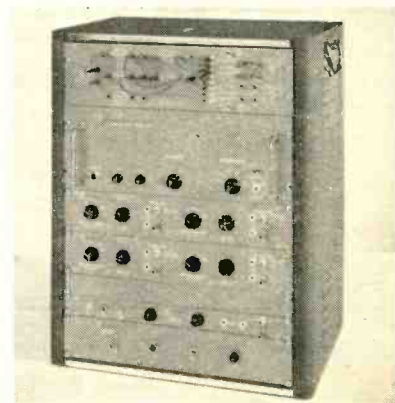

**Pulse Generator module construction**

RUTHERFORD ELECTRONICS Co., 8944 Lindblade St., Culver City, Calif. Model B3-2A is a high repetition rate multiple pulse generator. Unit consists of a generator providing repetition rates from 10 cps to 1 mc, + variable delay circuits with delay from 0 to 10,000  $\mu$ sec for

# Get out your pencil and help yourself to electronics READER SERVICE

## it's free—it's easy—it's for your convenience

Use these handy READER SERVICE CARDS for more information on:

ADVERTISEMENTS—NEW PRODUCTS—LITERATURE OF THE WEEK

- 1—Circle the number on the postpaid card below that corresponds to the number at the bottom of Advertisement, New Product item, or Literature of the Week selection.
- 2—Please print carefully, as it is impossible to process cards that are not readable.

**Additional Postage MUST be added to cards for all FOREIGN MAILINGS**

**A**

**FOR SPECIFIC ITEMS IN MULTI-PRODUCT ADVERTISEMENTS**

For more information on specific items in multi-product advertisements, print carefully on the Reader Service Card below in Box "A" the circle number of the advertisement and the specific product(s) on which you desire more information.

**HOW TO SUBSCRIBE TO electronics**

If you are not a subscriber and you desire to receive electronics regularly, fill in the section "FOR SUBSCRIPTIONS" on card below

Send no money, electronics will bill you at the address indicated on the Reader Service Card.

**JAN 9.59**  
CARD EXPIRES  
**MAR 9.59**

**electronics • READER SERVICE CARD • Please Print Carefully**

YOUR NAME \_\_\_\_\_ POSITION \_\_\_\_\_

COMPANY \_\_\_\_\_

ADDRESS \_\_\_\_\_

**CIRCLE THESE NUMBERS WHEN YOU ARE INTERESTED IN ALL ITEMS SHOWN**

1	2	3	4	5	6	7	8	9	10	11	12	13	14	15	16	17	18	19	20	21	22	23	24	25	26	27	28	29	30
31	32	33	34	35	36	37	38	39	40	41	42	43	44	45	46	47	48	49	50	51	52	53	54	55	56	57	58	59	60
61	62	63	64	65	66	67	68	69	70	71	72	73	74	75	76	77	78	79	80	81	82	83	84	85	86	87	88	89	90
91	92	93	94	95	96	97	98	99	100	101	102	103	104	105	106	107	108	109	110	111	112	113	114	115	116	117	118	119	120
121	122	123	124	125	126	127	128	129	130	131	132	133	134	135	136	137	138	139	140	141	142	143	144	145	146	147	148	149	150
151	152	153	154	155	156	157	158	159	160	161	162	163	164	165	166	167	168	169	170	171	172	173	174	175	176	177	178	179	180
181	182	183	184	185	186	187	188	189	190	191	192	193	194	195	196	197	198	199	200	201	202	203	204	205	206	207	208	209	210
211	212	213	214	215	216	217	218	219	220	221	222	223	224	225	226	227	228	229	230	231	232	233	234	235	236	237	238	239	240
241	242	243	244	245	246	247	248	249	250	251	252	253	254	255	256	257	258	259	260	261	262	263	264	265	266	267	268	269	270
271	272	273	274	275	276	277	278	279	280	281	282	283	284	285	286	287	288	289	290	291	292	293	294	295	296	297	298	299	300

INSIDE FRONT COVER \_\_\_\_\_ INSIDE BACK COVER \_\_\_\_\_ (2)

**FOR SUBSCRIPTIONS: (CHECK ONE BOX)**

DOMESTIC  1 yr. — \$ 6.00  
 2 yrs. — \$ 9.00  
 3 yrs. — \$12.00

CANADA  1 yr. — \$10.00

FOREIGN  1 yr. — \$20.00

Product(s) manufactured: \_\_\_\_\_

or Service(s) Performed: \_\_\_\_\_

**A**

Circle No.	Product
_____	_____
_____	_____
_____	_____
_____	_____

**JAN 9.59**  
CARD EXPIRES  
**MAR 9.59**

**electronics • READER SERVICE CARD • Please Print Carefully**

YOUR NAME \_\_\_\_\_ POSITION \_\_\_\_\_

COMPANY \_\_\_\_\_

ADDRESS \_\_\_\_\_

**CIRCLE THESE NUMBERS WHEN YOU ARE INTERESTED IN ALL ITEMS SHOWN**

1	2	3	4	5	6	7	8	9	10	11	12	13	14	15	16	17	18	19	20	21	22	23	24	25	26	27	28	29	30
31	32	33	34	35	36	37	38	39	40	41	42	43	44	45	46	47	48	49	50	51	52	53	54	55	56	57	58	59	60
61	62	63	64	65	66	67	68	69	70	71	72	73	74	75	76	77	78	79	80	81	82	83	84	85	86	87	88	89	90
91	92	93	94	95	96	97	98	99	100	101	102	103	104	105	106	107	108	109	110	111	112	113	114	115	116	117	118	119	120
121	122	123	124	125	126	127	128	129	130	131	132	133	134	135	136	137	138	139	140	141	142	143	144	145	146	147	148	149	150
151	152	153	154	155	156	157	158	159	160	161	162	163	164	165	166	167	168	169	170	171	172	173	174	175	176	177	178	179	180
181	182	183	184	185	186	187	188	189	190	191	192	193	194	195	196	197	198	199	200	201	202	203	204	205	206	207	208	209	210
211	212	213	214	215	216	217	218	219	220	221	222	223	224	225	226	227	228	229	230	231	232	233	234	235	236	237	238	239	240
241	242	243	244	245	246	247	248	249	250	251	252	253	254	255	256	257	258	259	260	261	262	263	264	265	266	267	268	269	270
271	272	273	274	275	276	277	278	279	280	281	282	283	284	285	286	287	288	289	290	291	292	293	294	295	296	297	298	299	300

INSIDE FRONT COVER \_\_\_\_\_ INSIDE BACK COVER \_\_\_\_\_ (2)

**FOR SUBSCRIPTIONS: (CHECK ONE BOX)**

DOMESTIC  1 yr. — \$ 6.00  
 2 yrs. — \$ 9.00  
 3 yrs. — \$12.00

CANADA  1 yr. — \$10.00

FOREIGN  1 yr. — \$20.00

Product(s) manufactured: \_\_\_\_\_

or Service(s) Performed: \_\_\_\_\_

**A**

Circle No.	Product
_____	_____
_____	_____
_____	_____
_____	_____

# ONE!

In every industry there's always ONE accepted Product and Data Buying Book...in electronics it's the BUYERS' GUIDE — fundamental in any sales program aimed at the electronics and allied industries. Its 52,000 paid subscribers are important Design-

Research/Production/Management Engineers, who, individually, or working in combination with one another, influence the purchase of products, materials and services... whatever is bought by the entire industry.



**electronics** 

A MCGRAW-HILL PUBLICATION

330 West 42nd Street • New York 36, N.Y.

**BUSINESS REPLY MAIL**

NO POSTAGE STAMP NECESSARY IF MAILED IN THE UNITED STATES

6¢ Postage Will Be Paid By

**ELECTRONICS**

Reader Service Dept.

330 West 42nd Street

New York 36, N. Y.

FIRST CLASS  
PERMIT NO. 64  
(SEC. 34.9 P.L.&R.)  
NEW YORK, N. Y.



**BUSINESS REPLY MAIL**

NO POSTAGE STAMP NECESSARY IF MAILED IN THE UNITED STATES

6¢ Postage Will Be Paid By

**ELECTRONICS**

Reader Service Dept.

330 West 42nd Street

New York 36, N. Y.

FIRST CLASS  
PERMIT NO. 64  
(SEC. 34.9 P.L.&R.)  
NEW YORK, N. Y.



controlling pulse position or pulse width, and 2 pulse forming units producing pulses of positive or negative polarity with rise and fall times of 0.02  $\mu$ sec and amplitude of 25 v. Circle 232 on Reader Service Card.

### Snap-Action Switch with mounting ears

GENERAL CONTROLS AUTOMATION DIVISION, 8070D McCormick Blvd., Skokie, Ill. Convenient rigid mounting back of panel or other surface in fixed relation to actuating mechanisms is provided by integrally molded ears on basic Klik-switches. Side mounting holes also permit use of the mounting ears for attaching various forms of actuating mechanisms. The snap-action switch mechanism is encased in molded phenolic. Switches are available with spdt or spst normally closed contacts rated 8 amperes at 115 v a-c, non-inductive load. Circle 233 on Reader Service Card.



### Servo Pots high precision

CIRCUIT INSTRUMENTS INC., 2801 Anvil St., North, St. Petersburg 33, Fla. A new series of servo-potentiometers combine high precision and electrical characteristics in various combinations of materials. Featuring low torque operation, linear or nonlinear windings and multiple taps, the line is available with diameters of  $\frac{7}{8}$  in.,  $1\frac{1}{16}$  in.,  $1\frac{1}{8}$  in.,  $1\frac{3}{4}$  in., 2 in. and 3 in. and ganged to requirement. Standard units employ all precision machined parts and precision ball bearings resulting in high mechanical accuracy, and are



# NOW!

*Certified*

## PRECISION STOCK GEARS

STOCK GEARS 32 TO 120 PITCH  
A.G.M.A. PRECISION #3...  
IMMEDIATE DELIVERY

Tens of thousands of gears of all types . . . 32, 48, 64, 72, 96 and 120 diametral pitches of  $14\frac{1}{2}^\circ$  and  $20^\circ$  pressure angles. APPCO offers them all for quick delivery. Each one "Certified" to meet or surpass A.G.M.A. specifications.

APPCO Certified Precision Stock Gears offer 7 finishing options on aluminum gears at no extra cost . . . compatible bore tolerances for accurate fitting of gears, shafts and bearings. Each gear is completely sealed on shipping tray with plastic cover . . . always "factory fresh" and free of dust, corrosion and scratches.

APPCO Precision Gears are engineered and manufactured to allow for accurate assembly of precision units . . . held to tolerances that assure precise fits to standard instrument bearings, shafting, etc., according to accepted industry practice and A.G.M.A. specifications. For complete technical data and catalog write to Atlas Precision Products Co., Castor and Kensington Aves, Phila. 24, Pa.



Division of  
**PRUDENTIAL INDUSTRIES INC.**

- **NOW AVAILABLE**
- **OFF-THE-SHELF DELIVERY**



**WINCHESTER  
ELECTRONICS  
INCORPORATED**

- **CONNECTORS**
- **TERMINALS**
- **ACCESSORIES**

**GREENE SHAW**  
COMPANY, INC.  
341 WATERTOWN ST., NEWTON 58, MASS.  
DEatur 2-9300 — DEatur 2-6500

CIRCLE 62 READERS SERVICE CARD



**FOREMOST**  
in  
**SONAR**

**EDO CORPORATION**  
College Point, L.I., N.Y.  
Since 1925

CIRCLE 63 READERS SERVICE CARD

supplied with turret terminals which are gold plated for ease of soldering. Circle 234 on Reader Service Card.



### **Distortion Meter covers a-f spectrum**

BARKER & WILLIAMSON, INC., Bristol, Pa. For accurate measurements of residual noise and harmonic content in the audio frequency ranges, as in FCC proof-of-performance tests, a reliable distortion meter is invaluable. A new distortion meter now available requires only 0.3 v for noise and distortion measurements, and measures fundamentals from 30 to 15,000 cps and harmonics to 45,000 cps. For measurements of low level audio voltages in determining noise and harmonic content, full scale readings of 0.3, 0.1, 0.03, 0.01, 0.003 v are provided. Circle 235 on Reader Service Card.

### **Silicon Rectifiers self-protecting**

TRANS-SIL CORP., 55 Honeck St., Englewood, N. J. The new diffused technique for producing silicon rectifiers makes it possible to protect such units against short circuits, surge currents and sustained overloads, through the use of low-cost standard, commercial fuses. Rectifier stacks are available in half-wave or full-wave configurations from 1.0 ampere to several thousand, with peak inverse ratings in 50 v multiples to thousands of volts. Circle 236 on Reader Service Card.

### **Controller and contact meter**

WATERS MFG., INC., Wayland, Mass. C-Trol, a new contact-meter-

# electronics READER SERVICE CARDS

...have increased the flow of product and service literature to readers.

...have helped increase manufacturers' sales.

Reader Service Cards have been provided to get quick and easy information on products.

Avail yourself of this Service to get all the information you need.

Manufacturers are cooperating wholeheartedly with the Service to supply information promptly.

**electronics**  
A MCGRAW-HILL PUBLICATION  
330 WEST 42nd ST. NEW YORK 36, N. Y.

controller, continuously controls or limits any electrical variable. The self-contained, transistorized unit uses no locking coils or magnetic contacts. Reset is automatic. Modular design permits separation of control unit and contact meter. Circle 237 on Reader Service Card.

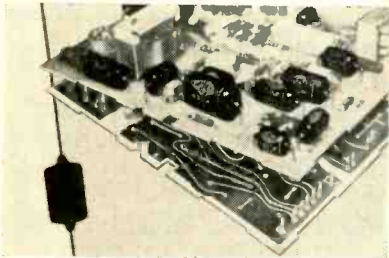

### Molded Capacitors bifilar winding

RHOMBIC ASSOCIATES, 60 West 45th St., New York, N. Y., has available Wima Tropicur molded capacitors. Their particular advantages are maximum safety with a minimum of size and negligible damping because of the bifilar winding. Also, they have a perfect seal between element and terminal wires due to an exclusive hot-dip fusing process. Circle 238 on Reader Service Card.

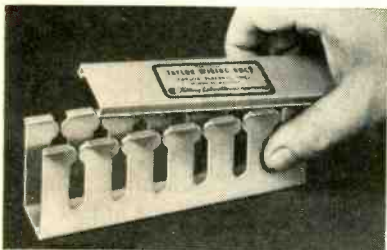

### Wiring Duct rigid vinyl

TAYLOR ELECTRIC, 15400 Dale, Detroit 23, Mich. A new wiring duct features slots instead of holes to speed installation of large lugged wires on control panels, switch gear and electronic consoles. Type 0 duct eliminates harness lacing or lug attachment after assembly. It holds all wires in place with snap-on cover. The duct is extruded from high impact rigid vinyl plastic, which is oil and acid resistant and self-extinguishing. Circle 239 on Reader Service Card.

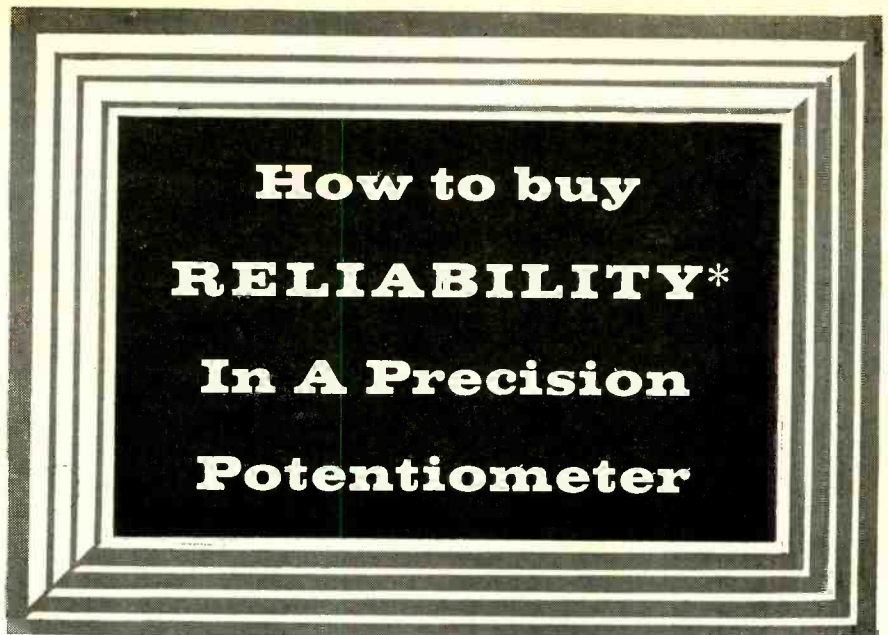

## Answer: SPECIFY ALL THESE FAIRCHILD RELIABILITY FEATURES *at the lowest price in the industry!*

1. Welded terminal and taps. A positive electrical and mechanical bond to withstand high temperatures, shock and vibration.
2. Machined metal case for retention of accuracy, especially under high temperature and/or humidity.
3. Metal inserts in molded wiper hubs for positive wiper positioning, for accuracy under shock, vibration, acceleration.
4. Precious metal resistance wires where needed for extremely low noise values, especially in corrosive atmospheres and for long storage life.
5. Precious metal contacts for low noise and high temperature.
6. One piece wiper construction for life, accuracy, low noise and low torque.
7. Stainless steel clamp bands capable of withstanding high torque, and the stresses and strains of shock, vibration and acceleration.
8. Precision stainless steel ball bearings — for low torque, high temperature, high vibration and shock characteristics.

PLUS 100% inspection AND a separate Quality Control program which puts 1 out of every 100 production units through complete environmental torture tests.

Since the ultimate price of a potentiometer is directly related to the reliability built into it . . . you only get what you pay for in a "pot".

Only Fairchild Linear and Non-Linear High Reliability Pots incorporate *all* of the above features. This High Reliability group can be had in  $\frac{7}{8}$ " to 2" diameters, single and multi-turn, in standard and high temp versions and with accuracies as high as .009%.

For more information write Dept. 11E.

\*Fairchild's Built-in SAFETY FACTORS Beyond the Specs for Reliability in Performance.



**FAIRCHILD**  
CONTROLS CORPORATION

#### COMPONENTS DIVISION

225 Park Avenue      6111 E. Washington Blvd.  
Hicksville, L. I., N. Y.      Los Angeles, Cal.

A Subsidiary of Fairchild Camera and Instrument Corporation  
Potentiometers • Gyros • Pressure Transducers • Accelerometers

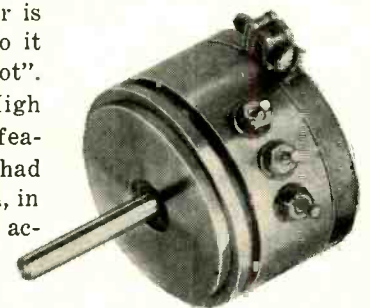

## ATTRACT AND HOLD TECHNICAL PERSONNEL

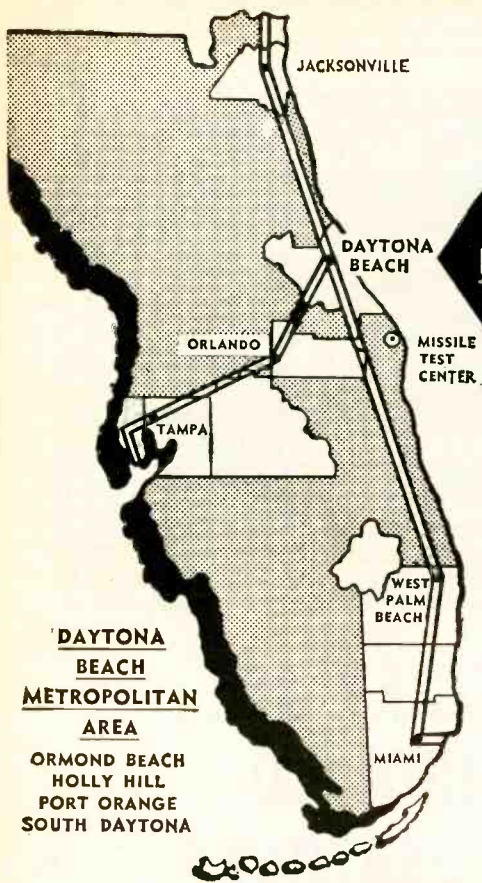

## STRATEGIC LOCATION FOR GROWTH INDUSTRIES **DAYTONA BEACH** **FLORIDA** Metropolitan Area Industrial Sites

Daytona Beach, the east-to-west terminal on the north-to-south route of the projected Federal Limited Access Freeway System, gives industry a plus for the future.

Write for new 101 page  
Industrial Brochure  
**R. H. MILES, MGR.**  
**INDUSTRIAL DEPARTMENT**  
**CHAMBER OF COMMERCE**  
**DAYTONA BEACH, FLORIDA**

CIRCLE 66 READERS SERVICE CARD

## Literature of

### MATERIALS

**Magnetic Shielding.** Magnetic Shield Division, Perfection Mica Co., 1322 No. Elston Ave., Chicago 22, Ill. Newly issued 31-page manual No. 101-122 is a comprehensive summation describing design and fabricating techniques for non-shock sensitive, non-retentive Netic and Co-Netic magnetic shielding. Circle 255 on Reader Service Card.

**Acetate Tapes.** Minnesota Mining and Mfg. Co., 900 Bush St., St. Paul 6, Minn. A four-page booklet lists physical and electrical properties of Scotch brand acetate tapes, as well as the military specifications met by the tapes. Circle 256 on Reader Service Card.

### COMPONENTS

**Servo Amplifiers.** Magnetic Amplifiers, Inc., 632 Tinton Ave., New York 55, N. Y. Bulletin S-893 describes the new line of miniaturized transistor-magnetic servo amplifiers with power ratings to 16 w. Circle 257 on Reader Service Card.

**Low Level D-C Measurements.** Microdyne, 300 W. Washington, Chicago 6, Ill. Low d-c potentials in the microvolt ranges can now be read easily by means of a new precision chopper inverter described in a recent 9-page brochure. Circle 258 on Reader Service Card.

**Solder Terminals.** Alpine Electronic Components, Inc., Waterbury, Conn. Catalog 158, section 1, contains information on a line of solder terminals, and introduces three new terminals specifically designed for molding into plastic headers for use with printed circuits or with miniature tube sockets. Circle 259 on Reader Service Card.

**Servo Motors.** Ketay Department, Norden Division, United Aircraft Corp., Commack, Long Island, N. Y. A recent bulletin contains applications data for stand-

## GREEN Pantograph Engravers ELIMINATE DELAYS!

PORTABLE  
40-POUND  
BENCH-  
MODEL  
106



Famous 2 or 3-dimensional engraver, successfully used by thousands, features 5 positive, accurate pantograph ratios. Versatile ball bearing spindle has three speeds up to 14,000 rpm; height of pantograph and position of cutter are continuously adjustable; one copy carrier (supplied) accepts all standard master type sizes.

The Model 106 has proven incomparable for speed and accuracy... yet reasonably priced.

Cutter grinders, rotary tables, master letters, compound slides, name plates and all required accessories. For complete information, write to

Keep the work  
in your own plant.

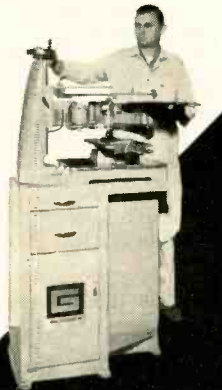

### MODEL D2 HEAVY-DUTY 2-DIMENSIONAL

- 575 pounds — rigid, sturdy, precise
- Vertical adjustment of copy table automatic with Pantograph
- Unobstructed on three sides to take large work
- Micrometer adjustment for depth of cut
- Ball-bearing construction throughout — super-precision ball bearing spindle
- Spindle speeds up to 26,000 rpm for engraving or machining modern materials
- Ratios 2 to 1 to infinity — master copy area 26" x 10"
- Vertical range over 10"



**GREEN  
INSTRUMENT  
COMPANY, INC.**

363 PUTNAM AVENUE, CAMBRIDGE 39, MASS.

CIRCLE 67 READERS SERVICE CARD



# the Week

ard and custom servo motors, including schematics of units operating direct plate to plate, with transistorized amplifiers and with magnetic amplifiers. Circle 260 on Reader Service Card.

## EQUIPMENT

**Synchro and Resolver Testing.** Theta Instrument Corp., 48 Pine St., East Paterson, N. J. A bound catalog describes in detail the theory and method of resolver testing. It attempts to remove the mystery of these complex tests through complete coverage of both the measurements and the test equipment. Circle 261 on Reader Service Card.

**Radio Interference Meters.** Stoddard Aircraft Radio Co., Inc., 6644 Santa Monica Blvd., Hollywood 38, Calif. Five new 4-page bulletins give specifications, military approval data and applications of radio interference and field intensity measuring equipments covering a frequency range of 30 cps to 1,000 mc. Circle 262 on Reader Service Card.

**Recorder Controller Assembly.** Leeds & Northrup Co., 4934 Stenton Ave., Philadelphia 44, Pa. Complete information about the model S Speedomax G multiple-point recorder controller assembly for two-position control on many processes involving multi-zone control is found in data sheet ND46-33(6). Circle 263 on Reader Service Card.

## FACILITIES

**Plug/Harness Systems.** Cannon Electric Co., 3208 Humboldt St., Los Angeles 31, Calif. A description of the company's plug/harness systems facilities is contained in the illustrated catalog HC-1. The systems described are used in missile circuitry and other applications where more than usual ruggedness and reliability are required. Circle 264 on Reader Service Card.

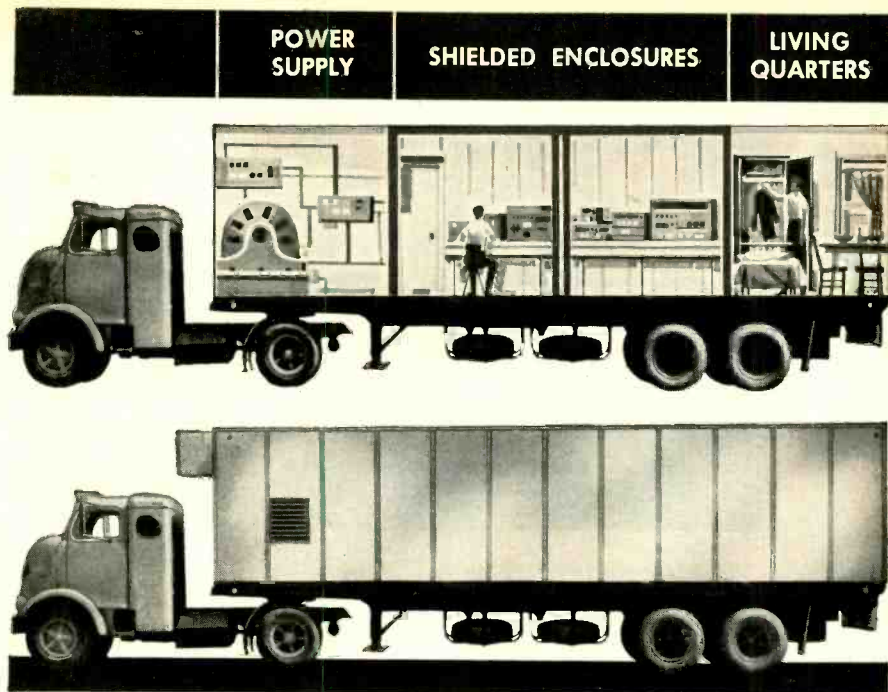

## MOBILE SHIELDED ENCLOSURES

custom designed for on-the-spot interference testing

Now you can get the reliability and the outstanding performance of ACE Shielded Enclosures on wheels! . . . complete with self-contained power source and living accommodations . . . custom designed to your specific requirements.

### 1. ACE SHIELDED TRAILERS & TRUCKS

Fabricated to ACE's patented RFI\* design, using one, two or three shields, these enclosures provide over 100 db attenuation at all frequencies from 15 kc through 1,000 mc and will closely approximate 100 db at 10,000 mc . . . exceeding the attenuation requirements of MIL-E-4957A (ASG). Provisions can be made for mounting antennas, shock-mounting test equipment, installing intercom systems and coaxial connector panels.

### 2. SELF-CONTAINED POWER SUPPLY

The mobile unit can be equipped with a power control panel and a diesel driven generator having outputs up to 20 kw. External power connections can also be furnished.

### 3. LIVING QUARTERS

Complete living quarters having all the facilities necessary for the comfort of operating personnel can be furnished. The entire trailer can be air conditioned or heated.

ACE handles the entire mobile shielded enclosure package — from the wheels on up. Every detail is carefully engineered to give the highest attenuation and the most efficient performance. The trailer is designed to meet the legal specifications of all states. Write to ACE outlining your mobile shielded requirements. Be sure to request a copy of ACE's standard enclosure catalog.

\*Lindsay Structure



First and Finest in Shielded Enclosures

ACE ENGINEERING & MACHINE CO., INC.

Tomlinson Road • Huntingdon Valley • Pennsylvania



## CEC Opens New Plant

CONTROL ELECTRONICS CO., INC., recently moved into its new plant in Huntington Station, N. Y. This building, embodying the latest in production and engineering facilities, comprises 11,000 sq ft of space.

Company manufactures precision delay lines and test equipment, such as phase angle meters, vhf/uhf frequency calibrators and radar range calibrators. Its engineering department, in addition to developing the company's products, does research and development for the government on complex electronic and electromechanical devices.

In keeping with its growth pattern set over the past few years, CEC has added more engineers and supporting personnel. It expects to be in full production shortly on new product lines consisting of band pass filters, precision frequency standards, and magnetostrictive delay lines.

According to Gene Wendolkowski, vice president, the new plant is laid out for efficient and rapid servicing of customers' needs. The plant layout allots 5,500 sq ft for production and assembly, 4,000 sq ft for engineering, and 1,500 sq ft for administrative functions. The engineering laboratories are equipped with the latest, highly accurate, electronic measuring equipment and standards. Additional R&D facilities include a separate r-f screen room and environmental chambers for temperature and life tests.

## ASCOP Names Technical V-P

NEWLY appointed technical vice-president of the Applied Science Corp. of Princeton is Erwin Donath.

In his new post he will report directly to ASCOP president Thomas C. Roberts and will participate in all top management actions. He will supervise the operation of the Instrumentation Division, the company's largest operating unit which develops and produces airborne and ground based telemetering equipment. In addition, he will be directly responsible for the full scope of the company's technical operations, from advanced research and

development through final product design and marketing.

Donath joined the company in 1948 as senior engineer and became chief engineer in 1953. For the last two years he has been responsible



for the direction of the company's long-range R&D programs, and the company's entry into commercial markets with new industrial telemetering and supervisory control equipment.

## Philco Appoints Four Managers

KEY APPOINTMENTS to handle Philco Corporation's increasing activities in the semiconductor field were recently announced by William H. Forster, director of research for the Solid State Electronics Research Department.

Charles H. Sutcliffe has been named manager of component development; James B. Angell, manager of circuit research; Marvin E. Lasser, manager of applied physics research; and Edmundo Gonzalez-Correa as manager of research planning.



## TMC Chooses Chief Engineer

TECHNICAL MEASUREMENT CORP., North Haven, Conn., manufacturer of nuclear radiation measurement equipment, appoints Donald S. Davidson as chief engineer.

Prior to joining TMC, Davidson was associated with Knolls Atomic Laboratory in Schenectady, N. Y. He is known for his work in the field of transistorized instrumentation, particularly multichannel pulse analysis systems, reactor con-

# Continental Connector

## TAPER PIN TERMINAL BLOCKS

SERIES 145-58  
DUAL ROW

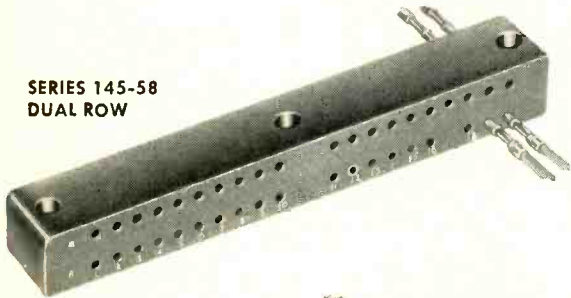

SERIES 145-58  
SINGLE ROW



SERIES 145-60  
FOR PRINTED  
CIRCUITRY

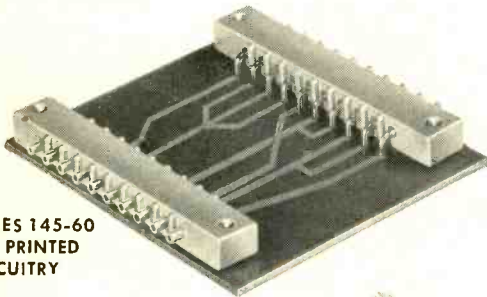

SERIES 145-48  
TRIPLE STACKED

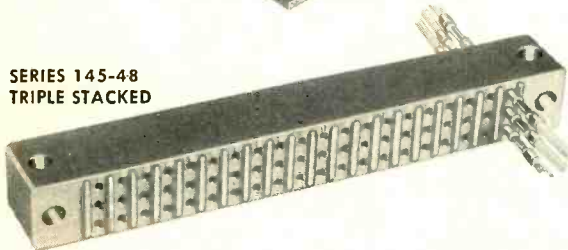

SERIES MB WITH  
SOLDER CUPS FOR  
CONVENTIONAL WIRING

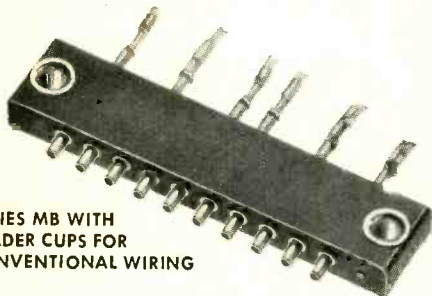

# for computer applications

### MACHINE TAPERED FOR PRECISION ... MOLDED IN FOR RUGGEDNESS

Here is an improved terminal block design with permanently molded-in and precision reamed taper pin receptacles for maximum durability. These receptacles maintain secure electrical and physical contact with AMP Series "53" solderless taper pin. The body is molded of high impact, glass reinforced Alkyd 446 (MIL-P-14E, Type MA160). Other molding materials on request. Taper receptacles are brass, gold plated over silver for low contact resistance.

Continental Connector can supply all types of taper pin blocks and connectors for conventional wiring and printed circuitry in any combination of feed-through shorting or non-shorting terminals. Our engineering department is prepared to cooperate in solving your connector application problems. Write today for technical information.

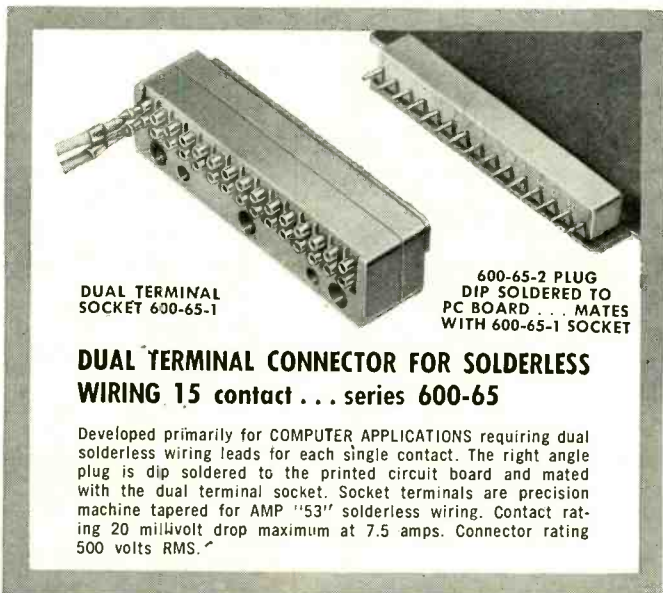

DUAL TERMINAL  
SOCKET 600-65-1

600-65-2 PLUG  
DIP SOLDERED TO  
PC BOARD . . . MATES  
WITH 600-65-1 SOCKET

### DUAL TERMINAL CONNECTOR FOR SOLDERLESS WIRING 15 contact . . . series 600-65

Developed primarily for COMPUTER APPLICATIONS requiring dual solderless wiring leads for each single contact. The right angle plug is dip soldered to the printed circuit board and mated with the dual terminal socket. Socket terminals are precision machine tapered for AMP "53" solderless wiring. Contact rating 20 millivolt drop maximum at 7.5 amps. Connector rating 500 volts RMS.

Manufactured by Continental Connector Corporation, Woodside 77, N. Y.

You're  
always  
sure  
with

# DeJUR

electronic  
components

Exclusive Sales Agent  
DeJUR-Amsco Corporation  
45-01 Northern Boulevard  
Long Island City 1, N. Y.

**AVAILABLE**  
**424**  
**Industrial Sites**

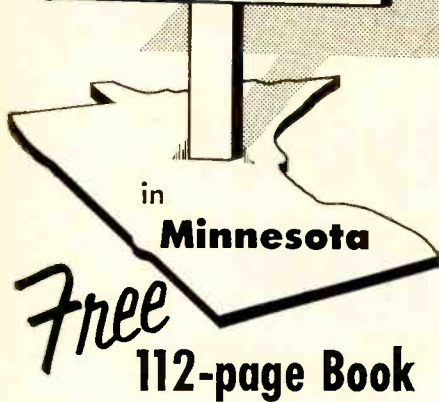

filled with photos and facts about latest industrial data on 123 Minnesota cities, their available sites, and names of local contact. A gold-mine of site-finding facts! For your copy of "Minnesota Welcomes New Industry," write on your firm's letterhead:

Dept. of Business Development, State Capitol,  
Dept. 436 St. Paul 1,

**Minnesota**

CIRCLE 70 READERS SERVICE CARD

**I Bought My Wife a Sports Car with the EXTRA MONEY**



**I earned in Mobile-Radio Maintenance!**

Sure, an engineer's pay is good—but mine just wouldn't stretch far enough to give my family all the nice things they deserve. So in my spare time I'm servicing commercial mobile-radios in my home town. And I'm mighty proud to think of my wife driving that new Thunderbird!

This can be your story, too. Send coupon for your free copy of "HOW TO MAKE MONEY IN MOBILE-RADIO MAINTENANCE." Published by Lampkin Laboratories, Inc., manufacturers of the 105-B Micrometer Frequency Meter & 205-A FM Modulation meter.

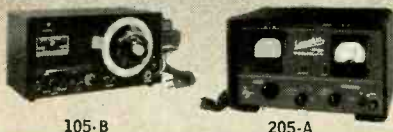

105-B

205-A

**LAMPKIN LABORATORIES, INC.**  
Instruments Div., Bradenton, Fla.

At no obligation to me please send "HOW TO MAKE MONEY IN MOBILE-RADIO MAINTENANCE."

Name \_\_\_\_\_  
Address \_\_\_\_\_  
City \_\_\_\_\_ State \_\_\_\_\_

CIRCLE 71 READERS SERVICE CARD

trol and safety instruments.

In addition to other duties at Technical Measurement Corp., Davidson will be responsible for the completion of a new line of transistorized instruments.



**California Gets New Company**

FORMATION of Continental Device Corp. in Hawthorne, Calif., was recently announced by Joseph S. O'Flaherty who will serve as the new company's president. O'Flaherty was formerly manager of the Semiconductor Division of Hughes Aircraft Co.

Continental Device Corp. will specialize in the research, development, and production of semiconductor devices.



**Oldfield Joins Raytheon**

HOMER R. OLDFIELD, JR. has been appointed assistant manager of the

**HOW ABOUT YOU?**

Do you know that many cancers can be cured if detected early? That an annual health checkup is your best protection against cancer?

Are you giving yourself this big advantage? Or are you taking chances with your life because of foolish attitudes about cancer like these?



**DON'T EVEN MENTION THAT WORD!**

Fear keeps some people from even *learning* cancer facts that can save their lives.

**NEVER FELT BETTER!**



Checkups help to detect cancer in its "silent" stage before you notice any symptom.



**COSTS TOO MUCH!**

Dollars you spend for the protection of your health can mean years of life.

Millions of Americans have made an annual checkup a habit... *for life*. How about you?

AMERICAN CANCER SOCIETY

Government Equipment Division for Raytheon Mfg. Co., Waltham, Mass.

A member of the General Electric firm for the past 13 years, Oldfield has resigned his position as general manager of the firm's computer department at Phoenix, Ariz., which he had held since 1955.

## Sprague Advances James LeGette

APPOINTMENT of James LeGette as manager of the Interference Control Laboratory located in Los Angeles, Calif., is announced by Fred Scarborough, manager of the Sprague Electric Company's Interference Control Field Service Department. He moves up from the post of assistant manager.

LeGette was previously with Chance-Vought Aircraft, having worked on such projects as the F8U Fighter and the Regulus missile.

## News of Reps

Donner Scientific Co., San Francisco Bay Area manufacturer of analog computers, linear servo accelerometers, and electronic test instruments, has named Hawthorne Electronics as engineering sales rep for Oregon, Washington and Idaho.

Four new reps were recently appointed by Scientific-Atlanta, Inc., Atlanta, Ga.

George G. Gostenhofer & Associates with offices in Waltham, Mass., will cover the New England states; D. B. Associates with offices in Syracuse and Buffalo, N. Y., will handle upstate New York; and the Gawler-Knoop Company with offices in Roseland, N. J., Wyncote, Pa., and Silver Spring, Md., will cover the rest of the territory formerly covered by the H. L. Hoffman Company. Phillips Electronics Industries, Ltd., of Toronto, Canada, will cover the Canadian territory which has been handled on a direct basis until this time.



**JUST  
PUBLISHED**

## New Working Aids from McGraw-Hill

### FOUNDATIONS OF INFORMATION THEORY

THIS authoritative book fills the need for a concise and thorough explanation of the mathematical theory of information. It is designed specifically to help you more effectively meet today's requirements in electronics, electrical engineering, and other technical fields. The book assumes no prior knowledge of information theory—it starts with basic concepts and takes you in logical fashion through discrete channels, semi-continuous channels, and the binary symmetric channel. By AMIEL FEINSTEIN, Acting Asst. Prof., Depts. of Statistics and Electr. Engg., Stanford U. 137 pp., \$6.50.

### CONTROL SYSTEM COMPONENTS

An analytic treatment of a number of the most commonly used components in servomechanisms and other feedback control systems. Methods of analysis and basic engineering principles are presented from the point of view of the systems engineer, rather than specific discussions of commercial devices. Main emphasis is placed on the calculation of transfer functions. Recent advances in magnetic amplifiers, transistors, and hydraulic and pneumatic systems are covered. By JOHN E. GIBSON, Assoc. Prof. of Electr. Engg., Purdue U., and FRANZ B. TUTEUR, Assoc. Prof. of Electr. Engg., Yale University. 480 pp., illus., \$12.00.

### LOGIC MACHINES AND DIAGRAMS

Gives you a complete survey of mechanical and electrical machines designed to solve problems in formal logic, and of geometrical methods for solving these problems. Covers logic diagrams, network diagrams for the propositional calculus, the Stanhope demonstrator, Jevons' logic machine, the Marquand machine, and other topics. Applications to such fields as operations research, information storing and processing, and efficient circuit designing are outlined and discussed. By MARTIN GARDNER. 259 pp., 96 illus., \$5.00.



### GLASS ENGINEERING HANDBOOK

Here is a highly informative volume on the composition, manufacture, properties, and applications of glass as an engineering material. It gives practical data on the use of glass and glass products in engineering, research, and various fields of manufacture including electron-tube manufacture, the nuclear field, guided missiles, and the automotive field. In addition to coverage on the more commonly known glasses, there is information on special topics such as photosensitive glass, glass ceramics, electrically conducting glass, glass in electronic circuit components, glass-reinforced plastics, and others. By E. B. SHAND, Technical Consultant, formerly Research Staff Engineer, Corning Glass Works. Second Edition, 488 pp., 222 illus., \$10.00.

### MAGNETIC RECORDING TECHNIQUES

Here is a practical guide to the technology of magnetic recording methods and devices for engineers and technicians concerned with their application in audio, video, communications, automation, computing, and other fields. Emphasizing the basic knowledge needed to attain top performance, it gives a fundamental coverage of the principles of the recording and reproducing processes; recording materials, including the theory of ferromagnetism; recording mechanisms; and established design standards. Provides a clear development of design methods. By W. EARL STEWART, Chief Product Engineer, The Standard Register Co. 268 pp., 150 illus., \$8.50.

### ENGINEERING ELECTROMAGNETICS

Gives ready access to the data, principles, and equations of electromagnetics. Steady magnetic field, electrostatics, time-varying fields, relaxation and iteration methods of experimental mapping . . . these and other topics are explained in detail. The book devotes special attention to Maxwell's equations and their application to such areas as circuit theory, wave motion, and radiation. Vector analysis is used throughout. Many clear illustrations and examples help make this volume especially useful in solving specific problems. By WILLIAM H. HAYT, JR., Assoc. Prof. of Electr. Engg., Purdue U. 328 pp., 89 illus., \$8.50.

### SAMPLED-DATA CONTROL SYSTEMS

Provides a clear, unified treatment of sampled data systems. Essential theory is developed in a way which helps you apply it not only to synthesis of control systems, but also to communications, data processing, filtering, and other areas. A helpful feature is the extensive use of the z-transform, particularly in developing time-domain synthesis methods. Many illustrative examples demonstrate practical applications. By JOHN R. RAGAZZINI, Dean College of Engineering, N.Y.U., and GENE F. FRANKLIN, Asst. Prof. of Electr. Engg., Stanford U. 331 pp., 186 illus., \$9.50.

## MAIL COUPON FOR 10-DAY FREE EXAMINATION

McGraw-Hill Book Co., Dept. F-1-9, 327 W. 41st St., N.Y.C. 36

Send me book(s) checked below for 10 days' examination on approval. In 10 days I will remit for book(s) I keep plus few cents for delivery costs, and return unwanted book(s) postpaid. (We pay delivery costs if you remit with this coupon—same return privilege.)

- Feinstein—Found. of Information Theory, \$6.50  
 Gibson & Tuteur—Control Syst. Comp., \$12.00  
 Gardner—Logic Machines & Diagrams, \$5.00  
 Stewart—Magnetic Recording Techniques, \$8.50  
 Hayt—Engineering Electromagnetics, \$8.50  
 Ragazzini & Franklin—Sampled-Data Control Systems, \$9.50  
 Shand—Glass Engineering Handbook, \$10.00

(PRINT)

Name .....

Address .....

City ..... Zone..... State.....

Company .....

Position .....

For price and terms outside U. S., write McGraw-Hill Int'l., N.Y.C.

F-1-9

## McGraw-Hill TECHNICAL WRITING SERVICE

TWS offers you a single INTEGRATED publishing service prepared to undertake a project from research and planning through finished manuscript and art, typesetting, mechanical preparation, printing and binding. Whatever the situation, whatever the type of literature you need, our editorial and art consultants can help you, bringing to your most specialized job the craft and skill of publishing experts.

## WRITING EDITING ILLUSTRATING PRINTING

TO YOUR OWN OR  
GOVERNMENT SPECIFICATIONS

Whether you need an instruction book or service manual, to accompany your equipment, written to government specifications . . . or product catalogues or training booklets . . . or annual reports . . . or company histories . . . our writing staff can do the job for you, our artists can create and execute the illustrations. And McGraw-Hill printing, binding, and paper resources are among the best in the country.

SAVE MONEY AND TIME  
LET OUR STAFF BE  
YOUR STAFF FOR  
TECHNICAL and BUSINESS  
PUBLICATIONS

ASK  
OUR REPRESENTATIVE  
TO CALL

Write • Phone

Technical Writing Service  
McGraw-Hill Book Co., Inc.  
330 W. 42nd St., N. Y. 36, N. Y.  
Longacre 4-3000

## COMMENT

### Kudo

We are quite favorably impressed with the editorial job done on our manuscript ("Tracking Man-Made Moons," p 33, Jan. 2). The meat of the article has been retained while the overall length is much reduced.

C. H. LOONEY

NATIONAL AERONAUTICS AND  
SPACE ADMINISTRATION  
WASHINGTON, D. C.

### Terminology

As part of our continuing process of keeping the terms in our Buyers' Guide directory issue up to date, we recently asked several score manufacturers what they thought about the proper way to classify various electronic products. One of our friends in Syracuse, N. Y., sent us this answer to our questions on printed circuits:

... In regard to terminology for printed circuits, the present situation is a highly confused one and general agreement is completely lacking.

Historically, the use of the term *printed circuits* started with the makers of resistor-capacitor circuit assemblies based on a barium titanate high-K baseplate and encapsulated in a phenolic cover coat. Some years later the makers of etched and plated wiring boards appropriated the term to describe their products.

This is obviously a technical misuse of the term, since you can't have a circuit unless some circuit elements—such as resistors, capacitors or inductors—are included. Such products should be called *printed wiring boards*, with a descriptive adjective such as *etched, plated, stamped*, etc., to describe the process.

Since the term *printed circuits* has become so misused, the makers of true printed circuits have inclined to the use of *printed electronic components, printed packaged assemblies*, etc., to get away from the confusion with printed wiring boards. Obviously the Insti-

## FOR PUBLIC ADDRESS, RADIO, and kindred fields, JONES 400 SERIES PLUGS & SOCKETS

of proven quality!

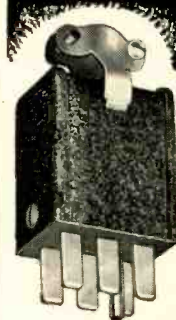

P-406-CCT

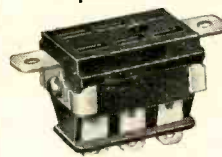

S-406-AB

Socket contacts phosphor bronze plated. Plug contacts hard brass cadmium plated. Insulation molded bakelite. Plugs and sockets polarized. 2, 4, 6, 8, 10, 12 contacts. Steel caps with baked black crackle enamel.

Catalog No. 22 gives full information on complete line of Jones Electrical Connecting Devices — Plugs, Sockets and Terminal strips. Write.

**Jones** HOWARD B. JONES DIVISION  
CINCH MANUFACTURING CORPORATION  
CHICAGO 24, ILLINOIS  
SUBSIDIARY OF UNITED-CARR FASTENER CORP.

CIRCLE 74 READERS SERVICE CARD

## SEEKING A NEW PLANT LOCATION?



LEARN THE INDUSTRIAL  
ADVANTAGES OF

## HOLLYWOOD FLORIDA

- Ideal living and working conditions
- Abundant, contented, skilled and unskilled labor
- Modern industrial buildings available
- Excellently located industrial sites
- Rail, truck, air, water transportation
- Convenient to U.S. and Latin American markets
- Hub of Florida's fastest growing market

FAST BECOMING AN  
ELECTRONICS CENTER.  
FIND OUT WHY!

Write for Industrial Brochure  
Inquiries held in strict confidence

INDUSTRIAL DIVISION, DEPT. E-2  
CHAMBER OF COMMERCE  
HOLLYWOOD, FLORIDA

PLEASE—NO job applications. We are swamped with  
employment inquiries.

CIRCLE 75 READERS SERVICE CARD

January 9, 1959 — ELECTRONICS

tute of Radio Engineers should have straightened out the mess a long time ago, but to date has shown no interest in the matter. Neither has the Electronic Industries Association, who have indeed added to the confusion by setting up a "Printed Circuits" Committee which covers both printed wiring boards and printed electronic assemblies.

My best wishes to you in your attempt to clarify the mess.

C. A. PRIEST

ELECTRONICS DIVISION  
ONONDAGA POTTERY CO.  
SYRACUSE, N. Y.

Reader Priest's firm, incidentally, calls its printed circuits printed electronic assemblies.

#### Department of Science?

It seems to me that the publications serving the various technologies should take a definite stand for the creation of a cabinet Department of Science. But strangely enough, I have never seen such a stand taken.

When you consider all the wasted effort that goes into duplicated research and pursuits down blind alleys, it becomes plain that a coordinating body is needed. Who could fulfill this function better than the federal government? Further, the expense of many research programs today cannot be sustained by private industry.

I can't understand the objections that prevent the establishment of such a department. The measure goes before Congress periodically, but is always shelved.

E. R. HINCHMAN

WORCESTER, MASS.

We're not so sure that a cabinet department is needed, unless reader Hinchman means a department that would aid the flow of information among the sciences and create a favorable atmosphere for the growth of scientific understanding. The Department proposed in S. 3126, the Science & Technology Act that was shelved in the last session, was much more than that, and the Senate was naturally leery of it.

If industry can't carry its own water, the nation is in pretty bad shape. We feel that it can.

# DELTA Air Freight

costs less than  
you think!



Holds down inventories! Holds down costs of crating, insurance, capital tie-up. Protects against deterioration and market declines!



Call Delta Air Lines,  
or write General Offices:  
Atlanta Airport, Atlanta, Ga.

**AIR FREIGHT**  
DOOR-TO-DOOR

CRATING  
DETERIORATION  
INSURANCE  
CAPITAL TIE-UP  
INVENTORIES

MOST COMPLETE ALL-CARGO SERVICE TO AND THRU THE SOUTH

CIRCLE 76 READERS SERVICE CARD

For Those Who Demand Service!

# COSMIC

ELECTROLYTIC  
& PAPER  
TUBULAR

COSMIC CONDENSER CO.  
853 Whittier St., Bronx, N. Y.  
PHONE  
LUdlow 9-3360

"35 YEARS OF PROVEN  
DEPENDABILITY"

## Condensers

CIRCLE 77 READERS SERVICE CARD

## Your Inquiries to Advertisers Will Have Special Value . . .

—for you—the advertiser—and the publisher, if you mention this publication. Advertisers value highly this evidence of the publication you read. Satisfied advertisers enable the publisher to secure more advertisers and—more advertisers mean more information on more products or better service —more value—to YOU.

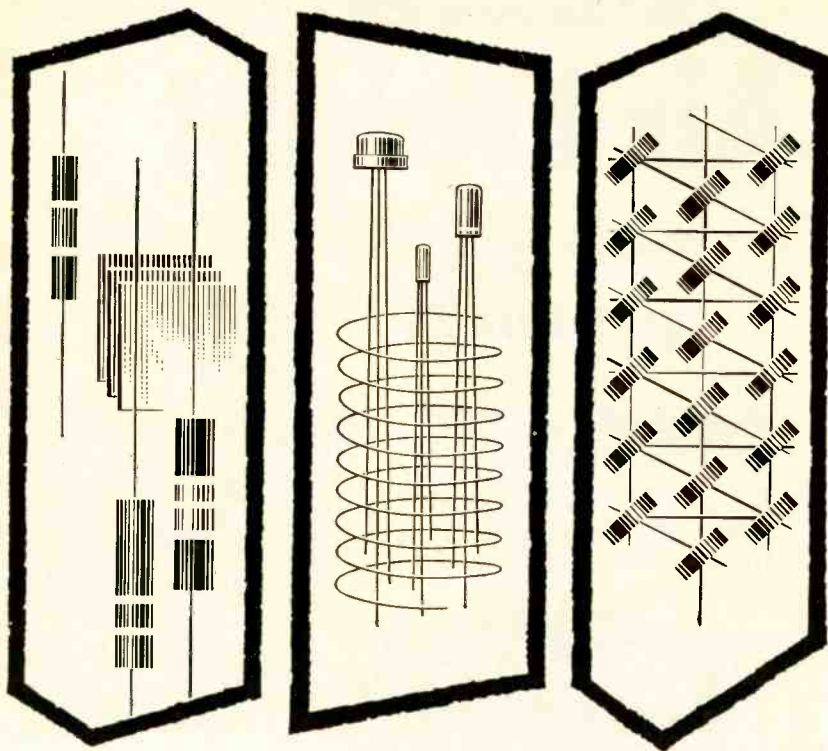

**VARIED  
ENGINEERING ASSIGNMENTS  
STIMULATE INTEREST ON  
RCA PROJECT BMEWS**

Positions with RCA's project for the new Ballistic Missile Early Warning System involve a broad range of duties. BMEWS problems demand new, adventurous approaches. Your headquarters will be in New Jersey at a location suburban to Philadelphia. You'll have the opportunity to demonstrate the feasibility of your engineering planning under actual environmental conditions in the Far North. Additional compensation for Far North trips. BMEWS' challenge requires experience in: Heavy Ground Radar Systems, Digital Computer Systems, Communications Systems, Data Handling.

Broad and liberal RCA benefits program to build security for you and your family • Work with the very latest in facilities and equipment • Every opportunity for progress in an RCA career.

**TO ARRANGE CONFIDENTIAL INTERVIEW**

Please send complete resume to:

Mr. Robert Vincent  
RCA, Dept. BM-4A  
1809 Bannard Street, Riverton, N.J.



**RADIO CORPORATION of AMERICA**

**ELECTRONIC  
ENGINEERS**

**Research & Development**

Move ahead with a young, rapidly expanding organization in Hicksville, LI, N. Y.

**PROJECT ENGINEERS  
SENIOR ENGINEERS  
ENGINEERS**

B.S. in E.E. or Physics

We need at once for lifetime careers—additional trained personnel, at all levels, experienced in circuitry and equipment design or applicable exp to work on UHF & VHF systems, wide band knowledge desirable; for challenging assignments on electronic counter-measure systems for military application and electronic instruments for civilian use.

Salaries commensurate with ability. Excellent benefits including Profit Sharing Retirement Trust Plan.



Call for interview  
J. V. Hicks  
Overbrook 1-7100  
or send resume  
in confidence to

**INSTRUMENTS FOR  
INDUSTRY, INC.**

101 New South Rd. Hicksville, LI, N. Y.

**CHIEF DESIGN ENGINEER  
ELECTRONIC CONNECTORS**

Excellent opportunity for experienced engineer with managerial and creative abilities to design, develop and administer a complete line of miniature AN, rack and panel and micro-miniature electrical connectors for commercial and military use. Individual should have specific experience on environmental connectors in cylindrical or rectangular configurations and be capable of assuming full responsibility for all stages of development and manufacture. Salary in five figures with substantial advancement possibilities for the right man. Specify age, education, experience, previous earnings, etc. in first letter.

METHODE MFG. CORP.  
7447 W. WILSON AVE., CHICAGO 31, ILL.

**RATES . . . . .  
"Employment Opportunities"**

Displayed—The advertising inch is \$28.67 per inch for all advertising appearing on other than a contract basis. Contract rates quoted on request.

An advertising inch is measured 7/8" vertically on a column—3 columns—30 inches to a page.

Subject to Agency Commission.

Undisplayed—\$2.40 per line, minimum 3 lines. To figure advance payment count 5 average words as a line.

Discount of 10% if full payment is made in advance for 4 consecutive insertions. Not subject to Agency Commission.

Send NEW ADS to ELECTRONICS, Class. Adv. Div., P. O. Box 12, New York 36, N. Y.





ON SEMICONDUCTOR FRONTIERS

# YOU can help 'beat the heat' at 200°C

ELECTRONIC ENGINEERS at TI's Semiconductor-Components division are beating the heat barrier with devices operating at 200°C and higher — twice the boiling point of water! Under the hot glare of infrared light simulating extreme operating conditions, the engineer shown above is testing a TI-introduced silicon power transistor operating in conjunction with the new *Sensistor* temperature-compensating silicon resistor.

Exploration of new frontiers in solid state electronics is a never-ending project at TI's S-C division with engineers, physicists and chemists combining their research efforts to extend frequency, power and temperature limits — building America's electronic future. If you are interested in joining other leading engineers and scientists at the industry's most modern research, development and production facilities — write or call for more information on Texas Instruments, a corporation nearly three decades old — recognized leader of the semiconductor industry.

Inquiries from experienced graduate engineers interested in furthering solid state electronic technology are welcomed by the TI Semiconductor-Components division. You can play a vital role in research or development engineering on:

**transistors, diodes, rectifiers, capacitors, resistors, IR detector cells, materials purification, circuit design and application, test equipment design, and design of complex automatic machinery.**

You will discover forward-looking personnel benefits more advanced than any other in the industry. For detailed information in confidence, write:

**Harry Laur**  
Personnel Administrator



**TEXAS INSTRUMENTS**  
INCORPORATED  
SEMICONDUCTOR-COMPONENTS DIVISION  
POST OFFICE BOX 312 • 13500 N. CENTRAL EXPRESSWAY  
DALLAS, TEXAS

ELECTRONIC ENGINEERS



PHYSICAL CHEMISTS

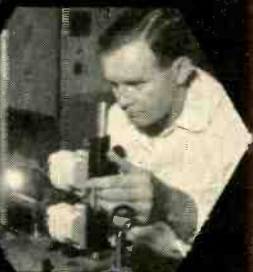

SOLID STATE PHYSICISTS



WORLD'S LARGEST SEMICONDUCTOR PLANT

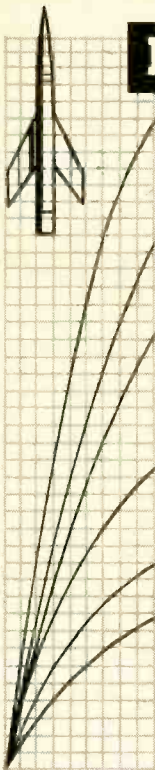

# ENGINEERS

JUNIOR • SENIOR • PROJECT

## STEP UP TO LEAR

Engineers, if you are experienced in the design and development of air and/or ground based communication and navigation equipment, here is the opportunity you have been looking for.

Lear, for twenty eight years a pioneer in aircraft radio communication, navigation equipment, automatic flight controls and flight indicators, is moving ahead in many new fields.

Lear offers unlimited opportunities for advancement and greater responsibilities to creative minded, electronic engineers.

If you would like to work in sunny Southern California on varied electronic projects, write to:

L. S. PECK, Manager  
*Industrial Relations*

**LEAR, INC.**, 3171 South Bundy Drive • Santa Monica, California

SENIOR ENGINEERS

### Senior Engineers

**TUBE ENGINEER** for staff position to take charge of program on gas tubes and/or subminiature vacuum tubes. Should be familiar with gas discharge phenomena, high vacuum techniques, glass-to-metal sealing, electron tube manufacture. Will be responsible for entire program from development to production.

**RESISTOR ENGINEER** to head up development program on deposited carbon and metal film resistors. Should be familiar with production techniques and encapsulation processes. Will be responsible for expanding product line.

**ELECTRONICS ENGINEER** or physicist at group leader level to head department concerned with design and development of radioisotope instrumentation. Heavy background in nuclear and isotope instrumentation.

IF YOU ARE NOW READY to make that important move upward, look into these attractive positions. They offer a personal growth opportunity in a growing company expanding into new fields. Salaries commensurate with experience and responsibility. Opportunity for participation in growth and attractive fringe benefits. Write in confidence to D. M. Mayhew, Vice President, for personal interview.



The  
**Victoreen Instrument Company**  
5806 Hough Avenue  
Cleveland 3, Ohio

## DO YOU NEED EXPERIENCED ENGINEERS ENGAGED IN:

Research  
Development  
Design  
Instrumentation

Servomechanisms  
Missiles  
Audio Systems  
Control Systems

Radar  
Computers  
Transistors  
Other Fields

Place an "ENGINEERS WANTED" advertisement in this EMPLOYMENT OPPORTUNITIES SECTION of ELECTRONICS. It's an inexpensive, time saving method of selecting competent personnel for every engineering job in the electronics industry. The selective circulation of ELECTRONICS offers you an opportunity to choose the best qualified men available throughout the industry.

For Rates and Information Write:  
**CLASSIFIED ADVERTISING DIVISION**

## McGRAW-HILL PUBLICATIONS

P. O. Box 12

New York 36, N. Y.



complete systems

- missile tracking**
- ground-space communications**
- airborne instrumentation**
- range design and operations**
- data processing**

these are the pursuits of

PHILCO  
**WESTERN  
 DEVELOPMENT  
 LABORATORIES**  
 PALO ALTO



For industry, for the military . . . for ground, air or space . . . electronic and electromechanical systems designed and developed in superb new Palo Alto facilities . . . by the world's finest new team of senior specialists.

A rewarding share in this can be yours; your confidential inquiry is invited. Urgently needed:

*Ph.D., MS, BS in*

- ELECTRONIC ENGINEERING    ENGINEERING PHYSICS
- MECHANICAL ENGINEERING    MATHEMATICS

experienced in any of our basic pursuits in military electronic systems. Please write H. C. Horsley, Dept. E.

**PHILCO WESTERN DEVELOPMENT LABORATORIES**

3875 Fabian Way, Palo Alto, California

A part of the Government and Industrial Division of Philco Corporation

8164



Measuring phase stability vs. temperature during prototype equipment development



Developmental helical antenna, part of sophisticated new direction-finder system



Pattern measurements—vital to development of microwave dish antennas



60' parabolic receiving antenna for missile telemetry and tracking

# reliability

*At Hughes the Systems Engineering approach is considered essential for optimum reliability.*

The basic design of complex electronic systems is relatively more advanced than the Reliability Engineering which will ensure their successful operation.

Thus, the challenge of the reliability barrier now requires the optimum application of creative engineering.

Several openings for both senior and junior engineers—preferably with radar systems, missiles, or communications backgrounds—now exist in these areas of reliability: Prediction, Design Review, Analysis, Promotion. Your inquiry is invited. Please write Mr. J. C. Bailey at the address below.

*the West's leader in advanced electronics*

## HUGHES

*Scientific and Engineering Staff*

**RESEARCH & DEVELOPMENT  
LABORATORIES**

*Culver City, California*

# INDEX TO ADVERTISERS

Ace Engineering & Machine Co., Inc. . . . .	105	Markem Machine Co. . . . .	96
*Amphenol Electronics Corp. . . . .	38	*McGraw-Hill Book Company . . . . .	32
Angelica Uniforms . . . . .	17	*McGraw-Hill Publishing Co. . . . .	14, 15
*Atlas Precision Products Co. . . . .	101	Metals and Controls Corporation . . . . .	6
		Miero Switch, a Div. of Honeywell . . . . .	8
*Barnstead Still & Sterilizer Co. . . . .	12	Minnesota Dept. of Business Development . . . . .	108
*Bentley, Harris Manufacturing Co. . . . .	72		
Black & Webster, Inc. . . . .	37	Nems-Clarke Company . . . . .	97
*Boesch Manufacturing Co., Inc. . . . .	80	North Electric Co. . . . .	16
*Brush Instruments Div. of Clevite Corp. . . . .	46	*Nothelfer Winding Laboratories, Inc. . . . .	92
*Celco-Constantine Engineering Laboratories Co. . . . .	83	*Oster Mfg. Co., John . . . . .	39
*Centralab, Div. of Globe-Union, Inc. . . . .	45		
*Constantine & Co., L. L. . . . .	25	*Potter Instrument Company, Inc. . . . .	27
*Constantine Engineering Laboratories Co. . . . .	83		
*Continental-Diamond Fibre . . . . .	10	*Radio Corporation of America . . . . .	4th Cover
*Cosmic Condenser Co. . . . .	111	Radio Industries, Inc. . . . .	36
		Ramo-Woolldridge, A Div. of Thompson	
Daytona Beach Chamber of Commerce . . . . .	104	Ramo Woolldridge . . . . .	13
*DeJur Amsco Corp. . . . .	107	*Raytheon Mfg. Co. . . . .	5
Delta Airlines . . . . .	111		
*Driver-Harris Co. . . . .	30	*Sola Electric Co. . . . .	87
		Sprague Electric Co. . . . .	34, 35
Edo Corporation . . . . .	102	Stackpole Carbon Co. . . . .	33
Electro-Data Div. of Burroughs Corp. . . . .	88	Stokes Corporation F. J. . . . .	73
Electronics . . . . .	2	*Sylvania Electric Products, Inc. . . . .	79
*Empire Devices Products Corp. . . . .	40		
		Taylor Fibre Co. . . . .	94
*Fairchild Controls Corp. . . . .	103	*Texas Instruments Incorporated . . . . .	93
Fansteel Metallurgical Corp. . . . .	76, 77	Textile Banking Co., Inc. . . . .	75
		*Tobe-Deutschmann Corp. . . . .	98
*General Electric Co.			
Apparatus Dept. . . . .	67	Virginia Electric and Power Co. . . . .	69
*General Transistor Corp. . . . .	11		
Good-All Electric Mfg. Co. . . . .	85	Waveline, Inc. . . . .	95
*Green Instrument Co., Inc. . . . .	104		
Greene Shaw Co., Inc. . . . .	102		
*Hewlett-Packard Co. . . . .	2nd Cover		
Hollywood, Florida Chamber of Commerce . . . . .	110		
*Hughes Aircraft Co. . . . .	116		
*Hughes Products Div. of Hughes Aircraft Co. . . . .	21, 22, 23, 24		
International Business Machines Corp. . . . .	89		
*International Rectifier Corp. . . . .	7		
*Jones, Howard B., Div. of Cinch Mfg. Corp. . . . .	110		
*Kay Electric Co. . . . .	91		
*Kennedy & Co., D. S. . . . .	3		
*Kepeco Laboratories, Inc. . . . .	71		
*Kintel, A Div. of Colu Electronics Corp. . . . .	3rd Cover		
*Lampkin Laboratories, Inc. . . . .	108		
Lockheed Missile Systems Division . . . . .	28, 29		
Mallory and Co., Inc., P. R. . . . .	18, 19		
*Markel & Sons, Frank L. . . . .	20		

CLASSIFIED ADVERTISING  
F. J. Eberle, Business Mgr.

EMPLOYMENT OPPORTUNITIES 112-115

ADVERTISERS INDEX

Instruments for Industry . . . . .	112
Lear Inc. . . . .	114
Methodie Manufacturing Corp. . . . .	112
Philco Western Development Laboratories . . . . .	115
Radio Corporation of America . . . . .	112
Texas Instruments Inc. . . . .	113
Victoreen Instrument Co., The . . . . .	114

\* See advertisement in the June, 1958 Mid-Month ELECTRONICS BUYERS' GUIDE for complete line of products or services.

This index is published as a service. Every care is taken to make it accurate, but ELECTRONICS assumes no responsibilities for errors or omissions.

# ONLY KIN TEL DIGITAL VOLTMETERS GIVE YOU ALL THESE ADVANTAGES

**1. SINGLE-PLANE READOUT:** KIN TEL digital voltmeters employ a simple projection system to present numbers on a readable single plane...no superimposed outlines of "off" digits...reduced possibility of error. Standard pilot lamps give extra long life.

**2. ADVANCED CIRCUIT DESIGN:** Transistors employed where they contribute to performance and reliability...relay drive coils energized with DC as in telephone type service to provide long, trouble-free operation...automatic, continuous standard cell calibration. No electronic circuitry in readout allows easy remote mounting. Sensitivity control permits stable reading of noisy signals.

**3. MANUFACTURING EXPERIENCE:** KIN TEL has manufactured over 10,000 "standard cell accuracy" DC instruments on a true production line basis. Only by this method, by years of repeated manufacturing experience, by an over-all awareness of the accuracies and tolerances involved, is it possible to guarantee consistent accuracy and reliability...to assure real value for every dollar you invest.

**4. NATIONWIDE APPLICATION ENGINEERING FACILITIES:** KIN TEL has engineering representatives in every major city. An experienced staff of over 200 field engineers is always immediately available to help solve your application problems, provide technical data, or prepare a detailed proposal. Factory level service is available in all areas.

**5. DESIDERATE SPECIFICATIONS (MODEL 401B DC DIGITAL VOLTMETER):** *Display*...4 digit with automatic polarity indication and decimal placement. Total display area 2" high x 7½" long, internally illuminated. Each digit 1½" high. *Automatic Ranges*... .0001 to 999.9 volts covered in 4 automatic ranges. Sensitivity control provides gain ÷10 setting and least digit sensitivities of .1, 1, and 10 mv. *Accuracy*... 0.01% ±1 digit. *Counting Rate*...20 counts per sec., providing average balance (reading) time of 1 sec. *Reference Voltage*...Chopper-stabilized supply, referenced to an unsaturated mercury-cadmium standard cell. *Input Impedance*...10 megohms, on all ranges. *Output*...Visual display, plus print control. Automatic print impulse when the meter assumes balance. No accessories required to drive parallel input printers. *Input*...115 volt, 60 cycle, single phase, approx. 75 VA. *Dimensions*...Control unit, 5¼" high x 19" wide x 18" deep. Readout display, 3½" high x 19" wide x 9" deep. *Weight*...Approx. 40 lb. *Price*...\$2,450.

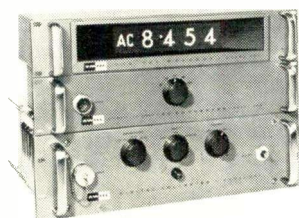
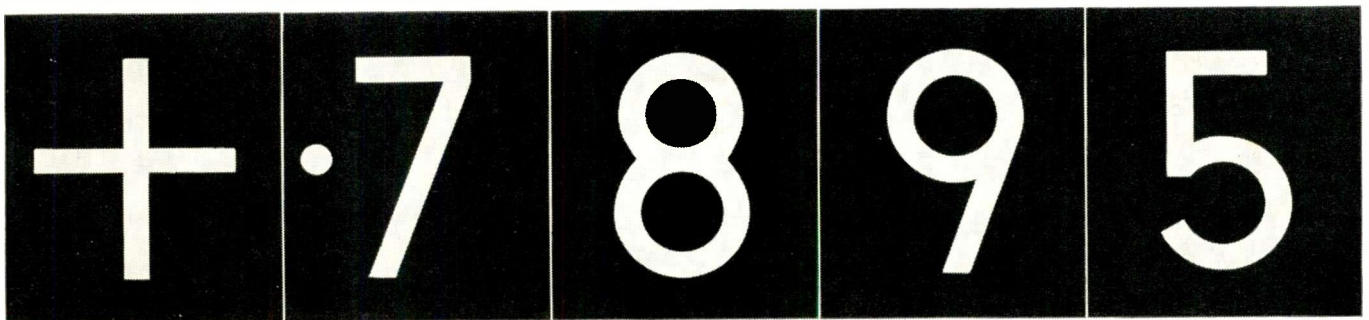

Model 402B AC/DC 4-digit



Model 401B DC 4-digit



Model 501 DC 5-digit

**6. WIDE RANGE OF MODELS—ACCESSORIES—SPECIAL SYSTEMS:** Versatile "digital building blocks" permit measurement of AC, ohms, ratios of AC and DC, automatic scanning of multiple inputs...4- or 5-digit models. Preamplifiers increase digital voltmeter sensitivity to 1 microvolt DC, 10 microvolts AC. Buffers permit driving typewriters, tape punches and printers. KIN TEL's Special Products Department can design and manufacture digital instruments to meet special requirements...complete digital systems for data logging, missile checkout and automatic production line testing.



Write today for descriptive literature or demonstration. 5725 Kearny Villa Road, San Diego 11, California

Announcing new

1N1763

# RCA SILICON RECTIFIERS

RCA is now in mass production of silicon rectifiers of the diffused-junction type for use in electronic applications. The two types now available are the initial units of a broad line intended for power supplies of entertainment, industrial, and military equipment.

**These RCA Silicon Rectifiers Offer You:**

- Low Cost—specifically priced for entertainment applications.
- Electrical Uniformity—precision controlled diffusion process forms superior junctions.
- Welded Hermetic Seal—each unit individually pressure-tested to provide complete protection against moisture and contamination.
- Rugged Construction—industrial-type “top-hat” design with axial leads for soldering-in applications; may also be mounted in standard fuse clip.



**New RCA “100 Production Pack”** saves time and motion. Package is specially designed for quick, convenient, operator handling. Saves inventory-control time; simplifies the “count”.

TYPE	MAXIMUM RATINGS			* CHARACTERISTICS		APPLICATION
	Peak Inverse Volts	RMS Supply Volts	DC Forward Ma	Max. Reverse Current at Indicated Peak Inverse Volts	Max. Instantaneous Forward Voltage at Indicated Instantaneous Forward Current	
1N1763	400	140	500	100 $\mu$ a at 400 volts	3 volts at 15 amperes	Black and white TV, radios, phonographs and other electronic equipment operating direct from power line
1N1764	500	175	500	100 $\mu$ a at 500 volts	3 volts at 15 amperes	Color TV, radios, phonographs and other electronic equipment operating from the power line through a step-up transformer

\* At ambient temperature of 25°C

**For sales information, contact your RCA Field Representative at any of these offices:**

**EAST:** 744 Broad Street  
Newark, N. J.  
HUmboldt 5-3900

**NORTHEAST:** 64 "A" Street  
Needham Heights 94, Mass.  
Hillcrest 4-7200

**EAST CENTRAL:** 714 New  
Center Bldg., Detroit 2, Mich.  
TRinity 5-5600

**GOV'T:** 224 N. Wilkinson St.  
Dayton, Ohio  
BALdwin 6-2366  
1625 "K" St., N. W.  
Washington, D. C.  
Distriet 7-1260

**WEST:** 6355 E. Washington  
Blvd., Los Angeles 22, Calif.  
RAYmond 3-8361

**CENTRAL:** Suite 1154, Merchandise Mart Plaza  
Chicago 54, Ill., WHitehall 4-2900



**RADIO CORPORATION OF AMERICA**  
Semiconductor and Materials Division  
Somerville, New Jersey

RCA Silicon Rectifiers are also available at your local authorized RCA Distributor!

New Designer's Data-Sheets Ready Now!  
Write RCA Commercial Engineering,  
Section A-19-NN-2 Somerville, New Jersey.