

# Electronics World

AUGUST, 1962

50 CENTS

**Special Feature: HI-FI COLOR INSERT—"SOUND"**

**BUILD YOUR OWN TRANSISTORIZED IGNITION SYSTEM  
FACSIMILE—A REVIEW OF TECHNIQUES & EQUIPMENT  
COIL-WINDING DESIGN CHARTS FOR R. F. APPLICATIONS**



## COLOR TV

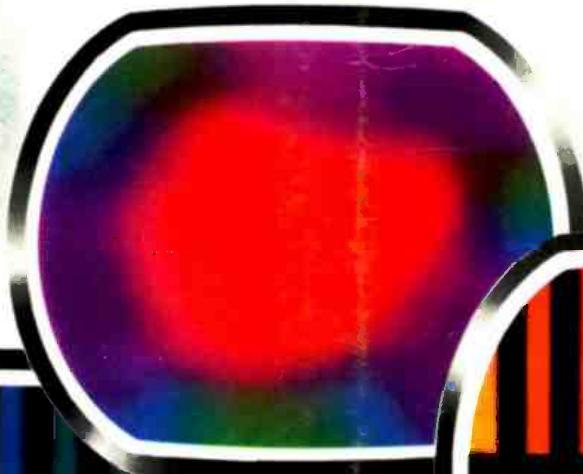

*4V Kelvin*

WIRI 13124  
W A RIESE  
25 15TH ST S W  
MASSILLON OHIO





# Prepare Now For The Higher Rewards The Electronics Age Offers You

There is an immediate and growing need for trained technicians in Industrial-Military Electronics, Radio-TV Servicing and Communications. Better than average jobs with high pay, interesting work, bright futures await you in the fast growing industry of the 1960's. Join thousands of NRI graduates now benefiting from career opportunities in this Electronic Age.

## Training Equipment Included



NRI "learn-by-practice" training is the time-proved way to higher earnings and advancement. Except for FCC License course, all NRI courses include—at no extra cost—special training equipment to give shop and laboratory experience in your own home. Makes NRI training come to life in an easy-to-grasp, interesting manner. Take the advice of job counselors, investigate Electronics if you are dissatisfied with your present job or pay, or you want to prepare for military service.

## Oldest and Largest School

For nearly 50 years NRI has featured Electronics training at reasonable cost because it is the oldest, largest home-study school of its kind. Take the first step to a new career now. Mail postage-free card. Approved for veterans—Korean GI Bill. National Radio Institute, Washington 16, D. C.



### NEW Short Course MATH FOR ELECTRONICS

From basic arithmetic review to graphs and electronic formulas . . . in a "short course" package of five carefully prepared texts. You'll learn short cuts to speed up and simplify circuit calculations, other ways math can help you in Electronics. Check and mail postage-free card for more information.



## Industrial ELECTRONICS

The NRI course in Electronics-Principles, Practices, Maintenance prepares you for a career as an Electronic Technician in industry, business, government, the military. Computers, telemetry, automation, missiles, rockets all employ the same basic Electronic principles . . . and that is what this NRI course stresses with illustrated lessons, special training equipment.



## Commercial FCC LICENSE

You must have an FCC License if you want to operate or service transmitting equipment used in TV and Radio Broadcasting, aviation, marine, microwave, facsimile or mobile communications. Even a service Technician needs an FCC License today to work on C-Band Radio equipment. From Simple Circuits to Broadcast Operation, this new NRI course trains you quickly to take Government exams.



## TV-Radio COMMUNICATIONS

In NRI's Communications course you get *actual experience* as NRI trains you for your choice of Communications fields. Commercial methods and techniques of Radio-TV Broadcasting; teletype; facsimile; microwave; radar; mobile and marine radio; navigation devices; multiplexing are some of the subjects covered. You work with special training equipment.



## Radio and TV SERVICING

NRI's time-tested course in Servicing not only trains you to fix radios, TV sets, hi-fi, etc., but also shows you how to earn spare-time money starting soon after enrolling. Fast growth in number of sets means money-making opportunities for you in your own spare-time or full-time business, or working for someone else. Special training equipment at no extra cost. Mail postcard.

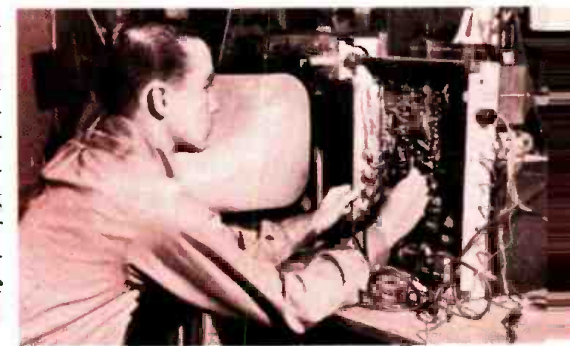



## HOW TO BUY YOUR FIRST (OR YOUR LAST) SPEAKER SYSTEM

If you demand magnificent sound . . . undistorted bass to beyond the limits of audibility—if you demand superb cabinetry and decor flexibility (with five interchangeable grille frames that snap on and off to match *any* decor) . . . then consider the unique University Medallion XII 12" Three-Way Speaker System. Medallion owners *stay* Medallion owners. Let's look inside the Medallion and see why.



Integrated within its precisely-matched cabinet are three superlative speaker components: the 12" high compliance woofer that delivers bass frequencies down to the very threshold of feeling; a newly-engineered 8" speaker to assure you of all-important mid-range *impact*; and the Sphericon super tweeter for highs unlimited. Result: virtually uniform response

compare

# UNIVERSITY

(in every price category)  
against all other brands

—smooth and rich—from 28 to 40,000 cps ( $\pm 2$ db at 22,000 cps). And at your fingertips, network controls to balance the Medallion sound to match the acoustics of your room—*any* room.

Amplifier requirements? Any amplifier capable of delivering a modest ten clean watts. Medallion dimensions? Only 24" x 17" x 11 $\frac{1}{4}$ " deep. Available with or without base—for use as highboy or lowboy. Finishes? Walnut, oiled walnut,



For a solution to a *really* difficult space problem, investigate the TMS-2 *single* cabinet stereo speaker system.

fruitwood, mahogany *and* unfinished for custom installations. And the Medallion is the world's *only* system with "select-a-style" snap-on grilles. Want to change your decor at some later date? The Medallion stays where it is—all you change is the grille! In Contemporary, Italian or French Provincial, Colonial and Swedish Modern. Medallion prices start at \$139.95, without grille. Grilles from \$9.95. Base, \$14.95.

Write for University's "Informal Guide to Component High Fidelity," Desk Set. University Loudspeakers, Inc., White Plains, New York.



For bookshelf speaker systems with astounding "big system" sound, look into University's RRL speaker systems.



A Division of Ling-Temco-Vought, Inc.

TIMELESS BEAUTY AND THE SOUND OF TRUTH

ELECTRONICS WORLD is published monthly by Ziff-Davis Publishing Company at 131 South Wabash Avenue, Chicago 5, Illinois. Subscription rates: one year United States and possessions \$5.00; Canada and Pan American Union countries \$5.50; all other foreign countries \$6.00. Second class postage paid at Chicago, Illinois and at additional mailing offices. Authorized as second class mail by the Post Office Department, Ottawa, Canada and for payment of postage in each. August, 1962 Vol. 68, No. 2.

August, 1962





**NEW LOW PRICES—ONLY CHANGE WE COULD THINK OF**



**TO MAKE THESE SPEAKERS SOUND BETTER THAN EVER!**

# simply say **Delco**

You've *always* been able to install Delco Auto Radio Speakers with complete confidence in their quality. *Now* you can sell this popular line at competitive prices as well!

And Delco hasn't sacrificed a single one of these outstanding features: Highest sensitivity for greater range of distortion-free sound from precision-engineered magnetic circuits • Extra-efficient, premium grade Alnico-V magnets • Continuous life testing program to assure dependable

performance under the most severe climatic conditions.

There's news in Delco *packaging*, too. Your choice 6 x 9's in new bulk-packs, 20 speakers to a carton, or individually boxed speakers if you like. Now that you can sell top quality Delco Auto Radio Speakers at new, competitive prices, better stock up and start cashing in! Call your supplier and—simply say Delco. **Delco Radio** Service Parts are distributed nationally through **United Delco**.

DELCO RADIO, Division of General Motors, Kokomo, Indiana



## CONTENTS

### INDUSTRIAL

Integrated Circuitry (Editorial)	W. A. Stocklin	6
Facsimile Techniques & Equipment	Arthur L. Plevy	21
Recent Developments in Electronics		28
Coil-Winding Charts	Donald W. Moffat	54
Electronics Manufacturing Occupations		66

### TEST EQUIPMENT

Using the Oscilloscope Delayed Sweep	Walter H. Buchsbaum	26
How to Make Your V.T.V.M. Reliable	J. B. Straughn	30
Compact, Transistorized Impedance Bridge	Stanley E. Bammel	46
Directory of Color-TV Test-Pattern Generators		51
EW Lab Tested (Eico Model 955 Capacitor Tester)		72

### HI-FI AND AUDIO

EW Lab Tested (ESL T-200 "Gyro/Spension" Turntable; "Knight" KN-4001B Tape Preamp; Fisher KS-1 "Slim-Line" Speaker System, page 16)		12
Sound (Special Chart)		35-36
Versatile Voltage, Power, and Decibel Nomograms (Special Chart)	Jim Kyle	37-38
Automatic Switching for Multiplex Adapters	George Mordwinkin	61
FM-Stereo Programs Reach 70-Million Listeners		75

### GENERAL

Status of Color TV		25
Analyzing Color Set Defects		40
Semiconductor Noise Filter	James E. Pugh, Jr.	71
Patent Information for the Inventor (Part 2)	Joseph F. Verruso	82

### CONSTRUCTION

High-Power Transistorized "Photorhythmicon"	Leon A. Wortman	31
Transistor-Operated Portable Lamp	Thomas J. Barmore	39
Transistorized Ignition System	Boghos N. Saatjian	52

### COMMUNICATIONS

Canadian Citizens Band	Leo G. Sands	34
Using the Nuistor on V.H.F. Bands	Joseph Marshall, WA4EPY	43
Low & Medium Frequency Converter	Ronald L. Ives	48

### MONTHLY FEATURES

Coming Next Month	4	Calendar of Events	75
Letters from Our Readers	8	Radio & TV News (S.I.N.)	76
Mac's Electronics Service	42	Electronic Crosswords	77
Within the Industry	69	Technical Books	84
New Products and Literature for Electronics Technicians...		87	

*Publisher*  
**PHILLIP T. HEFFERNAN**

*Editor*  
**WM. A. STOCKLIN, B. S.**

*Technical Editor*  
**MILTON S. SNITZER, W2QYI**

*Service Editor*  
**SIDNEY C. SILVER**

*Associate Editor*  
**ROBERT D. FREED**

*Associate Editor*  
**P. B. HOEFER**

*Editorial Consultant*  
**OLIVER READ, D.Sc., W4TWV**

*Industrial Consultant*  
**WALTER H. BUCHSBAUM**

*Art Editor*  
**MILTON BERWIN**

*Art and Drafting Dept.*  
**J. A. GOLANEK**

*Advertising Sales Manager*  
**LAWRENCE SPORN**

*Advertising Service Manager*  
**ARDYS C. MORAN**



ZIFF-DAVIS PUBLISHING COMPANY  
Editorial and Executive Offices  
One Park Avenue  
New York 16, New York  
ORegon 9-7200

MIDWESTERN and CIRCULATION  
OFFICE  
434 South Wabash Avenue  
Chicago 5, Illinois  
WAbash 2-4911  
Midwestern Advertising Manager  
Gilbert J. Jorgenson

WESTERN OFFICE  
9025 Wilshire Boulevard  
Beverly Hills, California  
CRestview 4-0265  
Western Advertising Manager  
Bud Dean

FOREIGN ADVERTISING  
REPRESENTATIVE  
D. A. Goodall Ltd., London, England

August, 1962

# 3 WAYS

## TO SPEED YOUR PROGRESS IN INDUSTRIAL ELECTRONICS

### 1. ELEMENTARY INDUSTRIAL ELECTRONICS by Leonard C. Lane

If you're ready to enter the fabulous field of industrial electronics, this two-volume course will arm you with the know-how necessary for success. If you're already in the field — operating equipment, servicing or maintaining it — even selling it, you'll do your job better, because you'll have a firmer grasp of the fundamentals of industrial electronics.

Only a basic knowledge of electricity and electronics is required to get the most out of this two-volume course. All the major areas of industrial electronics that you are likely to encounter are made absolutely clear. relays and switching magnetic amplifiers motor controls electronic heating instrumentation and many other topics.

Presentation is complete and clear so that you'll be able to progress rapidly from subject to subject. Mathematics is held to an absolute minimum. Illustrations, simplified diagrams reinforce and make each technical point understandable. The course bridges the gap between conventional radio and industrial electronics smoothly bringing you into the field. 2 Vol. Course \$7.80 (\$3.90 ea. vol.)

#### New Rider Industrial Electronics Series

### 2. BASIC PRINCIPLES & APPLICATIONS OF RELAYS by Harvey Pollack

Lucid introduction to the construction, operation and application of relays. Discusses relay components — including coils and contacts — in terms of their individual functions. DC relays, their rectifier arrangements selected circuits and contact protection are covered. The chapter on electronic relays, circuit covers thyratron circuits together with various light-operated, cold cathode and combination relays. Time delay circuits are discussed with practical applications. Factors governing the choice of a particular relay for a specific circuit are made clear. #250-1. \$2.90.

### 3. PHOTOELECTRIC CONTROL by Harvey Pollack.

Extremely informative text, illustrates how photoelectric devices are used in industrial electronic systems. It's so easy to understand how these components operate when you read this book. Especially clear circuits and operation descriptions of modern photoelectric devices which control measuring, counting, testing and separating tasks gives you a special insight to their applications versatility. #250-2. \$3.50.

#### Kit Building, Shop Hints, The Slide Rule

**HOW TO BUILD ELECTRONIC EQUIPMENT** by J. Richard Johnson. Saves money by helping you avoid common mistakes made in building equipment. Saves you time by providing practical tips on chassis layout. #286, hard cover \$6.95

**USEFUL ELECTRONIC SHOP HINTS** Edited by the staff of *Electronic Technician Magazine* — Crammed full of 200 practical, helpful and time saving shop hints. #295, \$1.95.

**USING THE SLIDE RULE IN ELECTRONIC TECHNOLOGY** Charles Alvarez — Transforms beginners into masters of this timesaving tool. #253, \$2.50. Mail to your distributor, book store or order direct:

#### ORDER TODAY — 10-DAY GUARANTEE

John F. Rider Publisher Inc. • EW-8

A Division of Hayden Publishing Co. Inc.  
116 West 14th St., New York 11, N. Y.

I have enclosed \$\_\_\_\_\_. Please send:  
 Elem. Indust. Elect. 2 Vol. Course \$7.80  
 Vol. I \$3.90  Vol. II \$3.90  
 Basic Principles & Application of Relays \$2.90  
 Photoelectric Control \$3.50  
 How To Build Electronic Equipment \$6.95  
 Useful Electronic Shop Hints \$1.95  
 Using The Slide Rule in Electronic Technology \$2.50

NAME \_\_\_\_\_  
 ADDRESS \_\_\_\_\_  
 CITY \_\_\_\_\_ ZONE \_\_\_\_\_ STATE \_\_\_\_\_  
 Satisfaction guaranteed, or I can return within 10  
 days of purchase for full refund.

## COMING NEXT MONTH

### Special Features

## Electronics World



**Fuel Cells**—New exotic power sources will be used to supply all of the electrical needs of space vehicles in flight. These cells produce electricity directly from chemical reactions with an efficiency far greater than any other non-nuclear power system. Status of current research is covered in article.

**"S" Meters for CB**—A survey of available circuits as used for signal strength indication in Citizens Band gear and suggestions for incorporating such a feature in your own CB rig. A large number of different methods are included.

#### FM STEREO—A BROADCASTER'S VIEWPOINT

*How one of the country's earliest multiplex broadcasters solved some technical transmission problems; along with suggestions for the listener who wants to get the best stereo reception. Included is a simple scope method of checking stereo signals for separation and channel identification.*

#### SELF-BALANCING POTENTIOMETERS

*Electronics technicians who fill industrial jobs encounter few devices more frequently than these pots. The author provides a rundown on the basic elements and available types.*

#### THE DIGITAL VOLTMETER

*Laboratory accuracy of up to  $\pm 0.01\%$  on the production line and in the field is possible with the digital voltmeter. This article explains the operation of three fundamentally different types.*

#### GETTING INTO U.H.F. TV

*Present tests in the New York metropolitan area are re-awakening interest in u.h.f. reception. For owners of v.h.f.-only receivers, conversion is less difficult and less expensive than is generally believed. Tips on antennas, converters, installations, and problems covered in this article will be of special interest to TV technicians.*

#### LOUDSPEAKER INTERCOM SYSTEMS

*Principles of operation and features provided by this widely used method of communication for home and industry. Different equipment hook-ups and features are covered in detail.*

*All these and many more interesting and informative articles will be yours in the September issue of ELECTRONICS WORLD . . . on sale*

August 23rd

#### ZIFF-DAVIS PUBLISHING COMPANY

William B. Ziff  
Chairman of the Board (1946-1953)

William Ziff  
President

W. Bradford Briggs  
Executive Vice President

Hershel B. Sarbin  
Vice President and General Manager

M. T. Birmingham, Jr.  
Vice President and Treasurer

Robert P. Breeding  
Circulation Director

Charles Housman  
Financial Vice President

Stanley R. Greenfield  
Vice President

Member  
Audit Bureau of  
Circulations



Radio & TV News • Radio News • Radio-Electronic Engineering Trademarks Reg. U.S. Pat. Off.

**SUBSCRIPTION SERVICE:** All subscription correspondence should be addressed to Electronics World, Circulation Department, 434 South Wabash Avenue, Chicago 5, Illinois. Please allow at least six weeks for change of address. Include your old address, as well as new—enclosing if possible an address label from a recent issue.

**EDITORIAL CONTRIBUTIONS** must be accompanied by return postage and will be handled with reasonable care; however publisher assumes no responsibility for return or safety of art work, photographs, or manuscripts.

ELECTRONICS WORLD



**"a CREI home study program helped me become an electronics engineer"**

—Robert T. Blanks

Engineer, Research & Study Division  
Vitro Laboratories, Silver Spring, Md.  
Division of Vitro Corporation of America



"THROUGH A CREI HOME STUDY PROGRAM I learned the practical theory and technology I needed to become a fully-qualified engineer—not a 'handbook' engineer, either—and I did it while I was on the job," says Robert T. Blanks. Today thousands of electronics personnel—engineering technicians, engineers, administrators, executives—attribute present high salaries and positions to home study of CREI Programs in Electronic Engineering Technology.

DEMAND FOR CREI-PREPARED MEN today far exceeds the supply—has exceeded the supply for many years. Designed to prepare you for responsible positions in electronics, CREI Home Study Programs are the product of 35 years of experience in advanced technical education. Aiding in their development are leading engineers and scientists from industry, government agencies and institutions of higher learning. Here Robert T. Blanks discusses CREI with Director Wayne G. Shaffer of Vitro Labs.



WHEN YOU ENROLL IN A CREI Home Study Program, you join more than 20,500 students working in electronics in all 50 states and most countries of the free world. One CREI Program helped Robert Blanks become an Electronics Engineer. Another helped Robert I. Trunnell become an Electronics Technician. While John H. Scofield—a Mathematician—is enrolled in still a different CREI Program relating mathematics to electronics. All work at Vitro Laboratories.

YOUR LIVING IS BETTER when you prepare for—and get—desired promotions through CREI Home Study. CREI alumnus Blanks is understandably proud of his home in a comfortable neighborhood. The positions of CREI-prepared men in such companies as Pan American Airways, Federal Electric Corporation, The Martin Company, Northwest Telephone Company, Mackay Radio, Florida Power and Light and many others attest to the high calibre of CREI Programs.

YOUR WHOLE FAMILY BENEFITS. Engineer Blanks' growing family pitched in to provide free time for his CREI Home Study. Now they share his success. We invite you to check the thoroughness and completeness of CREI Home Study Programs in Electronic Engineering Technology in the catalog provided on request. For those who can attend, CREI maintains a Residence School in Washington, D. C. offering ECPD Accredited Technical Institute Curricula.

INDUSTRY-RECOGNIZED CREI HOME STUDY PROGRAMS PREPARE YOU FOR INCREASED RESPONSIBILITIES, HIGHER-PAYING POSITIONS IN ELECTRONICS.

YOU CAN QUALIFY for a CREI Program if you have a basic knowledge of radio or electronics and are a high school graduate or the equivalent. If you are doubtful about your qualifications, let us check them for you.

JUST OFF THE PRESS! If you qualify, send for FREE 58-page book describing CREI Programs and career opportunities in advanced electronic engineering technology—the latest edition is just off the press. Mail coupon or write to: The Capitol Radio Engineering Institute, Dept. 1108-K, 3224 Sixteenth St., N.W., Washington 10, D. C.

New edition just off the press—Mail coupon today for FREE 58-page book



The Capitol Radio Engineering Institute Founded 1927

Dept. 1108-K, 3224 Sixteenth St., N.W., Washington 10, D. C.

Please send me details of CREI Home Study Programs and Free Book, "Your Future in Electronics and Nuclear Engineering Technology." My qualifications are noted to obtain immediate service.

CHECK FIELD OF GREATEST INTEREST:

<input type="checkbox"/> Electronic Engineering Technology	<input type="checkbox"/> Nuclear Engineering Technology
<input type="checkbox"/> Servo and Computer Engineering Technology	<input type="checkbox"/> Automation and Industrial Electronic Engineering Technology
<input type="checkbox"/> Aero and Navigational Engineering Technology	

Name \_\_\_\_\_ Age \_\_\_\_\_

Address \_\_\_\_\_

City \_\_\_\_\_ Zone \_\_\_\_\_ State \_\_\_\_\_

Employed by \_\_\_\_\_

Type of present work \_\_\_\_\_

Education: Years High School \_\_\_\_\_ Other \_\_\_\_\_

Electronics Experience \_\_\_\_\_

Check:  Home Study  Residence School  G.I. Bill

10A



and most  
versatile

... slim-compact

X-20

Here is unbelievably excellent sound quality combined with the ultimate in placement flexibility. Compact size (12 $\frac{7}{8}$ "H, 15 $\frac{3}{8}$ "W, 2 $\frac{5}{8}$ "D) takes little space on desk, table or shelf. The slim-compact X-20 is ideal for wall mounting with built-in brackets. Finish is oiled walnut. Convenient volume control on the side. There's a refreshing decorator touch in the two-tone harmonizing custom fabric on the front. 3 speakers—a woofer and 2 tweeters—provide smooth wide range sound. Perfect for FM Multiplex, very low cost stereo, other-room extensions.

X-20 3-speaker 2-way system. Impedance, 8 ohms. Power rating, 6 watts. Adequate room sound with 1 watt to speaker. In Oiled Walnut..... \$39.95

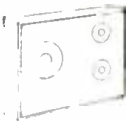

... ultra compact

X-10



Most popular ultra-compact hi fi speaker system. 2-way system in oiled walnut measuring 7 $\frac{1}{4}$ " H, 13" W, 4 $\frac{1}{2}$ " D.

X-10 2-speaker 2-way system. Impedance, 8 ohms. Power rating, 6 watts. Adequate room sound with 1 watt to speaker. In Oiled Walnut ... \$29.75



6601 SOUTH LARAMIE AVENUE, CHICAGO 38, ILLINOIS  
CANADA: RADIO SPEAKERS OF CANADA, LTD., TORONTO  
MEXICO: UNIVERSAL DE MEXICO, S.A., MEXICO, D.F.



## ... for the Record

By W. A. STOCKLIN  
Editor

# Integrated Circuitry

THE electronics industry has never stood still, especially not since World War II. New developments, new techniques, new ideas—all having been accelerated by our military and space programs, make our industry an exciting one, especially to those who progress with it.

Much has been said recently about a new art—that of Integrated Circuitry. To get first-hand information, we went to *Motorola's* semiconductor plant in Phoenix and to *Fairchild's* plant near San Francisco. We talked to engineers from *Texas Instruments*, *RCA*, and others. We have been convinced that a new component design technique is developing.

Every company in the field refers to this new technique by its own coined phrase: *Motorola* calls it "integrated-circuit electronics"; *Fairchild*, "Micrologic"; *General Instrument*, "nanocircuits"; etc. For want of a better name, let's just call it "integrated circuitry."

It is the art of fabricating complete circuits, including transistors, diodes, resistors, capacitors, and even inductors on a substrate similar in size to the active material used in our present-day transistor. The substrate may be ceramic with thin films deposited on it to produce the circuitry, or a silicon or germanium substrate may be employed with the circuit elements being applied by a diffusion technique. The diffusion process is similar to that used in making some transistors, but a great number of other components with their interconnections are added. *Fairchild* is actually producing units using a diffusion technique having as many as 9 transistors and 15 resistors on a substrate only about  $\frac{1}{4}$ " square.

As to which process will survive, or if both will be used, is relatively unimportant for the moment. Let's just say that both may find diversified applications and be able to compete profitably.

The point of interest is that these new techniques represent microminiaturization in the extreme. It is difficult to imagine the great number of individual components that could be mounted within a conventional transistor case. The only limiting factor would be the number of external lead connections.

There are, of course, other circuit limitations. Large capacitance and in-

ductance values are, at present, impossible to attain. However, even at the present state of the art, integrated circuits are beginning to find applications in computer and high-frequency design. Some of these circuits can even be found right now on the shelves of your local industrial parts distributor. Prices are high but, again, it is the hope of the industry to be able to produce these circuits at only a slightly higher price than that for a present-day transistor.

Although this new industry, if we can refer to it as such, is in its embryo stage, it has all the earmarks of becoming gigantic in time. It will have wide effects, not only on the component industry as such, but on design engineers and technicians.

As pointed out by Robert C. Sprague in a recent address at the 1962 Electronic Components Conference in Washington, our present-day concept of components such as resistors, capacitors, and inductors is not obsolete and will not be so for many years to come. However, our own guess is that ten years from now its effects on the components industry will certainly be felt.

Engineers and technicians who today are involved in circuit-design work will, without a doubt, find that in time their particular functions will change. All basic design work in this new field of integrated circuitry will be done by the manufacturer of the circuit rather than by its ultimate user. Future engineers and technicians will be devoting more of their efforts toward the packaging and assembling of complete systems from these already fabricated building blocks, which will be furnished by semiconductor manufacturers.

A new era and a new industry is in the formative stage now. With this thought in mind, we are making every effort to keep our readers abreast of these new developments. Our plans are to publish in an early issue an article from *Motorola* covering many of their philosophies in this field. We will follow this up with an article from *Fairchild* describing some of their production techniques and including problems involved and developments to date. Our hopes are that *Texas Instruments*, *Sprague*, and others will follow with articles on their approaches to this important phase of electronics. ▲



# The only electronics home study program that guarantees\*... **A Commercial FCC License** **... Or Your Money Back!**

No other electronics home study program can equal that offered by Cleveland Institute. And that's why we make this exclusive guarantee:

\*Completion of our Master Course prepares you for a First-Class Commercial Radio Telephone License with a Radar Endorsement. If you fail the FCC examination for this license after successfully completing the Master Course, you will receive a full refund of all tuition payments. This guarantee is valid for the entire duration of your enrollment period.

**This Course Is Designed Specifically For Men With Previous Electronics Training or Experience and Provides...**

- Advanced electronic theory and math. (You will receive a special 10" Electronic Slide Rule and complete instructions).
- Special training in the practical application of electronics skill in such advanced fields as Computers . . . Servo-Mechanisms . . . Magnetic Amplifiers . . . AC Circuit Analysis . . . Pulse Circuitry . . . Color TV . . . Radar . . . Advanced Measuring Techniques . . . Industrial Electronics . . . Instrumentation . . . Automation . . . Radio Telemetry . . . Semiconductors.



**Get This Handy Pocket Electronics Data Guide Free . . .**

Conversion factors, formulas, tables and color codes at your fingertips. Yours without obligation, simply for responding NOW to this opportunity to improve your future.

**Send This Coupon Today** →

**Cleveland Institute of Electronics**

1776 E.17th St., Desk RN-68, Cleveland 14, O.

Accredited by the Accrediting Commission of the National Home Study Council  
 (An Accrediting Commission Approved by the U. S. Office of Education).



**Three Free Booklets Tell How CIE Training Opens The Door To Unlimited Opportunities**



**More Reasons How CIE Will Help You Get Ahead in Electronics**

**Job Service . . .** every month, for three years, CIE will supply you with a listing of hundreds of job opportunities. High paying, interesting jobs . . . with top companies throughout the world. See how CIE training opens a whole new world in electronics opportunity.

**Electron Bulletin . . .** every month, every student receives a free copy of this informative bulletin. Keeps you up to date on what's going on in electronics.

I want to know more about your electronics home study training program. Please send me your free booklets described above plus your handy pocket Electronics Data Guide. I understand there is no obligation. I have had training or experience in electronics as indicated.

**Mail Coupon To**

Cleveland Institute of Electronics  
 1776 E. 17th St., Desk RN-68, Cleveland 14, Ohio

- |   |   |
|---|---|
| <input type="checkbox"/> Military           | <input type="checkbox"/> Amateur Radio      |
| <input type="checkbox"/> Radio-TV Servicing | <input type="checkbox"/> Broadcasting       |
| <input type="checkbox"/> Manufacturing      | <input type="checkbox"/> Home Experimenting |
| <input type="checkbox"/> Communications     | <input type="checkbox"/> Other              |

I'm now working in \_\_\_\_\_

I want to know about the following area of electronics \_\_\_\_\_

(please print)

Name \_\_\_\_\_ Age \_\_\_\_\_

Address \_\_\_\_\_

City \_\_\_\_\_ Zone \_\_\_\_\_ State \_\_\_\_\_

RN-68

# NEW

antenna specialists  
M-82 'Black Box'

## CB antenna amplifier

an entirely new class  
of citizens band power  
accessory that gives,  
you . . .

**FANTASTIC  
NEW  
PERFORMANCE  
INTO  
AND  
OUT OF  
YOUR  
PRESENT  
CB  
EQUIPMENT**

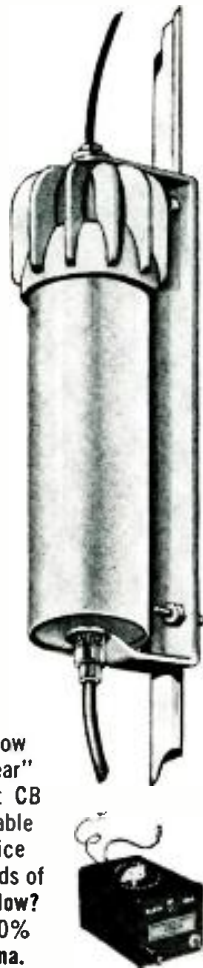

Forget everything you know about the "talk and hear" power of your present CB equipment. This remarkable new, self-powered device has changed the standards of "talk and hear" power! How? Produces a constant 100% legal power at the antenna. Result? 20 db gain (minimum) received . . . over 10 db transmit modulation gain (plus varying carrier gain) from base. Benefit! Clarity and volume never before possible at both ends. Drastic reduction of inherent mobile interference. It's like having another full turn on your volume control. Meets F.C.C. limitations, naturally.



You've got to hear it to believe it. Your local citizens band supplier probably is demonstrating the Antenna Specialists brand M-82 right now! . . . or write to

Reg. T.M. "Stripes of Quality"

**the antenna specialists co.**

12435 Euclid Avenue • Cleveland 6, Ohio  
Export Div., 15 Moore St., New York 4, N. Y.

# LETTERS

## FROM OUR READERS

### SOVIET ENGINEERS

To the Editors:

I get a kick out of a statement like that by M.A.S. in the March issue that he has been reading "Radio News and its progeny since 1946." That's 16 years of faithful readership, whereas I can go back prior to 1926 which is 36 years ago. And I still scan your worthy magazine, cover to cover, every issue.

That "USSR Technical Graduate" article on page 113 of the March issue was good, as far as it went, but it failed to give specific source information. And the article said nothing about the relative number of women engineers in the Soviet Union. Compared to the 7/10ths of 1% of women engineers in the United States, Russia has 36%.

So not only are their men students getting a more intensive, and inclined-towards-science education, but so are their women, and their children, as revealed by: "Education and Professional Employment in the U.S.S.R." by Nicholas DeWitt of the Harvard Russian Research Center, published by the National Science Foundation, NSF 61-40, 1st Ed, 1961, 856 pages, 8 x 10 1/2", GPO Cat. No. NS-1.2: So 8.3 (available from Superintendent of Documents, Government Printing Office, Washington 25, D.C. \$5.50), and "What Ivan Knows That Johnny Doesn't" by Arthur S. Trace, a comparison of USA and USSR schools, published by Random House, 1961, 214 pages, \$3.95.

PAUL S. SMITH  
Manager, Tech. Info. Service  
Motorola Inc.  
Franklin Park, Ill.

*The source for the information about Soviet technical graduates in our March issue was the National Science Foundation, Washington, D. C.—Editors.*

### OSCILLOSCOPE DIRECTORY

To the Editors:

The oscilloscope directory in your June issue was very good as far as it went, but it did not go far enough. For example, I noticed that Lavoie oscilloscopes, among others, were not included in your list. Why not?

SIDNEY A. THOMAS  
East Rockaway, N. Y.

*Severe space limitations prevented us from running more than a representative sampling of instruments. Here are some additional manufacturers of oscilloscopes along with their addresses. We suggest that our readers who want further information contact these manufacturers directly:*

*Allegany Instrument Co., 1091 Wills Mountain, Cumberland, Md.*

*Analog Instrument Corp., 750 Bloomfield Ave., Clifton, N.J.*

*Edgerton, Germchansen & Grier, 160 Brookline Ave., Boston 15, Mass.*

*Electronic-Instruments, Inc., 8611 Balboa Ave., San Diego, Calif.*

*Electronic Tube Corp., 1200 E. Mermaid Lane, Philadelphia, Pa.*

*Electronic Measurements Corp., 625 Broadway, New York, N.Y.*

*Hughes Industrial Systems Div., Bldg. 116, Mail Station 25, International Airport Station, Los Angeles 45, Calif.*

*I.T.I. Electronics, Inc., 369 Lexington Ave., Clifton, N.J.*

*Kingston Electronics, Div. Kingston Industries, Medfield, Mass.*

*Lavoie Industries, Inc., Matowan-Freehold Rd., Morganville, N.J.*

*Lumatron Electronics Corp., 116 County Courthouse Rd., New Hyde Park, L.I.*

*James Millen Mfg. Co., 150 Exchange St., Malden, Mass.*

*Precise Electronics & Development Corp., 76 E. Second St., Mineola, L.I.*

*Precision Apparatus Co., Inc., 70-31 84th St., Glendale 27, N.Y.*

*Sierra Electronics Corp., 3885 Bohannon Dr., Menlo Park, Calif.*

*Solartron, Inc., 1743 Zeyn St., Anaheim, Calif.*

*Waters Mfg. Co., Boston Post Rd., Wayland, Mass.—Editors.*

### BELOW THE BROADCAST BAND

To the Editors:

No doubt many old-timers like myself were interested in the article "Below the Broadcast Band" by R. Genaille (September 1961), and also the letter from Commander Harlow, USN (February 1962) on the same subject. I was particularly interested in the details of USN v.l.f. transmitters given by Commander Harlow, as I have been picking up several of them here in Scotland for some time, using a rather old RCA marine (4-tube) t.r.f. receiver. In particular, NAA (14.7 kc.) and NSS (22.3 kc.) come in at great strength, day and night, throughout the 24 hours. I also receive another station with a Navy call (NST) on around 65 kc., not listed by Commander Harlow.

For the benefit of readers in the United States, the following are a few European v.l.f. and l.f. stations that are to be heard between 14 and 100 kc.: FUB; GBR (Rugby, 16 kc.); GBT; GYC; MSF (Rugby, 60 kc.); OXF/OXC; SAW. The two Rugby transmitters are held to a very close frequency tolerance, and can be used as standards.

In case readers may be under the impression that a very long antenna is necessary for reception on these low



See Only the Scale You Want...in the Exact Range You Want

just set the range switch  
and the correct scale appears  
**AUTOMATICALLY**

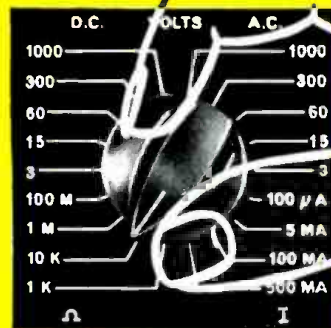

in the new **B&K**  
**VOM and VTVM**

### V O M A T I C 360 AUTOMATIC VOLT-OHM MILLIAMMETER

WITH  
BURN-OUT PROOF  
METER

Greatly simplifies your VOM use. Individual full-size scale for each range—and only one scale visible at any one time, automatically. Once you set the range switch, it is impossible to read the wrong scale. Reading in the range you want is amazingly easy—and direct. No reading difficulties, no multiplying, no errors.

**Sensitivity** 20,000 ohms per volt DC; 5000 ohms per volt AC. **Accuracy**  $\pm 3\%$  DC;  $\pm 5\%$  AC; (full scale). **DC Volts** in 6 ranges 0-6000. **AC Volts** in 6 ranges 0-6000. **AF (Output)** in 4 ranges 0-300 volts. **DC Current** in 5 ranges 0-10 amps. **Resistance** in 4 ranges 0-100 megohms. Supplemental ranges also provided on external overlay meter scales. Meter protected against extreme overload and burn-out. Polarity reversing switch. Automatic ohms-adjust control. Mirrored scale. Complete with 1½-volt and 9-volt batteries, test leads, and easy-viewing stand.

Net, \$5995



### DYNAMATIC 375 AUTOMATIC VACUUM-TUBE VOLTMETER

Once you set the range switch, you automatically see only the scale you want and read the exact answer directly. Saves time, eliminates calculation, avoids errors. Individual full-size direct-reading scale for each range. Simplifies true reading of peak-to-peak voltages of complex wave forms in video, sync and deflection circuits, pulse circuits, radar systems, etc. Includes DC current ranges, too.

**Accuracy**  $\pm 3\%$  full scale AC and DC. **Sensitive** 100 microampere meter movement. **DC Volts** in 7 ranges 0-1500. **AC Volts (rms)** in 7 ranges 0-1500. **AC Volts (peak-to-peak)** in 7 ranges 0-1500. **DC Current** in 3 ranges 0-500 ma. **Ohms** in 7 ranges 0-1000 megohms. Utilizes single DA-AC ohms probe and anti-parallax mirror. Swivel stand converts to carry-handle. Includes 1½ volt battery. Operates on 117 volts 50-60 cycle AC.

Net, \$8995

Ask Your B&K Distributor  
for Demonstration, or  
Write for Catalog AP20-N



**B & K MANUFACTURING CO.**  
Division of DYNASCAN CORPORATION  
1801 W. BELLE PLAINE AVE. • CHICAGO 13, ILL.  
Canada: Atlas Radio Corp., 50 Wingold, Toronto 19, Ont.  
Export: Empire Exporters, 277 Broadway, New York 7, U.S.A.

CLASSROOM TRAINING COURSES IN  
LOS ANGELES AND NEW YORK CITY

# START YOUR CAREER IN ELECTRONICS NOW AT RCA INSTITUTES...

Choose from this list

	Course	Qualifications	Length of Course
A	Electronics Technology (T-3)	High School Grad. with Algebra, Geometry, Physics or Science	Day 2¼ yrs. (N.Y., L.A.) Eve. 6¾ yrs. (N.Y.)
B	Industrial and Communications Electronics (V-7)	2 yrs. High School with Algebra, Physics or Science	Day 1½ yrs. (N.Y., L.A.) Eve. 4½ yrs. (N.Y.) Eve. 3 yrs. (L.A.)
C	Electronics and Television Receivers (V-3)	2 yrs. High School with Algebra, Physics or Science	Day 9 mos. (N.Y., L.A.) Eve. 2¼ yrs. (N.Y.) Eve. 1½ yrs. (L.A.)
D	Radio Telegraph Operating (V-5)	2 yrs. High School with Algebra, Physics or Science	Day 9 mos. (N.Y.) Eve. 2¼ yrs. (N.Y.)
E	Electronic Drafting (V-11, V-12)	2 yrs. High School with Algebra, Physics or Science	Eve. Basic: 1 yr. (N.Y.) Advanced: 2 yrs. (N.Y.)
F	Automation Electronics (V-14)	Radio Receiver and Transistor Background	Sat. 44 wks. (N.Y.) Eve. 9 mos. (N.Y.)
G	Digital Computer Electronics (V-15)	Radio Receiver and Transistor Background	Sat. 32 wks. (N.Y.) Eve. 6 mos. (N.Y.)
H	Computer Programming (C-1)	College Grad. or Industry Sponsored	Sat. 32 wks. (N.Y.) Eve. 6 mos. (N.Y.)
I	Computer Programming (C-2)	Programming Experience	Sat. 16 wks. (N.Y.) Eve. 3 mos. (N.Y.)
J	Color Television	Television Background	Eve. 3 mos. (N.Y., L.A.)
K	Transistors	Radio Background	Eve. 3 mos. (N.Y., L.A.)
L	Technical Writing	Electronics Background	Eve. 3 mos. (N.Y.)
M	Technical Writing (V-10)	High School Graduate	Eve. 1½ yrs. (L.A.)
N	Preparatory (P-1)	1 yr. High School	Day 3 or 6 mos. (N.Y.) Day 3 mos. (L.A.)
O	Preparatory Mathematics (P-0A)	1 yr. High School	Eve. 3 mos. (N.Y.)

RCA Institutes is one of the largest technical institutes in the United States devoted exclusively to electronics. Free Placement Service. Applications now being accepted for next term classes in Los Angeles and New York.



The Most Trusted Name  
in Electronics  
RADIO CORPORATION OF AMERICA



Send to the school nearest you -

RCA Institutes, Inc. Dept. EWR-82

Pacific Electric Building 350 West Fourth Street  
610 S. Main St., L.A. 14, Calif. New York 14, New York

Please send me your FREE catalog. I am interested in the courses circled below.

A B C D E F G H I J K L M N O

Name \_\_\_\_\_ (please print)

Address \_\_\_\_\_

City \_\_\_\_\_ Zone \_\_\_\_\_ State \_\_\_\_\_

For Home Study Courses See Ad On Opposite Page

frequencies, may I say that I have logged between 20 and 30 stations between 14 and about 150 kc., using no more than a semi-vertical piece of wire, 41 feet long, and very near to the roof of this building, which is a single story. The important thing is to use an antenna which is vertical, or mostly vertical, and is as high as possible. It should be as long as reasonably possible, but there is no need to worry if any horizontal part is not very long.

After starting in radio way back in 1921, listening to the old spark transmitters at Eiffel Tower (FL) on 2600 meters, and Nauen (Germany) on 3200 meters (we didn't talk in kc. then), it gives me a great kick to hear these modern tube transmitters on the l.f. and v.l.f. bands, and to think that after all these years (since the earliest days of long-distance radio communication, in fact) there is still a field of usefulness for these bands. (After all, steady signals, night and day, with no fading, is quite something compared with communication on the h.f. bands.) The only trouble is atmospheric static, which can be bad at times. I am perhaps fortunate in this northerly latitude (the same as Hudson Bay) in that static is rarely heard on these frequencies.

F.W.T. ATKIN  
Lionel, Port of Ness  
Isle of Lewis, Scotland

### PARALLEL-LINE NOMOGRAM

To the Editors:

The "Parallel-Line Impedance Nomogram" on page 31 of the February 1962 issue of *ELECTRONICS WORLD* is not correct. Mr. Kyle has apparently used the expression  $Z_c = 120 l_c (2s/d)$ , where  $s$  is the center-to-center spacing, and  $d$  is the diameter. However, this approximation is valid only as  $(s/d)$  approaches infinity. The common values of impedance must be found from the precise expression:  $Z_c = 120 \cosh^{-1}(s/d)$ , particularly when  $(s/d)$  approaches one.

ROB HARTOP  
Pasadena, California

*The following is a portion of Author Kyle's reply. We are sorry for the delay, but Mr. Kyle has been moving around the country quite a bit, and his mail has just caught up with him.—Editors.*

Dear Mr. Hartop:

The formula you quote is the exact version, while the one I used,  $Z_c = 276 \log_{10}(2s/d)$ , is an approximation.

However, I checked the amount of error at various ratios of  $s$  and  $d$ , and found that for most practical applications the error involved is negligibly small. For instance, at the point used in the published example ( $s/d$  ratio of 10), the exact formula gives a  $Z_c$  of 359.8 ohms while the nomogram reads 359 ohms. In either case, this figure would usually be rounded to "360." At higher impedance levels, the error becomes smaller. At lower levels (smaller  $s/d$  ratios), the error increases. It reaches 5 per-cent at an  $s/d$  ratio of 2.0, and remains less than 10 per-cent down to an  $s/d$  ratio of 1.6 ( $Z_c = 126$  ohms actual, 139 ohms from nomogram). At still smaller  $s/d$  ratios, the error rises rapidly, nearing 40 per-cent at the indicated 100-ohm point.

My sincere apologies to you and any other reader who may have been led astray; however, in the higher- $Z$  area (which applies to most of the values shown), I believe you will find the chart useful despite the very small percentage of error.

JIM KYLE  
Oklahoma City, Oklahoma

### WASHING RADIOS IN WATER

To the Editors:

The article "Salvaging Salt-Watered Radios" (March 1962) was very interesting. The procedure seems drastic, but is a common occurrence in our shops. When first told to clean a chassis with water, I balked. It took three senior technicians to stand over me, giving me instructions. But do you know, it really cleans things up.

CLYDE L. MILLER, JR.  
Oklahoma City, Oklahoma

*We felt the same way when we read it.—Editors.* ▲



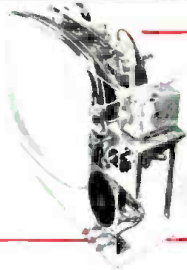

**TELEVISION  
SERVICING**



**ELECTRONIC FUNDAMENTALS**

**COLOR  
TELEVISION**

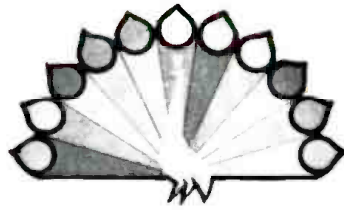

**COMMUNICATIONS  
ELECTRONICS**

**RCA INSTITUTES  
OFFERS A COMPLETE  
SELECTION OF  
HOME TRAINING  
COURSES IN  
ELECTRONICS**

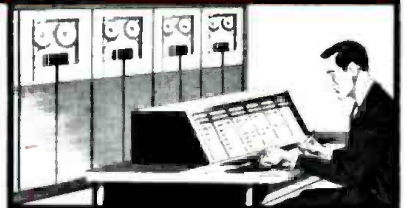

**COMPUTER  
PROGRAMMING**



**TRANSISTORS**



**AUTOMATION  
ELECTRONICS**

Prepare yourself for an exciting and profitable career in electronics. You need no special technical background to start your training. Even if you do not have high school training, you can start your training at home under the guidance of RCA Institutes. Choose from RCA Institutes' wide selection of courses including Electronic Fundamentals, TV Servicing, Color TV, Communications Electronics, Automation Electronics, Computer Programming, Transistors. Practical work starts with the very first lesson. You get

prime quality equipment that you keep and can later use on the job. You never have to take apart one piece of equipment to build another. Perhaps most important, RCA's liberal Voluntary Tuition Plan is the most economical home study method because you pay only for lessons as you order them. If you should interrupt your training at any time, you do not owe one cent. No other obligations. No installment payments required! Licensed by the New York State Department of Education. Approved for Veterans.

*Act today!* Send for this 64-page career book **FREE!**

**CLASSROOM TRAINING**

Classroom Training in New York City and Los Angeles. Day and Evening Classes start four times a year. In addition, Radio Corporation of America offers a limited number of basic courses in Chicago, Philadelphia, and Cherry Hill, N. J. (near Camden). Detailed information on request.

**RCA INSTITUTES, INC.** Dept. EW-82  
A Service of the Radio Corporation of America  
350 W. 4th Street, New York 14, N. Y.  
610 S. Main St., Los Angeles 14, Calif.



**The Most Trusted Name in Electronics**  
For Resident School Courses See Ad On Opposite Page

To save time, paste coupon on postcard

**RCA INSTITUTES, INC.** Dept. EW-82

A Service of the Radio Corporation of America  
350 West 4th St., New York 14, N. Y.

Please rush me your **FREE** illustrated 64-page book describing your home training programs. No obligation. No salesman will call.

Name \_\_\_\_\_ Age \_\_\_\_\_  
(please print)

Address \_\_\_\_\_

City \_\_\_\_\_ Zone \_\_\_\_\_ State \_\_\_\_\_

**CANADIANS**—Take advantage of these same RCA courses at no additional cost. No postage, no customs, no delay. Send coupon to: RCA Victor Company, Ltd., 5581 Royalmount Ave., Montreal 9, Quebec

# EW Lab Tested

AUDIO PRODUCTS TESTED BY HIRSCHHOECK LABS

**ESL T-200 "Gyro/Spension" Turntable**  
**"Knight" KN-4001B Tape Preamp**  
**Fisher KS-1 "Slim-Line" Speaker System** (page 16)  
**Eico Model 955 Capacitor Tester** (page 72)

## ESL T-200 "Gyro/Spension" Turntable

For copy of manufacturer's brochure, circle No. 57 on coupon (page 96).



THE *ESL* T-200 is a four-speed, belt-driven turntable with a simple and foolproof design. The turntable is cast aluminum, weighing four pounds. Its spindle rests on a ball thrust bearing and rotates in low-friction graphite sleeve bearings.

The T-200 is driven by a four-pole motor with the removable drive capstan slipping onto the motor shaft. There are two interchangeable capstans, one for 33/45 rpm and one for 16/78 rpm. The rubber belt couples the motor directly to an undercut portion of the turntable rim. Either of the two speeds on each capstan is selected by pushing the belt onto the upper or lower section of the capstan while the turntable is running. A metal cover hides the motor and belt during operation.

The T-200 has a rather novel motor mounting system, which is being patented by the manufacturer. The motor is suspended on three soft rubber vibration isolators. Two of them are elevated on a bracket which puts them in the plane of the capstan and the turntable rim. Because of this, the pull of the belt does not tend to tilt the motor.

With the motor remaining upright, the belt always runs true on the capstan, with no tendency to shift up or down or to slip.

The measured speed of the *ESL* T-200 was nearly exact (very slightly slow at 33 $\frac{1}{3}$  rpm). It was unaffected by line-voltage variations from 90 to 130 volts. There was ample torque to overcome the frictional drag from any usable stylus force. The vertical rumble was -36 db and the lateral rumble was -46 db, measured according to the NAB standards. Flutter was very low, 0.085%, and wow averaged 0.1% with an occasional peak of 0.2%. The external hum field from the motor was very low. (Editor's Note: According to the manufacturer, the rumble figures indicate that the rubber isolators in the drive system may have been deformed slightly in shipping and the drive should be re-aligned. New instruction sheets, not available at the time this early production model was tested, explain this important adjustment to the user.)

The T-200 turntable sells for \$54.95. A walnut base is available for \$9.95. It is also available, as the *ESL* C-71 "Concert Series" playback unit, complete with a mounted *ESL* S-2000 arm and "Red Head" cartridge, for \$119.45. ▲

## "Knight" KN-4001B Tape Preamp

For copy of manufacturer's brochure, circle No. 58 on coupon (page 96).

SEVERAL manufacturers offer tape-transport mechanisms with various head groupings, but without amplifiers. These cost much less than complete recorders and are often used when only playback is required. Equalization is supplied by a regular stereo preamplifier/control center.

The addition of a record/playback preamplifier, including a bias and erase oscillator, converts a basic tape transport into a complete tape recorder. The *Allied Radio* "Knight" KN-4001B is such a preamplifier, featuring in addition to considerable operating flexibility, a full complement of adjustments affecting equalization, recording current, bias current, and erase current. These adjustments are vital to obtaining maximum performance from any tape transport and are a virtual necessity in a preamplifier designed for general application.

The KN-4001B contains four independent amplifiers, two for playback and two for recording. A single slide switch controls recording and playback equalization of both channels, for either 3.75-ips or 7.5-ips tape speed. The re-

corded amplifiers have high-level and low-level (microphone) inputs, with separate concentric level controls. Slip clutches allow differential adjustment of gain as well as simultaneous control of both channels. The inputs and outputs are in the rear of the amplifier, except for the microphone jacks which are on the front panel.

The playback amplifiers also have concentric level controls, with a pair of standard phone jacks on the front panel for monitoring purposes. A slide switch permits monitoring the signal before recording or from the playback heads. In three-head machines, the latter po-

sition can be used for monitoring from the tape as the recording is being made.

There are two illuminated level meters, which indicate either recording or playback level, depending on the position of the monitor switch. There is also a switch which, with three-head machines, permits making multiple (sound-on-sound) recordings by connecting the playback output of the left channel to the recording amplifier of the right channel. The usual external signals may be simultaneously recorded on the right channel. Another setting of this switch connects the output of the left playback amplifier to the input of the left recording amplifier. This adds an echo effect to a recording as it is being made. The front-panel control complement is completed by a six-position se-





# F.C.C. COMMERCIAL OPERATOR LICENSE

## Training..

### F. C. C. LICENSE — KEY TO BETTER JOBS

An F. C. C. *commercial* (not amateur) license is your ticket to higher pay and more interesting employment. This license is Federal Government evidence of your qualifications in electronics. Employers are eager to hire *licensed* technicians.

### WHICH LICENSE FOR WHICH JOB?

The **THIRD CLASS** radiotelephone license is of value primarily in that it qualifies you to take the second class examination. The scope of authority covered by this license is extremely limited.

The **SECOND CLASS** radiotelephone license qualifies you to install, maintain and operate certain radiotelephone equipment but not commercial broadcast station equipment.

The **FIRST CLASS** radiotelephone license qualifies you to install, maintain and operate every type of commercial radiotelephone equipment including all radio and television stations in the United States, its territories and possessions. This is the highest class of radiotelephone license available. Many companies which employ industrial electronics technicians require this license.

### GRANTHAM TRAINING PREPARES YOU

The Grantham Communications Electronics Course prepares you for a **FIRST CLASS** F. C. C. license, and it does this by **TEACHING** you electronics. Each point is covered simply and in detail, with emphasis on making the subject easy to understand. The organization of the subject matter is such that you progress, step-by-step, to your specific objective—a first class F. C. C. license.

### CORRESPONDENCE OR RESIDENCE CLASSES

Grantham training is available by correspondence or in resident classes. Either way, you are trained quickly and well. Write, or mail the coupon below, to any division of Grantham School of Electronics. Our free booklet will be sent to you immediately.

### FOUR SCHOOLS TO SERVE YOU

To better serve our many students throughout the entire country, Grantham School of Electronics maintains four Divisions—located in Hollywood, California; Kansas City, Mo.; Seattle, Wash.; and Washington, D.C.

This booklet  
**FREE!**

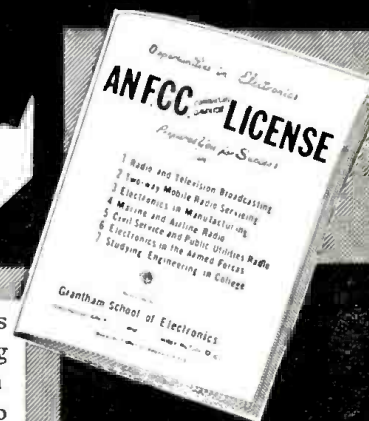

This free booklet gives details of our training and explains what an F. C. C. license can do for your future.

## Upgrade Your Income with a First Class F. C. C. LICENSE

HERE'S PROOF... that Grantham students prepare for F. C. C. examinations in a minimum of time. Here is a list of a few of our recent graduates, the class of license they got, and how long it took them:

	License	Weeks
James C. Bailey, 217 Behrends Ave., Juneau, Alaska	1st	12
Edward R. Barber, 907 S. Winnifred, Tacoma, Wash.	1st	20
M. A. Dill, Jr., 20 Cherry St., Gardiner, Maine	1st	12
Bernhard G. Fokken, Route 2, Canby, Minn.	1st	12
Kenneth F. Foltz, Broad St., Middletown, Md.	1st	12
James C. Greer, Mound City, Kansas	1st	12
Thomas J. Hoof, 216 S. Franklin St., Allentown, Pa.	1st	22
Clyde C. Morse, 7505 Sharronlee Dr., Mentor, Ohio	1st	12
Louis W. Pavek, 838 Page St., Berkeley 10, Calif.	1st	16
Wayne Winsauer, 2009 B St., Bellingham, Wash.	1st	12

Accredited by the National Home Study Council

## GRANTHAM SCHOOL OF ELECTRONICS

HOLLYWOOD CALIF.

1505 N. Western Ave. (HO 7-7727)  
Hollywood, Calif.

SEATTLE WASH.

408 Marion Street (MA 2-7227)  
Seattle, Wash.

KANSAS CITY MO.

3123 Gillham Road (JE 1-6370)  
Kansas City, Mo.

WASHINGTON D. C.

821 - 19th Street, N. W. (ST 3-3614)  
Washington, D. C.

## MAIL COUPON TO SCHOOL NEAREST YOU

(Mail in envelope or paste on postal card)

To: GRANTHAM SCHOOL OF ELECTRONICS

1505 N. Western • 408 Marion • 3123 Gillham Rd. • 821-19th. NW  
Hollywood • Seattle • Kansas City • Washington



Gentlemen:

Please send me your free booklet telling how I can get my commercial F. C. C. license quickly. I understand there is no obligation and no salesman will call.

Name \_\_\_\_\_ Age \_\_\_\_\_

Address \_\_\_\_\_

City \_\_\_\_\_ State \_\_\_\_\_

I am interested in:  Home Study,  Resident Classes 26-M

**BUY THIS**

**GET THIS FREE**

## MASTER CARTRIDGE SUBSTITUTION GUIDEBOOK

by JACK STRONG

RIDER publication

### POWERFUL PROFIT-PRODUCING COMBINATION—YOURS FROM SONOTONE

What a profit-making combination — the industry's finest replacement cartridges in the new, handy Sonotone 6-PAK plus the new Rider "Master Cartridge Substitution Guidebook" (regularly \$2.00), for the price of the cartridges alone. This guidebook, world's greatest source of cartridge replacement data, enables you to locate the exact or equivalent replacement for nearly every record player manufactured since 1930.

**HERE'S HOW TO GET YOUR FREE GUIDEBOOK—** Visit your distributor and select any 6 Sonotone cartridges. Or choose one of the pre-selected 6-PAK combinations that include the most needed cartridges for the most frequent replacements. With your purchase, your distributor will

give you a valuable coupon — one for every six Sonotone cartridges. Mail the coupon to Sonotone Corp., Electronic Applications Division, Elmsford, New York. You'll receive your free Rider "Master Cartridge Substitution Guidebook" by return mail. It will make your stock of Sonotone cartridges more valuable than ever before.

Visit your parts distributor today. Order a Sonotone 6-PAK — and receive your valuable "Cartridge Substitution Guidebook" Coupon. (This offer expires Aug. 15, 1962).

ELECTRONIC APPLICATIONS DIVISION

**SONOTONE® CORPORATION**

Elmsford, New York • Canada: Atlas Radio Corp., Ltd., Toronto  
Cartridges • Speakers • Tape Heads • Microphones  
• Electron Tubes • Batteries • Hearing Aids

lector switch which provides either recording or playback on left channel, right channel, or both channels simultaneously. A red light on the panel glows when the switch is in any of the record positions.

The bias/erase oscillator is a push-pull type operating at a nominal frequency of 65 kc. It has a balance adjustment to minimize harmonic content and resulting distortion. On the rear of the chassis are adjustments for setting the recording and erase bias currents, as well as the recording signal current delivered to the heads. There are four individual adjustments of high-frequency recording equalization for each channel and tape speed. These match the amplifier frequency response to the head characteristics for optimum high-frequency response.

The preamp uses nine dual triodes, plus silicon rectifier power supplies for plates and all tube heaters. The power switch controls two a.c. convenience outlets on the rear of the chassis which may be used to power the tape transport and power amplifiers.

The KN-4001B is available factory-wired or in kit form. (The unit we tested was factory wired.) It is a rather complex unit, which we imagine would take a good many hours to construct. Printed boards are used for much of the circuitry. The instruction manual is thorough in its description of the various modes of operation possible with this amplifier, and its application to various makes of tape decks. Set-up adjustments are simplified by listing recommended settings for the recording current, bias current, and erase current for a number of popular tape decks such as the "Knight" KN-4000 and KN-4200, the Viking 85 series, and the Sony 262D. Setting the bias currents for these machines is done with the aid of the preamplifier's level meters, which can be switched to read bias levels. Complete instructions are also given for setting up the proper operating conditions with decks of unknown characteristics.

We tested the KN-4001B in conjunction with the "Knight" KN-4000 tape transport (reported on in last month's issue), a three-head machine capable of utilizing the full flexibility of the preamplifier. Similar results should be expected with other machines of comparable quality.

The playback system was tested with the NCB Laboratories' 7.5-ips alignment and NAB equalization test tape. The azimuth of the playback heads was aligned for best high-frequency response from this tape, which then yielded a playback frequency response within  $\pm 3.5$  db from 50 to 15,000 cycles-per-second.

The recording heads were then aligned to match the playback heads (actually, all the heads were in good alignment as received). A series of tones was recorded at 20 db below maximum recording level and played back to obtain an over-all frequency response. This was a smooth curve within  $\pm 3$  db from 30 to 13,500 cps at 7.5 ips. Interestingly enough, the response at 3.75 ips

ELECTRONICS WORLD



# Brand New From Lafayette

The All New HE-29B 10-Transistor  
Citizens Band Walkie Talkie With  
Additional RF Stage —  
50% More Powerful For Greater  
Sensitivity And Distance



"WALKIE TALKIE"™

Ideal for Sportsmen — Boating — Fishing — Camping

- Transmits & Receives up to 2 miles
- Crystal Controlled on Both Transmit & Receive
- Push-to-Talk Operation
- 46" Telescoping Antenna
- Earphone For Personal Listening

Now Lafayette has done it again. The world Famous HE-29 has been further improved. Packed with power, 10 handpicked transistors plus 1 diode extend the range of the HE-29B up to two miles under average conditions i.e., no intervening obstructions.

No license or permit required. Compact, pocket size unit provides complete portable two way communications. Transmitter section is crystal controlled. Crisp, clear reception is furnished by the efficient superheterodyne receiver. Power is supplied by 8 miniature standard penlight batteries with a life expectancy of up to 50 hours.

Housed in a handsome black and chrome case. Supplied with leather carrying case w/shoulder strap, earphone, antenna, batteries and crystals for channel 10. Size: 6¾x3¼x1½". Shpg. wt., 3 lbs.

HE-29BL ..... Net 39.95  
Set of 2 ..... Net 78.88

**39<sup>95</sup>** SET OF 2—78.88  
NO MONEY DOWN



- Dual NARTB Equalized Transistor Preamps
- Frequency Response: 50-15,000 CPS @ 7½ ips
- Plays back: ¼ & ½ Track Stereo;  
½ Track & Full Track Monaural

New Lafayette 2-Speed Stereo  
Playback Tape Deck  
Complete With Built-In 6-Transistor  
Dual Playback Preamps

FOR LESS THAN THE PRICE OF A RECORD CHANGER!

Now you can enjoy the superlative reproduction and fidelity of prerecorded tape at the price you'd expect to pay for a record changer. Precision engineered, the RK-141 is equipped with its own 6-transistor stereo preamplifiers designed to play back ¼ track and ½ track stereo plus ½ track and full track monaural tape with true NARTB hi-fi tape equalization. Its tape handling mechanisms and heads are of a type found in costlier units. Accepts all size reels to 7". Measures 10¾Dx14¾Wx5"H. Complete with cables.

RK-141WX ..... Shpg. wt., 17 lbs. .... Net 59.50  
RK-148W Furniture Grade Walnut Base. Wt., 4 lbs. .... Net 6.95  
RK-147W Portable Carrying Case. Wt., 5 lbs. .... Net 9.95

**59<sup>50</sup>** NO MONEY DOWN

**LAFAYETTE'S**  
NEW MAIL ORDER HEADQUARTERS  
111 JERICHO TURNPIKE  
(2 Blocks West of South Oyster Bay Rd.)  
SYOSSET, LONG ISLAND,  
NEW YORK



JAMAICA, N. Y.  
165-08 Liberty Ave.  
NEW YORK, N. Y.  
100 - 6th Ave.  
BRONX, N. Y.  
542 E. Fordham Rd.  
BOSTON, MASS.  
110 Federal St.  
NEWARK, N. J.  
24 Central Ave.  
PLAINFIELD, N. J.  
139 W. 2nd St.  
PARAMUS, N. J.  
182 Route 17

LAFAYETTE RADIO DEPT. RH-2  
P.O. BOX 10, SYOSSET, L. I., N. Y.

- Rush my FREE Lafayette Summer Catalog Supplement
- Please send me # ..... Shipping Charges, Collect
- I am enclosing \$ .....

Name \_\_\_\_\_

Address \_\_\_\_\_

City \_\_\_\_\_ Zone \_\_\_\_\_ State \_\_\_\_\_

**FREE!**



**5 CORES**  
**WETS FASTER**  
**MELTS FASTER**  
**Solders Better**

**5-CORE SOLDER**  
**WORLD'S FINEST**

ERSIN  
*Multicore*

Multicore Sales Corp. Port Washington, N.Y.  
For information, write Department MK 42

was flatter and almost as wide as at 7.5 ips, within  $\pm 3$  db from 30 to 9000 cps. On one channel the high-frequency response was not quite as good, which may have been due either to the pre-amplifier or to the heads.

The hum level was 43 db below maximum recording level on one channel and only 30 db down on the other channel. This may have been due to a defective tube or component, but we did not attempt to locate the trouble. The stereo crosstalk at 1 kc. was below the hum level. The bias oscillator frequency was approximately 61 kc.

The listening quality of the preamp was excellent. In A-B comparison against the original program, no difference could be heard when recording from FM stereo broadcasts. When wide-range phonograph records were used, the slight loss of highs in the tape re-

recorder could be detected, but only on direct comparison. There was no audible distortion and negligible increase in noise level.

The use of a separate amplifier and tape mechanism, which has certain advantages, also has its hazards. There is no interlock between the recording bias oscillator and the tape transport, making it very easy to accidentally erase a tape. The warning light on the KN-4001B is near the brightly lighted level meters and is easily overlooked. A much more prominent recording light, or one which could be mounted directly on the tape deck itself, would be more desirable.

The "Knight" KN-4001B sells for \$139.95 factory-wired or \$89.95 in kit form. A portable case capable of mounting the amplifier and the KN-4000 tape transport sells for \$24.95. ▲

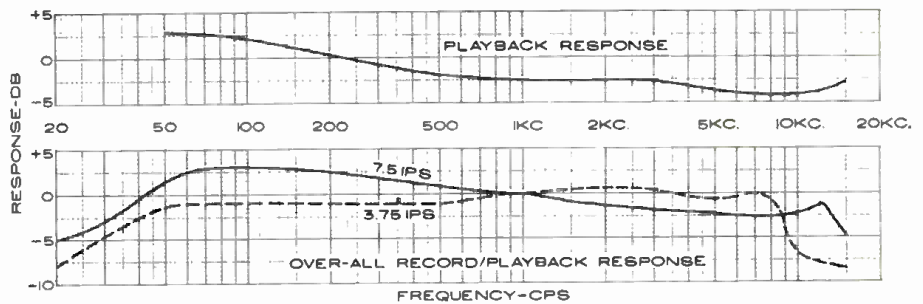

### Fisher KS-1 "Slim-Line" Speaker System

For copy of manufacturer's brochure, circle No. 59 on coupon (page 96).

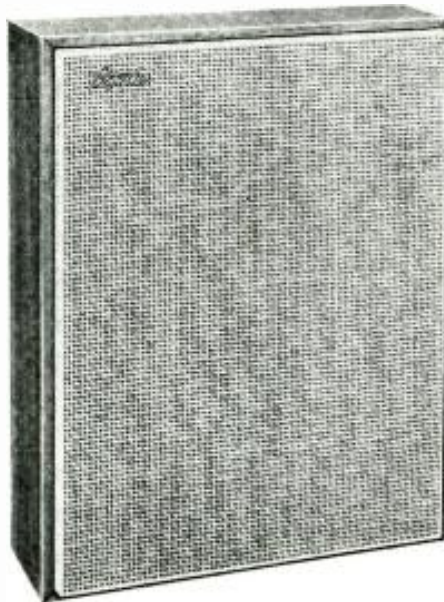

24" x 5 $\frac{3}{4}$ " deep. It can stand on the floor (legs are available if desired) or hung on the wall. The KS-1 is available in kit form with an unfinished enclosure or factory assembled.

The woofer is a 10" unit, with a compliant suspension, an 8-ohm 1 $\frac{1}{2}$ " diameter voice-coil, and a 4 $\frac{1}{2}$ -pound magnet assembly. The frequencies from 1400 to 5000 cps are handled by a 5" cone speaker. The space behind its cone is packed with glass fiber damping material and it is fully enclosed in the rear to prevent the backwave from the woofer from interfering with its action.

A small 3" diameter cone tweeter carries the frequencies above 5000 cps. Like the mid-range speaker, it is fully enclosed and packed with damping material. The three-way crossover network is contained within the enclosure, and has no level controls. The crossovers are gradual, with slopes of 6 db per octave.

The KS-1 kit is supplied with the wooden cabinet frame fully assembled. The speakers must be mounted on the front panel and wired to the pre-assembled crossover network. A tubular column is glued between the front and rear panels to provide stiffening. A sheet of glass fiber loosely fills the enclosure to damp internal resonances. The entire assembly took us about one hour. Even a neophyte should not require more than two hours to build it.

The frequency response of the KS-1 is rated at 40 to 18,500 cps. In our fre-

(Continued on page 72)

**N**OW that bookshelf-sized speakers are an accepted part of the high-fidelity scene, it seems that there is a trend toward even less conspicuous speakers. Some of these might be termed "slim" enclosures, whose depth is reduced to the point where they hardly protrude into the room, or may even be hung on the wall like a picture.

The new Fisher KS-1 "Slim-Line" speaker system belongs in this category. It is a three-way system, with full-sized speakers (not a cluster of small drivers), measuring only 18" x

**Ask By Name For GENUINE "NO NOISE" PRODUCTS**

your assurance of brand name quality

**No-Noise VOLUME CONTROL and Contact Restorer**  
• Cleans • Lubricates • Restores • Protects • Restores  
Not a Carbon Tet Solution  
2 Oz. Bottle \$1.00  
6 Oz. Spray Can \$2.25  
Net to Servicemen

**No-Noise TUNER-TONIC**  
with PERMA-FILM  
• Cleans, lubricates, restores all tuners, including wafers  
• Non-toxic, non-inflammable  
• For TV, radio and FM use.  
• Economical—a little does a lot.  
6 oz. Aerosol Can \$3.25  
Net to Servicemen

**FREE** with each can of ELECTRONIC CHEMICAL products — **5" PLASTIC EXTENDER**  
Push Button Assembly For Pin Point Applications—Does Not Cause Shorts

**Electronic Chemical** a new formula  
**EC-44**  
Lubricates, conditions, cleans all electrical contacts. Economical—little does a lot!  
6 oz. spray can \$3.50

**ELECTRONIC CHEMICAL CORP.**  
813 Communipaw Avenue Jersey City 4, N. J.



# Free

SEND TODAY FOR  
YOUR MONEY-SAVING  
464-PAGE

mail  
now

# ALLIED 1963 CATALOG

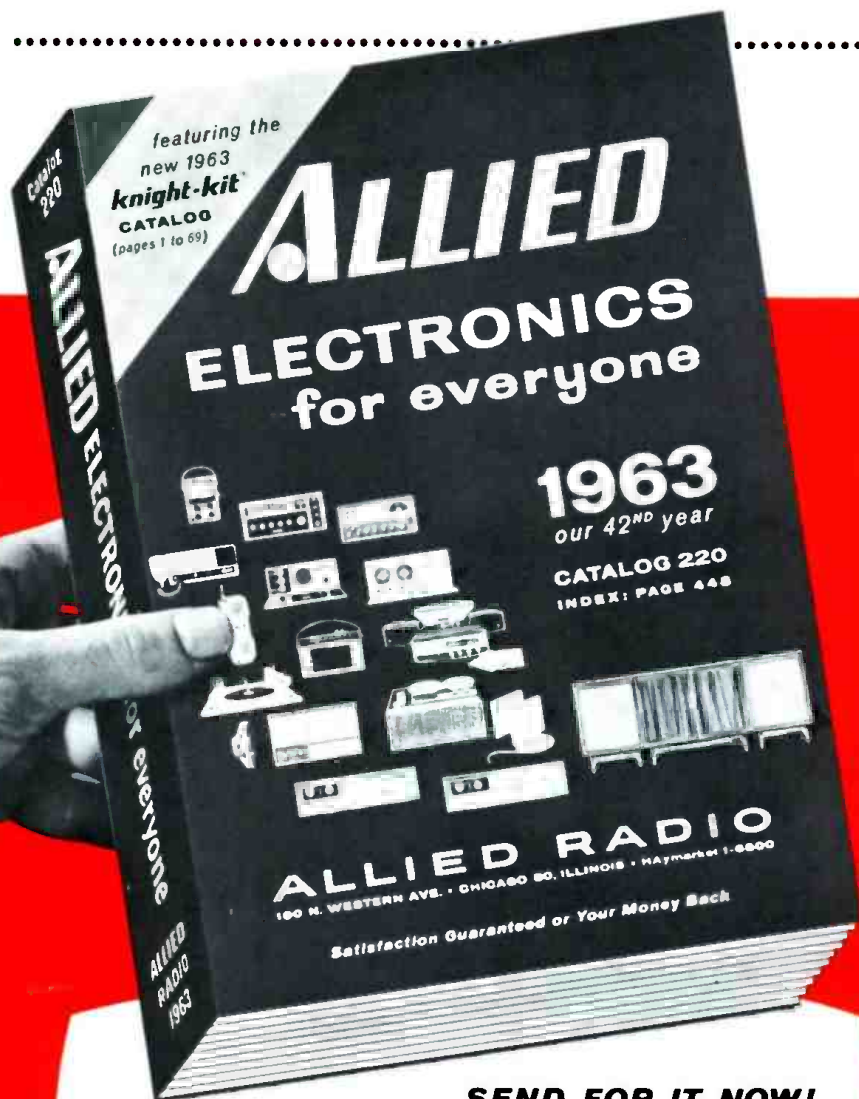

**SEND FOR IT NOW!**

**WORLD'S LARGEST ELECTRONICS CATALOG  
BIGGEST SELECTION • BIGGEST SAVINGS!**

*satisfaction guaranteed or your money back*

**NO MONEY DOWN:** OVER 50% MORE BUYING POWER WITH  
YOUR ALLIED CREDIT FUND PLAN

SEE  
OTHER  
SIDE

For your FREE 1963  
ALLIED Catalog, fill in  
card, detach and mail.  
(Please give second card  
to an interested friend.)

**SEND  
CARD  
TODAY**

mail  
now

Name  
PLEASE PRINT

Address

City

State

Zone

11TH



YOUR **Free**  
**ALLIED**  
1963 CATALOG

Name  
PLEASE PRINT

Address

City

State

Zone

11TH



YOUR **Free**  
**ALLIED**  
1963 CATALOG

mail now

**Free** SEND CARD TODAY FOR YOUR 464-PAGE

# ALLIED 1963 CATALOG

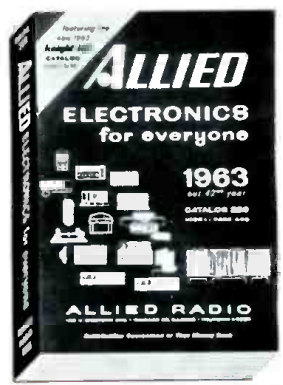

**WORLD'S LARGEST • BIGGEST SELECTION • BIGGEST SAVINGS**

TO:  
**ALLIED RADIO**  
100 N. WESTERN AVE.  
CHICAGO 80, ILL.

PLACE  
STAMP  
HERE

**NEW**

### 1963 knight-kits®



Over 100 great do-it-yourself kits: Hi-Fi, Hobby, Intercom, Amateur, Citizens Band, Instrument—savings up to 50%.

**NEW**

### Stereo Hi-Fi



Complete selection of components and systems; latest All-Transistor equipment and Stereo Multiplex FM.

**NEW**

### Tape Recorders



Complete recorders, tape decks, recording and pre-recorded tapes at big savings.

**NEW**

### Citizens Band Radios



Latest 2-way radio—no exam required—complete selection of top-value CB equipment, including Walkie-Talkies.

**NEW**

### Transistor, FM-AM Radios



Best buys in all types of compact transistor radios, including quality FM-AM portables.

**NEW**

### Phonographs & Records



Big values in phonographs; latest stereo portables; famous-brand records at amazing discounts.

**NEW**

### Ham Station Equipment



Largest selection of receivers, transmitters, antennas—everything in Ham station gear.

**NEW**

### Test Equipment



Save on every type of instrument for home or professional use—all leading makes available.

TO:  
**ALLIED RADIO**  
100 N. WESTERN AVE.  
CHICAGO 80, ILL.

PLACE  
STAMP  
HERE

**PLUS** • PA Systems & Intercoms • Top values in Power Tools, Soldering Guns, Hardware • Biggest selection of TV Tubes, Antennas; Parts, Tubes, Transistors, Books

**satisfaction guaranteed or your money back**

**NO MONEY DOWN:** Over 50% More Buying Power with Your Allied Credit Fund Plan!

mail now

**Free** MAIL CARD TODAY FOR YOUR 1963 ALLIED CATALOG  
AND GIVE THIS CARD TO A FRIEND  
[www.americanradiohistory.com](http://www.americanradiohistory.com)



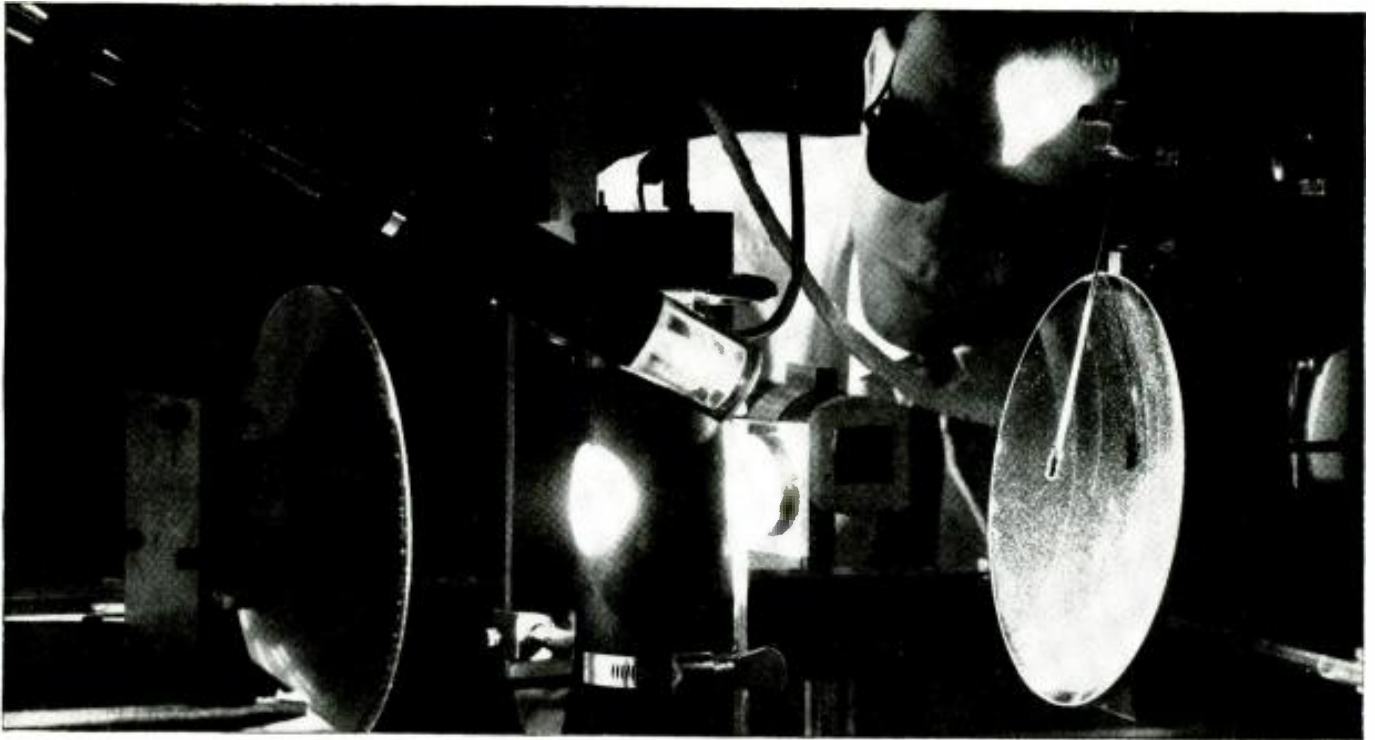

# Exploring the possibilities in Coherent Light

At Bell Laboratories, Donald F. Nelson studies a beam of coherent red light produced by a continuously operating ruby optical maser. The heart of the device is a uniquely shaped ruby crystal immersed in liquid nitrogen in the tubular glass dewar extending from upper left to center. Light from the mercury arc lamp (lower center) is reflected by round mirror at left to mirror at right and then is focused on the ruby crystal to produce maser action. Coherent light emerging from end of dewar is picked up by a detector.

Is it feasible to take advantage of the enormous bandwidth available at optical frequencies? Could coherent light, for example, be sent through protecting pipes to provide high-capacity communication channels between cities?

To study such possibilities it is, first of all, necessary to have a source of continuous coherent radiation at optical frequencies. Such a source was first produced when Bell Laboratories scientists developed the gaseous optical maser.

Recently, our scientists demonstrated the generation of continuous coherent light by solid materials. Using a crystal of neodymium-doped

calcium tungstate, a material developed at Bell Laboratories, continuous optical maser action was obtained in the near infrared. It has also been attained with visible light, using a new optical "pumping" arrangement to excite a ruby crystal. (See illustration above.)

Multichannel light highways for communications are still far from realization. But with continuous sources of coherent light available, it becomes possible to explore the problems of modulating, transmitting, detecting, amplifying and, in general, controlling light for possible communications applications.



**BELL TELEPHONE LABORATORIES**

*World center of communications research and development*



# 9 New Features Now In The New 1962 EICO RP100 Transistorized Stereo/Mono 4-Track Tape Deck

### A great tape recorder made greater:

1. New professional studio recording hysteresis-synchronous capstan motor: 24 stator slots for ultra-smooth drive, ultra-quiet and vibrationless professional bearing system.
2. Two new take-up and rewind reel motors, both extra-powered for effortless operation.
3. New cored-out steel capstan flywheel with all the mass concentrated at the rim for improved flutter filtering.
4. New optimally designed capstan drive belt brings wow down to negligibility.
5. New relay provides instantaneous extra power to the take-up reel motor at start to minimize tape bounce. Provides near-perfect stop-and-go operation and eliminates any risk of tape spillage when starting with a nearly full take-up reel.
6. New automatic end-of-tape stop switch cuts off take-up reel motor power. Also permits professional editing techniques, whereby tape being edited out runs off the machine while you are listening to it.
7. Playback preamps remain "on" during stop-standby mode to permit cueing.
8. Recording level adjustment during stop-standby.
9. Shock-absorbent helical spring tape lifters practically eliminate tape bounce at start of fast winding.

### And All These Well-known RP-100 Features:

Separate stereo 1/4 track record and playback heads permitting off-the-tape monitor and true sound-on-sound recording; separate transistor stereo record and stereo playback amplifiers meeting true high fidelity standards; monaural recording on 4 tracks; digital turns counter; electrodynamic braking (no mechanical brakes to wear out or loosen); all-electric push-button transport control (separate solenoids actuate pinch-roller and tape lifters); unequalled electronic control facilities such as mixing mic and line controls, two recording level meters, sound-on-sound recording selected on panel, playback mode selector, etc. Modular plug-in construction.

**Wow and flutter:** under 0.15% RMS at 7 1/2 IPS; under 0.2% RMS at 3 3/4 IPS. **Timing Accuracy:** ± 0.15% (±3 seconds in 30 minutes). **Frequency Response:** ± 2db 30-15,000 cps at 7 1/2 IPS, 55db signal-to-noise ratio; ± 2db 30-10,000 cps at 3 3/4 IPS, 50db signal-to-noise ratio. **Line Inputs Sensitivity:** 100mv. **Mike Inputs Sensitivity:** 0.5mv.

**Semikit: Tape transport assembled and tested; electronics in kit form \$299.95**  
**Factory-assembled: Handwired throughout by skilled American craftsmen \$399.95**

**An original, exclusive EICO product designed and manufactured in the U.S.A. (Patents Pending)**

**Carrying Case \$29.95**  
**Rack Mount \$9.95**



**FM-AM Stereo Tuner ST96**  
 Kit \$89.95 Wired \$129.95  
 Includes Metal Cover and FET



**70-Watt Integrated Stereo Amplifier ST70**  
 Kit \$99.95 Wired \$149.95  
 Includes Metal Cover  
**40-Watt Integrated Stereo Amplifier ST40**  
 Kit \$79.95 Wired \$129.95  
 Includes Metal Cover

**FM MULTIPLEX AUTOADAPTOR MX99 (Patent Pending)**  
 Kit \$39.95 Wired \$64.95 Cover Optional \$2.95

An original EICO contribution to the art of FM-Multiplex reception

The MX-99 employs the EICO-originated method of zero phase-shift filterless detection of FM Stereo signals (patent pending) described in the January 1962 issue of AUDIO Magazine (reprints available). This method prevents loss of channel separation due to phase shift of the L-R sub-channel before detection and matrixing with the L+R channel signal. In addition, the oscillator synchronizing circuit is phase-locked at all amplitudes of incoming 19kc pilot carrier, as well as extremely sensitive for fringe-area reception. This circuit also operates a neon lamp indicator, whenever pilot carrier is present, to indicate that a stereo program is in progress. The type of detection employed inherently prevents SCA background music interference or any significant amount of 38kc carrier from appearing in the output. However, very sharp L-C low pass filters are provided in the cathode-follower audio output circuit to reduce to practical extinction any 19kc pilot carrier, any slight amounts of 38kc sub-carrier or harmonics thereof, and any undesired detection products. This can prove very important when tape recording stereo broadcasts. The MX-99 is self-powered and is completely factory pre-aligned. A very high quality printed board is provided to assure laboratory performance from every kit. The MX-99 is designed for all EICO FM equipment (ST96, HFT90, HFT92) and component quality, wide-band FM equipment.

©1962 EICO Electronic Instrument Co. Inc.  
 3300 Northern Boulevard, L. I. C., N. Y.

EICO, 3300 N. Blvd., L.I.C. 1, N.Y. EW-9

- Send free 32-page catalog & dealer's name
- Send new 36-page Guidebook to Hi-Fi for which I enclose 25¢ for postage & handling.

Name \_\_\_\_\_  
 Address \_\_\_\_\_  
 City \_\_\_\_\_ Zone \_\_\_\_\_ State \_\_\_\_\_

Over 2 MILLION EICO Instruments in use.  
 Most EICO Dealers offer budget terms.  
 Add 5% in West.

Listen to the EICO Hour. WABC-FM, N. Y. 95.5 MC, Mon.-Fri., 7:15-8 P.M. Export Dept., Roburn Agencies Inc., 431 Greenwich St., New York 13





# FACSIMILE TECHNIQUES & EQUIPMENT

By ARTHUR L. PLEVY / Project Engineer, Westrex Corp.

A review of the basic operating principles and a description of the equipment employed to relay graphic material over conventional communications channels.

GLANCE below many of the photographs in the daily newspaper will often reveal such phrases as "wirephoto," "telephoto," or "radiophoto." Such photographs are pictures of events that occurred many thousands of miles away from the newspaper office and only a few hours before the paper went to press. Transmission of these photographs is made possible by means of *facsimile* equipment.

Facsimile refers to the transmission of graphic or visual intelligence over conventional communications channels. This branch of communications deals with the exact transmission of physical forms, reproducing the various amounts of light density and shadowing; thereby conveying an exact replica of the transmitted picture or text. Facsimile systems require accurate mechanisms and possess highly developed electrical and control systems to enable the transmission of such data.

### Early System

The technique itself is by no means a recent development. Back in the year 1840 Alexander Bain devised a crude system to be used in conjunction with a telegraph line. A pictorial representation of his system is shown in Fig. 1. The device operated this way: As the pendulum swings back and forth, the metal arm makes contact with that portion of the tinfoil not covered by the shellac picture. The d.c. potential of the battery now appears on the line. When the metal arm

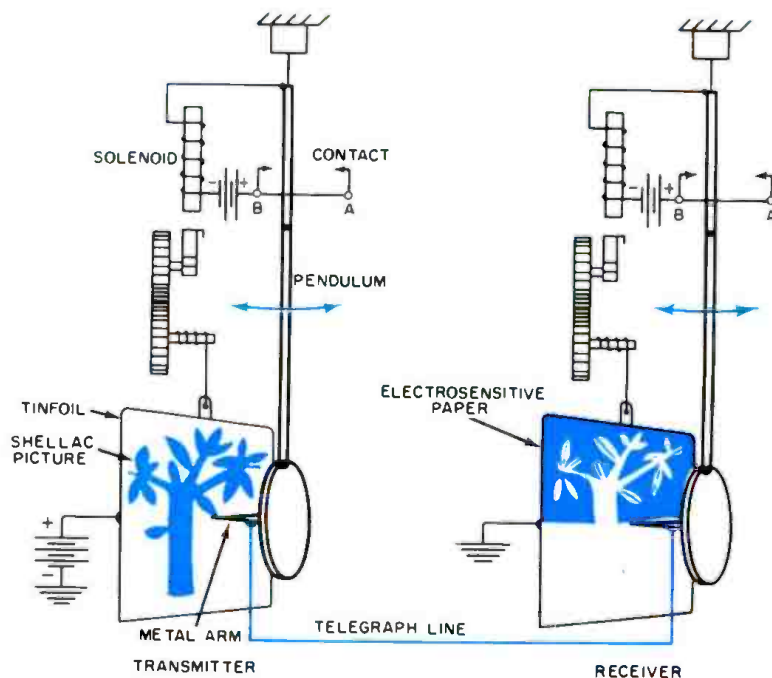
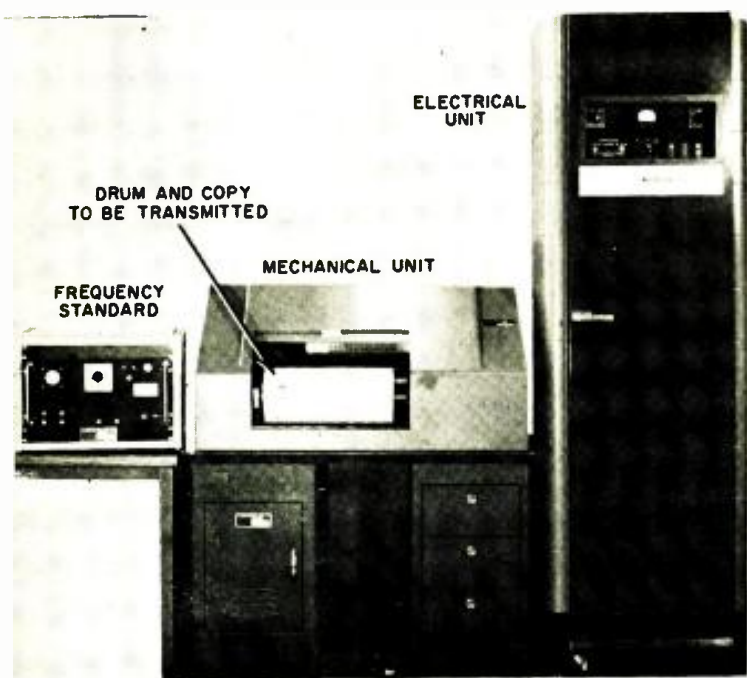

Fig. 1. Crude facsimile system devised in the year 1840.



A high-speed facsimile transmitter that will send full-size newspaper pages over video lines in less than 4 min. a page.

touches the shellacked portion, no d.c. appears on the line.

At the receiving end, another pendulum moves in synchronism with the one at the transmitting end. When the battery's d.c. appears on the receiver contact arm, it burns a mark on an electrosensitive paper. When the transmitting metal arm is insulated by the shellac, no d.c. is transmitted and the paper at the receiving end is not marked. In this way the picture or text is reproduced. As the pendulum completes each arc, it touches contacts *A* and *B*. These actuate a mechanism which lifts the tinfoil and the sensitive paper a slight amount, enabling the pendulum to transverse and record another line.

Bain's system was followed and improved upon by other men and manufacturers. Some of the more notable achievements were those of Casselli of Italy and Korn of Germany. Companies like *A. T. & T.*, *RCA*, *Times Facsimile*, and others improved the process and made facsimile available to the public.

At present there is an impressive variety of facsimile equipment available but the most widely used system, and the one to be discussed here, is that using the drum-type receiver and transmitter. Any facsimile system, whether it be the one devised by Alexander Bain or the most modern high-speed machine, has these things in common:

1. A method of scanning the copy to determine the amounts of the dark and light areas that are to be reproduced.

A facsimile recorder that is employed to print weather maps.

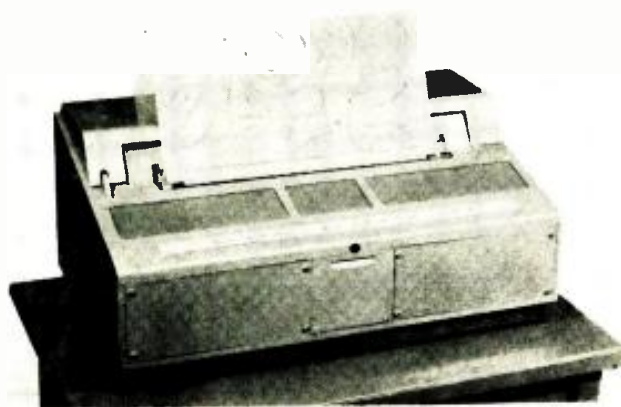

2. A method of moving the copy so that the entire copy is scanned and transmitted.

3. A method of sending the information representing the scanned copy over conventional communications channels.

4. An accurate means of synchronizing the motion of the scanning systems both at the transmitting and at the receiving ends.

### Simple Analogy

Before we proceed any further, let's take a simple example to illustrate the operation of a facsimile system. Let us take two identical spools (Fig. 2). One spool has a single layer of thread around it upon which there is a picture painted; the other spool is empty. If we unravel the spool and look at the thread, we notice areas of different shading representing portions of the original picture. If we take the empty spool and proceed, as shown, to wind the thread on it from the full spool, we would find the original picture transferred to the second spool of thread. The top spool in the illustration can be referred to as the "transmitter" and the bottom spool as the "receiver."

### System Operation

If reference is made to Fig. 3, we can see how the copy

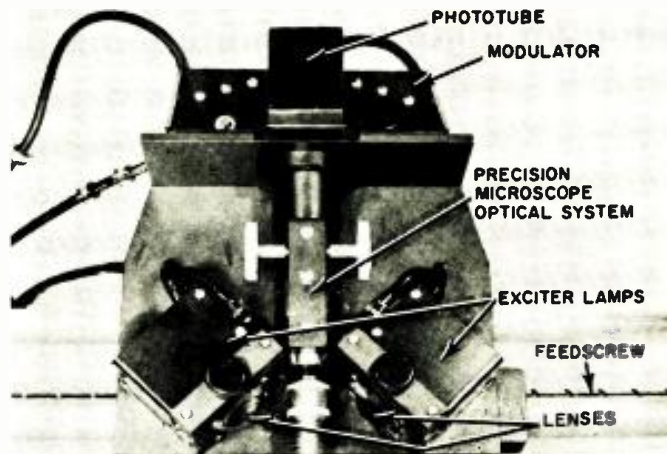

The transmitter optical system. The modulator is mounted on the optical-system carriage to minimize capacity and pickup.

is "unraveled" or scanned in an actual drum-type facsimile system. Such systems derive their name from the fact that the copy to be transmitted is wrapped around a drum. The exciter lamps illuminate an area at the surface of the drum. The light from these lamps is concentrated by means of lenses into a sharply focused spot of light. Light reflected from the copy is focused by means of an optical system onto the cathode of a phototube. The purpose of the aperture is to allow the phototube to see only a very small portion of the copy at a time so that picture definition is improved.

The phototube produces a d.c. level corresponding to the amount of light seen by its photo-cathode. Because of the fact that many communications channels cannot handle d.c. directly, the output of the phototube is used to modulate a carrier.

One such modulator is shown in Fig. 4. This type is called a "ring modulator." The circuit shown includes a phototube input and operates as follows. When the circuit is balanced and no light appears, there is no output from the system. When light appears on the photo-cathode of the tube, it causes a current to flow to the anode. This flow of current reduces the potential at the plate of the phototube. This change in voltage unbalances the bridge (changes the bias on the diodes) and allows carrier signal to appear at the



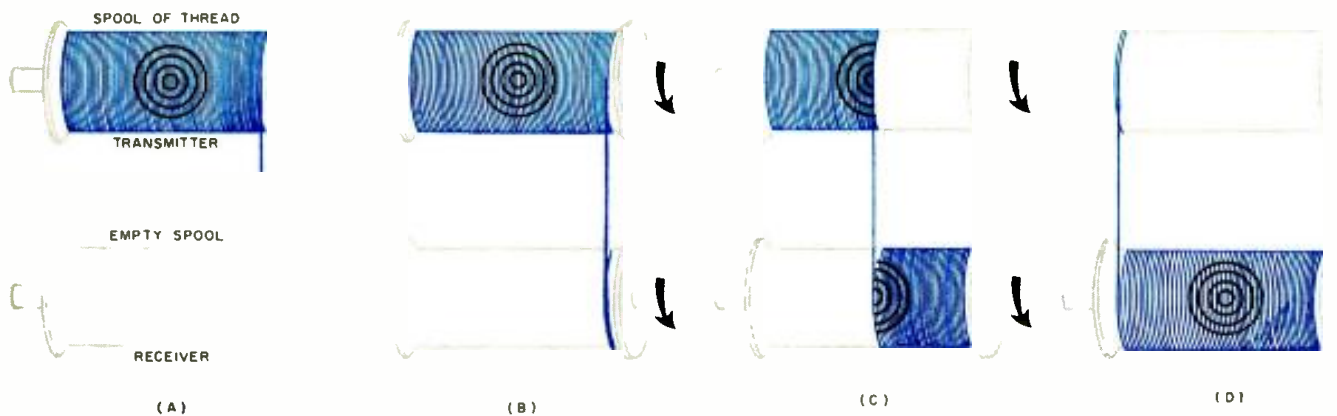

Fig. 2. Simple spools-of-thread analogy that illustrates the principles of scanning and facsimile transmission.

output. The signal is amplitude-modulated and the amount of modulation is strictly a function of the amount of light that the phototube sees, which naturally represents the amount of light that the copy reflects. By adjusting the bias on the diodes, one can balance the modulator in such a way that it is as easy to obtain a negative or a positive copy of the text at the receiver.

### Synchronous Motors

Imagine what would occur in Bain's system if one pendulum moved slower or faster than the other. As one completed its arc the other might be only halfway through. This would cause markings to be made at the wrong position on the paper. The net result would be a total destruction of the information.

In most modern facsimile systems the drum is driven by a synchronous motor, whose speed is directly related to the frequency. Using stable frequency sources at both the transmitter and receiver assures that the drum at the transmitter rotates at the same speed as that at the receiver. If this were not so, a horizontal line would appear at the receiver with a significant slope. The phenomenon produced by different speeds of the drums at the receiving and transmitting sites is called "skew."

The same motor usually drives the scanning system by means of a feedscrew and proper gearing. If one optical system moved slower or faster than the other, the copy would

be enlarged or reduced in size, as the case might be. As can be seen from the diagram, the optical system moves parallel to the surface of the drum. The sharp spot of light and the revolving drum actually "unravel" the copy just as in the case of our spools-of-thread analogy.

### Receiving System

The output from the balanced modulator is amplified and transmitted through a conventional communications channel. This output could be sent over a radio link or a telephone line. The signal is thus sent to the receiver location where it is detected and amplified. The detected signal is fed into a power amplifier which has a stylus on its output. When the stylus is energized, it makes a mark on an electro-sensitive paper and gives a direct reproduction of the transmitted text. This copy is usually not suitable for the reproduction of very fine detail as the stylus has a finite diameter and is unable to clearly reproduce fine text.

In high-definition systems photographic film and a light modulator are employed. The lamp used (called a "crater lamp") produces an intensity of light corresponding to the current energizing it. Fig. 5 is a block diagram of a receiver employing such a device. As can be seen from the diagram, the motor-control circuitry and the feedscrew and gear train are identical to those of the transmitter. The signal is taken from the communications channel and detected by a conventional peak detector. After detection, the original photo-

Fig. 3. Simplified block diagram of the circuits and electro-optical system employed in a modern facsimile transmitter.

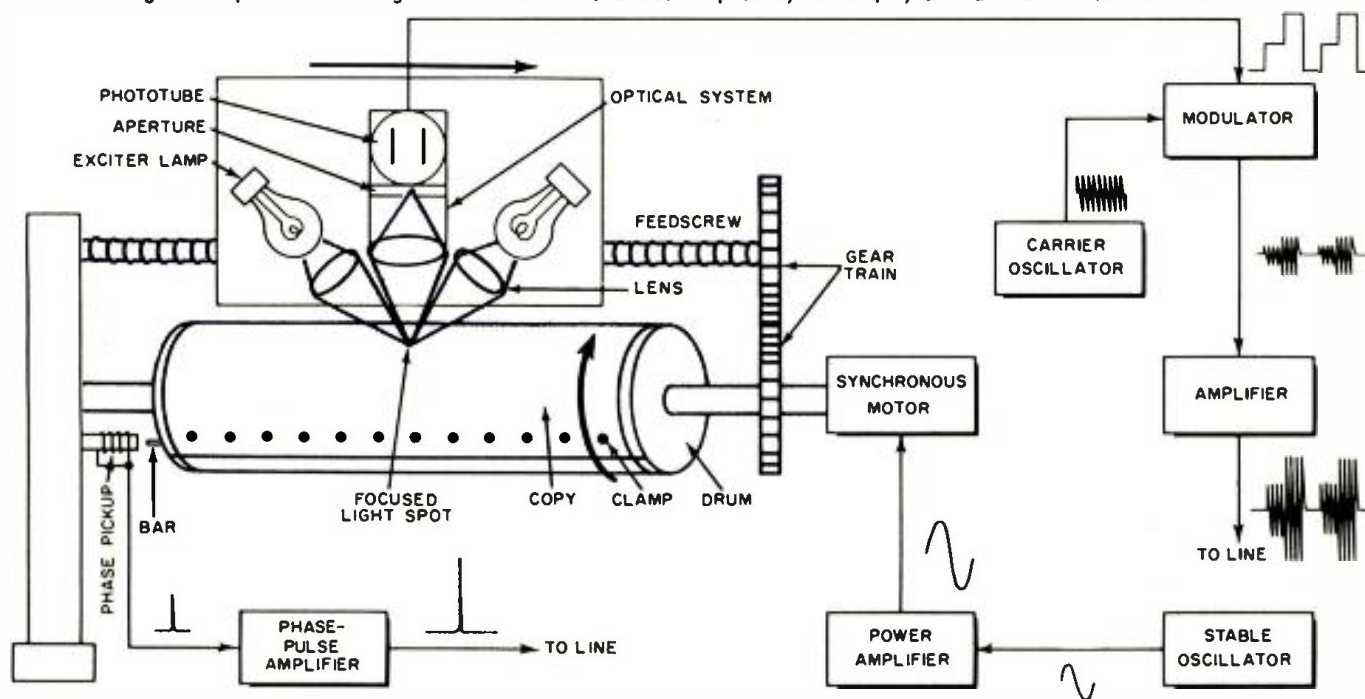

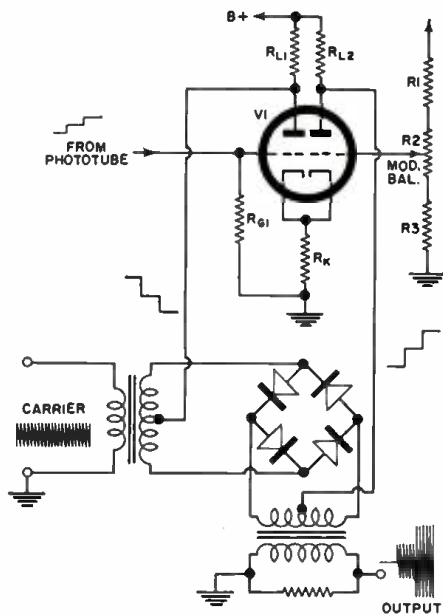
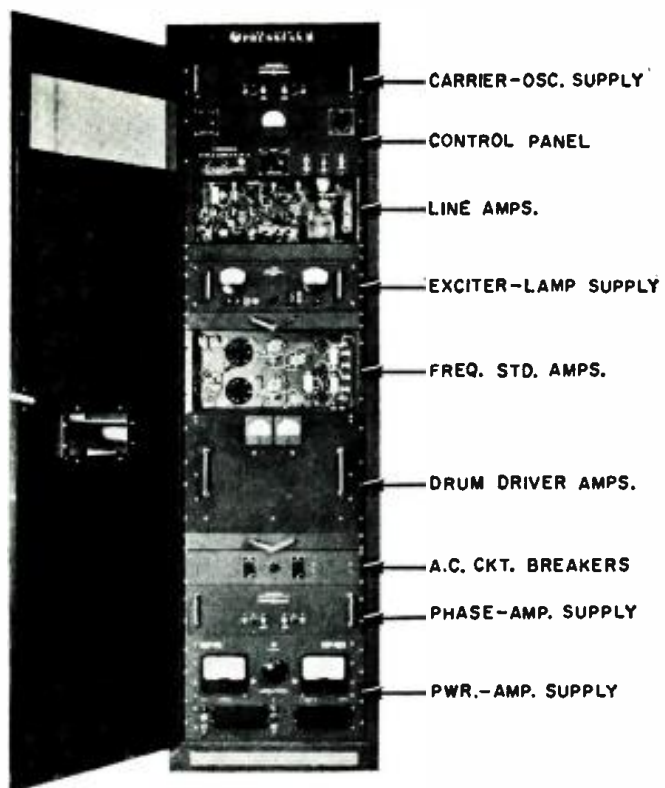

Fig. 4. Circuit diagram of ring modulator.

Relay rack of electronic equipment required for the facsimile transmitter. ▶



tube signal is restored and this signal is then amplified and used to modulate the beam of light put out by the crater lamp.

This varying-intensity light beam is sharply focused, by means of an optical system, onto the film which is wrapped around the receiver drum. The varying light exposes the film in accordance with the amount of light and dark on the original copy. Hence, after a transmission is completed, one has a film of the original copy, which is then developed and used for further copies of the text. In this system the receiver has to be placed in a darkroom so as not to expose the film.

Before copy can be transmitted and restored, the drums at the transmitter and receiver have to be in-phase. Phasing insures that the copy will start at the beginning of the clamp and end at the correct point.

In this system, a phase-pickup bar is placed at the center of the clamp at the transmitter and at the center of the clamp

at the receiver. Every time the bar passes the phase pickup, a pulse is produced. This pulse is amplified and, in the case of the transmitter, sent down the line before a transmission is to be made. The same events occur in the receiver-recorder where the pulse derived here is impressed on a comparator circuit. The pulse received from the transmitter is also applied to the comparator. This circuit puts out a d.c. voltage when the pulses are displaced from each other, and this signal is used to shift the phase of the receiver motor. When the pulses are in-phase, there is no output from the comparator, hence the drums are in-phase and the transmission can begin.

### Applications

Facsimile has played an increasingly important role in the field of communications. A complete network of facsimile  
(Continued on page 93)

Fig. 5. Arrangement utilized in a facsimile recorder-receiver that produces a film negative of the received copy.

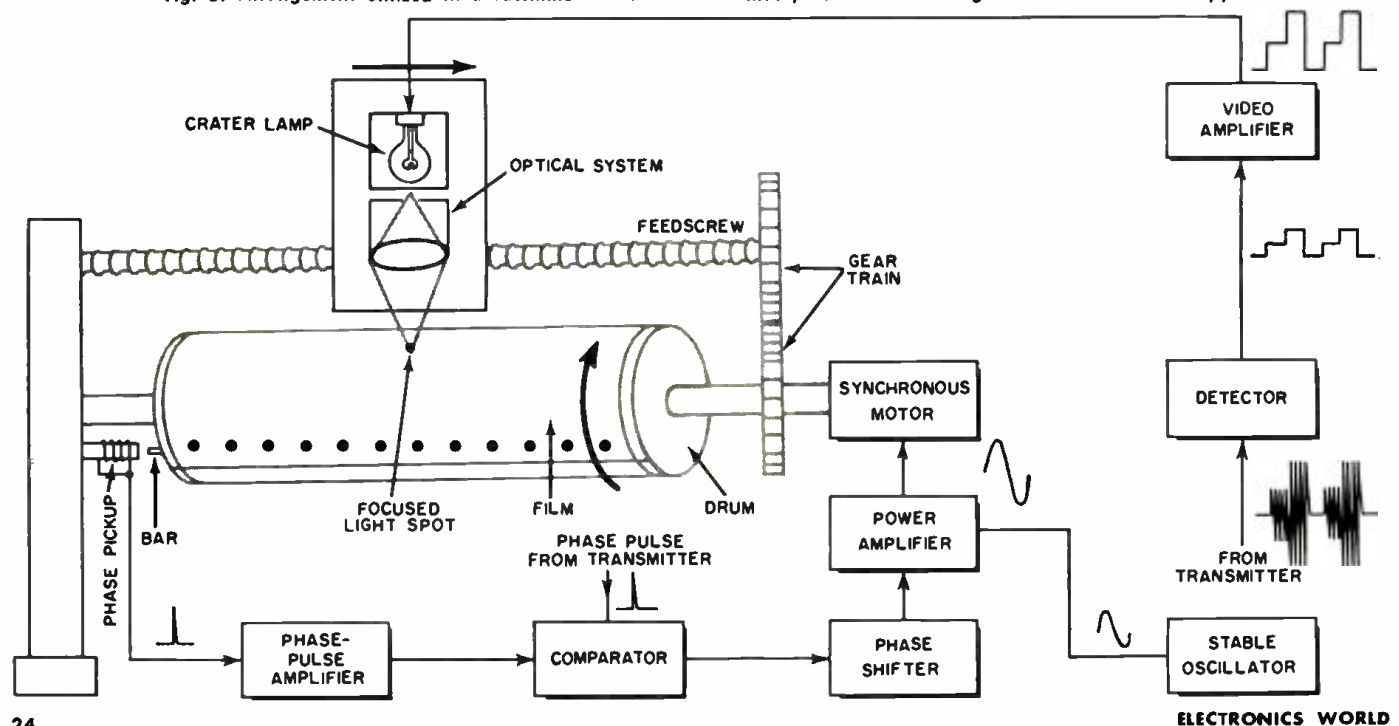



# STATUS OF COLOR TV

*Newer and more handsomely housed color receivers plus increased programming may make this a 500,000-set year for the industry.*

**A**FTER eight full years of color television, the upcoming 1962-63 season promises to be the biggest and best from every standpoint. With some ten or so firms now in production on color video sets and hundreds of hours of programming scheduled for the color cameras, those thinking in terms of color set purchase never had a greater incentive for going ahead with their plans.

As indicated in the graph below, NBC alone is offering 68 per-cent of its night-time schedule in color. ABC, which has recently announced its entry into the field, has regular colorcasts on its schedule in addition to an as-yet-undetermined number of color films. CBS is still a hold-out in the color race but may be forced into it on a competitive basis. They have indicated that perhaps one or two "specials" will be telecast in color in the current season but that there will not be any regular color programming.

Since over 200 stations are equipped to handle color program material (live and network), as more and more of this type of material is fed into the lines, the pattern of color transmissions is expected to widen to include larger areas of the country.

As far as color receivers are concerned, the consensus is that between 800,000 and 1,200,000 sets are now in the hands of the public with between 170,000 and 175,000 sets sold last year. The Commerce Department estimates that this figure will increase by as much as 50 to 100 per-cent in the current year, while industry sources are predicting color sales in the 250,000-500,000 range. A preliminary estimate for 1962 includes 200,000 sets for RCA, 100,000 for Zenith, from 50,000 to 75,000 for Admiral, and 50,000 for Warwick (making sets for Sears), and an over-all estimate of half a million receivers. This estimate includes sets from Magnavox, Wells-Gardner (making sets for Montgomery Ward and other private-brand labels), Westinghouse Electric, General Electric, Emerson, Packard-Bell, Olympic, and Philco plus imported receivers which will be marketed under the Delmonico brand-name.

RCA recently introduced its 1963 line to its distributors and the press in an early showing. Aside from some re-arrangement of the chassis which permits reduction of the over-all depth of the receiver, the most outstanding feature of the new line is the introduction of true furniture styling in the cabinets, eliminating the early "black box" appearance which characterized previous models.

Now available in handsome wood finishes in a wide variety of furniture styles,

RCA is offering decorator-designed hutches, breakfronts, and low-boys, some with FM-AM receivers and facilities for playing records. Some of the units are of open-front construction while many of the sets in the line are equipped with doors to close off the picture tube when the set is not in use. (This was a common complaint from homemakers who objected to the "blind eye" in their living rooms.)

A plus feature in the new line is the fact that despite improvements in circuitry and cabinet design, most of the new color sets will carry a lower price tag than comparable units of the previous year's line. The chassis has been re-designed to provide a shallower cabinet with less overhang of the color tube to the rear, making it possible to place the cabinet closer to the wall and in a less conspicuous position in the room.

The combination units provide stereo facilities—both record and broadcast—in addition to color reception, making the single cabinet serve as a complete entertainment center for the home.

Although there is widespread talk in the industry regarding the recently announced smaller, 90-degree color tube, sets marketed this fall will continue to include the current RCA color tube, with the new tube incorporated in next year's offerings at the earliest. In addition to RCA, Sylvania plans to resume the manufacture and marketing of color picture tubes. Present plans call for a 21-inch, 90-degree round shadow-mask type tube. Tubes for Zenith sets (and others) will be supplied by Rauland. The Motorola-National Video 23-inch rectangular 90-degree color tube won't be available for this year's models but there is hope that some sets can be so equipped by next fall.

Although the state of the general economy and the consumer's confidence in the future will intimately affect the color-TV set market, there is every indication that should the public continue buying durable goods at its present rate, the industry may come very close to meeting the estimates advanced by various sources indicating record sales for color receivers.

One bright spot is that there should be less distaff resistance both because of the improved design of the receivers themselves and the increased programming (both daytime and evening) of a greater variety of material.

It now appears that after 8 long years, color TV is ready to assume its full role in the industry.

The circuits are ready, the programs are available and color can take off! ▲

NBC's night-time schedule for 1962-63 will include an over-all total of 68 per-cent of its programs in color. Per-cent of color programs per night is shown in graph.

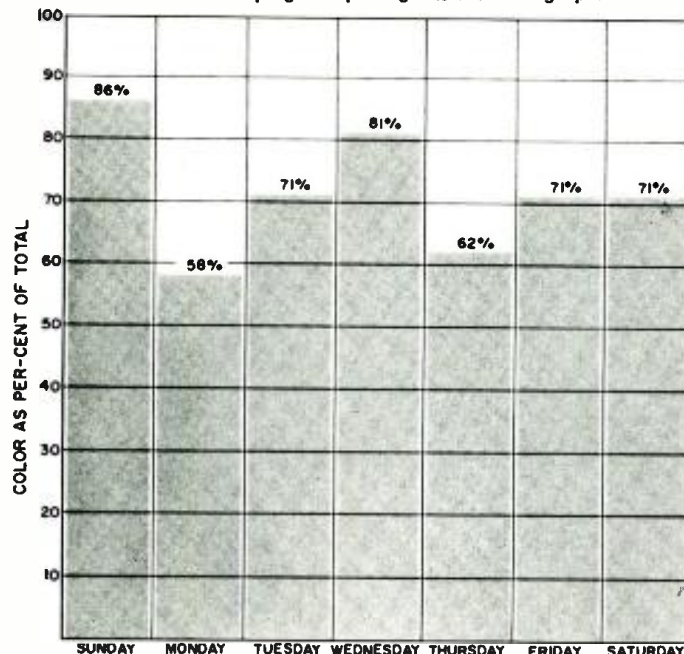

ESTIMATED TOTAL COLOR TV SETS SOLD FROM 1954 THROUGH 1961—800,000-1,200,000  
ESTIMATED TOTAL COLOR TV SETS TO BE SOLD IN 1962—500,000

# using the oscilloscope delayed sweep

By **WALTER H. BUCHSBAUM**  
Industrial Consultant, **ELECTRONICS WORLD**

*A second time-base generator makes possible extremely accurate time measurements and observations of any part of a complex waveform.*

**W**HENEVER a signal containing low- and high-speed phenomena with two or more repetition rates is to be observed with an oscilloscope, delayed and expanded sweep capabilities are essential. This added flexibility can also be used to (1) measure the time between a reference signal and a selected point of a complex signal or of a pulse train, (2) measure pulse-to-pulse time intervals in a pulse train, and (3) select one particular pulse from a group and expand it to fill the scope graticule.

To illustrate the first application, suppose you want to observe a 60-cycle signal such as a TV video signal for one complete field. On a conventional scope you would set the sweep frequency to either 30 or 60 cycles. At 30 cycles there would be two successive fields and at 60 cycles there would be one. The horizontal-synch pulses that occur during the vertical retrace period look quite different from those that control the start of each picture line. If you set the scope to 60 cycles and expand the horizontal sweep it will be possible to see most of the 15,750-cycle horizontal sync pulses that occur during the vertical-synch period. It is impossible to get enough expansion to observe a particular pulse and compare it with other pulses. By setting the sweep frequency to a subdivision of 15,750 cycles you will see all the horizontal-synch pulses superimposed, and it will not

be possible to observe a particular one. The delayed sweep is also used extensively when troubleshooting and maintaining radar systems, computers, control systems, and almost every type of digital device.

## Waveform Examination

In an ordinary oscilloscope, a signal such as that shown in Fig. 1A causes a trigger pulse (Fig. 1B) to start the horizontal sweep voltage of Fig. 1C. The signal appears on the screen as in Fig. 1G. The leading edge of the wide pulse is missing because it occurs during the triggering or retrace period. Often it is important to observe the leading edge and to do so, the delayed-sweep function is used. If the horizontal sweep can be made to start after the trigger pulse of Fig. 1B, by the amount of delay shown in Figs. 1D and 1E, then the pattern on the scope will appear as in Fig. 1H and will clearly display the entire wide pulse in relation to the adjoining pulses. (Note: Although the sweep appears to start to the right of the time zero position in Fig. 1F, it always starts at the left side of the scope graticule. Fig. 1F illustrates the time relationship between the start of the sweep and the train of pulses. The point at which the sweep starts during the pulse train is the point that will appear at the left side of the graticule.) In many scopes the two triggers (Figs. 1D and 1E) produce signals called time

bases A and B. The delay between them is the key to the delayed-sweep operation. The sweep length that can be produced by either time base is adjustable, and this, just as with ordinary sweeps, has the effect of expanding or compressing the trace on the graticule. The amount of delay is adjustable in steps of 1, 10, 100, etc.  $\mu$ sec., and continuously with a vernier control.

The principle of delayed sweep combined with expansion is shown in Fig. 2. By delaying the start of the horizontal sweep with time base B and shortening (speeding up) the sweep of time base A, a particular pulse in a signal containing two repetition frequencies can be singled out and expanded. This amounts to using a faster sweep at a slow repetition rate. In the example cited for a TV signal, a 15,750-cycle pulse could be displayed if time base B were set to 60 cycles and the sweep frequency of time base A set to 15,750 cycles.

The delayed sweep is obtained by having the normal sweep trigger start another timing circuit. The second circuit may employ a linear phantastron. Depending on the combined value of a manually selected capacitor and resistor, which form an RC discharge network, the phantastron will be cut-off after a fixed period of time. The phantastron output is a variable-length pulse that is differentiated so its trailing edge acts as a trigger for the delayed-sweep signal.

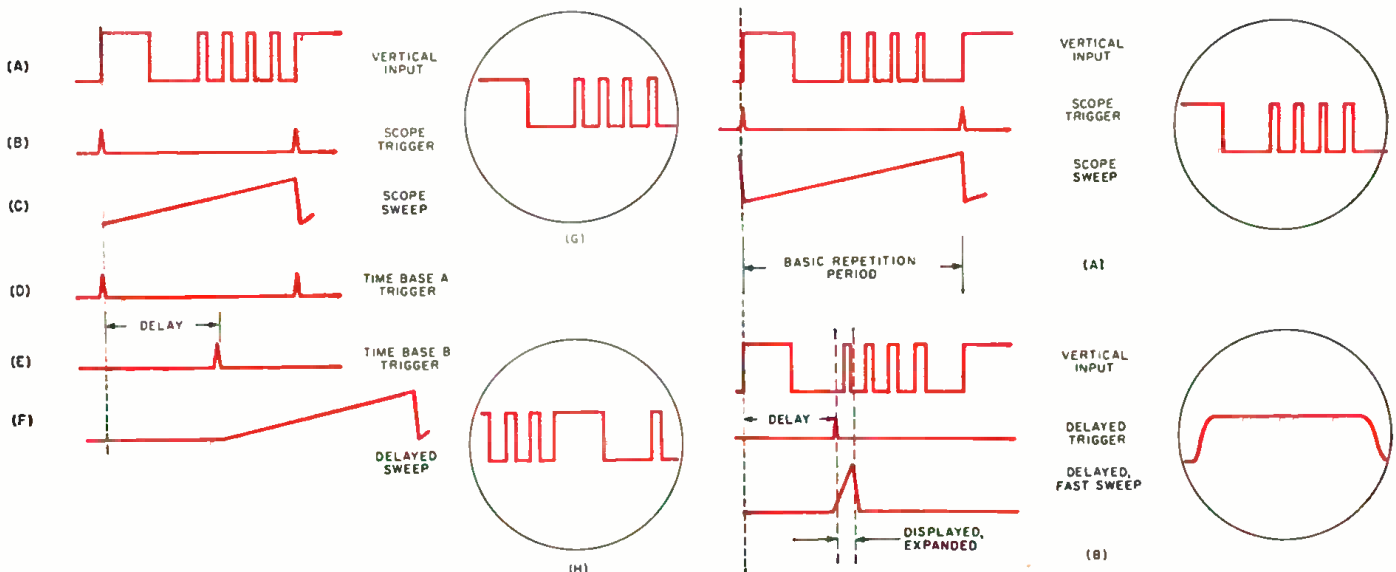

Fig. 1. To observe the leading edge of the wide pulse, the sweep start is delayed until approximately the third pulse.

Fig. 2. If the speed of the delayed sweep is increased, the second pulse can be expanded to fill the scope graticule.





Fig. 3. Train of time-marker pulses displayed with 10  $\mu\text{sec./cm.}$  sweep speed.

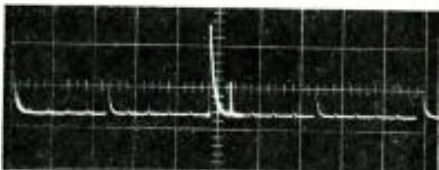

Fig. 4. Intensified center of waveform to be expanded to fill scope graticule.



Fig. 5. Intensified portion of waveform fills graticule with 1  $\mu\text{sec./cm.}$  sweep.

In other words, instead of using the normal trigger, a second trigger spike is produced, delayed by the length of the phantastron output. The phantastron pulse length is controlled by the "Time Cm. or Delay Time" switch, (Fig. 6) which selects the capacitor, and by a ten-turn potentiometer ("Delay-Time Multiplier") which varies the resistance of the RC network. Various techniques are employed to keep the phantastron pulse length linear, despite different settings of the potentiometer, to produce a precise time delay.

In order to observe one of a group of pulses with the delayed sweep, an intensifying *signal strobe* is used to brighten that portion of the undelayed display which is to be displayed expanded. Varying the speed of the delayed sweep also varies the brightened portion of the scope trace. Varying the time-delay control varies the position of the brightened strobe.

The waveform in Fig. 3 shows a typical train of pulses; the sweep speed is 10  $\mu\text{sec./cm.}$  To observe a particular portion of the waveform, you would adjust the "Delay-Time Multiplier" to produce the effect shown by the brightened portion to the left and right of the center line in Fig. 4. To really see the pulse shape clearly, the delayed sweep can be expanded still more. In Fig. 5, the delayed sweep ("Variable Time Cm.") control is set to 1  $\mu\text{sec./cm.}$  The time between the leading edge of the wide pulse and the leading edge of the narrow pulse to the right quite clearly appears to be slightly less than 6  $\mu\text{sec.}$

### Applications

The time-delay function in the Tektronix 535A and 545A oscilloscopes requires two separate time bases. One time-base generator is used for the basic repetition or sweep rate and the other is used for the delay. The "Horizontal Display" switch selects one of three time bases: "A Single Sweep," "A Del'd by B," or "B Intensified by A." The "A Del'd by B" setting produces the delayed sweep condition in Figs. 2A and 2B. The selection "B Intensified by A" produces the brightening effect in Fig. 4. It is possible to adjust the trigger mode, stability, and the sweep length independently for each of the two time bases and to adjust the delay time continuously by

means of the calibrated ten-turn potentiometer ("Delay-Time Multiplier").

The delayed sweep is most frequently used for two types of measurements: the first is general waveform study of a particular portion of a complex signal. In the example shown in Figs. 1 and 2 the rise and decay time of each pulse can be carefully measured, the flatness of the pulse top can be observed, and extraneous signals can also be seen.

The second application makes use of the "Delay-Time Multiplier" control. In Fig. 2 you will note that the time between the trailing edge of the wide pulse and a narrow pulse is different from the time interval between the narrow pulses. You may want to measure this time precisely to within 0.1  $\mu\text{sec.}$

Assume that the basic repetition rate is about 100  $\mu\text{sec.}$  and the entire signal is displayed on a 7-cm. portion of the scope face. The time interval between the wide pulse and the first narrow pulse will correspond to about 20  $\mu\text{sec.}$  displayed over 2 cm. This makes it very difficult to measure anything within 1  $\mu\text{sec.}$  or less. When using the Tektronix scope you would first view the pulse train with the undelayed sweep and then set the "Horizontal Display" control to "B Intensified by A." You would then set the sweep of the "Time Base A" generator to a length of about 1  $\mu\text{sec./cm.}$  to determine the size of the intensified portion. Next, move the brightening strobe to the trailing edge of the wide pulse by setting the "Delay-Time Multiplier." When you switch to delayed sweep, it is possible to adjust the "Delay-Time Multiplier" control so that the center of the trailing edge coincides with the center of the scope. Noting the dial reading on the "Delay-Time Multiplier"

control, you would adjust it until the center of the leading edge of the first narrow pulse is in the center of the scope. The concentric vernier dial of the "Delay-Time Multiplier" control will now read 1  $\mu\text{sec.}$  turn with the inner dial scale of 10 divisions of 0.1  $\mu\text{sec.}$  each. You can now read the time period within 0.1  $\mu\text{sec.}$  directly from the concentric dial of the potentiometer. ▲

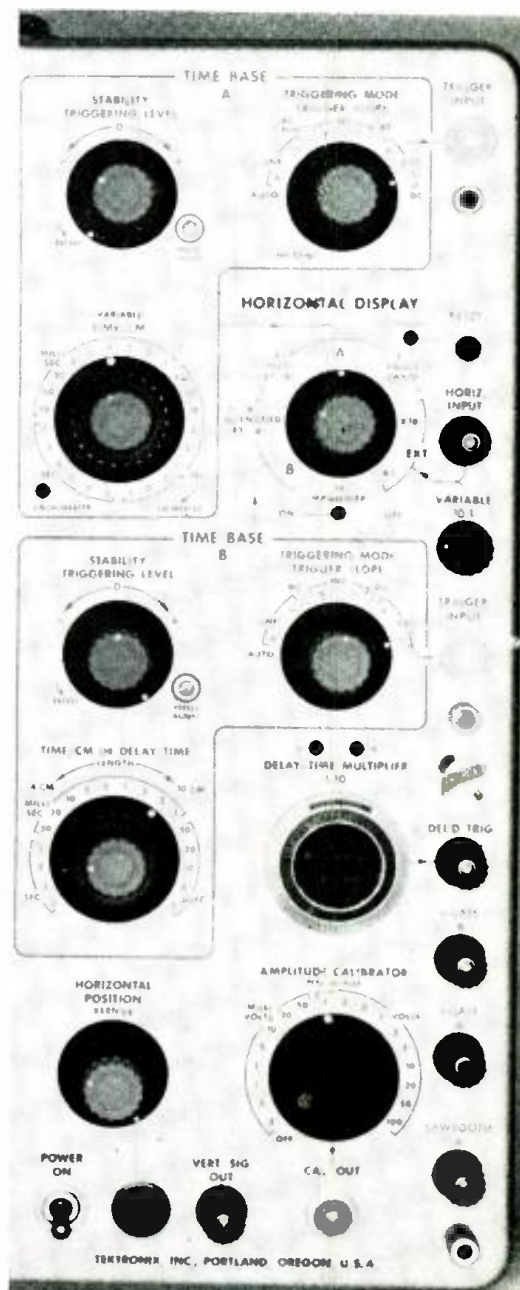
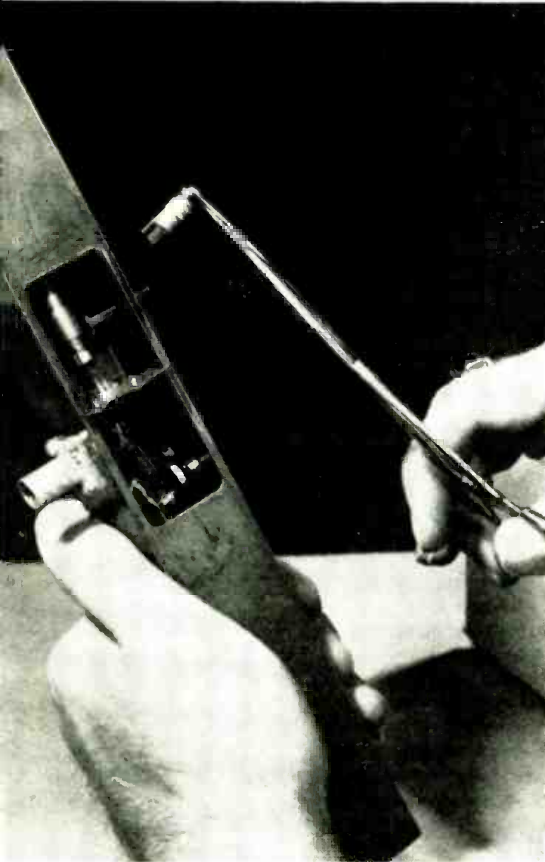

Fig. 6. Time-base controls on Tektronix 545A.

### “Shotgun” Microphone ▶

Dubbed the “shotgun” by Washington newsmen, this 7-foot-long microphone has been used regularly in President Kennedy’s televised press conferences. The mike’s ultra-directional characteristics permit pickup of questions from reporters, even though they may be in the rear of the huge auditorium. The unit, an Electro-Voice Model 643, is a dynamic line type that combines a cardioid pickup pattern for frequencies up to 100 cps with a much more highly directional pickup pattern at higher frequencies. This latter pattern is produced by distributed front openings in the long tubular housing.



## RECENT DEVELOPMENTS IN ELECTRONICS

### ◀ Small-Size Nuvistor

To demonstrate the low noise factor of a new half-watt nuvistor triode, developed by RCA for the U.S. Navy, engineers constructed this 1000-mc. coaxial r.f. amplifier. The tiny tube, one-half the size of commercial nuvistors, is expected to find use in miniaturized battery-operated u.h.f. equipment. Tubes delivered to the Navy have a transconductance of 11,000 micromhos at a plate dissipation of  $\frac{1}{2}$  watt and a noise factor of 7.5 db at 700 mc. in a cathode-drive circuit. There are 8 full-size industrial and entertainment nuvistors types.

### Microcircuit Package

New thin-film microcircuits being developed by Sylvania are formed on high-strength ceramic wafers smaller than a postage stamp and  $\frac{1}{100}$  inch thick. The wafers are stacked and interconnected through vertical, ceramic interwiring boards containing fused-on wiring—a method that packages the circuits in a small volume. The microcircuit package at the top of the photo contains the equivalent of 2 of the printed board shown. ▼

### ▶ Voiceprint Identification

Voice patterns are so distinctive that someday they may be used for identification purposes just as fingerprints are today. Bell Telephone Laboratories scientist, Lawrence G. Kersta, who is investigating voiceprint identification, is shown at the right making a print of his own voice. The spectrograph machine at right will make a voiceprint on the paper-covered drum at the bottom. The pattern produced is a voice spectrogram that shows the amount of voice energy at various frequencies. In tests, voiceprints were made of the same word spoken by different persons, each person uttering it several different times. Each utterance of the word was voice-printed on a separate card. Then the cards were shuffled, and trained subjects were asked to group the cards representing each voice. Out of about 25,000 decisions, these trained people made the right decisions more than 97% of the time.

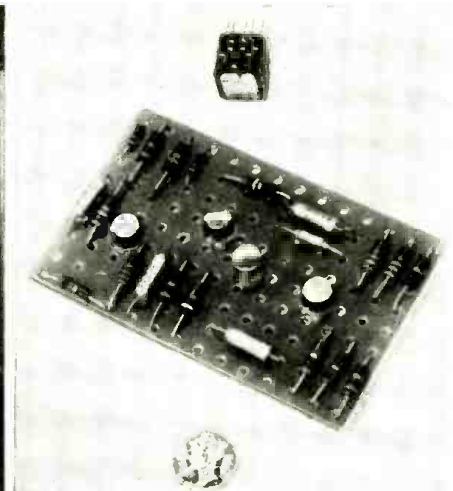



### High-Speed Computer Element ▶

This experimental computer element, a full serial binary adder, has been operated at a 125-mc. rate, one of the highest yet recorded. The adder is composed of fourteen matched-pair tunnel diode circuits. The wire loops above the circuit board are coaxial cable delay lines, an important feature of the new tunnel diode computer circuit developed at IBM's Research Center. Ordinarily, one of the more serious problems that arises with tunnel diode logic circuits is the tendency of one circuit to influence the switching of other circuits connected to the same power supply. This problem is eliminated by the delay lines, since the power supply does not "see" the switching of any given element until one nano-second ( $1/1000 \mu\text{sec.}$ ) has elapsed. This is much longer than the possible difference in time between the switching of any two circuits on the same power-supply terminals.

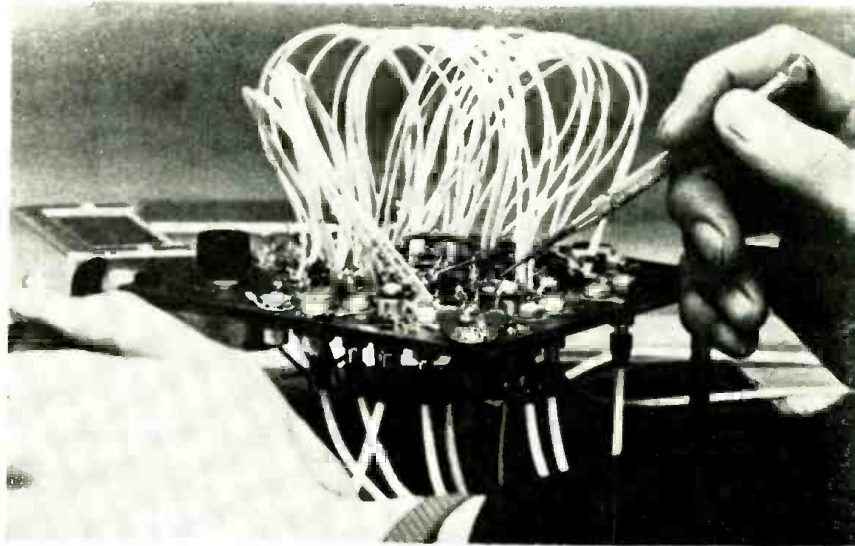

### Japanese TV Satellite ◀

Research leading to the development of three or four Japanese satellites, to be used for planned television coverage of the 1964 Tokyo Olympic Games, is now under way. The 105.5-pound cylindrical satellites, equipped with solar batteries, are under development by the Nippon Electric Co., Ltd. NEC-1, as the firm's satellite will be known, is to be mounted on either an American "Scout" or "Thor-Delta" type rocket. Selection of the vehicle to be used will probably be made by NASA. Choice of launching sites will also be left up to the discretion of the United States.

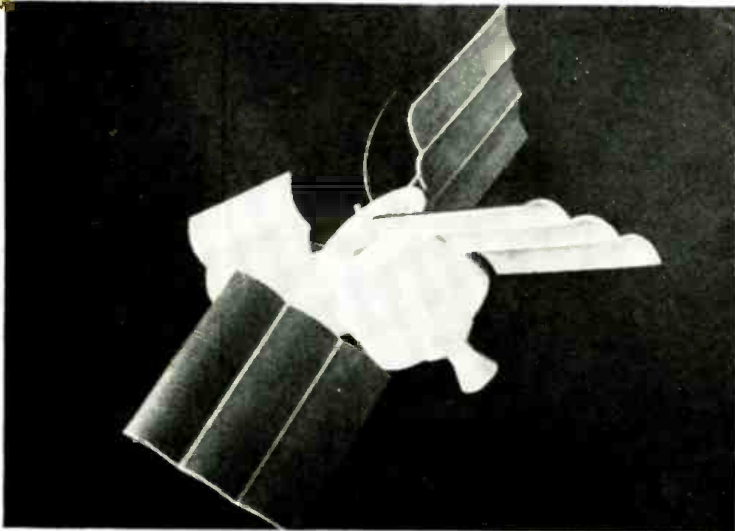

### "Polaris" Computer ▶

Complex electronic computer which will give new assurance of accuracy to the Navy's longest-range, 2500 nautical mile "Polaris" missiles, is given a final checkout by Sperry Gyroscope Co. technician prior to installation aboard the newest "Polaris" submarine "Lafayette." The computer is an improved version of a system developed three years ago by the company and produced for the navigations systems of the submarines. A unique combination of high-capacity and ultra-fast memory devices enables the computer to solve a navigational "fix" problem in spherical trigonometry in less time than it takes an operator to push the buttons on the console.

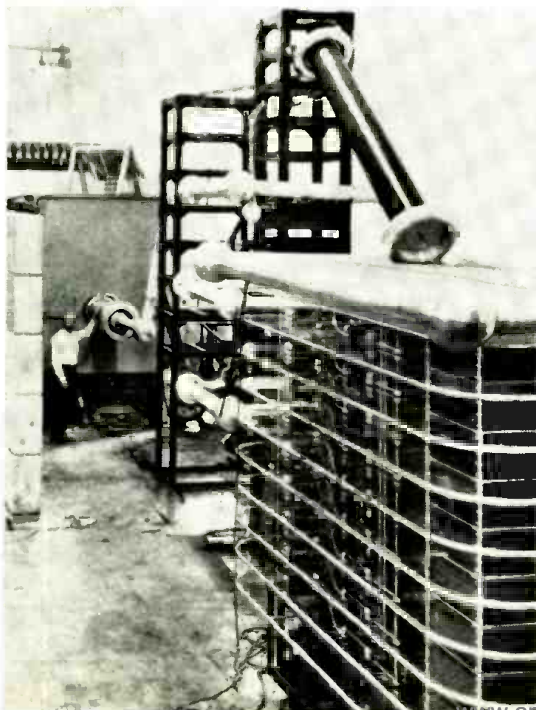

### 450-Kv. Power Supply ◀

Cascade rectifier high-voltage power supply is part of a complete facility for high-potential testing of h.v. switch tubes and other components. The circuit operates at 400 cps and is able to deliver an open-circuit voltage of up to 450 kv. Fully loaded, the supply is rated at 350 kv. at 50 ma. Radiation at Stanford engineers designed the power supply using a modular deck approach. Each deck is rated at 50 kv. and contains two silicon diode rectifier assemblies with surge-limiting resistors and h.v. shunting capacitors. Nine decks are used to provide the total output.

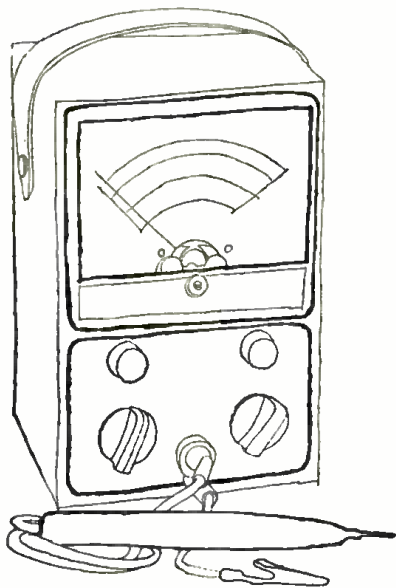

# How to Make Your V.T.V.M. Reliable

By J. B. STRAUGHN  
Chief, Consultation Service, Nat'l Radio Inst.

*Inaccuracy and constant need for re-adjustment go hand in hand. Eliminate their common cause if you want outstanding dependability and convenience.*

**A**LTHOUGH THE v.o.m. is liked for its stability and convenience, it is inevitably replaced in much service work by the v.t.v.m. The latter's high input resistance, especially on lower-voltage scales, gives a truer picture of conditions in high-impedance circuits because of its lower loading effect. In addition, with a 2-percent meter movement and 1-percent resistors in its voltage dividers, it can provide accuracy in the order of  $\pm 3$  per-cent on d.c.,  $\pm 5$  per-cent on a.c., and not much worse than this even on ohmmeter measurements, in which the bridge circuit is also used and its advantages continue to be realized.

However, there is another variable that can throw accuracy off considerably and, because it produces instability, cause inconvenience in use. By instability, we mean the need to re-adjust the zero-set control when the voltage range is changed or to re-adjust the ohms control when the resistance range is switched. The variable in question is the normal gas content of the twin triode used in the balanced bridge of all conventional v.t.v.m. circuits.

## Effect on Ohmmeter Function

To observe the effect of gas content, let us first examine the ohmmeter circuit of a typical instrument. The one of Fig. 1 is used in the Conar 211 v.t.v.m. If you are using it in the  $R \times 1$

meg. position, as shown, there is a resistance of 11.5 megohms ( $R_1 + R_2$ ) in the grid return for pin 2 with no external connection to the probe. In operation, the gas molecules will ionize. Positive ions will be attracted to the grid, strike it, and remove electrons. These electrons must reach the grid by flowing through  $R_1$  and  $R_2$ , thus producing a voltage drop across the two resistors, with the grid end more positive. As a result, the voltage on the grid is more positive than that provided by the ohmmeter battery alone. Since this tends to drive the meter needle off-scale to the right, the ohms-adjust control must be increased in value for correct full-scale indication.

Now suppose you switch to the  $R \times 100k$  range. The resistance in the grid return for pin 2 is only 2.5 megohms ( $R_1$  and  $R_2$ ), a reduction of 9 megohms. The gas-produced voltage drop across these two resistors is less than on the higher ohms range, and the pointer will drop below full-scale deflection. The ohms-adjust control must be reduced to bring the needle over the "infinity" mark.

If this nuisance were the only effect of normal gas content, it could be tolerated and the ohms-adjust knob could be re-set each time a different resistance range was selected. But something else takes place in actual use. Suppose you are going to measure

a 10-megohm resistor. The circuit of Fig. 1 will be set up on the  $R \times 1$  meg. range, with 11.5 megohms in the grid, as already noted, and adjustment will be made for accurate full-scale deflection with the external probe open. When the external, 10-megohm resistor is inserted, grid-return resistance drops to 6.5 megohms. The gas-produced

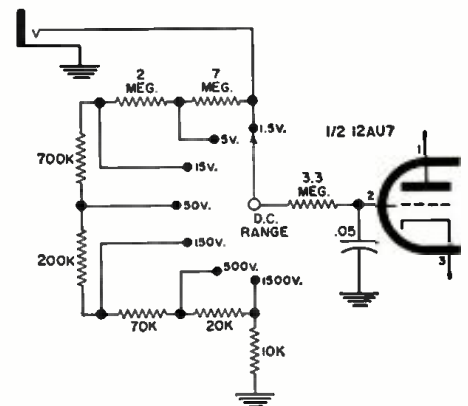

Fig. 2. Partial circuit of the Heath V-7A v.t.v.m., showing range switching in the d.c. voltage function, illustrates effect of gas-induced grid conduction.

voltage drop also reduces, and the meter will indicate some value less than 10 megohms. The degree of error will depend on how much gas there is in the tube, for a given resistance being measured. Also, for a given amount of gas, inaccuracy will increase as smaller values of resistance are measured on a given range.

This action explains another familiar experience. In the ohmmeter function, zero is often set first with the probes shorted; then the infinity reading is set with the probes open. When the probes are again shorted, the pointer swings below zero. Tube gas causes this. Actually, on the lowest resistance range, it is more reasonable to encounter a slight, above-zero, resistance reading with the probes shorted, which represents the resistance of the test probes. (A reading of several ohms, however, indicates a poor solder joint in the probe or associated wiring, a faulty contact in a switch, or some such connection in-

*(Continued on page 70)*

Fig. 1. How the v.t.v.m. bridge circuit is used to measure resistance. The arrangement has been simplified to show only range switching in the ohmmeter function. Used in the Conar 211, the configuration is typical of those in most v.t.v.m.'s.

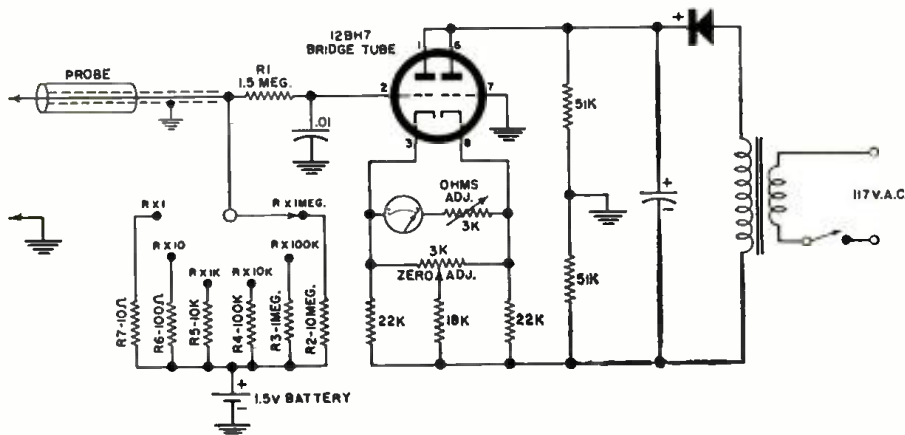





# HIGH-POWER TRANSISTORIZED "PHOTORHYTHMICON"

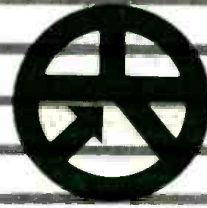

By LEON A. WORTMAN

## Construction of a novel semiconductor color organ with high light output that changes color and intensity with music.

A RECENT article by the author in the May 1962 issue of this magazine described a transistorized "Photorhythmicon" which employed a very simple circuit arrangement. The light output of the simple version was such that rather subdued room illumination was required in order to view the light display. With the somewhat more elaborate circuit described in this article, there is no such requirement; the display can be viewed in even brightly lighted rooms.

This transistorized light-control equipment features a combined maximum power capability of 150 watts. It includes three separate light-control channels, each producing a different color of light for three different bands of audio frequency. Each of these is varied in intensity in accordance with the amplitude of the audio signal source. The audio signal can be obtained from the output of any high-fidelity power amplifier.

In practice, this equipment delivers approximately 75 watts when all three channels are operated continuously at the maximum level. Why not operate at the maximum capability? In the interests of reliability and extended transistor life, the transistors were operated below their maximum ratings. The fact that the equipment has been in operation for approximately 4 hours a day for over a year without a single failure or apparent change in operation supports this design objective. Experiments with numerous lighting displays in the home, too, pointed up the fact that an increase in intensity or brilliance beyond the 75-watt level may tend to develop unpleasant viewing conditions with respect to eye comfort.

Further tests with the equipment illustrated here indicate that the light level is adequate to achieve the "dancing-light" effect even with direct sun-

light entering the viewing room. In other words, the amount of light generated by this display is sufficient under widely varying conditions of ambient light in the home.

The author selected the colors red, blue, and yellow for the bass, mid-range, and treble frequency ranges. These colors were produced by tinting or painting the light bulbs used in the display, although colored filters could have been used as well. The author used transparent color lacquers, available at art-supply stores, for tinting. As the

than one channel is in operation.

The three channels used in the "Photorhythmicon" to be described are identical in every respect except for the frequency-selective circuits. These circuits separate the bass, mid-range, and treble frequencies and apply these frequencies to each of the transistorized light-actuating channels.

Transistor  $V_2$  is operated near collector current cut-off by the nature of this circuit together with the use of a low ohmic resistance in the base circuit. The lights tied to the collector circuits

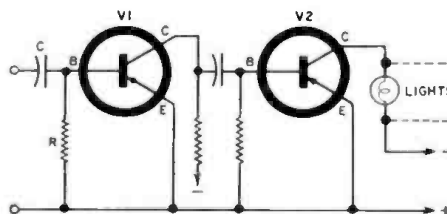

Fig. 1. Basic circuit of "Photorhythmicon".

colors strike a common surface, in this case a milk-white translucent cover panel of plastic material, they mix and produce additional colors. And, to add to the drama, as the lights vary in intensity with the audio signal each of the individual colors changes hue. One can visualize, then, the most fascinating multi-color effects synchronized automatically with the sound system.

### Circuit

The basic circuit for a typical channel is shown in Fig. 1. Two transistor stages are used.  $V_1$  acts as an amplifier-driver coupled to the light-actuating transistor  $V_2$ . The over-all gain of the two stages is more than adequate for full operation capabilities with very small signal input levels.  $C$  and  $R$  represent the frequency discriminating components or one "leg" of the crossover network when more

Color organ chassis is atop speaker system. A 4-wire cable connects unit to wall-mounted color-bar display, shown here with the translucent plastic cover temporarily removed.

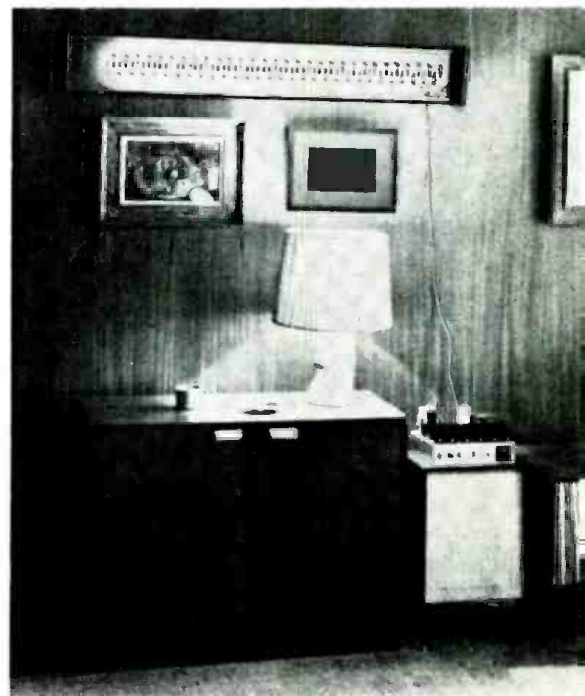

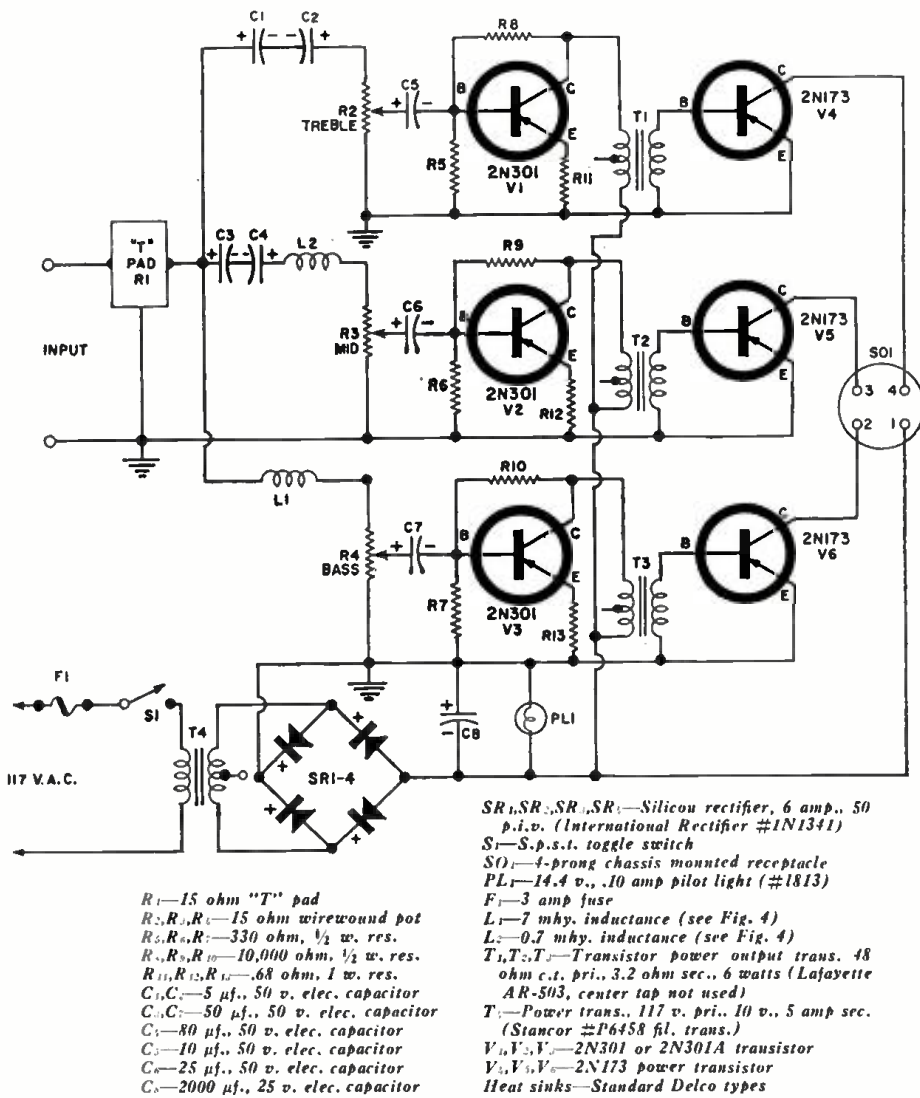

Fig. 2. Complete circuit diagram of the 3-channel unit. Input signal is obtained from voice-coil output of audio amplifier. Less than 1 watt of audio drive is needed.

are extinguished. When a signal is applied to the base of  $V_2$  from the collector of  $V_1$ , then output current—and light intensity—increases in direct accordance with the signal amplitude. (Note: This eliminates the need for an extra diode at the grid of the 6CL6 tubes specified in the vacuum-tube version of the "Photorhythmicon" which appeared in the August 1958 issue of this magazine.) The amount of increase in collector current depends on the  $\beta$  of transistor  $V_2$ .

The range of maximum to minimum limits for  $\beta$  is usually 2 to 1 for high-power transistors. Variations from unit to unit within a given type can be ex-

pected. However, this is of little importance in the "Photorhythmicon" because of the use of individual-channel balance controls as shown in the complete schematic of Fig. 2. These controls are potentiometers connected between the individual "legs" of the crossover network and the channels they feed.

Note, too, that transformer coupling is used between the amplifier-driver transistors and the light-actuating transistors. This takes maximum advantage of the power output capabilities of the driver transistors. Also, the low d.c. resistance of the secondary winding of the coupling transformer is exceptionally well suited to establish the

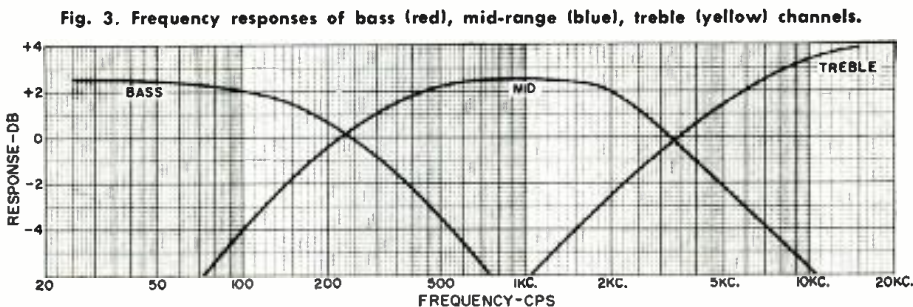

Fig. 3. Frequency responses of bass (red), mid-range (blue), treble (yellow) channels.

quiescent level of the collector current at or near cut-off for the light-actuating transistors.

### Crossover Networks

After experimentation, it was decided that  $LC$  networks are more desirable than  $RC$  configurations for channel separation. There are two reasons: (1) insertion losses are lower for an  $LC$  network and (2) sharper cut-off or better channel separation is obtained with an  $LC$  network. Hence, it was decided to use two of these networks in the unit for mid-range and bass channels.

Commercially manufactured inductors for the network are expensive and two are needed in the circuit shown. The  $RC$  configuration might cost only one-fourth as much. A solution to the problem is offered by winding one's own coils. The materials for two coils cost about as much as the components for an  $RC$  arrangement. No special tools are required. Construction details for the author's inductors are given in Fig. 4.

To maintain frequency characteristics of the networks (see Fig. 3), a "T" pad is used at the input. This enables continuously variable control of overall sensitivity and minimizes changes in loading effects of the "Photorhythmicon" on the amplifier to which it is connected whenever that sensitivity control is adjusted.

### The Light Display

The circuit of the light bar favored by the author is given in Fig. 5. Sixty bayonet sockets for #47 pilot bulbs are mounted side by side on a white painted plywood board, 7½" x 52". The switch provides a selection of one of two entirely different lighting effects. When section B is in the circuit, one sees a distinct separation of the three basic red, blue, and yellow colors displayed as color groups with red at the left, yellow at the right. This creates a fasci-

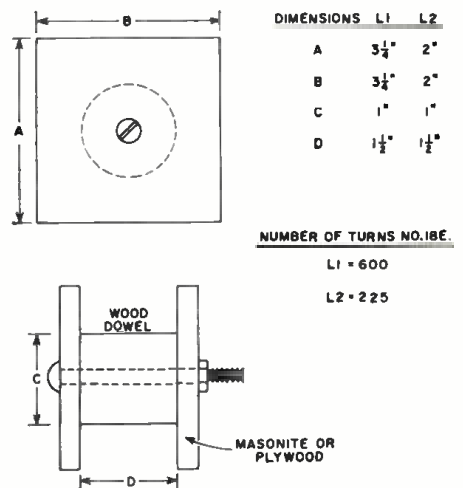
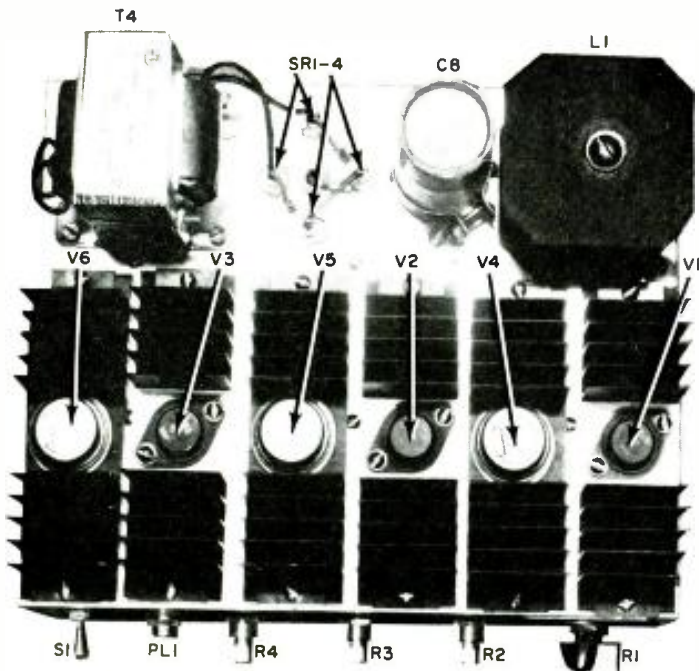

Fig. 4. Construction details for coils  $L_1$  and  $L_2$ . Approximate inductance values are 7 mhy. for  $L_1$  and 0.7 mhy. for  $L_2$ . Mounting bolts for the coil forms must be brass. After the proper number of turns of #18 enameled wire have been wound on the form, cover the winding with tape.





Top view of the color-organ chassis. Heat sinks may be omitted for transistors V<sub>1</sub>, V<sub>2</sub>, V<sub>3</sub>.

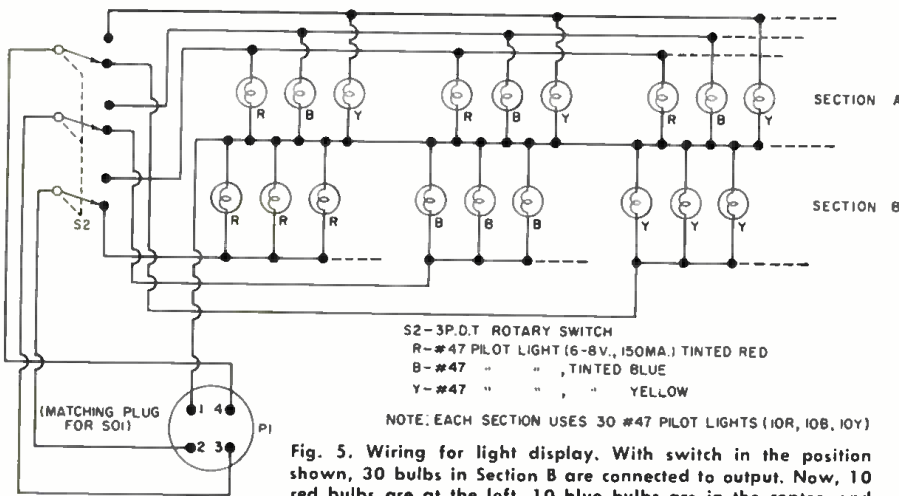

Fig. 5. Wiring for light display. With switch in the position shown, 30 bulbs in Section B are connected to output. Now, 10 red bulbs are at the left, 10 blue bulbs are in the center, and 10 yellow bulbs are at the right. Then when the switch is operated to insert the 30 bulbs in Section A, the colored bulbs are interleaved (red, blue, yellow, red, blue, yellow, etc.) along the entire length of the color bar.

nating ping-pong effect which becomes especially exciting during music dialogue such as tympani *contra* strings.

With the switch in position for section A, the effect is created of a single full-length bar of light that is constantly and uniformly changing in hue and intensity along its length. In this display the bulbs are stagger-wired red, blue, and yellow. Bulbs of like color are wired in parallel. A great deal of visual excitement is provided by this display as the entire bar of light changes in intensity, repeatedly flashing a multitude of colors as it follows the music.

There are ten bulbs per color in both sections A and B. To obtain maximum light output the #47 bulbs are operated beyond their rated voltage on audio peaks. However, in view of the fact that the peaks are not usually sustained for long periods, together with the low cost of the bulbs, neither the life of the bulbs nor the condition of the constructor's budget is appreciably affected.

The milk-white translucent plastic

panel referred to earlier is actually a cover for the 4-foot fluorescent lighting fixtures installed in many business offices. It is U-shaped, highly durable, and striated to give high efficiency in forward transmission of light. It is easily installed as a wrapper for the board-mounted bulbs. It is available through lighting-fixture or electrical-supply houses at surprisingly low cost.

There is really no limit to the arrangements one can plan and construct inexpensively for lighting displays. The author has experimented extensively with many kinds of lights, including floods and 6- and 12-volt high candle-power automobile lamps. Even automobile headlights and spotlights have been used to create special effects.

In conducting your own experiments around the author's control circuit, it is recommended that you monitor the collector current of the individual light-actuating transistors. One can do it by "feel." Normal operation is indicated when the transistors are barely warm. More accurate, of course, would be to monitor the current with an ammeter. Should the quiescent current begin to climb, shut off power immediately and allow a moment or two for the transistors to cool off. Overheating leads to thermal runaway and self-destruction of the transistor.

The author used good quality heat sinks, electrically insulated from the chassis, on all six transistors to insure high reliability and extended transistor life. However, if the circuit and the 8" x 10" x 2½" chassis layout are duplicated as shown, it is practicable to omit the radiator-like heat sinks from the 2N301 transistors. However, make certain the transistors are insulated from the chassis. Mica washers slightly larger than the outline of the transistor are available for the purpose.

It is entirely possible to use this display in mobile installations. A 12-volt storage battery will enable full operation of the equipment. In such an installation, the power-supply components are unnecessary. ▲

Bottom of chassis. Home-made crossover coils are utilized for the device.

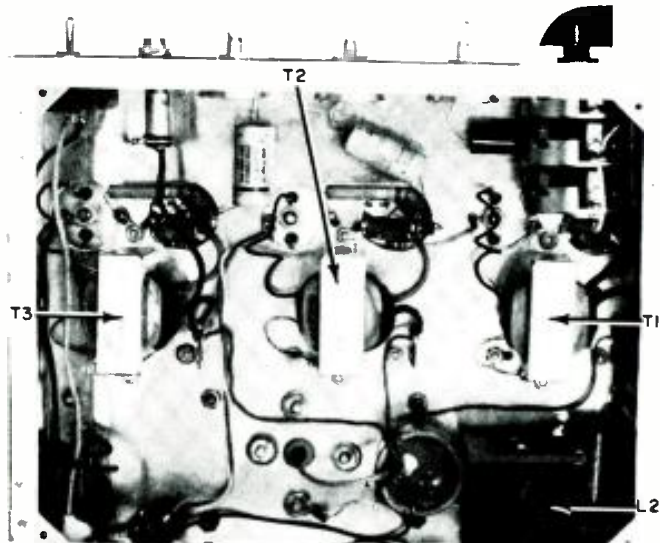

# CANADIAN CITIZENS BAND

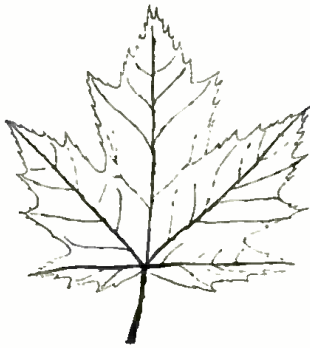

**Under new regulations,  
Canadian residents  
can use AM or FM  
on 19 CB channels.  
Here is a summary  
of the regulations.**

By **LEO G. SANDS**

**T**HE Canadian version of the Citizens Band was opened up on April first. In Canada, Citizens Radio type operations are permitted in what is known as the General Radio Service on 19 radiotelephone channels (similar to U. S. class D) and 4 radio-control channels (similar to U. S. class C).

It is much easier to get a General Radio Service (GRS) license in Canada

and landed immigrants are eligible for GRS licenses. As in the U. S., applicants must be at least 18 years of age.

Canadian GRS licensees may communicate only with other similarly licensed stations in Canada, utilizing ground-wave propagation exclusively. These requirements specifically prohibit communication with U.S. Citizens Radio stations and "skip" communications.

Channel Number	Freq. (mc.)	Channel Number	Freq. (mc.)
1	27.005	10	27.115
2	27.015	11	27.125
3	27.025	12	27.135
4	27.035	*	27.145
*	27.045	13	27.155
5	27.055	14	27.165
6	27.065	15	27.175
7	27.075	16	27.185
8	27.085	*	27.195
*	27.095	17	27.205
9	27.105	18	27.215
		19	27.225

\*Radio Control (Same as U. S. class C Station)

Table 1. Canadian General Radio Service Citizens Radio frequency allocations.

than a Citizens Radio Station license in the U. S. Instead of mailing an application to the FCC and waiting several weeks to get a license, Canadians may call in person at a regional Radio Regulations Office to file an application. If eligible, the license is issued immediately. A small fee is charged for a license which is good for three years.

In the U. S. it is mandatory that the applicant be a citizen, but in Canada, British subjects, Canadian corporations,

Either FM or AM can be used by Canadian GRS stations, while only AM (A3) can be used by class D Citizens Stations in the U. S.

Under Canadian regulations, a GRS station can be patched into a telephone circuit with the approval of the telephone company. But, in the U. S. the use of a phone patch is in violation of CB rules since "third party" communications are prohibited.

Only factory-built transmitters or

Table 2. Comparison between the United States and Canadian CB regulations.

	U. S.	CANADA
Band Limits	26.96 - 27.26 mc.	27.0 - 27.23 mc.
Number of Channels	23	19
Transmitter Power Output	Not specified	3 watts
Transmitter Power Input	5 watts	5 watts
Transmitter Frequency Stability	0.005 %	0.005 %
Type of Emission	AM (A3)	AM (A3) or FM (F3)
Modulation	100 % max.	70 % min. (AM) ±1 kc. min. (FM)
Spurious Emissions	Down 50 db	30 microwatts max.
License Applications	By mail	In person
License Fee	None	\$3.00
License Term	Five years	Three years
Type-Approved or Type-Accepted Equipment	Optional	Required
Kit-Type Equipment	Yes	No
Phone Patch	No	Yes
Antenna Height (maximum)	20' above support. structure	No limit

transceivers can be licensed. They must be type-approved by the Department of Transport, and the type-approved number must be permanently attached to the transmitter chassis.

In general, the equipment will be similar to Citizens Band sets used in the U. S. Some U. S.-made sets might not qualify for type approval in Canada since Department of Transport technical requirements are stricter than those imposed by the FCC on CB gear.

Transmitter power, in terms of watts input to the plate or collector of the final r.f. amplifier, is limited to 5 watts, the same as in the U. S. Power output, which is not specifically restricted in the U. S., is limited to 3 watts in Canada.

FCC regulations stipulate that modulation not exceed 100%, but D.O.T. regulations require that AM transmitters be capable of at least 70% modulation with rated audio input. Minimum FM transmitter deviation is ±1 kc. with rated audio input.

As in the U. S., transmitters must be crystal-controlled and frequency stabilized to 0.005%. In addition, spurious emissions and harmonics must not exceed 30 microwatts (about 50 db below carrier level) over the frequency range extending from the crystal oscillator frequency to 250 mc.

It is expected that U. S. manufacturers will find an eager Canadian market for Citizens Band sets. But, the bulk of the business, it is believed, will go to Canadian manufacturers who have been preparing for the opening of the GRS band. Equipment prices are expected to be slightly higher than in the U. S.

Since FM transmission is permitted, some of the new Canadian-built sets now being developed are expected to be FM types. FM sets can be expected to cost more than AM sets. However, the generally superior performance, especially with regard to ignition noise, should create considerable demand for such units.

Based on surveys, it is estimated that some 20,000 Canadians will apply for GRS licenses this year. GRS will not take off as slowly as Citizens Band radio did in the U. S. because of the wide publicity given CB radio during the past three years.

There are more potential GRS users per capita in Canada than potential CB users in the U. S. because it is not necessary to be a citizen to be eligible for a license. Since licenses are to be issued on the date of application, prospective GRS users can get on the air as soon as the equipment is installed.

While Canadian GRS licensees will be operating on the same frequencies as U. S. Citizens Band licensees, they will not be able to communicate with each other lawfully. Canadians cannot legally operate their GRS sets in the U. S. State-side CB licensees cannot operate their sets in Canada without the approval of the Canadian government. Across-the-border communications are prohibited, and the FCC warns that violators will be subject to severe penalties. ▲



# Versatile Voltage, Power, and Decibel Nomograms

By JIM KYLE

Two useful charts that enable the audio technician to find amplifier gains and losses even when voltage measurements are taken across different impedances.

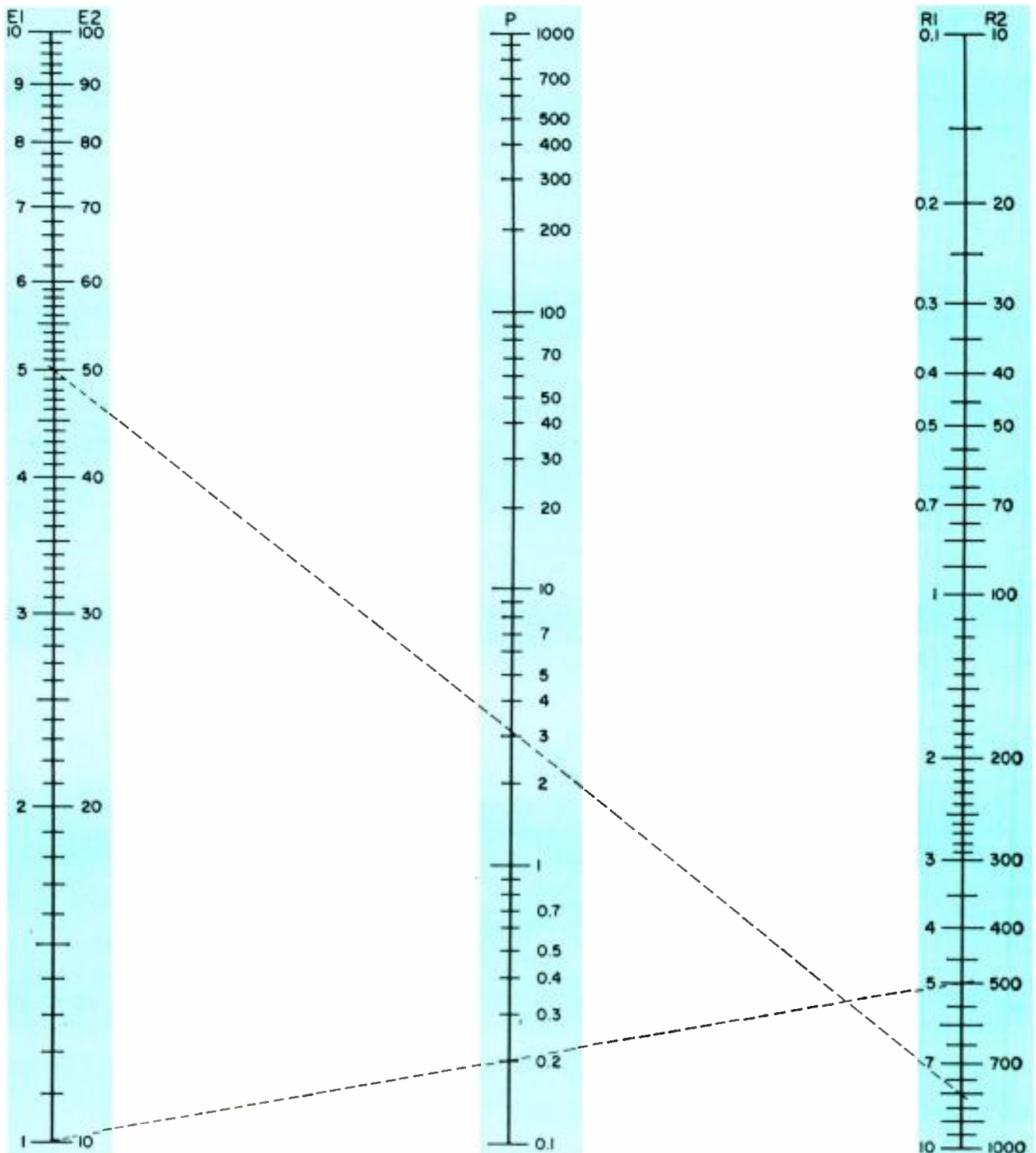

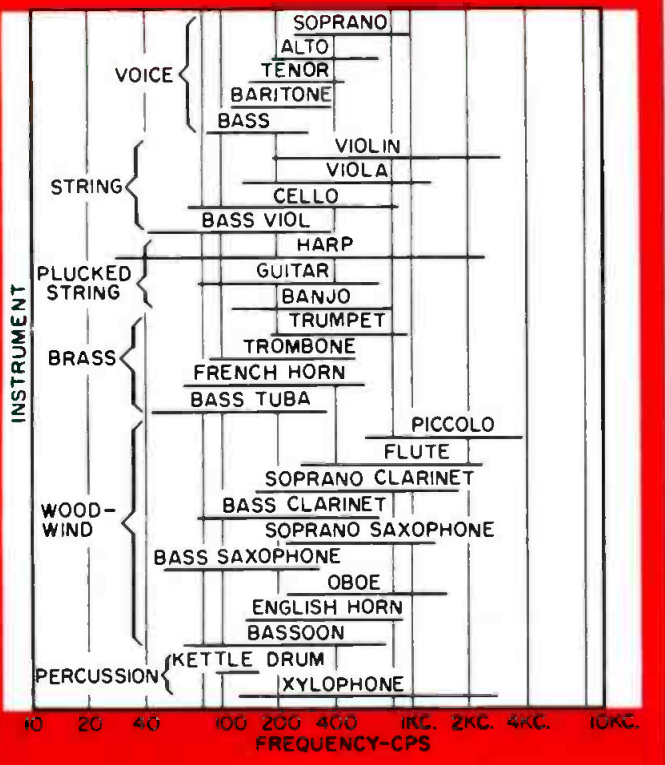

**MUSICAL FREQUENCY RANGES.** Fundamental frequency ranges of voices and musical instruments. Note that the range of the overtones, which give an instrument its particular timbre, is not shown. Although these vary widely depending on the instrument and how it is played, the overtones may extend the frequency range required to reproduce a given musical instrument by two or more octaves.

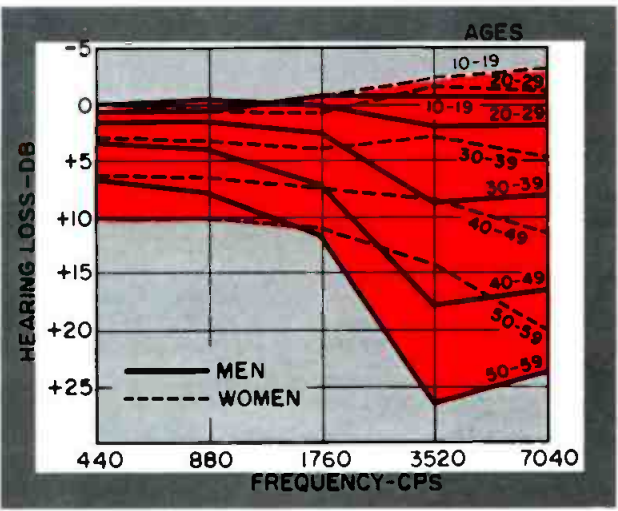

**HEARING LOSS WITH AGE.** Curves show the loss of hearing acuity with advancing age. Note that high-frequency hearing loss of women is considerably less than for men.

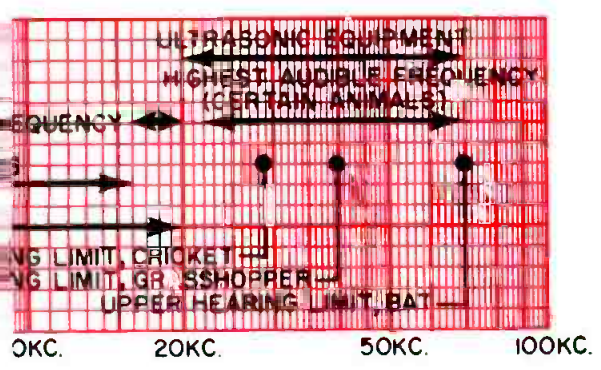

## RELATIVE LEVEL (DB)

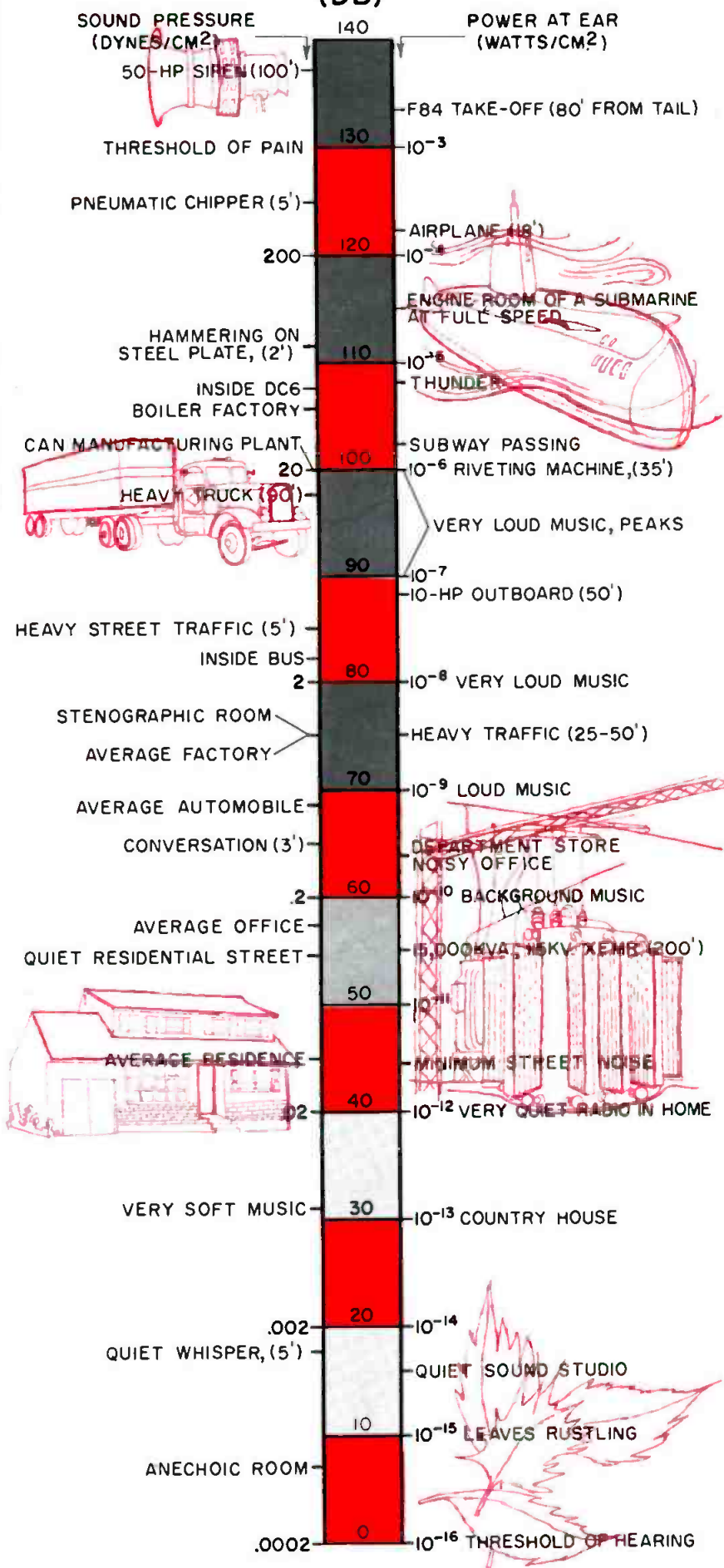

**SOUND LEVELS.** The relative levels of a number of common sounds and noises.



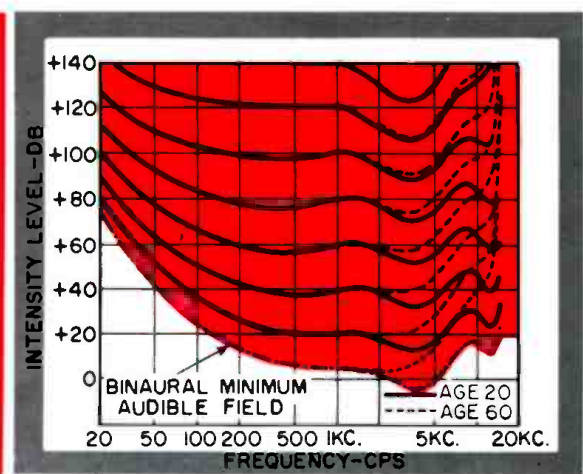
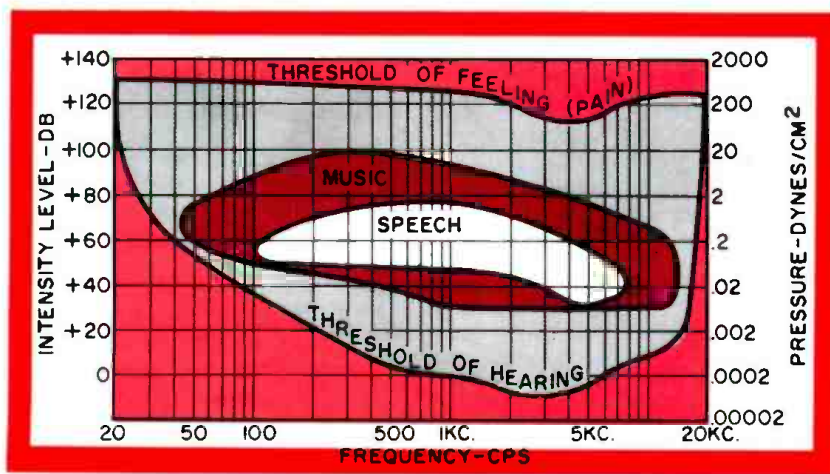

**FREQUENCY & VOLUME RANGES.** (Left) The approximate boundaries of normal hearing based on Fletcher-Munson data. No sound is heard below the level indicated by the lower contour. Sound levels that are in excess of those indicated by the upper contour are felt rather than heard and may be accompanied by a sensation of pain. Also shown are the volume levels and frequency ranges of music as well as speech.

**EQUAL LOUDNESS CURVES.** (Right) Sound intensities required to produce equal loudness at various sound levels. These curves, obtained by Robinson and Dadson, are slightly different from the older Fletcher-Munson data and have as yet to be internationally accepted. Both these curves and the Fletcher-Munson curves of equal loudness show the need to boost the bass substantially and to boost the treble slightly when listening at reduced volume levels. If this is not done, then bass and treble tones will appear to be lost.

# SOUND

**AUDIBLE SPECTRUM.** Some significant frequencies are shown on the audible spectrum along with the fundamental frequencies for notes on the piano keyboard. The equally tempered scale is used and it is based on the American Standard Pitch (A=440).

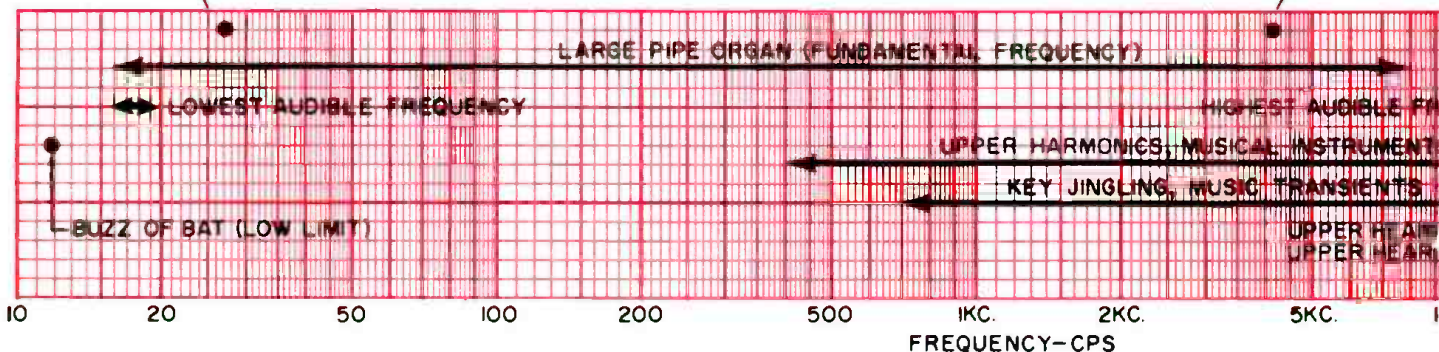
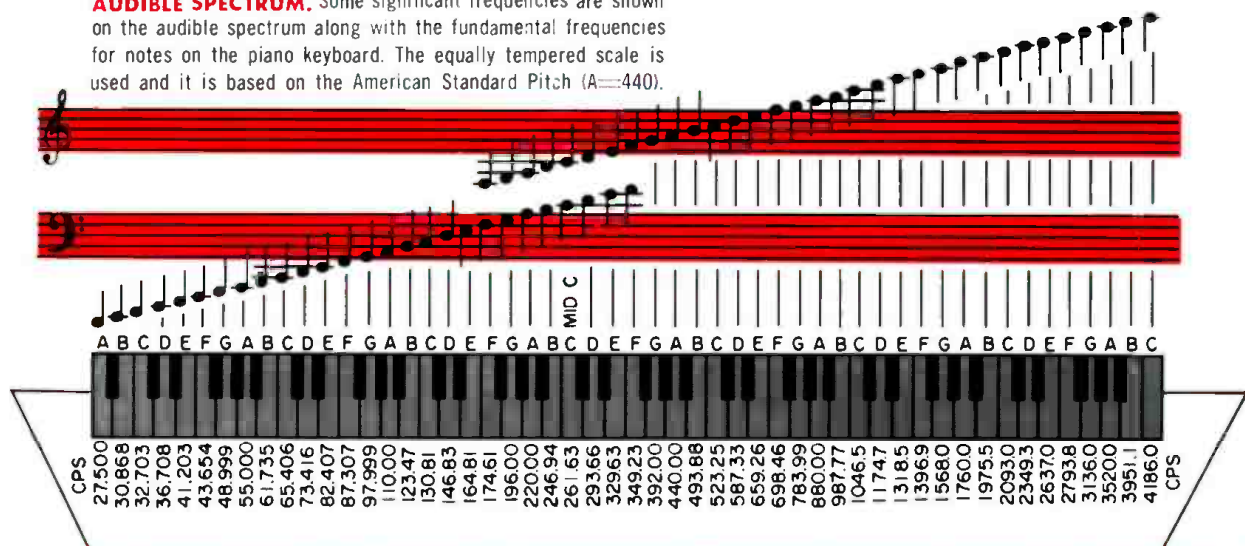

**C**ALCULATIONS of power levels and decibel ratios from voltage readings often lead to confusion for both experienced technicians and beginners, since the conventional formula for determining decibel ratio from voltage readings assumes that each reading is taken at the same impedance level.

Many charts, tables, and graphs have been published to aid in solving such problems. However, the charts shown here offer features not to be found in such previous aids. With them, power corresponding to any voltage reading can be determined if resistance is known, voltage can be determined if power is known, and the gain or loss in decibels of any equipment can be determined if input and output voltages and resistance can be measured.

Chart 1 (at the left) is used for voltage-power-resistance

calculations. Chart 2 (right) converts power levels directly to decibels gain or loss.

The voltage and resistance scales of Chart 1 bear two sets of graduations, labeled E1 and R1 and E2 and R2 respectively. Scales bearing the same suffix number are used together.

For example, suppose an amplifier is under test. A 10-volt signal applied to the 500-ohm input produces an output measured at 5 volts across 8 ohms.

First, determine input power from Chart 1. The line connecting 10 volts (E2 scale) and 500 ohms (R2 scale) passes through 0.2 watt. Output power is next. This time, the E1 and R1 scales of Chart 1 are used, yielding an answer of 3.1 watts.

Now we turn to Chart 2. Connecting the 3.1-watt input (P1 scale) and the 0.2-watt output (P2 scale) gives a total amplifier gain of just under 12 decibels. ▲

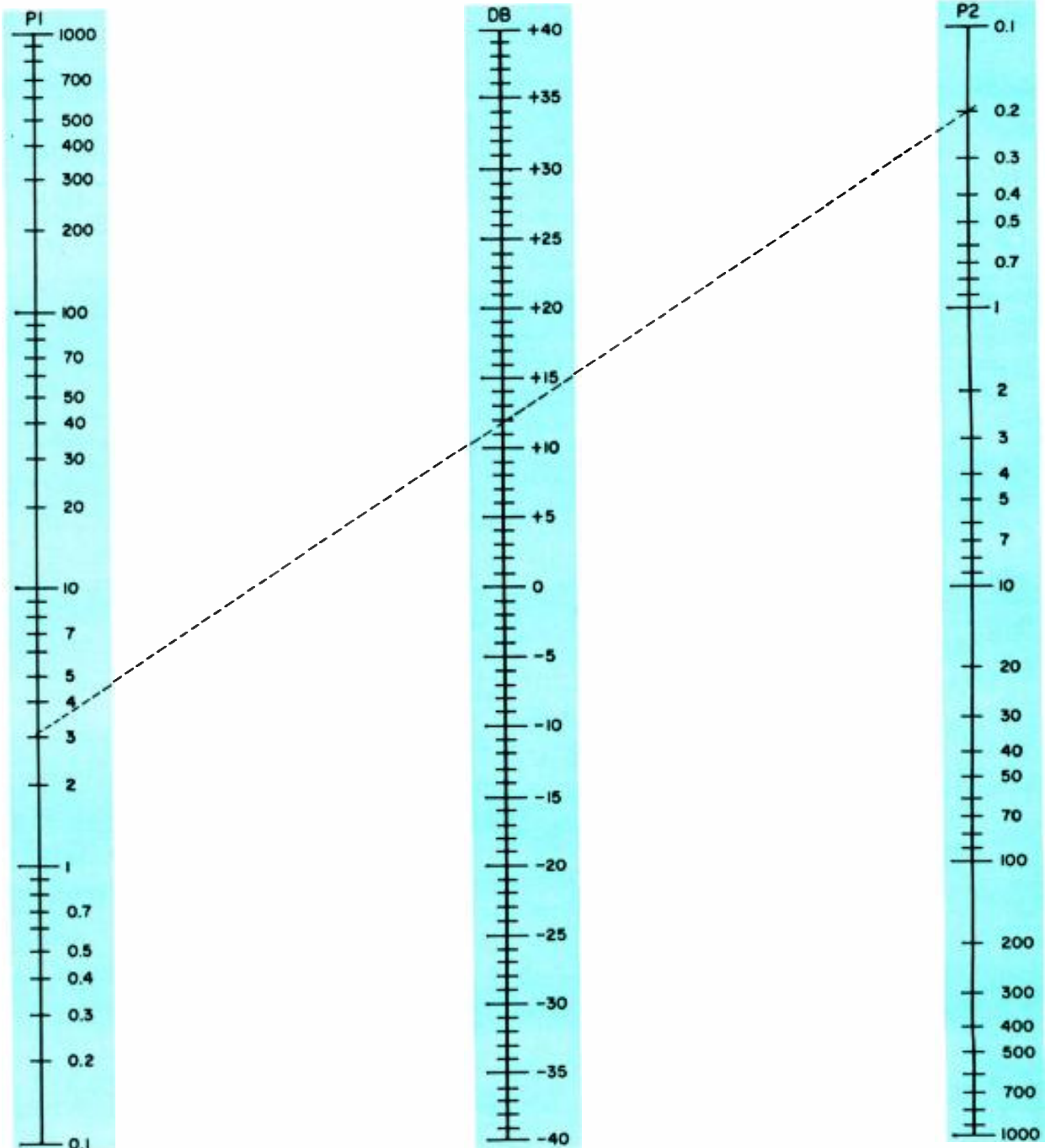



# TRANSISTOR-OPERATED PORTABLE LAMP

By THOMAS J. BARMORE

Construction details on a fluorescent utility or emergency light that is battery powered via a transistor oscillator.

**M**OST of us in the electronic repair business have had to work on equipment in the dark, with only a flashlight as a source of illumination. Even if you don't fall into this classification, you will appreciate this unusual light source if you've ever had to change a tire in the dark or had the power go off in your home at a crucial moment.

This fluorescent lamp is small, battery powered, and has a light output of 5 footcandles over an area of 16 square feet at a distance of two feet or 20 footcandles over an area of 4 square feet at a distance of one foot from the lamp. In order for a tungsten lamp to generate this same amount of light, 7.8 watts of power must be consumed while this unit draws only 3.7 watts (based on an average battery voltage of 5 volts and a power-supply efficiency of about 94%).

Unlike a conventional tungsten lamp, a fluorescent lamp is an electric-discharge source. It is a tube coated with a special powder (in this case, calcium phosphate) and filled with mercury vapor and a small amount of argon vapor. In the ends of the tube are filaments much like those found in directly heated vacuum tubes. These filaments are coated with an electron-emitting material which will give off a dense cloud of electrons when heated. In operation, these filaments are first heated while an a.c. potential is applied between the ends of the tube. Once the filaments are heated and the electron cloud present, the filament voltage is removed and an arc is established along the length of the tube.

Electrons, in collision with the mercury atoms, release ultraviolet radiation which is absorbed by the wall coating. Light is then given off as this coating fluoresces.

## Circuit Design

Since fluorescents must have a potential for starting and operation that is higher than can be conveniently supplied by batteries, the lamp employs a simple d.c.-to-a.c. converter, consisting of a transformer, two inexpensive power transistors, and two resistors.

This supply is much like those which use an electro-mechanical vibrator to switch the primary voltage. In this supply, the primary circuit is actually a high-current multivibrator with feedback supplied via winding N2 and controlled by resistors R<sub>1</sub> and R<sub>2</sub>. The switched d.c., or square wave, is applied to the primary winding (N1) and stepped up to about 100 volts.

The transformer used may be a com-

mercial unit such as a *Triad* TY-100 (which costs around \$12) or the constructor may wind his own. The author used a small tape-wound toroid about 1¼ inches in diameter, but a small audio transformer may be used with reduced efficiency. Winding N1 is about 50 turns, center-tapped, of #18 enameled wire wound about the periphery of the core. N2 is a center-tapped feedback winding of the same number of turns but of #30 enameled, wound between the windings of N1. Once these windings are in place and insulated with fiberglass tape, a secondary output winding of 600 turns may be wound over the top of the primaries. This secondary output winding is then insulated with cambic tape.

In operation, a fluorescent lamp behaves in a strange manner. Since it is an arc, some sort of current-limiting device must be used in series with the lamp. Since the lamp operates on a frequency of 5000 cps, a capacitor serves as an excellent current-limiting ballast as it has no power loss even though there is a voltage drop across it.

## Power Sources

Power for the lamp may be supplied by one of several sources. The author used a 5-volt sintered-plate nickel-cadmium battery that is normally used in the *Black and Decker* cordless drill, but this was used only because of its shape. It will supply about 1 amp. for over two hours and is rechargeable. A set of four *Burgess* #CD-7L nickel-cadmium cells will power the lamp for an hour, while an *Eveready* cathodic envelope battery #2744 will operate the lamp for three hours. An *Eveready* #744 will supply power for about one-half hour, while four size D flashlight cells will operate it for about 15 minutes. Of course the unit can use an automobile battery as a power source, provided it is 6 volts. Otherwise, resistors R<sub>2</sub> and R<sub>1</sub> should be changed to a total of approximately 600 ohms. Resistor R<sub>1</sub> is made variable in order to increase battery life. Starting is facilitated with weak cells by increasing the bias on the transistor bases, while less current is actually needed to operate the lamp.

The unit is housed in a simple 3" x 3" x 6" case. One-half of the case houses all components, while the lamp sockets and lamp are mounted on a concave cover plate. All controls are mounted on the rear, enclosed by a handle. ▲

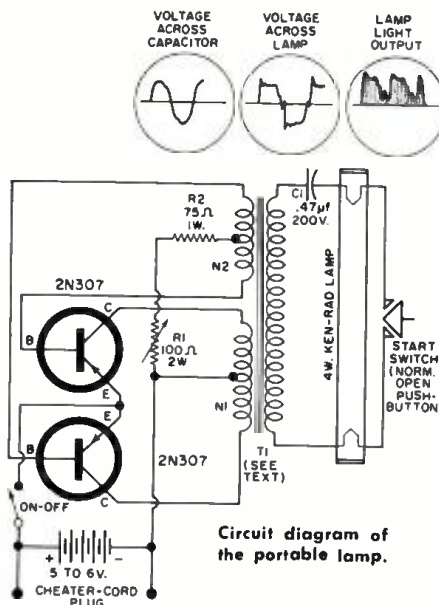

Ordinary 4-watt fluorescent tube is used.

A rear view of the battery-powered lamp.

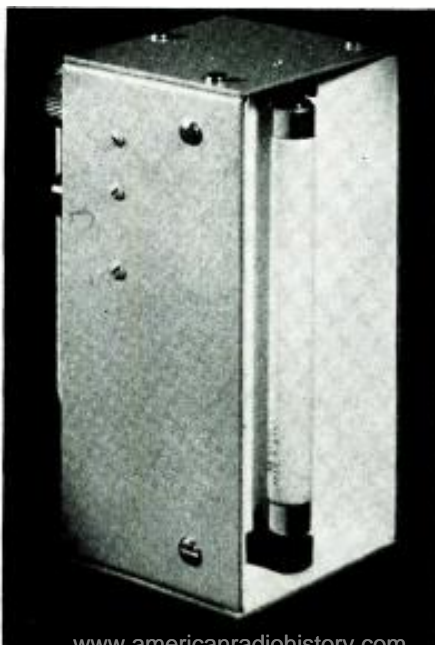



# ANALYZING COLOR SET DEFECTS

As with monochrome, a single glance at the picture can start you well on the way to finding the defect on a color set, if you know basic and can think.

**A**N EXPERIENCED technician enters a customer's home where the black-and-white TV set exhibits a familiar defect: horizontal sync is lost and cannot be restored by manipulation of the external hold control. Without hesitation, he proceeds to rear adjustments tied in with the horizontal circuit. If need be, he tries new tubes for the oscillator, output, a.f.c., and sync-separator stages.

The chances are that one of these attempts will get him out of the house in short order after a successful repair. If not, he takes the set back to the shop. There he will know where to start looking and how, hardly being aware of having to think about the matter.

What has happened here? Years of logical thinking and experience have enabled him, almost instantaneously, to associate a specific symptom with a specific part of the set and the most probable trouble points. In a few years from now, the same man will be handling color defects with the same deft assurance. But even today, he is probably better off than he knows.

A few years ago, monochrome defects did not "solve themselves" almost automatically. Our man had to stop and think. If he has gone through that period successfully and done his color "homework" (kept up with color circuits and their operation), he need only return to an earlier approach. He has not lost his ability to think. Employing it once more, his greatest difficulty will be the fact that color defects will take somewhat more time to correct.

Thus we are not concerned with the "how" of color service.

Scrupulous descriptions of convergence, chroma-alignment, and other special techniques abound. They are useless unless the technician knows "when" to apply them.

Consider the out-of-sync monochrome set with which we began. The receiver was doing something it shouldn't. More precisely (and more usually), it was *not* doing something it should. It failed to lock the picture horizontally. The technician immediately went to work on the horizontal section.

## *An Analogous Color Fault*

Consider pattern A in the upper, right-hand section of the facing page (shown more clearly on the cover). Signal is applied to the receiver from a gated, color-bar generator. We should see a series of separate, vertical bars, each of a different color in the sequence of Fig. 1A. Instead distinct bars can be seen, but color is scrambled. If the set were actually receiving a color broadcast, the picture would be quite recognizable, but indiscriminate bands of color would be weaving through the image.

The set is doing some of the things it should. It is reproducing a picture, so the video channels seem to be in order. That picture is recognizable, so the conventional sync circuits appear to be behaving. The receiver is "making color," so we can disregard a good portion of the chroma circuitry and the CRT, for the time being at least. The thing the set is *not* doing is the necessary matching of the produced colors to the picture elements, where they belong.

Quite simply, we have a synchronization problem. Color



sync is established by the 3.58-mc. oscillator in the receiver. Like the horizontal oscillator, the former should be locked in with specially transmitted synchronizing pulses—the "burst" signal, in this case. Burst is tapped off from the video channel, as are other sync pulses, fed to a separate burst amplifier, and then applied to the 3.58-mc. oscillator through an a.f.c. circuit. We are immediately restricted to these circuits as a starting point.

The first check will involve oscillator adjustments and the tube. If the oscillator appears to be working, the a.f.c. and burst stages are checked. As with the horizontal fault, some preliminary checks can be made at once, in the customer's home. In the illustrated case, a shop job was necessary. The oscillator was running, although out of sync. A little tracing led to an open resistor in the screen grid of the burst amplifier. This routine defect was unearthed with routine voltage and resistance readings in the affected stage—once simple recognition and analysis had directed the technician to that stage.

**Faults in Monochrome Reception**

The preceding case had the virtues of relating to another, familiar type of defect in black-and-white and of being relatively easy, which is all right to start out with. Others will be less obvious and also more frequent. Most TV broadcasts today are in monochrome, so even the owner of a color set will be doing most of his viewing in that medium. Defects that occur in these conditions are often dismissed as being familiar monochrome faults, pertaining to those circuits only. That will not always be true.

Fairly obvious exceptions will be monochrome pictures that show some color. Where a single color appears to predominate, the technician will first check tracking adjustments for the three guns of the CRT. A bluish cast to the picture will suggest that blue-gun output is greater than it should be and, if the gun is proven to be balanced against the other two, some tracing back into the matrixing and amplifying circuits feeding the blue gun is in order. Simple enough.

If the picture should happen to have a yellowish tinge, the matter is more complex, but not by much. In color TV, yellow is a combination of red and green. Blue-gun output would thus appear to be low or not present. If a color-signal generator is available—and some such equipment is indispensable—this is a propitious moment to hook it up. In a case like this, the blue bar in the center of the pattern (number 6 in

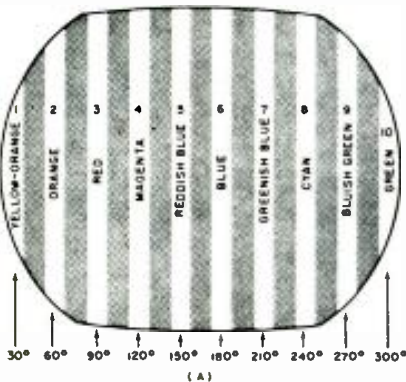

Fig. 1. Pattern (A) produced on a set from a color-bar generator. Theoretical signals (B, C, and D) at red, blue, and green guns with bar-pattern input to set.

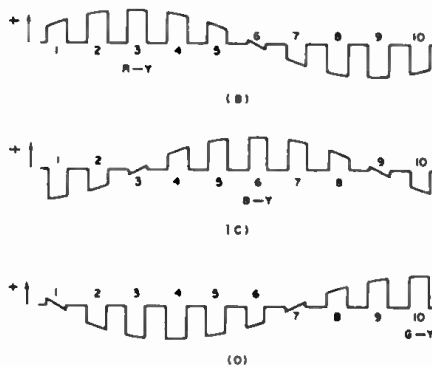
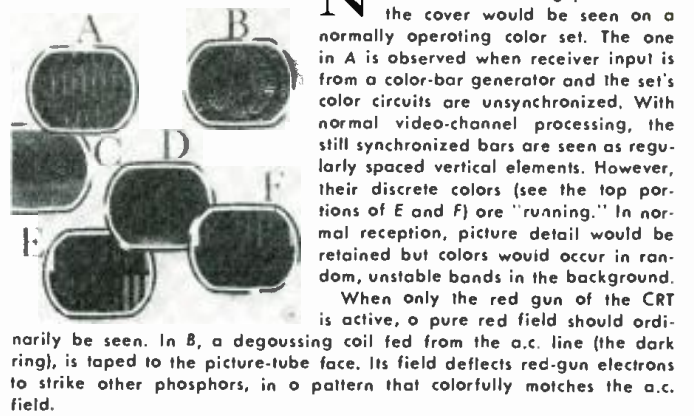

Fig. 3. Displays at red, blue, and green grids (top to bottom) as seen with scope.

Fig. 2. Red-grid signal showing overload, as from high setting of saturation control. Compare with the normal waveform at this point (topmost pattern of Fig. 3).



normally be seen. In B, a degaussing coil fed from the a.c. line (the dark ring), is taped to the picture-tube face. Its field deflects red-gun electrons to strike other phosphors, in a pattern that colorfully matches the a.c. field.

A hum bar due to cathode-heater leakage in a monochrome set is familiar enough. Something is added (C) when a color set is similarly afflicted. The bar may have any color. It may occur on color programs only or tint a monochrome picture. Considering such variables helps identify the guilty circuit.

Many defects can cause off-coloration at the raster edges. In D, purity-magnet misadjustment mars a pure red display by contaminating raster areas away from the center.

Two conditions are combined for comparison in the split-screen effect of E. The top shows normal reproduction with input from a gated, color-bar generator. Colors at the bottom, though synchronized, are all of the wrong hue. A frequent cause of this condition is a misadjusted hue control. The top of F is, once more, a normally displayed color-bar pattern. Too high a setting of the saturation control produces the overload at the bottom. Basic hues are correct, but abnormally deep and distorted. In a picture, pastels and shades would be lost, color heavy and smeared. Compare this with excessive contrast in monochrome: heavy blacks, few grays, and smearing would be noted.

(Illustration by George Kelvin)

Fig. 1A; also see the top portions of patterns E and F on the cover) would not appear on the screen.

Also fairly clear-cut are those cases where the monochrome picture is acceptably black-and-white toward the center of the raster but there is some color contamination along one or more edges. We have a fairly simple purity or convergence problem here, and the former will be checked before anything is done about the latter. Blue and green screen controls are generally turned down to produce an all red display. If the latter is contaminated, purity adjustments are made first, not so much to cover as much of the screen with red as possi-

(Continued on page 64)

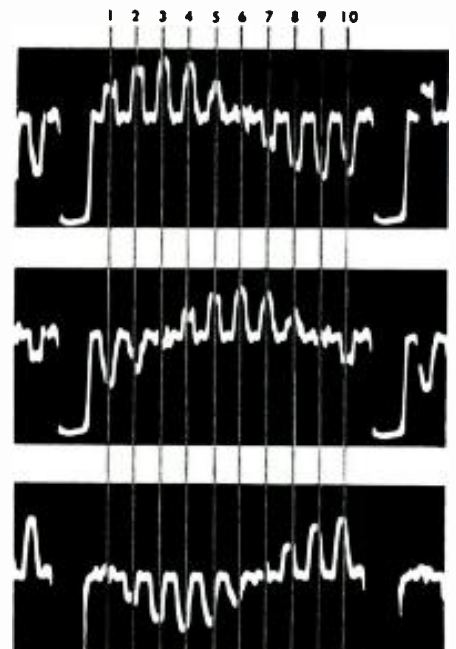

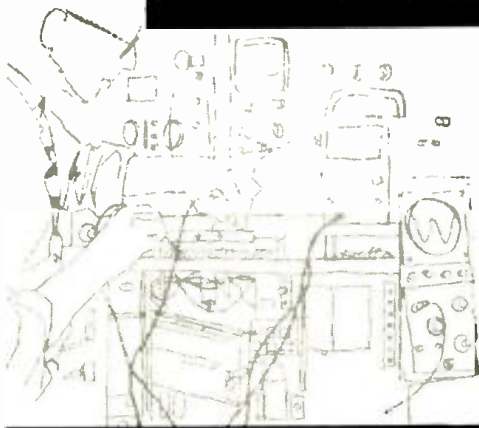

# MAC'S ELECTRONICS SERVICE

By JOHN T. FRYE

## Openers, Anyone?

"SURE took you long enough to clean that tuner." Mac commented acidly to Barney, his assistant, as the latter came into the service department. "Was the customer a good-looking girl?"

"No; matter of fact, she was an elderly widow," Barney retorted, parking his tube caddy on the side bench. "It didn't take me long to clean the tuner and reset the channels, but then the customer asked if I would look at her radio-controlled garage door opener that had gone on the fritz. Her late husband had bought the thing in kit form and had installed it himself. She could still operate the door with the push-button on the wall of the garage, but punching the button on the dashboard of her car had no effect whatever. She said the thing had worked perfectly until just this last week. Fortunately she is a methodical woman and had saved the instruction manuals that came with the transmitter and receiver; so I said I'd take a look at it.

"First I checked out the transmitter in the car. This was easy. Following instructions in the manual, I simply pulled out the antenna plug and stuck in a little dummy antenna consisting of a #47 pilot lamp fastened to an RCA phono plug. When I pushed the dash button, the bulb lighted to normal brilliance; so I figured the transmitter was okay.

"Next I took the case off the receiver unit fastened to the framework of the door-opening mechanism next to the motor. A 6BH6 was stone cold; so I put in a new one. That took care of the trouble. The transmitter opened and closed the door perfectly. But by now I was interested in the circuits; so I took a few minutes more to look over the diagrams of the transmitter and receiver and figure out how they work. Remember now: you're always telling me I should satisfy my curiosity about any electronic device, no matter if I expect to service it or not."

"Okay; so I talk too much," Mac grunted; but he grinned in spite of himself.

"The transmitter uses one-half a 6AU8 as a crystal oscillator and the other half as a power amplifier—or 'final,' as we hams call it. A 12BH7 with

its plates, grids, and cathodes strapped together functions as a power audio oscillator whose output modulates the final r.f. amplifier. By connecting different amounts of available fixed capacitance across the audio oscillator coil, any one of three different modulating frequencies can be had. A non-synchronous vibrator and transformer convert the 12-volt d.c. battery voltage into a stepped-up a.c. voltage that is rectified by two silicon rectifiers in a voltage doubling circuit to produce 220 volts for the plates of the tubes. The filaments are connected between ground and the ignition switch so they light whenever the switch is on. The dash push-button activates the vibrator to produce output from the transmitter.

"The receiver, though, is more interesting. Input from a quarter-wave antenna fastened beneath the car goes to an antenna transformer whose slug-tuned secondary feeds the grid of a 6BH6. Another transformer, this time with its tuned primary in the plate circuit of the 6BH6, feeds a crystal diode with the secondary. The d.c. voltage developed by the rectification of the car-

rier by this diode is used on the grid of the tube as a.g.c. voltage to keep the detector output relatively equal over a wide range of input signal strength. Audio recovered by the detector action is fed through a coupling capacitor to the grid of a 6AU6. A 5000-ohm relay coil is in the plate circuit of this tube, but there is little current through the coil normally because the grid of the tube is biased to cut-off with voltage developed by rectifying and filtering the 6-volt filament supply. Incidentally, this high bias keeps the tube from amplifying the audio on its grid by any appreciable amount.

"Now we come to the tricky part; so get out that mental blackboard of yours and let's see how good you are at following a word description of a circuit. Imagine the familiar diamond shape of a bridge circuit. The two right-hand legs are 220k resistors. Starting at the left corner and going up to the right, we see a 22k resistor and then a silicon diode with the plus terminal to the right. Starting at the same point and going down and to the right, we see a tapped variable inductance audio choke tuned with a 3000- $\mu$ f. capacitor; and the tap goes through a 220k-ohm resistor across the bridge to the junction of the other two 220k resistors. On beyond this notch filter—for that's what the resistor-choke-capacitor combination really is—there's another silicon diode with its plus terminal also to the right. Okay so far?"

"Drive on."

"Well imagine a 2- $\mu$ f. capacitor connected from top to bottom of our bridge, with the positive terminal at the top. Next picture a .01 capacitor connected from the right-hand corner to the bottom corner. Finally, in your mind's eye, connect the top of the bridge through a 220k resistor to the grid of the 6AU6, the bottom of it to our bias voltage developed by rectifying the filament voltage, and the left-hand corner through an .01 capacitor to the plate of the 6AU6. See how it works?"

"Oh I think so," Mac said with a faint smile. "The bias for the 6AU6 is fed to the grid of the tube through the resistive right-hand half of the bridge and suffers no alteration as long as no audio signal is delivered to the bridge from the plate of the 6AU6. Even when such a signal is delivered, as long as the frequency is far removed from the sharp resonant frequency of the notch filter, this bias voltage is not affected. This is because the notch filter presents very little impedance to the non-resonant signal—no more than that of the 22k resistor in the other leg of the bridge—so the signal is presented equally to the two silicon diodes and produces two equal bucking voltages across their respective load resistors in the right-hand side of the bridge. These two equal and opposing voltages cancel each other, and there is no effect on the bias of the 6AU6.

"However, when the audio signal is of the frequency to which the notch filter is tuned, this filter presents a very

(Continued on page 74)

The portion of the opener receiver Mac visualized on his "mental blackboard."

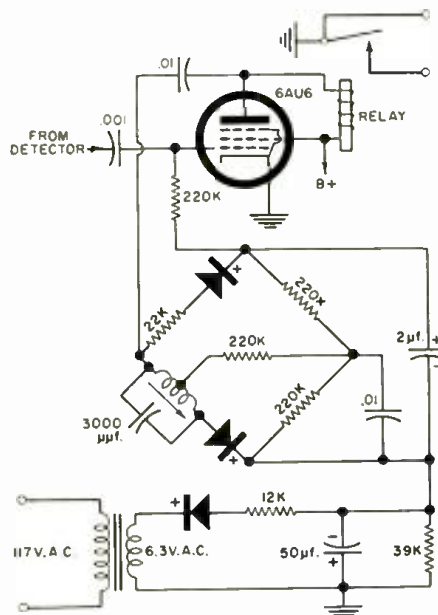





effect. Despite this, gain and noise figures have been obtained which are not significantly poorer. After all, a stable amplifier with slightly lower gain is much more useful and has a better noise figure than an unstable amplifier with higher gain.

### Neutralization

Similarly, although inductive neutralization is possibly more attractive, the author has experienced less trouble with capacitive neutralization. There are two problems with inductive neutralization. Because of the very low grid-to-plate capacitance, the neutralizing coil has to be rather large. But it must be positioned so that it is not mutually coupled to the input and output coils. If there is significant coupling, the coil will tend to increase feedback rather than neutralize it. The compactness of the nuvistor fosters the crowding of parts and, in the upper half of the v.h.f. range, they must be crowded to keep the distributed inductances low. It isn't easy to place the neutralizing coil in a position which both minimizes coupling to the other coils and keeps the lead lengths short.

Much of the trouble with inductive neutralization is often traceable to a very simple cause—the use of slug-tuned coils in which the slug is rather loose and therefore changes position with vibration. The neutralizing slot for these tubes is very sharp; even a slight movement of the slug can shift the parameters so that the tube goes out of neutralization. A simple but effective solution is to slip a cylinder of paper of appropriate thickness between the core and the inside of the coil form so the slug fits smoothly but snugly and cannot wobble inside the coil. A number of cases of instability have been cured in this simple manner.

Capacitive neutralization fits in nicely with an arrangement of components which also favors isolation between input and output circuits. As in the case of larger tubes, it is a good idea to place a shield across the nuvistor socket to isolate the grid and plate circuits and pins. The 47- $\mu\text{f}$ . capacitor can then be a feedthrough placed in this partition-

Filament voltage	6.3 volts
Filament current	0.13 amp.
Grid-to-plate capacitance	0.92 $\mu\text{f}$ .
Grid-to-cathode, heater shell	
input capacitance	4.1 $\mu\text{f}$ .
Plate-to-cathode, heater shell	
output capacitance	1.7 $\mu\text{f}$ .
Plate-to-cathode capacitance	0.18 $\mu\text{f}$ .
Heater-to-cathode capacitance	1.3 $\mu\text{f}$ .

#### Operation with Cathode Bias

Plate supply voltage	125 v. max.
Cathode bias resistor	130 ohms
Amplification factor	62
Plate resistance	6300 ohms
Transconductance	9800 $\mu\text{mhos}$
Plate current	7.6 ma.

#### Operation with Grid-Leak Bias

Plate supply voltage	70 v.
Grid resistance	47,000 ohms
Amplification factor	68
Plate resistance	5440 ohms
Transconductance	12,500 $\mu\text{mhos}$
Plate current	8 ma.

Table 1. Characteristics of the 6CW4 tube.

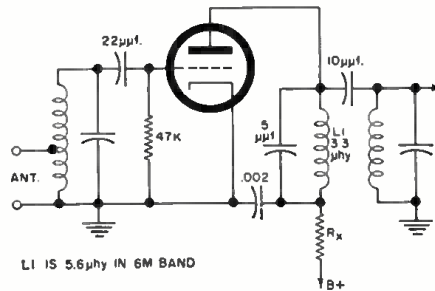
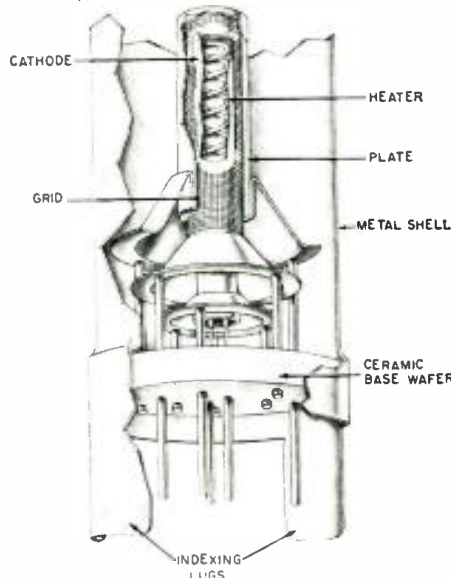
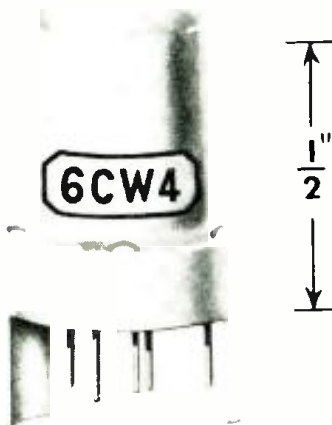

Fig. 2. R.f. amplifier for the FM band.

ing shield and the 2-8- $\mu\text{f}$ . neutralizing capacitor can be supported at one end by the feedthrough terminal and at the other by a terminal on the input coil, tuning capacitor, or a stiff wire from coil to tube grid. A miniature variable of the MAC type, in its smallest size, is most convenient for neutralization. However, a gimmick of twisted wires can be used although it is more trouble to adjust for complete neutralization. Because no tuned circuit is involved, capacitive neutralization is less critical in original adjustment and maintains



Cross-section of the RCA 6CW4 nuvistor triode.



complete neutralization over a wider bandwidth.

Whichever method of neutralization is used, the greatest range of stability is achieved when the neutralization is adjusted for the low edge of the band of frequencies to be received, or even slightly below—45 to 50 mc., for instance, for a 6-meter preselector or converter and 88 to 90 mc. for the FM broadcast band.

The simplest way to neutralize is to break the filament circuit, feed a strong signal into the unit and adjust the coil or capacitor for minimum output. A slightly better noise figure is achieved if a noise generator is available and the neutralization is adjusted for the best noise figure. However, the difference is not significant below the 2-meter band and adjusting for lowest feed-through provides a noise figure well below the antenna noise.

A good enough noise figure can be achieved through the 6-meter and even the FM broadcast band without neutralization in the circuit diagrammed in Fig. 2. Here the plate tank, consisting of the choke and fixed capacitor, is tuned roughly to a frequency well below the operating frequency—50 or 60 mc. for an FM broadcast-band tuner or 30 to 40 mc. for a 6-meter unit. This provides a low-impedance load at the operating frequency. This low impedance, of course, reduces the gain; however, this is partly compensated by a small amount of regeneration. Thus the gain is not lowered too much and the noise figure is still good enough to produce an IHFM sensitivity of 1.5  $\mu\text{v}$ . or better in the FM broadcast band.

### Cascade Circuits

Two nuvistors can be used in the cascade circuit. The author's attempts along this line have not been encouraging and many of the difficulties experienced in working with nuvistors have been due to the attempt to make them operate in cascade. The noise figure of the series cascade is not as good as that of the neutrode unless the plate-to-grid and plate-to-ground capacitance of the first section are both neutralized, as diagrammed in Fig. 3. This, however, requires two neutralizing coils and complicates the problem of placing them so that coupling to the output coil is avoided. Also the over-all gain increases to the point where instability due to mutual coupling is a serious problem.

Finally, nuvistors are no more immune to cross-modulation than other tubes used in series-cascade arrangements. Indeed, the high gain increases the problem and in any area where there are strong local signals, interference from cross-modulation is almost inevitable. The cascaded-cascade diagrammed in Fig. 4 minimizes both the neutralization and the cross-modulation problems, but the circuit is then as complex as it would be with two cascaded neutrodes or pentodes.

Actually, there is little point in trying to cascade nuvistors below the 2-meter band. A neutrode r.f. stage working into a good pentode mixer like the 6U8 or 6X8 produces a noise figure in the



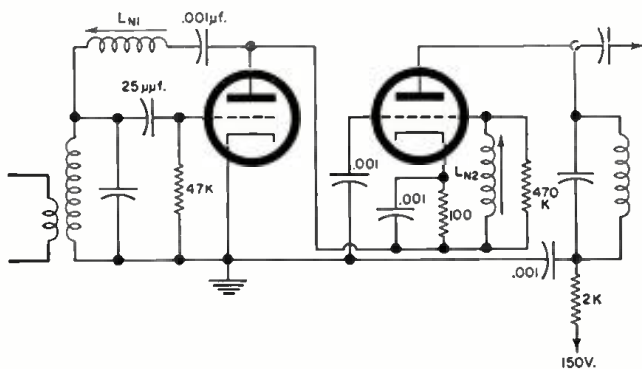

Fig. 3. Completely neutralized series cascode r.f. amplifier.

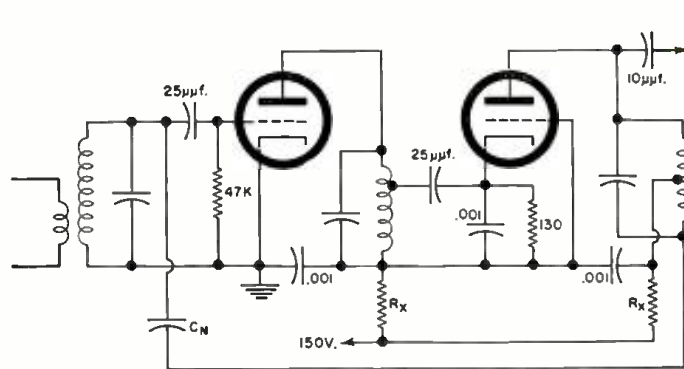

Fig. 4. Cascaded-cascode stage is as complex as two neutrodes.

3- to 4-db region through the FM band and this is enough to provide an IHFM sensitivity of  $1.5 \mu\text{v}$ . or better.

There is more point to a cascode in the 2-meter band and higher and since the neutralizing coils can be much smaller, the problem of mutual coupling is not as severe. However, a nuvistor neutrode first r.f. stage into a 6AK5 pentode second r.f. stage gives as good a noise figure at 2 meters with higher gain and no more complication in circuitry.

### Converters & Oscillators

An all-nuivistor front-end or converter can be built by using three 6CW4's, one as the r.f., another as a mixer, and the third as an oscillator. There is a tetrode nuvistor which can be used as a mixer for higher gain and, with screen injection, less oscillator pulling.

As a mixer the 6CW4 is connected exactly as it is when used as a grid-leak biased amplifier, with a 47,000-ohm grid-leak resistor and a 50- to 75- $\mu\text{f}$ . grid-leak capacitor. In the FM band and above, the length of the lead from the plate to the first i.f. transformer may be critical. A small inductance is helpful here to reduce input loading through the Miller effect. In the FM band, a lead length of about one inch is right.

The 6CW4 makes an excellent oscillator in any of the circuits useful in the v.h.f. range. The Colpitts arrangement is especially convenient. The capacitive voltage divider is provided by the grid-to-cathode tube capacitance and the cathode-to-ground capacitance augmented by a small capacitor across the cathode choke. The circuit of Fig. 5 works well through the 2-meter band. The author has had no personal experience with crystal-controlled nuvistor oscillators. It is generally agreed, however, that they present no problems that are not common to any other suitable triode. The circuit of Fig. 6 can be used with overtone-type crystals operating above 30 mc.

### Matching & Loading

One thing that is not always taken into consideration when a nuvistor preamp is placed ahead of a receiver or tuner is the impedance of the load the receiver input will present to the nuvistor. For example, one of the most logical applications of the nuvistor is as a preamplifier ahead of inexpensive

or medium-sensitivity FM tuners using a grounded-grid r.f. stage.

Many persons have been surprised and puzzled to discover that the addition of a nuvistor preamp in such a situation has not increased the gain appreciably. Actually, in this instance the gain of the nuvistor cannot be expected to be much more than 2 and may well be unity. In effect, the nuvistor stage becomes the first section of a cascode. The very low impedance of the grounded-grid amplifier loads it so heavily that little gain is realized. The high impedance of the nuvistor should increase the gain of the grounded-grid stage but this is not always the case since quite often the grounded-grid stage has been designed more with an eye to reducing radiation of the oscillator than for providing gain. Thus the resulting increase in gain by the addition of a nuvistor may be very modest. Nevertheless, the noise figure should be improved to some degree and this should increase the effective sensitivity of the tuner.

In such a case, it is often possible to improve matters in two ways. First, a link can be added to the nuvistor output tank so that there is a stepdown to match the low impedance of the tuner input. This will, of course, reduce the voltage fed into the tuner. However, this should be more than made up by the increased gain of the nuvistor itself.

In the tuner, the grounded-grid stage should be examined and, if necessary, modified slightly to provide the highest possible input impedance. Specifically, make sure the cathode tank is tuned to the operating frequency. When it is tuned, the impedance will be very much higher than when it is detuned. Usually this tank will tune considerably above the operating frequency when a preamplifier is connected in place of the antenna because the preamp will present a much lower capacitance than the antenna transmission line. A small trimmer can be added, if necessary, across the coil to bring it into resonance at the operating frequency.

Even when the receiver or tuner has a grounded-cathode input stage, matching the nuvistor preamp to the receiver input can have a significant effect on the nuvistor gain. Assuming, as is almost always the case, that the receiver has a 300- or 72-ohm antenna input, the nuvistor preamp should be link-coupled to the receiver or by tapping the output

off the output tank so that the low receiver input impedance does not load the nuvistor too heavily. It may pay to try links of various turns and coupling to obtain the best match which will be indicated by the highest gain.

Actually, with the exception of grounding, the nuvistor presents no problems that do not occur with any "hot" tubes at the same frequencies. Indeed, once this particular eccentricity is taken care of, it is rather less critical than any other tube the author has used in the v.h.f. range. If the nuvistor is treated with the same respect as to circuit layout, it is usually easier to neutralize and will remain in neutralization over a wider frequency range. While it will not perform miracles, it will deliver sensitivities in the v.h.f. region which were once idle dreams. ▲

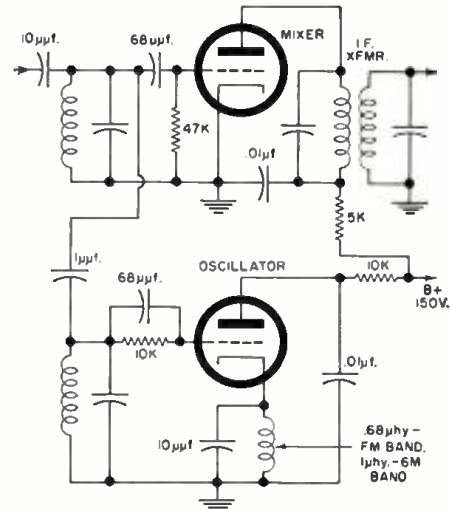

Fig. 5. Mixer-oscillator stage that may be employed up through the 2-meter band.

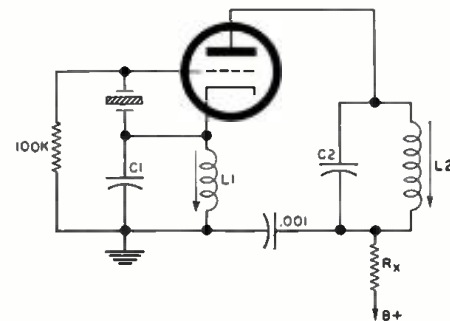

Fig. 6. Crystal oscillator for use with overtone crystals.  $L_1C_1$  is tuned to the overtone output frequency while  $L_2C_2$  may be tuned to the desired harmonic frequency.

# Compact, Transistorized Impedance Bridge



Front view of author's bridge which is about seven-inches wide.

By STANLEY E. BAMMEL

*Construction of a versatile test instrument. Measures inductance from 10  $\mu$ hy.-11 hy., capacitance from 3  $\mu$ f.-3.5  $\mu$ f., and resistance from 3 ohms to 3.5 megohms.*

ONE of the simplest ways of measuring inductance, capacitance, and resistance is with a bridge. The bridge is also capable of greater accuracy than direct-reading instruments.

This impedance bridge can measure inductance from 10  $\mu$ hy. to 11 hy., capacitance from 3  $\mu$ f. to 3.5  $\mu$ f., and resistance from 3 ohms to 3.5 megohms. There is provision for comparing an unknown with an external standard.

With sufficiently accurate component parts and careful calibration, accuracy should be at least 2 or 3%. However,

high accuracy is not this bridge's primary feature: convenience is. The use of transistors results in a sensitive, compact, and completely self-contained portable instrument which can be built at reasonable cost.

Fig. 1 is a basic inductance bridge circuit. Since the phase shift of  $L$ ? is opposite that of  $C$ ?, they are connected in opposite arms of the bridge. After proper adjustment of  $R$ ?, the phase shifts cancel and the bridge balances when  $E_1/E_2 = E_3/E_4$ . Each voltage is proportional to the reactance or resistance in its respective arm of the bridge.

Substituting for  $E_1$  to  $E_4$  in the above equations gives  $X_{L1}/(R_{21} + R_7) = R_8 / X_{L2}$ . Substituting the formulas  $X_L = 2\pi fL$  for  $X_L$  (inductive reactance) and  $1/2\pi fC$  for  $X_C$  (capacitive reactance) in the equation results in  $1/(2\pi fC_1)(R_{21} + R_7) = R_8/2\pi fL$ ?  $L? = R_8 C_1 (R_7 + R_{21})$ .  $R_{21}$  is the inductive balance control and  $R_{22}$  balances the resistive component in inductance  $L$ ?. However, the setting of  $R_{22}$  is not related to the resistance of the inductor being measured.

Figs. 2 and 3 are simplified diagrams of the capacitance and resistance bridges respectively. In both of these  $R_{21}$  is out of the circuit and  $R_{22}$  is the only balance control. As in Fig. 1, balance is achieved when  $E_1/E_2 = E_3/E_4$ . Note that  $R_5$ ,  $R_6$ , and  $R_{22}$  in Fig. 3 are reversed from their positions in Fig. 2. This is done in order to use the same scale calibration for capacitance and resistance. Were this not done, the scales would read in opposite directions.

Fig. 4 is the comparison bridge (position  $E$  of function switch  $S_1$  in Fig. 5). In this test configuration an unknown resistance or reactance can be compared with another unit of known value. Here,  $R_{22}$  and/or the known part is varied to obtain bridge balance.

## The Circuit

Fig. 5 shows the complete bridge circuit.  $V_1$ ,  $V_2$ , and their associated components constitute an oscillator whose frequency is about 1000 cps and whose waveform is reasonably free from harmonics. (Low harmonic content is essential to simplify nulling the bridge.)  $C_{11}$  in series with the secondary winding of  $T_1$  prevents oscillator overload. When the load becomes excessive,  $T_1$  resonates with  $C_{11}$  to prevent the load from killing oscillation. A three-pole, four-position

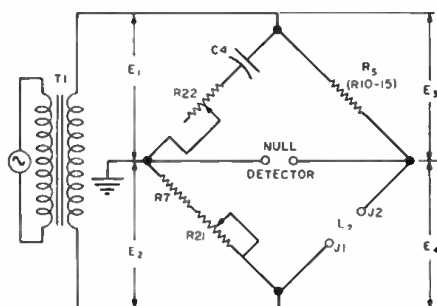

Fig. 1. Simplified inductance bridge.

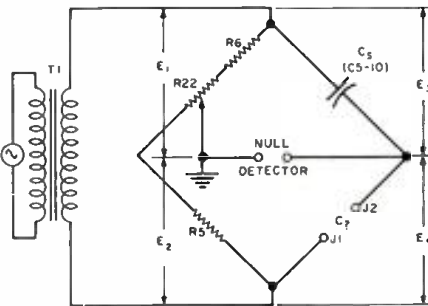

Fig. 2. Simplified capacitance bridge.

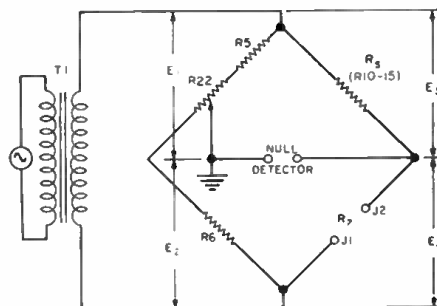

Fig. 3. Simplified resistance bridge.

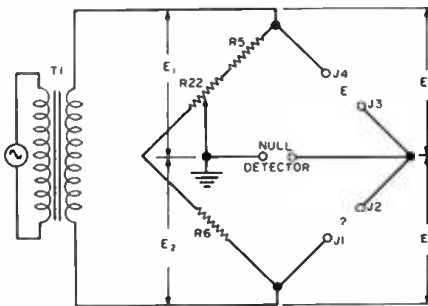
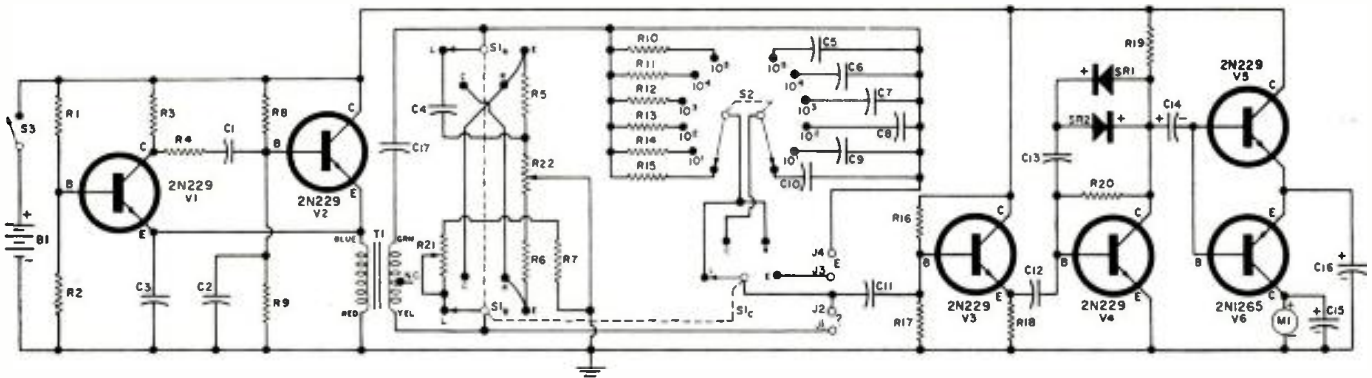

Fig. 4. Simplified comparison bridge.





- R<sub>1</sub>—33,000 ohm, 1/2 w. res.
- R<sub>2</sub>—1000 ohm, 1/2 w. res.
- R<sub>3</sub>—10,000 ohm, 1/2 w. res.
- R<sub>4</sub>—3330 ohm, 1/2 w. res. ± 1%
- R<sub>5</sub>—200 ohm, 1/2 w. res. ± 1%
- R<sub>6</sub>—100,000 ohm, 1/2 w. res. ± 1%
- R<sub>7</sub>—1 megohm, 1/2 w. res. ± 1%
- R<sub>8</sub>—10,000 ohm, 1/2 w. res. ± 1%
- R<sub>9</sub>—1000 ohm, 1/2 w. res. ± 1%
- R<sub>10</sub>—100 ohm, 1/2 w. res. ± 1%
- R<sub>11</sub>—10 ohm, 1/2 w. res. ± 1%
- R<sub>12</sub>—220,000 ohm, 1/2 w. res.
- R<sub>13</sub>—2200 ohm, 1/2 w. res.
- R<sub>14</sub>—470 ohm, 1/2 w. res.
- R<sub>15</sub>—47,000 ohm, 1/2 w. res.

- R<sub>10</sub>—2000 ohm linear-taper wirewound pot ("10 H") (Clarostat A58-2K or equiv.)
- R<sub>11</sub>—10,000 ohm linear-taper wirewound pot ("μF-Ohms") (Clarostat A58-10K or equiv.)
- C<sub>1</sub>, C<sub>2</sub>, C<sub>3</sub>—0.1 μf., 200 v. capacitor
- C<sub>4</sub>—1 μf., 10 v. capacitor
- C<sub>5</sub>—0.005 μf., 500 v. silver-mica capacitor
- C<sub>6</sub>—1 μf., 200 v. capacitor ± 10%
- C<sub>7</sub>—1 μf., 200 v. capacitor ± 10%
- C<sub>8</sub>—0.1 μf., 200 v. capacitor ± 10%
- C<sub>9</sub>—0.01 μf., 500 v. silver-mica capacitor
- C<sub>10</sub>—100 μf., 500 v. silver-mica capacitor
- C<sub>11</sub>—10 μf., 500 v. silver-mica capacitor
- C<sub>12</sub>—2 μf., 10 v. capacitor
- C<sub>13</sub>, C<sub>14</sub>—47 μf., 10 v. capacitor

- C<sub>15</sub>—2.2 μf., 3 v. elec. capacitor
- C<sub>16</sub>, C<sub>17</sub>—10 μf., 6 v. elec. capacitor
- T<sub>1</sub>—Transistor audio trans., pri: 100 ohms, sec: 1000 ohms (Stancor TA-3 or equiv.)
- S<sub>1</sub>—3-pole, 4-pos. rotary switch ("Function")
- S<sub>2</sub>—D.p., 6-pos. rotary switch ("Multiplier")
- S<sub>3</sub>—S.p.s.t. toggle switch ("On-Off")
- SR<sub>1</sub>, SR<sub>2</sub>—Low- or medium-current silicon diode (1N1692 or equiv.)
- B<sub>1</sub>—6-volt battery (4 penlite cells)
- J<sub>1</sub>, J<sub>2</sub>, J<sub>3</sub>, J<sub>4</sub>—5-way insulated jack
- M<sub>1</sub>—0-10 ma. d.c. meter (Shurite 3303 or equiv.)
- V<sub>1</sub>, V<sub>2</sub>, V<sub>3</sub>, V<sub>4</sub>, V<sub>5</sub>—"n-p-n" transistor (2N229 or equiv.)
- V<sub>6</sub>—"p-n-p" transistor (2N1265 or equiv.)

Fig. 5. Transistors V<sub>1</sub> and V<sub>2</sub> constitute an oscillator whose output is coupled to bridge by T<sub>1</sub>. If loading is excessive, C<sub>17</sub> and T<sub>1</sub> resonate and prevent oscillator from overloading. Null-detector amplifier consists of V<sub>3</sub> and V<sub>4</sub>. V<sub>5</sub> and V<sub>6</sub> drive M<sub>1</sub>.

switch (S<sub>1</sub>) is used to change from one type of bridge to another.

In order to realize the full accuracy of this bridge, a sensitive null detector is incorporated in the circuit. Its amplifier, V<sub>3</sub>, V<sub>4</sub>, V<sub>5</sub>, and V<sub>6</sub>, has a roughly logarithmic response which prevents overload yet still provides high sensitivity, that is, the amplifier has high sensitivity at low levels and low sensitivity at high levels. Without this feature, the amplifier would overload, its bias would change, and the output to the meter would be lowered, giving a false null. Such operation would make it almost impossible to find the true null.

The logarithmic response is obtained by applying negative feedback through silicon diodes SR<sub>1</sub> and SR<sub>2</sub>. A silicon diode does not begin to conduct appreciably until about .7 volt of forward bias is applied to it. Therefore, there will be little feedback at a low-level input. As the input level increases, the feedback increases, causing the gain to decrease.

The low sensitivity of M<sub>1</sub> makes a conventional bridge rectifier impractical. V<sub>5</sub> and V<sub>6</sub> act as amplifier-rectifiers and are both normally cut off. When an a.c. signal appears, V<sub>5</sub> conducts on the positive peaks and V<sub>6</sub> conducts on negative peaks. Amplified d.c. then flows through M<sub>1</sub>.

The total resistance in series with and including M<sub>1</sub> must be greater than 600 ohms or the needle will go off-scale at high-level inputs. The meter specified in the parts list has an internal resistance of approximately 800 ohms and therefore does not need an external resistance. However, if a different meter with an internal resistance less than 600 ohms is used, an appropriate resistor must be added.

### Construction

Fig. 6 is a photo of the inside of the instrument and indicates layout. Three

2" screws mount T<sub>1</sub>, the two circuit boards, and the terminal strip. This method of mounting is sturdy and prevents marring the finish on the box.

The oscillator and amplifier are mounted on two small polystyrene boards. Similar material, such as perforated phenolic boards with flea clips, is also suitable. It would also be feasible to use home-made printed circuits.

Accuracy of the bridge is no better than its built-in standards. One percent resistors are readily available, reasonably priced, and a worthwhile investment. Unfortunately, precision capacitors are not readily obtainable: ± 10% tolerance is common.

### Calibration

The bridge can be calibrated mathe-

matically, empirically, or by a combination of both methods. However, the mathematical approach requires nothing in the way of standards (other than those which are built into the instrument) and is probably easier. It is as accurate as if precision parts were used in the instrument.

The method used by the author and described here is mathematical. Tables 1 and 2 show the calibration for R<sub>22</sub> and R<sub>21</sub> in terms of per-cent of rotation. The following is the step-by-step calibration procedure.

1. See Fig. 7. Determine the distance (arc) over which R<sub>22</sub> and R<sub>21</sub> change resistance with an ohmmeter set on its lowest range. At each end of the potentiometers, the resistance is zero for a

(Continued on page 86)

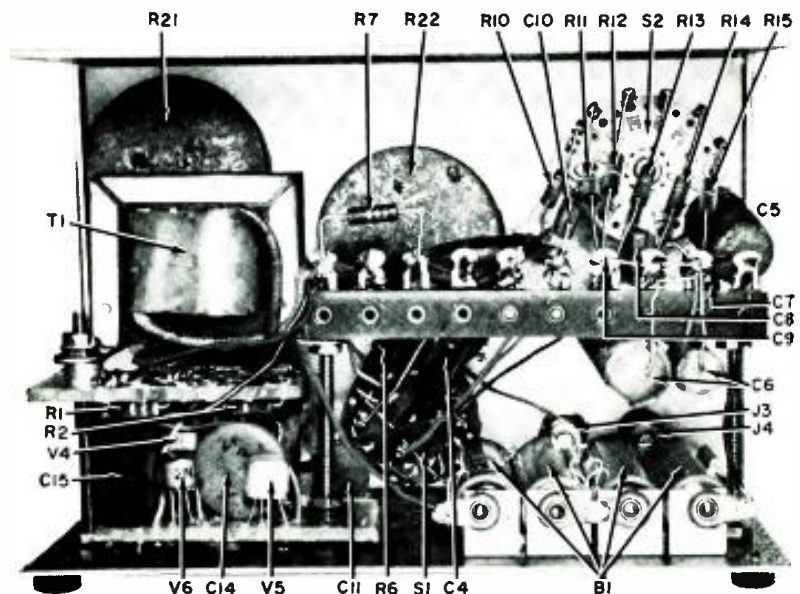
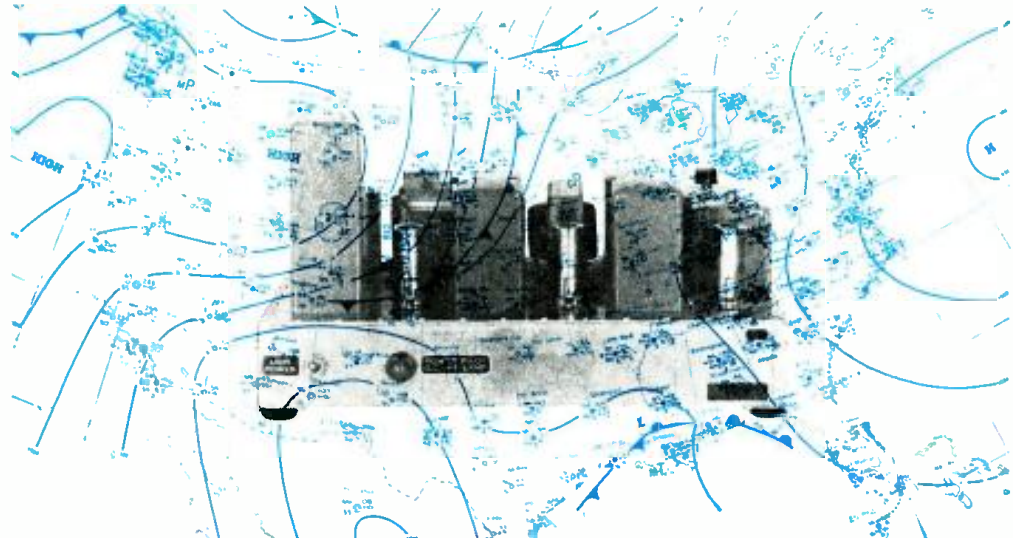

Fig. 6. Amplifier, bottom left, is supported by two-inch machine screws that also hold left leg of terminal strip and right flange of T<sub>1</sub>. Another machine screw, extreme left, holds oscillator above amplifier and secures the left flange of T<sub>1</sub>.



# Low & Medium Frequency Converter / Construction of a 150-550 kc. crystal converter to be added to any AM broadcast set to receive marine radiobeacons and continuous weather broadcasts.

By RONALD L. IVES

WITH the recent establishment of a nation-wide network of continuous weather broadcasting stations in the low- and medium-frequency range (190-400 kc.), and the increasing use of the adjacent marine information broadcasts, need for receiving equipment in the general range from 190-550 kc. has greatly increased.

Only a few receivers (such as the *National NC-66*, the *Hammamund RDF-10*, and the *Heathkit DF-2*), currently in manufacture, will cover this frequency range. Military surplus receivers, covering this range but usually needing from some to much modification and/or rehabilitation, include the *BC-453*, the *BC-348*, the *ARB*, and the *RAK-7*.

To the owner of a good general-coverage receiver, the purchase or construction of an entire new receiver to cover the low- and medium-frequencies seems wasteful, and possibilities of a converter seem quite attractive, both from the standpoint of operating convenience and for reasons of economy.

Although tunable converters which make use of the main receiver as a fixed-tuned i.f. system are entirely workable devices at all frequencies, including those in the low- and medium-frequency range, a crystal-controlled

fixed-tuned converter seems to offer the ultimate in operating convenience, concomitant with a greater economy of components.

## Circuit Principles

The general principles of a crystal converter are quite simple. The signal frequencies, which the receiver cannot tune, are combined with a locally generated frequency, so chosen that either the sum or the difference of the signal frequency and the local frequency are within the tuning range of the receiver.

For a low- and medium-frequency range of 150-550 kc., which covers the weather broadcasts with an ample margin of safety at both ends of the frequency scale, a local oscillator frequency of 600 kc. will put the desired signals in the 750-1150-kc. frequency range, using the sum frequencies. The difference frequencies, 450-50 kc. are outside the tuning range of most receivers with which a converter must be used, and can be disregarded as long as they are not radiated.

To be useful, the converter must accept only the desired frequencies and must reject the r.f. image (1350-1750 kc.), any spurious signals due to oscillator harmonics (such as 1050-650 kc. signals due to beating of the oscillator second harmonic with signals in the desired range), and second harmonic

images from the 1950-2350-kc. range.

Fundamentals in the desired tuning range of the receiver (750-1150 kc.) must not "feed through" the converter and there must be no radiation of either converted signals or oscillator frequencies. The magnitude of the "feed-through" problem is best realized when it is noted that in this area (Palo Alto, California), local broadcast signals are nearly 60 db above the signal from the nearest weather station (Oakland), and about 90 db above the weakest one normally receivable (Red Bluff).

Fig. 1 is a block diagram of the converter design finally adopted, along with a summary of component functions. The band-pass filters used here effectively attenuate the undesired frequencies while passing those to be received. These filters are not of the most advanced design, but were chosen because they will perform the requisite functions when constructed of easily available "over the counter" components without the use of complicated adjusting procedures or special test equipment. The band-pass filters are contained in the vertical cans shown in the front-view photograph shown above. Note that the only control is the "Main Power" switch.

The circuit diagram of the converter, Fig. 2, is quite conventional except for the band-pass elements, which are diagrammed separately in Fig. 3. Although additional amplification could be obtained by using a slightly more involved circuit, the extra gain would be useless, since the circuit as shown has the maximum amount of usable sensitivity.

## Construction

Construction is quite simple and straightforward. A chassis measuring approximately 8" x 13" x 2" will hold all components without crowding. The

Fig. 1. Block diagram of low- and medium-frequency crystal converter.

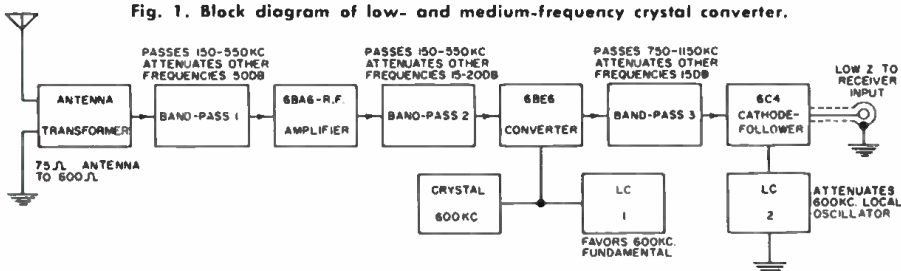



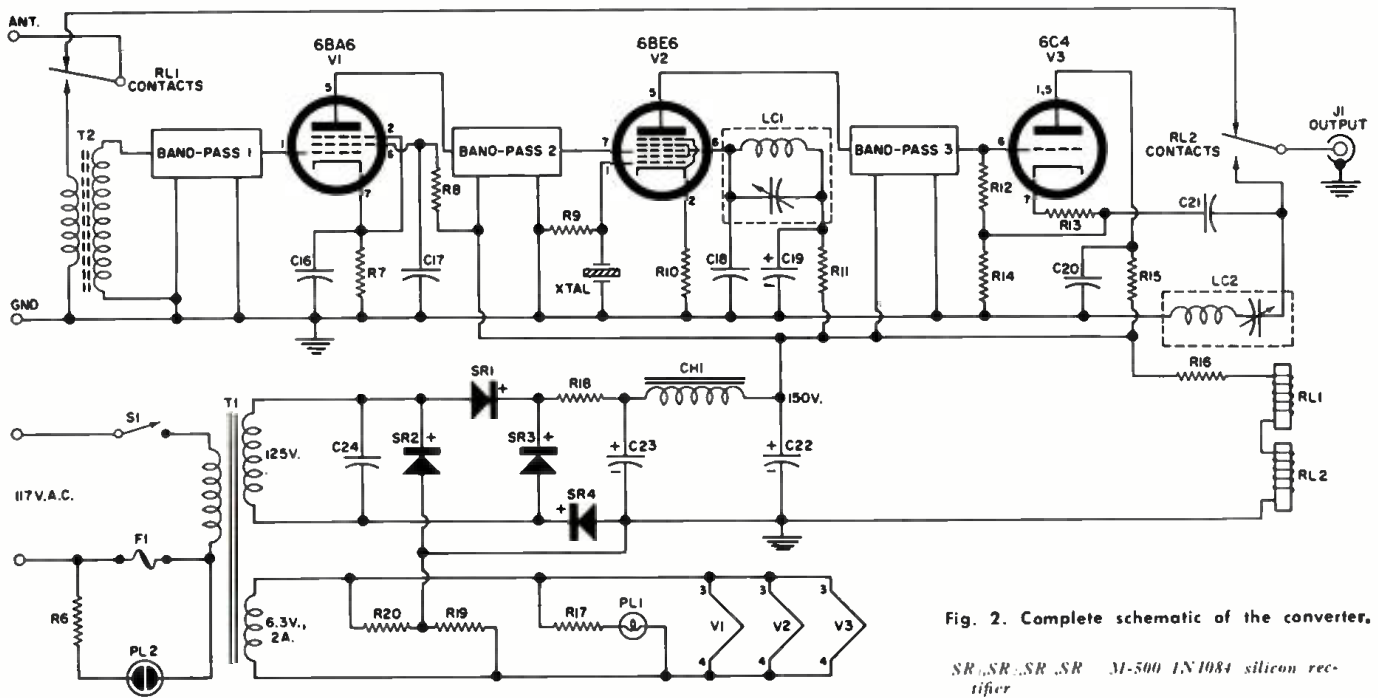

Fig. 2. Complete schematic of the converter.

- $R_8$ —100,000 ohm, 1/2 w. res.
- $R_7, R_{10}$ —47 ohm, 1 w. res.
- $R_1, R_5$ —22,000 ohm, 1 w. res.
- $R_{11}$ —6800 ohm, 2 w. res.
- $R_{12}$ —470,000 ohm, 1 w. res.
- $R_3$ —330 ohm, 1 w. res.
- $R_{13}$ —15,000 ohm, 2 w. res.
- $R_{14}$ —1000 ohm, 1 w. res.
- $R_{16}$ —27,000 ohm, 2 w. res.
- $R_{17}$ —10 ohm, 2 w. res.
- $R_{18}, R_{19}, R_{20}$ —100 ohm, 1 w. res.
- $C_{16}, C_{17}, C_{21}$ —.1  $\mu$ f., 600 v. ceramic capacitor
- $C_{15}$ —15  $\mu$ f., 600 v. tubular capacitor
- $C_{19}$ —8  $\mu$ f., 450 v. elec. capacitor

- $C_{18}, C_{22}$ —.1  $\mu$ f., 600 v. tubular capacitor
- $C_{14}, C_{23}$ —80  $\mu$ f., 300 v. elec. capacitor (Mallory EP-149)
- $C_{13}$ —.01  $\mu$ f., 600 v. tubular capacitor
- $RL_1, RL_2$ —S.p.d.t., 5000 ohm relay (Potter & Bramfield RS-5-D)
- $S_1$ —S.p.s.t. toggle switch
- $CH_1$ —15 hy., 75 ma. filter choke (Stancor C-1002)
- $LC_1$ —500-800 kc. wavetrap, shunt-connected (Miller 812-BC-3)
- $LC_2$ —Same as  $LC_1$  except series connected
- $PL_1$ —Type 44, 6-8 v. pilot light
- $PL_2$ —NE-51 bulb

- $SR_1, SR_2, SR_3, SR_4$ —M-500 1N1084 silicon rectifier
- $F_1$ —1 amp fuse (Type 3AG)
- $T_1$ —Power trans., 125 v., 50 ma.; 6.3 v., 2 amps (Stancor PA 8421)
- $T_2$ —Wide-band antenna trans., 75 ohms to 600 ohms (North Hills  $\approx$  1210A, made by North Hills Electronics, Inc., Glen Cove, N.Y. Type 1700AA may also be used with no connection to its center tap.)
- $Xtal.$ —600 kc. oscillator (Biley KY-3 or equiv.)
- $J_1$ —Coax. connector
- $V_1$ —6BA6 tube
- $V_2$ —6BE6 tube
- $V_3$ —6C4 tube

layout shown in the photographs seems to be about optimum, but any other reasonable arrangement of parts should also work. Construction is facilitated if the band-pass filters, whose constants and circuits are shown in Fig. 3, are made first as sub-assemblies. Mounting of filter components on epoxy board (Vector G-10) with suitable push-in terminals (Vector T-28) is most convenient here as both sides of the epoxy board can be used for mounting. Care should be taken to prevent intercoupling of the coils by mounting adjacent inductances with their axes at right angles. Heavier-than-usual shield cans are desirable on both the band-pass filters and the LC components, to insure against intercoupling and radiation.

If coverage of other frequency ranges is desired, it can be arranged by using a crystal of different frequency and band-pass filters of other characteristics. These can be computed by using the formulas given by Terman<sup>2</sup>, which require only simple algebra plus patience and ingenuity.

The top view of the completed converter, showing the arrangement of the components, is given in one of the photos. Note the mounting of the relay cans at the rear corners of the chassis to allow access for servicing if needed, and the placement of power rectifiers ( $SR_1, SR_2$ ) vertically on a bracket, facing toward the rear, for similar reasons. Filter capacitors are socket-mounted (Cinch 2-C-7 sockets) to permit rapid testing and component replacement.

Relays, which are wired to permit straight-through connection of the antenna when the converter is not in use and to automatically connect the converter between antenna and receiver when the converter power is on, are mounted on Bakelite disks bolted to gatted and reamed Cinch-Jones S-308-RP plugs. Covers are round shield cans which are a press fit over the inverted plug shells. The relay circuit, consisting of the two relays and a dropping resistor ( $R_{16}$ ), all in series across the power

supply, functions as a bleeder and requires no "spark suppressor" as it is shunted by the second filter capacitor ( $C_{22}$ ).

With a bit of careful planning, the under-chassis portion of this converter will acquire the "nothing to it" appearance of much well-constructed electronic equipment. Note the use of tie-points to support major parts, as shown in the photo on the next page.

Wiring of the r.f. stage ( $V_1$ ) is entirely conventional and needs no more

Top view of the converter. Four rectifiers are clip-mounted, one above the other.

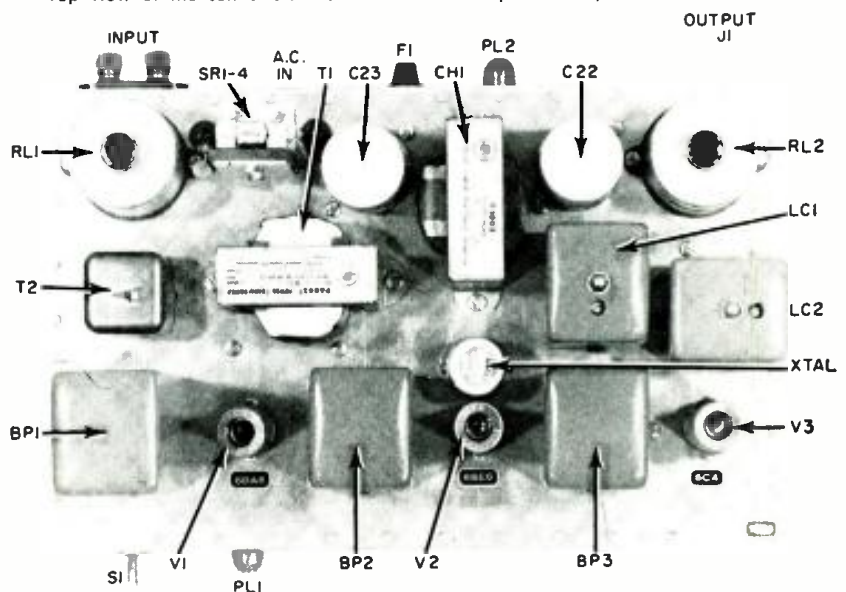

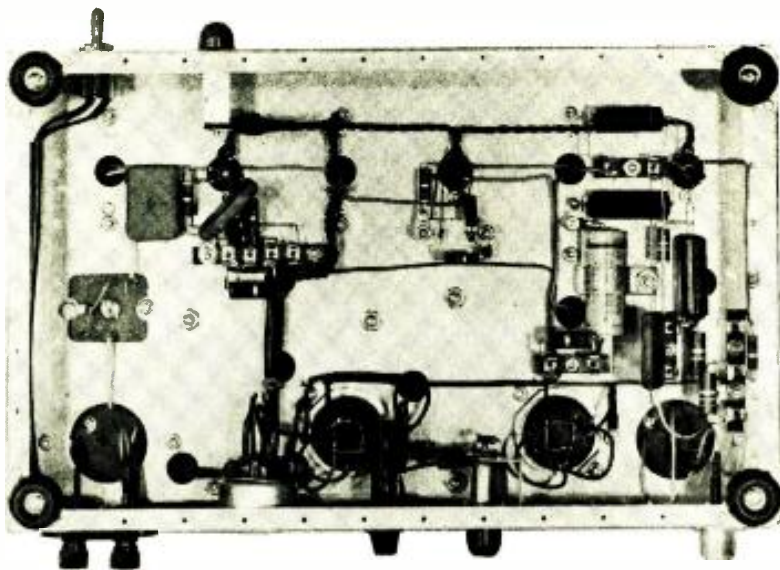

Bottom view of the home-built unit. Note the clean, uncluttered wiring layout.

precautions than an ordinary low-frequency i.f. stage. When this heater circuit is wired, it is advisable to wire the heater circuits of the other tubes and the pilot light (PL<sub>1</sub>) at the same time. The 10-ohm resistor in series with the pilot light (R<sub>17</sub>) is to reduce the brilliance of the bulb and extend its life expectancy.

Where the specified antenna-matching transformer is not available, its place may be taken by a small capacitor and resistor, connected as shown in Fig. 4. Under ideal conditions and with an antenna of approximately 75 ohms impedance, this works nearly as well as the transformer. Under unfavorable conditions (those usually prevailing), a signal loss of several decibels is to be expected when this expedient is used.

The converter stage (V<sub>2</sub>) will be recognized as a self-excited arrangement with crystal control. The tuned circuit in the screen (LC<sub>1</sub>) causes the oscillator to favor the fundamental frequency of the crystal (here 600 kc.), greatly reducing the harmonic output and, in con-

sequence, spurious frequencies therefrom.

The cathode-follower output stage (V<sub>3</sub>) isolates the last band-pass stage from the antenna circuit of the main receiver, reduces the converter output impedance, and permits use of a crystal-frequency attenuator (LC<sub>2</sub>) in the output. This makes the converter substantially independent of loads.

All connections are made on the rear chassis skirt, which also carries the fuse and the blown-fuse pilot. The author used labels on front and rear skirts, including specifications on replacements for pilot lamps, fuses, etc. Labeling involves a bit of extra effort during construction but saves valuable servicing time later on.

The power supply is entirely conventional and has a very wide margin of safety in all components so that slight aging of any of them will not result in sudden failure. The small capacitor (C<sub>21</sub>) across the power transformer secondary suppresses switching transients in the silicon rectifier circuit so that

the converter will not insert hum bars in neighboring TV receivers.

### Adjustments

After wiring is completed and a general check made of construction, a "smoke test" is in order, followed by alignment of the converter. Be sure that all tubes, pilot lights, fuses, and the crystal are in the correct sockets and that the tubes have approximately their correct supply voltages, then connect the output of the converter to the receiver with a shielded lead. This lead must be shielded or it will act as an antenna and pick up signals in the broadcast band.

Tune the receiver to 600 kc. and adjust the crystal oscillator circuit LC<sub>1</sub> to maximum "S" meter reading. Next adjust the output filter circuit LC<sub>2</sub>

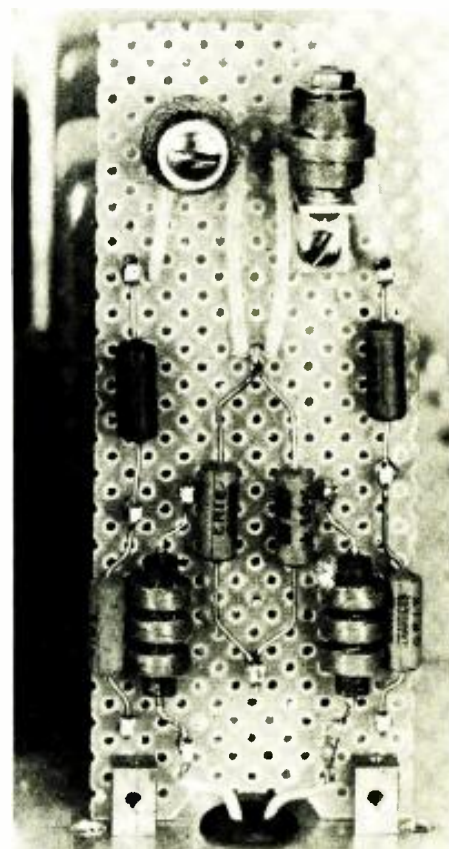

One side of the circuit board used for band-pass filter 1. A shield can is later mounted over the assembly shown.

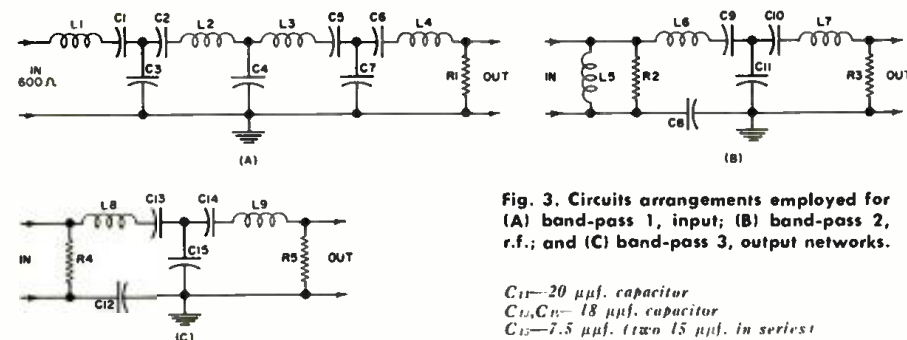

Fig. 3. Circuits arrangements employed for (A) band-pass 1, input; (B) band-pass 2, r.f.; and (C) band-pass 3, output networks.

- C<sub>11</sub>—20 μf. capacitor
- C<sub>12</sub>, C<sub>13</sub>—18 μf. capacitor
- C<sub>14</sub>—7.5 μf. (two 15 μf. in series)
- Note: Erie "Ceramic" Type GP-1-K capacitors were used by the author for all values stated in μf. In a similar converter, Elneca "Dur-Mica" 5c capacitors worked satisfactorily.
- L<sub>1</sub>, L<sub>2</sub>—24 mhy. r.f. choke (Miller 4646 or Stancor RTC 8529)
- L<sub>3</sub>, L<sub>4</sub>—52 mhy. r.f. choke (Miller 951 or Meissner 19-6832)
- L<sub>5</sub>—100 mhy. r.f. choke (Miller 960 or any r.f. choke from 80 to 150 mhy.)
- L<sub>6</sub>, L<sub>7</sub>—10 mhy. r.f. choke (Miller 4672, Meissner 19-2040, or National R-100)
- L<sub>8</sub>, L<sub>9</sub>—8.2 mhy. r.f. choke (Miller 4671 or Stancor RTC 9179)

- R<sub>1</sub>—600 ohms (made up of 330 + 270 ohm res.)
- R<sub>2</sub>, R<sub>3</sub>—23,500 ohms (two 47,000 ohm res. in parallel)
- R<sub>4</sub>, R<sub>5</sub>—22,000 ohms
- C<sub>1</sub>, C<sub>2</sub>—0.0259 μf. (made up of .002 μf., + 390 μf., + 200 μf.)
- C<sub>3</sub>, C<sub>4</sub>—0.0131 μf. (made up of 750 μf., + 560 μf.)
- C<sub>5</sub>, C<sub>6</sub>, C<sub>7</sub>—719 μf. (made up of 680 μf., + 39 μf.)
- C<sub>8</sub>, C<sub>9</sub>—1 μf., 600 v. ceramic plate capacitor
- C<sub>10</sub>, C<sub>15</sub>—128 μf. (made up of 110 μf., + 18 μf.)

to minimum "S" meter reading. This completes the adjustment of the converter.

Connect antenna and ground to the converter input terminals. When the converter is turned off, the receiver should work as before, as the relay circuit feeds the antenna through to the receiver when the converter is de-energized.

When the converter is turned on, signals in the aeronautical band will be tuned in, the receiver dial reading being exactly 600 kc. higher than the station frequency. Locations and frequencies of the radio-range stations are listed (Continued on page 85)



# Directory of COLOR-TV Test-Pattern Generators

**S**ERVICE technicians whose shops are now well equipped for black-and-white TV servicing should not have to make huge cash outlays for test equipment to "tool up" for color.

Assuming a wide-band scope, v.t.v.m., sweep generator, and a marker generator are at hand, only two new test instruments will be required: a color-pattern generator, and a white-dot/crosshatch-pattern generator.

Color-Pattern generators are used to troubleshoot and adjust the color circuits of the receiver. There are three different types: NTSC (National Television Systems Committee) color-bar generators produce a pattern of six fully saturated color bars at equal brightness levels and a black and a white bar all in accordance with NTSC standards.

Rainbow generators, which operate on what is called the offset-subcarrier principle (their output frequency differs by 15.750 kc. from the 3.58-mc. color subcarrier frequency) produce a pattern that is a smooth transition or blending of colors, like a spectrum or rainbow. The rainbow generator's principal usefulness is in determining if the color circuits are operating; it can be used in conjunction with a scope,

on which Lissajous patterns would be displayed, to make chroma and demodulator phasing adjustments.

An improvement on this instrument's design is the gated rainbow generator. The pattern produced by this instrument is basically a rainbow pattern that is gated (turned on and off) to produce a series of vertical color and black bars. Each of the ten color bars it creates, spaced precisely at 30° phase intervals, is a small segment of the rainbow pattern. This instrument is also more useful than the basic rainbow generator because it provides a horizontal-synch pulse and a color-burst signal.

White-Dot/Crosshatch-pattern generators are used for convergence adjustments. (Each of the three electron beams must strike only its associated color phosphor.) White, rather than black, lines and dots are more convenient to use since all three primary colors, produced simultaneously by the three guns, are required to generate white.

A number of currently available test instruments generate two or more of these patterns. Your decision to buy separate units or a multi-purpose generator depends on finances and whether you plan to do color work in homes or in the shop. ▲

MANUFACTURER	MODEL	B & W PATTERNS <sup>1</sup>				COLOR PATTERNS			OUTPUT			REMARKS	PRICE
		Dots	V	H	CH	Rainbow		NTSC	R.F. Channels	Video	Audio		
B & K Manufacturing Co. 1801 W. Belle Plaine Ave. Chicago 13, Illinois	850	X	X	X	X			X <sup>2</sup>	3, 4, 5	±	4.5 mc. from pix	disables each color gun; automatic deconvergence; video level control; 15.750 kc. output	\$199.95
	1076	X	X	X	X	X	X		2-8, 12, 13	X	4.5 mc. from pix	includes flying-spot scanner; provides a.g.c., sweep, and sync signals; performs other TV test functions	\$199.95
Heath Co. Benton Harbor, Mich.	CD-1	X	X	X	X		X		2-6, .0001-1v	±, 0-10v	4.5 mc. from pix	kit; shading bars for background adjustments	\$ 64.95
Hickock Electrical Inst. Co. 10514 Dupont Avenue Cleveland, Ohio	656XC	X	X	X	X			X <sup>2</sup>	2-6, .0001-1v	±, 0-2v	4.5 mc. from pix		\$549.00
	660	X			X	X			2-6, .001-.05v	±, 0-4v			\$243.00
	661	X	X	X	X			X <sup>2</sup>	3, 4	X			
Precision Apparatus Co. 70-31 84th Street Glendale 27, L.I., N. Y.	E-420	X	X	X	X				2-6	±, 0-6v		number of dots and bars is variable	\$175.95
	E-440						X		3	±, 0-8v	4.5 mc. from pix	15.750 kc., luminance, and 3.5637 mc. output	\$264.95
Radio Corp. of America RCA Electron Tube Division Harrison, New Jersey	WR-64A	X			X		X		3 or 4		4.5 mc. from pix	15.750 kc. output	\$189.50
Robertson Instrument Co. 1760 W. First, P.O. Box 834 Azusa, California	Hycon 616	X	X	X	X			X <sup>2</sup>	3, 4, .01v	±, 0-10v			\$385.00
Sencore, Inc. 426 S. Westgate Drive Addison, Illinois	CA122	X			X		X		4, 5, 9, 10	1v	4.5 mc. from pix	disables each color gun; provides r.f. output and sync pulses	\$187.50
Simpson Electric Co. 5200 W. Kinzie Street Chicago 44, Illinois	430							X <sup>2</sup>	2-6				\$395.00
	434A	X							2-6	±		adjustable dot size; provides horiz. and vert. sync pulses	\$149.95
Winston Electronics Div., Jetric Industries, Inc. Main and Cotton Streets Philadelphia 27, Pa.	150					X			2-6				\$ 49.95
	250	X	X	X	X				2				\$129.95

<sup>1</sup> V, vertical; H, horizontal; CH, crosshatch. <sup>2</sup> NTSC color bars produced individually. <sup>3</sup> Six NTSC color bars plus a black and white bar.





# TRANSISTORIZED IGNITION SYSTEM

By BOGHOS N. SAATJIAN / Design Engineer, Triad Transformer Corp. (Div., Litton Industries)

*Construction of simple system for 12-volt, negative ground cars that delivers good high-voltage spark even at top engine speeds. Longer point life and easier starting are other advantages of the system.*

**S**INCE the advent of power transistors, many car enthusiasts have looked upon them as the answer to their prayers for a non-mechanical switch to handle the relatively heavy currents encountered in an automobile ignition system.

## Standard Ignition System

The standard ignition system (see Fig. 1A) has been in use since 1910, with little change. Essentially, the system revolves around the distributor points, which are nothing more than a simple overloaded electrical switch. They have to carry currents of 5 to 8 amperes. They open and close thousands of times per mile. On top of this, the ignition coil used with the standard ignition system requires a high primary inductance to be able to generate enough self-induced voltage to be stepped up in the high-voltage secondary to about 20,000-25,000 volts to fire the spark plugs. Because of the high primary inductance and the reduced "on" time of the breaker points at high speeds, the primary current of the coil can not build up to its maximum design value at high engine rpm's. Hence, the spark plugs do not get the fat spark they require to fire the charge in the cylinders. Plug fouling and high-speed miss result.

The high primary current and self-induced voltage build up to such high power values across the points that arcing and pitting occur and points have to be replaced every 5000 miles or so.

Another consideration is cold-weather starting. At cranking speeds, the points, because they are opening and closing at a slow rate, have a much longer "on" time. This results in point oxidation or bluing, due to high point temperatures. The oxide on the points

is a poor conductor. Less and less power will thus be available for the coil primary, which means less high voltage at the spark plugs, and harder cold-weather starts.

## The Transistorized Circuit

The transistor, being an electronic switch with no moving parts to pit, should be the ideal solution to ignition problems.

A small bias or trigger current (see Fig. 1B) in the base circuit of the transistor will let a much larger current flow through the emitter-collector junction of the transistor. The distributor points can now be placed in the base circuit of the transistor, to serve as a trigger to fire the transistor at the correct instant. All other functions of the distributor remain the

same. The points control a base current of about 350 ma. Also notice that any self-induced voltage in the ignition coil primary is now in the emitter-collector circuit of the transistor. The points have thus been spared this high self-induced voltage. All they have across them is the 12-volt battery voltage at 350 ma. Compare this to about 200-300 volts at 5 to 8 amps, and you will agree that the points should last the life of the car.

The ignition coil can now be redesigned too, to provide for a fast current rise time. The coil primary can, therefore, have a lower inductance. Since this means fewer primary turns, a higher turns ratio is used to provide the needed voltage step-up. The new Mallory F-12T coil, for example, has a primary inductance of 1 mhy, and a turns ratio of 1:250 as compared to 2.5 to 3 mhy, and 1:100 turns ratio for the standard coil. The advantage of this design becomes apparent at high speeds. An ammeter placed in series with the primary of the coil in the author's car showed a current of approximately 7 amps. at idle and 6 amps. at 4500 rpm. This is a drop of only 1 amp. from idle to 4500 rpm. It can therefore be seen that the transistorized system will have full high voltage at the spark plugs from idle to top engine speed.

To sum up the advantages of the transistorized ignition system: The points carry only triggering power to the transistor, so there is no pitting and oxidation, resulting in excellent cold-weather starts. Clean points also mean silken acceleration at all engine speeds, with better gas mileage due to less plug fouling and high-speed miss. The capacitor across the points is not needed, so there is no capacitor breakdown.

After Mallory came out with a stock

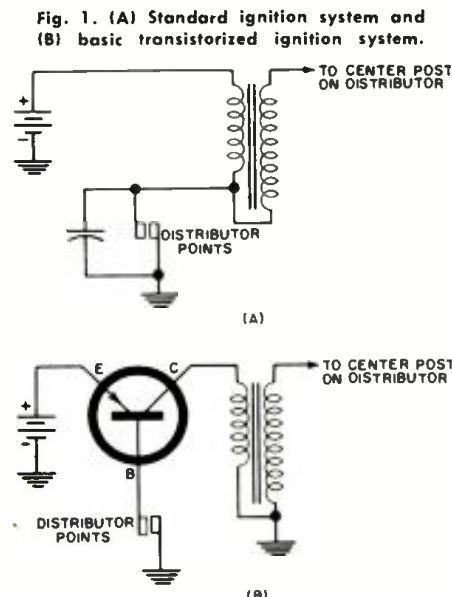



ignition coil, the F-12T, specially designed for transistorized ignition systems, we decided to experiment with one and design a circuit around it. The following circuit was developed, after experimenting for about a month with different set-ups and various component values.

Transistors have several drawbacks. First, there is the matter of heat. Transistors must be kept cool in operation or they start to conduct current even without base excitation. Second, they are ruined when a voltage higher than their maximum design value is applied across their emitter-to-collector junction, even for a period of a fraction of a second.

### Construction Details

The first problem in our set-up, that of high temperature under the hood, was solved by mounting the transistor and associated circuitry under the dashboard and running leads to the ignition coil and distributor points through a grommet on the firewall. In the author's car, a 1961 Buick "Electra," this was accomplished by running the wires through an existing grommet that had a few wires and could easily accommodate three more. We strongly recommend that builders of the circuit follow this procedure. If this is impossible, the next best location would be in the space between the radiator and the front grille of the car. Usually there is quite a space in this area to accommodate the heat sinks and the few parts. The resistors and the zener diode should now be enclosed in a small aluminum case, instead of mounting them on a tag board as shown in the accompanying photographs. Find a space as protected from spray water as possible, although no great damage would be inflicted by water because of the low voltages involved. Do not mount the heat sinks or the circuit components on the engine or near the exhaust manifolds.

The second drawback of transistors, that of breakdown voltage, was solved in the following manner. A look at the circuit diagram of Fig. 2 will show a 100- $\mu\text{f}$ . mica capacitor and a 60-volt, 1-watt zener diode across the emitter-collector junction of the transistor. The capacitor should be of the non-inductive type and should be soldered right on the transistor terminals, using as short leads as possible. This mica capacitor attenuates any high-frequency spikes generated when the primary coil current is interrupted. The zener diode limits voltage across the transistor to a maximum of 60 volts. As the transistor specified has an emitter-to-collector voltage of 80, there is a margin of safety of 20 volts.

The 150 p.i.v. diode,  $SR_1$ , shown in the circuit, has two functions. First, it guards the transistor against inadvertent reversal of input voltage polarity. Second, notice in the circuit diagram that a 500-ohm, 5-watt resistor ( $R_1$ ) is connected between the cathode of the diode and ground. This will allow a small current of about 30 ma. to flow

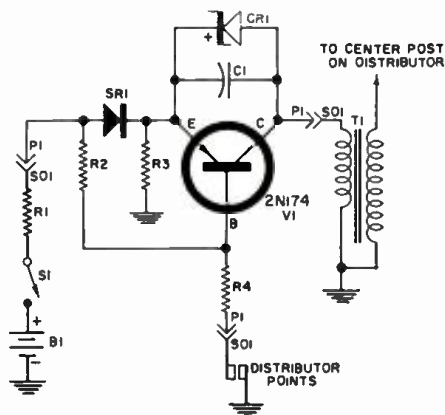

- $R_1$ —Three Delco D-1110 1957154 ballast resistors connected in parallel or two 1-ohm, 50-watt power resistors in parallel.
- $R_2$ —25 ohm, 5 w. wirewound res.
- $R_3$ —500 ohm, 5 w. wirewound res.
- $R_4$ —5 ohm, 25 w. wirewound res. (see text)
- $C_1$ —100  $\mu\text{f}$ ., 500 v. non-inductive mica capacitor
- $SR_1$ —Silicon rectifier, 25 amps., 150 p.i.v. (International Rectifier 251B15 or equiv.)
- $CR_1$ —Two 30-v. zener diodes in series or equiv. 60-volt, 1-watt unit (International Rectifier 1Z-30T5)
- $S_1$ —Car ignition switch
- $B_1$ —12-volt auto battery
- $P_1$ —Male plug (Jones  $\approx$  P-303-CCT)
- $S(1)$ —Female socket (Jones  $\approx$  S-303-CCT)
- $T_1$ —Molded ignition coil for transistorized ignition systems, 1:250 turns ratio (Mallory F-12T, available at all auto parts dealers handling Mallory line)
- 2—Heat sinks (Delco Radio  $\approx$  7270725 or equiv.)
- $V_1$ —Power transistor (2N174 or equiv.)

Fig. 2. Complete circuit of author's unit.

continuously through the diode. This will cause a 0.5 to 0.8 volt drop across  $SR_1$ , with the anode of the diode being positive with respect to the cathode. Now notice that the cathode side of the diode is tied to the emitter of the transistor and the anode is tied through a 25-ohm resistor ( $R_2$ ) to the transistor base. The base is, therefore, 0.5 to 0.8 volt positive with respect to the emitter at the time the points open. This action of the diode guarantees transistor cut-off even at even relatively high transistor operating temperatures.

Both heat sinks, one for the diode  $SR_1$ , and the other for the transistor, should be insulated from each other and from the car chassis. Use the special stand-off insulators available for heat sinks. Be very careful that the heat sinks do not ground to the car body under the dashboard. Use fish-paper or pieces of cardboard to insulate, if there is any danger of shorts. If desired, the transistor and diode could be insulated from the heat sinks by the use of special mounting kits. In this case the heat sinks could be bolted direct to the car chassis, thus providing better heat dissipation.

Special brackets have to be designed for each application to suit the available space under the dashboard. Parts location is not critical, except for the mica capacitor. Be sure to use silicone grease while mounting the transistor and rectifier on the heat sinks. A thin layer applied to the heat sink surface under the semiconductors will insure better heat transfer.

The ignition coil is mounted on the engine. We did not remove the standard ignition coil, which could be used in case of trouble with the transistorized circuit. The old coil could be removed, if desired, and the new coil mounted in its location.

Since the capacitor on the distributor will not be needed, it can be removed from the distributor and mounted somewhere near the standard coil with its leads connected to the negative side of the coil. The standard coil now serves as a standby.

The lead wires going to the coil from the circuit under the dashboard should be at least #14 to eliminate any voltage drop in them. A male and female Jones plug and socket were used between the circuit and the coil for greater flexibility and ease of removal of the circuit if necessary.

The ballast resistor used in the standard ignition system should be shorted out. Most GM cars use, as a ballast, a wire resistor that goes from  
(Continued on page 68)

Top view of the electronics portion of the transistorized ignition system.

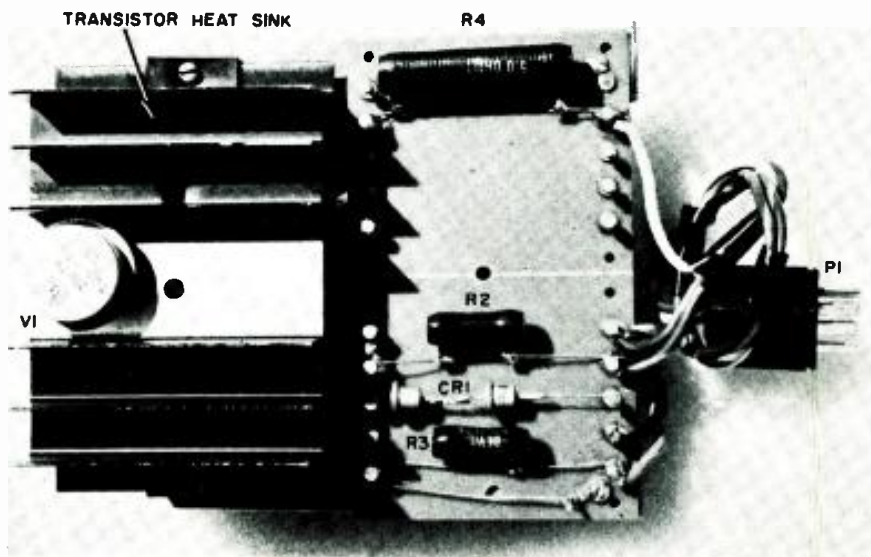

**I**NDUCTANCE is only one of the characteristics that determines a coil's suitability in a specific application. Distributed capacity is equally important because it, along with inductance, determines self-resonant frequency of the coil, the point at which the coil becomes useless as an inductor. In fact, above its self-resonant frequency, any coil will act for all the world as if it were a poor capacitor, except that it will not block direct current.

This article will explain how to use the dimensions of a coil to predict its inductance, distributed capacity, and self-resonant frequency. Nomograms are included so that all "calculations" are performed simply by drawing straight lines across the scales.

### Inductance

Inductance is the property for which coils are used in circuits, and distributed capacity is another property we must take into account in order to know the useful inductance available. Roughly speaking, inductance can be increased by increasing either the diameter of a coil or its number of turns.

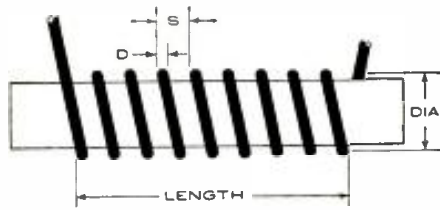

Fig. 1. Basic coil geometry used in charts.

Increasing the number of turns is more effective because inductance increases as the square of the number of turns. In other words, doubling the number of turns will increase the inductance by a factor of four, tripling the number of turns will increase the inductance by a factor of nine, and so on.

However, many of the changes made to increase inductance will also increase distributed capacity, and the over-all effect is to reduce the self-resonant frequency at a rapid rate. We can consider a practical coil as consisting of an ideal coil (pure inductance, and no capacity) in parallel with an ideal capacitor, and therefore increasing either one will reduce the resonant frequency according

to  $f = 1/(2\pi \sqrt{LC})$ . It is desirable, then, to have independent control over both inductance and distributed capacity. To a certain extent, such control is available to those who wind coils, through manipulation of the coil's silhouette. A series of 20-microhenry coils can be made, ranging from long and thin ones to short and fat ones. Although each coil has the same inductance, the different silhouettes will dictate that they have different values of distributed capacity and therefore different values of self-resonant frequency.

### Distributed Capacity

Dependence of distributed capacity on coil dimensions is not as straightforward as inductance is, but there are a few general rules to serve as guides. Coils that range from short (those whose diameter is greater than the length) to medium (those whose length is two or three times the diameter) will just about double their distributed capacity when the diameter is doubled. In longer coils, up to those whose length is 50 times the diameter, there is very little dependence on di-

# COIL-WINDING CHARTS

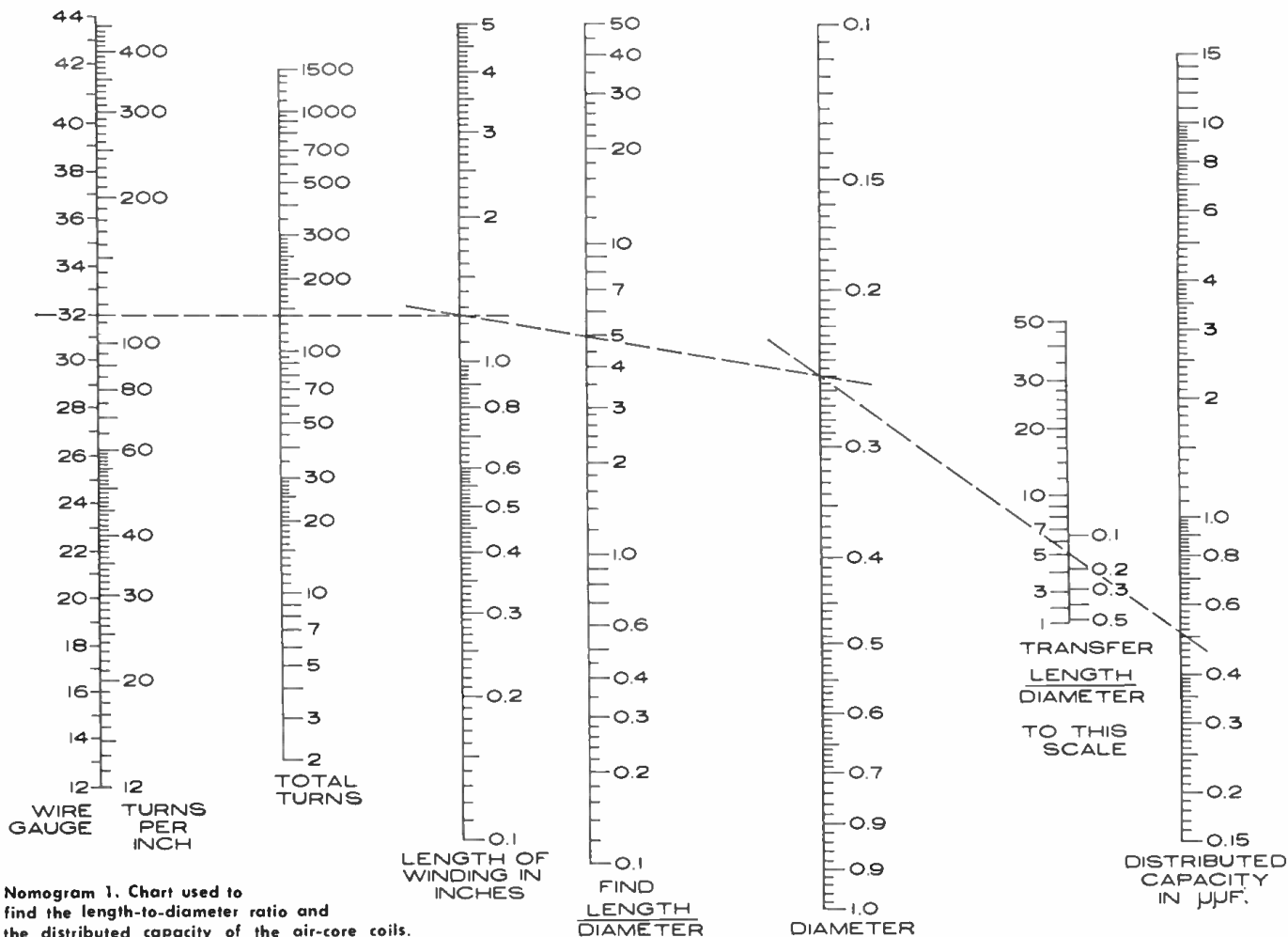



ameter. Beyond that, we have the very long coils, where there is a definite *reduction* in distributed capacity as the diameter is *increased*.

The length of a coil has an effect on its value of distributed capacity, but the number of turns within a certain length has very little effect. For instance, a coil one-inch long could be wound with 24 turns of No. 18 wire, or it could be wound with 92 turns of No. 30 wire, but the distributed capacity will be about the same in both cases. This is a means of exercising separate control over inductance and capacity because you can take an existing coil design and switch to a finer size wire. This will allow you to put more turns in the same length, having little effect on distributed capacity but increasing inductance by the square of the added turns.

These statements will prove helpful as long as you realize that they apply only in a very general way and are on the lookout for exceptions. The nomograms will give numerical answers which are adjusted to take care of exceptions to these generalities.

Usually, the goal is to wind a coil with

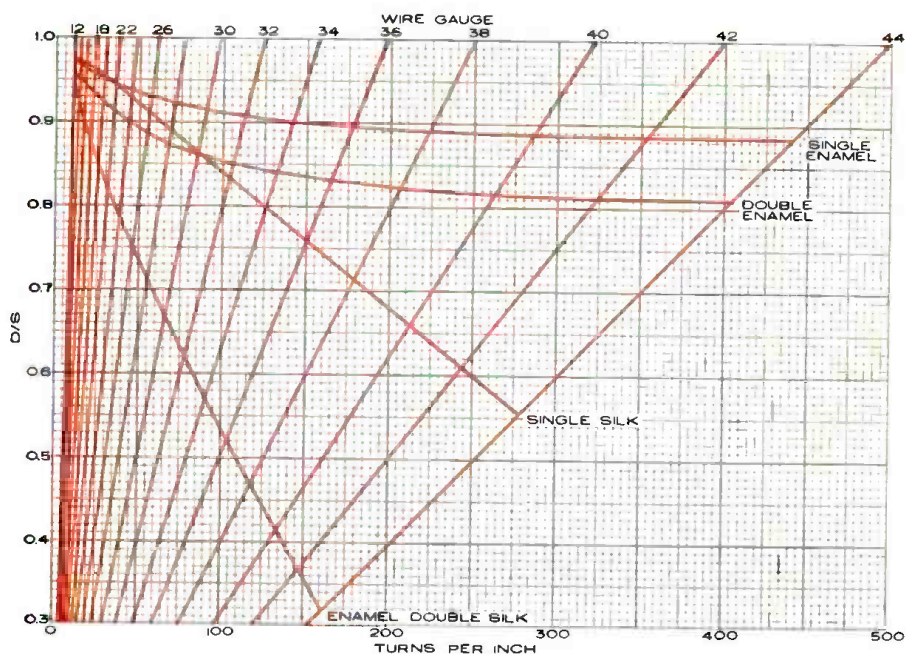
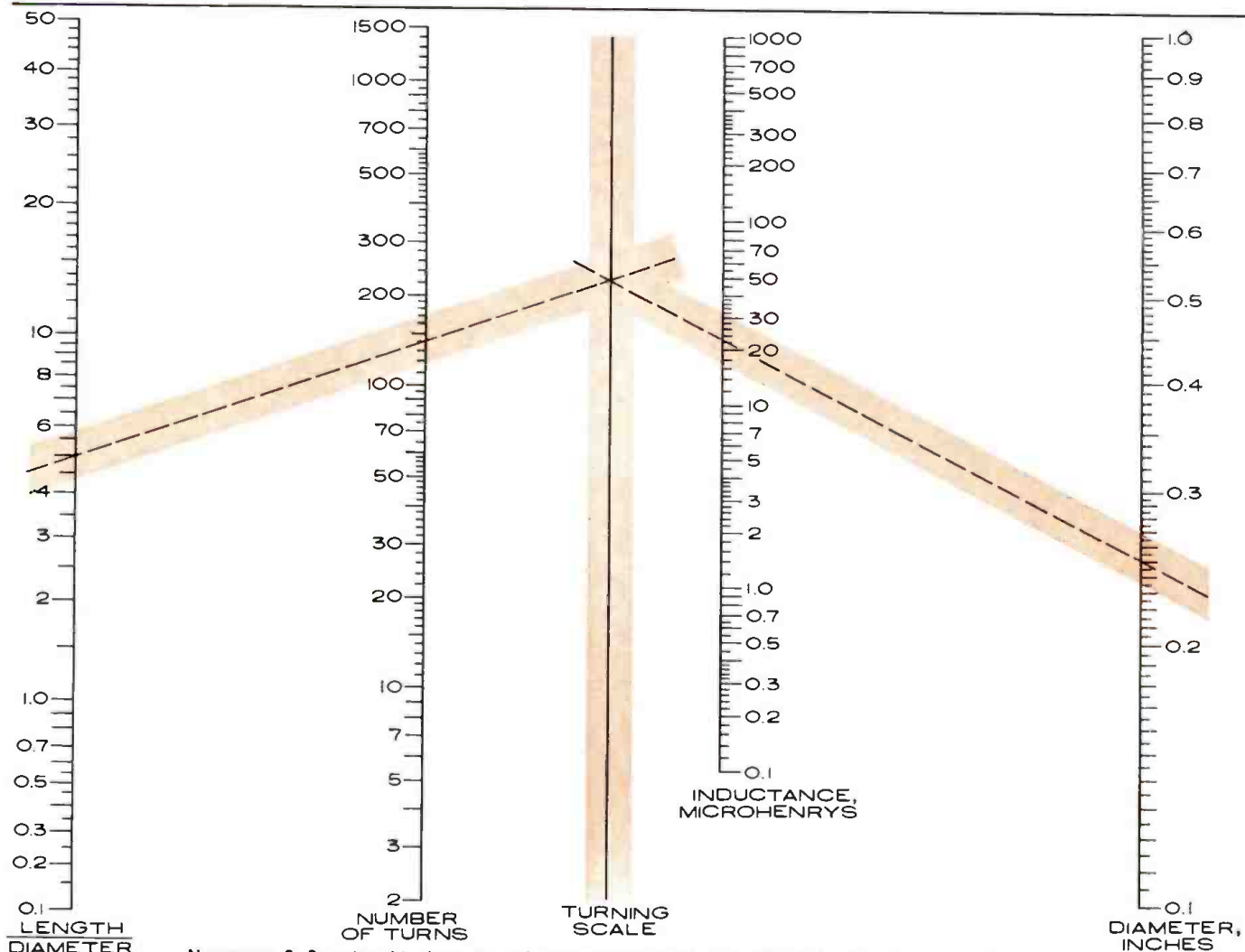

Fig. 2. The number of turns per inch for wire having various types of insulation.

*Nomograms for determining the inductance, distributed capacitance, and the self-resonant frequency of coils.*

By DONALD W. MOFFAT



Nomogram 2. By using this chart, the inductance values of air-core coils of the sizes shown may be found.

as little distributed capacity as possible. Even when a fair amount of capacity is acceptable, it should be controlled and its value known so that the coil will be compatible with the rest of the circuit. If minimum distributed capacity is the goal, the ideal coil is fatter than it is long, having a diameter about one and a quarter times its length. Unfortunately, this is not the most convenient shape to fit into an electronic chassis and it may be necessary to accept more than the minimum amount of capacity and arrive at a compromise coil shape. One advantage to the nomograms is that they make it easy to investigate various possibilities, as will be explained shortly.

### Coil Resistance

Every coil must have some resistance, which will determine the "Q" factor. However, this factor determines just the sharpness of resonance and has very little bearing on the actual frequency of resonance. Since this article is restricted to an investigation of the interaction between inductance and distributed capacity, it will be assumed that the results are independent of coil resistance.

### Computations

One of the most important factors in single-layer coils is the length-to-diameter ratio, which is used in the computations to follow. This ratio is found on Nomogram 1 and then is used as the first entry on the other two nomograms.

After the following instructions for using the nomograms, a simple numerical example will be presented.

**Distributed Capacity:** Nomogram 1 is used for finding both the length-to-diameter ratio and the distributed capacity.

There are two sets of numbers along the first scale. *Turns per inch*, on the right-hand side of the scale is the basic number that is used for computations, and can always be used. The left-hand side of the scale, *wire gauge*, is for convenience in the unique but common case where single enamel wire is used and there is no spacing between turns. For any other situation, the graph, along with Fig. 2, can be used to arrive at a value of turns per inch. If the windings are closely spaced, follow the line for the type of insulation out to where it crosses the line for wire gauge and at that crossing note the number of turns per inch. For instance, the line for No. 36 wire crosses the line for single silk insulation at 150 turns per inch. If the turns are not wound as close as possible, but have some space between them, determine the values of *D* and *S* (see Fig. 1) and then on Fig. 2 follow that line out until it crosses the line for wire gauge, at which point you will read the turns per inch. Remember that *S* in the figure includes the insulation over the wire, a quantity that becomes increasingly important for fine wires.

Once *turns per inch* is determined, locate that value on the first scale of Nomogram 1, and the *total number of turns* on the second scale. Draw a straight line through these two points

and extend it to cross the third scale, where you will read the *length of winding*. The actual value at this crossing is not important, as it is only the *point of crossing* that is going to be used for drawing the next line. On the other hand, if you knew the length of the coil, it would not be necessary to perform this first computation; simply locate that value on the *length* scale, and you are ready for the next step.

Next, locate the correct value on the *diameter* scale, and draw a straight line from that point to the indicated point on the *length* scale. Where that line crosses the middle scale, read a value of *length/diameter*, a value that will be used for each of the other computations. As with the length of the coil, this step does not have to be performed if the value is known, or if its computation can be done mentally. For instance, if your coil has a half-inch diameter and is one inch long, it is not necessary to draw the lines to determine that the ratio *length/diameter* is two.

The last step in determining distributed capacity starts with locating, on the next to the last scale, the value which was found for length/diameter. Diameter has already been located on its scale. Draw a straight line through these two points and extend the line to cross the last scale. Now read the appropriate value of *distributed capacity*.

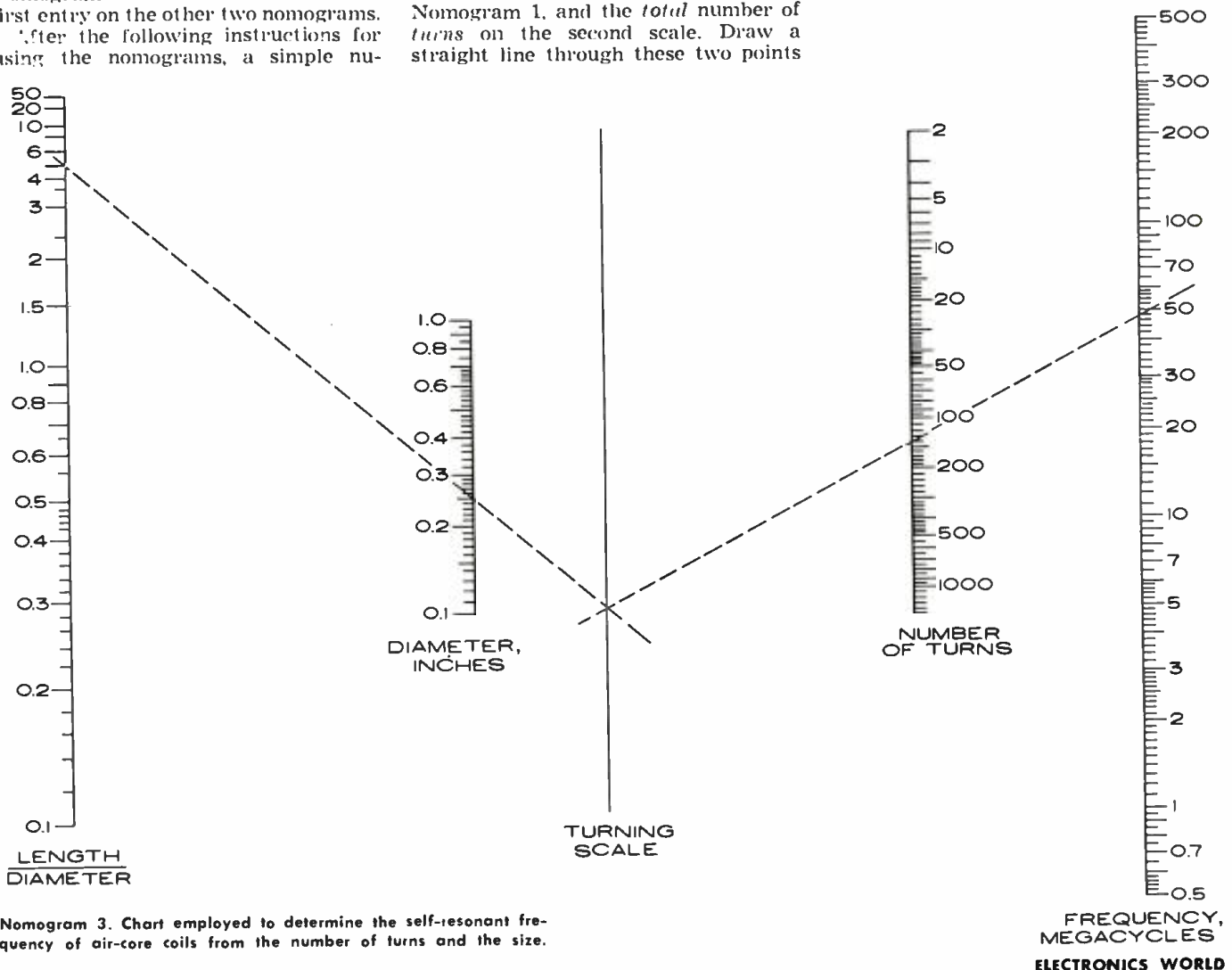



## New Heavy Duty RFI Suppression Kit For Mobile Radio



**R**ADIO HAMS, fleet owners, and CB operators can now enjoy clearer, more readable, less tiring mobile communications at longer effective ranges.

Sprague's new Type SK-1 SUPPRESSIKIT provides effective R-F Interference suppression—at moderate cost—up through 400 megacycles. Designed for easy installation on automobile, truck, or boat engines with either 6-volt or 12-volt generators, the Suppressikit makes possible high frequency interference control by means of Sprague's new, extended range, Thru-pass<sup>®</sup> capacitors.

The components in the SK-1 Suppressikit are neatly marked and packaged, complete with easy-to-follow installation instructions. All capacitors are especially designed for quick, simple installation.

The generator capacitor is a heavy-duty unit rated at 60 amperes, and will operate at temperatures to 125°C (257°F). This means you'll have no trouble with an SK-1 installation in the terrific temperatures found "under the hood" on a hot summer's day. There's no chance of generator failures from capacitor "short outs," as with general purpose capacitors. The Thru-pass capacitors for use on voltage regulators are also rated at a full 60 amperes.

The Deluxe Suppressikit is furnished complete with an 8-foot shielded lead on the generator capacitor which can be trimmed to necessary length for any car or small truck, preventing R-F radiation from armature and field leads.

Containing only 5 easy-to-install capacitors, the Deluxe Suppressikit is a well-engineered kit. The net price is a little higher than that of many thrown-together kits, but it saves you so much time and aggravation it's well worth the slight extra cost.

For additional information on the Type SK-1 Suppressikit, see your Sprague Electronic Parts Distributor.

LS-343 R2

August, 1962

**Sprague TWIST-LOK<sup>®</sup> Capacitors give you**  
**2 tremendous advantages over**  
**all other twist-prong electrolytics**



**1**

**The right size, the right rating, for EVERY replacement job**

**No need to compromise or improvise...the TWIST-LOK Line includes over 1690 different capacitors . . . It's the industry's most complete selection of twist-prong type capacitors, bar none!**

**2**

**Exclusive, improved cover design for greater dependability**

**Type TVL Twist-Lok Capacitors are now more dependable than ever! Sprague's new cover design provides a truly leak-proof seal and permits capacitors to withstand higher ripple currents.**

### Compare internal construction of TWIST-LOK to ordinary 'Lytic!

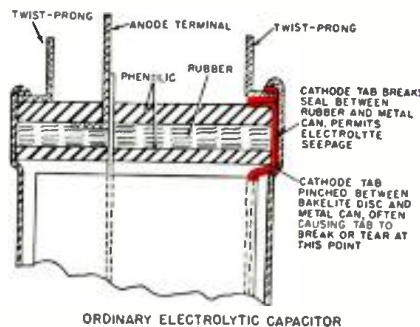

ORDINARY ELECTROLYTIC CAPACITOR

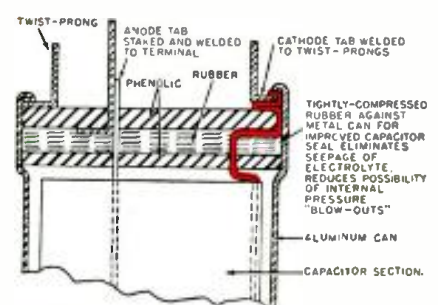

SPRAGUE TWIST-LOK<sup>®</sup> ELECTROLYTIC CAPACITOR

*Complete listings are shown in handy Wall Catalog C-457. Get your copy from any Sprague Distributor, or write to Sprague Products Company, 51 Marshall St., North Adams, Mass.*

**WORLD'S LARGEST**  
**MANUFACTURER OF CAPACITORS**



ON OFF  
Turn ON the QUIET  
Turn OFF the NOISE  
with QUIETROLE...

The quality, proved lubricant for effective silencing of noisy controls and switches on TV, radio and electronics instruments. And the FREE EXTENDER TUBE makes those once pesky places easy to reach. Put quality QUIETROLE in your repair kit and see how quickly and easily you satisfy more of your customers.



6 Oz. SPRAY PACK CAN (with FREE Extender Tube) 2, 4, 8 oz. Bottles (with Dropper)

Product of QUIETROLE COMPANY  
Spartanburg, South Carolina  
in Canada: CROSS CANADA ELECTRONICS  
12 Laurel Street, Waterloo, Ontario

THE INDUSTRY'S  
ONLY COMPLETE  
"LOOK-ALIKE" LINE  
Exact Replacement  
Needles/Cartridges



Highest quality guaranteed! At your E-V distributor's or write for FREE replacement guide, today! Electro-Voice, Inc., Buchanan, Michigan, Dept. 827N

Electro-Voice

Notice the peculiar layout of the sixth scale, to which the value of length/diameter was transferred. Numbers go down from 50 to about 1 and then the rest of the scale, down to 0.1, is folded back on itself, so that some spots on the scale are used as the location of two numbers. Another point of interest is that numbers at the lower end of the scale are quite crowded together, meaning that any ratios in this range will give about the same amount of distributed capacity. Almost no accuracy would be lost by saying that any value of length/diameter between 1.2 and 0.6 is to be transferred to a location "near" the lower end of the scale.

**Inductance:** Once length/diameter has been determined from Nomogram 1, locate that value on the first scale of Nomogram 2, and locate number of turns on the second scale. Draw a straight line through these two points, extending it to cross the third scale. On the last scale, locate the correct value of the diameter. Then a straight line drawn from that point to the point where the first line crossed the turning scale will cross the fourth scale at the inductance of the coil.

One of the advantages to the use of nomograms can be illustrated at this time. If the inductance that is found is not the desired value, you can rotate a straight-edge about the crossing on the turning scale until it passes through the desired inductance. The straight-edge will then cross the diameter scale at the diameter necessary to give that inductance. You can then work the first nomogram backwards to find a new length of winding, and the coil is redesigned for the required inductance.

**Self-resonant Frequency:** Once length/diameter has been determined from Nomogram 1, locate that value on the first scale of Nomogram 3, and locate the diameter on the second scale. Draw a straight line through these two points, extending it to cross the third scale. On the fourth scale, locate the correct number of turns, and draw a straight line through that point and the point where the first line crossed the turning scale. Extend that line to the last scale, where it will cross the self-resonant frequency for that coil.

Any coil is normally designed to operate at frequencies below self-resonance, where it has a useful inductance. At frequencies above self-resonance, nothing can be added to make the circuit resonate.

As with any other nomogram, it is easy to rotate a straight-edge about any point to see the effects of changing one or more of the numbers.

#### Example

In order to be certain the instructions are clear, let's run through it again, with numbers. Suppose you have 140 turns of No. 32 enameled wire on a quarter-inch form. On Nomogram 1, locate 32 on the right-hand side of the first scale and 140 on the second scale. A straight line through these two points will cross the third scale at 1.25, the length of winding. Next, locate 0.25 (quarter inch) on the diameter scale

and draw a line from that point to 1.25 on the length scale. It was not necessary to note that the length was 1.25 because that value is not used in any of the other computations and only the location of the crossing on that scale is important to further computations. A straight line drawn through these two points shows that the length/diameter ratio is 5. Locate 5 on the next to last scale and draw a line from 0.25 on the diameter scale, through 5 just located, and this line will cross the distributed capacity scale at 0.51  $\mu\text{f}$ .

Now, use Nomogram 2 to find the inductance. From 5 on its length/diameter scale, to 140 on its number of turns scale, draw a straight line and extend it to cross the turning scale. Draw another line from that crossing to 0.25 on the diameter scale and the answer of 22 microhenrys is found on the inductance scale.

Self-resonant frequency is found on Nomogram 3. Draw a straight line from 5 on the length/diameter scale to 0.25 on the diameter scale and extend it to cross the turning scale. From that point of crossing on the turning scale, draw a line through 140 on the number of turns scale and extend it to cross the last scale. At that last crossing, read a self-resonant frequency of 48 megacycles.

#### Accuracy

Several equations have been developed for computing the characteristics of a coil. Unfortunately, we do not have universal agreement on a single correct set of equations, each one seeming superior for different purposes. These nomograms have been based on equations that have been supported experimentally over the ranges of values used for the scales.

Coil leads, even though only a piece of straight wire, have both inductance and capacity that add to those of the coil proper. In fact, a straight piece of wire has a self-resonant frequency. For these nomograms, it has been assumed that there are no leads on the coil, an assumption that introduces negligible error until the coil is operating at frequencies of hundreds of megacycles and above. You can generally figure that the calculated value of self-resonant frequency is the maximum possible, and in the actual circuit, the coil will resonate at some lower frequency; some safety margin should always be allowed.

Usually, the number of turns cannot be determined precisely because the last turn does not have a definite ending, but tapers away from the rest of the winding. At least some part of the last turn (and of the first turn) is more of a lead than a part of the coil proper. Sometimes the last turn is wrapped around a terminal or a pigtail and soldered in place. Any wraps not shorted by solder will form another little coil, the characteristics of which will add to those of the main coil.

Weather conditions, such as temperature and humidity can have a noticeable effect on the characteristics of a coil, especially if sufficient and constant tension was not maintained during the winding.



**TR-1 15 watt mobile transistorized p.a. amplifier**

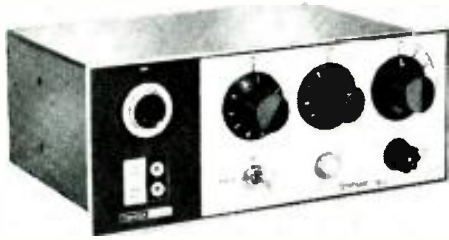

**TR-2 30 watt portable transistorized DC or AC/DC p.a. amplifier**



**Plug-in-accessories**



**Plug-in-accessories**

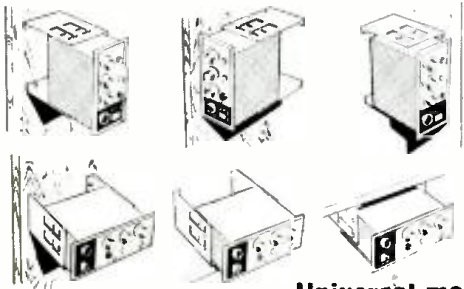

**Universal mounting**



**with LC-5 Carrying Cover**

**Harman-Kardon offers more operating features, more application versatility, more value than any other mobile or portable public address amplifier ever made... and they're transistorized!**

With the new Troubador Series, Harman-Kardon introduces exciting new potentials for mobile and portable p.a. amplifiers. Never before has there been equipment offering the extra value, the operating facilities and the flexibility of these advanced new units. For rentals, for regular and unusual applications, the TR-1 and TR-2 provide dramatic performance and economy benefits. The TR-1 will find use in police, fire, marine, military, construction and other mobile commercial applications where battery or ignition power is available but AC is not. The TR-2, in addition, includes on-chassis provision for optional AC-to-DC converter to give it limitless applications in schools, hospitals, stores... anywhere an amplifier is needed regardless of power source. Automatic switch-over to DC in event of AC power failure makes this the only amplifier to offer uninterrupted service. It is also the long-awaited answer for emergency control work.

**TR-1** • Simultaneous 2-channel operation: 1 mic, 1 music • Plug-In preamplifier module with equalization for tape head and mag phono • Universal mounting—TR-1 is free standing, also mounts flush on dashboards, panels, etc. Mounting brackets

permit installation on all surfaces in all positions. Removable without disturbing brackets • Provision to turn amplifier on or off from remote location or microphone • Constant voltage output in addition to voice coil impedances • Can't damage amplifier by grounding chassis or incorrect polarity • 4-position filter for maximum tone and acoustical control • And many other flexible operating features.

**TR-2** • Simultaneous 4 channel operation—2 mic, 2 music • Provision for on-chassis AC-to-DC solid state converter • On-chassis facilities for operation from AC with optional plug-in converter • Plug-in accessory provides automatic switchover to DC in event of AC power failure • Plug-in preamplifier module with built-in equalization for tape head and mag phono • Facility to turn amplifier on or off from microphone or remote location • Master Volume Control • Separate Bass and Treble Controls • Constant voltage output (25v & 70v balanced & unbalanced) and variety of voice coil impedances • Can't damage amplifier by grounding chassis or incorrect polarity • De Luxe Carrying Cover • Many other valuable operating and installation features.

*Built by Sound Men for Sound-Men*

**harman kardon**

For full details, write: Commercial Sound Div.

Desk E-8, Plainview, L. I., New York.

# YOUR PROFITS CAN ZOOM FROM THE CITIZENS BAND BOOM

Right now... Citizens Band occupancy totals more than 200,000 transmitters... the growth rate is over 8,000 installations per month! Only properly licensed and equipped servicemen can make frequency adjustments on these transmitters. **PREPARE YOURSELF NOW FOR THIS BUSINESS IN YOUR AREA!** To learn more, use coupon below.



Reliable... since 1938!

Citizens Band (CB) is just one part of booming mobile radio. There are over TWO MILLION other mobile radios, each needing regular maintenance. Your free copy of "How to Make Money in Mobile-Radio Maintenance" will show you how to start!

The LAMPKIN 105-B MICROMETER FREQUENCY METER is a natural for CB work. Small, portable and rugged. Guaranteed accuracy of 0.0025% is ample for CB. Calibration readings supplied free on request for all 23 Class D channels. Immediate delivery. Price only \$260.00, net.

**MAIL COUPON TODAY!**

**LAMPKIN LABORATORIES, INC.**  
MFM Division, Bradenton, Florida

At no obligation to me, please send free booklet and information on Lampkin meters.

Name \_\_\_\_\_  
Address \_\_\_\_\_  
City \_\_\_\_\_ State \_\_\_\_\_

NEW: THE PPM METER, an accessory for the Type 105-B. Accuracy better than 0.0001% for split-channel transmitters above 50 MC (not CB). PPM Meter price: \$147.00 net, immediate delivery.

**LAMPKIN LABORATORIES, INC.** MFM DIVISION  
BRADENTON, FLA.

## FREE Catalog OF THE WORLD'S FINEST ELECTRONIC GOV'T SURPLUS BARGAINS



### ANTENNA EQUIPMENT GROUND PLANE ANTENNA:

CITIZEN—COMMERCIAL—Made from sturdy surplus Insulated Base and screw-in type Elements. For use in the 25 to 50 MC Bands. Specially cut to your operating frequency (Specify Frequency when ordering). With Adapter for 1" pipe mounting... **\$10.95**

### MAST BASES—INSULATED:

MP-22 BASE—(Illustrated) Ins. spring action: direction of bracket can be raised or lowered easily... **\$2.95**

MP-S-33 BASE—Insulated type with heavy coil spring and 5" dia. Ins. Requires 2" hole for mounting. Weight: 9 lbs. **\$3.95**

MP-48 BASE—Rugged, w/Ins. above spring. Will take MS-53/54 mast sections. 3" dia. 16 1/2" high. Weight: 11 3/4 lbs. **\$2.95**

### MAST SECTIONS FOR ABOVE BASES:

Tubular steel, copper coated, painted, in 3 ft. sections, screw-in type. MS-53 used to make any length; with MS-52-51-50-49 for taper. Any Section: # 50¢ ea. Larger Dia. Section MS-54 Prices: F.O.B., Lima, O.—\$5.00 Minimum Order—25¢ Deposit on C.O.D.s. Mail Handy Coupon for Your copy of Free Catalog!

**FAIR RADIO SALES**  
2133 ELIDA RD. • Box 1105 • LIMA, OHIO

DEPT. EW 62-8  
Please send copy of FREE Catalog to:  
NAME: \_\_\_\_\_  
ADDRESS: \_\_\_\_\_  
CITY: \_\_\_\_\_ STATE: \_\_\_\_\_

### BC 442 ANTENNA BOX (ARC 5)

Contains RF Meter 1750 Ma., Relay, etc. See Coaxial Relay conv. "CQ" March 1960. Price **\$1.95**

### PANEL METERS

2" Meters	0-15 Volts AC... 3.95
100-0-100 Micro... 2.95	0-2.5 KV... 6.95
0-1 Ma... 1.50	West. Running Time
0-50 Ma... 2.95	110V 60 cy 0-99,999.5
0-40 Volts... 2.95	hrs. Used, Guar. 3.95
	Fram Freq. Meter 115V
	57.5 to 62.5 cycles... 8.00
	11 reeds... 9.95

### SILICON RECTIFIERS

PIV	Current	Price	PIV	Current	Price
100	500 Ma	.25	400	15 Amps	1.50
200	500 Ma	.30	200	15 Amps	2.75
400	500 Ma	.50	400	15 Amps	4.75
750	500 Ma	.90	50	50 Amps	4.00
200	750 Ma	.30	100	50 Amps	4.25
400	750 Ma	.50	200	50 Amps	8.00
500	2 Amps	3.5	75	240 Amps	4.95
500	2 Amps	5.5			

### BRAND NEW OIL CONDENSERS

50 MFD 200 VDC	4.50	2 MFD 500V VDC	1.50
2 MFD 1000 VDC	1.50	4 MFD 1000 VDC	1.50
3 MFD 1000 VDC	.60	6 MFD 2500 VDC	3.50
4 MFD 1000 VDC	.75	2 MFD 1000 VDC	6.25
5 MFD 1000 VDC	.80	1 MFD 1000 VDC	8.25
6 MFD 1000 VDC	.85	4 MFD 1000 VDC	12.95
8 MFD 1000 VDC	.95	1 MFD 5000 VDC	4.50
10 MFD 1000 VDC	1.10	2 MFD 1000 VDC	6.00
12 MFD 1000 VDC	1.30	5 MFD 7500 VDC	2.95
1 MFD 1000 VDC	.40	1 MFD 2500 VDC	6.95
2 MFD 1000 VDC	.70	2 MFD 2500 VDC	17.95
4 MFD 1000 VDC	1.35	2 MFD 1000 VDC	39.95
8 MFD 1000 VDC	1.85	2 MFD 12,500 VDC	34.50
10 MFD 1000 VDC	2.50	1 MFD 25,000 VDC	41.00
12 MFD 1000 VDC	2.95	2 MFD 10,000 VDC	69.50
1 MFD 12500 VDC	.45	1 MFD 20,000 VDC	59.50
1 MFD 15000 VDC	.75	5 MFD 25,000 VDC	69.95
2 MFD 15000 VDC	1.30	10 MFD 1000 VDC	1.95
4 MFD 15000 VDC	1.90	30 MFD 500 AC	2.25
8 MFD 15000 VDC	2.95	50 MFD 130 AC	2.95
1 MFD 20000 VDC	.85	8 MFD 5000 VDC	3.95

### RELAYS

Coax Relay SPDT 24V DC	\$3.95
6 Volt AC SPDT	1.25
6 Volt DC DPDT	.95
6 Volt DC Relay 3PST N.O.	.65
Guardian 110V AC 2PST (1 N.O. and 1 N.C.) Rpt. BC610	ea. 2.50
PB-5M5LS, 10,000 ohm 2 MA.	2.25
110 V. AC 4 PDT 60 cy 15 Amp.	3.95
Sens. Relay 11,000 ohm 1 Ma. Adj. SPDT	1.95
12 Volt DPDT DC	1.35
Sigma 22RJC 5,000 ohm SPDT	2.49

### PEAK ELECTRONICS CO.

66 W. Broadway, New York 7, N. Y., W0-2-2370

Although the example used a quarter-inch coil form and we used 0.25 on the diameter scale, diameter is really meant to be taken to the center of the wire. For fine wire, the difference between the diameter of the coil form and the diameter to the center of the wire is too small to have any bearing on the answer. However, when using heavy wire on a coil form of small diameter, the accuracy can be improved by adding the diameter of the wire to the diameter of the coil form.

The nomograms have been based on air-core coils because the use of other material introduces several other variable conditions. Modifying the charts just to provide for the effects of slugs would complicate them to the point where their usefulness would be questionable. With air-core coils, however, considerable time and effort can be saved by using the charts. ▲

## HI-LO VOLUME CIRCUIT

By L. M. DILLEY

WHILE on a service call at an Old Peoples' Rest Home, I was asked by the superintendent to help him solve a problem. It seems that some of the patients who were hard of hearing would increase the volume on the TV set more than was really necessary. A second group, whose hearing was more nearly normal, would then retaliate by turning the volume control to the other extreme. This, of course, was the cause of continual bickering with the result that none of the patients could enjoy a program.

After some thought I came up with a solution to their difficulties which may be equally applicable in private homes where there are Senior Citizens and children in the same household.

The solution lies in the inexpensive and relatively simple circuit shown in the diagram below.

The only parts needed are two extra volume controls of approximately the same resistance as the original volume control. These should be mounted on the TV chassis in close proximity to the regular control but in such a location that they are inaccessible and therefore tamper-proof. In this way the maximum and minimum volume levels are fixed although, psychologically, the user thinks he has complete control of the volume level. ▲

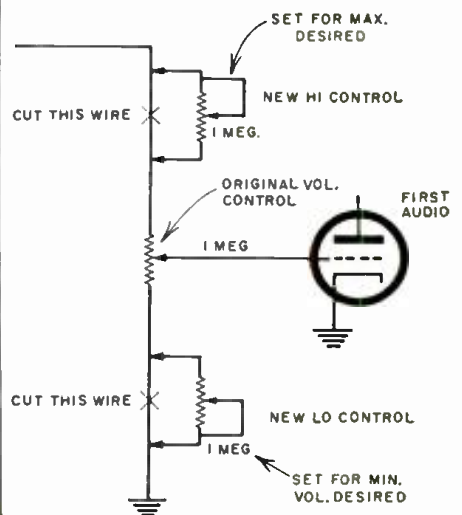





# CUT HOLES FAST



## GREENLEE CHASSIS PUNCHES

Make accurate, finished holes in 1½ minutes or less in metal, hard rubber and plastics. No tedious sawing or filing—a few turns of the wrench does the job. All standard sizes . . . round, square, key, or "D" shapes for sockets, switches, meters, etc. At your electronic parts dealer. Literature on request.

**GREENLEE TOOL CO.**  
2027 Columbia Ave., Rockford, Illinois

## Build your own superb SCOTT/KITS



### HAVE FUN . . . SAVE MONEY

Have fun . . . save money . . . build the best! Now you can get world-famous Scott stereo components in kit form. Think of it . . . you can build the fabulous new LT-110 FM Multiplex Stereo Tuner . . . your choice of two complete stereo amplifiers, or a preamp and separate power amp . . . all from H. H. Scott!

Write today! Find out about these exciting Scott kits.

### FREE Choice of 3 Booklets

# SCOTT

H. H. Scott, Inc., 111 Powdermill Road, Maynard, Mass. Dept. 160-08

Send me the booklets checked below

20-page "Guide to Custom Stereo"  Complete technical information on kits  16-page booklet explaining FM Stereo

Name \_\_\_\_\_

Address \_\_\_\_\_

City \_\_\_\_\_ Zone \_\_\_\_\_ State \_\_\_\_\_

Export: Morhan Exporting Corp., 458 Broadway, N.Y.C.

is adjusted so that the signal of the weakest stereo station will be able to operate the relay but not so sensitive that any incoming noise signal will trigger it.

For stabilization purposes, a capacitor is connected in parallel with the relay coil, introducing a slight delay action. Capacitor values from 2 to 5  $\mu$ f. are satisfactory.

When a stereo program is received, the 19-kc. signal appears at the secondary winding of the transformer, 1198AY (plate circuit of second stage). The signal is rectified and the resultant positive bias is applied to the grid of the relay-driver tube. This makes it conduct and the relay energizes.

For initial calibration purposes, the 19-kc. signal from a test generator can be applied to the multiplex input. This is tuned for maximum positive reading (minimum negative bias) at the grid

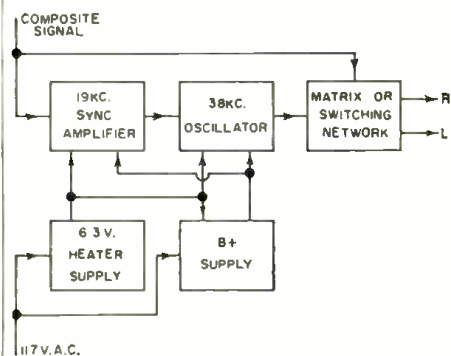

Fig. 3. Conventional multiplex adapter.

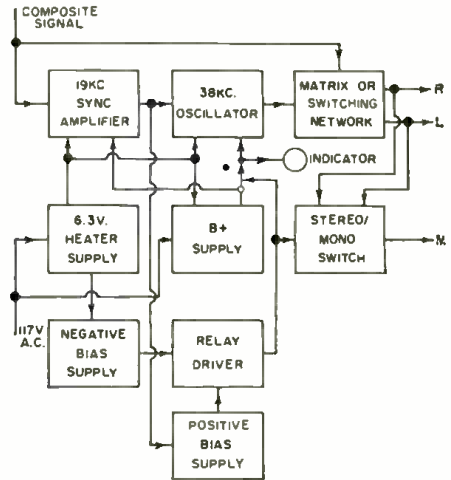

Fig. 4. Adapter with switching circuit.

of the relay-driver tube. When a 20-mv. signal is applied, approximately 4 volts d.c. appears at the output of the transformer and the negative bias at the grid of the relay-driver tube should drop from -8 volts to -4 volts.

In order to be able to perform the functions mentioned previously, the relay used should have two sets of "normally closed" contacts and one set of "normally open" contacts.

The normally open contacts disconnect the indicating light and the "B+" from the 38-kc. oscillator tube when stereo signal is not present.

The normally closed contacts connect both output channels in parallel for mono operation. ▲

## POOR MAN'S "STEREO"

By JAMES E. PUGH, JR.

FOR true "stereo" at its finest, it is hard to equal the quality obtainable with headphone listening. The full depth is always there no matter where you sit or how your head is held.

Many phono cartridges and headphones will work in the simple circuit below to make a "happy" combination that gives good "stereo" at the lowest possible cost. It is also a set-up that can be built in just a few hours. Both units being of the crystal type, they are a good match in both impedance and signal level. Quality and output level depend on the particular cartridge and earphones used. Inexpensive components have produced surprisingly good results.

Besides enjoyable listening two other uses are obvious. A simple demonstration with this phono set-up will convince any customer that stereo is superior to mono and thus raise your sales. Also, with this system it is easy to test all of your stereo records and label them according to phasing. Later, when played on this or a more elaborate system, the phase reversing switch is simply set in accordance with the label notation. There is no question as to which is the correct phase.

Switch S<sub>2</sub> is used to demonstrate the difference between stereo and mono reproduction using stereo records. It can be omitted if you have no need for this feature. ▲

Schematic diagram of the poor man's "stereo" phonograph setup. Inexpensive crystal stereo cartridge is employed to drive a set of crystal headphones directly. Switch S<sub>2</sub> permits quick comparison between stereo and mono playback.

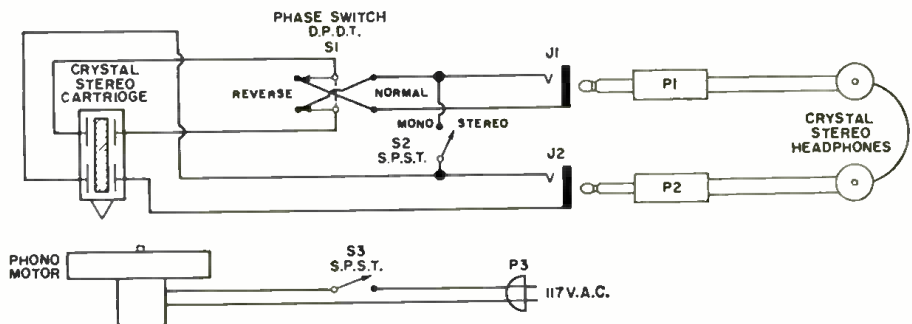



# First new concept in citizen's band equipment in two years! . . . Heathkit 4-Position Selective-Call kit

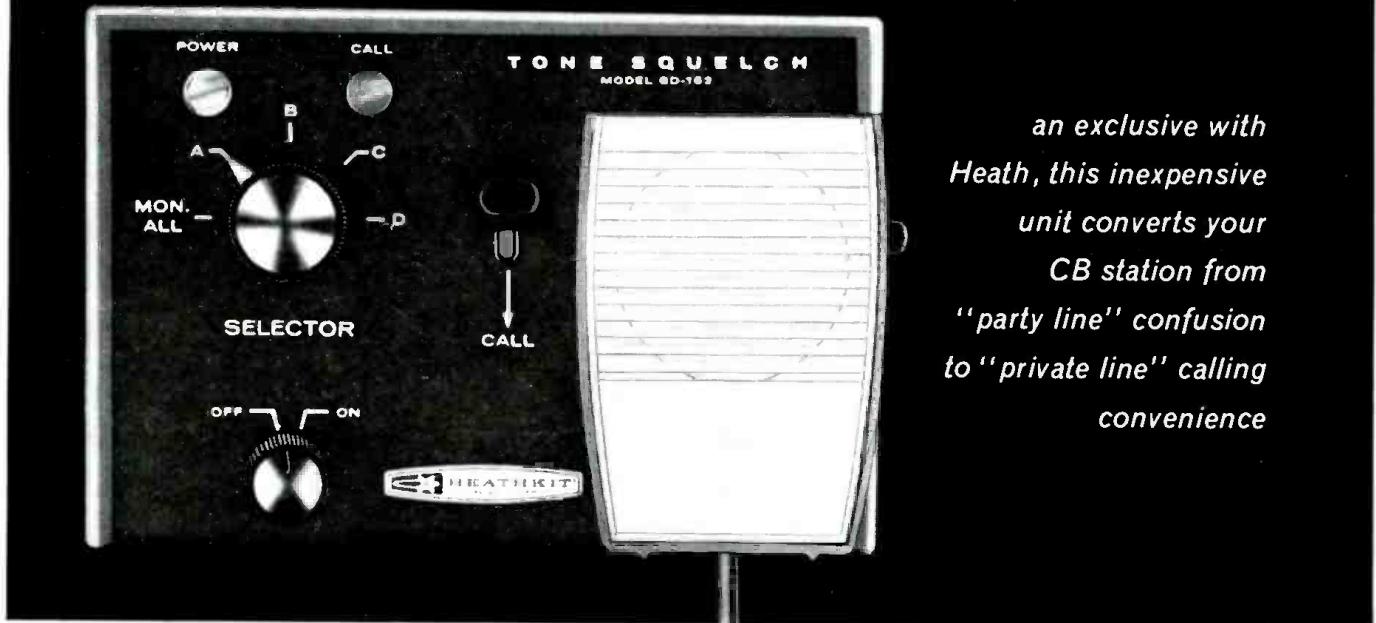

*an exclusive with  
Heath, this inexpensive  
unit converts your  
CB station from  
"party line" confusion  
to "private line" calling  
convenience*

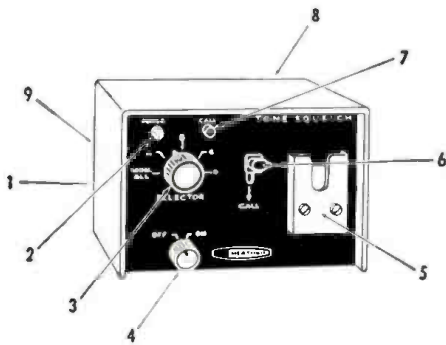

#### FEATURES

(1) squelch time-delay control. (2) power indicator. (3) tone selector switch (4 tones plus "monitor all" position). (4) tone squelch "defeat" switch for normal operation. (5) "lift-to-operate" microphone bracket. (6) "call" lever. (7) "call" indicator. (8) external alarm contacts to signal received call. (9) input and output level controls.

Here's welcome news for the serious user of Citizen's Band two-way radio. Heath's new Selective-Call Kit with tone squelch makes it possible for you to enjoy the calm of a CB station that is completely silent, yet ever alert for a personal call . . . makes it possible for you to call your choice of four specific units in your system at the touch of a button.

Using a unique new method, Heath's Selective-Call Kit features an *exclusive* 4-position rotary selected resonant-reed relay which responds only to calls transmitted by similarly equipped units using the same tone frequency. Upon receipt of the proper tone, your unit will automatically "come to life" permitting you to hear the call letters transmitted . . . you reply by merely lifting the microphone and acknowledging. At all other times, your station is peacefully quiet, allowing you to perform your job without one ear "cocked". For this unit does your listening for you.

To call another unit, just select the correct one of four tone frequencies, press the lever, and the called station will be waiting for you. Nothing could be simpler or more convenient. A "defeat" switch allows normal transceiver operation at any time. Equip all your CB units now with this economical new advance in communication ease . . . instructions included for installation with most popular CB transceivers using PTT.

**Kit GD-162A (AC), no money down. \$5 mo. \$33.95; Kit GD-162D (DC) \$37.95**



**GW-11** 3-channel transceiver from \$69.95



**GW-12** Single channel all crystal controlled transceiver from \$39.95



**GW-31** Low Cost "Walkie-Talkie" from \$24.95



**GW-21** Superhel "Walkie-Talkie" from \$44.95



**HEATH COMPANY**  
Benton Harbor 15, Michigan

**Ordering instructions:** Fill out the order blank. Include charges for parcel post according to weights shown. Express orders shipped delivery charges collect. All prices F. O. B. Benton Harbor, Mich. A 20% deposit is required on all C.O.D. orders. Prices subject to change without notice. Dealer and export prices slightly higher.

Enclosed is \$ \_\_\_\_\_; send \_\_\_\_\_

Name \_\_\_\_\_

Address \_\_\_\_\_

City \_\_\_\_\_ Zone \_\_\_\_\_ State \_\_\_\_\_

**Guaranteed! Crystals!**

**BUY NOW AND SAVE!!**

VERTONES: 10 to 30 Meg. Tol. .005%	\$2.95
AMATEUR & NOVICE Fundamental Tol. .005%	
HC-6 Herm. Sealed	2.95
HC-6—6 Meters (5th Overtone)	4.25
MARINE FREQ. HC-6 (Herm. Sealed) Tol. .005%	\$3.75

ALL MARINE FREQ.—FT-243, DC-34 Hold Tol. .005	\$2.50
POLICE, C.A.P., CD, MARS, Tol. .01%	\$2.00
CITIZENS BAND—11 METERS—.005% TDL	
26.965 to 27.225 MC, 3rd Overt. Herm. Seal. or FT-243	\$2.95
13.4825 to 13.6125 MC, 2nd Harm. Herm. Seal. or FT-243	\$2.95
6741.25 to 6806.25 Kc, 4th Harm. FT-243 only	\$2.50

**SPECIAL!  
STOCK CRYSTALS**

**\$1.19**

FT-243 Holders 5700 KC to  
8700 KC in steps of 25 KC's

SEND FOR FREE CATALOG

DC-34 Hold. 1690 KC to 4440 KC steps of 10 KC, ea. \$1.19

**NOVICE BAND FT-243 Fund. ea. \$1.49**

80 Met. 3701-3748—Steps of 1 KC. FT-243	
40 Met. 7150-7198—Steps of 1 KC. FT-243	
Dbl. to 40 Met. 3576-3599. Steps of 1 KC. FT-243	
15 Met. 5276-5312—7034-7083 Steps of 1 KC. FT-243	

FT-243—2 Meters (Steps of 1 KC)	\$1.49
FT-243—6 Meters (Steps of 1 KC)	\$1.49
FT-243—From 3000-4000	\$1.49
FT-243—From 1005-2999 (Steps of 5 KC)	\$2.50
FT-243—.005% Tol. From 3000-8750	\$2.50
FT-243—.01% Tol. From 3000-8750	\$2.00
FT-241 SSB Low Xtals 370 to 540 KC (Steps of 1.852 and 1.388)	\$ .69
FT-241 SSB Matched Pairs	\$2.39
FT-241—AN/TRC-1-721.167 KC-1040-625 (Steps of 1.042 KC—Except 1000 KC)	\$ .96

Include 5¢ per crystal postage. (U.S. only). Calif. add 4% tax. No C.O.D. Prices subject to chg. Ind. 2nd choice, sub. may be necess. Min. Order \$2.50

"The House of Crystals"

**U. S. CRYSTALS, Inc.**

1342 S. La Brea Ave. Los Angeles 19, Cal.

**NEVER FAIL—**

**ZONE YOUR MAIL**

The Post Office has divided

106 cities into postal delivery

zones to speed mail delivery.

Be sure to include zone num-

ber when writing to these

cities; be sure to include your

zone number in your return

address—after the city, before

the state.

## Color Set Defects

(Continued from page 41)

ble, so as to get the red area well centered (see pattern *D* on page 41 and on the cover). A similar procedure is used for the blue and the green guns. Convergence adjustment then takes care of the rest.

But these straightforward faults are not the only color defects that may mar black-and-white reception. Consider the rather attractive hum bar in pattern *C*. It may be of any color. We already know that such bars are associated with a tube that has cathode-heater leakage. What may startle the unwary is the fact that it is colored. After all, color circuits aren't supposed to be working on a black and white signal—or are they? And this is where we go back to some basic questions.

What is supposed to be working and what isn't? Some of the color circuits are "turned off," beyond question: the color killer takes care of that automatically. But it only shuts off color modulation (or color-difference signals) to the bandpass, chroma, or color-signal amplifiers. There is thus no modulation going into the color demodulators and succeeding amplifiers (if any), but these demodulators and amplifiers are active. In fact, they have to be if a monochrome picture is to be reproduced. Consider the fact that there is no separate "monochrome" gun in the CRT. All three color guns must be active for a proper black-and-white picture, and these guns are driven by their respective demodulator-amplifier-matrixing systems. The only modulation, that of the video or luminance signal, is applied equally to all guns. There is no information (color) applied to one gun only.

With our colored hum bar, we have obvious one-gun or two-gun modulation that doesn't belong there. Since the bandpass or chroma-signal section is cut off, hum must be modulating an operating demodulator or color-amplifier stage. The guilty tube in this instance was in a combined demodulator-amplifier stage. In modern color sets, there are seldom more than three tubes that could be involved.

This defect might tend to confuse the inexperienced. Yet, with a little thinking, it need never get beyond the household stage.

### "Color-on-Color" Hum

That last case leads right into a related condition in which, once more, the best piece of test equipment is the brain. A colored hum bar is noted during color reception. How would you start? The first step should be a switch to a channel with a monochrome transmission going, or to a "dead" channel. If the bar

persists, the situation is similar to the one just described. But the bar may now disappear. If it does, it evidently originates in those circuits that are cut off by the color killer during black-and-white reception. Localization is even closer here: there is likely to be only one tube in the bandpass or color-difference amplifier.

### Need for a Color Generator

Before analysis of what a symptom means can begin, there must be objective recognition of the nature of that symptom. That is not always so easy to determine in color reception. It may be obvious, for example, that tinting of objects in a picture is all wrong, but there may be no way of determining why because there is no way of determining what correct coloration should be. At such a time, nothing will serve better than a stable, standardized picture whose exact nature under normal conditions is known, remains unchanged, and can be recognized easily.

A color generator has many uses, but symptom identification is not the least of these. Cover patterns *A*, *E*, and *F*, for example, were taken with receiver input supplied by an RCA WR-61A, whose output is indicated in Fig. 1A.

Consider an improperly tinted picture whose character is hard to determine. Using the generator, the bottom portion of *E* is observed, as compared to the normal sequence at the top. All colors are present, although in the wrong order, and the line control cannot correct the sequence. Since no color is missing, a defect or misadjustment in one of the CRT guns is not considered.

Color-bar signals for the red, blue, and green guns are shown in Figs. 1B, 1C, and 1D, respectively. As seen on one set through a scope, they appear, top to bottom, in Fig. 3. Suppose there were no blue in the pattern. Is the blue gun misbehaving? If the center waveform in Fig. 3 cannot be obtained here, one would look ahead of the gun for the trouble.

Distorted tinting may be due to overload caused by excessive color-signal amplitude. Such a condition is shown at the bottom of pattern *F*. When it occurs, the waveform in Fig. 2 is seen (at the red gun, for example) instead of the display at the top of Fig. 3. The technician can trace back to find the point where distortion begins. Establishing such conditions is all but impossible while observing the constantly changing signal developed during a regular color transmission.

While a generator makes symptoms recognizable, interpreting them still takes brain power. The examples discussed certainly do not exhaust all possibilities, but they do demonstrate the analytical approach needed. ▲



# new in PHOTOFACT<sup>®</sup> the world's finest electronic service data

## 2 great firsts to save you valuable servicing time!

### SEPARATE FOLDERS FOR SUB-CHASSIS

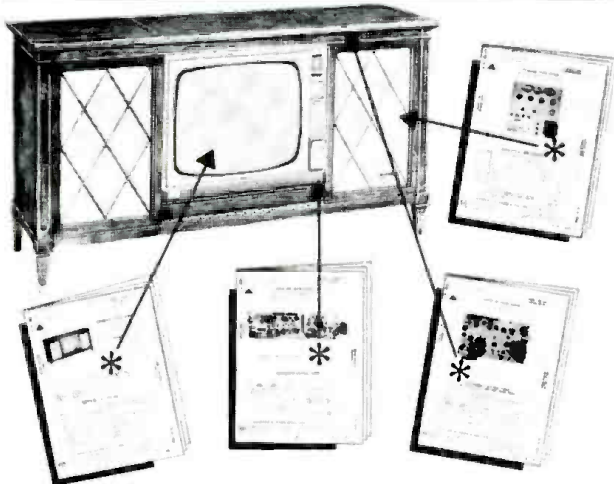

### now it's far easier for you to service Home Entertainment Combinations

Yes, PHOTOFACT now provides separate Folders (within each master TV Folder) on each of the sub-chassis which require servicing. Whether it's the TV section, Stereo amplifier, FM-AM tuner, or remote tuning device, you now conveniently select only the Folder required for the specific sub-chassis needing repair. There's no more searching; the separate Folders for each sub-chassis are easily identified and keyed within the master Folder. This ideal new system gives you more complete, handier coverage than ever—instantly locates detailed, separate data on all additional units used with the basic TV chassis. It's another great PHOTOFACT advance!

### AUTO RADIO REMOVAL INSTRUCTIONS

**NOTE:** To replace tubes remove four 1/4" hex screws holding cover and remove cover.

**RADIO REMOVAL**

1. Pull off knobs.
2. Disconnect speaker leads, "A" lead at fuse panel, tenna plug and pilot-light lead at wiring harness.
3. Remove two 1/2" hex nuts from control bushings.
4. Remove hex nut holding radio to rear mount.
5. Remove radio from rear of instrument panel.

**NOTE:** Ford radios can be removed opening -- required if air-conditioning.

**SPEAKER REMOVAL (1962 FORD)**

1. Reach through opening in upper left and remove two wing nuts holding speaker.
2. Raise right side of grill.

### a wonderful time-saving, effort-saving feature

Complete auto radio removal instructions are now included in all PHOTOFACT auto radio Folders! New step-by-step procedure tells you whether tubes are accessible without removing receiver; points out obstacles you may encounter; spells out tool requirements; gives wiring connections, etc. Data is based on actual unit removal research by the Sams Photofact engineering staff. Here's another tremendous time-saver that puts an end to the tough job of removing auto radios—another great PHOTOFACT feature!



These new advances are just a few of the dozens of great features in PHOTOFACT for fastest, easiest, most profitable servicing. See your Sams Distributor for full details on an Easy Buy Library or Standing Order Subscription!

#### ONLY \$10 DOWN

puts the complete PHOTOFACT Library in your shop—and you have up to 30 months to pay! And right now—to keep up with the industry—sign up for a standing order subscription to PHOTOFACT! See your Sams Distributor for full details on a Complete Library or Standing Order purchase.



**FREE**

#### PHOTOFACT INDEX

Your invaluable guide to over 53,000 TV, Radio, Electronic listings, covering virtually every model produced since 1946. Helps you locate the proper PHOTOFACT Folder you need to solve any service problem in any model. Send coupon today for your FREE copy of the latest PHOTOFACT Index!

#### HOWARD W. SAMS & CO., INC.

Howard W. Sams & Co., Inc., Dept. 5-H2  
4300 W. 62nd St., Indianapolis 6, Indiana

Send full information on:

- Easy Buy Plan     Standing Order Subscription  
 Send Free Photofact Cumulative Index

Shop Name \_\_\_\_\_

Attn. \_\_\_\_\_

Address \_\_\_\_\_

City \_\_\_\_\_ Zone \_\_\_\_\_ State \_\_\_\_\_

# ELECTRONICS MANUFACTURING OCCUPATIONS

Job opportunities for technicians, engineers, scientists will continue to expand rapidly over the next ten years.

EDITOR'S NOTE: The following material is based on information supplied by the Bureau of Labor Statistics, United States Department of Labor.

**J**OB OPPORTUNITIES in electronics manufacturing are expected to continue to expand rapidly over the 1960-70 decade. Electronic products are being used increasingly in the Nation's defense and in factories, offices, homes, schools, and hospitals. Opportunities will be particularly good for scientists, engineers, and technicians.

A large proportion of electronics workers are in engineering, scientific, and other technical jobs. Engineers and scientists alone made up about 15 percent of all electronics workers in 1960, according to an estimate by the Electronic Industries Association.

Many thousands of technicians and draftsmen are employed by electronics manufacturing firms, mainly to assist engineers and scientists.

Electronics technicians comprise a large group among technicians. Many are engaged in research and development work, assisting engineers in the design and construction of experimental models. They are also employed by manufacturers to work on electronic equipment in customers' establishments. Other electronics technicians work in certain highly technical inspecting, testing, and assembly jobs in the engineering laboratories of firms manufacturing electronic products.

Engineering aides are another important group of technicians. They assist engineers by making calculations, sketches, and drawings, and by conducting performance tests on components and systems.

Technical writers work closely with engineers, particularly in plants making military and industrial products and in establishments doing research and development work only. They prepare training and technical manuals describing the operation and maintenance of electronic equipment.

## Training, Other Qualifications

Beginning engineering jobs are usually filled by recent graduates of engineering colleges (some with advanced degrees). A small number of workers without college degrees have been upgraded to professional engineering classifications from such occupations as engineering assistant and electronics technician. Workers who have become engineers in this way usually have taken advanced electronics courses in night school or under other training programs. To keep up with new developments in their fields and to help them qualify for promotion, professional and technical personnel obtain

additional training, read technical publications, and attend lectures and technical demonstrations.

Technicians generally need some specialized training to qualify for their jobs. Most electronics technicians have attended a public, private, or Armed Forces technical school. Two years of training in a technical school and 5 or 6 years of experience are often the requirements for highly technical jobs. Some electronics technicians obtain their training through apprenticeships. Some testers and experimental assemblers have been upgraded to the job of electronics technician after they have developed required skills on the job and acquired the necessary knowledge in basic electronics theory, mathematics, drafting, and reading of schematic diagrams, by attending company-operated evening classes, or taking night school, junior college, technical school, correspondence, or other courses. Some technicians who do final testing that requires the operation of radio transmitting equipment must hold FCC licenses.

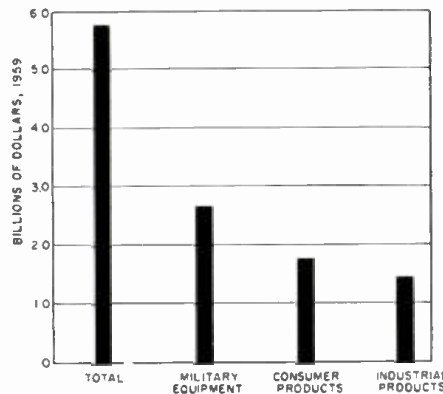

Value of output of electronic equipment.

Employers look for job applicants with an avocation in electronics for production as well as some office jobs. Employees with hobbies or other interests involving electronics, such as assembling radios, repairing radio and television sets, and ham-radio operation tend to show considerable interest in their jobs. Such employees are often given preference in promotion. Because of the nature of their work, assemblers, testers, inspectors, and electronics technicians need good vision, including good color vision; patience; manual dexterity; and good eye-hand coordination. Electronics technicians and other technical workers must be able to understand technical material.

## Employment Outlook

Many thousands of job opportunities will be available for new workers in electronics manufacturing plants each year over the 1960-70 decade. Elec-

tronics employment is expected to grow much more rapidly than manufacturing employment as a whole, but it probably will not increase as rapidly as it did over the 1950-60 decade.

One of the main reasons why employment in electronics manufacturing will expand will be rising expenditures for military electronic equipment.

Substantial growth in electronics production for industrial use is also expected because the trend toward modernization and automation of production processes will stimulate spending for new plants and equipment. An increasing proportion of these expenditures will be for the newer types of electronic equipment, such as computers and automatically controlled machine tools. Also, the demand for industry's older and more developed industrial products, such as broadcasting equipment, radio communications equipment, test instruments, and navigational equipment, will continue to expand. For example, the use of two-way radio communications equipment by police and fire departments, public utilities, taxicab and trucking companies, pipeline firms, and others is expected to spread rapidly. Production of electronic equipment for the medical field will also expand greatly.

More home television sets, radios, phonographs, and stereophonic and high-fidelity equipment will be purchased as population and the standard of living continue rising over the 1960-70 decade. These products will remain the principal electronic consumer items. In addition, other electronic consumer products which are already on the market or being developed (e.g., electronic ovens, garage door openers, dishwashers, lighting equipment, and air conditioners) may become standard household equipment in the years ahead.

Rising expenditures for research and development in the electronics field will stimulate employment in electronics manufacturing. Also, research and development will result in new military, industrial, and consumer products and in new types of components, all of which will provide more employment in electronics manufacturing.

The rates of employment growth will differ among the occupational groups and individual occupations in electronics manufacturing. Engineering, scientific, and other technical jobs will show the greatest rise over the next decade, because of the growing volume of research and development in electronics manufacturing and the increasing application of scientific and engineering principles to production operations. Employment of electronics engineers and electronics technicians will rise more quickly than that of most other technical workers. ▲



# LIVELY READABLE HOW-TO BOOKS FOR THE EXPERIMENTER AND ELECTRONIC HOBBYIST

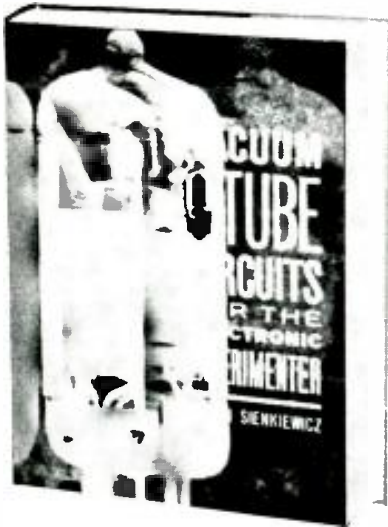

## VACUUM-TUBE CIRCUITS FOR THE ELECTRONIC EXPERIMENTER

by Julian M. Sienkiewicz

How many times has the experimenter wanted a diagram of a basic vacuum-tube circuit which he could use as a guide in building some practical electronic device? At last, in one book, he can find all the basic diagrams, schematics, and other vital information on vacuum tubes and their circuits. One hundred vacuum-tube schematic diagrams, plate-characteristic curves, simplified schematic diagrams, test circuits and other selected illustrations supplement the informative text to make this new publication one of the most useful and informative books available for the rapidly growing legion of experimenters and electronics hobbyists. 192 pages, 100 illustrations.

**\$4.95**

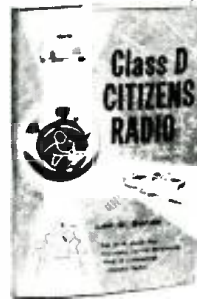

## CLASS D CITIZENS RADIO

by Leo G. Sands

The first and only book to be published in this important and rapidly expanding field. Leo Sands, author of almost 500 technical articles and 4 books, gives complete information on this important commercial class of radio and explains just what Citizens Radio service is and what are its many applications. Many illustrative circuits are shown and there is a special appendix of FCC rules and regulations. 181 pages, 72 illustrations.

**\$4.95**



## THE ELECTRONIC EXPERIMENTER'S MANUAL

by David A. Findlay

The ABC's of electronics experimentation and project construction are presented in this book in such plain language and in a style so easy to read, that anyone will become absorbed from the very first chapter. The projects advance from the simple to the more advanced. Through these pages the reader will acquire the knowledge and skill to turn out his own short-wave receivers, intercom systems, transistor radios, etc. 169 pages, 170 illustrations. **\$4.95**

## COMPUTERS AND HOW THEY WORK

by James D. Fahnestock

A solid and acclaimed introduction to this ever-expanding field. A completely understandable and comprehensive study that describes in clear and precise terms computer principles, manufacture, operation and maintenance. Provides a solid foundation for the study of computer techniques. Discusses computer memories, flip-flops, programming, etc. The 113 special illustrations provide a visual explanation of computer operation and principles. 228 pages.

**\$4.95**

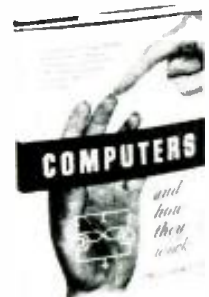

## USE THIS HANDY ORDER FORM

ELECTRONICS BOOK SERVICE—A. S. Barnes & Co. Inc.  
151-51 Seventh Avenue, Whitestone 57, N.Y. EW 5A

Please send me the books I have checked below:

I enclose \$ \_\_\_\_\_ (You pay all postal charges.)  Send C.O.D. (I pay charges)

\_\_\_\_copy(ies) VACUUM-TUBE CIRCUITS FOR THE ELECTRONIC EXPERIMENTER \$4.95

\_\_\_\_copy(ies) CLASS D CITIZENS RADIO \$4.95

\_\_\_\_copy(ies) COMPUTERS AND HOW THEY WORK \$4.95

\_\_\_\_copy(ies) THE ELECTRONIC EXPERIMENTER'S MANUAL \$4.95

NAME \_\_\_\_\_

ADDRESS \_\_\_\_\_ CITY \_\_\_\_\_ ZONE \_\_\_\_\_ STATE \_\_\_\_\_

If I am not fully satisfied I can return these books in seven days for a full and prompt refund.

# W90R98083

**“When does my  
subscription  
expire?”**

This question is often asked of us by subscribers to *Electronics World*. You can check the expiration date of your own subscription by reading the code line on the mailing label of *Electronics World* as follows:

**W**=*Electronics World*

**90**=The month and year in which your subscription started — in this case, Sept., 1960.

**R980**=(Filing instructions for our use only)

**83**=The month and year in which your subscription will expire — in this case, Aug., 1963.

## Transistorized Ignition (Continued from page 53)

the ignition switch to the primary of the ignition coil. This resistance wire should be paralleled with a #14 wire, starting from the ignition switch up to the new ballast resistors used with the transistorized ignition.

A 0.5-ohm, 100-watt ballast resistor is used in series with the primary of the coil to limit the current to around 7.5 to 8 amperes with the ignition key turned on but without the engine turning over. This resistor can be made from either three *Delco* D-1110 1957154 ballast resistors, wired in parallel, or two 1-ohm, 50-watt power resistors can be used in parallel.

We suggest that the builder first construct a breadboard circuit and test it on his engine before final mounting under the dashboard. The 5-ohm, 10-watt base-bias resistor ( $R_1$ ) should be experimented with to give the best engine start. Its value could vary between 3 and 10 ohms, depending on the individual transistor used. An adjustable resistor might be employed. With the correct resistor value the engine starts immediately with the turn of the ignition key.

The base-bias resistor gets quite warm in operation and should be as far removed from all diodes and the transistor as possible.

The power diode,  $SR_1$ , should have a back e.m.f. of at least 150 volts. If two units of lower current rating than about 12 amps. are available, they could be used in parallel, mounted on two opposite edges of the same heat sink. Also, two rectifiers having lower p.i.v. ratings but with the proper current rating could be used in series. Two 27-30-volt, 1-watt zener diodes can be substituted for a single 60-volt unit, if desired.

### Performance

The performance of the circuit has been excellent, to say the least. It has been in our car for 6000 miles when

this article was written. We have driven in all kinds of weather, from 120-degree desert heat to snow in Yosemite, without mishap. Point current at idle is 300 ma. and at 65 m.p.h. it goes up to 650 ma. Primary coil current at idle is 7.5 amps. and at 65 m.p.h. it drops to 6.6 amps., which means that at any speed the transistorized ignition system delivers constant high voltage, with only a slight drop at the higher speed ranges of the engine.

We were getting 14.5 miles-per-gallon in our *Buick* with standard ignition at speeds of 60 m.p.h. This was raised to 16 miles-per-gallon after the transistorized ignition system was installed. More dramatic results were obtained when the circuit was used on a *Fiat*, a *Corvaire*, and a *Falcon*. Those compact engines really went wild for the new ignition.

The performance capabilities of the circuit were proven in both winter and summer. When installed, you will have a contentedly purring engine that jumps to life at the turn of the key in zero weather or summer heat.

After the final adjustments are made and the circuit is ready to be mounted in the car, it is suggested that new points be mounted in the distributor. Point gap and dwell should be the same as specified for the car. The same spark-plug gaps should also be used as specified for the engine. Be careful to set the correct point gap and dwell, as these have important bearing on the final performance of the car.

Readers who have *Chrysler Corp.* cars can buy special points designed for transistorized ignition systems. They are called “power points” and have nylon bearings and rubbing blocks. If ordinary point sets with fiber rubbing blocks are used, do not omit an application of a thin film of high-temperature grease on the distributor breaker cam to keep the fiber rubbing block from wearing too fast. Points should last at least 25,000 to 50,000 miles. If they are replaced at all, it would only be due to the wearing out of the fiber rubbing block and not the points themselves. ▲

Bottom view of unit. Both transistor and diode must be insulated from ground.

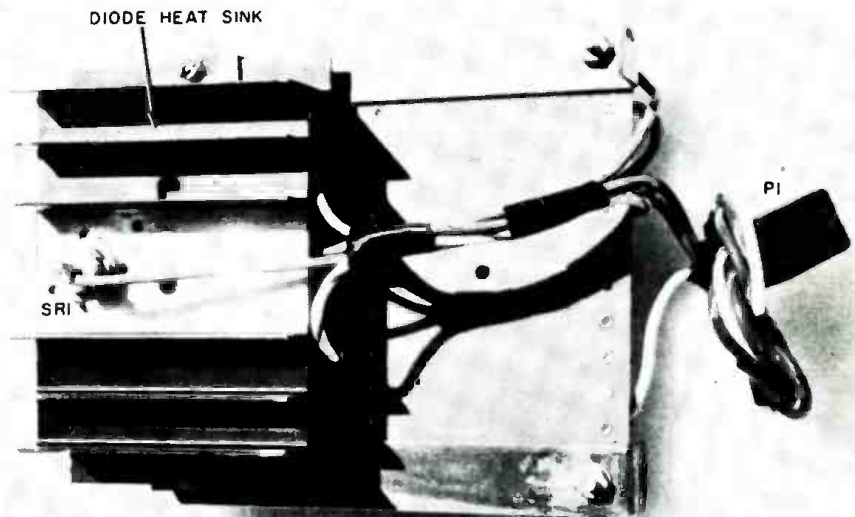



# Within the Industry

**IRVING KOSS** has been named general manager of the *E. F. Johnson Company* of Waseca, Minn., leaving his post as general manager of the *Motorola Inc.* military electronics division to accept the new position.



He is a graduate of MIT in business and engineering administration and holds a Masters degree in business administration from Harvard Graduate School. In his new post he will assume part of the administrative functions of the president who will devote greater time in other areas, including company growth and acquisition of other firms.

**HERBERT HOOVER, JR.** has been elected president of The American Radio Relay League, Inc., the national society of amateur radio operators in the United States and Canada. Serving with Mr. Hoover will be Wayland M. Groves, first vice-president; Alex Reid and Francis E. Handy, vice-presidents; John Hutton, secretary; and David H. Houghton, treasurer.

The board of directors also approved the building of a new headquarters office at 225 Main Street, Newington, Conn. The new structure, totalling 26,000 square feet of office space, is expected to be ready for occupancy early next year.

**JOHN H. FEDER, JR.** has been appointed general sales manager of *Cornell-Dubilier Electronics*. In his new position, Mr. Feder takes over the responsibilities of R. T. Leary, vice-president for sales, who has resigned to enter private business.



Mr. Feder has been associated with the company for over 12 years as a manufacturer's representative and more recently as district manager of the firm's Mid-Atlantic region. Previously he was sales manager for *Keystone Products*, a New Jersey specialty transformer firm.

He will make his headquarters in Newark, New Jersey.

**HAL F. BERSCHE**, head of *RCA Electron Division's* Distributor Products, has been elected president of Producers of Associated Components for Electronics,

Inc. (PACE), succeeding Thomas B. Ure, vice-president of *Hardwick Hindle, Inc.*

Officers and directors elected to serve with Mr. Bersche include: Howard Saltzman, *Alpha Wire Corp.*, first vice-president; George Silber, *Rek-O-Kut Co., Inc.*, second vice-president; Walter Jablon, *Musco-Fanon Corp.*, secretary-treasurer; and David Susser, executive vice-president and counsel. Directors include Walter Goodman of *Jerrold Electronics Corp.* and Abe Kosakowsky, of *Silicon Transistor Corp.* who will serve three-year terms.

Directors elected to serve two-year terms include Ed Abbo, *Saxton Products, Inc.*; Robert Ferree, *International Resistance Co.*; and Edward Rothenstein, *Arco Electronics, Inc.* Salo Nachtigall, *Fanon Electronic Industries, Inc.*, Herman Post, *Robin Industries Corp.*, and Irving Rosen, *Keystone Electronics Corp.* will serve one-year terms.

**DATOM INDUSTRIES** of Orange, N.J. has set up the **MADISON FIELDING DIVISION** for the manufacture and marketing of a complete line of AM, FM, and multiplex radio-phonograph consoles...

**SYSTRON-DONNER CORP.** has acquired 85% of the outstanding stock of **ELECTROMAGNETICS, INC.** of Los Angeles...

**WATSCO, INC.** of Hiialeah, Florida has established a new electronics division which will handle the manufacture of a capacity tester... **GENERAL PRECISION EQUIPMENT CORPORATION** and the **MITSUBISHI ELECTRIC MANUFACTURING CO., LTD.** of Japan have joined in the formation of a new electronic and precision equipment manufacturing company to be known as **MITSUBISHI PRECISION, INC.**

... **DELTA ELECTRONICS, INC.** has been established at 4206 Wheeler Ave., Alexandria, Va. to undertake the development and custom fabrication of specialized electronic equipment... **HAWLEY PRODUCTS LIMITED** of England has been acquired by **HAWLEY PRODUCTS COMPANY, St. Charles, Ill.**... The formation of a new electronics firm, **RCF COM-TRONICS, INC.**, has been announced. This new manufacturer of electronic communication systems and components will operate in Pulaski, N.Y. ... **RESISTOR CHEMICAL CO., INC.** has acquired management control of **CWS WAVEGUIDE CORPORATION** of Lindenhurst, L.I. ...

The Radio Standards Laboratory at the Boulder Laboratories of the **NATIONAL BUREAU OF STANDARDS** has been divided into a Radio Physics Division and a Circuits Standards Division to provide unified direction for a growing program

... **KAWECKI CHEMICAL COMPANY** and **DURHAM CHEMICAL GROUP LTD.** of England have agreed to form a joint enterprise at Birtley, England to produce master alloys for the aluminum and high temperature metallurgical industries.

**DR. JAY TOL THOMAS** has been appointed director of the newly established *Siegler Research Laboratories* with headquarters in Los Angeles.



Prior to joining *Siegler*, Dr. Thomas was director of research for the *Boston Division of Minneapolis-Honeywell*.

He was responsible for the development of new products in the fields of electro-mechanical components, solid-state transducers, fuel cells and their controls, high-powered semiconductor amplifiers, and magnetometers.

He has also been associated with *Sylvania*, *DuPont*, and the Naval Research Laboratory. He received his bachelor and master degrees from Harvard and his doctorate from Rutgers. He is a Fellow of the American Physical Society and a senior member of the IRE.

**WILLIAM F.E. LONG**, first manager of the Electronic Industries Association's Marketing Data Department, has returned as the association's director of marketing services. He succeeds George W. Westfall who has resigned.

Mr. Long first joined the EIA staff in 1951, leaving the organization in 1959 to become associated with the *Lansdale Tube Division* of *Philco Corporation*.

**J. R. CHRISTOPHERS** has been appointed assistant general manager of *Cossor Instruments Limited* of London. He was formerly technical sales manager of *Marconi Instruments Limited*... *Oak Manufacturing Co.* has announced the appointment of **EARL OLENICK** as general manager of its newly formed distributor division... **DR. JOHN E. McNAMARA** has been promoted to the new position of staff scientist for materials at *Motorola's Semiconductor Products Division* in Phoenix... **DR. JULIEN KEILSON** has been named senior scientist of *Sylvania Electric Products Inc.'s* Applied Research Laboratory in Waltham, Mass. ... *Radio Corporation of America* has named **GEORGE A. FADLER** to the post of staff vice-president, purchases... **E. H. KINNEAR**, manager of audio products for *Ampex of Canada, Ltd.*, has been elected president of the Dominion Hi Fi Association... **HARRY LEMMENS** has joined the engineering staff of *National Transistor Mfg., Inc.* as development engineer in charge of special packaging and multiple-element devices... **C. GUS GRANT** has been named to the newly created position of vice-president, marketing for *Ampex Corporation*... **JOHN SEVERINSEN** and **ROGER DIAMOND** have joined the engineering staffs of *Technical Appliance Corp.*

# 1962 CAR AND DRIVER YEARBOOK

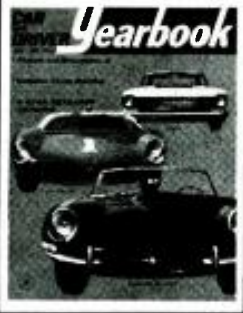

**your buying guide  
to 224 new cars**

Here's the one place you can compare the 224 foreign and domestic cars on the market today—complete with pictures, prices, performance data and specifications.

**Plus these exclusive features:**

- Road Research Reports on 8 top cars by the editors of CAR AND DRIVER
- Survey of technical developments
- Listings of all importers of cars in the U.S.—complete with addresses
- Gallery of famous drivers
- Interviews with top executives in the automotive industry and in government

The 1962 CAR AND DRIVER YEARBOOK is now on sale. Get your copy today at your favorite newsstand. Or send in this coupon and we will mail your copy. **Only \$1.00**

Retail Sales Division  
Ziff-Davis Publishing Co.—Dept. BT  
One Park Avenue  
New York 16, New York

Please send me a copy of the new 1962 CAR AND DRIVER YEARBOOK. I enclose \$1.00, the cost of the YEARBOOK, plus 10c to cover mailing and handling charges. (Canada and Foreign, \$1.25 plus 10c postage.)

Name \_\_\_\_\_

Address \_\_\_\_\_

City \_\_\_\_\_ Zone \_\_\_\_\_ State \_\_\_\_\_

(add 3% sales tax if New York City resident) EW862

## Make Your V.T.V.M. Reliable

(Continued from page 30)

(involving a small amount of undesirable resistance.)

### Effect on Voltage Readings

When the v.t.v.m. is used for voltage readings (part of the d.c. circuit of the Heath V-7A is shown in Fig. 2), the greatest resistance in the grid return is present on the lowest voltage range. Since the instrument's calibration control is normally adjusted against a dry cell, which is a low-impedance source, calibration will not be upset during measurement of customary voltages. However, it is the usual practice to set for zero on d.c. voltage readings with the probes open-circuited (high resistance in the grid return). Therefore when voltages across low-impedance sources are checked, false readings are caused because the zero adjustment is incorrect.

You can check your own v.t.v.m. for this error quite easily. Adjust for zero on the lowest positive d.c. range with the probes open; then short the probes together. The meter pointer will probably swing below zero. It will not move, however, if a gas-free tube is used.

The resultant inaccuracy increases as the voltages being measured are less than the calibrating voltage. For example, a zero reading might be obtained when there is actually .1 volt in the circuit being checked. Error of this type becomes very important when d.c. readings are taken on transistorized equipment. Magnitude of the voltages being checked is small to begin with, and the difference between normal base and emitter potentials is smaller yet.

Experience shows that there is considerable variation in the degree of instability and inaccuracy encountered, depending on the gas content of the particular tube used. Trying a few different tubes of the same type in the same instrument will show this variation. Yet it cannot be said that the tube manufacturer is at fault. He only attempts to bake out enough gas to ensure normal operation in the normal circuit applications, where grid resistance is seldom over a few megohms.

### How to De-gas a Tube

There is a common impression that the gas content of a tube used in the bridge of a v.t.v.m. can be reduced to

a satisfactory level simply by leaving the instrument turned on for 48 hours or more. This aging will indeed stabilize cathode emission, but accomplish little more. To bring gas content down to a satisfactory level, you must take up where the tube manufacturer left off in his curing process.

Fig. 3 shows the simple circuit used to de-gas the tube. The only parts needed are a filament transformer and a socket to match the particular tube. Note that the grids and cathodes are tied together to one side of the power line, while the plates are tied to the other side. Just plug the power cord from the transformer into a wall outlet and let the tube run for a minimum of eight hours. This is sufficient to cure the average tube.

After the tube has been cooled thoroughly and the gas ions have been trapped on the getter material—this takes about 30 minutes—plug the tube into the v.t.v.m. Allow normal warm-up time, then adjust the zero-set control with the function switch set for “- D.C. Volts.” Switch to the highest resistance range, R×1 meg., and set the ohms adjustment for proper deflection. Next switch to the R×100k range. If the tube is adequately cured, the meter pointer will not move more than one division to the left. If the movement is greater than this, try re-cooking the tube for a few more hours.

### Does Curing Always Work?

Tests involving thousands of tubes show that adequate curing can be achieved in 9 out of 10 cases. The few tubes that do not respond to this procedure are nevertheless satisfactory for most other applications. Thus the probability is very high that your first try will work and, if it doesn't, you still have a usable tube.

In some cases, when you switch from the 1-megohm to the 100k range, the meter pointer will swing to the right instead of to the left. If this occurs, re-cooking will not help. The tube should be rejected for use in a v.t.v.m. but, again, it will be satisfactory in a conventional circuit. It is believed that meter-pointer movement to the right when grid-circuit resistance is reduced is due to some contamination of the grid by material from the cathode.

The use of a gas-free tube enables you to pay less attention to the operation and adjustment of your v.t.v.m., in addition to improving accuracy. You will find that you can concentrate better on the work you are doing. You will also be saving time.

Our experience at NRI is quite revealing for the v.t.v.m. user. We have de-gassed more than 60,000 tubes for use in the *Conar* v.t.v.m. over the years and tested each for satisfactory operation. During this period, less than a dozen tubes have failed in the field. Some extra effort is required, but the resultant user satisfaction is worth the trouble. That satisfaction can be yours with your v.t.v.m. Get the gas out of your bridge tube and get the most out of your v.t.v.m. ▲

Fig. 3. Circuit for curing bridge tube requires only transformer and socket.

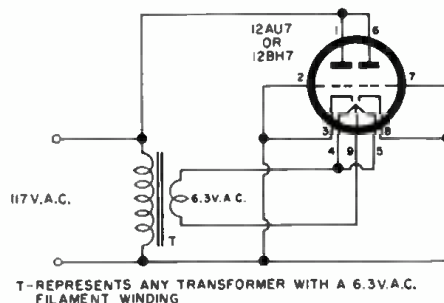



# SEMICONDUCTOR NOISE FILTER

By JAMES E. PUGH, Jr.

Simple transistorized circuit eliminates superimposed noise.

NOISE from a d.c. motor operated on the same low-voltage supply as an amplifier can be particularly troublesome in portable transistor circuits since there is generally not enough excess voltage above that actually required to allow for the normal loss in an RC filter. Or, to state it another way, why waste battery power in an RC filter when it isn't necessary? LC filters are usually ruled out for portable equipment because of the inductor size and weight.

A semiconductor filter, essentially the same as is used to filter the ripple out of rectified d.c. power supplies, is well suited to this application. The voltage drop can be made low, it is an excellent filter, and the size and weight are both small.

Component values will be determined by the input voltage available, noise level, and load current and voltage. Select a transistor that will handle the required load current and at the same time see that its collector-to-base voltage and dissipation ratings are not exceeded.

Unless the load is heavy, the zener diode can be nearly any type with a dissipation rating of 150 to 500 mw. If voltage regulation is not critical, it can be operated close to the minimum zener current since most noise spikes will not be hard to remove from this filter. The resultant larger value of  $R_1$  will minimize noise feedthrough from collector to base (through  $R_2$ ), and thus the output noise will be lowered.

Select a zener voltage as high as possible to minimize voltage loss across the transistor, but at the same time it must not be so high as to impair filter action. Narrow noise pulses with a low repetition rate will make it possible to use a higher zener voltage and thus a higher usable output voltage will be obtained. More severe noise will make it necessary to settle for a lower output voltage. Capacitors  $C_1$  and  $C_2$  are not critical—50 to 100  $\mu$ f. will be more than adequate for most cases. ▲

Small-sized, lightweight transistor circuit that is designed to filter out noise.

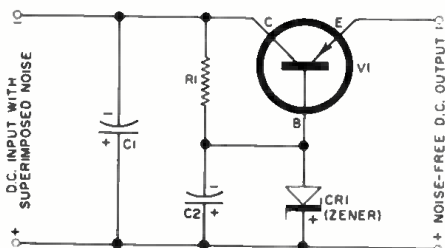

August, 1962

# Build the finest professional color TV Set ever designed

WITH

# color

## TV KITS

by **TRANSVISION**



"DeLuxe" Color Chassis with controls mounted on panel in a vertical position.



Custom wall installation of "DeLuxe" Color Chassis with horizontal controls separated from chassis.

**LEARN AS YOU BUILD:** Learn Color TV Theory, Practice, and Servicing. Complete course of study available for use in conjunction with the Kit—no technical background required to understand it.

**INSTRUCTION MANUAL:** Send \$5 for complete Assembly Manual, so that you can see how easy it is to build and service the Transvision TV Color Kit. Cost of manual refundable upon purchase of Kit.

**TRANSVISION ELECTRONICS, Inc.**

Grey Oaks Avenue, Yonkers, N. Y. Dept. EWC-8  
Telephone: (914) YOnkers 5-6900

This Color TV Kit is designed around the most expensive, thoroughly engineered and newest RCA TV Color Receiver.

Transvision has added improvements, features, and heavy-duty parts to this RCA licensed receiver in order to accommodate those who seek better quality than is commercially available.

### WITH or WITHOUT REMOTE CONTROL

All critical circuitry is wired, aligned, and pre-tested by RCA.

Anyone Can Assemble—No Special Knowledge Required Buy Assembly Manual and See Easy, Complete Instructions.

**Exclusive Features:** All controls are mounted separately from chassis for flexibility in custom installation. . . . Only the finest quality oversized, extra heavy-duty parts are used for long, trouble-free use, and they are FULLY GUARANTEED for ONE FULL YEAR.

The 21" Color Tube is RCA's newest and best tube. The safety glass is bonded to the tube face to reduce reflections and eliminate dust accumulation. . . . NEVER OBSOLETE—Your Transvision TV Color Kit is always up-to-date because circuit improvements in Kit form are passed on to the Kit builder as they occur.

Buy on Installment Plan. PAY AS YOU WIRE: \$50 gets you started on this fascinating TV Color Kit project.

### CHOICE OF MODELS:

- With Hi-Fidelity Sound System, complete with Color Tube . . . . . \$439.00.
- With Special Circuit (no audio) for connecting into your Hi-Fi System, complete with Color Tube . . . \$419.00.
- Remote Control optional . . . . . \$60.00 additional.

Also available as WIRED CHASSIS . . . Full line of Cabinets.

### START NOW — MAIL THIS COUPON.

- Send FREE Catalog on Color TV Kits . . .  I enclose \$5 for Assembly Manual, refundable on purchase of TV Color Kit.
- I enclose \$50 for Starting Package on pay-as-you-wire plan. (Complete Kits range from \$409 to \$499.) Dept. EWC-8

Name \_\_\_\_\_  
Address \_\_\_\_\_  
City \_\_\_\_\_ Zone \_\_\_\_\_ State \_\_\_\_\_

## RADIO PARTS STORES & HI-FI SALONS!

Hundreds of dealers across the nation profit by selling ELECTRONICS WORLD each month to their customers. Are you one of them? ELECTRONICS WORLD helps build store traffic . . . keeps customers coming back month after month for the merchandise you sell—and, best of all, you earn a neat profit on each copy sold—NO RISK INVOLVED.

So get details on selling ELECTRONICS WORLD, the world's largest selling technical electronics magazine. Or, order your copies now. Just use the handy coupon.

Retail Sales Department, Electronics World  
One Park Avenue, New York 16, New York

- Send me . . . . . copies of ELECTRONICS WORLD for resale in my store each month. No risk involved on my part.
- Send me details on selling ELECTRONICS WORLD in my store.

STORE NAME \_\_\_\_\_  
ADDRESS \_\_\_\_\_  
CITY \_\_\_\_\_ ZONE \_\_\_\_\_ STATE \_\_\_\_\_  
SIGNATURE \_\_\_\_\_

EW 862

# COLUMBIA GEMS!

**EXPORT SPECIALS**  
 TCS Home 1. **AN APS-6 Radar Set**  
 BC-610, BC-640, TCM, TDE RADAR TRANSMITTERS. Many Other Specials. Send for Complete Import-Export Catalog. Huge Inventory. Immediate delivery from OWN STOCK!

**MODEL 80 SIGNAL GENERATOR**  
 All excel. cond. All tested! All guaranteed!  
 BC-221 1.2 Mc. 200 Ma. 175.00  
 TS-174 U 200-250 Ma. 175.00  
 TS-175 U 200-250 Ma. 175.00

**FREQUENCY METER SPECIALS**  
 All excel. cond. All tested! All guaranteed!  
 BC-221 1.2 Mc. 200 Ma. 175.00  
 TS-174 U 200-250 Ma. 175.00  
 TS-175 U 200-250 Ma. 175.00

**RT-82/APX-6 TRANSCEIVER \$14.95**  
 Range in excess of 12 1/2 Mi. 200 Watts. 1000-10000 Kc. 1000-10000 Mc. 1000-10000 Mc. 1000-10000 Mc. 1000-10000 Mc. 1000-10000 Mc.

**ID-6/APN-4 LORAN INDICATOR \$8.95**  
 Takes 28 popular tubes! 1000 Kc. 1000-10000 Mc. 1000-10000 Mc. 1000-10000 Mc. 1000-10000 Mc. 1000-10000 Mc.

**48 PAGE NEW CATALOG! FREE! GET YOUR COPY TODAY!**

**COMMERCIAL RECVRs. & XMTRS**  
 R-28 ARC-5 TWO-METER & AIRCRAFT RECEIVER \$22.50  
 Q5'ER: 19-55 Mc. Excellent cond. 9.95  
 1-5-3 MC. RECEIVER: Excellent cond. 19.95  
 8-6 MC. RECEIVER: Excellent cond. 19.95  
 6-9 MC. RECEIVER: Excellent cond. 19.95  
 2-1-3 MC. TRANSMITTER: Brand new 8.95  
 3-4 MC. TRANSMITTER: Brand new 8.95  
 4-5-3 MC. TRANSMITTER: Brand new 8.95  
 4-5-7 MC. TRANSMITTER: Brand new 8.95  
 5-3-7 MC. XMTR: Brand new 8.95  
 MD-7 ARC-5 PLATE MODULATOR: 1000-10000 Mc. 4.95

**TUBES! ALL NEW & GUARANTEED!**  
 4-150A \$12.00 4E27 \$ 7.95  
 4-6SA 9.95 100TH 9.95  
 4-125A 19.50 250TH 22.50  
 4-250B 22.50 829B 22.50  
 4-400A 24.50 832A 3.95  
 4-1000A 75.00 8000 9.95

**BC-375 100 W. TRANSMITTER**  
 Ideal for domestic use, as well as export marine and mobile. 1000-10000 Mc. 1000-10000 Mc. 1000-10000 Mc. 1000-10000 Mc. 1000-10000 Mc.  
**\$14.95**  
 PE-73 DYNAMOTOR FOR ABOVE: 1000-10000 Mc. 4.95  
 TUNING UNITS: For BC-375 Etc. 51.95

**COLUMBIA ELECTRONICS**  
 4365 WEST PICO BLVD. LOS ANGELES 19, CALIF.

## EW Lab Tested (Continued from page 16)

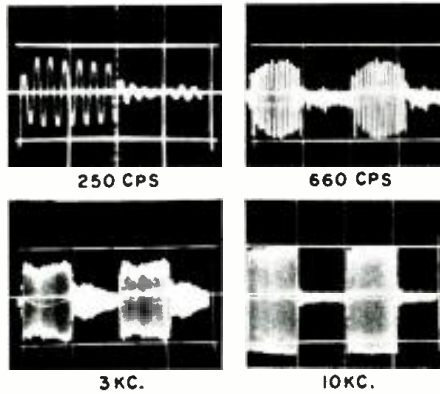

frequency-response measurements, we averaged the results of eight sets of data obtained indoors, with different microphone positions. The resulting curve was uniform within  $\pm 7.5$  db from 35 to 5000 cps, dropping smoothly and gradually at higher frequencies. Our measurement technique actually takes into account the directional properties of the speaker. Speakers with flat axial frequency response characteristics, but having some high-frequency "beaming" (as all do to some extent), will show a falling high-frequency response in our measurements.

The over-all response was quite smooth. Below 100 cps the output fell abruptly. Considerable output could be developed down to 30 or 40 cps, but harmonic distortion became appreciable at frequencies below 100 cps. We used a 10-watt input level at frequencies up to 1000 cps and 1 watt above 1 kc.

Tone-burst tests indicated a fairly good transient response at frequencies below 1000 cps and generally good transient response at higher frequencies. At certain critical frequencies (such as 3 kc.) there was some ringing between bursts, but at most higher frequencies the tone-burst response was excellent.

The system has a very pleasant listening quality: quite exceptionally so for a speaker in its price class. It is balanced and musical, with a fullness bellying its compact dimensions. A slight 10-ke. peak adds some sparkle, yet contributes surprisingly little background hiss level. At the low end, the subjective impression is that it goes far below 100 cps. Possibly the harmonic distortion generated by very-low-frequency signals contributes to the sensation of bass response. In any event, the absence of a low-frequency peak results in very natural voice reproduction, without any tendency to boominess.

The Fisher KS-1 sells (in kit form) for \$59.50 in unfinished birch and \$64.50 in unfinished walnut. It is also available assembled in finished birch or walnut, for \$84.50 and \$89.50 respectively. ▲

## Eico Model 955 Capacitor Tester

For copy of manufacturer's brochure, circle No. 60 on coupon (page 96).

THE ability to save time with in-circuit testing is important in determining the practical usefulness of a capacitor tester. The chief limitation on in-circuit testing, in turn, is circuit loading. Thus Eico engineers have designed as much immunity to loading as they could into the Model 955 Capacitor Tester.

It is rated to check shorted capacitors up to 2000  $\mu$ f. out of the circuit or in circuit with shunt resistance down to 1 ohm. It provides open indication with shunt resistance as low as 35 ohms and values down to 15  $\mu$ f., with normal adjustment. Critically adjusted, it is rated to read "open" down to 5  $\mu$ f. Permissible shunt resist-

ance, however, goes up at the low-capacitance end of this range (e.g.: 1500 ohms across 15  $\mu$ f.). It reads value directly between .1 and 50  $\mu$ f., in or out of the circuit. In addition, a simple, one-step calculation and an included conversion graph yield dissipation- or power-factor readings. Clear-cut indications are obtained with a 6FG6 electron-ray tube.

The short test applies a 6-volt, 60-cps signal to the component. One ohm or more across the test leads permits enough drop to keep the eye open; a lower impedance closes the eye to indicate a short. In the open test, output of an internal 22-mc. oscillator keeps the eye open.

## engineering degree in 27 mos.

Become an Electronics Engineer. College graduates enjoy higher income... sure advancement. Major corporations visit us regularly to interview and employ seniors. **BACHELOR OF SCIENCE DEGREE IN 27 MONTHS** in Electrical (Electronics or Power major), Aeronautical, Chemical, Mechanical, Civil Engineering. **IN 36 MONTHS** a B.S. Degree in Business Administration. Small classes. Campus. New dorms. *Low costs.* Enter Sept., Jan., Mar., June. Founded 1884.

Write I. H. McCarthy for Catalog and "Your Career in Engineering and Commerce" Book.

**TRI-STATE COLLEGE**  
 1682 College Avenue • Angola, Ind.

**JUST STARTING IN TV SERVICE?**  
**-- then you need us!**  
 GET STARTED RIGHT by writing for **FREE** 9 page catalog illustrating over 30 business forms and systems designed specifically for TV Radio Service.  
 ON SALE AT YOUR PARTS JOBBER  
 Delrich Publications • 4308 N. Milwaukee • Chicago 41, Ill.

**DOWN TO EARTH**  
 Everyone's going for Audion's "Down to Earth" Hi-Fi Values.  
 ... Write for free catalog.  
**audion**  
 25 E. OXFORD ROAD  
 MASSAPEQUA, L.I., N. Y.

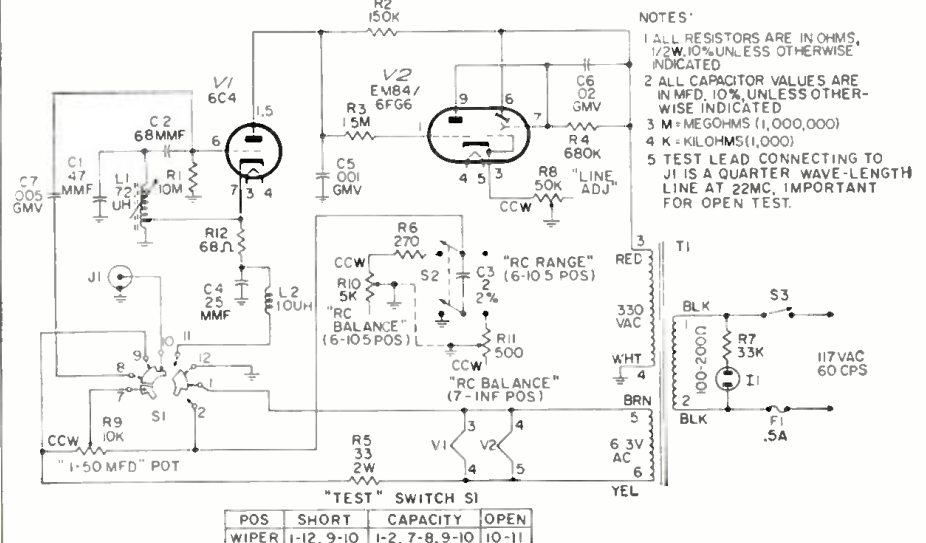





reading dial is rotated to null the bridge, closing the eye. A calibrated auxiliary "R-C Balance" control neutralizes in-circuit shunt resistance.

Our 955 kit was easy to assemble (about 5 hours at a leisurely pace), even though the accompanying manual—a withdrawn version, shipped only with a few early kits—was below the manufacturer's usual standard. Extensive revisions, from correction sheets provided, accounted for this. Eico invites any constructor who happens to get this old version of the manual in his kit to write directly to them for a free copy of the later edition. We completed construction successfully without it.

In actual use, tests were simple, fast, and clearly indicative. But for the capacitance-measuring function, nothing more than a simple switch need be operated. Since the calibration procedure used was that in the early-version addenda sheets, reading accuracy was somewhat outside the limits specified by the manufacturer. The procedure prescribed in the later manual has been revised to correct this deviation. It can also be corrected simply by re-orienting the capacitance dial to read the value of an accurately known capacitor connected to the test leads, if the user needs such precision.

Due to construction peculiarities in some types of electrolytics, they may give false open readings on this and other testers, although they are sound. In this unit, the technician can resolve any doubts by switching to the capacitance test. Considering the latter's range (which mostly covers electrolytic values), we suspect that this advantage was a chief consideration in adding the capacitance function in the first place.

Part of the manufacturer's new line of industrial equipment, the 955 is sturdily and attractively housed. The kit sells for \$19.95; the wired version for \$39.95.....E.W.

The test lead (along with lumped circuit constants) acts as a tuned quarter-wave line across part of the oscillator tank. Very low impedance at the output end of the cable reflects a very high impedance at the oscillator end, with circuit action unaffected. A higher external impedance (but still low, to cover low-value capacitors and high in-circuit loading) reduces impedance at the tank enough to kill oscillation. The eye then shuts for an "open" reading.

To check capacitance, the external component is put into a comparison bridge and a direct-



**19 D.B. GAIN! CUTS SNOW. BOOSTS SIGNAL**

Make any TV or FM Antenna work better by amplifying signals with the new Winegard Tenna-Boost.

19 DB gain—no peaks and valleys. Linear frequency response—extremely low VSWR. All AC power supply.



Because of its extra power, the Winegard Tenna-Boost can be used to operate up to 6 TV sets from one antenna. Works perfectly for black and white and color . . . plus FM and FM stereo.

There's a big difference in antenna amplifiers! Ask your distributor or write for technical bulletin.



**Winegard**

3003-8 Kirkwood, Burlington, Iowa

## ALL NEW SENCORE component substitutor



MODEL RC121

### All your favorite Sencore Substitution Time-Savers in One Compact Unit

A complete range of carbon resistors, wire wound power resistors, capacitors, electrolytics, and universal selenium and silicon rectifiers.

Imagine, all of these hard to locate parts at your fingertips for on the spot substitution. Say goodbye to messy, crumpled parts, unnecessary unsoldering and soldering of components for testing purposes only. Save valuable servicing time and be sure, by substituting.

NEW . . . each section operates independently with a value close enough for every substitution need. Components in each section are isolated from chassis and from the other sections. For example, a complete power supply can be constructed using the RC121 Components only.

NEW . . . dual electrolytics provided. A new circuit enables you to substitute up to 25 single electrolytic values or 9 duals. Exclusive surge protector provides protection on both singles and duals for both you and the circuit.

You save space and money. Equivalent Sencore substitution pieces purchased individually (H36, PR111, RS106, ES102) cost you \$54.00

RC121 (all hand wired, all American made) only **39.95**  
RC121K (Kit) . . . . . **27.95**

Now in stock at your Sencore Distributor. See him today!

**SENCORE**  
ADDISON 2, ILLINOIS

**SEND  
ELECTRONICS WORLD  
EVERY MONTH**



name \_\_\_\_\_

address \_\_\_\_\_

city \_\_\_\_\_ zone \_\_\_\_\_

state \_\_\_\_\_

Check one:

- 3 years for \$12
- 2 years for \$9
- 1 year for \$5

In the U.S., and possessions.

- Payment enclosed
- Bill me

Foreign rates: Canada and Pan American Union countries, add .50 per year; all other foreign countries, add \$1.00 per year.

- New
- Renewal

Mail to: **ELECTRONICS WORLD**  
Dept. EW 862H, 434 S. Wabash Ave.  
Chicago 5, Ill.

**Mac's Electronics Service**  
(Continued from page 42)

high impedance to the signal and practically none of it reaches the diode in that leg of the bridge. The signal passes as before through the 22k resistor in the other leg, though and the rectifier in this leg produces a positive voltage across the 2- $\mu$ f. capacitor that opposes the negative bias voltage flowing through the bridge. The bias on the 6AU6 goes down and the tube amplification goes up so that more signal is delivered to the unbalanced bridge, resulting in still more unbalance and more plate current through the 6AU6. This action continues to build up until the tube reaches a condition of saturated plate current and the relay contacts are closed, operating the door's opening and closing mechanism. That 2- $\mu$ f. capacitor requires an appreciable length of time to charge, and this prevents short-duration transients from tripping the mechanism."

"Well, I'll be—!" Barney marvelled. "It took me a long time to figure out that circuit, even with the description right in front of me; yet you reeled it off as though you were reading over my shoulder."

"I gotta confess," Mac said with a chuckle. "I *did* read the book. When you said that garage door opener came in a kit form, I suspected it might be the *Heathkit* job, and I had read up on that circuit not more than a month ago. I, too, was rather intrigued by the clever circuits, and their operation stuck in my mind. I like to think I could have puzzled out the operation of that receiver circuit eventually, but I most certainly would not have understood it just from hearing you describe the diagram."

"Well, that makes me feel a little better," a mollified Barney replied. "This is a pretty far cry from the first garage door opener, I'll bet."

"That would be a safe wager. I know the first radio-controlled door I ever saw was a very simple affair indeed. Both the transmitter and receiver were variable-tuned and inclined to drift. Keeping both on the same frequency for a week at a time was an undertaking in itself, especially with changes in temperature and humidity and the kind of components available at that time. You didn't need any a.g.c. action to limit the amount of input signal to the detector, either. The problem was to get *enough* r.f. to operate the simple squelch circuit that tripped the control relay that was used.

"Finally, though, this last problem was licked; and then came a silly period in which owners judged the quality of their garage door installations by the distance at which the car could control the door. I still remember one such owner complaining to me he could no longer control his garage door from two miles away! When I touched up the receiver for him so that he could make the door open when he was still a couple of miles from the city he was happy.

"As remote garage door openers became more common and as the v.h.f. channels became more crowded, however, owners came to place less emphasis on the 'remote' aspect and more on the 'reliable opening' of their gadgets. They discovered overly sensitive receivers, necessary for long-range operation, responded too easily to spurious signals. The doors tried to following the keying of amateur transmitters in the vicinity or went up and down every time a neighbor changed channels on his TV receiver. This led to the present era in which the transmitters are powerful and crystal-controlled and the receivers are made more selective and less sensitive and are keyed to certain specific audio modulation frequencies. If I remember right, that *Heathkit* transmitter inputs nearly five watts to the final; yet it is recommended that the receiving antenna be shortened until the car must be within sixty feet of the door to operate it."

"Other signals than c.w. or modulated r.f. have been used to open the doors, haven't they?"

"Oh, sure. Supersonic sounds, light shining on a photoelectric cell, low-frequency audio radiated from the car into a pickup coil buried beneath the driveway, or combinations of these and other actuating signals have all been given a try."

"Well, as garage door openers become more reliable, more and more people are installing them; and after a person is accustomed to the convenience of such an arrangement, he is most unhappy and frustrated when the thing quits working. It strikes me servicing these comparatively simple units might be a lucrative sideline for us."

"That's my boy!" Mac applauded as he patted Barney approvingly on the shoulder. "Keep up that kind of thinking, and you will go far!" ▲

**INTERMITTENT CAPACITORS**

By ELWOOD C. THOMPSON

**P**RACTICALLY every technician dread the task of locating an intermittent capacitor which makes a set change volume or go dead entirely. No matter which capacitor is bypassed with a spare, invariably the surge imposed on the circuit will restore the set to normal operation, perhaps for days. One way to eliminate erratic operation is to replace all the capacitors, but this is highly uneconomical. A more practical method of locating the capacitor trouble is outlined below.

The suspected capacitor is shunted by a series-connected RC combination consisting of approximately 22,000 ohms (this value is not critical) and the proper value of bypass capacitor. The purpose of this combination is to allow the intermittent capacitor to remain charged at the usual circuit voltage and to prevent the new unit from acting as a bypass. Then, when the set finally acts up, the series resistor is shorted out with test leads or a screwdriver. In this way, the unit that has lost its bypass capabilities will be located immediately. Of course, more than one section of a set can be treated at the same time. ▲

ELECTRONICS WORLD



# FM-STEREO PROGRAMS REACH 70-MILLION LISTENERS

**Broadcasting's new "child" is making adult strides in gaining public acceptance and in station compliance.**

ALTHOUGH only just past its first anniversary, FM-stereo broadcasting has made great strides in coverage of the major markets. Also, equipment manufacturers, after a rather sluggish start, are now keeping abreast of the demand for equipment to receive such broadcasts. These conclusions are based upon a survey that has been released by the Consumer Products Division of the Electronic Industries Association.

As of April 15th, eighty-one FM stations have converted to stereo and are broadcasting an average of 66½ hours of program material a week via multiplex. The EIA study also disclosed that 40 per-cent of the nation's population, or about 70 million persons, are within range of at least one of these FM-stereo broadcasts. In some areas, such as around New York City, listeners have a choice of no fewer than four FM-stereo broadcast stations. One of them even transmits stereo 24 hours a day.

The early lag in the manufacture of FM-stereo receiving equipment was due to the timing of the FCC order establishing the service. FM-stereo broadcasting officially began June 1, 1961, after most set manufacturers had frozen their product lines for the forthcoming year.

The industry quickly overcame this lag in receiving equipment and today at least 20 manufacturers are shipping FM-stereo-equipped consoles or table sets, adapters or tuners, or tuner-amplifier units.

According to the EIA, not only are sets available but their over-all quality is exceptionally high, due in large measure to the fact that manufacturers were not stampeded into crash programs and took cognizance of the need for careful design and sophisticated circuitry which FM-stereo reception involves.

With good receiving equipment on the market and the likelihood that no less than 300 stations may be broadcasting FM-stereo by the end of this year, the EIA views the future of this "new world of broadcast sound" with unqualified optimism. ▲

August, 1962

# Calendar of Events

## JULY 26-AUGUST 12

*Fourth Annual International Trade Fair.* Sponsored by the Chicago Association of Commerce and Industry. McCormick Place, Chicago, Ill. Open to public and trade at specified hours. Details from Association, 30 W. Monroe St., Chicago 3.

## AUGUST 8-10

*1962 Standards Laboratory Conference.* Sponsored by National Conference of Standards Laboratories. Boulder Laboratories of National Bureau of Standards, Boulder, Colo. Further details from Alfred E. Hess, Circuit Standards Div., NBS, Boulder.

## AUGUST 13-16

*Pacific Energy Conversion Conference.* Fairmont Hotel, San Francisco. Registration information from Wendell B. Freeman, c/o General Electric Co., 235 Montgomery St., San Francisco 4.

## AUGUST 14-16

*International Conference on Precision Electromagnetic Measurements.* Sponsored by NBS, IRE, AIEE. NBS Boulder Laboratories, Boulder, Colo. Program information from Dr. George Birnbaum, Hughes Research Labs., Malibu, Calif.

## AUGUST 21-24

*1962 Western Electronic Show & Convention.* Sponsored by Los Angeles & San Francisco Sections WEMA, all professional groups of IRE. Staller Hilton & Sports Arena, Los Angeles. Details on program from WESCON Business Office, c/o Technical Program Chairman, 1435 S. La Cienega Blvd., Los Angeles 35, California.

## AUGUST 22-SEPTEMBER 1

*29th National Radio and Television Exhibition.* Earls Court, London S.W. 5. Details from Andrew Reid, Press Officer, Radio Show, 17 Fleet St., London E.C. 4, England.

## AUGUST 23-26

*NATESA Annual Convention.* Pick-Congress Hotel, Chicago. Details from Frank J. Moch, Executive Director, 5806 S. Troy St., Chicago 29, Ill.

## AUGUST 29-SEPTEMBER 1

*1962 Congress on Information Processing.* Sponsored by International Federation of Information Processing Societies. Munich, Germany. Program information from Dr. E.L. Harder, Westinghouse Electric Corp., East Pittsburgh, Pa.

## AUGUST 28-30

*Fourth EIA Conference on Maintainability of Electronic Equipment.* Sponsored by Engineering Dept. of EIA in cooperation with the Dept. of Defense. University of Colorado, Boulder. Details from EIA, 1721 DeSales St., N.W., Washington.

## AUGUST 31-SEPTEMBER 9

*World's Fair of Music & Sound.* McCormick Place, Chicago. All phases of music and sound. Open to public.

## SEPTEMBER 3-7

*International Symposium on Information Theory.* Sponsored by the PGIT, Benelux Section & Belgian Societies. Free University of Brussels, Brussels, Belgium. Program details from F.L. Stumpers, Philips Research Labs., Eindhoven, Netherlands.

## SEPTEMBER 5-7

*Symposium on Measurement of Thermal Radiation Properties of Solids Sponsored by Aeronautical Systems Division USAF, NBS, NASA.* Biltmore Hotel, Dayton, Ohio. Details from C. Robert Andrews, Chairman of Arrangements, University of Dayton, Dayton 9, Ohio.

## SEPTEMBER 13-14

*Sixth National Symposium on Engineering Writing & Speech.* Sponsored by PGEWS of IRE. Mayflower Hotel, Washington, D.C. Program details from J.E. Durkovic, c/o ARINC, 1700 K Street, N.W., Washington.

*Tenth Annual Engineering Management Conference.* Sponsored by IRE, AICHe, AICE, AIEE, AIIE, AIME, ASCE, ASME. Roosevelt Hotel, New Orleans. Program details from J. S. Cave, AT&T, 195 Broadway, New York 7, New York.

## OCTOBER 1-3

*Eighth National Communications Symposium.* Sponsored by PGCS, Rome-Utica Section of IRE. Hotel Utico & Municipal Auditorium, Utico, New York. Program details from George Baldwin, Paris Road, R.D. #2, Clinton, New York.

## OCTOBER 2-4

*Eleventh Annual Symposium on Space Electronics and Telemetry.* Sponsored by PGSET. Hotel Fontainebleau, Miami Beach, Fla. Program details from Otto A. Hoberg, George C. Marshall Space Flight Center, NASA Redstone Arsenal, Alabama.

## OCTOBER 2-7

*New York Hi-Fi Show.* Sponsored by Institute of High-Fidelity Manufacturers, Inc. New York Trade Show Building. Open to public Oct. 3-7.

## OCTOBER 8-10

*National Electronics Conference.* Sponsored by IRE, AIEE, et al. McCormick Place, Chicago, Illinois. Dr. Thos. W. Buller, Jr., E.E. Dept., University of Michigan, Ann Arbor, Michigan, for program information.

## OCTOBER 15-18

*International Symposium on Space Phenomena and Measurement.* Sponsored by PGNS. Staller-Hilton Hotel, Detroit, Michigan. Program details from Michael Ilnat, Avco Corp., 201 Lowell St., Wilmington, Mass. ▲

# Radio & TV News

## Events in the Service Industry

OUR STORY on the ouster of Electronic Service Dealers Association of Western Pennsylvania by the National Alliance of Television & Electronic Service Associations ("Service Industry News," June 1962, p. 94; also July, p. 82), as expected, was not the last word on the matter. The first, prompt reaction from Frank J. Moch, NATESA's executive secretary, reached us before he had received our request for comment. Thus one of his several concerns was our apparent breach of "good journalism" in failing to inquire after NATESA's side. We answered and soon received a second letter. Excerpts of this sequence follows.

### The First Reaction

Concerning our preoccupation with unity, the writer appears to feel that excessive stress on a theoretical ideal that is unattainable in practice may do more harm than good. "The play on unity," he says, "continues to be a grave disservice to the service industry because it is a divisive tactic. NATESA is, as you should know, the biggest, most respected, and most united service group in the 40 odd years of the industry's existence. It is as united as any other group in any other industry."

"Further, because of the wide dissimilarity of purpose, certain other small groups can never be expected to merge. This was proven by the unfortunate, 1955, so-called unity meeting . . . These people went on to form several new groups with what appeared to be your blessing . . . those associated with these other attempts who, at a later date, did affiliate with NATESA, brought with them not unity but consistent attempts to take over or destroy, which terminated with the ouster of ESDA and other actions. Certainly it is the established parliamentary prerogative for any group to purge itself of undesirable members for due cause. The Directors at the Miami conference confirmed, by substantial vote, the ouster. Not one word of defense of Doyle's actions was heard. In your article you indicated that Doyle meant to defend himself and yet he failed to appear. Is this not indicative?"

"Your statements on lack of maturity are a slur against every last servicer, many of whom are subscribers to ELECTRONICS WORLD."

"Your suggestions for an arbitrator to dabble in the affairs of NATESA are unthinkable arrogance."

"May I suggest that even you, Mr. Silver, who have shown such great anti-NATESA bias, would not have dared print that article had you the decency of getting NATESA's side . . ."

### Our Reply

We answered that, although we would obviously take exception to certain points in the letter, it was a relevant

statement worth passing on, as we have done. Portions of our reply follow the points in the NATESA letter (italicized) on which they comment:

*"NATESA is . . . the biggest . . . most united service group . . ."* Probably a statement of fact. We know it is still denied by some unaffiliated groups, but how realistic is such wishful thinking? Recognition . . . should have nothing to do with how one feels about the organization, pro or con.

*" . . . as united as any group in any other industry . . . certain other small groups can never be expected to merge . . ."* Although it is an opinion, this point is well taken. Perhaps it is both unrealistic and unfair to require of NATESA, as of any action group dealing with sensitive matters, the sort of total unanimity that is seldom attainable anywhere . . . Every man must make up his own mind on this point, but there is food for thought.

*"These people went on to form several new groups with what appeared to be your blessing . . ."* We reported the events. We neither bless nor condemn.

*"Your statements on lack of maturity are a slur against every last servicer . . ."* We never leveled the charge against every last servicer. Certainly the disease infects a certain percentage . . . as in every field. And we deplore it anywhere.

*"Suggestions for an arbitrator . . . are unthinkable arrogance."* The suggestion may be unworkable, but it is not arrogant. The concept . . . is frequently unacceptable to the parties of a disagreement, sometimes with reason. Nevertheless, this ancient principle survives because it often works.

*" . . . such great anti-NATESA bias . . ."* We deny such bias categorically . . . we simply ask for an honest review of our treatment of NATESA and other industry affairs over the years. We also ask you to review your own correspondence file. We think you will find, here and there, copies of letters you sent us carrying words of praise . . . We are just as obliged to publish relevant material from sources that may be unfriendly to NATESA as we are to use appropriate NATESA material. That is the way we view 'good journalism.' We continue to be an open forum . . . We cannot sweep events under the rug because they are unpleasant to anyone, as they often are to us.

"After all's said and done, one point of irony remains: there is still scant information on the particular issue that culminated in the ESDA ouster. Does this mean that NATESA is ducking the matter? Not necessarily. It may simply indicate that wisdom has dictated avoidance of the sort of squabbling that can only lead to personal invective and magnification of disputes beyond their inherent importance. If that is the case, we are scarcely in a position to be

critical. After all, have we not deplored this skirmishing in the past?"

### Second NATESA Response

The follow-up letter over Frank Moch's signature presents additional data primarily "in the interests of fair play," since "nothing can be gained by a torrent of cross charges or explanations." Concerning disfranchisement of ESDA, the action was undertaken "by the Executive Council, under authority vested in it and on the basis of authentic evidence before it, which action has subsequently been upheld by a substantial majority of the Director's at the Miami meeting . . . The action . . . by the Executive Council of thirteen, with only one opposing vote . . . was substantiated by the Internal Affairs Committee, which had the case under study for at least three years."

"The offenses of Doyle are many . . . Three years ago he attempted, without the knowledge or consent of ESDA, to usurp the post of Director . . . Two years ago Doyle certified a member list, for which he voted, only to immediately thereafter ask for a refund on five of the alleged members. This last year he again certified a member list and immediately three alleged members voluntarily submitted disclaimers of membership. We have a large stack of legally acceptable evidence to show that Doyle was a key figure in a conspiracy to take over or destroy NATESA, which has not yet fully run its course. Recent resignations in Indiana and some yet to come . . . are part of this conspiracy. We still say that an on-the-spot investigation in Pittsburgh would reveal the facts."

" . . . At the ESDA elections about a year ago, when a stooge was elected president and Doyle secretary, neither received the margin of vote called for by the ESDA by-laws, and under these same by-laws, when a large block of members, including many Board members, resigned en masse in protest over repeated major flaunting of the by-laws and other infractions, ESDA could no longer conduct business because it had no quorum. Further, our completely proper attempt, on two occasions, to check the actual membership of ESDA revealed only five members willing to admit it. And yet in a recent trade-press article Doyle claimed 140 members while listing less than one-third of these with NATESA . . ."

"No, NATESA is not ducking out on the ESDA matter. We felt sincerely that the offenses were so sordid, revelation would not add to the stature of independent service . . ."

### Closing Comments

The "resignations in Indiana" to which Frank Moch refers are those of the Indianapolis TV Technicians Association, over the ESDA matter, and others in the state group (IESA) that are following on its heels. As to our own involvement, we are pleased to say that the second Moch letter is much friendlier in tone than the first. Readers now have the NATESA side. We never planned it otherwise. ▲



# ELECTRONIC CROSSWORDS

By N. F. LAVIGNE, JR.

(Answer on page 92)

## ACROSS

1. Variable resistor.
4. Light amplifier.
9. A wirewound 1 Across.
13. Old English.
14. One volt across one ohm =.
15. Weight (pl.).
17.  $1/(2\pi fC)$ .
18. Current.
19. Sly glance.
21. "J" scan pattern.
22. All the inductance in the circuit (schematic notation).
23. Unit of force.
26. Rare gas.
28. Formula for "E."
30. Chemical symbol.
31.  $C_m \times F_p$ .
32. Egyptian sun god.
33. We must, before we walk.
36. Organization for reformed drinkers.
37. Crystal cut.
38. First letter.
39. Every actor needs one.
41. Carry (colloq.).
43.  $2\pi fL$ .
44. Gas in auto exhaust.
45. Velocity (abbr.).
46. Women.
47. Schematic notation.
48. E/R.
49. 60 cps. for instance (abbr.).
52. Preposition.
53. Tube element.
56. Popular import from Puerto Rico.
58. It appears in Ohm's Law.
59. Used in digital computers.
60. Not me.
61. Its frequency is lower than r.f.

## DOWN

1. Opposite of theoretical.
2. Unit of resistance.
3. Lukewarm.
4. California city (fam.).
5. Reduce.
6. Meter often found in ham rigs.
7. Period of time.
8. Vibrates at natural frequency.
10. English digraph.
11. Parts list abbreviation.
12. British for video.
16. Metal in its natural state.
17. Inductive reactance.
20. It designates voltage.
21. Vertical axis.
25. Tune current for this in a parallel resonant circuit.
27. Speaks eloquently.
29. Means of transportation (abbr.).
31. Small current.
34. Part of a circle.
35. It handles the low frequencies.
40. All inclusive.
42. Eggs.
43. Has a very short wavelength.
48. Charged particle.
50. E/I =.
51. Which (Lat.).
54. Unknown in a formula, indicating a specific quantity.
55. Accomplish.
57. Amplification factor.
58. Heterodyned frequency (abbr.).

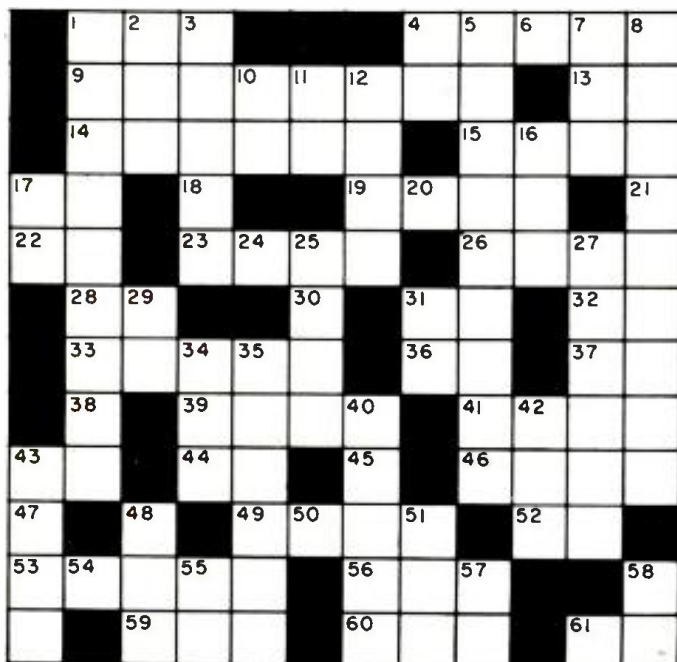

August, 1962

only **DON BOSCO**  
makes the **STETHOTRACER**,

the vest-pocket signal tracer that amplifies 1,000 times and locates defective circuits fast! Detects and demodulates any low level microwatt audio or modulated radio frequency signal.

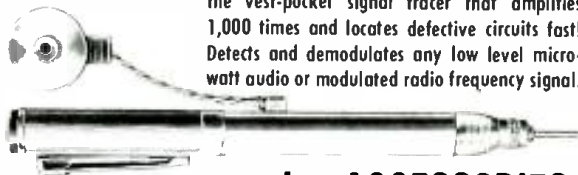

... its **ACCESSORIES**,

including the new, precision-built microwave demodulator, magnetic tape head (monaural), vibration pickup, miniature microphone, input adapter, output adapter, and telephone pickup.

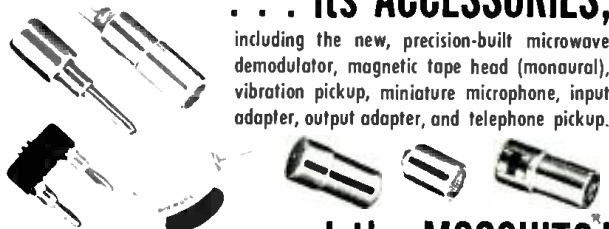

... and the **MOSQUITO!**

The signal generator for every trouble-shooting application. Pocket-size, cordless instrument generates and injects a rich signal covering the audio, IF and RF spectrums. Eliminates need for expensive generators.



World's Foremost  
Producer of  
Precision-Built,  
Pocket-Size  
Test Equipment.



See your local distributor, or write to:

**Don Bosco**  
ELECTRONICS INC.  
Littell Road • Hanover, N. J. • TUCKER 7-5575  
A Subsidiary of Howell Electric Motors Company

## Full Color Giant Fold-Out Charts Still Available!

Here's a complete series of colorful, authoritative fold-out wall-charts (originally appearing in the pages of **ELECTRONICS WORLD**)—yours for only 15¢ each. All in full-color—each suitable for framing.

2. **Hi-Fi Crossover Network Design Charts:** Tells how to build speaker nets for any crossover frequency. Complete coil-winding data, capacitor values given.
4. **Bass-Reflex Design Charts:** Complete data on building own bass-reflex enclosures for any speaker, including ducted-port enclosures.
5. **Radio Amateur Great Circle Chart:** For Hams and short-wave listeners—gives complete listing and map of amateur prefixes by calls and countries.

Reprint of:

7. "Build a Citizens Band Transceiver"—complete details on building an 11-meter transceiver for Citizens Band service.

**IMPORTANT: ORDER BY NUMBER! OUR SUPPLY OF THESE FOLD-OUT CHARTS LIMITED. OFFERED ONLY ON A FIRST COME, FIRST SERVED BASIS.**

Send 15¢ per selection to  
**ELECTRONICS WORLD**

Box 378, Church Street Station, New York 8, N. Y.

# 10,000 Things Electronic To Enjoy

10,000 WAYS TO SAVE IN  
Famous **RADIO SHACK CORPORATION'S**  
Brand New 1963 Electronics Catalog

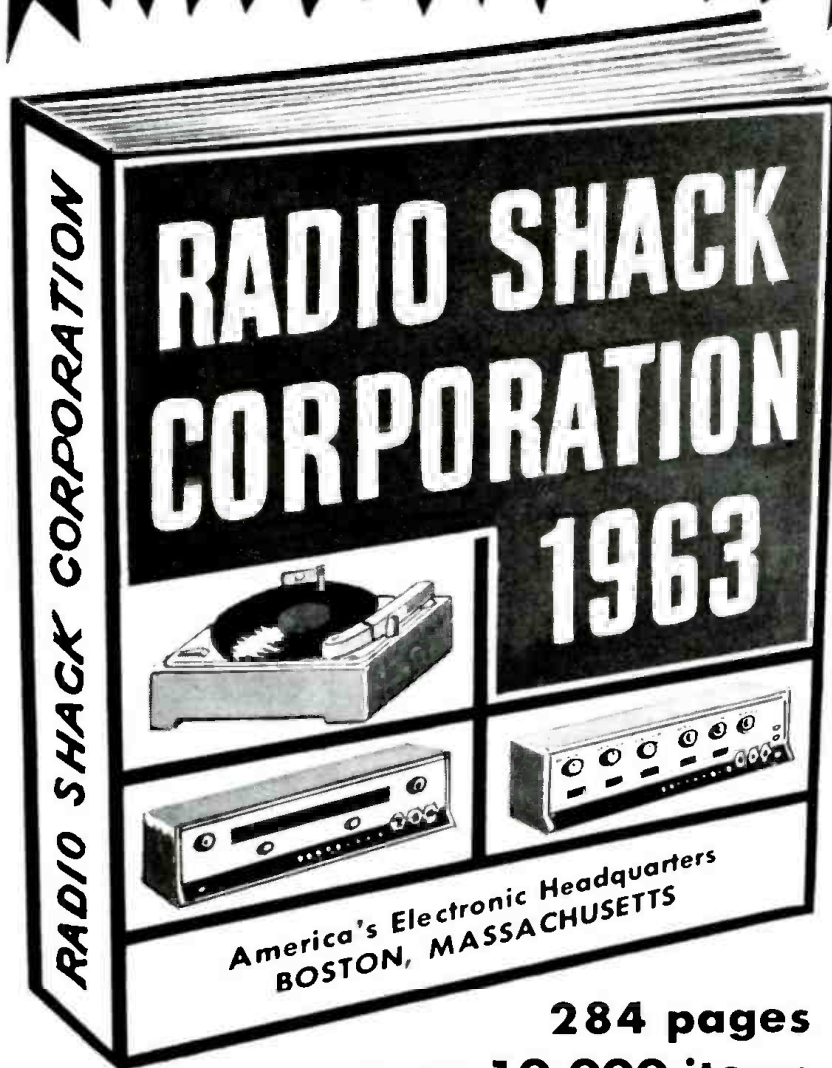

**284 pages**  
**over 10,000 items**

## Partial List of Products in our New 1963 Catalog

- Amateur Radio
- Antennas
- Batteries
- Books
- Capacitors
- Controls
- Hi Fi
- Microphones
- Needles
- Phonographs
- Public Address
- Radios
- Resistors
- Tape Recorders
- Test Equipment
- Tools
- Transformers
- Transistors
- Tubes
- Wire

# FREE

**FOR YOU AND  
TWO FRIENDS**  
Mail Card Today

## The Radio Shack Story

Radio Shack Corporation of Boston, Massachusetts is one of America's big 3 distributors of things electronic to the general public, industry, craftsmen and hobbyists. We offer a complete selection of precision built products by mail, through stores, and direct to manufacturers. Our exclusive REALISTIC® line of electronic products is famous nationwide for its high quality, dependable service and fine values. Our selection of national brand products is the largest in America.

Radio Shack Corporation has been serving the nation since 1923—from the very beginning of the electronic age. This year over 2,000,000 people—music devotees, ham operators, amateurs and professionals—will shop from our catalog because they get the most value for every penny they spend on their favorite products . . . they will buy on the easiest terms, cash or credit . . . they are assured by our guarantee of getting the most satisfaction on every purchase. Radio Shack Corporation invites you and your friends to get your share of these savings and satisfaction by mailing the card opposite today.

ELECTRONICS WORLD



# RADIO SHACK CORPORATION

BOSTON, MASSACHUSETTS  
America's Electronic Headquarters

Deluxe All-Transistor  
80-Watt Stereo Amplifier Kit

**\$139.95**  
\$8 Monthly

Easy Assembly; Fabulous  
Savings! Features  
Massive Transformers!



The proud result of creative engineering, this Realistic® HK-208 80-Watt Stereo Amplifier sets new standards of transient response and definition, delivers an extra margin of performance. Premium Minneapolis-Honeywell tetrode transistors utilized throughout! A host of spectacular technical features make this the unqualified leader in its field! 16½x7½x14½". No money down. Satisfaction guaranteed.  
30K90LX093, Amp. Kit, Wt. 19 lbs., \$8 Monthly, Net 139.95

LOOK FOR  
**RADIO SHACK'S**  
Nationally Famous

**REALISTIC** KITS

in our 1963 Catalog

Save up to 40% on our  
exclusive precision-en-  
gineered equipment  
kits. All easy to as-  
semble! See outstand-  
ing selection below.



12" Hi-Fi Speaker Kit  
Can Be Built in an Evening!  
**\$5 Monthly \$19.95**

Enjoy the fun of building the world's only hi-fi speaker in kit form . . . another Realistic® exclusive from Radio Shack! Assemble the entire speaker, from 1¾ lb. magnet to voice coil, basket and dual cone, using a precision jig for perfect alignment. No money down. Satisfaction guaranteed. Ship. wt. 7½ lbs. 40K90LX370, 12" Speaker . . . . . \$5 Monthly, Net 19.95

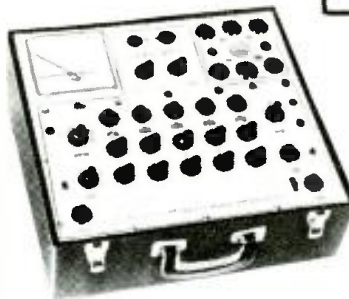

New! Professional Tube Tester Kit  
Realistic® Design! **\$99.95**  
Professional Accuracy!

Checks the complete condition of virtually all tube types with laboratory precision! Also tests transistors, incl. diodes, triodes and tetrodes, for leakage and gain. Roll-chart gives full test instructions. 16½x7½x14½". Cover and instructions included. No money down. Satisfaction guaranteed. Wt. 25 lbs. 22K94LX010, TK-113 Kit . . . . . \$6 Monthly, Net 99.95

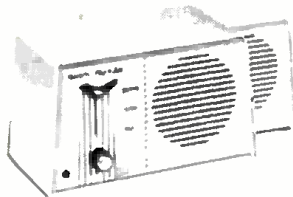

WIRELESS INTERCOM KITS

**2 KITS FOR \$29.50**

Easy to Build, Operate!  
Just Plug In and Talk!

Add convenient room-to-room, floor-to-floor intercommunication for truly modern living! Just plug into your house current and talk. Range over 1 mile. Size: 8x5x5". No money down! Wt. 10 lbs. 43K90LX844, Kit (pair) . . . . . \$5 Monthly . . . Net 29.50



Electronic Thermometer Kit  
Famous "Novatherm" **19.95**  
Accurate to ½°F.

Another Realistic® exclusive! Equal to precision thermometers selling for \$80 and up! Easy to assemble. Fast reaction to temperature change. Ideal for darkrooms, laboratories, freezers, amateur radio equip. Size 3¾x6¼x4½". Builder's manual included. No money down. Satisfaction guaranteed. 22K94LX095, Novatherm Kit, Wt. 5 lbs., \$5 Mo., Net 19.95



Good Quality FM Tuner Kit  
Realistic® Components  
Carefully Engineered **19.95**

For maximum listening enjoyment and top economy, it's Realistic's FM Tuner Kit! A pleasure to assemble. Lets you add quality FM reception to your home music center . . . at fantastically low cost! Incl. brushed gold case, instructions. No money down. Satisfaction guaranteed. 31K90LX070, Sh. wt. 6 lbs., \$5 Monthly . . . . . Net 19.95



FM Multiplex Adapter Kit  
Converts Monaural  
FM Tuners to Stereo! **19.95**

Fully self-powered; famous Realistic® quality; completely pre-aligned! No test equipment needed. Resp.: 50-15,000 cps, ±3db. Size: 3½"H x 4" W x 5"D. Black case incl. Uses 15 watts, 105-125V, 50/60 cy. Easy-to-follow instructions. No money down. Satisfaction guaranteed. 31K90LX099, Ship. wt. 4 lbs. Kit . . . . . \$5 Monthly, Net 19.95

## NO MONEY DOWN CREDIT TERMS

take up to 2 years to pay

## GUARANTEE

In addition to the manufacturers guarantee and warranty, Radio Shack Corporation guarantees complete satisfaction on every purchase or your money back.

### MAIL THIS ORDER FORM TODAY

Radio Shack Corporation P.O. Box No. 309  
Boston, Massachusetts 62H6

Name \_\_\_\_\_  
Please Print

Address \_\_\_\_\_

City & Zone \_\_\_\_\_ State \_\_\_\_\_

Please send me the following items:

Stock No.	Quantity	Name of Item	Price each	Total Price

Check or Money Order Enclosed (No Stamps, No C.O.D.'s)  
\* Express charges collect on delivery

† Conn. residents add 3½%,  
R.I. residents add 3% Sales Tax

Total for Mdse. \_\_\_\_\_

Amt. for Postage \_\_\_\_\_

\*Tax \_\_\_\_\_

**TOTAL AMOUNT** \_\_\_\_\_

# Patent Information for the Inventor

By JOSEPH F. VERRUSO  
Senior Lab Technician, Westrex Corp.

## Part 2. The procedures followed by the Patent Office leading up to the granting of a patent.

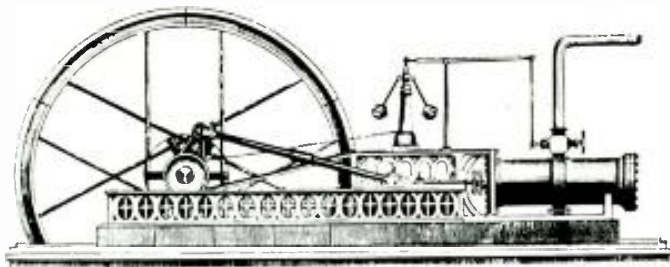

**I**N LAST month's installment, the author discussed the basic steps to be followed by an inventor in applying for a patent. Now, we consider what happens to a patent application after submission to the Patent Office.

With the application on its way to the Patent Office, the long wait begins, for it may take from 3 to 3½ years before a patent may be granted. The patent application process is a slow one as compared to the great scientific achievements taking place each day in our electronic era.

New methods are being sought by the Patent Office to reduce the amount of time involved in processing patent applications. By reducing this time and making the patents available to the public now and not 3 or 4 years from now, the engineer or scientist may be provided with the solution to some of his present-day problems.

Until a new application process is developed, however, the inventor will have to wait the prescribed time—for the final reward for an inventor's perseverance is a patent granted for his invention or process. With this in mind, we will proceed to show what steps are taken from the time the application arrives at the Patent Office until the final patent is granted.

### Application Procedures

When the application is received at the Patent Office, it is first examined for the proper filing fee and excess claims fee. If the appropriate fee is enclosed, the clerk will stamp the date of receipt on the first page of the application. This date is important, for it can mean the success or failure of a patent petition if any question should arise over the priority rights of the invention. Minor errors are not unusual, even with experienced inventors. If minor errors are detected, the inventor may be asked by mail to correct these errors, but if

important parts of the application are missing, such as the signature of the inventor or the oath, the application is considered incomplete.

When the application is complete and in order, it will be forwarded to the Application Branch of the Patent Office where it is examined once more. If the application is found in order, a serial or file number is then stamped on the application. The terms "serial number" and "file number" are used interchangeably in Patent Office language. Once the serial number is placed on the application, the filing fee cannot be returned to the inventor.

The words "patent pending" and "patent applied for" come into play now. With the application assigned a serial number, some inventors may decide to place their inventions on the public market. However, the words "patent pending" on the article for sale by the inventor, does not have any legal effect. The words "patent pending" or "patent applied for" only serve as a warning to other manufacturers that a patent is in the works and infringers may be liable to the inventor once a patent is granted.

The application is then placed in a file jacket, all the contents are listed on the front of the jacket, and the whole file is forwarded to the Record Branch of the Patent Office. The application is then processed through a series of automatic machines and punch-type typewriters, which prepare index cards for Patent Office records. During this time the drawings are placed on microfilm as a permanent record. The original application is then placed in the file jacket and examined to insure that all the relevant matter has been returned to the file.

The file jacket is then forwarded to a "routing specialist" of the Application Branch, who examines the application thoroughly and determines which examining division is then best suited to

evaluate that particular application.

A potential patent falls into three distinct categories: chemical, electrical, or mechanical. These are classified as groups, with Group I assigned to chemical, Group II to electrical, and Groups III to VII to mechanical inventions. These groups are subdivided into divisions, with each division having its own distinct field, relating to its particular group. For example, an invention relating to electronics will fall into Group II, which may have as many as 11 diversified divisions. Division 41, for example, evaluates applications on various television arts while Division 51 is concerned with applications relating to radio circuitry and electrical systems used for frequency control. The last division of any group is assigned the title of "Security Division." It is the responsibility of this division to evaluate the application for possible interest to the defense agencies.

The routing specialist will forward the application to the proper examining division, where a primary patent examiner will be assigned to evaluate the invention. The inventor is then notified by mail as to the division handling his application. The primary examiner reads the application thoroughly and refers the application to one of his assisting examiners who is judged best qualified to pass on the patentability of the invention.

The assistant examiner reviews applications in order, as determined by the serial number stamped on the application. It may take as long as six months before an assistant examiner is able to read the application. When the application finally comes up for examination, the examiner will read the application thoroughly and carefully inspect all drawings. If there are any minor errors the examiner will not delay the application any further. If the errors are such that the examiner cannot understand the invention, he will contact the inventor and request that the errors be rectified. The inventor will be expected to reply promptly.

The assistant examiner has at his disposal all the facilities of the Patent Office which includes the search room and scientific library. He is kept abreast of the achievements taking place in his particular field by means of published material, technical magazines, and clippings—which in some cases may assist him in the evaluation of an invention. The examiner checks each claim carefully for any possible infringements on other patents. If there is any flaw in the claims, which is to be expected due to the broad language in which they are written, the examiner will notify the inventor of these rejections. The examiner expects that the inventor will do all in his power to convince him that the claims are valid. The inventor is required to answer "action letters" from the examiner within six months and if he fails to do so, the application may be considered abandoned. However, a case is not officially abandoned until after the second or third action letter.

If the inventor wishes, he may request a conference with the examiner



to discuss subject matter that he is unable to convey in writing. The examiner welcomes these conferences so that each side can discuss the invention in less formal language. As a result, a compromise may be reached which may lead to the issuance of a patent.

#### Final Reward: A Patent

Once the application has passed the thorough examination given by the Patent Office and a patent is finally granted to the invention, the inventor will be notified by mail to send a final filing fee of \$30 and \$1.00 for every claim over twenty. Patents are issued every Tuesday at noon by the Issue and Gazette Branch of the Patent Office. The patents are then delivered to the Post Office for mailing to the applicants.

The patent is issued in the name of the United States of America, under the seal of the Patent Office, and signed by the Commissioner of Patents. The patent will give the title of the invention, plus the statement that the patent is being granted to the inventor, his "heirs or assigns for the term of seventeen years," giving him the right to prevent others from "making, using, or selling" the invention throughout the United States. The patent will refer to the specifications and drawings, and printed copies are made part of the patent.

Patents are granted for a period of seventeen years from date of issuance. However, this term can be extended in a number of ways, if the inventor so desires. For example, the inventor has six months in which to pay the final fee. By delaying this payment until the last possible day, the inventor may be able to negotiate a profitable deal with the knowledge that the patent has already been granted on his invention. This is only one method of extending the life of a patent, but the inventor should have professional advice before attempting this ploy.

Once a patent has been received by the inventor, it is no longer under the control of the Patent Office. If an infringement on the patent should occur, the inventor must defend his rights in court.

After the patent has been issued to the inventor there is no guarantee he will make a profit on the patented invention. As discussed last month, to insure a profit the invention must have features that are outstanding and attractive to the public. Even if a profit does not result from the patent, the prestige alone may be well worth the time and perseverance involved in obtaining the patent. ▲

#### BIBLIOGRAPHY

- Publications obtainable from the U.S. Patent Office, Washington 25, D.C., by remittance payable to the Commissioner of Patents: Patents (as issued)—order by patent number or inventor's name and date of issue, 25 cents each.
- Publications obtainable from the Superintendent of Documents, U.S. Government Printing Office, Washington 25, D.C. or the nearest field office of the U.S. Department of Commerce:
  - "Guide for Patent Draftsmen," 15 cents
  - "Patent Attorneys and Agents Available to Represent Inventors Before the United States Patent Office," 35 cents
  - "Patent Laws," 30 cents
  - "Patents and Inventions—An Information Aid for Inventors," 15 cents
  - "Rules of Practice of the United States Patent Office in Patent Cases," 50 cents

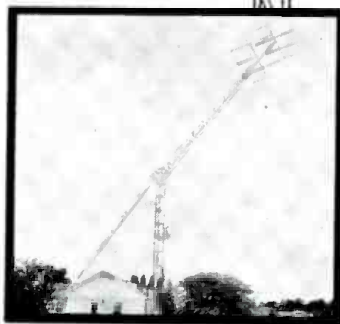
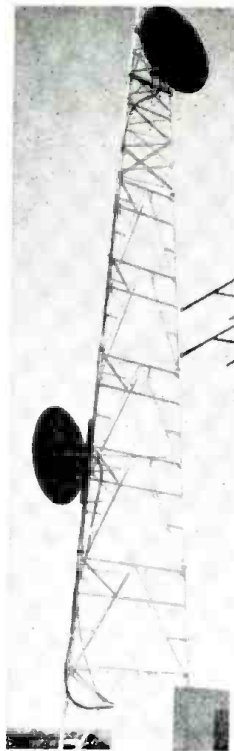

The most Famous Name in  
**TOWERS of ALL KINDS!**

Here are the advantages you get  
when you insist on **ROHN TOWERS**

**LARGEST FULL RANGE OF TOWERS**—you can get anything from home TV and amateur radio towers to heavy-duty communication and micro-wave towers. Included are 170 foot self-supporting towers, 1,000 foot guyed towers, and "fold-over" towers. Regardless of your needs, ROHN can supply it.

**UNQUESTIONED LEADERSHIP IN DESIGN AND MANUFACTURE**—you get the latest in advanced tower engineering. All communication towers are engineered to EIA specifications, and are proved by thousands of installations. No other manufacturer can surpass the quality and fine reputation of ROHN.

**QUALITY MATERIALS AND WORKMANSHIP**—Only highest quality steel is used which fully meets the specifications for the job. ROHN towers are hot-dipped galvanized **after fabrication**—a feature ROHN pioneered!

**SERVICE WHEREVER YOU WANT IT**—ROHN representatives are world-wide. Complete erection service for communication systems, broadcasting, micro-wave, and other needs is available; also competent engineering service to help you.

**Settle for the BEST in TOWERS**—ROHN—today the world's largest, exclusive manufacturer of towers of all kinds!

For your needs, contact your local ROHN salesman, distributor or dealer; or write direct for information.

SEND THE HANDY COUPON INDICATING YOUR NEEDS

**ROHN**  
Manufacturing  
Company  
BOX 2000  
PEORIA, ILLINOIS

ROHN Manufacturing Company  
Box 2000  
Peoria, Illinois

Send me complete literature on the following ROHN Products:

- |   |  |
|---|--|
| <input type="checkbox"/> Home TV Towers       | <input type="checkbox"/> Amateur Towers            |
| <input type="checkbox"/> Communication Towers | <input type="checkbox"/> AM-FM Broadcasting Towers |
| <input type="checkbox"/> Micro-Wave Towers    | <input type="checkbox"/> Government                |

Name \_\_\_\_\_

Firm \_\_\_\_\_

Address \_\_\_\_\_

City \_\_\_\_\_ State \_\_\_\_\_



If you've recently changed your address, or plan to in the near future, be sure to notify us at once. We'll make the necessary changes on your mailing plate, and see to it that your subscription continues without interruption. Right now—print the information requested in the spaces below and mail it to: ELECTRONICS WORLD, 434 So. Wabash Ave., Chicago 5, Illinois.

Name *Please PRINT!* \_\_\_\_\_

\*Account No. \_\_\_\_\_

Old Address \_\_\_\_\_

City \_\_\_\_\_ State \_\_\_\_\_

New Address \_\_\_\_\_

City \_\_\_\_\_ Zone \_\_\_\_\_ State \_\_\_\_\_

Mail copies to new address starting with \_\_\_\_\_ issue.

\* (Your Account Number appears directly above your name on the mailing label.)



# Technical Books

**"TELEVISION ENGINEERING: PRINCIPLES OF PRACTICE"** by Amos & Birkinshaw. Published by *Iliffe Books Limited*, London SE. 1, 273 pages. Price 36s/2 d including postage. Vol. 4 "General Circuit Techniques."

This is the second edition of the fourth and final volume in the *BBC Engineering Training* series covering the fundamentals of television theory and British practice.

This volume covers a wide range of circuit techniques which are applicable to electronics as well as television. There are sections on field and line output stages which have been completely rewritten and updated in this new edition.

The text also includes counter circuits, frequency dividers, principles and practice of d.c. restoration and clamping, gamma control amplifiers, delay lines, fixed and variable equalizers, electrical scanning coils, and the shunt-regulated amplifier.

No concessions are made to those weak in mathematics so would-be readers are hereby warned to sharpen their techniques before tackling this text.

**"AUTO RADIO MANUAL"** compiled by Sams Staff. Published by *Howard W. Sams & Co., Inc.*, Indianapolis. 160 pages. Price \$2.95. Soft cover. Vol. 14.

This is Vol. 14 in the publisher's compilation of service data covering radio receivers used in automobiles. This book covers 60 models produced in 1960 and 1961 and, like the preceding volumes, provides complete schematics, parts lists, chassis photos, resistance charts, alignment information, push-button adjustments as well as many time-saving servicing shortcuts.

Units marketed under the following brand names are included: *American Motors, Automatic, Blaupunkt, Buick, Chevrolet, Ford, Lafayette, Mopar, Motorola, Oldsmobile, Opel-Rekord, Pontiac, Riverside*, and *Stromberg-Carlson*.

**"RADIO REGISTRY: INDUSTRIAL RADIO SYSTEMS"** compiled and published by *Communication Engineering*, Mineola, N.Y. 313 pages. Price \$7.00.

This 1962 directory includes the additions, changes, and deletions which have occurred since last year's directory was issued in a special section for rapid checking and verification. The regular portion of the registry lists special industrial, petroleum and gas pipeline, power utility, forest products, relay press, motion picture, and v.h.f. mari-

time assignments first by licensees and then in a separate section by frequencies.

Those involved in two-way industrial radio installation, servicing, and troubleshooting will find this manual invaluable in their work. The mail address of the licensee, the locations of fixed stations, authorized mobile stations, call letters, frequencies, and the manufacturer of the equipment being used are all included in the tabulation.

**"1962 REPLACEMENT GUIDE FOR TV AND AUTO RADIO CONTROLS"** compiled by Sams Staff. Published by *Howard W. Sams & Co., Inc.*, Indianapolis. 126 pages. Price \$1.00. Soft cover.

This is a new and enlarged Fourth Edition of a popular reference work which covers replacement controls for 30,640 TV models and 1286 auto radio models. All the currently available and recommended radio and TV control replacements, as produced by *Centralab, Clarostat, CTS-IRC*, and *Mallory*, are included.

The material is completely cross-referenced and indexed by receiver manufacturers' parts numbers, industry numbers, control manufacturers' equivalents, and then further indexed in an industry-number replacement control section.

**"REVOLUTION IN ELECTRICITY"** by Martin Mann. Published by *The Viking Press, Inc.*, New York. 163 pages. Price \$5.00.

This is a popular treatment of the subject of semiconductors—their discovery, development, and application. Informed laymen will find this volume both instructive and entertaining. The author's style is informal and lively and the text is lavishly illustrated. He discusses crystal structure, transistors, masers and tunnel diodes, cryogenics, supermagnets, and prognosis for the future.

We believe that even those involved in electronics professionally will find much material of interest in this fascinating volume.

**"REPAIRING HOME AUDIO SYSTEMS"** by E. Eugene Ecklund. Published by *McGraw-Hill Book Company, Inc.*, New York. 311 pages plus "Hi-Fi Detecto-O-Scope Trouble Finder." Price \$6.95.

This is a complete treatise on how to troubleshoot, repair, and test amplifiers, preamplifiers, AM and FM tuners, record changers and turntables, tape decks,

speakers and speaker systems as used in both stereo and mono installations.

In keeping with the "practical" aspect of this volume, there are separate chapters on the profit opportunities in home audio servicing, the shop facilities and tools required, basic information on the operation of preamps, amplifiers, and tuners; repairing such components; phonograph records; replacing pickups and needles; record changers and their motors and drives; repairing tripping and dropping mechanisms; cycling pickup arms in changers; shut-off mechanisms; troubleshooting changers; tape recorders and their troubleshooting; plus the troubleshooting of complete music systems.

The use of hundreds of detailed line drawings helps the user visualize the various component parts involved in the troubleshooting procedures.

**"RADIOTELEPHONE LICENSE MANUAL"** by Woodrow Smith. Published by *Editors and Engineers, Ltd.*, Summerland, Calif. Price \$5.75. Third Edition.

This is a revised and up-dated study aid for those preparing to take FCC license examinations. Based on the first four elements of the government license manual, this volume indicates the scope of the questions included in the various elements in the radiotelephone license test.

The book is divided into the four elements (basic law, basic operating practice, basic radiotelephone, and advanced radiotelephone) and an appendix which includes formulas, mathematical calculations, and log tables.

The presentation is in the familiar "question and answer" form and those working toward their tickets will find this volume a valuable help.

**"HOW TO BUILD ELECTRONIC EQUIPMENT"** by J. Richard Johnson. Published by *John F. Rider Publisher, Inc.*, New York. 287 pages. Price \$6.95.

This is a thoroughly practical handbook for anyone who enjoys building his own electronic gear from kits or from scratch. Since the treatment is progressive, the reader can "enter the lists" at the point corresponding to his previous training and experience.

For those with no prior acquaintance with electronic construction, the author starts with the fundamentals such as selecting tools on a progressive basis, chassis and breadboards, the layout and mounting of components, soldering techniques, wires and wiring, cables and connectors and continues with pictorials, wiring, schematics and block diagrams; the wiring of components; circuit wiring; coil and coil winding; up to checking the completed circuit.

Probably the outstanding feature of this volume is the lavish use of actual construction photos illustrating every step described in the text as well as showing in detail the tools and equipment mentioned by the author. ▲

*Note: In connection with our June review of the book "Practical Television Servicing" by J. Richard Johnson, price of book was listed incorrectly. It should be \$7.95.*

ELECTRONICS WORLD



## Low-Frequency Converter

(Continued from page 50)

periodically in the "Airman's Guide" obtainable from the Government Printing Office, Washington 25, D.C. for 40 cents a copy (ask for an issue containing the station directory); or from the sectional aeronautical map for your area, which is available at most airports and is officially distributed by the U.S. Coast and Geodetic Survey, at forty cents a copy, postpaid. These maps are frequently revised and corrected.

Continuous weather broadcasts and other emissions from the radio-range

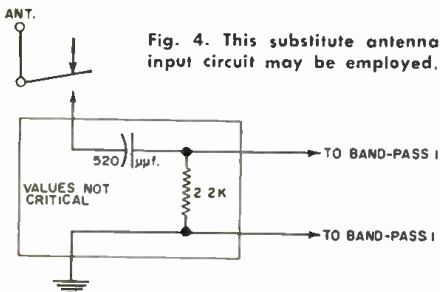

Fig. 4. This substitute antenna input circuit may be employed.

stations are of "communications" rather than "broadcast" audio quality. Power output is low so that static is sometimes a problem, making use of the main receiver noise limiter mandatory. Currently, interference is frequently serious, but the FAA and other agencies are making definite efforts to reduce this.

The 1020-cycle range signal, which accompanies some of the weather broadcasts, can be eliminated by use of an audio filter, such as a "Selectoject," or a surplus FL-8-A (or similar) audio filter. Current FAA plans call for the gradual elimination of this signal at many of the radio-range stations.

Converter performance, when used with a good grade general-coverage receiver with adequate shielding, is entirely satisfactory. Direct comparison shows that reception with the converter is slightly superior to direct reception with either an RAK-7 or an unmodified BC-453 but slightly inferior to that with a BC-453 to which a band-pass front end has been added to eliminate broadcast-station "feed through."

### REFERENCES

1. Genaille, Richard A.: "Below the Broadcast Band," *ELECTRONICS WORLD*, Sept. 1961.
2. Terman, F. E.: "Radio Engineers' Handbook," McGraw-Hill Book Company, 1943



"Don't reach out too... whoops! Hang on I'll get the ladder."

**R** FOR "DOCTORS OF SERVICING"



## on emergency calls...

Be sure to spray Shield on electrical contacts and switches. A few squirts of this trouble-shooter extraordinary *before* servicing cleans the set cleaner, lubricates it better—often cleans up the trouble at once. A "shot" *after* servicing provides sure-shot protection that lasts. Silicone Base means Total Cleaning Power. Write for handy guidebook to better cleaning. Channel Master Corp., Ellenville, N.Y.

The Professional Service Man's Cleaner

FREE! 7" extension tube with every can! Reach everything easy!

C 1962 CMC

**ENGINEERING DEGREE IN SCIENCE MATH 27 or 36 MOS.**

**B.S. degree - 36 mos. • B.E. degree - 27 mos.**  
 Accelerated year-round program Prepares for early employment in fields of Science and Engineering. Regular 4-year program for B.S. Degree completed in 36 months special engineering degree program in 27. Classes start - September, January, March, June, July. Quality education. Graduates employed from coast to coast. Government approved for veteran training. Students from 50 states, 40 countries. 20 buildings; dorms, gym, Campus. Save time and money. Earn board while studying. Write for catalog and complete information.  
 982 E. Washington Blvd., Fort Wayne 2, Indiana

**INDIANA TECHNICAL COLLEGE**

## SAY YOU SAW IT IN Electronics World

**BC-221 FREQUENCY METER. \$69.50**  
 "LIKE NEW" with original Crystal and original Calibration Book ..... Only  
 With Modulation ..... 89.50

**AN/APN-9 LORAN Receiver-Indicator with 24 Vac. Inverter Checked out. Exp. 124.95**

**AN/APN-4B LORAN Receiver-Indicator with 24 Vac. Inverter Checked out. Exp. 89.50**

**AN/APN-4 ..... 38-2200 MC Receiver with 1 Tuning Units. Excellent. 359.50**

**MAGNESYN COMPASS SYSTEM COMPLETE. Remote reading in plane or boat. Excellent condition. With Manual. 24.95**

**ARC-3 AM Receiver and Transmitter. 100-150MC. Excellent. Both for only 27.95**

Send Money Order or Check with Order  
 Write for Latest Flyer—LOADS OF BARGAINS!

**R W ELECTRONICS**  
 2430 S. Michigan Avenue Dept. EW  
 Phone: CALUMET 5-1281 Chicago 16, Ill.

### UNUSUAL SURPLUS BARGAINS

WE-255A Polar Relay for TTP .....	\$ 4.50
Hard to find sockets for above .....	2.50
Allied MHX-175 HS Submin. 26.5 vdc. 6 "C" contacts—New .....	3.50
Allied hi-volt relay 1R1-4 spdt—db. 26.5 vdc 6KV contacts—New .....	5.00
Chopper Stevens Arnold =222—18 vac. coil 110 vdc max. out.—New .....	5.00
Velvet vernier with knob and dial—New .....	2.50
600 ohm 30C watt non-inductive resistor .....	2.50
Bird model 74 coax switch 6 posn .....	22.50
Bird model 6250 watt meter 30-500 mc/s 250 milliwatts—New .....	45.00
Sperli vacuum SW for ART-13 etc.—New .....	1.00

### NEW TUBES

2C39A ..... 7.50	5V4G ..... .75	6AH6 ..... .90
3C100A5 ..... 14.50	5R5GY ..... .50	6AQ5 ..... .50
4X150A ..... 12.50	6AK5 ..... .50	6AL5 ..... .50
5881A ..... 1.50	6AG5 ..... .35	6J6 ..... .35
6F4 acorn ..... 1.75	6AS6 ..... .75	6X4 ..... .35
721B ..... 3.50	12AU7 or ..... .50	OB2 ..... .40
807 ..... 1.25	12AT7 ..... .50	12AX7 ..... .65

**COAX CONNECTORS PL-259—SO-239—M-359—UG-88/U—UG-100A/U any 3 1.00**

**RADIAC SET T-219—Automatically sets off alarm when exposed to radiation for pre-set time. Complete with ni-cad batteries, charger, and housed in portable carrying case.—Like new ..... 75.00**

**RCA DIRECTION FINDER DAE-1. 3 Band 240-2000 KC, 115 VAC with loop and cable. Complete, like new ..... 94.50**

**M-15/UR MICROPHONE. Noise-cancelling version of T-17. Latest specs Ideal for aircraft, mobile, marine etc. Brand new ..... 14.50**

WRITE FOR FREE BULLETIN —EW

Min order \$5.00. Pse include postage. Excess refunded immediately. All prices FOB our Warehouse, Bronx, N. Y.

Money back guarantee

**Space ELECTRONICS CO.**  
 218 West Tremont Ave., Bronx 53, New York  
 Tremont 8-5222

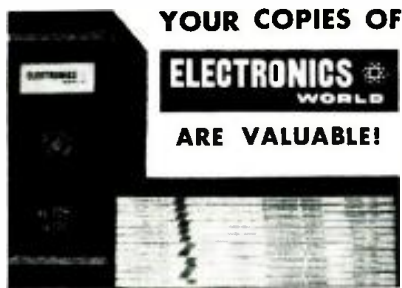

Keep them neat... clean... ready for instant reference!

Now you can keep a year's copies of ELECTRONICS WORLD in a rich-looking leatherette file that makes it easy to locate any issue for ready reference.

Specially designed for ELECTRONICS WORLD, this handy file—with its distinctive, washable Kivar cover and 16-carat gold leaf lettering—not only looks good but keeps every issue neat, clean and orderly.

So don't risk tearing and soiling your copies of ELECTRONICS WORLD—always a ready source of valuable information. Order several of these ELECTRONICS WORLD volume files today. They are \$2.50 each, postpaid—3 for \$7.00, or 6 for \$13.00. Satisfaction guaranteed, or your money back. Order direct from:

**JESSE JONES BOX CORP.**  
Dept. EW  
(Established 1843)  
Box 5120, Philadelphia 41, Pa.

## Impedance Bridge

(Continued from page 47)

short distance. The first indication of an increase in resistance is the beginning of the arc. Temporarily mark these points on the front panel with a pencil or some erasable marker.

2. With a compass, divide this arc into about 20 divisions.

3. Calculate where the calibrations belong with the formula:  $(\% \text{ of rotation}) \times (\text{total no. of marked divisions}) / 100 = \text{no. of divisions}$ . For example, say you marked off the divisions and came out with a total of 21.4. Arbitrarily take the resistance or capacitance value from Table 2. If, for example, you take "9," the corresponding per-cent of rotation would be 45.4. This is then substituted in the formula:  $45.4\% \times 21.4 / 100 = 9.73$  divisions. Mark the "9" on the front-panel scale 9.73 divisions from the beginning. Determine further percentages of rotation for the front panel from Tables 1 and 2 in the same way.

4. Intermediate calibrations can be interpolated accurately enough. The formula given with each table can be used to find other values that may be desired.

5. Permanently calibrate the front panel with decals to give a professional appearance. Also mark the extremes of knob rotation so that the knobs can be replaced accurately should they be removed.

### Operation

Operation of the bridge is uncomplicated but the inductance measurement is the most difficult. Both  $R_{21}$  and  $R_{22}$  must be adjusted simultaneously. Multiplier switch  $S_2$  may have to be set by trial and error. As mentioned, the setting of  $R_{22}$  has no effect on the inductance bridge. Its adjustment is necessary to obtain balance.

The capacitance and resistance bridges are easy to operate. Merely find the correct multiplier and set  $R_{22}$  for a null.  $R_{21}$  is out of the circuit on these two functions.

To use the comparison bridge, connect a component, whose value is

10 <sup>-5</sup> HENRY'S	% ROTATION
1	0
2	10
3	20
4	30
5	40
6	50
7	60
8	70
9	80
10	90
11	100

% Rotation = 10L - 10

Table 1. Per-cent rotation vs calibration for the inductance balance control,  $R_{21}$ .

OHMS OR $\mu\text{f.}$	% ROTATION
3	2.5
4	12.2
5	20.6
6	27.9
7	34.4
8	40.3
9	45.4
10	50.0
11	54.3
12	58.1
13	61.5
14	64.8
16	70.4
18	75.5
20	79.4
22	83.3
25	87.8
30	94.2
35	99.1
36.1	100.0

% Rotation =  $(138.3R - 383) / (10 + R)$

Table 2. Per-cent rotation vs calibration for balance control  $R_{22}$  (cap., res.).

known, to jacks  $J_1$  and  $J_2$  ( $E$ ). The unknown is connected, as usual, to jacks  $J_1$  and  $J_2$ . The bridge can now be balanced by varying either the standard or  $R_{22}$ . However, the range of  $R_{22}$  is somewhat limited and may not be broad enough to effect balance. The unknown in terms of the known and in respect to the setting of  $R_{22}$  is:  $\text{unknown} = .1 \times (\text{setting of } R_{22}) \times (\text{known})$  for resistance or inductance. For capacitance it is:  $\text{unknown} = 10 / (\text{setting of } R_{22}) \times (\text{known})$ .

To sum it up, this compact impedance bridge is a handy and worthwhile investment in time and money for the experimenter, designer, or technician. ▲

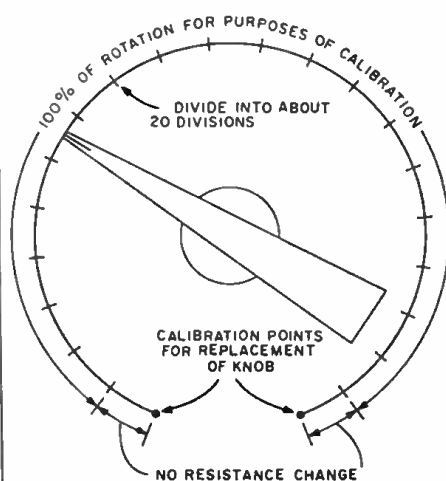

Fig. 7. Use this scale as your guide when calibrating the balance control,  $R_{22}$ .



"Solder! ... Iron! ... Pliers! ..."

ELECTRONICS WORLD



# New Products and Literature for Electronics Technicians

*Additional information on the items covered in this section is available from the manufacturers. Each item is identified by a code number. To obtain further details, simply fill in the coupon appearing on page 96.*

## VELOCITY PICKUP CALIBRATOR

**1** Tel-Instrument Electronics Corp. is now offering a new portable velocity pickup calibrator, the Model 510.

Designed primarily to recheck the calibration of velocity pickup transducers, the new unit is particularly useful for field checking or where a quick laboratory check becomes necessary. The instrument operates from 115-volt, 50/60 cps



sources. It calibrates pickups weighing up to 12 ounces with an accuracy of 1% in either vertical or horizontal planes. The instrument is completely portable, weighing only 26½ pounds, and has a self-contained shaker.

The precision potentiometer dial is calibrated from 50 to 150 mv./in./sec.

## TRANSISTORIZED COUNTER

**2** Northeastern Engineering, Inc. has recently introduced a transistorized 1-mc. counter, the Model 1530. The fully transistorized unit employs seven "Nixie" tubes for presentation of read-out information.

A simple push-button switch provides rapid



selection of the required facilities; decimal point placement is automatic. Frequency range is from 10 cps to 1 mc. and the maximum period measurement frequency is 100 kc. Standard output frequencies include: 1, 100, 10,000, 100,000, and 1 mc. The unit measures 12" x 9" x 17".

## SPECIAL SOLDERING TOOL

**3** Unger Electric Tools is now marketing a special soldering iron designed to meet the needs of intricate production line assembly operations in electronic, missile, and space industries.

Featuring a new heat-sink principle wherein a double cushion of air, combined with five heat transition surfaces, evenly dissipates heat and keeps the iron handle cool, the new unit is being



offered in pastel shades to reduce operator fatigue.

The 25/30/40 watt long life heat cartridges reduce watt density and insure longer electrical life. There are 11 interchangeable thread-on soldering tips for various applications.

## DYNAMIC BETA TESTER

**4** RD Instruments Division is now marketing the Model 1885 dynamic beta power transistor tester, a completely transistorized instrument which measures beta and leakage with accuracy of ±3%. It features a pulse technique for the dynamic beta test with pulse width continuously variable from 0.1-1.00 msec.

The instrument can also test diodes, zener diodes, tunnel diodes, silicon controlled rectifiers, and photo diodes. Collector voltage is contin-



uously variable from 0 to 100 volts, with up to 50 amps current. Base voltage is continuously variable from 0 to 10 volts with up to 5 amps current. A roll chart lists data for beta and leakage tests on more than 1550 transistors.

The unit measures 18" x 10½" x 11½" and weighs 17 pounds.

## PORTABLE FLUORESCENT

**5** IFT Industrial Products Division is now in production on a portable, long-life fluorescent lamp which is powered by ordinary flashlight batteries. Using one type of flashlight battery, the



lamp provides a minimum of 15 continuous hours of light with intensity equivalent to that of a 50-watt incandescent bulb.

The new lamp weighs only 7½ pounds and measures 18" x 6" x 4". It uses a standard 18" 15-watt fluorescent tube.

## TV SERVICE INSTRUMENT

**6** Precision Apparatus Co., Inc. has announced the availability of a combination sweep signal generator and marker adder which is being offered as the Model E-110.

Designed for the visual alignment of FM and TV receivers, the instrument provides for sweep



frequency coverage in five fundamental output ranges from 3 to 213 mc. Sweep width is continuously variable up to 30 mc. A built-in crystal oscillator supplies accurate fixed-frequency markers. Internal blanking automatically eliminates retrace.

The instrument measures 13" x 8½" x 7".

## LOW-POWER ROTARY SWITCH

**7** Oak Manufacturing Co. is now marketing a new ½ inch subminiature low power rotary switch for special applications in which compact size is of paramount importance. The switch is a full 12-position unit. Special features include long life silver alloy contacts, gold flashed to prevent tarnish, double wiping design; fabrication of stainless steel and other non-corrodible materials; and ability to withstand 50-hour salt spray tests.

This component is available in numerous switching configurations and can incorporate up to five switch sections.

## PLUG-IN RECTIFIERS

**8** Columbus Electronics is now marketing over 60 types of silicon rectifiers designed to permit direct plug-in replacement of vacuum or gas-type rectifier tubes. Available in ratings to 10,000 volts p.i.v. and 2.5 amps, this GP series of rectifiers permits the replacement of tube types 5C1, 6X4, 3B28, 866, 8008, and many others.

## DRAFTING KIT

**9** C-Thru Ruler Company is offering its "PDQ" kit which has been designed especially for engineers, draftsmen, and those designing electrical and electronic circuits.

Housed in a simulated calfskin portfolio, the kit is fitted with transparent pockets which hold five useful drawing and drafting instruments. In addition to an "H" drawing pencil and graph pad, the set includes 30/60 degree and 15/90 de-

# YOU SAVE MONEY!

RUSH US YOUR  
LIST OF HI-FI  
COMPONENTS  
FOR A SPECIAL  
QUOTATION  
WRITE FOR FREE  
AUDIO DISCOUNT  
CATALOG A-15

New low prices on amplifiers, tuners, tape recorders, speakers, etc.

**KEY** ELECTRONICS CO.  
120 LIBERTY STREET  
NEW YORK 6, N.Y.

**ELECTRONICS WORLD HAS**  
A BUYER FOR YOUR USED  
EQUIPMENT OR COMPONENTS!

The 200,000 purchasers of **ELECTRONICS WORLD** are always in the market for good used equipment or components. So if you have something to sell, let EW readers know about it through our classified columns. It costs very little: just 60¢ a word, including name and address. Minimum message: 10 words.

For  
further  
information  
write:

Martin Lincoln  
**ELECTRONICS WORLD**  
One Park Avenue  
New York 16, N. Y.

**WANTED M-315B  
Hydrogen Generators**  
For Gibson Girl Radio Set  
The Vets Distributing Company  
3613 N. Western Parkway • Louisville 12, Ky.  
SPRING 8-8904

gree triangles, a laminated protractor, a French curve, and a 12" calibrated T-square with inch and millimeter scales. Open, the kit measures 19"x13½" while closed it is a compact 9½"x13½".

#### PC TEST SYSTEM

**10** Lavoie Laboratories, Inc. has developed a complete checkout system for printed-circuit cards which takes 2½ minutes and includes all components and electrical connections. The system is capable of checking any size circuit boards and up to 250 access points which can be multiplied to 2500 if the occasion demands. Providing an over-all systems check at 1% accuracy or better, the system includes five different circuit board fixtures.

#### HI-FI—AUDIO PRODUCTS

##### AUDIO DISTRIBUTION UNIT

**11** Jerrold Electronics Corporation has recently introduced a modulator which can replace an entire audio distribution system for hotels, motels, or institutional use.

Designated the "Audio-Frol" Model AF, the unit provides for adding AM, FM, background music, or public announcements to any TV distribution system. Audio programming is piped from



the head-end of the TV distribution system to any room in which there is a TV receiver.

The unit can feed five separate channels of audio, even in a seven-channel TV area, since the circuitry has been engineered to prevent cross-modulation between adjacent channels. Channel conversion is achieved by providing a crystal-controlled video carrier and an FM sound carrier.

##### FM ANTENNA KIT

**12** Technical Appliance Corporation is now offering its "Lark Ad-A-Kit" which is designed for mounting on an existing TV antenna mast to provide the properties of a separate FM antenna. The kit comes complete with a 50-foot lead-in, wood-screw, and mast-type stand-offs. Easily assembled, the antenna can be installed in minutes.

The unit is omnidirectional, providing reception without rotation, from all directions up to 25 miles from the transmitter. The antenna is gold anodized and, according to the manufacturer, cannot rust or deteriorate.

##### P.A. SYSTEMS

**13** Harman-Kardon, Inc. is now marketing a new series of public address and engineered sound systems under the "Galaxy" trademark.

Included in the new series are 10-, 75-, and 150-watt amplifiers, an 8-channel preamplifier, power boosters, and a wide choice of easily installed preamplifier modules with multiple in-

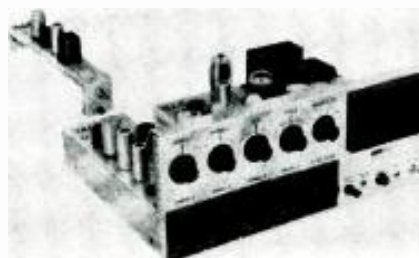

puts for every type of program source, including facilities for precedence and compression operation.

The amplifiers feature sockets for plug-in low-impedance microphone transformers, 600-ohm line transformers, and tape head or magnetic phono equalizers. Also included are anti-feedback microphone speech filters with front panel in-out switches, monitor headset jack and monitor volume control, and provision for an optional monitor loudspeaker or air meter.

##### MULTIPLEX RECEIVER

**14** RCA Electron Tube Division is now marketing a high-fidelity FM multiplex stereo AM receiver-amplifier, which features a muvistor FM tuner, as the MX 7.

The new instrument includes FM multiplex,



a high-fidelity FM tuner, AM tuner, and a master-control 30-watt high-fidelity stereo amplifier. It features a new multiplex demodulation system, muvistor r.f. amplifier tuner, a temperature-sensitive line current limiting resistor, plus a wide range of operating controls.

##### RECORDING TAPE

**15** Eastman Kodak Company has entered the magnetic recording tape field with 35 and 16 mm sizes for application in the motion picture, broadcast, and recording industries.

The recording tape is now available in 35 mm x 1000-foot rolls, 16 mm x 1000-foot and 16 mm x 1200-foot rolls and will soon be offered in 17.5 mm widths.

##### NEW SPEAKER SYSTEMS

**16** Rockbar Corporation is now marketing the new "Slimform" speaker system made by Goodmans Industries of England. These models are included in the new line, all in genuine hand-rubbed oiled walnut veneer cabinets.

The Model G-1 includes an 8" driver, 6" closed-

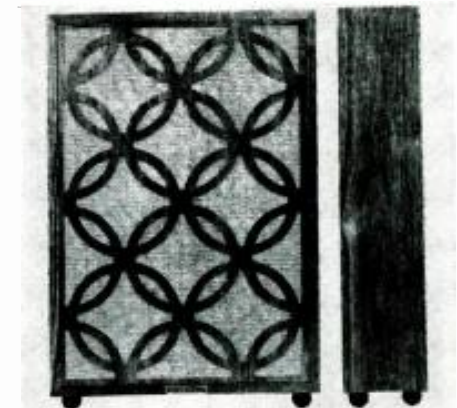

back midrange, 3½" tweeter and a frequency response of 10-17,000 cps. The Model G-2 has a 10" driver, 6" closed-back midrange, 3½" tweeter and the same frequency response. The Model G-3 includes three 8" drivers but in all other respects is the same as the other units.

All three models feature tuned port, crossover network, and 16-ohm impedance.

##### LIGHTWEIGHT TURNTABLE

**17** Weathers Industries Division is now marketing a lightweight, low-silhouette turntable, the "Synchronatic 66."

Weighing just six pounds and only two inches high, the instrument uses two precision hysteresis synchronous motors mounted on opposite sides of



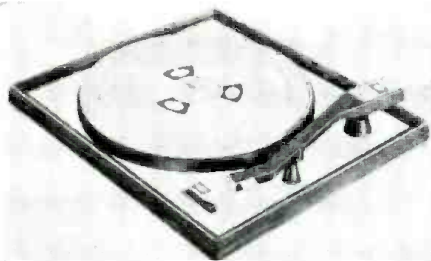

the deck. These drive two soft rubber lathe-turned wheels against the inside rim of the platter, producing rumble of only -40 db.

Other features include suspension on a neoprene "seismic platform" to provide isolation from floor vibrations of more than 500 to 1 accuracy within one revolution in 60 minutes, wow and flutter under 0.05 per cent. It will be offered in three versions: turntable alone, with integrated viscous damped arm, or with the firm's low-dynamic-mass pickup.

**18** **ANTENNA FOR FM MULTIPLEX** B&K Manufacturing Company has announced the availability of a 7-element FM antenna designed especially for multiplex stereo applications.

The "Mark Stereo 7" Model ST7B is omnidirectional. It is horizontally polarized and not affected by guy wires. There are no insulators to deteriorate and the aluminum elements resist oxidation. The antenna is 30" wide, 22" high, and 5 1/2" deep. It comes complete with all hardware for easy mast mounting.

**19** **OMNIDIRECTIONAL MIKES** Electro-Voice, Inc. has recently introduced two new dynamic microphones for general-purpose applications. The Models 633 and 634 are especially engineered for all types of pa. work but are suitable for paging systems, am-

teur, and general communications service as well. Both models have an output level of -57 db and a frequency response of 70 to 10,000 cps. They are available in either high-impedance or 150-ohm impedance versions. Their chrome and high-impact plastic construction makes the mikes suitable for indoor and outdoor use.

**MULTIPLEX ADAPTER**

**20** Paco Electronics Company, Inc. is offering a multiplex adapter (MX100) in either kit or factory wired versions.

The MX100 has been engineered to be usable with practically all FM tuners that have either a tape recorder or multiplex output. Separation is 28 db and frequency response is 15 to 15,000 cps  $\pm$  1 db. There are dual high-impedance cathode-

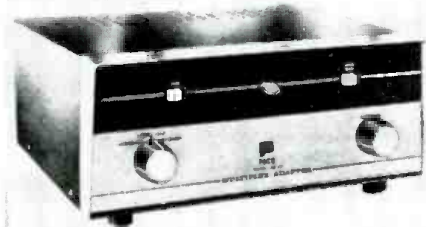

follower inputs, switch selected, one for wide-band tuners and one for narrow-band tuners. Power consumption is 30 watts and the unit measures 9" x 8 1/4" x 3 1/2".

**OFFICE INTERCOMS**

**21** Bogen-Presto Division has recently introduced a new series of office intercoms styled to match any office decor. The "Series X" units are housed in gray steel cabinets which are neat and inconspicuous.

The series includes Model X120 (10-station) master station, Model X220 (21-station) master station, and two remote stations designed to meet the needs of large or small organizations. The



RX1 remote station can initiate calls to one master station and the RX3 remote can selectively call any one of three masters.

**STEREO TAPE RECORDER**

**22** Heath Company is now offering a four-track stereo tape recorder in kit form. The Model AD-22 provides four-track stereo/mono record and playback; two vu type record-playback meters; two inputs per channel with mixing controls; fast forward and rewind; 3-digit counter;

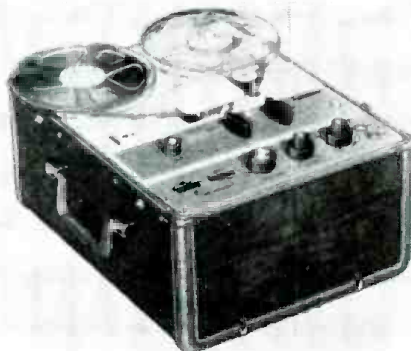

**1-YR. GUARANTEED RADIO & TV TUBES**  
**NEW LOW PRICE**

**\$30**  
Per 100 TUBES

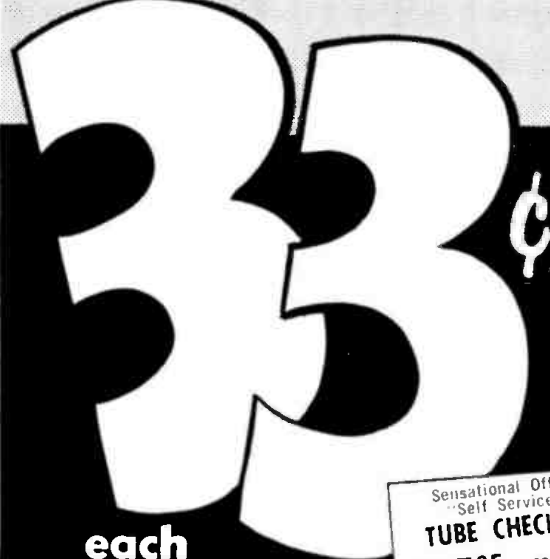

Factory One or Factory Second Tubes! TRU-VAC will replace FREE any tube that becomes defective in use within 1 year from date of purchase!  
**ALL TUBES INDIVIDUALLY BOXED! CODE DATED & BRANDED "TRU-VAC"**

Partial Listing Only . . . Thousands More Tubes in Stock!

SPECIAL! 6CB6		30c		6CQ8		30c	
0Y4	3Q4	6AC7	6AT6	6CF6	6J7	6V6GT	7F8
0Z4	3S4	6AF4	6AG5	6AG7	6W4GT	7G7	12A6
1A7GT	3V4	6AC5	6AU3GT	6CG8	6K7	6WG6T	7M7
1B3GT	4BQ7A	6AH3GT	6AUSGT	6C8	6N7	6X4	7N7
1W5GT	4B5B	6AM5	6AUS	6CL6	6Q7	6X5GT	7Q7
1L4	4B27	6AK5	6AV5GT	6CM6	6R4	6X7	7S7
1L6	4CB6	6AL5	6AV6	6CM7	6S7	6Y6	7X6
1NSGT	5AM8	6AM8	6AW8	6CN7	6SRGT	7A5	7X7
1RS	5AN8	6AN8	6AX3GT	6SA7	7A6	7Y4	7A4
1S5	5AT8	6AQ5	6AX5GT	6CR6	6S7	7A7	7Z4
1T4	5AV8	6AQ6	6BK5	6CS6	6SD7GT	7A8	12A8
1U4	5A7A	6AQ7	6BK7	6CS7	6S7	7B4	12AR5
1U5	5BR8	6AR5	6BL7GT	6CU5	6SF7	7B5	12AD6
1V2	5CG8	6A07	6BN6	6CU6	6SG7	7B6	12AF6
1X2	5J6	6HB	6B0GT	6D6	6SH7	7B7	12AQ5
2AF4	5R4	6RA6	6B07	6DE6	6S7	7B8	12AT6
2BN4	5TR	6HCS	6HR8	6DC6GT	6SK7	7C4	12AT7
2CY5	5U4	6HC8	6HS8	6DF6	6SL7	7C5	12AUG
3A5	5US	6BD6	6BY5G	6E5	6N7GT	7C6	12AU7
3AL5	5V1G	6BE6	6R26	6F5	6S7	7C7	12AV6
3AU5	5V6GT	6BF5	6R27	6F6	6SR7	7E5	12AV7
3CC5	5X8	6HGGG	6C4	6H6	6T4	7E6	12AX3GT
3BN6	5Y3	6BM6	6CAR	6J4	6TR	7A4	XXL
3BZ6	6A6	6B6	6CA8	6J5	6U5	7E7	12A7
6CB6	6AR4	6A5	6CD6G	6J6	6U8	7F7	12B4

**1-YEAR GUARANTEED TV PICTURE TUBES.** These tubes are made only from new parts and materials, except for the envelope which is re-used.

Below Listed prices do not include duty. Add Additional 10% tax on 21" and 21 1/2" on 21" and 21 1/2" tubes. Ship. refunded when duty is returned prepaid. Amnized tubes—\$4.00 extra. Picture tubes shipped only to continental USA and Canada—F.O.B. Harrison, N.J.

**ATTENTION QUANTITY USERS!** Big Discounts Are Yours . . . Call or Write For Our Tube Price Schedule. Attention: Headquarters, MGR.

**TRU-VAC (R) PAYS YOUR POSTAGE** with orders of 85 or more in USA and Territories. Send approximate postage on Canadian and foreign orders. Any order less than 85 requires 25¢ handling charge. Send 25¢ on C.O.D.'s. All orders subject to prior sale. Complying with Federal regulations, the following statement appears in all Tru-Vac advertising: Tubes in this ad may be FACTORY SECONDS or USED tubes and are clearly marked.

**LOOK! 1,000 USED TV'S**  
Comfy, famous make console models with little or no tube re-placement! Requires only minor adjustment. Perfect for resale, or as your own second set! 16", 17" and 19" screens—many smaller! Sets shipped FOB Harrison, N.J.  
**SPECIAL! TV CONSOLES** 10", 12", 14" while they last!  
**\$16.95** As Is  
**\$8.95** or is.

Sensational Offer! "Self Service"  
**TUBE CHECKERS**  
**\$37.95** FOB Our Warehouse  
Let your customers test their own tubes! These reliable, reconditioned 22-tube checkers will return your investment in one week or less with one week or less of your little or no effort on your part! Handsome, field-tested console models COMPLETE WITH KEY FOR BOTTOM DOOR AND NEON-LIGHTED HEAD!

**TRU-VAC** Dept. EW8

Harrison Avenue • Box 107 • Harrison, N. J. Humboldt 4-9770



Send for NEW  
FREE CATALOG #962  
with oscillator  
circuits

## Citizen Band Class "D" Crystals

\$2.95  
EACH



**CITIZEN BAND CLASS "D" CRYSTALS**  
3rd overtone — .005% tolerance —  
to meet all FCC requirements. Theoretically  
scaled "HC6/U" holders. 12 pin spacing,  
.050 pins. (Add 15c per crystal for .005  
pins.)

All 22 megacycle frequencies in stock: 26,965, 27,015, 27,065,  
27,115, 27,165, 27,215, 27,265, 27,315, 27,365, 27,415, 27,465,  
27,515, 27,565, 27,615, 27,665, 27,715, 27,765, 27,815,  
27,865, 27,915, 27,965.  
Matched crystal sets for ALL CB units (Specify equipment  
make and model numbers) \$5.90 per set

## RADIO CONTROL CRYSTALS in HC6/U HOLDERS—SIX FREQUENCIES

In stock for immediate delivery frequencies listed in  
megacycles, tolerance .005%, 12 pin spacing,  
.050 pin diameter, .093 pins available, add 15c per  
crystal. Specify frequency desired.  
**26,995, 27,045, 27,095, 27,145, \$2.95**  
**27,195, 27,255, \$2.95**  
(Add 5c per crystal for postage-handling)

**ENGINEERING SAMPLES** and small quantities for prototypes  
now made at either of our plants at Fort Myers, Florida with 24 hour  
service. IN: CHB-AGU, PIONEER, Gladstone 2-3335.

**IF YOUR PARTS DEALER DOESN'T STOCK** Texas Crystals,  
order direct and send us his name.

RUSH YOUR ORDER NOW TO

**TEXAS CRYSTALS**

1000 Crystal Drive, Fort Myers, Florida  
Dept. R-82 Phone WC 4-2100

FOR SHIPMENT VIA FIRST CLASS MAIL AT NO EXTRA  
COST ATTACH THIS ADVT. TO YOUR ORDER!

GET  
INTO

# ELECTRONICS



V.T.I. training leads to success  
as technicians, field engineers,  
specialists in communications,  
guided missiles, computers,  
radar and automation. Basic &  
advanced courses in theory &  
laboratory. Electronic Engi-  
neering Technology an ECPD  
accredited Technical Institute  
curriculum Assoc. degree in  
29 mos. B.S. also obtainable.  
G.I. approved Graduates in all  
branches of electronics with  
major companies. Start Sept.,  
Feb. Dorms, campus. High  
school graduate or equivalent.  
Write for catalog.

**VALPARAISO TECHNICAL INSTITUTE**  
Dept. RD, Valparaiso, Indiana

## TAPE RECORDERS

**HI-FI COMPONENTS  
SLEEP LEARN KITS**  
UNUSUAL VALUES  
FREE 1962  
Catalog  
DRESSNER  
1523RA Jericho Tpke., New Hyde Park, N.Y.



## \$3 TO \$5 AN HOUR REPAIRING ELECTRIC APPLIANCES

FREE BOOK tells  
about profitable  
business, 400 MILLION  
Appliances now in use.  
People need them fixed.  
YOU make good money  
doing it—right at home!  
Easy course trains you for  
top earnings. At no extra  
charge you get Appliance  
Tester. Get FREE Book.  
FREE Sample Lesson!

**NATIONAL RADIO INSTITUTE, Appliance Division**  
Dept. EH2, Washington 16, D.C.

Send Free Book, Free Appliance Repair Course  
Lesson.

Name .....  
Address .....  
City ..... Zone ..... State .....

four-pole motor; 7.5 and 3.75 ips tape speeds;  
and push-pull bias oscillator.

The recorder is being offered in several ver-  
sions, the AD-22 is the complete unit while the  
AD-12 (photo) is the mechanism only without  
electronics. A sturdy luggage-tan carrying case  
is available at extra cost for housing the AD-22  
for portable use.

### NEEDLE-FORCE GAUGE

**23** Aconstic Research, Inc. is marketing a low-  
cost, easy-to-use needle-force gauge which  
operates on the principle of a balance. Weights  
of  $\frac{1}{4}$ ,  $\frac{1}{2}$ , 1, and 2 grams are provided for making  
the tests. If stylus force is greater than 3 $\frac{1}{2}$   
grams, a U.S. penny may be used as an accurate  
3-gram weight.

An instruction sheet, with a photograph of the  
operation, is included with the gauge.

### AM-FM RADIO/INTERCOM

**24** Fanon Electronic Industries, Inc. is now of-  
fering its new Model 5500 home radio inter-  
com which combines AM-FM radio facilities with  
up to nine remotes and one master intercom  
stations.

Styled for flush wall installation, the FM tuner  
is equipped with a.t.c. which prevents drift and  
an a.t.c.-off switch which facilitates tuning weak  
or distant stations.

### PAGING SPEAKER

**25** University Loudspeakers, Inc. has developed  
a compact and efficient p.a. speaker which  
is being marketed as the ILL-8. Frequency re-  
sponse is 300 to 10,000 cps; power rating is 15  
watts; impedance is 8 ohms; and dispersion is  
110 degrees.

Decorator designed for unobtrusive installa-  
tion, the speaker measures 15 $\frac{1}{2}$ " x 6 $\frac{1}{2}$ " and  
weighs 1 $\frac{1}{2}$  pounds.

## CB-HAM-COMMUNICATIONS

### AUTOMATIC PHONE PATCH

**26** Stoner Electronics has just introduced an au-  
tomatic phone patch designed specifically for  
use with CB transceivers. Measuring only 2 $\frac{1}{2}$ " x  
2 $\frac{1}{2}$ " x 1 $\frac{1}{2}$ ", the unit is fully automatic. It can be



installed by connecting three lines—speaker, mike,  
and telephone. According to the manufacturer,  
noise and hum are eliminated while r.f. filters  
prevent feedback. A quality audio transformer  
permits full frequency response from the equip-  
ment with which it is used.

### CB TRANSCEIVER

**27** United Scientific Laboratories, Inc. is now  
marketing a new CB transceiver, the Model  
R-1050. The unit features six crystal-controlled  
receive and transmit channels; tunable, no-drift  
operation on all 23 channels; built-in "S" and  
plate current meter; three high-gain i.f. stages;  
push-to-talk ceramic microphone with electronic  
switching; adjustable squelch and full noise lim-  
iter; and invistor low-noise r.f. front end.

### NEW CB ANTENNAS

**28** Lafayette Radio Corporation is now offering  
three new CB antennas designed to meet  
varying communications requirements. The  
Model HE-57W is a 48" continuously loaded  
fiberglass whip designed for auto cowl or rear  
deck mounting. A special rocker support assures

8-point grounding. It fits 1 $\frac{1}{2}$ " to 1 $\frac{1}{4}$ "-inch  
mounting holes and comes complete with five  
feet of RG-58W cable.

The HE-63WX is a colinear ground plane for  
receiving or transmitting. Overall height is 20  
feet and of heavy wall, heat-treated aluminum  
tubing. The radials are 9 feet long with a  $\frac{3}{8}$ "  
o.d. It comes complete with matching stub.

The third unit, HE-64WX, is a vertical three-  
element beam which develops a forward gain of  
9 db. Front-to-back ratio is 25 db and front-to-  
side ratio is 10 db. Of all-aluminum construction,  
the boom is 8 feet long with elements 16 $\frac{1}{2}$  feet  
long.

### NOISE ELIMINATOR

**29** Seco Electronics, Inc. is now offering a new  
electronic noise eliminator and controllable  
squelch as the "Signal Filter." Measuring only  
1 $\frac{3}{8}$ " x 2 $\frac{1}{2}$ " x 1 $\frac{1}{4}$ ", the circuit incorporates a dual



high-mu triode and dual diode in an inverter  
circuit which electronically clips noise pulses out  
of the signal.

According to the manufacturer, the unit will  
eliminate ignition equipment interference, sleep  
wavetron "hash" and background noises as well  
as the need for elaborate suppression equipment  
on automotive and marine engines.

The unit is designed to be used with most CB  
transceivers using tubes and can be hooked up to  
any AM superhet with 6- or 12-volt a.c. or d.c. and  
150-volt "B" power supply—mobile or base sta-  
tion.

### HAND-HELD CB UNIT

**30** Cadec Industries Corporation has added a  
1.5-watt portable transceiver to its line of  
manufactured communications equipment. The  
"C-75" features plug-in, printed circuit,  
modular construction for ease of mainte-  
nance. The unit will  
operate at least 8  
hours on compact re-  
chargeable batteries  
and has a two-channel  
crystal-controlled  
transmitter and re-  
ceiver.

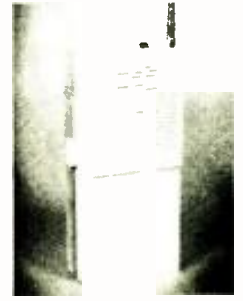

A built-in retract-  
able antenna and op-  
tional shoulder-strap  
antenna add to the versatility and range of the  
instrument. The unit weighs less than three  
pounds including batteries.

### SINGLE-CHANNEL CB UNIT

**31** Heath Company is offering a low-cost single-  
channel CB transceiver kit, the GW-12, for  
commercial applications. The circuit features





crystal-control of both transmitter and receiver on any single pre-determined frequency. The superhet receiver is provided with squelch and automatic noise-limiter functions while a minimum of operating controls provide for simple, easy operation.

The a.c. power supply is built-in and provision is made for using an accessory power supply for operation on 6 or 12 volts d.c. in mobile installations. The kit comes complete with microphone and crystals for one channel.

#### CB COMPRESSOR/AMPLIFIER

**32** Communications, Inc. is now offering a new audio compressor amplifier which has been specifically designed for mobile and base-station CB radio transceivers.

Tradenamed the "SpeakEasy," the new unit

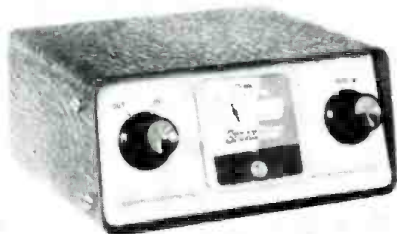

will amplify the softer modulated sounds while allowing the louder sounds to come through at their normal level. Thus total average modulation and talk-power is greatly increased, according to the company. A modulation meter allows proper modulation settings to be maintained by the operator. A less elaborate unit employs a 100% modulation indicating lamp.

#### FIELD-STRENGTH METER

**33** Blonder Tongue Labs Inc. is handling the U.S. distribution of the new Benco Model ESP-3 fully transistorized field-strength meter.



Weighing only 10 pounds and measuring 5 1/2" x 11 1/4" x 7 3/4", the ESP-3 covers the frequency spectrum from 52-220 mc. in one range and has a sensitivity of 5  $\mu$ v. minimum readable signal or 60  $\mu$ v. full-scale with sensitivity control at maximum.

Input impedance is 75 ohms unbalanced and 300 ohms balanced; bandwidth is 3 db at 0.5 mc. and overall accuracy is  $\pm 2$  db  $\pm 1$  db over the ambient temperature range of 0 to 120 degrees F. Percentage of AM modulation is measurable in two ranges, 0-5% and 0-50%.

## MANUFACTURERS' LITERATURE

#### POWER SUPPLIES

**34** Sorensen has published a 32-page brochure which describes a complete line of standard controlled power products for design engineers and purchasers of power supplies, voltage regulators, frequency changers, high-voltage testers, and inverters and converters.

The publication describes approximately 500 models, including the more than 40 models added to the line since last year. In addition to product data, the new catalogue also contains 8 pages of valuable background information on definitions

and characteristics terms used in this field and interpretive data on parameters used to specify controlled power equipment for standard items and custom equipment.

#### PRECISION RESISTORS

**35** Daven Division has published a completely new catalogue and price list covering its DA line of precision metal film resistors (1/10, 1/8, 1/4, and 1/2 watt) with specifications and performance characteristics; curves, charts, and photographs explaining the performance of metal film resistors; a full description of the company's reliability assurance program; ordering data; application information; and current price list.

#### CATALOGUE FOLDERS

**36** Hill Electronics, Inc. has issued five new two-color catalogue-type folders picturing typical examples and some technical information on quartz crystals, frequency sources, voltage-controlled oscillators, miniaturized low-frequency crystal filters, and LC filters made to customer specifications.

#### P.A. PRODUCTS CATALOGUE

**37** University Loudspeakers, Inc. has expanded its public address products catalogue to 12 pages to include, besides detailed product descriptions, helpful information on applications involving drivers, trumpets, paging-talkback speakers, sound columns, and hi-fi speakers for p.a. applications.

#### AEROSOL PRODUCTS

**38** Krylon, Inc. has issued a 16-page, full-color catalogue which pictures and describes the firm's line of aerosol finishes, protective coatings, cleaners, and lubricants for industry.

Designed to serve as a buying guide, a product reference book, and a technical catalogue, the booklet presents a wide variety of new products. A center section of the catalogue contains 64 color

**RAD-TEL**  
**WHY PAY MORE!**  
**RAD-TEL'S QUALITY**  
**BRAND NEW TUBES**  
**1 YEAR GUARANTEE**  
**TUBES FOR TV, RADIO, AND HI-FI**

UP TO **75% OFF**

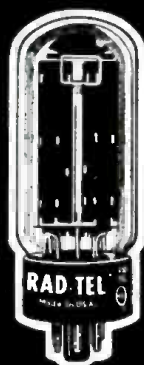

**1-DAY SERVICE**  
**OVER 500 TYPES IN STOCK**

\*Manufacturers Suggested List Price

#### SERVICEMEN:

### COMPARE 100 "Good Movers" 15 "Best Movers"\*

THESE TUBES ARE A MUST FOR YOUR CADDY

Qty.	Type	Price	Qty.	Type	Price	Qty.	Type	Price
—	0Z4*	.79	—	6AS5	.60	—	6X4	.39
—	1B3*	.79	—	6AT6	.43	—	6X8	.80
—	1R5	.62	—	6AU4	.82	—	7AU7	.61
—	1T4	.58	—	6AU6*	.52	—	12AQ5	.60
—	1U4	.57	—	6AU8	.87	—	12AT6	.43
—	1U5	.50	—	6AV6	.41	—	12AT7	.76
—	1X2	.82	—	6AW8	.90	—	12AU6	.51
—	2CY5	.70	—	6AX4*	.66	—	12AU7*	.60
—	3AL5	.42	—	6BA6	.50	—	12AV6	.41
—	3AU6	.51	—	6BC5	.61	—	12AX4	.67
—	3AV6	.41	—	6BE6	.55	—	12AX7	.63
—	3BC5	.54	—	6BG6	1.66	—	12BA6	.50
—	3BN6	.76	—	6BK7	.85	—	12BE6	.53
—	3BZ6	.55	—	6BN6	.74	—	12BH7	.77
—	3CB6	.54	—	6BQ6*	1.05	—	12BQ6	1.06
—	3V4	.58	—	6BQ7*	1.00	—	12BY7	.77
—	4BQ7	1.01	—	6BZ6*	.55	—	12L6	.58
—	4BZ7	.96	—	6BZ7	1.01	—	12SA7	.92
—	5AM8	.79	—	6C <sup>1</sup>	.43	—	12SK7	.74
—	5AN8	.86	—	6CB6*	.55	—	12SQ7	.78
—	5AQ5	.52	—	6CD6	1.42	—	12V6	.53
—	5J6	.68	—	6CG7*	.61	—	12W6	.69
—	5T8	.81	—	6CS6	.57	—	12X4	.38
—	5U4*	.60	—	6DQ6	1.10	—	25B06	1.11
—	5U8	.81	—	6J6	.67	—	25CD6	1.44
—	5Y3	.46	—	6K6	.63	—	25L6	.57
—	6AB4	.46	—	6S4	.51	—	35C5	.51
—	6AC7	.96	—	6SK7	.74	—	35W4*	.42
—	6AG5	.68	—	6SN7*	.65	—	35Z5	.60
—	6AF4	.97	—	6T8	.85	—	50B5	.60
—	6AL5	.47	—	6UB*	.83	—	50C5*	.53
—	6AM8	.78	—	6V6	.54	—	50L6	.61
—	6AN8	.93	—	6W4	.60			
—	6AQ5	.53	—	6W6	.71			

RAD-TEL TUBE CO. NOT AFFILIATED WITH ANY OTHER MAIL ORDER TUBE COMPANY

**FREE!**   
 Send For New Tube & Parts  
 Catalog & Trouble Shooting Guide



**RAD-TEL TUBE CO.**

EW8

55 CHAMBERS STREET, NEWARK 5, NEW JERSEY

TV, RADIO  
 AND HI-FI

TERMS: 25% deposit must accompany all orders, balance COD. Orders under \$5. add \$1 handling charge plus postage. Orders over \$5. plus postage. Approx. 3 tubes per 1 lb. Subject to prior sale. No COD's outside continental USA.

chips of the company's standard colors, industrial colors, engine enamels, primer coatings, and fluorescent colors.

**MICROLOGIC BROCHURE**

**39** Fairchild Semiconductor has announced the availability of a 12-page, full-color brochure which describes its approach to microminiaturization, i.e., integrated functional building blocks called "Micrologic" elements.

The brochure describes the manufacture of a typical element from silicon crystal growing through to final test. Available units currently in the line include a flip-flop, gate, buffer, half-shift register, half-adder, and counter adapter.

**HAND TOOL LINE**

**40** Xcelite, Inc. has issued a 16-page two-color catalogue covering its line of professional hand tools for the industry. Photographs, complete descriptions, and full specifications are given on an extensive line of screwdrivers, nut-drivers, pliers, cutters, seizers, wrenches, knives, blades and handles.

**MICROWAVE CONTROL DEVICES**

**41** Microwave Associates, Inc. is offering a 16-page brochure covering microwave solid-state limiters, duplexers, phase shifters, and voltage variable attenuators for applications over the frequency range from 1 mc. to 13,500 mc. All devices discussed in the booklet, "Semiconductor Microwave Control Devices," utilize either variable reactance or variable conductance junction diodes.

**SOLDERS AND FLUXES**

**42** Alpha Metals, Inc. has announced the availability of an all-new illustrated technical catalogue covering its solders, fluxes, preforms, special alloys, lead and tin products, and ultra-high-purity metals for use in various semiconductor devices.

Bulletin 103 is a condensed product catalogue accompanied by technical data and charts on solder alloys and fluxes.

**MOBILE RADIO EQUIPMENT**

**43** Communications Company, Inc. is offering copies of its new four-page brochure containing descriptions, photographs, specifications, and line drawings of the firm's new 25- and 75-watt high-band and 35- and 100-watt low-band mobile units.

**tone MULTIPLEX BROCHURE**

**44** RCA Microwave Department has issued a 16-page brochure describing its new CE-42 solid-state tone multiplex equipment. The booklet contains detailed data on equipment applications, frequency allocations, component diagrams, transmitter and receiver options, complete sys-

tem specifications, and other technical and operational information.

The unit itself can be used with existing microwave, carrier, or wire-line circuits to provide AM or frequency-shift data transmission, teletypewriter, telecentering, remote control, and signaling functions.

**ELECTRONIC GAGING**

**45** The Millitest Company is distributing a new specification brochure which describes in detail the advantages of its new "Electro-Dial" all-d.c. electronic gaging indicator.

Among the specifications included on the Model 658 are scale ranges, probe pressure, range of probe free travel, probe adjustability, system accuracy, dimensions, and power.

**TECHNICAL BULLETIN**

**46** Oak Manufacturing Co. has just published a booklet "A.C. Solenoid Operation" which describes in detail a new, compact, full-wave solid-state rectifier for operating d.c. solenoids directly from a.c. sources.

The brochure provides application data, general features, electrical ratings, operating characteristics, along with mechanical details on the unit.

**PRECISION WIREWOUNDS**

**47** RCL Electronics, Inc. has announced publication of a completely new technical catalogue covering its entire line of precision wirewounds and power resistors.

The publication includes complete technical data, charts, and illustrations on subminiature axial-lead resistors, printed-circuit resistors, axial-lead encapsulated types, lug-terminal types in addition to a section on how to select the correct resistor for the job at hand.

**RECTIFIER-CAPACITOR DATA**

**48** Fansteel Metallurgical Corporation is now publishing a bi-monthly journal offering technical information about rectifiers, capacitors, and semiconductor.

Titled "Re-Cap," the periodical is written for design and application engineers in electronics, electric utilities, automotive, and electrical manufacturing industries.

**INSTRUMENT CAPABILITY**

**49** General Electric Company is offering a 16-page booklet which describes the firm's Instrument Department engineering research and development, manufacturing, assembly and test, sales, service, and product innovation capabilities.

Each of the department's capabilities is explained and illustrated. The product section also includes a brief illustrated description of the department's line of indicating and recording instruments, instrumentation systems, laboratory

and special testing equipment, and aircraft instruments.

**SOLID-STATE STRAIN GAGES**

**50** Micro Systems Incorporated is offering a 14-page publication covering its "Micro-Sensor" solid-state strain gages and temp-sensor solid-state temperature gages.

The catalogue provides information on the firm's complete line of 11 solid-state units including a description of the devices, optimum usage, special applications, performance characteristics, and application guide lines.

**DISPLAY RACKS**

**51** Vaco Products Company has issued two new color catalogues which demonstrate in words and pictures how products should be displayed for maximum exposure and greatest sales potential.

Catalogue T-63 is entitled "Solderless Terminal Displays that Sell" while the second publication covers the firm's displays for screwdrivers. The text spells out merchandising techniques and gives examples of effective displays.

**"HIGH Q" REACTORS**

**52** Magnetic Metals Company is offering a comprehensive 24-page bulletin entitled "High Q Reactors for Low Frequencies" which outlines simple methods of designing and predicting the performances of E-lamination-constructed "high Q" reactors using nickel alloy materials for low audio and sub audio frequencies.

The booklet covers choice of lamination shape, basic design calculations, design permeability, "Q" calculations, optimum "Q" curves, and reactor design for optimum "Q." Illustrative graphs are plentiful, full-page, and easy to read.

**SOLDERING IRONS**

**53** Ungar Electric Tools has announced the availability of an 8-page catalogue which describes the "Imperial" soldering iron designed to meet the needs of intricate production line assembly operations in the electronic, missile, and space industries.

The four-color catalogue contains applications, specifications, and user net prices on the complete line of interchangeable components.

**INSTRUMENT RECTIFIERS**

**54** Conant Laboratories has issued a series of full-color data sheets covering an extensive line of instrument rectifiers.

The data sheets cover specifications and prices on standard types, miniature metallic rectifiers, the Series 80 subminiature line, and the Series 160-U copper-oxide instrument rectifiers.

**COUNTER DATA**

**55** The Rowan Controller Co. has announced publication of a 22-page catalogue which describes its complete line of counters. The new catalogue covers twenty-two different models divided into five types: electro-impulse, pre-determining, time, revolution, and ratchet counters. The booklet provides complete information on technical capabilities, mounting dimensions, schematics, and pictures.

**TRANSISTORS AND DIODES**

**56** General Instrument Semiconductor Division has released copies of its Bulletin SR 3099 describing a complete line of silicon planar epitaxial and germanium transistors, silicon and germanium diodes, silicon nanocircuits, and silicon zener diodes.

Included are technical data, dimensional diagrams, and application information. Typical performance specifications, circuits, and other nanocircuit design information are also shown. ▲

**PHOTO CREDITS**

Page	Credit
12 (top)	Electro-Sonic Labs
12 (bottom)	Allied Radio Corp.
16	Fisher Radio Corp.
21 (top)	Courtesy The New York Times
21 (color)	United Press International Photo Service
22, 24	Westrex Corp.
27	Tektronix, Inc.
28 (top)	Electro-Voice, Inc.
28 (bottom)	Bell Telephone Laboratories
28 (bottom right)	Sylvania Electric Products Inc.
29 (top)	IBM
29 (center left)	Nippon Electric Co. Ltd.
29 (center right)	Sperry Gyroscope Co.
29 (bottom)	Radiation at Stanford
40, 41, 44, 28 (center)	Radio Corp. of America
73	Eico Electronic Instrument Co.

**Answer to Electronics Crosswords**

(Appearing on page 77)

	P	O	T			L	A	S	E	R	
	R	H	E	O	S	T	A	T		O	E
	A	M	P	E	R	E		T	O	N	S
X	C		I		L	E	E	R	O		O
L	T		D	Y	N	E		N	E	O	N
	I	R		U		M	U	R	A		
	C	R	A	W	L		A	A		A	T
	A		R	O	L	E		T	O	T	E
X	L		C	O	V		E	V	E	S	
R		I		F	R	E	Q		A	S	
A	N	O	D	E		R	U	M			I
Y		N	O	R		Y	O			A	F

Fill in coupon on page 96 for additional product data.



## Facsimile Techniques

(Continued from page 24)

machines exists in the United States for the reception of weather maps. Facsimile is used by our law-enforcement agencies to transmit fingerprints and pictures of criminal suspects. Facsimile is used by our newspapers and magazines to receive photographs of current events from all over the world. Facsimile systems are also being used by the military for the transmission of weather information, battle plans, and other strategic visual material.

A few years ago, *Times Facsimile* (now *Westrex*) introduced a facsimile system called "Pressfax" that transmits full-size newspaper pageproofs with precise definition and at high speed over video circuits. This proved the feasibility of transmitting newspaper text over conventional communications channels. This technique is now being employed in the United States and in many other countries. For example, the larger Japanese newspapers use facsimile to transmit a proof or picture of the newspaper page to remote areas. A negative is obtained at the receiver and an engraving is made from this negative. Once the engraving is completed, the pages can be easily reproduced.

These are only a few of the many uses of facsimile. There is no doubt that the next few years will see rapid strides in this field and that there will be increased use of facsimile equipment to transmit pictures or text from one point to another.

The author wishes to acknowledge the aid given by J. R. Shonard, E. Evans and D. Peters on this article. ▲

### AUGUST HAMFESTS

**E**AST Coast V.H.F. Society has scheduled its Fourth Annual Hamfest and Old Style Picnic for Sunday, August 5, at Saddle Brook Park, Saddle Brook, N.J.

The affair, which will start at 10 a.m., will feature various events of interest to all members of the family. Registration and parking are free. Food and soft drinks will be sold at the park, if desired. Bring your picnic basket and family!

**G**LOUCESTER County Amateur Radio Club is holding its annual hamfest on Sunday, August 12 at Algonkin Gun Club, Route 581, south of Mullica Hill, New Jersey.

Milton L. Goldman, WA2ECR, is chairman of the event. Additional details on the program will be supplied on request.

**T**HE second annual Lonesome Pine Hamfest, sponsored by the Bristol Amateur Radio Club, will be held at the Southwest Virginia 4-H Center, 2 miles east of Abingdon, Va. on Saturday and Sunday, Aug. 18-19. Sleeping accommodations, meals, and swimming facilities are available. Contact the Club, P.O. Box 3162, Bristol, Tenn. for full details. ▲

August, 1962

## INVITATION TO AUTHORS

Just as a reminder, the Editors of *ELECTRONICS WORLD* are always interested in obtaining outstanding manuscripts, for publication in this magazine, of interest to technicians in industry, radio, and television. Articles covering design, servicing, maintenance, and operation are especially welcome. Articles on Citizens Band, audio, hi-fi, and amateur radio are also needed. Such articles in manuscript form may be submitted for immediate de-

cision or projected articles can be outlined in a letter in which case the writer will be advised promptly as to the suitability of the topic. We can also use short "filler" items outlining worthwhile shortcuts that have made your servicing chores easier. This magazine pays for articles on acceptance. Send all manuscripts or your letters of suggestion to the Editor, *ELECTRONICS WORLD*, One Park Avenue, New York City 16, New York.



**new Sony**

for portable use\*

**STERECORDER 464-D**

for custom installation

**only \$199.50**

## now both stereo recording & stereo playback!

An unprecedented price for the famed Sony quality! The long-awaited Sony Sterecorder 464-D—dual purpose, dual performance! Dual performance means both 4 track stereo recording and 4 track stereo playback. Dual purpose means custom component installation and portable use. Recording and playback pre-amps are built-in, and such features as sound on sound, language and music training, two speeds, push button track selection and Sony precision engineering make this the most outstanding tape recorder value at \$199.50. ■ All Sony Sterecorders are Multiplex-ready!

\*Carrying case optional

**SUPERSCOPE**

The Tapeway to Stereo

For literature or name of nearest dealer, write Superscope, Inc., Dept. M, Sun Valley, California

### ARC-3 RECEIVER!



Complete with All Tubes Exc. Used **\$18.95**  
Like New \$29.50

Crystal-controlled 17-tube Superhet, tunes from 100 to 15.6 Mc. AM, on any 8 pre-selected channels. 28-volt DC power input. Tubes: 1-9002, 6-6AK5, 1-12SH7, 1-12SG7, 1-9001, 1-12HE, 2-58L. Exc. Used \$18.95. Like New \$29.50.

### ARC-3 TRANSMITTER

Companion unit for above, tunes 100 to 15.6 Mc on any 8 pre-selected channels. 1-tube crystal controlled, provides tone and voice modulation. 28V DC Power Input. Complete with all tubes. Tubes: 3-6VN, 2-832A, 1-12SH7, 1-6J5, 1-12HE. Exc. Used \$18.95. Like new condition \$28.50. ARC-3 PUSHBUTTON CONTROL BOX \$5.95

### R77/ARC-3 RECEIVER POWER SUPPLY

Operates from 110 V 60 cycle AC. OUTPUT: 275 V DC @ 150 MA., and 12.0 V AC @ 4 Amps. Complete power supply includes transformer, choke, capacitor, switch, pilot lamp, 3-1/2"GT tube, matched chassis, wiring diagram. Weight 12 lbs. COMPLETE KIT OF PARTS \$19.95. Wired, Tested, Ready to Operate.

### SPECIAL! BC-603 FM RECEIVER CONVERTED FOR FREQ. RANGE 35 TO 50 Mc. BRAND NEW!

Checked out, perfect working condition, ready for operation. Continuous or Push-button tuning in 35 to 50 Mc. range. SPECIAL



EXTRA SET OF 10 TUBES FOR ABOVE model new in original box \$3.95

FT-237 MOUNTING BASE FOR BC-603 Rev and BC-604 Amplifier, Brand New \$5.95

12 or 24V Dynamotor for Above \$5.50  
Exc. Used \$4.25. Brand New

BC-603 FM Receiver, 27 to 38.4 Mc. Complete with all tubes, Exc. Used \$33.33

4-Section Antenna for BC-603, 603 Receivers. Complete with mounting base. BRAND NEW \$4.95

AC POWER SUPPLY FOR BC603, 603 Interchangeable receiver dynamotor. Has On-Off switch. NO RECYCLE CHANGE NEEDED. Provides 200 VDC @ 80 MA, 24VAC @ 2 AMP. \$12.95

Complete 240-page Technical Manual for BC-603, 604 \$3.15

BC-604 TRANSMITTER Companion unit for BC-603 Rev. above. With all tubes. BRAND NEW \$8.95

4-Section Antenna for BC-604, 604 Transmitters. Complete with mounting base. BRAND NEW \$4.95

We carry a complete line of spare parts for above.

### TS-100AP 'SCOPE

EXC. USED (worth \$750) OUR LOW PRICE **\$39.50**  
Brand New \$69.50



Can be used with linear sweep or general purpose test scope tubes attached. Also used with circular sweep as precision range calibrator. Self-contained in metal case 8" x 10" x 1 1/2" deep. For 110 V 50 to 120v. cycles AC. Excellent used, like new, with all tubes, including crystals and C.R. Tube.

### AN/ARN-6 RADIO COMPASS EQUIPMENT

Highly efficient airborne direction finding system. Frequency: 100 to 175 Mc. Input: 28V DC. 25.5 V DC Power Input. LIKE NEW. \$59.50

### BC-906 FREQ. METER—SPECIAL

Cavity type 145 to 235 Mc. Complete with antenna. Manual and original calibration cards included. BRAND NEW. OUR LOW PRICE \$11.88

### BC-221 FREQUENCY METER

SPECIAL BUY! This exact frequency meter is equipped with original calibration charts, and has ranges from 125 Kc to 20,000 Kc with crystal check. Complete with tubes, connecting cables, original Calibration Book, crystal, and all tubes—LIKE NEW!



Unmodulated \$72.50 Modulated \$99.50  
BC-221 1000 Kc Crystal Brand New \$8.95

### TS-16 APN TEST SET

For aligning and calibration of radio altimeters. May be used to check calibration of count or circuits and modulator sweep freq. and bandwidth of transmitter. Audio-oscillator ranges 300 to 7200 cycles. 24 V.D.C. input. Complete with tubes, connecting cables, instruction summary. BRAND NEW \$14.50

### TEST SET TS-175 U.

Portable crystal controlled heterodyne type used in field testing of CW or MCW RF Transmitters and Signal Generators. Range 85 to 1000 Mc. Power requirements: 4V DC and 135 VDC. Exc. Used \$169.50

### TEST SET TS-174 U.

Frequency Meter similar to above but for 250 Mc. Power Input 3.5V DC and 121.5 V DC. Exc. Used \$169.50

### TS-170/ARN-5 TEST OSCILLATOR

portable, battery-operated, crystal controlled, for frequencies 112.0 Mc. 300.0 Mc. and 325 Mc. Power Input 1.5 VDC and 90 VDC. Less Batteries. Exc. \$22.50

### SCR-625 MINE DETECTOR

Complete portable outfit in original packing, with all accessories. Brand New \$2750

### WESTERN ELECTRIC MERCURY RELAY

Single Pole Double Throw, 4500 ohm coil with 24 volt heater. Operating Current: 8 Ma. Release Current: 5.2 Ma. High Pressure Hydrogen Sealed. Uniform high speed operation even at sub-zero temperatures by heater enclosed in housing. Western Electric 216-171584. Equivalent to 275-19) BRAND NEW \$2.95

SCHEMATIC DIAGRAMS For most equipment on this page, each... 65c

### ATTENTION: IMPORTERS-EXPORTERS of ELECTRONIC EQUIPMENT

We specialize in the export of electronic equipment, Parts, and Electronic Tubes at LOWEST prevailing prices. All packing and shipping is made directly from our own warehouses in NYC. to give you substantial savings in handling costs! Your inquiries invited.

### LORAN APN-4 FINE QUALITY NAVIGATIONAL EQUIPMENT



Determine exact geographic position of your boat or plane. Indicator and receiver complete with all tubes and crystal. INDICATOR ID-6B/APN-4, and RECEIVER \$49.50 R-9B/APN-4, complete with tubes, Exc. used \$88.50 Same as above less meter. BRAND NEW \$88.50

### INVERTER POWER SUPPLY for Loran.

Made by Eclipse—Pioneer Div. INPUT: 24 V DC @ 75 A. OUTPUT: 115 V AC @ 10.5 Amps, 800 cycles. Complete with two connecting plugs BRAND NEW \$49.50

12-Volt Inverter Power Supply, Like New. P.U.R. Shock Mount for above \$2.95  
We carry a complete line of spare parts for above.

### LORAN R-65/APN-9 RECEIVER & INDICATOR



Used in ships and aircraft. Determines position by radio signals from known xmitters. Accurate to within 1% of distance. Complete with tubes and crystal. Exc. used. Value \$1200.00. Our Price \$79.50  
Used, less tubes, crystal and visor, but with 3BP1 C.R. tube \$29.50

INVERTER POWER SUPPLY. INPUT: 24 V DC. OUTPUT: 115 V AC. 800 cy. BRAND NEW \$49.50

12-Volt Inverter Power Supply, Like New. P.U.R. Shock Mount for above \$2.95  
Circuit diagram and connecting plugs available.  
We carry a complete line of spare parts for above.

### LORAN APN/4 OSCILLOSCOPE



Easily converted for use on radio-TV service bench. LIKE NEW! Less tubes, but including 5" Scope, \$14.50  
type 5CPI only

### BENDIX DIRECTION FINDERS

For commercial navigation on boats.

MN-24F 150-425 Kc. 32-3400 Mc. 34-4.7 Mc. Complete with tubes, dynamotor. BRAND NEW \$19.50
MN-24C Receiver Control Box Complete with tubes. \$4.95
MN-24M Receiver 120-1300 Kc. continuous tuning with 12 tubes and dynamotor. Used \$8.95
MN-24S Rotatable Loop for above \$2.50
MN-24J Receiver as above. BRAND NEW \$4.95
MN-24K Rotatable Loop for above \$2.95
MN-24Z Azimuth Control Box \$2.95

### SCR-274 COMMAND EQUIPMENT ALL COMPLETE WITH TUBES

Type	Description	Used	Like New
BC-451	Receiver 190-550 KC.	\$12.95	\$14.95
BC-452	Receiver 3-9 Mc.	\$2.45	\$7.95
BC-453	Receiver 6-9 Mc.	11.50	13.95
1-5 to 3 Mc. Receiver	Brand New		\$17.95

### 110 Volt AC Power Supply Kit for all 274-N and ARC-5 Receivers.

Complete with metal case, instructions. Factory wired, tested, ready to operate. \$12.50

SPLINED TUNING KNOB for 274-N and ARC-5 RECEIVERS. Fits BC-453, BC-451 and others. Only 49c

2-1 to 3 Mc. Transmitter, Brand New \$12.95
BC-457 TRANSMITTER-4-5.3 Mc. complete with all tubes and crystal, BRAND NEW \$9.75
Like New \$7.95
BC-458 TRANSMITTER-3-1 Mc. Complete with all tubes and crystal. BRAND NEW \$10.95
Like New \$7.95
T19 TRANSMITTER 34 m.c. complete with all tubes and crystal. Exc. Used \$9.95
All Tubes & Crystal, Like New \$11.95
BC-456 Amplifier. USED \$4.95 NEW \$9.95
MD7 Modulator, Like New \$9.95

ALL ACCESSORIES AVAILABLE FOR ABOVE

### 2 VOLT BATTERY "PACKAGE"

1-2V 20 Amp. Hr. Willard Storage Battery, Model #20-2, 3" x 4" x 5 1/2" high. \$2.79
1-2V 7 pronz Synchronous Plug-in Inverter \$1.49
1-Quart Bottle Electrolyte (for 2 cells) \$1.45
ALL BRAND NEW! \$5.45
Combination Price



### WILLARD 6-VOLT MIDGET STORAGE BATTERY

3 Amp. Hour, BRAND NEW 3 1/2" x 1 1/2" x 2 3/8" high. Standard Electrolyte \$2.95



### G & G RADIO SUPPLY CO.

Telephone: CO 7-4605  
77 Leonard St.  
New York 13, N. Y.

### AN/ART-13 100-WATT XMTR 11 CHANNELS 200-1500 Kc 2 to 18.1 Mc



exc. used **\$6950**

Complete with Tubes

Famous Collins Automatic Aircraft Transmitter. AM, CW, MCW. Quick change to any of ten preset channels by manual tuning. Speech amplifier clipper uses condenser or variable mike. Highly stable, highly accurate VFO. Built in Aial controlled oscillator. FFS is modulation. \$13 in stock up to 04/77, class "B" in Real "400" Ham buy at our low price! Orig. cost \$1800.

AN/ART-13 XMTR as above. Like New \$79.50

0-16 Low Freq. Osc. Coil for ART-13 \$7.95  
24V Dynamotor for ART-13 2-12H \$11.95  
Same as above less meter \$39.50  
We carry a complete line of spare parts for above.

### APR-1 Navy VHF-UHF radar search Receiver.

801 Mc. to 950 Mc. in 2 bands. BRAND NEW \$79.50

TUNING UNITS for above: TN-1, TN-2, TN-3. BRAND NEW, each \$39.50

AN APR-4 RECEIVER only, us to 1000 Mc in 5 tuning unit ranges. High precision lab instrument. Input 115 Volt ex. Like New \$79.50  
Tuning Unit TN-1B 17.1M each \$39.50  
Tuning Unit TN-1C Brand New \$89.50  
Tuning Unit TC-54 \$149.50

### SCR-522 2-METER RIG!

Terrific buy! VHF Transmitter-receiver, 100-156 Mc. 4 channels. Xal-controlled. Amplitude modulated voice. They're going fast! Excellent condition

SCR-522 Transmitter-Receiver, complete with all 18 tubes, top rack and metal case. COMBINATION. Exc. Used \$49.50

### FAMOUS BC-645 TRANSCEIVER 15 Tubes 435 to 500 MC



Can be modified for 2-way communication, voice or code, on ham band 430-450 Mc. Citizen band radio, 430-475 Mc. fixed and mobile 450-460 Mc. television experimental 470-500 Mc. 15 tubes (tubes alone worth more than sale price!)—4-7F7, 4-7H7, 2-7E6, 9-6X4, 6F6, 9-6X5 and 9-WE-311A. Now covers 460 to 480 Mc. Brand new BC-645 with tubes, less power supply in factory carton. Shipping weight 25 lbs. SPECIAL! \$19.50

PE-101C Dynamotor, 12/24V input \$7.95  
UHF Antenna Assembly \$2.45  
Complete Set of 10 Plugs \$5.50  
Control Box \$2.25

SPECIAL "PACKAGE" OFFER: BC-645 Transceiver, Dynamotor and all accessories above. COMPLETE. BRAND NEW \$29.50  
While Stocks Last.

### APN-1 FM TRANSMITTER-RECEIVER

420 to 460 Mc Aircraft Ratio altimeter equipment. Tubes: 3-9J5, 3-125H7, 4-125H7, 1-12V6. Complete with tubes. Brand new \$9.95  
APN-1 exc. Used \$6.95

### LIMITED QUANTITY SPECIALS!

BC-312 MOBILE RECEIVER 6 bands, 1500 Kc to 18 Mc. With Tubes and 14V Dynamotor. Like New \$79.50  
BC-312 for AC operation \$89.50

BC-348 SUPERHET RECEIVER 200 to 500 Kc. Ampl. to 1800 Mc. Voice, Tone, CW. Self-contained dynamotor for 24 V DC. Like New \$89.50

AN/APT-5 AIRBORNE RADAR SET, with tubes, Like New \$49.50

TC-34A KEYS, exc. used, like new \$24.50  
Complete set of 15 code practice tapes. New. P.U.R.

### MOBILE-MARINE DYNAMOTOR Model DM35

Input 12V DC, Output: 625 V DC @ 225 Ma. for press-to-talk intermittent operation. SWS, wt. 14 lbs. BRAND NEW \$14.95



### OTHER DYNAMOTOR VALUES: Excellent BRAND

Type	Input	Output	Used	BRAND NEW
DM-32A	28V 1.1A	250V .05A	2.45	4.45
DM-33A	28V 5A	575V .16A		
DM-34A	28V 7A	540V .25A	1.95	3.75
DM-34D	12V 2A	220V .080A	4.15	5.50
DM-53A	28V 1.4A	220V .080A	3.75	5.45
DM-64A	12V 5.1A	275V .150A		7.95
PE-73C	28V 20A	1000V .350A	8.95	14.95
PE-86	28V 1.25A	250V .050A	2.75	3.85

DM-32A DYNAMOTOR, Input 12 V DC @ 1000 Amps. Output 515 V DC @ 215 Ma. and 1030 V DC @ 260 Ma. Wt. 38 lbs. BRAND NEW, each \$6.95

DM-37 DYNAMOTOR, Input 28.5 V DC @ 9.2 A. Output 925 V DC @ 225 Ma. BRAND NEW, Each \$3.25

### CARTER GENERATOR

Input: 2.9 V DC @ 32 Amps. Output: 145 V DC @ 270 Amps. BRAND NEW, special \$8.95

### MICROPHONES

Model	Description	Exc. Used	BRAND NEW
T-1	Carlton Hand Mike	\$4.45	\$7.95
RS-38	Navy Type Carbon Hand Mike	3.95	5.75

### HEADPHONES

Model	Description	Exc. Used	BRAND NEW
HS-23	High Impedance	\$2.19	\$4.49
HS-33	Low Impedance	2.00	4.50
HS-30	Low Imp. featherwt.	3.00	4.65
HS-31	Imp. 12 HITS	3.75	7.95

TELEPHONES 400 ohm Low Impedance HEAD-SET. BRAND NEW. PER PAIR \$3.25

CD-307A Carbons, with plates and JK26 \$3.25

Earphone Cushions for above—pair \$0.50



# ELECTRONICS MARKET PLACE

RATE: 60¢ per word. Minimum 10 words. September issue closes July 10th. Send order and remittance to: ELECTRONICS WORLD, One Park Ave., N. Y. C. 16, N. Y.

## ELECTRONICS ENGINEERING AND INSTRUCTION

USED Correspondence Courses and Books sold and rented. Money back guarantee. Catalog Free. (Courses Bought.) Lee Mountain, Pisgah, Alabama.

ELECTRONICS! Associate degree—29 months. Technicians, field engineers, specialists in communications, missiles, computers, radar, automation. Start February, September. Valparaiso Technical Institute, Dept. N, Valparaiso, Indiana.

NEW Trade? Electronic, Mechanical Drafting pays \$150 week. Send \$2 first lesson, complete home study course \$25. Prior, Inc., 23-09 169 St., Whitestone 57, New York.

## FOR SALE

TV Tuners—Rebuilt or Exchanged \$9.95 complete—all types—fast, guaranteed service. Send tuner with all parts to: L. A. Tuner Exchange, 4611 West Jefferson Blvd., Los Angeles 16, California.

TUBES—TV, Radio, Transmitting And Industrial Types At Sensibly Low Prices. New, Guaranteed, 1st Quality, Top Name Brands Only. Write For Free Catalog or Call Walker 5-7000, Barry Electronics Corp., 512 Broadway, New York 12N, N. Y.

DIAGRAMS for repairing radios \$1.00. Television \$2.00. Give make, model. Diagram Service, Box 672-E, Hartford 1, Conn.

GOVERNMENT Surplus Receivers, Transmitters, Snooperscopes, Parabolic Reflectors, Picture Catalog 10¢. Meshna, Malden 48, Mass.

PROFESSIONAL Electronic Projects—Organs, Timers, Computers, Industrial, etc.—\$1 up. Catalog Free. Parks, Box 1665, Lake City, Seattle 55, Wash.

BEFORE You Buy Receiving Tubes or Hi-Fi Components send now for your giant Free Zalytron current catalog—featuring nationally known Zalytron First Quality TV-Radio Tubes, Hi-Fi Stereo Systems, Kits, Parts, etc. All priced to Save You Plently—Why Pay More? Zalytron Tube Corp., 220 W. 42nd St., NYC.

PRECISION Resistors, carbon-deposit. Guaranteed 1% accuracy. Millions in stock. 1/2-watt, 8¢. 1-watt, 12¢. 2-watt, 15¢. Leading manufacturer, Rock Distributing Co., 902 Corwin Rd., Rochester 10, N. Y.

SAVE dollars on radio, TV-tubes, parts at less than manufacturer's cost. 100% guaranteed! No rebrands, pulls. Request Bargain Bulletin. United Radio, 1000-W, Newark, N. J.

"FREE"—R.C.A., G.E. etc. tubes catalog. Discount to 75% from list. Picture tubes at 75¢ inch up. Parts, parts kits at 1/10 original cost. Needles, tube testers, silicones, seleniums 7" TV bench test tube—\$6.99—and more." Arcurus Electronics Corp., E.W. 502-22nd Street, Union City, New Jersey.

TRANSFIRE TRANSISTOR Electronics ignition. Save gas, tune-ups. Improved starting, high and low-speed performance. Parts. Complete Kits. Conversions, from \$34.95. Palmer Electronics, 2W, Carlisle, Massachusetts.

POCKET sized, low impedance, square-wave generator. Variable frequency, 200 to 4000 cycles. Build it yourself for \$9. Send \$1.00 and stamped envelope for schematic to, Ace, 11500-H NW 7th Ave., Miami 50, Florida.

SCHEMATIC diagrams, exact replacement parts orders: Japanese transistor or tube radios, recorders, transceivers, electronics equipment. Give model and manufacturer. \$1. Techservices, CPO 849, Tokyo, Japan.

KELLISON sport cars, complete, semi-complete, bodies and frames. Send \$1.00 for brochure. Kellison Car Co., Folsom, Calif.

TELEVISION cameras, build one. Write: Spera Electronics 37-10 33 St., L.I.C. 1, N. Y.

EXPERIMENTERS: Miniaturize equipment without printed circuits. Leading research lab technique . . . illustrated instructions \$1.00. Creativity, Inc., 5883 Blackwelder St., Culver City, Calif.

CONVERT any television to sensitive, big-screen oscilloscope. Only minor changes required. No electronic experience necessary. Illustrated plans. \$2.00. Relco, Dept. EW, Box 10563, Houston 18, Texas.

TV Camera—low cost—easily built—complete schematics, instructions 50¢. Denson Electronics, Rockville, Conn.

## WANTED

CASH Paid! Sell your surplus electronic tubes. Want unused, Clean radio and TV receiving, transmitting special purpose. Magnetrons, klystrons, broadcast types. Want military and commercial lab test equipment such as G.R.H.P., AN UPM prefix. Also want commercial Ham Receivers and Transmitters. For a Fair Deal write: Barry Electronics Corp., 512 Broadway, New York 12, N. Y. (Walker 5-7000).

TRIGGER—W91VJ We Buy Shortwave Equipment For Cash. 7361 North, River Forest, Ill. Phone PR 1-8616. CASH or Ham Gear: For all types Military Surplus PRC-GRC. UPM and teletype. Philmar Electronics, Morrisonville, New York.

QUICKSILVER, Platinum, Silver, Gold. Ores Analyzed. Free Circular. Mercury Terminal, Norwood, Massachusetts.

CASH, or trade new amateur equipment for teletype, Kleinschmidt, or Collins equipment. Alltrons-Howard, Box 19, Boston 1, Mass. (Richmond 2-0048).

PLATINUM electronic scrap bought. Noble Metals Co., Box One, Los Angeles 9, Calif.

## TAPE AND RECORDERS

TAPE Recorders, HI-FI Components. Sleep Learning Equipment, Tapes, Unusual Values. Free Catalog. Dressner, 1523 EW Jericho Turnpike, New Hyde Park, N. Y.

RENT Stereo Tapes—over 2,500 Different—all major labels—free catalog. Stereo-Parti, 811-G, Centinela Ave., Inglewood 3, California.

SELF-Hypnosis. New concept teaches you quickly by tape or LP-record. Free literature. McKinley Publishers, Dept. T6, Box 3038, San Bernardino, California.

4 TR Stereo Tapes—bought, sold, rented, traded! Free Catalog/bargain closeouts. (Columbia) 9651 Foxbury, Rivera, California.

SAVE 30% Stereo music on tape. Free bargain catalog/blank tape/recorders/norelco speakers. Saxitone, 1776 Columbia Road, Washington, D. C.

DON'T buy Hi-Fi components until you get our low, low quotation. We guarantee "We Will Not Be Undersold." Easy-Pay-Plan. Send 10¢ for wholesale catalog and Best Buy Hi-Fi list. Hi-Fidelity Center, 220-NC E. 23rd St., N. Y. 10, N. Y.

## HIGH-FIDELITY

DISGUSTED with "Hi" Hi-Fi Prices? Unusual Discounts On Your High Fidelity Requirements. Write. Key Electronics, 120 Liberty St., New York 6, N. Y. Cloverdale 8-4288.

RECORDERS, Components! Free wholesale catalogue! Carston, 125-R, East 88, N.Y.C. 28.

PRICES? The Best! Factory-sealed Hi-Fi Components? Yes! Send for free catalog. Audion, 1038R Northern Blvd., Roslyn, N. Y.

MIRACLE Hi-Fi enclosure, construction drawings and assembly instructions, \$2.00. Kits and assembled cabinets also available. Gough & Company, Box 254, San Carlos, California.

## PATENTS

PATENT Searches, \$6.00. For free. Invention Record, and "Information Inventor's Need," Write: Miss Heyward, 1029 Vermont Avenue, N.W., Washington 5, D. C.

## HELP WANTED

ELECTRONICS engineer. The research division of a major producer of synthetic fibers and dielectric materials has an attractive opening for a B.S. or M.S. in electrical engineering or physics with 2-6 years experience to work in electronic instrument design and development related to physical measurements in the field of polymer and fiber physics. Experience with strain gauges, thermocouples, and other transducers desirable. Must have knowledge of transistors as well as conventional vacuum tube circuitry. Pleasant working and living location near Asheville, N.C. Excellent benefit program; 5 day work week; moving expenses. Send complete resume, including salary requirements to Employment Manager, Enka, N.C. American Enka Corporation.

TECHNICIANS to \$5.50 Hr. Tech Writers to \$8.00 Hr. Designers & Draftsman to \$6.50 Hr. Engineers to \$12.00 Hr. Current rates paid by thousand engineering firms, coast to coast, border to border. Per diem. Overtime on many. Who, Where with Vital Technical Data in Job Shoppers Manual & Directory \$2.00 Cash, Check, Money Order Electro-Press, Box 315, Pasadena, Cal.

## GOVERNMENT SURPLUS

JEEPS \$278. Airplanes \$159. Boats \$7.88. generators \$2.68, typewriters \$8.79. are typical government surplus sale prices. Buy 10,000+ items wholesale, direct. Full details, 627 locations, procedure, only \$1.00. Surplus. Box 789-C97, Abbottstown, Penna.

Your classified ad in this space will be read by more than 200,000 buyers. It costs only 60¢ per word. For information, write: Martin Lincoln, Electronics World, One Park Avenue, New York 15, N. Y.

## SHOPPING GUIDE CLASSIFIED

A HANDY GUIDE TO PRODUCTS, NOT NECESSARILY ELECTRONIC, BUT OF WIDE GENERAL INTEREST.

## PHOTOGRAPHY-FILM, EQUIPMENT, SERVICES

PHOTOGRAPHY For Pleasure or profit. Learn at home. Practical basic training. Long established school. Free booklet. American School of Photography, 835 Diversey Parkway, Dept. 253C, Chicago 14, Illinois.

SCIENCE Bargains—Request Free Giant Catalog "CJ"—144 pages—Astronomical Telescopes, Microscopes, Lenses, Binoculars, Kits, Parts. War surplus bargains. Edmund Scientific Co., Barrington, New Jersey.

SEND Empty film box. Receive Surprise Gift. National Color Corporation, Atlanta 24, Georgia.

## STAMPS AND COINS

GIGANTIC Collection Free! Includes triangles, early United States animals, commemoratives, British Colonies, high value pictorials, etc. Complete collection plus big illustrated magazine all free. Send 5¢ for postage. Gray Stamp Company, Dept. Z2, Toronto, Canada.

## EDUCATIONAL OPPORTUNITIES

LEARN While Asleep, hypnotize with your recorder, phonograph. Astonishing details, sensational catalog free! Sleep-Learning Association, Box 24-ZD, Olympia, Washington.

## BUSINESS OPPORTUNITIES

SECOND Income From Oil Can End Your Toil! Free Book and Oilfield Maps! National Petroleum, Pan-American Bank Building—PP, Miami 32, Florida.

FREE Book "990 Successful, Little-Known Businesses," Work home! Plymouth-555W, Brooklyn 4, New York.

I Made \$40,000.00 Year by Mail Order! Helped others make money! Start with \$10.00—Free Proof. Torrey, Box 3566-N, Oklahoma City 6, Oklahoma.

ASSEMBLE artificial lures at home for stores. Materials supplied free. Profitable! Write: Lures, Ft. Walton Beach 1, Florida.

EXOTIC earrings! Details free. Pair \$1.00. OHGA, ZD-365, Sigakenkusatu, Japan.

INVESTIGATE Accidents—Earn \$750 to \$1,000 monthly. Men urgently needed. Car furnished. Business Expenses Paid. No Selling. No college education necessary. Pick own job location. Investigate full time Or earn \$6.44 hour spare time. Write for Free Literature. No obligation. Universal, CZ-8, 6801 Hillcrest, Dallas 5, Texas.

## MISCELLANEOUS

2700 Novelties, Tricks, jokes, science, hobbies. World's biggest gadget catalog 10¢. Johnson-Smith, D-528, Detroit 7.

INDEPENDENT Thinkers—investigate Humanism! Free literature. American Humanist Association, Dept. EW-1, Yellow Springs, Ohio.

HOMEBREWING! Beers, wines, Complete Instructions \$1. Guaranteed. Crystalco 28-BEWS, Millburn, New Jersey

AUTHORS! Learn how to have your book published, promoted, distributed. FREE booklet "ZD," Vantage, 120 West 31 St., New York 1.

HYPNOTIZE Unnoticed, quickly, effortlessly, or refund! Thousands satisfied! \$2, Timmer, Eox 244, Cedarburg, Wisc.

INVESTIGATORS, free brochure, latest subminiature electronic listening devices. Dept.-7B, 11500 NW 7th Ave., Miami 50, Florida.

"HYPNOTIZE . . . One word . . . One fingersnap," on stage. Satisfaction—or refund. \$2. Hypnomaster, Box 9309-E8, Chicago 90.

GIANT Arms." Dr. Young's, D.C. Revolutionary discovery. \$2. Satisfaction or refund. Gaucho, Box 9309-E8, Chicago 90.

WRITERS Send Your books, articles, stories, plays for free evaluation, screening and sale. Write today! Literary Agent Mead, 915 Broadway, N.Y.C. 10.

# ADVERTISERS' INDEX AUGUST, 1962

Advertisers listed below with code numbers have additional information available on their products in the form of catalogues and bulletins. To obtain more detailed data, simply circle the proper code number in the coupon below and mail it to the address indicated. We will direct your inquiry to the manufacturer for processing.

CODE NO.	ADVERTISER	PAGE	CODE NO.	ADVERTISER	PAGE	CODE NO.	ADVERTISER	PAGE
	Allied Radio .....	17, 18	116	Harman-Kardon .....	59	129	Radio Shack Corporation	78, 79, 80, 81
100	Antenna Specialists Co., The .....	8	117	Heath Company .....	63	130	Rider Publisher Inc. John F .....	4
101	Audion .....	72	118	Indiana Technical College .....	85	131	Rohn Manufacturing Company .....	83
102	B & K Manufacturing Co .....	9	119	Jensen Manufacturing Company ..	6	132	Sams & Co., Inc., Howard W .....	65
	Bell Telephone Laboratories .....	19	120	Key Electronics Co .....	88	133	Scott Inc., H.H. ....	62
103	Capitol Radio Engineering Institute, The .....	5	121	Lafayette Radio .....	15	134	Sencore .....	73
104	Channel Master Corp .....	85	122	Lampkin Laboratories, Inc .....	60	135	Sonotone Corporation .....	14
	Cleveland Institute of Electronics ..	7	123	Multicore Sales Corp .....	16	136	Space Electronics Co .....	85
105	Columbia Electronics .....	72				137	Sprague Products Company .....	57
106	Delco Radio .....	2				138	Standard Kollsman Industries, Inc	THIRD COVER
107	Don Bosco Electronics Inc .....	77		National Radio Institute		139	Superscope, Inc .....	93
108	Dressner .....	90			SECOND COVER	140	Texas Crystals .....	90
109	EICO (Electronic Instr. Co. Inc.) ..	20		National Radio Institute .....	90	141	Transvision Electronics, Inc .....	71
110	Electro-Voice, Inc .....	58	124	Oelrich Publications .....	72	142	Tri-State College .....	72
111	Electronic Chemical Corp .....	16	125	Peak Electronics Company .....	60	143	Tru-Vac .....	89
	Electronics Book Service— A.S. Barnes & Co. Inc .....	67	126	Quietrole Company .....	58	144	U.S. Crystals, Inc .....	64
112	Fair Radio Sales .....	60		RCA Institutes, Inc .....	10, 11	145	University Loudspeakers, Inc .....	1
113	G & G Radio Supply Co .....	94	127	R W Electronics .....	85	146	Valparaiso Technical Institute .....	90
114	Grantham School of Electronics .....	13	128	Rad-Tel Tube Co .....	91	147	Vets Distributing Company, The ..	88
115	Greenlee Tool Co .....	62		Radio Corporation of America		148	Winegard .....	73
					FOURTH COVER			

The coupon below can also be used to obtain additional information on the new product items shown on pages 87 through 92 as well as on the ads listed above.

<b>VOID 8</b> <b>AFTER</b> <b>AUG. 31, 1962</b>	<b>NAME</b> _____ <b>STREET NO.</b> _____ <b>CITY</b> _____ <b>ZONE</b> _____ <b>STATE</b> _____			
	<table border="1"> <tr> <td><b>ADVERTISED PRODUCTS</b> (SEE INDEX ABOVE)</td> <td>           100 101 102 103 104 105 106 107 108 109 110 111 112 113 114 115 116 117 118 119            120 121 122 123 124 125 126 127 128 129 130 131 132 133 134 135 136 137 138 139            140 141 142 143 144 145 146 147 148 149 150 151 152 153 154 155 156 157 158 159            160 161 162 163 164 165 166 167 168 169 170 171 172 173 174 175 176 177 178 179            180 181 182 183 184 185 186 187 188 189 190 191 192 193 194 195 196 197 198 199            200 201 202 203 204 205 206 207 208 209 210 211 212 213 214 215 216 217 218 219            220 221 222 223 224 225 226 227 228 229 230 231 232 233 234 235 236 237 238 239         </td> </tr> <tr> <td><b>NEW PRODUCTS &amp; LITERATURE</b></td> <td>           1 2 3 4 5 6 7 8 9 10 11 12 13 14 15 16 17 18 19 20            21 22 23 24 25 26 27 28 29 30 31 32 33 34 35 36 37 38 39 40            41 42 43 44 45 46 47 48 49 50 51 52 53 54 55 56 57 58 59 60         </td> </tr> </table>	<b>ADVERTISED PRODUCTS</b> (SEE INDEX ABOVE)	100 101 102 103 104 105 106 107 108 109 110 111 112 113 114 115 116 117 118 119 120 121 122 123 124 125 126 127 128 129 130 131 132 133 134 135 136 137 138 139 140 141 142 143 144 145 146 147 148 149 150 151 152 153 154 155 156 157 158 159 160 161 162 163 164 165 166 167 168 169 170 171 172 173 174 175 176 177 178 179 180 181 182 183 184 185 186 187 188 189 190 191 192 193 194 195 196 197 198 199 200 201 202 203 204 205 206 207 208 209 210 211 212 213 214 215 216 217 218 219 220 221 222 223 224 225 226 227 228 229 230 231 232 233 234 235 236 237 238 239	<b>NEW PRODUCTS &amp; LITERATURE</b>
<b>ADVERTISED PRODUCTS</b> (SEE INDEX ABOVE)	100 101 102 103 104 105 106 107 108 109 110 111 112 113 114 115 116 117 118 119 120 121 122 123 124 125 126 127 128 129 130 131 132 133 134 135 136 137 138 139 140 141 142 143 144 145 146 147 148 149 150 151 152 153 154 155 156 157 158 159 160 161 162 163 164 165 166 167 168 169 170 171 172 173 174 175 176 177 178 179 180 181 182 183 184 185 186 187 188 189 190 191 192 193 194 195 196 197 198 199 200 201 202 203 204 205 206 207 208 209 210 211 212 213 214 215 216 217 218 219 220 221 222 223 224 225 226 227 228 229 230 231 232 233 234 235 236 237 238 239			
<b>NEW PRODUCTS &amp; LITERATURE</b>	1 2 3 4 5 6 7 8 9 10 11 12 13 14 15 16 17 18 19 20 21 22 23 24 25 26 27 28 29 30 31 32 33 34 35 36 37 38 39 40 41 42 43 44 45 46 47 48 49 50 51 52 53 54 55 56 57 58 59 60			
<b>MAIL TO ELECTRONICS WORLD P.O. BOX 212</b> <b>VILLAGE STATION NEW YORK 14, N.Y.</b>				
<b>INDICATE NUMBER OF ITEMS REQUESTED</b> <input type="checkbox"/>				

 Make sure that your name and address are printed clearly.

## ELECTRONICS WORLD READER SERVICE COUPON





**FINALLY!**

# **A SUPERIOR LIQUID CONTACT CLEANER**

**Ultra-New CONTA-CARE KIT II**



**\$1<sup>25</sup>**

**Cleans Almost Instantly with Minimum Rubbing**

After years of painstaking research, Standard Kollsman *for the first time* can honestly recommend a liquid contact cleaner. You'll find it in the new Contacare Kit II. You'll also find a soft tough cloth—lint-free to avoid fouling . . . and a tube of non-evaporating grease for permanent channel lubrication and contact protection. Instruction sheet is clear, brief, and complete. Kit is compact and sturdy. Try it soon . . . and save your elbow grease for jobs that need it.

*INSIST ON THE GENUINE CONTACARE KIT II*

- NO RESIDUE
- NO SUBSEQUENT CORROSION
- NON-FLAMMABLE
- NON-CONDUCTIVE

**standard kollsman<sup>®</sup> INDUSTRIES, INC.**

FORMERLY STANDARD COIL PRODUCTS CO., INC., MELROSE PARK, ILLINOIS

**WORLD'S LARGEST MANUFACTURER OF TELEVISION TUNERS**

Essential service data at your fingertips...



## RCA TECHNICAL PUBLICATIONS HELP YOU DO YOUR JOB FASTER, BETTER, AND MORE PROFITABLY

How many times each day do you have to refer to electronic technical literature in order to do your job properly?

Of all major electronics manufacturers, RCA provides you with one of the most comprehensive, authoritative libraries of technical service literature in your industry... all designed to put service facts you need at your fingertips. This literature is as important to your job as your soldering gun.

- **RCA Receiving Tube Manual (RC-21)** Essential data and basing diagrams for over 1000 receiving tubes. Treats tube theory, applications, circuits.
- **RCA Receiving Tube and Picture Tube Catalog (1275K)** Classification, application, and characteristics charts and basing diagrams for over 1050 entertainment receiving and picture tubes.
- **TV Servicing (TVS-1030)** Fully-illustrated, easy-to-follow guide to help you locate and diagnose TV troubles.
- **TV Servicing, Supplement 1 (TVS-1031)** Problems encountered in servicing hard-to-service sets.
- **RCA Color TV Pict-O-Guide** Loose-leaf guide to help you recognize and repair color TV troubles. Illustrated, diagrammed, easy-to-follow.
- **RCA Triple Pindex (PINDEX 109)** Lets you look at base diagrams of three different receiving tubes simultaneously.
- **RCA Interchangeability Directory of Foreign vs. Domestic Receiving Tubes (1CE-197A)** Shows which U.S. receiving tubes to use to replace those hard-to-get foreign types.
- **RCA Service News** Keeps you up to date on RCA's new products and promotions.

... And much more, including RCA technical data bulletins, technical booklets and interchangeability directories on batteries, technical aids to more effective use of test equipment, etc. All are available from your Authorized RCA Electron Tube Distributor. Stop in to see him this week.

RCA ELECTRON TUBE DIVISION, HARRISON, N. J.



THE MOST TRUSTED NAME IN ELECTRONICS