

ELECTRONICS WORLD

NOVEMBER, 1960

50 CENTS

9

HI-FI POWER RATINGS & IM TESTS
WHICH TYPE OF ANTENNA FOR CITIZENS RADIO?
INFRARED CAMERA CONTROL FOR PHOTOGRAPHY
NEW TECHNIQUES OF FREQUENCY MEASUREMENT FOR INDUSTRY

THE MASER & SUGAR-SCOOP ANTENNA — KEY TO SPACE COMMUNICATIONS

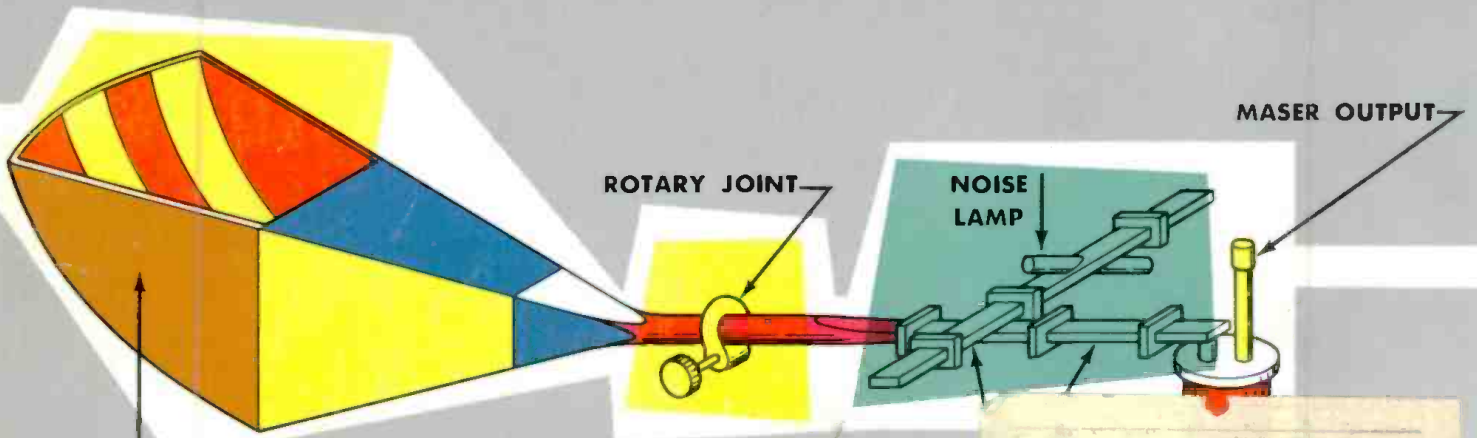

LOW-NOISE HORN-REFLECTOR ANTENNA

ROTARY JOINT

NOISE LAMP

MASER OUTPUT

COL WA

50F527041
AVIONICS G-4 AD F
MARINE CPS APR ST
CHERRY POINT NO C

ADD ARTHUR GODFREY TO YOUR SALES STAFF

WITHOUT ADDING HIM TO YOUR PAYROLL!



Tie in locally with the national Sylvania Silver Screen 85 TV Tube promotion featuring you, the independent service dealer

Arthur Godfrey, America's Number One Salesman, is selling – the Sylvania Silver Screen 85 TV picture tube—and Sylvania quality small tubes—in a dynamic national advertising campaign. Just look where you're being promoted . . . twice each week on 200 CBS Radio Network stations across the country . . . *The Saturday Evening Post* . . . and lots more!



To make the most of this sales-getting promotion, be sure you use all the local tie-in aids Sylvania now offers:

GIANT WINDOW DISPLAY—colorful, 3-dimensional features you and Arthur Godfrey. (Order #1139)

3-PIECE DECAL KIT—Sparkling glassine signs with Arthur Godfrey saying, "Stop Here For Quality TV Service." (Order #1138)

GIANT WINDOW POSTER—Big 20" x 26" poster promotes your service. (Order #2095)

Each and every promotion piece is designed to help you sell Sylvania Silver Screen 85 TV tubes plus Sylvania quality small tubes. For your supply—and helpful hints on how to make the best use of these selling aids—contact your Sylvania distributor. Do it today!

Electronic Tubes Division, Sylvania Electric Products Inc., 1740 Broadway, New York 19, New York

SYLVANIA

Subsidiary of **GENERAL TELEPHONE & ELECTRONICS** 

FIRST PHONE CALL VIA MAN-MADE SATELLITE!

"Project Echo" satellite went into a near-perfect circular orbit 1000 miles high, circling the earth once every two hours. Its orbital path covered all parts of the U. S.

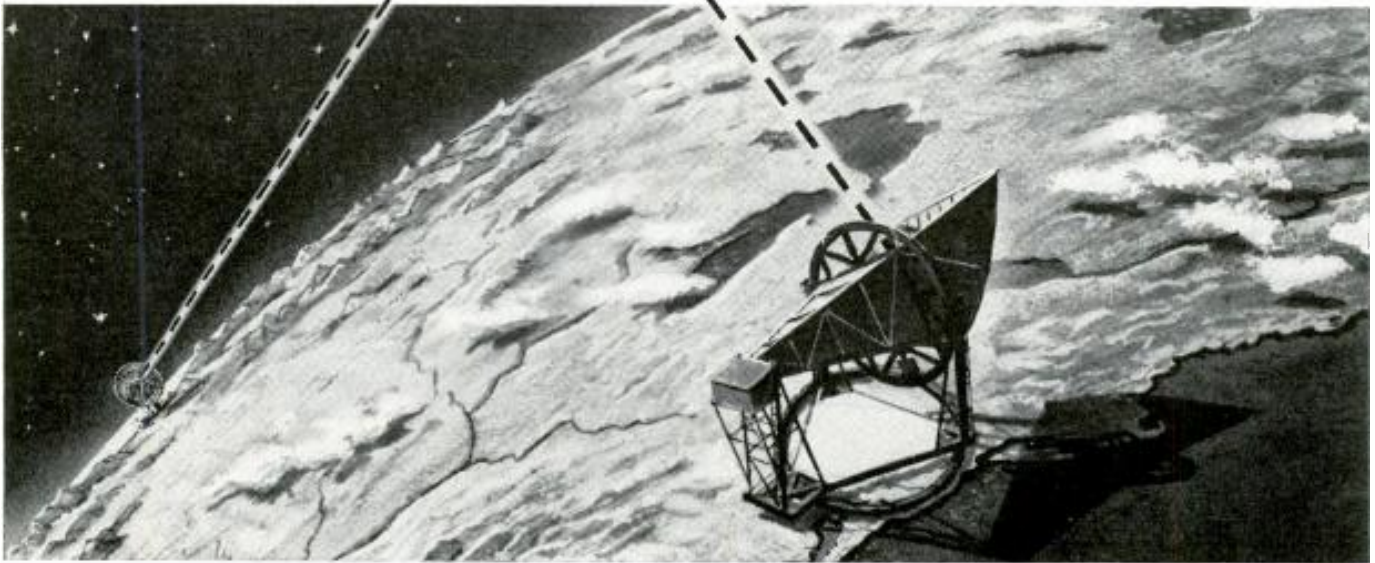

BELL TELEPHONE LABORATORIES BOUNCES VOICE OFF SPHERE PLACED IN ORBIT A THOUSAND MILES ABOVE THE EARTH

Think of watching a royal wedding in Europe by live TV, or telephoning to Singapore or Calcutta—*by way of outer-space satellites!* A mere dream a few years ago, this idea is now a giant step closer to reality.

Bell Telephone Laboratories recently took the step by successfully bouncing a phone call between its Holmdel, N. J., test site and the Jet Propulsion Laboratory of the National Aeronautics and Space Administration (NASA) in Goldstone, California. The reflector was a 100-foot sphere of aluminized plastic orbiting the earth 1000 miles up.

Dramatic application of telephone science

Sponsored by NASA, this dramatic experiment—known as "Project Echo"—relied heavily on telephone science for its fulfillment . . .

- The Delta rocket which carried the satellite into space was steered into a precise orbit by the Bell Laboratories Command Guidance System. This is the same system which recently guided the remarkable Tiros I weather satellite into its near-perfect circular orbit.
- To pick up the signals, a special horn-reflector antenna was used. Previously perfected by Bell Laboratories for microwave radio relay, it is virtually immune to common radio "noise" interference. The amplifier—also a Laboratories development—was a traveling wave "maser" with very low noise susceptibility. The signals were still further protected from noise by a special FM receiving technique invented at Bell Laboratories.

"Project Echo" foreshadows the day when numerous man-made satellites might be in orbit all around the earth, acting as 24-hour-a-day relay stations for TV programs and phone calls between all nations.

This experiment shows how Bell Laboratories, as part of the Bell System, is working to advance space communication. Just as we pioneered in world-wide telephone service by radio and cable, so we are pioneering now in using outer space to improve communications on earth. It's part of our job, and we are a long way toward the goal.

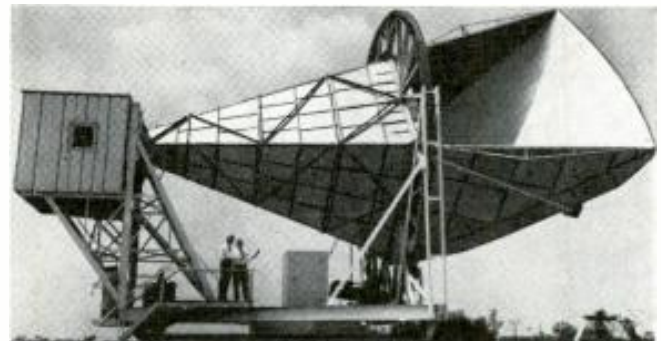

Giant ultra-sensitive horn-reflector antenna which received signals bounced off the satellite. It is located at Bell Telephone Laboratories, Holmdel, New Jersey.



BELL TELEPHONE LABORATORIES

WORLD CENTER OF COMMUNICATIONS RESEARCH AND DEVELOPMENT

ELECTRONICS WORLD

NOVEMBER, 1960

VOL. 64 • NO. 5

Editor
WM. A. STOCKLIN, B. S.

Technical Editor
MILTON S. SNITZER, W2QYI

Service Editor
SIDNEY C. SILVER

Associate Editor
P. B. HOEFER

Editorial Consultant
OLIVER READ, D. Sc., W1ETI

Industrial Consultant
WALTER H. BUCHSBAUM

Art Editor
MILTON BERWIN

Art and Drafting Dept.
J. A. GOLANEK
K. W. PAUL, JR.

Advertising Director
JOHN A. RONAN, JR.

Advertising Manager
GEORGE E. MORRISSEY

Midwest Adv. Manager
GILBERT J. JORGENSON

Western Adv. Manager
ADRIAN WHITED



ZIFF-DAVIS PUBLISHING COMPANY
William Ziff, President; W. Bradford
Briggs, Executive Vice-President;
Michael Michaelson, Vice-President
and Circulation Director; Hershel B.
Sorbin, Vice-President; J. L. O'Donnell,
Treasurer.

Editorial and Executive Offices
One Park Avenue
New York 16, N. Y. OR. 9-7200



Member
Audit Bureau of
Circulations

BRANCH OFFICES: Midwestern Office,
434 S. Wabash Ave., Chicago 5, Ill.;
Western Office, 9025 Wilshire
Blvd., Beverly Hills, Calif.; James R.
Pierce, manager.

FOREIGN ADVERTISING REPRESENTATIVES:
D. A. Goodall Ltd., London;
Albert Mithado & Co., Antwerp and
Dusseldorf.

First in radio-television-audio-electronics

CONTENTS

GENERAL ELECTRONICS AND INDUSTRIAL

Spot News.....	Washington Correspondent	28
Recent Developments in Electronics.....		46
Electronic Artificial Larynx.....		102
Calendar of Events.....		123
Crossword Puzzle—Electronics & Other Things.....	Margaret Le Fevre	127

HIGH FIDELITY AND AUDIO

Reverberation or Not? (Editorial).....	W. A. Stocklin	6
Outboard Signal-Level Indicator.....	Harold Reed	39
Preamp-Mixer for Electronic Organs.....	J. R. Cadden	43
Dual 14-Watt Stereo Amplifier.....	Robert M. Voss	48
Push-Pull Class B Transistor Power-Output Circuits.....	Walter H. Buchsbaum	55
Power Ratings & IM Tests.....	L. W. Born	58
Hi-Fi—Audio Product Review.....		76
Sound on Tape.....	Bert Whyte	84
Certified Record Revue.....	Bert Whyte	94

TELEVISION-RADIO

Finding Filter Faults.....	Kenneth Bramham	44
Handling the Service Complaint.....	Max Alth	50
Why "Dogs" Are Tough.....	Darwell H. Webster	54
Mac's Service Shop.....	John T. Frye	62
Service Industry News.....		106

TEST EQUIPMENT

New Techniques of Frequency Measurement.....	Ed Bukstein	51
Making the Most of Your Flyback Checker.....	H. R. Holtz	60
A Line-Voltage Adjuster.....	Ronald L. Ives	66
The Transistor "Alpha Box".....	Donald L. Stoner	86
Square-Wave Voltage Calibrator.....	John Potter Shields	99
New Tube Tester Data.....		126

COMMUNICATIONS AND AMATEUR

The Maser—Receiver for Signals from Space.....	Martin I. Grace & Joseph G. Smith	35
Sugar-Scoop Antenna (Cover Story).....		38
Antennas for Citizens Radio.....	Leo G. Sands	40
Receiver Input Impedance Matching.....	Richard A. Genaille, K4ZGM	68
EW Lab Report (Eico Model 762 CB Transceiver).....		108

ELECTRONIC CONSTRUCTION

Infrared Camera Control for Nature Photos.....	Walter B. Ford	63
Improved Thyatron Relay Control.....	John Potter Shields	104

DEPARTMENTS

Letters from Our Readers.....	10	Technical Books.....	114
Within the Industry.....	22	Manufacturers' Literature.....	130
What's New in Radio.....	136		

Circulation (Jan.-June) 251,750 (Publisher's Estimate)

Radio & TV News • Radio News • Television News Trademarks Reg. U. S. Pat. Off.

Copyright © 1960 by Ziff-Davis Publishing Company. All rights reserved.

SUBSCRIPTION SERVICE: Forms 3579 and all subscription correspondence should be addressed to Circulation Department, 434 South Wabash Avenue, Chicago 5, Illinois. Please allow at least four weeks for change of address. Include your old address as well as new—enclosing if possible an address label from a recent issue.

CONTRIBUTIONS: Contributors are advised to retain a copy of their manuscripts and illustrations. Contributions should be mailed to the New York Editorial Office and must be accompanied by return postage. Contributions will be handled with reasonable care, but this magazine assumes no responsibility for their safety. Any copy accepted is subject to whatever adaptations and revisions are necessary to meet the requirements of this publication. Payment covers all author's, contributor's, and contestant's rights, title, and interest in and to the material accepted and will be made at our current rates upon acceptance. All photos and drawings will be considered as part of the material purchased.

Men 17-55

READ THESE AMAZING FACTS ABOUT A MAN WHO COULD BE YOU!

Are **You** One of
the men who could
prepare for a job that
PAYS REAL MONEY in

**TELEVISION
RADIO**

Electronics

ONLY DeVRY OFFERS ALL THESE FEATURES!

Only DeVry Tech provides Training Movies to make the basic principles of Electronics crystal clear! DeVry's explanations and illustrations are a pleasure to follow. Over 300 practical experiments with actual Electronic parts are included to give you on-the-job type know-how. You even build your own test equipment.

EMPLOYMENT SERVICE

The Industry knows the quality of DeVry training. That's why our Employment Service usually has more demands for graduates than we can fill. We can also help you get started in your own shop.

ARE YOU PASSING UP THE PAYCHECK—THE SOLID FUTURE —THE REAL BREAK—YOU'VE ALWAYS DREAMED OF?

You meet them almost every day . . . the men who want to advance out of humdrum, low-pay, or no-future jobs. Some are men who had to quit school too soon; men just out of school with no idea of what to do; or men looking for help in planning a better future. Yet, many of them could—can, if they're 17-55—train at home, in their spare time, for an exciting career with real money and an inspiring future in the field of Electronics. And the tragedy of it is: they don't know it! They think they need an advanced education, or some special experience, or a lot of money, to start—but what they need most is the will to win. Maybe you're a man like that. Well, here's great news! It's not too late! Electronics offers men like you, when trained, dozens of different job opportunities—from guided missile control to running your own radio-television service shop. Get the full story of the jobs you may prepare for . . . NOW . . . BEFORE the years and responsibilities close in on you. Send coupon today no obligation.

EMPLOYMENT
SERVICE

NOTHING
ELSE
LIKE IT

NO
PREVIOUS
TECHNICAL
EXPERIENCE
NEEDED

NO
ADVANCED
EDUCATION
NEEDED

LEARN
AT HOME
OR . . .

. . . IN OUR
CHICAGO
OR TORONTO
LABORATORIES

2 MODERN TRAINING CENTERS

Large modern training centers in Chicago and Toronto offer DeVry students day and evening classes. The staffs, facilities and experience of these centers stand back of the home training programs. Whether you train at home or in residence, you're a DeVry Tech man. Look into it now!

Be A Standout in Electronics . . . Be A DeVry Tech Man!

Accredited Member of National Home Study Council
"One of North America's Foremost Electronics Training Centers"



DeVRY TECHNICAL INSTITUTE

CHICAGO 41, ILLINOIS



DON'T DELAY!

MAIL COUPON TODAY

DeVRY TECHNICAL INSTITUTE

4141 Belmont Ave., Chicago 41, Ill., Dept. EW-11-Q

Please give me your FREE booklets, "Pocket Guide to Real Earnings" and "Electronics in Space Travel," and tell me how to prepare to enter one or more branches of Electronics.

NAME _____ AGE _____

STREET _____ PLEASE PRINT _____ APT. _____

CITY _____ ZONE _____ STATE _____

Check here if subject to military training.

Canadian residents address: DeVry Tech of Canada, Ltd.
970 Lawrence Avenue West, Toronto, Ontario

2060

REVIEWS LIKE THESE...

The PR-500 Turntable . . .

"... a single speed (33 $\frac{1}{3}$ -rpm) turntable with an integrally mounted arm . . . employs a somewhat unconventional drive system which results in a totally inaudible rumble level, and low wow and flutter. The arm is simple yet effective, with a mounting system which makes the unit relatively insensitive to shock and vibration."

"The arm tracks well at the lowest stylus forces recommended by the cartridge manufacturer."

"The hum field surrounding the PR-500 is very low, and no difficulty should be experienced from this source even with poorly shielded cartridges."

"... the Stromberg-Carlson PR-500 performs in a manner comparable to that of the most expensive turntables and arms, yet sells for much less."

"The PR-500 is an excellent value at \$69.95."

Hirsh-Houck Laboratory—
High Fidelity Magazine, May '60

...hint at the performance of new

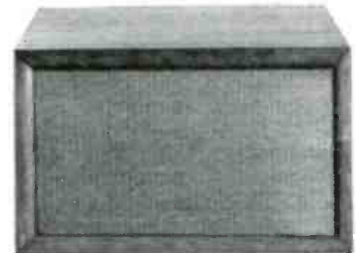
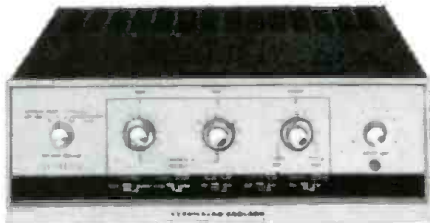

New Amplifiers . . .

ASR 660—an extremely clean, beautifully designed stereo amplifier • Continuous power: 36 watts (18 watts per channel) • Music power: (IHFM standard): 44 watts (22 watts per channel) • Total harmonic distortion: 0.6% at 18 watts per channel • Intermodulation distortion: 1% at rated output (4:1 ratio, 60 and 7,000 cps) • Frequency response: ± 0.5 db, 20-20,000 cps • Separate channel, clutch-type bass and treble controls • Scratch filter (18 db/oct); Rumble filter "Twin T" filter, null at 20 cps • Loudness contour switch; Balance control; Channel reverse switch; Program selector; Master gain control • DC on pre-amp heaters for low noise; A plus B center speaker terminals.

Suggested Audiophile net: \$159.95

ASR 220C — an unusually versatile medium power stereo amplifier • Continuous power: 24 watts (12 watts per channel) • Music power (IHFM standard) 28 watts (14 watts per channel) • Total harmonic distortion: 0.7% at 12 watts per channel • Intermodulation distortion: 2% at rated output (4:1 ratio, 60 and 7,000 cps) • Frequency response: ± 0.5 db, 20-20,000 cps • Separate channel clutch-type bass and treble controls • Scratch filter (18 db/oct); Rumble filter "Twin T" filter, null at 20 cps • Magnetic phono pre-amp with new, low noise tubes • A plus B center-speaker terminals.

Suggested Audiophile net: \$119.95

New Speaker Systems

Three new, wide range speaker systems. A new elliptical tweeter with a heavily silver-plated voice coil prevents harshness caused by cone breakup in conventional circular speakers. Woofers of extra-heavy cone stock are capable of long, linear excursions for outstanding low frequency power handling without distortion. Tweeter level switches included on all models. Enclosures are carefully matched to the woofer.

Suggested R5511 59.95 to 84.95
Audiophile net: R5514 74.95 to 99.95
(Prices vary with finish) R5516 105.00 to 135.00

For the sheer joy of listening . . . "There is nothing finer than a Stromberg-Carlson"

The FM-443 Tuner . . .

"The Stromberg-Carlson FM-443, one of the least expensive FM tuners on the market, approaches the performance of more expensive equipment. It is therefore an especially good value for anyone who wants to obtain the highest level of performance in a moderate-priced system.

"The distortion at 100% modulation is about 1% for signals stronger than 10 microvolts."

"The sensitivity measurement of the FM-443, according to IHFM standards, is amazing. Its usable sensitivity is 3 microvolts, a figure not usually found in tuners in this price range. This high sensitivity has not been obtained at the expense of IF bandwidth."

"The tuner sells for \$79.96."

Hirsh-Houck Laboratory —
High Fidelity Magazine, June '60

The ASR-880 Amplifier . . .

" . . . a compact integrated stereo amplifier rated at 32 watts per channel. Noteworthy . . . it exceeds its rated power substantially over most of the audio range, has excellent power-handling capabilities at both ends of the spectrum."

"Each channel delivered 50 watts at 2% harmonic distortion, or 48 watts at 1% distortion. This is unusual in an amplifier rated at 32 watts . . ."

"The distortion of the ASR-880 is very low at usual listening levels when correctly operated . . . it has a rare combination of very high gain and very low hum. The amplifier has a number of special features, such as center channel output and a very effective channel-balancing system, as well as the usual stereo control functions found in all good amplifiers."

"Only 0.6 or 0.7 millivolts at the phono inputs will drive the amplifier to 10 watts output per channel. At normal gain settings . . . the hum level is better than 70 db below 10 watts even on phono input. This is completely inaudible."

"With a listening quality matching its laboratory response, the Stromberg-Carlson ASR-880 must be considered a very good value at its \$199.95 price."

Hirsh-Houck Laboratory —
High Fidelity Magazine, Sept. '60



Stromberg-Carlson components like these:



New Tuners

FM-443A—an improved version of the highly rated FM-443 • New, high-accuracy, precision dial • Precision components in de-emphasis network, giving improved frequency response: 20-20,000 cps \pm 1 db • Sensitivity: 3.5 microvolts for 20 db quieting • Improved local-distance control in RF stage for lowest distortion and best signal-to-noise ratio on both local and distant stations • Total harmonic distortion; less than 1% full deviation.

Suggested Audiophile net: \$79.95

SR-445A—a combination of the FM-443A and an entirely new, wide-band AM section. FM specifications: identical to FM-443A • AM frequency response: Broad: 25 to 9,000 \pm 1½ db • Sharp: 25 to 2,500 cps \pm 1½ db • AM noise level: 60 db below 1 volt output • AM harmonic distortion: less than 1% at 100% modulation • Separate tuning indicators for AM and FM.

Suggested Audiophile net: \$139.95

All the new Stromberg-Carlson components have so many impressive features, you'll find a visit to your Stromberg-Carlson dealer most rewarding. He will be glad to demonstrate either an individual component or a complete Stromberg-Carlson Component Ensemble. See him or write: Stromberg-Carlson, 1477 — 011 North Goodman Street, Rochester 3, New York.

STROMBERG-CARLSON
A DIVISION OF **GENERAL DYNAMICS**

THE REMARKABLE SONY RADIO WIRELESS MICROPHONE

The convenience and variety of uses for this remarkable instrument are almost beyond the imagination. The Sony CR-4 mike and radio transmitter can be slipped into a coat pocket for completely wireless on-the-street interviewing, studio audience interviewing or on-the-spot broadcasting from awkward places. It gives complete freedom to active singers, dancers, comedians, performers with electric instruments and actors, eliminating the need for cumbersome mike booms and entangling wires.

Microphone, transmitter, receiver and carrying case, \$250. For information or literature, write: Superscope, Inc., Dept. 6, Sun Valley, California.



SONY
SUPERSCOPE The Tapeway to Stereo



... for the Record

REVERBERATION OR NOT?

WHICH is better, hi-fi or stereo?" This question has been a standing joke within the industry ever since the advent of stereo reproduction some two years ago and we feel sure that to most of our readers this question is obviously ridiculous. Yet, questions like this are indicative of the confusion that still exists in the minds of many would-be purchasers of hi-fi equipment.

Now another term, "reverberation," is coming to the forefront to add further problems, and it is the responsibility of everyone in the hi-fi industry to clarify the situation as quickly as possible. Reverberation units can be built directly into a hi-fi system or they can be added as an external component. They can be used with either monophonic or stereophonic equipment. In most such units, a portion of the input signal is applied to a delay line and then the delayed signal is fed back into the hi-fi system to produce an echo effect. In all the cases we know of, the delay line is a product made by the *Hammond Organ Company* and, at the time of this writing, the basic unit is not available to the home constructor as a separate part. No doubt it won't be long before some aggressive parts distributor will make one available.

New names are being coined daily to describe these systems—"Reverbaphonic Sound" (*Philco*), "Reverba-Tone" (*Zenith*), "Vibrasonic" (*Motorola*), "Reverber-Sonic" (*Checker Electronics Corp.*), "Dynamic Spacexpander" (*Fisher*), "Accompanist" (*Ecco-Fonic Corp.*), and "Resonant Stereo" (*General Electric*). See page 82 of our August issue for further details on the *Philco* and *Zenith* methods of using the delay line for reverberation.

All of the units available permit the home listener to add varying degrees of reverberation or echo effect to recorded or broadcast programs and thereby increase the illusion of aural perspective.

Not all manufacturers and hi-fi enthusiasts are in agreement on the importance of the added reverberation. The critical listener will look upon this unit strictly as a gadget since it adds distortion and it alters the nature of the original recording. Such a listener is usually a firm believer in reproducing recorded material just as the recording artist and recording engineer intended it to be played.

To the many hi-fi enthusiasts who enjoy music but are not classed as critical listeners, reverberation units may provide a new characteristic that is dramatic and pleasing. To those who are by nature showmen, those who particularly like the dynamic effect of stereo reproduction, here is a device that will prove exciting. We now have a situation similar to that existing with the electric guitar, which does not sound at all like a classical guitar. Something new has been added by the electronic circuitry which provides a tonal response that is different. We have talked to quite a few musicians on this point and the one universal comment is—sure it is different, but there are many who like it. So it is with this new reverberation device. It is different, it can provide you with a new tonal response and, undoubtedly, many will like it.

In the final analysis, one should attempt to obtain sound reproduction in the home equal to that obtained in a concert hall. With good stereo equipment and with the best recorded material available, one can come quite close in re-creating the spread and depth effect obtained in concert halls. At the present time, one cannot duplicate in the home the reverberation, or spacial effect, of large halls. If the acoustics of your living room are far from ideal—especially if the room is not as lively as it should be—added reverberation can enhance the sound reproduction and provide added pleasure, even to the most critical listener.

This is a step in the right direction. We now have available a device providing a variable amount of reverberation. Were we able to obtain another device that would provide us with a variable degree of reverberation delay time, then we would be extremely close to being able to reproduce concert hall realism in the home. We would then be able to simulate the complex reverberation characteristics of a 500,000-cubic-foot concert hall in a 2000-cubic-foot living room. Units of this type are available today, but at a price too high for the home music enthusiast. But again, like everything else, some manufacturer will develop a device that will be marketable at a price range suitable for our present hi-fi market. Until then, remember that reverberation units can enhance your sound reproduction, but let's use them with good taste. [30]

ALLIED value-packed 1961

444-PAGE ELECTRONICS CATALOG

including products available only from Allied

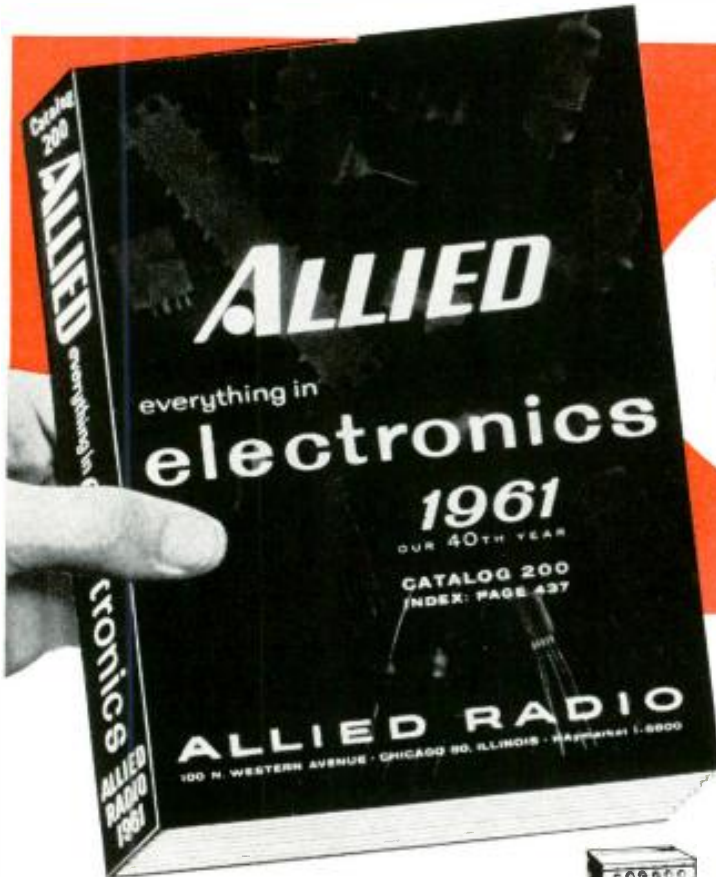

complete
up-to-date

free

send for it today!

SAVE MOST ON EVERYTHING IN ELECTRONICS



- Newest Stereo Hi-Fi Systems— Everything in Hi-Fi Components
- Money-Saving, Build-Your-Own KNIGHT-KITS® for Every Need
- Best Buys in Recorders & Supplies
- Newest Public Address Systems, Paging and Intercom Equipment
- Amateur Receivers, Transmitters, and Station Gear
- Citizen's Band 2-Way Radio
- Test and Laboratory Instruments
- TV Tubes, Antennas, Accessories
- Huge Listings of Parts, Tubes, Transistors, Tools, Books

BUY ON EASIEST TERMS

ONLY \$2 DOWN

Yes, only \$2 down on orders up to \$50; only \$5 down on orders up to \$200; only \$10 down over \$200. Up to 24 months to pay.

ALLIED Exclusives:

MONEY-SAVING KNIGHT-KITS®—truly the very best in build-your-own electronic equipment—designed to save you money, easiest to assemble—the only kits offered with Free Inspection Privilege. See the complete selection of Stereo hi-fi kits, Hobbyist kits, Test Instrument and Amateur kits. KNIGHT-KITS are an exclusive ALLIED product.

KNIGHT® STEREO HI-FI—comparable to the best in quality and performance, yet priced far lower in cost. Select super-value KNIGHT components or complete systems and save most. Also see the largest selection of famous-name hi-fi components and money-saving ALLIED-recommended hi-fi systems.

ALLIED RADIO

our 40th year

**SATISFACTION GUARANTEED
OR YOUR MONEY BACK**

World's Largest Electronic Supply House

Get every buying advantage at ALLIED: lowest money-saving prices, fastest shipment, expert personal help, easiest-pay terms, satisfaction guaranteed or your money back.

free

the most complete
electronics catalog!



ALLIED RADIO, Dept. 1-L
100 N. Western Ave., Chicago 80, Ill.

Send FREE 1961 ALLIED Catalog.

Name _____

Address _____

City _____ Zone _____ State _____

RTS "STAKES" YOU TO A BUSINESS OF YOUR OWN!

The famous **RTS BUSINESS PLAN** was established to fill the need for a **REAL** and **LASTING** service for graduates which will give them a genuine helping hand at the time of graduation, when such assistance is most appreciated.

The **RTS BUSINESS PLAN** actually takes qualified graduates of this school and finances, without interest or carrying charges, the necessary equipment and supplies to enable them to start and operate a radio and television service shop of their own.

DESIGNED TO FILL A VERY IMPORTANT NEED!

Throughout the long history of Home Study Schools, great emphasis has always been placed, and rightly so, on accomplishments of the student **while in training**. What are the student's grades? How is he progressing? Is he maintaining proper interest in his studies?

But, very limited indeed has been the attention given to the student who has completed his training and graduated. Once given his diploma, the student has been strictly "on his own."

Will he get a job in the field for which he has studied? Will he earn the wages he has a right to expect? Will he attain some measure of independence and security? These are questions which, in the past, have gone unanswered and, in nearly all cases, remain unanswered to this day.

It is true that some schools maintain a so-called "placement service" with the avowed intention of finding suitable employment for graduates. Yet, under the law, no school is permitted to promise a student employment, and in most states they are prohibited from acting as employment agencies. Thus, even with the best intentions, the average school is prevented from rendering any effective employment help for graduates.

WHAT WILL THE RTS BUSINESS PLAN DO FOR YOU?

Have you ever had the ambition to quit working for the "other man?" Have you ever had the hope that one day you could set up a business of your own, be your own boss, make your own profits and keep them, and answer only to yourself?

If you ever had this urge, then you will understand what there is in the **RTS BUSINESS PLAN** for you.

Yes . . . **RTS Approved Shops** are opening throughout the country. Albuquerque, New Mexico . . . Clearwater, Florida . . . Stevens, Washington . . . Perry, Michigan . . . Hixson, Tennessee . . . Los Angeles, California . . . to name just a few locations. Graduates of Radio Television Training School now have **RTS Approved Shops**, sponsored by the **BUSINESS PLAN**, from coast to coast. Graduates everywhere are taking advantage of this amazing plan declared to be "The Greatest Business Opportunity ever offered by a trade school."



Here's The Offer No Other Radio-TV School DARES MAKE!

LEARN AT HOME in Spare Time!

YOU DO MANY PRACTICAL JOBS with the kits we send you. That's right, you PRACTICE what we TEACH! You build a Signal Generator, AC-DC Power Pack, and AC-DC Superheterodyne Radio Receiver and top quality 21 inch TV Set. EARN AS YOU LEARN with the famous RTS 30 Day Income Plan. Full instructions provided. **NO HIGH SCHOOL DIPLOMA NECESSARY.** This is a COMPLETE course which starts with basic subjects and gradually advances to Radio-TV. . . . ALL FOR A PRICE YOU CAN AFFORD!

THE ONLY VERTICAL MULTI-CHASSIS 21" TV KIT OFFERED BY ANY RADIO-TV SCHOOL



YOU BUILD THESE AND OTHER UNITS!



COMPLETE COLOR TV INSTRUCTION INCLUDED!

Each student is entitled to unlimited consultation service. All questions are answered promptly and completely by highly specialized instructors.

MULTITESTER KIT INCLUDED!

*Tubes Excluded

RTS' Membership in The Association of Home Study Schools is your assurance of Reliability, Integrity and Quality of Training.



RADIO-TELEVISION TRAINING SCHOOL

815 E ROSECRANS AVENUE
LOS ANGELES 59, CALIFORNIA

L 101F

Est. 1922



Rush Coupon for FREE FACTS!

RTS Will Train You at a Price You Can Afford and When You Are a Qualified Graduate Will Help You Open a Service Shop of Your Own and Supply You With Every Bit of Equipment You Need to Get Started - Plus an Inventory of Parts and Necessary Supplies.

ALL FINANCED WITHOUT INTEREST OR CARRYING CHARGES!!

You Also Receive . . . Advertising Help and Material, Shop Plans, Business Systems, Letterheads, Calling Cards and Much More!

Here's What Two of Many Business Plan Shop Owners Have to Say!

This business takes in between \$1500 and \$2000 a month. I've had to hire help to keep up with it.

CULLEN W. IRBY
Corpus Christi, Texas

The school lives up to its promises 100%. RTS does not lose interest in its students once they graduate.

HAROLD R. STANLAKE
Perry, Michigan

DON'T LOSE OUT — FIND OUT!

RADIO TELEVISION TRAINING SCHOOL, Dept. EW-110
815 E. Rosecrans Ave. Los Angeles 59, Calif.
Rush me full information by return mail. (Please Print)

NAME _____ AGE _____
STREET _____
CITY _____ ZONE _____ STATE _____

NO SALESMAN WILL CALL ON YOU!

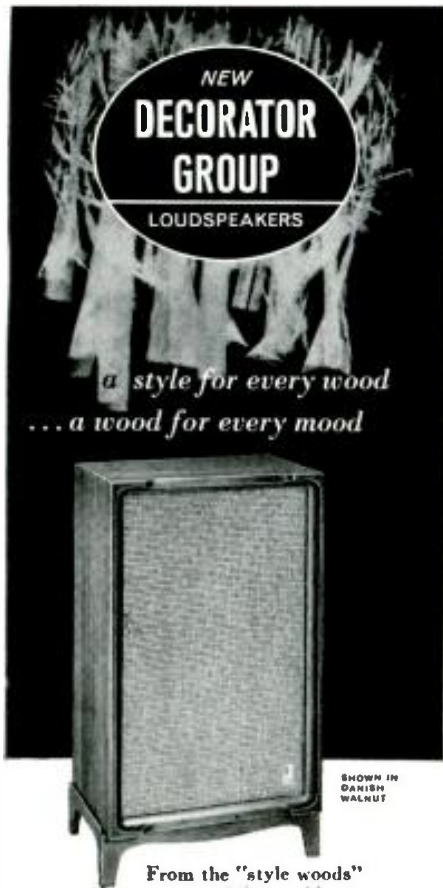

From the "style woods" of the world,
Jensen

chooses only the finest for their exclusive Decorator Group speaker cabinetry. You may choose from smart modern Danish in warm Walnut, subtle Contemporary in clean Lined Oak, elegant Traditional in rich Mahogany, authentic Provincial in lustrous Cherry, or a special unfinished utility model. Use as shelf type or as a diminutive console with matching base.

Jensen's reputation assures you of superior-quality components to provide the finest home speaker systems ever produced. Visit your high fidelity center and see the Jensen TR-30 TRI-ette system soon. Hear a demonstration of the rich full-range sound. You will find it a rewarding experience.

Write for free illustrated brochure "KU."

TR-30 TRI-ETTE furniture models—\$159.50 (without base)
unfinished model—\$134.50
Console base—\$ 9.95

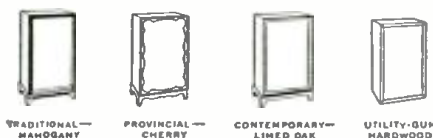

TR-30 TRI-ette

3-WAY SPEAKER SYSTEM

Featuring a new advanced-design 12" FLEXAIR* woofer, precisely coordinated with the BASS-SUPERFLEX* enclosure to carry base down lower and better than ever before. Midrange and tweeter components are smoothly balanced with new compression unit designs.



JENSEN MANUFACTURING COMPANY
DIVISION OF THE MUTER CO.
6601 S. Laramie Ave., Chicago 38, Illinois
In Canada: Renfrew Electric Co., Ltd., Toronto
In Mexico: Universal De Mexico, S.A., Mexico D. F.

Letters

from our Readers

MORE MATCHED STEREO MIKES

To the Editors:

I noticed in the August issue of ELECTRONICS WORLD that there is an article by Norman Crowhurst entitled "Record Live Stereo at Home." Congratulations on this fine article on home stereo recording.

I found it very informative in many respects. You mentioned that *Electro-Voice*, *Shure*, and *Turner* are now making matched stereo microphones. I do not know if you are aware that *Sonotone* is also selling matched stereo microphones.

CHARLES CONDIKE
Distributor Sales Manager
Sonotone Corp.
Elmsford, New York

We are glad to learn that Sonotone along with other microphone manufacturers not listed in the original article recognize the importance of this use of their product and are making matched pairs available.—Editors.

* * *

CAPACITANCE RELAY

To the Editors:

I have had some correspondence from readers concerning the capacitance relays whose construction I described in the February issue.

Some readers have mentioned an apparent lack of sensitivity of the circuit shown in Fig. 5. This difficulty may be caused by not using a sufficiently large sensing element. The circuit was designed to be used with a sensing wire strung over a 7-foot doorway; in which case the relay would be actuated when a

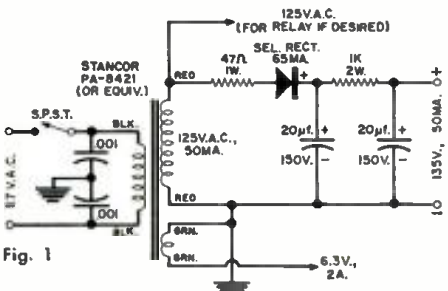

Fig. 1

person passed through the doorway. I would recommend the circuit shown in Fig. 4, if a smaller sensing element is to be used. (See original article for these figures.)

Some readers have requested a sketch of a simple, isolated power supply that may be used to operate the circuits shown in the article. I would recommend the circuit shown above in Fig. 1.

A final problem had to do with the listing of the oscillator coils to be used in Figs. 4 and 5. The proper coils are tapped, 456-kc. oscillator coils, as indi-

cated in the parts list and diagram. However, the *Meissner* part number shown was incorrect. The proper number is *Meissner* 14-1033 or a *Miller* 5481-C. Both these coils are standard units easily obtainable at local electronics parts distributors.

JOHN POTTER SHIELDS
Mansfield, Ohio

We have had quite a few letters requesting a suitable power supply for these circuits. The simple supply shown here should do the trick.—Editors.

* * *

WHO INVENTED RADIO?

To the Editors:

I have read with great interest Theodore M. Hannah's article "Did Popov Invent Radio?" in the July issue of ELECTRONICS WORLD. I agree with the author that the invention of wireless telegraphy (radio) cannot be attributed to any one person. However, it is most distressing to find that practically every school text, from elementary grades up, imputes the invention of wireless to Marconi. There can be no doubt about Marconi's tireless efforts in this field, and credit should be given on his behalf. It is also true, however, that Marconi's success was in part due to discoveries of men preceding him in this field.

One cannot do justice in writing an account about the invention of wireless without including the name of Nikola Tesla. During his lectures in the early nineties, Tesla clearly described the principles of high-frequency resonant circuits. Many of Tesla's wireless patents were under litigation in the courts. It was not until several months after Tesla's death that the United States Supreme Court, in a continuing suit held over from World War I, declared Marconi's four-tuned-circuit wireless patent, his most important, invalid because the four-circuit wireless had been anticipated by Tesla, Stone, and Lodge. Stone and Lodge, incidentally, found inspiration for their work in Tesla's earlier lectures.

Professor A. Slaby, wireless leader of Germany, wrote to Tesla explaining his own work in wireless experiments. Slaby clearly acknowledged Tesla as the "father" of wireless. Perhaps no one person invented radio, as Mr. Hannah stated, but it is important and only justified that we give each pioneer in the cause of wireless telegraphy, radio, TV, etc., his proper place in recognition of his contribution to the progress of humanity.

HARRY GOLDMAN
Glens Falls, New York

Certainly no attempt should be made

Do you WISH you were EMPLOYED in ELECTRONICS?

F.C.C. LICENSE—THE KEY TO BETTER JOBS

An F.C.C. commercial (not amateur) license is your ticket to higher pay and more interesting employment. This license is Federal Government evidence of your qualifications in electronics. Employers are eager to hire *licensed* technicians.

WHICH LICENSE FOR WHICH JOB?

The THIRD CLASS radiotelephone license is of value primarily in that it qualifies you to take the second class examination. The scope of authority covered by a third class license is extremely limited.

The SECOND CLASS radiotelephone license qualifies you to install, maintain and operate most all radiotelephone equipment except commercial broadcast station equipment.

The FIRST CLASS radio telephone license qualifies you to install, maintain and operate every type of radiotelephone equipment (except amateur) including all radio and television stations in the United States, its territories and possessions. This is the highest class of radiotelephone license available.

GRANTHAM TRAINING PREPARES YOU

The Grantham course covers the required subject matter completely. Even though it is planned primarily to lead directly to a first class FCC license, it does this by TEACHING you electronics. Some of the subjects covered in detail are: Basic Electricity for Beginners, Basic Mathematics, Ohm's and Kirchoff's Laws, Alternating Current, Frequency and Wavelength, Inductance, Capacitance, Impedance, Resonance, Vacuum Tubes, Transistors, Basic Principles of Amplification, Classes of Amplifiers, Oscillators, Power Supplies, AM Transmitters and Receivers, FM Transmitters and Receivers, Antennas and Transmission Lines, Measuring Instruments, FCC Rules and Regulations, and extensive theory and mathematical calculations associated with all the above subjects explained simply and in detail.

OUR GUARANTEE

If you should fail the F.C.C. exam after finishing our course, we guarantee to give additional training at NO ADDITIONAL COST. Read details in our free booklet.

Get Your First Class Commercial F.C.C. LICENSE QUICKLY!

Learn by Correspondence or in Resident Classes

Grantham training is offered by correspondence or in resident classes. Either way, we train you quickly and thoroughly---teach you a great deal of electronics and prepare you to pass the F.C.C. examination for a first class license. Get details now. Mail coupon below.

This booklet FREE!

This free booklet gives details of our training and explains what an F.C.C. license can do for your future. Send for your copy today.

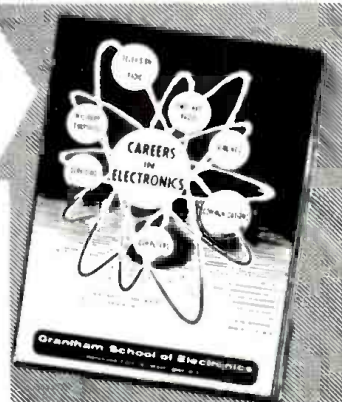

To get ahead in electronics—first, you need the proper training; then, you need “proof” of your knowledge. Your first class commercial F.C.C. license is a “diploma” in communications electronics, awarded by the U.S. Government when you pass certain examinations. This diploma is recognized by employers. Grantham School of Electronics specializes in preparing you to earn this diploma.

Grantham training is offered in resident classes or by correspondence. Our free booklet gives complete details. If you are interested in preparing for your F.C.C. license, mail the coupon below to the School's home office at 1505 N. Western Ave., Hollywood 27, California—the address given in the coupon—and our free booklet will be mailed to you promptly. No charge—no obligation.

Grantham School of Electronics

HOLLYWOOD
CALIF.

SEATTLE
WASH.

KANSAS CITY
MO.

WASHINGTON
D. C.

RESIDENT CLASSES
HELD IN FOUR CITIES

If you are interested in attending day or evening classes mail the coupon for free information to our home office in Hollywood, Calif.



(Mail in envelope or paste on postal card)

To: GRANTHAM SCHOOL OF ELECTRONICS
1505 N. Western Ave., Hollywood, Calif.

Gentlemen:

Please send me your free booklet telling how I can get my commercial F.C.C. license quickly. I understand there is no obligation and no salesman will call.

Name _____ Age _____

Address _____

City _____ State _____

I am interested in: Home Study; Seattle classes

Hollywood classes, Kansas City classes, Washington classes



06-S

MAIL COUPON NOW—NO SALESMAN WILL CALL →



As easy as using a screwdriver

EVERY ROOM A TV OR FM ENTERTAINMENT CENTER NEW BLONDER-TONGUE TV/FM HOME SYSTEM KIT

It's so easy to enjoy brilliant TV or FM performance on up to four sets. Good reception starts with a remarkable new indoor antenna  Installs easily in attic or other convenient indoor areas. In primary signal areas, eliminates the need for an outdoor antenna, yet provides the reception capabilities of an outdoor antenna. The TV signal is distributed by a quality engineered 4-set coupler  providing exact match, low loss, interset isolation. And, you get sparkling TV or FM performance here. Only \$9.95 list



engineered and manufactured by
BLONDER-TONGUE LABORATORIES, INC., 9 ALLING STREET, NEWARK 2, N. J.

Canadian Div.: Benco Television Assoc., Ltd., Toronto, Ont. Export: Morhan Export Corp., New York 13, N. Y.
home TV accessories • UHF converters • master TV systems • industrial TV systems • FM-AM radios

to take credit away where credit is due. However, we felt that many of our readers had access to information detailing the contributions of Marconi as well as Tesla. Our idea in running the article was to give some information on Popov's contributions to let our readers know why the Russians consider him to be the father of radio. In addition, Author Hannah has pointed out in a recent letter to us that: "a discussion of Tesla in my article would have taken us out of the wireless field and into the electric power field. Tesla's main interest was always the transmission of electric power by radio. This is not to say that he did nothing in wireless communication, but such experiments as he made in this field were largely by-products of his attempts to transmit power by radio. Furthermore, his experiments in long-distance transmission proved to be failures.

"Tesla is rightfully respected for his many contributions to the electric power field, but as far as radio communication is concerned, perhaps the best observation is that made by the IRE in its final tribute to Tesla:

'He consistently lived in a land of brilliant concepts, idealized dreams and aspirations so lofty as to be foredoomed.'—Editors.

OPERATING MOBILE IN CANADA

To the Editors:

This is in regard to certain inaccuracies in the article titled "Operating Mobile in Canada" published in the August issue of your magazine.

We are enclosing a page from the Commission's Amateur Radio Service Rules which reproduces, in "Appendix 4," the Title and Article III of the May 1952 Convention between the United States and Canada. Articles I and II are concerned with Radio Services *other than* the Amateur Radio Service and, therefore, are *not* considered applicable to the Amateur Radio Service. Hence, the author's statement that "... there is no use applying for a permit to operate a portable or a fixed station in Canada" is not considered applicable to the Amateur Radio Service because he bases his statement upon the provisions of Article II. In fact, Article III provides that for radiotelephone operation, the visiting amateur will identify his station by "the amateur call-sign in English issued to him by the licensing country followed by the words 'fixed', 'portable' or 'mobile', as appropriate, and the amateur call-sign prefix and call area number of the country he is visiting."

Canadian amateurs visiting this country are not limited to mobile operation, and we are sure that such a limitation is not applied to United States amateurs visiting Canada. Should you wish to communicate with the appropriate Canadian authorities, your inquiry should be addressed to Mr. F. G. Nixon, Director, Telecommunications and Electronics Branch, Department of Transport, Ottawa, Canada.

In addition to the above, the Commission
(Continued on page 16)

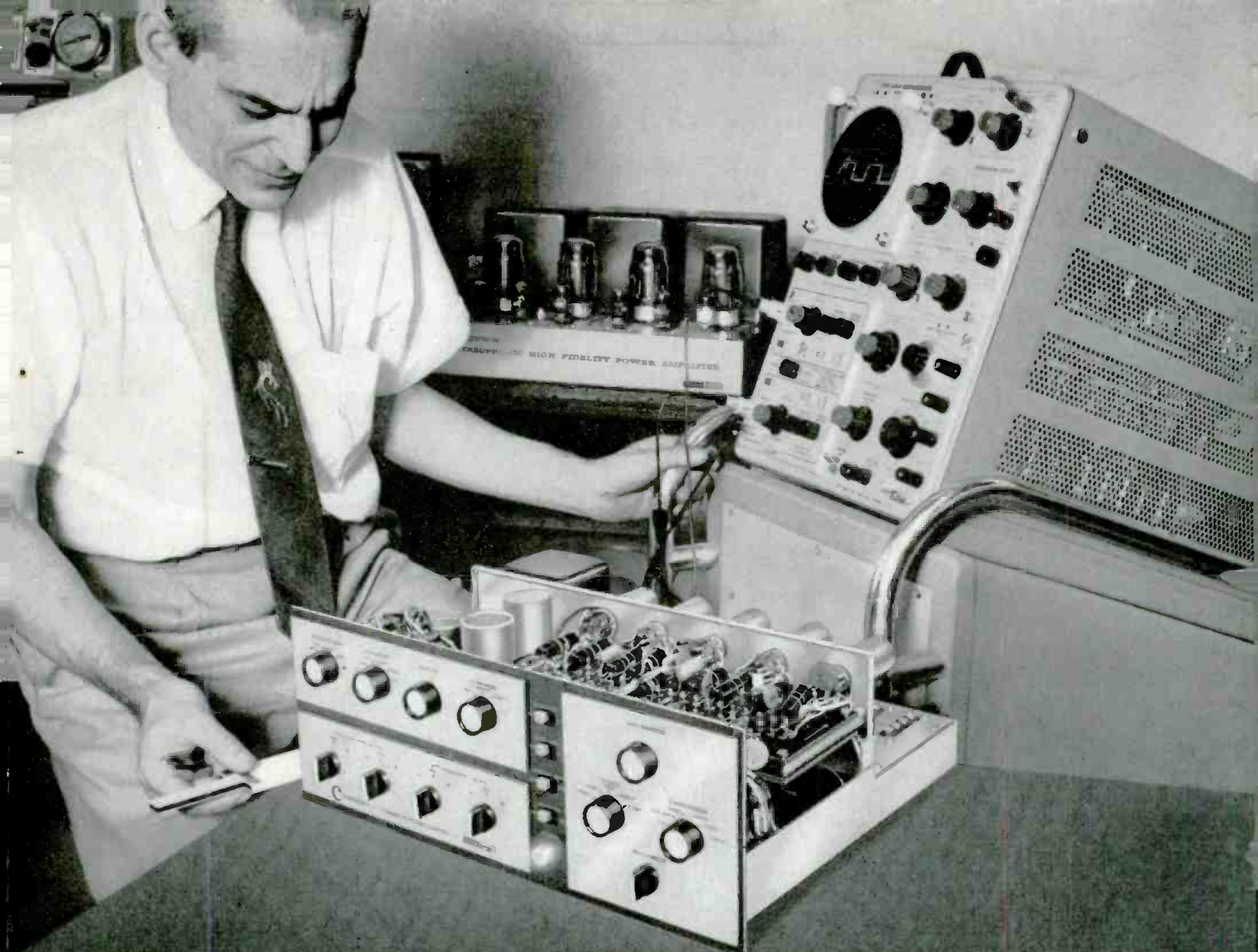

AT NORMAL LISTENING LEVELS THE ONLY MEASURABLE DISTORTION COMES FROM THE TEST EQUIPMENT!

Measuring intermodulation, harmonic or phase distortion on the new Citation Kits can be a unique experience for any engineer. He will find that *at normal listening levels the only measurable distortion comes from the test equipment.*

But let's put the numbers away. The real distinction of Citation is not in its specifications — remarkable as they are. It is, rather, in its performance — which goes well beyond the point of numbers. *Citation actually sounds recognizably best.* The "Citation Sound" has created so profound an impression, that the words have become part of the language of high fidelity.

In *AUDIO MAGAZINE*, editor C. G. McProud, wrote: *"When we heard the Citations, our immediate reaction was that one listened through the amplifier system clear back to the original performance, and that the finer nuances of tone shading stood out clearly and distinctly for the first time."*

The basic quality of the "Citation Sound" was summed up by the Hirsch-Houck Labs in *HIGH FIDELITY*: *"The more one listens...the more pleasing its sound becomes."* Another glowing tribute to Citation and its talented engineering group, headed by Stew Hegeman (shown above), came from Herbert Reid who said in *HI-FI STEREO REVIEW*: *"Over and above the details of design and performance, we felt that the Citation group bore eloquent witness to the one vital aspect of audio that for so many of us has elevated high fidelity from a casual hobby to a lifelong interest: the earnest attempt to reach an ideal — not for the sake of technical showmanship — but for the sake of music and our demanding love of it."*

THE CITATION I, Stereophonic Preamplifier Control Center... \$159.95; Factory-Wired... \$249.95; Walnut Enclosure, WC-1... \$29.95.

THE CITATION II, 120 Watt Stereophonic Power Amplifier... \$159.95; Factory-Wired... \$229.95; Charcoal Brown Enclosure, AC-2... \$7.95. All prices slightly higher in the West.

For a complete report on these remarkable instruments, write Dept. EW-11, Citation Kit Division, Harman-Kardon, Plainview, N. Y.

Build the Very Best **CITATION KITS** by **harman kardon**

GIVE YOUR STORE THE WITH NEW EYE-



PROSPECTS WILL STOP...LOOK...ENTER YOUR STORE
when they see this attractive full-color window exhibit.

**PUT YOUR WINDOWS, COUNTERS, CORNER AREAS TO WORK
SELLING TV SERVICE! LET PROFESSIONAL-DECORATOR SKILL
INCREASE YOUR CUSTOMER LIST!**

THIRTY-FOUR display pieces are included in this year-round General Electric program to build customer traffic for your store or shop. All displays are handsomely processed in full colors. Many are reversible, with a different message and color treatment on either side. The range of decorative combinations that can be made up for window, counter, wall, or corner is almost unlimited. You can have a new display treatment every week in the year, if desired!

Easy-to-follow instructions show you how to create a number of attractive effects. Every grouping will be modern, lively, interesting—sure to draw attention, packed with “sell” that pays off in more service, tube, and parts business. Now—at low, low cost—step out ahead of other shops that don’t advertise! See your G-E tube distributor! Or use the coupon to order direct! *Distributor Sales, Electronic Components Division, General Electric Co., Owensboro, Ky.*

PROFIT BY SERVICING PORTABLES!

Use this kit of full-color stand-up displays—one large, three small—to draw customers who want good service fast!

SELL MORE TUBES AND MORE SERVICE!

Four colorful die-cut cards feature the importance of tubes and tube testing... with you as the expert to consult.

THERE'S MONEY IN HI-FI SERVICE!

You want your share, and these full-color displays will help you get it. All are keyed to music and your audio facilities.

GET THOSE AUTO-RADIO DOLLARS!

Keep them from rolling on by! Motorists will pull up at your shop when they see these effective service reminders.

LOOK OF TOMORROW CATCHING G-E DISPLAYS!

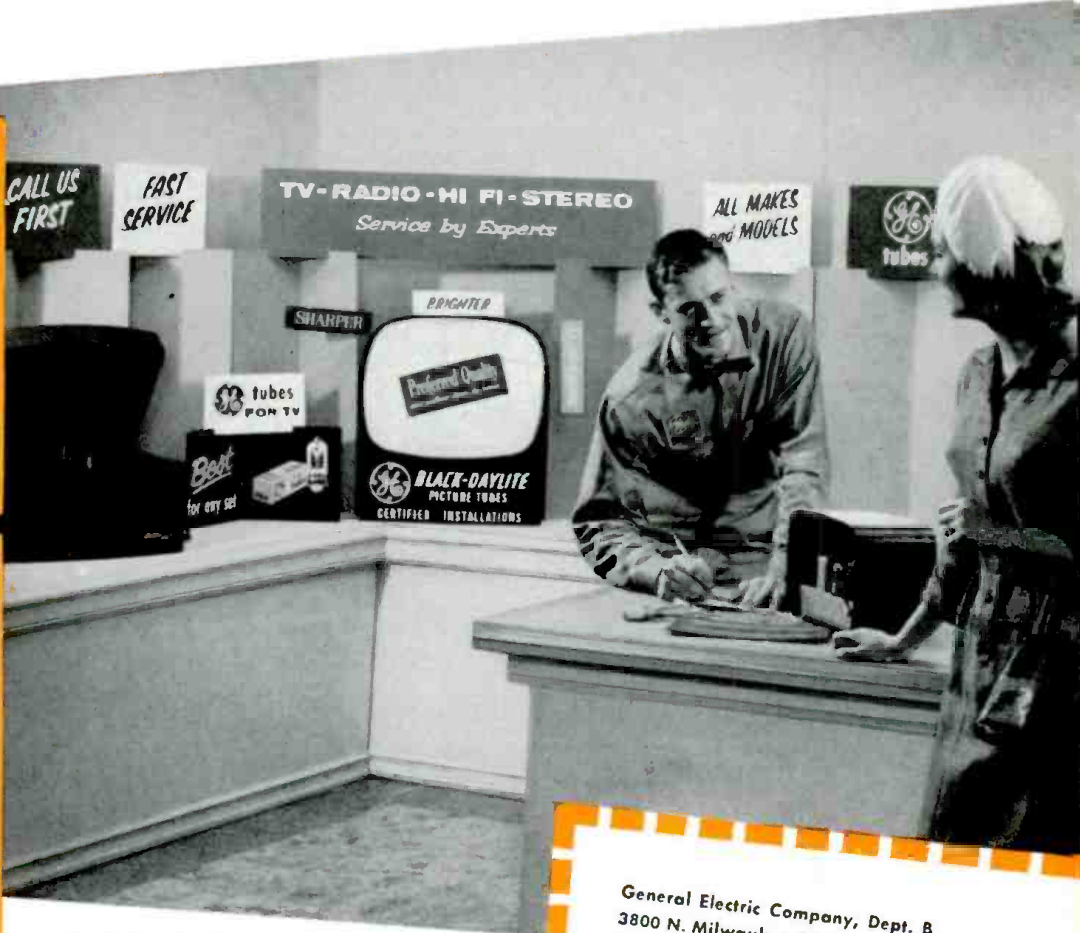

THAT "DRESS-UP" LOOK INSIDE! Mount a full-color interior display to tell your service story!

\$8.00 DECORATES YOUR STORE FOR A WHOLE YEAR!

That's the bargain combination offer on both packages below! Mail coupon at right to the Chicago warehouse address given. Individual display-package costs are:

ETR-2244. "Dress-up" decorator package for store window and interior, 18 pieces in all, as shown in two large pictures across top. \$5.00

ETR-2313. "Self-Merchandiser" package of service-specialty kits, each with four stand-up cards, as shown in vertical illustrations at left. 16 pieces in all. \$5.00

General Electric Company, Dept. B
3800 N. Milwaukee Ave.
Chicago 41, Illinois

Kindly ship me prepaid:

ETR-2244 at price of \$5.00 each.

ETR-2313 at price of \$5.00 each.

Combinations (both the above) at \$8.00 per pair.

My check money order is enclosed for the required amount plus any sales or use tax applicable in my area.

MY NAME _____

STREET ADDRESS _____

CITY AND STATE _____

Progress Is Our Most Important Product

GENERAL  ELECTRIC

RCA KITS

FOR VALUE, QUALITY AND PERFORMANCE!

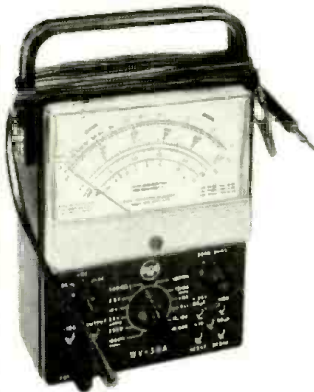

RCA WV-38A (K) VOLT-OHM-MILLIAMMETER

only **\$29.95*** (includes batteries, probe and cable with slip-on alligator clip, ground lead and clip, assembly and operating instructions) (available factory-wired and calibrated—only \$43.95*)

Exclusive features make this RCA VOM kit the buy of a lifetime! Extra 1-volt and 0.25 volt (250 mv) ranges for wider usage in transistor servicing—new handle clip accommodates probes and test leads for extra carrying convenience. Assembles in a breeze!

FEATURING: ohms-divider network fuse-protected • easier-to-read scales • extra-large 5/8 inch meter • polarity reversal switch • excellent frequency response • full-wave bridge rectifier • low circuit loading • standard dbm ranges.

SPECIFICATIONS: Input Resistance—20,000 ohms per volt on DC; 5,000 ohms per volt on AC • Accuracy—± 3% DC, ± 5% AC (full scale) • Regular Scales—2.5, 10, 50, 250, 1000, 5000 volts, AC and DC; 50 ma 1, 10, 100, 500 ma, 10 amps (DC) • Extra Scales—250 mv. and 1 volt (dc) • Frequency Response—AC-flat from 10 cycles to 50 Kc (usable response at 500 Kc) • Ohms—3 ranges: Rx1—(0-2,000 ohms); Rx100 (0-200,000 ohms); Rx10,000 (0-20,000,000 ohms) • Dimensions—W. 5 1/4", H. 6 7/8", D. 3 1/4"

RCA WO-33A (K) 3-INCH OSCILLOSCOPE

only **\$79.95*** (complete with Low-Cap, Direct Input Probe and Cable) (also available factory-wired and calibrated—only \$129.95*)

The first 'scope kit with "get-up-and-go!" Use it for practically everything—video servicing, audio and ultrasonic equipment, low level audio servicing of pickups, mikes, pre-amps, radios and amplifiers, troubleshooting ham radio, hi-fi equipment, etc.—and you can take it with you, on the job, anywhere!

FEATURING: voltage-calibrated frequency-compensated, 3 to 1 step attenuator • scaled graph screen and calibrating voltage source for direct reading of peak-to-peak voltages • "plus-minus" internal sync... holds sync up to 4.5 Mc • shielded internal cable with low capacitance probe included • weighs only 14 pounds • includes built in bracket to hold power cord and cables.

SPECIFICATIONS: Vertical Amplifier (Narrow Band Position)—Sensitivity, 3 rms mv/inch; Bandwidth, within -3 db, 20 cps to 150 Kc • Vertical Amplifier (Wide Band Position)—Sensitivity, 100 rms mv/inch; Bandwidth, within -3db, 5.5 cps to 5.5 Mc • Vertical Input Impedance—At Low-Cap cable input... 10 megohms, 10 μf (approx.); At Direct-cable input... 1 megohm, 90 μf (approx.) • Sweep Circuit—Sawtooth Range, 15 cps to 75 Kc; Sync, external, ± internal; Line Sweep, 160° adjustable phase.



RCA WV-77E (K) VOLT OHMYST®

only **\$29.95*** (also available factory-wired and calibrated only \$43.95*)

Think of It—an RCA VoltOhmyst Kit at this low, low price! You get famous RCA accuracy and dependability, plus the easiest to assemble kit you've ever seen!

FEATURING: ohms-divider network protected by fuse • ultra-slim probes and flexible leads • sleeve attachment on handle stores probes, leads, power cord • separate 1 1/2 volts rms and 4 volts peak-to-peak scales for accuracy on-low ac measurements • front-panel lettering acid-etched.

SPECIFICATIONS: Measures: DC Volts—0.02 volt to 1500 volts in 7 overlapping ranges; AC Volts (RMS)—0.1 volt to 1500 volts in 7 overlapping ranges; AC Volts (peak-to-peak)—0.2 volt to 4000 volts in 7 overlapping ranges; Resistance—from 0.2 ohm to 1000 megohms in 7 overlapping ranges. Zero-center indication for discriminator alignment • Accuracy—± 3% of full scale on dc ranges; ± 5% of full scale on ac ranges • Frequency Response—flat within ± 5%, from 40 cycles to 5 Mc on the 1.5, 5, and 15-volt rms ranges and the 4, 14, and 40-volt peak-to-peak ranges • DC Input Resistance—standard 11 megohms (1 megohm resistor in probe).
*User Price (Optional)

See them all at your local RCA Test Equipment Distributor!



RADIO CORPORATION OF AMERICA
ELECTRON TUBE DIVISION HARRISON, N. J.

sion's Amateur Radio Service Rules is no longer available at the ten-cent price. The enclosed Administrative Bulletin No. 1 lists the Commission's publications, the cost, and the method of obtaining them. Volume VI of the Rules, which contains the amateur rules, is available at a cost of \$1.25.

BEN F. WAPLE
Acting Secretary
Federal Communications Commission
Washington, D. C.

Author Kitchin did supply us with a correction to his article to the effect that U. S. hams may operate fixed, portable, and mobile in Canada, provided the appropriate permit is obtained, also that the price of the FCC rules has been increased. Unfortunately, however, the correction did not arrive until after the article was in print.—Editors.

PHOTOFLASH BATTERIES

To the Editors:

Some readers have written to ask some questions concerning the nickel cadmium batteries specified in my article "Professional Electronic Photoflash" which appeared in the July issue.

The batteries specified are supplied with special types of filler caps or screws designed to release the gas which is produced by this type of cell during the last 20 per-cent of the charging period. Thus, on charge, it's only necessary to be sure that the batteries are upright. My flash unit is constructed so that the entire assembly can be removed from the wood and Masonite case by removing four screws. The four cells are held in place with tape, which is easily removed when the batteries need recharging—a once or twice a year proposition.

The charger plugs into the top panel so that the only time the case must be opened is to check water level. The charging rate is so slow, and tapers to such a low rate as the batteries become fully charged, that I simply give the unit an overnight charge after each use. Any slight overcharge which results causes no damage.

If the cells are sealed with ordinary machine screws, it will be necessary to loosen these screws during charging. Readers may wish to make a case of somewhat different design which can be easily opened to make the batteries accessible for charging, or readers may place a hole in the top panel over each sealing screw and simply loosen the screws with a screwdriver through these access holes when charging.

Nickel cadmium cells have a fantastically long life. Unless the sodium or potassium hydroxide electrolyte is spilled, it's only necessary to refill to cover the plates with distilled water when necessary. They generate no gas during discharge and only a little as they approach full charge.

R. L. WINKLEPECK
Terre Haute, Indiana

We know our readers will find the above additional information on these batteries most useful.—Editors. [30]

Learn RADIO, TELEVISION AND ELECTRONICS by Practicing at Home in Your Spare Time

At No Extra Cost you get specially developed Electronic Training Kits for practical experience. Shop and laboratory practice at home make learning easier, interesting, faster. You do not need a high school diploma or previous experience.

Increasing Demand for Trained Men

This is the Electronics age. Men with Electronic know-how are in demand. They enjoy high pay and growing opportunities for advancement. Satellites, Radar, Automation in Industry, Missiles, Rockets, Planes, Stereo, TV, Radio, Two Way Communications for transportation are a few of the fantastic developments in the fast growing Electronics industry. If you are not completely satisfied with your work; if you are doubtful about your future, investigate Electronics.



High Pay, Prestige, Bright Future

What branch of Electronics interests you? Thousands of successful NRI graduates prove that NRI's learn-by-practice method is the way to success. You start in your chosen career 'way ahead of the man who only learns from books. You do not need to give up your job. You do not need to go away to school. You learn at home, get practical knowledge from training kits NRI provides.



NRI Has Trained Thousands for Success



"I get over twice the salary I made before enrolling. NRI training gave me a thorough understanding." H. ATKINSON, Austin, Tex.

"I started with station CJIC, now in charge of sound effects for CBC. NRI opened doors to greater opportunity for me." F. TUDOR, Toronto, Ontario

"Averaged \$150 a month spare time before I graduated. Now have my own full time business and employ 2 men." F. W. COX, Hollywood, Cal.

NEW COURSE IN ELECTRONICS TURN PAGE

Cut Out and Mail—No Stamp Needed

64-PAGE CATALOG FREE

No Salesman will call. (Please PRINT) YZ

Name _____ Age _____

Address _____

City _____ Zone _____ State _____

OLDEST & LARGEST HOME STUDY RADIO-TV SCHOOL
National Radio Institute
WASHINGTON 16, D. C.

ACCREDITED MEMBER NATIONAL HOME STUDY COUNCIL

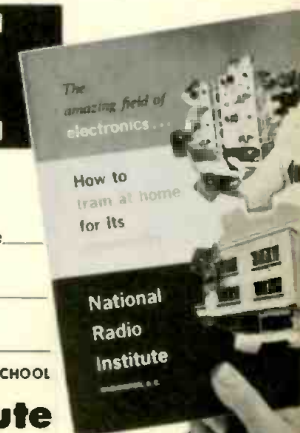

Train With the Leader

NRI is the world's oldest and largest home study Electronics school. You benefit from the experience NRI has gained from training men for 45 years. NRI offers you proven courses of home study in Electronics; Principles, Practices and Maintenance—Radio Television Communications—Radio Television Servicing.

Start Soon to Earn More

Soon after enrolling NRI shows you how to apply your knowledge to earn extra money doing Electronics repairs or servicing Radio and Television sets for friends and neighbors. Take the first step toward success now. Find out what NRI offers you. Mail the postage-free card. No obligation. Cost of NRI training is low. Monthly payment plan available. NATIONAL RADIO INSTITUTE, Washington 16, D.C.



JOB COUNSELORS ADVISE LEARN ELECTRONICS



SPECIAL TRAINING KITS NO EXTRA COST

NEW Home Study Course in **ELECTRONICS** Principles-Practices-Maintenance **NOW READY**

This is the Electronic Age. Electronic equipment is already being used to count and control flow of liquids, solids, gases. Electronics is employed to search for oil, make surveys, control traffic, machine complex parts and in atomic installations. Military uses of Electronics are great and expanding rapidly. In business, Automation with Electronics plays an important part, prepares payrolls, calculates engineering formulas.

Learn More to Earn More

Now, to meet the growing demand for trained Electronic Technicians NRI has developed a comprehensive, complete course in Electronics Principles, Practices, Maintenance. This training stresses fundamentals. It is a course specially prepared for beginners and for Technicians. You get both theory and practical experience in an interesting, exciting way.

Ten Special Training Kits Give Practical Experience

You get practical experience with Thyatron Tube circuits, Multivibrators, build a D'Arsonval type Vacuum Tube Voltmeter (Kit 2); work and experiment with pentode tubes, selenium resistors, oscillators, transistors, magnetic amplifiers; and get practical experience in telemetry circuits as used in earth satellites, digital and analog computers (Kit 9).

NRI — Oldest and Largest School

Wishing for success won't bring success. You must act. Get FREE 64-page Catalog from America's oldest and largest home study Electronic-Radio-Television school. It gives facts, opportunities in Industrial and Military Electronics careers, also shows what you learn, tells about NRI's other courses in Radio Television Servicing and Radio Television Communications. Monthly payments plan. Mail Postage Free Card for 64-page Catalog.
NATIONAL RADIO INSTITUTE, Washington 16, D.C.



← **SEE OTHER SIDE** →

FIRST CLASS
Permit No. 20-R
(Sec. 34.9, P. L. & R.)
Washington, D.C.

BUSINESS REPLY CARD

No Postage Stamp Necessary if Mailed in the United States

POSTAGE WILL BE PAID BY

National Radio Institute
3939 Wisconsin Avenue
Washington 16, D.C.

**POSTAGE FREE CARD
MAIL NOW**

NEW for '61 FROM INTERNATIONAL

MOBILETTE 61



A New "Advanced Engineered" All Transistor, Crystal Controlled Short Wave Converter AMATEURS • CITIZEN LICENSEES • CIVIL AIR PATROL

Mobilette 61, International's *new improved* all transistor, crystal controlled converter provides a "quick and easy" way to convert your car radio for short wave reception. Mobilette 61 units cover a specific band of frequencies providing a broad tuning range. Mobilette units are quickly interchangeable.

Check these all new features! New and improved circuit for increased gain . . . New internal jumper for positive and negative grounds . . . New RF amplifier, mixer/oscillator . . . New separate input for broadcast and short wave antennas . . . Installs neatly under dash.

Mobilette 61 is available in a wide choice of frequencies covering the Amateur bands 75 through 6 meters, Citizens band, *Civil Air Patrol* low band frequencies, WWV time and frequency standards.

Designed for 12 VDC, Mobilette 61 will operate on 6 VDC at reduced output.

See the Mobilette 61 at your dealer today.

Complete, ready to plug in and operate only **\$22.95**

Any frequency in the range 2 MC to 50 MC available on special order \$25.95

International Mobilettes cover these short wave bands.

Catalog No.	Frequency
630 - 110	6 meters (Amateur) 50 - 51 MC
630 - 111	10 meters (Amateur) 28.5 - 29.5 MC
630 - 112	11 meters (Citizens) 26.9 - 27.3 MC
630 - 113	15 meters (Amateur) 21 - 21.6 MC
630 - 114	20 meters (Amateur) 14 - 14.4 MC 15 MC (WWV)
630 - 115	40 meters (Amateur) 7 - 7.4 MC
630 - 116	75 meters (Amateur) 3 - 3.6 MC
630 - 117	10 MC (WWV)
630 - 118	CAP (Low Band)
630 - 119	Special Frequencies 2 MC - 50 MC

Write for International's complete catalog of precision radio crystals, and quality electronics equipment . . . yours for the asking.



This is the one you've

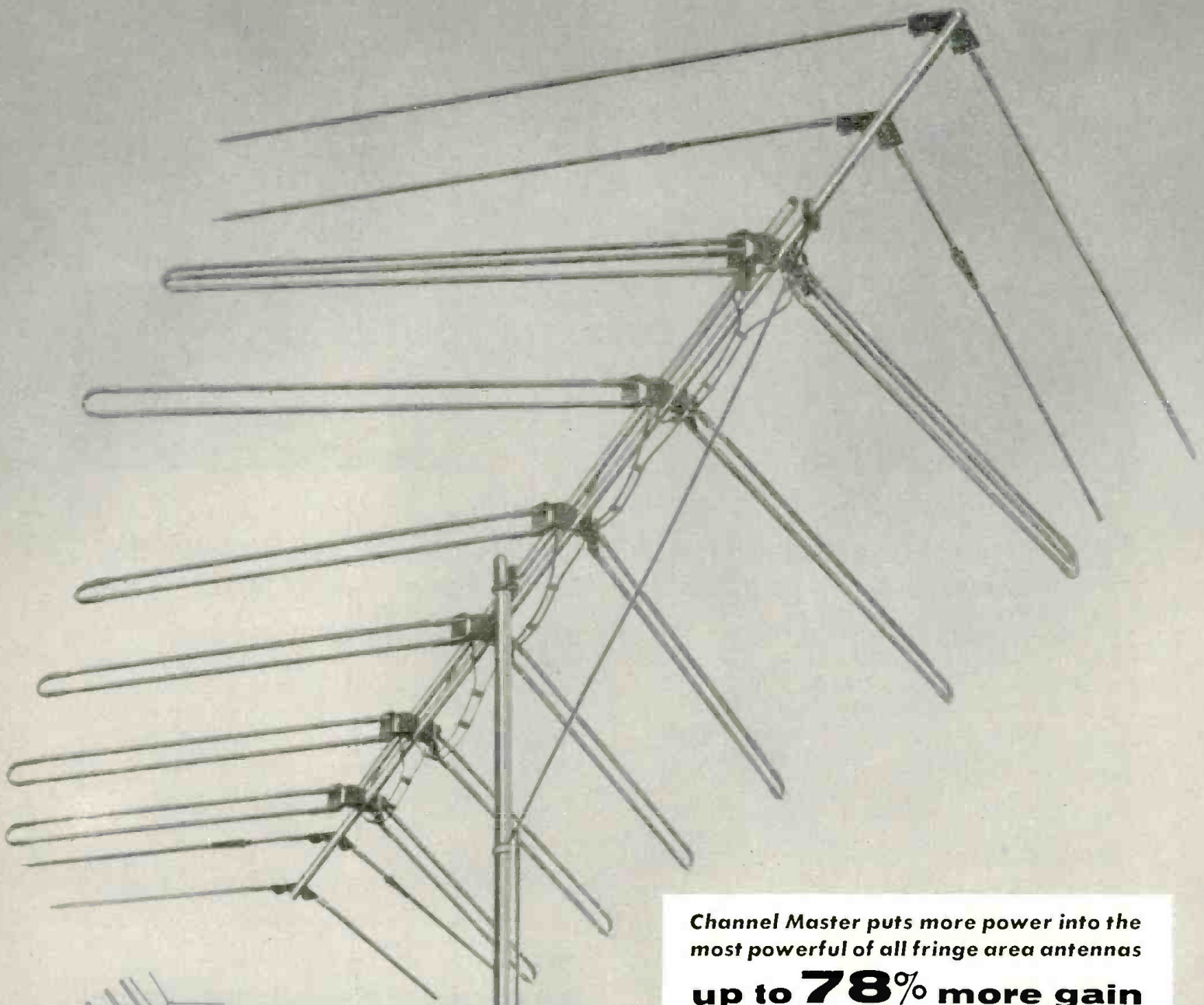

All T-W's can be stacked for even greater power.

Channel Master puts more power into the most powerful of all fringe area antennas

up to **78%** more gain than the famous 7-Element T-W

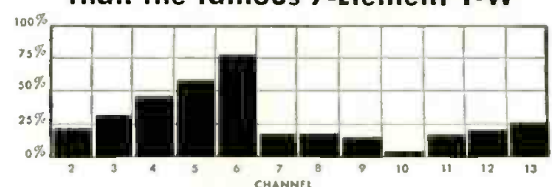

Illustrates only the difference between the two antennas on each channel, not their total gain.

CHANNEL MASTER CORP.

ELLENVILLE, NEW YORK

www.americanradiohistory.com

been waiting for!

Out in the super fringes,
where nothing less will
do, step up to the new

CHANNEL MASTER® SUPER 10 T-W

model no. 358

10-Element Traveling Wave Antenna

Channel Master's T-W* is the most thoroughly tried...the most widely used...and the most enthusiastically acclaimed of all the broad band fringe antennas. Its performance has never been equalled.

Now—Channel Master takes another forward step with a bigger and better version of the T-W. This new antenna has more of what you want...more of what you need...in the super fringe areas.

New 10-Element T-W...ingeniously combines Channel Master's famous hairpin dipoles with 4 parasitic low band and co-linear high band elements. Reaches new highs in gain and front-to-back ratios.

New low band director and reflector system...increases gain up to 2½ db more than a 7-Element T-W—a 78% power increase!

New high band co-linear elements...add 20% to the T-W's high band gain. The co-linear reflector and director are each actually 3 half-wave elements placed end to end.

Ruggedized, all-weather construction...Including heavy duty weatherproof harness that won't let rain or salt air impede reception.

DEALERS: SPECIAL INTRODUCTORY OFFER

Buy **6** Super T-W's—get **1** free

Call your Channel Master Distributor today

NOW...

THERE ARE 5
for every problem...
for every area...
pick a T-W

3-Element T-W
model no. 352

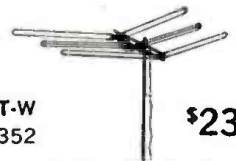

\$23⁵⁰
LIST

5-Element T-W
model no. 351

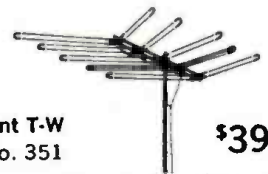

\$39²⁵
LIST

7-Element T-W
model no. 350

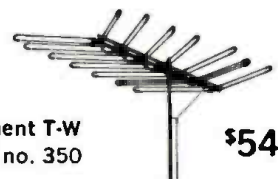

\$54⁹⁵
LIST

Super 10 T-W
model no. 358

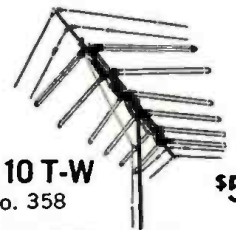

\$59⁹⁵
LIST

**and introducing
the new**

SUPER 8 T-W

Model no.
359

8-Element
fringe area
powerhouse.
Four driven elements,
4 parasitic elements.

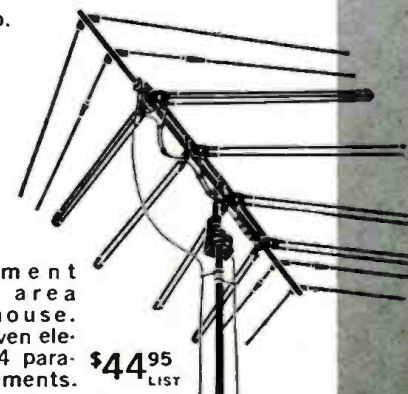

\$44⁹⁵
LIST

ALL PRICES SLIGHTLY HIGHER IN CANADA

NEW 4-WAY POCKET TOOL

a real "working partner"
for removing backs of TV sets
and installing antennas



1 It's a 1/4" nut driver!
Fits Parker-Kalon screws.

Genuine Xcelite plastic handle —
shaped and
balanced for
working ease.
Equipped with
pocket clip.

2 It's a 7/16"
nut driver!
Ideal for
antenna
installations.

3 It's a No. 1
Phillips
screwdriver!

Double-end blade
inserts in 7/16" hex
opening. Just push
it in or pull it out!
Patented spring
holds it firm.

4 It's a 3/16"
slotted screwdriver!

Ask to see
"No. 600"
next time you
pick up parts ...



XCELITE, INC. • ORCHARD PARK, N.Y.
Canada: Charles W. Pointon, Ltd., Toronto, Ont.

Within the Industry

RAYMOND T. LEARY has been named vice-president - marketing of the *Cornell-Dubilier Electronics Division, Federal Pacific Electric Co.* Since 1959, Mr. Leary has been general sales manager of this organization. He joined *Cornell-Dubilier* in 1947 and became distributor sales manager in 1952. Six years later he was elected a vice-president of the corporation.

From 1941 to 1945, he served in the U.S. Navy, attaining the rank of Lt. Commander. For 43 months he was a PT Boat Captain and Area Commander in the Pacific combat zone.

SAM PONCHER of *Newark Electronics Corp.* has been elected president of the Electronic Industry Show Corporation for a one-year term. Other new officers are: vice-president, Robert D. Ferree of *International Resistance Co.*, representing PACE; secretary, Norman Triplett, *Triplet Electrical Instrument Co.*, (EIA); and treasurer, Robert E. Svoboda, *Amphenol-Borg Electronics*, (EP&EM).

The Show Corporation's board of directors is already planning the 1961 Electronics Parts Distributors Show which will be held at the Conrad Hilton Hotel, Chicago, next May 15, 16, and 17.

SEYMOUR MINTZ has been appointed to the new position of vice-president and general sales manager of the *Caphart Corp.*, Richmond Hill, N.Y. He will be in full charge of marketing and sales of the company's stereo radio - phonograph and television receiver lines.

Formerly president of *CBS Columbia*, Mr. Mintz has also served as vice-president in charge of marketing for the *Admiral Corp.* He has acted as merchandising consultant to the *Kudner Agency*, working on the Frigidaire account, as well as sales supervisor of appliances and radios for *Montgomery Ward's* retail stores.

FRANCIS E. CHRISTY has been named products manager for *Globe Electronics*, a division of *Textron Electronics, Inc.* ... **DONALD R. SMITH** is the new manager of distributor sales for *Motorola Semiconductor Products, Inc.* ... **ED. J. KRUG** has been appointed to head the newly formed international division of *Wen Products, Inc.* ... **KENNETH E.**

HUNTER has been appointed vice-president of engineering at *Hycon Mfg. Co.*, Pasadena, Calif. ... **ALVIN GRAD** has been named national sales manager of *Mercury Electronics Corp.* He will direct sales from *Mercury's* west coast office in North Hollywood, Calif. ... **FRED NEUBAUER** will serve as assistant to the president at *Utah Radio & Electronic Corp.* ... **JOHN A. WITHERELL**, formerly of *Motorola Inc.*, has been appointed merchandising manager of *Pentron Sales Co., Inc.* ... **T. GERALD DYAR** has joined *Gray Mfg. Co.* as manager of the special products division, handling high-fidelity components and commercial broadcast equipment ... **MILTON C. JORDAN** has been appointed plant manager of *International Resistance Company's* operation in Vega Baja, Puerto Rico ... **CHARLES H. MILLER** is the new manager of the television picture tube plant of *Sylvania Electric Products Inc.* at Ottawa, Ohio. ... **ROLAND T. CARR**, senior vice-president of *Riggs National Bank*, and **EDWARD E. BOOHER**, president of *McGraw-Hill Book Co.*, have been elected to the board of directors of *Capitol Radio Engineering Institute*.

ROBERT E. SNARE has been appointed national sales manager for replacement tubes of the cathode-ray tube department at *General Electric*, Syracuse, N.Y. Formerly the Pittsburgh - district sales manager for the company's distributor sales organization, Mr. Snare in his new post will assume over-all responsibility for marketing policies, including advertising and sales promotion.

Mr. Snare has been associated with *General Electric* for 16 years, having joined the *Maqua Company, General Electric's* printing affiliate, in 1944.

BOND P. GEDDES, radio industry pioneer, former newspaperman, and trade association executive, died recently in Georgetown Hospital, Washington, D.C., following a brief illness. He was 78 years old.

His 23 years of industry service spanned the development of modern radio and television, electronic developments of World War II, and the depression of the 1930's. Representing industry, Mr. Geddes successfully opposed early efforts of several states and cities to prohibit automobile radio when it was feared to be a traffic hazard.

Until his retirement in 1950, he was executive vice-president and secretary of the Radio Manufacturers Association,





It's a 2-in-1 radio:

- Trim portable in smart "sling" case
- Home table model

where others fizzle...this one
SIZZLES!

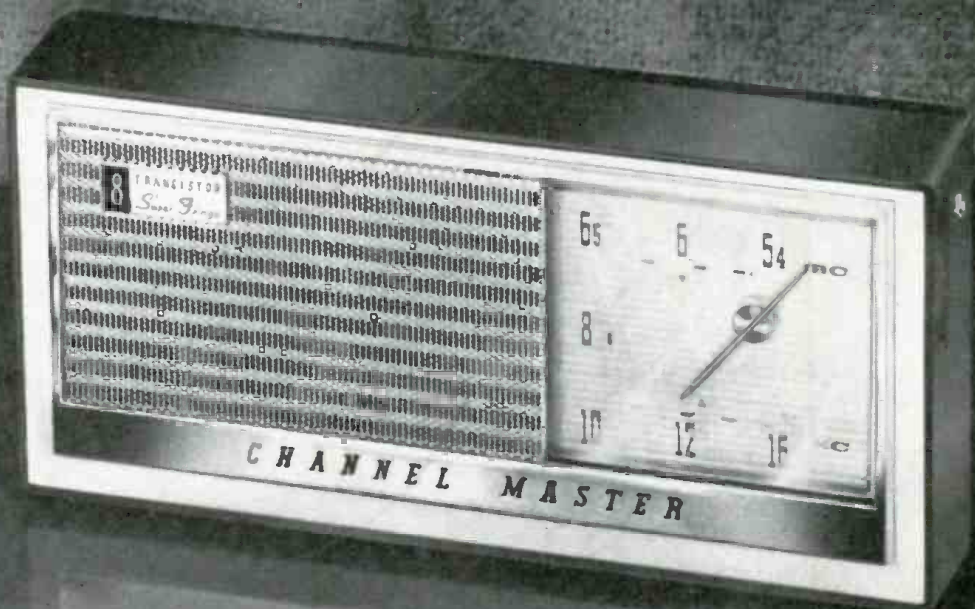

model 6515

new **CHANNEL MASTER**
8 transistor "super fringe"

The most sensitive transistor radio ever made!

- RF amplification stage
- 3-gang tuning condenser
- New fringe area circuit
- Extra long built-in ferrite antenna
- Highest signal-to-noise ratio
- Easy, precise vernier tuning
- King-size 3½" speaker
- Plays for almost one year on a set of ordinary flashlight batteries (Based on average daily use)

The astonishing performance of this new radio is another reason why the dealer who features Channel Master gets ahead—and stays ahead—of his competition.

\$59.95
List

slightly higher in Canada.

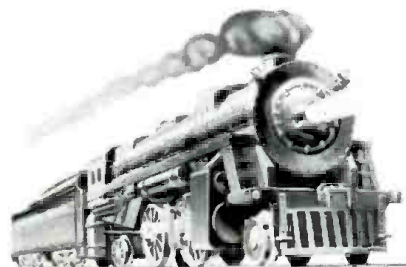

FREE Lionel Electric Train Set

Dealers:

Get a big 42-piece LIONEL Electric Train Set (worth \$75.00) with your order for only 10 assorted Channel Master radios at regular price. A fabulous pre-Christmas deal. Ask your Channel Master Distributor for full details about the "Main Line" promotion. Limited time only.

CHANNEL MASTER works wonders in sight and sound

www.americanradiohistory.com





The "Big Picture"

... informative shop talks

by AL MERRIAM, Sylvania Natl. Service Mgr.

No more
"cluster
fluster"!

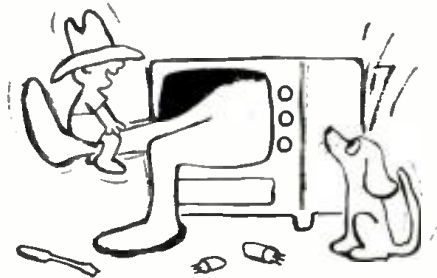

WHAT a guy has to go through sometimes just to remove the chassis from a TV set! Means practically turning the set inside out—pulling control knobs or disconnecting shafts—screws, nuts, bolts and leads! I call it "cluster fluster," and I'm happy to report that Sylvania has licked it!

You don't have to crawl inside the new Sylvania TV sets to separate the chassis and controls from the cabinet. And you don't have to pull any knobs (and break or lose them), or disconnect any shafts (and worry about connecting them again). Look—



1 Just remove the two screws in the mounting bracket holding the cluster.

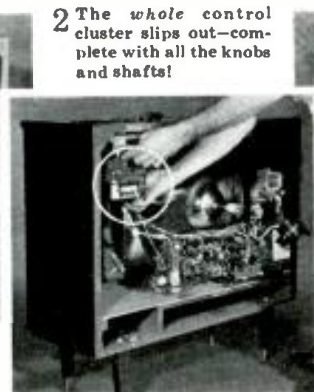

2 The whole control cluster slips out—complete with all the knobs and shafts!

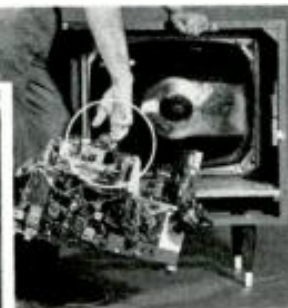

3 The cluster locks to the chassis, and the mounting bracket is a carrying handle.

How about the way the control cluster and chassis snap together into one compact unit for easy carrying and practical testing! Light, too—only 13 pounds. No loose parts or wires dangling either—even a special yoke hanger on the chassis. It's really quite a simple thing, but just typical of the thought and care that goes into Sylvania TV sets.

I believe I could go on forever giving you tips and facts about this fast-moving field of TV electronics, but the best way to keep up-to-date with the "Big Picture" is through the Sylvania Service Bulletins and the Sylvania Service Clinics. Ask your Sylvania TV distributor for details on the next clinic session in your area, or I'll be glad to fill you in — Al Merriam, Sylvania Home Electronics Corp., Batavia, New York.

SYLVANIA

Subsidiary of GENERAL TELEPHONE & ELECTRONICS 

now the Electronic Industries Association. Since 1950 he served as a consultant. Prior to his radio industry career, Mr. Geddes was for many years a leading Washington newspaper man.

KENNETH B. SHAFFER has been named manager, distributor sales, RCA Electron Tube Division.



In his new position, Mr. Shaffer will be responsible for nationwide sale of tubes, components, and semiconductor products in the distributor market.

Manager of distributor field sales for the past three years, Mr. Shaffer has been in tubes sales activities since 1926 when he joined the E. T. Cunningham Company. Five years later, when that company was merged with RCA, he was named to head RCA's replacement and adjustment activities.

AMPEREX ELECTRONIC CORP., Hicksville, Long Island, N.Y., has completed a new wing which adds 13,000 square feet of production area to the 123,000 square feet of the present building... **IE MANUFACTURING** has acquired a new building at 3039 West Carroll Ave. in Chicago...

SETCHELL-CARLSON, INC. announces completion of an addition to its television cabinet factory in New Brighton, St. Paul 12, Minn. . . . **CORNING GLASS WORKS** reports new laboratory facilities for ultrasonic delay-line development at its electronic components plant in Bradford, Pa. . . . **CANNON ELECTRIC CO.** has opened a new central service store at 107 Gateway Rd., Bensenville, Ill. The warehouse will service industrial customers and distributors in 14 midwestern states.

SPECTROLAB, INC., which produced most of the solar energy converters supplying power to U.S. satellites, has become a division of **TEXTRON ELECTRONICS, INC.** The acquisition was through an exchange of stock . . . **B & H INSTRUMENT CO., INC.** and **HOWELL INSTRUMENT CO.**, both of Fort Worth, Texas, have combined their activities under the new name of **HOWELL INSTRUMENTS, INC.** . . . Jay E. Bass, president and controlling stockholder of **NATION WIDE RADIO CO.**, Illinois, has purchased all capital stock of **WALKER-JIMIESON**, large midwestern electronic parts distributor. The combination of these two distribution outlets is said to make the Bass holdings the largest branch operation in the metropolitan Chicago area. . . . **LANGVIN**, manufacturer of professional audio equipment, has been purchased by **SONOTEC INCORPORATED** of Santa Ana, Calif. . . . **ECCO-FONIC, INC.** of Los Angeles has been acquired by Milton Brucker, chairman of the board of **STANDARD BRANDS PAINT CO.** . . . **EMERSON RADIO & PHONOGRAPH CORP.** has received an option to purchase approximately 540,000 out of the 1,000,000 shares of **GRANCO PRODUCTS, INC.** Under terms of a recent agreement, **EMERSON** will provide sales assistance. [30]

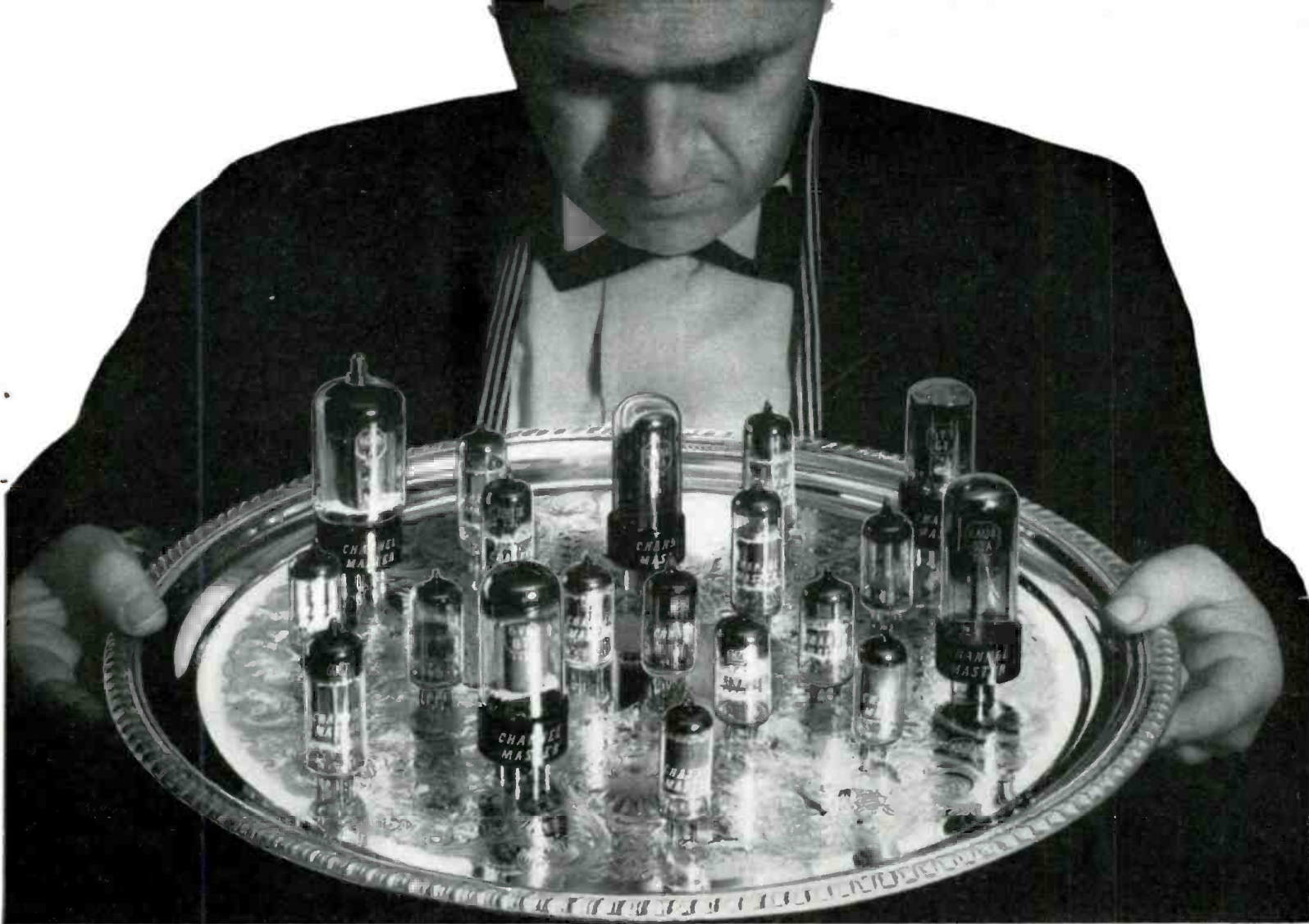

They're so good, we bring them to you on a **Silver Platter** (a real one!)

Good News:

Channel Master more than *DOUBLES* its line of replacement tube types

How would you best describe Channel Master tubes? Most dealers use the word "dependable". Dependable uniformity, dependable performance, dependable long life.

And now, with the addition of many new tube types, you can make Channel Master your first choice in *over 75% of all service calls!* Find out for yourself why Channel Master Premium Quality tubes have become America's fastest growing line.



FREE! Genuine Wm. Rogers Holloware Service

Luxurious, beautiful Silverplate...made by International Silver Company.

Well & Tree Platter • 16" Round Tray
Chip 'N Dip Dish • Double Vegetable Dish

Get the piece of your choice with surprisingly small purchases of Channel Master tubes. Tell your Channel Master distributor how many holloware sets you'd like before Christmas.



Find out the:



**PRICE • SPEED
CARTRIDGE
ACCOMMODATION
CHANGE CYCLE
SPINDLE TYPE
SHUTOFF SYSTEM**

and every other important factor

ON EVERY *RECORD CHANGER* on the market!

It's yours with December **ELECTRONICS WORLD**—in the most comprehensive comparative survey of record changers ever made.

You'll also find these informative December **ELECTRONICS WORLD** features to be of special interest:

● **BUILD A CITIZENS BAND FIELD-STRENGTH METER**

Tune up your Citizens Band transceiver by building this sensitive indicator of relative field strength. Complete construction plans are in December **ELECTRONICS WORLD**.

● **DESIGNING AND USING ANECHOIC ROOMS**

Rooms without echoes are widely used to test loudspeakers, microphones, and other audio devices. Here's a rundown on what goes into the construction and designs of these soundproof rooms.

● **TRANSISTOR RADIO SERVICE TIPS**

Do a top-notch servicing job on the transistor radios that come into your shop. December **ELECTRONICS WORLD** brings you a handy, quick-check rundown—plus a list of common problems and how to handle them.



Don't miss **December ELECTRONICS WORLD**
Authoritative . . . Informative . . . Important

BREAK THROUGH TO HIGHER PAY

in ELECTRONICS

TV-RADIO

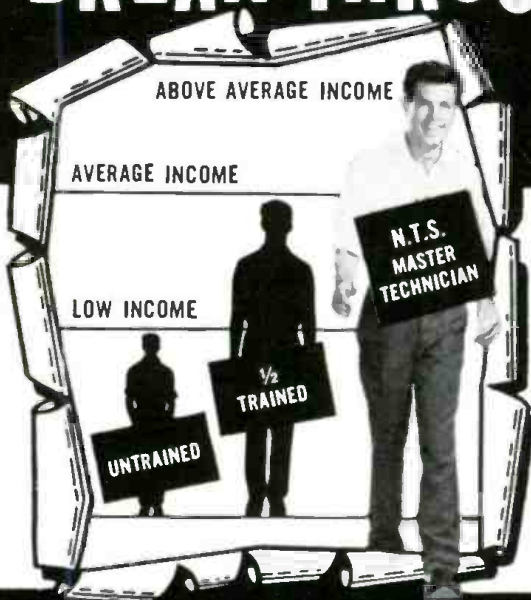

START NOW! Break through the Earning Barrier that stops half-trained men. N.T.S. "All-Phase" training prepares you — at home in spare time — for a high-paying CAREER in Electronics — TV — Radio as a MASTER TECHNICIAN. One Master Course at One Low Tuition trains you for unlimited opportunities in All Phases: Servicing, Communications, Preparation F.C.C. License, Broadcasting, Manufacturing, Automation, Radar and Micro-Waves, Missile and Rocket Projects.

A more rewarding job... a secure future... a richer, fuller life can be yours! As an N.T.S. MASTER TECHNICIAN you can go straight to the top in industry... or in your own profitable business.

You work on actual job projects



SUCCEED IN MANY HIGH-PAYING JOBS LIKE THESE...

- TV-Radio Sales, Service and Repair
- Profitable Business of Your Own
- Communications Technician — F.C.C. License
- Hi-Fi, Stereo & Sound Recording Specialist
- TV-Radio Broadcasting Operator
- Technician in Computers & Missiles
- Electronics Field Engineer
- Specialist in Microwaves & Servomechanisms
- Expert Trouble Shooter
- All-Phase Master Technician

19 BIG KITS YOURS TO KEEP

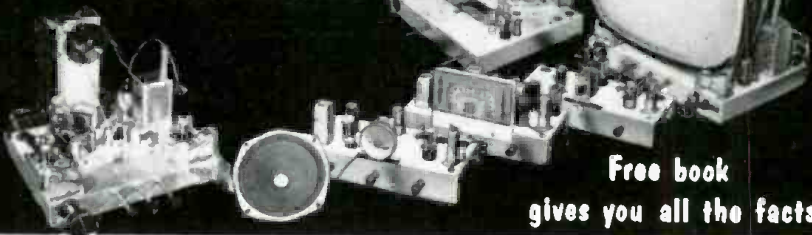

Free book gives you all the facts

NATIONAL TECHNICAL SCHOOLS

WORLD-WIDE TRAINING SINCE 1905
4000 S. FIGUEROA ST., LOS ANGELES 37, CALIF., U. S. A.

Write Dept.



ACCREDITED MEMBER... the only nationally recognized accrediting agency for private home study schools.

RESIDENT TRAINING AT LOS ANGELES
If you wish to take your training in our Resident School at Los Angeles, start NOW in our big, modern Shops and Labs. Work with the latest Auto and Diesel engines — all types — fuel injection, automatic transmissions, all power equipment — most complete facilities offered by any school. Expert, friendly instructors. Graduate Employment Service. Help in finding home near school — and part time job while you learn.
WRITE FOR SPECIAL RESIDENT SCHOOL CATALOG AND INFORMATION

N.T.S. Shop-Tested HOME TRAINING is **Better, More Complete, Lower Cost**... and it is your key to the most fascinating, opportunity-filled industry today!

YOU LEARN QUICKLY AND EASILY THE N.T.S. SHOP-TESTED WAY

You get lessons, manuals, job projects, unlimited consultation, graduate advisory service.

You build a Short Wave-Long Wave Superhet Receiver, plus a large-screen TV set from the ground up, with parts we send you at no addi-

tional cost. You also get a Professional Multitester for your practical job projects.

EARN AS YOU LEARN... WE SHOW YOU HOW!

Many students pay for entire tuition — and earn much more — with spare time work they perform while training. You can do the same... we show you how.

SEND FOR INFORMATION NOW... TODAY! IT COSTS YOU NOTHING TO INVESTIGATE.

N.T.S. HOME TRAINING is

- Classroom Developed
- Lab-Studio Planned
- Shop-Tested
- Industry-Approved
- Specifically Designed for Home Study



MAIL COUPON NOW for **FREE BOOK** and **ACTUAL LESSON**

NO OBLIGATION! NO SALESMAN WILL CALL

NATIONAL TECHNICAL SCHOOLS

WORLD-WIDE TRAINING SINCE 1905

Mail Now To
National Technical Schools, Dept. RH-110
4000 S. Figueroa St., Los Angeles 37, Calif.

Please rush **FREE** Electronics-TV-Radio "Opportunity" Book and Actual Lesson. No Salesman will call.

Name _____ Age _____

Address _____

City _____ Zone _____ State _____

Check here if interested ONLY in Resident Training at Los Angeles.
VETERANS: Give date of discharge _____



Latest Information

on the Electronic Industry

Spot News

By ELECTRONICS WORLD'S
WASHINGTON CORRESPONDENT

WORLD'S LARGEST RADAR TO BE BUILT FOR DEFENSE DEPARTMENT—Construction of the biggest radar in the world, costing over \$5-million, will soon be begun for the Ionospheric Research Facility of the Department of Defense. The radar site will be 10 miles south of Arecibo, Puerto Rico. To be completed during the autumn of 1961, the installation will feature a 1000-foot diameter antenna covering 18 acres. Apart from its huge size, the most striking characteristic of the radar will be its unique design. It will completely fill a small valley or pocket formed by several mountain peaks and will be literally carved out of the valley. The resulting bowl, carefully graded and contoured, will be lined with wire mesh suspended a few feet off the ground. The wire mesh will serve as the reflector for transmission and reception. Initial research to be undertaken will involve studies of the nature and characteristics of the ionosphere. For this purpose, experts say, this radar will provide the most sensitive instrumentation yet built. The power of this equipment will be so great that it will be possible to obtain strong echoes from such distant planets as Venus, Mars, and Jupiter. Refer to the artist's sketch of this projected unit on page 47 of this issue.

NO GOVERNMENT CHANNELS FOR TV—All hopes that the government would surrender some of its channels for TV use were dashed recently by Leo A. Hoegh, Director of the Office of Civil and Defense Mobilization. It was bluntly noted that today's international climate forbids dislocation of any bands in the vital 222- to 450-mc. region. Military operation readiness considerations, Hoegh said, dictate continued use of these channels, since they represent a primary tactical communication band heavily used not only by the armed forces in this country but by NATO and SEATO.

GROWING IMPORTANCE OF SALT-WATER ELECTRONICS STRESSED—In a dramatic address on the West Coast recently, Rear Admiral J. A. Japp, Director of Development Programs, underscored the increasing need for salt-water electronic development activity. Noting that five-sixths of the surface of the earth and several hundreds of feet of depth below the surface is salt water, there are, he said, incomprehensibly large and varied tasks ahead. One very important environmental limit encountered in ships is space—not outer space or astro-space—but good old-fashioned space; place to put things. The design of equipment must be married to the design of the vehicle that carries it, the Admiral pointed out. An interesting example is the mating of modern sonar equipment and submarine hulls. Other examples appear in nuclear-powered ships—the carrier "Enterprise" and the cruiser "Long Beach"—whose island and bridge structures have been designed for mounting large static, linear-array, multi-purpose antennas.

NEARLY 90 PER-CENT HOUSEHOLDS NOW HAVE TV—Almost 9 out of every 10 homes in the nation have TV, according to a survey conducted by the Bureau of Census. The popularity of television is indicated not only by the spread to more homes, but by the growing number of households with more than one set. In a recent study, it was found that 11 per-cent of all homes had two or more receivers, compared with 8 per-cent a year ago. Geographically, the Northeast has the highest percentage of TV ownership; 92 per-cent. North Central and the West are next, with the South following behind.

\$2.5-MILLION CONTRACTS ISSUED FOR POLARIS MISSILE SUB-SYSTEMS—Two Navy "Polaris" missile contracts, totaling more than \$2.5-million, covering production of prototype electronic sub-systems for advanced guidance systems, have been awarded. Most of the systems will contain welded modular assemblies which, it is said, will reduce the over-all weight of the system to one-fourth its present weight. Elsewhere, over \$8-million has been appropriated for short-range surveillance drone systems. Also, a \$2-million letter contract has been let for the construction of satellite communication equipment and associated ground terminal for "Project Advent."

[30]

Opportunities in Electronics

Do you know how you can convert your present electronics knowledge into a profitable and interesting career in any of the fields listed here?

Thousands of interesting well paid jobs in electronics must be filled. To fill such jobs, you need sound technical training. An FCC license is convincing proof of technical skill. Send for the three Cleveland Institute booklets offered here. They explain how you can prepare for an interesting and profitable career in electronics. Mail the coupon today—no obligation.

Find out how modern technical training and a Government License (FCC) can lead to profitable employment in any branch of electronics.

POCKET
**ELECTRONICS
DATA
GUIDE**

A pocket guide of commonly used conversion factors, formulas, tables and color codes.

**GET THIS HANDY
POCKET ELECTRONICS
DATA GUIDE**

Free . . .

Puts all the commonly used conversion factors, formulas, tables, and color codes at your fingertips. Yours absolutely free if you mail the coupon today. No further obligation!

**TO GET THIS FREE
GIFT, JUST MAIL
COUPON TODAY!**

Cleveland Institute Announces An Exclusive Technicians Training Program

**in Computers, Servo Mechanisms,
Magnetic Amplifiers and others**

Other advanced fields covered include Basic Math, A. C. Circuit Analysis, Pulse Circuitry, Color TV, Radar, Advanced Measuring Techniques, Industrial Electronics, Instrumentation, Automation, Radio Telemetry. Send for information today.

- Radar
- Guided Missiles
- Broadcasting
- Aeronautical Electronics
- Computers
- Automation
- Industrial Electronics
- Home Electronics



**Send for these
3 FREE Booklets**

*Accredited by
the National
Home Study
Council*



Cleveland Institute of Electronics

Desk RN-47

4900 Euclid Ave.

Cleveland 3, Ohio

Please send FREE Career Information Material prepared to help me get ahead in Electronics. I have had training or experience in Electronics as indicated below:

- | | |
|---|---|
| <input type="checkbox"/> Military | <input type="checkbox"/> Home Experimenting |
| <input type="checkbox"/> Radio-TV Servicing | <input type="checkbox"/> Telephone Company |
| <input type="checkbox"/> Manufacturing | <input type="checkbox"/> Other _____ |
| <input type="checkbox"/> Amateur Radio | |
| <input type="checkbox"/> Broadcasting | |

In what kind of work are you now engaged?

In what branch of Electronics are you interested?

Name _____ Age _____

Address _____

City _____ Zone _____ State _____

RN-47

America's Most Popular, Most Authoritative Books on High Fidelity, Stereo and Tape

Here are some of the world's greatest hi-fi books... chosen carefully by Ziff-Davis Electronics Book Service as among the best in their field. Right now, one or more of these great books will be sent to you for 7 days FREE! Simply write your choices on the coupon below and mail it today. When your books arrive, read and enjoy them for seven full days. If, after that, you don't agree that they are everything you need and want, return them and owe nothing.



2751. HI-FI GUIDE-STEREOPHONIC SOUND, Hoefler

A "how-to" book on hi-fi, written in simple language. Will help you buy the right equipment and see that you get the most out of your stereo or monaural investment. \$2.50



2752. HIGH QUALITY SOUND REPRODUCTION, Meier

The perfect manual for both the professional engineer and the serious amateur interested in high fidelity. The "why" and "how" of sound reproduction is covered in complete detail. \$15.00



2753. LOW-COST HI-FI, Hoefler

Hundreds of hints for budget hi-fi will be found in these fourteen chapters with over 300 detailed photographs, drawings and diagrams. Will save you money in starting or improving your system. \$2.50



2755. THE PRACTICAL HI-FI HANDBOOK, King

A guide to high fidelity sound reproduction for the service engineer and amateur. Chapters on amplifiers, loudspeakers, pickups, microphones, record players, disc, tape and stereo. \$5.95



2756. REPAIRING RECORD CHANGERS, Ecklund

A practical manual on repair of mechanical elements of record changers, including pickups, needles, changer actions, motors, drives, tripping, dropping and shut-offs. Also magnetic recorder repairs. \$5.95



2760. HI-FI STEREO FOR YOUR HOME, Whitman

Tells what stereo is, how it differs from hi-fi, how it works, how it affects home listening habits, and how to install and maintain it. Complete list of terms defined. Generously illustrated. \$3.50



42. REVERSE TAPE RECORDER GUIDE, Tydings

The first non-technical book to provide useful information on the Reverse Tape Recorder. Also a basic guide to the entire field of tape. Will show you new uses and add to your enjoyment. \$1.95



49. TAPE RECORDING GUIDE, Marshall

Designed to help you get the most out of your tape recorder, whether for business, pleasure or professional use. A handy guide to have around, no matter what equipment you own. \$1.95



2750. ELEMENTS OF MAGNETIC TAPE RECORDING, Haynes

Here's how to get professional results with tape the way the experts do. Complete nomenclature, basic techniques, how to splice and edit, how to repair and maintain your recording equipment. \$7.95



2754. MAGNETIC TAPE RECORDING, Spratt

Designed to give principles of magnetic recording and to enumerate characteristics of both the medium and the machines. Excellent for adapting magnetic recording to special needs and wider applications. \$8.95



2757. RIBBONS OF SOUND, Barleben

A handbook on the fundamentals of magnetic tape recording simply and interestingly presented. Factual information you can use no matter what type or make of recorder you own. Paper. \$2.50, 2772. Cloth. \$3.50



2758. TAPE RECORDERS AND TAPE RECORDING, Weiler

An ideal sourcebook of information on all aspects of tape recording. Covers all fundamentals necessary to realize full potential of your tape equipment. Special sections on accessories. \$2.95



2000. STEREO HI-FI GUIDE, 1960, Ziff-Davis

1960 edition features 60-page exclusive by Joseph Marshall on components and how they work. Includes "what you should know before buying stereo". Complete, interesting, invaluable! \$1.00



2002. ELECTRONIC KITS DIRECTORY, 1960, Ziff-Davis

New 1960 edition lists over 750 kits, latest models, prices and features for hi-fi kits—preamps, amplifiers, tuners, speakers—ham radio, SWL, Citizens Band. Fun and education. \$1.00



2004. HI-FI ANNUAL & AUDIO HANDBOOK, Ziff-Davis

1960 edition. Prepared by the editors of Electronics World. An excellent advanced guide to theory, construction and circuitry. Over 40 pages on stereo amplifiers and equipment. \$1.00



2005. HI-FI DIRECTORY & BUYERS' GUIDE, Ziff-Davis

1960 edition. World's only complete listing of all hi-fi and stereo equipment, components and accessories. Five big sections, data on more than 1200 components, over 1,000 illustrations! \$1.00



2006. ELECTRONIC EXPERIMENTER'S MANUAL, Findlay

With a few dollars worth of basic tools and this book to guide you, you can explore the wonderful world of electronics experimentation more completely than ever before. 10 big sections. \$4.95



2769. THE ELECTRONIC MUSICAL INSTRUMENT MANUAL, Douglas

Covers every design phase of the modern electronic musical instrument—including theory, schematics of organ circuits, the science of sound as well as the art of music. \$7.50

Yours For a 7-Day Free Examination from **ELECTRONICS** Book Service!

Each volume is designed to help you get more use and pleasure from your high fidelity equipment. Whether you're planning to buy or ready to improve your system—whether you now enjoy stereo or plan to convert to stereo

—whether you're a music-lover or a hi-fi do-it-yourself—you'll find one or more books of interest below! For yourself or for gift-giving—use the coupon below today!



2762. FROM MICROPHONE TO EAR, Slot

A complete survey of the technique of sound recording and reproduction, discussing the entire chain from microphone to loudspeaker. A practical book for music-lovers as well as sound technicians. \$4.95



2764. ELEMENTS OF SOUND RECORDING, Frayne and Wolfe

A discussion of basic problems in sound recording and reproducing for the designer, engineer, technician and student. Covers acoustics, vacuum tubes, audio amplifiers, etc. 686 pages. 483 illustrations. \$12.00

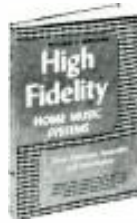

2766. HIGH FIDELITY HOME MUSIC SYSTEMS, Wellman

Authoritative advice on choosing the right type of system for your needs with practical information on the functions of each unit—selection, assembly and installation. \$4.50



2767. HIGH FIDELITY TECHNIQUES, Newitt

A comprehensive treatment of both the principles and practice of modern high fidelity sound systems—how to plan a new system, how to improve an existing one. A goldmine of hi-fi information. \$7.50



2771. HI-FI HANDBOOK, Kendall

How to plan your home music system, choose the best components, install your system easily and maintain it by yourself. All these, and ways to save money, are presented in this basic book. \$3.50



2759. TECHNIQUES OF MAGNETIC RECORDING, Taill

Translates the complexities of a science into practical, easy-to-follow techniques. New ideas, new standards, especially for the amateur who wants a good working knowledge of magnetic recording. \$8.50



2763. MAGNETIC RECORDING TECHNIQUES, Stewart

Covers the technology of magnetic recording methods and devices for engineers and technicians concerned with their application in audio, TV, communications, computers and other fields. \$8.50



2765. YOUR TAPE RECORDER, Marshall

Based on 2500 experiments with almost every type of recorder, this book helps to eliminate trial and error under all conditions. Includes illustrations of 55 magnetic recorders with specifications. \$4.95



2768. MAGNETIC RECORDING, Begun

Thoroughly covers the theory of magnetic recording, various types and makes of recorders, their applications and performance measurements. Includes chapter on important research problems. \$5.00



2770. HOW TO USE A TAPE RECORDER, Hodgson and Bullen

Written to help business and home recorder owners to learn how to get full value from their machines. Explains basic working of tape recorders and accessories as modern tools of communication. \$4.95

*See Your
Hi-Fi Dealer
Or Use This
Coupon Today!*

Leading hi-fi dealers and salons and radio and electronics parts jobbers are making their stores headquarters for books on every electronics subject. You can take this list to your favorite dealer for immediate purchase.

If your local dealer does not carry books, use the coupon for prompt delivery from ELECTRONICS BOOK SERVICE, on a 7-day free trial basis.

ELECTRONICS BOOK SERVICE, One Park Avenue, New York 16, N. Y.



Please send me the book(s) I have listed below for a FREE 7-day Trial Examination. I understand that if I am not completely satisfied, I may return my selection(s) and I'll owe you nothing. Otherwise, I will send you payment for the book(s) of my choice, plus postage and handling.

NUMBER	TITLE	PRICE
(If you need more space to list additional titles, attach a sheet of paper with additional list.)		*TOTAL

SAVE MONEY! Enclose payment in full for the book(s) of your choice and we will pay shipping charges. Same return privileges and prompt refund guaranteed.

Please send me FREE CATALOG, when published.

*New York City Residents, please add 3% sales tax.

NAME _____ EF519

ADDRESS _____ PLEASE PRINT CLEARLY

CITY _____ ZONE _____ STATE _____



PUZZLED

...no need to be

look to this sign of assurance!

The Distributor displaying this sign will solve your tuner problems at a profit to you.

He has available the New Standard Tuner Replacement Guide, including replacement parts listings. This is the only Guide of its kind in the world. Covers all Standard tuners produced through 1959. Includes replacements for many tuners not produced by Standard. He handles our 48-hour Factory Guaranteed Repair Service and Trade-In Allowance on unrepairable Standard tuners.

See This Authorized Distributor Today



standard kollman

INDUSTRIES INC. Formerly Standard Coil Products Co., Inc.
2085 N. HAWTHORNE AVENUE, MELROSE PARK, ILLINOIS



DESIGNED

AS YOU WOULD DESIGN IF YOU WERE AN ELECTRONICS ENGINEER...

Praised by the experts as Best Buys... **EICO**

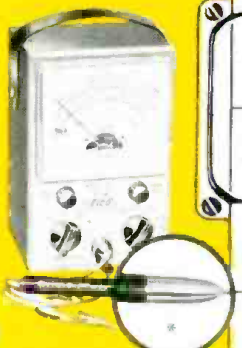

A PEAK-TO-PEAK VTVM #232 & UNI-PROBE KIT \$29.95 WIRED \$49.95



B COLOR & MONOCHROME DC TO 5 MC LAB & TV 5" OSCILLOSCOPE #460 KIT \$79.95 WIRED \$129.50

Also available:
5" Push-Pull Oscilloscope #425
Kit \$44.95 Wired \$79.95



C RF SIGNAL GENERATOR #324 KIT \$26.95 WIRED \$39.95
Turn Page For More EICO Values

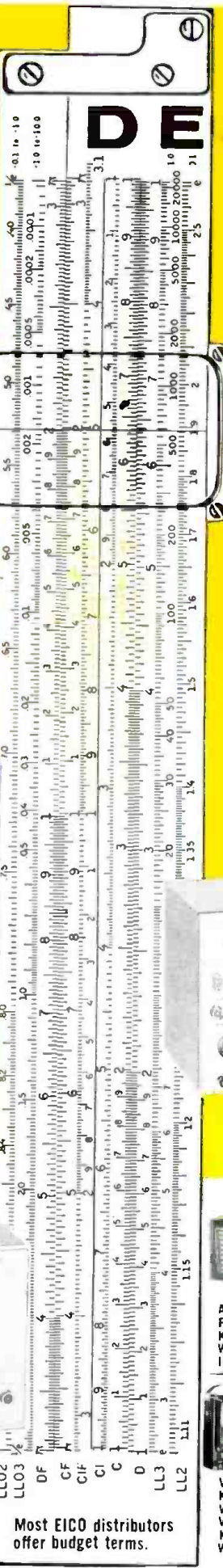

Most EICO distributors offer budget terms.

A By far the best professional VTVM value in electronics; nobody but EICO brings you such outstanding instrument performance for so low a price! Calibration without removing from cabinet. Measure directly p-p voltage of complex & sine waves: 0-4, 14, 42, 140, 420, 1400, 4200. DC/RMS sine volts: 0-1.5, 5, 15, 50, 150, 500, 1500 (up to 30,000 volts with HVP probe, & 250 mc with PRF probe). Ohms: 0.2 ohms to 1000 megs. 4 1/2" meter, can't-burn-out circuit. 7 non-skip ranges on every function. Zero center. Features EICO's exclusive UNI-PROBE: your terrific time-saver, performs all functions: a half turn of probe-tip selects DC or AC-Ohms!

B An engineering achievement unmatched in the industry! EICO-designed for laboratory precision and EICO-priced for lowest cost. Features DC amplifiers. Flat from DC to 4.5 mc, usable to 10 mc. Vert. Sens.: 25 mv/in.; Input Z 3 megs; direct-coupled & push-pull throughout. 4-step frequency-compensated attenuator up to 1000:1. Sweep: perfectly linear 10 cps-100 kc (ext. cap. for range to 1 cps). Pre-set TV V & H positions. Auto sync limiter & amplifier Direct or C coupling; balanced or unbalanced inputs; edge-lit engraved lucite screen with dimmer control.

C More features and versatility, more range and accuracy than in generators costing three to four times as much. 150 kc to 435 mc with ONE generator in 6 fundamental bands and 1 harmonic band! ±1.5% frequency accuracy. Colpitts RF oscillator directly plate-modulated by K-follower for improved modulation. Variable

depth of internal modulation 0-50% by 400 cps Colpitts oscillator. Variable gain external modulation amplifier: only 3 volts needed for 30% mod. Turret-mounted, slug-tuned coils for max. accuracy. Fine & Coarse (3-step) RF attenuators. RF output 100,000-uv, AF output to 10 v.

D Provides more ranges, greater ease and accuracy and better performance than any competitive unit. Entirely electronic sweep circuit with accurately-biased inductor for excellent linearity. Extremely flat RF output. Exceptional tuning accuracy. Hum & leakage eliminated. 5 fundamental sweep ranges: 3-216 mc. Variable marker range: 2-75 mc in 3 fund. bands, 60-225 mc on harmonic band. 4.5 mc crystal marker osc., crystal supplied. Ext. marker provision. Attenuators: Marker Size, RF Fine, RF Coarse (4-step decade). Narrow range phasing control for accurate alignment.

E Speedy, simple operation, unexcelled sensitivity and accuracy; superb electrical and mechanical design. Tests all receiving tubes (picture tubes with adapter), n-p-n and p-n-p transistors. Composite indication of Gm, Gp & peak emission. Simultaneous selection of any one of 4 combinations of 3 plate voltages, 3 screen voltages, 3 ranges of continuously variable grid voltage (with 5% accurate pot.). Sensitive 200 ua meter. 10 six-position lever switches: freepoint connection of each tube pin. 10 push-buttons: rapid insert of any tube element in leakage test circuit. Direct reading of Inter-element leakage in ohms. New gear-driven rollchart. CRA Adapter \$4.50.



D TV-FM SWEEP GENERATOR & MARKER #368 KIT \$69.95 WIRED \$119.95

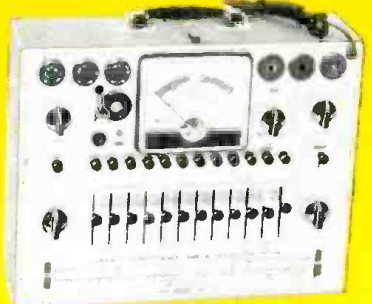

E DYNAMIC CONDUCTANCE TUBE & TRANSISTOR TESTER #666 KIT \$69.95 WIRED \$109.95
Complete with steel cover and handle



All Transistor Portable RA-6 Kit \$29.95 Wired \$49.95 less battery



Power & Bias Supply for Transistorized Eqt. #1020 Kit \$19.95 Wired \$27.95



DeLuxe Multi-Signal Tracer #147 Kit \$24.95 Wired \$39.95



Tube Tester #625 Kit \$34.95 Wired \$49.95 Pix Tube Test Adapter \$4.50



6 & 12V Battery Eliminator & Charger #1050 Kit \$29.95 Wired \$38.95 #1060 Kit \$38.95 Wired \$47.95



V-O-M #565 Kit \$24.95 Wired \$29.95 V-O-M #536 Kit \$12.90 Wired \$14.90



R-C Bridge & R-C-L Comparator #950B Kit \$19.95 Wired \$29.95

EICO 33-00 Northern Blvd., L.I.C. 1, N.Y. EW-11
 Show me HOW TO SAVE 50% on Test Instruments
 Hi-Fi Ham Gear. Send free Stereo Hi-Fi Guide. Send me FREE Catalog, name of neighborhood dealer. Send free Short Course for Novice License.

Name.....
 Address.....
 City..... Zone..... State.....

© 1960 EICO 33-00 N Blvd. L.I.C. 1, N.Y. Add 5% in the West

SEE OUR OTHER ADVERTISEMENT ON PAGE 127

Over 2 MILLION EICO instruments in use throughout the world. Add 5% in the West.



IF YOU LOVE TO CREATE... BUILD **EICO** KITS

In **STEREO** and

**Mono Hi-Fi...
the experts say
your Best Buy
Is EICO**



Stereo Amplifier-Preamp HF81†



Stereo Preamp HF85††



FM Tuner HFT90††
AM Tuner HFT94††
FM/AM Tuner HFT92††



100W Stereo Power Amplifier HF89
70W Stereo Power Amplifier HF87
28W Stereo Power Amplifier HF86



Stereo Integrated Amplifier AF4††



3-Way Speaker System HFS3
2-Way Bookshelf Speaker Systems
HFS5 and HFS1



NEW!
Stereo Automatic Changer/
Player 1007



- Exclusive advanced systematized engineering
- Latest and finest quality parts
- Exclusive "Beginner-Tested" easy step-by-step instructions
- Exclusive TRIPLE quality control
- Exclusive LIFETIME guarantee at nominal cost

IN STOCK — Compare, then take home any EICO equipment — right "off the shelf" — from 1500 neighborhood EICO dealers throughout the U. S. & Canada, most of whom offer budget terms.

HF81 Stereo Amplifier-Preamp selects, amplifies, controls any stereo source & feeds it thru self-contained dual 14W amplifiers to a pair of speakers. Provides 28W monophonically. Ganged level controls, separate balance control, independent bass and treble controls for each channel. Identical Williamson-type, push-pull EL84 power amplifiers. "Excellent" — SATURDAY REVIEW. "Outstanding... extremely versatile." — ELECTRONICS WORLD. Kit \$69.95. Wired \$109.95. Incl. cover.

HF85 Stereo Preamp: Complete master stereo preamp/control unit, self-powered. Distortion borders on unmeasurable. Level, bass, & treble controls independent for each channel or ganged for both channels. Inputs for phono, tape head, mike, AM, FM, & FM-multiplex. One each auxiliary A & B input in each channel. "Extreme flexibility... a bargain." — HI-FI REVIEW. Kit \$39.95. Wired \$64.95. Incl. cover.

New HF89 100-Watt Stereo Power Amplifier: Dual 50W highest quality power amplifiers. 200W peak power output. Uses superlative grain-oriented steel output transformers for undistorted response across the entire audio range at full power, assuring utmost clarity on full orchestra & organ. 60 db channel separation. 1M distortion 0.5% at 100W; harmonic distortion less than 1% from 20-20,000 cps within 1 db of 100W. Kit \$99.50. Wired \$139.50.

HF87 70-Watt Stereo Power Amplifier. Dual 35W power amplifiers identical circuit-wise to the superb HF89, differing only in rating of the output transformers. 1M distortion 1% at 70W; harmonic distortion less than 1% from 20-20,000 cps within 1 db of 70W. Kit \$74.95. Wired \$114.95.

HF86 28-Watt Stereo Power Amp. Flawless reproduction at modest price. Kit \$43.95. Wired \$74.95.

FM Tuner HFT90: Prewired, prealigned, temperature-compensated "front end" is drift-free. Prewired exclusive precision eye-tronic® traveling tuning indicator. Sensitivity: 1.5 uv for 20 db quieting; 2.5 uv for 30 db quieting, full limiting from 25 uv. IF bandwidth 260 kc at 6 db points. Both cathode follower & FM-multiplex stereo outputs, prevent obsolescence. Very low distortion. "One of the best buys in high fidelity kits." — AUDIOCRAFT. Kit \$39.95*. Wired \$65.95*. Cover \$3.95. *Less cover, F.E.T. incl.

AM Tuner HFT94: Matches HFT 90. Selects "hi-fi" wide (20-9000 cps @ -3 db) or weak-station narrow (20-5000 cps @ -3 db) bandpass. Tuned RF stage for high selectivity & sensitivity. Precision eye-tronic® tuning. "One of the best available." — HI-FI SYSTEMS. Kit \$39.95. Wired \$65.95. Incl. cover & F.E.T.

FM/AM Tuner HFT92 combines renowned EICO HFT90 FM Tuner with excellent AM tuning facilities. Kit \$59.95. Wired \$94.95. Incl. cover & F.E.T.

AF4 Economy Stereo Integrated Amplifier provides clean 4W per channel or 8W total output. Kit \$38.95. Wired \$64.95. Incl. cover & F.E.T.

HF12 Mono Integrated Amplifier (not illus.): Complete "front end" facilities & true hi-fi performance. 12W continuous, 25W peak. Kit \$34.95. Wired \$57.95. Incl. cover.

HFS3 3-Way Speaker System Semi-Kit complete with factory-built ¾" veneered plywood (4 sides) cabinet. Bellows-suspension, full-inch excursion 12" woofer (22 cps res.) 8" mid-range speaker with high internal damping cone for smooth response, 3½" cone tweeter. 2¼ cu. ft. ducted-port enclosure. System Q of ½ for smoothest frequency & best transient response. 32-14,000 cps clean, useful response. 16 ohms impedance. HWD: 26¾" x 13¾" x 14¾". Unfinished birch. Kit \$72.50. Wired \$84.50. Walnut or mahogany. Kit \$87.50. Wired \$99.50.

HFS5 2-Way Speaker System Semi-Kit complete with factory-built ¾" veneered plywood (4 sides) cabinet. Bellows-suspension, ¾" excursion, 8" woofer (45 cps. res.), & 3½" cone tweeter. 1¼ cu. ft. ducted-port enclosure. System Q of ½ for smoothest freq. & best transient resp. 45-14,000 cps clean, useful resp. 16 ohms.

HWD: 24" x 12½" x 10½". Unfinished birch. Kit \$47.50. Wired \$56.50. Walnut or mahogany. Kit \$59.50. Wired \$69.50.

HFS1 Bookshelf Speaker System complete with factory-built cabinet. Jensen 8" woofer, matching Jensen compression-driver exponential horn tweeter. Smooth clean bass; crisp extended highs. 70-12,000 cps range. 8 ohms. HWD: 23" x 11" x 9". Kit \$39.95. Wired \$47.95.

HFS2 Omni-Directional Speaker System (not illus.) HWD: 36" x 15¼" x 11½". "Fine for stereo" — MODERN HI-FI. Completely factory-built. Mahogany or walnut \$139.95. Blond \$144.95.

New Stereo/Mono Automatic Changer/Player: Jam-proof 4-speed, all record sizes, automatic changer and auto/manual player. New extremely smooth, low distortion moisture-proof crystal cartridge designed integrally with tonearm to eliminate mid-range resonances. Constant 4½ grams stylus force is optimum to prevent groove flutter distortion. No hum, turntable attractions, acoustic feedback, center-hole enlargement. Only 10¾" x 13". 1007S: 0.7 mil, 3 mil sapphire, \$49.75. Incl. F.E.T. and "Magnadaptor."

†Shown in optional Furniture Wood Cabinet WE71: Unfinished Birch, \$9.95; Walnut or Mahogany, \$13.95.

††Shown in optional Furniture Wood Cabinet WE70: Unfinished Birch, \$8.95; Walnut or Mahogany, \$12.50.

EICO, 33-00 N. Blvd., L.I.C. 1, N. Y. EW-11
Show me how to SAVE 50% on easy-to-build top-quality HI-FI. Send FREE catalog, Stereo HI-FI Guide plus name of neighborhood EICO dealer.

Name.....
Address.....
City..... Zone..... State.....

Listen to the EICO Hour, WABC-FM, N. Y. 95.5 MC; Mon.-Fri., 7:15-8 PM.

© 1960 by EICO, 33-00 N. Blvd., L. I. C. 1, N. Y.

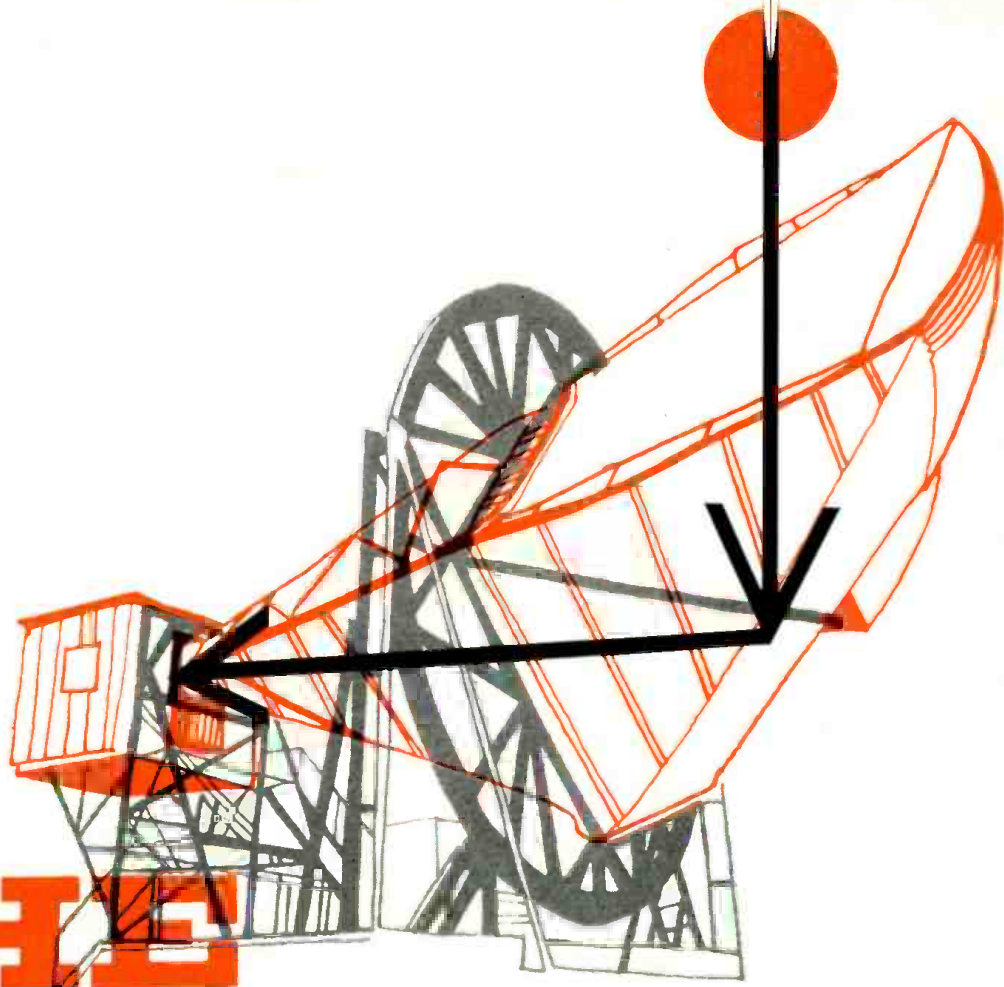

THE MASER

RECEIVER FOR
SIGNALS FROM SPACE

By MARTIN I. GRACE & JOSEPH G. SMITH

Airborne Instruments Laboratory, Div. of Cutler-Hammer Inc.

Radar pulses bounced back from distant planets, communications with space vehicles, receivers to listen for radio signals from outer space, satellite-reflected telephone and TV microwave signals—these are all possible because of the remarkable maser, which uses atomic forces within a super-cooled ruby to amplify.

SOME two-hundred times better than a good, conventional radar receiver, the maser receiver affords scientists in the fields of space communications, radar, and radio astronomy the possibility of amazing improvements. This is because the maser receiver is an almost theoretically perfect receiver insofar as sensitivity and low noise are concerned. Radar range can be increased, or for the same range, the transmitter power can be cut by a factor of 10. Satellite and deep space communication will be extended. Coast-to-coast and continent-to-continent microwave communication links without repeater stations (i.e., via satellite reflector) should be realized. Radio astronomers will be able to "see" much deeper into space, helping to answer some of the basic questions about the universe, and perhaps, discover another civilization. This is not as preposterous

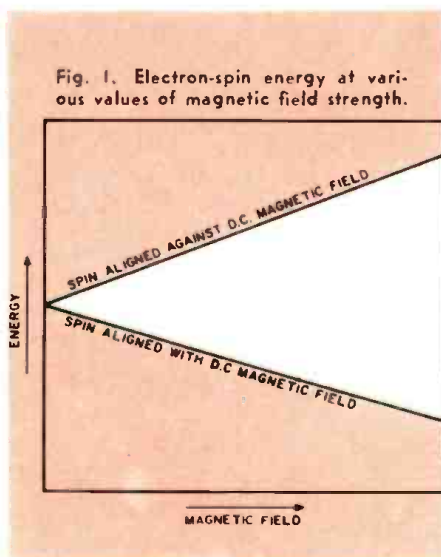

as it sounds. Project "Ozma" has been initiated to listen continuously for intelligent transmissions of radio signals from outer space. The project will use a maser for the ultimate in listening range.

An excellent example demonstrating the ability of a maser to amplify very weak signals was the Venus radar bounce disclosed last year. In this experiment conducted at the Millstone Radar Site of the MIT Lincoln Laboratory, a radar signal was beamed at the planet Venus. A small portion was reflected back toward earth where it was detected by a maser receiver. The scientists involved in the bounce admit the project would have been unsuccessful without the maser. Calculations showed that the transmitter power necessary for the bounce, using a conventional receiver, would have been so high that the air directly in front of the



Dr. R. H. Kingston prepares the maser for the Venus observations at M.I.T. Lincoln Laboratory's Millstone Hill Radar Observatory.

antenna would have been ionized.

Prof. C. H. Townes of Columbia University coined the word "maser" by taking the first letters of its more technical description, "microwave amplification by stimulated emission of radiation." Prof. Townes proposed a maser in 1953 and experimentally verified it three years later with a maser which was essentially an ultra-stable-micro-

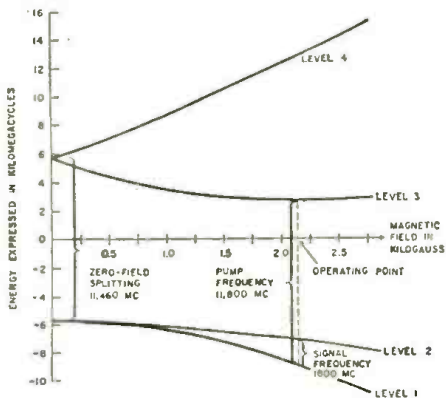
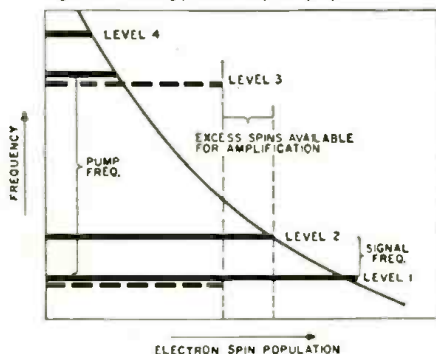

Fig. 2. Energy-level diagram for ruby showing magnetic field and pump frequency needed to operate at 1800 mc.

Fig. 3. Energy-level spin population.



wave type oscillator. Based on these results, Prof. N. Bloembergen of Harvard University proposed in 1956 a maser capable of continuous-wave amplification and, within three months the theory was embodied in an operating unit.

How It Works

The maser is a rather exotic piece of equipment, combining a rare gem (usually ruby) and extremely low temperatures to produce amplification. Unlike most other devices in electronics, the maser makes use of bound electrons to accomplish amplification. There is no flow of electrons as in a tube or transistor. It is a property of these bound electrons that they spin on their axes very much the same way as the earth spins on its axis. We all know that a moving charge is a current and, associated with every current is a magnetic field. The spinning electron is charge in motion and this causes the electron to have a magnetic field. Normally the spin is randomly oriented but when this

one spin aligned with and one spin aligned against the d.c. field. In the case of three net electron spins, there are four energy levels and so on. Chromium-doped ruby, which is the primary maser material today, has three net electron spins per atom. Ruby is a single crystal of aluminum oxide with a small percentage (.05%) of chromium. This small percentage of chromium is what gives ruby its characteristic red color. It is also the chromium which provides the three net electron spins necessary for maser action.

Quantum physics states that the difference in energy (ΔE) between two levels can be equated to frequency (f) by the simple formula: $\Delta E = hf$, where h is Planck's constant. Now we can change the graph of energy levels and write frequency in place of energy. Fig. 2 shows the energy levels for ruby plotted in this manner.

There are approximately 7×10^{19} electron spins in a cubic centimeter of ruby



Lincoln Laboratory's Radar Observatory at Westford, Mass. Venus was "seen" with the maser-equipped dish at the right. Frequency used was about 300-500 mc.; pulse power was 265 kw.; dish size was 84 feet. Maser is at feed point of dish antenna.

"electron spin" is placed in a d.c. magnetic field, the electron's magnetic field normally aligns itself parallel to the d.c. field. The action is similar to that of a compass needle.

The electron spin with its field aligned with the d.c. field possesses a discrete amount of energy. Now, the electron spin can take up another position, namely, against the field. Energy must be expended in "flipping" the spin over. Thus, an electron spin aligned against the d.c. field has more energy than one aligned with it. In a substance containing many of these spins, the condition pictured in Fig. 1 will exist. Some spins will be aligned with and some against the d.c. field. It can be seen that two definite energy levels exist and that the difference in energy is directly proportional to the applied d.c. magnetic field.

The above condition is for a substance possessing one net electron spin per atom. If the substance possesses two net electron spins per atom, it will have three energy levels—one for both spins aligned with the d.c. field, one for both spins aligned against, and one for

and, of these, a certain percentage of spins are in each of the four energy levels. The number of spins in each level is a function of the temperature of the crystal. At room temperature the four levels are almost equally populated but at liquid helium temperature, 4.2° above absolute zero, the populations of the four levels are substantially unbalanced. (Absolute zero is also known as zero degrees Kelvin, or K, and represents a temperature of 273 degrees below zero C or 460 degrees below zero F.) The solid bars in Fig. 3 represent a typical energy population distribution for ruby. From the diagram it can be seen that the lower energy levels are more heavily populated than the higher ones.

The operation of a 3-level maser can be explained from an energy level diagram. The term "3-level maser" means that only three energy levels are used in attaining maser operation even though there may be a greater number of energy levels in the material. If we inject into the crystal a strong r.f. signal from a local oscillator, equal in frequency to the difference between

energy levels 1 and 3, an interesting phenomenon takes place. Some of the electron spins in the lower level absorb energy from the r.f. field and jump to level three. If the local-oscillator r.f. signal, usually called the "pump signal," is strong enough, the "pump" transition (level 1 to level 3) can be saturated, i.e., the number of spins in level 3 can be made equal to that in level 1. The total number of spins in the two levels has not changed, but now they are equally populated. Levels 2 and 4 are unaffected since their natural frequencies have not been involved. This "pumped" condition is shown in Fig. 3 by the dashed bars. It can be seen that level 2 now possesses more electron spins than level 1. This is contrary to the normal equilibrium condition.

If a signal which is equal in frequency to the difference between energy levels 1 and 2 is now fed into the crystal, spins in level 2 will be stimulated to emit energy to the signal rather than absorb energy from it. In the process they will flip over and fall

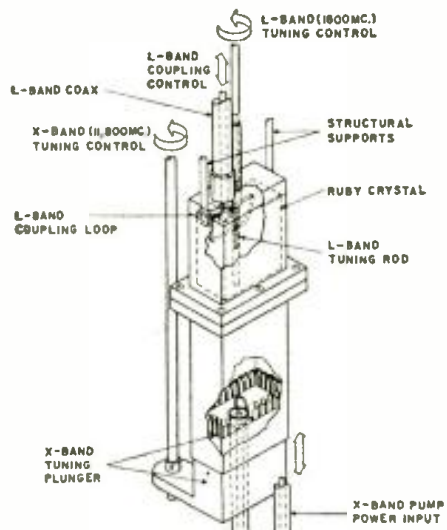
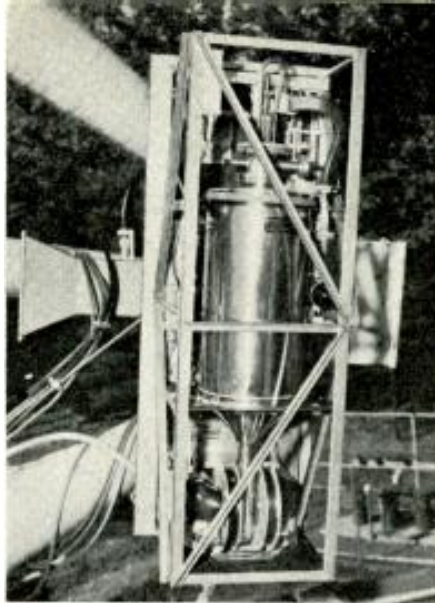
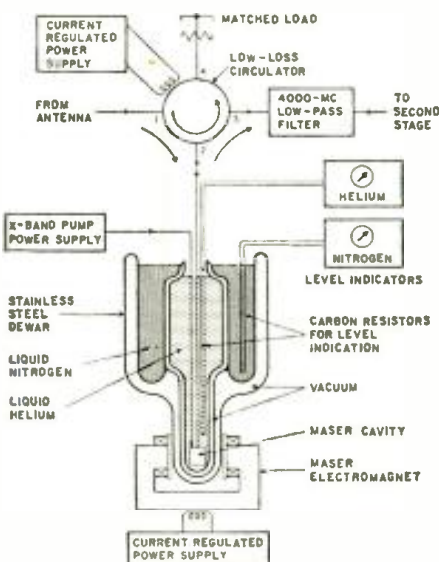

Fig. 4. Tunable maser cavity structure used in Airborne Instruments Laboratories gear.

Fig. 5. System diagram of maser operation.



Close-up of Harvard maser mounted at antenna feed. Protective covers have been removed to show electromagnet at bottom and dewar structure that is utilized. The receiving waveguide horn is located at left.

back down to level 1. This giving up of energy to the signal frequency is amplification. By varying the d.c. magnetic field, the operating point in Fig. 2 is varied, thereby changing the spacing of the levels and "maser action" can be obtained at other frequencies. This is the basic scheme of maser operation. Sophisticated techniques have been developed using more than three levels, double-pumping and sub-harmonic schemes; but it all boils down to the same fact. To accomplish amplification, a greater population must exist in a higher energy level than in a lower one.

The low-noise characteristic of a maser is more difficult to explain but it is extremely important. In conventional receivers the main source of background noise is from random emission from hot cathodes, shot noise in tubes, and random thermal noise in resistors. Since, with the maser, amplification occurs without the use of hot cathodes and tubes, it is logical to expect that noise from such sources does not exist. Also, the components that could produce noise are at an extremely low temperature, a few degrees above the point where all thermal motion ceases to exist. This is only part of the low-noise story because, for quantum-mechanical reasons, noise is even lower than the helium-bath temperature would predict.

Types of Masers

There are two basic types of maser configuration, the *cavity maser* and the *traveling-wave maser*, or TWM.

The first maser amplifiers constructed were cavity masers. In this type, resonant circuits are used to inject the r.f. signals into the ruby crystal. The early cavity masers consisted of a single microwave waveguide cavity resonant at two frequencies; the pump and the signal. The maser material was placed inside the microwave cavity. This first type of cavity maser had the disadvantage of operating at a single fixed frequency. Later, cavity masers of a tunable nature were designed. A

tunable maser structure is shown in Fig. 4. It consists of a waveguide resonant cavity which is resonant at the pump frequency, and a quarter-wave coaxial resonator, resonant at the signal frequency. The coaxial resonator is constructed inside the waveguide resonator. The maser material is placed inside the resonant cavity. The r.f. signals are coupled into the cavity by adjustable loops.

The cavity maser is a one-port amplifier; that is, the input and output have the same common terminals. In order for this type of amplifier to operate, a non-reciprocal device called a "circulator" is necessary. The circulator acts as a traffic cop (see Fig. 5). A signal that enters port 1 is directed to port 2, a signal that enters port 2 is directed to port 3; and so on around the loop.

The cavity maser has many inherent problems: (1) it must be manually tuned; (2) the noise figure is degraded by "lossy" input components; (3) the unit's stability is not too good; and (4) saturation effects occur at relatively low power levels. At the onset of saturation the maser loses gain and becomes transparent, acting very much like a piece of transmission line. The receiver's second stage is usually capable of picking up the saturating signal and completing the reception. Once the maser saturates, it takes a considerable amount of time after the saturating signal is withdrawn to return to normal operation. If, during this time, a low-level signal enters the system, it is lost. This is the only drawback of the maser. Presently, this "recovery" time is on the order of 50 milliseconds but crystalline materials are being developed which will reduce this figure to insignificance.

The traveling-wave maser corrected most of the drawbacks of the cavity type. It employs a transmission type of coupling between the r.f. signal energy and the crystal rather than the reso-

Harvard University's 60-foot parabolic dish with maser installed at feed point.



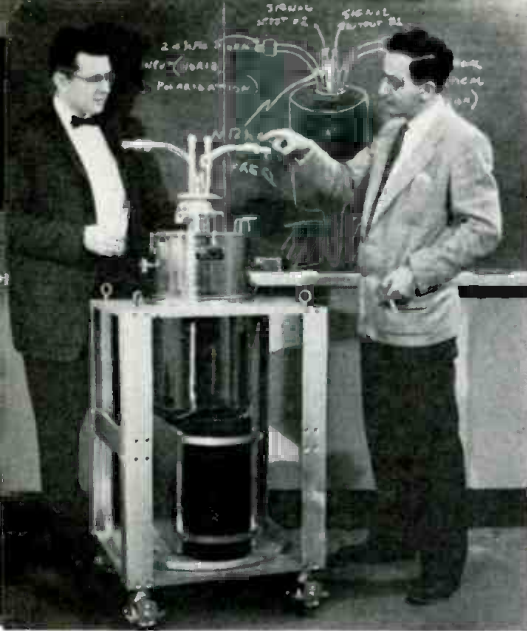

H. E. D. Scavil of Bell Laboratories points out to R. W. DeGrasse an input coax of the two-channel traveling-wave maser designed for satellite communication. This maser is being used with a horn-reflector antenna.

nant technique used in the cavity maser. There are many advantages in this type of unit. The over-all system noise figure is reduced by the elimination of the circulator, it is much more stable, it can be electronically tuned, its bandwidth is greater, and its saturation characteristic is improved.

In this method of operation (Fig. 6), the signal enters at one end of the structure, travels along a transmission line past a slab of ruby, picking up gain as it goes. The amplified signal leaves at the other end. In a cavity maser the fields are built up by a reso-

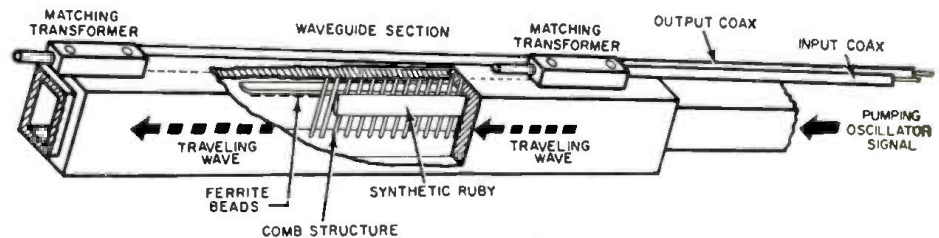

Fig. 6. Comb-type slow-wave structure designed for traveling-wave maser of type employed in Bell Telephone Laboratories and Airborne Instruments Labs. equipment.

nant technique to enhance the interaction of the signal with the crystal. In the TWM, the signal reacts very weakly with the crystal and the gain per inch of structure is small. For a signal traveling at its normal speed, the speed of light, the structure would have to be 50 to 70 feet long to attain a gain of 20 db. This is not practical so the signal is slowed down by using a series of metal rods forming a comb structure in which the signal is bounced back and forth before it emerges at the output. The signal is then slowed down, and this increases the reaction time between the signal and the ruby crystal. Gains of 25 db can be obtained in lengths of 5 to 10 inches in sections of this type. This technique is not new, it has been used very effectively in many devices. The traveling-wave tube is an excellent example of a device using the same technique. The TWM is made oscillation-proof by the inclusion of small ferrite isolators between each finger in the slow-wave structure. These isolators look transparent to a signal traveling in the forward direction but very "lossy" to a signal traveling in the reverse direction. This elim-

inates any regenerative effects which are the primary cause of instability and oscillations. The pump power is introduced into the crystal in the same resonant manner as in the cavity maser.

Cryogenics

In order to operate a maser, the ruby crystal must be kept at a very low temperature, usually at or below 4.2° absolute. The only substance that is liquid at such low temperatures is helium. Liquid helium boils (that is, turns into a gas) at 4.2° absolute. Because liquid helium boils at such a low temperature, elaborate systems have had to be devised to contain it. In fact, the whole science of cryogenics has developed around liquid helium, its production, storage, and effect on other

(Continued on page 120)

Complete ruby maser developed for Signal Corps by Hughes. Assembly weighs 25 lbs. and is 30" high and 5" in diameter. Double vacuum assembly contains liquid helium and nitrogen for supercooling a half-inch square ruby crystal to only a few degrees above absolute zero. The ruby and a 12-ounce permanent magnet are inside the structure at the very bottom of assembly.

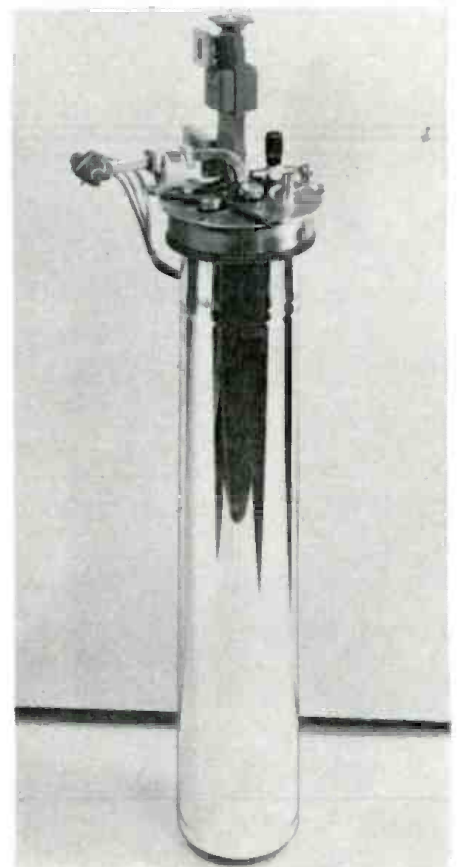

Cover Story

Sugar-Scoop Antenna

High on a hill in the New Jersey Highlands near the birthplace of radio astronomy is the unusual-looking antenna that appears on our cover this month. This antenna, shaped like a giant sugar scoop, is Bell Telephone Laboratories' low-noise horn-reflector antenna. Already having been used to receive ultra-weak voice signals from California, after these signals have been bounced off the moon, the antenna is playing a star's role in NASA's project "Echo." In this project, a 100-foot aluminized balloon, launched by rocket, served as a reflector for coast-to-coast radio signals.

According to Frederick R. Kappel, President of American Telephone and Telegraph Co., the type of research that is being done by telephone scientists today in space communications is aimed at creating thousands of high-quality voice channels and, ultimately, television channels, that would interconnect all parts of the globe by way of satellites.

The unusual shape of the antenna is required not only to obtain very high gain (about 43 db) and a narrow beam width (1 1/4°) but also to eliminate any side or rear lobes from the antenna's directional pattern. Even with large and highly directive parabolic-reflector antennas, some undesired lobes are directed toward the ground and the sky. These produce some noise in a system that cannot be tolerated because of the extremely weak signals.

The entire structure, made largely from aluminum, is about 50 feet long and about 35 feet high. The horn opening measures around 20 by 20 feet. The entire assembly can be rotated through 360 degrees on its circular track, and the large upright wheel allows it to be oriented at any vertical angle.

The output signals from the horn are applied through a rotary joint and some r.f. plumbing to the ruby maser amplifier located in the small cab at the end of the antenna. The maser maintains the high sensitivity and extremely low noise characteristics that are so essential in working with very weak signals.

The maser employed is a two-channel device operating at a signal frequency of 2400 mc. The two channels are useful in picking up signals having either clockwise or counterclockwise circular polarization. The heart of the maser, a slab of ruby crystal, is kept at a temperature just a few degrees above absolute zero (-460°F), by being submerged in a container of liquid helium. This, in turn, is submerged in liquid nitrogen to prevent heat losses. The two tanks of helium and nitrogen are located underneath the cabin that houses the maser. Together with the horn-reflector antenna and an FM demodulation system, the maser makes the system the most sensitive voice radio receiver yet built. [30]

(Cover photo by Bell Telephone Labs.)

Outboard Signal-Level Indicator

By HAROLD REED

Eye-tube and rectifier form self-contained audio indicator that may be employed in tape recorders or in AM or FM tuners.

THE unit to be described is a general-purpose, detached-tuning or signal-level, indicator suitable for many applications in electronic work. It may be employed, too, as a remote indicator.

AM-FM receiver tuning indicators and audio-signal-level indicators for tape recorders may consist of meter circuits or electron-ray tube circuits, commonly known as "magic eye" tubes. A meter presents some disadvantages to the audiophile: it is more expensive than other types of indicators and it cannot be placed across certain sections of a circuit without considerable loading effect. This loading condition can be overcome by using a high-impedance bridging input circuit for the meter, but with quite a reduction in sensitivity, usually making it necessary to add a voltage-amplifier stage to raise the signal level enough to provide satisfactory meter indication.

An electron-ray tube, such as the 6E5 and 6U5 which have been used extensively for this purpose, provides a high-impedance input indicator which may be connected across most circuits to be monitored and includes an amplifying triode unit. However, these relatively large tubes require considerable space. They are also difficult to mount for proper viewing since the shaded pattern produced on the fluorescent target appears at the top of the bulb which has an over-all length of 4 inches.

Construction Details

The indicator to be described uses the miniature 6DA5/EM81 tube which also includes a d.c. amplifying triode section. It plugs into a 9-pin socket.

The completed unit showing the eye-tube mounted inside cut-out tube shield. If constructed directly into a recorder or tuner, it takes only small amount of space compared to the 6E5 tube.

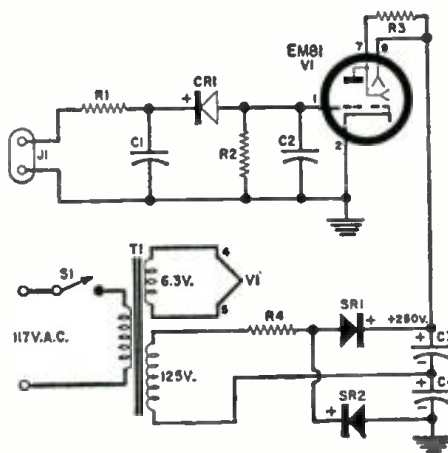
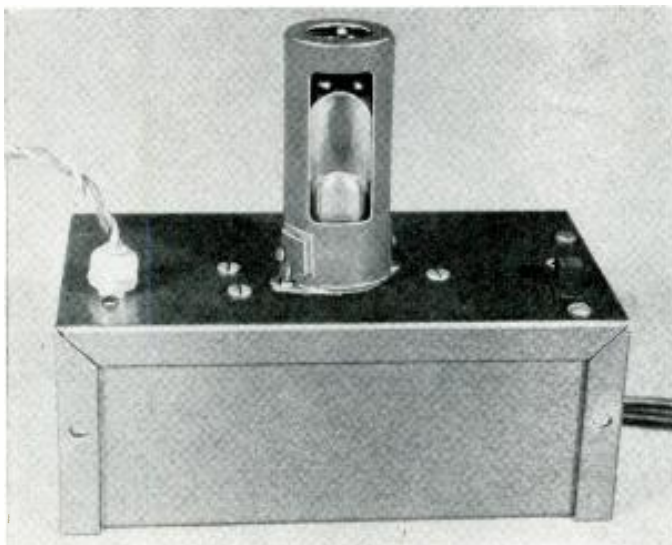

- R₁—100,000 ohm, 1/2 w. res.
- R₂—2.2 megohm, 1/2 w. res.
- R₃—680,000 ohm, 1/2 w. res.
- R₄—3300 ohm, 1/2 w. res.
- C₁—50 μf. ceramic capacitor
- C₂—.02 μf. disc ceramic capacitor
- C₃, C₄—16/16 μf., 250/250 v. elec. capacitor (Sprague TU-216)
- CR₁—Crystal diode (Amperex 1N478 or 1N34 may be used, see text)
- SR₁, SR₂—500 ma., 400 p.i.v. silicon diode (International Rectifier SD-94, 20 ma., 130 v. r.m.s. selenium units may be used)
- S₁—S.p.s.t. slide switch ("On-Off")
- J₁—Miniature double-pin jack
- T₁—Power trans. 125 v. @ 15 ma.; 6.3 v. @ .6 amp (Stancor PS8415)
- I—Ventilated tube shield, 2 3/8" (Elco 195V, see text)
- I—5 1/4" x 3" x 2 1/8" chassis box (Bud CU-2106-A)
- V₁—Electron-ray tube, EM81/6DA5 (Amperex)

Circuit diagram of the level indicator. CR₁ is not critical and can be almost any crystal diode. SR₁ and SR₂ must have peak inverse voltage ratings of about 350 volts. An EM80/6BR5 may be used instead of the EM81/6DA5 as shown. The EM80 has a somewhat different pattern with two shadow areas and it is a little less sensitive.

The socket is fitted with one of the ventilated-type tube shields. These shields have three cut-outs along their length but two of the cut-outs were enclosed by a piece of thin metal. This metal covering was cut from a tin can, formed around the shield, and soldered in place. The remaining open cut-out of the shield provides a viewing window for the electron-ray tube, as can be seen in the photograph of the completed unit. This shield assembly was then given several coats of grey enamel.

The tube is mounted on the top of a 5 1/4" x 3" x 2 1/8" chassis box. All other component parts, including the small power transformer, are attached to this upper portion of the box. The compact size of the Stancor transformer makes possible the use of a small chassis box. A miniature jack is mounted at the left side of the box for signal input to the indicator tube. An a.c. slide-type power switch is attached to the right side of the enclosure.

The power transformer furnishes the 6.3-volt heater supply for the tube and 125 volts a.c. to the diode rectifiers for plate and target potentials. A full-wave, voltage-doubler type of rectifier is used. Theoretically, a no-load d.c. output, 2.83 times the a.c. input to the diodes, is to be expected from this circuit. Resistor R₁ in the transformer secondary drops the output potential to the desired 250 volts. This resistor also limits the initial surge current while the capacitors are being charged, providing protection to the crystal diodes.

Operational Data

When an audio signal is applied to (Continued on page 98)

Internal view of the self-powered signal-level indicator showing the location of the components. Unit may also obtain power from associated equipment. In this case, cost is less than meter.

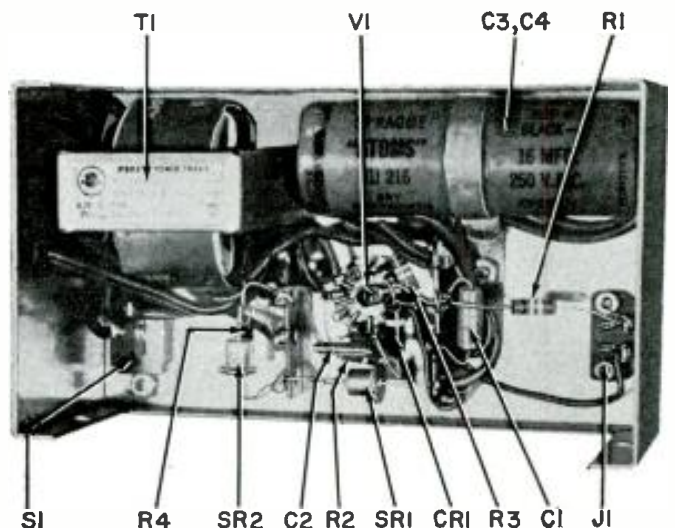

**Increase the operating range of your Citizens
Radio equipment by using the right kind of antenna
and transmission line in a proper installation.**

By **LEO G. SANDS** / Author, "Class D Citizens Radio"

THE range of a class D Citizens Band radiotelephone depends, primarily, on its antenna system. While it will work using a plug-in indoor antenna, its signal will reach farther when connected to a proper outdoor antenna. Increasing range by raising transmitter power beyond the five-watt input limit (as measured at the plate of the tube which feeds power into the antenna) is not permitted. So instead of using a bigger lamp bulb, figuratively, you hoist it up in the open where it can be seen for a greater distance. However, the FCC also stipulates that the height of the antenna shall be no greater than 20 feet above the ground or the structure which supports the antenna mast. If only 20 feet above the ground in flat country, the range would be limited to about five miles or less. If placed 20 feet above the ground on a hilltop, with the antenna clear of surrounding trees, the range could be considerable since it is the *effective antenna elevation*, not

height, that is the important thing.

The 20-foot limitation isn't as restrictive as it sounds. You can put your base station antenna on a TV antenna mast to project its tip 20 feet above the roof, or, if you live in a tall apartment building, you can hoist the tip of your antenna 20 feet above the roof and talk for many miles. You can also attach it to the transmitting tower of an existing radio station, irrespective of height, just as long as the antenna does not extend above the top of the tower. See Fig. 1.

Antenna height and *effective antenna elevation* do not mean the same thing and are often confused. The effective height of an antenna is considered to be the height of the antenna above the effective ground level, as measured from the antenna's *center* of radiation. Antenna height, as far as FCC regulations covering Citizens Band stations are concerned, is the height of the *top* of the antenna above

the surface on which the antenna support is mounted. But, the range of a Citizens Band station is determined by the *effective antenna elevation*.

An antenna whose top extends 20 feet above the surface of the earth in unwooded, flat country has a height of 20 feet and an effective elevation of 20 feet. But, if the earth is the knoll of a hill 500 feet high, as shown in Fig. 2, the antenna height is still 20 feet but the effective antenna elevation is 520 feet. The same situation exists when an antenna is on a tall building.

The communicating range is roughly considered to be approximately equal to $1.4 (\sqrt{H_1} + \sqrt{H_2})$. If the effective elevation of the base station antenna (H_1) is 100 feet and that of the mobile unit is 6 feet (H_2), the computed range would be $1.4 (10 + 2.5)$ or 17.5 miles. But it really isn't so except under non-typical conditions, because of intervening objects, absorption by foliage, and background noise.

Antennas for Citizens Radio

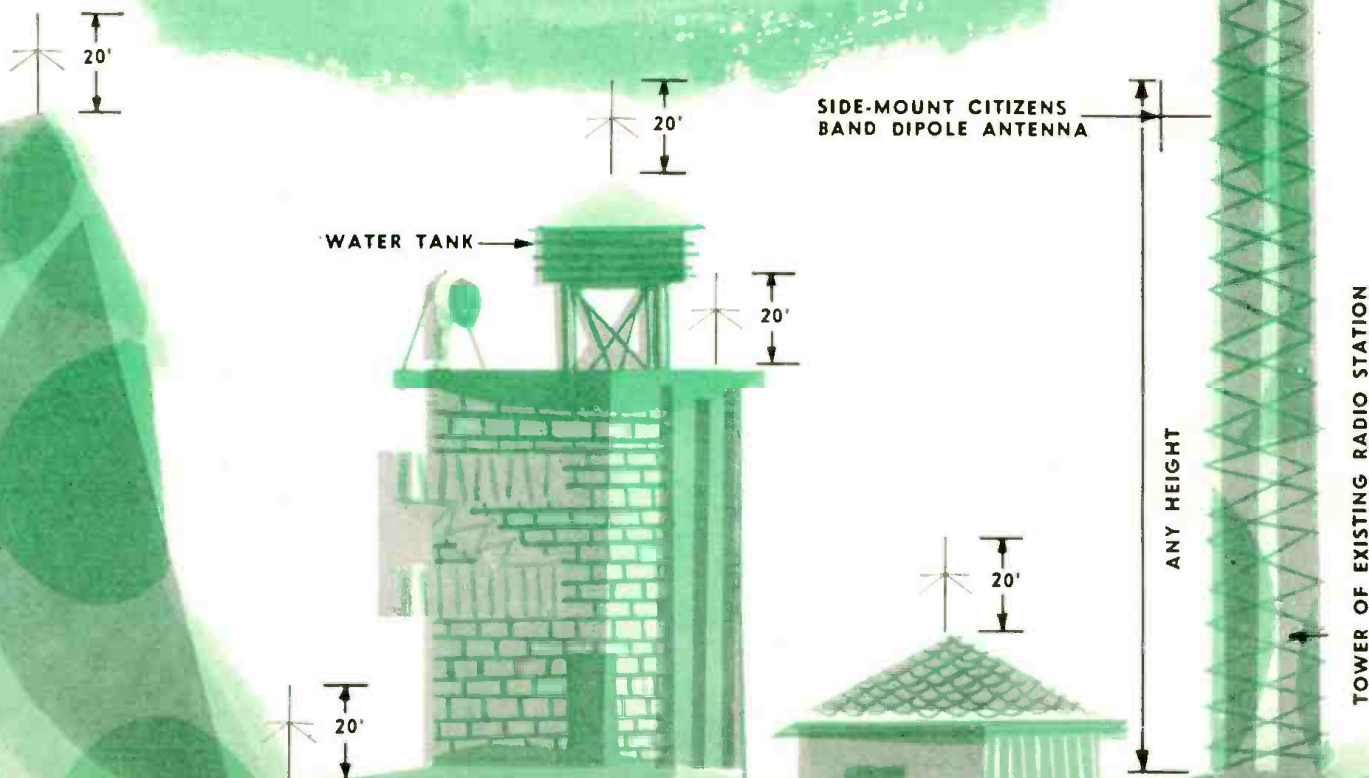

Fig. 1. These antennas are all within FCC height limitations.

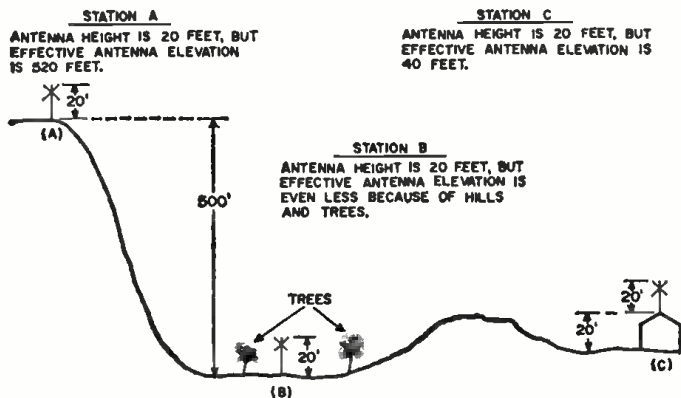

Fig. 2. Antenna height versus effective antenna elevation.

There is a loss in signal strength through space and noise also has to be considered. Furthermore, intervening objects in the radio path make it necessary for the signal to take a devious reflected path. In addition, foliage greatly attenuates the radio signal.

If the signal at a distance of ten miles is two microvolts at the distant receiver's antenna terminals, the usefulness of the signal will be determined by the level of the noise at the receiver location. Even if the receiver has a rated sensitivity of $\frac{1}{10}$ th microvolt, the receiver will not be useful on such weak signals when the noise level is much higher.

Maximum range can be achieved by (1) providing an efficient antenna system at all stations in the system, (2) installing the antenna so as to obtain the highest possible *effective antenna elevation*, and (3) keeping noise level at a minimum.

Omnidirectional Antennas

For general, all-around use, the antenna should be omnidirectional, that is, it should transmit and receive equally well in all horizontal directions.

You have a wide choice of such antennas for base stations. You can make your own simple doublet antenna from a piece of 72-ohm twin-lead, as shown in Fig. 3. When installed vertically, it is omnidirectional but you can often get better results by using a ground-plane antenna or a coaxial antenna. Ground-plane antennas are available from radio parts stores, mail-order houses, and mobile radio manufacturers for \$19.95 or less, including a 50-foot length of coaxial cable. Some ground-plane antennas can cost as much as \$100 or more.

A full-size ground-plane antenna for the 27-mc. band consists of a vertical whip about 9 feet long. See Fig. 4. At the bottom are three or four horizontal or drooping rods (which protrude from the hub where the vertical radiating element is attached) which are connected together but insulated from the vertical radiating element. Some of these antennas have telescoping rods which are extended when placed in operation. There are also antennas, developed especially for class D Citizens Band stations, which have three drooping ground rods and one vertical rod which are about a third of the usual

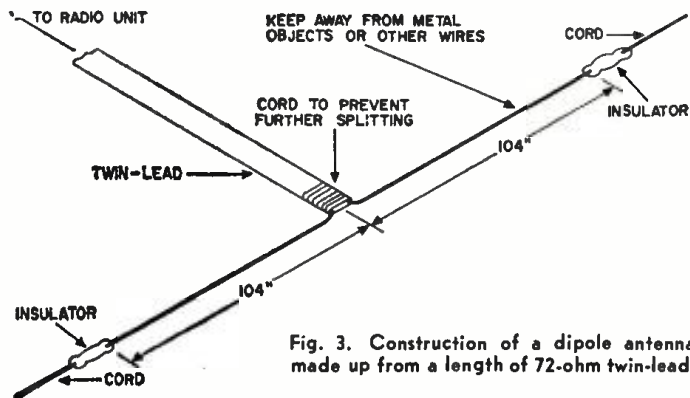

Fig. 3. Construction of a dipole antenna made up from a length of 72-ohm twin-lead.

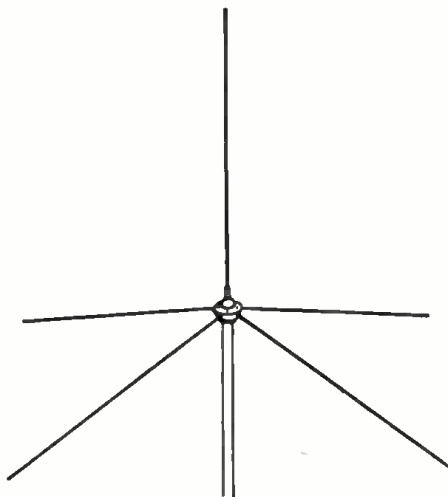

Fig. 4. Ground-plane antenna employing four drooping ground radial rods.

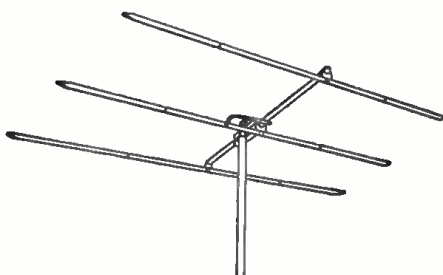
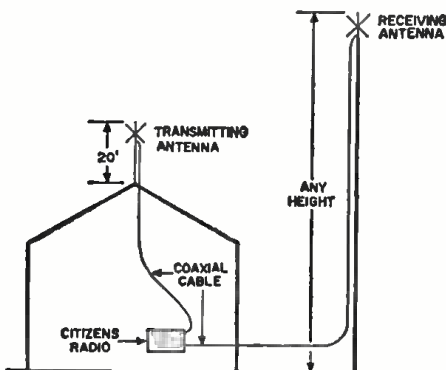

Fig. 5. Three-element yagi antenna. Although shown here horizontally polarized, the elements may be oriented vertically in order to produce vertical polarization.

Fig. 6. A separate receiving antenna of any height may be used to increase range of the receiver as is shown in this figure.



length. Loading coils at the base of the vertical element and at the hub end of each of the three ground radials provide the electrical effect of a longer rod. While not quite as efficient as a full-size ground-plane antenna, the smaller antenna can be installed where space is limited. It is not as cumbersome to handle and presents a neater appearance.

A coaxial antenna has no horizontal or drooping elements. It looks like two pieces of vertical pipe, of which the upper section is generally of smaller diameter than the lower section. For the class D band, a coaxial antenna is about 18 feet long.

Directional Antennas

When communication in all directions is not required, a directional antenna may be used. It will transmit and receive better in one (unidirectional) or two (bidirectional) directions than in all other directions. An omnidirectional antenna can be likened to a bare light bulb while a directional antenna is comparable to a lamp equipped with a reflector. A directional antenna increases the e.r.p. (effective radiated power) of the transmitter as well as the sensitivity of the receiver in the favored directions. Not only does a directional antenna increase the strength of the signal and the range in the favored direction, but it also reduces radiation and reception in other directions. Hence, a directional antenna can be used for eliminating or at least reducing interference to and from other stations.

A modified form of the ground-plane antenna, using two spaced antenna elements and known as a cardioid, transmits best in a heart-shaped pattern from the base station. In the most favored direction, the e.r.p. of the transmitter is doubled (3 db). A figure-8 pattern (bidirectional) can be obtained with a special type of antenna which consists of two coaxial, dipole, or ground-plane antennas separated by a critical distance. Gain in the two favored, opposing (forward and backward), directions is 3 db.

For concentrating most of the energy in one direction, a yagi antenna can be used. A 3-element yagi, designed for class D use, can be obtained for as little as \$29.95. See Fig. 5. More complex yagi arrays may have as many as five

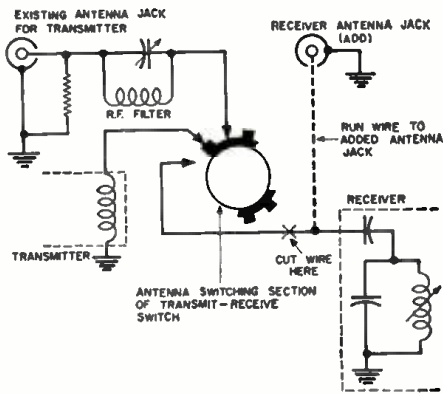

Fig. 7. Separate receiving antenna jack may be added as in this typical circuit.

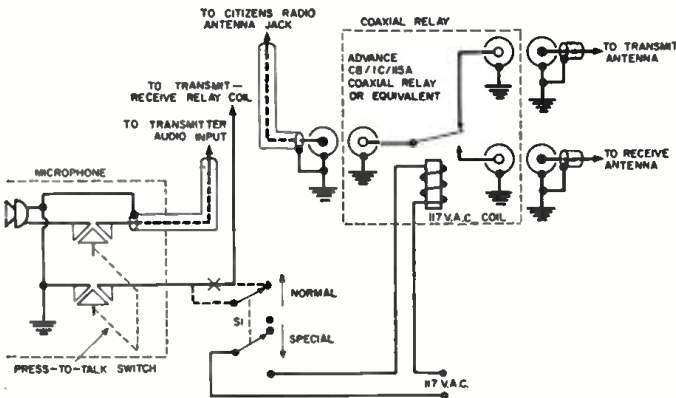

Fig. 8. Use of external coax relay with special receiving antenna. When S_1 is on "special," press-to-talk circuit is opened to prevent transmitter from being connected to special receiving antenna. In "normal" position, regular antenna is employed for transmitter and receiver.

elements. There are much more expensive antennas with very high gains (e.r.p. is increased 20 times) which can be used by class D Citizens Band stations. One such array, consisting of two yagi antennas side-by-side, has a rated gain of 13 db in the forward direction. This means that the effective radiated power is 20 times as great as the power fed to it by the transmitter. Thus, a class D transmitter, which puts out around two watts (for 5 watts input), can be as effective as a 40-watt-output transmitter connected to a conventional antenna.

Increasing Receiving Range

While the FCC limits the height of the transmitting antenna for class D stations, it does not have jurisdiction over the height of receiving antennas for this service. Thus, it is possible for a class D station to be equipped with separate transmitting and receiving antennas. See Fig. 6. The former must be installed in conformity with the 20-foot, FCC-imposed height limit but the latter may be installed at any height.

This may not sound like it makes sense, but it does in some cases. The author, for example, lives in a house near two busy roads. The ignition interference caused by passing cars is so high that receiving distance is greatly curtailed. But, being at an advantageous location otherwise, the transmitting range is adequate. The solution to the problem, therefore, is to use a separate antenna for reception and to locate it as far as possible from the street. It is necessary, of course, to provide separate connectors at the radio

unit for receiver and transmitter antenna inputs. The receiver antenna input circuit is disconnected from the antenna switching relay and is run to an added jack or coaxial connector. To cite an example, Fig. 7 shows the wiring changes required in the *Heath CB-1*. Alternatively, an external coaxial relay (which costs about \$12.00) can be used to switch from one antenna to another, as shown in Fig. 8.

The author tried another stunt that works well. Instead of modifying the CB unit, it was left as is. The receiver portion is used with its regular antenna when incoming signals are strong enough to override the ignition noise. At other times, a conventional ham-

the antenna high enough to cancel out the capacitive reactance of the antenna, so that the antenna looks like a resistance at the operating frequency.

While a base-loaded antenna is not as efficient as an ideally located quarter-wave whip, it often works as well, if not better, when installed in the center of the metal roof of the vehicle. Since it is not always feasible or desirable to put the antenna in the center of the car top (it does jeopardize the trade-in value of the car), it is often installed on the cowl or a fender.

It is extremely important that the ground connection of the antenna-mounting device make good contact with the car body since the body is a vital part of the antenna system. While clip-on antennas will work, special attention should be given to making good electrical contact with the car body. This has an important effect on ignition noise as well as on the transmitting range of the equipment.

Antennas for Portable Operation

The plug-in antenna, which comes with many Citizens Band units, is equipped with a base loading coil. In some sets, the loading coil is a part of the set. With this kind of antenna, communicating range is only fair, for three reasons: first, the antenna is not a full quarter-wave long; second, it is not in the most advantageous location; and third, and quite important, the metal case of the set which functions as the

(Continued on page 124)

type short-wave receiver, which can be tuned through the class D Citizens Band, is used for receiving. Instead of the usual factory-made antenna, a vertical 18-foot zepelin antenna is used for receiving. It is connected at the bottom end of the vertical wire to the receiver antenna input through 300-ohm lead-in wire.

Mobile Antennas

The most commonly used mobile antenna is a quarter-wave vertical whip, about nine feet long, mounted by means of a spring assembly to the bumper, cowl, or fender of a vehicle. See Fig. 9. It forms an efficient radiator since it is approximately a quarter of a wavelength long at the operating frequency. The body of the vehicle serves as the ground plane and is part of the antenna system. But, because the body of the vehicle shields the antenna in some directions, it is more effective in some directions than in others. Ideally, the antenna should be mounted in the center of the metal roof of the vehicle but there it would be both cumbersome and unsightly to say nothing of the damage it does to the top of the car.

More attractive, and easier to install, are the many special base-loaded whip antennas which are much shorter than a full-length, quarter-wave whip. At the base of the shorter whip is a coil, called a loading coil. The coil, which is a part of the antenna, makes it possible to use a shorter whip. The shorter whip, without the coil, has too little inductance at the operating frequency but the coil provides the requisite inductance, raising the inductive reactance of

Fig. 9. Parts of a conventional whip.

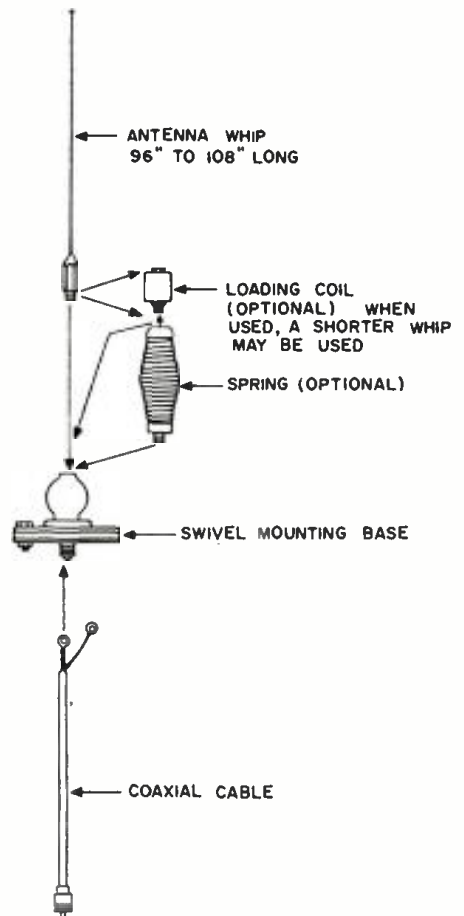

Preamp - Mixer For Electronic Organs

By J. R. CADDEN / Chief Production Engr., CBS Electronics

Insert this circuit in order to raise signal levels for better dynamic range and improved tone coloration.

IF YOUR organ seems to lack power, color, or good dynamics, try adding this preamp-mixer to your system. You will be amazed at the improvement.

The organ for which this unit was built features separate buses for the swell manual tones, the great manual tones, and the pedal tones. Due to the nature of the tone-generating and tone-coloring system, the signal levels on the buses are low.

The level on the swell and great buses for a single note is about 100 microvolts using a single basic stop. The level on the pedal bus is higher (about 500 microvolts). For this reason it is desirable to raise the signals in order to obtain a better range of dynamics and tone differential.

Most electronic organs use only a single swell shoe which controls the volume of all outputs simultaneously. In order to use a system wherein each bus output can be controlled by individual swell shoes, it is necessary to have a mixing system. Should the individual swell shoe system not be used, however, manual controls will provide an easy means of varying the balance among

the three signal buses that may be employed in the organ.

The preamp can use type 12AU7A and 12AT7 tubes or CBS types 7025 and 7247. For this organ application, two 7025's and one 7247 proved most practical. Due to the varying levels of signals and the desirability of a heavy pedal sound, the final preamp-mixer uses 7025's for the swell and great buses and a 7247 for the pedal bus. The 7247

permits high gain in all stages but will accept a much higher signal level without overload distortion than will the 7025. With full gain, the 7025 sections will overload at about 400 microvolts. The 7247 will not overload until the signal level approaches 30 millivolts.

Use of a filtered, full-wave bridge, direct-current heater voltage supply and careful shielding gives a hum and noise output (with inputs grounded) of

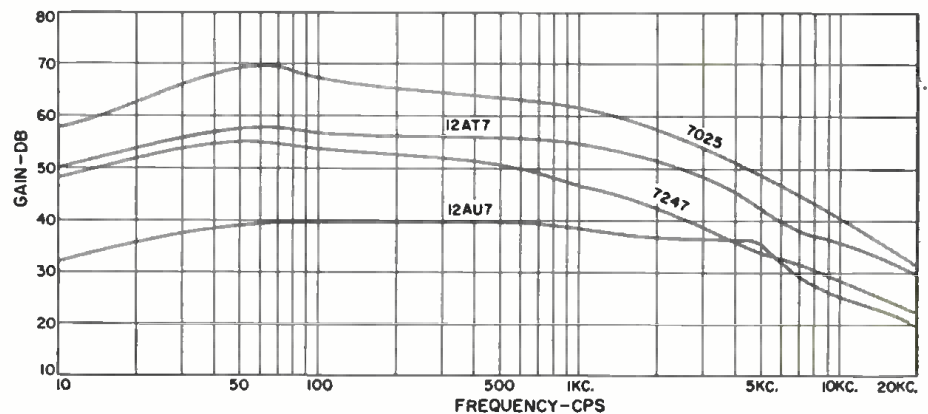
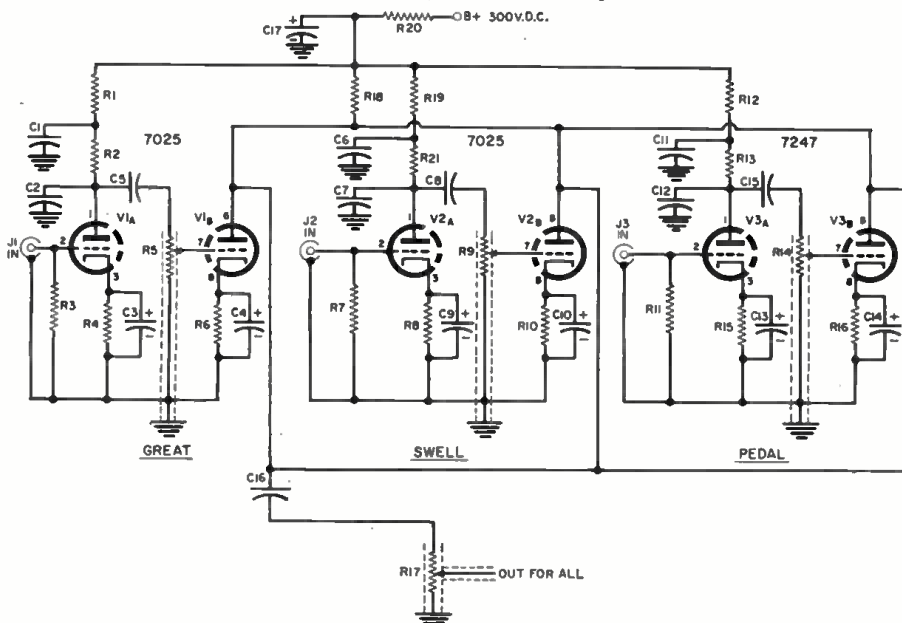

Fig. 2. Frequency response for recommended tubes as well as for some substitutes.

Fig. 1. The pedal channel has a somewhat better low-frequency response and handles somewhat greater signal amplitudes than the great and swell channels.



R₁, R₁₂, R₁₆, R₁₇—100,000 ohm, 1 w. res.
 R₃, R₁₃, R₁₄—270,000 ohm, 1 w. res.
 R₅, R₇, R₁₁—2.2 megohm, 1/2 w. res.
 R₄, R₆, R₁₅—3300 ohm, 1 w. res.
 R₈, R₉, R₁₀—250,000 ohm pot.
 R₂, R₁₀, R₁₄—4700 ohm, 1 w. res.
 R₁—500,000 ohm pot.
 R₂₀—10,000 ohm, 1 w. res.
 C₁, C₈, C₁₁—.25 μf., 600 v. capacitor

C₂, C₇, C₁₅—.005 μf., 400 v. capacitor
 C₃, C₉, C₁₂—25 μf., 25 v. elec. capacitor
 C₄, C₁₀, C₁₃—10 μf., 25 v. elec. capacitor
 C₅, C₆—.03 μf., 400 v. capacitor
 C₁₄, C₁₅—.1 μf., 400 v. capacitor
 C₁₇—20 μf., 450 v. elec. capacitor
 J₁, J₂, J₃—RCA-type phono jack
 V₁, V₂—7025 tube (CBS)
 V₃—7247 tube (CBS)

only about 2 millivolts. Frequency response is shown in Fig. 2. Curves are drawn for the tubes recommended previously as well as for some substitutes. These curves are for the great and swell sections only; the pedal section has slightly better low-frequency response than shown.

It will be noted that the frequency response is down at the higher frequencies. This is due to the use of the .005-μf. capacitors at the plates of the input sections of the tubes. However, for this application the frequency drop-off is desirable in order to reduce key-click noise and pickup noise from the stop-switch assembly and other wiring. It does not adversely affect the tone qualities. Without the bypass capacitors the frequency response will be improved, but will still drop off in the 20,000-cps region.

If other tubes are used, there is a trading of lower gain for the ability to accept a higher signal level without distortion.

The circuit diagram and parts list for the preamp-mixer is shown in Fig. 1. Construction is straightforward and not critical as to layout. A 5" x 6" x 2" chassis with closed bottom is used. RCA-type phono jacks are used for all signal-carrying inputs and outputs and controls. Externally shielded wire is used. [30]

Finding Filter Faults

By KENNETH BRAMHAM

When an output filter fails, an important bypass to ground is lost. Effects may not be obvious.

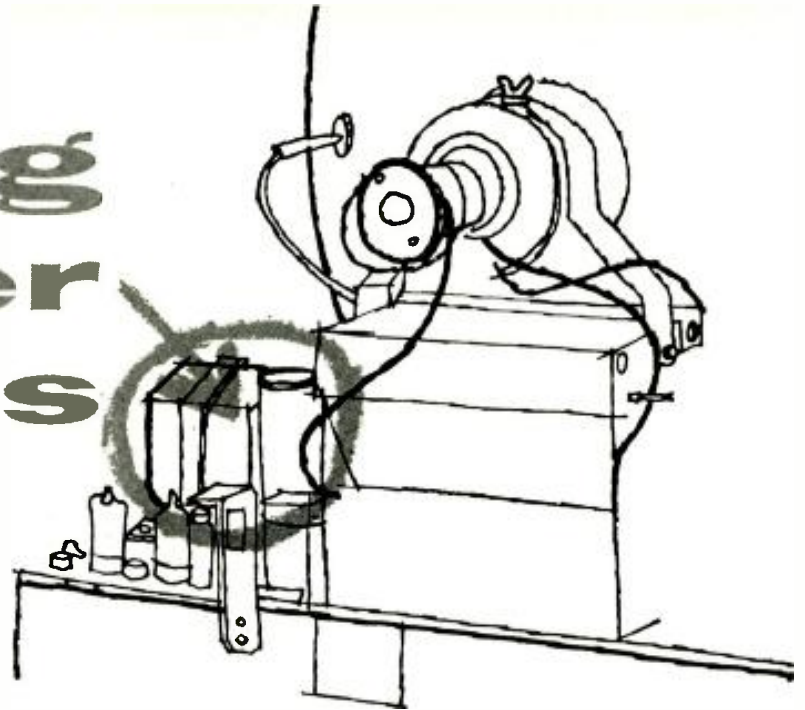

ONE OF THE FIRST radio or television troubles we learn to recognize is the open filter capacitor. The familiar 60-cycle (or 120-cycle) buzz from the speaker, unaffected by the volume control setting, or the single band of dark shading across the TV screen immediately rings a bell labelled, "filter capacitor" in the mind of the service technician. There are, however, many other symptoms caused by defective filter capacitors which, due to the complexity of supply circuits in the modern TV receiver, are not always so easy to recognize.

Before discussing the less obvious effects, a brief discussion of filter circuits is in order. Referring to the power-supply circuit of Fig. 1B, we see the standard filter network used in most transformer-type TV sets, better-quality radios, and high-fidelity amplifiers. In some circuits the filter choke is replaced by a resistor, but this does not alter the basic principle.

The waveforms at different points in the power supply circuit in Fig. 1 illustrate the effect of the filter components on the fluctuating d.c. For example, the waveform of the rectified a.c. is shown, in Fig. 1A, to be a series of positive-going parts of the a.c. input sine wave. When a large-value filter capacitor is added to the circuit (C_1 in Fig. 1B), the output waveform becomes approximately a saw-tooth riding on d.c., which is still too uneven to power a TV receiver although the actual voltage does not now fall to zero at any time.

Adding choke CH_1 increases the d.c. component still further and reduces the saw-tooth component of the voltage to a slight ripple. Finally when capacitor C_2 is added, it virtually removes the last traces of ripple. It would appear that this second filter capacitor has very little effect on the circuit. While this may indeed be true as far as the 60- or 120-cycle supply filtering is concerned, C_2 serves the very important purpose of filtering out other a.c. components generated by the various stages of the receiver circuit.

Each part of the receiver circuit produces or processes some a.c. or varying d.c. component and, unless each stage is very effectively isolated, this component is fed back into the "B+" line to become part of the supply voltage to all other stages in the receiver. In the circuit of Fig. 3A, different parts of a TV receiver are represented as a.c. generators coupled to a common supply. A single "generator" may represent, for example, a horizontal oscillator, a front-end oscillator, or the screen connection of a pentode amplifier.

The frequencies generated by these various circuits cover a range from the lowest video and audio signal frequencies to the front-end v.h.f. signal, but bypass networks in the tuner and i.f. circuits limit the highest frequencies impressed on the "B+" line to those developed in the video circuit. The resultant voltage on the supply line is the sum of the d.c. supply plus the output of all other generators combined, as shown in Fig. 3A. When a filter capacitor is added across the supply (Fig. 3B), the output of all the generators is effectively shorted to ground at that point. Of course, as far as the d.c. supply is concerned there is no short; but a well-filtered supply must have sufficient capacitance to provide a very low impedance to ground (virtually a short circuit) to even the lowest a.c.

frequency generated in the circuit. The second filter capacitor, C_2 shown in Fig. 1B provides this short-circuited path.

In most TV receivers, the supply circuit is not as simple as the circuit shown in Fig. 1. It is common practice to utilize at least two supply voltages, say 300 and 150 volts, and these circuits, being isolated from each other to some extent, must be separately filtered. Often an additional circuit is used for the video-amplifier tube screen and yet another for the audio-output tube screen. These again must be filtered to provide a low-impedance path for a.c. signals to ground. In Fig. 2, a simplified "B+" circuit for a typical TV set is shown and, by considering the frequencies generated in each circuit branch, we can estimate what is likely to happen if any of the filter capacitors should become "open" or low in value. (In the event of a shorted filter capacitor, the most likely result will be a burned resistor or fuse.)

In the 300-volt branch, we have the horizontal oscillator and output stages, part of the sync circuit, and the vertical oscillator stage. If the filter capacitor in this branch becomes ineffective, feedback among these stages will result. The output from the horizontal-output tube may feed back to the horizontal oscillator and make these two circuits self-oscillating at a frequency different from the required 15,750 cps. The sync circuit may then be unable to pull this new oscillator into line, and the result will be either a raster that is way off frequency or no raster (if the frequency is so far off that the flyback action will not occur and the high voltage drops below the level needed to light the screen).

Alternately, it may be the vertical oscillator frequency that feeds back into the sync circuit and causes a loss of vertical sync. At the same time any distortion of the horizontal-output waveform is likely (besides reducing the high voltage) to upset the a.g.c. gating pulse and create overloading

Fig. 1. Rectifier output (A) is pulsating d.c. C_1 , C_2 , and CH_1 smooth it (B), but C_2 also has another function.

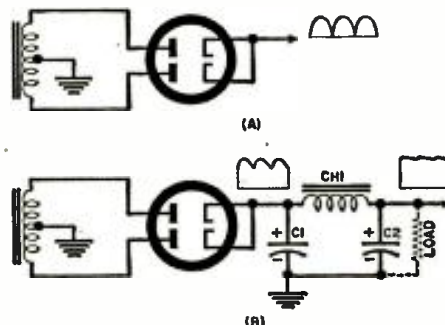

conditions varying with signal strength. Thus the loss of a filter capacitor can have results indicating troubles in the tuner, i.f. stages, video circuit, high-voltage circuits, or even the audio stages. Such a possibility must be considered before extensive work is done on the circuits mentioned.

The 150-volt branch of the supply circuit is usually less subtle in its behavior although it is often complicated by the audio-output tube being used as a voltage-dividing resistor, with the 150-volt supply taken from its cathode. As the predominating a.c. impressed on this branch will be at audio frequencies with the highest-amplitude signals in the lower audio range, the most common effect of an open filter capacitor will be sound bars in the picture, as all amplifier stages from the first i.f. to the picture tube are modulated by the audio signal. Side effects may also be present due to other feedback loops, but the most obvious effect demanding attention will be sound bars.

The main supply branches are those carrying 300 and 150 volts, but the other supply circuits, sometimes handling only one "generator," can produce some strange effects. The audio-output screen, for example, will feed back to the plate of the tube itself if its filter capacitor becomes open; the result is an audible, often very loud

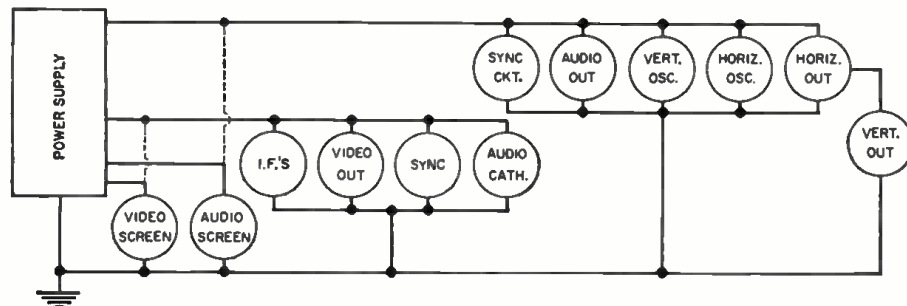

Fig. 2. The d.c. "branches" in the power supply of a typical TV receiver.

whistle from the speaker. Similarly, the video amplifier may break into oscillation, but with less obvious results. As the audio i.f. and sync signals are fed from the video-output tube in many receivers, this oscillation may result in some very unusual sync conditions and picture break-up accompanied by distorted audio, or possibly a high-pitched whistle from the speaker, or even from the horizontal-output components.

The "B" boost line can be considered as a branch of the supply system where the "generator" is used to supply an added voltage. In this case, only a small-value filter capacitor (.1 μ f.) is used to remove the high-frequency component, but additional filtering with large-value electrolytics is used when this boosted voltage must supply the vertical-output stage. In this case, the filter is used to maintain the required voltage for the high-current 60-cycle pulses taken by the vertical circuit. A failure in this capacitor will usually be pretty obvious: there just isn't sufficient vertical sweep.

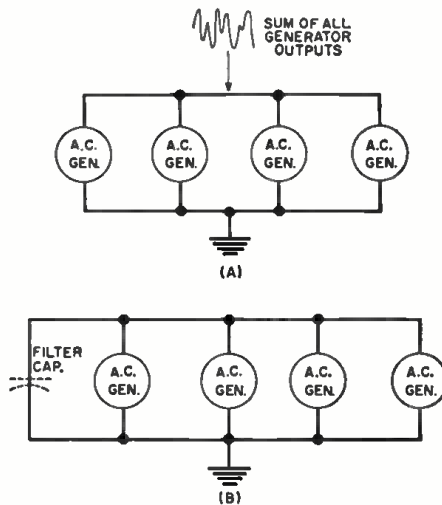

Fig. 3. Circuits sharing the same power supply (A) produce a combined a.c. signal, bypassed by output filter (B).

Treating the supply circuit as a number of individually filtered branches in this way, we are able to predict the effect of filter capacitor failure; or, starting with an effect, make a pretty good guess at the possible cause, especially if we are able to isolate the cause to a particular branch.

There is, however, another possible condition resulting from the use of multiple filter capacitors. One multiple

"can" may contain as many as four capacitor sections filtering four different branches of the circuit, and they may be treated, for most purposes, as four separate capacitors. Unfortunately they do have one thing in common; the ground connection. If this connection becomes open, (either outside or inside the container), we have a condition not only where none of the branches of the supply circuit are filtered but, as far as a.c. is concerned, all four branches are connected together.

Bridging any single capacitor of the four to ground with a good capacitor will not correct the strange feedback effects completely, and may lead to a series of time-consuming checks and substitutes that are not needed to correct the trouble. The only reliable method of tracing this kind of condition, and the fastest way of finding any bad filter capacitor, is with a scope.

While on the subject of multiple capacitors, we might as well discuss the problem of replacement. If one capaci-

tor out of four is bad, should we change the entire unit or simply add a single capacitor? This usually comes down to the cost or availability factor but, as a general rule, if it is possible to get the correct manufacturer's replacement, it should be installed. The added expense is usually small compared to the chance of having to replace a second, third, or even fourth capacitor within a short time.

Now to return to the power-supply filter capacitors, shown in Fig. 1B and, for a voltage-doubler circuit, in Fig. 4. The basic function of these units is to provide a steady d.c. voltage, and the output voltage is determined, to a great extent, by the value of the capacitors. A reduction in capacitance will result in a reduced output voltage with reduced width, brightness, and sensitivity, and increased hum or buzz as the most likely symptoms. The only way to restore the set to correct working condition is to replace the defective capacitor with the correct type, checking both capacitance and working voltage.

Often there is the tendency to use a "close" substitute—often this is not close enough. Too small a value will give a reduced voltage, too large a value will, especially in the voltage-doubler shown in Fig. 4, where semiconductor rectifiers are used, place too great a load on the rectifiers during the initial surge when the set is switched on. This may cause other, additional trouble. As for correct voltage ratings, the best cure for any tendency to treat this lightly is to have an electrolytic capacitor "blow up" and then have to clean up the results.

The connections on a multiple capacitor unit are often used as tie-points for several leads, so that replacing a unit can be quite a chore. Here is an easy way: cut each tab away from the capacitor, leaving all the leads intact on the tabs. Twist off the mounting tabs with a strong pair of pliers, after removing any solder with a heavy iron or solder gun, and remove the unit. When installing the replacement, the mounting tabs are securely twisted (at least one should also be soldered) and the old tabs with leads intact are soldered to the new tabs—not tacked, but well soldered to make a joint mechanically capable of supporting the leads.

A defective filter capacitor can be the easiest fault to locate, or it can be one of the most elusive. By remembering the concept of individually filtered branches in a single supply, service time and profit can be saved, to say nothing of the prestige of the technician doing the job. [30]

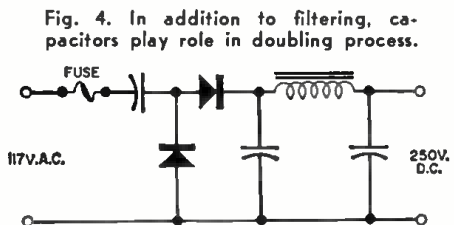
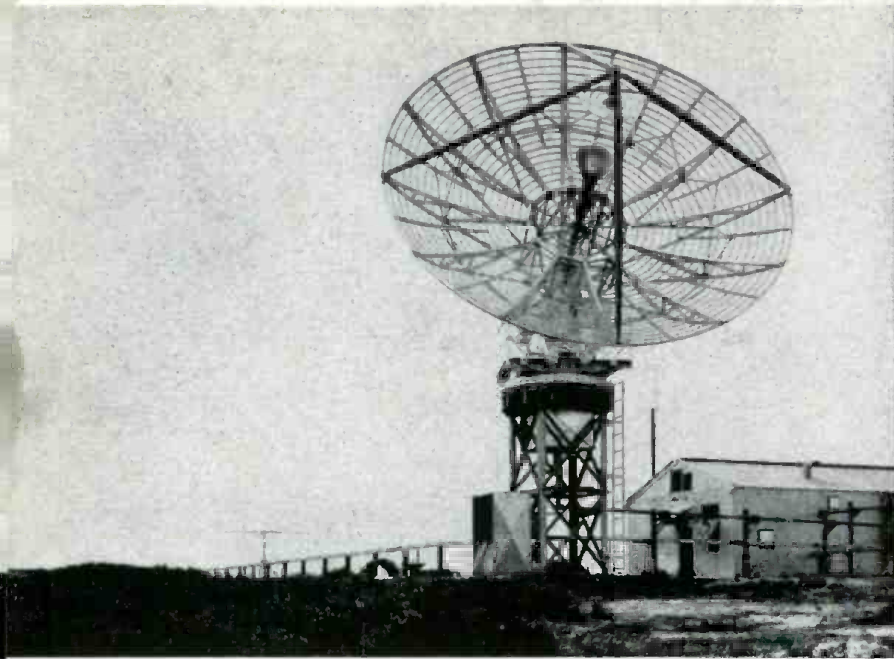

Fig. 4. In addition to filtering, capacitors play role in doubling process.



◀ Space-Tracking Station

Designed and constructed by *Collins Radio Co.*, this space-tracking and communication station near Cedar Rapids, Iowa, took part in one of the U.S.'s major space communication experiments—Project Echo. The company and its system's subsidiary at Richardson, Texas, successfully established communication by bouncing radio signals off a metalized plastic balloon orbiting in space around the earth. The balloon-satellite was launched by NASA at Cape Canaveral. *Bell Telephone Laboratory* scientists also used the balloon many times during its flight to establish communications between New Jersey and California and between New Jersey and England.

Recent Developments in Electronics

▶ Weatherproof Electroluminescent Light

The engineer at the right is submerging an electroluminescent panel in a tank of water to test the brightness of the glow under extreme weather conditions. The flat, glare-free light panels have low power consumption and long life. *RCA's* plant in Lancaster, Pa., is manufacturing the units in five colors for illuminating highway signs, signals, safety devices, and dials on home appliances.

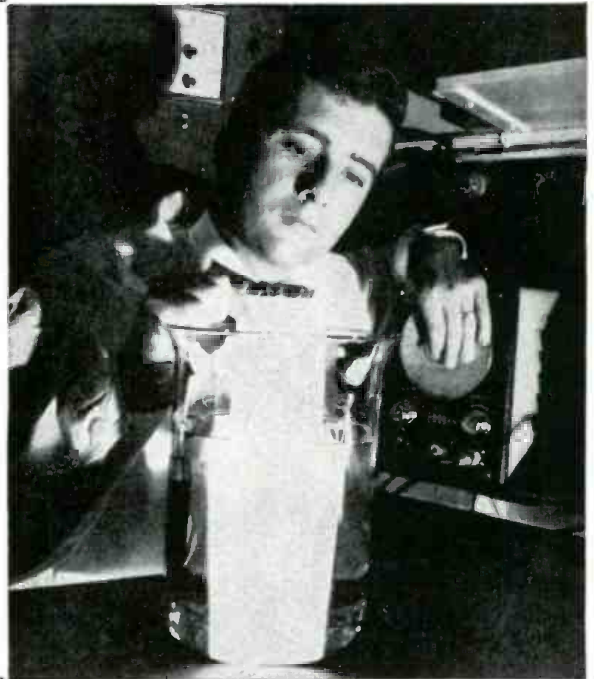

◀ Radio-Controlled Lawn Mower

This electronically guided lawn mower, developed in the research laboratories of Chicago's *DeVry Technical Institute*, has rounded the far turn and is heading into the home stretch. After it has automatically cut the lawn, it can put itself away in a garage or other storage space. The mower is an experimental model developed as an educational project. In operation a wire probe on the front of the mower picks up electric impulses from a number of buried wires. These signals are then applied through a transistor amplifier to the mower's drive and directional assembly.



◀ Automatic Machine Tools

Bringing automation within the reach of the small machine-shop operator is made possible with this new numerical machine tool control system unveiled by *Minneapolis-Honeywell*. The new system is designed to control any three-axis machine used in turning, milling, punching, drilling, slotting, or routing. Punched paper tape is used to give orders to the machine under control.

Electronic Language Laboratory

An advanced training aid for the effective teaching of foreign languages is shown at the right. Each student uses an individual booth which is interconnected with the teacher's console. Magnetic tape is used to provide much more aural and oral instruction than is possible with traditional classroom, grammar-translation methods. This language laboratory was recently introduced by *Bernco Inc.*

1000-foot Radio Telescope

Artist's concept of astronomical radio telescope to be located at Arecibo, Puerto Rico, shows giant 1000-foot reflector and suspended movable line feed assembly. Construction is under the general direction of Air Force Cambridge Research Laboratory with Cornell University serving as major contractor. The fixed reflector design avoids structural difficulties encountered in supporting large movable dishes within rigid tolerances. The transmitter to be used with the giant dish, to be built by *Levinthal Electronic Products*, will produce a peak power of 2½ megawatts at 430 mc.



Giant Electronically Controlled Organ

Mr. L. W. Sprinkle, Sr., fills the Caverns of Luray, Va., with music as he plays the cavern organ that derives musical tones directly from cavern's stalactites. Small steel rods are bolted through the stalactites, close to tiny electromagnets. When the electronically controlled hammer strikes a stalactite, the combination becomes a tone generator.

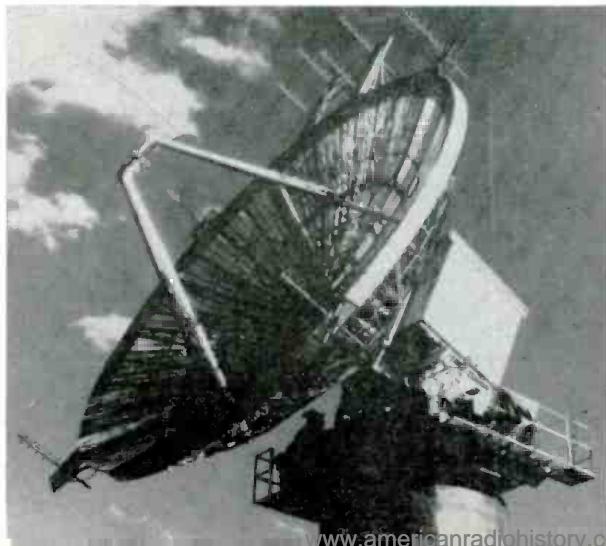

Satellite-Tracking Antenna

U.S.A.F.'s Rome Air Development Center has installed a North-South communications link between Trinidad and Rome, New York. An antenna for the *Philco*-designed system is shown at the left. The installation is one of the global passive satellite communications links using the Project Echo balloon launched from Cape Canaveral. In addition to serving as communications link, the Trinidad site tracked the original launch and orbits of the satellite with a powerful radar set.

Dual 14-Watt Stereo Amplifier

By
ROBERT M. VOSS

Construction of a medium power hi-fi amplifier with common cathode bias for improved power regulation.

EDITOR'S NOTE: The exact method of measuring music power is still subject to some disagreement. This author has gone ahead and used his own ideas on how this measurement should be taken and has indicated the results so obtained. Until more specific instructions are included in the standards that have set up the music-power rating, the method described here appears to be a reasonable way to make this measurement.

STEREO power amplifiers, to many people merely two monophonic amplifiers on a single chassis with a common power supply, are really a great deal more. It is the purpose of this article to describe a simple, easy-to-build stereophonic amplifier and use it as an example of the application of certain techniques which enable the

audio designer to achieve both better amplifier performance and economy of construction.

Let us first consider the common power supply. Assume an output stage which at zero signal draws 50 ma. and at the clipping point 100 ma. With a monophonic amplifier, remembering that the output stage provides most of the load, the maximum output current is 200% of the zero signal. This will lead to a considerable drop in the "B+" voltage, causing a loss of power output and, in some cases, instability due to shifting supply voltages to the earlier stages.

With the equivalent stereo amplifier, the difference between both amplifiers

idling and one clipping is the difference between 100 ma. and 150 ma., a much easier load change for the power supply to handle. While it is true that both amplifiers may overload simultaneously, it must be remembered that the difference between 10 watts and 5 watts is only 3 db and that with any significant amount of stereo separation there is bound to be considerable electrical difference between the signals received by the two amplifiers.

The second matter which must be considered is the bias source for the output stage. In a self-bias class AB₁ amplifier stage (the most common type), the voltage drop across the cathode resistor will increase in proportion to the current drawn by the stage. As this happens, the effective bias increases and a new operating point is established. Although the use of a large capacitor bypassing the cathode resistor will slow this shift, permitting the amplifier to follow short transients, the capacitor will not prevent the ultimate operating-point shift and its consequent reduction of power output. (This is one reason for the great difference between music-power and continuous sine-wave power ratings of some amplifiers.) If a single resistor (of, of course, half the ohmage and twice the power rating) is used for two output stages, a regulating element similar to that in the power supply will have been introduced. The schematics of Fig. 1 will clarify this point.

The Circuit

Fig. 3 is the schematic diagram of a dual 14-watt stereo amplifier which incorporates the ideas just promulgated. The use of KT61's is rather rare in high-fidelity circuits; however in "Ultra-Linear" operation they produce extremely small amounts of distortion,

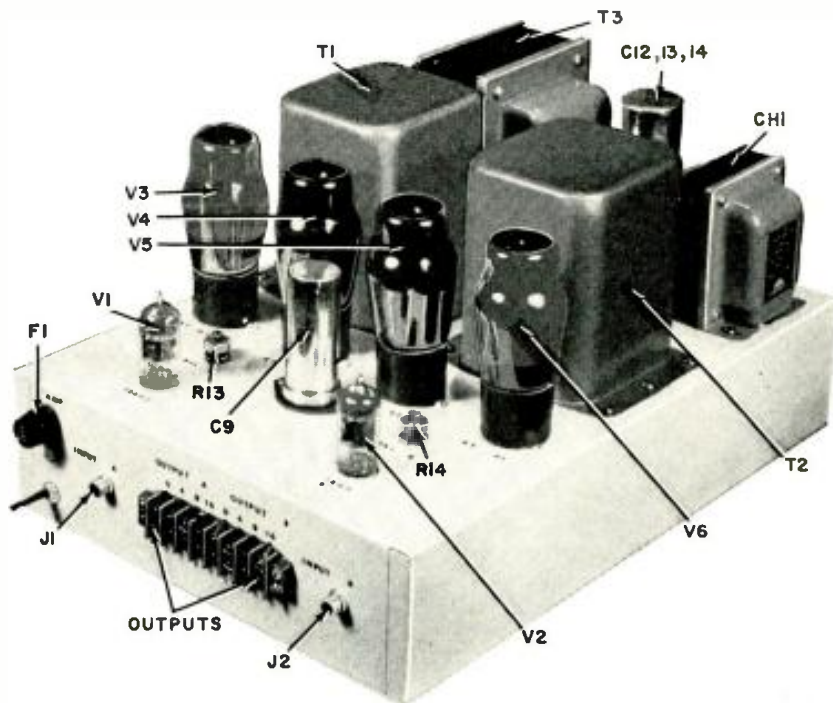

Note the symmetrical arrangement used. Channel A is on left side of chassis while channel B is on the right side. Power-supply components are at the rear.

Under-chassis view. Note the use of Vector-type sockets for low-level stages.

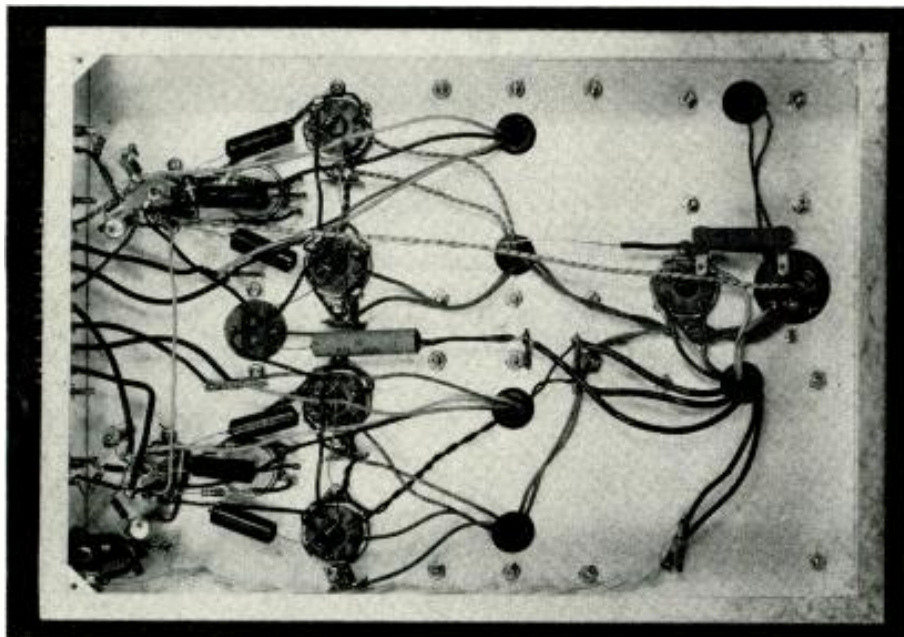

require very meager grid signals, and show a comparatively small difference between zero and maximum-signal total plate and screen current. In all of these respects, the KT61's are superior to the more common 6V6's.

The remainder of the circuit is conventional. It is, basically, Acro's recommended circuit for its TO-310 transformer. One change has been incorporated—instead of feeding the lower phase inverter grids from the junction of two resistors, balance controls have been provided to permit the constructor to trim for equal voltages at the KT61 grids or (preferably) for lowest intermodulation distortion.

Construction

Some of the construction practices followed by the author may be worthy of mention. The power supply is separated from the input jacks (see photos) to keep hum to a minimum. Separate ground buses are used for each amplifier, with the power supply grounded to one of them. Chassis connections are, according to standard practice, made only at the input jacks. The heater winding center-tap is connected to the output tube cathodes to eliminate the possibility of heater-cathode breakthrough in the 12AX7's. The resulting hum and noise level is more than 100 db below rated power with grounded inputs. The use

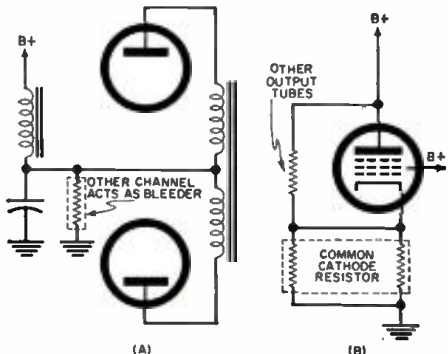

Fig. 1. (A) Power-supply regulation and (B) bias stabilization principles.

Fig. 2. Setup employed by author to take the music-power measurements.

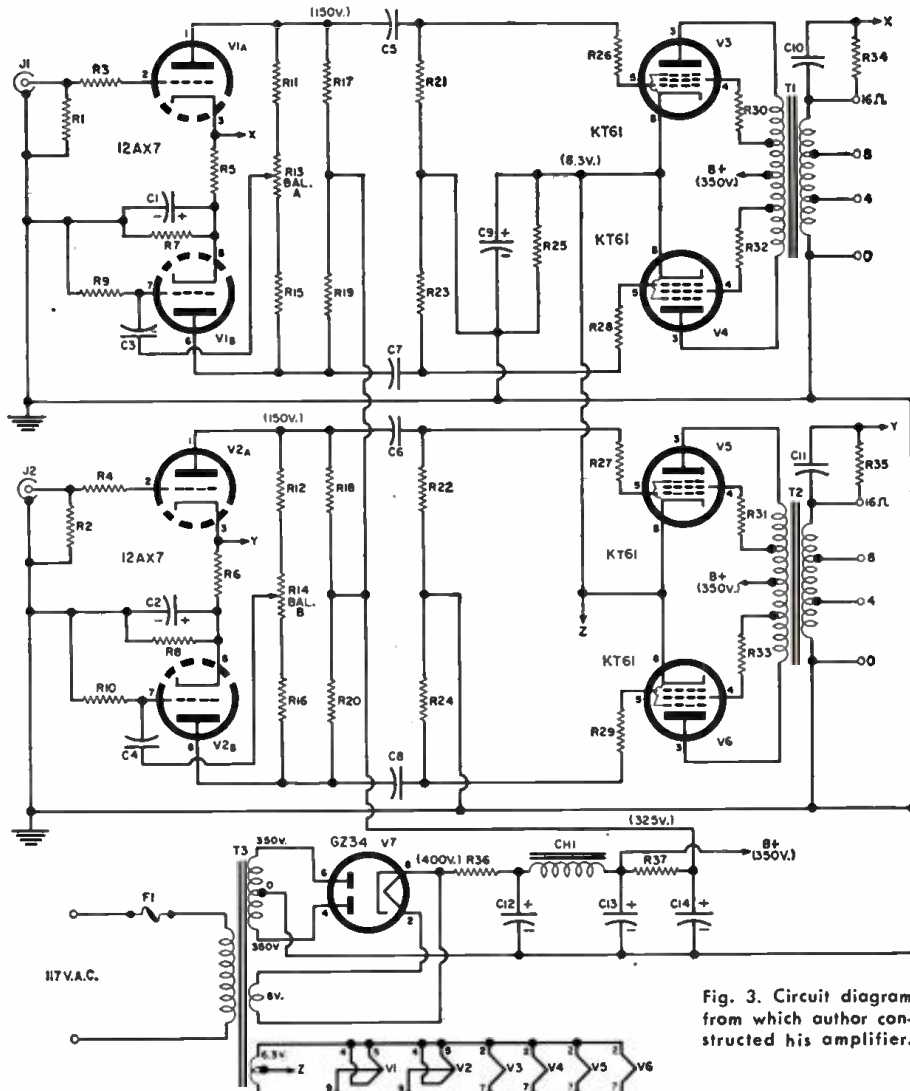
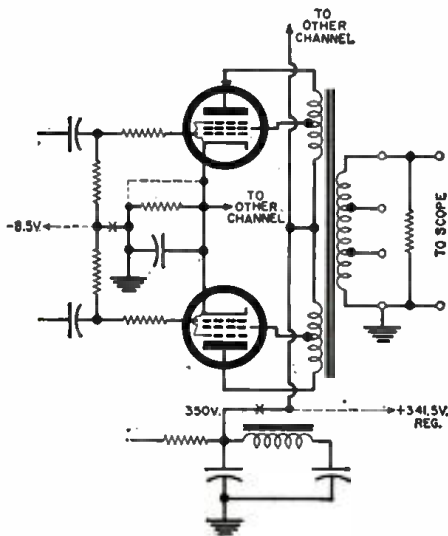

Fig. 3. Circuit diagram from which author constructed his amplifier.

- R₁, R₂, R₃, R₄, R₁₀, R₂₁, R₂₂, R₂₃, R₂₄—470,000 ohm, ½ w. res.
- R₅, R₆—10,000 ohm, ½ w. res.
- R₇, R₈, R₉—56 ohm, ½ w. res.
- R₁₁, R₁₂, R₁₃, R₁₄—1000 ohm, ½ w. res.
- R₁₅, R₁₆, R₁₇, R₁₈—240,000 ohm, ½ w. res.
- R₁₉, R₂₀—500,000 ohm locking pot.
- R₂₅, R₂₆, R₂₇, R₂₈—150,000 ohm, 1 w. res.
- R₂₉—50 ohm, 10 w. wirewound res.
- R₃₀, R₃₁, R₃₂, R₃₃—22,000 ohm, ½ w. res.
- R₃₄, R₃₅, R₃₆—100 ohm, ½ w. res.
- R₃₇—200 ohm, 10 w. wirewound res.
- R₃₈—4700 ohm, 1 w. res.
- C₁, C₂—250 µf., 6 v. miniature elec. capacitor
- C₃, C₄, C₅, C₆, C₇, C₈—.05 µf., 400 v. capacitor

- C₉—1000 µf., 15 v. elec. capacitor
- C₁₀, C₁₁—.001 µf., 400 v. capacitor
- C₁₂, C₁₃, C₁₄—10/40/40 µf., 450 v. elec. capacitor
- F₁—2 amp. 3A G fuse
- J₁, J₂—Phono jack
- CH—6 hy., 200 ma. filter choke (Triad C14-A)
- T₁, T₂—Output trans. 3000 ohms push-pull to 4, 8, 16 ohms, 20 watts (Acrosound TO-310 or equiv.)
- T₃—Power trans. 350-0-350 v. @ 200 ma.; 6.3 v. c.t. @ 8 amps.; 5 v. @ 3 amps. (Triad R20-A or equiv.)
- V₁, V₂—12AX7 tube
- V₃, V₄, V₅, V₆—KT61 tube (matched pairs)
- V₇—GZ 34 tube

of screen as well as control-grid damping resistors is rare in American amplifiers; however, since the power they consume is virtually unmeasurable and since the KT61's have unusually high transconductance, it is wise to include them.

Performance

Crosstalk is -65 decibels, which is far better than the best program sources currently available. It could, however, be improved by the use of a Mumetal shield running down the center of the chassis from the input end to the far side of the output transformers.

The rated power is shown in the graph of Fig. 4. The fact that there is only a small difference between the combined output and twice the individual channel output is due to the excel-

lent inherent regulation of the output stage. The music-power rating is about 14 watts (individual) and 28 watts (combined).

The music-power rating was calculated as follows: A power supply of virtually perfect regulation over the required current range was adjusted to deliver exactly 341.5 volts (350 minus 8.5) to the center-tap of the output transformers, replacing the self-contained power supply. With the output cathodes grounded, the grid resistors were removed from ground and connected to a fixed bias supply of -8.5 volts. The output waveform was then watched for signs of clipping, which started at the equivalent of 14 watts for each channel or 28 watts for the two in parallel. See Fig. 2.

(Continued on page 132)

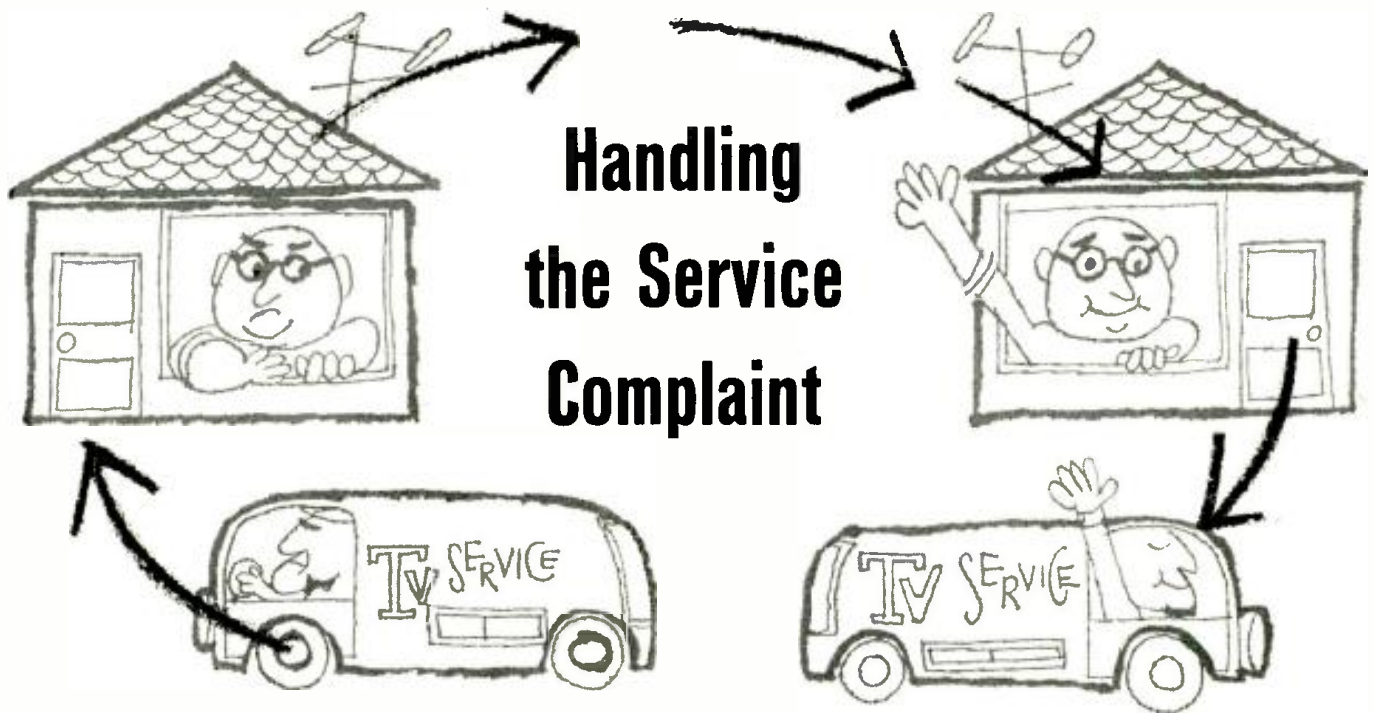

Handling the Service Complaint

By **MAX ALTH**
Herold Radio Corp.

How to cope with call-backs and other touchy cases without losing either your customer or your shirt.

EDITOR'S NOTE: Although his present position does not directly involve him with service, the author's experience in this direction is considerable. It includes several years as a technician with a large radio-TV sales-and-service chain; time with an agency that handled work on a contract basis for sales-only outlets; and experience as an independent, service-shop owner. Thus he can see the key problem of customer relations from more than one angle.

FOR THE TYPE of operation that survives by selling as much merchandise as possible—the “shlock” house—there is little concern when the customer complains after a sale has been made. Service calls are farmed out and forgotten. Ill will is part of the business, and is offset simply by spending more money for scream advertising to bring in new customers.

The straight service organization or the one founded on sales and service cannot afford to take that attitude. Keeping a customer, based on retaining his good will, is important. If you are in service and you are beginning to think that the job of preserving and improving your business reputation is getting to be a bit old-fashioned, check your records. You may find that as much as eighty per-cent of your service calls comes from old customers and word-of-mouth advertising.

Effective service advertising is difficult and relatively expensive. In sales you can get action by offering a set at half price. In service, if you should offer repairs at half price, you will just get a few more calls than you normally receive. No matter what bargains are available, customers have their sets repaired only when those repairs are needed. Service advertising is therefore a year-round rather than a one-shot operation and the calls picked up per dollar of advertising are comparatively few. Thus the most economical way to build up good volume is to keep a cus-

tomers; and this means retaining his good will at almost any cost.

Fortunately this good will is less dependent on financial expenditure than on psychology. The old saw stating that a drop of honey draws more flies than vinegar still cuts true and clean. It can be applied to the three key steps into which the procedure for complaint-handling may be divided: listening, deciding, and acting. Notice, please, that no mention at all is made of the legitimacy (or even the rationality) of the complaint. Whether the customer's first contact with you is over the telephone or following his entrance into your shop, the *first* thing you must do is *listen*.

Yes, listen. Whoever is likely to deal with the customer initially in your operation must be made to understand this fully. The customer must have his or her full say, all the way to the possibly bitter and boring end. There are no short cuts. The process of complaining is the customer's only release. It is an emotional compensation for dissatisfaction with the equipment that has betrayed him and possibly for any other unpleasantness that has occurred during the day.

If you are in a generous mood, commiserate with him. If not, simply hold your tongue. That is not always easy to do. However any customer will eventually reach the point where he has had his full say and, if you have done nothing more than keep quiet, you are ready to chalk up a victory in most cases. Whether the customer is right or wrong has little to do with the matter.

The relationship is most critical in the case of a call-back. A certain percentage of these will be valid. For reasons that are generally beyond your control, the equipment has ceased to

function properly not too long after you have worked on it.

Another percentage of calls stems from the desire of the equipment owner, conscious or unconscious, either to dump the equipment or make the company that sold it “rue the day.” The size of this group will depend on the method of operation used in the original sale.

To illustrate this point, we refer to a period when we handled contract service for a furniture-sales outfit that used to sell radios on “time.” They disposed of odd models and models that were two years old, often charging 50 percent over list price—but they gave credit at a time when credit was a dirty word. Since there was nothing basically wrong with the equipment, a particular set would work fine—until the owner learned that he had overpaid. Then the fun would begin. Since he was already bound to a signed contract, all he could do was complain in the hope of either getting his money back or a new model.

The complainants were lying—but we never permitted them to realize that we knew their stories were make believe. Instead we patiently went over their complaints again and again. On the average, it took about two calls for each one to realize that he was simply punishing an innocent bystander for his own failure to buy wisely and to put an end to his efforts.

The customer's reaction in one case we remember makes an interesting point. He met us at his door with a written list of twelve troubles. We went over it patiently, one item at a time. In those days, a short-wave band on home receivers was in vogue. A sample complaint was the fact that he couldn't get Rome any time he wished. When we were leaving, his comment was, “Well,

(Continued on page 133)

New Techniques

of Frequency Measurement

By ED BUKSTEIN / Author, "Digital Counters and Computers"

Highly accurate methods of measuring frequency with digital devices are widely used in industry. Here's how they work.

THE art of frequency measurement has progressed a long way since the days of the absorption wavemeter. Prompted by industry's demands for more accuracy, electronic engineers have developed new instruments and techniques for frequency measurement—achieving a degree of accuracy that would have been considered amazing a few years ago and highly improbable a generation back. The need for a more accurate means of measuring frequency has increased proportionately as more highly complex equipment and systems have come into being. Today, the target-seeking accuracy of a missile and the reliability of telemetering apparatus might well depend upon the availability of adequate frequency-measuring instruments.

To eliminate inaccuracies of dial resolution, backlash in controls, and human reading-errors, many modern instruments employ digital read-out—as simple to read as the mileage indicator of an automobile. Not only are these instruments easier to read, but they are faster. Simply feed the unknown frequency into a front-panel jack, and read the frequency as displayed by numbered indicator lights on the panel of the instrument.

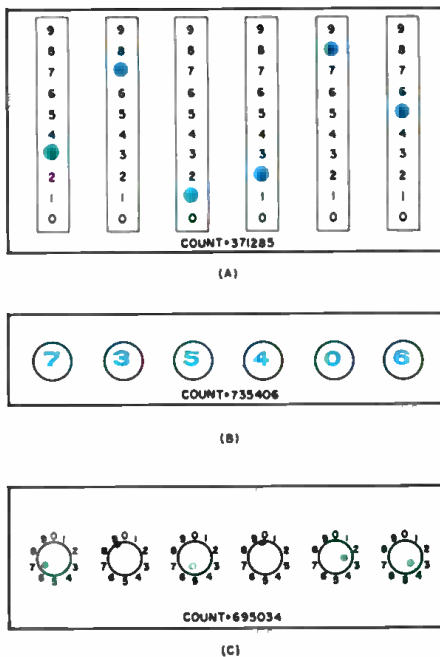

Fig. 2. Display lamps of decade counters may be numbered neon lamps (A) Burroughs "Nixie" tubes (B), or glow-transfer counting tubes (C). These are three very common methods that may be employed to indicate a count directly.

As illustrated in Fig. 1, the unknown frequency is applied to a squaring and pulse-shaping circuit. The resulting pulses, still at the frequency of the unknown, are now applied to a gate circuit. The gate is so designed that the input pulses cannot pass through until a *start* pulse is applied. The gate then opens and allows the input pulses to feed through until, at some time later, a *stop* pulse is applied. The pulses that pass through the gate circuit, during the time the gate is open, are applied to decade counters (see "Basic Decade Counters," ELECTRONICS WORLD, August 1958) where the pulse count is displayed by front-panel indicator lamps. If the *stop* pulse is applied exactly one second after the *start* pulse, the gate will remain open for one second and the decade indicator lights will display the value of the unknown frequency in cycles per second.

Fig. 2 illustrates various types of indicators used in frequency-measuring instruments. In Fig. 2A, the small (1/25 watt) neon lamps are numbered from 0 through 9. The unknown frequency is determined by reading the numbers of the glowing neon lamps. Fig. 2B illustrates the use of Burroughs "Nixie" indicators. This indicator is a

Fig. 1. Unknown frequency is measured by opening gate circuit for a period of one second. The frequency is then indicated by means of lights in the decade counters. This block diagram illustrates the basic principle of frequency measurement by means of digital devices in which the frequency is indicated directly by a digital count.

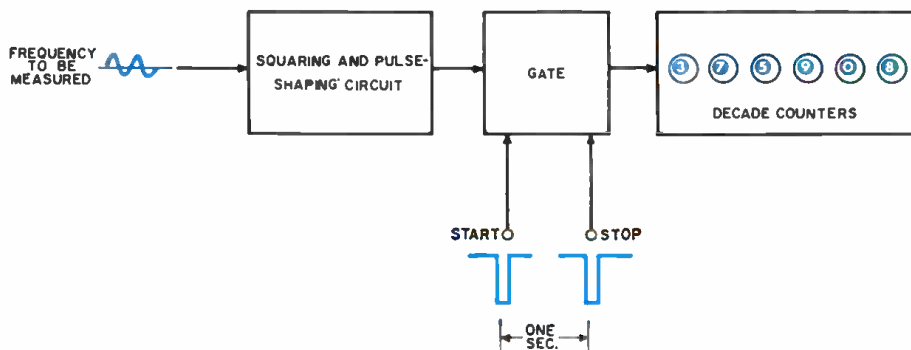
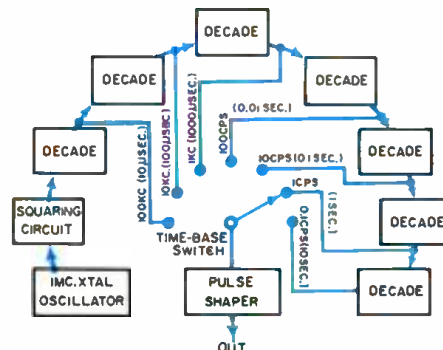

Fig. 3. Start and stop pulses are derived from crystal-controlled oscillator. Frequency dividers produce pulses at intervals of 10, 100, and 1000 microsec., and .01, .1, 1, and 10 seconds.



neon bulb having ten cathodes and one anode. The cathodes are lengths of wire bent into the shapes of the numerals 0, 1, 2, 3, etc. When voltage is applied between the anode and one of the cathodes, the characteristic orange glow of ionized neon surrounds the cathode wire in the form of a numeral. Some frequency-measuring instruments employ an optical read-out device in which images of the numerals are projected on a ground-glass screen.

Fig. 2C illustrates the use of the glow-transfer counting tube. This is a gas-filled tube having ten pin-shaped cathodes arranged in a circle around a central anode. As input pulses are applied to the tube, ionization transfers around the circle from cathode to cathode. The position of the ionization glow therefore indicates the pulse count. As shown in Fig. 2C, the glow-transfer tubes are panel-mounted and the cathode positions are numbered on the panel.

The accuracy of the frequency measuring technique illustrated in Fig. 1 is limited by the accuracy of the time-spacing between the start and stop

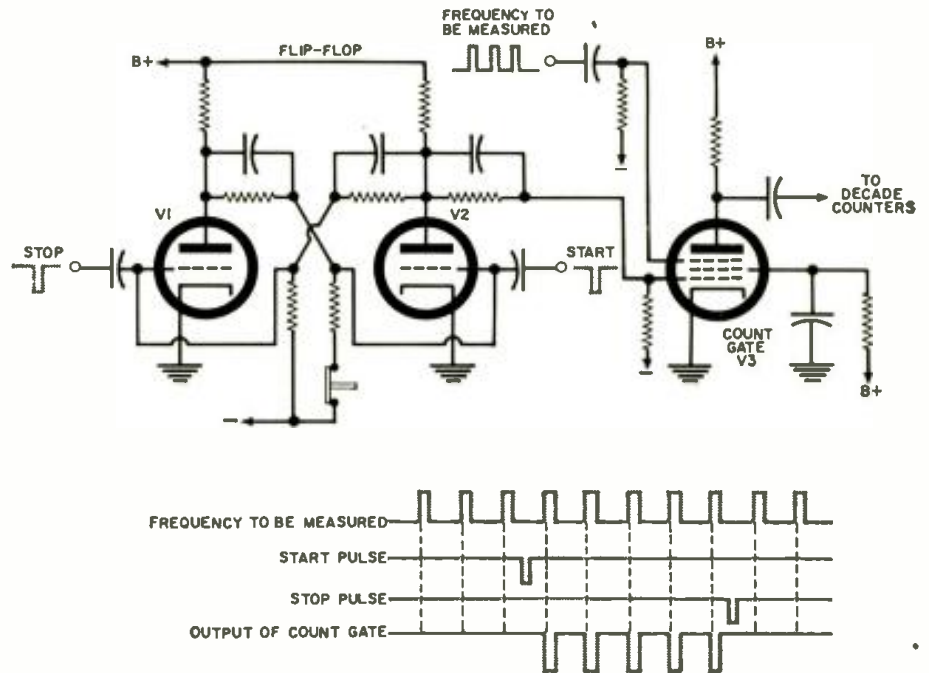
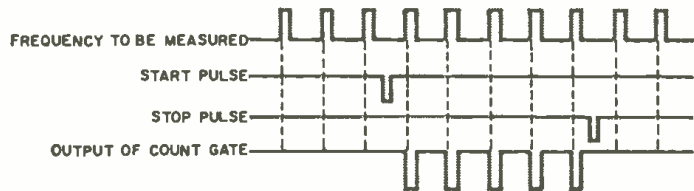

Fig. 5. Pulses applied to suppressor of count gate produce output only during interval when V_2 is below cut-off. Gate is open only during time between start and stop pulses.



Beckman/Berkeley counter features in-line read-out. Numerals are formed by optical projection of selected line segments.



This Computer-Measurements Co. instrument is used for pulse-counting, frequency measurement. Six-decade read-out is used.

pulses. If this spacing is more than one second, the indicated frequency will be too high. If the stop pulse occurs too soon, the indicated frequency will be low. A temperature-stabilized crystal is therefore used to generate the start and stop pulses. As shown in Fig. 3, the one-megacycle output of the crystal oscillator is applied to a number of cascaded decades (ten-to-one frequency dividers). These decades provide submultiple frequencies of 100 kc., 10 kc., 1 kc.,

Fig. 4. Seven-digit measurement can be performed on a 6-digit counter by first using 1-sec. time base (A), and then 10-sec. time base (B). The frequency indicated here is 481,635.9 cps.

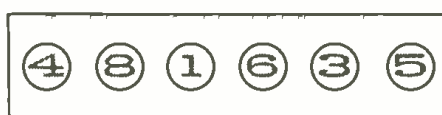

(A)



(B)

100 cps, 10 cps, 1 cps, and 0.1 cps. Any one of these frequencies can be selected by means of the time-base switch and applied to a pulse-shaping circuit. In this way, pulses occurring at intervals of 10, 100, or 1000 microseconds, or 0.01, 0.1, 1, or 10 seconds can be obtained for use as start and stop pulses.

The time-base selector is usually set for a one second counting interval, but other values are used occasionally. The ten-second time base, for example, may be used to obtain an additional digit in the frequency reading. This technique is illustrated in Fig. 4. The frequency measurement is first performed using a one-second time base, and the frequency is determined to a number of digits depending upon the capacity of the counter (six digits in Fig. 4A). The frequency measurement is now repeated using a ten-second time base. Since the gate now remains open ten times as long, ten times as many pulses are applied to the counter. This number of pulses exceeds the capacity of the counter and the highest-order digit overflows. This is of no consequence because the value of this digit has already been determined by using the

one-second time base. As shown in Fig. 4B, this technique permits a seven-digit measurement on a six-digit counter. The measurement may be extended to an eighth digit by using a 100-second time base, but this further increases the time required to perform the measurement.

Most instruments designed for frequency-measuring applications are equipped with a built-in time-delay circuit that periodically (1) clears the counter to 000000 and (2) allows another pair of start and stop pulses to repeat the measurement. Such periodic measurement reveals any drift that may be occurring in the frequency being measured.

A representative gate circuit is shown in Fig. 5. Gate tube V_3 has two input grids both of which are biased below cut-off. A mixer-type tube may be used in this application or, as shown in Fig. 5, a pentode may be used with the suppressor functioning as a second control grid. Positive pulses derived from the unknown frequency are applied to the suppressor, but V_3 produces no output because its control grid is still below cut-off.

The flip-flop is a direct-coupled (bi-stable) multivibrator biased sufficiently to prevent free-running operation. Initially, V_1 is below cut-off and V_2 is conducting. This condition is established by means of a push-button switch that removes the bias from V_2 . When a start pulse is applied however, V_2 is driven to cut-off and its increased plate voltage raises the grid of V_1 above the cut-off level. The circuit will now remain in this condition, V_1 conducting and V_2 below cut-off, until a stop pulse is applied. The stop pulse cuts off V_1 , and the increased plate voltage of this tube raises the grid of V_2 above cut-off. Since V_2 remains below cut-off during the interval between the start and stop pulses, its plate voltage remains high for this length of time. During this interval the plate of V_2 holds the control grid of V_1 above cut-off. As a result, each positive pulse at the suppressor produces an output pulse in the plate circuit of V_1 . As shown in Fig. 5, V_1 produces output pulses only during the interval that exists between the start pulse and the stop pulse.

Since the time-base generator produces a continuous series of pulses, additional circuitry is required to (1) select a pair of successive pulses to provide the start and stop functions and (2) to feed the selected start and stop pulses to the appropriate terminals of the circuit in Fig. 5. These functions are performed by the circuit shown in Fig. 6.

The lock-out binary of Fig. 6 controls the two pentode gate tubes so that one gate is open and the other is closed. Initially, the right-hand tube of the binary is conducting and the left-hand tube is below cut-off. This condition is established by means of the push-button switch which removes the bias from the right-hand grid (this is the same push-button that controls the flip-flop of Fig. 5). At this time, the start gate is open and the stop gate is closed. Since the left-hand tube of the lock-out binary is below cut-off, its plate voltage is high

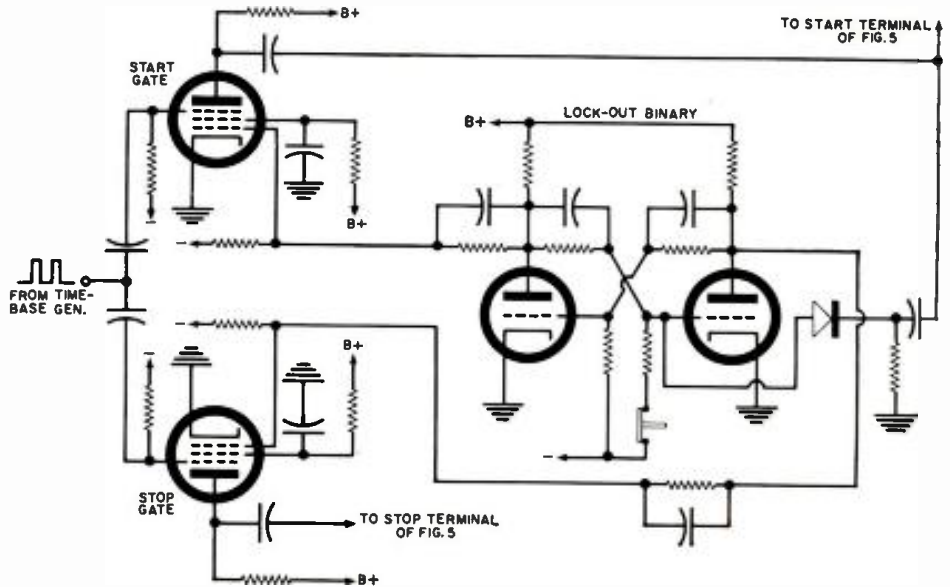

Fig. 6. Lock-out binary is initially set so that start gate is open and stop gate is closed. Output of start gate reverses binary, and next pulse passes through stop gate.

and the control grid of the start gate is above cut-off. The start gate is therefore open. Because the right-hand tube of the binary is conducting, its plate voltage is low and the control grid of the stop gate is below cut-off. The stop gate is therefore closed under these conditions.

When the push-button of Fig. 6 is released, the next positive pulse from the time-base generator passes through the start gate but not through the stop gate. The negative pulse that appears in the plate circuit of the start gate is applied to the start terminal of Fig. 5, opening the count gate and allowing the unknown frequency to feed through to the counting decades. In addition, the negative pulse from the start gate is applied to the right-hand tube of the lock-out binary. As a result, the right tube cuts off and the left tube conducts. The start gate is now closed and the stop gate is open. For this reason the next pulse from the time-base generator

passes through the stop gate but not through the start gate. The negative pulse that appears in the plate circuit of the stop gate is applied to the stop terminal of Fig. 5. The count gate now closes so that the unknown frequency can no longer feed through to the decade counters, and the decade indicator lamps now display the frequency being measured. The circuit remains in this condition, start gate closed and stop gate open, until manually reset by means of the push-button or automatically by a time-delay relay in the instrument.

Period Measurement

Two factors limit the accuracy of the frequency measurement: the stability of the crystal in the time-base circuit and the random occurrence of the start (and stop) pulse with respect to the pulses derived from the unknown frequency. The first of these sources of

(Continued on page 116)

Hewlett-Packard decade counter with 10-lamp read-out. Numbers are illuminated in succession as input pulses are applied to the decade.

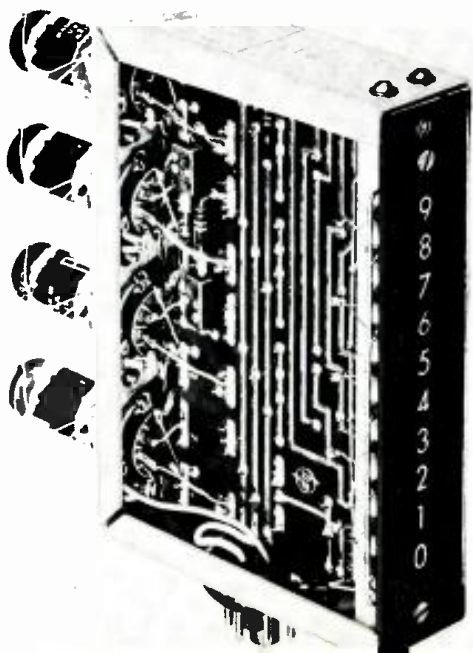

One-megacycle counter-timer made by Transistor Specialties is completely transistorized and features 6-digit in-line "Nixie" read-out.



WHY

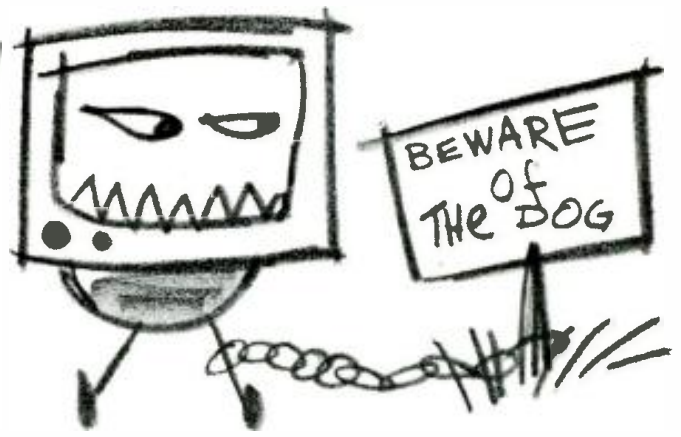

“Dogs” Are Tough

By **DARWELL H. WEBSTER**
 Electronics Instructor
 Southern Technical Electronics School
 Tampa, Fla.

Is your lack of basic circuit “know-how” turning comparatively tame service jobs into real “dogs”?

WHAT makes a defect a tough dog? Take any problem in radio or TV servicing that is a tough dog for one technician, and you are bound to find other bench men who could have handled it as a routine repair. A variation in troubleshooting technique is enough to account for the difference in difficulty. This, in turn, is likely to depend on how well a technician understands and remembers basic theory and how successful he is in applying it consistently (see “Troubleshoot with Basic Theory,” *ELECTRONICS WORLD*, October, 1960). There are few better ways to illustrate this point than with actual “dogs” that have come the author’s way from service shops.

Transistor Set Motorboats

After checking all decoupling capacitors and resistors in the transistor portable in question, the technician sought help on this “hopeless” case. After a couple of hours of searching, the discovery was made—with much embarrassment, because it was not thought of sooner—that one of the flashlight-type dry cells used to power the radio had a higher-than-normal internal resistance. This provided the feedback path responsible for the motorboating.

What is the reasoning behind this? Theoretically speaking, the causes of motorboating have to do with the differences in application and operation between the alternating (signal) volt-

ages and currents in the equipment, on the one hand, and the direct voltages and currents. Between “B+” and ground or “B-”, it is desirable to have a high impedance to d.c. and a low impedance to a.c. The d.c. is present only to enable the circuits to function. The a.c. is normally the signal desired to provide some sort of output that will do some work; for example, it may drive a speaker, a deflection coil, or a picture tube. To do this work properly, the a.c. signal must be coupled efficiently from one stage to another where desired, but the “B+” side of each plate (or collector) load must be at a.c. ground.

If several stages use a common source of “B+”, the variations of loading in the power supply by each stage will create undesired coupling (feedback) from high-level to low-level

stages, and motorboating results. This is the reason that most competent technicians replace output filter capacitors in line-operated equipment at the first sign of motorboating, such as C_1 in Fig. 1.

To keep circuit interaction to a minimum, additional filtering of the “B+” to individual circuits is also used. This is accomplished by decoupling capacitors (those other than C_1 in Fig. 1) and resistors. The capacitor itself can only couple and decouple voltage variations. The resistor is inserted between the circuit and “B+” in such a way that it will develop a voltage proportional to current variations in the circuit. This enables the capacitor to do its job of keeping the voltage at the “B+” side of the plate load constant against all types of variation. Thus all variations

(Continued on page 122)

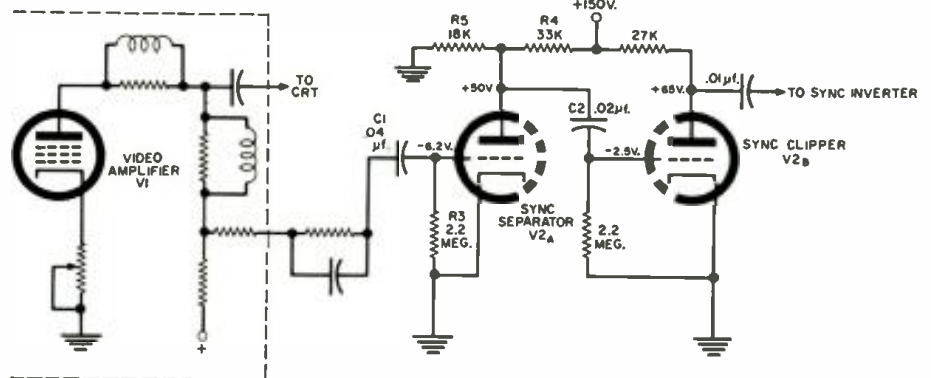

Fig. 2. An open coupling capacitor, C_1 , resulted in a “no sync” report.

Fig. 1. Block diagram of transistor set on which complaint was motorboating.

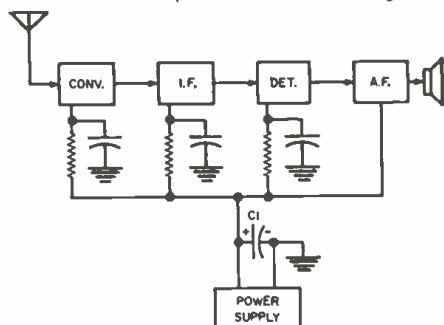
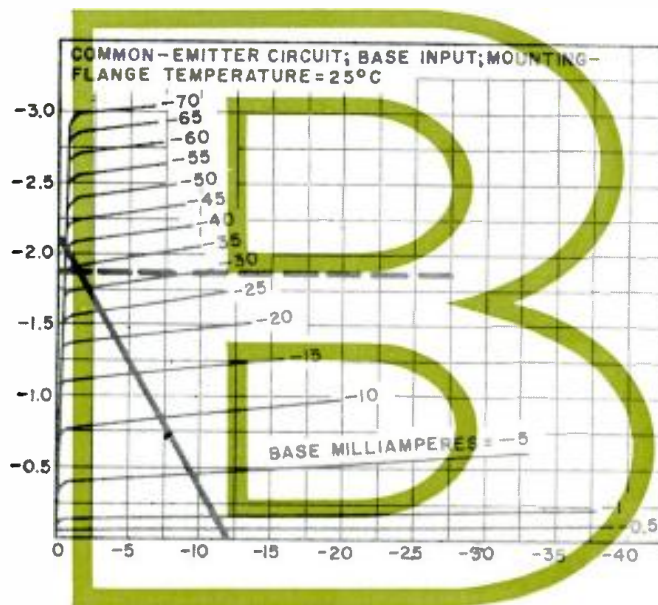

Table 1. Possible combinations of voltage readings most likely to cause trouble in the TV circuit, Fig. 2.

	E_g Low	E_g High	E_g Normal	E_g Near Zero
E_p Low	Insufficient signal. input or C_1 leaking.	C_2 leaking.	C_2 leaking.	No input signal (C_1 open).
E_p High	Tube (V_{2A}) has low emission.	Excessive signal and R_3 open.	R_3 open.	Tube (V_{2A}) has low emission.
E_p Normal	Low Emission in V_{2A} & C_1 leaking or C_2 shorted.	Excessive signal and R_3 increased in value.		Low emission in V_{2A} & C_1 leaking.
E_p Near Zero		R_4 open.		

Push-Pull Class



Transistor Power-Output Circuits

By **WALTER H. BUCHSBAUM** / Industrial Consultant, *ELECTRONICS WORLD*

Simple design procedure that will help to understand this very useful and popular transistorized circuitry.

TRANSISTOR audio amplifiers have many advantages over their vacuum-tube counterparts, but one circuit that really highlights these advantages is the Class B push-pull power amplifier. The great efficiency and simplicity of transistors really shine in this application. With no filament power required and a relatively low "B+" voltage, the power drain during quiet periods is negligible and the over-all circuit efficiency extremely high. These are certainly very desirable features.

Another attraction is the price of germanium power transistors which compares favorably with vacuum tubes. In this article a typical 8-watt amplifier design, which uses transistors costing about \$3.00 each, will be illustrated. The same design procedure can be used for amplifiers at other power levels and for different transistor types. Those readers who are more concerned with troubleshooting transistor audio amplifiers will find the material helpful in understanding the sources of the most frequent defects they are apt to find in transistor circuits.

Class B operation means that each transistor will amplify only one-half of the signal and will "rest" while its mate amplifies the opposite-polarity portion of the signal. Because power dissipation is one of the most critical factors in transistors, Class B operation is particularly suited to the task of insuring

low dissipation for each transistor. There are only two drawbacks to this type of transistor circuit: crossover distortion and thermal runaway. These will be discussed below.

Crossover distortion occurs when one transistor stops conducting before the other has started and is a typical problem with all Class B circuits. Thermal runaway can occur in any transistor application but power transistors are especially susceptible. This trouble is due to the fact that, as a transistor heats up, it will tend to draw more current which, in turn, will cause the collector to heat up even more until the unit burns out. There are well-established and relatively simple cures for both crossover distortion and thermal runaway and they will be described here in some detail. Let us first consider the characteristic curves.

Most of our readers will be somewhat familiar with the characteristic curves used in vacuum-tube circuit design. Similar curves are furnished by transistor manufacturers and are used in the same manner. In last month's article on Class A transistor power-output circuits we described some of the special aspects of transistor characteristic curves, a discussion which will not be repeated here. Instead, we will concentrate on the design of a typical amplifier and point out how crossover distortion, thermal runaway, and some

of the minor problems can be handled.

Amplifier Design Procedure

In any power amplifier design the governing factors will be the desired power output, available voltage, and component efficiency. Assuming that we wish to be able to deliver 8 watts to the loudspeaker, we must first account for the losses in the output transformer, which may be about 80 percent efficient. This immediately brings the actual maximum power that the two transistors must deliver up to about 10 watts. If we want to allow for 25 percent overload capacity, the power is increased to 12.5 watts or 6.25 watts per transistor. A typical supply voltage would be 12 volts which would permit operating the equipment direct from an automobile battery or two 6-volt lantern batteries. It would also be possible to build a well regulated supply, using a standard 12.6-volt filament transformer as power source.

Once the power and the voltage are determined, we can select a transistor type. It must be able to handle at least 6.25 watts and must have a collector-to-emitter voltage rating of at least twice the supply voltage, which means 24 volts. For our example we have selected the 2N301 which is made by *RCA, Bendix, Sylvania, and CBS*, and is readily available at parts distributors. This transistor is rated at 40 volts

collector potential and can dissipate 11 watts at 80°C which means about 25 watts at room temperature. These ratings are higher than our minimum requirements but they afford us a much needed margin of safety.

To get an idea of what the peak-current swing per stage can be, we can calculate:

$$6.25 \text{ watts} \times \frac{4}{12 \text{ volts}} = 2.1 \text{ amps.}$$

The manufacturers' data shows that the 2N301 can handle up to 3 amps. peak current. To get the load resistance per stage we divide the 12-volt supply voltage by the 2.1 amp. peak current and this is roughly 6 ohms. One of the characteristics of Class B push-pull circuits is the fact that the total primary impedance of the output transformer is four times the load resistance per stage or 24 ohms in our example.

At this point it is useful to study the characteristic curves of the transistor in question. Fig. 1 shows the collector characteristics for the 2N301 for various values of base current. The a.c. load line for the 6-ohm load resistance is drawn by connecting the 12-volt, zero-current point to the 2.1-amp., zero-voltage point. To calculate maximum power handling ability we have accounted for 25 per-cent overload capacity, but for normal operation the current and voltage swing will be limited by a factor:

$$k = \sqrt{\frac{1}{1.25}} = 0.896$$

Therefore, the normal full-load current swing will be only 2.1 amp. \times 0.896 = 1.88 amp., as shown by the dotted line in Fig. 1. Another curve, Fig. 2, shows the average transfer characteristic which is simply a plot of collector current vs base voltage. For 1.88 amps. of collector current, the base voltage will have to be 0.78 volt and this, on the base characteristic curve of Fig. 3, will cause a base current of 34 ma. The product of 34 ma. \times 0.78 volt is the input power, 26.5 mw.

The input impedance per transistor can be found by Ohm's Law from 0.78 volt divided by 34 ma., or 23 ohms. We can now draw a basic diagram of the Class B amplifier with its input and output requirements, as shown in Fig. 4. This simple circuit will, however, suffer from the disadvantages inherent in Class B transistor amplifiers. If we drive this amplifier with a sine-wave signal of maximum amplitude, 0.78 volt peak at the base of each stage, then the output signal at the loudspeaker will have the waveform of Fig. 5A, which shows the typical symptoms of crossover distortion.

Crossover Distortion

Fig. 5 illustrates one of the most frequent defects in Class B transistor amplifiers and the technician working with these circuits will soon become quite familiar with the appearance of these distorted output signals. To understand the cause for crossover distortion we need only look at the average transfer characteristic curve of Fig. 2 and study the lower portion of the

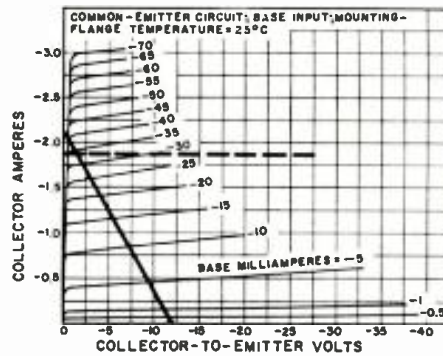

Fig. 1. Collector characteristics of 2N301.

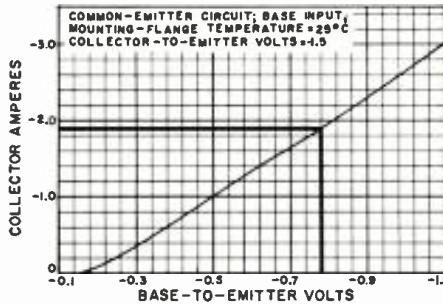

Fig. 2. Transfer characteristics of 2N301.

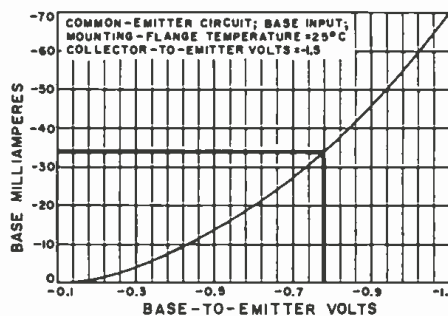

Fig. 3. Base characteristics of the 2N301.

curve below 0.2 volt of base bias. Here the curve flattens out and stops completely at 0.13 volt. This means that from about zero to 0.13 volt of base signal, no current flows in the collector circuit. When the base signal is very small the collector signal will take the form of the curve of Fig. 5B, with current flowing only during that portion of the sine wave which corresponds to more than 0.13 volt of base voltage. Since the two push-pull transistors have the same characteristics, the distortion will be balanced about the zero line of the sine-wave signal.

To overcome this trouble it will be necessary to pre-bias each transistor slightly. In effect, for small signals, the transistors then operate as Class A amplifiers. This method can completely eliminate crossover distortion but it means that each transistor draws some current at all times and this reduces the efficiency of the Class B stages. In a good design, the pre-bias voltage is set carefully to minimize the quiescent collector current.

Returning to the design of Fig. 4, we can see two places where a pre-bias might be inserted. We could insert an additional battery between ground and the two emitters or, and this is the simpler approach, we can utilize a por-

tion of the 12-volt collector supply to bleed a small negative voltage to the two bases. This will cause a loss in input signal due to the impedance of the biasing network. In a circuit of this type the bias resistors cannot be bypassed because the capacitor would charge up to the signal voltage level and this would increase the fixed bias too much.

The 2N301 characteristic curves of Figs. 2 and 3 indicate that a pre-bias of about -0.13 volt is required. Previously we calculated the peak input impedance to be about 23 ohms. The bias resistor should usually be about three times as large so we select a value of 68 ohms, a readily available and standard unit. By using Ohm's Law we find the current through the resistor to be 1.91 ma. At 0.13 volt the base current itself is practically zero so that only about 2 ma. will flow in the bias resistor. Because of the variations among individual transistors and other circuit constants, it is advisable to include a potentiometer in the bias voltage divider and set the actual voltage level for minimum collector current, commensurate with minimum crossover distortion.

Looking at the revised circuit of Fig. 6, we can now see that the input power of 26.5 mw. which we calculated previously will not be sufficient because the actual input impedance, per stage, is not now 23 ohms but a total of 91 ohms. The ratio between the I^2R input power for equal current is simply the ratio of 23 and 91 ohms, which is 3.95. This corresponds to approximately 6 db, the increase in input needed to overcome the effect of the pre-biasing network. The input power required to drive the circuit of Fig. 6 for peak output is, therefore, 105 mw. Accounting for transformer losses of 20 per-cent, we find that the actual peak driving power delivered by a driver amplifier to the primary of the input transformer will have to be about 135 mw.

Driving circuits for Class B power amplifiers deserve a lengthy article in themselves, but in this limited space we can only point out that Class A single-stage amplifiers or Class A push-pull circuits are usually used in this application. There are a number of circuits which avoid the use of a driving transformer and provide phase splitting and impedance matching directly. For the example cited here it would be possible to use a single-stage Class A 2N301 as driver or else a Type 2N32, 2N44, or 2N226, all suitable and readily available from jobber stocks. The prime requirement of a driver stage is power handling ability. If the reader refers to last month's article on Class A power amplifiers, all of the circuit designs can be followed except that the Class B push-pull stage input impedance must be substituted for the load on the output transformer secondary.

Thermal Runaway

One of the basic facts about semiconductor physics is the interdependence of current flow and temperature.

As the temperature goes up, more current flows. As current flows, heat is generated in the transistor. These two facts impose a severe restriction on the circuit designer, especially when germanium transistors are used where the critical temperatures are relatively close to room temperature. Silicon devices have a somewhat higher critical temperature. The transistor characteristic curves of Figs. 1, 2, and 3 all bear the notation "mounting flange temperature 25°C" and this means that at a higher or lower temperature the characteristics shown may be changed somewhat.

If a transistor were 100 per-cent efficient it would have no power loss in the transistor itself but such a device is, of course, unavailable. The 2N301, according to the published data, will dissipate 3 watts for an output of 12 watts in a Class B push-pull circuit. The 3 watts of heat must be conducted away from the transistor or else it will build up to a progressively higher temperature. If the flange temperature increases, the current through the collector increases and the amount of power which is dissipated in the transistor also increases. In other words, if the mounting arrangement of the transistor cannot dissipate 3 watts of power, the resulting temperature build-up will burn out the transistor. It is possible, by careful design, to mount each transistor so that it can easily radiate 3 watts into the surrounding air, but on a hot day the efficiency of this heat transfer will suffer because the surrounding air itself is warmer.

In last month's article on Class A power amplifiers we illustrated several techniques for mounting power transistors for maximum heat radiation. The same approach should be used for Class B push-pull circuits except that we must be careful not to allow the heat from one transistor to contribute to the other, unless the dissipation from both can be radiated readily.

In addition to the mechanical mounting methods, there are simple electronic means of preventing thermal runaway and maintaining stability with varying temperatures. The most widely used method involves base bias control by means of a temperature-sensitive resistor or "thermistor." A thermistor can either increase or decrease in resistance with temperature, but the latter type is more common. In using a thermistor to control the bias of a transistor the thermistor is mounted close to the transistor heat sink so that any heat rise in the transistor will affect the resistance of the thermistor.

Returning once again to our example of a typical Class B push-pull circuit we can see how a thermistor is used in the circuit of Fig. 7. Here the thermistor, R_T , part of the bias network and in parallel with the 210-ohm carbon resistor, provides the desired 68 ohms at 25°C. When the temperature increases to 50°C the thermistor will be only 40 ohms and this will reduce the pre-bias enough to cut the transistor collector current down to a safe value. The prin-

ciple is simply to reduce bias as temperature goes up and to do this in conformity with the transistor characteristics. If the right thermistor were used, the fixed resistance R_1 would not be required, but most commercially available thermistors are more temperature sensitive than needed and therefore a fixed shunting resistor is often used.

Transformer Considerations

Before we can build the final circuit

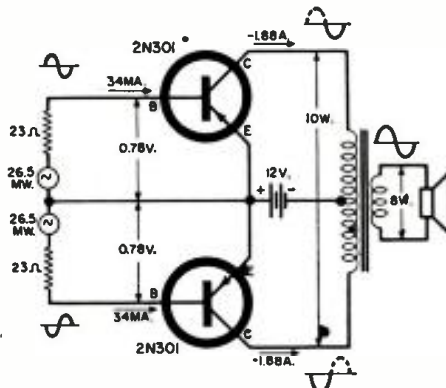

Fig. 4. Basic design of the 8-watt amplifier.

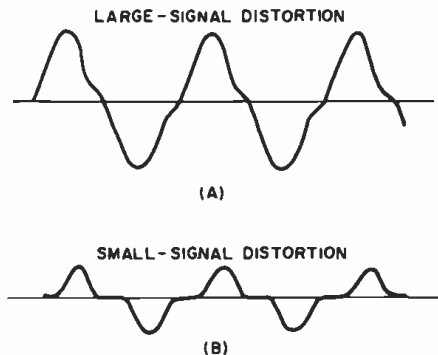

Fig. 5. The distortion due to the crossover.

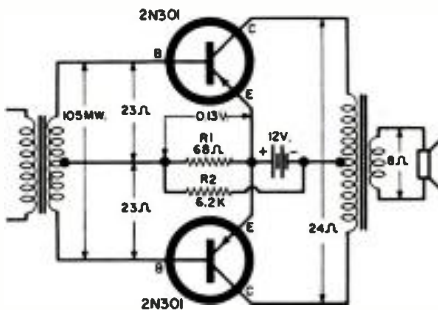

Fig. 6. Pre-bias circuit for the amplifier.

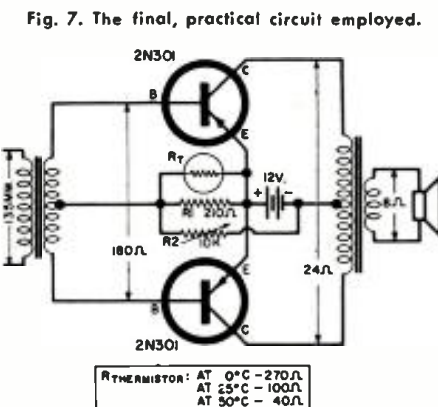

Fig. 7. The final, practical circuit employed.

of Fig. 7, we must give some thought to the two transformers. These items must be selected from available stock types and, if a perfect match is not possible, the effects of mismatch will have to be evaluated. Starting at the output stage, we immediately know that this transformer will have to be the bigger one since it must handle at least 8 watts. Actually a 10-watt unit will be the standard size. In checking through the catalogue we find that a number of manufacturers make suitable units of this type. To cite just one, consider the Triad TY-29X. It has a center-tapped primary with an impedance of 24 ohms and a secondary with either 8- or 4-ohm impedances. It can handle 10 watts of audio power. We can see that it meets our requirements exactly.

There are a number of other transformers equally suitable, such as the Stancor T-14 or Chicago TAMS-12. It may happen that in another design the calculated output impedance turns out to be a value which cannot be matched by a commercial output transformer. We can then use the nearest available transformer type or change the design of our circuit. The first method is recommended when the nearest available transformer impedance is not more than 25 per-cent higher than the transistor output impedance. Otherwise it is possible to change the output impedance by redrawing the load line. We can change either the supply voltage or the peak power and, if necessary, select a different transistor type.

When we consider the input transformer we see that, as far as the Class B amplifier is concerned, we can select only the secondary and the power ratings. In our example the input transformer must be capable of handling at least 135 mw. and must match the input impedance of 182 ohms. Actually, to minimize distortion, the source impedance should be lower than the input impedance so we should select a transformer which has less than 182 ohms secondary impedance. A good choice would be the Thordarson TR64 which has a 100-ohm center-tapped secondary and a primary impedance of 100 ohms. It can handle 0.5 watt which is ample for this circuit. Because the secondary impedance is lower, some loss in power transfer will occur here which means that the driver stage will have to deliver more than the 135 mw. previously calculated. In a conservative design the driver stage will be capable of delivering at least twice the driving power calculated for the Class B output stages.

Conclusion

Class B transistor amplifiers have the great advantage of requiring almost no quiescent power and are, therefore, very efficient. The design principles are the same as for vacuum-tube push-pull Class B circuits, except that the transistor's temperature characteristics must be taken into account. The detailed design procedure presented here requires only a knowledge of Ohm's Law, arithmetic, and an understanding of characteristics curves. [30]

WE HAD sold the amplifier kit, a well known 60-watt basic amplifier, only a few days before and we now had a pretty unhappy owner on our hands.

"This amplifier won't come even close to putting out 60 watts without terrible distortion," he said with disgust. "There must be something loused up with it!"

"How do you know it's not putting out its rated power?" we asked. "Does it sound bad or overload easily?"

"Well, no, it seems to sound pretty good. But a friend of mine came over with his IM distortion analyzer and measured it for me. About the most it would do was 40 watts, and that's a far cry from the 60 watts it's supposed to deliver."

he inquired with a skeptical glance. "Read the power on the 150-watt scale," we replied.

"But that's not showing 60 watts; that indicates only about 40 watts, just as I said!"

"True," we agreed, "but you must remember that we are not measuring a simple sine wave. We are using a complex wave consisting of two sine waves: one at a frequency of 60 cycles per second, and the other at a frequency of 7000 cycles mixed together in a voltage ratio of four-to-one respectively. With such a complex signal, the wattmeter reading must be multiplied by a factor of 1.47 to obtain the equivalent single sine-wave power."

It was apparent that we were not getting through. "Look," we said, "let's

feed a single-frequency sine wave into the amplifier and adjust the input until the wattmeter reads 60 watts." The scope showed a beautiful waveform, and the amplifier delivered 60 watts easily. "Now, notice the vertical deflection on the scope. We adjust the gain of the scope until the pattern covers ten divisions. Next we adjust the horizontal scale when we add the 7000 cycle signal which was preset to 10 divisions. With the value of the 60-cycle signal: the amplifier is obviously overloading. Next we reduce the combined input signal until the scope shows the same ten-division deflection that we saw corresponded to a power output of 60 watts. Then we are still driving the amplifier to its maximum peak-power output, but because we are no longer

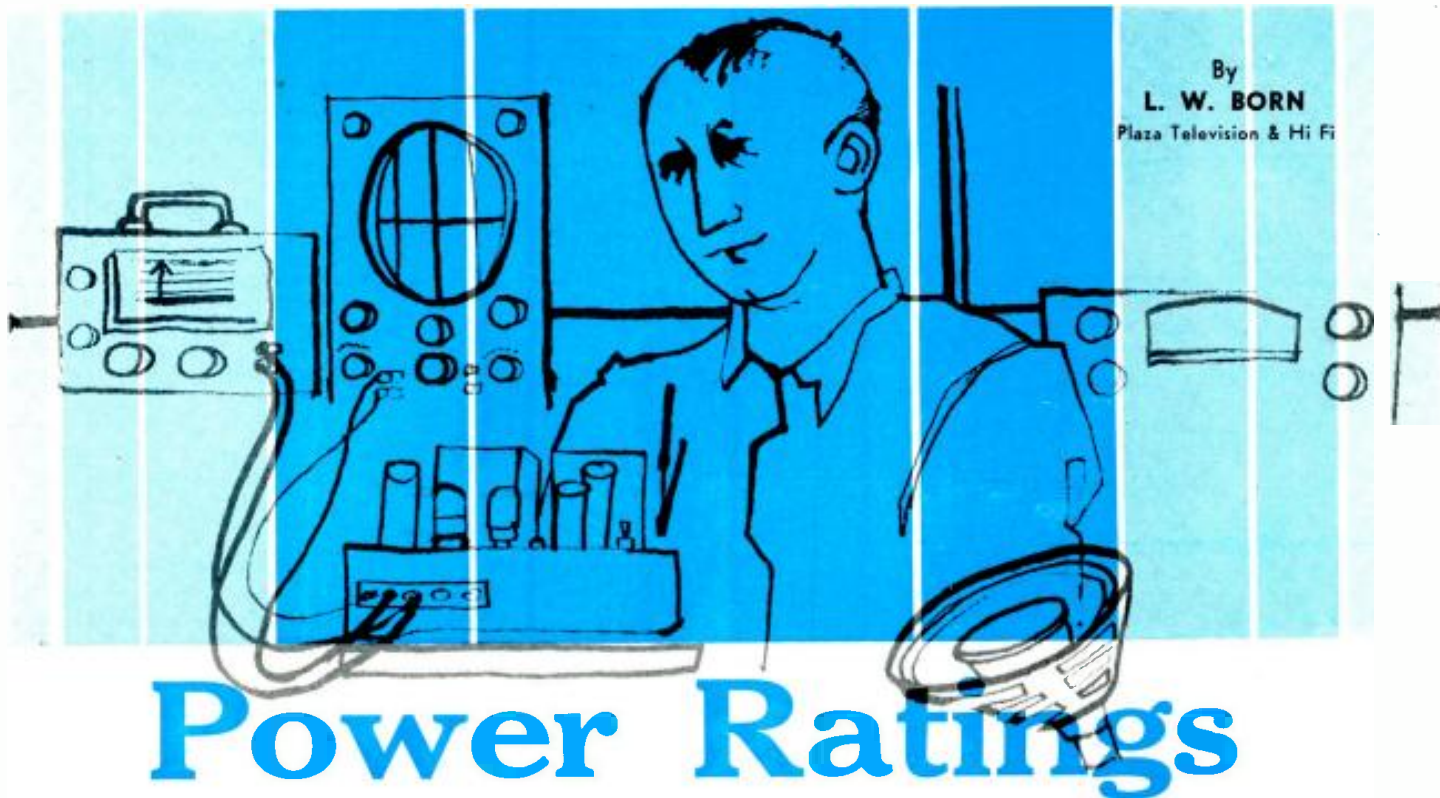

By
L. W. BORN
Plaza Television & Hi Fi

Power Ratings

& IM Tests

Further questioning revealed that he had, in fact, been quite pleased with the sound quality produced by his new amplifier, but since it had been measured and found wanting, it no longer seemed to sound quite right. We set up the amplifier on the test bench, loaded it into our 300-watt non-inductive load, clipped the scope across the output terminals for visual observation of the waveform, and proceeded to check it out.

Everything seemed in order. We touched up the bias adjustment slightly and, with rated output, measured considerably less than one per-cent intermodulation distortion. Our "friend" kept his eyes glued to every move that was made. "It's doing a real good job," we said. "It's running about six-tenths of one per-cent distortion at 60 watts."

"Wait a minute, now; what scale are you reading on the wattmeter?"

Be careful of what power rating you are quoting when checking hi-fi units for IM distortion.

measuring a simple sine wave, and because the wattmeter happens to be an average-power instrument, the wattmeter shows the true average power output of 40.8 watts."

"You mean that a sixty-watt amplifier can overload even when it's producing only 40 watts output?" he asked incredulously.

"Absolutely! As a matter of fact, it can overload when it is putting out much less than 40 watts average power, depending on the waveform it is handling. With some very complex waveforms generated by many kinds of music, it is entirely possible that an average power output of only a few watts could demand peak powers in excess of the capacity of the 60-watt amplifier.

"In many ways, it would be better if we used the peak-power output rating for amplifiers rather than av-

erage-power ratings, because when an amplifier is producing its maximum peak-power output, this is its limit no matter what the average-power output may be. With a single sine-wave signal, the peak-power output is exactly twice the value of the average-power output. In other words, when your amplifier was delivering 60 watts as measured by the wattmeter when using the single sine-wave signal, it was necessarily and mathematically producing 120 watts peak-power output. This simple two-to-one ratio is true *only* for a simple sine-wave input. With complex waveforms, the ratio can be many times as great. With the 4-to-1 ratio signals used in intermodulation distortion measurements, the ratio of peak-to-average power is 2.94 to 1, and as the wave becomes more complex, the ratio in general becomes even larger.

"When your friend measured the distortion at an indicated power of 40.8 watts, he was actually measuring the distortion with the amplifier delivering 120 watts peak power with the complex wave and that's all the amplifier can deliver."

"Then the amplifier is really all right?"

"Yes, sir. It's doing even better than the specifications call for and we're certain you will be completely satisfied with its performance. And, by the way, ask your friend with the analyzer to come in for a chat, will you?"

Improper Power Ratings

Misunderstandings and dissatisfaction occur repeatedly in connection with IM distortion measurements caused by improper evaluation of amplifier output when using complex waveforms, despite words of caution from the manufacturers of the test equipment. Let's look into the problem a little more deeply.

Let's assume we have an amplifier set up and adjusted in such a manner that with an input signal of 60 cycles per second measuring one volt on a meter indicating r.m.s. value, an average power output of ten watts is produced in a 16-ohm load. Elementary a.c. theory tells us that the peak value of the input voltage is 1.414 times the r.m.s. value or, in this instance, 1.414 volts peak.

Looking at the output side of the amplifier, we would measure an r.m.s. voltage across the load of 12.65 volts with a corresponding peak value of $1.414 \times 12.65 = 17.89$ volts, as in Fig. 1.

Using the well-known relationship: $Power = E^2/R$ we find average power is $\frac{12.65 \times 12.65}{16} = 10$ watts peak

power is $\frac{17.89 \times 17.89}{16} = 20$ watts.

Here again, we find the situation where the peak power is exactly twice the average power, using a single sine wave.

Now, if we remove the 60-cycle, 1-volt signal and substitute a 7000-cycle, ¼-volt signal with all other adjustments unchanged, we find the peak value of the input signal is 1.414×0.25

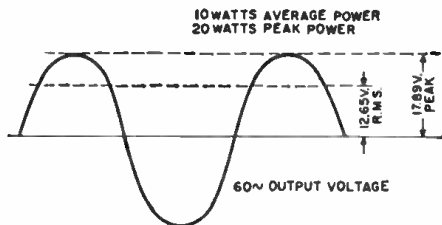

Fig. 1. With a single-frequency sine-wave signal applied to the amplifier, these are the output power relations.

$= 0.3535$ volt. At the load we now find an r.m.s. voltage of 3.1625 volts with its corresponding peak value of 4.4725 volts. With the ¼-volt input signal we find average power is

$$\frac{3.1625 \times 3.1625}{16} = 0.625 \text{ watt}$$

$$\text{peak power is } \frac{4.4725 \times 4.4725}{16} = 1.25$$

watts and again, since a single sine wave is involved, the ratio of peak-power output to average-power output is two-to-one.

In intermodulation distortion measurements, these two above signals are mixed or added together, and the higher frequency component "rides" on the lower frequency signal as shown in Fig. 2, producing a combined-signal peak voltage that is 1.414 plus $0.3535 = 1.7675$ volts at the amplifier input. At the output, assuming no overloading, we find a peak voltage equal to the sum of the two separate peak values, or 17.89 plus $4.4725 = 22.36$ volts.

This value of peak voltage indicates a peak power of

$$\frac{22.36 \times 22.36}{16} = 31.24 \text{ peak watts. Yet}$$

the average power with the combined signals is actually the same as if each of the two signals operated independently, or 10 plus $0.625 = 10.625$ watts. Hence it is seen that adding the high-frequency signal to the larger low-frequency signal adds only 0.625 watt to the average power output while at the same time, it increases the peak-power output from 20 watts to 31.24 watts.

A single sine wave that would produce a peak-power output of 31.24 watts would have an average-power output of one-half this amount, or 15.62 watts. Thus we say the above complex signal produces an equivalent sine-wave power of 15.62 watts.

The ratio of the equivalent sine-wave power to the actual average power is therefore $15.62/10.625$ or 1.47. Hence, if the wattmeter used to measure power responds to average power, it will be necessary to multiply the indicated reading by the factor of 1.47 to obtain the equivalent sine-wave power. Likewise, if a voltmeter is used to measure the output voltage across the load, and power output computed from this measured voltage, and if the voltmeter responds to the r.m.s. value of voltage, the power output computed from the meter reading must be multiplied by the same 1.47 factor.

Other Instruments

If the wattmeter or voltmeter used

to measure power responds to the peak value, no correction factor should be used since the meters will be indicating equivalent sine-wave power or voltage. Different types of instruments respond differently to the same a.c. wave. Thus in addition to those that respond to peak values, simple rectifier or diode types produce a deflection in an d'Arsonval meter movement proportional to the average value of the rectified wave; thermocouple, electrodynamicometer, moving-iron, and electrostatic type instruments produce a deflection proportional to the r.m.s. value of any waveform. Vacuum-tube voltmeters may produce a deflection which range from proportionality to the average value up to the peak value, depending upon the design of the instrument.

Where available, the oscilloscope may be used to adjust the output of the amplifier under test to have the same peak output with the complex wave as it had with the single sine wave of known power output. Then the amplifier will have the same equivalent sine-wave output when using the two-frequency test signal.

Should there be some uncertainty as to just what the wattmeter or voltmeter is responding to, a simple test may be performed to determine "watts what." Adjust the amplifier under test to produce a power output of about half its rated power output, using a 60-cycle signal of known voltage at the input. Introduce the 7000-cycle signal of a value just one-fourth that of the 60-cycle voltage. The indicated power output should then increase 56.2% and the indicated output voltage should increase 25%. Should these percentages not be obtained, it is a simple matter to determine from the observed increases, how much correction factor is required for the particular meter in question to obtain the necessary percentage increases. It must be remembered that the correction factors so determined are valid only for two-frequency signals mixed in a four-to-one ratio for the particular meter in question. [30]

Fig. 2. When two frequencies are applied for an intermodulation distortion test, the picture changes considerably.

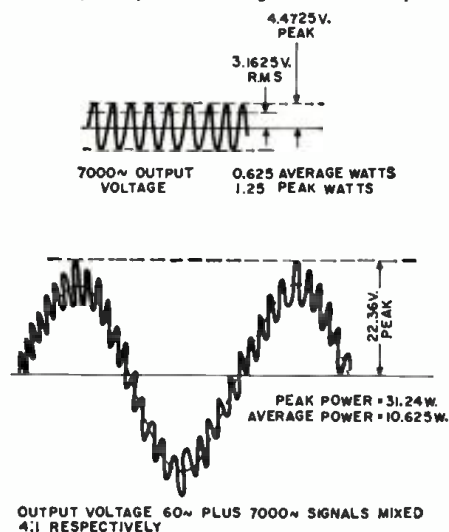

IN many test-equipment instruction manuals you will find a phrase that goes something like this: "The usefulness and versatility of this instrument is limited only by the ingenuity of the user." This may evoke a skeptical grin. However, the expression can be largely true, as we shall see.

An instrument with an apparently limited application is the popular flyback tester, designed, ostensibly, only to check horizontal-output transformers and deflection yokes. These are intended to be checked out of the circuit by an audio frequency, much in the manner of the grid-dip oscillator.

Fig. 1 shows, in simplified form, the basic circuit of one popular type. A triode-connected pentode is employed to support oscillations (at about 600 cps) generated in the grid's tank circuit.

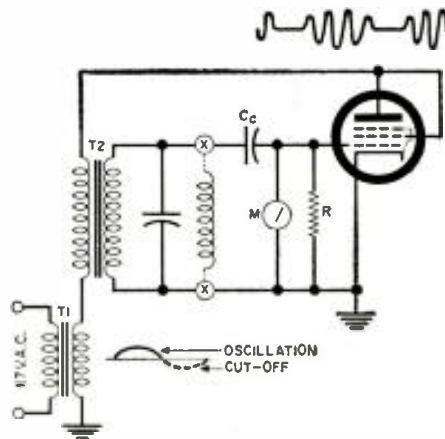
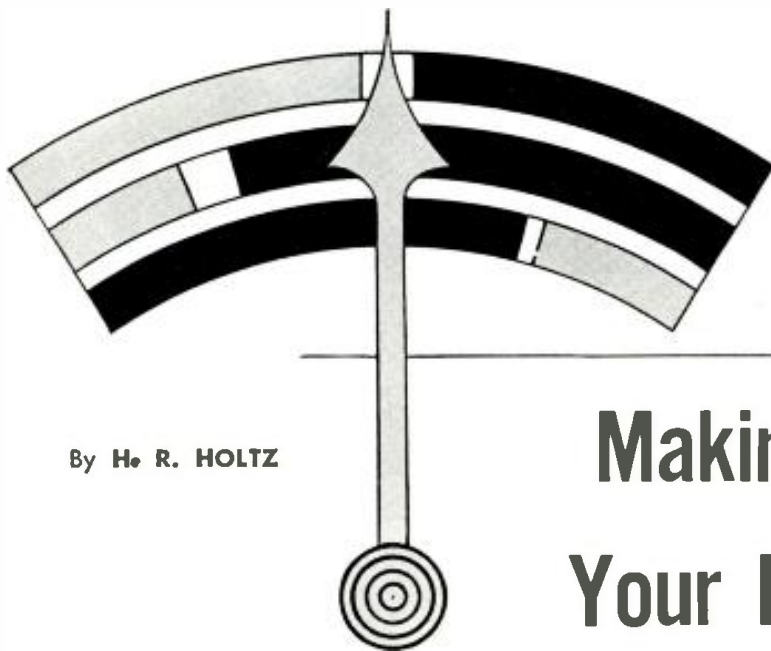

Fig. 1. Oscillatory circuit of typical flyback tester. Flyback connects across tank via external terminals marked "X."

terminals "X." The characteristics of transformers are such that a shorted turn may exist anywhere in one of the windings and still provide the conditions that will indicate a short when tested in the manner described. This is shown in Fig. 2. A single shorted turn in any winding of a transformer under test will be reflected to the winding to which the output of the flybacker has been applied, making this latter appear to have a low impedance. This appears to the flybacker as a short, damps its waveform sharply, and causes the meter incorporated in the instrument to deflect to "Bad."

By monitoring the output with an oscilloscope across the circuit, the action can be plainly seen. Hook up your flyback checker to a perfectly good transformer and clip your scope leads



By H. R. HOLTZ

It can do more than test flybacks and yokes. Here are other useful tests to which it can be adapted.

Making the Most of Your Flyback Checker

The plate-grid feedback arrangement for oscillation is *via* primary-to-secondary coupling of T_2 .

The 600-cps oscillation thus established occurs in bursts at a 60-cps rate, due to the fact that oscillation takes place only during the positive half-cycle of the a.c. voltage applied to the plate. The signal-biased grid thus develops a negative voltage, which is indicated by the high-impedance voltmeter connected across grid-leak resistor R .

Terminals marked "X" indicate the points at which the inductance under test is connected into the circuit. This is, of course, directly across the oscillator tank and will change the operating frequency. As a matter of fact, it greatly increases the operating frequency since it effectively reduces the total amount of X_L in the tank.

As long as the inductance so connected is large, presenting a large impedance, the slightly reduced amplitude of the oscillatory waveform is compensated by the increased frequency, which

allows R less time to leak off the charge on C , and so maintains the *average* voltage on the grid. In fact, a high- Q coil will actually *increase* this bias and deflect the needle even further into the "Good" region. A low impedance, however, loads the circuit and reduces the amplitude of the oscillations to such an extent that the grid bias is seriously reduced and the needle sinks into the "Bad" region. A low impedance is, in effect, a short across the tank.

Shorted turns present such a low impedance and need not necessarily be in the specific transformer winding across

across the test set-up. You will see the oscillatory bursts shown to the upper right in Fig. 1. Then wrap a single turn of hook-up wire around the transformer and short the ends together—or short the ends of the 1B3 (or 1X2) filament winding, which is only one or two turns. You can then observe the sharp diminishing of the oscillator's output along with the drop of the meter needle into the "Bad" region. This, incidentally, is why you must remove the high-voltage rectifier when making tests: the rectifier's filaments provide a low-impedance path across the winding, resembling a short.

In practice, the most effective way to employ this instrument is to hook it across the horizontal-output plate lead and high-voltage rectifier plate lead, removing the high-voltage rectifier from its socket. If the reading is "Good," you may safely assume that the transformer is free from suspicion. Be sure that you have established *continuity* through the transformer first, either with an ohm-

Fig. 2. Shorted turn in secondary of flyback acts to damp out tank circuit.

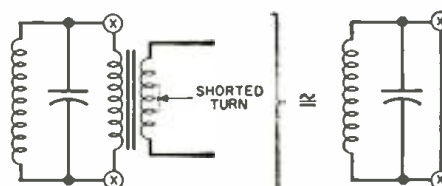

meter or the instrument's own continuity indicator, since an open winding will also indicate "Good" on the short test.

On the other hand, if the reading is "Bad," further testing is necessary. Now you may begin to appreciate the instrument's full utility: This reading does not necessarily indicate a defective transformer because there are still many components connected to the latter. One of these may be the culprit. It is now time to begin disconnecting them, one by one, and observing the effect in each instance on the meter or scope.

First, the damper. If removing it deflects the needle to the "Good" side, you may be reasonably certain that the damper is shorted. A new one will establish this quickly enough.

The yoke should be disconnected. If this test points suspicion towards the yoke, it may be tested separately, following the instructions for your particular instrument. If the yoke removal produces no change, continue disconnecting leads. Only when all have been broken away and the completely isolated transformer still checks "Bad" should it be condemned and replaced.

In other words, by this method you are testing the entire output section, rather than two components only. You will find, after a bit of practice with this method, that you can run down most high-voltage troubles very rapidly and will rarely, if ever, install a new yoke or transformer with the vague hope that "this is it."

This is not the end of the story. There are still other useful applications to which the flybacker can be put. Some of them are worth the price of the instrument, aside from its original, intended use.

Power transformers are a case in point. Expensive as they are, particularly the larger ones, we want to be sure before condemning them. Now we can be. Of course, we have a little problem: in most cases, the primaries and, of course, the filament secondaries of power transformers are of comparatively few turns. This makes them, by nature, of low impedance, hence unsuitable for our purpose.

But who says we must feed our test signal from the tester into the primary? We have at least one high-impedance secondary: the "high-voltage" secondary—the one that goes across the rectifier plates. We can turn this into our primary (for test purposes) and, in one fell swoop, test the entire transformer (Fig. 3), since a short *anywhere* in the transformer will be reflected to our secondary-turned-primary. Be sure that continuity exists in the various windings and particularly sure that no external shorts exist *across* any winding. This means that you should either disconnect one side of each secondary or remove all tubes and any other low-impedance paths.

This principle can be further extended to any other coil or transformer whose impedance is not prohibitively low. This includes most audio outputs, vertical outputs, and blocking oscillators, in addition to others. Experiments

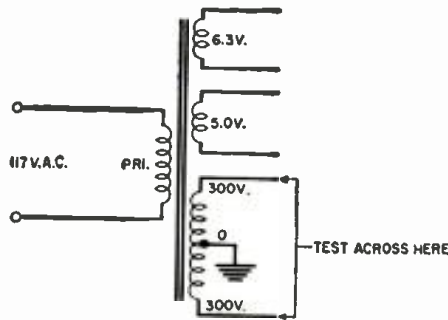

Fig. 3. To check a power transformer (with low-impedance primary), connect high-voltage (high-impedance) secondary to checker as though it were primary.

with an assortment dredged out of your junk box will establish the approximate limits for your particular model of flyback tester.

Speaking of junk boxes, how many times have you picked up a transformer and wondered what its turns ratio was or what transformer in that bunch would match a 50L6 to a 3.2-ohm speaker? Your flybacker can give you a pretty good answer.

Apply the tester to the high-impedance side of the unknown transformer. Measure peak-to-peak voltage with a scope or an a.c. voltmeter. Measure the voltage at the secondary. Actual values are not important. What is important is the *ratio*. Once this voltage ratio is established, we know the turns ratio, which is the same. We also know the current ratio: it is the inverse. And we can easily determine the impedance ratio, since it is the square of the turns ratio.

Let's pick an audio-output transformer out of the box and measure it. Across the primary we get a waveform on the scope; and we adjust the scope gain control for a trace that is exactly five graduations on the graph screen. Now we transfer the scope leads to the secondary. Of course, the trace is off the screen at top and bottom. Without touching the continuous gain control, we turn the calibrated step attenuator up until the trace is reduced enough to measure it. We find it to be twenty graduations high, and we have moved the step attenuator one position from an original 10:1 setting so that it now reads 100:1. That means we have reduced our trace by a factor of 10, making our new reading equal to 200 graduations. Therefore, our ratio is 200:5 or 40:1. The square of 40 is, of course, 1600. Our impedance ratio is then 1600:1.

This means that, if we use a 3.2-ohm speaker (voice-coil impedance), we should employ an output tube whose plate resistance is 1600 multiplied by 3.2 or, approximately 5000 ohms. This is rather a low value for pentodes. Very likely the transformer was originally used with a 6- to 8-ohm speaker, which would permit plate resistances of upwards of 10,000 ohms. This would include most of the better known output tubes such as 50C5, 50L6, and 6V6. In our case here, we could continue searching for a transformer with a greater

turns ratio or employ either a 6- to 8-ohm speaker or two 3.2-ohm speakers in series.

Of course the formula can be used in reverse. If we have an output tube with a plate resistance (found by consulting the tube manual) of 13,000 ohms and a 3.2-ohm speaker, we want a transformer with an impedance ratio of 13,000/3.2, or 4000:1. The turns ratio should be the square root of 4000. This is approximately 63:1. So we search for a transformer whose turns ratio is within 10 per cent of this figure.

You can apply these principles to any transformer. By such methods you can exhume a power transformer from the depths of the junk box and determine what voltages will be available from each secondary for any given input to the primary. Ditto vertical outputs.

Speaking of verticals, we have used our flybacker to drive a vertical-output stage to assure ourselves that it was the oscillator, not the output, that was defective. Some sets employ the output tube as a combination output and multivibrator section, making diagnosis difficult. (Which came first, the chicken or the egg?) Of course, the waveform is all wrong, but it is still a great help to know that the multivibrator is at fault (or is not). Fig. 4 shows where we would connect the flyback checker for this test.

The additional functions for the basic instrument described here, while interesting and useful, are not simply intended to define new although somewhat broader limits for the flyback tester. Rather, they are intended to suggest that even more such possibilities exist than the ones used for illustration.

High-impedance inductances other than transformers can be checked. Just to cite one more possibility, in passing: The basic flyback checker can serve as an emergency generator for signal injection. In this service, it is useful in any amplifier that will respond to its output signals. This means that it can certainly be used for some tests normally made with an audio generator. It also means that it could be used to check the operation of video amplifiers.

A resourceful user may be able to come up with any number of applications, none of which have even come close to the author's ken. [30]

Fig. 4. As a test oscillator, the flybacker can be used to check combination vertical oscillator and output circuits.

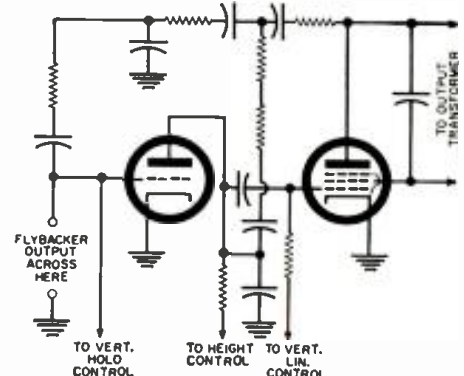



An Ill Wind

"OK, you two." Matilda greeted Mac and Barney sharply as they returned to the service shop after a protracted lunch hour; "you trying to starve a girl to death, or something? I thought you'd never get back."

"I'm really sorry, Matilda," Barney said. "I was sure Mac would be here; so I drove around a little to see what that storm Saturday night did to antennas."

"I'm sorry, too," Mac apologized. "I was having lunch with our parts distributor, an insurance adjuster, and a couple of TV antenna installers; and they got into a discussion about storm-damaged TV antennas that was most interesting. Since I thought Barney would be here to relieve you, I stuck around. But let me make it up to you. Tell Gus at the cafe your lunch today is on me, and don't spare the menu."

The small frown faded from Matilda's face as she snatched her handbag from her desk and swished out the door. "You're forgiven, but don't let it happen again," she called back over her shoulder.

"Whew! We got out of that pretty easy," Barney remarked as he wiggled his way into his shop coat. "Say, that storm really did a job on TV antennas. The city has finally managed to cut through the fallen trees on most of the streets so a guy can get around, and I was astonished at how many towers are down, masts are bent over, and antenna elements are broken off."

"That storm was a dinger," Mac commented. "The air base lost power for a brief time and consequently has a break in its wind velocity recording; but during the time the recorder was working, gusts up to seventy-five miles-per-hour were clocked. While it was a straight northwest wind instead of a tornado, it was very gusty and rocked things back and forth violently. That, plus the fact the ground was soft from previous rains, accounts for the hundreds of trees and dozens of stand-alone towers that were uprooted in town."

"It certainly showed up skimpy tower foundations," Barney added. "People now know it takes a lot of concrete,

or the equivalent, to take the place of guy wires, especially when the ground is soft and spongy from rain or thawing. But not all the towers were uprooted. A lot of them simply broke in two. Several I saw broke off about a foot above the ground. Some snapped off about the middle. One I saw didn't actually break, but it is bent like a bow so that a marble dropped from the top would land seven or eight feet from the base. On the other hand, very few guyed towers—or, for that matter, even guyed lengths of pipe—came down. By the same token, those unguyed towers supported with a bracket fastened to the gable of a house fared equally well. That little extra stiffening apparently spelled the difference."

"Yes, but remember guyed or supported towers are not practical on many narrow city lots where several factors dictate the placement of the tower. Keep in mind, too, how many stand-alones came through the storm undamaged, even though they were never designed to support a heavy, wind-catching, fringe-area TV antenna in a gusty seventy-miles-per-hour-plus wind. People apparently understand this, for the TV antenna installers were telling me at lunch that in most cases the owner of a fallen stand-alone tower was replacing it with another, often of the identical make."

"How about that lunch?" Barney asked with a grin. "You said you were eating with a distributor—an insurance adjuster, and some TV antenna installers. Were you eating or refereeing?"

"The conversation became a little heated at times, but we all parted friends," Mac answered. "Even though we ourselves do not go in very heavily for antenna installation—I'm too old to climb towers, and of course I could never risk the neck of my invaluable assistant—I picked up a lot of interesting and useful pointers that only can be acquired by going through an experience like this."

"The insurance man estimates the Saturday night storm did about equal damage for a radius of twenty-five or

thirty miles; yet we lost between six and seven hundred TV antennas in this town alone. That created serious problems for many TV owners and for every insurance company, TV-antenna installer, and distributor in the area.

"The TV antenna installers said their telephones began to ring before they were out of bed on Sunday morning, and they have kept right on ringing ever since. People wanted estimates to present to their insurance companies. One of the fellows had his truck equipped for two-way radio, and he said this was a tremendous help in keeping up with calls pouring into his home or office, especially when he was working in the suburban areas. The other had no radio, but he provided his office girl with an up-to-the-minute copy of his itinerary. She kept intercepting him by telephone along his route with new names to add to his list, and he said this worked out quite well.

"Neither made any effort to start actual antenna work for the first two or three days. They concentrated on making estimates, securing 'go aheads,' and rounding up material. One of them came up with several thoughtful observations about this procedure: he said it was most important to move quickly to obtain as many jobs as possible; yet it was essential to convince each TV owner you were concentrating entirely on his troubles. Reveal you were in a hurry to get going, and you were dead!

"Being equipped with just a few well-worked-out, illustrated, and priced antenna-tower-rotator combinations was a great help. Presenting the customer with too many choices merely confused him and wasted time. In a high percentage of cases, the customer wanted a better installation than the one he lost: a higher tower, a different rotator, a better antenna, or the addition of a u.h.f. antenna. Most of the customers accepted the fact that they would have to pay the difference between the insurance for the loss of the old antenna and the cost of the new one; but a few hinted very broadly that they wanted the estimate-of-loss padded to cover the new, costlier installation.

"This touched off the insurance adjuster. He said insurance companies were fully aware a certain percentage of their customers would always try to take advantage in this fashion; but in many other cases, he charged, it was the TV installer who suggested and encouraged the gouging. He mentioned cases in which only the top portion of a tower was lost but a whole new tower was installed; in which a complete new rotator was used simply because the U-bolts of the old one broke; and in which an entire new tower foundation was poured right beside the old one that still had the undamaged tower mounts sticking up out of it.

"The installers didn't deny such shenanigans took place; but they argued that in the case of the tower with the top broken off, quite often the remaining portion had been wracked and the rivets loosened so that to put a new

(Continued on page 128)

THE compact infrared photocell unit to be described will serve as a worthwhile aid for the camera enthusiast who wishes to extend his interests into the field of nature photography. While this particular unit was designed primarily for wild-life photography, it has several additional features that should appeal to the electronic experimenter as well as the camera hobbyist.

For example, this control unit will turn on a light in the home at the approach of darkness and turn it off at sunrise. This is a handy thing to have, especially when the family is away on vacation. It may also be used to signal the entry of a person into a specific area and, if desired, operate a camera shutter and flashgun to photograph the intruder.

For daytime nature photography where conditions make it difficult to set up a steady source of light to operate the unit, such as photographing birds in trees, the photocell circuit may be switched so that it can be operated by a strong flashlight beam from a distance of several hundred feet.

In addition to the solenoid which operates the camera shutter, a latching relay which may be switched in and out of the circuit at will has been in-

cluded. This relay provides added versatility with "on" and "off" operation for motors, lights, or other equipment.

Shutter Solenoid

Drill the mounting plate for the shutter solenoid as shown in Fig. 1. The two holes in the lower end of the plate are for mounting another piece of metal (not indicated) at a right angle to permit the unit to be attached to the camera at the tripod socket. Since the length of this piece will vary with different types of cameras, no dimensions have been given. Make the coil form by first sweating a piece of round steel (stationary core) in one end of a piece of brass tubing, $\frac{1}{2}$ " x $2\frac{1}{2}$ ". This may be done by first coating the steel with a thin layer of solder, then forcing the steel rod into one end of the brass tubing to which soldering paste has been applied and finally heating that end until the solder melts and secures both pieces firmly together. Complete the coil form by placing a fiber washer at each end, as shown in the diagram.

Wind six layers of 22-gauge enameled magnet wire on the form and bring the coil leads out the end near the steel insert. About a quarter pound of wire will be needed for the coil. As the winding



Infrared Camera Control

By
WALTER B. FORD

Construction details on a simple, compact unit that will help the wild-life photographer in his quest for some unusual shots.

for
**Nature
Photos**

If the flashlight beam is close to the ground, small animals and reptiles can operate the control mechanism. The author had to journey out into the desert where the temperature was around 118 degrees in order to get this sand-lizard photograph.



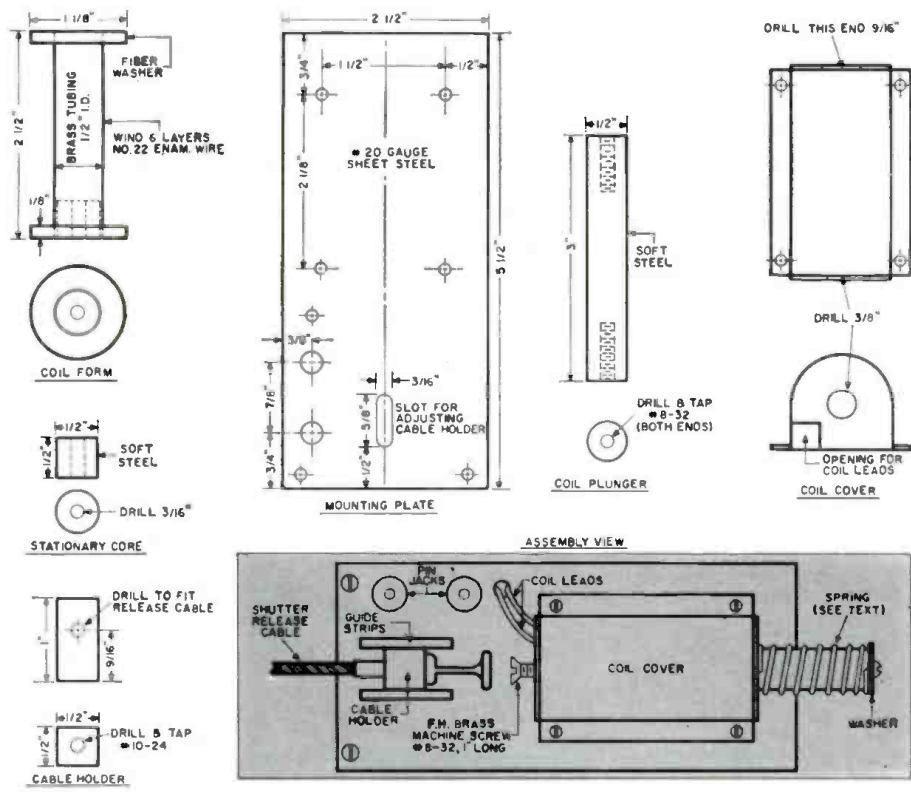

Fig. 1. Mechanical details showing construction of the shutter cable coil.

proceeds, apply shellac or other binder to the coil to avoid the possibility of the coil plunger separating the parts of the coil. Make a cover for the coil from 20-gauge sheet steel as indicated. This cover serves a dual purpose, one of which is to hold the coil in place and the other to provide a closed path for the magnetic flux, thereby increasing the downward force of the plunger. Solder ends on the coil cover and drill the holes where indicated.

Secure the coil and cover to the mounting plate with small machine screws, as shown in the "Assembly

View." Secure two pin jacks in the holes provided in the mounting plate and connect the coil leads to the jacks.

Drill and tap a piece of soft steel rod, 1/2" x 3". This piece moves downward through the coil and actuates the camera shutter cable when the coil is energized. Insert the steel plunger, through the center of the coil, and secure a flat-head brass machine screw to the lower end, as shown in the "Assembly View." Do not substitute a steel screw for the specified brass screw, otherwise the plunger will not operate as it should. The spring shown at the top end of the

Assembly of parts needed in order to make the shutter coil used by author.

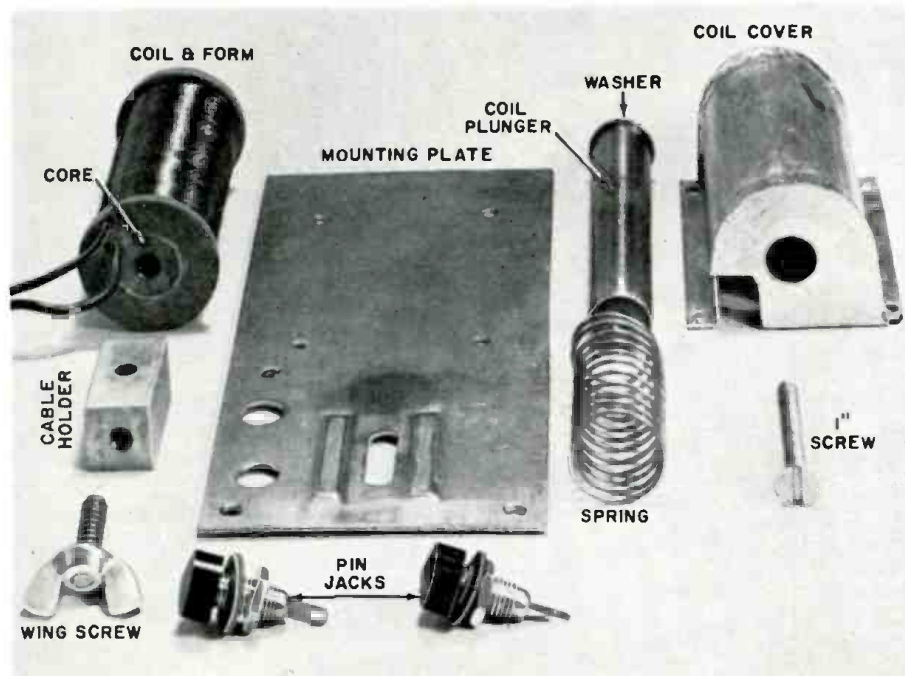

steel plunger consists of 8 to 10 turns of 22-gauge brass wire and whether or not it will be needed will be determined by whether or not the spring in the camera shutter cable is strong enough to return the plunger to its upper position. If a spring is required, care should be exercised not to make it so strong that extra battery power will be required to overcome its resistance.

The camera shutter cable holder consists of a piece of brass, 1/2" x 1/2" x 1", drilled and tapped as shown and secured to the base with a wing screw through the slotted hole. This permits locating the holder in the proper position for the particular camera being used. Solder two pieces of sheet steel on the mounting plate to serve as guide strips for the cable holder, as shown in the "Assembly View." These will keep the cable in an upright position when the holder is moved upward or downward.

Circuit Employed

Since the unit was to be used in the field, portability and low current drain were among the major considerations when the design was being formulated. A *Clairex* CL-3 photocell made possible a simple circuit that not only met those

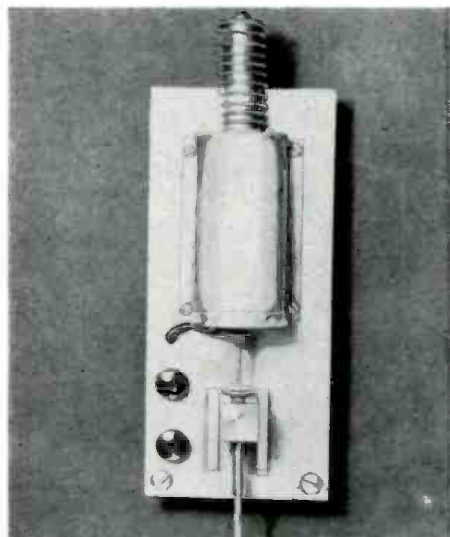

Shutter coil with release cable in place.

conditions, but also provided sensitivity not previously considered possible without amplification.

As can be seen in the diagram, Fig. 2, the photocell is connected to a sensitive relay through B_1 , R_1 , RL_1 , S_1 , and M . The battery voltage, B_1 , in the author's unit is 135 volts, which has been found to provide more than ample sensitivity. However, the photocell is rated at 300 volts, so if for any reason additional sensitivity is desired, it may be obtained by increasing B_1 within that limit.

Sensitive relay, RL_1 , should operate on 0.5 to 0.7 ma. The resistance of these relays usually runs from 10,000 to 16,000 ohms. The relay used by the author is a *Kurman* BK-35 or 31002/42Y with a resistance of 11,500 ohms. The sensitive relay contacts are connected through a s.p.d.t. switch to relay RL_2 so that the unit will operate by flashing

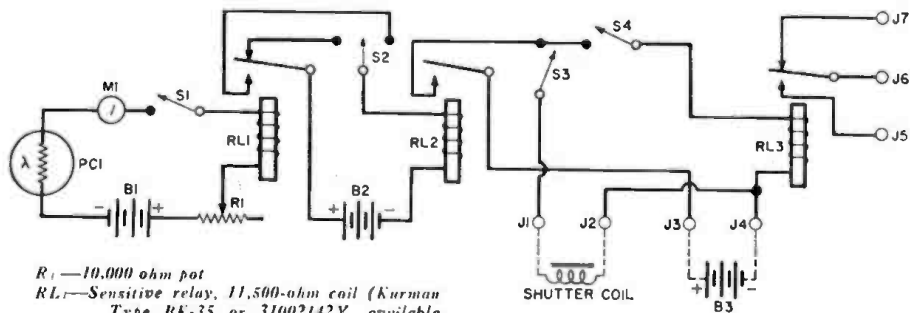

- R₁*—10,000 ohm pot
- RL₁*—Sensitive relay, 11,500-ohm coil (Kurman Type BK-35 or 31002/12V, available from Radio Shack Corp., Boston, see text)
- RL₂*—6-volt general purpose relay
- RL₃*—S.p.d.t., 6-volt latching relay
- S₁, S₂, S₃*—S.p.s.t. toggle switch
- S₄*—S.p.d.t. toggle switch
- J₁, J₂, J₃, J₄*—Tip jack
- M₁*—0-1 ma. milliammeter
- PCI*—Photocell (Clairex CL-3)
- B₁*—67½-135 v. radio "B" battery (Author used two 67½-volt batteries in series)

- B₂*—6-volt battery (Size "C" or "D" flashlight cells, four in series required)
 - B₃*—6-volt battery (Four No. 6 dry cells in series required)
 - I*—Shutter coil (See text)
- Note: The "U.S. Army 5-mile Signal Light" complete with red filter, extra light bulbs, and other accessories is available from Radio Shack Corp. of Boston as its Stock No. 23F001-5. This light is perfect for operating the photocell unit from a distance, as described in the text.

Fig. 2. Complete circuit diagram and parts listing for the control unit employed.

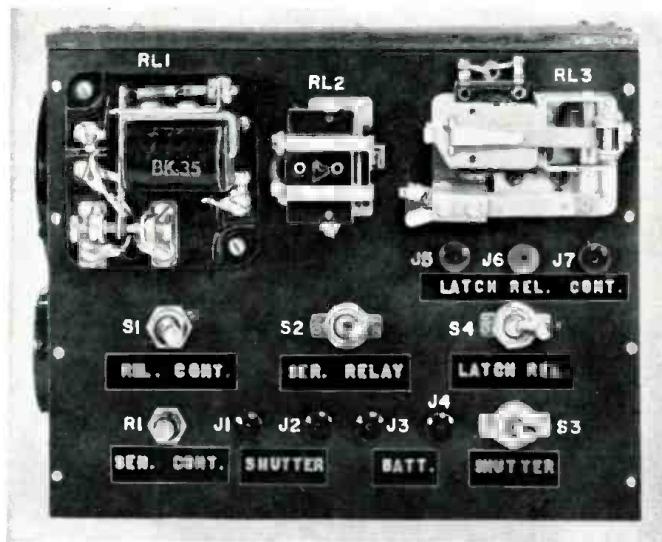

Mount relays, controls on one side of box for easy adjustment.

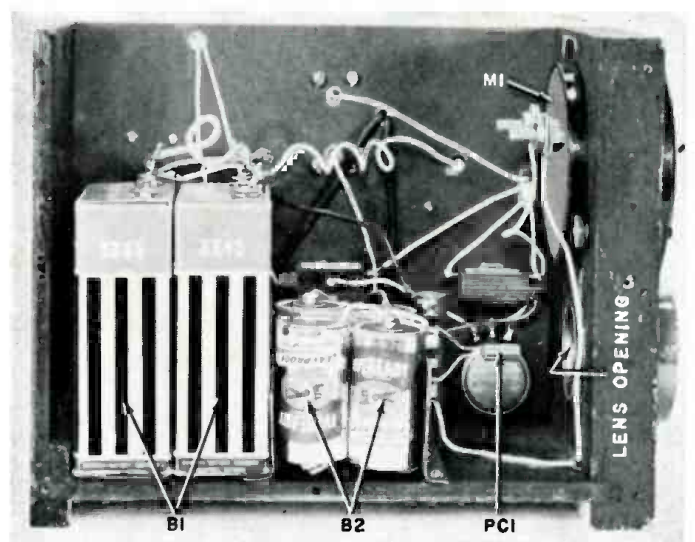

Inside of box shows photocell mounted behind the lens opening.

a light on the photocell or by breaking the beam of a light shining steadily on the photocell. While the latching relay (*RL₁*) is not required when operating the unit as a camera shutter control, it is a very worthwhile addition for extending the usefulness of the unit and one for which a resourceful experimenter will find many applications.

Enclosure

In the author's unit the photocell and batteries are enclosed in a plywood box with a Micarta panel serving as one side. The relays, switches, sensitivity control, and pin jacks are mounted on the panel, so that any part is accessible for adjustment. The interior of the box is painted with flat black paint to minimize stray reflections of light. The milliammeter is mounted in the front end of the box so that the beam of the actuating light may be positioned accurately from a distance.

A hole is provided directly below the meter for a cardboard tube and a small condensing lens. This lens may be any type of small convex lens with a focal length of two or three inches. An old flashlight lens serves the purpose nicely. The photocell is mounted so that its

face will be exactly at the focal point of the condensing lens, as shown in Fig. 3A.

If the unit is to be used in a dark or semi-dark location, a tube six or eight inches long will be sufficient to exclude extraneous light. If the unit is to be used out of doors in daylight, a longer tube with baffles is necessary. These baffles consist of cardboard washers spaced at regular intervals inside the tube with the holes getting progressively larger toward the lens. The inside of the tube and baffles should be coated with flat black paint. The tube

used with the author's unit is a mailing tube, 1½" in diameter, 14" long, with a front opening of one-half inch and three baffles spaced along its length. Fig. 3B shows a section of the tube with baffles in place.

Since varying degrees of pressure are required to operate the shutters on different type cameras, the number of dry cells needed to operate the shutter coil will also vary. Of the author's three cameras, a 4 x 5 will operate on 3 volts, a 2¼ x 2¼ reflex requires 4½ volts, and a 35 mm., with an unusually stiff release spring, needs 6 volts to set it off. The shutter coil section of the circuit should be wired with No. 14 or 16 stranded wire to keep voltage drop to a minimum. This includes the connections to the general-purpose relay contacts; switch *S₃*; pin jacks *J₁*, *J₂*, *J₃*, *J₄*; and the leads to the shutter coil and to batteries *B₃*.

Light and Set-Up

The amount of light required to operate the photocell will depend on the distance between the light and the unit. For distances up to ten feet the author uses a converted flashlight fitted with a camera filter holder, infrared filter, and a 1½-volt flashlight bulb. Infrared filters are available at camera stores in a variety of densities, ranging from 25A to 89A, with the larger numbers indicating the darkest filters. The author has experimented with filters of different densities in connection with wild-life

(Continued on page 111)

Equipment set up to photograph ground squirrel. Arrow shows path of light beam.

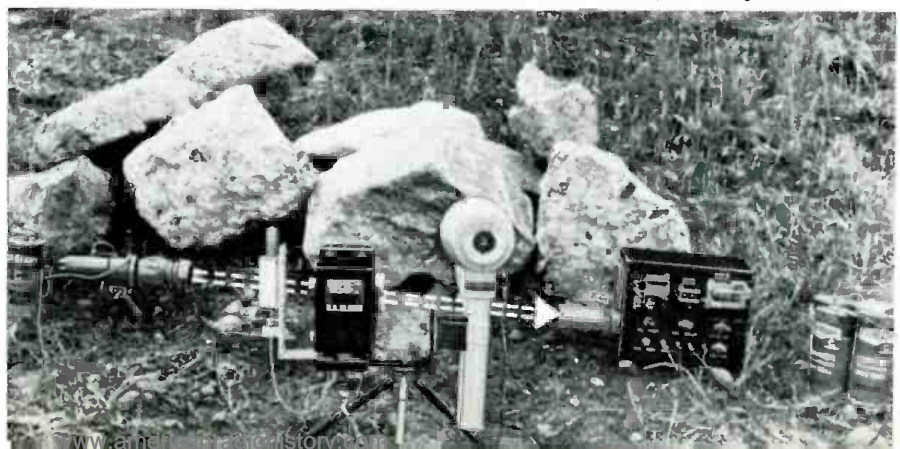

A Line-Voltage Adjuster

By RONALD L. IVES

High-power units are expensive. Save by building a portable one to yield over 400 watts in the shop or on outside calls.

THE TV SERVICE range extends into regions that are "fringe areas" not only for TV signals, but also in terms of electrical power distribution. Thus line-voltage problems are often of great importance to the service technician. The difficulty is increased because most variations seem to occur at inconvenient times and places and may be short-lived. This makes accurate analysis still more elusive.

Although high voltage sometimes occurs, low voltage seems to be the most common trouble, and it is noted at specific periods of heavy load. Thus the TV picture will appear to shrink (along with other symptoms) during the most popular programs, in the evening, when many people are using their sets; or in the worst weather, when most people stay at home to watch TV and also use electric heaters and other power-consuming devices.

Regulation close to the local load, preferably automatic, is desirable. It is also possible with a constant-voltage transformer, but it can be very expensive. The regulating transformer is likely to cost about 15 cents and weigh about 1½ ounces per volt-ampere. It is also likely to have a large leakage field, requiring mounting some distance away from sensitive a.f. circuits or extensive shielding.

Manual adjustment, customarily set up with a variable-voltage transformer

and a voltmeter, is electrically and mechanically satisfactory for most locations, but is also costly and takes up a good deal of space. Cost of high-current transformers is about four cents per volt-ampere or more. For example, the Varitran V1-M, a combination adjustable autotransformer and voltmeter rated at 570 watts, costs about \$35.00. Yet such arrangements of suitable capacity are often very desirable for installation in the customer's home and virtually indispensable to the shop that suffers from line-voltage fluctuations.

Actually, for correction of most discrepancies, the full range of the usual adjustable transformer is not needed, as the line voltage needs to be raised or lowered by something less than 20 percent. In consequence, most of the available range on a fully adjustable transformer is unused, even though it is paid for.

By connecting a small stepdown transformer with its primary across the supply line and its secondary in series with the load and the line voltage (Fig. 2), the line voltage can be raised or lowered (depending on the polarity in which the windings are wired) by approximately the secondary voltage. An advantage lies in the fact that primary current of the transformer is small, being approximately the secondary current divided by the stepdown ratio.

As an example, let us suppose that we

wish a capacity of 10 amperes (over 1100 watts) at 115 volts. Also let us suppose, for the sake of illustration, that available line voltage drops down to about 109 volts (E_L in Fig. 2). This can be corrected with a transformer whose secondary voltage is 6.3 volts (E_s), which will also be at 10 amperes. However, the primary current drawn by T_1 to provide the secondary requirement, with a step-down ratio of about 18:1, is only .55 ampere.

The transformer that will meet this requirement is relatively small, light, and cheap. To make the total output voltage (E_o) variable over a satisfactory range, we need only add a variable-

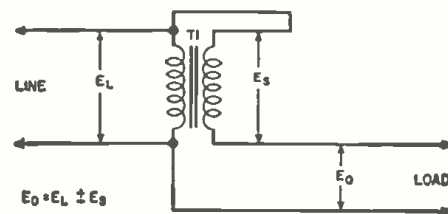

Fig. 2. Line-voltage alteration by use of small auxiliary transformer is shown.

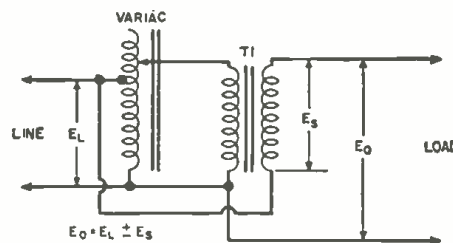

Fig. 3. Output-voltage control with variable autotransformer and stepdown unit.

Fig. 1. Panel view of the line-voltage control box, as constructed by the author. Superimposed numbers for switches and other components correspond with Fig. 4.



voltage transformer to control the small current drawn by the stepdown transformer, as shown in Fig. 3. Again, the variable unit need only be a modest one as compared to a transformer that would give direct, full-range control for the same capacity.

Use of the principle illustrated makes possible the construction of any number of useful line-voltage compensators with standard components to meet various requirements. The one to be described provides many "plus" features that will give it added usefulness in a shop, yet it is sufficiently compact to be carried to a customer's home and sufficiently foolproof to be left there so that the set owner can be instructed in its use for tracking down intermittent troubles probably due to voltage variation while the technician is absent. For permanent installation as a manual regulator in the home, a version with many of the extras removed can be assembled.

The circuit finally chosen is shown in

Fig. 4. It can raise or lower line voltage up to about 26 volts at 4 amperes or 12 volts at 8 amperes. It can supply low a.c. voltages variable from about 0-15 volts at 8 amperes or 0-28 volts at 4 amperes, electrically isolated from the supply line, on a continuous basis, or slightly lower voltages at currents that are 50 per-cent higher for periods up to 15 minutes, on a 30 per-cent duty cycle. Voltages and currents actually measured on the author's unit, with an a.c. input of 120 volts, appear in Table 1.

The power switch, S_1 , permits the entire unit to be turned on or off. When it is on, power can be isolated from all components other than meter M , by the input switch, S_2 , by placing the latter in its center-off position. If desired, the available line voltage can be fed directly to the output terminals by throwing S_2 into the bypass position. With the latter in its feed position, the transformer circuits are in operation. The meter can be connected to read voltage at either the input or the output with switch S_4 .

With the transformers in the circuit and output switch S_6 in the outlet position, line voltage plus or minus (depending on the position of phase switch S_5) the output of fixed transformer T_2 is supplied to the a.c. outlet. T_2 output may, of course, be varied with T_1 . With output switch S_6 in the terminals position, the low a.c. output from T_2 alone, variable by T_1 , is available at the terminals of binding post J , electrically isolated from the line.

Output from stepdown transformer T_2 , in addition to being continuously

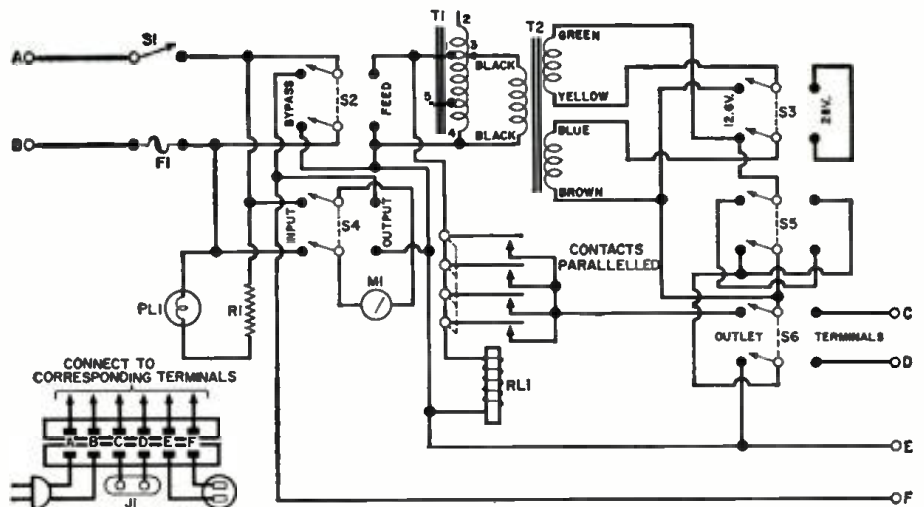

- R —600 ohm, 40 w. fixed resistor (made from two 300 ohm, 20 w. wirewound res. in series)
- F —10 amp. fuse (Littelfuse 3AG in holder)
- M —0-150 v.a.c. meter (Triplett 331-S or equiv.)
- PL —6.3 v., .25 amp. pilot light (G-E 44)
- RL —S.p.s.t. normally open, 115 v. a.c. relay (Potter & Brumfield MA-17 with contacts paralleled)
- S —S.p.s.t. bat-handle toggle switch

- S_2, S_4 —D.p.d.t., center off, bat-handle toggle switch
- S_1, S_3, S_5 —D.p.d.t. bat-handle toggle switch
- T —Variable autotransformer (Variac V-2 or equiv.)
- T_2 —Stepdown trans. 12.6 v. @ 4 amp.; 12.6 v. @ 4 amp. (Merit P2963 or equiv.)
- J —Two-terminal binding post (Eby 21-R)
- I —6-contact connector
- I —A.c. plug (male)
- I —A.c. receptacle (female)

Fig. 4. Complete circuit diagram and parts listing of the line-voltage adjuster.

The arrangement shown was used simply because, in the author's case, all other equipment in the shop uses Type 44 indicator lamps.

Rear view of the assembly is shown in Fig. 5. All components mounted on the panel are held firmly to it with brackets. All input and output connections were

brought to a 6-terminal connector (Cinch-Jones No. 1406 or equivalent) with a matching six-point plug to carry these connections to the two-terminal binding post, the input a.c. plug, and the recessed a.c. receptacle for output voltage. The latter three items are mounted on the steel case. This method of making interconnections between the panel-mounted components and those on the box avoids the nuisance of unsoldering half a dozen leads when the unit must be taken apart for minor repair.

The two resistors in back of T_1 comprise dropping resistor R , for the pilot light, and will not be used if a neon lamp is substituted. Relay RL , upper right, is used to eliminate a "sneak circuit" through T_1 and the primary of T_2 when the input switch is set in the bypass position. Relay hum can be suppressed

(Continued on page 112)

S_2 POS.	S_3 POS.	S_5 POS.	S_6 POS.	OUTPUT
Bypass	—	—	Outlet	Line voltage, terminals not connected
Feed	12.6 v.	—	Terminals	0-16 v. no load; 0-14.8 v. @ 8 amps.
Feed	28 v.	—	Terminals	0-33 v. no load; 0-27.6 v. @ 4 amps.
Feed	12.6 v.	"—"	Outlet	120-102 v. no load; 120-108 v. @ 8 amps.
Feed	28 v.	"—"	Outlet	120-88 v. no load; 120-94 v. @ 4 amps.
Feed	12.6 v.	"+"	Outlet	120-136 v. no load; 120-132 v. @ 8 amps.
Feed	28 v.	"+"	Outlet	120-151 v. no load; 120-146 v. @ 4 amps.

Table 1. Performance of the line-voltage adjuster is indicated above, with an a.c. input line voltage measuring 120 volts, and with power switch turned on.

variable, is obtained in two ranges by manipulation of transformer switch S_2 . The two 12-volt windings are connected in series for approximately 28 volts at 4 amperes or in parallel for 15 volts at 8 amperes. Polarity is controlled by phase switch S_5 , which connects the secondaries of the fixed transformer in series-aiding with the load for increased voltage but series-bucking for a decrease.

Panel view of the voltage adjuster, assembled in a 5" x 6" x 9" steel utility box, is shown in Fig. 1. The white ring around the dial of T_1 was a thin disc of metal added purely for the sake of appearance. Without it an out-of-square illusion resulted from the difference in diameter between the dial and the panel meter.

The pilot light was connected across the line in series with 600 ohms to reduce voltage. Substitution of a neon bulb with its limiting resistor is economical.

Fig. 5. Rear view of adjuster, showing construction details and connector plug between panel assembly and case. Resistors in center are the pilot-light dropping resistors.

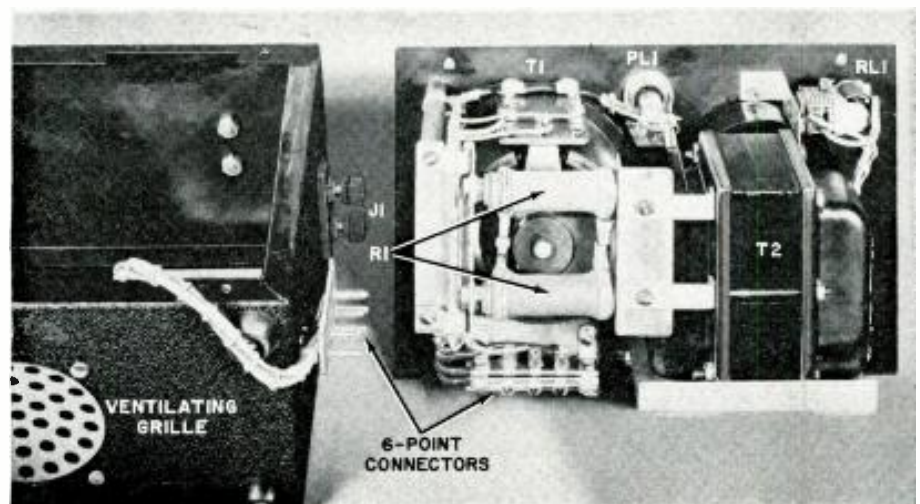

Receiver Input Impedance Matching

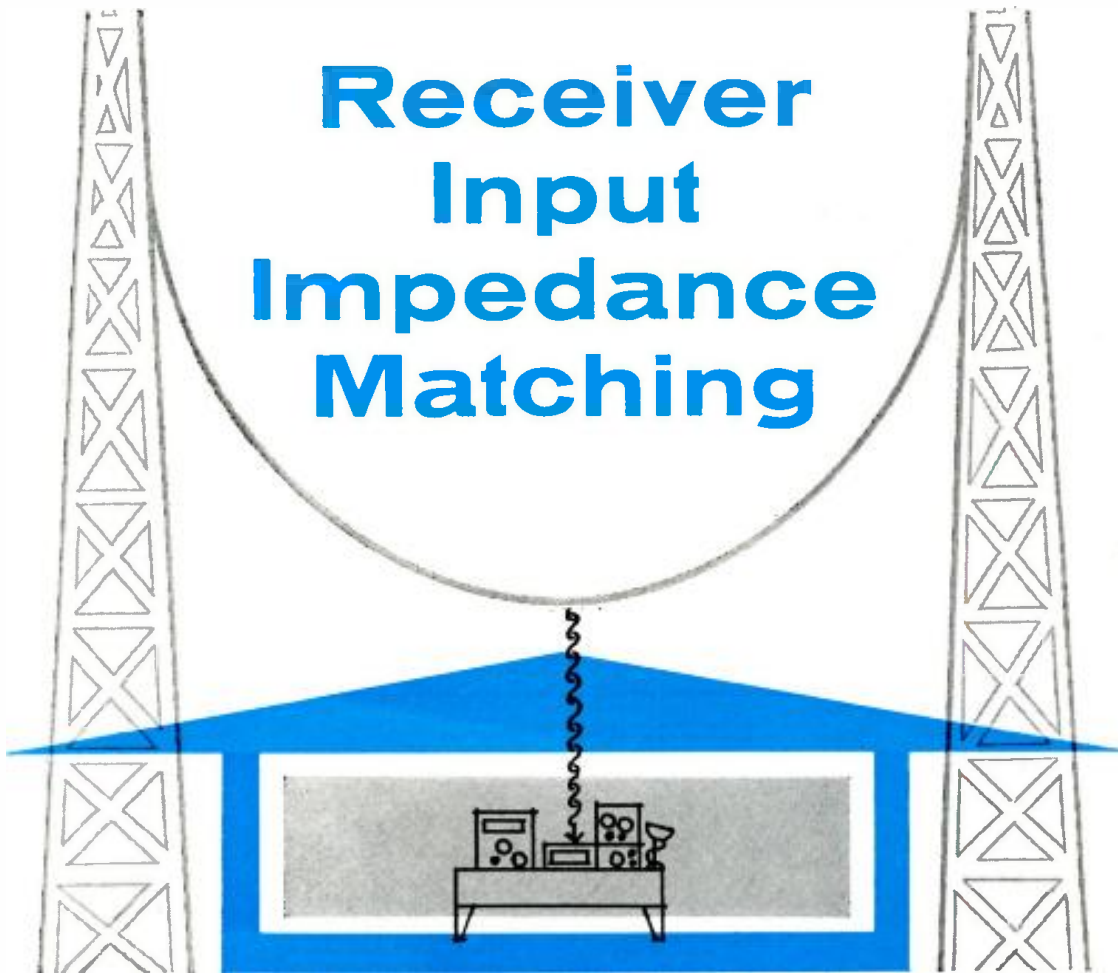

By **RICHARD A. GENAILLE, K4ZGM**

Practical information on improving the performance of ham or s.w. receivers by proper antenna matching.

HAVE you ever had the feeling that your receiver is not as "hot" as it should be on one or more of the ham or short-wave bands you use? Do you feel that it is a "lemon" when compared with other identical receivers or receivers in the same price range? If you do, receiver input-impedance matching may be just the thing to "soup" up your receiver, especially on the higher frequency ranges.

The purpose of this article is to illustrate several methods for determining your receiver's input impedance as well as discuss ways in which you can match your receiver input to the station transmission line. Your problem of improving your receiver's sensitivity and ability to reject certain types of interfering signals can be solved quite simply and with a minimum of parts. You probably own or have access to the test equipment necessary to do the job and your "junkbox" will more than likely yield the required parts.

For some years now the author, as well as many other amateur operators, has spent considerable time and effort in matching impedances from the transmitter to the station antenna. There is hardly an active ham operator

today who has not made use of or at least heard of antenna impedance bridges, standing-wave-ratio indicators, and reflected-power meters. Unfortunately, most hams have completely overlooked the fact that these test instruments are just as useful in checking impedances and s.w.r. when looking from the antenna toward the station receiver. The problem is the same no matter which way you look down the transmission line. From the transmitter you want all of the "soup" to go down the transmission line to the antenna. From the antenna you want all of the very limited amount of received signal energy to go down the transmission line and get right into the receiver.

With the possible exception of several of the more expensive receivers on the market today, the average general-coverage receiver is designed to operate from a single-wire antenna or doublet with anything from 52- to 600-ohm transmission line. The nominal receiver input impedance is usually around 300 ohms. For those operators who are using folded dipoles and 300-ohm line, the receiver input appears to be an almost perfect load for the antenna and transmission line. However,

with the widespread use of 52- and 72-ohm coaxial cable for the station transmission line, it becomes pretty obvious that unless some form of impedance matching is undertaken between the receiver and the low-impedance coaxial line, as much as a 6 to 1 mismatch can exist between the transmission line and the receiver input.

Needless to say, slapping a low-impedance antenna system across a high-impedance receiver input can result in rather poor operation of the receiver. The perfect match that one might have between the antenna and its transmission line does not guarantee a low s.w.r. on the line when the transmission line itself is not properly terminated at the receiver input. What the transmission line "sees" at the receiver antenna-input terminals is what determines the s.w.r. on the line and the losses as far as receiving is concerned. If the impedances aren't matched all along the line, you just won't get the maximum power transfer from the transmitter to the antenna nor maximum received signal energy from the antenna to the receiver. Considering the small amount of signal that you have to work with when receiving,

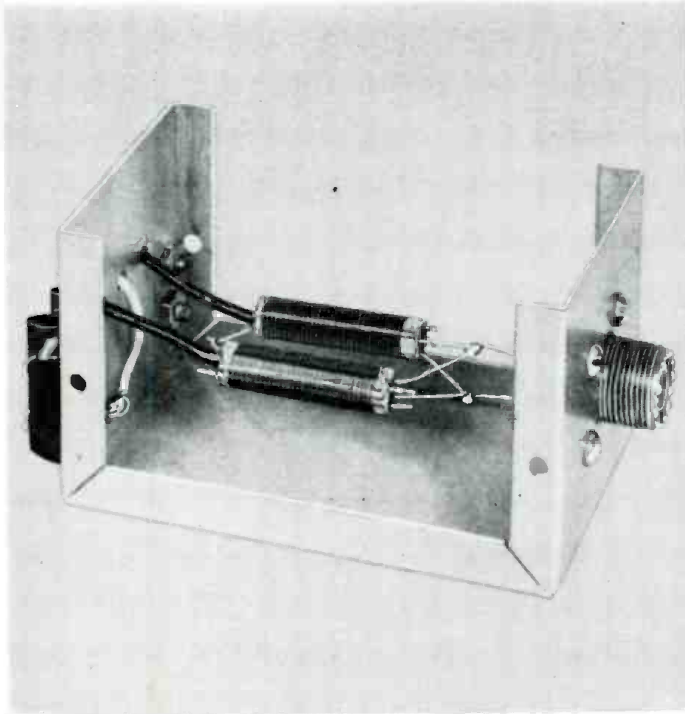

Fig. 1. Balun coil impedance matcher with cover removed.

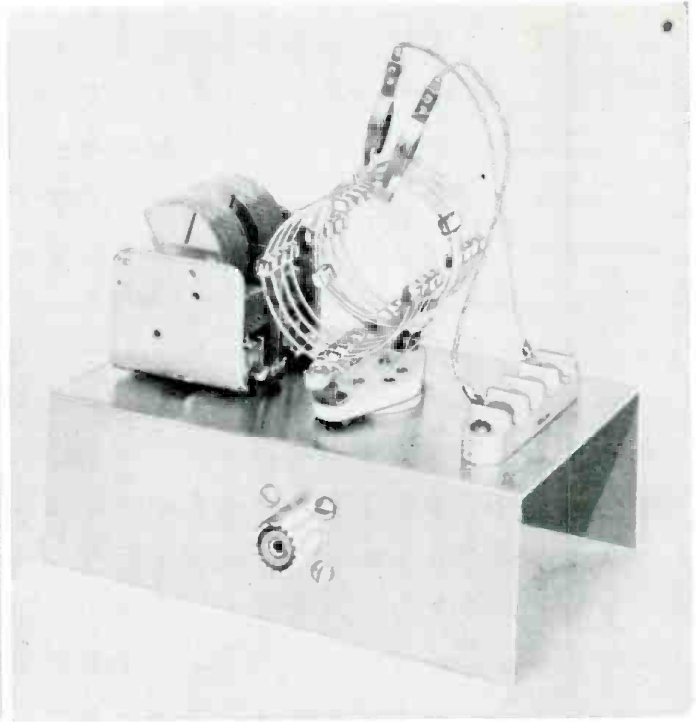

Fig. 2. Link-coupled impedance matcher with plug-in coils.

you don't have any signal to waste. What it all boils down to is that there is a need for matching the receiver input impedance to that of the station transmission line. Let's see how simple it really is to correct a situation that many of us have overlooked for too long.

Receiver Input Impedance

The receiver input impedance can be easily determined, with sufficient accuracy, in several ways. Two are shown in block form in Figs. 3 and 4. The two methods are quite similar except for the use of test equipment of different nomenclature. Fig. 3 shows the use of an antenna impedance bridge. The antenna bridge can be used to determine antenna resistance and resonance, standing-wave-ratio, and receiver input impedance. This piece of test equipment alone can be used to make a complete match of the antenna-receiver-transmitter impedances at the station. As shown in Fig. 3, the antenna bridge requires an external signal source which can be a grid-dip oscillator or signal generator having adequate output. The station transmitter may also be used as a source of r.f. energy for operation of the bridge providing some means are available for controlling the transmitter output level.

Fig. 4 shows the use of a low-power standing-wave-ratio bridge to actually

check s.w.r. when the receiver input is used as the load for the 52-ohm or 72-ohm bridge. The method shown in Fig. 4 is quite satisfactory since any adjustments made to an impedance-matching device at the input terminals of the receiver will be made with a goal of unity s.w.r. on the transmission line. The receiver input impedance can be determined by the use of the s.w.r. bridge merely by substituting resistances of known value as the load on the bridge until one is found which gives the same s.w.r. reading as when the receiver was used as the load.

If a 52-ohm bridge is used and the s.w.r. is the same whether the receiver input or a 300-ohm non-reactive resistor is used as the load on the bridge, it can be assumed that the receiver input is in the ratio of 6 to 1 to the impedance of the bridge. This means that the receiver input could be either 9 or 300 ohms. Since most communications receivers are designed to have an input impedance between 52 and 600 ohms, it is a safe bet that the input impedance, in this case, is around 300 ohms and not 9 ohms.

In performing the tests using the arrangements shown in Figs. 3 or 4, it should be remembered that the receiver must be tuned to the frequency at which the measurements are being made. If the signal source for the antenna bridge or s.w.r. bridge is 7.2 megacycles, the receiver input tuned

circuit must also be adjusted to this same frequency. The author found, in making impedance measurements on several general-coverage ham receivers, that whether power was applied to the receiver or not made little or no difference in the results. In making measurements of receiver input impedance it must be remembered also that the receiver tuned input circuits can be damaged by excessive r.f. energy. For this reason, a low-power device such as the antenna bridge or s.w.r. bridge must be used rather than the reflected power meter or reflectometer type of s.w.r. indicator. The latter instruments require considerably greater power for satisfactory operation, much more than can be safely handled by a receiver front-end. Typical low-power bridge circuits may be found in several of the popular amateur radio handbooks. Needless to say, before attempting to check the receiver input impedance or to match the receiver input to the transmission line, make certain that the receiver front-end has been aligned in accordance with the manufacturer's instruction manual.

At the author's station, 52-ohm RG-8/U and RG-58/U coaxial cables are used throughout as station transmission line and antenna switching is accomplished through the use of a coaxial relay. All antennas are adjusted to match the 52-ohm coaxial

Fig. 3. Impedance-bridge method of measuring the input impedance of receiver.

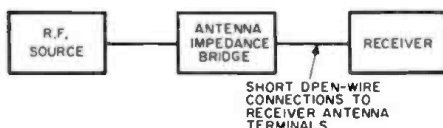

Fig. 4. Measuring standing-wave ratio when receiver input is used as load.

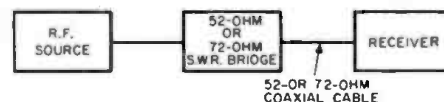
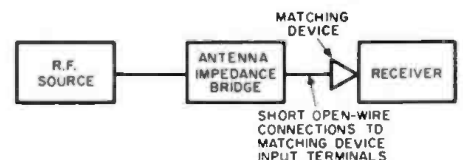

Fig. 5. Bridge-type method of measuring input impedance with matching device.



line. In order to determine the necessity for receiver input matching the author made use of the set-up shown in Fig. 4 using the s.w.r. bridge. The station receiver is a popular general-coverage type costing in the neighborhood of \$300. This receiver reflected an input impedance between 90 and 300 ohms on the various ham bands from 80 through 10 meters. There was no frequency covered by this receiver where the input impedance was the same as that of the 52-ohm station transmission line. Obviously, unless some method of impedance matching was accomplished the receiver input could never be a suitable load for the line.

After you have discovered that the front-end of your receiver is not the perfect load for the antenna system that you thought it might be and you have a good idea of the approximate input impedance of your receiver for the particular bands that you might operate, let's see what can be done at the input of the receiver so that the transmission line will see a correct termination whatever your choice of transmission-line impedance.

Proper Matching Techniques

In the moderately priced communications receiver, the only means of making adjustments to the first tuned circuit feeding the grid of the r.f.

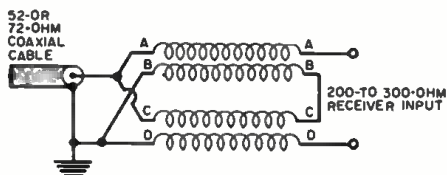

Fig. 7. Balun circuit discussed in text.

amplifier is usually an under-chassis trimmer or externally controlled antenna trimmer. Most receivers make use of slug-tuned coils for the first tuned circuit providing another adjustment point which can effect a variation in the input impedance. On the more expensive communications receivers, with strictly ham-band coverage, it is possible for the manufacturer to design the tuned input circuit to provide almost any popular transmission-line impedance at the antenna terminals. In some instances the manufacturer may even specify that the receiver's nominal input impedance is 52, 72, or 300 ohms.

For those receivers that have an input impedance variation of from near 52 ohms to 300 ohms, impedance matching can be accomplished by the use of any of the popular impedance-matching networks that are commonly used in the final amplifier of a transmitter. A pi-network can be used very conveniently and effectively to make the impedance transformation. The manner in which the receiver input is matched to the station transmission line is a matter of individual choice

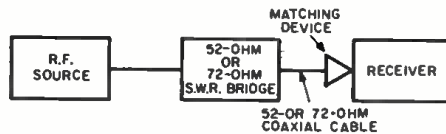

Fig. 6. S.w.r. bridge method showing the addition of matching device.

and convenience. The main thing is to match the receiver input to the line. For receiver matching, the components used can be of the low-power variety since we are not dealing with any substantial amounts of r.f. energy.

Figs. 7, 8, and 9 show three popular methods of impedance matching for r.f. work. The balun circuit of Fig. 7 not only makes a conversion from an unbalanced line to a balanced load but gives a 4 to 1 impedance transformation as well. The 4 to 1 ratio is fixed and may not be suitable for use over the entire receiver range. Balun coils may be fabricated per instructions found in amateur handbooks or may be purchased at very low cost from TV repair shops or local radio parts dealers. These baluns are of the type found in TV tuners where they are used for impedance-matching purposes. Baluns designed for lower frequency work are also available but are normally designed for transmitter application which results in a larger and more costly arrangement. The TV baluns

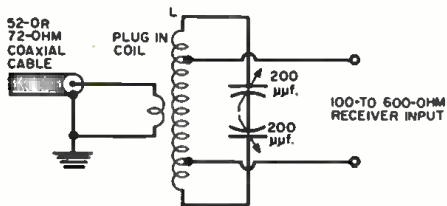

Fig. 8. Link coupling method of matching.

are primarily useful above 14 megacycles.

A view of a simple balun matching device constructed by the author for use at his station is shown in Fig. 1. This unit consists of two of the TV balun coils costing a total of 75 cents, a small "Mini-box," Amphenol UHF 83 series coax receptacle, and a 3-point terminal block.

The circuit of another useful matching circuit that the author uses for all-band coverage is shown in Fig. 8. This circuit is the familiar antenna tuner circuit so often used for coupling between the link output of a final amplifier and an open-wire or other high-impedance line. For receiver work, the antenna tuner coupling link connects to the low-impedance transmission line while the higher impedance tap points feed the balanced receiver input. Fig. 8, like the balun circuit, also provides the means of going from unbalanced line to a balanced load. The coil can be a low-power, plug-in type normally used in low-power excitors or it may be fabricated from "Miniductor" stock. The tuning capacitor need only have re-

ceiver spacing between plates. Fig. 2 shows the mechanical simplicity of this type of circuit. This unit was constructed by the author as an experimental unit and proved to be quite satisfactory.

Another simple matching circuit is shown in Fig. 9 and is recognizable as the popular pi-network. Here, again, the circuit is used to go from a low impedance to a higher impedance, just the reverse of what is normally accomplished when used in the plate circuit of a final amplifier. The coil (L) may be made from "Miniductor" stock cut to size and tapped by experimentation. Capacitors (C_1) and (C_2) can be 500 $\mu\text{f.}$ and 150 $\mu\text{f.}$ receiving-type variables, respectively. Other impedance-matching networks may be used as long as the match we are seeking is accomplished. The circuits shown in Figs. 7, 8, and 9 are about the simplest for the individual to construct and adjust.

Installation & Use

Once it has been decided which circuit is to be used, the impedance-matching unit should be constructed and installed at the receiver antenna input terminals. The receiver is then tuned to the particular ham or short-wave band or bands for which the unit was designed and a signal, of the proper frequency, fed to the receiver through the matching device, using

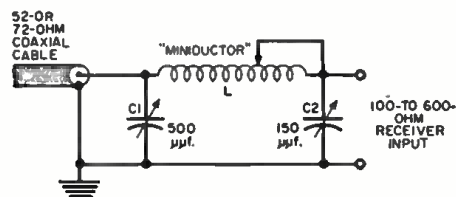
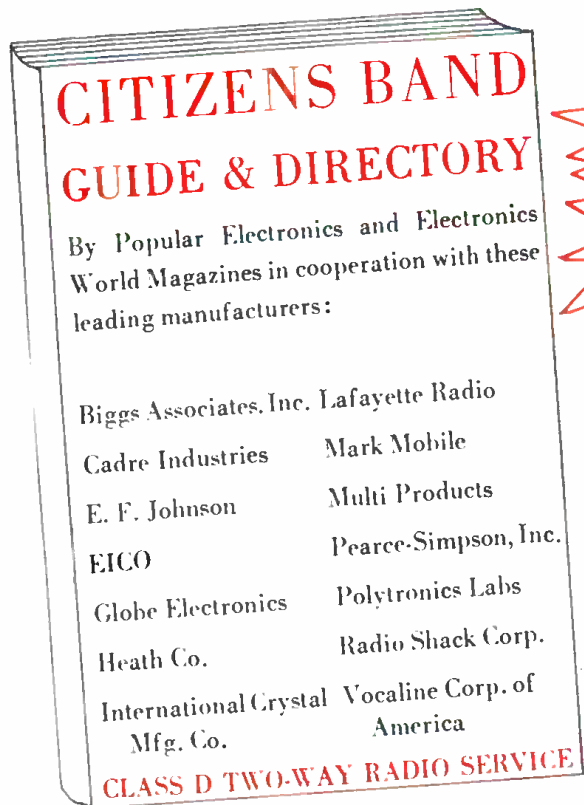

Fig. 9. Pi-network method of matching.

either of the test arrangements shown in Figs. 5 or 6. If the balun circuit of Fig. 7 is used, no adjustment can be made. The antenna bridge will indicate the impedance which will be reflected to the line by the matching device. The s.w.r. indicator will indicate a mismatch in terms of the standing waves existing on the transmission line. In the case of Figs. 8 and 9, one need only adjust the variable components and taps until the s.w.r. indicator shows unity s.w.r. or the antenna bridge, if used, indicates that the load reflected by the matching circuit at the receiver antenna input terminals is the same as that of the transmission line being used.

With these hints for you to start with, matching the input of your receiver to the station transmission line should become as common an operation at your station, for assuring top performance of your equipment, as that of matching your antennas to the transmission line. Here's hoping that you can get more signal delivered from your antenna to your receiver so that you, too, can pull in those elusive DX signals you have been missing. [30]



NEW 32-PAGE BOOKLET TELLS HOW YOU CAN GET STARTED WITH YOUR OWN CITIZENS BAND TWO-WAY RADIO WITHOUT ANY EXAMINATION!

Here's your chance to get on the Citizens Band Wagon! Thousands of Americans all over the country have discovered the advantages and economy of owning their own two-way radio sets. No FCC examination is required to own and operate Citizens Band Radio. Be sure to send for your FREE copy of this 32-page Guide to Citizens Band, prepared by Popular Electronics and Electronics World Magazines.

This booklet contains valuable information on...

- The newest in Citizens Band equipment, including actual photographs, prices, specifications.
- How to use Citizens Band: effective ranges, types of antennae, effect of terrain, special applications for you.
- How to get a Citizens Band license *without* an examination.
- Where you can see the newest equipment demonstrated (complete directory of 1200 local dealers included).
- PLUS background of Citizens Band radio, latest FCC regulations, and much more!

ALL YOU HAVE TO DO TO GET THIS FREE BOOKLET IS TO FILL IN AND MAIL THIS COUPON. ►

ACT NOW!

Supplies are limited.
Order your free booklet today!

To: Electronics World & Popular Electronics
Box 206—Village Station
New York 14, N. Y.

Send me my FREE copy of CITIZENS BAND GUIDE AND DIRECTORY

Name _____
(please print)

Street _____

City _____ State _____

W11

for the ultimate in Christmas giving...



for the ultimate in electronic
design

**THIS YEAR
GIVE A
HEATHGIFT**

HEATHKIT[®] **BY** DAYSTROM

NOW ONLY

HEATHKIT[®]

Brings You

ALL 3!

1.
HEATHKIT
for the do-it-yourself
hobbyist

2.
HEATHKIT
factory-wired &
tested units ready for
immediate use &
enjoyment

3.
HEATHKIT
Science Series ...
entertaining,
instructive
explorations into
science & electronics
for youngsters

"DELUXE" AM/FM STEREO TUNER

Exciting new styling and advance-design features rocket this Heathkit to the top of the Christmas value list. Featured in this outstanding tuner are: complete AM, FM, Stereo reception, plus multiplex adapter output; individual flywheel tuning; individual tuning meters on each band; FM automatic frequency control (AFC) and AM bandwidth switch. 24 lbs.

Model AJ-30 (kit) \$9.75 dn. **\$97.50**
 Model AJW-30 (wired) . . . \$15.30 dn. **\$152.95**

HI-FI RATED 50-WATT STEREO AMPLIFIER

In the inimitable style of the Heathkit AJ-30 Tuner above, this complete stereo amplifier offers you the ultimate in stereo conveniences. Jam-packed with extra features, including: mixed-channel center speaker output; "function selector" for any mode of mono or stereo operation; "stereo reverse"; "balance" and "separation" controls; ganged volume controls; and separate concentric bass and treble tone controls. 30 lbs.

Model AA-100 (kit) \$8.50 dn. **\$84.95**
 Model AAW-100 (wired) . . \$14.50 dn. **\$144.95**

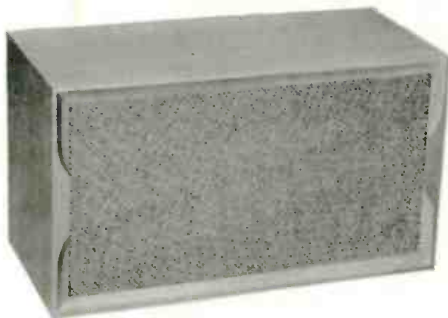
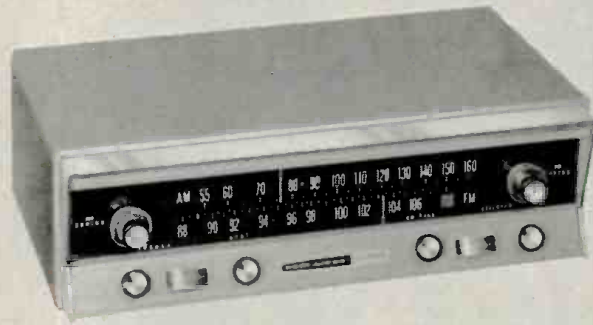

ACOUSTIC SUSPENSION SPEAKER SYSTEM KIT

Its "bookshelf" size belying its gigantic capabilities, this amazing unit outperforms speakers 4-times its size. A 10" acoustic suspension woofer and two "dispersed-array" cone tweeters deliver high-fidelity tone with fantastic brilliance over the entire range of 30-15,000 cps, ± 5 db. Preassembled cabinet in choice of finishes or unfinished woods. Measures 24" L x 11 1/2" D x 13 1/2" H. 28 lbs.

Model AS-10M or W (mag. or wal.) . . \$6.50 dn. **\$64.95**
 Model AS-10U (unfinished) . . . \$6.00 dn. **\$59.95**

STEREO EQUIPMENT ENCLOSURE ENSEMBLE

Now, just in time for Christmas, Heathkit introduces new factory-assembled, ready-to-use equipment and speaker cabinets designed to house complete monophonic or stereophonic systems. The cabinets, resplendently styled in a timeless and universally compatible motif, are available in rich hand-rubbed walnut or mahogany finishes . . . or unfinished if desired. 3/4" stock is used for all exterior panels and supports; solids for edgings, furniture grade veneers for front and side panels and shelves. Versatile in accommodations, the center cabinet has room for all components of a complete stereo or mono hi-fi system except speakers. The changer compartment will accept any Heathkit record changer or most tape recorders. The storage compartment holds records and tapes or using an accessory slide-out drawer may be used for a tape recorder. Two shelf compartments accept tuners and amplifiers. The power amplifier compartment will hold any Heathkit stereo power amplifier, a pair of UA-2 mono amplifiers or any single mono amplifier. The handsome speaker-wing cabinets in two models for 12" and 15" speakers are designed to blend into the flowing lines of the center cabinet and are perfectly acceptable as single console speaker enclosures. Adapter rings are provided for using other size speakers, while a special port is provided for installation of a horn-type tweeter.

Complete ensemble as low as **\$133.50**. Send for details in FREE HEATHKIT CATALOG.

completely assembled
. . . quality construction
. . . contemporary styling . . . low cost



HEATHKIT®... for finer

PORTABLE 4-TRACK STEREO TAPE RECORDER KIT

What better gift than this? ... a compact portable tape recorder just waiting to record the caroling, frolicking family joys of the holiday season! You'll thrill to the natural stereophonic sound of this new unit that also serves as a hi-fi power center for your tuner and record player. Tape deck and cabinet are preassembled.

Model AD-40... \$18.00 dn., \$16.00 mo. **\$179.95**

STEREO/MONO PORTABLE STEREO PHONO KIT

Thrill to your favorite Christmas recordings in life-like stereo! This GD-10 offers you complete stereo and mono operation *plus* portable convenience. Handsome aqua and white two-tone vinyl clad cabinet and four-speed automatic changer come preassembled—you build only the amplifier in just a few enjoyable hours. Changer has turnover diamond and sapphire stereo cartridge. Complete tone controls. Measures 15½" W x 18" D x 8¾" H. 28 lbs.

Model GD-10... \$7.00 dn., \$7.00 mo. **\$69.95**

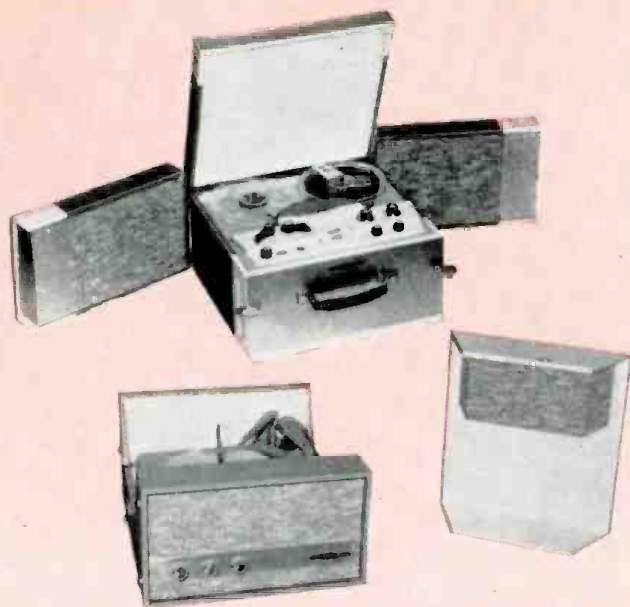

HIGH FIDELITY AM TUNER KIT

Here is the AM counterpart of the best selling Heathkit FM-4 tuner bringing you high fidelity AM reception plus many extras. Switch selection of broad or narrow band width, flywheel tuning, edge-lighted slide-rule dial, built-in antenna, self-powered. Styled to match Heathkit FM-4.

Model AJ-20 **\$29.95**



AUTOMATIC RECORD CHANGER KIT

Jam-proof mechanism ... quick-change cartridge holder ... "muting" switch ... and "size-selector" for intermixing 7", 10" and 12" records of the same speed! Holds up to 10 records for hours of delightful stereo or mono listening enjoyment.

Model AD-50... **\$49.95 to \$54.95** depending on cartridge.

Other models from **\$22.95**. Send for **FREE** Heathkit catalog today!



EDUCATIONAL KIT

Perfect gift for all ages ... a basic course in radio that teaches radio theory in a way you can understand. Actual experiments are performed with radio parts supplied leading in successive steps from the construction of a simple crystal radio to a genuine regenerative radio receiver. Designed as a continuation of the popular E.K.-1 Educational Kit but equally valuable as a starting point in radio electronics.

Model EK-2A ... 8 lbs. **\$19.95**



HAND-HELD CITIZENS BAND TRANSCEIVER

The perfect HEATHKIT for everyone on your shopping list! No license required ... anyone can use this 2-way radio! Operates up to a mile between units ... more with regular Citizens Band stations. It's ideal for hunting, fishing, boating ... most anywhere you need 2-way communications. Features 4-transistor circuit; fixed-tuned, super-regenerative receiver and crystal-controlled transmitter. 3 lbs.

Model GW-30 (kit) **\$32.95** (64.95 a pair)

Model GWW-30 (wired) **\$50.95** (99.95 a pair)

DELUXE 2-WAY CITIZENS BAND TRANSCEIVER

This Christmas, give the best that money can buy in a Citizens Band Transceiver. The efficient superheterodyne receiver has an automatic "noise limiter" and adjustable "squeal" control, single channel "crystal" or continuous tuning. The transmitter has press-to-talk microphone and can be switched to any of the three crystal-controlled channels. Choose the "under-dash" DC mobile model or "fixed" station AC unit. 11 lbs.

Model GW-10 (kit) \$6.30 dn., \$6.00 mo. **\$62.95**

Model GWW-10 (wired) ... \$10.00 dn., \$9.00 mo. **\$99.95**

(specify 117 v AC or 6 or 12 v DC model)

gifts of lasting value!

"SPACE-SAVER" 3" DC OSCILLOSCOPE KIT

Almost, but not quite tiny enough for a Christmas stocking, this compact scope saves valuable work-bench space, while providing versatile features to fill a multitude of applications in medical, industrial and general service fields. Ideal as a "read-out" for computers; for wave-form observations; and for voltage, frequency and phase shift measurements. Identical vertical and horizontal DC coupled amplifier, transformer operated power supply—and many more outstanding features.

Model IO-10... 14 lbs... \$8.00 dn., \$8.00 mo. **\$79.95**

LABORATORY 5" OSCILLOSCOPE KIT

A real time-saver in audio and TV service work, where the same sweep frequencies are used over and over; the IO-30 offers two extra, switch-selected, pre-set sweep frequencies. Kit is supplied with capacitors appropriate for TV service giving preset frequencies of 30 cycles and 7875 cycles; by changing capacitor values, any two desired preset frequencies within the sweep frequency range can be made available.

Model IO-30... 22 lbs... \$7.70 dn., \$7.00 mo. **\$76.95**

2 new scopes . . .
just in time for Christmas!

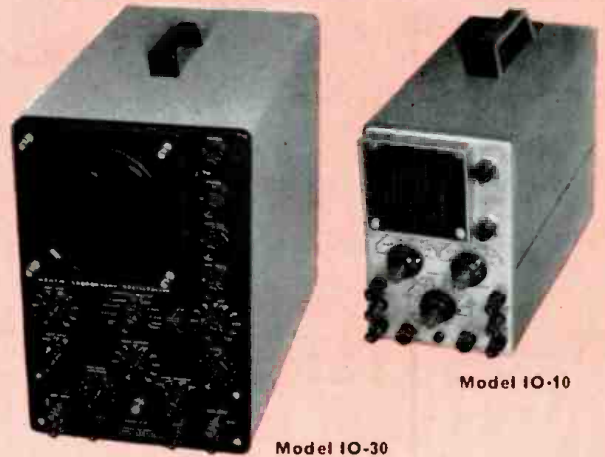

Model IO-10

Model IO-30



PHONE AND CW TRANSMITTER KIT

Brand-new in every respect, the DX-60 combines smart styling, top-flight performance and low Heathkit cost to offer the "Amateur rig" value of the season. Ideal for General class Amateurs, the Transmitter may also be run at reduced power for novice operation. Covers 80 through 10 meters. Power input: 90 watts peak, carrier controlled phone or CW. 27 lbs.

Model DX-60... \$8.30 dn. **\$82.95**



2, 6 & 10 METER TRANSCEIVER KITS

Make a hit with the "Hams" on your gift list by giving one of these outstanding transceivers. All are identically styled to the popular Heathkit CB-1 Citizens Band Transceiver; feature variable-tuned superregen receivers; 5-watt input crystal-controlled transmitters. All are supplied with mike, power cables and AC power supply.

Model HW-30... (2 meter) **\$49.95**

Model HW-29... (6 meter) or

HW-19 (10 meter) **\$39.95 ea.**



DELUXE VACUUM TUBE VOLTMETER KIT

Hobbyist and professional alike will prize this useful gift. This brand-new Heathkit features big, easy-to-read 6" meter with multi-color scales; high-visibility switches; greater accuracy; longer meter scales; special low voltage AC scales; broader frequency response; thumb-wheel controls and easy-access adjustments.

Model IM-10... 7 lbs. **\$32.95**



SEND FOR
YOUR FREE
HEATHKIT®
CATALOG



You'll find the perfect gift for family or friends among the over 200 Heathkit items for hi-fi fans, amateur radio operators, students, technicians, marine enthusiasts, sports car owners and hobbyists. And many Heathkit products are now available in both wired and kit form!

ORDER DIRECT BY MAIL OR SEE YOUR HEATHKIT DEALER



ORDERING INSTRUCTIONS

Fill out the order blank below. Include charges for parcel post according to weights shown. Express orders shipped delivery charges collect. All prices F.O.B. Benton Harbor, Mich. A 20% deposit is required on all C.O.D. orders. Prices subject to change without notice.

HEATH COMPANY,
Benton Harbor 15, Michigan

Please send the following HEATHKITS:

ITEM	MODEL NO.	PRICE

Ship via () Parcel Post () Express () COD () Best Way

() SEND MY FREE COPY OF YOUR COMPLETE CATALOG

Name _____

Address _____

City _____ Zone _____ State _____

Dealer and export prices slightly higher.

IMPROVE Your Present Amplifier by Replacing with Mullard

EL34/6CA7



Recognized as the finest high power output pentode up to 100 watts in push-pull. Designed specifically for High Fidelity and produced by precision craftsmen with these design features:

- Golden grids
- Linear characteristics
- Low-drive voltage
- Clean crisp output

Replaces 6L6G, 6L6GB, 6L6GC, 5881, EL37, 7027



Trade Mark Mullard Ltd.

OTHER Mullard TUBES
designed specifically for High Fidelity:

EB91/6AL5	Double Diode
ECC81/12AT7	Low-noise medium μ dual triode
ECC82/12AU7	Low-noise low μ dual triode
ECC83/12AX7	Low-noise high μ dual triode
ECC85/6AQ8	RF Double triode
ECC88/6AQ8	Frame grid RF Double triode
ECC82/6U8	RF triode pentode
ECL82/6BM8	Triode with Output Pentode
EF86/6Z67	Low-noise input pentode
EF94/6AU6	RF AF pentode
EL37	High-power Pentode, 69 W PP
EL84/6BQ5	Miniature output pentode 20 W PP
EM84/6FG6	Miniature tuning indicator
EZ80/6V4	Miniature rectifier cathode type, 90 ma.
EZ81/6CA4	Miniature rectifier cathode type, 150 ma.
GZ34/5AR4	Bantam rectifier cathode type, 250 ma.
7189	Miniature output pentode 20W PP
7025	AF Double triode

Available at all leading distributors.



NOW AVAILABLE: "Mullord Circuits for Audio Amplifiers"—136 pages of Stereophonic and Monophonic Audio Amplifiers, AM Tuners, Preamplifiers—only \$2.50 from your dealer or by mail.

For detailed technical data and application information write:

INTERNATIONAL ELECTRONICS CORP.
81 Spring Street, New York 12, N. Y.

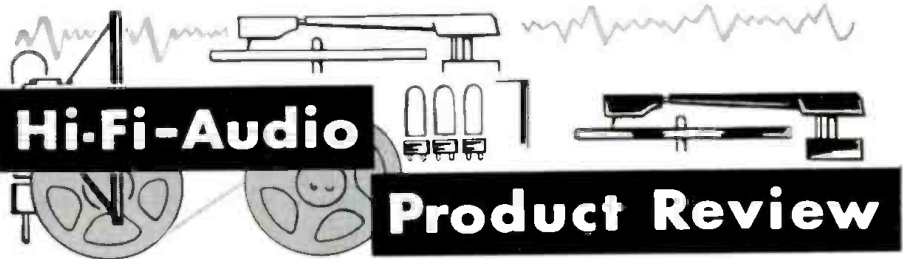

STEREO TUNER-AMPLIFIER
Eric Engineering, 1823 Colorado Ave., Santa Monica, Calif. has brought out a stereo FM-AM tuner, with a dual-channel integrated amplifier on one chassis. The tuner section receives FM and AM



broadcasts individually or simultaneously. The amplifier sections, rated at 10 watts per channel, provide inputs and controls for all mono and stereo program sources. Response, of both the tuner and amplifier sections, is given as 20-20,000 cycles.

The manufacturer also has announced its Model 2457 FM tuner which features sensitivity of 1.5 microvolts for 20 db of quieting, and a front-panel "defeat" switch for the a.f.c. circuit. Additional information may be obtained from the manufacturer.

NEW HEATHKITS

Heath Company, Benton Harbor, Mich. has announced several new audio kits, suitable for hi-fi stereo or mono applications. These include a dual 25-watt integrated amplifier (Model AA-100, kit; Model WAA-100, wired) and a stereo FM-AM tuner (Model AJ-30, kit; Model AJW-30, wired).

Available only in kit form is the new Model AA-10 35-watt power amplifier. Other new kits include the AD-50 and AD-60 series of four-speed record changers, and the AD-70 tape player for 4-track playback of pre-recorded stereo tapes. The signals from the tape deck may be connected directly to existing stereo preamplifiers or integrated amplifiers having suitable "tape head" inputs.

The cabinet grouping, shown here, is available only in ready-built form, but



may be purchased unfinished or finished in walnut or mahogany. Model AE-20

designates the center unit (for equipment). Model AE-30 is an enclosure for 12-inch speakers, while Model AE-40 is a 15-inch speaker enclosure.

STEREO CONTROLS

Clarostat Mfg. Co., Inc., Dover, N. H. has made available matched element controls that provide tracking characteristics suitable for use in dual-channel sound systems.

The new controls are dual assemblies made up on the basic Series 37 or Series 47 designs by this company. Tracking is available to ± 2 db with a range of 80 db. Other tolerances, including ± 4 and 6 db tracking in 40, 60, and 80 db ranges, are also available.

CERAMIC CARTRIDGE

Sonotone Corp., Elmsford, N.Y. has announced its Model 9T ceramic stereo cartridge. Claimed response is 20 to 17,000 cps ± 1 db.



The new 9T is a turnover type which plays all speeds and either stereo or mono discs. It is available with two sapphire tips, or one diamond and one sapphire. Output voltage is 0.4 volt. High compliance (stated as 3.5×10^6 cm./dyne) is said to reduce tracking pressure to as little as 2 grams for professional tone-arms and 3 grams for changers.

According to the manufacturer, the 9T has mechanical improvements that eliminate the accumulation of dust around the stylus. Needles can be replaced easily and the pre-wired terminal plug simplifies installation. The cartridge is shielded electrically and mechanically.

STEREO TAPE RECORDER

Viking of Minneapolis, Inc., 9600 Aldrich Ave. So., Minneapolis 20, Minn. has announced its "Stereo-Compact" unit, combining the Viking 85 tape transport with dual tape preamplifiers on one integrated chassis. The system will record stereo tapes from any stereo program source. Independent use of either channel for mono recording is also possible. Similarly, the new unit also plays back in mono or stereo.

It is available in two models. Model ESQ offers half-track erase and recording heads and short-gap, quarter-track play heads. Model RMQ offers quarter-track recording with exclusive wide-gap

recording heads and short-gap play heads.

A new feature of these units is the

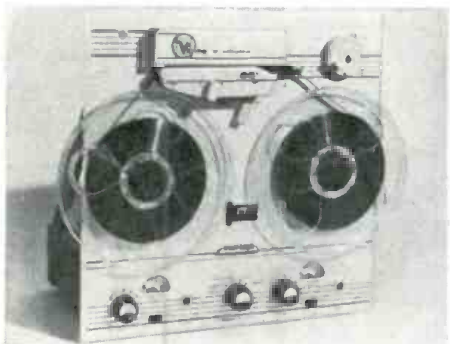

"Erase-Protek" system which insures against accidentally erasing previously recorded material.

CONDENSER MICROPHONE

Electronic Applications, Inc., Stamford, Conn. has announced the C-14 microphone, designed and built by *AKG* of Vienna. The microphone requires a polarizing voltage of 160 v., provided by two 87½-volt dry cells or tapped from recorder circuits.

Furnished with the microphone is an input plug, capacitor, and two resistors required in the mike circuit, and instructions for circuit modification.

The C-14 is said to have an omnidirectional characteristic, a sensitivity of 3 mv./microbar, and a response from 30 to 18,000 cps \pm 6 db. It is a high-impedance type.

STEREO POWER AMPLIFIER

Fisher Radio Corp., 21-21 44th Drive, Long Island City 1, N.Y. has brought out its model SA-300-B basic stereo amplifier. Rated at over 35 watts r.m.s. per channel, the new amplifier is said to deliver 45 watts of music power per channel. Each channel has connections for 4-, 8-, and 16-ohm speakers. Additionally, terminals are provided for adding a resistor to match the speaker's recommended damping factor.

Another feature is the "center channel" output jack which allows a third amplifier and speaker to be connected.



This additional sound source can be used as a remote monophonic system, or as a "fill" between two stereo speakers.

The SA-300-B uses ten tubes. Controls include input level, a.c. balance, d.c. balance, and hum balance for each channel, plus a balance-adjust switch, and a bias control.

78 RPM CARTRIDGE

H. H. Scott, Inc., 111 Powdermill Road, Maynard, Mass. has announced a new *London-Scott* "broadcast quality" cartridge, with 3-mil stylus, for playing 78 rpm records. The new cartridge is

November, 1960

economy without tears...



in a hi-fi turntable

TD-134, \$59.95 net. Optional base, \$6.00

It's the Thorens TD-134—one hi-fi bargain that's *really* a bargain.

Buy a Thorens TD-134, and you get the matchless Swiss-precision craftsmanship that make the superb Thorens TD-124 turntable the talk of hi-fi circles, here and abroad. Your dealer invites you to examine the mirror-finished, precision machining that contributes so much to the smooth-running, low-rumble characteristics of *all* TD-series turntables.

You save with an integral, built-in, high-performance tone-arm that has

tracking ability and distortion characteristics to equal those of much more costly separate arms.

Last but not least, TD-134, like all the TD family of fine turntables, is backed by the Thorens one-year guarantee . . . a feature that gives you confidence in your decision to buy any Thorens turntable.

See the TD-134 at your franchised Thorens dealer's today, and, while you're there, get acquainted with all the fabulous TD turntables. You won't regret it.

O.4

Guaranteed for one full year.

Sold only through carefully selected franchised dealers.



THORENS

SWISS MADE PRODUCTS
HI-FI COMPONENTS • LIGHTERS
SPRING-POWERED SHAVERS
MUSIC BOXES
NEW HYDE PARK, NEW YORK

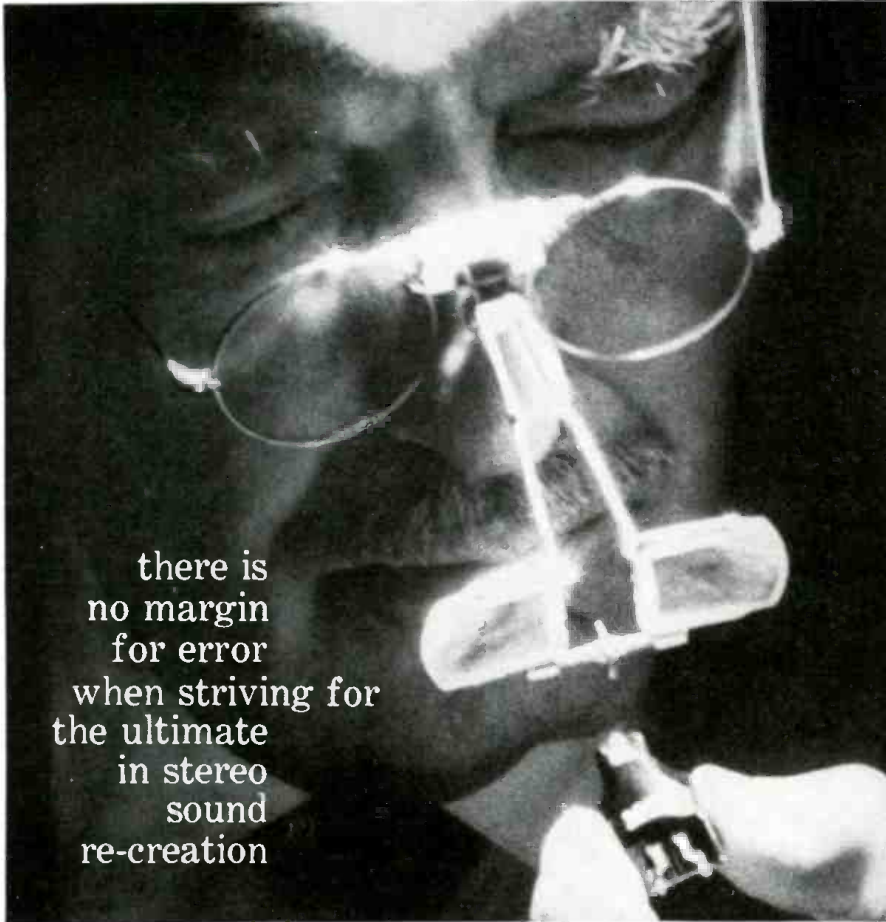

there is
no margin
for error
when striving for
the ultimate
in stereo
sound
re-creation

SHURE

Stereo Dynetic

HI-FI PHONO CARTRIDGES

Tiny though it is, the cartridge can make or break a stereo system. For this breathtakingly precise miniaturized electric generator (that's really what it is) carries the full burden of translating the miles-long undulating stereo record groove into usable

electrical impulses... without adding or subtracting a whit from what the recording engineer created. Knowing this keeps Shure quality standards inflexible. Shure Brothers, Inc., 222 Hartrey Avenue, Evanston, Illinois.

CARTRIDGES

- Standard M8D. A superb blend of quality and economy... \$16.50
- Custom M7D. Widely acclaimed; moderately priced... \$24.00
- Professional M3D. Overwhelming choice of the critics... \$45.00
- Laboratory Standard Model M3LS. Individually calibrated, limited quantity... \$75.00



TONE ARMS

- Studio Dynetic. Integrated arm and cartridge. Cannot scratch records... \$89.50
- Professional Independent Tone Arm. For any quality cartridge... \$29.95

Lag-55 Audio Generator Sine Square

A multi-purpose generator for measurements on audio equipment—amplifiers, speakers, networks. Three waveforms: sine, square and complex for all types of measurements including response, distortion, transient and I-M distortion checks. Full range is from 20 to 200,000 cps, output 5 volts with minimum amplitude variation throughout whole range.

new "LEADER" test instrument



OHMATSU ELECTRIC CO. LTD.

850 Tsunashima-Cho, Kohoku-Ku
Yokohama, Japan.

interchangeable on the *London-Scott* arm with the same manufacturer's Model 1000 stereo-LP cartridge.

The company also has announced that it will replace any of its original Model 1000 stereo cartridges—irrespective of age or condition—with a new, ruggedized version. For full information, write to the manufacturer.

NEW SPEAKER SYSTEMS

Jensen Manufacturing Co., 6601 S. Laramie Ave., Chicago 38, Ill. has announced its new "Decorator Group" speaker systems. The TR-30 "Tri-ette" is a complete 3-way system utilizing a



12-inch "Flexair" woofer. Power rating is 30 watts (60 watts peak); impedance is 8 ohms; frequency range is listed as 20 cycles to beyond audibility.

The new "Galaxy III," shown here, is a stereo speaker system consisting of a bass-center unit and two satellites. A 12-inch "Flexair" woofer reproduces the bass up to 350 cycles on both channels, while the two satellite speakers handle the mid-range and treble separately for each channel.

Model TF-3 is a 3-way speaker system utilizing four drivers. These include a 10-inch "long travel" "Flexair" woofer, two mid-range units, and a new spherical sector super-tweeter for extreme highs.

All systems are available in a variety of wood styles and finishes.

THICK-PANEL PHONE JACK

Switchcraft, Inc., 5555 N. Elston Ave., Chicago 30, Ill. has introduced a new phone jack that can be mounted in panels up to 1¼-inches thick. It mates with the company's "Little Plug" and is available in two-conductor or three-conductor type.

The jack is shielded, with no exposed contact springs, and is said to eliminate the hum caused by pickup with unshielded types.

FM TUNER KIT

Lafayette Radio, 165-08 Liberty Ave., Jamaica 33, N.Y. has announced a new FM tuner kit. Designated by stock num-



ber KT-650, the tuner features a low-noise front end with triode mixer, plus double-tuned dual limiters, and wide-

band Foster-Seeley discriminator. Sensitivity is 2 μ v. for 30 db of quieting.

Variable a.f.c. is included. Frequency response is given as 15 to 35,000 cps \pm 1/2 db with a standard 75 μ sec. de-emphasis network. Distortion and noise are stated to be better than 55 db below 1.5 volts at 100% modulation.

Construction features include the use of printed circuits and pre-aligned i.f. and discriminator coils.

"SOFT SOUND" AMPLIFIER

Electronic Systems Engineering Co., 903 Cravens Bldg., Oklahoma City, Okla., has announced its Model SS-10 Limpander "soft sound" amplifier.

Designed for public-address work, the SS-10 boasts a background noise suppression system. All input controls are tamper-proof and the output control can be adjusted without the howls of feedback.

The amplifier is equipped with three low-impedance inputs for microphone and phono. Outputs include 4-, 8-, and 16-ohm speaker connections. According to the manufacturer, output will be substantially constant with 50 db change in input. The SS-10's high-speed

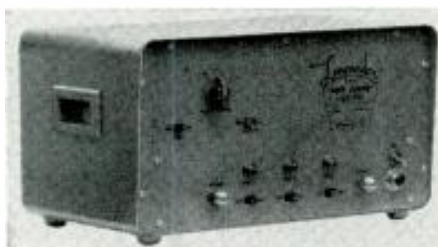

limiter has a 150 μ sec. attack and a 75 msec. release. This produces "soft sound" amplification with a resultant improvement in intelligibility.

Response is said to be flat from 50 to 15,000 cps; output power is "sufficient for auditoriums with 1000 seating capacity."

CEILING SPEAKER

Olson Radio Corp., 260 S. Forge St., Akron, Ohio has announced its model



S-394 thin-line speaker, designed for flush mounting on a wall or ceiling. The six-inch speaker has an over-all depth of 3 inches; impedance is 8 ohms. Response is given as 60 to 13,000 cycles.

GRAY PHONO COMPONENTS

The High Fidelity Division of *Gray Manufacturing Co.*, 16 Arbor St., Hartford 1, Conn., has announced its new line of turntables and tone-arms.

Heading the line is the Model ST-33 turntable, shown here with the company's 212-TN arm and Model C-33



"REK-O-KUT"—the safest word you can say to your dealer

For sixteen years, Rek-O-Kut has been synonymous with highest quality in turntables. As other brands have risen, fallen and even completely disappeared, Rek-O-Kut has won consistent acclaim as the overwhelming choice in its field. In performance ratings as well as engineering contributions to turntable design, Rek-O-Kut has compiled a record unchallenged by any other turntable producer. Now, this tradition is again emphasized by the introduction of the N-34H STEREOTABLE... a professional quality, two speed (33 1/3 and 45 rpm) turntable. Quiet power is furnished by a Rek-O-Kut hysteresis synchronous motor and an efficient new belt-drive system. Speeds can be changed even while the table is rotating, merely by pressing a lever.

The N-34H is a symphony of crisp, clean lines accentuated by the unusual deck design. Mated with the new tapered base, the N-34H becomes one of the proudest and most beautiful components ever to grace a home music system. See it at your dealer's.

N-34H STEREOTABLE only—\$79.95 net. Shown with new Rek-O-Kut Micropoise Stereo Tonearm, Model S220, \$29.95 net. Tapered base in hand-rubbed, oiled walnut, \$14.95.

**A NEW DIMENSION
IN TURNTABLES—12 5/8" x 19"—
DESIGNED TO FIT
NARROW CABINETS
AND BOOKSHELVES!**



SPECIFICATIONS: Noise Level:—53db below average recording level; Wow and Flutter: 0.15% Drive: Nylon, neoprene-impregnated endless belt. 2-Speeds, 33 1/3 and 45 rpm.

NOTE: COMING SOON... ANOTHER GREAT DEVELOPMENT... Rek-O-Kut AUTO-POISE—makes any Rek-O-Kut tonearm you buy now—fully automatic



**REK-O-KUT
STEREOTABLES**

Export: Morhan Exporting Corp., 458 Bway, N.Y. 13
Canada: Atlas Radio, 50 Wingold Ave., Toronto 19



Rek-O-Kut Company, Inc., Dept EW-11
38-19 108th Street, Corona 6B, N.Y.
Please send me complete details on the
new N-34H STEREOTABLE:

Name _____
Address _____
City _____ Zone _____ State _____

LESA... for STYLE and PERFORMANCE

The classic, smart appearance of the LESA CD2/21 stereo record changer previews the perfection of performance you can expect from this precision component, custom crafted in the discriminating Italian tradition. Whether you are just stepping into hi-fi, or have been an enthusiast for some time, compare... you'll find LESA has everything.

- Fully automatic, 4-speeds • pre-wired for monaural and stereo • Minimum rumble, flutter and wow • Constant speed-change cycle—only 6 seconds • Absolutely jam-proof • Automatic size intermix • Heavy duty four-pole motor • Gentle record handling • Universal plug-in head • No background noise • Stop without rejecting • Automatic click suppressor • Finished most attractively in smart continental styling. Write for free LESA literature and name of nearest dealer to: Electrophono & Parts Corp. 530 Canal St. New York, N. Y.

\$44.50

Slightly higher
in the West

CD2/21 High-Fidelity Stereo Record Changer

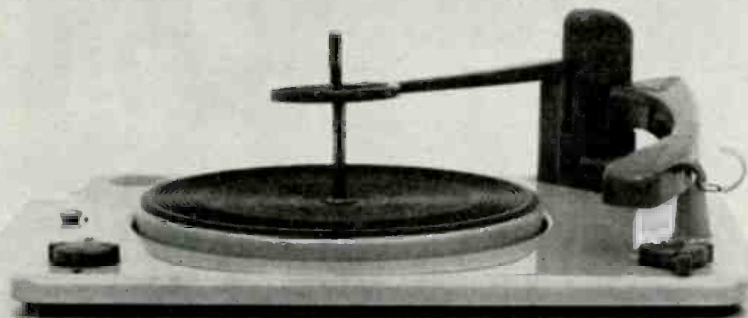

LESA

MILLER

FM tuner

assembly for
experimenters

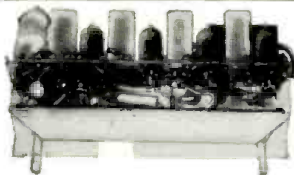

MODEL 579

—hi-fi performance
at minimum cost

Here is a completely wired and tested high fidelity FM tuner—sold for less than you would pay for parts alone. All critical circuits are assembled and aligned. You add only a simple power supply to operate.

Quality Features: Tuned R.F. stage • Ultra-stable permeability tuning • Dual limiters • Oscillator stage fully shielded • Negligible warmup drift • AFC with defeat control • Outputs: cathode—follower audio, FM multiplex.

Specifications: Six tubes • Tuning range: 86 to 110 mc • Typical sensitivity: 1.0 μ V for 20 db quieting; 2.1 μ V for 30 db quieting. Typical selectivity: 200 kc at 6 db • Frequency response: 15 to 25,000 cps.

Model 579—completely wired PRICE: \$37.50

Model 580 — in attractive 2-tone cabinet \$69.50

Ask your Miller distributor for

"The Coil Forum," Vol. 1, No. 2, or write direct.



J. W. MILLER CO.

5917 South Main Street, Los Angeles 3, Calif.
Manufacturers of Quality Radio
and TV Equipment Since 1923

mounting base. The ST-33 has a hysteresis-synchronous motor and belt drive. The PK-33 turntable kit is similar to the ST-33, but comes in "do-it-yourself" form. The 212 series of tone-arms all use viscous damping and are available in four models. The 212-TN and 212-TG arms are factory assembled and need only a screwdriver for installation. The SAK-12N and SAK-12G arms are kit versions.

The 212-TN and SAK-12N have brushed aluminum finish with black



trim. Models 212-TG and SAK-12G have a gray baked-enamel finish with contrasting gray trim.

All arms in the series are rotationally balanced with slides and weights which allow a choice of cartridges without upsetting the arm's dynamic balance or requiring special adjustment of tracking pressure when a cartridge is changed.

ADAPTER BUSHING

Centralab, Division of Globe-Union, Inc., 900 E. Keefe Ave., Milwaukee 1, Wis., is offering an adapter bushing for hi-fi chassis mounting.

According to the manufacturer, this adapter fits over the standard bushing on the controls of a high-fidelity unit

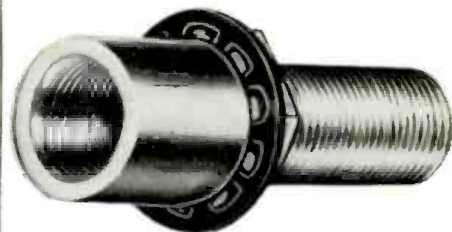

and extends through the panel of the cabinet. Although it is designed primarily for mounting a chassis in a cabinet, it also is suited for mounting T-pads and L-pads in speaker enclosures.

Known as the AK-31 adapter bushing, the unit measures 1½ inches overall. It will extend the standard ¾-inch, ⅜-32 thread bushing to one inch.

REK-O-KUT STEREO ARM

Rek-O-Kut Co., Inc., 38-19 108th St., Corona 68, N.Y., is offering a new stereo tone-arm that features a permanently attached cable for direct connection to an amplifier.

Called the "Micropoise," the arm comes in two models: a 12-inch unit, Model S-220; and a 16-inch version, Model S-260.

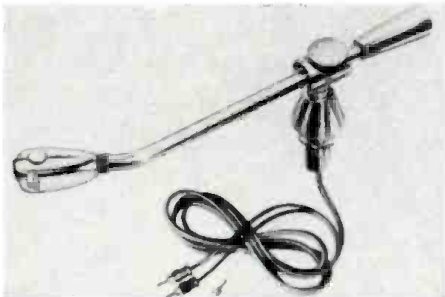

The cable terminates in two color-coded plug-in leads, two shields, and a ground wire. This assembly eliminates the need for soldering and handling separate wires.

The "Micropoise" arm is statically balanced by counterweight adjustment. Then, by dialing the spring-tension knob which is calibrated from 0 to 6 grams, proper dynamic balance and stylus pressure can be adjusted. Free vertical and lateral movement is accomplished by the arm's gimbal assembly which includes twin sets of five-ball, one-millimeter bearings.

TRANSISTOR TAPE RECORDER

Telectrosonic Corp., Consumer Products Division of Telectro Industries Corp., 35-18 37 St., Long Island City 1, N.Y. has announced what it calls "the

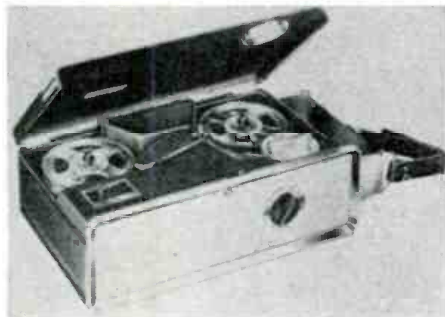

first low-cost American transistorized portable tape recorder." Designated as Model MR511, the new recorder may be operated interchangeably on regular house current, on a 12-volt automobile system, or on its own batteries. It uses 3-inch reels and can record for 1½ hours at 1½ inches-per-second.

AUDIO CATALOGUES

NEW NEEDLE CATALOGUE

Jensen Industries, Forest Park, Ill. has issued a 12-page booklet listing 800 different types of special-shank phono needles and matching cartridges.

Called the "Jenseneedlog," the guide furnishes a complete cartridge-number-to-needle-number reference section as well as a full condensation of Jensen's needle wall chart.

"HOW-TO" TAPE GUIDES

ORR Industries, Opelika, Ala. has issued two booklets for tape recordists. "How to Make Better Tape Recordings" offers precise advice on recording practice, microphone placement, selection of tape, and other hints valuable to the amateur recordist.

"Tape It Off the Air" details the techniques involved in making good tape recordings from broadcast sources. Both booklets are free on request. [30]

*Time to
clean up
your system...*

Norelco®

T-7 LOUDSPEAKERS

with voice-coil magnets of Ticonal-VII alloy (30% more efficient than Alnico-V)

**GUILD-CRAFTED BY
PHILIPS OF THE
NETHERLANDS**

TO GIVE YOU

30% more efficient response to the full signal range of your amplifier... whether its rated output is ten watts or a hundred... at any listening level from a whisper to a shout!

TO GIVE YOU

the audio realism you originally expected from your system!

TO GIVE YOU

**THE CLEANEST
SOUND
AROUND**



Ask for a demonstration wherever good sound is sold, or write to:

**NORTH
AMERICAN
PHILIPS
CO., INC.**

High Fidelity
Products Division
230 Duffy Avenue,
Hicksville, L.I., N.Y.



STANDARD PROFESSIONAL

TUBE TESTER

★ Tests all tubes, including 4, 5, 6, 7, Octal, Lock-in, Hearing Aid, Thyatron, Miniatures, Sub-miniatures, Novals, Subminars, Proximity fuse types, etc.

★ Uses the new self-cleaning Lever Action Switches for individual element testing. Because all elements are numbered according to pin-number in the RMA base numbering system, the user can instantly identify which element is under test. Tubes having tapped filaments and tubes with filaments terminating in more than one pin are truly tested with the Model TW-11 as any of the pins may be placed in the neutral position when necessary.

★ The Model TW-11 does not use any combination type sockets. Instead individual sockets are used for each type of tube. Thus it is impossible to damage a tube by inserting it in the wrong socket.

★ Free-moving built-in roll chart provides complete data for all tubes. All tube listings printed in large easy-to-read type.

NOISE TEST: Phono-jack on front panel for plugging in either phones or external amplifier will detect microphonic tubes or noise due to faulty elements and loose internal connections.

EXTRAORDINARY FEATURE

SEPARATE SCALE FOR LOW-CURRENT TUBES: Previously, on emission-type tube testers, it has been standard practice to use one scale for all tubes. As a result, the calibration for low-current types has been restricted to a small portion of the scale. The extra scale used here greatly simplifies testing of low-current types.

The Model TW-11 operates on 105-130 Volt 60 Cycles A.C. Comes housed in a handsome, portable Saddle-Stitched Tex-on Case. Only.....

\$47⁵⁰

Model TW-11—TUBE TESTER . . . Total Price \$47.50—Terms: \$11.50 after 10 day trial, then \$6.00 per month for 6 months if satisfactory. Otherwise return, no explanation necessary!

SUPERIOR'S NEW MODEL 80



20,000 OHMS PER VOLT ALLMETER

THE ONLY 20,000 OHMS PER VOLT V.O.M. SELLING FOR LESS THAN \$50 WHICH PROVIDES ALL THE FOLLOWING FEATURES:

- ✓ **6 INCH FULL-VIEW METER** provides large easy-to-read calibrations. No squinting or guessing when you use Model 80.
- ✓ **MIRRORED SCALE** permits fine accurate measurements where fractional readings are important.
- ✓ **CAPACITY RANGES** permit you to accurately measure all condensers from .00025 MFD to 30 MFD in addition to the standard volt, current, resistance and decibel ranges.
- ✓ **HANDSOME SADDLE-STITCHED CARRYING CASE** included with Model 80 Allmeter at no extra charge enables you to use this fine instrument on outside calls as well as on the bench in your shop.

• A built-in Isolation Transformer automatically isolates the Model 80 from the power line when capacity service is in use.
• Selected, 1% zero temperature coefficient metalized resistors are used as multipliers to assure unchanging accurate readings on all ranges.

SPECIFICATIONS:

- 7 **D.C. VOLTAGE RANGES:**
(At a sensitivity of 20,000 Ohms per Volt)
0 to 15/75/150/300/750/1500/7500 Volts.
- 6 **A.C. VOLTAGE RANGES:**
(At a sensitivity of 5,000 Ohms per Volt)
0 to 15/75/150/300/750/1500 Volts.
- 3 **RESISTANCE RANGES:**
0 to 2,000/200,000 Ohms. 0-20 Megohms.
- 2 **CAPACITY RANGES:**
.00025 Mfd. to .3 Mfd. .05 Mfd. to 30 Mfd.
- 5 **D.C. CURRENT RANGES:**
0-75 Microamperes. 0 to 7.5/75/750 Milliamperes. 0 to 15 Amperes.
- 3 **DECIBEL RANGES:**
- 0 db to + 18 db + 34 db to + 58 db + 14 db to + 38 db

Model 80 Allmeter comes complete with operating instructions, test leads and portable carrying case. Only

\$42⁵⁰ NET

Model 80 — ALLMETER . . . Total Price \$42.50—Terms: \$12.50 after 10 day trial, then \$6.00 monthly for 5 months if satisfactory. Otherwise return, no explanation necessary!

NOTE: The line cord is used only for capacity measurements. Resistance ranges operate on self-contained batteries.

GENOMETER

7 Signal Generators in One!

- ✓ R.F. Signal Generator for A.M.
- ✓ R.F. Signal Generator for F.M.
- ✓ Audio Frequency Generator
- ✓ Bar Generator
- ✓ Cross Hatch Generator
- ✓ Color Dot Pattern Generator
- ✓ Marker Generator

A versatile all-inclusive GENERATOR which provides ALL the outputs for servicing:

A.M. Radio • F.M. Radio • Amplifiers • Black and White TV • Color TV



Model TV-50A—Genometer
Total Price\$47.50
Terms: \$11.50 after 10 day trial, then \$6.00 monthly for 6 months if satisfactory. Otherwise return, no explanation necessary.

R. F. SIGNAL GENERATOR: The Model TV-50A Genometer provides complete coverage for A.M. and F.M. alignment. Generates Radio Frequencies from 100 Kilocycles to 60 Megacycles on fundamentals and from 60 Megacycles to 180 Megacycles on powerful harmonics.

VARIABLE AUDIO FREQUENCY GENERATOR: In addition to a fixed 400 cycle sine-wave audio, the Model TV-50A Genometer provides a variable 300 cycle to 20,000 cycle peak wave audio signal.

BAR GENERATOR: The Model TV-50A projects an actual Bar Pattern on any TV Receiver Screen. Pattern will consist of 4 to 16 horizontal bars or 7 to 20 vertical bars.

THE MODEL TV-50A comes absolutely complete with shielded leads and operating instructions.

CROSS HATCH GENERATOR: The Model TV-50A Genometer will project a cross-hatch pattern on any TV picture tube. The pattern will consist of non-shifting, horizontal and vertical lines interlaced to provide a stable cross-hatch effect.

DOT PATTERN GENERATOR (FOR COLOR TV): Although you will be able to use most of your regular standard equipment for servicing Color TV, the one addition which is a "must" is a Dot Pattern Generator. The Dot Pattern projected on any color TV Receiver tube by the Model TV-50A will enable you to adjust for proper color convergence.

MARKER GENERATOR: The Model TV-50A includes all the most frequently needed marker points. The following markers are provided: 189 Kc., 262.5 Kc., 456 Kc., 600 Kc., 1000 Kc., 1400 Kc., 1600 Kc., 2000 Kc., 2500 Kc., 3579 Kc., 4.5 Mc., 5 Mc., 10.7 Mc., (3579 Kc. is the color burst frequency)

\$47⁵⁰ NET

EXAMINE BEFORE YOU BUY!
USE APPROVAL FORM ON NEXT PAGE

The Model 88....A New Combination TRANSISTOR RADIO TESTER and DYNAMIC TRANSISTOR TESTER



The Model 88 is perhaps as important a development as was the invention of the transistor itself, for during the past 5 years, millions of transistor radios and other transistor operated devices have been imported and produced in this country with no adequate provision for servicing this ever increasing output.

The Model 88 was designed specifically to test all transistors, transistor radios, transistor recorders, and other transistor devices under dynamic conditions.

AS A TRANSISTOR RADIO TESTER

We feel sure all servicemen will agree that the instruments and methods previously employed for servicing conventional tube radios and TV have proven to be impractical and time consuming when used for transistor radio servicing. The Model 88 provides a new simplified rapid procedure — a technique developed specifically for transistor radios and other transistor devices.

An R.F. signal source, modulated by an audio tone is injected into the transistor receiver from the antenna through the R.F. stage, past the mixer into the I.F. Amplifier and detector stages and on to the audio amplifier. This injected signal is then followed and traced through

the receiver by means of a built-in High Gain Transistorized Signal Tracer until the cause of trouble whether it be a transistor, some other component or even a break in the printed circuit is located and pinpointed. The injected signal is heard on the front panel speaker as it is followed through the various stages. Provision has also been made on the front panel for plugging in a V.O.M. for quantitative measurement of signal strength.

The Signal Tracing section may also be used less the signal injector for listening to the "quality" of the broadcast signal in the various stages.

AS A TRANSISTOR TESTER

The Model 88 will test all transistors including NPN and PNP, silicon, germanium and the new gallium arsenide types, without referring to characteristic data sheets. The time-saving advantage of this technique

is self-evident. A further benefit of this service is that it will enable you to test new transistors as they are released!

SPECIFICATIONS:

✓ Model 88 operates on a self-contained 4½ volt battery and is always ready for instant use on the bench or in the field.

Signal Injector:

The signal injector used in the Model 88 is a new departure in signal source design. Previously, signal sources were provided by signal generators operating on a single frequency and requiring retuning. The Signal Injector of the Model 88 employs a transistor in a grounded emitter self-modulating blocking oscillator generating a low R.F. frequency providing stable harmonics to 30 megacycles. A power output of over 2.5 volts peak to peak is provided. An attenuator prevents overload of the receiver or the amplifier under test.

Signal Tracer:

Two high-gain grounded emitter transistors are utilized in a high gain amplifier with sufficient output to operate the built-in 4½" Alnico V Speaker. A diode is used as a "clamp" to prevent overloading of the output stage. A volume control permits attenuation of strong signals. Provision is also made on the front panel for the addition of a meter or an oscilloscope for quantitative evaluation of the signal strength.

Transistor Tester:

The transistor tester used in the Model 88 measures the two most important transistor characteristics needed for transistor servicing; leakage and gain (beta).

The leakage test measures the collector-emitter current with the base connection open circuited. A range from 50 ohms to 100,000 ohms covers all the leakage values usually found in both high and low power transistor types.

The gain test (beta) translates the change in collector current divided by the base current. Inasmuch as the base current is held to a fixed value of 50 microamperes, the collector current calibrated in relative gain (beta), is read directly on the meter scale.

The Model 88 will test all transistor types, including NPN or PNP, germanium, silicon, gallium arsenide and the newer diffused junction and mesa types.

Model 88 comes housed in a handsome portable case. Complete with a set of Clip-On Cables for Transistor Testing, an R.F. Diode Probe for R.F. and I.F. Tracing, an Audio Probe for Amplifier Tracing and a Signal Injector Cable. Complete—nothing else to buy!
Only

\$38⁵⁰

SHIPPED ON APPROVAL NO MONEY WITH ORDER — NO C.O.D.

Try any of the instruments on this or the facing page for 10 days before you buy. If completely satisfied then send down payment and pay balance as indicated on coupon. No Interest or Finance Charges Added! If not completely satisfied return unit to us, no explanation necessary.

MOSS ELECTRONIC, INC.

Dept. D-821, 3849 Tenth Ave., New York 34, N. Y.

Please send me the units checked on approval. If completely satisfied I will pay on the terms specified with no interest or finance charges added. Otherwise, I will return after a 10 day trial positively cancelling all further obligations.

Model 88 Total Price \$38.50
\$8.50 within 10 days. Balance \$6.00
monthly for 3 months.

Model TW-11 Total Price \$47.50
\$11.50 within 10 days. Balance \$6.00
monthly for 6 months.

Model TV-50A Total Price \$47.50
\$11.50 within 10 days. Balance \$6.00
monthly for 6 months.

Model 80 Total Price \$42.50
\$12.50 within 10 days. Balance \$6.00
monthly for 6 months.

Name

Address

City Zone..... State.....

All Prices net. F.O.B., N. Y. C.
Export Division: Rocke International Corp.
13 East 40th Street, New York 16, N. Y.



FA-4

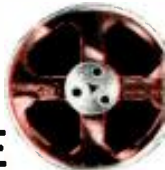

THE ONLY TAPE FORMULATION THAT CAPTURES THE FULL DYNAMIC RANGE OF MUSIC AT NO EXTRA COST!

In the year since their introduction, Soundcraft Tapes with FA-4 frequency adjusted formulation have won unprecedented acclaim from professional and home recordists. The ability of these tapes to capture more of the full dynamic range of sound . . . to reproduce subtler "highs" with full clarity, was instantly hailed as a major improvement in tape recording — and a particular boon in 4-track and slower speed applications. Whether your equipment is new or old — you will never enjoy its full capabilities until you hear your first reel of Soundcraft Tape with FA-4!

**FA-4 formulation exclusive with
SOUNDCRAFT TAPES**

FA-4

frequency
adjusted

REEVES SOUNDCRAFT CORP.

Great Pasture Rd., Danbury, Conn. ■ Chicago: 28 E. Jackson Blvd. Los Angeles: 342 N. LaBrea ■ Toronto: 700 Weston Rd.

Sound on Tape

By **BERT WHYTE**

THE TAPE WORLD remains rather quiet, except for some of the victory celebrations as the last holdouts on 4-track, reel-to-reel tape surrendered. Yes, *Columbia* announced its intention of releasing new material in this medium, thus all the major companies and most of the smaller companies are now on the 4-track bandwagon.

Does this move mean that *Columbia* is giving up on its fancy cartridge deal with *Minnesota Mining*? I think not and most informed sources seem to feel that is merely that between the prototype *Columbia* demonstrated and actual production of units, there is a long road yet to travel. In the meantime, why shouldn't they get into this present market which is now assuming sizable proportions and shows every sign of being a stable force for some time to come.

So, I am now hard at work trying to mulct some tapes out of *Capitol*, *RCA*, and *Columbia* and hope I'll have some for next month's reviews. As noted in the record column, the New York High Fidelity Show is almost upon us and while I expect that there will be plenty of new tape machines exhibited to cater to the 4-track market, I don't feel that anything radical will be shown, except perhaps a further trend towards miniaturization with transistorized recording and playback preamps.

Rumor has it that the Japanese are going to spring some really tiny little recorders on us. Could be . . . they certainly are great craftsmen in things small and delicate. In any case, I'll be reporting to you, very soon, all the significant tape developments at the Show.

TCHAIKOVSKY

SWAN LAKE BALLET (Complete)
L'Orchestre de la Suisse Romande conducted by Ernest Ansermet. London Stereo LCK80028. Price \$11.95.

One of the advantages of tape, and 4-track tape in particular, is readily apparent on this reel . . . here is the complete "Swan Lake" on one reel! Surely the complete ballet never occupied so small a space on a music lover's shelf. As was noted in the stereo disc, this is an outstanding production, with Ansermet fully in charge and affording a reading that, although very symphonic at times, never loses the essential element of the ballet.

The orchestra plays magnificently and, with the aid of the *London* engineers, produces a vast sonorous sound of extreme richness. I am certain that *London* is adhering to its old and very

successful recording method here . . . the frequency range is very wide and so are the sometimes awesome dynamics. The strings are a shimmering, smooth delight and the brass is extremely brilliant. The percussion, especially the tympani, are of great weight and impact and, I might add, ultra-precise.

My only quibble is the same as in the preceding album . . . obvious cross-channel noise and the tape hiss, while less here, is still apparent. And I would have preferred just a little less bass which had a slight tendency towards boominess. In matters of stereo the tape is all one could desire, with fine sense of directivity and depth. Summing up . . . with an awareness of these minor faults . . . a wonderful musical experience which I can freely recommend to any ballet lover.

GRIEG

INCIDENTAL MUSIC TO PEER GYNT
London Symphony Orchestra conducted by Oiven Fjeldstad. London Stereo LCL80020. Price \$7.95.

I understand this tape is enjoying a healthy boom . . . and understandably so after hearing it. This is familiar, pleasant music beautifully played by the London Symphony in an entirely gratuitous performance by a conductor who obviously knows and loves the music. He may not have the finesse of a Sir Thomas Beecham, who has done this music, but I think it is more idiomatic and has more heart and warmth of expression.

The sound is huge in the *forte* sections, with great brass and thunderous percussion, the strings are lovely and smooth and the winds, always a strong feature of this orchestra, do a superb job and are very mellow and pure sounding.

The stereo is quite good with excellent directivity, good center fill, and pinpoint aural positioning of instruments. Acoustics are just spacious enough to add realism without obscuring detail. My only quibble here is more cross-channel noise than usual, and somewhat elevated hiss when played at a good room-filling level.

GILBERT & SULLIVAN

H.M.S. PINAFORE (Complete)
The D'Oyly Carte Opera Company. London Stereo LOH90021. Price \$11.95.

The only word for this is overwhelming! The beloved production is as authentic as the famous D'Oyly Carte Company can make it . . . and that is the

very best. You name the quality or feature and this has it plus . . . the personnel? Devoted to their roles and living every minute of them, the performance in my book is nigh flawless.

The sound is simply staggering! In the overture is positively the biggest monster of a bass drum I've ever heard. Ka-whump! and if you own a speaker system up to the job it will hit you right in the breadbasket. Now add to this every other element as huge and sonorous as you can imagine. The brass is so bright and weighty you can almost taste it, and the chorus is unbelievably articulate and gorgeously balanced. The stereo adds so much that, hearing this, one won't settle for the mono version.

The acoustics of whatever hall was used are fabulous and used to full effect . . . there is all the detail you could want and yet everything has that wonderful rounded sound you experience in a really good hall. I could go on and on . . . take my word for it . . . even if you are not a Gilbert and Sullivan fan, this will flip you. For aficionados, this is an absolute must!

DAVID ROSE PLAYS DAVID ROSE
David Rose and his Orchestra. MGM 4-track STC3748. Price \$7.95.

David Rose is the kind of composer you either accept for his clever and witty material and like him, or you can't stand him. The ditties he whips up are certainly not deathless masterpieces, but I feel they qualify nicely as innocuous and often amusing bits.

Here is a magnum serving of Rose, some being old standbys like his famous "Holiday for Strings" and "4:20 A.M.," and other new material like his "Stereophonic March."

The sound here is of the big lush, Hollywood style with, for my taste, too much reverb, which obscures detail.

SONGS OF THE FABULOUS FIFTIES
Roger Williams, pianist, with orchestra. Kapp Stereo KXL5000. Price \$7.95.

In contrast to "Pinafore," this seems almost trite-trite . . . however everyone to his own poison and this Williams boy has been fabulously successful.

This, as the name implies, is a collection of songs from the 1950's and includes a distinguished assemblage of hits such as "High Noon," "Too Young," "Secret Love," "Hey There," "Three Coins in the Fountain," "April in Portugal," and many others. They are played in the distinctive Williams style, with one of the doggondest piano sounds I have ever heard . . . the orchestra in this case is really a backward group with the piano, ten times bigger than life, coming from the ghost middle.

The piano is miked so close I don't see how they got away with so little hammer-action noise. I mean that mike must be six inches from the strings! It is a kind of monstrously overblown weird sound for a piano to make, but it is curiously compelling and commands attention, whether you like it or not. I'll say this . . . it is different and might just be your dish of tea! Me, I'll have a beer. [30]

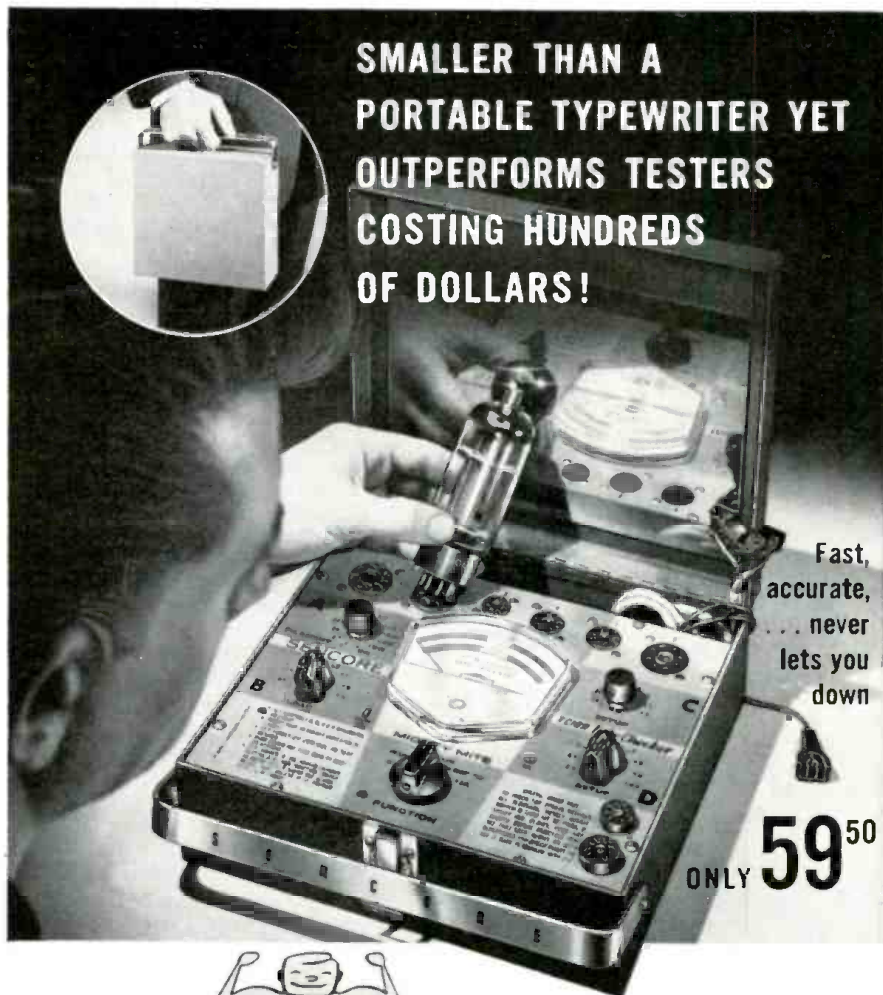

The MIGHTY MITE by SENCORE

The TC109 Tube Checker is a real money maker for the serviceman and a trusty companion for engineers, maintenance men and experimenters. Even students and hobbyists can afford the Mighty Mite for their own use or to service an occasional Radio or TV set. This small complete tester is a tremendous performer that spots bad tubes missed by costly mutual conductance testers.

New unique "stethoscope" approach tests for grid emission and leakage as high as 100 megohms, yet checks cathode current at operating levels. Special short test checks for shorts between all elements. The MIGHTY MITE will test every radio and TV tube that you encounter (over 1300!) plus picture tubes, foreign, five star and auto radio tubes (without damage). As easy to set up as a "speedy tester" from easy to follow tube booklet. New tube charts free of charge. Simple operating instructions are screened on the front panel.

Check these plus Sencore features • Meter glows in dark for easy reading behind TV set • Stainless steel mirror in cover for TV adjustment • Rugged, all steel carrying case and easy grip handle • Smallest complete tester made • Inner chassis can be easily transferred to tube caddy, bench or counter. • Only 9" x 8" x 2½". • Wt. 8 lbs.

See your Distributor . . . if he cannot help you, Pat will

SENCORE, ADDISON 8, ILLINOIS

Dear Pat: Will you please . . .

Send me _____ Mighty Mite

Check or M.O. enclosed (PP Prepaid.) Send C.O.D.

Distributor's Name (if any) _____

Your Name _____

Street _____

City _____ Zone _____ State _____

PAT RUDE, Customer Service

ALL UNITS FULLY GUARANTEED OR MONEY BACK WITHIN 10 DAYS

The Transistor "Alpha Box"

By DONALD L. STONER

Check the h.f. capabilities of unknown transistors with this relatively simple and inexpensive tester.

SOME time ago, the author received a windfall consisting of several computer-type transistors left over from a special project. With no immediate plans to construct a computer, the transistors were looked upon as expendable items for r.f. experiments. If they should become damaged during experimentation, there would be no great loss. Where they worked out, they could subsequently be replaced with readily available types.

As a rough check of high-frequency

complex, for the impedance of the transistor must be matched and other factors must be taken into account carefully. However a laboratory instrument of this kind is much too expensive for the average experimenter or other technician.

However, the "Alpha Box" comes acceptably close, even for some laboratory applications. It connects the transistor to be tested in a common-base oscillator circuit. Generated r.f. energy is rectified, amplified, and indicated on a meter. A

tuning capacitor and four switched coils provide frequency coverage from 5.5 to 140 megacycles in four ranges.

Although a transistor can be made to oscillate well above its *alpha* cut-off, there is a relationship between these two frequencies. Generally speaking, the maximum frequency of oscillation is about twice the *alpha* cut-off frequency. Thus, if the former is determined, the latter may be assumed with a good degree of accuracy. In practice, the tester described here comes much closer to indicating the cut-off frequency directly.

Although it was not "planned that way," circuit losses in the "Alpha Box" reduce the maximum frequency of oscillation (F_{max}) for a given transistor to a point well below its actual capability. As a result, the maximum frequency in the test circuit is very close to actual *alpha* cut-off. This phenomenon was verified by a random check with twenty different types of transistors whose characteristics were known. In each case, the maximum oscillation frequency obtained with the tester was very close to the manufacturer's *alpha* cut-off specification.

Even if this were not so, the unit would be invaluable where comparative checks of high-frequency performance, rather than absolute measurement, are desired. For example, it is simple to determine which transistor from several available has the highest *alpha*. Also, separate testing for shorts, open conditions, intermittents, and current gain should not be necessary. Transistor defects of these types become obvious during the test procedure.

Circuit Analysis

Fig. 1 is the schematic diagram for the transistor tester. A "universal" tran-

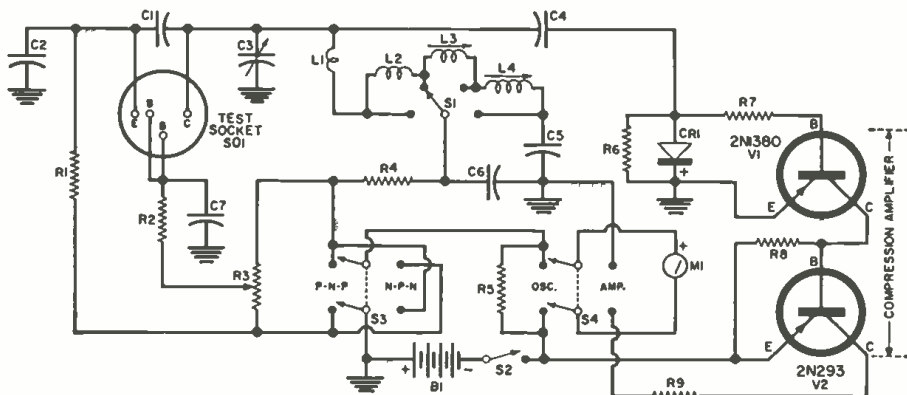

- R₁—220 ohm, 1/2 w. res.
- R₂, R₃—22,000 ohm, 1/2 w. res.
- R₄—50,000 ohm linear taper pot (Centralab B-31)
- R₅, R₆—1000 ohm, 1/2 w. res.
- R₇—100 ohm, 1/2 w. res.
- R₈—15,000 ohm, 1/2 w. res.
- R₉—4700 ohm, 1/2 w. res.
- C₁—4.7 μf. disc capacitor
- C₂—25 μf. disc capacitor
- C₃—10-50 μf. var. capacitor (Miller #2110, modified per text)
- C₄—1.5 μf. disc capacitor
- C₅, C₆, C₇—0.1 μf. disc capacitor
- CR₁—1N60 germanium diode
- L₁—1 t. #14 tinned, 1/8" dia., 1/4" leads

- L₂—5 t. #18 tinned, 1/8" dia., spaced dia. of turns (Air Dux 516)
- L₃—9 t. #22 en., 1/8" dia., closewound on slug-tuned form (Miller #4403)
- L₄—25 t. #28 en., 1/8" dia., closewound on slug-tuned form (Miller #4405)
- M₁—0.1 ma. meter
- S₁—S.p. 4-pos. wafer switch (Centralab PA 1001)
- S₂—S.p.s.t. switch (part of R₄, Centralab KB-1)
- S₃, S₄—D.p.d.t. toggle switch
- SO—"Universal" transistor socket
- B₁—4.5 volt "C" battery (RCA VS0 28)
- V₁—2N1380 transistor (Texas Instruments)
- V₂—2N293 transistor (G-E)

Fig. 1. An oscillator, a meter, and a d.c. amplifier are key circuit elements.

formance capability, the transistors were first tried out in a Citizens Band receiver. Those that failed to operate in this equipment were next tried in a 7-mc. c.w. transmitter. Rejects from this "test" were then checked at 455 kc. in a pocket AM radio. The remaining "wash-outs" were assumed to be usable at audio frequencies.

The process of "testing" two dozen assorted transistors with this method required considerable time and left something to be desired as far as accuracy was concerned. The need for an easier and more reliable technique to appraise questionable transistors was clear. The result was a device that has been dubbed the "Alpha Box."

In the strictest sense, the name is something of a misnomer. The tester does not measure the *alpha* cut-off frequency directly and with laboratory precision. Devices that do so are quite

Fig. 2. Front panel of the "Alpha Box," which uses few controls and adjustments.

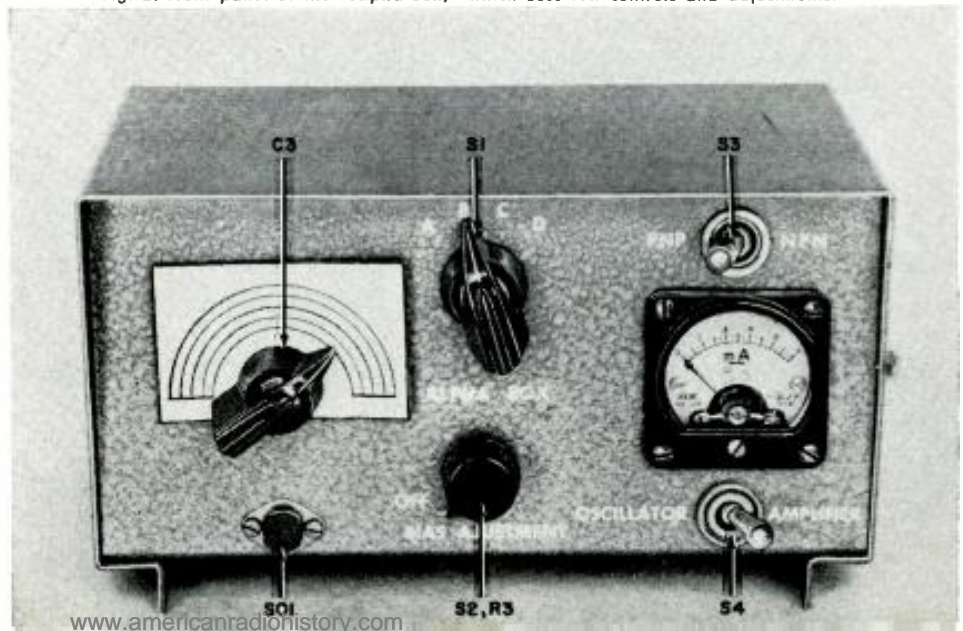

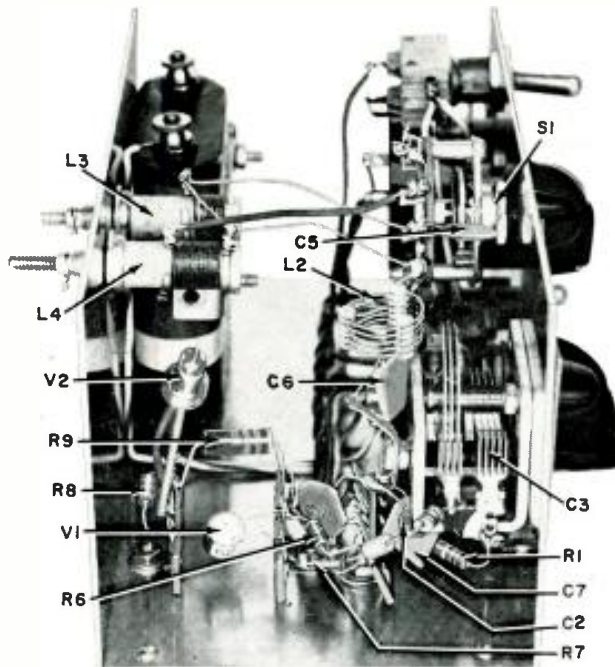
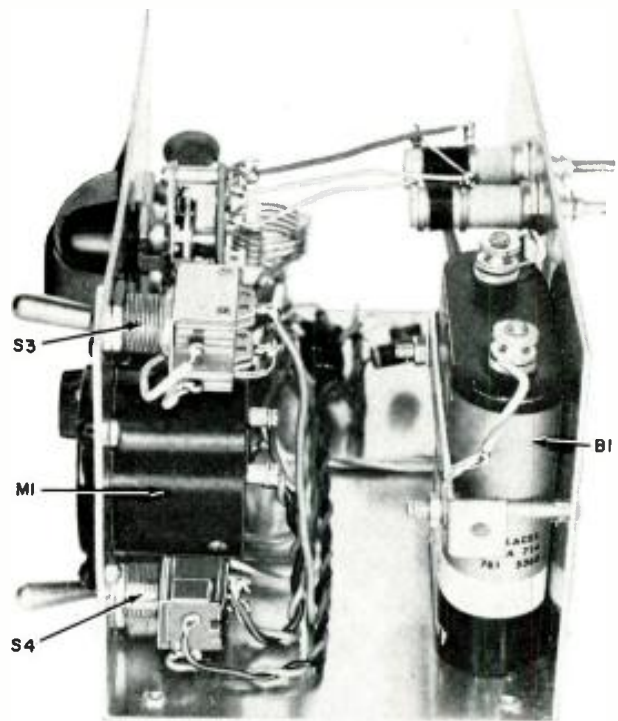

Fig. 3. Chassis viewed from left to show component layout.

Fig. 4. Right-side view reveals detail not shown in Fig. 3. ▶



sistor test socket (to accommodate in-line and TO-9 types) is used to connect the transistor to the circuit. Feedback for oscillation, between collector and emitter, occurs through the capacitive divider consisting of C_1 and C_2 . A tuned circuit, consisting of C_3 and one or more of the four coils (L_1 to L_4) is connected in series with the collector. A potentiometer, R_3 , is used to adjust the transistor bias voltage. The collector current is measured by M_1 when switch S_1 is placed in the "Osc." position.

The r.f. from the oscillator circuit is capacitively coupled to the shunt-connected crystal diode. The diode conducts on positive cycles, leaving negative half-cycles. This negative voltage is "smoothed" by R_2 and the input capacitance of V_1 (2N1380). The negative bias voltage causes V_1 to conduct, which increases the conduction of V_2 due to the voltage drop across R_3 . This two-stage, d.c.-coupled amplifier exhibits a gain up to 30 db, depending on the level.

A compression feature is built into the amplifier. This was necessary due to the fact that r.f. generated by high-frequency transistors is considerably less than that obtained from low-frequency types. But for this addition, it would have been necessary to install a gain potentiometer in addition to the existing controls. The 4700-ohm resistor, R_4 , connected in series with the collector of V_2 , limits the maximum current flow through M_1 to slightly more than 1 ma. Note that in Fig. 1, the plus and minus voltage circuit in the oscillator section is isolated from chassis ground. This was done so that switch S_2 can select between $p-n-p$ and $n-p-n$ transistors by reversing the potential applied to the collector and emitter.

Complete safety is built into the "Alpha Box." A low collector potential (4.5 volts) is used so that surface-barrier transistors may be tested with-

out damage and without changing batteries. The base current is limited to a safe value by resistor R_5 . The combination of R_5 and R_1 serve to limit the maximum collector current to approximately 3 ma. under maximum conditions. Thus the maximum dissipation of the device is limited to approximately 13.5 milliwatts, which is acceptable even for the smallest transistors. It is even safe to reverse the collector-to-emitter potential on the transistor! If the collector of a $p-n-p$ type transistor were made positive with respect to the emitter, for example, the transistor would saturate and appear as a short. Since this effectively places R_1 in parallel with the battery, the maximum current which can flow is 4.5 ma., or slightly more than 20 milliwatts. This is not excessive.

Eagle-eyed readers may note that resistor R_5 , shunting the meter, will cause incorrect meter readings. Although the exact collector current is not critical, the meter *does* give an accurate indication. The base current, and the flow through R_5 , almost exactly offset the shunting effect of R_5 .

Construction

The "Alpha Box" was built into a new style of metal cabinet made by L. M. Bender Co. (LMB), the type number W2-C. Through a simple design, metal feet tilt the panel for ease in use.

Fig. 5. Calibrated template in author's version covers 5.5 to 140 mc. in 4 bands.

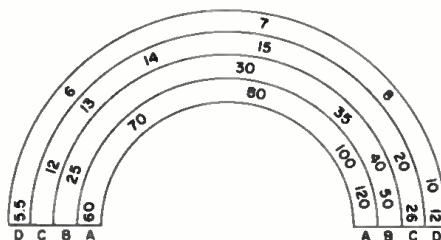

Figs. 2, 3, and 4 make the construction almost self-explanatory, with the possible exception of the oscillator circuit. The socket is mounted directly below tuning capacitor C_3 (see Fig. 2) for the shortest possible leads. All front rotor plates were removed from C_3 before installation. In addition, all but three of the rotor plates were removed from the rear section. Two solder lugs, one up and one down, were connected to the rear lip of the capacitor with a short self-tapping sheet metal screw used for each lug. Capacitors C_5 and C_6 are grounded to the upper lug. The bottom lug serves to ground C_2 and C_7 . After mounting C_3 , a wiper was bolted under one of the mounting nuts. The wiper rubs on the front of the shaft, providing a superior ground at maximum capacitance. If this is not done, the reading may be erratic at the low-frequency end of the dial.

The coils warrant special discussion to aid in duplicating the "Alpha Box." Coil L_1 (which tunes 60-140 mc.) comes straight up from the rear capacitor terminal, makes a $\frac{3}{8}$ " (i.d.) loop, and continues up to the switch terminal adjacent to the wiper contact. Capacitor C_6 is stretched between the wiper and the solder lug on the rear of C_3 . Coil L_2 (24-60 mc.) is supported by its leads on the switch contacts. Coils L_3 and L_4 are mounted on the rear apron of the "U"-shaped chassis. Both of these coils are slug-tuned so that they may be adjusted for continuous coverage between 12 and 26 mc. (L_3) and 5.5 and 12 mc. (L_4).

The remainder of the circuitry is in no way critical. The d.c. amplifier transistors, and the associated components, are mounted on terminal strips by their lead wires.

Testing

Check the d.c. amplifier first. Tempo-

FREE CAREER BOOKLET



to guide you to a successful future in

ELECTRONICS RADIO-TV COMPUTERS ELECTRICAL ENGINEERING

This interesting pictorial booklet tells you how you can prepare for a dynamic career as an Electrical Engineer or Engineering Technician in many exciting, growing fields:

**MISSILES • RADAR • RESEARCH
ELECTRICAL POWER • ROCKETRY
AUTOMATION • AVIONICS
SALES • DEVELOPMENT**

Get all the facts about job opportunities, length of study, courses offered, degrees you can earn, scholarships, part-time work — as well as pictures of the Milwaukee School of Engineering's educational and recreational facilities. No obligation — it's yours free.

MILWAUKEE SCHOOL OF ENGINEERING

MAIL COUPON TODAY!

MILWAUKEE SCHOOL OF ENGINEERING
Dept. EW-1160, 1025 N. Milwaukee St.
Milwaukee, Wisconsin MS-113

Please send FREE "Your Career" booklet
I'm interested in Electronics Radio-TV
 Computers Electrical Engineering
 Mechanical Engineering
(PLEASE PRINT)

Name..... Age.....

Address.....

City..... Zone..... State.....

I'm eligible for veterans education benefits.
Discharge date.....

rarily connect a 100,000-ohm resistor from the base of V_1 to -4.5 volts. The meter, with S_1 in the amplifier position, should read approximately 0.95 ma. Remove resistor.

Connect a voltmeter between the collector and emitter pins of the transistor socket. With S_2 in the $n-p-n$ position, the collector pin should be 4.5 volts positive with respect to the emitter. In the $p-n-p$ position, the meter should be reversed.

Next check the potential between base and emitter. The bias potentiometer should vary this voltage between 0 and 4.5 volts. If these checks are satisfactory, it is safe to insert a transistor to test the oscillator circuit.

Operation

Insert the transistor to be tested in the socket, turn the unit on, and adjust S_1 to its highest frequency range. Switch S_1 to the oscillator position and set the bias potentiometer in the center of its range. If the potentiometer has no effect on collector current, or if the meter thumps against the stop, reverse the $p-n-p-n-p-n$ switch (S_2).

Set the bias potentiometer for 0.5 ma. of collector current and switch to the amplifier position. If the transistor is oscillating strongly, the meter will read full-scale. If there is no meter indication (except for I_{c0} of V_2 , approximately 0.1 ma.) progressively switch to lower frequency ranges and adjust the tuning dial until the transistor does oscillate.

To check the maximum frequency of oscillation, increase the frequency setting while adjusting the bias potentiometer for the strongest oscillation. A point will be reached where the transistor refuses to oscillate no matter what adjustments are made. This $F_{0\ max}$, as mentioned earlier, is roughly equal to the actual *alpha* cut-off frequency.

After you get the "feel" of the tester, you will note that the transistor can be "coaxed" upwards in frequency by reducing the collector current. With reduced collector current, the junction capacitance decreases and improves high-frequency gain. This experiment shows why it is difficult to obtain large output powers at high frequencies.

The author also has observed that transistors which operate into the hundreds of megacycles (such as *Philco* T-1696 and *Texas Instruments* T-1360) are reluctant to work at low frequencies in this circuit. The reason for this effect is not known, but it does point up the fact that transistors should be tested from the high frequency down. The *Philco* and *TI* transistors mentioned work very well at low frequencies in a common-emitter circuit, but this configuration is not suitable at higher frequencies. Thus the tester becomes somewhat of a compromise in this regard. However, when the user is aware of the effect, it should not create any particular problem.

Calibration

Stray capacitance and lead inductance will affect the dial calibration. However, if the builder follows the construction details closely, it should be possible to

make the oscillator track closely with the dial scale reproduced in Fig. 5. Although extreme accuracy of frequency calibration is not necessary (it is difficult to obtain, as a matter of fact, due to the different interelement capacitances of various transistors), the reader can make his own dial scale by beating the oscillator with an accurate signal generator.

Modifications

Once a project is completed, an experimenter can usually see a better way to do it. Such is the case with the "Alpha Box." As an example, the crystal diode could have been mounted on the front panel with terminals. This would allow the user to check the relative rectification efficiency of unknown diodes at any frequency between 5.5 and 140 mc.

If the construction style is modified slightly, the "Alpha Box" can be used as a "dipper." Whenever a resonant circuit is coupled to the oscillator circuit, it draws off r.f. energy from the tank. This difference would be indicated on the meter. It would be necessary to install a gain-control potentiometer in this case. This could be accomplished by substituting a 15,000- to 25,000-ohm pot for R_2 and connecting R_1 to the arm or wiper of this pot.

By connecting a 10- μ f. capacitor between the emitter pin of the test socket and an additional terminal on the front panel, the "Alpha Box" could be used as a signal generator.

It is also possible to listen to the noise generated by the oscillator transistor, for the d.c. amplifier works well at audio frequencies. By coupling high-impedance headphones (through a 0.1- μ f. capacitor) to the collector of V_2 , the noise may be heard. The "Alpha Box" will also work as a heterodyne frequency meter (for detecting oscillations) by using this same technique. Beat notes between an external oscillator and the "Alpha Box" will be heard in the headphones. In fact, this system was used by the author for initial calibration.

There may be other uses for the device which have not occurred to the author. However, the main purpose (testing high-frequency transistors) makes it a valuable addition to any lab or service shop. [30]

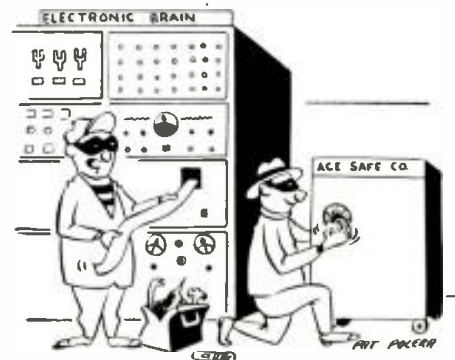

"It says, two turns right, 22, one turn left..."

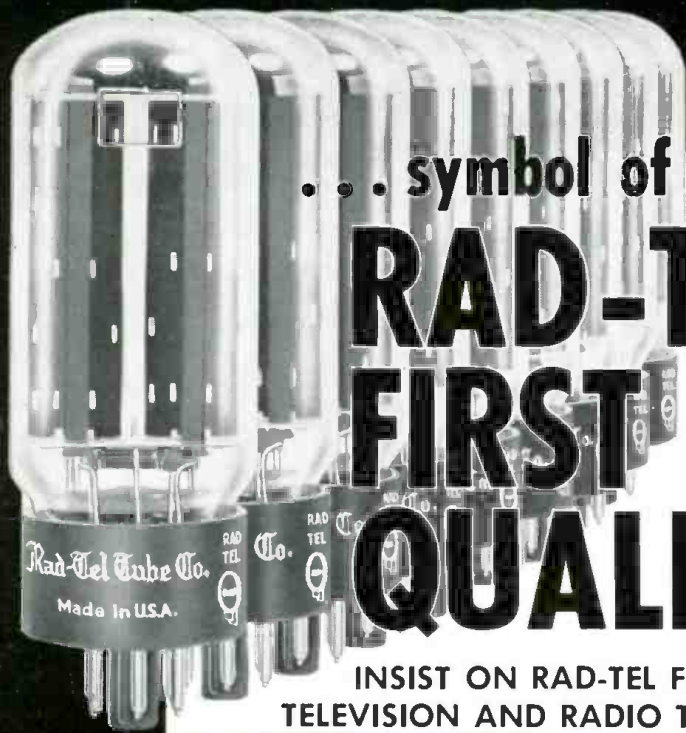

... symbol of
RAD-TEL
FIRST
QUALITY

INSIST ON RAD-TEL FOR EVERY TELEVISION AND RADIO TUBE NEED

TRANSISTORS
at fabulous discounts

 **RF** MIXER and IF **49¢** ea.

 **AF** DRIVER and OUTPUT **39¢** ea.

 **AUTO TYPE** **80¢** ea.
POWER OUTPUT

 **HIGH POWER** **\$1.40** ea.
15 AMP Collector Current

Up to 75% OFF on BRAND NEW TUBES

GUARANTEED ONE FULL YEAR!

You Can Rely On Rad-Tel's Speedy One Day Service!

Not Used — Not Pulled Out Of Old Sets • Each Tube Individually and Attractively Boxed!

Qty.	Type	Price	Qty.	Type	Price	Qty.	Type	Price	Qty.	Type	Price	Qty.	Type	Price	Qty.	Type	Price	Qty.	Type	Price							
—	024M	.79	—	3D16	.50	—	6A84	.46	—	6B16	.62	—	6E08	.79	—	12A4	.60	—	12BD6	.50	—	12EG6	.54	—	198G6	1.39	
—	1AX2	.62	—	3Q5	.80	—	6AC7	.96	—	6BK7	.85	—	6EA8	.79	—	12AB5	.55	—	12BE6	.53	—	12EZ6	.53	—	1978	.80	
—	1B3GT	.79	—	3S4	.61	—	6AF3	.73	—	6BL7	1.00	—	6HG6T	.58	—	12AC6	.49	—	12BF6	.44	—	12F5	.66	—	21EX6	1.49	
—	1DN5	.55	—	3V4	.58	—	6AF4	.97	—	6BN4	.57	—	6J5GT	.51	—	12AD6	.57	—	12BH7	.73	—	12F8	.66	—	258Q6	1.11	
—	1G3	.73	—	4BC5	.56	—	6AG5	.65	—	6BN6	.74	—	6J6	.67	—	12AE6	.43	—	12BL6	.56	—	12FM6	.45	—	25C5	.53	
—	1J3	.73	—	4BC8	.96	—	6AH6	.99	—	6BQ5	.65	—	6K6	.63	—	12AF3	.73	—	12BQ6	1.06	—	12K5	.65	—	25CA5	.59	
—	1K3	.73	—	4BN6	.75	—	6AK5	.95	—	6BQ6GT	1.05	—	6S4	.48	—	12AF6	.49	—	12BY7	.74	—	12SA7M	.86	—	25C06	1.44	
—	1L6	1.05	—	4BQ7	.96	—	6AL5	.47	—	6BQ7	.95	—	6SA7GT	.76	—	12AJ6	.46	—	12BZ7	.75	—	12SK7GT	.74	—	25C06	1.11	
—	1LN5	.59	—	4BS8	.98	—	6AM8	.78	—	6BR8	.78	—	6SK7	.74	—	12AL5	.45	—	12C5	.56	—	12SN7	.67	—	25D06	1.42	
—	1R5	.62	—	4BU8	.71	—	6AN4	.95	—	6BU8	.70	—	6SL7	.80	—	12AL8	.95	—	12CA5	.59	—	12SQ7M	.73	—	25EH5	.55	
—	1S5	.51	—	4BZ6	.58	—	6AN8	.85	—	6BY6	.54	—	6SN7	.65	—	12AQ5	.52	—	12CN5	.56	—	12U7	.62	—	25L6	.57	
—	1T4	.58	—	4BZ7	.96	—	6AQ5	.50	—	6BZ6	.54	—	6SQ7	.73	—	12AT6	.43	—	12CR6	.54	—	12V6GT	.53	—	25W4	.68	
—	1U4	.57	—	4CS6	.61	—	6AR5	.55	—	6BZ7	.97	—	6T4	.99	—	12AT7	.76	—	12CU5	.58	—	12W6	.69	—	25Z6	.66	
—	1U5	.50	—	4DE6	.62	—	6AS5	.60	—	6C4	.43	—	6U8	.78	—	12AUG	.50	—	12CU6	1.06	—	12X4	.38	—	35C5	.51	
—	1X2B	.82	—	4DK6	.60	—	6AT6	.43	—	6CB6	.54	—	6V6GT	.54	—	12AU7	.60	—	12CX6	.54	—	17AX4	.67	—	35L6	.57	
—	2AF4	.96	—	4DT6	.55	—	6AT8	.79	—	6CD6	1.42	—	6W4	.57	—	12AV5	.97	—	12DB5	.59	—	17BQ6	1.09	—	35W4	.52	
—	3AL5	.42	—	5AM8	.79	—	6AU4	.82	—	6CF6	.64	—	6W6	.69	—	12AV6	.41	—	12DE8	.75	—	17C5	.58	—	35Z5GT	.60	
—	3AU6	.51	—	5AN8	.86	—	6AU6	.50	—	6CG7	.60	—	6X4	.39	—	12AV7	.75	—	12DL8	.85	—	17CA5	.62	—	50B5	.60	
—	3AV6	.41	—	5AQ5	.52	—	6AU7	.61	—	6CG8	.77	—	6X5GT	.53	—	12AX4	.67	—	12DM7	.67	—	17D4	.69	—	50C5	.53	
—	3BA6	.51	—	5AT8	.80	—	6AU8	.87	—	6CM7	.66	—	6X8	.77	—	12AX7	.63	—	12DQ6	1.04	—	17DQ6	1.06	—	50DC4	.37	
—	3BC5	.54	—	5BK7A	.82	—	6AV6	.40	—	6CN7	.65	—	7AU7	.61	—	12AZ7	.86	—	12DS7	.79	—	17L6	.58	—	50EH5	.55	
—	3BE6	.52	—	5BQ7	.97	—	6AW8	.89	—	6CR6	.51	—	7A8	.68	—	12B4	.63	—	12DZ6	.56	—	17W6	.70	—	50L6	.61	
—	3BE6	.52	—	5BR8	.79	—	6AX4	.65	—	6CS6	.57	—	7B6	.69	—	12BA6	.50	—	12EL6	.50	—	19AU4	.83	—	117Z3	.61	
—	3BN6	.76	—	5CG8	.76	—	6AX7	.64	—	6CU5	.58	—	7Y4	.69	—			—									
—	3BU8	.78	—	5CL8	.76	—	6BA6	.49	—	6CU6	1.08	—	8AU8	.83	—			—									
—	3BY6	.55	—	5EA8	.80	—	6BC5	.54	—	6CY5	.70	—	8AW8	.93	—			—									
—	3BZ6	.55	—	5EU8	.80	—	6BC7	.94	—	6CY7	.71	—	8BQ5	.60	—			—									
—	3CB6	.54	—	5I6	.68	—	6BC8	.97	—	6DA4	.68	—	8C7	.62	—			—									
—	3CF6	.60	—	5T8	.81	—	6BD6	.58	—	6DB5	.69	—	8CM7	.68	—			—									
—	3CS6	.52	—	5U4	.60	—	6BE6	.55	—	6DE6	.58	—	8CN7	.97	—			—									
—	3CY5	.71	—	5U8	.81	—	6BF6	.44	—	6DG6	.59	—	8CX8	.93	—			—									
—	3DK6	.60	—	5V6	.56	—	6BG6	1.66	—	6DQ6	1.10	—	8EB8	.94	—			—									
—			—	5X8	.78	—	6BH6	.65	—	6DT5	.66	—	1DDA7	.71	—			—									
—			—	5Y3	.46	—	6BH8	.87	—	6DT6	.53	—	11CY7	.75	—			—									

Not a Kit, but Completely Wired
STEREO AMPLIFIER
CHASSIS \$4.95

- Single, \$5.95 ea.
- Set of tubes: 2-35C5; 1-12AX7; 1-35W4 \$1.15
- Lots of 3 ea.
- Set of 3 grey 1/2" knobs 30c



SEND FOR FREE TROUBLE SHOOTER GUIDE AND NEW TUBE & PARTS CATALOG.

NOT AFFILIATED WITH ANY OTHER MAIL ORDER TUBE COMPANY.

RAD-TEL TUBE CO. 55 Chambers St
Newark 5, N. J.

TERMS: 25% deposit must accompany all orders — balance C. O. D.
\$1 HANDLING CHARGE FOR ORDERS UNDER \$5. Subject to prior sale.
Please add postage. No C. O. D.'s outside continental U. S. A.

EW-1160

**CREI's Extension Division offers Engineering Technicians and Engineers a combination of courses in advanced electronic engineering technology.*

**The program is designed to meet your present and future employment requirements and to increase your professional status and earning power.*

-this CREI College-level Home Study Program in Electronics is Comparable in Technological Content to Advanced Residence Courses!!!!

The CREI home study program is the culmination of 33 years of working closely with leading companies and Government agencies in the critical field of electronics. This accredited program is designed for men already employed in a technical capacity in the electronics industry.

This CREI college-level program is comparable in technological content to advanced residence courses. You may complete the program in 2 to 4 years, depending on the amount of free time you can devote to study, and the courses you choose.

For several years the electronics industry has suffered a serious shortage of technical personnel with

modern advanced education, and there is every indication that this shortage will increase in the years ahead. New jobs are being created daily through the application of electronic developments in missiles, space exploration, automation, instrumentation, computers, telemetering and many other fields. These positions must be filled by men with modern advanced education, which fact is evidenced by the experience of the CREI Placement Bureau, where the demand for graduates and advanced students far exceeds the supply. It is of interest to note that Help Wanted ads frequently specify "CREI education or equivalent."

CREI is recognized by industry and government

Another reason why CREI men are respected and eagerly sought by industry and Government agencies alike is the accreditation and enthusiastic approval accorded the CREI home study program in advanced electronics. We co-founded the National Council of Technical Schools, and we were among the first three technical institutes whose curricula were accredited by the Engineers' Council for Professional Development. Further, the U.S. Office of Education lists CREI as "an institution of higher education."

Of equal importance, we believe, is the appreciation expressed by industry and government for the CREI programs. Dozens of major electronics organizations, ranging from industrial giants to the Government's Voice of America, have agreements with CREI for enrollment of students under company sponsorship. U.S. Navy electronic personnel in the number of 5,240 are enrolled in CREI extension programs. The British Royal Air Force, Army and Navy have approved CREI courses under their tuition assistance plan. The following companies comprise only a partial list of the organizations which not only recommend CREI study but actually, in many cases, pay all or part of the tuition for employees taking CREI courses:

National Broadcasting Company
Jerrold Electronics Corporation
Pan American Airways
Radio Corporation of America
Canadian Aviation and Electronics
Federal Electric Corporation
The Martin Company
Voice of America
Canadian Broadcasting Corporation
Northwest Telephone Company
Commercial Cable, Incorporated
Canadair Limited
Columbia Broadcasting System
All America Cable and Radio
Canadian Marconi
Mackay Radio
United Air Lines
Gates Radio Company
Mohawk Airlines
Florida Power and Light Company

RESIDENCE SCHOOL

... in Washington, D.C., for those who can attend classes. Day and evening classes start at regular intervals. Graduates earn AAS degree in 27 months. Electronics experience is not required for admission.

QUALIFICATIONS FOR CREI ENROLLMENT FACTS ABOUT TUITION, REGISTRATION

If you have a high school diploma or equivalent, basic electronic training and practical experience in electronics, you meet the minimum requirements for enrollment. Tuition is reasonable and may be paid monthly, if you wish. Veterans qualify for this program under the GI bill.

Over 20,500 CREI students find home study convenient and profitable

You can pursue the CREI program while you continue your regular full-time job. You study at home during hours chosen by you. You are not rushed and you have plenty of time to do your best.

The courses are prepared in easy-to-understand format, and the CREI staff of experienced instructors guides your progress all along the way. These instructors stand ready to assist you whenever you need help. You will find our personal assistance and guidance efficient and helpful, because 33 years of experience in home study teaching enables us to anticipate questions in our lesson material.

Many CREI students have learned that they do not have to wait until they have completed the program to realize significant improvement in their status and income. The very fact that you are ambitious enough to pursue this college-level program enhances your opportunities for rapid promotion. Project leaders and supervisors recognize the value of CREI education.

How you benefit from CREI program of home study

CREI students are electronic engineers and technicians engaged in every phase of electronics. They are in research laboratories and manufacturing plants. They work on the design, development and production of the latest computers; on the latest military and civilian aircraft; on the electronic equipment associated with the Nation's missiles and space exploration efforts; on communications equipment of all kinds; they maintain electronic equipment for the air lines, the Government and private corporations. You will find CREI students in all 50 States and in most foreign countries of the free world.

To the serious-minded and ambitious CREI student our home study program offers a series of important benefits:

1. You gain a solid college-level education in advanced electronic engineering technology; you keep abreast of continuous new developments in the field.
2. You can gain higher status and enjoy the increased respect of your associates.
3. You facilitate more rapid professional advancement with corresponding significant increases in pay.
4. You gain the personal satisfaction that comes from working and communicating intelligently with your technical colleagues and superiors.

WRITE FOR DETAILED 44-PAGE BOOK of curricula and other information about CREI, entitled "Insurance for Your Future in the New World of Electronics." USE POSTAGE-PAID CARD ATTACHED, or write to Dept. 1111-G

The Capitol Radio Engineering Institute

*ECPD Accredited Technical
Institute Curricula
FOUNDED 1927*

3224 16th Street, N.W.
Washington 10, D.C.
Dept. 1111-G

CITIZEN BAND

CLASS "D"

CRYSTALS

All 22 Frequencies in Stock



3rd overtone. .005% tolerance—to meet all FCC requirements. Hermetically sealed HC6/U holders. 1/2" pin spacing—.050 pins. (.093 pins available, add 15c per crystal.)

2.95

each

We can supply matched sets for Globe, Ganset, Citi-Fone and Hollicrafters units at \$5.90 per set. Specify transmitting frequency and make of equipment.

Following frequencies in stock (frequencies listed in megacycles): 26.965, 26.975, 26.985, 27.005, 27.015, 27.025, 27.035, 27.055, 27.065, 27.075, 27.085, 27.105, 27.115, 27.125, 27.135, 27.155, 27.165, 27.175, 27.185, 27.205, 27.215, 27.225,

RADIO CONTROL CRYSTALS in HC6/U holders in stock for immediate delivery—all channels. Pin diameter .050. \$2.95 ea. .093 pin spacing, add 15c. **SEALED OVERTONE CRYSTALS** Supplied in metal HC6/U holders.

Pin spacing .486, diameter .050

15 to 30 MC .005 tolerance **\$3.85** ea.
30 to 45 MC .005 tolerance **\$4.10** ea.
45 to 60 MC .005 tolerance **\$4.50** ea.

QUARTZ CRYSTALS

for every service



All crystals made from Grade "A" imported quartz—ground and etched to exact frequencies. Unconditionally guaranteed! Supplied in:

FT-243 holders MC-7 holders
pin spacing 1/2" pin spacing 1/2"
pin diameter .093 pin diameter .125

DC-34 holders FT-171 holders
pin spacing 1/2" pin spacing 1/2"
pin diameter .156 banana pins

MADE TO ORDER CRYSTALS

1001 KC to 2600 KC:
.01% tolerance \$2.00 ea. .005% tolerance \$2.75 ea

2601 KC to 9000 KC: .005% tolerance \$2.50 ea

9001 KC to 11,000 KC: .005% tol. \$3.00 ea

Specify holder wanted

ANY AMATEUR, NOVICE, TECHNICIAN BAND CRYSTALS

80 meters 3701-3749 KC .01% tolerance
40 meters 7152-7198 KC
15 meters 7034-7082 KC
6 meters 8335-8650 KC within 1 KC)

1.50 ea.

MARINE FREQUENCY CRYSTALS—All marine frequencies from 2000-3200 KC. .005 tolerance \$2.50 ea. (supplied in either FT-243, MC-7 or FT-171 holders)

STOCK CRYSTALS in FT-243 holders from 5675 KC to 8650 KC in 25 KC steps 75c each or 3 for \$2.00

FT-241 Lattice Crystals in all frequencies from 3700 KC to 540 KC (all except 455 KC and 500 KC) 50c ea. Pin spacing 1/2" Pin diameter .093

Matched pairs—15 cycles \$2.50 per pair

200 KC Crystals \$2.00 ea.
455 KC Crystals \$1.50 ea.
500 KC Crystals \$1.50 ea.
100 KC Frequency Standard Crystals in HC6/U holders \$4.50 ea.

Socket for FT-243 crystal 15c ea.
Dual socket for FT-243 crystals 15c ea.
Sockets for MC-7 and FT-171 crystals 25c ea.
Ceramic socket for HC6/U crystals 20c ea.

FREE! Write for new Catalog #860 with oscillator circuits.

ASK YOUR PARTS DEALER FOR TEXAS CRYSTALS
See big red display . . . if he doesn't stock them, send us his name and order direct from our factory.

ORDER FROM OUR NEW FLORIDA PLANT
Use coupon below for 1st Class shipment

TEXAS CRYSTALS

Dept. R-110, 1000 Crystal Drive, Fort Myers, Fla.
For Fastest Service, Phone WE 6-2100

FILL OUT AND ATTACH THIS COUPON TO YOUR ORDER FOR SHIPMENT VIA 1ST CLASS MAIL AT NO EXTRA COST!

NAME.....

ADDRESS.....

CITY.....ZONE.....STATE.....

TERMS: All items subject to prior sale and change of price without notice. All crystal orders must be accompanied by check, cash or M. O. with PAYMENT IN FULL. NO COD'S. Dept. R-110



CERTIFIED RECORD REVUE

ONE of the sure signs that Autumn is coming is the annual crop of "Hi-Fi Shows" which begin to appear in early September. The granddaddy of all the Shows is the New York High Fidelity Show, sponsored by the Institute of High Fidelity Manufacturers, Inc.

As usual, this show will be held in the New York Trade Show Building during the first week in September. Publishing deadlines being what they are, this issue will actually reach you after the Show is over, but a report on same must wait until later. In the meantime, however, we'll venture a few predictions and try to give an advance looksee into what manner of fascinating hi-fi gadgetry has been dreamed up to loosen our purse strings.

Hardly a factor a year ago, but now slowly coming to the fore, is a spate of transistorized stereo preamps and power amplifiers. With transistors, many of the shortcomings of conventional vacuum-tube circuitry can be overcome, and thus these units can be made considerably smaller, operate virtually hum-free, dissipate less heat, and exhibit a more stable and longer life. Thus far, most transistorized amplifiers have been rather low powered, rarely exceeding 20 watts. In going beyond this figure, into the area of 40- and 50-watt units, some of the disadvantages of transistors begin to crop up. Power transistors capable of this higher output and linear enough to satisfy hi-fi requirements are costly when compared to vacuum tubes with the same power-handling capacity. At these higher ratings, however, heat dissipation once again becomes a problem. Last, but not least, procurement of these transistors is not easy since military production throughout the country places huge demands on the present output.

Needless to say, the trend towards integrated stereo amplifier and preamp/amplifier combinations in the higher power ratings continues to mount. Indications are that there will be a number of stereo units which will offer 60 watts per channel and perhaps even higher outputs!

There will be several new turntables, all more or less conventional in design and a like number of new cartridges and pickup arms. There is still plenty of room for development in this area for, as far as I am concerned, nobody has come up with a unit that is absolutely rumble-free when used with really big speakers with extended low-frequency response.

In the realm of speakers, miniaturization continues and while I admit it is remarkable what bass response some of these units can achieve, I will continue to decry the philosophy that these small units are superior to several of the very fine, but admittedly big, infinite-baffle and horn-loaded systems. Electrostatics, the big news of a few years

back, will continue in the few currently successful models, but nothing will appear beyond that and the long-promised full-range system with really respectable low-frequency response, will still be just a promise.

There may be a few FM tuners with built-in multiplex facilities shown, but with the final FCC decision on the multiplex system to be adopted not a matter of public record until after the Show, this item will probably not be seen in any quantity until the Los Angeles show in the Spring. My guess is that after all the fuss and fuming and the evaluation of many types of multiplex, the decision will go to the Crosby system, which was the obvious choice in the first place.

With the stereo disc itself, you can look for a lively skirmish between those who say that their discs are truly compatible and can be played with monophonic equipment without damage to the stereo capacity and those who maintain that this is wishful thinking and not much else. I can tell you this... there has been some new experimental work done and when the results are published, the "compatible" controversy will really glow white hot!

In the tape recorder section, the four-track, reel-to-reel machine will rule uncontested, with only the most hardy and venturesome offering a new cartridge concept. The CBS/Minnesota Mining cartridge may be demonstrated, but I doubt that any units will be offered for sale at this time.

One novelty at the show will be a number of reverberation units. These proved to be the hit of the NAMM Show in Chicago and the package boys have gone for them in a big way. Built and used intelligently, there are some interesting things you can do with these devices. As incorporated in package units, the results are nothing short of terrifying! With the acoustic situation in a stereo recording one of the most important aspects and one of the most difficult to control, here is a gimmick that allows the untutored ear to change the reverb characteristics at will, for the most part destroying the balances the engineers took so much pains to achieve. At an early opportunity I will go into this matter of the uses and abuses of these units.

Well, that is about it. I could be wrong, but I don't expect there will be anything at the Show which will cause undue sensation or revolutionize the field.

BARTOK

BLUEBEARD'S CASTLE (Opera in One Act)
Dietrich Fischer-Dieskau, baritone; Hertha Topper, contralto; with Radio Symphony Orchestra of Berlin conducted by Ferenc Fricsey. Deutsche Grammophon Stereo 138030. Price \$5.98.

One of Bartok's most wonderful scores is

here given a performance which is at one and the same time quite good and not wholly satisfactory. For one thing, I thought it was more effective sung in its original Hungarian rather than in German. For another, DGG should have provided an English libretto instead of German alone.

On the credit side, Fischer-Dieskau is marvelously controlled and in superb voice as "Bluebeard" while Hertha Topper sings with great conviction and acts with distinction her role of the wretched "Judith."

Peter Bartok's recording was a wonderful mono achievement some years ago and, in many ways, his version is closer to the heart of this work, but there is no denying the terrific impact that stereo affords. The voices are beautifully articulate, even down in the whispered *sotto voce* sections.

While this is an M/S type of stereo recording, it was miked a little closer than usual and directional effects are benefited thereby. All the orchestral elements are finely separated and the voices are in superb balance with the orchestra. Adding just the right amount of hall reverb lends a compelling sense of spaciousness. Fricay is surer of himself than was the conductor in the Bartok edition.

Once, again, kudos to those superbly quiet DGG surfaces, which in a work like this lends just that extra fillip of realism.

RAVEL

LE TOMBEAU DE COUPERIN
VALEES NOBLES ET SENTIMENTALES

DEBUSSY

PETITE SUITE

AFTERNOON OF A FAUN (Prelude)
Detroit Symphony Orchestra conducted by Paul Paray. Mercury Stereo SR90213. Price \$5.95.

As you might expect, Maestro Paray is in his element with such "French" repertoire. I am not certain, but I believe the "Tombeau" and the "Petite Suite" are "first" stereo recordings. In any case Paray's near-definitive performances are the ones to own. He treads neatly the line between lightness and lyricism and balances all most expertly.

I thought the "Valse" a little slow-paced and the "Faun" a less ingratiating experience than I remember with Paray, but with the superb sound they, as well as the other works, are afforded they still take precedence over any competing versions.

The sound is very clean and bright, yet has that fine solidity and all the stereo virtues we have come to expect of the Mercury recordings made in the shabby but acoustically beautiful old orchestra hall of Detroit.

STILL

SAHDJI BALLET
GINASTERA
CREOLE FAUST (Overture)
GUARNIERI

THREE DANCES

Eastman Rochester Orchestra conducted by Howard Hanson. Mercury Stereo SR90257. Price \$5.98.

This is a sensational recording, designed to pick up the most jaded of hi-fi appetites! The "Sahdji Ballet" is a work of our gifted Negro composer, William Grant Still. It is a derivative piece based on African tribal music. As you might expect, the music is an amalgam of African motifs, especially the complex rhythms of the percussion and a chanting chorus, with the American elements centered around the jazz idiom. The combination is unusual and stimulating and seeing the ballet itself must be quite an experience.

Argentinian Ginastera and Brazilian Guaranierni furnish us with the type of thing they have both become famous for...

November, 1960

NEW FM TUNER
FROM H. H. SCOTT

\$89.95*

**NOW... BUILD AN FM KIT
THAT WORKS AS WELL AS
FACTORY ALIGNED TUNERS**

NEW! Kit-Pak Container®
Opens to a self-contained work area you can use anywhere.

NEW! Part-Chart®
Speeds your work. All parts are mounted on Kit-Pak cover in numerical sequence. And every part meets H.H. Scott's tough test standards.

NEW! Ez-A-Lign System®
Requires no extra equipment. You align this tuner using the meter on the tuner itself! All needed alignment tools are included.

NEW! Pre-Stripped, Pre-Cut Wire
Every piece of wire is included. And each piece is pre-cut to proper length, stripped and tinned.

LT-10 Laboratory Tuner Specifications
• Usable (IHFM) sensitivity 2.5µv
• Signal: noise ratio 60 db below 100% mod. • Harmonic distortion 0.8% • Drift 0.02% • Frequency response 30 cps—15Kc ± 1 db. (IHFM measurements are made only in the range 30-15,000 cps. The LT-10 actually has far wider frequency range than shown here.)

The new LT-10 Tuner Kit will work as well as factory units, yet it can be aligned without expensive equipment. You align this tuner using the meter on the tuner itself. All needed alignment tools are included. This is the first kit to use H. H. Scott's Wide-Band circuitry. This results in greater selectivity and sensitivity than possible with any other kit on the market.

The exclusive H. H. Scott silver plated front end is completely pre-assembled and pre-aligned. All parts are mounted in sequence of assembly. All wires are pre-cut to proper length and stripped. Parts such as tube sockets and terminal strips are already riveted to the chassis. Here's a kit that's fun to build, and that you'll be proud to own.

* Prices slightly higher west of Rockies. Accessory case extra.



WORLD'S LEADING COMPONENT MANUFACTURER

H.H. SCOTT INC., 111 Powdermill Rd., Maynard, Mass.

Please send me FREE the following booklets: EW-11
 Colorful new 1961 catalog and hi fi guide.
 Complete technical specification sheets on your new products, including your new LT-10 Tuner Kit.

Name _____

Address _____

City _____ Zone _____ State _____

Export: Telesco International Corporation, 36 West 40th Street, N. Y. C.

YOUR NEEDLE IS DESTROYING YOUR LP'S

(if it isn't a Fidelitone Pyramid Diamond)

Ordinary ball point needles contact record micro-grooves at only two microscopic points. This causes a tremendous concentrated pressure that accelerates record wear, and reduces the life of quality reproduction.

Fidelitone's new Pyramid Diamond, shaped like the original recording stylus, allows more surface contact between needle and record. This distributes the tone arm weight over a larger surface area, and lowers unit area pressure. Your LP records will last many times longer.

HERE'S WHY...



Recording Stylus Ordinary Needle Pyramid Diamond

Fidelitone's new Pyramid Diamond is shaped similar to the stylus that recorded the original sound. It perfectly follows every contour created by the recording stylus.



In an unmodulated, or low frequency groove, the recording stylus (A) cuts a groove (W-1) wide enough to let an ordinary ball point needle (C) and the Fidelitone Pyramid Diamond (B) track the centerline of the groove accurately, and contact all recorded sound impressions.

As the groove is modulated by high tones, the groove width (W-2) cut by the recording stylus (A-1) narrows. This causes the ordinary ball needle (C-1) to rise and "pinch out" of the record groove. It bridges modulation crests, mistracks centerline and distorts sound impressions. The Pyramid Diamond (B-1), because of its new shape, stays solidly in the record groove, smoothly glides along the centerline positively driven by the groove walls.



BALL POINT DIAMOND PYRAMID DIAMOND

And the new shape of the Pyramid Diamond allows more surface contact between needle and record, substantially reducing contact pressure. This greatly increases needle and record life.

See your record dealer or hi-fi specialist today. Demand the Fidelitone Pyramid Point. You owe it to your records and your listening pleasure.

For the complete story on the revolutionary new Pyramid Diamond, or the name of your nearest dealer, write Fidelitone, Chicago 26, Illinois.

Fidelitone

"Newest shape on records"

lively, spirited dance suites employing a wide variety of their native percussion instruments which lends great vitality and color to the scores.

As noted, the hi-fi fan will get his due here, with great brilliant brass and sparking woodwinds set against the exotic thud, boom, crash, and scrape of the percussion. All is very clean and has a very wide dynamic scope. The stereo effects are well carried out, with good directivity, excellent depth perception, and nice separation. All in all, an off-beat record most hi-fi fans will thoroughly enjoy.

EILEEN FARRELL SONG RECITAL
Eileen Farrell with George Trovillo, pianist. Columbia Mono ML5484. Price \$4.98.

EILEEN FARRELL SINGS PUCCINI ARIAS
Eileen Farrell with Columbia Symphony Orchestra conducted by Max Rudolph. Columbia Mono ML5483. Price \$4.98.

Speaking of Eileen Farrell, those of you who admire her as much as I do, will rejoice in these two new albums. In the "Song Recital" she is heard to great advantage and one realizes that there are few vocal artists who can match this voice for sheer tonal beauty. One has only to listen to the exquisitely rendered "Beau Soir" of Debussy to realize what a phenomenon we have in our midst. In addition to this Debussy, there are four others and the works of Schubert, Schumann, and Poulenc as well.

In the album of Puccini arias, Farrell is tremendous and gives us a hint of what is to come in her Metropolitan Opera debut. She soars gracefully and effortlessly in "Mi Chiamano Mimi" and displays astonishing control in "Vissi d'arte." With equal facility and rare tonal beauty she traverses "Non las Sospiri" from "Tosca" and "Un bel di" from "Madama Butterfly."

One could rave on about the rest of the album. I suggest if you are any sort of an opera fan, this should be required listening.

MOZART
SYMPHONY #1 ("Jupiter")
MARRIAGE OF FIGARO (Overture)
DON GIOVANNI (Overture)
MAGIC FLUTE (Overture)
Vienna State Opera Orchestra conducted by Felix Prohaska. Vanguard Stereo SRV185D. Special Demo price \$2.98.

Another in Vanguard's continuing series of outstanding stereo bargains, this time featuring friend Mozart. Prohaska obviously knows his way with Mozart and gives us an idiomatic performance in the best Viennese traditions.

There is no tempi-tampering here or other mannerisms... just straight lined to the score and the better for it, I say, than some of the "interpretations" we have been saddled with lately.

The sound is an excellent example of the Vanguard engineering philosophy... a smooth, clean sound, taking full advantage of the acoustics of the recording hall and producing stereo that has all of the attributes one could desire, but is never overdone as to directionality or other obtrusive factors.

All of this makes for easy listening and we chalk up another win and a remarkable value from Vanguard.

PROGRAM OF BACH ARIAS
The Bach Aria Group directed by William H. Scheide. Decca Stereo DL79408. Price \$5.98.

If you have a predilection for Bach arias, performed in the most exemplary fashion, this record is for you. It would be hard to find a more illustrious group of artists than the participants here: Eileen Farrell, Jan Peerce, Carol Smith, Julius Baker, Robert

Bloom, and others. Each is a virtuoso in his or her own right and when they bring these remarkable talents together the result is some memorable music making.

Outstanding is the aria from Cantata #115 and #205. The sound is beautifully clean and well modulated and a good balance is maintained between vocal and instrumental elements. Stereo effects are not too pronounced in this type of music but what there is is well handled.

TABOO, VOLUME TWO
Arthur Lyman and his Orchestra. Hifi-record Mono R822. Price \$4.98.

This recording has been on the best-seller charts for some time and thus when it arrived I hastened to find out why. Well, on the basis of music, it is just pretentious tomfoolery... as a unique "sound picture or entertainment," it has its points.

What has been done is to take a group of numbers... some original and some old chestnuts like "Moon of Manakoora," "Ebb Tide," and "Hi Lili Hi Lo," and dress them in some of the wildest and most exotic arrangements imaginable. Lyman pulls out all stops here and unabashedly uses some old cliches, too.

The central theme is more or less Polynesian a la Hollywood and so we are served with a full complement of war drums and myriads of other percussion instruments, interspersed with the cries of jungle birds and seagulls, the wash of the sea, and... well you name it!

To my way of thinking, it is so corny it is good fun. The sound is whooped up at a very high level and is over-verberated to lend atmosphere. Very clean, though, and exceptionally well done, if what we hear is what the producer intended we should hear.

An item like this sounds especially well when played on the packaged-variety systems which probably explains its high rating on the pop charts.

MEDALLION MUSICAL MASTERPIECES
Kapp Stereo Record MSS-1. Price \$4.95.

This is in the nature of a "sampler" containing excerpts from four Kapp albums in the new "Medallion Series." Labeled rather simply, "The Sound of Top Brass," "The Sound of Musical Pictures," "The Sound of Strings," and "The Sound of a Chorus," these albums are designed to show off the sound quality in this new series.

In this sampler, the company has succeeded very well, although the level of musical inspiration isn't very high. Frankly, these are very overblown arrangements of pop material which ranges from "Holiday for Strings" and "Sentimental Journey" to "Whistler and His Dog."

This is also one of that new breed of records that is cropping up which claims to be the "living end" in sound. As far as I can determine this claim to fame lies solely in first recording everything on a strict multi-mike basis, which furnishes very close-up and bright sound of high level, but little dynamics. All the elements of the orchestra are given an enormously wide spread, which aids in maintaining a high level of separation.

The sound is very clean and, in the brass section, outstanding for its brilliance. This is the type of recording which will impress a great many people and which will sound great on many of the package systems. I must say that the more erudite will find the whole concept rather pretentious and they would be more willing to evaluate these recordings as something special in sound if the energy had been expended on symphonic compositions in which "perfect" sound is much more difficult to record.

Despite my protestations, if you want a really big sounding recording of this type of music, I can assure you that this will fill the bill.

RACHMANINOFF

**PIANO CONCERTO #2
PRELUDE IN C# MINOR
PRELUDE IN E FLAT MAJOR**

Byron Janis, pianist, with Minneapolis Symphony Orchestra conducted by Antal Dorati. Mercury Stereo SR90260. Price \$5.98.

This is the Rachmaninoff "Second" played to the hilt in the grand old manner. Janis, a young man, is surprising in his resemblance to a younger Rubenstein. His fingers are steel and his tone robust and grandiose. He scurries through difficult phrases with clean, precise touch and strikes an awesome thunder in his chords.

His pace is a little faster than most in the first movement and, in the second, a little slower and perhaps more introspective but at all times he is eloquently lyrical and properly romantic in approach, with never a tendency to over-sentimentalize.

Dorati is in excellent form here and the rapport between these artists is audibly evident. The sound is recorded somewhat close-up and is tremendously full-bodied and sonorous. All is very clean and the stereo aspects are all one could desire.

My only quibble was that, at times, I thought the balance was a little off... in some passages for winds and piano the winds were somewhat obscured... at other times in full ensemble playing, I thought the piano might have been projected a little more forward for added presence. The piano sound itself was extraordinarily rich with a huge bass tone, too often missing in other recordings.

In short, perhaps not a definitive version but, especially as regards stereo, it has no competition from any other disc currently available.

MOZART

CONCERTO FOR PIANO AND ORCHESTRA # 22

HAYDN

CONCERTO FOR PIANO AND ORCHESTRA IN D MAJOR

Jorg Demus, pianist, with Radio Symphony Orchestra of Berlin conducted by Franz Paul Decker. Deutsche Grammophon Stereo 138049. Price \$5.98.

The remarks that applied to the above DGG recording could well apply to this. The playing is exemplary in the Mozart, less satisfactory in the Haydn which is a little heavy handed.

The sound is also recorded much closer than in most DGG recordings and again proves very good and, to my taste, to be preferred. The reverb is different in this hall, a shade less than in the other recording, and here is where a little more would have helped to soften the contours of the Haydn. Directionality was still not as pronounced as in American-style recordings, but because of the closer pickup was easier to perceive than is usual with DGG discs.

And once again a tip of my hat to those incredibly quiet DGG surfaces. I understand from someone recently a guest of DGG in Hamburg that the pressing cycle is approximately twice as long as ours and that, plus the thicker compound they use, may account for these magical surfaces.

Still slow and a sign of the present doldrums of the record business are new releases of any real portent. However, a few items have begun to trickle in and next month should see us out of the woods.

In the meantime, happy listening to the "goodies" mentioned above. [30]

STEREO QUALITY SOARS TO NEW HEIGHTS...



THE "PROFESSIONAL QUALITY" 9T!

Now, the ceramic cartridge proved in independent A-B listening tests to perform as well as the highest-priced "professional" types. It's Sonotone's revolutionary new 9T. So superior, you can expect faithful reproduction from the most robust musical passages to the most subtle overtones. Sonotone's new 9T series stereo cartridge:

GUARANTEES performance equal to cartridges costing up to 3 times as much—as proven in A-B listening tests.

GUARANTEES highest compliance—allows major reduction of tracking force.

GUARANTEES more than adequate channel separation.

GUARANTEES crisp definition.

GUARANTEES superior, more compact mechanical design—including revolu-

tionary new needle design with instant "snap-in, snap-out" replacement needle feature and built-in jewel tip protector.

ELIMINATES distortion—incidentally flat response of ± 1 db from 20 to 17,000 cps—cuts listening fatigue.

ELIMINATES dust pile-up—at recent trade show the 9T ran 4 straight hours, collected no dust.

ELIMINATES most record groove noise or hiss—no "needle talk".

Imagine, the 9T boasts all these "professional" features...yet sells for less than half the price of the least expensive "professional" cartridge. Simplify your inventory...cut call-backs—increase sales and profits—with Sonotone's great new 9T cartridge...unsurpassed for performance—and for value.

LIST PRICE:	9T-S...\$16.50 (0.7-mil and 3-mil sapphires)	9T-S77...\$16.50 (Two 0.7-mil sapphires)	9T-SD...\$19.50 (Sapphire-Diamond)
-------------	---	---	---------------------------------------

Sonotone

ELECTRONIC APPLICATIONS DIVISION, ELMSFORD, N. Y. DEPT. C1-110

IN CANADA, CONTACT ATLAS RADIO CORP., LTD., TORONTO

LEADING MAKERS OF

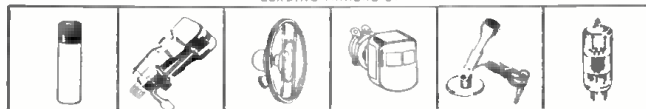

BATTERIES · CARTRIDGES · SPEAKERS · TAPE HEADS · MIKES · ELECTRONIC TUBES

COYNE'S New Complete Pin-Point TROUBLE SHOOTING Series

See All 4 Books On 7-Day FREE TRIAL! Takes Headaches Out Of All Servicing Problems!



Pin-Point
TRANSISTOR TROUBLES
IN 12 MINUTES!

Trouble-shoot every type of circuit in ALL transistorized equipment! 525 pages; hundreds of illustrations; 120 check charts! \$5.95



Pin-Point
RECORD CHANGER
TROUBLES IN 5 MINUTES!

Locate mechanical and electronics troubles fast. Covers all makes. 320 pages; 450 photos; 58 check charts! \$3.95



Pin-Point
TV TROUBLES
IN 10 MINUTES!

Find the exact sound or picture trouble in any TV set from 700 possibilities! 300 pages; 300 diagrams, check charts! \$4.95



Pin-Point
COLOR TV TROUBLES
IN 15 MINUTES!

Covers every type of color TV and picture tube! 550 pages; 362 check charts, diagrams, picture patterns! \$5.95

Simple Check Chart System Saves Time

These amazing practical handbooks with an ENTIRELY NEW METHOD, show you how to find the trouble in ANY tv, record changer or transistor circuit FAST! Index tells you where to look; famous Check-Charts help you pin-point the exact trouble in minutes! These on-the-job books quickly pay for themselves in profitable new business and valuable time saved!

SEND NO MONEY!

Just mail coupon for free trial. After 7 days, send only low price or return books and pay nothing! If you keep all 4 books, send only \$4 after 7 days. Pay \$18.35 balance plus postage at \$4 per month.

VALUABLE FREE GIFT!
Send for FREE TRIAL OFFER of all 4 Pin-Point books and get FREE book, "Bigger Profits in TV" whether you keep series or not!

FREE TRIAL OFFER... Mail Coupon Now!

Educational Book Publishing Div.
COYNE ELECTRICAL SCHOOL, Dept. 80-RT
1455 W. Congress Pkwy., Chicago 7, Ill.

Rush 4-book PIN-POINT Series for 7-day FREE TRIAL per offer. For individual books, check below.

RECORD CHANGER (\$3.95 plus postage)

TRANSISTORS (\$5.95 plus postage)

TV (\$4.95 plus postage)

COLOR TV (\$5.95 plus postage)

Name Age.....

Address

City Zone..... State.....

\$19.95 Cash Price enclosed; Coyne pays postage.

Send C.O.D. for \$19.95 plus M.O. fee; Coyne pays postage. 7-Day money-back guarantee on Cash or C.O.D. orders.

Signal-Level Indicator

(Continued from page 39)

the indicator input, it is rectified by the crystal diode, CR₁. Incidentally, almost any type diode can be used for this purpose. A negative d.c. voltage is thus applied to the tube grid. This d.c. voltage increases as the audio signal is increased, causing the two lighted segments of the tube to become larger and closer together, thus reducing the size of the dark area of the viewing portion of the tube. With the circuit values given in the parts list, the two lighted segments begin expanding when a sine-wave signal level of about .5 volt is applied to the input terminals.

For example, in one application, that of a tape recorder system, the indicator circuit would be connected to a point in the recorder circuit where an audio signal level is available which will cause the two lighted segments of the tube to just meet at maximum recording level. Overlapping of the lighted segments would then be regarded as the overload, or distortion, point.

Although the unit as described is an external, detached, general-purpose signal-level indicator, the circuit may be incorporated directly into a tape recorder system or AM-FM receiver, in which case the heater and d.c. supply may be obtained from the power supply of the device with which it is used. The heater requires 6.3 volts at 0.3 ampere and the d.c. potential needed is 250 to 300 volts with current drain of just 2.5 ma. [30]

TRANSISTORIZED PUSH-PULL OUTPUT DRIVER

By DAVE STONE

PUSH-PULL transistor output stages are generally driven by a transformer-coupled driver stage. Most miniature transistor interstage transformers have losses which narrow the frequency response, resulting in poor fidelity. Try the circuit shown in the diagram below to eliminate the driver transformer and increase the frequency response.

The driver transistor is resistance-coupled to the first 2N109 push-pull amplifier. A small portion of the 2N109's output is fed, via the 1-μf. capacitor and 15,000-ohm resistor, to the base of the second 2N109. The amplitude of this signal is approximately equal to the first 2N109's base signal amplitude. The 100-ohm unbypassed emitter resistance helps to eliminate oscillation tendencies. [30]

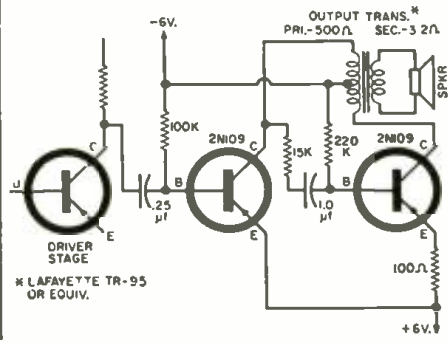

* RECORDING TAPE

*Oxide guaranteed not to rub off or squeak—or money back. Compare ours with other "Bargain" tapes. You'll find it's more than just "price" when you deal with us. We are original pioneers in the tape recorder business and our reputation means everything to you.

600' Acetate (plastic), 5"	.75
900' MYLAR (Polyester), 5"	.95
1300' MYLAR, 1/4 mil, 5" reel	1.28
1300' Acetate (plastic), 7"	1.29
1300' MYLAR, 1/4 mil (strong)	1.85
1300' acetate (plastic), 7"	1.79
1300' MYLAR 1 mil thick, 7"	2.69
2400' MYLAR, untempered, 7"	2.59
2400' MYLAR, tempered, 7"	3.49

Studio Log—Tapes Even Lower

NORELCO SPEAKERS

Famous 9710M, twin-cone 8" speaker, original list \$8.95, usual NET \$3.97. NOW, while they last 1/2 off net... \$1.98 plus postage. (discontinued model). Frequency 60-20,000 cy. Other SENSATIONAL speaker reductions on a first come, first served basis. SEND FOR SPEAKER SPECIFICATION SHEET.

COMMISSIONED ELECTRONICS CO.
1776 Columbia Road Washington, D. C.

ORDER YOUR ENCLOSURE KITS FROM HOMEWOOD

Bring out the best in your speakers... save dollars in assembly and finishing costs... get the fun of "doing-it-yourself"!

ONLY \$11.95

MODEL 6

Factory assembled, ready for finishing. Makes your 8" speaker sound like a million! Made of 1/2" hardwood ply, beautifully grained and smoothly sanded. 10" h. x 16" w. x 9" d. 9 lbs. Order two for matched stereo performance.

MODEL 1

4 1/2 cubic feet of baffle space assures you crisp, cleanest bass response from any 12" speaker system. Full-grained white birch ply, with pre-attached bracing cleats for easy assembly. Kit includes everything you need for assembly. 29" h. x 20" w. x 12 1/2" d. (5" legs). 25 lbs. \$18.95

MODEL 2

Clear-grained on four sides for bookshelf or floor use. Acoustically accurate for 12" systems, with adapter board for 8" speakers. Sturdy, 3/4" ply eliminates unwanted resonances, improves bass response. 14" h. x 21" w. x 11 3/4" d. 20 lbs. In Birch, \$14.50 In Walnut, \$19.95

MODEL 13. Finishing kit; includes generous quantities of everything you need to do a professional, long-lasting finishing job, plus brush, sandpaper and easy-to-follow instructions. Specify: Mahogany, Walnut, Blonde, Oak, Fruitwood, Maple, Cherry, Ebony, Natural. \$3.88

Ten-day money-back guarantee. All items shipped freight collect. Please send check or M.O. (No C.O.D's)

HOMWOOD INDUSTRIES, Inc.

26M Court Street, Brooklyn 1, N.Y.

Please send me:

Model 6 Model 1 Model 2 (Birch) (Walnut)

Model 13

Homewood catalog

I enclose remittance in the amount of \$.....

Name.....

Address.....

City..... Zone..... State.....

Square-Wave Voltage Calibrator

By JOHN POTTER SHIELDS

MANY times it is desirable to have a square-wave generator capable of producing square waves of accurately known amplitude. Such a generator is useful for calibrating scope vertical amplifiers, voltage references, as well as for testing audio and video amplifiers.

The writer, in need of such a unit, devised a simple generator; the schematic of which is shown in Fig. 1. Its operation is based on the fact that a silicon junction diode will not conduct in the forward direction until the voltage across the junction reaches 0.6 volt. This "gap voltage" is constant for all types of silicon junction diodes; varying only slightly with temperature extremes. By using this principle, it is possible to design a simple diode clipper that does not require any "unhandy" back biasing voltages.

As is shown in Fig. 1, two silicon junction diodes are connected together with reversed polarities across the 6.3-volt a.c. supply. The dropping resistor, R_1 , is used to limit the forward current through the diodes. The square wave, actually a clipped sine wave, output is taken from across the diodes through an isolating capacitor, C_1 . In operation, on the positive half cycle, CR_1 will not conduct until the voltage across its junction reaches a value of 0.6 volt. Above this voltage, it will conduct; clipping the top of the positive half cycle. On the negative half cycle, CR_2 will operate in the same manner; clipping the negative half cycle after its amplitude has reached 0.6 volt. Thus, the voltage appearing across the two diodes will be a clipped sine wave with a peak-to-peak amplitude of two times 0.6 or 1.2 volts.

The construction of the device is extremely simple and it can be easily installed right in the scope or other piece of equipment with which it is to be used. Simply connect its input to the 6.3 volt heater winding on the power transformer, or if desired, it can be operated right off the 117-volt a.c. line by changing the limiting resistor, R_1 , to 100,000 ohms.

While the writer used a pair of Hughes HD-6003 diodes, other diodes such as type 1N538 or 1N302 can be used with equal success.

If desired, this clipper can be used on higher frequencies with equally satisfactory results. [30]

Fig. 1. A simple square-wave generator.

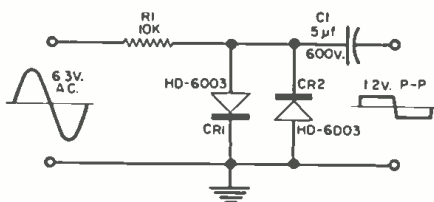

DESIGNED FOR STEREO



PAS-2 \$59.95

- New stereo control preamp with complete flexibility, fastest construction, and simplest operation
- All long life components, 1% parts used in critical circuits
- 2 pre-assembled heavy duty printed circuit boards make construction simple and bug-free
- Truly unmeasurable distortion—below 0.05%. Lowest possible noise



Stereo 70 \$99.95

- Two outstanding 35 watt channels (160 watts peak) to power any speaker. Less than .5% distortion at rated power
- Unequaled transient response—excellent square wave performance
- Absolute stability with every loud-speaker without restriction of band-width
- Smooth and crystal clear sound with superb delineation of heavy passages

WITH DYNAKIT YOU KNOW YOU HAVE THE BEST!

The finest high fidelity you can buy at any price

STEREO IN EASY STEPS

START WITH A SUPERB MONOPHONIC SYSTEM

EXPAND TO MATCHLESS STEREO



PAM-1 \$34.95

- History-making "no-distortion" preamplifier which has never been equalled
- All feedback design and close tolerance parts result in lowest noise, lowest distortion and finest sound
- 6 hour assembly



Add the DSC-1 \$12.95

- Every stereo function at your fingertips—including Dyna Blend control
- Unsurpassed flexibility
- Utilized panel or cabinet mount available as an accessory



Mark IV \$59.95

- Either the renowned 60 watt Mark III or its new little brother, the 40 watt Mark IV
- 3 hours to build
- A quality of performance unexcelled at any price



Two Mark III's \$79.95 each

- Just add a second Mark III or Mark IV and you have the most recommended, most desired stereo amplifier ensemble
- Dynakits provide the finest in high fidelity

See and hear Dynakits at your local dealer

A post card will bring complete specifications

Coming! The New DYNATUNER

DYNACO, INC., 3916 POWELTON AVENUE, PHILA. 4, PA.
CABLE ADDRESS: DYNACO, PHILA.

see the exciting **1961**

knight-kits[®]

A PRODUCT OF ALLIED RADIO

in this value-packed **ALLIED** catalog

free

**444 pages
most complete**

send for it!

use coupon
on next page

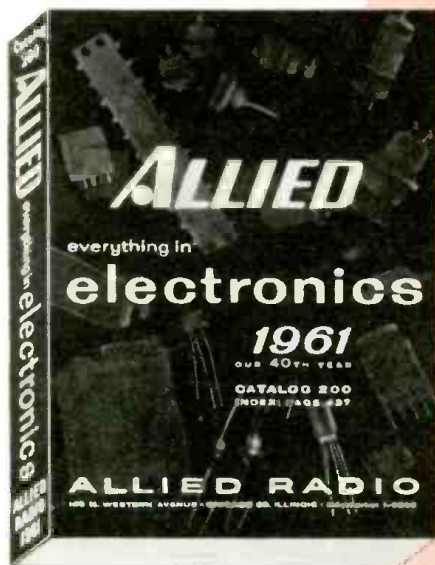

knight-kits—Best by Design

FUN TO BUILD Building it yourself is always satisfying fun—it's fun at its best when you build Knight-Kits—they're so beautifully engineered, so much easier, more pleasurable to work with...

YOU SAVE You save substantially because you buy direct from Allied at our money-saving big-volume-production prices—and because you do the easy building yourself...

YOU OWN THE BEST You'll be glad you built a Knight-Kit, because you'll own and enjoy with pride a true custom-built product, professionally engineered and styled—designed for superior performance...

EASIEST TO BUY **only \$2 down** on orders up to \$50; \$5 down up to \$200; \$10 down over \$200—up to twenty-four months to pay...

exclusive knight-kit MONEY BACK GUARANTEE

Every Knight-Kit is unconditionally guaranteed to meet our published specifications for performance or your purchase price is refunded in full.

**Buy Any Knight-Kit!
...Build and Use It!
It Must Perform
Exactly as Claimed!**

Your Satisfaction is Guaranteed

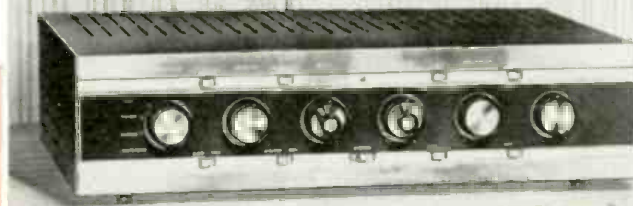

**70-Watt
Super-Power
Stereo!**

DELUXE 70-WATT STEREO AMPLIFIER

Super-power to drive any of today's speakers; the ultimate in control flexibility and functions. 83 YU 934 **\$119.95** only **\$5** down

see many more great **HI-FI KITS**

Stereo Preamp	18-Watt Amplifier
60-Watt Stereo Amplifier	12-Watt Amplifier
Stereo Control	FM Tuner
25-Watt Amplifier	Speaker Systems

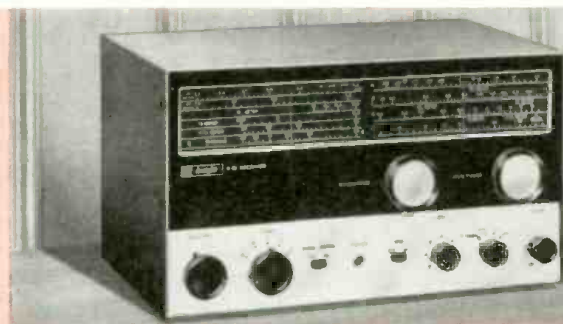

ALL-BAND SUPERHET RECEIVER

Covers 540 kc to 36 mc, plus 6 meters; general coverage tuning and calibrated Amateur bandspread tuning. 83 YU 935 **\$67.50** only **\$5** down

see many other **HOBBYIST KITS**

"Space Spanner" [®] Receiver	Transistor Radios
"Ocean Hopper" Radio	Intercom Systems
Radio-Intercom	Electronic Lab Kits
Clock-Radio	Photoelectric System



BEST VTVM VALUE

High sensitivity general-purpose VTVM; 11 meg input resistance; balanced-bridge circuit; 4½" meter. 83 Y 125. . . . **\$25.75**

only **\$2** down



only **\$2** down

From original concept to final design, each Knight-Kit is produced by and comes directly to you from ALLIED

sold exclusively by

ALLIED

knight-kits: best in build-your-own electronic equipment

STEREO TAPE RECORD/PLAY PREAMP

Professional quality; permits tape monitoring, sound-on-sound and echo effect; use with any tape transport. 83 YX 929 (less case) \$79.95

only \$5 down

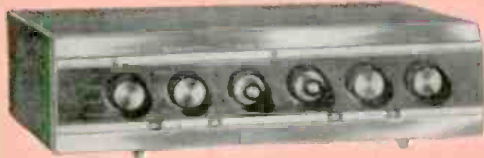

DELUXE 40-WATT STEREO AMPLIFIER

Full frequency center channel. Finest amplifier available anywhere in this price range. 83 YU 774.....\$76.95

only \$5 down

DELUXE FM-AM STEREO HI-FI TUNER

Dynamic Sideband Regulation, variable AFC, "Magic Eye" slide-tuning, multiplex add-in. 83 YU 731.....\$87.50

only \$5 down



Only \$39.95 For Full 20 Watts Stereo!

SUPER-VALUE STEREO HI-FI AMPLIFIER

20-Watt Stereo Hi-Fi Amplifier, with special clutch-type dual-concentric level control; biggest bargain in Stereo hi-fi. 83 YX 927.....\$39.95

only \$2 down



SUPERHET CITIZENS BAND TRANSCEIVER

Dual-conversion receiver for highest sensitivity and selectivity; 2-channel crystal-controlled 5-watt transmitter. 83 YX 712-2.....\$79.95

only \$5 down



\$39.95 For This Citizen's Band Transceiver

only \$2 down

TOP VALUE CITIZENS BAND TRANSCEIVER

Lowest-priced complete Citizens Band Transceiver. Tunable 22-channel super-regenerative receiver; 5-watt transmitter. 83 Y 713-2.....\$39.95

only \$2 down

SENSATIONAL 4-BAND "SPANMASTER" RECEIVER

For thrilling world-wide reception; exciting Short-wave and Broadcast; band-switching, 540 KC to 80 MC. With cabinet. 83 YX 258.....\$25.95



FM-AM HI-FI TUNER BUY

Outstanding FM-AM Hi-Fi Tuner; with AFC and tuned RF stage on FM; includes multiplex jack. 83 YX 928.....\$49.95

only \$2 down

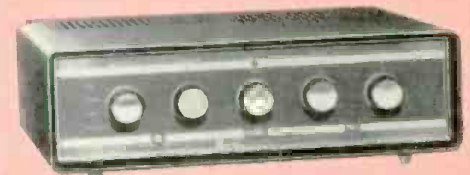

32-WATT STEREO AMPLIFIER VALUE

Money-saving 32-Watt Stereo Hi-Fi Amplifier; high power at low cost; full frequency center channel. 83 YU 933.....\$59.95

only \$5 down



only \$2 down

"600" TUBE CHECKER

Checks over 700 types; illuminated roll-chart; obsolescence-proof design. 83 YX 143...\$32.95

RF SIGNAL GENERATOR

Output to 112 mc on fundamentals; 400-cycle modulation. 83 Y 145.....\$19.75

full selection of INSTRUMENT KITS

5" Oscilloscopes
AC VTVM
Tube Checkers
Signal Tracer
Audio Generator
Sweep Generator
Battery Eliminator
Capacity Checker
Transistor Checker
R/C Tester,
plus many others

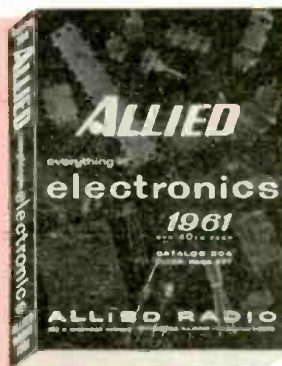

free

SEND FOR THE 444-PAGE 1961 ALLIED CATALOG

Write today for the world's biggest electronics catalog, featuring the complete KNIGHT-KIT line. See the big news in quality electronic kits—save on everything in Electronics. Send for your FREE copy.

send for it today!

ALLIED RADIO, Dept. 161-L
100 N. Western Ave., Chicago 80, Ill.

Send FREE 1961 ALLIED Catalog

Name _____

Address _____

City _____ Zone _____ State _____

RADIO

Pioneer in electronic kit development

SPECIAL MICROAMMETERS
 TRIPLETT 3" 0-50 Microamps (Scale 0-100) Special \$4.50
MICROAMMETERS 4 INCH SQ.
 50-0-50 Microamps, each \$6.95
 0-50 Microamps, each \$7.95

EIMAC TRANSMITTING TUBE
 450TL—Brand New—Fully Guaranteed. Each \$39.50

DYNAMOTOR SPECIAL
 12 Volts Input-Output 440V. @ 200Ma., 12 Volts Input-Output 225V. @ 100Ma. All in one Dynamotor. BRAND NEW. Ea. \$7.95

BRAND NEW CARTER DYNAMOTOR
 INPUT 5.9 VOLTS, OUTPUT 405 V. @ 270 MA. SMALL SIZE. Ea. \$4.95

NEW VACUUM CAPACITORS
 50 MMF-5KV95
 25 MMF-10KV 2.25
 EIMAC VC 12 MMF-32KV ea. \$6.95
 EIMAC VC 25 MMF-32KV ea. 7.95
 EIMAC VC 50 MMF-32KV ea. 12.95
 JENNINGS 100 MMF-20KV ea. 12.95
 JENNINGS JHC-150 MMF-50KV ea. 24.95

POWER TRANSFORMER
 Primary 110V. 60 cy. Sec 445-0-445V. @ 150 Ma. 6.3V. @ 6 Amps. 5V. @ 3 Amps. Fully shielded. Ea. \$3.95
 Write for quantity prices

CHOKE—FULLY CASED
 5 HENRY @ 200 Ma. 1.95
 5 HENRY @ 250 Ma. 2.25
 4-12 HV (Swinging) @ 300 MA. 3.95
 10 HENRY 300 Mil. 6.00
 4 HENRY 400 Mil. 3.95
 12 HENRY 500 Mil. 5.95
 4 HENRY 600 Mil. 2.95
 6 HENRY 600 Mil. 5.95
 4 HENRY—1 amp. 13.95

BRAND NEW OIL CONDENSERS
 3 MFD 600 VDC .60
 4 MFD 600 VDC .75
 5 MFD 600 VDC .80
 6 MFD 600 VDC .85
 8 MFD 600 VDC .95
 10 MFD 600 VDC 1.10
 12 MFD 600 VDC 1.50
 15 MFD 600 VDC 1.70
 3x8 (24 MFD) 600 VDC. 2.50
 1 MFD 1000 VDC .50
 2 MFD 1000 VDC .70
 4 MFD 1000 VDC 1.35
 5 MFD 1000 VDC 1.95
 10 MFD 1000 VDC 2.50
 12 MFD 1000 VDC 2.95
 15 MFD 1000 VDC 3.50
 1 MFD 1200 VDC .45
 1 MFD 1500 VDC .75
 2 MFD 1500 VDC 1.10
 4 MFD 1500 VDC 1.95
 8 MFD 1500 VDC 2.95
 1 MFD 2000 VDC .85
 2 MFD 2000 VDC 1.50
 4 MFD 2000 VDC 3.50
 6 MFD 2000 VDC 4.95
 8 MFD 2000 VDC 5.95
 2 MFD 2500 VDC 2.50
 1 MFD 3000 VDC 1.85
 2 MFD 3000 VDC 1.50
 1 MFD 4000 VDC 3.25
 2 MFD 4000 VDC 6.25
 3 MFD 4000 VDC 8.95
 4 MFD 4000 VDC 12.95
 15 MFD 5000 VDC 35.50
 1 MFD 7500 VDC 2.95
 1 MFD 7500 VDC 6.95
 2 MFD 7500 VDC 17.95
 2 MFD 10,000 VDC 29.95
 1 MFD 12,500 VDC 19.95
 1 MFD 12,500 VDC 34.50
 1 MFD 15,000 VDC 34.95
 5 MFD 25,000 VDC 34.95
 1 MFD 25,000 VDC 69.95
 10 MFD 30,000 VDC 29.95
 20 MFD 350 AC. 2.95
 8 MFD 600 AC. 2.95
 2 MFD 600 VDC .50

RELAYS
 GUARDIAN 110V AC. 2 Pole Single Throw (1 N.O. & 1 N.C.) Repl. BC-610. \$2.50
 Potter-Brumfield SMSLS 5000 ohm. 4 Ma. Sens. \$2.25
 Hermetically Sealed Relay Coil 110V AC 60 cy SPDT Contacts 8 Amps. \$1.50
 6 Volt OC DPDT H.S. 99c
 12 Volt DPDT OC Relay. ea. \$1.35
 SIGMA type 22RJC 8,000 ohm SPDT. small sealed relay. \$2.49
 Sealed Relay, SPDT, 8,000 ohm coil. \$1.95
 G.E. Relay control, contains 8000 ohm relay, sensitivity 2 mils. 10 for \$9.25. ea. \$1.10
 SIGMA SF—16,000 ohm SPDT. operates on 500 Microamperes or less. \$3.95

PANEL METERS
 STANDARD BRANDS
1 1/2" METERS
 0-1 Mil. 2.95
 0-100 Micro 3.95
2" METERS
 0-100 Micro 4.50
 0-1 Ma 3.50
 100-0-100 Micro 3.95
 0-50 Micro (0-5 scale) 4.95
 0-10 Amps DC 2.95
 0-20 Volts DC 2.95
 18-36 Volts DC 1.99
 0-150 V. AC 3.49
3" METERS
 100-0-100 Micro Amps DC 5.95
 0-1 Mil DC 3.95
 0-10 Mills DC 3.95
 0-500 V. DC 3.95
 0-1 Amp RF 4.50
 0-15 Amps RF 4.50
 0-50 Micro Amps 6.95
 0-15 Volts AC 3.95
 REED Freq. Meter —110V. AC. 57. 63 cy. 9.95

MISCELLANEOUS SPECIALS
 1000 KC Plug in Crystal for BC 221 or LM Freq. Meters. \$5.95
 SPERTI Vacuum Switch used in ART13 ea. \$1.50
 3-12 MMF Erie Ceramic Trimmers. 21c
 MAGNETIC PICK-UP TOOL gets Nuts, Bolts, Tacks, etc. out of difficult places. Each 79c
 CUTLER-HAMNER TOGGLE SWITCH SPDT (ST42D) 4 for \$1.00. ea. 29c
 WILLARD STORAGE CELL—2V. 28 Amp hrs. Clear plastic case. Shipped dry. \$2.50
 Write for quantity prices on all special items

All merchandise sold on a 10 day money back guarantee
 Min. Order \$3.00—25% with Order—F.O.B. New York

PEAK

ELECTRONICS COMPANY
 66 W. Broadway, New York 7, N. Y., W0-2-2370

ELECTRONIC ARTIFICIAL LARYNX

Permits persons to talk who have lost their voices through surgical removal or paralysis of vocal cords.

AN ARTIFICIAL LARYNX for persons who have lost their voices through surgical removal or paralysis of their vocal cords has been designed by Bell Telephone Laboratories' scientists. The electronic larynx is to be made on a non-profit basis by Western Electric and it will be sold by Bell telephone operating companies for a price in the order of \$60.

The underlying principle of the artificial larynx is a vibrating driver held against the throat. Completely self-contained and cylindrically shaped, the unit measures only 1 3/4 inches in diameter by 3 1/4 inches long. Included in this one small package is a modified telephone receiver serving as the throat vibrator, a highly efficient transistorized pulse generator with pitch control, and a battery power supply.

To use the unit, the laryngectomized person presses the vibrator against his throat. Switching on the pulse generator with his finger, he transforms vibrations transmitted into his throat cavities into speech sounds by normal use of his throat cavity, tongue, mouth, teeth, and lips. Output speech volume is equal to that of a person speaking at a normal conversational level, although the sound is a bit buzzy and mechanical.

The device employs two transistors in a relaxation oscillator whose frequency is controlled by a variable resistance, and whose pulse width is determined by a feedback network. The output is a negative pulse which occurs at a frequency of 100 cps. This may be varied from about 100 to 200 cps by a user-op-

erated rheostat. This is done while speaking so as to produce changes in the pitch of the voice. A third transistor acts as a single-ended power-output stage. A diode serves to isolate the multivibrator from the amplifier between pulses, for stable operation.

Two 5.2-volt mercury cells in series power the unit for about 12 hours. These batteries have a 250-ma.-hr. rating with a maximum permissible current drain of



In use, the hand-held artificial larynx is pressed against the throat while the lips, mouth, and tongue are used normally. The thumb-operated control varies the pitch.

25 ma. With push-to-talk operation, such as the laryngectomized patient requires, 12 hours of continuous operation should be equivalent to several days or even weeks of normal talking. An alternative to using the batteries might be the use of a small a.c. power supply which can be fed from a normal wall outlet at home or in the office. [30]

Circuit diagram of the artificial larynx is seen to consist of highly efficient transistorized pulse generator with modified telephone receiver used as throat vibrator.

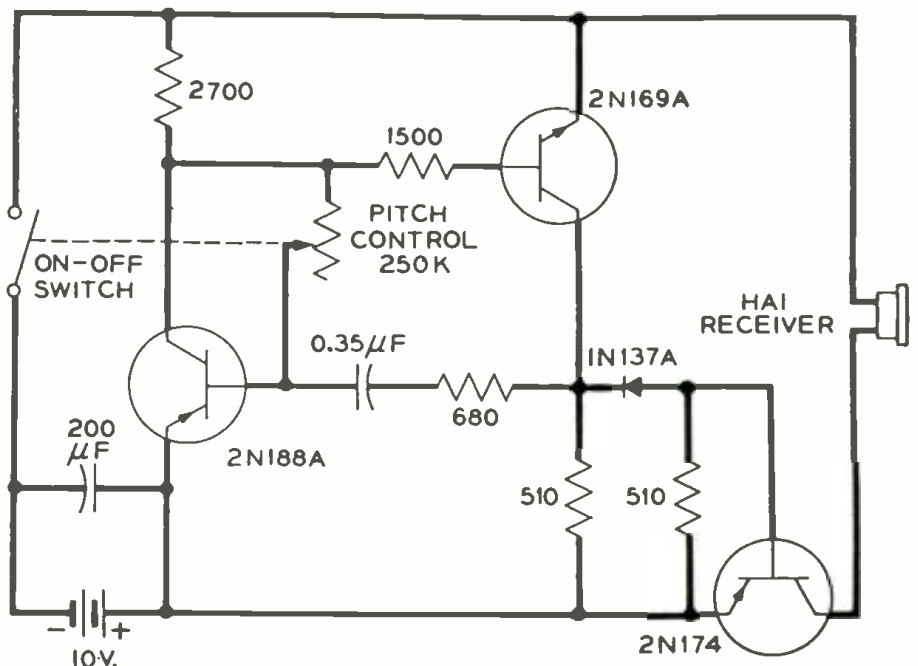

how much? \$2450

Consider the new 15" Wolverine full-range speaker—not just bigger—better, too!

The larger radiating area of the Wolverine LS15 gives it a performance edge in the bass region. The greater air load of the larger cone lowers the speaker's resonant frequency, allows the LS15 to radiate more sound power at those hard-to-get bass frequencies.

You can see the superior strength and rigidity of the cone of the LS15 that maintains truer rigid-piston motion at bass frequencies, and provides better control of the more complex modes of operation that come into play at higher frequencies.

Compare the Wolverine loudspeaker series with any other make. Whether you're interested in the LS8 (8"), LS12 (12") or the LS15 (15"), you'll find more quality per feature, and more features per dollar, in the remarkable Wolverine components . . . by Electro-Voice.

You get all these specific quality features. Heavy duty, diecast frames permanently maintain the alignment of the voice coil in the high-precision magnetic gap . . . glass coil forms maintain voice coil shape for life . . . edgewise-wound voice coil increases efficiency 18% over conventional coils . . . two specialized cones give efficient reproduction of both bass and treble frequencies . . . compact design makes them easy to install in today's sound-conditioned homes.

When your budget allows, you can get even wider range and better overall listening quality with Wolverine midrange and high-frequency step-up kits, easily added to any of the three basic Wolverine full-range speakers. Add the HF1 first, to bring out the subtle brilliance of modern stereo records, tape, and FM radio. Then, add the MF1, for greater midrange clarity, spread more evenly throughout the room by the famous E-V diffraction principle.

If you're shopping for quality and economy, your finest choice is an Electro-Voice Wolverine speaker.

Model LS15 — Specifications — Frequency response 35 to 13,000 cps; EIA sensitivity rating 46 db. Free-space cone resonance 35-45 cps. Power-handling capacity 20 watts program, 40 watts peak. Impedance 8 ohms. Mechanical crossover 4500 cps. 15½ inch diameter, 6½ inch depth, 13¼ inch baffle opening; mounts with four holes ½ inches equally spaced on 14¼ inch circle. Net weight 11 pounds. Shipping weight 12 pounds. Net each \$24.50.

Electro-Voice®

Dept. 11N Consumer Products Division

ELECTRO-VOICE, INC., BUCHANAN, MICHIGAN

WOLVERINE LS 15 FULL RANGE 15-INCH LOUDSPEAKER

Full Color Giant Fold-Out Charts Still Available!

Here's a complete series of colorful, authoritative fold-out wall-charts (originally appearing in the pages of *ELECTRONICS WORLD*)—yours for only 15¢ each. All in full-color—each suitable for framing.

- Hi-Fi Crossover Network Design Charts:** Tells how to build speaker nets for any crossover frequency. Complete coil-winding data, capacitor values given.
- Color Codes Chart:** Gives you coding for capacitors, resistors, transformers, resistance control tapers—all in easy-to-use form.
- Bass-Reflex Design Charts:** Complete data on building own bass-reflex enclosures for any speaker, including ducted-port enclosures.
- Radio Amateur Great Circle Chart:** For Hams and short-wave listeners—gives complete listing and map of amateur prefixes by calls and countries.

ALSO AVAILABLE:

Reprint of:

- "Build a Citizens Band Transceiver"**—complete details on building an 11-meter transceiver for Citizens Band service.

IMPORTANT: ORDER BY NUMBER! OUR SUPPLY OF ALL GATEFOLDS AND REPRINTS IS LIMITED. OFFERED ONLY ON A FIRST COME, FIRST SERVED BASIS.

Send 15¢ per selection to

ELECTRONICS WORLD, Dept. N 1160

Box 378, Church Street Station

New York 8, New York

\$1 ELECTRONIC SALE

Buy one at the low price listed and get the second for only \$1.00 more. Price includes postage and insurance.

All merchandise is new, tested, guaranteed, and meets FCC specifications where required. Tubes, transistors, and crystals are included. Power supplies and cabinets are not.

- **TRANSMITTER**, Code #253275. 5 watt, 27 mc. crystal controlled citizens band. \$14.99 ea. 2 for \$15.99.
- **TRANSMITTER**, Code #253505. 5 watt, 50 to 54 mc., crystal controlled, amateur band. \$14.99 ea. 2 for \$15.99.
- **TRANSMITTER**, Code #925327. 100 milliwatt, 27 mc., crystal controlled, citizens band, completely transistorized. Shirt pocket size. \$18.99 ea. 2 for \$19.99.
- **OSCILLATOR**, Code #923027. 100 milliwatt, 27 mc. Similar to above transmitter but contains crystal oscillator stage only. \$12.99 ea. 2 for \$13.99.
- **CONVERTER**, Code #260270. adapts any broadcast radio to 27 mc. citizens band. Tunes all 22 channels. \$14.99 ea. 2 for \$15.99.
- **CONVERTER**, Code #926027. similar to above except uses 3 high frequency transistors. Operates on 6 or 12 volts. \$24.99 ea. 2 for \$25.99.
- **NOISE SILENCER**, Code #113300. for super-het radio receivers. A superior circuit using 2 dual tubes which provides the most effective noise clipping and adjustable squelch without audio distortion or loss of gain. \$14.99 ea. 2 for \$15.99.
- **RECEIVER**, Code #715271. frequency range 27 to 29 mc. citizens band and 10 meter amateur band. Sensitivity better than 4 microvolts. Battery operated. \$9.99 ea. 2 for \$10.99.
- **RECEIVER**, Code #971527. 27 mc. citizens band. Pocket size, completely transistorized. Operates on 4 pen-light cells. \$16.99 ea. 2 for \$17.99.

Limited Quantity—no catalogs or literature available. All merchandise on display at our retail store at 196-23 Jamaica Ave., Hollis 23, N.Y.

Mail your order direct to our factory below.

VANGUARD ELECTRONIC LABS.

Dept. EW-11, 190-48 99 Ave.

Hollis 23, N.Y.

PURCHASING A HI-FI SYSTEM?

Send Us Your List Of Components For A Package Quotation

WE WON'T BE UNDERSOLD!

All merchandise is brand new, factory fresh & guaranteed.

Free Hi-Fi Catalog

AIREX RADIO CORPORATION

64-R Cortlandt St., N. Y. 7, CO 7-2137

PARTIAL LIST OF BRANDS IN STOCK

Jim Lansing*
Alec Lansing
Electrovoice
Jensen
Hartley
University
Acoustic Research
Janszen
Wharfedale
USL Citizen Band
Gonset • Hallicrafter
Texas Crystals
Concertone • Viking
Bell • G.E.
Weathers
Harman—Kardon
Eico • Pilot
Sherwood*
Acrosound
Quad Ampl-Spkrs*
Dual Changer
Bogen • Leak
Dynakit • Fisher
H. H. Scott
Thorens*
Pentron • Revere
Amplex • DeWald
Sony • Roberts
Challenger
Wollensak
Garrard • Norelco
Miracord
Glaser-Steers
Rek-O-Kut
Components
Tandberg*
Fairchild
Pickering • Gray
Audio Tape
Magnacord*
Rockford Cabinets
Arizon Cabinets
*Fair Traded

Improved Thyatron Relay Control

By JOHN POTTER SHIELDS

SMALL thyatrons, such as the 2050 and 2D21, have for many years enjoyed wide popularity as relay control tubes. These tubes boast high sensitivity coupled with a "snap-action," go, no-go characteristic which insures positive relay operation. With all of its many advantages, however, the thyatron possesses one distinct weakness—it badly loads the input circuit to which it is connected when it "fires" or is in the conducting state.

In an attempt to overcome this problem, the author devised the circuit shown in the diagram below. In essence, it is a thyatron directly coupled to a cathode-follower isolation stage. As is the case with cathode-followers, the input impedance of the circuit is extremely high: allowing the input resistor, R_1 , to be as high as 10 megohms. As a result, the circuit will cause negligible loading when fed from very high impedance sources.

The cathode of the thyatron, V_2 , is connected to the arm of the pot, R_1 , which with R_2 forms a voltage divider between "B+" and ground. The arm of this pot is normally adjusted so that with no signal input, the cathode of V_2 is sufficiently positive with respect to its grid to prevent conduction. Now, when the cathode of V_1 becomes more positive, the grid of V_2 , which is directly coupled to the cathode of V_1 , will become more positive than its cathode and V_2 will "fire," closing the relay. Since the plate of V_2 is connected through the relay coil to a d.c. source, once V_2 fires it will continue to conduct until the reset switch, S_1 , is opened, breaking the plate voltage. This "lock-in" feature has its advantages and does not require the use of a separate set of holding contacts as would be needed in the case of a vacuum-tube stage.

If it is desired to have the relay open or re-cycle when the input signal is removed, the plate circuit of V_2 can be connected to 117-volts a.c., as indicated by the dotted line in the diagram. In this case, a capacitor must be connected across the relay coil to prevent chattering of the relay. [30]

Circuit of "improved" thyatron relay control.

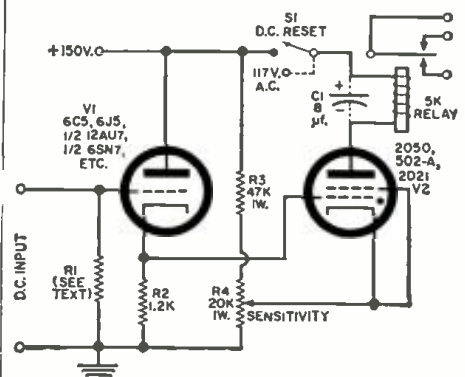

FAMOUS BC-645 TRANSCEIVER

15 Tubes 435 to 500 MC



Can be modified for 2-way communication. Receives or sends on high band 435-499 Mc. citizens radio 470-475 Mc. fixed and mobile 450-500 Mc. AM and CW. Special crystal 470-500 Mc. 15 tubes tubes also included. More than 500 parts. \$19.50

BRAND NEW
499 Mc. limited new BC-645 with tubes, less power supply in factory setting.
Shipping weight 23 lbs. SPECIAL!
PE-101C Dynamotor, 12/24V input
UHF Antenna Assembly
Complete Set of 10 Plugs
Control Box

SPECIAL "PACKAGE" OFFER:

BC-645 Transceiver, Dynamotor and all accessories above COMPLETE BRAND NEW. \$29.50
While Stocks Last.

BC-929 3-INCH SCOPE



Low cost station inductor and/or bench scope. Has Horiz. focus, sweep, intensity. Standard Tubes: 2-8N7, 2-11H5, 1-6X5, 1-6G6, 1-2N2, 10P1 CR Tube. Voltage req. 115V 100 cy. and 24 VDC. Complete with tubes, exc. \$9.95 used.

BRAND NEW \$12.95
Conversion Instructions for 110V 60 cycle AC \$6.50

LORAN R-65/APN-9 RECEIVER & INDICATOR



Used in ships and aircraft. Determines position by radio signals from known stations. Accurate to within 1/2 of distance. Complete with tubes and crystal. Exc. used. Value \$120.00. Our price \$79.50

Used, less tubes, crystal and visor, but with 3BH1 CR tube
12 Volt Inverter Power Supply for above. BRAND NEW \$32.50
28 Volt Inverter Power Supply, exc. cond. \$49.50
Shock Mount for above, exc. cond. \$2.95 (great mounting and mounting plate available. We carry a complete line of spare parts for above.

LORAN APN-4 FINE QUALITY NAVIGATIONAL EQUIPMENT



Determine exact geographic position of your boat or plane. Indicator and receiver complete with all tubes and crystal.
INDICATOR ID-68/APN-4, and RECEIVER R-98/APN-4, complete with tubes, Exc. used. \$49.50
Receiver-Indicator as above, BRAND NEW \$88.50

12V Inverter Power Supply, BRAND NEW \$32.50
28V Inverter Power Supply, exc. cond. \$49.50
Shock Mount for above, exc. cond. \$2.95
We carry a complete line of spare parts for above.

ARC-5/R28 RECEIVER



2-meter Superhet. 100 to 156 Mc in 4 crystal channels. Complete with 10 Tubes. BRAND NEW \$24.45
110V AC Power Sup. Kit for above \$9.75

ARC-5/T-23 TRANSMITTER

100-150 Mc Includes 2-832A, 2-1025 Tubes. BRAND NEW \$21.50

SPECIAL limited quantity ARC-5/T23 transmitters. OFFER! Excellent Used, less tubes \$5.95

MD-7 MODULATOR for T-23, complete with 4 tubes, LIKE NEW \$9.95

ARC-5 MARINE RECEIVER-TRANSMITTER

Navy Type Comm. Receiver 1.5 to 3 Mc BRAND NEW with 6 tubes \$16.95

Navy Type Comm. Transmitter 2.1-3 Mc BRAND NEW with 4 tubes and Xtal MODULATOR for above, new with tubes \$5.95

SCR-274 COMMAND EQUIPMENT

ALL COMPLETE WITH TUBES		
Type	Description	Used Like NEW
BC-453	Receiver 100-350 KC	\$12.95 \$14.95
BC-451	Receiver 3-40 Mc.	10.45 12.45
BC-455	Receiver 6-10 Mc.	11.50 13.95
BC-450	Receiver Control Box.	1.29 1.75

110 Volt AC Power Supply Kit, for all 1-4-N and ARC-5 Receivers. Complete with metal case, instructions. Complete with metal case, instructions. Tested, ready to operate. \$11.50

SPLINED TUNING KNOB for 274-N and ARC-5 RECEIVERS. Fits BC-453, BC-454 and others. Only \$4.95

BC-457 TRANSMITTER-4-5.3 Mc. complete with all tubes and crystal. BRAND NEW \$8.95

BC-458 TRANSMITTER-5.3 to 7 Mc. Complete with all tubes and crystal. BRAND NEW \$9.75

BC-459 TRANSMITTER-7-9.1 Mc. complete with all tubes and crystal. BRAND NEW \$13.95

BC-456 Modulator. USED \$3.45 NEW \$5.95

BC-451 Transmitter Control Box. \$2.25 NEW \$4.49

ALL ACCESSORIES AVAILABLE FOR COMMAND

EE-8 ARMY FIELD PHONES. Excellent condition checked out, perfect working order. complete with all parts less battery. Each \$12.95

WILLARD 6-VOLT MIDGET STORAGE BATTERY
3 Amp. Hour, BRAND NEW, 3 1/2" x 1-13/16" x 2 3/4". Uses Standard Electrolyte. Only \$2.95

2 VOLT BATTERY "PACKAGE"
1-2V, 20 Amp. Hr. Willard Storage Battery, Model = 20-2, 3" x 4" x 3 1/2" high. \$2.79
1-2V, 7 Amp. Synchronous Plug-in Vibrator \$1.49
1-Quart. Bottle Electrolyte for 2 cells \$1.45
ALL BRAND NEW!
Combination Price \$5.45

ARC-3 RECEIVER!



Complete with All Tubes Exc. Used \$16.95

Crystal-controlled 17-tube superhet, tunes from 100 to 156 MC. AM, on any 8 pre-selected channels. 28-volt DC power input.

ARC-3 TRANSMITTER

Companion unit for above, tunes 100 to 156 MC on any 8 pre-selected channels. 9 tubes, crystal controlled, provides tone and voice modulation. 28V DC Power input. Complete with all tubes. Exc. Used. Only \$16.95
Like new condition \$24.50

5-TUBE AMPLIFIER

Made by Pioneer Instrument Co. Uses 6GSN7, 1-6X5, 6H6 tubes. BRAND NEW VERY SPECIAL \$2.95

AN/ART-13 100-WATT XMTR

11 CHANNELS
200-1500 Kc
2 to 18.1 Mc



\$48.50

Complete with Tubes
Famous Collins Autotune Aircraft Transmitter. AM, CW, MW. Quick change to any of ten preset channels or manual tuning. Special amplifier clipper uses carbon or magnetic mixer. Highly stable, highly accurate VFO. Built in X-tal controlled calibrator. PPM's modulate 813 in final up to 90% class "B". A Real "HOT" Ham buy at our low price! \$119.95
Orig. cost \$180.00. Exc. Used \$48.50
0-16 Low Freq. Osc. Coil for ART-13 \$7.95
24V Dynamotor for ART-13 \$9.50
Same as above, less meter \$39.50
We carry a complete line of spare parts for above.

POWER SUPPLY for BC-620, 659, available for 6, 12 or 24 Volts DC. Specify \$8.95

BC-659 TRANSMITTER & RECEIVER
27 to 38.9 Mc. P.M. Two pre-selected channels crystal controlled. 5 watts. Complete with speaker. 11 tubes. Exc. used \$10.95
Less tubes, used \$5.95
Antenna for 10-19 Tubes (for 20 to 38 Ft) \$2.95

NAVY AIRCRAFT RADIO RECEIVER

ARR CRV 4611-190 to 9050 Kc in 4 bands. 6 Tube Superhet. easy to use. With local and remote tuning. Band change. Sharp and broad tuning. AVC, CW, III and IIIA. Complete with crystal and dynamotor. BRAND NEW \$34.50
Like New \$26.50
Power Supply 110 V. AC. Wheel \$6.50



BC-906 FREQ. METER-SPECIAL
Cavity type, 145 to 235 Mc. BRAND NEW, complete with antenna. Manual included. OUR LOW PRICE \$10.88

SCR-625 MINE DETECTOR
Complete portable outfit in original packing, with all accessories. Brand New \$22.50

DYNAMOTOR ASSEMBLY

Very fine unit, made by Collins Radio. Consists of TWO dynamotors mounted on filter base.
Dynamotor #1 INPUT OUTPUT
12VDC @ 3.8A 220VDC @ 100 MA.
Dynamotor #2 INPUT OUTPUT
12VDC @ 9.9A 400VDC @ 180 MA.
BRAND NEW, in original packing. \$10.95
shp. wt 29 lbs.
OUR LOW PRICE

MOBILE-MARINE DYNAMOTOR

Model DM35
Input 12V DC, Output: 825 V DC @ 225 MA. for press-to-talk intermittent operation.
Shp. wt. 14 lbs. OUR LOW PRICE, BRAND NEW \$8.45

OTHER DYNAMOTOR VALUES: Excellent BRAND			
Type	Input	Output	Used NEW
DM-25	12V 2.2A	250V .050A	\$4.50
DM-1A	28V 1.6A	230V .100A	3.25
DM-2B	28V	224V .07A	2.75 4.75
DM-32A	28V 1.1A	250V .05A	2.45 4.45
DM-33A	28V 5A	575V .16A	
	28V 7A	540V .25A	1.95 3.75
DM-34D	12V 2A	220V .080A	4.15 5.50
DM-53A	28V 1.4A	220V .080A	3.75 5.45
DM-64A	12V 5.1A	275V .150A	7.95
PE-73C	28V 20A	1000V .350A	8.95 14.95
PE-86	28V 1.25A	250V .050A	2.75 3.85

BD-77 DYNAMOTOR Input 14V @ 38A, Output 1000V @ .350A with starting solenoid, Filter Box and Mounting Base. Like New \$14.95

SCHEMATIC DIAGRAMS For any equipment on this page, each \$6.50
Please include 25¢ deposit with order-Balance C.O.D., or Remittance in Full. 50¢ Handling Charges on all orders under \$5.00. All shipments F.O.B. Our Warehouse, N.Y.C. All Merchandise subject to Prior Sale and Price Change.

G & G Radio Supply Co.
Telephone: CO 7-4605
51 Vesey St., New York 7, N. Y.

BC-603 FM RECEIVER

20 TO 27.9 MC. \$14.95
Excellent Used \$14.95
BRAND NEW \$17.95



10 Channel, pushbutton tuning or continuous tuning. Complete with speaker, tubes, switch.
12 or 24V Dynamotor for Above.
Exc. Used \$4.25 BRAND NEW \$5.50
BC-604 TRANSMITTER Companion unit for BC-603 Receiver. With all tubes. BRAND NEW \$19.95
With Tubes, Used \$4.95
We carry a complete line of spare parts for above.

SPECIAL! BC-603 FM RCVR CONVERTED FOR ANY FREQUENCY FROM 30 TO 50 MEGACYCLES!

BRAND NEW! Checked out, perfect working condition, ready for operation. Specify Frequency desired (between 30-50 Mc) when ordering. \$27.50

AC POWER SUPPLY FOR BC603, 683
Interchangeable replaces dynamotor. On-Off switch. NO RCVR. CHANGE NEEDED. Provides 220 VDC @ 80 Ma. 24VAC @ 2 Amps. \$10.49
Complete 240-page Technical Manual for BC-603, 604 \$3.15

AN/APR-4 RECEIVER

up to 4000 Mc in 5 tuning unit ranges. High precision laboratory instrument used to monitor or indicate frequency of any signals within its range. Includes wide and narrow band IF strip selected from panel. Outputs provided for attachments to pulse analyzer, hamameter, etc. Input 115 V 60 cy. LIKE NEW \$69.50
Tuning Units: TU18, TU17, TU18... each \$39.50
TU19... each \$89.50

FAMOUS SCR-510 COMPLETE SET READY FOR OPERATION

Consisting of: BC-620 FM TRANSCEIVER, 20-28 Mc., with Power Supply for 6 or 12 Volt DC operation, including all components: Antenna, Mast Base and Sections, Hamset, Technical Manual and all other accessories, ready for operation. BRAND NEW, in original packing. OUR LOW PRICE. While They Last! \$59.50

RECEIVER SPECIALS!

BC-312 MOBILE RECEIVER 6 Bands, 1500 Kc to 18 Mc. With Tubes and 14V Dynamotor. Exc. Used \$59.50
BC-342 RECEIVER 1.5 to 18 Mc. AC only. Exc. Used \$69.50
BC-348 SUPERMET Receiver frequency 500 Kc and 1.5 to 1800 Mc. Voice, tone, CW. Self-contained dynamotor for 24 VDC. Like NEW \$89.50

BC1206-C BEACON RECEIVER

195 to 420 Kc. Made by Satche Carlson. Works on 24-28 volts DC. 135 Kc. IF. Complete with 5 tubes. Size 4" x 4" x 6". Wt. 4 lbs. BRAND NEW \$9.99
Brand New, less tubes \$5.95
USED, with tubes \$9.95
USED, less tubes \$2.95



SCR-522 2-METER RIG!

Terrible buy! VHF Transmitter-receiver, 100-156 Mc. 4 channels. Auto-controlled. Variable modulated voice. They're going fast! Excellent condition. SCR-522 Transmitter-Receiver, complete with all 18 tubes and metal case. BRAND NEW \$29.50

MICROPHONES

Model	Description	Excellent BRAND Used NEW
T-17	Carlson Hand Mike	\$5.45
T-30	Carlson Throat Mike	\$3.34 7.74
T-45	Army and Navy Lip Mike	1.25
TS-9	Handset	3.88
TS-11	Handset	3.98
TS-13	Handset	4.25
TS-28	Handset	4.75

HEADPHONES

Model	Description	Excellent BRAND Used NEW
HS-23	High Impedance	\$2.19 \$4.49
HS-33	Low Impedance	2.69 4.59
HS-30	Low Imp. (featherwt.)	.90 1.65
H-16 U	High Imp. (2 tubes)	3.75 7.95
TELEPHONE HEADPHONES	for above HEADPHONES, BRAND NEW, PER PAIR	\$3.25
CD-307A	Cords, with PL35 plug and JK26 Jack	.99
Earphone Cushions for above		.50

TG-34A CODE KEYS

Self-contained automatic unit, reproduces code practice signals recorded on paper tape. By use of built-in speaker, provides code-practice signals to one or more persons at speeds from 5 to 25 WPM. Checked out, exc. used \$18.95
Signal Reels of Tape, Each \$1.85



BC-221 FREQUENCY METER

SPECIAL BUY! This excellent frequency standard is equipped with original calibration charts, and has ranges from 125 Kc to 20,000 Kc with crystal check points in all ranges. Exc. Used. Used with original Calibration Book, Crystal, and all tables \$59.50



STANDARD TUBES

Removed from Brand New Gov't Equipment			
RECEIVING	1207	75	807
6AQ5	.35	6J5	.65 813
12AT7	.45	6H6	.55 814
6X5	.55	6SL7	.85 815
6C4	.25	12A6	.45 826
6AL5	.38		1025
6AV7	.55		4X450
6J6	.35	2C39	3.50 6072
6V6	.65	3E29	4.25 1P25A

BC-605 INTERPHONE AMPLIFIER

BRAND NEW Each \$4.95

234-258 MC RECEIVER

AN/ARR-2
BRAND NEW 11-tube UHF Tunable Receiver with schematic. Only a few at this low price!
Complete with tubes \$8.88



Send Name, Address on Post Card for FREE CATALOG of Wonderful Surplus Buys!

IMPORTANT NEW SAMS BOOKS



Electronic Organ Handbook

by H. Emerson Anderson

**ONLY BOOK OF ITS KIND
ON THIS IMPORTANT SUBJECT**



Here's all the information you need to get into this brand-new servicing market! Over 1,000,000 electronic organs are now in use. With your radio-TV servicing experience, plus the wealth of schematics, detailed operating data and troubleshooting information in this book, you'll be ready for

profitable service work in this big new field. Twelve comprehensive chapters cover these popular organs: Baldwin, Conn, Gulbransen, Hammond, Kinsman, Lowrey, Thomas and Wurlitzer. First chapter explains general operation of the electronic organ. Also includes data on the Leslie organ speaker, the Conn Strobotuner and Peterson Chromatic Tuner. The book you've been waiting for! Over 140 illustrations. 272 pages; 5½ x 8½". Only..... **\$4.95**

Video Speed Servicing

NEW VOLUME 5

Latest volume in Sam Marshall's very useful series. Consists of 456 more practical troubleshooting hints for solving hard-to-find faults in major makes of 1959-60 TV receivers. All models are indexed by brand name, model and chassis number for quick reference. Each hint is accompanied by an explanatory diagram or schematic. An invaluable, time-saving shop reference. 160 pages; 8½ x 11". Only **\$2.95**



TV Tube Location Guide

NEW VOLUME 10



Latest in this invaluable series. Gives tube location data for TV sets produced in 1959-1960. Shows position and function of tubes in hundreds of models—just find the trouble and replace defective tubes without removing chassis! Shows major component placement; signal path; pin orientation on socket; series string filaments; fuse location. Includes tube failure check charts. 96 pages; 5½ x 8½"; spiral bound. Only..... **\$1.25**

HOWARD W. SAMS REPLACEMENT GUIDE FOR TV & AUTO RADIO CONTROLS

Vol. 3. Greatly expanded—covers 27,000 TV and over 1,000 auto radio models. Lists recommended replacement controls of Centralab, Clarostat, IRC and Mallory. **\$1.00**
8½ x 11". Only.....



HOWARD W. SAMS & CO., INC.

Order from your Sams Distributor today, or mail to Howard W. Sams & Co., Inc., Dept. L-10 1720 E. 38th St., Indianapolis 6, Ind.

Send me the following books:

- "Electronic Organ Handbook" (EOA-1)
- "Video Speed Servicing" Vol. 5 (VSM-5)
- "Television Tube Location Guide" Vol. 10 (TGL-10)
- "Replacement Control Guide" (RCG-3)

\$..... enclosed. Send Free Book List

Name _____

Address _____

City _____ Zone _____ State _____

(Outside U.S.A. priced slightly higher)

SERVICE INDUSTRY

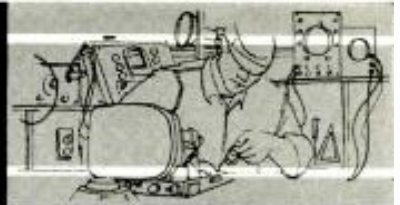

NEWS

THE SERVICE industry in New York State is now operating under certain restrictions imposed by legislation that has just gone into effect. Unfortunately, it is probable that very few of the dealers and technicians directly involved are fully aware of the nature of this legislation. In fact, there may be some uncertainty on the part of those who will be responsible for enforcing the new regulations, since attempts by members of the industry to obtain official clarification have been only partly successful. However, with or without an authentic interpretation, some discussion of provisions is necessary to give the people involved an idea of where they stand. Indirectly, such a discussion is useful to industry members everywhere who are concerned with legislative situations they may have to face themselves in the future.

The legislation, which is an amendment (Article 29-B) to the general business law, is intended to protect the consumer by requiring clear identification of receiving and picture tubes as to their new or used status. A "used" or "second-hand" tube is defined therein as "one that has been subjected to consumer or demonstrator use as an entity." A "used component" is "any part or material salvaged from a used or second-hand tube." A "tube utilizing used components" is "a tube which has not been used as an entity but which in the manufacture thereof has utilized one or more used components. Such a tube shall not be deemed to be a used or second-hand tube." A "reactivated tube" is a "weak, worn-out or defective tube which has been temporarily reactivated by the administration of a charge of high-voltage electric current to the elements thereof."

Alert readers will already have noted that "reject" or "surplus" tubes which have not been subjected to prior use are not adequately defined and that there are other possible loopholes and ambiguities.

The article does not prohibit the distribution or sale of tubes falling into the defined categories, but does require that they be clearly identified in accordance with the legal definitions. This identification must appear, in some way, on the tube itself and on its carton or container as well. Representing tubes in these categories in any way, directly or indirectly, as being new is forbidden.

In addition, it is illegal to own any equipment that can be used for or adapted to reactivating tubes (Doesn't this apply to conventional bench power

supplies found in most shops?) or to reactivate tubes—if there is intent to deceive. Evidently reactivation is legal if there is full disclosure to the consumer of what is being done. (Better get something in writing.)

Concerning guarantees, it is not legal to say simply that a tube is "guaranteed." There must be a full disclosure in writing to the consumer setting forth the extent, limitations, duration, and nature of the guarantee. Also the guarantor must be named and his obligations defined.

As to prices, there are prohibitions of phony discounts based on fictitious list prices. These provisions seem primarily intended to stop the use of manufacturer list prices for all-new, first-line tubes when advertising the "reduced" prices of tubes of inferior quality from other sources. It is also now illegal to mislead as to the actual manufacturer of a tube by such devices as references to patents. For example, a manufacturer other than RCA could not primarily identify his picture tube as being "RCA licensed" in order to deceive.

Finally, it will be possible to prosecute a service dealer under this article even though there is evidence that his violation of the article was unintentional—"but proof that the defendant did not knowingly or intentionally violate such provision shall constitute a good defense in any prosecution."

What is one to make of this bill? Not a great deal until there has been a chance to see how it shapes up in enforcement, but it does seem like a mixed blessing. It is an attempt to protect the consumer against misrepresentation and also, to some extent, the service dealer, in that it may protect him against some irresponsible price competition. On the other hand, provision for enforcement appears to be largely at the point of the dealer-consumer relationship. While this may be most convenient from the viewpoint of enforcement, it is also unrealistic in that the dealer, at the bottom of the pyramid, is scarcely in a position of control over the manufacturers and distributors who supply him, and who will have more say than he does in determining or knowing the nature of the tubes he sells.

Under the circumstances, the dealer's best way of protecting himself against prosecution would seem to be uncompromising adherence to this rule: "Everything must be in writing." On the one hand, he must insist that his suppliers provide him with exact definitions in print of the nature of all tubes (and

their guarantees) that he receives from them, unless they wish him to take his business to other suppliers who will be more cooperative. On the other hand, he must be strict about conveying all information required by law to his customers and to obtain their signatures on his own copies of record of bills or other papers, confirming that he has indeed passed on the required information.

By and large, any business-like service dealer who has been using satisfactory business forms and drawing up his bills carefully will have little trouble complying with the new requirements. However, many ethical men who have been rather careless in their billing habits and are not properly informed on the nature of the new regulations will be exposing themselves to possible prosecution although there may be no intent to mislead.

For service people outside New York State, there is a great deal to be learned from this development. It once more establishes the necessity for keeping a close eye on any proposed legislation that may bear on the industry. This has nothing to do with whether one's stand on licensing or any other proposal is "pro" or "con." The "watchdog" role is of the utmost importance in any case. It is too early to say whether the New York bill will help the dealer more than it will harm him. Nevertheless, with the passage of legislation along the lines described virtually a certainty, vigilant service groups in New York were at least able to win revisions based on inequities and loopholes they were able to ferret out. But for their activity, service people in the state might have been placed in an unfortunate position indeed. As it is, an enormous educational job remains to be done before the many honest dealers in the state who do not even know that Article 29-B exists are in a position to protect themselves against their own ignorance.

Our thanks to Bob Larsen, of Radio-TV Guild of Long Island and of Empire State Federation of Electronic Technicians Associations, for calling attention to some problems discussed here involving the new legislation.

Service Helps Broadcaster

When service associations join hands with operators of TV stations, it is usually to the end that the broadcasters will help promote the service interests favorably with the viewing public. Thus it is gratifying to report an incident in which the tables have been turned. Operators of channel 7 serving the area of Seattle, Wash. have been concerned because, although they are putting out a strong signal, they are not being received satisfactorily by all members of their potential viewing audience. Since channel 7 is a relative newcomer, many existing antenna installations were never designed or oriented to pick up its signal. Service technicians are conducting a campaign, reports "TSA Service News," to let viewers know that they can indeed get good reception if they will only trouble to take care of their antenna problems. [30]

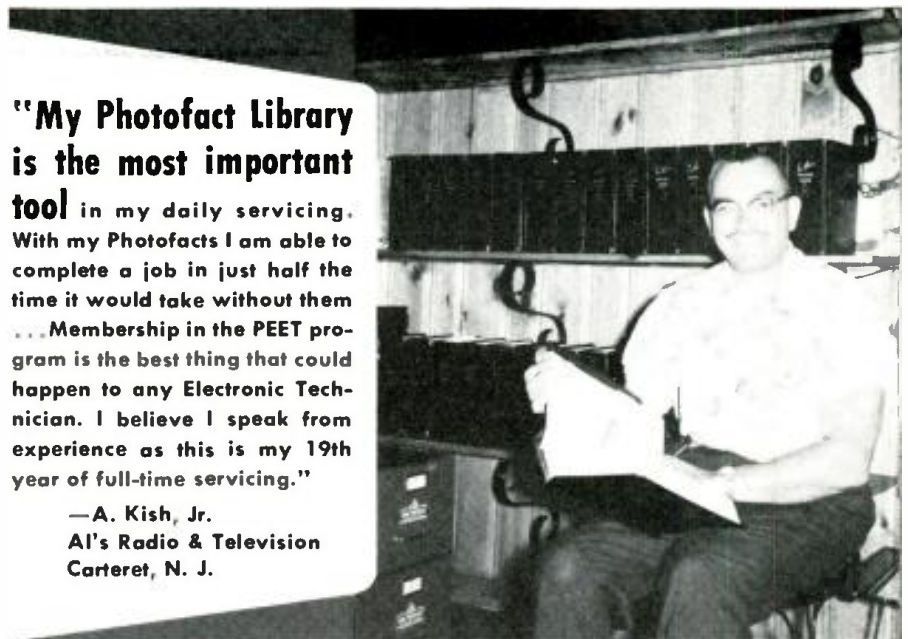

"My Photofact Library is the most important tool in my daily servicing. With my Photofacts I am able to complete a job in just half the time it would take without them . . . Membership in the PEET program is the best thing that could happen to any Electronic Technician. I believe I speak from experience as this is my 19th year of full-time servicing."

—A. Kish, Jr.
Al's Radio & Television
Carteret, N. J.

Service Technicians! YOU EARN MORE... YOU RATE with the public when you own the PHOTOFACT® service data library!

You enjoy maximum earnings as the owner of a complete PHOTOFACT Service Data Library! It's inevitable, because no matter how expert you are, you can always *save more time on any job, get more jobs done daily*—EARN MORE, DAY IN AND DAY OUT...

What's more—as the owner of a complete PHOTOFACT Library, you know your customers' sets *best*. You can actually show each customer you have the PHOTOFACT Folder covering his very own set. Result: You command public respect and acceptance which paves the way to more business and earnings for you.

HOW TO STAY AHEAD...

Yes, the truly successful Service Technicians are those who own the complete PHOTOFACT Library, who can meet and solve any repair problem—faster and more profitably. And these men *keep ahead* because they're on a Standing Order Subscription with their Distributors to receive all new PHOTOFACTS as they are released monthly. (They're eligible for the benefits of membership in PEET, too—see below!)

ONLY \$10 DOWN puts the complete PHOTOFACT Library in your shop—and you have up to 30 months to pay. See your Sams Distributor today, or write to Howard W. Sams

NOW IS THE TIME TO JOIN

"PEET"

THE POWERFUL NEW PROGRAM FOR QUALIFIED TECHNICIANS

If you now own a PHOTOFACT Library or plan to own one, you can apply for membership in "PEET." It's the first industry program really designed to build powerful public acceptance for the Service Technician who qualifies. Builds enviable prestige and business for its members. Benefits cost you absolutely nothing if you qualify. Ask your Sams Distributor for the "PEET" details, or mail coupon today.

HOWARD W. SAMS & CO., INC.

1724 E. 38th St., Indianapolis 6, Ind.

- Send me full details on the new "PEET" Program.
- Send full information on the Easy-Buy Plan and Free File Cabinet deal.
- I'm interested in a Standing Order Subscription.
 - I'm a Service Technician full-time; part-time

My distributor is _____

Shop Name _____

Attn: _____

Address _____

City _____ Zone _____ State _____

SAVE MORE with

SONAR TUBES

You can't afford to pass up this golden opportunity to save on used tubes!

- Tested for mutual conductance in our own labs!
- One year free replacement guarantee!
- Prompt refunds on defective merchandise!

SPECIAL PURPOSE TRANSMITTING TUBES AND INDUSTRIAL TUBES

TYPE	PRICE	TYPE	PRICE	TYPE	PRICE	TYPE	PRICE	TYPE	PRICE
0A2	.60	4X150A	8.50	813	8.30	957	.30	5751	.90
0A3	.70	5R4GY	1.00	815	1.70	2050	.90	5763	.80
0A4	.75	C6J	6.50	829B	7.00	2051	.75	5814A	.75
0B2	.45	6D4	1.50	832	3.00	2625W	1.15	5879	.90
0B3	.65	6X4W	1.00	832A	5.50	5654	.75	6080	2.75
0C3	.50	6J4WA	1.15	843	.30	5686	1.50	6082	3.75
0D3	.40	218	8.00	866A	1.05	5687	.75	6135	1.00
2C44	.75	304TL	35.00	872A	1.05	5702	1.50	6146	2.45
2D21	.55	313C	1.25	884	.80	5703	1.50	6159	2.75
2E24	1.95	5J29	.50	885	.75	5725	.90	6189	1.00
2E26	1.95	750TL	32.00	954	.20	5726	.40	6201	1.00
3A4	.45	807	1.00	955	.30	5749	.70		

JAN SURPLUS TUBES

TYPE	PRICE	TYPE	PRICE	TYPE	PRICE	TYPE	PRICE	TYPE	PRICE
0Z4	.42	6AG7	.44	6CL6	.59	7C4	.39	14A7/12B7	
1A7GT	.45	6AH4GT	.55	6CM6	.59	7C5	.44		.48
1B3GT	.52	6AH6	.42	6CM7	.40	7C6	.46	14B6	.48
1H4G	.39	6AK5	.43	6CN7	.40	7C7	.48	14Q7	.48
1H5GT	.45	6AL7	.45	6CS6	.42	7E6	.46	19	.48
1L4	.39	6AM8	.49	6OE6	.44	7E7	.44	19AU4GT	.49
1L6	.42	6AN8	.54	6OQ6	.79	7F7	.42	19BG6G	1.00
1N5GT	.52	6AQ5	.44	6F6	.69	7F8	.42	19J6	.48
1Q5GT	.44	6AQ6	.42	6H6	.37	7H7	.40	19T8	.58
1R5	.41	6AQ7GT	.48	6J4	1.00	7N7	.48	24A	.48
1S5	.39	6AR5	.48	6J5	.44	7Q7	.48	25AV5	.75
1T4	.41	6AS5	.42	6J7	.59	7X7/XXFM		25BQ6	.79
1U4	.41	6AT6	.42	6K6GT	.33		.44	25DN6	.99
1U5	.42	6AT8	.48	6K7	.48	7Y4	.39	25L6GT	.40
1V2	.49	6AU4GT	.40	6K8	.58	7Z4	.38	25W4GT	.41
1X2	.52	6AU5GT	.50	6L7	.49	12A8	.42	25Z5	.44
2A3	.95	6AU6	.40	6N7	.59	12AQ5	.52	25Z6	.44
2AF4	.88	6AU8	.49	6O7	.59	12AT6	.42	26	.40
3BC5	.48	6AV5GT	.49	6S4	.40	12AT7	.81	35A5	.45
3BN6	.80	6AV6	.42	6S8GT	.40	12AU6	.40	35B5	.44
3BZ6	.40	6AW8	.40	6SA7	.40	12AU7	.44	35C5	.46
3CB6	.41	6AX4GT	.50	6SC7	.44	12AV6	.42	35L6GT	.48
3CF6	.42	6AX5GT	.49	6SF5	.49	12AV7	.63	35W4	.43
3CS6	.42	6B8	.44	6SF7	.55	12AX4GT	.50	35Y4	.39
3LF4	.49	6BA6	.46	6SJ7	.55	12AX7	.51	35Z5GT	.47
3Q4	.44	6BC5	.44	6SK7	.40	12AZ7	.55	37	.48
3S4	.44	6BC8	.49	6SL7GT	.50	12B4	.42	39/44	.35
3V4	.44	6B06	.40	6SN7GT	.40	12BA6	.44	42	.45
4BQ7A	.65	6BE6	.44	6SQ7	.40	12BA7	.69	43	.45
4BZ7	.65	6BF5	.45	6SS7	.62	12BE6	.44	45	.47
5AS8	.52	6BF6	.40	6T4	.62	12BF6	.44	50A5	.45
5AT8	.44	6BG6G	.99	6T8	.61	12BH7	.51	50B5	.48
5AV8	.44	6BH6	.41	6U8	.66	12BQ6	.53	50C5	.48
5AW4	.49	6BJ6	.41	6V6	.44	12BR7	.48	50L6GT	.48
5BK7	.58	6BK5	.65	6W4GT	.39	12BY7	.55	50X6	.51
5J6	.51	6BK7	.68	6W6GT	.43	12CA5	.46	56	.43
5T8	.49	6BL7GT	.68	6X4	.37	12J5	.45	57	.43
5U4G	.39	6BN6	.70	6X5	.40	12K7	.40	58	.43
5U8	.49	6BQ6GT	.73	6X8	.65	12L6	.40	71A	.59
5V4G	.49	6BQ7	.68	6Y6G	.69	12Q7	.45	75	.60
5V6GT	.45	6BY5	.60	7A4/XXL	.44	12SA7	.44	76	.45
5X8	.45	6BZ6	.42	7A5	.42	12SG7	.48	77	.45
5Y3GT	.42	6BZ7	.68	7A6	.44	12SJ7	.48	78	.60
5Y4G	.55	6C4	.39	7A7	.42	12SK7	.44	80	.52
6A7	.60	6C5	.60	7A8	.45	12SN7GT	.46	84/6Z4	.48
6A8	.60	6C6	.60	7B4	.42	12SQ7	.44	117Z3	.44
6AB4	.40	6CB6	.44	7B5	.41	12V6GT	.40	117Z6	.90
6AC7	.55	6CD6G	.99	7B6	.46	12W6GT	.40	117L7	1.95
6AF4	.82	6CF6	.42	7B7	.48	12X4	.46	117M7	1.95
6AG5	.40	6CG7	.40	7B8	.44	12Z3	.46	117P7	1.95

6-12 VIBRATORS 89¢ each

Write Dept. EW-1160 for complete list of tubes and special purpose tubes.

All advertised tubes not necessarily new but may be electrically perfect factory seconds or used tubes. Each is clearly marked. All tubes

postage paid. Include 25¢ handling for orders under \$5. Include 25% deposit on C.O.D.'s. Send approx. postage on Canadian and foreign orders.

SONAR ELECTRONIC TUBE CO.

112 MARTIN ST., PATERSON 3, N. J.

EW Lab Report

Eico Model 762 CB Transceiver

THERE are so many CB transceivers on the market today that we have difficulty keeping up with them all. The latest that we have just finished building and checking out is the Eico Model 762. This compact, attractive, and conservatively engineered kit consists of a single-channel, crystal-controlled 5-watt transmitter and a tunable single-conversion super-het receiver. The receiver's audio stages do double-duty as speech amplifier and



modulator in the transmitter, with all circuits being powered by a common a.c. power supply using a pair of silicon diodes as voltage doublers. A 12-volt battery may also be used to power the transceiver by way of a built-in vibrator that feeds the same power transformer.

The transmitter features pre-set and sealed crystal oscillator circuit elements to prevent oscillator adjustments from being made and to maintain proper frequency tolerance. If you want to change transmitting frequency, it is important to use a crystal supplied by the manufacturer of the kit or one that specifically matches the oscillator circuit's shunt capacity. Just because a crystal is certified to have a .005 per-cent tolerance does not mean that such a crystal may be used in any oscillator circuit to produce an output that is within this tolerance. It is necessary to know the type of oscillator circuit, and especially the circuit's shunt capacity, in order to obtain the proper frequency tolerance.

Another important feature is the use of pi-network antenna coupling that makes it possible to properly load just about any type of antenna. As a matter of fact, two different antenna fittings are provided so that the user has a choice depending on what type of fitting his particular antenna has. A meter jack is provided in the final amplifier's cathode circuit so that a milliammeter may be plugged in and the rig tuned up properly. A 6-volt pilot lamp is supplied to be used as a dummy load for off-the-air tuning, while a neon lamp, loosely coupled to the hot side of the output tank, serves as output indicator.

Tuning is simplicity itself, as any ham will tell you who has a pi-network in his rig. It is just a matter of adjusting the plate-tuning capacitor for a dip in the output tube's plate current, and then bringing the antenna coupling capacitor up until the current rises to the proper amount for the rated power output. In the case of this transceiver, we had no trouble at all in getting the cathode current up to the 27 ma. (21 ma. plate current plus 6 ma. screen current) required for the 5-watt legal limit of plate input power.

Although the tuned circuits in the receiver are pre-aligned, a slight touch-up was helpful here. A simple but effective alignment procedure is given in the instruction manual in which the transmitter's crystal oscillator is used as the signal generator. Although the transmitter is normally completely disabled when the receiver is turned on, the oscillator may be energized by temporarily patching in a 100,000-ohm resistor from the oscillator plate to "B+."

Although building the kit does take a little time, no particular problems should be encountered.

The Model 762, available in kit form for \$69.95, may also be obtained completely factory-wired for \$99.95. Other models are available for 117-volt a.c. and 6-volt d.c. operation, or for 117-volt a.c. only operation (at ten dollars less than the above prices).

[30]

**Courses in Radio and
Electronic Fundamentals –
TV Servicing – Color TV –
Electronics for
Automation –
Transistors**



**SEND FOR THIS FREE
64 PAGE BOOK TODAY!**

Check Home Study!

RCA Institutes Home Study School offers a complete program of integrated courses for beginners and advanced students . . . all designed to prepare you for a rewarding career in the rapidly expanding world of electronics. Practical work with your very first lesson. And you get top recognition as an RCA Institutes graduate!

CANADIANS — take advantage of these same RCA courses at no additional cost. No postage, no customs, no delay. Send coupon to:
RCA Victor Company, Ltd., 5581
Royalmount Ave., Montreal 9, Que.

SEE OTHER SIDE

CUT OUT AND MAIL THIS POSTAGE-FREE CARD TODAY!

RCA INSTITUTES, INC., DEPT. EW-NO

350 W. Fourth St. • New York 14, N.Y.

Please rush me your FREE illustrated 64-page book describing your electronic training programs. No obligation. No salesman will call.

Home Study Book

Resident School Book

Name _____ Age _____

Address _____

City _____ Zone _____ State _____

Korean Vets: Enter Discharge Date _____



RCA TRAINING CAN BE THE SMARTEST INVESTMENT YOU EVER MAKE

With RCA Institutes Home Study training you set your own pace in keeping with your own ability, finances and time. You get prime quality equipment as a regular part of the course . . . and you never have to take apart one piece to build another. Perhaps most important, RCA's liberal Pay-As-You-Learn Plan is the most economical home study method *because you pay only for lessons as you order them . . . one study group at a time!* If you drop out at *any* time, for *any* reason, you do not owe RCA one penny! No other obligations! No monthly installment payments! Licensed by New York State Education Department.

START YOUR CAREER IN ELECTRONICS NOW AT RCA INSTITUTES in Los Angeles-New York City

CHOOSE FROM THIS LIST . . .

	Course	Qualifications	Length of Course
A	Advanced Electronic Technology (T-3)	High School grad, with Algebra, Physics or Science	Day 2¼ yrs. Eve. 6¾ yrs.
B	TV and General Electronics (V-7)	2 yrs. High School, with Algebra, Physics or Science	Day 1½ yrs. Eve. 4½ yrs.
C	Radio & TV Servicing (V-3)	2 yrs. High School	Day 9 mos. Eve. 2¼ yrs.
D	Transistors*	V-3 or equivalent	Eve. 3 mos.
E	Electronic Drafting (V-9)*	2 yrs. High School, with Algebra, Physics or Science	Eve. 3 yrs.
F	Color TV	V-3 or equivalent	Day 3 mos. Eve. 3 mos.
G	Audio-Hi Fidelity*	V-3 or equivalent	Eve. 3 mos.
H	Video Tape*	V-3 or equivalent	Eve. 3 mos.
I	Technical Writing (V-10)	V-3 or equivalent	Eve. 3-18 mos.
J	Radio Telegraph Operating (V-5)*	2 yrs. High School, with Algebra, Physics or Science	Day 9 mos. Eve. 2¼ yrs.
K	Radio Code (V-4)*	8th Grade	Eve. as desired
L	Preparatory Math & Physics (P-0)	1 yr. High School	Day 3 mos.
M	Preparatory Mathematics (P-0A)	1 yr. High School	Eve. 3 mos.

*Courses to be added to Los Angeles Curriculum

SEE OTHER SIDE

First Class

Permit No. 10662
New York, N. Y.

BUSINESS REPLY CARD

No Postage Stamp Necessary if Mailed in U. S.

Postage will be paid by—

RCA INSTITUTES, INC., DEPT. EW-NO

350 West Fourth Street

New York 14, N. Y.

RCA Institutes is one of the largest technical institutes in the United States devoted exclusively to electronics. Co-educational Day and Evening classes. Free Placement Service. Applications now being accepted.



SEND FOR THIS FREE ILLUSTRATED BOOK TODAY. Fill in the other side of the postage-free card and check Resident School.

RCA INSTITUTES, INC. A Service of Radio Corporation of America • 350 W. 4th St., New York 14, N.Y. • 610 S. Main St., Los Angeles 14, Calif.



The Most Trusted Name in Electronics

OVER 1300 HI-FI COMPONENTS

at your fingertips in the

1961 STEREO & HI-FI DIRECTORY

The world's most comprehensive hi-fi reference gives you facts, data, prices, illustrations, performance analysis on virtually every piece of hi-fi equipment manufactured. Entire sections on:

TUNERS • RECORD PLAYERS • TAPE RECORDERS • CARTRIDGES • TONE ARMS • TURNTABLES • AMPLIFIERS • PRE-AMPS • LOUDSPEAKER SYSTEMS • RECORD CHANGERS
ENCLOSURES AND CABINETS

*On sale at your
newsstand or electronics
parts store October
4th, or order by
coupon today.*

ONLY \$1.00

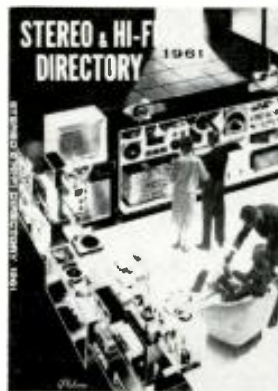

Ziff-Davis Publishing Company
Department 2001
434 S. Wabash Avenue, Chicago 5, Illinois

Please send me a copy of the 1961 STEREO AND HI-FI DIRECTORY. I enclose \$1.00, the cost of the DIRECTORY, plus 10¢ to cover mailing and handling charges. (Canada and foreign, \$1.25 plus 10¢ postage.)

NAME _____

ADDRESS _____

CITY _____ ZONE _____ STATE _____

Line-Voltage Adjuster (Continued from page 67)

by the use of a rubber mount for RL_1 . Transformer hum from T_2 was rendered undetectable by replacing the four original screws on the case with six steel aircraft-type screws of high tensile strength and tightening them to the stripping point.

A ventilating grille at the bottom of the housing can be seen in the lower left of Fig. 5. Another was put at the top of the case. These were cut-down, chrome-plated sink strainers. Whatever method is used, there should be adequate provision for heat dissipation. Rubber feet bolted to the bottom of the case permit air to enter at the bottom and also protect the surface on which the instrument will stand.

A standard door pull bolted to the top facilitates transportability despite the weight of the unit, which was under 14 pounds in the author's version. Cost can be reduced by using components of lower quality than those suggested, such as "radio" switches in place of "industrial" quality units, but this is false economy.

Performance leaves little to be desired. Measured output at various switch settings and conditions are given in Table 1, with an input line of 120 volts a.c. Use of the adjuster in ordinary electronic shop work is fairly obvious: it makes it possible to operate a wide variety of devices at rated line voltage without regard to the line voltage actually available, within wide limits.

In addition, the low-voltage taps are useful in heating filaments of mobile, aircraft, surplus, and other miscellaneous equipment. With the addition of a bridge rectifier and a filter capacitor (4000 μ f. recommended), a very satisfactory, adjustable source of low-voltage d.c., electrically isolated from ground, is available.

For determining the nature of intermittent troubles related to line-voltage variation, this adjuster is well suited. It can be installed in a few minutes and adjusted so that a customer of ordinary intelligence can be instructed to read the meter, report what the voltage is when trouble occurs, and correct the line voltage, perhaps eliminating the trouble.

For this type of work, the panel markings are very important. A duplicate of the panel, perhaps a photograph of it, can be kept in the shop near the phone. When trouble occurs after the adjuster has been installed in the customer's home, he can be instructed, one step at a time, exactly what adjustments to make, while reporting on the effects directly. This can avoid the waste of time and expense in sending out a skilled technician to handle the problem, in many cases.

It is hard to schedule a skilled man to be in the customer's home exactly when a voltage variation occurs. Avoiding this is itself sufficient justification for the adjuster. [30]

the only one of its kind!



NOW . . . THE *First* ANALYZER DESIGNED EXCLUSIVELY FOR TESTING TRANSISTOR CIRCUIT CAPACITORS!

SPRAGUE MODEL TCA-1 TRANSFARAD*

THERE'S NOTHING LIKE IT ON THE MARKET ANYWHERE . . . AT ANY PRICE!

Here, for the first time, is a precision-made instrument which is specifically designed to *safely* test low-voltage aluminum and tantalum electrolytic capacitors, film and paper capacitors, and ceramic capacitors. *No laboratory or shop working with transistor circuit capacitors can afford to be without one!*

CAPACITANCE BRIDGE: 1 μ f to 2,000 μ f in five overlapping ranges, with laboratory accuracy.

INSULATION RESISTANCE: 50 megohms to 20,000 megohms. Only 25v d-c is applied, permitting measurements on low-voltage ceramic, paper, mica, and film capacitors. For ceramics rated below 25 volts, IR may be calculated from leakage current measurements at exact rated voltage.

POWER FACTOR: Measured by Wien Bridge from 0 to 50%.

LEAKAGE CURRENT: 0.6 μ a to 600 μ a in 7 ranges. Measured directly on meter at exact rated d-c voltage of capacitor. No guessing on eye-width or counting lamp blinks!

A-C BRIDGE VOLTAGE: Only 0.5v is applied to the bridge. The voltage across the capacitor is less than this applied voltage, the amplitude depending upon capacitance being measured. No danger of overheating and ruining even a 1-volt electrolytic or a 3-volt ceramic.

POLARIZING VOLTAGE: Continuously adjustable, 0 to 150v.

STABILITY: Dual regulation of the power supply assures short-time reliability, while specially processed etched circuits and complete encapsulation of the critical meter amplifier insure long-time stability.

MAGIC-EYE TUBE: Simplifies bridge balancing for capacitance and power factor measurements.

HIGH GAIN AMPLIFIER: Sensitivity control for magic-eye null detector permits accurate measurements of small capacitances.

CAPACITANCE DIAL: Latest design jet black dial with brilliant white calibrations for quick, accurate readings from any position.

BINDING POSTS: Shielded for protection against pick-up of strays, assuring greater accuracy during low-capacitance measurements. 5-way connection feature for use with all types of test leads.

SAFETY DEVICES: Automatic discharge of capacitor after testing. Three-wire line cord grounds instrument case.

OPERATING PROCEDURES: Easy-to-follow operating procedures clearly shown on pull-out slide at base of instrument. Always handy for ready reference.

MODERN CASE: Handsome grey Hammerloid finish on heavy-gage steel. Measures 8 $\frac{1}{2}$ " high, 14 $\frac{1}{2}$ " wide, 9 $\frac{1}{2}$ " deep. Weighs only 21 pounds.

See the remarkable new TCA-1 TRANSFARAD at your Sprague distributor or write for descriptive folder M-792a to Sprague Products Company, 51 Marshall Street, North Adams, Massachusetts.

ONLY
\$197.50
NET

*Trademark

SPRAGUE®

world's largest capacitor manufacturer

COLUMBIA HAS MOVED!

NOW! One of the largest combination retail store-warehouses on the coast! At one address—under one roof you get the biggest selection of electronics—at greatest savings. Visit us—and see!

PRS-3 MINE DETECTOR
Latest model. Light Weight. More sensitive than previous models. Waterproof. Complete with case. Excellent. **\$34.95**

RA-94 AC POWER SUPPLY
110 V. For Super-Tro Receiver. New condition. **\$9.95**

BC-669 TRANSMITTER-RECEIVER
Freq. 1000-450 kc.; 75 W. AM Transmitter. 6 crystal controlled, pre-set channels on both xmit. and receiver, as well as VFO control. F.B. for marine or land use. Built-in speaker. Full set of controls on front panel. Power requirements: 12 V. filament, 250 V. @ 100 mA for Receiver, 350 V. @ 400 mA for Xmit. Original design by Phil-Herzberg for marine use. Excel. cond. **\$89.50**
PE-110 Power Supply for above. **\$49.95**
110 V. Excel. **\$3.50**
DS15 Connecting Cable for above. Excel. **3.50**

RECEIVER-TRANSMITTER COMBO!
LINK HIGH BAND TRANSMITTER Model 170 Mc. FM. 50W Built-in 6 V. dynamotor. Model 2240. Terrific tube line-up: 7AG7, 7F7, 7W7, 2-2E20, 820-B. 3-channels. Excellent. **\$19.95**
ONLY
LINK HIGH BAND RECEIVER Model 1905. Contains 7B5, 7C7, 7A6, 4-7AG7 PLUS OTHERS. Built-in 6 V. supply. Companion to transmitter. Above. Excellent. **\$19.95**
SPECIAL COMBO DEAL! BOTH FOR ONLY **\$29.95**
Instruction Book for above. **\$3.00**

EE-8 FIELD TELEPHONE
Operates up to 10 miles with use of 2-conductor wire! BUILT-IN BATTERY. Works like a charm on 2 flashlight batteries. Excellent. **\$12.50**

U.H.F. MOBILE RECEIVER
Navy model RDR. Mig. by RCA. Freq. 225-310 MC. 10 channel. Crystal controlled. Compact size: 2 1/2" x 9" in. Ready to install in 12 VDC car. Like new. With instruction book, only **\$19.95**

TUBES! ALL NEW! ALL SPECIALS!
4-65A \$ 7.50 4X250B \$20.00
4-125A 19.95 4-401A 25.00
4X150A 7.95 4-1000A 75.00
Rafts of Other Tubes! Tell us your need!

CITIZENS BAND SPECIALS!
BC-620 TRANSMITTER with spare 12V. Govt. recommended. Includes 6 or 12 V. power supply. Makes F.B. Citizens' Bands! Freq.: **\$19.95**
20-27.0 Mc. This month ONLY.

BC-604 TRANSMITTER
20-28 Mc. 30 W. New condition. **\$4.95**
DM-35 DYNAMOTOR 11 V. In output: 625 V. 9 or 225 MA. Brand new. **7.95**

VRC-2 FM TRANSMITTER-RECEIVER COMBO!
30-40 Mc. A must for every radio hobbyist! Contains 30 W. transmitter and dual conversion receiver, both crystal controlled! This is the Army equivalent to Motorola Model FM 30-B. Excellent condition. For combo only. **\$39.95**

APP-1 RECEIVER SPECIALS!
30 Mc. 1F. 1.5 V. Like new. Brand new. **\$24.50**
Plug-In Units For Above
TN-1: 38-90 Mc. **\$14.95** COMBO DEAL!
TN-2: 90-300 Mc. **\$14.95** App. Receiver PLUS
TN-3: 300-1000 Mc. **14.95** TN-1, TN-2, TN-3 **\$62.50**
APP-4 TUNERS—WILL WORK WITH ABOVE REC'R
TN-16: 38-90 Mc. **\$14.95**
TN-17: 90-300 Mc. **14.95** COMBO DEAL!
TN-18: 300-1000 Mc. **14.95** TN-16, TN-17, TN-18.
TN-19: 1000-3300 Mc. **49.95** TN-19 **\$95.00**

SCR-625 MINE DETECTOR BARGAIN
Locate that hidden pipe, metal, treasure! Use for parts! With case. Excellent. **\$22.50**
ART-13 XMTR: Model T-47. Freq.: 2-18 Mc. Excellent. Only **\$34.50**

APT-1 TRANSMITTER: 100-200 Mc. 10 TUBES in all including 832-A driver, 820B final and 931 photo tube. New cond. **\$9.95**

ARC-5 VHF & UHF EQUIPMENT SPECIALS!
R-28/ARC-5 RECEIVER: 100-150 Mc. 4-channels. Crystal controlled. Excel. cond. Only **\$19.95**
T-23/ARC-5 TRANSMITTER: Companion to above. Same freq., 4-chann. crystal controlled. **12.95**
R-23/ARC-5 RECEIVER: 190-555 kc. Excellent. This is the Q-5'er! **9.95**
R-25 ARC-5 RECEIVER: 1.5-3 Mc. Excellent. **14.95**
R-26/ARC-5 RECEIVER: 3-6 Mc. Excellent. **7.95**
R-27/ARC-5 RECEIVER: 6-6 Mc. Excellent. **7.95**
T-18/ARC-5 TRANSMITTER: 2.1-3 Mc. Excellent. **4.95**
T-19/ARC-5 TRANSMITTER: 3-4 Mc. Excellent. **7.95**
T-20/ARC-5 TRANSMITTER: 4.5-5 Mc. Excellent. **4.95**
T-21/ARC-5 TRANSMITTER: 5.3-7 Mc. Excellent. **4.95**
T-22/ARC-5 TRANSMITTER: 7-9 Mc. Excellent. **8.95**
MD-7/ARC-5 MODULATOR: For use with the above Transmitters. Excellent. Bargain @ only **6.95**

BC-375 100 W. TRANSMITTER
Ideal for domestic use, as well as export marine and mobile. Freq. 200-12.5 Mc. 10 TUBES in tuning unit. CW or MCW. Like new condition. Only **\$14.95**
ABOVE, but in good condition. **\$9.95**
PE-73 DYNAMOTOR FOR ABOVE: Input 24 V. Output, 1000 V. @ 300 ma. W/filtering base. Excel. cond. **\$7.95** Good cond. **\$4.95**
RC-306 ANTENNA TUNER for above. BC-375. Excel. **\$1.95**
TUNING UNITS TO COVER ABOVE FREQS: TU-5, TU-6, TU-7, TU-8, TU-9. **\$1.95**
Excel. Ea. **\$1.95**
PLUGS: For any of above. Each only **\$0.50**
RACKS: For any of above. Each only **1.50**

BC-191 TRANSMITTER
Same as above BC-375 but uses 12 VDC or 110 VAC power supply. Excellent. **\$14.95**
BD-77 12 V. POWER SUPPLY: for BC-191. New boxed **\$12.95**

All orders FOB Los Angeles. 25% deposit required. All items subject to prior sale. NOTE MINIMUM ORDER \$3.00. WRITE TO DEPT. R.

Columbia ELECTRONICS
4365 WEST PICO BLVD.
LOS ANGELES 19, CALIF.



"BASIC CARRIER TELEPHONY" by David Talley. Published by John F. Rider Publisher, Inc., New York. 170 pages. Price \$4.25, soft cover; \$5.75, hard cover.

A fundamental, but technically rigorous, text, this volume deals with the transmission of multiple telephone and signaling intelligence over a single radio circuit, cable, or wire line. The growth of the telephone industry, and the need for using carrier telephony, is also discussed.

First establishing telephone definitions and notations, the author delves into circuitry, controls, and switching. The book utilizes the "pictured-text" method of explanation.

"CONTROL SYSTEMS ENGINEERING" edited by William W. Seifert & Carl W. Steeg, Jr. Published by McGraw-Hill Book Co., Inc., New York. 964 pages. Price \$15.00.

Containing contributions by leading industrial authorities, this massive volume can serve as a text for the advanced student as well as a reference book for research workers in industrial and governmental laboratories. It is, in a word, a fairly complete coverage of the mathematical aspects of modern control systems engineering as applied to the study of complex, large-scale automatic control systems. Suggestions for further study are included as well as an appendix that provides a table of integrals.

"SERVICING UNIQUE ELECTRONIC APPARATUS" by Jack Darr. Published by Howard W. Sams & Co., Inc., Indianapolis, Ind. 125 pages. Price \$2.50. Soft cover.

Of interest to the service technician, this volume explains the general functioning and provides how-to service information on a number of recent industrial and consumer products using electronics. Among the items discussed are diathermy machines, liquid-flow timers, electronic photoflash units, electric scoreboards, r.f. heaters, garage-door openers, ultrasonic cleaners, and so on.

"DIGITAL COMPUTER AND CONTROL ENGINEERING" by Robert Steven Ledley. Published by McGraw-Hill Book Co., Inc., New York. 835 pages. Price \$14.50.

This book provides a comprehensive and unified treatment of the field of digital computers and digital controls, covering almost all aspects from a detailed engineering point of view. Divided into five parts, the text treats of programming, systems design, logical design as applied to circuits, current methods in circuit design, and electronic design utilizing solid-state and magnetic core components.

Essentially a textbook at the advanced level, the volume leans heavily on mathematical explanations, contains many diagrams, charts, illustrations, exercises, references, and two exhaustive indexes.

"MARINE RADIO AND ELECTRONICS" by Allan Lytel. Published by Cornell Maritime Press, Cambridge, Maryland. 242 pages. Price \$7.00.

Intended for the operators of pleasure craft, commercial and fishing craft, as well as for the merchant marine operator, this volume describes various communications devices and other electronic gear for marine use. The viewpoint is that of the user of the equipment rather than the mechanic or maintenance man. Although most of the book concerns itself with two-way radiotelephone, there are sections on radiotelegraph, loran and radar, direction finders, depth finders, gyro-compass, and so on. An appendix lists important and relevant information on the FCC and U.S. Coast Guard, and other data of interest to maritime operators.

"TUBE CADDY-TUBE SUBSTITUTION GUIDE-BOOK" by H. A. Middleton. Published by John F. Rider Publisher, Inc., New York. 53 pages. Price 90 cents.

Compact enough to be carried in a technician's tube caddy (or even slipped into his pocket), this volume contains substitution tube listings, covering some 1819 receiving tube types, 219 European-to-American substitutions, 297 American-to-European types, and 75 ruggedized types. It contains only those substitutions which can be made readily, without wiring changes.

"ELECTRONIC TIPS AND TIMESAVERS" by John A. Comstock. Published by Howard W. Sams & Co., Inc., Indianapolis, Ind. 96 pages. Price \$1.50.

Over 300 time-saving tips and kinks for the service technician and electronic experimenter are presented in this book. The material is divided into eight sections, covering bench servicing, field servicing, general equipment, soldering, tools, test equipment, construction and experimentation, and miscellaneous hints. Nearly every item is illustrated.

"TRANSISTOR CIRCUIT ANALYSIS AND DESIGN" by Franklin C. Fitchen. Published by D. Van Nostrand Co., Inc., Princeton, N.J. 356 pages. Price \$9.00.

Written for the engineer or advanced student with a heavy math background, this book concentrates on the information required to solve circuit design problems most likely to be encountered with the simpler semiconductor devices.

The author considers the current-generator equivalent tee; the hybrid equivalent, and the hybrid- π equivalent.

"USING AND UNDERSTANDING PROBES" by Rudolf F. Graf. Published by *Howard W. Sams & Co., Inc.*, Indianapolis, Ind. 190 pages. Price \$3.95. Soft cover.

The right probe for the right job is the aim of this book, which describes the use of probes in radio and TV servicing, as well as the special purpose types used in industry and other fields. Numerous illustrations and an index add to the volume's usefulness as a practical guide as well as a general introduction to the subject.

"RAPID PRINTED CIRCUIT REPAIR" by G. Warren Heath. Published by *Howard W. Sams & Co., Inc.*, Indianapolis, Ind. 128 pages. Price \$1.95.

The fundamentals of printed circuitry, various special components used, and a host of related servicing techniques are treated in this book. Defects most commonly encountered and their remedies are also covered.

"SO YOU WANT TO BE A HAM" by Robert Hertzberg. Published by *Howard W. Sams & Co., Inc.*, Indianapolis, Ind. 188 pages. Price \$2.95. Soft cover.

This second edition of a popular introduction to amateur radio has been enlarged and revised to bring it up to date since its first printing some four years ago. The author, himself a radio ham as well as a prolific writer, touches on all points that would be of interest and importance to a prospective radio ham. License requirements, practices, and equipment are all covered.

"SERVICING TRANSISTOR RADIOS" by Sams Engineering Staff. Published by *Howard W. Sams & Co., Inc.*, Indianapolis, Ind. 160 pages. Price \$2.95. Soft cover. Vol. 6.

The latest volume in this series contains a collection of "Photofact" folders covering servicing information on 62 domestic and foreign transistor radios produced in 1959 and 1960. Included are schematics, dial-cord stringing arrangements, alignment data, parts lists and replacement data, and other valuable material. A cumulative index covers this volume plus the five earlier ones in this same series.

"GETTING THE MOST OUT OF VACUUM TUBES" by Robert B. Tomer. Published by *Howard W. Sams & Co., Inc.*, Indianapolis, Ind. 160 pages. Price \$3.50.

The purpose of this book is to show how premature tube failures can be prevented through proper maintenance. Written for the engineer as well as the technician, the text discusses engineering practices leading to early tube failures and maintenance practices contributing to additional failure. According to the author, extensive records, covering thousands of tubes in all types of electronic apparatus all over the world, back up his interesting and informative statements. [30]



FREE Catalog Of The WORLD'S FINEST GOV'T SURPLUS ELECTRONIC BARGAINS

AUTOMATIC CONTROL UNIT

- INDUSTRIAL • ELECTRONIC AUTOTUNE
 - RAILROADING
- 115 Volt 60 cycle 1/100 HP Capacitor type Motor with automatic gear and ratchet assembly that enables you to Pre-set motor stops any 10 positions within 360 degrees. Unit is geared to a two deck 12 position ceramic waver switch that terminates into a plug-in socket. Local control panel has channel position selector, light dimmer control and local/remote switch that enables unit to be operated local or remote position. Part of RDZ-1 Transmitter Autotune Assy. Collins #596A-1. Size: 9 x 4 x 6". Stock No. EW-23491—Price—NEW **\$14.95**

F-56 FAIRCHILD AIRCRAFT CAMERA

20 Inch Recording Type, Quickwind, Automatic. Adaptable to oblique spotting and vertical mapping. Can be operated manually or from 24 VDC. Complete in trunk, with cables, intervalometer, and spare magazine and reels. Price—Unused: **\$300.00**

BC-603 \$16.95 RE-NEW	BC-683 \$34.95 RE-NEW	BC-923 \$39.95 RE-NEW
-----------------------------	-----------------------------	-----------------------------

BC-603 FM Rec. 20 to 27.9 MC. Re-New: \$16.95
 BC-683 FM Rec. 27 to 39.1 MC. Re-New: \$34.95
 BC-923 FM Rec. 27 to 39.1 MC. Re-New: \$39.95
 BC-604 FM Transmtr. 20-27.9 MC: U: \$4.95
 BC-684 FM Transmtr. 27 to 39.1 MC. Used: \$ 7.95
 FT-237 MOUNTING for Rec.-Trans. Re-New: \$ 7.95
 FT-346 MOUNTING for Receiver only. Re-New: \$ 4.95
 DM-34 DYN. 12V. 1/BC-603-683-U: \$2.95-R-N: \$4.95
 DM-35 DYN. 12V. 1/BC-604-684-U: \$8.95-R-N: \$ 9.95
 FT-384 TEST ADAPTER For BC-603-683-923—Used for testing various Voltages and Alignment of Receivers. Plug into rear of set; has metering switch & provision for attaching output meter & V.T.V.M. Complete with 6 Ft. Battery Leads and Clips. Prices: USED: \$2.95. RE-NEW: \$4.95

BC-620 \$12.95 RE-NEW	BC-659 \$14.95 RE-NEW	PE-120 \$7.95 RE-NEW
-----------------------------	-----------------------------	----------------------------

BC-620 FM Rec.-Transmtr. 20 to 27.9 MC. Re-New: \$12.95
 BC-659 FM Rec.-Transmtr. 27—39.1 MC. Re-New: 14.95
 PE-120 Power Supply for BC-659 or BC-620; with Vibrator for 12 Volt operation. Re-New: 7.95
 BA-41 Bias battery for BC-659-620. New: 4.95
 AN-29 Telescoping Antenna F/BC-659. New: 2.95
 AN-45 Telescoping Antenna F/BC-620. 1.05
 FT-253 Shock Mounting
 F/BC-659-PE-120. Used: 4.95

Address Dept. EW • All Prices F.O.B., Lima, Ohio. \$5.00 Minimum Order, 25% Deposit on all C.O.D.'s.

FAIR RADIO SALES
2133 ELIDA RD. • P.O. Box 1105 • LIMA, OHIO

RECEIVERS:

NAVY ARB/CRY 46151—190 to 9500 KC. U: \$18.95
 ARC-3 AM Rec. 100 to 156 MC. Used: 24.95
 BC-733 Localizer Rec.—106.3 to 110.3 MC. Used: 4.95
 R-23/BC-453 Rec.—190 to 550 KC. Used: 14.95
 R-4/ARR-2 Rec.—540-830 KC: 230-258 MC. R-N: 8.95
 BC-1206 Beaton Receiver—200 to 400 KC. Re-N: 9.95
 BC-632 Receiver—2 to 6 MC.—Less Dyn. Used: 19.95
 BC-344 Rec.—150 to 1500 KC—For AC op. Used: 49.50

TELEPHONES, HEADSETS, MICS., Etc.:

TS-9 Handset. Used: \$2.95—New: \$ 3.95
 TS-13 Handset, w/PL-55 & PL-68. U: \$2.95—N: 3.95
 T-17 Microphone. Used: \$12.95—Recond: 16.95
 BD-71 Switchboard—6 Line. U: \$14.95—New: 24.95
 RM-29 Control Unit. New: \$6.95—W/Handset 8.95
 RM-52 Control Unit (Patch Found.) U: \$1.95—N: 2.95
 M-16/U Headset—8000 ohm. U: \$1.95—New: 2.95
 HS-33 Headset—300 ohm. U: \$4.95—New: 7.95

T-67/ARC-3 AIRCRAFT TRANSMITTER AM

100—156 MC. Crystal Control. 8 channel, electric band change. With tubes: 2/832, 2/6L6, 3/6V6, 1/12SH7, & 1/6J5. Used: \$24.95

SEND FOR FREE CATALOG!

FREE

ask your hi-fi dealer for



audio empire
STEREO/BALANCED HIGH FIDELITY COMPONENTS DYMA-EMPIRE, INC.
1075 STEWART AVE., GARDEN CITY, N. Y.
EXPORT: EMEC, PLAINVIEW, N. Y.
CANADA: ACTIVE RADIO & TV LTD., TORONTO 2, ONT.

Ask By Name For **GENUINE** "NO NOISE" PRODUCTS
your assurance of brand name quality

NO-NOISE TUNER-TONIC With PERMA-FILM

- Cleans, lubricates, restores all tuners, including wafer type.
- Non-toxic, non-inflammatory.
- For TV, radio and FM use.
- Economical — a little does a lot.

6 Oz. Aerosol Can **\$3.25**

NO-NOISE VOLUME CONTROL and CONTACT RESTORER

- Lubricates
- Cleans
- Protects

Not a Carbon Tet Solution 2 Oz. Bottle \$1.00 6 Oz. Spray Can \$2.25

Not to Servicemen

FREE At Your Jobbers
5" PLASTIC EXTENDER

- Push Button Assembly
- For Pin-Point Applications
- Does Not Cause Shorts

ELECTRONIC CHEMICAL CORP.
813 Communipaw Avenue Jersey City 4, N. J.
P.S. Be Sure to Ask for **NO-NOISE RUBBER COAT** 6 Oz. Spray Can **\$3.25**



DIGITAL COUNTERS and COMPUTERS

... an easily understood guide to theory, design and application including the interpretation and use of their output

Invaluable for technicians, students, and experimenters alike, this new, fully-illustrated 248-page book explains the "mysteries" of modern computer technology in clear, easily understood terms.

Actually, the complexity of computers is not because of any highly involved circuitry, but largely because so many circuits are needed to perform the necessary functions. Once a relatively few circuit configurations have become clear, you will have gone far toward understanding digital circuits, theory and operation in general! Written by an acknowledged expert, Ed Bukstein, Instructor in Advanced Electronics, Northwestern Television and Electronics Institute, the book contains much material never before published in book form.

Subjects include:

- Number systems - Binary counters - Readout indicators and special counter tubes - Decade counters - Storage devices - Computer control - Logic circuits - Input-output devices - Computer applications ... and many others.

DIGITAL COUNTERS and COMPUTERS approaches computer technology first from the subject of electronic circuitry. Included are remarkably clear explanations of the basic "flip-flop," logic and switching circuits. Once these features have been thoroughly clarified, the book then explains the number theories and counting systems by which computers perform their work.

Subsequent chapters deal with the "readout" devices which translate a computer's results into usable form, memory equipment and all the other technical details so puzzling to those who have not made a particular study of computer development. A special section deals with the frequently discussed topic of digital-to-analog and analog-to-digital conversion.

---10-DAY FREE TRIAL!---

Dept. RN-110, Technical Div.
HOLT, RINEHART and WINSTON, Inc.
 383 Madison Ave., New York 17, N.Y.

Send Ed Bukstein's 248-page DIGITAL COUNTERS and COMPUTERS book for 10-day Free Examination. In 10 days, I will either send you \$8.75 (plus postage) in full payment or return book postpaid and owe you nothing.

SAVE! Send \$8.75 with order and we pay postage. Some 10-day return privilege with money refunded.

Name _____
 Address _____
 City, Zone, State _____

OUTSIDE U.S.A.—Price \$9.25 cash with order. 10-day return privilege with money refunded.

Frequency Measurement

(Continued from page 53)

error is minimized by operating the crystal in a temperature-controlled oven. Errors from the other source occur because the start (or stop) pulse may occur slightly before, slightly after, or in coincidence with one of the pulses of the unknown frequency. This factor produces a possible error of \pm one count. As shown in Fig. 7, the one-second interval between A and A' contains four pulses of the unknown frequency. If the start pulse is applied at time B instead of A, the one-second interval from B to B' will contain five pulses of the unknown frequency. For this reason, the frequency measurement

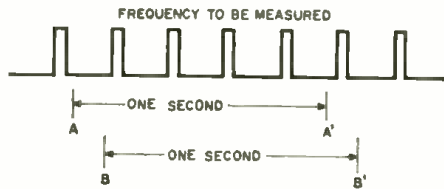

Fig. 7. One-second interval starting at A contains four pulses, but interval starting at B contains five. Measurement taken is therefore subject to an error of plus or minus one pulse.

may be in error by \pm one pulse. If the unknown frequency is relatively high, many thousands of pulses will pass through the gate during the one-second time base. An error of one pulse out of many thousands is not a significant percentage. If the unknown frequency is relatively low however, only a few hundred pulses (or less) may pass through the gate during the counting interval. An error of one pulse out of a few hundred is a significant percentage. For this reason, low frequencies can be more accurately measured by the period-measurement technique.

As shown in Fig. 9, the period measurement is accomplished by feeding the crystal-controlled one-megacycle signal to the gate circuit, and using the unknown frequency to open and close the gate. The unknown frequency is converted to a square wave and then differentiated. Two successive positive spikes from the differentiator are used as start and stop pulses. Since these spikes are separated in time by an interval equal to one cycle of square wave, the count gate remains open for a length of time equal to the period of the unknown. During this period pulses at the one-megacycle rate pass through the gate and into the counter. The indicator lights of the counter therefore

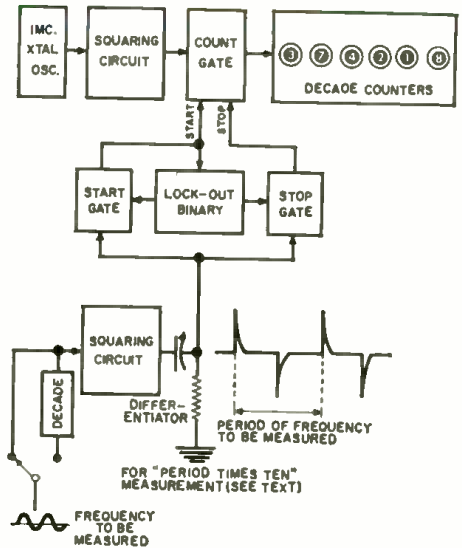

Fig. 9. For period measurement, count gate is opened and closed by pulses derived from unknown frequency. Decade counters are then utilized to indicate period of unknown frequency.

display (in microseconds) the period of the unknown. The frequency of the unknown is now determined by dividing the period into one.

The unknown frequency is sometimes fed through a decade (ten-to-one) frequency divider before being applied to the start and stop circuits. Under these conditions, known as a *period times ten* measurement, the gate remains open for an interval of ten periods of the unknown frequency. Since ten times as many pulses now pass through the gate, the uncertainty factor of \pm one pulse represents an even smaller percentage of error.

A variation of the period measurement technique may be used for measuring the speed of servomotors, generators, or other rotary equipment. As shown in Fig. 8, a disc is mounted on the shaft whose speed is to be measured. A photocell, illuminated by light passing through an opening in the disc, produces one output pulse for each revolution of the shaft. These pulses, corresponding to the unknown frequency, are used as start and stop pulses. The number of pulses produced by a one-megacycle oscillator is counted during the interval between two successive pulses from the photocell. The decade indicator lights then display the time, in microseconds, for one revolution of the shaft.

Recent advances in miniaturization and microminiaturization techniques suggest that some day automatic frequency-measuring circuits may be built into audio generators and other similar instruments. [30]

Fig. 8. Photocell receives illumination through the window in disc, producing an output pulse for each revolution of shaft. Output pulses are used to open and close count gate.

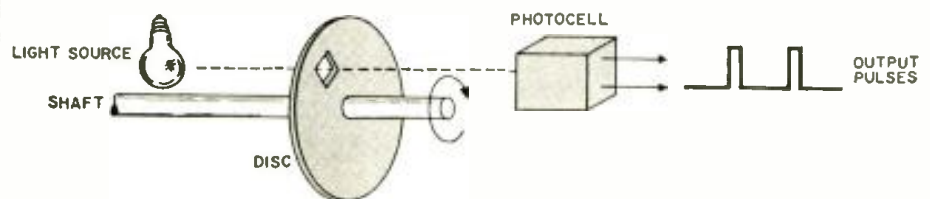

FREE!

LAFAYETTE'S 1961 CATALOG 324 GIANT SIZED PAGES

The Complete Catalog Featuring
"The Best Buys In The Business"

- Stereophonic Hi-Fi Equipment
- Public Address Systems
- Tape Recorders
- Radio and TV Tubes and Parts
- Citizen Band Equipment
- Amateur Equipment
- Industrial Supplies

Send for Lafayette's FREE Catalog—the most complete, up-to-the-minute electronic supply catalog crammed full of everything in electronics at our customary down-to-earth money-saving prices.

CONTAINS HUNDREDS OF EXCLUSIVE LAFAYETTE ITEMS NOT AVAILABLE IN ANY OTHER CATALOG OR FROM ANY OTHER SOURCE — SEND FOR YOUR COPY NOW!

A "must" for the economy-minded hi-fi enthusiast, experimenter, hobbyist, engineer, technician, student, serviceman and dealer.



Our 40th Year

EASY PAY PLAN—the simplest, and quickest way to get what you want when you want it. As little as \$2 down . . . up to 24 months to pay.

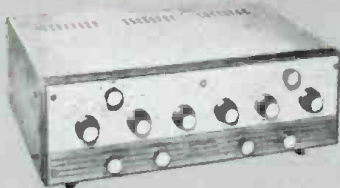

Stereo Control Center
KT-600, Kit LA-600, Wired
79.50 134.50



RW-60 20,000 Ohms Per Volt Multitester
13.50



KT-650 FM Tuner Kit
54.50



RK-400 2-Speed Portable Tape Recorder
49.50



TE-15 Tube Checker
19.95



Communications Receiver
KT-200, Kit HE-10, Wired
64.50 79.95

LAFAYETTE RADIO

Mail the coupon today for your FREE copy of Lafayette Radio's 1961 catalog.



Lafayette Radio Electronics Corp.

Dept. RK-6, P.O. Box 190
Jamaica 31, N. Y.

Send me the FREE Lafayette 324 page
1961 catalog 610

Name _____

Address _____

City _____ Zone _____ State _____

**Emergency
Industry
Farming
Pleasure**

NEW! LAFAYETTE HE-15A 2-WAY SUPERHET CITIZENS BAND TRANSCEIVER!

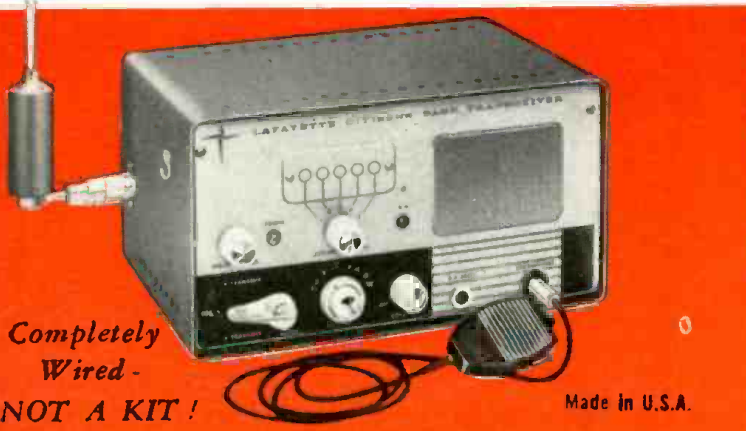

**Completely
Wired -
NOT A KIT!**

Made in U.S.A.

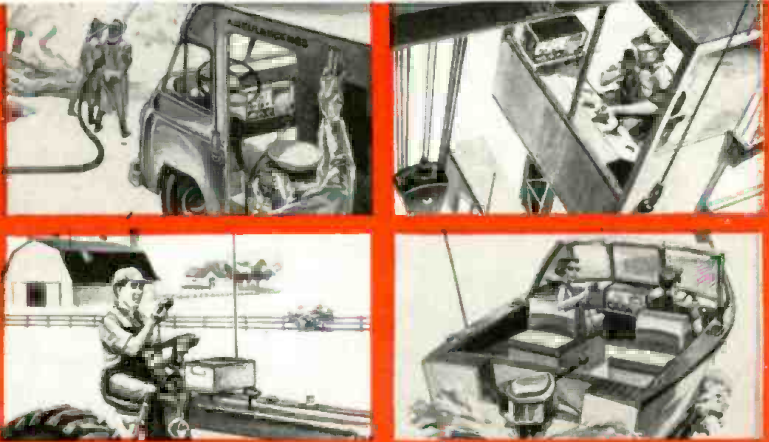

Not Superregenerative but SUPERHET!

COMPLETE 2-WAY COMMUNICATIONS FOR
BUSINESS, HOME, FARM, BOAT, AND SPORTS

NOW WITH ADDED FEATURES

- Effective Full-Wave Variable Noise Limiter
- Five Prong Microphone Jack For Easy Relay Addition
- RF Jack on Front Panel
- 5 Transmitting Positions
- Tuneable Receiver Over Full 23 Channels
- Planetary Vernier Tuning
- Complete with Transmitting Crystal for Channel 9

57⁵⁰
Only
5.00 Down

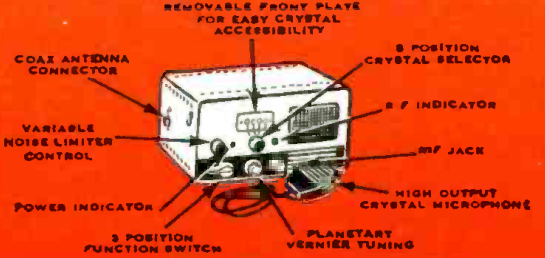

CITIZENS BAND — The New Two-Way Personal Communications Method for Everyone — Fill out the FCC form enclosed with each Lafayette Transceiver. No examination or technical knowledge required — Any citizen 18 years or older is eligible for a license.

THE GREATEST VALUE in the CITIZENS BAND FIELD

Just think . . . now you can have economical, efficient 2-way radio communication from your home, office, store, auto, truck or boat . . . literally hundreds of uses. The Lafayette HE-15A Superheterodyne Transceiver is both a compact precision transmitter and receiver designed to operate on the new class D "Citizens Band." Two or more of these units furnish your own communications system covering up to a 20 mile or more radius depending on antenna height and terrain. The Lafayette HE-15A meets all FCC requirements and operates in much the same manner as police and other short-wave communications systems. The Transceiver features 5 crystal controlled transmitting channels operating at a maximum legal power input of 5 watts fully modulated, RF stage in both transmitter and receiver. The 5 position crystal selector on the front panel selects any one of 5 transmitting frequencies. These 5 crystals are readily accessible by means of a removable front plate. The superheterodyne receiver is tuneable over the full 23 channel band with 3 watts audio output, AVC, and an amazingly effective Full-Wave Variable Noise Limiter. The noise limiter is continuously variable from the front panel for diminishing ignition and other unwanted noise pickup. A new 5 prong microphone jack makes

conversion to a push-to-talk relay a cinch. RF jack on the front panel may be used to monitor the current in the final tube using external meter.

Controls include a 3 position function switch (transmit, receive, and transmit with spring return), planetary vernier tuning plus variable noise limiter. Output impedance matches 52 and 72 ohm antenna with Amphenol type coax connector. Has large 4" PM speaker; input jack for crystal or ceramic microphone; power receptacle in rear for AC line and 6 or 12 volt external power supply. Supplied with single transmitting crystal for channel 9, high output crystal microphone, and brackets for easy mounting of units in auto, boat, etc. Operates on 115 volts AC. Addition of 6 or 12 volt power supply (separately supplied) adapts transceiver for mobile operation. Size 10 1/4 x 5 1/2 x 6 3/8" D. Tube complement: 2-6U8A/6E8B, 1-6AL5, 16V6, 1-12AX7, 1-64W8. Shpg. wt., 11 lbs.

- HE-15A 5.00 Down Net 57.50
- POWER SUPPLY:** Adapts HE-15A for mobile operation. Complete with cable, 6 or 12 volt vibrator and mounting flanges. Completely enclosed. Size 4 1/4 x 6 x 4 1/4" H. Shpg. wt., 4 lbs.
- HE-16 For 12 Volts Net 10.95
- HE-18 For 6 Volts Net 10.95
- TRANSMITTING CRYSTALS:** For any of the 23 channels. Specify channel or frequency.
- HE-830 Net 1.95



6.95

SENSATIONAL LAFAYETTE CITIZEN BAND MOBILE ANTENNA

THE SCOOP BUY FOR CITIZENS BAND MOBILES

- CHROME SWIVEL BASE
 - PLUS STAINLESS STEEL SPRING
 - PLUS STAINLESS STEEL WHIP FOR OPTIMUM 11 METER PERFORMANCE
- Chrome swivel ball mount base designed to be mounted on any surface. Stainless steel spring holds rod in properly adjusted position and prevents rod damage from shocks and blows. Stainless steel whip for maximum resiliency and strength. Shpg. wt., 4 lbs.

HE-800WX Net 6.95

NEW! LAFAYETTE TELESCOPIC CITIZENS BAND WHIP ANTENNA

- Chrome Plated
- Telescopes From 16 1/2 to 40"
- Mounts Vertically or Right Angle

3.95

An outstanding antenna value. This high quality three section telescoping antenna is designed for attachment directly to your citizens band transceiver. Ideal for point to point service over short distances. Molded base loading coil has a threaded stud with a PL-259 plug—connector for vertical or right angle mounting. Shpg. wt.; 1 lb.

HE-19 Net 3.95



NEW! 10,000 OHMS PER VOLT MULTITESTER

Outperforms Instruments Many Times Its Size

9.95

- Extra Large 3 1/2" Meter Face
- Completely Wired and Tested
- All Accessories Included

A convenient, pocket-sized instrument with an unusually sensitive 14,000 ohms-per-volt AC-DC meter, 1% resistors, single range selector switch. First capacity range requires 120V AC, second range requires 6V AC. Durable Bakelite case and panel; probes and flexible leads are plastic coated and color coded. Complete with battery. 4 1/2 x 3 1/2 x 1 1/8". Shpg. wt., 1 1/2 lbs.

TE-10 Net 9.95
TE-14 Pigskin Carrying Case, shpg. wt., 8 oz. Net 1.95

NEW! LAFAYETTE RADIO FIELD INDICATOR

- Provides a Continuous Indication of Transmitter Output
- Requires 200 ua Meter Movement
- Completely Portable
- Requires No Electricity, Batteries or Transmitter Connection.

7.95

With this rugged, new radio field indicator you can check performance of your marine, mobile or fixed transmitter . . . actually measures the RF field generated by any transmitter between 100KC and 250MC regardless of power. Features a 200 ua meter movement with a variable sensitivity control. Phone jack at rear of indicator accepts earphones thus providing an aural check of transmitter output. Antenna extends from 3 1/4 to 10 3/4". Powerful magnet on bottom plate allows easy mounting on car dashboard or metal surfaces. Use anywhere . . . requires no electricity or batteries. Dimensions: (less antenna) 3 1/4 x 2 1/4 x 2" D.

TM-14 Net 7.95



PLEASE INCLUDE SHIPPING CHARGES WITH ORDER

LAFAYETTE RADIO
165.00 FIFTEENTH AVENUE JAMAICA 33 NEW YORK

NEW YORK, N. Y.
100 6th Avenue

NEWARK, N. J.
24 Central Avenue

BRONX, N. Y.
542 E. Fordham Rd.

PARAMUS, N. J.
182 Route 17

BOSTON, MASS.
110 Federal Street

PLAINFIELD, N. J.
139 W. 2nd Street

LAFAYETTE HI-FI KITS

Build A Path to A New World of Entertainment



KT-253A
50-WATT STEREO AMPLIFIER... 74.50



KT-500A
FM-AM STEREO TUNER... 74.50



KT-600A
STEREO PREAMPLIFIER... 79.50



KT-600 FM TUNER... 24.50



KT-236A
36-WATT STEREO AMPLIFIER... 59.50



KT-550 100-WATT
BASIC STEREO AMPLIFIER... 134.50

MONEY-BACK GUARANTEE

Lafayette Kits are exclusive products of Lafayette Electronics. Each Lafayette Kit must meet or exceed its published specifications, or your money is refunded in full.

ENGINEERING:

Created with the non-technical builder in mind. There's much more fun in assembling your own kit... and it's so easy.

DESIGN:

Each kit has the fine professional-looking touch. Styled to blend with every decor.

VALUE:

You can't get better units at these money-saving prices.

QUALITY:

Top performance due to high quality parts and engineering.

All Lafayette Kits are Available on the Easy Pay Plan.



CUT OUT
AND PASTE
ON POST
CARD

Lafayette Radio Dept. RK-6
P.O. Box 190 Jamaica 31, N. Y.

Send me the FREE 324-Page
1961 Catalog No. 610

Name _____

Address _____

City _____ Zone _____ State _____

MOBILE-RADIO MAINTENANCE

**CAN MEAN
A BETTER HOME...
A BIGGER CAR...
AND MONEY
IN THE BANK!**



Mobile radio—already a great and growing business—will grow far larger. The FCC is assigning many more channels . . . and now any type of business or industry can have its own 2-way radio system. Right now there are over 2,000,000 transmitters in the Safety and Special Radio Services. Citizens Radio is exploding. This equipment needs installation . . . maintenance . . . repair . . . and FCC-required checks. Most earn profits for their owners and must be kept on the air 12 months a year (often 24 hours a day)—so this work pays well.

Not many radio and TV servicemen bother to qualify to profit in this booming business—because an FCC operator's license is necessary. A far-sighted few are making big money. To learn how you can be one of these few, mail coupon below for your free copy of the booklet "HOW TO MAKE MONEY IN MOBILE-RADIO MAINTENANCE".

**MAIL THE COUPON NOW—
THERE'S NO OBLIGATION!**

LAMPKIN LABORATORIES, INC.
MFM Division, Bradenton, Florida

At no obligation, please send me the free booklet "HOW TO MAKE MONEY IN MOBILE-RADIO MAINTENANCE." Also, technical data on Lampkin meters.

Name _____
Address _____
City _____ State _____

**Lampkin meters are the preferred
mobile-radio test equipment!**



**LAMPKIN 105-B
FREQUENCY METER
RANGE 0.1 TO 175 MC.
AND UP
PRICE \$260.00**

**LAMPKIN 205-A FM
MODULATION METER
RANGE 25 TO 500 MC.
PRICE \$270.00**



NEW: The Lampkin PPM Meter to check frequency on split channels above 50 MC. Accuracy 0.0001%. Price \$147.00.

LAMPKIN LABORATORIES, INC.
MFM Division
BRADENTON, FLORIDA

Advance

**BEST BUYS
OF THE MONTH!**

MAR Power Supply

115V. 60 cyc. input, 12-14 VDC, 2 amp. output, filtered & fully housed. **895**
SPECIAL

POWER SUPPLY KIT!

Pri. 115VAC Sec. 400-0-400 @ 200 ma., 6.3 V @ 4 amp., 5V @ 3 amp. 2 Cap. & 1 Choke. 8 mfd. @ 500V. **750**
KIT

Pri. 115 VAC, 24 VDC. 2 amp. Tsfmr, rectifier, condenser **475**
SPECIAL

★ ★ OIL CONDENSERS ★ ★

4 Mfd. 600 VDC \$.85	4 Mfd. 2500 VDC \$3.25
6 Mfd. 600 VDC .85	4 Mfd. 3000 VDC 3.95
8 Mfd. 600 VDC .90	
10 Mfd. 600 VDC 1.10	3 Mfd. 4000 VDC 8.75
24 Mfd. 600 VDC 1.95	4 Mfd. 4000 VDC 14.50
16 Mfd. 600 VDC 1.75	1 Mfd. 5000 VDC 3.95
6 Mfd. 1000 VDC 1.55	2 Mfd. 10000 VDC 16.95
8 Mfd. 1000 VDC 1.95	1 Mfd. 12500 VDC 16.95
12 Mfd. 1000 VDC 2.65	

★ ★ PANEL METER BARGAINS! ★ ★

1 1/2" METERS		3" METERS	
0.500 Micro-amps \$3.50	0-100 Micro-amps \$4.25	0-15 VAC 3.95	0-150 VAC 4.25
2" METERS		0-1 ma. 4.45	0-1 Milli (scale 0-50) 4.25
0-1 ma. 3.75	0-100 ma. RF w/shunt 3.50	0-100 ma. 3.95	0-200 ma. 3.95
0-3 amps RF 3.50	0-15 VAC 3.25		
0-15 VAC 3.95	0-150 VAC 3.95		

SOLENOIDS

24 VDC 14 oz. pull 79	230 VAC 2 lb. pull 1.65
24 VAC 2 lb. pull 1.45	115 VAC 18 lb. pull 4.75
115 VAC 2 lb. pull 1.75	115 VAC 22 lb. pull 5.75

CHOKES—Fully Cased

6 hy. 100 ma. 1.15	10 hy. 200 ma. 2.95
22 hy. 100 ma. 2.19	10 hy. 350 ma. 3.95
20 hy. 110 ma. 2.09	

Min. Order \$3.00—25% with order F.O.B. New York 10 DAY GUAR. PRICE OF MDSE. ONLY

Advance Electronics
6 West Broadway - New York 7, N. Y. - Rector 2-0270

WHO NEEDS MILES OF WIRE?

**GET
HOME ELECTRICITY
ANYWHERE
WITH A**

terado
CONVERTER

Change 6 or 12 volt D.C. to 110 volt, 60 cycle A.C.

No Installation—Just plug into cigarette lighter of car, truck, or boat, and it's ready to go!

Operate lights, electric shavers, dictation machines, record players, small electric tools, portable TV, and testing equipment.

**Models from 15
to 200 watts,
priced as low as \$1295**

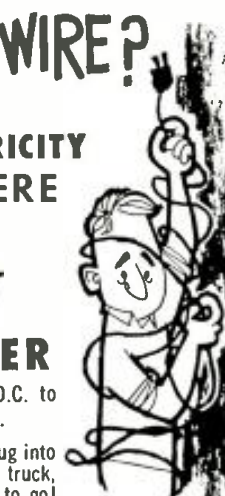

See Your Electronic Parts Dealer or Jobber
terado COMPANY
DESIGNERS & MFRS. OF ELECTRONIC EQUIPMENT SINCE 1927
1058 RAYMOND AVE., ST. PAUL 14, MINNESOTA
In Canada: ATLAS RADIO CORP. LTD.—Toronto, Ont.

The Maser (Continued from page 38)

materials at very low temperatures. Most masers employ a double dewar system to establish the continuous cold necessary for operation. A functional sketch of such a system is shown in Fig. 5 and a number of stainless-steel double dewars are shown in the photos. The double dewar is nothing more than one vacuum bottle inside another. The inner one is filled with liquid helium and the outer is filled with liquid nitrogen to reduce dissipation of the helium (liquid nitrogen boils at 77° absolute). The maser structure is immersed in the liquid helium, supported on long narrow stainless-steel rods which reduce boil off. With proper design, a single charge of liquid can last from 18 to 24 hours, after this the dewar system must be recharged. Cryogenic engineers are developing a closed-cycle system which will allow continuous operation without recharging. This type of system collects the helium gas as it boils off, re-liquifies it, and returns it to the dewar. When these closed systems become readily available, we can expect to see greater use of masers. Currently, the open helium systems are not very desirable—recharging is tricky and costly, storage of the liquids is difficult, and the supply of liquid helium is very limited.

The operation of a TWM with a closed-loop refrigerating system forms a very practical low-noise receiver. It can be remotely operated for extended periods of time without maintenance.

Systems Applications

The systems applications of masers have been slow in coming, because many components in present systems were not designed for use with an ultra-low-noise receiver. For a maser to be useful, the noise contributions of the rest of the system should be of the same order as that of the maser. It is for this reason that the *Bell Telephone Laboratories* had to develop a special low-noise antenna for use with the maser for project "Echo." This is the first system engineered to take maximum advantage of the maser's characteristics. (See "Cover Story" on page 38.)

Among the many systems that can make good use of the low-noise characteristics of a maser are: preamplifiers for radio astronomy receivers, radar front ends, and numerous systems that do not suffer from high background noise.

To take full advantage of a maser one would have to mount it directly at the feed of an antenna. Giordmaine and Meyer of Columbia University operated a 9000-mc. radio telescope with a maser preamplifier mounted on the feed of a 50-foot parabolic reflector at the Naval Research Laboratory. The effective noise temperature of the complete system was 85°K with the maser contributing about 4° maximum and

the antenna 20°. The rest of the noise contributions were due to input losses and the second stage. If a typical X-band mixer had been used instead of a maser, a noise temperature of 2000°K would not be uncommon. This shows an improvement on the order of 25 times in the reduction in noise and hence increase in sensitivity with the use of a maser.

B. F. C. Cooper and J. V. Jelley operated a maser radio telescope at 1420 mc. with the maser mounted at the feed of a 60-foot reflector located at the Harvard College Agassiz Station. The over-all noise characteristics of this maser system were similar to those of the X-band maser radio telescope mentioned previously. A unique feature of this system was a closed-loop feedback system to keep the maser gain constant.

The use of a maser as a preamplifier for a radar receiver was first accomplished by *Hughes Aircraft Company*. A 10-db improvement in the effective noise temperature was obtained as compared to the normal receiver operation. The main problem with a maser when used with a pulsed radar is that the maser saturates from pulse leakage. To overcome this deficiency, a special low-loss ferrite switch had to be constructed. This switch inserted about 30-db loss when the radar was in the transmitting state. In the receiving state the switch loss was only about 0.25 db. The over-all 10-db improvement with the use of a maser almost doubled the range of the radar.

The maser has proven that it can detect and amplify signals better than any other type of receiver. We can expect the maser to develop from a laboratory curiosity to the workhorse of ultra-low-noise receiving systems. The major drawback to a maser is the necessity of maintaining low temperature for operation. *Hughes Aircraft* has operated a maser successfully at liquid nitrogen temperatures using the present maser material (ruby).

In the future we can expect the development of new materials that will permit operation at higher temperatures. For masers operating at 4.2°K, there is a recovery time problem, which will only be corrected with the development of new maser materials. There are a number of new materials that look promising for 4.2°K and higher temperatures, among them iron-doped sapphire and iron- or chromium-doped titanium dioxide (known as rutile or titania). For frequencies above 10,000 mc., there is no other type of amplifier that can approach, even closely, the extremely low noise and high sensitivity of a maser. Masers have already been operated from 400 to 75,000 mc. Many laboratories are trying to develop infrared and light masers. If successful, these will be the first amplifiers for such types of electromagnetic radiation. These are but a few of the things that can be expected. The future for this amazing receiver is certainly beyond the skies. [30]

*See "The Laser—a Light Amplifier" in our September issue.

It's what you know about INSTRUMENTS that really counts!

**What types to buy...
Exactly how to use them!**



**... CUT TEST
TIME IN HALF!**

**... DON'T
WASTE MONEY**
on instruments you
don't need!

Probably the most important factor in TV-radio or industrial electronic service is a complete working knowledge of instruments—which ones you really ought to have—which ones to use for specific jobs—how to substitute one for another—and how to use instruments properly in following professional time-saving procedures every step of the way. That's exactly the kind of practical, easy-to-understand training these famous manuals bring you! 570 pages and over 360 clear pictures provide above-average instrument training that equips you for better, faster work and higher earnings.

A COMPLETE MANUAL OF MODERN INSTRUMENTS (1) A money-saving guide to every type in common use

This 254-page Basic Electronic TEST INSTRUMENTS is a complete working guide to practically every instrument in common use. Teaches you the advantages and disadvantages of various types; helps you get more for your instrument dollars and avoid buying those you don't really need; outlines instrument construction and operation; ex-

plains instrument features and the particular applications for each; tells how to calibrate and care for them, and how to select the ones most suitable for your particular needs. Includes the newer instrument types as well as the old "standbys"—over 60 different types. A complete instrument training course! Price separately \$6.25.

New guide to TIME-SAVING TEST PROCEDURES (2) How to troubleshoot better, faster and more accurately!

This big manual brings the kind of "brass tacks" training that helps you locate troubles in a jiffy by teaching you up-to-date time-saving methods for making practically any test on home AM, FM, Hi-fi and TV receivers as well as industrial electronic equipment. Teaches you what instruments to use and exactly how, where and why to use them. Shows how to save money by substituting one instrument for another. For instance you learn to check distortion with either an oscilloscope, a rejection filter, harmonic distortion meter, wave analyzer or audio oscillator—and so on through a long list of instrument substitution possibilities. BASIC ELECTRONIC TEST PROCEDURES covers: Current Checks; making measurements

of Power, Capacitance, Inductance, Resistance, AF, RF, Phase, Distortion and Modulation; Checking Sensitivity, RF Gain, Fidelity, AVC Voltage, Operating Voltages, etc. Includes visual alignment techniques—even transmitter and industrial electronic test procedures. 316 pages, 190 how-to-do-it pictures and dozens of step-by-step troubleshooting procedures. Price \$8.00 separately.

PRACTICE 10 DAYS FREE!

Dept. RN-110, Technical Division,
Holt, Rinehart & Winston, Inc.,
383 Madison Ave., New York 17, N.Y.
Send books checked for 10-day FREE examination. In 10 days I will either remit price shown (plus postage) or return books postpaid and owe you nothing.

Basic Electronic TEST INSTRUMENTS, Price \$6.25
 Basic Electronic TEST PROCEDURES, Price \$8.00
 MONEY SAVING COMBINATION. Send both books of special price of only \$13.00 plus postage for the two. Regular price \$14.25—you save \$1.25!

EXTRA SAVING! Send cash with order and we pay postage! Same 10-day return privilege with money promptly refunded.

Name
Address
City, Zone, State

SAVE \$1.25
on this complete
2-volume instrument li-
brary!



OUTSIDE U.S.A. Cash with order only. Add 50¢ to price of each book. Money refunded if books are returned in 10 days.

**RECORD
"STEREO"**

**IF YOU ARE EQUIPPED
TO PLAY BACK STEREO TAPE
YOU CAN NOW RECORD THE
SECOND CHANNEL WITH A CLARITY
AND BRILLIANCE TO MATCH YOUR
MONAURAL RECORDINGS—WITH THE
"STERECORDER"**

EASY TO INSTALL—THEN JUST PLUG IT IN—
ONLY \$23.95 POSTPAID—INCLUDING TAXES—FOR
WOLLENSAK, V-M & PENTRON STEREO TAPE RECORDERS
STATE MAKE, MODEL & NUMBER OF TRACKS
INQUIRE ABOUT OTHER MAKES & MODELS

BILT-RITE ELECTRONICS CO.

2995 N.W. 76 ST.
MIAMI 47, FLA.

Get the best in Electronics

- For today's enjoyment
- For Christmas giving
- For year 'round pleasure

Send for Radio Shack's

FREE

Electronics CATALOGS

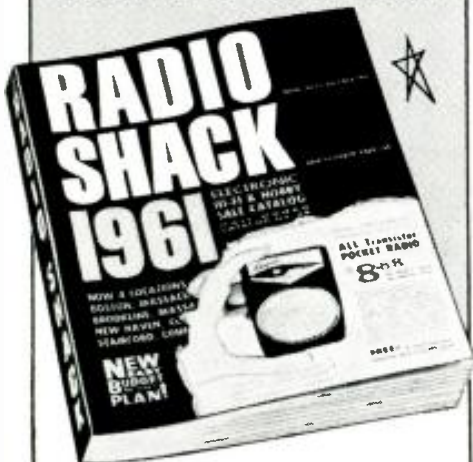

Mail coupon for latest free 192-page Radio Shack catalog plus every new issue for full year.

★

See world's largest line of electronics items: Hi-Fi, Ham Radio, Stereo, like values shown below.

★

Buy on Easy Budget terms, up to 2 years to pay. Money-back guarantee on every item always.

TYPICAL VALUES IN RADIO SHACK CATALOGS

 All Transistor Pocket Radio \$8.88	 T-5 FM-AM Stereo Tuner \$59.50
 3.98 & 4.98 Stereo Records Each \$1.00	 Duo Remote Control Speaker \$3.98

RADIO SHACK CORPORATION
730 Commonwealth Ave., Boston 17, Mass.

MAIL COUPON NOW

Radio Shack Corp. Dept. 60L6
730 Commonwealth Ave., Boston 17, Mass.
Send latest Electronics Catalog plus
every new issue for one year, FREE.

Name _____
Address _____
Postoffice _____
or City _____ Zone _____ State _____

Tough Dogs

(Continued from page 54)

are coupled to "B—" through this low-impedance a.c. path to ground. Such measures are required in both vacuum-tube and transistor circuits.

In the receiver just mentioned, the decoupling capacitors bypass a.c. only partially, with reliance on the relatively low impedance of the normal dry cells used in the common power supply for the rest of the decoupling action, just as the output filter capacitor is relied upon to provide this function in vacuum-tube sets. The relatively high internal impedance of a single dry cell—which happened to be a fresh one—permitted the feedback that resulted in motorboating.

Although a technician might quickly replace the output filter in a tube receiver with such a symptom, he would probably do so on the basis of habit and experience, without resorting to the original logic that has motivated the action. Thus the analogous role of the batteries, without analysis, does not occur to him, and the same defect that results in a simple repair in a tube set becomes a "tough dog" in this case. But it could have been avoided with an application of theory.

Grid-Leak Bias

A TV receiver with a synchronizing system similar to that shown in Fig. 2 was brought in with the complaint, "No sync, but all sync-circuit components checked good, and I even tried substituting most of the parts." As the service technician had mentioned that *all* grid and plate voltages in the sync circuit were abnormal but that "B+" to the circuit was normal, the first check was to determine the type of sync circuits employed in the receiver. The defect: an open coupling capacitor (C_1 in Fig. 2) from the video amplifier.

Circuits using grid-leak bias are found throughout the standard TV receiver. Some examples are the horizontal oscillator, horizontal amplifier (output), vertical oscillator, vertical amplifier, sync separators, and sync clippers. When this grid-leak bias voltage is other than at its normal level in any such stages, many technicians immediately begin checking any and all parts in the particular circuit, feeling that this is quicker than trying to figure out the possible specific causes of the trouble. A brief analysis will illustrate how good knowledge, and the ability to use this knowledge, can save the technician's time and his customer's money.

Fig. 2 shows the sync circuits found in the previously mentioned television receiver, with normal voltages and component values given. If the plate voltage of video amplifier, V_1 , is going positive at a given instant, due to its input signal, electrons will be attracted to the grid side (V_2) of coupling capacitor C_1 . These electrons, migrating to the capacitor plate from the control grid of V_{2A} , leave this grid with a positive potential at that moment. The control

grid, in turn, attracts some of the electrons passing through it on their way to the plate. The plate current of V_{2A} at this instant is maximum and, since this current also passes through plate-load resistor R_1 , it causes the plate voltage of V_{2A} to be very low.

When its varying signal causes V_1 to conduct more, its plate voltage will decrease. As a result, electrons are forced from the grid-side plate of coupling capacitor C_1 . These electrons cannot be emitted from the control grid in a normal tube, and therefore must migrate (slowly) to ground through grid-leak resistor R_2 . The accumulation of these electrons on the grid tends to cut off V_{2A} , and the latter tube stays cut off until the electrons on the grid have leaked off through R_2 to a level below cut-off, or until V_1 cuts off again. Note that, since V_{2B} is biased similarly, operation of the latter will be influenced by V_{2A} in the same way that V_{2A} is influenced by V_1 .

By applying theory concerning the development of grid voltage in this way, it is possible to localize the symptom simply by measuring two voltages (plus a third, at the screen grid, in the case of a pentode) and checking one or two components in the circuit. If the first voltage (at the grid) measures low, the plate voltage is measured next.

Suppose that the plate voltage had been found to be high, instead of low. Since this indicates that plate current through the tube is lower than normal rather than higher, the cathode circuit is the next point for attention. Low emission (from the cathode) in the tube or a cathode resistor that has increased in value are probable causes. In the circuit of Fig. 2, however, there is no cathode resistor.

Table 1 shows possible combinations of d.c. grid (E_g) and plate (E_p) voltage conditions along with the most likely sources of trouble in each case, for V_{2A} in Fig. 2. The reader may find it interesting, for each combination, to reconstruct the theoretical reasoning that led to each probable cause. In such circuits where pentodes are used, the screen grid with insufficient voltage will give the same indications described for a triode with high bias, and may be caused by a screen-grid resistor that has increased in value or a screen decoupling capacitor that is leaking. If screen voltage is high, the tube may have insufficient emission due to too much grid-leak bias, possibly caused by too much drive signal.

Phantom A.G.C. Voltage

A TV receiver was brought in by a student technician who had no success with the symptom of poor picture quality and low contrast on all channels. He had discovered the important fact that a.g.c. voltage was more highly negative than it should have been, even when the receiver was tuned off-channel. Suspecting oscillation, he had run all tubes through a tester and checked all decoupling capacitors in the video i.f. system. All of these components seemed to be OK, and he could find no other cause.

After a few moments of thought, the tubes were removed, one by one, while the a.g.c. line was being monitored. Removal of the last video i.f. tube caused a.g.c. voltage to drop to zero. Replacement of this tube restored normal operation. Rechecked on a tube tester, the faulty tube gave a normal reading.

The defect was probably an open shield within the tube. Failure of this internal-shield connection would permit the interelectrode coupling that can produce oscillation at high frequencies, but this condition would not show up on most checkers. Even transconduct-

ance testers use a test signal whose frequency is low enough to avoid this condition. A simple understanding of the difference between the tube's operation in the checker and the conditions in the circuit indicates the possibility.

To avoid working by rote, every service technician, no matter how his knowledge was originally obtained, should set aside a few hours every week to review past theory and study new material that requires analysis—or else run the risk of gradually losing ground in a field that is becoming more complex each year. [30]

Sun	Mon	Tue	Wed	Thu	Fri	Sat
		1	2	3	4	5
						12
						19
						26

CALENDAR of EVENTS

OCTOBER 24-26

Seventh Annual East Coast Conference on Aeronautical & Navigational Electronics. Sponsored by IRE. Lord Baltimore Hotel, Baltimore, Md.

OCTOBER 26-27

1960 Computer Applications Symposium. Sponsored by Armour Research Foundation. Morrison Hotel, Chicago.

OCTOBER 27-28

Electron Devices Meeting. Sponsored by

PGED of IRE. Shoreham Hotel, Washington, D. C.

OCTOBER 27-29

1960 Industry Display. Sponsored by Aircraft Electrical Society. Pan Pacific Auditorium, Los Angeles.

OCTOBER 31-NOVEMBER 1-2

13th Annual Conference on Electrical Techniques in Medicine and Biology. Sponsored by IRE. Sheraton-Park Hotel, Washington, D. C.

1960 Radio Fall Meeting. Sponsored by EIA and IRE Professional Groups. Hotel Syracuse, Syracuse, N. Y.

NOVEMBER 3-4

Ninth Annual Instrumentation Conference. Sponsored by School of Engineering, Louisiana Polytechnic Institute, Ruston, La.

NOVEMBER 14-16

MAECON Semiconductor 60's Program. Sponsored by IRE. Muehlebach Hotel, Kansas City, Missouri.

voices from outer space!

SPECIAL OFFER, 25¢

Dramatic Events Recorded First Time From Short Wave Radio!

President's voice from outer space . . . police capture of a gunman . . . radio contact with record altitude flight! Many other fascinating, historic events—ships, planes, foreign stations—all transcribed on a limited-edition recording, "The Amazing World of Short Wave Listening," narrated by world-famous newscaster Alex Dreier. If you're alert, adventuresome, send for this remarkable recording today!

As heard on Hallicrafters precision receivers, \$59.95 to \$395.00.



Hallicrafters Department 20, Chicago 11, Ill.
Enclosed is 25¢. Please rush "The Amazing World of Short Wave Listening."

NAME _____
ADDRESS _____
CITY _____ STATE _____



LEARN TUNNEL DIODE THEORY:

General Electric Transistor Manual

New Fifth Edition of an Industry Classic

These days you hear a lot about the amazing tunnel diode—100 times faster than the fastest transistor. But do you know its basic theory of operation . . . how it performs a feat considered impossible in terms of classical physics?

You will after you've studied the new Fifth Edition of General Electric's famous Transistor Manual—one book that's indispensable for a working knowledge of the transistor field. New material in its 320 fact-filled pages includes tunnel diode switching circuits and amplifiers . . . hi-fi and radio circuits . . . feedback and servo amplifiers . . . silicon controlled rectifiers . . . and complete specs and JEDEC listings.

Get your copy today from your G-E Semiconductor Distributor or by mailing one dollar with the coupon below.

General Electric Company, Semiconductor Products Dept., Section 522110, Electronics Park, Syracuse, N. Y.

Rush me the enlarged new 5th Edition of the General Electric Transistor Manual. I enclose \$1.00. (No stamps, please.)

Name _____

Address _____

City _____ Zone _____ State _____

GENERAL  ELECTRIC

BIG, BIG SAVINGS on PARTS from Tee Vee Supply

Antennas for Citizens Radio
(Continued from page 42)

**TINY CAPACITOR KIT \$1.89
NEEDED NOW!**



50 assorted tiny capacitors in a variety of mfd and voltages ideal for small electronic assemblies such as transistor sets or other applications. Consists of 35 tiny insulated paper capacitors and 15 ceramic capacitors. All mfd's clearly printed on each. Wt.: 3 oz.

SPRING KIT \$1.49



200 piece spring assortment consists of 8 different types of springs including compression and expansion types commonly used in TV, radio and phonographs. Shipped in a really useful heavy duty plastic box with hinged lid. Wt.: 8 oz.

TRIMMER CONDENSER KIT \$1.69



25 postage stamp mica compression trimmers many with brackets. The 25 different condensers in this kit represent a wide range of capacities from 3 to 280 MMFD. Packaged in a clear plastic bag. Wt.: 8 oz.

CROSSOVER CONDENSER KIT 5 CROSSOVER COND. \$1.89



5 non-polarized capacitors ideal for coupling the tweeter to the woofer speakers . . . anyone of which can do the job, ranging from .5 mfd to 10 mfd and priced so low, that one capacitor only would cost more than the kit. You will be pleased. Order now Wt.: 12 oz.

**21 MC. TV I.F. KIT 99¢
10-21 MC. TV I.F.S.**



Here's an amazing value!! 10 standard type 21 to 26 megacycle I.F.s — include a liberal variety of shielded and unshielded types . . . All are replaced by popular Stoncor-Merit numbers. Use just one and it pays for the entire kit. Order now at great savings . . . Wt.: 4 oz.

TV COIL KIT \$1.69



25 assorted TV coils for the repair shop or lab. Contains peaking coils. I.F.s, width and ratio detector coils in a plastic bag. The use of one or two coils will more than pay for the entire kit. Priced real low! Wt.: 8 oz.

TAB MOUNT CONTROLS \$1.99



10 tab mount volume controls. Hard to get items, not normally available in distributor stocks!! Kit includes a wide range of ohmages used in radio phono, and TV work. All controls are designed for direct mount to the chassis. These are the most commonly used controls in modern design automation and printed circuit work.

DUAL CONCENTRIC CONTROLS \$3.29



10 assorted dual concentric controls used in TV and auto radio. Kit includes 5 each controls with and without switch. All were made for very large TV and auto radio mfgs . . . Wt.: 1 lb. Order now at great savings!

VERTICAL MOUNT CAPACITORS



All Popular Values
20 Vertical Capacitors
\$1.69

Here is an assortment of plastic cased vertical mount tubulars for all printed circuit chassis today. A wide variety of mfd's to meet most demands, ranging from .00 to .1 Twenty all packed in clear plastic bags. This is a must for all servicemen and experimentors today. Order now at our low price! Wt.: 6 oz.

Send 25% deposit with order, balance C.O.D. plus postage. Freight prepaid on orders of \$50.00 or more. SEND FOR COMPLETE CATALOGS OF KITS.

TEE-VEE SUPPLY CO. 3211 Washington St., Jamaica Plain 30, Mass.

antenna system's ground plane is too small.

By placing the set on top of a metal filing cabinet, the roof of a car, or other large metal surface the signal strength can be increased noticeably. So, for short-range communication the combination of the plug-in antenna and the set's cabinet form a fairly satisfactory antenna system.

Transmission Lines

Irrespective of the type of antenna used, the transmitting antenna should be connected to the CB unit through coaxial cable, not microphone cable, twin-lead, or twisted-pair wire. Coax costs from about 7 cents per foot for small diameter cable to around \$1.00 per foot for heavy, low-loss cable. The kind you should use depends on how long a cable is required. Always get a cable in one piece; don't attempt to splice coaxial cable. If two pieces must be used, join them at the break with the proper coaxial connectors.

For runs of 50 feet or less for 27-mc. (class D) band operation, you can use RG-58/U (50-ohm) or RG-59/U (75-ohm) cable (cost about 7 cents a foot), the type depending on the kind of antenna used (50-ohm for ground-plane type, 75-ohm for dipole). In a 50-foot run, the loss is 1.25 db which means that even under ideal conditions about 25% of the available transmitter power is lost due to cable attenuation. For longer runs, use the larger, more expensive RG-8/U (50-ohm) or RG-11/U (75-ohm) cable (cost about 17 cents per foot) which wastes less of the transmitter power in the cable itself. The loss is about one db in 100 feet of cable, which means that 80% of the power should reach the antenna. If you want to get maximum range, and cost is not a consideration, you can use extra-heavy RG-17/U cable or what is known as hollow transmission line. Here the cost runs about 80 cents per foot or more, plus several dollars apiece for connectors. By using such low-loss cable (0.42 db attenuation per 100 feet), around 90% of the transmitter power gets through to the antenna. The quoted losses are applicable only if the impedance is matched at both ends of the cable. It is obvious that length of the coaxial cable should be kept at a minimum because of the power losses in the cable. No matter what type of cable is used, it is often advantageous to get the antenna up high and in the clear since the added height will often more than offset cable loss effects.

More cable loss can be tolerated when a gain-type antenna is employed than when a unity gain or less-than-unity gain type antenna is used. If, for example, an antenna is used which has 3 db gain (such as a cardioid type), you could stand losing 50% of the available power (3 db) and still come out farther ahead than when using a unity-gain

**YOUR COPIES OF
ELECTRONICS
WORLD
ARE VALUABLE!**



**Keep them neat . . .
clean . . . ready for
instant reference!**

Now you can keep a year's copies of ELECTRONICS WORLD in a rich-looking leatherette file that makes it easy to locate any issue for ready reference.

Specially designed for ELECTRONICS WORLD, this handy file—with its distinctive, washable Kivar cover and 16-carat gold leaf lettering—not only looks good but keeps every issue neat, clean and orderly.

So don't risk tearing and soiling your copies of ELECTRONICS WORLD—always a ready source of valuable information. Order several of these ELECTRONICS WORLD volume files today. They are \$2.50 each, postpaid—3 for \$7.00, or 6 for \$13.00. Satisfaction guaranteed, or your money back.

(Be sure to specify whether you want lettering to be Electronics World or its former title, Radio & TV News.)

Order direct from:

JESSE JONES BOX CORP.
Dept. EW
(Established 1843)
Box 5120, Philadelphia 41, Pa.

LOOK



NO FURTHER . . . IF YOU'RE UNHAPPY WITH "HI" MI-FI PRICES. WRITE FOR OUR UNUSUAL AUDIO CATALOG.

KEY ELECTRONICS CO.
120-C Liberty St., N. Y. 6.
Phone CLoverdale 8-4288

BARGAIN HUNTING? TV SERVICEMEN!



Write for SENSATIONAL CATALOG

HENSHAW RADIO SUPPLY
3619 TROOST KANSAS CITY, MO.

**WE CAN FINANCE
THIS OUTSTANDING
INVESTMENT OPPORTUNITY**

Your investment dollars will be returned 3-5 times annually if you can sell 100 or more picture tubes weekly. Windsor franchised TV Tube rebuilding enables you to produce custom built, highest quality tubes. Costs are low. Local distribution eliminates freight charges.

We train your men and while so doing produce 100 or more tubes you can sell. Our engineers are at your service for duration of lease.

WINDSOR ELECTRONICS
999 N. Main Glen Ellyn, Ill.

antenna with a lower loss line—provided that the long transmission line does not introduce other undesirable effects.

Most Citizens Band transmitters can be used with any length of antenna transmission line. Some, however, according to their instruction books, should be used only with a specified length (or multiple of that length) of transmission line. Most antennas for Citizens Band use, except dipoles, have a rated impedance of 50 ohms, requiring the use of a 50-ohm transmission line.

The transmission line should see a 50-ohm impedance looking back into the transmitter, as well as looking into the antenna. When the impedance at both ends matches the surge impedance of the cable, there are no standing waves. The current in the line is the same at all points.

The output impedance of the transmitter is adjustable by tuning the plate tank and antenna circuits as well as by adjustment of the coupling of the antenna and plate tank coils. By following the manufacturer's instructions on transmitter tuning, the desired output impedance may be obtained. When correctly tuned, the antenna system (antenna and cable) should look like a 50-ohm resistance to the transmitter.

If the antenna impedance does not match the cable at the operating frequency, the antenna will not absorb all of the energy fed to it. Instead, some of it is reflected back to the transmitter, causing standing waves to appear on the transmission line. It is therefore important that the antenna match the transmission line at the operating frequency as closely as possible. Most commercial antennas made for Citizens Band use come pretty close to meeting this requirement.

Kinks, sharp bends, and splices in a coaxial cable cause a change in the impedance of the line, resulting in a higher standing-wave-ratio and should be avoided. It is for this reason that suitable connectors must be used at each end of the coaxial cable for connecting to the antenna and the radio. Sometimes the antenna is designed so that a connector is not used at the antenna end and the cable is connected directly to the antenna. The inside wire (center conductor) of the coaxial cable connects to the vertical radiating element; the shield braid connects to the ground-plane radials.

Connectors for use with RG-8/U, RG-11/U, RG-58/AU, and RG-59/U cable cost around 75 cents each. If both the antenna and radio are equipped with receptacles to mate with coaxial cable plugs, two will be required, one at each end of the cable. Some Citizens Band radios use other kinds of plugs at the set end, such as a phono plug or the type used for connecting an antenna to a regular auto radio. No matter what type of plug is used, it should be carefully soldered to the cable, taking care to keep strands of the shield from contacting the center conductor or plug pin. [30]

FREE

GIANT 1961 204 PAGE CATALOG

SAVE UP TO 50% ON B-A SELECTED KITS

TOP VALUES IN POWER AND HAND TOOLS

HI-FI AND STEREO SYSTEMS & COMPONENTS

30 PAGES OF BARGAINS NOT IN ANY OTHER CATALOG

100'S OF NEW ITEMS LISTED HERE FOR 1ST TIME

BURSTEIN-APPLEBEE 1012-14 McGEE ST., KANSAS CITY 6, MO.

**BURSTEIN-APPLEBEE CO. Dept. M,
1012-14 McGEE St., Kansas City 6, Mo.**

Send Free 1961 B-A Catalog No. 611

NAME _____

ADDRESS _____

CITY _____ STATE _____

RUSH COUPON TODAY!

SEND
ELECTRONICS WORLD
EVERY
MONTH

name _____

address _____

city _____ zone _____ state _____

Check one:
 3 years for \$12 2 years for \$9
 1 year for \$5

In the U. S., its possessions, and Canada
 Payment enclosed Bill me

Foreign rates: Pan American Union countries, add .50 per year; all other foreign countries, add \$1.00 per year.

Mail to: **ELECTRONICS WORLD**
 Dept. EW 116, 434 S. Wabash Ave., Chicago 5, Ill.

"TAB" Tubes Tested, Inspected, Boxed
Six Months Guarantee! No Rejects!
NEW & Used Gov't & Mfrs. Surplus!

Orders \$10 or more. Receiving type only ppa. 48 states

0A2	.80	8B16	.69	12A7	.59	12B8	1.00
0B2	.65	8BK7	.99	12AT7	.83	12Z6	1.10
0C3	.69	8BL7	1.25	12AU6	.69	4-6SA	16.00
0D3	.35	8BN6	.08	12AU7	.69	2021	2/51
0Z4	.35	8C07	1.19	12AX7	.73	2023	3/51
1A7	.89	8E27	1.25	12BA6	.65	717A	5/81
1B3	.78	8C4	.43	12BA7	.90	4-125	19.00
1R5	.78	8C5	.69	12B6	.59	12-250	35.00
1S4	.78	8CB6	.80	12BE6	.59	4E27	7.00
1Y4	.78	8CD6	1.49	12BF6	.59	4PR60	20.50

Send \$6 for Catalog

1U4	3/81	8M6	3/81	12BH7	.99	4X150G	\$15
1U5	.73	8J5	.48	12BY7	.98	4X250	\$35
1X2A	.68	8J6	.48	12E27	.99	4X300	\$38
3Q4	.68	8M6	.59	12CUG	1.45	5BP1	4.98
3Q5	.80	8K7	1.25	12SA7	.94	5BP4	4.98
3S4	.68	8L6	1.19	12SQ7	.89	35T	4.00
3V4	.83	8S4	.59	12SM7	.89	100T	7.00
5R4	.98	8S6	.99	12SJ7	.75	318A	5/81
5U4	.59	8SA7	.69	12SK7	.94	388A	3/81
5V4	.89	8SB7	1.19	12SQ7	.84	4188	16.00

Wanted Surplus Electronics from schools & U

5Y3	.59	6SC7	.89	198G6	2.15	450T	42.00
6A4	.89	6AQ7	.79	97B	1.19	807	1.00
6AC7	.70	6SM7	.69	258Q6	1.39	809	3.00
6AG7	.89	6SJ7	.69	25L6	.69	811	4.40
6AH6	.99	6BK7	.79	25M6	.79	812	4.00
6AK5	.69	6SL7	.89	25Z5	.63	813	0.00
6AL3	2/81	6SN7	2/81	25Z6	.75	814	3.45
6AS5	.69	6T7	.84	25Y6	3.49	815	2.75
6AS7	3.00	6SR7	.79	EL37	2.49	826	.59
6AT6	.49	6T8	.08	35L6	.69	829B	8.00

Wanted 5017L tubes Top \$ & Paid

6AU4	1.10	6U8	.98	35W4	.49	822A	7.00
6AU5	1.10	6U8T	.98	35Z5	.63	1625	5/81
6AU6	.69	6W4	.79	35Z5	.63	1625	5/81
6AX4	.70	6W6	.89	50A5	.89	1446	4.00
6EA6	.59	6A4	2/81	50B5	.89	179	.08
6EA7	1.00	6X5	.49	50C5	.69	5851	2.70
6BD6	.89	6Y6	.67	50L6	.69	6550	3.00
6ES5	.69	6W7	.84	50P6	3.29	5654	1.00
6BG6	1.50	12AL5	.59	75	.89	5994	12.00
6BH6	.72	12AQ5	.75	80	.59	7193	10.81

TUBES WANTED! WE BUY! SELL & TRADE!

"SUNTAB" BATTERY-SELENIUM PHOTOCELL

5AP—Round 1 1/2" Dia. \$1.00
 10AP—ROUND 1 1/2" Dia. \$1.00
 15AP—ROUND 1 1/2" Dia. 1.75
 20AP—ROUND 1 1/2" Dia. 3.00
 25AP—RECT. 3/4 x 7/16 .70
 30AP—RECT. 3/4 x 7/16 .70
 35AP—RECT. 3/4 x 7/16 .70
 40AP—RECT. 1-11/16 x 7/8 .70
 45AP—RECT. 1-11/16 x 7/8 .70

Kit ALL SIX ONE EACH
 ORDER QTY'S. TEN OR MORE DEDUCT 20%
 This Item Shipped Postpaid Orders \$5 Up

"TAB" KITS! "TAB" THE BEST KITS! "TAB"

All Kits Contain Most Popular Values & Sizes

- Kit 2 Eng. Parallel Rules
- Kit 38 Precision Resistors
- Kit 10 Switches
- Kit 75 Resistors 1/2 1/2W
- Kit 150 Carbon Resistors
- Kit 25 Panel Lamps
- Kit 12 Electrolytic Cond's
- Kit 56 Tube Sockets
- Kit 65 Tubular Cond's
- Kit 500 Lugs & Eyelets
- Kit 10 Bathing Oil Cond's
- Kit 5 lbs. Surprise Pckg.
- Kit 10 Xmitr. Mica Cond's
- Kit 3 Phone Patch Xfms
- Kit 2 Searchlights
- Kit Circular Slide Rule
- Kit 12 Algr. Clip Ass'd.
- Kit 5 Sub-Min Tubes
- Kit 40 Random Insulators
- Kit 35 Power Resistors
- Kit 75 Mica Condensers
- Kit 5 Crystal Diodes
- Kit 100 Fuses, Assorted
- Kit 100 Ceramic Cond's
- Kit 10 Germanium Diodes
- Kit 5 FT243 Xtal Holders
- Kit 5 Silicon Diodes
- Kit 10 50 Ft. Heating Wire
- Kit 4 Asstd Rectifiers
- Kit 2 PNP Transistors
- Kit 2 50 Ft. Heating Wire
- Kit 2 Veeder Counters
- Kit—Computer Toroids
- Kit High Gain XTL Mite

BUY 10 KITS—GET ONE FREE EACH KIT 99¢

NEW POWER CONVERTER
 12VDC to 200VDC 100 Watts; Tap at 250VDC Type C1250E \$35. Hi efficiency, low ripple, low idle current—silicon rectifiers; Toroidal filter; magnetic tape wound transformer, fused & short circuit proof, small in size! Great light weight! C1250E built, ready to go. Conservatively Rated. Delco Transistors Heavy Copper-Heat Sink. 12VDC to 250VDC up to 150MA Type C1225A \$30.



NEW SILICON 750MA* DIODES TOP HATS

GENERAL PURPOSE 400 PIV at 250 MA
 SPECIAL 39c 25 FOR \$8

rms/piv	rms/piv	rms/piv	rms/piv
35/50	70/100	140/200	210/300
19c	29c	34c	39c
rms/piv	rms/piv	rms/piv	rms/piv
280/400	350/500	420/600	490/700
50c	89c	89c	99c
rms/piv	rms/piv	rms/piv	rms/piv
580/800	630/900	700/1000	770/1100
\$1.05	\$1.25	\$1.30	\$2.00

*CAPACITOR INPUT DERATE 20%
 (\$3 or more we pay postage 48 states).

NEW Selenium Radio & TV Rectifiers! GTD.

55MA 45c, @ 10/58; 100MA 45c, @ 12/58; 200MA 85c, @ 10/58; 300MA 85c, @ 10/58; 500MA \$1, @ 10/58, 25/58

Orders this item \$10 or more. Postpaid 48 States!
 SNOOPERSCOPE TUBE 2" \$5 @ . 2 for \$9
 AN-AREZ RCVR GOOD COND. tube. \$1.39
 HVY DTY 115V/60 CY SEL.SYNS TWO for \$9

NEW "TEKSEL" SELENIUM RECTIFIERS

FULL WAVE BRIDGE RECTIFIERS, ONE YEAR GTD!

AMP.	18VAC	36VAC	72VAC	144VAC
CONT.	14VDC	28VDC	56VDC	112VDC
1AMP	\$ 1.30	\$ 2.00	\$ 4.90	\$ 6.30
2AMP	2.15	3.00	6.30	12.30
3AMP	2.90	4.00	8.60	16.75
6AMP	4.15	6.00	16.75	36.15
10AMP	6.10	12.15	30.30	65.90

Write for Complete Rectifier Catalog

TRANSISTORS & ACCESSORIES

2N441	\$3	2N442	\$4.50	2N277	\$4	2N278	\$5	
2N155	\$1.39	2N176	\$1.80	2N177	\$1	2N178	\$1.75	
2N274	\$1.50	2N255	\$1.20	2N270	\$3.95	2N274	\$1.25	
2N274	\$1.25	2N244	\$2.99	2N274	\$2.99	2N274	\$1.80	
2N278	\$2.20	2N581	\$1.25	2N582	\$2.10	2N174	\$8.50	
2N443	\$6.50							

DIAMOND BASE MICA MOUNTING KIT. \$.30
 DELCO ROUND BASE MICA MOUNTING KIT. \$.30
 DELCO POWER HEAT SINK WITH FINS. \$.75

"TAB"

TERMS: Money Back Guarantee!
 Our 15th year. \$2 min. order
 F.O.B. N.Y.C. Add ship charges
 or for C.O.D. 25% Dep. Prices
 shown subject to change.

111-WP LIBERTY ST., N. Y. G. N. Y.
 Send 25¢ for Catalog
 PHONE: RECTOR 2-6245

New Tube Tester Data

Owners of RCA hole-card automatic testers: here are hole locations to be punched for new tubes.

RCA AUTOMATIC TESTER, WT-110A

TUBE TYPE	HOLE LOCATIONS TO BE PUNCHED	NOTES
1AD5	A5, B4, D2, E8, G7, J6, K7, K8, L1, M2, M6, N1, N6	Use WG-339A adapter.
1AN5/DF97	A7, B1, B4, B5, D6, E3, G2, J2, K3, K4, L1, M5, M6, N3, N6	
1E5G1	A2, B7, D10, E4, G3, J10, K9, L1, M3, M6, N2, N6	
1F7 Diode	A2, B7, F4, G5, K5, L4, M3, M6, N2, N6	Test P1 and P2. Reject if below 2.
1F7 Pentode	A2, B7, D10, E6, G3, J9, K5, L1, M3, M6, N2, N6	
1J6	A2, B7, D4, D5, F3, G6, J2, K2, L1, M3, M6, N2, N6	Test P1 and P2. Reject if below 3.
1R4/1294	A1, B8, C7, G4, K10, L3, M5, M6, N3, N6	
1U6	A7, B1, B6, D4, E5, G2, G3, J6, K8, L1, M5, M6, N3, N6	
3BY7	A4, B5, C1, C3, C9, D2, E8, G7, I6, I7, J1, K6, L1, L6, L7, M2, M6, N4, N6	
3C4/DL96	A1, B7, D6, E3, G2, J9, K3, K4, L1, L6, L7, M4, M6, N2, N6	
3EJ7	A4, B5, C1, C6, C9, D2, E8, G7, I6, I10, J2, K4, L1, L6, L8, M4, M6, N2, N6	
3E1H7	A4, B5, C1, C6, C9, D2, E8, G7, I6, I10, J4, K4, L1, L6, L8, M4, M6, N2, N6	For gas test, see instructions.
4E1H7	A4, B5, C1, C6, C9, D2, E8, G7, I6, I10, J4, K4, L1, L6, L8, M1, M6, N4, N6	For gas test, see instructions.
4EJ7	A4, B5, C1, C6, C9, D2, E8, G7, I6, I10, J2, K4, L1, L6, L8, M1, M6, N4, N6	
6AF6	A2, B7, C8, E5, G3, G4, L1, M5, M10, N2, N9	P1—Eyes closed. P2-P3, Eyes open; no meter reading.
6AG6/EL33	A2, B7, C8, D5, E4, G3, I6, I10, J4, K1, L1, L6, L7, M4, M10, N2, N9	
6AM5/EL91	A3, B4, C2, D1, E7, G5, I6, I10, J7, K2, L1, M5, M10, N2, N9	
6BE7/EQ80	A4, B5, C3, C8, C9, D2, D7, E1, G6, J2, K9, L1, M5, M10, N2, N9	
6HL8/ECF80 Triode	A4, B5, C8, D9, G1, I6, I10, J4, K5, L1, L6, L7, M5, M10, N2, N9	
6HL8/ECF80 Pentode	A4, B5, C7, D2, E3, G6, I6, I10, J2, K4, L1, L6, L7, M5, M10, N2, N9	
6BX6/EF80	A4, B5, C1, C3, C6, C9, D2, E8, G7, I6, I10, J2, K2, L1, L6, L7, M5, M10, N2, N9	For gas test, see instructions.
6CF8/EF86/6267	A4, B5, C3, C8, D9, E1, G6, I6, I10, J3, K5, L1, M5, M10, N2, N9	
6C116/EL822	A4, B5, C3, C9, D2, E8, G7, I6, I10, J4, K6, L1, L6, L8, M3, M10, N1, N9	
6CJ6/EL81	A4, B5, C3, C9, D2, E8, G10, I6, I10, J10, K2, L1, L6, L7, M3, M10, N1, N9	
6CK5/EL41	A1, B8, C3, C7, D6, E5, G2, I6, I10, J6, K8, L1, L6, L8, M3, M10, N1, N9	Use special adapter.
6CK6/EL83	A4, B5, B8, C3, C6, D2, E1, G7, I6, I10, J2, K6, L1, L6, L8, M3, M10, N1, N9	
6CQ6/EF92	A3, B4, C2, C6, D1, E7, G5, I6, I10, J3, K4, L1, M5, M10, N2, N9	
6CT7/EAF42 Diode	A1, B8, C7, G3, K9, L3, M5, M10, N2, N9	Use special adapter. Reject if below 3.
6CT7/EAF42 Pentode	A1, B8, C7, D6, E5, G2, I6, I10, J3, K3, L1, M5, M10, N2, N9	Use special adapter.
6CV7/EBC41 Diode	A1, B8, C7, F6, G5, K2, K3, L4, M5, M10, N2, N9	Use special adapter. Test P1 and P2. Reject if below 4.
6CV7/EBC41 Triode	A1, B8, C7, D3, G2, J2, K8, L1, M5, M10, N2, N9	Use special adapter. For gas test, see instructions.
6CW7/ECC84	A4, B5, C1, C7, C8, D2, D6, F3, G9, I6, I10, J3, K2, L1, L6, L7, M5, M10, N2, N9	Test P1 and P2.
6DZ7	A2, B7, C8, D1, D5, E4, F3, G6, I6, I10, J5, K1, L1, L6, L7, M3, M10, N1, N9	Test P1 and P2.
6EB5	A3, B4, C1, C5, C6, F2, G7, I6, I10, K6, K7, L3, M5, M10, N2, N9	Test P1 and P2. Reject if below 4.
6N8/EBF80 Diode	A4, B5, C3, F7, G8, I6, I10, K1, L4, M5, M10, N2, N9	Test P1 and P2. Reject if below 3.
6N8/EBF80 Pentode	A4, B5, B9, C3, D2, E1, G6, I6, I10, J6, K3, K4, L1, M5, M10, N2, N9	
6P5	A2, B7, C8, D5, G3, I6, I10, J6, K6, L1, M5, M10, N2, N9	
6R3/EY81	A4, B5, C10, G2, G9, I6, I10, K6, L4, L6, L10, M3, M10, N1, N9	Reject if below 4.
6U3/EY80	A4, B5, C3, G9, I6, I10, K4, K5, L4, L6, L10, M3, M10, N1, N9	Reject if below 4.
6V4/EZ80	A4, B5, C3, F7, G1, I6, I10, K5, L4, L6, L9, M5, M10, N2, N9	Test P1 and P2. Reject if below 4.
6X2/EY51	A1, B7, G10, K1, L5, M5, M10, N2, N9	Reject if below 3. Use WG-338A adapter. Connect base leads to Pins 1 and 7. Connect top lead to "plate" connector.

CROSSWORD PUZZLE

—Electronics & Other Things

By MARGARET LE FEVRE

(Answer on page 140)

ACROSS

2. A stream of _____ forms our TV picture.
12. To complete the circuit we turn the switch _____.
14. The negative electrode.
15. The picture tube is a _____ tube (abbr.).
16. New (combining form).
18. Tensile strength (abbr.).
19. Ourselves.
20. "Dead on Arrival" (abbr.).
21. Unit of electromotive force.
22. Ceramics are baked here.
23. Aim or purpose.
24. Symbol for tantalum.
26. Most snap-action switches are _____ d.t. (abbr.).
28. Current flow is usually from neg. to _____.
29. Two-thirds of c.w. signal report.
30. Unit of electrical resistance.
31. Most power transformers have a center _____.
33. 2N247 and 2N274 are both _____ amplifiers.
34. Kits usually give _____ by _____ instructions.
35. Formal verse.
37. To activate.
39. French painter.
41. Old-time auto.
42. Land measure.
43. Doer (suffix).
44. Manufacturers' trade association (abbr.).
45. To grate or scrape.
47. To strike with force.
48. Electromagnetic radiation of very short wavelength.
49. Most people repair TV's for filthy _____.
51. Some speakers are covered with a fine _____ fabric to keep out dust.
54. Many millions of radio parts and kits are bought and sold by _____.

DOWN

55. While.
56. The portion we hear.
57. Reactance meter (abbr.).
1. A device for increasing the tuning range of a receiver.
3. Product determining frequency (abbr.).
4. Do you _____ to live or live to _____?
5. Cents (abbr.).
6. Symbol for thorium.
7. A line.
8. Lyric poem.
9. Simple saw-tooth tube (abbr.).
11. To change from higher to lower voltage or vice versa.
13. Bulbs using the glow discharge principle.
15. "Bring-it-alive" feature in new TV sets.
17. Aged.
20. We tune the circuit to resonance by looking for the _____.
24. Eighth Greek letter.
26. _____ gives 3D effect to sound programs.
27. Tubular _____ capacitors.
30. Output-transformer input (abbr.).
32. Tube connection.
34. Washes vigorously.
36. One- or two-bay _____ antennas are popular for v.h.f. TV.
38. Biblical king.
40. Medical.
46. Scrooge said, "Humbug."
47. Leakage of a.c. into d.c. circuits can cause _____.
50. A tree.
51. Mother.
52. _____ is an amplification factor.
53. Short for "fidelity."

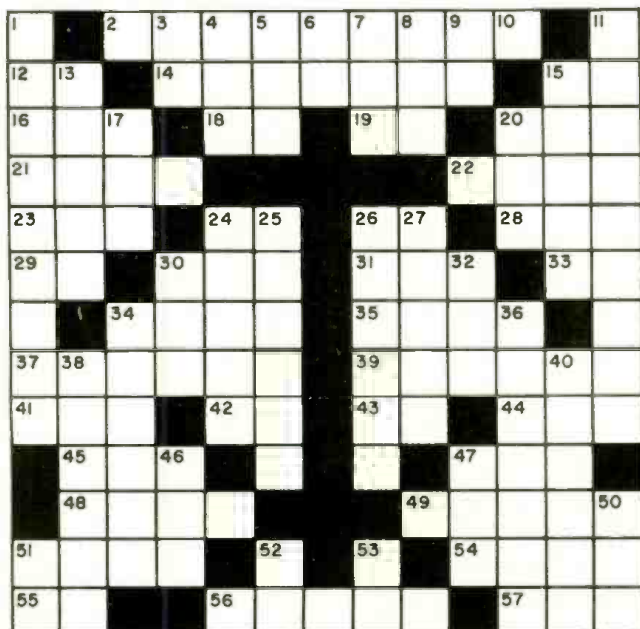

from **EICO**
... a completely new
CITIZENS BAND TRANSCEIVER

that meets FCC regulations*

Model 760: 117 VAC
Kit \$59.95 Wired \$89.95

Model 761: 117 VAC & 6 VDC { Kit \$69.95
Model 762: 117 VAC & 12 VDC { Wired \$99.95
Incl. mtg. bracket (Pat. Pend.)

*EICO premounts, prewires, pretunes, and seals the ENTIRE transmitter oscillator circuit to conform with FCC regulations (Section 19.71 subdivision d). EICO thus gives you the transceiver in kit form that you can build and put on the air without the supervision of a Commercial Radio-Telephone Licensee!

Highly sensitive, selective SUPERHET (not regenerative) receiver with 5½ dual function tubes and RF stage. Continuous tuning over all 23 bands. Exclusive Super-Hush® noise limiter. AVC 3" x 5" PM speaker. Detachable ceramic mike. 5-Watt crystal-controlled transmitter. Variable "pi" network matches most popular antennas. 12-position Posi-Lock® mounting bracket. 7 tubes and 1 crystal (extra xtals \$3.95 each). Covers up to 20 miles. License available to any citizen over 18—no exams or special skills required, application form supplied free. Antennas optional.

TOPS IN DESIGN . . . QUALITY

All-Transistor Portable RA-6
Kit \$29.95 Wired \$49.95
High sensitivity & selectivity. New type plug-in transistors. 4" x 6" speaker; push-pull audio. Prealigned RF & IF transformers. Less battery. Incl. FET.

High-Level Univ. Mod.-Driver #730
Kit \$49.95 Wired \$79.95
Delivers 50W undistorted audio. Modulates transmitters having RF inputs up to 100W. Unique over-modulation indicator. Cover E-5 \$4.50.

New! 60-Watt CW Transmitter #723
Kit \$49.95 Wired \$79.95
Ideal for novice or advanced ham needing low-power, stand-by rig. 60W CW, 50W external plate modulation. 80 through 10 meters.

Grid Dip Meter #710
Kit \$29.95 Wired \$49.95
Includes complete set of coils for full band coverage. Continuous coverage 400 kc to 250 mc. 500 ua meter.

90-Watt CW Transmitter* #720
Kit \$79.95 Wired \$119.95
"Top quality"—ELECTRONIC KITS GUIDE. Ideal for veteran or novice. 90W CW, 65W external plate modulation. 80 through 10 meters.
*U.S. Pat. No. D-184,776

Compare — judge for yourself! — at your neighborhood EICO distributor. For FREE catalog on over 70 models of easy-to-build professional test instruments, hi-fi and ham gear, fill out coupon on Page 33

Most EICO distributors offer budget terms.

3300 N. Blvd., L.I.C. 1, N. Y.
Add 5% in the West

PERFORMANCE THAT SPEAKS FOR ITSELF



Precision Crafted

CITIZENS BAND RADIOS

5 watts input, low current drain (3.2 amps at 12 volts standby), automatic noise limiter, squelch, built-in transistor power supply. Compact, easily movable.

CBD-1: Single channel, 12 volt DC or 115 AC complete with crystal, microphone, both power supply cables, universal mounting bracket \$159.50

CBD-5: Five channel set, 12 volt DC or 115 AC complete with crystals for one channel, microphone, both power supply cables, universal mounting bracket \$170.00

CBD-5: Same as above but 6 volt only \$170.00

DEALER INQUIRIES INVITED. Dealer efforts backed by strong national advertising campaign. Write today for details.

For free brochure write to:

PEARCE-SIMPSON, INC.

A Leader in Creative Electronics

Dept. E, 2295 N.W. 14th St., Miami 35, Fla.

GET INTO ELECTRONICS

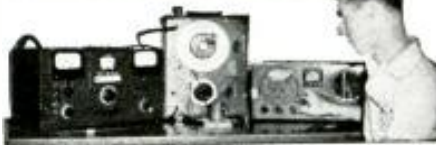

V.T.I. training leads to success as technicians, field engineers, specialists in communications, guided missiles, computers, radar and automation. Basic and advanced courses in theory and laboratory. Associate degree in electronics in 20 months. U.S. in electronic engineering obtainable. ECPD accredited. G.I. approved. Graduates in all branches of electronics with major companies. Start February, September. Dorms, campus. High school graduate or equivalent. Catalog.

VALPARAISO TECHNICAL INSTITUTE
Dept. RD Valparaiso, Indiana

Mac's Service Shop

(Continued from page 62)

section on this weakened base would be simply to invite the whole thing to come down again with the next brisk wind. They pointed out the TV antenna installer was caught between the insurance company, who wanted as inexpensive a replacement job as possible, and the customer, who was determined to get everything coming to him for all those insurance premiums he had paid. The installer's lot is not a happy one!"

"What do the insurance companies do about the installers who try to hook them?" Barney wanted to know.

"I asked that, and the insurance adjuster said that when it was evident a TV man was consistently padding his bills, they scrutinized every estimate or bill he turned in very carefully; and when they were asked to suggest someone to do TV work, that man's name would never be mentioned. The sharp operator might think he was doing all right sliding his bloated estimates through during the press of a disaster in which everyone is trying to get repairs made as quickly as possible; but when things returned to normal—and most of a man's living is made under normal conditions—he would discover he had killed the goose laying the golden eggs.

"Here, the parts distributor mentioned some of his problems that rode in on the storm. Normal demand for antennas, pipe, tower, lead-in, rotators, and guy wire suddenly shot up many times. He could do nothing Sunday, when factories and warehouses were closed, except to try to estimate his needs; but Monday morning bright and early he got on the telephone and called all his suppliers and urged them to put large quantities of the needed items on trains, trucks, and busses with all possible speed.

"Apportioning this material when it started to trickle in brought some nasty headaches. First, technicians from adjoining areas, not normally customers of the distributors, tried to come in and buy up items they could not get from their own distributors. The only thing he could do was to turn them down, explaining that he had to take care of his own customers first. Then some of his own customers, afraid it might be a long time before sufficient supplies could be brought in, wanted to buy up and hoard the things they thought they might need. He talked the fellows out of this by appealing to their sense of fair play and by assuring them the material would be on hand when they needed it if they waited until they needed it. Finally he said his credit policy had to be greatly relaxed in the emergency. Customers who usually bought \$500 worth of parts in a month needed \$5000 worth, and they did not have the cash, nor would they have the cash until the insurance checks started coming through. By easing up on credit, he secured the business of these fellows and cemented friendship with them—



ELECTRONICS WORLD HAS

A BUYER FOR YOUR USED EQUIPMENT OR COMPONENTS!

The 245,000 purchasers of ELECTRONICS WORLD are always in the market for good used equipment or components. So if you have something to sell, let EW readers know about it through our classified columns. It costs very little: just 60¢ a word, including name and address. Minimum message: 10 words.

For
further
information
write:

Martin Lincoln
ELECTRONICS WORLD
One Park Avenue
New York 16, N. Y.

TRANSISTORS



explained in 32 pages of terse copy and modern illustration. Invaluable to Service and Installation Technicians and Students. Available at \$1.25 a copy, 10 copies or more \$1.00 each. Special rates to schools.

saedi unlimited

628 SOUTH FEDERAL STREET
CHICAGO 5, ILLINOIS



OUT OF SPACE?

You bet we'd be... if we were to tell you all about AUDION'S 'Out of this World Hi-Fi Values'

Write for
free
Catalog

audion

25-W Oxford Road
Massapequa, New York

MAIL ORDER HI-FI

You can now purchase all your Hi-Fi from one reliable source and be assured of perfect delivery. Carston makes delivery from NY stock on most Hi-Fi, Recorders and Tape within 24 hours. SEND US A LIST OF YOUR HI-FI REQUIREMENTS FOR OUR WHOLESALE QUOTATION and our FREE wholesale catalogue.

CARSTON STUDIOS

125-TD East 88 St. New York 28, N.Y.

PACKAGE HI FI or SINGLE COMPONENTS

You'll find our prices low and service fast.

Write for our quotation.

CENTER INDUSTRIAL ELECTRONICS, Inc.
74-L Cortlandt Street, New York 7, N. Y.

TAPE RECORDERS



**HI-FI COMPONENTS
SLEEP LEARN KITS**

MERITAPE UNUSUAL VALUES
Low cost, high quality recording tape, in boxes or cans. FREE 1961 Catalog
DRESSNER, 69-02 RA, 174 St., Flushing 65, N.Y.

hey, are you listening?" Mac broke off sharply.

"Sure, I'm listening," Barney said indignantly as his blue eyes opened wide. "I was closing my eyes so I could concentrate on what you were saying. Want me to prove it? Listen to this:

"When wind or ice takes down a large number of antennas in a service technician's area, he must be prepared to handle a large number of estimates in a minimum of time. In dealing with customers, the idea is to take care of each case rapidly without seeming to be in a hurry. Concentrating on a few good basic installations carefully selected to cover the majority of cases is the best way to do this. It's perfectly legitimate to try and talk the customer into putting up a better installation than he lost if you make it clear he will have to pay the difference. Padding the damage estimate to cover this is out. Besides being plain crooked, that's a dandy way to get a bad name with the insurance companies; and they are in a position to steer a lot of business toward you, or away from you, when they wish. The technician who normally spreads his business very thinly among several distributors will find himself out in the cold as they take care of their good customers first. On the other hand, a distributor to whom you have been loyal will take care of you by seeing to it you get your share of scarce items and by being generous with credit until you can collect for the insurance jobs. How's that?"

"Darned good, and I apologize," Mac

said. "You were not only listening; you were thinking. And I was thinking that no one in his right mind would wish for a storm such as that one to hit his community; but truly it's an ill wind that blows no one good. Many TV viewers are seeing a better picture today because the storm forced them to replace their rusty, corroded, weather-worn antennas with improved new types. Distributors and TV men got a lot of extra, lucrative business out of the big wind. In the long run, even the insurance companies will profit. After seeing what the storm did to TV antennas, people are going to be buying a lot of riders on old policies, or new policies, that cover those antennas. But we've had enough wind for today; let's do a little work!" [30]



HOW TO GET YOUR "TICKET" in a jiffy!

Cash in on radio where the pay is best!



A practical study guide for **FCC LICENSE EXAMS**

Get one of radio's best paying jobs—as a commercial operator aboard ship, in aviation, in broadcasting or telecasting and the many other places where an FCC license is a "must"!

LICENSE MANUAL FOR RADIO OPERATORS by J. R. Johnson is a quick, low cost guide to help you breeze through FCC exams. Written so you can easily understand and remember it.

Covers ALL EIGHT exam elements—not just some of them. Reviews almost 2200 typical questions. Includes the changes in exam elements 1 and 2. Covers all data from electrical and radio fundamentals, to navigation and related subjects. Price only \$6.75.

JOB OPPORTUNITY NEWS! Under a new ruling, only holders of 1st or 2nd class radio-phone licenses can do any work that affects the broadcasting of a transmitter. This is just one of many good job opportunities open to license holders!

10-DAY FREE EXAMINATION
Dept. RN-110, Technical Division,
HOLT, RINEHART & WINSTON, Inc.
383 Madison Ave., New York 17, N. Y.

Send **LICENSE MANUAL FOR RADIO OPERATORS** for free examination. In 10 days I will either send \$6.75 (plus postage) in full payment or return book and owe nothing.
(Save! Send \$6.75 with order and we pay postage. Same 10-day return privilege.)

Name.....
Address.....
City, Zone, State.....
OUTSIDE U.S.A.—\$7.25 cash with order.

TRU-VAC 1-YEAR GUARANTEED RADIO and TV TUBES

Factory Used or Factory Second Tubes! TRU-VAC will replace FREE any tube that becomes defective in use within 1 year from date of purchase!

ALL TUBES INDIVIDUALLY BOXED! CODE DATED & BRANDED "TRU-VAC"

Partial Listing Only . . . Thousands More Tubes in Stock!

SPECIAL! 6SN7GT 30¢ 6W4GT 30¢

OY4	3CB6	6AG	6AX4CT	6CA8	6M6	6T8	7E6	12A27	12L6	25Z6GT
OZ4	3Q4	6AB4	6AX3CT	6CB6	6J4	6U5	7E7	12B4	12Q7	2T2
1A7CT	354	6AC7	6BB	6CD6G	6J5	6U8	7F7	12BA6	12R5	35A5
1B3CT	3V4	6AF6	6BA6	6CF6	6J6	6V6GT	7F8	12BA7	12S7	35B5
1M5CT	4BQ7A	6AC3	6BC3	6CC7	6J7	6W6GT	7C7	12BD6	12SJ7	35C5
1L4	4B5B	6AM4GT	6BC8	6CC8	6K6GT	6X4	7M7	12BE6	12SK7	35W4
1L6	4B27	6AM6	6BD6	6CM8	6K7	6X3GT	7N7	12BF6	12SN7CT	35Z5
1N5CT	4CB6	6AN5	6BE6	6CL6	6M7	6X2	7Q7	12BH7	12SQ7	36
1R5	5AM8	6AL5	6BF5	6CM6	6Q7	6Y6G	7S7	12BQ6	12V6GT	38
1S5	5AN8	6AM8	6BG6G	6CM7	6S4	7A4 /XXL	7X6	12BR7	12W6GT	39/44
1T4	5AT8	6AN8	6BH6	6CN7	6S7	7A5	7X7	12BT7	12X4	41
1U4	5AV8	6AQ5	6BJ6	6CQ8	6S8GT	7A6	7Y4	12CA5	14A7 /12B7	42
1U5	5AZ4	6AQ6	6BK5	6CR6	6SA7	7A7	7Z4	12CN5	14B6	43
1V2	5BR8	6AQ7	6BK7	6CS6	6SD7GT	7A8	12A8	12D4	14C7	50A5
1X2	5CC8	6AR5	6BL7GT	6CS7	6SF5	7B4	12AB5	12F5	19AU4CT	50B5
2AF4	5J6	6AS5	6BN6	6CUS	6SF7	7B5	12AQ5	12F8	19BC6G	50C5
2BN4	5R4	6AT6	6BQ6GT	6CU6	6SG7	7B6	12AT6	12K5	1946	50L6
2CY5	5T8	6AU6	6BQ7	6D6	6SM7	7B7	12A77	12K7	1978	56
3A5	5U4	6AU4GT	6BR8	6DE6	6S7	7B8	12AUG	24A	80	84/624
3A15	5UR	6AU5GT	6BS8	6DD6GT	6SK7	7C4	12AU7			117Z3
3AU6	5V4C	6AU5	6SY6C	6DF6	6SL7	7C5	12AV6			
3BC5	5V6GT	6AV3GT	6BZ6	6E5	6SQ7	7C6	12AV7			
3BN6	5X8	6AV6	6BZ7	6F5	6SR7	7C7	12AX4GT			
3BZ6	5Y3	6AW8	6C4	6F6	6TA	7E5	12AX7			

Any Tube Not Listed Also Available at 35¢ Each!
BRAND NEW 1-YEAR GUARANTEED TV PICTURE TUBES

Below Listed prices do not include dud Add Additional \$3.00 Deposit on tube sizes to 20"; on 21" and 24" tubes—\$7.50. Deposit refunded immediately when dud is returned prepaid. Aluminized tubes—\$4.00 extra.
Picture tubes shipped only to continental USA and Canada—All tubes F.O.B., Harrison, N.J.

10BP4	7-90	16KP4	11-90	17HP4	16-90	20HP4	17-90	21AWP4	17-49	21XP4	17-49
12FP4	10-40	18KP4	12-10	17IP4	16-90	21AP4	21-40	21BP4	17-38	21YP4	16-38
14CP4	11-90	17QP4	11-90	17QP4	13-90	21P4	16-38	21R4	17-38	21ZP4	17-49
18AP4	16-90	21VP4	15-49	17IP4	16-90	21AP4	16-79	21K4	16-38	24AP4	39-49
18CP4	15-10	22P4	15-49	18AP4	16-90	21AP4	15-90	21P4	22-38	24P4	27-49
18GP4	16-90	17CP4	16-90	20CP4	13-90	21AD4	16-78	21P4	16-38	24P4	26-79
19AP4	17-10	17DP4	17-90	20BP4	15-90	21AV4	16-78	21P4	16-38	24P4	26-79

ATTENTION QUANTITY USERS! Big Discounts Are Yours . . . Call or Write For Our 1000 Tube "Private Label" Special Attention Branding Dept. MGR.

Money cheerfully refunded Within Five (5) Days, if Not Completely Satisfied!

TRU-VAC (R) PAYS YOUR POSTAGE—On orders of \$5 or more in USA and Territories. Send approximate postage on Canadian and foreign orders. Any order less than \$5 requires 25¢ handling charge. Send 25¢ on C.O.D.'s. All orders subject to prior sale. Complying with Federal regulations, the following statement appears in all TRU-Vac advertising. Tubes appearing in this ad may be FACTORY SECONDS or USED tubes and are clearly marked.

Sensational Offer!
"Self Service"
TUBE CHECKERS
\$37.95 FOB Our Warehouse

Let your customers test their own tubes! Test their own conditioned 22-socket tube checkers will return tube investment in one week or less with little or no effort on your part! Handsome, field-tested console models COMPLETE WITH KEY FOR BOTTOM DOOR AND NEON-LIGHTED HEAD!

LOOK! 1,000 USED TV'S
Costly, famous make console models with little or no tube replacement! Perfect for resale, or as your own second set! 16", 17" and 18" screens . . . none smaller! Sets shipped FOB, Harrison, N.J.

\$16.95 As Is

TRU-VAC
Harrison Avenue • Box 107 • Harrison, N. J. HUmboldt 4-9770

FREE!

\$50⁰⁰ WORTH OF RADIO-TV PARTS
 Add 25¢ for Handling (over 150 pcs.)

PLUS \$1 POLY PAK[®] OF YOUR CHOICE LISTED BELOW

BOTH FREE with Every \$10.00 Order
 Sale ends December 25, 1960

- 10 INSTRUMENT KNOBS
 Pointer types, black \$1
 Brass inl. "notch" ws.
- 8-PC. NUTDRIVER SET
 Plastic handle, 3/16 thru 7/16 nutdrivers \$1
 In hand case. Worth \$3.
- 35 POWER RESISTORS
 Asst. 5 to 50W to 10,000 ohms. Vitrous \$1
 types. 100. Worth \$12.
- 70 MICA CONDENSERS
 Incl: silver top, 0.0025 to .01 to 500V. \$1
 Worth \$20.
- 10 ELECTROLYTICS
 Incl: can & paper types.
 Incl: 100 to 1000 uf to 450V. Worth \$12.
- 80 TUBULAR COND'N'RS
 Papers, molded, oils, ceramic. 0.001 to 1 meg. up to 500 V. Worth \$10.
- 60 RADIO 'N TV KNOBS
 Asst: colors, sizes, shapes; some worth \$1 \$1 ea.
- 1 1/2 LBS. HARDWARE
 Nuts, bolts, etc. wide variety. Handy shop \$1 asst.
- 30 MOLDED COND'N'RS
 Pop. values, black beautiful, oils, etc. Lasts for life! Worth \$8.
- \$30 RELAY SURPRISE
 Popular shop & lab. \$1 asst.
- 50-FT. 'ZIP' CORD
 For speaker extensions. At 10¢ 2-lead. par- \$1 alted. Worth \$3.
- 60 TERMINAL STRIPS
 1 to 10 the points. Used in every type of \$1 proj. Worth \$5.
- 70 COILS & CHOKES
 RF, ant. osc. slug-tuned. I.F. Wonderful shop \$1 asst. Worth \$18.
- 70 1-WATT RESISTORS
 Incl: pre-tensions, W.W., carbon film, 1 meg. to 5% top. Worth \$20.
- 65 COND'N'R SPECIAL
 Incl: discs, ceramics, molded, mica, etc. \$1 pers. oils, etc. Worth \$12.
- 15 ROTARY SWITCHES
 Asst gauges, contact for power & circuit \$1 changing. Worth \$17.
- VEEDER ROOT COUNTER
 Counts into 999. Exc. for tape recorders & \$1 coll makers. Worth \$5.
- 100 1/2-WATT RESIST'RS
 1% top. Worth \$18. \$1 1% top. Worth \$18.
- 3 AC-DC RECTIFIERS
 SILICON. 110V. 0.5 to 300 ma. half \$1 wave. Worth \$3.
- 40 TUBE SOCKETS
 4 to 12 prongs, auto ceramic & mica fitted \$1 & mintypes. Worth \$8.

\$5 ORDERS
 WE WILL GIVE YOU
\$5 worth of radio parts **FREE**

RADIO-TV PARTS by the POUND

- 1 lb. Precision Resistors. Worth \$100. NOW \$30
- 1 lb. Disc Condensers. . . . Worth \$50. NOW \$15
- 1 lb. Ceramic Condensers. Worth \$85. NOW \$25
- 1 lb. Discs & Ceramics. . . Worth \$75. NOW \$20
- 1 lb. Discs, Ceramics, Precisions \$70. NOW \$20 per lb.

BUY 4 for \$11 500-1000 pcs. per pound
COMPLETE SATISFACTION—MONEY BACK GUARANTEE

MINIMUM ORDER \$2—Avg. wt. 1 lb. per pak

HOW TO ORDER Check items. Return ad w/check or m.o., including postage. Excess returned. C.O.D. orders 25% down; rated, net 30 days. Print name, address WITH POSTAL ZONE in markin.

LEKTRON 133 Everett Ave. CHELSEA 50, MASS.

Manufacturers' Literature

NEW EICO CATALOGUE
 Its complete line of stereo and mono hi-fi equipment, test instruments, ham equipment, CB transceivers, and radios in both kit and wired form is covered in the new 28-page catalogue just issued by *Electronic Instrument Co., Inc.*, 33-00 Northern Blvd., Long Island City 1, N. Y.

The four-color catalogue contains pictures, as well as detailed descriptions, specifications, and prices of every item in the line. Copies are available from the manufacturer or at *EICO* distributors throughout the country.

CCTV BULLETIN
 The Communication Products Department of *General Electric Company*, P. O. Box 4197, Lynchburg, Va. has issued Bulletin ECL 85, covering its new transistorized closed-circuit TV camera, Type TE-9-A.

Detailed information covering the high reliability and performance capabilities of the self-contained, single-unit Vidicon camera is offered. The bulletin also explains the low installation, operating, and maintenance costs of this new model which is designed to perform under extreme vibration and noise.

BRITISH SEMICONDUCTOR GUIDE
Heywood & Company Limited, Drury House, Russell St., Drury Lane, London W.C. 2, England has issued the "British Semiconductor Guide" which lists the essential technical characteristics of 963 different semiconductor devices now available from British manufacturers.

Presented in tabular form, the information is divided into three main sections covering transistors, diodes and rectifiers, and photosensitive devices.

The new publication is priced at 5 shillings a copy (70 cents U. S. plus postage).

AMPHENOL CATALOGUE
Amphenol Cable & Wire Division, Chicago 38, Ill. has issued Catalogue W3, a 38-page booklet describing its line of radio-frequency coaxial cables and transmission lines.

Designed for insertion in 3-ring loose-leaf binders, the new catalogue is said to contain the most complete and informative data on coaxial cable of any available publication. Included are specifications as well as general reference material.

MOTOROLA PRODUCTS GUIDE
Motorola Inc., Technical Training Division, 4545 W. Augusta Blvd., Chicago 51, Ill., announces a series of four booklets intended to acquaint service technicians with operating principles, service procedures, and technical data on certain of its popular products.

Included in the series is material on

engineering degree in 27 mos.

Become an Electronics Engineer. Share rewards awaiting college men . . . higher income, rapid advancement. Important firms visit Tri-State to interview seniors. *Bachelor of Science Degree in 27 months* in Electrical (Electronics or Power major), Mechanical, Civil, Aeronautical, Chemical Engineering. In 36 months a B.S. in Business Administration (General Business, Accounting, Motor Transport Management majors). For earnest, capable students. Small classes. More professional class hours. Well-equipped labs. Dorms. Campus. Modest costs. Year-round operation. Enter Jan., Mar., July, Sept. Founded 1884. Write *J. H. McCarthy, Director of Admissions*, for Catalog and "Your Career" Book.



25 50 75 100 125 150

AUTHORIZED REPAIR STATION FOR WESTON — SIMPSON — EICO PRECISION — ILLINOIS TEST. LAB.

Simpson and Triplett Parts in Stock

INDUSTRIAL INSTRUMENT WORKS
 P.O. BOX 13393 NEW ORLEANS 25, LA.

NEVER FAIL—ZONE YOUR MAIL

The Post Office has divided 106 cities into postal delivery zones to speed mail delivery. Be sure to include zone number when writing to these cities; be sure to include your zone number in your return address—after the city, before the state.

RENT stereo tapes

- OVER 1500 DIFFERENT ALBUMS
- POSTPAID TO AND FROM YOUR HOME

SEND FOR FREE BROCHURE **stereo-parti 60**
 811-BC Centinela Ave., Inglewood 3, Calif.

LEARN TO DRAW; READ BLUEPRINTS. SCHEMATICS. WIRING DIAGRAMS; and to render any Mechanical, Electronics, Architectural & Art Drawing or Painting

SELF STUDY COURSES & Drafting Room Essentials available in simplified form. Plan 1: Send \$2.25 for any one of the above desired "individual" chapters. Plan 2: Send \$9.00 for the "Special Main Chapters" of our book entitled, "Encyclopedia of Drawing & Design" (for Home Study or School Text).

Publisher: (Author's experience: Chief Draftsman, Art Director, Engineer). **LOUIS D. PRIOR, INC.**, 23-09 169th Street, Whitestone 57, New York, N. Y.

ENGINEERING DEGREES

E.E. Option Electronics or Power Civil, Mechanical, Physics. Also in Liberal Arts

Earned through Home Study

Pacific International College of Arts & Sciences
 Primarily a Correspondence School
 Resident classes also available
 5719-R Santa Monica Blvd., Hollywood 38, Calif.

the firm's "Astronaut," a large-screen transistorized TV receiver; booklets on two record changers; and a guide to noise-free car radio installation.

Booklets are available from all of the company's consumer products distributors.

SOLDERING TOOL DATA

Vulcan Electric Co., 88 Holten Street, Danvers, Mass., has issued a new catalogue describing its line of soldering irons, soldering pencils, safety tool holders, solder pots, wax pots, glue pots, and branding irons.

Designated as Catalogue VG-250, copies are available upon direct request to the manufacturer.

PRINTED-CIRCUIT MANUAL

Sprague Products Co., 51 Marshall St., North Adams, Mass., has published an up-to-date edition of its "Printed-Circuit Replacement Manual."

Listed as Manual K-352, it contains a complete listing of ceramic-base printed electronic circuits used in radio and TV sets manufactured from January 1950 through January 1960.

Also included in this 16-page manual is a complete tabulation of the firm's entire catalogue line of 179 replacement printed circuits, showing schematic drawings, capacitance and resistance ratings, catalogue numbers, and list prices.

Copies of the manual may be obtained without charge from the company's distributors. It may also be ordered from the manufacturer, by sending 10 cents to cover handling and postage.

ZENITH SERVICING MANUAL

Zenith Sales Corp., a subsidiary of *Zenith Radio Corp.*, 6001 W. Dickens Ave., Chicago 39, Ill., announces publications of a new parts, tubes, and accessories manual.

Covering 12 years of its TV and radio receivers, record players, and phonograph combinations, the new manual includes information on items ranging from antennas and batteries to tubes, knobs, tuners, and wrenches. Over 275 pages and more than 400 illustrations and charts are included, as well as suggested retail prices and substitution data.

The manual is a loose-leaf type, bound in heavy-duty vinyl plastic. Each of its 20 sections is tabbed and indexed for quick reference. The volume is available through *Zenith* distributors exclusively, at a special introductory price.

SWITCHCRAFT CATALOGUE

Switchcraft, Inc., 5555 N. Elston Ave., Chicago 30, Ill., has issued a 4-page catalogue of molded cable assemblies for the industrial electronics field.

The new publication, Catalogue M-701, features standard assemblies of various plugs molded to different types of cables. Illustrations and dimensions are included.

CAPACITOR CATALOGUE

Efcon, Inc., Garden City, Long Island, N.Y., has issued a new catalogue describing its complete line of Mylar

We'd like to send you these important new books for a 7-day free trial examination

Class D CITIZENS RADIO

by Leo G. Sands

Here is the first complete book on Citizens Radio Operation. Ever since the initial use of 2-way radiotelephone by police departments, this field has been growing in importance and application. Now, with more than a million vehicles equipped for its use, Citizens Radio is a major phase of the electronics field. This important new volume covers every aspect of the field—its history, rules, and everything about how it works—in seven big chapters with one hundred major sections. You'll learn exactly what Citizens Radio is, its applications, what equipment you need, the full story on receiver circuits and transmitters, antennas, installation, and maintenance, full FCC rulings, how to apply for licenses, etc. Many illustrations. **\$4.95**

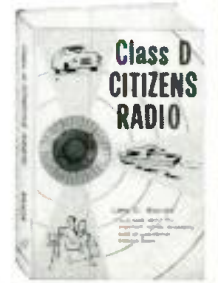

COMPUTERS AND HOW THEY WORK

by James D. Fahnestock

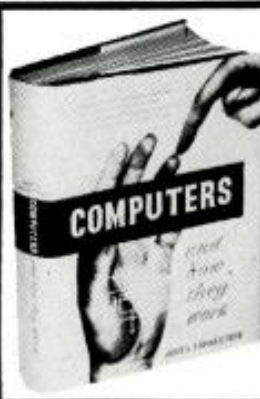

Here is a fact-filled exciting guidebook to the wonderworld of electronic computers, with more than 110 illustrations and easy-to-follow tables in 10 big chapters. Step by step, you'll see and understand the workings of many types of computing machines. This important new book illustrates the basic principles of computers in methods that require no knowledge of electronics. You'll learn all about computer memories, flip-flops and the binary counting system. You'll learn the mathematical language of computers where $1 + 1 = 10$. Other chapters show you how computers use tubes and transistors to make complex logical decisions in thousandths of a second. **COMPUTERS AND HOW THEY WORK** is must reading for career minded students and for electronics pros who want a more complete knowledge of this field. **\$4.95**

THE ELECTRONIC EXPERIMENTER'S MANUAL

by David A. Findlay

With a few dollars worth of basic tools, and this hook to guide you, you can explore the magic of electronics experimentation more completely than ever before. In a few short hours, you'll start your first project. You'll learn about every component used in experimentation, every tool, its function and why it is used. There are 8 big sections, each covering a specific phase of construction. There is a giant section of projects you can build, test equipment you'll construct and use in your future work. **THE ELECTRONIC EXPERIMENTER'S MANUAL** will give you the professional know-how you must have no matter what phase of electronics is your specialty. **\$4.95**

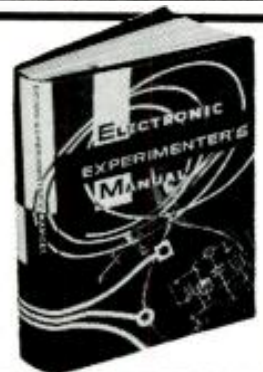

7-DAY FREE EXAMINATION

When your books arrive, read and enjoy their diversity of contents, their thoroughness of coverage. Then after seven days examination, if you decide that they are not everything you want, send them back and receive a complete refund of the purchase price.

USE THIS CERTIFICATE FOR 7-DAY FREE EXAMINATION

ELECTRONICS BOOK SERVICE
One Park Avenue, New York 16, N. Y.



Please send me _____ copies of **CITIZENS RADIO** and bill me at only \$4.95 a copy plus postage and handling.

Please send me _____ copies of **COMPUTERS AND HOW THEY WORK**, and bill me at only \$4.95 a copy plus postage and handling.

Please send me _____ copies of **THE ELECTRONIC EXPERIMENTER'S MANUAL** and bill me at only \$4.95 a copy plus postage and handling.

If I don't agree that this is one of the best electronics investments I've ever made, I may return the book(s) within seven days and get a full refund.

\$ _____ enclosed. (SAVE MONEY! Enclose payment with your order and we'll pay the postage.)

Name _____

Address _____

City _____ Zone _____ State _____

EF518

SAVE on everything in
stereo hi-fi
and
electronics

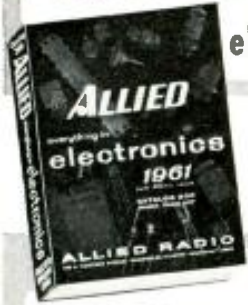

send for the 1961

ALLIED
CATALOG

free

444-PAGES • VALUE PACKED. Write today for the leading Electronics Catalog. World's largest selection, including products and values available only from ALLIED. SAVE ON:

- Everything in Hi-Fi Music Systems & Components • Biggest Selection of Hi-Fi Cabinetry
- Exclusive Knight® Super-value Stereo • Knight-Kits®—Best in Build-Your-Own Hi-Fi
- Tape Recorders and Phono Equipment • Everything in Electronic Parts, Tubes, Transistors, Test Equipment, Amateur Gear, P.A. Systems, TV Accessories, Tools, Books.

Save most at ALLIED. Write for FREE 1961 Catalog today!

ALLIED RADIO

only \$2 down
on orders
up to \$50

free
catalog

ALLIED RADIO, Dept. 101-L
100 N. Western Ave., Chicago 80, Ill.

Send FREE 1961 ALLIED Catalog.

Name _____

Address _____

City _____ Zone _____ State _____

CRYSTAL CONTROLLED CONVERTERS

- POLICE • FIRE • COMMERCIAL
- CITIZENS' BAND •



For use with
12 V. Transistor type
car radios
26-50 MC
\$24.95

Complete with crystal and tubes. Requires no high voltage supply. Operates on 12 volts DC. Can be self installed in seconds. Other models for 108-162 MC available.

A practical converter for emergency use with powered home or auto sets. Tunable over 12 MC 26-54 MC or 108-174 MC. **\$13.95**



Also available crystal controlled up to 54 MC. **\$19.95**

Full line of converters & receivers for every application.

ORDER TODAY or WRITE for LITERATURE

KUHN ELECTRONICS
20 GLENWOOD CINCINNATI 17, OHIO

ELECTRONICS

PREPARE FOR A GOOD JOB!
BROADCAST ENGINEER
RADIO SERVICING AUTOMATION

TELEVISION SERVICING
BLACK & WHITE—COLOR

APPROVED FOR VETERANS AND SURVIVORS
OF VETERANS
BUILDING AIR CONDITIONED
SEND FOR FREE LITERATURE

BALTIMORE TECHNICAL INSTITUTE
1425 EUTAW PLACE, BALTIMORE 17, MD.

miniature capacitors, Teflon high-temperature, polystyrene miniature, high-stability, Glasscon acetate high-voltage, and new miniature solid tantalum electrolytic types.

The spiral-bound volume includes engineering data, test information, application notes, drawings and rating charts, and reflects substantial changes that have been made in tolerances, sizes, and ratings.

"SILVERCEL" BATTERIES

Yardney Electric Corporation's Technical Information Services, 40-50 Leonard St., New York, N.Y., has issued a brochure describing its line of "Silvercel" batteries.

The 10-page booklet contains data and illustrations covering the physical, electrical, and typical application characteristics of these rechargeable silver-zinc batteries. The "Silvercel" line comes in two types: high-rate for complete discharge in less than an hour, and low-rate for discharge rates longer than an hour.

GLASS FIBER DATA

Fibrous Glass Products, Inc., Alpa Plaza, Hicksville, N.Y., announces the availability of a bulletin covering glass fiber.

Included is technical data as well as applications of fiber glass, particularly

for use in package cushioning, vibration damping, and acoustical isolation. Performance data indicates that the product meets the requirements of MIL-C-17435 and MIL-C-7769 specifications.

CITIZENS BAND BULLETIN

Lafayette Radio, 165-08 Liberty Ave., Jamaica 33, N.Y. has published a two-color, 8-page booklet containing a general introduction to Citizens Band communications, and detailing features of its new model HE-15A CB transceiver.

A large portion of the booklet discusses antennas for CB operation, with information and illustrations covering mobile antennas, fixed installations, etc.

SELENIUM RECTIFIERS

Sarles Turzian, Inc., Semiconductor Division, 415 College St., Bloomington, Ind., has released a new 8-page selenium rectifier catalogue, No. 4002, containing information on the physical and electrical characteristics of the company's line.

MODULAR POWER SUPPLIES

Dressen-Barnes Corp., 250 N. Vinedo Ave., Pasadena, Calif., has released a data sheet describing a new series of 24 modular power supplies. The data sheet shows photographs of the unique packaging method designed to dissipate transistor and transformer heat without the use of auxiliary dissipators. [30]

14-Watt Stereo Amplifier

(Continued from page 49)

The purpose of these measurements was to calculate the maximum power that the amplifier could deliver for short periods ("short" meaning not long enough to permit the operating conditions to change). Naturally, with these criteria, there is no difference in the power output between the parallel out-

put sum and the single-channel output when it is doubled.

The difference between the frequency response of the two channels is a result of feedback capacitor tolerances. No doubt both capacitors could be trimmed for a response curve which is dead flat to 90 kc., with sharp roll-off thereafter.

Try building this amplifier as your first stereo project. With a little care devoted to its construction the amplifier will perform well and last for many, many years. [30]

Fig. 4. Continuous-power measurements and frequency response of amplifier. Music-power ratings are 14 watts for each channel and 28 watts for both of the channels.

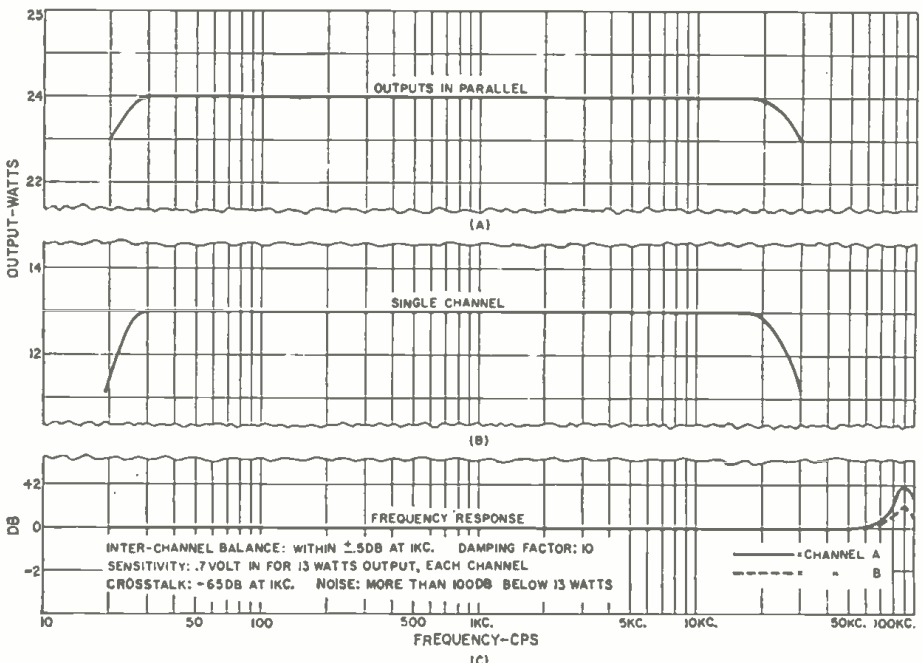

Handling the Complaint

(Continued from page 50)

you didn't do anything, but I feel a lot better."

Many complaints will not be complaints at all, but poorly expressed requests for information: "This thing don't want to play stereophonic, like it says." If you take the time to *listen* without first going on the defensive, you will realize that a few words of explanation of operation are all that is needed.

Other complaints are poorly disguised attempts to stretch the guarantee period: "My uncle gave me this portable for Christmas. I didn't use it at all until I took it to the beach a couple of days ago."

Whatever the basis for the call, simply by listening you are putting yourself on the side of the injured party. You make him feel that you are willing to help him. You are establishing an atmosphere for cooperation rather than enmity.

When most people call for service, it is with strangely mixed emotions. They are angry and annoyed over the fact that their equipment has "betrayed" them, so they have chips on their shoulders. On the other hand, they are fighting against an inner timidity. Experience tells them that they are not likely to force anything out of the other side, especially when they are bucking what they consider to be a "big company."

The complaining customer is at a serious disadvantage. True, he may never deal with you again if he gets no satisfaction, and this could conceivably put you out of business, if repeated many times over the long haul. In each individual case, however, you could tell him to go to the devil and he knows it. The best he could do is hope to recover a few dollars by going to the trouble of bringing you into court. The more afraid and angry he is, the more likely will he be to lose his head and fly into a tantrum and then you will be in for some real trouble.

Give him a chance to relieve himself until this danger point has been passed. If he feels that he is communicating his problem in a satisfactory way then your problem, the one of keeping a customer without losing money, is well on its way to solution.

As the next step in handling complaints, we mentioned deciding. Reaching a decision on what you should offer or not offer is something you do while the first step, listening, is still in progress. The more you listen, in fact, the more time you have to reach the decision. In any event, some decision involving some course of action must have been reached before you open your own mouth.

Do not postpone the decision with something like, "Well, if he insists, I'll do it." This has been used by more than one unsuccessful organization in the past. Under such circumstances, the customer will know that he has had to argue you into making a repair or some

TARZIAN Offers 48-Hour, Direct Factory Service on Tuner Repairs

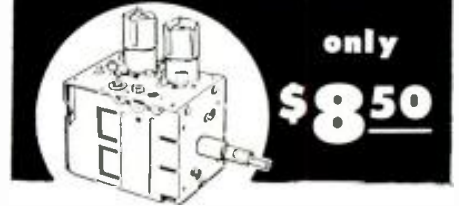

only
\$8.50

That's right. Net, \$8.50 per unit and \$15 for UV combinations, including ALL replacement parts. 90-day warranty against defective workmanship and parts failure. Tuners repaired on approved, open accounts. Replacements offered at these prices* on tuners not repairable:

VHF 12 position tuner \$22.00
VHF 13 or 16 position 23.00
VHF/UHF combination 25.00
UHF only 15.50

*Subject to change



Tarzian-made tuners are easily identified by this stamping on the unit.

When inquiring about service or replacements for other than Tarzian-made tuners, always give tube complement . . . shaft length . . . filament voltage . . . series or shunt heater . . . IF frequency, chassis identification and allow a little more time for service. Use this address for fast, 48-hour service:

SARKES TARZIAN, Inc.

Att.: Service Mgr., Tuner Division

Dept. 6

Bloomington, Indiana

Just Out

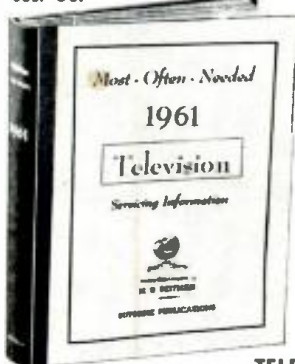

New SUPREME 1961 TV Manual

AMAZING BARGAIN

The new 1961 TV manual is the bargain of the year. Covers all important sets of every make in one giant volume. Your price for this mammoth manual is only \$3. This super-value defies all competition. Other annual volumes at only \$3 each. Factory service material simplifies repairs. Includes all data required for quicker TV servicing. Practically tells you how to find each fault and make needed repair. More pages, more diagrams, more service data per dollar of cost.

TELEVISION SERVICING COURSE

Let this new course help you in TV servicing. Amazing bargain, complete, only \$3, full price for all lessons. Giant in size, mammoth in scope, topics just like a \$200.00 correspondence course. Lessons on picture faults, circuits, adjustments, short-cuts, UHF, alignment facts, hints, antenna problems, trouble-shooting, test equipment, picture analysis. Special, only **\$3**

SIMPLIFIED RADIO SERVICING (Introduction to TV)

Explains how to use comparison method to find most radio faults in minutes. Many practical tests without any equipment. Also several sections on use of instruments, introduction to TV, Schematics, charts, service hints. Job sheets cover all sets. New edition. Only **\$1.50**

RADIO VOLUMES



RADIO DIAGRAMS

SUPREME is your best source for all needed RADIO diagrams and service data. Covers everything from the most recent 1960 radios to pre-war old-timers; home radios, stereo, combinations, transistor portables, FM, and auto sets. Sensational values. Only \$2 for many volumes. Every manual has extra large schematics, all needed alignment facts, printed boards, voltage values, trimmers, dial stringing, and helpful hints. Volumes are large in size, 8 1/2 x 11 inches, about 190 pages. See coupon at right for a complete list of these popular radio service manuals. →

COVERS ALL POPULAR SETS

Here is your service data for faster, easier TV repairs. Lowest priced. Best by comparison. SUPREME TV manuals have all needed service material on every popular TV set. Helpful, practical, factory-prepared data that will really make TV servicing easy for you. Benefit and save with these amazing values in service manuals. Only \$3 per large, yearly volume.



The repair of any television set is really simple with SUPREME TV service manuals. Every set is covered in a practical manner that will simplify trouble-shooting and repair. This is the help you need to find toughest faults in a jiffy. Most \$3 TV volumes cover a whole year of service material. New Television Servicing Course will aid you in learning TV. Be wise. Buy Supreme Manuals only once each year instead of spending dollars every week.

SIMPLIFIES TV REPAIRS

These giant TV manuals have complete circuits, needed alignment facts, printed boards, servicing hints, production changes, voltage charts, waveforms, and double-page schematics. Here are your authentic service instructions to help you do expert work quicker; and priced at only \$3 per large annual manual. Repair any TV model ever made by having in your shop all 15 volumes as listed in coupon. Your special price for all, only \$40. Or try the new 1961 TV manual to see what an amazing bargain you get for \$3. Send no-risk trial coupon today.

NO-RISK TRIAL ORDER COUPON

SUPREME PUBLICATIONS, 1760 Balsam Rd., Highland Park, Ill.

- 1960
 1959
 1958
 1957
 1956
 1955
 1954
 1953
 1952
 1951
 1950
 1949
- Popular RADIO Diagram Manuals at only **\$2.50** each.....
Radio Manual, only \$2
- These annual RADIO volumes specially priced at only **\$2.50** each.....

THIS GROUP ONLY

\$2 EACH

- 1926-1938 Manual, \$2.50
 Simplified Servicing, \$1.50

Rush today TV manuals checked below and Radio manuals at left. Satisfaction Guaranteed.

- New 1961 TV Manual, \$3. 1960 TV, \$3.
 Additional 1959 TV, \$3. Early 1959 TV, \$3.
 1958 TV Manual, \$3. Additional 1957 TV, \$3.
 Early 1957 TV, \$3. 1956 TV Manual, \$3.
 Additional 1955 TV, \$3. Early 1955 TV, \$3.
 1954 TV, \$3. 1953 TV, \$3. 1952 TV, \$3.
 1951 TV, \$3. 1957-58 RCA TV Manual, \$1.50
 New Television Servicing Course, complete... \$3.

- I am enclosing \$..... Send postpaid.
 Send C.O.D. I am enclosing \$.... deposit.

Name:

Address:

Supreme Publications
Sold by All Leading Parts Jobbers

ONCE IN A LIFE TIME SALE!

New spare parts purchased from one of the largest PROFESSIONAL TAPE RECORDER Manufacturers! Complete termination of materials for new manufactured products or spare parts for operating equipment.

STOCKS LIMITED

Shipments will be made in order of receipt.

PROFESSIONAL TAPE RECORDER HEADS

BT-1 Full track erase	\$10.00
BT-3 Full track record	10.00
BT-5 Full track playback	10.00
BT-2 Half track erase	8.00
BT-4 Half track record	8.00
BT-6 Half track playback	6.00
BB-3 Stereo record (stacked)	12.00
BB-5 Stereo playback (stacked)	10.00
Cinemascope 35MM playback	30.00
Four track (1" tape) combo	27.50

"VU METERS"



4 1/2" internal 115 VAC illumination. M/G by Phasotron. Metal escutcheon. 1 ma basic movement \$12.50

WESTON model 862 illuminated DB meter. 4 1/2" rectangular case. 0 DB - 0.639V. New Price \$64.00 SPECIAL \$24.50

ADVANCE type 6004 sensitive miniature telephone-type plate relay. 16,000 ohm DP.DT 2.75

PHIL-TROL SOLENOID. Ideal for mechanical tracking. 47.5 ohms, 24 V. DC. long stroke. 2 1/2 lb./in. pull \$2.00

SSELINUM RECTIFIER. 24 VDC at 2 amps. 1.29

DAVEN "T" PAD. 600 ohm balanced line. 14 steps of .5 db attenuation. 7 db total. Fully shielded \$2.75

TECHLAB "T" PAD. 600 600 ohm. 10 steps of 1 DB attenuation. Shielded. with knob and escutcheon \$3.00

DRIVE MOTORS



BODINE MCI-33 induction drive motor. 115 V. 60 cy. 45A. 540/1080 RPM. 4 1/2" dia by 5 1/2" long. Rear shaft: 7/8" long. Front shaft: 1 1/2" long and ground for 7 1/2" and 15 ips \$17.50 please add \$1.50 per motor for postage and handling.

FASCO reeling and rewind motors. Can be used in conjunction with above drive motors. 115 V. 60 cycle. 3 1/2" dia by 4 1/2" long. Shaft 2 1/2" long and finished for standard reel lock. Best quality available for professional use \$9.50

SPECIAL Motor starting capacitor for above drive and other motors. 2 x 5 mfd at 330 VAC. With mtg bracket \$1.75

California residents add 4% sales tax. Terms: cash with order or 25% deposit, balance COD. All prices FOB Los Angeles.

H. D. STERN CO.

1221 Venice Boulevard, Los Angeles 6, Calif.

other concession that you did not want to give. Like love, service must seem to be given freely if the recipient is to accept it in the right spirit. If you let him feel that he has had to force you into doing what he considers the proper thing, you have lost him. You are wasting your time and money, because he will not want to do business with you again even if you give in.

Decide while listening whether you are going to make the repair without charge, whether you will expect full payment, or whether you are going to meet the customer half way. Remember that, once you have made your offer, it is too late to change it even if you feel that you should.

If you cannot honestly make an immediate decision, you should indicate as much, but even this can be done definitely instead of vaguely. State that, since the particular request is unusual, you want to think it over. If you must, put off the decision by requesting time to refer to records. Or else, switch authority for a final decision to someone who is not present: "The boss will have to decide on that."

In any event, decide on something on which you can act, and when you act, do so decisively. You may be surprised at how much better a customer will take a forthright answer, even if it is a flat no, than hesitant or apologetic mumbling.

If your decision has been to satisfy the customer without further charge, say so in clear and simple words. If you have decided on a compromise, clarity and definiteness are even more important. For example, "We will furnish the parts without charge, but we do expect to be paid for our labor." A compromise is difficult. You are wasting the generosity of your concession if, at the end, a confused set owner resentfully feels that he got less than he thought was promised.

You must carefully avoid such tricks as padding up your half of a compromise charge to make up for the loss on what you have conceded to the customer. Aside from ethical considerations, this is good business sense. Never give the equipment owner so good an opportunity to feel that he has been turned into a sucker. You can bid him good-bye if you do.

In being specific on compromise offers, try to spell things out particularly carefully where dollars and cents are involved, whenever possible. "We will replace the defective speaker free of charge if you bring the receiver into our shop. If we have to come out to your home to do the job, there will still be no charge for the speaker, but we must be paid X dollars to cover the trip." Never say, "We will replace the speaker free of charge, but we don't know what the labor charge will come to."

There will be times when you must make a flat refusal. When you do so, be as definite about it as with any other course of action, with no hemming and hawing. It is better to say simply, "Your guarantee period is up and we must

12 VOLT DYNAMOTOR

Output: 440 V. @ 200 ma. cont. Size: 4" dia. x 7" L. Brand New \$5.50

AIRCRAFT BATTERY CABLE

= 4 flexible aluminum, rubber covered. New, Per ft. \$15¢

SERIES WOUND MOTOR

Use on AC or DC. 12 or 24 V. Air cooled, rated .8 HP @ 7000 RPM. on 27 V. DC. Compact. 4" Dia. (1" flange) x 6 1/2" L. 3/8" splined shaft. Cost Navy \$200.00. New \$5.95

REGULATED POWER SUPPLY

National. 115 V. input. Output: 150 V DC, regulated; 300 V DC @ 200 Ma.; 6.3 V AC @ 6 A. (Ratings with Choke Input Filter; for higher voltage, connect Cond. Input.) Chassis 18 1/2 x 5 1/2". Removed from Navy Equipment. \$39.00

LINE VOLTAGE STABILIZER

General Electric. 2 KVA. Input 110 to 135 V. Output 113, 115, 117 V. Used Good \$65.00

POWER TRANSFORMERS (115 V. Pri.)

800 V. C.T. @ 250 ma. \$3.95
2.5 V. C.T. @ 10 A. New \$3.95
490 V. C.T. @ 130 ma. 6.3 V. @ 4.1 A. 5 V. @ 3 A. New \$2.95

RELAYS (G.E., Westinghouse)

3 pole, 2 throw. 24 V. coil (180-75 ma.) New \$1.75
SPST, 125 Amp. 120 V. \$5.75
24 V. coil (60-250 ma.) New \$5.75

NATIONAL U.H.F. RECEIVER

R.O.Z. 200 to 400 Mc. 115 V. input. Used Good \$45.00

- Panel Mounting Circuit Breakers
- Toggle switch type, 115 V. 10 Amp.
- Push button type, 115 V. 50 Amp.
- Cable, 20" with BNC male connector each end.
- 25 Watt Pot, 60 ohm. Suitable for NO trains. All New. ea. \$1.00

F.O.B. Mont Vista, Calif. buyers add 4% tax. Minimum order \$3.00. No COD's.

WOOD DEVELOPMENT CO.

10271 Imperial Ave., Mont Vista, Calif.

TS 36 WE X BAND POWER METER

\$14.95

TS 45 X BAND SIGNAL SOURCE \$14.95

TS 76 TEST METER \$9.95

TS 102A CALIBRATOR \$14.95

TS 173 FREQUENCY METER \$124.50

TS 196 BRIDGE \$24.95

TS 247 WAVE METER \$14.95

STANDARD LABORATORY RECEIVER

APR-4 with 3 Tuning Units. Frequency 3.8-1000 MC. Checked out \$159.50

MEASUREMENTS CORP. 79-B PULSE GENERATOR—Checked out \$39.50

GEN. ELECT. COMPUTER TESTER.

New \$29.95

MD 7 MODULATOR with Tubes \$5.95

BC 442 ANTENNA RELAY with Condenser \$2.95

Less Condenser \$1.49

ARC 3 RECEIVER 100-156 MC. \$14.95

ARC 3 TRANSMITTER 100-156 MC with 2-832A's \$16.95

BC 620 TRANSCEIVER—Citizens Band FM-20-28 MC \$16.95

METER—3" 0.5 MA. 270° indication By-Pass Shunt and add scale.

Excellent condition \$1.29

TELEGRAPH KEY—J 47. New \$1.29

ART-13 TRANSMITTER with tubes and meters \$29.95

Send M.O. or check with order Write for Bargain Flyer

R W ELECTRONICS

2430 S. MICHIGAN AVE. DEPT. N
Phone: CALUMET 5-1281 Chicago 16, Ill.

KEEP CANDEE HANDEE!

FAMOUS Q 5'ER 1 1 1

This is the fabulous one! 100-550 kc. The receiver you've been looking for \$9.95
BC-454: 8-11 Mc. \$7.95
BC-455: 6-9.1 Mc. \$7.95
MD-7 MODULATOR: Special \$5.50

A TRIO OF HEADSET BARGAINS!

MS-23: Hi impedance. Leather covered headband. Brand new. Great buy. Only \$4.95
MS-33: Low impedance. Leather covered headband. Brand new. A J. J. Candee Special \$5.95
Hi Fi Headset: 15,000 cycles! Brand new with channels cushions. Hi's terrific! Only \$8.95
CD-307A Headset Extension Cord: Brand new. Approximately 5 ft. length. Only 49¢

APN-1 FM TRANSCEIVER

420-460 Mc. Comp. with tubes. Exc. Ea. \$2.95 Approx. ship. wt. per unit 25 lbs. TWO for 5.00

YOU GOT IT! WE WANT IT! LET'S DEAL? We're buying top \$\$\$ for GIC-9; IRC-6; A-10; GN-58A: All elect. test equip.

APX-6 TRANSPONDER

A full-size warehouse of parts! Blowers, three Veeder-Root counters, 1 E. strips, cavity, over 30 tubes etc. Includes 3E29 tube. Good \$9.95 cond. A STEAL AT ONLY \$2 for \$10.00!

R-4A/ARR-2 RECEIVER

284-25R Mc. 11 tubes. UHF. tunable receiver. See Aug/75B C.G. Magazine for conversion. Excellent cond. TWO for \$5.00. Each \$2.95

All items FOB Burbank, Calif., subject to prior sale. In Calif. add 4%. Min. order \$3.95.

FREE! Send For New Spring Bargain-Filled Flyer!

J. J. CANDEE CO.

Dept. R
509 No. Victory Blvd., Burbank, Calif.
Phone: Victoria 9-2411

A NOTE TO THE HI-FI BUYER

AIR MAIL us your requirements for on IMMEDIATE LOWEST PRICE QUOTATION Components, Tapes and Records SHIPPED PROMPTLY AT LOWEST PRICES

WRITE TODAY FOR FREE CATALOG

AUDIO UNLIMITED

714-W Lexington Ave.
New York 22, N. Y.

charge for all parts and service from now on." than to weasel, "Gee, I'd like to make the repair free, but you know how it is: I'd be losing money, and how long could I be in business with all my expenses and stuff?" The latter refusal will make the other party feel that you are lying. If you felt right about your decision, you wouldn't have to apologize for it.

Since call-backs, under the best conditions, involve a certain amount of delicacy, it is worthwhile to consider their prevention in addition to methods for handling them after they have occurred. If you sell or install equipment, make certain that its proper use and its limitations are carefully explained to the owner. Let the customer go through each step of its operation under instruction and supervision to give him confidence.

Avoid partial repairs like a plague. This is not always possible, but do your best to sell "complete repairs." You should charge enough for your work to cover inspection of the entire equipment for defects other than the immediate cause for service, and possibly to take care of other, minor work that may be needed at the same time. You will have much less trouble standing behind your guarantee when another, unrelated difficulty arises.

Take the time to educate your customer as to what you are actually doing to his equipment. This does not entail a free course in electronic service. Indicate what work you have done and what parts you have replaced. If possible, turn over the defective parts to him. This helps forestall him from saying afterward simply that "you fixed the set and now it's not fixed anymore."

Give him a definite piece of paper when he pays his bill so that he doesn't call you in a few weeks to test your sincerity. Some people feel they must call you back fairly soon, even if the equipment is working in a satisfactory way, just to keep themselves on your mind. A printed bill and guarantee, properly executed, will save your money by reducing this waste of time. [30]



"Ever notice how leaning over a workbench all day frays the front of your trousers?"

WE TRADE HIGHER!



Howdoody...

Here's a revoltin' switch . . . an evaluator gettin' eevaluated. Okay, I'm a moron, but write me anyway, about your old ham gear* and I'll quote some trade-in-prices that'll make you as happy as I'm stupid.

You'll love me madly,

Jack S.

* only amateur receivers and transmitters made since 1945

DO YOU HAVE OUR NEW CATALOG? IT'S FREE!

All prices f. o. b. St. Louis . Phone CHestnut 1-1125



OUR 38TH YEAR

WALTER ASHE RADIO COMPANY
1125 Pine Street, St. Louis, Mo.

Push Surprise Trade-In Offer on my _____
for _____ (show make and model of new equipment desired)

Send new FREE Walter Ashe catalog. H-11-1411

Name.....
Address.....
City..... State.....

ADD TO YOUR INCOME Learn at Home to Fix APPLIANCES

FREE
SAMPLE
LESSON

Tester Furnished—No Extra Charge.
National Radio Institute trains you at home. Every service customer is worth more when you can fix his electrical appliances. Mail coupon for Lesson and Catalog.

National Radio Inst., Dept. EMO Washington 16, D.C.
Please send me Electrical Appliance Sample Lesson and Catalog FREE (No salesman will call).

Name..... Age.....
Address.....
City..... Zone..... State.....
ACCREDITED MEMBER NATIONAL HOME STUDY COUNCIL

ENGINEERING DEGREE IN SCIENCE MATH 27 or 36 MOS.



Accelerated year-round Program prepares for early employment in fields of Science and Engineering. Regular 4-year program for B.S. Degree completed in 36 months, special engineering degree program in 27. Classes start quarterly—January, March, June, July, September. Quality education. Graduates employed from coast to coast. Government approved for veteran training. Students from 50 states, 40 countries. 20 buildings: dorms, gym, Campus. Save time and money. Earn board while studying. Write for catalog and complete information.
9110 E. Washington Blvd., Fort Wayne 2, Indiana

INDIANA TECHNICAL COLLEGE



FREE!

Olson Radio Catalogs FOR ONE YEAR

- ★ 8 Different Issues
- ★ All Bargain Packed



FREE One Year Subscription to OLSON RADIO'S Fantastic Bargain Packed Catalog—Unheard of LOW, LOW WHOLESALE PRICES on Brand Name Speakers, Changers, Tubes, Tools, Hi-Fi's, Stereo Amps, Tuners and other Bargains.

Another **OLSON** Bargain!

NEW! TUBE TESTER



* Made in U.S.A.



FACTORY WIRED
No. TE-148 \$18.83

KIT FORM
\$14.83
No. KB-92

Olson Radio brings you the smallest lowest priced domestic tube tester on the market. Only 6 1/2" w x 2 1/2" d x 5 1/4" h. Not just a filament checker, but a real tube tester that checks each section of multi-purpose tubes for quality of emission and inter-element shorts. Tests for opens and intermittents also. Checks all miniature 7 and 9 pin tubes plus 8 pin octals and 8 pin locals. Quality of emission is indicated on easy to read 2" meter with 2 color dial. 10 switches select individually each element so that short tests can be made easily and quickly. Neon lamp indicates shorts. This tube tester will also test ballast tubes and voltage regulator tubes. Operates on 117 volts AC. Completely flexible and obsolescence proof. Comes with instructions and tube charts.

Picture Tube Test Adaptor.....No. TE-149.....Eo. \$3.83

MAIL COUPON TODAY

Fill in coupon below for your FREE one year subscription to Olson's Bargain Packed Catalog. To order Tube Tester, simply check wired or kit model (also Adaptor if desired) and send remittance along with coupon. (Include enough for postage or parcel post shipment. Send \$2.00 deposit for C.O.D. orders.)

- FREE Olson Catalogs for One Year
- Tube Tester Kit No. KB-92.....\$14.83
- Tube Tester Wired No. TE-148 \$18.83
- Picture Tube Test Adaptor
No. TE-149.....\$ 3.83

NAME _____

ADDRESS _____

CITY _____ ZONE _____ STATE _____

OLSON RADIO CORPORATION

613 S. Forge St., Akron 8, Ohio

What's

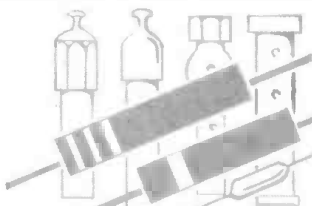

HEATH 3-INCH SCOPE

Heath Company, Benton Harbor, Mich. has added a 3-inch oscilloscope to its line of test equipment in kit form.



The Model IO-10 "Space-Saver" d.c. scope is suitable for applications in the medical, industrial, and general service fields. It may be used as a read-out for computers; for wave-

form observation; and for voltage, frequency, and phase-shift measurement.

The circuit features identical vertical and horizontal d.c.-coupled amplifiers with low relative phase shift characteristics; external sync binding posts; external capacity binding post for sweep frequencies lower than 5 cps; transformer-operated power supply; and voltage-regulated "B+" and bias.

The unit operates from 105-125 volt, 50-60 cycle a.c. and draws 100 watts. It measures 7 5/8" x 4 5/8" x 11".

FROZEN YOKE SPRAY

Walsco Electronics Mfg. Co., 100 W. Green St., Rockford, Ill. has added a frozen-yoke remover spray to its line of electronic chemicals.

"Ez-Off" comes in a spray-type can that gets the chemical well into the yoke. The solvent goes to work immediately and in a few minutes the yoke will slip off.

Those wishing additional details on this product should contact the company direct.

2-METER TRANSCEIVER

Gonset Division, Young Spring & Wire Corp., 801 South Main St., Burbank, Calif., has announced its new "Communicator IV" transceiver for operation



on the 2-meter amateur radio band. Designed as a successor to the company's "Communicator III," the new equipment features increased input power and a triple-conversion receiver



New in Radio

with high sensitivity and "exceptional" noise figure.

The unit, a completely self-contained v.h.f. station, houses transmitter, receiver, and power supply in one compact, lightweight unit. The transmitter is rated at 20 watts input power, with 100 per-cent AM modulation. It is crystal controlled and any of six frequencies may be selected by a front-panel switch.

The equipment will operate from 12 volts d.c. and 117 volts a.c. Complete information is available from the company.

CAPACITOR ANALYZER

Sprague Products Company of North Adams, Mass. has developed a new capacitor analyzer, the Model TCA-1, which is designed specifically to test low-leakage, low-voltage tantalum and



aluminum electrolytic capacitors; solid tantalum capacitors, low-voltage film and paper capacitors; and ultra-low-voltage ceramic capacitors of the type found in transistor circuits.

The unit features five overlapping capacitance ranges from 1 μ f. to 2000 μ f.; direct meter reading of insulation resistance from 50 ohms to 20,000 meg-ohms, direct meter reading of leakage current down to fractional microamperes at exact rated d.c. voltage, and power-factor measurements by Wien bridge from 0 to 50%.

Housed in a sturdy steel cabinet with grey hammerloid finish, the new instrument measures 8 7/8" x 14 5/8" x 9 1/2" and weighs 21 pounds.

AMPLIFIED COUPLER

Jerrold Electronics Corporation, 15th and Lehigh Ave., Philadelphia 32, Pa. is now in production on a coupler with amplification for better TV/FM reception in the multi-set home. The Model HSA-43 amplified 3-set coupler can feed any combination of up to three TV and/or FM sets from a single antenna source.

A single tube and special circuitry



The Perfect
Workshop
Companion For
The Advanced
Audiophile

THE 1961 AUDIO YEARBOOK

Over 25 projects and features covering stereo, hi-fi, components, acoustics—every phase of audio! Advanced discussions and instructions on:

- CONSTRUCTING THE BI-PHONIC COUPLER
- STEREO MICROPHONE TECHNIQUES
- FINDING FAULTS IN HI-FI SYSTEMS
- WIDE SPACE STEREO
- MULTIPLEXING MUSIC ON ONE RECORDER
- ROOM ACOUSTICS FOR STEREO
- Plus many other authoritative articles

audio 1961
yearbook



ONLY
\$1.00

Ziff-Davis Publishing Company, Dept. 2000
434 S. Wabash Avenue
Chicago 5, Illinois

Please send me a copy of the 1961 AUDIO YEARBOOK. I enclose \$1.00 plus 10¢ to cover mailing and handling charges. (Canada and Foreign \$1.25 plus 10¢ postage.)

NAME _____

ADDRESS _____

CITY _____ ZONE _____ STATE _____

supply a minimum of 5 db gain on all TV/FM channels from two outputs and unity gain from a third output. Built-in isolation and match prevent set interaction and ghosting. Input and output impedances of 300



ohms permit the use of twin-lead. Serrated washer terminals eliminate the need for wire stripping. The amplifier measures 4½" x 4½" x 3".

NEW FRAME-GRID PENTODES

International Electronics Corp., 81 Spring St., New York 12, N.Y. has announced the current availability of two new Mullard frame-grid r.f. pentodes for i.f. amplifier stages of TV receivers.

The new tubes, EF183/6EH7 and EF184/6EJ7, are said to provide a gain bandwidth product 55% higher than currently used conventional i.f. tubes. According to the company, two frame-grid tubes can do the job of three conventional tubes with a cost saving to the manufacturer. The EF183, a variable-mu r.f. pentode has a transconductance of 13,000 μmhos, a plate voltage of 200, and plate current of 12 ma. The EF184, a sharp cut-off pentode, features a transconductance of 15,000 μmhos and an amplification factor of 60.

Additional information, application and engineering assistance are available from the U.S. distributor upon request.

BROWNING CB TRANSMITTERS

Browning Laboratories, Inc., Laconia, New Hampshire, has brought out three new transmitters, intended to fill different needs for individuals and organizations operating on the Citizens Band.

Model T-2700 has a built-in power supply and can be operated independent of the R-2700 receiver. The second transmitter, Model T-2700-S, derives its power from the R-2700 and is, therefore, available only in combination with the R-2700 at a special package price.

The third transmitter, the "S-Nine," is said to introduce revolutionary new



features and advanced components not previously utilized in CB communications. It is designed to minimize the effects of today's heavy traffic on all CB channels.

All three models feature six crystal-controlled transmit channels selectable from the front panel. Models T-2700 and

NEW REDUCED SIZE CITIZENS BAND MOBILE WHIPS

FROM **Hy-gain**

CITIZENS MOBILE DISGUISE ANTENNA

The Hy-Gain Model CM may be quickly mounted in its place with the standard automotive base mount. High efficiency base loading coil and the exclusive L-matching network results in perfect 50 ohm match with radiating efficiency equivalent to a full sized whip. Extends to 73" telescopes down to 23" for easy parking. Heavily chrome-plated. Base loading coil enclosed in polypropylene plastic for maximum weather ability.

Model CM
\$14.95
List

COMMERCIAL DUTY STAINLESS STEEL LOADED WHIP

Designed for commercial duty, the Model CMS is constructed of high strength, high flexibility stainless steel 52" high. Antenna may be mounted on rooftops for increased radiation efficiency. High efficiency base loading coil (completely enclosed in polypropylene plastic) and exclusive L-matching network matches 50 ohms perfectly and maintains radiating efficiency equivalent to full size whip. Complete with standard automotive body mount for quick and easy single hole mounting.

Model CMS
\$14.95
List

Both Broadcast & CB Reception One Antenna — No Switching

Broadcast to Citizens Band Coupler — A unique isolating network allows use of any Citizens Band mobile antenna for both CB and AM broadcast. Coupler enclosed in small aluminum box. Complete with SO-239 coaxial chassis receptacle for attachment of Citizens Band antenna. Provided with 2-foot lead and automotive type plug for connecting broadcast radio and two feet of lead with PL-259 coaxial plug for connecting to Citizens Band transceiver.

Model CPR
\$14.95
List

Get More Information
Now!

FREE
Antenna
Catalog

Complete Line
of
Citizens Band
Antennas



EW-11 **Hy-gain** antenna products

1138 NO. 22nd ST. LINCOLN, NEBRASKA

PLEASE SEND:

- FREE CITIZENS BAND CATALOG
 COMPLETE DEALER INFORMATION

Name: _____

Firm: _____

Address: _____

City & State: _____

TELTRON

Leading VALUES in TUBES



AN Tubes Individually Boxed
1-YEAR UNCONDITIONAL GUARANTEE
 Send For Free Complete Tube List & Order Blank
FREE EICO TUBE TESTER
 With every receiving tube order of \$199 or more
 within 60 days. Tests all new tubes and six used
 May be purchased from Teltron for \$34.95

FREE BONUS

ONE YEAR FREE subscription to
ELECTRONICS WORLD PLUS ONE
SCHEMATIC DIAGRAM OF Your Choice
 With Every Receiving Tube Order of \$38
 or More!
NOTE: If you are a subscriber, one year will
 be added FREE!

TELTRON ELECTRIC CO.
 428 Harrison Ave., Harrison, N. J.

Send me one year FREE subscription to
 Electronics World PLUS one FREE schematic
 diagram (state model # of radio or TV)

Name _____
 Address _____
 City _____ State _____

Mail This
 Coupon
 Today

SAVE ON ALL TUBES

Quan.	Type	Price	Quan.	Type	Price	Quan.	Type	Price
1	6X4	1.18	1	6X4	1.18	1	6X4	1.18
1	6X5	1.18	1	6X5	1.18	1	6X5	1.18
1	6X6	1.18	1	6X6	1.18	1	6X6	1.18
1	6X7	1.18	1	6X7	1.18	1	6X7	1.18
1	6X8	1.18	1	6X8	1.18	1	6X8	1.18
1	6X9	1.18	1	6X9	1.18	1	6X9	1.18
1	6X10	1.18	1	6X10	1.18	1	6X10	1.18
1	6X11	1.18	1	6X11	1.18	1	6X11	1.18
1	6X12	1.18	1	6X12	1.18	1	6X12	1.18
1	6X13	1.18	1	6X13	1.18	1	6X13	1.18
1	6X14	1.18	1	6X14	1.18	1	6X14	1.18
1	6X15	1.18	1	6X15	1.18	1	6X15	1.18
1	6X16	1.18	1	6X16	1.18	1	6X16	1.18
1	6X17	1.18	1	6X17	1.18	1	6X17	1.18
1	6X18	1.18	1	6X18	1.18	1	6X18	1.18
1	6X19	1.18	1	6X19	1.18	1	6X19	1.18
1	6X20	1.18	1	6X20	1.18	1	6X20	1.18
1	6X21	1.18	1	6X21	1.18	1	6X21	1.18
1	6X22	1.18	1	6X22	1.18	1	6X22	1.18
1	6X23	1.18	1	6X23	1.18	1	6X23	1.18
1	6X24	1.18	1	6X24	1.18	1	6X24	1.18
1	6X25	1.18	1	6X25	1.18	1	6X25	1.18
1	6X26	1.18	1	6X26	1.18	1	6X26	1.18
1	6X27	1.18	1	6X27	1.18	1	6X27	1.18
1	6X28	1.18	1	6X28	1.18	1	6X28	1.18
1	6X29	1.18	1	6X29	1.18	1	6X29	1.18
1	6X30	1.18	1	6X30	1.18	1	6X30	1.18
1	6X31	1.18	1	6X31	1.18	1	6X31	1.18
1	6X32	1.18	1	6X32	1.18	1	6X32	1.18
1	6X33	1.18	1	6X33	1.18	1	6X33	1.18
1	6X34	1.18	1	6X34	1.18	1	6X34	1.18
1	6X35	1.18	1	6X35	1.18	1	6X35	1.18
1	6X36	1.18	1	6X36	1.18	1	6X36	1.18
1	6X37	1.18	1	6X37	1.18	1	6X37	1.18
1	6X38	1.18	1	6X38	1.18	1	6X38	1.18
1	6X39	1.18	1	6X39	1.18	1	6X39	1.18
1	6X40	1.18	1	6X40	1.18	1	6X40	1.18
1	6X41	1.18	1	6X41	1.18	1	6X41	1.18
1	6X42	1.18	1	6X42	1.18	1	6X42	1.18
1	6X43	1.18	1	6X43	1.18	1	6X43	1.18
1	6X44	1.18	1	6X44	1.18	1	6X44	1.18
1	6X45	1.18	1	6X45	1.18	1	6X45	1.18
1	6X46	1.18	1	6X46	1.18	1	6X46	1.18
1	6X47	1.18	1	6X47	1.18	1	6X47	1.18
1	6X48	1.18	1	6X48	1.18	1	6X48	1.18
1	6X49	1.18	1	6X49	1.18	1	6X49	1.18
1	6X50	1.18	1	6X50	1.18	1	6X50	1.18
1	6X51	1.18	1	6X51	1.18	1	6X51	1.18
1	6X52	1.18	1	6X52	1.18	1	6X52	1.18
1	6X53	1.18	1	6X53	1.18	1	6X53	1.18
1	6X54	1.18	1	6X54	1.18	1	6X54	1.18
1	6X55	1.18	1	6X55	1.18	1	6X55	1.18
1	6X56	1.18	1	6X56	1.18	1	6X56	1.18
1	6X57	1.18	1	6X57	1.18	1	6X57	1.18
1	6X58	1.18	1	6X58	1.18	1	6X58	1.18
1	6X59	1.18	1	6X59	1.18	1	6X59	1.18
1	6X60	1.18	1	6X60	1.18	1	6X60	1.18
1	6X61	1.18	1	6X61	1.18	1	6X61	1.18
1	6X62	1.18	1	6X62	1.18	1	6X62	1.18
1	6X63	1.18	1	6X63	1.18	1	6X63	1.18
1	6X64	1.18	1	6X64	1.18	1	6X64	1.18
1	6X65	1.18	1	6X65	1.18	1	6X65	1.18
1	6X66	1.18	1	6X66	1.18	1	6X66	1.18
1	6X67	1.18	1	6X67	1.18	1	6X67	1.18
1	6X68	1.18	1	6X68	1.18	1	6X68	1.18
1	6X69	1.18	1	6X69	1.18	1	6X69	1.18
1	6X70	1.18	1	6X70	1.18	1	6X70	1.18
1	6X71	1.18	1	6X71	1.18	1	6X71	1.18
1	6X72	1.18	1	6X72	1.18	1	6X72	1.18
1	6X73	1.18	1	6X73	1.18	1	6X73	1.18
1	6X74	1.18	1	6X74	1.18	1	6X74	1.18
1	6X75	1.18	1	6X75	1.18	1	6X75	1.18
1	6X76	1.18	1	6X76	1.18	1	6X76	1.18
1	6X77	1.18	1	6X77	1.18	1	6X77	1.18
1	6X78	1.18	1	6X78	1.18	1	6X78	1.18
1	6X79	1.18	1	6X79	1.18	1	6X79	1.18
1	6X80	1.18	1	6X80	1.18	1	6X80	1.18
1	6X81	1.18	1	6X81	1.18	1	6X81	1.18
1	6X82	1.18	1	6X82	1.18	1	6X82	1.18
1	6X83	1.18	1	6X83	1.18	1	6X83	1.18
1	6X84	1.18	1	6X84	1.18	1	6X84	1.18
1	6X85	1.18	1	6X85	1.18	1	6X85	1.18
1	6X86	1.18	1	6X86	1.18	1	6X86	1.18
1	6X87	1.18	1	6X87	1.18	1	6X87	1.18
1	6X88	1.18	1	6X88	1.18	1	6X88	1.18
1	6X89	1.18	1	6X89	1.18	1	6X89	1.18
1	6X90	1.18	1	6X90	1.18	1	6X90	1.18
1	6X91	1.18	1	6X91	1.18	1	6X91	1.18
1	6X92	1.18	1	6X92	1.18	1	6X92	1.18
1	6X93	1.18	1	6X93	1.18	1	6X93	1.18
1	6X94	1.18	1	6X94	1.18	1	6X94	1.18
1	6X95	1.18	1	6X95	1.18	1	6X95	1.18
1	6X96	1.18	1	6X96	1.18	1	6X96	1.18
1	6X97	1.18	1	6X97	1.18	1	6X97	1.18
1	6X98	1.18	1	6X98	1.18	1	6X98	1.18
1	6X99	1.18	1	6X99	1.18	1	6X99	1.18
1	6X100	1.18	1	6X100	1.18	1	6X100	1.18

Send for FREE complete list of most often used tube types

New Price Schedule of Television Picture Tubes

Picture Tube	Price	Picture Tube	Price	Picture Tube	Price
10BP4	7.95	17CP4	17.25	21AMP4	18.75
11LP4	10.75	17DP4	17.95	21BP4	18.75
14BP4	11.75	17HP4	16.40	21TP4	19.25
14CP4	11.95	17IP4	16.40	21UP4	19.25
14DP4	13.25	17LP4	17.45	21VP4	19.25
16BP4	16.45	17QP4	13.25	21WP4	18.75
16CP4	12.49	17TP4	16.49	21XP4	17.25
16DP4	16.99	17UP4	16.49	21YP4	19.25
16HP4	11.95	20CP4	19.75	21ZP4	21.25
16RP4	11.95	20HP4	17.75	21WP4	17.25
17AP4	16.75	21CP4	21.15	21XP4	18.75
17VP4	18.75	21HP4	18.75	21YP4	18.75

Aluminized on any tube, 44 extra. All picture tubes require
 dep. on dug. Add additional 33 on tube size to 17". Add 87
 on size 19", 20", 21", 24". Cash dep. refunded on receipt of
 dud prod. Pic tubes shipped from our warehouse (US Cont.
 & Canada only). Harrison, N.J.

NEW LIBERAL TERMS: No min. order. Free postage on
 all tubes & parts orders over \$5 in U.S.A. APDs & Territories
 33% dep. required on CODs. Please send approx. post-ge-
 rant Canadian & foreign shipments. Express refunded. All
 pic tubes & outdoor antenna shipped R/R Harrison, N.J.
 25c Handling Charge on Orders under \$3.
 Tubes may be factory seconds or used tubes
 and are clearly marked.

Humboldt
 4-9848 Dept. EW 11

TELTRON ELECTRIC CO.
 428 HARRISON AVE. HARRISON, N. J.

LEARN THE SHORT-CUTS

Professional TELEVISION All-Practice TRAINING

Jump your earnings fixing black-and-white and color sets. Get
 into the top-pay bracket. NRI's concentrated spare time, low-
 cost training can do it for you. You'll fix sets faster, easier.
 Special course for Radio-TV servicemen—not for beginners.
 Write National Radio Institute, Dept. O.M.T., Washington 16,
 D.C. Just say, "Send me Professional TV Servicing Catalog."

T-2700-S feature self-contained audio
 circuitry for full modulation; neon out-
 put "on the air" indicator; and highly
 efficient pi-network circuitry for trans-
 fer of energy to the antenna. The deluxe
 "S-Nine" also features the pi network,
 as well as low harmonic radiation; a
 spotting switch for channel identifica-
 tion; push-to-talk microphone; illumina-
 ted modulation meter; and limited
 audio range for improved modulation.
 The voice-operated (Vox) feature per-
 mits duplex operation between two base
 stations.

"DYNAMIC DEMONSTRATOR"

Transvision Electronics, Inc., New
 Rochelle, N.Y. is now marketing a new
 electronic teaching device which has
 been designed for both classroom and in-
 dustrial use.

Called the "Electronic Dynamic Dem-
 onstrator," the new unit is inexpensive

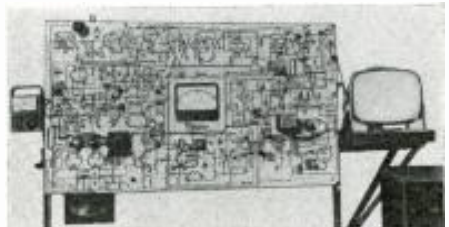

and comes complete with a teacher's
 manual and an electronics course of
 study. The unit consists of a 3-foot x
 5-foot breadboard, displayed blackboard
 style. The demonstrator is assembled
 and studied circuit by circuit including
 the following: filament circuit, power
 supply, audio amplifier, and TV circuits.
 Optional equipment includes a mobile
 stand, classroom-size meter, picture
 tube and housing, and v.t.v.m.

HEAT SINKS

Vemaline Products Co., Franklin
 Lakes, New Jersey, has introduced a
 new line of heat sinks for use with
 diodes, transistors, and rectifiers.

Designated as Series 6030, the heat

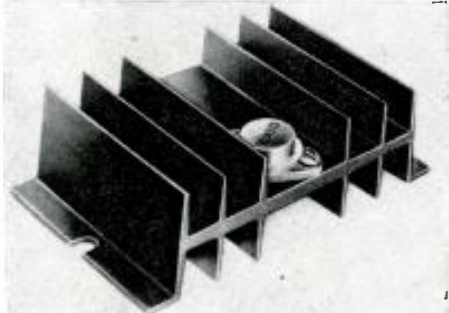

sinks are made of aluminum and are
 anodized. Special hardcoat anodizing
 is available which withstands over 1000
 volts r.m.s. Descriptive literature is
 available from the manufacturer.

PORTABLE POWER SUPPLY

Collins Radio Company's Amateur
 Sales Division, Cedar Rapids, Iowa, has
 introduced a portable power supply to
 enable the traveling ham operator to
 carry a complete single-sideband sta-
 tion in a suitcase.

Weighing 13½ pounds, including a

built-in auxiliary speaker, the PM-2
 supply operates from either 117-volts
 a.c. or 220-volts a.c. at 50-400 cps. It
 provides all the voltages necessary for
 the firm's KWM-2 SSB transceiver.

The power supply slips directly onto

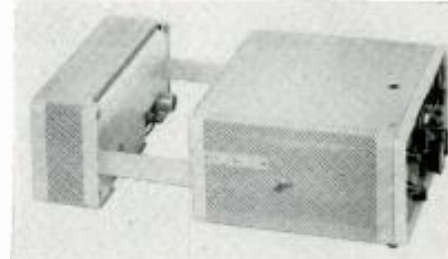

the back of the KWM-2 and is held in
 place by an arm-like extension. A pen-
 dant patch cable for the antenna is sup-
 plied with the PM-2. The complete
 station weighs less than 45 pounds.

TRANSISTORIZED CAR RADIO

Abtronics Inc., 5211 N.E. 2nd Ave.,
 Miami 37, Florida is now in production
 on two completely transistorized auto
 radios, especially designed for the
 sports-car market.

One receiver features its own built-in
 5" speaker while the second unit, which
 measures only 6¼" x 2¼" x 3", has a sepa-
 rate speaker. The radios will operate
 from either 6- or 12-volt automotive
 battery systems and drain .5 amp. Audio
 output is 2½ watts.

Full specifications and prices are
 available from the manufacturer on re-
 quest.

HEAVY-DUTY SOLDER GUNS

Cummins Portable Tools, a division
 of *John Oster Mfg. Co.*, 5055 N. Lydell
 Ave., Milwaukee,
 Wis., has an-
 nounced two new
 solder-gun mod-
 els.



Designed for
 heavy-duty ap-
 plications, Model
 490-02 is a single-
 heat unit; Model
 492-02, a dual-
 heat unit. Each gun comes with an
 exclusive alloy tip that provides instan-
 taneous heat. According to the manu-
 facturer, the new tips are very durable
 and never require filing. Retinning is
 accomplished by wiping the heated tip
 with a dry rag. The tip will not pit, a
 feature which is expected to appeal to
 technicians who use their solder guns
 constantly. The new tips also cool
 quickly to avoid delay in tip changing.

The single-heat gun is rated at 285
 watts; the dual-heat from 240 to 300
 watts.

CB TRANSCEIVER

Radio Shack Corporation, 730 Com-
 monwealth Ave., Boston 17, Mass. is now
 offering a new superhet CB transceiver
 as its "Realistic" Model TRC-27.

The unit comes completely wired and
 is a duo-powered circuit which operates
 from both 117-volt a.c. and 12-volt d.c.
 power sources. There are 10 tubes, 5 of
 them with dual stages. The power sup-



ply is transistorized. Other features include a tuned r.f. stage, crystal-controlled oscillator transmitter and receiver with 22 possible channels on each, 4½-inch PM speaker, and push-to-talk operation. The unit measures 5" x 13" x 7" and is housed in a light grey cabinet.

MARKER GENERATOR

Johnson Electronics, Inc., P.O. Box 1675, Casselberry, Florida has available a fully transistorized marker generator which weighs only 8 ounces and measures not much more than a package of cigarettes.

The "Pocket Pippin" utilizes crystal control to provide a 10-microsecond and a 1-millisecond pulse to accurately calibrate the sweep of an oscilloscope. The Model 100 MG 1 operates on its own self-contained 9-volt battery for one year of normal use. A convenient switch provides instant change from the 10-μsec. to the 1-msec. pulse.

STANCOR TRANSFORMERS

Chicago Standard Transformer Corp., 3501 Addison, Chicago 18, Ill., has announced three new 70.7-volt line-to-voice coil transformers, designed for

public address work. Each covers a 5-watt power range, in steps of one watt.

Model A-8080 is rated from 1 to 5 watts; A-8081 is 6 to 10 watts; while Model A-8082 is 11 to 15 watts. All units have primary impedances that are matched to the proper 70.7-volt line power steps and have secondary impedances of 8 and 16 ohms.

TWO-WAY RADIO

General Electric's Communication Products Dept., Lynchburg, Va., has introduced a table model two-way radio for use by business organizations, governmental agencies, and military services.

Units up to 60 watts are available in low band (25-54 mc. and 72-76 mc.), up to 50 watts in high band (144-174 mc.), and 15 watts in u.h.f. (450-470 mc.).

Depending on the frequency selected,



power amplifying equipment can be obtained on an optional basis, providing 250/330 watts output. Also on an optional basis.

Television RADIO-ELECTRONICS Electricity ELECTRONICS IN NEW SHOP-LABS OF COYNE

TRAIN QUICKLY! OLDEST, BEST EQUIPPED SCHOOL OF ITS KIND in U.S.

Get practical training in New Shop-Labs of Coyne. Prepare for a better job and a successful future in a top opportunity field. Advanced education or previous experience not needed. Employment service to graduates.

Enroll NOW—Pay Later

Finance Plan and Easy Payment Plan. Also Part Time Employment help for students.

FREE BOOK Clip coupon or write to address below for Free Illustrated Book. "Guide to Careers"—Describes all training offered. No obligation and No Salesman Will Call. Act NOW.

B. W. Cooke, Jr., President
COYNE ELECTRICAL SCHOOL
1501 W. Congress Pkwy., Chicago, Dept. 7D

Use this coupon to get our free book "GUIDE TO CAREERS"

COYNE ELECTRICAL SCHOOL training at Coyne
1501 W. Congress Pkwy. training at home
Chicago 7, Ill. Dept. of Electronics 7D

NAME _____
ADDRESS _____
CITY _____ STATE _____

Unlike most other schools, we do not employ salesmen.

SAVE! CHECK THESE PLATT BARGAINS... EVERY ONE IS A SPECIAL!

Platt Electronics has available a complete inventory of all LINK past and present equipment. Its technical staff, with considerable experience in the 2-way FM Communications field, is in a position to give Link product users excellent service. Inquiries are invited.

FEDERAL PORTABLE MOBILE SIGNAL GENERATOR 110 V AC POWER—TYPE 104A



Designed to facilitate alignment of FM mobile and land station receivers in the field. Provides a continuous source of frequency modulated carrier, the frequency of which is determined by the multiplier-type crystal that is used in the unit. It will, by the proper selection of crystals, provide a signal suitable for the alignment of FM mobile receivers in both the 25-50 MC band and the 144-174 MC band. In addition to these frequencies, the type 104A Mobile Signal Generator provides a 1000 cycle signal that may be used to check audio circuits. Unit has external power facilities. **\$49.50**

SPECIAL!

Current Westinghouse 832-A Tube, boxed. **\$4.95**
Sensationally priced at only.....



AMAZING KIT SALE!

Kit of 25 Assorted 10 & 20 watt RESISTORS. Popular Sizes **\$1.97**
Kit of 25 CONDENSERS—Baird's, Electrolytics & High Voltage Mica. **\$1.89**
Kit of 15 Assorted Popular WAFER SWITCHES. **\$1.59**
Kit of 20 AIR PADDER VARIABLE CONDENSERS. Popular sizes. **\$1.89**

NEW CHICAGO PLATE TRANSFORMER TR-1040

115 VAC Primary, 2500 VDC @ 250 MA DC Secondary. 3" High. 3½" wide, 7" deep. Weight 60 lbs. **\$39.95**

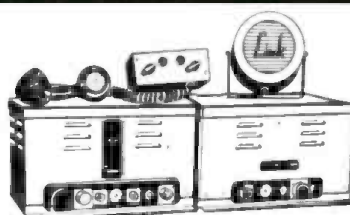

2-PIECE MODEL FMTR 30-50 MC ED. 7 FM MOBILE TRANS. & REC.—6 OR 12 VOLTS

Unit complete with Peak Modulation control head, mike, antenna, cables & crystals Ground to your specific frequency. Modified.

6 Volt—\$109.95 12 Volt—\$149.95

2-PIECE MODEL FMTR 152-174 MC ED. 7, 25 W. FM MOBILE TRANS. & REC.—6 OR 12 VOLTS

Supplied as illustrated above.

6 Volt—\$134.95 12 Volt—\$174.95

SPECIAL!

17 LBS. of ASSORTED RADIO PARTS
Now at give-away price of only..... **\$1.59**



While They Last! T-17 HAND-HELD CARBON MIKE

For use in voice communication. Effectively covers the audio frequency range from 300 to 2000 cps. 200 ohms, with press-to-talk switch. 5 ft. rubber cord & plug. **\$3.95**

MINIMUM ORDER \$5.00

Immediate Delivery. Include 20% deposit with order—balance C.O.D. All shipments F.O.B. our warehouse, N. Y. C. (N. Y. C. residents add sales tax to your remittance.)

MODEL 2210 152-162 MC FM MOBILE TRANS. & REC. 6 OR 12 VOLTS



Antenna, cables, control head, mike, crystals. Complete for immediate installation. Specially Priced.

6 Volt **\$139.50**
12 Volt **\$162.50**

MODEL 2365 25-40 OR 30-50 MC FM MOBILE TRANS. & REC.—6 OR 12 VOLTS

Supplied as illustrated above. Complete for immediate installation.

6 Volt—\$119.50 12 Volt—\$149.50

FREQUENCY METERS

For the maintenance shop and field service, BC-221 Frequency Meters complete with original calibration book. Available in modulated and unmodulated types as well as a-c operated models. Factory tested, checked for frequency alignment and GUARANTEED.

Unmodulated Type..... **\$119.50**
Modulated Type..... **\$139.50**
Modulated Type with AC Power Supply..... **\$159.50**

NEW! Our own version of the famous BC-221 with built-in mirror eye zero-beat indicator. Add \$25.00 to any model.

Take Advantage of this Tremendous Saving!

BRAND NEW CARTER GENEMOTOR

Input 26.1 VDC @ 7 amps. **\$7.95**
Output 405 VDC @ .270 amps.



PLATT ELECTRONICS CORP.

20 MURRAY ST., NEW YORK 7, N. Y.
Telephone: COrland 7-2575

TV PICTURE TUBES AT LOWEST PRICES

NEW TUBES	14RP4 \$16.95	21CEP4 \$22.95
ALL ALUMINIZED:	14W/ZP4 16.95	21DEP4 22.95
	17BJP4 19.95	24AEP4 26.95
	17BZP4 19.95	24AMP4 26.95

10BP4 \$ 7.95	17BP4 \$ 9.95	21AMP4 \$15.75
12LP4 8.50	17CP4 17.00	21ATP4 15.75
14B/CP4 9.95	17GP4 17.60	21AUP4 15.75
16DP4 12.00	17HP4 12.50	21EP4 13.50
16EP4 12.75	17LP4 11.50	21FP4 14.50
16GP4 14.50	17QP4 9.95	21WP4 14.00
16KP4 9.95	17TP4 17.00	21YP4 14.50
16LP4 10.95	19AP4 16.00	21ZP4 13.50
16RP4 9.95	20CP4 13.50	24CP4 23.50
16WP4 12.00	20HP4 14.50	24DP4 24.50
16PT4 9.95	21AP4 22.10	27PA 39.95
17AVP4 12.50	21ALP4 15.75	27RP4 39.95

1 Year Warranty

Aluminized tubes \$3.00 for 21"; \$5.00 for 24" and 27" additional. Prices include the return of an acceptable similar tube under vacuum. These tubes are manufactured from reprocessed used glass bulbs. All parts and materials including the electron gun are brand new.

ALL PRICES FOR CHICAGO, ILLINOIS. Deposit required, when old tube is not returned, refundable at time of return. 25% deposit required on COD shipments. Old tubes must be returned prepaid. Tubes shipped Rail Express. Shipped only to Continental U. S. and Canada.

WRITE FOR COMPLETE LIST.

—PICTURE TUBE OUTLET—
2923 MILWAUKEE AVE., CHICAGO 16, ILLINOIS
Dickens 2-2048



-- then you need us!

GET STARTED RIGHT by writing for FREE 8 page catalog illustrating over 30 business forms and systems designed specifically for TV-Radio Service.

ON SALE AT YOUR PARTS JOBBER

Delrich Publications • 4308 N. Milwaukee • Chicago 41, Ill.

SOME SPECIALS FROM OUR NEW GREENSHEET CATALOG

(Order Direct or write for catalog for further details.)

G.E. Hi-Volt. Sel. Rectifiers. 1450 RMS @ 100 Ma. Use # in Bridge Cra't to obtain approx. 1500 V.D.C. @ 200 Ma. 95¢ ea. (4 for \$2.95).
Acme Hi Volt Xfms. Pri: 115 V. @ 60 CPS. Sec: 2000 V. @ 10 Ma. Brand new. Boxed. \$2.95.
Relief Maps of USA & World. Self-framed, ready to hang. Beautiful color. Accurate, decorative, treat yourself or send as a gift. Specify USA or World. 28 1/2" x 18 1/2" —\$9.95, 26" x 41" —\$24.95, 42" x 60" —\$46.95.
Klystron Tubes for "X-Band" Use: 2K25 @ \$8.00, 723A/B @ \$4.00.
Large stock of Microwave Components. Write. Tremendous and varied stock of Special Purpose & receiving TUBES. Write.
All prices FOB, NYC. (.50¢ service charge for orders under \$5.00.)



*A complete catalog of specialized industrial Electronic TUBES and COMPONENTS... featuring Barry Electronics savings to industry, Hams & Experimenters. Prove these values to yourself! Complete and mail the coupon below for your copy of the "Greensheet." We'll also purchase your equipment and unused tubes. Send details: BARRY ELECTRONICS CORP., 512 Broadway, New York 12, N. Y. Dept. EW-11. Please send me a copy of the "Greensheet and add my name to your mailing list. (EW-11)

Name Title

Company

Address

City State

tional basis, units with selective-calling features can be made available, enabling a dispatcher to send a message to a single car or group of vehicles.

The new equipment may be used to talk to in-plant vehicles, on-the-road vehicles, or personal portables on the same frequency.

DUAL-PURPOSE TEST UNIT

Mercury Electronics Corporation, 77 Searing Ave., Mineola, N.Y. is now offering a dual-purpose test instrument, the Model 400 "VOM-Capacity Tester."

Designed especially for the service field, the unit combines a 20,000-ohms-per-volt v.o.m. with an efficient capacity meter. The instrument has only three knobs and three jacks to speed up operation. The 4 1/2" meter has large, easy-to-read scales.

Complete details on the Model 400 are available from the manufacturer on request.

POCKET-SIZED CB UNIT

Morrow Radio Manufacturing Co., Salem, Oregon is now marketing a small, portable 100 mw. crystal-controlled radiophone with receiver squelch as its Model VP-100. The new unit has an average range of one-half to three miles. Operating on any one of the 22 channels of the Citizens Band, the unit is fully transistorized and completely self-contained, with the exception of the lapel microphone.

Power is provided by one 9-volt battery which is replaceable through a panel in the back of the unit. The instrument measures 3"x1 1/2"x6" and features two external jacks for long-wire antenna and earphones.

NEW HAMBAND RECEIVER

National Radio Company, Inc., Malden, Mass. is now offering a new double-conversion amateur receiver, with 6-meter coverage, as its Model NC-270.

The unit features a patented "Ferrite Filter" and an effective bifilar T-notch



which, combined, is said to provide a degree of selectivity equal to the needs of the most serious c.w. operator and sideband enthusiast.

The new receiver measures 8 5/8" x 15 1/2" x 9". Shipping weight is 28 pounds. Full details are now available from the company's distributors.

SUBMINIATURE DIODES

International Rectifier Corp., 1521 E. Grand Ave., El Segundo, Calif., has announced manufacture of subminiature "tri-sealed" silicon zener diodes.

The new diodes are intended to facilitate the design of smaller, lightweight, and more rugged voltage-regulation cir-

cuits, and at low cost. The diodes are so small that 200 will fit into 1 cubic inch of volume. Not counting leads, a diode measures 0.300 inch long by 0.125 inch in diameter. It is rated at 250 milliwatts power dissipation.

A complete series of 17 types covers the voltage range from 5.6 to 27 volts. Bulletin XSR-258, containing details, will be sent upon written request to the manufacturer.

ULTRAMINIATURE CAPACITORS

Electramics Corp., Cliff at Cedros St., Solana Beach, Calif., has introduced a new line of "Ceramim" high-precision, ultraminiature ceramic capacitors. These new units are said to be especially useful for ultraminiature circuitry applications as in airborne or spaceborne equipment, as well as the general solid-state computer field.

"Ceramim" capacitors measure (less leads) 0.250 inch long. They are 0.098 inch in diameter for capacitances from 47 to 560 µf., and 0.125 inch in diameter from 680 to 1200 µf. when fully encapsulated in glass. [30]

PHOTO CREDITS

Page	Credit
36	Massachusetts Institute of Technology
37	Harvard University
38 (top), 102	Bell Telephone Laboratories
38 (bottom)	Hughes Aircraft Co.
46 (top)	Collins Radio Co.
46 (center right)	Radio Corporation of America
46 (center left)	DeVry Technical Institute
46 (bottom)	Minneapolis-Honeywell
47 (top)	Bernco, Inc.
47 (center left)	Levinthal Electronic Products
47 (center right)	Alleghany-Ludlum Steel Co.
47 (bottom)	Philco Corporation
52 (left)	Beckman/Berkeley
52 (right)	Computer Measurements Co.
53 (left)	Hewlett-Packard
53 (right)	Transistor Specialties
108	Eico

Answer to Puzzle Appearing
on Page 127

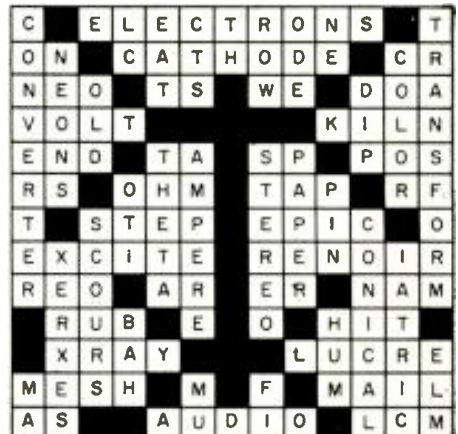

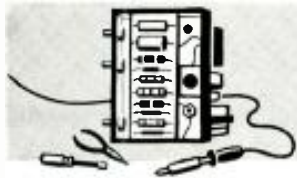

ELECTRONICS MARKET PLACE

RATE: 60¢ per word. Minimum 10 words. January issue closes November 4th. Send order and remittance to ELECTRONICS WORLD, One Park Ave., N. Y. C. 16, N. Y.

RADIO ENGINEERING & INSTRUCTION

USED Correspondence Courses and Books sold and rented. Money back guarantee. Catalog Free. (Courses bought.) Lee Mountain. Pisgah, Alabama.

LEARN Code. Qualify for Amateur or Commercial License. Free Book. Candler System, Dept. EW-11, Box 9226, Denver 20, Colo.

LEARN the Morse in minutes by a proven method, copyright 1960, send \$2.00 to: Easy Method Morse System, Box 86, Perrysburg, Ohio.

FOR SALE

KNOBBS For All TV Sets, Hard To Get Radio & TV Components—Complete Hi-Fi & Stereo Equipment. Receiving Tubes at discounts. Special Colts, Special Resistors, Transformers, Controls, Condensers, Diodes, etc. Free Technical Hints and Tips for repair and maintenance of TV Sets. Send for free catalog. Stevens Electronics, Inc., 459 C Broadway, Hicksville L.I., N.Y.

GOVERNMENT Sells: Surplus Electronics; Test Equipment; Oscilloscopes; Transceivers; Jeeps; Boats; Aircrafts; Misc.—Send For U.S. Depot Directory & Procedure \$1.25—Brody Surplus, Box 425 RT, Nanuet, N. Y.

GDVERNMENT Surplus Receivers, Transmitters, Snooperscopes, Parabolic Reflectors, Picture Catalog 10¢. Meshna, Malden 48, Mass.

TUBES—TV, Radio, Transmitting And Industrial Types At Sensibly Low Prices. New, Guaranteed, 1st Quality, Top Name Brands Only. Write For Free Catalog or Call WALKER 5-7000, Barry Electronics Corp., 512 Broadway, New York 12N, N. Y.

SDMETHING for sale? Place a classified ad in this section. Low-cost, fast results. It's easy.

DIAGRAMS for repairing radios \$1.00. Television \$2.00. Give make, model. Diagram Service, Box 672-RN, Hartford 1, Conn.

NEW, Transistorized Signal Generator. 150 KC. to 120 MC. on fundamentals. Battery operated. Internal 400 cycle, any external audio modulation. Socket for Citizens Band Crystals. Send for free information. Pell Electronics, Box 555, Ridgewood, New Jersey.

TV, radio, tubes, top name brands, manufacturer's boxes, new, first quality. Guaranteed, no rejects terrific discounts on other good buys. Teletube Supply Co., 159 Western Promenade, Cranston, Rhode Island.

FREE: 1961 catalogs for newest, best electronic bargains available. Stereo, hi-fi, ham radio, 1000 other items. Alco Electronics, Lawrence 7, Mass.

200 Assorted terminal strips \$1.00 postpaid—Ace Plastics, Marion, Va.

REMOTE Control for Citizen Band Units. Write manufacturer. Frontier Electronics, Orr, Minnesota.

TV & Radio Tubes, precision tested and guaranteed, mostly used, boxed—3 for \$1.00. 100 assorted for \$30. Lou-tronics, 131 Lawrence Street, Brooklyn 1, New York.

POLYTRONICS IISD latest transceiver, new, \$125. Suite 6K, 84-20 51 Ave., Elmhurst.

BC433 15 tube ADF Receiver. Used, \$6.95. Write for flyer. Downs, 906 Allendale, Baltimore.

TV & Radio Tubes—All top Name Brands—R.C.A., etc.—60-10-5%. Full replacements—regular boxed—no jobs or closeouts. (Representatives wanted for all states.) Radio Tube Specialists, 397 7th Ave., Brooklyn 15, N.Y.

SERVICEMEN: Free—to our tube customers—a mink stole for your wife—buy your top name brand tubes from us—first quality—full replacements—60% plus free tube bonus. Radio Tube Specialists, 397 7th Avenue, Brooklyn 15, New York.

TRANSISTOR portable radio kits, \$6.95. TV's, console models, 16", 17", 19", used, \$14.95. Heavy duty solder gun, free extra tip, solder, \$5.95. Channel Master conical antenna, \$6.95. Switch-type indoor antenna, \$2.99, 6 for \$2.49 ea. Parallel picture tube brightener, 99¢; series type, \$1.39. Auto vibrators, 6V 4 prong Universal, \$1.59, 12V 3 prong Standard, \$1.79, 12V 4 prong Standard, \$1.99. Fiber fuse clips, 15¢ ea., 12 for \$1.65. RCA cheater cords, 39¢ ea., 6 for \$1.95. Write for free catalog of tubes, parts. All postpaid except used TV and channel master antenna, FOB Harrison. N. J. Teltron Electric Co., Dept. EW10, 428 Harrison Ave., Harrison, N. J.

AUTO Radio Distributor, Selling, Servicing. Becker Glaupt, FM-AM, other European, American Sets. Save 30%+. Square Electronics, 150-60 Northern Blvd., Flushing, N. Y.

RADIO & TV Tubes at Manufacturer's prices! 100% Guaranteed! Brand New! No re-brands or pulls! United Radio, Box 1000-W, Newark, N. J.

RADIO and television tubes, brand new, 1st quality, original boxed name brands only. Discounts up to 66 2/3% off list. Positively no seconds. Send for free price schedule. Edison Tube Co., Menlo Park, N. J.

TV Tuners—Rebuilt or Exchanged \$9.95 complete—all types—fast, guaranteed service. Send tuner with all parts to: L. A. Tuner Exchange, 4611 West Jefferson Blvd., Los Angeles 16, California.

TUBES—TV and Radio tubes, Guaranteed—Save up to 80%—Write: Emkay Electronics, P.O. Box 142, Blythebourne Station, Brooklyn 19, N.Y.

B & K TV analyst \$150.00. Other bargains in test equipment. Virginia Battery and Ignition Inc., 21 E. Bank St., Petersburg, Virginia.

NEW, unusual, low-priced. Electrical Devices. Literature 10¢. Wellsco, Box 3055, North Hollywood, California.

WANTED

CASH paid for short-wave ham receivers and transmitters. Treger, W91VJ—2023C N. Harlem Ave., Chicago 35, TUxedo 9-6429.

WANT to buy good equipment and accessories? Place a low-cost classified ad in this space.

SURPLUS measurement model 78 or 80 signal generators. Also federal 804 or I-122 or used Motorola two-way equipment. State quantity, price, and condition. Communications Service, Inc., 3209 Canton Street, Dallas, Texas.

CASH Paid! Sell your surplus electronic tubes. Want unused. Clean radio and TV receiving, transmitting special purpose. Magnetrons, Klystrons, broadcast types. Want military and commercial lab/test equipment such as G.R.H.P., AN UPM prefix. Also want commercial Ham Receivers and Transmitters. For a Fair Deal write: Barry Electronics Corp., 512 Broadway, New York 12, N. Y. (Walker 5-7000).

F.A.D. Andrea 1938 5" Television, radios manufactured in 1920's. Send description, price. Hagen, 1079 Juneau, Akron, Ohio.

TAPE & RECORDERS

HI-FI Components—Tape Recorders. All brands in stock at "We Will Not Be Undersold Prices." Quotations. Free Wholesale Catalog return mail. Hi-Fidelity Center, 1797NC First Avenue, New York 28, N. Y.

AMPEX, Concertone, Magnecord, Presto, Bogen, Tandberg, Pentron, Sherwood, Rek-O-Kut, Scott, Shure, Dynakit, others, Trades. Boynton Studio, Dept. RT, 10 Pennsylvania Ave., Tuckahoe, N. Y.

OVER 245,000 buyers and sellers will read your ad when placed in this space. It costs only 60¢ per word; minimum of 10 words including your name and address.

NEW concept of learning self-hypnosis. Now on tape or record. Free literature. McKinley-Smith Co., Dept. T-6, Box 3038, San Bernardino, Calif.

RENT Stereo Tapes—over 1,500 different—all major labels—free catalog. Stereo-Parti, 811-L, Centinela Ave., Inglewood 3, California.

HIGH-FIDELITY



WANT A Quote on recorders? Bayla Co., Box 131-E, Wantagh, N.Y.

INDUCTORS for Crossover Networks. 118 types in stock. Send for brochure. C&M Coils, 3016 Holmes Ave., N.W. Huntsville, Ala.

PRICES? The Best! Factory-sealed Hi-Fi Components? Yes! Send for free catalog. Audion, 25T Oxford Road, Massapequa, N.Y.

DISGUSTED with "Hi" Hi-Fi Prices? Unusual Discounts On Your High Fidelity Requirements. Write: Key Electronics, 120 Liberty St., New York 6, N. Y. Cloverdale 8-4288.

RECORDERS, Components. Free wholesale catalogue. Carston 125-R, East 88, N.Y.C. 28.

NEW Matching Hi Fi Tuner and 8 watt Stereo amplifier. Value \$75, Factory Sale \$16.95 each, guaranteed. Capri Electronics, 3118 W. 48th, Los Angeles 43, Calif., Dept. 29.

REPAIRS & SERVICING

ELECTRONIC kits wired and tested at reasonable cost, John R. Simpson, 46A Cedar St., Waltham, Mass.

BUSINESS OPPORTUNITIES

FREE book "990 Successful, Little-Known Businesses." Work home! Plymouth-454M, Brooklyn 4, New York. **EARN** big money. Self service tube checkers, console model, 22 sockets. Customers test own tubes. Includes neon light head, key for bottom door. \$39.95, FOB warehouse. Teltron Electric Co., Dept. EW10, 428 Harrison Ave., Harrison, N.J.

RADIO Parts Stores & Hi-Fi Salons! Someone "borrowing" your personal copy of Electronics World each month? You ought to be taking advantage of Electronics World convenient re-sale plan. Sell copies in your store . . . perform a good service for your customers . . . with no risk involved. For details, write: Direct Sales Department, Electronics World, One Park Avenue, New York 16, N. Y.

MISCELLANEOUS

EMBOSSED plastic labels, width 1/2", durable, highly legible. Pressure sensitive backing. Identify switches, meters, fuses, files, equipment. Information and sample free. Special, your name 15¢. Nova Crafts, Box 1412, Milwaukee 1, Wis.

SHOPPING GUIDE Classified

A HANDY GUIDE TO PRODUCTS, NOT NECESSARILY ELECTRONIC, BUT OF WIDE GENERAL INTEREST.

PHOTOGRAPHY—FILM, EQUIPMENT, SERVICES

GUARANTEED quality processing, 35mm, 8mm Kodachrome \$1.00. Send for free mailers, photographic discount catalogue. Carterchome, Box 645, Utica 1, New York.

FREE! New 1960 catalog of all photographic books available. For your copy, send postcard with name and address to Catalog Popular Photography Book Service, One Park Ave., New York 16, N. Y.

MUSIC

SONGS into Dollars! Share \$33 million dollars yearly for New Songwriters, Songpoets. Any subject, songs composed. Published, promoted by largest firm. Information, appraisal Free. Send Nordyke Music Publishers, 6000 Sunset, Hollywood 283, California.

MAGNETS

ALNICO Multi-purpose Holder Magnets, 10 for \$1 (refundable). Postpaid. Magnetics, 7777 Sunset, Dept. PB, Los Angeles 46.

HELP WANTED

DETECTIVES—Experience unnecessary. Detective particulars. Wagoner, 125-Z West 86th, N. Y.

OVERSEAS Employment. High Pay. Comprehensive job information. Foreign Opportunities, Box 172, Columbus 16, Ohio.

EARN Extra money selling advertising book matches. Free Samples furnished. Matchcorp, Dept. MD-110, Chicago 32, Ill.

HAVE you read "How To Get A Good Job?" Secrets heretofore highly guarded now revealed. Free Literature. Write: Employment Information, Box 10634, Jackson 9, Miss.

WRITE Martin Lincoln, Electronics World, 1 Park Avenue, New York 16, N. Y. for information on how to place a classified ad in this section.

EDUCATIONAL OPPORTUNITIES

COMPLETE Your High School at home in spare time with 63-year-old school. Texts furnished. No classes. Diploma. Information booklet free. American School, Dept. X836, Drexel at 58th, Chicago 37, Illinois.

LEARN while asleep (methods 92% effective). Develop will power and dynamic personality, control weight and tension through electronically proven transitional sleep techniques. Details free. A.S.R. Foundation, Box 21-eg., Henry Clay Station, Lexington, Kentucky.

LEARN While Asleep, Hypnotize with your recorder, Phonograph. Astonishing details, unusual catalog free! Sleep-Learning Association, Box 24-ZD, Olympia, Washington.

HIGHLY effective home-study review for FCC commercial phone exams. Free literature. Wallace Cook (EG10), Box 10634, Jackson 9, Miss.

NOTICE: International School of Electronics, 422 Washington Building, Washington 5, D.C.

LEARN Practical Electronics—Home study and resident training offered. Southern Technical Electronic School, 3806 W. Gray Street, Tampa 9, Florida—Catalogue sent—No Obligation—No Salesman.

BUSINESS OPPORTUNITIES

MAKE \$25-\$50 Week, clipping newspaper items for publishers. Some clippings worth \$5.00 each. Particulars free. National, 81-DG, Knickerbocker Station, New York.

MISCELLANEOUS

SKYSCRAPER-Heel Shoes, Wasp-Waisted Corsets! Photo catalog, \$2.00. Finecraft, Box 442-P, Hollywood 28, Calif.

BIZARRE Fashions! Illustrated Catalogue, \$1.00. Renee, Box 2804-P, Hollywood 28, Calif.

"WINEMAKING," "Beer, Ale." Highest powered methods. Illustrated. \$2.20. Eaton Bookstore, Box 1242-X, Santa Rosa, California.

WIN contest money. Our Contest Bulletin gives hundreds of tips. Lists current contests, rules. Sample, 25¢. General Contests, 1609-F East Fifth St., Duluth, Minn.

ELECTRO-Scribe! Engraves all Metals, \$2.00. Beyer Mfg., 10511-ZD Springfield, Chicago 43.

FUN Gifts and jokes galore. Catalog 10¢. Greenland Studios, Miami 47, Florida.

FREE Illustrated, Hypnotism Catalogue. Write: Powers, 8721 Sunset, Hollywood 46, California.

SPORT stop wristwatch \$9.95, checkwriter \$8.95, golf cart \$14.95. TWECO 155. Indio, Calif.

BUY wholesale, send for free shop at home catalog today. Dixon Co., Box 836, Hawthorne, Calif.

INVESTIGATE Accidents—Earn \$750 to \$1,000 monthly. Thousands of Insurance companies, airlines, steamship lines urgently need Accident Investigators. Free Book. Write: Universal Schools, CZ-11, 6801 Hillcrest, Dallas 5, Texas.

INDEX OF

Advertisers

NOVEMBER
1960

ADVERTISER	PAGE NO.	ADVERTISER	PAGE NO.
Advance Electronics	120	Miller Co., J. W.	80
Airex Radio Corporation	104	Milwaukee School of Engineering	88
Allied Radio	7, 100, 101, 132	Moss Electronic, Inc.	82, 83
Ashe Radio Co., Walter	135	National Radio Institute	17, 18, 135, 138
Audio Empire	115	National Technical Schools	27
Audio Unlimited	134	North American Philips Co., Inc.	81
Audion	128	Oelrich Publications	140
Baltimore Technical Institute	132	Ohmatsu Electric Co. Ltd.	78
Barry Electronics Corp.	140	Olson Radio Corporation	136
Bell Telephone Laboratories	1	Pacific International College of Arts & Sciences	130
Bilt-Rite Electronics Co.	121	Peak Electronics Company	102
Blonder-Tongue Laboratories, Inc.	12	Pearce-Simpson, Inc.	128
Burstein-Applebee Co.	125	Picture Tube Outlet	140
Candee Co., J. J.	134	Platt Electronics Corp.	139
Capitol Radio Engineering Institute, The	90, 91, 92, 93	Prior, Inc., Louis D.	130
Carston Studios	128	R W Electronics	134
Center Industrial Electronics, Inc.	128	RCA Institutes, Inc.	109, 110
Channel Master Corp.	20, 21, 23, 25	Rad-Tel Tube Co.	89
Cleveland Institute of Electronics	29	Radio Corporation of America	16, Fourth Cover
Columbia Electronics	114	Radio Shack Corp.	122
Commissioned Electronics Co.	98	Radio-Television Training School	8, 9
Coyne Electrical School	98, 139	Reeves Soundcraft Corp.	84
DeVry Technical Institute	3	Rek-O-Kut Company, Inc.	79
Dressner	128	Saedi Unlimited	128
Dynaco, Inc.	99	Sams & Co., Inc., Howard W.	106, 107
EICO	33, 34, 127	Sarkes Tarzian, Inc.	133
Electro-Voice, Inc.	103	Scott Inc., H. H.	95
Electronic Chemical Corp.	115	Sencore	85
Electronics Book Service	30, 31, 131	Shure Brothers, Inc.	78
Electrophone & Parts Corp.	80	Sonar Electronic Tube Co.	108
Fair Radio Sales	115	Sonotone Corp.	97
Fidelitone	96	Sprague Products Company	113
G & G Radio Supply Co.	105	Standard Kollsman Industries Inc.	32
General Electric Company	14, 15, 123	Stereo-Parti	130
Goodheart Co., R. E.	111	Stern Co., H. D.	134
Grantham School of Electronics	11	Stromberg-Carlson	4, 5
Hallicrafters	123	Superscope, Inc.	6
Harman-Kardon	13	Supreme Publications	133
Heath Company	72, 73, 74, 75	Sylvania Electric Products Inc.	24, Second Cover
Henshaw Radio Supply	124	TAB	126
Holt, Rinehart and Winston, Inc.	116, 121, 129	Tee-Vee Supply Co.	124
Homewood Industries, Inc.	98	Teltron Electric Co.	138
Hy-gain Antenna Products	137	Terado Company	120
Indiana Technical College	135	Texas Crystals	94
Industrial Instrument Works	130	Thorens	77
International Crystal Manufacturing Co., Inc.	19	Tri-State College	130
International Electronics Corp.	76	Triplett Electrical Instrument Company	Third Cover
Jensen Manufacturing Company	10	Tru-Vac	129
Key Electronics Co.	124	Valparaiso Technical Institute	128
Kuhn Electronics	132	Vanguard Electronic Labs	104
Lafayette Radio	117, 118, 119	Windsor Electronics	124
Lampkin Laboratories, Inc.	120	Wood Development Co.	134
Lektron	130	Xcelite, Inc.	22

... the smartest move you can make

is to **TRIPLLETT VOMs**

... the world's most complete line of VOMs for every purpose!

TRI
Quality
First to last



Model 639-N Case \$9.50. Handsome, black cowhide leather. Center-cover flaps snap back for full view of scales and complete access to instrument without removal from case.

Model Pt. T-225-A-33 Tester Stand \$0.50. Metal, holds tester in approximately 45° angle; facilitates easy reading.

Probe for High Voltage Testing \$14.50. For models 630, 630-A, 630-PL, 630-APL, and 631. Completely insulated polystyrene; guard-type handle. 11¼" long; 48" hi-voltage wire lead with banana plug at tester end. Available in 0-12,000 AC or DC volts, and 0-30,000 AC or DC volts.

Model 630-T \$54.50. Specially designed for telephone maintenance. 2% accuracy on DC. Fused protected circuit protects resistors and meter in ohms ranges. Special neck strap holds instrument, freeing both hands. Banana Jack connectors eliminate all shock hazard. Completely insulated case protects from ground.

Model 666-R Pocket VOM \$29.50. Hand size, ideal for electrical maintenance. With recessed range knob it fits easily into case. AC rectifier pre-calibrated unit for easy replacement. Banana jacks at panel top prevent leads falling over meter dial. Single king-size selector switch minimizes incorrect settings, burnouts, 20 ranges. Molded case streamlined, fully insulated.

Model 666-HH Pocket VOM \$27.50. Compact, hand-size; 3" meter integral with panel, adjusted to 400 microamperes at 250 millivolts. Only 3 jacks necessary for all ranges, 19 ranges.

Model 625-NA \$54.50. Dual sensitivity for extra ranges; large mirror scale for super readability. 3-color meter scale 5" long. 6" instrument. 0-50 microamp. AC volts at 10,000 Ω/V for checking many audio and high imped-

ance AC circuits usually requiring VTVM. 38 ranges. Molded insulated case.

Interior View showing advanced engineering features of all Triplett VOMs. Molded mounting for resistors and shunts allows direct connections without cabling. Eliminates shorts. Longer life.

Model 630 \$44.50. Popular, streamlined; long meter scales for easy reading. Outstanding linear ohm scale; low reading .1 ohm, high 100 megs. Single king-size selector-switch minimizes incorrect settings, burnouts. High sensitivity: 20,000 ohms per volt DC; 5,000 AC. Molded, fully insulated case.

Model 630-A \$54.50. Laboratory type; ½% resistors for greater accuracy. Long mirrored scale eliminates parallax. Banana jacks, low resistance connections; high flux magnet increases ruggedness. Single king-size selector switch minimizes incorrect settings, burnouts. Molded fully insulated case.

Model 630-PL \$44.50. Instant vision, wider spread scales; streamlined case; handsome modern design. Unbreakable window. Outstanding linear ohm scale; low reading .1 ohm; high to 100 megs. Single king-size selector switch minimizes incorrect settings, burnouts. 5 to 500,000 cps frequency response in AC measurements. DC Polarity Reversing switch. High sensitivity: 5,000 ohms per volt AC; 20,000 ohms per volt DC.

Model 10 Clamp-On Adapter \$14.50. Checks line loads with model 310 (can also be used with 6 other models). Instant, accurate, safe. No circuit breaking or work interruption. Easy range-switching. Available in 6 AC Ammeter ranges: 0-6-12-30-60-120-300. Clips around single wire to read AC. Amperes direct. Use with adapter 101 to instantly divide 2-conductor cords. Molded case fully insulated, black plastic with engraved white markings.

Model 630-APL \$54.50. Laboratory type with ½% resistors, more accurate movement. Long mirrored scales eliminate parallax. Unbreakable window. Single king-size switch minimizes incorrect settings, burnouts. 5 to 500,000 cps frequency response in AC measurements. DC Polarity Reversing switch. High sensitivity: 5,000 ohms per volt AC; 20,000 ohms per volt DC. Molded case fully insulated.

Model 630-NA \$74.50. Super DeLuxe with 70 ranges—nearly double conventional types. Frequency compensated from 35 cps to 20 kc. Temperature compensated. Accurate within 1½% full scale reading on DC. Large open front meter easy to read. Unbreakable window. Mirrored scale. Meter protection against overloads. Molded fully insulated case.

Model 631 Combination VOM and VTVM \$64.50. Two fundamental units at the price of a single tester. The No. 1 instrument for all electronic men. Battery operation assures VTVM stability and long life. Sensitivity PLUS. 1.2 volt (VTVM) range is equal to more than nine million ohms per volt. Large easy to read meter with unbreakable face. Single king-size selector switch minimizes incorrect settings, burnouts. Molded case fully insulated.

Model 310 \$34.50. The only complete miniature VOM with 20,000 ohms per volt and selector range switch. Self-shielded against strong magnetic field. Rugged, high torque, barring instrument. Unbreakable plastic meter window. Converts to common probe—frees one hand—by fitting interchangeable test prod into top. Standard sensitivity 20,000 ohms per volt DC, and 5,000 ohms per volt AC. Accuracy 3% DC. Molded fully insulated case.



**TRIPLLETT ELECTRICAL INSTRUMENT COMPANY
BLUFFTON, OHIO**

How do your customers rate you?



Your reputation is based largely on what happens *after* you leave the scene of each service call. For this reason the name on the tubes you install makes a world of difference. RCA tubes are designed and manufactured to assure customer confidence in you as well as in RCA.

RCA tube quality is your best insurance against call-backs due to premature tube failure.

RCA tube performance puts your workmanship in the best light and protects it through rigid quality control.

RCA's trademark symbolizes a name and reputation customers have respected for decades.

Your customers know that those red-white-and-black RCA tube cartons in your tube caddy represent the most trusted name in electronics. Remember, customer confidence is the cornerstone of your business.

To protect your service reputation before, during and after every service call, make sure your next tube order specifies... **RCA TUBES.**

RCA ELECTRON TUBE DIVISION, HARRISON, N. J.



SIGN OF A SERVICE JOB WELL DONE



The Most Trusted Name in Electronics
RADIO CORPORATION OF AMERICA