

ELECTRONICS WORLD

SEPTEMBER, 1960

50 CENTS

- THE CITIZENS BAND & ITS USES
- CAREER OPPORTUNITIES IN ELECTRONICS
- FM AUTO RADIO PROBLEMS

WHAT MICROPHONE WOULD YOU USE?

(See Page 35)



WSOFS27041
AVIONICS G-4 AD MAW
MARINE OPS AIR STA
CHERRY POINT NO CAR



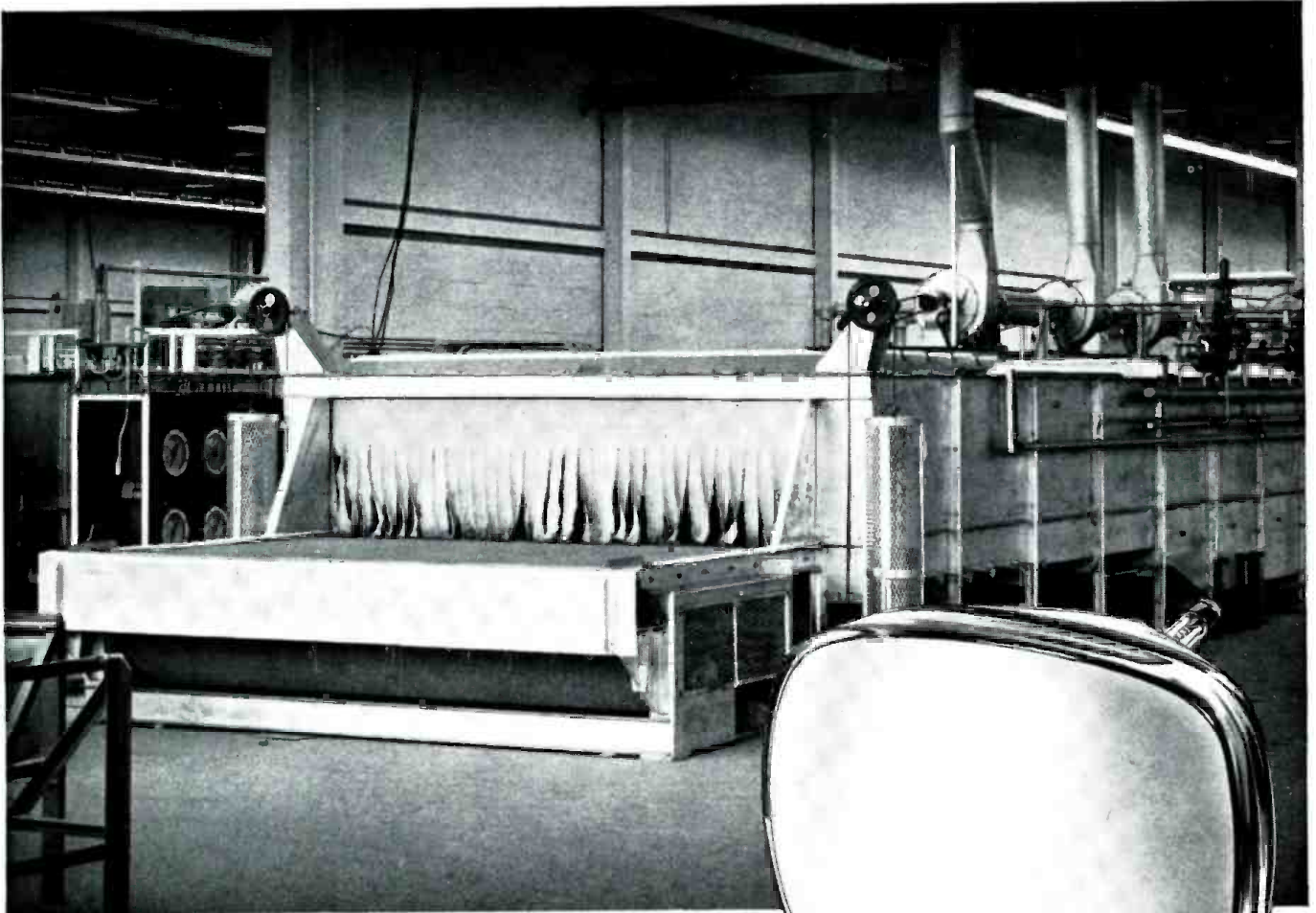

Have you ever seen the SYLVANIA "Bakery"?

"Bakery"? An "Oven"? Yes, but not for bread. For Silver Screen 85 Picture Tubes! Giant ovens (Lehrs) — each about one-third the length of a football field — "bake in" the big differences that make Sylvania Silver Screen 85 the finest replacement TV picture tube . . . *second to none!*

The giant ovens heat-treat the glass and bake the phosphor screen and other internal coatings. Important, too—this process removes residual volatile materials such as lacquer and water used in applying the phosphor screen.

This treatment must be done slowly, under careful controls and is very essential to the proper processing of the bulb. This process also assures "stronger" glass,

free of undesired strains. It extends picture tube life by ridding the bulb of contaminants that could later cause inter-element leakage, gassing and loss of emission. The manufacturer who employs expensive equipment such as this can assure you of a consistently top-quality product.

So, when you recommend a replacement picture tube, recommend the finest . . . a Sylvania Silver Screen 85. It gives your customers what they want: better pictures for a longer time. Gives you what you need: profitable TV service calls.

*Electronic Tubes Division,
Sylvania Electric Products Inc.,
1740 Broadway, New York 19, N. Y.*

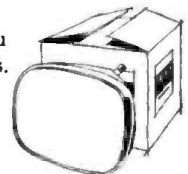

SYLVANIA

Subsidiary of **GENERAL TELEPHONE & ELECTRONICS**



make your first move to **ROHN**



You Have the Greatest Sales Potential by Far With America's MOST COMPLETE LINE OF

TOWERS—MASTS ROOF TOWERS Installation Accessories

ROHN TV TOWERS

ROHN makes the finest towers available for television reception! Illustrated is the No. 25 with amazing "zig-zag" cross bracing design. The entire tower is rated 33% stronger than other similar sized towers. Yes, sell and install the No. 25 up to 50 feet self-supporting or, properly guyed, up to 360 feet!

Or if you prefer, sell the popular ROHN No. 6 tower with the famous "Magic Triangle" cross-bracing. Both are fully HOT DIPPED GALVANIZED AFTER FABRICATION! Sections in easy-to-handle 10 ft. lengths.

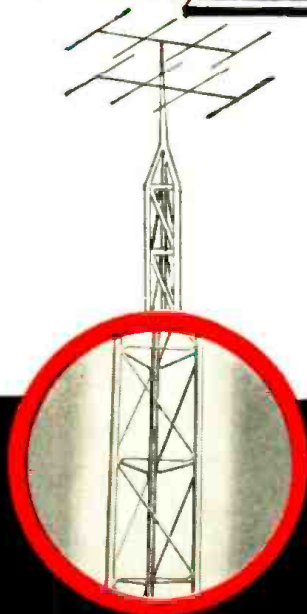

From every standpoint, ROHN Towers offer you MORE . . . more quality, more variety, more advanced design, more sales features, more service, more total sales and more PROFITS! Move forward with these ROHN items!

ROHN COMMUNICATION TOWERS

Here you have FIVE complete lines of heavy-duty, FULLY ENGINEERED communication towers to fulfill any communications requirement. Shown is the ROHN "SS" tower which is self-supporting up to 130 feet. Other models — (30-40-50-60) are available in heights up to 630 feet when guyed! Handle these towers for the demand in your area. There's a complete NEW catalog on this line. Get a copy so you'll have it on hand.

AMATEUR "FOLD-OVER" TOWERS

Specially designed "fold-over" towers are the best ever designed for amateur radio and experimentation. They are the most desired because they "fold-over" completely so you work on the ground for ease and safety. Three sizes, including heavy-duty type to handle any needs. All hot dipped galvanized.

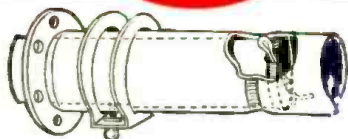

TELESCOPING MASTS

Unexcelled in design, structural strength, and sales appeal. All popular sizes, heights, and weights available. Also, mast tubing in exact specifications that's demanded today.

ROOF TOWERS . . .

in 10, 5, 3, and 2½ feet heights — very popular — easily shipped — ideal in use — the best ever designed — in hot-dipped galvanized finish — truly a big profit item for you!

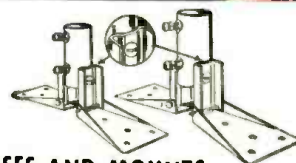
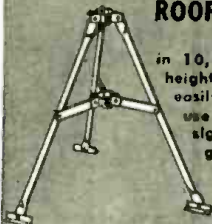

BASES AND MOUNTS

Wide variety of bases and mounts. Special features include "locking" device — also cast aluminum roof mounts — and a host of other installation items . . . get full details.



TV SERVICE TABLE

For holding TV sets while servicing, or storing, or for mobile use of set in such places as motels, hospitals, etc. Ideal for dozens of uses — thousands sold. Large casters — a real work-saver.

ROHN

Manufacturing
Company

116 Limestone, Bellevue
Peoria, Illinois

Get complete catalog from your ROHN representative or jobber or MAIL THIS COUPON!

Gentlemen: Please send me literature on ROHN Towers and Accessories.

Firm _____

Name _____ Title _____

Address _____

City _____ State _____

ELECTRONICS WORLD is published monthly by Ziff-Davis Publishing Company, William B. Ziff Chairman of the Board (1946-1953), at 434 S. Wabash Ave., Chicago 5, Ill. Second class postage at Chicago, Illinois. Authorized by Post Office Department. Ottawa, Canada.

September, 1960

Editor
WM. A. STOCKLIN, B. S.

Technical Editor
MILTON S. SNITZER, W2QYI

Service Editor
SIDNEY C. SILVER

Associate Editor
P. B. HOEFER

Editorial Consultant
OLIVER READ, D. Sc., W1FTI

Industrial Consultant
WALTER H. BUCHSBAUM

Art Editor
MILTON BERWIN

Art and Drafting Dept.
J. A. GOLANEK
K. W. PAUL, JR.

Advertising Director
JOHN A. RONAN, JR.

Advertising Manager
GEORGE E. MORRISSEY

Midwest Adv. Manager
GILBERT J. JORGENSEN

Western Adv. Manager
ADRIAN WHITED



ZIFF-DAVIS PUBLISHING COMPANY
William Ziff, President; W. Bradford Briggs, Executive Vice-President; Michael Michaelson, Vice-President and Circulation Director; Hershel B. Sarbin, Vice-President; J. L. O'Donnell, Treasurer.

Editorial and Executive Offices
One Park Avenue
New York 16, N. Y. OR. 9-7200



Member
Audit Bureau of
Circulations



BRANCH OFFICES: Midwestern Office, 434 S. Wabash Ave., Chicago 5, Ill.; Western Office, 9025 Wilshire Blvd., Beverly Hills, Calif.; James R. Pierce, manager.

FOREIGN ADVERTISING REPRESENTATIVES: D. A. Goodall Ltd., London; Albert Milhado & Co., Antwerp and Dusseldorf.

First in radio-television-audio-electronics

CONTENTS

GENERAL ELECTRONICS AND INDUSTRIAL

A Friend & Associate (Editorial).....	W. A. Stocklin	6
Spot News.....	Washington Correspondent	23
The Laser—A Light Amplifier.....		39
Recent Developments in Electronics.....		40
Electronic pH Measurement.....	Tom Jaski	44
Making Your Career in Electronics.....	Norman Eisenberg	47
Teleprinter Sets Speed Record.....	Jordan McQuay	51
Radio Aids to Aircraft Navigation (Part 3).....	Francis A. Gicca	57
Name-the-Scientist Puzzle.....	John A. Comstock	103
Tubes and Semiconductors—A Forecast of Sales.....	Louis Martin	114
Calendar of Events.....		140

HIGH FIDELITY AND AUDIO

How to Choose the Proper Microphone.....	George Riley	35
Cover Story.....		38
A New Approach to Loudness Compensation.....	Herman Burstein & Henry C. Pollak	42
Home-Built Acoustic-Suspension-Type Speaker System.....	W. F. Hughes	62
Hi-Fi—Audio Product Review.....		72
New Audio Test Report (Scott Model 314, Audax CA-60, Homewood Model 2) EW Lab Tested.....		108
Certified Record Revue.....	Bert Whyte	120
Sound on Tape.....	Bert Whyte	122

TELEVISION-RADIO

Don't Underrate Transistors.....	James R. Spencer	52
FM Reception on Wheels.....		64
Cascade Circuits: How and Why.....	Jim Kyle	66
Mac's Service Shop.....	John T. Frye	70
A Vibrator "Washer".....	Frank De Bra	82
Service Industry News.....		106
K. C. Licensing Killed.....		127
British TV Changes Looming.....	Patrick Halliday	133

TEST EQUIPMENT

TV Remote-Control Aligner-Tester.....	Frank Hadrick	68
New Tube Tester Data.....		86

COMMUNICATIONS

The Citizens Band & Its Uses.....		54
A National Travel Service Frequency for Citizens Banders.....		55
Citizens-Band Converter.....	J. H. Thomas	61
CB Call Letters Not to be Assigned by Suppliers.....		92

ELECTRONIC CONSTRUCTION

Mobile Transistor Power Supply.....	Donald C. Chayot	96
-------------------------------------	------------------	----

DEPARTMENTS

Letters from Our Readers.....	10	Manufacturers' Literature.....	124
Within the Industry.....	30	Technical Books.....	128
What's New in Radio.....	136		

Circulation (Jan.-June) 251,750 (Publisher's Estimate)
Radio & TV News • Radio News • Television News Trademarks Reg. U. S. Pat. Off.
Copyright © 1960 by Ziff-Davis Publishing Company. All rights reserved.

SUBSCRIPTION SERVICE: Forms 3579 and all subscription correspondence should be addressed to Circulation Department, 434 South Wabash Avenue, Chicago 5, Illinois. Please allow at least four weeks for change of address. Include your old address as well as new—enclosing if possible an address label from a recent issue.

CONTRIBUTIONS: Contributors are advised to retain a copy of their manuscripts and illustrations. Contributions should be mailed to the New York Editorial Office and must be accompanied by return postage. Contributions will be handled with reasonable care, but this magazine assumes no responsibility for their safety. Any copy accepted is subject to whatever adaptations and revisions are necessary to meet the requirements of this publication. Payment covers all author's, contributor's, and contestant's rights, title, and interest in and to the material accepted and will be made at our current rates upon acceptance. All photos and drawings will be considered as part of the material purchased.

Men 17-55

READ THESE AMAZING FACTS ABOUT A MAN WHO COULD BE YOU!

Are **YOU** One of
the men who could
prepare for a job that
PAYS REAL MONEY in

**TELEVISION
RADIO**

Electronics

ONLY DeVRY OFFERS ALL THESE FEATURES!

Only DeVry Tech provides Training Movies to make the basic principles of Electronics crystal clear! DeVry's explanations and illustrations are a pleasure to follow. Over 300 practical experiments with actual Electronic parts are included to give you on-the-job type know-how. You even build your own test equipment.

EMPLOYMENT SERVICE

The Industry knows the quality of DeVry training. That's why our Employment Service usually has more demands for graduates than we can fill. We can also help you get started in your own shop.

ARE YOU PASSING UP THE PAYCHECK—THE SOLID FUTURE —THE REAL BREAK—YOU'VE ALWAYS DREAMED OF?

You meet them almost every day . . . the men who want to advance out of humdrum, low-pay, or no-future jobs. Some are men who had to quit school too soon; men just out of school with no idea of what to do; or men looking for help in planning a better future. Yet, many of them could—can, if they're 17-55—train at home, in their spare time, for an exciting career with real money and an inspiring future in the field of Electronics. And the tragedy of it is: they don't know it! They think they need an advanced education, or some special experience, or a lot of money, to start—but what they need most is the will to win. Maybe you're a man like that. Well, here's great news! It's not too late! Electronics offers men like you, when trained, dozens of different job opportunities—from guided missile control to running your own radio-television service shop. Get the full story of the jobs you may prepare for . . . NOW . . . BEFORE the years and responsibilities close in on you. Send coupon today—no obligation.

EMPLOYMENT
SERVICE

NOTHING
ELSE
LIKE IT

NO
PREVIOUS
TECHNICAL
EXPERIENCE
NEEDED

NO
ADVANCED
EDUCATION
NEEDED

LEARN
AT HOME
OR . . .

IN OUR
CHICAGO
OR TORONTO
LABORATORIES

2 MODERN TRAINING CENTERS

Large modern training centers in Chicago and Toronto offer DeVry students day and evening classes. The staffs, facilities and experience of these centers stand back of the home training programs. Whether you train at home or in residence, you're a DeVry Tech man. Look into it now!

Be A Standout in Electronics . . . Be A DeVry Tech Man!

Accredited Member of National Home Study Council
"One of North America's Foremost Electronics Training Centers"



DeVRY TECHNICAL INSTITUTE

CHICAGO 41, ILLINOIS



DON'T DELAY!

MAIL COUPON TODAY

DeVRY TECHNICAL INSTITUTE

4141 Belmont Ave., Chicago 41, Ill., Dept. EW-9-Q

Please give me your FREE booklets, "Pocket Guide to Real Earnings" and "Electronics in Space Travel," and tell me how to prepare to enter one or more branches of Electronics.

NAME _____ AGE _____

STREET _____ PLEASE PRINT _____ APT. _____

CITY _____ ZONE _____ STATE _____

Check here if subject to military training.

Canadian residents address: DeVry Tech of Canada, Ltd.
970 Lawrence Avenue West, Toronto, Ontario

2060

75 OHM PERMANENT CONNECTION

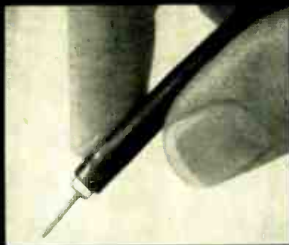

Strip the cable



Slide the ring over the cable



Insert the cable into the coax connector



Crimp the ring with Model CR-1 Crimping Pliers and presto . . . a permanent connection

NEW BLONDER-TONGUE SOLDERLESS COAX CONNECTORS

save
installation
time . . . improve
75 ohm
connection

Now you can make solderless 75 ohm coax connections in a matter of seconds, and be assured that the TV system will perform better, last longer. The reason — positive electrical contact is made, eliminating mismatch and loss caused by poor connections.

NEW CRIMPING PLIERS — Model CR-1. For use with these new solderless coax connections.

\$6.75 net

NEW "Q-D" SOLDERLESS COAX CONNECTORS. New Blonder-Tongue connectors are easy to use; eliminate bulk and are economical in system installations. Complete "Q-D" assembly only 39c net.



75 OHM "QUICK-DISCONNECT" INSTALLATION



Strip the cable



Slide the ring over the cable and insert cable into the "Q-D" connector

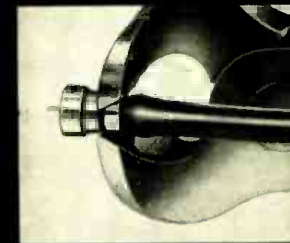

Crimp the ring with Model CR-1 Crimping Pliers.



Insert the "Q-D" into the coax connector on the B-T equipment for a "Quick-Disconnect" installation.

The Blonder-Tongue 10th anniversary line of reception improving tv products employs these new solderless coax connectors for 75 ohm connection, and exclusive Blonder-Tongue "stripless" terminals for rapid, positive 300 ohm connection.



Model B-24 two-set pow-r booster



Model CB single-channel, mast-mounted TV amplifier



Model HAB all-channel TV/FM amplifier

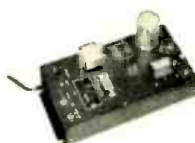

Model BT-3 all-transistor broadband TV/FM amplifier



Model AB-2 mast-mounted antenna booster



Model MCSb vhf single channel amplifier



Tapoffs, Splitters, Baluns

Available through parts distributors. Write for free catalog Dept. EW-9



BLONDER-TONGUE LABORATORIES, INC. 9 ALLING ST., NEWARK 2, N.J.

In Canada: Teleequipment Mfg. Co., Ltd., London, Ont. Export: Morhan Export Corp., N. Y. 13, N. Y. hi-fi components • UHF converters • master TV systems • industrial TV cameras • FM-AM radios



ELECTRONICS WORLD

BREAK THROUGH TO HIGHER PAY in ELECTRONICS TV-RADIO

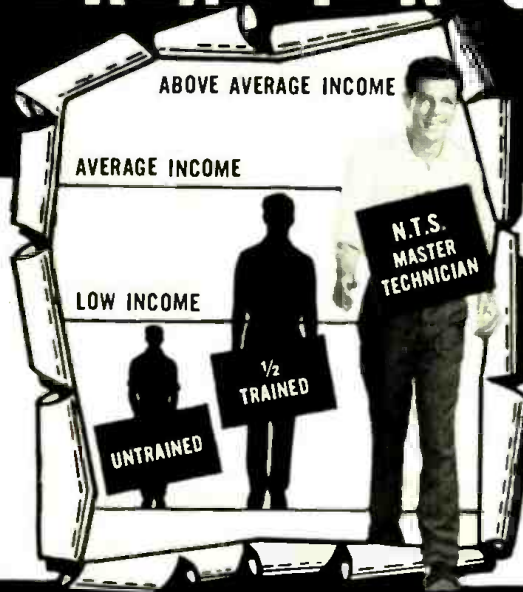

START NOW! Break through the Earning Barrier that stops half-trained men. N.T.S. "All-Phase" training prepares you — at home in spare time — for a high-paying CAREER in Electronics — TV — Radio as a MASTER TECHNICIAN. One Master Course at One Low Tuition trains you for unlimited opportunities in All Phases: Servicing, Communications, Preparation F.C.C. License, Broadcasting, Manufacturing, Automation, Radar and Micro-Waves, Missile and Rocket Projects.

A more rewarding job... a secure future... a richer, fuller life can be yours! As an N.T.S. MASTER TECHNICIAN you can go straight to the top in industry... or in your own profitable business.

You work on actual job projects

SUCCEED IN MANY HIGH-PAYING JOBS LIKE THESE...

- TV-Radio Sales, Service and Repair
- Profitable Business of Your Own
- Communications Technician — F.C.C. License
- Hi-Fi, Stereo & Sound Recording Specialist
- TV-Radio Broadcasting Operator
- Technician in Computers & Missiles
- Electronics Field Engineer
- Specialist in Microwaves & Servomechanisms
- Expert Trouble Shooter
- All-Phase Master Technician

19 BIG KITS YOURS TO KEEP

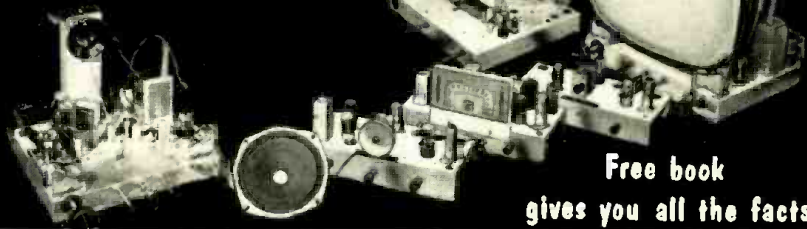

Free book gives you all the facts

NATIONAL TECHNICAL SCHOOLS

WORLD-WIDE TRAINING SINCE 1905
4000 S. FIGUEROA ST., LOS ANGELES 37, CALIF., U. S. A.

Write Dept.
RH-90



RESIDENT TRAINING AT LOS ANGELES
If you wish to take your training in our Resident School at Los Angeles, start NOW in our big, modern Shops and Labs. Work with the latest Auto and Diesel engines — all types — fuel injection, automatic transmissions, all power equipment — most complete facilities offered by any school. Expert, friendly instructors. Graduate Employment Service. Help in finding home near school — and part time job while you learn.
WRITE FOR SPECIAL RESIDENT SCHOOL CATALOG AND INFORMATION



ACCREDITED MEMBER
the only nationally recognized accrediting agency for private home study schools.

N.T.S. Shop-Tested HOME TRAINING is **Better, More Complete, Lower Cost**... and it is your key to the most fascinating, opportunity-filled industry today!

YOU LEARN QUICKLY AND EASILY THE N.T.S. SHOP-TESTED WAY

You get lessons, manuals, job projects, unlimited consultation, graduate advisory service. You build a Short Wave-Long Wave Superhet Receiver, plus a large-screen TV set from the ground up, with parts we send you at no addi-

tional cost. You also get a Professional Multitester for your practical job projects.

EARN AS YOU LEARN... WE SHOW YOU HOW!

Many students pay for entire tuition — and earn much more — with spare time work they perform while training. You can do the same... we show you how.

SEND FOR INFORMATION NOW... TODAY! IT COSTS YOU NOTHING TO INVESTIGATE.

N.T.S. HOME TRAINING is

- Classroom Developed
- Lab-Studio Planned
- Shop-Tested
- Industry-Approved
- Specifically Designed for Home Study



MAIL COUPON NOW for FREE BOOK and ACTUAL LESSON

NO OBLIGATION!
NO SALESMAN WILL CALL

NATIONAL TECHNICAL SCHOOLS

WORLD-WIDE TRAINING SINCE 1905

Mail Now To
National Technical Schools, Dept. RH-90
4000 S. Figueroa St., Los Angeles 37, Calif.
Please rush FREE Electronics-TV-Radio "Opportunity" Book and Actual Lesson. No Salesman will call.

Name _____ Age _____
Address _____
City _____ Zone _____ State _____

Check here if interested ONLY in Resident Training at Los Angeles.
VETERANS: Give date of discharge _____

RECORDS SOUND BEST
with

DYNACO B&O STEREODYNES

Choose either the Stereodyne II (mounts in all standard arms) or the slim, trim TA-12 arm-cartridge combination for the most natural sound from both stereo and mono recordings.



DESIGNED TO THE HIGHEST
DYNACO STANDARDS

- ★ unequalled performance
- ★ outstanding engineering
- ★ unsurpassed value

Rigorous laboratory testing of every unit assures that your cartridge will exceed every specification.

- Smoothest response: ± 2 db from 30 cps to 15 KC. With standard Westrex TA test disc.
- True stereo: More than 22 db channel separation effectively maintained throughout the audio spectrum, with accurate balance and proper phase relationship.
- Superior tracking: highest compliance, low mass, plus exclusive symmetrical push-pull design for minimum record wear and lowest distortion.
- Complete freedom from hum.

Hear and compare it at your favorite dealer's showroom.

Write for complete specifications

DYNACO, INC.

3912 Powelton Ave. • Phila. 4, Pa.
CABLE ADDRESS: DYNACO, PHILA.

...for the Record

By **W. A. STOCKLIN**
Editor



A Friend & Associate

It is with deepest emotion that we announce that Dr. Oliver Read, Publisher of *ELECTRONICS WORLD*, has retired from the *Ziff-Davis Publishing Company*. He was the guiding light for this publication for the last 22 years and, more recently, he was both Editor and Publisher of our sister publication, *POPULAR ELECTRONICS*, as well as being Publisher of *HiFi/STEREO REVIEW*.

Although we are all sorry to see Ollie leave us, his retirement will give him more time to devote to writing and to electronics product engineering and development, especially in the marine electronics field. It will also give him some time to enjoy his many hobbies. He will not be lost to us completely though, since he will continue to serve as advisor to the *Ziff-Davis Electronics Division*.

Many old-timers, who are still readers of *ELECTRONICS WORLD*, will remember him prior to his days with *Ziff-Davis* when he was working at *Utah Radio* developing a completely new line of amateur-radio kits, and writing many articles for this publication. He started as Technical Editor of *RADIO NEWS* (one of our former names) in November, 1938, and then progressed rapidly to be named Managing Editor in October, 1941, Editor in October, 1945, and then Publisher in July, 1956.

When he first started with this publication, with its staff of only two other people, it was far from being a profitable enterprise. But by 1944, conditions had changed and we found ourselves the leading publication in our field. Many of our readers, both in and out of

the Armed Forces, during the Second World War will remember our famous U. S. Army Signal Corps issue in 1944 as a milestone in the field of publishing.

We know that we will never forget his reports of the Bikini A-Bomb test in 1946. This was the fourth atomic explosion, and Ollie was one of those privileged to attend and witness this history-making event.

Amateur radio is another field in which he obtained recognition. Many present-day hams will remember Ollie's call, W9ETI, from Chicago and, more recently,

W1ETI, from Connecticut. In addition, he was trustee for WA2GNH, *POPULAR ELECTRONICS'* Amateur Radio Station, which is located right in our New York office.

There are those who will remember him for his books. He was author of "The Recording and Reproduction of Sound" and, more recently, co-author of "From Tin Foil to Stereo—Evolu-

tion of the Phonograph." Both of these books represented fields in which he was greatly interested in the last few years. Many have seen and enjoyed his collection of old-time phonographs, which he restored as a labor of love.

Those of us who are close to him will always remember his kindness, gentleness, and consideration. There is no doubt that we will all miss him since we will not see him each day as we have for many years, but we do know that his future activities will be less hectic than publishing inevitably must be. We are sure that we can speak for his many friends in wishing him good luck in everything that he will be doing. —50—



Dr. Oliver Read

ALLIED value-packed 1961

444-PAGE ELECTRONICS CATALOG

including products available only from Allied

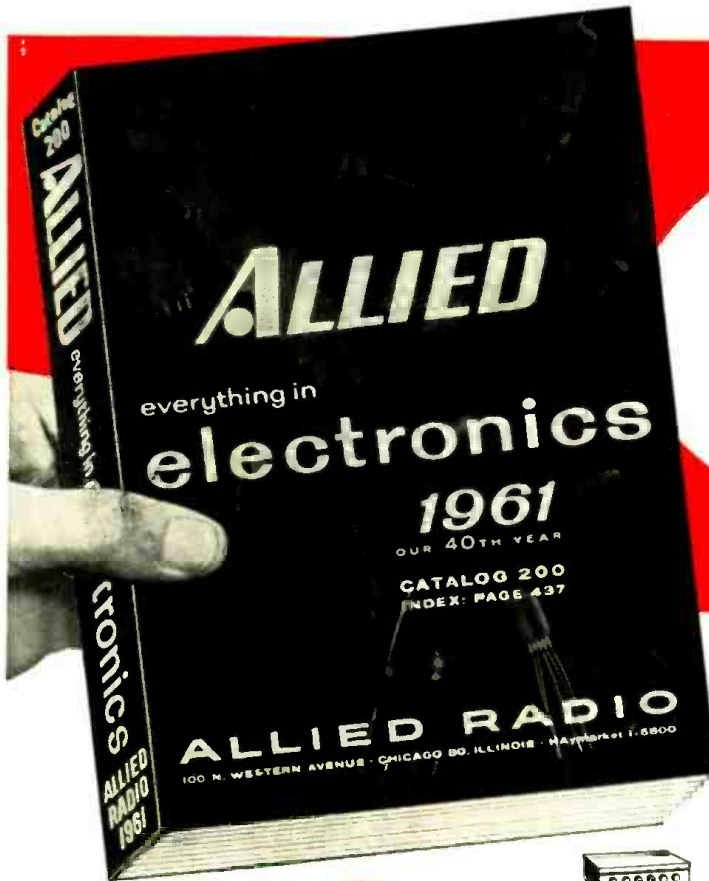

world's
biggest

free
send for it today!

SAVE MOST ON EVERYTHING IN ELECTRONICS

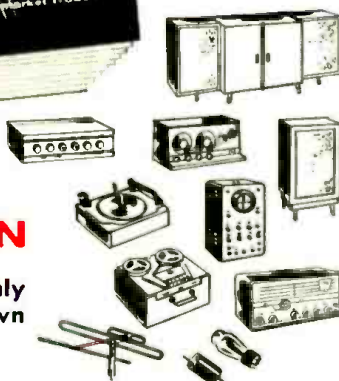

- Newest Stereo Hi-Fi Systems—Everything in Hi-Fi Components
- Money-Saving, Build-Your-Own KNIGHT-KITS® for Every Need
- Best Buys in Recorders & Supplies
- Newest Public Address Systems, Paging and Intercom Equipment
- Amateur Receivers, Transmitters, and Station Gear
- Citizen's Band 2-Way Radio
- Test and Laboratory Instruments
- TV Tubes, Antennas, Accessories
- Huge Listings of Parts, Tubes, Transistors, Tools, Books

EASIEST \$ **2** TERMS
ONLY **DOWN**

Yes, only \$2 down on orders up to \$50; only \$5 down on orders up to \$200; only \$10 down over \$200. Up to 24 months to pay.

ALLIED Exclusives:

MONEY-SAVING KNIGHT-KITS®—truly the very best in build-your-own electronic equipment—designed to save you money, easiest to assemble—the only kits offered with Free Inspection Privilege. See the complete selection of Stereo hi-fi kits, Hobbyist kits, Test Instrument and Amateur kits. KNIGHT-KITS are an exclusive ALLIED product.

KNIGHT® STEREO HI-FI—comparable to the best in quality and performance, yet priced far lower in cost. Select super-value KNIGHT components or complete systems and save most. Also see the largest selection of famous-name hi-fi components and money-saving ALLIED-recommended hi-fi systems.

ALLIED RADIO

our 40th year

**SATISFACTION GUARANTEED
OR YOUR MONEY BACK**

World's Largest Electronic Supply House

Get every buying advantage at ALLIED: lowest money-saving prices, fastest shipment, expert personal help, easiest-pay terms, satisfaction guaranteed or your money back.

free

send for the biggest
electronics catalog!



ALLIED RADIO, Dept. 1-J
100 N. Western Ave., Chicago 80, Ill.

Send FREE 1961 ALLIED Catalog.

Name _____

Address _____

City _____ Zone _____ State _____

"BEST OF ALL CONTACT SPRAYS"

AS REPORTED BY INDEPENDENT PRODUCT-TESTING LABORATORY

	Shield	A	B	C	D	E	F	G	H	I
Lubrication After Rubbing For 90 Sec.	GOOD	Fair	Very Poor	Poor	Good	Poor	Very Poor	Good	Poor	Fair
Cleaning After Rubbing For 90 Sec.	GOOD	Good	Good	Good	Good	Fair	Poor	Good	Fair	Poor
Protection After 30 Sec. Exposure to H ₂ S Gas	GOOD	Fair	Fair	Good	Good	Fair	Very Poor	Good	Very Poor	Good
Protection After 2 Hours Exposure to H ₂ S Gas	BEST	—*	—*	2nd Best	5th Best	—*	—*	3rd Best	—*	4th Best
Flash Characteristics	None at 200°F.	—*	—*	Greatest tendency	Boils at 70°F. Tendency to ignite	—*	—*	Tendency to ignite	—*	Slight tendency to ignite
Attack On Plastic Material	NO	—*	—*	Yes**	Yes**	—*	—*	Yes**	—*	Yes**

*Not tested further following sub-standard performance in 30-second exposure test.

**Presence of solvents and chlorinated hydrocarbons.

Channel Master introduces the first triple-action spray!

Channel Master set out to provide a superior cleaner, lubricant, and protector for electrical contacts. Contact Shield was the result.

To verify our own estimates of the product's effectiveness, Contact Shield was submitted to a nationally known independent testing laboratory.

This famous testing organization made a thorough study of Contact Shield, as well as of nine similar products on the market. The above findings demonstrate conclusively that this new Channel Master product is the most reliable contact spray you can buy!



Here's why **Contact Shield** is best:

- provides the most long-lasting protection
- eliminates background and resistance, noises
- is safer. Will not ignite, flash, or cause short circuits... propellant is actually a fire extinguisher
- contains no solvents to attack plastics
- performs at temperatures from -95°F. to +320°F.

CHANNEL MASTER works wonders in sight and sound
Ellenville, New York

www.americanradiohistory.com

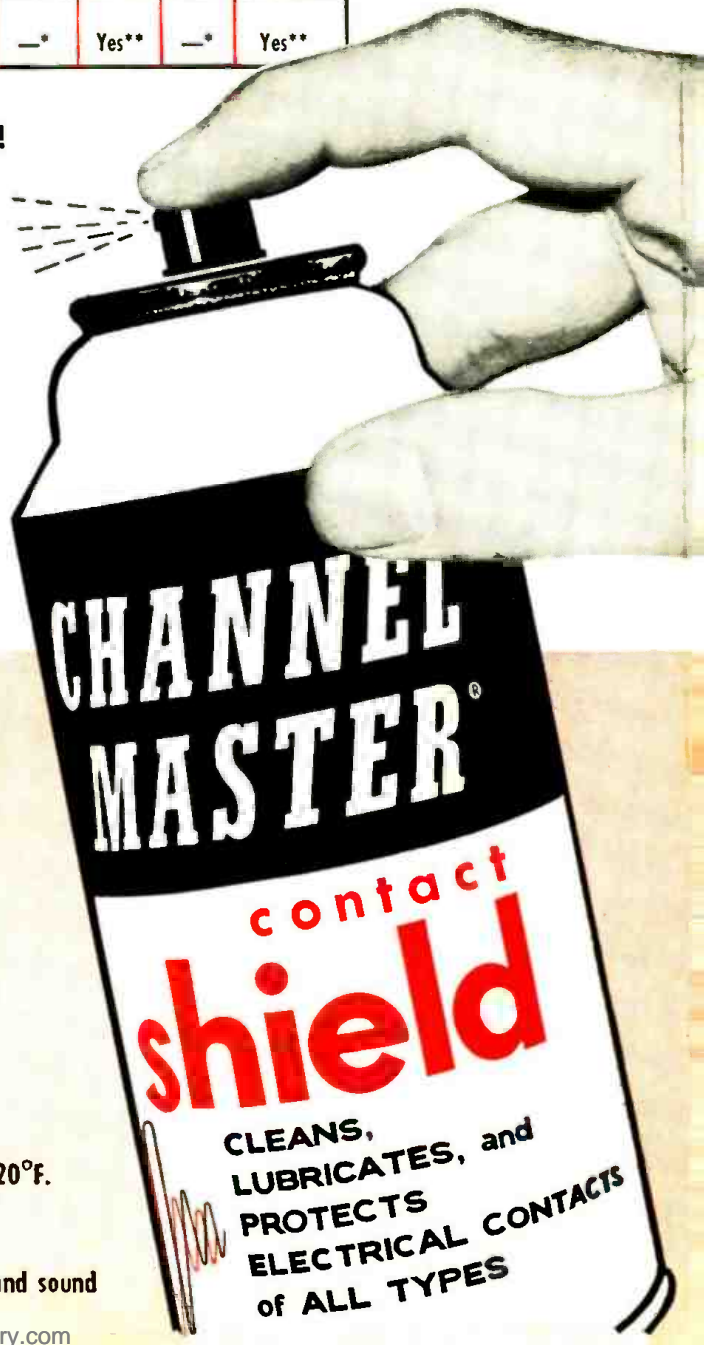

CHANNEL MASTER

contact
shield

CLEANS,
LUBRICATES, and
PROTECTS
ELECTRICAL CONTACTS
of ALL TYPES

Copyright 1968 Channel Master Corp.

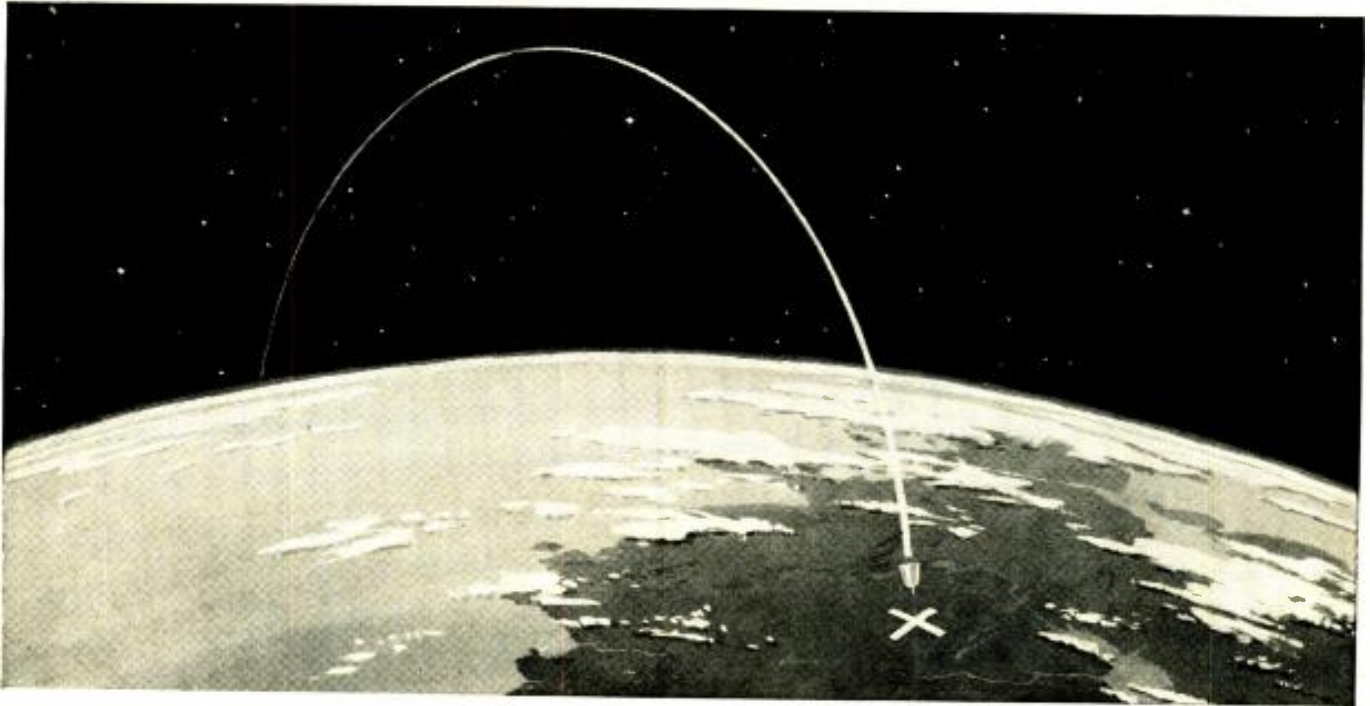

ASSIGNMENT: HIT A TARGET 6000 MILES AWAY

Can you guide a 110-ton Air Force Titan missile far up into the sky, to bring its nuclear warhead down with pinpoint accuracy on a target one-fourth the way around the globe—a target you not only can't see but which continually moves with the spinning earth?

This was the problem in missile guidance the Air Force presented to Bell Telephone Laboratories and its manufacturing partner, Western Electric. The answer was the development of a command guidance system which steers the Titan with high accuracy.

Unlike self-contained systems which demand complex guidance equipment in the missile itself, Bell Laboratories' Command Guidance

System keeps its master control equipment on the ground where it can be used over and over again. Thus a minimum of equipment is carried in the missile, and the ground station has full control of the missile during its guided flight. Techniques drawn from the communications art render the system immune to radio jamming.

Bell Laboratories scientists and engineers designed the transmission and switching systems for the world's most versatile telephone network, developed much of our nation's radar, and pioneered in missile systems. From their vast storehouse of knowledge and experience comes the guidance system for the Titan.

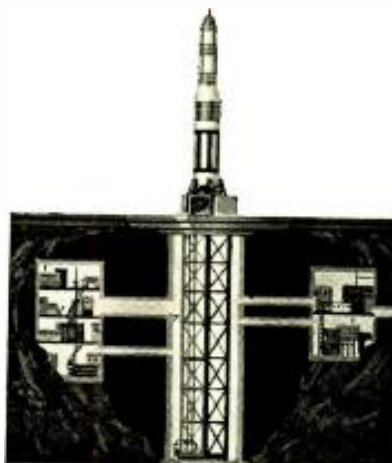

BELL TELEPHONE LABORATORIES

WORLD CENTER OF COMMUNICATIONS RESEARCH AND DEVELOPMENT

PERFORMANCE THAT SPEAKS FOR ITSELF



Precision Crafted

CITIZENS BAND RADIOS

by PEARCE-SIMPSON, INC.

A Leader In Creative Electronics

Powerful two-way radio for personal or business use created by Pearce-Simpson, Inc., makers of "The World's Finest Marine Radios". Available are single and multi channel sets. Shown above is the CBD-5, a powerful, precision crafted five channel set with low current drain (3.2 amps at 12 volts standby). This set available in both dual 12 volts DC, 115 AC, or 6 volt only. Full 5 watts input.

Sets are compact, easily movable, complete with crystals for one channel, microphone, both power supply cables and universal mounting bracket.

CBD-1: Single channel set \$159.50

**CBD-5: Five channel set
(6 volt or 12 volt) \$170.00**

Dealer Inquiries Invited

A limited number of dealerships are available. Dealers efforts are backed by strong national advertising in consumer publications such as Wall St. Journal, Business Week, etc., as well as leading electronic magazines. Write for details.

Send today for free brochure

Pearce-Simpson, Inc.
2295 N.W. 14th St.,
Miami 35, Florida
Please send me your brochure on the
CBD line.

Name

Address

City State

PEARCE-SIMPSON, INC.
A Leader in Creative Electronics
2295 N.W. 14th St., MIAMI 35, FLA.



AUSTRALIAN TELEVISION

To the Editors:

Since you left us out of your "Spot News" (May, 1960 issue) under "Big Gains in Overseas TV," you might be good enough to publish this letter.

Australia is, in area, almost the same size as the United States, but in population we are only about 10,000,000 strong. Our first TV station, TCN Channel 9, opened in Sydney late in 1956, and we now have 16 stations operating with many more to open soon. But the important matter relative to your article is that we have almost one million licensed TV receivers now operating, practically all of them manufactured in this country in the short space of about 3½ years.

We have commercial stations as in the U. S., and we view your popular programs through them. In addition, government-owned stations operate too, and every viewer must buy an annual license costing \$12.00 for which he may own any number of TV sets. Two-set homes are already common and, in addition, quite a number of motor cruisers, caravans, and the like are fitted with TV receivers in addition to multiple installations in motels, hotels, etc. Human nature being what it is the world over, there are probably a number of "freeriders" (or is it "freeloaders" you call them). Consequently, the over-all total of TV sets is well in excess of the known license figures.

Now, Sir, since you give honorable mention to a country with a mere 100,000 sets, I think a bleat from down under is justified in view of the rapid development of TV in Australia, which *pro rata, per capita*, or what have you, might be a world record.

W. M. FERRIS, Director
Channel Master Pty, Ltd.
Brookvale, N.S.W.
Australia

We know our readers are always interested to learn about the status of TV overseas. Incidentally, no offense was meant in leaving out Australia from the countries listed.—Editors.

MUSIC-POWER RATING

To the Editors:

I have recently read your editorial in the June issue on music-power ratings. There were a number of points raised which I think misled rather than clarified readers on the various amplifier power ratings. First, I would like to point out that the music-power ratings were included in the IHFM standards before they were adopted by the EIA.

Concerning the value of music-power versus steady-state sine-wave ratings,

I would like to point out that even though two amplifiers do not have the same steady-state power ratings, the results when *playing music* will be the same for both amplifiers, if all other factors are equal and each amplifier has the same *music-power* rating. This is because the waveform of music has a high peak-to-average value, and the biases and voltages do not shift nearly as much as with a high amplitude steady-state sine-wave signal.

Why has this music-power rating become popular? Certainly, it often gives a higher rating than the steady-state rating, but that is not the fundamental reason. The fundamental reason is that it gives a more realistic rating so that the customer can tell from the rating how his amplifier is going to reproduce *music*. I am sure you will realize there are many important characteristics in an amplifier aside from power output and frequency response. To name a few, there are ability to recover quickly from overload, clean clipping, freedom from parasitic oscillation and instability during overload, stability regardless of load conditions, heating, etc.

The same factors which determine the power output, namely the various voltages and impedances with which the output tubes are associated, and also the feedback circuits and networks, influence all of these other characteristics. In many amplifiers in the past everything has been sacrificed for maximum steady-state sine-wave output power, a condition never encountered in reproducing music. Many such amplifiers have been unstable, have distorted horribly when overloaded even slightly, etc.

We have been building high-fidelity amplifiers for many years—in fact, to the best of my knowledge, our 210-A, first announced in 1946, was the first one. We are fully convinced that music power is the proper way to rate an amplifier for reproducing music. In order to give the customer the best reproduction for his music, the amplifier should be designed for maximum music-power output. Steady-state sine-wave output is of secondary importance in the reproduction of music. The leading advantage of steady-state sine-wave measurements is that they are about the easiest of all measurements to make.

H. H. SCOTT
H. H. Scott, Inc.
Maynard, Massachusetts

Mr. Scott has been for many years one of the leading proponents of the type of power measurement embodied

ELECTRONICS WORLD

Here's The Offer No Other Radio-TV School DARES MAKE!

LEARN AT HOME in Spare Time!

YOU DO MANY PRACTICAL JOBS with the kits we send you. That's right, you PRACTICE what we TEACH! You build a Signal Generator, AC-DC Power Pack, and AC-DC Superheterodyne Radio Receiver and top quality 21 inch TV Set. EARN AS YOU LEARN with the famous RTS 30 Day Income Plan. Full instructions provided. NO HIGH SCHOOL DIPLOMA NECESSARY. This is a COMPLETE course which starts with basic subjects and gradually advances to Radio-TV. . . . ALL FOR A PRICE YOU CAN AFFORD!

***THE ONLY VERTICAL MULTI-CHASSIS 21" TV KIT OFFERED BY ANY RADIO-TV SCHOOL**



YOU BUILD THESE AND OTHER UNITS!

COMPLETE COLOR TV INSTRUCTION INCLUDED!



Each student is entitled to unlimited consultation service. All questions are answered promptly and completely by highly specialized instructors.

MULTITESTER KIT INCLUDED!

*Tubes Excluded

RTS' Membership in The Association of Home Study Schools is your assurance of Reliability, Integrity and Quality of Training.

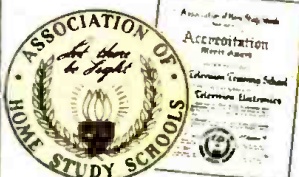

RADIO-TELEVISION TRAINING SCHOOL

815 E. ROSECRANS AVENUE
LOS ANGELES 59, CALIFORNIA

L 101D

Est. 1922

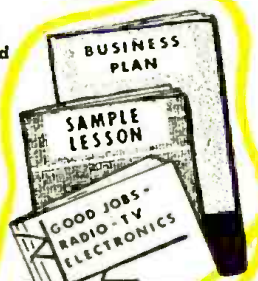

Rush Coupon for FREE FACTS!

RTS Will Train You at a Price You Can Afford and When You Are a Qualified Graduate Will Help You Open a Service Shop of Your Own and Supply You With Every Bit of Equipment You Need to Get Started - Plus an Inventory of Parts and Necessary Supplies.

ALL FINANCED WITHOUT INTEREST OR CARRYING CHARGES!!

You Also Receive . . . Advertising Help and Material, Shop Plans, Business Systems, Letterheads, Calling Cards and Much More!

Here's What Two of Many Business Plan Shop Owners Have to Say!

This business takes in between \$1500 and \$2000 a month. I've had to hire help to keep up with it.

CULLEN W. IRBY
Corpus Christi, Texas

The school lives up to its promises 100%. RTS does not lose interest in its students once they graduate.

HAROLD R. STANLAKE
Perry, Michigan

DON'T LOSE OUT — FIND OUT!

RADIO TELEVISION TRAINING SCHOOL, Dept. EW-90

815 E. Rosecrans Ave. Los Angeles 59, Calif.

Rush me full information by return mail. (Please Print)

NAME _____ AGE _____

STREET _____

CITY _____ ZONE _____ STATE _____

NO SALESMAN WILL CALL ON YOU!

A PLEASURE TO BUY at your franchised Thorens dealer's

A PLEASURE TO OWN... more features, more craftsmanship, more superb music-making quality for monaural or stereo

A PLEASURE TO RECOMMEND to friend or favored customer, with the confidence-inspiring Thorens 1-year guarantee

THE THORENS TD-124 TRANSCRIPTION TURNTABLE

More rotating pounds than any comparable 12" turntable!
More features per pound! Look at them:

- 4 speeds . . . 16 $\frac{2}{3}$, 33 $\frac{1}{3}$, 45, 78
- 11 $\frac{1}{2}$ pound table for smooth running
- Exclusive double-table with clutch for fast starts
- Precision, hairline adjustment for all speeds
- Built-in illuminated strobe
- Easy arm installation or change . . . no metal drilling, no unsightly holes after arm change
- Built-in precision circular level
- Large, knurled, leveling screws
- Motor operates on 50/60 cps, any voltage from 100 to 250. o.2

... and many more. See the TD-124 at your franchised Thorens dealer's today.



TD-124
\$99.75 net
(Base only \$9.00)

Guaranteed for one full year.

Sold only through carefully selected franchised dealers.



THORENS

SWISS MADE PRODUCTS
HI-FI COMPONENTS • LIGHTERS
SPRING-POWERED SHAVERS
MUSIC BOXES
NEW HYDE PARK, NEW YORK

in the music-power concept. We are glad to give him the opportunity to express some of his views on this important subject about which there is still much difference of opinion.

For an article that discusses many of these points, we suggest that our readers watch for "Music-Power Rating—Help or Hindrance?" scheduled for next month's issue.—Editors.

FLASHLIGHT-CELL VOLTAGES

To the Editors:

I wonder if it is possible to use ordinary D-size flashlight cells for meter-calibration purposes? Just what voltages do these cells produce under conditions of very light loading, such as would occur when measurements are made with a v.t.v.m. or sensitive v.o.m.?

MARC SAUL
Floral Park, New York

About the freshest D-size flashlight cells that are available, whose age is not over six months, should have open-circuit voltages averaging 1.57 volts. After about a year's storage, this voltage falls to about 1.56 volts. At ages of around 1 $\frac{1}{2}$ to 3 years, the open-circuit voltage should be 1.55 volts. These voltages are for well-sealed, leakproof-type cells that have been stored and measured at 70°F.

You might also try using a mercury cell for calibration purposes. For example, a new Mallory RM-1 cell has an initial voltage of close to 1.358 volts. This value drops to 1.352 volts after a year's storage at 70°F.

Still another suggestion is to measure the open-circuit voltage of a fully charged lead-acid storage battery. This should measure 2.12 volts exactly. If the battery is partly discharged so that its specific gravity is around 1.240, then an open-circuit voltage of 2.08 volts should be measured.—Editors.

MEASURING TAPE SPEED

To the Editors:

Mr. Burstein's article "Measuring Tape Speed," page 39 in the June, 1960 issue, did a very thorough job of discussing this parameter and promoting devices for its measurement.

Of what practical value is such an article. There is absolutely nothing that the average tape recorder enthusiast can do to correct long term, cumulative time errors. Even the factory can seldom help him.

Flutter and wow are of far greater importance to the user, and the devices described will do nothing at all to pinpoint these problems.

You have a splendid publication and Mr. Burstein is a very able man. However, please don't waste your space on such non-constructive material.

J. H. MCCONNELL
Murray Hill, New Jersey

We cannot quite agree with Reader McConnell here. We believe the very first step in correcting an error or trying to get someone to do something about that correction is to know that

ELECTRONICS WORLD

Through
HOME STUDY
or in
RESIDENT CLASSES

ELECTRONICS

— field of opportunity —

the Grantham Communications
Electronics Course prepares you
for your first class commercial
F.C.C. LICENSE

The Grantham home study course teaches you principles of electronics in a simple "easy-to-grasp" manner. Each new principle is explained first in *everyday language* and then, after you understand it, is associated with the proper *technical language*. You learn and remember more, because the emphasis is on *understanding* rather than on memorizing.

This correspondence course is directed toward two major objectives—(1) to *teach* you a great deal about electronics, and (2) to prepare you to *pass* all of the F. C. C. examinations required for a first class commercial operator's license. We teach you step by step and have you practice with FCC-type tests which you send to the School for grading and comment. You prepare for your F. C. C. examinations under the watchful direction of an instructor who is especially qualified in this field.

Grantham training is the easy way to learn more quickly—to prepare more thoroughly—for F. C. C. examinations. And your first class license is the quick, easy way to prove to your employer that you are worth more money.

Get details concerning *how* we can prepare you for your F. C. C. license and *how* that license can help you advance in electronics. Mail the coupon below to the home office of Grantham School of Electronics in Hollywood, Calif., and our free catalog will be sent to you promptly.

offers

interesting and profitable careers in
RADIO AND TV BROADCASTING • TWO-WAY RADIO COMMUNICATIONS • RESEARCH AND DEVELOPMENT • RELAY STATION MAINTENANCE • AUTOMATION ELECTRONICS • TECHNICAL WRITING IN ELECTRONICS • INDUSTRIAL ELECTRONICS • ELECTRONIC COMPUTERS • MILITARY ELECTRONICS • INSTRUMENTATION • TELEMETERING • AERONAUTICAL ELECTRONICS • SPACE ELECTRONICS

and many other

interesting and profitable fields of the present and future

To get ahead in electronics, you must have the proper training and your employer must know that you have that training. Your F. C. C. license is a "diploma" in communications electronics granted by the U. S. Government, and it is recognized as such by employers. Grantham School of Electronics specializes in preparing you to earn this diploma.

HERE'S PROOF... that Grantham students prepare for F. C. C. examinations in a minimum of time. Here is a list of a *few* of our recent graduates, the class of license they got, and how long it took them:

	License	Weeks
Edgar T. Phelps, 931 Hickory Street, Poplar Bluff, Mo.	1st	12
Wayne Hogg, 4830 San Fernando Rd., Glendale, Calif.	1st	20
Robert Watson, Star Route, Box 24, Renovo, Pa.	1st	12
William H. Patchin, 3865 Westview Ave., NW, Canton, Ohio	1st	12
V. Dean DeVore, 309 Bess Street, Washington, Ill.	1st	16
Edward T. Wall, Box 184, Kenly, N. C.	1st	12
James W. Wranich, 4236 Michigan Street, Kansas City, Mo.	1st	20
Robert E. Sullivan, 2475 E. Douglas, Des Moines, Iowa	1st	12
Nelson S. Kibler, 1413 Patrick Henry Dr., Falls Church, Va.	1st	18
Barry L. Ulrich, 1110 Chestnut Ave., Barnesboro, Pa.	1st	14
Jerry E. Milligan, 707 Ragsdale Dr., Milan, Tenn.	1st	12
Robert S. Davis, 2100 - 10 Ave., So., Apt. 12, Birmingham, Ala.	1st	13

If you are interested in details concerning our training, indicate in the coupon below whether you prefer home study or resident classes, and mail the coupon to the School's home office in Hollywood, California—to the address given in the coupon—for free details.

GRANTHAM SCHOOL OF ELECTRONICS

HOLLYWOOD

SEATTLE

KANSAS CITY

WASHINGTON

FIRST CLASS F.C.C. LICENSE IN 12 WEEKS

Grantham resident schools are located in four major cities—Hollywood, Seattle, Kansas City, and Washington, D.C. Regularly scheduled classes in F. C. C. license preparation are offered at all locations. New day classes begin every three months, and new evening classes begin four times a year. The day classes meet 5 days a week and prepare you for a first class F. C. C. license in 12 weeks. The evening classes meet 3 nights a week and prepare you for a first class license in 20 weeks. For more information about the Grantham resident schools, indicate in the coupon the city of your choice and then mail the coupon to the School's home office in Hollywood, Calif. Free details will be mailed to you promptly.

GRANTHAM SCHOOL OF ELECTRONICS
1505 N. Western Ave., Hollywood 27, Calif.

MAIL COUPON FOR FREE DETAILS—NO SALESMAN WILL CALL—



(Mail in envelope or paste on postal card)

To: **GRANTHAM SCHOOL OF ELECTRONICS**
1505 N. WESTERN AVE., HOLLYWOOD 27, CALIF.

Gentlemen:

Please send me your free booklet telling how I can get my commercial F.C.C. license quickly. I understand there is no obligation and no salesman will call.

Name _____ Age _____

Address _____

City _____ State _____

I am interested in: Home Study Kansas City classes
 Hollywood classes Seattle classes Washington classes

06-1*



BRIGHT NEW VIEW

for Multi-set TV-FM
Home Operation ...



...and a

Bright Profit Outlook for YOU with

NEW JERROLD HSA-43

Amplified 3 SET COUPLER

Here's a new precision-perfected amplifier that provides *5 DB min. gain across all TV-FM channels* on two outputs and no loss in the third output. Housed in a rugged, compact and handsome case. The HSA-43 features single tube operation (6DJ8), A.C. interlock and no-strip twin lead terminals. Its excellent isolation and match prevents set interaction and ghosting. IDEAL FOR FEEDING ONE FM AND TWO TV SETS FROM THE SAME ANTENNA.

***\$29.95 list**

TYPICAL APPLICATIONS

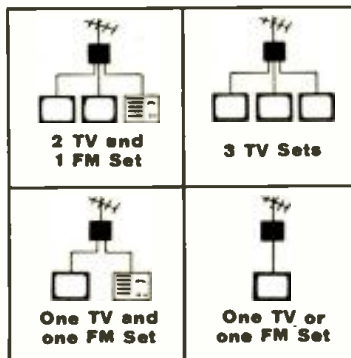

Write Jerrold today for full details on this new Profit Outlook!

JERROLD ELECTRONICS CORPORATION, Distributor Sales Division
Dept. IDS-64, Philadelphia 32, Pa.
Jerrold Electronics (Canada) Limited, Toronto
Export Representative: CBS International, New York 22, N.Y.

LEADER AND LARGEST MANUFACTURER OF TV DISTRIBUTION SYSTEM EQUIPMENT

it exists. Our article attempted to show simple means of determining whether or not speed errors do occur in tape measurements and what their extent is.

We would like to point out that although most of our material is "practical" an occasional "think piece" or theory article is useful.—Editors.

FM BOOSTER

To the Editors:

I live in the fringe area of an FM station which I would like to receive, so the article on a simple FM booster in your April, 1960 issue caught my attention.

Since I am interested in boosting the signal of one particular station, is it reasonable to attempt a modification of the design to obtain higher gain with narrower bandwidth? If, for example, the gain could be increased from 20 db to 26 or 27 db, this would give me a voltage gain of 20 instead of 10, which might make full limiting possible.

I am a little uncertain about the actual dimensions of the 1/2-inch coil form to be used in winding the input and output coils. At first I assumed that this meant 1/2 inch in diameter, but if the inductance is to be .3 microhenry for 4 1/2 turns in one inch, the 1/2 inch must refer to the radius of the coil form. I may have miscalculated, and would very much appreciate getting this definitely settled, since I would like to try building the booster.

FRANK EVANS

Los Alamos, New Mexico

It is possible to increase gain by narrowing bandwidth. However, there always exists the problem of oscillation, if this is carried to an extreme. Since the amplifier is not neutralized in our circuit, we would not recommend attempting to increase the gain much further because of the fairly good chance of causing the booster to oscillate.

According to Author Gicca, Reader Evans is correct about the dimensions of coils L_1 and L_2 . The inductance indicated in the parts list will be obtained with 1/2-inch radius coil forms. Using 1/2-inch diameter forms, the inductance actually amounts to .1 microhenry. Fortunately, the tuning capacitors C_1 and C_2 are sufficient to resonate either inductance into the FM booster so that either coil size may be used. The author actually employed the 1/2-inch diameter forms.

In addition, some of our readers have been having problems with the two radio-frequency chokes shown in our parts list. The National Company part number shown for RFC₁ is actually a 1-millihenry choke while the National Company part number shown for RFC₂ is a 1.3-microhenry choke. Neither of these two chokes is particularly critical, and the circuit should operate properly with chokes having either the values shown in the parts list or those designated by the part numbers.—Editors.

—50—

ELECTRONICS WORLD

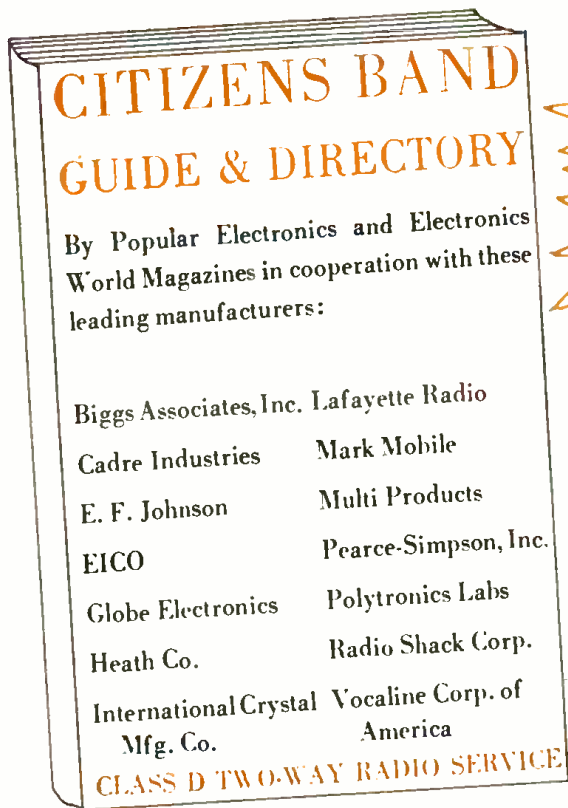

NEW 32-PAGE BOOKLET TELLS HOW YOU CAN GET STARTED WITH YOUR OWN CITIZENS BAND TWO-WAY RADIO WITHOUT ANY EXAMINATION!

Here's your chance to get on the Citizens Band Wagon! Thousands of Americans all over the country have discovered the advantages and economy of owning their own two-way radio sets. No FCC examination is required to own and operate Citizens Band Radio. Be sure to send for your FREE copy of this 32-page Guide to Citizens Band, prepared by Popular Electronics and Electronics World Magazines.

This booklet contains valuable information on...

- The newest in Citizens Band equipment, including actual photographs, prices, specifications.
- How to use Citizens Band: effective ranges, types of antennae, effect of terrain, special applications for you.
- How to get a Citizens Band license *without* an examination.
- Where you can see the newest equipment demonstrated (complete directory of 1200 local dealers included).
- PLUS background of Citizens Band radio, latest FCC regulations, and much more!

ALL YOU HAVE TO DO TO GET THIS FREE BOOKLET IS TO FILL IN AND MAIL THIS COUPON. ►

ACT NOW!

Supplies are limited.
Order your free booklet today!

To: Electronics World & Popular Electronics
Box 206—Village Station
New York 14, N. Y.

Send me my FREE copy of CITIZENS BAND GUIDE AND DIRECTORY

Name _____
(please print)

Street _____

City _____ State _____

W90

the only one of its kind!



NOW... THE *First* ANALYZER DESIGNED EXCLUSIVELY FOR TESTING TRANSISTOR CIRCUIT CAPACITORS!

SPRAGUE MODEL TCA-1 TRANSCAP*

THERE'S NOTHING LIKE IT ON THE MARKET ANYWHERE... AT ANY PRICE!

Here, for the first time, is a precision-made instrument which is specifically designed to *safely* test low-voltage aluminum and tantalum electrolytic capacitors, film and paper capacitors, and ceramic capacitors. *No laboratory or shop working with transistor circuit capacitors can afford to be without one!*

CAPACITANCE BRIDGE: 1 μ f to 2,000 μ f in five overlapping ranges, with laboratory accuracy.

INSULATION RESISTANCE: 50 megohms to 20,000 megohms. Only 25v d-c is applied, permitting measurements on low-voltage ceramic, paper, mica, and film capacitors. For ceramics rated below 25 volts, IR may be calculated from leakage current measurements at exact rated voltage.

POWER FACTOR: Measured by Wien Bridge from 0 to 50%.

LEAKAGE CURRENT: 0.6 μ a to 600 μ a in 7 ranges. Measured directly on meter at exact rated d-c voltage of capacitor. No guessing on eye-width or counting lamp blinks!

A-C BRIDGE VOLTAGE: Only 0.5v is applied to the bridge. The voltage across the capacitor is less than this applied voltage, the amplitude depending upon capacitance being measured. No danger of overheating and ruining even a 1-volt electrolytic or a 3-volt ceramic.

POLARIZING VOLTAGE: Continuously adjustable, 0 to 150v.

STABILITY: Dual regulation of the power supply assures short-time reliability, while specially processed etched circuits and complete encapsulation of the critical meter amplifier insure long-time stability.

MAGIC-EYE TUBE: Simplifies bridge balancing for capacitance and power factor measurements.

HIGH GAIN AMPLIFIER: Sensitivity control for magic-eye null detector permits accurate measurements of small capacitances.

CAPACITANCE DIAL: Latest design jet black dial with brilliant white calibrations for quick, accurate readings from any position.

BINDING POSTS: Shielded for protection against pick-up of strays, assuring greater accuracy during low-capacitance measurements. 5-way connection feature for use with all types of test leads.

SAFETY DEVICES: Automatic discharge of capacitor after testing. Three-wire line cord grounds instrument case.

OPERATING PROCEDURES: Easy-to-follow operating procedures clearly shown on pull-out slide at base of instrument. Always handy for ready reference.

MODERN CASE: Handsome grey Hammerloid finish on heavy-gage steel. Measures 8 $\frac{1}{2}$ " high, 14 $\frac{1}{2}$ " wide, 9 $\frac{1}{2}$ " deep. Weighs only 21 pounds.

See the remarkable new TCA-1 TRANSCAP at your Sprague distributor or write for descriptive folder M-792a to Sprague Products Company, 51 Marshall Street, North Adams, Massachusetts.

ONLY
\$197.50
NET

*Trademark

SPRAGUE®

world's largest capacitor manufacturer

ELECTRONICS WORLD

Learn RADIO, TELEVISION

AND ELECTRONICS

by Practicing at Home in Your Spare Time

At No Extra Cost you get specially developed Electronic Training Kits for practical experience. Shop and laboratory practice at home make learning easier, interesting, faster. You do not need a high school diploma or previous experience.

Increasing Demand for Trained Men

This is the Electronics age. Men with Electronic know-how are in demand. They enjoy high pay and growing opportunities for advancement. Satellites, Radar, Automation in Industry, Missiles, Rockets. Planes. Stereo, TV, Radio, Two



Way Communications for transportation are a few of the fantastic developments in the fast growing Electronics industry. If you are not completely satisfied with your work; if you are doubtful about your future, investigate Electronics.

High Pay, Prestige, Bright Future

What branch of Electronics interests you? Thousands of successful NRI graduates prove that NRI's learn-by-practice method is the way to success. You start in your chosen career 'way ahead of the man who only learns from books. You do not need to give up your job. You do not need to go away to school. You learn at home, get practical knowledge from training kits NRI provides.



Train With the Leader

NRI is the world's oldest and largest home study Electronics school. You benefit from the experience NRI has gained from training men for 45 years. NRI offers you proven courses of home study in Electronics; Principles, Practices and Maintenance—Radio Television Communications—Radio Television Servicing.

Start Soon to Earn More

Soon after enrolling NRI shows you how to apply your knowledge to earn extra money doing Electronics repairs or servicing Radio and Television sets for friends and neighbors. Take the first step toward success now. Find out what NRI offers you. Mail the postage-free card. No obligation. Cost of NRI training is low. Monthly payment plan available. NATIONAL RADIO INSTITUTE, Washington 16, D.C.

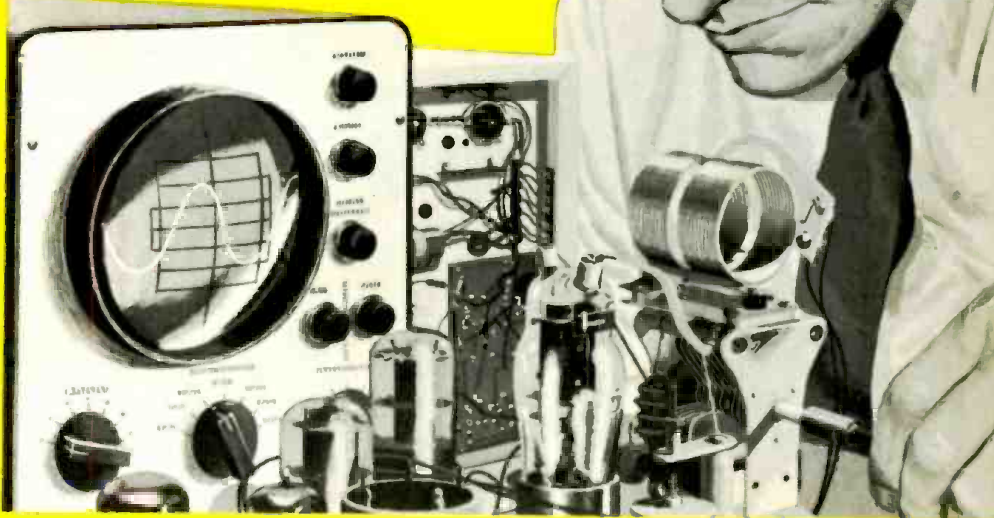

NRI Has Trained Thousands for Success



"I get over twice the salary I made before enrolling. NRI training gave me a thorough understanding." H. ATKINSON, Austin, Tex.



"I started with station CJIC, now in charge of sound effects for CBC. NRI opened doors to greater opportunity for me." F. W. TUDOR, Toronto, Ontario



"Averaged \$150 a month spare time before I graduated. Now have my own full time business and employ 2 men." F. W. COX, Hollywood, Cal.

NEW COURSE IN ELECTRONICS TURN PAGE

Cut Out and Mail—No Stamp Needed

64-PAGE CATALOG FREE

No Salesman will call. (Please PRINT) YZ

Name _____ Age _____

Address _____

City _____ Zone _____ State _____

National Radio Institute
OLDEST & LARGEST HOME STUDY RADIO-TV SCHOOL
 WASHINGTON 16, D. C.
 ACCREDITED MEMBER NATIONAL HOME STUDY COUNCIL

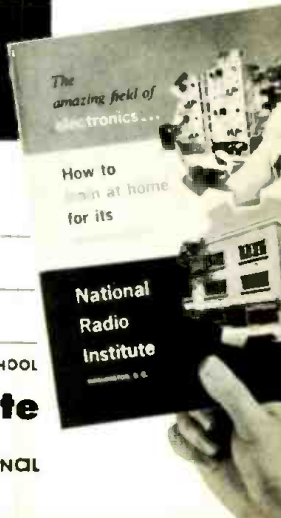

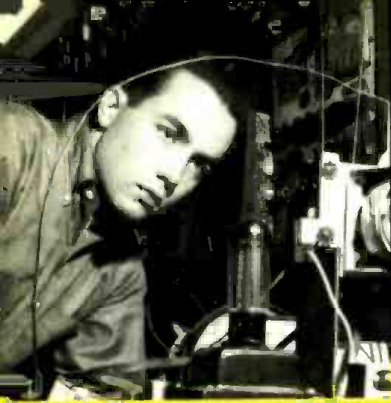

JOB COUNSELORS ADVISE LEARN ELECTRONICS



SPECIAL TRAINING KITS NO EXTRA COST

NEW Home Study Course in ELECTRONICS Principles-Practices-Maintenance NOW READY

This is the Electronic Age. Electronic equipment is already being used to count and control flow of liquids, solids, gases. Electronics is employed to search for oil, make surveys, control traffic, machine complex parts and in atomic installations. Military uses of Electronics are great and expanding rapidly. In business, Automation with Electronics plays an important part, prepares payrolls, calculates engineering formulas.

Learn More to Earn More
Now, to meet the growing demand for trained Electronic Technicians NRI has developed a comprehensive, complete course in Electronics Principles, Practices, Maintenance. This training stresses fundamentals. It is a course specially prepared for beginners and for Technicians. You get both theory and practical experience in an interesting, exciting way.

Ten Special Training Kits Give Practical Experience

You get practical experience with Thyatron Tube circuits, Multivibrators, build a D'Arsonval type Vacuum Tube Voltmeter (Kit 2); work and experiment with pentode tubes, selenium resistors, oscillators, transistors, magnetic amplifiers; and get practical experience in telemetry circuits as used in earth satellites, digital and analog computers (Kit 9).

NRI—Oldest and Largest School

Wishing for success won't bring success. You must act. Get FREE 64-page Catalog from America's oldest and largest home study Electronic-Radio-Television school. It gives facts, opportunities in Industrial and Military Electronics careers, also shows what you learn, tells about NRI's other courses in Radio Television Servicing and Radio Television Communications. Monthly payments plan. Mail Postage Free Card for 64-page Catalog.
NATIONAL RADIO INSTITUTE, Washington 16, D.C.



← SEE OTHER SIDE →

FIRST CLASS
Permit No. 20-R
(Sec. 34.9, P. L. & R.)
Washington, D.C.

BUSINESS REPLY CARD

No Postage Stamp Necessary if Mailed in the United States

POSTAGE WILL BE PAID BY

National Radio Institute
3939 Wisconsin Avenue
Washington 16, D.C.

POSTAGE FREE CARD
MAIL NOW

The Sounding Board



FINE DYNAMIC MICROPHONES

YOU CAN DEPEND ON — Always

"How stable?" is the question asked most often about a microphone. Once the type of installation is determined, it is essential that frequency response and directional sensitivity characteristics remain unaffected. This is *stability* — and should remain constant. It is a clue to the wide acceptance and universal use of the Electro-Voice family of dynamic microphones — a family comprising 35 different models, each designed for a specific application. Highly developed precision tooling, extensive research, and functional design have created instruments of outstanding ruggedness and durability. All internal parts nest or interlock to prevent any movement of the reproducing mechanism even when the case is subjected to severe shock. In addition, the exclusive Acoustalloy diaphragm assures smooth response and reliability far surpassing ordinary demands. This vital moving element has no equal in withstanding high humidity, temperature extremes, corrosion and mechanical impact. Laboratory tests reveal only two ways to damage Acoustalloy: heat the microphone so hot it can't be handled, or actually puncture or tear the diaphragm. Each microphone type is field-tested prior to acceptance for manufacture and, when in production, every model is evaluated for exact frequency response, level and possible distortion, or mechanical imperfections prior to shipment. Such care in manufacturing and testing assures maximum reliability, all-important stability, and remarkable uniformity within dynamic types.

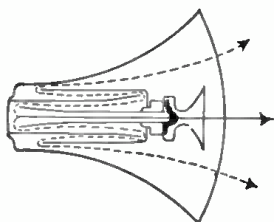

MORE SOUND FROM FEWER SPEAKERS

WITH ELECTRO-VOICE C D P

The Compound Diffraction Horn was created initially by Electro-Voice to handle the extremely difficult sound

dispersion problems encountered by the U. S. Navy on flight decks of aircraft carriers. Maximum dispersion was achieved by designing a compact horn which would provide optimum diffraction of sound waves — and replace the inefficient, bulky horns formerly used for this application.

Lower frequencies disperse easily. High frequencies, because their wave lengths are usually smaller than the radiator dimensions, are directional. In the Compound Diffraction Projector, Electro-Voice has narrowed the horizontal dimension to less than the wave length of the most important frequencies to be reproduced and extended the vertical dimension to preserve the area necessary for loading efficiency. This results in wide lateral dispersion and reduction of unneeded vertical dispersion.

Electro-Voice Compound Diffraction Projectors assure wide frequency range without "dead spots". This is achieved by acoustically loading both sides of the diaphragm with respective horns for the high and low frequencies. Diffraction Horns insure intelligibility and excellent quality at all points within the area they cover. Thus, the inherent limitations of conventional reentrant or multi-cellular horns are overcome.

There are E-V Compound Diffraction Projectors designed specifically for hard-to-handle public address situations whatever they might be. Greater audio range makes them the ideal PA speakers for music as well as speech (as much as 2½ octaves wider response). Because each speaker is capable of delivering uniform spread at all frequencies, intensity and intelligibility are assured without the expense of adding speakers.



NEW HAM RECEIVER

PASSES THE TOUGHEST TEST OF ALL

An interesting story lies behind the recent performance testing of the first RME 6900 Communications Receiver. After final inspection of the first unit, one of the RME executives (W9IOP), decided to use this new receiver in the 1960 Radio Amateur Sweepstakes. This contest, sponsored each year by the Amateur Radio Relay League, de-

termines which amateur operator can establish the most radio contacts in a given 40 hour period.

The receiver was delivered to W9IOP only three hours before the contest began. In spite of his lack of familiarity with the receiver, W9IOP not only won the contest, but logged a record-breaking 1,369 contacts to establish a new national Sweepstakes record.

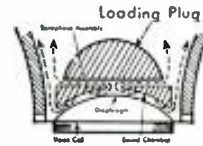

HORN-LOADED TWEETERS PROVIDE

CLARITY WITHOUT DISTORTION

Electro-Voice Tweeters are noted for clarity and low distortion. But obtaining that clarity was a critical problem until E-V's development of the Avedon Sonophase Throat Design.

VHF tweeters handle the widest range of response — from 3500 to 20,000 cps. E-V tweeters function as a true piston in the lower range, but at the critical point (about 12 kc) sound must be taken from the center of the diaphragm and from the periphery at the same time. Without some way to prevent it, sound cancellation occurs because of diaphragm deformation at and above this critical frequency. This deformation causes phase shift to occur between the center and periphery of the diaphragm. Increasingly higher frequencies cause the phase shift to be more pronounced because of an ever increasing deformation of the diaphragm. The Avedon Sonophase Throat Design accomplishes the vital restoration of phase relationship and level by incorporating a compression driver with unique loading plugs which properly phase upper frequencies while leaving lower frequencies unaffected. The loading plugs force the sound to travel a circuitous path, producing in-phase sound regardless of the frequency of the signal.

Coupled to the Avedon Sonophase Throat Design is the Hoodwin Diffraction Horn, designed to insure sound dispersion throughout the listening area. This is especially important in stereo application to prevent the "beamed" or directional nature of most high frequencies.

Want more information on any of the items mentioned in the Sounding Board? Simply check the appropriate boxes below and mail the coupon to Dept. 90N, Electro-Voice, Inc., Buchanan, Michigan.

- Microphones
- RME 6900
- Horn-loaded Tweeters
- C D P

NAME _____

ADDRESS _____

Electro-Voice®

ELECTRO-VOICE, INC.
BUCHANAN, MICH.



STANDARD PROFESSIONAL

TUBE TESTER

★ Tests all tubes, including 4, 5, 6, 7, Octal, Lock-in, Hearing Aid, Thyatron, Miniatures, Sub-miniatures, Novals, Subminars, Proximity fuse types, etc.

★ Uses the new self-cleaning Lever Action Switches for individual element testing. Because all elements are numbered according to pin-number in the RMA base numbering system, the user can instantly identify which element is under test. Tubes having tapped filaments and tubes with filaments terminating in more than one pin are truly tested with the Model TW-11 as any of the pins may be placed in the neutral position when necessary.

★ The Model TW-11 does not use any combination type sockets. Instead individual sockets are used for each type of tube. Thus it is impossible to damage a tube by inserting it in the wrong socket.

★ Free-moving built-in roll chart provides complete data for all tubes. All tube listings printed in large easy-to-read type.

NOISE TEST: Phono-jack on front panel for plugging in either phones or external amplifier will detect microphonic tubes or noise due to faulty elements and loose internal connections.

EXTRAORDINARY FEATURE

SEPARATE SCALE FOR LOW-CURRENT TUBES: Previously, on emission-type tube testers, it has been standard practice to use one scale for all tubes. As a result, the calibration for low-current types has been restricted to a small portion of the scale. The extra scale used here greatly simplifies testing of low-current types.

The Model TW-11 operates on 105-130 Volt 60 Cycles A.C. Comes housed in a handsome, portable Saddle-Stitched Tex-on Case. Only.....

\$47⁵⁰

Model TW-11—TUBE TESTER . . . Total Price \$47.50—Terms: \$11.50 after 10 day trial, then \$6.00 per month for 6 months if satisfactory. Otherwise return, no explanation necessary!

SUPERIOR'S NEW MODEL 80



20,000 OHMS PER VOLT ALLMETER

THE ONLY 20,000 OHMS PER VOLT V.O.M. SELLING FOR LESS THAN \$50 WHICH PROVIDES ALL THE FOLLOWING FEATURES:

- ✓ **6 INCH FULL-VIEW METER** provides large easy-to-read calibrations. No squinting or guessing when you use Model 80.
- ✓ **MIRRORED SCALE** permits fine accurate measurements where fractional readings are important.
- ✓ **CAPACITY RANGES** permit you to accurately measure all condensers from .00025 MFD to 30 MFD in addition to the standard volt, current, resistance and decibel ranges.
- ✓ **HANDSOME SADDLE-STITCHED CARRYING CASE** included with Model 80 Allmeter at no extra charge enables you to use this fine instrument on outside calls as well as on the bench in your shop.

• A built-in Isolation Transformer automatically isolates the Model 80 from the power line when capacity service is in use.
• Selected, 1% zero temperature coefficient metalized resistors are used as multipliers to assure unchanging accurate readings on all ranges.

SPECIFICATIONS:

- 7 D.C. VOLTAGE RANGES:**
(At a sensitivity of 20,000 Ohms per Volt)
0 to 15/75/150/300/750/1500/7500 Volts.
- 6 A.C. VOLTAGE RANGES:**
(At a sensitivity of 5,000 Ohms per Volt)
0 to 15/75/150/300/750/1500 Volts.
- 3 RESISTANCE RANGES:**
0 to 2,000/200,000 Ohms. 0-20 Megohms.
- 2 CAPACITY RANGES:**
.00025 Mfd. to 3 Mfd.. .05 Mfd. to 30 Mfd.
- 5 D.C. CURRENT RANGES:**
0-75 Microamperes, 0 to 7.5/75/750 Milliamperes. 0 to 18 Amperes.
- 3 DECIBEL RANGES:**
- 6 db to + 18 db + 14 db to + 38 db
+ 34 db to + 58 db

Model 80 Allmeter comes complete with operating instructions, test leads and portable carrying case. Only

\$42⁵⁰ NET

Model 80 — ALLMETER . . . Total Price \$42.50—Terms: \$12.50 after 10 day trial, then \$6.00 monthly for 5 months if satisfactory. Otherwise return, no explanation necessary!

NOTE: The line cord is used only for capacity measurements. Resistance ranges operate on self-contained batteries.

GENOMETER

7 Signal Generators in One!

- ✓ R.F. Signal Generator for A.M.
- ✓ R.F. Signal Generator for F.M.
- ✓ Audio Frequency Generator
- ✓ Bar Generator
- ✓ Cross Hatch Generator
- ✓ Color Dot Pattern Generator
- ✓ Marker Generator

A versatile all-inclusive GENERATOR which provides ALL the outputs for servicing:

A.M. Radio • F.M. Radio • Amplifiers • Black and White TV • Color TV

R. F. SIGNAL GENERATOR: The Model TV-50A Genometer provides complete coverage for A.M. and F.M. alignment. Generates Radio Frequencies from 100 Kilocycles to 60 Megacycles on fundamentals and from 60 Megacycles to 180 Megacycles on powerful harmonics.

VARIABLE AUDIO FREQUENCY GENERATOR: In addition to a fixed 400 cycle sine-wave audio, the Model TV-50A Genometer provides a variable 300 cycle to 20,000 cycle peak wave audio signal.

BAR GENERATOR: The Model TV-50A projects an actual Bar Pattern on any TV Receiver Screen. Pattern will consist of 4 to 16 horizontal bars or 7 to 20 vertical bars.

THE MODEL TV-50A comes absolutely complete with shielded leads and operating instructions.

MARKER GENERATOR: The Model TV-50A includes all the most frequently needed marker points. The following markers are provided: 189 Kc., 262.5 Kc., 456 Kc., 600 Kc., 1000 Kc., 1400 Kc., 1600 Kc., 2000 Kc., 2500 Kc., 3579 Kc., 4.5 Mc., 5 Mc., 10.7 Mc., (3579 Kc. is the color burst frequency)

\$47⁵⁰ NET



Model TV-50A—Genometer
Total Price\$47.50
Terms: \$11.50 after 10 day trial, then \$6.00 monthly for 6 months if satisfactory. Otherwise return, no explanation necessary.

CROSS HATCH GENERATOR: The Model TV-50A Genometer will project a cross-hatch pattern on any TV picture tube. The pattern will consist of non-shifting, horizontal and vertical lines interlaced to provide a stable cross-hatch effect.

DOT PATTERN GENERATOR (FOR COLOR TV): Although you will be able to use most of your regular standard equipment for servicing Color TV, the one addition which is a "must" is a Dot Pattern Generator. The Dot Pattern projected on any color TV Receiver tube by the Model TV-50A will enable you to adjust for proper color convergence.

EXAMINE BEFORE YOU BUY!
USE APPROVAL FORM ON NEXT PAGE

The Model 88.... A New Combination TRANSISTOR RADIO TESTER and DYNAMIC TRANSISTOR TESTER



The Model 88 is perhaps as important a development as was the invention of the transistor itself, for during the past 5 years, millions of transistor radios and other transistor operated devices have been imported and produced in this country with no adequate provision for servicing this ever increasing output.

The Model 88 was designed specifically to test all transistors, transistor radios, transistor recorders, and other transistor devices under dynamic conditions.

AS A TRANSISTOR RADIO TESTER

We feel sure all servicemen will agree that the instruments and methods previously employed for servicing conventional tube radios and TV have proven to be impractical and time consuming when used for transistor radio servicing. The Model 88 provides a new simplified procedure — a technique developed specifically for radio's and other transistor devices.

An R.F. Signal source, modulated by an audio tone is injected into the transistor receiver from the antenna through the R.F. stage, past the mixer into the I.F. Amplifier and detector stages and on to the audio amplifier. This injected signal is then followed and traced through

the receiver by means of a built-in High Gain Transistorized Signal Tracer until the cause of trouble whether it be a transistor, some other component or even a break in the printed circuit is located and pinpointed. The injected signal is heard on the front panel speaker as it is followed through the various stages. Provision has also been made on the front panel for plugging in a V.O.M. for quantitative measurement of signal strength.

The Signal Tracing section may also be used less the signal injector for listening to the "quality" of the broadcast signal in the various stages.

AS A TRANSISTOR TESTER

The Model 88 will test all transistors including NPN and PNP, silicon, germanium and the new gallium arsenide types, without referring to characteristic data sheets. The time-saving advantage of this technique

is self-evident. A further benefit of this service is that it will enable you to test new transistors as they are released!

SPECIFICATIONS:

- ✓ Model 88 operates on a self-contained 4½ volt battery and is always ready for instant use on the bench or in the field.
- ✓ **Signal Injector:**
The signal injector used in the Model 88 is a new departure in signal source design. Previously, signal sources were provided by signal generators operating on a single frequency and requiring retuning. The Signal Injector of the Model 88 employs a transistor in a grounded emitter self-modulating oscillator generating a low R.F. frequency providing stable harmonics to 30 megacycles. A power output of over 2.5 volts peak to peak is provided. An attenuator prevents overload of the receiver or the amplifier under test.
- ✓ **Signal Tracer:**
Two high-gain grounded emitter transistors are utilized in a high gain amplifier with sufficient output to operate the built-in 4½" Alnico V Speaker. A diode is used as a "clamp" to prevent overloading of the output stage. A volume control permits attenuation of strong signals. Provision is also made on the front panel for the addition of a meter or an oscilloscope for quantitative evaluation of the signal strength.

- ✓ **Transistor Tester:**
The transistor tester used in the Model 88 measures the two most important transistor characteristics needed for transistor servicing; leakage and gain (beta).
The leakage test measures the collector-emitter current with the base connection open circuited. A range from 50 ohms to 100,000 ohms covers all the leakage values usually found in both high and low power transistor types.
The gain test (beta) translates the change in collector current divided by the base current. Inasmuch as the base current is held to a fixed value of 50 microamperes, the collector current calibrated in relative gain (beta), is read directly on the meter scale.
The Model 88 will test all transistor types, including NPN or PNP, germanium, silicon, gallium arsenide and the newer diffused junction and mesa types.
Model 88 comes housed in a handsome portable case. Complete with a set of Clip-On Cables for Transistor Testing, an R.F. Diode Probe for R.F. and I.F. Tracing; an Audio Probe for Amplifier Tracing and a Signal Injector Cable. Complete—nothing else to buy!

\$38⁵⁰

SHIPPED ON APPROVAL NO MONEY WITH ORDER — NO C.O.D.

Try any of the instruments on this or the facing page for 10 days before you buy. If completely satisfied then send down payment and pay balance as indicated on coupon. No Interest or Finance Charges Added! If not completely satisfied return unit to us, no explanation necessary.

MOSS ELECTRONIC, INC.
Dept. D-809, 3849 Tenth Ave., New York 34, N. Y.

Please send me the units checked on approval. If completely satisfied I will pay on the terms specified with no interest or finance charges added. Otherwise, I will return after a 10 day trial positively cancelling all further obligations.

<input type="checkbox"/> Model 88..... Total Price \$38.50 \$8.50 within 10 days. Balance \$6.00 monthly for 5 months.	<input type="checkbox"/> Model TW-11..... Total Price \$47.50 \$11.50 within 10 days. Balance \$6.00 monthly for 6 months.
<input type="checkbox"/> Model TV-30A..... Total Price \$47.50 \$11.50 within 10 days. Balance \$6.00 monthly for 6 months.	<input type="checkbox"/> Model 80..... Total Price \$42.50 \$12.50 within 10 days. Balance \$6.00 monthly for 5 months.

Name

Address

City Zone..... State.....

All prices net, F.O.B., N. Y. C.
Export Division: **Rocke International Corp.**
13 East 40th Street, New York 16, N. Y.

AIWA

UNI-DIRECTIONAL RIBBON MICROPHONE MODEL VM-18

INTRODUCES A NEW SMALL-SIZE BI-DIRECTIONAL RIBBON MICROPHONE MODEL VM-16



Features:

- * Small size and slim shape facilitate handling.
- * Comparatively high sensitivity and fine response characteristics.
- * Sturdy construction with short ribbon diaphragm.
- * Humming minimized
- * Equipped with a low frequency attenuation circuit.

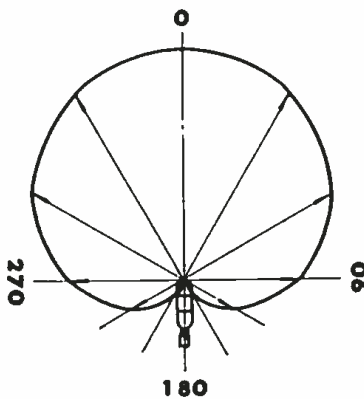

VM-18

VM-18

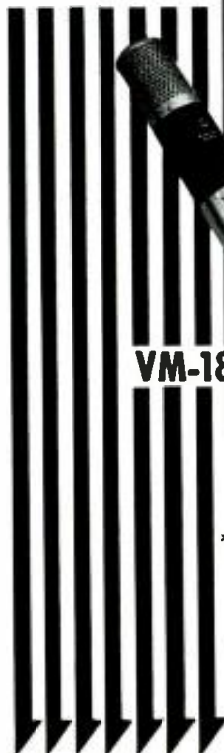

Features:

- * Superlative high quality response characteristics.
- * Engineered in collaboration with the Technical Research Laboratory of the Japan Broadcasting Corporation (NHK).
- * Outstanding results when used for FM broadcasting and high fidelity recording because of its exacting quality of tone reproduction.
- * Because of the above superior characteristics, small size and non-reflecting satin-chrome finish is ideally suited for TV broadcasting.

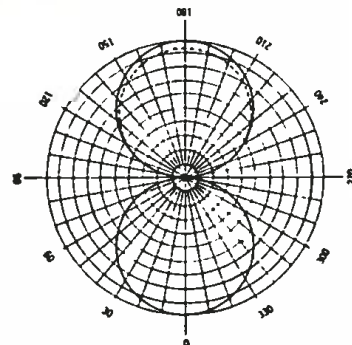
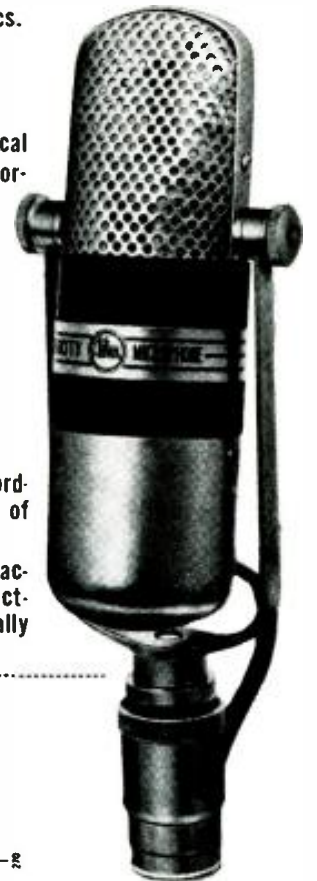

VM-16

Directional Characteristic
— 500 c/s, 1000 c/s, ... 8000 c/s

Specifications:

- * Type: Ribbon Microphone
- * Impedance: 600 ohm \pm 20% (At 1000 c/s at 0 point of the switch)
- * Sensitivity: 75 db (0db = 1V/m bar 1000 c/s)
- * Directionality: Uni-directional
- * Noise Level: Below 30 db
- * Dimensions: 9 5/8" (length) 1 1/2" (dia.) Weight 2.2 lbs. (9 feet-cord & plug included)

Specifications:

- * Frequency Response: 50-15,000 c/s \pm 3 db
- * Output Level: 80 db (150 ohms/1,000 c/s)
- * Impedance: 150 ohms, 250 ohms or 600 ohms
- * Directional Characteristics: Bi-directional
- * S/N 20 db or below (in parallel field at 1 m Gauss)



AIWA CO., LTD.
4 Motosakuma-Cho Kanda Chiyoda-Ku Tokyo, Japan



**Latest Information
on the Electronic Industry**

Spot News

By **ELECTRONICS WORLD'S
WASHINGTON EDITOR**

LUNAR MAPPING STUDY TO FEATURE USE OF RADAR AND TV—A lunar analysis and mapping program—coded "Project Lamp"—has been scheduled by the Corps of Engineers of the Department of the Army. It will revolve about the use of radar and TV techniques for making a rapid and accurate dimensional survey of the entire lunar surface, including the back of the moon. Commenting on this remote-type visual-direction application in a Congressional report, prepared for the Committee on Science and Astronautics, Army engineers said that the radar system, which is quite light (on the order of 1000 pounds payload) will employ a radar altimeter, multiple-frequency surface interrogator, and passive distance-measuring devices. As the space vehicle with this system flies around the moon, radar will record the profile of the surface directly beneath the flight path. After a number of such flights, a record of the moon's surface would be built up and stored in a computer. By plotting many profiles, a map could be produced if it were found desirable. Television will be used to obtain stereoscopic coverage of the moon's surface, as well as for obtaining star and earth positional data to preserve the geometric relationship necessary for stereo-photo mapping. Basically, the TV system will take pictures of the moon and transmit them to earth. To orient these pictures, another TV camera in the satellite will take and transmit a picture of the stars at the same time to determine proper orientation.

TROUBLE-FREE SCATTER COMMUNICATION NETWORK OPENED IN PACIFIC—A 6500-mile communications system, said to be virtually trouble-free, is now in operation in the Pacific area. Called the "Pacific Scatter Communication System", the network employs a technique in which signals are sent upward to a layer of the atmosphere—the ionosphere—and then bounced back in scatter fashion to earth. Oddly enough, the signals themselves are not broken up; they are merely scattered. One receiver picks up the clearest signal and should this one fade, another operational receiver picks up another signal without a lapse. This assures a constant stream of trouble-free signals. One of the largest of its kind in the world, featuring eight interconnected stations, the network extends from Oahu, Hawaii to Luzon in the Philippines. Between all adjacent sections there are high-capacity communication channels which can handle separate teletypewriter messages up to 100 words a minute.

DREAM-ANALYZING ELECTRONIC UNIT UNDER STUDY—A subvocal interpreter—described as a "dream analyzer"—which can codify speech that cannot be heard from a sleeping person is now under study by Bell Telephone Labs at the request of University of Chicago doctors. The unique device will measure lip movements and vocal cord vibrations, then translate them into symbols for interpretation.

ELECTRONIC COMPUTER FOUND TO AID METALLURGICAL RESEARCH—Automatic electronic digital computers can be used economically for both routine and complex calculations required in metallurgical research, according to the Bureau of Mines. Three years' experience with computers has disclosed that they can perform key calculations basic to the production of iron, steel, and other metals. Government experts in charge of these studies said that the speed and accuracy advantages offered by these computers make them extremely practical tools for research labs.

SUPER-HIGH BANDS SOUGHT FOR VITAL REMOTE CONTROL—The FCC has been asked to allocate 100 mc., in one block or in segments, within the 13,000 to 35,000 mc. band, for the control by radio of highly specialized equipment designed to perform complex tasks under conditions that would be dangerous to humans.

OVERSEAS TV STATIONS UP ABOUT 14 PER-CENT SINCE FIRST OF YEAR—Overseas television stations of all types have increased by nearly 14 per-cent since the beginning of the year; from 1088 to 1237. Altogether 109 new stations went into operation in the Free World, 98 of which were in Western Europe, 40 new ones went on the air in the Sino-Soviet bloc. Television sets in use abroad now number 34,500,000, with the Free World accounting for 28,950,000, an increase of about 2,150,000. The Soviet countries have about 5,600,000, up nearly 300,000.

—30—

will send you your choice of the world's greatest electronics books for a **7-DAY FREE EXAMINATION**

Here are some of the world's greatest electronics books... chosen carefully by Ziff-Davis Electronics Book Service as among the best in their fields. You'll find top-notch texts and manuals on theory and instruction...important volumes covering radio and TV servicing, transistors and tubes...reference books to help you understand such fields as computers, citizens band, communications, and electronics experimentation.

Each volume is designed to help you get more know-how, greater enjoyment from your electronics specialty—and each is yours for 7 days FREE! Simply write your choices on the coupon below and mail it today. When your books arrive, read and enjoy them for seven full days. If, after that, you don't agree that they are everything you want, return them and owe nothing. Here is the perfect way to build the library every man in electronics must have.

THEORY AND INSTRUCTION

RADIO AND TV SERVICING

AND TUBES TRANSISTORS

Get started in radio, TV, communications by using these simple step-by-step guides to electronic principles for students and operators!

Save time and labor in radio and TV maintenance by referring to professional handbooks!

Keep abreast of the latest designs and concepts in both transistors and tubes by using the charts, diagrams, and photographs in these practical books!



2500. BASIC ELECTRONICS, Grob
An introductory text on the fundamentals of electricity and electronics for technicians in radio, television and industrial electronics. \$9.25

2501. ELEMENTS OF ELECTRONICS, Hickey and Villines

This basic electronics text offers an excellent course for training radio and electronics technicians and for students in television, radar and sonar. \$6.95



2511. UNDERSTANDING RADIO, Watson, Welch and Eby
For those with little or no technical knowledge who wish to know the fundamentals of radio theory and servicing. \$7.95

2412. TELEVISION AND FM ANTENNA GUIDE, Noil & Mandl

Two antenna experts tell you their secrets of antenna choice and installation for best reception in any area. Loaded with useful tips on improving reception in fringe and difficult areas. \$5.25



2519. HANDBOOK OF BASIC CIRCUITS, Mandl
A basic guide to circuitry combining comprehensive coverage of major circuits with detailed information on circuits used in TV, FM and AM. Simply written and easy-to-understand. \$7.95

2512. PRIMER OF ELECTRONICS AND RADIANT ENERGY, Caverly

Clear and simple explanation of electronics and electronic tubes and circuits for all concerned with the manufacture, application, operation of household or industrial electronic devices. \$7.50

2407. HOW TO GET AHEAD IN THE TELEVISION AND RADIO SERVICING BUSINESS, Marcus

Shows the easy way to get started as a TV-Radio repairman, how to earn while you learn, how to get and keep customers. \$3.50



2415. MANDL'S TELEVISION SERVICING, Mandl

This standard text book in the T.V. servicing field provides clear descriptions of the fundamentals of T.V., and practical instruction on the diagnosis and correction of typical troubles. \$6.95

2408. ESSENTIALS OF ELECTRICITY FOR RADIO AND TELEVISION, Slurzberg and Osterheld

Provides necessary background of principles for understanding T.V., FM and radio circuits. \$8.00



2404. FM RADIO SERVICING HANDBOOK, King

A practical guide to FM V.H.F. receivers, their design, construction, alignment and repair. \$5.00

2400. PROFITABLE RADIO TROUBLESHOOTING, Marcus and Levy

Explains in easy-to-understand manner the use of simple and advanced test instruments, opening a radio servicing business, pitfalls, and successful procedures for a full-grown business. \$5.95



2442. BASIC ELECTRONIC TEST INSTRUMENTS, Turner

Over 60 instruments described, their uses fully explained, and valuable work-saving short-cuts outlined. \$4.95



2600. TRANSISTORS, Gillie

Describes and analyzes semi-conductors and transistors and how they behave. 300 pages, illustrated. \$7.95

2604. BASIC ELECTRON TUBES, Geppert

A text for a first course in electronics. It covers the tubes themselves, not the circuit applications. Basic principles governing operation of specialized tubes are explained. \$7.50

2605. FUNDAMENTALS OF VACUUM TUBES, Eastman

A text midway between the purely descriptive and the purely mathematical. Discusses the principal types of vacuum tubes. \$10.50

2606. ELECTRON-TUBE CIRCUITS, Seely

A clear analytical method in the study of electron-tube circuits. Provides a broad background in preparing for work in radio and electronic engineering. \$10.50



2601. TRANSISTORS IN RADIO, TELEVISION AND ELECTRONICS, Kiver

A descriptive, non-mathematical text for radio, television, electronics technicians and for those who need to gain a working knowledge of transistors and transistor circuits. \$7.95

2603. VACUUM-TUBE AND SEMICONDUCTOR ELECTRONICS, Millman

The first book to integrate vacuum tubes and transistors. Teaches electronic circuit theory to provide an intimate understanding of the vacuum-tube and semiconductor device as a circuit element. \$10.00

Construction and Experimentation

Wonderful "how to" books to help you build and enjoy practical electronic devices simply and easily.



2006. ELECTRONIC EXPERIMENTER'S MANUAL, Findlay

With a few dollars worth of basic tools and this book to guide you, you can explore electronics experimentation more completely than ever before. 10 big sections. \$4.95

2002/60. ELECTRONIC KITS DIRECTORY, Ziff-Davis Publishing Company

New 1960 edition lists over 750 kits, latest models, prices and features for hi-fi, ham radio, SWL, shop improvement, Citizen's Band, fun and education. \$1.00

2351. RADIO PROJECTS, Marcus

10 easy to construct radios described in this book cover the field thoroughly and completely, progressing in difficulty from the simple crystal detector to the super-heterodyne receiver. \$3.85

2001/60. ELECTRONIC EXPERIMENTER'S HANDBOOK, Ziff-Davis Publishing Company

40 projects for home and shop, 20 of which are transistorized. Special section on understanding transistor circuits. \$1.00; 2001C, cloth \$1.95

Communications and Broadcasting

Here are books which simplify basic and advanced theory — and open new horizons to you in the field of communications!

2901. HAM RADIO, Hertzberg

Tells exactly how to become a "ham"—how to obtain a ham "ticket", how to learn code, how to select receivers and transmitters — everything you need to know is between the covers of this handy guidebook. \$2.50

2900. BROADCASTING TELEVISION AND RADIO, Kingson, Cowgill, Levy

A simple, practical introduction to broadcasting, dealing with performance before the microphone and camera. \$8.65

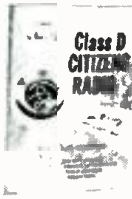

2008. CLASS D CITIZENS RADIO SANDS

First complete book on Citizens Radio operation. Covers Class D history, rules, applications, how it works. Many illustrations. \$4.95

2907. RADIO OPERATING QUESTIONS AND ANSWERS, Hornung & McKenzie

Presents specific information on radio law, operating practices and theory for those studying to pass the FCC commercial radio operator exams of the various license grades. \$6.00

Special Topics

Choose any of these practical books—to take advantage of the growing opportunities in the exciting field of electronics

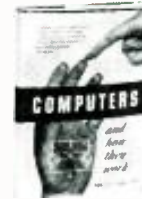

2007 COMPUTERS AND HOW THEY WORK, Fahnestock

A fact-filled guidebook to electronic computers. Explains the workings of every major computer system. Must reading for all who want a more complete knowledge of this important field. \$4.95

2914. THE RADAR POCKET BOOK, Boulding

A clear and concise handbook of information on basic electrical principles and formulae applicable to radar, together with data on the various parts of a radar installation. \$3.85

2301. ELECTRONICS DICTIONARY, Cooke & Markus

An authoritative dictionary containing accurate, understandable definitions of nearly 6500 terms used in radio, television, industrial electronics, facsimile, sound recording, etc. \$6.50



2000/60. STEREO HI-FI GUIDE, Ziff-Davis Publishing Company

Just published! 1960 edition features 60-page exclusive by Joseph Marshall on components and how they work. \$1.00

*See Your
Parts Jobber
Or Use This
Coupon Today!*

Leading radio and electronics parts jobbers, hi-fi dealers and salons are making their stores headquarters for books on every electronics subject. You can take this list to your favorite dealer for immediate purchase.

If your local parts jobber or dealer does not carry books, use the coupon for prompt delivery from ELECTRONICS BOOK SERVICE, on a 7-day free trial basis.

ELECTRONICS BOOK SERVICE

One Park Avenue, New York 16, N. Y.

Please send me the book(s) I have listed below for a FREE 7-day Trial Examination. I understand that if I am not completely satisfied, I may return my selection(s) and I'll owe you nothing. Otherwise, I will send you payment for the book(s) of my choice, plus postage and handling.

NUMBER	TITLE	PRICE
*TOTAL		

*New York City Residents, please add 3% sales tax.

(If you need more space to list additional titles, attach a sheet of paper with additional list.)

SAVE MONEY! Enclose payment in full for the book(s) of your choice and we will pay shipping charges. Same return privileges and prompt refund guaranteed. 506

Please send me FREE CATALOG, when published.

NAME _____ PLEASE PRINT CLEARLY

ADDRESS _____

CITY _____ ZONE _____ STATE _____

Another exciting development by University

New Medallion XII Enclosure Kit Features Five Decor-Matching 'Snap-On' Grille Styles

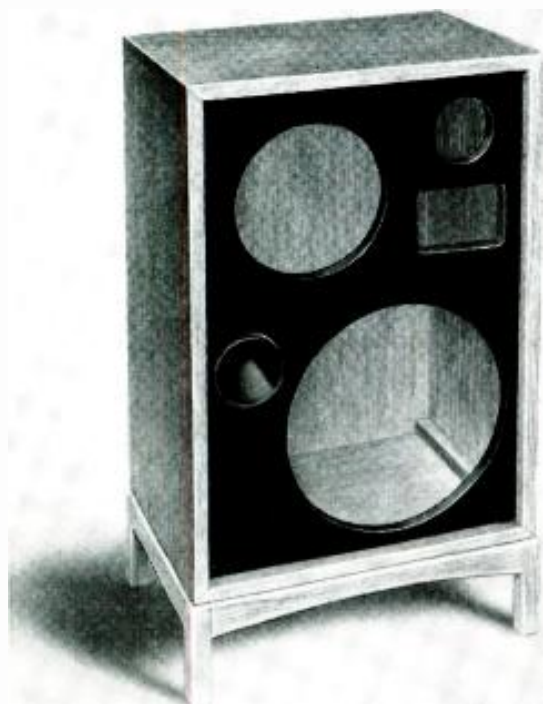

THE MEDALLION XII: Here's everything you've ever wanted in an enclosure kit. A complete choice of styling. Compact dimensions for stereo... (the Medallion is only 24" x 17" x 12 1/2" deep). And versatility of placement as a highboy or lowboy, on the floor, on its matching base... or even as a built-in. Net prices: Enclosure kit—\$49.95. (Prices on grille and base kits to be announced.)

WORLD'S WIDEST CHOICE OF SPEAKERS AVAILABLE FOR PLANNING YOUR SYSTEM

University's new award-winning Series 200 wide-range speakers offer today's most advanced design features that produce the finest high fidelity performance from a wide variety of compact enclosures. The Medallion is a perfect example. All Series 200 woofer cones have two highly compliant cloth suspensions—inner and outer—that achieve lowest bass reproduction with complete clarity and accuracy.

Their one-piece die-cast baskets provide life-long rigidity and reliability for the entire speaker structure. And for maximum ease of installation, each Series 200 speaker mounts from the front or the rear of the baffleboard.



NEW MODEL 312 12" 3-Way Diffaxial with Diffusicone mid-range, and Sphericon Super Tweeter. Response: 28-40,000 cps. \$73.00 net.

NEW MODEL 6201 12" Coaxial. Improved version of the most popular speaker ever made. Response: 28-18,500 cps. \$57.75 net.

Advantages of Radiation Resistance Loading Now Yours in Kit Form

Radiation Resistance Loading has become widely recognized as a significant advance in the art of compact speaker enclosure design over the older, fully-sealed high compliance systems. With RRL, you realize greater efficiency and cleaner response from any woofer.

This results from the precisely matched acoustic coupler which enables the woofer to develop ample output with only a small portion of its excursion potential. There is fully 75% less bass distortion at higher output levels... and perfect reproduction from amplifiers with as little as 10 clean watts.

University's Unique "Select-a-Style" Concept Opens Up Many New Possibilities for Kits

Now, for the first time ever in high fidelity cabinetry, you have a complete choice of styles in kit form... Contemporary, Colonial, Swedish Modern, French Provincial and Italian Provincial. This is the important difference of Medallion cabinetry... "Select-a-Style" snap-on grilles that let you match your decor exactly.

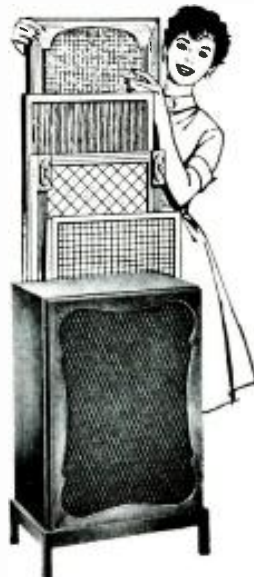

Each grille is authentic in period and crafted with meticulous care. Choose the style you prefer, assemble it, finish it and snap it on. It's that easy! What if you ever change your decor? Just change the grille. It's that economical! *Doubly* economical when you consider its modest price.

Putting it Together Was a Snap! Sounds Great, Too!

That's what you'll say after assembling your Medallion enclosure. Every piece is machined to the closest tolerances... pre-cut and pre-drilled for quick and precise assembly. Smooth-grained birch veneers assure you a professional furniture finish.



Tools you need for assembly? Just enthusiasm and a screwdriver... everything else is included... screws, glue, sandpaper, grille fabric and complete, easy-to-follow instructions. In just a few pleasure-packed hours, you'll be enjoying the superb performance that only the Medallion XII can give you.

Versatile Baffleboard Takes 12" Woofer, Wide Variety of Mid & High Range Speakers

For building multi-speaker systems, University offers a complete line of woofers, both high compliance and high efficiency. They feature the built-in flexibility and advantages of adjustable response, dual impedance and the patented dual voice coil for single-woofer stereo use.

There are also many mid-range speakers and wide-angle horn loaded tweeters to complete any 2-way or 3-way system... plus the sensational new Sphericon, described below.

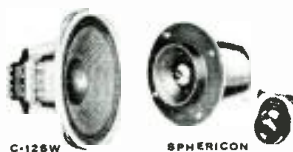

MODEL C-12SW 12" Dual Voice Coil Woofer. High end response adjustable to 700, 2500, 5000 cps. Overall response, 40-6000 cps. \$39.50 net.

MODEL T202 SPHERICON Super Tweeter. Major breakthrough in high frequency engineering. Response: 3000-40,000 cps (± 2 db to 22,000 cps). \$24.95 net.

Full Medallion Story Covered In New University Catalog

It's just off the press with complete descriptions of all the new and exciting University speakers and speaker systems. See your dealer, or write Desk S-9, University Loudspeakers, Inc., White Plains, N. Y.



A Division of Ling-Altec Electronics, Inc.

How to Get a Commercial FCC License

do you know what an FCC license really can do for you in Electronics?



Automation



Microwave and Mobile Radio



Guided Missiles



Radio & TV Broadcasting



Aeronautical Electronics

1 More income for you every week

2 A more interesting job in electronics

Chances are if you are reading this magazine, you can qualify for the really good jobs in electronics, like those shown at left . . . and it won't take long to do it. Your past training and experience in radio & TV repair, armed forces electronics, ham operator, etc. can be your foundation for a profitable career as an electronics technician. Send for the Career Information Material shown below today.

Cleveland Institute Announces an EXCLUSIVE Technician Training Program in Computers, Servo Mechanisms, Magnetic Amplifiers and others

Other advanced fields covered include Basic Math, A. C. Circuit Analysis, Pulse Circuitry, Color TV, Radar, Advanced Measuring Techniques, Industrial Electronics, Instrumentation, Automation, Radio Telemetry. Send for information today.

CLEVELAND INSTITUTE OF ELECTRONICS

Desk RN-45
4900 Euclid Ave.
Cleveland 3, Ohio

1. Raytheon Manufacturing Company
2. Radio Corporation of America
3. Jupiter IRBM, Army Ordnance Missile Command
4. Collins Radio Company
5. Radio Corporation of America

GET THIS HANDY POCKET ELECTRONICS DATA GUIDE

Free . . .

Puts all the commonly used conversion factors, formulas, tables, and color codes at your fingertips. Yours absolutely free if you mail the coupon in 30 days. No further obligation!

TO GET THIS FREE GIFT, MAIL COUPON Within 30 Days!

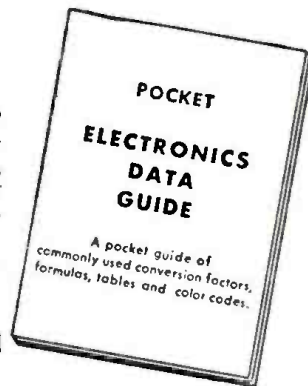

Free!



CLEVELAND INSTITUTE OF ELECTRONICS
Desk RN-45, 4900 Euclid Ave., Cleveland 3, Ohio

Please send FREE Career Information Material prepared to help me get ahead in Electronics. I have had training or experience in Electronics as indicated below:

- | | |
|---|---|
| <input type="checkbox"/> Military | <input type="checkbox"/> Broadcasting |
| <input type="checkbox"/> Radio-TV Servicing | <input type="checkbox"/> Home Experimenting |
| <input type="checkbox"/> Manufacturing | <input type="checkbox"/> Telephone Company |
| <input type="checkbox"/> Amateur Radio | <input type="checkbox"/> Other |

In what kind of work are you now engaged? _____

In what branch of Electronics are you interested? _____

Name _____ Age _____

Address _____

City _____ Zone _____ State _____

FIND OUT HOW:

1. The new electronic devices can be handled by you
2. To solve the problems that will stump your fellow technicians
3. Training is Job Insurance when employment is tough to find . . . and more money for you when times are good



see the exciting **1961**

knight-kits[®]

A PRODUCT OF ALLIED RADIO

in this value-packed ***ALLIED*** catalog



**70-Watt
Super-Power
Stereo!**

only **\$5** down

Y-934 Deluxe 70-Watt Stereo Amplifier; super-power to drive any of today's speakers; offers the ultimate in control flexibility and functions..... **\$119.95**

see many more great **HI-FI KITS**

- | | |
|--------------------------|-------------------|
| Stereo Preamp | 18-Watt Amplifier |
| 60-Watt Stereo Amplifier | 12-Watt Amplifier |
| Stereo Control | FM Tuner |
| 25-Watt Amplifier | Speaker Systems |

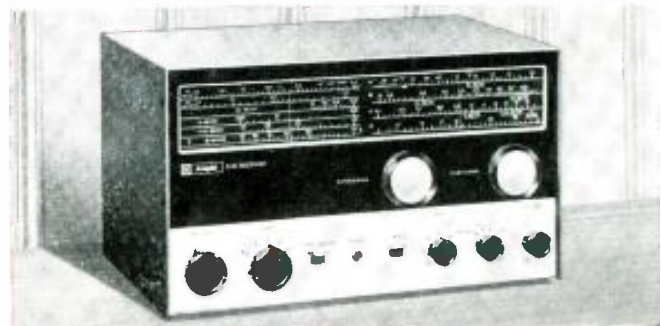

only **\$5** down **Y-935 Model R-55 All-Band Superhet Receiver**; covers 540 kc to 36 mc, plus 6 meters; general coverage tuning and calibrated Amateur bandsread tuning on slide-rule dial..... **\$67.50**

see many other **HOBBYIST KITS**

- | | |
|---------------------------------------|------------------------|
| "Space Spanner" [®] Receiver | Transistor KITS |
| "Ocean Hopper" Radio | 2-Way Intercom |
| Radio-Intercom | Electronic Lab Kits |
| Clock-Radio | Photoelectronic System |



Y-125 High sensitivity general-purpose VTVM; 11 meg input resistance; balanced-bridge circuit; big 4½" meter..... **\$25.75**

only **\$2** down



only **\$2** down

From original concept to final design, each Knight-Kit is produced by and comes directly to you from **ALLIED**

sold exclusively by
ALLIED

free

**444 pages
world's biggest**

send for it!

use coupon
on next page

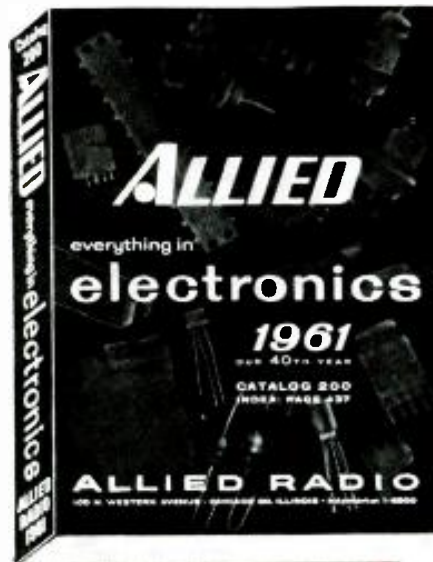

knight-kits—Best by Design

FUN TO BUILD Building it yourself is always satisfying fun—it's fun at its best when you build Knight-Kits—they're so beautifully engineered, so much easier, more pleasurable to work with...

YOU SAVE You save substantially because you buy direct from Allied at our money-saving big-volume-production prices—and because you do the easy building yourself...

YOU OWN THE BEST You'll be glad you built a Knight-Kit, because you'll own and enjoy with pride a true custom-built product, professionally engineered and styled—designed for superior performance...

EASIEST TO BUY only **\$2** down on orders up to \$50; \$5 down up to \$200; \$10 down over \$200—up to twenty-four months to pay...

exclusive knight-kit MONEY BACK GUARANTEE

Every Knight-Kit is unconditionally guaranteed to meet our published specifications for performance or your purchase price is refunded in full.

*Buy Any Knight-Kit!
...Build and Use It!
It Must Perform
Exactly as Claimed!*

Your Satisfaction is Guaranteed

knight-kits: best in build-your-own electronic equipment



only \$5 down

Y-929 Professional quality Stereo Tape Record/Playback Preamp; permits tape monitoring, sound-on-sound and echo effect; use with any tape transport... less case..... **\$79.95**



only \$5 down

Y-774 Deluxe 40-Watt Stereo Amplifier; full frequency center channel. Finest amplifier available anywhere in this price range..... **\$76.95**



Only \$39.95
For Full 20 Watts
Stereo!

only \$2 down

Y-927 Super-value 20-Watt Stereo Hi-Fi Amplifier, with special clutch-type dual-concentric level control; biggest bargain in Stereo hi-fi. **\$39.95**

Y-731 Deluxe FM-AM Stereo Hi-Fi Tuner, with Dynamic Sideband Regulation, variable AFC, "Magic Eye" slide-pointer tuning; includes multiplex add-in feature..... **\$87.50**

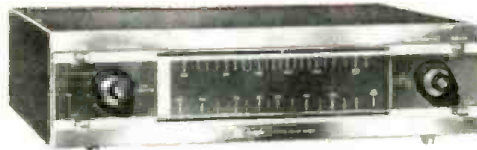

only \$5 down

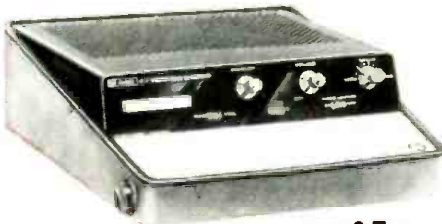

only \$5 down

Y-712 Model C-27 Superhet Citizen's Band Transceiver; dual-conversion receiver for highest sensitivity and selectivity; 2-channel crystal-controlled 5-watt transmitter; finest at any price.... **\$79.95**



only \$2 down

**\$39.95 For
This Citizen's Band
Transceiver**

Y-713. Top value, lowest-priced complete Citizen's Band Transceiver. Tunable 22-channel super-regenerative receiver; 5-watt transmitter... **\$39.95**

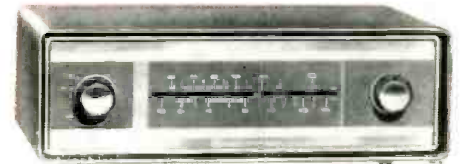

only \$2 down

Y-928 Outstanding FM-AM Hi-Fi Tuner; with AFC and tuned RF stage on FM; includes multiplex jack. **\$49.95**

Y-258 Sensational 4-Band "Span Master"® Receiver; renowned for thrilling world-wide reception; complete with cabinet..... **\$25.95**



only \$2 down



only \$5 down

Y-933 Top value 32-Watt Stereo Hi-Fi Amplifier; high power at low cost; plus full frequency center channel. **\$59.95**



only \$2 down

Y-143 Model "600" Tube Checker; checks over 700 types; illuminated roll-chart; obsolescence-proof design..... **\$32.95**

Y-145 RF Signal Generator; output to 112 mc on fundamentals; 400-cycle modulation..... **\$19.75**

full selection of INSTRUMENT KITS

5" Oscilloscopes
AC VTVM
Tube Checkers
Signal Tracer
Audio Generator
Sweep Generator
Battery Eliminator
Capacity Checker
Transistor Checker
R/C Tester,
plus many others

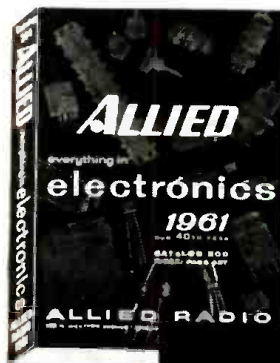

free

SEND FOR THE 444-PAGE
1961 ALLIED CATALOG

Write today for the world's biggest electronics catalog, featuring the complete KNIGHT-KIT line. See the big news in quality electronic kits—save on everything in Electronics. Send for your FREE copy.

RADIO

*Pioneer in electronic
kit development*

Poly-Comm II

THE POWERHOUSE

Citizens Band Transceiver

Designed for Industrial Use

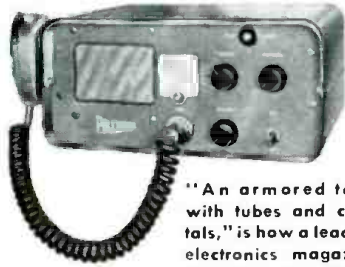

"An armored tank with tubes and crystals," is how a leading electronics magazine described the **Poly-Comm II**, known as the "Workhorse of Industry." The **Poly-Comm II** is most rugged and reliable citizens band transceiver made. Designed for continuous duty and featuring a super-sensitive dual conversion superhet receiver . . . optimum selectivity through dual conversion with 16 tuned circuits and three 455 Kc IF stages, (If you hear him he's on your channel) . . . completely weather and rust proof . . . teflon wiring . . . solid steel cabinet and chassis for rugged use under any conditions.

Additional Features: 3 watts power output. Super-sensitive squelch circuit. Delayed automatic volume control. 100% modulation capability. Push to talk without relays. Floating series gey-type noise limiter. Comes with universal mounting bracket and professional microphone.

\$179.50 user net
Complete

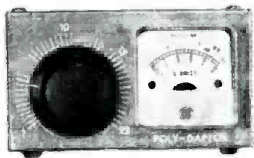

The Poly-Daptor is a remote control variable tuner and S-meter covering 26,965 Mc (channel 1) to 27,225 Mc (channel 22). Retains use of 4 transmit channels with instant switching of crystal control or variable control or variable or crystal controlled receiver.

\$29.50 user net
Complete



The Poly-Comm 6-2 operates on 6 and 2 meters, V.F.O. or crystal control and triple conversion superhet receiver with squelch and ANL, S-meter and instant band switching.

\$299.50 amateur net
Complete

Within the Industry

ALBERT COUMONT has been appointed sales manager of *Sprague Products Co.*, the distributors' supply subsidiary of the *Sprague Electric Co.*



In his new post Mr. Coumont will be responsible for the management of field sales of components and transistors to a nationwide network of distributors, succeeding Harry Kalker who has held the dual posts of president and sales manager of the subsidiary.

Mr. Coumont first joined the division in 1956 as assistant to the president, after serving as service coordinator of the RETMA (now EIA). Prior to that post he was manager of sales for electronic products of the *International General Electric Company* in New York. He has been in the electronic field since 1936.

* * *

H. E. McCALLICK, former associate dean of the College of Technology, University of Houston, has been named executive vice-president of *Capitol Radio Engineering Institute* of Washington, D. C. . . . **A. B. BUCHANAN**, assistant communication engineer of the *Detroit Edison Company*, has retired after 38 years of radio and electronic work to establish a consulting engineering practice in the mobile radio systems field . . .

F. P. RICE, director of operations for *International Resistance Co.* since 1958, died recently at the age of 49 . . .

DR. WILLIAM L. FIRESTONE is the new director of engineering for *Motorola's Communications Division* . . . **WILLIAM B. VOORHIS** has joined the staff of *National Electronics, Inc.* as production manager of the new thyatron and rectifier division. He was formerly with *Tung-Sol* . . .

ALLEN W. DAWSON has been named manager of the television bulb sales department of the Electrical Products Division of *Corning Glass Works* . . . **CLYDE W. KAERICHER**, former executive of *Minneapolis-Honeywell*, has joined *Telex, Inc.* as vice-president in charge of corporate affairs

MUEL L. BARAF president of *Transformer Corporation* . . . **WESSELL** vice-president of *General Electric* . . . **JOHN R. WELTY** is the new manager for diodes and transistors of *Motorola's Semiconductor Division* . . . **ROBERT SACK** has been elected executive vice-president and chief operating officer of *General Electric* . . . The Solid State Department of *CBS Laboratories* . . . **ALFRED F. KASPAUL** to

the post of manager. He has been with the *Laboratories* since 1957 . . . **JOSEPH N. BENHAMIN**, president of the *Bogen-Presto Division*, has resigned his post. No immediate announcement of his future plans was forthcoming . . . **HOWARD P. MUNDAY** has been named training and communications coordinator for the *CBS Electronics Division* . . . **GEORGE L. MALLORY** has been appointed to the newly created post of vice-president, operations, for *Gates Radio Company* . . . Appointment of **LUIS H. URDANG** to the post of manager for quality control at the Mountaintop, Pa. plant, has been announced by *Radio Corporation of America* . . . *Amperex Electronic Corporation* has promoted four senior applications engineers to positions as section heads in the applications engineering department. Those promoted include **BERTRAM GREEN**, **WALLACE HICKMAN**, **ALBERT H. KATZ**, and **KEVIN REDMOND**.

DR. PEI WANG has been named to the newly created post of engineering manager in charge of device services for the Semiconductor Division of *Sylvania Electric Products Inc.*



In his new position, Dr. Wang is responsible for material engineering, chemistry, device techniques, and service. He will continue to maintain offices at the division's headquarters laboratory in Woburn, Mass. where he has been a senior engineering specialist since 1958.

Dr. Wang joined the company in 1953 as a material and chemistry engineer. Prior to that he was a research associate at the University of Wisconsin.

WESTON INSTRUMENTS DIVISION has opened new district sales offices and service facilities at 1125 Marshall St. in Redwood City, California . . . **WEST-REX CORPORATION** has moved its eastern operations into a six-story building at 540 W. 58th St., New York City . . . Construction of a new 10,000-square-foot plant for **CONDENSER PRODUCTS COMPANY** has begun in Brooksville, Florida. Occupancy is scheduled for September 1st and will complete the shift of the firm's operations from New Haven, Conn. . . . The San Carlos plant of **EITEL-McCULLOUGH, INC.** is being expanded by the addition of two new buildings which are being built at a cost of over one-million dollars. Scheduled for completion in November, the new buildings will cover 63,000 square

ELECTRONICS WORLD

CONVERT YOUR CAR RADIO FOR SHORT WAVE RECEPTION WITH ...



INTERNATIONAL'S ALL TRANSISTOR, CRYSTAL CONTROLLED CONVERTER

Now, in a matter of minutes, your standard broadcast car radio becomes a short wave receiver . . . bringing in domestic and foreign stations.

Designed by International for AMATEURS, CITIZEN LICENSEES, SHORT WAVE LISTENERS, HOBBYIST.

Available in SEVEN frequency ranges covering the Amateur bands, 75 through 10 meters, the Citizens band, and WWV National Bureau of Standards Time Broadcasts.

Three simple steps to install. (1) Remove antenna lead from car radio and plug into input of Mobilette. (2) Plug jumper wire from Mobilette into antenna connection of car radio. (3) Plug power connector into cigarette lighter socket. It's that easy!

Works on either 6 or 12 volts without change. Mobilette normally wired for negative ground battery system. When ordering positive ground, add Suffix "P" to catalog number.

International Mobilettes cover these short wave bands.

Catalog No.	Frequency
630 — 105	75 meters (Amateur)
630 — 104	40 meters (Amateur)
630 — 106	10 MC (WWV Time Broadcasts)
630 — 103	20 meters (Amateur)
630 — 102	15 meters (Amateur)
630 — 101	11 meters (Citizens)
630 — 100	10 meters (Amateur)
	28.5 — 29.5 MC

Available soon for 6 and 2 meters at slightly higher price.



Complete, ready to plug in and operate . . . only \$19.95

Order direct from International. Terms F. O. B. Okla. City. Include postage. Shipping Weight 2 lbs.

**INTERNATIONAL
CRYSTAL MFG. CO. INC.**
18 NORTH LEE — OKLA. CITY, OKLA.

INTERNATIONAL CRYSTAL MFG. CO., INC., 18 NO. LEE
OKLAHOMA CITY, OKLAHOMA

GENTLEMEN: PLEASE SHIP THE FOLLOWING MOBILETTES @ \$19.95 EACH.

CATALOG NO.	FREQ.	QUANTITY
_____	_____	_____

SHIP TO — NAME _____
AMOUNT ENCLOSED ADDRESS _____

INCLUDE POSTAGE WITH ORDER.



The "Big Picture"

...informative shop talks

by AL MERRIAM

Sylvania National Service Manager

How to avoid that "strapped" feeling!

I'm talking about the way ordinary picture tubes are strapped into the TV set. Boy, I've felt "strapped" more than once . . . and bet you have, too . . . but now there's an "easy out."

And that's Sylvania Bonded Shield 23". Mounting or removing a Bonded Shield picture tube is easier and faster simply because there are no old-fashioned straps. The mounting "ears" are a strong part of the shield, and the door-latch mounting clips are easy as pie. How easy is that? Look . . .

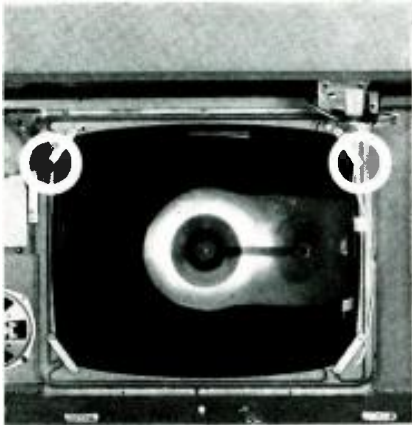

Take out one screw on the two top clips . . . loosen the rest of the screws.



That's all there is to it . . . the tube is removed that easily!

What's more, Bonded Shield picture tubes are much safer . . . both for you and the people "out front." This tough, "contoured cap" makes the *whole* tube stronger and implosion-resistant . . . and, no mounting hardware ever contacts that highly stressed picture tube! I'm sure you'll like the idea.

And here's another service tip. A discriminator transformer drift may be causing a low level buzz in the audio, and you can clear it up with a quick and easy readjustment to the transformer. Our tests indicate that many transformers "age" in the first few hours of operation, and the drop in frequency causes the buzz. Sylvania Home Electronics Corp., Batavia, N. Y.

SYLVANIA

Subsidiary of **GENERAL TELEPHONE & ELECTRONICS** 

feet . . . **RAYTHEON COMPANY's** new Airborne Equipment Center has been dedicated at Sudbury, Mass., the firm's seventh major facility to be completed and become operational within the past year . . . **GENERAL ELECTRIC COMPANY** will add another 260,000 square feet of office, engineering, and manufacturing space to its transistor and tunnel diode facilities at Electronics Park, Syracuse . . . **RADIO CORPORATION OF AMERICA** will open a new research laboratory in Japan to conduct fundamental studies in the physics and chemistry of solids. The facility will be located in a new building now under construction in Tokyo.

* * *

R. R. FORBES has been appointed manager of the Semiconductor Department of *P. R. Mullory & Co. Inc.'s* Elkon Division at Du Quoin, Illinois.



In his new capacity, Mr. Forbes will have charge of all of the department's activities including research and development, production, quality control, and sales. He also assumes the duties of Dr. C. H. Moore who has resigned to take a position with another company.

Mr. Forbes joined the organization as president of *Mullory Plastics Company*, Chicago. Before that he was manager of the radio and television division of *Sylvania Electric Canada Limited*.

* * *

CHARLES D. BROWN has been appointed manager of marketing at *General Electric Company's* Instrument Department in West Lynn, Mass. . . . **DR. ROBERT A. NOTTENBURG** has been appointed director of education for the *Cleveland Institute of Electronics*. He was formerly dean of the faculty for *International Correspondence Schools* . . . **RUSSELL W. SWIGART** has been named credit manager of *World Radio Laboratories* . . .

C. T. KIERULFF has been named president and chief executive officer of *Kierulff & Company* while **C. R. KIERULFF** moves up to the post of chairman of the board . . . *General Instrument Company* has announced the election of **MOSES SHAPIRO** as president and **MONTE COHEN** as vice-chairman of the board . . . **RAY D. BARR** has been appointed vice-president and controller of *Globe Electronics* . . . **F. D. MEADOWS** has been named manager of video products administration for *Ampex Professional Products Company* . . . *Sangamo Electric Co.* has appointed **ROGER R. MILLER** to the new post of sales manager of electronic components . . .

WILLIAM D. HOGAN has been named manager of field engineering, a newly created post within the Semiconductor Division of *Sylvania Electric Products Inc.* He was formerly with *Raytheon* at Waltham . . . **LT. COL. JOHN F. RIDER** (U.S.A., Ret.) was honored at a testimonial dinner held by the Lt. Harold G. Blumberg Post of the American Legion. He was honored for his "contribution to the American Way of life."

—50—

The specs prove it...your best buy is



B
**TV-FM SWEEP GENERATOR
 AND MARKER #368**
 KIT \$69.95 WIRED \$119.55

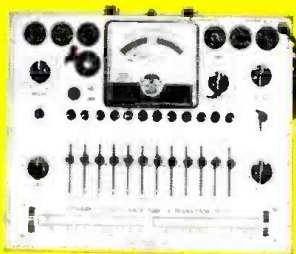
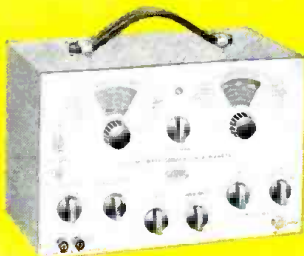

A
**DYNAMIC CONDUCTANCE
 TUBE & TRANSISTOR
 TESTER #666**
 KIT \$69.95 WIRED \$109.95
 Complete with steel cover & handle

RF SIGNAL GENERATOR #324
 KIT \$26.95 WIRED \$39.95



D
**PEAK-TO-PEAK
 VTVM #232 &
 UNIPROBE**
 KIT \$29.95
 WIRED \$49.95



E
**COLOR & MONOCHROME
 DC TO 5 MC LAB & TV
 5" OSCILLOSCOPE #460**
 KIT \$79.95 WIRED \$129.50
**5" PUSH-PULL
 Oscilloscope #425:**
 Kit \$44.95 WIRED \$79.95

A Tests all receiving tubes (picture tubes with adapter), n-p-n and p-n-p transistors. Composite indication of Gm, Gp & peak emission. Simultaneous selection of any one of 4 combinations of 3 plate voltages, 3 screen voltages, 3 ranges of continuously variable grid voltage (with 5% accurate pot.). Sensitive 200 ua meter. 10 six-position lever switches: freepoint connection of each tube pin. 10 pushbuttons: rapid insert of any tube element in leakage test circuit. Direct reading of inter-element leakage in ohms. New gear-driven rollchart. CRA Adapter \$4.50.

B Entirely electronic sweep circuit with accurately-biased inductor for excellent linearity. Extremely flat RF output. Exceptional tuning accuracy. Hum and leakage eliminated. 5 fund. sweep ranges: 3-216 mc. Variable marker range: 2-75 mc

In 3 fund. bands, 60-225 mc on harmonic band. 4.5 xtal marker osc., xtal supplied. Ext. marker provision. Attenuators: Marker Size, RF Fine, RF Coarse (4-step decade). Narrow range phasing control for accurate alignment.

C 150 kc to 435 mc with ONE generator in 6 fund. bands and 1 harmonic band! $\pm 1.5\%$ freq. accuracy. Colpitts RF osc. directly plate-modulated by K-follower for improved mod. Variable depth of int. mod. 0-50% by 400 cps Colpitts osc. Variable gain ext. mod. amplifier: only 3.0 v needed for 30% mod. Turret-mounted, slug-tuned coils for max. accuracy. Fine and Coarse (3-step) RF attenuators. RF output 100,000 uv, AF output to 10 v.

D Uni-Probe — exclusive with EICO — only 1 probe performs all functions: half-turn of probe tip selects DC or AC-Ohms. Calibration without re-

moving from cabinet. Measure directly p-p voltage of complex & sine waves: 0-4, 14, 42, 140, 420, 1400, 4200. DC/RMS sine volts: 0-1.5, 5, 15, 50, 150, 500, 1500 (up to 30,000 v. with HVP probe, & 250 mc with PRF probe). Ohms: 0.2 ohms to 1000 megs. $4\frac{1}{2}$ " meter, can't-burn-out circuit. 7 non-skip ranges on every function. Zero center.

E Features DC amplifiers! Flat from DC to 4.5 mc, usable to 10 mc. Vert. Sens.: 25 mv/in.; input Z 3 megs; direct-coupled & push-pull throughout. 4-step freq.-compensated attenuator up to 1000:1. Sweep: perfectly linear 10 cps — 100 kc (ext. cap. for range to 1 cps). Pre-set TV V & H positions. Auto sync. lim. & ampl. Direct or cap. coupling; bal. or unbal. inputs; edge-lit engraved lucite screen with dimmer control; plus many more outstanding features.

FREE CATALOG shows you HOW TO SAVE 50% on 65 models of top quality professional test equipment. MAIL COUPON NOW!



**New Transistor
 Portable Radio RA-6**
 Kit \$29.95
 Wired \$49.95
 Incl. F.E.T.; less 9V batt.
 Prealigned RF, IF
 xfms; push-pull
 audio; 6" spkr.



**NEW Power & Bias
 Supply for
 Transistorized
 Eqpt. #1020**
 Kit \$19.95
 Wired \$27.95



**NEW Tube &
 CRT Fil.
 Tester #612**
 Kit \$3.95
 Wired \$5.95
 Fast-checks
 radio/TV tubes,
 pilot lamps, etc.



**Series/Parallel
 R-C Combination
 Box #1140**
 Kit \$13.95
 Wired \$19.95



Tube Tester #625
 Kit \$34.95
 Wired \$49.95
 • tests 600 mil
 series string type
 tubes
 • illuminated
 roll-chart
**Pix Tube Test
 Adapter..... \$4.50**



**6V & 12V Battery
 Eliminator
 & Charger #1050**
 Kit \$29.95
 Wired \$38.95
 Extra-filtered for
 transistor equip.
 #1060 Kit \$38.95
 Wired \$47.95



**20,000 Ohms/Volt
 V-O-M #565**
 Kit \$24.95
 Wired \$29.95
**1000 Ohms/Volt
 V-O-M #536**
 Kit \$12.90
 Wired \$14.90

SEE OUR OTHER ADVERTISEMENT ON PAGE 102



33-00 Northern Blvd. L. I. C. 1, N. Y.

Add 5% in the West.

TURN PAGE FOR MORE EICO VALUES

© 1960

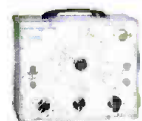

**R-C Bridge & R-C-L
 Comparator #950B**
 Kit \$19.95
 Wired \$29.95
 Reads 0.5 ohms-
 500 megs,
 10 mmfd-5000 mfd,
 power factor



VTVM Probes

	Kit	Wired
Peak-to-Peak	\$4.95	\$6.95
RF	\$3.75	\$4.95
High Voltage Probe-1		\$6.95
High Voltage Probe-2		\$4.95
Scope Probes		
Demodulator	\$3.75	\$5.75
Direct	\$2.75	\$3.95
Low Capacity	\$3.75	\$5.75

EICO
 33-00 Northern Blvd.
 L. I. C. 1, N. Y.

EW-9

Show me HOW TO SAVE 50% on Test Instruments
 Hi-Fi Ham Gear. Send free Stereo Hi-Fi
 Guide. Send FREE Short Course for Novice License.
 Send me FREE Catalog, name of neighborhood dealer.

Name.....
 Address.....
 City.....Zone.....State.....

Over 2 MILLION EICO instruments in use throughout the world. Add 5% in the West.



IF YOU LOVE TO CREATE... BUILD **EICO** KITS

In **STEREO** and

**Mono Hi-Fi...
the experts say
your Best Buy
is EICO**



Stereo Amplifier-Preamplifier HF81t



Stereo Preamplifier HF85t



FM Tuner HFT90t
AM Tuner HFT94t
FM/AM Tuner HFT92t



100W Stereo Power Amplifier HF89
70W Stereo Power Amplifier HF87
28W Stereo Power Amplifier HF86



Stereo Integrated Amplifier AF4t



3-Way Speaker System HFS3
2-Way Bookshelf Speaker Systems
HFS5 and HFS1



NEW!
Stereo Automatic Changer/
Player 1007



- Exclusive advanced systematized engineering
- Latest and finest quality parts
- Exclusive "Beginner-Tested" easy step-by-step instructions
- Exclusive TRIPLE quality control
- Exclusive LIFETIME guarantee at nominal cost

IN STOCK — Compare, then take home any EICO equipment — right "off the shelf" — from 1500 neighborhood EICO dealers throughout the U. S. and Canada.

HF81 Stereo Amplifier-Preamplifier selects, amplifies, controls any stereo source & feeds it thru self-contained dual 14W amplifiers to a pair of speakers. Provides 28W monophonically. Ganged level controls, separate balance control, independent bass and treble controls for each channel. Identical Williamson-type, push-pull EL84 power amplifiers. "Excellent" — SATURDAY REVIEW. "Outstanding... extremely versatile." — ELECTRONICS WORLD. Kit \$69.95. Wired \$109.95. Incl. cover.

HF85 Stereo Preamplifier: Complete master stereo preamplifier-control unit, self-powered. Distortion borders on unmeasurable. Level, bass, & treble controls independent for each channel or ganged for both channels. Inputs for phono, tape head, mike, AM, FM, & FM-multiplex. One each auxiliary A & B input in each channel. "Extreme flexibility... a bargain." — HI-FI REVIEW. Kit \$39.95. Wired \$64.95. Incl. cover.

New HF89 100-Watt Stereo Power Amplifier: Dual 50W highest quality power amplifiers. 200W peak power output. Uses superlative ultra-linear connected output transformers for undistorted response across the entire audio range at full power, assuring utmost clarity on full orchestra & organ. 60 db channel separation. IM distortion 0.5% at 100W; harmonic distortion less than 1% from 20-20,000 cps within 1 db of 100W. Kit \$99.50. Wired \$139.50.

HF87 70-Watt Stereo Power Amplifier. Dual 35W stereo amplifiers identical circuit-wise to the superb HF89, differing only in rating of the output transformers. IM distortion 1% at 70W; harmonic distortion less than 1% from 20-20,000 cps within 1 db of 70W. Kit \$74.95. Wired \$114.95.

HF86 28-Watt Stereo Power Amp. Flawless reproduction at modest price. Kit \$43.95. Wired \$74.95.

FM Tuner HFT90: Prewired, prealigned, temperature-compensated "front end" is drift-free. Prewired exclusive precision eye-tronic® travelling tuning indicator. Sensitivity: 1.5 uv for 20 db quieting; 2.5 uv for 30 db quieting, full limiting from 25 uv. IF bandwidth 260 kc at 6 db points. Both cathode follower & FM-multiplex stereo outputs, prevent obsolescence. Very low distortion. "One of the best buys in high fidelity kits." — AUDIOCRAFT. Kit \$39.95. Wired \$65.95. Cover \$3.95. *Less cover, F.E.T. incl.

AM Tuner HFT94: Matches HFT 90. Selects "hi-fi" wide (20-9000 cps @ -3 db) or weak-station narrow (20-5000 cps @ -3 db) bandpass. Tuned RF stage for high selectivity & sensitivity. Precision eye-tronic® tuning. "One of the best available." — HI-FI SYSTEMS. Kit \$39.95. Wired \$65.95. Incl. cover & F.E.T.

New FM/AM Tuner HFT92 combines renowned EICO HFT90 FM Tuner with excellent AM tuning facilities. Kit \$59.95. Wired \$94.95. Incl. cover & F.E.T.

New AF-4 Economy Stereo Integrated Amplifier provides clean 4W per channel or 8W total output. Kit \$38.95. Wired \$64.95. Incl. cover & F.E.T.

HF12 Mono Integrated Amplifier (not illus.): Complete "front end" facilities & true hi-fi performance. 12W continuous, 25W peak. Kit \$34.95. Wired \$57.95. Incl. cover.

New HFS3 3-Way Speaker System Semi-Kit complete with factory-built ¾" veneered plywood (4 sides) cabinet. Bellows-suspension, full-inch excursion 12" woofer (22 cps res.) 8" mid-range speaker with high internal damping cone for smooth response, 3½" cone tweeter. 2¼ cu. ft. ducted-port enclosure. System Q of ½ for smoothest frequency & best transient response. 32-14,000 cps clean, useful response. 16 ohms impedance. HWD: 26½", 13¾", 14¾". Unfinished birch. Kit \$72.50. Wired \$84.50. Walnut or mahogany. Kit \$87.50. Wired \$99.50.

New HFS5 2-Way Speaker System Semi-Kit complete with factory-built ¾" veneered plywood (4 sides) cabinet. Bellows-suspension, ¾" excursion, 8" woofer (45 cps. res.), & 3½" cone tweeter. 1¼" cu. ft. ducted-port enclosure. System Q of ½ for smoothest freq. & best transient resp. 45-14,000 cps clean, useful resp. 16 ohms.

HWD: 24", 12½", 10½". Unfinished birch. Kit \$47.50. Wired \$56.50. Walnut or mahogany. Kit \$59.50. Wired \$69.50.

HFS1 Bookshelf Speaker System complete with factory-built cabinet. Jensen 8" woofer, matching Jensen compression-driver exponential horn tweeter. Smooth clean bass; crisp extended highs. 70-12,000 cps range. 8 ohms. HWD: 23" x 11" x 9". Kit \$39.95. Wired \$47.95

HFS2 Omni-Directional Speaker System (not illus.) HWD: 36", 15¼", 11½". "Fine for stereo" — MODERN HI-FI. Completely factory-built. Mahogany or walnut \$139.95. Blond \$144.95.

New Stereo Automatic Changer/Player: Jam-proof 4-speed, all record sizes, automatic changer and auto/manual player. New extremely smooth, low distortion moisture-proof stereo crystal cartridge designed integrally with tonearm to eliminate mid-range resonances. Constant 4½ grams stylus force is optimum to prevent groove flutter distortion. No hum, turntable attractions, acoustic feedback, center-hole enlargement. Only 10¾" x 13". Model 10070: 0.7 mil diamond, 3 mil sapphire dual styli, \$59.75. 10075: 0.7 mil, 3 mil sapphire, \$49.75. Incl. FET.

†Shown in optional Furniture Wood Cabinet WE71: Unfinished Birch, \$9.95; Walnut or Mahogany, \$13.95.

‡Shown in optional Furniture Wood Cabinet WE70: Unfinished Birch, \$8.95; Walnut or Mahogany, \$12.50.

EICO, 33-00 N. Blvd., L.I.C. 1, N. Y. EW-9
Show me how to SAVE 50% on easy-to-build top-quality Hi-Fi. Send FREE catalog, Stereo Hi-Fi Guide plus name of neighborhood EICO dealer.

Name.....
Address.....
City..... Zone..... State.....

See and hear all—EICO Stereo at N. Y. Hi-Fi Show, Rooms 305 and 306. Listen to the EICO Hour, WABC-FM, N. Y. 95.5 MC, Mon.-Fri., 7:15-8 PM.

© 1960 by EICO, 33-00 N. Blvd., L. I. C. 1, N. Y.

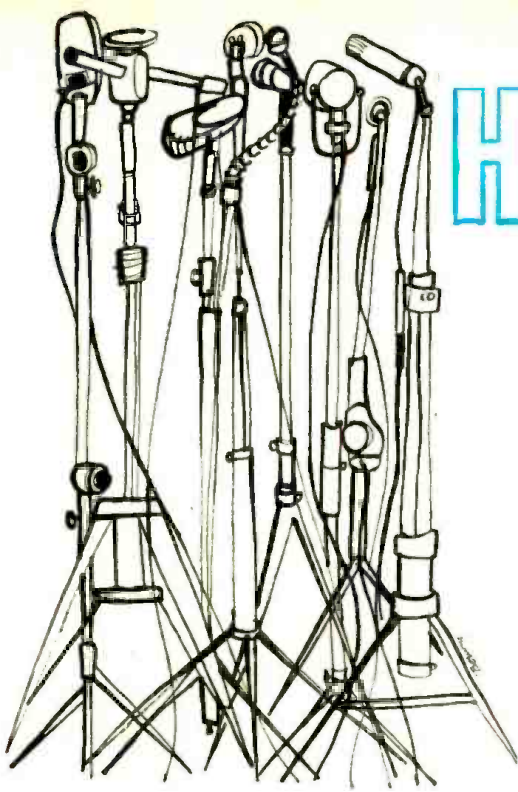

HOW TO CHOOSE THE PROPER MICROPHONE

By **GEORGE RILEY**
Electro-Voice, Inc.

Picking the right mike for your particular application will certainly pay dividends in price and performance.

PICKING the wrong microphone for your sound installation can be much like putting the wrong carburetor on your automobile. While it might work, you won't get top performance unless you've chosen the right one by mere coincidence. The odds are that you will end up with mediocre performance, without realizing it could be much improved.

Complex as it may be, the field of sound equipment is one where a small amount of accurate information can go a long way. It can be built upon to form a firm foundation for choosing, using, and getting the most out of the equipment you buy. The results show up in dollars saved and in performance

far above that obtainable by guesswork or casual advice. Quite often, proper application of an inexpensive microphone will produce superior performance over a much more expensive microphone wrongly applied, in the same installation. Broadcast stations, for example, have actually gone on the air using \$30 microphones throughout, with acceptable results. This, however, is the extreme—like using a box camera to record sporting events. But it can be done, and the point is that application "know-how" pays long dividends.

Actually, only three points must be considered when picking the proper microphone for any application, whether

it be home recording, professional broadcasting, or a communications system in the roaring noise of a steel plant. These are: (1) the type of generating element best suited to the conditions, (2) the most desirable microphone pickup pattern, and (3) the final quality desired. To obtain optimum results in most applications, the first two factors must be carefully considered. On the other hand, if low-cost equipment is being used in the balance of the system and price is a controlling factor, or on special applications such as radio communications equipment, the third factor may be compromised to some extent.

In a microphone, the energy of sound

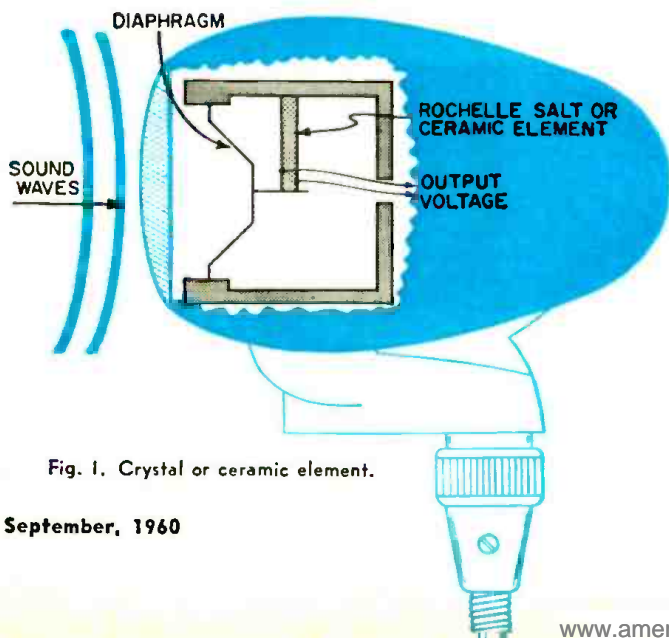

Fig. 1. Crystal or ceramic element.

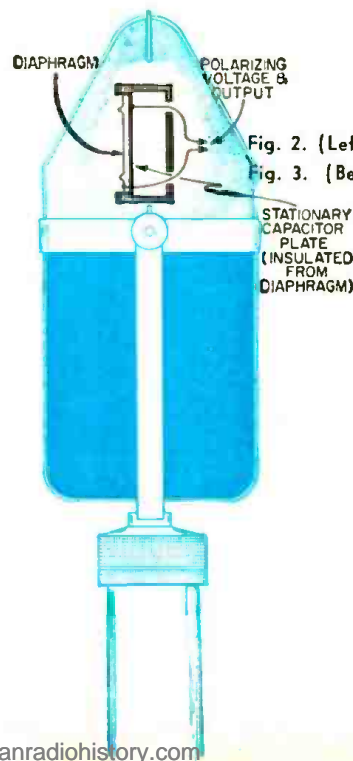
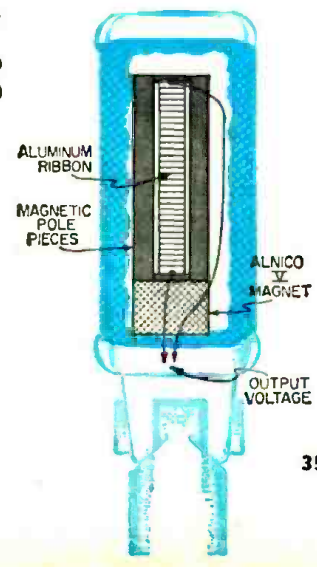

Fig. 2. (Left) Capacitor microphone element.
Fig. 3. (Below) Ribbon microphone element.



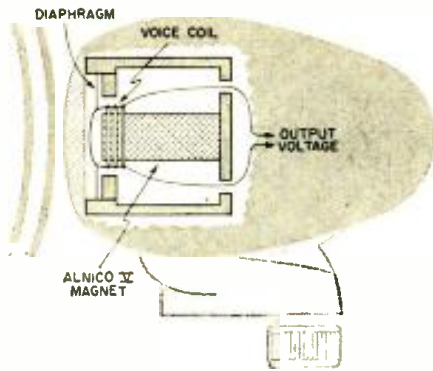

Fig. 4. Dynamic generating element.

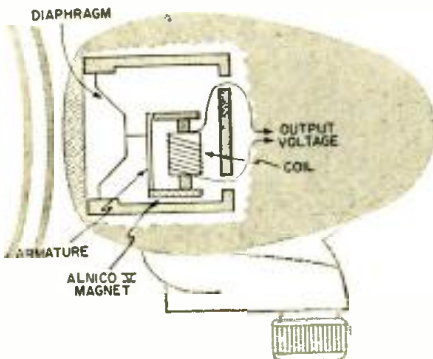

Fig. 5. Magnetic generating element.

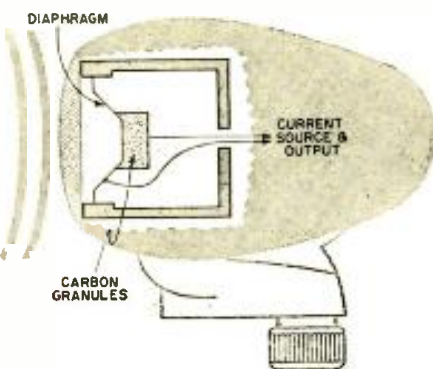

Fig. 6. Carbon microphone element.

waves is used to actuate a diaphragm—to make it vibrate at the identical rate of the sound source. How closely it does this depends on the skill of the engineers who design microphones. In most microphones, the energy of the vibrating diaphragm is then used to generate an electrical voltage. It is very difficult to amplify sound itself, but in the form of an electrical voltage which varies in frequency as the sound varies in pitch, it can be easily amplified to perform almost any job we desire, from driving a loudspeaker or making a tape recording to vibration-testing a full-sized ship!

Not all microphones generate a voltage directly. Some types change a direct current to one which varies and is controlled by the movement of the microphone diaphragm. This allows us to obtain an output voltage across a resistor in series with the microphone.

Microphones which fall into the class of true voltage generators are the crystal, ceramic, dynamic, ribbon, and magnetic. All generate a voltage which

is an electrical facsimile of the sound waves actuating the microphone diaphragm. In the remaining class are the carbon and capacitor microphones which modify the direct current supplied to them into one which varies in an identical manner according to the movement of the microphone diaphragm.

Next, consider the problem of pickup pattern. We may not always wish to pick up sounds coming to the microphone from *all* directions. For example, in recording a wedding, the words of the participants must be picked up distinctly, but a cough in the crowd or even the footsteps of the ushers would be distracting in the final recording. In directing his men at the scene of a large conflagration, it might be impossible for the fire chief to make himself heard above the noise unless a microphone which cancels *all* sound except that of his own voice is used.

The fact that the human brain has the ability to sort out undesirable sounds and ignore them has led many an amateur recordist into a dilemma. It is not difficult for two persons to converse in a noisy bus, but try to record that conversation and one suddenly discovers that the microphone is truly an ear without a brain. Proper use of directional microphones, however, can usually provide satisfactory results even under the most difficult conditions.

Characteristics of a microphone which

determine its quality will be discussed in detail later. No reasonable person would expect top performance using a \$5 microphone with a \$500 tape recorder. The more costly the microphone, the greater is the need to make the proper choice if good value is to be obtained.

With these fundamentals in mind, we can return to the three basic requirements for proper choice of a microphone and discuss them in greater detail.

Crystal and Ceramic Elements

Some crystalline materials have the property of generating an electrical voltage when a thin slab of the crystal is bent or twisted. Rochelle salt (potassium sodium tartrate) is one of the most suitable substances since it can be grown synthetically and at a comparatively low cost. It can be cut into small slabs for use in low-cost microphones. Physically, it is sufficiently compliant so that a microphone diaphragm, with a diameter of around 2 inches, coupled to it mechanically will produce high output level. Fig. 1 shows how sound waves moving the diaphragm of this type of microphone transmit a force which bends the crystal element to produce the electrical signal we require. Many low-cost microphones use Rochelle salt crystal elements from which they derive their general identification as "crystal" microphones.

CONDITION OR CHARACTERISTIC	CRYSTAL	CERAMIC	DYNAMIC	RIBBON	MAGNETIC	CAPACITOR	CARBON
High Temperature (112°F. or above)		•	•	•	•	•	•
Low Temperature	•	•	•	•	•	•	•
High Humidity		•	•	•	•	•	•
Rough Handling			•		•		•
Very High Output							•
High Output	•	•			•		
Wide Frequency Range			•	•		•	
Low Cost	•	•	Some		•	•	•
Long Mike Line ¹			•	•	•	•	
Low Distortion			•	•		•	

¹Choose low-impedance models where hum or long lines (over 20 feet) may be encountered.

Table 1. Choose type of element best suited to use and with desired characteristics.

ACOUSTIC CONDITION	OMNI-DIRECTIONAL	BIDIRECTIONAL (Ribbon Only)	UNIDIRECTIONAL (CARDIOID, LINE)	DIFFERENTIAL (CLOSE-TALKING)
Low Reverberation	•	•	•	
High Reverberation		•	•	
Low Random Noise	•	•	•	
Very High Noise				•
Source Far From Mike			•	
Source Close	•	•	•	Less than 3"

Table 2. Select the pickup pattern that is best suited to the acoustic conditions.

Table 3. The final choice will be determined by the quality desired and application.

APPLICATION	APPROX. PRICE RANGE	TYPICAL EXAMPLES			
		OMNI-DIRECTIONAL	BI-DIRECTIONAL	UNI-DIRECTIONAL	DIFFERENTIAL
Low-cost home recording, P.A.	\$5 - \$30	Crystal Ceramic Dynamic Magnetic		Crystal Ceramic	
High-quality home recording, P.A.	\$30 - \$70	Dynamic	Ribbon	Dynamic Ribbon	
High noise level and Mobile	\$15 - \$35	Crystal Ceramic Carbon Dynamic Magnetic			Carbon Dynamic
Professional recording, Broadcast	\$50 - over \$300	Dynamic Capacitor	Ribbon	Dynamic Ribbon Capacitor	

While Rochelle salt crystals permit the construction of quite low-cost and high-level microphones, this material has some disadvantages. Its composition is two molecules of water of crystallization to every molecule of Rochelle salt. Additional moisture from high humidity or evaporation of the water of crystallization from high heat causes a breakdown of the crystal structure and a useless microphone. Given reasonable care in the cool climates of the northern hemisphere, crystal microphones usually last for a good many years. What is more, special protective coatings are sometimes applied to the crystalline element to help it resist the effects of moisture and humidity. But in tropical or semi-tropical countries, where heat and humidity are common, the same type microphone may last only a few weeks or perhaps even only a few days. Leaving a crystal microphone in an automobile in the summer with the windows closed may cause damage.

Because of this problem, most microphone manufacturers have recently begun substituting barium titanate ceramic elements for Rochelle salt. Unlike the early crystal elements, the ceramic material is not affected by extremes of temperature and humidity. In addition, its cost is low, permitting its use in inexpensive microphones. Construction of ceramic microphones is identical to that of the crystal microphone shown in Fig. 1. While the output level is slightly lower than the crystal, it is sufficiently high to operate most standard audio equipment.

Dynamic Generating Elements

The construction of the dynamic element shown in Fig. 4 will be familiar to anyone who has examined a cross-sectional diagram of a dynamic loudspeaker. When sound strikes the diaphragm, the voice coil attached to the diaphragm moves forward and back through a strong magnetic field formed by the magnet structure. The signal thus generated is taken off through the voice-coil leads and fed into an amplifier.

Use of Alnico V magnets produce output levels almost on a par with those obtained with average crystal microphones. Development of non-metallic diaphragm materials has made possible greatly extended frequency response and extremely rugged construction. A well-designed dynamic microphone, for example, can be soaked by rain and dried out with no ill effects. It can even be used to drive nails without damage to anything but the finish of the microphone case.

Since the generating elements themselves can be built compactly, dynamic microphones may take the form of tiny lavalier microphones worn on a neck cord as well as the larger, high-quality slim studio microphones. Cost is reasonably low although it does exceed that of crystal microphones.

Ribbon Microphones

Ribbon generating elements made

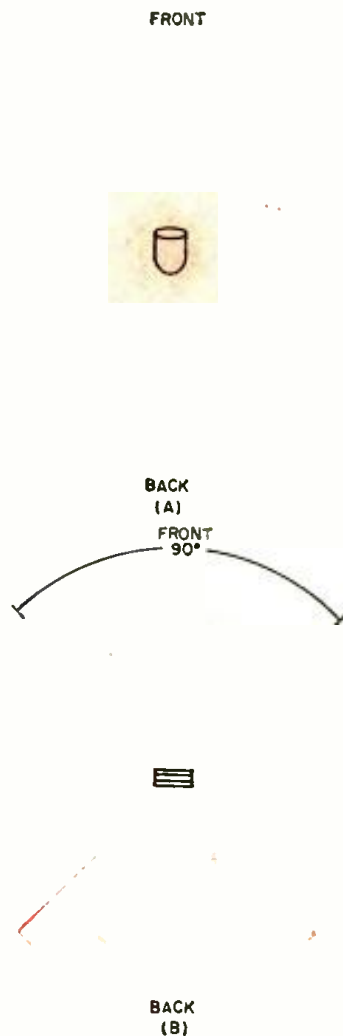

Fig. 7. (A) Omnidirectional and (B) bi-directional microphone pickup patterns.

possible the first high-quality microphones in the early thirties. These early microphones have been drastically improved since that time and today's small, attractive ribbon microphones have little resemblance to their heavy, bulky predecessors.

While wide-range response can be achieved with ribbon elements, use of this type microphone is somewhat restricted. As Fig. 3 shows, the generating element consists of an extremely thin, corrugated aluminum ribbon suspended in a magnetic field. Electrically, this ribbon can be considered as a single turn of a straightened-out voice

coil which also acts as the diaphragm. The ribbon must be extremely compliant since its area is small, yet it must respond to very small sound pressures. This high compliance becomes a problem when the ribbon microphone is used outdoors since wind will cause the ribbon to flutter, resulting in high-level, undesirable noise. This limits the use of the ribbon microphone to indoor applications where good results can be obtained.

In operation, sound waves actuate the ribbon just as they do the diaphragm in a dynamic microphone. Since the ribbon is suspended in a strong magnetic field, it passes through magnetic lines of force as it moves forward and backward. The voltage thus generated is taken off the ends of the ribbon which are, of course, insulated from the magnetic structure.

Magnetic Generating Elements

Fig. 5 shows the structure of the magnetic generating element, sometimes called the variable- or controlled-reluctance element. Here the diaphragm drives an armature which is a part of a magnetic circuit. As the armature moves, it varies the magnetic field passing through the coil. The fluctuating voltage generated in the coil is taken off at its output leads.

The magnetic microphone enjoys several advantages. First, its output is relatively high—comparable to that of a crystal type. It is rugged, inexpensive, and will usually withstand rough handling. Balanced against these advantages is the disadvantage of limited range response which makes this type element most useful in low-cost applications.

Carbon Types

Probably the most common of all microphone types is the simple carbon microphone (Fig. 6) as this is the mike used in conventional telephone handsets. In this type, a moving diaphragm exerts more or less pressure on a small "button" or container of carbon granules. When a low-voltage d.c. source is connected to the button through a series resistor, the current is made to vary in accordance with the changes of resistance of the carbon granules. This variation is in step with the sound pressure changes exerted on the diaphragm, thus we have converted the

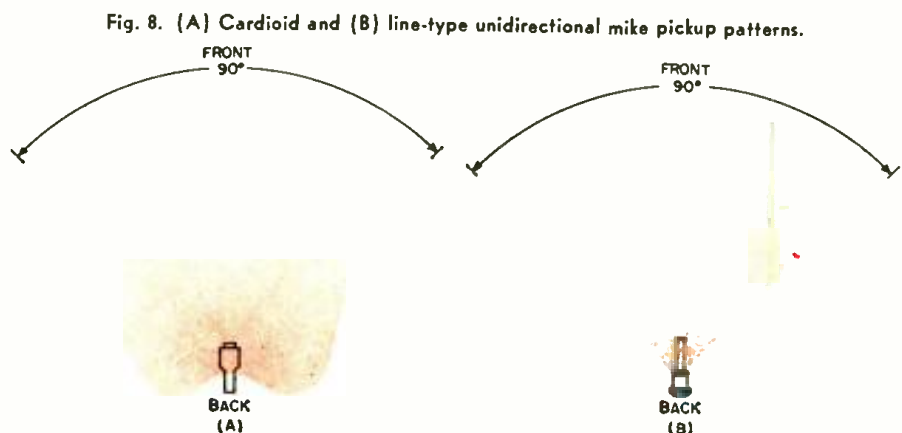

Fig. 8. (A) Cardioid and (B) line-type unidirectional mike pickup patterns.

sound waves into an electrical signal.

Because of the limited frequency response and noise generated by this type of element, its use is restricted to voice communications and then only when intelligibility of speech rather than high-quality reproduction is required. This type of microphone has a very high output level so that it does not need the preamplification required for most other types. In addition, the carbon microphone is extremely rugged.

Capacitor Microphones

The development of the capacitor

microphone in the late twenties was the first improvement over early carbon microphone designs and provided much better quality. This element (Fig. 2) does not generate a voltage directly but merely converts a direct current fed to it into one which alternates or varies in accordance with sound-pressure waves impressed on the diaphragm. This means that each capacitor microphone must have its own power supply, adding cost to an already expensive assembly and increasing chances for equipment failure.

An advantage, however, is the fact

that this unit can be built to furnish very wide frequency response, particularly in the miniaturized types. The inherently rising response (increasing output level as frequency increases) of some of these types gives a "presence" which has made it popular for professional recording applications. Its popularity, however, has been limited by its high cost and the development of high-quality dynamic types.

Pickup Patterns

The second step in choosing a microphone
(Continued on page 76)

Cover Story



MANY of our readers have used or are acquainted with some of the microphones shown on our cover this month. True, the mikes are usually protectively housed so that their "innards" are not visible, but we thought it would be interesting to partially disassemble some examples of the various types to see what they look like. We have chosen mikes that are used for mobile communications, home recording, professional recording, broadcasting, and public-address system applications. Included are examples of capacitor, ceramic (or crystal), dynamic, carbon, and ribbon types.

At the extreme left (A) is a capacitor microphone of professional quality, the Sony C-37A. This mike, which sells for just under \$300, may be adjusted for either a unidirectional (cardioid) response or an omnidirectional response. According to the manufacturer, the frequency response is within ± 2 db from 20 to 18,000 cps. The mike's diaphragm is a special plastic film, one side of which is coated with a thin film of gold that forms the movable plate of the capacitor that generates the audio signal. A fixed electrode behind the diaphragm is the capacitor's fixed plate. Our photo shows the movable gold plate clearly, along with the wire that connects the fixed plate to the mike's cathode-follower preamp directly below it. The built-in preamp is required to convert the very high impedance of the capacitor mike into a much lower impedance (200 ohms) so that long lengths of output cable can be used without a loss of highs. Also, since the capacitance of the mike is so low, it must be operated into a very high impedance for good low-frequency response. The cathode-follower, a 6AU6 tube, obtains its power from a separate power supply which also supplies polarizing voltage to the micro-

phone. When one speaks into this mike, the moving-plate diaphragm vibrates in accordance with the sound. This varies the capacitance, and therefore the charging current, in the grid resistor of the cathode-follower. A replica of the audio signal at the grid, but at a slightly lower level, is obtained at the cathode. This signal is fed through RC networks (in the power supply unit) for various low-frequency roll-offs, if desired, then to a microphone transformer that connects the audio signal to the output cable.

Second from the left (B) is an example of a hand-held ceramic microphone, the Astatic 333. This mike is an inexpensive (about \$11) unit suitable for home recording and p.a. systems. The manufacturer rates the frequency response from 30 to 12,000 cps. Another model, the 331, using the same housing but a differently shaped diaphragm, is limited to voice frequencies from 300 to 5000 cps. This latter model is useful for communications, Citizens Band applications, and paging. In our cover photo, the grille and upper part of the housing have been removed to show the metal diaphragm. Cemented to the center of the back surface is a small linkage that engages one end of a $1/2$ " long x $1/16$ " wide ceramic bar, fixed in position at its other end. When sound waves strike the diaphragm, it vibrates. This bends the ceramic bar and, because of its piezoelectric properties, an audio voltage is generated. The voltage is now ready to be applied to a microphone preamp for amplification. The ceramic microphone, like the capacitor mike, is a high-impedance device. Mikes of this type are also made with Rochelle salt crystalline material (crystal mikes) instead of the ceramic element (barium titanite) employed in this unit. The slide switch is spring-loaded in the Model 331 and has an extra set of contacts in order to provide push-to-talk operation as well as a power-switching function.

The third microphone from the left (C), the Electro-Voice Model 664, is a dynamic (moving-coil) type with a cardioid directivity pattern. This mike, designed mainly for high-quality public-address system installations, sells for about \$50. The manufacturer specifies a frequency response from 40 to 15,000 cps. In order to show the special ribbed diaphragm and moving coil, we have removed the grille screen, retainer grille, filter, and magnetic shield screen that normally enclose the front of the microphone. The moving coil fits in the circular air gap of a permanent-magnet structure, in principle much like an ordinary PM speaker. When sound causes the diaphragm to vibrate, it moves the coil that is immersed in the intense magnetic field. As a result, an audio voltage is generated which is applied to the primary of a built-in microphone transformer. This transformer steps up the normally very low impedance of the moving coil to either 150 ohms for low-impedance circuits or to a much higher value for high-impedance circuits. Openings in the mike's case serve to admit sound through three internal passages to the rear of the diaphragm. These are to

provide a uniform cardioid pattern at all frequencies.

The microphone that is third from the right (D) is a hand-held carbon mike. This unit, the Turner SR-90R, is designed mainly for portable communications equipment. The mike is suitable for voice frequencies only, having a frequency response from 200 to 4000 cps. The diaphragm, backed by a small container of carbon granules, and the external contact assembly are all built as a single self-contained cartridge. This cartridge, incidentally, appears to be identical with the microphone cartridge used in the ordinary telephone. When the diaphragm is vibrated by speech, it changes the resistance of the carbon granules as they are alternately compressed and released. When a low-voltage d.c. source is connected through a load to the mike, the resultant current then varies in accordance with the speech. The microphone is a low-impedance device with an impedance value of about 80 ohms. A spring-loaded, push-to-talk switch is included in the metal housing. Price of the mike is around \$16.

Second from the right (E) is the Norelco Model EL3752/01 dual-dynamic stereo microphone. This mike, designed mainly for home stereo tape recording, consists of two separate moving-coil elements that are mounted at right angles to each other in a single lightweight plastic housing. The directivity of each element is a cardioid, and because of the mounting, one element responds mainly to sounds originating at the left and the other responds to sounds at the right. The movement of the diaphragm-mounted coils in the fixed magnetic fields generates audio signal voltages as previously described. Directly at the centers of the front housings of the two microphone elements are mounted two small transformers. These step up the low impedance of the moving coils to about 25,000 ohms for use in high-impedance circuits. The stereo mike retails at about \$40.

At the extreme right (F) is a ribbon microphone with the outer grille removed. This mike, the Shure Model 300, is a unidirectional type suitable for broadcast, recording, and high-quality p.a. system installations. Its cost is around \$70. The manufacturer quotes a frequency response of $\pm 2\frac{1}{2}$ db from 30 to 15,000 cps. The black rubber horn at the front of the mike directs the sound energy toward a sensitive metal ribbon suspended vertically between the poles of a magnetic structure. When this ribbon is caused to vibrate in the intense magnetic field, a voltage is generated across the ribbon terminals. Openings covered with a blue cloth material near the back of the structure terminate the backside of the ribbon and maintain proper response and directivity of the microphone. Because of the extremely low impedance of the ribbon, a built-in step-up transformer at the base of the mike is used to provide an output impedance of 50, 150, or 250 ohms, depending on the position of the built-in switch. (Cover Photo: Bob Loeb)

The Laser



Dr. Theodore H. Maiman of Hughes Research Laboratories studies the laser's main parts. These include a light source (a special photoflash-like spiral tube) which surrounds synthetic ruby crystal rod through which excited atoms are stimulated to produce an intense beam of coherent, single-frequency light.

EDITOR'S NOTE: *The principles of operation of this new experimental, laboratory device are similar to those employed in the maser except that the laser operates at frequencies that are in the visible light part of the electromagnetic spectrum instead of the microwave region. In the case of the maser, the ruby crystal is supercooled to just a few degrees above absolute zero, and a microwave oscillator supplies the pumping signal needed for operation. The laser operates at room temperature and the pumping signal is supplied by a photoflash-like tube high-intensity light source. For complete details on the operation of the maser, which has now progressed to practical use outside of the laboratory, see our lead article on this subject in a forthcoming issue.*

AT A RECENT press demonstration, Hughes Research Laboratory scientists showed for inspection a new solid-state electronic device that can be used to amplify light. The device, smaller than a water tumbler and containing a rod of synthetic ruby, is an optical maser or "laser" (from Light Amplification by Stimulated Emission of Radiation). Some possible future applications of the light amplifier include its use as a scientific tool for investigating properties of matter and for performing basic experiments of physics. The device will also permit focusing of light into high-intensity beams for space communications and

A Light Amplifier

An optical maser which amplifies light by means of stimulating atomic radiation within ruby crystal.

for industrial, chemical, and medical purposes. By communicating on the frequencies of visible light, there would be a large number of channels available that are not currently in use for communications.

Most of the applications of the laser stem from the fact that the device is able to generate "coherent" light. The smaller the portion of the electromagnetic spectrum over which any particular source generates energy, the more coherent is the source. Previous sources of light energy, such as incandescent lamps, are "incoherent" sources since they simultaneously generate energy over a relatively large part of the spectrum. R.f. sources, on the other hand, are very coherent. The laser then is used to generate single-frequency light, much like an r.f. carrier, but in the visible-light portion of the spectrum.

In operation, a light source, in the form of a powerful flash-tube lamp, irradiates a synthetic ruby crystal which absorbs energy over a broad band of

frequencies. This optical energy excites the atoms to a higher energy state from which the energy is re-radiated in a very narrow band of frequencies. The excited atoms are coupled to an optical resonator and stimulated to emit the radiation together, rather than individually and in random, as in ordinary light sources. Small mirrored surfaces at both ends of the long, thin ruby crystal keep the light energy bouncing back and forth long enough for the proper interaction to occur. Small pinhole openings in the mirrored surfaces permit entry of the light that is to be amplified and emission of the amplified light at the other end.

Because of the coherence of the generated light, perfectly parallel, needle-sharp beams could be generated less than one-hundredth of a degree wide. What is more, this beam would not spread or scatter as does ordinary light. As a result of such concentration, extreme brightness and intense local heat would be produced, -30-



▲ **High-Intensity Sound System**

Acoustical engineer at *Stromberg-Carlson* makes preliminary test—at low power—of big array of loudspeakers destined for Wright Air Development, Ohio. There they will be a key part of a large high-intensity sound system being used in studies of the physiological effects of high-intensity sound. Each of a pair of high-power amplifiers feeding the speakers has an output of 7000 watts, over the entire audio range. Every one of the 32 separate speaker baffles mounts 3 woofers and 12 tweeters.

Recent Developments in Electronics

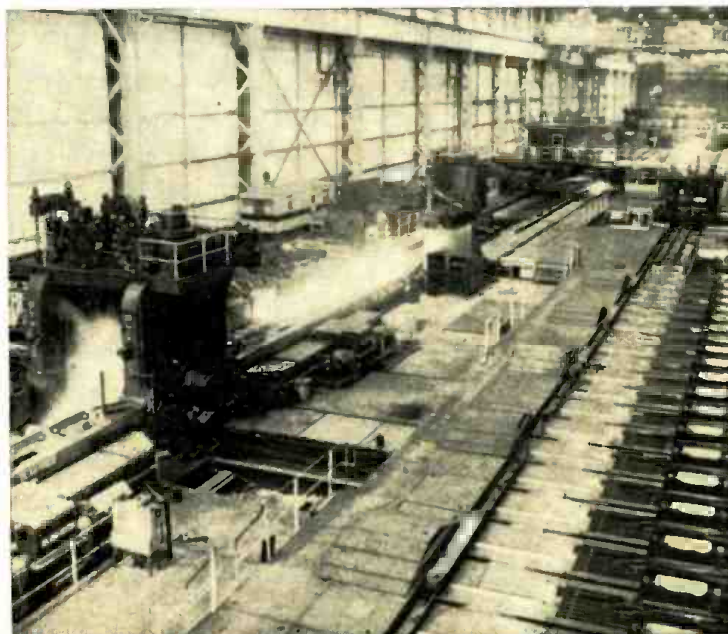

▲ **Punch-Card-Controlled Rolling Mill**

Over-all view of the rolling area in *U. S. Steel's* new Chicago structural mill which is capable of turning out 250-foot beams and bars at the rate of one every 19 seconds. To achieve this production rate, a *G-E* drive and control system speeds 5-ton slabs of hot, raw steel through the mill at rates approaching 20 m.p.h. The specially engineered control system uses punched-card data to automatically direct all operations in the mill. A total of 43 operations are automatically controlled and sequenced by preselected data stored on punched cards and fed into the control system by static logic elements.

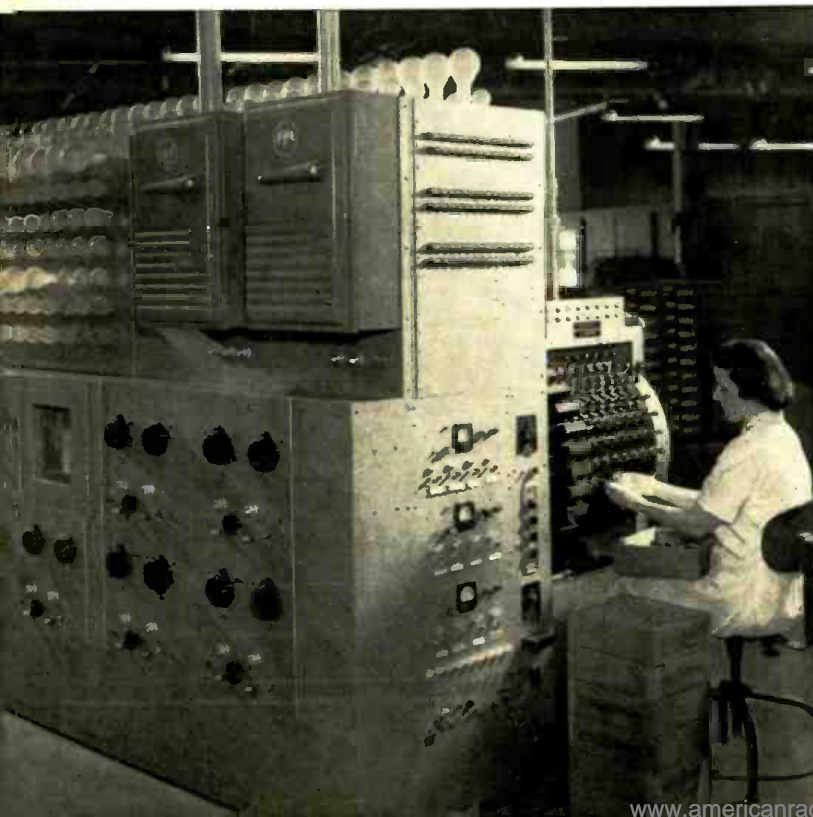

▲ **New Tube-Aging Machine**

Operator loads miniature tubes for radio and TV sets into this new aging machine developed by *RCA Electron Tube Div.* This device, capable of aging 2000 tubes per hour, has been placed in operation in the company's manufacturing plant in Cincinnati. Aging is a process of operating tubes for a short time under controlled conditions to improve stability and performance. This assures greater uniformity and quality. The operator inserts tubes into sockets which are conveyed through the complete aging schedule and automatically removed from the machine.

Fast Computer-Converter

The engineer shown below is inspecting electronic, component-loaded cartridge of *Raytheon's* new compact analogue-to-digital converter. Said to be about 50 times faster than any similar unit now on the market, the new converter pours out two and one-half million samples of information per second. It is less than a cubic foot in size. In spite of the high speed, accuracy remains high—one-half per-cent of full scale. Among other tasks, the converter-computer combination can measure stress or strain of an airplane wing. As the wing stretches, an analogue signal is produced that is then converted into more usable digital form. Converters can also ride inside missiles to convert environmental data to digital form for easier transmission to monitor stations. ▼

"Ten-Pin" Tubes

Samples of *Sylvania's* new "Ten-Pin" tube are shown at the right. This is a new construction in miniature receiving tubes which combines multiple circuit function in a single bulb or envelope. The new design should substantially reduce chassis designing costs by simplifying circuitry and wiring. The "Ten-Pin" utilizes the regular 9-pin base arrangement of the conventional miniature envelope with an additional pin centered in the pin circle. First tubes to incorporate the new design are a double-tetrode for use as an r.f. amplifier and oscillator-mixer in FM tuners and receivers; and a triple-triode for use as an r.f. amplifier, oscillator-mixer, and a.f.c. control. The new tube design is intended for use in both entertainment as well as industrial applications.

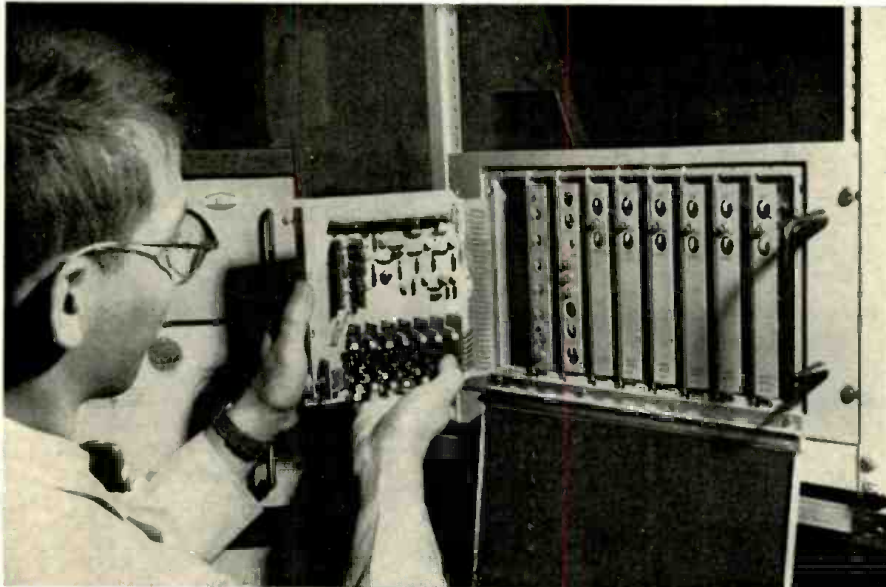
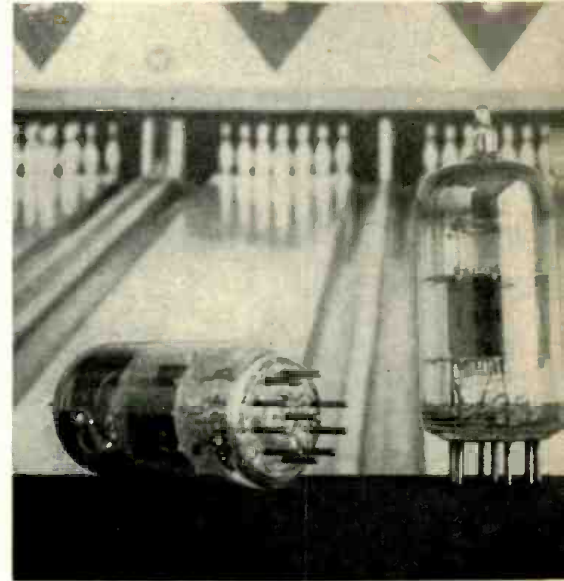

All-Transistorized Computer

IBM engineers make final performance checks on a new all-transistorized data-processing system prior to its formal acceptance by *Texas Instruments*. The computer, installed in a special glass-enclosed, environment-controlled area of 1300 sq. ft., consists of 22 units with a total weight exceeding 17 tons. It is the first fully transistorized data-processing system delivered to private industry. The computer will add or subtract 17,000 five-digit numbers per second; can "remember" instructions stored in half a million ferrite memory cores and put this information to work in 6 microseconds. It can also read magnetic tape at a rate of up to 62,500 characters per second. ▼

Transistorized Flight-Performance Recorder

A transistorized, lightweight flight-performance tape recorder developed by *Minneapolis-Honeywell* is shown here installed aboard a company plane for demonstration to the *FAA*. Data obtained can be used to determine when maintenance is required and the type of maintenance needed. ▼

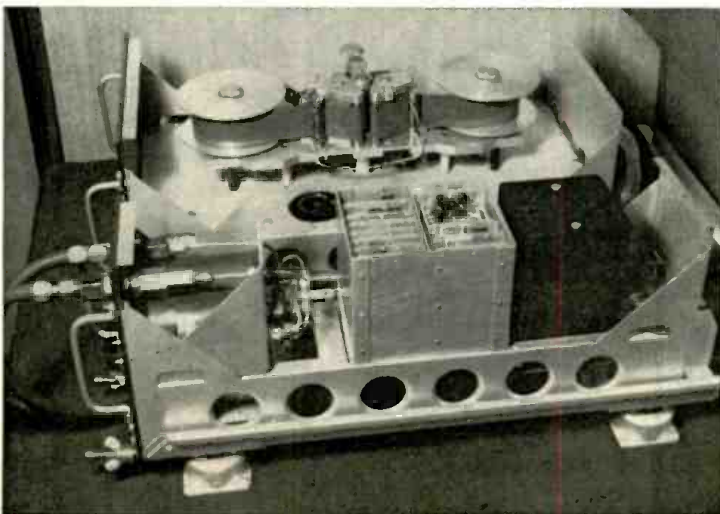

A NEW APPROACH TO

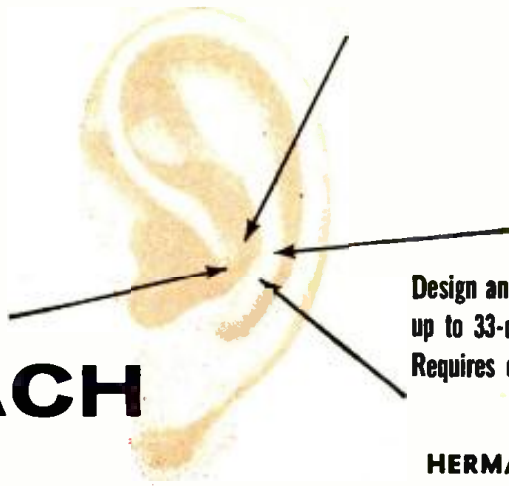

Design and installation of variable bass control to supply up to 33-db boost at 40 cps for very low-level listening. Requires only one additional pot, resistor, and capacitor.

By
HERMAN BURSTEIN/HENRY C. POLLAK

LOUDNESS COMPENSATION

IT IS generally agreed that the Fletcher-Munson effect—the ear's decreasing sensitivity to low frequencies when volume is reduced—necessitates bass boost when the listening level is below that of the original performance. But there is no agreement as to the best method of supplying such boost.

An article by one of the authors¹ pointed out the difficulties of the loudness control, which is often employed to automatically supply increasing bass boost as volume is lowered. In brief, they are: (1) complex operation, involving constant resetting of the level control (sometimes accessible only from the back of the control amplifier) so that the loudness control will operate in the correct range for program sources of different volume levels; and (2) departure of *individual* hearing characteristics from the Fletcher-Munson curves, which represent a group *average* and usually are the basis for the frequency characteristics of the loudness control.

The same article pointed out that the bass control can generally provide sufficient bass boost to cope with the Fletcher-Munson effect in most situations. That is, volume is seldom reduced more than 30 db below the original performance level and, in the case of a 40-cycle note—about the lowest frequency commonly encountered in music—this would require about 19-db boost, which most bass controls can

provide within a few db. Moreover, the bass control as an instrument for achieving loudness compensation has the advantages of simpler operation and being able to tailor the bass boost to the individual's specific hearing characteristics.

On the other hand, the bass control may fall down in two respects. (1) If volume is reduced more than 30 db, as may occasionally happen, the control ordinarily can no longer provide enough bass boost to overcome the Fletcher-Munson effect. (2) If some bass boost is used for other purposes—for example, to compensate for room characteristics, speaker characteristics, bass deficiency in the program sources, the listener's preference as to bass-treble balance, etc.—there may not be enough boost left to also take care of the Fletcher-Munson effect at very low listening levels.

The occasional inadequacy of the bass control could be overcome if it provided something like 30 db or more bass boost at the extreme low end rather than the conventional 15 to 18 db of emphasis. But this raises other problems. For one thing, additional bass boost is achieved by attenuating the rest of the audio range, which means loss of gain. To restore the original gain of the control amplifier might well require another amplifier stage, entailing more cost, more bulk, and perhaps more distortion and noise, which tend to increase with each additional stage. Another problem is that the availability of as much as 30 db

or more bass boost might overload the following stage, particularly at high volume levels. Moreover, if so much bass boost were applied at high volume level, either intentionally or accidentally, this might blow out the speaker.

Variable Bass Control

What we really want, therefore, is more available bass boost only at low levels, that is, when the gain control is turned down. This can be termed a *variable bass control*. And we want this extra bass boost without substantially increasing cost and with no increase in noise and distortion. We would like to eat our cake and have it.

Fortunately, all these desiderata can be had through a very simple and economical circuit, shown in Fig. 1A. As stated in the previous paragraph, it can be called a variable bass control, because at any setting *above mid-position* it provides an increasing amount of bass boost as the gain control is turned down. The circuit operates at no expense in gain, so that an additional stage is not required. The *extra* bass boost is derived directly from the gain sacrificed by the volume control. In other words, some of the gain given up through the gain control is retrieved at low frequencies, thereby achieving bass boost.

The circuit can be incorporated in new or existing equipment. In the case of existing equipment, it would be necessary to replace the pot in the bass control circuit with a pot of the same value and taper but permitting the ad-

¹ Burstein, Herman: "Is a Loudness Control Necessary?" RADIO & TV NEWS, July, 1958.

dition of a ganged control, namely R_1 , in Fig. 1, so that both will be operated by a single shaft.

To help explain the circuit, Fig. 1B shows it in slightly different form and with R_1 omitted. For simplicity, the series combination of R_{2B} and R_3 is termed R . The arm of R_2 is assumed to be positioned so that R_{2A} is 245,000 ohms and R_{2B} is 5000 ohms. R_{2A} and R form a voltage divider. At high frequencies, C is a virtual short-circuit to ground, so that the output voltage is determined by the ratio of R to $R + R_{2A}$. At the lower frequencies, however, C is not a short-circuit to ground. As frequency decreases, the increasing reactance of C causes a larger portion of the input voltage to appear across the output terminals. The upper turnover frequency, where the reactance of C equals R , is 260 cycles, and there is a 3-db rise in output at this point. Output continues to rise with decreasing frequency owing to the rising impedance of the output leg of the voltage divider. However, when the reactance of C equals $R_{2A} + R$, the bass boost approaches an end. At this lower turnover frequency, bass boost is within 3 db of the maximum attained; the maximum boost of course is equal to the input voltage. The greater the ratio of R_{2A} to R , the greater is the total bass boost; also, the higher is the frequency at which boost commences.

It can be seen that bass boost is due to the role played by C . If C were to be shorted, then no bass boost would occur; instead there would be the same attenuation for all frequencies. Returning to Fig. 1A, we can now understand the role played by R_1 . When the bass control is at mid-position or below (counterclockwise), R_1 , which is ganged with the bass control, is at a minimum and effectively bypasses C . Hence there is no extra bass boost due to C . As the bass control is turned above mid-setting (clockwise), C is no

Fig. 1. Variable bass control circuit is shown at (A). (B) Equivalent circuit is indicated with resistor R_1 omitted.

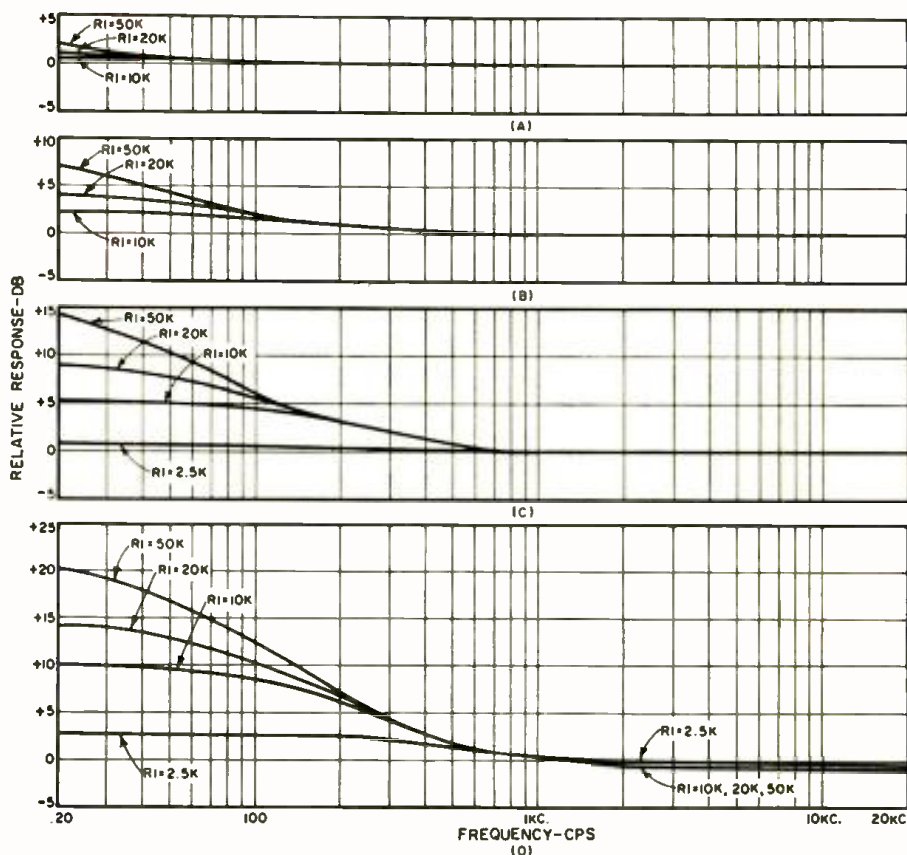
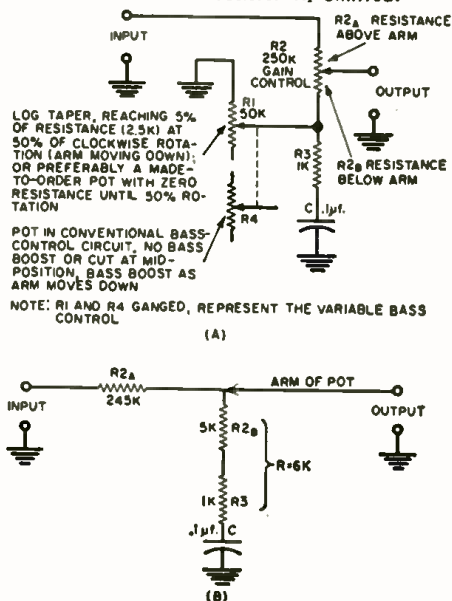

Fig. 2. Effect of R_1 upon response when the gain control is set for various degrees of attenuation at 1000 cps as follows: (A) -10 db, (B) -20 db, (C) -30 db, (D) -40 db.

longer bypassed, so that it can introduce extra bass boost. The amount of extra bass boost produced by C depends upon the extent to which it is bypassed by R_1 . The more the bass control is above mid-setting, the greater is the resistance of R_1 , the smaller is its bypassing action, and therefore the greater is the extra bass boost due to C .

At the same time, the amount of extra bass boost depends upon the position of the arm of R_2 . The lower the setting of the arm, the greater is the ratio of R_{2A} to R (see Fig. 1B), and therefore the greater is the potential extra bass boost. However, this potential can be realized only if the bass control is clockwise of mid-position, so that R_1 does not effectively bypass C .

The purpose of R_3 is to limit the frequency at which bass boost commences (3 db rise) at very low settings of the gain control. R_3 in conjunction with R_{2B} and C keeps the upper turnover frequency below 1000 cycles until the gain control is turned practically all the way down. The value of the gain control, R_2 , is chosen so that it will be suitable in most control amplifiers, that is, low enough not to produce a significant high frequency loss in conjunction with the input capacitance of a high-mu triode (typically a 12AX7) following the control. On the other hand, the 250,000-ohm value of R_2 is high enough not to load down the typical preceding stage apt to be encountered.

Effects of Control

Figs. 2A, 2B, 2C, and 2D show the effect of various values of R_1 , these values depending upon the extent to

which the bass control is turned clockwise of mid-position. Each figure shows the effect of R_1 for a given setting of the gain control. These settings represent volume reductions of 10, 20, 30, and 40 db at 1000 cycles.

Fig. 2A shows that when volume is reduced 10 db, very little extra bass boost is produced, even when the bass control is all the way up and therefore R_1 is at maximum resistance, permitting maximum extra boost. At 40 cycles, only about 1 db extra boost is obtained. In such a situation, namely with volume reduced only 10 db, it is to be expected that the conventional bass control will be perfectly able to cope with the various factors requiring bass boost.

When volume is reduced 20 db, more than 5 db extra boost can be had at 40 cycles. When volume is decreased more than 20 db—which is when the conventional bass control may become inadequate to the tasks it faces—copious amounts of extra bass boost become available. When volume is reduced 30 db at 1000 cycles, 40 cycles can be boosted an extra 11.5 db; assuming that the conventional bass control can supply 15 db boost, this makes 26.5 db boost in all. When volume is reduced 40 db, 40 cycles can be boosted an extra 18 db, or a likely 33 db in all.

If still greater amounts of extra bass boost are desired than indicated by the graphs of Fig. 2, this can be achieved by simply decreasing the value of C , causing boost to commence at a higher frequency. Values between .025 μ f. and .1 μ f. appear to be practical, serving to

(Continued on page 104)

Electronic pH Measurement

By TOM JASKI

This widely used processing technique involves many electronic technicians in industrial work.

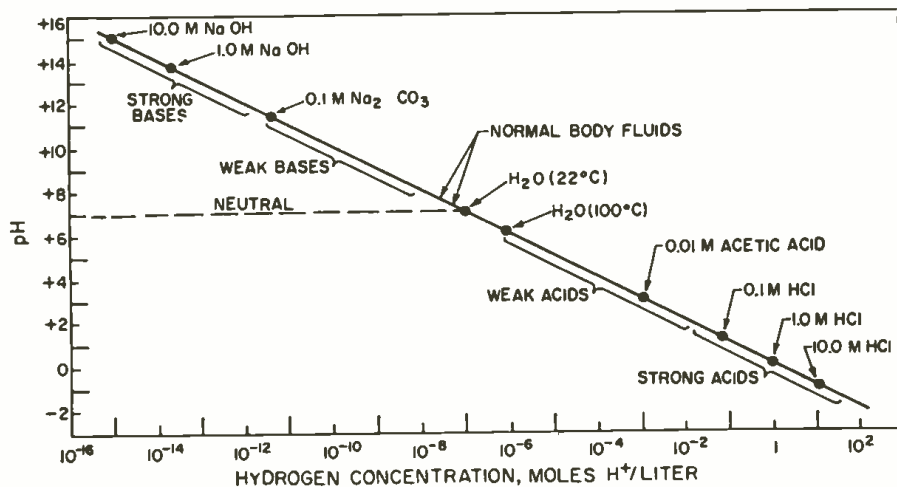

Fig. 1. The pH factor is a logarithmic function of hydrogen-ion concentration.

IF YOU ARE an electronic technician who has moved over into industrial work, you may encounter a mysterious instrument called a pH meter. This encounter may take place if you are in the food industry, the oil industry, the paper and textile industry, a chemical or cosmetic plant, a medical laboratory, or a biological research center. What is it, why do we use it, and how does it work?

The pH factor is the yardstick for measuring acidity or alkalinity, particularly of liquids. This happens to be an extremely important measurement, because human and animal life is possible only within a very narrow range of pH for the body fluids. Excess acidity leads to coma and death. Excess alkalinity can cause convulsions and, eventually, death.

We can protect ourselves against such extreme forces of nature as heat

Fig. 2. Glass (left) and calomel reference (right) electrodes by Beckman.

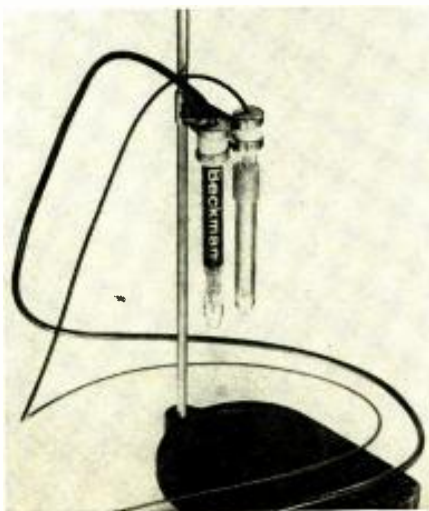

and cold. We can withstand other unusual environmental conditions or compensate for them (such as using supplementary oxygen at very high altitudes). However, there is little that can be done rapidly to counteract a pH that has gone awry. If our pH goes up from its normal, slightly base (alkaline) point, we've had it.

Small wonder then that pH measurements are used in any industry dealing with articles that human beings consume, wash in, smear on themselves, or feed to their pets. We find it used anywhere from water-supply systems, to sewage-treatment plants, to bakeries.

Only electronic techniques are sensitive enough to measure pH—at least where any sort of convenience or reasonable speed is required. Chemical titration (adding one drop at a time of a neutralizing solution to a liquid being tested) is a long, slow process, although it may actually be somewhat more accurate.

The term pH is actually a ratio for the concentration of hydrogen ions in a solution. Specifically, $pH = \log$

$\frac{H \text{ ion concentration, in moles/liter.}}{1}$
The liter, metric unit of capacity, is equal to approximately one quart. The "mole" is a popular abbreviation for the gram molecule. A gram molecule is that quantity of any element or compound which has a weight (in grams) equal numerically to its molecular weight. The molecular weight of a substance is the number of times its molecule is heavier than a molecule of hydrogen, whose molecular weight is 1.

To take a specific example, the molecular weight of oxygen is 32. Thus a molal (gram-molecular) solution of

oxygen would be one in which every liter of liquid would have 32 grams of oxygen dissolved in it.

The reason the mole is used is that it *always* contains the same number of molecules, whatever substance is involved. If a substance is heavy (has molecules that weigh more), we use a proportionately greater number of grams. When a substance is light (has "lighter" molecules), we use fewer grams, keeping the number of molecules the same. A mole always contains 6.06×10^{23} molecules, as a matter of fact. This makes the formula for defining pH pretty sensible, for all it says is that we want to know how many hydrogen (H^+) ions are floating about in a given quantity of solution.

The pH chart of Fig. 1 shows that this factor is a logarithmic function of hydrogen ion concentration (horizontal axis). Actual pH numbers were established arbitrarily, with the value of 7 being assigned to absolutely neutral water (which is not practical to achieve). Above this number we have a base, or alkaline solution; below this number we are dealing with an acid. The lower the number, the stronger the acid; the higher the number, the stronger the base. A strong (10-molal) solution of hydrochloric acid (HCl) is shown at one extreme of the scale, with a strong solution of lye (sodium hydroxide, NaOH, pH of 15) at the other extreme.

Note that the range of pH in which life can exist is extremely small, slightly base. Note also that we may have to

pletely insensitive to H^+ ions in a solution. The two electrodes are shown diagrammatically in Fig. 5, and the actual electrodes are shown in Fig. 2.

Now the glass electrode is such a complicated device that whole books have been devoted to its theory of operations; so we will not try to explain it here. Just remember that between the outside solution, which is the solution to be measured, and the inside "buffer solution" (usually hydrochloric acid) a potential is created proportional to the number of H^+ ions in the former. Also note that the calomel electrode is so saturated with ions that it is completely insensitive to outside ion changes, but that it always produces a potential of .282 volt at 22 degrees C. The temperature is important, because the potential changes with temperature and we must always either compensate or correct for this when reading pH.

Now if we use some sensitive instrument to measure the potential between the glass electrode and the reference calomel-potassium chloride (KCl) electrode, when both are dipped into a solution whose pH we want to know, we will read a voltage proportional to the H^+ ions less the voltage of the reference electrode. The glass electrode has extremely high internal resistance, on the order of 100 megohms or more. We cannot measure the potential with an ordinary instrument, for we would virtually short the elec-

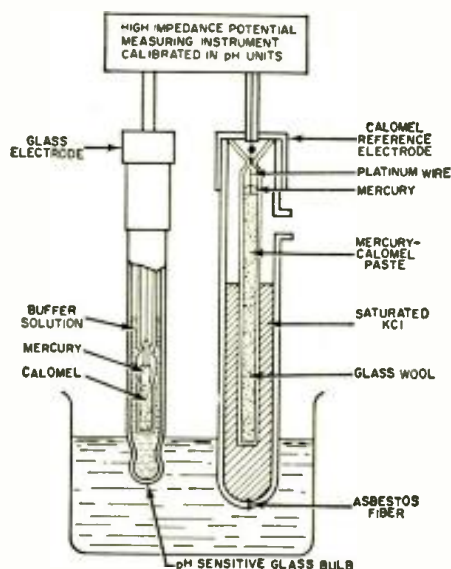

Fig. 5. Cut-away shows details of the glass and reference electrodes.

trode, even with a good v.t.v.m. This would, in fact, actually damage the electrode. It would "polarize" in the same way as a battery does under heavy discharge, and would become useless for days until it recovered.

We must use an instrument with very high input resistance, as well as a sensitive one. Such an instrument is called an electrometer. It is a specially designed v.t.v.m. with no resistance from grid to cathode, except leakage over the very special vacuum tube used, something that can be measured in the thousands of megohms.

Fig. 4 shows a special pH measuring instrument designed by Beckman. Fig. 3 is the schematic diagram. But, since this is a bit cluttered, let's look at Fig. 8, which is a simplified diagram showing the basic action with all the refinements left out. Here you can see a bridge type of circuit to provide a precise voltage for the tube. This voltage is connected in opposition to the input voltage from the electrodes. Thus when the bridge voltage is adjusted to

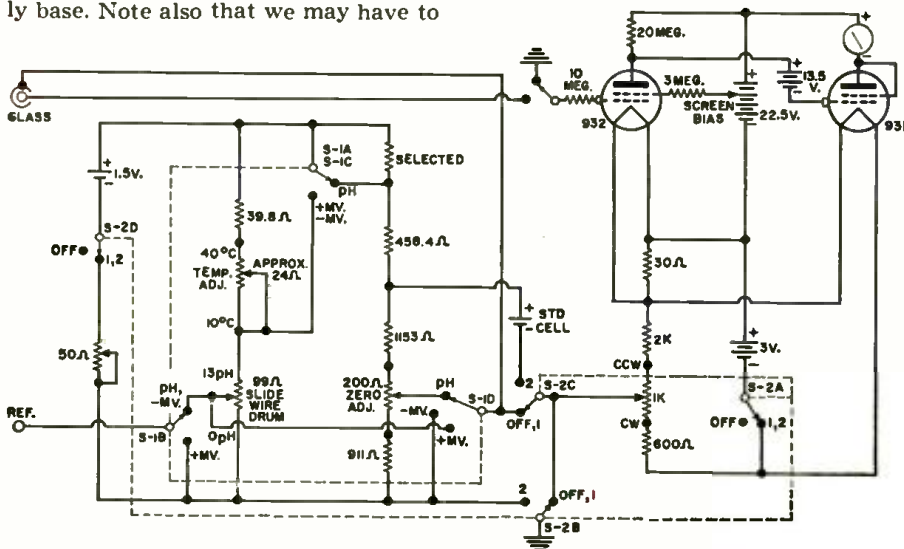
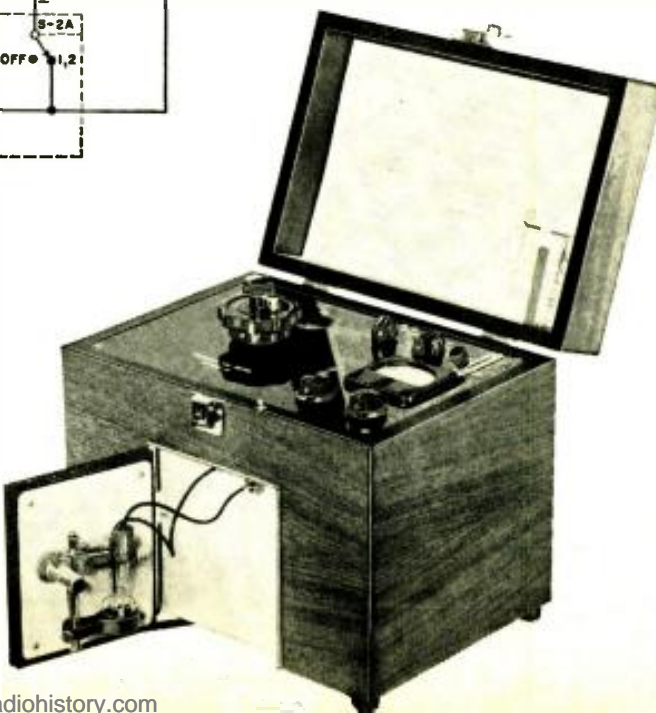

Fig. 3. This circuit measures voltage difference between electrodes with an electrometer. Latter is a sensitive v. t. v. m. with very high input R.

measure, for strong bases, a very small number of ions. We must measure down to about 10^{-15} mole, or only about 10,000,000 ions in the solution. Now if you consider that we could not put enough zeros on this page to write out the total number of molecules in a liter of water, you can see that this must indeed be a sensitive measurement.

Our means to this end is a very good electrode, called a glass electrode, which is sensitive to the number of H^+ ions in a solution. We compare the measurement we get from this glass electrode with a standard, which we call the calomel (mercurous chloride) electrode. The latter electrode is com-

Fig. 4. This Beckman pH meter includes a voltage bridge and a sensitive electrometer (circuit of Fig. 3) in addition to the two external, test electrodes shown mounted on the door's inside panel.



exactly the same voltage provided by the external electrodes, not even grid current for the small vacuum tube can flow, the meter will show null (plate current is kept down by the applied bias), and so the glass electrode has no load on it. This is important for accurate measurement.

Now, looking back at Fig. 3, you can quickly distinguish some refinements to this basic circuit. There we see temperature compensation (the 24-ohm control), and a variable resistance (50 ohms) to compensate for battery voltage drop (which is of course important to accuracy). We also see a standard cell which is used to check the battery voltage. In the MV position of switch S_1 , the instrument is set up to compare battery voltage. The temperature adjustment control is graduated in degrees; it is set after the temperature is read separately on a thermometer. Note that in the MV position the instrument is also usable for the measurement of very small voltages.

The slide-wire scale (99 ohms) is graduated in small pH units. Thus when we have balanced the bridge perfectly for battery voltage and temperature, we then connect our two electrodes and null balance for these with the slide-wire drum. Now we can read pH directly on the calibrated slide-wire scale. The meter is connected to the electrometer tube through an added cathode-follower stage, instead of being shunted across the electrometer stage, since otherwise the low meter resistance would shunt the vacuum-tube plate load resistor. Note that the bias is obtained from the 3-volt filament battery, and adjusted by means of the 1000-ohm potentiometer.

Accurate as this measuring instrument is, it is not very convenient for a processing situation. In the latter, we will very likely prefer to have a means of continuously recording the changes in pH which may occur during a proc-



Fig. 7. This General Electric continuous recorder charts pH level changes.

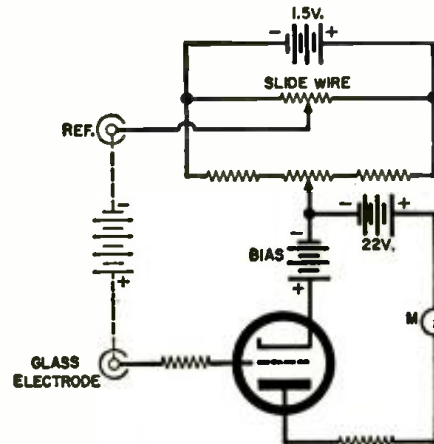

Fig. 8. Basic electrometer circuit to read voltage with negligible loading.

ess. For this we would add some sort of continuous recorder, like the instrument shown in Fig. 7. The diagram for this type of unit is given in Fig. 6. This is a sensitive recorder by virtue of an integral, high-gain a.c. amplifier.

Although the small voltage we wish to measure is a d.c. potential, we can use an a.c. amplifier because the input circuit of the instrument is provided with a chopper. The latter may be described as a precision vibrator or d.c.-to-a.c. inverter. Because of its accuracy, the a.c. output is reliably propor-

tional to the direct current input.

The change on the glass electrode is approximately 59 millivolts per unit of pH. Thus to measure pH within the range of the values suitable to human life, which is .2 unit of pH (7.3 to 7.5), we need measurements covering little more than 10 millivolts full scale.

This is well within the range of the instrument shown. Temperature compensation is still needed, and we will use the same type of bridge circuit to obtain the "bucking" voltage for the electrodes. However, in the continuous kind of measurement we would use a more rugged voltage source, such as a well regulated power supply, and for temperature compensation a separate temperature bulb (Fig. 9) is also immersed in the liquid being tested. The bulb then would automatically perform the function of the manual temperature-adjusting potentiometer in Fig. 5. Output from the amplifier drives the recording assembly through a servomotor.

Accuracy of the continuous kind of recording would, in all probability, be less than with the electrometer instrument, but it would have the advantage that at least we would detect changes in pH readily, and we could trace back in time to see when such changes occur. This would give us a clue as to what part of the process caused the changes, and allow adjustments or corrections to be made.

Service on pH instrumentation will seldom concern the electrodes. Cracked electrodes cannot be mended, and must be replaced; indication of cracked electrodes is given when the electrode fails to respond to a known "test" pH change. The manufacturer usually recommends that new electrodes, which are made from extremely thin glass, be soaked in water for some time before being placed in service. This has to do with initial changes in the electrode,

(Continued on page 130)

Fig. 6. Circuitry for the General Electric recorder (Fig. 7) used to keep a continuous record of variations in fluid pH level.

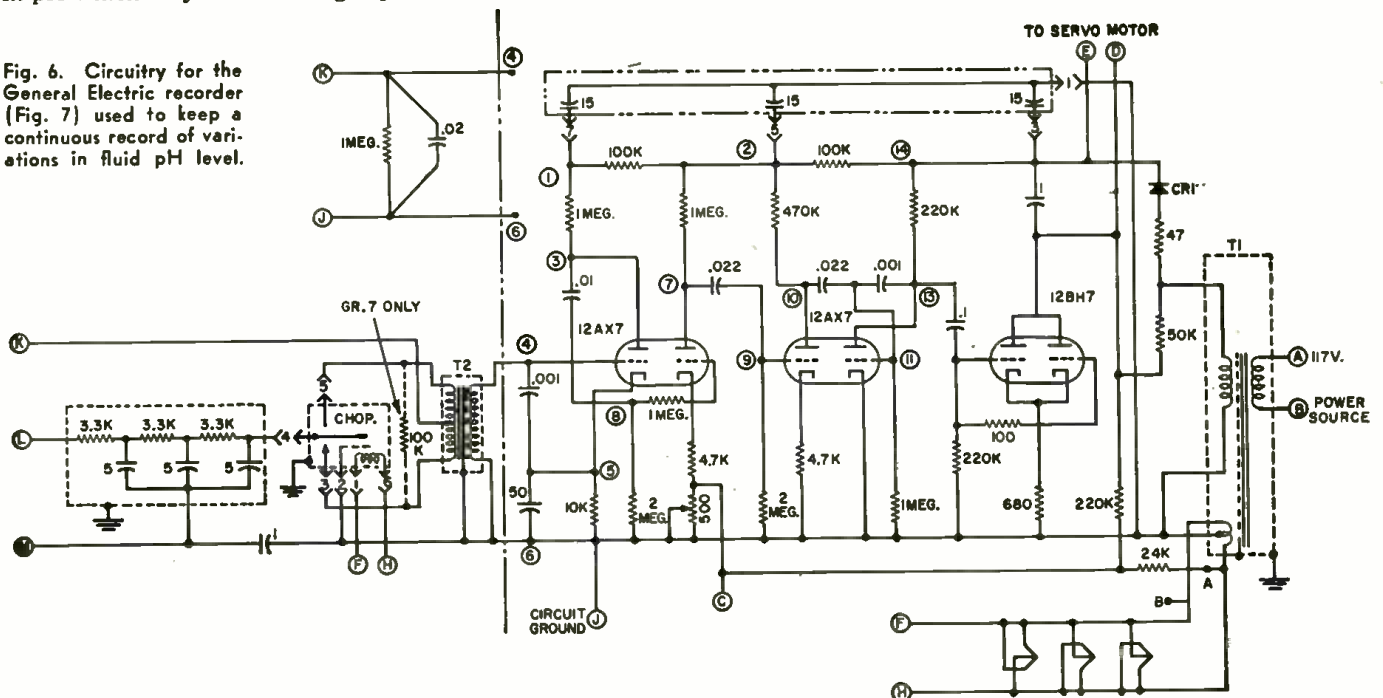

THOMAS EDISON, trying to improve his incandescent lamp in 1883, noted that electrical energy seemed capable of crossing a gap between two conductors—a hot filament and a positively charged plate—in a vacuum. Why this “Edison effect” occurred or how it could be used was not understood. Some 13 years later, Sir J. J. Thomson provided clues, involving the flow of electrons, in his investigations and conclusions concerning the electron theory. Then, in 1907, Lee de Forest found a way of controlling this electron flow in a vacuum tube by introducing a grid.

The last event triggered a series of developments which, as history views such things, rapidly projected the world into a new era, the age of electronics. From Edison’s modest observation, electronics has become, in little more than two generations, a complex and pervasive area of science and technology, comprising many fields, “sub-fields,” and combined fields that cut across, up, and down through virtually all fields of endeavor in all parts of the world. It has furnished us with products our grandparents could only have dreamed about (or could not even have dreamed about) from miniature hearing aids to space ships. It has involved large numbers of people in many ways.

There was a time—within the memory of most of us—when the “man in electronics” was a fellow down the street who fixed radios. Today a “man in electronics” may be testing critical metals, or using a 200,000-power microscope, or measuring miniscule voltages

from a living brain, or listening to signals from outer space, or designing an industrial control system—or still doing well at repairing home radios plus a host of other appliances including TV sets, auto radios, hi-fi equipment, and Citizens Band gear. Still growing, this gigantic industry has already become the fifth largest in the U.S.A., with an estimated annual revenue approaching \$15-billion and employing more than 1,700,000 men and women.

Are There Openings?

Impressive as the size of this “task force” is, we are often told it is inadequate for present assignments and anticipated expansion—not always in terms of available numbers but (perhaps more important) in terms of *specific skills and training*. Thus, while electronics undeniably offers a vast job market, it often is a *selective* market, particularly with respect to advancement and the better paying jobs. For the same reason, of course, it is somewhat competitive—although, at the top job levels, the jobs themselves often compete for the man.

In any case, electronics is one of the best career-potential fields today. According to a recent study made by David L. Golan, a leading employment consultant and head of *Stevens Associates*, N.Y.C., its horizons are constantly changing to present new vistas. One of the results, for example, of a recent Supreme Court decision involving patents and design development was to place a number of designs into public domain. As a result, companies with

sufficient capital could move ahead into diverse areas that were not before practical, opening new opportunities. Since mid-1959, for example, *RCA* has made a commitment of some \$800-million to be invested in the next five years in computers. Others, such as *Philco*, *Burroughs*, *National Cash Register* have also entered this area or are about to do so. According to Golan, this is just one example of how “the field suddenly explodes into new facets, with newly created job openings for qualified personnel,” even where the supply of trained people seemed adequate a short time before.

Throughout the field and its many ramifications—of which computers, ultrasonics, nucleonics, automation, and so on are only a few—there is, of course, difference as to what constitutes “qualified personnel,” how much they can earn, and how far they can go. Different types of operations, different products and services, sometimes different parts of the country all add up to create exceptional dips and peaks in any “average” or “normal” line of development. Nonetheless, and keeping the possibility of exceptions in mind, it is feasible to describe something of a pattern as regards training, jobs, salary levels, and advancement.

Details and specifics are listed in the accompanying tables, based largely on the recent Golan-*Stevens* study and other industry sources. As indicated, the entire field of electronics, from a job standpoint, can be classified in terms of positions requiring relatively little technical training; those that re-

Making Your Career in Electronics

Photo 1: Technician stands behind azimuth alignment theodolite (made by Perkin-Elmer) at base of Jupiter missile. Photo 2: Technician for Picker X-Ray Corp. radiographically checks a stainless-steel coating. Photo 3: A Kearfott technician uses a test console to check a gyroscope.



1

By **NORMAN EISENBERG**

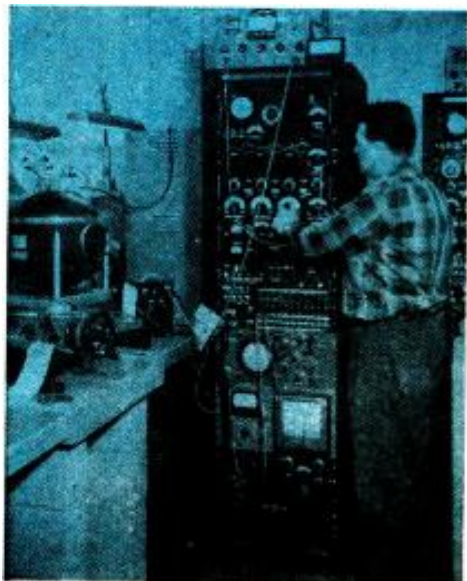

3



2

Competence in electronics does not automatically guarantee you a brilliant future; but, with wise judgement, you can find one of the good positions to be had on most levels of technical qualification.

quire technical training of a specific nature below the college level; some with college training, although not necessarily a degree; and those which definitely demand a college degree. Note that the indicated requirements are for *entering* a specific job; advancement almost always involves additional training and study.

Bottom of the Ladder

To begin with, let's take the person with little or no specific technical training or job experience, but with interest and proven or indicated aptitude—a budding radio ham, for example, or a man who has tinkered with small electronic construction projects at home. At the very least, such a person could

it is generally the men who take over.

Promotion in this area may lead to line foreman, or assistant foreman, or into quality control. With solid mathematical training, plus specialized courses and proven administrative ability, one could eventually work into statistical quality control, a fairly high-paying type of work. At the quality-control level, you generally move out of the "hourly rate" class into the "yearly salary" range, specifically \$6000 to \$8000. Statistical quality control pays up to \$10,000-\$11,000 a year.

Sales and Service

Yet another major area for the untrained, but talented, beginner would

times" as a result of periodic fluctuations or intra-industry undercurrents that are tricky to assess. On the other hand, they can be compensated for. For example, when AM sales went down, FM sales began to go up. Hi-fi components cut into package sets, and so on. Somewhat less obvious would be periodic changes in car radio sales. Here, the number of sets sold relates directly to the number of new cars sold; and the latter number follows an apparent three-to-four year cycle. Thus, a man who did very well in 1955 selling car radios might find his earnings down in 1956 and 1957, but picking up again in 1958. The sales work field takes, among other qualifications, a "head" for this sort of anticipatory reckoning



Engineers and technicians, in hearing-aid development for Sonotone Research Laboratories, are making acoustic tests.



Neither chief of electronic design dept. (left) nor engineering assistant (right) for M. Ten Bosch has a degree.

start as a trainee or "junior electronic technician." An example of the kind of job he could get might be, perhaps, simple wiring and testing under supervision, at a salary of \$55 to \$70 a week. Actually, such a job would constitute an apprenticeship.

Under conditions of normal industrial growth, that man could expect to earn between \$85 and \$100 a week after one or one-and-a-half years. With suitable training (either at an outside school or through in-plant training), he could rise steadily. It is not uncommon to find, after a three-year period, that such a man is designated as "senior electronic technician" at pay up to \$130 a week, or as "junior foreman" at \$100 to \$105 a week, or even "senior foreman" at \$125 to \$150 a week.

Work such as testing or mock-up wiring, at a higher-than-beginner level, would require that a man have the ability to visualize things spatially. Higher positions in this area would require some knowledge of mathematics as well. On the other hand, another major area of work primarily involves manual dexterity. This would be in parts and components assembly. Interestingly enough, many of the jobs requiring so-called manual skills are being filled—and quite well, too—by women, although in supervisory posts

be in sales and service. A newcomer might start as an apprentice at the bench, under supervision, earning \$50 to \$65 a week. After two years, if all went well, he should have learned enough to warrant a salary of \$90 to \$100 a week. In time, he could be earning about \$125 a week; as a field service technician he might get \$150 weekly.

An entry into sales work could be made, perhaps, after two years with the company. Naturally, the company's needs and the man's own abilities would have to agree for this to happen. The sales field, generally, is tricky and difficult to generalize about. Admittedly, in sales, you will find some of the highest paying positions in any industry. Industrial sales generally offer higher average earnings than consumer-product sales, although individuals in consumer-goods sales do, at times, earn more than industrial sales personnel.

In any case, sales work, despite its well-known returns, can be unstable. Take, for example, the steady decline in the sales of specific types of home entertainment equipment—notably AM radios—which, according to EIA figures, went downward after 1948. Also consider the slow fall in TV set sales after 1956. Often as not, such declines are not so much a matter of "bad

as well as the ability and wherewithal to "ride it out" at times.

Technical Training

For the technically trained, non-college, non-sales-minded person there are other well paying areas. The specific form of training could be that obtained through a technical school, either residence, or correspondence, or a combination of both; a military-service technical school; a company-sponsored school such as those conducted by RCA, IBM, AMF, and others; or through in-plant or on-the-job training. And it could be obtained before or during actual employment.

The most typical electronic schooling would give a man a solid grounding in basic electronic theory and circuits, plus laboratory or workbench practice. He would become familiar with test equipment as well as some of the maintenance and operation of practical equipment. The more math he can absorb during this training, the better off he is likely to be in the long run. While math may not be essential to filling a good many jobs successfully at the outset, it may be a requisite for advancement later on. It would be a "must" in certain fields such as design work or advanced jobs involving computers.

GROUP I

All positions in this group, beyond the beginning level, can be attained by progression within the individual job categories indicated.

JOB TITLE	FIELDS	LEVEL	TRAINING & EXPERIENCE	SALARY RANGE (Annual)
Assembler	Manufacturing and production, electronic components and equipment	Trainee	High school	\$ 2600-3200
		Junior	H.S. + 6 mos. job experience	2800-3900
		Senior	H.S. + 2 yrs. job experience	3600-5200
		Inspector	Same, or experience as sr. assembler, or tech. school grad. + 2 yrs. job experience	4400-6500
		Foreman		4400-6900
Electronic Technician	All phases of the industry (See Group II for further information and higher job levels.)	Trainee	H.S.	2500-3300
		Junior	H.S. + 1 yr. exp., or some technical schooling	3100-4200
Laboratory Technician	Research and development, private industry as well as gov't. and military (See Group II for further information and higher job levels.)	Trainee	H.S. + indicated or demonstrated aptitudes	2800-3900
Sales	Electronics distributors; retail sales; sales divisions of mfrs., etc. (See Group II for further information and higher job levels.)	Trainee	H.S. + indicated or demonstrated aptitudes; science or math interest preferred	3100-5200
Service Technician	Components and equipment mfrs.; service organizations; gov't. and military (See Group II for further information and higher job levels.)	Trainee	H.S. for computer trainee, math, aptitude, and some training preferred	3100-3600 (up to 3900 for computer service trainees)
		Junior	Technical school graduate, or on-the-job training	3600-5200 (plus per diem in some cases)

GROUP II

All positions in this group require technical school training, or specialized company courses, or some college training.

JOB TITLE	FIELDS	LEVEL	TRAINING & EXPERIENCE	SALARY RANGE (Annual)
Assistant Engineer	Electronic equip. mfrs.	Junior	Graduate of technical school, service school, or on-the-job training. Could be upgraded from technician, service trainee, or sr. draftsman	\$ 3000-4200
		Intermediate		4200-6000
		Senior		6000-8000
Cameraman	TV studio	Junior	Technical School or other special training	7500-9000
		Senior		9000-12,000
		Supervisor		10,000-14,000 +
Civil Service Specialists	Government and airways services, military electronics	Classified by Government index system; for details, consult Civil Service Commission	H.S. + technical training. Various combinations of job experience and schooling possible to qualify for different positions	4600-13,500
Computer Technician, Wiring	Various phases of civilian and military production, service, and maintenance	Levels not specified	Technical school, or appropriate military school, or H.S. + on-the-job training	3600-6800
Computer Technician, TAB Operator	As above, plus various business applications	Junior	As above	3300-4200
		Intermediate		3900-5200
		Senior (Supervisor)		4500-7800
Computer Technician, Programmer	All phases of business and industry, banking, commerce, consulting work, research and development, etc.	Trainee	Tech school or 2 yrs. college; college grad	4200-5200
		Junior	As above	5200-7000
		Intermediate	As above, plus math. aptitude	6500-9000
		Senior	College grad with major in math, physics, engineering, or accounting	8000-12,500
		Designer	Technical school; appropriate military school; also may be upgraded from draftsman	4000-6000 5200-8000
Draftsman	Same as above	Senior	Engineering degree, or equivalent in college-level trng. + experience	7800-12,500
		Trainee	H.S. + mech. aptitude	3200-4200
		Junior	Technical or military school; or from training as above	3900-4500
		Intermediate	As above	4400-7000
		Senior	As above	6500-10,000

(Continued on next page)

GROUP II—(CONTINUED)

JOB TITLE	FIELDS	LEVEL	TRAINING & EXPERIENCE	SALARY RANGE (Annual)
Electronic Technician	All phases of manufacturing, service, research	Intermediate	Technical school or equivalent, or upgraded from jr. technician	4500-6000
		Senior		5500-7500
Field Engineer	Liaison, maintenance for manufacturer, or distributor, or military	Junior	Technical school or equivalent; also may be recruited from technicians, draftsmen, others	5000-6000
		Intermediate		5600-8000
		Senior		7500-9600
Field Maintenance and Repair	Equipment mfrs.; military airways; utilities; computers and business machines	Junior	Technical school or selected from technicians	4250-6000
		Senior		5500-7500 plus per diem
Foreman, plant	Manufacturing	(Not applicable)	Technical school and generally specialization in experience	4400-7800
Inspector, parts and quality control	Manufacturing; research and development	Junior	Technical school or recruited from assembler	4400-5600
		Senior		6000-7500
		Supervisor	Some college	6500-8000
Instrument Technician	Missiles; Airlines; CAA	Junior	Technical school	4400-6600
		Senior		6000-8000
Laboratory Technician	Test equipment; research and development	Intermediate	High school and technical school, and with experience at lower level in category	4500-6000
		Senior		5500-7500
		Note: can progress to Prototype and Model Maker		to 10,000
Radio Operator	Airlines; ships; other communications	Varies with situation	Technical or company school; FCC ticket	6000-7500 +
Radio/TV Transmitter Engineer	Various governmental posts as well as commercial broadcasting	As above	Appropriate schooling; FCC ticket	6000-14,500
Sales Engineer	Technical sales at various business and industry levels	As above	Technical school with special product training preferred	6000-22,000 + (too varied to specify exactly)
Sound Specialist	Recording, radio, TV broadcasting		Technical school	6000-10,000
Technician	Communications; utilities; airlines; telephone	Varies	Technical school, sometimes plus company school	6000-8400
Technical Writer	Manufacturers; military; communications; many others	Junior	Some college, degree preferred	4500-6000
		Intermediate		5500-7500
		Senior		7200-9600
		Editor		8500-12,500
				(Per diem sometimes added in top 3 categories)
Test Engineer	Manufacturing	Junior	Technical school or some college plus experience at lower level in category	4600-6600
		Intermediate		6000-8000

All positions in Groups I and II, appearing above and on the preceding page, are open to personnel without college degrees.

A broad academic base in electronics often saves a man years of job apprenticeship. It also permits him to start at a higher level than he could without schooling. A spokesman for *Reeves Instrument Corp.* has said that a man with only six months of real electronic schooling is likely to be more valuable to the company than a man with 18 months of job experience and no equivalent schooling.

Not only can the trained man start at a higher level (what might be for the untrained man an intermediate level), but he can move up faster and higher, and into more interesting and diverse fields. Research and development, industrial controls, broadcast engineering, and instrumentation are only a few. A beginning laboratory

technician, for example, in instrumentation, might start at \$65 to \$85 a week. After a three- to five-year period, he'd be earning up to \$125 a week. If, in the course of his work, he became a specialist at, say, wiring prototype models, he'd earn \$8500 a year. Once in this area, he could take advanced study and eventually find his way into design work, with a salary in the five-figure bracket.

An "intermediate technician," could also use his background and experience to qualify for such fields as airways communications, government monitoring, or general broadcasting.

The man "moving up" is invariably a man "brushing up." Sometimes when a company finds "its man," it will sponsor his schooling at a reputable

institute, which may or may not lead to a degree, depending on the courses chosen and the needs of the particular study program. Recently, for example, a relatively small company in Brooklyn, N. Y., which specializes in microwave research and development, was looking for a senior electronic technician. The salary offered was \$125 to \$130 a week, plus fringe benefits. Among the latter were a medical plan and other conventional advantages—plus sponsorship through a college degree in engineering or physics, all expenses paid.

Military Training

What about military service schools? These provide training similar to that
(Continued on page 94)

Teleprinter Sets Speed Record

By
JORDAN McQUAY

Technical details on world's fastest message printer that operates at speeds up to 12,000 words per minute. New electrostatic printing techniques are utilized.



Fig. 1. Components of the high-speed teleprinter along with copy prepared by unit.

FASTEST message printer in communications history is a high-speed teleprinter that operates at rates up to 1000 characters *per second*—or about 12,000 words per minute!

This is 200 times faster than an ordinary teletypewriter, 150 times faster than an average typist, and 75 times faster than the average person talks.

Developed for the Army Signal Corps by the *Burroughs Corporation*, the teleprinter (Fig. 1) has no type bars or faces like conventional teletypewriters. It uses a new method of electrostatic recording to form letters and figures on dielectric-coated paper, without the use of chemicals. The only mechanical motion is the paper-drive mechanism, and even this movement is controlled electronically.

The system is also equipped with a standard keyboard for low-speed manual operation, or for preparing tapes which later may be fed back into the system at much higher operating speeds. But its principal feature is its ability to receive and record messages

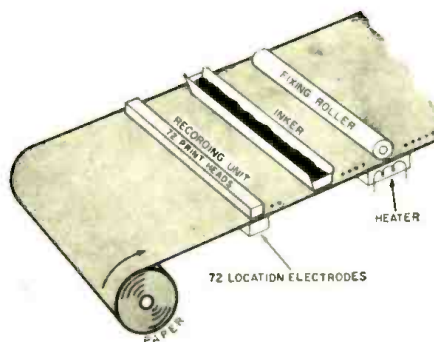
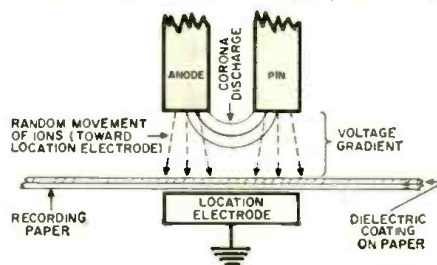

Fig. 2. Electrostatic recording system used.

Fig. 3. Electrostatic action between the anode and the pin of a single print head.



at high speed using a new technique of page printing with electronic control.

The electrostatic recording system produces visible marks on paper in accordance with applied electrical signal intelligence. Alphanumeric characters are formed almost instantly, and in any font or format.

The recording system (Fig. 2) consists essentially of a complex recording unit, an inker, and a fixing roller.

The recording unit is composed of a single row of 72 small *printing heads*. Opposite each head is a *location electrode*. Paper passing between the row of printing heads and the row of location electrodes is acted upon by one or more of the printing heads, each of which can produce any letter, figure, line, or symbol on the paper by electrostatic action.

To illustrate this action, refer to Fig. 3.

Each printing head is composed of an array of *pairs* of anodes and pins. The pairs are arranged in a 7 x 5 matrix. Each *anode* has its respective *pin*.

The anode—known as the *column selector*—is pulsed by 800 volts. At the same time, the pin is pulsed by about

(Continued on page 102)

Don't Underrate Transistors

By JAMES R. SPENCER

Explanation of maximum ratings of junction transistors and how to determine maximum operating capabilities.

Storage Temperature, t_s	-40 to +65°C
Collector-to-Emitter Voltage, V_{CE}	-20 volts
Collector Current, I_C	-150 ma.
Collector Dissipation at 25°C Ambient Temperature, P_C	200 mw.
Junction Temperature Rise (without heat sink), k	0.2°C/mw.
Junction Temperature Rise (with heat sink), k	0.065°C/mw.

Table 1. Absolute maximum ratings of typical junction transistor used as example.

NORMALLY transistors are not operated at their maximum ratings; however, there are many times when it may be desirable to operate a transistor very close to these maximum ratings. An understanding of the interrelationship among the various maxima is necessary if the demise of many a good transistor is to be prevented.

Manufacturers of transistors supply specification sheets which provide information comparable to that found in a tube manual. Usually after a brief description of the transistor and its mechanical specifications, the absolute maximum ratings are listed. A typical list of such ratings for a germanium *p-n-p* junction transistor is shown in Table 1. The transistor is a medium-power unit intended for audio-output applications.

Storage Temperature

The storage temperatures are the two temperature extremes, low and high, to which the entire transistor—case, leads, whiskers, and semiconductor blank—can be subjected without

permanent damage. The low-temperature extreme is usually determined by cold-induced mechanical stresses which may cause the germanium blank to crack. The effects which determine the high-temperature extreme are not as simple. For example, I_{CS} , the a.c. parameters, and the life expectancy of the transistor may all deteriorate with extended storage at elevated temperatures. The results of transistor life tests, however, indicate that life expectancy is an exponential function of the ambient storage temperature and, therefore, the maximum storage temperature is usually chosen to yield a reasonably high life expectancy.

The storage temperatures also have the following influence on transistor operation. The transistor case temperature cannot be below the low-temperature extreme during operation and the transistor junction cannot exceed the high extreme.

Maximum Ratings

The absolute maximum collector-to-emitter voltage is the maximum re-

verse voltage which may be impressed between the emitter and collector without permanently damaging the transistor. The value of this maximum voltage is usually determined by what is known as punch-through. Punch-through occurs when the electric field generated by the collector voltage extends completely across the base region. When this point is reached, transistor action ceases and an extremely large current flows between the emitter and collector.

The common-emitter output characteristic curves for the transistor given in Table 1 are shown in Fig. 1. The diagonally hatched area indicates the region on the curves where operation is not possible without exceeding the absolute maximum voltage rating of the transistor.

The absolute maximum collector current is the maximum current which can flow through the base-collector junction without irreversibly damaging the transistor. This value is determined by the maximum current density the base-collector junction can tolerate. It is a function of base-collector junction area, semiconductor material resistivity, and is different for each type of semiconductor.

Fig. 2 shows the limitations placed on the output curves by both the absolute maximum collector voltage and the absolute maximum collector current.

Fig. 1. Collector curves showing limits due to voltage rating.

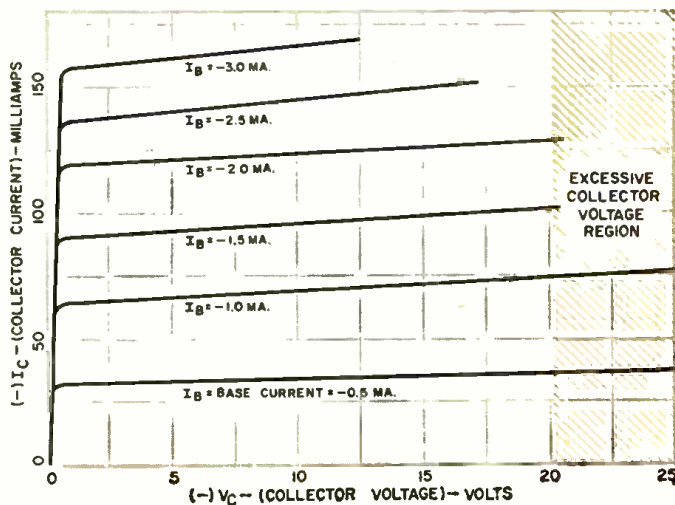
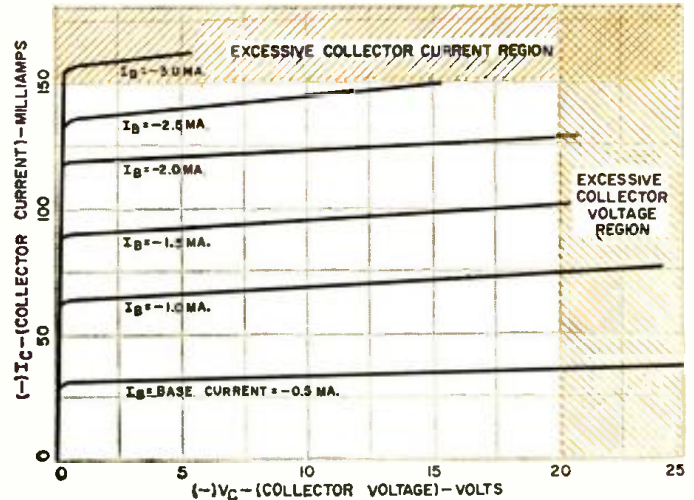

Fig. 2. Limits imposed by collector voltage and current maxima.



The product of the two maxima in Fig. 2 gives a power rating of 3 watts. The manufacturer, however, has specified in Table 1 an absolute maximum collector dissipation of 200 milliwatts at an ambient temperature of 25°C (77°F. See Table 2 for converting centigrade to Fahrenheit.) The power dissipated within the transistor and termed collector dissipation is the familiar I^2R loss of electrical power which is converted into heat. The maximum allowable collector dissipation is a function of the thermal resistance of the junction and is limited by the maximum allowable junction temperature. The maximum junction temperature is the same as the high temperature limit of the storage temperature ratings discussed earlier. The temperature of the junction is elevated above the ambient, or case, temperature when the transistor is operating, due to collector dissipation. The junction temperature may be calculated for any transistor using the equation:

$$t_j = t_a + kP_c \quad (1)$$

where t_j is the junction temperature, t_a is the ambient temperature, k is the thermal drop of the transistor, and P_c is the collector dissipation. Here k is a function of the mechanical design and heat dissipating mechanism of

CENTIGRADE (DEG.)	FAHRENHEIT
-40	- 40
-35	- 31
-30	- 22
-25	- 13
-20	- 4
-15	+ 5
-10	+ 14
- 5	+ 23
0	+ 32
+ 5	+ 41
+10	+ 50
+15	+ 59
+20	+ 68
+25	+ 77
+30	+ 86
+35	+ 95
+40	+104
+45	+114
+50	+122
+55	+131
+60	+140
+65	+149

Table 2. Temperature conversion table.

by the maximum collector dissipation rating, a maximum power dissipation area is shown on the collector characteristic curves in Fig. 3. The cross-hatched area indicates the region on the curves where operation at an ambient temperature of 25°C is not possible without exceeding the absolute maximum collector dissipation rating.

If the transistor is operated at an ambient temperature that is higher than 25°C, the collector dissipation must be derated. For example, if the transistor is operated in a sealed equipment case that also contains operating vacuum tubes, the ambient temperature may be as high as 122°F. The maximum collector dissipation allowable for operation without a heat sink at this ambient temperature can be determined by a restatement of equation (1).

$$P_c = \frac{t_j - t_a}{k} \quad (2)$$

$$P_c = \frac{65 - 50}{0.2}$$

$$P_c = 75 \text{ mw.}$$

Thus it is possible to operate the transistor in an ambient temperature of 122°F provided precautions are taken to limit the maximum collector dissipation to 75 milliwatts. The limitation imposed on transistor operation at 122°F ambient is illustrated in Fig. 4.

The relationship between collector dissipation and ambient temperature shown in equation (2) indicates the possibility of safely operating the transistor beyond the manufacturer's absolute maximum collector dissipation. (Continued on page 135)

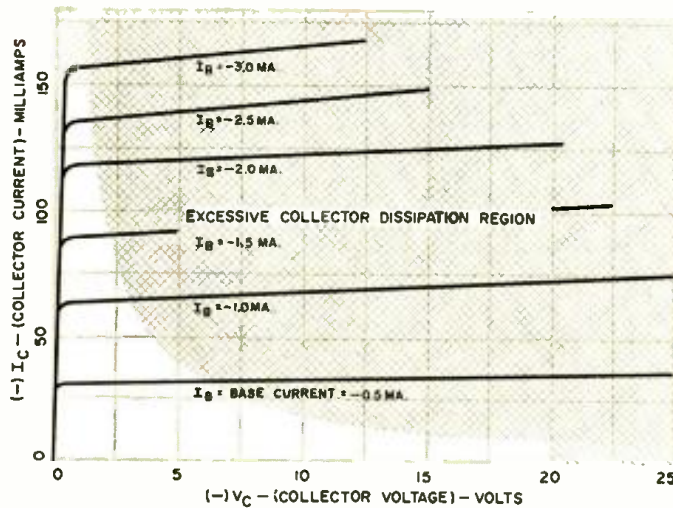

Fig. 3. Limitation imposed by maximum collector dissipation when transistor is operated at 25° C without using heat sink.

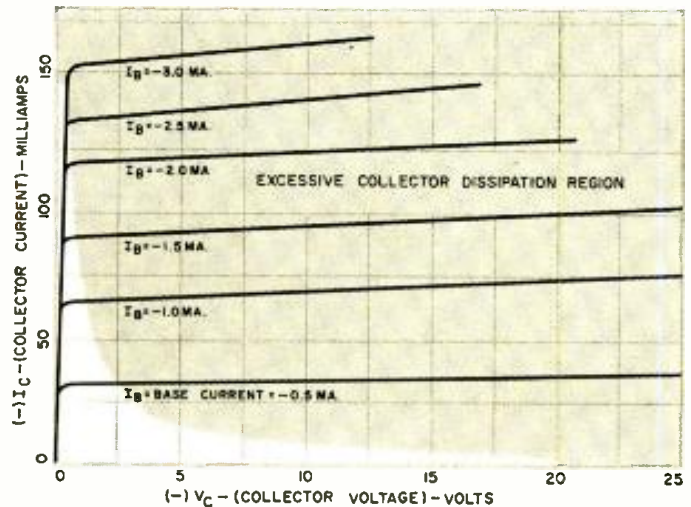

Fig. 4. Limitation imposed by maximum collector dissipation when transistor is operated at 50° C without using heat sink.

the transistor. Two values for k are given in Table 1; one for when the transistor is used without a heat sink and the other for when an infinite heat sink is used. The junction temperature of this transistor, when operated at the absolute maximum collector dissipation specified by the manufacturer, can be obtained by substituting values in equation (1):

$$t_j = 25 + 0.2 \times 200$$

$$t_j = 65^\circ\text{C}$$

Collector Dissipation

It can be seen from the above that the manufacturer has stipulated a maximum collector dissipation rating that will provide safe junction temperature when the transistor is operated at normal room temperatures. To illustrate the limitations imposed

Fig. 5. Collector dissipation limitations for operation at an ambient temperature of 0° centigrade with a heatsink employed. Compare the region of excessive collector dissipation shown here with that obtained under operating conditions shown in the previous figure.

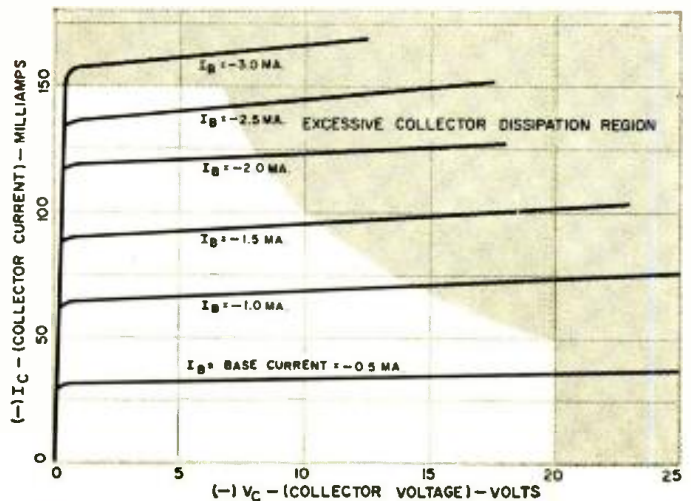

THE CITIZENS BAND & ITS USES



**More efficient and economical business operations—
more pleasurable uses of our leisure hours—these
and more are offered by Citizens Radio equipment.**

THE growth of the public communications network in the United States is one of the major reasons for our country's economic strength. We are able to communicate rapidly by means of telephones and to bring the public up-to-the-minute through broadcast radio and television. Another means of communication, personal mobile communications, is now enjoying tremendous popularity.

We have long had two-way mobile radio services for use by police and fire departments, and businesses able to show a real need. But the technical requirements have been stringent, resulting in relatively high-cost equipment. Then, in 1947, the Citizens Radio Service was authorized.

Three classes of stations were set up. These are:

Class A (460-470 mc., 50-watts maximum power) This service is used by groups not eligible for a license in other services but, because of technical requirements, equipment is quite expensive, around \$700 and up.

Class B (465 mc., 5-watts maximum

power) Any citizen over 18 years old can get a license; relatively loose technical requirements allowed low-cost sets (around \$100), but because of the power limits and the line-of-sight propagation characteristics of radio signals at this frequency, only very short range is possible.

Class C (27 mc., 5-watts maximum power or 30 watts under certain conditions) This is allocated exclusively for remote control of objects (model planes and boats, garage doors, etc.).

Even with the range limitations of the Class B service, two companies,

Vocaline Company of America, Inc. and *Stewart Warner Corporation*, marketed low-cost equipment. An estimated 12,000 to 15,000 licenses were issued with some 35,000 radios in service.

Because of the interest generated by use of the Class B Citizens Band and other considerations, the FCC re-evaluated the allocations of certain frequency bands and came up with two major changes. One of these was the establishment of the Business Band, with its less strict eligibility requirements for a station license. The other was the setting up of an additional class of station in the Citizens Band, the Class D. Such stations operate on some 23 voice channels in the 27-mc. band with a maximum power of 5 watts (plate power input).

When the Class D Band was first opened up, some irresponsible manufacturers advertised that their equipment could be used as a license-free amateur band, just to gab or to see at what distances one could reach another station, and fill up the airwaves with



A National Travel Service Frequency for Citizens Banders

IT WASN'T too long ago, in fact in our February, 1960, issue (page 8) that *ELECTRONICS WORLD* suggested the desirability of having specific channels assigned for use by those interested in marine applications of Class D Citizens Band equipment. It would be rather foolish if every boat owner were left on his own to choose a channel out of the 23 available. Chaos would result, and communication between boats and marinas would be utter confusion. Partly as a result of our editorial, but more likely because of the wholehearted cooperation of everyone concerned with the operation of CB equipment, channels 9 and 13 were chosen for marine applications. The use of these frequencies, of course, is not compulsory, but it is the hope of everyone in the industry that these channels will be accepted on a voluntary basis so that a more efficient use of this new band will result.

Because of the enthusiastic support from the marine field, it became obvious that a similar arrangement should be set up for use by tourists, when traveling on our highways, to call motels, service stations, or to call for any form of help under emergency conditions. Channel 15 (27.135 mc.) was thought most desirable, and it is to be referred to as the "National Travel Service Frequency." The thought did come up that there might be a possibility of violating section 19.61 (g) of the FCC rules and regulations for Class D operation. This rule prohibits "any transmission designed to elicit a response from random or unknown stations," and requires that the transmissions from a Class D station "be ad-

ressed to specific persons or stations" except in an emergency situation.

The FCC, in a letter to Vocaline Company of America, Inc., clarifies the regulations as they would apply in this case as follows: "Section 19.61 does not mean it is necessary to address the persons or stations by call sign or by name in a situation of this type. Accordingly, it is permissible for a licensee of a Class D station to direct a transmission to any motel, gas station, or garage within a particular limited area, as long as the privilege is not abused. It is emphasized that the procedure most clearly indicates that it is not a general call to any or all stations hearing that transmission, and the transmission must be adequately specific to indicate the station or stations desired even though the names and call signs of the stations involved are not known." The transmission should be made in the following form: "This is 1W0000 calling any motel in the (specified) area. I am located at and require accommodations for the night. Can you advise if you have an opening and, if so, the best route to follow."

Since no further obstacles remain, Channel 15 is now to be used as a "National Travel Service Frequency." Plans are being formulated to bring this to the attention of all motor clubs, motels, service stations, and emergency services. Once again, the industry has shown leadership in trying to make the Class D Citizens Band an effective and useful means of communication. As in the marine field, the use of this channel is not compulsory. -50-

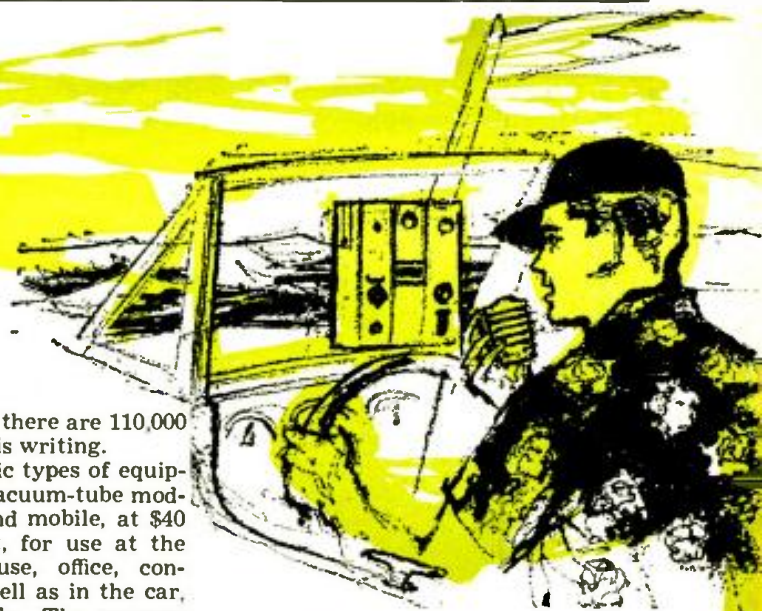

unnecessary conversation. This was contrary to what Congress and the FCC had in mind for the new Citizens Band. The rules have recently been restated to more clearly indicate what was intended. Communications on the Citizens Band must fill a specific need, and this it can certainly do.

The rules of use can be summed up briefly. Any citizen over 18 years of age or any business organization owned and operated by citizens may obtain a Class D station license. No operator's license is needed, and this means no tests or examinations. Use is limited to the transmission of substantive and purposeful messages, of either a personal or business nature. Hobby-type or radio-amateur type of communications are prohibited.

In the two years since September, 1958, when the Class D Band became a reality, and the present, over fifty manufacturers have put Citizens Band transceivers on the market, indicating a knowledge, at least on the part of manufacturers, that a tremendous potential market exists. Their faith has

been rewarded in that there are 110,000 stations licensed at this writing.

There are three basic types of equipment available: (1) Vacuum-tube models for base station and mobile, at \$40 to over \$200 per unit, for use at the control location (house, office, construction shack) as well as in the car, truck, or other vehicle. The average range from base to mobile station is about five to ten miles. These units have the maximum allowable plate input power of 5 watts and are provided for operation from 117-volts a.c. or 6- or 12-volts d.c. Some equipment can be used on either a.c. or d.c. just by changing the line cord. (2) Small portable models, at \$100 to \$170 per unit. These are completely transistorized, hand-held sets with built-in microphone, weighing from 8 oz. to 4 lbs. Power is less than one-tenth watt and the range is very limited, up to perhaps one mile. Not even a station license is required if these little portables are used with one another and not with a bigger licensed set. (3) Larger portable models, at \$200 to \$300 per unit.

These are shoulder-carried, with separate microphone, weighing around 8 lbs. with batteries. Transistorized receivers and tube transmitters are common, with about one watt of power. Range is about 3 miles and a station license is required.

There are 23 voice-channel frequencies in the Class D Citizens Band. A station license does not limit the operation to one or a limited number of frequencies as is the case in some other radio services. This is of distinct advantage if a given area becomes crowded with many systems on the same frequency because it is only necessary for the owner to change his channel of operation to a less congested frequency.

Use of two-way radio has required, and always will require, patience on the part of the user. There are only so many frequencies available for communication and this results in a "party-line" situation. Users of any radio service are bound to have other stations operating on the same frequency. This will result in interference. This should not pose too serious a problem since most messages should take less than a minute and the great majority are only five to ten seconds long.

Applications

It is not necessary to have a business or commercial reason for using the Citizens Band. For example, one of the largest uses is in pleasure boating. The range over open water is from 5 to 40 miles depending on the quality of the set, the noise suppression of the engine, and the antenna installation. If you have a cottage on or near the shore of a body of water, you can use the Citizens Band to let your wife know that the fishing is good and you're going to stay out another hour, or you ran into Charlie and you're on your way over to his house for a beer, or you ran out of gas and want her to send someone out. You can talk to others who have sets in their boats to find out where the fish are biting, where to rendezvous, what sea conditions are, and so on.

It has been suggested that Channel 13 (27.115 mc.) be used as the non-commercial marine frequency. All clever marina operators will probably monitor this so that boat owners will always be able to call for their facilities or other information. Because many boats and marinas are presently equipped with sets and many thousands more will be by next season, a certain degree of safety is afforded. However, the Coast Guard does not monitor the Citizens Band and any boat operating in coastal or Great Lakes waters should be equipped with a regular marine radiotelephone so that the Coast Guard may be summoned should help be necessary.

If your car and house are equipped with Class D radios, you can let your wife know you are stuck in traffic and will be late, or you can ask her if she wants you to stop at the store. Families travelling together on a vacation can

pass road information back and forth between cars.

Although the above indicates some legal pleasure uses for the Citizens Band, its prime function is in aiding the operation of a wide variety of commercial enterprises. All businesses that use trucks, cars, tractors—any vehicle—can put the Citizens Band to good use.

How many times has the driver of a service vehicle arrived back at the shop only to find that he had another call he could have made a mile from where he was and 10 miles from the shop. All types of services are in this category, oil delivery and furnace maintenance, radio and TV service, refrigeration and other appliance services, rural sewage maintenance, and so on. Then there are laundry and dry cleaning pick-up and delivery trucks, ready-mix concrete, sand and gravel trucks, and other similar services.

In addition, CB equipment can be used in the control of construction equipment, cranes, bulldozers, and trucks; tractors, trucks, and combines on large farms; lift trucks and other yard machinery at industrial plants; real-estate salesmen's cars; maintenance equipment on golf courses, cemeteries, and parks; and crop dusting, exterminating, small town taxis, and local trucking.

Professional use of CB gear is also suggested for doctors in rural communities and veterinarians with a large-animal practice. School buses have been equipped with Citizens Band radios in rural areas for safety and convenience during snow storms or if breakdown occurs.

Auxiliary police and volunteer fire departments use Class D equipment for primary or supplementary communications; county road maintenance crews use it to speed up operations and help re-route traffic.

But why the Citizens Band? Why not the Business Band? Most commercial enterprises are eligible for a Business Band license but many thousands cannot afford the higher priced equipment. Most do not need the few extra advantages of a somewhat greater range and partial protection from interference that the Business Band offers.

No discussion of this type would be

complete unless the liabilities are also mentioned. There are two major disadvantages to use of the Class D Citizens Band, or any other service for that matter that operates on frequencies up to 50 mc. The first is "skip," in which radio signals are reflected back to earth by the ionosphere. These signals are received a thousand miles or more away by someone who couldn't care less. This effect is sporadic and should not seriously hamper the use of the band. Patience is required at times, but users will usually find some other people on their channel locally.

The other disadvantage is the electro-mechanical and atmospheric noise that is created between 20 and 30 mc. This is overcome in several ways and brings us to receiver design considerations and eventually to relative equipment cost. Although differences in transmitter efficiency and type of modulation account for variations of up to perhaps 40 per-cent in transmitter output (the FCC limits the power *input* to 5 watts), the major dissimilarities in performance between one manufacturer's unit and another are the result of receiver design.

Receiver Design

Many Class D channels are spaced only 10 kc. apart. If a receiver does not have a high degree of selectivity (ability to receive only what it is supposed to), the user will hear stations transmitting on adjacent channels. This can be extremely disconcerting. Further, the ever-present noise generated in this frequency will appear along with the signal to a degree that requires a relatively strong signal to override the noise.

The degree of sensitivity (ability to respond to a weak signal) now becomes a factor. As you get farther away from the station you want to reach, your transmitted signal becomes weaker. The better the receiver's sensitivity, the farther you will be able to go before losing the other station.

If the inherent noise suppression built into the receiver is inadequate, good selectivity and sensitivity are of little value. Fortunately, good noise suppression usually goes hand-in-glove with a highly selective and sensitive circuit, but not always.

When a receiver is turned on, everything that is picked up by the antenna is applied to the receiver, noise as well as signal. The various tuned circuits begin eliminating the unwanted noise and signal as they amplify the desired signal. But there is always some residual noise and, unless there is something to quiet the noise, an operator can find it annoying. "Squelch" is the name given to the circuit that keeps the receiver completely quiet until a wanted signal arrives. To be of real value, the squelch must "open" to a signal as weak as the receiver can use. It is also helpful to have the squelch variable so it can be adjusted to the desired level of signal strength to be received.

(Continued on page 90)

Table of the channels and corresponding frequencies that may be used in Citizens Band.

CHANNEL	FREQUENCY	CHANNEL	FREQUENCY
1	26.965 mc.	12	27.105 mc.
2	26.975 mc.	13	27.115 mc.
3	26.985 mc.	14	27.125 mc.
4	27.005 mc.	15	27.135 mc.
5	27.015 mc.	16	27.155 mc.
6	27.025 mc.	17	27.165 mc.
7	27.035 mc.	18	27.175 mc.
8	27.055 mc.	19	27.185 mc.
9	27.065 mc.	20	27.205 mc.
10	27.075 mc.	21	27.215 mc.
11	27.085 mc.	22	27.225 mc.
		23*	27.255 mc.

* Shared with Class C radio-control and not recommended for use in Class D Band.

Radio Aids to Aircraft Navigation

By FRANCIS A. GICCA
Senior Engineer, Raytheon Co.

Description of two widely used electronic systems that will allow a pilot to perform a safe instrument landing.

IN THE previous articles of this series we discussed the three systems of long-range aircraft navigation which allow a pilot to guide his airplane between distant cities. These three systems: radio ranges, direction finding, and VOR, can make long-range navigation almost automatic. As a matter of fact, there are several aircraft autopilot systems which operate with ADF or VOR bearings and actually keep a plane on course automatically. However, the most exact enroute navigation is of no avail unless a landing can be successfully completed at the destination. This final article will describe the two widely used systems of terminal navigation which allow a pilot to perform a safe instrument landing.

Before an instrument approach and landing can be performed, it is obvious that an airplane must first be guided away from its long-range enroute course and on a course which leads the airplane to the vicinity of the terminal airport. Most low-frequency radio-range stations have been so located that one of the four courses lies directly over the instrument runway of a nearby major airport. An airplane flying along this on-course radial will thus fly right over the airport and can receive terminal navigation signals to perform an instrument landing.

Likewise, ADF beacon and VOR stations are located so that airplanes flying along a specified radial will be guided over a major airport. In high density areas where several major airports exist it would be impractical to locate long-range navigation stations so that all airports are covered. In this case, each airport maintains its own short-range navigation station designed to guide airplanes to its vicinity. ADF beacons are widely used by airports for this purpose. Such beacons will guide airplanes to the airport area but not necessarily along a radial which lies along the instrument runway, due to wind-drift effects. Since VOR inherently eliminates the wind-drift problem, VOR is also used to navigate airplanes to the instrument runway. Such terminal short-range VOR is

known as "TVOR." All short-range navigation aids are designed to guide airplanes within about 25 miles of the airport where terminal navigation can begin.

Instrument landings should be called instrument approaches since terminal navigation does not actually land an airplane. Rather, terminal navigation allows an aircraft to make a low instrument approach to the end of the runway and, if the runway comes into sight without exceeding specified minimum conditions of ceiling and visibility, a normal landing can be executed. In general, these instrument landing minima are: ceiling 1000 feet, visibility 3 miles. If the weather causes airport conditions to be below these minima then a landing is not legally possible, even with radio aids, and an alternate airport with acceptable weather must be used.

Two systems of terminal navigation are in widespread use in the United States today. These are ILS and GCA. ILS allows an instrument approach by reference to cockpit instruments alone. GCA, on the other hand, requires no cockpit instrumentation since all navigation equipment is on the ground. The airplane needs only a functioning v.h.f. transmitter and receiver in order to maintain contact with the GCA controller.

ILS

The ILS (Instrument Landing System) of terminal navigation was developed during World War II in order to enable properly equipped aircraft to make a safe instrument approach

PART

3

Terminal Instrument Navigation (ILS & GCA)

and landing during poor weather conditions without visual reference to the ground. ILS also helps reduce the length of time aircraft must be held aloft during periods of traffic congestion by speeding up instrument approaches.

The standard ILS navigation system consists of three separate navigational aids combined to provide a sharply defined radio path to the end of the instrument runway. These three aids, the "Localizer," "Glide Slope," and "Marker Beacon," combine to provide lateral and vertical guidance to the runway as well as positive radio fixes along this approach. The transmission and reception of each separate element of the ILS navigational system will be discussed individually and then combined in order to study the over-all operation of this unique system of terminal navigation.

The "Localizer" portion of ILS provides a beam course for horizontal, left-right, guidance. It is similar to the low-frequency radio ranges in that it provides a horizontal radio range course oriented along the direction of approach. Fig. 10A shows a simplified block diagram of a typical ILS Localizer transmitter. A 200-watt v.h.f. transmitter operating in the 108-112 mc. band broadcasts the range signal. In the low-frequency radio-range system, position away from the on-course signal is marked by an off-course Morse Code signal which is audibly noted. Obviously, such a system would not be suitable for marking the Localizer course since aircraft position should not depend upon a pilot's ability to hear deviations from on-course when his airplane is so close to the ground. Small deviations from the Localizer course at low altitudes could cause a disaster. The on-course signal, therefore, must be coded in a manner that allows deviations to be electronically detected by an aircraft receiver and displayed on an appropriate cockpit meter.

Fig. 10A shows how the on-course signal is coded. The v.h.f. carrier power is fed to two independent amplitude

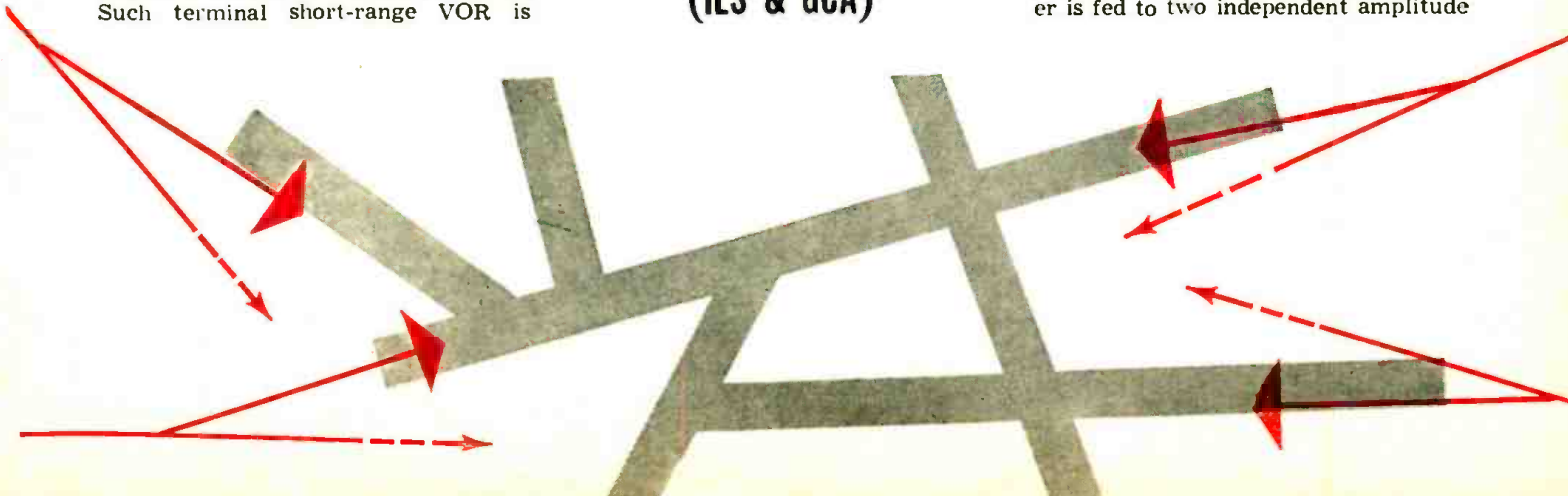



ILS localizer transmitter shack. The localizer array inside the building is an 8-antenna linear array. Two antennas, which are placed close together in the center, radiate the modulated carrier signal, and the other six loops are placed symmetrically on either side to form the necessary horizontal localizer course.

modulators where the carrier is 20% amplitude modulated by 90- and 150-cycle signals. The modulated Localizer signal is then applied to a broad horizontal antenna array which transmits the Localizer signal. The 150-cycle modulated signal is beamed to the right of the runway centerline while the 90-cycle modulated signal is beamed to the left of the runway centerline. As in the low-frequency radio ranges, these two signals overlap in a narrow beam along the centerline of the runway. Along this beam both signals will be received with equal intensity. To the right of the runway the 150-cycle modulated signal will be stronger while to the left of the runway the 90-cycle modulated signal predominates. Because of the extremely directional characteristics of the v.h.f. antenna array used, the horizontal beam—where both signals are equal in intensity—is extremely narrow. Thus, position from the Localizer centerline can be simply determined by measuring the relative intensity difference between the 90- and 150-cycle signals detected by a v.h.f. receiver.

Fig. 11A shows the simple receiver used to detect and display Localizer signals. The v.h.f. receiver is generally the same receiver that is used for v.h.f. communication and reception of VOR signals since these also lie within the 108-127 mc. receiver band. Following detection of the 90- and 150-cycle on-course coding signals by the receiver's audio detector, these signals are separated by tuned filters. The separated signals are then diode detected in order to produce two d.c. voltages proportional to the received strength of the 90- and 150-cycle coding signals. A left-right meter is connected between these two d.c. voltages so that it indicates the difference between them. Thus, if the 90-cycle signal is stronger than the 150-cycle signal, its d.c. voltage will be larger—which will cause the left-right meter to deflect to the right. This indicates that the airplane is to the left of the runway centerline and a corrective turn to the right should be executed until the meter is centered. The indicator is so sensitive that an angular position error of less than two degrees will deflect the meter off-scale. In most aircraft installations, the left-right meter used for Localizer indications is the same meter used by the VOR converter.

The "Glide Slope" portion of ILS provides a second beam for vertical, up-down, guidance. Operation of the

Glide Slope is almost identical to that of the Localizer, that is, position from a vertically inclined beam which intersects the end of the runway is determined by measuring the relative amplitude of 90- and 150-cycle coding signals.

Glide Slope transmitters broadcast in the u.h.f. band of 328.6 to 335.4 mc. and radiate a maximum power of 20 watts. Fig. 10B shows a simplified block diagram of a Glide Slope transmitter. As in the Localizer, the u.h.f. Glide Slope carrier is amplitude modulated to about 48% in two modulators by 90- and 150-cycle coding signals. Two simple horizontal dipole antennas

Glide-slope transmitter shack and antenna system. Note the two dipole radiators on pole. These are placed at different heights and are moderately directive horizontally. The lobing of the two antennas in the vertical plane differs because of different heights, and the glide-slope course is formed by the junction of the lower lobe of the lower antenna and the two lower lobes of the upper antenna. The angle of the resultant course is controlled by antenna heights. Signals above glide slope have mainly 90-cps modulation, while those below glide slope have mainly 150-cps modulation. A third (modifier) antenna array maintains the glide slope perfectly straight to the touch-down point.

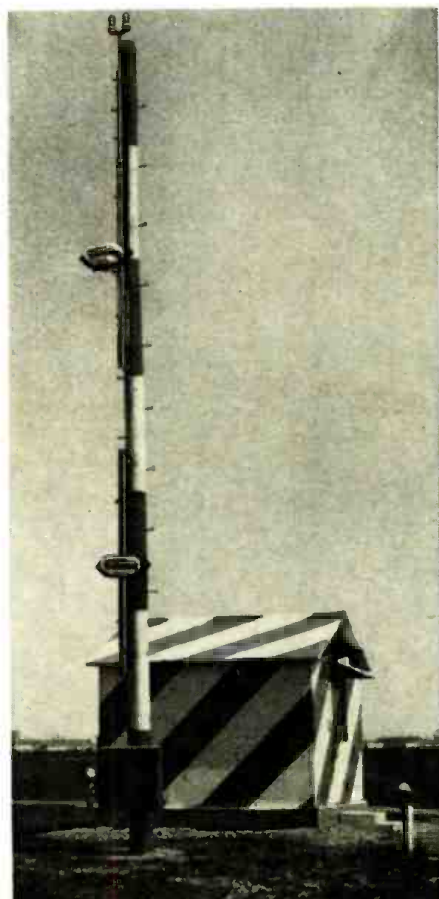

mounted on a mast are used to transmit the Glide Slope signal. The upper dipole beams the 90-cycle modulated signal upwards and the lower dipole beams the 150-cycle modulated signal downwards. The beam formed by the overlapping of these two signals is inclined at between $2\frac{1}{4}$ and 3 degrees to the end of the instrument runway and thus forms a vertical glide path that will lead aircraft down to the end of the runway. The actual angle chosen depends upon the nature of the terrain beyond the runway.

Fig. 11B shows that the typical Glide Slope receiver is also similar to that used for receiving Localizer signals. However, the Glide Slope receiver is used only for reception of u.h.f. Glide Slope signals whereas the Localizer v.h.f. receiver is also used for communications and VOR navigation. Detected Glide Slope coding signals are separated by two 90- and 150-cycle tuned filters. The signals are then rectified and used to deflect an up-down meter. If the 150-cycle signal is stronger than the 90-cycle signal, the up-down meter will deflect upwards indicating that the aircraft is below the glide path and the pilot must execute a climb until the meter is centered.

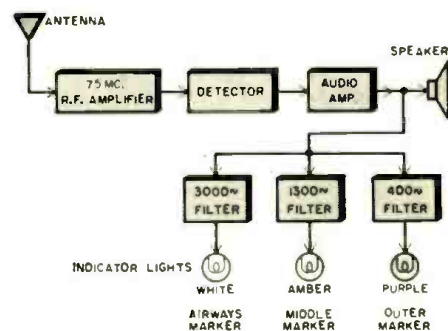

Fig. 9. Marker-beacon receiver.

Since the glide path angle can be as small as $2\frac{1}{4}$ degrees from the horizontal, the Glide Slope indication must be extremely sensitive to small angular position errors since an error of only a couple of degrees could cause a serious crash. For this reason, an angular error of less than half a degree will cause full-scale deflection of the Glide Slope up-down meter.

Localizer and Glide Slope indications are often combined in a single cockpit panel meter which may also include a VOR course selector thereby centralizing most navigation functions in a single indicator. The Lear Model 4087 indicator, used in the NAVCOM 100 navigating system, is typical of such a multiple indicator.

By following the lateral and vertical guidance provided by the Localizer and Glide Slope transmitters, a pilot can perform an accurate instrument let-down to the end of a runway. However, horizontal and vertical guidance alone is not sufficient for a safe instrument landing for it is vital that a pilot also know his relative position along the approach path. Unless this additional information is provided, it is en-

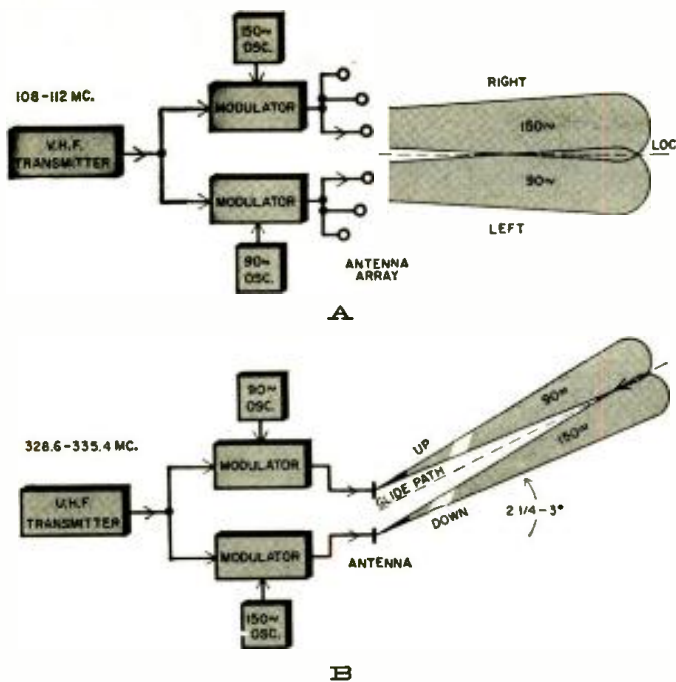

Fig. 10. (A) Localizer and (B) glide-slope transmitters.

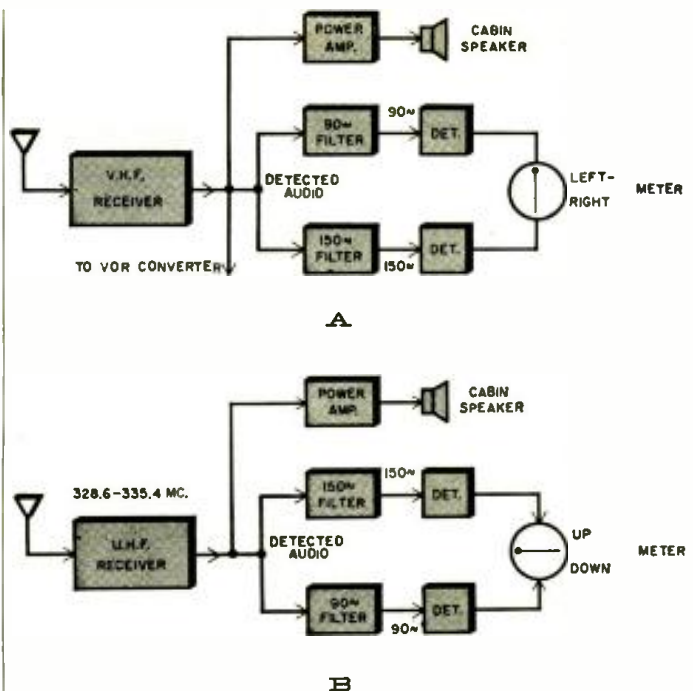

Fig. 11. (A) Localizer and (B) glide-slope receivers.

tirely possible for an airplane to run into the ground at the end of the runway because the pilot did not know he was so close to the ground and could not see the runway. True, the aircraft carries an altimeter, but unfortunately an altimeter is not sufficiently accurate since it is sensitive to barometric pressure weather changes and furthermore tends to lag true altitude during a descent. Therefore, a more accurate, or "positive," fix must be provided. The "Marker Beacon" portion of the ILS system provides this position fix.

A "Marker Beacon" is simply a low-powered v.h.f. transmitter whose radiation is sharply beamed upwards to form a flat cone-shaped vertical beam above the station. When an aircraft passes over a Marker Beacon station the signal is received and the pilot then knows he is directly over the station. Thus, appropriately placed Marker Beacons along the approach path indicate an aircraft's position on the path.

There are three different types of Marker Beacons. All operate on a frequency of 75 mc. and all radiate about two watts of power. The first type of beacon, known as an Airways Marker Beacon, is used to provide long-range navigation fixes. These airways beacons are located along airways and provide positive location on long flights. Airways markers are identifiable because they are amplitude modulated with a 3000-cycle continuous tone and are keyed continuously with 6 dots per second. At some airports, the airways marker is also used as a runway boundary marker and is located about 250 feet from the approach end of the instrument runway.

The two remaining types of Marker Beacons are used exclusively for ILS approaches. The "Outer Marker" (OM) Marker Beacon, as its name implies, is located farthest from the run-

way and generally serves to mark the point at which a descent should begin. Outer Markers are amplitude modulated with a 400-cycle continuous tone and keyed continuously with 2 dashes per second. The Outer Marker is located between 4 and 7 miles from the end of the runway.

The "Middle Marker" (MM) Marker Beacon generally marks the point at which descent should cease if the runway is not in sight. Middle Markers are amplitude modulated with a 1300-cycle continuous tone and keyed continuously with alternating dots and

dashes. Middle Markers are located about 3500 feet from the end of the runway.

A Marker Beacon receiver may consist of a 75-mc. r.f. amplifier and audio detector feeding a cockpit loudspeaker, or it may incorporate circuitry which automatically separates the identifying modulations and indicates type of beacon on a cockpit indicator. Most Marker Beacon receivers used by light aircraft rely upon the pilot to audibly identify the Marker Beacon Morse Code identification. That is, if the pilot hears a succession of dots and dashes

Fig. 12. Simplified ILS approach chart for San Francisco's Oakland Airport.

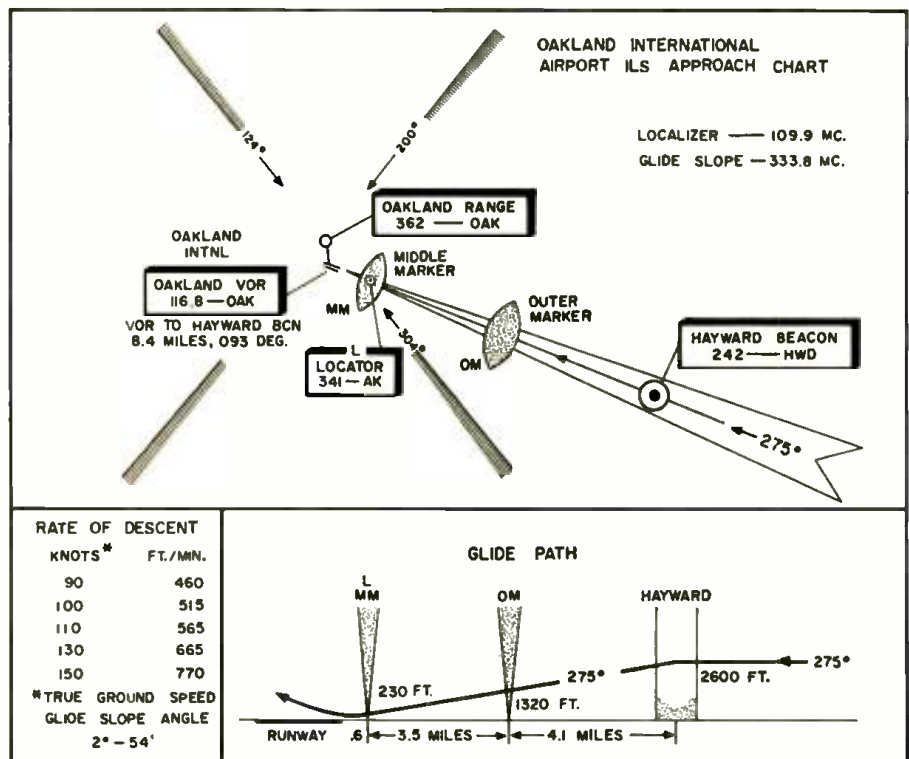



Traffic controllers at GCA radar scopes. Scopes at right are for the Airport Surveillance Radar (ASR), while those at left are for the Precision Approach Radar (PAR).

from his loudspeaker, he knows he is passing over a middle marker. If, instead, he hears a series of dashes he is over an outer marker, or an airways marker if he hears a series of dots.

Fig. 9 shows a type of Marker Beacon receiver which automatically indicates the type of Marker Beacon. A 75 mc. r.f. amplifier, detector, and audio amplifier extract the coding information from the Marker Beacon signal. Three filters tuned to 400, 1300 and 3000 cycles separate the coding signals and apply them to three colored indicator lights. A blue (sometimes purple) light is connected to the output of the 400-cycle filter and flashes when passing over an outer marker. An amber light flashes when 1300 cycles is present indicating the middle marker, and a white light flashes when passing over a 3000-cycle coded airways or boundary marker.

Most middle and many outer Marker Beacon transmitter sites also trans-

mit a low-frequency "compass locator" signal. This consists of a 25-watt non-directional signal in the 200 to 415 kc. low-frequency band. The compass locator provides a signal for direction finders aboard the aircraft and thus furnishes a means for determining the heading of the aircraft with respect to the desired approach course. In congested areas, low-frequency Marker Beacons are also used to indicate the point at which descent should be started.

A unique ILS indicator is used by Bendix in its complete v.h.f. navigational system. A single 3-inch indicator provides Marker Beacon three-light indication as well as left-right, up-down Localizer and Glide Slope metering. A VOR course selector is also included.

Terminal Navigation with ILS

Fig. 13 shows a complete ILS installation that can be found at most large

airports and summarizes the operation of the complete ILS system. Light airplanes generally do not use the complete ILS system because most small plane owners cannot afford the luxury of a separate Glide Slope receiver. As was previously pointed out, the Localizer signal is generally recovered from a v.h.f. receiver which is also used for communication and VOR navigation. The additional cost of a Localizer converter and simple Marker Beacon receiver is small in comparison to the added cost of an additional u.h.f. Glide Slope receiver and converter. National Aeronautical Company's inexpensive Mark II VOR receiver, described in Part 2, also includes a Localizer converter and aural Marker Beacon receiver thereby allowing simple ILS navigation. The lack of a Glide Slope receiver deprives the light airplane of vertical glide-path guidance so the pilot must accomplish his descent with reference to a Rate of Descent meter. ILS navigation charts specify a recommended rate of descent from a fixed altitude over the Outer Marker for various speed aircraft.

In the earlier articles we examined how an aircraft can navigate to the San Francisco area using long-range navigation aids. We shall now examine how an instrument approach and landing can be completed at San Francisco's Oakland International Airport using ILS.

Fig. 12 shows a simplified ILS approach chart for Oakland Airport. Notice that this particular ILS approach pattern uses a low-frequency radio (Continued on page 112)

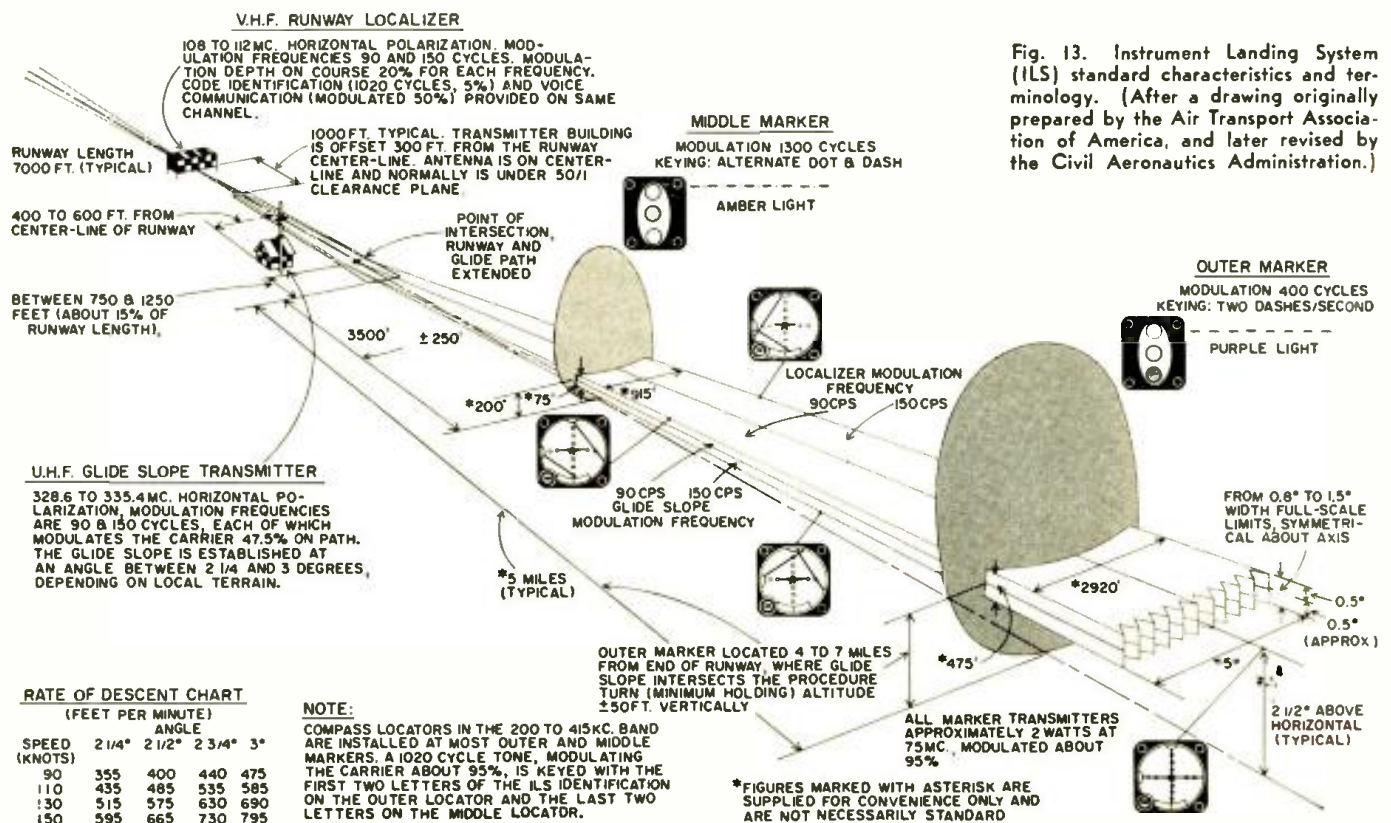
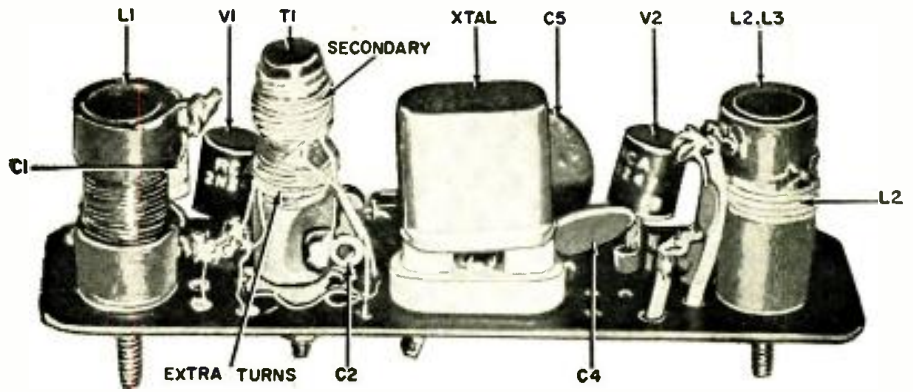
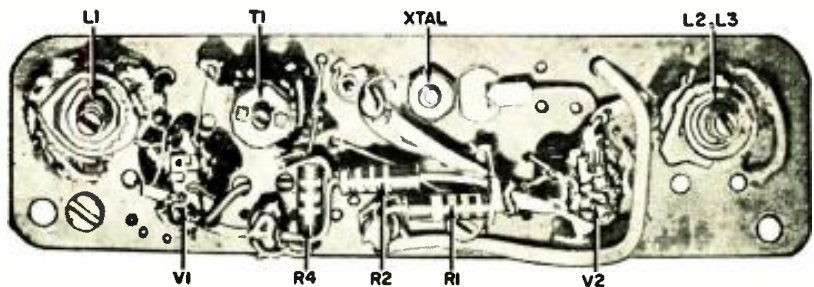

Fig. 13. Instrument Landing System (ILS) standard characteristics and terminology. (After a drawing originally prepared by the Air Transport Association of America, and later revised by the Civil Aeronautics Administration.)



View showing components that are mounted on top of plastic board used as chassis.

Citizens-Band Converter



Bottom view of plastic chassis board showing resistors and coil-slug adjustments.

Construction of a single-channel transistorized converter unit that works with a broadcast set.

By J. H. THOMAS

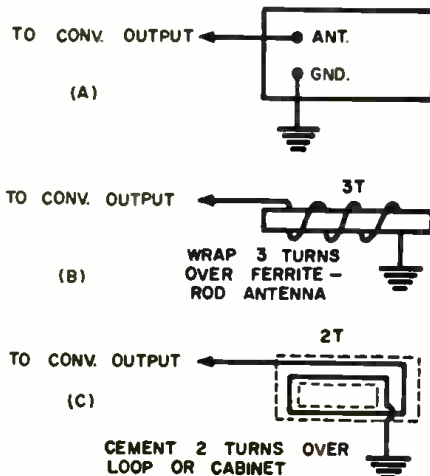

Fig. 1. Connecting converter to receiver.

ALTHOUGH the transistorized Citizens-Band converter to be described was specifically designed to be used with transistor receivers of the pocket variety, it can, of course, be used with any other radio provided the proper supply is available. This is not a difficult requirement since the converter will work at almost any voltage from 3 to 12 volts negative. It is somewhat more expensive than a tube-type converter but, of course, much more versatile and, because of the crystal-control, quite stable.

The Circuit

As can be seen from the schematic diagram of Fig. 2, the circuit is quite conventional in that it consists of a

well-known transistorized crystal oscillator and a mixer. The output of the oscillator is fed to the base of the mixer stage, where it is mixed with the incoming signal.

The converter, as shown, is designed for fixed-frequency operation but of course you can listen to other channels with slightly less efficiency by tuning the broadcast receiver into which the 1000 to 1600 kc. i.f. signal is fed.

The two RCA 2N247's are used because both transistors must be capable of operating up to 30 mc. If you have a 2N384 on hand, this can be substituted for either of the 2N247's.

Construction

The entire unit is built on a narrow strip of plastic. In the author's unit this shape was required so that the converter could be fitted into the cabinet of the portable receiver, but any other layout will do as well provided the oscillator coil is a reasonable distance from the antenna coil or at right angles to it, to prevent radiation of the oscillator frequency.

The coils were wound on forms from a piece of surplus gear. They were $\frac{3}{8}$ " o.d. and have a copper slug, $\frac{1}{4}$ " diameter and $\frac{1}{4}$ " long, for tuning. A similar

commercial coil is the CTC Type LS-3 coil with 2013-C brass slug.

The output transformer was made by adding turns to a Crest #200-6 variable inductance which is tunable from 70 to 225 μ hy. To get the tapped primary, 30 turns of #34 s.c.e. are wound on the end in the same direction as the original coil and then cemented into place. The secondary consists of 20 turns on top of the original coil and wound at the other end of the form. This makes very close coupling but since the oscillator is crystal-controlled, no "pulling" of the separate oscillator need be anticipated. With the capacitor specified, the primary of this home-made transformer will tune down to about 1000 kc. With more capacitance you can reach any spot on the broadcast band.

A miniature transistor i.f. transformer, using external capacitance only, can be used by making the capacitance much lower than shown in the transformer diagram. How much lower will depend on the transformer. Another alternative would be to use a standard i.f. transformer with reduced capacitance, although it may be necessary to first remove some turns and then add a few to achieve a tapped primary.

(Continued on page 88)

By W. F. HUGHES

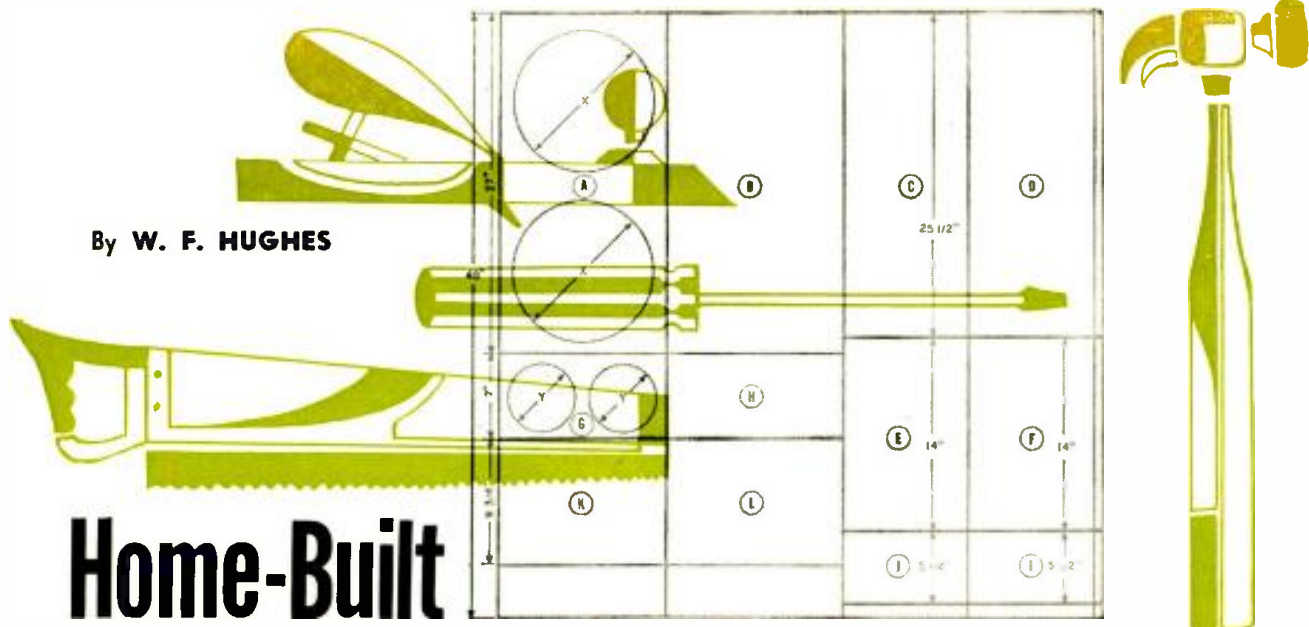

Home-Built

Acoustic-Suspension-Type Speaker System

DURING the past few years considerable advance has been made in the commercial production of speaker systems using the acoustic-suspension principle. The cost of such systems is substantially below the cost of the best systems available prior to their development and their proponents consider that no compromises have been made in performance. Quality acoustic-suspension speakers produced commercially, when coupled with a suitable tweeter, provide very good results indeed at moderate cost.

Even so, the budget-minded hi-fi enthusiast may not be able to afford an acceptable commercial unit of this type. This article describes a simple home-made system, using inexpensive speakers, which will perform surprisingly well in comparison with ready made units.

The system is built around two 12" woofers and two optional 5" mid-range speakers. The two woofers are housed in one bookcase-sized enclosure and, if the mid-range speakers are used, they can be housed in a small enclosure which can be fastened to the woofer cabinet to form one compact unit. The

Construction of simple hi-fi system that can be built for under \$30. When used with suitable tweeter, result is a good, wide-range unit

EDITOR'S NOTE: The performance of this home-built, acoustic-suspension-type speaker system should not be expected to be as good as commercially available units whose loudspeakers are especially made to match their enclosures. Because of the low cost and ease of construction, however, the project is definitely worthwhile for the audio enthusiast who wants good performance and compact size.

mid-range speakers are not at all essential and, if the recommended woofers are used, they alone will result in an adequate system which can be built for a total cost of under thirty dollars.

One of the small, inexpensive electrostatic tweeters can be added to give

better performance above 5000 cps and, when used with the woofers alone, will result in acceptable sound at a minimum cost. The mid-range speakers can be added at a later date to provide a slight improvement in the range from 3000 to 5000 cps. However, even without the mid-range speakers the over-all result is comparable, even in the mid-range, to the moderately priced commercial units.

The Loudspeakers

The speakers used were "Shield Crest" types purchased from *Olson Radio Corp.* for about eleven dollars per woofer and about six dollars per mid-range, but any similar quality speakers may be used. Since the performance of the speakers depends on the cones being fairly compliant, the cones must be treated if the outer edges are stiff. The "Shield Crest" speakers were fairly good in this respect, one of the reasons why they were selected, so no treatment was necessary. Other speakers, if not fairly compliant, can be treated by coating the outer edge of the cone with *Kodak "Photo Flo"* diluted about one part to 100 in water. After drying, the edge is then painted with a saturated solution of silica gel (calcium chloride) in water. Commercial softening kits are also available from some radio suppliers. This wet-



Fig. 1. Completed woofer section before covering. Speakers are mounted from front with sealing compound and machine screws.

Fig. 2. Steady-state acoustic frequency-response measurements taken with the woofers and inexpensive electrostatic tweeter.

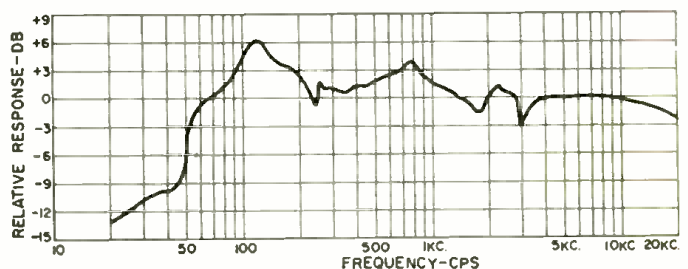

ting treatment loosens the cone, lowering its resonant frequency, and allowing it to act more freely against the air spring of the air trapped in the enclosure. This acoustic spring controls the speaker movement rather than the mechanical stiffness of the cone itself. It is vital, then, not to puncture the cone accidentally or to allow an air passage into the sealed enclosure.

The Enclosure

The two woofers are mounted in a box made of $\frac{3}{4}$ " plywood which is completely screwed and glued together before the speakers are mounted. Fig. 5 gives the general layout for the box and shows how the entire system can be fabricated from a piece of 4-foot x 4-foot plywood. Care should be taken to mate the joints carefully and a liberal amount of glue should be used, along with closely spaced #8 or #6 wood screws, in order to insure tightness. The box must be absolutely air tight.

Before assembling the box, the speaker holes should be cut just large enough to allow the speakers to fit in from the front after the box is put together. Fig. 3 shows a cross-section of the speaker mounting.

Four wires, about four-feet long, should be cut and fed through a small hole in the rear panel. The wires can be stapled or fastened to the inside and outside of the rear panel near the hole so that they will not move in the hole and break the seal—which is made by filling the hole with plastic wood or glue. A terminal strip may be fastened later to the rear panel, forming a convenient junction for the speaker leads from the amplifier or crossover network.

After assembly and installation of the lead wires, but before installing the

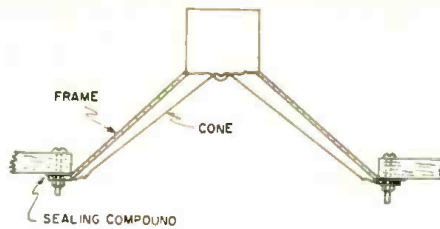
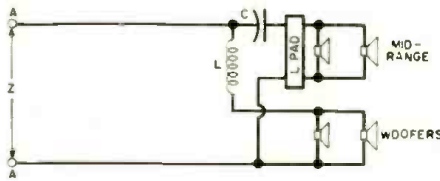

Fig. 3. Sealing and mounting of speakers.



Z-ohms	L-mhy	C- μ f	
4	0.8	50	SPEAKERS IN PARALLEL AS SHOWN
16	3.0	12	SPEAKERS IN SERIES

Fig. 4. Crossover network used for 700-cps crossover. L-pad allows proper balancing. If electrostatic tweeter is used, the 16-ohm arrangement is employed and the low-frequency signals from the tweeter crossover network are applied to points A-A.

speakers, the entire box must be filled (through the speaker holes) with fiber glass acoustic padding. The inside walls should first be lined and then layers laid in the box until it is completely filled except for space left for the speakers. A light dripping of glue on the padding will keep it in place.

When the box is filled, the speakers can be wired and put into place. The leads should be clearly marked before sealing the cabinet. A thin covering of cloth can be used on the back of the speakers to insure that the fiber glass does not get into the mechanism.

Special precautions must be taken

not to puncture the cone while mounting it from the front. Machine screws, #8 or #6, about 1½-inch long should be fed from inside the box and allowed to protrude. The speaker is then placed over these bolts and washers and nuts put into place.

In order to effect a good seal, some sort of sealing compound can be used between the speaker rim and the wooden front panel. "Duxseal" (Johns Manville), "Tub Tight," or even "Permagasket" can be used. "Duxseal" seems preferable since it remains plastic and will not shrink or crack. The photograph of Fig. 1 shows the completed woofer section with the speakers in place and sealed.

After the woofer section is completed, a mid-range section can be built in the same way. After completion, the two boxes can be mounted together and covered with grille cloth and veneered if desired.

Wiring

Depending on the impedance of the amplifier and speaker used, the speakers can be wired in a variety of ways. Fig. 4 shows an arrangement for 8-ohm speakers (the impedance of the speakers used) being fed by a 4- or 16-ohm amplifier. The woofers and mid-range speakers are wired in series for 16-ohm operation and in parallel for 4-ohm operation. If the woofers are used alone, a tweeter can be added to give good high-frequency response and to smooth out the mid-range. A suitable crossover network must be used with the tweeter. This can be made fairly easily or purchased as an accessory unit with the tweeter. The woofers can then be wired in series and a 16-ohm crossover network used.

(Continued on page 134)

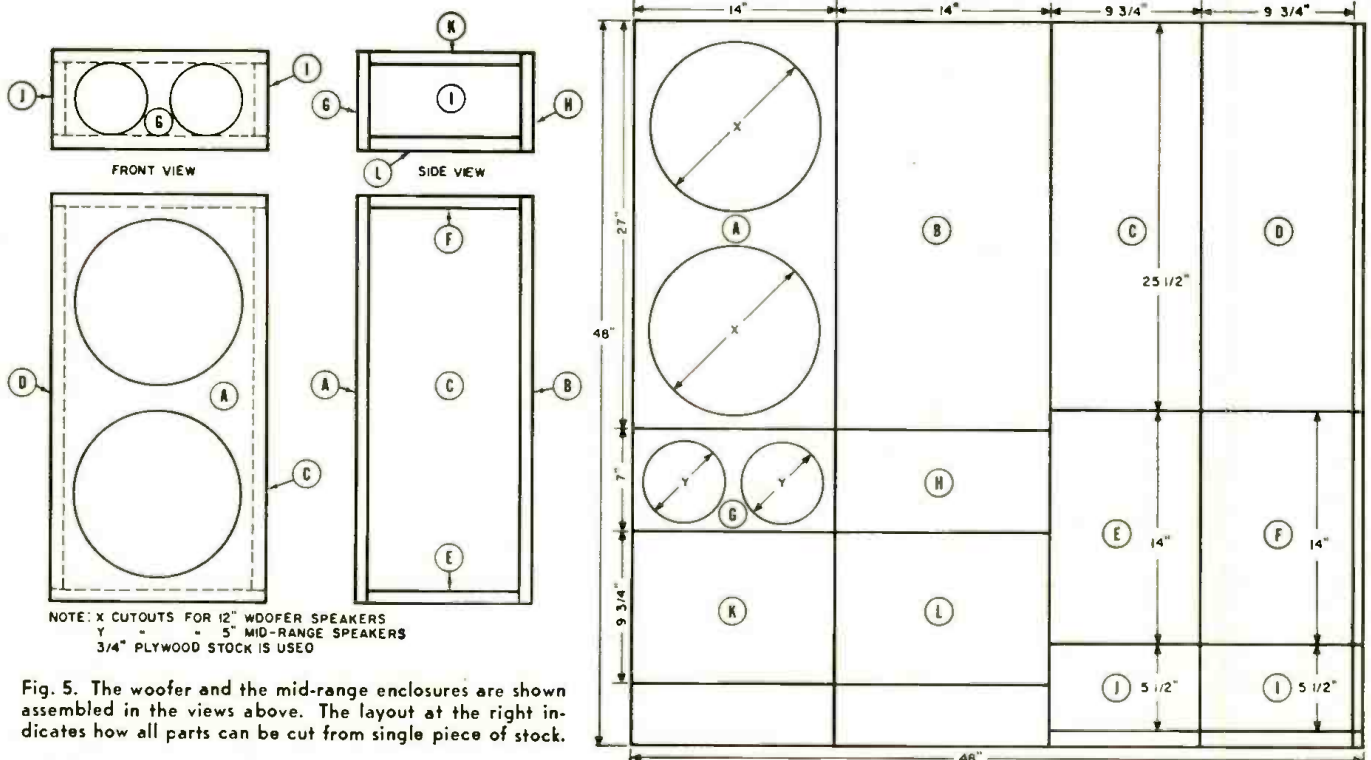
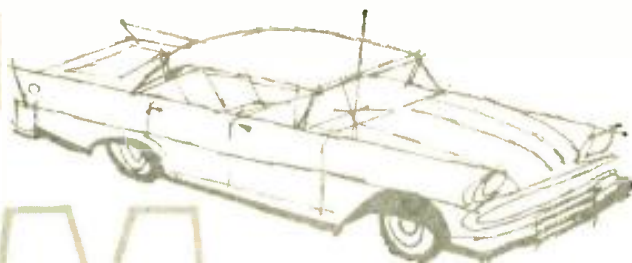

Fig. 5. The woofer and the mid-range enclosures are shown assembled in the views above. The layout at the right indicates how all parts can be cut from single piece of stock.

FM



Reception on Wheels

It isn't easy, but understanding the special problems helps. The Motorola FM-900 includes many solutions.

SINCE FM reception in the home has enjoyed widespread acceptance for many years, one may wonder why receivers of this type have not been marketed for use in automobiles until quite recently. Today one has hardly finished looking over the last FM car radio offered to the public when another is announced. The potential purchaser (and the reader interest, over the years, on information for converting standard FM tuners and receivers for vehicular use indicates that there are such potential purchasers) may ask, "What took them so long?"

The fact is things are not as simple as they seem. Take the matter of noise and interference, where FM is particularly considered to outshine AM. Due to the specific vehicular environment, an axiom involving the relative merits of these two types of modulation is reversed. Unless given its due consideration, noise can actually be a greater problem on FM. Furthermore, this is just one of the problems involved.

The result is that a suitable FM auto receiver must be something quite different from just another FM set for home use, even with modest changes. The *Motorola FM-900* shows a recognition of the difficulties involved and indicates conscientious design efforts to overcome them. Accordingly, it makes a good starting point for our discussion on several grounds. It will serve as a guide to anyone wishing to adapt any FM receiver to his vehicle. Also, where such conversion is not practical, it will help the prospective listener to select

and properly install an alternate tuner or receiver.

As to the matter of noise, any owner of a v.h.f. receiver (TV or FM) must have some idea that reception in this spectrum is peculiarly responsive to interference generated by automotive ignition systems. When a car or truck rolls by, the TV owner knows about it without having to look out of his window. The black, horizontal streaks marring his picture are a sure giveaway. His TV sound (or the usually whisper-quiet background when he is listening to his FM set) is interrupted by annoying, crackling noises.

Not only is the ignition system of the average vehicle a superior generator of this type of noise; the ignition wiring used generally adds insult to injury by acting as a highly efficient antenna system for propagating this undesired r.f. It happens that the ignition-wire lengths used tend to be resonant at or near the FM band.

When this interference occurs dur-

ing home reception, the irritated listener has the consolation of knowing that the noise will pass soon, with the passage of the offending vehicle. Inside a moving automobile, the listener is in the position of carrying the noise source with him wherever he goes. Furthermore, it is never more than a few feet away from his receiver's antenna and antenna input, where it can easily compete with signal. Thus ignition-suppression measures considerably more effective than those required for reasonable AM reception become necessary. More will be said concerning these measures later.

Another problem involves the receiving antenna. The sizable, roof-top unit that may cap a home installation is simply not practical on a moving vehicle. A simpler, more modest entity is needed, and it should preferably be the same whip used for the AM receiver that is likely to be in the auto already. Such a signal interceptor will provide considerably less input for the FM receiver for two reasons: regarded only as an antenna, it will not have the same gain that a more sophisticated device would provide; also, it will suffer in line-of-sight pickup because it is necessarily low to the ground instead of being high on a roof-mounted mast. In addition, it will be much closer to the noise source than would a home-use antenna.

Already we can see how the separate problems of auto reception begin to run into each other. The closely coupled ignition system makes high sensitivity and superior noise rejection

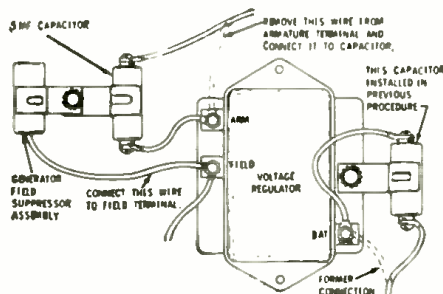
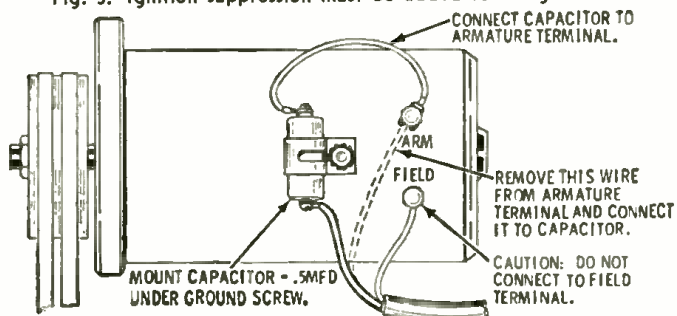

Fig. 2. Extra suppressor capacitors at the voltage regulator may be needed.



Fig. 1. The compact radio is made for under-dash mounting.
Fig. 3. Ignition suppression must be added to the generator.



mandatory. Limitations on the antenna installation cut down available signal.

Since v.h.f. reception, whether on TV or FM, is largely limited by the horizon, the service area from the station over which the moving vehicle can obtain good reception is more restricted than with AM. This would seem to inhibit reception too far away from a city—but also cut it down in the streets of a metropolis itself, where tall buildings block direct transmission. Fortunately, the latter is not necessarily true. Such v.h.f. signals bounce and ricochet off nearby structures. Thus multi-path reception of a reasonably strong signal down on the city's streets is quite feasible. One of TV's great metropolitan hazards, "ghosting," becomes a boon in the new context. In fact, this ability of FM transmissions to "bounce" assists in many situations where AM usability disappears, as when the vehicle is moving through a tunnel or underpass.

Although signal may still be available in what would ordinarily be "dead spots," it is certainly attenuated. Thus we are still left with a potentially serious impairment of listening enjoyment: fading. These fluctuations must be ironed out.

Problems enough? Don't go away; there are more. Due to the relatively small ratio between the bandwidth of a single FM station and the full extent of the assigned band, and also due to the problems of frequency stability in this spectrum, tuning is quite critical, as it often is on home instruments. At

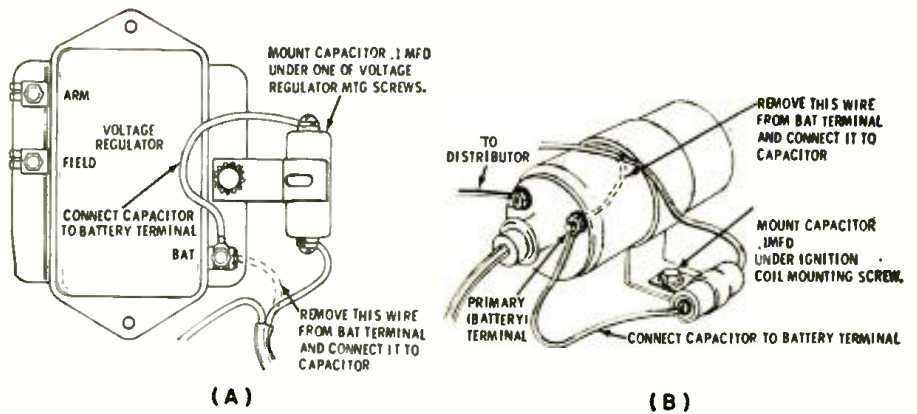

Fig. 5. Suppressor location for the voltage regulator (A) and ignition coil (B).

home, you can take your time. In a car, according to a widespread belief, the driver is supposed to keep his eye on the road and his hand on the wheel. Safety demands that he be able to tune quickly, easily, and with the least possible visual distraction.

The normal requirement of frequency stability is aggravated by the fact that it can be affected by changing supply voltages—and the auto's battery-generator system is not famous for constant output. Voltage fluctuation can also produce variations in sensitivity and audio-output level.

How can these problems be met? Let's examine Fig. 4. The signal circuits, which appear to be most conventional, get first consideration. The antenna-input system does not seem to be startling, but it does have one im-

portant difference from its home-receiver counterpart. Since a match to conventional antennas is useless here, input impedance is in the vicinity of 50 ohms instead of 300. The ordinary, telescoping antenna used on an auto, when manually adjusted for peak reception with this circuit, will be a quarter-wavelength affair, which matches the lower impedance.

The entire front end consists of a single twin triode, V1. This may seem like cutting corners in the wrong place, but it isn't. The circuit used is that of the grounded-grid r.f. amplifier followed by an autodyne converter. This type of circuit (see "Don't Dodge the One-Tube FM Front End," *ELECTRONICS WORLD*, August, 1959) has many virtues. It can provide commendable

(Continued on page 132)

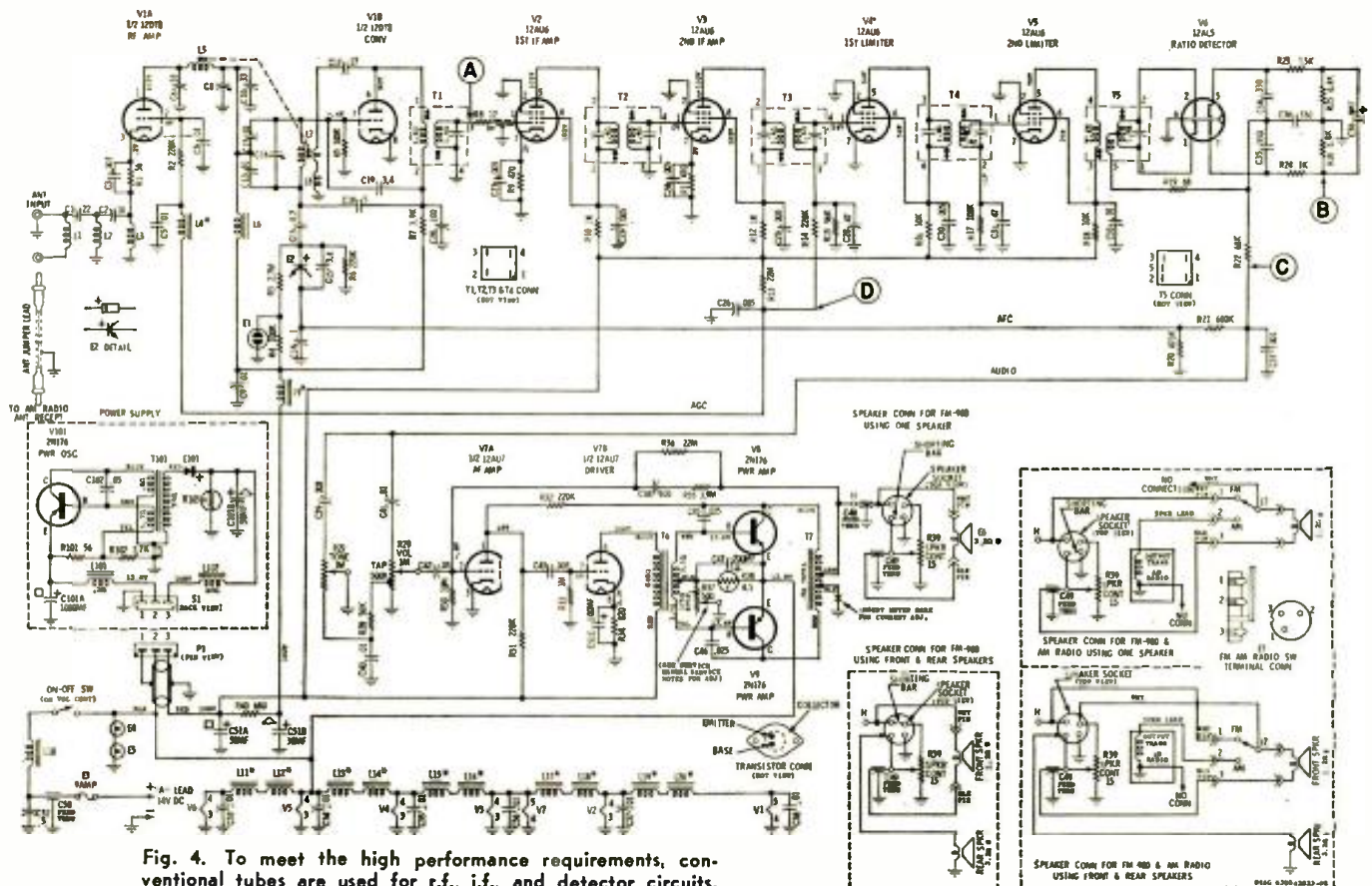

Fig. 4. To meet the high performance requirements, conventional tubes are used for r.f., i.f., and detector circuits.

Cascode Circuits: How and Why

By JIM KYLE

Study of a circuit widely used in TV tuners and other applications. Variations and service considerations.

BORN of a war-time need for long-range radar and brought to maturity in the TV-booming mid-1950's, the cascode amplifier circuit today can be found in almost any application where a low-noise, high-gain amplifier is required. Nevertheless, although the circuit itself is a relatively simple and straightforward means of obtaining radio-frequency amplification, many technicians, in and out of the service field, show occasional bewilderment about it.

Some of that aura of mystery can be removed. Along the way, commonly encountered, practical problems can be pointed out, as well as methods for handling such problems and improving the operation of cascode circuits in general.

A good starting point is an understanding of what we mean by "a cascode circuit." In the past, the term "cascode" has been applied to a number of amplifier circuits. On top of this, there are several variations of the basic Wallman amplifier that have been given the name. Stripped of non-essential detail, the cascode circuit consists of a conventional grounded-cathode amplifier stage coupled to a grounded-grid stage. Each stage normally employs a triode tube or tube section. Both stages together provide about as much gain as a single pentode—with a much lower noise contribution from the tubes.

The circuit came into its own with the introduction of the famed "cascode tuner" for television. In fact, the TV tuner is still the most likely place to find this type of amplifier. However, as the possibilities of this amplifier configuration became more evident, its use broadened out. Today one may find a cascode circuit in an FM tuner, a communications receiver, commercial two-way equipment—and in portions of the TV receiver aside from the tuner itself, as in the i.f. amplifier.

Essential features of the basic series cascode circuit are shown in Fig. 1. An incoming signal from the antenna goes to the grid of the first stage. Amplified signal voltage at the plate is then fed directly to the second-stage cathode through L_6 . The grid of stage two is grounded for r.f. energy by capacitor C_8 . The signal, amplified still more by this triode, goes from the second-stage plate to T_9 , and so to the next portion of the set. (Typical values for this schematic and others discussed later are consolidated in Table 1.)

In this circuit, R_2 is the a.g.c. isolation resistor; R_1 is the cathode bias resistor for the first stage, and R_7 provides a d.c. return from the grid of the second stage to its cathode. Capacitors C_3 and C_5 are for bypass purposes.

No Oscillation?

At this point, some of the confusion associated with the circuit begins to crop up. For example, why doesn't the cascode circuit oscillate? Many tech-

nicians, including those familiar with the ancient triode-t.r.f. days, will recall that, when input and output circuits of a triode amplifier are tuned to the same frequency, the circuit quickly turns itself from an amplifier into an oscillator unless it is properly neutralized. In fact, a circuit familiar to many amateurs, the TNT (tuned-not tuned) oscillator, makes use of this fact.

The cascode is a tuned triode amplifier, yet it does not oscillate. True, coil L_6 of the typical circuit is often called a neutralizing coil, yet satisfactory operation may be obtained without it. Strangely enough, the reason for the circuit's stability lies, not in the first stage (which would seem to be ripe for oscillation), but in the second—the grounded-grid amplifier. The input impedance of a grounded-grid amplifier is extremely low. About 700 ohms is typical in most cascode applications. This is the load resistance for the first stage, and it is low enough to damp out oscillation.

Another way of saying this is that the low load resistance *reduces amplification* of the first stage below the minimum necessary to sustain oscillation, since amplification is a function of a tube's load (R_L) as well as of its amplification factor (μ).

Where's the Gain?

The last statement makes sense when considered all by itself. However, it leads directly to the next sequence of head-scratching when we consider it in the light of the claim that the complete circuit exhibits about as much gain as an efficient pentode circuit, and far more than a single triode. How is this seeming contradiction resolved? One way of explaining what happens is to resort to a column of mathematical calculations involving tube characteristics and circuit relationships. However, a general picture can be given without doing so.

Although amplification of the first stage considered alone is quite low, its output signal actually passes through the second, grounded-grid stage before reaching the working "load" for the entire amplifier, T_9 of Fig. 1, across which the amplified signal is developed. (In this connection, note that the output signal of the first stage, which is also the input signal for the second stage, is in series with the output signal of the second stage. This is not the case with a conventional grid-input amplifier, where input and output

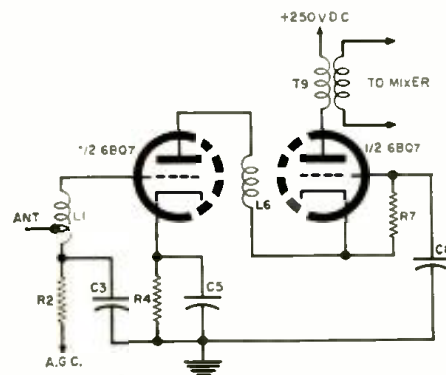

Fig. 1. A basic series cascode circuit, showing the essential elements.

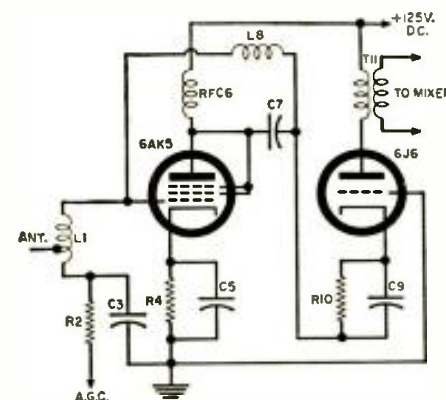

Fig. 2. The original Wallman cascode circuit used a triode-connected pentode.

Table 1. Components used in Figs. 1-5.

COMPONENT	VALUE AND COMMENTS
R_2	100,000 ohms
R_1	82 to 100 ohms
R_4	0 to 47 ohms
R_7, R_8	470,000 ohms
R_{10}	100 ohms
C_3 to C_9	.001 μ f. disc ceramic
L_1, L_6, L_8	Resonant with circuit capacitance at signal frequency
RFC ₆	1 millihenry
T_9, T_{10}, T_{11}	R.f. transformers

signal voltages are in opposite phase.) The second stage may thus be considered as a network between the first stage and the load.

With the amplification factor of the first stage unchanged and its effective load thus increased, amplification goes up, as the formulas in any tube-characteristic manual show. However, oscillation is still prevented. The second stage has already been likened to a network between the first stage and the load. Actually, this network provides isolation in one direction. Although it passes signal on to the load, the grounded-grid configuration makes the grid act as a shield between the cathode (input) and plate (output), drastically reducing the cathode-to-plate capacitance. This capacitance, in a triode amplifier, is normally the coupling path that feeds back the signal which produces oscillation.

Cascode Variations

As with most other basic circuits, there are countless possible variations on the cascode theme, some of which we will consider. Actually, the popular versions vary from the original Wallman circuit of Fig. 2. Making use of tube types then available, the latter employed a triode-connected 6AK5 pentode for the first stage and one section of a 6J6 for the second. Also, as far as supply voltages are concerned, the two stages were in parallel, but the signals were in series. In modern applications, the two stages are in series with each other across the supply voltage, as shown in Fig. 1 and the other circuit variations with this article.

The latter arrangement simplifies the coupling between the two stages, eliminating two components, R_{FC} and C_1 (Fig. 2). The simplification is the reason that the TV industry developed the version, now almost universally used, in which the two triodes are in series or stacked across "B+".

An important variation of the series cascode circuit is shown in Fig. 3, where the voltage divider composed of resistors R_7 and R_8 replaces the second-stage grid return resistor (R_7 of Fig. 1). This change converts the circuit from semi-remote cut-off operation to nearly full remote cut-off condition. Here's how it works:

Applying a.g.c. voltage to the input grid increases bias of the first stage, which reduces current through this triode. The voltage drop across the tube itself is increased, which means

that voltage at the plate goes up. Since the two tubes are in series across the fixed supply voltage (with the first-stage plate connected to the second-stage cathode through neutralizing coil L_n in Figs. 1 and 3), an increase in the drop across the first stage reduces the voltage available for the second stage. This reduces gain of the latter. The over-all effect provides semi-remote cut-off operation in any series cascode circuit, with gain for both stages being influenced by a control voltage at the first grid.

However, in Fig. 3, second-stage grid voltage is clamped to the design value by the voltage divider, R_7 and R_8 . Normally, this is chosen so that the second-stage grid is about one volt less positive than the second-stage cathode in the absence of a.g.c. voltage.

Now when a.g.c. voltage is applied to the first stage (causing its plate voltage to rise), the change in voltage also increases the grid bias of the second stage by increasing the potential difference between cathode and grid. This lowers over-all gain for the circuit even more smoothly than is the case with the circuit of Fig. 1, resulting in extension of the cut-off characteristic. By manipulating values of R_7 and R_8 , the design engineer can choose from a wide range of gain characteristics.

In addition to the clamped-grid refinement and other features already mentioned, the circuit used in the cascode TV tuner has other modifications. Since these tuner circuits are widely available in service data and other sources, a complete circuit has not been included here. In general, the modifications in typical TV tuner applications involve the addition of components to make operation more reliable over the wide range of conditions and frequencies found in such applications. They have little or no effect on the theory of operation and, once the basic circuit and its elements are understood, the additions can be recognized and understood more readily.

Additions will include the coil-switching at the antenna input and at the plate load of the second triode, trimmer capacitors for tuning and bandpass adjustment at such points as the first-triode grid and second-triode plate, feedthrough capacitors mounted on the tuner subchassis to replace more conventional types, and filament bypassing.

Another important variation of the basic circuit (most often encountered

in communications receivers but seldom in TV or FM tuners) is shown in Fig. 4. By replacing neutralizing coil L_n with resistor R_n , one adjustment is eliminated at almost no sacrifice in efficiency. As explained earlier, coil L_n is not necessary to prevent oscillation. Its chief purpose is to improve gain at higher frequencies by "tuning out" the second-stage input capacity. The gain improvement shows up in the set as in-

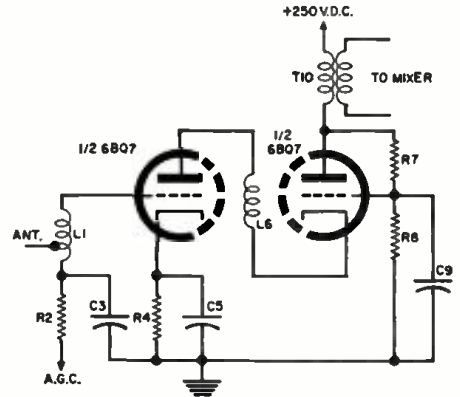

Fig. 3. Clamping grid of second triode improves over-all a.g.c. action.

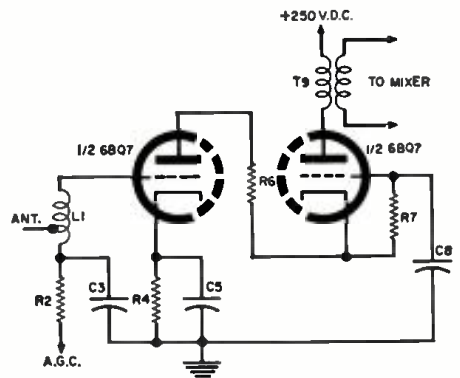

Fig. 4. At some frequencies, L_n may be replaced by R_n with no impairment.

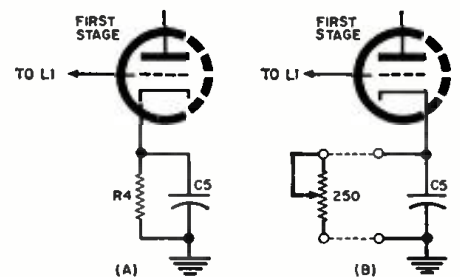

Fig. 5. The cathode bias resistor may be individually adjusted for more gain.

Table 2. Twin triodes used in cascode r.f. designs, with their special features.

TYPE	HEATER CURRENT (amps.)	RELATIVE GAIN	SPECIAL CHARACTERISTICS
6BC8	.400	97	Low cross-modulation
6BK7B	.450	147	Very high gain to 300 mc.
6BQ7A	.400	100	Low noise
6BS8	.400	113	High cascode transconductance
6BX8	.400	105	Low plate voltage (65 v.)
6BZ7	.400	107	Low noise
6BZ8	.400	125	Low cross-modulation
6DJ8	.365	196	Very high gain, low plate voltage
6ES8	.365	196	Same as 6DJ8 (90 v.)

creased sensitivity or less snow on the screen of a TV set.

However, at frequencies below 52 megacycles, the circuit provides plenty of gain without coil L_n . In such a case, the coil can be replaced either by a piece of wire or a resistor (R_n in Fig. 4) with no loss of efficiency.

Other variations of the circuit which may be encountered include changes in input and output connections (from parallel-resonant to series-tuned circuits) and use of lower and higher sup-

(Continued on page 126)

Tv

Remote-Control Aligner-Tester

By FRANK HADRICK, Simpson Electric Co.

A new test instrument designed for checking and aligning ultrasonic TV remote-control equipment.

NEARLY all manufacturers of TV receivers now offer remote-control features of one type or another with their sets. The steady increase in the number of models so equipped is one indication of increasing public acceptance. It follows that the service technician is steadily encountering more of these sets in his work and that the occasions on which he must service them are also increasing.

Although there are various, basic types of remote-control systems, the wireless, supersonic type appears to be the most popular (see "Ultrasonic TV Remote Controls," August 1960, page 54). In this system, when the hand-held transmission unit is operated, an acoustic, ultrasonic signal is produced by either mechanical or electronic means. This signal is picked up by a concealed transducer (microphone) at the TV receiver, where it is converted to an electrical signal, amplified to a usable level, then detected and used to operate a relay controlling a particular

function. From this point, complexity of the system depends mainly on the number of functions, such as "on-off," volume control, and channel selection, that are remotely controlled. The frequencies at which these systems operate are usually in the range from about 37 to 43 kc., with an accuracy of about plus or minus 15 to 20 cps.

Since the average service shop is not likely to have the facilities for checking performance in the course of troubleshooting, the *Simpson Model 407 Remote Aligner* (Fig. 2) has been designed for the purpose. The com-

pact instrument includes a crystal-controlled generator that will produce any of a group of four fixed frequencies that may be chosen between 35 and 45 kc.

The modified, crystal-controlled Pierce oscillator (Fig. 1) produces sine-wave output signals at twice the desired frequency, which are coupled to the 2:1 divider (blocking oscillator) stage. For example, if the selected crystal will oscillate at 80 kc., output of the divider will be 40 kc. This occurs because the free-running range of the blocking oscillator is 35 to 45 kc. Therefore, when crystal-oscillator signal is applied to the blocking oscillator, it acts to synchronize the latter at exactly half the crystal frequency with great accuracy. A tunable wave-shaping network in the plate of the pentode (Fig. 3), pre-set at the factory, is adjusted so that output over the operating range is sinusoidal.

The crystal selector switch on the front panel permits a choice of any of

Fig. 1. A crystal-controlled oscillator provides accurate output signals.

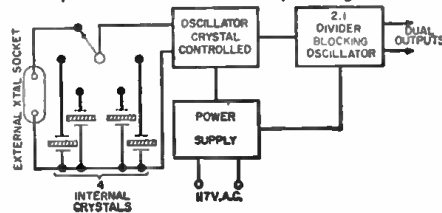

Fig. 2. The Simpson Model 407, shown with its attenuator probe, has dual outputs, one of which is used for monitoring level.

four internal frequencies, which may be specified by the purchaser. These may be chosen to accommodate the remote-control systems the owner is most likely to encounter in his work. An external crystal socket provides for the insertion of crystals to produce other frequencies within the operating range should they become necessary. The typical crystal and output frequencies shown in Fig. 3 are not necessarily those of any particular manufacturer.

Output level is continuously variable from approximately 100 microvolts to 1 volt r.m.s. A low-output range from 0 to about 10 microvolts is obtained with the 100,000:1 accessory probe, shown schematically in Fig. 4,

determined by observing the monitored v.t.v.m. reading at this point. These remote-control amplifiers usually have very high sensitivity, on the order of only a few microvolts.

The procedure recommended not only can determine whether one function's sensitivity is adequate, it can also be used to make certain that all functions of the same remote-control system have approximately the same sensitivity, which provides additional information about possible defects. For example, if sensitivity on one function only is low, alignment on that function only or adjustment of the relay involved may be all that is required.

An alternate method of checking relative sensitivity of all functions,

curacy and align the receiver to track with the former. This has drawbacks in all cases, but particularly in the case where the transmitter output is mechanically produced by a tuning-fork system rather than electronically. Tuning-fork output is a short burst of several sine-wave cycles, rather than a continuous wave. Accurate alignment against this elusive signal is extremely difficult, if not impossible. With the Remote Aligner, a c.w. signal of known, adjustable amplitude and accurate frequency is used instead.

In addition, even where electronic transmitters are used, some other standard reference is needed, as the former unit may itself be giving trouble. Frequency accuracy of the Remote Aligner, against which transmitters may be checked, is within .01 per-cent, and accuracy of output-amplitude measurement depends on accuracy of the v.t.v.m. used for monitoring.

While it may be desirable to check the frequency accuracy of the instrument itself at times, this function is performed with the internal crystals. To calibrate it, an oscilloscope is connected between the left jack on the external-crystal socket and instrument ground. The scope is adjusted to display several cycles of a stable pattern. The output should be a steady sine-wave pattern, with a pulse appearing on every other cycle, for each of the four positions of the crystal-selector switch. If not, the frequency-lock adjustment on the front panel is manipulated until such a pattern is achieved on all four switch positions with the same frequency lock setting. After the output amplitude has been thus calibrated, output amplitude from one selector position to another should be constant within 1 db.

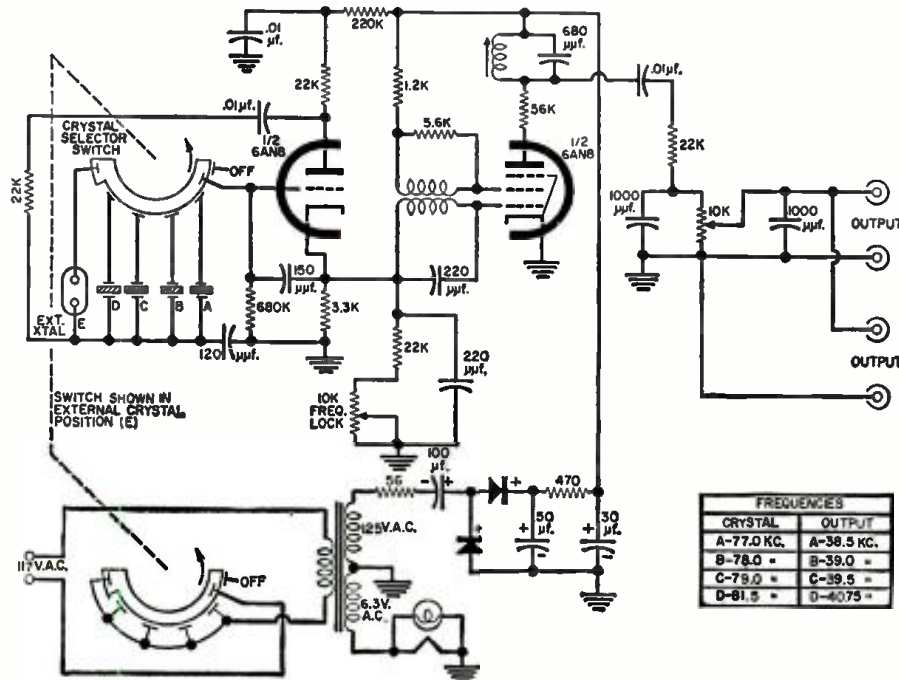

Fig. 3. Output oscillator works at half the frequency of the selected crystal.

which is a capacitive voltage divider. If the low range is desired, the probe can be connected directly to one of two pairs of output terminals provided, and a v.t.v.m. can be connected to the remaining output for monitoring. With the v.t.v.m. on its lowest a.c. range, scale readings are multiplied by 10 for the probe output in microvolts. (On some units a phono jack replaces the output terminal shown in Fig. 1 at the upper right.)

This method of output calibration is extremely valuable for sensitivity checks and measurements. It is sometimes necessary to determine the sensitivity of a particular remote-controlled function at the receiver (the input-signal level required to energize the relay involved). In this check, the acoustic output is not involved, so the transducers at the transmitter and receiver are not used. Voltage output from the probe is connected directly to the remote-control amplifier input at the TV set, as shown in Fig. 5A. The output control of the Model 407 is advanced from minimum until the relay in question is energized. Sensitivity is

shown in Fig. 5B, also includes the receiver microphone in the over-all check. Instead of the output probe, a microphone assembly is connected to the instrument's output, and the receiver microphone is left in place. With the two microphones separated by some specific, constant distance, all receiver functions are checked for relative sensitivity.

Where alignment is necessary at the receiver-amplifier, any of several methods can be used. Probe output from the Model 407 can be introduced at the amplifier input or some other point in the circuit, and adjustment of amplifier and/or discriminator circuits can be made. Alignment can also be achieved using the coupling method shown in Fig. 5B. In addition to these two ways of injecting signal, for alignment or troubleshooting, others are possible. The best one to use is that recommended by the manufacturer of the television receiver in his service data.

With many remote systems, the technician is content to use the transmitting unit as his standard for ac-

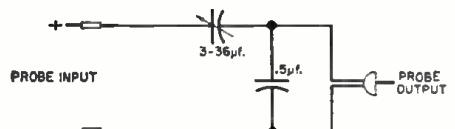
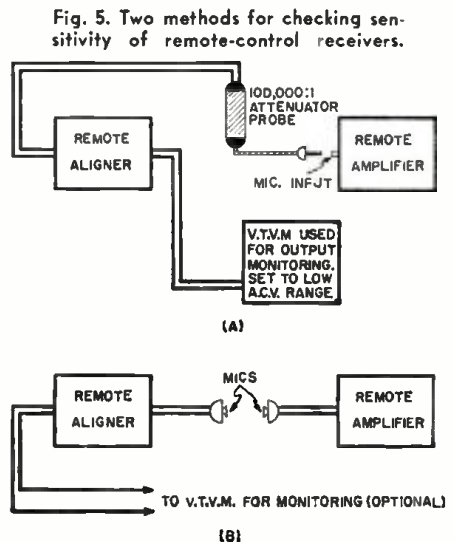
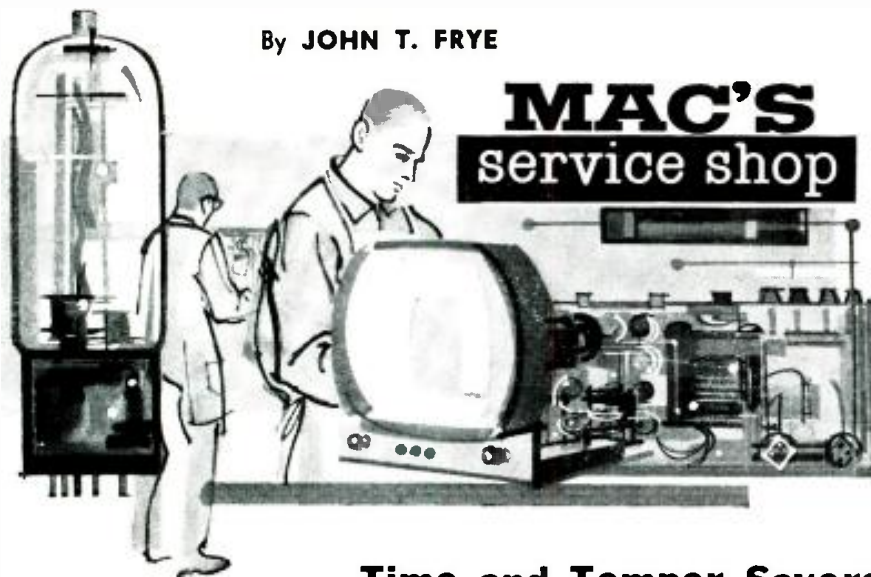

Fig. 4. The 100,000-to-1 attenuator probe is a capacitive voltage divider.



By JOHN T. FRYE



Time and Temper Savers

"OK, OK!" Barney was saying as he came through the door of the service department Monday morning; "what were you doing here last night? Marge and I saw a light on at ten o'clock as we drove past, and your car was parked out front."

Mac, Barney's employer, heaved an exaggerated sigh of resignation. "A man can't get away with a thing, can he? You won't rest, though, until you know. Actually it all started when I went to Doc Briney for my regular physical checkup Saturday."

"Nothing's wrong with you, is there?" Barney asked with quick concern.

"Not really. My blood pressure was up a trifle, and he asked if there was anything 'irritating or exasperating' about my work. The more I thought about that the more I grinned; for you'll agree, I'm sure, there are several things about radio and TV servicing that might aptly be termed irritating or exasperating—even excluding the customers."

"And how!" Barney soulfully agreed.

"Sunday the wife went to a class reunion and left me sort of at loose ends. I got to thinking about some of the petty little goat-getters here at the bench; so I decided to come down and see what I could do about a few of them. The project became so interesting I didn't quit until after eleven last night."

"These are new," Barney observed as he pointed to a row of lidless transparent plastic boxes fastened up behind the bench.

"Yeah. They are to receive the knobs, back-cover trimounts, and chassis screws and washers you remove and either scatter around over the bench or place carefully in a box on the bench and promptly upset. You know: the same little parts that gradually dribble off the bench during the heat of your tussle with the set and hide on the floor where they can't be found when you're ready to put the chassis back in the cabinet. You can see at a glance what each one of the plastic

boxes contains, and notice they are tilted out so that even a tiny lock-washer can be slid up over the side with a forefinger."

"A couple of the boxes have stuff in them now."

"Those are extra trimounts, dial-cord springs, and knob springs to replace those that still will manage to get away in accordance with Murphy's Law. We're through spending dollars-an-hour time hunting fraction-of-a-cent hardware. Along the same line, I want you to observe and use this little red plastic nut-starter. It is a real time and temper saver. When I think of all the time I've wasted trying to start a nut on an i.f. can spade lug buried down under a nest of wires with fingers that suddenly seem as large and clumsy as bananas, or tried to improvise a nut-starter from a length of solder or a holding-type screwdriver—well, I can really appreciate something like this; but if it is to save time it must be used right in the beginning, not as a last resort. As you can see, the recess in one end can be pressed down over a $\frac{3}{16}$ " nut and that in the other end over a $\frac{1}{4}$ " nut. Either size nut will be held firmly in the end of the slender tube while it is easily started in the most cramped quarters."

"What's the purpose of the big clipboard mounted behind the bench?"

"It's to hold diagrams, step-by-step alignment instructions, or other service literature where it can be easily seen as you work and where it will not be burned with the soldering iron, torn with a sharp chassis corner, soaked and stained in excess contact cleaner, or otherwise mutilated. Not being able to read the value of a component or the number of a trimmer can waste a lot of time. We have a very substantial investment in our service literature, and it behooves us to take care of it."

"This doohicky that looks like a small piece of plywood hinged to the back of the bench is new. What's it supposed to be?"

"Swing it out and you'll see that a

two-turn loop of wire is fastened to the back side. The signal generator output cable connects to those terminals on the top and permits us to radiate a signal from the two-turn coil into the loop antenna of a set on the bench, as is usually specified in the adjustment of r.f. trimmers. In the past we have tried to get by by simply connecting a piece of wire across the output terminals of the signal generator and draping this near the loop antenna of the set. It was always shorting out, falling off, or sagging away from the loop and giving us misleading output indications. It was hard to be sure if the change in output was produced by a trimmer adjustment or by a change in the position or shape of the radiating loop. This coil can be swung so as to give us any degree of coupling to the loop antenna we wish, and it will stay where we put it. What's more, since we'll always be using the same radiating coil, we'll soon learn what constitutes normal receiver response to a given signal generator output and a controlled amount of coupling between the radiating coil and the loop.

"Along that same line," Mac continued, "here's another little item I think will aid in keeping down the blood pressure. It's a simple extension cord for connecting a cabinet-mounted speaker of an a.c.-d.c. receiver to the chassis outside the cabinet. The speaker is mounted in the cabinet in a high percentage of the current printed-circuit sets, and connection to the chassis is usually made through a pair of short, comparatively stiff wires permanently connected to the chassis and fitted with plugs that go into simple jacks mounted on the speaker frame. It is virtually impossible to work on the set out of the cabinet with these wires connected. Even if you do manage to turn on the receiver, you are almost certain to break off one or both wires in moving the chassis about. On the other hand, if you use clip leads to extend the wires, these are forever shorting together or slipping off. As you can see, the 'extension' consists of a couple of lengths of flexible insulated wire soldered to two speaker jacks mounted on a piece of Bakelite. The other ends of the wires terminate in pins to fit the speaker jacks. With this in use, the chassis can be turned every which way, as it often must be in examining, servicing, or aligning, without impairing the connections to the speaker."

"That will come in handy," Barney conceded. "If we like, we can connect those pins to the binding posts of our substitute speaker; but I prefer to use the set speaker when I can. Sometimes it has an intermittent defect that may be overlooked if the substitute speaker is used during the servicing."

"That's my boy!" Mac applauded; "but speaking of 'overlooking,' you missed this new cheater cord coming out of our variable-voltage isolation transformer. It's connected internally across the 'normal' voltage output socket and will carry the voltage

(Continued on page 93)

SUCCESSFUL SERVICEMEN



**SAVE
CUSTOMERS**



**SELL MORE
TUBES**



**MAKE
MORE MONEY**

WITH **B&K**

DYNA-QUIK

DYNAMIC MUTUAL CONDUCTANCE

TUBE AND TRANSISTOR TESTERS

Many thousands of servicemen today insure their professional reputation and make each job more profitable—with B&K testers. Each model is based on actual servicing experience, and combines both speed and accuracy. Each is designed to meet individual servicing needs. Each is a top value, with features that mean more for your money.

Measures true dynamic mutual conductance— not just emission. Makes complete tube test under the actual dynamic operating conditions of the TV set. Tests complete set in minutes. Shows your customer the true tube condition. Sells more tubes right-on-the-spot. Saves costly call-backs. Pays for itself over and over again. It's good business to choose B&K.

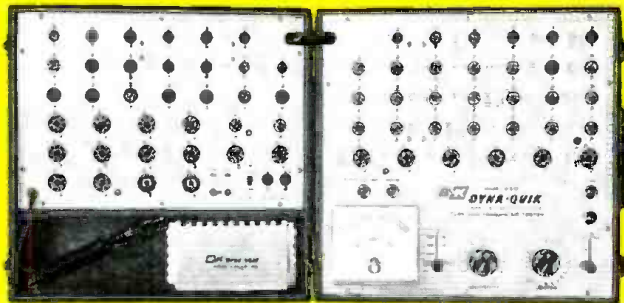

MODEL 650. Fastest and most complete portable Tube and Transistor Tester. Checks over 99% of the tubes most widely used in television receivers. Tests each section of multiple tubes separately for Gm, Shorts, Grid Emission, Gos, and Life. Includes spare sockets and filament voltages for future new tube types. Tests transistors, too. Net, **\$179⁹⁵**



MODEL 675. Completely reliable, long-service Automatic Tube and Transistor Tester. Only 60 indexed phenolic Dyno-Cards test over 99% of tubes most widely used in television receivers. Tests each section of multiple tubes separately for Gm, Shorts, Grid Emission, Gas, and Life. Easily kept up-to-date with extra cards and punch included. Tests transistors, too. Net, **\$169⁹⁵**

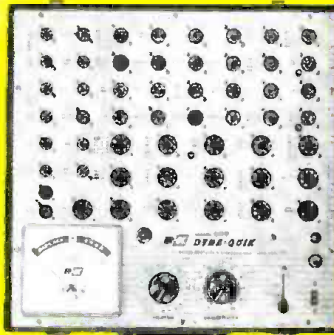

MODEL 550. Low-cost professional model for limited budgets. Provides 52 tube sockets to test more tubes faster, easier. Accurately quick-checks most of the television tubes usually encountered in everyday service work. Tests each section of dual tubes separately for shorts, grid emission, gas content, and leakage. No multiple switching. Big value. Net, **\$119⁹⁵**



See Your B&K Distributor or Send for Bulletin AP15 N

B & K MANUFACTURING CO.
1801 W. BELLE PLAINE AVE • CHICAGO 13, ILL.

Canada: Atlas Radio Corp., 50 Wingold, Toronto 10, Ont. • Export: Empire Exporters, 277 Broadway, New York 7, U.S.A.

DYNACO B&O

Wide-Band Ribbon Microphones

- SMOOTHEST RESPONSE
- PRECISE FIGURE 8 PATTERN
- FOR PROFESSIONAL AND HOME USE

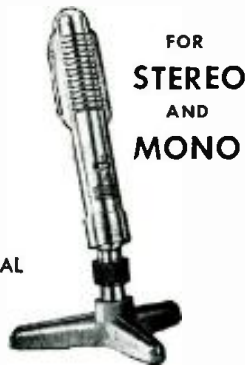

FOR
STEREO
AND
MONO

STEREO SPACER

for consistently superior stereo recordings



Complete Data Available on Request



DYNACO
Super Fidelity
OUTPUT TRANSFORMERS

Advanced pulse techniques and Dynaco's patented para-coupled windings and massive grain-oriented cores insure superior square wave performance and near-perfect transients. All transformers handle full rated power from 20 cps to 20 KC, and are conservatively rated and guaranteed to handle double nominal power from 30 cps to 15 KC.

SPECIFICATIONS

Response: Plus or minus 1 db 6 cps to 60 KC.
Power Curve: Within 1 db 20 cps to 20 KC.
Square Wave Response: No ringing or distortion from 20 cps to 20 KC.
Permissible Feedback: 30 db.

MODELS

A-410	15 watts	EL-84, 6V6, 6AQ5	14.95
A-420	30 watts	5881, EL-34, KT-66	19.95
A-430	60 watts	KT-88, EL-34	29.95
A-440	120 watts	KT-88, 6550	39.95
A-450	120 watts	pp par KT-88, EL-34	39.95
A-470	35 watts	pp par EL-84, EL-34	24.95

(all with tapped primaries except A-440 which has tertiary for screen or cathode feedback)

Write for complete data on Dynaco transformers including suggested circuits and modernization of Williamson-type amplifiers to 50 watts output.

DYNACO INC.

3912 Powelton Ave., Philadelphia 4, Pa.

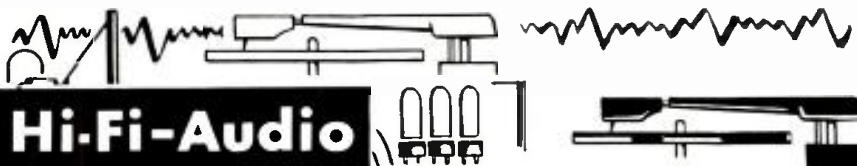

Hi-Fi-Audio

Product Review

FOUR-CHANNEL MIXER

Sigma Electric Co., 11 East 16 St., New York 3, N. Y. has introduced its Model SA3761, a four-channel audio mixer for professional use in recording and broadcasting studios as well as in central sound systems.

The mixer contains four separate single-stage amplifiers, each employing a triode-connected type 5879 tube and

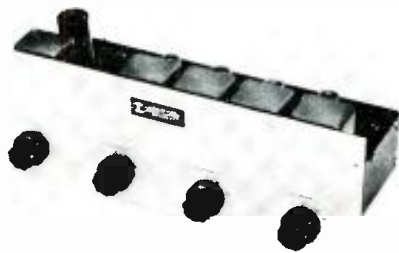

each provided with an individual input transformer. The impedance of each of the four inputs may be adjusted individually to 50, 125, 150, 200, 250, 333, 500, or 600 ohms. The output impedance may be similarly set. The mixer is designed to feed directly into the microphone input of *Ampex* recorder Models 402, 403, and 350, and when used with a special adapter cable, it will work into *Ampex* Models 400, 400A, 401, and 401A.

STEREO CHANGER/PLAYER

Electronic Instrument Co. Inc., 33-00 Northern Blvd., Long Island City 1, N. Y. is now offering a new four-speed automatic record changer/automatic-manual single-record player as the *Eico* Model 1007.

The low-distortion stereo crystal cartridge has been designed integrally with the extra-long tone arm to eliminate mid-range resonances which can sometimes occur when tone arm and cartridge come from different makers.

The unit is supplied with a dual RC

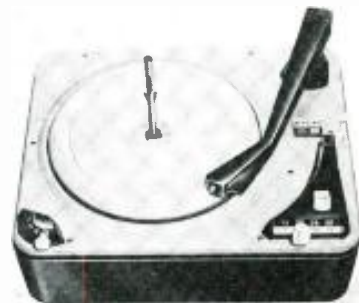

magnetic input adapter. The cartridge snaps in and out of the tone arm without tools and features an instantly replaceable twin stylus. The factory adjusted stylus force is 4.5 grams.

The Model 1007 features a special speed-change and power transmission

mechanism with four individual intermediate compound idlers, one for each speed. In addition, the changer mechanism is controlled by a central precision cam-wheel which eliminates excess linkages and makes for a jam-proof mechanism.

FIDELITONE TAPE HEAD

Fidelitone, Incorporated, 6415 Ravenswood Ave., Chicago 26, Ill. has added a compact, four-track magnetic recording and playback head to its line of audio components.

One of the smallest four-track heads yet developed, it meets all the dimensional requirements of the EIA Standard. The heart of the unit contains two separate channels with a unique solid core. These tapered cores provide a flat response to 15 kc. (with standard compensations) obtainable at 3.75 ips.

The manufacturer will supply complete specifications on this new head upon request.

FM CAR RADIO/CONVERTER

Kinematrix, Inc., 1616 N. Damen Ave., Chicago 47, Ill. has developed a versatile FM radio/converter for auto-



mobiles. Called the "Skylark," the new equipment features a modular concept. The basic tuner serves as a converter, ready to be used by car owners who already have an AM radio installed. The addition of the compact "KX Audio Pak" makes a complete 15-watt FM radio, so that if a new car—without an AM radio—is purchased at a later date, the owner can have an FM system.

The "Skylark" is said to be the slimmest FM car radio available, extending only 2¼-inches below the dashboard. It is reported to work efficiently on existing car antennas. The set features one-knob control placed close to the driver, as well as an edge-lighted FM and logging scale.

TRANSISTORIZED RECORDER

The Electronics Division of the *Morse Sewing Machine Company*, 122 W. 26th St., New York, N. Y. has a 4½-pound transistorized tape recorder on the market, the Model 300.

This unit features a single control for record, rewind, and replay. Designed as an office machine or for vari-

ELECTRONICS WORLD

ous portable applications, this 8½" x 7¼" x 3¾" recorder operates at 3.75 ips speed. The circuit is completely transistorized and uses six transistors and a varistor.

Available accessories include a crystal microphone, crystal earphone, recording tape with 3" reels, a 3" take-up reel, and a telephone adapter. Complete performance specs and price information are available from the manufacturer.

SPEAKER-BAFFLE COMBO

Utah Radio & Electronic Corp., 1124 E. Franklin St., Huntington, Indiana is now marketing a ready-to-use speaker and baffle combination which utilizes its new "Magni-Magic" inverted speaker unit.

The dual-diameter design features

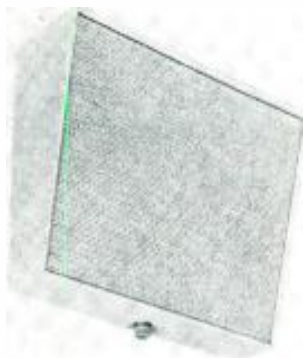

an 8-inch, 8-ohm speaker capable of handling 5 watts and screw terminals that eliminate soldering. In four different series, the speaker-baffle combination is available with (a) speaker-baffle, 70-volt transformer and volume control, (b) speaker-baffle and volume control, (c) speaker and baffle only, and (d) speaker-baffle and transformer only. Completely wired and ready for immediate use, the combination measures 12" wide, 9½" high, and 4" deep at the top and 2¼" at the bottom.

The models are available in mahogany, blonde, and walnut finishes. Complete specifications are available from the manufacturer.

WIDE-RANGE OSCILLATOR

Jackson Electrical Instrument Co., 124 McDonough Street, Dayton, Ohio is now offering a wide-range oscillator that supplies both sine- and square-wave output for checking hi-fi, stereo, and audio amplifier circuits for operation, voltage, gain, and frequency response.



The Model 605 features push-button range selection and continuously variable output power. Frequency range is 20 to 200,000 cps, in four ranges. The square wave is generated by a Schmitt trigger circuit which is actuated by the sine wave.

SELECTIVITY: ±5Kc at points 6db down!

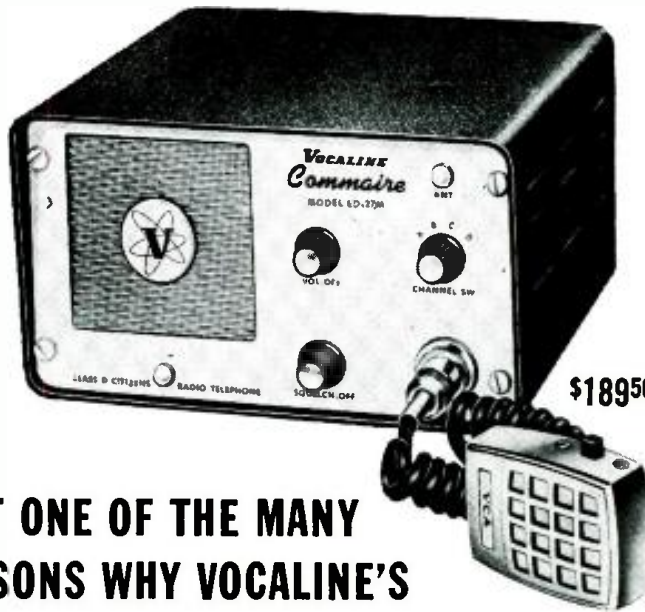

\$189.50 each, list

JUST ONE OF THE MANY REASONS WHY VOCALINE'S NEW COMMAIRE ED-27M IS THE WORLD'S FINEST* MULTI-CHANNEL CITIZENS BAND RADIO!

Only Vocaline, specialist in unique circuitry for defense projects, could produce a remarkable performer like the ED-27M Commaire multi-channel Class D citizens band radio. This brilliantly-engineered unit assures the same uniform output, sensitivity and selectivity over the entire 22 citizens band channels. Selectivity is ±5 kc at points 6 db down, sensitivity: 0.3 mv! Audio output is 4.5 watts. Incorporates Vocaline's exclusive "Silent-Aire" squelch with special noise suppression circuit to assure complete silence in stand-by. The receiver is a double conversion superheterodyne with single crystal. For mobile operation, a transistorized power supply affords dependable, economical operation. Supplied with crystal for one channel (additional crystals can be supplied installed at \$5.00 each), push-to-talk microphone, hanger and universal mount. 2 models: 115 VAC-12 VDC and 115 VAC-6 VDC. *4 CHANNELS

The Commaire ED-27 Single-Channel Citizens Band Radio... in a class by itself:

The single-channel version of the Commaire—proven to be the finest radio in the Class D field. Incorporates the same patented features as the ED-27M. Unequaled for range, signal-to-noise ratio, audio fidelity and dependability. \$179.50 each, list.



Send complete literature to:

Name _____
 Address _____
 City _____ Zone _____ State _____

VOCALINE
 COMPANY OF AMERICA
 165 Couffer Street
 Old Saybrook, Conn.

THE REMARKABLE SONY RADIO WIRELESS MICROPHONE

The convenience and variety of uses for this remarkable instrument are almost beyond the imagination. The Sony CR-4 mike and radio transmitter can be slipped into a coat pocket for completely wireless on-the-street interviewing, studio audience interviewing or on-the-spot broadcasting from awkward places. It gives complete freedom to active singers, dancers, comedians, performers with electric instruments and actors, eliminating the need for cumbersome mike booms and entangling wires.

Microphone, transmitter, receiver and carrying case, \$250. For information or literature, write: Superscope, Inc., Dept. 6, Sun Valley, California.

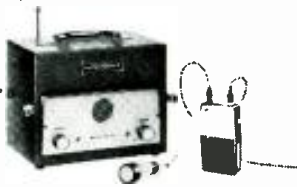

SONY
SUPERSCOPE The Tapeway to Stereo

Accuracy is 3% or 1 cycle, whichever is greater. Output voltage is 0 to 5 volts r.m.s. sine-wave and 20 mv. to 7 plate-to-plate volts square-wave. Output level is ± 1 db over the full range.

The unit measures 11" high, 7 $\frac{7}{8}$ " wide, and 13" deep. It draws 50 watts and will operate from any 50/60-cycle, 110-120-volt power source.

TWO-SPEED TURNTABLE

Ercona Corp., 16 West 46 St., New York 36, N. Y., has introduced a new "Connoisseur" turntable for operation at 33 $\frac{1}{3}$ and 45 rpm speeds. The turn-



table uses a hysteresis synchronous motor. Speed change is accomplished by a double-stepped cone, ground integrally on the motor shaft to assure concentricity. The motor shaft is suspended in graphite nylon bearings and all revolving shafts are precision ground and lapped to a "mirror finish."

According to published performance figures, the rumble factor is down -50 db when referred to 7 cm./sec. at 1 kc. Wow is stated to be .15%; flutter, 0.1%. Hum level is down to -80 db. The turntable itself is 12 inches in diameter and lathe-turned of anti-magnetic non-ferrous metal.

TRANSISTORIZED MIXER

Westrex Corporation, Recording Equipment Department, 6601 Romaine St., Hollywood, Calif. has introduced a completely transistorized mixer for audio recording.

The Type RA-1627 mixer accepts up to eight inputs at a nominal level of -5



dbm and provides a single channel of equalized output in the range of -20 to +16 dbm. Input and output connections are made through a terminal strip on the front. A jack field is provided to facilitate special circuit configurations.

Modular construction makes possible configurations to meet any need in disc recording, radio, television, p.a., or motion pictures. Response is flat within ± 0.5 db from 40 to 12,000 cps.

Built for table mounting, the mixer is housed in a hardwood cabinet which measures 13" x 16 $\frac{1}{2}$ " x 40 $\frac{1}{2}$ ". Access to all electronic modules is from the front for easy servicing.

NEW VU METER

Robins Industries Corporation, Flushing, N. Y. has added the Model VU-100 vu meter to its line of audio accessories.

The meter measures 4 $\frac{1}{2}$ inches and has a two-color scale; modulation calibrations from 0 to 100% are provided with vu calibrations from -20 to +3. The instrument provides dual impedance inputs for use with high- or low-impedance circuits. Sensitivity of the basic movement is 200 μ a. The meter mounts in a 2 $\frac{3}{4}$ " diameter hole and extends to a depth of 1 $\frac{1}{2}$ " inches.

"MUSI-KAR" TUNER

Trans-Pacific Electronics Inc., 4216 Lankershim Blvd., North Hollywood, California has developed and is marketing a new FM tuner for cars which has been tradenamed "Musi-Kar."

The unit is a true tuner, not a converter, and merely uses the audio stage of the car radio, the tuner output being cut into the volume control of the auto set. The tuner provides full 86.5 to 109.5 mc. coverage. Sensitivity is 1.5



μ v. (antenna loaded) with quieting sensitivity of 2.5 μ v. for 20 db quieting at 98 mc. The standard 50- to 72-ohm car-type antenna is used with the tuner. The circuit employs six tubes and a power transistor.

Dimensions of the tuner are 8 $\frac{3}{4}$ " x 3 $\frac{1}{2}$ " x 5". Complete details are available from the manufacturer on request.

REMOTE SPEAKER SWITCH

Centralab, 900 E. Keefe Ave., Milwaukee 1, Wis. has added a stereo remote speaker switch to its line of electronic controls.

The Model 1486 enables switching from the "main pair" of stereo speakers to a remote pair of stereo speakers as well as permitting operation of all four speakers simultaneously.

The switch is 1 $\frac{1}{32}$ " high and 1 $\frac{3}{64}$ " wide. The $\frac{1}{4}$ " diameter shaft measures 1 $\frac{1}{2}$ " from the bushing with $\frac{1}{2}$ " split knurl. It is supplied with a black and chrome push-on knob and complete installation instructions. This new item is now available at all of the company's distributors.

NEW ESL CARTRIDGES

Electro-Sonic Laboratories, Inc., 35-34 36th St., Long Island City 6, N. Y. has introduced two new stereo cartridges. Model ESL-C99 fits any stand-

ELECTRONICS WORLD

ard changer or arm. Model ESL-P99 "Micro/Flex" is designed for use only with the ESL-S310 professional series arm. Both cartridges have otherwise



similar characteristics. Each uses patented d'Arsonval elements, said to be inherently linear. These elements are coupled to the new "micro-flex" frictionless stereo separating system.

Specifications, listed by the manufacturer, are: vertical compliance, 5×10^{-5} cm./dyne; lateral compliance, the same; dynamic mass, .0025 gram; output per channel, 1 mv. at 10 cm./sec.; channel separation, 20 to 25 db.; frequency response, with *Elektra* 35 test record, ± 2 db, 18 to 20,000 cps.

AUDIO CATALOGUES

DATA FOR AUDIO BUILDERS

Telectrosonic Corporation, 35-18 37th Street, Long Island City, N. Y. has published a colorful and informative brochure showing how hi-fi fans can start modestly and build up a complete stereophonic tape system.

The brochure features the company's Series 900 of "building block" stereo tape decks and related preamplifiers. Through text and diagram, the booklet shows how to start with a "playback only" unit and eventually wind up with an integrated record-play, four-track stereo system.

HI-FI/STEREO EQUIPMENT

Kierulff Sound Corporation has just published a new catalogue covering high-fidelity and stereo equipment.

The 84-page booklet contains product and price information on a wide variety of audio equipment and accessories. Copies are available from any of the company's six locations in downtown Los Angeles, West Los Angeles, Riverside, Long Beach, Studio City, and Orange, California.

NEEDLE REFERENCE GUIDE

Recoton Corp., 52-35 Barnet Ave., Long Island City 4, N. Y. has announced publication of its 9th annual "Simplified Replacement Needle Reference Guide".

This easy-to-read, all-inclusive guide now includes a phonograph manufacturers' index, both monophonic and stereo, and a convenient cross-reference guide. Also included on the cover page is a spot check listing from needle to cartridge manufacturer and *vice versa*.

—50—

September, 1960

the ultimate in
a dynamically-
balanced
tonearm
NEW

REK-O-KUT *Micropoise*TM STEREO TONEARM

with superb new features for higher playback quality and installation ease:

Model S-220
12" arm

\$29.95
net

MICROPOISE DYNAMIC BALANCE CONTROL—By dialing the cushioned, spring-tension Microscope Balance Control, the arm is dynamically balanced and set for accurate stylus pressure:

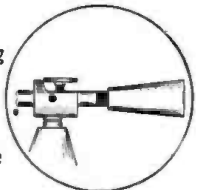

PERMANENTLY ATTACHED PLUG-IN CABLE—fully shielded single-jacket cable is anchored to the arm—includes two color-coded plug-in leads, 2 shields and a ground wire. No soldering! No hum problem! Fast, correct installation assured!

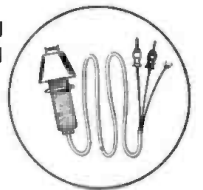

FAST SINGLE-HOLE MOUNTING: Arm base mounts through single hole by tightening of single locknut.

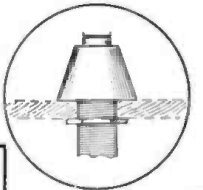

Revolutionary automatic control accommodating the S-220 will soon be announced!

PLUS THESE EXTRA FEATURES...

- Acoustically isolated counterweight.
- Exclusive precision low friction Silicone damped horizontal bearing — eliminates horizontal oscillation.
- Exclusive gimbal assembly incorporates individual double sets of 5 ball, 1 mm. bearings — provides freest lateral and vertical motion and assures perfect tracking.
- Plus many other exclusive Rek-O-Kut features.
Model S-260...16" arm.....34.95 net
Extra Stereo Shell—
Model PS-20L..... 5.95
Still available—
Model S-120. 12" arm..Now 24.95 Net
Model S-160. 16" arm..Now 27.95 net



Rek-O-Kut Company, Inc., Dept. EW 9
38-19 108th St., Corona 68, N. Y.

Please send me free brochure:

Name _____
Address _____
City _____ Zone _____ State _____

Export: Morhan Exporting Corp. 458 Broadway, N. Y. 13.
Canada: Atlas Radio, 50 Wingold Ave., Toronto 19.

YOUR NEEDLE IS DISTORTING SOUND BY AS MUCH AS 85% (if it isn't a Fidelitone Pyramid Diamond)

A conventional needle with a rounded ball tip can't fit the microgroove accurately. Its rounded shape prevents proper contact in the high tonal passages. Result? Distortion and noise.

But, Fidelitone's new Pyramid Diamond is shaped like the original cutting stylus to fit the record groove exactly. It maintains proper contact in all frequency areas. This lowers background noise and distortion by as much as 85%, and reproduces only maximum true sound — stereo or monaural.

HERE'S WHY...



Fidelitone's new Pyramid Diamond is shaped similar to the stylus that recorded the original sound. It perfectly follows every contour created by the recording stylus.



In an unmodulated, or low frequency groove, the recording stylus (A) cuts a groove (W-1) wide enough to let an ordinary ball point needle (C) and the Fidelitone Pyramid Diamond (B) track the centerline of the groove accurately, and contact all recorded sound impressions.

As the groove is modulated by high tones, the groove width (W-2) cut by the recording stylus (A-1) narrows. This causes the ordinary ball needle (C-1) to rise and "pinch out" of the record groove. It bridges modulation crests, mistracks centerline and distorts sound impressions. The Pyramid Diamond (B-1), because of its new shape, stays solidly in the record groove, smoothly glides along the centerline positively driven by the groove walls.

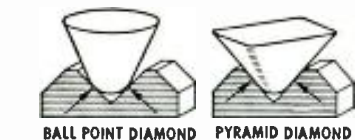

And the new shape of the Pyramid Diamond allows more surface contact between needle and record, substantially reducing contact pressure. This greatly increases needle and record life.

See your record dealer or hi-fi specialist today. Demand the Fidelitone Pyramid Point. You owe it to your records and your listening pleasure.

For the complete story on the revolutionary new Pyramid Diamond, or the name of your nearest dealer, write Fidelitone, Chicago 26, Illinois.

Fidelitone

"Newest shape on records"

The Proper Microphone

(Continued from page 38)

phone for your particular application consists of selecting the proper pickup or polar pattern, either omnidirectional or directional. Each type of microphone, irrespective of the generating element, has its own pickup characteristics. In the case of directional microphones, these characteristics are designed for a specific purpose.

It is not always easy to tell from the microphone's appearance what its directivity is. For example, a generating element mounted in a case with an open grille in front but closed in the back may be an omnidirectional (also called non-directional) microphone. Its looks are misleading since it would appear to pick up sound only from the front through the open grille. But sound waves from the back and sides of the case will produce as much output in some microphone types as does sound from the front. There are also microphones available whose directivity pattern can be changed from omnidirectional to directional by simply turning a screw.

Omnidirectional microphones (Fig. 7A) can be built with nearly any type of generating element. These microphones are available from the lowest to the highest price classes. The more expensive types represent the highest quality and most uniform response available in today's microphones.

These pickup characteristics, however, limit the applications in which the omnidirectional type can be used. If used under poor acoustical conditions, these microphones will pick up undesirable noise, echo, and reverberation. These, in public-address applications, will cause feedback or acoustic howl as the microphones pick up, and the speakers reproduce, the same echo over and over again. But for some types of studio use, general nonstereo recording in the home, or under favorable acoustic conditions, omnidirectional microphones, particularly the better quality dynamic types, are unsurpassed.

The ribbon microphone provided the first "control" of sound pickup. Its main pickup areas are from the front and back of the microphone along a line at right angles to the surface of the ribbon itself. It attenuates sounds arriving from either side, or from above or below the microphone. This attenuation helps to eliminate feedback and other undesirable noise by proper positioning of the microphone. Fig. 7B shows the two-way directivity (bidirectional) characteristic of the ribbon microphone. Although this type of response is unique with the ribbon, it is possible to eliminate the back lobe of response entirely and produce a unidirectional pattern.

Unidirectional microphones, with a heart-shaped or cardioid polar pattern, provide greatly improved control of sound pickup and, even for the novice, are quite easy to use. These highly

versatile microphones pick up sound across approximately 45° to either side of the front axis and attenuate sounds arriving from the sides and back. The farther off-axis the source of sound is beyond 45°, the greater the attenuation, until at the back of the microphone there is almost no pickup at all, as shown in Fig. 8A. This means that one need merely aim the microphone at the person or group being recorded, keeping the back of the microphone positioned toward any source of echo, crowd, or other interfering noise. Whether the application is public address or recording, the elimination of this unwanted noise is a prime necessity. If the 90° acceptance angle (45° each side of the front axis) across the front of the cardioid microphone is too narrow, the microphone need merely be moved back until the entire group is within that angle. In the case of large choirs or orchestras, an additional microphone or two should be used.

It should be remembered that while an omnidirectional microphone is used only under good acoustical conditions, the cardioid is not limited to just poor conditions but can be used to advantage under either. Professional cardioid models are among the finest directional microphones available, although it is possible to obtain less expensive cardioid types. Practically any of the generating elements previously described can be used in the cardioid microphone.

An even greater control of sound pickup is produced by a new type "line" microphone. With this type, a short length of tubing or transmission line, a foot or more long with openings along its length, is arranged in front of the generating element. This type, as with the cardioid, picks up sound across an angle of about 45° each side of the front axis of the microphone. However, at the sides as well as the back, arriving sounds are virtually cancelled. With this greater control, the microphones can be moved back much farther from the source of sound than even the cardioid and normal pickup maintained. This makes the line microphone especially useful on stage pickups or any application where the microphone cannot be used close to the performer or other source of sound.

The one remaining type is perhaps much more specialized but is highly useful where there is a high level of surrounding noise. Such conditions are found in industrial plants, at sporting events, and on emergency work. Microphones of the differential or noise-cancelling type and built with a carbon or a dynamic element are employed here.

The case of the differential microphone has two openings, one leading to the front and one to the back of the diaphragm. When used very close to the lips, the sound pressure on the front of the diaphragm is much greater than on the back since the sound must travel quite a bit farther to reach the back of the diaphragm. Under these conditions, the microphone operates

normally. However, sounds originating more than 3 inches from the microphone have about the same distance to travel to the front and back of the diaphragm. As a result, cancellation occurs. Even extremely loud sounds, such as jet engine noise and gunfire, are cancelled. Applications for this microphone are quite obvious.

Quality of Performance

The one remaining choice to be made is the quality of performance desired. This will depend on many things, including the amount that one wants to pay for the microphone. The owner of a low-cost tape recorder may desire professional results. He may never quite achieve them, but the use of a better microphone than that furnished with the recorder, the application of the principles covered above, careful placement, and some patience, will, in many cases, produce substantial improvements.

Quite naturally, the owner of a *Cadillac* will not fuel it with kerosene. Nor should the owner of professional equipment, whether it be a tape recorder or a public-address installation in a cathedral, suddenly become economy minded in choosing microphones for his use. They represent a long-term investment and one of the few variables where great improvement in performance can be obtained.

Most medium-priced tape recorders will produce dramatic improvements in recordings when at least a medium-priced microphone, properly chosen, is added. Public-address installations need not be expensive to produce fine quality, but they must include the proper microphone.

The simple principles of choosing the proper generating element, pickup pattern, and desired quality will not only assure the best value but can provide much satisfaction in the final results obtained.

-30-

SUBSTITUTE GRILLE CLOTH

By GLEN F. STILLWELL

IF YOU need a small piece of grille cloth and the genuine article is not available, try using a piece of burlap bag. This isn't as silly as it sounds because even the coarsest and cheapest material can be made presentable by spraying it with a coat or two of aluminum or gold paint. If only a very small piece is required, it may be dipped into the paint, then hung out to dry. In this way, soiled grille cloth may be renovated to look like new.

-30-

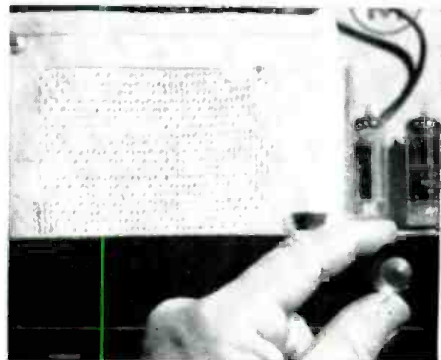

September 1960



CROWN
Professional Tape Recorder

CROWN INTERNATIONAL
Proudly Presents the

SUPRA "PROFESSIONAL" RECORDER

"800" Series



CROWN "X" CONTROL
(All Electric)

- MICRO QUEING
- THIRD HEAD MONITOR
- PHOTO-CELL AUTOMATIC STOP
- FULL REMOTE CONTROL
- STANDARD RACK MOUNT

RECORD PERFORMANCE

4T FREQUENCY RESPONSE	IPS SPEED	FLUTTER & WOW	NOISE RATIO
=2 db 30-30,000 CPS	15	.06%	58 db
=2 db 20-22,000 CPS	7 1/2	.09%	55 db
=3 db 30-15,000 CPS	3 3/4	.18%	51 db

The SUPRA Professional excels practically all "Professional Standards" of ALL other recorders. For information write Box 261, Elkhart, Indiana, or phone Jackson 2-8583.

Debut at September
New York — Chicago
Hi-Fi Shows

CROWN INTERNATIONAL
Division of
INTERNATIONAL RADIO & ELECTRONICS CORP.
ELKHART, INDIANA

PURCHASING A HI-FI SYSTEM?

Send Us
Your
List of
Components
For A
Package
Quotation

WE WON'T BE
UNDERSOLD!

All merchandise is
brand new, factory
fresh & guaranteed.

AIREX RADIO

CORPORATION
64-R Cortlandt St., N. Y. 7, CO 7-2137

PARTIAL LIST OF BRANDS IN STOCK

Jim Lansing*
Alec Lansing
Electrovoice
Jensen • KLH Spkrs*
Harley • Stephens
University
Acoustic Research
Janzen
Wharfedale
Karlson Cabinets
Viking • Hallcrafters
Concertone
Bell • G.E.
Weathers
Harman—Kardon
Eico • Pilot
Sherwood*
Acrosound
Quad Ampl-Spkrs*
Dual Changer
Bogen • Leak
Dynakit • Fisher
H. H. Scott
Uher Recorder
Thorens*
Pentron • Revere
Amplex • DeWald
Sony • Roberts
Challenger
Wollensak
Garrard • Norelco
Miracord
Glaser-Steers
Rek-O-Kut
Components
Tandberg*
Fairchild
Pickering • Gray
Audio Tape
Magnecord*
Rockford Cabinets
Artizan Cabinets
*Fair Traded

TUNE ELECTRONIC ORGANS ACCURATELY—QUICKLY WITH A NEW

Schober AUTOTUNER

Every organ owner and service technician requires this valuable aid to precision organ tuning. This instrument enables anyone to quickly tune any electronic-oscillator organ (except Thomas) without previous knowledge or skill.

An automatic stroboscopic indicator visually shows true pitch to an accuracy of 1/100 of a semitone (more accurate than human hearing), yet you pay about 1/3 the price of other tuning devices of similar precision.

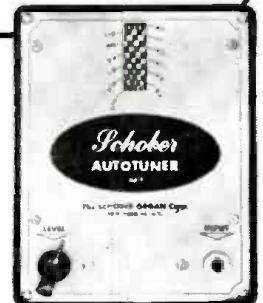

Black plastic case with etched satin aluminum front panel. So lightweight it may be carried in your pocket. Size 6 1/4" x 5 1/4" x 2 1/4". Detailed instructions included.

\$6950

(completely assembled)

\$4950 (in assemble-it-yourself kit)

(N.Y.C. Residents add 3% Sales Tax)

MAIL ORDERS FILLED PROMPTLY • FULLY GUARANTEED
THE SCHOBER ORGAN CORPORATION, Dept. NR7
43 West 61st Street, New York 23, N. Y.
Manufacturers of the World-Famous Schober Organ Kits.

HEATH
PRESENTS
18
NEW
ITEMS
your for
summertime
enjoyment

DAY a subsidiary of
DAYSTROM, INCORPORATED



"ECONOMY" STEREO AM/FM TUNER KIT (AJ-10)

Full fidelity AM and FM reception, plus up-to-the-minute design features are yours at minimum cost with this new Heathkit stereo tuner. Features include: 2.5uv sensitivity for 20 db quieting; individual flywheel tuning; separate magic-eye tuning indicators for AM and FM; AM bandwidth switch; 3-position (off-half-full) automatic frequency control (AFC); FM multiplex adapter output. 14 lbs.

AJ-10 **\$59⁹⁵**

\$6.00 dn., \$6.00 mo.

HI-FI RATED 25/25 WATT STEREO AMPLIFIER (AA-50)

In one handsome package, you get both stereo power and control, with a host of deluxe features. Hi-fi rated at 25 watts per stereo channel (50 watts mono), this new Heathkit design includes channel separation control; new mixed center speaker output; stereo reverse and balance controls; separate tone controls for each channel with ganged volume controls; five switch-selected inputs for each channel (stereo "mag. phono," tape head, 3 hi-level). Extra input for mono "mag. phono." Special outputs for tape recording. Ease of assembly assured by two circuit boards. 30 lbs.

AA-50 **\$79⁹⁵**

\$8.00 dn., \$8.00 mo.

**MIXED LOWS
STEREO CROSSOVER KIT (AN-10)**

Permits using one bass woofer and more economical "wing" speakers for stereo. Delivers non-directional bass of both channels below 250 cps to one woofer; passes higher frequencies to wing speaker. Takes 25 watts per channel; 8, 16 ohm woofers; 8 ohm high freq. speakers. 10 lbs.

AN-10 **\$19⁹⁵**

**Player Kit by Heath—
Mechanism by Garrard**

**MANUAL
STEREO RECORD PLAYER KIT (AD-10)**

Rubber matted heavy turntable is shock mounted, and idler wheels retract to prevent flat spots. 4-pole motor; 16, 33 $\frac{1}{3}$, 45 and 78 RPM; Sonatone 8TA 4-SD ceramic stereo turnover cartridge with diamond and sapphire styli; preassembled mechanism and base. 10 lbs.

AD-10 **\$33⁹⁵**



Quality Stereo at Minimum Cost

ECONOMY STEREO PREAMPLIFIER KIT (AA-20)

A low-cost, versatile stereo preamp-control center. Four inputs each channel accept magnetic cartridge, crystal or ceramic cartridge, and tuner, tape, TV, etc. Six position function switch gives flexible stereo or monophonic use. Features cathode-follower outputs plus hi-level outputs for tape recorder drive, calibrated Baxandall-type tone controls for each channel, clutch-type volume controls, filament balance controls, and accessory AC sockets. Self-powered. Styled in black and gold. 8 lbs.

AA-20 **\$34⁹⁵**

PROFESSIONAL RATED 35/35 WATT BASIC AMPLIFIER KIT (AA-40)

Doubles as a superb dual 35 watt stereo amplifier or a full-fledged 70 watt monophonic amplifier. Features a mixed-channels center speaker output for fill-in sound, and individual level controls for stereo. "Stereo-Mono" switch ties both amplifiers to one level control for monophonic use. Dual outputs for 4, 8, 16, and 32 ohm speakers. Paralleling outputs for 70 watt monophonic use matches 2, 4, 8, and 16 ohm speakers. 41 lbs.

AA-40 **\$79⁹⁵**
\$8.00 dn., \$8.00 mo.

HI-FI RATED 14/14 WATT BASIC STEREO AMPLIFIER KIT (AA-30) (not illustrated)

14 watts per channel, separate level controls, local/remote power switch, circuit board. Styled like AA-40 above. 21 lbs.

AA-30 **\$45⁹⁵**

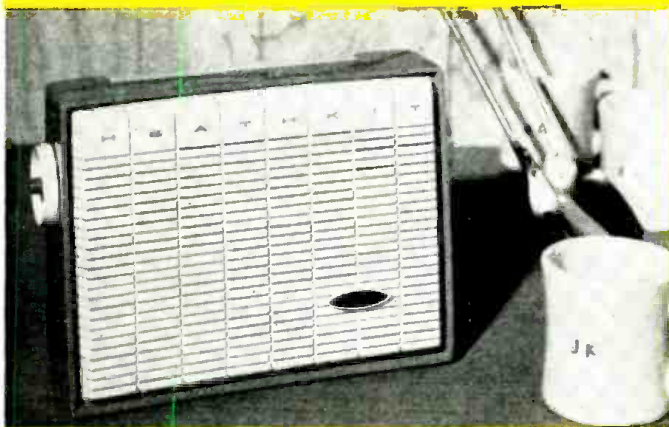

MOBILE PA SOUND EQUIPMENT

Perfect for political campaigns, advertising, sporting events... hundreds of PA applications. The 10 watt amplifier operates from any 12 to 15 volt battery. Features an all-transistor circuit for rugged, dependable performance and long life. No warm-up time required. Mounts easily under auto dash. Inputs for microphone and music source. Two channel mixing circuit "fades" auxiliary input when used with microphone supplied... lets you override music with voice without changing control settings. Outputs for 8 and 16 ohm speakers.

MOBILE PA AMPLIFIER KIT (AA-80) 7 lbs. **\$39.95**

COMMERCIAL SOUND SYSTEM (CSS-1) consists of AA-80 Amplifier, microphone, car-top carrier, one 16 ohm, 15 watt outdoor speaker. 19 lbs. **\$84.95**

COMMERCIAL SOUND SYSTEM (CSS-2) same as above except with 2 speakers. 25 lbs. **\$99.95**

EXTRA HORN SPEAKERS (401-38): As described above. 6 lbs. **\$19.95**

Perfect for Summer Sun and Fun!
6-TRANSISTOR PORTABLE RADIO KITS (XR-2 Series)
Assembled in only a few hours, both of these models incorporate superior design features that will give you portable-listening enjoyment day after day. Vernier tuning control gives smooth, easily-separated station tuning. Large 4" x 6" PM speaker with heavy magnet provides "big set" richness of tone. Operates on standard size "D" flashlight batteries. Six Texas Instrument transistors.

XR-2P (plastic) 6 lbs. **\$29⁹⁵**

XR-2L (simulated leather) 7 lbs. **\$34.95**

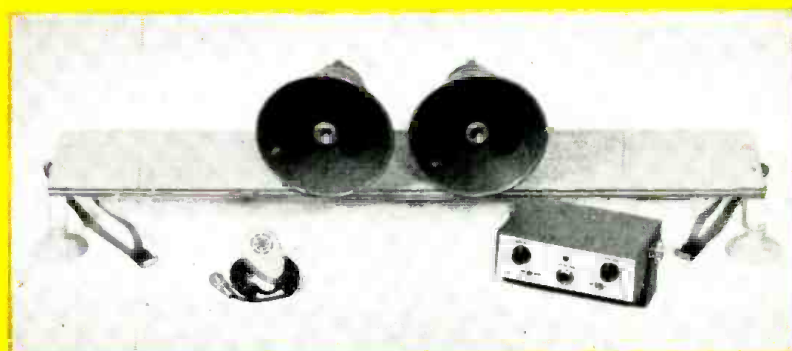

FREE CATALOG

Send for your free Heathkit catalog today... describes over 150 hi-fi, ham, test, marine, and general kits.



NEW! Citizens Band Transceiver...

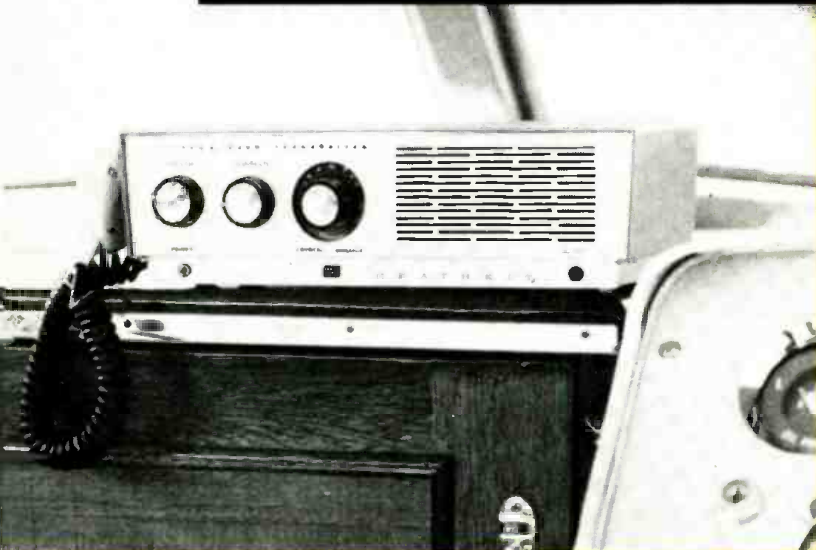

CITIZENS BAND TRANSCEIVER KIT (GW-10)

Now, from Heath, a new 2-way Citizens Band Transceiver with every modern improvement for clear, noise-free operation. The superheterodyne receiver section may be either crystal controlled on any one predetermined channel, or all 23 channels may be continuously tuned by the front panel tuning knob; a front panel switch selects either crystal or variable control. An automatic "series gate" noise limiter minimizes impulse-type noises (ignition interference, etc.). Adjustable squelch control silences the receiver during "stand-by." Press-to-talk microphone features a coil-core connection to the transceiver. Transmitter is crystal controlled on any one of 23 assigned channel frequencies chosen. Order model GW-10A for 117v AC operation; order GW-10D for 6 and 12v DC operation, both with self-contained power supply. 11 lbs.

GW-10A or GW-10D **\$62⁹⁵** each

\$6.30 dn., \$6.00 mo.



3 band "Mariner" TRANSISTOR DIRECTION FINDER KIT (DF-3)

Features nine-transistor circuit, flashlight battery power supply, pre-assembled, pre-aligned tuning section, three bands (beacon-aeronautical, broadcast and marine-telephone), and a new "sense" antenna system that eliminates 180° ambiguity in bearings. Splash resistant. 13 lbs.

DF-3 **\$99⁹⁵**

\$10.00 dn., \$9.00 mo.



For Boating, Fishing, Skindiving

TRANSISTOR DEPTH SOUNDER KIT (DS-1)

Completely transistorized. Indicates depth, type of bottom, and submerged objects, from 0 to 100 feet. Powered by 6 flashlight batteries for complete portability. Transducer included may be mounted through hull, or temporarily outboard. Rugged, splash-resistant cabinet. Adjustable mounting bracket. 10 lbs.

DS-1 **\$69⁹⁵**

\$7.00 dn., \$7.00 mo.



Ten-transistor "Mohican"

GENERAL COVERAGE RECEIVER KIT (GC-1)

First kit of its kind to use ceramic IF "Transfilters." Covers 550 to 30 mc on 5 bands, with 5 separately calibrated bands to cover amateur frequencies (including 11 meter citizens band). Powered by 8 flashlight batteries. Built-in 54" whip antenna, tuning meter, headphone jack. 20 lbs.

GC-1 **\$109⁹⁵**

(Less Batteries)

\$11.00 dn., \$10.00 mo.

First of a Series

EDUCATIONAL KIT (EK-1)

Teaches, as you build, the basic "yardsticks" of electronics... opens up fascinating areas of study for youngsters and adults alike. The combination kit and text-workbook gives you a practical demonstration of the principles of voltage, current and resistance, the theory and construction of direct current series and parallel circuits, voltmeter, ammeter and ohmmeter circuits and the application of ohms law to these circuits. The completed meter is used to verify ohms law and the maximum power transfer theorem, one of the most important theorems in electronics. The finished kit, a practical volt-ohm-milliammeter, may be used in a variety of applications. Procedures for checking home appliances and automobile circuits included with the kit. The EK-1 will serve as a prerequisite to following Heathkit Educational kits; get started NOW in this "learn-by-doing" series. 4 lbs.

EK-1 **\$19⁹⁵**



Outstanding Professional Quality...

**MUTUAL CONDUCTANCE
TUBE TESTER KIT (TT-1)**

An impressive list of electronic and mechanical features make this tube tester one of the finest values in the electronics industry. Test Gm (amplifiers) from 0 to 24,000 micromhos. Emission, Leakage, Grid Current (1/4 microampere sensitivity), Voltage Regulators (built-in variable DC power supply), low power Thyatron and Eye tubes. Features 300, 450 and 600 ma constant current heater supplies. Life test, Hybrid tube test, built-in switch-operated calibration circuit. Large, easy-to-read meter. Constant tension, free rolling illuminated chart. Kit includes 7 wiring harnesses. Assembly skill of technician or higher recommended; assembly time, 40 hours average. Black leatherette case with white trim, nylon feet, removable top. A specialized tool of unusual value that will pay for itself many times over. 27 lbs.

TT-1 **\$134⁹⁵**

\$13.50 dn., \$12.00 mo.



**New Improved Design
TRANSISTOR MOBILE
POWER SUPPLY (HP-10)**

All transistor circuit! Operates from 11 to 15VDC input; at 12VDC provides 600 VDC @ 200ma. or 600VDC @ 150ma & 300VDC @ 100ma simultaneously, at 120 watts. Negative 125V @ 30 ma also provided. Max. ambient temp. 150° @ 120 watts ICAS. Input required: 2 amps idling; 13 amps full output. Includes heavy filtering, remote relay primary control, silicon rectifiers, aluminum heat sinks. 10 lbs.

HP-10 **\$44⁹⁵**



**NEW Six and Ten Meter
TRANSCIVER KITS
(HW-19 and HW-29)**

Combination crystal controlled transmitters and variable tuned receivers operating fixed or mobile on the 6 and 10 meter amateur bands (50-54 mc for HW-29 and 28-29.7 mc for HW-19). Superregenerative receiver pulls in signals of 1 microvolt; transmitter input approximately 5 watts. Built-in 117 VAC power supply, metering jack, press-to-talk switch. 10 lbs.

HW-19 (10 meters) **\$39⁹⁵**
HW-29 (6 meters) **ea.**

Less crystal



**send today for Your
FREE HEATHKIT® CATALOG**

Over 150 items of hi-fi, marine, amateur, test and general equipment are illustrated and described in the complete Heathkit catalog.



**Heathkit® gives you more
in these 10 ways**

1. BUILDING A HEATHKIT IS EASY—Check-by-step instruction manuals make it virtually impossible for you to fail.
2. BUILDING A HEATHKIT IS QUICK—No complicated, technical jargon for you to decipher; at most, a Heathkit takes only a few evenings to assemble.
3. BUILDING A HEATHKIT IS ECONOMICAL—Mass production and purchasing economies are passed directly along to you, our customers.
4. BUILDING A HEATHKIT IS EDUCATIONAL—As you build, you learn . . . more about electronics, more about the component units and when and where to add them.
5. BUILDING A HEATHKIT IS FUN—Nothing quite equals the sense of achievement you receive when you successfully complete a Heathkit unit and "tune-in" for the first time.
6. YOUR HEATHKIT IS GUARANTEED—Every Heathkit unit is guaranteed to meet advertised performance specifications . . . or your money will be cheerfully refunded.
7. YOUR HEATHKIT IS AVAILABLE ON CONVENIENT CREDIT—Our time payment plan makes it possible for you to order now . . . pay later.
8. YOUR HEATHKIT IS TOPS IN QUALITY—The very finest in electronic equipment comes to you in kit form from the Heath Company.
9. HEATHKIT DEALERS CAN SERVE YOU LOCALLY—Carefully selected Heathkit representatives are available in many localities. The convenience of local Heathkit sales and service costs but a few dollars more.
10. HEATHKIT SERVICE IS CUSTOMER SERVICE—Our staff of technical experts is always ready to answer your questions or help you if you have any difficulty.

A



ORDERING INSTRUCTIONS

Fill out the order blank below. Include charges for parcel post according to weights shown. Express orders shipped delivery charges collect. All prices F.O.B. Benton Harbor, Mich. A 20% deposit is required on all C.O.D. orders. Prices subject to change without notice.

a subsidiary of
DAYSTROM, INCORPORATED

HEATH COMPANY, Benton Harbor 15, Michigan

Please send the following HEATHKITS:

ITEM	MODEL NO.	PRICE

Ship via () Parcel Post () Express () COD () Best Way

() SEND MY FREE COPY OF YOUR COMPLETE CATALOG

Name _____

Address _____

City _____ Zone _____ State _____

Dealer and export prices slightly higher.

Double Power

IN ALL DIRECTIONS . . .

WITH THE **Hy-gain**

**Colinear Ground Plane
FOR
Citizens Band**

**3.4 DB
OMNIDIRECTIONAL**

Model CLR,
\$49.95 List

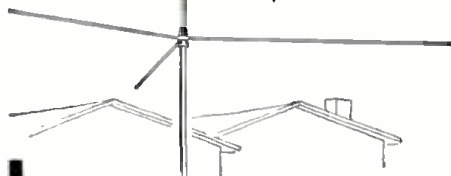

Unlike multi-element beam antennas which concentrate energy in one or more directions at a sacrifice in power in other directions, the Hy-Gain Colinear Half Wave Length Ground Plane achieves gain through colinear action which concentrates more power at lower angles to the horizon . . . performing equally well receiving or transmitting. Exclusive Hy-Gain design, precision tuned and matched for 52 ohm coax cable, conforms to legal limitations, overall height 18 ft., built to heavy duty commercial specs, radiator 1-1/4" OD to 3/4" OD heavy wall heat treated aluminum tubing, radials 9 ft. long of 5/8" OD aluminum tubing. Cycloc plastic base insulator . . . accepts masts to 1-5/8". Complete with matching stub.

Investigate the **Hy-gain**

COMPLETE CITIZENS BAND LINE

including

**BEAMS
GROUND PLANES
AND ANTENNAS
FOR MOBILE,
CLOSE RANGE
AND
PORTABLE USE**

**NEW, FREE
CATALOG AVAILABLE**

**SEE YOUR NEAREST JOBBER
OR WRITE TO**

Hy-gain
antenna products

1135 No. 22nd St.

Lincoln, Nebr.

A Vibrator "Washer"

By

FRANK DE BRA

A handy "conditioner" for service shops handling automotive, two-way mobile, or marine radio work.

SOMETIMES a new vibrator just won't start, as you fellows who do any automobile radio and other mobile work already know. Or, if it does start, it doesn't produce the voltage it should.

The reason for this is that the contact points become oxidized while the vibrator is lying around on the shelf waiting to be put into service. This oxidation does not hurt the vibrator, it just keeps it from operating.

Nearly every technician has, at one time or another, resorted to the use of a lamp in series with the 117 volts a.c. to get a vibrator started. While this "gimmick" works, after a fashion, it is not really satisfactory since it is capable of getting the technician "all shook up" if he is careless and gets himself instead of the vibrator across the 117!

To get a new vibrator to vibrate satisfactorily, it is necessary to burn the oxidation off all the contact points, not just the pull and interrupter. In our shop we built a "vibrator washer." Each new vibrator goes through the washer and gets all its contact points thoroughly "washed" before it goes into service.

The diagram (Fig. 1A) shows how our unit is made. Our business is marine electronics and we handle 6-, 12-, 24-, and 32-volt vibrators, synchronous and non-synchronous. Other versions for other types of service work are shown in Figs. 1B and 1C. Our washer has proved itself capable of handling 95% of our vibrator types. The various vibrator sockets and the lamp socket are mounted in a "Minibox". No fuse is necessary because a short merely lights the lamp.

If this particular model doesn't suit your needs, it is a simple matter to redesign it. See Figs. 1B and 1C.

First, make a list of the various types of vibrators you will want to "wash." Vibrators with the same base are not necessarily the same inside, so refer to a vibrator guide to determine the number of different sockets or differently wired sockets you will need. Then, still referring to the guide, work up a wiring diagram.

In determining the correct wiring, there are two things which must be kept in mind: 1. Be absolutely certain that the lamp is *always* in series with the line. The 117 volts of a.c. directly across the contacts can ruin a good vibrator in nothing flat; and 2. In order to do a thorough job, each pair of contacts must have a.c. across them. If they

don't make and break with the a.c. across them, they won't burn clean.

A good idea is to open one of each type of vibrator you use, insert it in the proper socket, and watch to see that each set of points is making and breaking with the voltage across it. Sparking each time the vibrator is started and stopped indicates that the vibrator is being properly "washed". Also this gives you a positive check on whether you wired the socket correctly or not.

The lamp may be any value from 75 watts down. The lower the wattage of the lamp, the lower the current through it and across the vibrator contacts. Twenty-five watts should be about right but 50 watts won't hurt anything.

One word of caution: Don't leave the vibrator operating in the "washer" longer than necessary. A few seconds is usually all that is required to burn off the oxidation. Longer operation can damage the points by too much burning.

The diagrams of Fig. 1 will cover most of your requirements. However, be sure to check a vibrator chart to determine your specific needs. -30-

Fig. 1. Various vibrator socket arrangements for types most often used in (A) marine, (B) automotive, and (C) mobile communications radio equipment.

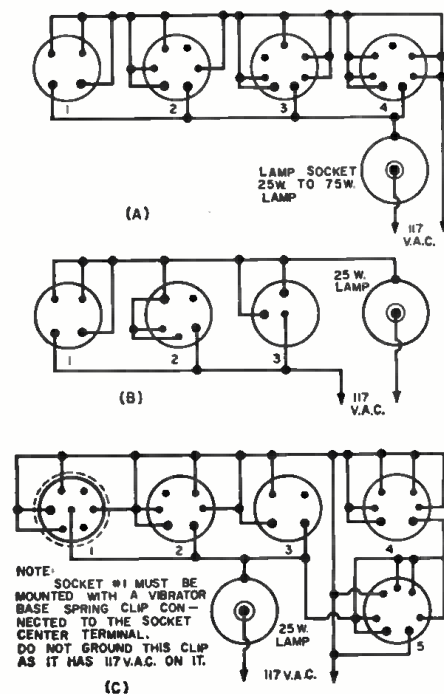

a new way to measure amplifier power!

It's no secret that the new Music Power Rating system is now being used by many hi-fi manufacturers in determining amplifier power. How does this new system compare to the conventional sinewave continuous power method? Is it of real value to both manufacturer and consumer? October **ELECTRONICS WORLD** examines Music Power Rating in depth—answering these questions and many others. It's just one of the many important hi-fi features coming your way in the October issue of **ELECTRONICS WORLD**.

October **ELECTRONICS WORLD** also brings you many other features on servicing, construction, test equipment. You'll want to read about:

Pneumatic Devices for Electronic Circuits

The technician who deals with electronic gear that works in conjunction with other non-electronic equipment must have a thorough understanding of the entire picture. Here's a rundown on the role of pneumatic devices that tie in with electronic systems.

Hand Held Citizens Band Transceiver

Complete construction details on a transistorized transceiver that weighs less than two pounds and has a range of one mile. Perfect for intercom applications, it may be operated without a license.



**Don't miss October
ELECTRONICS WORLD—authoritative
...informative...important!**

**Emergency
Industry
Farming
Pleasure**

NEW! LAFAYETTE HE-15A 2-WAY SUPERHET CITIZENS BAND TRANSCEIVER!



**Completely
Wired -
NOT A KIT!**

Made in U.S.A.

Not Superregenerative but SUPERHET!

COMPLETE 2-WAY COMMUNICATIONS FOR
BUSINESS, HOME, FARM, BOAT, AND SPORTS
NOW WITH ADDED FEATURES

- Effective Full-Wave Variable Noise Limiter
- Five Prong Microphone Jack For Easy Relay Addition
- RF Jack on Front Panel
- 5 Transmitting Positions
- Tuneable Receiver Over Full 23 Channels
- Planetary Vernier Tuning
- Complete with Transmitting Crystal for Channel 9

CITIZENS BAND — The New Two-Way Personal Communications Method for Everyone — Fill out the FCC form enclosed with each Lafayette Transceiver. No examination or technical knowledge required — Any Citizen 18 years or older is eligible for a license.

THE GREATEST VALUE in the CITIZENS BAND FIELD
Just think . . . now you can have economical, efficient 2-way radio communication from your home, office, store, auto, truck or boat . . . literally hundreds of uses. The Lafayette HE-15A Superheterodyne Transceiver is both a compact precision transmitter and receiver designed to operate on the new class D "Citizens Band." Two or more of these units furnish your own communications system covering up to a 20 mile or more radius depending on antenna height and terrain. The Lafayette HE-15A meets all FCC requirements and operates in much the same manner as police and other short-wave communications systems. The Transceiver features 5 crystal controlled transmitting channels operating at a maximum legal power input of 5 watts fully modulated, RF stage in both transmitter and receiver. The 5 position crystal selector on the front panel selects any one of 5 transmitting frequencies. These 5 crystals are readily accessible by means of a removable front plate. The superheterodyne receiver is tuneable over the full 23 channel band with 3 watts audio output, AVC, and an amazingly effective Full-Wave Variable Noise Limiter. The noise limiter is continuously variable from the front panel for diminishing ignition and other unwanted noise pickup. A new 5 prong microphone jack makes

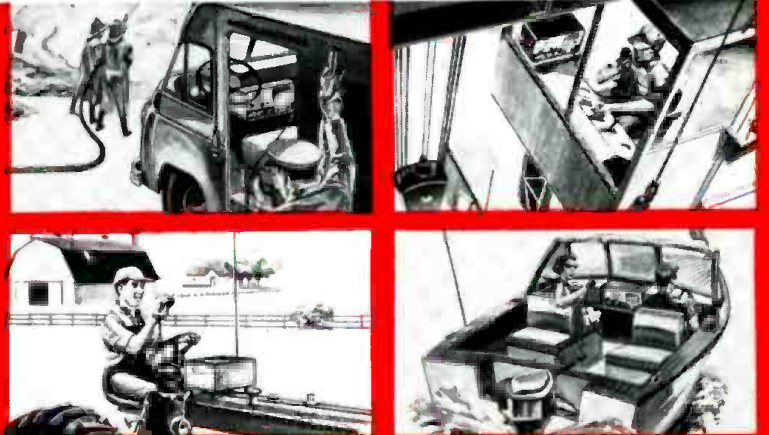

64⁵⁰
ONLY
5.00 Down

REMOVABLE FRONT PLATE FOR EASY CRYSTAL ACCESSIBILITY

COAX ANTENNA CONNECTOR

VARIABLE NOISE LIMITER CONTROL

POWER INDICATOR

3 POSITION FUNCTION SWITCH

8 POSITION CRYSTAL SELECTOR

RF INDICATOR

RF JACK

HIGH OUTPUT CRYSTAL MICROPHONE

PLANETARY VERNIER TUNING

conversion to a push-to-talk relay a cinch. RF jack on the front panel may be used to monitor the current in the final tube using external meter.

Controls include a 3 position function switch (transmit, receive, and transmit with spring return), planetary vernier tuning plus variable noise limiter. Output impedance matches 52 and 72 ohm antenna with Amphenol type coax connector. Has large 4" PM speaker; input jack for crystal or ceramic microphone; power receptacle in rear for AC line and 6 or 12 volt external power supply. Supplied with single transmitting crystal for channel 9, high output crystal microphone, and brackets for easy mounting of units in auto, boat, etc. Operates on 115 volts AC. Addition of 6 or 12 volt power supply (separately supplied) adapts transceiver, for mobile operation. Size: 10 1/4" W x 5 1/2" H x 6 3/4" D. Tube complement: 2-6U8A/6EA8, 1-6AL5, 16V6, 1-12AX7, 1-6AW8. Shpg. wt., 11 lbs.

HE-15A 5.00 Down Net 64.50

POWER SUPPLY: Adapts HE-15A for mobile operation. Complete with cable, 6 or 12 volt vibrator and mounting flanges. Completely enclosed. Size 4 1/4" D x 6" W x 4" H. Shpg wt., 4 lbs.

HE-16 For 12 Volts Net 11.95

HE-18 For 6 Volts Net 11.95

TRANSMITTING CRYSTALS: For any of the 23 channels. Specify channel or frequency.

HE-830 Singly Net 2.95 4 for 10.95



6.95

SENSATIONAL LAFAYETTE CITIZEN BAND MOBILE ANTENNA

THE SCOOP BUY FOR CITIZENS BAND MOBILES

- CHROME SWIVEL BASE
- PLUS STAINLESS STEEL SPRING
- PLUS 102 1/2" STAINLESS STEEL WHIP FOR OPTIMUM 11 METER PERFORMANCE

Chrome swivel ball mount base designed to be mounted on any surface. Stainless steel spring holds rod in properly adjusted position and prevents rod damage from shocks and blows. Stainless steel whip for maximum resiliency and strength. Shpg. wt., 4 lbs.

HE-800WX Net 6.95

NEW! LAFAYETTE TELESCOPIC CITIZENS BAND WHIP ANTENNA

- Chrome Plated
- Telescopes From 16 1/2 to 40"
- Mounts Vertically or Right Angle

3.95

An outstanding antenna value. This high quality three section telescoping antenna is designed for attachment directly to your citizens band transceiver. Ideal for point to point service over short distances. Molded base loading coil has a threaded stud with a PL-259 plug—connector for vertical or right angle mounting. Shpg. wt.; 1 lb.

HE-19 Net 3.95



NEW! 10,000 OHMS PER VOLT MULTITESTER

Outperforms Instruments Many Times Its Size

9.95

- Extra Large 3 1/2" Meter Face
- Completely Wired and Tested
- All Accessories Included

A convenient, pocket-sized instrument with an unusually sensitive 14,000 ohms-per-volt AC-DC meter, 1% resistors, single range selector switch. First capacity range requires 120V AC, second range requires 6V AC. Durable Bakelite case and panel; probes and flexible leads are plastic coated and color coded. Complete with battery. 4 1/2" x 3 1/4" x 1 1/8". Shpg. wt., 1 1/2 lbs.

TE-10 Net 9.95
TE-14 Pigskin Carrying Case, shpg. wt., 8 oz. Net 1.95

NEW! LAFAYETTE RADIO FIELD INDICATOR

- Provides a Continuous Indication of Transmitter Output
- Rugged 200 ua Meter Movement
- Completely Portable
- Requires no Electricity, Batteries or Transmitter Connection.

With this rugged, new radio field indicator you can check performance of your marine, mobile or fixed transmitter . . . actually measures the RF field generated by any transmitter between 100KC and 250MC regardless of power. Features a 200 ua meter movement with a variable sensitivity control. Phone jack at rear of indicator accepts earphones thus providing an aural check of transmitter output. Antenna extends from 3 1/4 to 10 3/4". Powerful magnet on bottom plate allows easy mounting on car dashboard or metal surfaces. Use anywhere . . . requires no electricity or batteries. Dimensions: (less antenna) 3 1/4" W x 2 1/4" H x 2" D.

TM-14 Net 7.95



PLEASE INCLUDE SHIPPING CHARGES WITH ORDER

LAFAYETTE RADIO

165-08 LIBERTY AVENUE JAMAICA 33, NEW YORK

NEW YORK, N. Y.

100 6th Avenue

NEWARK, N. J.

24 Central Avenue

BRONX, N. Y.

542 E. Fordham Rd.

PARAMUS, N. J.

182 Route 17

(1 Mi. North Garden State Plaza)

BOSTON, MASS.

110 Federal Street

PLAINFIELD, N. J.

139 W. 2nd Street



FREE!

Lafayette Radio's 324 PAGE 1961 Catalog

America's "Electronics & Hi-Fi Shopping Center"

40 years of service to Audiophiles, Experimenters, Hobbyists, Engineers, Technicians, Students, Servicemen and Dealers. **HERE IT IS** — the biggest, best and most comprehensive catalog you can ask for. Choose from thousands of items, all available for immediate delivery at the lowest, money-saving prices. And, as always, **SATISFACTION GUARANTEED OR MONEY REFUNDED.**

"The Best Buys In The Business"

- Stereophonic Hi-Fi Equipment
- Public Address Systems
- Tape Recorders
- Radio and TV Tubes and Parts
- Citizen Band Equipment
- Amateur Equipment
- Industrial Supplies

Exclusive at Lafayette. Lafayette Kits: Build a path to a new world of entertainment. Created, designed and engineered for top quality at top performance — there's more fun in doing it yourself, especially when it's so easy. An exclusive product of Lafayette Electronics — easily the best value for your money any day.

PLUS Hundreds of "specials" you'll find only at Lafayette.

Easy Pay Plan. The simplest, and quickest way to get what you want, when you want it. As little as \$2 down . . . up to 24 months to pay.

Mail the coupon today for your **FREE** copy of Lafayette Radio's 1961 catalog.



KT-650 FM Tuner Kit
54.50



TE-15 Tube Checker
19.95



RW-60 20,000 Ohms Per Volt Multimeter
9.95



RK-400 2-Speed Portable Tape Recorder
49.50



Stereo Control Center
KT-600, Kit 79.50
LA-600, Wired 134.50



Communications Receiver
KT-200, Kit 64.50
HE-10, Wired 79.95



Lafayette Radio Electronics Corp.
Dept. RI-6, P.O. Box 190
Jamaica 31, N. Y.

Send me the **FREE** Lafayette 324 page 1961 catalog 610

Name.....

Address.....

City..... Zone..... State.....

you've been told
**THERE'S
 NOTHING
 BETTER...**

**BUT
 THERE IS!!**

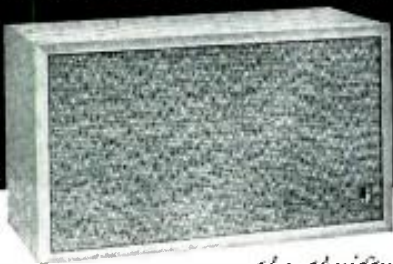

the thrifty
 4-speaker TF-3
 from **Jensen**

In the "budget" price range, there is no finer speaker system on the market. In fact, careful comparison proves that Jensen's beautifully balanced TF-3 is unquestionably the finest... not only the best "buy"... but point for point, the best system—and you pay much less.

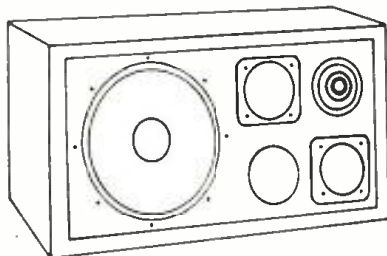

compare...

components: The TF-3 uses a 10" Flexair woofer, effective from 25 cycles, two special midrange units, and the new Jensen Sono-Dome Ultra Tweeter... so brilliant a speaker, it does not even begin to operate until 10,000 cycles!

power ratings: The TF-3 drives to full room volume with a good quality 10 watt amplifier. It does not require a 20 watt amplifier for clean performance.

enclosures: In the Jensen TF-3 you get top quality construction 3/4" gum hardwood, rigidly built. It stains beautifully—or paint or build-in as you choose. Dimensions: 13 1/2" H., 23 3/4" W., 11 1/4" D.

compare...

price: There is no real comparison. \$79.50

You are invited to make these comparisons—and any others you wish—between the Jensen TF-3 and any other "rated" speaker system on the market regardless of price. Comparison with the thrilling sound of the TF-3 will still further prove that...

there is always something better from

JENSEN MANUFACTURING COMPANY

DIVISION OF THE MUTEC CO.

6601 S. Laramie Ave., Chicago 38, Illinois

In Canada: Renfrew Electric Co., Ltd., Toronto

In Mexico: Universal De Mexico, S.A., Mexico D.F.

New Tube Tester Data

Recent listings with which owners of Triplet tube checkers can keep roll charts up to date.

TRIPLETT MODEL 3414

FIL.	TYPE	1	2	3	4	5	6	7	8	9	0	CKT.	LCAD
I	5GH8	—	—	—	U*	D*	—	—	D	D	—	3	81
I	5GH8 Test 2	—	D	—	U*	D*	—	D	—	—	—	3	45
J	6EV7	—	D	D	U*	D*	—	—	—	—	—	6	38
J	6EV7 Test 2	—	—	—	U*	D*	—	D	D	—	—	6	38
J	6GC6	—	U*	D	—	D	—	D*	—	—	—	3	23
4 & 8 show short													
J	6GM6	D	D	U*	D*	—	—	—	—	—	—	3	32
J	6GM8/ECC86	—	D	D	U*	D*	—	—	—	—	—	5	95
J	6GM8 Test 2	—	—	—	U*	D*	—	D	D	—	—	5	95
K	7DJ8/PCC88	—	—	—	U*	D*	—	D	D	—	—	4	58
K	7DJ8 Test 2	—	D	D	U*	D*	—	—	—	—	—	4	58
K	8ET7	—	—	—	U*	D*	D	D	—	—	—	3	59
K	8ET7 Test 2	D	D	—	U*	D*	—	—	—	—	—	3	42
K	8ET7 Test 3	D	—	D	U*	D*	—	—	—	—	—	3	42
N	12FR8	D	D	D	U*	D*	—	—	D	D	—	1	33
N	12FR8 Test 2	D	D	D	U*	D*	D	D	—	D	—	1	70
N	12FR8 Test 3	D	D	D	U*	D*	—	—	—	—	—	1	20
N	12FX8	—	—	—	U*	D*	D	—	—	—	—	1	88
Pin 7 shows leakage above 1 megohm													
N	12FX8 Test 2	—	D	—	U*	D*	D	D	D	—	—	1	40
N	12FX8 Test 3	D	D	—	U*	D*	—	D	—	D	—	1	10
N	12GA6	D	D	U*	D*	—	—	—	—	—	—	1	77
N	12GA6 Test 2	—	D	U*	D*	—	—	D	—	—	—	1	9
N	12GC6	—	U*	D	—	D	—	D*	—	—	—	3	23
4 & 8 show short													
O	14GT8	—	—	—	U*	D*	—	D	—	—	—	2	60
O	14GT8 Test 2	D	—	—	U*	D*	—	—	—	—	—	4	22
O	14GT8 Test 3	—	—	D	U*	D*	—	—	—	—	—	4	22
T	35GL6	D	D	U*	D*	—	D*	—	—	—	—	5	63
Pin 1 shows leakage													
J	7247	—	—	—	D*	D*	—	D	D	U*	—	7	55
J	7247 Test 2	—	D	D	D*	D*	—	—	—	U*	—	6	25
J	7408	—	U*	—	—	D	—	D*	D	—	—	3	52
J	7581	—	U*	—	—	D	—	D*	D	—	—	4	63

*Denotes square around U or D.

TRIPLETT MODEL 3444

TUBE	A	B	ELEMENTS	C	D	REI/AVG	NOTES
2-01C	5.0	0	1200-0-0000	11	8	Diode	F (6)
2C36	6.3	12	1254-0-0000	2	3	2.2/4.5	F
2C39	6.3	4	1254-0-0000	1	3	3.0/6.0	F
3E29	6.3	5	1563-2-5100	3	4	7.0/14.	(6)
(Connect two plate terminals with jumper.)							
4-65A	6.3	15	1605-0-6200	2	2	1.2/2.4	(6)
829B	6.3	5	1563-2-5100	3	4	7.0/14.	(6)
(Connect two plate terminals with jumper.)							
832-A	6.3	8	1563-2-5100	3	3	3.5/7.0	(6)
(Connect two plate terminals with jumper.)							
5894/AX9003	6.3	7	1563-2-5100	3	4	6.5/13.	(6)
(Connect two plate terminals with jumper.)							
6263	6.3	40	1235-4-0000	1	3	3.5/7.0	

Note: To test tubes listed above on the Model 3444, use the CG adapter.

the people who brought you the



**MORE POWER
PER POUND
SPEAKER** now offer
**MORE SOUND
PER LIFE**

in the revolutionary
Utah

LIFETIME SPEAKER

guaranteed
for the life of the owner

24 hours a day, we lay our reputation (and our profits) on the block! We *guarantee* perfection of performance for a lifetime. To do this, we *have* to make the speakers of our lifetime . . . and we do!

Order a Utah Lifetime for your next replacement and see! (All popular sizes and shapes).



Utah Radio & Electronic Corp., Huntington, Ind.

THE LIFETIME GUARANTEE

Utah will renew or replace free this loudspeaker due to any performance failure at any time during the lifetime of original owner. No charge made for handling, inspection, labor, materials or servicing for any repair or replacement. Customer pays postage only.

GLOBE ELECTRONICS'
NEW
"Pocketphone"
GIVES YOU



*
ACTUAL
SIZE
1 3/4 x 2 3/4 x 6 1/4
RANGE—1/2 to 1 Mile
HANDY PAGING SYSTEM
REQUIRES NO LICENSE

New portable high styled two-way radio that actually fits into your pocket. Exclusive "power-pak" rechargeable battery lasts a year or more... For factory, surveying, construction, department stores, stock-yards, hospitals, firemen, policemen, golf, office, and home. Price \$125.00 each.
Can also be used with Globe Electronics' CB100 or CB200 two way citizens band radios, for longer ranges.

Citizens Broadcaster



Complete 3-channel, 2-way station for permanent installation or travel. Only 3 1/2 x 10 1/2 x 13. Easy to install, operate. Only 3 controls. Range 5-15 miles. Complete with one set crystals, push-to-talk microphone, \$129.95 each.

Broadcaster Deluxe



Especially designed for the commercial user and consumer desiring a more rugged unit. Five crystal controlled channels for transmitting. Four crystal channel receiving plus one tunable position over entire band. Adapted for selective calling system. Dual conversion eliminates interference. Absolutely quiet. Size: 3 7/8 x 12 x 10 1/8... \$179.95 each.

GLOBE ELECTRONICS A Division of Teatron Electronics Inc
22-30 So. 34th St., Council Bluffs, Iowa

PLEASE SEND ME COMPLETE INFORMATION:
ON GLOBE ELECTRONICS' EW
CB

POCKETPHONE CB-100 CB-200

Name _____

Address _____

City & State _____

Citizens Band Converter

(Continued from page 61)

The diagram of Fig. 1 shows the methods used to connect the converter to the broadcast receiver. Depending on the type of receiver with which the converter is to be used, the connections can be made direct to the antenna terminals, through a few turns wrapped on the ferrite-rod antenna in the receiver, or by means of a few turns of wire cemented to an existing loop antenna. In the latter two alternatives you have a choice as to how tight the coupling is to be made.

Remember that on a transformerless a.c.-d.c. receiver the chassis is one side of the line, in which case you must not connect the converter direct to the chassis.

If the converter is to be employed with an automobile receiver, it can be used as shown if the auto battery is of the type with positive ground. If the negative of the battery is grounded the converter should be used either with a "floating" ground or grounded only through a .05- μ f. capacitor. Another alternative would be to use 2 *n-p-n* transistors in which case the battery's connections should be reversed. The *n-p-n* equivalents of the 2N247 should be chosen to be r.f. amplifier transistors that have a cut-off frequency of at least 30 mc.

Current requirements of the con-

verter are minimal; the transistors draw less than 10 ma. (how much depends on the voltage) and the bias voltage divider passes 2 ma. at 6 volts. Remember to arrange the converter so that the battery is disconnected when the converter is not being used or there will be a continuous drain on the battery.

Frequency drift of the transistor oscillator, because of the crystal, is very low, but remember that the crystal is somewhat affected by temperature so that if you install the converter in an existing receiver, keep it away from heat-producing tubes.

For the converter you will need a crystal which differs from the desired channel frequency by the i.f. frequency. Thus, if you want to use the 27.255 mc. channel and receive the signal on 1000 kc. on your dial, the crystal must be 26.255 or 28.255 mc. Such crystals are readily available, particularly the lower band type, many of which can be obtained surplus as well as new.

The antenna required need only be a short length of wire but if you are transmitting on 27 mc. anyway, you can use the transmitting antenna. A normal automobile whip antenna will do nicely for the receiver.

Building this converter is a little more expensive, because of the transistors, than some of the single-transistor superregenerative versions. There are compensations, however, for you will end up with a very sensitive Citizens Band receiver.

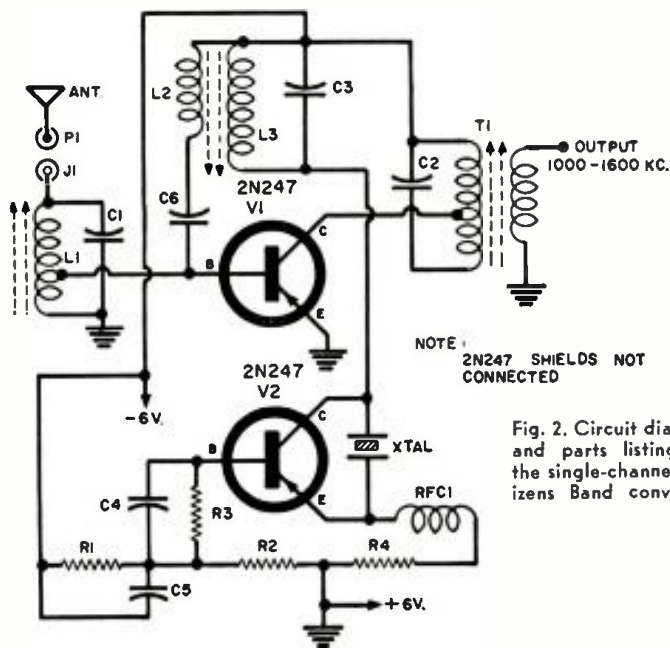

NOTE:
2N247 SHIELDS NOT
CONNECTED

Fig. 2. Circuit diagram and parts listing for the single-channel Citizens Band converter.

- R₁—2700 ohm, 1/2 w. res.
- R₂—1000 ohm, 1/2 w. res.
- R₃—22,000 ohm, 1/2 w. res.
- R₄—470 ohm, 1/2 w. res.
- C₁—20 μ f. tubular ceramic capacitor
- C₂—80 μ f. tubular ceramic capacitor
- C₃—6.8 μ f. disc ceramic capacitor
- C₄, C₅—.01 μ f. disc ceramic capacitor
- C₆—10 μ f. disc ceramic capacitor
- RFC1—300 μ h. r.f. coil
- Xtal.—Receiving crystal for desired Class D band (see text)
- P₁—Antenna plug

- J₁—Antenna jack
- L₁—20 t. #26 en. antenna coil wound on 3/8" form with slug. Tap at 5 t. (see text)
- L₂—4 t. #26 en. wound over L₁ on CTC Type LS-3 3/8" o.d. coil form with 2013-C brass slug (author used surplus coil form, see text)
- L₃—20 t. #26 en. wound on same form as L₂ (see text)
- T₁—Output trans. Author modified a Crest #200-6 variable inductor (70-225 μ h.), see text. Also refer to article for alternatives.
- V₁, V₂—*n-p-n* transistor (RCA or Sylvania 2N247)

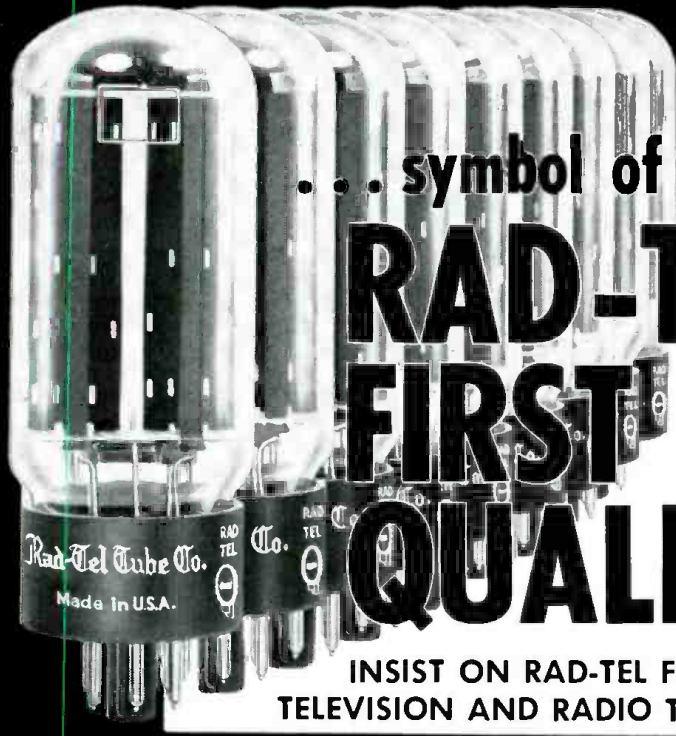

... symbol of
RAD-TEL
FIRST
QUALITY

INSIST ON RAD-TEL FOR EVERY TELEVISION AND RADIO TUBE NEED

Super-Special!

KIT OF 100

Bi-Pass CONDENSERS

Over 50% Are 600V

at
LESS THAN
4¢ each

\$3.95

Goodall Semi-Molded Paper and MYLAR

Made up of approx. 16-200V, 20-400V and 64-600V.

Values .001 to 1 mf

Up to 75% OFF on BRAND NEW TUBES

GUARANTEED ONE FULL YEAR!

You Can Rely On Rad-Tel's Speedy One Day Service!

Not Used — Not Pulled Out Of Old Sets • Each Tube Individually and Attractively Boxed!

Qty.	Type	Price	Qty.	Type	Price	Qty.	Type	Price	Qty.	Type	Price	Qty.	Type	Price	Qty.	Type	Price	Qty.	Type	Price						
—	024M	.79	—	30T6	.50	—	6AB4	.46	—	6B16	.62	—	6E8	.79	—	12A4	.60	—	12B06	.50	—	12EG6	.54	—	19B06	1.39
—	1AX2	.62	—	30S	.80	—	6AC7	.96	—	6BK7	.85	—	6E8	.79	—	12A85	.55	—	12B06	.53	—	12E26	.53	—	19T8	.80
—	1B3GT	.79	—	3S4	.61	—	6AF3	.73	—	6BL7	1.00	—	6HG6T	.58	—	12AC6	.49	—	12BF6	.44	—	12F5	.66	—	21EX6	1.49
—	10N5	.55	—	3V4	.58	—	6AF4	.97	—	6BN4	.57	—	6J5GT	.51	—	12AD6	.57	—	12BH7	.73	—	12F8	.66	—	25B06	1.11
—	1G3	.73	—	4BC5	.56	—	6AG5	.65	—	6BN6	.74	—	6J6	.67	—	12AE6	.43	—	12BL6	.56	—	12FM6	.45	—	25C5	.53
—	1J3	.73	—	4BC8	.96	—	6AH6	.99	—	6BQ5	.65	—	6K6	.63	—	12AF3	.73	—	12BQ6	1.06	—	12K5	.65	—	25CA5	.59
—	1K3	.73	—	4BN6	.75	—	6AK5	.95	—	6BQ6GT	1.05	—	6S4	.48	—	12AF6	.49	—	12BY7	.74	—	12SA7M	.86	—	25C06	1.44
—	1L6	1.05	—	4BQ7	.96	—	6AL5	.47	—	6BQ7	.95	—	6SA7GT	.76	—	12A16	.46	—	12B27	.75	—	12SK7GT	.74	—	25C06	1.11
—	1LN5	.59	—	4BS8	.98	—	6AM8	.78	—	6BR8	.78	—	6SK7	.74	—	12A15	.45	—	12C5	.56	—	12SN7	.67	—	25C06	1.42
—	1R5	.62	—	4BU8	.71	—	6AN4	.95	—	6BU8	.70	—	6SL7	.80	—	12AL8	.95	—	12CA5	.59	—	12SQ7M	.73	—	25EH5	.55
—	1S5	.51	—	4BZ6	.58	—	6AN8	.85	—	6BY6	.54	—	6SN7	.65	—	12A05	.52	—	12CN5	.56	—	12U7	.62	—	25L6	.57
—	1T4	.58	—	4BZ7	.96	—	6AQ5	.50	—	6BZ6	.54	—	6SQ7	.73	—	12AT6	.43	—	12CR6	.54	—	12V6GT	.53	—	25W4	.68
—	1U4	.57	—	4CS6	.61	—	6AR5	.55	—	6BZ7	.97	—	6T4	.99	—	12AT7	.76	—	12C05	.58	—	12W6	.69	—	25Z6	.66
—	1U5	.50	—	4DE6	.62	—	6AS5	.60	—	6C4	.43	—	6U8	.78	—	12A06	.50	—	12C06	1.06	—	12X4	.38	—	35C5	.51
—	1X2B	.82	—	4DK6	.60	—	6AT6	.43	—	6CB6	.54	—	6V6GT	.54	—	12A07	.60	—	12C06	.54	—	17AX4	.67	—	35L6	.57
—	2AF4	.96	—	4DT6	.55	—	6AT8	.79	—	6CD6	1.42	—	6W1	.57	—	12AV5	.97	—	12D05	.69	—	17B06	1.09	—	35W4	.52
—			—	5AM8	.79	—	6AU4	.82	—	6CF6	.64	—	6W6	.69	—	12AV6	.41	—	12D08	.75	—	17C5	.58	—	35Z5GT	.60
—			—	5AN8	.86	—	6AU6	.50	—	6CG7	.60	—	6X4	.39	—	12AV7	.75	—	12DL8	.85	—	17CA5	.62	—	50B5	.60
—	3AL5	.42	—	5A05	.52	—	6AU7	.61	—	6CG8	.77	—	6X5GT	.53	—	12AX4	.67	—	12DM7	.67	—	17D4	.69	—	50C5	.53
—	3AU6	.51	—	5AT8	.80	—	6AU8	.87	—	6CM7	.66	—	6X8	.77	—	12AX7	.63	—	12D06	1.04	—	17DQ6	1.06	—	50C04	.37
—	3AV6	.41	—	5BK7A	.82	—	6AV6	.40	—	6CN7	.65	—	7A07	.61	—	12AZ7	.86	—	12D07	.79	—	17L6	.58	—	50EH5	.55
—	3BA6	.51	—	5BQ7	.97	—	6AW8	.89	—	6CR6	.51	—	7A8	.68	—	12B4	.63	—	12D06	.56	—	17W6	.70	—	50L6	.61
—	3BA6	.51	—	5BR8	.79	—	6AX4	.65	—	6CS6	.57	—	7B6	.69	—	12BA6	.50	—	12EL6	.50	—	19A04	.83	—	117Z3	.61
—	3BC5	.54	—	5CC8	.76	—	6AX7	.64	—	6CU5	.58	—	7Y4	.69	—			—								
—	3BE6	.52	—	5CL8	.76	—	6BA6	.49	—	6CU6	1.08	—	8A08	.83	—			—								
—	3BN6	.76	—	5EA8	.80	—	6BC5	.54	—	6CY5	.70	—	8A08	.93	—			—								
—	3BU8	.78	—	5E08	.80	—	6BC7	.94	—	6CY7	.71	—	8B05	.60	—			—								
—	3BY6	.55	—	5I6	.68	—	6BC8	.97	—	6DA4	.68	—	8CG7	.62	—			—								
—	3BZ6	.55	—	5T8	.81	—	6BD6	.58	—	6DB5	.69	—	8CM7	.68	—			—								
—	3CB6	.54	—	5U4	.60	—	6BE6	.55	—	6DE6	.58	—	8CN7	.97	—			—								
—	3CF6	.60	—	5U8	.81	—	6BF6	.44	—	6DG6	.59	—	8CX8	.93	—			—								
—	3CS6	.52	—	5V6	.56	—	6BG6	1.66	—	6DQ6	1.10	—	8E8B	.94	—			—								
—	3CY5	.71	—	5X8	.78	—	6BH6	.65	—	6DT5	.66	—	10DA7	.71	—			—								
—	3DK6	.60	—	5Y3	.46	—	6BH8	.87	—	6DT6	.53	—	11CY7	.75	—			—								

PLEASE PRINT NAME AND ADDRESS CLEARLY

Name

Address

City

State

SEND FOR FREE TROUBLE SHOOTER GUIDE AND NEW TUBE & PARTS CATALOG.

NOT AFFILIATED WITH ANY OTHER MAIL ORDER TUBE COMPANY.

RAD-TEL TUBE CO.

55 Chambers St
 Newark 5, N. J.

TERMS: 25% deposit must accompany all orders — balance C. O. D.
 \$1 HANDLING CHARGE FOR ORDERS UNDER \$5. Subject to prior sale.
 Please add postage. No C. O. D.'s outside continental U. S. A.

EW 960

HELIWHIP* ANTENNAS

and Beacon
Fixed Station Antennas
for the 27 mc.

**CLASS "D"
CITIZENS BAND**

Mobile Unit
(Model HW-11)

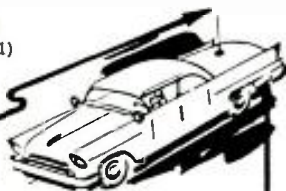

**Three Model HW Heliwhips*
cover every citizen band
application! Compact! Efficient!**

MARK MOBILE, Inc. offers a completely integrated antenna package for all 27 mc. 11-meter Citizens Band requirements.

The "BEACON" Base Station Antenna is a new concept in fixed station antenna design. Requiring no radials or "skirts" it is a full half-wave radiator with exceptional efficiency.

The HELIWHIP* (patented) mobile antennas, a basic development of the MARK engineering staff, provide full efficiency in vehicular applications with compact and attractive units. No need to use unsightly long steel whips on your automobile.

For Marine applications the MARINE HELIWHIP* with Launcher-Matcher Cable eliminates the need for metal ground plane and permits full efficiency of antenna when mounted on fiberglass and wood boats as well as mast mounting.

Base Station
(Model CBB-1)

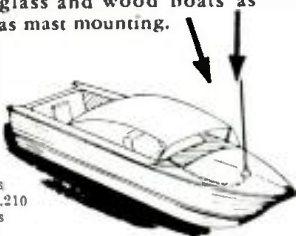

Marine Unit
(Model HW-11-6M)

*U. S. Process
Patent No. 2,938,210
(Other patents
pending)

MARK MOBILE, Inc.
VEHICULAR COMMUNICATIONS ANTENNAS
Dept. EW-9 5441 W. Fargo Ave., Skokie, Illinois
Phone: ORchard 5-1500

The Citizens Band (Continued from page 56)

Like most everything else, a good Citizens Band radio must have a combination of good features; in this case selectivity, sensitivity, noise suppression, squelch, and an efficient transmitter. The more of these features included, the higher the cost, in most cases.

Because the Citizens Band is provided primarily for systems communication (a given group communicating among its members, a tunable receiver is not usually necessary, but it is sometimes valuable in determining which channels are the least crowded.

The noise generated by the diathermy equipment found in many hospitals is one of the worst enemies of the Citizens Band user in an urban area. Because of this, and temporary channel crowding, many users have found multi-channel equipment advantageous. Diathermy is liable to appear at any time and anywhere in the Class D band. If it does, or congestion takes place on the normally used channel, you can switch to another frequency with a multi-channel set. Boat owners should also have gear that is equipped with more than one channel because of change of location, or the desirability of having different channels for cottage-to-boat, club-to-boat, and boat-to-boat.

Antennas

A two-way radio station is no better than its antenna installations. A good antenna installation can help a fair piece of equipment work pretty well, but a fair antenna installation and a good piece of equipment are poor economies.

For permanent base-station installations there are five common types of antennas: ground plane, coaxial sleeve, center-fed dipole, end-fed dipole, and various types of directional beams. The first four are for omnidirectional use, that is, they will radiate and receive in all directions more or less equally.

The Federal Communications Commission limits the height of the top of an antenna to 20 feet above any existing man-made or natural structure on which it is mounted. For best performance, the base antenna should be mounted as close to this height as possible.

The ground-plane type is probably the most common base-station antenna. At 27 mc. they measure almost 9 feet high and have either 3 or 4 radials of the same length protruding horizontally or downward at a 45-degree angle from the base of the 9-foot vertical radiating element. An isolating skirt (additional set of ground radials) is sometimes helpful in obtaining maximum performance.

Coaxial-sleeve and dipole antennas are about 18 feet long. These antennas should all be mounted vertically to provide best communication with mo-

bile units which usually employ simple vertical whip antennas.

The most common directional antenna is the three-element yagi. Some of these can be mounted vertically for use with mobile units operating in one general direction from the base station, or horizontally for station-to-station use.

Directional antennas have two distinct advantages: they increase the operational distance and reduce or eliminate interference caused by nearby stations not in the radiation pattern of the antenna.

Mobile & Marine Antennas

The most common mobile antenna is the simple vertical whip, working against ground (which may be a vehicle's body and chassis or a boat's hull). One common antenna for the Class D band is about 9 feet long, made of stainless steel (fiber glass encapsulated ones are also available), and provided with a mount and connecting cable. The vehicle acts as the ground and the antenna location on the vehicle is most important.

The ideal location is in the electrical center of the vehicle, normally the center of an automobile's roof. We know of several Volkswagen buses with 9-foot antennas up there that outperform base stations. It is a little impractical to do this in most cases and very often the desired range does not require such an extreme installation.

A good location on an automobile is high up on a rear fender, near the trunk lid; as high as practical on a station wagon, pick-up, or panel truck; and near the top of the cab on bigger trucks.

Bumper-mounted antennas result in two main losses in efficiency. Part of the antenna is shielded by the body of the car and all of the "ground" is on one side, causing a directional signal which is most undesirable for mobile operation.

There is a way of shortening the physical length of antennas while still allowing the antenna to operate properly, although with a decrease in efficiency. A coil, of the proper inductance determined by the desired length of the antenna, can be inserted at the antenna's base, middle, or near the top. These coils cause a reduction in efficiency that is often compensated for by allowing the antenna to be mounted at a more favorable location on the vehicle, because of the antenna's shorter physical length. There is no advantage in shortening, by use of a coil, a base-station antenna other than to reduce its size.

The antennas used with small portable Class D sets are always short, being less than 48 inches long. Most of them are of the telescoping type either with an external coil or a coil built inside the unit. Because the "ground" (the portable unit itself) is poor, performance varies greatly with the relative location of the unit. For instance, resting the unit on the roof of an automobile will greatly increase the effec-

tive ground area and the performance.

The physical dimensions of full-size ground planes, coaxial sleeves, or dipoles, make their use impractical on boats under thirty feet long. Even with larger boats, a ground plane would be unsightly, and the ground radials might be in the way.

Unless the antenna is mounted on a metal boat, which would provide a ground at the feed point of the antenna, the use of a simple, vertical whip will not result in the best performance. However, these antennas can be used with more success if ground radials are run fore and aft. If a ground wire is run from the equipment to a ground plate or the engine, the radiation pattern will vary from boat to boat. Even without the best ground system, because of capacitive coupling to the water itself, which usually serves as a good "ground," operation over water is usually fairly good with simple antennas.

There are available some antennas made especially for marine use. One is a shortened coaxial-sleeve type, fiber glass encapsulated and 11 feet long. Another is an odd type of ground plane, with only two ground radials and a 5-foot radiating element using loading coils.

Of prime importance with outdoor antennas, particularly for marine use, is that the antenna must be sturdy mechanically and able to withstand corrosion. Another point to check, especially when buying an antenna made

by a company other than the one which made the radio unit, is the type of antenna connector used. This must match the connector on the set or it will have to be changed.

Servicing

All electronic equipment needs service for continuing operation and Citizens Band sets are no exception. Although most qualified radio and television service technicians can maintain receivers, an FCC operator's license is required to perform complete service on the transmitters.

There are people in almost every community who hold such licenses, allowing them to work on Citizens Band transmitters. Those who are in the business of maintaining two-way equipment can be found in the classified pages of every telephone book we have seen under the heading "Radio Telephone." Very often, if a radio and television service company is not in a position to maintain the sets, they know who can do the work locally.

Necessary service is normally similar to that needed on a radio or TV set. Parts and tubes need occasional replacement and minor alignment adjustments are sometimes necessary.

The Class D Citizens Band may be considered a tool, which if properly utilized, can provide more economical business operations and more pleasurable use of our leisure hours. Why don't you put the Citizens Band to work for you?



TRAIN QUICKLY! OLDEST, BEST EQUIPPED SCHOOL of ITS KIND in U.S.

Get Practical training in New Shop-Labs of Coyne. Prepare for a better job and a successful future in a top opportunity field. Advanced education or previous experience not needed. Employment service to graduates.

Enroll NOW—Pay Later

Finance Plan and Easy Payment Plan. Also Part Time Employment help for students.

FREE BOOK Clip coupon or write to address below for Free Illustrated Book, "Guide to Careers"—Describes all training offered. No obligation and No Salesman Will Call. Act NOW.

B. W. Cooke, Jr., President

COYNE CHARTERED NOT FOR PROFIT ESTABLISHED 1899
ELECTRICAL SCHOOL 1501 W. Congress Pkwy., Chicago 7, Ill., Dept. 60-6C

COYNE Electrical School
1501 W. Congress Pkwy., Chicago 7, Ill.
Dept. 60-6C

Send FREE book "Guide to Careers" and details of all training you offer. However, I am especially interested in:

ELECTRICITY TELEVISION BOTH FIELDS

NAME.....

ADDRESS.....

CITY.....STATE.....



"More than Citizens' Radio" ...

a complete, fully engineered "industrial-type" transceiver!

VIKING *Messenger*

Anyone can operate—license issued by the FCC on request

from **\$134⁹⁵**

- Complete 23 channel Citizens' Band coverage—choose 1 of any 5 channels by the flip of a switch.
- Maximum legal power—excellent range—meets all FCC requirements.
- Excellent receiver sensitivity and selectivity—full fidelity voice reproduction.

"More than just 2-way Citizens' Radio equipment"—the Viking "Messenger" will deliver the finest performance of any equipment available in the field. Designed throughout for 10 watt power level—limited to 5 watts for Citizens' Radio. Easy to install anywhere in your home, business location, car, truck or boat... offers many unique features found only on more expensive communications systems. Built-in Squelch, Automatic Volume Control, and Automatic Noise Limiter. Compact, modern styling—only 5 1/2" high, 7" wide, and 11 3/4" deep. Complete with tubes, push-to-talk microphone, and crystals for one channel.



Available from authorized Johnson Electronic or Marine Distributors. Installation and service coast-to-coast at all General Electric Communications Service Stations.

 Farming, delivery or fleet operation	 Boat-to-boat or ship-to-shore communication	 Your own personal or family use	 Construction or "off-the-road" equipment
--	---	-------------------------------------	--

FREE
Color Brochure

WRITE TODAY

E. F. JOHNSON COMPANY

103 Second Ave. S. W. • Waseca, Minnesota
• Please rush me your full color brochure describing the Viking "Messenger" Citizens' Transceiver.

NAME.....

ADDRESS.....

CITY.....STATE.....

Manufacturers of the world's most widely used personal communications transmitters

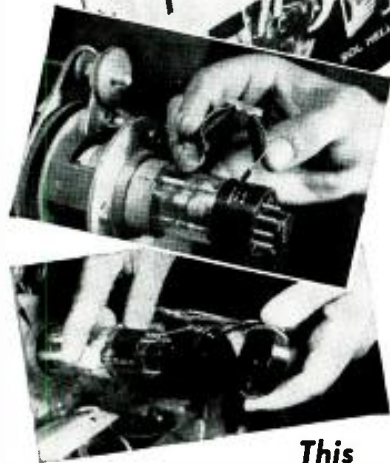
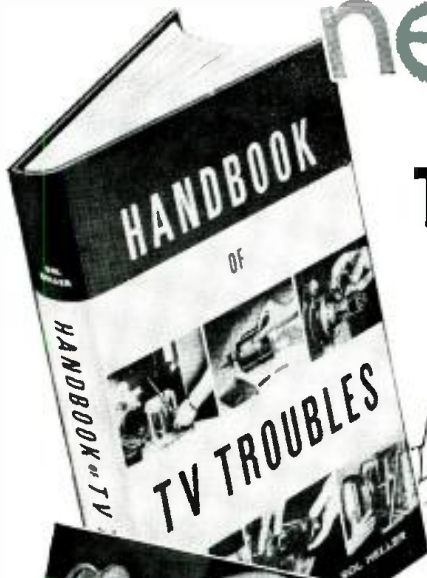

This "automatic teacher"

TAKES THE GUESSWORK OUT OF TV TROUBLE-SPOTTING AND REPAIR!

Covers all causes of practically every trouble you are likely to be called on to fix including:

- BRIGHTNESS TROUBLES—CONTRAST TROUBLES—PICTURE DISTORTION—UNSATISFACTORY PICTURE DETAIL—LINE OR BARS IN PICTURE—SYNCHRONIZATION TROUBLES—MISSING PICTURE—SIZE AND CENTERING TROUBLES—SOUND TROUBLES—TELEVISION INTERFERENCE, ETC.

new MASTER GUIDE TO TIME-SAVING TV SERVICE

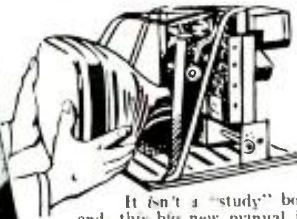

A modern manual for fast, "symptomatic trouble analysis" and servicing of TV receivers

It isn't a "study" book! From beginning to end, this big new manual is designed for daily use right at the bench as an outstandingly complete, easily understood guide to practically any job on any TV receiver.

Just turn to the Index. Look up the trouble symptoms exhibited by the TV you're working on. The HANDBOOK OF TV TROUBLES then tells you exactly what and where to check. Outlines time-saving short cuts. Explains puzzling details. Eliminates guesswork and useless testing. More than 150 test pattern, wave form and circuit illustrations explain test results, details and procedures so clearly you can hardly fail to understand.

LOOK! LISTEN! Then Follow This Easy Guide!

Almost regardless of set make or model, this remarkable new 302-page Handbook helps you track down TV troubles from the symptoms they produce in the set itself—screen intermittently dark; "blooming"; abnormal contrast in spots; "snow"; poor detail; sync troubles; sound troubles—and all the many other symptoms that indicate something is wrong. Then it explains how to make needed adjustments or parts replacements.

HANDBOOK OF TV TROUBLES is printed in large type and has sturdy, varnished covers for "on the job" use. Its QUICK GUIDE TV TROUBLE INDEX helps you find what you want in a jiffy. Throughout, the Handbook is a real time-saving money-maker for beginners and experienced service men alike! Try it for 10 days AT OUR RISK. You be the judge!

TRY IT 10 DAYS—See for Yourself!

Dept. RN-90, HOLT, RINEHART AND WINSTON, INC., Technical Div., 383 Madison Ave., New York 17, N. Y.

Send new 302-page HANDBOOK OF TV TROUBLES for 10-day FREE trial. If I decide to keep book, I will then send you \$7.50 in full payment. If not, I will return book postpaid and owe you nothing.

SAVE: Send \$7.50 with order and we pay the postage. Same 10-day return privilege with money promptly refunded.

Name

Address

City, Zone, State

OUTSIDE U.S.A.—Price \$8.00 cash only. 10-day return privilege with money refunded.

CB Call Letters Not To Be Assigned By Suppliers

FCC clamps down on call assignments made for the purpose of "demonstration."

EDITOR'S NOTE: The following information is based on a recent FCC release. It should be of interest to all of our readers who use, buy, sell, or manufacture Citizens Band equipment.

AN INCREASING number of reports have reached the FCC concerning the practices of some suppliers of Business and Citizens Radio equipment in advising their customers that such equipment may be operated by them prior to the issuance of a radio station license by the Commission. In some instances, sellers have "assigned" radio station call signs to purchasers along with the sale of the radio gear. In a few such cases, these call signs have been the same as those authorized to be used by the manufacturer or seller of the equipment.

Although a radio operator's license is not needed to operate a Citizens Band station, a radio station license is required. With the exception of certain low-power equipment described in Part 15 of the Commission's Rules, the operation of any radio transmitter by a person other than the one to whom the station license has been issued, or by a person directly under his control or supervision, is illegal and may result in the imposition of severe criminal sanctions.

Under Section 310(b) of the Communications Act, the prior consent of the Commission is required for the transfer or assignment of any radio station license or the rights granted thereunder. One who fails to observe this provision by the transfer of his operating authority subjects himself to possible license revocation and such other enforcement action as the Commission may consider warranted. The designation of such unlawful activities as "equipment demonstrations" does not render them less illicit.

This matter is being brought to the attention of manufacturers, distributors, and retail vendors of Business and Citizens Radio equipment in the belief that they share the Commission's conviction that the development of these services is hampered by the above practices. Anyone who engages in such practices, in addition to the possibility of having drastic enforcement action instituted against him, may be sacrificing the long-range good will of a misadvised customer for the benefit of an immediate sale. All prospective users of CB equipment should therefore be advised that they must await the arrival of their own license in order to operate.

-30-

LEADER TEST INSTRUMENTS

Lag-55 Audio Generator Sine Square

A multi-purpose generator for measurements on audio equipment—amplifiers, speakers, networks. Three waveforms: sine, square and complex for all types of measurements including response, distortion, transient and I-M distortion checks. Full range is from 20 to 200,000 cps, output 5 volts with minimum amplitude variation throughout whole range.

OHMATSU ELECTRIC CO. LTD.

2596, 5-Chome, Kamimeguro, Meguro-Ku
Tokyo, Japan
Cable Address "OHMATSUELEC" TOKYO

new "LEADER" test instrument



Mac's Service Shop

(Continued from page 70)

shown in the selector-switch window. It's to be used on any a.c.-d.c. set that employs a safety line-cord connector mounted on the back cover when you want to turn the set on with the back off. In the past, I've seen you use an ordinary cheater cord for this purpose and plug it straight into the light line because you were too lazy to turn on the isolation transformer. Now I'm making it *easier* for you to use the isolation transformer on these sets, and I better not catch you using anything else!"

"Aye, aye, sir!" Barney said with a grin as he tugged at a curly red forelock. "Watch your blood pressure, sir!"

"This goes into your house-call tool kit," Mac said, ignoring him, as he handed over a gleaming little chrome-plated tube. "It's a penlight with a completely adjustable dental mirror mounted at the light bulb end. One way to use it is to adjust the mirror so it reflects light from the bulb around corners and into spots you could never illuminate directly. Another use is to shine the light on a spot and adjust the mirror so you can see, by reflection, the illuminated area. This will come in mighty handy when you have to replace a miniature tube in a hidden socket in a TV set. Nothing makes a technician look more stupid or gets his

goat quicker than to have to fumble around five or ten minutes replacing a tube he just removed."

"I'll buy that," Barney interrupted with deep feeling: "it makes you feel like a real schnook."

"Finally," Mac went on, "here are a handful of soft colored crayons to be used to mark the points from which wires are unfastened or unsoldered during testing or replacement of parts. I know paint or fingernail polish would be more durable, but they're also more difficult to apply and to keep ready for instant use. All we need is something to mark the spot from which a wire was removed until we are ready to replace the wire. These will do the job nicely. There are enough colors here to match the colors usually found on wire insulation."

"I'll tell you another place where one of those crayons will come in handy," Barney offered. "It's to mark the position of a miniature i.f. transformer can on the chassis, a speaker in the cabinet, or any other part you intend to remove and later replace in exactly the same position. One swipe with a crayon down the side of the part and onto the adjacent area will do it. Then all you have to do is to match up the ends of the broken crayon line and you know the part is just where it was."

"Good! That winds up the list of actual devices I dreamed up to save time and temper, but I've been thinking there are a few *procedures* that will contribute to the same end. Take,

for example, the matter of replacing a slipping dial cord. If the cord has been slipping on the drive shaft for some time, that shaft will be polished as smooth as glass; and even the new properly installed, properly tensioned cord will often slip. To prevent this, all you need to do is to make a few swipes around the drive shaft with a bit of sandpaper to knock off the glaze *before* installing the new cord. Fail to do this and you may have to do the whole job over."

"I read you loud and clear!" Barney exclaimed; "and I can think of another example of how a few seconds spent in proper preparation can save minutes. I'm talking about tinning leads before trying to solder them into a circuit. A properly tinned lead requires a minimum amount of heat to make it join in a good soldered joint; but I've actually destroyed a tube socket by overheating a lug in trying to solder an untinned lead to it. And if you think the tube socket lug was hot when this happened, you should have seen me!"

Mac chuckled sympathetically. "I know. Half the anger we feel about the annoying things in servicing we've been discussing is directed at our own laziness, stupidity, and lack of foresight that permits them to happen. Any time we can remove a source of irritation from our work, we've taken a step toward being a better-balanced, more efficient service technician—and we'll probably live one heck of a lot longer too!"

-50-

2-WAY CITIZENS RADIO TELEPHONE

(27 MC. CLASS D)



PRICE *
\$134.50
Slightly Higher
on West Coast

No exam for FCC license ... !

for ● **BOATING** ● **MOBILE**
● **HOME** ● **BUSINESS**
● **FARMING** ● **SPORTS**
● **CAMPING** ● **INDUSTRY**

5 CRYSTAL CONTROLLED CHANNELS

SQUELCH CIRCUIT • NOISE LIMITER

5 WATTS OF POWER • 7 TUBES IN RECEIVER

Two Models: MODEL CD-5/6 6 VOLT DC AND 110 VOLT AC
MODEL CD-5/12 12 VOLT DC AND 110 VOLT AC

See your dealer, now!

Citi-fone®

by

MULTI-ELMAC

*Price includes: MICROPHONE, 1 SET OF CRYSTALS,
1 AC CORD, 1 DC CORD WITH CIGAR LIGHTER PLUG

MULTI-PRODUCTS COMPANY

21470 COOLIDGE HWY.

OAK PARK, MICHIGAN

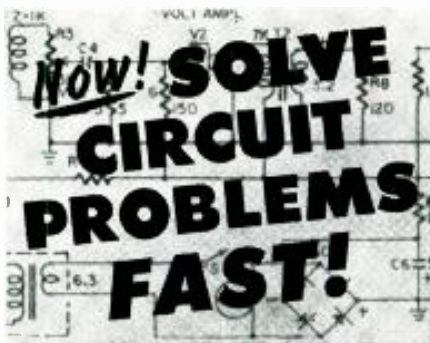

Goodbye to trial-and-error methods. Every circuit calculation you need can now be done accurately with

THE ALGEBRA OF ELECTRONICS

YOU'LL BE AMAZED at how easy it is to figure resistances, load inductances, impedances, etc. for ANY part of ANY electronic circuit. With this new book, THE ALGEBRA OF ELECTRONICS, you will quickly gain a knowledge of the tools, techniques and shortcuts needed.

Three Great Books in One!

First, it's a textbook. All practical mathematical techniques explained clearly step-by-step; easy to follow by those with no more math training than high-school algebra and simple differential calculus.

Second, it's a handbook. Graphs and tables answer common electronic problems for those not wishing to work out complex derivations themselves.

Third, it's a review. Every equation is discussed, along with its practical on-the-job applications. 100 problems are shown with methods and answers provided.

THE ALGEBRA OF ELECTRONICS was written by Chester H. Page, Consultant to the Director of the National Bureau of Standards. Dr. Page discusses basic laws and fundamental principles, practical methods of solving simultaneous equations. He develops elementary Fourier waveform analysis, shows effects of frequency selectivity, modulation, and analyzes tubes, transistors and power supplies.

Try It FREE for 10 Days

Whether you're a repairman, technician, or engineer, you'll find THE ALGEBRA OF ELECTRONICS both profitable and interesting. Send coupon for a FREE 10-DAY EXAMINATION. No obligation — unless you want to keep the book. Mail coupon today to

D. Van Nostrand Co., Inc.
Dept. 379, Princeton, N. J.
Established 1848



- 127 TOPICS**
341 Pages
252 Illustrations
- Nonlinear Resistance
 - Network Topology
 - Mesh Currents
 - Kirchoff's Law
 - Voltage Variables
 - Triangularization
 - Simultaneous Equations
 - Kramer's Rule
 - Thevenin's Theorem
 - Wheatstone Bridge
 - Conjugacy
 - Black Box Variables
 - Image Impedances
 - Attenuators
 - Capacitance
 - Dielectrics
 - Sinusoidal Voltage
 - Energy Storage
 - Series-Tuned Circuits
 - Series Resonance
 - Complex Phasors
 - Mutual Inductance
 - Transformers
 - Critical Coupling
 - F-M Discriminator
 - Impedance Matching
 - Hyperbolic Functions
 - Diodes
 - Amplifiers
 - Transistors
 - Thermal Noise
 - Demodulation
 - many more

Careers in Electronics
(Continued from page 50)

obtained at other schools. They can, and often do, prepare a man for comparable opportunities in private industry. Some industrial firms, however, may deprecate the value of military technical training to the extent that the applicant's performance level cannot be readily ascertained, due to the inaccessibility of the man's detailed performance record while in service. Nonetheless, completed military technical training, plus in-service performance in the man's indicated specialty, does provide higher-level entry into private industry than any school training with no job experience.

A radio transmitter operator, for example, will have experience considered "directly transferable" for, say, broadcast studio work. Even more "directly transferable" would be men in such specializations as Ground-Control Approach or Instrument-Landing systems. Here, competent men would qualify readily for field service work with equipment manufacturers, or as operators of the equipment directly at airfields.

Advanced Training

A number of well-paying careers may be developed by those who do not have a degree, but do have some (two years or more) college training in a specialized interest group, such as math, physics, design, or engineering. This kind of training, combined with some experience in any specific phase of electronics, could qualify a man for any of several jobs that start at the \$6000- to \$8000-a-year level. Much would depend, of course, on personal interests and abilities, as well as available openings. Such areas would include: field service engineering; sales engineering; sales promotion (including advertising and public relations); technical writing; product engineering; design engineering; special work with computers; and many more. These jobs

Unlike the positions in the preceding groups, these require college degrees.

GROUP III

These positions require a college degree, or its educational equivalent, i.e., college plus technical schooling, or company course, etc. In general, these are engineering level positions, implying a degree in Electrical Engineering, Mechanical Engineering, or Physics. In the computer field, a B.S. in E.E., Math, or Physics is desirable. At the higher levels of design and development, more and more a Master's degree is a requisite. In specialized research, a Master's is a minimum, a Ph.D. desirable. Because of requirements such as these, it is obviously impossible to detail the many engineering categories in the same manner as for Group I and Group II positions. Instead, we list approximate salary ranges covering the most general engineering classifications.

CLASSIFICATION	YEARS EXPERIENCE	SALARY RANGE
Engineer	0-2	\$5500-7500
Intermediate Engineer	2-5	7200-10,000
Senior Engineer; Senior in Design and Development	5-8	8500-13,500
Project Engineer; First Level Administrator; Research Head	8 and up	10,000-19,500
Administrator; Section Chief	10 and up	14,000-23,500

D. VAN NOSTRAND COMPANY, INC.,
Dept. 379, PRINCETON, N. J.
(In Canada: 25 Hollinger Rd., Toronto 16)

Send-for free examination—THE ALGEBRA OF ELECTRONICS. If I don't feel it can make electronic calculations clearer, easier, and faster, I may return it within 10 days; owe nothing. Otherwise, I will pay \$2.75 down, plus small delivery cost, and \$3 per month for 2 months.

Name
(Please Print Plainly)

Address

City Zone State

SAVE! Enclose \$8.75 WITH coupon and we will pay ALL shipping costs. Same ten day money-back privilege. (Foreign and A.P.O.—please send \$8.75 with order.)

man himself and the job he is to fill. As an example, it is no longer enough for a company to look for a "communications engineer." Now the category must be narrowed to, say, a "microwave specialist." Or, again, take the specialty known as "analogue-computer circuitry designer." Digital computer circuitry designers need not apply! And so it goes, into ever-narrowing and more specific types of work. Recruitment consultants and personnel men alike find it difficult to screen applicants for such specializations, which require a kind of pin-pointing referral demanded by many of today's electronic firms. This intra-industry problem, as well as the question of sheer numbers required *versus* those available, contributes to what has been called our "manpower shortage," although the term is often misunderstood. This shortage, actually defined by the need for extreme specialization, puts college graduates—as well as others with less training presently employed or planning to enter the field—in the position of being faced with many choices, of job type, of company, of locality in which to work and live.

Evaluating Job Situations

To these people, a host of factors must be weighed in arriving at a decision. Among them would be the stability of a particular company, its policies regarding personnel development, fringe benefits, educational extension opportunities, and so on. Also to be considered, if information is available, are such factors as the nature of the company's growth. A favorable sign would be continued increases in expenditures for both sales and research, as indicated in stockholders' reports. A relatively small annual turnover in personnel is another favorable sign. The seasonal or non-seasonal nature of its products might also be important.

Finally, there is the matter of the living conditions in the area related to where you'll be employed. Travel distance to and from work might be considered, as well as the residential aspects of the area in terms of cultural, social, religious, and educational factors that may be important to you or your family. In other words, "case the area"—using your own good sense (and senses) to evaluate it in terms of your interests and needs. For specific information, consult the local Chamber of Commerce, talk with real estate agents or other local people. One revealing indication of the "liveability index" of an area would be the published lists of teachers' salaries, generally available from the Board of Education or the Town Clerk.

In sum, for maximum job satisfaction you should do a little "market research" of your own. Less than a generation ago, such an attitude was well-nigh unheard of. But then, so were transistor radios, electronic thinking machines, and a lot of other things that today we take for granted in this growing field.

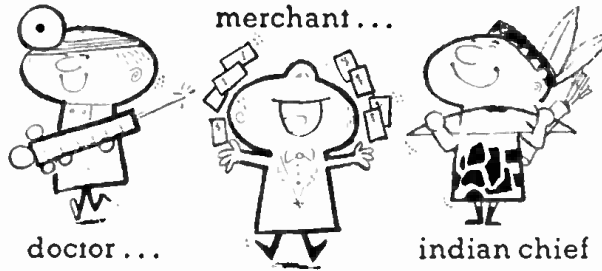

doctor...

merchant...

indian chief

There's
SOMETHING
for
EVERYBODY
in the new

LASALLE C/B TRANSCEIVER

Fully field-tested for 15-tube performance, 5-channel operation. Compact, completely mobile, complete with cable for 6 volt or 12 volt auto to 115 volt home operation. Quality-engineered, economy-priced.

WRITE FOR COMPLETE DATA SHEET

\$159⁹⁵ 10 tubes plus 1 diode, 3KCS wide superhetrodyne

receiver, automatic noise limiter, adjustable squelch, 1 RF and 3 IF stages, 5 watts input, full modulation, press-to-talk microphone, weight 12 lbs.



Manufactured by:
BIGGS ASSOCIATES, INC
UTICA, ILLINOIS

SAVE on everything in
stereo hi-fi
and
electronics



send for the 1961

ALLIED
CATALOG

free

444-PAGES • WORLD'S BIGGEST. Write today for the leading Electronics Catalog. World's largest selection, including products and values available only from ALLIED. **SAVE ON:**

- Everything in Hi-Fi Music Systems & Components • Biggest Selection of Hi-Fi Cabinetry
- Exclusive Knight® Super-value Stereo • Knight-Kits®—Best in Build-Your-Own Hi-Fi • Tape Recorders and Phono Equipment
- Everything in Electronic Parts, Tubes, Transistors, Test Equipment, Amateur Gear, P.A. Systems, TV Accessories, Tools, Books.

only \$2 down on orders up to \$30

Save most at ALLIED. Write for FREE 1961 Catalog today!

ALLIED RADIO

ALLIED RADIO, Dept. 101 J
100 N. Western Ave., Chicago 80, Ill.

Send FREE 1961 ALLIED Catalog.

Name _____

Address _____

City _____ Zone _____ State _____

free
catalog



DEALERS

This is the ONE Citizen's Band transceiver your business, farm and professional customers WANT and NEED NOW!

Mobilair

by Lakeland Electronics, Inc., Box 14, Warsaw, Ind.

- "BARRIER" selectivity, 4 kc.
- NO TECHNICAL experience required of the user.
- SIX CHANNELS (Xtals for one supplied).
- FULL TALK POWER with speech clipping and audio limiter for real punch and maximum modulation.
- MATCHED optional components and accessories available where required.
- ALL POWER inputs from 6 or 12 volts dc to 115 volts ac. Transistor power supply.

Mobilair series 2761 CB transceivers employ TWO stages of IF and other special circuitry to give you BARRIER selectivity at 4 kc. Additionally you can get the complete CB package of matched extras to satisfy the demands of ANY user who ever walked into your "store".

rugged enough for a tank
beautiful enough for the office

INQUIRE NOW

*Our first
consumer products
had to be
**THE FINEST
OF THEIR TYPE**

THE **Cadre**
**Citizens Band
TRANSIFONE
PORTABLES**

100% TRANSISTORIZED
100% RELIABLE
100% CONVENIENT

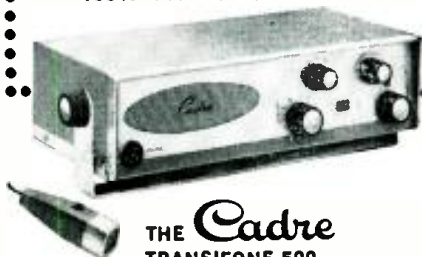

THE **Cadre**
**TRANSIFONE-500
5-WATT TRANSCEIVER**

A truly professional, unbelievably compact transceiver for commercial and private use. 12-transistor CADRE circuit requires minimum power absorption... provides maximum transmitter efficiency (virtually no signal-wasting radiations)... and noise-free reception on all 22 channels!
Transmitter: Range: 10 miles (20 on water). 5 crystal-controlled channels (simply change crystals to operate on any of the 22 channels).
Single-Conversion Superhet Receiver: 5 crystal-controlled channels free of adjacent-channel interference. • Receives all 22 channels. • High quality speaker - easily intelligible above noise of car or boat. • Squeech and ANL. 2 Power Supplies: Standard 12 V DC; and 115 V AC. Dimensions: 11"x5"x3". Weight: only 6 lbs. • Completely waterproof. Guaranteed for One Year.

Complete with dynamic microphone, cables, mounting brackets and hardware for car or boat installation

THE **Cadre**
**TRANSIFONE-100
100-MW TRANSCEIVER**



Completely transistorized, shirt pocket-sized... with self-contained battery! Transmits and receives on any one channel. Built-in microphone/speaker. Additional shoulder-strap antenna for use as pocket paging system. Telescoping antenna for long distance. Compact: 6"x2 1/2"x 1 3/4" deep. Featherweight: 16 ounces. Guaranteed for One Full Year.

Complete with battery and antennas

For complete information, write:
Cadre INDUSTRIES CORPORATION
•Manufacturers of computer sub-assemblies
and laboratory equipment
Endicott, New York

Mobile Transistor Power Supply

By **DONALD C. CHAYET**

G. P. S. Instrument Co.

Construction of simple unit that converts 12 v. d.c. to 200 v. d.c. at 75 ma. without expensive components.

TRANSISTOR power supplies are the most efficient way of converting low-voltage d.c. to higher voltages for use as "B plus" in mobile converters, tuners, and transceivers.

The present methods of building such supplies utilize toroidal transformers. These range in price from \$16 to more than \$30. The author decided that it was possible to achieve similar results using inexpensive, on-hand stock parts.

The first consideration in the design of this unit was to supply sufficient feedback current to make the transistors oscillate when full collector current was drawn. It was found that an inexpensive driver transformer of approximately 2.5:1 ratio, with the 2.5 section center-tapped, would supply sufficient bias for power transistors of approximately 25 watts dissipation. The power output is taken through a 10 volt, 5 amp. filament transformer into a full-wave silicon diode bridge.

The largest single item of cost was for the two power transistors; a *Sylvania* 2N307 and a *Workman* "Power 25." Both of these types worked quite well. A *Bud* "Minibox" measuring 7" x 5" x 3" was used as a chassis. The natural aluminum finish was chosen to facilitate heat dissipation. The driver transformer is a *Merit* #A-2920 while the output transformer is a *Thordarson* 21F18. The four silicon diodes were chosen as the least expensive available and were rated at a peak inverse voltage of 400 volts.

The transistors must be insulated from the chassis and each other. *Bendix Radio Division* makes plastic insulators and bushings for use with this type of transistor. The bushings must be trimmed approximately 1/16th inch because they are designed for 1/8-inch panels and the chassis specified is a 1/16th-inch type.

The U-shaped section of the "Minibox" was used for mounting all of the components. The two transistors were mounted, one on each side, with the driver transformer in the middle.

The output transformer was mounted on one side and the space between the top of the transformer and the other side was used to mount the pot. The terminal block was mounted on the side opposite the output transformer.

The only possible pitfall in the construction of this unit is if the circuit fails to oscillate. If this occurs, reverse the base leads on the transistors. When this unit is used in temperatures of less than 50 degrees F, it may refuse to start with a load. It is permissible to remove the load so that the oscillator can build up to normal operating frequency. This should take 1 to 3 seconds.

This circuit should be wired with #20 wire or heavier, due to the fact that the current can go as high as 4 amperes. The parts placement and lead lengths are not critical.

The 10,000-ohm resistor from the base to collector can be connected to either transistor and is used only to cause it to break into oscillation under loads. The 500-ohm pot is used to control the output voltage by controlling the oscillating frequency of the circuit. Its exact dissipation and resistance are not critical. Approximately 500 ohms and 2 watts are common values and were found to work quite well.

The bias control is set, using any one of three different methods. All three methods require the use of a 2500-ohm, 10-watt resistor as a load. The input current to the device may be monitored and the bias control set for 3 amps. input under this load. The second method involves monitoring the output voltage and adjusting the bias control to a point where the voltage is down 10 volts from maximum. The third method calls for the insertion of a milliammeter in series with the load and setting the bias control for a current of 75 ma.

All of these methods may be utilized for determining the maximum operating point of the transistors and the minimum resistance setting of the pot. The pot may be turned down further to give less voltage if the output of the device is too high.

This inverter will supply 75 ma. at 200 volts, with a current drain of 3 amperes at 12 volts. The over-all operating efficiency of this type of inverter, as compared to vibrators or dynamotors, is at least twice as high and will, in many cases, exceed this.

Other rectifier systems can be used in place of the bridge in order to obtain other output voltages and currents.

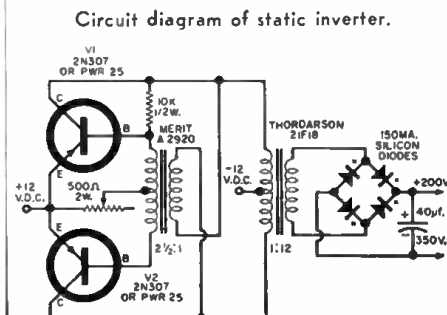

A CREI college-level extension program in advanced electronic engineering technology that offers you...

high professional status and better income



DYNAMIC EXPANSION OF ELECTRONICS INDUSTRY CREATES OUTSTANDING JOB OPPORTUNITIES.

No other major field of engineering has enjoyed a more rapid growth or promises a more brilliant future than electronics. New developments in space exploration, guided missiles, automation, computers, and many other fields create new jobs daily, jobs which have to be filled by men with a modern advanced education in electronics. The shortage of competent electronic personnel will grow more acute over the next decade, and salaries and professional stature of technical men are expected to reach new highs.

The fact that new positions must be filled by men with an up-to-date education is evidenced by the experience of the CREI Placement Bureau, where the demand for graduates and advanced students has far exceeded the supply for several years. It is of interest to note that

many leading companies regularly visit CREI strictly for the purpose of recruiting CREI graduates and students.

Many CREI students have learned that they do not have to complete the program to realize considerable increases in their status and income. Their own employers realize that if you are ambitious enough to pursue this college-level program, you are a better candidate for rapid promotion. Professional people in supervisory positions recognize the value of CREI education.

HOME STUDY IS CONVENIENT AND

TIME SAVING. You will find more than 20,500 CREI students working in most every phase of electronics in all 50 states and in most foreign countries of the free world. Just like them, you can pursue the CREI

CREI's Extension Division now offers you a college-level program in electronics comparable in technological content to advanced residence courses.

CREI offers college-level opportunity to the man who wisely realizes that the recognition and rewards in electronics are now going to other men—especially the man with modern advanced education.

Within two to four years, depending on the courses you select and amount of stick-to-itiveness brought to bear, you can complete the CREI program in advanced electronic engineering technology. The program was developed hand-in-hand with leading private companies and government agencies contributing to the Nation's efforts in electronics, communications, missiles and space exploration.

OFFICIALS OF PRIVATE COMPANIES AND GOVERNMENT AGENCIES APPROVE CREI FOR THEIR OWN PERSONNEL.

The quality and advanced standing of the CREI educational program is readily seen in the appreciation expressed for it by both industry and government. At present there are 5,240 U. S. Navy electronics personnel enrolled in CREI extension programs. More than fifty leading electronics organizations in this country and in foreign nations actually pay all or part of the tuition for employees taking CREI courses. The list below comprises a few of these organizations:

National Broadcasting Company • Jerrold Electronics Corporation • Pan American Airways • Radio Corporation of America • Canadian Aviation and Electronics • Federal Electric Corporation • The Martin Company • Voice of America • Canadian Broadcasting Corporation • Northwest Telephone Company • Commercial Cable, Incorporated • Canadair Limited • Columbia Broadcasting System • All America Cable and Radio • Canadian Marconi • Mackay Radio • United Air Lines • Gates Radio Company • Mohawk Airlines • Florida Power and Light Company • British Air Force, Army, Navy

program while you continue your regular full-time job. You study at home during hours chosen by you, and you are not rushed. Also, you do not have to waste valuable time traveling to and fro but can concentrate on your studying at the hours most convenient to you.

The courses are prepared in easy-to-understand format, and your progress is guided all along the way by the CREI staff of experienced instructors. These instructors always stand ready to give you personal assistance and help whenever you may need it.

ECPD Accredited Technical Institute Curricula • Founded in 1927

The Capitol Radio Engineering Institute

3224 16th Street, N.W., Washington 10, D.C., Dept. 1109-G

TO THE SERIOUS-MINDED MAN, CREI OFFERS THESE IMPORTANT BENEFITS:

- * You gain a solid college-level education in electronics; you keep abreast of continuous new developments and sophistications in the field of electronics.
- * You can gain higher status and enjoy the increased respect of your associates.
- * You facilitate more rapid professional advancement and corresponding increases in pay.
- * You gain the personal satisfaction that comes from working and communicating intelligently with technical colleagues and superiors.

The accredited program is designed to meet your present and future employment requirements and to increase your professional status and earning power.

PROFESSIONAL STANDING

CREI was founded in 1927 and is one of the oldest technical institutes in America. We co-founded the National Council of Technical Schools, and we were among the first three technical institutes whose curricula were accredited by the Engineers' Council for Professional Development. The U. S. Office of Education lists CREI as "an institution of higher education."

QUALIFICATIONS FOR CREI

You qualify for CREI study if you have a high school diploma or equivalent, and if you have had basic electronic training and practical experience in some phase of electronics. Tuition is reasonable and may be paid monthly, if you wish. Veterans qualify for this program under the GI Bill.

CREI RESIDENCE SCHOOL

CREI conducts a residence school in Washington, D.C. for those who can attend classes. Day and evening classes start at regular intervals. Graduates earn AAS Degree in 27 months of study. Electronics experience or training is not required for admission.

SEND FOR THIS FREE 48-PAGE BOOK TODAY... USE POSTAGE-PAID CARD ATTACHED.

Write for the detailed and informative book "Insurance for Your Future in the New World of Electronics." It is yours for the asking without cost or obligation. The book gives details about curricula and CREI and answers several searching questions about the future in electronics. The book is of vital interest to every man employed in electronics.



proven reliability...
acclaimed by thousands...

EICO®



Model 760: 117 VAC
KIT **\$59.95** WIRED **\$89.95**

CITIZENS BAND 2-WAY COMMUNICATIONS TRANSCEIVER
that meets FCC regulations*

*EICO premounts, prewires, pretunes, and seals the ENTIRE transmitter oscillator circuit to conform with FCC regulations (Section 19.71 subdivision d). EICO thus gives you the transceiver in kit form that you can build and put on the air without the supervision of a Commercial Radio-Telephone Licensee!

And only EICO offers you all these other features:

- 5½ dual function tube SUPERHETERODYNE (not regenerative) receiver with RF stage for high sensitivity — with the selectivity you need for reliable operation. Continuously tunable over all 23 Citizen Band channels.
- Exclusive built-in Super-Hush® noise limiter minimizes background noise when the receiver is left on in anticipation of a call, without the risk of missing a signal entailed in the use of a "squelch" circuit in the presence of high ambient noise.
- Built-in AVC automatically boosts gain on weak signals.
- Built-in 3" x 5" oval PM speaker and detachable ceramic-element microphone.
- 5-W xtal-controlled transmitter—can transmit on any of the 23 Citizen Band channels.
- Station license available to any citizen over 18 — no exams or special skill required. Application form supplied free.
- ANYONE can build this kit by following the easy simplified "beginner-tested" step-by-step instructions.
- Variable "pi" network permits matching to most popular antennas.
- Covers up to 20 miles depending on terrain and antenna height.
- Unique Posi-Lock® mounting bracket (patent applied for) permits 360° rotation and positive lock at 30° intervals.
- 7 tubes & 1 xtal (extra xtals available).

Compare — judge for yourself — at your neighborhood EICO dealer. For free catalog of over 70 models of easy-to-build professional test instruments, hi-fi and ham gear, fill out coupon on Page 33.

Model 761: 117 VAC & 6 VDC
Model 762: 117 VAC & 12 VDC
Including mounting bracket

\$69.95 **\$99.95**
KIT WIRED

EICO® 33-00 N. Blvd., L.I.C. 1, N.Y.
© 1959.
Add 5% in the West.

Teleprinter Sets Record

(Continued from page 51)

—1000 volts (biased at 450 volts), producing a difference between the anode and pin of 1350 volts.

This causes an arc between the anode and pin, resulting in a source of ions. Because of the voltage gradient from the arc to the paper (at ground potential), there is a migration of ions to the paper causing a deposit of charged particles on the surface of the paper. The placement of such a "dot" can be controlled by selecting various pairs (of anodes and pins) in each printing head.

The paper then passes through an ink, which contains powdered ink that adheres to any charged areas on the paper. In this way, images on the paper become visible to the human eye.

The paper then passes over a heater and through a fixing roller, where the particles of ink are pressed into the softened polyethylene-coated surface of the paper. This permanently fixes the alphanumeric images on the paper.

Electronic Control

The problem of providing suitable pulses to the particular pairs of anodes and pins contained within any of the 72 printing heads is solved by electronics. A simplified circuit diagram is shown in Fig. 4.

Initially, a conventional "start-stop" teletypewriter signal is converted to a five-bit parallel code by means of a receiver distributor using solid-state techniques. This is basically an electronic analogue of a mechanical distributor.

This five-bit parallel code is converted to dot locations produced by the 72 printing heads in two steps: (1) from binary to one-out-of-50 character circuits by means of a decoding network, and then (2) from a character circuit to 35 output circuits by means of an encoding network.

The decoding network is essentially a diode matrix composed of 176 diodes and 35 resistors. Output of this network consists of 50 signals representing the characters to be printed plus

eight output signals that are used for control functions—such as line feed, carriage return, spacing, etc.

The encoding network consists of 340 diodes. It has one input circuit for each character to be printed. And it has 35 outputs, one for each "dot" location in the matrix of a printing head.

These 35 outputs are applied to a pin pulser, which produces a pulse of about —1000 volts for any desired pin of the matrix of a printing head.

Thus, when a character circuit is selected by the decoding network, the connection of the diodes in the encoding network is such that appropriate output circuits are energized to pulse appropriate pins in the matrix of any of the 72 printing heads.

The exact printing head selected for application of such pulses is determined by the anode pulses, which are selected cyclically by means of 72 separate pulse transformers, synchronized by a control voltage from the decoding network. See Fig. 4.

Commercial types of power supplies are used for all high-voltage pulse requirements. Other power is obtained from solid-state devices.

Operating Speeds

The teleprinter is equipped with six preset operating speeds. One of these —750 words per minute—is the accepted standard for Army communications purposes.

Only factors limiting the present top speed to 1000 characters per second are mechanical considerations of inking and of moving the paper past the printing heads of the recording system.

Development work is continuing toward solving this problem, and the Burroughs Corporation now believes it is possible to attain operating speeds of more than 5000 characters per second through mechanical improvements in the basic system design.

All of the transistorized electronic circuits of the system are now fully capable of responding to such future high-speed requirements—making certain the reception and reproduction of future messages at the rate of more than 50,000 words per minute! —30—

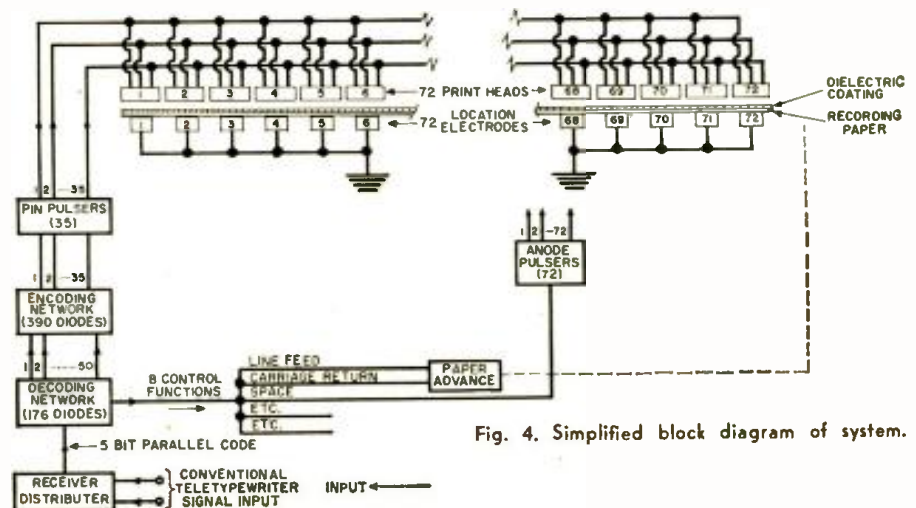

Fig. 4. Simplified block diagram of system.

Name-the-Scientist Puzzle

By
JOHN A. COMSTOCK

YOUR association with the electronics field should include familiarity with the many famous scientists without whom radio, TV, hi-fi, and electronics would be impossible. Try your hand at working this puzzle. If you can fill in the correct names and words, you have paid small tribute to these outstanding men who have helped make life easier for all of us through electronics.

(Answer on page 140)

ACROSS

4. Inventor of superhet circuit and FM system of broadcasting.
8. Inventor of the cylinder phonograph.
9. "Gauss" is unit of _____ density.
10. First man to demonstrate electromagnetic radiation phenomenon.
12. An electronic device invented by Fleming (abbr.).
13. De Forest's early triode.
14. The relationship between current flow and magnetic flux was investigated by _____.
16. William Gilbert is closely linked with _____ (abbr.).
18. Unit of inductance bears this U.S. physicist's name.
20. Discoverer of e.m.f.
22. Well-known New England technical school. (colloq.).
23. British engineer after whom unit of power consumption was named.
25. German physicist, Kirchoff's, initials.
26. Armstrong's first name.
28. First name of the "Father of the Vacuum Tube."
29. In 1946 it was proved possible for radar to _____ the moon and be reflected back to earth.
30. X _____ were discovered by the German physicist, Wilhelm K. Roentgen.
33. _____ Forest invented the triode by adding a grid to Fleming's diode.
34. Man famous for his contributions to sound measurement.
35. "Alva's" first and last initials.

DOWN

1. Inventor of telephone.
2. Angstrom is noted for his contributions in measuring the wavelength of _____.
3. The French mathematician, Jean B. J. _____ whose name is associated with wave analysis.
5. W. C. Sabine developed a well-known formula for _____ measurement.
6. German physicist after whom the unit of resistance was named.
7. The unit of flux density was named after this German mathematician.
11. He added a third element to the diode.
15. Inventor of the "Iconoscope."
16. The CGS unit of magnetic flux was named after this British physicist.
17. Scientist whose name is associated with sound range because of his investigations into this phenomenon.
19. Japanese inventor of an antenna.
21. French physicist after whom the unit of current flow was named.
24. The hand that is employed for motors.
27. _____ analysis was investigated by Fourier.
31. First and last initials of the man who gave us the practical unit of current intensity.
32. Unit for designating length of light waves was named for this physicist (first and last initials).

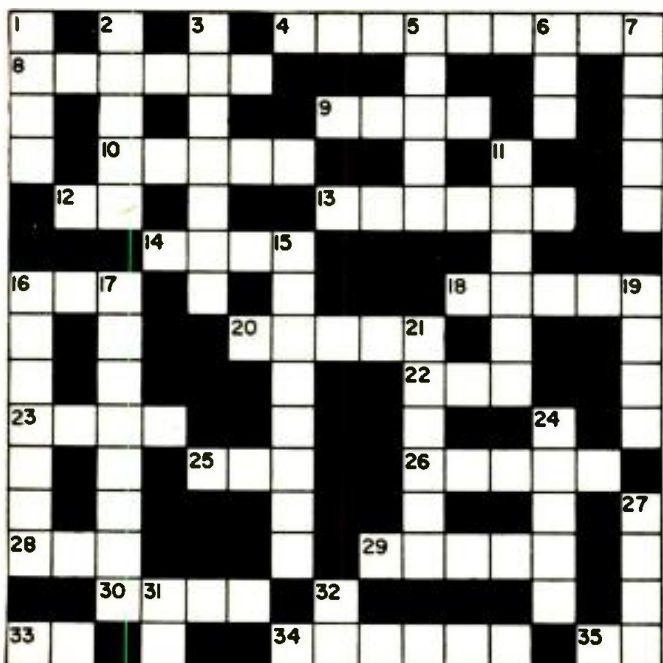

SAVE MORE with

SONAR TUBES

You can't afford to pass up this golden opportunity to save on used tubes!

- Tested for mutual conductance in our own labs!
- One year free replacement guarantee!
- Prompt refunds on defective merchandise!

SPECIAL PURPOSE TRANSMITTING TUBES AND INDUSTRIAL TUBES

TYPE	PRICE	TYPE	PRICE	TYPE	PRICE	TYPE	PRICE	TYPE	PRICE
0A2	.60	4X150A	8.50	813	8.50	957	.30	5751	.90
0A3	.70	5R4GY	1.00	815	1.70	2050	.90	5763	.80
0A4	.75	6G1	6.50	829B	7.00	2051	.75	5814A	.75
0B2	.45	6D4	1.50	832	3.00	2625W	1.15	5879	.90
0B3	.65	6X4W	1.00	832A	3.50	5654	.75	6080	2.75
0C3	.80	6J4WA	1.15	843	.30	5686	1.50	6082	3.75
0D3	.40	218	8.00	866A	1.05	5687	.75	6135	1.00
2C44	.75	304TL	35.00	872A	1.05	5702	1.50	6146	2.45
2D21	.55	313C	1.25	884	.80	5703	1.50	6159	2.75
2E24	1.95	5J29	.50	885	.75	5725	.90	6189	1.00
2E26	1.95	750TL	32.00	954	.20	5726	.40	6201	1.00
3A4	.45	807	1.00	955	.30	5749	.70		

JAN SURPLUS TUBES

TYPE	PRICE	TYPE	PRICE	TYPE	PRICE	TYPE	PRICE	TYPE	PRICE
0Z4	.42	6AG7	.44	6CL6	.59	7C4	.39	14A7/12B7	
1A7GT	.45	6AH4GT	.55	6CM6	.58	7C5	.44		.48
1B3GT	.52	6AH8	.42	6CM7	.40	7C6	.46	14B8	.48
1H4G	.39	6AK5	.43	6CN7	.40	7C7	.48	14Q7	.48
1H5GT	.45	6AL7	.45	6CS6	.42	7E6	.48	19	.48
1L4	.39	6AM8	.49	6DE6	.44	7E7	.44	19A4GT	.49
1L6	.42	6AN8	.54	6DQ6	.79	7F7	.42	19B6GG	1.00
1N5GT	.52	6AQ5	.44	6F6	.69	7F8	.42	19J6	.48
1Q5GT	.44	6AQ6	.42	6H6	.37	7H7	.40	19T8	.58
1R5	.41	6AQ7GT	.48	6J4	1.00	7N7	.48	24A	.48
1S5	.39	6AR5	.48	6J5	.44	7Q7	.48	25AV5	.75
1T4	.41	6AS5	.42	6J7	.59	7X7/XXFM		25BQ6	.79
1U4	.41	6AT6	.42	6K6GT	.33		.44	25DN6	.99
1U5	.42	6AT8	.48	6K7	.48	7Y4	.39	25L6GT	.40
1V2	.49	6AU4GT	.40	6K8	.58	7Z4	.38	25W4GT	.41
1X2	.32	6AU5GT	.50	6L7	.49	12A8	.42	25Z5	.44
2A3	.95	6AU6	.40	6N7	.59	12AQ5	.52	25Z6	.44
2AF4	.88	6AU8	.49	6Q7	.59	12AT6	.42	26	.40
3BC5	.40	6AV5GT	.49	6S4	.40	12AT7	.61	35A5	.45
3BN6	.30	6AV6	.42	6S6GT	.40	12AU6	.40	35B5	.44
3BZ6	.40	6AW6	.40	6SA7	.40	12AU7	.44	35C5	.46
3CF6	.42	6AX4GT	.50	6SC7	.44	12AV6	.42	35L6GT	.48
3CS6	.42	6AX5GT	.49	6SF5	.49	12AV7	.63	35W4	.43
3LF4	.49	6B8	.44	6SF7	.55	12AX4GT	.50	35Y4	.39
3Q4	.44	6B8C5	.44	6SK7	.40	12AX7	.55	37	.48
3S4	.44	6B8C	.49	6SL7GT	.50	12B4	.42	39/44	.35
3V4	.44	6BD6	.40	6SN7GT	.40	12B6	.44	42	.45
4BQ7A	.65	6BE6	.44	6SQ7	.40	12B7	.69	43	.45
4BZ7	.65	6BF5	.45	6SS7	.62	12BE6	.44	45	.47
5AS8	.52	6BF6	.40	6T4	.62	12BF6	.44	50A5	.45
5AT8	.44	6BG6G	.99	6T8	.61	12BH7	.51	50B5	.48
5AV8	.44	6BH6	.41	6U8	.66	12BQ6	.53	50C5	.48
5AW4	.49	6BJ6	.41	6V6	.44	12BR7	.48	50L6GT	.48
5BK7	.58	6BK5	.65	6W4GT	.39	12B7	.55	50X6	.51
5J6	.51	6BK7	.68	6W6GT	.43	12CA5	.48	56	.43
5T8	.49	6BL7GT	.68	6X4	.37	12J5	.45	57	.43
5U4G	.39	6BN6	.70	6X5	.40	12K7	.40	58	.43
5U8	.49	6BQ6GT	.73	6X8	.65	12L6	.40	71A	.59
5V4G	.49	6BQ7	.68	6Y6G	.69	12Q7	.45	75	.60
5V6GT	.45	6BY5	.60	7A4/XXL	.44	12SA7	.44	76	.45
5X8	.45	6BZ6	.42	7A5	.42	12SG7	.48	77	.45
5Y3GT	.42	6BZ7	.68	7A6	.44	12SJ7	.48	78	.60
5Y4G	.55	6C4	.39	7A7	.42	12SK7	.44	80	.52
6A7	.60	6C5	.60	7A8	.45	12SN7GT	.46	84/6Z4	.48
6A8	.60	6C6	.60	7B4	.42	12SQ7	.44	117Z3	.44
6AB4	.40	6CB6	.44	7B5	.41	12V6GT	.40	117Z6	.90
6AC7	.55	6CD6G	.99	7B6	.48	12W6GT	.40	117L7	1.95
6AF4	.82	6CF6	.42	7B7	.48	12X4	.46	117M7	1.95
6AG5	.40	6CG7	.40	7B8	.44	12Z3	.46	117P7	1.95

6-12 VIBRATORS.....89¢ each

Write Dept. EW-960 for complete list of tubes and special purpose tubes.

All advertised tubes not necessarily new but may be electrically perfect factory seconds or used tubes. Each is clearly marked. All tubes postage paid. Include 25¢ handling for orders under \$5. Include 25% deposit on C.O.D.'s. Send approx. postage on Canadian and foreign orders.

SONAR ELECTRONIC TUBE CO.

112 MARTIN ST., PATERSON 3, N. J.

Rush Coupon for your **FREE** Famous RADIO SHACK Electronics CATALOGS



Receive giant Electronics Buying Guide and all new issues for a full year! See the newest and best in electronics at money-saving prices.

Over 100,000 items for "Pro" and Amateur

SAVE UP TO 50% ON TYPICAL VALUES LIKE THESE!

MORE VALUES:

- Hi-Fi
- Ham Radio
- Tapes
- Kits & Parts
- Test Equipment
- Sports Goods

15-day no-risk home trial on any item. Send for your catalogs now! If coupon is clipped, write to
RADIO SHACK CORP.
Dept. 60J6
730 Commonwealth Avenue
BOSTON 17, MASS.



**2-SPEED
TAPE RECORDER**
COMPARE AT \$99.95
only
\$49.50



**CODE PRACTICE SET
WITH KEY
AND BUZZER
COMPLETE**
only **\$1.79**



**FULLY WIRED
STEREO AMPLIFIER**
only **\$9.95**

MAIL COUPON TODAY!

RADIO SHACK CORP. Dept. 60J6
730 Commonwealth Ave., Boston, Mass.

Without obligation, please send me **FREE POSTPAID**, your latest giant Electronics catalog plus every new issue for one full year.

Name _____
Address _____
Post Office or City _____ Zone _____ State _____

New Loudness Compensation
(Continued from page 43)

keep boost toward the low end of the audio range, where it properly belongs since the Fletcher-Munson effect principally involves frequencies below 400 cycles.

Limitations

The circuit of Fig. 1A does not permit infinite attenuation, as gain controls generally do. Instead, it provides about 45-db maximum attenuation. This does not appear to be a serious limitation. It is difficult to conceive of a situation in the home where 45-db attenuation is insufficient. Bearing in mind that about 30-db attenuation is generally the most that is used, and that the dynamic range of most program sources is no more than 45 to 50 db, it seems that attenuation of 45 db should be enough. In fact, the limited attenuation can be an asset, as in the case of the absent-minded listener who may turn down the volume to answer the telephone and then forget to shut off the set before retiring; the fact that the audio system does continue to put out a minute amount of sound can be a valuable reminder. However, one way of increasing the maximum attenuation is to reduce R_s , at the same time proportionately increasing C and decreasing R_i ; the drawback is that the size of C tends to become unwieldy.

A second criticism which might be directed at the circuit of Fig. 1A is that at mid-position of the bass control R_i is not zero, as it theoretically should be, but is 2500 ohms, thereby causing some extra bass boost to take place. R_i is a stock item, namely a log-taper pot that attains 5% of its total resistance at 50% of its clockwise rotation. However, when volume is reduced 10 or 20 db at 1000 cycles, a value of 2500 ohms for R_i produces virtually no extra bass boost. Even when volume is reduced 30 db, a 2500-ohm resistance causes less than 1-db extra bass boost, as shown in Fig. 2C. Only when volume is down 40 db does a 2500-ohm resistance cause significant extra bass boost, and still this is less than 3 db, as shown by Fig. 2D. It is difficult to believe that anyone would wish to listen to music at a level of 40 db below the original performance without using a good deal more than 3-db bass boost.

Both criticisms—incomplete attenuation and residual bass boost—can be avoided altogether by using a special pot for R_i , namely one that has zero resistance in the first 50% of its clockwise rotation. Mallory and IRC have indicated to the authors that a special pot can be made to order at an extra charge of about \$10.

Conclusion

In conclusion, the authors wish to point out that Fig. 1A embodies a truly new approach to the problem of loudness compensation. True, if the bass control is set to the right of mid-posi-

**ENGINEERING
HOME STUDY COURSES**

Courses written by world authorities in all branches of engineering and science and proved successful by thousands of our graduates. One hour each day in your spare time will start you off to higher pay, security and prestige. Personalized instruction methods ensure rapid progress. Fill in the coupon and indicate the course of interest. We will send you a complete outline of the course and a booklet describing the Institute and our advanced teaching methods.

- RADIO ELECTRONICS
- TELEVISION CIRCUIT
- MATHEMATICS
- ELECTRICAL ENG.
- TELEPHONY
- CIVIL ENG.
- SURVEYING
- ARCHITECTURE
- MINING
- STRUCTURAL MECHANICAL ENG.
- INDUSTRIAL ENG.
- & MANAGEMENT
- REFRIGERATION
- DRAFTING
- PLASTICS
- AERONAUTICAL ENG.
- HIGH SCHOOL CHEMICAL
- MATHEMATICS
- JOURNALISM
- ACCOUNTING

MAIL THIS COUPON TODAY

CANADIAN INSTITUTE OF SCIENCE & TECHNOLOGY LIMITED
752 Century Bldg., 412, 5th St. N.W., Wash., D.C.

NAME.....
ADDRESS.....
CITY.....STATE.....
COURSE OF INTEREST.....

Canadians: Send to C.I.S.T., 752 Garden Bldg., 263 Adelaide St. West, Toronto, Ontario.

C. I. S. T.

Ask By Name For
GENUINE
your assurance
of brand name
quality

"NO NOISE" PRODUCTS



NO-NOISE TUNER-TONIC
With PERMA-FILM

- Cleans, lubricates, restores all tuners, including water type.
- Non-toxic, non-inflammatory.
- For TV, radio and FM use.
- Economical—a little does a lot.

6 Oz. Aerosol Can
\$3.25
Net to Servicemen

NO-NOISE VOLUME CONTROL and CONTACT RESTORER

- Lubricates
- Protects
- Cleans
- Protects

Net a Carbon Tet Solution 2 Oz. Bottle
6 Oz. Spray Can
\$1.00 \$2.25
Net to Servicemen



FREE At Your Jobbers
5" PLASTIC EXTENDER

- Push Button Assembly
- For Pin-Point Applications
- Does Not Cause Shorts

ELECTRONIC CHEMICAL CORP.
813 Communipaw Avenue Jersey City 4, N. J.

P.S. Be Sure to Ask for **NO-NOISE RUBBER COAT** 6 Oz. Spray Can **\$3.25**

tion, so that R_1 becomes appreciable in value and enables extra bass boost to take place, the gain control behaves in the manner of a loudness control, providing increasing bass boost as the volume goes down. However, this is not the intended mode of operation, although a number of listeners may find it to be a satisfactory one.

Instead, the authors have in mind not an automatic form of loudness compensation, as in the case of the loudness control, but a manual form of compensation, where the listener adjusts the bass control to give him what his ear indicates is satisfactory balance; no one has yet disputed the fact that the ear should be the final arbiter. The variable bass control can provide as much as 20 db *extra* bass boost above that supplied by the conventional bass control, and it does so only when the extra boost is needed, at low listening levels. Moreover, unlike the case of the loudness control, the user can always return to flat response simply by setting the bass control to mid-position (unless volume has been reduced 40 db or more, which is extremely rare).

Fig. 1A does not necessarily represent the ultimate version of the variable bass control. However, it does incorporate what the authors feel is an important principle: If bass boost is made necessary by the Fletcher-Munson effect, then the bass control should be able to provide all the bass boost needed to compensate this effect, with enough left over for other factors that also require bass emphasis. —30—

TEST-LAMP IDEA

By H. LEEPER

PENCIL-TYPE soldering irons, of the type that have the heating element and tip removable in a single piece, can be readily converted into handy test lamps for the service bench.

It is only necessary to remove the one-piece element and tip and substitute a 120-volt lamp bulb of the same base size, as shown in the photograph below.

Such bulbs or lamps are available in low wattage—which will be adequate for use in and around electronic equipment.

Once you have tried this handy "tool," chances are the soldering iron will never be idle even where a repair calls for no soldering operations at all. —30—

How pencil-type soldering iron can be "converted" to serve as a versatile test lamp.

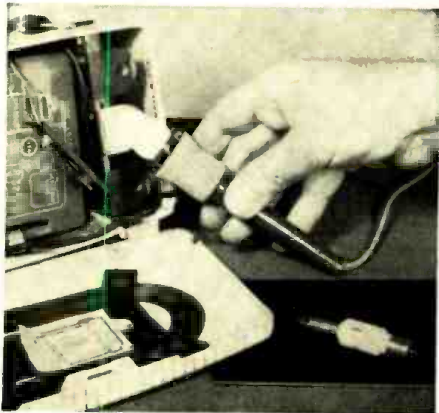

September, 1960

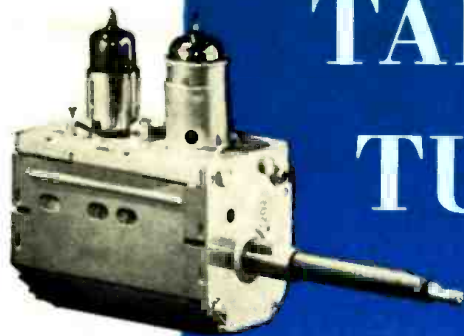

HOT ROD
(turret-type)

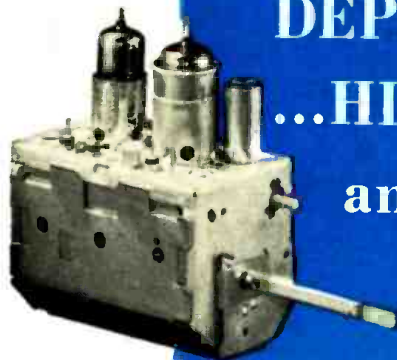

SILVER SEALED
(switch-type)



HI FI
(FM) Tuner

TARZIAN TUNERS

Noted for their
DEPENDABILITY
...HIGH QUALITY
and LOW COST

That's why the world's leading set manufacturers rely on the trouble-free TARZIAN TUNER for the excellent performance of their receivers.

Today TARZIAN TUNERS are backed up by more than 15 years of experience in the design . . . development . . . and production of more than 15 million TV Tuners.

And, Tarzian is the only commercial manufacturer offering both the HOT ROD (turret-type) and SILVER SEALED (switch-type) . . . as well as the newer Hi Fi FM Tuner. All embody the high standards of QUALITY . . .

DEPENDABILITY . . . and PERFORMANCE that have made Tarzian a leader in the field.

For more information, write to: Sales Department
Tuner Division



SARKES TARZIAN INC

east hillside drive • bloomington, indiana

Manufacturers of Semiconductors, Air Trimmers and Broadcast Equipment

IMPORTANT NEW SAMS BOOKS

Getting the Most Out of Vacuum Tubes

by Robert Tomer



The author of the CBS "Tech Tip" series has come up with a "must" book for every technician, designer and engineer. Vacuum tubes account for nearly 80% of equipment failures—yet according to Bud Tomer this doesn't have to be! He explains why tubes fail and what can be done to obtain maximum tube life and usage. Covers character-

istic variables and how to predict them; selected and premium tubes; why so many tube types; predicting performance; special-purpose tubes; tube testing; methods for lengthening tube life, etc. 160 p., 5 1/2 x 8 1/2", hardbound. Only \$3.50

Servicing Transistor Radios. Vol. 6

LATEST IN THE SERIES



Gives you a complete analysis of 62 domestic and foreign transistor radios produced in 1959-60. Here's all you need to know to service transistor radios; full data based on actual analysis of each receiver includes: Sams Standard Notation Schematics with exclusive CircuiTrace; chassis photos; alignment data; servicing tips; complete replacement parts lists. Special editorial section on using voltage analysis to pinpoint circuit troubles.

160 pages; 8 1/2 x 11". Only \$2.95

So You Want To Be a Ham

by Robert Hertzberg, W2DJJ



Brand-new edition, completely revised and enlarged. Tells how to meet license requirements, how to learn the code painlessly, how to select suitable equipment, how to be a good operator. Describes the amateur game in detail; conquering the code; getting your ticket; price ranges of equipment; going on the air; going mobile; test equipment and safety

measures; organization of amateur radio; the ham in military service; electronics as a career. Everything the novice needs to know. 192 pages, 5 1/2 x 8 1/2". Only \$2.95

BEST SELLER

TUBE SUBSTITUTION HANDBOOK

Tube substitution handbook includes over 3,800 direct substitutions! Lists over 1,500 American receiving tubes. Special sections list 169 industrial and 489 European additional substitutes for American receiving tubes. Also has section recommending 301 American substitutes for European types. Includes directory of 400 picture tubes. Contains helpful facts on tube substitution. Handy 5 1/2 x 8 1/2" size. Only \$1.50



HOWARD W. SAMS & CO., INC.

Order from your Sams Distributor today, or mail to Howard W. Sams & Co., Inc., Dept. J-10 1720 E. 38th St., Indianapolis 6, Ind.

Send me the following books:

- "Getting the Most Out of Vacuum Tubes" (VTT-1)
- "Servicing Transistor Radios, Vol. 6" (TSM-6)
- "So You Want To Be a Ham" (HAM-2)
- "Tube Substitution Handbook" (TUB-1)

\$.....enclosed. Send Free Book List

Name _____
Address _____
City _____ Zone _____ State _____

(Outside U.S.A. priced slightly higher)



WE ALL LIKE to think of ourselves as civilized beings capable of dealing with abstract notions. Indeed we are, but such refined activity still cannot match the forcefulness of our responses when we are confronted with the specific and concrete elements of reality. Thus it is easy to consider broad international problems—or broad service-industry problems—calmly and then forget about them without having generated much heat or without having taken much action. It is only when they hit us in direct, tangible form that we really become excited.

Take the matter of coordinated service-association activity on all levels, local, statewide, regional, and national. Most of us would agree broadly that certain problems, which cut across artificial boundaries, need such activity. But where's the fire?

Out of Monon, Indiana comes a letter from T.P., where there is a fire, and Monon's service dealers, including the correspondent, aren't calm. Strictly speaking, the conflagration is raging out of the state, in Chicago, Illinois, but the men of Monon can feel the heat from the flames. They have an area association—but it doesn't reach as far as Chicago.

The problem that T.P. is up against begins with the fact that metropolitan Chicago newspapers are widely circulated in his home town. The Sunday editions carry the usual TV sections, which list the weekly program line-ups for Chicago's five channels, receivable in Monon. These supplements also carry advertising, many of them on TV service, and the latter are larded with handsome claims (sometimes direct, but more often artfully "suggested").

Some of the ads boast of "one-hour" TV service. To Monon residents who are not in a position to find out for themselves (many Chicago residents have learned better), this means any set can be repaired within one hour of the time that the call for service is made. At best, the ads can only be pinned down to mean that a technician will be in the caller's home within one hour (if he can make it).

Other ads sell "guaranteed" picture tubes (up to two years' warranty) at startlingly low prices including installation, if the set owner brings his TV to the CRT vendor. To meet these prices, T.P. says he would have to take a loss on every picture tube he sells. There are other advertised claims, but these are the principal ones. Monon set owners are making their service dealers' lives miserable with demands to know why service and replacement

parts are so exorbitant in their town and why service is less speedy. We directed queries to Chicago to find out what was going on.

Our reply came from Frank Moch, executive director for NATESA, on behalf of the national group and its local affiliate, TESA-Chicagoland. The latter group has accumulated much evidence against these advertisers and worked with the state's attorney to bring some of the offenders to justice. There also has been cooperation with the local Better Business Bureau, which has massive complaint files against many of the advertisers but seems powerless to take effective action under existing legislation. It has been possible to get Internal Revenue agents to take some of the questionable operators in tow.

As to the picture tubes, they appear to be rebuilt units although the ads do not usually trouble to mention this (in at least one case they are claimed to be new). Also not generally mentioned is the fact that the "dud" allowance for the old CRT is included in the quoted price. Concerning the two-year warranties, orders to cease and desist have been issued in several cases of these unsupported promises.

Clearly the service people in Chicago have an uphill battle on their hands against this sort of competition. However, they have the advantage that enough set owners in their city have been "taken" to provide them with ammunition for answering their customers' questions. To set owners in Monon, where no one has had a chance to learn the hard truth, it seems that only thornless roses grow in Chicago.

With some of the evidence now in his hands, T.P. should fare better in dealing with his irate clientele. Still better, his letter may be an instrument in eliminating the harmful advertising altogether. It appears that his Chicago colleagues have been trying to involve the Federal Trade Commission in their difficulty for some time, on the grounds that Chicago's metropolitan newspapers are in interstate commerce, but they need evidence to support their contention. With the cooperation of T.P. and other Indiana service dealers, FTC intervention may become a reality.

If it does, it will please this publication to know that it has made some contribution by bringing together people who need each other's help. Nevertheless, it is important that such coordination should always be possible directly within the service industry itself. Occurrences like the mutual Monon-Chicago problem, which are scarcely unusual, provide all the concrete evi-

dence we need to establish the need for such cooperation.

Tube Call-Back Losses

The "Crusade Against Call-Backs" sponsored by Raytheon has reached the point at which the official list of "ten toughest types" is available. These are: 1B3GT, 6AU4GTA, 6AX4GT, 6BQ6GTA/B, 6SN7GTB, 1X2A/B, 6CB6A, 6CG7, 6X8, and 12AT7.

For readers who have not kept up with this campaign, it is based on two premises: the many service dealers who make no service charge for call-back replacement of tubes still in warranty are taking a beating, and the problem seems to be centered about a relatively small number of tube types that are notorious for early breakdown. As a result, Raytheon conducted a nation-wide survey among service professionals to determine the ten most (un)popular types.

The "winners" of this contest will constitute the first ten tubes in the manufacturers new "Uniline" series. Others will be added later. Uniline types will be manufactured under special supervision to insure high reliability, with an elaborate system of quality-control checks. To back up this series and to allay some of the call-back loss suffered by service operators, Raytheon offers a special guarantee. For any tube in the line that fails during the warranty period, the dealer will not only receive the usual replacement at no charge, but he will also receive one dollar as partial compensation for his no-charge call.

New Monthly Format

Congratulations are in order to the Television Service Association of Northeastern New York on the new format for its monthly "TSA Newsletter." It has always been an informative publication, although run off as a mimeographed affair in the past. The organ is now being printed professionally. The latest issue we have received gives an explanation of provisions of the state-wide licensing bill supported by TSA and the broader New York group of which it is a member, ESFETA.

More on Sears

Independent technicians who are called in to work on sets carrying the "Silvertone" brand name of Sears Roebuck are running into trouble in more than one part of the country. We recently had occasion to report on an incident in Pennsylvania. Another incident originates in King County, Washington. An independent called in by the set owner found that the picture tube and other tubes, still in warranty, were defective. An attempt to obtain warranty replacements from the local Sears service agency proved fruitless. A complaint to the main electronics division in Chicago brought a quick reversal. Sears affirms the fact that guaranteed parts remain guaranteed without regard to who works on the receiver.

-30-

"SAMS PHOTOFAC TS MAKE IT EASY"

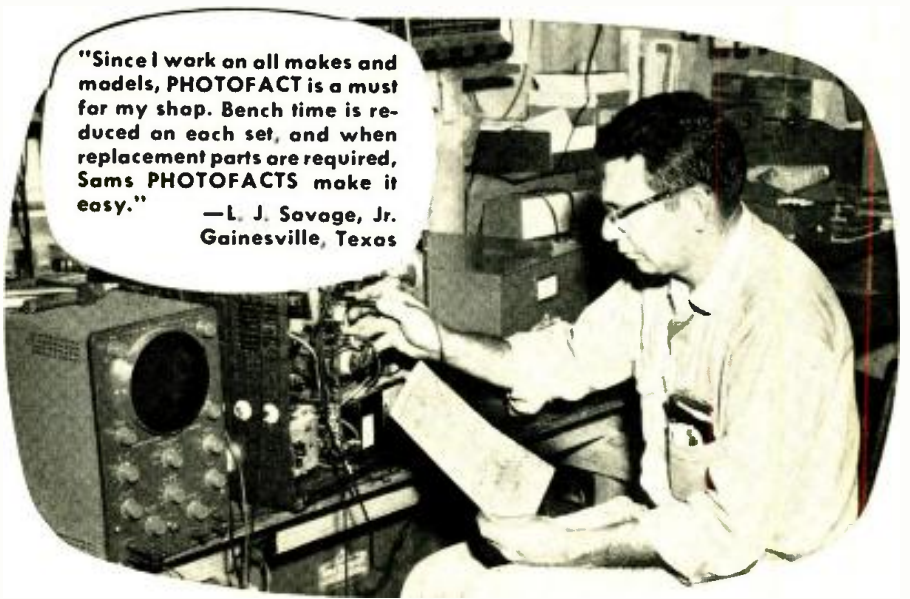

"Since I work on all makes and models, PHOTOFACT is a must for my shop. Bench time is reduced on each set, and when replacement parts are required, Sams PHOTOFAC TS make it easy."

—L. J. Savage, Jr.
Gainesville, Texas

Service Technicians! YOU EARN MORE... YOU RATE with the public when you own the PHOTOFAC T service data library!

You enjoy maximum earnings as the owner of a complete PHOTOFAC T Service Data Library! It's inevitable, because no matter how expert you are, you can always *save more time on any job, get more jobs done daily—EARN MORE, DAY IN AND DAY OUT...*

What's more—as the owner of a complete PHOTOFAC T Library, you know your customers' sets *best*. You can actually show each customer you have the PHOTOFAC T Folder covering his very own set. Result: You command public respect and acceptance which paves the way to more business and earnings for you.

HOW TO STAY AHEAD...

Yes, the truly successful Service Technicians are those who own the complete PHOTOFAC T Library, who can meet and solve any repair problem—faster and more profitably. And these men *keep ahead* because they're on a Standing Order Subscription with their Distributors to receive all new PHOTOFAC TS as they are released monthly. (They're eligible for the benefits of membership in PEET, too—see below!)

ONLY \$10 DOWN puts the complete PHOTOFAC T Library in your shop—and you have up to 30 months to pay. See your Sams Distributor today, or write to Howard W. Sams

NOW IS THE TIME TO JOIN

"PEET"

THE POWERFUL NEW PROGRAM FOR QUALIFIED TECHNICIANS

If you now own a PHOTOFAC T Library or plan to own one, you can apply for membership in "PEET." It's the first industry program really designed to build powerful public acceptance for the Service Technician who qualifies. Builds enviable prestige and business for its members. Benefits cost you absolutely nothing if you qualify. Ask your Sams Distributor for the "PEET" details, or mail coupon today.

HOWARD W. SAMS & CO., INC.

1724 E. 38th St., Indianapolis 6, Ind.

- Send me full details on the new "PEET" Program.
- Send full information on the Easy-Buy Plan and Free File Cabinet deal.
- I'm interested in a Standing Order Subscription.
 - I'm a Service Technician full-time: part-time

My distributor is _____

Shop Name _____

Attn: _____

Address _____

City _____ Zone _____ State _____

LESS HUM LOWEST NOISE with Mullard 7025



58An exact pinout replacement for the most troublesome tube in High Fidelity equipment. Mullard special design and construction, including special mica supports and internal structure make the 7025 superior particularly in critical high gain circuits where lowest level of hum, noise and microphonics are required.

A Plug-In Replacement for
ECC83, 12AX7, 12AX7A



OTHER Mullard TUBES
designed specifically for High Fidelity:

EB91/6AL5	Double Diode
ECC81/12AT7	Low-noise medium μ dual triode
ECC82/12AU7	Low-noise low μ dual triode
ECC83/12AX7	Low-noise high μ dual triode
ECC85/6AQ8	RF Double triode
ECC88/6AQ8	Frame grid RF Double triode
ECL82/6U8	RF triode pentode
ECL82/6BM8	Triode with Output Pentode
EF86/6267	Low-noise input pentode
EF94/6AU6	RF AF pentode
EL34/6CA7	High-power pentode, 100 W PP
EL37	High-power pentode, 69 W PP
EL84/6BQ5	Miniature output pentode 20 W PP
EM84/6FG6	Miniature tuning Indicator
EZ80/6V4	Miniature rectifier cathode type, 90 ma.
EZ81/6CA4	Miniature rectifier cathode type, 150 ma.
GZ34/SAR4	Bantam rectifier cathode type, 250 ma.
7189	Miniature output pentode 20W PP

Available at all leading distributors.



NOW AVAILABLE: "Mullard Circuits for Audio Amplifiers"—136 pages of Stereophonic and Monophonic Audio Amplifiers, AM Tuners, Preamplifiers—only \$2.50 from your dealer or by mail.

For detailed technical data and application information write:

**INTERNATIONAL
ELECTRONICS CORP.**
81 Spring Street, New York 12, N. Y.

New Audio Test Report

LAB TESTED
ELECTRONICS WORLD

H. H. Scott Model 314 FM Tuner
Audax CA-60 Speaker System
Homewood Model 2 Speaker Enclosure Kit

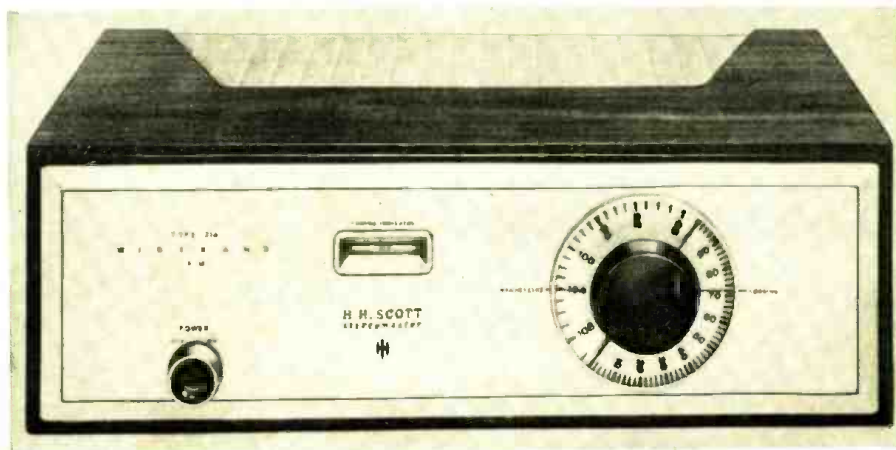

H. H. Scott Model 314 FM Tuner

THE new H.H. Scott Model 314 wide-band FM tuner is one of the finest that we have had a chance to check. The tuner is not only extremely sensitive and fully meets all the other specifications quoted for it by its manufacturer, but it shows evidence of considerable "know-how" in the field of tuner design. Because of the wide-band circuitry used, no a.f.c. is required to keep stations in tune. The high sensitivity means that even weak signals will be received and will produce adequate limiting. Complete front-end shielding prevents interference with nearby TV sets and helps eliminate cross-modulation.

Mechanically it also differs from many others on the market in that it does not use printed wiring, but has conventional components on a copper bonded to aluminum chassis. The chassis is large enough to permit the placement of the power supply section at a fair distance from the signal circuits, a feature which probably accounts for the very low inherent hum level. Heater leads are carefully twisted and routed for minimum hum pick-up and a hum balancing potentiometer is included. The "B+" is filtered through a 3-section filter and the audio output stage gets its plate voltage through a fourth filter section. Actual hum measurements indicated that the hum level was well below 60 db below 1 volt, the limit of our test set-up.

The Model 314 tuner has only an "on-off" control and the tuning dial on the front panel. Audio level is adjusted from the rear. In place of a dial cord, the tuning shaft is driven directly from the front control through a planetary friction drive. A tuning eye indicates

correct station adjustment. Although no a.f.c. is needed because of the wide-band circuitry, all critical circuits use temperature compensation to minimize oscillator drift.

The r.f. section uses a 6BQ7A in a cascode circuit, followed by a 6U8 which contains the oscillator and mixer. Two stages of i.f. amplification and a third stage as a limiter provide ample gain at broad bandwidth. The second i.f. stage also acts as limiter so that actually two cascaded limiters are in the circuit on very strong signals. A wide-band ratio detector using crystal diodes drives the audio output stage. To provide for FM multiplex reception, a separate audio output is available which does not go through the volume control and the output stage.

A number of measurements on a typical tuner yielded the following results:

Usable sensitivity for 20-db quieting (100% modulation): 90 mc., 1.4 μ v.; 98 mc., 1.4 μ v.; 106 mc., 1.6 μ v.

Usable sensitivity for 30-db quieting (100% modulation): 90 mc., 2.0 μ v.; 98 mc., 2.5 μ v.; 106 mc., 2.5 μ v.

Volume sensitivity for 20-db audio loss (100% modulation): 90 mc., 1.0 μ v.; 98 mc., 1.0 μ v.; 106 mc., 1.0 μ v.

Detector peak separation: 2.1 mc.

Detector linear region: 1.2 mc.

Oscillator drift: after 10 minute warmup ± 20 kc., approx.

Audio output: 1.2 volts r.m.s. undistorted.

Audio response: within ± 1 db from 30 cps to 15,000 cps except for standard de-emphasis curve.

Actual "on-the-air" tests of this tuner verified the measured data and also indicated a very high interference re-

jection ratio. It performed very well in capturing weak stations located adjacent to strong ones, and generally gives the user everything one comes to expect in a high-quality FM tuner. The unit is available for \$114.95 and comes complete with one audio cable and a 300-ohm twin-lead antenna. —30—

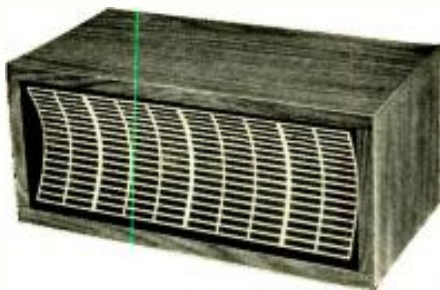

Audax CA-60 Speaker System

HERE at last is a bookshelf speaker system that really lives up to its name. The Audax CA-60 will actually fit comfortably on a normal bookshelf since it measures only 9½" x 10" x 18". What is more, the highly decorative inward-curved satin aluminum grille coupled with the oiled walnut cabinet results in a strikingly attractive over-all appearance.

The speakers used are two 6-inch high-compliance types for low and mid-frequencies along with a 3-inch cone-type tweeter for the highs. The tweeter is mounted between the two woofers along with its built-in high-pass filter, a series-capacitor type. Below the tweeter is a small rectangular ducted port which serves to lower the fairly high resonant frequency of the compact enclosure. Sound-absorbing material is used to line the back cover.

In sweeping the Audax unit with an audio oscillator, we found its mid-range and low-frequency performance fairly smooth down to about 70 to 75 cps. The cone tweeter has a gradual roll-off at the very high treble frequencies, so that the over-all effect is one of good balance between highs and lows. The mid-range performance was clean and there was no evidence of spurious resonances or "birdies." Also, there was no exaggerated bass effects nor was there any "barrel-house boom" in the reproduction of the lower tones.

We were impressed with the very high efficiency of the unit which would permit its use with low-powered phonos and amplifiers. As a matter of fact, as little as 5 watts of amplifier power should be adequate to fill the average living room with sound when this speaker system is used. The power-handling ability of the system is about 20 watts of peak program material.

This system should find acceptance among the large number of people who either do not want to pay for or do not require the extremes of the frequency range. Such individuals may have less expensive record players, for example, with which a speaker system with extended low-frequency response would serve to intensify the hum and rumble. In addition, especially for stereo, where

THIS IS THE GREATEST 'CONTINENTAL' OF THEM ALL...



the *Norelco*®

CONTINENTAL '400'

New 4-track
stereo-record/stereo-playback
tape recorder
guild-crafted by
Philips of the
Netherlands

The
exciting
specifications
on the new Norelco
CONTINENTAL '400'

(EL3536/54) provide only
an indication of what "the great-
est Continental of them all" holds in
store for the music lover, studio-recordist or
high fidelity enthusiast who is seeking a profes-
sional quality stereo machine at a modest price.

- ◆ **FOUR-TRACK STEREOPHONIC RECORDING AND PLAYBACK** ◆ **FOUR-TRACK MONOPHONIC RECORDING AND PLAYBACK** ◆ **THREE TAPE SPEEDS—1⅞, 3¾ AND 7½ IPS**
- ◆ **COMPLETELY SELF-CONTAINED, INCLUDING DUAL RECORDING AND PLAYBACK PREAMPLIFIERS, DUAL POWER AMPLIFIERS AND TWO NORELCO WIDE-RANGE LOUDSPEAKERS (SECOND IN LID)**
- ◆ **CAN ALSO BE USED AS A QUALITY STEREO HI-FI REPRODUCING SYSTEM WITH TUNER OR RECORD PLAYER** ◆ **FACILITY FOR MIXING PHONO AND MIKE INPUTS**
- ◆ **HEAD-GAP WIDTH—.00012"** ◆ **FREQUENCY RESPONSE—50 TO 18,000 CPS AT 7½ IPS** ◆ **WOW AND FLUTTER—LESS THAN .15% AT 7½ IPS** ◆ **SIGNAL-TO-NOISE RATIO—48 DB OR BETTER** ◆ **CROSSTALK—55 DB** ◆ **PORTABLE STYLED BY THE CONTINENT'S TOP DESIGNERS** ◆ **RUGGED**



A Norelco dual element stereo-dynamic microphone is standard equipment with the **CONTINENTAL '400'**



For a
convincing
demonstration
of all of the features
and qualities that
make the Continental
'400' "the greatest
'Continental' of them
all," visit your favorite
hi-fi center, or photo
dealer, or write for
complete literature to:

North American Philips Co., Inc.
High Fidelity Products Division
230 Duffy Avenue,
Hicksville, L. I., N. Y.

YOU'RE "IN THE CONCERT HALL" WITH KOSS STEREOPHONES

Add dramatic new realism to your recorded music

With dramatic Koss Stereophones, you'll thrill to new worlds of stereo sound reproduction. Your records or tapes sound just as if you had an orchestra seat in Carnegie Hall. Through these comfortable Stereophones, you hear music as perfectly as it can be recorded. Add personalized listening and sound perfection to your high fidelity stereo installation. \$24.95.



the use of two speaker systems will enhance the bass, these units should do an entirely suitable job.

In summary, the Model CA-60 is a compact, attractive, general-purpose high-fidelity speaker system with adequate performance at a reasonable price. The unit is available at dealers for \$59.95. A vinyl-covered model, with 25 feet of cable, a handle, and a volume control, is also available at the same price.

-30-



Homewood Model 2 Speaker Enclosure Kit

FOR those who are in need of a well-designed, inexpensive speaker enclosure, and prefer to construct one from a kit, the Homewood Industries, Incorporated Model 2 might be just the answer. It is a book-shelf-type unit, measuring 14" high, 21" wide, and 12 $\frac{1}{4}$ " deep. The enclosure is constructed of $\frac{3}{4}$ " hardwood plywood, and its design is of the bass-reflex type. It is available in either birch or walnut and, since all four sides are finished surfaces, this model is suitable for either horizontal or vertical placement. The design is for use with either 12" or 8" speakers. The speaker to be used should be of the wide-frequency-range type, such as a coaxial unit. Both 8" and 12" speakers will be suitable but we would, of course, prefer the larger of the two since it would provide better low-frequency response. Since the internal volume of the cabinet is approximately 1 $\frac{1}{8}$ cubic feet and the port area is 17 $\frac{1}{2}$ square inches, the most desirable speaker for a perfect match should be one having a free-air cone resonance of approximately 80-85 cps.

The construction of the kit is not difficult. All corners are extremely well-mitred, providing a sturdy assembly. A special tape is supplied with the kit that is used to temporarily hold the cabinet corners together while the glue dries. This method, even for the complete novice in wood craftsmanship, results in a fairly good job. We tried one corner using this method, and found no problems. For the balance of the assembly, we used wood clamps to really squeeze the joints together, and the construction turned out perfectly. Very little sanding was required.

As in all bass-reflex cabinets, some form of sound absorption material should be used on at least three of the non-parallel sides of the cabinet to

Full Color Giant Fold-Out Charts Still Available!

Here's a complete series of colorful, authoritative fold-out wall-charts (originally appearing in the pages of **ELECTRONICS WORLD**)—yours for only 15¢ each. All in full-color—each suitable for framing.

1. **V.H.F. TV Spectrum and Interference Chart:** Servicing aid for TV technicians and hams—saves hours by tracking down interference.
2. **Hi-Fi Crossover Network Design Charts:** Tells how to build speaker nets for any crossover frequency. Complete coil-winding data, capacitor values given.
3. **Color Codes Chart:** Gives you coding for capacitors, resistors, transformers, resistance control tapers—all in easy-to-use form.
4. **Bass-Reflex Design Charts:** Complete data on building own bass-reflex enclosures for any speaker, including ducted-port enclosures.
5. **Radio Amateur Great Circle Chart:** For Hams and short-wave listeners—gives complete listing and map of amateur prefixes by calls and countries.
6. **Sound:** Fundamental data on all phases of Sound: frequency ranges, sound levels, equal loudness curves. A must for all audiophiles.

ALSO AVAILABLE:

Reprints of:

7. **"Build a Citizens Band Transceiver"**—complete details on building an 11-meter transceiver for Citizens Band service.
8. **"Electrical Shock: Fact and Fiction"**—must reading for everyone whose work or hobby involves electricity. Ideal for utility companies . . . service associations.

IMPORTANT: ORDER BY NUMBER! OUR SUPPLY OF ALL GATEFOLDS AND REPRINTS IS LIMITED. OFFERED ONLY ON A FIRST COME, FIRST SERVED BASIS.

Send 15¢ per selection to

ELECTRONICS WORLD, Dept. N 960

Box 378, Church Street Station

New York 8, New York

eliminate standing waves within the box. We used 1" thick glass wool available from our local parts distributor since this material was not supplied with the kit.

One of the greatest advantages of obtaining an unfinished speaker cabinet is that it gives one the opportunity to finish it to match the decor in the house. In the case of this particular speaker, we stained it to match the wood paneling of the room, and then finished it off with two thin coats of satin-finish varnish. This particular kit is available in birch for \$14.50 and in walnut for \$19.95.

VR HINT

By DAVE STONE

DO YOU want to regulate a power supply with VR tubes but find that the power supply's output voltage is too low to start or "fire" the VR tubes? Voltage regulators such as the 0A2 and 0B2 require an average starting voltage of 25 to 35 volts higher than their nominal regulating voltage. The 0A2 regulates at a nominal 150 volts but requires about 185 volts to fire while the 0B2 regulates at 100 volts but requires about 130 volts for starting.

The problem of too-low starting voltage becomes tougher when two of the same type VR's are added in series across the power supply to regulate a higher voltage, because the starting voltage must then be approximately doubled, i.e., two 0A2's require about 370 volts while two 0B2's take 260 volts.

This problem can be solved if the power supply can furnish at least 10 to 20 volts above the nominal regulating voltage under normal loading conditions. A diode and two resistors added to the series regulating circuit will enable the power supply to fire the VR tubes in parallel and, once fired, the VR tubes will regulate in series.

The two 47,000-ohm resistors pass enough current initially to start the VR's in parallel and also bias the diode so that it does not conduct. When the VR tubes fire, the diode conducts and places both tubes in series across the supply voltage. The same circuit and parts can be used successfully with two 0A2's in series for 300-volt regulation or two 0B2's in series for 200-volt regulation. The 2500-ohm series potentiometer is adjusted to obtain proper regulation when the normal load is connected to the power supply and may be replaced by fixed resistance of equivalent value if desired.

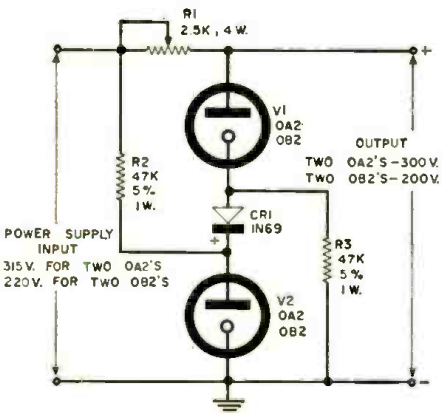

\$850 TEST OSCILLOSCOPE FOR ONLY \$39.50

TS-34 AP. Why modify radar scopes? This is ready to plug into 120 v, 60 cy. Used, but checked out and OK'd, in carrying case, less cords which are easy to make, with reprint of the most important 17 pages of the Tech Manual. You look into light-shielding hood thru a magnifying lens, and the small-tube picture is same as on a 5" screen. 0-40 db attenuators in 2 db steps are so accurate that you use a VTVM. Video flat 40 cy-2 1/2 mc. Contin. variable sweep 10 cy-50 kc. **BEST OF ALL**, there is a "Start-Stop" sw. position in which pulses to be viewed each trigger their own sweep, with durations of 5, 50, or 250 u-sec so accurate and linear that you use to measure pulse width. **INVALUABLE TO VIEW TV PULSES!** Pulses may be periodic or random, pos. or neg., as low as 0.1 v, and from a pip to 200 u-sec wd. Built-in delay lets sweep start before pulse appears. **AT THIS LOW PRICE NO ONE NEEDS DO WITHOUT THIS WONDERFUL SCOPE!** 50 lbs fob Los Angeles, only **\$39.50**

SAME, but BRAND NEW, with all cords and complete tech manual, fob Los Angeles... **\$69.50**

TS-34A AP. No cords or carrying case. Checked and certified equal to new. Same as TS-34 AP except that it triggers for frequency & Speed 4 1/2-9. **\$39.50**

LOOK! \$49.50 BUYS AN APR-4 RECEIVER!
AN APR-4 Receiver Unit, ready to accept plug-in tuning units from 38 to 4000 mc. This is the 30 mc I.F. amp., with choice of 0.6 or 4 mc pass band, for communications or for Morse & Speedy analysis. A built-in 120 v, 60 cy power supply, Panadaptor output, Video output, Phones outputs, 5-Meter, BFO, and Voice control receiver, and guaranteed. **AT THIS PRICE EARLIER MODEL APR-1; THIS IS APR-4!** In apparently EXCELLENT condition (visual inspection) **\$49.50** less tuning units, fob Los Angeles.

0.1% DC WHEATSTONE BRIDGE. 4 dials 1-10,110 ohms, and Ratio dial X.001 to X100 in decade steps. Built-in galvanometer. Same specs as L&N #5430. 1-49, ZM-4-U. Checked and guaranteed, **\$109.00** fob Los Angeles. (Our choice of mfrs.)

535% IMPROVEMENT FOR YOUR RECEIVER!
QX-535. A complete receiver 8 1/4" wd, 6 1/4" h, 13" deep, with panel speaker and phone jack, which tunes 190-550 kc and which uses 2 stages of 85 kc I.F. Ready to plug into 120 v, 60 cy, and includes a plug-in isolating transformer, power supply and total of 7 tubes. Note that the tuning range includes YOUR receiver's I.F. probably 455 kc. You feed your I.F. output, undetected, to the antenna post of QX-535, and tune the latter to 455 kc. Now your receiver's I.F. output is amplified in the RF stage of QX-535, double superheterodyne down to 85 kc, and detected at 85 kc, detected, and put thru the AF amplifier of QX-535. For CW, you use the BFO in QX-535. Suppose your receiver and the QX-535 have the same Q and pass 1/2% of their I.F.'s. 1/2% of 455 kc is 2275 cy, but 1/2% of 85 kc is only 425 cy. The ratio of 2275 to 425 is 5.35 to 1, so you have effected a 535% improvement in your receiver's SELECTIVITY, plus the tremendous SENSITIVITY improvement you should expect from all those extra stages of low-noise amplification. 16 lbs fob Los Angeles, only **\$37.50**

A TERRIFIC BUY IN XMR POWER SUPPLY & VOLUME-COMPRESSING AUDIO AMPLIFIER
You get a plug-in module 30 W speech amp. that holds output to +55% for input blast of +95% above the 90-95% modulation level. 6-tube chassis includes keyed tone ps. and sidetone. Carbon or dyn. mike. Pk. 807's, 6 K ohm out. You also get a plug-in module HV power supply, puts out filtered DC's of 600 v, 445 ma, 300 v, 175 ma, and 47 v bias. Uses 4 10C23's for which you can substitute Silicon diodes. You also get two FW selenium supplies, waging taps and 115 v 60 cy blower, to furnish filtered DC's of 120, 110, and -115 v. 1/2 A input 115 v, 60 cy, W schematic parts, characteristics, and complete instructions. 175 lbs fob Los Angeles, but shipped as Transformers at very low rate, less tubes. Only **\$14.95**

0.1% SORENSEN LINE VOLTAGE REGULATOR
=50005 brand new at a low surplus price! Output is adjustable 110-120 volts and holds the present voltage to ±0.1% at line frequency, or to ±0.25% if the line frequency drifts 5%. Taps for 50 or 60 cy, 1 phase. Regulates against line changes of 95-130 V, and against load changes from 0 to 5000 VA. Because of the low price, it is very smart planning to use it for lower-power applications which may later be expanded to 5 KVA. Max. harmonics less than 3%. Recovery time 0.15 seconds. In rack cabinet 28" h, 22" wd, 15" dp. Net wt 190 lbs. Note that input to control circuit can be moved to actual point of use of power, to compensate for line drop. Shpg wt 285 lbs. FOB Utica, N. Y. warehouse. Packed for export. (13 cu ft.) Catalog net price is \$65.00, less spares. Our price, new, in original packing, **\$349.50** WITH SPARES, is only

TIME PAY PLAN: 10% down if mdse is new, 25% if used. Add \$10.00 minimum to order. Balance, Monthly payment is 1/12 of that total.



our own 120 v 60 cy power supply (shown alongside the receiver in the picture) which also furnishes **\$149.50** DC to drive the automatic tuning motor in the receiver if you wish to use it. FOB Los Angeles. Time Pay Plan: \$14.95 down & 12 mo. Payments of \$12.33.

NAVY VERSION OF GENERAL RADIO #605-B

LP Microvoltage-Signal Generator. Has calibrated output 1/2-100,000 microvolts at frequencies of 5 1/2 kc, which is Audio; continuous in 7 bands to 30 mc! Directly calibrated on dial with accuracy of 1%. An 8th band, uncalibrated, is 30-50 mc. RF is CW or modulated with an external signal 0-15 kc, or modulated with the internal oscillator which is adjustable 0-1000 cy. Percent modul. adjustable 0-50% and read on the panel meter. Has a 1 Volt output jack. Built-in VTVM is set to red line (1 volt) and then accurately attenuated with calibrated dial and multiplier to get the exact output in microvolts desired. STABILITY: You can set it to WWV or to a .01% accuracy with a freq. meter or xti-controlled Xmr. Leave it on all night, come in the morning and find that the drift from zero beat is a very low pitched audio tone! Approved by the F.A.A. for all aeronautical electronic servicing. You get it completely checked out and certified, fob Los Angeles. **\$179.50**

NBFM SWEEP-FREQUENCY MICROVOLTER
1-208 is 1.9-4.5 and 19-45 mc, with frequency sweeps per second from the internal wobblulator of 150, 400, 1000, 2500, 5000 or from an external osc. up to 50 kc/sec. Oscillator has 0.1-100,000 uv output call center freq. can be set by zero-beat in the panel spkr or phone jack with an external source. 0-10 uv dial and decade multiplier give 0.1-100,000 uv output calibration. Schematic and instructions pasted inside hinged cover. Works on 120 v, 60 cy or on 12 v dc with the self-contained dynamotor. Acquisition cost \$1800.00 each, in apparently excellent condition (visual inspection) fob Occatur, Ill. **\$69.50** only

VHF MICROVOLTER SIGNAL GENERATOR
LAF-2, 90-600 mc, accuracy 1%. For FCC VHF Mobile and Aircraft service work, can be set within 1/2% by beating crystal-controlled Xmr of receiver being serviced. Accurate balometer-bridge circuit meters a output 1-100,000 microvolts. Checked and certified by Standards Lab. With calibration charts. **\$89.50** schematic, instructions, ONLY

LAE: Same, except 520-1300 mc. With calibration charts, checked OK. **\$99.50**

LAF or LAE (specify) less charts, visually good but unchecked, only **\$29.95**

X-BAND SPECTRUM ANALYZER
TS-148 UP at lowest price ever offered! Main unit only, no case or cords, checked and certified OK, fob Los Angeles, only **\$299.50**

RT-18/ARC-1
10-channel xti-controlled Autotune Xmr-rvcr 100, 155 mc. Favorite for ham operators, now available to amateur. Export packed by NavAer in absolutely like-new condition. With schematic & instructions, fob Corpus Christi, Texas **\$49.50** Add \$19.50 for rack, 3 plugs, and control box.

ARMED FORCES GEIGER COUNTER
AN/PDR-8C Radiac set measures Beta & Gamma radiation on 4 scales, 0-500 MR/hr. Excellent condition, fob Los Angeles **\$29.50**

VISUAL PLOTS OF TUBE PARAMETERS
A console unit, desk and two wings, which plots all parameters of receiving tubes on an oscilloscope. Made by Naval Ordnance Lab engineers at a cost of \$85,000.00! In excellent condition, with instruction book and writeup for an I.R.E. presentation. Will arrange for your inspection at warehouse in Silver Spring, Md. **\$1995.00**

TRANSMIT 4 X 400 WATTS A1, A2, A3
AN/FRT-1 complete and brand new, 2 sets available. Four transmitters T-4/FRC can be set up to 4 different frequencies 2-18 mc, crystal or MO. Each emits 400 watts RF in simultaneous operation. All modulated by one MD-1/FRC, and all 5 pieces powered simultaneously by one PP-1/FRC from 220 v, 1 phase, 50-60 cy. Export boxed, w/spares **\$4950.00** FOB Los Angeles, each complete set

GET THIS VERSATILE MULTITAP ISOLATOR
565 watt 50-60 cy transformer has 4 120v 1.3 A primaries for 120, 240, 480v, and a 4.1 A secondary tapped 142, 133, 127, 120, 114, 109, 104v, with diagram. Shipped only by collect RailEx. FOB Los Angeles. Send us only **\$7.95**

SCHEMATICS/CONVERSIONS, SURPLUS GEAR
List G. NEW! Send long stamped addressed envelope. Includes many Tech Manuals. Add 25c for chart examining AM Nomenclature, Examining Broadcast Band 20-page book on 1-177, with diagram of MX-949/U socket adapter, & tube data compiled to March 1957. \$5.00. RT-18/ARC-1 Chem & tune-up instr. \$2.00. MAR-22 Pages & 5 large pullout schematics. \$5.00.

FINE ENOUGH

to cut a human hair

STURDY ENOUGH

to cut 12-gauge copper wire



Specially Designed
CHANNEL LOCK[®]

**No. 748 Long-reach
End Cutter**

Here's the answer to your hard-to-get-at wire cutting jobs . . . the CHANNELLOCK Long-Reach End Cutter. Gets into tight places you can't reach with any other cutter. Especially handy for electrical, radio, TV, Hi-Fi and electronics work. Precision-honed, specially hardened cutting edges. Long, blue-plastic coated handles. Top quality polished forged steel. Ask your tool supplier for a CHANNELLOCK No. 748 End Cutter. If he doesn't have one, ask him to order it for you.



Write for Catalog of
Complete Line of Pliers



#718 LONG-REACH FLAT-NOSE PLIER



#728 LONG-REACH DIAGONAL CUTTER



#738 LONG-REACH ROUND-NOSE PLIER

Channellock Pliers are made only by

CHAMPION DeARMENT TOOL COMPANY
Meadville, Pennsylvania

Radio Aids to Navigation

(Continued from page 60)

beacon, Hayward Beacon at 242 kc., to mark the point at which an ILS descent should begin. Therefore, a pilot's first task is to bring his airplane over Hayward Beacon at the proper altitude and heading before an ILS descent can begin.

The simplest procedure is to use an ADF receiver to home-in on the beacon itself. Oakland VOR can also be used since the 93-degree radial from Oakland VOR passes directly over Hayward Beacon. The actual procedure to be followed will depend upon the equipment on board the aircraft and specific instructions from the instrument traffic control operator at Oakland.

If an aircraft flies towards Hayward Beacon from the east on a heading of 275 degrees and intercepts the beacon at an altitude of 2600 feet, the plane will intersect the ILS Localizer and Glide Slope signals over the beacon. Note that the Localizer signal, at 109.9 mc., intersects Hayward Beacon at a bearing heading of 275 degrees and that the Glide Slope signal, at 333.8 mc., being directed upwards at an angle of 2 degrees—54 minutes intercepts Hayward Beacon at an altitude of 2600 feet. A compass locator broadcasting at 341 kc. is located at the middle marker to help aircraft in lining up along the proper heading of 275 degrees.

Upon passing over Hayward Beacon, the Localizer and Glide Slope signals can be followed down to the runway. The outer marker is located 4.1 miles from the end of the runway and an aircraft should pass over this marker at an altitude of 1320 feet. The middle marker is located 0.6 mile from the end of the runway and an aircraft should pass over this marker at an altitude of

Multipurpose ILS and VOR indicator which shows "Up-Down" glide-slope indications, "Left-Right" VOR or localizer indications. Lights at upper left are marker-beacon indicators. VOR course selector shows radial angle in numeral window, and "To-From" indication shows in window at upper right.

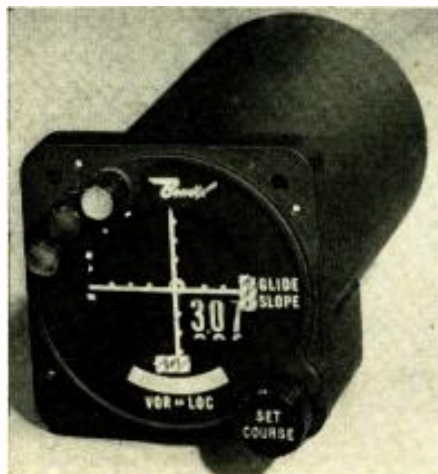

230 feet. If the runway is not in sight when passing over the middle marker, the airplane must pull up from its descent. If the runway is in sight, a normal landing may then be made and the aircraft has successfully completed its flight.

If the aircraft does not possess a Glide Slope receiver, then descent must be made with reference to a Rate of Descent meter. The ILS approach chart for Oakland specifies various rates of descent from Hayward Beacon for various aircraft speeds in knots. Note that the rate is based upon true ground speed of the landing aircraft. True ground speed is calculated by correcting true air speed for wind air speed. Thus, the pilot must compute his true ground speed before beginning an ILS descent.

GCA

GCA (Ground Controlled Approach) represents the only terminal navigation system that does not require any navigational instruments on board the landing aircraft. GCA consists simply of a ground-based radar which is capable of accurately tracking approaching aircraft in azimuth and elevation. A GCA traffic controller on the ground observing a radar display can guide an airplane to an instrument landing by literally "talking" the pilot down along a glide path to the runway.

GCA was developed originally for the armed forces during World War II and consisted of several independent radar transmitters. Civil GCA today consists of two radar units. An "Airport Surveillance Radar" (ASR) scans an area about 30 miles from the center of the airport and is used for establishing initial contact with aircraft and guiding them along a proper approach course to within about 5 miles from the end of the runway. A second radar, the "Precision Approach Radar" (PAR), then takes over and guides the aircraft down a glide path to the runway.

The Airport Surveillance Radar display consists of a Plan Position Indicator (PPI) type of display which shows azimuthal (left-right) direction of aircraft from the airport. The Precision Approach Radar presents two separate displays. A limited angle PPI (B Scope) display shows azimuthal position along the direction of approach. A Range-Height Indicator (RHI) display shows elevation (up-down) position along this approach path. The photograph of a GCA control center clearly shows the types of displays used.

GCA could be used as a primary terminal navigation aid, but it is not. Its high cost in comparison to ILS is certainly one of the reasons why ILS is found at every large airport and GCA is not. Furthermore, pilots prefer ILS because it gives them a reassuring shipboard visual indication of position which GCA cannot provide. As a result, ILS forms the main radio aid to terminal navigation in this country. GCA is mainly used as an aid in emer-

gency situations where either ILS equipment fails or an unequipped airplane is caught in poor weather.

During the past three months we have examined the operation of our country's major civil aids to aircraft navigation. These navigational systems are unique in the world and illustrate typical American engineering ingenuity. No other federal government in the world provides a more extensive array of aids to civil aviation than the United States, and this is important. In most other countries, civil aviation is virtually non-existent due to tight federal restrictions. In the United States, however, private aircraft far outnumber commercial airliners. In June 1959, for example, privately registered aircraft accounted for 96.2% of all registered airplanes in comparison to the airlines' 1.8%. This means that radio navigation aids should be simple in principle and inexpensive to receive. All present radio aids are just that.

As the airlines adopt higher speed jet transports, present navigational aids may not be adequate and longer range aids will be needed.

The future will see the development of many new radio aids that will simplify the staggering job of air traffic control and ease air navigation for every pilot, private or commercial. It is certain that these radio aids will strengthen our country's unique belief in the freedom of the airplanes.

In closing, the author would like to

thank the Federal Aviation Agency, Collins Radio Company, Aero Signal Labs, the National Aeronautical Company, Lear, Incorporated, and the Bendix Aviation Corporation for their friendly cooperation and assistance which made these articles possible.

BIBLIOGRAPHY

- Terman, F. E.: "Radio Engineer's Handbook," McGraw-Hill Book Company, Inc., New York, 1943 edition. Section 12, pages 872-941.
- Henney, K.: "Radio Engineering Handbook," McGraw-Hill Book Company, Inc., New York, 1950 edition. Chapter 21, pages 1068-1158.
- Bond, D. S.: "Radio Direction Finders," McGraw-Hill Book Company, Inc., New York, 1944.
- Hall, J. S.: "Radar Aids to Navigation," MIT Radiation Laboratory Series, Vol. 2, 1947.
- Lyon, T. C.: "Practical Radio Navigation," Aeronautical Services, Inc., Annapolis, 1955.
- U. S. Air Force Manual 51-43, Washington, 1962.

EDITOR'S NOTE: Readers of these articles will be interested in a series of long-play records released by Aero-Progress, Inc., 10493 Santa Monica Blvd., Los Angeles 25, Calif. dealing with radio aids to aircraft navigation. The first of these, entitled "On Course. On the Glide Path" (priced at \$5.98 direct from the company), describes and illustrates by means of actual in-the-air recordings the use and sounds of the radio aids covered by Author Gieca.

Other records in the series, entitled "Instrument Flight" and "Aircraft Communications," cover an actual instrument flight from take-off to touchdown and illustrate the use of other aircraft radio equipment by actual examples. For further details, we suggest that our readers contact the company at the above address. -30-

SEND ELECTRONICS WORLD EVERY MONTH



name _____
 address _____
 city _____ zone _____ state _____

Check one:
 3 years for \$12 2 years for \$9
 1 year for \$5
 In the U. S., its possessions, and Canada
 Payment enclosed Bill me
 Foreign rates: Pan American Union countries, add .50 per year; all other foreign countries, add \$1.00 per year.
 Mail to: **ELECTRONICS WORLD,**
 Dept. EW 96, 434 S. Wabash Ave., Chicago 5, Ill.

TRU-VAC 1-YEAR GUARANTEED RADIO and TV TUBES

Factory Used or Factory Second Tubes! TRU-VAC will replace FREE any tube that becomes defective in use within 1 year from date of purchase!

ALL TUBES INDIVIDUALLY BOXED! CODE DATED & BRANDED "TRU-VAC"

Partial Listing Only . . . Thousands More Tubes in Stock!

SPECIAL! 6SN7GT 30¢ 6W4GT 30¢

0Y4	3C85	6A6	6BC8	6CM8	6Q7	7A4/XXL	12A8	12F5	26	56
0Z4	3Q4	6AB4	6B06	6CL6	6S4	7A5	12A05	12H7	27	57
1A7GT	354	6AF4	6BE6	6CM6	6S7	7A6	12A05	12L6	35	58
1B3GT	3V4	6AM4GT	6BF5	6CM7	6S8GT	7A8	12AT6	12Q7	35A5	72A
1H5GT	4BQ7A	6AH6	6BG6G	6CN7	6SOTGT	7B4	12AT7	12S47	35B5	75
1L4	4B5B	6AK5	6BH6	6CQ8	6SF5	7B5	12AU6	12SJ7	35C5	76
1L6	4BZ7	6AL5	6BJ8	6CR6	6SF7	7B6	12AV6	12SW7	35W4	77
1NSGT	4C86	6AM8	6BK5	6CS8	6SO7	7B7	12AV7	12SN7GT	35Z5	78
1R5	5AM8	6AN8	6BK7	6C5U5	6SH7	7B8	12AX6GT	12SOT	36	80
1S5	5AN8	6AQ5	6BL7GT	6C6U6	6S17	7C6	12AX7	12V6GT	38	84/6Z4
1T4	5AT8	6AQ6	6BN6	6D6	6SK7	7C7	12AZ7	12W6GT	39/44	117Z3
1U4	5AV8	6AQ7	6B0GT	6D6G	6SL7	7E3	12B4	12X4	41	
1V5	5AZ4	6AR5	6BQ7	6D6GCT	6SQ7	7E6	12BA6	14A7/12B7	42	
1V2	5BR8	6AS5	6BR8	6DQ6	6SR7	7E7	12BA7	14B6	43	
1X2	5C8B	6AT6	6B5B	6E5	6T4	7F7	12B06	14Q7	45	
2AF4	5J6	6AU4GT	6BY5G	6F5	6T8	7F8	12BE6	19AU4GT	50A5	
2BN4	5K4	6AUSGT	6BZ6	6F6	6U5	7G7	12B7	19BGG	50B5	
2CV5	5T8	6AUB	6BZ7	6H6	6UB	7H7	12C6	19J6	50C5	
3A5	5U4	6AVSGT	6C4	6J4	6V6GT	7Q7	12B87	19T8	50L6	
3AL5	5U8	6AV6	6CA8	6J5	6W6GT	7S7	12B7	24A		
3AU5	5V4G	6AW8	6CB6	6J6	6X4	7X6	12B87	25A		
3BC5	5V6GT	6AXSGT	6CD6G	6J7	6X5GT	7X7	12C45	25A		
3BN6	5X8	6BB	6CF6	6K7	6X8	7Y4	1204	252GT		
3BZ6	5Y3	6BC5	6CG8	6N7	6Y6G	7Z4				

Any Tube Not Listed Also Available at 35¢ Each!
BRAND NEW 1-YEAR GUARANTEED TV PICTURE TUBES
 Below Listed prices do not include duty. Add Additional \$5.00 Deposit on tube sizes to 20" on 21" and 24" tubes—\$7.50. Deposit refunded immediately when dud is returned prepaid. Aluminized tubes—\$4.00 extra.
 Picture tubes shipped only to continental USA and Canada—All tubes F.O.B. Harrison N. J.
 10HP4 7.99 16K1P4 11.99 1711P4 16.99 20H1P4 17.49 21AW4 17.49 21XP4 17.49
 12L1P4 10.49 16L1P4 12.19 1711P4 16.99 21A1P4 21.49 21EP4 17.29 21YP4 18.39
 14H7CP4 11.99 161P4 11.99 17Q1P4 13.99 21ALP4 18.79 21FP4 18.39 21ZP4 17.49
 16A1D4 16.09 17AV1P4 15.49 17T1P4 16.99 21ATP4 18.79 21K1P4 18.39 24AP4 30.49
 16DP4 12.19 17BP4 13.49 18AP4 18.39 21AMP4 17.99 21MP4 22.39 24CP4 27.79
 16CP4 15.09 17CP4 16.99 20C1P4 15.99 21AU4 18.79 21YP4 18.39 241P4 29.79
 1811P4 12.19 17Q1P4 17.89 20DP4 15.89 21AV1P4 18.79 21W1P4 17.49
ATTENTION QUANTITY USERS! Big Discounts Are Yours. Call or Write For Our 1000 Tube "Private Label" Special Attention Branding Dept. NGB.
Money Cheerfully Refunded Within Five (5) Days. If Not Completely Satisfied!
TRU-VAC PAYS YOUR POSTAGE—On orders of \$5 or more in U.S.A. and Territories.
 Send approximate postage on Canadian and foreign orders. Any order less than \$5 requires 25¢ handling charge. Send 25¢ on C.O.D.'s. All orders subject to prior sale.
 Complying with Federal regulations, the following statement appears in all Tru-Vac advertising: Tubes appearing in this ad may be FACTORY SECONDS or USED tubes and are clearly marked.

33¢
Per 100 TUBES

1 Month Only!
TRU-VAC 1-YR. GUARANTEED RADIO AND TV TUBES
 Get 2 Tubes for the Price of 1 Plus a Penny!
35¢ 33¢
 EACH TUBE EACH PER 100 TUBES
 *Buy all the tubes you want for 35¢ each and get extra tubes for 33¢ each.
 *Get 100 extra tubes for 33¢ each and take your pick... types may be mixed!
 6AC7 6C07 7C4 12CN5
 6AG5 6C8 7C5 12KA
 6AL5 6K6GT 7Y7 12K6
 6AX4GT 6S47 12A17 12L5
 6BA8 7A7 12BF6

35¢ Sale

TRU-VAC

Harrison Avenue • Box 107 • Harrison, N. J. HUmboldt 4-9770



By **LOUIS MARTIN**

General Marketing Manager, Westinghouse Electric Corp., Electronic Tube Division

Tubes and Semiconductors

A Forecast of Sales

An informed estimate of the relative importance of the tube and semiconductor market for the year 1962.

WHEN the semiconductor emerged from the relative seclusion of the laboratory into the bright sunlight of practical application, a wave of fear that the vacuum tube was dying traveled over the engineering grapevine system. Many new equipments in which tubes could outperform semiconductors had the latter designed into them, because the romantic appeal of the new offspring transcended the operating advantages of tubes.

There are applications where the superiority of semiconductors is unquestioned. Examples are: hearing aids, portable radios used for entertainment purposes, and simple applications requiring "information diodes." On the other hand, in those applications in which temperature variations are important, in which extremely small size is not too important, in which power consumption is not a major consideration, engineers would be well advised to examine carefully the relative characteristics of tubes before commitments on final design are made. Cost, which is nearly always a consideration, is generally on the side of tubes at this time, although this can change in the future. Some additional factors influencing the choice of tubes or semiconductors are: upper frequency limit, noise figure, high-voltage requirements, nuclear radiation, and reliability. The choice is not always a simple one.

It should be mentioned that tube companies are not asleep at the switch. Almost every, if not all, major manufacturer of receiving tubes is working on basically new designs, which will increase their advantages in some areas and thus make the decision of the equipment design engineer easier.

As far as the distributor is concerned, however, equipment appears in the field with either tubes or semiconductors. His job, therefore, is to furnish replacements for these equipments and to supply laboratories and small OEM (original equipment manufacturer) accounts with either tubes or semiconductors, so that the research man or design engineer can work to his heart's content to freeze his design—with either tubes or semiconductors. And, like an undertaker, the distributor gets the business at the end.

Where will this business be in 1962?

Will distributors be selling as many tubes then as they did in 1958? Or will semiconductors sweep the field like molten lava?

The answer is that, because tubes and semiconductors each have relative advantages, both will be with us for a long time to come.

Some Figures

Let us look at some figures.

Industrial and commercial electronic equipment increased from \$680 million in sales in 1950 to \$2.5 billion in 1958. Of this \$2.5 billion, \$1.0 billion was derived from factory installation, operation, distribution, and repair. It is estimated that this business will be \$3.7 billion in 1962 and that, of this amount, about \$1.5 billion will represent factory installation, operation, distribution, and repair.

The home entertainment electronics market is composed of two parts: the factory value of the sets and the value added through distribution. In 1958, this market was about \$2.3 billion and it is estimated that it will be \$3.2 billion in 1962.

On the average, the value added through distribution is between 35%-40% of the total. It is more difficult to estimate this market than commercial or military markets, because radio, TV, and hi-fi are more susceptible to price changes—a fact well known to those who are radio and TV, as well as parts distributors.

The replacement market is served by two types of electronic distributors: the industrials, who obtain 20%-25% of this market, and the entertainment distributors, who get 75%-80% of this business. A tabulation of this market is as follows (in millions of dollars):

	1950	1958	1962 (est.)
Service & Installation	330	1,140	1,350
Tubes	60	280	350
Other Parts	180	610	760
Distribution Revenue	160	620	740

Service and installation represent the charge to the consumer for time and labor of the technician. Approximately 85%-90% of this is for servicing radio and TV. The growth of this business, four times between 1950 and 1958, is significant, and the total dollars is greater than any of the other major categories.

Tube sales to distributors, \$280 million in 1958 and \$350 million in 1962, represent about 30% of all distributor

purchases, and is undoubtedly the most important single category in the distributor business.

Other parts represent electronic components and devices of all types, exclusive of tubes. This market more than tripled in eight years.

Distributor revenue represents the mark-up charged by the distributor and the technician for the functions they perform.

The Semiconductor Market

The semiconductor market may be broken down into three parts: (1) transistors, (2) diodes and rectifiers (germanium and silicon), (3) others (thermistors, dynistors).

A tabulation of sales of transistors and diodes shows the following (in millions of dollars):

	1955	1958	1962 (est.)
Transistors	15	115	300+
Diodes & Rectifiers	15	100	160
Total	30	215	460+

These figures are estimates of total sales, OEM and distributor. A breakdown is extremely difficult, because the accuracy of the data, especially during the early years, is not too good. The fact remains, however, that the tremendous increase in sales automatically will be felt in the distributor market, although the numerical extent is subject to some debate at this time.

One reason for this is the lack of accurate statistical data on field performance of semiconductors. In the case of tubes, such data are available, simply because they have been in existence for so long. As time goes on and field data are collected, assembled, and analyzed, more accurate predictions can then be made for semiconductors.

There are some who believe that the replacement business of semiconductors should be small, because they have such long life. This statement should not be made at this time. The "long life" reputation of semiconductors, for the most part, is an extrapolation of laboratory-controlled data and is not supported by sufficient field data, as stated previously. Failures of components in equipment other than the semiconductors, sudden large power surges, large increases in temperature, even for short intervals, and mechanical mis-handling all tend to shorten



Pablo Picasso by Irving Penn

the 1961 PHOTOGRAPHY ANNUAL

Features on:

- Photojournalism
- Glamor
- Abstraction
- Nudes from Japan
- International Portfolio
- Industrial Advertising

Plus the work of

- Cartier Bresson
- Davidson
- Halsman
- Haas
- Heyman
- Nakamura
- Penn
- Winquist
- and many others

PHOTOGRAPHY
ANNUAL



All in the world's greatest showcase of fine photographs. Now on sale at newsstands and camera stores everywhere—or you can use this handy coupon to order today.

Only \$1.25

Ziff-Davis Publishing Company
Department EW 96
434 S. Wabash Avenue, Chicago 5, Illinois

Please send me a copy of the 1961 PHOTOGRAPHY ANNUAL. I enclose \$1.25, the cost of PHOTOGRAPHY ANNUAL, plus 10¢ to cover mailing and handling charges.

NAME _____

ADDRESS _____

CITY _____ ZONE _____ STATE _____

semiconductor life. This, of course, requires replacement in the field. A good illustration of this is in the extent of sales of selenium and silicon rectifiers for TV sets. Certainly, industry-wide, they are not negligible. One final, important consideration is manufacturing technique—it is one thing to make nearly theoretically perfect transistors in the laboratory and quite another to mass-produce them for an untold number of applications.

It should also be mentioned that transistors have not yet achieved the state of standardization of tubes.

Tube Market

A comparison of the corresponding total manufacturers' tube sales, OEM and distributor, is as follows (in millions of dollars):

	1955	1958	1962 (est.)
Receiving Tubes	360	340	320
Power Tubes	115	140	180
Total	475	480	500

Note that cathode-ray tubes have not been tabulated or discussed. The reason is simple. As yet, no one has designed a semiconductor to replace a cathode-ray tube.

Comparing these figures with those of semiconductors, it is expected that total tube sales will be about equal to semiconductor sales by about 1962. Because, in general, receiving tubes correspond to transistors and power tubes to semiconductor diodes, a comparison of each of these categories shows that they each will be about equal by 1962.

Several conclusions can be drawn from these figures.

(1) Transistors and semiconductors are an essential part of the market.

(2) Tubes will increase in sales with time, but not nearly as rapidly as semiconductors.

(3) Tubes and semiconductors will have about the same dollar volume of sales by 1962.

(4) Power tube sales show a steady increase with time.



"You say the sound went pffft . . . pffft . . . spissish, and the picture blacked out. But are you quite sure it didn't go pflunk . . . pflunk . . . sissich, instead?"

FREE CAREER BOOKLET

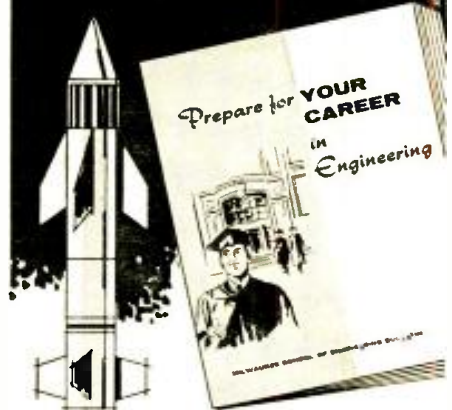

to guide you
to a
successful future
in

ELECTRONICS RADIO-TV COMPUTERS ELECTRICAL ENGINEERING

This interesting pictorial booklet tells you how you can prepare for a dynamic career as an Electrical Engineer or Engineering Technician in many exciting, growing fields:

MISSILES • RADAR • RESEARCH
ELECTRICAL POWER • ROCKETRY
AUTOMATION • AVIONICS
SALES • DEVELOPMENT

Get all the facts about job opportunities, length of study, courses offered, degrees you can earn, scholarships, part-time work — as well as pictures of the Milwaukee School of Engineering's educational and recreational facilities. No obligation — it's yours free.

MILWAUKEE SCHOOL OF ENGINEERING

MAIL COUPON TODAY!

MILWAUKEE SCHOOL OF ENGINEERING
Dept. EW-960, 1025 N. Milwaukee St.
Milwaukee, Wisconsin MS-113

Please send FREE "Your Career" booklet
I'm interested in Electronics Radio-TV
 Computers Electrical Engineering
 Mechanical Engineering
(PLEASE PRINT)

Name _____ Age _____

Address _____

City _____ Zone _____ State _____

I'm eligible for veterans education benefits.

Discharge date _____

A PROPHECY

For men and women with a sincere desire to succeed



“In the years that have passed since my days on the faculty of RCA Institutes, I have become even more firmly convinced that the individual who continues his education . . . particularly his technical education . . . is the individual who profits both as a thinking man and as a working man. Science and industry will reward you for your talents and energy. Out of your efforts may come inventions, new products, processes and services. There is everything good yet to be accomplished in our lives and in our work. What man has done, man can do better.”

David Sarnoff

Chairman of the Board,
Radio Corporation of America

RCA Institutes Offers the Finest of Home Study and Resident Training for Your Career in the Rapidly Expanding World of Electronics

RCA Institutes, founded in 1909, is one of the largest technical institutes in the United States devoted exclusively to electronics. A service of Radio Corporation of America, RCA Institutes offers unparalleled facilities for technical instruction . . . tailored to *your* needs. The very name “RCA”

means dependability, integrity, and scientific advance.

RCA Institutes Home Study School, licensed by the New York State Department of Education, offers a complete program of integrated courses for beginners and advanced students rang-

ing from electronic fundamentals to automation. All courses are designed to prepare you for a rewarding career in the rapidly expanding world of electronics. *The caliber of the training you receive is the finest!* And you get top recognition as an RCA Institutes graduate!

HOME STUDY COURSES *in* *Electronic Fundamentals • TV Servicing* *Color TV • Electronics for* *Automation • Transistors*

Pay-Only-As-You-Learn With No Further Obligation. All RCA Institutes Home Study courses are available under the liberal "Pay-As-You-Learn" Plan. This plan affords you the most economical possible method of home study training, *because you pay only for lessons as you order them . . . one study group at a time!* If you drop out at *any time, for any reason,* you do not owe RCA Institutes one penny. No other obligations! No monthly installment payments!



RCA Instruction is Personal. With RCA Home Study training you set *your own pace* in keeping with *your own ability,* finances, and time. The Institutes allows you ample time to complete the course. Your lesson assignments are individually graded by

technically trained personnel, and helpful comments are added where required. You get theory, experiment, and service practice beginning with the very first lesson. All lessons are profusely illustrated. You get a *complete training package* throughout the entire course.

You Get Prime Quality Equipment. All kits furnished with the course are complete in every respect, and the equipment is top grade. You keep all the equipment furnished to you for actual use on the job . . . *and you never have to take apart one piece to build another!*

* * *

RESIDENT SCHOOLS *in* *Los Angeles and* *New York City* train *you for any field of* *Electronics you may* *choose!*

No Previous Technical Training Required For Admission. RCA Institutes Resident Schools in Los Angeles and New York City offer training that will prepare you to work in re-

warding positions on research and production projects in fields such as automation, communications, technical writing, television, computers, and other industrial and advanced electronics applications. Even if you did not complete high school, RCA will prepare you for such training with courses specially designed to provide the basic math and physics required for a career in electronics.

Free Placement Service. RCA Institutes graduates are now employed in important jobs at military installations such as Cape Canaveral, with important companies such as IBM, Bell Telephone Labs, General Electric, RCA, and in radio and TV stations all over the country. Many other graduates have opened their own businesses. A recent New York Resident School class had 92.06% of the graduates who used the Free Placement Service accepted by important electronics companies . . . *and had their jobs waiting for them on the day they graduated!*



Coeducational Day and Evening Courses. Day and Evening Courses are available at Resident Schools in New York City and Los Angeles. You can prepare for your career in electronics while continuing your normal full-time or part-time employment. Regular classes start four times each year.



**SEND POSTCARD FOR FREE
 ILLUSTRATED BOOK TODAY!
 SPECIFY HOME STUDY OR
 RESIDENT SCHOOL**

RCA INSTITUTES, INC. A SERVICE OF RADIO CORPORATION OF AMERICA, 350 W. 41st St., New York 14, N. Y., 610 S. Main St., Los Angeles 14, Calif.



The Most Trusted Name in Electronics

CITIZEN BAND

CLASS "D"

CRYSTALS

All 22 Frequencies in Stock



3rd overtone. .005% tolerance—to meet all FCC requirements. Hermetically sealed HC6/U holders. 1/2" pin spacing—.050 pins. (.093 pins available, add 15c per crystal.) **\$2.95 EACH**

We can supply matched sets for Globe, Gonset, Citifone and Hallicrafters units at \$5.90 per set. Specify transmitting frequency and make of equipment.

The following frequencies in stock (frequencies listed in megacycles): 26.965, 26.975, 26.985, 27.005, 27.015, 27.025, 27.035, 27.055, 27.065, 27.075, 27.085, 27.105, 27.115, 27.125, 27.135, 27.155, 27.165, 27.175, 27.185, 27.205, 27.215, 27.225.

RADIO CONTROL CRYSTALS in HC6/U holders in stock for immediate delivery—all channels. Pin diameter .050. \$2.98 ea. .093 pin spacing, add 15c. **SEALED OVERTONE CRYSTALS Supplied in metal HC6/U holders.**

Pin spacing .486, diameter .050
15 to 30 MC .005 tolerance **\$3.88 ea.**
30 to 45 MC .005 tolerance **\$4.10 ea.**
45 to 60 MC .005 tolerance **\$4.30 ea.**

QUARTZ CRYSTALS

for every service

All crystals made from Grade "A" imported quartz—ground and etched to exact frequencies. Unconditionally guaranteed! Supplied in:

FT-243 holders MC-7 holders
pin spacing 1/2" pin spacing 1/2"
pin diameter .093 pin diameter .125
OC-34 holders FT-171 holders
pin spacing 1/2" pin spacing 1/2"
pin diameter .156 banana pins

MADE TO ORDER CRYSTALS

1001 KC to 2600 KC: .01% tolerance **\$2.00 ea.** .005% tolerance **\$2.75 ea.**
2601 KC to 9000 KC: .005% tolerance **\$2.50 ea.**
9001 KC to 11,000 KC: .005% tol. **\$3.00 ea.**
Specify holder wanted

ANY AMATEUR, NOVICE, TECHNICIAN BAND CRYSTALS

80 meters 3701-3749 KC .01% tolerance
40 meters 7152-7198 KC
15 meters 7034-7082 KC
6 meters 8335-8650 KC within 1 KC) **1.50 ea.**

MARINE FREQUENCY CRYSTALS—All marine frequencies from 2000-3200 KC .005 tolerance **\$2.50 ea.** (supplied in either FT-243, MC-7 or FT-171 holders)
STOCK CRYSTALS in FT-243 holders from 5675 KC to 8650 KC in 25 KC steps **73c each** or **3 for \$2.00**
FT-241 Lattice Crystals in all frequencies from 370 KC to 540 KC (all except 455 KC and 500 KC) **50c ea.**
Pin spacing 1/2" Pin diameter .093
Matched pairs — 15 cycles **\$2.50 per pair**
200 KC Crystals **\$2.00 ea.**
455 KC Crystals **\$1.50 ea.**
500 KC Crystals **\$1.50 ea.**
100 KC Frequency Standard Crystals in HC6/U holders **\$4.50 ea.**

Socket for FT-243 crystal **15c ea.**
Dual socket for FT-243 crystals **13c ea.**
Sockets for MC-7 and FT-171 crystals **25c ea.**
Ceramic socket for HC6/U crystals **20c ea.**

FREE! Write for new Catalog #860 with oscillator circuits

ASK YOUR PARTS DEALER FOR TEXAS CRYSTALS
See big red display... if he doesn't stock them, send us his name and order direct from our factory.

ORDER FROM OUR NEW FLORIDA PLANT
Use coupon below for 1st Class shipment!

TEXAS CRYSTALS

Dept. R-90, 1000 Crystal Drive, Fort Myers, Fla.
For Fastest Service, Phone WE 6-2100

FILL OUT AND ATTACH THIS COUPON TO YOUR ORDER FOR SHIPMENT VIA 1ST CLASS MAIL AT NO EXTRA COST!

NAME.....
ADDRESS.....
CITY.....ZONE.....STATE.....

TERMS: All items subject to prior sale and change of price without notice. All crystal orders must be accompanied by check, cash or M. O. with PAYMENT IN FULL. NO COD'S. Dept. R-90



By
BERT WHYTE

CERTIFIED RECORD REVUE

WITH this column, I begin my eighth year of reviewing for this magazine. No wonder I am getting gray around the temples! All kidding aside, time certainly does fly. It seems only yesterday that I was campaigning in these pages for a thing called pre-recorded tape... and it was "monaural" yet!

And then we went to bat for a new-fangled thing called "binaural" sound... and then soon came stereo tape and of course the stereo disc. And in between were the Audio Fairs, where every year the technology of hi-fi became ever more precise and more sophisticated.

During those years we have had our great debates... the rise of the small speaker and it versus the big... an argument that still rages and probably will continue for years to come. The hi-fi world expanded and evolved during those years and some cynics think that the period up to 1958 was the "golden years of hi-fi" and something which we will not see again.

Well the hi-fi scene has changed and admittedly some of the changes are less than desirable. There are too many pundits expounding on stereo who actually are babes in the woods on the subject, there are too many fast buck boys climbing on the stereo bandwagon, and the result is far too great a percentage of the public still pretty confused about this stereo business. The general consensus among knowledgeable people in this industry is that it is time for a housecleaning and a more honest presentation of facts to the public. Otherwise the record industry will continue in its present rather chaotic state and this will be reflected in slumping sales figures.

As I write this column it is early July and while a seasonal slump in sales has always been a part of the record business, this year they are really singing the blues. And many feel it is directly traceable to all this hysterical "oversell" on packaged stereo, where the majority of the units give only marginal stereo, if that.

Thus, for a variety of reasons, my expected deluge of new recordings did not happen and it will probably be the November issue before any of the big fall issues begin to show. In the meantime there are still a few choice items to discuss.

STRAUSS, RICHARD DEATH AND TRANSFIGURATION DON JUAN

Minneapolis Symphony Orchestra conducted by Antal Dorati. Mercury Stereo SR90202. Price \$5.95.

Two staples of the symphonic repertoire are here given rather intense, brooding performances by Dorati. He elicits some playing of great precision from the Minneapolis musicians, and if this is one of his best recordings with this orchestra (Dorati retired from this post at the end of the season), he leaves a fitting legacy to his successor.

The sound is sheer magnificence, especially

the "Death and Transfiguration." It is really huge, ultra-sonorous with great groaning basses and formidable brass and percussion. Directivity and depth are handled with taste and the reverb is calculated to lend a rich "bloom" to the over-all sound.

This disc again refutes those who say that a stereo disc cannot maintain a sufficiently strong bass response.

FRANCK SONATA IN A MAJOR FOR VIOLIN AND PIANO

DEBUSSY SONATA FOR PIANO AND VIOLIN IN G MINOR

Isaac Stern, violinist, and Alexander Zakin, pianist. Columbia Mono ML5470. Price \$4.98.

A small-scaled, but nonetheless delectable item for those who favor chamber music. Two of the loveliest sonatas for piano and violin ever written, are given thoughtful, rather cerebral performances, which also have their lyrical moments.

Stern's tone is ravishingly beautiful and no one could help but admire Zakin's estimable playing as well. The recorded sound is moderately close-up but, in my opinion, this type of repertoire calls for less reverb than was used. Very clean and bright sound throughout.

CHOPIN CONCERTO FOR PIANO AND ORCHESTRA #1 IN E MINOR KRAKOWIAK (Op. 14)

Stefan Askenase, pianist, with Residentie Orchestra, The Hague, conducted by Willem van Otterloo. Deutsche Grammophon Stereo 138085. Price \$5.98.

Here is another of those fabulously quiet-surfaced records pressed by DGG in Germany. This is a rousing perusal of the Chopin "Piano Concerto #1" by Chopin specialist Askenase. He brings to the work a remarkable facility of touch coupled with a big tone and brilliantly expressive dynamics.

The same can be said of his traversal of the difficult grand rondo the "Kracowiak." This DGG recording is miked quite a bit closer than is usual for them and with the M/S stereo technique. I personally like it, as it gives a more accurate positioning of instruments and affords better detail. As usual, reverb is brilliantly handled and the over-all result is one of the best DGG I have heard as yet.

DUPRE AT SAINT-SULPICE Marcel Dupre, organist. Mercury Stereo SR90228. Price \$5.95. Vol. 3.

This is part of a continuing series of recordings Mercury has been making with the great organist Marcel Dupre and at his favorite organ in Saint-Sulpice in Paris... this time the music of Franck. The church is huge, second only to Notre Dame and the organ is

one of the largest in Europe. There were some formidable problems of reverb to overcome so as to retain the churchly echoes and yet not obscure the detail in the scores. *Mercury* has succeeded brilliantly and the result is an overwhelming experience in organ sound.

Of stereo effects there is little . . . the main use here is to capture the balances and reverb properly. Dupré plays the grandiose "Grand Piece Symphonique," a "Fantasie" and "Pastorale." Needless to say the performances are superb, with Dupré cleverly maintaining tempi which coincide with the reverb time so as not to blur his lines.

All in all an outstanding find for organ lovers. Thunderous bass for hi-fi, too.

DVORAK

SYMPHONY #2

SLAVONIC DANCES 1, 3, 7, 8

Concertgebouw Orchestra of Amsterdam conducted by Bernard Haitink. Epic Mono LC3668. Price \$1.98.

Young Bernard Haitink is one of the most highly regarded of young Dutch conductors and in recognition of his abilities, he has recently been appointed co-conductor of the great Concertgebouw along with Eugen Jochum.

In this unjustly neglected Dvorak symphony Haitink displays a steady beat and authoritative view of the score and an impressive command of conductorial techniques in general. The work itself combines lyrical elements with strong rhythmic accents which appear to be derived from folk dances. Sound-wise, this is recorded moderately close-up, with fair detail and with fairly broad acoustics. Frequency range was quite wide and dynamic response was good.

PROKOFIEV

LOVE FOR THREE ORANGES SUITE

SCYTHIAN SUITE

St. Louis Symphony Orchestra conducted by Eduard van Remoortel. Columbia Mono ML5162. Price \$1.98.

This is one of the first recordings for Columbia of Remoortel and the St. Louis Symphony. As such, one might have felt that they would have given Remoortel rather different repertoire, since the competition here is rather fierce. Our young friend strives mightily, but he is outgunned by Dorati in the "Three Oranges" and by Markevitch in the "Scythian." Each has a more intuitive insight into the score than Remoortel seems able to summon at this stage of his development.

This is mono and is a nice job of recording, although I might quibble with some of the inner balances at times. It is quite clean with good dynamic and frequency range. —30—

CONCERTS SCHEDULED

ACOUSTIC Research and Dynaco are jointly sponsoring a series of "Live vs Recorded" concerts during the 1960 New York High Fidelity Music Show. A pair of AR-3 speakers and Dynakit pre-amplifier and Mark III amplifiers will vie with the Fine Arts Quartet in direct comparison tests.

The concerts will be open to the public without charge at the New Orleans Room of the Hotel New Yorker, across the street from the Trade Show Building where the Hi-Fi Show will be held.

The concert schedule is as follows: Wed. Sept. 7th, 3, 4, 8, and 9 p.m.; Thurs. Sept. 8th, 6, 7, 8, and 9 p.m.; Fri. Sept. 9th, 6, 7, 8, and 9 p.m.; Sat. Sept. 10th, 6, 7, 8, and 9 p.m.; Sun. Sept. 11th, 3 and 4 p.m. Programming will include music of Tchaikovsky, Bartok, and others. —30—

September, 1960



Cut servicing and installation time on all crystal-controlled 2-way radio equipment!



CITIZENS' RADIO TEST SET

Compact, portable, use it anywhere. Designed to assist you in the following applications:

- CHECKS WIDE RANGE OF CRYSTAL TYPES! Checks fundamental types at fundamental frequency—5th and 7th overtone types at fundamental frequency—3rd overtone types in 25-30 mc range in special overtone circuit.
- RF POWER INDICATOR FOR DIRECT OR REMOTE METERING! Simply place next to antenna or use 15 ft. remote metering cable furnished with unit.
- MODULATED RF CRYSTAL-CONTROLLED SIGNAL GENERATOR!
- MODULATION CHECKER! • BEAT FREQUENCY DEMODULATOR!
- PLATE MILLIAMMETER FOR RF TUNING! • AUDIO FREQUENCY SIGNAL GENERATOR!

MODEL 500—Fully transistorized—the perfect "assist" instrument even for the fully equipped shop.

\$29⁹⁵ NET



NEW! Only Grid Circuit Tube Tester with full TV tube coverage!

Includes voltage amplifiers; power output and heater type diodes; types with Grid, Plate or Cathode caps; hundreds of Foreign and Industrial tube types. Tests for Grid Emission, leakage, shorts and gas in one operation! ALSO two exclusive checks: Cathode Continuity Check and Inter-element Short Test. Easy to operate—fast! Available in metal case with exposed panel (GCT-9-S) or mounted in carrying case (GCT-9-W). MODELS GCT-9-S or GCT-9-W. **\$32.95**



NEW!

PIGGY-BACK ADAPTER for tube caddies!

Developed by Seco to save you steps! Free with Seco tube testers or by enclosing 25¢ with coupon.



SECO ELECTRONICS, INC. W-1
5015 Penn Ave. So.—Minneapolis 12, Minn.

Please send free literature on all Seco Test Equipment.

I have enclosed _____ Please send _____ Seco "Piggy-Back" Adapters. (25¢ each.)

NAME _____

ADDRESS _____

CITY _____ ZONE _____ STATE _____

EAST CANADA: Daveco Agencies, Ltd., Montreal, Quebec

WEST CANADA: Rex Merritt Co., Vancouver 1, B. C.

GET INTO ELECTRONICS



V.T.I. training leads to success as technicians, field engineers, specialists in communications, guided missiles, computers, radar and automation. Basic and advanced courses in theory and laboratory. Associate degree in electronics in 20 months. B.S. in electronic engineering obtainable. ECFE accredited. G.I. approved. Graduates in all branches of electronics with major companies. Start September, February. 16 terms, campus. High school graduate or equivalent. Catalog.

VALPARAISO TECHNICAL INSTITUTE
Dept. RD Valparaiso, Indiana

* RECORDING TAPE

Tape Recorders

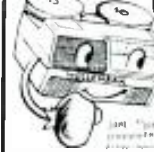

1200 MYLAR (4 trace)	1.29
1200 MYLAR (1/2 mil)	1.85
1800 Acetate (4 trace)	1.79
1800 MYLAR Polyester	2.39
2400 MYLAR Polyester	2.49

(includes large spools even lower)

*Oxide guarantee not to rub off or squeak—or money back. Compare ours with other "budget" tape. You'll find it's more than 100% "better" when you deal with us. We are original manufacturer of the tape recorder business and our reputation is growing by leaps and bounds. Send For Free Catalog.

NORELCO SPEAKERS

Famous AD-3800M twin-cone, 8" speaker, original list 16.50, usual NET 9.90, NOW, while they last, 1/2 off net. **4.95 ea.** (discontinued model).

Other sensational speaker reductions on a first come, first served basis. Send for speaker specification sheet.

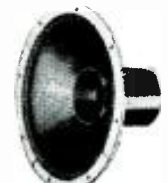

COMMISSIONED ELECTRONICS CO.
1776 Columbia Road Washington, D. C.

only for those who want the ultimate

SHERWOOD

"TOP RATED"
again and again
—and NOW AGAIN!



Model S-5000, 20+20 watt "stereo"
Dual Amplifier-Preamplifier, Fair Trade Price—\$189.50



Model S-2200, FM-AM-MX Stereo tuner,
Fair Trade Price—\$179.50



AMERICAN
AUDIO INSTITUTE



394 EAST 19th ST. PATERSON 4, N.J.

October 27, 1959

Sherwood Electronic Labs., Inc.
4300 North California Avenue
Chicago 18, Illinois

Gentlemen:

We find that the incorporation
of a center-channel output and
a damping factor selector in
July, 1959, increases the
Summary Rating of the Sherwood
S-5000 to the highest of all
18 Stereo Amplifiers tested in
the AAI Evaluation Test Reports.

Sincerely,

AMERICAN AUDIO INSTITUTE

Felix R. Breyer
Felix R. Breyer
Executive Director

The "Most honored of them all" S-5000 stereo amplifier-preamplifier is joined by the S-2200 stereo tuner. As with its "Top Rated" predecessors, the S-2200 features FM "Interchannel Hush" plus push button selector, internal plug-in adaptor for Stereo FM Multiplex, 2 "Acro-beam" tuning indicators, simulcast FM/AM stereo. All Sherwood tuners feature FM sensitivity below 0.95 microvolts and 1/3% distortion @ 100% FM. For further details write: Sherwood Electronic Laboratories, Inc., 4300 N. California Avenue, Chicago 18, Illinois.

For complete specifications write Dept. EW-9

S Sound on Tape

By BERT WHYTE

THAT four-track tape is now an established medium is indisputable fact and no space need be wasted in discussing this point. For a very large segment of the public, 4-track tapes fill their needs very adequately. But just as there are *Fords* and *Chevys* on the market and at the other end of the automotive scale there are *Rolls Royce* and *Bentley*, so it is with recorded tape.

There still is a market, bigger than some people realize, for a recorded tape medium that appeals to the audio perfectionist. I know a considerable number of these people and frankly they will have none of the current 4-track material, or for that matter of most two-track stereo either.

Says one friend of mine very candidly, "tape quality is being sacrificed on the altar of commercialism." A strong statement, but from his ivory tower viewpoint he defends his position with vigor. "I will concede that big strides have been made in the quality of tape itself and in improvements in head structure and in more sophisticated equalization circuits," he says, "so that a speed of seven-and-a-half inches per second is sufficient for extended frequency response. However, I still insist that at 15 inches per second, there is more snap and brilliance in the transient response."

My friend goes on to say that today anyone with one of the higher quality tape recorders and a top quality mike, can make his own live recordings which, in quality, surpass anything that is commercially available. He goes on to say that he has been fortunate enough to visit a professional recording studio where he heard stereo tape that really was up to expectation.

For the first time, he related, he was able to listen to the music without the intrusion of various noises and effects due to technical limitations. "That is what I want," he told me, "... a recorded tape that neither adds nor detracts from the music ... with no problems of crosstalk, with no restrictions as to frequency range and dynamic response, and above all with signal-to-noise ratio that makes tape hiss completely inaudible, even when the tape is played at relatively high room volume." And he said smiling, "since I'm asking for the moon, you might as well make sure the tape you furnish is a genuine three-channel stereo."

Whew! Quite a tall order my friend

is asking for, eh? When I pointed out the commercial exigencies to him, he said rather wearily that he had heard all that jazz before and that didn't alter his desires. When I emphasized the delicate point of the cost factors involved, he came right back with this statement: "When stereo first arrived on the scene I was paying up to 16 and 18 dollars for a production. It wasn't perfect but it represented something unique and, if you will recall, by the time the stereo disc came along and the bubble burst, stereo tape at these prices had reached the proportions of a sizable market." Then he went on, "I'll admit that advances have been made so that today's tapes are equal or even superior to the older product and at a much lower price. At the same time, even with the older material we recognized its limitations and were looking for something better.

"Now my whole point is this ... the art has advanced and the prices have come down ... but I'm still the same guy who bought those 16-dollar tapes and my income today is better than it was back in 1953. I'm still willing to pay that kind of dough for a stereo tape, if somebody will give me a tape with the quality I have asked for and which, at these prices, should now be possible to achieve."

Well, my friend certainly has a point. The high-priced two-channel stereo tape up to the advent of the stereo disc had indeed become a sizable market and, if I recall, in the boom year of 1957 sales had reached 5-million dollars a year. Now I certainly do not advocate a return to two-track tapes and higher prices *per se*. The stereo tape market is daily becoming much greater than it ever was and has achieved a certain degree of stability which is all to the good. But it would appear that, for some enterprising manufacturer, there exists a market big enough to warrant cultivation. This is the audio perfectionist, a man of taste with a pocketbook to indulge these tastes. There are enough of these people around to keep *Cadillac* in business, and the manufacturers of cabin cruisers, and 12-year-old Scotch as well.

Nuff said, but before leaving this dream realm of quality, I'll make a statement I am pretty sure would be well supported ... if our present 4-track tapes could be made with signal-to-noise ratio good enough to really

eliminate tape hiss, most people would be willing to pay a few dollars extra for this boon. At least that is the impression I get from a lot of people who are not what you would call out and out audio perfectionists, but to whom tape hiss is the most annoying flaw in many commercial tapes.

RAVEL

DAPHNIS AND CHLOE (complete)
 London Symphony Orchestra conducted by Pierre Monteux with chorus of the Royal Opera House, Covent Garden. London 4-track LCL80034. Price \$7.95.

I reviewed the stereo disc version of this fabulous work some time ago, and while my comments were generally favorable, I was unhappy with certain aspects of the sound. Here on tape is the most clear-cut evidence of the superiority of tape over disc.

On the other side of the coin, the greater clarity of the tape brings out flaws hidden in the disc. For example the wordless chorus which accompanies the opening section is not too well balanced against the orchestra at times, being too submerged in the orchestral texture.

All in all, however, this is a thing of beauty, beautifully conducted and played and with all of stereo's bright virtues shining through. Directionality is present but discreetly balanced and the depth effects, through expert handling of the acoustics and instrumental positioning, are outstandingly realistic.

HAYDN

SYMPHONY #96 ("Miracle")
SYMPHONY #104 ("London")
 Vienna Philharmonic Orchestra conducted by Karl Munchinger. London 4-track Stereo LCL80017. Price \$7.95

Two of the late symphonies of Haydn are here afforded carefully detailed, very scholarly performances by Munchinger and are audibly improved in sound from the previously released stereo disc.

There is nothing sensational here, but good mike placement and intelligent use of acoustics have made for very pleasant listening . . . a very clean sound that never appears strained. The stereo effects are all one could desire with this type of scoring.

THE QUEEN'S BIRTHDAY SALUTE
 The Herald Trumpeters and Band of the Royal Regiment of Artillery with 21 gun salute. Vanguard 4-track VTC1602. Price \$7.95.

This, too, is an example of tape superiority, although not as concrete as the above. The stereo disc of this fascinating royal panoply was one of Vanguard's greatest achievements. Even so the thundering clatter of horses hooves and the boom of cannon have much greater weight and impact.

This was recorded outdoors in Hyde Park and it is surprising the amount of decay the sound has. There is little over-all directionality on this tape, but the run by of the artillery passes very dramatically from left to right speaker, and it is just the thing to impress new inductees to stereo! For all Anglo-philites, a "must" recording.



The Perfect
 Workshop
 Companion For
 The Advanced
 Audiophile

THE 1961 AUDIO YEARBOOK

Over 25 projects and features covering stereo, hi-fi, components, acoustics—every phase of audio! Advanced discussions and instructions on:

- CONSTRUCTING THE BI-PHONIC COUPLER
- STEREO MICROPHONE TECHNIQUES
- FINDING FAULTS IN HI-FI SYSTEMS
- WIDE SPACE STEREO
- MULTIPLEXING MUSIC ON ONE RECORDER
- ROOM ACOUSTICS FOR STEREO
- Plus many other authoritative articles

On sale at your newsstand or electronics parts store
 September 8th or order by coupon today.

audio 1961
 yearbook



ONLY
 \$1.00

Ziff-Davis Publishing Company, Dept. EW 96
 434 S. Wabash Avenue
 Chicago 5, Illinois

Please send me a copy of the 1961 AUDIO YEARBOOK. I enclose \$1.00 plus 10¢ to cover mailing and handling charges. (Canada and Foreign \$1.25 plus 10¢ postage.)

NAME _____

ADDRESS _____

CITY _____ ZONE _____ STATE _____

AUTOMATIC CONTROL UNIT INDUSTRIAL • ELECTRONIC AUTOTUNE

• RAILROADING



115 Volt 60 cycle 1/100 HP Capacitor type Motor with automatic gear and ratchet assembly that enables you to pre-set motor stops any 10 positions within 360 degrees. Unit is geared to a two deck 12 position ceramic water switch that terminates into a plug-in socket. Local control panel has channel position selector, light dimmer control and local/re-

remote switch that enables unit to be operated local or remote position. Part of RDZ-1 Transmitter Autotune Assy. Collins #596A-1.

Size: 9 x 4 x 6" **\$14.95**
Stock No. EW-23491—Price, NEW:

Coaxial Cable Less Than 3¢ Per Foot

RG-54 A/U CABLE—Designed for long life and constant attenuation, with polyethylene jacket. 58 ohms .250 OD— **\$10.95**

370 FOOT ROLL \$10.95
70 FOOT ROLL \$1.95
RG-8/U—8 Ft. w/PL-259 ea. end \$1.95
RG-8/U—50 Ft. w/PL-259 ea. end \$9.95

COAXIAL ANTENNA CHANGE-OVER RELAY:
12/24 VDC with 3 SO-239 Connectors. Mounted in metal box 3 x 3 1/2 x 2" Ea.: \$1.95
Connector for Power Plug \$1.00

TELEPHONES, HEADSETS, MICS., Etc.:

TS-9 Handset. Used: \$2.95 New: \$ 3.95
TS-13 Handset. w/PL-55 & PL-68. U: \$2.95 N: 3.95
T-17 Microphone. Used: \$1.95 New: 6.95
EE-8 Field Telephone. Used: \$12.95 New: 16.95
BD-71 Switchboard—6 line. U: \$1.95 N: 21.95
RM-29 Control Unit. New: \$6.95 W/Handset 8.95
RM-52 Control Unit (Patch Found.) U: \$1.95 N: 2.95
H-16/U Headset—8000 ohm. U: \$1.95—New: 2.95
HS-33 Headset—300 ohm. U: \$1.95—New: 7.95

BC-603 • \$14.95 • RE-NEW

BC-603 FM RECEIVER—
20 to 27.9 Mc. Re-New: \$14.95
BC-604 FM TRNSMTR—20 to
27.9 MC. U: \$11.95 New: 7.95
BC-684 FM TRNSMTR—27 to
39.1 MC. U: \$7.95—New: 12.95
FT-237 MOUNTING for Rec-
Trans. Price. Re-New: 7.95
FT-346 MOUNTING—for Rec-
ceiver only. Re-New: 4.95
DM-34 DYN. 12 V /BC-603-
683 U: \$2.95—R-N: \$1.95
DM-35 DYN. 12 V /BC-603-684 U: \$4.95—R-N: 9.95
AC POWER SUPPLY—F/BC-603-683—Output: 220
VDC 80 MA & 24 VAC 2 Amps. Transformer & Tube
type. Chassis not hot. Mounts on rear Plug of BC-603-
683. Can be adapted to other Receivers. **\$14.95**
KIT: \$10.00 WIRED:



GROUND PLANE ANTENNA CITIZEN—COMMERCIAL

Made from sturdy surplus Insulated Base and Screw-in type Elements. For use in the 25 to 50 MC Bands. Specially cut to your operating frequency. (Specify Freq. when ordering.) With Adapter for 1" pipe mounting. **\$14.95**

BC-221 FREQUENCY METER



Frequency 125 to 20,000 KC Crystal Calibration in all ranges. Can be used as a signal generator and V.F.O. Complete with original crystal & calibration book. Voltage required 6 VDC @ .9 amp. & 135 VDC 20 MA. Price—Used—less Modulation **\$79.50**

TS-175 FREQUENCY METER—
Same as BC-221, only covers the range of 85 to 1000 Mc. With Modulation—Price. **\$99.50**
Used, Excellent:

METAL CASES ONLY—No Canvas Covers!

RECEIVERS:

NAVY ARB/CRV 46151—190 to 9050 KC. U: \$18.95
ARC-3 AM Rec. 100 to 156 MC. U: \$14.95
BC-733—Localizer Rec.—108.3 to 110.3 MC. Used: 21.95
R-23/BC-453 Rec.—190 to 550 KC. U: 11.95
R-4/ARR-2 Rec.—540-830 KC: 230-258 MC. R-N: 8.95
BC-1206 Beacon Receiver—200 to 400 KC. R-N: 9.95
BC-652 Receiver—2 to 6 MC—Less Dyn. U: 19.95
BC-344 Rec.—150 to 1500 KC—For AC op. Used: 19.95

PREVIOUSLY ADVERTISED ITEMS STILL AVAILABLE:

TCK-7 TRANSMITTER—Navy Type. New: 150.00
TS-108/APN TEST SET—w/case. U: 15.00
I-166 VOLTOHMETER. New: 16.95
I-176 VOLTOHMETER. Used: 19.95

SEND FOR FREE CATALOG!

Address Dept. EW • All Prices F.O.B., Lima, Ohio.
Minimum Order \$5.00, & 25% Deposit on all C.O.D.'s

Fair Radio Sales
2133 FLIDA ROAD
P. O. BOX 1105 LIMA, OHIO

Manufacturers' Literature

REACTANCE SLIDE RULE

Shure Brothers, Inc., 222 Hartrey Ave., Evanston, Ill. has re-issued its handy reactance slide rule for the simple calculation of resonant frequency, capacitive reactance, and inductive reactance.

The slide rule also solves coil "Q" and dissipation factor problems that cover a frequency range from 5 cps to 10,000 mc.

The rule is priced at \$1.00 and is obtainable direct from the company.

MASTER TV DATA

Blonder-Tongue Laboratories, Inc., 9 Alling St., Newark 2, N. J. is currently offering a 24-page book which covers TV systems for motels, hotels, apartment houses, hospitals, institutions, of-
fice buildings, etc.

Entitled "Designing and Installing Master TV Systems", the new publication is written for both lay and professional people. The manual covers different types of building construction, the design of systems, and the installation of cables and components. Block diagrams illustrate typical combinations of antennas, amplifiers, cable and distribution components.

Master TV installation and maintenance personnel may obtain a copy of this publication by writing the main sales office of the company at the above address.

BELL LABS' SCIENCE FILMS

Bell Telephone Laboratories has produced two new sound motion pictures for use in college science and engineering classes.

The films, entitled "Memory Devices" and "Similarities in Wave Behavior", were prepared under the guidance of Bell Labs scientists and engineers and are available on free loan through local Bell Telephone Company offices.

"Memory Devices" runs 27 minutes and is in 16 mm. color with sound. The second film is in 16 mm. black-and-white and runs 26 1/2 minutes. It features a demonstration lecture by Dr. J. N. Shive. These new releases are the seventh and eighth productions in the audio-visual aids series on science education at the college and university level.

SUPREME "MASTER INDEX"

Supreme Publications, 1760 Balsam Road, Highland Park, Ill. has announced release of its 1960 "Master Index" covering radio and television manuals.

The index serves as a reference to all material included in television manuals covering the years 1948-1960 and radio volumes from 1926-1960. The in-

dex permits immediate reference to the volume in which service material for a specific make or model receiver was covered.

The index is available for 25 cents a copy, postage prepaid.

BRIDGE RECTIFIER DATA

Radio Receptor Company, Inc., 240 Wythe Ave., Brooklyn 11, N. Y. has issued a data sheet on its new miniature open bridge assembly, the selenium rectifier "Flat" 155V90.

Bulletin F-313 provides complete technical data, circuit and dimensional diagrams, and mounting instructions on this miniature unit which is rated 90 ma. d.c. at 155 volts r.m.s.

A copy of the bulletin or additional information on the firm's complete line of selenium "Flats" may be obtained from Dept. F of the company.

NEW ARROW CATALOGUE

Arrow Electronics, Inc., 65 Cortlandt St., New York 7, N. Y. has announced publication of its new 1960-61 "Hi-Fi, Stereo, and Amateur Radio" catalogue.

The 154-page buyer's guide to components and systems provides full coverage to equipment in the hi-fi, stereo, and amateur fields. It is available without charge direct from the distributor.

INTERCHANGEABILITY GUIDE

The Distributor Products Division of Raytheon Company has issued a handbook of industrial tube interchangeabilities.

The new guide lists some 900 tube types including miniatures, sub-miniatures, voltage regulator-voltage reference, radiation counter pencil, transmitting, klystrons, industrial CR, special purpose tubes, etc.

Common types of tubes now installed in industrial equipment are tabulated alongside their Raytheon direct replacement or electrical equivalent types. The brochure also invites technicians and distributors to utilize the company's engineering consulting service to answer questions on applications and replacements.

The handbook is being offered without charge by all the firm's franchised distributors.

INSTRUMENTS & METERS

Precision Apparatus Company, Inc., 70-31 84th Street, Glendale 27, N. Y. and its subsidiary Pace Electrical Instruments Co., Inc. have issued a combined reference-catalogue covering electronic test instruments and panel meters for industrial and communications applications.

The catalogue features detailed electrical and mechanical specifications which should prove helpful to engineers and designers. Copies of Catalogue Number 28/Industrial are available on letterhead request only.

METER REPAIR FACILITIES

Ram Meter Inc., 1100 Hilton Road, Ferndale 20, Michigan is offering a 4-page brochure outlining its facilities for servicing meters and instruments of all types.

The booklet points out that the firm is prepared to repair and calibrate meters, modify standard meters, design and produce special scales, repair electronic instruments, and provide certification service, in addition to manufacturing special testing and indicating equipment for laboratory, production, or military applications.

FILM ON TV RECEPTION

Channel Master Corporation, Ellenville, N. Y. has produced a 4½-minute film on antenna replacement which it is offering free to TV broadcasters throughout the country.

Narrated by Robert Trout, the film stresses that clear pictures transmitted by the stations are often weak, fuzzy, or snowy on the home set because of poor antenna installations. The film shows how proper antenna installation can make a tremendous difference in the quality of reception.

Prints of the film are available through the company's advertising department.

TWO-WAY RADIO DATA

The Communication Products Department, *General Electric Company*, P. O. Box 4197, Lynchburg, Va. is offering a new 24-page bulletin covering communication equipment available for businesses.

Designated as Bulletin ECR-497B, the publication describes frequency allocations and the various combinations of two-way radio possible in each frequency. Also shown is the difference between tubed and transistorized equipment. The publication carries sections covering amplifiers, portable hand-carried two-way units, desk-type base stations, floor-mounted units, selective-calling, antennas, microphones, remote control, and pocket voice-message receivers. -30-

HAM CLUB TO MEET

THE Findlay Radio Club of Findlay, Ohio, W8FT, will hold its annual hamfest on Sunday, September 11, at the Findlay Riverside Park. Families are invited.

There will be a ham equipment and ladies' handcraft swap shop as well as two Elmac AF-68 multi-band mobile transmitters as door prizes. Other prizes will be awarded. Mobile talk-in will be on 3812 kc.

Advance registration is \$1.00 per family or \$1.50 at the park. Tickets and information are available from Paul A. Chapin, W8K11, RFD 5, Findlay, Ohio.

-30-

September, 1960



Choose a career in **ELECTRONICS!** It's wide open...with interesting jobs for engineers, technicians, technical writers. And the all-new 1961 edition of **JOBS AND CAREERS IN ELECTRONICS** is your perfect guide to this big, exciting field!



Five Giant Sections Covering:

• **OPPORTUNITIES IN ELECTRONICS**

Where are the jobs in electronics today? This section pinpoints the best areas in the country in which to look for a job!

• **CASE HISTORIES OF CAREERS IN ELECTRONICS**

What kind of jobs are available in electronics? Here are 11 accounts of people at work in various branches of electronics!

• **HOW TO PLAN A CAREER IN ELECTRONICS**

How do you start out in electronics? This section is devoted to training—includes information on the military, correspondence schools, courses to study, much more!

• **TESTING YOUR ELECTRONICS APTITUDE**

Do you qualify for an electronics career? This special testing section gives you an accurate picture of your ability to qualify for a technical job.

• **SPARE TIME ELECTRONICS**

Want to earn money in your spare time? Here's a rundown on spare time radio repair, complete with a listing of the tube types you'll need.

Buy your copy at your favorite newsstand or electronics parts store—or order by handy coupon below.

On sale September 6th – Only \$1.00

Ziff-Davis Publishing Company
 Department EW 96
 434 S. Wabash Avenue, Chicago 5, Illinois

Please send me a copy of the 1961 **JOBS AND CAREERS IN ELECTRONICS**. I enclose \$1.00, the cost of **JOBS AND CAREERS IN ELECTRONICS**, plus 10¢ to cover mailing and handling charges. (Canada and Foreign, \$1.25 plus 10¢ postage.)

NAME _____

ADDRESS _____

CITY _____ ZONE _____ STATE _____

Cascade Circuits

(Continued from page 67)

ply voltages. None of these are widespread (with the possible exception of the input-circuit change) and in no case will they affect the basic theory of operation, maintenance, or repair.

Cascade Troubleshooting

Several possible troubles are unique to the cascade circuit, and some of them can prove extremely difficult to pinpoint. They may be caused by tube failure, by defective parts, or by misadjustment. As in most electronic circuits, many cascade problems are caused by tube failure. The most common tube defect is a second-stage heater-cathode short, caused by the high potential between the heater and this cathode, with plate-cathode shorts in the second stage running a close second. After replacing a tube with a plate-cathode short, be sure to check for cooked resistors and coils.

One of the most puzzling cascade defects is oscillation. It may result in either a blank, white raster or a blacked-out screen when it occurs in a TV set. In an FM tuner, oscillation can produce either squeals or no sound at all. In an AM receiver, the most usual effect is a loud hiss or buzz-saw noise, with signals receivable from only the strongest stations, and then accompanied by a "siren wail."

Frequently, oscillation is caused by misadjustment of the neutralizing coil (L_n in Figs. 1 and 3). While this coil cannot prevent oscillation, it may cause it by increasing circuit gain past the point of stability. In other cases, oscillation may result from a defective grid bypass capacitor (C_1 in Figs. 1 and 4; C_2 in Fig. 3). If this component should open up for any reason, it places the second-stage grid above r.f. ground, removing the low-impedance load from the first stage and so producing oscillation.

Lead dress may also cause oscillation. At the frequencies involved in TV and FM broadcasting, a difference of a fraction of an inch in wire spacing may mean the difference between perfect operation and wild oscillation caused by accidental feedback. A safe rule when working under the chassis of a cascade circuit is always to return every lead and part to its original position.

Failure of a resistor in the grid-clamped cascade (R_1 or R_2 in Fig. 3) will prevent the circuit from operating. These resistors can be checked most easily by measuring the second-stage grid-cathode voltage. If the grid is between .5 and 1.5 volts negative with respect to the cathode (with no input signal) the resistor network is satisfactory. Any other reading suggests a defective resistor.

Adjusting the Circuit

Basic alignment of the cascade circuit is not very different from align-

ment of any other r.f. amplifier. However, cascades do have some uncommon features. The most obvious is the so-called neutralizing coil. In many TV tuners, this coil is non-adjustable; in other cascade amplifiers, it can be adjusted. Two techniques are applicable.

To follow the most accurate method, disconnect the tube's filament and turn on the set. Apply a strong input signal, and connect a v.t.v.m. across the video detector, first limiter, or second-detector load resistor, depending on the type of receiver. Adjust the coil (L_n in Figs. 1 and 3) for minimum signal. Reconnect the filament.

With a series-filament circuit, this procedure is impractical. In this case, simply adjust L_n for minimum noise while tuned to a weak or attenuated signal near the upper frequency limit of the amplifier. Then check carefully to make certain the amplifier does not oscillate at any point in its operating range.

For weak-signal use, the cascade circuit can be improved by adjustment of grid bias. This is done by substituting a resistor of different value in place of the first-stage cathode resistor. (This is R_1 in Figs. 1 to 4; also in Fig. 5A). Since optimum bias for least noise varies from tube to tube, the proper value of resistor to use is determined by disconnecting R_1 and putting in its place a length of shielded cable connected to a 250-ohm composition potentiometer, as in Fig. 5B. Don't use a wire-wound unit; its inductance will produce unusable results.

With the potentiometer set for maximum resistance, tune in a weak signal and adjust the potentiometer for best reception. Then, without disturbing the adjustment, disconnect the potentiometer and measure the resistance used. Wire in a fixed resistor of equal value.

Let's Look at Tubes

The original Wallman cascade circuit, as noted, used a triode-connected 6AK5 and a 6J6, but present-day cascade amplifiers use tubes designed especially for this type of service. More than a dozen special twin-triodes have been developed for cascade use; most of these tubes are plug-in replacements for each other, more or less, since nearly all of them have the same base connections and require similar operating voltages.

However, indiscriminate tube substitutions are never recommended. Before switching to another tube type, be sure you know what you intend to accomplish. The most frequent reasons for switching tubes are to achieve higher gain and to escape cross-modulation effects.

Interchangeable cascade tubes and special features of each type are listed in Table 2. When making substitutions on a set using series-string filaments, be sure that the new tube chosen has the same heater voltage and current ratings as the old one. Series-string versions exist for most of the 6-volt proto-types listed.

AIRCRAFT & 2-METER RECEIVER SPECIAL!

Commercial—not surplus! Mfg. by Aircraft Radio Corp., Model RT-19, 28 V. Tubes: 6X4, 6BE6, 6AR5, 6AV6. Has 2 RF amplifiers and 1 LF amp. 9 tubes. Dim.: 5 1/2 x 13 x 10 1/2 in. \$29.95

RECEIVER-TRANSMITTER COMBO!

LINK HIGH BAND TRANSMITTER: 120-170 Mc. FM. 50 W. Built-in 6 V dynamotor. Model 22-10. Ferrite tube line-up: 7AG7, 7F7, 7W7, 2-2E24, 829-B. 3-channels. Excellent. \$19.95

ONLY LINK HIGH BAND RECEIVER: Model 1905. Contains 715, 7C7, 7AG, 1-7AG7 PLUS OTHERS! Built-in 6 V. v.b. supply. Companion to above. Excellent. Radio look only! \$19.95

SPECIAL COMBO DEAL! BOTH FOR ONLY \$29.95

U.H.F. MOBILE RECEIVER

Navy model R6B, Mfg. by RCA. Freq. 225-290 Mc. 10 channel. Crystal controlled. Compact size: 2 1/8 x 10 1/2 in. Ready to install in 12 VDC car. Like new. With instruction manual only! \$19.95

EE-8 FIELD TELEPHONE

Operates up to 10 miles with use of 2-conductor wire! Built-in RINGER! Works like a charm on 2 1/2-hr. high batteries. Excellent. \$12.50

20 W. MODULATION XFMR.: 18X3332 in. 6000 ohms to 6000 Ohm CT. Actually handles up to 20 W. of audio! NEW. 10 for only \$7.95. EACH only \$95c

1-208 FM SIGNAL GENERATOR

20-30 Mc. AND 1.9-4.3 Mc. Built-in 110 VAC supply. 12 V. dynamotor. Excellent! \$49.50

FILTER CHOKES: 6 Henry, 150 millihenrys, 2500 V. insulation. New 3x3x1 1/2 in. 10 for \$7.95. 95c

110 VAC POWER SUPPLY for BC-603 or BC-657. Mounts in place of dynamotor. BRAND NEW. \$9.95

SAVE AS ABOVE, but in kit form. \$7.49

CITIZENS BAND SPECIALS!

BC-620 TRANSMITTER: With spare tubes. Great, reconditioned. Includes 6000 Ohm CT. dynamotor. Makes F.B. Citizens' Band! Freq.: 26-27.9 Mc. This month ONLY! \$19.95

Accessories for above: \$3.95

TS-13 HANDSET: A real \$3.95

RA-120 POWER PACK: This is the 110 V. unit. Like new. \$22.50

T-17 MICROPHONE: Excellent cond. \$3.95

Brand New Only. \$5.95

BC-604 TRANSMITTER

20-28 Mc. 30 W. New condition. \$4.95

D9-35 DYNAMOTOR: 12 V. for above BC-604. Like new. \$6.95

Set of 80 crystals. For above. New. \$4.95

VRC-2 FM TRANSMITTER-RECEIVER COMBO!

30-10 Mc. A terrific 6 Volt installation! Consists of 10 W. transmitter and 500 Ohm impedance receiver, both crystal controlled! This is the Army equivalent to Motorola Model FM 30-D. Excellent! \$39.95

Pror. combo only.

ALL PURPOSE ARB COMMUNICATION RECEIVER

195-9000 kc. 4 bands. Built-in, directly calibrated tuning control. Includes 6000 Ohm CT. dynamotor. Like new! Excellent cond. \$17.50

CONTROL BOX & PLUGS: For above. Only \$4.95

APR-1 RECEIVER SPECIALS!

30 Mc. IF. 115 V. 60 cps. Like new cond. \$24.50

Plug-in Units For Above

TN-1: 38-50 Mc. \$14.95 COMBO DEAL!

TN-2: 60-100 Mc. 14.95 Apr-1 Receiver PLUS

TN-3: 300-1000 Mc. 14.95 TN-1, TN-2, TN-3 \$65.50

APR-4 TUNERS—WILL WORK WITH ABOVE REC'R

TN-16: 38-50 Mc. \$14.95 COMBO DEAL!

TN-17: 60-100 Mc. 14.95 TN-16, TN-17, TN-18

TN-18: 300-1000 Mc. 14.95 TN-16, TN-17, TN-18

TN-19: 1000-3300 Mc. 49.95 TN-19 only \$95.00

SCR-625 MINE DETECTOR BARGAIN

Locate that hidden pipe, metal, treasure! Use for parts! With case. Excellent. \$22.50

ART-13 XMTR: Model T-47. Freq.: 2-18 Mc. Excellent. Only \$34.50

APT-1 TRANSMITTER: 100-200 Mc. 10 TUBES in all including 822A driver, 829B final and 821 phono tube. New cond. \$9.95

VHF SPECIALS!

R-19/TRC RECEIVER

70-100 Mc. Crystal controlled. Dual conversion. FM built-in speaker and 110 VAC 60 cps power supply. Self-contained table-top model which may be rack mounted. Companion to T-14/TRC Transmitter below. Excellent condition. \$24.50

T-14/TRC TRANSMITTER

JUST REDUCED! For action this month! 70-100 Mc. 50 W. input power on phono. Single channel. Built-in 110 V. 60 cps power supply. Table top size. Easily converted to 6 meters. Complete. Good condition, excellent! \$19.95

Like new. \$19.95

COMBO DEAL! Both units for only \$39.50

BC-375 100 W. TRANSMITTER

Ideal for domestic use, as well as export marine and mobile! Freq.: 200-12,500 kc. with proper tuning unit. CW or MCW. Like new condition. Only \$14.95

ABOVE, but in good condition. \$9.95

PE-73 DYNAMOTOR FOR ABOVE: Input 21 V. output, 1000 V., @ 300 mill. W./hour. 500 Ohm base. Excel. \$4.95

BC-306 ANTENNA TUNER for above BC-375: Excel. \$1.95

TUNING UNITS TO COVER ABOVE FREQS.: TU-5, TU-6, TU-7, TU-8, TU-9, TU-10. \$1.95

Each. \$1.95

PLUGS: For any of above. Each. \$0.50

RACKS: For any of above. Each. \$1.50

BC-191 TRANSMITTER

Same as above BC-375 but uses 12 VDC and 110 VAC power supply. Like new. \$24.95

BC-77 12 V. POWER SUPPLY for BC-191. New. boxed \$12.95

All orders FOB Los Angeles. 25% deposit required. All items subject to prior sale. NOTE

MINIMUM ORDER \$3.00. WRITE TO DEPT. R

ELECTRONICS

2251 W. WASHINGTON BLVD.

LOS ANGELES 18, CALIF.

Columbia

126

K. C. Licensing Killed

Circuit Court in Jackson County, Mo., invalidates ordinance on TV service.

ONE OF the few municipalities in this country to have passed local legislation licensing and regulating the activities of electronic service professionals, Kansas City, Mo., has seen the ordinance declared illegal before it was put into force. This development was the result of action by The Electronic Association of Missouri (TEAM), a group opposed to licensing, which sought to stop enforcement by seeking injunctive relief.

Other service professionals, principally those affiliated with Television Service Engineers in the same city, had endorsed the voided bill. There is evidence that proponents of service licensing will work for the early passage of a substitute ordinance whose provisions will overcome the court's objections.

The decision to void was made by the Honorable Tom J. Stubbs on July 7, 1960, in Division 5 of the Circuit Court of Jackson County, Missouri, at Kansas City. While the jurist was of the opinion that the Council of Kansas City does indeed have the charter authority to adopt an ordinance regulating the service of television equipment, he felt that the definition of television service in the particular ordinance was too broad.

He added, "I think the ordinance is bad for a further reason where, in Section 39.1087 of the ordinance, in paragraphs (a) and (c), the Board of Examiners are directed to take into account the character and reputation of the applicant for a license and, as I construe the ordinance, may refuse to recommend an applicant for a license if the Board concludes his character is such that he shouldn't have a license."

On the subject of whether or not the city has the police power to impose such a regulation as a measure of prevention of fraud, Judge Stubbs said, "No, you are going too far now; there are many laws in Missouri, state laws and city ordinances both, by which criminal conduct is punishable."

The justice's decision was based on specific provisions in the voided bill rather than on the principle of licensing itself. Since this left the path open for the introduction of new licensing legislation, the *Kansas City Times* was already reporting two days later, July 9, that an alternate television service ordinance had been introduced in the City Council.

With members of the Council apparently in favor of some kind of service licensing, it is too early to say whether the court's action does or does not mean an end to such legislation in this city. TEAM officials have expressed their intention of keeping on top of alternate proposals with an eye to blocking them.

OVER 1000 SOLD THE 1st MONTH — Not one returned to date!

JUMBO PAKS! RADIO-TV PARTS by the Pound

500-1000 pcs. per pound

MONEY BACK GUARANTEE

\$3.00
per pound

BUY 4* pick the 5th FREE

*Please note, any pak listed below is not allowed with this purchase!

- ONE POUND Precision Resistors Worth \$100, NOW
- ONE POUND Disc Condensers Worth \$85, NOW
- ONE POUND Ceramic Condensers Worth \$85, NOW
- ONE POUND Discs and Ceramics Worth \$75, NOW
- ONE POUND Discs, Ceramics, Precision Resistors Worth \$70, NOW
- ONE POUND Carbon Resistors Worth \$60, NOW
- ONE POUND "Tiny" Paper Condensers Worth \$60, NOW

- 3 TRANSR RECT'FRS Selenium; designed for submini. ckts. Only 5/16 x 4/16"; 1/2 wave. 99¢
- 4 TRANSR OSC. COILS For 450 kc superhet radios. Mini. size. 99¢
- 4 PILOT LITES Assemblies with 1/2" green jewel. Fits mini bay, bulbs, Dialo type. 99¢
- 3 TRANSISTOR CHOKES For making mini transistor power supplies. Only 5 x 7 x 8 3/4". Open frame, leads. Worth \$3. 99¢
- \$30 PR. CKT SURPRISE Includes printed circ., transformer, chokes, resistors, condensers, sockets, board (transf., alone worth \$15). 99¢
- 40 TINISTI RESISTORS Only 3/16" long; with long axial leads. For transistor ckts, color-coded. World's smallest! 99¢
- 5 MICRO-SWITCHES U.S. made. Burglar alarms, photo-electric ckts, etc. For 115V AC. SPST. Worth \$1.50 ea. 99¢
- 15 AC-DC LINE CORDS 2-conductor, with molded plugs, rubber coated, insulated, cut lengths. 99¢
- \$30 RELAY SURPRISE Popular lab and shop asst. 99¢
- 20 TRANSISTOR DISCS Condensers, incl: .02, .03 & .05 mfd. @ 30 to 100V. Worth 25¢ ea. 99¢
- CRYSTAL MIKE Sensitive 100 to 7,000 cps. Worth \$2.98. 99¢
- 4 TRANSISTOR DIODES Assorted, long axial leads. For submini & transistor semi-cond. 99¢
- 2 PNP TRANSISTORS By Western Elec. 99¢
- 300-FT. HOOKUP WIRE Assorted colors, insulation sizes. Worth \$3. 99¢
- 1500 PCS. HARDWARE Nuts, bolts, etc.; wide variety. Handy shop 99¢
- 30 MOLDED CONDENSERS Oils too! Lasts for 99¢
- 40 2-WATT RESISTORS Incl: 1/2 to 2W. Assorted values. 99¢
- 8 SIL. & XTAL DIODES Assorted values. 99¢
- 4 OUTPUT TRANSFRS 500A, etc. Open frame types. Worth \$8. 99¢
- 6 115VAC SWITCHES Panel, toggle type. SPST, DPDT. Etc. type. A shop must. 99¢
- 70 INSULATED RES'TRS IRC, Allen Bradley, stockpile makers. 1/2, 1W, 100 ohms to 1 meg. 1/2, 5¢ ea. Worth 99¢

POLY PAK®
PRICES SMASHED TO SMITHEREENS

10 for \$8.80
99¢ each

FREE! Any Poly Pak Listed Below Free With Every \$10 Order!

- 99¢ POLY PAK HEADLINERS**
- 2000-ohm PHONE cord & plug 99¢
 - XTAL PHONE cord & plug 99¢
 - CRYSTAL RADIO SET 99¢
 - 10-3-sec. TIM'G DEVICES 99¢
 - 40 ASST. SILVER MICAS 99¢
 - 50 ASST. DISC CONDENSERS 99¢
 - 5 1N34 CRYSTAL DIODES 99¢
 - 30 PANEL LITE BULBS 99¢
 - 3 HOBBY TRANSISTORS 99¢
 - 15 "POLY" BOXES 99¢
 - 125 CERAMIC CONDENSERS 99¢
 - 12 GERMANIUM DIODES 99¢
 - 7 SIL. DIODES 1N21, 1N22 99¢
 - 15 ROTARY SWITCHES asst. 99¢
 - \$15-radiation DETECTORS 99¢
 - 125 ASST. RESISTORS 99¢

- 10 PANEL SWITCHES Assorted, micro, power, primary types. Excl. variety. Worth \$10. 99¢
- 60 RESISTOR SPECIAL Carbon, precision, hi-Q. W.W. carbon-films. to 50W, 1/2 to 2W. Worth \$10. 99¢
- 10 VOLUME CONTROLS Assorted, 1 meg. Some with switch. Worth \$15. 99¢
- 4 I.F. TRANSFORMERS 450k. Only 1 1/2" sq. Transistor ckts. Worth \$3. 99¢
- 60 PLUGS & RECEPT'LS Incl: power, audio, battery, etc. Worth \$8. 99¢
- NEEDLE-STAMP CK'KR Battery-operated. Checks IN, etc. stampers. 99¢
- 10RC PLUG & JACKSETS For amps, tuners. 99¢
- 13-IN-1 PAK Diodes, carbon, W.W., precision, hi-Q resistors; disc, ceramic, molded, oil, paper, mica condensers; socket; coils. Worth \$8. 99¢
- 3 FERRITE LOOPSTOCKS Adjustable: 5-40 to 99¢
- 1600 kcs. Worth \$2. 99¢
- "POLY" WIRE PAK Assorted colors, 6-25 ft. mils; plastic ins. #18 thru #22. Worth \$3. 99¢
- 40 TRANSR RES'TRS Assorted, to 3 meg. 1/2, 500 watt rating. Color-coded. Worth \$5. 99¢
- SOLDERING IRDN 115VAC 10" with cord & plug. Nifty hob. 99¢
- 20-PC. TWIST DRILL SET Incl: 1/16 thru 1/4". For all types of drills. 99¢
- 24 ARTISTS BRUSHES 100's, pure bristles. 99¢
- \$25 SURPRISE PAK Wide variety of usable radio-TV, hobby parts. 99¢
- 6 SPOOLS OF SOLDER Rosin core type. Handy shop. 99¢
- 4 CBS SEMI-COND'RS 1N22A silicon diodes. Reg. 50¢ ea. 99¢
- SPRAGUE 40-40-40 MFD @ 450V Electrolytic, twist lock. Most pop'l'r power supply replacement. Fresh stock! Reg. \$2.50. 99¢

- 50-PC. COBALT MAGNET Set: 100's of uses for schools, tool shops, for the experimenter of magnetic properties. 99¢
- 2 500-MIL RECTIFIERS Silicon, hi-hat, with long axial leads. 99¢
- 4 SELENIUM RECTIFIERS 115VAC 1C half wave. To 350 mts. Nifty shop pak. 99¢
- TRANSR RADIO BASIC For 110 VAC; incl: transistor, socket, loopstick, diode case. Worth \$2. 99¢
- 50 PRECISION RES'TRS 1/2 asst. values. 99¢
- 1/2 W to 2W. 99¢
- 8 NEON INDICATORS Incl: 150V; mini; bay. types. 99¢
- 100 1/2-WATT RES'TRS Assorted values. Sum: 99¢
- 10% Worth \$18. 99¢
- 10 INSTRUMENT KNOBS brass insert & set. 99¢
- 8-PC. NUTDRIVER SET Plastic handles. 3/16 thru 7/16 nutdrivers in handy case. Worth \$3. 99¢
- 35 POWER RESISTORS Assorted, 1/2 to 50W to 10, 000 ohms. Vitreous. Worth 60¢. 99¢
- 70 MICA CONDENSERS Assorted values. .001 to .01 to .01 to 600V. 99¢
- 10 ELECTROLYTICS Plastic can & paper types. Duals lock. To 1000V mfd to 450V. Worth \$12. 99¢
- 80 TUBULARS Papers, molded, incl: mfd to 600V. Worth \$16. 99¢
- 40 TUBE SOCKETS 4 to 12 prongs, mica filled tool & mini types. Worth \$8. 99¢
- 4 AC & DC CHOKES Power & radio types; to 300 mA. Open frame types. Worth \$10. 99¢
- 50-FT. 'ZIP' CORD For spkr. extns, AC/DC 2-cond parallel. 99¢
- 60 TERMINAL STRIPS 1 to 19 the points. Used in every type of 99¢
- 70 COILS & CHOKES Incl: ant. osc. shig-tuned. I.F. Wonderful shop 99¢
- 70 1-WATT RESISTORS Incl: carbon, W.W., ceramic, 1/2 & 5¢. 99¢
- 60 CONDENSER SPECIAL Incl: disc, ceramic, molded, mica, papers, oils, etc. Worth \$12. 99¢
- 6 TRANSISTOR* RADIO KIT Basic: 20 pcs, incl: IF's, osc. coils, var. cond. in on-off-transf., sockets, instructions. \$5.88

MINIMUM ORDER \$2.00—Avg. wt. 1 lb. per pak

HOW TO ORDER Check items. Return ad w/ check or M.O., including sufficient postage; excess returned. C.O.D. orders 25% down; rated, net 30 days. Print name, address WITH POSTAL ZONE in margin.

LEKTRON 133 Everett Ave. CHELSEA 50, MASS.

ADD TO YOUR INCOME
Learn at Home to Fix **APPLIANCES**

Tester Furnished—No Extra Charge. National Radio Institute trains you at home. Every service customer is worth more when you can fix his electrical appliances. Mail coupon for Lesson and Catalog.

NATIONAL RADIO INST., Dept. EJO Washington 16, D.C.
Please send me Electrical Appliance Sample Lesson and Catalog FREE (No salesman will call).

Name.....Age.....
Address.....
City.....Zone.....State.....

ACCREDITED MEMBER NATIONAL HOME STUDY COUNCIL

HIGHLY PROFITABLE T V TUBE REBUILDING

is a solid substantial business yielding profits up to 50% for local operator. Small plants succeed—big plants fold. Windsor Machinery and training makes the difference. Your area may be available for franchise. Requires \$3,000. Annual volume possible of 50M to 75M. Write:

WINDSOR ELECTRONICS
GLEN ELLYN, ILLINOIS
OR PHONE HOPKINS 9-8210

**how often
could you
have used...**

**an
Xcelite
"Seizer"?**

Handy as an extra hand or helper. Clamps lightly or tightly ... for moments or minutes.

two-position snap-lock

slim, serrated jaws

Outreaches, out-holds needle-nose pliers. Hardly a spot too small for it. Approx. 6" long. Dozens of uses: Holds and positions wires for soldering ... retrieves small parts from inaccessible places ... it's a heat sink. Two-position snap-lock won't slip, yet releases with a twist of the fingers. All stainless steel — precision machined and tempered for smooth action and years of service.

2 Models: No. 43H curved nose and No. 42H straight — Ask your distributor to show you Xcelite Seizers today.



XCELITE, INC. • ORCHARD PARK, N. Y.
Canada: Charles W. Pointon, Ltd., Toronto, Ont.



FOR THE TECHNICIAN

"SERVICING VIDEO SYSTEMS" by Jesse H. Dines. Published by *Howard W. Sams & Co., Inc.*, Indianapolis, Ind. 224 pages. Price \$3.95. Soft cover.

This is a comprehensive discussion of TV video systems, from the mixer to the picture tube, detailing a wealth of information, including servicing hints, that will be used by the service technician. The book is amply illustrated with diagrams and photos.

"101 MORE WAYS TO USE YOUR SCOPE IN TV" by Robert G. Middleton. Published by *Howard W. Sams & Co., Inc.*, Indianapolis, Ind. 160 pages. Price \$2.50. Soft cover.

The author, a well-known writer on TV technology and servicing, here details an impressive series of tests through various parts and stages of TV receivers by using an oscilloscope. Equipment needed, connections to make, and thorough explanations of tests are covered. Photos of scope traces are included.

"2-WAY MOBILE RADIO HANDBOOK" by Jack Helmi. Published by *Howard W. Sams & Co., Inc.*, Indianapolis, Ind. 208 pages. Price \$3.95. Soft cover.

Equipment, basic circuits, and servicing of mobile radios are treated in ten clearly written and profusely illustrated chapters. The author takes the reader from the microphone to the speaker and back, touching on all important points between.

"HANDBOOK OF TV TROUBLES" by Sol Heller. Published by *Holt, Rinehart and Winston, Inc.*, N.Y. 302 pages. Price \$5.95.

The bulk of this volume is devoted to picture troubles, with one chapter on sound troubles and a final one covering TV interference problems. All possible causes of troubles are carefully examined, with hints for correcting them supplied. Schematic diagrams and photographs of troubled TV screens enhance the book's usefulness to the service technician.

"VIDEO SPEED SERVICING" by Samuel L. Marshall. Published by *Howard W. Sams & Co., Inc.*, Indianapolis, Ind. 160 pages. Price \$2.95. Soft cover. Vol. 4.

This is the fourth in a series of volumes that present hundreds of practical troubleshooting hints, each accompanied by a diagram or partial schematic, for solving troubles in specific makes and models of TV receivers. The problems and solutions presented

are based on actual cases and are indexed for easy reference.

"SERVICING TRANSISTOR RADIOS" by Sams Engineering Staff. Published by *Howard W. Sams & Co., Inc.*, Indianapolis, Ind. 160 pages. Price \$2.95. Soft cover. Vol. 5.

Like its four predecessors in this series, the present volume contains a collection of "Photofact" folders covering technical and physical features of 52 domestic and foreign transistor radios produced during 1958 and 1959. A special section covers alignment, measurements, and troubleshooting hints.

"AUTO RADIO MANUAL" by Sams Engineering Staff. Published by *Howard W. Sams & Co., Inc.*, Indianapolis, Ind. 160 pages. Price \$2.95. Soft cover. Vol. 10.

This is the latest in the series of bound volumes of "Photofact" folders covering auto radios. Thirty-one models produced in 1958 and 1959 are covered. Schematics, detailed photos, and parts lists are included.

THEORY AND FUNDAMENTALS

"ELECTRONICS FOR THE BEGINNER" by J. A. Stanley. Published by *Howard W. Sams & Co., Inc.*, Indianapolis, Ind. 192 pages. Price \$3.95.

Simply written and clearly illustrated, this volume is intended for the absolute novice with no previous electronic training. Some theory is covered, but the book "teaches" its lessons mainly by a series of interesting and low-cost construction projects for the beginner.

"BASICS OF INDUCTION HEATING" by Chester A. Tudbury. Published by *John F. Rider Publisher Inc.*, N.Y. Vol. 1, 140 pages; Vol. 2, 144 pages. Price \$3.90 per volume. Soft covers. Vols. 1 & 2. Also available in single volume, hard cover.

Aimed at readers who are familiar with electrical fundamentals, these two volumes explain the electrical and thermal aspects of induction heating as well as the mechanical problems associated with fixturing. Lively drawings help clarify points in the text.

"INDUSTRIAL ELECTRONICS AND CONTROL" by Royce Gerald Kloeffer. Published by *John Wiley & Sons, Inc.*, N.Y. 540 pages. Price \$10.00.

Of primary interest to engineers or engineering students, this volume approaches its subject through solid-state theory rather than by way of vacuum and gaseous tubes. The discussion is not based on heavy mathematical ex-

planations but does presume previous training in electronics or physics.

"APPLICATIONS OF ELECTRONICS" by Bernard Grob and Milton S. Kiver. Published by McGraw-Hill Book Co., Inc., N.Y. 628 pages. Price \$7.00.

Circuits and equipment are described for all modern applications of electronics. The approach of the authors is suited to the technician who has mastered fundamentals. The use of mathematics is kept to a minimum.

"ELECTRONIC FUNDAMENTALS AND APPLICATIONS" by John D. Ryder. Published by Prentice-Hall, Inc., Englewood Cliffs, N.J. 721 pages. Price \$13.35.

This is the second edition of a textbook for the serious, advanced student, or technician, updated to include new material on recent solid-state devices. The discussion is quantitative, and relies heavily on advanced math.

"BASIC ULTRASONICS" by Cyrus Glickstein. Published by John F. Rider Publisher, Inc., N.Y. 144 pages. Price \$3.50. Soft cover.

Here is a simple and basic introduction to this field. Topics covered include: theory of ultrasonic waves, their generation, design of equipment, applications, biological and chemical effects, cameras and instrumentation. Important points are highlighted with simple drawings.

"FUNDAMENTALS OF SEMI-CONDUCTORS" by M. G. Scroggie. Published by Gernsback Library, Inc., N.Y. 160 pages. Price \$2.95. Soft cover.

This book is a practical discussion of the theory and types of semiconductors. It covers transistors, rectifiers, photoelectric devices, thermistors, varistors, masers, and mavors. Written in simple, straightforward style, the volume is illustrated with drawings and photos.

"DIGITAL COMPUTER PRINCIPLES" by Wayne C. Irwin. Published by D. Van Nostrand Co., Inc., Princeton, N.J. 321 pages. Price \$8.00.

This introduction to the subject is aimed at students and industrial personnel without previous specific training. It includes a basic discussion of computation methods and then gradually develops the topics essential to the use of digital computers.

"ELECTROMAGNETIC FIELDS, ENERGY, AND FORCES" by Robert M. Fano, Lan Jen Chu, and Richard B. Adler. Published by John Wiley & Sons, Inc., N.Y. 520 pages. Price \$12.00.

This book develops electromagnetic theory and discusses the relation between circuit theory and field theory. Based on work at the Massachusetts Institute of Technology, it is developed in successive steps from the Lorentz force, the integral form of Maxwell's equations in free space, and suitable macroscopic models of polarized and magnetized matter.

WE TRADE HIGHER!



Howdoody...

I'm Jack S., head evaluator of trade-ins at the Walter Ashe Radio Co. Now, I don't evaluate heads! So don't go sendin' in no shrunken, head-hunters handiwork, 'spectin' cash allowance on new merchandise. What I mean is . . . I'm in charge of the Dept.

The picture shows me getting down to the office bright and early . . . well, early! My chauffeur drives me down in a long white limousine, with an assistant chauffeur at his side. They both help me off with my coat . . . it's a little tricky . . . and stand at attention while I evaluate old store-bought eelectronic stuff people want to trade in on fine new merchandise. (Nothin' older than 1945)

The Boss says I'm doin' a bang-up job! My department took a whoppin' loss last month . . . which is the way the Boss wants it. He fired my predesse . . . predicesse . . . predasesse . . . the guy what had the job before me for showing a \$1.89 profit in a three month period. Heck my salary alone loses him that much in a day's time! He says I got real job security if I can stay as moronic as I am!

Write when you get work, or when you decide to trade!

Jack S.

DO YOU HAVE OUR NEW CATALOG? ITS FREE!

All prices f. o. b. St. Louis. Phone CHesnut 1-1125



OUR 38TH YEAR

WALTER ASHE RADIO COMPANY
1125 Pine Street, St. Louis, Mo.

— Rush — Surprise — Trade-in Offer on my _____

Name _____
Address _____
City _____ State _____

(Show make and model of new equipment desired) _____

Send now—FREE Walter Ashe catalog _____



Accelerated Year-round program prepares for early employment in fields of Science and Engineering. Regular 4-year program for B.S. Degree completed in 36 months, special engineering degree program in 27. Classes start quarterly—September, January, March, June. Quality education. (Graduates employed from coast to coast. Government approved for veteran training. Students from 50 states, 40 countries. 20 buildings; dorms, gym. Campus. Save time and money. Earn board while studying. Write for catalog and complete information.

990 E. Washington Blvd., Fort Wayne 2, Indiana

INDIANA TECHNICAL COLLEGE

TWO 3" GALVANOMETERS—Test Leads, Multiplier Switch in hinged carrying case. G.E. Servo Testmeter. **BRAND NEW . . . \$9.95**

X-BAND POWER LEVEL TEST SET, TS-36/AP, BRAND NEW, in original packing, with accessories. Measures 10 to 30 dbm. 8700-9500 mc. (Acq. cost \$477.00). **ONLY \$14.95**

METER—3"—0-5 Ma. 270° indication. By-Pass Shunt and add scale. Excellent condition. **\$1.29**

TELEGRAPH KEY—J 47, New . . . \$1.29

ART-13 TRANSMITTER with tubes and meters **\$29.95**

Send M.O. or check with order
Write for Bargain Flyer

R W ELECTRONICS
2430 S. MICHIGAN AVE. DEPT. N
Phone: CAIumet 5-1281 Chicago 16, Ill.

27 MC citizens band

Shakespeare
FIBERGLASS

WONDERRODS

The Quality Line of Antennas
The Company that sets the standard in fishing equipment now sets the standard in quality antennas.

- Loaded Coaxial Sleeve Antenna. Both marine and base station application. Terminated with UHF connector. STYLE 72-0 — \$42.50
- Normal Made Helical Antenna. Distributed-load antenna eliminates additional loading coils. 4' length permits choice of mounting positions. STYLE 73-0 Std. model, metallic gray — \$11.25
- Ground Plane Antenna. High strength fiberglass radiating elements. Fits 1 1/2" pipe thread. Terminated with UHF connector. STYLE 61-0 — \$41.60
- Rain Gutter Mounted Antenna. Convenient, detachable installation with exceptional benefits of light-weight fiberglass. Includes 9' RG 58/U cable. STYLE 74-0 — \$14.40
- Standard 96" Whip Antenna. Light weight . . . high flexural and impact strength . . . corrosion resistant. Whip — STYLE 10-3 — \$6.95

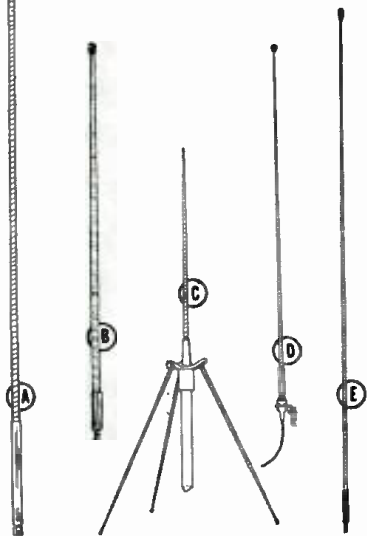

Look for the spiral markings of genuine Shakespeare Wonderrods



COLUMBIA PRODUCTS COMPANY

A subsidiary of Shakespeare Co.
Columbia, South Carolina

engineering degree in 27 mos.

Become an Electronics Engineer. Share rewards awaiting college men . . . higher income, rapid advancement. Important firms visit Tri-State to interview seniors. Bachelor of Science Degree in 27 months in Electrical (Electronics or Power major), Mechanical, Civil, Aeronautical, Chemical Engineering. In 36 months a B.S. in Business Administration (General Business, Accounting, Motor Transport Management majors). For earnest, capable students. Small classes. More professional class hours. Well-equipped labs. Dorms. Campus. Modest costs. Year-round operation. Enter Jan., Mar., July, Sept. Founded 1884. Write J. H. McCarthy, Director of Admissions, for Catalog and "Your Career" Book.



TRI-STATE COLLEGE

1690 College Ave., Angola, Indiana

Electronic pH Measurement

(Continued from page 46)

and will give greater accuracy in service.

The calomel electrode, having a small asbestos fiber connecting the outside solution being tested with the KCl (Fig. 5) will come protected by a rubber cap, which must of course be removed before placing it in service. Since the KCl (potassium chloride) can slowly leak out and evaporate, always check the KCl level in the calomel electrode and replenish if necessary.

A strong alkali can attack the very thin glass of the glass electrode, even though a special sodium-free glass is used. Over a period of time the strong base would dissolve part of the glass and change readings. Eventually it would eat through the glass, making a pin-hole somewhere.

Electrodes must be kept free from encrustation and the only way to safely remove crusts from the glass is to soak the electrode in a weak solution of opposite nature—acid for base crusts, and base for acid crusts. Do not use extremely hot water or slosh the electrode around wildly. Remember it is extremely delicate—and quite expensive!

An erratic reading of pH may not be a malfunction of the instrument or the electrodes at all. Solutions which are not in water but in some other liquid may not have an evenly distributed pH, and may cause the erratic movements. Always test with some standard test solution, as will be specified by the equipment manufacturer, before assuming the instrument or the electrodes have gone haywire.

Where the electrodes are mounted in some continuous-process piping system,

Fig. 9. Black rod between electrodes senses and compensates for temperature.

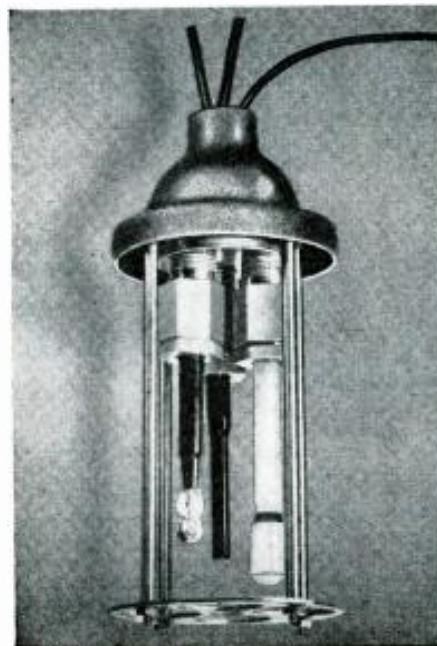

ONCE IN A LIFE TIME SALE!

New spare parts purchased from one of the largest PROFESSIONAL TAPE RECORDER Manufacturers! Complete termination of materials for new manufactured products or spare parts for operating equipment.

STOCKS LIMITED

Shipments will be made in order of receipt.



DRIVE MOTORS

BODINE NC1-33 induction drive motor. 115 v. 60 cy. .45A, 540/1080 RPM. 4 1/4" dia by 5 1/2" long. Rear shaft: 7/8" long. Front shaft: 1 1/2" long and ground for 7 1/2" and 15 iph. \$17.50

BODINE NC8-33 Hysteresis-synchronous. Same mechanical specifications as above, except 600/1200 RPM \$29.50

Please add \$1.50 per motor for postage and handling.

FASCO reeling and rewind motors. Can be used in conjunction with above drive motors. 115 v. 60 cycle, 3 1/2" dia by 4" long. Shaft 2 1/2" long and finished for standard reel lock. Best quality available for professional use. \$9.50

SPECIAL Motor starting capacitor for above drive and other motors. 2 x 5mfd at 330 VAC. With mtg bracket. \$1.75

PROFESSIONAL TAPE RECORDER HEADS

BT-1	Full track erase.	\$10.00
BT-3	Full track record.	10.00
BT-5	Full track playback.	10.00
BT-2	Half track erase.	8.00
BT-4	Half track record.	8.00
BT-6	Half track playback.	6.00
BB-3	Stereo record (stacked).	12.00
BB-5	Stereo playback (stacked).	10.00
Cinemascope	35MM playback.	30.00
Four track	(1 1/2" tape) combo.	27.50

"VU METERS"



4 1/2" internal 115 VAC illumination. Mfg by Phaostron. Metal escutcheon. 1 ma basic movement \$12.50
Same as above, except plastic case. Mfg by Marion and others. Requires external lamp source. \$7.50

WESTON model 862 illuminated DB meter. 4 1/2" rectangular case. 0 DB = 0.639V. New Price \$64.00. \$24.50

SPECIAL \$24.50
DAVEN "T" PAD. 800 ohm balanced line. 14 steps of .5 db attenuation, 7 db total. Fully shielded \$2.75

TECHLAB "T" PAD. 600/600 ohm. 10 steps of 1 DB attenuation. Shielded, with knob and escutcheon \$3.00

California residents add 4% sales tax. Terms: cash with order or 25% deposit, balance COD. All prices FOB Los Angeles.

H. D. STERN CO.

1221 Venice Boulevard, Los Angeles 6, Calif.

A NOTE TO THE HI-FI BUYER

AIR MAIL us your requirements for an IMMEDIATE LOWEST PRICE QUOTATION

Components, Tapes and Recorders SHIPPED PROMPTLY AT LOWEST PRICES

WRITE TODAY FOR FREE CATALOG

AUDIO UNLIMITED

714-W Lexington Ave.
New York 22, N. Y.



OUT OF SPACE?

You bet we'd be . . . if we were to tell you all about AUDION'S "Out of this World Hi Fi Values"

Write for free Catalog

audion
25-W Oxford Road
Massapequa, New York

MAIL ORDER HI-FI

You can now purchase all your Hi-Fi from one reliable source and be assured of perfect delivery. Carston makes delivery from NY stock on most Hi-Fi Recorders and Tape within 24 hours. SEND US A LIST OF YOUR HI-FI REQUIREMENTS FOR OUR WHOLESALE QUOTATION and our FREE wholesale catalogue.

CARSTON STUDIOS

125-TD East 88 St. New York 28, N. Y.

ELECTRONICS WORLD

they will of course be protected by a screen against possible damage from rapidly moving particles which may be carried in the liquid. In that case, encrustation or fouling of the protective screen may be one cause for erroneous readings. Regular checks are recommended. Finally—if all common-sense checks have been made for cleanliness, proper installation, and intact electrodes—look for circuit problems.

Most circuit difficulties in pH measurement arise from electrical leakage. Because of the very high resistance of the electrodes, any inadvertent shunting in the circuit has a disastrous effect on the accuracy of measurement. Because the pH equipment is necessarily placed in a liquid-carrying environment, scrupulous cleanliness must be observed for the electrode terminals, leads, and connectors.

Next most frequent are grounding problems. Thorough grounding of the case, the amplifier, and the piping involved may be of help. Ground loops and a.c. pickup are as much a problem here as in any hi-fi installation. Precipitation or encrustation of the electrodes and supporting structure may restrict the flow of liquid around them. Frequent inspection of the electrodes may be required. Accidental shorting or loading of the electrodes will cause polarization. They will recover, if left alone, but it may take a long time, possibly days.

If radioactive material is present in the liquid, ions may collect around the electrodes and give false (high) readings. Sodium, lithium, and potassium in high concentrations will cause the electrodes to respond more vigorously, and corrections must be made for these solutions. The manufacturer of the electrodes will supply the data needed. What we have said for pH is also mostly valid for other potentiometric measurements made with these electrodes.

A pH measurement used to be a tedious, hand-worked problem of titration which had to be done in small batches. Once more, electronics has come to the rescue to enable rapid, continuous pH determination in our automated world.



"Let me know when that picture tube goes."

September, 1960

DOES YOUR BUSINESS SLUMP AS TEMPERATURES SOAR?

DIVERSIFY WITH 2-WAY MOBILE-RADIO MAINTENANCE!

Hundreds of progressive radio servicemen are filling the summer slump in entertainment radio—by adding mobile-radio maintenance! Actually, mobile-radio service is business 12 months out of the year—often on contract basis—paid for by going organizations. So rise above competition—and end that summer slump—send coupon below for "How to Make Money in Mobile-Radio Maintenance". It's free!

THIS BOOKLET IS BASED UPON A CAREFUL SURVEY OF THE ACTUAL OPERATING PRACTICES OF SUCCESSFUL MOBILE-RADIO ENGINEERS. IT SHOWS TYPICAL CONTRACT PROVISIONS . . . MONTHLY FEES . . . INSTALLATION CHARGES . . . LABOR RATES . . . ETC.

Lampkin instruments are the most popular mobile-maintenance meters.

MAIL COUPON TODAY ➔

LAMPKIN LABORATORIES, INC.
BRADENTON, FLA.



LAMPKIN 105-B
FREQUENCY METER
RANGE 0.1 TO 175 MC AND UP
PRICE \$260.00 NET



LAMPKIN 205-A
FM MODULATION METER
RANGE 25 TO 500 MC
PRICE \$270.00 NET

LAMPKIN LABORATORIES, INC.
MFM Division, Bradenton, Florida

At no obligation to me, please send

Free booklet Data on Lampkin meters

Name _____

Address _____

City _____ State _____

NEW! INDUCTANCE QUALITY TESTER



As the name implies, this instrument determines the quality of an inductance such as found in flybacks, audio output transformers, vertical output transformers, chokes, yokes, etc. It has the remarkable property of high sensitivity combined with adequate energy level to provide actual operating voltages. For example, the instrument will detect a single shorted turn in a flyback transformer and yet deliver approximately 1500 volts peak-to-peak across the primary of an average transformer! Design engineers and technicians alike should find this instrument extremely useful.

For complete information write: TELSON ELECTRONIC PRODUCTS, INC., Rapid City, South Dakota or contact your distributor.

• THE BENDIX PORTABLE TRANSCIEVER (Pack-set) MHT-90 Range 138 MC . . . 1 Watt. w/ vibrator power supply MP-103A. (Rev. is xtal control, dual conversion, superhet with 5 stages of amplification. Entire unit has 19 tubes) (Transmitter is xtal control. Can be modified to supply audio and modulation circuit. Unit orig. cost \$400.00) Weight 9 lbs. Complete with schematic and spec. sheet. F.O.B. Baltimore. . . . CADISCO'S PRICE TO YOU . . . \$42.50

• HERE IS AN IDEAL YET INEXPENSIVE FREQUENCY STANDARD THAT ORIGINALLY COST \$178.00 ea. for only . . . \$5.75
• (Contains a 500 KC precision min. xtal CRV type in a BMS Labs. xtal oven heated with a 58-10 tube w/padders for adjust. Herm. sealed rect. nickel-plated brass with 7 pin miniature socket prong at base. 4 1/2" x 1 1/4" x 1 1/4". SPECS: 500 KC ±0.0012% at 75V (6.3 V for 5840 tube)
• THIS RCA PRECISION CRYSTAL OSCILLATOR RP . . . only . . . \$5.75

• OTHER CADISCO SPECIALS

• 955 Acorn Tubes. . . \$0.16	• HC 733D Satellite Rev. . . \$9.99
• 5P8T Mm. Togg. Sw. \$0.12	• S814 825 Mine Detect. . . \$22.50
• UG 695 2 1/2 Cond. \$0.35	• HC 1333 Receiver. \$9.95
• 2000-15V Capacit. \$0.35	• HC 1033A Receiver. \$7.95
• 6N03T Amper. . . \$0.35	• R4/ARR2 Receiver. \$5.95
• Relay . . . \$0.35	• TS 153 AP Relative Field Strgh Meter 0-100 MC . . \$17.95
• 6C5 Amperite . . . \$0.35	
• 808 RCA Tubes. . . \$0.35	
• 811 RCA Tubes. . . \$0.40	
• MODULATION XFORMER Primary 5.500 ohms	
• Mfr. RCA 600716 Secuml. 2,800 ohms 250 MA DC . . . \$5.95	
• STANCOR P-6309 Fil. Xformer. B.3 at 2 1/2 Amp. \$6.95	
• SMOOTHING CLOCK Raytheon U-8001. 12 HV's at .325A . . . \$10.95	
• CG 357 Coaxial Cable RG 59 A/U (50 ft w/ connect.) . . . \$1.95	
• 12 Octal Steatite Sockets or 15 Shock Mount Octal . . . \$0.99	
• 7 pin mica sockets stripped from equipment 12 for . . . \$0.99	
• 50 K carbon pot. long shaft for knob . . . \$0.25	
• 45 ohm 1KW Resistor RW 350-500 for . . . \$0.25	
• ELECTRONIC REGULATED POWER SUPPLY removed from new equipment. Input 115-00 Output 250-300 VMC at 100-125 MA ± a HV Intermittent 1600 Volt Supply . . . \$24.95	
• .65-12.500VDC Oil-Filled Capacitor. Aerovox Type JP20 (Price from Mfr. \$175.00). CADISCO'S SPECIAL . . . \$12.95	
• 1N91 GE Short Lead . . . \$0.89	• Drake Pilot Lite 80. \$0.32
• 1B22 Radar Tube. \$0.35	• Microamp . . . \$5.75
• 3BP1A Scope Tube. \$1.49	• 3" 0-500 DC Mils. \$5.75
• 3C14 Thyr. Tube. \$5.75	• 2" 0-150 DC Mils. \$3.75
• Meter Rectifier	• 2P3T Rotary Mm. . . \$0.25
• Conant 500 Series" Black . . . \$0.95	• Switch Tungrol G127 7V . . . \$0.25
	• Relay . . . \$0.25

• TERMS. Min. Order \$2.00. 25% with order. Balance C.O.D. All prices fob Balto. subject to change without notice. WE ALSO BUY SURPLUS ELECTRONICS. PARTS TEST EQUIP'T . . . ETC.

• CADISCO 1425 W. Baltimore St. Baltimore 23, Md.

**ORDER
YOUR
ENCLOSURE
KITS FROM
HOMWOOD**

Bring out
the best in
your speakers ...
save dollars in
assembly and
finishing costs ...
get the fun of
"doing-it-yourself"!



ONLY
\$11.95

MODEL 6

Factory assembled, ready for finishing. Makes your 8" speaker sound like a million! Made of 1/2" hardwood ply, beautifully grained and smoothly sanded. 10" h. x 16" w. x 9" d. 9 lbs. Order two for matched stereo performance.



MODEL 1

4 1/2 cubic feet of baffle space assures you crisp, cleanest bass response from any 12" speaker system. Full-grained white birch ply, with pre-attached bracing cleats for easy assembly. Kit includes everything you need for assembly. 29" h. x 20" w. x 12 1/2" d. (5" legs). 25 lbs. \$18.95



MODEL 2

Clear-grained on four sides for bookshelf or floor use. Acoustically accurate for 12" systems, with adapter board for 8" speakers. Sturdy, 3/4" ply eliminates unwanted resonances, improves bass response. 14" h. x 21" w. x 11 3/4" d. 20 lbs.

In Birch, \$14.50
In Walnut, \$19.95

MODEL 13. Finishing kit; includes generous quantities of everything you need to do a professional, long-lasting finishing job, plus brush, sandpaper and easy-to-follow instructions. Specify: Mahogany, Walnut, Blonde, Oak, Fruitwood, Maple, Cherry, Ebony, Natural. \$3.88

Ten-day money-back guarantee. All items shipped freight collect. Please send check or M.O. (No COD's)

HOMWOOD INDUSTRIES, Inc.

26M Court Street, Brooklyn 1, N.Y.

Please send me:

- Model 6 Model 1 Model 2 (Birch) (Walnut)
 Model 13
 Homewood catalog

I enclose remittance in the amount of \$ _____

Name _____

Address _____

City _____ Zone _____ State _____

FM Reception on Wheels

(Continued from page 65)

sensitivity with high conversion efficiency and superior frequency stability.

The subsequent i.f.-limiter-detector strip might seem overdesigned for a home receiver—but this isn't a home receiver. V_2 and V_3 are conventional i.f. amplifiers. These are followed by two stages of limiting, V_4 and V_5 . Furthermore, the limiters are double-acting affairs providing both grid and plate limiting. The signal path so far provides excellent gain and limiting. In fact, this could be considered quite good in an FM home tuner whose discriminator is of the Foster-Seeley type, which provides no limiting on its own. Where a ratio detector, which also provides good limiting, is employed, the manufacturer begins to cut down on stages of i.f. amplification or pre-detector limiting. This is not so here, where the ratio detector is used. The combination of exceptionally good noise clipping with high sensitivity gives the user a much better chance in his battle against vehicular handicaps.

While sensitivity and noise rejection (as far as the circuit is concerned) have been considered, the four limiting points (grids and plates of two stages) prior to the detector accomplish another purpose. All signals strong enough to produce limiting tend to be cut down to the same size. Thus fluctuations in signal strength occurring during motion, which would ordinarily produce fading and fluttering in the audio output, are well controlled above a certain threshold. Where comparable limiting appears in home FM sets, the a.v.c. loop is often left out. However, since the control of fading is particularly important here, a feedback loop originating at the grid of the first limiter, up to which signal-strength variations still exist, is returned (point D) to the front end for a.v.c.

There is still a need to consider stability, both of frequency and voltage. As to the former, we have an a.f.c. loop involving a back-biased semiconductor diode (E_2) between the center of the balanced ratio detector (point C) and the grid of the converter stage. Such diodes act as voltage-sensitive variable capacitors. The error voltage provided by the detector when the set is off frequency retunes the oscillator tank correctly. This takes care of frequency stability and also gets rid of the problem of critical tuning. As with most a.f.c. circuits, there is a fairly broad range on either side of the precise tuning point over which a desired station may be pulled in easily, without the driver having to pull his car over to the curb to make the adjustment.

Voltage stability becomes particularly important where a biased diode is used in an a.f.c. loop. If the biasing voltage varies, for example, erratic action of the diode may do more harm

than leaving the diode out altogether. A neon bulb (E_1 , which may be found between the top of E_2 and the lead from the power supply) provides the necessary voltage stability.

Of additional interest in the FM-900 are the power supply and audio circuits. Although the set uses tubes mixed with transistors, it cannot be called a conventional hybrid receiver, in which the tubes use low plate voltages. The latter types would doubtless require unacceptable design compromises. Thus conventional tubes requiring "B+" in the order of 100 volts are found here. While this requirement could be met with a vibrator type of power supply, noise problems might again arise. Thus a transistor power oscillator, V_{osc} , with a step-up transformer is used to provide a satisfactory a.c. voltage, which is rectified by a selenium diode and filter. A varistor (R_{100}) at the rectifier output also helps stability here. The power pack is on a separate subchassis.

Receiver controls (left to right in Fig. 1) are "Volume-On-Off," "Tone," "Speaker Selector," and "Tuning." A pair of push-pull 2N176 transistors provide 15 watts of peak audio output, 9 watts undistorted. A feedback loop keeps response flat from 50 to 10,000 cps. Sensitivity is given as 3 microvolts for 20 db quieting. A 12-volt battery system, with battery negative grounded, is required. An accessory "radio switch" permits alternate use of an existing AM receiver.

The accessory kit contains ignition-suppression equipment to be installed in addition to that which may already exist for AM. A .5- μ f. capacitor (Fig. 3) must be installed on the generator. A .1- μ f. unit (Fig. 5A) is installed on the voltage regulator. (If more suppression is needed here, the .5- μ f. unit shown in Fig. 2 is also added later.) Another .1- μ f. capacitor (Fig. 5B) is installed on the ignition coil. If still more suppression is needed, ignition wiring should be checked to make certain that it is of the resistance-wire type. If it is not, replacement with resistance wire is in order.

Ground straps to prevent ground loops by insuring good electrical conductivity between various metal parts of the car may also cut down ignition noise. Suggested points are from the engine block to the firewall; from the engine block to the car frame; from the negative battery terminal to the car body; and from this battery terminal to one of the voltage-regulator mounting screws. Where noise is stubborn, rear-deck mounting of the antenna can help. These useful hints apply to any FM auto installation.

Suppression effectiveness can be checked by driving the car away from a transmitted signal to the point where "picket fencing" begins. This is the audio flutter produced in the moving vehicle as it goes out of transmitter range toward the fringe. If background noise does not become evident until the picket-fencing level is approached, suppression is effective.

INFRARED SNOOPERSCOPES

SEE IN TOTAL
DARKNESS...
UNDETECTED!

- FOR:
• Research
• Crime Detection
• Wildlife Study



Now available...complete Snooperscopes...PRICED \$50 TO \$85

LAMPS • OPTICS • TUBES • PARTS

Write today for FREE Infrared Catalog...

Contains amazing low prices of assembled units...individual parts. Also, detailed description and applications.

We have one of the world's largest stocks of infrared parts and equipment.

McNEAL ELECTRIC & EQUIPMENT CO.
4736 Olive St., Dept. EW-9, St. Louis 8, Mo.

British TV Changes Looming

By PATRICK HALLIDAY

Gradual change from 405- to 625-line system recommended.

THE long-awaited report of the official British Television Advisory Committee—representing government departments, broadcasting authorities, and the electronics industry—recommends a gradual change from the British 405-line system (in use since 1936) to 625-line definition with a full 8-mc. channel.

The new standards would apply at first only to projected u.h.f. stations in Bands IV (470-585 mc.) and V (610-960 mc.) but later all existing television stations in Bands I (41-68 mc.) and III (174-216 mc.) will, if the report is implemented, be converted to 625 scanning lines.

To avoid political and commercial repercussions among the 10-million owners of 405-line receivers, the British Postmaster General has emphasized that 405-line services will be continued for "many years" but has estimated that 625-line programs on u.h.f. could start by 1964.

The Committee, backed by the research facilities of the *British Broadcasting Corporation*, has been carrying out field trials with a 10-kw., 650-mc. vision transmitter radiating a 5-mc. video channel, as widely used in continental Europe and Australia. It is reported that although the 625-line pictures did not prove, on over-all assessment, to differ significantly from 405-line pictures, there was marked reduction in the visibility of the scanning lines. The Committee believes that by adopting a 5.5-mc. video bandwidth with a 1.25-mc. vestigial sideband, requiring an 8-mc. channel—as at present used in some Iron Curtain countries—the picture would show a definite over-all superiority over the existing ones.

Even higher definition pictures, for example, the French 819-line, 13-mc. channel ones, have been rejected on the grounds that the wide bandwidth would reduce drastically the number of possible programs. A major advantage of the 625-line system is that it would facilitate the international exchange of programs along the Eurovision network. At present, all programs coming into or going out of the United Kingdom are passed through "standard converters" with resulting degradation of picture.

There seems little chance of British viewers seeing regular color programs for a long time to come; the Committee which has been experimenting with a 405-line color system adapted from NTSC standards has now urged that plans for color service be delayed. —30—

LESA...for STYLE and PERFORMANCE

The classic, smart appearance of the LESA CD2/21 stereo record changer previews the perfection of performance you can expect from this precision component, custom crafted in the discriminating Italian tradition. Whether you are just stepping into hi-fi, or have been an enthusiast for some time, compare... you'll find LESA has everything.

- Fully automatic, 4-speeds • pre-wired for monaural and stereo • Minimum rumble, flutter and wow • Constant speed-change cycle—only 6 seconds • Absolutely jam-proof • Automatic size intermix • Heavy duty four-pole motor • Gentle record handling • Universal plug-in head • No background noise • Stop without rejecting • Automatic click suppressor • Finished most attractively in smart continental styling. Write for free LESA literature and name of nearest dealer to: Electrophono & Parts Corp. 530 Canal St. New York, N. Y.

\$44⁵⁰

Slightly higher
in the West

CD2/21 High-Fidelity Stereo Record Changer

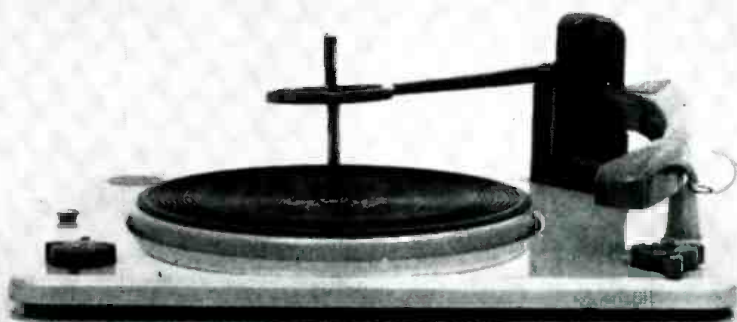

LESA



Olson



FREE

Fill in coupon for a FREE One Year Subscription to OLSON RADIO'S Fantastic Bargain Packed Catalog—Unheard of LOW, LOW, WHOLESALE PRICES on Brand Name Speakers, Changers, Tubes, Tools, Hi-Fi's, Stereo Amps, Tuners and thousands of other Electronic Bargains.

NAME _____

ADDRESS _____

CITY _____ ZONE _____ STATE _____

If you have a friend interested in electronics send his name and address for a FREE subscription also.

OLSON RADIO CORPORATION

611 S. Forge St. Akron 8, Ohio

ELECTRONIC TECHNICIANS!

Raise your professional standing and prepare for promotion!

Win your diploma in
**ENGINEERING MATHEMATICS, or
ADVANCED
ENGINEERING MATHEMATICS,**
from the
Indiana Home Study Institute

We are proud to announce two great new courses in Engineering Mathematics for the electronics industry.

These unusual courses are the result of many years of study and thought by the President of Indiana Home Study, who has personally lectured in the classroom to thousands of men, from all walks of life, on mathematics, and electrical and electronic engineering.

You will have to see the lessons to appreciate them!

NOW you can master engineering mathematics, and actually enjoy doing it!

WE ARE THIS SURE: you sign no contracts—you pay only AFTER you have completed each Unit of your course.

In plain language, if you aren't satisfied you don't pay, and there are no strings attached.

Write today (a postcard will be fine), for more information and your outline of courses.

You have nothing to lose, and everything to gain!

The INDIANA Home Study Institute
924 E. Columbia Avenue, Fort Wayne, Indiana

FIX ANY TV OR RADIO ever made!

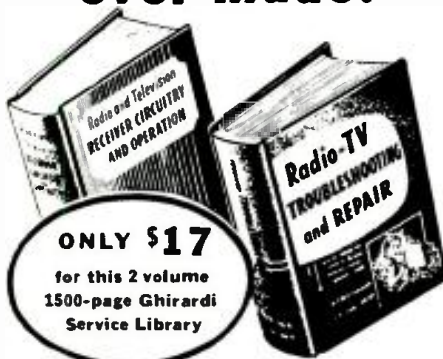

ONLY \$17

for this 2 volume
1500-page Ghirardi
Service Library

COMPLETE TRAINING FOR BETTER RADIO-TV SERVICE JOBS

These two giant Ghirardi home training manuals make it easy for you to be an expert on ALL types of TV-AM-FM service . . . at only a fraction of the price you might expect to pay for such complete training. Almost 1500 pages, over 800 clear illustrations and dozens of procedure charts explain each detail of every service job as clearly as A-B-C. Each book contains up to the minute data. Each is based on approved professional methods. You learn time-saving shortcuts. You learn to work better, more profitably. Ideal as complete training for beginners or as a handy reference library for experienced servicemen who want to look up puzzling jobs or develop new and faster methods.

A complete guide to TROUBLESHOOTING & REPAIR

① This \$20-page **RADIO & TV TROUBLESHOOTING AND REPAIR MANUAL** guides you through each service procedure . . . from locating troubles to making repairs fast and right. Step-by-step charts cover practically every type of troubleshooting from Television problems to AM and FM reassignment to IF and Detector Sections, car radios, record players, communications receivers, etc. 417 illustrations. Price \$10 separately. (Outside U.S.A. \$10.50.)

The complete "know how" of SET CIRCUITS & OPERATION

② Learn all about circuits and their peculiarities and watch your service "headaches" disappear! This 669-page **RADIO & TV RECEIVER CIRCUITRY AND OPERATION** manual covers all basic circuits and circuit variations used in modern home equipment; explains their likely trouble spots; teaches you to go right to the seat of trouble without useless testing; helps you develop fast, truly professional service techniques. Price \$9 separately. (Outside U.S.A. \$9.50.)

SAVE \$2.00—Pay As You Learn!

If sold as a course and sent to you in lesson form, you'd regard these two famous manuals as a bargain at \$100 or more. Instead you buy them complete in handy book form for only \$17 for the two (regular price \$19.00). You save \$2.00 . . . and you have 3 months to pay if desired. No lessons to wait for! Everything is at your finger tips. You learn fast . . . and you learn right! **OUR MONEY-BACK GUARANTEE PROTECTS YOU FULLY!**

STUDY 10 DAYS FREE!

HOLT, RINEHART and WINSTON, Inc.
Dept. RN-90
Technical Div., 383 Madison Ave.,
New York 17, N. Y.

MONEY-SAVING OFFER!

Send Radio & TV TROUBLESHOOTING AND REPAIR and Radio & TV CIRCUITRY & OPERATION home training manuals for 10-day free examination. If I decide to keep books, I agree to pay \$17 (plus postage) for the two . . . a saving of \$2.00 over the regular price of \$19. I will pay \$8 (plus postage) after 10 days and \$3 a month thereafter until \$17 has been paid, otherwise I will return books and owe you nothing. (SAVE! Send \$17 with order and we pay postage. 10-day money-back guarantee if you're not more than satisfied.)

Name

Address

City, Zone, State

(Outside U.S.A.—\$18 for both books. Cash with order only, but same return privilege with money refunded.)

Home-Built Speaker System

(Continued from page 63)

If the mid-range speakers are used, a suitable crossover at about 700 cps is required. Fig. 4 shows one such network which provides a 6 db-per-octave attenuation. Further details as to network construction can be found in the "References" at the end of the article. An "L" pad should be used with the mid-range speakers since they are more efficient than the woofers and require some attenuation for proper balance.

When wiring the speakers together they must be properly phased. The woofers can be phased together since their polarity is known. The same is true for the mid-range speakers. However, when the tweeter or mid-range system is combined with the woofers, the phasing can be accomplished by working with two systems at a time. The tweeter is connected to the woofers and the leads to one reversed until the sound seems most natural. Probably the easiest way to do this is by using a test record of speech or a single instrument and reversing the leads to one of the speaker systems until the sound seems to come from a single source instead of two distinct sources.

Results

As with all speaker systems, the proof of the sound is in the hearing. Test curves show little since so many factors enter into the over-all performance of a system. The author feels that the system described here sounds almost as well if not as well as the medium-priced commercial systems. Tests were made with speech and piano, the acid test of any speaker and they sounded exceptionally well. Steady-state frequency response is indicated in Fig. 2. This curve is only qualitatively meaningful since so many factors enter into recording responses of this type and they must not be regarded as a definite criteria of speaker performance. The response curve shown in Fig. 2 was made using the woofers and electrostatic tweeter without the mid-range system. The mid-range system smooths the mid-region slightly but the woofer and tweeter alone seem adequate.

Since the acoustic spring is stiffer than the mechanical springiness of the cone itself, the speaker system will be somewhat inefficient compared to conventional systems. However, in return for a loss in efficiency, the performance is more linear and tighter. A 20-watt amplifier will prove adequate and one of half that power will drive this system. However, in order to have reserve power on the peaks and minimize distortion, the more power the better, and 60 watts is not too much.

REFERENCES

- Hitchcock, R.: "A Survey of Crossover Networks," *Audio Engineering*, November, 1956.
- Cohen, A. B. and Cohen, P. D.: "Hi-Fi Crossover Network Design Charts," *ELECTRONICS WORLD*, May, 1959.

Old "Radio News" Issues WANTED

In order to complete our office file, we are anxious to obtain back issues of RADIO NEWS from the years 1919 through 1937. If you have any of these magazines, in good condition, will you please forward a list, including month, year, and price desired to: The Editor, ELECTRONICS WORLD, One Park Ave., New York 16, N. Y. Please do not send the magazines themselves until you receive word from us. All communications will be acknowledged.



ELECTRONICS WORLD HAS

A BUYER FOR YOUR USED EQUIPMENT OR COMPONENTS!

The 245,000 purchasers of ELECTRONICS WORLD are always in the market for good used equipment or components. So if you have something to sell, let EW readers know about it through our classified columns. It costs very little: just 60¢ a word, including name and address. Minimum message: 10 words.

For further information write:

Martin Lincoln
ELECTRONICS WORLD
One Park Avenue
New York 16, N. Y.

New Isotronic Training Method

LEARN TV REPAIR IN ONE SHORT WEEK!

Now, after 5 year's research—a streamlined training system that obsoletes all others! In just 7 days you may earn \$150 weekly, without paying up to \$250 for training, studying long months! Developed by electronic scientists in cooperation with major TV mfr's, the new Isotronic method is the most practical ever devised! For conclusive proof, write for details and FREE SAMPLE LESSON. Use it on your own set or a friend's—repair it—convince yourself you can make big money immediately in your own TV business! Hurry—Free Lesson supply limited. Write: TV Servicing Systems, Dept. D-769 1088 So. La Brea Ave., Los Angeles 19, Calif.

PACKAGE HI FI or SINGLE COMPONENTS

You'll find our prices low and service fast.

Write for our quotation.

CENTER ELECTRONICS Co., Inc.
74-L Cortlandt Street, New York 7, N. Y.

TAPE RECORDERS



HI-FI COMPONENTS SLEEP LEARN KITS

MERITAPE
Low cost, high quality recording tape, in boxes of cans.
DRESSNER, 69-02 RA, 174 St., Flushing 65, N. Y.

UNUSUAL VALUES
FREE 1960 Catalog
1960 Catalog



BARGAIN HUNTING?

TV SERVICEMEN!

Write for SENSATIONAL CATALOG
HENSHAW RADIO SUPPLY
3619 TROOST KANSAS CITY, MO.

Don't Underrate Transistors

(Continued from page 53)

tion rating if the ambient temperature is kept below 25°C.

One method of lowering the ambient temperature is to mount the transistor on a suitable heat sink and then immerse the entire assembly in ice water to a point just short of shorting out the transistor leads. Many mechanical arrangements can be devised to obtain this type of ice bath, and with it, it is possible to maintain an ambient temperature of 0°C (32°F).

The maximum allowable collector dissipation with a depressed ambient temperature can be determined by substituting the appropriate values in equation (2).

$$P_c = \frac{65 - 0}{0.065}$$

$$P_c = 1000 \text{ mw.}$$

These calculations indicate that it is possible to operate the transistor with a collector dissipation of 1 watt if the ambient temperature is 0°C. The new value of k for operation with a heat sink was obtained from Table 1. Of course, for continuous operation precautions must be taken to insure that the 0°C ambient temperature is maintained. Fig. 5 shows the output characteristic curves with the 1-watt power dissipation curve.

Since the power output of a transistor power amplifier is approximately equal to collector dissipation times collector efficiency, any increase in collector dissipation without exceeding the manufacturer's absolute maximum ratings results in increased power output.

Many manufacturers, rather than providing the values for k , give a collector dissipation—ambient temperature derating curve. Fig. 6 is such a curve for the transistor described in Table 1. From this curve it is possible to read the allowable maximum collector dissipation in milliwatts for any ambient temperature. —30—

Fig. 6. Collector dissipation versus ambient temperature derating curve.

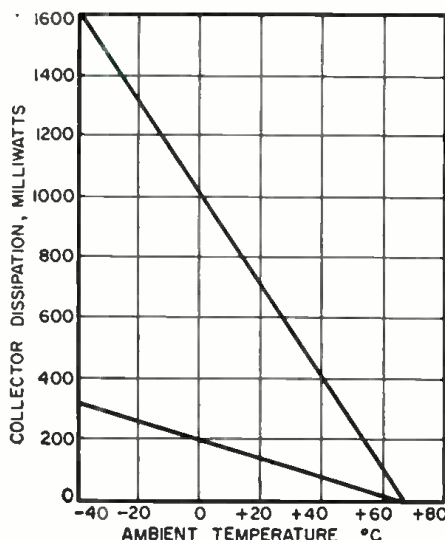

Now... INCREASE YOUR RADIO SALES with the SEG RADIO DEMONSTRATION SYSTEM

- Radios sell immediately on demonstration
- Completely hidden
- No direct connection
- Simple to install
- FM & Shortwave outlet

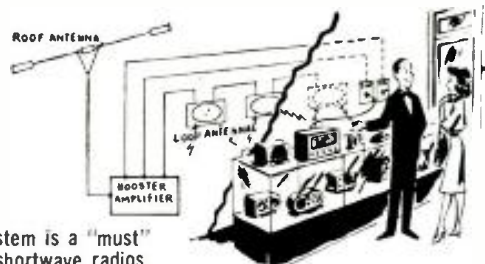

The new Master Radio Demonstration system is a "must" for every retailer who sells AM, FM or shortwave radios. Powerful signals are sent out by concealed loop antennae to give all the radios on your display shelves strong and clear input signals... permitting them to function at the peak of their capacity, despite interference from fluorescents, elevator starting motors, or any other steel construction in the building that might introduce noise or weaken the signal.

Demonstrate with Pride—No Excuses



- MODEL SPA
- Channels 2-13
 - Over 26db gain
 - 6-8 mcs band width

SUPER POWERED SINGLE CHANNEL AMPLIFIER OVER 20V—5 WATTS OUTPUT

DELIVERS TREMENDOUS SIGNALS OVER LONG DISTANCES

- Response flat ± 2 db
- Input 1 Volt max.
- 75 OHM Termination
- Linear Class—A operation
- C. C. S. Service

U. S. Govt. Install. Panama Canal Zone, Iwo Jima.

Write for details today

SEG ELECTRONICS

1778 FLATBUSH AVE., BROOKLYN 10, NEW YORK

LOOK

NO FURTHER... IF YOU'RE UNHAPPY WITH "HI" HI-FI PRICES. WRITE FOR OUR UNUSUAL AUDIO CATALOG.

KEY ELECTRONICS CO.
120-C Liberty St., N. Y. 6.
Phone C Loverdale 8-4288

TV PICTURE TUBES AT LOWEST PRICES

NEW TUBES	14RP4 \$16.95	21CEP4 \$22.95
	14W/ZP4 16.95	21DEP4 22.95
ALL ALLUMINIZED:	17BJP4 19.95	24AEP4 26.95
	17BZP4 19.95	24AHP4 26.95

10BP4 \$ 7.95	17BP4 \$ 9.95	21AMP4 \$15.75
12LP4 8.50	17CP4 17.00	21ATP4 15.75
14B/CP4 9.95	17GP4 17.60	21AUP4 15.75
16DP4 12.00	17HP4 12.50	21EP4 13.50
16EP4 12.75	17LP4 11.50	21FP4 14.50
16GP4 14.50	17QP4 9.95	21WP4 14.00
16KP4 9.95	17TP4 17.00	21YP4 14.50
16LP4 10.95	19AP4 16.00	21ZP4 13.50
16RP4 9.95	20CP4 13.50	24CP4 23.50
16WP4 12.00	20HP4 14.50	24DP4 24.50
16PT4 9.95	21AP4 22.10	27P4 39.95
17AVP4 12.50	21ALP4 15.75	27RP4 39.95

1 Year Warranty

Aluminized tubes \$3.00 for 21"; \$5.00 for 24" and 27" additional. Prices include the return of an acceptable similar tube under vacuum. These tubes are manufactured from reprocessed used glass bulbs. All parts and materials including the electron gun are brand new.

ALL PRICES FOB CHICAGO, ILLINOIS. Deposit required. When old tube is not returned, refundable at time of return. 25% deposit required on COD shipments. Old tubes must be returned prepaid. Tubes shipped Rail Express. Shipped only to Continental U. S. and Canada.

WRITE FOR COMPLETE LIST.

—PICTURE TUBE OUTLET—
2922 MILWAUKEE AVE., CHICAGO 19, ILLINOIS
DICKENS 2-3648

WHO NEEDS

MILES OF WIRE?

GET HOME ELECTRICITY ANYWHERE WITH A

terado

CONVERTER

Change 6 or 12 volt D.C. to 110 volt, 60 cycle A.C.

No Installation—Just plug into cigarette lighter of car, truck, or boat, and it's ready to go!

Operate lights, electric shavers, dictation machines, record players, small electric tools, portable TV, and testing equipment.



Models from 15 to 200 watts, priced as low as **\$12.95**

See Your Electronic Parts Dealer or Jobber

terado COMPANY
DESIGNERS & MFRS. OF ELECTRONIC EQUIPMENT SINCE 1937
1058 RAYMOND AVE., ST. PAUL 14, MINNESOTA
In Canada: ATLAS RADIO CORP. LTD.—Toronto, Ont.

ADVANCE TRANSFORMER MONTH

******* TRANSFORMERS *******

ALL 115 VOLT PRIMARY

SEC	AMP	SALE	SEC	AMP	SALE
6.3	4	2.19	18	18	4.25
6.3	15	3.95	24	2	2.49
12.6	1 1/2	1.49	24	3	2.95
18	4	3.25	2 1/2	20	3.75

---POWER TRANSFORMERS!---

115 VOLT PRIMARY					
SEC VOLTS	MA	SEC	AMPS	SEC	AMPS
300-0-300	100	6.3	2	3	2
300-0-300	450	—	—	—	—
350-0-350	250	6.3	3	5	3
360-0-360	200	6.6	10	5	3*
385-0-385	150	6.7	5	5	3
400-0-400	200	6.3	5	5	2
400-0-400	250	6.3	9	5	2
400-0-400	375	6.3	5	5	4
450-0-450	250	6.3	8	5	3
500-0-500	100	6.3	8	5	4
525-0-525	250	6.3	7	5	3

400 CYCLE

540-0-540	320	6.3	14	5	9**	12.50
-----------	-----	-----	----	---	-----	-------

*Plus 12.6V 3A **Plus 2.5V 7.5A

SPECIAL! PRI \$49.50

OUTPUT TRANSFORMER

1200 ohms input, 0-1-12-24 ohm out 50 watts. Response \pm 2 db. fm 50 to 10 Kc. **S.C.O.O.P!** **\$8.95**

STEP UP/DOWN TRANSFORMER \$10.95
110/220, 10 amp. ONLY

SOLA CV TRANSFORMER \$9.95
115-125 V, 60 cy. input, 20 V @ 1 amp output

******* CHOKES *******

HY	MA	SALE	HY	MA	SALE
8	200	2.15	20	110	2.49
10	100	1.75	30	300	7.95
12	200	*2.25	300	300	2.99

SWINGING CHOKE

230 V, 5 Hy @ 500 Ma. to 15 Hy @ 100 Ma. **SPECIAL! \$17.95**
Min. Order \$3.00-25% with order F.O.B. New York 10 DAY GUAR. PRICE OF MDSE. ONLY

Advance Electronics
6 West Broadway • New York 7, N. Y. • Rector 2-0270

SOME SPECIALS FROM OUR NEW GREENSHEET CATALOG

- BC-640-8100-156 Mc.Xmtr. New. Unused-orig. crate \$395.00
- 2 KW. Mod. Xfmr. 10K 3750 & 7500 Ohms. \$44.50
- TS148 UP "X" Band Spectrum Analyzer. \$595.00
- 2 Mid 7500 VDC Sprague Capacitor. New. \$12.50
- Altec-Lansing Output Xfmr. 3300 CT 500/250 Ohms. Herm. sid. New. A \$20.00 value for only \$2.50
- TS-173 (90/180 Mc) \$150.00
- TS-175 (85/1000 Mc) \$195.00
- TS-497-A/URR Sig. Gen. (2 to 400 Mcs. in 6 ranges). Similar to Measurements Model 80. \$350.00
- UTC CG-442. Brand new. 870 VCT w/ Bias Plus 4 Hls. (Reg. Net \$21.00). \$4.50
- BC-221-\$89.00-LM Freq Meter \$79.00-BC-221 Modulated \$99.00

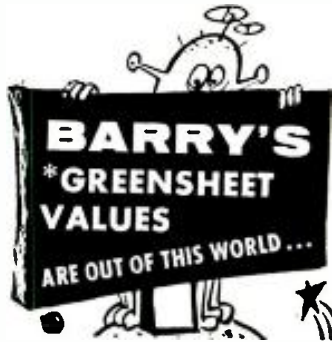

*A complete catalog of specialized Industrial Electronic TUBES and COMPONENTS... featuring Barry Electronics savings to industry, Hams & Experimenters. Prove these values to yourself! Complete and mail the coupon below for your copy of the "Greensheet." We'll also purchase your equipment and unused tubes. Send details: **BARRY ELECTRONICS CORP., 512 Broadway, New York 12, N. Y. Dept. EW9.** Please send me a copy of the "Greensheet" and add my name to your mailing list.

(EW9)

Name Title.....

Company

Address

City State

What's

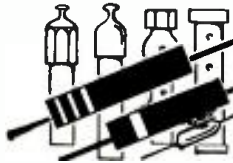

New in Radio

"T-BIRD" ANTENNA

Technical Appliance Corporation, Sherburne, N. Y. has developed an improved broad-band yagi which is being marketed as the Taco "T-Bird."

The new antenna has been engineered to provide greater gain through-

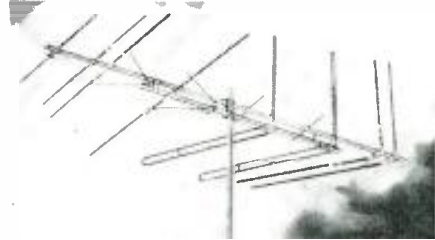

out channels 2 through 13 and an improved pattern which virtually eliminates all side lobes, resulting in cleaner, sharper pictures on the TV receiver screen.

Among the electrical features are a T-match system which provides electrical coupling for both the high and low band, completely eliminating "deadening" on any channel in the v.h.f. band. Also incorporated is the new signal injector which maintains electrical stability throughout the v.h.f. frequency range. The "T-Bird" utilizes multiple driven elements for higher gain and better impedance match to the transmission line. All parasitic elements are electronically tuned to operate on every channel.

The antenna is currently available in three models. The company will supply a data sheet giving complete details on request.

NEW A.C. V.T.V.M.

Simpson Electric Company, 5200 W. Kinzie St., Chicago 44, Ill. has added the Model 715 a.c. vacuum-tube voltmeter to its line of test instruments.

Designed for general-purpose applications where versatility is required,



the instrument features high input impedance, multi-voltage ranges, and wide frequency response, making it suitable for hi-fi and general low-level work such as hum and ripple measurements as well as for i.f. gain and vibration analyzing.

The new unit measures a.c. sine-wave voltages from 0.2 millivolt through 300 volts r.m.s. with frequency response 10 cps through 400 kc. A specially designed meter scale provides decibel markings on both the voltage-range positions and the meter scale.

A data sheet on the Model 715, giving complete specifications, is available on request.

BETA TESTER

The Hickok Electrical Instrument Company, 10514 Dupont Ave., Cleveland 8, Ohio has announced the development of a versatile dynamic beta transistor tester, the Model 870.

The new unit tests transistors according to manufacturers' specifications. Collector current and collector voltage can be varied to provide the proper conditions for correct beta measurements.

The tester measures large-signal d.c. beta on power transistors as well as small-signal a.c. beta on low- and



medium-power units. Collector test current is variable up to 2 amperes, permitting measurements of power transistors.

The instrument has three *I_{cc}* ranges and two beta ranges. Setups can be made quickly on the easy-to-read panel. Settings for over 1500 popular transistors are included on the built-in roll chart.

"FLEXI-CORE" TRANSFORMERS

Sylvania Electric Products Inc., Ipswich, Mass. has introduced a new type of electrical transformer which is smaller and lighter than conventional types with identical operating characteristics.

Tradenamed "Flexi-Core," applications for the new transformer range from the home to the launching pad. The heart of the new transformer is a formed core that consists of nests of laminations, or layers, of fabricated steel strips from a continuous roll. Each of these cores consists of two "U"-shaped nests of strips; two nests

C.E.I. CITIZEN'S BAND

Two-Way Transceiver Kits Complete—
New Low Price

No examination required for use of this equipment. Made from parts of finest quality. Meets F.C.C. Requirements.

Kits are complete, including Cabinet, Pre-punched Chassis, Power Transformer, all components, Mike, Crystal. Easy to follow instructions and schematic. F.C.C. form 505 furnished with each order.

SPECIFICATIONS

Superheterodyne Receiver with the 1000 DK has RF Stage. One micro volt sensitivity, over two watts Audio Transmitter 5 Watts of RF, 100% AM Modulated, 40 to 80 Ohms Antenna Output. Power Transformer operates on 6VDC, 12VDC and 117VAC. All units can be operated as base or mobile.



Special One Time Offer at This Price

MODEL 1000 DK

Has Tuneable Receiver. Receives all 22 channels and 10 meter band. Has fixed squelch and noise limiter.

In Kit..... **45.95**

This model can be easily converted to 6 Meter operation by changing coil winding and crystal. This new price offer is limited. Order now.

All units complete. 15% deposit required with all C.O.D. orders or send cash and take 2% discount. F.O.D. Chickasha. Prompt shipment.

CHICKASHA ELECTRONICS, Inc.
Chickasha, Oklahoma

NEVER FAIL— ZONE YOUR MAIL

The Post Office has divided 106 cities into postal delivery zones to speed mail delivery. Be sure to include zone number when writing to these cities; be sure to include your zone number in your return address—after the city, before the state.



-- then you need us!

GET STARTED RIGHT by writing for **FREE** 8 page catalog illustrating over 30 business forms and systems designed specifically for TV-Radio Service.

ON SALE AT YOUR PARTS JOBBER

Oetrich Publications • 4308 N. Milwaukee • Chicago 41, Ill.

are fitted together, with the strips at the top of the "U's" interleaved. The resulting unit is a hollow rectangle, square, or other shape. The flexibility of core design permits transformers to be engineered for specific applications rather than circuits designed around existing transformers.

Inquiries regarding this new component should be addressed to Dept FT of the company.

TWO-METER CONVERTER

American Electronics Co., 178 Hericks Road, Mineola, N. Y. is now marketing a two-meter converter in both kit and wired versions.

The converter is crystal-controlled and features a 6ES8 high-gain, low-noise cascode first r.f. amplifier, a 6U8A second r.f. amplifier and mixer, and a 6J6 oscillator-multiplier.

Spurious and image rejection is better than 70 db while the noise figure is better than 4 db. Gain is said to be in excess of 30 db while i.f. rejection is over 100 db. Power requirements are 30 ma. at 100 to 150 volts d.c. and 1.26 amps. at 6.3 volts which can be obtained from the companion receiver or from the company's model PS-1 power supply which is housed in a matching chassis.

A data sheet on both the 2-meter and 6-meter converters, available from the company, will be forwarded on request.

LINE VOLTAGE REGULATOR

Vidair Electronics Mfg. Corp., 44 Church St., Baldwin, N. Y. has introduced its Model LR-10 voltage regulator. The device is designed to restore proper operating voltage to equipment when the line voltage varies up or down from the nominal 117-volt rating.

The LR-10 is said to provide a full 350 watts without undue heating. A four-position slide switch may be used to increase or reduce line voltage by 10 per-cent, feed line voltage direct, or shut off the equipment. Additional data is available on request.

PROGRAMMER FOR PC'S

The Industrial and Automation Division, Radio Corporation of America, 12605 Arnold Avenue, Detroit 39, Mich., has developed a high speed tape-controlled unit which is capable of punching up to 10,000 holes per hour in printed circuit boards. The unit will handle boards up to 6" wide x 18 1/4" long, as well as multiples of sheets which can be held in the same plane by means of suitable fixtures. All holes are accurately punched on 1/10" coordinates without breakout.

The new programmer involves a perforated tape which may be prepared simply and easily. The tape, 12" wide x 36" long, is ruled in 1/8" coordinates and perforations are made with a dinking

COYNE'S New Complete Pin-Point TROUBLE SHOOTING Series

See All 4
Books On 7-Day
FREE TRIAL!

Takes Headaches Out Of
All Servicing Problems!



Pin-Point TRANSISTOR TROUBLES IN 12 MINUTES!

Trouble-shoot every type of circuit in ALL transistorized equipment! 525 pages; hundreds of illustrations; 120 check charts! \$5.95



Pin-Point RECORD CHANGER TROUBLES IN 5 MINUTES!

Locate mechanical and electronics troubles fast. Covers all makes. 320 pages; 450 photos; 58 check charts! \$3.95



Pin-Point TV TROUBLES IN 10 MINUTES!

Find the exact sound or picture trouble in any TV set from 700 possibilities! 300 pages; 300 diagrams, check charts! \$4.95



Pin-Point COLOR TV TROUBLES IN 15 MINUTES!

Covers every type of color TV and picture tube! 550 pages; 362 check charts, diagrams, picture patterns! \$5.95

Simple Check Chart System Saves Time

These amazing practical handbooks with an ENTIRELY NEW METHOD, show you how to find the trouble in ANY tv, record changer or transistor circuit FAST! Index tells you where to look; famous Check-Charts help you pin-point the exact trouble in minutes! These on-the-job books quickly pay for themselves in profitable new business and valuable time saved!

SEND NO MONEY!

Just mail coupon for free trial. After 7 days, send only low price or return books and pay nothing! If you keep all 4 books, send only \$4 after 7 days. Pay \$18.37 balance plus postage at \$4 per month.

**VALUABLE
FREE GIFT!**
Send for FREE TRIAL OFFER of all 4 Pin-Point books and get FREE book, "Bigger Profits in TV" whether you keep series or not!

FREE TRIAL OFFER...Mail Coupon Now!

Educational Book Publishing Div.
COYNE ELECTRICAL SCHOOL, Dept. 90-RT
1455 W. Congress Pkwy., Chicago 7, Ill.

- Rush 4-book PIN-POINT Series for 7-day FREE TRIAL per offer. For individual books, check below.
- RECORD CHANGER (\$3.95 plus postage)
- TRANSISTORS (\$5.95 plus postage)
- TV (\$4.95 plus postage)
- COLOR TV (\$5.95 plus postage)

NameARE.....

Address

City Zone... State.....

- \$19.95 Cash Price enclosed; Coyne pays postage.
- Send C.O.D. for \$19.95 plus M.O. fee; Coyne pays postage. 7 day money back guarantee on Cash or C.O.D. orders.

EIMAC TRANSMITTING TUBE
450TL—Brand New—Fully
Guaranteed. Each **\$39.50**

DYNAMOTOR SPECIAL

12 Volts Input-Output 440V. @ 200Ma., 12 Volts
Input-Output 225V. @ 100Ma. All in
one Dynamotor. BRAND NEW. Ea. **\$7.95**

BRAND NEW CARTER DYNAMOTOR
INPUT 5.9 VOLTS, OUTPUT 405 V. @ **\$4.95**
270 MA. SMALL SIZE. Ea.

COAX CABLE

RGRU-52 Ohm Impedance—Fresh Stock—500
feet on sealed wooden spools **\$32.50**
Each
RGG2A U-92 ohm impedance—Fresh Stock—1000
Foot Spools **\$38.50**
Smaller quantities 7½¢ per ft. Min. order 25 ft.

NEW VACUUM CAPACITORS

50 MMF-5KV 95
25 MMF-10KV 2.25
EIMAC VC 12 MMF-32KV ea. 56.95
EIMAC VC 25 MMF-32KV ea. 7.95
EIMAC VC 50 MMF-32KV ea. 8.95
JENNINGS 100 MMF-32KV ea. 12.95
JENNINGS JNC-150 MMF-50KV ea. 24.95

POWER TRANSFORMER

Primary 110V, 60 cy., Sec 445-0-445V. @ 150
Ma. 6.3V. @ 6 Amps, 5V. @ 3 Amps. **\$3.95**
Fully shielded. Ea.
Write for quantity prices

CHOKE—FULLY CASED

5 HENRY @ 200 Ma 1.95
5 HENRY @ 250 Ma 2.25
4-12 HY (Swinging) @ 300 MA 3.95
4 HENRY 400 MHl 3.95
500 MHl 12.95
4 HENRY 900 MHl 12.95
6 HENRY 600 MHl 6.95

BRAND NEW OIL CONDENSERS

3 MFD 600 VDC .60	4 MFD 2000 VDC 3.50
4 MFD 600 VDC .75	6 MFD 2000 VDC 4.95
5 MFD 600 VDC .80	8 MFD 2000 VDC 5.95
6 MFD 600 VDC .85	8 MFD 3000 VDC 2.50
8 MFD 600 VDC .95	1 MFD 3000 VDC 1.85
10 MFD 600 VDC 1.15	2 MFD 3000 VDC 3.25
12 MFD 600 VDC 1.50	1 MFD 4000 VDC 3.25
15 MFD 600 VDC 1.70	2 MFD 4000 VDC 6.25
3x8 (24 MFD) 600 VDC .250	3 MFD 4000 VDC 5.95
1 MFD 1000 VDC .60	4 MFD 4000 VDC 12.95
2 MFD 1000 VDC .85	5 MFD 5000 39.50
4 MFD 1000 VDC 1.35	5 MFD 7500 VDC 2.95
8 MFD 1000 VDC 1.95	2 MFD 7500 " 17.95
10 MFD 1000 VDC 2.50	2 MFD 10,000 " 29.95
12 MFD 1000 VDC 2.95	1 MFD 12,500 " 19.95
15 MFD 1000 VDC 3.50	2 MFD 12,500 " 34.50
1 MFD 1500 VDC .45	1 MFD 15,000 " 42.50
1 MFD 1500 VDC .75	1 MFD 25,000 " 69.95
2 MFD 1500 VDC 1.10	10 MFD 330 AC .195
4 MFD 1500 VDC 1.95	1 MFD 660 AC .295
8 MFD 1500 VDC 2.95	2 MFD 660 AC .295
1 MFD 2000 VDC .85	8 MFD 600 VDC .50
2 MFD 2000 VDC 1.50	

RELAYS

GUARDIAN 110V AC, 2 Pole Single Throw
(1 N.C. & 1 N.C.) Repl. CR-810 **\$2.50**
24V. AC 4PDT. ea. **\$1.85**
ALLIED 110V. AC 4PDT. ea. **\$2.75**
Potter-Brumfi. #SL5 5000 ohm. Ea. **\$2.25**
4 Ma. Sens. Ea.
Hermetically Sealed Relay Coil 110V AC
60 cy SPDT Contacts 5 Amps. ea. **\$1.50**
6 Volt DC OPDT H.S. ea. **99c**
12 Volt DPDT DC Relay. ea. **\$1.35**
SIGMA type 22RJC 8,000 ohm
SPDT, small sealed relay. ea. **\$2.49**
Sealed Relay, SPDT, 6,000 ohm
coil ea. **\$1.95**
G.E. Relay control, contains 8000 ohm
relay, sensitivity 2 mils. 10 for \$9.29. ea. **\$1.10**
SIGMA 5F—16,000 ohm SPDT, operates
on 500 Microamperes or less. ea. **\$3.95**

PANEL METERS

STANDARD BRANDS		3" METERS	
1½" METERS		100-0-100 Micro Amps	
0-1 Mill 2.95	DC 5.95	0-1 Mill DC 3.95	
0-100 Micro 3.95	0-10 Mills DC 3.95	0-100 Mills DC 3.95	
	0-150 Mills DC 3.95	0-500 V. DC 3.95	
	0-500 V. DC 3.95	0-1 Amp RF 4.50	
	0-1 Amp RF 4.50	0-15 Amps RF 4.50	
	0-15 Amps RF 4.50	0-12 Volts AC 3.95	
	0-12 Volts AC 3.95	0-15 Volts AC 3.95	
	0-15 Volts AC 3.95	REED Freq. Meter —110V. AC, 57- 0-150 V. AC 3.49	63 cy 9.95

MISCELLANEOUS SPECIALS

JOHNSON Var. Cond. 250 MMF
3500 V. **\$2.50**
SPERTI Vacuum Switch used in ART13 ea. \$1.50
36 OHM 50 Watt Globar Non-Ind. Res. 60¢ ea.
3-12 MMF Eria Ceramic Trimmer. 2 for \$2.16
FULL WAVE SELENIUM RECTIFIERS—20 Plates
per section—Output 320V. @ 4 Amps. **\$4.95**
Ea.
MAGNETIC PICK-UP TOOL gets Nuts, Bolts, Tacks,
etc. out of difficult places. **79c**
Each
CUTLER-HAMMER TOGGLE SWITCH **29c**
SPDT (ST42D) 4 for \$1.00. ea.
WILLARD STORAGE CELL—2V. 28 Amp
hrs. Clear plastic case. Shipped dry. **\$2.50**
Write for quantity prices on all special items

All merchandise sold on a 10 day money back guarantee
Min. Order \$3.00—25% with Order—F.O.B. New York

PEAK

ELECTRONICS COMPANY
66 W. Broadway, New York 7, N. Y., WO-2-2370

die at selected intersections to conform to the desired pattern. A vacuum head pickup on the reader bar eliminates the need for precise location of the holes in the tape.

The punching cycle is automatic. The punch head contains 59 free-floating punches .052" diameter for component insertion and one with a .105" diameter for the locating or processing hole. Spacing of the .052" holes is ¼" which establishes the cross grid. Indexing rate is 180 per minute.

3-IN-1 TESTER

Mercury Electronics Corp., 77 Searing Avenue, Mineola, N. Y. is now offering a "three-in-one" instrument as its "Model 300 Combination Tester."

"The unit incorporates a versatile multiple-socket tube tester, a CRT tester-reactivator, as well as a volt-

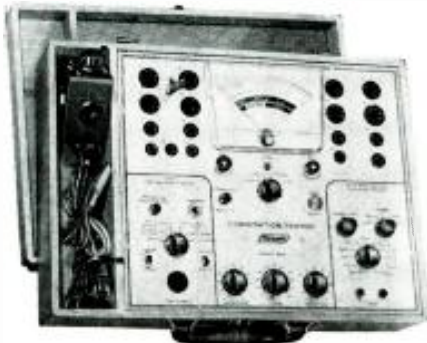

ohmmeter (20,000 ohms per volt). The tube tester checks emission of over 700 tube types, checks for interelement shorts and leakage, checks for gas content, and each section of multipurpose tubes.

The CRT-tester-reactivator tests the quality of every black-and-white or color picture tube (including 110-degree tubes) from 8" to 30". It will test each color gun separately as well as for interelement shorts and leakage up to 1 megohm. There is a separate short test provided for each element in the picture tube. Reactivation is seen and controlled on the meter as it takes place, eliminating the danger of stripping the cathode of the oxide coating.

The unit comes in a hand-rubbed oak carrying case with detachable cover. It measures 17½"x13½"x4½".

PROXIMITY PICKUP

Electro Products Laboratories, 4500 N. Ravenswood Ave., Chicago 40, Ill. has announced a new miniature pickup for use as a sensing unit in proximity control systems.

Designated as model 4912-AN, this unit is reported to detect metal parts having a diameter of less than ¼ inch whether they are stationary or moving past the pickup at a rate of 60,000 per minute. Additional information may be obtained from the manufacturer.

ANTENNA FOR MARINE CB

Mark Mobile Inc., 5441 Fargo Ave., Skokie, Ill. has developed a new antenna which has been specifically designed for class D marine CB use.

CRYSTAL CONTROLLED CONVERTERS

POLICE • FIRE • COMMERCIAL
• CITIZENS' BAND •



For use with
12 V. Transistor type
car radios
26-50 MC
\$24.95

Complete with crystal and tubes. Requires no high voltage supply. Operates on 12 volts DC. Can be self installed in seconds. Other models for 108-162 MC available.

A practical converter for emergency use with powered home or auto sets. Tunable over 12 MC 26-54 MC or 108-174 MC. **\$13.95**



Also available crystal controlled up to 54 MC. \$19.95

Full line of converters & receivers for every application.
ORDER TODAY or WRITE for LITERATURE

KUHN ELECTRONICS

70 GLENWOOD CINCINNATI 17, OHIO

ELECTRONICS

PREPARE FOR A GOOD JOB!
BROADCAST ENGINEER
RADIO SERVICING AUTOMATION

TELEVISION SERVICING
BLACK & WHITE—COLOR

APPROVED FOR VETERANS AND SURVIVORS
OF VETERANS
BUILDING AIR CONDITIONED
SEND FOR FREE LITERATURE

BALTIMORE TECHNICAL INSTITUTE
1425 EUTAW PLACE, BALTIMORE 17, MD.

CITIZEN BAND KIT SALE!

We're closing out our large stock of Citizen Band Transceiver Kits. These were nationally advertised at \$39.95. All Kits complete with cabinet, tubes, parts, crystal, FCC form, Instructions, less mike. All sales final.

110 VOLT TRANSCIVER KITS. \$19.95
12 VOLT TRANSCIVER KITS. \$22.95
6 VOLT TRANSCIVER KITS. \$22.95
Famous Make CITIZEN BAND XMTG CRYSTALS \$1.99

Send for our Citizen Band Sale Flyer. Loads of Value! Sorry, no C.O.D.'s. Incl. Postage. Shpg. Weight—15 lbs.

GROVE ELECTRONICS, Dept. EW
4078 Milwaukee Ave. Chicago 41, Illinois

* **KEEP CANDEE HANDEE!** *
* **FREE!** Bargain-filled Summer Flyer! *
* Get your copy today! *
* **J. J. CANDEE CO.** *
* 509 N. Victory Blvd., Burbank, Calif. *

ENGINEERING DEGREES

E.E. Option Electronics or Power
Civil, Mechanical, Physics.
Also in Liberal Arts
Earned through Home Study
Pacific International
College of Arts & Sciences
Primarily a Correspondence School
Resident classes also available
5719-R Santa Monica Blvd., Hollywood 38, Calif.

RENT stereo tapes

• OVER 1500 DIFFERENT ALBUMS
• POSTPAID TO AND FROM YOUR HOME
SEND FOR FREE BROCHURE | **stereo-part** |
811-BC CENTINELA AVE., INGLEWOOD 3, CALIF.

The "Heliwhip" antenna, Type HW-11-6M, has been engineered for boats made of fiber glass or wood where a conventional quarter-wave type of antenna would otherwise require radial wires or a large metal surface.

The HW-11-6M is 6 feet long and operates in half-wave resonance, with a unique impedance launcher-matcher cable section. It can be mounted virtually anywhere that is convenient and may be connected by any length of 50-ohm coax to the transceiver equipment.

Write the manufacturer for a four-page spec sheet on this and other CB antennas in the line.

CB CRYSTAL METER

Seco Electronics Incorporated, 5015 Penn Ave., So., Minneapolis, Minn., is now offering a compact tester designed especially for use with class D CB and other crystal controlled two-way radio equipment.



The Model 500 CB test set is said to cut servicing and installation time and be capable of handling both transmitters and receivers. It will check crystal activity on third-overtone transmitter crystals with a visual indication on a separate output meter scale, and check fundamental types and third-overtone receiver crystals at the fundamental frequency.

Completely self-contained and portable, the Model 500 is powered by a 1.5-volt "C" battery. It measures 2 1/4" x 3 1/4" x 6 1/4" and is fully transistorized. It comes complete with 15-foot remote cable and "C" battery.

6-METER MOBILE TRANSCEIVER

Globe Electronics, Inc., 22-30 South 34th Street, Council Bluffs, Iowa is now marketing a new mobile 6-meter transceiver which has been tradenamed the "Mobiline Six."

This compact transmitter and receiver can be adapted for either fixed or mobile applications, operating from



115 volts a.c., 12 volts d.c., or 6 volts d.c., all with the power supply provided. The unit weighs only 20 pounds and measures 5"x12"x12".

The receiver portion uses seven tubes, including an r.f. stage delivering better than 1- μ v. sensitivity. A squelch control is also provided. The transmitter section features internal v.f.o. which is voltage-regulated and shock-mounted to provide maximum stability under mobile conditions. The 2E26 final amplifier stage is conservatively rated at 20 watts input power. Other features

We'd like to send you these important new books for a 7-day free trial examination

Class D CITIZENS RADIO by Leo G. Sands

Here is the first complete book on Citizens Radio Operation. Ever since the initial use of 2-way radiotelephone by police departments, this field has been growing in importance and application. Now, with more than a million vehicles equipped for its use, Citizens Radio is a major phase of the electronics field. This important new volume covers every aspect of the field—its history, rules, and everything about how it works—in seven big chapters with one hundred major sections. You'll learn exactly what Citizens Radio is, its applications, what equipment you need, the full story on receiver circuits and transmitters, antennas, installation, and maintenance, full FCC rulings, how to apply for licenses, etc. Many illustrations. **\$4.95**

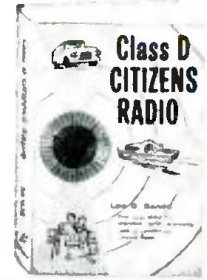

COMPUTERS AND HOW THEY WORK by James D. Fahnestock

Here is a fact-filled exciting guidebook to the wonderworld of electronic computers, with more than 110 illustrations and easy-to-follow tables in 10 big chapters. Step by step, you'll see and understand the workings of many types of computing machines. This important new book illustrates the basic principles of computers in methods that require no knowledge of electronics. You'll learn all about computer memories, flip-flops and the binary counting system. You'll learn the mathematical language of computers where $1 + 1 = 10$. Other chapters show you how computers use tubes and transistors to make complex logical decisions in thousandths of a second. COMPUTERS AND HOW THEY WORK is must reading for career minded students and for electronics pros who want a more complete knowledge of this field. **\$4.95**

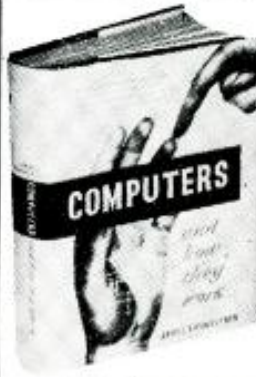

THE ELECTRONIC EXPERIMENTER'S MANUAL by David A. Findlay

With a few dollars worth of basic tools, and this book to guide you, you can explore the magic of electronics experimentation more completely than ever before. In a few short hours, you'll start your first project. You'll learn about every component used in experimentation, every tool, its function and why it is used. There are 8 big sections, each covering a specific phase of construction. There is a giant section of projects you can build, test equipment you'll construct and use in your future work. THE ELECTRONIC EXPERIMENTER'S MANUAL will give you the professional know-how you must have no matter what phase of electronics is your specialty. **\$4.95**



7-DAY FREE EXAMINATION

When your books arrive, read and enjoy their diversity of contents, their thoroughness of coverage. Then after seven days examination, if you decide that they are not everything you want, send them back and receive a complete refund of the purchase price.

USE THIS CERTIFICATE FOR 7-DAY FREE EXAMINATION

ELECTRONICS BOOK SERVICE
One Park Avenue, New York 16, N. Y.

Please send me _____ copies of CITIZENS RADIO and bill me at only \$4.95 a copy plus postage and handling.

Please send me _____ copies of COMPUTERS AND HOW THEY WORK, and bill me at only \$4.95 a copy plus postage and handling.

Please send me _____ copies of THE ELECTRONIC EXPERIMENTER'S MANUAL and bill me at only \$4.95 a copy plus postage and handling.

If I don't agree that this is one of the best electronics investments I've ever made, I may return the book(s) within seven days and get a full refund.

\$ _____ enclosed. (SAVE MONEY! Enclose payment with your order and we'll pay the postage.)

Name _____

Address _____

City _____

Zone _____

State _____

505





SURPLUS at New Low Prices!



A B C

- (A) **HIGH FREQUENCY TRANSMITTER**
Type CAY 52239. Frequency Range 3000 to 18,000 KCS. Input volts DC: 12, 2,000, 500. Amperes: 5.0, 0.175, 0.2. A unit of Model THW 3 radio equipment. Mfr. Westinghouse Electric & Mfg. Co. WGT. 50 Lbs. **\$12.95**
- (B) **LOW FREQUENCY TRANSMITTER**
THW Type CAY 52238. Input volt 7.5, 10, 15 volt AC. 500-200 volt DC. Mfr. Westinghouse Electric & Mfg. Co. WGT. **\$9.95**
41 Lbs. Excellent Cond.
- (C) **POWER SUPPLY FOR ABOVE TRANSMITTERS**
WGT. 40 Lbs., Excellent **\$7.95**
Cond.
- CABLE FOR ABOVE TRANSMITTERS.....Ea. **\$1.00**

WATER PROOF SPEAKERS
U. S. Navy. Horn Type. Heavy Duty. All New Outdoor Permanent Magnet Speakers, with Universal Output Transformer. Voice Imp. 6 Watts. 11.40 Ohms. 10 3/4 Dia. 8 3/16 Deep. Weight, in original Cases—23 lbs. **12.95**

Our Low Price.....Ea.

TELESCOPIC AND ANTENNA MASTS
Par Citizen Band; Amateur and FM Radio; Television, etc. Made of Heavy Duty Aluminum In 4 Foot, 10 Inch Sections, Diam—2 Inches. Weight of each section is appr. 3 Lbs. Make the Mast as high as you wish as each section inter-fits the other.

All New.....Per Section **1.45**

RECORDING BLANKS
16" Recording Blanks. Make your own recordings. Aluminum base, Lacquered both sides. Professional quality. All New Stock.....Ea. **50c**
Package of 10.....**\$3.50**
Package of 100.....**\$30.00**

DIAL TELEPHONES
French type phone made by Com. Tel. & Tel. Can be used for standard extension line. With Dial. Excellent Cond. Wgt. 7 lbs. Ea. **\$4.95**

RESET COUNTERS
Unit Counter, changes by one digit. Reset: 000 to 999. Ideal for counting turns when winding Cells, Transmitters, and General Counting Work. Size is small, 1 1/4" x 3/4" x 1".....Ea. **\$2.50**

REVERSIBLE MOTOR
1/40 H. P. Ball-bearing 3450 RPM in Blast-proof case. Needs only a capacitor for starting. All Brand New. 110 V. 40 Cy. Special Low Price. Ea. **\$2.95**
Starting Capacitor.....\$0.48 Ea.
WGT. Approx. 8 Lbs.

FIELD PHONES
Type EE-R. Magneto Ringer Phones. Use 2 Flashlite Batts. for Power. Operate over wire. Approx. 2 Miles. Excellent Condition. **\$25.00**
Pair

SURPLUS METER SPECIALS

- Miniature Meter, 0 to 1 Ma. DC.....Ea. **\$2.50**
- 2 In. 0 to 1 AC Amp. Meters.....Ea. **2.50**
- 2 In. 0 to 15 Volt Meters—400—800—Cy. Ea. **1.50**
- 2 In. 0 to 120 Decibel Meters.....Ea. **2.50**
- 1 1/2" Dual Scale—0 to 50—0 to 100 MA. DC.....Ea. **2.50**
- 3 In. 0 to 50 MA. DC Meter.....Ea. **2.95**
- 3 In. 0 to 100 Ma DC. Meter.....Ea. **2.95**
- 3 In. 0 to 200 MA. DC Meters.....Ea. **2.95**
- 3 In. 0 to 200 Microamp. Meters.....Ea. **4.95**

See our Previous ad for Special Surplus Items. All prices F.O.B. S. F., Calif. Calif. orders add 3% Tax. No COD's. Remit Full Amount with All Orders.

STANDARD SURPLUS
1230 Market St., San Francisco 3, Calif.
Telephone HEMlock 1-3106

include v.f.o. or crystal control, an "S" meter, tuning meter, slide-rule dials, v.f.o. spotting, and class B modulation.

NEW TRIPLETT OHMMETER
The Triplett Electrical Instrument Company of Bluffton, Ohio has introduced a new general-purpose ohmmeter with ranges to 20 megohms.

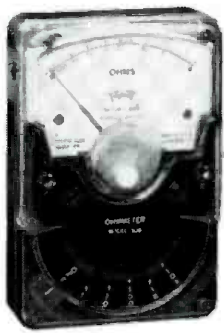

Designed for industrial, laboratory and general service use, the Model 309 features a handy selector switch which provides a choice of five ranges; 0-2000 ohms; 0-20,000 ohms; 0-200,000 ohms; 0-2 megohms; and 0-20 megohms.

The tester, which measures 2 3/4" x 4 1/4" x 1 3/16", fits easily into the palm of the hand. A back-mounted elastic strap slips over the hand and anchors the tester securely in the palm. The Model 309 has a control knob on the side of the case to compensate for variations in battery voltages.

Sun	Mon	Tue	Wed	Thu	Fri	Sat
			2	3	4	5
						12
						19
						26

CALENDAR of EVENTS

SEPTEMBER 7-9
First Joint Automatic Control Conference. Sponsored by ISA, AICHe, AIEE, ASME, IRE. Massachusetts Institute of Technology, Cambridge, Mass. Contact Dr. James Mozley, Johns Hopkins University, Baltimore, Md., for details.

SEPTEMBER 7-11
1960 New York High Fidelity Show. Sponsored by Institute of High Fidelity Manufacturers, Inc. New York Trade Show Building, N.Y.C. Open to public: Adults, \$1.00; children under 12, 50 cents.

SEPTEMBER 11-17
Reliability Training Conference. Sponsored by IRE and American Society for Quality Control. Dallas-Ft. Worth, Tex. Contact Henry Schiflett, Texas Inst., Box 3-12, Dallas, Texas.

SEPTEMBER 14-15
Fourth Annual Joint Military-Industrial Electronic Test Equipment Symposium. Sponsored by Office of Director of Defense Research and Engineering and Dept. of Army Signal Corps. Armour Research Foundation, Chicago. Inquiries should be addressed to R. Brausch, conference secretary, Armour Research Foundation, 10 W. 35th St., Chicago 16, Ill.

SEPTEMBER 15-17
Upper Midwest Electronic Conference. Minneapolis Auditorium, Minneapolis. Open to purchasing agents, engineers, distributors, factory reps, and manufacturers. Write the conference at 1915 Hiawatha Ave., Minneapolis.

SEPTEMBER 19-21
1960 National Symposium on Space Electronics and Telemetry. Sponsored by PGSET of IRE. Shoreham Hotel, Washington, D. C.

SEPTEMBER 23-25
Ninth Annual Chicago High Fidelity Show. Sponsored by International Sight and Sound Exposition, Inc. Palmer House.

INVITATION TO AUTHORS

Just as a reminder, the Editors of ELECTRONICS WORLD are always interested in obtaining outstanding manuscripts, for publication in this magazine, covering the fields of audio and high-fidelity and radio-TV-industrial servicing. Articles in manuscript form may be submitted for immediate decision and projected articles can be outlined in a letter in which case the writer will be advised promptly as to the suitability of the topic. We can also use short "filler" items outlining worthwhile shortcuts that have made your servicing chores easier. This magazine pays for articles on acceptance. Send all manuscripts or your letters of suggestion to the Editor, ELECTRONICS WORLD, One Park Avenue, New York City 16, New York.

Answer to Puzzle
Appearing on page 103

B	L	F	A	R	M	S	T	R	O	N	G
E	D	I	S	O	N			H	A		
L	G	U	F	L	X	M	U				
L	H	E	R	T	Z	N	F	S			
	V	T	I	A	U	D	I	O	N	S	
			L	E	N	Z		R			
M	M	F	R	W			H	E	N	R	Y
A	L		V	O	L	T	A	S	A		
X	E		R		M	I	T		G		
W	A	T	Y		P		R	I			
E	C		G	R	K		E	D	W	I	N
L	H		I		R		G		W		
L	E	E		N		R	E	A	C	H	A
		R	A	Y	S	A			T	V	
D	E		A		S	A	B	I	N	E	T

PHOTO CREDITS

Page	Credit
39	Hughes Aircraft Co.
40 (top)	Stromberg-Carlson
40 (center), 46	General Electric Co.
40 (bottom)	RCA
41 (top)	Sylvania Electric Co. Inc.
41 (center)	Raytheon Co.
41 (bottom left)	Minneapolis-Honeywell
41 (bottom right)	IBM
44, 45, 130	Beckman Instruments Inc.
51	Burroughs Corp.
58, 60	Federal Aviation Agency
64, 65	Motorola Inc.
68	Simpson Electric Co.
108	H. H. Scott, Inc.
109	Audax, Inc.
110	Homewood Industries, Inc.
112	Bendix Radio

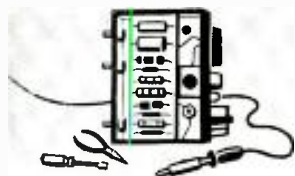

ELECTRONICS MARKET PLACE

RATE: 60c per word. Minimum 10 words. November issue closes September 9th. Send order and remittance to ELECTRONICS WORLD, One Park Ave., N. Y. C. 16. N. Y.

FOR SALE

RADIO and Television tubes, brand new, 1st quality, original boxed name brands only. Discounts up to 66 2/3% off list. Positively no seconds. Send for free price schedule. Edison Tube Co., Menlo Park, N. J.

RADIO & TV Tubes at Manufacturer's prices! 100% Guaranteed! Brand New! No re-brands or pulls! United Radio, Box 1000W, Newark, N. J.

DIAGRAMS for repairing radios \$1.00. Television \$2.00. Give make, model. Diagram Service, Box 672-RN, Hartford 1, Conn.

TUBES—T.V. and Radio tubes, Guaranteed—Save up to 80%—Write: Emkay Electronics, P. O. Box 142, Blythebourne Station, Brooklyn 19, N. Y.

SOMETHING for sale? Place a classified ad in this section. Low-cost, fast results. It's easy.

GOVERNMENT sells: Surplus Electronics; Test Equipment; Oscilloscopes; Transceivers; Jeeps; Boats; Aircrafts; Misc—Send for U. S. Depot Directory & Procedure \$1.25—"Brody Surplus," Box 425—RT, Nanuet, N. Y.

AUTO Radio Distributor Selling Servicing Becker Blaupunkt, FM-AM, other European, American Sets. Save 30% + Square Electronics, 150-60 Northern Blvd., Flushing, N. Y.

GOVERNMENT Surplus Receivers, Transmitters, Snooperscopes, Parabolic Reflectors, Picture Catalog 10c. Meshna, Malden 48, Mass.

TUBES—TV, Radio, Transmitting and Industrial Types at Sensibly Low Prices. New Guaranteed, 1st Quality, Top Name Brands Only. Write for Free Catalog or Call Walker 5-7000, Barry Electronics Corp., 512 Broadway, New York 12N, N. Y.

REMOTE control for Citizen Band Units. Write Manufacturer Frontier Electronics Orr, Minnesota.

RADIO & TV Tubes at Manufacturer's prices! 100% Guaranteed! Brand New! No re-brands or pulls! United Radio, Box 1000-W, Newark, N. J.

TV & Radio Tubes—all top name brands—R.C.A. etc.—60-10-5%, full replacements—regular boxed—No job lots or closeouts. (Representatives wanted for all states.) Radio Tube Specialists, 397-7 Ave. Bklyn. 15, N. Y.

TV, radio tubes, top name brands, manufacturer's boxes, new, first quality, Guaranteed, no rejects, terrific discounts on other good buys. Teletube Supply Co., 159 Western Promenade, Cranston, Rhode Island.

55ADP 7" PPI. 28 tubes, 110 volts, 60 cycles. \$14.95. Write for catalog. Downs, 906 Ailendale, Baltimore, Maryland.

REMOTE indicating Anemometer kit. Wind speeds up to 100 miles per hour. Long life ball bearing generator. Finest D'Arsonval meter. Aluminum construction. No batteries required. \$24.95. Dyno-Speed Instrument Company, P.O. Box 47, Lakewood, New Jersey. LA 6-8187.

130 Photofact's six binders \$145; Battery Eliminator Capacitor Tester, Oscilloscope, Alignment Generator \$20 each. Norelco Projection unit, Tube Tester, Boosters, distribution Amplifiers. Shaw, Box 1171, Poughkeepsie, N. Y.

WANTED

CASH for used Short-Wave Ham Receivers, Transmitters and Accessories. Tregor, W91VI, 2023 N. Harlem Ave., Chicago 35C, Tuxedo 9-6429.

WANTED: Military and Commercial laboratory test instruments, communications and broadcast equipment, tubes, etc. Electronicraft, Mt. Kisco, N. Y.

WANT to buy good equipment and accessories? Place a low-cost classified ad in this space.

SURPLUS measurement model 78 or 80 signal generators. Also Federal 804 or I-122 or used Motorola two-way equipment. State quantity, price, and condition. Communications Service, Inc., 3209 Canton Street, Dallas, Texas.

WANTED: Cash Paid! Sell your surplus electronic tubes. Want unused, Clean radio and TV receiving, transmitting special purpose, Magnetrons, Klystrons, broadcast types. Want military and commercial lab/test equipment such as G.R.H.P., AN UPM prefix. Also want commercial Ham Receivers and Transmitters. For a Fair Deal write: Barry Electronics Corp., 512 Broadway, New York 12, N. Y. (Walker 5-7000.)

RADIO ENGINEERING & INSTRUCTION

ELECTRONICS! Associate degree—29 months. Technicians, field engineers, specialists in communications, missiles, computers, radar, automation. Start September, February. Valparaiso Technical Institute, Dept. N, Valparaiso, Indiana.

ENGINEERING and Art Degrees earned through home study. Electronics, Electrical, Mechanical, Civil, Physics, Business Administration, Accounting, Liberal Arts. When writing, specify course desired. Pacific International College of Arts & Sciences, primarily a correspondence school. Resident classes also carried. 5719-C Santa Monica Boulevard, Hollywood 38, California.

USED Correspondence Courses and Books sold and rented. Money back guarantee. Catalog Free. (Courses Bought). Lee Mountain, Pisgah, Alabama.

HIGHLY effective home-study review for FCC commercial phone exams. Free literature. Wallace Cook (EW9), Box 10634, Jackson 9, Miss.

USED correspondence courses, books bought, sold, rented, catalog free, Vernon Summerville, Ga. (1)

HIGH-FIDELITY



INDUCTORS for Crossover Networks. 118 types in stock. Send for brochure. C & M Coils, 3016 Holmes Ave., N.W., Huntsville, Ala.

RECORDERS, Components. Free Wholesale Catalogue. Carston, 125-R East 88, N.Y.C. 28.

PRICES? The Best! Factory-sealed Hi-Fi Components? Yes! Send for free catalog. Audion, 25T Oxford Road, Massapequa, N. Y.

DISGUSTED with "Hi" Hi-Fi Prices? Unusual Discounts On Your High Fidelity Requirements. Write. Key Electronics, 120 Liberty St., New York 6, N. Y. Cloverdale 8-4288.

NEW matching Hi Fi, FM Tuner and 8 watt Stereo amplifier. Value \$75. Factory Sale \$16.96 each, guaranteed. Capri Electronics, 3118 W. 48th, Los Angeles 43, Calif. Dept. 23.

TAPE & RECORDERS

RENT Stereo Tapes—over 1,500 different—all major labels—free catalog. Stereo-Parti, 811-L, Centinela Ave., Inglewood 3, California.

OVER 245,000 buyers and sellers will read your ad when placed in this space. It costs only 60c per word; minimum of 10 words including your name and address.

AMPEX, Concertone, Magnecord, Presto, Bogen, Tandberg, Pentron, Sherwood, Rek-O-Kut, Scott, Shure, Dynakit, others, Trades, Boynton Studio, Dept. RT, 10 Pennsylvania Ave., Tuckahoe, N. Y.

RECORDING TAPE 1800' Mylar \$1.89, 10 for \$18.00; 2400' Mylar \$2.95, 10 for \$27.50. First quality, splice-free, brand new, manufactured by one of the top four U.S. tape companies. Absolutely uniform frequency response. G.E. VR II 3-play diamond cartridges \$9.95 (reg. \$19.95). ESL arms \$26.75 (reg. \$34.95). Wollensak 1515-4's \$159.95. Free stereo cartridge (your choice to \$25.00) with the purchase of any changer and base. Many more bargains, write for catalog. All items unconditionally guaranteed. The Sound Room, 7959 Melrose Ave., Los Angeles 46, California.

LOW Quotes on everything HiFi & Stereo Tapes. Bargain Lists. HiFi, Dept. E4, Roslyn, Pa.

TAPE Recorders, Hi-Fi Components. Sleep Learning Kits, Tapes. Unusual Values. Free Catalog. Dressner, 69-02R 174 St., Flushing 65, N. Y.

Hi-Fi Components-Tape Recorders. All brands in stock at "We Will Not Be Undersold Prices." Quotations. Free Wholesale Catalog return mail. Hi-Fidelity Center, 1797NC First Avenue, New York 28, N. Y.

SELF-hypnosis tape. New! Free literature. McKinley-Smith Co., Dept. T6, Bos 3038, San Bernardino, Calif.

SHOPPING GUIDE Classified

A HANDY GUIDE TO PRODUCTS, NOT NECESSARILY ELECTRONIC, BUT OF WIDE GENERAL INTEREST.

PHOTOGRAPHY—FILM, EQUIPMENT, SERVICES

WHATEVER your needs, Electronics World classified can solve them. Simply place an ad in these columns and watch your results pour in.

OPTICAL—Science—Math Bargains—Request Free Giant Catalog "CJ"—128 pages—Astronomical Telescopes, Microscopes, Lenses, Binoculars, Kits, Parts. Amazing war surplus bargains. Edmund Scientific Co., Barrington, New Jersey.

STAMPS & COINS

TERRIFIC Stamp Bargain! Israel—Iceland—Vatican Assortment—plus exotic triangle set—also fabulous British Colonial Accumulation—Plus large stamp book—All four offers free—Send 10c to cover postage. Empire Stamp Corp., Dept. 22, Toronto, Canada.

WRITE Martin Lincoln, Electronics World, One Park Avenue, New York 16, N. Y., for information on how to place a classified ad in this section.

MUSIC

SONGS into Dollars! Share 33 million dollars yearly for New Songwriters, songpoets. Any subject, songs composed. Published, promoted by largest firm. Information, appraisal Free. Send Nord/ke Music Publishers, 6000 Sunset, Hollywood 283, California.

HELP WANTED

HIGH Pay Overseas. Domestic Jobs. Men, Women. Generous Benefits. Companies Pay Transportation. For info, write: World Wide, Dept. E2, 149 N. Franklin St., Hempstead, N. Y.

OVERSEAS Employment. American Firms and United States Government. Comprehensive job information \$2.00. Foreign Opportunities, Box 172, Columbus 16, Ohio.

EARN Extra money selling advertising book matches. Free Samples furnished. Matchcorp, Dept. MD-90, Chicago 32, Ill.

BUSINESS OPPORTUNITIES

\$\$\$ Sparetime with your recorder—Audio Greeting Cards—Details free. Audiographic Laboratories, 2913 Santa Fe, Independence, Missouri.

MAKE \$25-\$50 Week, clipping newspaper items for publishers. Some clippings worth \$5.00 each. Particulars free. National, 81-DG, Knickerbocker Station, New York.

RADIO Parts Stores & Hi-Fi Salons: Someone "borrowing" your personal copy of Popular Electronics each month. You ought to be taking advantage of Popular Electronics' convenient re-sale plan. Sell copies in your store . . . perform a good service for your customers . . . with no risk involved. For details, write: Direct Sales Department, Popular Electronics, One Park Avenue, New York 16, New York.

MISCELLANEOUS

"WINEMAKING," "Beer, Ale Brewing," "Cider," Methods, Illustrated, \$3.00. Eaton Books, Box 1242-X, Santa Rosa, California.

KEY Chains, personalized ashtrays, smoke sets. Useful novelties for home, office and gifts. Inexpensive items. Send 10¢ for illustrated brochure. House of Brand, Dept. EW-4, 3458 Fish Avenue, New York 69, N. Y.

BUSINESS Cards \$3.75 Thousand. Postpaid, Free Samples. Imagination, Box 761, Hollywood 28, Calif.

SKYSCRAPER-Heel Shoes, Wasp-waisted Corsets! Photo Catalogs, \$2.00. Finecraft, Box 442-P, Hollywood 28, California.

FREE! New 1960 Catalog of all Photographic Books available. For your copy, send postcard with name and address to Catalog, Popular Photography Book Service, One Park Ave., New York 16, N. Y.

CONTRACT Work Wanted: Plastics Compression Molder with excess capacity desires contract work. Battery of 150 and 200 Ton Stokes presses. Metropolitan New York City area. Write Box 572, Electronics World, One Park Ave., New York 16, New York.

RUBBER stamps for home or office. 3 line personalized stamps \$1.65. Special rates on stock stamps. Precision Industries, 262 Farmers Ave., Lindenhurst, N. Y.



Keep them neat . . . clean . . . ready for instant reference!

Now you can keep a year's copies of ELECTRONICS WORLD in a rich-looking leatherette file that makes it easy to locate any issue for ready reference.

Specially designed for ELECTRONICS WORLD, this handy file—with its distinctive, washable Kivar cover and 16-carat gold leaf lettering—not only looks good but keeps every issue neat, clean and orderly.

So don't risk tearing and soiling your copies of ELECTRONICS WORLD—always a ready source of valuable information. Order several of these ELECTRONICS WORLD volume files today. They are \$2.50 each, postpaid—3 for \$7.00, or 6 for \$13.00. Satisfaction guaranteed, or your money back.

(Be sure to specify whether you want lettering to be Electronics World or its former title, Radio & TV News.)

Order direct from:

JESSE JONES BOX CORP.
Dept. EW
(Established 1843)
Box 5120, Philadelphia 41, Pa.

INDEX OF Advertisers

SEPTEMBER 1960

ADVERTISER	PAGE NO.	ADVERTISER	PAGE NO.
Advance Electronics	136	Lafayette Radio	84, 85
Airex Radio Corporation	77	Lakeland Electronics, Inc.	95
Aiwa Co. Ltd.	22	Lampkin Laboratories, Inc.	131
Allied Radio	7, 28, 29, 95	Lektron	127
Ashe Radio Co., Walter	129	McNeal Electric & Equipment Co.	132
Audio Unlimited	130	Mark Mobile, Inc.	90
Audion	130	Milwaukee School of Engineering	115
B & K Manufacturing Co.	71	Moss Electronic, Inc.	20, 21
Baltimore Technical Institute	138	Multi-Products Company	93
Barry Electronics Corp.	136	National Radio Institute	17, 18, 127
Bell Telephone Laboratories	9	National Technical Schools	5
Biggs Associates, Inc.	95	North American Philips Co., Inc.	109
Blonder-Tongue Laboratories, Inc.	4	Oelrich Publications	137
Cadisco	131	Ohmatsu Electric Co., Ltd.	92
Cadre Industries Corporation	96	Olson Radio Corporation	133
Canadian Institute of Science & Technology Limited	104	Pacific International College of Arts & Sciences	138
Candee Co., J. J.	138	Peak Electronics Company	138
Capitol Radio Engineering Institute, The	98, 99, 100, 101	Pearce-Simpson, Inc.	10
Carston Studios	130	Picture Tube Outlet	135
Center Electronics Co., Inc.	134	Polytronics Lab Inc.	30
Champion DeArment Tool Company	112	RCA Institute, Inc.	116, 117, 118, 119
Channel Master	8	R W Electronics	129
Chickasha Electronics, Inc.	137	Rad-Tel Tube Co.	89
Cleveland Institute of Electronics	27	Radio Corporation of America	FOURTH COVER
Columbia Electronics	126	Radio Shack Corp.	104
Columbia Products Company	130	Radio-Television Training School	11
Commissioned Electronics Co.	121	Rek-O-Kut Company, Inc.	75
Coyne Electrical School	91, 137	Rohn Manufacturing Company	1
DeVry Technical Institute	3	Sams & Co., Inc., Howard W.	106, 107
Dressner	134	Sarkes Tarzian Inc.	105
Dynaco, Inc.	6, 72	Schober Organ Corporation, The	77
EICO	33, 34, 102	Seco Electronics, Inc.	121
Electro-Voice, Inc.	19	Seg Electronics	135
Electronic Chemical Corp.	104	Sherwood Electronics Laboratories, Inc.	122
Electrophono & Parts Corp.	133	Sprague Products Company	16
Electronics Book Service	24, 25, 139	Sonar Electronic Tube Co.	103
Fair Radio Sales	124	Standard Surplus	140
Fidelitone	76	Stereo-Parti	138
G & G Radio Supply Co.	97	Stern Co., H. D.	130
Globe Electronics, A Division of Textron Electronics, Inc.	88	Superscope, Inc.	74
Goodheart Co., R. E.	111	Sylvania Electric Products, Inc.	32
Grantham School of Electronics	13	SECOND COVER	
Grove Electronics	138	TV Servicing Systems	134
Heath Company	78, 79, 80, 81	Telson Electronic Products, Inc.	131
Henshaw Radio Supply	134	Terado Company	135
Holt, Rinehart and Winston, Inc.	92, 134	Texas Crystals	120
Homewood Industries, Inc.	132	Thorens	12
Hy-gain Antenna Products	82	Tri-State College	130
Indiana Home Study Institute, The	133	Triplett Electrical Instrument Company	THIRD COVER
Indiana Technical College	129	Tru-Vac	113
International Crystal Mfg. Co., Inc.	31	University Loudspeakers, Inc.	26
International Electronics Corp.	108	Utah Radio & Electronic Corp.	87
International Radio & Electronics Corp.	77	Valparaiso Technical Institute	121
Jensen Manufacturing Company	86	Van Nostrand Company, Inc., D.	94
Jerrold Electronics Corporation	14	Vocaline Company of America	73
Johnson Company, E. F.	91	Windsor Electronics	127
Key Electronics Co.	135	Xcelite, Inc.	128
Koss Inc.	110		
Kuhn Electronics	138		



BAR-RING TYPE MOVEMENTS (Exclusively Triplet)

- Self Shielded
- Not affected by magnetic panels or substantially by stray magnetic fields.
- More Torque
- Lower Terminal Resistance
- Faster Response
- Exceedingly Rugged and Accurate
- All Case Sizes

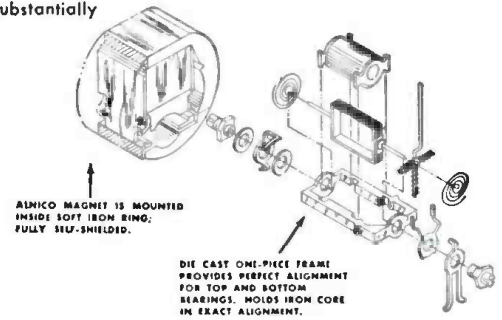

TRIPLETT—For over 56 years, a leader in the field of meter and test equipment design and manufacture.

TRIPLETT offers a complete line of:

- Panel Instruments
- Portable Instruments
- Test Equipment: Radio, TV, Electrical and Electronic

All standard Triplet products available nationally through authorized Triplet Distributors.

For information on special application instruments write direct to:

TRIPLETT ELECTRICAL INSTRUMENT COMPANY, BLUFFTON, OHIO

Burton Brown Advertising

The World's Most Complete Line of VOMS for Every Purpose.

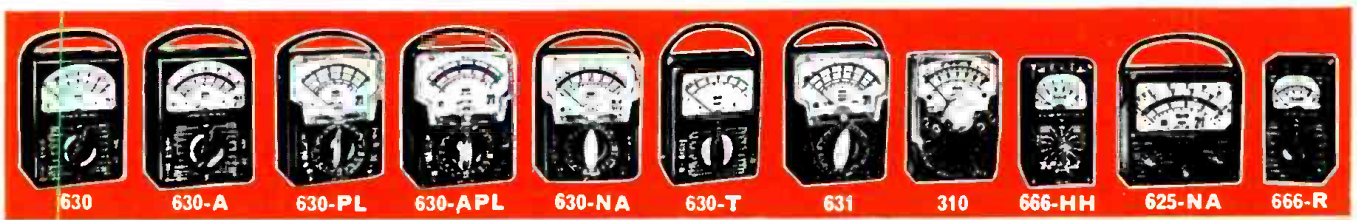

TRIPLETT ELECTRICAL INSTRUMENT COMPANY, BLUFFTON, OHIO

How do your customers rate you?



Your reputation is based largely on what happens *after* you leave the scene of each service call. For this reason the name on the tubes you install makes a world of difference. RCA tubes are designed and manufactured to assure customer confidence in you as well as in RCA.

RCA tube quality is your best insurance against call-backs due to premature tube failure.

RCA tube performance puts your workmanship in the best light and protects it through rigid quality control.

RCA's trademark symbolizes a name and reputation customers have respected for decades.

Your customers know that those red-white-and-black RCA tube cartons in your tube caddy represent the most trusted name in electronics. Remember, customer confidence is the cornerstone of your business.

To protect your service reputation before, during and after every service call, make sure your next tube order specifies... **RCA TUBES.**

RCA ELECTRON TUBE DIVISION, HARRISON, N. J.



SIGN OF A SERVICE JOB WELL DONE



The Most Trusted Name in Electronics
RADIO CORPORATION OF AMERICA