

BEST

ELECTRONICS PROJECTS

from **ELECTRONICS ILLUSTRATED**

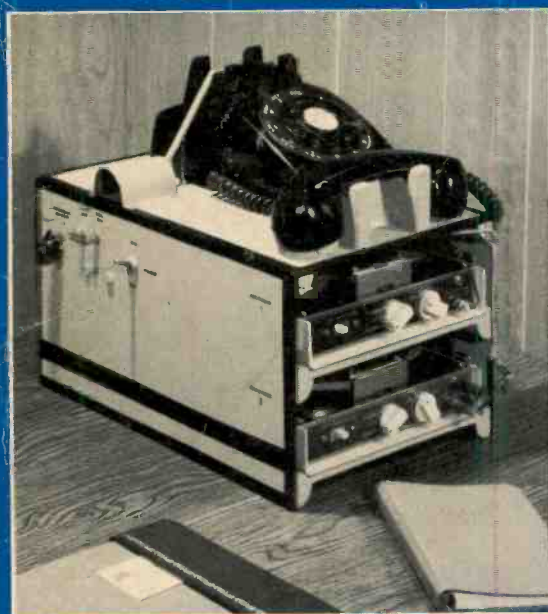

Telephone Answering Set



Gate-Dip Oscillator

Dozens of Electronics Ideas for Every Home Experimenter



Modulation Scope

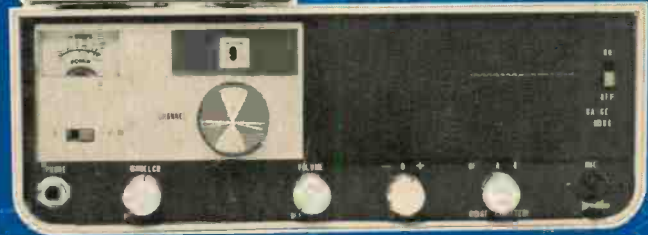



A SUBSIDIARY OF **BELL-HOWELL**

SEE WHY so many DeVry-trained Men Step Into Electronics Jobs the Day after Graduation!

***EVERY GRADUATE CAN ALSO RECEIVE EMPLOYMENT HELP
THROUGH HIS ENTIRE CAREER, AT NO ADDED COST***

DeVry's greatest claim to fame is the progress of its graduates. Our aim is to prepare a man so thoroughly that we can recommend him to employers . . . ready to step into a job the day after graduation. If we expect to continue to help employers, our graduates have to be good! That is why we provide top quality instruction—followed by career-long employment service at no added cost.

For FREE Information

Lack of technical experience is no barrier to the man who wants to prepare for a career in ELECTRONICS. Send coupon for two FREE booklets and find out why.



DeVry's educational programs are designed to prepare men 17-45 in their spare time at home or in any of our three well-equipped, modern resident schools in Chicago, Phoenix or Canada. Why not fill in and mail coupon for free facts today?

Approved for Veterans.

DEVRY INSTITUTE of TECHNOLOGY
4141 Belmont Avenue, Chicago, Ill. 60641, Dpt. PEH-9-X

Please give me your two free booklets, "Pockets Guide to Real Earnings," and Electronics in Space Travel"; also include details on how to prepare for a career in Electronics. I am interested in the following opportunity fields (check one or more):

- | | |
|--|---|
| <input type="checkbox"/> Space & Missile Electronics | <input type="checkbox"/> Communications |
| <input type="checkbox"/> Television and Radio | <input type="checkbox"/> Computers |
| <input type="checkbox"/> Microwaves | <input type="checkbox"/> Broadcasting |
| <input type="checkbox"/> Radar | <input type="checkbox"/> Industrial Electronics |
| <input type="checkbox"/> Automation Electronics | <input type="checkbox"/> Electronic Control |

Name _____ Age _____

Address _____ Apt. _____

City _____ State or Province _____ Zone or Zip Code _____

Check here if you are under 16 years of age.

**HOME STUDY AND RESIDENT SCHOOL PROGRAMS
AVAILABLE IN CANADA. SEND FOR DETAILS.**

2106

Accredited Member of National Home Study Council

DEVRY INSTITUTE OF TECHNOLOGY

4141 BELMONT AVENUE, CHICAGO, ILLINOIS 60641

Cast your ballot for a successful future!

53 I.C.S. COURSES



I.C.S. is the oldest, largest correspondence school. Over 200 courses. Business, industrial, engineering, academic, high school. One for you. Direct, job-related. Breaker facts and theory plus

practical application. Complete lesson and answer service. No skimping. Diploma to graduates.

Send for the 3 free booklets offered here and find out how I.C.S. can be your road to success.

ACCOUNTING
Accounting for Business
Programmers
Accounting (Canadian)
Auditing Business Law
Cost Accounting
C.P.A. Review
Estate & Trust Accounting
Executive Accounting
Federal Tax
General Accounting
Industrial Accounting
Junior Accounting
Legal Accounting
Office Accounting
Personal Income Tax
Procedure
Practical Accounting
Public Accounting
Small Business Accounting
Starting & Managing a
Small Bookkeeping Ser.

**ARCHITECTURE
AND BUILDING**
Arch. Drawing & Designing
Architecture
Building Contractor
Building Estimator
Building Inspector
Building Maintenance
Carpenter-Building
Carpentry & Millwork
House Planning & Interior
Design

Mason Painting Contr.
Reading Arch. Blueprints
Review in Arch. Design &
Practice
Review of Mech. Systems
in Buildings

ART
Amateur Artist
Commercial Art
Commercial Cartooning
Illustrating with Options:
— Magazine
— Advertising Layout
— Illustration
Interior Decorating
Oil Painting for Pleasure
Show Card & Sign Prod.
Show Card Writing
Sign Painting & Designing
Sketching & Painting

AUTOMOTIVE
Automatic Transmission
Specialist
Automobile Body
Rebuilding & Refinishing
Automobile Electrical Tech.
Automobile Engine Tune-Up

Automobile Technician
Automotive Mechanic
Diesel-Gas Motor Vehicle
Engines
BUSINESS
Advertising
Basic Inventory Control
Business Administration
Canadian Business Courses
Condensed Bus. Practice
Direct Mail & Mail
Order Advertising
Industrial Psychology
Magazine & Newspaper
Advertising
Managing a Small Store
Marketing
Marketing Management
Marketing Research
Modern Exec. Management
Office Automation
Office Management
Production Management
Purchasing Agent
Retail & Local Advertising
Retail Bus. Management
Retail Merchandising
Retail Selling
Systems and Procedures
Analysis

CHEMICAL
Analytical Chemistry
Chemical Engineering
Chemical Process Operator
Unit Operations
Chemical Laboratory Tech.
Chemical Process Operator
Elements of Nuclear Energy
General Chemistry
Instrumental Laboratory
Analysis

**CIVIL
ENGINEERING**
Civil Engineering
Construction Eng'g
Technology
Highway Engineering Tech.
Principles of Surveying
Reading Highway Bl'pts
Reading Structural
Blueprints
Sanitary Engineering Tech.
Sewage Plant Operator
Structural Eng'g Tech.
Surveying and Mapping
Water Works Operator

COMPUTERS
COBOL Programming
Fortran Programming for
Engineers

Programming for Digital
Computers
Programming the IBM
1401 Computer
Programming the IBM
SYSTEM/360 Computer

DRAFTING
Aircraft Drafting
Architectural Drafting
Design Drafting
Drafting Technology
Electrical Eng'g Drafting
Electronic Drafting
Introductory Mech. Draft.
Mechanical Drafting
Pressure-Vessel and Tank
Print Reading
Sheet Metal Layout for
Air Conditioning
Structural Drafting
ELECTRICAL
Electric Motor Repairman
Electrical Appliance Ser.
Electrical Contractor
Electrical Engineering
(Power option or
Electronic option)
Electrical Engineering Tech.
Electrical Instrument Tech.
Industrial Electrical Tech.
Power Line Design
and Construction
Power Plant Operator
(Hydro or Steam option)
Practical Electrician
Reading Elec. Blueprints

ENGINEERING
(Professional
Refresher Courses)
Chemical Civil Electrical
Engineer-in-Training
Industrial Mechanical
**ENGLISH AND
WRITING**
Better Business Writing
Free Lance Writing
for Fun & Profit
Introductory Technical
Writing
Modern Letter Writing
Practical English
Short Story Writing
HIGH SCHOOL
High School Business
High School (Canadian)
High School College
Prep. (Arts)
High School College Prep.
(Engineering & Science)

High School General
High School Mathematics
High School Secretarial
High School Vocational
LANGUAGES
(Edited by Berlitz)
French German
Italian Spanish

LEADERSHIP
Basic Supervision
Industrial Foremanship
Industrial Supervision
Modern Woman
as a Supervisor
Personality Development
Personnel-Labor Relations
Supervision
MATHEMATICS
Advanced Mathematics
Mathematics and Mechanics
for Engineering
Mathematics and Physics
for Technicians
Mathematics and Physics
for Engineering
Modern Elementary Stat.

MECHANICAL
Aircraft & Power
Plant Mechanics
Hydraulic & Pneu. Power
Industrial Engineering
Industrial Management
for Engineers
Industrial Eng'g Tech.
Industrial Instrumentation
Machine Design
Mechanical Engineering
Quality Control
Safety Eng'g Tech'g
Tool Design Value Analysis
Vibration Analysis
and Control

PETROLEUM
Natural Gas Production
& Transmission
Oil Field Technology
Petroleum Production
Petroleum Prod. Eng'g
Petroleum Refinery Oper.
Pipeline Engineering Tech.
PLASTICS
Design of Plastic Products
Plastics Technician
**PLUMBING, AIR
CONDITIONING**
Air Conditioning
Air Conditioning Maint.
Domestic Heating with
Oil & Gas
Domestic Refrig. Heat'g

Heating & Air Conditioning
With Drawing
Industrial Air Conditioning
Industrial Heating
Pipe Fitting Plumbing
Plumbing & Heating
Plumbing & Heating Est.
Practical Plumbing
Refrigeration
Refrigeration & Air Cond.

PULP AND PAPER
Paper Machine Operator
Paper Making, Pulp Making
Pulp & Paper Engineering
Pulp & Paper Making
S.A.L.E.S. MANSHIP
Creative Salesmanship
Real Estate Salesmanship
Sales Management
Salesmanship
SECRETARIAL
Clerk-Typist Commercial
Engineering Secretary
Legal Secretary
Medical Secretary
Professional Secretary
Shorthand
Typewriting

SHOP PRACTICE
Drill Operator
Foundry Practice
Industrial Engineering
Industrial Metallurgy
Lathe Operator
Machine Shop Inspection
Machine Shop Practice
Machine Shop Practice &
Toolmaking
Metallurgical Eng'g
Technology
Milling Machine Operator
Multiflat Maintenance
Mechanic
Practical Millwrighting
Reading Shop Prints
Rigging
Tool Eng'g Tech'g
Tool Grinder Toolmaking
Turret Lathe Operator
Welding Engineering Tech.
Welding Processes

**STEAM AND
DIESEL POWER**
Boiler Inspector
Industrial Building Eng'r
Power Plant Engineering
Stationary Diesel Engines
Stationary Fireman
Stationary Steam Eng'g
TEXTILES
Carding
Carding and Spinning

DYEING & FINISHING
Loom Fixing Spinning
Textile Designing
Textile Mill Supervisor
Textile Technology
Warping and Weaving
TRAFFIC
Motor Traffic Management
Railway Rate Clerk
Traffic Management
**TV-RADIO-
ELECTRONICS**
Color Television Principles
& Servicing
Communications Techn'gy
Electronic Fundamentals
Electronic Fundamentals
(Programmed)
Electronic Fundamentals
with Electronic Equip-
ment Training
Electronic Technician
& Servo Fundamentals
Electronic Principles for
Automation
Electronics and Applied
Calculus
Electronics Technician
First Class Radiotelephone
License
Fundamentals of Electronic
Computers
General Electronics
General Electronics with
Electronic Equip. Trng.
Hi-Fi Stereo and Sound
Systems Servicing
Industrial Electronics
Industrial Electronics Eng.
Industrial Electronics
Engineering Technician
Numerical Control
Electronics & Maint.
Practical Radio-TV Eng'g
Practical Telephony
Principles of Radio-
Electronic Telemetry
Principles of Semiconductor-
Transistor Circuits
Radio Servicing with
Equipment Training
Radio & TV Servicing
with Equipment Training
Second Class Radiotele-
phone License
Sound Systems Specialist
Telephony Electronics and
Radio Communications
TV Receiver Servicing
TV Technician

Clip coupon here... take your first step to real success! I.C.S., Scranton, Penna. 18515



Accredited member,
National Home Study Council.
Convenient payment plan.
Special Canadian courses
In French and English.
Approved for veterans under
the new G. I. Bill.
Special rates to members
of the U. S. Armed Forces.

INTERNATIONAL CORRESPONDENCE SCHOOLS Dept. N2180J, Scranton, Penna. 18515

(In Hawaii: P.O. Box 418, Honolulu, Canadian residents mail to Scranton, Penna. Further service handled through I.C.S. Canadian Ltd.)

Without cost or obligation, rush me your famous "Success Package"—(1) "How to Succeed" booklet, (2) sample lesson demonstrating I. C. S. method, (3) catalog for program of study I'm interested in:

Mr. _____ (Print name of course. See list.)
Miss _____ Age _____
Mrs. _____
Address _____
City _____ State _____ Zip Code _____
Occupation _____ Employed by _____ Working Hours _____ A.M. to _____ P.M.

BEST

ELECTRONICS PROJECTS

from **ELECTRONICS ILLUSTRATED**

A FAWCETT BOOK • NUMBER 649
 LARRY EISINGER • EDITOR-IN-CHIEF
 GEORGE TILTON • MANAGING EDITOR
 SILVIO LEMBO • ART EDITOR
 HAROLD E. PRICE • ASSOC. ART EDITOR

W. H. Fawcett, Jr. President
 Roger Fawcett General Manager
 Gordon Fawcett Secretary-Treasurer
 Roscoe K. Fawcett Circulation Director
 Donald P. Hanson Assistant General Manager
 George H. Allen Vice President
 Ralph Daigh Vice President
 R. Bruce Besten Production Director
 Al Allard, Ralph Mattison Art Directors

JOSEPH PIAZZA **EDITOR**

STAFF ARTISTS

Mike Gaynor • John Selvaggio
 Alex Santiago • Herbert Jonas
 Mel Skriloff • Paul Howard
 Bill Kuch

Catherine S. Carr Production Editor
 Claire Herman Assistant Production Editor

BEST ELECTRONICS PROJECTS FROM ELECTRONICS ILLUSTRATED, Fawcett Book 649, is published by Fawcett Publications, Inc., Greenwich, Connecticut. Editorial and Advertising Offices: 67 West 44th Street, New York, New York 10036. General Offices: Fawcett Building, Greenwich, Connecticut 06830. Printed in U.S.A. Copyright © 1966, 1967 by Fawcett Publications, Inc. BEST ELECTRONICS PROJECTS FROM ELECTRONICS ILLUSTRATED is registered in the U.S. Patent Office.

Printed by Fawcett-Haynes Printing Corp., Louisville, Ky.

Fawcett Publications, Inc., is a member of American Book Publishers Council, Inc.

CONTENTS

Tonics for Tape Recorders	4
Flip Flop	10
In-a-Socket Dimmer	13
How Do You Do It?	16
Those Multiplying Cells	19
Add a Monitor Head to Your Recorder	22
Super-Speed Strobe	24
FM Guitar Broadcaster	30
The Easy Way to Install CB in Your Car	34
Crystal-Controlled SW Signal Generator	37
A Sizable Speaker System	41
The Secret of the New Electric Cars	43
2 Meters on 2 Tubes	47
Automatic Telephone Answering Service	51
Vest-Pocket Modulation Scope	62
7 Steps to Better Tapes	67
Char-Analyst for Batteries	71
Band-Switched VHFer	75
CB Alignment Generator	79
Try an Attic Antenna	84
Gate-Dip Oscillator	87
Probe-Size Signal Injector	91
Stamp Out Mobile Noise	94
All Purpose Audio Mixer	97
CB Control Console	102
Pocket CB Converter	107
The Case of the Buried Treasure	110

BUILD YOUR OWN RADIO

CIRCUITS AT HOME
with the New Improved

only
\$26.95



Training Electronics Technicians Since 1946

PROGRESSIVE RADIO "EDU-KIT"®

A Practical Home Radio Course

Now Includes

- ★ 12 RECEIVERS
- ★ 3 TRANSMITTERS
- ★ SQ. WAVE GENERATOR
- ★ SIGNAL TRACER
- ★ AMPLIFIER
- ★ SIGNAL INJECTOR
- ★ CODE OSCILLATOR

- ★ No Knowledge of Radio Necessary
- ★ No Additional Parts or Tools Needed
- ★ EXCELLENT BACKGROUND FOR TV
- ★ SCHOOL INQUIRIES INVITED
- ★ Sold in 79 Countries

**YOU DON'T HAVE TO SPEND
HUNDREDS OF DOLLARS FOR A RADIO COURSE**

The "Edu-Kit" offers you an outstanding PRACTICAL HOME RADIO COURSE at a rock-bottom price. Our Kit is designed to train Radio & Electronics Technicians, making use of the most modern methods of home training. You will learn radio theory, construction practice and servicing. THIS IS A COMPLETE RADIO COURSE IN EVERY DETAIL. You will learn how to build radios, using regular schematics; how to wire and solder in a professional manner; how to service radios. You will work with the standard type of punched metal chassis as well as the latest development of printed circuit chassis. You will learn the basic principles of radio. You will construct, study and work with RF and AF amplifiers and oscillators, detectors, rectifiers, test equipment. You will learn and practice code, using the Progressive Code Oscillator. You will learn and practice trouble-shooting using the Progressive Signal Tracer, Progressive Signal Injector, Progressive Dynamic Radio & Electronics Tester, Square Wave Generator and the accompanying instructional material.

You will receive training for the Novice, Technician and General Classes of F.C.C. Radio Amateur License. You will build Receiver, Transmitter, Square Wave Generator, Code Oscillator, Signal Tracer and Signal Injector circuits, and learn how to operate them. You will receive an excellent background for television, Hi-Fi and Electronics. Absolutely no previous knowledge of radio or science is required. The "Edu-Kit" is the product of many years of teaching and engineering experience. The "Edu-Kit" will provide you with a basic education in Electronics and Radio, worth many times the low price you pay. The Signal Tracer alone is worth more than the price of the Kit.

THE KIT FOR EVERYONE

You do not need the slightest background in radio or science. Whether you are interested in Radio & Electronics because you want an interesting hobby, a well paying business or a job with a future, you will find the "Edu-Kit" a worth-while investment. Many thousands of individuals of all

ages and backgrounds have successfully used the "Edu-Kit" in more than 79 countries of the world. The "Edu-Kit" has been carefully designed, step by step, so that you cannot make a mistake. The "Edu-Kit" allows you to teach yourself at your own rate. No instructor is necessary.

PROGRESSIVE TEACHING METHOD

The Progressive Radio "Edu-Kit" is the foremost educational radio kit in the world, and is universally accepted as the standard in the field of electronics training. The "Edu-Kit" uses the modern educational principle of "Learn By Doing." Therefore you construct, learn schematics, study theory, practice trouble-shooting—all in a closely integrated program designed to provide a thorough and interesting background in radio.

You begin by examining the various radio parts of the "Edu-Kit." You then learn the function, theory and wiring of these parts. Then you build a simple radio. With this first set you will enjoy listening to regular broadcast stations, learn theory, practice testing and trouble-shooting. Then you build a more advanced radio, learn more advanced theory and techniques. Gradually, in a progressive manner, and at your own rate, you will find yourself constructing more advanced multi-tube radio circuits, and doing work like a professional Radio Technician.

Included in the "Edu-Kit" course are Receiver, Transmitter, Code Oscillator, Signal Tracer, Square Wave Generator and Signal Injector circuits. These are not unprofessional "breadboard" experiments, but genuine radio circuits, constructed by means of professional wiring and soldering on metal chassis, plus the new method of radio construction known as "Printed Circuitry." These circuits operate on your regular AC or DC house current.

THE "EDU-KIT" IS COMPLETE

You will receive all parts and instructions necessary to build twenty different radio and electronics circuits, each guaranteed to operate. Our Kits contain tubes, tube sockets, variable, electrolytic, mica, ceramic and paper dielectric condensers, resistors, tie strips, hardware, tubing, punched metal chassis, instruction Manuals, hook-up wire, solder, selenium rectifiers, coils, volume controls and switches, etc.

In addition you receive Printed Circuit materials, including Printed Circuit chassis, special tube sockets, hardware and instructions. You also receive a useful set of tools, a professional electric soldering iron, and a self-powered Dynamic Radio and Electronics Tester. The "Edu-Kit" also includes Code Instructions and the Progressive Code Oscillator, in addition to F.C.C. Radio Amateur License training. You will also receive lessons for servicing with the Progressive Signal Tracer and the Progressive Signal Injector, High Fidelity Guide and a Quiz Book. You receive Membership in Radio-TV Club. Free Consultation Service. Certificate of Merit and Discount Privileges. You receive all parts, tools, instructions, etc. Everything is yours to keep.

PRINTED CIRCUITRY

At no increase in price, the "Edu-Kit" now includes Printed Circuitry. You build a Printed Circuit Signal Injector, a unique servicing instrument that can detect many Radio and TV troubles. This revolutionary new technique of radio construction is now becoming popular in commercial radio and TV sets. A Printed Circuit is a special insulated chassis on which has been deposited a conducting material which takes the place of wiring. The various parts are merely plugged in and soldered to terminals.

Printed Circuitry is the basis of modern Automation Electronics. A knowledge of this subject is a necessity today for anyone interested in Electronics.

FREE EXTRAS

- SET OF TOOLS
- SOLDERING IRON
- ELECTRONICS TESTER
- PLIERS-CUTTERS
- VALUABLE DISCOUNT CARD
- CERTIFICATE OF MERIT
- TESTER INSTRUCTION MANUAL
- HIGH FIDELITY GUIDE & QUIZZES
- TELEVISION BOOK & RADIO TROUBLE-SHOOTING BOOK
- MEMBERSHIP IN RADIO-TV CLUB
- CONSULTATION SERVICE & F.C.C. AMATEUR LICENSE TRAINING
- PRINTED CIRCUITRY

SERVICING LESSONS

You will learn trouble-shooting and servicing in a progressive manner. You will practice repairs on the sets that you construct. You will learn symptoms and causes of trouble in home, portable and car radios. You will learn how to use the professional Signal Tracer, the unique Signal Injector and the dynamic Radio & Electronics Tester. While you are learning in this practical way, you will be able to do many a repair job for your friends and neighbors, and charge fees which will far exceed the price of the "Edu-Kit." Our Consultation Service will help you with any technical problems you may have.

FROM OUR MAIL BAG

J. Stataitis, of 25 Poplar Pl., Waterbury, Conn., writes: "I have repaired several sets for my friends, and made money. The "Edu-Kit" paid for itself. I was ready to spend \$240 for a Course, but I found your ad and sent for your Kit."

Ben Valerio, P. O. Box 21, Magna, Utah: "The Edu-Kits are wonderful. Here I am sending you the questions and also the answers for them. I have been in Radio for the last seven years, but like to work with Radio Kits, and like to build Radio Testing Equipment. I enjoyed every minute I worked with the fine. Also like to let you know that I feel proud of becoming a member of your Radio-TV Club."

Robert L. Shuff, 1534 Monroe Ave., Huntington, W. Va.: "Thought I would drop you a few lines to say that I received my Edu-Kit, and was really amazed that such a bargain can be had at such a low price. I have already started repairing radios and phonographs. My friends were really surprised to see me get into the swing of it so quickly. The Trouble-shooting Tester that comes with the Kit is really swell, and finds the trouble, if there is any to be found."

PROGRESSIVE "EDU-KITS" INC.
1186 Broadway, Dept. 510 KK, Hewlett, N. Y. 11557

UNCONDITIONAL MONEY-BACK GUARANTEE

Please rush my Progressive Radio "Edu-Kit" to me, as indicated below: Check one box to indicate choice of model.

- Regular model \$26.95.
- Deluxe model \$31.95 (same as regular model, except with superior parts and tools plus Radio & TV Parts Jackpot worth \$15.)

Check one box to indicate manner of payment.

- I enclose full payment. Ship "Edu-Kit" post paid.
- Ship "Edu-Kit" C.O.D. I will pay postage.
- Send me FREE additional information describing "Edu-Kit."

Name _____
Address _____

PROGRESSIVE "EDU-KITS" INC.

1186 Broadway, Dept. 510 KK, Hewlett, N. Y. 11557

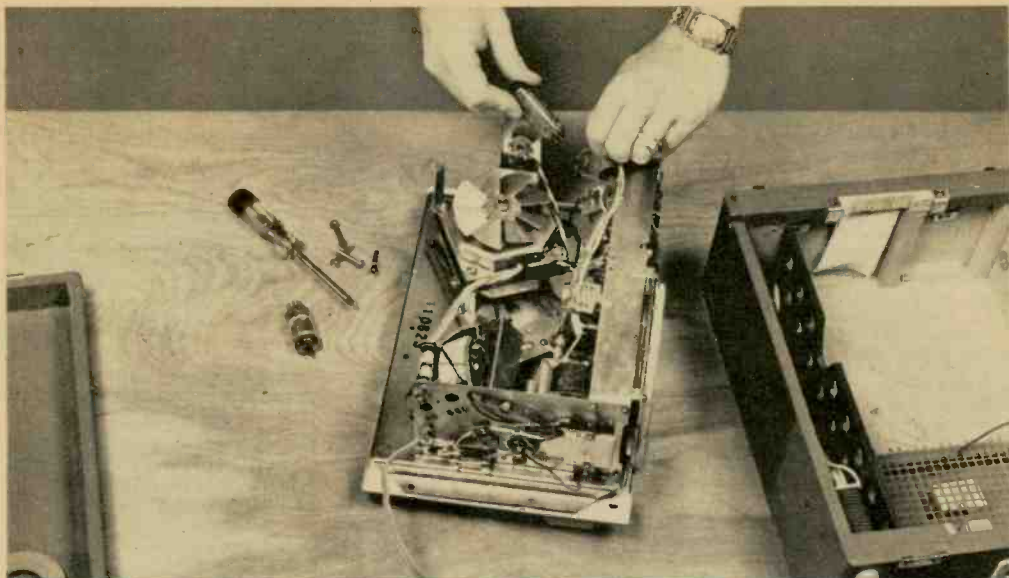

TONICS FOR TAPE RECORDERS

By **HERMAN BURSTEIN** SURE, it may have seen better days and played sweeter music. And it probably could boast that enough tape has passed its heads to reach the moon. It has aged quite a bit since it was unpacked but, like most old tape recorders, it just won't lie down and die. It's pooped-out, all right, but a shot or two in the arm will give it new life.

Heads go askew, dirt accumulates in the wrong places, the drive mechanism falters and tubes give up the ghost. It's an easy matter to rescue a recorder long before sounds get soggy. All it takes are sharp ears, a few accessories, plus a VTVM and an audio generator.

Preliminaries

Even if your machine still produces good sound, a bit of routine maintenance will help keep it that way. Most important thing is to keep the heads clean. Swab away bits of dirt and tape oxide with a Q-tip moistened in tape-head cleaner. Remove deposits from the erase, record and playback heads as well as tape guides, rollers and posts. And all those metal parts that contact the tape also should be demagnetized at this time. If your machine uses drive belts, replace them if there are signs of stretching. Replace all rubber that's

worn flat or is made rock hard by ageing.

Gently move the connecting cables between input and output connectors and the machine's electronics while making a test recording. Do the same with leads to the erase, record and playback heads. If hum level changes or there's noise, look for a broken or loose connection. Lubricate the machine exactly as explained in the manufacturer's instructions. Don't squeeze the oil can too hard, and wipe away all excess oil—especially if it's near the rubber parts. Check all tubes on a tube tester.

Playback Response

Those preliminaries will take care of small but nagging things that cause general degradation of performance. If you want to check the results of your efforts, run a frequency-response test. The setup to use is shown in Fig. 1. A test tape (such as Ampex No. 31321-04) is required to provide a series of constant-level signals from 50 to 15,000 cps. If the machine has good playback response it will reproduce each tone equally well, as indicated on the VTVM.

The procedure is to use the tape's 1,000-cps frequency to first establish a reference level on the VTVM. The machine is doing fine if the meter indicates that frequencies

CTI AUTOMATION ELECTRONICS HELPS YOU CRACK THE \$12,000-A-YEAR BARRIER

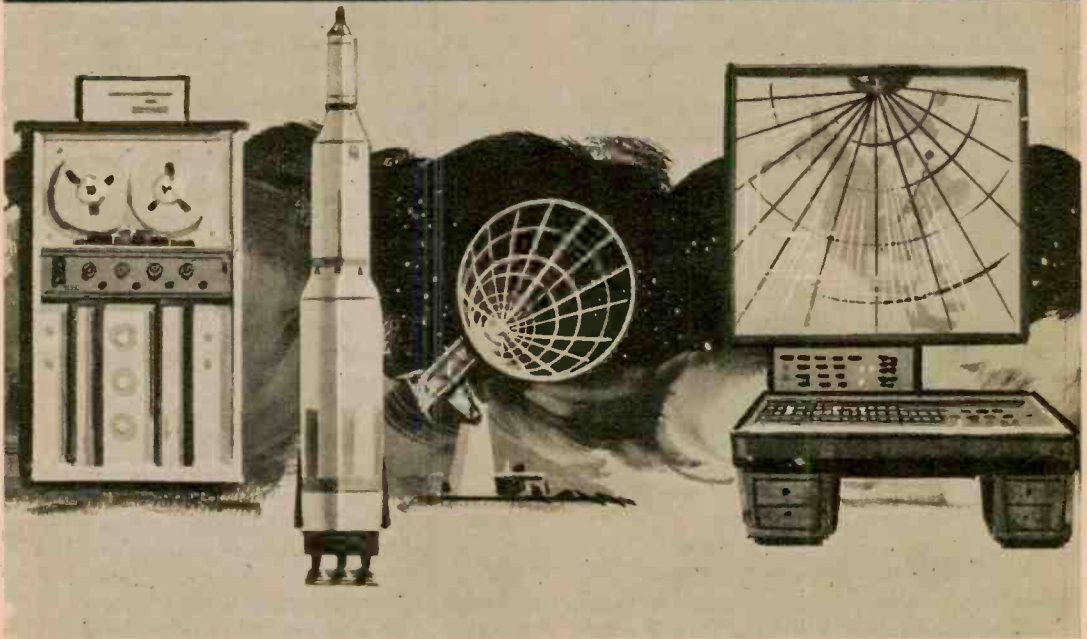

This is one of America's fastest growing industries! It offers higher pay, more job security and more job opportunities than most other fields. If you are 18 or over and want an exciting, big pay

future in this dynamic field, CTI training is for you! Get the facts that can put more money in your pockets—fast! Use the coupon to send for the free CTI book—now!

APPROVED FOR GI TRAINING

If you served since January 31, 1955 or are in service, check GI line in coupon

COMMERCIAL TRADES INSTITUTE

1400 Greenleaf Avenue • Chicago, Illinois 60626 • Dept. EH-6768
Accredited Member National Home Study Council

Mail
This
Coupon
Today!

Send Me The
FREE BOOK



CTI—Dept. EH-6768 1400 Greenleaf, Chicago, Illinois 60626

Please send me all the facts, complete details on CTI training in Automation Electronics.

Name _____ Age _____

Address _____ Zip Code _____

City _____ County _____ State _____

Check for facts on GI Bill

CTI also specializes in training men for jobs in 4 other high-paying fields. For free information on these courses, check one line below.

- Air Conditioning, Refrigeration and Heating
- Color TV
- Building Construction
- Modern Automotive Mechanics

from 50 to 15,000 cps are reproduced within 2 or 3 db of the reference-tone's level. (That's for a tape speed of 7½ ips. At 3¾ ips, don't expect the same high-end response.)

Test tapes cost plenty—as high as about \$20 for the Ampex we specified. One way to get around this expense is to check response by ear. It's a cinch if you taped a new record when the recorder was unpacked and in mint condition. Play that tape now and compare it with the sound from the disc. The test isn't an end all, but it can offer valuable information about playback quality.

A similar test requires a few dollars for superior-quality prerecorded tape and a disc recording of the same musical selection. When new tape and disc are played back simultaneously on comparable-quality equipment you should be able to make a reasonably good comparison.

Most common fault during playback is loss of high-frequency, or treble, response. This could arise from a worn playback head, which, of course, can be replaced. But if a component in the machine's electronics (other than a tube) is defective, the repair might require the skill of a service technician. Another treble killer is poor head alignment, which we'll get to in a moment.

Record/Playback Response

If the recorder passes playback tests, there's still no guarantee it will make it on a record test. An ear test is helpful. Copy a brand new record on tape, then compare disc against tape at playback.

You can make a more critical appraisal if you have an audio generator and VTVM. The test setup is shown in Fig. 2. Begin by recording frequencies from 50 to 15,000 cps. Make sure the output from the generator is kept constant (using the switch, connect the VTVM to the recorder's input) and well

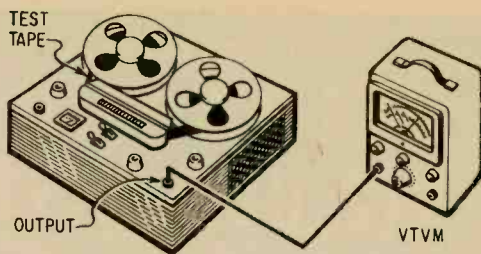

Fig. 1—For playback frequency-response test, measure the machine's output with a test tape that has constant-level tones from 50-15,000 cps.

below the recorder's overload point. Play back the recorded frequencies. The VTVM will indicate how well the recorder performs during record.

If an audio generator isn't available, next choice is a test record with series of tones that you copy on the tape. This test, of course, assumes your hi-fi equipment has substantially flat response. These frequency tests provide a valuable profile of how wide and smooth the machine's response is.

Head Alignment

High frequencies will disappear if the tape doesn't move past the heads at a 90° angle, as shown in Fig. 3. If a head's position shifts it must be corrected. If your machine has only one head for both record and playback—and you never intend to play a tape recorded on another machine—head alignment is less critical. The error cancels itself. But a head that has moved slightly could adversely affect the quality of your older tapes. Best practice, therefore, is to adjust to 90°.

A test tape on which is recorded a steady high-frequency signal is the best thing to use for azimuth alignment of a head. Again, the indicator is a VTVM connected to measure the recorder's output. As you play back the tape, tilt the head very slightly to the left and

Fig. 2—Setup for measuring record/playback response of a machine. You record audio signals from 50 to 15,000 cps, then measure the playback level with the VTVM. Purpose of the switch is to connect the VTVM to the recorder's input when making the tape. This enables you to keep the level of input signal constant.

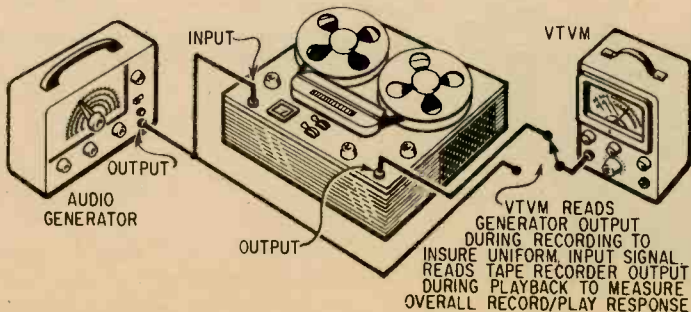

"Look who's smiling now!"

"The department head's job had just been left vacant. When the boys in the office learned I was gunning for it, they gave me their widest grins. One thing they didn't know: I had made up my mind sometime back to take LaSalle training that would qualify me for a better job. My study paid off so fast it surprised even me—I was picked for that shiny promotion over everyone's head. Who wouldn't be smiling with a neat new \$1,500 increase!"

LA SALLE'S FILES are filled with letters with this kind of story from LaSalle graduates who have rapidly climbed the ladder of success. You, too, can qualify for the career opportunity of your choice through LaSalle home study—without interfering with your present work—and by devoting only a little of your spare time.

LaSalle has been an acknowledged leader in home education for more than half a century. It has enrolled more than 1,000,000 ambitious men and women in its many types of training courses. LaSalle's distinguished faculty includes some of the country's foremost practicing specialists and instructors. That's why your training is in good, experienced hands... why your LaSalle diploma will be respected by employers.

Mailing the LaSalle coupon below may be the first step in getting a better job, higher pay, and all of the good things that go with success. Simply check the program in which you are most interested, and we will send you a valuable free booklet describing the opportunities in that field. Mail the coupon to LaSalle, 417 South Dearborn Street, Chicago, Illinois 60605.



LASALLE EXTENSION UNIVERSITY

A Correspondence Institution • 417 South Dearborn, Dept. 69-201, Chicago, Illinois 60605

Please send me, without cost or obligation, FREE booklet and full information on the field I have checked below:

ACCOUNTING

- Complete Accounting with CPA Training
- General Accounting
- Income Tax
- Accounting Fundamentals
- Auditing
- Controllership
- CPA Training
- Modern Bookkeeping

BUSINESS MANAGEMENT

- Complete Business Management
- Credit and Collections
- Office Management
- Personnel Management
- Business Correspondence

LAW COURSES

- Bachelor of Laws Degree
- Business Law
- Insurance Law
- Claim Adjusting Law
- Law for Police Officers
- Law for Trust Officers

SALESMANSHIP

- Sales Management
- Complete Sales Training

DRAFTING

- Basic Drafting
- Aeronautical Drafting
- Architectural Drafting
- Electrical Drafting
- Mechanical Drafting
- Structural Drafting

REAL ESTATE

- Complete Real Estate
- Real Estate Brokerage
- Real Estate Management
- Real Estate Sales

TRAFFIC AND TRANSPORTATION

- Complete Traffic Mgt.
- Transportation Law
- Rates and Tariffs

- Agency and Services
- Motor Truck Traffic

STENOTYPE

- Machine Shorthand

TECHNICAL COURSES

- Mechanical Refrigeration
- Air Conditioning, Refrigeration and Heating
- Diesel

HIGH SCHOOL

- High School Diploma

CAREERS FOR WOMEN

- Interior Decorator
- Dental Assistant
- Secretarial
- Accounting
- Bookkeeping
- Real Estate

Name Age

Address City State Zip No.

Occupation Working Hours A.M. P.M.

right, using the adjustment screws near the base of the head, until the meter indicates maximum output.

If you don't have a VTVM, your ears will do, too. If the frequency of test tone is too high for you to hear, cut the tape speed in half. This will make a 15,000 cps tone drop to 7,500 cps. If neither meter nor test tape is available, you can take a crack at head adjustment while playing a prerecorded tape. Simply listen for best treble response. The technique may appear sloppy, but some audio engineers prefer the ear-only, rather than the instrument, approach to aligning a head.

If your machine has separate record and playback heads, first align the playback head. Then align the record head with reference to it. You do this by recording a high frequency signal and simultaneously playing it back (usually possible on three-head machines that have provision for monitoring while recording).

Using the VTVM to monitor the playback signal, adjust the record head for maximum indication on the meter. If you cannot get an audio generator, try one of the other methods mentioned earlier: that is, a test record or judging by ear using music as a program source.

Bias Current

This adjustment isn't for Sunday putterers, but we'll include it anyway for serious audiophiles. (If your machine does not have a bias-adjust control, skip over this section.)

Bias is a high-frequency signal (usually between 50 and 100 kc) which is applied to the record head simultaneously with the signal being recorded. It improves the signal-to-noise ratio and reduces distortion. But you can have too much or too little of a good thing. Ideal bias for one brand of tape might cause treble loss in another. If you want to attempt this adjustment, here's the general procedure: Find out what the manufacturer of the recorder recommends for the bias test frequency (usually between 1,000 and 3,000 cps). Then record that signal. Play back the tape and note the playback level.

Record the tone several times each at different bias settings. The setting that produces the highest playback level is the correct one. But remember, this setting is for the particular tape you used. Switch to a different brand and you should set the bias again for optimum performance.

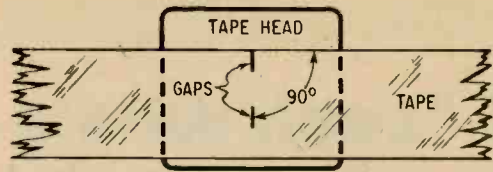

Fig. 3—Azimuth angle (angle between tape edge and gaps in head) always must be 90°. Head's mounting screws are often used for alignment.

A second method of adjusting bias is shown in Fig. 4. You determine bias current by measuring the voltage drop developed across a 100-ohm resistor inserted in one lead of the record head. Using Ohm's Law ($I=E/R$) divide the voltage indicated on the meter by 100 and you get bias current. Compare this current with the manufacturer's recommended current and make the necessary adjustment to the recorder. If you attempt bias adjustment without test equipment, you'll have to try for flattest record/playback response. Tape speed should be $7\frac{1}{2}$ ips.

Head Height

This adjustment is especially critical in stereo machines, and you can see why in Fig. 5. If the head is too high or low, the gap intended for a particular track may pick up signal from another track as well. The tape edge should be .001 in. above the upper gap. Head adjustments are much simpler with a special alignment tape that tells your ear, not your eye, when head height is correct. The tape to use is an RCA No. 12-5-64T. It has a steady tone recorded across its entire width except for track 3, as shown in Fig. 6. As the tape goes through the machine, you adjust the playback head's position until you hear the *least* signal from track 3.

Another way to make the adjustment is to play a steady low-frequency tone recorded on a quarter-track tape and visually position the

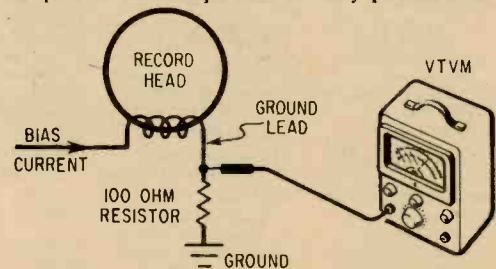

Fig. 4—Measure voltage drop across resistor connected in series with record head's ground lead, then use Ohm's Law ($I=E/R$) to find bias current.

head so it's too high. Then gradually move the head down until you hear, or note on the meter, *maximum* output signal. There's an additional step if your machine has a separate record head. After aligning the playback head, as already described, record a low-frequency tone and simultaneously play it back. Adjust the record head for maximum playback signal.

Some accessories make recorder track visible. There's Magne-See solution and a special viewer made by the Minnesota Mining and Mfg. Co. (3M). They permit you visually to adjust record-head height, then use the tape as a reference for adjusting the playback head. These accessories are also valuable for determining if the erase head completely wipes off the recorded track. Once you've made height adjustments to any of the heads, chances are that azimuth alignment will be disturbed slightly. Azimuth should be rechecked and adjusted if there's been any change.

Tape-Motion Problems

If a machine is up to professional standards, its speed is accurate to within 0.3 per cent. This means that in a half hour of playing time the tape will run not more than 5.4 seconds fast or slow. The best home machines may be accurate within 0.5 per cent. Some models are within 1 per cent. Fair machines run within 2 per cent.

How much your machine deviates from the correct speed can be determined with a special stroboscope tape or strobe disc (made by Robins Industries and others). You illuminate the tape or disc with a lamp operated on 60-cps house current. If the bars on the tape appear to move in the direction of tape travel, tape speed is fast. If the bars move in the opposite direction, the tape speed is slow. You can tell whether the error is acceptable by observing the number of bars that move past a point (such as a pencil tip) each minute. Seventy two bars per minute mean a speed error of 1 per cent. Other errors are proportional. For example, 36 bars mean a speed error of 0.5 per cent. But as long as you're not going to play pre-recorded tapes or tapes made on other machines, speed differences aren't too important. Anyway, there's not much you can do about incorrect speed.

Other tape motion problems are wow and flutter. You'll have to use your ear to detect

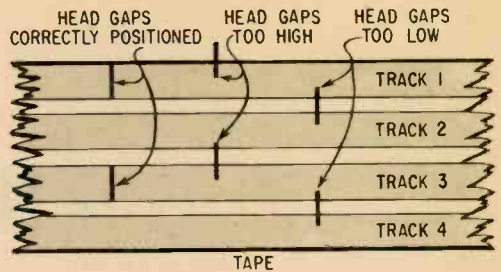

Fig. 5—Diagram shows relationship of gaps and tracks. If height of the head is incorrect, gap will pick up signal from two tracks instead of one.

them since suitable instruments are extremely expensive. One technique is to record and play back a steady tone of approximately 3,000 cps. (The ear is especially sensitive to speed changes in this region.) Wow, a slow-rate change, is a wavering or souring of the tone. Flutter is a rapid change in frequency which imparts a grainy, indistinct quality to the sound.

These errors in tape motion are usually produced in the tape-transport mechanism. They could be due to slippage, worn or hardened rubber parts, mechanical wear, possibly excessive force at the pressure pads against tape heads. But before you get inside the machine, carefully clean all parts that come in contact with the tape. Even small quantities of dirt can introduce friction and drag.

Final Notes

Don't overlook items outside the machine. Get rid of bent reels that squeak when they turn. They could be ruining the edges of good tape. Lubricate your old, squeaky tapes with a silicone compound. And a final autumn tonic: treat yourself to a new, inexpensive, gadget—like a tape threader to help tranquilize fumbling fingers. 🗑️



Fig. 6—Test tape will aid you in adjusting head height. You move the head slightly up or down until the output from the blank track (3) is at minimum.

FLOP FLIP FLOP FLIP FLOP FLIP

TAKE two transistors, add a half dozen or so standard parts and you have what's called a flip-flop—the building block of computers. On a more down-to-earth level, flip-flops are used to lock your TV picture in with the signal from the transmitter. To see how one works, we're going to build a flip-flop audio generator and light flasher.

The first flip-flop we'll talk about is called an astable (not stable—it operates continuously after power is applied) or free-running multivibrator. Basically it is an electronic see-saw in which two transistors work like a pair of switches—when one is closed or on, the other is open, or off. But before we discuss how our flip-flop works, let's review a few fundamentals of transistor operation.

The first is that a negative signal on the base of an NPN transistor becomes a positive signal at the collector. A positive signal on the base becomes a negative signal at the collector. An NPN negative signal applied to the base of a PNP transistor turns it on and a positive input signal turns it off.

Take a look at Fig. 1, a simplified schematic of a flip-flop along with oscilloscope photos of signals. When you connect the battery a negative transient signal appears on the

base of Q1. Q1 is now turned on and it sends a positive signal to the base of Q2. This turns Q2 off. And as this happens, Q2 sends a negative signal through C2 back to the base of Q1. Everything is reinforced, that is, Q1 is driven further into conduction and Q2 is driven further off. When Q1 is fully on, the voltage at its collector is a steady negative DC. All this happens very quickly, then the action of the circuit comes to an abrupt halt.

Things don't stay off for long. Eventually, C1 and C2 come into action again. Remember, capacitors C1 and C2 block DC but will pass a rapidly-changing signal. Such a signal exists when Q1 and Q2 are turning on or off. However, C1 and C2 have been charged by the voltage at the collectors of Q1 and Q2. After Q1 and Q2 have switched, C1 and C2 begin to discharge and reverse the on-off state of Q1 and Q2.

Consider C2. After Q2 is completely off, C2 begins to discharge and the positive charge, or voltage, on its left plate is applied to the base of Q1. This turns Q1 off which subsequently turns Q2 on. The circuit then goes through the same cycle again. Q1 and Q2 switch on and off at a frequency determined by the value of the components.

Fig. 1—Schematic of basic flip-flop (astable multivibrator). Pulses on base of Q1 (photo at left) are positive because they're from left plate of C2 when it discharges. Waveform at collector of Q2 is collector voltage. Flattened part near the horizontal axis is due to the saturation of Q2 when it is in the full-on condition.

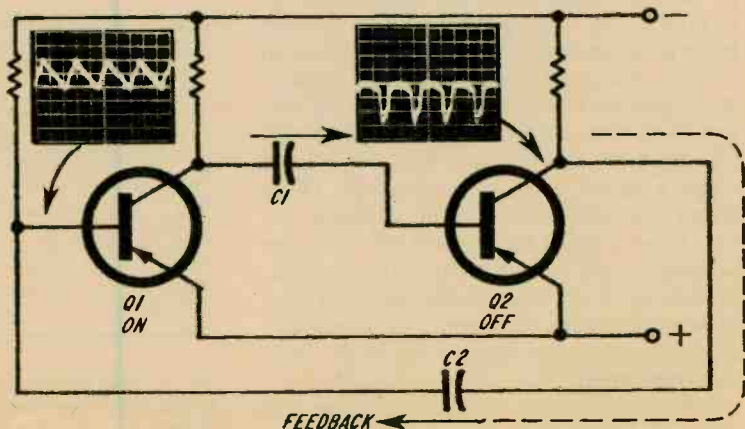

FLIP FLOP FLIP FLOP FLIP FLOP FLIP FLOP

Use large capacitors or increase resistance in the base circuit, and you'll reduce the speed.

Build the flip-flop on a piece of perforated circuit board or masonite as in Fig. 3. Note the values to use for R1, R3, C2 and C3 in the chart below the schematic in Fig. 2. When power is turned on, you should hear about a 400-cps tone. The tone sounds considerably fuller than that of a sine-wave oscillator because it is rich in harmonics.

You can produce a lower or higher-frequency tone by installing a 1-megohm potentiometer (R6) in place of R1. Also install

a 4,700-ohm resistor (R5) in series with R6 to limit Q1's collector current.

To convert the circuit to an electronic timer, just put a 30 μ f electrolytic capacitor in parallel with C3 with the polarity shown. This, in conjunction with R6, slows down the speed to about a tick every 30 seconds.

To make a flasher, remove the speaker and connect the lamp (P1) and R4 as shown in the schematic. (Also change components indicated in the chart in Fig. 2.) When power is applied, the bulb will flash on and off. To vary the speed, use a higher-value resistor for R1. (If R1's resistance is too low, the lamp

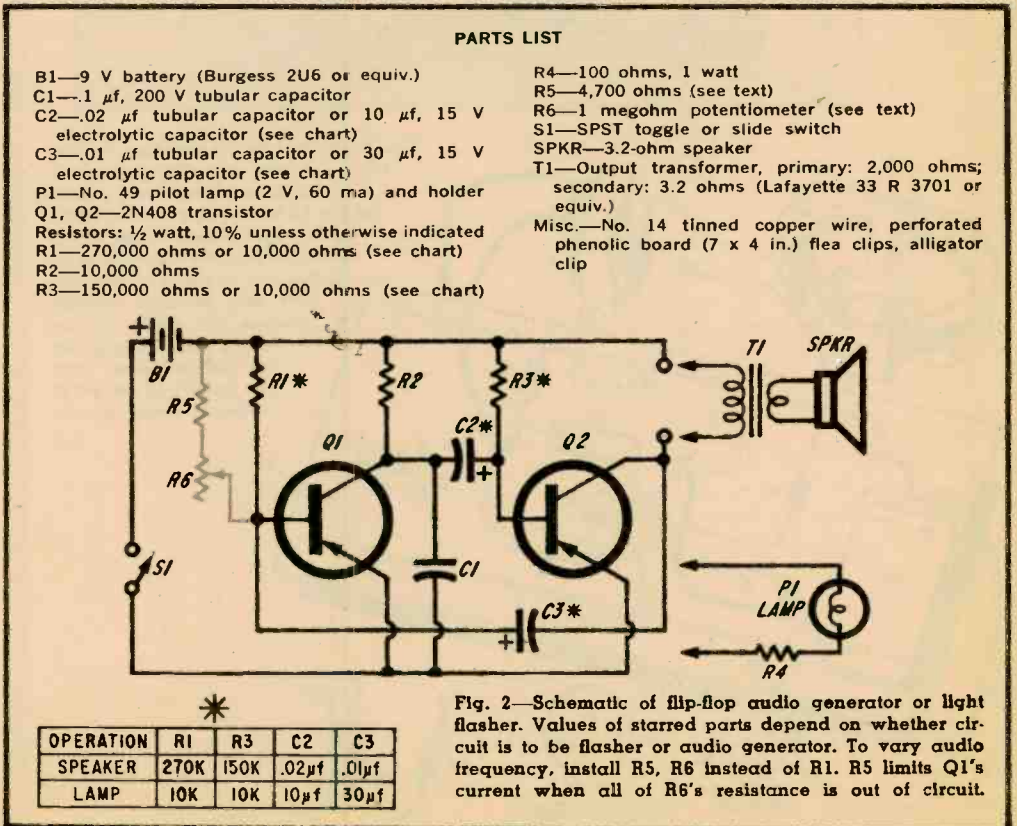

P FLOP FLIP FLOP FLIP FLOP FLIP FLOP FLIP

will remain on since its filament cannot cool off between flashes.)

Monostable Multivibrator. Another important flip-flop is the monostable. When a pulse is applied to the circuit Q1 and Q2 go through one on-off cycle then just sit there waiting for another pulse. The monostable responds to nearly any triggering signal and is valuable where such signals may differ in strength or duration.

You can observe this type operation with the lamp circuit and with C3 removed. Removing C3 opens the closed feedback loop

between Q1 and Q2 and prevents continuous operation. When power is applied to the circuit, the lamp should remain on. Now disconnect the end of R1 that goes to the negative power buss. Tap the free lead of R1 against the negative power buss to apply a triggering signal to Q1. You'll see that no matter how you tap the resistor lead—for a long or short time period—the lamp goes from on, to off, to on again. And it repeats this in a manner relatively independent of how you apply the trigger signal.

—H. B. Morris

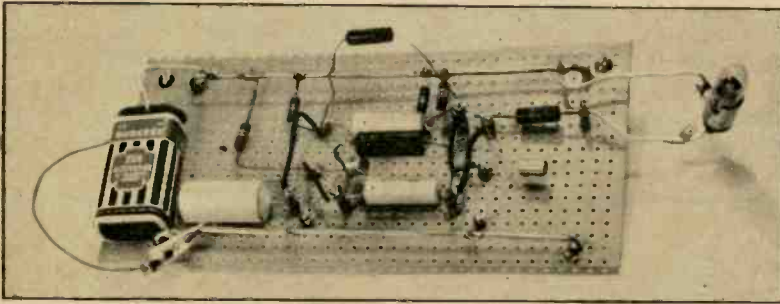
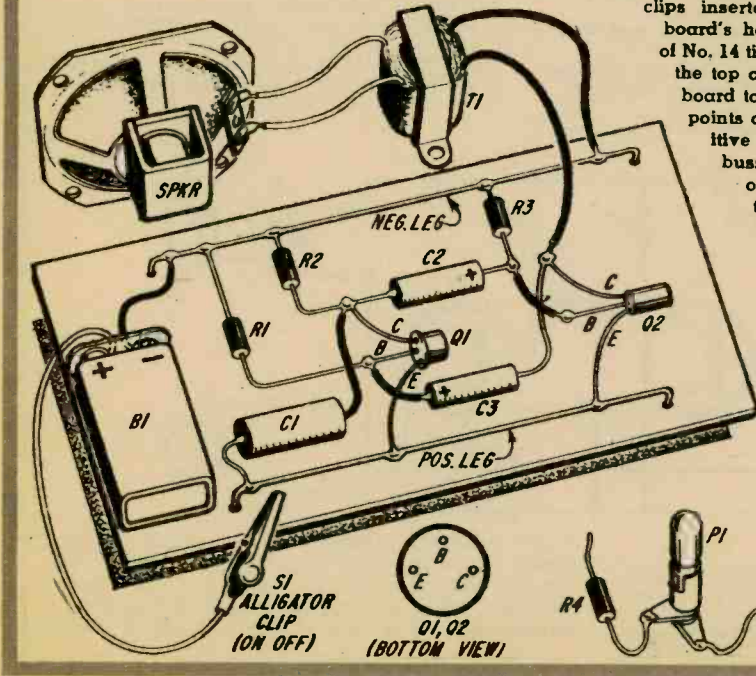

Fig. 3—Parts can be soldered to flea clips inserted into the perforated board's holes. Install two pieces of No. 14 tinned copper wire along the top and bottom edges of the board to provide convenient tie points and to serve as the positive and negative voltage busses. We didn't use an on-off switch. Simply clip the positive lead from the battery to the lower buss to apply power.



THREE-way bulbs have an annoying habit of burning out a lot faster than ordinary bulbs. Keep track of how frequently you replace them, convert the statistics into dollars and cents and you'll store your three-way lamps in the attic. We don't know why the bulbs are so short-lived but they must be doing something wrong.

There's a way to beat the conspiracy. Replace the switch in the lamp socket with our solid-state dimmer, then use a conventional 150-watt bulb. Did you get that? A complete solid-state *full-wave* dimmer built right in the bottom of an ordinary lamp socket!

Compare prices: a 50-100-150-watt three-way bulb costs about 70¢. An ordinary 150-watt bulb costs about 35¢. In no time at all the savings in bulbs will pay for the dimmer, which will set you back about \$5. And a dimmer will lengthen the life of the bulb because the dimmer applies current gradually. A switch sends a surge of current through the bulb. Besides all that, our In-A-Socket Dimmer is an interesting project in itself.

IN-A-SOCKET DIMMER

By BERT MANN

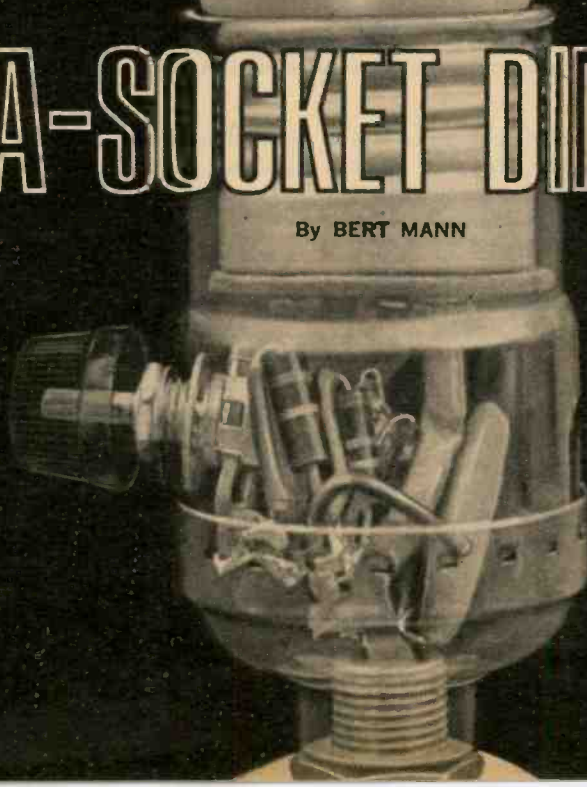

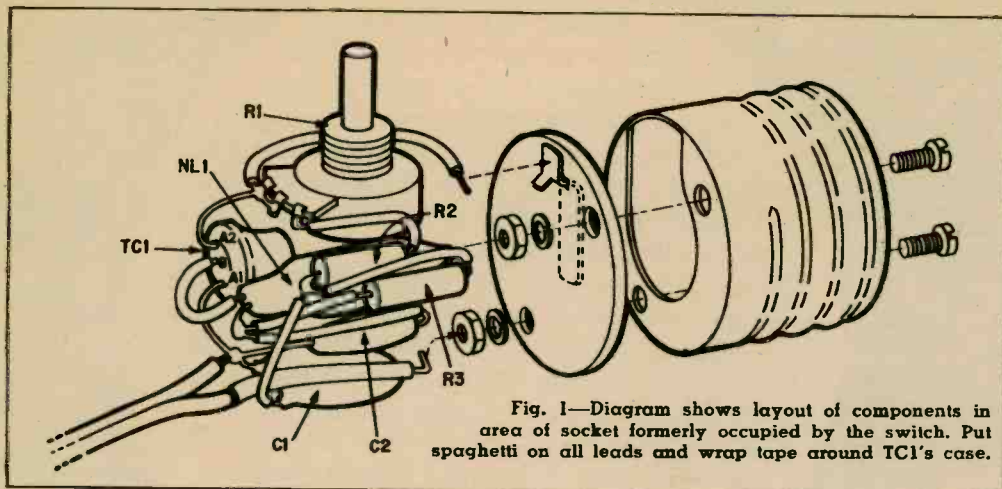

Fig. 1—Diagram shows layout of components in area of socket formerly occupied by the switch. Put spaghetti on all leads and wrap tape around TC1's case.

IN-A-SOCKET DIMMER

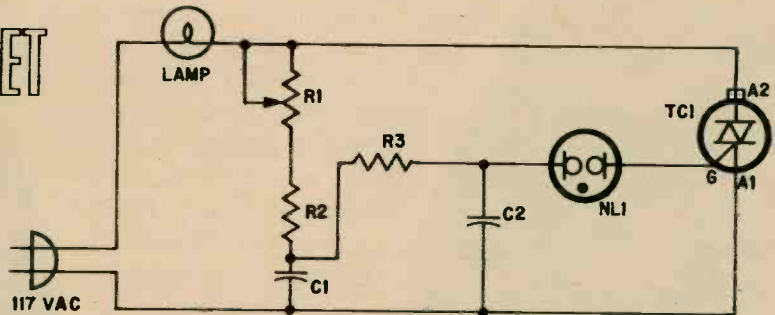

Fig. 2—Dimmer schematic. Because TC1 is bidirectional, it conducts both halves of AC cycle (full wave) in a way similar to two SCRs connected front-to-back (inverse-parallel). Phase-shift network (R1, R2 and C1) causes neon lamp NL1 to generate varying-amplitude pulses which are fed to the gate of TC1. Pulse amplitude determines how much of each half of AC cycle TC1 conducts. When R1's wiper is at top, pulse amplitude is greatest. TC1 conducts almost entire AC cycle and lamp is brightest.



Figure 2 shows the complete dimmer circuit. All components except the plug fit in the socket. Note that there is no on-off switch because R1 turns off TC1 and the bulb. TC1 is a bidirectional thyristor made by RCA. RCA's name for the device is a Triac. It conducts current in two directions, as might two silicon controlled rectifiers connected front-to-back and in parallel. The range of illumination control is from off to full on.

Construction. We built our dimmer in a push-thru socket, as is found in most lamps. We suggest you build your dimmer in this type socket because the construction of a turn-knob socket is somewhat different and our illustrations would not be suitable.

There's not a bit of extra space available in the lamp socket; therefore, you must use the miniature components specified in the Parts List. To avoid shorts and to eliminate

shock hazard, assemble the dimmer exactly as shown in Fig. 1, using spaghetti on every lead longer than 1/8 in.

First, remove the socket from its metal case or shell. Look down into the base and you'll see two screws. Loosen them until the switch falls away from the base. If rivets are used, drill them out. Take care not to lose the tab—the part of the socket that touches the bulb's bottom contact.

Replace the screws (or rivets) with No. 2 or No. 3 by 1/2-in.-long machine screws. Fasten together the fiber insulator disc and the threaded base. Cut one screw at the nut but do not cut the other because you connect one side of the AC line to it.

Solder a 2-in. piece of No. 22 solid insulated wire to the center-contact tab, insert the tab into the fiber insulator disc, then slip the base into the cylindrical cardboard in-



Fig. 3—If rivets were used to hold the socket together, drill them out. Discard switch assembly (in hand) but save all other parts. Cut short the screw (No. 2 or No. 3, ½ in. long) indicated by pencil—the one opposite the center-contact slot.

PARTS LIST

- C1—.1 μ f, 200 V ceramic disc capacitor (Sprague type TH-P10, Allied 43 D 6606. 78¢ plus postage; not listed in catalog)
- C2—.02 μ f, 200 V microminiature paper tubular capacitor (Aerovox type P95ZN, Lafayette 34 C 7327)
- NL1—NE-83 neon lamp
- R1—50,000 ohm miniature potentiometer (Lafayette 32 C 7359)
- R2—2,700 ohm, ½ watt, 10% resistor
- R3—12,000 ohm, ½ watt, 10% resistor
- TC1—Triac, RCA type 40485 (Allied \$3.14 plus postage; not listed in catalog)

sulator. Fit the insulator into the socket case. Temporarily install R1 in one of the two switch slots in the socket case. Check that neither of the two base mounting screws is touching R1's case (if they are, the socket case will be connected to the AC line).

If possible, rotate the base so R1 is centered between the screws. (If necessary later on, apply a drop or two of silicon-rubber adhesive between the base and the cardboard insulator to prevent the base from turning when the bulb is inserted.) Route the lead previously connected to the center-contact tab against the insulator and connect it to R1's right and center lugs, as shown. Carefully remove this assembly from the socket.

Cut off the tab on TC1's case and file the edge smooth. Because the A2 lead of TC1 is connected internally to TC1's case, the case must be wrapped with a turn or two of tape.

Place NL1, pointing toward the base, directly against TC1. Making the shortest possible connection, connect one of NL1's leads to the G lead from TC1. Then connect lead A1 to one side of the AC line cord and to one of C1's and C2's leads. Before installing any other components, solder one side of the AC line cord to the long base-mounting screw. Finally, install R2 and R3.

Limitations and Use. The dimmer can handle a maximum of 150 watts. Do not use a larger bulb. Rotate R1 full counterclockwise and plug in the line cord. Slowly advance R1 until the bulb comes on. (The bulb will light at a higher brightness level than its minimum brilliance, obtained when you turn R1 counterclockwise from full on.)

Safety Check. To make certain there's no shock hazard caused by a short to the socket case, connect one lead of an AC voltmeter (set to indicate more than 125 VAC) to the case and connect the other lead to a ground, such as a cold-water pipe. Turn the dimmer full on and note whether the meter indicates about 117 VAC. Then reverse the power plug and look for an indication. If the meter fails to indicate either way, all is well. If the meter indicates voltage, there is a short.

HOW DO YOU DO IT?

By CHARLES GREEN, W3IKH



Why let sloppy-looking projects embarrass you when the touch of the pro is but six steps away?

THE man who said, "Whatever is worth doing at all, is worth doing well," could have had construction projects in mind. It takes only a little more effort, but think of the feeling of pride you'll get from a well-built project like that amplifier above. The expert's look is just a matter of planning ahead with these steps in mind:

- Layout the chassis
- Cut the holes
- Make brackets and shields
- Mount the components
- Wiring
- Mark the chassis.

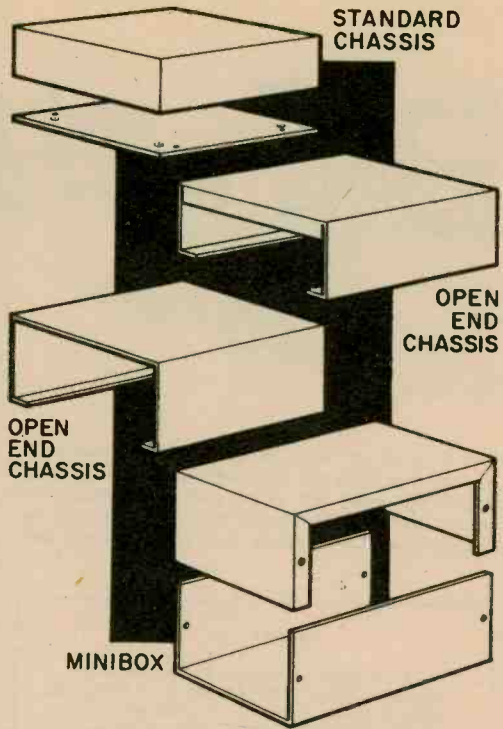

Four basic chassis are available in unpainted aluminum or gray hammertone. The standard (available in steel for heavy projects) has four sides and bottom plate. Open-end chassis have side access. Miniboxes are best for small projects.

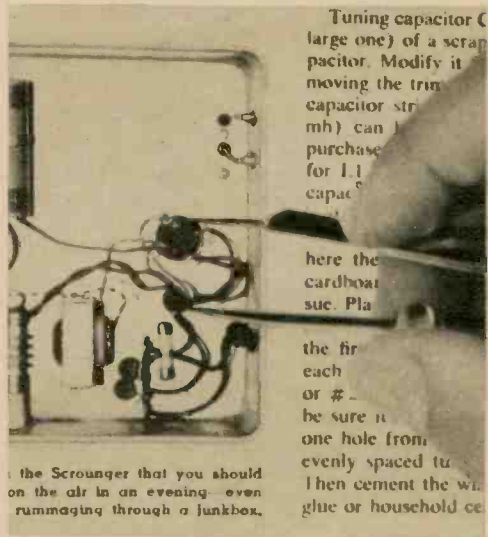

the Scrounger that you should on the air in an evening - even rummaging through a junkbox.

To scale the chassis, measure the width of the photo (dividers and ruler) and the chassis. If the photo is 2-in. wide and the chassis is 6-in. wide, multiply all of the photo dimensions by 3.

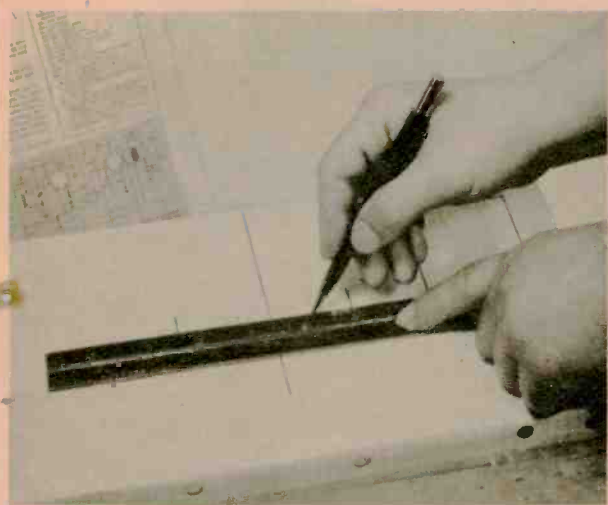

Tape graph paper on the chassis then layout center lines for all holes and identify the hole diameters. And it's a good idea to use a compass to draw circles the same size as each of the holes.

Use a centerpunch before drilling and you'll find the job a lot easier. Always start off with a small bit and work your way up. A block under the chassis will prevent the metal from bending.

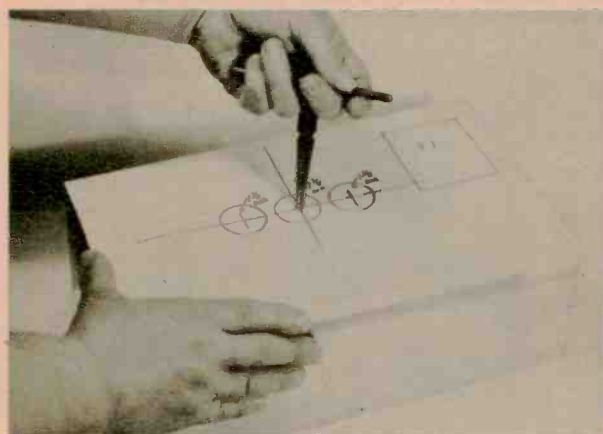

After drilling all holes, use a taper reamer to enlarge the tube-socket holes to $\frac{3}{8}$ -in. dia. for the socket-punch lead screw. Use the reamer for potentiometer and variable capacitor holes, too.

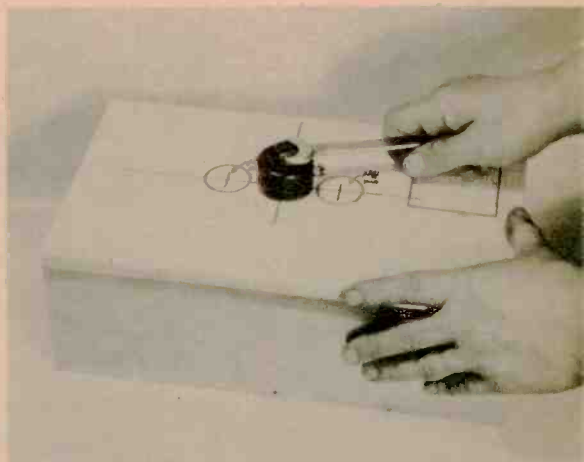

Socket holes should be cut without removing the graph paper. You have to put a lot of muscle into the wrench so hold the chassis firmly. Use $1\frac{1}{8}$ -in., $\frac{3}{4}$ -in. and $\frac{3}{8}$ -in. dia. socket punches, respectively, for octal, 9-pin and 7-pin sockets.

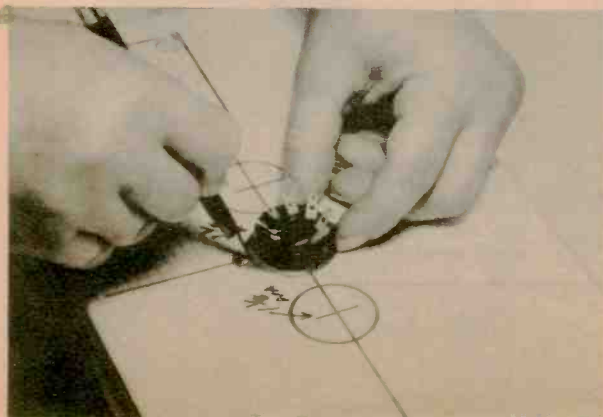

Socket mounting holes can be located by using the socket itself as a template. Place all other components on the chassis then mark their mounting holes on the graph paper. Do not mount any of the parts until all holes have been drilled.

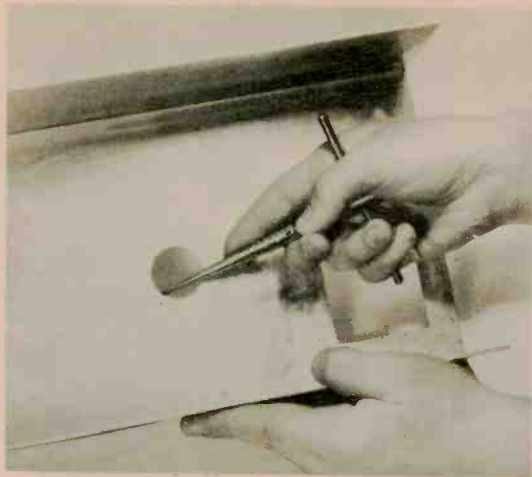
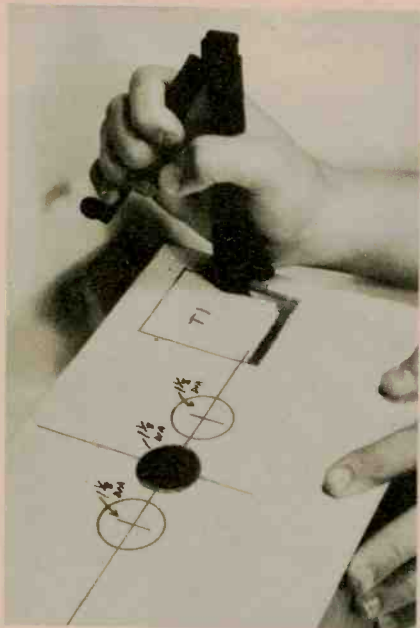

Remove burrs from all holes with either a tapered reamer, a triangular or a half-round file. Grasp the tool loosely and slant it in hole. Then clean up the edge of the hole on both sides of the chassis.

Large holes can be cut easily with a nibbling tool. If such a tool isn't available, back up the chassis with a wood block and drill a series of small holes. Then use a chisel or hacksaw blade to remove metal between the holes.

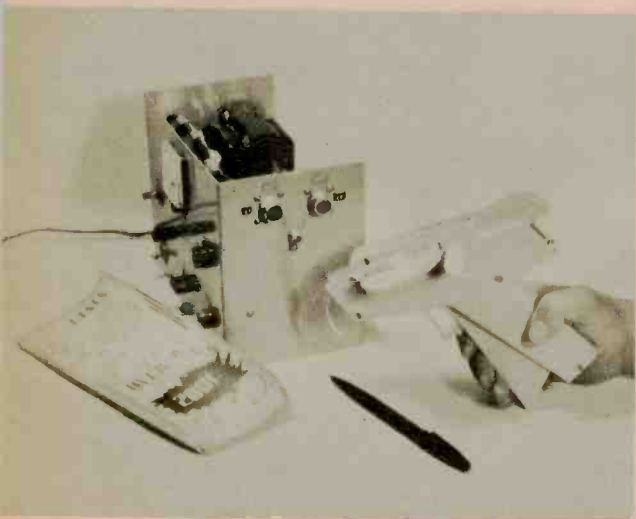

Chassis lettering can be done easily with a label-maker that prints on strips of adhesive plastic. You can also use decals or dry transfer lettering sheets.

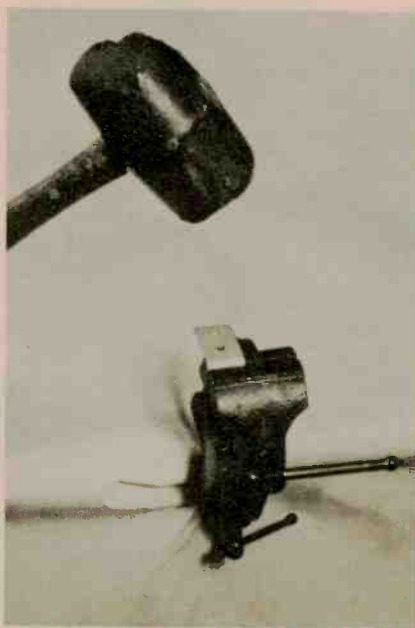

Small brackets and shields can be formed by using a heavy mallet and a vise. Drill all mounting and component holes before bending. And make sure that you use untempered metal that will bend without cracking.

Those Multiplying Cells

AIM a camera, push the shutter release and the exposure is perfect every time. Send a space vehicle into orbit and forget about the batteries dying since operating power will come from the sun. The magic component that makes all this possible? The semiconductor photocell.

The examples we've used rely on two basic types. The first is a *photoconductive* photocell. Since it works just like a variable resistor, it also is called a *photoresistive* cell. The cell's resistance changes in inverse proportion to the intensity of the light striking it. The greater the light, the lower the resistance and vice versa. Thus, the cell is used to *control* current flow in a circuit.

The other type is the *photovoltaic* photocell. Also called a solar cell, sun battery or simply a self-generating cell, it *generates* current when exposed to natural or artificial light.

The operation of both photocells is based on semiconductor action. The material used in the photoconductive cell is cadmium sulphide (CdS). The cell's construction and operation are shown in Fig. 1.

The cell is made by depositing a thin layer of cadmium sulphide, to which electrodes are attached, on a ceramic base as shown in A. During the manufacture of the cadmium sulphide, an impurity is added to convert it to a N-type semiconductor—a material rich in free electrons.

If there's no light on the cell electron activity is low and the resistance of the cadmium sulphide, and consequently between the terminals, is high.

When light energy in the form of photons strike the cell, the cell absorbs energy and electron activity increases. Assume that the cell shown in Fig. 1-B is connected to a battery. Free electrons now will be attracted to the positive side.

As the electrons move to the positive terminal they leave behind what are called holes. The holes, which have a positive charge, are attracted by the negative terminal.

In other words, light energy stimulates current carriers within the cell. The more light, the greater the number of carriers and the greater the current flow. The effect of this, the increase in current, is the same as would be produced by a variable resistor connected to the battery. Lower the resistance and current will increase. The cell, load and battery can be connected without regard to polarity since the action will take place in either direction.

The operation of the photovoltaic or solar cell is more complex. It's made of P-type and N-type semiconductor materials (either selenium or silicon) as shown at the left in Fig. 3. This is the way this cell works:

When the P and N semiconductor materials are joined, a potential barrier region is built up. When the cell is in darkness, holes

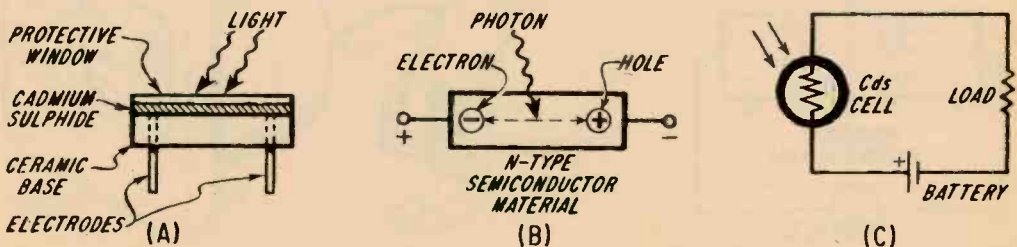

Fig. 1—Diagram A shows photoconductive cell construction. In B, activity of free electrons is increased by light which causes them to be attracted by positive external voltage. Holes left behind are attracted by negative side. This results in a current flow whose magnitude is determined by light intensity.

Those Multiplying Cells

and electrons (circled plus and minus signs, respectively) move toward the junction because of their mutual attraction. This movement eventually stops.

When light strikes the junction, photons force the electrons and holes across the junction, causing electron-hole pairs to be formed. The activity caused by the combining of the electrons and holes produces a difference in potential between the electrodes, which is indicated by the meter as a current flow.

To witness the operation of a photovoltaic cell, connect one to a meter as shown in Figs. 2 and 3. You now have a simple meter that measures light intensity. The cell to use is an International Rectifier type B2M (Allied 7 U 876). Connect the cell's red lead to the positive meter terminal and the black lead to negative terminal. If the meter is a 0-100 μ a DC microammeter, it will indicate approximately the intensity of light falling on the cell in foot-candles per square foot. The table below converts current to light level.

Meter indication (microamperes)	Foot-candles / square foot
0	0
20	6.4
40	12.8
60	26.0
80	52.0
100	104.0

The B2M cell can also be used to power a small transistor radio. The cell's output in

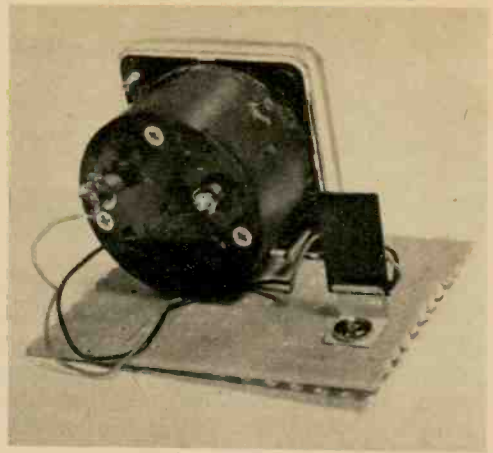

Fig. 2—Experimental setup to demonstrate photovoltaic-cell light meter. You could mount the meter and cell in cabinet for portable applications.

sunlight is approximately 0.4 V at 2 ma. If this voltage is too low, connect cells in series to add their voltages. Higher currents can be obtained by connecting several cells in parallel. A series-parallel arrangement boosts both voltage and current.

In electronic parts catalogs you will find other cells (silicon) whose output is greater. Some have nearly a 1-V output at over 20 ma in sunlight. The International Rectifier type S5M, for example, has a 0.6- to 0.85-V output at 18 to 25 ma.

A cadmium-sulphide photoconductive cell can be connected in a circuit in the same way as a variable resistor. But there is one important thing to keep in mind—maximum applied voltage. If you wish to connect the cell in a 117-VAC circuit, choose a cell with a 250- to 300-V rating. Lower-voltage cells

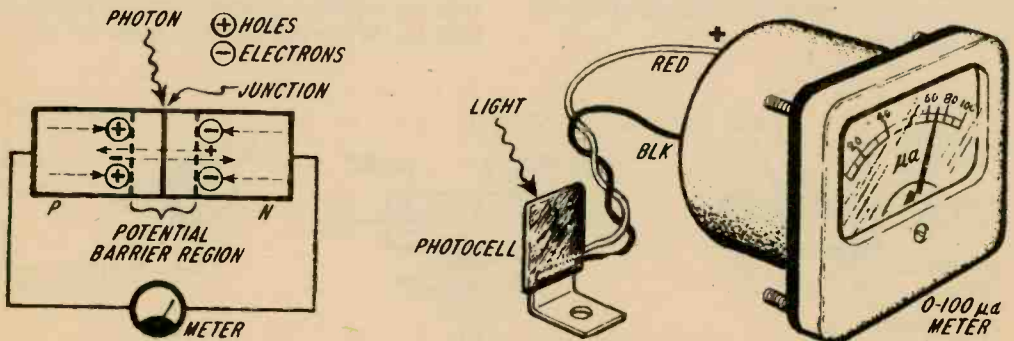
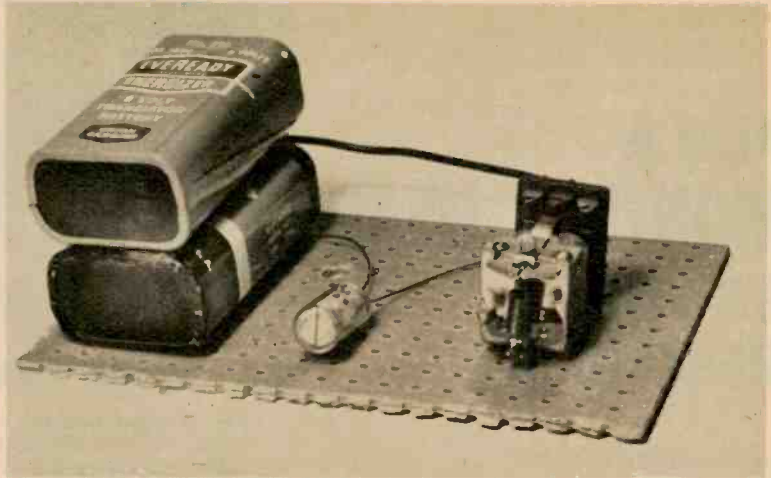

Fig. 3—In diagram of photovoltaic cell at left, holes and electrons are caused by light to cross potential barrier region and combine. Minority carriers which are created pass through the junction and are actually the current developed by the cell. Diagram at the right is of photovoltaic-cell light-level meter.

Fig. 4—Photoconductive cell connected in series with two 9-V batteries and a sensitive DC relay can be used to turn on lamp as darkness approaches. Make sure current drawn by external circuit does not exceed rating of the contacts. A 10,000-ohm potentiometer connected in series with the relay can be used to control the sensitivity.



can be used safely with batteries. The cell's ratings and other important details, such as resistance under light conditions, also will be listed in parts catalogs.

Another value that must not be exceeded is the cell's maximum power dissipation in watts. If it's not stated in the catalog, it can be determined by multiplying maximum voltage and current ratings of the cell.

A simple setup in which a photoconductive cell can be used to control a relay directly is shown in Figs. 4 and 5. This circuit is useful for applications like triggering an alarm or turning on a lamp as when darkness approaches. The cell to use is Clairex type CL-602 (Allied 7 U 460). It's resistance is about 3,000 ohms in bright room light and many times higher in darkness. The relay, (Lafayette Stock No. 99 R 6091) is a sensitive DC type (5,000-ohm coil) that closes when the coil current is about 2 ma.

With these specs you find out that the relay requires 10 volts for its contact to close. Here's how: Using the formula $E=IR$, we find that $.002 \times 5,000 = 10$ V. Since the photocell's resistance is 3,000 ohms when illuminated, it will have a voltage drop across it. Thus, if the required current is 2 ma (.002 A) and cell resistance 3,000 ohms, the voltage drop across the cell will be 6 V. Therefore, about 16 V is required to operate the circuit. Two 9-V transistor-radio batteries in series will do the job.

When using this circuit with 117 VAC, you should enclose it in a cabinet so you don't get a shock. Also, an AC relay that will handle higher voltage will have to be substituted. However, a better approach is to use a step-down transformer to reduce line voltage to a safer level. Then long leads may be run to the photocell and other parts with safety.

—H. B. Morris

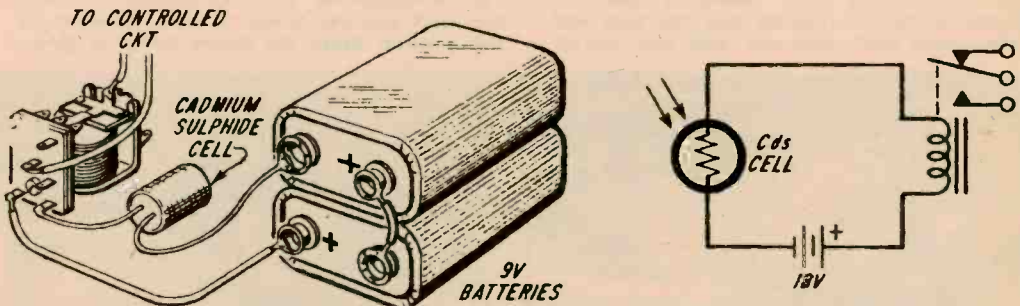

Fig. 5—Schematic of photoconductive-cell control device. Sixteen volts is required to provide current to cause relay contacts to close. Clairex cell we specify (not shown above) can handle up to 300 V and can, therefore, be used with AC relay in line-operated circuits. Cell handles up to 75 milliwatts.

ADD A MONITOR HEAD TO YOUR RECORDER

By LAWRENCE GLENN

WHAT a blow it is to discover you have worse than nothing on that tape you made at the last party! Sure, the level indicator was moving and what you may have heard via something called the *monitor jack* led you to believe you'd have a good recording.

But these clues were misleading because they did not reveal whether anything actually was being *put on the tape*. At best, they indicated simply that the recorder's electronics was working.

To know with certainty whether you have a tape and how good it is, your machine must have a monitor head—a third head which lets you listen to the recording a fraction of a second after it's made.

There's no need to trade in or scrap your present recorder for a more expensive machine that boasts three heads since you can add a monitor head to your present machine.

Fig. 2—Nortronics TG-7 tape-guide post, indicated by pointer, insures that the tape will wrap around head gently and oxide won't rub off.

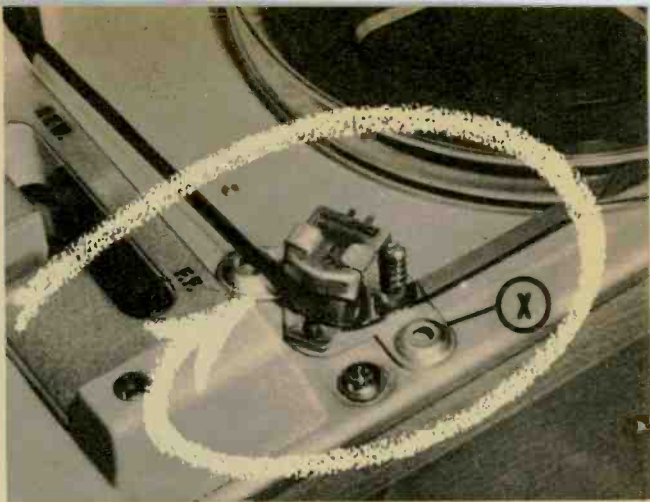

Fig. 1—Head mounted at corner of deck. Tape-guide post goes in bracket marked X to keep the oxide from being rubbed off due to tight wrap.

And a four-track monitor head on an old half-track machine will let you play pre-recorded stereo tapes, to boot.

The job may take a little ingenuity since all machines are not the same as the one we show here. Matter of fact, the mounting just may be quite simple because you don't have to get involved with the existing head mount. The new head is mounted on the deck itself—the biggest problem may be finding space for it.

If your recorder is an older model—the large let's-not-crowd-things type, you'll have no trouble finding an extra square inch or so on the deck for the monitor head. The four-track head we installed is a Nortronics No. 1001 (Lafayette 28 C 5715). The head and its mount are supplied with installation instructions.

If your machine is one of those new compacts on which there isn't an extra inch of

Fig. 3—Completed deck installation. Connecting block attaches cables to head. Adhesive in the grommet keeps the cables firmly in place.

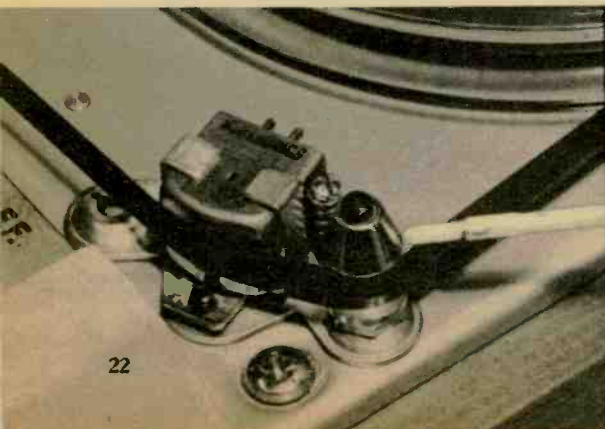

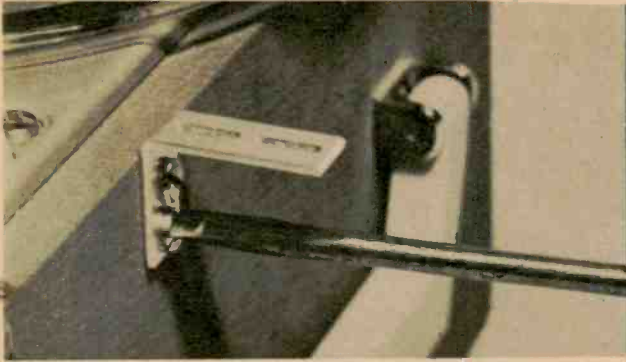

Fig. 4—No room on deck means you'll need a Nortronics L-5 (Allied 15 A 8796) bracket. Install it so that the head assembly is even with deck.

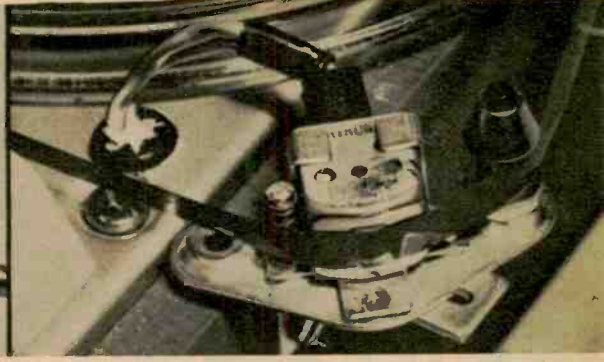

Fig. 6—Completed outboard installation. Again, a Nortronics connector is used to attach cables to head. Don't forget adhesive in the grommet.

deck space you'll have to add the head outboard.

Whether you go inboard or outboard avoid tight, right-angle wrap-around by using a tape-guide post (Nortronics TG-7, Lafayette 28 C 5761)—a polished metal pole that positions the tape for gentle wrap around the head.

Using a Nortronics Type QK adjustable head-mount assembly (Allied 15 A 8891 S) you'll have no problem positioning a tape guide since the mount is predrilled for best tape-guide position.

For deck mounting, simply install the head mount in any convenient spot. If you have to go outboard, mount a Nortronics L-5 L-bracket (also Lafayette 28 C 5762) on the side of the recorder as shown in Fig. 4 and then screw the head mount on the bracket.

Pass leads from the head through a small grommeted hole drilled in the deck. You'll

probably be tight on space so push all the leads under the deck and then fill the grommet hole with an adhesive. The leads should be connected to a two-circuit jack mounted on the side of the recorder cabinet. The monitor-head output should be fed into the tape-head or magnetic-cartridge input on your stereo amplifier.

For optimum performance, the monitor head must be properly positioned. The height of the head must first be set so the head is centered behind the tape. If a tape guide is used it also must be positioned correctly.

Finally, the mount's alignment screw—the one that pivots the head in an arc—must be adjusted to get the head in perfect azimuth alignment. This is accomplished by adjusting a screw while monitoring a tape for best high-frequency response. Again, detailed alignment instructions are supplied with the head and mount.

Fig. 5—Leads from extra head can be brought out to jack in side of recorder's cabinet. A four-track head will require a three-circuit phone jack.

Fig. 7—Mount assembly has several provisions for head alignment. Screws permit adjustment of the height, azimuth and tilt from perpendicular.

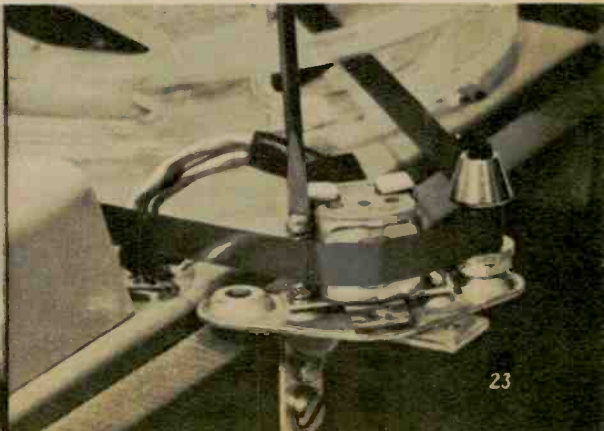
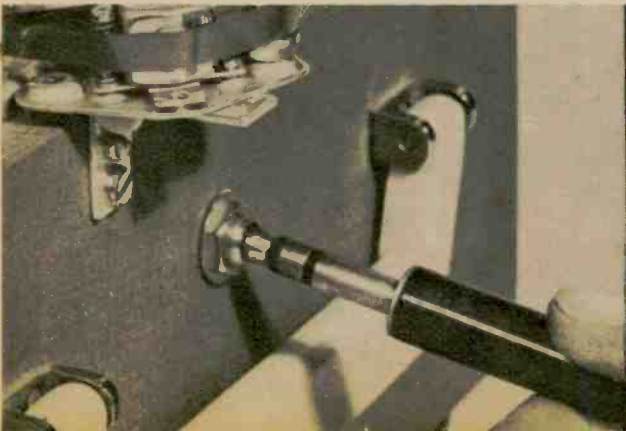

**SUPER
SPEED
STROBE
CAN
STOP
THIS →
ACTION!
AND
THIS!**

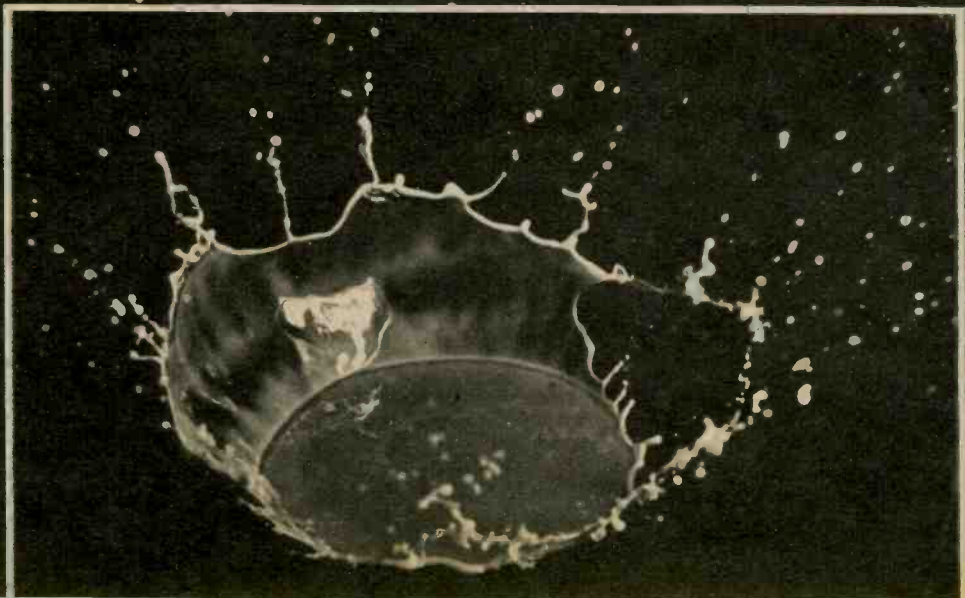
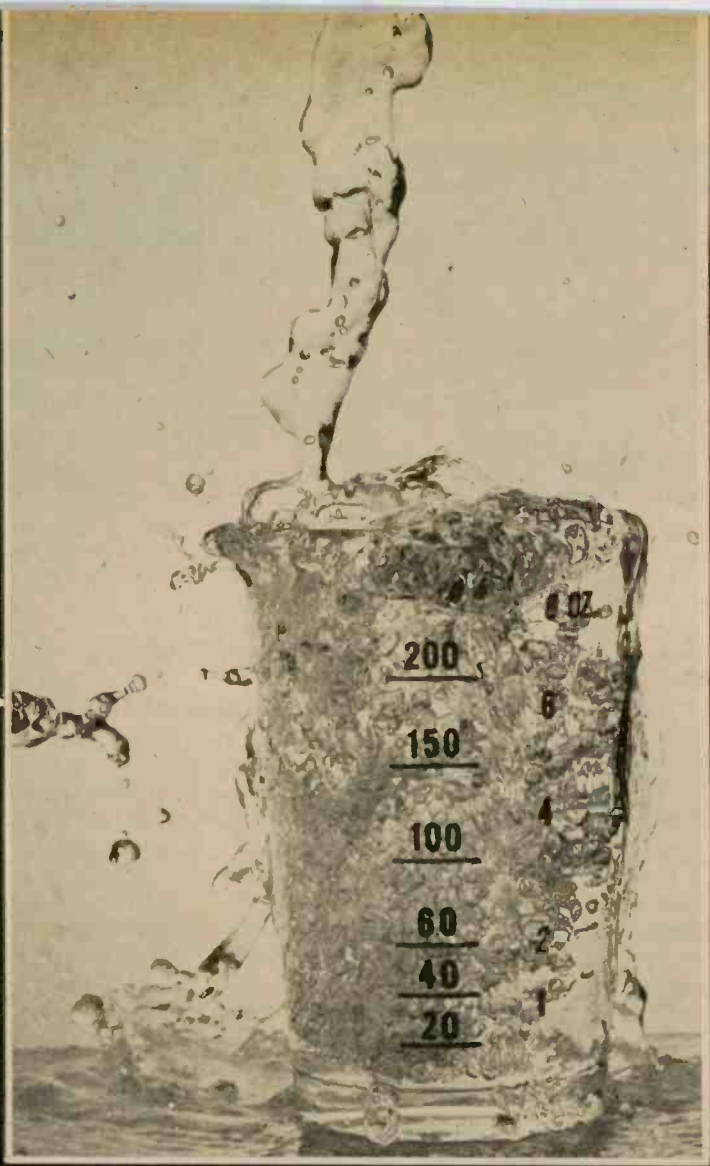

By JIM KYLE, K5JKX A DROP of milk strikes a surface. The eye and an ordinary strobe flash see nothing but a blur. But the 1/10,000-sec. flash of EI's Super-Speed Strobe freezes the action and the milk drop turns into a crown shape in the magnificent photo shown at the bottom of the opposite page. A stream of water falling into a graduate becomes an arresting still-life in the upper photo.

These spectacular photographs could have been taken with a commercial strobe—but only with one manufactured a dozen years ago, not with a modern model. Those early models, though fast, were bulky, had high operating voltages and cost plenty.

As strobes developed over the years, size and cost decreased. But, unfortunately, a price was paid for this—flash speeds decreased. Today, ordinary strobes have speeds that range from about 1/1,000 sec. to 1/2,500 sec.

High-speed photography does not require the expensive bulky strobe equipment of yesteryear. The Super-Speed Strobe proves this. Its power pack is 4 x 5 x 6 in. and it is not much heavier than a dozen or so rolls of film. Best of all, its cost is low. Less than \$50 should put it in your hands.

The Circuit. Before we build it, let's take a quick look at the circuit in Figs. 6 and 7. The power supply is a conventional half-wave voltage doubler that furnishes 450 VDC to storage capacitor C2. To achieve the 1/10,000-sec. flash speed, C2 must be a computer-grade electrolytic capacitor. The type specified in our Parts List is not expensive (\$1.12) and you *must not* substitute an ordinary electrolytic for it.

The charge on C2 is applied to the flash-tube through a connecting cable that should not be longer than 10 ft. After power is turned on, capacitor C3 charges to 225 VDC through R1 and the primary of T2. When the shutter contacts close (SO1's or SO3's contacts are shorted),



Fig. 1—Strobe consists of 4 x 5 x 6-in. power pack and 6 $\frac{3}{4}$ -in.-dia. flash head. Flash head plugs in socket at top of power pack. Socket below is for sync cable to camera.

SUPER SPEED STROBE

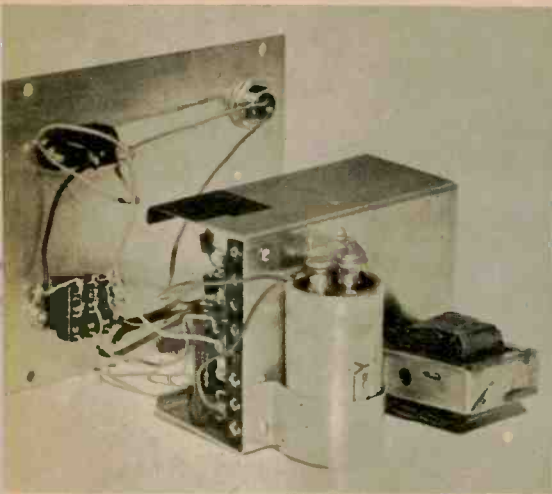

Fig. 2—View of chassis shows how transformer is mounted. Capacitor C2 is held in place with home-brew strap using screws which hold terminal strips. Leads to cover should be at least 6-in. long.

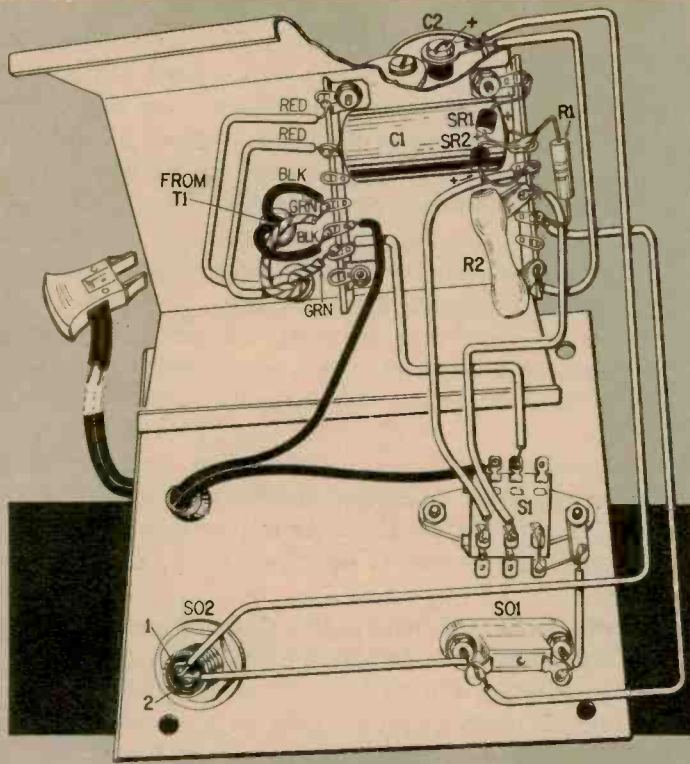

Fig. 3—View of underside of chassis shows wiring to sockets and switch on cabinet cover plate. Negative lug on C2 is connected to chassis with a strap made of scrap aluminum. Before closing cabinet check to make sure lugs on S1 and S01 don't touch edge of chassis.

C3 discharges through T2's primary, causing T2 to produce a 3-kv pulse. This pulse is applied to the flashtube and fires it.

Resistors R3 and R4 (Fig. 6) are a voltage divider for the neon ready-light (NL1). Capacitor C4 causes NL1 to blink, indicating the unit is ready to fire again. The lower C4's capacitance, the faster the blink rate. C2's recharge time and the time it takes NL1 to start blinking after a flash normally are under three seconds.

Construction. Start off with the power supply, which is built on a 2 x 4½ x 3½-in. aluminum chassis as shown in Figs. 2 and 3. Mount transformer T1 and connect its leads but *do not* cut or solder them. Apply 117 V to T1's primary and measure voltage across the red secondary leads. Now interchange the connections of the 6.3-V (green) leads and measure the voltage again. If it's higher, solder the leads in place. If the voltage is lower, *reverse* the connections of the green leads and solder them. Now solder T1's other leads.

Next, install C1, R1 and R2. When connecting SR1 and SR2, hold their leads with

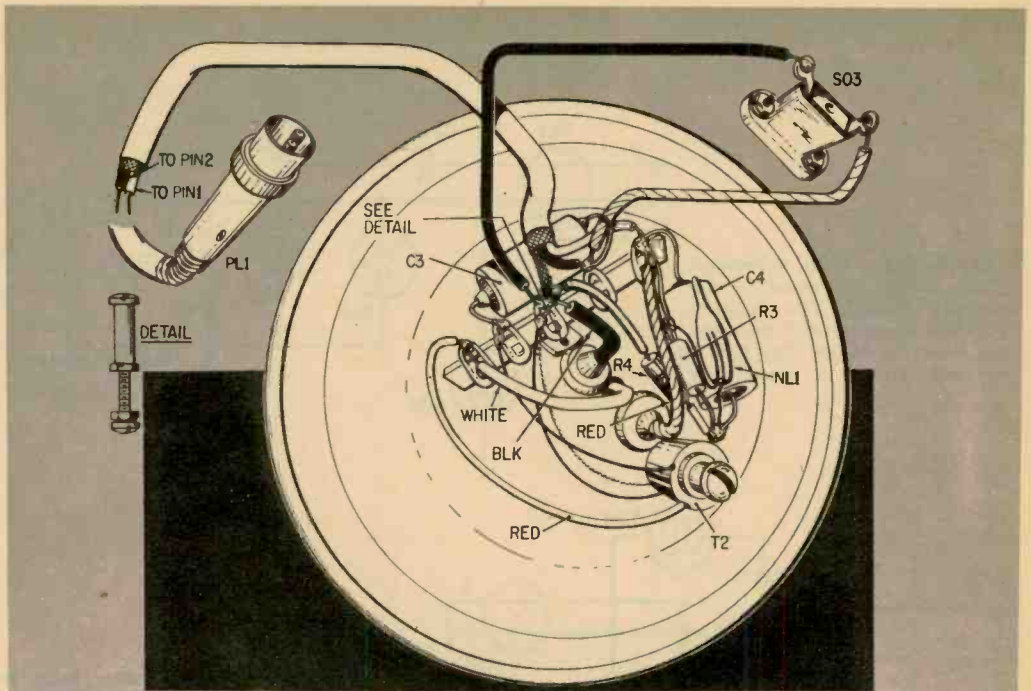

Fig. 4—Back of flash head. Reflector is supplied with holes predrilled for red, white and black leads from flashtube and screws that hold terminal strip and T2. Detail sketch at left shows how a 1¼-in. screw is installed through the reflector to hold the terminal strip and the back cover.

long-nose pliers to prevent heat damage. Mount S1, SO1 and SO2 on one of the box's cover plates and install a grommet for the line cord. Install the line cord then mount C2 (next to T1) on the top of the chassis (Fig. 2) with a homemade clamp. Watch the polarity when connecting C2. After wiring to S1, SO1 and SO2, attach the chassis to the box's other cover plate.

Fit the flashtube's glass lead stems through grommets in the reflector then put two 6-32 x 1-in. long machine screws through the pre-drilled holes (1¾-in. centers) in the reflector. Run nuts on both screws then slip T2 on one of the 1-in. screws. Put a terminal strip and nut on the other screw as shown in Fig. 4 and 5. (Use a fiber washer on both sides of T2 so you don't damage its windings.)

When connecting the flashtube's leads to the terminal strip shown in Fig. 4, use care or you'll break its glass stems. Now install R3, R4, C3, C4 and NL1.

Drill holes in the reflector's back cover for the cable and for SO3. Attach PL1 to the cable making sure the 450-V lead goes

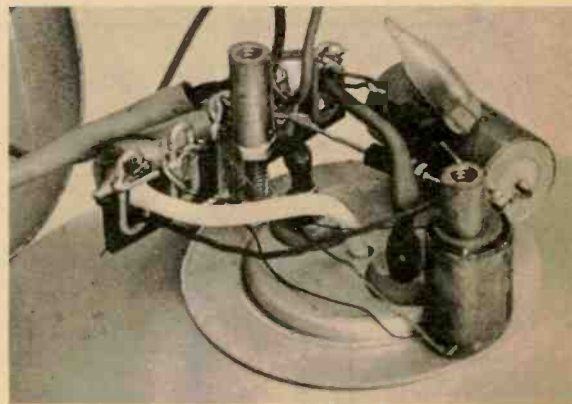

Fig. 5—Back of flash head. Threaded spacer on terminal-strip mounting screw is ⅜ in. long. The threaded spacer that holds T2 is ¼ in. long.

to pin 1 and the 225-V lead goes to pin 2. Put threaded spacers on the ends of the two 1-in. screws and tighten them so that the rim of cover touches the back of the reflector. Attach the cover with 6-32 x ¼-in. screws.

Checkout. Plug in the line cord and turn

Fig. 6—Flash head schematic. When shutter is tripped C3 discharges through T2's primary. T2 steps up pulse to 3 kv. causing flashtube to fire. The SO3 is optional (shown at lower left).

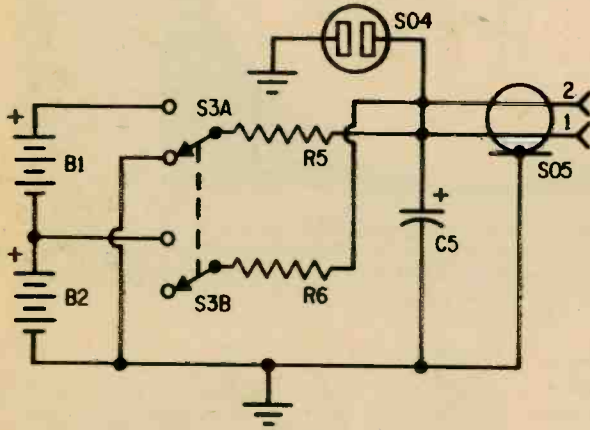
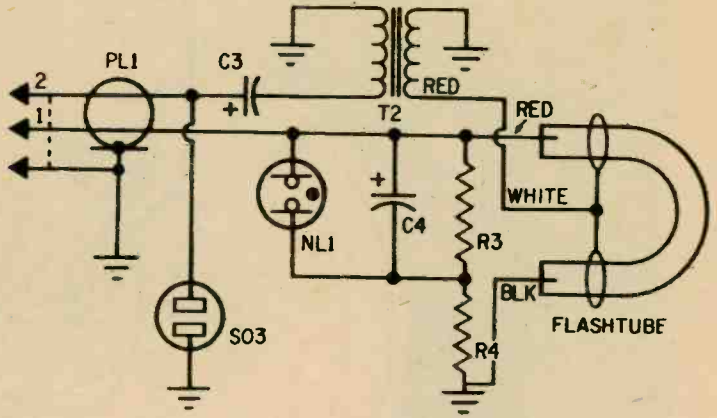

Fig. 8—For portable operation build this power supply, which uses 225-V batteries. However, keep in mind that batteries cost almost \$8 each and their life will be short.

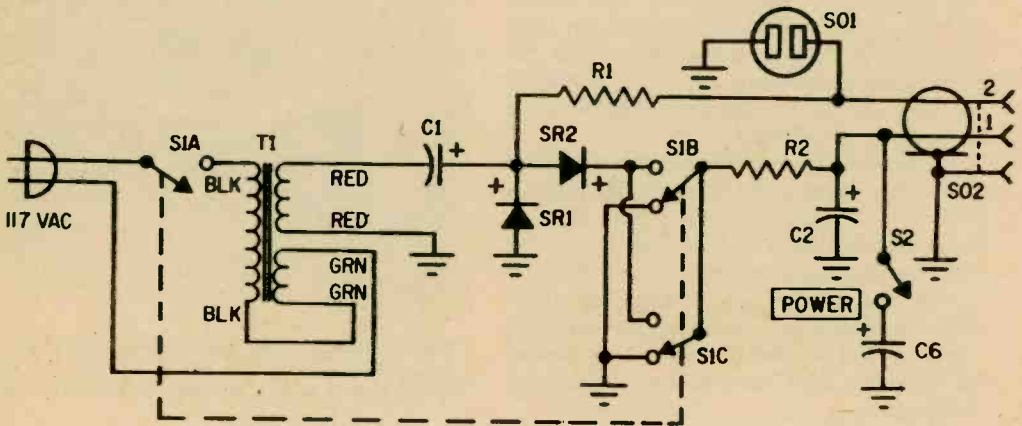

Fig. 7—Power supply. For greater light output but slower speed, add C6 and S2. For high-speed operation leave S2 open. Always turn power off before closing S2.

Flashtube voltage vs. time-average of 50 measurements made with a Tektronix 545-A oscilloscope.

S1 on. Ready-light (NL1) should begin to blink within 15 seconds. If it does not, connect a jumper across either SO1's or SO3's contacts and see if there's a flash. If there is, the trouble is in NL1's circuit and is not serious. If you don't get a flash, turn everything off and check your wiring. Before you touch anything, discharge C2. *If you touch it when it's charged the shock could be fatal!*

Using The Strobe. Connect the sync jack on your camera to the strobe at either SO1 or SO3. Operation is the same as that of any other strobe but exposures are different. In order to achieve such high speed we've sacrificed light output. As a result, the power rating of the stroke is 5 watt-seconds.

The extremely fast flash affects film differently than does the longer flash of conventional strobes or flashbulbs. This means negatives will have less contrast. Thus, film should be developed from one and a half to two times the normal time for comparable contrast.

The photographs on the first page of this article were taken with a Rolleiflex and Tri-X pan film, using an ASA guide number of 20. The shot of the graduate was made with a piece of white translucent screen 6 in. behind the graduate. The strobe light was placed one

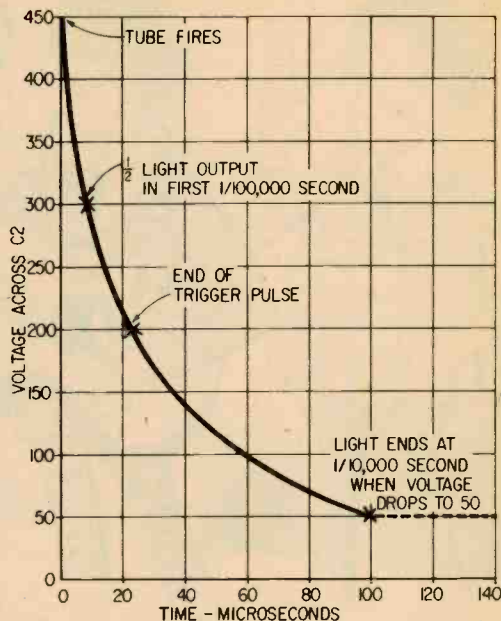

foot behind the screen and the camera was 12 in. in front of the graduate.

The shot of the drop of milk was taken with the camera and light side by side 12-in. away. In both cases, the diaphragm was set at f.22. The film was developed in Microdol-X for about 22 minutes.

PARTS LIST

B1, B2—180/225 V battery (Eveready 492 or equiv.) Optional, see Fig. 8.
 C1—8 μ f, 450 V electrolytic capacitor
 C2, C5—40 μ f, 450 V computer grade electrolytic capacitor (Mallory, Lafayette 30 R 5738 or equiv.)
 C3—.1 μ f, 600 V tubular capacitor
 C4—.1 μ f to 4 μ f (metallized paper, not electrolytic) 200 V capacitor. See text.
 C6—525 μ f, 450 V energy-storage electrolytic capacitor. Sprague FF-1, Allied 15 Z 726, \$13.50. Not listed in catalog.
 NL1—NE-2 neon lamp
 PL1—Double contact plug. Amphenol 80-MC2M. Lafayette 32 R 1920 or equiv.)
 R1, R6—22 megohm, $\frac{1}{2}$ watt, 10% resistor
 R2, R5—300 ohm, 10-watt resistor
 R3—1.5 megohm, $\frac{1}{2}$ watt, 10% resistor
 R4—3.3 megohm, $\frac{1}{2}$ watt, 10% resistor
 S1A, S1B, S1C—3 pole, DT slide switch (Lafayette 99 R 6166 or equiv.)
 S2—SPST switch
 S3A, S3B—DPDT switch

SO1, SO3, SO4—Chassis mount AC socket (Cinch-Jones 2R2 or equiv.)
 SO2, SO5—Double contact chassis connector. Amphenol 80-PC2F. (Lafayette 32 R 1919 or equiv.)
 SR1, SR2—Silicon rectifier; 750 ma, 400 PIV (Allied 39 U 669M or equiv.)
 T1—Power transformer; secondaries: 125 V @ 15 ma, 6.3 V @ 0.6 A. (Allied 61 U 410 or equiv.)
 T2—Flashtube ignition transformer; primary: 180 V, secondary: 3-5 kv. Amglo ST-25, Allied 7 Z 914, \$2.50 plus postage. Not listed in catalog.
 FLASHTUBE—Amglo HD-1, Allied 9 Z 380, \$9.50 plus postage. Not listed in catalog.
 Misc.—Reflector: Amglo AR-365-D, Allied 6 P 637, \$8.00 plus postage (not listed in catalog); flash head back cover: Amglo R-65C, Allied 6 P 636, \$6.75 plus postage (not listed in catalog); 4 x 5 x 6-in. utility box (Bud AU-1029 or equiv.); 2 x 4 $\frac{1}{2}$ x 3 $\frac{1}{4}$ (Bud CB-1625 or equiv.); terminal strips; wire.



FM Guitar Broadcaster

By **LAWRENCE GLENN** IMPORTANT thing swingers must have to really make the big scene these days is a guitar. Most everywhere you go—the beach, picnics, a ski resort, parties—you'll hear the instrument going all the time. The fad has grown tremendously.

Many guitar owners lay out quite a bit of extra cash for an amplifier to soup-up the instrument's volume. But EI's FM Guitar Broadcaster gives your guitar the big sound and saves you money to boot. The Broadcaster puts out a low-power signal in the FM broadcast band. This means you can use your stereo system (provided it includes an FM tuner or receiver) as the guitar's amplifier.

By operating your own popular-music broadcasting station (the Broadcaster has an input for a mike over which you can make announcements) you'll always be a step ahead of the other strummers in the crowd. About \$10 worth of parts and an hour or two of easy work will put you on the air.

Other possibilities? You can serenade the girl next door even when it's raining. No need to stand under her window and get wet. Just sit in your favorite arm chair and strum. She'll be able to pick you up on her FM radio.

If you're really good at playing and singing,

you might take the guitar to the beach or lake and serenade the crowd through their FM portables.

Heart of the Broadcaster is a low-power FM transmitter module. It's a prewired, encapsulated FM transmitter and modulator to which you simply connect a contact mike, battery and switching facility for a mike.

You mount the components on a piece of perforated phenolic board, or other plastic material, then install the board *inside* the guitar, as shown. Of course, we don't recommend you hack away at a \$100 guitar. We suggest you install the transmitter in the \$20 guitar you knock around at parties.

Construction

Our transmitter is built on a 2¼- x 3-in. piece of perforated board. Note that the board is only large enough to hold a single battery clamp for one penlight cell. One cell will produce a range of up to about 50 ft. For slightly more distance, connect two cells in series and use a larger board to accommodate a larger battery holder.

Before mounting any components drill four mounting holes—one at each corner of the board—for #6 screws. (The mounting screws should be self-tapping.) Then, on

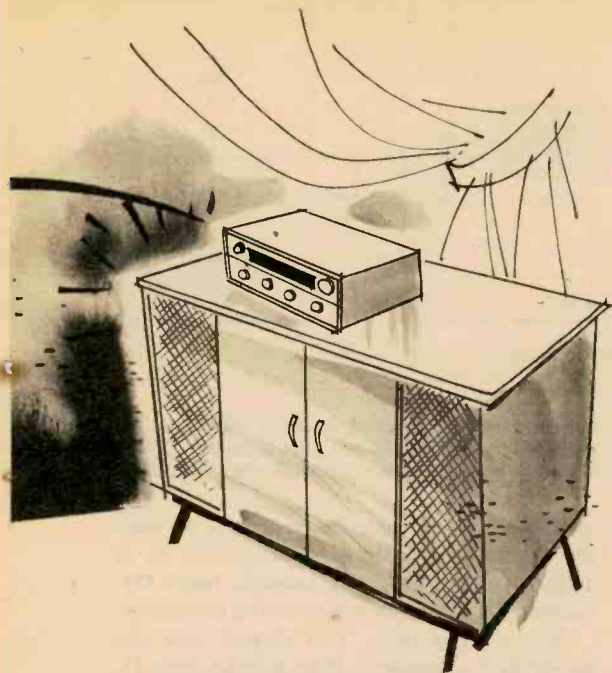

Broadcaster is built on 2¼- x 3-in. piece of perforated board. Model shown has one penlite cell, which will give a range of up to about 50 ft. For a slightly greater range, use larger board, two penlite cells and install a double battery holder. Note in pictorial, wire connected to D on module (FM1). It is an antenna and its length determines operating frequency. Be sure to get connections to S2 correct. M1 should normally be connected to module. When S2 is pressed, crystal mike plugged in J1 is connected to the module.

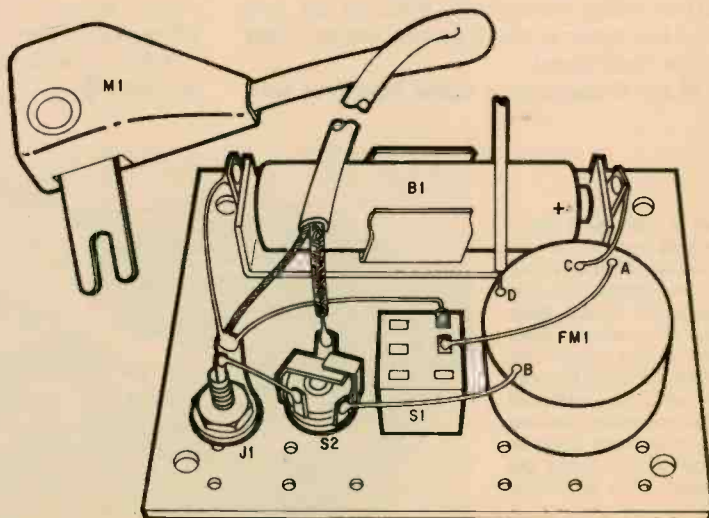

top of the guitar, position the board and mark an outline of it with a pencil or scribe. Since hand capacity will detune the transmitter, position the board as far as possible from the normal playing position of your hand and arm.

Drill a ½-in.-dia. hole ⅛ in. in from the scribed line at one corner. Using a fine-tooth-blade keyhole saw—preferably a sheet-metal blade—cut out the opening for the transmitter board. Note in the photo of the guitar that the corners are angled so there's support for each mounting screw.

Next, position the contact microphone (M1) on top of the guitar near the sound hole and drill a #28 hole for M1's mounting screw. When drilling the hole, keep in mind that the contact mike will be turned over when it is mounted inside the guitar. Mount M1 by passing it through the transmitter cutout. Keep M1 near the transmitter hole or you'll have to remove the strings in order to get your hand inside the guitar.

Now assemble the components on the perforated board. Remember that there will be ⅛ in. of wood under the board, so keep the components at least ⅛ in. in from the board's edges. First mount the single or double battery holder. Then mount mike jack J1, push-button switch S2 and power switch S1.

Switch S1 is a miniature DPDT type (use the one specified) whose unused lugs should be cut off. Using a thin layer of silicon rubber adhesive, such as GE's RTV or Silastic,

PARTS LIST

B1—1.5 V penlite cell (see text)
 FM1—FM transmitter module: Cordover Type
 FMG-1, Carl Cordover & Co., 104 Liberty
 Ave., Mineola, N.Y. \$3.50 plus postage
 J1—Phono jack
 M1—Crystal contact microphone (Lafayette
 99 R 4516)
 S1—DPDT subminiature toggle switch
 (Lafayette 99 R 6162); Modified, see text
 S2—Miniature SPDT pushbutton switch
 (Lafayette 99 R 6218 or equiv.)
 Misc.—Perforated board, battery holder,
 guitar, crystal microphone.

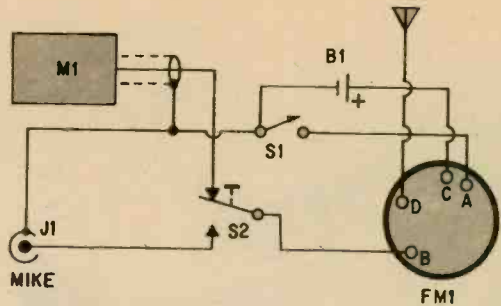

Schematic of Broadcaster. S1 turns on power. S2 is shown connecting contact mike to module. When S2 is pressed, it connects external mike to module.

FM Guitar Broadcaster

cement the FM module to the board, positioning it up against S1 and the battery holder. If you don't cement the FM module against the switch and holder you'll have to add wire to the module's leads.

Cut off the excess shielded cable from the contact mike (M1), leaving about 3 in. protruding from the hole. Connect the mike to the circuit and install the assembly in the guitar. If you don't like the color of the board, paint it with quick-drying model paint.

Tune Up

The Broadcaster's output frequency is around 100 mc. Place an FM radio near the guitar, or place the guitar near your stereo system's FM receiver. Turn on power with S1 and tune the FM receiver for the dead carrier being transmitted. Flick S1 on and off a few times to make certain you've tuned in the right signal.

If the Broadcaster's signal interferes with

an FM station, change its frequency by adding a small length of wire—about ½ in. at a time—to the module's antenna (wire D). Increasing D's length will raise the frequency.

Now play a tune. You should hear the guitar in the receiver. Plug a mike into J1, press S2, and speak into the mike. You should hear yourself, or a horrible squeal (feedback) if the receiver's volume is too high. If the Broadcaster fails to operate, check S2's wiring. If the connections are reversed the mike will normally be connected while the contact mike will be switched on when you press S2.

For convenience, especially if you plan to announce all your numbers, the announce mike may be taped to the neck or frame of the guitar enabling you to keep both hands free at all times. To operate the mike you simply press S2. When S2 is released, you're all ready to play.

Okay, standby; 10 seconds. You're on-the-air!

Use a fine-tooth-blade keyhole saw to cut out a section (under hand) of the guitar for the transmitter board. Position the contact mike close to the cutout and mount it inside the guitar with its shielded cable passing through the transmitter hole. A single screw holds the contact mike in place.

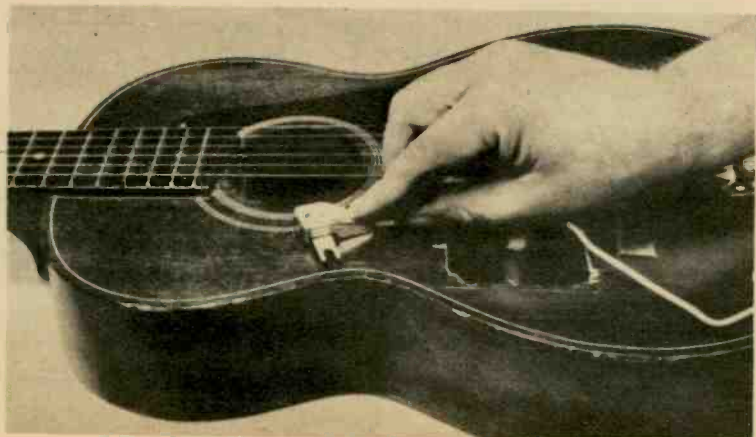

10 Reasons why RCA Home Training is your best investment for a rewarding career in electronics!

1 LEADER IN ELECTRONICS TRAINING

RCA stands for dependability, integrity and pioneering scientific advances. For over a half century, RCA Institutes, Inc., has been a leader in technical training.

2 RCA AUTOTEXT TEACHES ELECTRONICS FASTER, EASIER

Beginner or refresher - AUTOTEXT, RCA Institutes' own method of Home Training will help you learn electronics faster, easier, almost automatically.

3 THOUSANDS OF WELL PAID JOBS ARE OPEN NOW

RCA Institutes can help you qualify for a rewarding career if you have an interest in electronics. Every year, thousands of well paid electronics jobs go unfilled just because not enough men take the opportunity to train themselves for these openings.

4 WIDE CHOICE OF CAREER PROGRAMS

Start today on the electronics career of your choice. On the attached card is a list of "Career Programs", each of which starts with the amazing AUTOTEXT method. Look the list over, pick

the one best for you and check it off on the card.

5 SPECIALIZED ADVANCED TRAINING

For those working in electronics or with previous training, RCA Institutes offers advanced courses. Start on a higher level. No wasted time on material you already know.

6 PERSONAL SUPERVISION THROUGHOUT

All during your program of home study, your training is supervised by RCA Institutes experts who become personally involved in your efforts and help you over any "rough spots" that may develop.

7 VARIETY OF KITS, YOURS TO KEEP

At no extra cost, a variety of valuable specially engineered kits come with your program—yours to keep and use on the job.

8 FROM RCA INSTITUTES, INC. TRANSISTORIZED TV KIT AND VALUABLE OSCILLOSCOPE

All students receive a valuable oscilloscope. Those enrolled in the TV program or courses receive the all-new Transistorized TV Receiver—both at no extra cost and only from RCA.

9 UNIQUE TUITION PLAN

You progress at your own pace. You only pay for lessons as you order them. There's no long-term contract or large down-payment to lose. Even if you decide to interrupt your training, you don't lose a single cent.

10 RCA GRADUATES GET TOP RECOGNITION

Thousands of graduates of RCA Institutes are now working for leaders in the electronics field; many others have their own profitable businesses... proof of the high quality of RCA Institutes training.

SEND ATTACHED CARD TODAY FOR FREE DESCRIPTIVE BOOK

All courses and programs approved for veterans under new G.I. Bill.

CLASSROOM TRAINING ALSO AVAILABLE. FREE CATALOG ON REQUEST. NO SALESMAN WILL CALL.

RCA INSTITUTES, INC. Dept. EG-97

350 West 4th Street
New York, N.Y. 10014

ACCREDITED MEMBER
National Home Study Council

Transistor experiments on programmed breadboard - using oscilloscope.



The Most Trusted Name In Electronics

Construction of Oscilloscope

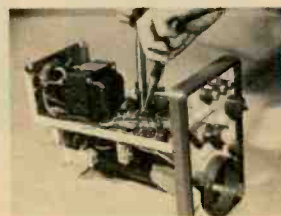

Construction of Multimeter

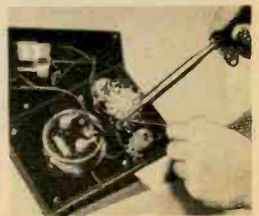

The Easy Way

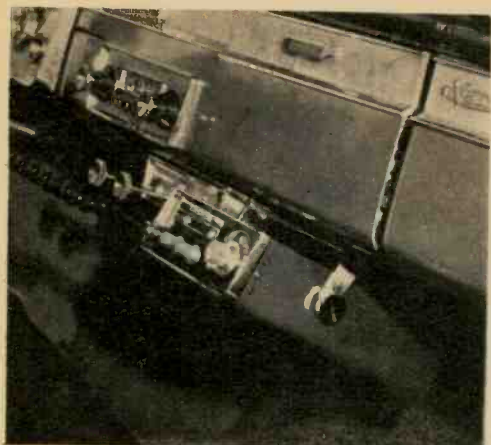

It took 15 minutes to install 2 $\frac{3}{8}$ x 6 $\frac{1}{4}$ x 8-in. Lafayette HB-525 transceiver. Rig is so small there's legroom for passenger in middle seat.

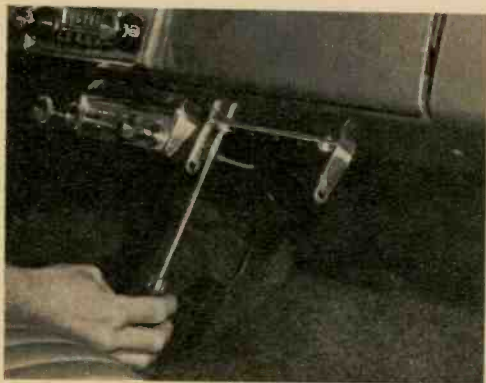

Only two No. 8 self-tapping screws were required to install bracket for typical solid-state transceiver. You start holes with punch, then drill.



Secure transceiver with two gimbal-bracket screws, connect power cord to any hot wire under dash, attach antenna cable and the rig is ready to go.

By AL TOLER REMEMBER the good old days of mobile CB installations? The dashboard bent under 20 lbs. of weight, there were firewall braces, power cables almost as thick as your finger and the rear seat was out in the gutter so the antenna cable could be snaked through the trunk. It was great fun.

Then there was the antenna-bracket hole in the fender that ended up costing you \$100 at trade-in time. Or maybe there was a rear bumper mount that was sheared off when the guy behind you kissed bumpers as he pulled out. And did you ever notice how a CB rig became a yard wide when you tried to find space for it under the dash? Or was it strapped to the driveshaft tunnel where it would cut your ankle whenever you moved your right foot from brake to gas pedal?

All these irritations now are history. The modern mobile CB transceiver—complete with antenna and cables—can sit on the palm of your hand. It requires no new body holes and can be installed without power tools. All you need is a punch, open-end wrench, screwdriver and possibly a soldering iron.

First Things First. We'll start with the transceiver. Solid-state rigs no longer are high-price, second-rate performers. A modern solid-state rig, such as the Lafayette HB-525 we show being installed here, contains

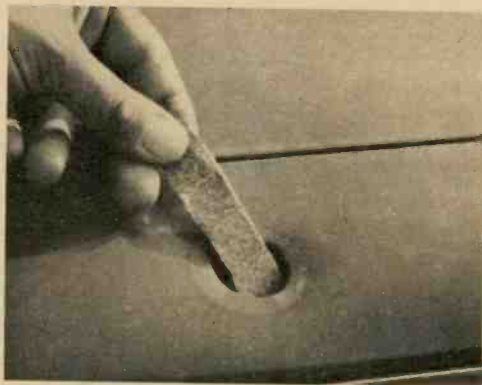

After removing existing auto-radio antenna, remove with sandpaper all dirt and rust on underside of fender to assure good ground connection.

to Install CB in Your Car

all the important features of the big tube jobs. It has full 23-channel crystal-controlled coverage in both the transmit and receive modes, delta tuning, squelch, a modulation-boost circuit, and the new PA feature. Best of all, solid-state rigs are priced competitively with tube rigs.

You can squeeze a solid-state transceiver into almost any car—even a sports job. Mounting takes three steps: punch two holes in the underside of the dash (you don't need an electric drill) secure the rig's mounting bracket with two No. 8 self-tapping screws, splice the power cable into *any* hot lead (such as the cigarette lighter) under the dash and the job is done.

CB Antennas Made Easy. A modern CB antenna is even easier to install. There are several dual-purpose, CB/AM antennas available. These antennas, such as the Antenna Specialists M-103 and M-143 or Lafayette's 99 C 3060, work both as an auto-radio antenna and as a CB antenna.

They are made specifically to fit in an existing fender or cowl hole; absolutely no body

work is needed. Our diagram below shows how they work. When fully extended the length of the antenna is around 46 in. Approximately 8 in. below the top is a loading coil for CB operation. The coil, consisting of relatively few turns, has virtually no effect at the broadcast frequencies; therefore, the full antenna length—which just about equals a standard AM antenna—picks up the AM broadcast signals.

So as far as CB signals are concerned, the antenna is resonant and most sensitive at CB frequencies. Since the car itself is part of the antenna system, the length of the antenna section *above* the coil is made adjustable to allow fine tuning of antenna system.

The Magic Coupler. Most natural question is how does one keep the auto-radio from shorting out CB signals and vice versa? The answer is a CB/AM antenna coupler (supplied with the antenna or optional) which is connected between the antenna, the auto radio and the CB transceiver.

Our schematic on the next page shows a typical CB/AM coupler—there might be

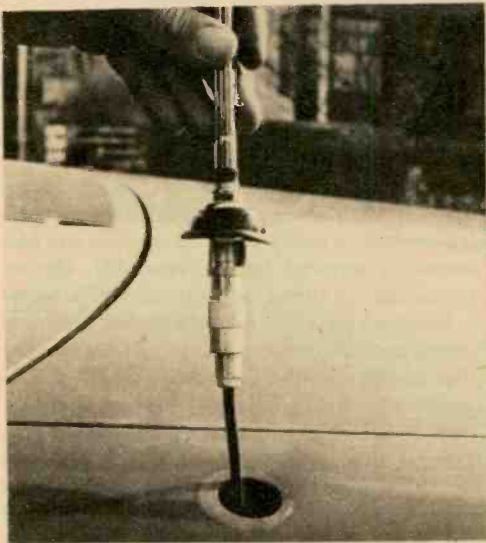

Attach connector on cable from CB/AM coupler to antenna. A locking bracket snaps into position when the antenna base passes through the hole.

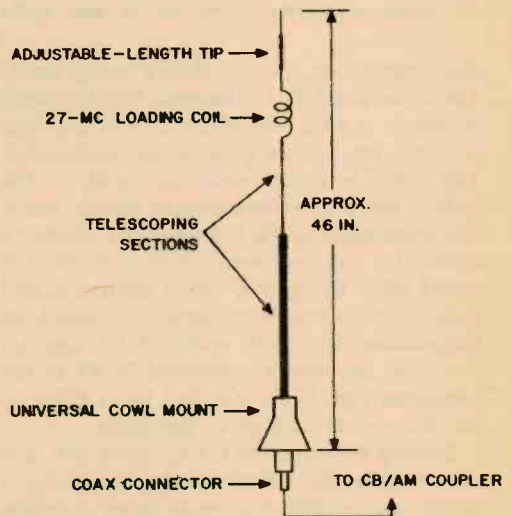

Combination CB/AM antenna has a universal mount and is no longer than average auto-radio antenna. Top loading coil resonates system to 27 mc.

The Easy Way to Install CB in Your Car



Tighten the lock nut on antenna mount with open-end wrench. Do not use pliers. Combination CB/AM antenna is ready to go since it is factory tuned.



A slight adjustment in the length of the antenna section on top of the loading coil might be required to minimize the antenna system's SWR.

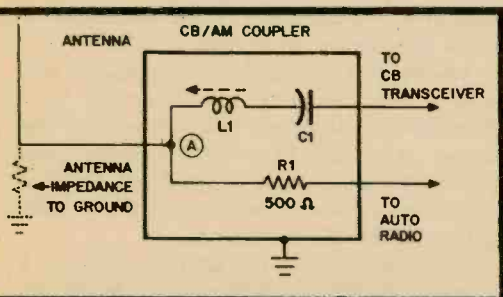

Coupler connects single antenna to auto radio and CB transceiver. Incoming signal splits at A. R1 keeps transmitter output out of auto radio.

slight variations but the theory is the same. The signal from the CB antenna is fed to point A, where it sees two paths. One is a series-resonant (at 27 mc) path to the transceiver. The other is a high-resistance path to the radio. Since a series-resonant circuit has a low impedance at the frequency to which it's tuned (L1 can be tuned to 27 mc), the CB signal takes the path of least resistance and goes to the transceiver input. At broadcast frequencies, the small value of C1 appears as a high impedance compared to R1 so the broadcast signals are blocked from going to the transceiver and go to the radio.

During transmit the C1-L1 path still is a low impedance; therefore, the transmitter's energy goes without losses to point A where it sees the low-impedance of the antenna or the high impedance (500 ohms) of R1. Therefore the signal goes to the antenna. The CB/AM coupler is efficient and there is

virtually no loss at 27 mc.

Installing the CB/AM Antenna hardly could be easier. Remove your existing antenna and its cable. Pass the antenna lead from the coupler up through the fender or cowl hole and connect it to the new antenna. If the hole is too small to pass the coax connector attached to the coupler's cable, cut off the connector, pass the cable through the holes and reinstall the connector. This is a lot easier than trying to enlarge the cable hole in the fender. Fit the new CB/AM antenna into the hole, tighten the nut and the antenna is installed.

Connect the remaining coupler cables to the CB transceiver and the radio. Since most solid-state transceivers are factory tuned (usually with sealed tuning adjustments) the transceiver is ready to go as soon as the connector is screwed tight. Generally, the antenna can be tuned up with an SWR meter.

Connect an SWR meter between the transceiver and the coupler and adjust the top section of the antenna for *minimum* SWR. The adjustment has a narrow range so don't expect to see a large variation in SWR. As a general rule an SWR of 2.5:1 or better, is desirable. Finally, tune the car radio to match the antenna. All car radios have a small trimmer capacitor located near the antenna-input jack. Tune in a weak station near the high end of the band and adjust the trimmer for maximum volume. ●

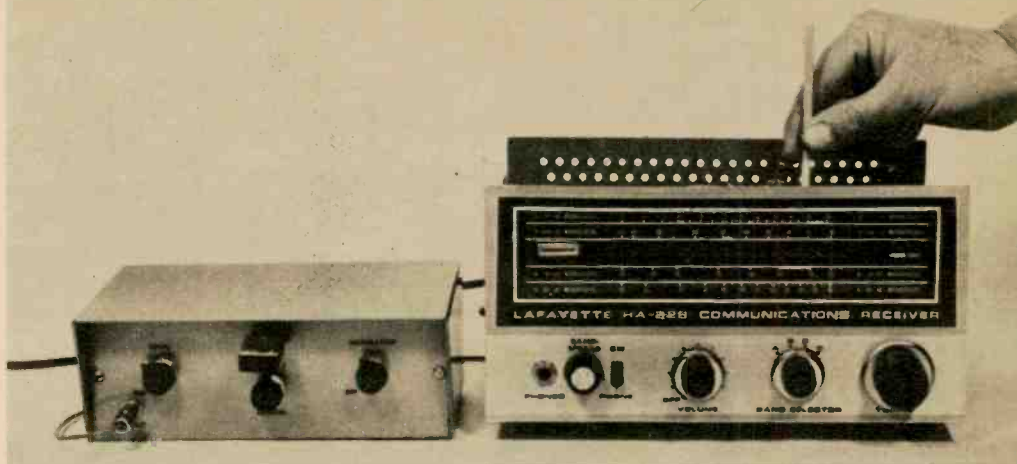

CRYSTAL-CONTROLLED SW SIGNAL GENERATOR

By LAWRENCE GLENN

THE short-wave bands are as jammed as a discothèque's dance floor these days. With no big holes anywhere, you either tune to a station's exact frequency right off or waste hours in dial twisting. But with a precisely calibrated receiver, tedious station-hunting becomes a thing of the past.

While a better-quality, expensive signal generator is capable of doing a reasonably accurate alignment job on your receiver, few experimenter-grade generators have the necessary stability and accuracy.

Most SW receiver alignment (or calibration) procedures require you to skip back and forth several times between the high and low end of each band. Rare is the experimenter-grade generator that can be reset to, say, exactly 20 mc. But our generator puts you right on frequency every time because it's crystal controlled. Sure, it takes a handful of crystals to cover all the bands on your receiver but at least you'll have the equipment to get the maximum calibration accuracy your receiver is capable of.

The generator is designed specifically for SW receivers. Its frequency range is from 1 to 20 mc on fundamentals. The circuit provides an output rich in harmonics. This means that a crystal can be used to provide more than one spotting frequency. For example, using a 2-mc crystal, the generator will deliver harmonics at 4, 6 and 8 mc. Naturally, the higher the harmonic the lower the output. Though 20 mc is the recommended upper limit, a 14-mc crystal will produce a harmonic output at 28 mc. (The oscillator circuit is designed for fundamental crystals.)

To prevent feeding too great a signal to the receiver (alignment should be done with the minimum usable signal level) our model's maximum output level is approximately 100,000 μ v. However, if you really need a big signal, reduce the value of R3 to increase the output level to 2 V (at 1600 kc). R3 should not be less than 560 ohms.

To permit easy spotting of the signal and to enable you to align by

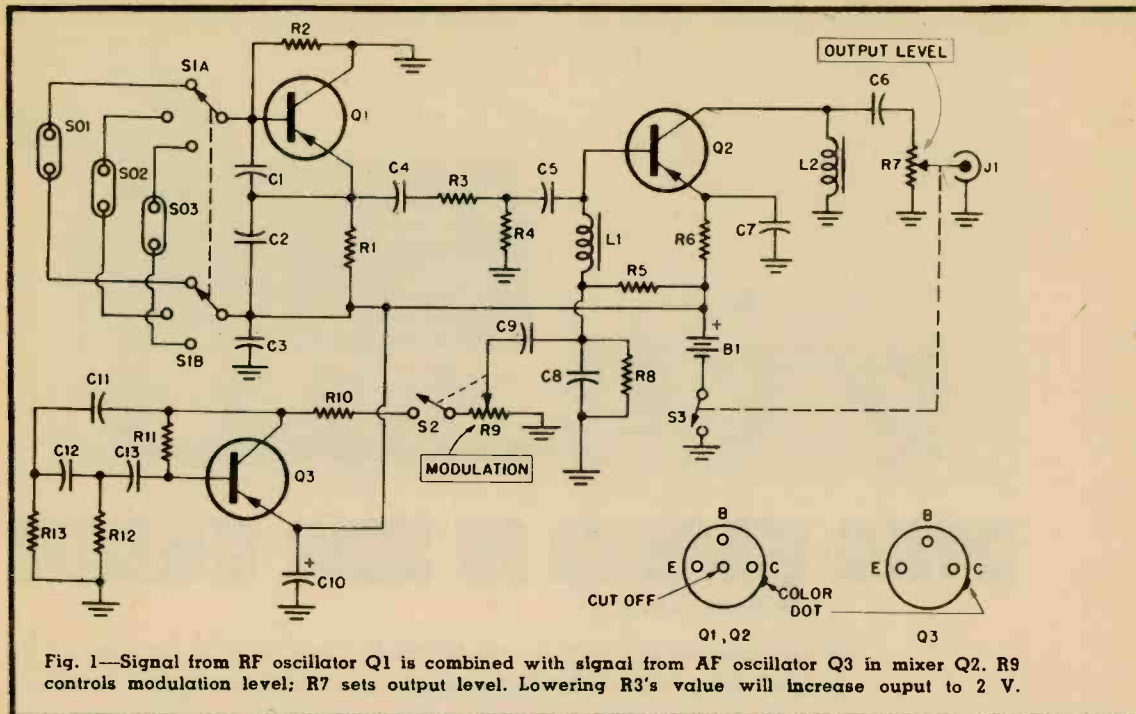

Fig. 1—Signal from RF oscillator Q1 is combined with signal from AF oscillator Q3 in mixer Q2. R9 controls modulation level; R7 sets output level. Lowering R3's value will increase output to 2 V.

CRYSTAL CONTROLLED SW SIGNAL GENERATOR

adjusting for maximum audio output, an adjustable-level modulation signal at approximately 1 kc is provided. The modulator can be turned off if you don't need it.

The generator also can be used as an accurate frequency spotter. For example, suppose your favorite SW station is R. Ivorienne (Abidjan, Ivory Coast) on 11820 kc. This signal hardly gets out of Africa's back yard, let alone into your antenna. How can you find it on a crowded band? Simple. Get a crystal cut for 11820 kc and put it in the generator. To find or spot R. Ivorienne you simply turn on the generator, tune the receiver for the generator's signal, turn off the generator then wait for the voice of the Ivory Coast to come in.

Our model has three crystal sockets—two inside the cabinet and one on the front panel. The panel-mounted crystal socket permits any crystal to be installed immediately in the circuit. Within the allowable interior and front-panel space there is no limit to the number of

PARTS LIST

- B1—9 V battery (Burgess M6 or equiv.)
- Capacitors: 15 V or higher
- C1—1,200 μmf silvered mica
- C2—75 μmf silvered mica
- C3—.05 μf
- C4—250 μmf
- C5—.001 μf
- C6, C7, C11, C12, C13—.01 μf
- C8—.005 μf
- C9—.25 μf
- C10—160 μf electrolytic
- J1—Phono jack
- L1, L2—1 mh RF choke (J. W. Miller 70F103A1. Allied 54 D 1885, 75¢ plus postage. Not listed in catalog)
- Q1, Q2—2N274 transistor
- Q3—2N2613 transistor
- Resistors: $\frac{1}{2}$ watt, 10% unless otherwise indicated
- R1—1,000 ohms
- R2—220,000 ohms
- R3—4,700 ohms (see text)
- R4—560 ohms
- R5, R6—470 ohms
- R7, R9—500 ohm linear-taper potentiometer with SPST switch
- R8—68,000 ohms
- R10—2,200 ohms
- R11—470,000 ohms
- R12, R13—4,700 ohms
- S1A, S1B—2 pole, 3 position, non-shorting rotary switch (Mallory 3223J)
- S2, S3—SPST switch on R9, R7
- SO1, SO2, SO3—Crystal sockets (see text)
- Misc.—3 x 8 x 6-in. cowl-type aluminum Minibox (Bud SC-2132. Allied 42 A 8686 or equiv.), knobs

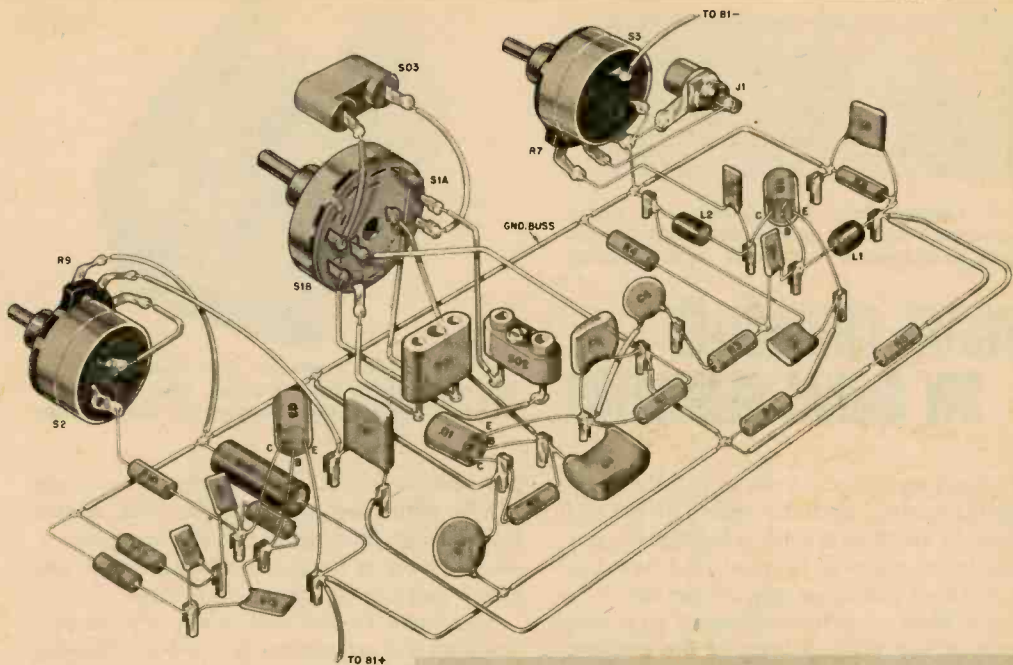
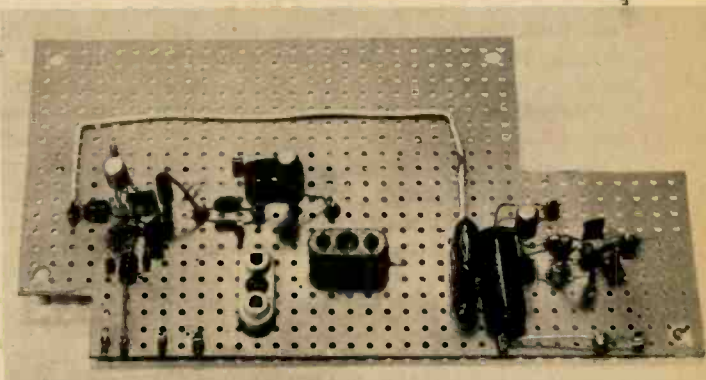

Fig. 2—While it is possible to mount all components on top of perforated circuit board as shown, we installed the following parts on the underside: capacitors C2,C3,C5,C7,C8; resistors R1,R3,R4,R5,R6,R8,R11,R12 and R13.

Fig. 3—Photo of top of board shows location of components. Note how most of the resistors are mounted on end. Cutout in upper right corner is for battery. Cutout at lower left corner of board is for output jack J1.



built-in or external crystal sockets you can use.

Crystals can be purchased ground to virtually any frequency from Texas Crystals, 1000 Crystal Dr., Fort Myers, Fla. 33901 and International Crystal Mfg. Co., 18 N. Lee, Oklahoma City, Okla. Since a crystal's price is determined by tolerance and holder, we suggest you write to each company for a catalog then select what you need. We recommend Texas Crystal's FT-241 or FT-243 holders or International Crystal's FA-5 holders as they are low in cost running from under \$2 to roughly \$6, depending on frequency and tolerance. When ordering, be sure to specify parallel-resonant crystals.

While some overtone crystals, such as CB

crystals, will work in the generator, keep in mind that the indicated overtone frequency generally is not an exact multiple of the fundamental frequency. For example the fundamental output of a 27-mc third-overtone crystal will not be 9 mc ($\frac{1}{3}$ of 27 mc). It will be slightly lower.

Construction. The generator is built in the U-section of a 3 x 6 x 8-in. cowl-type Mini-box. All parts values are critical; no substitutions should be made.

To avoid a parts jam, with resultant improper operation, the three circuits (AF oscillator, RF oscillator, mixer-modulator) are spaced widely on a piece of perforated circuit board. Since there is enough room inside the cabinet we suggest you follow the pictorial



Fig. 4—Controls from left to right are output level, crystal selector, modulation level. Larger cabinet permits more front-panel crystal sockets.

CRYSTAL-CONTROLLED SW SIGNAL GENERATOR

and photographs and do not crowd the components together. Similarly, install on the underside of the board those components not visible in the photo of the top of the board in Fig. 3. Don't put them atop of the board.

Cut a piece of perforated-board so it will just about cover the bottom of the cabinet. Then trim the board about $\frac{1}{4}$ in. all around to clear the cabinet's top-cover mounting flanges. Cut a notch out of one corner of the board for the battery and another near output jack J1.

Before mounting any components, install all of the panel controls, crystal sockets and J1. Mark the board directly under each control to make certain you do not install any components under the controls.

Crystal sockets SO1, SO2 and SO3 should match the crystal used. In general, the Texas Crystal type SSO-1 socket is preferred since it matches the FT-243 and FT-241 crystal holders.

Note in Fig. 3 that several resistors are mounted on end. (For the sake of clarity we show them mounted flat in the pictorial.) Either flea clips or Vector T28 terminals can be used for tie points. To avoid soldering heat damage to the transistors, do not trim their leads shorter than $\frac{3}{4}$ in. and use a heat sink.

Connections to the crystal sockets are made by soldering No. 22 solid wire to the terminals and passing the wires down and up through holes in the perforated board. The other ends are soldered to selector switch S1 after the board is installed in the cabinet. If you want to use more than three crystal sockets, substitute for S1 a two-pole rotary switch having the appropriate number of positions.

Final Assembly. Slide the perforated board under the controls and secure it to the cabi-

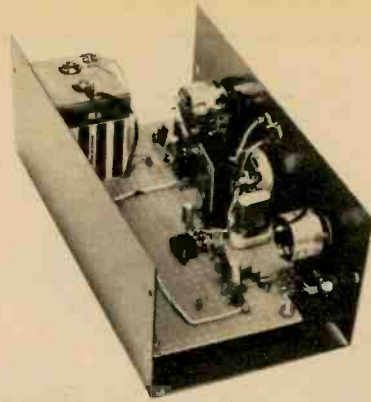

Fig. 5—Inside of generator. Note location of battery and how it's held in place. Also notice how board is raised above bottom of the cabinet.

net with screws at four corners. To prevent the tie points and parts on the back of the board from shorting to the cabinet, place a $\frac{1}{4}$ in. spacer or stack of washers between the board and the cabinet at each screw.

Checkout. Do not plug in any crystals yet. Set *output level* control R7 and *modulation* control R9 counterclockwise so their switches click off. Connect the battery's negative lead to the generator and connect the positive lead to the positive terminal of a DC milliammeter set to indicate 10 ma or higher. Connect the meter's negative terminal to the battery terminal on S3. There should be no meter indication. If there is, check for a wiring error.

Apply power by turning R7 clockwise; the meter should indicate about 5 ma, though it may be somewhat higher or lower. If the meter indicates more than 10 ma look for a wiring error in the oscillator (Q1) or the mixer (Q2) circuit. Next, apply modulator power by advancing R9; the meter indication should rise 1 or 2 ma. If the total meter indication exceeds 10 ma look for a wiring error in the AF-oscillator (Q3) circuit.

Connect J1 to your receiver's antenna terminals through a section of thin coax such as RG58/U and plug a crystal into any of the crystal sockets. Set S1 to the appropriate position and tune the receiver until you pick up the generator's signal. Then check the operation of R7 and R9. Adjusting R7 will vary the amount of modulation.

Receiver Alignment. Since short-wave receivers are all aligned differently, it's best for you to follow the alignment instructions supplied with your model. Because our generator does not supply a 455-kc IF signal, you simply align the IF transformers by peaking them on a signal fed to the antenna terminals.



A SIZABLE SPEAKER SYSTEM

Lafayette Lowboy

THE audio scene is changing again. After a few years of watching speaker enclosures diminish in size, we're beginning to see them get bigger. And as the trend continues, an old standby—the large bass-reflex enclosure—is coming back into the limelight.

The bass-reflex design is not at all new. As things go in the world of audio, it has grown quite a beard since it was patented in 1932. Properly designed and tuned, a bass-reflex speaker system is capable of delivering excellent sound.

Tucked away on page 103 of Lafayette's 1967 catalog is a bass-reflex enclosure kit. Available in either a high- or low-standing design, it sells for \$32.92, unfinished. Its volume is about 5 cu. ft. Though Lafayette says the cabinet is made of plywood, it actually is flakeboard covered with white-birch veneer.

The 20 C 0122WX (the stock number)

kit is supplied with a variety of mounting boards to accommodate almost any speaker system. Choices are single- (full-range), two- or three-speaker systems. The three-speaker systems can be made up with a 12- or 15-in. woofer, 6- or 8-in. midrange and a variety of tweeters.

The system we built and tested used a \$22.95 12-in. woofer (stock No. 21 C 4720), a \$6.50 midrange (stock No. 21 C 4718), a \$9.95 dome-lens compression tweeter (stock No. 99 C 6250) and a \$14.95 three-way crossover network (stock No. 99 C 0022). All told, our system cost \$87.30. A 15-in. woofer costing \$23.95 (stock No. 21 C 4719W) is available but we do not recommend it for reasons to be discussed later.

What was it like to put together a cabinet whose parts were said to be precision cut so they would fit together snugly? The first set

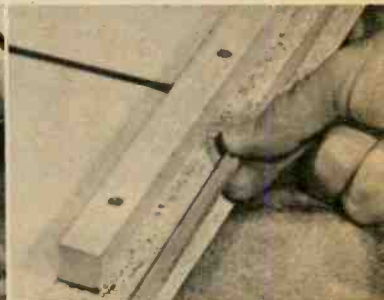

Biggest problem in cabinet assembly is at top corners. Note in photo at left that excess stock between dado and mitered edge must be removed before assembly. In center photo, glue is shown being applied to spline groove. In photo at right, the spline is inserted in the groove, after which it is tapped gently into place.

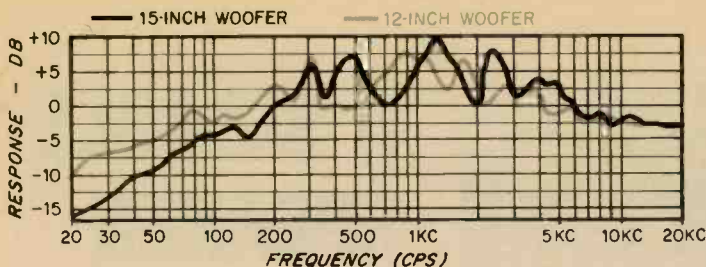

Curve in color shows response of system with 12-in. woofer. Black curve is response with 15-in. woofer. Poorer low-end response with 15-in. woofer is due more to speaker than cabinet. When size of port is reduced to $2\frac{1}{2} \times 5$ in., response down to 40 cps with 12-in. woofer is improved and is better than with the 15-in. woofer.

A SIZABLE SPEAKER SYSTEM

of instructions supplied with the kit was vague and somewhat confusing. We found it was easier to assemble the cabinet by referring to an exploded-view drawing. But the instruction sheets have since been revised and, except for one omission, they are satisfactory.

The omission covers splines (thin wood strips) which are furnished with the kit. They are not mentioned nor are they shown in the drawings. It would not be surprising, therefore, for an inexperienced builder to throw them out since they look like strips of scrap. They are used to align the mitered joints and to prevent the glued surfaces from shifting.

Assembly wasn't difficult. You place the top panel face down on a flat surface and attach the cleats. Spread some glue (supplied) in the joint, then draw the cleat tight with the screws. Put some glue in the spline grooves and insert the splines. The top and sides are assembled with screws. The bottom and sides are screwed together without cleats.

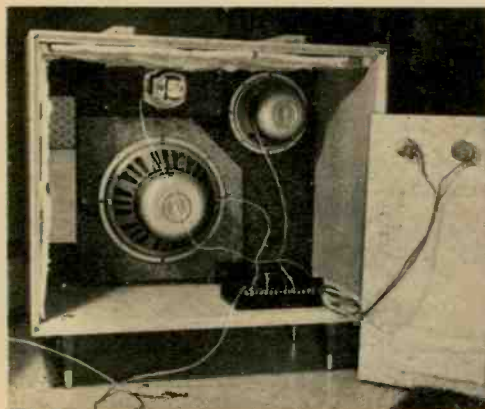

Ready to be closed up. Crossover network is mounted in bottom of cabinet. Midrange and tweeter-level controls are in cabinet's rear panel.

Tufflex acoustic material is attached with staples to the top, one side and the rear panel.

We checked the enclosure with two different 3-way speaker systems, using the same 8-in. midrange speaker and tweeter with a 12-in. and a 15-in. woofer. The crossover network was wired for 700 cps and 3,000 cps.

Impedance curves for the two woofers revealed that the port size was correct for the 15-in. woofer but too great for the 12-in. woofer. There were no instructions for tuning the cabinet and there is no convenient way of reducing the size of the port. (Lafayette has advised us that tuning instructions will be included with future kits.)

Response measurements of the system were made with a PML type EC-61A calibrated condenser microphone. The curves shown with this article indicate what we consider mediocre low-frequency response with the 15-in. woofer. But this was due primarily to the speaker and not the enclosure. Despite the fact that the enclosure was not at first tuned for the 12-in. woofer, much better performance was obtained with this speaker than the 15-in. woofer. After we reduced the port size to $2\frac{1}{2} \times 5$ in., response with the 12-in. woofer was smooth down to 40 cps.

We found the 8-in. midrange speaker to be too efficient for the woofer and tweeter and it tended to peak a bit below 600 cps. By setting the midrange level control at the 9 o'clock position, we improved balance.

The tweeter displayed smooth, clean response out to 20 kc. The only fault we found with the tweeter (for use in this system) was its 16-ohm impedance. (The woofer and midrange are 8 ohms.) However, we balanced the tweeter by setting its level control at the 3 o'clock position.

Three hours after starting construction we put the test equipment and tools aside and sat down to listen for a while. The sound was great—no doubt about it—from the lowest bass right on out to 20 kc.

THE SECRET

BATTERY



MOTOR

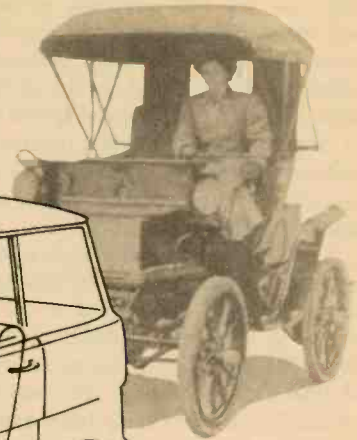
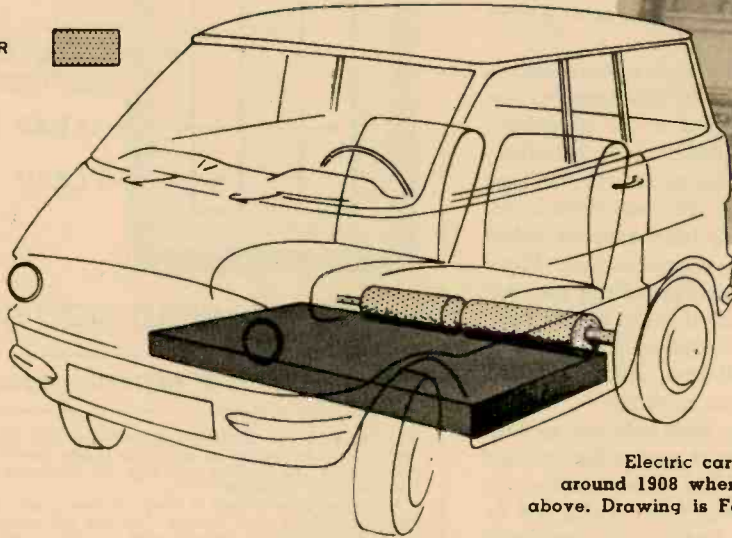

BETTMANN
ARCHIVE

Electric cars were the cat's miaow around 1908 when Kimball made the one above. Drawing is Ford's idea for updating.

OF THE NEW ELECTRIC CARS

By J. K. LOCKE

New batteries challenge the range, speed and cost of gasoline.

ONE DAY last fall in a Detroit laboratory, I watched physicist Neil Weber hook the leads from a small electric motor to a pair of wires sticking out of a glass bottle the size and shape of a straightened-out banana. As he made the connection, the motor began to spin.

The bottle was a new type of battery—a sodium-sulfur cell—developed by Dr. Neil Weber and Dr. Joseph Kummer of the Ford Scientific Laboratory. The battery (and the demonstration) looked ordinary enough. But this new super-power device, with 15 times the energy-storage capacity of the familiar lead-acid battery that starts your car, could be the most important development to hit the auto industry since the internal combustion engine. "With the invention of this battery," says Dr. Michael Ference, Jr., Ford vice-president in charge of scientific research, "we have surmounted one of the major problems—the lack of a sufficiently powerful battery—that must be resolved before an electric vehicle can become a commercial reality."

Ford isn't the only company working to pack more kilowatts into smaller, lighter packages. Gulton Industries of Metuchen, N.J. (a firm known for its

work on the now-common nickel-cadmium cell that powers most rechargeable cordless devices) has a super-high performance unit called the lithium cell. And two firms—Lee-sona Moos Laboratories of Great Neck, N.Y. (a firm that has pioneered in fuel cell work) and the General Atomic division of General Dynamics—are working on a new gadget called the zinc-air battery.

The impetus for the high-energy efforts toward high-energy battery development has come largely from efforts to do something about a growing problem: air pollution. Scientists say the air-borne gunk—millions of tons of it—hanging over our cities is responsible for everything from running nylon stockings to corroding stone statues. More important, many authorities believe increasing pollution is a principal cause of the soaring death rates from respiratory diseases. And more than half the pollution, say the experts, comes from automobile tailpipes.

Electric automobiles, with exhausts as pure as so many spring zephyrs, seems the obvious answer. The British have been working in this direction for several years and a bill to promote research on electric autos has been introduced into the U.S. Senate. Electric autos are, of course, nothing new—they enjoyed considerable popularity from the turn of the century to World War I—and electric utility vehicles are still used today.

But until now the electric has had one giant problem: range. A car simply couldn't carry enough conventional lead-acid batteries to drive it more than 50 miles or so, although M. G. Smith of the Electric Storage Battery Co., who make lead-acid batteries, has hinted that his company might team up with others in a joint development program.

The old standby lead-acid battery has what engineers call an energy density of 10 watt-hours per pound (wh/lb.). That means that every pound of battery can store enough energy to put out ten watts of power for one hour. A fully-charged ten-pound lead-acid battery, in other words, can light a 100-watt bulb for one hour.

Nickel-cadmium batteries, widely used in rechargeable electric gear such as portable tape recorders, have ratings of about 15 wh/lb. Even the prohibitively expensive silver-zinc batteries can store up to 50 wh/lb. (Yardney Electric Corp. of New York, who make them, have suggested *renting* the costly silver, which is not consumed in use.)

All three of the new systems, by way of

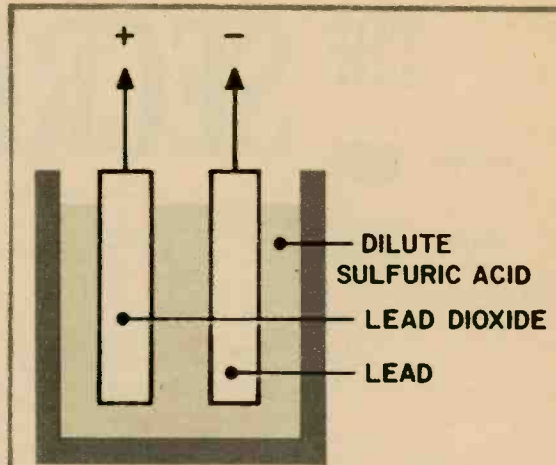

DIAGRAM 1- LEAD-ACID CELL

HOW THE NEW BATTERIES WORK:

ALL OF THE new batteries—in common with older batteries—work by extracting electrical energy from a chemical reaction. The familiar lead-acid cell (Diagram 1) demonstrates the principle:

The negative electrode is made of pure lead; the positive electrode is lead dioxide. The two are suspended in a dilute solution of sulfuric acid. In the solution each sulphuric acid molecule splits into two positively-charged hydrogen ions and one sulfate radical—a sulfur-oxygen ion carrying a double negative charge.

A sulfate ion finding its way to the negative electrode will combine with a lead atom to form a molecule of lead sulfate—and release two electrons in the process. Meanwhile another sulfate ion and the two hydrogen ions, finding their way to the positive plate, will combine with the lead oxide to make lead sulfate plus water—this time drawing two electrons from the electrode in the process.

The important thing about this process is that it is reversible. Apply a reverse (charging) current and the negative electrode turns back into lead, the positive one again becomes lead dioxide and the partially depleted sulfuric acid comes back to full strength.

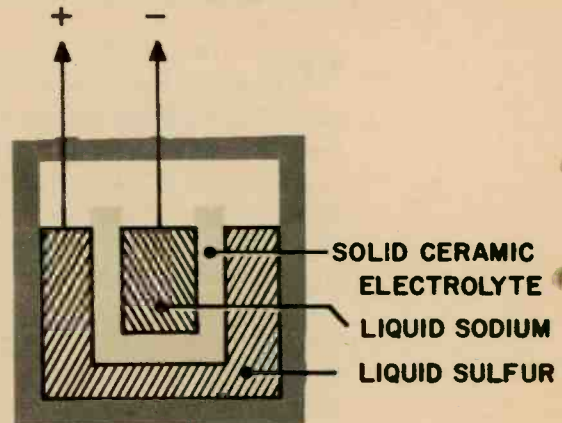

DIAGRAM 3- SODIUM-SULFUR CELL

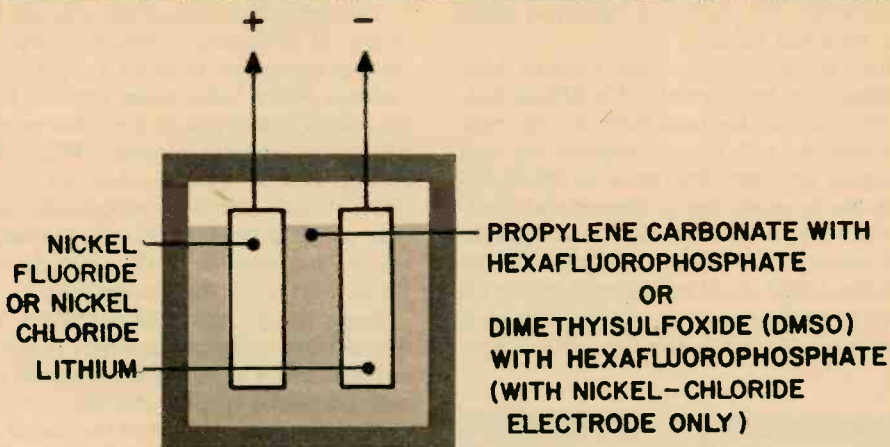

DIAGRAM 2 - LITHIUM CELL

Closest in operating principle to the lead-acid cell is the lithium cell (Diagram 2). During discharge, a fluoride ion from the electrolyte combines with an atom of lithium from the negative electrode to form lithium fluoride, simultaneously freeing an electron. Nickel fluoride from the positive electrode combines with two electrons from the external circuit to form pure nickel and two fluoride ions, which flow off in the electrolyte. The alternate reaction using a nickel chloride positive electrode is very similar.

The sodium-sulfur cell (Diagram 3) pulls a switch by using liquid electrodes and a solid electrolyte. The liquid sodium (negative electrode) is contained in a ceramic tube. The tube, in turn, is suspended in a bath of liquid sulfur (positive electrode). The ceramic material is the electrolyte. The atomic structure of the ceramic is impervious to liquid sulfur and liquid sodium. But it will let sodium ions (sodium atoms with an electron missing) through. When the sodium ions combine with the sulfur

on the other side of the ceramic sieve they form sodium sulfide. But the sodium sulfide is incomplete—it has one electron missing, hence the positive charge. The other electrode is negative because of the electrons left behind by the sodium that has passed through the sieve.

The zinc-air cell is somewhat more complicated, as Diagram 4 shows. Oxygen (or oxygen-containing air, pumped into the electrolyte in this version of the cell through a porous nickel positive electrode) is ionized in the electrolyte (potassium hydroxide) taking free electrons from the positive electrode in the process. The oxygen ions travel to the negative zinc electrode. There, the zinc and oxygen combine, forming zinc oxide and releasing electrons.

The circulating electrolyte is vented (to allow excess air to escape) and filtered (to keep zinc oxide from clogging the cell). When the battery is recharged the zinc oxide is pumped back and electroplated onto the negative electrode once more as metallic zinc.

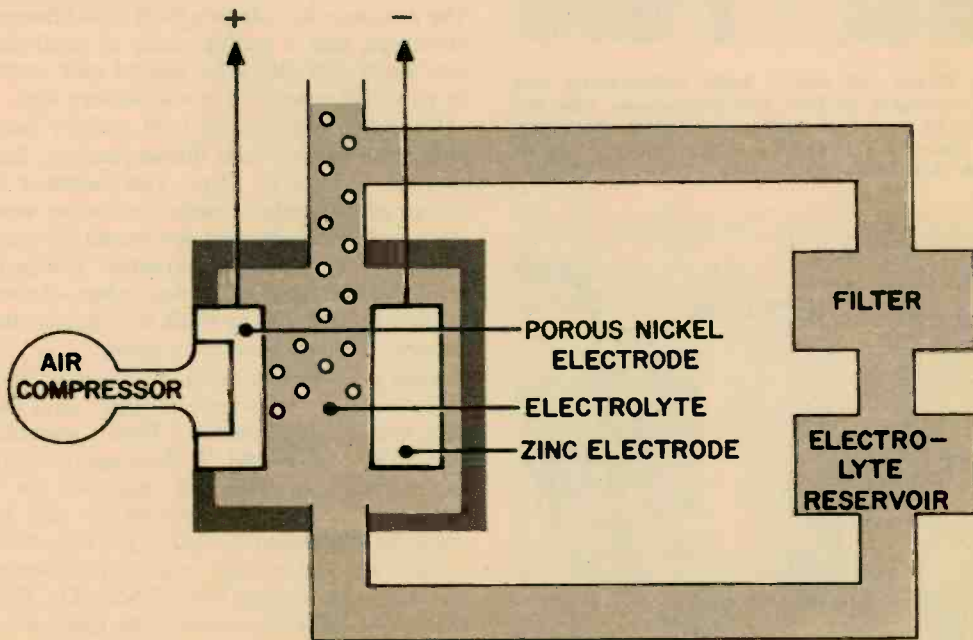

DIAGRAM 4 - ZINC-AIR CELL

contrast, show promise of future ability to pack in some 150 wh/lb.—15 times as much as the lead-acid battery.

While all three of the new systems look promising, problems remain. The lithium battery, for example, has been built only in small sizes; scale-up will present engineering and production problems that must be solved before it can be made into a commercial product. The sodium-sulfur battery must operate in the vicinity of 500°F. to keep the sodium and sulfur liquid. Ford engineers think they'll be able to design insulated containers to keep the units hot for weeks at a time. Waste heat

should keep temperatures high enough.

The main drawback of the zinc-air battery comes in designing auxiliary pumping and cooling equipment to make it work properly. Leeson Moos (who make zinc-air batteries for military electronics) have one novel solution to the recharge problem. When the battery runs down—that is, when the zinc plates are used up—operators will simply slip new ones in. Only trouble with this technique for use in automobiles is that putting in new plates costs more than recharging.

Some of the new super-batteries will be available for use soon, however. A few of the Leeson Moos replaceable-electrode zinc-air batteries are now on the market. The smallest (25 ampere-hours) is about the size of a transistor radio and weighs less than two pounds. Largest one to date is smaller than a loaf of bread (5 x 5 x 7 in.), weighs eight pounds and puts out 100 ampere-hours—as much as an automobile battery weighing some 40 pounds. (Like any first-run item, it's expensive. A 12 V, 100-ampere-hour battery costs \$570. Large production runs would slash prices substantially.)

The General Atomic division of General Dynamics, together with a combine of 14 electric companies helping to bankroll the work, will plow \$150,000 into rechargeable zinc-air battery development work this year. The company has already built a 28-kilowatt prototype, and is getting ready to build one four times that size. This second unit would be powerful enough to run a delivery van.

To date, Gulton has built only a half-pound, 18-ampere-hour lithium battery. But, says Dr. Robert C. Shair, vice-president in charge of research, if some car maker were interested, a car-sized version would be ready quickly: "If some automobile company would like to do it on a joint basis—if they would engineer the car while we engineer the battery—it could be done in a year."

Ford is predicting rapid development, too. "We foresee no scale-up problems," says Dr. Jack Goldman, director of Ford's scientific laboratory. "It should be a straightforward engineering job. The first step will be a 2-kilowatt, 22-pound unit, which will be ready by this December (1967). Then scale-up to a size big enough to drive an automobile will take another year." Adds Dr. Ference, "We have the money, the manpower, and the desire to move ahead as rapidly as possible."



Dr. Weber (left above) holds sodium-sulfur cell he developed for Ford with Dr. Kummer, who sits next to model of 2,000-watt battery. Prototype of General Dynamics' zinc-air battery (below) was developed jointly with 14 electric utilities.

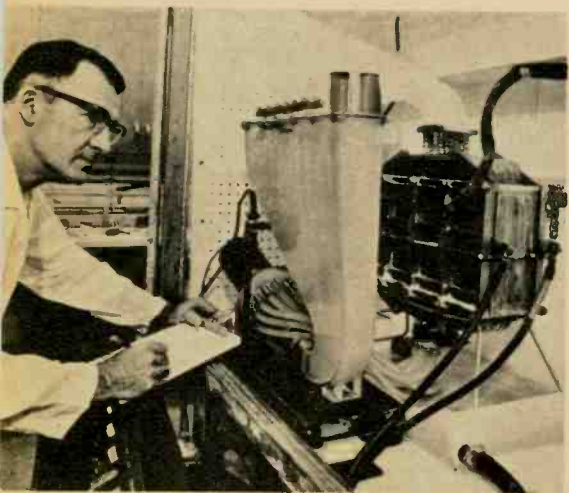

2 Meters on 2 Tubes

With this really basic receiver you can pull in a fascinating mixture of local OM's and Novices on the most popular VHF band.

By CLARE GREEN, W3IKI

IT'S a busy, friendly world up on 2 meters. The high frequency, 144 to 148 mc, means mostly local contacts, though there are rare DX openings, when signals go halfway across the country.

Regulars on 2 get to know each other well. There's a lot of local rag-chewing and some hams call the band a big party line. Though in most areas 2 meters means phone operation, at times you can find a greater variation in hamming—and hams—than anywhere else in the spectrum. All hams—Generals, Novices, Technicians, everybody—can operate on 2 (it's the only band where Novices are permitted on phone) and practically anything that oscillates is allowed, including regular CW, modulated CW, unmodulated carriers, facsimile, TV, FM and RTTY.

You also will find a lot of 2-meter inhabitants who know their onions and who build their own equipment. Readymade rigs are relatively scarce when compared to 10-80 gear. That means a lot of home-brew equipment, which in turn means a fair level of technical competence because VHF circuitry can be quite tricky and critical.

Besides hams being hams, you also will find CAP stations and MARS nets on and at the edges of 2 meters.

With our cool 2-tube it's an easy matter to listen in on the band. The receiver sports a superhet front-end followed by a superregenerative detector. Two stages of audio drive a speaker. Headphones can be plugged in to dig out those weak stations.



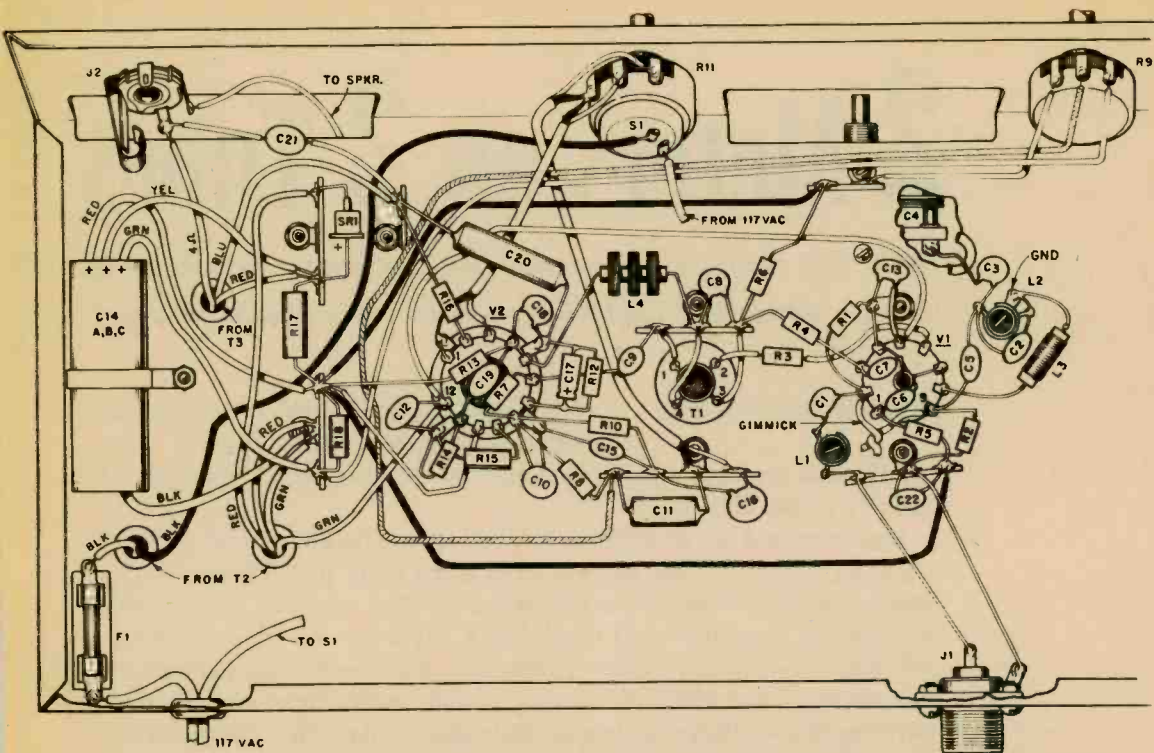

Because the receiver operates from 144 to 148 mc, placement of parts, especially around V1 at the right, is critical. And it also is important to install the parts exactly where shown around V2. For the purpose of making things as clear as possible, we have shown some parts smaller than their real-life size. Note the cutouts in the chassis near J2 and between R11 and R9. The cutout at the left is for the speaker frame; the cutout at the right is for the 2 3/4-in.-dia. pulley on the back of the slide-rule dial. Circle around T1 is 3/4-in.-dia. hole in the chassis through which leads (soldered on coil's lugs before mounting) to T1 pass. As parts around V1 and V2 are quite close, use spaghetti on the leads to prevent shorts. Detailed sketches of coils L1 and T1 are shown on schematic on the last page of the article.

2 Meters on 2 Tubes

Construction. Our receiver is built on a 7x11x2-in. aluminum chassis. After cutting all holes, mount the components where shown in the photos and pictorial. Locate the position for T1's shield, then cut a 3/4-in.-dia. hole in the chassis for the leads to the coil's lugs. Make cutouts on the front of the chassis to provide clearance for the dial's pulley and the speaker's frame.

Before mounting C4, make sure its shaft lines up with the dial pulley's hub. Always use lockwashers when mounting the terminal strips, fuse holder, potentiometers and output jack J2. Put rubber grommets in all chassis holes through which wires pass to prevent the insulation from being frayed.

The wiring and placement of parts in the front-end and detector circuits are critical.

If leads are too long the receiver may tune out of the band or may not work at all. Use short, direct leads when installing all components. Slip spaghetti on all leads that cross or are near each other. Before mounting T1, solder leads to its lugs since it will be difficult to get to the lugs through the hole in the chassis after the coil is in place.

Alignment and Operation. Turn on the receiver and allow it to warm up a few minutes. If a signal generator is available, set it for an 8-mc modulated output and connect it to J1. With *volume* control R11 full clockwise, turn up *regen* control R9 until you hear the typical superregen hiss. Adjust T1 for maximum output. Set tuning capacitor C4 so the dial pointer is opposite 20 on the logging scale.

Set the signal generator for a 144-mc modulated output. Adjust L2 (starting with the iron core all the way *in*) until you hear the signal. Set the signal generator for 145 mc

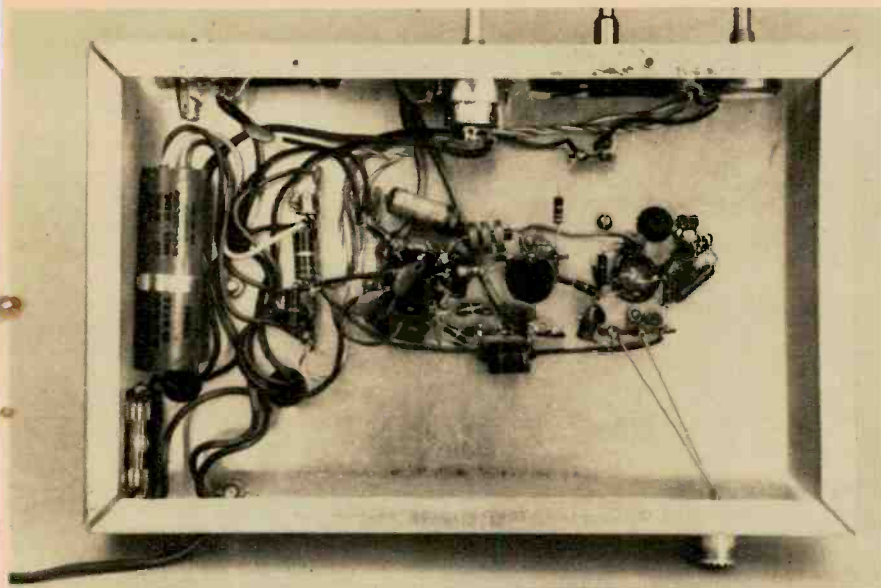

Best place to start construction is around V1 at the right. Fit every part in carefully and keep leads short and direct. Then work your way left to T1, V2 and the power supply at the extreme left. Install controls, dial and speaker last. Just because there's a lot of empty space doesn't mean you can spread parts out. Keep them tight around the tube sockets. Use No. 14 buss wire to hook the antenna connector at lower right to terminal strip near V1.

and tune C4 until you hear the signal. Adjust L1 for maximum signal amplitude while rocking C4 back and forth to keep the signal tuned in. Calibrate the rest of the dial with the signal generator. We used transfer type to mark the dial's scale at 1-mc intervals from 144 to 148 mc.

If you don't have a signal generator, set

T1's slug-adjustment screw so it is 1/4-in. out of the top of the form. Set L1's and L2's slug adjustment screws so they are 3/8 in. out of the form.

Wait until evening when the 2-meter band is most active and connect an antenna to J1. (The best antenna for this receiver is a high-gain multiple-element beam.) With the dial

PARTS LIST

Capacitors: 1,000 V ceramic disc unless otherwise indicated

C1, C9—47 μf C2, C3—4.7 μf
 C4—3-15 μf variable capacitor (Bud MC-1850. Allied 13 Z 530; \$1.82 plus postage. Not listed in catalog)

C5—10 μf C6—500 μf
 C7, C8, C13, C15, C18, C22—.001 μf
 C10—100 μf C11—.25 μf , 200 V tubular
 C12, C16, C19, C21—.005 μf
 C14A, B, C—50/30/20 μf , 150 V electrolytic
 C17—8 μf , 12 V electrolytic
 C20—.05 μf , 400 V tubular

F1—1 A fuse and chassis-mount holder
 GIMMICK—Capacitor made of two turns of hook-up wire (see text)

J1—Chassis mount coax connector (Amphenol 83-1R)
 J2—closed-circuit phone jack
 L1, L2—0.1 μh adjustable RF coil (J.W. Miller 20A107RB1. Lafayette 34 R 8944)
 L3—1.72 μh RF choke (J.W. Miller RFC-144. Lafayette 34 R 8973)
 L4—1 mh 3-section RF choke (J.W. Miller 4652. Lafayette 34 R 8829)

Resistors: 1/2 watt, 10% unless otherwise cated

R1—1 megohm R2—22,000 ohms
 R3, R16—33 ohms R4—10,000 ohms

R5, R6, R12—4,700 ohms
 R7—6.8 megohms R8, R10—120,000 ohms
 R9—250,000 ohm linear-taper potentiometer
 R11—1 megohm audio-taper potentiometer with SPST switch (S1)
 R13, R14—220,000 ohms
 R15—100 ohms, 2 watts
 R17—1,800 ohms, 2 watts
 R18—15,000 ohms, 1 watt
 S1—SPST switch on R11
 SPKR—4-in., 4-ohm speaker
 SR1—Silicon rectifier; minimum ratings: 500 ma, 400 PIV
 T1—1.7-5.5 mc RF coil (J.W. Miller B-5495-RF. Lafayette 34 R 8715. Shield for above, J.W. Miller S-33. Allied 62 Z 571; 51¢ plus postage. Not listed in catalog.)

T2—Power transformer; secondaries: 125 V @ 50 ma, 6.3 V @ 2 A (Allied 61 G 411 or equiv.)
 T3—Output transformer; primary: 10,000 ohms. Secondary: 4 ohms. 5-watts. (Allied 61 U 448 or equiv.)

V1—6BL8 tube
 V2—6AF11 compactron tube
 Misc.—Slide-rule dial (J.W. Miller SL-16. Allied 60-090; \$6 plus postage. Not listed in catalog), 7 x 11 x 2-in. aluminum chassis, 7 x 11-in. aluminum chassis bottom plate, 9-pin tube socket, compactron tube socket, terminal strips.

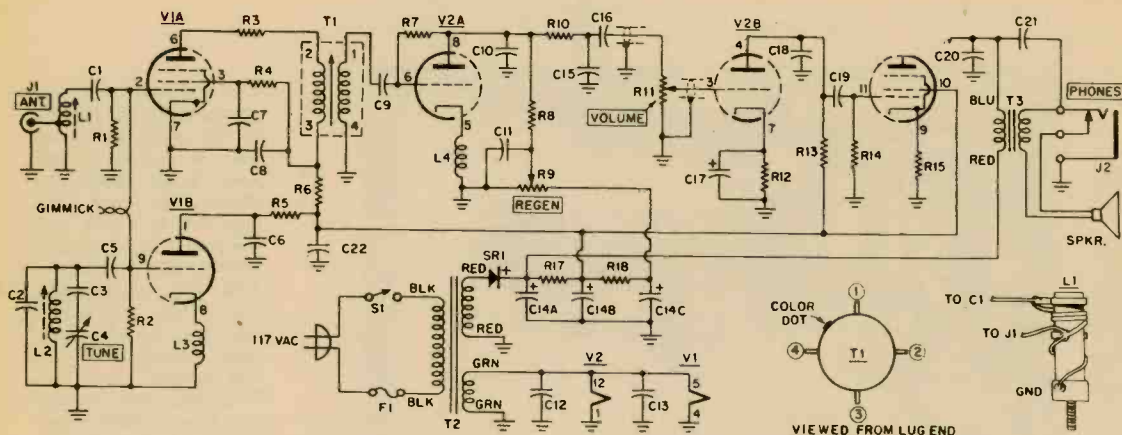

Receiver schematic. Signal from antenna and oscillator V1B go to grid of mixer V1A; 8-mc mixer output goes to superregen detector V2A. Audio is fed to audio amp V2B then to output pentode, V2C. Wind 1 turn of #22 solid wire on L1 between lower lug and base. Space wire to prevent a short.

2 Meters on 2 Tubes

set to 40 on the logging scale (145 mc), adjust L2 until you hear signals. Adjust L1 for maximum volume.

Most 2-meter signals are polarized horizontally so vertical whip and ground-plane antennas will not be effective. However, you'll be able to get good results with a TV antenna. In normal operation, turn up *regen* control R9 until you hear a hissing, then tune for stations.

How it Works. Take a look at the schematic. Signals from the antenna are fed directly to L1, which is broadly tuned to 145 mc. The signals then go via C1 to the grid of mixer V1A. Oscillator V1B, whose output is coupled via the gimmick capacitor (two tight-wound turns of hookup wire) to V1A's grid, operates 8-mc below the incoming signal. The oscillator is tuned by C2/L2 and C3/C4.

The resultant 8-mc IF signal at V1A's plate is fed via T1 to the superregenerative de-

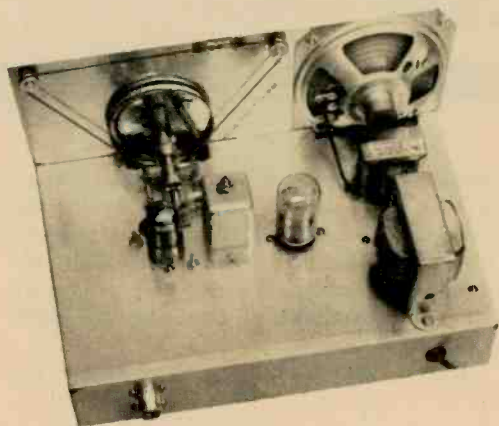

Top view of chassis. Note cutouts in the front for slide-rule dial pulley and speaker frame. Install 7 x 11-in. aluminum plate in chassis bottom.

tor, V2A. R9 controls regeneration.

The detected audio signal is connected via the low pass filter (R10/C15) to volume control R10 then to the grid of the first AF amplifier, V2B. The amplified audio is fed by C19 to power amplifier V2C. The signal is coupled by output transformer T1 to the speaker. When phones are plugged into J2, the speaker is automatically disconnected. B+ and the tube heater power are supplied by T2, SR1 and the filter circuit comprising R17, R18 and C14A,B,C.

TUBE VOLTAGES												
Pin	1	2	3	4	5	6	7	8	9	10	11	12
6BL8	80	-4.5	90	0	6.3**	100	0	0	-3.5	—	—	—
6AF11	0	150	0	58	0	-2*	-1.7	72	2.3	132	0	6.3**

Measured with a VTVM, $\pm 20\%$. *R9 full clockwise. **AC

If the receiver doesn't work properly, first thing to do is measure voltages on tubes to turn up a wiring error or defective component. All voltages must be measured with a VTVM and not a VOM.

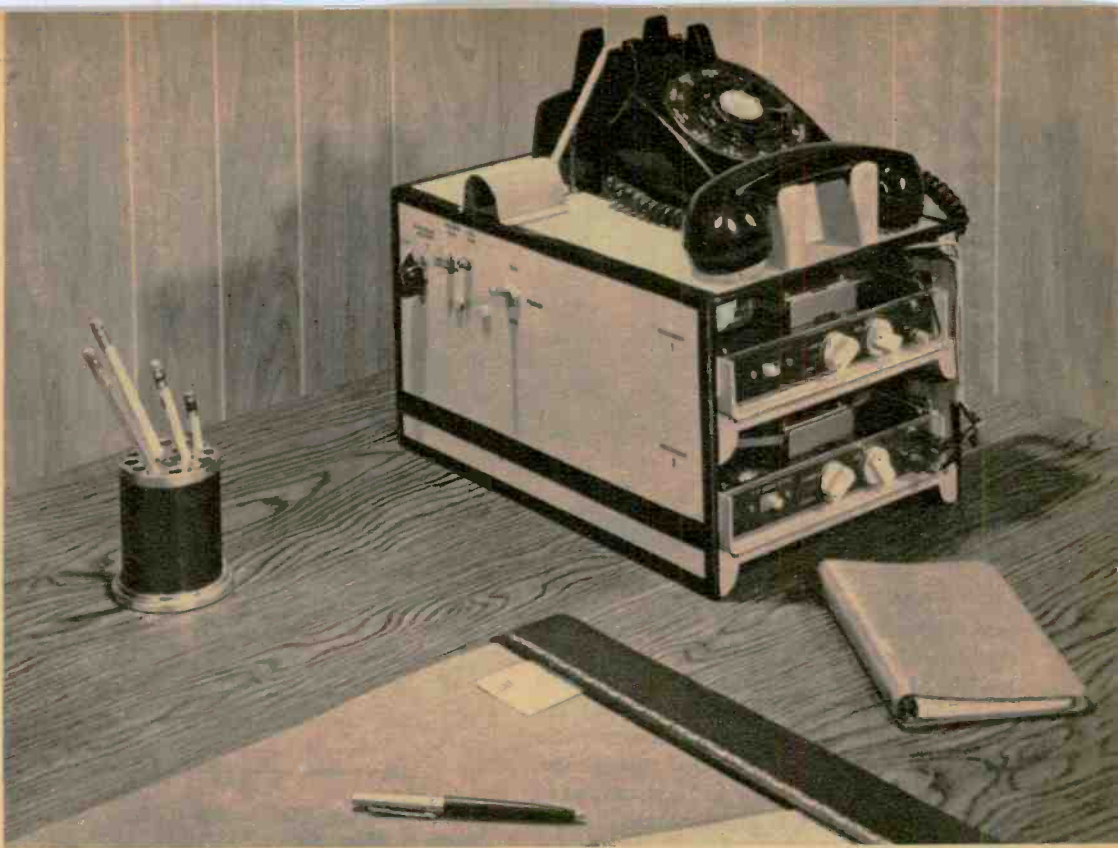

Automatic Telephone Answering Set

You'll never miss a phone call with our electronic secretary on the job.

By FRED BLECHMAN, K6UGT "HELLO, this is the Blechman residence. No one is home right now. This is a recording. If you'd like to leave a 40-second message, please start it at the sound of the tone. B-e-e-p."

This is what you hear if you call when we are out. Forty seconds after the first tone you hear another tone, then a click as the phone is hung up. When we arrive home we are able to listen to your message as well as about 15 others.

Designed to be built for about \$50, the Automatic Telephone Answering Set (TAS) will do the same job as commercial message recorders that might set you back a few hundred dollars.

The TAS has been designed around two inexpensive battery tape recorders. One recorder answers the telephone with a pre-recorded message. The other recorder tapes the caller's message for 40 seconds.

The timing of all operations is controlled by a 1-rpm motor which drives four poker-chip cams which in turn operate microswitches. Each microswitch controls a separate function. The phone is coupled inductively to the TAS for ring-sensing and message recording. Direct connections to the telephone line are not necessary. The answering message is acoustically fed to the hand-set's mouthpiece.

How it Works. Take a look at Fig. 4, a schematic of the TAS. When the telephone rings, a pickup coil (L1) near the telephone base, picks up the bell's magnetic field and feeds a signal to the two-transistor ring amplifier. A relay (RY1) at the output of the ring amplifier then starts the 1-rpm timing

Fig. 1—The ring amplifier is built on a small piece of perforated board which is mounted on the inside of the chassis' rear panel. Use spacers between the board and the chassis to prevent parts from touching the chassis.

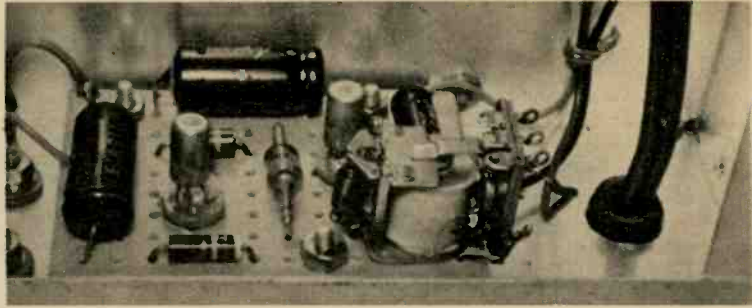

Automatic Telephone Answering Set

motor. During the third ring, cam 1, which controls solenoid L2, turns and trips micro-switch S1 which energizes L2. L2 lifts a spring-loaded lever which latches (S6) the timing motor and lets the telephone-cradle pushbutton rise. This "answers" the phone.

One second later *recorder 1* is energized by cam 2 which closed microswitch S2. This plays the pre-recorded answering message into the answering speaker (SPKR 1) which is located underneath the telephone handset mouthpiece. *Recorder 1* stops after about 14 seconds and the tone is started by another microswitch, S4. The tone sounds through SPKR 1 for a fraction of a second.

Next, *recorder 2* records the caller's message via handset-earpiece coil L3. Thirty-seven seconds after *recorder 2* starts, the tone

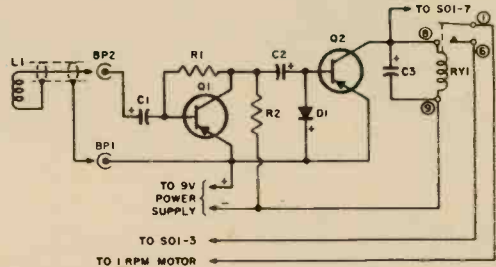

Fig. 2—Ring-amplifier schematic. Ring signal at phone is picked up by L1, fed via shielded wire to Q1, amplified and fed to Q2 which closes RY1.

sounds again, *recorder 2* stops and 2 seconds later L2 is released. This causes the spring-loaded arm to press down the telephone cradle pushbutton. When L2 is released, RY1 is unlatched and the motor stops turning.

If you cannot obtain the tape recorders shown in our model, use any battery-operated

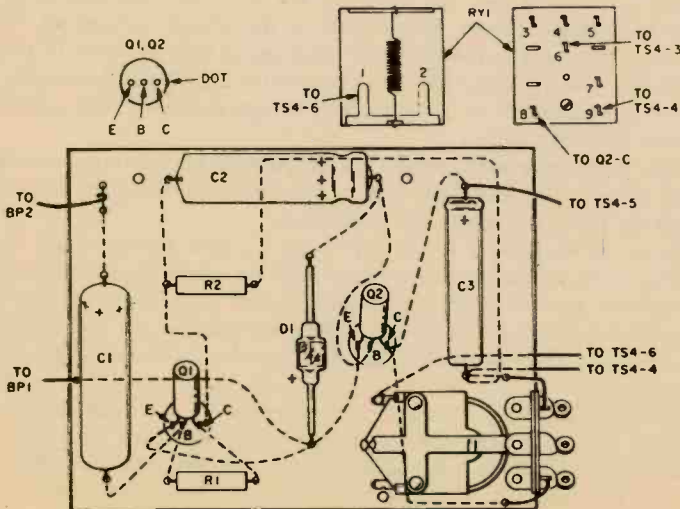
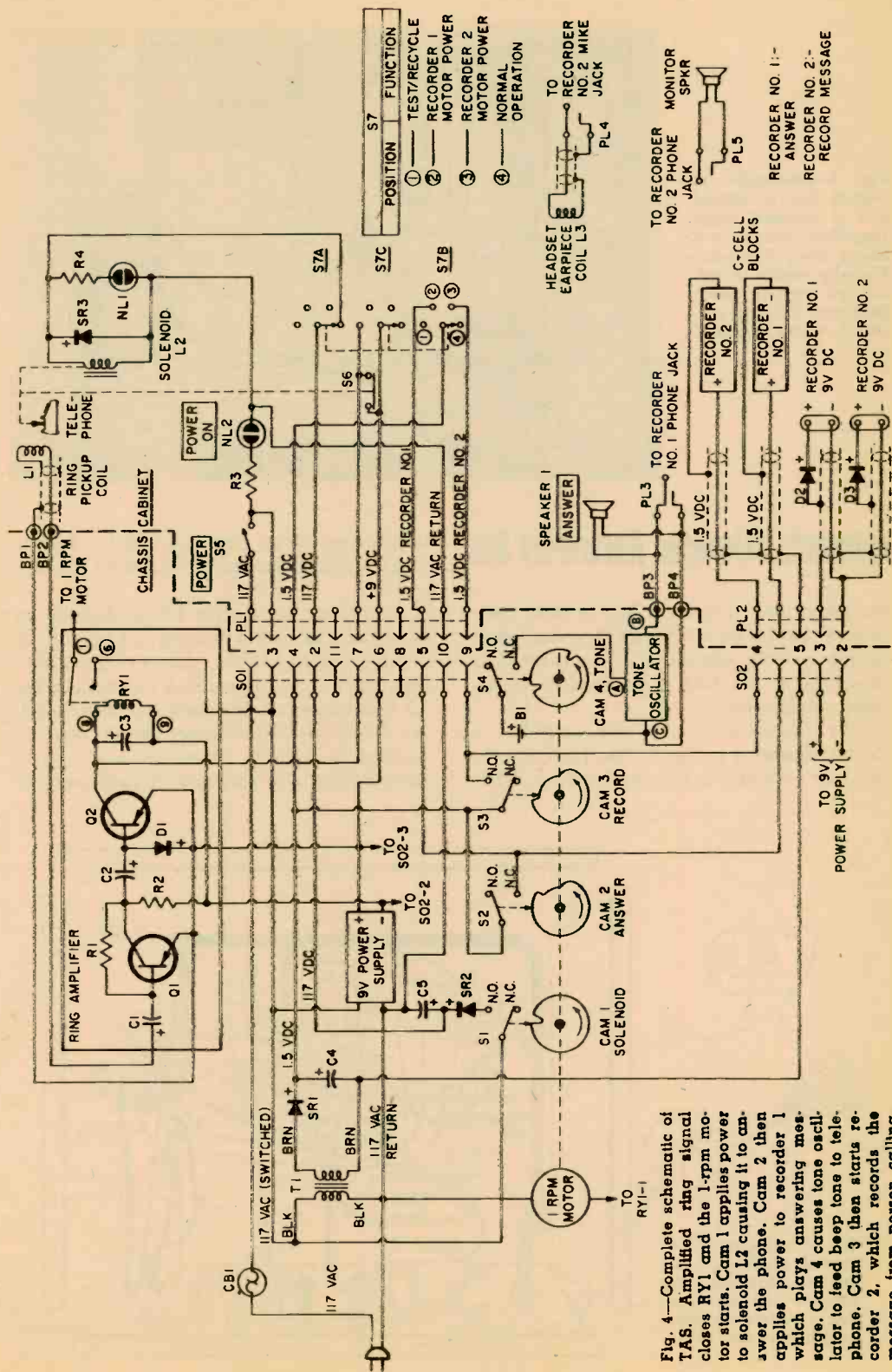

Fig. 3—Pictorial of ring amplifier. We used sockets for transistors in our model, but you could solder Q1's and Q2's leads directly into circuit. Flea clips will serve well as tie points. Sketches at the top show numbers we have assigned to the lugs on relay RY1.



POSITION	FUNCTION
①	TEST/RECYCLE
②	RECORDER 1 MOTOR POWER
③	RECORDER 2 MOTOR POWER
④	NORMAL OPERATION

Fig. 4—Complete schematic of T.A.S. Amplified ring signal closes RY1 and the 1-rpm motor starts. Cam 1 applies power to solenoid L2 causing it to answer the phone. Cam 2 then applies power to recorder 1 which plays answering message. Cam 4 causes tone oscillator to feed beep tone to telephone. Cam 3 then starts recorder 2, which records the message from person calling.

Fig. 5—Underside of control chassis. Liberal use of terminal strips simplifies wiring and keeps everything neat. Partially visible at bottom are tone generator (left) and the ring amplifier (right) boards.

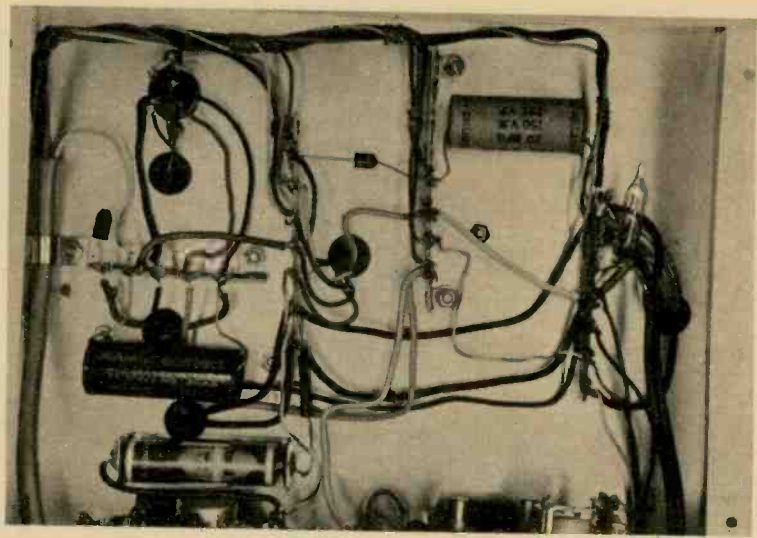

Automatic Telephone Answering Set

transistor tape recorders. But be sure their motors operate on 1.5 V and their amplifiers operate on 9 V. These requirements are very important as the TAS is designed to supply these voltages only.

The schematic of the ring amplifier is shown separately in Fig. 2. The 1.5 V for the recorder's motors is obtained from a 2.5-V

transformer (T1), rectified (SR1), filtered (C4) and is controlled by S2 and S3 (cams 2 and 3).

The power to operate L2 is obtained by rectifying (SR2) and filtering (C5) 117 VAC and is controlled by S1 (cam 1). Diode SR3 suppresses arcing across S7A's contacts when L2 is deenergized. Function switch S7A,B,C is a 3-pole 4-position rotary switch, used for making the master answering tape and to allow rewind and playback of each recorder

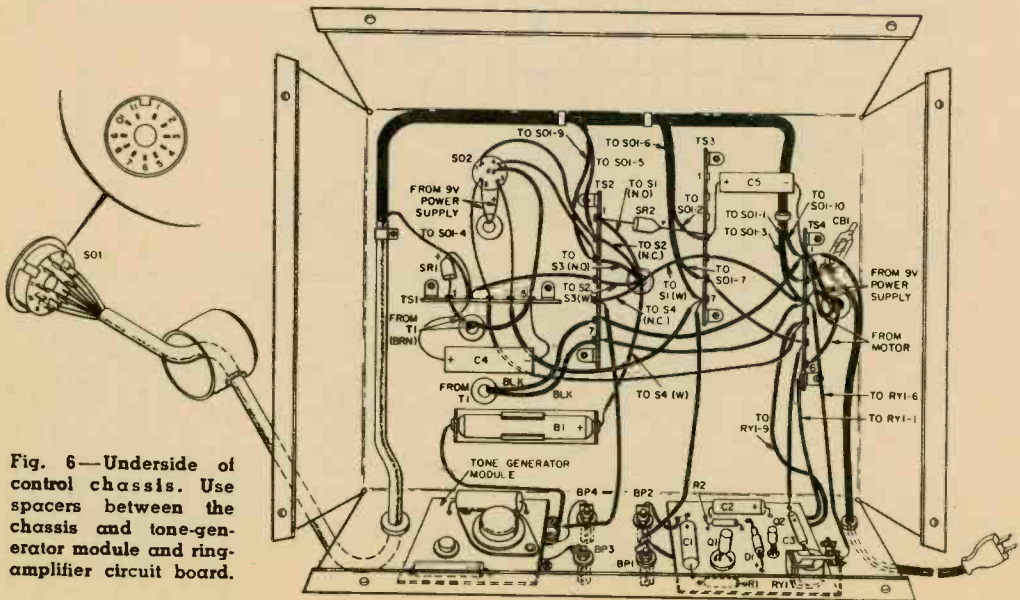

Fig. 6—Underside of control chassis. Use spacers between the chassis and tone-generator module and ring-amplifier circuit board.

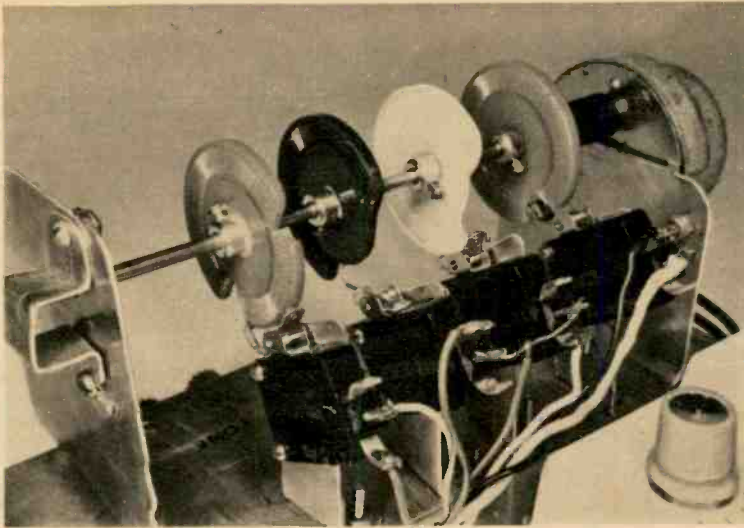

Fig. 7—Timing assembly. U-shaped bracket which supports drive motor (upper right) and cam shaft is home brew. Dimensions are not critical. Note the hubs which are glued on all the poker chips.

independently of the timer and the solenoid. Pilot light NL2 comes on when power is applied to the TAS. A green light (NL1) comes on when solenoid power is applied.

Since components are located in the cabinet and on the chassis, a multi-conductor cable is used to connect the two. The cable is equipped with an 11-pin connector (SO1) to provide easy separation. Similarly, the shielded cables that provide power to the recorders are connected to a single plug (PL2)

that plugs in SO2 on the chassis. Diodes D2 and D3 are necessary to DC-isolate the recorders from each other. If you don't use them you'll find strange interactions.

Construction. The ring-amplifier (Figs. 1,2,3) can be built on a small piece of perforated board. Be sure to observe proper diode and capacitor polarity. The value of resistor R2 may have to be changed to provide about 0.7-ma drain from the 9-V supply with *no* ring signal. A ring signal should

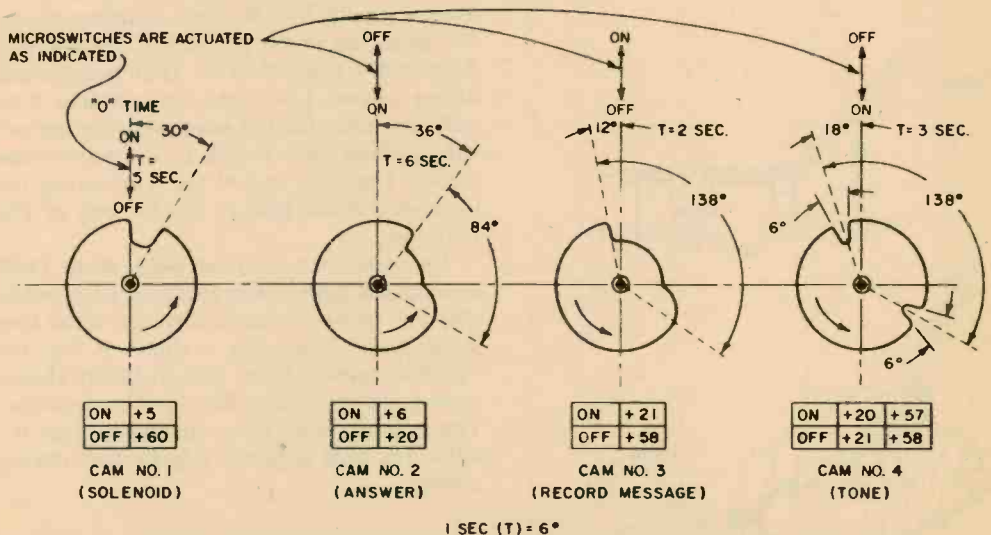

Fig. 8—Cam dimensions. Make all cuts with a jewelers saw then use sketches to line up cams on shaft. Numbers in boxes below cams show time after motor starts that the cams should actuate their associated circuit. Cam 1, for example, should turn L2 on after 5 seconds and off after 60 seconds.

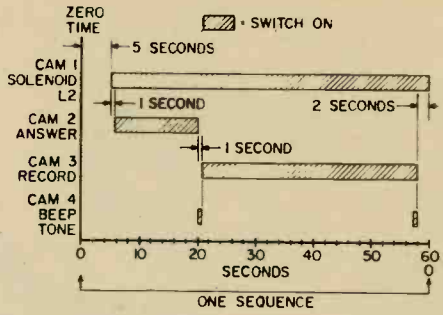
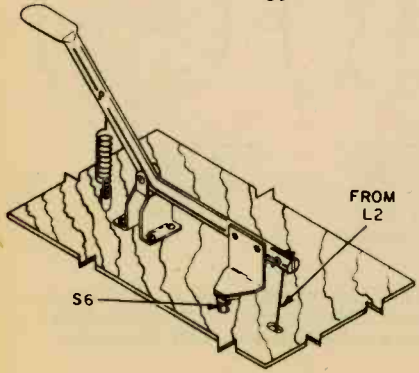
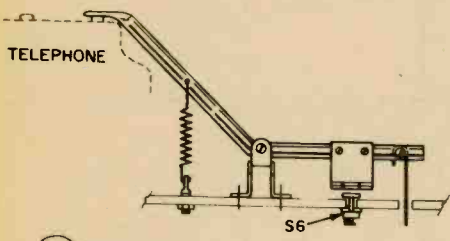
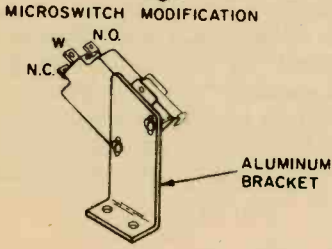
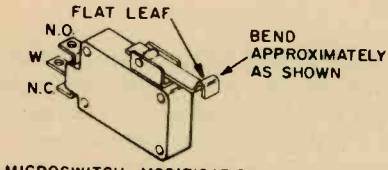
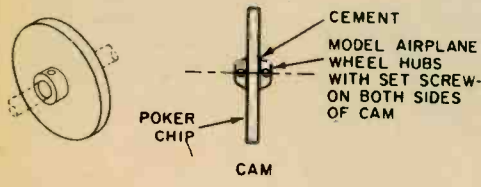
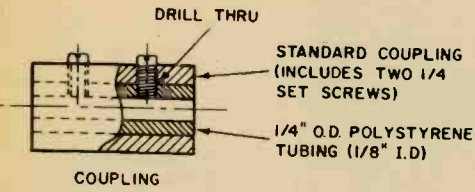

Fig. 9—Cam-timing sequence. Duration of time a switch is on may change. Do not change the time intervals between operations of the switches.

cause the current to rise to about 2 ma. Capacitor C3 is necessary to prevent relay chatter.

A flat telephone pickup coil *must* be used. Place it alongside the phone base, as shown in Fig. 13. During preliminary tests later, have someone call you several times to find the best coil location for fast relay closure. Be sure to use shielded wire from L1 to the amplifier to prevent random noise from triggering the amplifier and relay.

The frame for the timing motor and cams is made by bending a piece of aluminum into a U shape, as shown in Figs. 11 and 12. The dimensions are up to you. On one end mount the motor. Add about a 6-in. length of 1/8-in. dia. brass rod or tubing to the motor shaft using a standard 1/4-in. shaft coupling, modified as shown at the top of Fig. 10. All you do is push a piece of 1/4-in. O.D. polystyrene tubing (1/8-in. I.D.) into the coupling then drill two holes for the setscrews. The screws will cut their own threads in the polystyrene tubing. The other end of the brass tubing fits through a small hole in the far end of the U frame.

The cams are made from poker chips. Drill a 1/8-in. dia. hole in the center of each poker chip and cement a model airplane wheel hub to each side to the chip, as shown in Fig. 10. These aluminum hubs, sold in hobby shops, have a 1/8-in. center hole and a setscrew. The setscrew hubs allow individual cam rotation for final sequence adjustments during testing.

Fig. 10—Miscellaneous construction details. Coupling at top connects motor and cam shaft. Diagrams below show cam construction, microswitch modification and construction of answering arm.

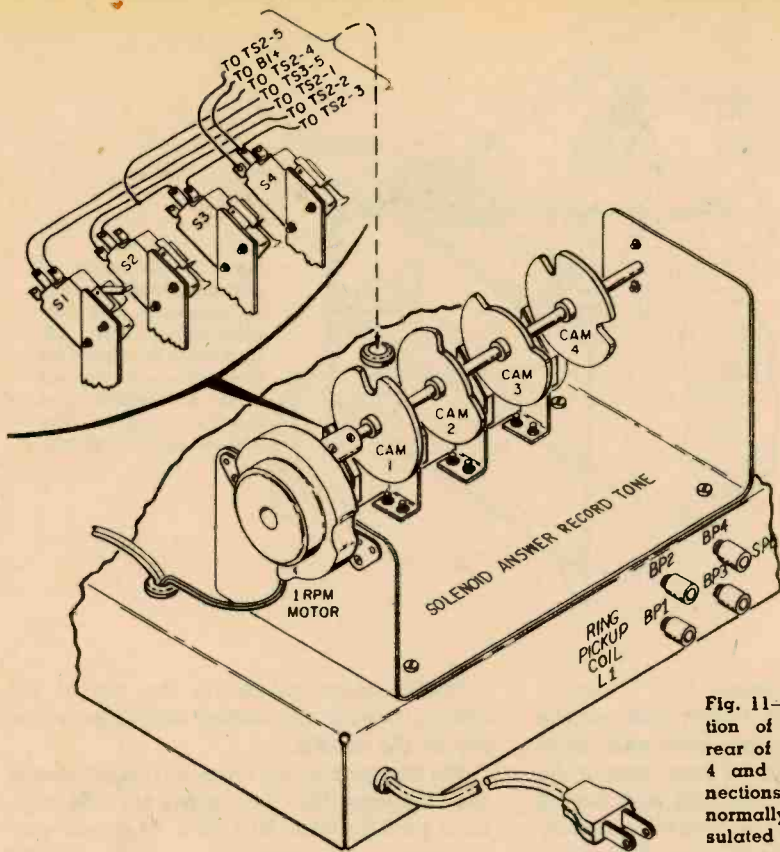

Fig. 11—Diagram shows location of timing assembly on rear of chassis. Refer to Figs. 4 and 10 to determine connections to normally-open and normally-closed lugs on micro-switched from timing chassis.

Figure 8 shows the cam configurations and Fig. 9 shows the timing sequence in our model. If you prefer to have a longer answering message and shorter recording period, change the angular cutouts accordingly, remembering that one second equals 6 degrees of rotation. Once set and tightened, the cams need not be touched again.

The four microswitches are mounted on

sheet-metal brackets (Fig. 10) and adjusted later on. The flat-leaf actuator of each micro-switch should be bent as shown in Fig. 10 for better action. The timing blocks in Fig. 9 show the times the cams should actuate their associated microswitches.

Note that for proper sequencing, cam 2 must activate *after* cam 1. Cam 3 activates 1 second *after* cam 2 deactivates. Cam 3 must

Fig. 12—Control chassis. Transformer T1, used to provide power to tape recorders' motors is at right. 9-V power supply is at upper left of the chassis.

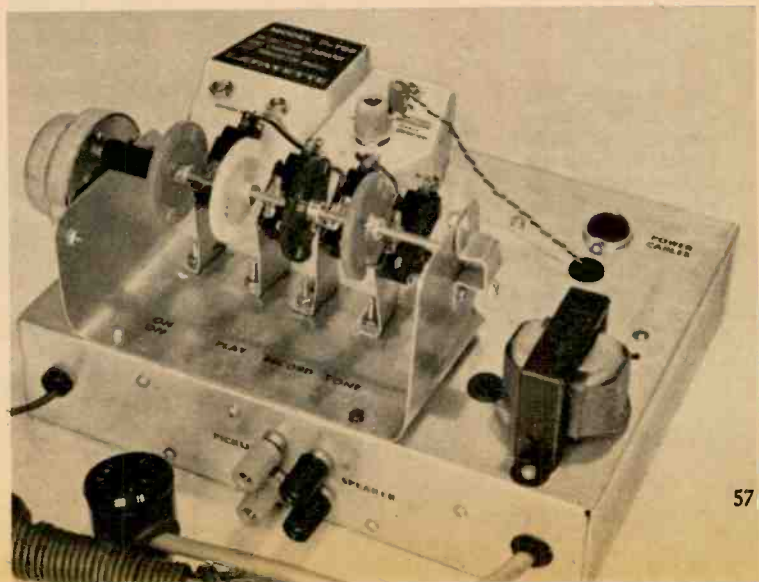

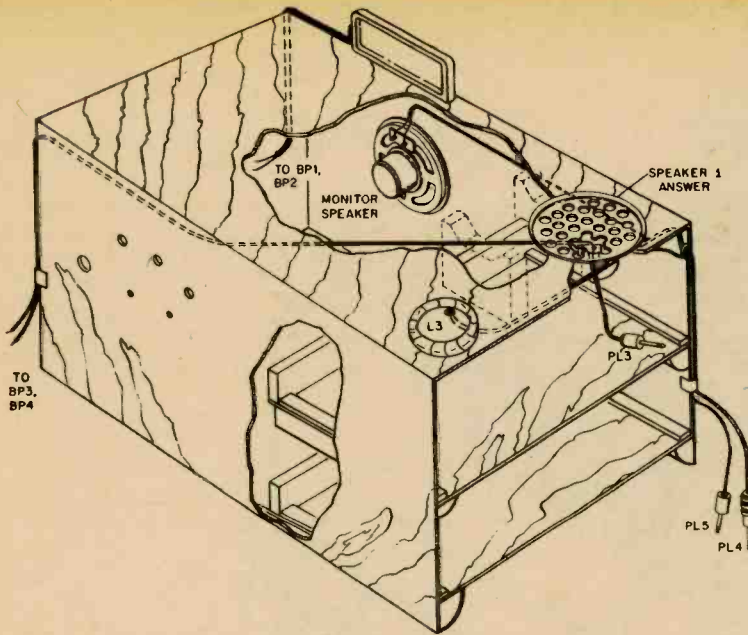

Fig. 13—Cutaway of cabinet shows location of speakers and ear-piece-pickup coil L3. Drill holes in cabinet for speakers and cement them to cabinet. Put handset in place before cementing L3 to cabinet.

deactivate 2 seconds *before* cam 1 deactivates. Some latitude in timing and spacing can be tolerated, but the *sequence* must be as shown. The position of the beep tone in the sequence is not critical, so long as it occurs near beginning and end of recording period.

Chassis Assembly. Remove the 9-V power supply's bottom cover. Then drill three holes in it and install mounting screws and nuts; the latter will act as studs. Now replace the bottom cover. The extended studs are used with nuts to mount the power supply to the chassis. Mount the transformer on the top of the chassis using grommets in its leads' holes. Mount a 5-pin socket (SO2) for the

recorder power cables on the top of the chassis. Mount the timing assembly on the top of the chassis.

On the back of the chassis (inside) mount the ring amplifier, tone generator and insulated binding posts BP1-BP4. Make no *connections* to the chassis. Since a flat toroidal pickup coil (L3, left, Fig. 13) is not available commercially, you must make your own by random-winding 1,600 turns of No. 34 enameled wire on a 1¼-in. dia. form. Remove the coil, tightly bind it with masking tape and solder a shielded lead to the ends. The resistance of the coil should be about 150 ohms.

Fig. 14—Other side of cabinet shows location of mode switch S7, indicator lamps and power switch S5. Note location of ring pickup coil L1. Detail of corner of cabinet marked with the letter A is in Fig. 16.

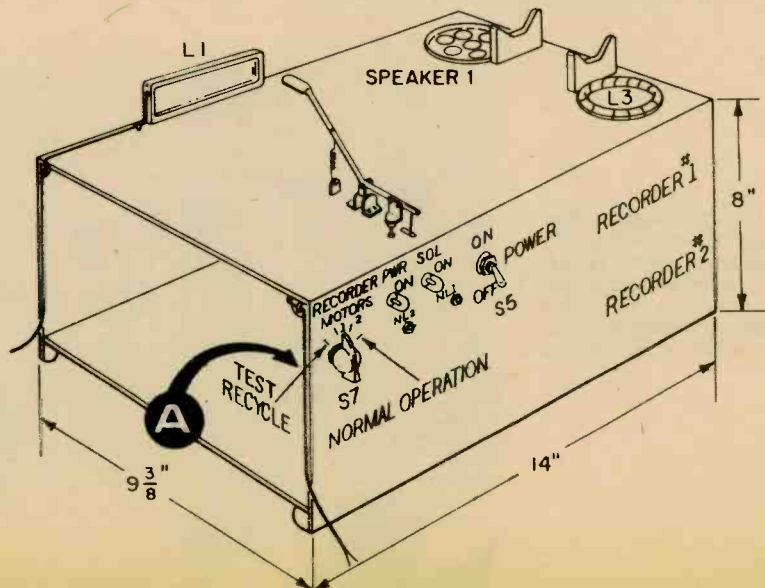

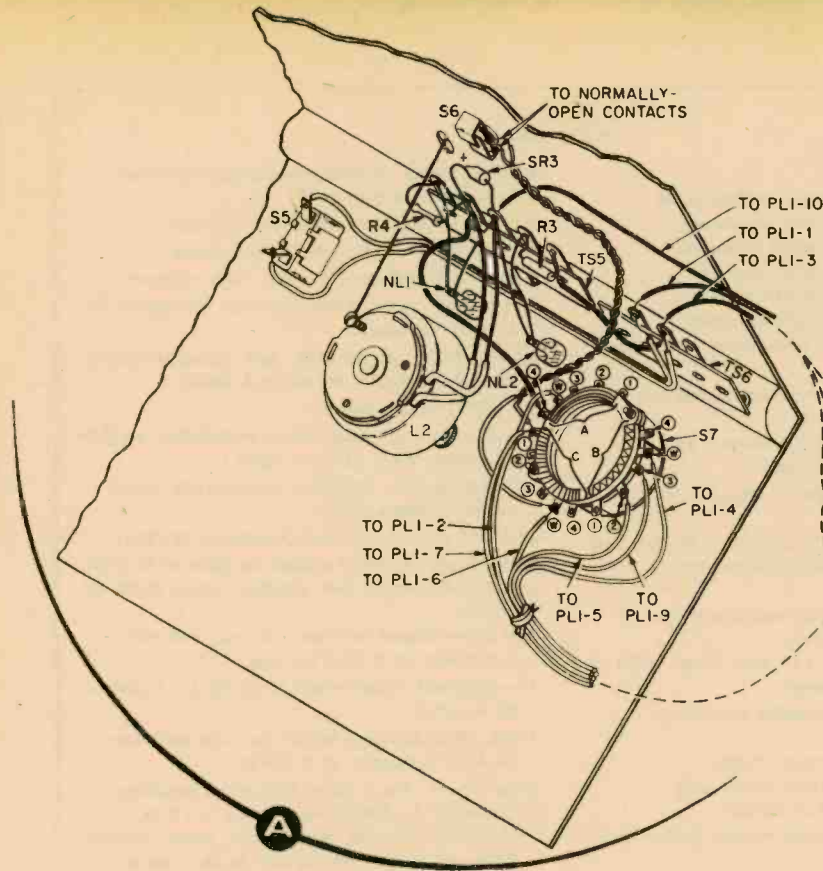
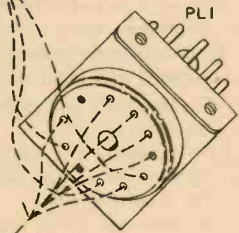

Fig. 16—Inside view of corner of cabinet referred to in Fig. 14. Solenoid L2 specified in Parts List is plunger type and requires different installation. Be sure solenoid pulls enable/disable arm down causing it to press firmly on switch S6.



Cabinet Assembly. Our cabinet was built from 1/4-in. plywood and held together with strips of molding in the corners. Details are shown in Figs. 13 and 14. The telephone handset holder is made from two wooden blocks. Drill small holes for the two miniature speakers (Fig. 13) and cement them to the inside of cabinet. Note in Fig. 10 that the latching pushbutton switch (S6) must be mounted so that it is pressed when the sole-

noid pulls down the back of the enable/disable arm.

The arm, by the way, is made from 1/4-in. aluminum tubing. One end is flattened so it will press down the phone's pushbutton to hang up the phone. The arm is pivoted on a small screw held in a home brew sheet-metal bracket.

A short length of piano wire couples the solenoid to L2. When L2 is energized it pulls

Fig. 15—Top view of front of TAS. Note location of blocks on which handset is placed. Also note the locations of the speaker at the mouth-piece position and the home-brew coil at the earpiece position (left).

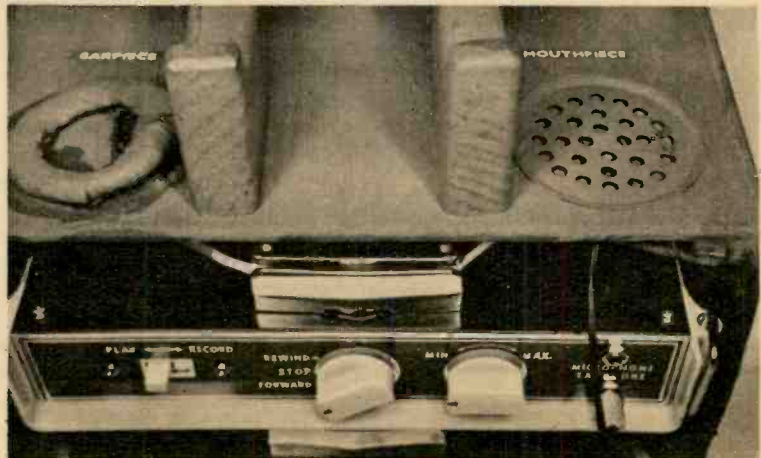

PARTS LIST

- B1—1.5 V penlite cell
 BP1-BP4—5-way, insulated binding posts
 C1—50 μ f, 15 V electrolytic capacitor
 C2—100 μ f, 15 V electrolytic capacitor
 C3—20 μ f, 15 V electrolytic capacitor
 C4—1,000 μ f, 15 V electrolytic capacitor
 C5—20 μ f, 150 V electrolytic capacitor
 CAMS 1-4—Cams made from poker chips (see text)
 CB1—1 A circuit breaker (Sylvania MB-315 Mite-T-Breaker. Allied 56 A 4075)
 D1-D3—General-purpose germanium diode (Lafayette 19 C 4901 or equiv.)
 L1—Telephone pickup coil (Lafayette 99 C 1034 or equiv.)
 L2—Solenoid: 115 VAC, $\frac{1}{8}$ - $\frac{1}{2}$ -in. stroke, continuous duty, 65-oz. lift. (Guardian No. 14. Allied 41 A 5895 or equiv.)
 L3—Induction pickup coil wound with No. 34 enameled wire (see text)
 MOTOR—1 rpm motor, 117 VAC (Olson MO-113)
 NL1,NL2—NE-2 neon lamp
 PL1—11-pin chassis connector (Amphenol 86-CP11.)
 PL2—5-pin plug (Amphenol 71-5S)
 PL3,PL4,PL5—Subminiature phone plug (Lafayette 99 C 6210 or equiv.)
 POWER SUPPLY—9 V power supply (Lafayette 99 C 9021)
 Q1,Q2—2N217 transistor
 RECORDERS 1, 2—Battery-operated transistor tape recorder (see text)
 R1—47,000 ohm, $\frac{1}{2}$ watt, 10% resistor
 R2—33,000 ohm, $\frac{1}{2}$ watt, 10% resistor
 R3,R4—100,000 ohm, $\frac{1}{2}$ watt, 10% resistor
 RY1—SPDT relay, 5,000-ohm coil (Lafayette 99 C 6091 or equiv.)
 S1-S4—SPDT microswitch, leaf actuator (ACRO 2CMD1-2AXX-A24. Allied 56 A 5030)
 S5—SPST toggle switch
 S6—Normally-open miniature pushbutton switch (Lafayette 99 C 6159 or equiv.)
 S7A,B,C—3-pole, 4-position non-shorting rotary switch (Mallory 3234J)
 SO1—11-pin cable socket (Amphenol 78-PF11)
 SO2—5-pin miniature socket (Amphenol 78-S5S)
 SPKR 1, 2—8-ohm, 2-in. speaker (Olson S-636 or equiv.)
 SR1-SR3—Silicon rectifier, 750 ma, 400 PIV (Lafayette 19 C 5001 or equiv.)
 T1—Filament transformer: 2.5 V @ 1.5 A (Allied 54 A 3712)
 TONE OSCILLATOR—Miniature code oscillator module (Lafayette 19 C 1513)
 Misc.— $\frac{1}{4}$ -in. dia. x $\frac{1}{4}$ -in. long shaft coupling (Allied 47 A 1108 or equiv.), 7 x 9 x 2-in. aluminum chassis, 9-conductor cable (Belden 8449 or equiv.), penlite-cell holder, wheel collars.

the back of the arm down, and pulls the flattened end upward to "answer" the phone. At the same time, the back of the arm presses S6, which latches RY1 to keep the timing motor running. Make sure S6 is pressed firmly. If the timing motor isn't kept running, L2 will stay pulled in, keeping the phone off the hook indefinitely!

Handset-earpiece coil L3 is cemented to the top of the cabinet right under the earpiece. Terminate the shielded wires from L3 and both speakers (unshielded) with miniature phone plugs near the mating recorder jacks. The shielded wires from L1 and unshielded wires from *speaker 1* go to the chassis binding posts.

Power Cable Harness. The tape recorders suited to the TAS use 1.5-V batteries to operate the motor and 9-V for the amplifier. In the TAS, four separate *shielded* cables terminate in a 5-pin plug (PL2) at one end and home-brew connectors at the other end. The schematic of the harness is shown at the bottom of Fig. 4.

Especially important is the use of diodes D2 and D3 and their proper installation.

Shielded wire (thin mike cable) is necessary to prevent excessive motor noise pickup from the amplifier power leads. For the 1.5-V battery terminations, cut a $1\frac{1}{8}$ -in. piece of 1-in. dia. wood dowel and push thumbtacks into the ends for contacts. Solder the wire ends to the thumbtacks. The dowel assembly should be installed in place of a C-cell. Wrap the dowels with tape and label them *recorder 1* or *recorder 2*. If your recorders use two C-cells, make two more dummy batteries from the dowel to take up the space and to maintain the contact pressure.

Parts Substitutions. While the TAS lends itself to modification, take it slowly. The motor, solenoid and microswitches specified work well together in this application. Any 1-rpm motor might be substituted, but you may encounter mounting and shaft-coupling problems. The specified microswitches require very little operating force so they don't cause the cams and motor to stall.

Final Assembly. Insert plug PL2 into chassis socket SO2. Slide the chassis into the back of the cabinet, placing the *recorder 1* C-cell block and one of the 9-V connectors on the

bottom shelf. Push cable plug PL1 into cabinet socket SO1. Connect the shielded wire from pickup coil L1 to insulated binding posts BP1 and BP2 on the back of the chassis, and connect the wires from *speaker 1* to BP3 and BP4.

Load the recorders with tape and put their function switches in the *stop* position. Install the dummy batteries and attach the 9-V connectors (made from the connectors of dead 9-V batteries) to each recorder. Slide the recorders onto the shelves in the cabinet, folding the power cables under each recorder so they won't interfere with reel rotation. The miniature plug from the monitor speaker goes into the headphone jack of *recorder 2*. Headset earpiece (recording) coil L3 plugs into the mike jack of *recorder 2*.

Preliminary Checkout. Make sure switch S5 is *off*, and that function switch S7 is in *normal-operation* position. Both recorders should be set at *stop*. Plug in the line cord—nothing should happen. Now turn on S5—the red pilot light (NL2) should come on. If *cam 1* is not in the neutral position, L2 will actuate the rocker arm and the timer motor will run. Let it complete the sequence, at which time L2 will release the rocker arm and the timer will stop. Now, put function switch S7 in the *recorder 1* position. *Recorder 1* should now operate completely independently of all the other parts of the TAS. You should be able to record, rewind and playback by using the recorder controls in a conventional manner. Try this to be sure your power harness is wired properly. Now put S7 in the *recorder 2* position. This will allow *recorder 2* to operate independently as just described for *recorder 1*. Try out each recorder for recording, rewinding and playing to verify proper power harness wiring.

Now, turn off S5. Put S7 in the *test/recycle* position. Position the controls of *recorder 1* for playback and of *recorder 2* for recording, with volumes set at low levels. Now turn S5 on. The timing motor should run continuously and all sequencing should take place except the operation of L2. Slight readjustment of the cam positions will correct sequencing problems. Make sure the cam setscrews are tight so the cams don't rotate on the shaft.

Final Checks. Make the master answering tape on *recorder 1* by placing function switch S7 in the *test/recycle* position and plugging a microphone into *recorder 1's* microphone jack. Set *recorder 1's* control to record. Keep

the volume low enough to avoid acoustic feedback from answering speaker. Wait a couple of seconds after *recorder 1* starts and time your answering message to end a few seconds before *recorder 1* stops. The message used at the beginning of this article is typical of one you might want to use. Now wait until the sequence has come around again, and when *recorder 1* starts, repeat the answering message. Using 600 ft. of tape on 3-in. reel, you can get almost 30 answers on a tape. *Recorder 2* will have enough tape to record about 15 messages. After the 15th answering message, your message should tell the caller to try again in a few hours, since you *cannot* record the message after the 15th call without resetting the unit.

Near the end of the final message, turn S7 to the *normal-operation* position. This will shut off the timing motor at end of the cycle. Remove the microphone from *recorder 1* and get ready to accept incoming calls. With S7 in the *recorder 1* position, put *recorder 1* in the playback mode and rewind the tape to the beginning. Use a long white leader on the tape to give you a definite starting point and to avoid unreeling the tape by rewinding too far. Set switch S7 to *recorder 2* and rewind *recorder 2's* tape to the beginning, then set it up for recording.

Put S7 in the *normal-operation* position and shut off S5. This is to prevent S6 from being pressed and running the timer as you raise the enable/disable arm to position the phone. Remove the telephone handset and place the phone base so that the spring-loaded arm holds down the phone pushbutton. Place the handset on the wooden cradle, with the mouthpiece over the speaker and the earpiece over L3.

The telephone may be used normally by pushing it slightly backward to release the pushbutton. Call a friend and ask him to call you back. Reposition the phone base under the arm, put the handset back on the cradle, turn on switch S5 and wait. The phone should ring about three times before solenoid L2 pulls in, lifts the arm and . . . well, by now you should be familiar with what happens. Adjust playback and record volumes (you'll be able to hear the caller through the monitor speaker as the recording is being made).

Make certain the phone is really hung up or callers will just get a busy signal. Tighten or shorten the spring and position the phone base under the arm to insure full pressure on the pushbutton.

Vest-Pocket Modulation Scope

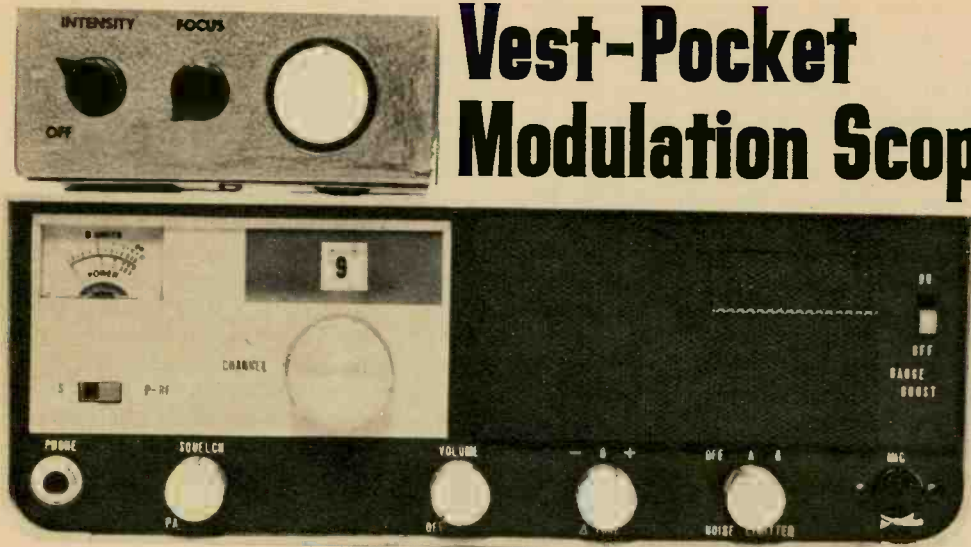

See what your signal looks like and you can have the best on the air!

By HERB FRIEDMAN, KB19457

CITIZENS BANDERS are constantly being drowned in a sea of modulation theory. As a result, they overlook the one really important but simple rule: modulation should reach 100 per cent as much of the time as possible. Less than 100 per cent means feeble talk power. Over 100 per cent means distortion and sideband splatter (and perhaps a nice note from old Fox Charlie Charlie).

So they go ahead and try speech clippers, compressors, limiters and other modulation boosters. What happens? They still end up with poor reception reports.

Clippers and compressors boost only the average voice power. It is the peak power you have to watch out for—it causes overmodulation.

The only way to be sure you're putting out a potent signal is to put the signal on display. Unfortunately, peak-indicating modulation meters cost hundreds of dollars and are manufactured mainly for commercial applications.

How, then, can you accurately and at a glance tell just how good your modulation is? By using our Vest-Pocket Modulation Scope, of course. It's a peak-indicating modulation instrument which can be built for well under \$50—under \$25 if you pick up a surplus 1EP1 cathode-ray tube (CRT).

With the scope connected to your rig, you can see instantly what your modulation percentage is. Over 100 per cent and you can expect your signal to be distorted. (Actually, 100 per cent *negative* modulation causes trouble. A transmitter which reaches 200 per cent positive modulation but less than 100 per cent negative modulation does not cause distortion or sideband splatter.)

Our scope is designed specifically for CB modulation measurements. A special RF input transformer amplifies the low RF voltage going to the antenna to about 100 V but does not increase the SWR or cause a loss in RF output. A capacitive voltage divider across the transformer permits adjustment for 1 to 3 watts of transceiver output power. A single component change permits operation with transceivers whose output is in excess of 3 watts (to a maximum of 4 watts).

The scope will provide either a trapezoid or a modulation-waveform (MW) display. All tube transceivers have a relatively high modulation voltage—approximately 200 V, which will be adequate to drive the 1EP1's horizontal plates for the trapezoid pattern. In solid-state rigs, however, the voltage isn't sufficient to produce a trapezoid pattern. Therefore, if you have a solid-state rig use the MW connections. An advantage to the MW-

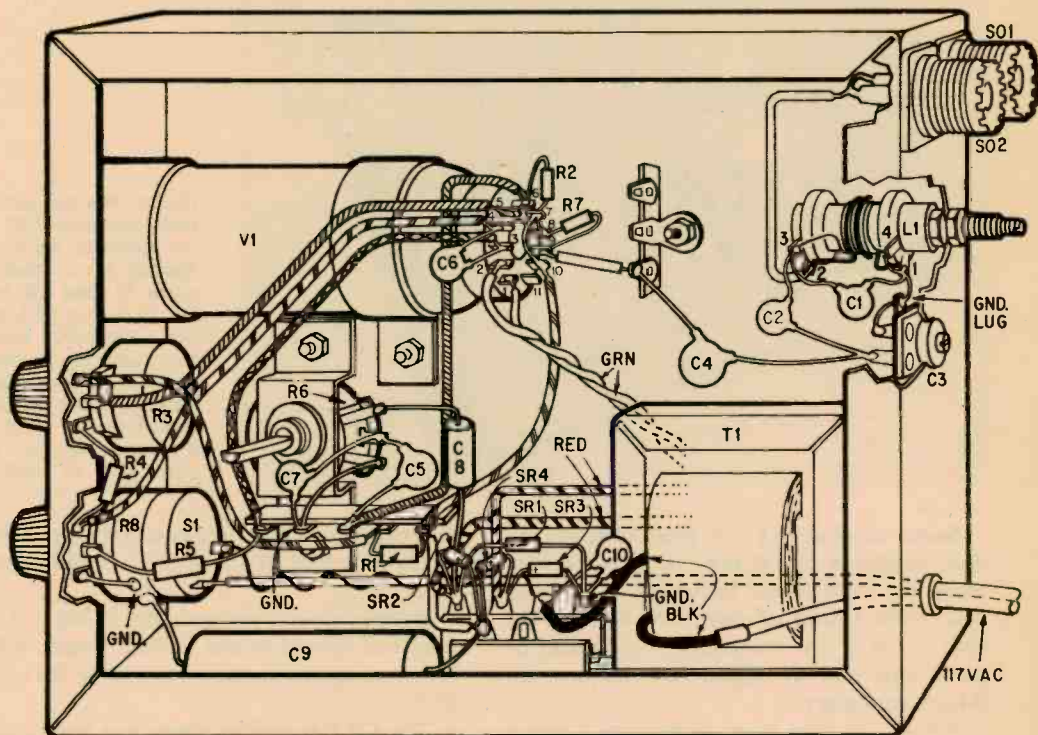

Fig. 1—Space is at a premium in 5 x 7 x 2-in. chassis so mount parts exactly where shown. We used a special socket on V1; however, you may solder wires and components to tube's pins.

display setup is that an internal modification in the transceiver is not required.

As the scope has no effect on the RF output, it can be left permanently connected to the transceiver so that the modulation can be monitored at all times.

Construction: All part values are critical and no substitutions can be made. Because the layout also is important, the pictorial and photographs should be followed as closely as possible. Our scope was built in a 5x7x2-in. aluminum chassis.

Cut all holes before mounting any components. Note the cabinet's internal corner flanges. Locate the opening for the CRT on the 5 x 2-in. side so the hole just clears the flange—don't cut into the flange.

Cut the opening for the CRT with a 1/4-in. chassis punch or a hole saw. Take up the slight extra clearance between the CRT and the cabinet by wrapping two turns of tape around the front edge of the CRT. Position *focus* control R3 and *intensity* control R8 between the CRT and the edge of the cabinet,

but take care that the hole for R3 does not break off the corner flange.

We specify SO-239 connectors for SO1 and SO2. However, you may use a different type to match those you now have. Cut the holes for L1 and C3 at least 1/8 in. below a line between the centers of SO1 and SO2. Trimmer capacitor C3 requires a hole slightly larger than 1/2 in. First drill a 1/2-in. hole and then enlarge it with a round file.

Coil L1 must be wound carefully or there will be a loss in antenna efficiency. If L1 is wound sloppily, take it apart and start all over again. Refer to the sketch of the coil in Fig. 3. Wind the secondary first. Tensitize a 2-ft. length of #26 enameled wire by clamping one end in vise and pulling on the other end until the wire goes dead slack. (If the wire isn't tensitized the coil will unwind.) Scrape approximately 1/4 in. of insulation from one end of the wire and solder it to lug 4. Run the wire along the form for 1/4 in. and then wind 8 closewound turns. Solder the other end of the wire to lug 3.

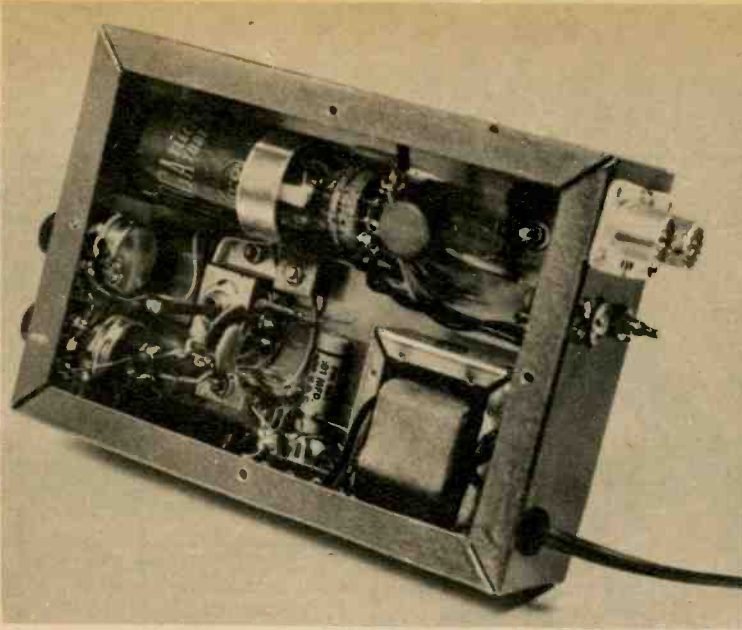

Fig. 2—We did not install connector SO3 in our model for trapezoid display. If you wish to, move L1 and C3 (see Fig. 1) toward SO1 and SO2, install SO3 below L1. Shaft on potentiometer R6 (directly under V1's mounting bracket) should be cut short so it doesn't protrude beyond side of cabinet.

Solder the end of a 2-ft. piece of tinsilized #22 enameled wire to lug 1 and run the wire along the form to the beginning of the first coil. Wind 2 turns as shown and connect the wire to lug 2. The completed coil consists of the 2-turn primary slightly overlapping the 8-turn secondary.

Solder a jumper between the lugs 1 and 4 and extend this jumper about 1 in. past the secondary's start lug (4). Connect 10- μmf

disc capacitor C1 across secondary lugs 3 and 4. Cut one lead of C2 to $\frac{3}{4}$ in. and connect it to lug 3.

Attach a 3-in. insulated lead to lug 2. This lead will be cut to the correct length when L1 is connected to the wire joining SO1 and SO2.

The CRT is held in place by a strap made of $\frac{1}{2}$ -in.-wide scrap aluminum. Simply wrap the strip around a broom handle to form a

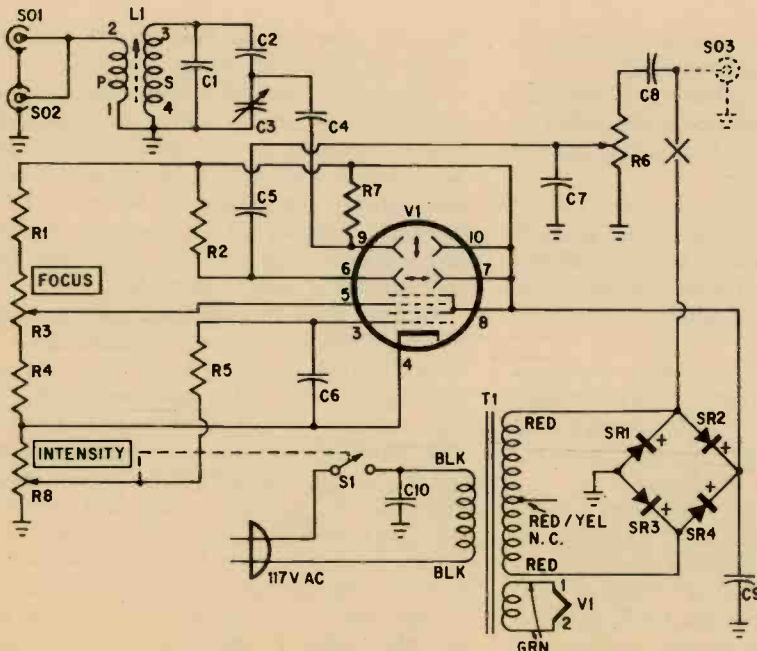
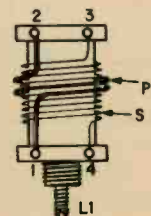

Fig. 3—For trapezoid display, break lead going from SR1, SR2 to C8. Then connect C8 to connector SO3. For clarity in coil diagram below, primary winding (P) is shown centered over secondary winding (S). It should be wound over secondary at beginning of windings near lugs 1, 4.



clamp shape. But be careful. If the clamp is too tight it may crack V1. A single mounting screw is all that's needed to hold the clamp.

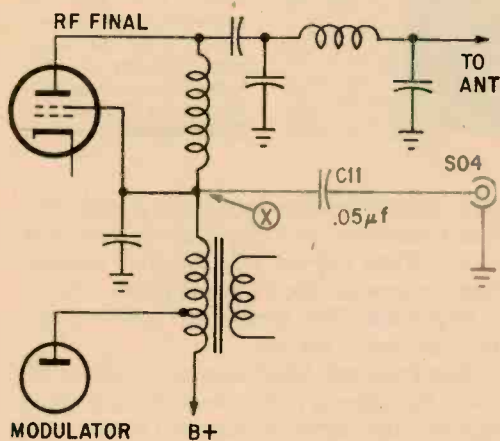

Fig. 4—Add components shown in color to transceiver for trapezoid display. To locate point X in your transceiver, refer to the set's schematic.

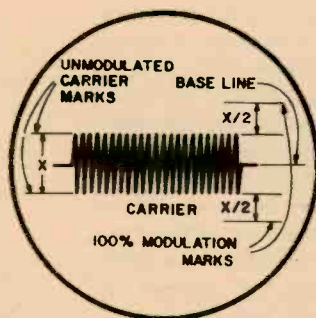
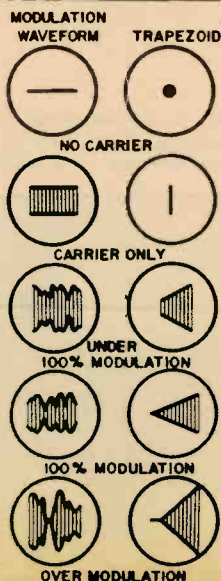

Fig. 5—Pattern shown represents unmodulated carrier. The height will double when the 100 per cent modulation level is reached.

Fig. 6—Nearest patterns are called modulation waveforms. Patterns in far column are referred to as trapezoid displays. To display trapezoid pattern (not possible on solid-state transceivers), you must modify transceiver as shown in Fig. 4 to feed part of audio modulating signal to the scope.



A 3/8-in. spacer or stack of washers between the clamp and the chassis will center the CRT. (Do not install the CRT yet.)

Horizontal-gain control R6 is mounted on a U-shape potentiometer mounting bracket inside the chassis. Temporarily install R6 and mark the shaft where it lines up with the edge of the chassis. Cut the shaft at the mark and then hacksaw a slot into it for a screw-driver.

To avoid a parts jam, install the components in the following order: connectors SO1, SO2 (and SO3, positioned halfway down the rear panel, if a trapezoid display is desired). The line cord and T1. Next, R3, R6, R8 and all terminal strips. Install the SO1-SO2 jumper, L1 then C3. Complete all wiring associated with these components. Install all remaining components with SR1-SR4 last.

Install R2, R7 and the jumpers between pins 8, 7 and 10 on V1 directly on V1's pins. Install V1. To be sure of getting a horizontal trace, turn V1 so that pin 1 is aimed toward T1. Complete all wiring to V1's pins and leave sufficient slack in the wires so V1 can be turned for a horizontal trace.

Checkout. Connect the positive lead of a VOM set to indicate at least 400 V (DC) to the junction of SR1 and SR2. Connect the

PARTS LIST

- Capacitors: 400 V or higher unless otherwise indicated
- C1, C2—10 μ f ceramic disc
 C3—7-35 μ f trimmer capacitor (Centralab 827-D, Allied 43 A 1519 or equiv.)
 C4, C5, C8, C10—.01 μ f tubular or ceramic disc
 C6—.1 μ f, 75 V ceramic disc
 C7—.005 μ f ceramic disc
 C9—.5 μ f, tubular
 C11—.05 μ f, ceramic disc
 L1—Coil wound on J. W. Miller 42A000CB1 coil form (Allied 54 D 3913, \$1.56 plus postage. Not listed in catalog)
- Resistors: 1/2 watt, 10% unless otherwise indicated
- R1—1 megohm
 R2, R7—1.2 megohms
 R3—250,000 ohm, linear-taper potentiometer
 R4—150,000 ohms
 R5—470,000 ohms
 R6—1 megohm, linear-taper potentiometer
 R8—50,000 ohm, linear-taper potentiometer with SPST switch
 S1—SPST switch on R8
 SO1, SO2, SO3, SO4—SO-239 coax connector (see text)
- SR1-SR4—Silicon rectifier: 750 ma, 400 PIV (Allied 24 A 9693)
- T1—Power transformer; secondaries: 250 V @ 25 ma, 6.3 V @ 1 A. (Allied 54 A 2008)
- V1—1EP1 cathode ray tube (RCA. Allied 1EP1-Dept. 59D1, \$25.75 plus postage. Not listed in catalog)
- Misc.—5 x 7 x 2-in. aluminum chassis, 5 x 7-in. aluminum chassis-bottom plate, terminal strips, AC line cord

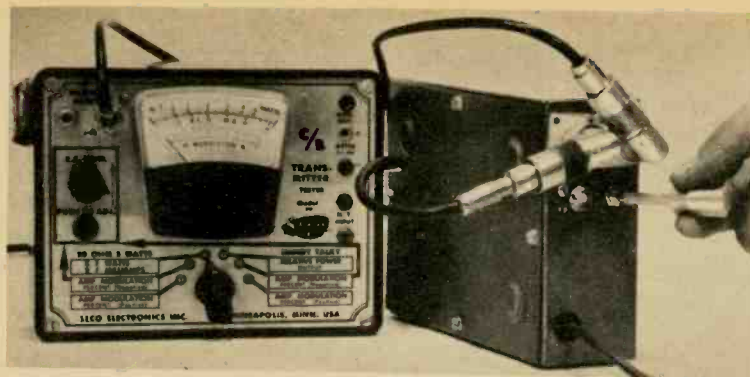

Fig. 7—Adjust L1 by feeding the transmitter output through the scope to a load. Then adjust L1's slug for maximum output power, lowest SWR or maximum display height. Instrument here is Seco Electronics Model 510 CB-transmitter tester.

meter's negative lead to the chassis. Set R3, R6 and R8 full clockwise and turn on power. If the meter doesn't rise to over 350 V immediately pull the plug quickly and check the power supply for a wiring error.

If all is okay, a horizontal trace will appear on the CRT after a short wait. The trace will be centered. Turning R6 counterclockwise will cause the trace to shrink to a small dot in the center of the screen. The correct setting for R6 is that which makes the trace just touch the edges of the CRT. Focus the trace with R3.

Connect the transceiver output to SO1 and the antenna or a dummy load to SO2. We suggest that an SWR meter be connected between SO2 and the load.

When you transmit, the trace should expand. Using an alignment screwdriver, adjust L1's slug for maximum pattern height. This should correspond to lowest SWR and maximum output power. Now adjust C3 so the pattern is about $\frac{1}{2}$ in. high. If high transmitter output prevents the pattern from being reduced to $\frac{1}{2}$ in., change C2 to 5 μf .

Talking into the microphone will cause the CRT to display the waveforms shown for MW in Fig. 6. Note that at 100 per cent modulation, the negative valleys just reach the baseline (appearing as a bright dot) while the positive peaks (peak-to-peak) are exactly twice the height of the unmodulated carrier. When the modulation exceeds 100 per cent the peak-to-peak height will be more than twice the unmodulated carrier height and there will be a distinct break at the baseline. The break is caused by more than 100 per cent *negative* modulation.

If you prefer the trapezoid pattern, the CRT will display them as shown in Fig. 6 under *trapezoid*. Note that with no carrier and no modulation there is no horizontal line. While modulating, adjust R6 so the horizontal sweep occupies about $\frac{3}{4}$ the total width of the CRT. Note that at 100 per cent modula-

tion, the pattern forms a point at the baseline (equivalent to the dot in the MW pattern). When 100 per cent negative modulation is exceeded the trapezoid grows a tail—a bright line. The greater the over-modulation the longer the tail.

The Trapezoid Modification. To obtain the trapezoid pattern make the following modification after the Scope has been checked out for the MW pattern. Install SO3 on the rear of the cabinet. Disconnect C8 from SR1-SR2 and connect C8 to SO3.

Install a connector (SO4) on the rear of your transceiver and connect the center conductor of SO4 to the modulated B+ feed point in your transceiver's RF final stage. A typical installation is shown in Fig. 4. Point X is the B+ feed point. Regardless of the exact circuit used in your transceiver, the modulated B+ feed is from between the modulation transformer and the RF final's plate input. While capacitor C11 is not needed (as there's a DC blocking capacitor at the input of the Scope) it is recommended as a safety feature to keep the high DC voltage off SO4. Connect SO4 to SO3 with coax.

Fig. 8—To determine where to put modulation reference lines, refer to Fig. 5. Then scribe the lines on face of the CRT with a grease pencil.

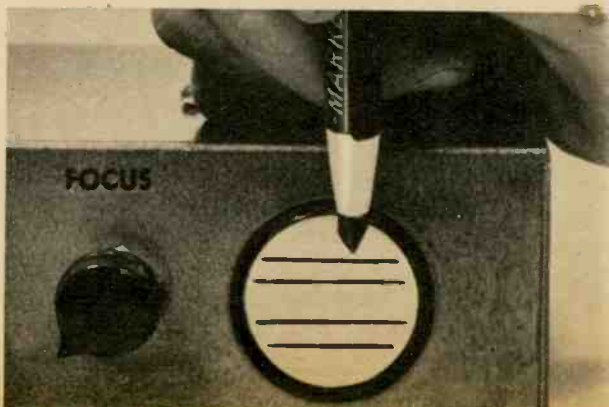

7 Steps



TO BETTER TAPES

By REID ET TA THERE she sits in a sealed carton. You tear away the cover, toss the instruction manual to one side, fight ten minutes to work your way through a mountain of plastic foam. Finally—*your spanking-new tape recorder!*

Quickly now, and she's on the table. Ogle from adults and shrieks from children. And suddenly it hits you. The only thing sitting on top of the machine is an empty take-up reel (if you were lucky enough to get one with the recorder). And, unfortunately, no one yet has figured out how to record on thin air.

In order to capture those golden sounds forever, you obviously will need *recording tape*. But what kind? There are more varieties and prices of tape on the market than flies in a fruit market. Basically, however, we can reduce everything to two types: name-brand tape and white-box tape (which usually sells for several bucks less than the name-brand stuff). Since you know at least three tape buffs who swear by white-box tape, you naturally will be inclined to join the save-a-buck brigade. But will you really save? Or will you foul your recording heads and capstan, suffer through dropouts during your favorite symphony and make a mess out of a routine editing job?

Assuming reasonably good electronics (which most recorders have), the tape itself

determines the final results of your recording efforts. And for recordings of highest fidelity the tape must be free from surface irregularities, which can cause signal drop-out. It must be free of oxide clumps, which cause excessive head wear (with resultant loss of high-frequency response). It must have oxide bound tightly to the base to avoid excess flake-off to foul the heads and capstan, resulting in uneven drive speed and microscopic tape lift-off from the heads. It must display practically no variation in recorded level from beginning to end of a reel so sections can be spliced together without noticeable changes in playback level. And it must have frequency and distortion characteristics which enable your recorder to deliver on its maximum capabilities.

Sound like tough specifications? They are. And while you could start with white-box tape, as a general rule it simply isn't suited to quality music recordings. White-box tape, among other things, can be cut-down new or used computer tape; second-quality tape, i.e., tape which plain couldn't meet manufacturer's standards; or it even might be used tape. Or it could be cheaply-made tape with poor oxide adhesive and a surface like sandpaper. All things considered, tape by reputable manufacturers—Audio Devices, Kodak, 3-M, RCA and others—always is to be preferred for serious recording.

7 Steps to better tapes



Then there's the question of the material itself. Total recording time depends on the size of the reel and the thickness of the tape. Standard tape, such as Scotch 111, is 1.5-mil acetate. This means the base is made of acetate and the base plus oxide coating is 1½ thousandths (.0015) of an inch thick. Though such tape is suitable for average use, acetate deteriorates with age—and if permanence is important the somewhat more expensive heat- and humidity-resistant Mylar-base tape is a wiser choice.

When a standard reel offers insufficient recording time extended-play tape should be considered. For use of a thinner base means more tape can be wound on a given size reel. Extended-play tape can be purchased in both the +50% and +100% sizes, though the +100% tape is extremely thin and comparatively easily stretched or broken.

Having selected your tape, you slap a reel on the machine and away you go. The tape inventory builds and builds: Aunt Mini singing at sister's birthday party (not to mention

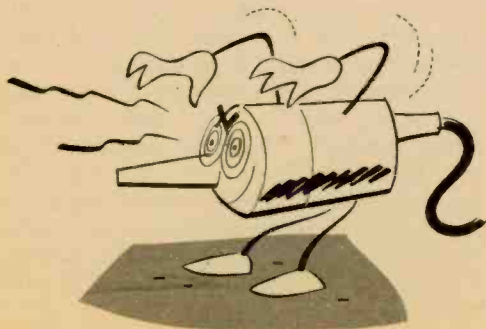

Uncle Harold's tired sweet-sixteen jokes), 50 mi. of music off the tuner, three weeks' salary in prerecorded tapes. And then it happens. First the tapes seem to have a funny hiss. Later, the hiss grows louder and is anything but funny, no matter how defined. Head magnetization has struck again.

Except on those machines with built-in demagnetization, sharp-impulse overloads can (and do) magnetize the recording head, just as contact with a magnetized tool can magnetize a record or playback head. When tape passes over a magnetized head a hiss is superimposed, much as though you passed the tape over a weak magnet. Another symptom of a magnetized head is partial erasure of prerecorded high frequencies (this is what takes the sparkle out of prerecorded commercial tapes).

To avoid the magnetization problem, simply use a *head demagnetizer*, such as the Robbins HD-6, at periodic intervals—say once a week if the recorder gets moderate service. It takes just a second or so to hold a demagnetizer against a head but those few seconds can mean the difference between noise-full and noise-free listening.

Okay, you now are all set for the best in recording—or are you? If yours is a professional or semi-pro machine, there's good chance you didn't get a *microphone*. Then again, even if you did get a mike, chances

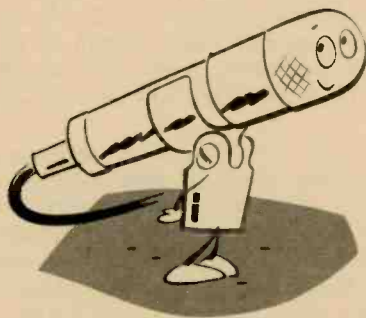

are your live recordings have nowhere near the fidelity you get from a tuner or from prerecorded tape. Microphones supplied with most recorders often are just fancy-cased versions of the cheapie models that come with budget recorders. And all leave a lot to be desired in the way of fidelity and convenience.

Quality recordings require quality microphones but you don't have necessarily to go for broke. Good mikes start at about \$30, going up the ladder to \$150 for broadcast

quality. If you want to keep costs down, by all means consider the Electro-Voice 636 and the Shure 550S. Both exhibit a notably smooth quality that enhances the sound from budget recorders. A little better quality for medium-price recorders can be found in the AKG line, the Norelco D119ES, the Shure 556S and the Electro-Voice 676. And if you want your tapes to sound like a good-music station try a broadcast mike such as the Electro-Voice 666.

While you're concentrating on putting the highest of fi on tape, don't overlook dynamic range—the variations in speech and music levels. Sure, recorders are equipped with some sort of volume indicator: a flashing lamp or magic eye or a VU meter. But such devices give an accurate indication of recorded level only when feeding from one sound source. They tell you next to nothing when you're trying to blend such sources as tuner or phono with a mike or several mikes.

For optimum sound balance it's best to monitor while recording. Matter of fact, it's the only way to obtain precise balance. And while nearly all recorders provide for monitoring when recording from a tuner, phono or another tape recorder, silence descends when you use mikes (unless you're in the mood for the squeals of acoustic feedback). So your next step is to *monitoring headphones*.

Inexpensive headphones, such as used for experimenter projects or ham radio, usually are unsuitable since their high distortion and poor low-frequency response do not give an accurate representation of what's being fed into the recorder. Just as you would use hi-fi phones, such as those made by Kess, Norelco and Telex (among others), with your amplifier, so you must use hi-fi phones with your recorder.

Thing to avoid is the impedance pitfall

since this can have dire effects on any recording. Usually a recorder's headphone jack is in the speaker circuit and any of the low-impedance phones can be used. But it's just possible that your recorder's headphone jack is in a high-impedance circuit and that the loading caused by low-impedance phones, therefore, would alter the recorder's frequency response. When high-impedance phones are called for, use the crystal type, such as the Clevite-Brush BA-200B, which have a 90,000-ohm impedance. (If you're in doubt whether to use low- or high-impedance phones, best check with your dealer or manufacturer.)

Speaking of several sound sources, the average recorder, even if it sports both high- and low-level inputs, has but one volume control and only one sound source can be controlled at a given time. While some of the higher-price recorders have so-called mixing controls, usually only the mike and a high-level input, such as a tuner, can be mixed.

Yet best recordings of musical groups are made when several mikes are used to balance individual instruments or sections. While you sometimes can connect several mikes in parallel you still have only one volume control. For multiple mike setups or even for multiple high-level sound sources (tape recorder and amplified turntable, for example), a *mixer*—a device that accommodates several sound sources each with its own volume control—is required.

Two types are available to the hobbyist. The first is the passive mixer, such as Lafayette's audio mixer, which is nothing more than a small metal cabinet with two input jacks, two volume controls and an output plug to match the recorder's input jack. The

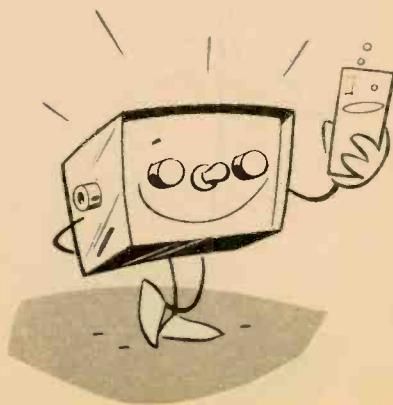

7 Steps to better tapes

passive mixer will mix any two high-impedance sources into a single high-impedance input with individual control of each source. Most passive mixers have a slight loss in gain, however (generally on the order of 6 to 9db), and the Lafayette is no exception.

More flexible mixing can be obtained with an amplified mixer, which accommodates up to four inputs, either high- or low-level. A tube model such as the Bogen MX-6A provides nearly 60db mike gain. This means that even if you're mixing mikes, the mixer output can be connected to the recorder's high-level input, bypassing the noise of the recorder's mike preamplifier. If you want to save a buck there are the small transistor mixers (such as Lafayette's 99 R 4535) which mix four mike inputs and provide a small overall gain.

And while you're mixing the sounds of that musical aggregation, you may wish to consider what best to do with the mike(s). Most recorder mikes, if supplied with a stand at all, have an inexpensive metal arrangement that just about keeps the mike from falling over when placed on a table. And the table stands supplied for some of the more costly mikes are no better. To record a musical or even a dramatic performer it often is necessary to prop a stack of books on a chair, stick the mike(s) on top of the tower and then trust someone doesn't upset the applectart by knocking down your house of cards.

A better approach is a portable *floor stand*

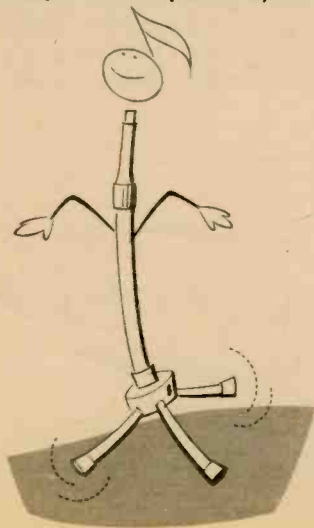

like the pros use, a good example being the Atlas CS-33 Take-Apart Floor Stand. The CS-33 has removable legs which form a rigid triangular brace, yet it folds up small enough to be hidden away in a closet. When open, the three legs cover a wide base so, though light in weight, you can stick your best mike on it without fear of it being knocked over.

Though taping now should be as easy as listening there still is one giant step that can lead to the best in tape recording. That step—like the six that preceded it—is a step up, of course, this time to a microphone *matching transformer*.

Nearly all home recorders use high-impedance mikes and high-impedance mike inputs. While this arrangement is perfectly suitable for mike cable lengths up to 25 ft., beyond that the internal capacity of shielded mike cable attenuates the high frequencies. Further, the high-impedance cable itself is sensitive to hum pickup.

When long mike leads are needed, as they are when recording a high-school band or similar ensemble, it's best to use a low-impedance microphone rated at 50, 150 or 250 ohms. Impedances of this order permit cable lengths up to several hundred feet. Further, when the line finally reaches the recorder's high-impedance input all that's needed is a transformer, such as the Electro-Voice 502A, to match the low-impedance line to the high-impedance input.

Conversely, the matching transformer can be used to convert a high-impedance mike to a low-impedance output. One also is needed when you choose to use a low-impedance broadcast-type mike with your high-impedance recorder.

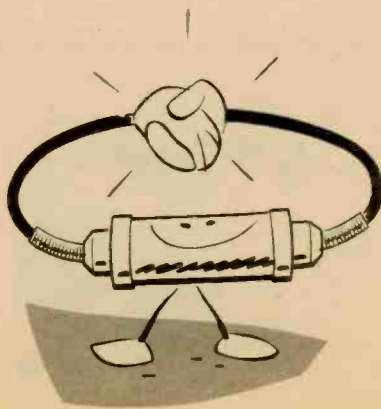



Char-Analyst for Batteries

Banish your battery budget forever (well, almost) with our super-duper do-all and end-all tester/charger (pew!).

BY BERT MANN

BBATTERIES by the carload! That's almost the way you have to buy them these days to keep everything from junior's toys to dad's heavy-duty flashlight running all the time.

Before you discard those apparently-dead batteries, however, connect them to the Char-Analyst. In quick time it will check them under load and show you the true condition. If the battery is on its last legs, merely shift a pair of leads, flip a switch or two and the Analyst will charge the battery, making it almost as good as new.

Often a battery no longer may be able to power a particular piece of equipment; however, it usually is capable of giving several more months of service in other gear which pulls less current.

For example, an old C cell required to supply 200 ma to a walkie-talkie might be too pooped to push the signal 10 ft. down the block. Recharge that battery and put it in a transistor mike mixer that pulls about 10 ma and months later the same battery will be going strong.

Reason for this is that as the battery ages its internal resistance increases. When the battery is connected to a load that pulls a lot of current the high internal resistance causes the terminal voltage to drop.

When terminal voltage falls to the cutoff value—the voltage below which the equipment will not operate—the battery is said to be dead. But in a device that draws little current it will take much longer for the terminal voltage to drop to cutoff value. The

Fig. 1—Because of the angle at which the front panel slants back, it will be more convenient to install the meters, controls and binding posts on the panel before bolting panel and chassis together. When wiring to the terminal strip at the right of T1 make sure you don't make any connections to the ground lug since the circuit must be isolated electrically from the metal cabinet.

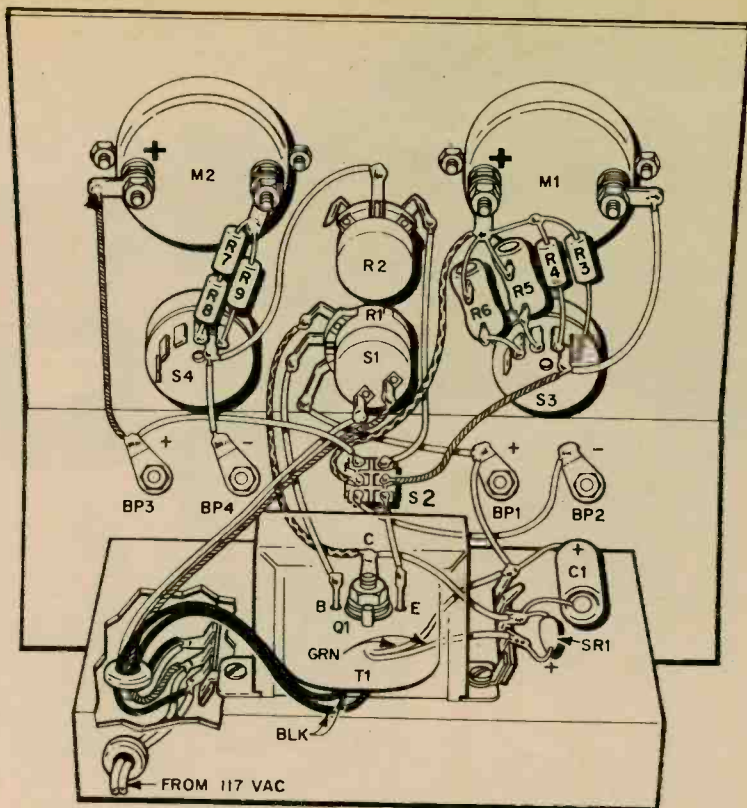

Char-Analyst for Batteries

PARTS LIST

- BP1-BP4—5-way binding post
- C1—100 μ f, 50 V electrolytic capacitor
- M1—0.3 ma DC milliammeter (500 ohms), Shurite Type 950 (Lafayette 38 C 6083).
- M2—0.1 ma DC milliammeter, Shurite Type 950 (Lafayette 38 C 6081)
- Q1—40 watt PNP power transistor (Lafayette 19 R 1503)
- R1—2,000 ohm, linear taper potentiometer with SPST switch
- R2—2,000 ohm, linear taper potentiometer
- R3—56 ohm, $\frac{1}{2}$ watt, 10% resistor
- R4—10 ohm, $\frac{1}{2}$ watt, 10% resistor
- R5—5 ohm, 5 watt wirewound resistor
- R6—1 ohm, 5 watt wirewound resistor
- R7—2,000 ohm, $\frac{1}{2}$ watt, 5% resistor
- R8—13,000 ohm, $\frac{1}{2}$ watt, 5% resistor
- R9—1,500 ohm, $\frac{1}{2}$ watt, 10% resistor
- S1—SPST switch on R1
- S2—DPDT toggle or slide switch
- S3, S4—1 pole, 5 position rotary switch (Mallory 3215J or equiv.)
- SR1—Silicon rectifier; minimum ratings: 500 ma, 100 PIV
- T1—Filament transformer; secondary: 24 V @ 1 A (Lafayette 99 C 6266 or equiv.)
- Misc.—Power transistor (TO-36 size) mounting kit (Lafayette 19 C 1532 or equiv.), 4 x $6\frac{1}{8}$ x 1-in. open-end aluminum chassis (Premier ACH-1360), 8 x 8 x 8-in. sloping-panel cabinet (Premier SFC-500).

Analyst's test section shows you a battery's true terminal voltage by simulating loads that pull up to $1\frac{1}{2}$ A.

The Analyst tests and charges AA, AAA, C and D zinc-carbon, mercury, alkaline and nickel-cadmium cells. Charging current can be adjusted over a wide range of values.

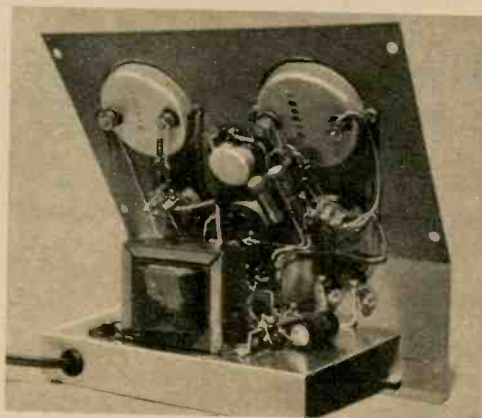

Fig. 2—Chassis is attached to front panel with machine screws. Note the $\frac{3}{16}$ -in. space between the bottom of chassis and bottom of front panel.

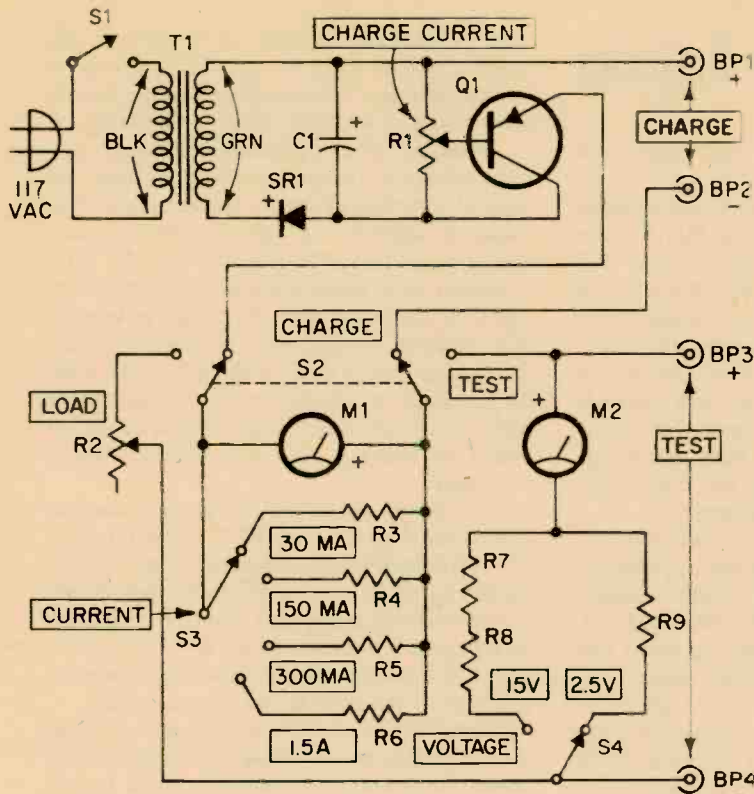

Fig. 4—T1, SR1, C1, R1 and Q1 constitute power supply whose output is controlled by varying Q1's bias voltage with R1. When S2 is in charge position (shown), M1 is connected in negative buss to measure charge current. S3 connects appropriate shunt resistor (R3-R6) across M1. When S2 is set to "test," R2, M1 and selected shunt resistor (R3-R6) are connected across battery terminals. M2 then indicates battery voltage as R2 increases test current.

To simplify connections to the batteries, we mounted several different size holders on the top of the cabinet. If you have a specific need, say, to charge ten D cells together, the holders can all be for D cells.

Construction. Our Analyst is built in an 8 x 8 x 8-in. sloping-panel cabinet. All com-

ponents (except those in the power supply, which are mounted on a 4 x 6 1/8 x 1-in. open-end chassis) are mounted on the cabinet's front panel.

Note that transistor Q1 is mounted under the chassis so connections can be made to its terminals on top of the chassis. The entire circuit is isolated electrically from the cabinet to prevent damage to Q1 should a test lead touch the cabinet.

As supplied, the transistor mounting kit does not include an insulator for Q1's threaded mounting stud, which also is the collector lead. Drill an oversize hole (9/16 in.) for the threaded stud. Then insulate the stud with a few turns of electrical tape or an insulating sleeve. Make no connections to Q1 until you measure the resistance between its base, emitter and collector leads and the chassis. If you measure any resistance at all track down the trouble before going on.

The specified meters (substitutes are not permitted) must have their scales changed. To remove them, gently take off the front cover by bending back the tabs at each corner. Then remove the two screws holding

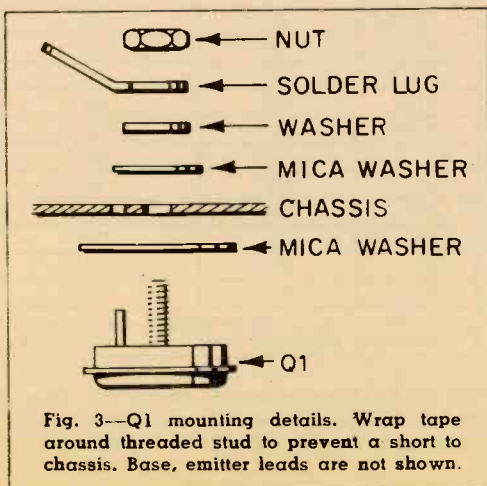

Fig. 3—Q1 mounting details. Wrap tape around threaded stud to prevent a short to chassis. Base, emitter leads are not shown.

Char-Analyst for Batteries

the scale and *slide* the scale out, taking care you don't bend the pointer.

Using rubber cement, cover the existing meter scales with the scales in Fig. 5. The 3-ma meter, M1, now has two scales: 0-3 and 0-15 ma. This provides 30, 150, 300 and 1,500-ma ranges. The 0-1 ma meter, M2, will have two voltage scales, 2.5 and 15 V.

Mount the chart in Fig. 6 on the side of the cabinet. The chart shows test currents and the 16-hr. charge currents for many popular batteries. If you plan to charge nickel-cadmium batteries, use the charge current specified by the manufacturer.

Testing. Set S2 to *test*, R2 to full counterclockwise and S3 and S4 to the appropriate current and voltage ranges. Then connect the battery to BP3 and BP4 with clip leads. Rotate R2 until M1 indicates the exact test current. Batteries that indicate above 1.2 V per cell are good. (To determine the number of cells divide the battery voltage by 1.5). An indication less than 0.8 V for each 1.5-V cell in the battery means the battery is exhausted and should be recharged. If the vol-

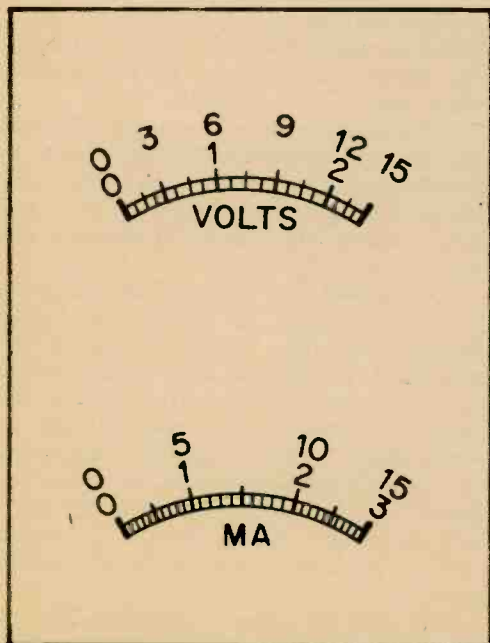

Fig. 5—Top scale is for M2, bottom is for M1.

tage is between 1.0 and 1.2 V per cell, the battery can be pepped up with a charge at about half the recommended rate (precise charge rate is determined by experience).

Charging. The recommended charge current usually is 150 per cent of the energy removed, distributed over a 16-hr. period. For example, suppose a D cell was used in a circuit that pulled 300 ma for ten hrs. This amounts to 3 ampere-hours (ampere-hours, A-H, = current in amperes x time in hours). To recharge the battery, 150 percent of the exhausted energy of 3 A-H (4.5 A-H) must be put back in. At the recommended charge time of 16 hrs. the charge current (A-H divided by time) is 4.5/16 or 0.28A (about 300 ma).

To charge, set S2 to *charge* and connect the batteries to BP1 and BP2. Turn R1 from the full counterclockwise position until power switch S1 clicks on. Set S3 to the appropriate charge-current range and adjust R1 until the exact current is indicated on M1. Keep your eye on the current for the first minute or so to prevent its creeping to too high a value.

Note. Always set S3 to the current range *before* testing or charging. Since the shunts affect the operation of both circuits it is normal for S3 not to decade accurately when switching from range to range when testing or charging. For example, if testing at 200 ma with S3 set to the 300-ma range, the test current might shoot up to 500 ma when S3 is changed to the 1.5-A position.

TYPICAL TEST AND CHARGE CURRENTS		
Battery Voltage	Test Current (ma)	Charge Current for 16 hrs. (ma)
1.5(AAA)	30	20
1.5(AA)	50	50
1.5(C)	50	150
1.5(D)	270	150
1.5(D)*	50	150
4.5	100	150
4.5*	50	80
6.0**	270	150
6.0*	50	50
9.0*	9	16
13.5	9	16

*Transistor radio or electronic-applications type
 **Lantern or heavy-duty type

Fig. 6—For future reference, attach this chart of typical battery test and charge currents either on the front or on the side of the charger's cabinet.

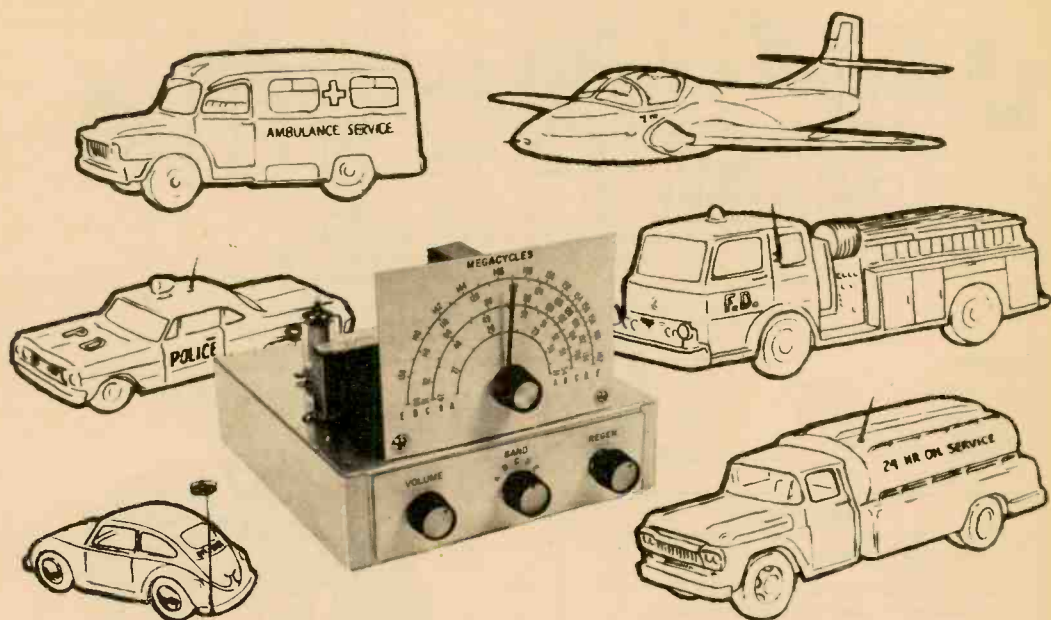

Band-Switched VHFer

Our rig tunes hot listening from 26 to 162 mc without annoying coil changing.

BY CHARLES GREEN, W6FFQ

IT started as a sad story—Hans Christian Andersen's tale of the Ugly Duckling. But it had a happy ending after the swan grew up and found that in his own right he, too, was a real swinger.

So it is with the VHF portion (30-300 mc) of the radio spectrum. Once neglected, the VHF frequencies now are radio's most wanted. They're loaded with good listening. The line-of-sight characteristic of VHF transmissions has changed from a handicap into a blessing in disguise. Reason is, it permits constant day-and-night coverage of local areas. This mode of transmission has proven itself to be ideal for commercial and special-service broadcasting of many types.

With our three-tube VHF receiver, you can listen in on the most active parts of the VHF spectrum. Band *A* (26-31 mc) covers the Citizens Band and the 10-meter ham band. Band *B* (47-54 mc) tunes police and fire departments, as well as the 6-meter ham band. Band *C* (91-107 mc) covers most of the FM broadcast band. Band *D* (114-134 mc) lets you listen to the aircraft band and Band *E* (137-162 mc) covers the Civil Air Patrol, the 2-meter ham band and public-safety vehicles.

Our receiver's circuit uses a frame-grid triode in a reflexed grounded-grid RF stage. This stage feeds a superregen detector followed by a power amplifier stage that drives an external speaker. The receiver, with its AC power supply, is built on a 7 x 7 x 2-in. aluminum chassis. Construction is straightforward and the coils are easy to wind.

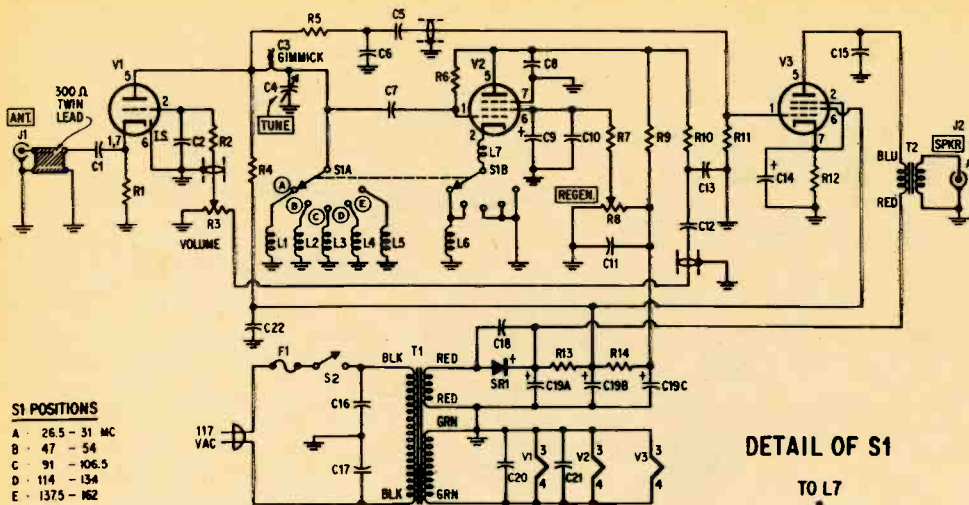

S1 POSITIONS

- A 26.5 - 31 MC
- B 47 - 54
- C 91 - 106.5
- D 114 - 134
- E 137.5 - 162

DETAIL OF S1

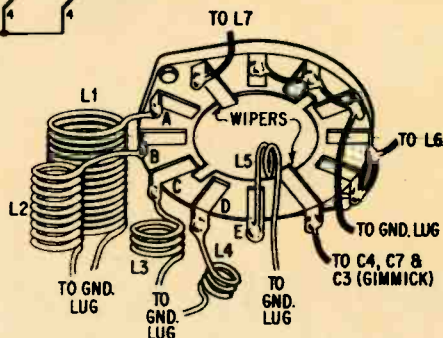

PARTS LIST

Capacitors: 1,000 V ceramic disc unless otherwise indicated

- C1, C7—47 μf
- C2, C10, C11, C20, C21, C22—470 μf
- C3—Gimmick capacitor; three turns of hookup wire (see text)
- C4—6.5-13 μf variable capacitor (Lafayette 32 C 0917)
- C5, C12, C15—.01 μf
- C6, C13, C16, C17, C18—.001 μf
- C8—100 μf
- C9—5 μf , 150 V electrolytic
- C14—10 μf , 15 V electrolytic
- C19A, B, C—50/30/20 μf , 150 V electrolytic
- F1— $\frac{1}{2}$ A pigtail-lead fuse
- J1, J2—Phono jack
- Coils: No. 16 enameled wire (see text)
- L1—15 turns, 9/16-in. I.D., $\frac{1}{4}$ and $\frac{1}{2}$ -in. leads
- L2—9 turns, $\frac{3}{8}$ -in. I.D., $\frac{3}{8}$ -in. leads
- L3—3 turns, $\frac{3}{8}$ -in. I.D., $\frac{3}{8}$ -in. leads
- L4—3 turns, $\frac{1}{4}$ -in. I.D., $\frac{3}{8}$ -in. leads
- L5—1 $\frac{1}{2}$ turns, $\frac{1}{4}$ -in. I.D., $\frac{3}{4}$ -in. leads
- L6—24 μh RF choke (J. W. Miller RFC-28, Lafayette 34 C 8971). Remove 10 turns from each end (see text)
- L7—1.72 μh RF choke (J. W. Miller RFC-144, Lafayette 34 C 8973)

Resistors: $\frac{1}{2}$ watt, 10% unless otherwise indicated

- R1—270 ohms
- R2, R7—10,000 ohms
- R3—1 megohm audio-taper potentiometer with SPST switch
- R4, R5, R10—120,000 ohms
- R6—8.2 megohms
- R8—50,000 ohm linear-taper potentiometer
- R9—220,000 ohms
- R11—1 megohm
- R12—470 ohms, 2 watts
- R13—1,800 ohms, 2 watts
- R14—15,000 ohms
- S1A, S1B—2-pole, 5-position ceramic rotary switch (Mallory 173C, Lafayette 30 C 4058)
- S2—SPST switch on R3
- SR1—Silicon Rectifier, minimum ratings: 200 ma, 400 PIV
- T1—Power transformer; secondaries: 125 V @ 15 ma, 6.3 V @ 0.6 A (Allied 54 A 1410 or equiv.)
- T2—Output transformer; primary: 10,000 ohms; secondary: 4 ohms (Allied 54 A 1448 or equiv.)
- V1—6ER5 tube
- V2—6CB6A tube
- V3—6AK6 tube
- Misc.—2 x 7 x 7-in. aluminum chassis, 7 x 7-in chassis bottom plate, 7-pin tube sockets (3), terminal strips

Band-Switched VHFer

Construction

Tape a piece of graph paper over the chassis top and front. Lay out on the paper all chassis holes, scaling your dimensions from our under-chassis photo. Do not spread out the parts. Keep them in the same places shown in the pictorials. As in all high-frequency circuits, parts placement and wiring are critical—especially around bandswitch S1.

The bracket which supports tuning capacitor C4 on top of the chassis is made from a piece of scrap aluminum. The dimensions are not critical so long as the bottom of C4 is about 3/16-in. above the chassis. Our bracket is 1 $\frac{1}{2}$ -in. high by 2 $\frac{1}{4}$ in. wide; it has a $\frac{3}{8}$ -in. mounting foot.

Position the ground lugs for coils L1 through L5 on a line between bandswitch S1 and V2's socket. Wind the coils on either wooden dowels or drills. The number of turns, inside diameter and lead lengths of the coils are detailed in our Parts List. Be sure the coil lead lengths are as specified and the coils are mounted as shown in the dia-

Incoming signal amplified by grounded-grid stage (V1) is fed via C3 and C7 to superregen detector stage (V2). Audio is fed through low-pass filter (R10-C13) back to V1. Amplified audio is fed by low-pass filter (R5-C6) to audio amplifier V3.

gram under the schematic.

The coil-winding information is approximate. This means the tuning range of each coil will vary, depending on the way you wind it (wind each coil as shown in the detail pictorial of S1 under the schematic) and your wiring layout. Do not crimp the wire leads of the coils on the bandswitch lugs and ground lugs. Just solder them so they can be detached easily. This will pay off later when you are calibrating the dial and wish to adjust the tuning range of each coil.

Carefully unwind ten turns of wire from each end of L6 and solder the remaining wires to the leads coming out of the ends of the form. This modification is necessary to raise the self-resonant frequency of the coil at the

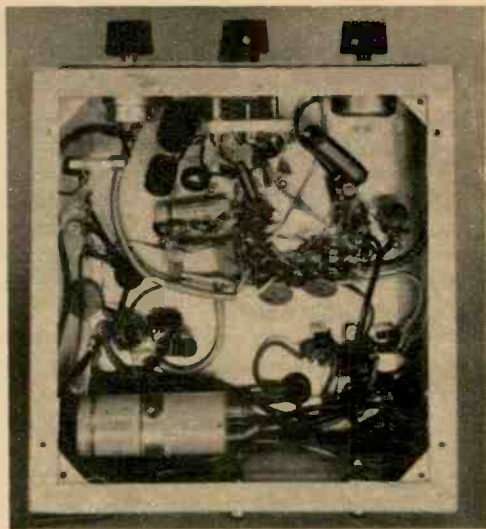

Because of operating frequencies it is important to duplicate our layout. Multiply dimensions in photo by 3.1 to lay out 7 x 7-in. chassis. Wiring details of S1 and coils are under schematic.

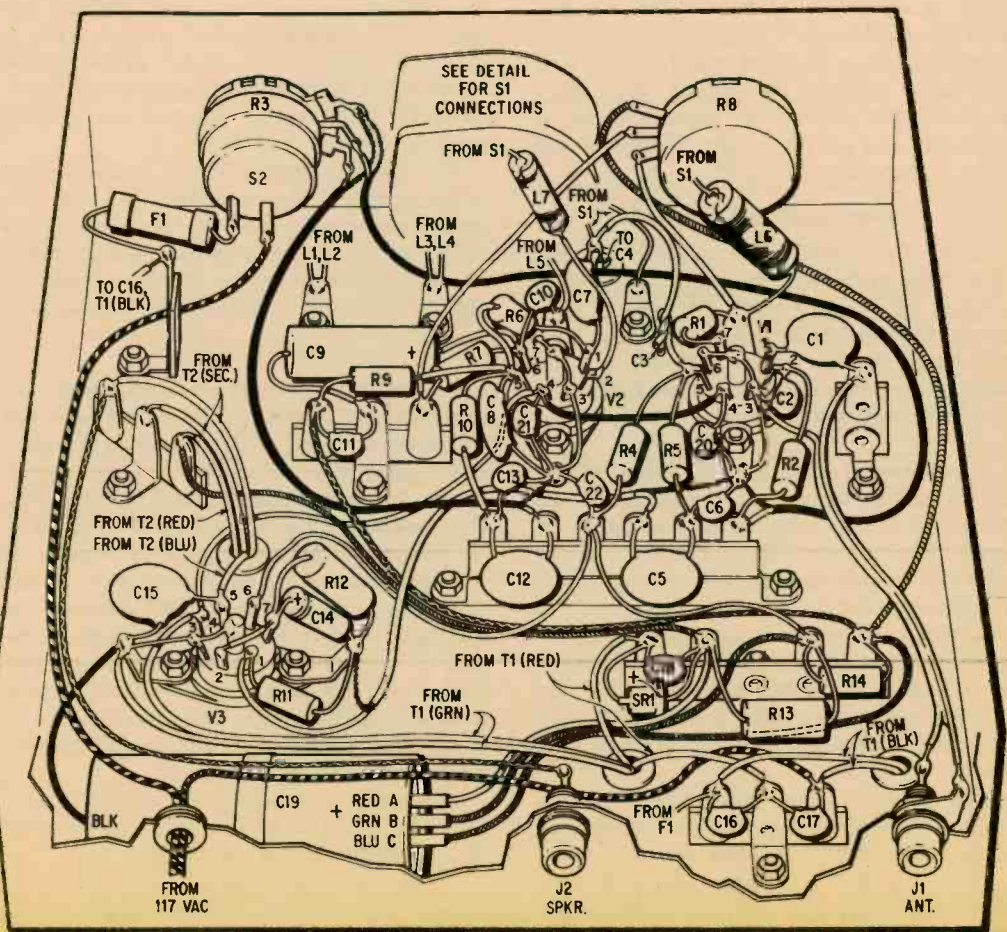

Band-Switched VHFer

top end of the 6-meter band (above 54 mc).

Fabricate gimmick capacitor C3 by soldering a length of hookup wire to pin 5 of V1 and another length of wire to the appropriate lug on S1. Run the wires in a straight line toward each other and twist them together three turns. Cut off the excess and make sure the ends do not touch.

Use spaghetti over the fuse and its leads, as well as on all resistor and capacitor leads that cross, to prevent shorts. Position the wiring as shown in the photo and keep component leads to tube sockets as short as possible. Use a short length of 300-ohm twinlead to connect J1 to the mounting strip to which C1 is connected.

After the chassis wiring is completed, cut a piece of cardboard and fit it on front of the receiver over the tuning-capacitor's shaft. Mount it on the chassis with small brackets at each side. Our dial is 3½ x 5 in. and is made of heavy bristol board. Make a dial pointer by soldering a length of heavy wire to a small piece of sheet metal. Then bend the metal around the tuning capacitor's large-diameter shaft. Cut another piece of cardboard and put it over the controls on the front of the chassis.

Calibration and Operation

Install the chassis bottom plate and the tubes. Plug in the receiver, turn it on and let it warm up a few minutes. Set *volume* control R3 full clockwise until you hear the typical superregen hiss. This indicates the detector stage is working on at least one band. Check R8's action on other bands selected by S1.

If you have a signal generator that covers the receiver's frequencies, connect it to antenna jack J1 and calibrate the dial lightly in pencil. Then remove the dial and ink in the markings, or use transfer type to make a professional-looking dial.

If necessary, the coils can be squeezed or compressed to change frequency coverage. Or you can remove the coils and either add or remove turns to change the range. A grid-dip meter is helpful in setting up each coil's range.

The antenna is not critical; anything from a 6-ft. length of hookup wire (for strong stations), to an outside TV antenna will work.



Rear view of receiver. V1 is at top, left. V2 is in center. V3 is at right below T2. T1 is at lower left. Note tuning capacitor's mounting bracket.

Some signals (particularly the aircraft and emergency-service bands) are vertically polarized; an outside 2-meter ground plane is good for these bands. Refer to the *Radio Amateur's Handbook* for construction details on VHF antennas. Or you can buy a commercial antenna.

The receiver drives a 3.2- to 8-ohm external speaker. *Regen* control R8 and the tuning capacitor should be readjusted each time you tune a station until signal is strongest. FM stations must be tuned in on either side of the signal to achieve slope detection.

How it Works

Antenna signals at J1 are amplified by the grounded-grid reflex circuit of V1 and fed by gimmick capacitor C3 to the grid of superregen detector V2. Coils L1 to L5 are tuned by C4 for each band selected by S1A. The RF chokes, L6 and L7, are switched by S1B for the proper feedback for each band.

Regen control R8 varies the gain of the detector stage. The detected audio is fed through low-pass filter R10-C13 back to the grid of V1. V1 also amplifies the audio and feeds it via low-pass filter R5-C6 to the grid to power amplifier V3. The audio output of V3 is coupled through output transformer T2 to external-speaker jack J2.

Power for the circuits is supplied by T1, SR1 and the R/C filter comprising resistors R13, R14 and C19A, B, C.

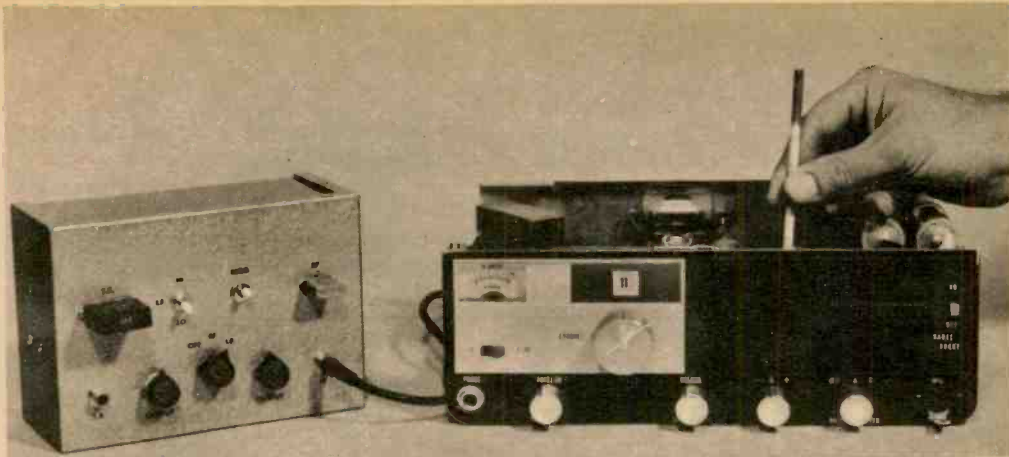

CB Alignment Generator

You can peak both RF and IF circuits with this 3-transistor instrument.

By HERB FRIEDMAN, KBI9457

IT'S the receiver section of a CB rig that makes the difference between reliable and undependable communications. You can have the biggest antenna on the street but if the receiver's RF and IF stages aren't tuned up perfectly you'll simply be spinning your wheels.

So far as the transmitter is concerned, even if its output decreases slightly or the modulation percentage drops from, say, 85 to 50 the loss will often go unnoticed. But if the receiver isn't up to snuff the effect will be apparent immediately. A loss in input sensitivity means you won't hear weak signals at all. And a change in IF alignment, caused by aging components, will lead to annoying adjacent-channel interference.

While normal wear and tear and component aging have only slight effect on transmitter circuits, receiver alignment can be altered drastically. All it takes is a simple receiver alignment job to produce a startling improvement in performance.

While most service-grade RF signal generators could be used for alignment, the job should be done with a crystal-controlled generator, such as our CB Alignment Generator.

Our generator provides modulated or unmodulated crystal-controlled IF signals of 455 kc or any frequency from 1300 to 2000 kc. And the generator also supplies an RF (26.96-27.25) signal produced by a third-overtone CB transmit crystal. The output

levels of both the IF and RF oscillators are adjustable—maximum output being about 150,000 microvolts.

The output frequencies are user-selected. It is necessary only to plug in the crystals needed for your particular receiver. The generator is designed for single- or double-conversion receivers. It should not be used with receivers that have frequency-synthesizing circuits. Such rigs generally require special test equipment.

Figure 2 is the generator's schematic. Note that there are three separate circuits. Q1 is the IF oscillator. When S1 is in the *high* position, an IF signal will be produced in the 1300-to-2000-kc range, depending on the crystal in SO1. Plug a 455-kc crystal in SO1, set S1 to *low*, and the output frequency will be 455kc.

Transistor Q3 is the RF oscillator. Plug a third-overtone crystal into SO2 and you'll get a signal anywhere in the Citizens Band.

Transistor Q2 is the modulator oscillator. When S2 is open the modulator is disabled and either Q1 or Q3 will produce unmodulated IF or RF output signals. When S2 is closed, battery voltage is applied to the modulator and the RF and IF signals will be modulated about 25 per cent by a 1-kc signal.

Switch S3 controls power to *either* the RF or IF oscillators. Simultaneous RF and IF outputs cannot be obtained.

CB Alignment Generator

Construction

To insure proper operation, the generator must be built exactly as shown in the pictorial

and photographs. Use only the components specified—make no substitutions.

The generator is built on the main section of a 7 x 5 x 3 inch Minibox. Start construction by mounting the oscillator-board support brackets. Then install all the components on

PARTS LIST

B1—6-V battery (Burgess Z4 or equiv.)
Capacitors: 10 V or higher
 C1—50 μf silvered mica
 C2—15 μf silvered mica
 C3,C4,C5—.05 μf , ceramic disc
 C6—.25 μf , ceramic disc
 C7—50 μf , 10 V electrolytic
 C8—25 μf silvered mica
 C9,C10—.001 μf , ceramic disc
 C11—.5 μf , 600 V temperature compensating tubular (Centralab Type TCZ, Lafayette 33 R 2131 or equiv.)
 J1,J2—Phono jack
 L1—3.46-5.8 mh adjustable RF coil (J.W. Miller 21A473RB1, Lafayette 34 R 8886 or equiv.)
 L2—RF coil wound on J.W. Miller 4400 form (Lafayette 34 R 8752 or equiv.) See text
 Q1—GE-1 transistor (General Electric)
 Q2—2N217 transistor (RCA)
 Q3—2N274 transistor (RCA)
Resistors: $\frac{1}{2}$ watt, 10% unless otherwise indicated
 R1—330,000 ohms
 R2,R9—5,000 ohm linear taper potentiometer

R3—270,000 ohms
 R4,R7—10,000 ohms
 R5—150 ohms R6—220,000 ohms
 R8—560 ohms
 S1,S2—DPDT subminiature toggle switch (Lafayette 99 R 6162) See text
 S3—2 pole, 5 position subminiature rotary switch, Lafayette 99 R 6164 or equiv.)
 SO1—Crystal socket for type FT-241 crystal.
 SO2—Crystal socket for type HC-6/U crystal.
 T1—Transistor output transformer; primary 500 ohms, center tapped. Secondary: 3.2 ohms. (Argonne AR-119, Lafayette 33 R 8558)
 XTAL-1—IF-frequency crystal. Available from Texas Crystals, 1000 Crystal Drive, Fort Myers, Fla. 33901. Prices are postpaid. 455 kc: Type TC-21, .01%, \$1.25. 1001 to 1600 kc: Type TC-23, \$4.50. 1601 to 2000 kc: Type TC-23, \$3.55. Specify frequency when ordering.
 XTAL-2—Third-overtone CB transmit crystal
 Misc.—Perforated board, flea clips, 7 x 5 x 3-in. Minibox

Fig. 1—Leads shown as broken lines go from front-panel controls to board's underside. Sockets SO1, SO2 and switches S1 and S2 are mounted above the board. J2,R9,S3,R2 and J1 are installed under the board.

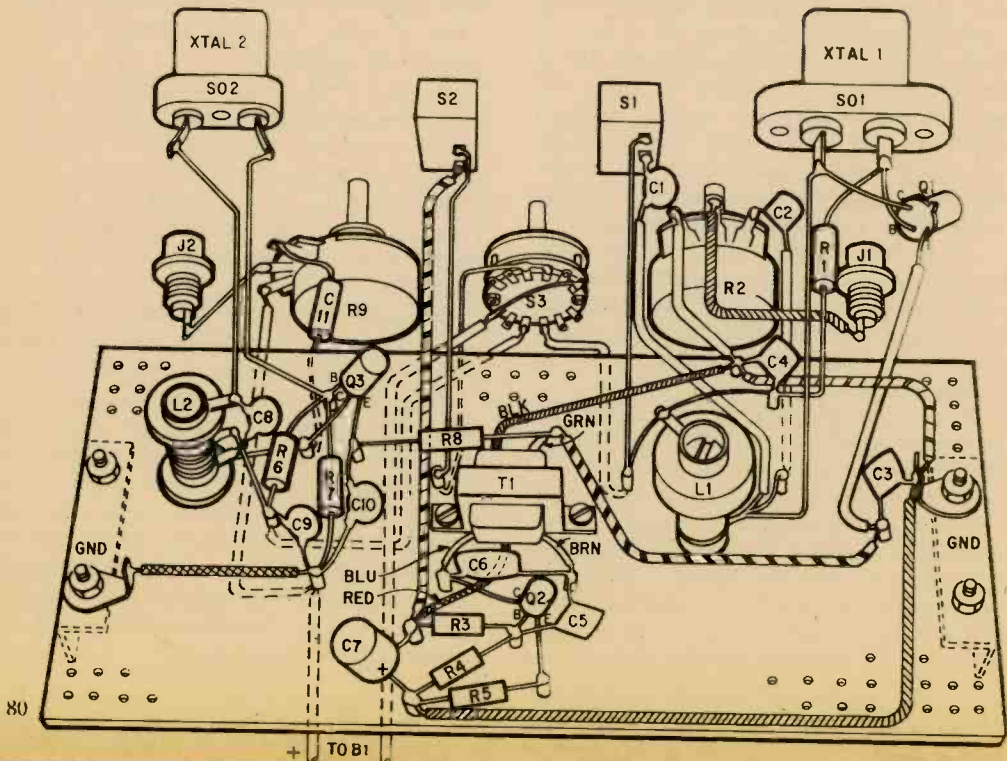

CB Alignment Generator

Fig. 4—Underside of circuit board. Note the board's mounting brackets at each side. Screws protruding through board at left and right are slug-adjustment screws of L1 and L2. Leads from components under board are wired to tips of flea clips. Wires running out of cabinet go to battery which is mounted in the cabinet's cover.

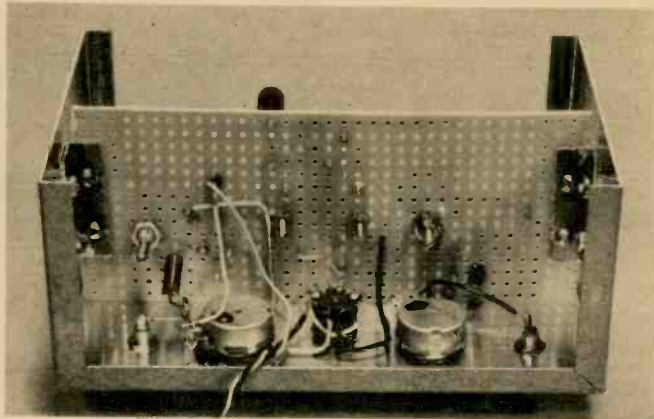

L1 is a stock coil and is used as is. Coil L2 is made by winding #22 enameled wire on a J.W. Miller Type 4400 RF coil form. Take about 2 ft. of the wire, clamp one end in a vise and pull on the other end until the wire goes dead slack (tensilized). Scrape off $\frac{1}{4}$ -in. of enamel from one end of the wire and solder it to the lug nearest the form's mounting nut. Run the wire along the form for $\frac{3}{16}$ in. and then wind six closewound turns. Bring the wire out from the form for about 2 in., fold it back to the form making a loop, twist the loop together and then wind five more close, tight turns in the *same direction* as the first six turns. Scrape off about $\frac{1}{4}$ inch of insulation from the free end of the wire and solder it to the lug at the other end of the form opposite the starting lug.

Scrape the insulation off the loop and solder the two loop wires together. Then cut off the excess, leaving a $\frac{1}{4}$ inch stub—this is L2's tap.

To avoid damage when soldering, assemble the oscillator board in this order: S1 to L1 and the remainder of Q1's circuit (do not connect Q1's emitter yet). SO2 to L2, C8, then the remainder of Q3's circuit with the exception of R6. Q2's entire circuit, T1's green lead to Q1's emitter and R8 from Q3's emitter to T1's green lead.

Finally, complete the wiring on the underside of the oscillator board as shown in Fig. 1. Mount the battery in a standard D-cell holder centered at the bottom of the cabinet cover. Make certain it is at the bottom so it doesn't short any of the terminals sticking through the board. Connect only B1's positive (ground) lead. Do not connect B1's negative lead to S3, as a meter must be con-

nected in this part of the circuit for final adjustment.

Adjustment

Connect an 0-10 ma DC milliammeter between B1's negative lead and S3's wiper—the meter's positive terminal connects to B1 and the meter's negative terminal goes to S3. Adjust L1's slug-adjustment screw so it sticks out $\frac{3}{8}$ in. Do not plug a crystal into SO1. Set S3 to IF and note the meter indication—it should be about 0.8 ma. If you are using a 455-kc crystal, close S1 and insert the crystal—the meter indication should drop to about 0.5 ma.

If the meter's indication does not fall, the oscillator isn't working. Try adjusting L1's slug until the meter indication drops with the crystal in the socket. When L1 is adjusted for 455 kc, it will also be aligned for crystals in the 1200- to 2000-kc range. If you plan to use crystals for only 1200- to 2000-kc, the $\frac{3}{8}$ in. slug adjustment should require no further change.

Next, plug a third-overtone CB transmit crystal (preferably a center-band frequency like channel 11) into SO2 and set S3 to the RF position. Adjust L2's slug-adjustment screw until the meter indication *rises*. Then try a low-(channel 1) and a high-(channel 23) frequency crystal. Note the meter indication with no crystal in SO2, then plug in the crystal again. If the high- or low-band crystal does not cause an increase in the meter indication, readjust L2's slug very slightly until there is an increase in meter indication regardless of the frequency of the crystal in SO2.

Finally, with crystals plugged in, close modulation-switch S2. The meter indication,

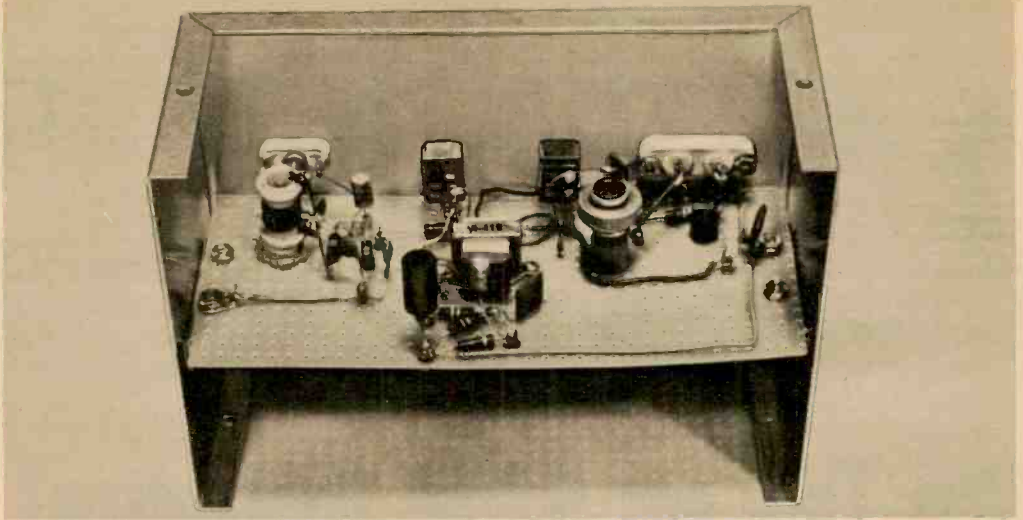

Note that the installed oscillators are in three distinct groups: RF oscillator on left, IF on right, and modulator oscillator in center foreground. Below, drilling template for cabinet controls (front view).

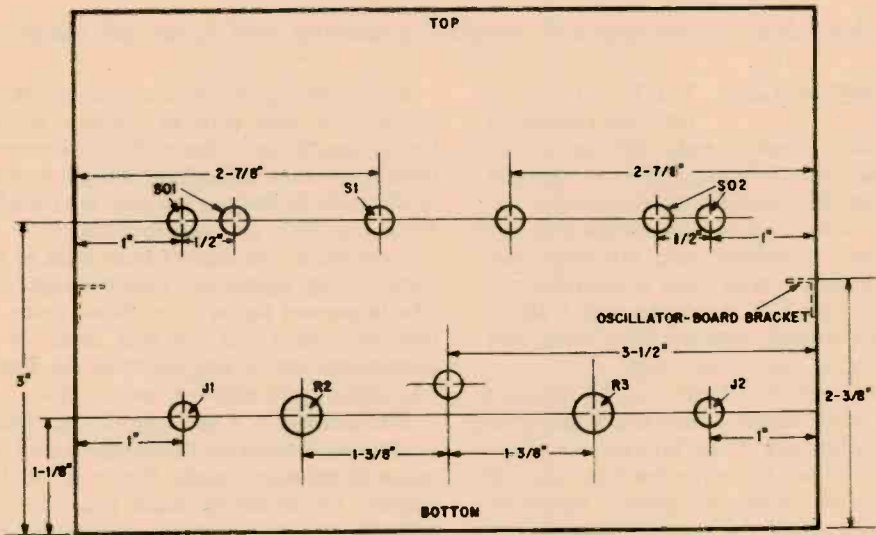

with S3 in either the IF or RF position, should increase by 3 to 5 ma. If it fails to increase there is a wiring error in Q2's circuit.

Using The Generator

Connection between the generator and the equipment being serviced should be made with coax cable such as RG58/U. To align an IF amplifier use a modulated signal and align the receiver for maximum audio output (in this case you must reduce the generator's output to the minimum usable value to prevent the receiver's AVC from masking

alignment changes). Or, use an unmodulated signal and adjust for maximum receiver AVC voltage.

Similarly, for RF alignment, align either for maximum audio output from the receiver or maximum AVC voltage. Many lower-cost receivers can be aligned to a center channel such as channel 11 or 12. Some receivers will require two-point alignment on channels 1 and 23, while some receivers must be aligned to channel 1, 11 and 23. In every case, always follow the alignment instructions supplied with the rig. 

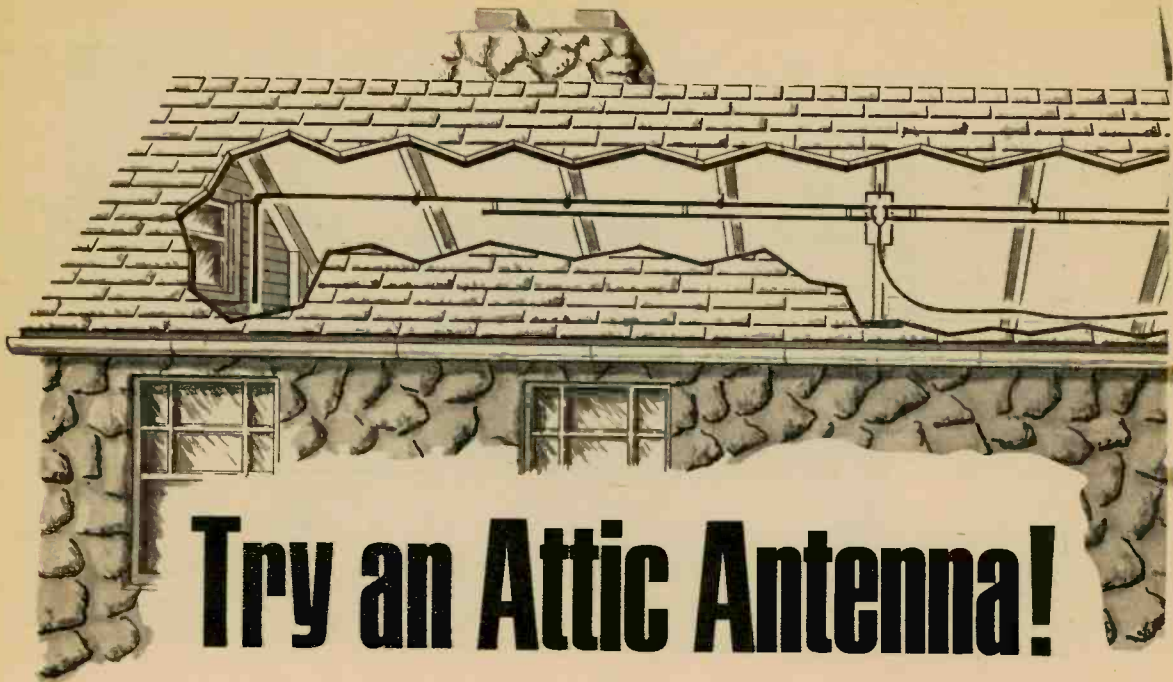

Try an Attic Antenna!

It's invisible, solves space & weather problems and tunes all bands!

By **LEN BUCKWALTER**, **THOUGH** safe from the ravages of summer heat, winter winds, driving rain or pelting hail, this swinging skyhook manages to bring in the most-distant short-wave stations. The attic location also means that our multi-bander is hidden from the suspicious eyes of neighbors who think a receiving antenna can cause TVI. Along the way, it eliminates tree-climbing, erection of a tower and purchase of a 2-acre back yard.

Another important feature is that it *tunes* the short-wave bands, unlike many antennas that simply lie there. Take, for example, those that are described in the instruction manuals packed with communications receivers. You'd think after reading the descriptions that all it takes is a simple long-wire or compromise-length half-wave dipole to pull in stations.

Not so, unless the only stations you're after are 250 kilowatts like the BBC or the Voice of America. Use an antenna like one of those to try for Radio Pakistan or Outer Mongolia and you just might go to Helsinki before you could find them!

In addition to building up signal levels as a half-wave dipole at the higher frequencies—where it counts—our antenna becomes a conventional long-wire antenna at the flip of a switch.

How's through-the-roof reception? No different from that with an outdoor antenna. Radio signals don't know the difference between a fir stud, an asphalt shingle or a hole in the wall. So long as the roof isn't made of metal, doesn't contain insulation in foil-covered bags, and doesn't have a lot of electrical wiring, signals will pass through freely. The important factor is available space. But read on and you'll see that some of our dimensions can be juggled to fit the antenna into almost any attic—or even a silo.

The antenna is a multiple dipole. That is, it consists of separate tuned dipoles for four major short-wave bands. You can build the antenna for whatever bands you want. Our table shows several short-wave bands, their frequencies and half-wave dipole antenna lengths.

A novel feature is that all elements of our antenna are tied together at the center. This reduces the number of feedlines to just one, a coax cable, and eliminates bandswitching. The appropriate elements become active naturally and automatically on the frequency for which they're cut.

For those who raise eyebrows at the thought of the multiple connection to the cable and possible mismatching, rest assured. Despite the common connection, the dipoles are decoupled electrically from each other

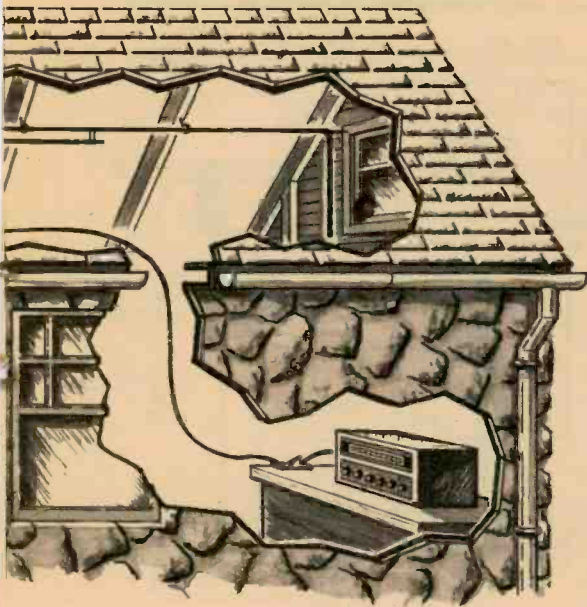

because of the different lengths. The result is that each dipole presents about a 70-ohm impedance to the 73-ohm coax cable.

To keep construction simple we've used a piece of 300-ohm TV twinlead for each pair of dipoles, or two bands. Both 19-meter and 16-meter dipoles, for example, are made from a single 31-ft. length of twinlead.

Building it. First, cut a length of twinlead to the 19-meter length (30 ft., 6 in.), then cut short one wire in the ribbon to the 16-meter length (26 ft., 4 in. that is, 25 in. shorter on each end). In similar fashion, cut another length of twinlead for 31 meters (48 ft., 6 in.) and cut one wire in the twinlead for 25 meters (39 ft., 6 in.).

Now to fit the antenna in your attic. If you have a ranch-type home with a long attic you might have room to include a 65-ft. dipole for 41 meters. Or, if you inhabit a bowling alley, there might be room for a real long 60-meter dipole (95 ft., 5 in.). But these are exceptional cases. Chances are, you'll have to switch to long-wire, rather than dipole operation, on these lower-frequency bands.

This explains the function of the knife switch shown at the receiver end of the coax in our diagram. Throwing it to *long-wire* means the coax shield is disconnected from ground and connected to the receiver's antenna terminal. The result is a long-wire antenna which picks up energy all along

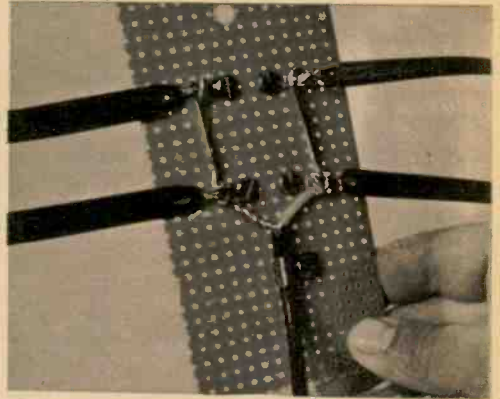

Board at center where twinlead, coax join. Dipoles can be added for other bands so long as dimensions in diagram on last page are adhered to.

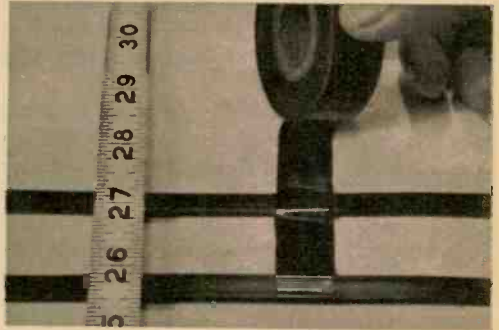

Tape wrapped between twinleads provides support and 1-in. spacing between each pair of dipoles. Space the twinlead with tape every 2 ft.

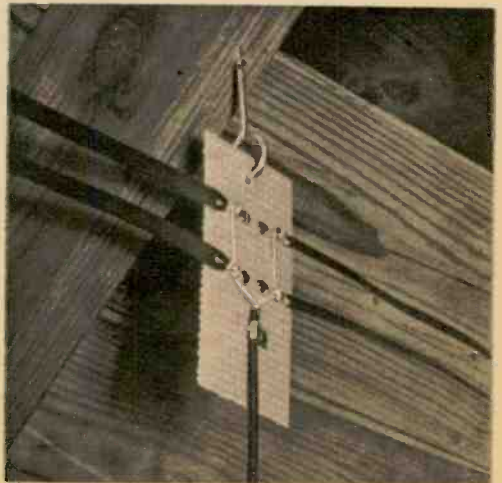

We suspended our board from rafter, which just happened to be in center of roof, with a screw-in TV standoff. A home-brew hook will work, too.

BILL OF MATERIALS

300-ohm twinlead, as required
 RG59/U coax cable, as required
 Twinlead stand-off insulators, as required
 SPDT knife switch
 Plastic electrical tape (Scotch No. 33 or equiv.)
 2 3/4 x 5 1/2-in. piece of phenolic, Bakelite or plastic board, solder lugs
 Cable clamp, 6-32 screws and nuts

the coax, plus the combined dipole elements. In other words, the entire antenna installation becomes a conventional long-wire antenna.

Long-wire operation on the lower-frequency bands won't result in much loss in signal. It is the higher-frequency bands that need the benefit of a resonant half-wave dipole. Ample signal should be picked up at 41 and 49 meters with the antenna operating as a long-wire.

Thus, the longest attic dimension required for the antenna we show is about 95 feet for the 60-meter band. If you're tight for this amount of space, here are two possible solutions, the first based on the fact that a dipole antenna picks up most of the signal near its center. The ends are mainly for resonating the dipole on the frequency for which it's cut. It little disturbs the antenna if both ends drop straight down for about 20 per cent of the total length. For the 31-meter band this is about 10 ft., or 5 ft. at each end.

You might push this a little by zigzagging the ends slightly but don't overdo it. If a dipole is bent like a pretzel it will mismatch the line and develop an erratic pickup pattern. The second trick is to bring the dipole ends outside and down the sides of the house. In many attics this can be done through vents or windows.

Since a dipole is bidirectional, tending to be most sensitive in the two directions broadside to or facing the station, give a little thought to orientation. As one sage said about extremely long dipoles and the problem of directionality—simple, just turn the house. Until someone markets a suitable house rotor, there'll have to be some compromise. If Europe, say, is to the east or west of your location, a north-south running attic would provide the best orientation. But short-wave signals also have an affinity for taking the short hop over the poles—which suggests an

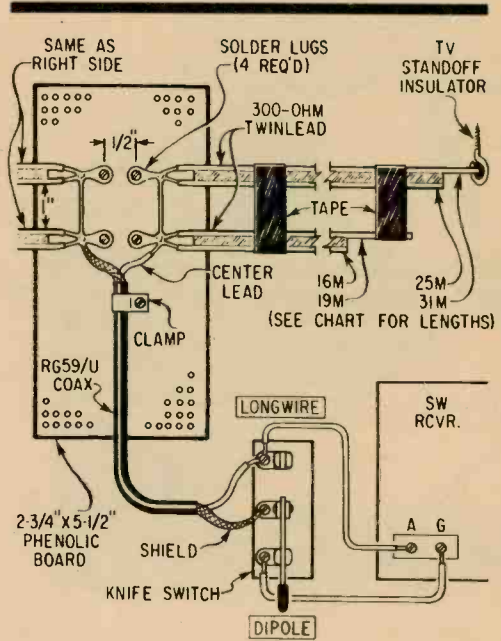

Center-board dimensions. Each piece of twinlead contains two dipole antennas. Slit wire on the long dimension, then cut off the shorter antenna.

east-west antenna. Again, it's a matter of compromise.

Other installation details are shown in the photographs. TV standoffs and friction tape support the elements and eliminate sag. During installation try to avoid close proximity to masses of metal which will reduce antenna efficiency. Such things as rain gutters just outside the roof, plumbing, electrical wiring in attic walls, floor and ceiling will affect performance adversely.

Short-Wave Bands and Half-Wave Dipole Lengths		
SW Band (meters)	Frequency (mc)	Total Length (ft.-in.)
11	25.60-26.10	17-9
13	21.45-21.75	21-7
16	17.70-17.90	26-4
19	15.10-15.45	30-6
25	11.70-11.975	39-6
31	9.50-9.775	48-6
41	7.10-7.300	65-0
49	5.95-6.200	78-0
60	4.75-5.060	95-5

New! Build a Gate-Dip Oscillator

By CLARE GREEN, W6FFS

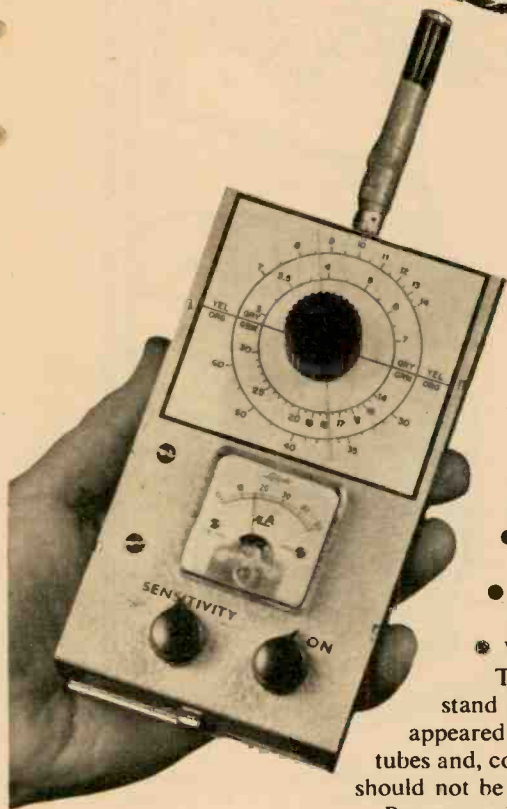

ASK the ham who owns one and he'll tell you a GDO (grid-dip oscillator) is the most useful test instrument he has in his shack. For the money, it's impossible to beat a GDO when it comes to building, servicing and tuning up transmitters and receivers. Take a look at some of the things it can do:

- Serve as a calibrated signal generator.
- Function as a local oscillator when you are troubleshooting a receiver.
- Indicate a signal's relative strength.
- Determine the resonant frequency of such tuned circuits as filters, traps, antennas, feedlines and such.
- Operate as an oscillating detector for making frequency measurements.
- Work as a modulation monitor.

The abbreviation GDO, of course, always has been known to stand for *grid-dip oscillator*. But in the last few years GDOs have appeared on the market that are solid state. This means they have no tubes and, consequently, there are no grids. Therefore, these instruments should not be called GDOs.

But our solid-state dipper *can* be called a GDO since the letter G stands for gate—the control element in the instrument's field-effect transistor.

Basically a GDO unit is a very accurately calibrated oscillator which includes a meter that indicates change in grid current. When an external tuned circuit is inductively coupled to the oscillator's tuned circuit (both at the same frequency), the GDO's meter indicates a drop, or dip, in grid current. This is because the external tuned circuit absorbs RF energy from the oscillator.

Our GDO, a gate-dip oscillator, uses a field-effect transistor in a circuit that works the same way as a tube GDO. It is completely portable since it is powered by a 9-V battery. It is housed in a 5¼ x 3 x 2¼-in. metal box. Four plug-in coils cover a range of 3 to 60 mc.

How it Works

Take a look at the schematic in Fig. 3. As you can see, the GDO is a simple oscillator (Colpitts) whose operating frequency is determined by C1A, C1B and the coil plugged into J1. You tune it over the range of each

Gate-Dip Oscillator

coil with dual variable capacitor C1. Built-in meter M1 indicates the change in Q1's gate current.

When an L-C circuit which is resonant at the same frequency as the GDO is located near the pickup coil (L1-L4), the external tuned circuit will absorb some of the RF energy generated by the oscillator. As a result, this pulls RF energy from the GDO and Q1's gate current drops. Consequently, M1 will indicate a lower current.

The RF produced by the oscillator is detected in Q1's gate-source circuit. The resulting DC through gate-leak resistor R1 is coupled via sensitivity control R2 to M1.

Plug a pair of phones into J2 and you disconnect M1. This converts the GDO into a heterodyne detector which you can use to determine whether or not a receiver's oscillator is working.

Construction

Because of the frequencies at which the GDO operates, parts placement and wiring are critical. Follow as closely as possible the pictorial and photos when installing components. So the dial will lie flat against the cabinet, use flat-head screws and countersunk holes to mount tuning capacitor C1 in the main section of the Minibox. Use spacers or nuts to keep C1's shaft-bearing housing from touching the cabinet. We kept C1 a quarter inch away from the panel in our model.

Mount a 1¼-in. square piece of perforated board on the bottom of C1 spaced approximately ¼-in. from C1. Install flea clips on the board, then connect and wire the components as shown in Fig. 1.

Make sure that J1 is installed so its outside shell and ground lug do not touch the cabinet. You do this by first drilling a ⅝-in.-dia. hole in the top of the cabinet. Then cut a piece of cardboard and put it between J1 and the cabinet.

Make a bracket for B1 to hold it in place. Cut out the dial in Fig. 4 and cement or tape it to the panel around C1's shaft. We used a piece of clear plastic (with a line scribed down the center and filled with ink) fastened to the knob as an indicator. Short pieces of wire cemented to the knob also work.

Refer to the coil detail drawing in Fig. 5. Cut the ⅜-in. dowels to the lengths indicated and make slots for the wires where shown. Solder a large ground lug to each phono plug

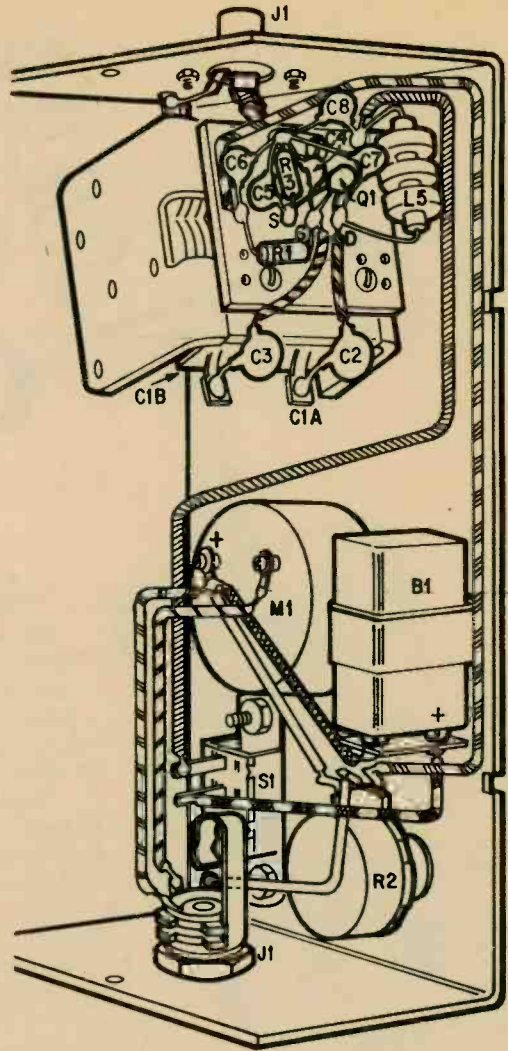
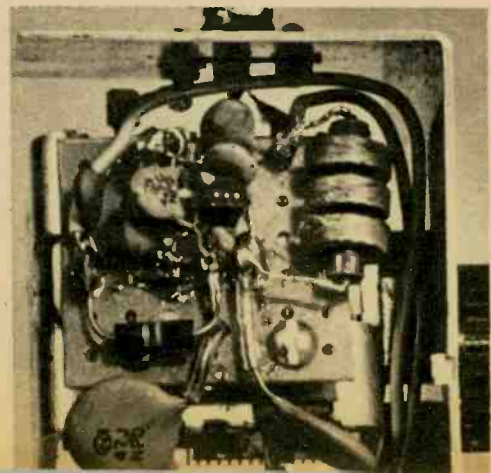

Fig. 1—It's important to install the parts associated with C1 exactly where shown on a 1¼ x 1¼-in. piece of perforated board. Mount the board on C1 as shown, keeping it ¼-in. away from C1's frame with two hex nuts. Cut a ⅝-in.-dia. hole for J1 so its ground lug doesn't touch the cabinet.



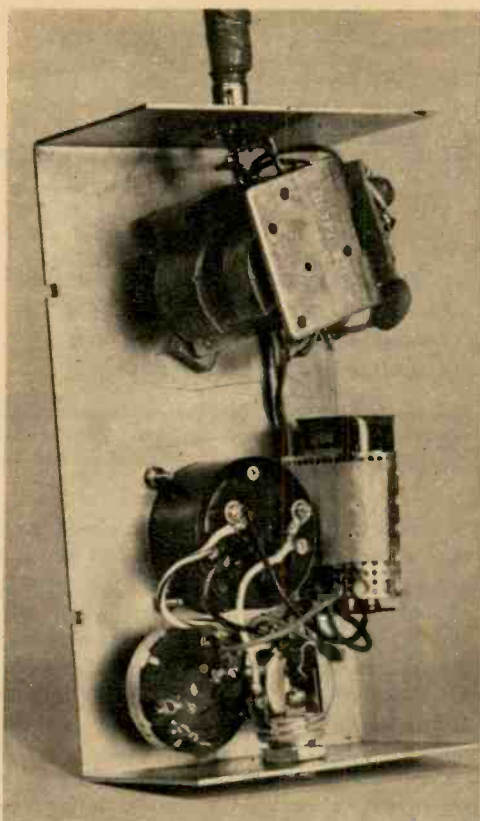

Fig. 2—Parts placement in bottom of cabinet isn't critical; however, mount tuning capacitor at top exactly as shown. We used a rotary switch for S1.

and fasten the other end of the lug to the dowel with a small wood screw. Slip a short length of spaghetti over the coil wire, then slip the wire into the center connector of each phono plug. Wind the coils as shown, keeping the wire tight. Solder the other end of the coil to the ground lug and wrap the entire coil with tape. We used colored plastic tape to identify

FARTS LIST

- B1—9 V battery (Burgess 2U6 or equiv.)
- C1A,C1B—Two-section variable capacitor; front section: 10.5-365 μf , rear section: 7.6-132 μf . (Lafayette 32 R 1101 or equiv.)
- C2,C3—47 μf , 1,000 V ceramic disc capacitor
- C4,C7—4.7 μf , 1,000 V ceramic disc capacitor
- C5—470 μf , 1,000 V ceramic disc capacitor
- C6,C8—1,000 μf , 1,000 V ceramic disc capacitor
- J1—Phono Jack
- J2—Closed-circuit phone jack
- L1,L2,L3,L4—Plug-in coil (see text)
- M1—0.50 μa DC microammeter (Lafayette 99 R 5049 or equiv.)
- PL1—Phono plug (4 reqd.)
- Q1—2N3819 FET (Texas Instruments, Allied, \$3.75 plus postage. Not listed in catalog.)
- L5—.55 mh RF choke (J.W. Miller 4649, Lafayette 34 R 8829 or equiv.)
- R1—10,000 ohm, $\frac{1}{2}$ watt, 10% resistor
- R2—10,000 ohm, linear taper potentiometer
- R3—120 ohm, $\frac{1}{2}$ watt, 10% resistor
- S1—SPST slide switch
- Misc.— $5\frac{1}{4} \times 3 \times 2\frac{1}{8}$ -in. Minibox, perforated board, flea clips, $\frac{3}{8}$ -in. dowel (10 in.).

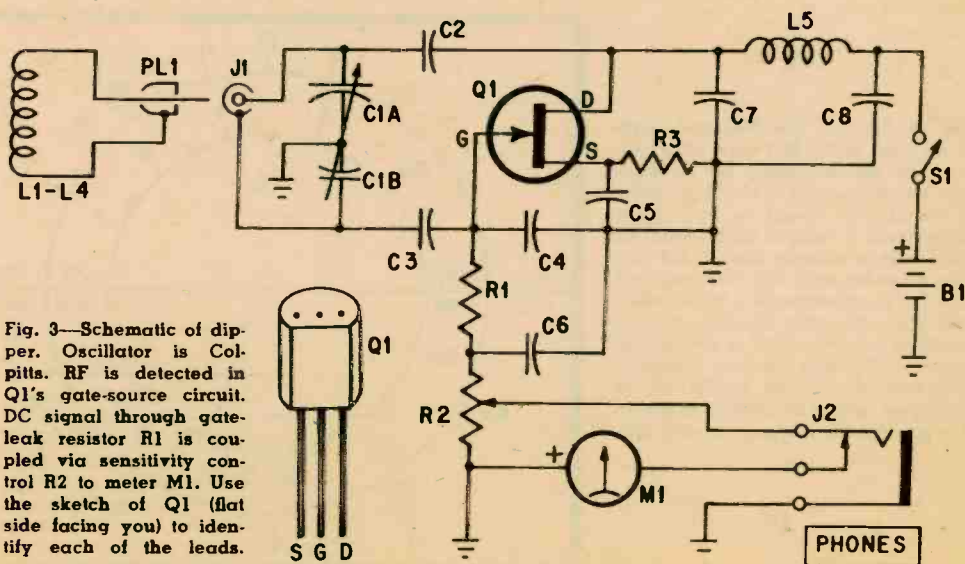

Fig. 3—Schematic of dipper. Oscillator is Colpitts. RF is detected in Q1's gate-source circuit. DC signal through gate-leak resistor R1 is coupled via sensitivity control R2 to meter M1. Use the sketch of Q1 (flat side facing you) to identify each of the leads.



Gate-Dip Oscillator

each coil and to key it to the appropriate dial scale.

Calibration

There are three ways to calibrate the dipper: the first requires a receiver(s) which tunes to 60 mc, the second requires another GDO, the third requires a signal generator.

If you have an all-band receiver, plug in each coil and tune the receiver until you hear the dipper's output signal (the receiver will go silent). Mark the GDO's dial accordingly.

We used a tube GDO to calibrate our dipper by placing the coils of the two units near each other and tuning for a dip. This calibrates the dipper under a load similar to that used in actual operation.

The third method is to couple a signal generator's output to the GDO with a two-turn coil of wire connected to the generator's output. Plug a pair of phones in J1. When the GDO is tuned to the generator's frequency, you'll hear a beat note in the phones. Start at the bottom of the frequency range so you won't accidentally tune in a harmonic.

The number of turns for each coil is approximate and may have to be changed depending on how you wire your unit. Add or subtract from the specified number of turns to change the range of each coil to correspond to the frequencies marked on the dial.

Fig. 4—Cut out this dial and paste it on your GDO. Not only will it be a good starting point for calibrating the instrument, but it will dress it up as well. Colors on each scale correspond to colored tape wound on each coil to simplify finding the correct scale for each coil. You may find the dial's calibration is a bit off when checking the unit against another GDO or receiver. This is because of slight differences in coil construction and layout, and easily can be corrected simply by adding or removing a few turns of wire from each coil.

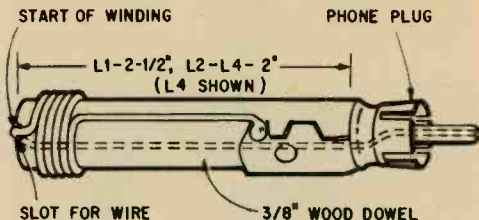
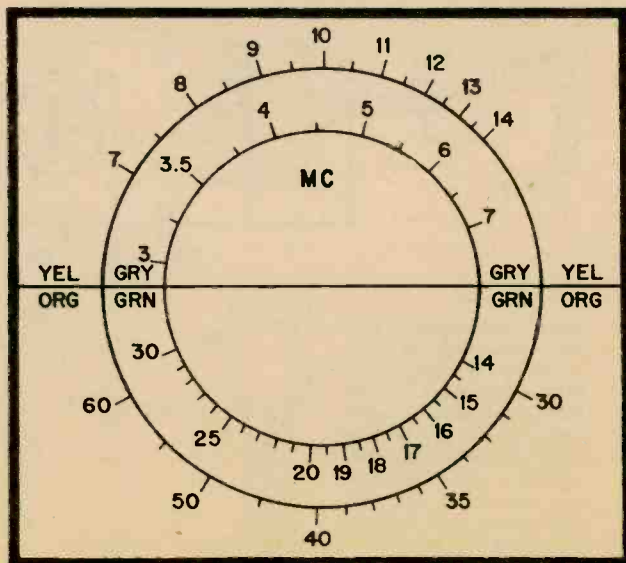

- L1-(GREY) 3-7 MC, 120 T. No. 28 ENAM. WIRE
- L2-(YEL) 7-14 MC 30 T. No. 28 ENAM. WIRE
- L3-(GRN) 14-30 MC 18 T. No. 20 ENAM. WIRE
- L4-(ORG) 30-60 MC 5 T. No. 20 ENAM. WIRE

Fig. 5—Coil details. Colors refer to tape, wrapped around wire, we used for fast identification. Plug is held on dowel with a large ground lug.

The way to use the dipper to check a coil is to adjust sensitivity control R2 so M1 indicates near to full scale. Sensitivity control R2 should be turned full clockwise when using the highest-frequency coil (30-60mc). L4. This is necessary because at this frequency Q1 is less efficient and M1 will not indicate full scale. However, the dip will be as apparent as it was at lower frequencies.

With the power off and phones plugged in, the dipper can be used as a tuned detector for checking the output of transmitters. Be careful not to apply too much RF to the dipper or you may burn out the FET. Check the Radio Amateur's Handbook, published by the ARRL, for other ways to use a GDO.

Probe-Size

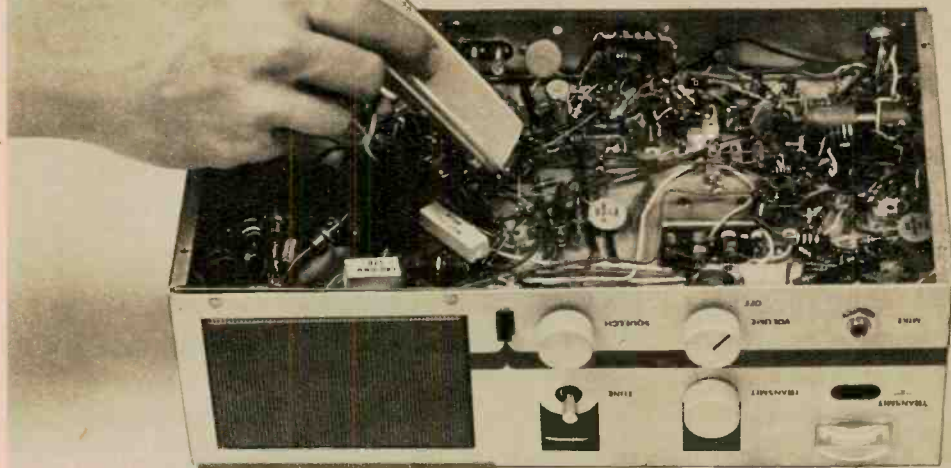

Signal Injector

Troubleshooting is a snap with this 600-cps to 30-mc signal generator.

By CHARLES GREEN, W3IKH

IT always comes as a blow when you discover that the dead tubes in a radio or amplifier check out good. Don't kick the tube tester! Chances are, it's telling the truth. What next? Only one thing—you've got to get into the circuit to find the defective stage and component.

But you don't need a shop full of test equipment to do this. Our signal injector, with the help of the inoperative equipment itself, will enable you to pinpoint the trouble in a matter of minutes.

Heart of the seven-component injector is a unijunction transistor which generates a basic 600-cps signal. This frequency is ideal for audio work. Harmonics up to 30 mc are produced by the circuit for troubleshooting RF stages. The injector is housed in an easy-to-hold, inexpensive plastic toothbrush case.

How the Unijunction Transistor Works

Before we get to the construction and use

of the injector, let's see how the unijunction transistor and the circuit work.

A unijunction transistor basically is a diode to which an extra connection is made (for this reason it first was called a double-base diode). As shown at the left in Fig. 1, the transistor consists of a bar of doped silicon to which connections are made at the ends—called the bases (B1 and B2). In the center of the bar there's a semiconductor junction which forms the emitter (E).

The silicon bar acts like a resistance; therefore, if a voltage is applied across B1 and B2 current will flow through the bar. Assume that the voltage applied to B2 (positive) and B1 (negative) is 20 V. Because the bar's resistance is uniform, the voltage at the P-N junction will be 10 V positive with respect to base B1.

Apply another voltage (+ to E, - to B1) that is less than 10 V to the E/B1 junction and the junction will simply be reverse biased.

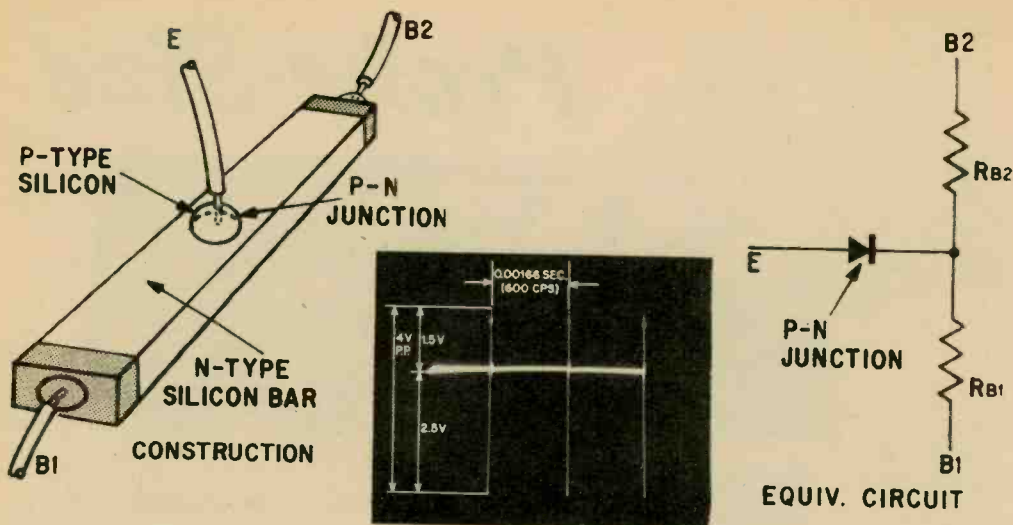

Fig. 1—Simplified diagram at left shows construction of unijunction transistor. In equivalent-circuit schematic at right, diode represents P-N junction between emitter and bar. RB1 and RB2 represent resistance of doped-silicon bar, injector's fundamental output (center photo) is 600-cps, 4-V (P-P) spikes.

Probe-Size Signal Injector

Only a small reverse current will flow in the E/B1 junction. (Schematic at right, Fig. 1.)

But apply a voltage (with the same polarity) greater than 10 V to E/B1 and a heavy current will flow through the E/B1 junction because it is forward-biased. The resistance of the bar between E and B1 will drop abruptly to a low value

This, in turn, causes the resistance of the bar between B1 and B2 to decrease markedly. As a result a heavy current flows through the bar from B1 to B2. When the voltage is removed from E, the bar's resistance increases and the current flow from B1 to B2 returns to normal.

Take a look at the injector's schematic in and the voltage at Q1's emitter (the junction Fig. 3. When S1 is closed, C2 begins to charge of R2 and C2) begins to rise. When Q1's critical firing voltage is reached, Q1's E/B1 junction conducts and discharges C2. This causes a sharp current pulse to flow through R1 and L1. The pulse is fed through C1 to PL1.

The values of R2 and C2 cause the pulses to be produced at a rate of about 600 per second. (The frequency can be raised or lowered by changing the values of R2 and C2.) Because the pulses are sharp they are rich in

PARTS LIST

- B1—8.4 V mercury battery (Burgess H126 or equiv.)
- C1—.005 μ f, 1,000 V ceramic disc capacitor
- C2—.1 μ f, 200 V tubular capacitor
- L1—1 mh subminiature iron-core RF choke (J.W. Miller 70 F103A1. Allied 61 Z 885. 75¢ plus postage. Not listed in catalog.)
- PL1—Phono plug
- Q1—2N2160 unijunction transistor
- R1—47 ohm, 1/2 watt, 10% resistor
- R2—18,000 ohm, 1/2 watt, 10% resistor
- S1—SPST slide switch
- Misc.—plastic toothbrush case, perforated board, flea clips.

harmonics—this is why the injector's output goes up to about 30 mc

Construction

Our model is built in a plastic toothbrush case which can be obtained at drug or variety stores. The component layout is not critical and may be changed to suit any housing.

Cut a hole in one end of the case to accommodate the neck of phono plug PL1. Carefully solder a ground lug on the neck of the plug inside the case. Solder a length of insulated wire to PL1's center pin. Mount slide switch S1 at the right end of the lid. Position the battery temporarily near the switch to determine the remaining space. Cut a 2 3/4 x 3/4-in. piece of perforated board to fit in the left side of the case.

Mount the components shown in Fig. 2 on

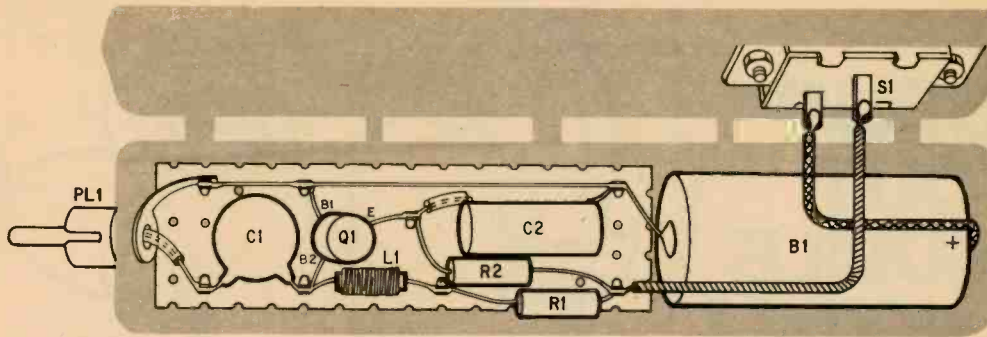

Fig. 2—Diagram above shows location of parts on a 2 3/4 x 3/4-in. piece of perforated board. Layout isn't critical; you may change it to suit whatever enclosure the injector is to be built in. Board is held in place by ground lug fitted over plug PL1's neck and soldered to flea clip in upper left corner of board. Use flea clips for tie points for parts.

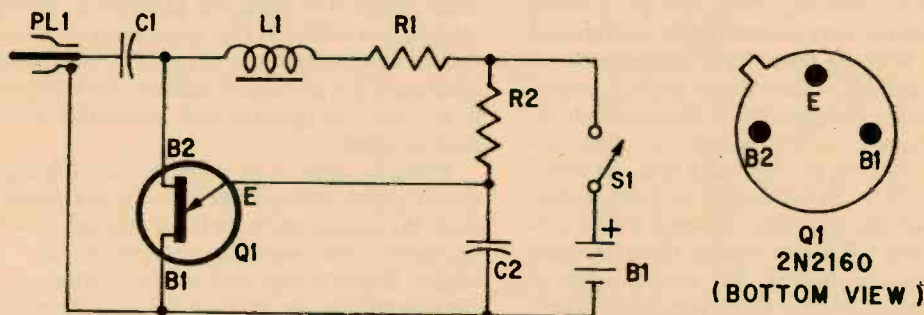
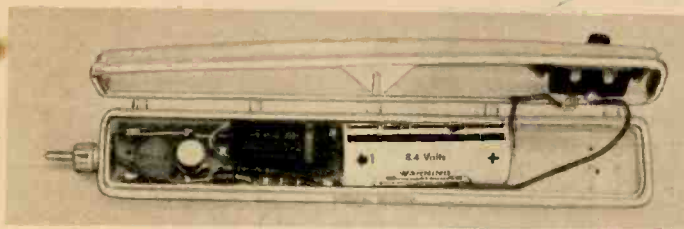

Fig. 3—Injector schematic. When S1 is closed, voltage builds up across C2 until E/B1 junction conducts. C2 then discharges and sends a pulse through L1. Pulse is rich in harmonics and output goes up to 30 mc.

the perforated board with flea clips, then install the board in the case. Connect PL1's ground lug to a flea clip on the board to provide mechanical support for the board. Make sure the connecting wires to S1 are long enough to allow the case to be opened easily.

Do not use a low-voltage capacitor for C1. The reason we used a 1,000-V capacitor for C1 is to prevent the injector from being damaged should you touch PL1 accidentally to a point in the circuit at which there is high-voltage DC. A low-voltage capacitor would break down and most likely would destroy the unijunction transistor.

Operation

The output voltage of the injector depends on the impedance of the stage to which it is connected. Without a load, the amplitude of

the pulses is 4-V, P-P, as shown in the photo in the center of Fig. 1. The injector's output impedance is high, which means it will work best with high-impedance tube circuits. It cannot be used to check, say, speakers.

The way to use the signal injector is to place PL1's center pin on the grid or base of a tube or transistor (with the volume control at maximum gain) and listen for the signal in the speaker. Always start, in the case of a radio, near the output and work your way back toward the input. When the signal disappears, you have located the inoperative stage.

For some RF and low-gain audio circuits, the level of the signal from the injector can be increased by touching your finger to PL1's outside shell or by connecting the shell to the chassis.

STAMP OUT MOBILE NOISE!

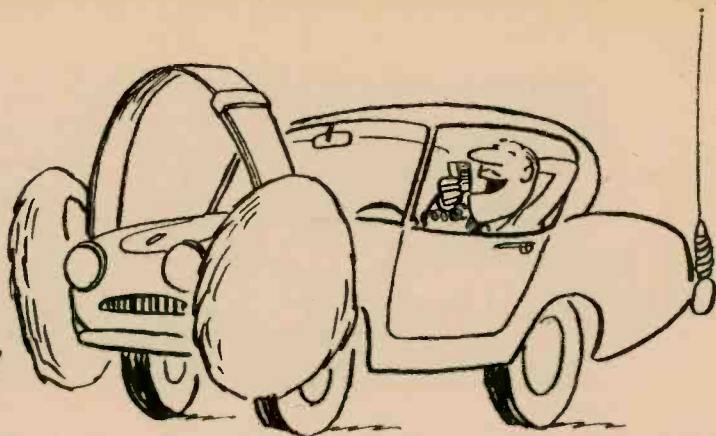

By CHET STEPHENS YOUR transceiver may be a deluxe job with RF and IF noise limiters, but when it comes to suppressing mobile noise, it may simply spin its wheels like those of a car stuck in snow. Although built-in noise limiters remove most annoying clicks and pops, there often remains a continuous noise background which is stronger than the desired signal.

For example, considering today's super-performance transceivers, a 10-microvolt received signal is considered of moderate strength. Yet the average car's mill can easily generate 20 to 50 microvolts of hash, clicks, pops, crackles and other assorted roars! Obviously, any CB signal weaker than the noise is going to be buried. But mobile noise is easily eliminated providing you know where it comes from. Names and addresses of suppliers of the noise-suppression devices we will be talking about are at the end of this article.

There are two types of noise: The most annoying is *radiated* interference caused by the making and breaking of current flow. Points generate RF noise when they break the coil's current. Plugs, producing sparks of several-thousand volts, are great noise generators. They're just like old-time spark transmitters which used a spark to generate radio signals. In a car, a spark produces RF interference which is broadcast by the car's electrical wiring. Best way to get rid of radiated noise is simply to prevent it from being radiated.

The second type of noise is *conducted noise*—noise carried by the wiring, rather than radiated by it, directly into the transceiver. This noise can be eliminated by good solid grounds. The first thing to do is to identify the noise so you know how to attack

it. Filtering a lead that contains or radiates no noise simply wastes money.

Where's The Noise? Turn on the transceiver and drive the car at a moderate speed. Let up on the gas and turn off the ignition. While you're coasting to a stop, notice if the noise stops. If it does, the problem is in the alternator (we'll refer to generators as alternators here)/regulator system. If the noise continues, but at a lower volume, the problem is in both the ignition *and* alternator/regulator systems.

Ignition noise is a popping, or sputting, sound which varies with the engine's speed. Race the engine and note if the sputting speed increases. Alternator noise sounds like a whine. If you're not sure which is which try slipping off the alternator drive belt. With the engine running, a reduction in noise points to the alternator/regulator. If the noise per-

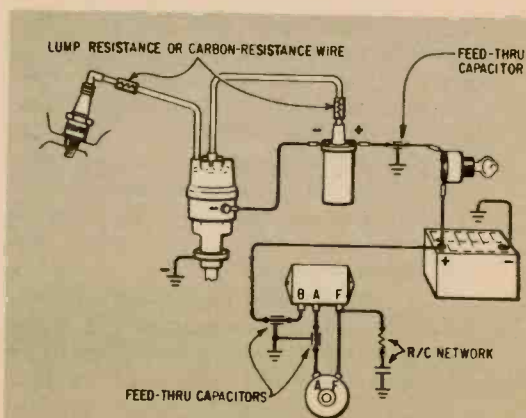

Fig. 1—Completely suppressed ignition system. Resistance plugs may be substituted for resistance suppressor at top of plug; retune engine.

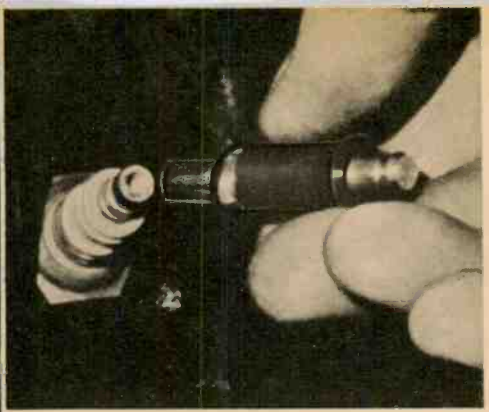

Fig. 3—Top. If your car does not have resistance plugs or resistance-wire plug cables, a carbon noise suppressor must be added at each plug. Left. All primary ignition leads including the feed to the high-voltage coil should be filtered with coax shielded capacitor. Make certain all of the connections are good and tight.

sists you've got ignition interference. Roars and crackling sounds point to the instruments: a gas gauge or an electric clock.

Generator noise is easily suppressed with a tuned parallel-resonant network which prevents the 27-mc noise components from getting into the ignition wiring from which it is radiated. The filter is connected in series with the generator's armature (A) lead.

Many cars are factory equipped with a generator filter, which is a bypass capacitor from the armature lead to ground. Although these filters are effective at broadcast frequencies, they are next to useless at 27-mc and should be replaced with a shielded capacitor or a tuned trap.

For an alternator a tuned trap might work, but the more costly alternator filter is the

better thing to use. This device filters just about everything but DC charging current.

Regulator noise, caused by arcing (sparking) at the regulator contacts, sounds like a steady, even-volume crackling that you hear only when the regulator is working. Such noise must be filtered by brute force—with a shielded feed-thru coaxial capacitor in the B (battery) and A (armature) leads. The F (field) lead cannot be filtered by a coaxial capacitor without causing damage to the regulator. Instead, the F lead is bypassed to ground through a .002- μ f capacitor in series with a 3.9-ohm, 1-watt carbon (not wire-wound) resistor. These components can be installed on an L-bracket as shown in Fig. 2. As a general rule, alternator regulators are not as noisy as generator regulators.

Should the regulator continue to radiate noise, as evidenced by failure of the filtering, your only recourse is to shield the regulator and filters in a metal cabinet firmly attached to the car body. If you haven't the inclination to make the enclosure you can purchase a shield assembly complete with filters from the Hallett Mfg. Co.

Crushing the Snaps, Crackles and Pops. Ignition noise means all out war. While most cars have resistance spark-plug wiring to suppress the ignition noise, it is generally inadequate at 27 mc. And even if your car has resistance wiring, resistance suppression very well may be required. Resistance suppressors are simply resistors mounted in a plastic holder and installed in each plug's wire. This point is important: The suppressors must be installed at both ends of the wire to each plug. As a general rule, American cars

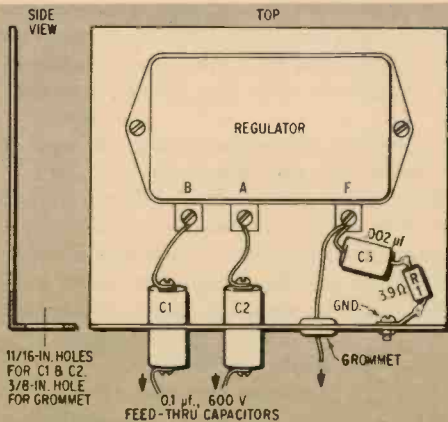

Fig. 2—To filter regulator, mount it on L-bracket and route A and B leads through coax feed-thru capacitors. Filter F lead with R/C network.

made within the last 5 years use resistance wires. If in doubt, check with the car manufacturer, the local distributor, or your favorite mechanic.

The spark at the distributor, caused by arcing at the points is primary source of ignition interference; therefore, each distributor wire must be suppressed. Connect a 10,000-ohm suppressor between the rotor wire (the one in the center) and the wire socket at the distributor. Install a 5,000-ohm suppressor at the distributor between each stator terminal and the wire to the spark plug. Place a 5,000-ohm suppressor at the end of each plug wire. Or, you may replace your plugs with resistor plugs and eliminate the suppressor at both ends of the plug wire. But, you must retune the engine when suppressors are added to the ignition circuit.

The ignition coil, even though it can be in a metal can, will generate noise. Be certain it is firmly connected to the car frame. If necessary, connect a metal strap from the coil case to the frame. We also suggest that the input lead to the coil be filtered with a shielded (coax) capacitor.

Once the ignition coil, distributor and its leads are filtered, there's nothing more you can do to reduce ignition noise except to shield all the wiring. This step is a bit expensive, but if the previous treatment hasn't reduced the noise to almost zero, it must be done to get dead silence. Prefab shielding is available from Hallett and consists of shielded wires for the plugs, plug shields, a shield for the distributor and a shield for the coil.

Once you've crushed ignition and alternator noise you're almost home. All that's left is to suppress noise generated by the instruments. This is easily done by connecting a coaxial capacitor across each gauge and the clock.

A final note, the little ball at the tip of the car radio's antenna is not a decoration. It drains off static charge accumulated in the antenna as the antenna moves through the air. Without the ball you will hear popping similar to ignition noise, but not as consistently. If you lose the ball it *must* be replaced. Any $\frac{3}{8}$ -in. or $\frac{1}{2}$ -in. dia. plastic ball will do—it doesn't have to be metal.

Special Noise-Suppression Components are available from several places. The 0.1 μ f.

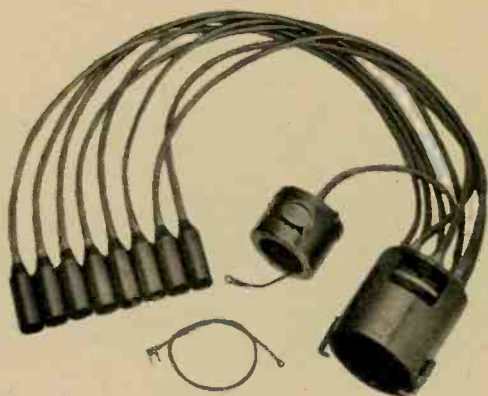

Fig. 4—Complete noise-suppression kit, including shields for distributor and coil, is made by Hallett. Note shielded leads, covers for each plug.

600V feed-thru shielded coaxial capacitors (C1 and C2, Fig. 2) are Sprague Type 80P3. They're available from Allied Radio (Stock No. 43 D 5689. Not listed in catalog.) Price is \$1.77 plus postage.

Plug suppressors are Erie's (Erie Technological Products, Inc.) L7VR-10ME (10,000 ohms) and L7VR-5ME (5,000 ohms). These are not generally stocked and will have to be ordered through your regular electronic-parts distributor.

A generator filter is available from Allied Radio for \$2.35 plus postage. The stock No. is 17 A 8512. Other noise-suppression parts are on page 480 of Allied's catalog. A basic **auto/marine-engine noise-suppression kit** containing a full set of suppressors and filter capacitors and shielded generator cable is available from Lafayette Radio. The stock No. is 42 R 0905. It's on page 145 of Lafayette's catalog and the price is \$9.45. And on the same page you see a generator-noise filter, voltage-regulator filter and feed-thru capacitors.

A complete **noise-suppression kit**, including shields for the distributor and coil is available from the Hallett Manufacturing Co. Ash at Regent, Inglewood, Calif. 90301. The firm can also supply a shield box containing filters for a voltage regulator. Write stating the make of your car, the year and the number of cylinders and they will send you the price and further information.

Using the methods just described, you should be able to get rid of that persistent noise once and for all. It will take a little work, but there's no other way out.

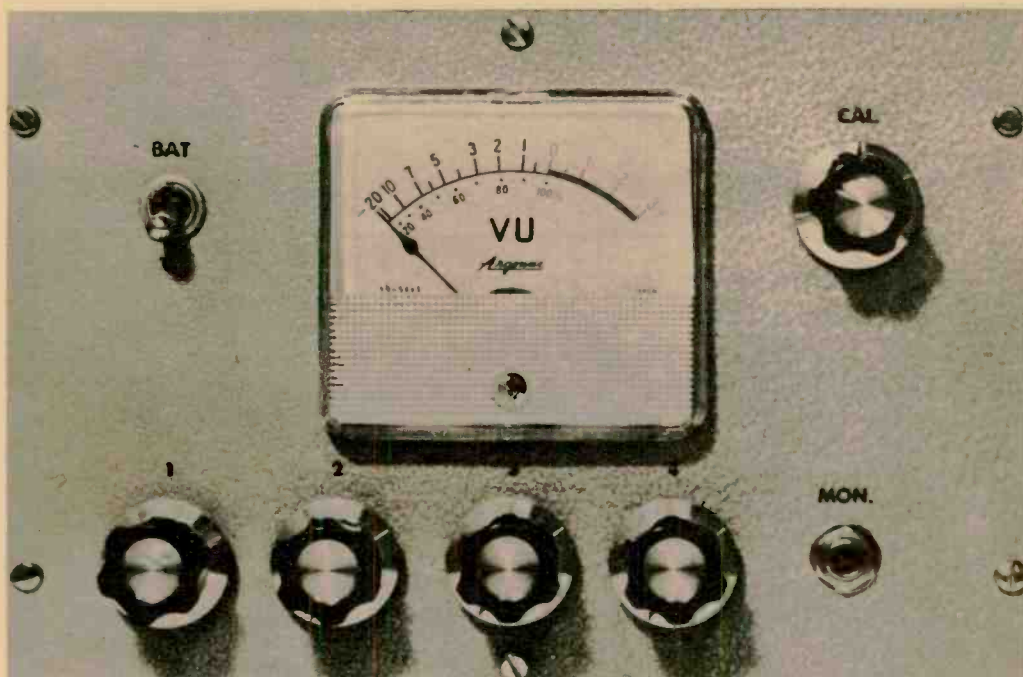

All-Purpose Audio Mixer

ONCE the initial thrill of recording is over, the owner of a tape machine quickly realizes that a single mike input for each channel imposes severe limitations. For example, amateur musicians—even good ones—may sound like the kindergarten fife and wood-block corps when they are recorded in a living room and picked up by a single mike.

For professional-sounding tapes, you've got to be able to mix *several* sound sources. More than one mike is needed if you're recording a group of musicians or even a singer and accompanist. And if you're trying to record a group conference you need more than one mike or the group will sound as though it is meeting in a cave. To do all these things you need a mixer—a device that combines the outputs of several microphones, of a record player and of high-level inputs such as another tape recorder.

Our solid-state mixer has four low-level and two-high level inputs. Any combination

of program sources can be mixed into a single output. There is a level control for each input. To insure proper output level, the mixer is equipped with a VU meter and a high-level headphone-monitoring jack. To make the mixer portable and hum-free, the circuit is battery powered. The VU meter doubles as a battery-condition meter.

Note in Fig. 2 that the input transistors are FETs (field-effect transistors). This means each channel's input impedance is high. In fact, almost as high as that of a vacuum tube, which means you can use crystal or ceramic mikes with the mixer. The input impedance of each mike channel is determined by R1, R5, R9 and R12, which are 2.2 megohms each. You may increase or decrease the value of these resistors to match the impedance of the mike.

For normal operation, capacitors C1, C2, C3 and C4 *do not* have to be installed. Without these capacitors the overall gain is about 5db at three-quarters settings of the level con-

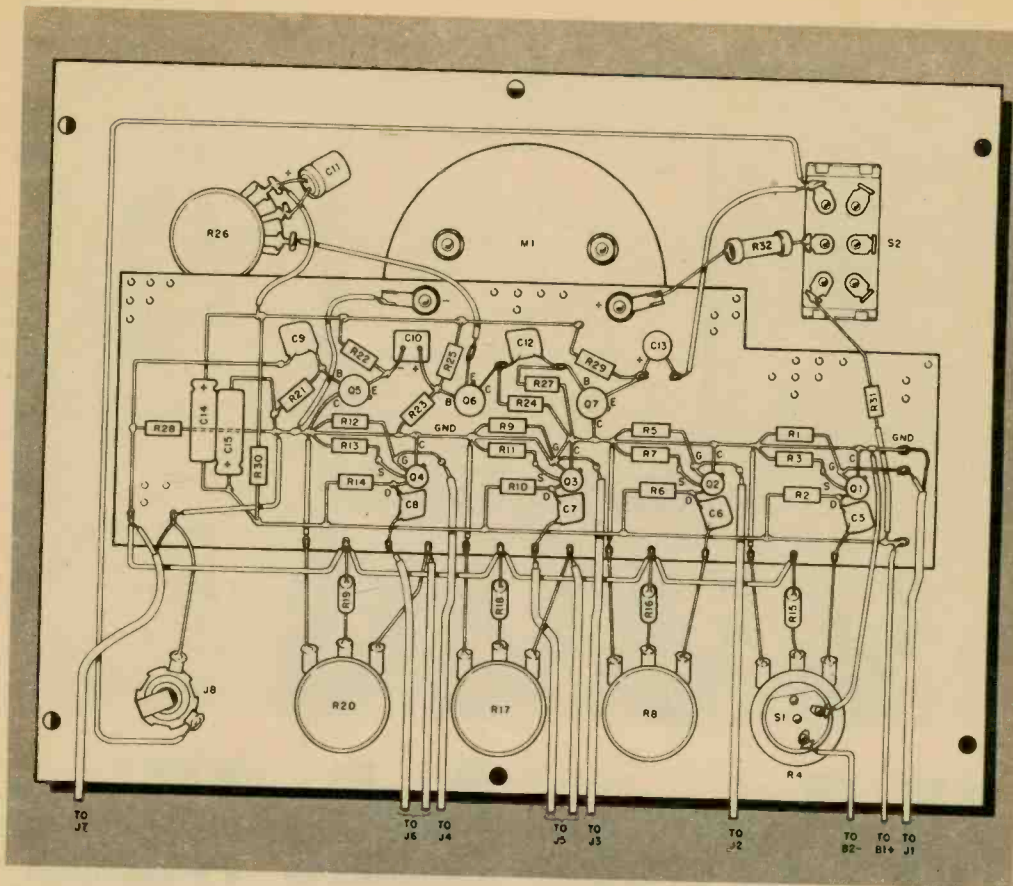
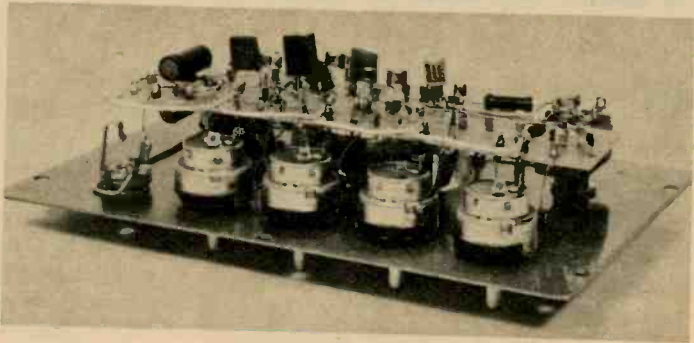

Fig. 1—In pictorial, the following parts are mounted on top of board: all transistors, C9, C10, C12, C13, C15, R28 and R31. All other parts are mounted on back of board. Board is mounted on M1's terminals.

All-Purpose Audio Mixer



trols. This means that if your mike has an output level of -50db the signal at the mixer's output jack will be -45db. Without the capacitors the frequency response is almost ruler-flat from 10 to 20,000 cps. Distortion at normal mike levels is almost unmeasurable. At input levels as high as .03 V (rms), distortion without the capacitors is slightly less than 1 per cent. If you need a little extra gain, an additional 5db to 7 db can be obtained by installing C1, C2, C3 and C4. With them in

the circuit, response will be flat from about 40 to 20,000 cps. Distortion at normal mike levels will be about 0.5 per cent. High-level signals (0.3 V rms) into J1 through J4 then will produce distortion somewhat in excess of 1 per cent. You can build the entire mixer or any part you want. For example, if you don't need a VU meter, drop off all the components associated with Q5, Q6 and Q7 (this includes C9 and R32). The VU meter can be retained as

a battery-condition indicator or it, too, can be dropped off, thereby eliminating R31, R32 and S2. If you have no need for high-level inputs you may drop off J5 and J6. Then connect C7 to R17 and C8 to R20. If you need only a two-channel mixer drop off all circuitry associated with Q1 and Q2.

Before getting into construction note that Q1 thru Q4 have a *negative* ground—their sources (S) are connected to ground via R3, R7, R11 and R13. The positive supply feeds R2, R6, R10, and R14.

On the other hand, Q5 thru Q7 have a *positive* ground. That is, the emitters are re-

PARTS LIST

B1, B2—9 V battery (Burgess C6X or equiv.)

Capacitors:

C1, C2, C3, C4, C11—30 μ f, 6 V electrolytic
C5, C6, C7, C8, C9, C12—1 μ f, 75 V ceramic disc

C10—10 μ f, 15 V electrolytic

C13—30 μ f, 12 V electrolytic

C14—160 μ f, 15 V electrolytic

C15—50 μ f, 25 V electrolytic

J1, J2, J3, J4, J8—Phone jack (see text)

J5, J6—Closed-circuit phone jack

J7—Phono jack

M1—VU meter (Lafayette 99 C 5043)

Q1, Q2, Q3, Q4—HEP-801 transistor (Motorola)

Allied HEP-801. \$3.39 plus postage)

Q5, Q7—HEP-250 transistor (Motorola, Allied

HEP-250. 79¢ plus postage)

Q6—HEP-252 transistor (Motorola, Allied

HEP-252. 89¢ plus postage)

Resistors: $\frac{1}{2}$ watt, 10% unless otherwise

indicated

R1, R5, R9, R12—2.2 megohms

R2, R6, R10, R14—560 ohms

R3, R7, R11, R13—6,800 ohms

R4, R8, R17, R20—500,000 ohm, audio taper poten-

tiometer with SPST switch (Lafayette 32 C 7288)

R15, R16, R18, R19, R28, R31—100,000 ohms

R21, R27—470,000 ohms

R22, R29—4,700 ohms

R23—120,000 ohms

R24, R25—10,000 ohms

R26—1,500 ohm, linear taper potentiometer

R30—470 ohms

R32—3,600 ohms (supplied with M1)

S1—SPST switch on R4

S2—SPDT toggle or slide switch

Misc.—Perforated board, 9 x 6 x 5-in. aluminum

utility cabinet (Premier AC-695 or equiv.),

shielded wire, flea clips

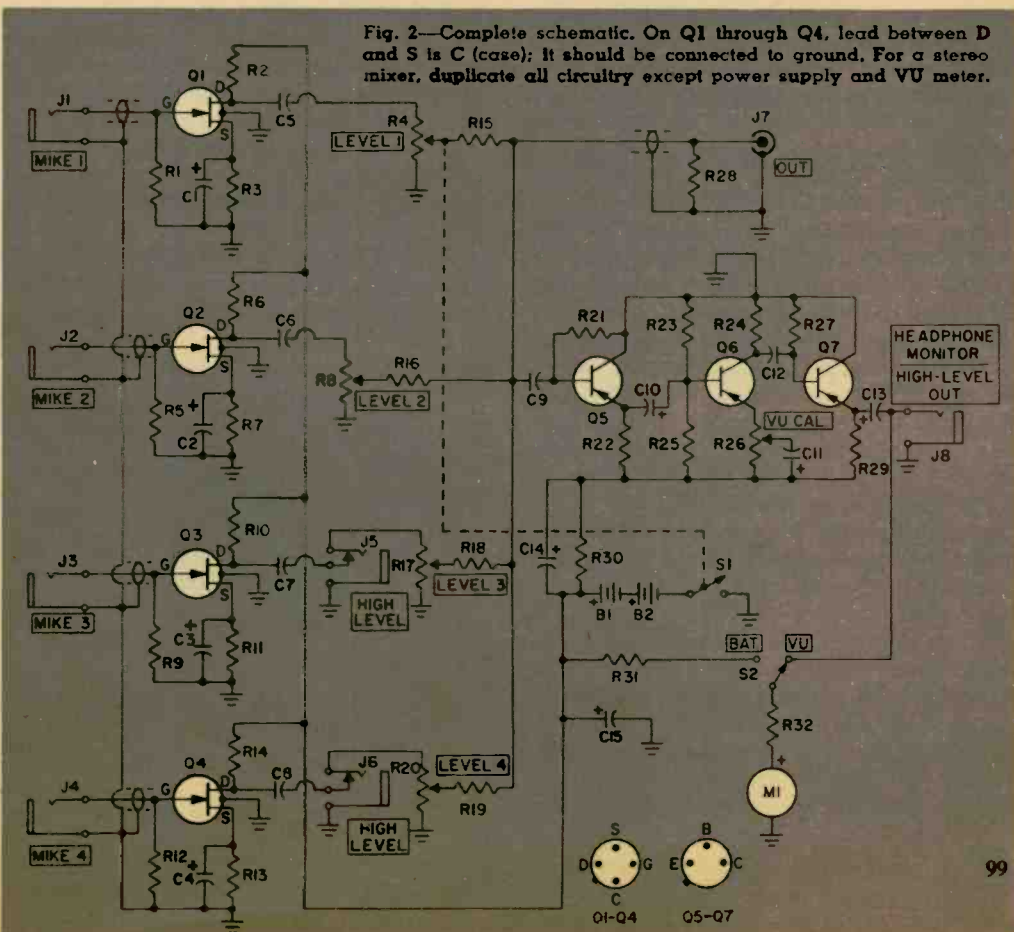

All-Purpose Audio Mixer

Fig. 3—Photo at top is of top of circuit board. Photo at bottom is of underside of board. Triple-check your wiring as it will be difficult to remove the board to correct an error after the board is installed.

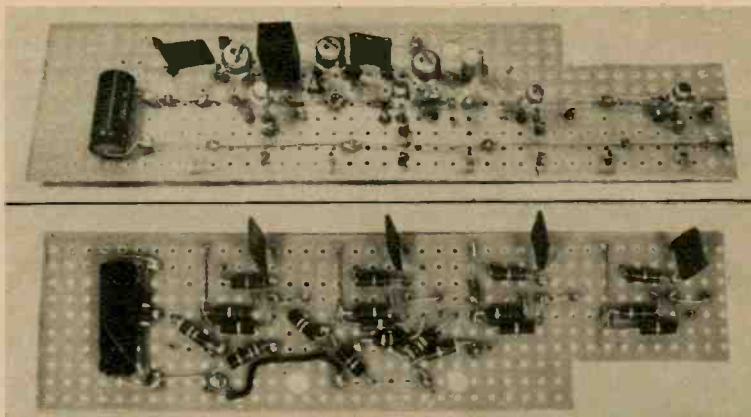

turned to the positive supply voltage, which is not connected to the chassis. Also note that the collector resistors of Q5, Q6 and Q7 are connected to true ground—the chassis—battery negative. Do not mix up the chassis ground connections.

Construction. Our mixer is built in a 9x6x5-in. aluminum utility cabinet—actually on the front and rear panels. The resistors, capacitors and transistors are mounted on a piece of perforated board on which flea clips or Vector T28 push-in terminals are used for tie points. All resistor and capacitor values are critical and no substitutions should be made. If money is no object, we suggest you use low-noise *deposited carbon* or *film-type* resistors for R1, R2, R3, R5, R6, R7, R9, R10, R11, R12, R13 and R14.

Start construction by mounting all the front-panel components. Install level controls R4, R8, R17 and R20 and put monitor jack J8 as close to the bottom panel edge as is possible. VU meter M1 should be mounted close to the top panel edge. Install *Bat. VU* switch S2 and *VU Cal.* control R26 between M1 and the edges of the panel about 1/2 in. above M1 horizontal center-line. Orient level controls R4, R8, R17 and R20 so their terminals point straight up as shown in Fig 1.

All controls are shown with a switch because the type specified in the Parts List comes with a switch and sells for half the usual price.

Next, install the rear-panel jacks and a metal bracket, made from scrap aluminum, to hold the two batteries. To keep costs down we show standard open-circuit jacks for J1 through J4. To avoid open-circuit noise, we suggest you use shorting-type jacks which will automatically ground the input when the

mike plug is removed. High-level jacks J5 and J6 are closed-circuit jacks that automatically disconnect mike amplifiers Q3 and Q4 when high-level plugs are inserted.

Cut a 2 x 7 3/4 -in. piece of perforated board. Notch the board as shown so that S2's terminals are in the clear. Before mounting any components on the board, install positive and negative buss wires across the full length of the board. The buss in the center of the board is the battery negative, or ground buss. It is connected to cabinet via J1's shielded lead. Next mount Q1 through Q4 and associated components. Resistors R15, R16, R18, R19, R31 and R32 are installed after the board is mounted on the meter terminals.

Use a 25- to 35-watt iron and use a heat sink, such as an alligator clip, on each transistor and resistor lead when soldering. To provide clearance for the meter case, keep the components on the underside of the board flat against the board.

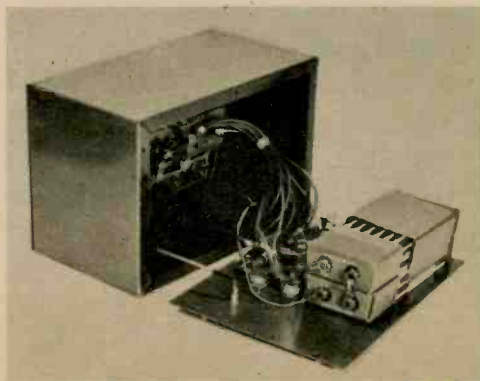
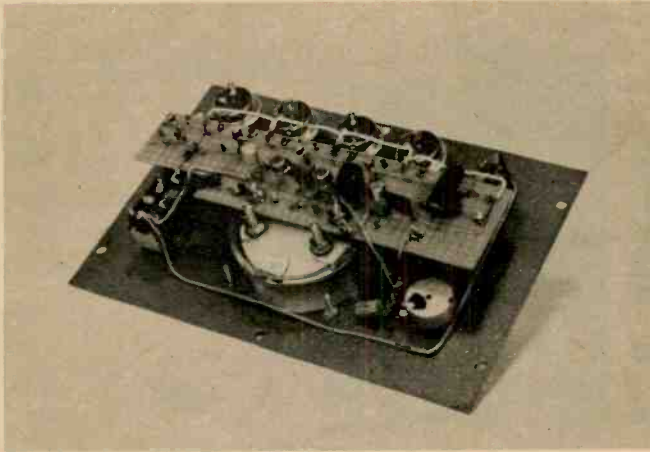

Fig. 4—Completed mixer. Note home-brew bracket which holds batteries. 12-in. leads to all jacks allow for easy installation of panels in cabinet.



When the board is completed, it is installed on top of the meter, and final connections are made between the board terminals and all the front panel components.

After the board wiring is completed, install the board on the meter terminals as shown, using the hardware supplied with the meter. To provide clearance for the board components install a set of nuts on the metal terminals and then place the board over the terminals. Place the meter solder lugs on top of the board, install the original lockwashers, and then mount and tighten the mounting nuts. Complete the wiring to the front-panel components. Resistor R32, the meter multiplier, is provided with the meter.

The shielded leads from the front to the rear panel are 12-in. lengths of RG-174/U coax. Note that only the cable connected to J1 has the shield connected at both ends. One end is connected to J1's ground lug and the other end is connected to the board's ground buss. The remaining cable shields including the cable to J7 are connected only to the circuit-board ground buss. Tape the jack end of the cables to prevent a strand of wire from shorting the cable.

Using the Mixer. Connect the mixer via J7 to your tape recorder's mike input with shielded wire. Connect the mikes to jacks J1 to J4. Set your recorder's volume control to the normal setting, then advance the level control of the channel to which a mike is connected and speak into the mike. Advance the mixer's level control until the recorder's volume indicator shows the usual or normal recording level. While still speaking, advance *VU Cal.* control R26 until M1 indicates the same level on speech peaks as the recorder's level meter. Then, tape or lock (with a shaft lock) R26 so it cannot be accidentally

changed. If you have an AF signal generator, a more accurate adjustment of M1 can be made. Set the recorder's level control to normal, feed a 1,000-cps signal at about -45db into J1 and advance R4 until the recorder level meter indicates peak recording level. Then adjust R26 until M1 indicates 0 VU. Then lock R26.

Up to four microphones can be mixed simultaneously. You can also mix a high-level signal, such as from another tape recorder or ceramic cartridge, by connecting the high-level source to either J5 or J6. Note that the high-level source kills the mike input associated with it. For example, connect a high-level source to J5 and you will disable the mike plugged in J3.

The signal level at jack J8 is more than adequate for a comfortable headphone volume. Use headphones rated at 2,000 ohms impedance or higher—crystal phones are recommended. The level at J8 is about 1 V, rms. You can connect the output at this jack to any high-level amplifier input designed to accept a 1-V signal. However, distortion and noise level at J8 are slightly higher than at J7.

With power switch S1 on, setting S2 to the *bat* side will cause M1 to indicate the battery condition. As long as the meter pointer indicates in the red region above the 0 VU mark, the batteries are okay. Depending on the FETs you use, the batteries may still be usable when the pointer falls below 0 VU. Don't discard the batteries if the pointer falls below 0 VU. Wait until you can just about hear or start to measure an increase in distortion or sharp loss in gain. ●

CB CONTROL CONSOLE

By LEN BUCKWALTER, KBA4480



IT gets tiring when you have to do the watusi every time you check out your CB rig. First you connect one antenna, then disconnect another and . . . well, you know how long that can go on.

But mount your rig on our CB Control Console and you'll be able to sit back and simply twist switches. The console places at your fingertips a half-dozen different measuring instruments. No need to haul out a lot of separate meters and connecting cables when a turn of a switch lets you see everything from antenna efficiency to transmitter power and modulation. And you won't need your rig's schematic to hook up the console. It just plugs into the antenna socket.

The console is designed for convenience. First, it raises a set off the table, making knobs a snap to grasp and turn. And the panel meter will be elevated so numbers are easier to read. The slight tilt upward aims the panel at your eyes, not your tummy. There are other benefits, too. You can store

crystals and other small items under the console and there's an antenna-selector switch that lets you connect to either of two outdoor antennas.

Then there's a field-strength meter to enable you to tune up a rig or check its output. A built-in dummy load lets you work on a transceiver without radiating a signal. Finally, the console will make your set look less like a table radio and more like a communications center.

Construction

The console's panel must be a sturdy piece of metal. You can save a lot of work by using a standard 5¼ x 19 x ¼-in.-thick aluminum rack panel. Using a hacksaw, cut the panel width to 14 in. Most difficult cut to make is the 2½-in.-dia. hole for the meter. Cut it by drawing a circle on the panel, then drill a series of small holes on the circle until the center piece drops out.

The two legs for the console are heavy

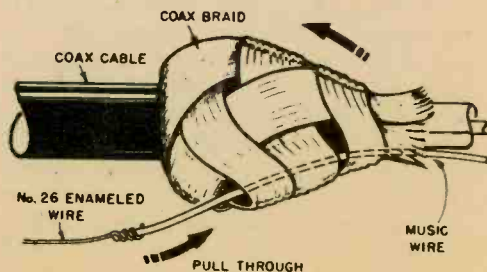
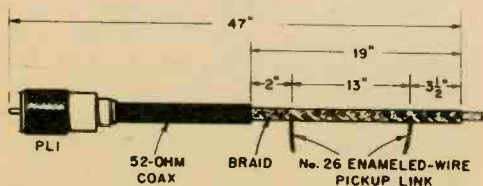

Fig. 1—Top diagram shows how to prepare a 47-in. length of coax for pickup link. Sketch at right shows how to bunch braid to insert the piano wire. Pull braid tight after installing the pickup link.

strips of $\frac{3}{4}$ in.-wide aluminum. Bend the strips as shown in Fig. 2 and drill holes for No. 6 mounting screws. The support platform is a piece of $8 \times 11\frac{3}{4} \times \frac{1}{8}$ -in.-thick Masonite. This size should support just any set. At the rear of the console is an L-shape aluminum bracket for antenna sockets SO1 and SO2. Holes for the sockets can be made in minutes if you have a $\frac{3}{8}$ -in.-dia. socket punch.

The Pickup Link. The installation of a 13-in. pickup link inside a length of coaxial cable requires patience and care. Purpose of the link is to take a sample of RF energy to operate the console's SWR meter (to measure antenna efficiency). To make the link,

take a 47-in. length of RG58/U coaxial cable and install PL1 at one end. Then prepare the cable as shown in Fig. 1. Note that you strip away 19 in. of the black plastic jacket. Do this with a razor blade, being careful not to nick the braid.

The link is a piece of No. 26 enameled wire inserted *between* the braid and the insulation around the center lead. Since the No. 26 wire is flexible, you'll have to use a stiff piece of wire to snake it through, as shown in Fig. 1. Start by pushing the braid toward the cable's jacket to get it to bunch up. Insert through the braid a stiff piece of wire, such as piano wire, 2 in. from the insulation and push it through until it exits at

Fig. 2—Rear of console's control panel. Note how coax with the pickup link is routed from upper-right corner, where braid is soldered to ground lug, around the meter and down to lower-right corner. Braid is not grounded at end but is soldered to the braid of coax cable coming from the rotary selector switch, S2.

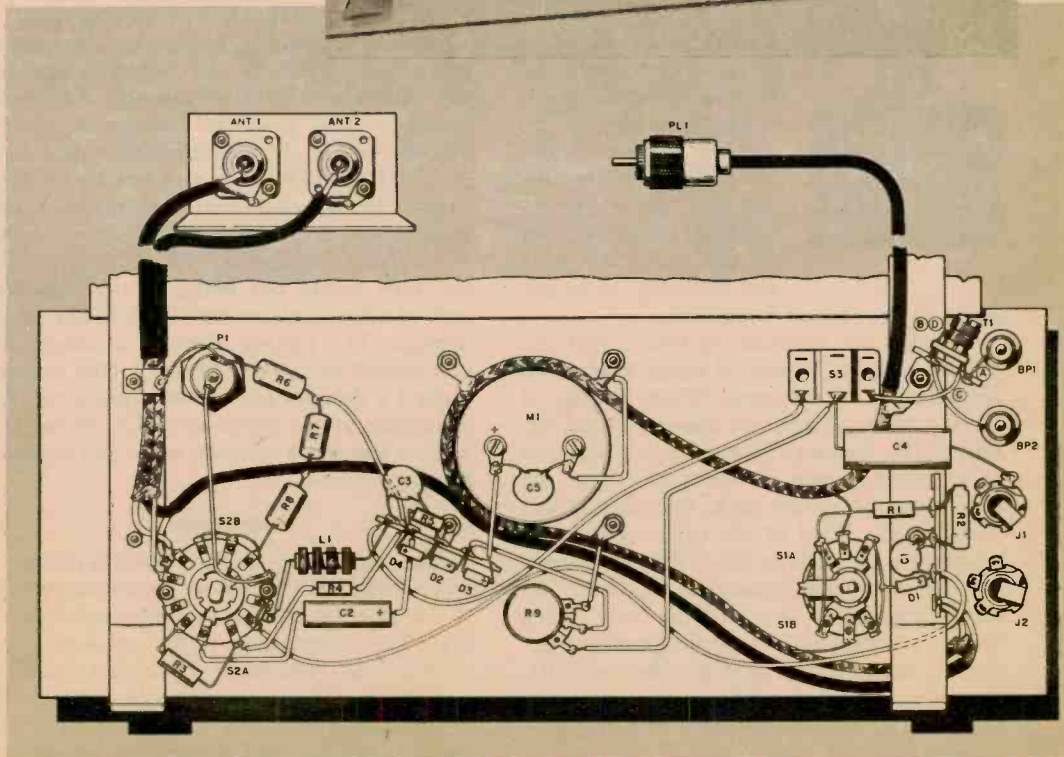
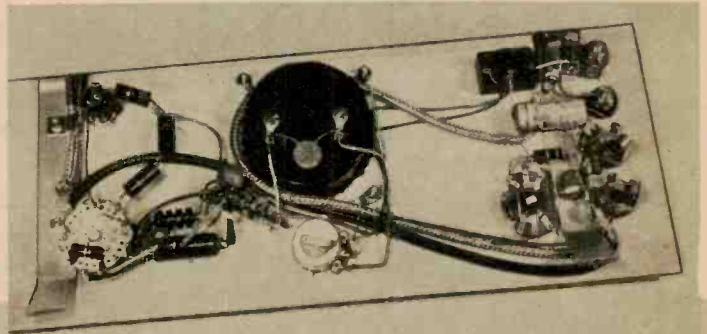

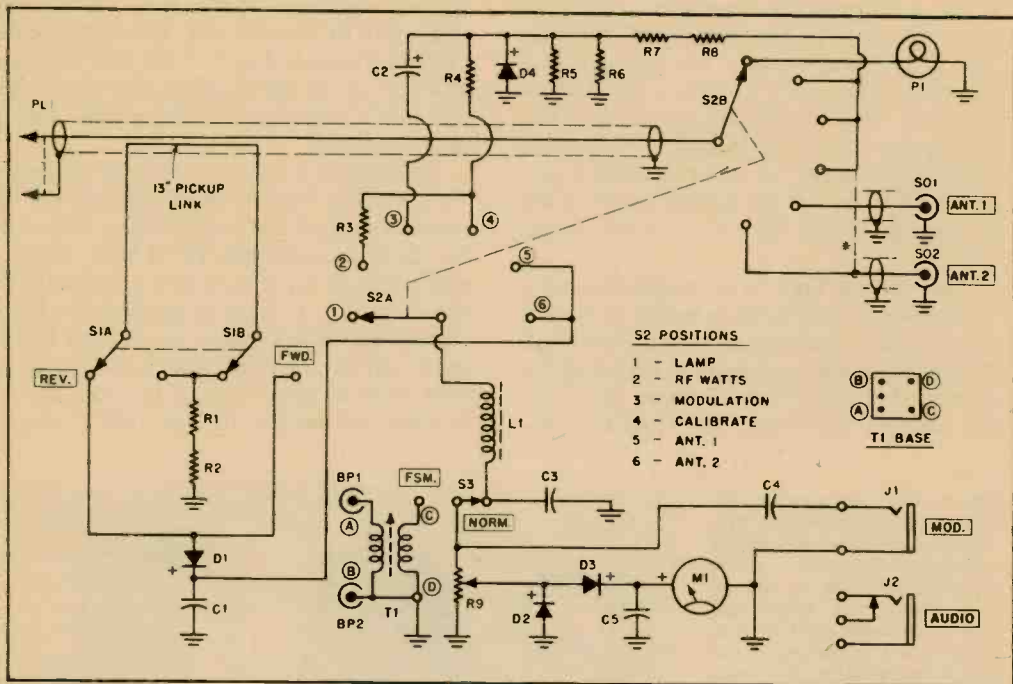

Fig. 3—Connect PL1 to rig's antenna connector and connect audio jack J2 to the transceiver's speaker.

CB CONTROL CONSOLE

a small hole in the braid 13 in. away. Once the wire is through, attach a length of No. 26 enameled wire to it and pull both wires through and out. Scrape the insulation from the ends of the enameled wire and it's ready to be soldered to the appropriate points.

desired to the appropriate points.

Note in the pictorial in Fig. 2 that the braid is soldered to several solder lugs which are grounded to the panel. There are two at the top of the meter, one above R9 and one near S3. At the end of the cable that connects to a terminal strip at the lower right, the braid must be pulled back, twisted and soldered to the braid of the other coax cable which also connects at this point. The braids are not soldered to ground at this end. The same treatment is given to the coax braids near S2. These two braids are grounded under the metal clamp next to pilot lamp P1. Note that one lamp wire also goes to this point and is soldered to both clamp and coax braids.

Protective Jumper. There's one important precaution to take if you intend to operate the console with only one antenna. You must install a short piece of hookup wire (see asterisk in Fig. 3) between terminals 4 and 6 of S2B. Switch S2 can select one of two external antennas. If you hook up only one antenna you accidentally might switch to the unused antenna socket with the transmitter on. This would not bother a tube rig but lack of a load on a transistor job might cause damage. The jumper prevents accidents. If you mistakenly switch to *ant 2* (the unused socket) a dummy load automatically will be connected to the transmitter. Of course the jumper should be removed when you connect another antenna.

Installation

Place the CB rig on the console's platform and connect PL1 to the set's antenna socket. If one external antenna is used, connect it to SO1. This corresponds to the *ant 1* position of switch S1. The other socket is for *ant 2*.

Since the CB rig is at an angle, it may tend to slide toward the rear of the console. This can be cured with the backstop shown in

PARTS LIST

BP1, BP2—Five-way insulated binding post
 C1, C3, C5—.005 μ f, 1,000 V ceramic disc capacitor
 C2—4 μ f, 50 V electrolytic capacitor
 C4—.1 μ f, 400 V tubular capacitor
 D1, D2, D3, D4—1N60 diode
 J1, J2—Phone jack
 L1—2.5 mh RF choke
 M1—0-50 μ a microammeter (Lafayette 99 C 5042 or equiv.)
 P1—No. 47 (6 V) pilot lamp and socket
 PL1—PL-259 coax connector
 R1—33 ohm, 1 watt 10% resistor
 R2—18 ohm, 1/2 watt, 10% resistor
 R3—12,000 ohm, 1 watt, 10% resistor
 R4—5,600 ohm, 1/2 watt, 10% resistor
 R5—1,000 ohm, 1/2 watt, 10% resistor
 R6, R7, R8—16 ohm, 2 watt, 5% resistor
 R9—50,000 ohm, linear-taper potentiometer
 S1—2-pole, 2-position shorting-type rotary switch (Centralab 1462. Allied 56 A 4082 or equiv.)
 S2—2-pole, 6-position shorting-type rotary switch. (Centralab PA-2002. Allied 56 A 4901 or equiv.)
 S3—SPDT toggle switch
 SO1, SO2—SO-239 coax connector
 T1—27-mc antenna coil (Lafayette 99 C 6200)
 Misc.—RG58/U coax cable, No. 26 enameled wire, knobs, aluminum panel, terminal strips



Fig. 4—To peak T1, supported by soldering its lugs to terminal strip, set up for FSM measurements and adjust the slug with alignment tool.

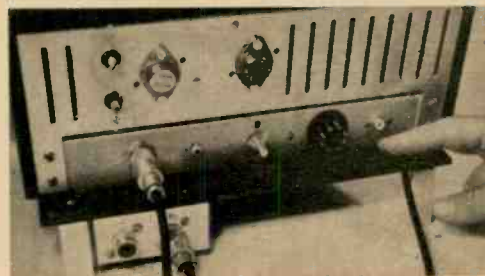

Fig. 5—Finger points to weatherstripping at back of deck. It prevents rig from slipping off. The antenna-connector bracket is at the lower left.

Fig. 5—a piece of weatherstripping coated with an adhesive on one side. Now you're ready to put the console into operation.

Operation

Normal. Here's how to set up the switches for normal CB operation: set *fsm.-norm.* switch S3 to *norm.* Set S1 to *fwd.* and set S2 to *ant 1.* Turn R9 full counterclockwise (lowest sensitivity). Start transmitting and turn R9 clockwise until M1 indicates about halfway up the scale.

With the console so set up, it will indicate the relative power sent to the antenna. The needle falls to zero during receive, then rises each time you press the transmit button. If you wish to tune the output stage of the CB rig the meter becomes an output indicator.

SWR Measurements. Here the console measures overall efficiency of your antenna system. It can detect trouble, for example, such as broken elements or poor cable connections that might originate in the roof antenna. Any problem along the line or at the antenna is apt to affect the system's standing-wave ratio (SWR).

To check SWR set up the controls as before. Turn on the CB rig to transmit and adjust R9 until M1 indicates exactly full scale.

Then, with the transmitter still on, flip S1 to *rev.* M1 should drop below 10 if efficiency is high and SWR is low. If you want to know the true SWR reading, the meter scale in Fig. 6 (it fits over the scale of the meter specified in the Parts List) gives the three most important values. Any SWR indication under 1.5 is fine. It isn't serious if the indication goes nearly to 2. But check for trouble if the SWR is anything over 2. Readings over 3

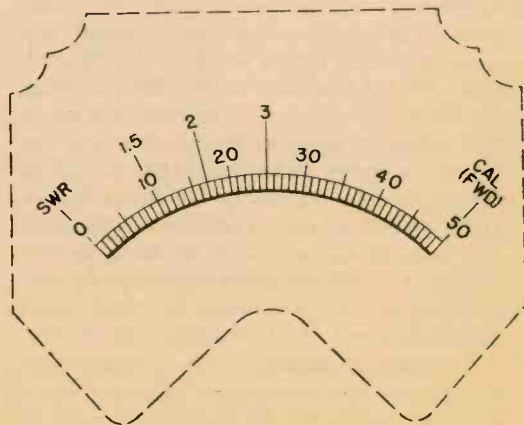

Fig. 6—Cut out and paste over meter's scale.



Best way to check your modulation is to listen to your transceiver's output. Just plug a pair of high-impedance phones in jack J1 on front panel.

mean most of your signal is cancelling itself.

Such SWR measurements are accurate enough for most jobs. You simply adjust or repair the antenna system for lowest meter indication. It's possible, though, to improve absolute accuracy by changing the combined value of R1 and R2. You'll need an accurate dummy load of 52 ohms to do this (Lafayette 42C 0902). Install the load at the *ant.* 2 socket and measure SWR. Since the load is correct, SWR should fall nearly to zero. If the reading is below 4 (microampere scale on the meter) consider your console accurate enough. But if the reading is higher you'll need a different value for R2 (specified as 18 ohms) to bring the SWR down. Try other resistors just above and below 18 ohms to see whether you can lower the meter indication. This procedure makes up for differences in circuit layout. If the reading is below 4 (microamperes scale) you can calculate any SWR by doing the following: (1) add the meter indication (in *rev.* position) to 50; (2) subtract the same meter indication from 50; (3) divide (1) by (2).

Checking Modulation. The console gives a choice of two modulation checks. First is with the meter. Set S3 to *norm.*, set S1 to either position; set S2 to *calibrate* and turn R9 fully counterclockwise. Turn on the CB

transmitter and, without speaking, turn R9 until M1 indicates 50. Keeping the transmitter on, turn S2 to *modulation* and begin talking into the mike. The needle now should move in step with your voice. When M1 *occasionally* hits about 35, it's equivalent to about 100 per cent modulation. The indication is only approximate since meter ballistics prevent a perfect display of modulation percentage; yet this can serve as a guide. After you're accustomed to a given amount of needle movement, you'll know when something's amiss.

The other modulation check can be made by plugging earphones into *mod.* jack J1. You'll be able to hear speech quality as it would be transmitted over the air.

RF Power. This test indicates the transmitter's approximate output power in watts. Set S2 to *RF watts* and turn R9 full clockwise. With the CB set to transmit, M1 now should indicate transmitter output power directly: that is, 20 on the meter equals 2 watts, 30 equals 3 watts, etc. Since this is *output* power, an indication of about 3.5 watts is the highest you'll see. (During this test, the power is that developed in the console's internal dummy load and is *not* RF power delivered to the antenna.)

Visual Output Indicator. A quick check on output RF can be made by turning S2 to *lamp*. The red lamp (P1) is a dummy load which is lit by RF power. It should flicker as you speak into the mike. Note the lamp is only a test position.

Field-Strength Measurement. Built into the Console is provision for checking signal strength. M1 will respond to a transmitted signal and indicate its relative strength. Thus the *fsm* function is useful for tuning up a walkie-talkie, for example, or a mobile rig.

Set up the console for this function by setting S3 to *fsm*. (Note that this is the *only* time this switch is moved from *norm.* Be sure to move it back to *norm.* after checking field strength or the meter will not operate for the other functions.) Attach a 10-in. length of stiff wire to BP1. With the CB rig transmitting, adjust T1's core for highest meter indication. If M1 goes off scale, reduce its sensitivity with R9.

Other Functions. Jack J2, marked *audio*, is a spare that can be wired up according to your needs. Some possibilities: connect it to the rig's speaker and you can feed receiver audio to a speaker in the basement. ●

POCKET CB CONVERTER

By CHARLES GREEN, W6FFQ



*Take one transistor, add a few parts then
tune the Citizens Band on any broadcast radio.*

THE original purpose of CB—to make two-way radio available to almost anyone who needed it—has been served. But there are often times when only one-way communication is required. For example: suppose you regularly have to call the children in from the ballfield for dinner. In this situation it is only necessary that you get a message out to them. They do not have to reply.

Let's say you now have a 5-watt-station set up—one rig's at home and the other is in the car. Naturally the mobile is going to be used by the man of the house during the day. It can't be conveniently taken to the game and operated from a storage battery.

At least you have a transmitter at home to get the call out. But how are the children to hear you? You could provide them with a walkie-talkie, but if it has any kind of sensitivity to pick up your signal it will cost at least \$25.

Now most kids these days carry a transistor radio with them at all times. It's as much standard equipment as the flask was to the flappers in the roaring twenties. If you could only use that 5-watt rig at home to call them on their radio. That is, if there were only a way to be able to pick up a

27-mc CB signal on any broadcast radio.

It can be done and without modifying your 5-watt rig or the radio. You use an electronic middleman called a converter. Our converter is a simple one-transistor, one-evening project which will set you back less than \$10. Combined with a transistor radio (or, for that matter, any radio, it will do a better job of picking up your signal than most walkie-talkies with superhet receivers. Here's the way it works.

You tune the radio to a spot on the dial where there's no station, place the radio on top of the converter and you're in business. You do not have to make a connection between the converter and the radio as the converter radiates its signal into the radio. All you need is an antenna; the converter is battery-powered for portable operation.

The converter can be tuned to receive any CB channel. As we said, you merely set your radio to any quiet spot on the broadcast dial and do the tuning on the converter.

If you do not have an application for one-way communications as we suggested, using a converter and a radio is an easy and inexpensive way to just monitor the band while you use your 5-watt rig for regular communications.

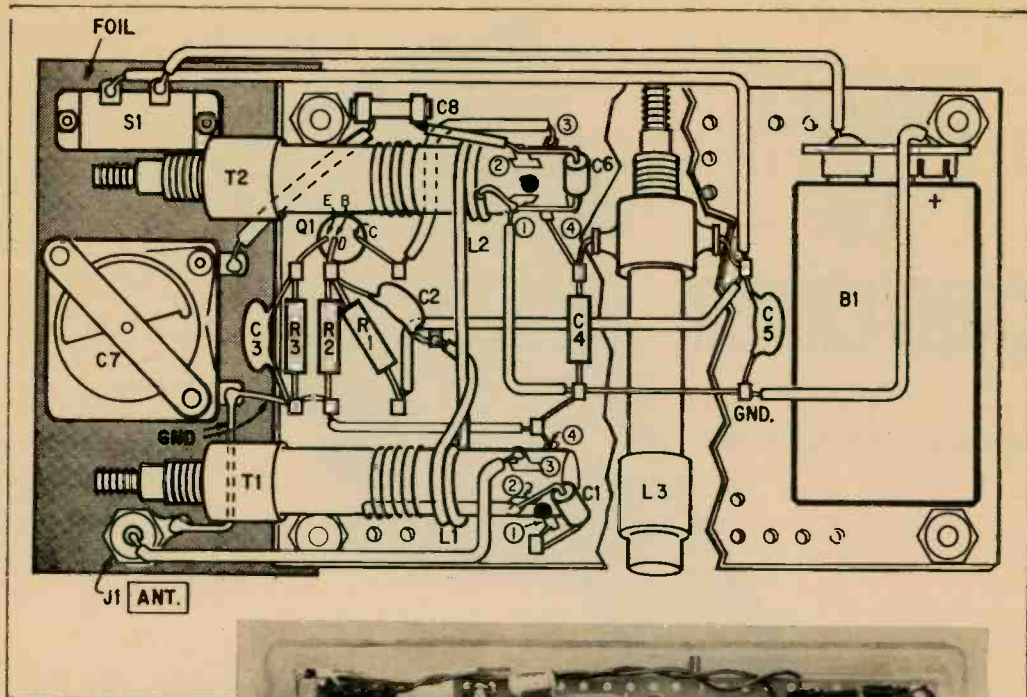

POCKET CB CONVERTER

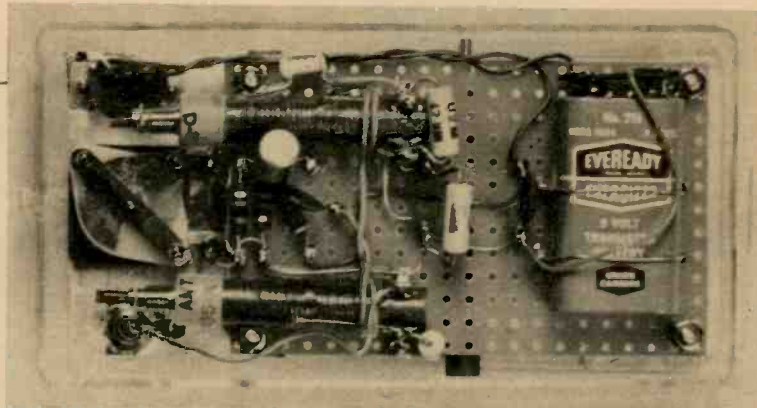

First, cement a $1\frac{1}{4} \times 2\frac{1}{2}$ -in. piece of aluminum foil at left end of case cover. Then install S1, C7 and J1. Next, mount other parts on $4 \times 2\frac{1}{2}$ -in. piece of perforated board. Only L3 goes on back of board. Use $\frac{3}{8}$ -in. spacers between board and cover. Be sure you wind L1/L2 coils over T1 and T2 exactly as shown.

The Circuit

Take a look at the schematic. Signals from the antenna are coupled via jack J1 to the primary winding of transformer T1. They are tuned by fixed capacitor C1 which is connected across T1's secondary. (T1 is tuned to the center of the Citizens Band by C1). The 2-turn coil (L1) couples the signals via C2 to the base of transistor Q1. The base of Q1 is also coupled via the other 2-turn coil (L2) to oscillator transformer T2. T2 is tuned by C6, C7 and C8 so the oscillator operates approximately 1 mc above the frequency of the incoming signal. The IF

signal is produced by mixing the incoming signal with the oscillator's signal.

Construction

Our converter is built in a $5\frac{3}{4} \times 3 \times 1\frac{1}{2}$ -in. plastic box. A wood or bakelite box can be used, but you must not use a metal box as it will prevent the RF from getting out to the radio.

All of the components except C7, J1 and S1 are mounted with flea clips on a $4 \times 2\frac{1}{2}$ -in. piece of perforated board. Before installing the board on the cabinet cover, mount coil L3 on the rear of the board by soldering its lugs to two flea clips. Space the

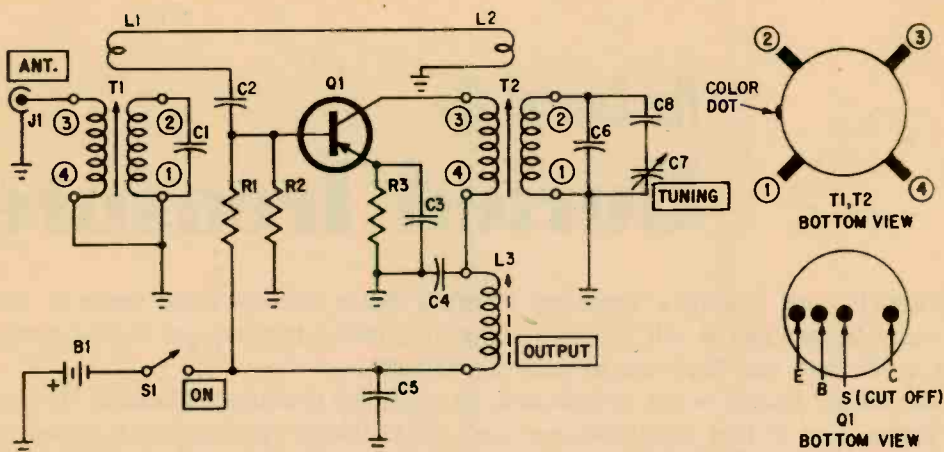

Incoming signals go to the primary of transformer T1, which is tuned to center of Citizens Band by C1. L1 couples signals via C2 to base of Q1 which is also coupled by L2 to oscillator transformer T2. As T2 is tuned about 1 mc above incoming signal, an IF signal is produced. It's radiated by L3.

board above the box's cover with $\frac{3}{8}$ -in. spacers mounted at the board's corners.

Install the parts exactly where shown as the wiring and spacing of components are critical. Before mounting any parts on the cover cement or tape a piece of aluminum foil on the inside at one end of the cover. This will minimize the effects of hand capacitance when you bring your hand near C7 to tune. Connect the foil to the circuit ground with the mounting nuts and bushings of C7 and J1. Cut off the shield lead of Q1.

Wind coils L1 and L2 next. They are each 2-turns of No. 22 hookup wire wound on T1 and T2 as shown in color in the pictorial. Keep the turns just to the left of the coil lugs. If you wind the turns too close to the existing windings there will be over-coupling which will prevent oscillation.

Alignment and Operation

Turn T1's slug-adjustment screw so $\frac{1}{4}$ -in. of the screw is out of the form. Set T2's slug-adjustment screw so it is $\frac{1}{8}$ -in. out of the form. Set L3's slug-adjustment screw so it is $\frac{1}{2}$ -in. out of the form. Set C7 to full capacity (full counterclockwise) and place a transistor radio on top of the converter so the radio's loopstick antenna is directly above and parallel to L3. Set S1 on *on* and tune the radio to a quiet spot near 1200 kc.

Connect a signal generator set up to feed a 26.96 mc modulated signal to J1. Tune T2 until you hear the signal in the radio and

PARTS LIST	
B1	—9 V battery
Capacitors:	
C1, C6	—47 μf , 600 V tubular ceramic
C2, C3, C5	—0.02 μf , 1,000 V ceramic disc
C4	—100 μf , 600 V tubular ceramic
C7	—10-360 μf variable (Lafayette 99 C 6217)
C8	—10 μf , 600 V tubular ceramic
J1	—Phono jack
L1, L2	—2 turns No. 22 hookup wire wound over T1 and T2 (see text)
L3	—Ferrite antenna coil (J. W. Miller No. 6300, Lafayette 34 C 8705)
Q1	—2N1180 transistor (RCA)
R1	—4,700 ohm, $\frac{1}{2}$ watt, 10% resistor
R2	—2,700 ohm, $\frac{1}{2}$ watt, 10% resistor
R3	—1,000 ohm, $\frac{1}{2}$ watt, 10% resistor
S1	—SPST slide switch
T1	—Antenna coil, 12-36 mc. (J.W. Miller D-5495-A, Lafayette 34 C 8720)
T2	—Oscillator coil, 12-36 mc. (J.W. Miller D-5495-C, Lafayette 34 C 8722)
Misc.	— $5\frac{3}{4} \times 3 \times 1\frac{3}{16}$ -in. plastic box (Lafayette 14 C 4403), perforated board.

adjust T1 and L3 for maximum volume.

Keep the level of the signal from the generator as low as possible for best alignment. Repeat the adjustment several times. Cement a dial on C7's knob then calibrate the dial.

Disconnect the signal generator from J1 and connect a good antenna to J1. For strong local signals, a 5- or 6-ft. length of wire will work. For best reception, a high outside antenna is better. Find a strong signal in the center of the band and peak up T1 for best reception. Other frequencies can be used on the radio instead of 1200 kc, but this will require peaking L3 and T2 again.

The Case of the Buried Treasure

PIRATES and plumbers, attention! Here's a device that will boost business. It's a metal locator and it will find everything from buried treasure and hidden pipes to nails in the wall and hardware in your crackerjacks.

Because our locator is not complicated, its sensitivity is somewhat limited. However, our explanation of how metal locators work will enable you to design your own circuit so you can dig farther for riches—or way in for that elusive hot-water pipe. We'll first examine two important circuits used in these devices, then construct a simple, practical project.

First circuit is that of a proximity detector—a device once used in wartime to explode a shell at the most effective instant before it hit the target. Take a look at the left schematic in Fig. 1. It's of an oscillator which generates an RF signal. As the signal flows from tuned circuit to tube grid (along arrow marked *normal*) it sets up steady negative voltage on the grid. That's the oscillator's operating bias voltage produced by grid-leak action. Point is, when the tube oscillates, little plate current flows and the relay contacts remain open.

But bring metal near the sensing antenna and the RF signal will be pulled away from the grid. Now there's less signal available to produce negative bias; therefore, plate current increases. The relay pulls in (and explodes the shell).

This basic detector is also known as the capacity relay. It responds most strongly to metal, but a hand brought close to the sensing plate will also detune, or load down, the oscillator causing it to energize the relay.

Our second circuit (shown at the right in Fig. 1) is the beat-frequency metal locator.

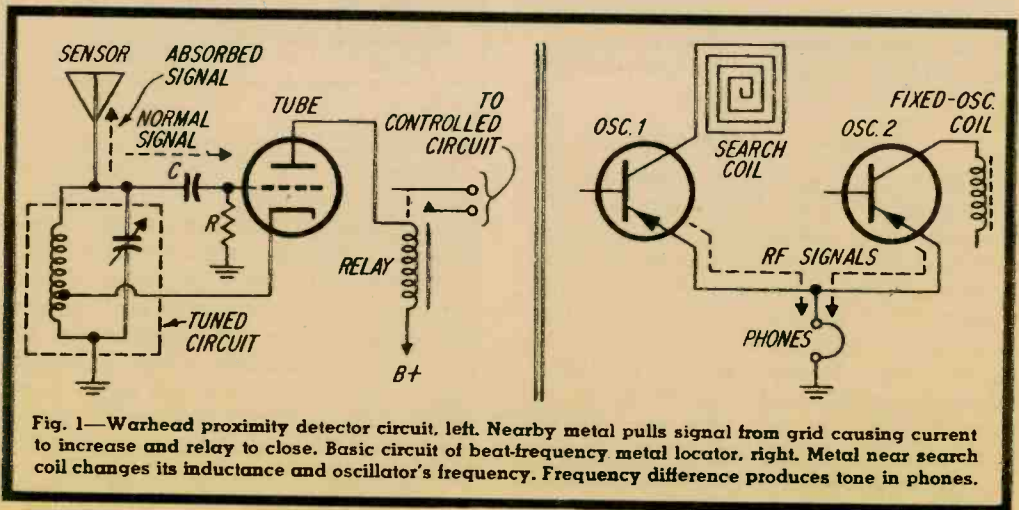

Fig. 1—Warhead proximity detector circuit, left. Nearby metal pulls signal from grid causing current to increase and relay to close. Basic circuit of beat-frequency metal locator, right. Metal near search coil changes its inductance and oscillator's frequency. Frequency difference produces tone in phones.

Its operation is based on the heterodyne action between the outputs of two RF oscillators. Such action produces an audible signal. Instead of a relay, you listen with earphones for a change in tone, which reveals the presence of metal. Note that *Osc. 1* has a special loop called a search coil which gets moved over the area being inspected. When it passes over metal, the coil's inductance changes. This shifts the frequency of oscillation.

The other section of the device contains a similar fixed-frequency oscillator whose coil is shielded. Since both oscillators feed the earphones, signals mix and the difference is heard as an audible tone. For example, if both oscillators are set to generate a 1,000-kc signal you will hear no sound in the phones. But if the metal near the search coil reduces the frequency to 998 kc, you'll hear the 2,000-cps difference frequency.

In a practical metal locator, there's a mixer stage between the oscillators and phones. Although the basic circuit shown here can produce beat notes, it's plagued by pulling—a change in one oscillator's frequency tends to shift the other's frequency. The mixer stage introduces isolation between them.

Our metal locator's design is based on the beat-frequency principle. The circuit, however, has been greatly simplified by constructing just one oscillator with a search coil. You use any portable transistor radio to perform the remaining functions—mixing and producing the tone. The fixed-frequency signal is supplied by a broadcast station.

Start construction by winding the 3½-in.-dia. search coil around the perimeter of a

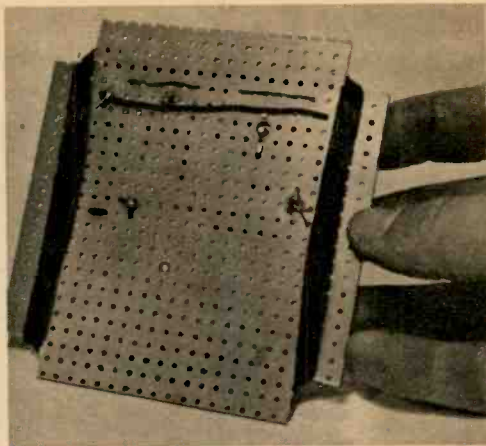

Fig. 3—Back of metal locator shows how the search coil (17 turns of No. 22 enameled wire) is wound on a 4½-in.-square piece of perforated board.

4½-in.-square piece of perforated board whose corners are notched. You'll have to enlarge three holes in the board to mount trimmer-capacitor C1. One center hole is to allow the tuning-screw threads to protrude through the board. Two others are for the mounting tabs. If the solder lugs on your trimmer are bent, straighten them so they remain on the component side of the board.

The battery can be taped or glued to the wood handle. You can mount an on-off switch in a free area on the board, if you wish. In our model we simply connected an alligator clip to the positive battery terminal.

The operating frequency of the oscillator falls in the upper portion of the BC band. If you wish to lower the frequency, either add more turns to the search coil, or connect an additional capacitor (about 100 μμf) across C1.

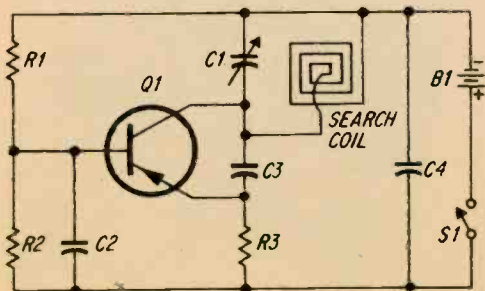

Fig. 2—Our metal locator's oscillator. Search coil and C1 determine frequency. Adjust C1 to produce heterodyne whistle with station tuned on radio.

PARTS LIST

- B1—9 V battery
- C1—25-280 μμf trimmer capacitor (Lafayette 34 C 6832 or equiv.)
- C2—.02 μf, 400 V tubular capacitor
- C3—100 μμf, 1,000 V ceramic disc capacitor
- C4—.05 μf, 400 V tubular capacitor
- Q1—PNP transistor, general-purpose RF (GE-1 or equiv.)
- R1—47,000 ohm, ½ watt, 10% resistor
- R2—10,000 ohm, ½ watt, 10% resistor
- R3—680 ohm, ½ watt, 10% resistor
- S1—SPST slide or toggle switch
- SEARCH coil—17 turns No. 22 enameled wire wound 3½-in. square
- Misc.—4½-in. square perforated board, 1-in. square X 6-in. long piece of wood

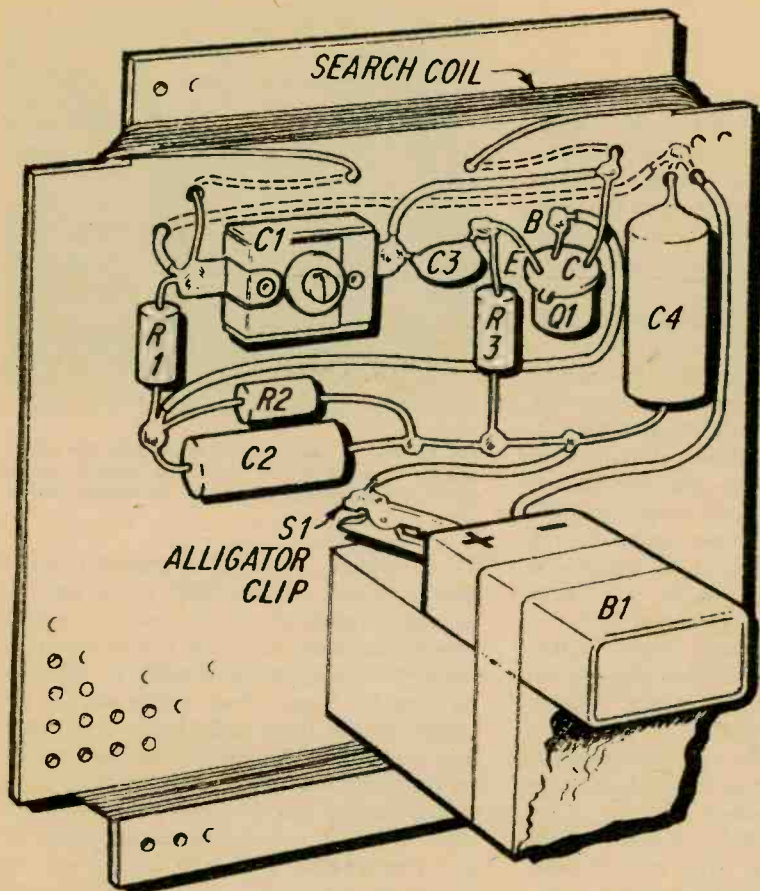

Fig. 4—On our model, parts are held on board by weaving wires through holes. However, you could use flea clips. To turn on locator, we simply attach an alligator clip to positive battery terminal. Switch S1, shown on schematic, would be connected between lead going to alligator clip and positive lug on B1.

To operate the locator, tune a BC radio to a station at the high end of the band. Next, adjust C1 until you hear steady tone from the radio.

As you move the search coil near metal objects, the tone should vary. Since your hand will also vary the tone (due to body capacity) hold the wood handle at the end.

After a little experience, you should be able to improve your skill. You'll find that the tone shifts in one direction for body capacity and in the reverse for metal. If you wish to convert the unit into a complete, portable instrument, devise some simple mounting arrangement for a transistor radio on the wood handle.

As a matter of fact, it would be best to mount the radio on the handle anyway so the radio's antenna always remains in a fixed position relative to the search coil. This will stabilize the tone. —H. B. Morris.

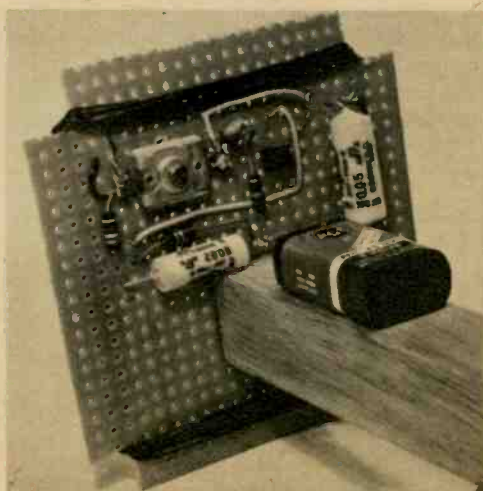

Fig. 5—Completed locator. Handle on our model is 6-in. long to keep hand away from circuit. This prevents hand from changing oscillator's frequency.

NOW 12 EASY, EXCITING WAYS TO LEARN ELECTRONICS, TV-RADIO WITH NRI

NRI has a training plan to fit your interest, your need, your education . . . from Color TV Servicing to Electronics for Printers. Pick the field of your choice and mail postage-free card now.



TELEVISION-RADIO SERVICING

Learn to fix home entertainment equipment like radio, hi-fi and stereo sets, all kinds of TV sets. Training kits include choice of black-and-white or color TV set you build. A profitable field full or part-time.

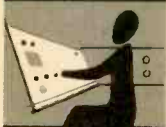

INDUSTRIAL-MILITARY ELECTRONICS

From basic principles to computers. Comprehensive training teaches fundamentals, then takes you into such modern-day miracles as servos, telemetry, multi-plexing, phase circuitry, others.



COMPLETE COMMUNICATIONS*

Teaches and provides actual practice in operation, service, maintenance of AM, FM, and TV broadcasting stations. Also covers marine, aviation, mobile radio, facsimile, microwave, radar.



FCC LICENSE*

Prepares you for First Class FCC Radiotelephone License exams. You begin with fundamentals, advance to required subjects covering equipment, procedures.

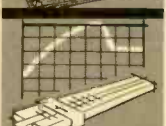

MATH FOR ELECTRONICS

A brief course for engineers and technicians who need a quick review of essential math used in industry, communications, government. Basic arithmetic review, short-cut formulas, modern digital number systems, much more.

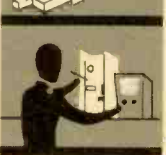

BASIC ELECTRONICS

A concise course in Electronic terminology and components. A wealth of useful information to help you better understand the field. For anyone who wants a basic understanding of Radio-TV Electronics.



ELECTRONICS FOR AUTOMATION

Not for beginners, but for men with some knowledge of Electronics who want an understanding of process control, ultrasonics, telemetering and remote control, electromechanical measurements, other subjects.



AVIATION COMMUNICATIONS*

Prepares you to install, maintain, service direction finders, ranges, markers, Loran, Shoran, Radar, landing systems. Earn your FCC License with Radar Endorsement.



MARINE COMMUNICATIONS*

Covers transmitters, direction finders, depth indicators. Radar, Sonar, other equipment on commercial ships, pleasure boats. Prepares for FCC License with Radar Endorsement.



MOBILE COMMUNICATIONS*

Learn to install and maintain mobile transmitters and receivers used by police and fire departments, public utilities, construction firms, taxis, etc. Prepares for FCC License.



ELECTRICAL APPLIANCE REPAIR

Prepares you quickly to repair all types of appliances, including air conditioning, refrigeration, small gasoline engines. An easy, practical course leading to profitable part-time or full-time business of your own.



ELECTRONICS FOR PRINTERS

Designed to teach operation and maintenance of Electronic equipment which controls the latest devices developed for the graphic arts industry. From basic principles to computer circuits. Approved by major manufacturers.

* NOTE: You must pass your FCC License exam (any Communications course) or NRI refunds in full the tuition you have paid.

SEE
OTHER
SIDE

EARN YOUR FCC
LICENSE OR YOUR
MONEY BACK

FILL OUT
AND MAIL
POSTAGE-FREE
CARD



TRAIN UNDER NEW GI BILL.
If you served since Jan. 31, 1955,
or are in service now, check GI
line in postage-free card.

BUSINESS REPLY MAIL
NO POSTAGE STAMP NECESSARY IF MAILED IN THE UNITED STATES

POSTAGE WILL BE PAID BY

NATIONAL RADIO INSTITUTE

3939 Wisconsin Avenue

Washington, D.C. 20016

FIRST CLASS
PERMIT
NO. 20-R
Washington, D.C.





EXPERIENCE IS STILL YOUR BEST TEACHER

Discover the Ease and Excitement of Learning TV-Radio, Electronics at Home the NRI Way

Begin now an exciting adventure. NRI — the home-study school that pioneered and proved the value of learn-by-doing training kits — brings you custom designed Color TV training equipment. Learn Color TV Servicing the most practical way — by building your own high-quality set and getting "on-the-job" experience as you train. Your family enjoys the thrill of TV in vibrant color. And thanks to NRI training, you do your own servicing — no costly service contracts.

to earn \$4 to \$6 an hour extra in spare time while learning; how to be your own boss in a full-time Radio-TV Servicing business, or qualify quickly for jobs in the fascinating fields of broadcasting/communications, industrial electronics, automation and space projects.

Earn \$4 to \$6 an Hour Extra Spare Time

Color TV is booming. Set sales exceed 5,000,000 a year now. 10 million-color-set years are predicted soon. And 60% of color set owners also own black-and-white sets. TV Technicians are in demand now to serve this giant, money-making, growing market. NRI shows you how to cash in on Color TV: how

Act Now to Move Ahead

NRI offers you a choice of 12 different training plans, designed for people with all kinds of interests, all levels of education. Courses are described briefly on the other side of this page. To find out how you can be a part of the Electronics Age, mail postage-free card for free NRI color catalog. Don't delay. Electronics and Color TV need you now. NATIONAL RADIO INSTITUTE, Electronics Div., Washington, D.C. 20016. No salesman will call.

◀ SEE OTHER SIDE

NATIONAL RADIO INSTITUTE, ELECTRONICS DIVISION
WASHINGTON, D.C. 20016

41-097

Please send me your new color Catalog. I have checked the field(s) of most interest to me. (No obligation. No salesman will call.)



- | | |
|---|--|
| <input type="checkbox"/> Television-Radio Servicing | <input type="checkbox"/> Electronics for Automation |
| <input type="checkbox"/> Industrial Electronics | <input type="checkbox"/> Aviation Communications |
| <input type="checkbox"/> Complete Communications | <input type="checkbox"/> Marine Communications |
| <input type="checkbox"/> FCC License | <input type="checkbox"/> Mobile Communications |
| <input type="checkbox"/> Math for Electronics | <input type="checkbox"/> Electrical Appliance Repair |
| <input type="checkbox"/> Basic Electronics | <input type="checkbox"/> Electronics for Printers |

Check for facts on New GI Bill

Name..... Age.....

Address.....

City..... State..... Zip Code.....

PICK YOUR FIELD and mail postage-free card for free color catalog



OVER 50 YEARS OF LEADERSHIP IN ELECTRONICS TRAINING

ACCREDITED MEMBER NATIONAL HOME STUDY COUNCIL