

MAY/JUNE 1972  
Fifty Cents

# **Electronics Digest**<sup>®</sup>

**BIOGRAPHY • HISTORY • NEWS • BASIC ELECTRONICS**

## *Lightning...*

(See page 7)

**complexity, mystery, danger**



# The ultimate turntable for sophisticated systems.

The BSR McDonald 810 Transcription Series.



BSR makes more automatic turntables than any other manufacturer. More than all the other manufacturers in the world put together. But of all the turntables we make, the BSR McDonald 810 Transcription Series is the finest. It is a triumph of years of painstaking efforts and research in our Engineering Laboratories in Warley, Worcestershire, England.

The 810 offers an impressive group of design innovations for serious music lovers . . . for professional users of transcription turntables . . . and for the audiophile who revels in sophisticated high fidelity equipment. It has the tightest specifications for rumble, wow and flutter of any automatic turntable made. We would be pleased to send you detailed technical specs upon request. As a matter of fact, few—if any—automatic turntable manufacturers publish complete specifications as we do. Only your personal inspection can reveal the overall excellence of this fine instrument. We suggest a visit to your BSR McDonald dealer.

**BSR**  
McDONALD



**Sequential Cam System**  
New smoothness and quietness of operation and overall reliability. Eight independent pre-programmed cams eliminate the light stampings and noisy moving parts of conventional cam gear and swing plate used in every other turntable mechanism.

**Transcription Tone Arm System**  
The 8.562" pivot-to-stylus length reduces tracking error to less than 0.5° per inch. Low-mass aluminum arm assures extremely low resonance. Counterbalanced horizontally and vertically.

**Automatic Tone Arm Lock**  
Automatically locks arm to rest post when unit is off. Prevents damage to stylus or record. Automatically unlocks in any mode. (See large photo.)

**Stylus Setdown Adjustment**  
Adjusts stylus setdown to initial record groove. Once adjusted setdown correct for all record sizes on automatic or semi-automatic. (See large photo.)

**Synchronous Power Unit**  
New high-torque, ultra-quiet synchronous induction power unit achieves unwavering constancy of speed, independent of voltage input or record load.

**Concentric Gimbal Arm Mount**  
Gyroscopically pivoted on 4 pre-loaded ball-bearing races to assure virtually no friction in horizontal or vertical planes. Provides 1/4 gram tracking capability.

**Rotating Manual Stub Spindle**  
Rotates with platter, eliminating record drag and center-hole wear. Interchanges with automatic spindle. (See large photo.)

**Viscous-Damped Cue and Pause Control**  
Gentle silicone oil-damped tone arm descent. Other anti-skate systems tend to move arm outwards in descent. Our positive friction Cue-Clutch prevents this. Arm returns to identical groove every time. Cueing operates in automatic and manual.

**Viscous-Damped Tone Arm Descent**  
Same gentle cueing descent functions during automatic and semi-automatic play.

**Stylus Overhang Adjustment**  
Cartridge slide has ±1/8" stylus overhang—quickly and accurately set by removable locating gauge. Once set, gauge replaced by stylus whisking brush provided.

**Stylus Pressure Adjustment**  
Resiliently mounted gliding counterweight adjusts to zero-balance over full range of cartridge and stylus masses. Precision micrometer wheel allows continuous infinite stylus pressure settings 0 to 5.0 grams.

**Dual-Range Anti-Skate Control**  
Dynamic anti-skate control system adjusts for all elliptical or conical styli. Applies continuously corrected compensation regardless of stylus location.

**Variable Pitch Control**  
Infinitely variable 6% range of speed adjustment (33 1/3 and 45 RPM) to match pitch of record to live instrument or other playback device.

**Integral Strobe Disc**  
Enables precise adjustment of turntable speed with pitch control for 33 1/3 and 45 RPM.

**Push-Button Operation**  
Unexcelled flexibility. Settings for manual, semi-automatic, infinite repeat of one record, or fully automatic play. (See large photo.)

**12" Dynamically Balanced Turntable Platter**  
Full 12" die-cast, non-ferrous 7 lb. platter machined and precision-balanced to run true for optimum performance and maximum record support.



## MAKING "WAVES"

### CADENCE—the musical instrument speakers

Making better, clearer, amplified sound waves is the **THING** Cadence does . . . better than anything else in the industry. Cadence Speakers are built to withstand heat from sustained notes at a high power level and the vibrations and stresses which are continually placed upon them. Cadence is guaranteed **one full year** at the power level specified. This proven speaker family has been selected by the manufacturers of most of the world's fine amplified music instruments.

If making beautiful, clear sound waves is your thing, ask for **CADENCE SPEAKERS**. For complete information and the name of your Cadence Dealer, write:



**UTAH ELECTRONICS DIVISION**  
Utah-American Corporation  
1124 East Franklin Street  
Huntington, Indiana 46750

## Hire a veteran. Hire experience.

**A veteran electrician,  
a veteran cook,  
a veteran construction worker,  
a veteran mechanic,  
a veteran administrator,  
a veteran medical specialist,  
a veteran programmer,  
a veteran policeman.**

**Don't forget. Hire the vet.**

For help in hiring veterans, contact your local office of the State Employment Service; for on-the-job training information, see your local Veterans Administration office.



## *A Heritage of Life*



With one sentence in your will, you can help significantly in the fight to conquer cancer. Over the years, this disease strikes two of three American families. It kills two out of three of its victims.

Great strides are being made in controlling cancer. But there can be no let-up until we have the answers to all the unanswered questions.

Today your bequest will be a gift of hope. Tomorrow, it could be a heritage of life. Contact your nearest ACS Unit for more information on the subject.

 **AMERICAN CANCER SOCIETY**

# Electronics Digest®

AMERICA'S MOST INFORMATIVE ELECTRONICS MAGAZINE



A TANDY CORPORATION COMPANY

Volume Five / Number Six

May / June 1972

## FEATURE ARTICLES

- 7 **Lightning: Complexity, Mystery, Danger**  
*This highly informative article explains some of the phenomena associated with lightning — a timely subject, since the month of May marks the beginning of the thunderstorm season in part of the U. S. and other countries.*
- 13 **Questions and Answers About the National Weather Service**  
*If you live in a tornado belt, hurricane-prone coastal area, river flood plain, or a city in the path of severe weather . . . a few minutes of warning can make a life or death difference.*
- 14 **Laser Light Used to Lift Tiny Glass Spheres**  
*Optical levitation demonstrated for the first time by Bell Labs scientists who have raised small glass spheres and held them aloft for hours in a stable position.*
- 19 **Illustrated History of the Vacuum Tube, Part 3**  
*A new generation of vacuum tubes made its appearance as operating frequencies were extended into the UHF and microwave regions. It began with the discovery of the magnetron in 1924.*

*Editor*  
William M. Palmer  
WSSFE

*Associate Editor, Feature Articles*  
Anne Leaton

*Associate Editor, News Orbit*  
Kitty Bates

*Contributing Editor*  
Arthur Trauffer

*Advertising Manager*  
James W. Graham

*Production Graphics*  
Vicky C. Owens

*Staff Assistants*  
Jeanne M. Atchison  
Debra K. Griffin

## DEPARTMENTS

- 5 **Today & Tomorrow / Electronics Newsletter**  
● *Power for the Environment* ● *Pollution Control*  
● *Sewage Treatment* ● *Recycling* ● *Street Lighting*  
● *Mass Transportation*
- 16 **In Remembrance / Memoriam**  
● *Lee de Forest* ● *Almon Brown Strowger*  
● *Joseph Henry*
- 18 **From An Album / Pictorial History of Electronics**  
● *Birthplace of Samuel F. B. Morse* ● *Sending of the First Telegraph Message: "What hath God wrought."*
- 23 **News Orbit / Around the World of Electronics**  
● *Minicomputers and the Construction Industry* ● *Electronics for scientists* ● *New radiometers for 1973 Mariner* ● *United States' lunar mission great success* ● *Dial-a-Test for phone repairmen*  
● *Direct reading loran receiver* ● *Computer-voice teaches workers on assembly line*
- 26 **Old-Time Radio / Replica and Other Projects**  
● *Modern Radio in Old-Time Dress*
- 29 **Electronics, Jr. / Science Projects**  
● *Installing Coax Connectors*

Publication Office: Electronics Digest, 1024 Currie Street, Fort Worth, TX 76107. Published bimonthly. Subscription rate: \$2.50 a year in the United States and possessions, in Canada and Mexico; all other countries \$4.00 a year. Single copies: 50 cents. Payment must be made in U. S. funds. Second-class postage paid at Fort Worth, Texas. Published by Electronics Digest Division, Tandy Corporation. Contents copyright 1972 by Electronics Digest Division, Tandy Corporation. All rights reserved. Quedan reservados todos los derechos. Electronics Digest is a registered trademark. Manuscripts and illustrations submitted to Electronics Digest will be handled with all possible care, but the publication does not assume responsibility for their safety. Inquiry should be made prior to submitting manuscripts for consideration. The opinions expressed by authors are their own and do not necessarily reflect the policy of Electronics Digest.

Printed in the United States of America

May/June 1972

### POWER FOR THE ENVIRONMENT

NO MATTER WHETHER THE U.S. ELECTRIC POWER CONSUMPTION NEARLY DOUBLES EVERY 10 YEARS, as now seems likely, or expands at some lesser rate, it is evident that electric energy will increasingly be called upon to combat the environmental degradation that offends us all. The point was well made in a New York Times column by Robert Bendiner, a member of that paper's editorial board: ". . .we need more (electric) power to do the very recycling of waste that is so desirable. We need it to operate the vastly expanded sewage treatment plants that a growing population demands. We need it for that immeasurably developed system of mass transportation that our metropolitan areas must have if the automobile is not to make the human lung outmoded. We need it for the herculean cleanup of the nation's lakes and rivers. And, not least, we need it if all who are just emerging from dire poverty are to enjoy a standard of living we have so come to take for granted that many now hold it in scorn or pretend to."

Although public speakers and the news media increasingly recognize the coming demands of these energy-intensive environmental programs, few have been able to translate the scope of energy needs into kilowatts and kilowatt-hours. The Forum's Public Affairs and Information Program staff has compiled the following random but representative data from reliable sources, and offers them for your background information. To place kilowatt-hour (kwhr) figures into better perspective, note that in 1970 the average American household consumed 7,000 kwhr.

### POLLUTION CONTROL

SEVERAL PACIFIC NORTHWEST METAL SMELTERS USE MORE THAN 60-MILLION KWHR PER YEAR EACH FOR CONTROL OF AIR AND WATER POLLUTION ALONE. That's equivalent to the electrical consumption of 8,500 typical households.

In Chicago, Commonwealth Edison Co. reports that eight out of 13 area foundry and steelmaking facilities have converted from polluting processes to electrical power. Recently, U.S. Steel and Republic Steel alone have asked Commonwealth to supply more than 200,000 kilowatts of additional power for electric furnaces and other purposes, thus more than doubling their total electric requirements.

An electrostatic scrubber for a large industrial plant requires as much as 50,000 kilowatts of capacity.

A 1970 survey by the Bonneville Power Administration showed that of the two million homes served by electricity in the Pacific Northwest, 25 per cent were heated electrically. Based on an average unit consumption (for that region) of 12,000 kwhr annually, this totalled 6-billion kwhr per year for heating use only. The other 1.5-million Pacific Northwest homes were heated by oil (50 per cent), gas (18 per cent) and coal and wood (7 per cent), and BPA estimates that their heating plants contributed 33,000 tons of particulate matter to air pollution last year. Northwestern utilities anticipate that power demand for home heating will more than triple by 1990, when 50 per cent of the projected 3.5-million homes in that region will be heated electrically. Quite a few large office buildings and industrial plants are installing high-temperature (1600° F) electric incinerators. One such installation, the Goder incinerator, requires a connected load of 32 kilowatts in order to process 400 pounds of waste per hour and to control attendant air pollution.

*(Continued on next page)*

(Continued from preceding page)

The efficient disposal of garbage and trash is calculated by some experts to require as much as 2-million kilowatts for the country as a whole. There may be some trade-offs if incinerators can be designed to produce rather than to consume power, but the control of air pollution caused by the burning of garbage and sewage will in turn require substantial amounts of electric energy.

#### SEWAGE TREATMENT

PRIMARY SEWAGE TREATMENT REQUIRES 21KWHR PER YEAR PER PERSON, ACCORDING TO A SURVEY OF OREGON AND WASHINGTON STATE COMMUNITIES. Secondary treatment, which most American municipalities do not yet have, raises this to about 38 kwhr/year/person. The Federal Water Quality Administration calculates that in 1968 the U.S. consumed close to 2-billion kwhr for sewage treatment. It estimates that in 1973 the needs of an urban population of 165-million Americans will require that this be more than doubled.

#### RECYCLING

A CONCEPTUAL DESIGN OF A TOTAL RECYCLING PLANT, COMMISSIONED BY THE ALUMINUM ASSOCIATION, ENVISAGES A FACILITY THAT WOULD TAKE IN GARBAGE AT ONE END AND PRODUCE SALEABLE RAW MATERIALS AT THE OTHER. Designed to serve a city of 175,000 to 200,000 people, such a plant could consume nearly 10-million kwhr per year.

In 1969, some 20-million tons of scrap iron and steel were reclaimed in the U.S., mostly by means of electric furnaces, and this total is even higher today. Metal industry sources say that to recycle one ton of scrap requires 500 kwhr of power, which would mean 1969 consumption for this purpose of 10-billion kwhr.

One Chicago plant, typical of its kind, uses nearly 4,000 kilowatts of electrical power to grind up junk automobiles into metal shreds for remelting.

#### STREET LIGHTING

GENERAL ELECTRIC REPORTS THAT EVEN WITH A HIGHLY EFFICIENT LAMP, SUCH AS ITS 400-WATT LUCALOX, IT TAKES 44,000 KWHR PER YEAR PER MILE TO PROPERLY ILLUMINATE A FOUR-LANE STREET AND 66,000 KWHR/YEAR/MILE FOR A SIX-LANE HIGHWAY. The 1,000-watt mercury clear lamps in common use today require approximately three times as many kilowatts per foot candle as the Lucalox, according to G.E.

#### MASS TRANSPORTATION

THERE ARE SOME 110-MILLION REGISTERED MOTOR VEHICLES IN AMERICA, EACH TRAVELING AN AVERAGE OF 10,000 MILES A YEAR. THAT'S A TRILLION MILES. To convert just a fraction of that mileage from internal combustion power to electric propulsion would take a great deal of energy. Chargeable batteries used in several experimental electric vehicles by the Eugene, Ore., Water & Electric Board draw about 1 kwhr for each mile of travel. Bruce C. Netschert, a prominent energy consultant, has estimated that the ultimate conversion of this vast automobile fleet to electricity would require approximately 450-billion kilowatt hours, or about a third of the total U.S. output today.

The 160-mph Metroliner railroad cars developed for the Northeast Corridor are designed for maximum acceleration and deceleration. Each Metroliner car has a peak energy demand of 2,500 horsepower, or 25,000 hp for a 10-car train. This is equivalent to an electrical load of nearly 15,000 kilowatts. Although the Metroliner does not draw peak loads continuously, it does require close to full power a good 50 per cent of the time because the train automatically changes speed almost constantly as it negotiates the conventional roadbed. If the train operates 70 per cent of the time over the course of the year its average power requirement could run to 45-million kwhr.

There are about 220,000 miles of railroad track in this country, of which barely 1 per cent is electrified. Power required to move loads over electrified lines can go as high as 20 kwhr per 1,000 gross ton miles of expedited traffic, according to General Electric's Transportation Systems Division. A rule of thumb among railroaders when estimating power consumption is 1-million kwhr per year per mile of electrified track.

# Lightning: Complexity, Mystery, Danger

This highly informative article explains some of the phenomena associated with lightning – a timely subject, since the month of May marks the beginning of the thunderstorm season in parts of the U. S. and other countries

## Special Report

Thunderbolts have always intrigued and frightened mankind. In recent history lightning and thunder have also amazed scientists, who have sensed with their instruments things that totally escape the eye and ear.

There is a small number of scientists working full time on basic lightning research in a few laboratories, including the Westinghouse Research Laboratories. They have gathered a wealth of data, especially in the last decade, but no one can explain exactly what causes lightning or precisely how it takes place.

Yet lightning is common: 600 flashes occur every second somewhere on the globe. It is economically significant: \$100 million in property damage and ten thousand forest fires result from lightning each year in the U. S. And it is dangerous: the Americans it kills every year number in the hundreds.

Lightning can occur in several ways. Most often it happens entirely within a cloud. It can also go from cloud to cloud, and sometimes even appears as the proverbial bolt out of the blue, when there is no cloud around.

But the flash between a thundercloud and the ground is the most commonly seen, and is the case of most interest and importance.

Just before lightning strikes, people in the target area may see hair stand on end and a soft blue gas discharge glow around the tips of pointed objects, even blades of grass, and they may hear a hissing sound. This is known as St. Elmo's fire.

The strike can occur with energy equal to that which would lift the Queen Mary six feet into the air. The eye sees a crooked, forked streak sometimes several miles long. It usually flickers rapidly several times

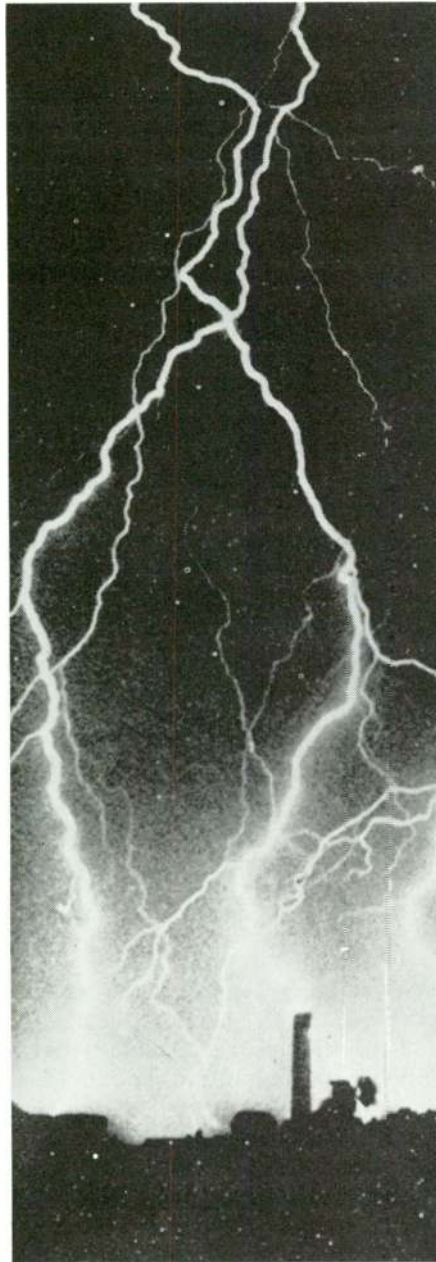

Westinghouse Electric Corp.

*This photo illustrates the intensity of lightning during a severe thunderstorm. Lightning causes more than \$100 million in property damage annually in the United States. It also causes thousands of forest fires. Yet it is not known exactly what causes lightning.*

and is over in the wink of an eye—about a fifth of a second or so.

It is usually followed by the claps and rumble of thunder, which usually last for many seconds.

### HIGH-SPEED CAMERA

The flash happens so quickly that the unaided human senses can not register all its details. But as other scientists have telescopes and microscopes to enlarge their vision, so the lightning specialist has his instrument—the high-speed camera, which can photograph aspects of lightning that last only as long as a millionth of a second.

The camera reveals that a lightning flash can have several components: stepped leader, ascending streamer and return stroke, usually followed alternately by dart leaders and more return strokes.

The stepped leader is the first stage of the typical flash. A bright streak about 150 feet long and three to thirty feet wide extends from the bottom of the cloud. The streak descends toward the ground by a series of pulsating, jerky steps, each step lasting about 50 millionths of a second.

In its wake, the streak leaves a faintly glowing trace, with forks where other streaks have branched off.

When the stepped leader gets near the ground, streamers of light pop up here and there from the earth striving to meet it.

When one of these streamers contacts the stepped leader, the preliminaries are over and the main event begins—a stream of intense light races from the ground to the cloud along the stepped leader.

Called the return stroke, it starts out at a speed of as much as 100 million miles per hour but slows as

*(Continued on next page)*

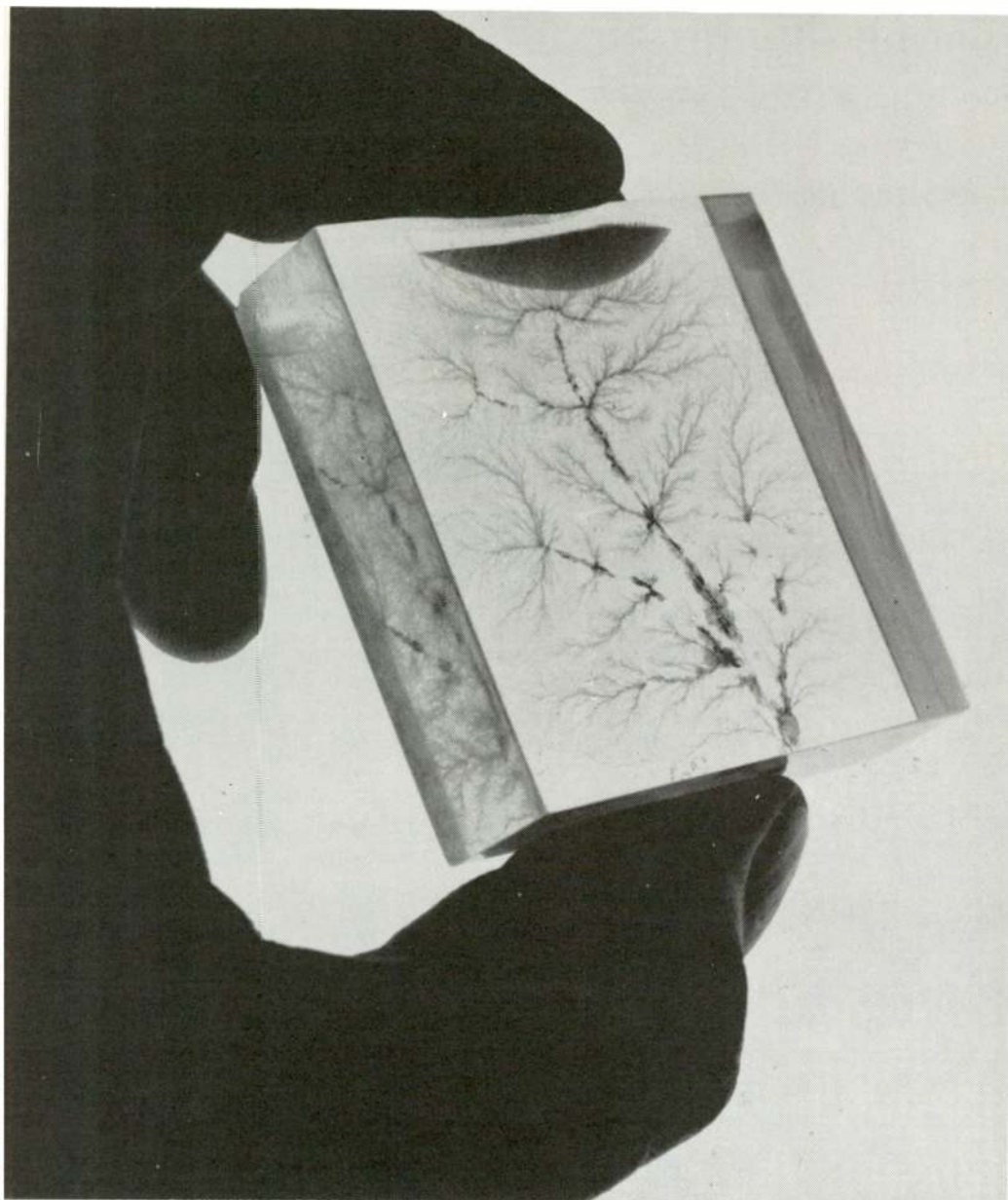

Westinghouse Electric Corporation

*This plastic block was electrically charged like a thundercloud, and discharged from a point on the bottom. A special "developing" process revealed the pattern formed by the electricity as it drained from the simulated thundercloud.*

## LIGHTNING

*(Continued from preceding page)*

it rises. A typical stroke takes something like 70 millionths of a second to reach the cloud.

This may be the end of the flash. But usually about 40 millionths of a second later a 150-foot-long dart of light, called the dart leader, runs down the same path as the return stroke, but avoiding the dead-ends, at a speed of four million miles per hour.

When it hits the ground, another return stroke shoots upward along the dart leader's path. Two more dart-leader and return-stroke combinations occur in the average flash,

and as many as 26 have been known to occur. The stroke path also sometimes lights up all at once without another leader or return stroke occurring.

Thus the apparently simple lightning flash is quite complex when examined in detail. Scientists think that faster cameras might reveal an even greater complexity if they could record events happening faster than a millionth of a second.

## ELECTRICITY

Other instruments are used to record thunder and the electro-magnetic field, current, temperature and chemistry of lightning.

Data reveal that a thundercloud is positively charged on top and nega-

tively charged on the bottom. This probably results from strong up-drafts, falling water and ice particles, and temperature differences within the cloud, although nobody knows for sure.

It is an unstable situation and results in many lightning flashes within the cloud.

Electrostatic forces from the bottom of the thundercloud induce a positive charge in the ground beneath it. This is what causes St. Elmo's fire. One ampere of current at almost a billion volts flows continuously between the average thundercloud and the ground.

Lightning is basically a long spark, a result of static electricity like the sparks that jump from hand to metal in winter.

The stepped leader is a breakdown, or ionization, of the air due to the high voltage. The air is an insulator separating the two highly charged regions of the cloud and the ground; the stepped leader is like a crack developing in this insulator because of the voltage stress.

The typical "crack" is filled with electrons and the atoms from which they have been torn (ions), and with electrons poured into it from the negative bottom of the cloud.

Scientists say that this particle-filled channel, about an inch in diameter, forms the core of the stepped leader, and that the outer portion of the stepped leader is corona discharge from the core. The high voltage of the stepped leader causes the streamers that leap up from the ground to meet it.

When the stepped leader contacts one of these streamers, electrons start pouring out the bottom and electrons all along the channel move down a few feet. This progressive movement of electrons, starting at the bottom of the channel, is what forms the return stroke. After all electrons in the channel have moved down a few feet, and those at the bottom have poured into the ground, the return stroke ends.

Power during the return stroke is not steady, but for a brief instant at its peak can reach a billion kilowatts. This heats the channel to nearly 60,000 degrees Fahrenheit, which is five times hotter than the surface of the sun.

This can set fire to trees, houses and other flammable structures, but

*(Continued on next page)*



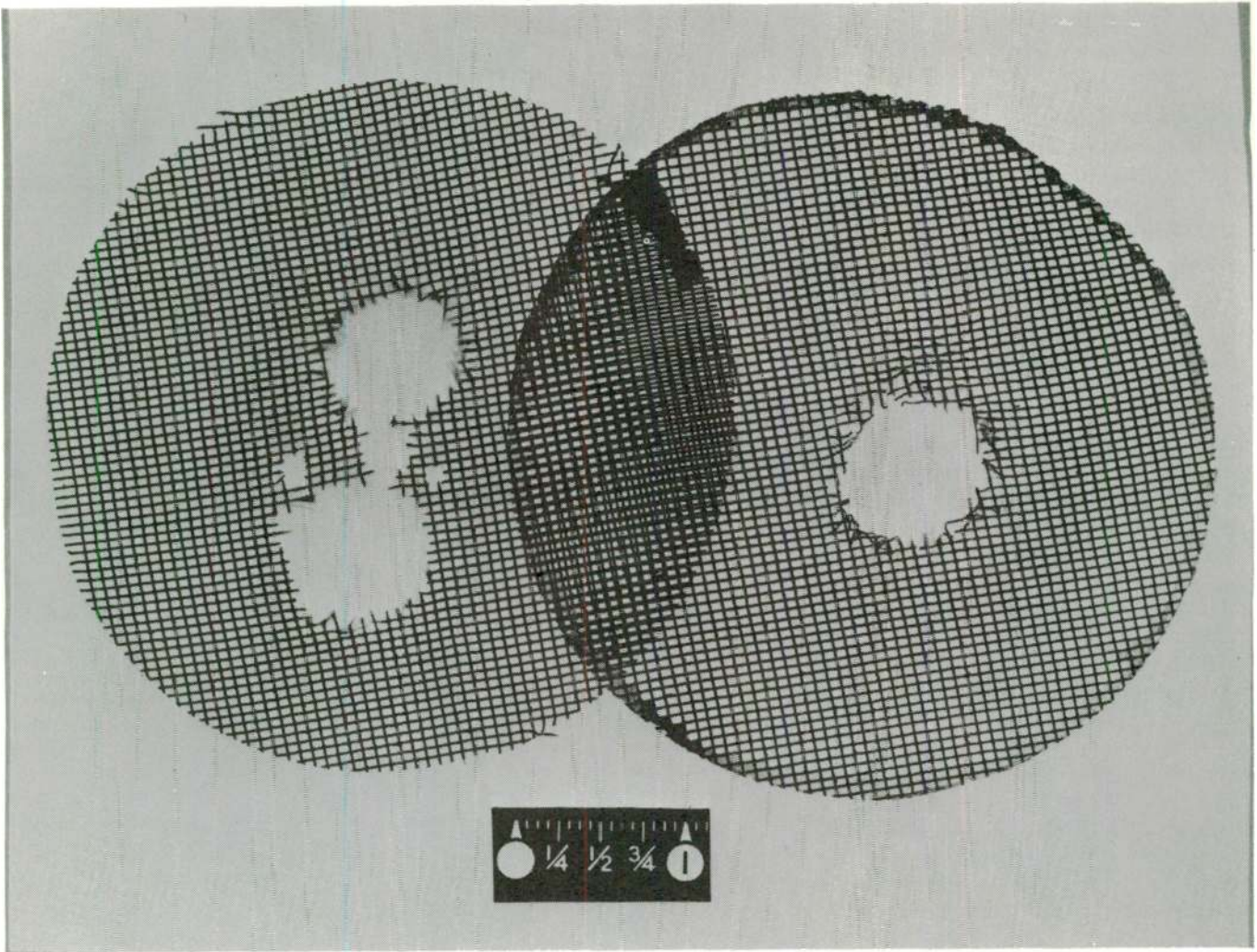

Westinghouse Electric Corporation

*The holes in these pieces of screening were made by lightning flashes going through the screening, and it graphically shows the width of the lightning channel. The screening had been mounted next to a lightning rod, as experiment, in order to measure the diameter of the lightning channel.*

not always—if the return stroke lasts less than about 40 millionths of a second, there is not enough time for fire to begin, just as a person can pass his hand so quickly through a flame that he does not get burned.

After the return stroke ends, the “crack” in the air remains and possibly even spreads upward into a higher region of negative charge. When this happens a dart leader descends, greatly increasing the ionization of the channel and filling it with electrons. When it hits the ground another return stroke occurs.

The total amount of electricity discharged by a typical flash is about 350 kilowatt-hours, which would cost a person about \$7.00 on his electric bill.

In addition to the general features of lightning, there are details of interest mostly to scientists; the K

change, for example, is a small, rapid change in electric field that occurs between and after the strokes of a multiple-stroke flash.

And there are exceptions to many of the processes described for the typical flash; a stepped leader, for instance, can move upward from a tall structure instead of downward from a cloud, and can carry positive instead of negative charge.

Not only do scientists not fully understand the intricacies and exceptions to lightning, but their understanding of the main features is incomplete—nobody knows why the stepped leader is stepped, for example, or why the dart leader is like a dart. And scientists aren’t certain of the specific mechanisms by which air breaks down to permit lightning in the first place.

Thus there are still unknown basic facts about atmospheric electric phe-

nomena that scientists at the Westinghouse Research Laboratories and elsewhere are trying to discover.

#### THUNDER

If a person standing close to a lighting flash were not electrocuted, he might still be killed by the explosion of the lightning channel after the flash. Instantaneous heating of the air in the channel may raise its pressure to more than 1500 pounds per square inch, causing it to expand explosively as a shock wave moving at supersonic speed.

The shock wave slows down as it rushes outward, and turns into sound waves of thunder after it has gone thirty feet or so.

The first sound a person hears comes from the part of the lightning channel closest to him. The rumble that follows occurs as sound from successively farther portions of the

*(Continued on next page)*

## LIGHTNING

*(Continued from preceding page)*

channel reaches him.

Claps during the rumble come from sections of the channel that are perpendicular to the person's line of sight, so that all sound from a section reaches him at about the same time.

A person can tell how many miles away a flash was by dividing the number of seconds between flash and thunder by 5; sound travels about one-fifth of a mile per second.

Thunder can usually be heard from as far away as 15 miles but normally no farther, because the atmosphere refracts (bends) upward the path of sound. The atmosphere also absorbs high-pitched sound waves, so that the remaining low-pitched sounds account for the deep rumble of distant thunder.

Thunder includes sound waves too low-pitched to hear, and there are reports of lightning occurring without any audible sound at all. Scientists think that this can happen when the stepped leader ascends from a tall structure, instead of descending from a cloud. The current may increase to its peak value too slowly in this case to cause an explosive shock wave.

In addition to acoustic noise, lightning also produces radio noise, principally in the very low frequencies, that can cause static in radio sets. Westinghouse scientists study the world-wide pattern of lightning-produced radio noise, and its change with time and season, to provide forecasts of communications conditions for global radio systems such as those of the military.

"Whistlers," strange sounds heard on low-frequency radio receivers, are caused by radio waves from lightning that travel along the earth's magnetic lines of force, going out into space and then curving back to earth in the opposite hemisphere; whistlers in the United States come from lightning flashes in South America.

Scientists have suggested that some unexplained radio noise from space may be caused by lightning

*(Continued on page 12)*

*The spidery image recorded on film by a klydonograph confirmed the theory that a nearby lightning stroke could cause a hazardous surge in a high-voltage transmission line.*

Westinghouse Electric Corp.



Westinghouse Electric Corporation  
*Large "ball lightning" frightens peasants in this old woodcut illustration from an 1840 French science book (courtesy Brundy Library). Ball lightning refers to floating, short-lived globes of light seen by many people, but never recorded scientifically. Scientists at the Westinghouse Research Laboratories have suggested that it may be a mixture of extremely hot air and soot formed by ordinary lightning striking a tree or other object.*



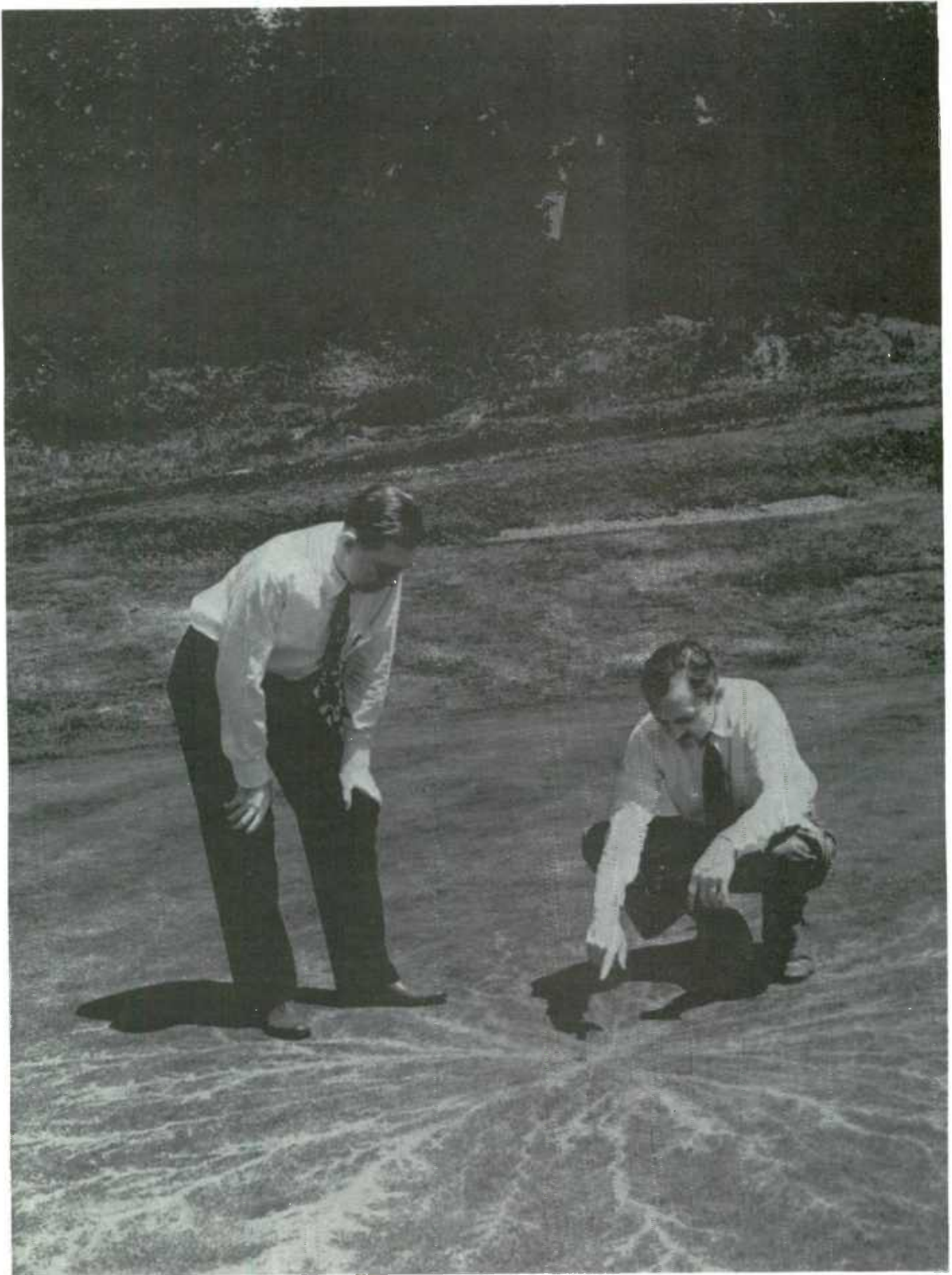

*In this photo Westinghouse scientists examine an unusual pattern on a golf course which was formed by lightning dissipating along the surface after it struck the ground. Since lightning may travel a short distance along the surface before it dissipates, it can electrocute a person on the ground or in nearby water.*

Westinghouse Electric Corporation

## LIGHTNING

(Continued from page 10)

flashes on other planets.

The electromagnetic field generated by a close lightning flash can cause malfunction of sensitive electronic and computer systems, and can detonate explosive devices.

Other effects of lightning include chemical changes in the atmosphere; many compounds of nitrogen and oxygen form in the lightning channel.

### LIGHTNING VARIETIES

Special names have been given to various appearances of lightning:

- Sheet lightning. Clouds light up and thunder is heard but the flash itself isn't seen; due to flashes within or between clouds.
- Heat lightning. A large area of the sky is illuminated with a pale light, but no thunder is heard; caused by bright flashes within clouds or beyond the horizon.
- Rocket lightning. Cloud-to-air flash itself is not seen; due to out the tip winding its way across the sky; occurs when the stepped leader path is so long that there is a perceptible time from beginning to end, and there is no return stroke.
- Ribbon lightning. Ribbons of light appear instead of the usual single streak; presumably caused by high winds blowing in lightning channel sideways, so that the strokes occur in different places.
- Bead or chain lightning. Flashes that appear normal until they break up into long-lasting segments many yards in length; cause unknown, but possible explanations include lightning channels being pinched at points along their length by magnetic forces, or something making portions of the channel wider and hence slower to lose brightness than the rest of the channel.
- Ball lightning. Mysterious, glowing grapefruit-sized globes of light that are sometimes seen drifting near the ground during thunderstorms; unexplained, but speculations include that it may be caused by unusual electromagnetic forces, or that it may be a mass of very hot air combined with soot-like particles re-

sulting from a lightning strike.

In trying to solve the puzzles of lightning, scientists at the Westinghouse Research Laboratories carry out theoretical studies and experimental studies in the field and in the laboratory.

They developed pioneering lightning research tools, including the klydonograph, invented in 1926 to measure voltage, and the fulchronograph, invented in 1938 to measure current.

Recent projects have delved into almost every aspect of the physics of lightning and thunder, using modern electronic instrumentation, spectroscopy and photography, with analysis often aided by computer.

Some projects involve long laboratory sparks, sometimes called artificial lightning. Scientists point out that differences in initiation and magnitude between lightning and man-made sparks are great, but that they are similar enough to use sparks for certain aspects of research and testing. The Westinghouse Research Laboratories has a three-million volt impulse generator, used for basic research on lightning and other high voltage phenomena.

The most powerful Westinghouse spark maker, and one of the most powerful in the world, is the impulse generator maintained by the Westinghouse Power Systems Company at its Trafford, Pa., plant. Capable of generating 6,400,000 volts, it is used primarily to test equipment for its ability to withstand high voltage impulses and lightning strikes.

### LIGHTNING PROTECTION

The equipment tested includes lightning arresters manufactured by Westinghouse. Lightning arresters protect electrical transmission apparatus by draining into the ground excess currents caused by lightning. They are so designed that they do not drain off normal currents.

The first lightning arrester to give universal lightning protection was the Autovalve arrester invented in 1922 by the internationally known Dr. Joseph Slepian of the Westinghouse Research Laboratories.

The development followed from his pioneering studies of the nature of electrical sparks in air, which showed the importance of ions in conducting current. The same studies led to the famous Deion family of circuit breakers.

Buildings and other facilities are

protected by lightning rods, which prevent current from ever reaching the structures. When a thundercloud passes overhead, lightning rods conduct positive charge up above the structure. Attracted by the stepped leader, streamers move upward from the rod and "grab" the leader before it contacts the structure underneath.

Persons can protect themselves from lightning only by getting out of the way. Houses, buildings and automobiles—with windows closed—are quite safe. But small sheds and booths may be unsafe.

Airplanes are good conductors of electricity, and their presence in an atmospheric electric field can trigger lightning. As a result they are often struck—one source estimates that 500 strikes occur every year to commercial jet aircraft in the United States alone—but in most cases there is very little damage.

A person is in danger in the open during a thunderstorm if he is the tallest target, or if he is near an isolated tree, post or mast. A tall wooden object may initially attract lightning, but a person is a better conductor than wood and may provide a more attractive path to ground. Lightning may therefore "flash over" from the object to a nearby person.

Also, lightning may travel a short distance along the surface before it dissipates, and could electrocute a person on the ground or in the water nearby.

Indoors or out, there is some danger near plumbing, wiring, metal fencing, rails and other extended metallic things that could conduct current from the vicinity of a lightning strike.

But even as lethal as lightning can be, two-thirds of people who are shocked by it recover. Physicians say that victims can often be revived even if heartbeat and breathing have stopped, if they are aided quickly enough.

To sum up: lightning is complex, mysterious and dangerous, and Westinghouse scientists and engineers continue seeking to know it, to understand it and to tame it.

**EDITORS NOTE:** Readers who wish to explore the subject of lightning in greater depth will enjoy reading the book "Understanding Lightning," by Martin A. Uman of Westinghouse Laboratories in Pittsburgh, Pa. For information write to: Bek Technical Publications, Inc., 100 West Mall Plaza, Carnegie, Pa., or contact your local public library or bookstore. Please mention *Electronics Digest*.

# Questions and Answers About the National Weather Service

If you live in a tornado belt, hurricane-prone coastal area, river flood plain, or a city in the path of severe weather . . . a few minutes of warning can make a life or death difference.

## Special Public Service Report

**Q. What is the national weather service?** A. The national weather service of the National Oceanic and Atmospheric Administration (NOAA) is a part of the Nationwide Natural Disaster Warning System (NADWARN). This system provides 24-hour continuous radio broadcasts of area weather conditions designed to speed warnings of environmental hazards to threatened areas. Taped messages are repeated every four to six minutes and updated every two to three hours. When dangerous weather threatens, routine transmissions are interrupted and an emergency warning is broadcast.

**Q. Are these strictly emergency broadcasts?** A. No. Although the weather warnings will be directed to the public at large, they are especially useful for schools, hospitals, news media, civic and local government offices, as well as Civil Defense and public safety officials who are responsible for local preparedness programs.

The broadcasts will also provide useful information for boating enthusiasts, fishermen, tugboat operators, farmers, ranchers, campers, and motorists.

**Q. Where, and how, is this information broadcast?** A. Transmissions are broadcast on VHF frequencies of 162.40 and 162.55 MHz (see map). There are Weather Stations broadcasting now in many cities and more are opening all the time. Effective range of most VHF Weather receivers is about 40 miles, so check the map to see if there's a station in your area.

**Q. What kind of equipment do I need to receive this information?** A. Any radio receiver in the VHF 162.40

to 162.55 MHz range can receive weather service broadcasts. This includes high-police-band receivers, some communications receivers and many portables, such as Radio Shack's Realistic Weatheradio.

**Q. How does this information benefit me?** A. If you can live in a tornado belt, hurricane-prone coastal area, river flood plain, or a city in the path of winter storms, a few extra minutes of warning can make a life-or-death difference. And instant Weather information — anywhere — can be a real convenience in planning trips and outings.

## HEAR WEATHER BROADCASTS IN THESE AREAS



Akron	*Fort Worth	Norfolk
*Anchorage	Galveston	Portland, Me.
*Atlanta	Honolulu	Portland, Or.
Atlantic City	Jacksonville	Sacramento
Baton Rouge	Kansas City, Mo.	*Salt Lake City
Boston	Lake Charles, La.	*San Diego
Brownsville	Los Angeles	Sandusky
Buffalo	Miami	San Francisco
Charleston	*Milwaukee	Seattle
Chicago	*Minneapolis	St. Louis
Cleveland	*Mobile	Tampa
Corpus Christi	Monterey, Calif.	Washington, D.C.
*Dallas	New London	*West Palm Beach
*Detroit	New Orleans	*Wichita
*Erie	New York City	*Wilmington
Eugene, Or.		
Eureka, Calif.		
	*Broadcasting Soon	

Radio Shack's WEATHERADIO™.

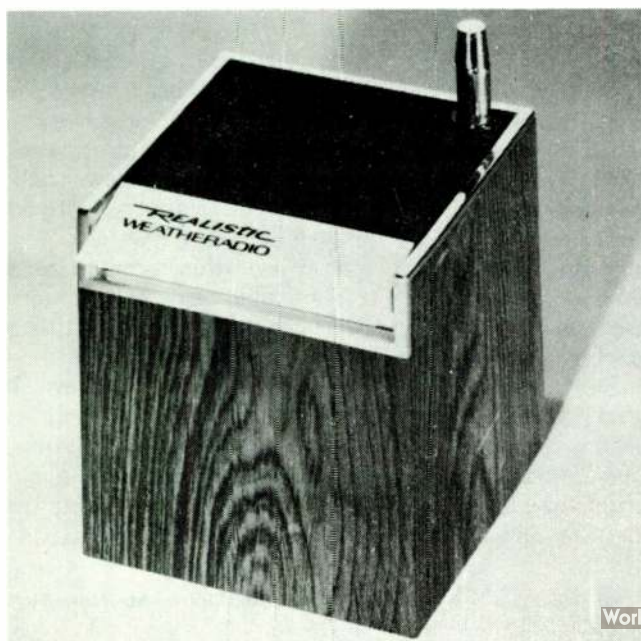

# Laser Light Used to Lift Tiny Glass Spheres

Optical levitation demonstrated for the first time by Bell Labs scientists who have raised small glass spheres and held them aloft for hours in a stable position

## Special Science Report

Using a beam of laser light, Bell Labs scientists have raised small transparent glass spheres off a glass surface and held them aloft for hours in a stable position. The experiments, which demonstrated optical levitation for the first time, were conducted by Arthur Ashkin and Joseph Dziedzic of Bell Labs, Holmdel, N.J.

The new technique is expected to provide simple, precise methods for manipulating small particles without mechanical support. It could be useful in communications research to measure scattering loss caused by particles, either in the atmosphere or in other transmission media. Such measurements may help in developing optical communications systems for the future.

In their experiment, Ashkin and Dziedzic focus a laser beam upward on a tiny glass sphere about 20 microns in diameter (about one-thousandth of an inch). Radiation pressure from the light not only counteracts gravity and raises the particle, but also traps the sphere in the beam and prevents it from slipping out of the beam sideways. In the experiment, which has been successfully demonstrated in air and in a partial vacuum, they thus generate a stable optical trap for holding particles which they term an "optical bottle."

"Light photons have momentum as well as energy," Dr. Ashkin, head of Bell Labs physical optics and research department, says. "When we focus a quarter-watt laser on a small transparent particle, the extremely small force exerted by light is then sufficient to lift the sphere off the surface and suspend it."

The sphere is launched by lifting it off a transparent glass plate with the light beam. Initially, radiation pressure is not sufficient to over-

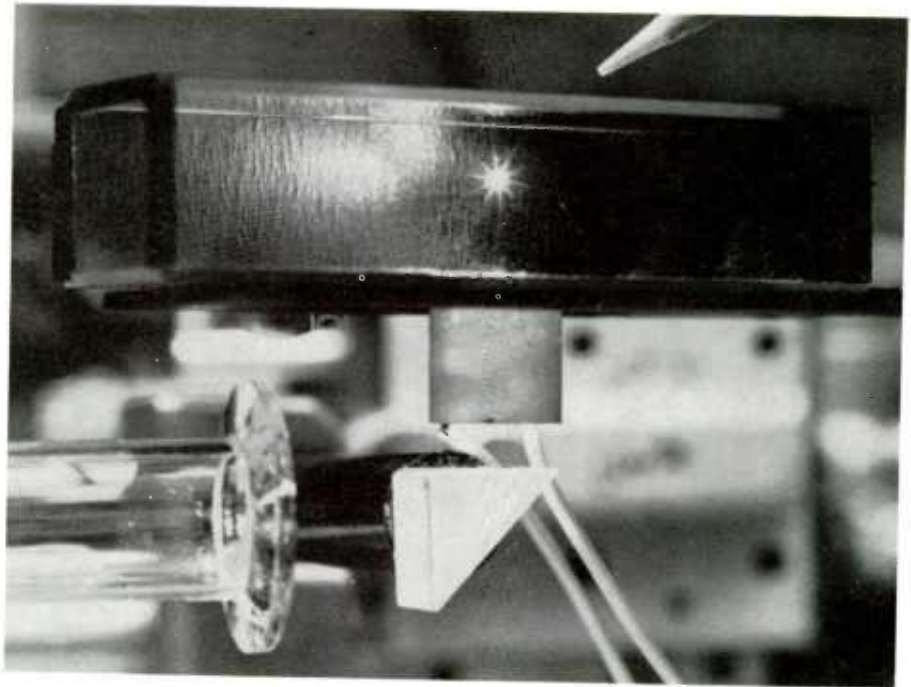

Bell Telephone Laboratories

*"OPTICAL BOTTLE" HOLDS PARTICLE ALOFT - The tiny star-like particle in the center of the photograph is being held aloft in air by light. Although not visible in the photo, laser light passing through a lens at the end of the glass tube is being bent by the triangular prism to focus on the transparent glass particle from below.*

come molecular attraction between the sphere and the glass plate. This attraction, known as Van der Waals force, is about ten-thousand times gravity for a 20-micron sphere. For this experiment, the Van der Waals attraction is broken acoustically by vibrating a ceramic cylinder attached to the plate.

When the attraction is broken, the sphere rises in the light beam and comes to rest where the upward pressure caused by the laser is balanced by the earth's gravity. In this position, it can be held aloft as long as the light is focused on it. By changing the position of the focus, the trapped sphere can be moved up and down or sideways very precisely.

In the experiment, these trapping forces were also studied, using a second laser focused on the particle from the side. As the power of the

second laser is increased, the particle is displaced within the first beam until it is finally driven out and falls.

"Any laser will produce the levitation effect," Dr. Ashkin says. "However, the particle is preferably transparent. If the beam were focused on objects that absorb light, most would melt. By remaining cool, the transparent sphere allows radiation pressure to be studied without any disturbing thermal effects."

The laser levitation technique may also be a valuable research technique for suspending particles in optically induced thermonuclear fusion experiments. When used in an evacuated environment, where damping effects on the particle are negligible, the technique may also have applications in inertial devices such as gyroscopes and accelerometers.

Special Feature Pull-Out Section

# Old-Time Radio<sup>T.M.</sup>

**HISTORICAL EVENTS IN ELECTRONICS**

Edited by  
William M. Palmer, W5SFE

- BIOGRAPHICAL SKETCHES OF GREAT MEN
- HISTORY OF INVENTION
- PICTORIAL HISTORY OF ELECTRONICS
- OLD-TIME RADIO PROJECTS *(page 26, this issue)*
- NEWS OF HISTORICAL INTEREST

*The human mind is sleepless in the pursuit of knowledge.  
It is ever seeking new fields of conquest. It must advance;  
with it, standing still is the precursor of defeat.*

—From History of Civilization  
by E. A. Allen  
Published in 1891, by Central  
Publishing House, Cincinnati,  
Ohio

Published by

**Electronics Digest**

1024 Currie Street, Fort Worth, TX 76107

Copyright 1972 by Electronics Digest Division  
Tandy Corporation

# IN REMEMBRANCE...

By William M. Palmer

*Let us honor our men of science  
Who once walked upon the planet Earth  
Along the uncharted trails of electricity  
In search of a better way of life  
For all mankind*

## FOR THE MONTHS OF MAY/JUNE 1972

### LEE DE FOREST

August 26, 1873 • June 30, 1961

Lee de Forest was born in the little Congregational Church parsonage in Council Bluffs, Iowa, on August 26, 1873. His father, Henry de Forest, was pastor of the church at that time. His mother, Anna (Robbins) was the daughter of Reverend Alden Robbins of Muscatine, Iowa.

Lee de Forest graduated from Yale in 1896, and received a Ph. D. from Yale Sheffield Scientific School in 1899. After a brief respite, he began an eventful career of invention in the field of radio communications.

In the years to follow, Dr. Lee de Forest was often called the "Father of Radio." During his lifetime, he patented more than 300 inventions, the best known of which was the three-element radio tube. The year was 1906 — the name of the new invention: the Audion. Thus was born the forerunner of the modern radio tube which could perform as an amplifier, a detector of radio waves, or a generator of radio frequency waves (carrier waves).

The Audion, which has been called "one of the greatest inventions of all time," led the way to many of our modern electronic devices — radio, television, guided missiles, radar, and the complex computing machines used in government, business, and science.

De Forest also invented the first practical radio telephone, and electronic sound-on-film that made possible our modern "talking" motion pictures.

There were times during his long career that de Forest had faced poverty, failures, indignities, and keen disappointments. He was once indicted by the U.S. Government on charges of defrauding the public by selling stock to manufacture a worthless device called the three-element vacuum tube . . . a tube that turned out to be one of the greatest inventions of all time. But justice prevailed and he was acquitted of the charge. He was victimized by unscrupulous businessmen and promoters who secured rights to some of his inventions

at a fraction of their true worth. Yet his indomitable spirit refused to be defeated by these adversities of life. His childhood upbringing had given him the character and strength of purpose that carried him through the lean years of his long life.

In Hollywood, California, June 30, 1961, Dr. Lee de Forest died peacefully in his sleep at the age of eighty-seven. Thus ended an inventive career in electronics that had, in the later years of his life, brought him fame and honor in the United States and in many other countries of the world.

### ALMON BROWN STROWGER

October 19, 1839 • May 26, 1902

The "will to achieve" belongs to men and women of all nations. It belongs to unpretentious people from every walk of life whose courage, perseverance, and vision have made possible man's continued progress down through the ages — men like Joseph Tykociner and his sound-on-film experiments; Royal E. House and his telegraph printer; and Almon Brown Strowger, the man who invented the automatic "dial" telephone.

As is frequently the case, not all of these pathfinders received due honor and recognition for their singular achievements. Their contributions to our way of life, like the "dial" telephone, are often "taken for granted."

Today's nationwide network of automatic (or "dial") telephones had its beginning 76 years ago, November 3, 1892, with the opening of the first Automatic Telephone Exchange for the public at LaPorte, Indiana. But it actually began some time before that in the mind of Almon Brown Strowger.

Strowger, "a nervous, energetic little man with white hair and bushy white whiskers" as he was described by those who knew him, was born on October 19, 1839, in Penfield, New York. His ancestors came from Suffolk County, England, and settled in the eastern part of the United States. Not much is known about Strowger's early childhood. He was considered to be a patriotic young

man who, in 1861, at the age of 22 enlisted in Company A, 8th New York Cavalry. He was commissioned a Second Lieutenant in 1864.

After the Civil War, Strowger taught school. He later became principal of the little school that he had attended as a boy. He also taught at Villa Ridge and Anna in Illinois, North Lansing, Michigan, and in Kansas where he had moved in 1883. In 1888, at age 49, Strowger moved to Kansas City, Missouri.

On March 12, 1889, Strowger filed his first patent for an "Automatic Telephone Exchange," and famous Patent No. 447,918 was granted two years later, on March 20, 1891. As is the case with many other inventions, the principle of this step-by-step, up and around switching mechanism that was moved by pawls and electromagnets was so simple and straightforward that one wonders why it was overlooked for so many years.

Like Alexander Bell and other famous inventors, Strowger found that people were skeptical; no one would seriously consider his new invention. Fortunately, an enterprising salesman, Joseph Harris, who was looking for novel ideas for the World's Columbian Exposition in Chicago, scheduled for 1892, heard of Strowger's device and saw in it great possibilities for development.

Harris finally prevailed upon Strowger to come to Chicago where they formed a company to manufacture the new device. Their company, the Strowger Automatic Telephone Exchange was organized in 1891.

This company, which originated the dial system of telephony, was the predecessor of the present Automatic Electric Company, a subsidiary of General Telephone & Electronics.

On November 3, 1892, the world's first automatic telephone exchange was placed in service at LaPorte, Indiana. It was a simple push-button instrument. To call number "74," for example, the caller pushed one button seven times and another button four times.

In the fall of 1896, Strowger went to Florida because of failing health. Thereafter, he took no part in the develop-

*(Continued on next page)*



## IN REMEMBRANCE

(Continued from preceding page)

ment of the system which bears his name. The inventor died in St. Petersburg, Florida, on May 26, 1902. On his simple tombstone in St. Petersburg's Greenwood Cemetery was inscribed only, "Lieut. A. B. Strowger, Co. A, N. Y. Cav."

### JOSEPH HENRY

December 17, 1797 • May 13, 1878

More than a hundred years ago, a grammar school drop-out, while restlessly recuperating from an injury, thumbed through the pages of the book "Lectures of Experimental Philosophy, Astronomy and Chemistry" which had been left by a family acquaintance. Although he possessed only moderate reading skill, his comprehension of the section expounding the natural laws of the universe — eternal truths that control the order of all things — was sufficient to excite an interest that would continue for the rest of his life. He read the book over and over again, each time contemplating the magnitude of these ideas that explain once and for all why the many forces in nature respond as they do according to set laws. The experience shocked him into the realization that knowledge is an important asset, and he was firmly resolved to acquire it. So, at age sixteen he went back to school . . . this time with all of his mental resources committed to the achievement of a new goal. The present generation may never have heard of this young man whose name was Joseph Henry. His later accomplishments gained him recognition as the foremost physicist of his day and election as the first secretary of the Smithsonian Institution in Washington, D. C.

Joseph Henry was born on December 17, 1797, in Albany, New York, the eldest son of William and Ann Alexander Henry who were of Scottish ancestry. They were devoutly religious people of the Presbyterian faith.

In 1832, Joseph was appointed to the chair of natural philosophy at the College of New Jersey (which later became Princeton University).

In December 1846, Joseph Henry was elected as the first secretary of the newly formed Smithsonian Institution which was to become, under his able leadership, the focal point and guiding center for American science.

He was the first to indicate weather conditions on a map, and the first to make weather observations from data

observed. The Smithsonian meteorological work eventually resulted in the establishment of the U. S. Weather Bureau.

He was also instrumental in organizing the National Academy of Science, and later served as its second president.

Joseph Henry, who lived a long and useful life, died shortly before his eighty-first birthday in Washington, D. C., May 13, 1878.

## yesterday & today

News of Historical Interest

### ELECTRONICS DIGEST PLANS TO EXPAND HISTORICAL SECTION

*Electronics Digest* will feature an expanded historical section under the title *Old-Time Radio* beginning in the July/August issue. The historical section will combine biographical sketches of great men — inventors and business leaders — in electronics and electricity, plans for building replicas of old-time radio devices and equipment, history of invention, pictorial history, and general news of historical interest — both past and present.

Beginning with the September/October issue, *Electronics Digest* will accept a limited number of classified ads from our readers who are collectors of antique radio equipment, as a "Shop and Swap" convenience. All ads, of course, must be related to the buying, selling or swapping of antique radio items. The cost of the ads will be: \$1.90 per line (seven words) with a 3 line minimum. If interested, write for information: Electronics Digest, Dept. HCA, P. O. Box 9108, Fort Worth, TX 76107.

A limited number of news items will also be accepted from bona fide historical groups or associations relating to awards, achievements and activities.

### INCREASING INTEREST IN ELECTRONICS HISTORY

A growing number of people are becoming interested in wireless (radio) history — the technology and methods of communications of the past, and the people who made it possible. Many of them are interested in the collection and restoration of vintage equipment.

There are a number of associations dedicated to the collection and preservation of memorabilia related to the early beginnings of wireless communi-

cations. Two highly esteemed organizations in this field are: Antique Wireless Association, Inc., of Holcomb, New York, and Canadian Vintage Wireless Association of Toronto, Canada.

The AWA is "An amateur organization devoted to the history of wireless." The official journal of the AWA is *The Old Timer's Bulletin*, published for the old time wireless operator, historian, and collector. Membership is limited. Many famous Americans are, or have been, members of AWA.

The Canadian Vintage Wireless Association, of Toronto, Canada, " . . . is an organization formed for the purpose of providing a meeting ground and a means of communication for the growing number of people who are interested in the history and technology of the early days of wireless communication, and are interested in the restoration and collection of vintage equipment." Some members are students, and others are working, or have worked, at all levels of industry and education. Interested? Write to: Mr. Sid Prior, 102 Parkhurst Blvd., Toronto 17, Ontario, CANADA. The official bulletin of the CVWA is *The Cat's Whisker*.

### LITTLE KNOWN FACTS ABOUT SAMUEL MORSE

Morse, the son of a noted clergyman, author, and friend of George Washington, Jedediah Morse, was born with attributes which won him a place of honor in the history of mankind. His mother, Elizabeth Ann Breese, was the granddaughter of Samuel Finley, president of Princeton College.

In addition to the fame he was accorded from his invention of the telegraph, Morse also became equally famous as an artist. After graduation from Yale in 1810, he went to England to pursue further study in art under the masters.

He returned to the United States in 1815 and then began painting portraits in this country. According to historical notes, Morse spent four winters in Charleston, South Carolina, during which time he did a likeness of President Monroe for the City Hall of Charleston, and portraits of hundreds of old Southern families who cherished work painted by him.

Morse married Lucretia P. Walker, of Concord, N. H., on October 1, 1818.

In 1821-22, Morse did a large painting of the House of Representatives with many portraits of members. This painting now hangs in the Corcoran Art Gallery.



Photo courtesy of Western Union

*THIS IS THE HOUSE IN WHICH SAMUEL F. B. MORSE WAS BORN on April 27, 1791, at Charleston, Mass. Morse, often called "Father of the Telegraph," possessed a natural aptitude for art that was evident from his early youth. During the early part of his life, his great love for art took him to Europe, where he studied and painted for a period of time. He was one of the founders of the National Academy of Design, and was its first president. The scientific years of his life did not begin until age 41, when he first conceived the idea of the telegraph as a communications device.*

## The First Telegram Sent 128 Years Ago: "What hath God wrought"

Picture courtesy of Western Union



*SAMUEL MORSE COMPLETED HIS FIRST WORKABLE TELEGRAPH APPARATUS IN 1837, and it was shortly thereafter exhibited in New York City. Seven years were to pass before he could convince skeptical government officials that it was in fact something more than "a toy, of doubtful use as a communication device." In 1843, Congress finally appropriated funds for a test line from Baltimore to Washington D. C. The next year, May 24, 1844, in the Chamber of the Supreme Court, Morse sent the now famous message, "What hath God wrought," The message was chosen by Miss Annie Ellsworth, the daughter of a government official.*

# History of the Vacuum Tube

A new generation of vacuum tubes made its appearance as operating frequencies were extended into the UHF and microwave regions. It began with the discovery of the magnetron in 1924.

## PART THREE

by Robert G. Middleton

Vacuum-tube operation at progressively high frequencies is accompanied by reduced efficiency for two basic reasons. It becomes necessary to consider the time required for electrons to travel from cathode to plate. In an ordinary triode, this transit time is in the range of from  $10^{-8}$  to  $10^{-10}$  second. When we attempt to operate the tube in the microwave region, no response is obtained. Therefore, new concepts of tube construction become necessary.



Fig. 2 Basing and socket arrangement for the acorn tube.

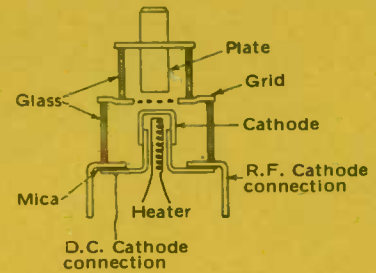

Fig. 3 Plan of the lighthouse triode.



Fig. 1 Trend to high-frequency tube design. Left to right: 201A, lighthouse tube, acorn tube.

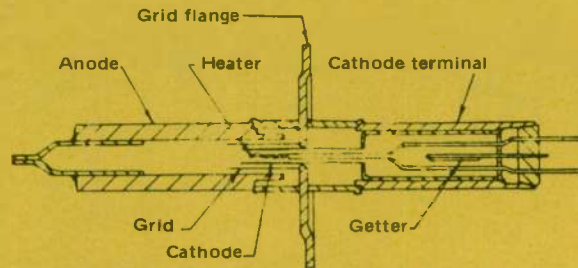

Fig. 4 Construction of the pencil triode.

Another cause of reduced efficiency at high frequencies is the bypassing action of interelectrode capacitance, and also the excessive choking effect of the lead and electrode inductance.

Triode efficiency in high-frequency operation can be improved by using small closely-spaced electrodes. This design provides reduced interelectrode capacitance and residual inductance, as well as a shorter transit time for electrons. Three types of the triode are the 201-type tube, a lighthouse tube, and an acorn tube (Fig. 1). The 201 operates poorly at 50 MHz, whereas the acorn tube maintains reasonable efficiency up to 600 MHz. The lighthouse tube can be operated up to 3,000 MHz. An acorn tube has essentially conventional construction, although a special basing and socket are employed (Fig. 2).

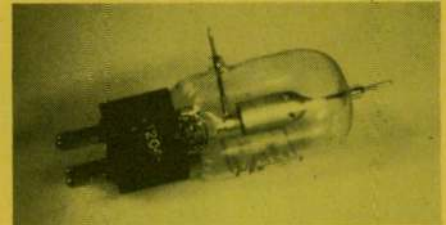
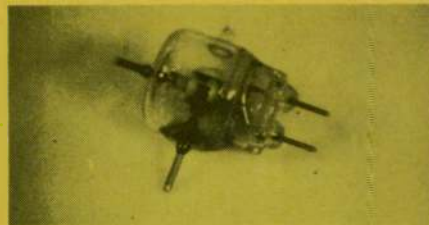

Fig. 5 Examples of triodes designed for transmitter application at very high frequencies.

Lighthouse tube construction differs somewhat from that of a conventional triode (Fig. 3). The cathode, grid, and plate are closely spaced, are planar in form, have small areas, and are integral with the basing structure. Reduction in physical size necessary involves a trade-off with power output, and a lighthouse tube can provide only 15 watts, approximately, at 3,000 MHz. The pencil triode

is essentially a receiving-type tube, and cannot provide enough output power to be practical in transmitter applications.

To minimize the input and output capacitances of a triode, the grid and plate leads must be widely spaced. Therefore, the very-high-frequency transmitting tubes employ grid and plate leads that are brought out directly

(Continued on next page)

# ILLUSTRATED HISTORY OF THE VACUUM TUBE PART III

(Continued from preceding page)

through the glass walls of the envelope (Fig. 5). The classic Western Electric doorknob tube could be operated up to 700 MHz (Fig. 6). The rated plate dissipation of this tube was 30 watts. Another tube is in the same general class, but is capable of operation up to 1,700 MHz (Fig. 7).

### New Approaches

The magnetron, an important new approach to high-frequency tube design, was discovered in 1924. However, it was not until World War II that significant development was undertaken (Fig. 8). There are two basic types of magnetrons. An electronic magnetron oscillator operates by exploiting the electron transit-time characteristics of a vacuum tube. This type of tube is capable of

generating very large peak-power outputs at frequencies in the thousands of megahertz. Next, a negative-resistance magnetron oscillator operates by development of a static negative resistance between its electrodes and has a frequency equal to the natural period of the tuned circuit that is connected to the tube.

A magnetron is a type of diode in which a magnetic field is set up perpendicularly to the electric field between cathode and plate. The magnetic field is provided by a permanent magnet. In an early form of magnetron tube, the magnetic field passes through a cylindrical plate, with a coaxial cathode (Fig. 9). A tuned circuit (not shown) is connected between cathode and plate. If the magnet were absent, electrons would flow in direct straight lines to the plate. However, as stronger magnetic fields are applied, the electron path

curves into a complete circle (Fig. 10). The electron beam is just cut off at the critical field strength. At this critical point, the magnetron tube can produce oscillations at an ultra-high frequency because of the currents induced electrostatically by the moving electrons. This frequency is determined by the time that it takes an electron to travel toward the plate and back again. Transfer of UHF power to a load is obtained when an external circuit is connected between cathode and plate.

Another type of tube in this general category is called the split-anode negative-resistance magnetron. Its advantages are that it can operate at a higher frequency and produce more output power. Its construction is similar to the basic magnetron, except that it has a split plate (Fig. 11). These half plates are operated at different potentials,

(Continued on next page)

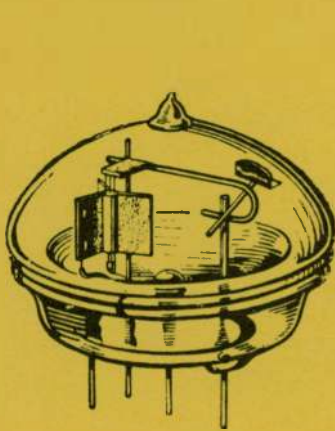

Fig. 6 The classical Western Electric doorknob tube.

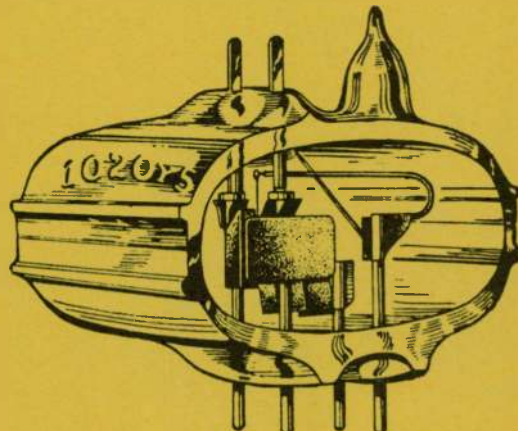

Fig. 7 The Western Electric 368A high-frequency triode.



Fig. 8 A typical magnetron.

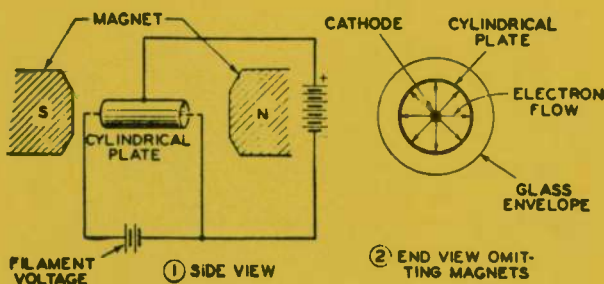

Fig. 9 An early form of magnetron tube.

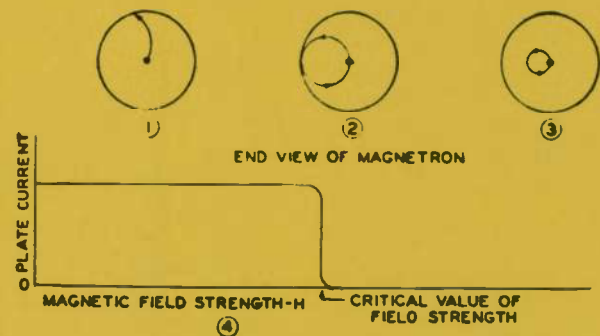

Fig. 10 Effect of the magnetic field in a magnetron tube.

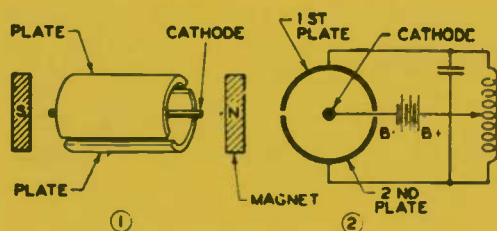

Fig. 11 Split-anode type of magnetron, and its circuit.

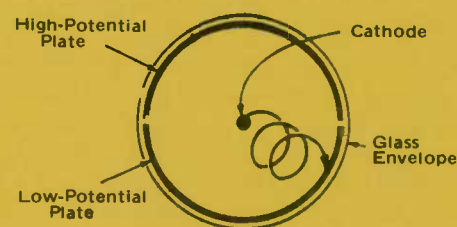

Fig. 12 Electron path in a split-anode magnetron.

# ILLUSTRATED HISTORY OF THE VACUUM TUBE PART III

(Continued from preceding page)

and produce an electron motion (Fig. 12). An electron leaving the cathode and progressing toward the high-potential plate is deflected by the magnetic field at a certain radius of curvature. After passing the split between the plates, the electron enters the electrostatic field set up by the lower-potential plate. In turn, the magnetic field has more effect on the electron, and it becomes deflected at a smaller radius of curvature. Thus, the electron follows a series of loops until it strikes the low-potential plate.

Oscillation in the split-anode magnetron can be started by applying the proper value of magnetic field strength which exceeds the critical value. Heavy-

walled plates are used in these magnetrons, and air or water cooling is often provided to dissipate the large quantities of heat that accompany high output power.

Still another type of magnetron, and one which has enjoyed wide use, is the split-anode electron-resonance design (Fig. 13). The plate itself is constructed to resonate, and function as a tuned circuit. Power is fed directly to a transmission line. The electron path is a curve that has a series of abrupt points (Fig. 14). Eight segments are commonly used in the split-plate arrangement. During World War II, magnetrons were developed which utilized an anode formed with resonant cavities (Fig. 15). Tunable magnetrons are still more sophisticated anode structures which have been developed to permit variation of the oscillating frequency over a 4-to-1 range by adjustment of the operating

voltage (Fig. 16).

## Klystron Tubes

Another important type of high-frequency tube, called the klystron, was introduced in 1939 (Figs. 17 through 19). Klystrons, also called velocity-variation or velocity-modulation tubes, are used at frequencies of about 3,500 MHz. In construction and operation, an electron gun is followed by two sets of closely-spaced grids and a collector plate. Each of these pairs of grids forms part of a resonant cavity, tuned to the operating frequency of the tube. When the buncher cavity is operating at its resonant frequency, electrons passing through its grids during the negative half cycle will be slowed down, and electrons passing during the positive half cycle will be accelerated. Through the drift space between buncher and catcher, they travel in bunches. That is, the

(Continued on next page)

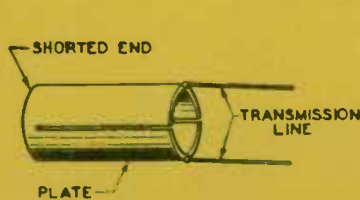

Fig. 13 Split plates connect to a transmission line.

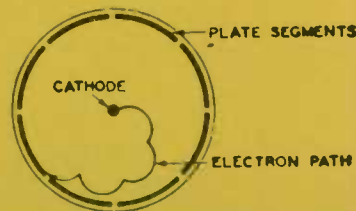

Fig. 14 Electron path in an electron-resonance magnetron.

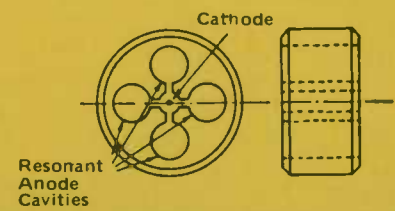

Fig. 15 A magnetron anode formed with resonant cavities.



Fig. 16 A typical tunable magnetron.



Fig. 17 A typical klystron tube.

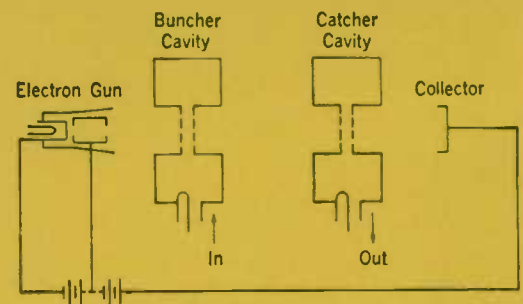

Fig. 19 Basic features of a klystron.

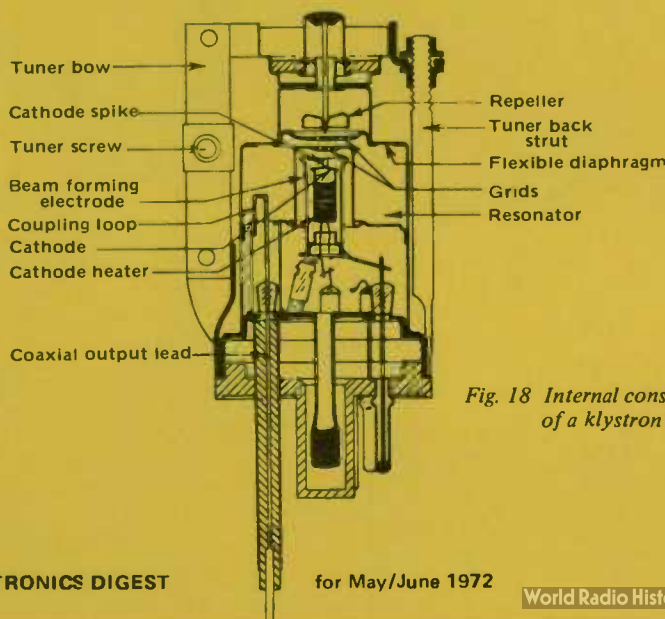

Fig. 18 Internal construction of a klystron tube.

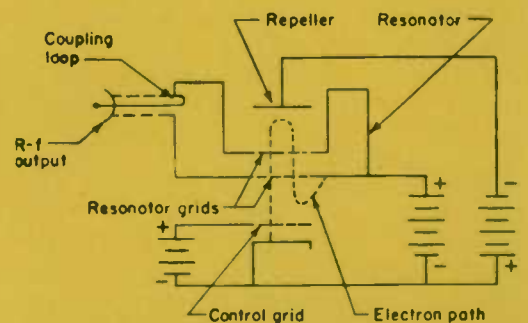

Fig. 20 Electron path in a reflex-klystron tube.

## ILLUSTRATED HISTORY OF THE VACUUM TUBE PART III

(Continued from preceding page)

electron current is varying in amplitude. It gains energy as it approaches the catcher, and induces an amplified oscillation in the catcher cavity.

To operate the basic klystron as an oscillator, a coupling loop is provided to feed back energy from the catcher cavity to the buncher cavity. A design variation is utilized, and the tube is called a reflex klystron (Figs. 17 through 19). In operation, the emitted electrons first pass through the grids where they undergo a velocity variation. Then, the electrons have acquired energy from the dc field, and deliver their accelerated energy to the cavity as they pass back through the grids. A reasonable range of tuning can be obtained by varying the cavity size, accompanied by a suitable change in repeller voltage. A reflex klystron has the advantage of simplicity, but is quite restricted in power output, compared with the two-cavity design.

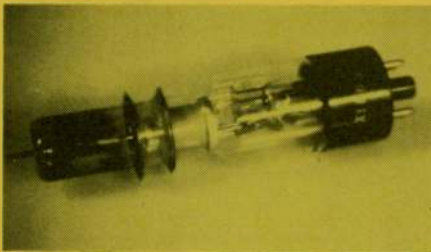

Fig. 21 A reflex klystron with a fixed cavity size.

A reflex klystron may have a fixed cavity size (Fig. 21). However, it is not completely restricted to operation at a particular frequency. By adjusting the operating voltages, the tube can be tuned over a small frequency range. In construction and operation, the tube is mounted in a resonant cavity, which develops the output power (Fig. 22). A pair of tuning plugs are provided, so that the cavity can be exactly resonated with the operating frequency of the klystron.

### Traveling-Wave Tube

Another important type of high-frequency tube is the traveling-wave design (Figs. 23 and 24). It can be operated at frequencies up to 7,500 MHz, and at bandwidths as great as 5,000 MHz. An electron beam is passed down the helix, in the direction of wave propagation. Because the electrons acquire energy from the dc field, the electron beam provides a power gain for the traveling wave in the helix. The ends of the helix are coupled to coaxial

lines for input and output ports. The maximum power output of this type of traveling-wave tube is about 3 watts.

Backward-wave oscillators are much like traveling-wave tubes, except that the electron beam travels in the opposite direction from the wave in the helix. When the speed of the electron beam is correctly adjusted, it induces energy into the helix in a manner that reinforces

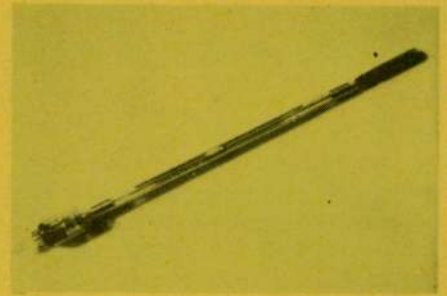

Fig. 23 A traveling-wave tube.

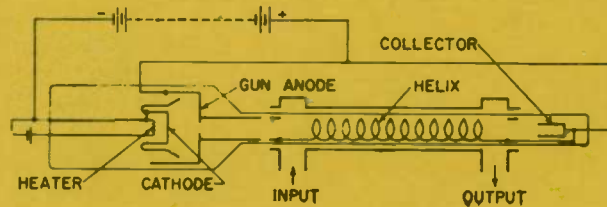

Fig. 24 Structure of the traveling-wave tube.

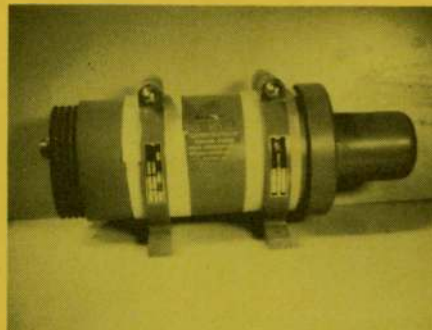
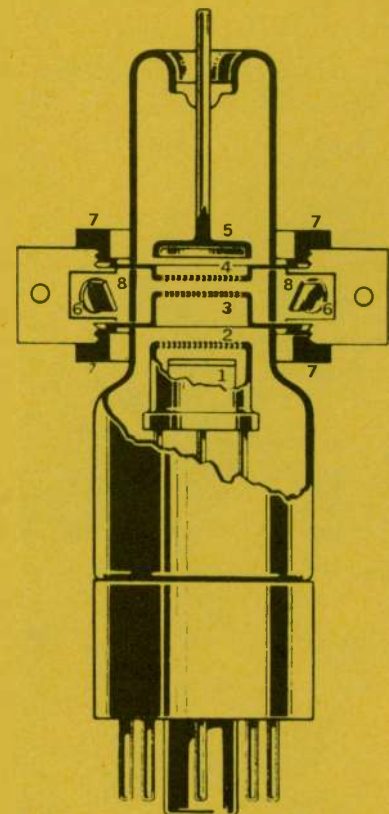

Fig. 25 Appearance of a carcinotron.

the traveling wave. One advantage of the backward-wave oscillator is that the tube supplies its input for oscillation without the use of an external feedback circuit. A high-power backward-wave oscillator has an oscillating frequency that is tunable over the range of from 1,000 to 2,000 MHz by adjustment of the operating voltage (Fig. 25). It is called a carcinotron by microwave engineers.

### Conclusion

As the operating frequency of an electronic device is progressively increased, residual capacitances and inductances can no longer be neglected. Although expedients can be used to extend the application of conventional tube designs into the VHF region, completely new approaches become necessary in the UHF region. Thus, a new generation of vacuum tubes made its appearance as operating frequencies were extended into the UHF and microwave regions.



- 1 Cathode
- 2 Control Grid
- 3 Cavity Grid
- 4 Cavity Grid
- 5 Repeller Plate
- 6 Tuning Plugs
- 7 Clamping Ring
- 8 Cavity

Fig. 22 Construction of a fixed-cavity klystron.

## THE CONSTRUCTION INDUSTRY

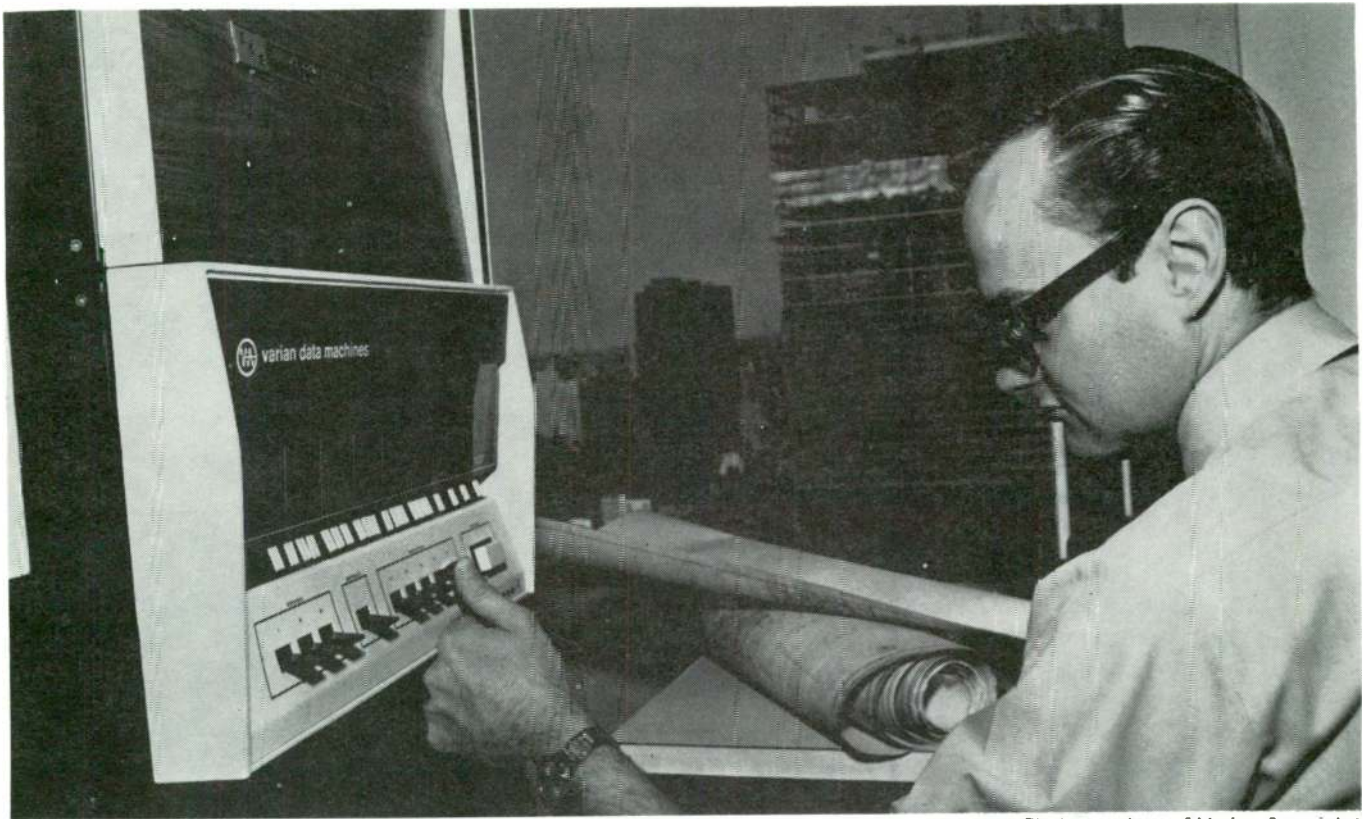

Photo courtesy of Varian Associates

*The benefits of minicomputers to the construction industry is demonstrated by Walter Phillips, manager of computer operations for Diesel Construction Company with a minicomputer. The mini helps the firm cut costs and meet project datelines for a \$100 million Mount Sinai Hospital project in New York City.*

## Minicomputers and the Construction Industry

*Minicomputer system is planned for constructing the world's tallest building — Sears/Chicago*

Construction companies now can assure on-time project completion with a new material inventory and scheduling system developed by Bridge Computer Systems, Inc. The minicomputer system also can manage the flow of architect's drawings and provide cost control, accounts payable and payroll functions.

Designed around a Varian 620 series 16-bit-word minicomputer with only 4K of memory, the system enables a project manager on a construction job to talk directly to a computer and receive instantaneously any information he needs about deliveries of materials, schedules, reasons for delays and other status

reports on project materials. The operator need have no previous experience whatsoever with data processing equipment.

The system, designed to accelerate construction and minimize costs, is being used currently for the \$100 million Mount Sinai Hospital Annenberg Pavillion addition and for the \$40 million annex to Memorial Hospital, both in New York City.

The projects, required to be completed within four and two years, respectively, are virtually assured of on-time completion and a significant reduction in delays, according to Charles J. Satuloff, Bridge Computer Systems vice president. Satu-

loff estimates that an economically significant number of man-hours have been saved already on the two projects with the minicomputer system.

"Essentially," Satuloff said, "Our new systems allow small and large construction firms alike to automate their operations. They don't have to hire expensive computer talent to operate the equipment, either. A clerk can be trained in this function quite easily."

The value of the minicomputer system has also been demonstrated by Diesel Construction Company, a division of Carl A. Morse, Inc., a

*(Continued on next page)*

## CONSTRUCTION INDUSTRY

*(Continued from preceding page)*

wholly-owned subsidiary of ARA Services, Inc. A spokesman for Diesel, the contracting firm for both the Mount Sinai and Memorial Hospital projects, said using the 620 series minicomputers so far has enabled his firm to control projected construction milestones in its strategic plans for each job. Diesel is planning to put its Sears/Chicago project—the world's tallest building—on its minicomputer system.

The Bridge data processing system for monitoring the performance of various manufacturers and suppliers for a construction job consists of a 4K Varian mini, a teletype, one magnetic tape unit, a line printer and two magnetic disc storage systems. Other system configurations are available, the firm said. A large construction project can have as many as 25,000 different items in inventory, hence the disc drives are used for storage under minicomputer control. Construction companies using minicomputer systems can retrieve and display partial data such as: individual item; room number on a given floor; floor, trade or both; all late items by floor or trade; number of days late; days due; and status of manufacturer.

The construction industry is yet another field that has felt the impact of the Computer Age—the era of progress so rapid that it is often beyond one's imagination.

## EDUCATION

### Electronics for scientists

An intensive course in electronics for scientists who use electronic instruments will be given for the 13th time this summer at the University of Illinois at Urbana-Champaign.

A \$63,214 National Science Foundation grant will support the course.

For 20 of 60 persons attending, the course will include special instruction on computer interfacing and completely automated instrumentation. This will be for persons who have completed the general course or had similar training.

Prof. Howard Malmstadt, who has presented the annual summer courses since 1960, is a chemist who during

World War II worked with Navy radar. When he returned he found scientists facing an increasing number of electronic tools whose workings were completely mysterious to them.

To take out the mystery, he prepared a course, writing a text with Christie G. Enke, then a graduate student at Illinois and now a professor at Michigan State, and developing special laboratory-quality equipment manufactured by the Heath Co. of Benton Harbor, Mich.

Through summer courses at which teachers from other schools are sponsored by the National Science Foundation, the course has been spread over the nation. A small number of scientists from industry, medical centers and other non-teaching organizations also are admitted each summer.

During the regular school year the course is offered at Illinois to undergraduate, graduate and postdoctoral students.

Over the years it has kept up with changes in electronic instrumentation. The new work on computer interfacing and completely automated instrumentation was added this year.

## SPACE EXPLORATION

### New radiometers for 1973 Mariner

Santa Barbara Research Center, a subsidiary of Hughes Aircraft Company is building infrared radiometers to measure thermal emission from the planets Venus and Mercury during the 1973 Mariner fly-by mission.

The Jet Propulsion Laboratory of California Institute of Technology, Pasadena, Calif., prime contractor for the National Aeronautics and Space Administration, awarded the contract as part of its planned scientific investigation of Venus and Mercury, the two planets between the earth and the sun.

The spacecraft, using the gravitational attraction of Venus, will pass within a few thousand kilometers of that planet, then will swing inward for a close fly-by of Mercury.

The instrumentation will be designed to measure the thermal emission from the planets in two spectral bands. The data will enable scien-

tists to determine the thermal structure and cloud-top temperatures on Venus as well as surface temperatures on both the day and night sides of Mercury.

The radiometers will provide a temperature resolution capability of about 1.0° at 100° Kelvin, the minimum temperature expected on Mercury, and a spatial resolution of 14 kilometers from the closest expected range of 1600 kilometers.

The new instruments will be the fourth generation of radiometers built by Santa Barbara Research Center for planetary research. All use a sensitive thermopile detector developed by the firm.

Stillman C. Chase of SBRC is the principal investigator for the infrared experiment, and Jack L. Engel is project manager for the radiometer development.

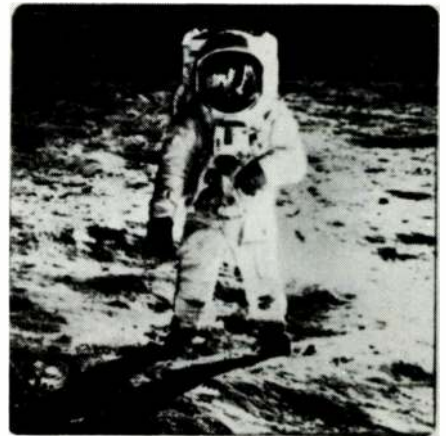

### United States' lunar mission great success

The amazingly successful lunar mission of America's Apollo 16 has added a thrilling chapter to the history of mankind. It was the fifth landing on the lunar surface by American astronauts.

We salute Astronauts Thomas Mattingly II, John Young, and Charles Duke, Jr., for their courageous accomplishment—a 1.2 million mile space mission which was completed on April 27 when the Command Module, Casper, splashed down in the Pacific, and was picked up by the U. S. S. Ticonderoga.

A few of our countrymen call the mission a "waste of money." They would have opposed the voyage of Columbus to America. Most of our people support today's research and technological development upon which may depend the survival of future generations of mankind.



## NEWS ORBIT

(Continued from previous page)

### COMMUNICATIONS

#### Dial-a-Test for phone repairmen

Bell System repairmen may soon be using a new testing device designed to perform a number of electrical checks over coin telephone circuits. The new device allows repairmen to select various electrical tests for public telephones by simply dialing a series of code numbers from a coin station. This new approach to testing public telephones is being developed by a team of engineers at Bell Laboratories in Holmdel, New Jersey.

The testing device is actually an array of electro-mechanical relay switches, similar to those that help Bell System customers complete some 320 million calls daily. Similar devices may someday be located in central switching offices throughout the country. When signalled, the device will automatically set up a two-way communications channel or "test line" between a public tele-



Bell Telephone Laboratories

*"THIS IS A TEST" . . . Engineer J. Arthur Grandle listens to a continuous tone being transmitted from an experimental model of a new public telephone testing device (at right). The tone indicates the telephone's coin return mechanism is in proper working order. When the testing device is signalled from the coin station, electro-mechanical relay switches, similar to the one in Grandle's hand, transmit electrical pulses over telephone lines to the return mechanism. If it doesn't respond properly, a beeping tone will be heard. Similar performance checks can be made on other electrical components in the telephone by simply dialing a different series of code numbers for each check.*

phone and itself.

In the past, repairmen had to rely on telephone operators or technicians based at a central switching office to assist them with electrical testing. The new testing device eliminates the need for assistance from a second party, leaving more time for operators and technicians to handle the immediate needs of telephone users.

By dialing a single digit for each test, the electrical performance of several different public telephone components can be checked in a matter of minutes. These components include the coin collect, coin return, and coin totalizer mechanisms as well as the station's circuit connections.

Electrical pulses from the testing device are sent over the "test line" to run the components through a series of performance checks. And, coded tones or ringing alert repairmen to particular problems.

### MARINE NAVIGATION

#### Direct reading loran receiver

A new heavy duty, direct-reading loran receiver leads Raytheon's line of marine electronic equipment for navigation, communications, and safety for 1972. Also making their boat show debuts are a full-power VHF/FM radiotelephone and a combination Fathometer depth sounder that reports the depth of water as either a profile graph or an instantaneous flashing light.

Positions can be determined in less than a minute to an accuracy within a few hundred yards. In addition to defining the position of a boat offshore in terms of latitude and longitude for navigation purposes or to assist the Coast Guard in locating a boat in distress, the loran positions are commonly used in sport and commercial fishing to pinpoint charted wrecks on the ocean floor and to aid fishermen in returning to a favorable fishing spot.

The new loran operates from either 12 to 24-volt DC power lines.

Raytheon's new DE-725C combination flasher/recorder flashes the depth of water under the keel to depths of 360 feet and charts them to 300 feet.

### COMPUTER INSTRUCTOR



Western Electric Company

*COMPUTER TELLS HOW-TO-DO-IT for Mrs. Kay Darnall, a switching equipment "wireman" at the Oklahoma City plant of Western Electric Co.*

#### Computer-voice teaches workers on assembly line

In a recent experiment, Bell Laboratories and the Western Electric Company gave a computer a "voice" so it could speak instructions helpful to production-line workers assembling complex communications equipment.

Previously, computers had been used to calculate efficient wiring instructions, and to print them in typewritten form. To get the instructions into a spoken form—so the assembler need not divert eyes or hands from the job—they were read aloud by a human announcer, and recorded, checked and corrected by technicians. Frequent changes in the complex wire lists meant frequent re-recording and re-checking, a tedious time-consuming job, subject to human error.

In the recent experiment, the human steps were by-passed, and the computer made to "speak" the wiring instructions directly to an automatic recorder. The synthetic computer voice was produced by equipment and programs devised by engineers of the Acoustics Research Department at Bell Labs, Murray Hill, New Jersey.

Wiring instructions from the "voice of the computer" were then tested on the production line by a wireman assembling telephone cross-bar switching equipment at the Oklahoma City plant of Western Electric.

## Modern Radio in Old-Time Dress

The fun in this project lies in making a modern radio look like a 1925 model. Besides being an interesting conversation piece for a home or school museum, you can use it every day.

By Arthur Trauffer

The fun in this project lies in making a modern radio look like a 1925 model. Figure 1 is an example of what can be done. Besides being an interesting conversation piece for a home or school museum, you can use it every day. Also, you will get improved performance because of the large rotatable loop antenna and the larger PM speaker to be added.

### The Radio

You can use the chassis of just about any small table radio (tube or solid-state type) which has a direct-drive tuning dial (dial on gang-condenser shaft), and it can have either a loop antenna or a ferrite loopstick. However, in either case choose one that has only two wire leads going to the loop because this will make it easier to replace the loop with the outboard rotatable loop. The small PM speaker in the radio will be replaced with a 6-inch or 6½-inch PM speaker for improved tone quality. The tuning dial and the volume control knob will be replaced with replicas of old-time ones.

### Cabinet and Panels

The cabinet and panels are made and assembled first, and then the "works" are added. Figures 2 and 3 show construction details. The writer used ½-inch mahogany put together with Sears Hide Glue and 1-inch flathead wood screws. The top edges of the top and bottom pieces were beveled off, as shown. The wood was sanded smooth on the outside, and stained with mahogany stain, and rubbed hard with facial tissues.

The two 12-by 2-by 2-inch wood strips were nailed about 3/8-inch back from the front of the cabinet (these hold the radio panel, speaker panel, and speaker grille).

Most old-time radios used black Bakelite, Formica, or hard rubber panels. If you have trouble finding black Formica, simply use 1/8-inch composition-board and cover the smooth front side with black "Contact" adhesive plastic material, or give the composition-board a smooth coat of black semigloss paint.

The front side of the speaker mounting panel was painted with flat black paint so it wouldn't show through the grille cloth so easily.

### Adding the "Works"

Different makes and models of radio chassis will present different panel-mounting problems. In the writer's case it was necessary only to drill two No. 36 holes through the front end of the gang-condenser frame — thread the holes with a 6-32 tap — and mount the chassis to the panel with short flathead machine screws.

Old-time radios didn't have the power switch on the rear of the rheostats, so disconnect the power leads from the switch on the back of the volume control and connect them to a separate AC switch, as shown in Figure 3. Many old-timers used toggle switches, but you can use a push switch, or a rotary switch as the writer did.

The two leads that formerly went to the small PM speaker now go to the 6-inch or 6½-inch PM speaker mounted on the speaker panel with four bolts.

The two leads that formerly went to the loop antenna in the radio now go to the 2-conductor open-circuit phone jack mounted to the inside top of the cabinet by means of a 2-by 2-inch composition-board panel. Center the opening in the jack directly under the center of the 7/8-inch diameter hole in the top of the cabinet.

NOTE: If your radio chassis is an AC-DC chassis having a possible "hot" chassis, be on the safe side and connect a .05-mfd., 200-volt, fixed-capacitor in series with the lead going from the gang-condenser frame to the loop antenna. This will isolate the loop from a possible "hot" chassis. This detail is shown in Figure 3 and schematic in Figure 4. Also completely cover the back of the cabinet with 1/8-inch composition-board, perforated to provide ventilation for tubes (if a tube radio). However, if your radio chassis is solid state (working

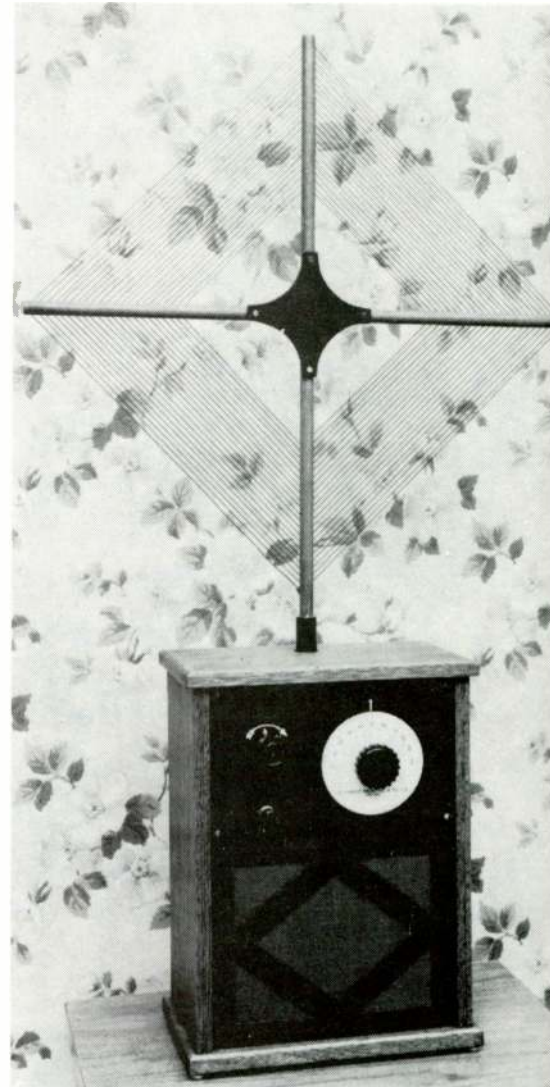

Photo by Art Trauffer

This photograph shows the completed "Modern Radio in Old-Time Dress." It combines the old and the new for an interesting, practical, radio receiver for the den or Ham shack at home, office, or school science department.

on batteries only) you will not need the isolating capacitor in the loop lead or the protective back panel.

Now we come to the old-time rotary loop antenna to be plugged into the loop jack on top of the cabinet. Com-

## MODERN RADIO IN OLD-TIME DRESS

(Continued from preceding page)

plete details for making this loop were published in the January/February 1971 issue of *Electronics Digest*. In your case you may have to use fewer or more turns of wire in the loop, and adjust the trimmer capacitor in the rf section of the gang-condenser, in order to get best tracking. Experiment for best results.

If you cannot find an old-time dial, make a replica of the famous de Forest 3½-inch dial shown in the photos. Use a piece of stiff white cardboard, having a good inking surface, and calibrate your dial (from 0 to 100) using a pen and India ink. Cement a black fluted knob in the center of the dial, directly over a ¼-inch hole in the center of the dial. If your chassis is AC-DC, the setscrews in the dial knob should not be exposed to the fingers.

Use a matching black fluted knob for the shaft of the volume control. A round arrow is painted over the knob with white enamel, and a small pointer is cut from metal and cemented under the knob, as shown.

Use your own imagination in making  
(Continued on next page)

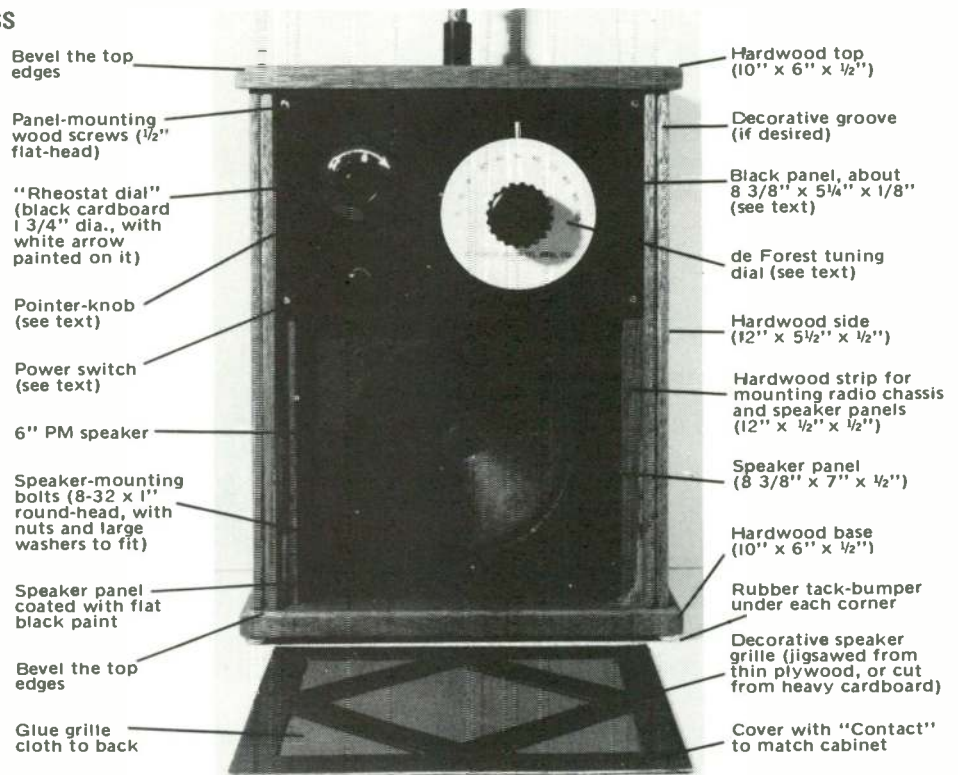

Fig. 2 Front view of assembly

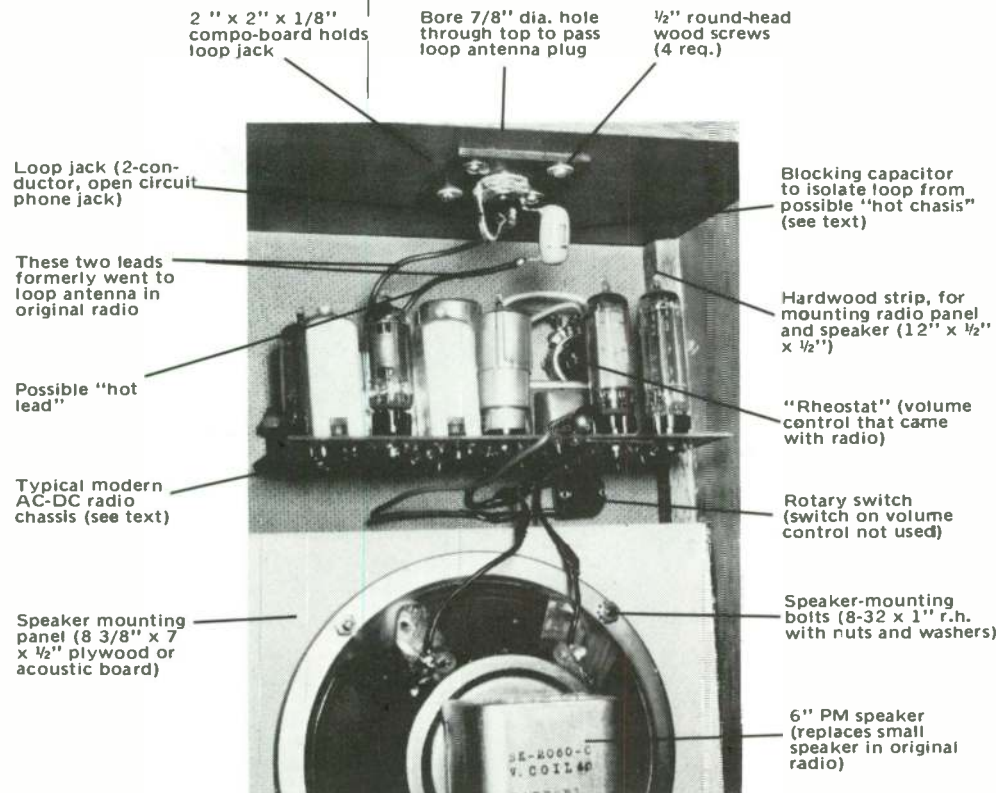

Fig. 3 Modern Radio in Old-Time Dress - Interior view

## MODERN RADIO IN OLD-TIME DRESS

(Continued from preceding page)

the speaker grille. The writer cut his from heavy cardboard using a razor blade and straightedge, then covered it with "Contact" having a wood grain pattern nearly matching the wood cabinet. Grille cloth was glued to the back of the cardboard grille.

Tack a 1/2-inch diameter rubber tack bumper under each corner on the bottom of the cabinet base.

### MATERIALS LIST

#### Radio

- Chassis removed from modern table radio (see text)
- Old-time rotary loop antenna (see January/February 1971 *Electronics Digest*)
- One 2-conductor open-circuit phone jack to fit plug on loop antenna (Radio Shack 932 B 0480 — 30¢)
- One old-time 3 1/2-inch-diameter tuning dial to fit the radio's variable-capacitor shaft (see text)
- One black fluted knob to fit the radio's volume-control shaft (Lafayette Radio 32 F 24060—23¢)
- One 0.05-microfarad, 200-volt, fixed capacitor for loop antenna (see text)
- One panel-mounting AC power switch (toggle switch, rotary switch, or push switch per text)
- One 6- or 6 1/2-inch PM speaker (replaces small speaker in original radio)

#### Old-time Radio Cabinet (and panels for same)

- Two pieces of hardwood 12 by 5 1/2 by 1/2 inch for sides (mahogany, walnut, or oak)
- Two pieces of hardwood 10 by 6 by 1/2 inch for top and bottom (mahogany, walnut, or oak)
- Two strips of hardwood 12 by 1/2 by 1/2 inch (holds radio panel, speaker panel, and grille)
- One black panel for radio, about 8 3/8 by 5 1/4 by 1/2 inch (see text)
- One piece of plywood or acoustic board, about 8 3/8 by 7 by 1/2 inch (for mounting speaker)
- One piece of 1/8-inch plywood or heavy cardboard, about 8 3/8 by 6 3/4 inches (for making speaker grille)
- One piece of speaker grille cloth
- One piece of perforated composition board, about 12 by 9 1/2 by 1/8 inch (protective back for radio cabinet)
- One piece of composition board 2 by 2 by 1/8 inch (for mounting loop jack)

#### Hardware

- Six flatheaded wood screws 1 inch long (for assembling cabinet)
- A few 3/8-inch finishing nails
- Ten flatheaded wood screws 1/2-inch long (for mounting radio panel and the perforated back panel)
- Four 8/32 by 1 inch roundheaded bolts, with washers and nuts to fit (for mounting FM speaker)
- Four roundheaded wood screws 1/2 inch long (for mounting loop jack panel)
- Four 1/2-inch-diameter rubber tack bumpers (for bottom of cabinet)

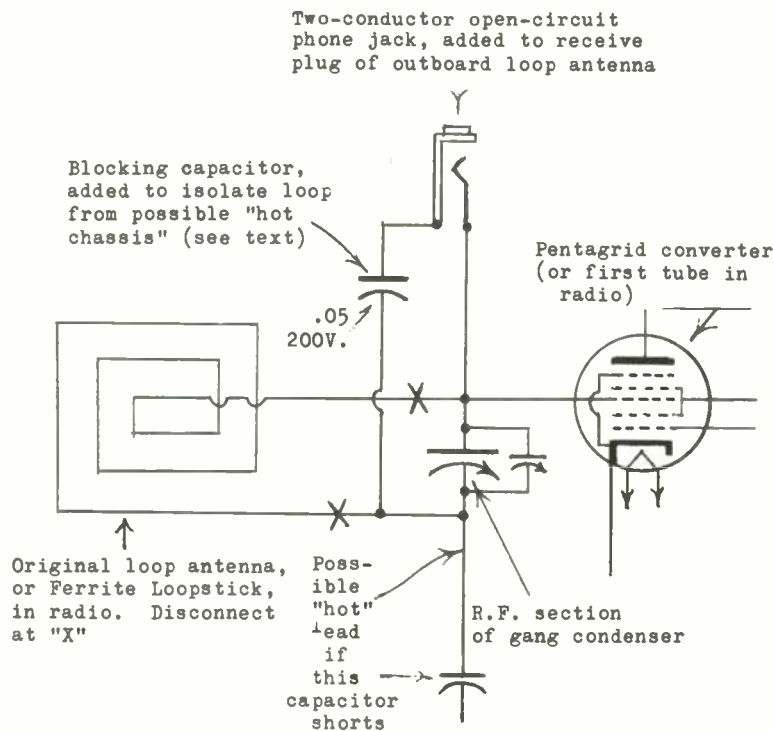

Fig. 4 Schematic diagram of connections for the loop antenna to first tube in radio.

## SUBSCRIBER SERVICE

Please include an address label when writing about your subscription to help us serve you promptly.

AFFIX LABEL

If you have no label handy, print OLD address here.

please print

name

address

city

state

zip-code

**CHANGE OF ADDRESS:**  
Please let us know you are moving at least four to six weeks in advance. Affix magazine address label in space to the right and print new address below. If you have a question about your subscription, attach address label to your letter.

**TO SUBSCRIBE:**  
Check boxes below.  
 New  Renewal

**\$250**  
**Per Year**

(6 Issues)  
U. S., Canada & Mexico

All other Countries \$4.00

## Electronics Digest®

ADVERTISING/EDITORIAL OFFICES  
1024 Currie Street, Ft. Worth, Texas 76107

NAME

ADDRESS

CITY

STATE

ZIP

## BACK ISSUES AVAILABLE

Use this coupon to order back issues of  
**Electronics Digest®**

We have a limited supply of back issues that can be ordered on a first-come, first-served basis. Just fill in the coupon below, enclose your remittance in the amount of 75¢ for each copy ordered.

Please send the following back issues of

**Electronics Digest®**

1024 Currie Street  
Fort Worth, Texas 76107

I am enclosing ..... to cover cost of the magazine, shipping and handling.

Month ..... Year .....

Month ..... Year .....

Month ..... Year .....

Name .....

Address .....

City .....

State ..... Zip .....

Payment must be enclosed with order

## Installing Coax Connectors

This article shows a "trouble-free" way to attach connectors to coax cable used with radio, audio, and TV equipment — to insure no slippage of conductors within the connectors, and no damage to the heat-sensitive coax insulation

By Marshall Lincoln, W7DQS

Attaching connectors to coax cable used with radio, audio and TV equipment can leave an electronic experimenter with a vague troubled feeling when he finishes the job because it's generally impossible to see the completed connection inside the connector to be sure it is satisfactory.

However, by following procedures that insure there can be no slippage of conductors within the connectors, and by protecting the heat-sensitive coax insulation during soldering, you can be assured of connections that will be trouble-free.

The accompanying photos illustrate how to work with various types of coax connectors to make reliable connections.

You may find illustrations in sales literature showing dimensions to observe in stripping the end of a length of coax. However, you'll probably find the easiest way is to place the coax alongside the connector, envision how it will fit, and strip the coax accordingly.

When cutting through the outer insulating sheath, bend the coax over a finger and make cuts at the outside of the bend, applying *light pressure* with a *sharp* knife. Use of a dull knife may cause you to use too much pressure and cut through the braid before you realize it. By holding the coax in a sharp bend as you cut, you can better see how the cut is progressing.

Among the connectors most widely used by electronic experimenters and hobbyists are the PF-259 type.

If you're using small diameter coax, such as RG-58A-U, you'll also need to use a reducing adapter to install on the coax to mate with the male plug. Place this adapter on the coax before you strip off the outer insulation, so as to avoid prematurely fraying out any of the strands of the shield braid.

Incidentally, there are two sizes of these adapters. Type 83-185 is used for 52-ohm cable, such as RG-58/U and RG-58A/U, while type 83-168 has a slightly larger inside diameter to accom-

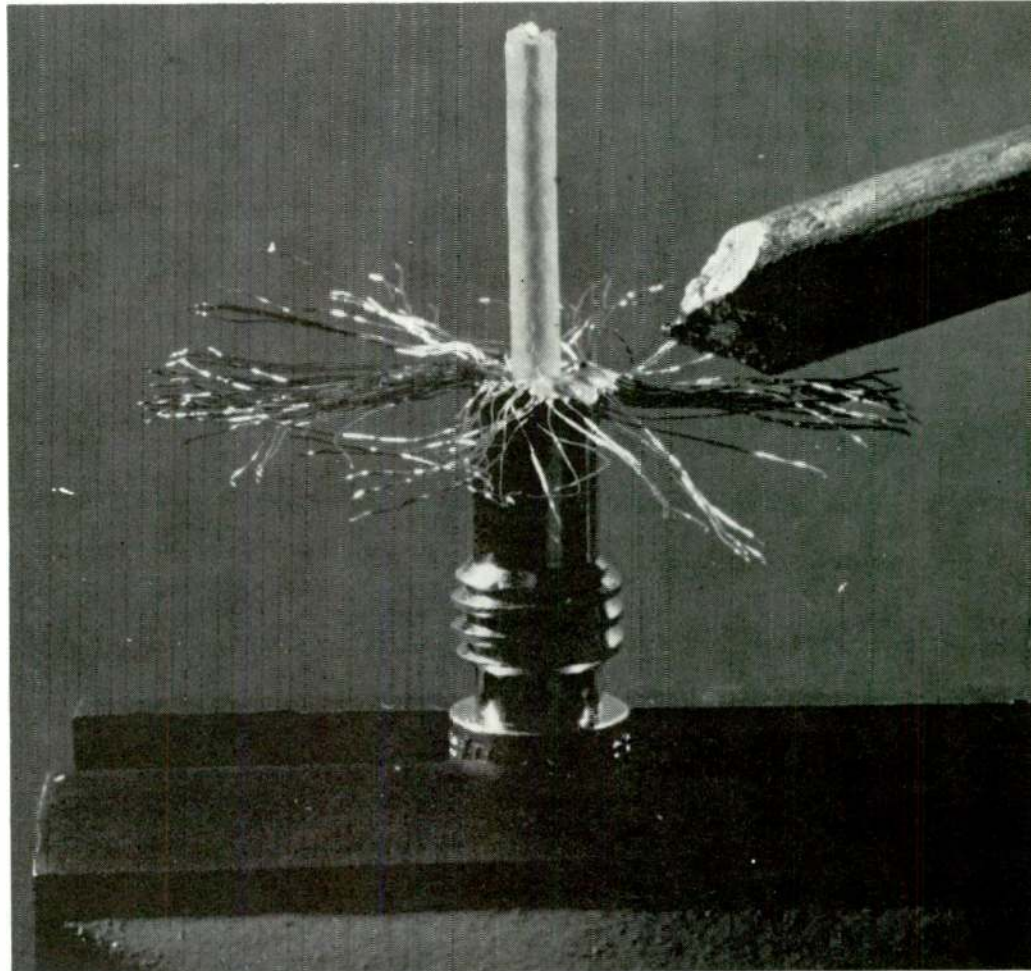

Photo by Marshall Lincoln

*Installing Connector on Small Diameter Coax — Photo 1.*

*Slide adapter forward to where braid wires flare out, clamp it lightly in vise, and solder shield wires to front edge of adapter. Observe precautions explained in text to avoid shorting center conductor to braid.*

modate 73-ohm cable such as RG-59/U.

After removing the necessary length of outer insulation from the end of the coax and unwinding the braid, position the wires to stick straight out from the coax, and slide the reducing adapter forward on the coax until it touches the braid wires. Some instructions say to merely bend the braid wires back over the outside of the reducing adapter, but you will get a more reliable connection if you solder the wires to the adapter

and cut off the excess wire. This must be done very carefully to avoid excessive softening of the inner insulation which surrounds the center conductor and causing a short.

Clamp the adapter *lightly* in a small bench vise with the forward end of the adapter sticking straight up (photo 1). Be careful not to mash the adapter in the vise.

Be very careful your soldering iron

*(Continued on next page)*

## COAX CONNECTORS

*(Continued from preceding page)*

doesn't touch the plastic insulation surrounding the center conductor, and solder the braid wires to the front rim of the adapter. Apply the heat to the *adapter*, and flow solder carefully onto the wires where they touch the rim of the adapter.

As the heat builds up on the braid wires, the center insulation will become soft . . . you can detect this happening as you see the insulation's normally milky white color changing to a nearly clear, transparent appearance. That's the signal to remove the soldering iron and allow the insulation to cool. As the milky color slowly returns, watch the center conductor very carefully, and nudge it if necessary to be sure it remains centered in the soft center insulation. Otherwise, it might sag through the softened insulation and touch the braid wires, causing the coax cable to be shorted. This part of the entire job is the most critical, but it's also the part that guarantees you a good shield connection.

As soon as the center insulation has rehardened, resume soldering the braid to the adapter. As the center insulation softens again with the heat, stop for a bit just as before. With practice, you'll develop the skill to do this whole operation in no more than two or three separate applications of the soldering iron.

While the procedure just described may seem a bit unorthodox, the author has found that when done carefully it will provide a more reliable connection than merely bending the braid wires over the end of the adapter and screwing it into the PL-259 plug.

After the adapter cools, clip off the ends of the wires, and file off the excess solder which has built up around the outside of the adapter (photo 2), so the adapter will slip smoothly inside the PL-259 plug. Be sure there is no solder build-up or loose braid wires protruding forward where they might contact the center connector pin in the male plug.

Carefully strip off the insulation around the center conductor about 1/8-inch forward from the location where the braid is soldered to the adapter. If you're using coax with stranded center wires, twist and tin them immediately so they don't fray.

Screw the adapter with coax attached into the PL-259 male plug body, tighten firmly with pliers, and flow solder into the center pin. Do this by leaving the

*(Continued on next page)*

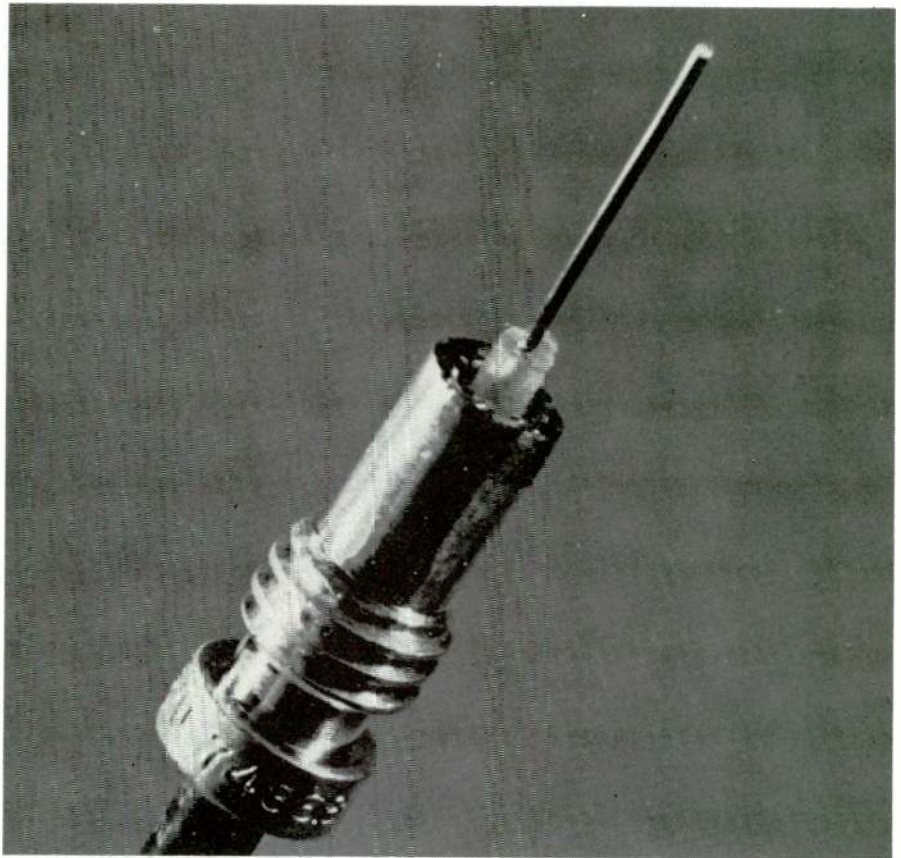

Photo by Marshall Lincoln

### *Installing Connector on Small Diameter Coax – Photo 2.*

*After all braid wires are soldered to reducing adapter, clip off ends and file down excess solder to achieve this smooth, finished appearance. There must be no loose shield wires or solder which could contact center pin in plug.*

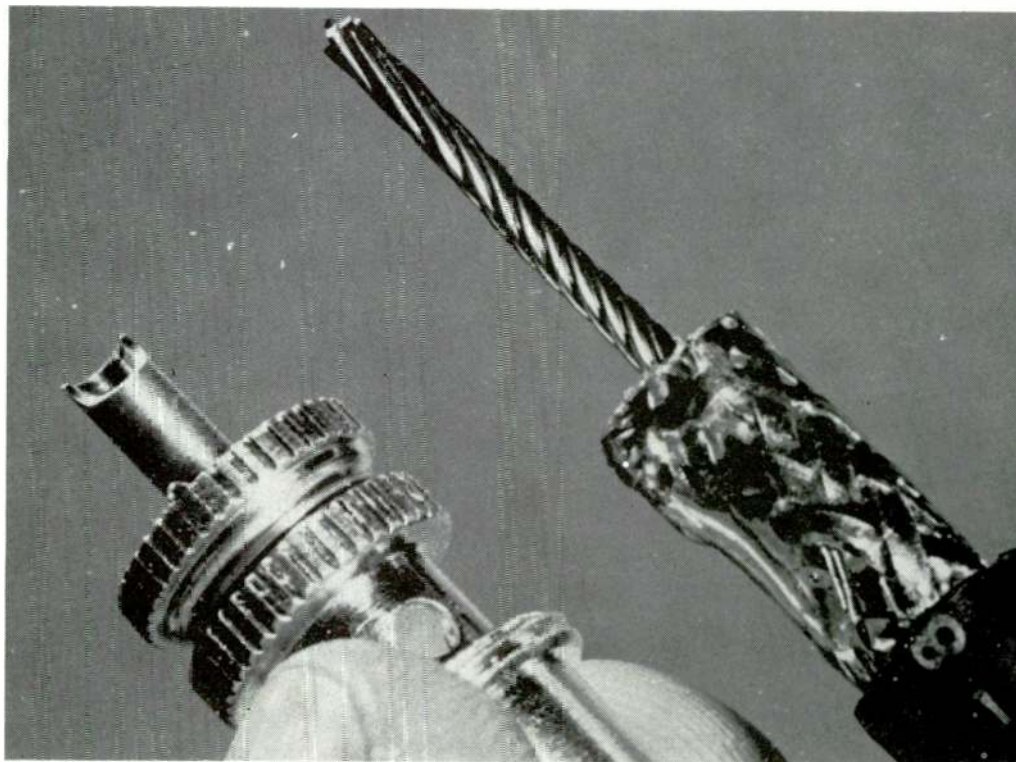

Photo by Marshall Lincoln

### *Installing Connector on Large Diameter Coax – Photo 3.*

*Tinned shield braid and center insulation is trimmed off at a point which will extend inside PL-259 plug just past the solder holes inside of the plug body. Outer insulation sheath should reach short distance inside plug body for neat and strong installation.*

## COAX CONNECTORS

(Continued from preceding page)

soldering iron on its stand and touching the center pin to the tip of the iron as you apply solder. With the center pin pointed down at a slight angle, the solder will flow up into the hollow pin, forced by capillary action as the pin becomes hot.

Don't try to use the little solder holes in the side of the body of the male connector, since applying heat to the connector body now might loosen some of the braid wires which you soldered in place so carefully on the adapter.

Clip off any excess center conductor wire protruding from the center pin of the connector, and file off any excess solder on the side of the connector pin.

Preparing large diameter coax to be installed in a male coax plug is easier, since you don't need to use any reducing adapter. Strip off sufficient outer sheath from the coax so the remaining sheath will extend just inside the body of the connector when it's completed. Don't loosen the braid, but tin it carefully, keeping the iron in motion so you don't heat the inner insulation excessively.

Cut through the braid and center insulation so the portion of tinned braid which remains will be long enough to extend inside the PL-259 plug just past the solder holes in the connector (see photo 3).

Twist the stranded center conductor wires and tin them, then insert the prepared coax into the coax plug. You may need to use a right-hand twisting motion to screw the outer sleeve into the rear of the male plug, but the tinned braid should slip in easily.

Flow solder into the little solder holes in the side of the main plug body. It takes quite a bit of heat to warm the plug body enough to do this, but with the center conductor wires already held in the center by having been thrust through the hollow center connector pin, there should be no danger of them sagging against the shield during the soldering process.

After solder has been flowed into the solder holes to make a good connection, solder the center pin as before.

For soldering coax to the pesky RCA phono-type connectors, a similar technique is used, except the shield braid is soldered to the outside of the connector.

Strip off the outer insulation sheath a distance from the end of the cable slightly greater than the full length of the connector. Fan out the braid wires at right angles to the cable, and remove

(Continued on next page)

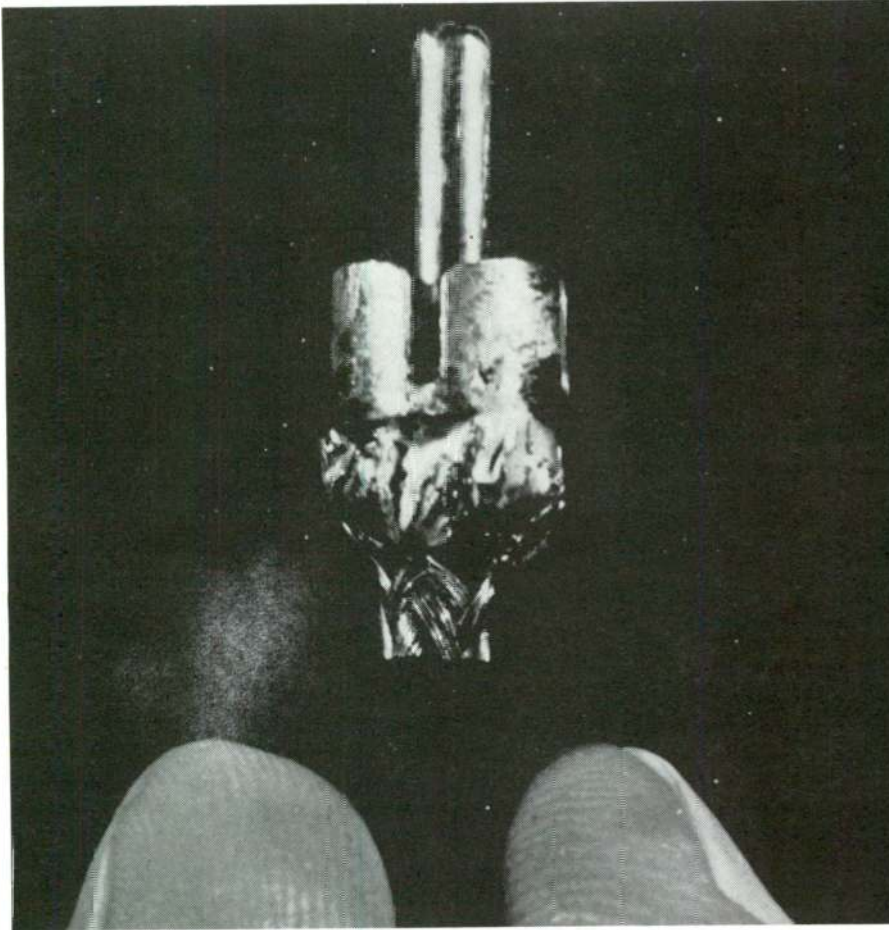

Photo by Marshall Lincoln

### Installing RCA Phono Connectors – Photo 4.

Solder shield braid to outside of connector, turning assembly frequently while working and pausing if necessary to prevent overheating of center insulation. File wire ends smooth after cooling.

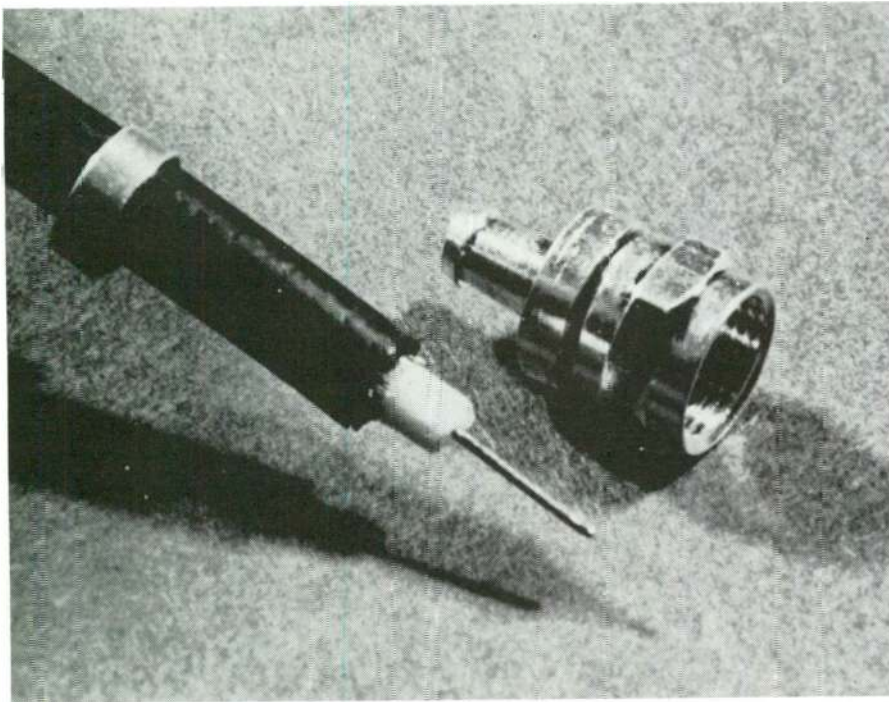
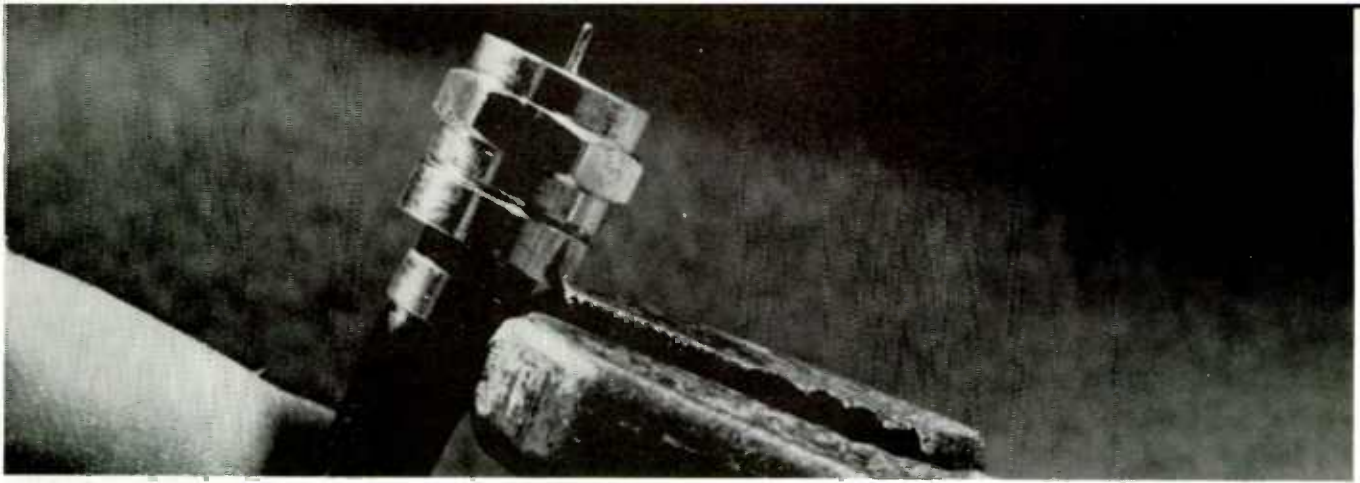

Photo by Marshall Lincoln

### Installing F-59 Connectors – Photo 5.

Strip outer sheath and shield braid so they will reach over full length of connector shank when center conductor extends about 1/16 inch beyond front rim of connector. Place crimp ring on coax before attaching coax to connector.



**Installing F-59 Connectors – Photo 6.**  
*Special crimping tool is made for this job, but ordinary pliers will serve if used carefully. Crimp ring off center, as shown, to tighten it on insulation sheath over shank of connector. Don't crimp so tightly that ring cracks.*

Photo by Marshall Lincoln

## COAX CONNECTORS

*(Continued from preceding page.)*

enough center insulation to allow the center conductor wires to extend through the hollow center conductor pin.

With the center conductor and its insulation inserted into the male connector up to the point where the braid wires have been fanned out, press these wires around the outside of the connector body and solder them to it. Rotate the combined connector and cable frequently to distribute the heat and prevent excessive heating of the center insulation.

When the connector body has cooled, solder the center conductors in the pin the same way as was explained for PL-259 plugs.

After the connector cools, use wire

clippers or a file to smooth up any sharp projecting ends of the shield wires attached to the plug body (photo 4).

Among the connectors being used increasingly in home are the F-59 connectors used on the coax TV antenna feed lines. No soldering is required in installing these connectors, so the job is easier than for some other types. These connectors are designed so the solid center conductor of the coax used with them serves as the center pin of the male connector. The shield and outer sheath are both attached with a single crimp ring (see photo 5).

To install, cut the outer insulation and the shield braid so the center conductor wire will extend past the front edge of the plug about 1/16 inch, with the front edge of the shield braid and sheath fitting over the narrow rear shank of the plug.

Remove enough center insulation so the front edge of the remaining insulation will be flush with the inner portion of the plug.

Place the crimp ring onto the coax, then push the cable onto the rear shank of the plug with the center conductor and center insulation inside the shank, and the shield braid and outer insulation sheath sliding over the outside of this shank. With the shield and outer insulation pressed onto this shank as far as they will go, slide the crimp ring forward past the ridge which is on the shank near its tip, and crimp the ring tight enough to prevent the cable from slipping off the shank. A special crimping tool is made for this, but ordinary pliers, applied slightly off-center of the shank, will work. Be careful not to crimp the ring too tightly, or it will crack (see photo 6).



**\$3.50**  
EACH

MAROON VINYL  
STAMPED IN SILVER

**WRITE OR USE  
ORDER FORM**

## SPECIAL MAGAZINE BINDER

**... to Protect Your Copies of Electronics Digest®**

The CUSTOM MAGAZINE BINDER is the ideal way to keep your copies of ELECTRONICS DIGEST in one convenient location . . . for ready reference. The binder, which will hold up to 12 issues of the magazine, is made of leather-like maroon vinyl with the name of the publication stamped in silver, and is especially designed for use at home, school, or public library.

Fill out the coupon below, or write for your copy today.

### **Electronics Digest®**

1024 Currie Street, Fort Worth, TX 76107

Dear Sirs: Please ship the following items to me postage paid for which I am enclosing payment in full,  check  money order.

- 1-Year (Bimonthly) subscription to Electronics Digest at \$2.50  
 Custom Magazine Binder, for Electronics Digest at \$3.50 each

Name.....

Address.....

City..... Zip Code.....

Please Print



# GIVE A GIFT... THAT GIVES ALL YEAR



**ELECTRONICS DIGEST**®

A new kind of electronics magazine that is easily read by the entire family. An ideal science magazine for students and teachers alike. Regular features include history, biography, electronics and our environment, and basic electronic projects. Published bimonthly.

Cat. No. A-13 1-year subscription \$2.50

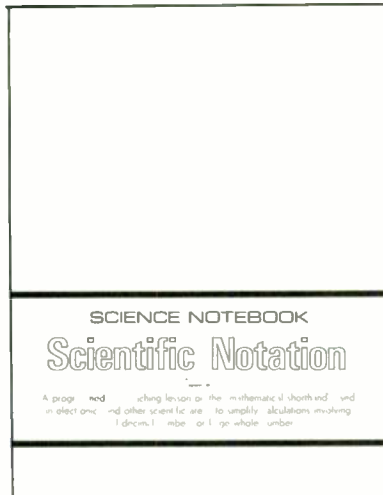

**SCIENTIFIC NOTATION**

A programmed self-teaching lesson on the "mathematical shorthand" used in electronics and other scientific areas to simplify calculations involving small decimal numbers or large whole numbers. An excellent "short course" for students, hobbyists, or as a teaching review of the subject.

Cat. No. A-14 Each \$1.00



**GREAT MEN IN ELECTRONICS**

Biographical sketches and photographs of sixteen outstanding inventors and business pioneers in electronics. It features under one cover a most unusual collection of old photographs of interest to students, teachers, hobbyists, and historians.

Cat. No. A-15 Paperback Edition, \$2.00



**HISTORY'S HALL OF HONOR**

A special loose-leaf collection of brief biographies of great inventors and business leaders in electronics, illustrated throughout with historical photographs of electronic pioneers and the golden era of radio. Handsomely bound in a 8 1/2 x 11 3-ring binder for convenient study by students, or classroom use by teachers.

Cat. No. A-16 in 3-Ring Binder \$3.50

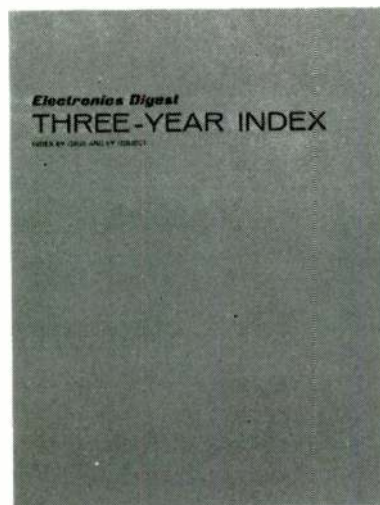

**THREE-YEAR INDEX**

Electronics Digest Three-Year Index features two sections — one indexed by issue of the magazine, the other by subject. It covers many, outstanding developments in electronics, history, biography, environmental electronics and basic electronics.

Cat. No. A-17 Three Year Index \$1.00

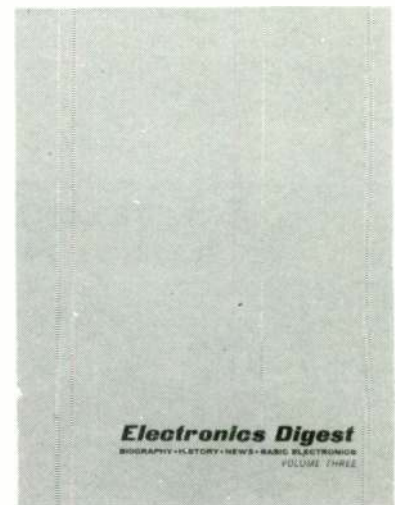

**ANNUAL BOUND VOLUMES**

Electronics Digest annual bound volumes contain a wealth of electronic information not featured by any other electronic magazine on today's market. It's an ideal gift for student, teacher, or hobbyist; Available in volumes 1, 2, 3 and 4, attractively bound with flexible covers.

Cat. No. A-18 Volume \$4.95

- A-13 \$2.50 in U. S. and Possessions; Canada and Mexico. Other Countries \$4.00
- A-14 \$1.00 U. S. and Possessions; other countries Add 50 cents (U.S.)
- A-15 \$2.00 U. S. and Possessions; other countries Add \$1.50 (U.S.)
- A-16 \$3.50 U. S. and Possessions; other countries Add \$1.50 (U.S.)
- A-17 \$1.00 U. S. and Possessions; other countries Add 50 cents (U.S.)
- A-18 \$4.95 Each U. S. and Possessions; other countries Add \$2.00 (U.S.) Please Check:  Volume 1  Volume 2  Volume 3  Volume 4

## Electronics Digest® (published bimonthly)

Dept. 0055, 1024 Currie Street, Fort Worth, TX 76107

Gentlemen: Enclosed is a check / money order for \$ \_\_\_\_\_  
Please send items checked at left to:

Name \_\_\_\_\_  
Address \_\_\_\_\_  
City \_\_\_\_\_ State \_\_\_\_\_ Zip \_\_\_\_\_  
Send Gift Card Signed \_\_\_\_\_

# World-Wide Listening Post!

EVERYTHING YOU NEED FOR ONLY 119.95

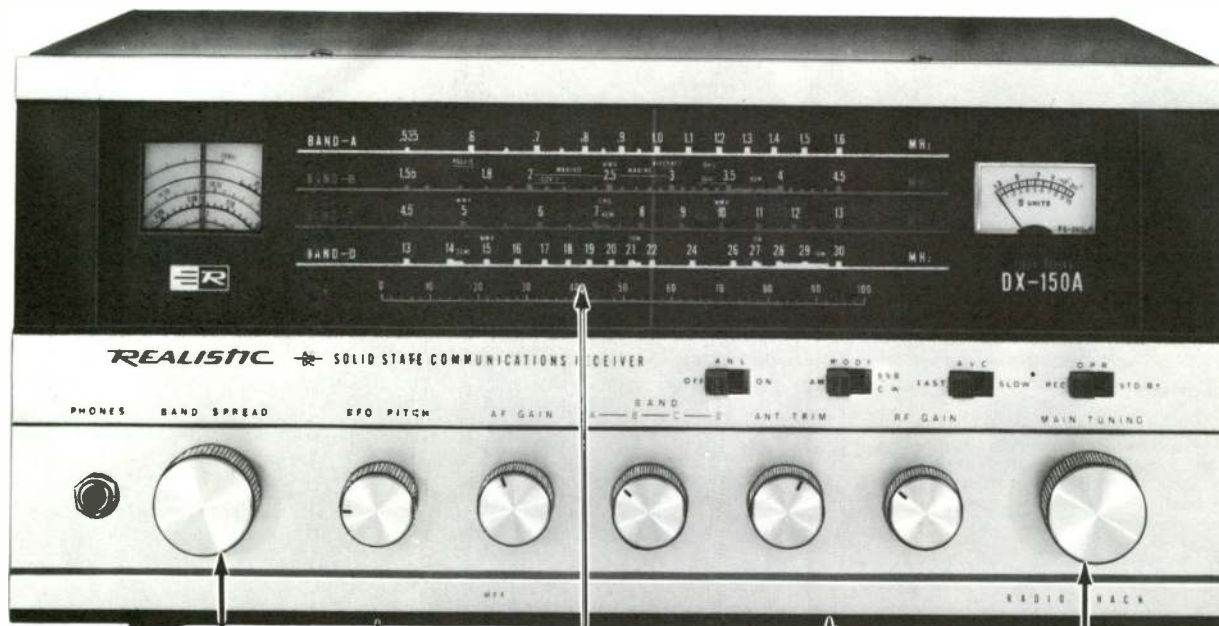

160-10 Meter  
Bandspread Tuning

Battery/AC Operation  
Heavy-Duty Transformer

5-Color 12 1/4"  
Lighted Dial

Built-In Speaker  
100% Solid State

4-FET RF Stage  
With 3-Gang  
Tuning Capacitor

## No Extra Cost! \$20.04 Accessory Package!



Outboard Speaker  
Reg. \$9.95

Headset  
Reg. \$5.95

Long-Distance  
Antenna Kit  
Reg. \$2.19

SWL  
Guidebook  
Reg. \$1.95

## Realistic® DX-150A . . . The Low-Cost Communications Receiver With GUTS!

Loaded with "Pro" features to bring you superior reception of foreign broadcasts, Hams, CB, ships-at-sea, aircraft and more! Tunes 535 kHz to 30 MHz. Automatic noise limiter cuts down ignition and other electrical interference. Antenna trimmer assures peak reception anywhere on the dial. Mechanical filter "slices" through crowded stations. BFO and product detector for outstanding Single Sideband and Code. "S" meter gives a visual indication of signal strength. Headphone jack for private listening. Impressive extruded aluminum panel, solid metal knobs. Complete outfit is ready to use — make it the start of a really rewarding hobby!



at any of our  
over 1400 stores  
in 49 states. Find  
us in the phone  
book in almost  
every town  
and city.

# radio shack

and ALLIED RADIO STORES

A TANDY CORPORATION COMPANY

2725 W. 7th St. Ft. Worth, Texas 76107

# Chemistry plus electronics equals Liquid Crystals.

A technology to watch from Texas Instruments.



Longines' new electronic watch with liquid crystal readout and internal circuitry from TI.

*From wristwatch readouts to electronic "window shades," liquid crystals offer great promise. Though actually observed in the laboratory as early as 1888, their many applications are just now becoming practical. It's for certain you'll soon see liquid crystals in a variety of innovative uses. Here's a brief explanation of how they work.*

Liquid crystals are chemical compounds which fall between the liquid and solid states. The most useful molecular structure in this *mesophase* for electronic application is the *nematic* structure where molecules are arranged parallel to each other like spaghetti lying flat in a box.

When this nematic liquid crystal is sandwiched between transparent electrodes, it is transparent. But, when an electric field is applied, the thread-like molecular structure is broken into smaller units which act as mirrors to reflect and disperse light.

## Liquid crystal displays

There are two types of information display cells built with liquid crystals—*transmissive* (back lighted) and *reflective* (front lighted).

In the transmissive type, the display cell is formed with two transparent electrodes. The cell is illuminated from the back, and where no electric field is applied (bottom portion of transmissive draw-

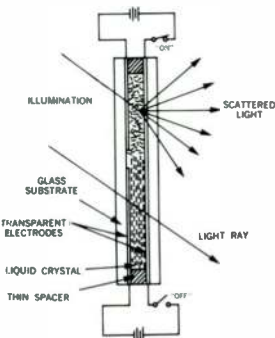

Transmissive type.

ing) the liquid crystal is transparent—dark to the observer. Where the electric field is applied, a dynamic scattering effect reflects the incoming light at many different angles. This scattered light is much brighter than the area where the electric field is absent.

In the reflective cell, the operation is similar except the back electrode is opaque and illumination is from the front. The scattered light is reflected back from the area where the electric field is applied which appears much brighter.

## Applications abound

Reflective displays are prime candidates for use in wristwatches, calculators, dashboard displays, and many other applications where front lighting is more readily available.

Transmissive liquid crystal devices have other types of possible applications. For example, electronic "sunvisors" at the top of car windshields; or electronic "window shades" which turn dark at the press of a button. Practical applications for these versatile "systems" are virtually unlimited. It's a technology to watch.

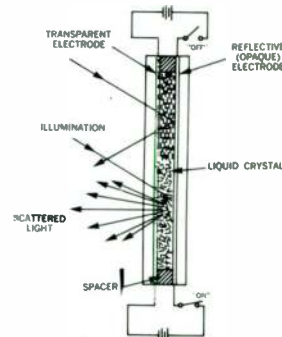

Reflective type.

**NOW... WATCH FOR QUALITY TI TRANSISTORS AT YOUR NEARBY RADIO SHACK.**



Texas Instruments and Radio Shack have initiated a program to offer quality TI electronic components under the familiar Archer label through all of the 1300 Radio Shack Stores. This is the first time for TI to make its quality semiconductors available to hobbyists, professionals and educators through a retail outlet.

Watch for the quality brand.



**TEXAS INSTRUMENTS**  
INCORPORATED

MARCH / APRIL 1972  
Fifty Cents

# Electronics Digest

BIOGRAPHY • HISTORY • NEWS • BASIC ELECTRONICS

FEB 74  
GUTHRIE WALTER J  
44 BELLVIEW ST  
CHAGRIN FALLS OH 44022

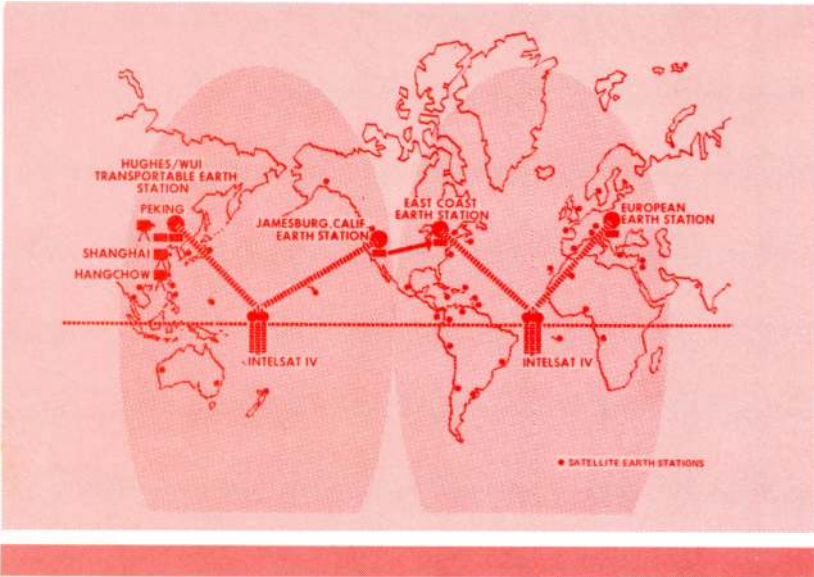

## The China Visit . . .

AND ELECTRONICS

(See page 10)

## The relevant look in electronics

Today, more than ever before, there is a thirst for information throughout the land. Science-minded Americans, young and old alike, want to know what electronics is doing, constructively, for our environment — how it began in the past, and how it is going to shape the world of tomorrow.

Electronics Digest is the electronics magazine that answers these questions. Now in its fifth year of publication, Electronics Digest has been endorsed by many leading educators, libraries, and educational institutions throughout the U. S. and Canada.

Its schoolish format features crisp articles on the latest

developments in electronics . . . ecology, oceanology, medicine, space exploration, and industry. Other topics include history, biography, basic electronic projects for the student/hobbyist, study-guides, and old-time radio projects — replicas of early-day equipment — that make a unique display for a school museum.

Electronics Digest builds student interest in science! It provides an excellent reference source, as well as an important teaching/learning aid for the field of vocational education. Annual subscription rate is: \$2.50 per year (published bimonthly). Special group rates for classroom use available on request.

MAIL YOUR ORDER, NOW!

### Electronics Digest®

THE ELECTRONICS MAGAZINE FOR HOME AND SCHOOL

Division of Tandy Corporation

1024 CURRIE STREET, FORT WORTH, TX 76107

Please enter my order (check/money order enclosed) as checked below:

- One-year subscription (bimonthly) to Electronics Digest, \$2.50
- FREE Three-Year Index, by subject and issue

Name \_\_\_\_\_ Title \_\_\_\_\_  
 School/Organization \_\_\_\_\_  
 Street \_\_\_\_\_  
 City \_\_\_\_\_ State \_\_\_\_\_ Zip \_\_\_\_\_