

*Wireless Telegraphy Number*

# ELECTRICIAN AND MECHANIC

INCORPORATING AMATEUR WORK

## CONTENTS

STORAGE BATTERIES  
NAVY WIRELESS TELE-  
PHONES  
MAGNETIC DETECTOR  
INDEPENDENT INTERRUPTER  
INDOOR WIRELESS  
FOUR-INCH SPARK COIL  
MECHANICAL DRAWING  
HALL UTILITY SEAT  
SIXTEEN-FOOT LAUNCH  
RACE AROUND THE WORLD  
WIRELESS TELEGRAPH  
DETECTORS  
MAINTAINING TELEPHONE  
INSTALLATIONS  
MODEL ENGINE AND BOILER  
PHOTOGRAPHIC COM-  
PETITION  
QUESTIONS AND ANSWERS  
BOOK REVIEWS  
EDITORIALS—TRADE NOTES



PUBLISHED MONTHLY BY  
**SAMPSON PUBLISHING CO.**  
6 BEACON ST. BOSTON MASS.



Price, 10 Cents

April, 1908

## Carpenters' Tools

Box-wood and Ivory  
Rules

Architects', Caliper,  
Bound, Zig-zag and  
Shrinkage Rules

Board, Log, Wood  
Measures

Plumbs, Levels,  
Level Sights

Mason's and  
Machinist's Levels

T Bevels and Try  
Squares

Mitre Squares

Mitre Boxes

"Bed Rock" Planes

Block, Smooth,  
Jointer, Jack, Fore,  
Rabbet, Circular,  
Tonguing-Grooving  
Planes

Dado, Beading, Core-  
box and Universal  
Planes

Scrapers

Spoke Shaves

Trammel Points

Countersinks

Marking Gauges

Cornering Tools

Bit Braces

Clapboard Gauges

Awls, Mallets

Tack Hammers

Saw and Plane Han-  
dles

Screw Drivers

SEND FOR  
CATALOGUE



## "BED ROCK" PLANES

*The  
Best  
Plane  
Made*



☞ In the "BED ROCK" plane we have perfected a design which allows a combination of the utmost solidity and rigidity, together with a wide range of adjustments.

☞ The entire bottom surface of the frog is in contact with the plane body, thus giving the plane iron the same solid bedding as if resting on the plane body itself. The heel of the plane iron rests on the frog; the bevel is the only part of the plane iron not so supported. These features prevent any possibility of the plane iron or frog jumping or springing up or down when in use.

☞ Any possibility of side shifting of the frog is overcome by means of a tongue on the bottom side of the frog and a groove in the plane body. The tongue and groove conform to each other and thus prevent side shifting, and also ensures that the frog moves at a true right angle when adjusted.

☞ These points will commend themselves to all mechanics. Ask to see the "BED ROCK" plane; examine it yourself, and test our statements by the article as you find it.



☞ Furnished with corrugated bottoms without additional expense if so ordered.  
☞ If your dealer does not have them, send for a descriptive circular and prices.

### STANLEY RULE & LEVEL CO.

WORKS AND GEN'L OFFICE, NEW BRITAIN, CONN.  
New York Office and Export Dept. :: :: 107 Chambers Street

## This is a Warning Against Damage to Your Woodwork, Furniture and Floors



**P**EACH-JUICE will stain your table linen—probably, you can take out part of the stain—possibly, you can take it all out—but the table linen may be ruined.

That's *always* the trouble with all "stains"—you never know whether they're in to stay, or in to come out, or partly stay in and partly come out.

When you want to color any fabric properly—you dye it.

And this is every bit as good judgment in regard to the woodwork, furniture and floors of your home as it is to your dresses and things.

Most wood and varnish "stains" are made of such cheap, poor aniline or coloring matter that they smudge over the grain of wood and hide all its beauty because the color particles are too coarse to penetrate the pores—thus they show "laps," light and dark spots and streaks, and they "rub off" on your hands and clothes.

Now when you once get wood stained—maybe you can "do something with it" to rectify the error and maybe you can't—it's better not to take chances—particularly when it isn't necessary.

Johnson's Wood Dyes are really *dyes*—not mere stains—Johnson's Wood Dyes *develop* the beautiful grain of wood, accentuating the high lights and low lights, because we use the finest and most expensive colors—colors which we must import because their equal cannot be obtained in this country.

And Johnson's Wood Dyes actually *color* the wood *deeply*—because they possess a peculiar penetrative power due to the use of a liquid vehicle which we have found to be to the chemistry of wood finishing what "lanolin" is to medicine—the greatest "pore penetrator."

That is why Johnson's Wood Dyes give an unequalled richness of tone and permanency—and a perfectly even texture which will not rub off.

Many manufacturers combine stain and *varnish* in "varnish stains."

Years ago, an advertising man suggested that we put up such a preparation, calling it Johnson-lac. We wouldn't do it because we know that all stains and varnishes, shellacs, hard oils and similar preparations are nothing more than *surface* coat-ers, which mask the beauty of the wood and make woodwork, furniture and floors a constant source of care and trouble.

It is simply impossible for such preparations to give the

soft, smooth, artistic effects of Johnson's Artistic Wood Finishes, because varnish and shellac and hard oil are too "thick" to penetrate the wood, and so they must remain upon the surface to show white marks with every scratch and scrape and mark the white wood where worn through.

There are other good reasons against stains and varnishes and shellacs—the principal objection being that "shiny" wood finish is a good way to make everything in the home look cheap and ugly—even fine pianos are being given a "dull" finish now.

The only modern finish that will not scratch and mar and show every heel print like varnish, hard oil and shellac, and will not catch and hold dust and dirt like ordinary furniture and floor wax, is Johnson's Prepared Wax.

This is because Johnson's Prepared Wax contains 20 per cent more of the hard and very costly polishing wax than any other wax on the market—thus it covers a fifth more space and can be brought to the most beautiful and lasting polish with the least labor.

And the liberal percentage of hard wax enables you to secure a rich, subdued satiny surface impossible with any other finish.

When any part of a shellaced or varnished surface becomes worn or marred it is necessary to refinish the entire surface but Johnson's Prepared Wax is so hard that any part of its surface may be rewaxed without showing any "lapping"—thus you can easily keep everything in perfect condition.

We want to send you, with our compliments, a very handsome and interesting 48-page, illustrated book which tells you about "The Proper Treatment for Floors, Woodwork and Furniture," in detail.

S. C. JOHNSON & SON,

Station EM 4

Racine, Wis.

"The Wood Finishing Authorities."

### JOHNSON'S WOOD DYES

"For the Artistic Coloring of All Woods"

in the following shades:

No. 106—Light Oak	No. 128—Light Mahogany
No. 107—Dark Oak	No. 129—Dark Mahogany
No. 108—Hickory Oak	No. 110—Box Oak
No. 109—Weathered Oak	No. 121—Moss Green
No. 131—Brown Weathered Oak	No. 122—Forest Green
No. 132—Green Weathered Oak	No. 172—Flemish Oak
No. 140—Manilla Oak	No. 178—Br. Flemish Oak

Half Pints, 30c; Pints, 50c; Quarts 85c—at your paint dealer's.



THERE ARE NO SUBSTITUTES FOR

**JOHNSON'S**  
ARTISTIC WOOD FINISHES  
**JOHNSON'S**

FOR FURNITURE, WOODWORK AND FLOORS



# PATENTS SECURED PROMPTLY

And with Special Regard to the  
Legal Protection of the Invention

**Handbook for Inventors and Manufacturers Sent Free upon Request**

Consultation Free. No charge for opinion as to the Patentability and Commercial Value of Inventors' Ideas. Highest References from Prominent Manufacturers.

**C. L. PARKER, Patent Lawyer**

Patents, Caveats, Trade-marks, Copyrights, Reports as to Patentability, Validity, and Infringement. Patent Suits conducted in all States.

REFERENCES:—Globe Machine and Stamping Co., Murray Engineering Co., Morgan Machine and Engineering Co., Berkshire Specialty Co., Stewart Window Shade Co., Macon Shear Co., Acme Canopy Co., Lippincott Pencil Co., Salisbury Tire Association of America, Inventors' and Investors' Corporation, Oakes Manufacturing Co., Cox Implement Co., Columbus Buggy Co., National Index Co., By-Products Co., Alabama Brewing Co., National Offset Co., Antiseptic Supply Co., Richmond Electric Co., Railway Surface Contact Supplies Co., National Electric Works.

Mr. Parker, on November 1st, 1903, after having been a member of the Examining Corps of the U. S. Patent Office for over five years, resigned his position as Examiner to take up the practice of patent law.

Address, 52 Dietz Building, Washington, D. C.

## PATENT WHAT YOU INVENT



**Our Three Books Mailed Free.**

"U. S. LETTERS PATENT" gives full information in patent matters.

"THOUGHTS THAT PAY" gives list of what to invent.

"THOUGHTS THAT HAVE PAID" gives history of successful inventions.

**Write for them.**

No charge for opinion as to patentability; send sketch or model.

Patent obtained or fee returned.

Patents advertised for sale free.

**WOODWARD & CHANDLEE, Patent Attorneys**  
1282 F Street, WASHINGTON, D. C.

## PATENTS

Send Sketch or Model for FREE Examination and Report as to Patentability. Patents promptly secured. ADVICE FREE; Rates Reasonable; highest references and best services. WRITE FOR FREE BOOKS.

**WATSON E. COLEMAN,**  
Registered Patent Attorney, Washington, D. C.

## PATENTS SECURED

OR FEE RETURNED. Send Sketch for FREE REPORT as to Patentability. GUIDE BOOK and WHAT TO INVENT, with valuable List of Inventions Wanted, SENT FREE. One Million Dollars offered for one invention; \$16,000 for others. Patents secured by us advertised free in World's Progress; Sample Free.

**EVANS, WILKENS & CO.**  
100 F Street Washington, D. C.

## Patents

Valuable Book on Patents FREE. Tells how to secure them at low cost. How to Sell a Patent and What to Invent for Profit. Gives Mechanical Movements invaluable to Inventors. Full of Money-making Patent Information. New Book FREE to all who write.

**O'MEARA & BROCK, PATENT ATT'YS**  
938 F Street WASHINGTON, D. C.

## TELEPHONE BRACKET

FITS ANY 'PHONE

For Desk, Wall, or Partition  
Made of one piece heavy steel wire  
Nickel or enameled in colors

PRICE, 50c.

Postage, 10c.

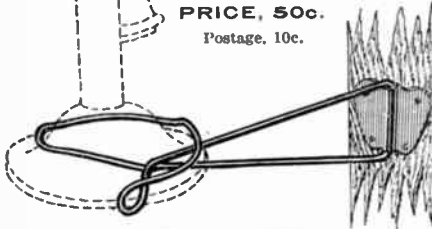

PATENTED 3-22-04

Lower prices in quantities Representatives Wanted

## NEVER-LOSE RULE CLAMP

The Never-Lose Clamp is easily adjusted to fit any rule and is always ready to take or give up your rule instantaneously. Every mechanic should have one of these very useful articles, which we send to any address on receipt of 15 cents. MONEY BACK if dissatisfied with it. Write

**READ & WALKER**

903 Lippincott Bldg. Philadelphia, Pa.

## YOU can Prolong the LIFE

Of your Mother, Wife, Sweetheart, Sister, or Daughter, by urging them to use *our* sewing-machine. **MOTOSE**, operated by water, to run their sewing-machine. Motor supplied with patent stopping and speed regulating attachment, from \$8.50 up. Cash. Runs the Sewing-machine without exertion. Anybody can attach them.

With Interchangeable  
**CHUCKS**  
and  
**PARTS**

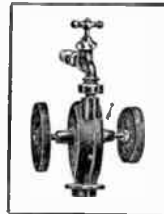

Can be ATTACHED  
Direct to FAUCET or  
Attached to Stand

Copyrighted 1906

by A. Rosenberg

Liberal Discount to Dealers and Agents  
Live Agents who sell (50) fifty during 1908 will be presented with *handsome* Gold Watch.

Pat. June 28, 1898  
Pat. Sept. 10, 1907

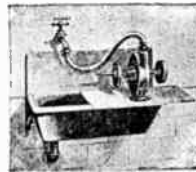

**A. Rosenberg Motor Mfg. Co.**

Dept. E. M. BALTIMORE, MD.

<p><b>FREE</b> <b>TWO BOOKS</b> 68-Page "Inventor's Guide" —AND— "Fortunes in Patents" "What and How to Invent"</p>	<p><b>PATENTS THAT PAY</b> Protect Your Idea <b>SPECIAL OFFER:</b> Send sketches or model and description of invention for <b>FREE SEARCH</b> of Patent Office Records and Report as to patentability. You will save <b>TIME and MONEY. Highest References.</b> <b>E. E. VROOMAN,</b> Regis't'd Patent Attorney Box 60, Washington, D.C.</p>	<p><b>REFERENCES:</b> American National Bank Washington, D. C. Little Giant Hay Press Co. Dallas, Texas Gray Lithograph Co. New York City, N. Y. Farmers Manufacturing Co. Norfolk, Va.</p>
---	--	---

<p><b>NOW READY</b> <b>FOURTH EDITION</b> <b>Modern Examinations of Steam Engineers</b> BY W. M. WAKEMAN. 6 x 8 in. 272 pages. Handsomely bound in Cloth. \$2.00 This book has been especially written for Engineers, Firemen, and all others who are preparing to take an examination for U. S. (Government or State license where such licenses are required, and gives in a plain, practical way just what you must know before you can hope to obtain a license. We supply any book by mail, postage prepaid, on receipt of the publication price. Send for catalogue. The American Industrial Publishing Co., Box E, Pridgeport, Conn.</p>	<p><b>MY BOOK FREE</b>  <b>THE KEY TO SUCCESS</b></p>	<p><b>"HOW TO REMEMBER"</b> Sent Free to Readers of this Publication <b>Stop Forgetting</b> Your are no greater intellectually than your memory. Easy, inexpensive. Increases income; gives ready memory for faces, names, business details, studies, conversation; develops will public speaking, personality. Send for Free Booklet. Dickson Memory School, 920 Auditorium Bldg., Chicago</p>
---	--	---

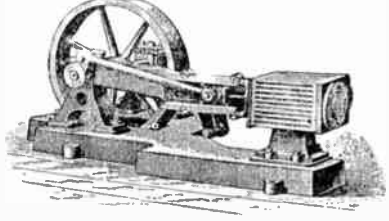
	<p><b>Why Don't You Build an Engine?</b> <b>WE</b> sell sets of castings with cylinders from <math>\frac{7}{8} \times \frac{7}{8}</math> to <math>2\frac{1}{2} \times 3\frac{1}{2}</math> and of a variety of designs. Also partly finished sets, small locomotive sets, boilers, gas engine sets, etc., etc.</p>
<p><b>The SIPP ELECTRIC AND MACHINE CO., Paterson, N. J.</b> 32-Page Catalogue, 10 Cents in Stamps This is refunded with first order amounting to \$1.00 or over</p>	

**Eugene Dietzgen Co.**  
214-220 East Twenty-third St.  
NEW YORK

No. 1189 P  No. 1189 P

On receipt of \$5.45  
Bank draft on New York or express or postal money order we will send you one set of our German Silver

**Reliance Instruments**  
in pocketbook-style case as per the above illustration

Kindly refer to this Ad

**A SAFETY RAZOR SENSATION**  
**"SHRP SHAVER"**

<p>Price <b>25c</b> In Cash</p>		<p>Or <b>13-2c</b> Stamps</p>
<p><b>5</b> Extra Blades <b>25c</b></p>	<p><b>Shrp Shavr</b> Stropper <b>10c</b></p>	

**EASY TO SHAVE**  
Because the Blade is the best money can buy. The Frame is made at the proper shaving angle which gives the best result and insures safety.

**EASY TO ADJUST**  
The Blade slides into the right side of Frame. Is held rigid. Cannot work loose or fall out.

**EASY TO CLEAN**  
The Frame is made of highly finished nickel steel, in one piece; can be readily washed and dried.

**EASY TO BUY**  
A Sensational Price; Razor, 5 Extra Blades and Stropper **60c**  
**THE COMPLETE OUTFIT** **60c**  
"The Razor at the Top"

**WE GUARANTEE SATISFACTION OR MONEY REFUNDED**  
You can make money as our agent

**Clemens Schroeder Co., 320 Broadway, NEW YORK**



# SPECIAL 30-DAY OFFER

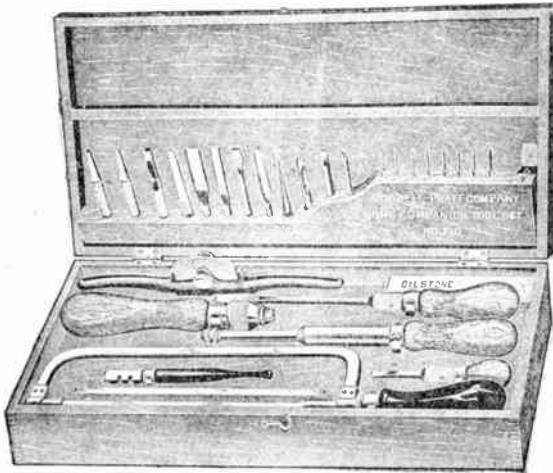

## \$5.00 BUYS IT

To introduce our line of Home Companion Tool Sets among the readers of *Electrician and Mechanic* we are offering for a limited time only our

### No. 710 Set for \$5.00 and Expressage

These Tool Sets of ours comprise tools of our own manufacture, whose quality is well known, put up in handsome hardwood cases.

A complete list of the tools in each of these assortments will be found in our No. 8 Catalog which we will send free to any address.

No. 700 \$3.50 No. 711 \$8.00 No. 712 \$10.00 No. 713 \$12.00

**GODELL-PRATT CO., GREENFIELD, MASS., U. S. A.**



## A School Within Itself

HERE are XX chapters in all, XIX carrying you from the fundamental principles of electricity on through the various branches to a point where the careful student comprehends the complete designing, care, and operation of a dynamo or motor, and 1 chapter on electric automobiles, outlining their construction, care, and operation, and all about storage batteries and how to handle them. Each subject is carefully written and to the point. After a student studies a subject, he is questioned on that subject in such a manner as to bring clearly to his mind the points he needs to know regarding same. A DICTIONARY in back of book will enable

him to learn the meaning of any electrical word, term, or phrase used in this book, as well as hundreds of others in common use. All required tables necessary in the study are in it.

### TABLE OF SUBJECTS

#### Chapter

- I. Wiring
- II. Electric Batteries, Electro Plating
- III. Magnetism
- IV. The Magnetic Circuit
- V. Magnetic Traction
- VI. Magnetic Leakage
- VII. Energy in Electric Circuit
- VIII. Calculation of Size of Wire for Magnetizing Coils

#### Chapter

- IX. Calculation of E. M. F.'s in Electric Machines
- X. Counter E. M. F.
- XI. Hysteresis and Eddy Currents
- XII. Armature Reaction
- XIII. Sparking
- XIV. Winding of Dynamos and Motors
- XV. Proper Method of Con-

#### Chapter

- necting Dynamos and Motors — Self Excitation
- XVI. Diseases of Dynamos and Motors, their Symptoms and How to Cure Them
- XVII. Arc and Incandescent Lamps
- XVIII. Measuring Instruments
- XIX. Alternating Current
- XX. Automobiles

A Dictionary of over 1500 Electrical Words, Terms, and Phrases, giving a brief meaning of all which are in common use

\$2.00 PER COPY—FOURTH EDITION—20,000 COPIES SOLD

The offer we make of refunding money if book is not satisfactory upon examination is an unusual one in connection with the sale of a book. But we have no fear of its return. Your decision will be what thousands of others has been. Money would not buy it if it could not be duplicated. We could print testimonials by the hundreds. It is best to order and be your own judge of its merits

**CLEVELAND ARMATURE WORKS, Cleveland, Ohio**

AMERICA'S GREATEST REPAIR WORKS. Armatures and Fields Wound—Commutators Filled

This  
Book  
is  
**FREE**



# Make Your Future Sure

## Earn \$3000 to \$5000 a Year

### Booklet That Tells All is Free

**Ambitious Men and Women, Make Your Future Sure. You Can.**

In a few months' time, by home study without interference with your present occupation, you can have at your fingers' ends a profession of class and elevated degree that will make you forever superior to position-hunting and position-holding.

In a few months' time you can prepare yourself to face the future with a mind calm and content in the knowledge that you possess a new skill of brain and hand that will unflinchingly produce enough income to enable you to live elegantly for the rest of your life.

In a few months' time you can raise yourself socially to a level with the best people in the community by becoming a recognized professional man or woman, a Doctor of Mechano-Therapy; lay the foundation of a future fortune and start to build up a practice in one of the most delightful and fascinating callings imaginable.

### Learn Mechano-Therapy -- Earn \$3000 to \$5000 a Year.

Any man or woman of ordinary common school education may come to this college and learn in class or be taught with the greatest success at his or her convenience at home by mail the principles and practice of this absorbing and elevating profession that is simpler and more effective than Osteopathy and which has the unqualified endorsement and active support of the medical profession.

Write us at once and we will send you a large illustrated book that tells all about Mechano-Therapy; tells why it offers an ideal opportunity for those without capital to rise financially and socially; tells why men and women succeed in it so quickly and gives the names and photos of a number; explains how we guarantee success in the study of this splendid calling, describes the authorized diplomas granted our graduates, and explains the reasonable cost of tuition and the convenient terms of payment.

Write for this book now—while special rates for tuition are in force—it is sent free and prepaid to the address of any man or woman in the world.

Do this at once and learn how you may become in a few months really and actually independent in future of any chance of financial misfortune or distress—address

**THE AMERICAN COLLEGE OF MECHANO-THERAPY**  
DEPARTMENT 515 . — 120-122 RANDOLPH STREET. — CHICAGO, ILLINOIS

## JUST OUT

### Catalogue "E"

OF

### ELECTRICAL NOVELTIES

Write for One

**Maryland Electrical Supply Co.**

Eutaw and Mulberry Sts. BALTIMORE, MD.

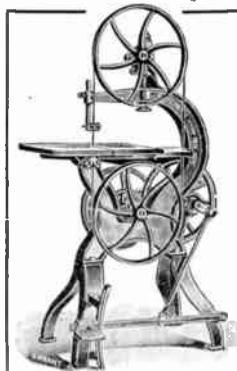

## MARSTON'S

PATENT  
Hand, Foot, and Power  
**Wood Working**  
**MACHINERY**

Catalogue Free

**J. M. MARSTON & CO.**  
203 Ruggles St.  
Boston, Mass.

London Agents

**CHAS. CHURCHILL & Co.**  
15 Leonard Street  
LONDON ENGLAND

## ELECTRIC

SUPPLIES—TELEPHONES—NOVELTIES

Catalogue of 200 Free

If it's Electric we have it. Big Catalogue 4 cents

**OHIO ELECTRIC WORKS**  
**CLEVELAND, OHIO**

The World's Headquarters for Dynamos, Motors,  
Fans, Toys, Batteries, Belts, Bells, Lamps, Books

We undersell all Want Agents



We Want You to Become Familiar With  
**The Reece Threading Tools**  
Including SCREW PLATES, TAPS, DIES, etc.



**SPECIAL TRIAL OFFER**

"Reece Premier" No. 1 T Tap  
Wrench and one each No. 2-56,  
3-48, 4-36, 6-32, 8-32, 10-24, 12-24  
and 14-20 "Hercules" Machine  
Screw Taps. Sent post paid to  
any address on receipt of \$1.25

84-Page Catalogue Free

**E. F. REECE CO.** - Greenfield, Mass.

# "OLIVER" MACHINERY COMPANY

Nos. 10 to 20 Clancy Street  
GRAND RAPIDS, MICH., U. S. A.

MAKERS OF

Machinery and Small Tools

FOR

## MANUAL TRAINING

Special Catalogue in Preparation

EVERYTHING HIGH GRADE

Write us for Machinery, Benches, Vises, Clamps,  
Planes, Chisels, Saws, Grinders, etc., etc.  
We have them.

BRANCH OFFICES

OLIVER MACHINERY CO., 120 Liberty Street, New York  
OLIVER MACHINERY CO., First Nat'l Bank Bldg., Chicago  
OLIVER MACHINERY CO., Pacific Bldg., Seattle

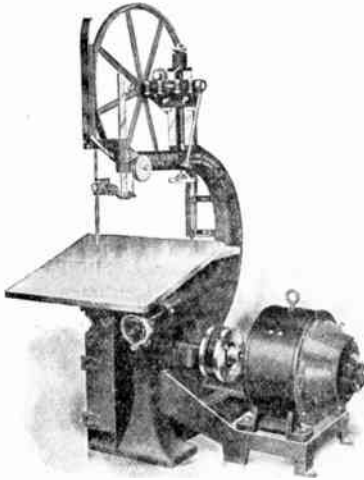

OLIVER "C" BAND SAW  
MOTOR DRIVEN  
MOTOR HEAD SPEED LATHES  
A SPECIALTY

## HOME BENCHES

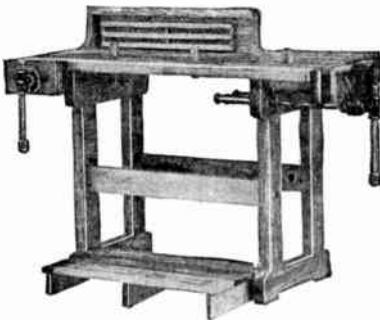

No. 55

Write for Catalog

**GRAND RAPIDS HAND  
SCREW CO.**

930 Jefferson Avenue  
Grand Rapids - Michigan

Largest Manufacturers of Manual Training  
and Home Benches in the World

## Gas Review

A Magazine for the  
Gasoline Engine User

Gas Review will bring into your home—place on your library table—the wisdom, the knowledge, and the experience of the foremost experts on gas and gasoline engines.

A lesson on gas engine operation appears in each issue. Compression, ignition, mixture, battery troubles, fuel consumption, the exhaust, insulation, lubrication, wiring, electricity, and, in fact, every feature in the construction and care of gas and gasoline engines is covered fully yet in a simple, easily understood way.

Think of getting a complete course in gasoline engineering—one not only equal to but far superior to the average gasoline engine course costing from thirty to fifty dollars, all for

**50 CENTS PER YEAR**  
Sample Copies on Request

### GAS REVIEW

14 Cantwell Building

Madison . . . Wisconsin



# Disston <sup>HAND</sup> BOOK ON <sup>BOOK ON</sup> Saws

MAILED FREE

*Contains 208 Pages of Useful and Practical Information*

ARTICLES ON THE MAKING OF DISSTON SAWS, TOOLS, AND FILES, GIVING THE PROGRESSIVE STEPS IN THEIR MANUFACTURE, A LARGE NUMBER OF ILLUSTRATIONS OF THE WORKS, TOGETHER WITH TREATISES ON THE CARE AND USE OF SAWS, ETC.

## HENRY DISSTON & SONS

(INCORPORATED)

KEYSTONE SAW, TOOL, STEEL, AND FILE WORKS  
PHILADELPHIA, PA.

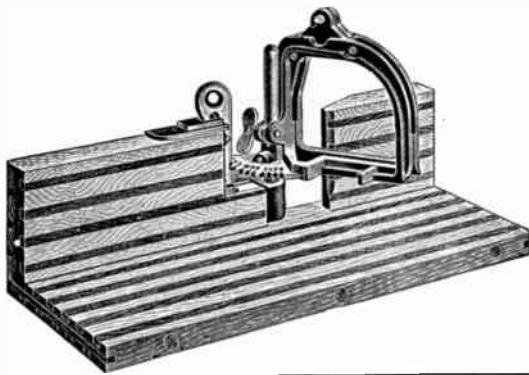

## PERFECTION Mitre Box

*Accurate, Convenient, Light  
Compact*

Manufactured by

**TOWER & LYON CO.**

95 Chambers St., New York



## GAS POWER A MONTHLY MAGAZINE

Devoted exclusively to the gas and gasoline engine subject. It will tell you how to keep your engine running and save you money in expensive repairs. Its contents are of a semi-technical character that cannot fail to interest people operating or contemplating the purchase of a combustion engine.

### PLAIN GAS ENGINE SENSE

Presenting the primary principles of the Gas Engine in simple language—but supplying enough practical knowledge to successfully operate a gas engine. Regular subscription price of GAS POWER, \$1.00 a year.

PLAIN GAS ENGINE SENSE sells for 50 cents a copy.

**A special limited offer is now open of GAS POWER, one year, and one copy of Plain Gas Engine Sense for \$1.00.**

Mail orders at once. **GAS POWER PUBLISHING CO.**

Address - - - **100 COURT STREET**

**ST. JOSEPH, MICHIGAN**

Free sample copy of GAS POWER, if desired.



# The Story The Street-Car Tells— The Trained and the Untrained Man

Side by side they sit;—one filling an important position in the world—the other poorly paid and discontented. The difference between them is due to the fact that one man is *trained*—an expert in his line of work, while the other is *not*.

If you're the *untrained* man and want to advance, write to-day to the International Correspondence Schools and learn how you can better *your* position—how you can have *your salary raised*.

You'll be surprised when you learn how easy it all is. Do it *now*, while it's fresh in your mind. Tear out the coupon, mark it opposite the occupation you like best and mail it to-day. There's no string to this—no obligation on your part—no charge for the information and advice that the coupon will bring. Isn't your *whole future* worth the finding out? Then, *do it now*.

Doesn't matter how old you are, where you live or what you do—so long as you can *read and write* the I. C. S. can help you without your having to lose a day's work or leave home. Mark the coupon.

Doesn't the fact that during November 265 students *voluntarily* reported better positions and higher salaries obtained as a direct result of I. C. S. training prove the willingness and ability of the I. C. S. to raise *your salary*? This is the average number of similar successes reported every month. *Mark the coupon NOW*.

**International Correspondence Schools,  
Box 930, SCRANTON, PA.**

Please explain, without further obligation on my part, how I can qualify for a larger salary in the position before which I have marked X.

Bookkeeper Stenographer Advertisement Writer Show Card Writer Window Trimmer Commercial Law Illustrator Civil Service Chemist Textile Mill Supt. Electrician Elec. Engineer	Mechanical Draftsman Telephone Engineer Elec. Lighting Supt. Mechan. Engineer Surveyor Stationary Engineer Civil Engineer Building Contractor Architect Architect Draftsman Architect Structural Engineer Banking Mining Engineer
--	--

Name \_\_\_\_\_

Street and No. \_\_\_\_\_

City \_\_\_\_\_ State \_\_\_\_\_

# *Electrician and Mechanic*

*Incorporating*

*Bubier's Popular Electrician, Established 1890*

*Amateur Work, Established 1901*

---

VOLUME XVIII

APRIL, 1908

NUMBER 10

---

## ELECTRICAL ENGINEERING—Chapter XXII

### STORAGE BATTERIES. PART I

#### Theory and Construction

A. E. WATSON, E.E., PH.D.

A STORAGE battery acts like a reservoir. It can be charged and discharged an indefinite number of times, and at rates largely at the wish of the user. Of course the device does not actually store electricity, for if such was resident in the plates or solution of which the cell is composed, analysis might reveal the essential nature of the mysterious force, but such investigations show only the original materials, somewhat changed in form, though with the same aggregate weight.

What the battery does is to experience a chemical change, and the ability of the electric current to produce such changes forms one of the most remarkable and inscrutable of all chemical and physical transformations. So wide is this field of research and commercial development as almost to make electro-chemistry constitute a separate science. The subject of storage batteries belongs in this field, but borders on that of electrometallurgy; in the second part of this topic will be considered the use and manipulation of storage batteries, while the twenty-fourth, and last of this series, will describe some of the other developments of electro-chemistry.

If the idea of actual storage of electricity be sought, perhaps the spectacle of a Leyden jar comes the nearest to real existence. There is surely no chemical change produced when the electric charge is imparted to the tinfoil coatings, and certainly nothing else than a force is resident in them. That no actual electricity is present in the charged storage battery is no different conception than is presented by a copper and zinc plate in a primary battery. Whatever current is pro-

duced is entirely due to the different nature of the metals, in the presence of a solution that dissolves the one and is also in contact with the other. As soon as the chemical change is completed, though all the substance still remains, the electric current stops. The ability of a battery to store electric energy will then be readily conceived as limited to such materials as can receive a chemical change by the passage of the electric current through them, and experience no undoing of that change except upon the allowance of a current to flow in the opposite direction.

A canvass of the available materials that would comprise even a tolerable battery, to say nothing of a perfect one, will reveal the list to be surprisingly small. To be in keeping with present realizations it must be confessed that there is really only one metal and one solution that in any satisfactory manner fills the requirements. It is fortunate, too, that these materials are cheap, their preparation and manipulation involving special but no exceptional skill.

It is not to be inferred that because a suitably constructed storage cell will make good returns when new, that it will last indefinitely. All things depreciate by use, and lack of realization of the peculiar weaknesses of storage batteries led to many disastrous failures during their early days and brought considerable undeserved discredit upon their intrinsic worth. As soon as the storage principle was discovered, it was thought sufficient to adopt almost any construction, to charge the plates when de-

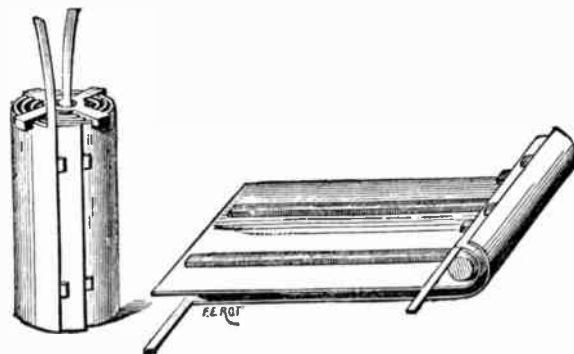

FIG. 114

Original Form of Planté Storage Battery

sired, to let them entirely discharge, and when their use was not imperative, to let them get dry of liquid as well as of energy, to install them in some out-of-the-way place, out of sight, as well as most of the time out of mind. The present attitude is to recognize the batteries as quite as expensive as dynamo machinery and as deserving of similar care. It is certain that neglected machinery will rust and spoil, and only when reasonable attention was accorded to these chemical store-houses of electricity did they have a favorable chance to show their reliability and efficiency. A person would certainly not operate an engine without the presence of an engineer. Though the man often be merely watching, there are times when his services are imperative, and under his skilled touch long life and satisfactory operation are assured. A steam boiler is not to be operated without a pressure gauge, or gauge glass; the water level is not supposed to be left to the convenience of the fireman, but maintained with great watchfulness. So, with appropriate instruments and attention for the storage battery, similar desired results may be assured.

In this article sufficient directions will be given for making and using batteries of the very best types, but only those should build or buy them who realize the necessity of providing a suitable equipment of instruments, and can devote regular attention to their needs. Of course a person may build one for an experiment, but after a long season of disuse he must not be surprised if he finds the battery useless.

In 1860 Planté made the first storage cells by rolling together two long and fairly wide strips of sheet lead, separated merely by coarse canvas, and immersed in a solution of dilute sulphuric acid. After sending a

current through the solution, from one plate to the other, for several hours, he found that the couple would return a current, of course in the opposite direction from that which did the charging. Since the acid soon destroyed the cloth separator, the cell was rather short-lived. In 1872 he improved the construction by using two long soft rubber strips for separators, and this material was sufficiently durable to enable the plates to be more fully "formed," and to display the unexpectedly large storage power of the element. Figure 114 shows the method of rolling together the lead sheets as well as the coils in their finished state and ready for immersion in the solution. Rather stronger solution than the standard ten per cent mixture was found to increase the storage capacity.

Primary batteries were the only source of energy for charging the cells, and in consequence of the meagerness of these currents a long time was required to produce much chemical change in the plates. Yet by allowing many repeated charges and discharges, extending over a year or more, very respectable, though expensive, cells were made. For laboratory experiments the invention of the storage cell even in this form put a new tool into the hands of scientists, for the energy that might be storing for weeks or months could at will be expended in a short time with correspondingly great intensity, and emphasize the great power of the electric current considerably before dynamos became common. Even now it is not a bad installation for an amateur or experimenter to have a few small storage cells charged from gravity batteries. The latter can be permanently connected to the storage cells, and as long as the "blue-stone" crystals are in contact with the copper, and the zinc is in

the clear solution, there need be little other care than to supply water lost by evaporation. Even this care can be minimized by pouring a layer of about a quarter of an inch of paraffin oil on the solution in both gravity and storage cells. At least three gravity cells in series will be needed to charge a single cell of the other sort, and the builder must not be discouraged if a year is required to get the plates into good working condition.

As the formation of a storage battery proceeds, it is noticed that the plate by which the current enters during the charge, and leaves during the discharge, acquires a dark color, almost black, — and the material is recognized as peroxide of lead,  $PbO_2$ ; although thus passing the current in both directions, this plate is commonly called the positive. The other plate normally retains the natural color of lead, but is found to become covered with a sort of scum, or lead in the spongy form. Realizing the length of time and considerable expense of producing these materials by means of the weak primary battery currents, Faure (pronounced like number four), in 1881, sought to anticipate some of this work by applying to the lead plates the well-known commercial oxides of lead that were nearest in chemical constitution to the coatings desired. He spread a layer of red lead (minium, represented by  $2PbO + PbO_2$ ) upon the sheet intended for the positive, and litharge ( $PbO$ , having a yellow color) on the other. The two thus "pasted" were separated with a layer of felt and rolled together in much the same manner as was first used by Planté. Faure's expectations were fully realized, for he found that good working cells were obtained in much less time, and with corresponding saving in expense, than with the simpler construction. The invention was quickly patented in France, and application for a patent in this country was entered.

Brush, the "Father of arc lighting," had also been experimenting with storage batteries, and had apparently just anticipated Faure. Contention in the Patent Office over the conflicting claims was so protracted that the real issue was not decided until 1886, and then in Brush's favor. In trying to develop this sort of plate, the Brush Company found certain inherent weaknesses, and did not realize the commercial success they had anticipated. Contention between infringing manufacturers left the field in an unsettled state, until a sort of trust, The Electric Storage Battery Company, was

formed, to utilize all the good features of various forms of cells and processes of manufacture. Long before the expiration of the fundamental Brush patent it was found that the original Planté form of plate, in which the active materials were formed electrically out of the metallic lead, was by far superior in life and efficiency to the Faure type, and the pasted forms of positives gradually disappeared, and now some of the largest manufacturers have dropped this construction for the negatives as well.

Without attempting to describe the various and quite numerous varieties of constructions of plates, it will be sufficient to mention a few, at once the simplest and best. It is of great importance to recognize one principle, now well established, and that is to have plates and not rolls, — for the better circulation of solution, — and to suspend them from the top, rather than to stand on the bottom of jars. Lead is not a stiff metal, and sags under its own weight; this defect, added to the buckling or warping due to the natural expansion of the active material, renders the plates, especially those made in large sizes, less reliable than the sort which hang in a manner to keep themselves straight. In use there is also an unavoidable shedding of the active material from the surface of the plates, and in case the support is from the bottom, the accumulation of this "mud" causes noticeable short-circuiting, with consequent running down of cells. Common practice demanded the setting of the plates upon ledges raised above the general level of the bottoms of the jars, but this expedient is only moderately effective. It is just as easy and far better to hang the plates from lugs extending from the upper corners.

Figure 115 shows a form of grid with top supports, adapted for either Planté or Faure formation. A cast frame of pure lead, about  $\frac{1}{4}$  inch or  $\frac{3}{8}$  inch thick, — depending upon the other dimensions of plate, — is filled with strips of lead ribbon in alternately straight and crimped shape, the shape of a strip both before and after crimping being also shown. These ribbons are only about 1-32 inch thick, and come flush with the surface of frame; the ends need to be securely attached to the frame, and by "burning" rather than by soldering. For this purpose a tiny blow-pipe flame, preferably using hydrogen gas, is the best, and after a little practice, the builder can attain considerable facility with this somewhat delicate operation. Such a flame as is now commonly employed with pyrog-

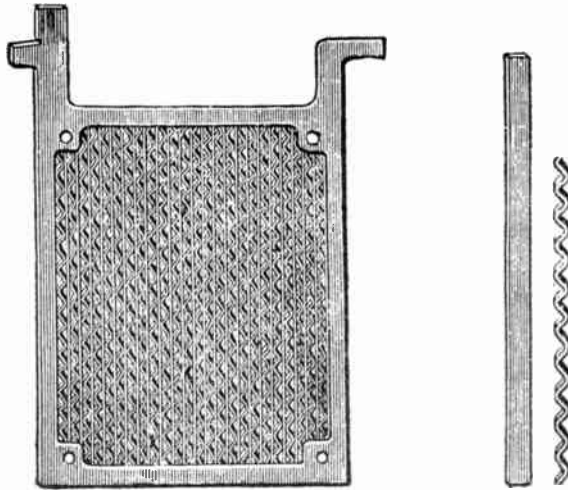

FIG. 115  
Latticed Grid for Planté or Faure Formation

raphy sets ought to be well adapted for this melting of the strips to the larger mass. If solder is used, it ought to be of specially poor quality, that is, containing as little tin as possible, and the flux should be plumber's candle or resin, — in no case the ordinary chloride of zinc solution. Four holes are shown in the corners of the frame, into which may be driven wood or hard rubber pins, projecting  $\frac{1}{4}$  inch on each side, for the purpose of keeping plates apart. It is obviously sufficient to put these in one set of the plates only, preferably the negative, for that experiences the less deterioration, and the pins will remain tightly in place.

Of course the pins will not keep the plates apart if buckling or warping takes place, and so it is common practice to put in other separators, the best being of perforated hard rubber, but that material is so expensive as to lead to the substitution of thin wood slipped into slots cut in ordinary dowel-pin sticks. The wood is about the thickness used for fruit baskets, and when wet by the solution seems to offer no sensible resistance to the passage of the electrical energy. Perforations are, however, desirable to allow circulation of the acid. The objections to the use of separators of wood are based upon its gradual carbonizing, and therefore becoming somewhat of a conductor, and forming a leakage path through which the battery may slowly discharge, or by its chemical disintegration which may lead to the formation of acetic acid, the presence of which is highly detrimental to the storage qualities. Glass rods and corrugated

perforated, hard rubber sheets form the ideal separators.

With the plates made in the shape shown in Fig. 115, any desired number can be grouped in a single cell, always observing the rule to have one more negative than positive plate. This is necessary in order that both sides of every positive be equally acted upon, and to allow for uniform expansion as more and more of the metallic lead is converted into peroxide. If pasted plates are desired, the interstices between the strips can be filled with the proper oxides. To do this, the plate should be laid upon a pane of glass, and the oxide mixed with dilute acid and spread over and into the places. As these oxides (red lead for the positives and litharge for the negatives) set quickly, like plaster of Paris, only enough for one plate at a time should be mixed, and that rather thin; after waiting a moment for the setting, the plate can be completely slid from the glass, and the other side similarly treated. After the pasting process the plates should be allowed to dry for a day, then once daily plunged into dilute acid, until all sizzling or heating disappears. Unless this precaution is taken, the assemblage of the plates in the regular acid will result in such an evolution of hydrogen gas as to dislocate and even expel some of the filling.

Each set of plates is connected together by means of the lugs at the top being soldered to cross-bars. A separation between like plates can well be  $\frac{7}{8}$  inch to 1 inch. It is a mistake to crowd them closer. Neither



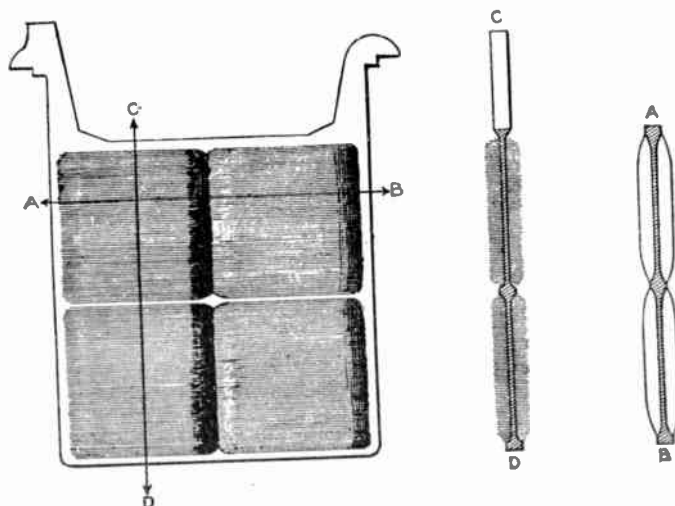

FIG. 116  
Battery Plate with Deep-rolled Grooves

should the edges of plates come nearer than  $\frac{1}{2}$  inch from sides of jars. Even greater space is desirable. Space must be provided for the insertion of the hydrometer for measuring the specific gravity of the solution, and also for allowance for the natural growth of the positive plates.

Another form of plates that combines most of the desirable features of a successful battery is represented in Fig. 116. In this a slab of pure lead is cast or pressed into the general shape shown, and then the surface nearly cut through with grooves, so as greatly to increase the area presented to the action of the acid. No metal is removed, but the thin disks of the rolling tool press into the slab and raise the neighboring portions into fins or ridges. The two sections show the resulting shape, along with the uncut stiffening ribs.

An amateur can make similarly effective plates from rolled or cast lead slabs, by cutting the grooves entirely across by use of an appropriate tool in a planer or shaper. The proper shape of tool can be judged by considering how a sheet of paper would best be cut by drawing a knife over it. The blade would not be held perpendicularly, nor poked under like a hook, but given a considerable slant; if now, in addition to this slant, the blade be tipped sidewise, at an angle of  $30^\circ$  or  $45^\circ$ , the shape of the cutting edge of the planer tool is given. Like the farmer's plow, the tool is to cut into the metal and turn it over like a furrow, but not to remove the stock. From 14 to 16 cuts per inch should

be allowed, and if the slab is  $\frac{1}{4}$  inch or 5-16 inch thick to start with, the final thickness, allowing for an uncut backing of  $\frac{1}{8}$  inch, will be nearly  $\frac{1}{2}$  inch.

Chemically pure materials must be used, else the impurities present will allow the formation of other compounds than those intended, and the battery will fail to hold its charge, and return the expected energy. Lead of the desilverized quality should be sought, and this costs only about one-half cent more per pound than the ordinary commercial pig lead. Sulphuric acid is readily obtainable from the manufacturers in the proper dilution, and unless the distance is so great as to render the transportation of the dilute acid too great, this is better than purchasing the concentrated grade and then diluting it on the spot. The builder does not ordinarily have vessels large enough to mix the whole quantity at once, yet all the cells need filling at closely the same time. Distributing the solution in many small vessels leads to inevitable differences of density. At the works the concentrated acid receives its final treatment in stills made of platinum, and conducted in gold pipes. Although it is a common statement that these metals are unaffected by the acid, it is a matter of serious knowledge to the owners that the stills and pipes gradually disappear. It is found that of all foreign metals in a storage-battery, the least trace of platinum will work the most harm, and gold comes next. Therefore if the dilute acid is purchased, — direct from the works of course, — the sort that

has received only a moderate degree of concentration in leaden vessels, the chances are favorable for securing a pure quality at moderate cost.

The proper strength of solution to be used is that having a specific gravity of 1.21, water being 1; it will be explained a little later that in the normal operation of the battery this density changes, and this variation serves as one of the surest indications as to the condition of charge or discharge. It is well, however, to purchase acid a little stronger than this, for as soon as the plates are immersed, some lead is changed to lead sulphate, or some of the oxides suffer further decomposition, and this means the using up of some acid. To forestall the necessity of then adding strong acid, that of a density of about 1.25 or 1.26 may well be purchased in the first place. The builder who tries to do any serious work with a storage battery must not think of ignoring the use of the hydrometer. A steam engineer could as well dispense with a water gauge on his boiler. If Baume's graduations of hydrometer be used, the mark of about 24.5 is to be followed, or if the kind at hand is marked 1150 to 1250, a decimal point is to be imagined after the first figure, and then the instrument becomes direct reading.

Hydrometers are weighted with either mercury or fine lead shot. Since the breakage of the tube will spill the contents into the cell, it is seen that the latter sort is preferable, — mercury being highly detrimental to the life of the plates. A mercury-weighted hydrometer is shown in Fig. 117.

Since the Planté method of formation is now commonly practiced, it is usual for manufacturers to use "forming" solutions for hastening the process; such usually involve the introduction of dilute nitric acid. By them, and the aid of powerful dynamo currents, formations that took the original inventor a year are now accomplished in thirty to seventy hours. The disadvantages of such solutions lie in the inability effectually to eliminate the nitric acid. It is very persistent in its adherence to the lead, and only long washings in running water will suffice to eradicate it. Chlorides, too, are difficult to eliminate, and the particular process involved in the "Chloride" plates is now completely abandoned — the name being retained merely as a trade-mark.

After assembling the plates of a battery, they must not be placed in the solution until the charging current is all ready. Batteries

suffer more from inaction than use, and especially must the plates not be left in the discharged condition. Whether home-made or purchased, the plates when assembled are in the discharged condition, and inattention to the proper initial conditions may give the

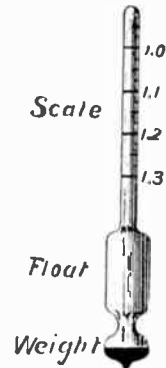

FIG. 117

Hydrometer for Measuring Specific Gravity of Battery Evolution

plates a setback almost impossible to overcome. Continuous charging for twenty-four hours is imperative, and the manufacturers usually demand double that, or until the voltage and specific gravity have reached certain high and definite limits. After thus putting the cells into proper good initial condition, no such overcharging is needed, except at long intervals. Still, in places where reliability of operation is of prime importance, as in telephone exchanges, it is not uncommon practice to overcharge the cells once a week.

The chemistry of storage battery operation consists in the fact that upon the first immersion of the plates in the sulphuric acid solution, some metallic lead on both plates is acted upon, whereby lead sulphate is formed and hydrogen gas liberated. After this exceedingly thin skin of sulphate has formed, no further action takes place until a charging current of electricity is sent through. Even in this case, metallic lead is not transferred to the negative plate, as would be the case in a plating cell, for the fundamental reason that the solution is not a salt of the metal of which the anode is composed. If lead was to be electrically deposited, a solution involving lead acetate or potassium plumbate would be needed. Since the solution, however, contains no lead, — this metal being practically insoluble in sulphuric acid, — the passage of

the current merely decomposes the solution. Authorities somewhat disagree as to some of the intermediate transpositions of the molecules or atoms, but the final products are plain. The acid is decomposed or disassociated, the hydrogen passing with the current to the negative plate, while the remainder of the molecule — the sulphuric oxide — goes against the current to the positive plate. Here the latter "ion," being rich in oxygen, unites with lead sulphate and water to form lead peroxide and two molecules of acid. Also, the hydrogen that reached the negative plate displaces the lead in the lead sulphate, deposits it in the spongy form, and produces another molecule of acid. Thus it is seen that in the charge, for every molecule of acid decomposed, three have been formed. Confirmation of this gain in acid is conclusive from the indications of the hydrometer, and the progress and amount of the charge is faithfully testified by this simple instrument. As the charging proceeds, the voltage somewhat rises, though on an ordinary voltmeter the readings are not so conclusive as those of the float. During the discharge the opposite steps could be traced, with the result of showing that sulphuric acid was used up, the specific gravity of the solution consequently falling.

In Fig. 119 is given a set of curves depicting the performance of a small cell during periods of charge and discharge extending over about three hours. At the beginning of the charge the voltage of cell was nearly 2.1 volts, and for a long interval was not far from 2.2 volts, but finally reached 2.3. The specific gravity, however, went from somewhat less than 1.175 to 1.196, a very readable difference on a hydrometer. After a short wait, the disengagement of the excess hydrogen gases had allowed the voltage to fall to the value of 2.15, from which, during the discharge, the pressure gradually approached the 2-volt line, holding that for considerable time, but at length reaching the minimum safe limit of 1.8, at which point the discharge was properly stopped. As seen from the diagram, the lowering of the specific gravity of the solution was constant and unmistakable.

To the person, then, who would regard the storage battery, not as a haphazard arrangement to be toyed with at will, but as a scientific implement of complex chemical and physical structure, it will give a wonderful stimulus of thought and respect. The device cannot be called perfect, but this estimate must not be based on the mere factor of

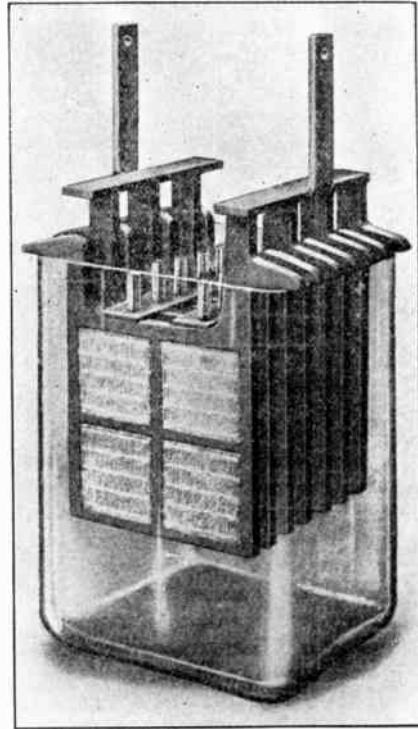

FIG. 118  
Small Size of Battery assembled in Glass Jar

great weight, for many mechanical devices are admittedly heavy, and yet highly satisfactory. On the score of efficiency the storage cell can readily return seventy-five per cent of the energy put in, so in this respect it stands in the foreground with steam-engines and water-wheels. The real shortcomings of the batteries have been exposed through the somewhat improper uses to which they have been put. The positive plates are little else than lead ashes, and ashes in any form are not accredited with much mechanical strength. Therefore for portable use, on automobiles and railway cars, the short life experienced is quite explainable. In central stations and for other stationary uses, when as skilled attention has been accorded to them as to the machinery, they have filled all reasonable expectations.

It is true that this sort of battery has its frailties, and some of these are of peculiarly insidious character. Chief among them may be emphasized the possibility of the plates — particularly the negative — acquiring an excess of lead sulphate, more than is regularly changed by the current to the peroxide or

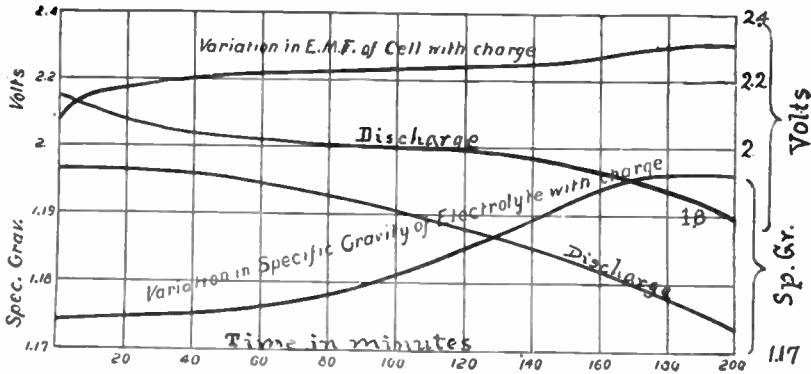

FIG. 119  
Curves of Battery Charge and Discharge, showing Change in Voltage and Specific Gravity

into spongy lead. This sulphate readily forms when the battery is left in a discharged condition, or when the solution is too weak. Being essentially a non-conductor of electricity, whatever portions of the plate are covered are thereby prevented from receiving their normal charge, the remaining parts are charged or discharged more than expected, with consequent warping and other kindred troubles. Without entering into details, it is sufficient to affirm that most of the failures of storage batteries in the hands of inexperienced attendants can be attributed to this "sulphating."

Until lately the positive plates of a battery have been looked upon as the weaker, and subject to the greater solicitude. Experience has led to the construction of very satisfactory plates for this polarity, and now it is found that the negative has its own causes of depreciation. The evidence has been manifested in the gradual diminution of storage capacity of the cells, even with new positives. Examination shows the ultimate reason to be that the negative plate, instead of retaining the lead in the spongy condition, with great area exposed for chemical action, becomes somewhat reduced to the condition of solid metallic lead. Remedies for this lapse are now being sought, and by some inventors claimed to have been found.

Direct sunlight seems to have some injurious effect upon the batteries, the real nature being rather obscure. While there is importance in having the cells in a sufficiently light place to be regularly seen and cared for, some caution must be observed not to put them in a place too light and hot.

For experimenters and owners of small installations, the use of a layer of paraffin oil on the cells is to be recommended. Evaporation of the water and spraying of the acid will be largely suppressed, but it might be well for the experimenter to try it on one cell, and see how he regards it. The use of the hydrometer is interfered with, for to use it, a sample of the liquid must be withdrawn with a pipette, and run into a test-tube. As a matter of fact, for laboratory purposes, or for other irregular uses, daily hydrometer readings are not necessary, and the use of oil is quite allowable. While accumulation of dust and oil makes a rather nasty combination, and one not particularly inviting in case of overhauling, the oil is really something of a protection for the hands, for with a coating of that unguent, the attacks of the acid are mollified.

At the outset of this article it was stated that only one metal and one solution have yet been found for producing a good storage cell. The reader has seen what these two are. Other materials have been zealously sought, but in every case some insurmountable defects have been found. There is not space here to explain the various attempts at lead-zinc and nickel-iron couples, for if so, a false estimate of their commercial value might be given. Nor is it to be expected that any new metals will be discovered of greater promise in electrical storage properties than those now at hand.

In the next chapter will be given some explanation of the switchboard arrangements and methods of practical operation of the batteries.

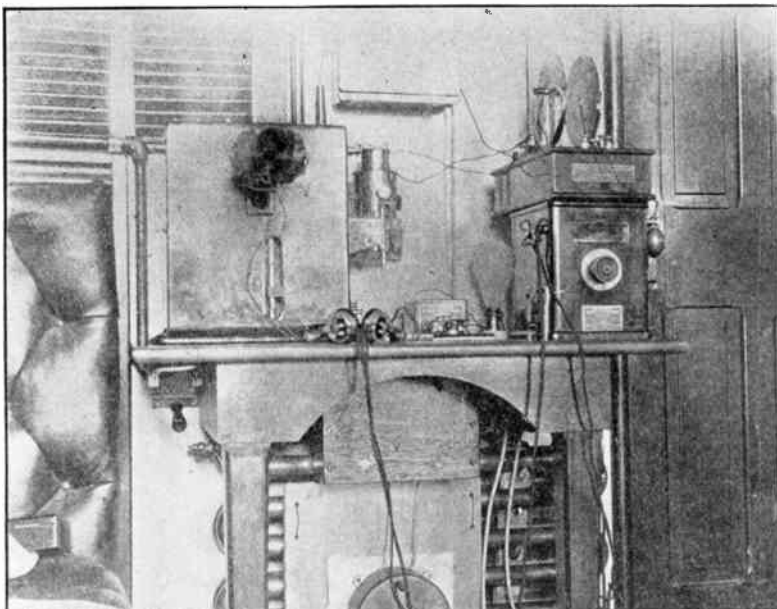

Set of De Forest Radio-telephone Apparatus, Chart Room, "Virginia"

## WIRELESS TELEPHONES IN THE AMERICAN NAVY

FRANK C. PERKINS

THE accompanying illustrations show the electrical apparatus used for wireless telephone service on the U. S. S. "Connecticut" and being installed on thirty-two other American war vessels.

This is certainly evidence enough that the radiophone has passed the experimental stage and is now considered practical for use in the navy. It is stated that naval attachés of several foreign governments are negotiating for similar equipments to those in service on the United States fleet.

It is maintained that the wireless telephone service on the "Virginia" and "Connecticut" worked perfectly over distances up to twenty-two miles, while the North Atlantic battleship fleet was having target practice in Cape Cod Bay. It is stated that the contract with the government calls for intelligible communication over a distance of five miles, although this distance has been exceeded several times over. During recent tests the words spoken into the radio-telephone transmitter on the "Connecticut" were distinctly heard on the "Kentucky" and the "Illinois," eleven miles away, although those ships were not equipped with wireless telephones, but ordinary telephone receivers

were attached to the wireless telegraph instruments. The words were repeated back to the "Connecticut" verbatim by wireless telegraph.

The new Pacific fleet is being equipped with the radio-telephone system of Dr. Lee De Forest, as the experiments during target practice of the North Atlantic battleship fleet were so satisfactory and proved the possibility of telephonic intercommunication between the cruisers, torpedo boats, destroyers, and battleships of the American navy. One of the most important instruments included in the radio-telephone apparatus installed on the flagship of Admiral Evans, the "Connecticut," is the De Forest "audion," which is a specially sensitive device which takes the place of the coherer, electrolytic detector, or magnetic detector of the wireless telegraph system. It has the appearance of a small incandescent lamp, but has a plate and a grid of platinum sealed into the bulb with a filament of tantalum which glows from the action of a storage battery current.

A current of 220 volts from the battleship's electric lighting plant is conducted to the transmitting instrument, flowing through

choke coils, the latter preventing high frequency alternating currents from passing. The current is then conducted to the oscillator, an arc maintained in the flame of an alcohol lamp being used for this purpose.

It will be noted that the radio-telephone depends for its action, like wireless telegraphy, upon the production of electric waves which travel through the atmosphere at about one sixth of a million miles per second. The interruption is entirely different in wireless telephony from wireless telegraphy, although the production and transmission of the electric waves is practically the same.

It is essential that a current of high frequency pass through the primary of the transformer, and in this apparatus a frequency of 40,000 per second is used, a condenser being interposed in the circuit. The human voice has vibrations varying from 500 in some tones up to 20,000 per second for certain of the overtones, and in wireless telegraphy a few interruptions per second only are essential.

The secondary of the transformer of the radio-telephone transmitter is connected with the aerial conductors or antennæ, and waves of the proper frequency may be sent out into the atmosphere by arranging the two circuits and adjusting them to produce the required aerial wire oscillations. The resistance in the carbon granules of the microphone trans-

mitter varies with the vibrations of the voice, and this affects the intensity or amplitude of the waves transmitted by the antenna into the air. In wireless telephony the variations are what produce the desired results, while in wireless telegraphy the waves are cut off entirely and in this way produce the Morse signals.

The radio-telephone receiving instrument is connected to a similar aerial wire and to a transformer which has one end of its coil connected to earth. There are two condensers in the secondary of the transformer, the "audion" being also connected in the secondary circuit with a separate storage battery, together with a telephone receiver, with another battery for this local telephone circuit.

A series of oscillations is set up as the electric waves impinge upon the antennæ, affecting the "audion" through the circuit of the transformer. It is stated that the resistance of the gas ionized by the heat of the glowing lamp filament is varied by the changing amplitude of the oscillations in the aerial wires. The diaphragm of the receiving telephone is thus caused to vibrate, reproducing exactly the sound which the transmitter received.

As noted in the accompanying illustrations, the transmitter of the radio-telephone system is seen at the left, the oscillator being

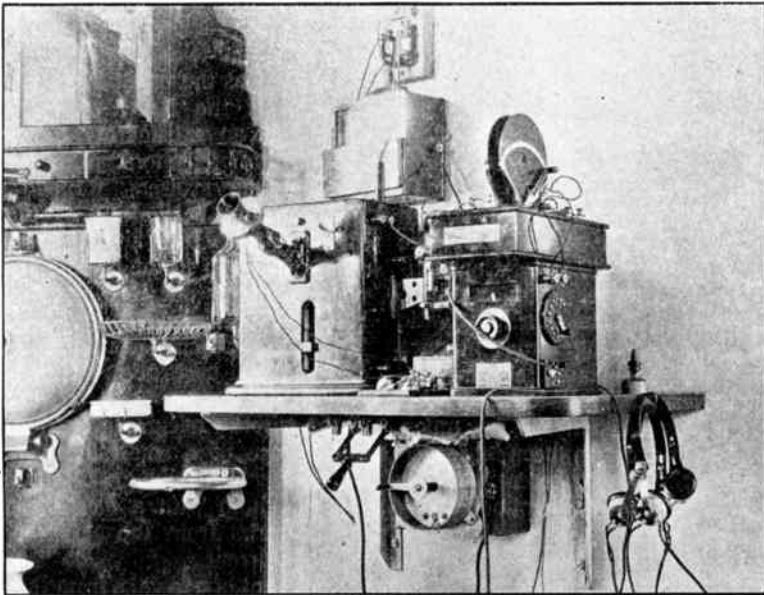

De Forest Radio-telephone Set, Admiral's Emergency Cabin, Flagship "Connecticut"



at the right side of this box, the alcohol lamp being shown under the nickel-plated casing.

There is a small handle moving in the slot at the side of the box which is used in tuning the transmitting circuit and a listening key is provided in order to connect either the

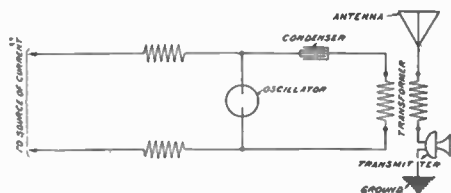

Diagrams of Radio-telephone Transmitting Apparatus

transmitting or receiving instruments to the aerial wire when desired.

A "chopper," consisting of a telegraphic key and a box similar to a buzzer, is arranged in such a manner that wireless telegraph messages may be sent by Morse signals at will by throwing the proper switch.

The apparatus noted at the right in the illustration is the radio receiving instrument, the lower box containing the "audion," with proper switches and resistances, and the upper box containing an adjustable condenser and impedance coils, the two pan cake tuning device or syntonizer being mounted on top and consisting of two coils, the number of turns being varied at will.

During the regatta of the Interlake Association at Put-in Bay on Lake Erie, the reporting was done by wireless telephones of this type installed on the cruiser yacht

"Thelma" of Commodore W. R. Huntington, of Elyria, Ohio, in communication with similar radio-telephones at a shore station at Fox Dock, at Put-in Bay. The aerial wires were led through the roof of the wheelhouse to a cross-arm on the top of the foremast, and from there to another cross-arm on the mainmast, while grand connection was made to the propeller shaft of the twin screws, also two zinc plates on the bow of the yacht's hull. A 1 h. p. 220-volt electric generator was belted to the fly-wheel of the starboard 20 h. p. engine, and the current conducted to the radio-telephone transmitting apparatus on a table in the main cabin. On the shore a motor generator was used, the motor taking 110 volts and the generator supplying a current of 220 volts.

The telephonic messages were sent and received with great accuracy, and there was no difficulty in either receiving or transmit-

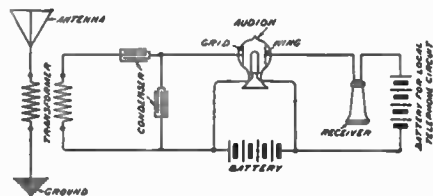

Radio-telephone Receiving Apparatus

ting the reports of the races. There is every reason to believe that wireless telephony has come to stay, and will ultimately be developed to send and receive messages at very great distances by the human voice instead of by signals.

## THE CONSTRUCTION OF A MAGNETIC DETECTOR

EDWARD G. GAGE

THE researches of Joseph Henry brought out the fact that the discharge of a Leyden jar through a coil of wire surrounding a needle produces an effect quite unlike that of a voltaic current. Instead of being uniformly magnetized, the needle is seldom magnetized twice alike throughout its length, and its poles are often reversed.

Although Henry rightly guessed the true cause of this irregular magnetization, namely, that the discharge is oscillatory, the principle was not applied by him in detecting oscillations at a distance; but Rutherford, some fifty years later, utilized this principle in his detector of electric waves.

A small magnetometer was placed near one end of the needle, previously magnetized to saturation, and the changes in magnetism caused by oscillations from the distant oscillator passing through the coil surrounding the needle were noted by the deflections of the magnetometer.

This apparatus was, of course, suitable for experiments only, in that a freshly magnetized needle was required after every discharge of the oscillator.

Marconi overcame this difficulty by supplying a constant source of variable magnetism in the shape of a permanent magnet, which, being slowly revolved by clockwork

with its poles facing the coil of wire, supplied fresh magnetism to the core, which instead of a needle was now a bundle of thin iron wires.\* As a further improvement Marconi discarded the magnetometer for noting the passage of oscillations, and in its place wound a second coil of fine wire over the first, which picked up the induced currents, and led them to a telephone receiver in which a click could be heard for every spark discharge of the transmitter.

Even this form of detector had its drawbacks, as the signals received were constantly varying, being strongest upon the approach of the magnet poles to the core, and weaker when receding, making it unsuitable for practical work. Again Marconi has overcome the difficulty by arranging the detector in the manner later described.

Although the operation of the magnetic detector is commonly called one of hysteresis, in which the magnetism of the core lags behind the magnetizing force of the permanent magnet, and is suddenly set free by the passage of oscillations through the primary coil surrounding it, the true operation, like that of the electrolytic detector, is disputed by several investigators.

It is sufficient, however, for practical needs to accept the hysteresis theory, and to so proportion the windings, core, magnet, etc., that they shall be best suited to a happy medium of wave lengths, telephone receivers, and signal strengths.

This has been accomplished in the modern commercial detector, which is due to Marconi, and is wonderfully constant, "fool-proof," and ranks next to the barretter or electrolytic detector in sensitiveness.†

Directions for making a home-made detector of this character are as follows:—

A suitable baseboard for the instrument is first selected from straight-grained pine, 18 inches long, 6 inches wide, and  $\frac{7}{8}$  inch thick.

Procure the works from an ordinary clock, preferably of the eight-day variety, although those from an ordinary alarm clock will be chosen here for the sake of simplicity. Remove the balance wheel and all unnecessary cogs, screws, etc. To one end of the spindle of the last cog-wheel solder a narrow strip of tin 1 inch long and  $\frac{1}{8}$  inch in width, to

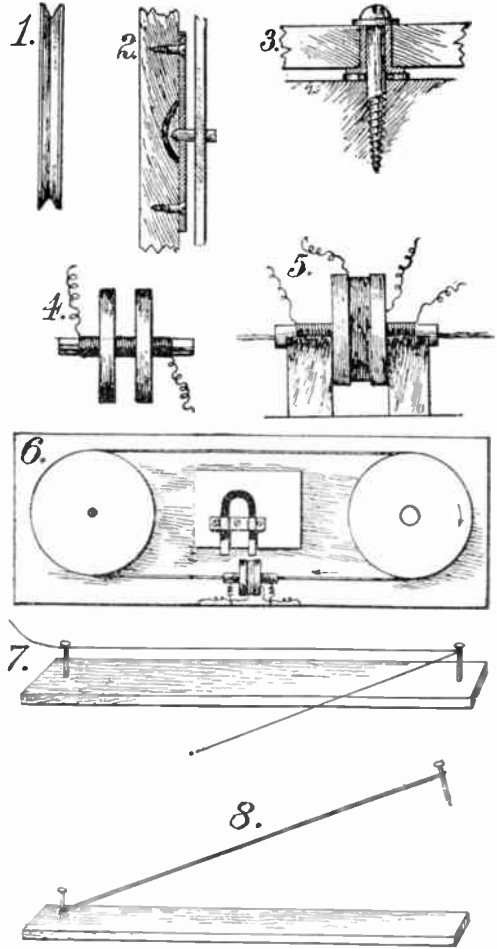

serve as a dog to hold a wind-brake, this to cause the wheels to revolve slowly and quietly. The tin strip should have a small hole punched through the center and placed over the end of the spindle, which projects a trifle from the under frame. A small drop of solder will secure it, after which any form of small cloth or paper vane may be attached by a wire loop or frame. Owing to the difference in construction of various clock-works, it is difficult to specify any shape or position of the brake, but the one shown in Fig. 11 gives the general idea. Cloth over a frame is preferable to paper or cardboard, as it moves silently. Allowance should be made for the movement of the vane, either by cutting away the wood around it, or projecting the vane through a hole in the base, and supporting the whole instrument on a superficial base by means of cleats. The spindle to which the hands are attached

\* See paper by Marconi before Royal Inst. of Great Britain, June 13, 1903, in *ELECTRICIAN*, June 27, 1903, p. 388.

† The recent introduction of the compound of silicon and carbon as a detector of electric waves, and also a modified form of Fleming's rectifier used for the same purpose, renders this statement liable to error.

serves for the driving shaft, and should be soldered to the cog-wheel through which it passes, as ordinarily it is held by the friction of a spring pressing against it.

Two wooden disks, preferably birch, are now cut out, 4 inches in diameter and  $\frac{3}{8}$  inch thick. Upon the periphery of each disk is cut a groove of the shape shown in Fig. 1.

From a piece of heavy sheet brass cut a square 2 x 2 inches and drill a  $\frac{1}{8}$ -inch hole in each corner and one in the center to fit the driving spindle on the clockwork. Place in position on the spindle and fasten with solder, being careful to keep it true. Hollow out the center of one of the wooden disks sufficiently to contain the lump of solder so formed, and fasten it to the brass square by means of small steel screws passed through the hole in each corner (Fig. 2). A small magnetic screw driver will be found very useful for passing the screws into place through the open work of the clock frame.

The clockwork is now mounted on one end of the board, the center of the disk being 3 inches from the edge. Stove bolts passed through open parts in the frame from the bottom of the baseboard and fitted with nuts and washers will be found the best method of doing this. A hole should be bored in the baseboard immediately beneath the winding stem, to allow for the insertion of the key. Next cut a block of soft wood 5 inches square and of a thickness 1-16 inch less than the distance between the top of the baseboard and the under side of the mounted disk. The remaining disk is now fitted with a brass bushing and a 1-inch round-head brass screw selected to fit the hole in the bushing nicely, and passed through it into the block of wood just mentioned, placing a washer beneath the disk and one under the screw head (Fig. 3). Fasten the block to the baseboard in a position so that the distance between centers of the disk shall be 12 inches.

This finishes the framework, and the coils should now be wound and adjusted. Obtain a piece of annealed glass tubing, as thin as possible, 2 inches long and  $\frac{1}{4}$  inch external diameter. Hold the ends in a Bunsen flame just long enough to smooth the rough portions, flaring one end slightly with a small stick of wood. This prevents chafing of the iron rope.

In winding the primary coil over this tube it is a good plan to tie the ends tightly with thread, to prevent slipping. The wire used should be No. 36 silk-covered, and should

measure 10 feet in length. It is wound in a single layer as closely and evenly as possible, leaving 6 inches of the wire at each end for connecting. The coil when wound should occupy a space of  $1\frac{1}{2}$  inches in the center of the tube. Give the whole a good coat of shellac and allow to dry.

Over the coil and tube so formed are slipped two small disks of  $\frac{1}{4}$  inch soft wood  $1\frac{1}{2}$  inches in diameter (Fig. 4). The hole in the center of the disks should be just large enough to fit over the coil tightly, and shellac used to hold them in place. They should occupy a position in the center of the tube, being set  $\frac{3}{8}$  inch apart. When they have become firmly fastened in place the space between them is wound full of No. 36 silk-covered wire, leaving free ends about a foot long for connecting (Fig. 5).

Tube and coils are now placed in position on the baseboard so that the interior of the tube is in line with the grooves on the periphery of the disks, and the coils midway between them (Fig. 6). Support the tube on a pair of blocks, as shown, using a liberal amount of shellac to hold it in place.

Cut out another wooden block 4 inches long, 2 inches wide, and of about the same height as those supporting the tube. Fix this block lengthwise in the center of the baseboard. Procure a small permanent magnet of the horseshoe variety, and mount it on the block in such a position that its north pole will be pointing directly in front of and nearly touching the outside turns of the secondary coil (Fig. 6), while its south pole will be opposite one end of the tube. If the disk on the clockwork revolves from right to left (as it ought), the south pole should be to the left of the center of the tube and coils; if in the opposite direction, to the right. It is immaterial which pole is in front of the secondary coil, as long as the remaining pole is in the proper relation to the direction of the moving band, about to be described. The commercial instrument is fitted with two magnets, like poles adjoining, and facing the center of the secondary coil, but the difference in effectiveness of this arrangement is so slight as to be unnoticeable.

We now come to the last, and if not properly made, the most difficult and exasperating part of the detector, the moving band or rope of iron wire. To the uninitiated this has always been a source of great difficulty and annoyance, and though simplicity itself when made in the following manner, at-

tempts at other methods are almost sure to result in a bungling, tangled mass of stray loops and ends.

The wire of which the band is made is No. 36 silk-covered, iron wire. Select a soft pine board  $\frac{1}{8}$  inch thick, about 3 feet long and 4 inches or 5 inches wide. Drive two nails to a depth of  $\frac{1}{2}$  inch in the board

glass tube, passing it around both pulleys and bringing the ends together between them. The two ends are linked together by threading a separate piece of the iron wire through and through them (Fig. 9), drawing tight after each threading, and connecting the ends of the wire by tying or twisting, as in the case of the band.

This completes the working parts of the detector, and any casing may be fitted to it and finished according to the ideas of the operator.

A good casing is made by fitting the sides and ends with  $\frac{3}{4}$ -inch hard wood strips extending  $\frac{1}{2}$  inch above the surface of the disks. This forms a box with the top open, and a nice looking instrument is made by attaching a glass door by hinges to cover it and protect the working parts from dust and injury (Fig. 10).

The ends of the primary coil are brought to binding posts in the side of the box nearest them, and those of the secondary connected to another pair of binding posts, one on each side of the first two. If desired, a false bottom of pressboard can be fitted beneath the disks, leaving only the coils and tube, magnet, band, and disks visible.

It will be noticed in the case herein cited that the winding stem is situated in the base of the instrument — a great inconvenience that can be remedied only by gears or ratchets; but this is hardly worth while, in view of the great advantage to be gained by using an eight-day clock, which, in addition to its ability for long running, usually has the winding stem on its face. The proper speed of the driving disk is that which will cause the moving band to complete the circuit through the tube in about two minutes.

Aerial and ground are connected to the terminals of the primary coil, and the telephone to those of the secondary. An almost inaudible hissing sound, in the telephone, as the band slowly threads its way through the tube and around the pulleys, shows the detector to be in working order. — *Scientific American*.

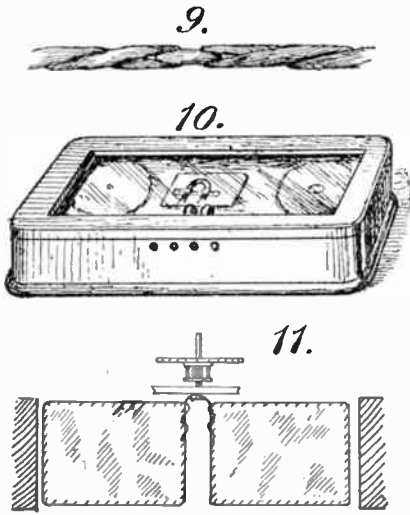

THE CONSTRUCTION OF A MAGNETIC DETECTOR

at a distance apart equaling twice the circumference of the oval formed by the two wooden disks, when measured by a string passed around the grooves. Starting at one nail (Fig. 7), wind the wire from one to the other, always winding in one direction; that is, so as to inclose the two nails in a narrow coil of wire. When the total number of strands equals 100, the ends are connected, and one nail is cautiously withdrawn from the board, keeping the wire still on it, and drawn taut (Fig. 8). Twist the strands into a rope, keeping them taut, and remove the remaining nail from the board. Both nails are now removed from the ends of the band, being careful not to disturb the loops formed by them. Thread the band through the

## CONSTRUCTION OF AN INDEPENDENT INTERRUPTER

ROBERT C. DENNY

THE most common form of current interrupter is ordinarily seen on the end of an induction coil, and is called a vibrator. It serves to interrupt the direct current from

the battery by a series of rapid breaks. The action of this form of interrupter depends entirely upon the magnetism of the core in the coil. Often the welding action

of the current joins the two pieces of platinum so tightly that the magnetic pull is not sufficient to separate them. It is then evident that the iron head of the vibrator not only hinders the vibrator from starting up quickly, but also helps to weld the contacts.

Fig. 1-Plan.

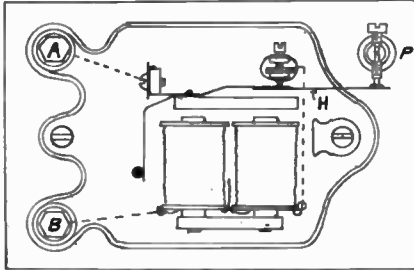

In the case of wireless telegraphy, where the induction coil plays so important a part, it is realized that a regular interruption is required. An operator would get sadly out of patience with an interrupter when, in sending a dot, he would be required to hold the key down a second in order to get the vibrator started. What he wants is a vibrator that is ready to interrupt the current at any given instant, without delay. About the only way to accomplish this end would be to have the interrupter vibrating all the time.

The name independent interrupter would imply that the action of the interrupter did

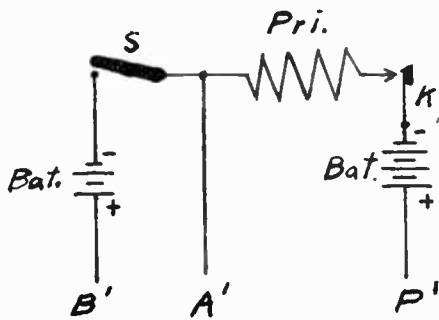

Fig. 2

not depend on the magnetism in the induction coil core. This is indeed correct, for the independent interrupter is an instru-

ment, separate from the induction coil, and in most cases is operated by a separate battery. The following description should be so simple that any amateur could make one of these instruments and put it to a good use.

Figure 1 shows a common form of an instrument known as a buzzer (which can be bought for a small sum at any electrical supply house). It has the cover removed, and is screwed down to a base. It differs from the ordinary buzzer only in that the armature spring is extended and an extra contact point placed at P. The spring H is made of a piece of  $\frac{1}{8}$ -inch spring steel  $\frac{3}{8}$  inch wide and  $1\frac{1}{2}$  inches long. A piece of platinum is first soldered or riveted to the end of it, and it is then soldered to the armature spring, as shown. The post which carries the contact point P is then fastened to the base, and the instrument is complete. A and B are the buzzer binding posts. Figures 2 and 3 show the connections when the interrupter is used with an induction coil. Figure 2

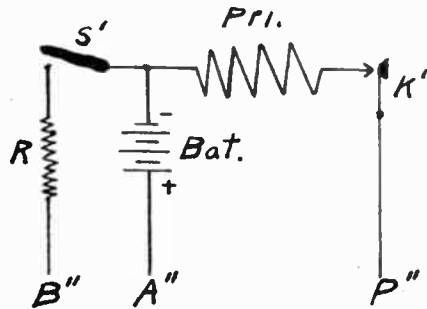

Fig. 3.

shows the connections when a separate battery is employed to run the interrupter. Wires B', A', P' connect with points B, A, and P respectively in Fig. 1. When the same battery is used to run both coil and interrupter, connections shown in Fig. 3 are used. In this case an extraneous resistance, R, is cut in as shown. It should let enough current through to operate the buzzer, B'', A'', and P'', connected with respective points in Fig. 1. Better results are obtained in first case, where a separate battery is used to run the interrupter. The condenser (which, of course, is not done away with) is connected between A and P in Fig. 1.

## AN INDOOR WIRELESS

J. H. FENTRESS

It is a common idea among some amateurs that wireless telegraphy is far too difficult for them to grasp. It is a wrong idea, for any one with a slight knowledge of the subject may, with a small apparatus, do some very clever experimenting indoors.

The transmitter is very simple, and consists of a small induction coil, made in the usual manner. A core consisting of a large number of iron wires is surrounded with glass or other insulated material, and over this is wound a few turns of No. 16 insulated copper wire. The secondary consists of many turns of No. 36 wire, wound over and insulated from the primary. The ends of the secondary are connected to two small brass balls, separated a very short distance from each other. When the current is broken in the primary, a spark occurs at this gap. An automatic break may be used in the primary, or the current may be broken by hand. In both cases, a condenser or Leyden jar should be bridged across the contact points. With such a coil, giving only  $\frac{1}{8}$ -inch spark, the author has obtained waves that could be detected in any part of the house. One side of the

spark gap should be connected to a single short, bare wire, which will serve as the antenna or aerial. The other side should be connected to a gas or water pipe in the same room or near by. This will give a free path to the earth.

The receiver also is very simple. The microphone detector gives very good results. This consists of two carbon plates, sharpened to a knife edge, with a fairly large needle resting on them. One side is connected to the antenna, and the other side should be grounded, as with the transmitter. In shunt with the detector is a battery and a telephone receiver. A rheostat should be used to regulate the current.

This comprises the apparatus. The transmitter may be in one room and the receiver in another, but a small spark at the transmitter will give out waves that will traverse the needle, causing it to cohere for an instant with the carbon, and thereby producing a click in the telephone receiver.

In this way messages may be sent all over the house, and the amateur will find this a good starting-point, if he wishes to learn something about wireless.

## THE CONSTRUCTION OF A 4-INCH SPARK COIL

B. A. HUNT

THE materials and tools required are simple and few in number. The ordinary light wood and metal working tools possessed by the average amateur should suffice to turn out a well-finished and efficient coil. The aid of a lathe will greatly facilitate the construction, but it is by no means indispensable. It would be well for the amateur to read up the theory of the induction coil in a good electrical text-book if he does not already thoroughly understand it.

The secret of building a good coil with the minimum amount of secondary wire is to have it most thoroughly insulated and well arranged with regard to its primary winding. The best method of insulating the wire is rather a tedious one, but it will well repay by results for the time and care spent upon it. The following method of construction was adopted by the writer, and the finished coil gave results equal to, if not better than a coil by one of the standard

makers, and at a cost of materials of about \$25.

The first thing to do will be to obtain all the materials. Several firms advertising in this paper will supply the amateur's needs capitally. The most expensive item will be the secondary wire: obtain  $4\frac{1}{2}$  pounds s.c.c. wire, No. 36 gauge; this is about \$4 per pound (silk insulation is unnecessary); for the primary, 1 pound No. 14 D.C.C. wire, at 80 cents per pound; 1 pound thin tinfoil, at 75 cents per pound; one piece of ebonite tube,  $8\frac{3}{4}$  inches long by  $1\frac{1}{8}$  inches diameter outside and  $\frac{1}{8}$  inch thick, 50 cents; two pieces of  $\frac{1}{2}$ -inch sheet ebonite,  $4\frac{1}{2} \times 4\frac{5}{8}$  inches, at 60 cents;  $\frac{3}{4}$  pound No. 22 soft iron wire, 25 cents;  $1\frac{1}{2}$  quires white filter paper (obtain at chemical warehouse), 50 cents;  $\frac{3}{8}$  inch of No. 16 platinum wire, at \$2; two large galvanometer terminals, two small ditto, at 10 cents each; a few square inches of  $\frac{3}{16}$ -inch sheet brass, 15 cents; 4 inches of  $\frac{1}{2}$ -inch width



clock spring; one long contact screw (and, if possible, a lock nut), one piece of soft iron rod,  $\frac{5}{8}$  inch diameter and 1 inch long; four  $\frac{3}{16}$ -inch metal screws,  $1\frac{1}{2}$  inches long; two  $\frac{1}{8}$ -inch metal screws,  $\frac{1}{2}$  inch long; two  $\frac{3}{16}$ -inch screws (brass),  $\frac{3}{4}$  inch long; two dozen assorted wood screws,  $\frac{3}{8}$  inch to  $\frac{3}{4}$  inch long, about 50 cents the lot; a few square feet of  $\frac{3}{8}$ -inch baywood, or good pine, for the base, 50 cents; 2 pounds paraffin wax, about 15 cents per pound; solder, resin, and shellac varnish. These quantities are a liberal allowance for a coil this size, and are intended only as a guide for the amateur.

sketched. This can be done in the lathe or by means of a fret saw, finishing off true with a half round file. Two holes must now be drilled in the lower edges and tapped for a  $\frac{3}{16}$ -inch screw; also one hole in the top edge for the terminals of secondary wire.

THE INSULATING TUBE (Fig. 3) must be obtained, cut to size, straight and circular; be very careful that no minute holes perforate the walls. This would cause a speedy breakdown of the coil. If an ebonite tube cannot be obtained, make one by wrapping thin "paper" ebonite round a mandrel, cementing each layer with shellac varnish.

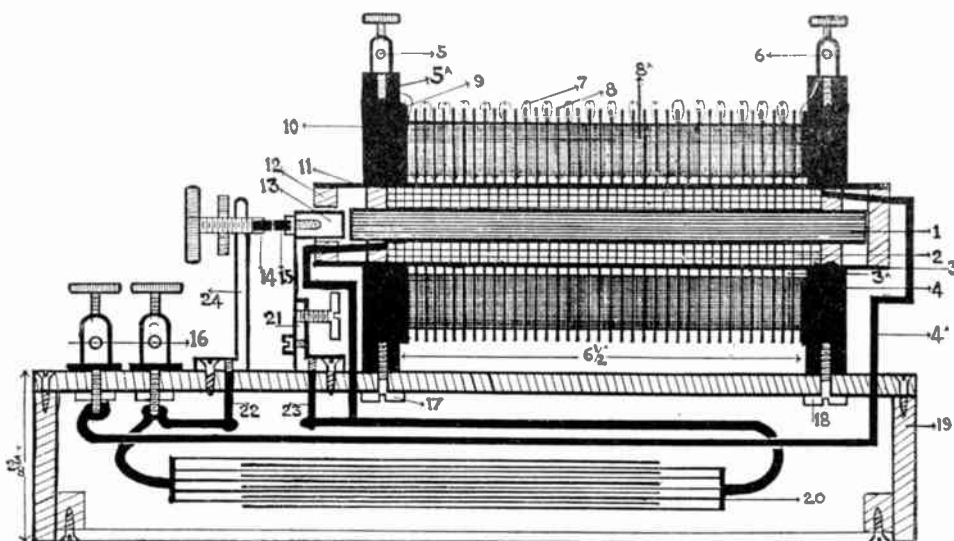

LONGITUDINAL SECTION OF A 4-INCH SPARK COIL.

#### MAKING THE PARTS

FIRST, THE BASEBOARD (Fig. 19). — This is in the form of a shallow box,  $12\frac{1}{2} \times 7\frac{3}{4} \times 2\frac{3}{8}$  inches deep. It will be a fairly simple piece of work; the joints being either screwed or dovetailed together, according to the skill of the worker. The main thing is to make it strong and square. Smooth up the sides and top well, so that it can be varnished. It will be seen from the sketch that the underside is covered in by a thin, well-fitting board. This is fixed by screws to fillets glued into the corner of the box.

THE COIL ENDS (Figs. 4 and 10). — The best possible material for these is ebonite, although paraffined teak would make a good substitute. These must be nicely filed up to size, and the edges and surfaces finished off with fine emery cloth and oil. Then bore a  $1\frac{1}{8}$ -inch hole (a good fit for ebonite tube) a little above the center, as

THE SOFT IRON WIRE CORE (Fig. 1). — Cut the hank of 22 iron wire into 8-inch lengths; straighten and make into a neat round bundle  $\frac{7}{8}$  inch in diameter. Next pour some shellac varnish down between the wires and dry in the oven. Two wood flanges must now be made (Fig. 11) so as to fit the core tight at the ends and slip easily into the ebonite tube. Fix on tight so as to leave a space of 7 inches between them. A layer of paper should now be cemented round the core, and three layers of No. 14 D.C.C. wire wound in the space. Two small holes will require to be drilled, one at each end, 12 inches of the wire being passed through the hole close to the core from the inside; the end of the third layer is brought out through the hole drilled in the edge of the opposite flange. Keep the winding as close and tight as possible, and finally give it a coat of shellac varnish.

**THE SECONDARY SECTIONS** (Fig. 8). — A section winder will be required for making these. This will be understood by looking at the sketch. It consists of two disks of hard wood  $3\frac{1}{2}$  inches diameter, separated an  $\frac{1}{8}$  inch by a disk of metal  $1\frac{1}{8}$  inches diameter. The three are fixed upon a screw spindle and clamped together by nuts. This has now to be mounted in uprights secured to a wood base. A small handle is bent or attached to the end of the spindle. This being made, the bobbins of No. 36 wire must be well saturated with hot paraffin. This will best be done by obtaining a metal vessel deep enough to hold the bobbin. Melt the paraffin carefully in it (avoid overheating it), and then immerse the bobbin in it till no more air-bubbles are driven out; the bobbin may then be hung up to drain. Now fix the winder securely to the table and fix a stout wire horizontally and about 2 feet above the table. On this the bobbin is placed, and a Bunsen burner fixed underneath; the hot air rising from it will render the paraffin on the wire soft. Secure a turn of wire around the center disk of the winder, and proceed to carefully wind till the space is full. Then cut the wire and remove the inner disk of the winder; the wire section will readily come away from the disk, this being tapered for the purpose. The wax will reset on the turns of wire and hold them quite firm. Forty sections must be made, and it would be advisable to test them for continuity with battery and galvanometer before mounting.

**THE INSULATING DISKS** (Fig. 8). — These are to be made from filter paper, and soaked in paraffin wax. For melting the wax obtain a shallow baking tin, which should not be less than 11 x 7 inches. As the condenser sheets will also require paraffining, make a true cardboard gauge 4 inches diameter by  $1\frac{1}{8}$ -inch hole in center; place this over a number of the sheets together, and cut through with a sharp penknife. About ninety disks will be required. Next have the paraffin nicely melted, and soak the disks in it; take them out, one at a time, allow to set for an instant, and then place them on a clean sheet of paper to cool. It is important that no dust or metallic particles adhere to the surfaces.

**THE CONDENSER** (Fig. 20) consists of sixty sheets of paraffined paper, interleaved with tinfoil. Cut the papers 10 x  $6\frac{1}{2}$  inches, and paraffin them as before. The foil sheets must be cut to size (8 x 5 inches), with a connecting lug, as sketched. This is best

done by first cutting the sheet  $\frac{1}{2}$  inch longer and slitting it across to within 1 inch of the edge, then simply bend back the lug thus formed. Proceed to build up the condenser by first cutting two pieces of cardboard 10 x  $6\frac{1}{2}$  inches. Lay one flat on a level table; on top place a sheet of paraffined paper; next place a foil sheet symmetrical with it, with its lug projecting over the edge; over this a paper sheet, next a foil sheet, with its lug at the opposite lower corner, and so on alternately, till the full number are built up. Fasten the lugs on each side firmly together. The other cardboard sheet is now to be placed on top. Heavily weight it for some hours, and afterwards tie firmly together with tape.

**THE CONTACT BREAKER OR INTERRUPTER** (Figs. 21 and 24). — The construction of this part will be readily understood from the sketch. The soft iron armature is made from a piece of  $\frac{3}{8}$ -inch round iron, 1 inch long. This is drilled and tapped and secured to the spring, this being rigidly attached to a brass angle plate. A screw passes through so as to press against the spring and increase the tension if necessary. The head of the armature screw must be filed down, and a small hole drilled in its center to allow a small piece of No. 16 platinum wire being driven in tight. The contact screw end must be tipped in the same manner. This screw is supported by a long angle-piece, into which it screws nicely. A lock nut should be added to the screw, or else a slot cut through into the hole, so that the sides can be closed up on to the screw to keep it firm. Holes for small wood screws are drilled, as shown, into the bases of the plates; also a third hole, to allow of a connecting-pin being screwed or soldered in.

**THE COMMUTATOR, OR REVERSER**, is not really necessary, but is a useful addition to the coil. The form illustrated is as good as any. It consists of a short cylinder of ebonite or hard wood (E), through the center of which passes a brass pin (F). This is really in two parts, so as to be insulated from each other. Two contact plates are screwed to opposite sides of the cylinders, and one put into contact with each of the pins by a screw passing through. The cylinder is supported by two angle-pieces (A and B) and two brass springs (C and D), arranged to press against the contact plates. An ebonite or brass handle is attached to the spindle. Plates A and B join the terminals, and the springs C and D are attached —

one to the free end of the primary coil and the other to the contact screw. It will readily be seen that the springs C and D can be put into contact with either poles of the battery, at will, by simply turning the cylinder round.

**FITTING THE PARTS TOGETHER.**—The most important detail is to build up the secondary. For this a small vessel of melted paraffin, soldering iron, solder, resin, and a warm laundry iron will be required. Have all the disks and sections at hand, and fix the ebonite tube into one of its flanges, so as to pass through  $\frac{3}{4}$  inch, and stand it up vertical. Slip three or four paper disks over the tube and flat against the flange; then fix a section in position, withdraw inner end of the wire and arrange it concentric with the tube. The space (Fig. 3A) must be filled up solid with melted paraffin. When set, place two insulating disks on top (the wire being brought up through them); then smooth them down with the warm iron. The sections must be connected—two insides together, then two outsides, then insides, and so on. Be most careful to get the proper face down, otherwise some of the sections will be opposing each other. The proper way is shown on diagram. The joints will require to be soldered, the inner joint being neatly tucked in the space between section and tube. The outer joint (Fig. 7) is brought over the top of disks, and then slipped in between them. When all the sections are in place, bring the inner end of the last one up between three or four insulating disks, and place on the other coil flange. Any space between it and the last sections, when the tube is projecting through equally on each side, should be filled in with more paraffined disks. Two small holes are now to be drilled slantwise up through the flange to the terminals 5 and 6, and the secondary wires passed through and joined to them.

The position of the fastening down holes on the base is now to be found, and the holes drilled to allow the screws to pass through into the holes in the flanges (Figs. 17 and 18). The primary is now slipped into the tube, and two tight fitting end pieces of wood (Fig. 12) made to fit the tube. One must have a  $\frac{3}{4}$ -inch hole drilled through its center (Fig. 12), and both will require small holes drilling to pass the primary wires through. These are then taken through holes in the baseboard. The contact breaker should now be fixed in position, as shown on the diagram,

and the end of the wire nearest soldered to the brass pin in the armature support. The contact screw is taken direct to one of the large terminals (Fig. 16), the other terminal making contact to the free end of the primary (Fig. 4A). The lugs of the condenser are put in contact, one to each (contact pillar and spring). Make a good connection to foil lugs by wrapping some No. 24 tinned copper wire tightly round them and making a soldered connection to each of the pins 22 and 23. The condenser can be wedged in place with a few strips of wood and the wood base cover screwed on, when all is secured inside.

The covering for the secondary consists best of "paper" ebonite, cut to a good fit between the flanges and made to overlap about 1 inch. The lap is cemented with strong shellac varnish, a few turns of string keeping it in place till set. An excellent substitute for ebonite is paraffined cartridge paper, fixed in the same way, afterwards varnished black. The coil can now be tested. Arrange the armature to be about  $\frac{3}{8}$ -inch from the bore, and adjust the contact screw, so that when the armature touches the core the circuit is broken  $\frac{1}{2}$  inch. Next fix a short piece of wire in each secondary terminal, so that they stand 4 inches apart. On connecting three large bichromate cells in series on to the primary terminals, the interrupter should vibrate and produce a torrent of sparks between secondary terminals. If the full length of spark is not obtained right off, try putting more or less tension on the armature spring till successful. No difficulty should occur in obtaining a full  $4\frac{1}{2}$ -inch spark if the directions are closely followed. If storage batteries are used to work the coil place a small resistance in series, otherwise the platinum contacts will burn away quickly, due to the heavy current on short circuiting at the contacts; also be careful not to overwork the coil with too many cells.

The appearance of the coil will be greatly improved by finishing off the brass work, such as the contact breaker, commutator, and terminals, to as high a polish as possible; then lacquer the parts with silico enamel or cold white lacquer. The commutator, if used, is best placed in the position shown on the baseboard plan.

A word of warning should also be given, against using the coil on high voltage circuits with the electrolytic interrupter. The insulator is almost certain to be broken down



## MECHANICAL DRAWING

W. C. TERRY

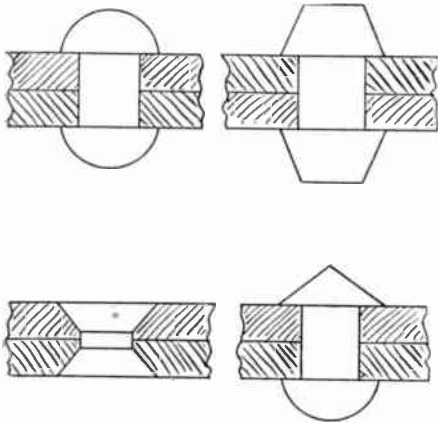

Fig. 1

**MACHINE ELEMENTS.** — We will continue machine fastenings with riveted joints as shown in Fig. 1. Riveted joints are generally represented by two views; a general plan showing the lap or butt joint with plate with the figures for spacing rivets, and a sectional view showing thickness of metal, size and shape of head of rivets. Riveted joints can be grouped into three classes: Government work on warships, boilers, and general structural work.

**RATCHETS.** — Figure 2 represents a ratchet, which, in combination with a pawl, allows revolution in one direction only.

To lay out the teeth; draw circles for the outside diameter and the diameter at the bottom of the teeth or notches. Space the teeth on outside circle, and draw radial lines from the common center, and connecting the circles drawn.

**GEARING.** — Motion may be transmitted between lines of shafting by means of friction surfaces; and if there be no slipping of the contact surfaces, the circumference of the one will have the same velocity as the circumference of the other. The number of revolutions of the shafts will be inversely proportional to the diameter of the friction surfaces, and this ratio will be maintained constant under the condition of no slip. In order to transmit force, as well as motion, and to insure its being positive, it will be necessary to place cogs, or elevations, on one of the friction surfaces, and make suitable depressions in the other surface. If the shafts are parallel, the friction surfaces

would be cylinders, and the gears designed to produce the same condition as to the velocity are called "spur gears."

If the shafts intersect, the friction surfaces would be cones and the gears called "bevel gears."

**CIRCULAR PITCH.** — The distance measured on the pitch line between corresponding points of consecutive teeth is called the "circular pitch," and is equal to the circumference of the pitch circle, divided by number of teeth.

**DIAMETRICAL PITCH.** — In order to express in a more direct and simple manner the ratio between the diameter of the pitch circle and the number of teeth, and to easily determine the proportions of the teeth, it has been found expedient to apply the term "pitch" or "diametrical pitch" to designate the ratio between the number of teeth and the diameter of pitch circle. This is a ratio, and means so many teeth per inch of diameter.

*Illustration.* — A pinion has 12 teeth and is 4 inches diameter. Pitch is 3.

Figure 3 shows the various parts of gear teeth. The illustration represents a pinion meshing with a rack.

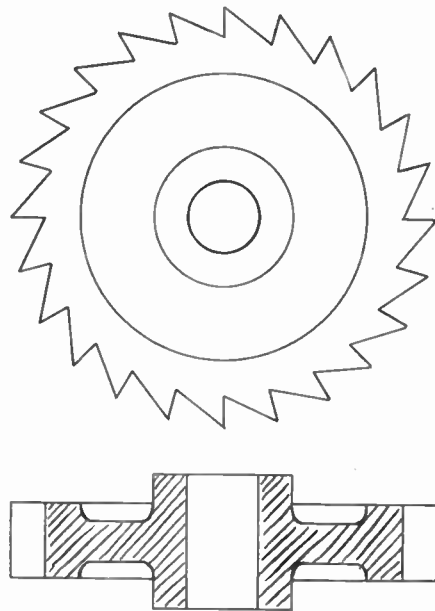

Fig. 2

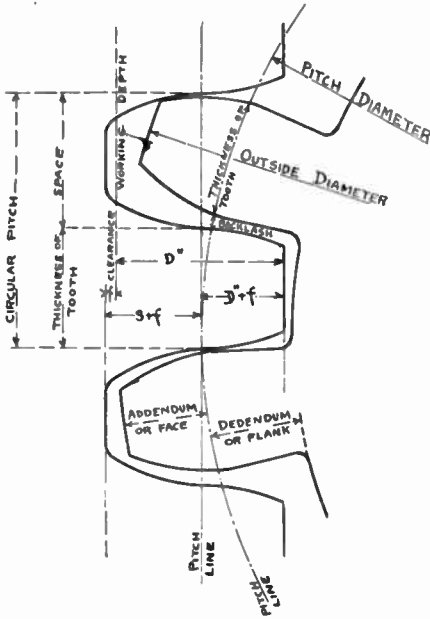

Fig. 3

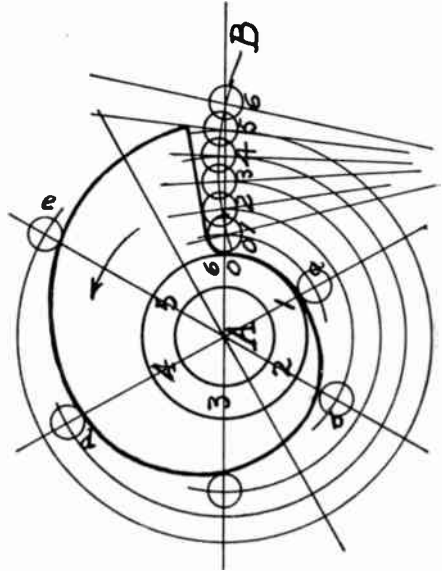

Fig. 5

The various parts of bevel gears are given in Fig. 4 at A.

In laying out bevel gears, first decide upon the pitch and draw the center lines BB and CC (see B, Fig. 4), intersecting at right angles at A. Then draw the lines DD to EE the same distance each side of BB and

parallel to it; the distance from DD to EE being as many eighths of an inch—if it be 8 pitch—as there are to be teeth in the gear. In the example the number of teeth is 24; therefore the distance from DD to EE will be  $24 \div 8$ , or  $1\frac{1}{2}$  inches each side of BB. KK and LL are similarly drawn, but there being

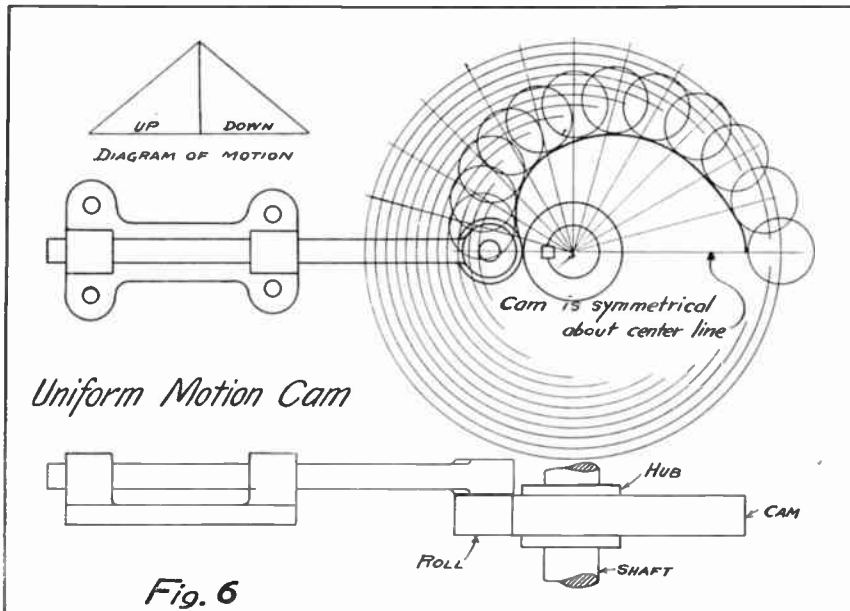

Fig. 6



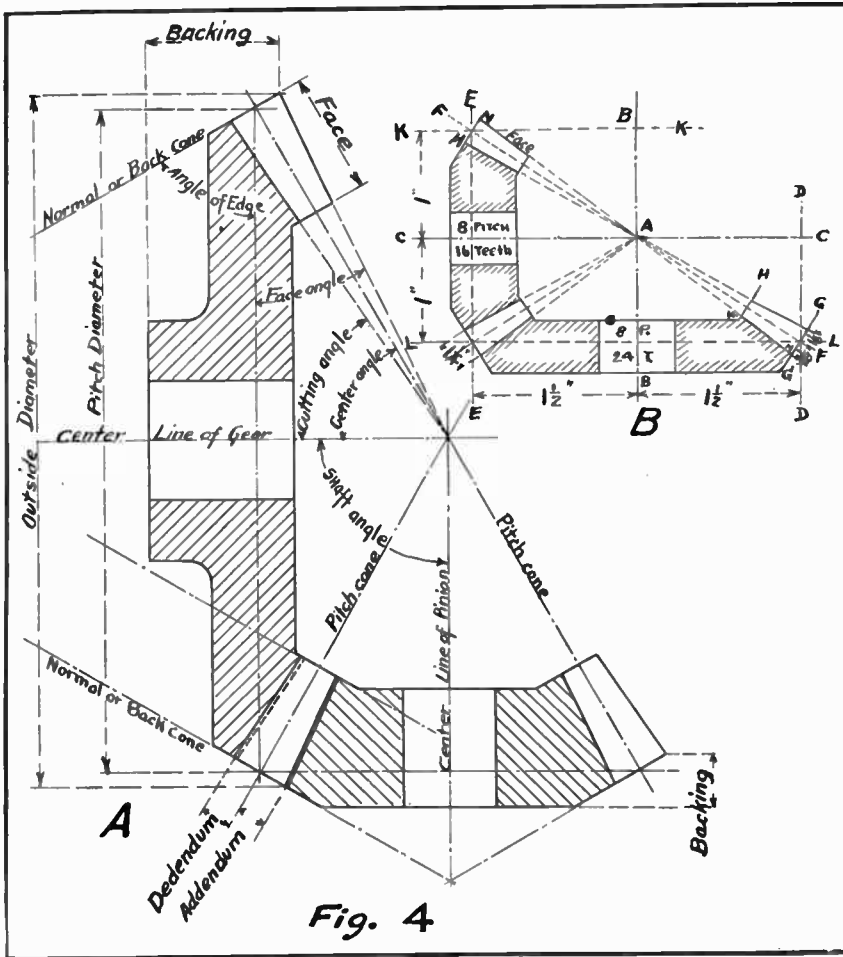

Fig. 4

only 16 teeth in the small gear, the distance from KK to LL will be 16-8, or 1 inch each side of CC. Then through the intersection of DD and LL, EE and LL, and EE and KK draw the diagonals FA. These are the pitch lines. Through the same point draw lines as GG at right angles to the pitch lines, forming the backs of teeth. On these lines lay off  $\frac{1}{8}$  inch each side of the pitch lines, and draw MA and NA, forming the faces and bottoms of the teeth. The lines HH are drawn parallel to GG, the distance between them being the width of the face. The face of the larger gear should be turned to the lines MA and the small gear to NA. For other pitches the same rules apply. If 4 pitch, use 4ths instead of 8ths; if 3 pitch, 3ds, and so on.

Bevel gears should always be turned to the diameters and angles of the drawings.

**CAMS.** — Cams are used to obtain various motions and changes of motions in automatic and semi-automatic machinery.

**CAM OF COMPLETE REVOLUTION.** — Let A (Fig. 5) be the center of motion of a cam and let the arc B be the path of the center of the follower or roller.

Suppose the cam lever to be keyed to a pinion shaft. The pinion gear runs in a rack attached to a sleeve in which a drill spindle revolves. The feed of the drill is to be uniform. The cam is to revolve uniformly at the rate of one revolution in 36 seconds. Each number on the arc B shows the required position of the center of the roller at the end of each 6 seconds.

Describe a circle passing through the center of the roller in its first position.

Draw six equidistant radii, the first radius passing through the center of the roller in its

first position. Describe circles through the center of the roller in its several positions, 0, 1, 2, 3, etc.; the circle, through the center of the roller in this first position, cuts the radius,  $A_1$ , in the point, a; the circle, through the center of the roller in its second position, cuts the radius,  $A_2$ , in the point, b; in like manner, c, d, and e are found.

Through these points as centers, describe circles of a diameter equal to the diameter of the roller; draw the curve, as shown, tangent to these circles; the resulting curve is the out-

line of the required cam. The curve is also drawn tangent to the roller in its sixth position, but the cam is cut away, as shown in order to let the roller return quickly but easily to its first position. The interval of rest, indicated by the coincidence of the numbers, 0 and 1, is obtained by means of the circular arc included between the radii.  $A_0$  or 6 and  $A_1$ . The arrow-head, in the figure, shows the direction of rotation.

Figure 6 represents a cam of uniform motion.

## MISSION FURNITURE CONSTRUCTION

### III.—HALL UTILITY SEAT

WILL B. HUNT, 2D

Rubbers here, umbrellas there,  
Hats and coats in every chair.

THIS state of things need not be when one can so easily make a coat tree at home. The Mission design this month is a combination coat rack, umbrella stand, and overshoe repository. It will be found useful, taking comparatively little space, and saving much clutter around the house.

This article of furniture is made from cypress, and requires 78 running feet. It comes in widths from 12 to 18 inches. Instructions are given on 12-inch basis. This width requires considerable joining and glueing, but is given thus for the benefit of those using the 12-inch width.

After sawing boards for No. 1, plane edges, join, and glue. Cut Nos. 2 and 3, and treat in the same way; also Nos. 4 and 5. When the glued parts have remained clamped for 24 hours, to fully set, fasten Nos. 2 and 3 to No. 1, as shown in plans (Fig. 1). Place No. 5 in proper position; put in place No. 8, which is the partition between the umbrella and overshoe compartments. No. 8 is shown in Fig. 2 in its proper place. No. 4, being the cover, may be put on with brass hinges, and the back of this cover rests on cleats, as shown in Nos. 1, 2, and 8, and on top of No. 5.

Put in place Nos. 6 and 7, one end resting on No. 8, the other fastened by screws to outside of No. 3. Put in the bottom. Use brass screws, round headed, indicated on plans by black dots. Coat hooks may be of brass or otherwise to suit builder.

Stain any desired shade, being careful not to stain the screws, which should be kept polished.

### Flemish Oak Effect

WHAT is known as Flemish oak is more properly a black oak, for it is done with black all through. The method is to dissolve  $\frac{1}{2}$  pound of bichromate of potash in 1 gallon of water; apply this, when it has been strained, and, when it is perfectly dry, sandpaper with fine paper down smooth. Now mix up some Japan drop black with turpentine to a thin liquid, and apply one coat. In a few minutes you may wipe off clean, coat with grain alcohol shellac, and sandpaper with fine paper. The wax finish is made from beeswax, 1 pound to the gallon of turpentine, adding 4 ounces of the best drop black. Wipe off clean with cheesecloth.

### White Oak Leads Hard Woods

WHITE oak is the most widely distributed and commercially important tree of the hardwood variety in the United States. Its annual product of over 2,000,000,000 feet of lumber is more than double that of any other hardwood. The wood is compact and close grained, hard, tough, strong, heavy, and durable in contact with the soil. It is the favorite timber for railway ties, and of the 90,000,000 ties purchased each year nearly one half are oak. Its other uses are for car stock, boards, planking, beams, dimension stuff of all sizes, ship building, tool handles, wagon spokes, and furniture.

To hire a cheap man is no sign you are going to get your work done at small expense. Cheap men, like cheap machines, frequently produce more trouble than profit.

# MISSION - FURNITURE

Plans and Text by Will B. Hunt 2nd

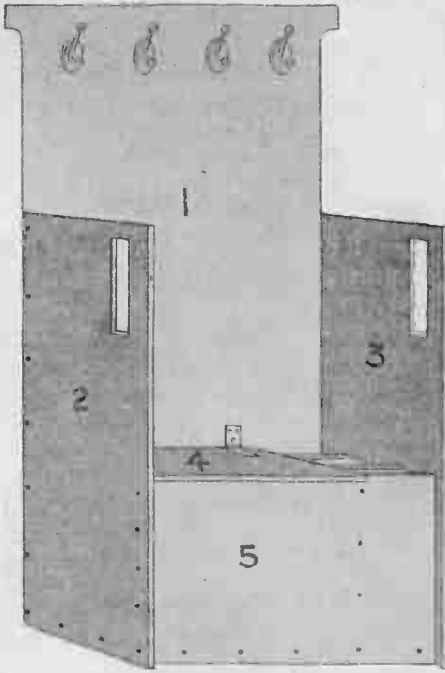
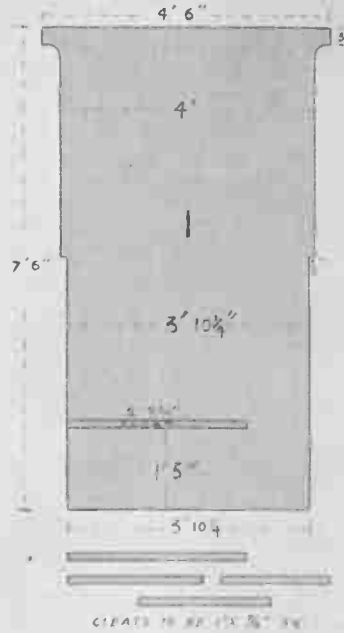

FIG 1



CLEARANCE TO BE 1/2" TO 3/4" IN

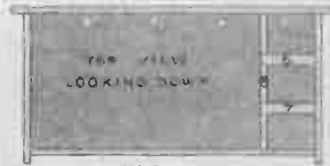
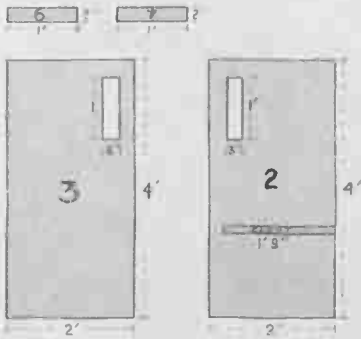
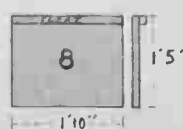
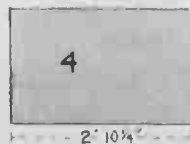
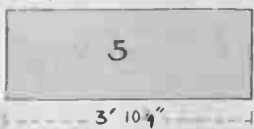
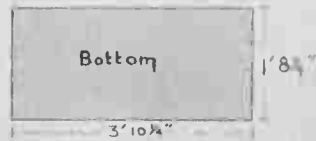

FIG 2



## HOW TO BUILD A SIXTEEN-FOOT LAUNCH

## V.—INSIDE FITTINGS AND FINISHING

CARL H. CLARK

THE first step in the inside work will be the laying of the floor. The upper surface of the floor is 3 inches below the L.W.L., and parallel with it. The floor is  $\frac{3}{4}$  inch thick, of spruce, laid in narrow boards, about 3 inches wide. The beams for the floor are  $\frac{3}{4}$  inch thick and 2 inches deep, fastened across the boat alongside of each frame, and supported by a brace near the middle. The brace must be at least 2 inches away from the middle, to clear the engine shaft. The exact point to which the floor will extend forward cannot be fixed here, as it will vary somewhat, according to the engine dimensions. The floor boards are fastened to the beams with galvanized nails, except two or three boards near the middle of the boat, which are left loose for the present. The boards at the outside are neatly fitted around the frames, and if desired, a piece of quarter round moulding may be fitted in the corner. Across the front edge of the floor, just aft of the engine, a half round or other form of moulding is run.

At this point it will be well to add the finishing touches to the outside, which has been left rough planed. The entire hull should be gone over with a smoothing plane, set fine, so as to smooth and yet remove as little stock as possible. It should be planed until the entire surface is fair and smooth, with no projecting ridges at the plank edges. The deck also should be planed in the same way.

The hull should now be calked with cotton calking. This is special cotton made for this purpose, and can be purchased at any yacht supplies store, together with a "calking iron," which is necessary for its insertion. In use, a thread of cotton is driven into the seam by the calking iron, which is tapped lightly with a hammer. The seam should be painted and enough cotton inserted to fairly well fill it. The strand of cotton should be chosen of such a size that it can be looped, and the loops then driven into the seam, as this method holds better than a single large strand driven in straight. The calking should not be driven in too tightly, as it must be remembered that the planks will swell when put into the water, and some freedom must be allowed or they may warp and become uneven. In

case that the special calking cotton cannot be obtained, a cotton may be purchased at a dry-goods store, which is very soft and may be rolled into strands and used for the same purpose. If the seams are small, a putty knife may be used to drive it in.

The entire surface of hull and deck is now given a thorough sandpapering, first with coarse and then fine sandpaper, until it is well smoothed. The outside should be given a priming coat of paint. If the deck is to be finished bright, as is best, it and the washboard should be given a priming coat of white shellac. All seams are now to be filled with putty, except those below the water line, which are best filled with elastic cement.

Figures 11 and 12 show a good arrangement of seats, although any other may be adopted, according to the desire of the builder. If the above is used, the seats should be about 14 inches wide, extending across the boat, and supported at the ends on cleats screwed to the inside of the frames. At the middle they should be supported on turned ornamental posts, as shown. The stock for the seats should be  $\frac{3}{4}$  inch; if a nice piece of work is desired, mahogany may be used for both seat and back. The back should be of good height, to support the body; if the edge is on the same level as the coaming, it will be about right. The top edge should be given an upward curve. They may be fastened to the seats with hinges, but it is better to have them entirely removable and held in place by chock pieces on the seats and on the inside of the coaming. This arrangement of seats will be found to be very comfortable, with the sloping backs, much more so than the old fore-and-aft arrangement. If more seats are desired, two or more camp stools may be used. If desired, lockers may be fitted under the seats; a couple of drawers under the forward one will be convenient for storing tools and supplies.

The hood or cover over the engine is made light and easily removable. It serves to shield the engine from rain or spray, but may yet be easily removed to get at the engine. A light frame is made, of the proper shape to cover the end of the standing room; it should have considerable crown to the

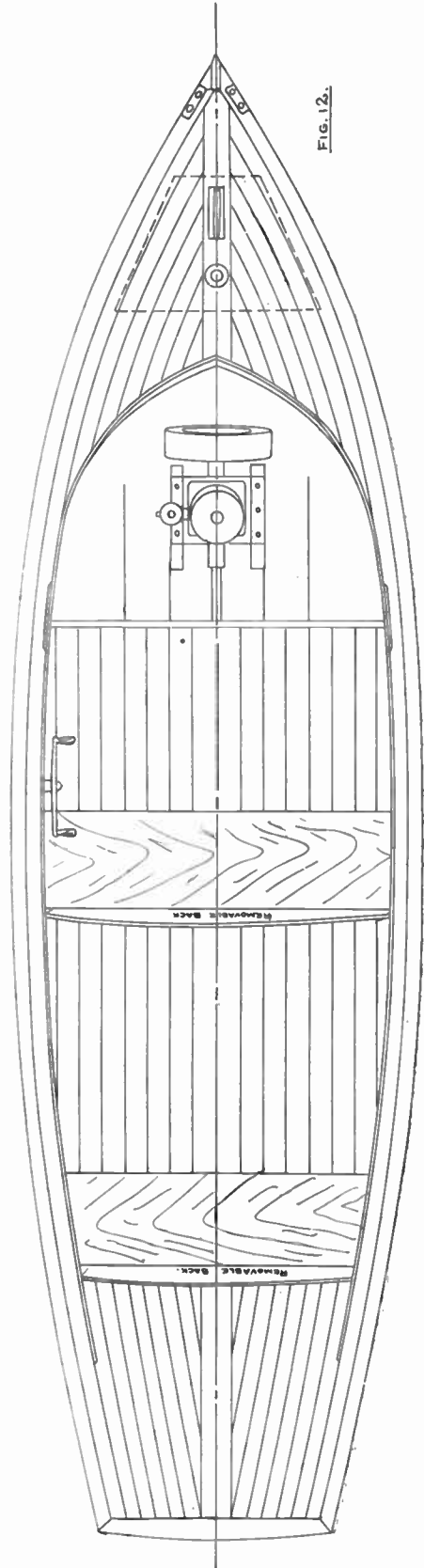
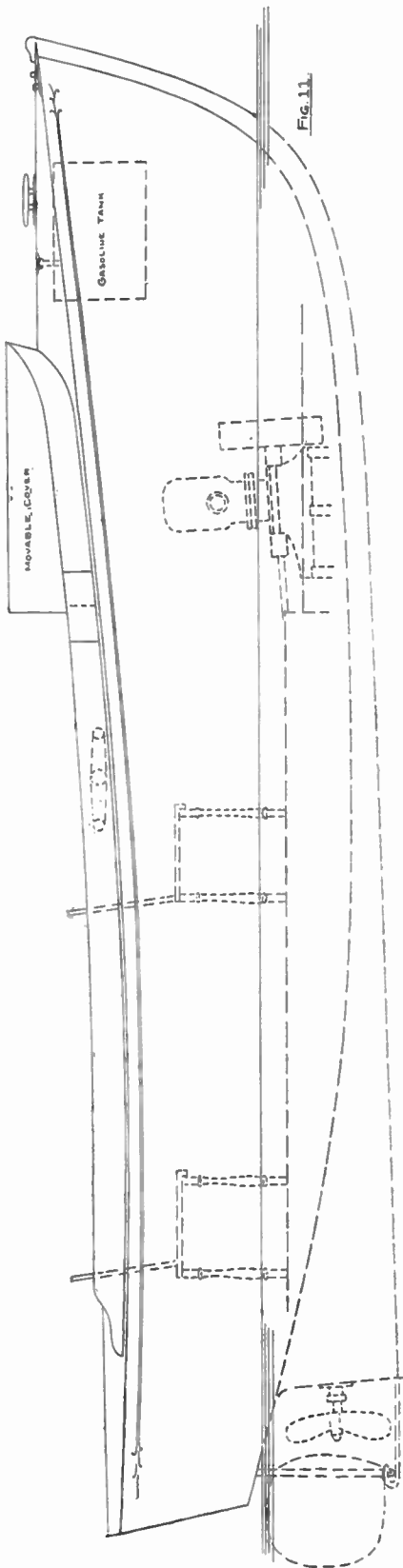

beams, so as to match well with the curvature of the fore deck. This frame may then be covered with  $\frac{3}{8}$ -inch sheathing, or even heavy waterproof canvas will answer well for the purpose. Hooks or latches must be provided to fasten it in place.

It may be well to fit a pair of rowlock sockets on the washboard for use with oars, in case of emergency, but in a small boat, such as this, canoe paddles can be used effectively, and are much easier to stow.

The face of the stem is covered with a brass half round stern band, fastened on with brass screws. The band should be carried up over the curve at the top of the stern to protect the end grain.

The rudder and skeg are made as shown in Fig. 8. The rudder post is made from a piece of  $\frac{3}{4}$ -inch iron pipe, long enough to extend above the upper end of the piece of pipe already in place. The lower end has a solid end welded in, with a  $\frac{1}{4}$ -inch hole for a split pin. The upper end is squared to fit the tiller, or hole may be drilled through both pipe and tiller and a pin driven through. Three or four  $\frac{1}{2}$ -inch holes are drilled through for rivets to fasten the blade in place. The tiller is forged from a piece of iron, and is about 12 inches long, with an eye at the end to take the wheel ropes. The blade is made from  $\frac{3}{4}$ -inch oak, made up of narrow pieces running parallel with the post; the pieces should be about 3 inches wide, and are bored with holes to match those in the post. The whole is then fastened together with long  $\frac{1}{8}$ -inch iron rods, riveted over washers. The edges are nicely rounded and smoothed. The skeg is made from a piece of  $\frac{3}{8}$  x  $1\frac{1}{2}$  inch flat bar; the outer end is turned up and over, as shown, and a hole drilled in the turned part to fit the end of the rudder post. A space of about an inch should be allowed between the bend and the straight part. The skeg is fastened to the bottom of the keel with  $\frac{3}{8}$ -inch lag screws. If the boat is intended for use in salt water, both skeg and rudder post should be galvanized.

For steering, the two-handled crank, as shown, is the best, although a wheel may be used. It should be located convenient to the forward seat, with the tiller ropes leading along under the deck. A pulley placed opposite the end of the tiller on each side will lead them out to the tiller. In a small boat like this, it is sometimes desirable to run the tiller rope in pulleys all the way around the standing room; the boat may then be controlled from any point by grasping the rope.

A pair of chocks should be fitted at the bow, and a large cleat is to be fastened to the king plank to take the mooring rope. A similar cleat on the after deck is handy for use in towing or for mooring alongside a float. A pair of flagpole sockets should also be fitted, one each at bow and stern.

There are many fittings, which the experience or wishes of the builder may suggest as the work goes on, which may be added to suit the individual tastes.

The bright work should all be given three coats of the best spar varnish and the painted work three coats of paint. The part below the water line should have two coats of anti-fouling paint.

The boat is now ready for the fitting of the engine.

### Electricity in a Modern Hotel

THE Hotel Astor in New York is equipped with nearly every new and useful electrical invention. In addition to the new system of telephones, of which the switchboard is a complete central office, equipped with over one thousand small incandescent lamps, serving as operator's signals which blink in more than seven thousand calls daily, are twenty telautograph stations. The telautograph is a machine by means of which the reproduction of any written message can be transferred to the paper on the other end of the line from the sender in the exact likeness of the original handwriting. There is also an arrangement by which the guests in their rooms receive a signal the moment the clerk in the lobby of the hotel drops a letter into their mail box.

ONE of the best ways to make a glue brush is to wet the end of a strip of bass-wood bark, then pound it until the fibers separate. Such a brush is as soft as camel's hair, wears longer than the best bristle, and if a fiber does come off in a joint, it is so fine and soft that it does no harm.

A NORWEGIAN firm has patented a process of manufacturing colored woods. Whole stems of green trees are colored, the sap being pressed out of the stem by force, and the dye injected in its place. It is claimed that wood treated by this process is much more durable than ordinary wood, and will not warp.

## A RACE AROUND THE WORLD

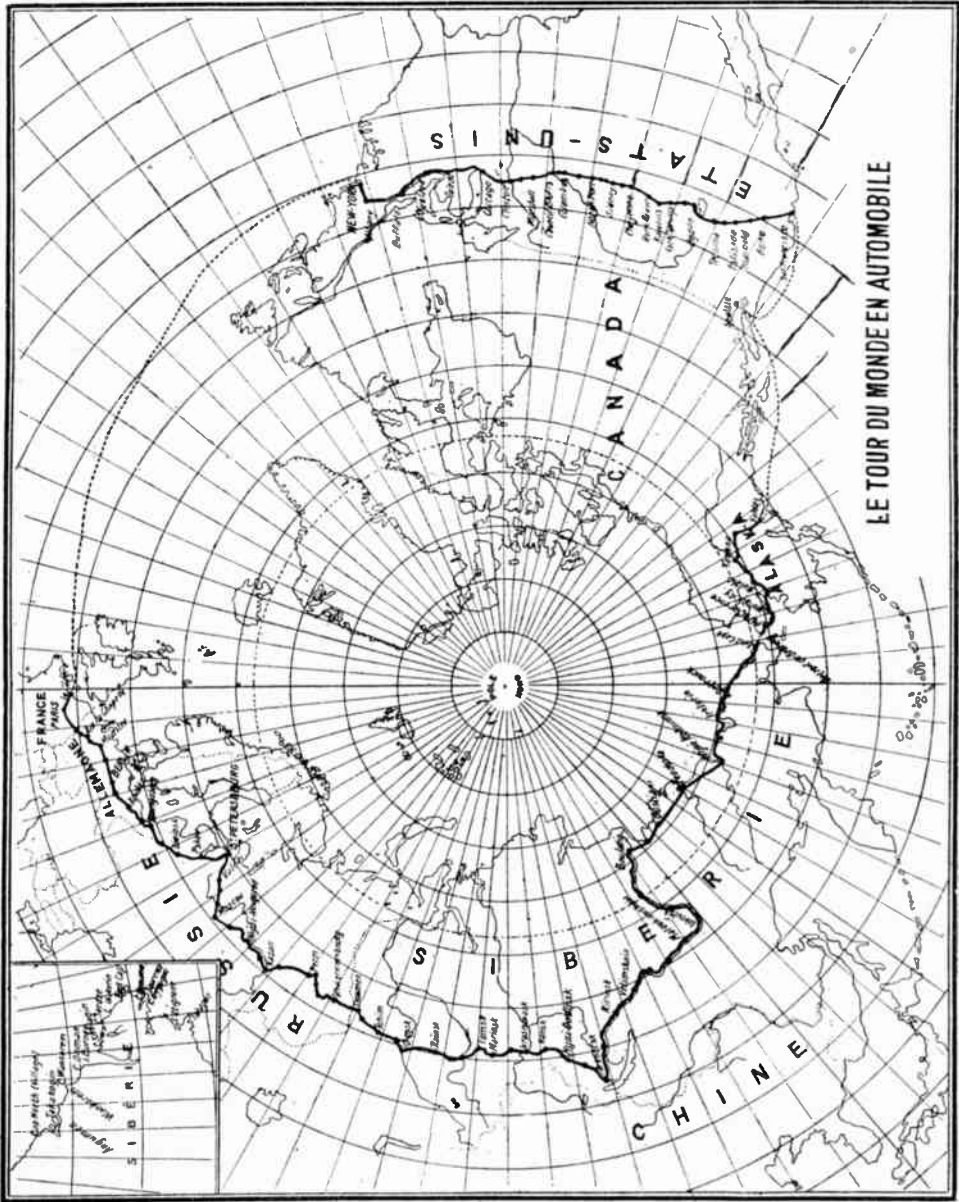

The map above shows the course of the great automobile race now in progress from New York to Paris. Of the six automobiles, American, French, German, and Italian, which started from New York in February, one soon dropped out, and the others are at present strung out from Nebraska to Utah, the American car being far in the lead. From San Francisco steamer will be taken to Alaska, and then the frozen snow will be traversed across Alaska and Siberia.

## THE PROPER ADJUSTMENT OF WIRELESS TELEGRAPH DETECTORS WHEN USED ON TUNED CIRCUITS

W. C. GETZ

ABOUT nine out of every ten amateurs who start to experiment with wireless telegraphy never get beyond the "filings-coherer" stage. This is generally due to the fact that this instrument in question is only a toy,—but a rather expensive toy,—and that the amateur either outgrows the novelty of the thing, or gets disgusted at its inefficiency and loses his interest in it.

I once remarked to a well-known manufacturer of electrical goods that I thought it about time the dealers were producing a suitable wireless instrument that embodied some up-to-date features, and he replied: "Instruments such as you experiment with are too complicated for the amateur; he wants something simple. He would not understand the tuned system." I differ with this gentleman. The amateur wants the up-to-date features, and he will understand their operations—after you show him. If the manufacturers made tuned circuit instruments, no amateur would buy an old-type filings-coherer instrument, when he could get a tuned circuit instrument as cheap.

At its best, the filings coherer will work only a few miles, and is almost useless in the city for long-distance service, owing to the electrical disturbances that are constantly occurring, such as arc-lamp flickering, trolley flashes, static machines, etc. And again, the size of the induction coil necessary to operate it over any distance prohibits its use to the average amateur, owing to the cost of same.

There have been frequent articles of late, in both this magazine and its contemporaries, on the later and more efficient types of detectors, such as the microphonic, electrolytic, silicon, etc., and in some of these very well-written articles have appeared directions for making these detectors.

Now the average amateur, on seeing these descriptions, either makes himself a detector or buys one, and proceeds to experiment as before, using a relay or tape recorder bridged around detector, and then wonders why it doesn't work.

The first thing that should be understood by every experimenter in the wireless field is that any very sensitive detector, such as

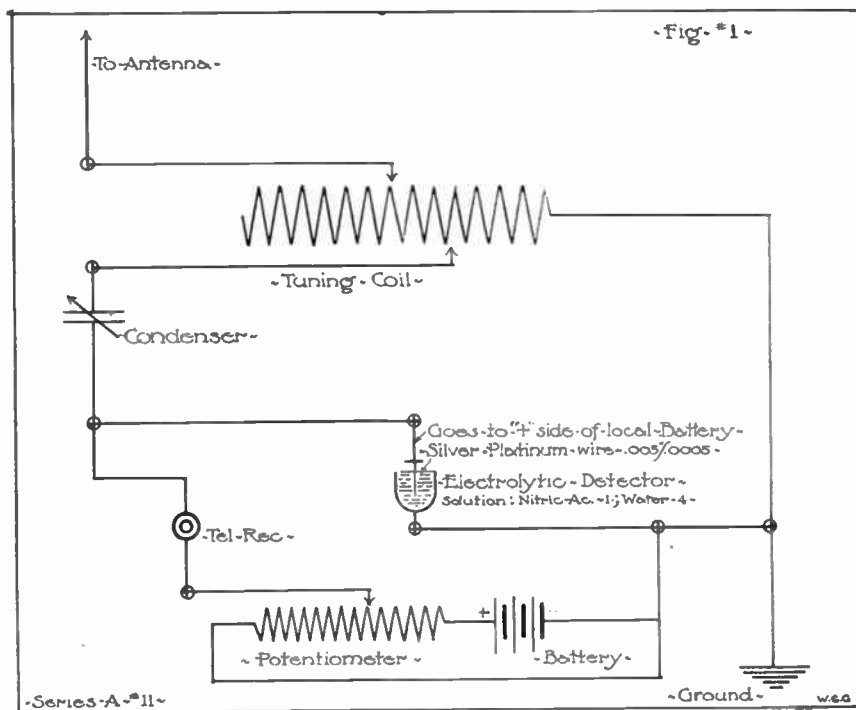



the electrolytic, microphonic, etc., will not be suitable for working a relay or tape recorder, but should be equipped with either a galvanometer or telephone receiver.

The telephone receiver is in universal use in all government and commercial wireless stations, inasmuch as it is, next to the mirror galvanometer, the most sensitive device known for the detection of the presence of an electric current.

When I am asked what material or instruments are required for a wireless telegraph receiving station, the first thing I think of is a telephone receiver. Any old kind of a receiver will do for a start, though, of course, a standard watch-case receiver with head band is to be preferred.

With a good detector and a telephone, you can "hear" static electricity, trolley flashes; after a while you are able to tell, by the tone difference, what wireless station is sending, without getting call letter; you can hear any swinging cross on the electric wires within

coil is not properly adjusted, the majority of the energy of the wave goes direct to ground. By making the condenser adjustable, the tone of the station may be sharpened or dampened.

The local battery, consisting of about three dry cells, is bridged across a potentiometer or adjustable resistance of about 300 ohms. A tap is taken from the negative side of the battery to the base terminal of the electrolytic detector, thence to ground.

Via sliding contact, local current goes from potentiometer to receiver, thence to silver-platinum wire of detector. It is absolutely essential that the *silver-platinum* wire be on the *POSITIVE* side of the *local battery*, otherwise the detector will not work.

The adjustable condenser is of low capacity, and may be made of two pieces of tin, about 4 x 6 inches, with pasteboard between, so that they may be slid apart.

To put the detector into operation, first dip the silver-platinum wire, which should be .005-.0005 inch in diameter, into the electrolytic solution to a depth of 1-32 inch. With telephone to ear, move slide contact of potentiometer to left, until a rumbling, bubbling noise is heard. After a second this will turn to a hissing noise, and when it does, move the sliding contact back until the hissing just disappears; then raise the silver-platinum wire until only the tip just touches the solution. In doing the latter, the hissing noise may come back; if so, move sliding contact of potentiometer back until it just ceases.

The proper adjustment of the electrolytic detector is just a little back of the point where the frying noise is heard. This may be tested by the use of an ordinary bell buzzer connected, as shown in Fig. 2, and placed about 6 feet from detector. When the key is depressed, the sound in the telephone receiver will be found strongest when detector is adjusted as directed. In connecting up a testing buzzer, care should be used to ground it, as shown in sketch, the ground coming from the point between break and magnets.

If you live within 50 miles of a wireless station of the government, or some commercial station, you can receive from same by using the above circuit, and only a 30-foot mast on your roof is necessary. In the country, by using an antenna swung say about 60 feet in the air, with a 100-foot span, using tall trees as masts, a receiving radius of 300 miles is easily possible on favorable nights.

Fig 2

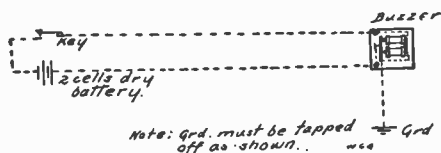

several miles. There are many strange things that you come across when "listening-in" that tend to arouse your scientific curiosity and put your thoughts toward Nature's elements.

The sketch shown in Fig. 1 represents a tuned receiving diagram that is probably the most sensitive arrangement in wireless design. By "tuning" I mean varying the capacity and inductance of my apparatus until it equals the capacity and inductance — or wave period — of the station I am trying to get. Without going deeply into the theory of wireless, I might state that the period of oscillation of any wave is equivalent to  $2 \times 3.1416 \sqrt{LC}$ , in which L is the inductance and C is the capacity. Thus, by varying either one or the other, the wave period can be varied.

By referring to the diagram, it is seen that the electric wave passes down the antenna, through sliding contact to tuning coil, which, if at proper adjustment, allows it to pass through other sliding contact to condenser, thence to detector, and to ground. If tuning

But the amateur must bear in mind that it is absolutely necessary to have all the instruments as shown in sketch, and no others connected in. To attempt to use a tape recorder with an electrolytic detector would be like trying to hitch a milk wagon to an express train, and the results of either would be equally interesting.

By consulting drawings of standard tuned circuit diagrams, the amateur can find a number of other systems that might better suit his particular station.

In conclusion, my advice to all, whether starting or already started, is get right—use a telephone receiver, and study tuned circuits.

## MAINTENANCE OF TELEPHONE INSTALLATIONS

### WITH SPECIAL REFERENCE TO INTERCOMMUNICATION SYSTEMS

H. E. HAYES

As a general rule, most up-to-date engineering and other large factories are the possessors of a telephone installation of some description. It may be that during the installation of electrical plant or wiring, the suggestion was made by the contractor. In any case, this telephone system is occasionally "the last straw which breaks the camel's back." Charge hands will pardon the comparison, but it must be admitted that they too sometimes "get the hump," to use an expressive shop phrase.

Some of these installations were perhaps carried out in a substantial and workmanlike manner, and faults occurring on such are naturally to be regarded as fair wear and tear. In other cases, the instruments and cabling were simply "thrown up any-

of effecting reliable and lasting repairs may be of interest. Just commenting on the methods of running inside telephone lines we have:—

- (a) Ordinary 20 S. W. G. bell wires to the required number in bell casing.
- (b) Ordinary 20 S. W. G. bell wires to the required number in steel tubing.
- (c) Multiple cables in one-groove casing.
- (d) Multiple cables in steel tubing.
- (e) Bare copper or phosphor-bronze wires on hard wood battens or small button insulators (where space and dryness allow).

Classes *b* and *d* may be regarded as the safest and most durable systems for factory and mill work. In buildings where chemical and allied processes take place, and where corrosive fumes consequently exist, system *d* is without an equal, especially if the piping is well painted after erection with anti-sulphuric enamel, or, if expense is a consideration, shellac varnish. The tubing used should be "brazed," not "close joint"; the difference in price is little in comparison with the quality of the finished job.

In old and badly designed factory jobs, it will generally be found that some particular portion of the wiring is giving continual trouble, due perhaps to its proximity to steam, corrosive fumes, etc. Complete re-wiring of this portion is, in the long run, the best procedure. The engineer should make a determined attack on the faulty sections, trace or test out the circuits affected, committing same to paper for future reference, and then cut away without scruple any wiring which looks at all suspicious, in which joints exist, or portions bared for previous testing purposes. The lines being now cut back clear of joints, etc., may be terminated at a suitable point on a terminal box, such as that shown in Fig. 1. The figure shows

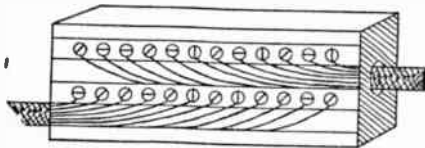

Fig. 1.

how," and at this latter class of work the suggestions offered by the writer are particularly directed. As an example of a particularly bad job, the following would appear to be not an exaggerated case. A certain bread factory intercommunication system had the wiring carried out in multiple cable. This cable was run without external protection through walls and floors, and stapled with large galvanized wire fence staples. This was quite bad enough, but the cables were stapled on damp walls, touching hot pipes, and even carried 5 feet in the open from one window to another.

Now, this class of work invariably breaks down after being in operation a few months—perhaps less. A few notes as to methods

two multiple cables entering a terminal box, but ordinary bell wires are treated in exactly the same way. The top row of terminals are, of course, short-circuited to the bottom row at the back of the box — one to one, two to two, etc. This box may be obtained from five-way upwards, or, if desired, a very good substitute can be made, using a hard wood base and small screws and washers, under which the wires may be clamped.

The wires left free by the removal of the faulty portion (at the other end) may now

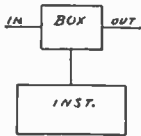

Fig. 3.

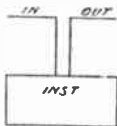

Fig. 2.

be jointed and run back to the terminal box, where they meet their proper circuits again. By this arrangement but one joint per wire is required, the terminal box taking the place of the other, in addition to providing a disconnecting point — naturally a great disadvantage in locating future faults. When the joints are being made, care should be taken to “stagger” the joints, *i.e.*, to have each individual joint at least its own length behind the foregoing one. This keeps down the outside diameter of the batch of wires, which may otherwise exceed that of the casing or tubing. It also minimizes risk of contacts between wires.

Intercommunication systems form a large percentage of private telephone installations, and sometimes it will be found the multiple cables are looped on the instrument line terminals. This is very bad practice, and a prolific source of trouble, owing to the difficulty of neatly looping two cables in the restricted space provided even in the best type of instrument. Figure 2 shows this method in diagrammatic form. When repairs or new extensions are in progress, the engineer should endeavor to have three-way rosettes or terminal boxes, such as that shown (Fig. 1), but with an extra row of screws, fitted one per instrument (see Fig. 3). These remarks apply with equal force to systems wired in ordinary bell wire. When a batch of bell wires requires to be carried round pillars, or in any position where the use of casing or tubing is undesirable, the following method insures a neat and sound job. The wires are first laced with twine, as shown in Fig. 4. This particular knot is called a

“lock stitch,” and is used extensively in telephone exchange work, when large batches of single wires require to be kept tidy, yet accessible without delay.

To fix the laced wires in position, fairly long staples are driven along the proposed run, laying under each a piece of scrap wire (as shown in Fig. 5). These scrap pieces are to be used for tying up the batch in position, and their ends should be neatly cut off. The ties should be close enough together to prevent any sag between adjacent ties. This method of securing the wires is much preferable to stapling the lot together, and greatly reduces the risks of “shorts” and “earths.” An earthing line on a private telephone installation may seem of small importance to some, but it is quite capable of causing some very troublesome faults, and, of course, if two or more lines be making partial earths, the whole system may be more or less deranged. When the main battery becomes exhausted in an abnormally short time, the cause will generally be traced to earthing battery leads. A very good practice, after recharging this battery, is to disconnect the main lead or leads and insert a galvanometer in series with the whole system. This will detect any useless current discharge leaving the cells and returning *via* earth faults or contacts. A rough idea of the magnitude of such current can be obtained by noting the deflection.

A bell may be used in lieu of a galvanometer, but it must be remembered a comparatively heavy current is required to actuate a bell, and this may not be flowing, owing to the leak or contact being a high resistance one; yet enough may be flowing to rapidly run the battery down, being, as it were, a continual drain on it. If the main battery is so connected that it supplies both ringing and speaking current, the instrument switch-



Fig. 4.



Fig. 5.

hooks should be looked over to ascertain if the primary circuit of any instrument is permanently made. Receiver cords and other flexible conducting cords should be examined frequently. They are generally composed of brass tinsel, which easily frays at the connectors and thus causes trouble. The symptoms and appearance of an exhausted battery need scarcely be commented



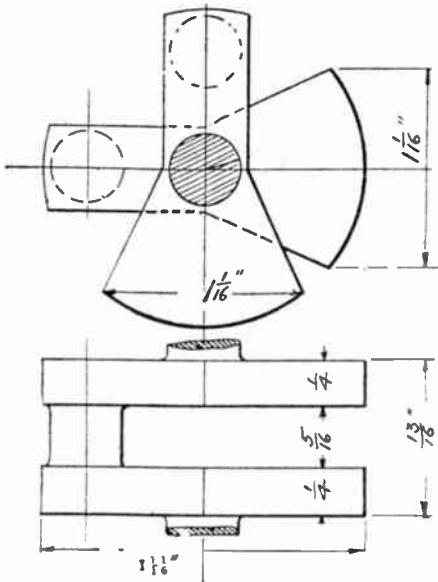

FIG. 32.—CRANKSHAFT WITH COUNTERWEIGHT SOLID WITH THE WEBS.

before the two parts are joined with solder for the machining.

While talking about the machining of the connecting-rod, attention may be called to the virtues of the pin drill for facing the sides of both little and big ends. In such cases where the lathe will not swing the rod a very good finish may be obtained in this way. The pin drill used for the big end would, of course, require a broad face edge, which

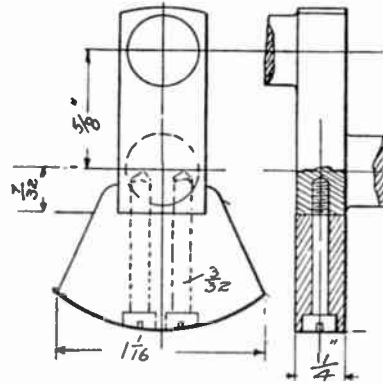

FIG. 33.—CRANKSHAFT WITH SEPARATE COUNTERWEIGHTS.

would also have to be recessed to form the projecting collar.

The next parts described are the crankshaft and fly-wheel. A reference to the general arrangement drawing which accompanied the first article will show that balanced cranks were considered; but while these are desirable features in any engine which has no balance weights in the fly-wheels, and where the pistons and other reciprocating parts are not balanced in themselves, they are in the present case by no means essential to success. This being so, the writer shows in Fig. 31 a crankshaft with ordinary square webbed cranks. This may be made from a steel casting or from a piece of 1/2-inch x 1 1/4-inch cast iron plate, the superfluous parts being drilled and sawn away,

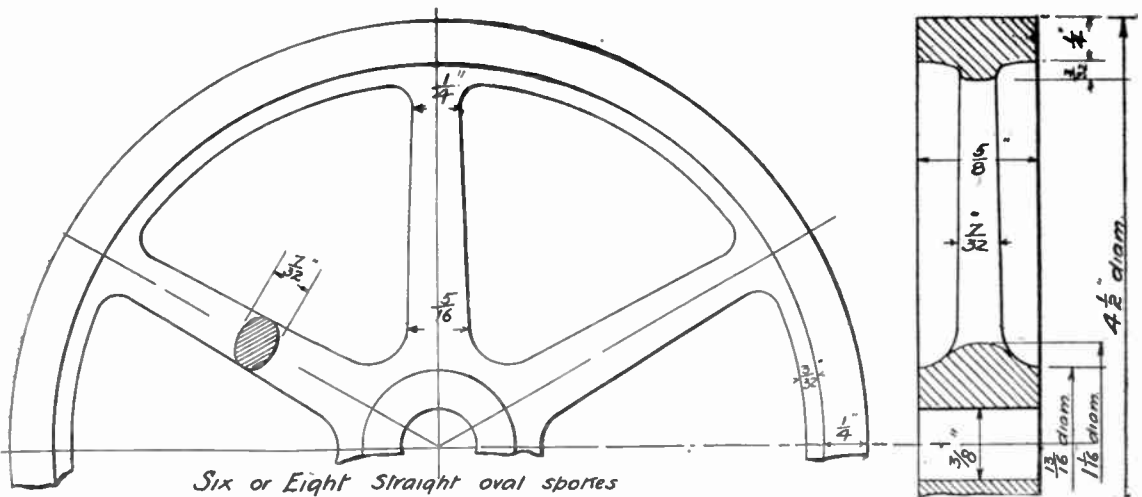

FIG. 34.—FLYWHEEL FOR UNDERTYPE ENGINE.

and the crank-webs twisted at right angles, whilst the middle part (the center journal) is red hot. End plates centered in the usual manner (see "Practical Lessons in Metal-Turning," by P. Marshall), will, of course, be required for machining the crank-pins.

The balance weights, if used, may be solid with crank-webs, as shown in Fig. 32. The only drawback to this is the fact that a very long tool must be used to turn the crank-pins, projecting nearly 2 inches from the tool-rest, and therefore the writer also shows (Fig. 33) the balance weights made separately from the crank-shaft and attached by means of screws to the webs. This method is commonly used in model work, but, as in the present instance, the dimensions of the shaft are necessarily small, the counterweights should fit the crank-webs tightly and may be secured by sweating, as well as screwing, to the webs. When fixed the sides and edges of the weights may be turned up in the lathe. When the bearings are fixed down they may very well be turned up in the manner adopted by Mr. Ferreira and described in the recent report of his paper before the Society (see Fig. 19, page 580, issue of 20th inst.), the rod used being the same as the crank-shaft, viz.,  $\frac{3}{8}$  inch diameter.

The fly-wheel is detailed to full size in Fig. 34. Only half of the wheel is shown. The number of spokes may be six to eight, but six will be found quite enough in such a small wheel. Should, however, any reader require an eight-spoke wheel, he can easily arrange the pattern with this number without altering any of the other dimensions of the fly-wheel. Soft cast iron should be used. The wheel should be bored a driving fit for the axle, and the edges and face of the rim turned up with the wheel on a short  $\frac{3}{8}$ -inch mandrel placed between centers, the driver being placed through the spokes of the wheel. The writer thanks Mr. T. C. Howard (Manchester) for pointing out that the dimension given to the bore of the l. p. cylinders in the plan view (Fig. 5) should read, as in all other views, 1 inch instead of  $1\frac{1}{4}$  inches.—*The Model Engineer and Electrician.*

(To be continued)

### The New Haven's Electric Line

A FEW months ago the New York, New Haven & Hartford ran four trains into the Grand Central Station, New York, marking the inauguration of the largest electrified branch of railroad in the world. The stretch

is from Stamford, Conn., to New York, a distance of thirty-four miles, and to run one hundred and forty trains daily over this distance establishes a world's record.

The contract for all the equipment was in the hands of the Westinghouse people, and the work of installing the system was practically left to them, being, of course, supervised by Vice-president McHenry and Engineer Murray, of the New Haven system.

One of the most difficult and most important requirements of the new system was the training of the men to the unusual conditions. In a few months a thousand men had to be adjusted to new rules, new habits, and the handling of a new principle, and this was all accomplished without a serious accident, although, of course, many amusing blunders were made.

For instance, the firemen of the locomotive engines are now employed as "assistants" to the "motormen," but neither the engineers nor the firemen of the old school will ever be anything else but "engineers" and "firemen," and the lateness of an electric train was on one occasion explained by the "absence of the fireman."

Both the overhead trolley system and the third rail are used on the New Haven, the latter because it runs into the Grand Central Station on the New York Central rails from a little beyond Woodlawn, and the construction of a locomotive adapted to both systems involved new and complicated problems in electrical engineering which have been solved successfully.

### Good Reading for Inventors

THE legal wars which Thomas Edison has participated in with moving picture machine manufacturers and dealers for the past nine years have been settled through the formation of an \$8,000,000 combination to control the entire moving picture business of the world. A complete understanding has been reached, and in lieu of the settlement of the legal battles in which Mr. Edison has indulged with the manufacturers, he will receive from the combination \$200,000 a year royalty, for which he is to permit no other concerns to use any of his patents, without which films cannot be made. The manufacturers claim the combination is justified, in that without the Edison patents manufacturers are helpless, and it was necessary to protect the investments.

## OUR PHOTOGRAPHIC CONTEST

EVERY month, if space permits, we will publish the prize picture, and give the results of our photographic contest. The prize each month is \$1 in cash or a year's subscription, and any person, whether a subscriber or not, may send in examples of work. This department is increasing in



Taking a Rest

Robert F. Adams

popularity, and we trust may prove interesting and helpful to all our readers who are working along photographic lines. Prints may be submitted on any subject and will be considered for the forthcoming issue. In order to be sure of consideration, prints should be in our hands by the 10th of the previous month; that is, for our May issue,



Trespassing

C. A. French

prints to be considered must be here by the 10th of April. Those coming later will be considered for the June or next issue.

We take pleasure, this month, in awarding Robert F. Adams the first prize for his



Cows in Pasture

M. S. Pentecost

print, entitled, "Taking a Rest." The print is photographically very good and also interesting. It seems to tell a story. Honorable mention is given to C. A. French for "Trespassing" and to M. S. Pentecost for "Cows in Pasture." All prints submitted to us will be carefully considered and criticized, if requested. We would be pleased to see examples of indoor work, in order to see what you are doing in this line.

AMONG the most useful tools for use wherever reading or writing is among the daily occupations of men, is a dictionary. Every educated man finds it one of the indispensable necessities of his library or study table. The best dictionary should always be the one chosen, and the weight of authority in America is in favor of Webster's International Dictionary. This has been the standard of the U. S. Government Printing Office since 1869, and has been adopted as such by the U. S. Supreme Court, and almost all other courts in this country.

Now that the warmer weather makes it possible to work more comfortably out of doors, we presume there will be found a larger number of apparatus put into working order, such as telephones, wireless outfits, boats, etc. To all working out these problems, we will try and be of service. If we are called upon, and it is possible for us to respond.

THROUGH an error, the chapter on Electrical Engineering, by A. E. Watson, in our March, 1908, issue, was marked XX. It should have read Chapter XXI. Better correct your copy, if you desire to have it read correctly, later on, when you bind your numbers for the year.

# Electrician and Mechanic

Incorporating  
**BUBIER'S POPULAR ELECTRICIAN**  
 Established 1890  
**AMATEUR WORK**  
 Established 1901

PUBLISHED MONTHLY BY  
**SAMPSON PUBLISHING CO.**  
 BOSTON, MASS.

A. E. WATSON }  
 M. O. SAMPSON } *Editors*  
 F. R. FRAPPE }

## SUBSCRIPTION, IN ADVANCE, \$1.00 PER YEAR

In the United States and dependencies, and Mexico. In the Boston Postal District and Canada, \$1.25. Other countries, \$1.50.

Subscribers wishing to have their addresses changed must give both old and new addresses. Notice of change of address must reach us by the 15th of the month to affect the number for the month following.

## SINGLE COPY, 10 CENTS

### Advertising Rates on Application

Forms close on the 10th of the month preceding date of publication.

Contributions on any branch of electrical or mechanical science, especially practical working directions with drawings or photographs, solicited, and if accepted, paid for on publication. No manuscripts returned unless postage is enclosed.

All communications should be addressed

**SAMPSON PUBLISHING COMPANY**

6 Beacon Street, Boston, Mass.

ELECTRICIAN AND MECHANIC may be obtained from all newsdealers and branches of the American News Co.

CHICAGO REPRESENTATIVE—Gordon Boyd, Suite 309, 253 La Salle Street.

FOREIGN AGENTS—Arthur F. Bird, 22 Bedford Street, Strand, London.

The Argosy Co., Ltd., Georgetown, British Guiana.

Copyright 1908, by the SAMPSON PUBLISHING COMPANY

Entered as Second-Class Matter July 13, 1906, at the Post Office at Boston, Mass., under the Act of Congress of March 3, 1879.

VOL. XVIII. APRIL, 1908 No. 10

## EDITORIALS

OF all the subjects which interest our readers, wireless telegraphy seems to be foremost. Therefore, we have chosen a large proportion of our articles this month in this field. The subjects cover the field in several directions, but are all chosen with regard to the needs of the experimenter, and are wholly practical. May they prove useful to those who are working on this subject.

\* \* \*

In this connection, we will call attention to the fact that two articles in this number, on the construction of electro-magnetic detectors and induction coils respectively, are reprinted from the number for July, 1907. Although we printed a large extra supply

of this number, the calls for it have been so continuous that it has gone completely out of print, and we have purchased a large number of copies, at 10 cents each, to fill orders on file, although the number was originally published at 5 cents. We wish to give notice here that we cannot supply single copies of July, 1907, at any price.

\* \* \*

A BILL is pending in Congress to restrict the sending of wireless messages in such a manner as to interfere with government despatches, and to punish by heavy fine the sending of false messages. At first it was proposed to absolutely prohibit the setting up of stations without government license, but it now seems probable that all but government stations will be forbidden to send impulses of wave lengths between 375 and 425 meters. This will secure official stations against interruption, and at the same time leave plenty of opportunity for commercial and experimental stations. The average experimental station has such weak power and is so far from official stations that the new regulation, even if it becomes law, will not interfere with it. At the same time, our young readers who have been accustomed to call up the forts and navy yards on the Atlantic coast, and bother the operators, may find their operations rudely interrupted by the detectives of the Secret Service.

\* \* \*

WE have just issued a new sixteen-page catalogue of electrical and mechanical books, which we are prepared to supply. This includes a very large number of books which we have never listed before, and is very strong in low-priced books on manual work and arts and crafts. It will be sent free on request to any one who is interested.

\* \* \*

WE want to know what our readers want to see in the magazine, and how they think it could be made better. To induce you to write us about it, we will make the following offer: We will give a year's subscription to the magazine to the five readers who send in the most useful suggestions or the best ways to improve the magazine. These may be subjects for articles or ways to improve anything you do not like in the way the magazine is conducted. Do not be afraid to say what you think. If we have weak spots, we want to know it.



## QUESTIONS AND ANSWERS

Questions on electrical and mechanical subjects of general interest will be answered, as far as possible, in this department free of charge. The writer must give his name and address, and the answer will be published under his initials and town; but if he so requests, anything which may identify him will be withheld. Questions must be written only on one side of the sheet, on a sheet of paper separate from all other contents of letter, and only three questions may be sent in at one time. No attention will be given to questions which do not follow these rules.

Owing to the large number of questions received, it is rarely that a reply can be given in the first issue after receipt. Questions for which a speedy reply is desired will be answered by mail if fifty cents is enclosed. This amount is not to be considered as payment for the reply, but is simply to cover clerical expenses, postage, and cost of letter writing. As the time required to get a question satisfactorily answered varies, we cannot guarantee to answer within a definite time. Neither do we guarantee that the answers will be satisfactory for any special use or purpose required.

If a question entails an inordinate amount of research or calculation, a special charge of one dollar or more will be made, depending on the amount of labor required. Readers will in every case be notified if such a charge must be made, and the work will not be done unless desired and paid for.

555. **Ignition-Spark Troubles.** H. H., Coldwater, Mich., states that the irregular action of the spark plug on his Marsh motor-cycle gives him some trouble, and asks if the coil itself suffers deterioration from use? Why are platinoid contacts used on the spark plug? Ans. — While the failure of the ignition apparatus is usually to be accorded to the running down of the batteries, there are plenty of other causes ever present to add their contribution of worry and expense. First of all, the contacts must be kept clean from accumulation of oil and lampblack. Then the wires lying along on the frame must be well insulated. The effects of jar and vibration cannot but weaken the insulation on the coil, but deterioration from this cause can be determined by trying the coil apart from the machine. Platinum is little burned by the continual flashing, and the pure metal is to be preferred to the cheaper alloys that figure under the modified name.

556. **Voltmeter Current.** J. A., Pittsburg, Pa., sends a sketch showing a dynamo, the external circuit of which consists in one case of a voltmeter with 100 ohms external resistance, and in another case of 200 ohms. He states that with the principle that the electromotive force varies with the resistance, how is the interpretation made, for in the first case, if the dynamo generates 10 volts, there will be 1-10 ampere, while in the other case to force 1-20 ampere the same potential will suffice. Ans. — Your diagrams are quite wrong, the statements very muddled. A voltmeter is never to be connected in series as the only circuit for the current, but directly across the poles, and the main current has quite another path. You must recognize that such an instrument has a very high resistance,—one of the Weston type for a 15-volt scale having 1500 ohms; the wire is No. 40, so incapable of carrying more than 1-100 ampere without burning out. If you put 100 ohms more in the circuit, the instrument would simply read a little less than before. The current would not be 1-10 ampere, as you state, but 1-150 ampere. Did you think the voltmeter had no resistance at all? In the second case, the current would be still less than in the other, for the total resistance would be 1700 ohms, instead of 1500. The current that flows in a circuit, under the action of a fixed e. m. f., say 10 volts, varies inversely as the resistance, and if a fixed current is desired through a variable resistance, as a circuit of arc lamps in series, it requires that the volts increase directly as the resistance.

557. **Series-Multiple.**—J. B. T., Annandale, Minn., asks (1) What sizes are the samples of wire sent? (2) What is "series multiple"? (3) How is the "secret" calling done on a party telephone line? (4) What is the e. m. f. and ampere rating of a zinc-carbon sal-ammoniac battery? Which is the best way to connect batteries, in series or parallel? Ans.— (1) Nos. 17 and 30. (2) Such a scheme is illustrated by early examples of connecting eight 50-volt incandescent lamps in parallel with each other, but the group in series with regular arc lamps. (3) There are various modifications of methods, one, imitating the principles of quadruplex telegraphy, depending upon the particular strength and polarity of the current,—the other using the "harmonic" system of ringing, whereby only a certain bell will respond to one rate of alternations. The ordinary two-party line rings between one main and the ground, but the talking is carried on over the two wires. (4) Have the cells in series, and so wind the motors as to fit the full potential. For dead resistances, like incandescent lamps or telegraph lines, the resistance of the exterior circuit should be not less than the internal resistance of the cells. One such cell will give 1.4 volts on open circuit, and 8 to 20 amperes on short circuit. The internal resistance of cell may then be about .2 ohm or less. If you use 20 such cells in series, you can get a momentary working current of 8 amperes through an external resistance of 4 ohms. In case of a motor you do not consider so much the ohmic resistance as the counter e. m. f.

558. **Telegraph Sounder.** L. W. V., Seattle, Wash., asks (1) What size and quantity of wire to use for a 20-ohm telegraph sounder? (2) What size is the sample of wire sent? (3) What is a good lightning arrester for wireless telegraph circuits? Ans. — (1) 14 layers of No. 25 (B. & S.) wire, 67 turns per layer per spool. (2) No. 14 (B. W. G.), or slightly larger than No. 12 (B. & S.). (3) J. H. Bunnell & Co., New York, make quite a variety for all such purposes. You might address them.

559. **Jump-spark Dynamo.** C. R. W., Burlington, Vt., asks various questions regarding the feasibility of trying to ignite the charges in a gas engine by using a telephone magneto without the adjunct of an induction coil. Ans. — Such a machine will not stand the speed of 2000 revolutions you propose. The armature wires would fly off, and you could not maintain the proper

lubrication of the bearings. Even if these limitations were not encountered you would find that the insulation would be quite insufficient. The electromotive force that would jump a distance within the engine cylinder would jump from the wire of the armature to the iron core. A second-hand generator might be bought for \$5, but we think a new one would be cheaper. Write to the General Electric Co., at their Boston office, for a bulletin describing their new igniter.

560. Capacity of Dynamo. M. H., Seattle, Wash., asks (1) How to rewind a No. 18 Carlisle & Finch dynamo that gives 15 volts and 2 amperes for the same voltage but for 4 to 10 amperes? (2) Is compound field winding better than series or shunt for operating lamps and motors? (3) How many lamps will it be possible to light from a two-wire or three-wire 110-volt alternating current circuit? Ans. — (1) This is quite impossible; you must get a larger machine. (2) Yes, but not for charging storage batteries. (3) As many as you please. The electric lighting company puts in transformers large enough to supply any desired number of lamps.

561. Condenser. S. H., Rye, N. Y., asks (1) What size and construction of condenser will fit a 2-inch spark coil? (2) Where can tinfoil be obtained? (3) What size of German silver wire should be used for reducing 110 volts to 6 volts? Ans. — (1) The description of the 4-inch coil in the July, 1907, magazine, will give you good ideas; use about one half as much tinfoil as there specified. (2) From the International Brass and Electric Co., 76 Beekman Street, New York. (3) We cannot tell without knowing how many amperes you require; the amount will vary for every different strength, therefore an adjustable rheostat is about the only satisfactory sort of device for meeting the conditions. A bank of incandescent lamps makes a convenient and cheap arrangement.

562. Magnetizing Steel. H. B., Lynn, Mass., asks (1) How to magnetize a piece of steel for use in a voltmeter? (2) Is Bessemer steel the best kind to use for the shaft of a dynamo? (3) How many storage cells can be charged from a 20-volt 4.5 ampere dynamo? Ans. — (1) We do not know what kind of an instrument you have in mind, but you can readily magnetize any suitable piece of steel by putting it inside a coil of wire and sending a current of electricity through. If you have a strong permanent or electro-magnet, merely lay the piece to be magnetized across the poles. (2) Yes, but the grade known as "machinery" steel may be cheaper and just as good. (3) Eight cells, each with two positives, 4 x 6 inches.

563. Battery Charging. W. R. P., Gonzales, Tex., asks how to charge a few cells of storage battery from a 110-volt direct current lighting circuit, how to make a small battery, and how to tell when the charging is complete? Ans. — Open one of the main wires of the lighting circuit in your house, say by removing a fuse, and insert the battery directly in the line; by turning on more or less lamps you can control the charging; allow 1-2 ampere for every lamp lighted. The June, 1907, magazine contained just such an article as fits your needs. After sufficient charging, the voltmeter will show 2.5

volts per cell, immediately after the charging current has been shut off. In many regular plants an overcharge, indicated by 2.6 volts per cell, is given once a week.

564. Electric Heaters. T. F. E., Manchester, Mass., asks for an article to be published in the regular columns of the magazine describing the making of various sorts of electric heaters. Ans. — This particular field of engineering is one of the most vexatious yet experienced. A great deal of ingenuity has been displayed to make the devices durable, and many a manufacturing company has regretted its attempts to make them compete with other forms of heaters. Before making any we would advise you to solicit such information as can be gathered from some of the makers, possibly the Simplex Electric Co., of Boston.

565. Condenser. L. J. K., Gladbrook, Ia., has made a condenser from tinfoil and sheets of paraffined paper, but is surprised that by use of a battery a spark can be obtained at the lugs. Is this right? Ans. — Yes, for the battery puts a charge into the tinfoil. If you could get no spark, you might suspect error.

566. Insulated Lightning Rods. L. P., Minneapolis, Minn., asks (1) What use are the glass insulators on a lightning rod? (2) What changes should be made in the winding of a K. & D. No. 9 dynamo to adapt it for 10 volts, with shunt field, and will six commutator segments be sufficient? Ans. — (1) They are a detraction from the usefulness of the rods and should be removed. (2) As you did not state the voltage obtainable from the present winding, we cannot just state. Increase the number of turns in the armature winding in direct proportion to the two voltages, and put on the field magnet all the wire you can, using about three sizes smaller than that calculated for the armature.

567. Length of Aerial. A. L., San Francisco, Cal., asks if the length of wire from coil to aerial of a wireless telegraph set is of any consequence? Do we have a book on the subject of "wireless"? Ans. — Yes, the length of this wire has to be counted in as part of the real length. We have a twenty-five cent book by Collins, but if you wish to know something of the theory and the arrangements of large installations, we think Poincare's treatise on Maxwell's Theory and Wireless Telegraphy about the most satisfactory. The practical part is written in an exceedingly plain manner.

568. Isolated Lighting Plant. W. R. B., Tustin, Cal., asks (1) What size of dynamo will suffice to light a house with 36 16-c. p. 110-volt incandescent lamps? (2) What will a storage battery cost to operate that number of lamps for 6 hours per night? (3) Where can a light foot-power metal turning lathe be obtained? Ans. — (1) To light all at once, you will need a 3 kw. dynamo. Ordinarily only one quarter of the total number of lamps that are wired need to be allowed for. (2) Sixty-two cells, costing about \$12 each, besides the switchboard apparatus. (3) From the Seneca Falls Manufacturing Co., Seneca Falls, N. Y.

569. Wireless Outfit. Bro. A., College St. Cesaire, P. Q., says that when his 5-inch spark coil is connected to the aerial and ground, only 1-inch sparks are obtainable, and asks if this length of spark will suffice for sending messages

for a distance of 9 miles? Ans. — We cannot give you exact advice, but in general it is found that the coil that gives the longest spark may not be best for wireless work. Even for quite long distances, sparks only about 1-2 inch long are needed. These should be rather "fat," and represent considerable energy. The entire question of transmitting over long distances is one of seeing how much energy can be dissipated at the spark-gap. Have you eliminated all iron work from the aerial? Such metal readily absorbs the electrical energy. If your coil is wound with wire rather coarser than No. 36, we think you will be able to communicate over the desired distance.

570. **Magneto Generator.** J. E. C., Kennett Sq., Pa., asks (1) What size of wire to use for winding the armature of the magneto generator described in the March, 1907, magazine, to adapt it to an 8 to 12-volt circuit, and how many revolutions will it make? (2) Why cannot miniature lamps be lighted with the current from an ordinary telephone generator? Ans. — (1) We would suggest about No. 23 wire, but not knowing the strength of the magnets, the only sure way will be to try some particular size, and then from the results judge what the final winding should be. The speed will depend upon the load you apply. (2) The fine wire has such a high resistance, that even on a short circuit only a small fraction of an ampere of current will flow; the miniature lamps may require one or two amperes.

571. **Leyden Jar.** H. S., Olean, N. Y., asks (1) If the thickness of the glass of a Leyden jar is of any consequence? (2) What is the size and resistance of the sample of wire enclosed, and how much would be needed to make a 1-2 inch spark coil? Ans. — (1) Yes, for the amount of electricity that can be stored is directly proportional to the thinness of the glass. The quality, too, is of consequence, for some glass, especially the grades containing considerable lead, will leak the electricity almost as fast as it is put in. Better use tinfoil and double sheets of paraffined paper. (2) No. 31, having a resistance of 130 ohms per thousand feet. About one pound ought to suffice, with other parts of coil well proportioned.

572. **Dynamo Output.** J. S. P., New York City, asks (1) If the power to generate 500 volts and .5 ampere is the same as for 500 amperes and .5 volt? (2) What horse-power would be needed to drive a generator having an output of 500 volts and 500 amperes? Ans. — (1) Excepting for the allowance for extra mechanical friction at the larger commutator in the second case, just the same power. (2) This is 250 kw., and for steady driving not less than a 400 h. p. engine should be allowed.

573. **10-inch Spark Coil.** R. H. C., Nashville, Tenn., asks for directions for winding various sizes of spark coils, say for sparks from 4 inches to 10 inches long, and operated from 10-volt and 100-volt circuits. Ans. — This is quite beyond our ability, and possibly more expensive than you think. We would advise you to follow the directions given for the 4-inch coil in this issue.

574. **Direct and Alternating Current.** J. de St. LeM., Ottawa, Canada, asks if there is any method of getting direct current from an alternating current, for charging a 6-volt storage bat-

tery, aside from a motor-generator set? Ans. — We think the latter is the most practicable thing. Of course, there are various grades and qualities of workmanship and design. By no means get a mercury arc rectifier.

575. **Motors.** A. H., Brooklyn, N. Y., asks which is the better form of motor carrying a load, the series or shunt wound? Ans. — The particular qualifications of these two windings were clearly set forth in the engineering series, — Chapters VIII and IX. In general, the shunt motor must be used for ordinary constant speed machinery, while the series sort belongs to railways and hoisting devices.

576. **Crocker-Wheeler Fan Motor.** J. A. S., Allegheny City, Pa., asks what the power of a Crocker-Wheeler fan motor would be if used for power, or if for a generator, what output, and would an ordinary water-faucet motor be sufficient to drive machine? Pressure, 150 pounds. Ans. — Such machines are designed rather stingily, and the fan is depended upon to keep not only the man but the motor cool. If you remove the fan and substitute a pulley, you will find that the motor gets ruinously hot. As a generator there would be the same frailty. Also, in consequence, the fields being series-wound, you would find the generator of rather limited usefulness for experimental purposes. The water motor would give enough power, but would prove rather expensive.

577. **Cement Floor.** F. M. B., Nevada, Ia., asks what preparation can be placed on the cement floor in a basement to prevent the rise of disagreeable dust? Ans. — Repeated coatings of linseed oil make the surest remedy. Of course quite a lot of oil will be absorbed by the cement, but the first coats can be of cheap grade, — the sort adulterated with cotton seed oil. The oil will soon make a skin, and if desired, can then be painted. We have seen a lot of old paint worked off in this manner, and the gain even by one coat to be remarkable.

578. **1-2 h. p. Dynamo.** A. W. E., Camden, N. J., is making a small dynamo with "Manchester" type of field magnet and ring armature. It is desired to get 100 watts output. He asks several questions as to the procedure. Ans. — If you alter the proportions, especially allowing more iron in the armature core, you can readily generate 200 watts with this size of machine. You will find the most helpful directions for a machine of this size and construction in Watson's "How to make a ½ h. p. Dynamo."

579. **Burning Lead Joints.** H. P., Rochester, N. Y., has trouble in "burning" lead joints for the bottoms of jars to be used for electrolytic interrupters. He asks if we can give any advice to help him in making the corners of the square boxes tight, without danger of melting a hole through. Ans. — Your description of procedure shows that you have acquired considerable facility in the use of the blow pipe, and probably know more about the business than we do. We have almost been on the point of trying the sort of burner used for amateur pyrography. This gives a very small and pointed flame. We think such a burner ought to be useful in storage battery connecting. Lack of time has prevented the trial. Is it imperative to use square vessels? Perhaps you could dodge the issue of the corners by using cylindrical forms, like battery jars,

even though you inserted them in square wooden boxes.

### BOOK REVIEWS

**WIRELESS TELEGRAPHY FOR AMATEURS.** A handbook on the principles of radio-telegraphy and the construction and working of apparatus for short-distance transmission. By R. P. Howgrave-Graham. Fully illustrated. New York, Spon & Chamberlain, 1907. Price, \$1 net.

Of all the books on wireless telegraphy which have been published at a moderate price, this, in our opinion, is likely to prove most useful to the amateur, for the reason that it goes most fully into the details of construction and operation of a station which will work over a distance of a few miles. The apparatus described is principally that of the Lodge-Muirhead system, considerably different from what most American experimenters are working with, but none the less welcome. The book will give new ideas to all our wireless experimenters. Our publishers will be glad to supply it on receipt of the price.

**ELECTRICAL INSTRUMENTS AND TESTING.** How to use the voltmeter, ohmmeter, ammeter, potentiometer, galvanometer, the Wheatstone bridge, and standard portable testing sets. By Norman H. Schneider. With new chapters on testing wires and cables and locating faults, by Jesse Hargrave. Third edition, revised and considerably enlarged, with twenty-eight new diagrams. New York, Spon & Chamberlain, 1908. Price, \$1 net.

The title of this book so fully describes its scope that it is hardly necessary to say much about it. The fact that it has gone into its third edition in three years speaks for itself. It is the most complete practical American handbook for telegraph, telephone, dynamo, and motor testing.

**THE "PRACTICAL ENGINEER" POCKET BOOK AND DIARY, 1908.** Technical Publishing Co., Manchester. Price, 50 cents.

**THE "PRACTICAL ENGINEER" ELECTRICAL POCKET BOOK AND DIARY, 1908.** Technical Publishing Co., Manchester. Price, 50 cents.

These two handy little pocket companions comprise the greatest amount of information in their respective fields that is to be found for the money between any pair of covers we have yet seen. They contain most of the tables and information to be found in far more expensive pocket books in the same fields, and are of the utmost value to the steam engineer and the practical electrician. While some of the matter is especially adapted to English needs, most of it is equally useful on this side of the water, and worth many times the price.

### TRADE NOTES

**GENERAL ELECTRIC FAN MOTORS.** — One of the most artistic electric fan catalogues of the season is Bulletin No. 4560, just issued by the General Electric Company. The 1908 fan motors are plainer and handsomer, if possible,

than those of previous design, possessing, as well, all the superior qualities of efficiency, speed control, and reliability that were found in last year's product. The direct current fans are equipped with a universal joint, by means of which a desk motor may be instantly transformed into one of a wall-bracket type, without the aid of tools. The catalogue is conveniently arranged for reference, two or three fan motors being shown on each page, with a brief description in tabulated form, and data as to voltage, catalogue numbers, list prices, etc. Descriptions are included of ceiling fans, exhaust fans, and some miscellaneous small motors for blower, drills, buffing and polishing machines, sewing-machines, etc. The general color scheme of the book is cream and brown, light tint blocks being used on all the pages. The frontispiece is an excellent reproduction of the painting "Fame," by Edith Prellwitz, and the cover is a portrait medallion in bright colors.

**THE Ferro Machine and Foundry Co., Cleveland, Ohio,** have just issued a most beautifully printed, illustrated, and bound pamphlet, entitled "Marine Gasoline Engines, — a Practical Treatise." This it certainly is. Every reader who has the least interest in gas engines for any purpose would do well to write for a copy of the book. It describes the mode of operation of the two-cycle gas engine, compares the two-cycle and four-cycle types, and shows just how they work in practice. It then describes in the minutest detail the construction of a two-cycle engine and the function of every part. Full directions are given for installing a marine engine in all types of boats. This is especially valuable to any readers who are building motor boats or who wish to turn a boat they may own into a motor boat. Gasoline system and ignition system for the boat are fully explained. Naturally the book also lists and describes the various models of engines made by its publishers. It is full of valuable information for every present or prospective user of a gas engine, and may be had by writing to the address given above.



THE annexed cut represents the Utery Pocket-knife Tool Kit, one of the most useful things which a man can carry in his pocket. The knife is a high-grade pocket-knife, which is ordinarily used in the common fashion. When there is occasion for the use of a reamer, file, saw, chisel, or screw-driver, the proper blade is instantly and firmly attached, as shown by the arrow in the cut, and is ready for the required use. The whole outfit goes in a compact leather pocketbook, 4½ x 3½ inches. The kit is very useful for camping, boating, teaming, driving, in the shop, factory, office, or automobile, on the farm or bicycle, or at home. The price is \$2.25, and it is manufactured by the U. J. Utery Co., H7½ Warren Street, New York City, who will be pleased to furnish it on receipt of price, or give further information.

# Naval Architecture

HERE IS A CAREER WHICH IS NOT OVER-CROWDED AND OUR COURSE IN NAVAL ARCHITECTURE WILL FIT YOU FOR THIS CAREER

THE Navy is growing. We are building ships. We are going to build *more* ships. With more ships and merchant vessels, there is a crying need for men to design and build them. The Government maintains a large force of ship draftsmen, and as this force is constantly being depleted by those who take other positions of greater responsibility, their places must be as constantly filled.

Private concerns, in addition to the draftsmen required on war-ships, need men to work on designs of merchant vessels. This opens a new field. Only one college in the country has a course in Naval Architecture, and its students are engaged long before they graduate.

The Massachusetts Correspondence Schools aim to stand first in every branch, and in this particular branch—Naval Architecture—we believe that we have not a single competitor. This means that on graduating from this course you will not have to meet competition.

The M. C. S. course gives a man a thorough foundation in the principles of Naval Architecture and Modern Ship Construction, and equips him to take a place in the drafting room of any ship-building company.

**Send To-day for a Catalog**

**Become a Naval Architect**

Cut out this coupon and mail it

Massachusetts Correspondence Schools  
(Chartered by the Commonwealth  
of Massachusetts)

194 Boylston Street, Boston, Mass.

Please send your free catalog on  
Naval Architecture and Modern Ship-  
building.

Name \_\_\_\_\_

St. and No. \_\_\_\_\_

City \_\_\_\_\_ State \_\_\_\_\_

**BUILD FURNITURE**  
**\$1.00** Will bring you Monthly for One Year, Complete plans for Construction of Mission Furniture.  
 SINGLE COPIES, 10c. EACH  
**WILL B. HUNT - MILTON, MASS.**

**Teachers and Professors of Engineering**  
 and Manual Training wanted for Colleges and Technical Schools. Salaries, \$900 to \$4000. No advance fee required. Address  
**THE ALBERT TEACHERS' AGENCY**  
 378 Wabash Ave. Established 23 years Chicago, Ill.



**THE WHITE EAGLE ELECTRIC MOTOR**  
 Post-paid, 75c.  
 We make working models of inventions. Send for illustrated catalogue of Model Supplies.  
**THE PIERCE MODEL WORKS**  
 134 Pierce Ave. Chicago, Ill.

**BEWARE OF IMITATIONS**  
 For the protection of our customers we advise that Klein's Files are being imitated, to look like Klein's. This, however, does not make them Klein's.  
**CAUTION**—Look for this stamp, M. KLEIN & SONS, on the inside of handles—none are genuine without this stamp. Use only genuine Klein's. They are the product of years of experience and have stood the test of time.  
**MARTIN KLEIN & SONS**  
 97 W. VAN BUREN STREET CHICAGO, ILL.



**NOW IS THE TIME TO STUDY TELEGRAPHY**  
 The new law will require many new operators.  
**GET BUSY**—Manual of Telegraphy, 25 cents.  
 We have the only standard adjustment instrument for beginners on the market. Send stamp for our catalogue.  
**The Bridmar Co., Dept. A., Chicago, Ill.**

**For Sale at a Great Sacrifice** CASH OR INSTALLMENTS  
 A two-seated Surrey type Steam Automobile having a nearly new 19 1/2-inch Boiler, a 10 horse-power Mason Engine, run less than 200 miles. Stanley firing system complete, nearly new Boston Gear Works' Wheel Steer. This machine will be sold complete at a very low price, or the Boiler, Engine, Burner, and Wheel Steer will be sold together, making a splendid outfit for any amateur who wishes to build his own car. For further particulars, prices, etc., address  
**Prof. Putnam, New Hampshire College, Durham, N. H.**

**FOR SALE** Several 16-inch Locomobile Copper Tube Boilers, A1 condition, price, \$45.00 each; 16-inch Locomobile Steel Tube Burners, \$7.00 each; several 4 1/2 h. p. Locomobile Steam Engines, \$20.00 each; several 4 1/2 h. p. Mason Steam Engines, \$20.00; Ratchet Feed Lubricators, \$6.00 each; Safety Valves, \$1.00 each; Klinger Water Gauges, \$6.00; several 34x4 Goodrich Shoes or Castings, \$18.00 each; 32x3 1/2 Shoes, \$15.00 each; 32x4 Single Tube Tires, \$8.00 each.  
**R. ROTH, 1423 North Avenue, Bridgeport, Conn.**

**R-U INTERESTED in the STUDY of ELECTRICITY**  
 Limited offer. One Set (No. 1) Comprising 10 Leading Instruments, \$5.50. Junior Set (No. 2) 7 Instruments, \$4.50. For Circulare enclose stamp to **FALKER ELECTRICAL INSTRUMENT CO., 2814 Street, above Market, Philadelphia, Pa.**

**AUTOMOBILES \$100 UP**  

 FREE, our large Illustrated Bargain Sheet of slightly used Automobiles, showing accurate photographs of nearly sixty different makes of Automobiles offered as low as \$100.00. Send name and address only. Write plainly to  
**N. GRAHAM AUTOMOBILE CO.**  
 Established 17 years. 601-603-605 Madison Street, Chicago, Ill.

**Are You Building a Boat?**  
 You will need fastenings, tools, anchors, rope, paint, deck fittings and a hundred other things. Write for our illustrated catalogue of marine hardware. Sent free on receipt of 5c. for postage.  
**A. S. MORSS CO., 5 Lewis St., Boston**

**SPANGENBERG'S PRACTICAL ARITHMETIC Self-Taught**  
**ARITHMETIC Self-Taught**  
 A plain, easily-understood volume for ALL who have not had the opportunity of learning this subject thoroughly, or who have forgotten what they have once learned. 257 pages. **REQUIRES NO TEACHER.** This great little book sent post-paid for **60 CENTS** (stamps accepted), leather binding, \$1.00.  
**GEO. A. ZELLER BOOK CO.**  
 No. 4496 W. Belle Place St. Louis, Mo.

**The Simplest Motor on Earth**  
 One long bearing, no Commutator, no Bolts, no wire on Armature, will run 40 hours on one good dry Battery. 75 cents post-paid. **PAUL M. JANKE, Mt. Carmel, Illinois.**



**HOROLOGICAL DEPARTMENT**  
**BRADLEY POLYTECHNIC INSTITUTE**  
 Formerly Parsons Horological Institute  
**PEORIA, ILLINOIS**  
**LARGEST and BEST WATCH SCHOOL IN AMERICA**  
 We teach Watch Work, Jewelry, Engraving, Clock Work, Optics. Tuition reasonable. Board and rooms near school at moderate rates. Send for Catalogue of Information.



**\$1.50 FLASHER, 55c.**  
**BEST CHRISTMAS PRESENT** offered. A high-grade Ever Ready Tubular Electric Flashlight for only 55c. (postage 10c.) Big money for agents—the light retails at \$1.00. Ask for free catalogue.  
**JOHN NELSON ELECTRICAL CO. Dept. E, Kewanee, Ill.**



**Every Boy His Own Toy Maker**  
 Greatest boys' book ever written. Tells how to make a Steam Engine, a Camera, Windmill, Microscope, an Electric Telegraph, Telephone, Magic Lantern, Boats of every kind, kites, balloons, electrical and mechanical toys, traps, fishing tackle, rustic cottages. 200 illustrations. Every boy should have this great book. Price, only 10 cents, post-paid, 3 for 25 cents.  
**WESTERN PUZZLE CO. 334 Jackson St., St. Paul, Minn.**



**\$5 EARN \$5.00 A DAY \$5**  
 Learn to be a plumber in from 4 to 6 months, on easy payments. For particulars address **Master Plumbers' Trade School, 3421 Lindell Ave., St. Louis, Mo.**

## For Manual Training Schools The Wells Grinder

Not as large as some but with every attachment wanted from a plain machine, as shown, to a full UNIVERSAL GRINDER.

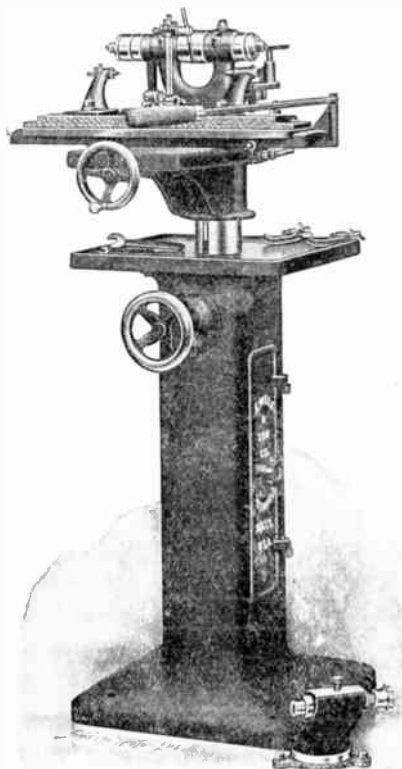

### WHAT OTHERS SAY

#### NEW HAMPSHIRE COLLEGE

William D. Gibbs, M. S., President

Department of Drawing and Machine Design

F. W. Putnam, B. S., Supervisor.

Durham, N. H., Jan. 18, 1908

F. E. WELLS & SON CO., Greenfield, Mass.

Gentlemen:—I am glad to be able to recommend your machines to manual training, trade, and technical school instructors, and to any person interested in the purchase of machines such as you manufacture. I have examined carefully the machines themselves, have tested them and seen the thorough manner in which these machines are built at your shops in Greenfield. I thoroughly believe your machines to be the best on the market for the money.

Yours very truly,

*F. W. Putnam*

Send for further description of grinding machines, lathes, small screw machines for manual training and technical schools.

VISITORS ALWAYS WELCOME

**F. E. WELLS & SON CO.**

25 RIDELL STREET, GREENFIELD, MASS.

## TALK IT OVER WITH YOURSELF



*Look things squarely in the face.* No matter how you may wish to impress others, you cannot deceive yourself. *You know* what your failings are—*You know* why you do not occupy a better position. *Talk it over with yourself.* Isn't it worth a little effort to break away from the binding influence of poorly paid work that offers nothing in the future and little enough in the present?

The American School of Correspondence, Chicago, is constantly fitting thousands of ambitious men to begin life in positions which offer an assured future. It is taking older men from poorly paid, uncongenial work and placing them where they secure better pay, better hours, better work and better futures. Half an hour a day spent in systematic study will do this. Our courses in Electricity are entirely complete, practical and thoroughly up to date.

## WITHOUT COST TO YOU

We will send you, without extra charge, a set of the Reference Library of "Modern Engineering Practice," in 12 volumes, Half Morocco, 6000 pages, page size 7 x 10 inches, *provided* you enroll in a full course before April 30, 1908. This is the most comprehensive and authoritative work on Electricity and Engineering ever published.

Mark on the coupon the subject that interests you most, sign your name and address plainly, and mail at once. *Take the first step to-day.*

## American School of Correspondence CHICAGO

..... COUPON ..... Clip and mail to-day.....

Elect. & Mech. 4-08

### American School of Correspondence

Please send me FREE illustrated 200-page hand book of engineering information. I am interested in the course marked "X."

- |                         |   |
|-------------------------|---|
| .....Electrical Eng.    | .....Telephone Practice                   |
| .....Mechanical Eng.    | .....Sheet Metal                          |
| .....Electric Lighting  | .....Pattern Drafting                     |
| .....Electric Railways  | .....Heating, Ventilating<br>and Plumbing |
| .....Stationary Eng.    | .....Mathematics                          |
| .....Mechanical Drawing | .....Architecture                         |
| .....Structural Eng.    | .....Civil Eng.                           |
| .....Locomotive Eng.    | .....College Preparatory<br>Course        |
| .....Telegraphy         |   |

Name .....

Address .....

Occupation.....

**PRACTICAL and EFFICIENT****THE K. & D.****GENERATOR No. 9**

This machine is shunt wound; it is particularly suitable for experimental purposes, requiring a small amount of current. It will light to full candle-power, 12 6-volt, 3 candle-power lamps. It may also be used successfully as a plating dynamo.

The armature is laminated; slot wound. Brushes of woven wire; the holders being of the radial type on adjustable yoke.

The field is of the ring type, cast solid with the frame. Coils are form wound. In short: This machine is constructed for real service and is not a toy.

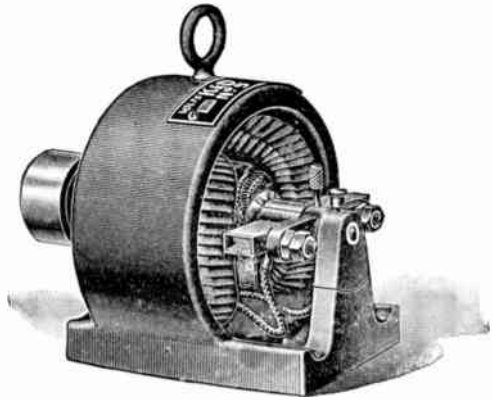

R. P. M., 2200. Volts, 6. Amperes, 6. Weighs 9 lbs. Length of shaft, 6 in. Diameter of pulley, 1 1/2 in., width 3/4 in. Space occupied, 6x4 3/4x6 in. Finely finished in black enamel. . .

**Price, \$8.00**

We also wind this machine as a Battery Motor for 6 volts, 2 amperes. Known as Motor No. 5. And as a special Plating Dynamo, 2 volts, 6 amperes. Same price. Special windings to order. . . . .

MANUFACTURED BY

**KENDRICK & DAVIS****Lebanon, New Hampshire**

IF YOU ARE INTERESTED  
IN

**DRAFTING**

SUBSCRIBE FOR THE  
MAGAZINE BY THAT NAME

The subjects are all to help the draftsman or young man in the shop who is interested in this subject.

There is also a "Shop Knowledge" department.

Subscription, \$1.00 per year. Issues are monthly, and contain four data sheets each.

ADDRESS

**The Inland Publishing Co.**

COLLINWOOD STA.

CLEVELAND, OHIO

**Here They Are!****WIRELESS TELEGRAPHY**

A handbook on the principles of Radiotelegraphy and the Construction and Making of Apparatus for Short Distance Transmission.

By **R. P. HOWGRAVE-GRAHAM**, 160 pages, 51 illustrations, 12mo., cloth, \$1.00 net.

**FLYING MACHINES**

A popular account of Flying Machines, Dirigible Balloons and Aeroplanes.

By **A. W. MARSHALL** and **HENRY GREENLY**, 128 pages, 24 illustrations, and 23 page plates, 12mo., 50c. net.

**EDUCATIONAL WOOD WORK**

By **A. C. HORTH**. A complete manual for teachers and organizers of wood-working classes. Contents of Chapters: 1. First Year Course. 2. Second Year Course. 3. Third Year Course. 4. Fittings and Furniture. 5. Discipline. 6. Organization and Method. 7. The Instruction of the Physically and Mentally Deficient and Blind. 8. Object Lessons. Fully illustrated with reproductions from photographs, drawings, and facsimile black-board lessons.

158 pages, 12mo., cloth, \$1.00 net.

**SPON & CHAMBERLAIN**

Publishers of Technical Books

123 E.M. LIBERTY ST. - NEW YORK



## "Yankee" TOOLS WORK EASY

Mere pressure on the handle drives the screw or drills the hole. The satisfaction of doing your work quickly with ease removes the drudgery and makes life worth living

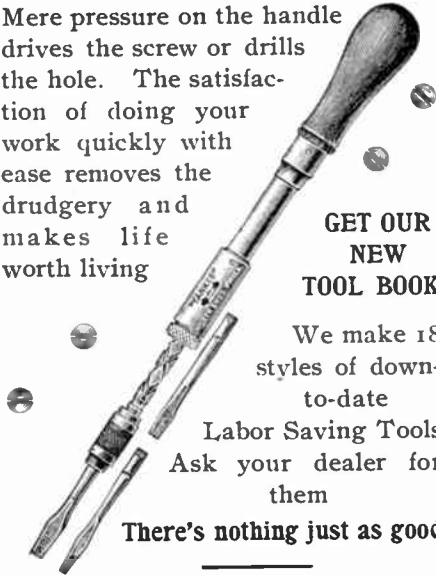

GET OUR  
NEW  
TOOL BOOK

We make 18  
styles of down-  
to-date

Labor Saving Tools  
Ask your dealer for  
them

There's nothing just as good

North Bros. Mfg. Co. 2d & Lehigh Ave.  
Philadelphia, Pa.

## Gas Engine Manual



This volume just published gives the latest and most helpful information respecting the construction, care and management of **Gas, Gasoline and Oil Engines, Marine Motors and Automobile Engines**, including chapters on Producer Gas Plants and the Alcohol Motor.

The book is a practical educator from cover to cover, and is worth many times the price to any one using a gas engine of any type or size. Contains 512 pages, 27 chapters, 156 diagrams, size 5 1/4 x 8 1/4 inches, weighs 2 pounds, is handsomely bound, and in every way a fine volume.

### SPECIAL OFFER

The only way the practical merit of this MANUAL can be given is by an examination of the book itself, which we will submit to the readers of **ELECTRICIAN AND MECHANIC**, free for examination, to be paid for or returned, after looking it over.

Upon receipt of the following agreement (which can be either cut out or copied), the book will be immediately forwarded.

No money in advance required, sign and return  
Theo. Audel & Co., 63 Fifth Ave., New York  
Kindly mail me a copy of "Audel's Gas Engine Manual,"  
and, if found satisfactory, I will immediately remit you  
\$2.00, or return the book to you.

Name.....  
Address.....

# Navy Trade Schools

The Navy trains young men for every branch of the service. Even men who have mastered a trade may take advantage of the opportunity offered for a higher technical course.

The **Electrical School** receives electricians by trade, and students of electricity with a good education, if over eighteen. The course is most complete, and includes a Theory Section, Ship's Watch, Mechanical, Practical Electricity, and Wireless Telegraphy.

The **Artificer School** consists of the Carpenter or Shipwright Class, Blacksmith Class, Plumber and Fitter, Painter and Shipfitter Classes.

The **Yeoman School** trains men for clerical duties of the Navy, and consists of classes for Captain's Yeoman, Equipment, Pay and Ship's Writer, embodying instruction in stenography, book-keeping, penmanship, etc.

The **School for Ships' Cooks, Bakers, etc.**, instructs men in the duties of the various trades in the Commissary Branch. The instruction is of a practical nature.

The **Seaman Gunners' Class** is open to men of the Seaman Branch on reenlistment, while the **Machinists' School** is open to honorably discharged men in the lower ratings of the Engine Room.

The **Hospital Corps Training School** instructs recruits in the duties of caring for the sick and injured, the preparation of medicines, etc.

Write for full particulars, stating your trade and age. Address

**BUREAU OF NAVIGATION, Box 38**  
**Navy Recruiting** **Washington, D. C.**

# THE BEST Moving Picture Machine

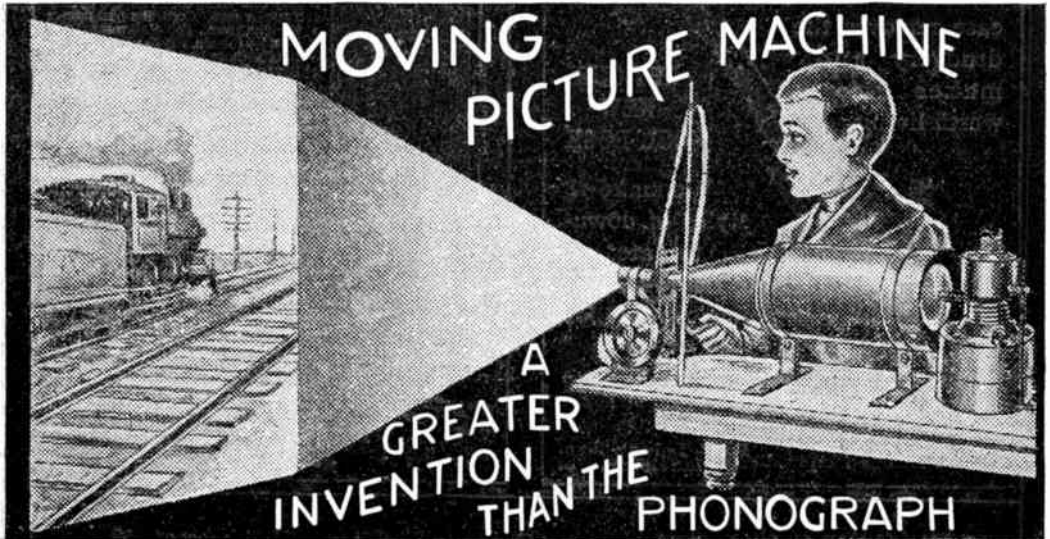

The machine is made of Russian metal, black japan; eight-wheel mechanism which drives the moving pictures; excelsior diaphragm lens, triple polished, standard double extra reflector, throwing ray of light 20 feet, enlarging the picture up to about 4 feet in diameter; lamp is fitted with great safety carbide generator, and produces the highest light power. Has far greater light power than the ordinary electric light, producing 500 candle-power on the screen, and bringing out every detail of the picture with pronounced distinctness. The carbide is *absolutely safe, much safer* than a kerosene lamp. We *guarantee* its absolute safety.

With the outfit we send book with instructions, telling how to operate this marvelous machine. Any child can learn in five minutes how to run this marvelous machine.

**This is absolutely the Best Machine for producing Moving Pictures** that has so far been made. It is not manufactured by the trust, and can, therefore, be sold at a lower price than any other machine on the market. With the machine we furnish one film of three hundred moving pictures. It reproduces exactly the same as the large machines in use in the theatres, and is absolutely safe. If your dealer hasn't this machine, write us direct, sending ten dollars, and we will ship you the machine, complete, by return express.

**Agents, Write for Special Terms**

**WE HAVE STILL SOME OPEN TERRITORY FOR LIVE AGENTS**

**C. G. MAHONY COMPANY**

DEPT. A

125 Franklin Street, New York

\$1.00 Will Bring  
Glass Water Set



This Beautiful Cut  
To Your Home.

This set consists of 7 1-2 Inch one-quart Water Bottle, 6 half-pint star-cut Tumblers, and a beautiful 14-inch beveled Belgium Glass Mirror.

THIS GENUINE CUT-GLASS WATER SET is unsurpassed for its distinctive character. Its clear crystal color adds a lustrous effect to the dining table or sideboard.

Send \$1.00 for one year's subscription to COMMON-SENSE and receive the cut glass at once; afterward you pay \$1.00 a month for ten months.

We are making this unheard-of offer to introduce COMMON-SENSE to a wider circle of readers. Common-Sense has a mission—to help you attain ambition, to suggest ways of increasing your earning capacity, and to make your life a greater success. Sample copy free, if you mention this magazine when writing.

**Common-Sense Publishing Co.**  
Desk 208. 88 Wabash Ave., Chicago



Only  
**\$1.00**

Puts this magnificent Cuckoo Clock in your home.

A Perfect Time-keeper, calling the Hour and the Half-hour.

Nearly Two Feet High, 14 Inches Wide, in Solid Walnut Case.

The inlaid woods of Ash, Ebony, and Mahogany ornaments are put together with minute care.

You never had such an opportunity to get so beautiful and useful an ornament for your den or your home—on such easy terms—mail us \$1.00 for one year's subscription to COMMON-SENSE, afterwards you pay \$1.00 a month for eight months, which completes the payments on both the clock and the magazine; and, mind you, the clock will be in your possession from the time of the first small payment.

**Common-Sense Publishing Co.**  
Dept. 208, 90 Wabash Ave. Chicago, Ill.



## Electricity Is The Connecting Link

ELECTRICITY unites the hemispheres. The wireless telegraph and the transatlantic cable flashed to both shores the story of the "Lusitania's" voyage. Yesterday men talked across the ocean by wireless. What will to-morrow bring forth?

Are you keeping abreast of the times? Every new discovery or invention means greater opportunities, greater power, greater chances for advancement for the man who is up to date.

## CYCLOPEDIA OF APPLIED ELECTRICITY

Six Volumes, 3000 pages; page size 7x10 inches; special illustrations, diagrams, tables, formulas, etc. Bound in half Red Morocco.

This work will post the electrical worker on all the latest developments in his trade; it will teach the student the principles of electricity and its newest applications. The chapters on Electric Wiring and Testing are especially complete and authentic, as are also the chapters on Localization and Remedying of the various troubles which arise in connection with dynamos and motors, such as Sparking at the Commutator, Heating of the Different Parts, Failures of Operation, Etc., with instruction for determining causes, together with their remedies.

**\$18.00 instead of \$36.00**

Sent by prepaid express for 5 days' free examination. If you wish to keep the books, pay \$2.00 cash and \$2.00 per month thereafter until you have paid the special \$18.00 price. Notify us to send for them at our expense if they do not meet your needs.

We employ no agents to bother you. Our books offer the best plan to demonstrate the superiority of our methods of instruction and for this reason we are making this special offer.

### BRIEF LIST OF CONTENTS

Electrical Measurements—Electric Wiring—The Electric Telegraph—Wireless Telegraph—The Telautograph—Insulators—Electric Welding—Direct Current Dynamos—Types of Dynamos—Electric Machinery—Direct Current Motors—Electric Motors—Storage Batteries—Electric Lighting—Electric Railways—Management of Dynamos—Power Stations—A Modern Central Station Design—The Alternators—The Transformer—Switchboard and Station Appliances—Power Transmission—Mercury Vapor Converter—Telephone Instruments—Telephone Lines—Telephone Exchanges—Common Battery Systems—Telephone Systems—Automatic Telephone—Wireless Telephony—Review Questions.

## American School of Correspondence CHICAGO

..... COUPON CLIP AND MAIL TO-DAY.....  
Elec. & Mech. 4-08

American School of Correspondence:—

Please send set Cyclopaedia Applied Electricity for 5 days' free examination. I will send \$2 within 5 days and \$2 a month until I have paid \$18.00; otherwise I will notify you to send for the books.

Name .....

Address .....

Occupation .....

Employer .....

**SALE AND EXCHANGE**

Advertisements under this heading, without display, 2 cents per word, cash with order, minimum, 50 cents. Black-faced type, 4 cents a word, minimum, \$1. Exchange advertisements will be inserted for subscribers once in twelve months without charge, subsequent insertions of same copy, 1 cent a word.

**BLACKSMITHS.** — Young men who wish to become master mechanics and expert tool workers may do so in a very short time by using Toy's treatise on new steels, explaining how to work them, with seventy-five new methods for working all difficult jobs. Ten receipts for making your own compounds for welding different kinds of steel solid. Thermite welding fully explained; also two colored tool tempering charts; chart A explains all annealing and hardening; chart B explains both scientific and plain tempering to a standard. Neatly arranged in pamphlet form for the small price of \$1. Valuable samples free. W. M. TOY, Sidney, Ohio. P.S. — Get in line for big salaries later; good blacksmiths are scarce.

**WILL EXCHANGE** anything which can be procured in the Philippine Islands, including unused postage stamps, for anything electrical, or small steam or gasoline engine. DR. B. ALTMAN, Mauban, Tayabas, Luzon, Philippines.

**COMING TO CLEVELAND?** Send us \$1 and the name of your trade, and we will send you a list of employers who use men in your line. Cleveland is booming. OHIO INFORMATION SERVICE, Cleveland, Ohio.

**WIRELESS TELEGRAPHY.** — How to make a practical outfit cheaply. Complete details and diagrams, 2 cents, post-paid. EDWIN ARNOLD, 102 Gelston Street, Buffalo, N. Y.

**PHOTO-FINISHING FOR THE AMATEURS.** — Special attention given to the developing of plates and films, and printing therefrom. It will pay you to write for our price-list. PHOTO-CHEMICAL CO., 17 Kingsley Street, Hartford, Conn.

**MAKE YOUR OWN FURNITURE** from our full-size patterns. New plan. Simple and easy. Send 10 cents for sample pattern of book-rack or candlestick, and illustrated catalogue showing other pieces. THE HOME FURNITURE PATTERNS CO., 2017 First National Bank Building, Birmingham, Ala.

**TWO NEW 3 H. P.** constant current 40-volt motors, \$50 each. Also new volt and ammeter. J. L. LUCAS, 2 Fox Street, Bridgeport, Conn.

**AIR-SHIP.** — Easily built by any one at small cost. Complete set of blue-prints and instructions sent upon receipt of \$1. BOX 108, Dayton, Ohio.

**WATCH FOB FOR MECHANICS.** — Leather strap, with a fine solid nickeloid emblem of your trade attached. Emblem is a miniature tool and may be used as a chain charm. Price, 25 cents, post-paid. Agents wanted in every factory. Ask for catalogue EM. L. F. GRAMMES & SONS, Allentown, Pa.

**FOR SALE.** — One Porter No. 4 motor, cost \$10, and is as good as new; price, \$5. Also have \$5 medical induction coil, sell for \$2.50. \$1.50 Ajax motor, for 75 cents; \$1 magneto engine, for 60 cents. C. H. KRANEVELL, Albert Lea, Minn.

**SPARK COILS.** — 1½ inch, \$7.50; 2 inch, \$12; 4 inch, \$25. Secondary coils, 1½ inch, \$5.25; 2 inch, \$8. ILLINOIS COIL CO., 1763 East Wood Street, Decatur, Ill.

**INDUCTION COIL FOR WIRELESS TELEGRAPHY.** — Set of twelve blue-prints, giving complete design of high-tension coil. Price, \$1. W. C. GETZ, 645 N. Fulton Street, Baltimore, Md.

**WIRELESS TELEGRAPH APPARATUS.** — Imperial receiver, price, \$2.50, works six miles with ½-inch spark. Set consists of sensitive telephone receiver, cords, wire, battery, and Imperial detector. Detector alone, \$1. Complete sending and receiving apparatus, with 1-inch coil, batteries, switches, etc., \$11.25. Circulars for stamp. INTERNATIONAL WIRELESS CO., Lima, Ohio.

**EXCHANGE.** — A 750-watt dynamo, with two armatures and two sets of field coils for each, one for 110 volts, the other for 30 to 40 volts, according to speed. For a 3 Kw. dynamo, 110 volt. Address, BOX 304, Burlington, Kan.

**WILL PAY CASH** for technical magazines and books. Must be clean and no torn pages. Always write first. CARROLL A. PITKIN, Montpelier, Vt.

**WILL EXCHANGE.** — "Hopkin's Experimental Science," \$5; "Hiscox's Gas, Gasoline, and Oil Engines," \$3.50; and a number of other electrical and mechanical books. Also a 4 x 5 box plate camera, \$5; Eastman's No. 4 Bullet Special Film and Plate Camera, with nine plate holders and leather carrying case, \$25. Also other things mechanical and electrical. I want a printing press and material, telescopes or binoculars, or anything I can use. What have you? SAMUEL GIBEAU, Red Lake Falls, Minn.

**FOR EXCHANGE.** — One Midget dynamo. Want 4 x 5 camera. Address, ELBERT E. BICKWELL, Hoyt, Colo.

**FOR EXCHANGE.** — One ½ h. p. gas engine and 75-watt dynamo. Want 1½ h. p. gas or gasoline engine, automobile flash boiler, or 1 Kw. dynamo. C. O. CRANSTON, 348 N. 10th Street, Kansas City, Kan.

**FOR SALE.** — Patterns of 1½ h. p. bicycle engine; also some castings. ½ h. p. dynamo castings. Photos for stamp. CRIFFIELD MOTOR WORKS, 225 3d Street, Lincoln, Ill.

**FOR SALE.** — One Ajax motor, fine condition, \$1, cost \$1.50; one electro-magnetic engine, rewound with No. 28 wire, 75 cents; one 1-40 h. p. motor, permanent field magnet type, 75 cents, good as new; one 40-segment hard-drawn copper commutator on ¼-inch steel shaft, with two-speed pulley, \$1; one Baltimore No. 9 printing-press and outfit, \$1.50, cost, \$3; one omnigraph transmitter, with ten extra dials, \$1.75, cost, \$2.90; one cloth-covered book, "Modern Electroplating," 25 cents, cost, 50 cents. H. L. FRITZ, Albert Lea, Minn.

**FOR SALE OR EXCHANGE.** — A and B5 clarinets, value, \$20; casting outfit, value, \$9; 24-watt dynamo and motor, value, \$3.50; Little Hustler motor; 1 pound, No. 36 double cotton-covered magnet wire, and electrical books. Will exchange for camera of equal value, but prefer cash. HOWARD GIBBS, Greenville, Mich.

**FOR SALE OR EXCHANGE.** — One disk talking machine, one bridging telephone, one copy "Hopkin's Experimental Science," and several new fountain pens. I want self-inking printing-press, type, etc., or a foot blower; or what have you? IRWIN ELLESTAD, Lanesboro, Minn., P. O. Box 266.

**EVERYBODY IS INTERESTED** in Knouse's GREAT PADLOCK SECRET or how he opens them without keys. Best padlock release known; used by all handcuff magicians. 50 cents, prepaid. WILL KNOUSE, 2610 8th Avenue, Allentown, Pa.

**SALE OR EXCHANGE.** — I can interest you if you have anything to buy, sell, or exchange. Write for descriptive circular. BOX 780, Trenton, N. J.

**LEARN MIRROR SILVERING** and start a money-making business for yourself; write for full particulars. Address, C. S. MINTER, Expert Mirror Maker, Little Rock, Ark.

# The Mystic Reflector

THE ORIGINAL POST-CARD PROJECTOR

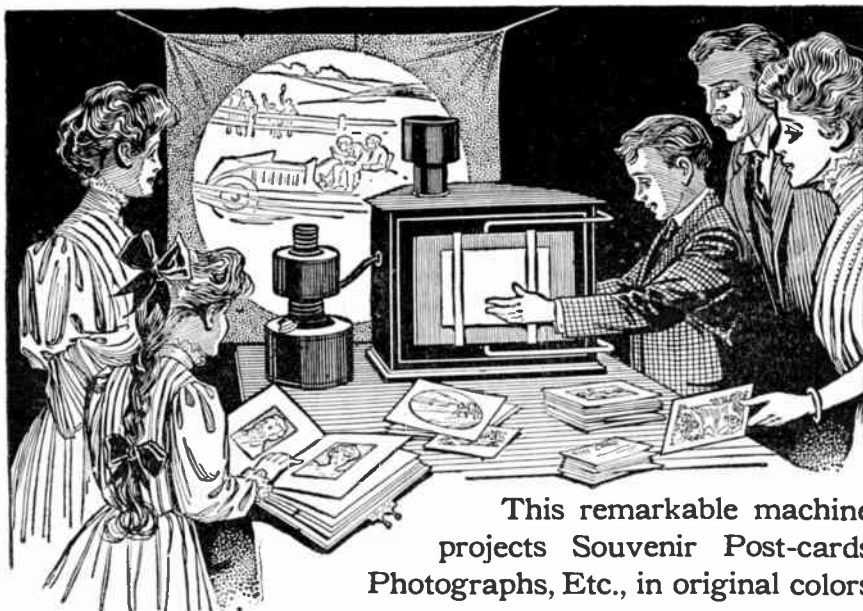

This remarkable machine projects Souvenir Post-cards Photographs, Etc., in original colors

**T**HE MYSTIC REFLECTOR is constructed on the order of the magic lantern, except that instead of using glass slides the machine is so constructed that any photograph, souvenir post-card, letter, or any other article can be reproduced directly upon a sheet or white wall. It is the greatest invention of modern times. It can be also used for illustrating phonograph songs and will be found very delightful as a means of entertainment. This machine can be purchased at any phonograph dealer's in the United States. If your dealer hasn't one, send us his name and we will send you by return mail five beautifully colored picture post-cards. Price of the machine, complete, \$5.00.

AGENTS, WRITE FOR SPECIAL TERMS  
THIS IS THE BIGGEST SELLER THIS YEAR HAS PRODUCED

**New York & Lima Trading Co.**  
Department B 203 West Broadway, New York



**Benches, Tools & Supplies**

Lowest Prices. Headquarters. Send for Catalogue.  
Special Discount for Schools and Classes.

**CHANDLER & BARBER**  
192 Summer Street - Boston, Mass.



**\$4  
P  
O  
S  
T  
P  
A  
I  
D**

Most practical amateur **Wireless Telegraph Receiving Set** ever designed. A wonderful instrument; hundreds in use in Colleges, High Schools and by students in Wireless Telegraphy.  
**N. E. COIL WINDING CO. ATLANTIC, MASS.**

**Hotel Westminster**

IRVING PLACE AND 16th STREET

**NEW YORK CITY**



One block from UNION SQUARE. Surface, Elevated, and Subway Cars. Midway between leading WHOLESALE and RETAIL STORES and THEATRES, and yet far enough from Broadway to insure COMFORT and FREEDOM from the noise and bustle of that thoroughfare.

PERFECTLY QUIET Locality and HOMELIKE in every respect.

**EXCELLENT CUISINE, EUROPEAN PLAN**

Single Rooms, \$1.00 per day and up. Room with Bath, \$2.00 per day and up. Parlor, Bedroom, and Bath, \$3.00 per day and up.

... Send for Booklet ...

**O. H. FOSTER, Proprietor**

**BUY IN NEW YORK**

Let us know what you want. We can give it to you cheaper and better than any house on earth

**NO SALESMEN NO AGENTS  
MAIL ORDER ONLY**

☐ Everything sold by the producer direct to the home. Therefore only one profit and that we share with you.

☐ Write for our large Catalogue containing the latest New York Fashions in jewelry, shoes, women's and children's clothing.

**AMERICAN SUPPLY COMPANY**

Dept. E., West Broadway, Leonard and Franklin Sts., New York City



### Koeth's Combination Kit

The sharp competition of the twentieth century has marked a new era in the manufacture of tools. The latest economical production is **K. K. K.**, comprising fifteen distinct tools operated with one set of handles, made of tempered tool steel, fully warranted. At all dealers or we will deliver them to you for **\$3.50**. Money back if wanted. Postal brings catalogue.

Currier-Koeth Mfg. Co. Coudersport, Penn.

### LEARN WATCHMAKING

Refined, profitable labor—Competent men always in demand. We teach it thoroughly in as many months as it formerly took years. Does away with tedious apprenticeship. Money earned while studying. Positions secured. Send for catalogue. **St. Louis Watchmaking School, St. Louis, Mo.**

### VENTRILOQUISM

Learned by any Man or Boy at Home. Small cost. Send to-day 2-cent stamp for particulars and proof. **O. A. SMITH, ROOM 682—2040 KNOXVILLE AVE., PEORIA, ILL.**

## SELF-EDUCATION

TEACH YOURSELF AND INCREASE YOUR WAGES  
**ONLY DRAKE'S PLAINLY WRITTEN PRACTICAL BOOKS**  
 CAN TEACH YOU WITHOUT THE AID OF INSTRUCTORS

Every volume positively **UP-TO-DATE** and written in a language so plain that even a child can understand. **DRAKE** is the largest publisher of Modern Mechanical Books for home and shop study in the world. We publish good books on every mechanical subject. Our large illustrated Catalog now ready. Sent free.

**FREDERICK J. DRAKE & COMPANY**  
 350 Wabash Avenue CHICAGO, U. S. A.  
 In ordering our catalog please mention this paper.

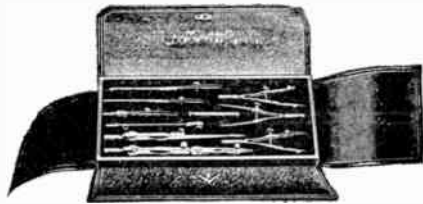

No. 1900

### Barclay Drawing Instruments

Eleven pieces, in flexible, folding pocket case sent prepaid on receipt of \$7.50.

**KOLESCH & CO.**

138 Fulton Street

NEW YORK

## Books to Help You

### IF INTERESTED IN DRAWING

we have books on

- LETTERING . . . . . 25c
- Dimensions of Pipe, Fittings and Valves . . . . . 50c
- Course in Mechanical Drawing  
 Only book in the market arranged to help the student (2 parts) each, 50c
- Course in Structural Drawing, \$1.00
- Trigonometry Simplified . . . 50c

### THE INDUSTRIAL MAGAZINE

(Formerly "The Draftsman")

Has much matter for Draftsmen, Designers and Superintendents.

**\$1.00 per Year - 10c per Copy**

Address all orders to the above magazine  
**COLLINWOOD, OHIO**

## MANY BOOKS IN ONE WEBSTER'S INTERNATIONAL DICTIONARY

Do you know that the **INTERNATIONAL** answers with final authority **A LL KINDS** of questions in Language, The Trades, Arts and Sciences, Geography, Biography, Etc.? Note Plan of Contents as follows:

- Colored Plates, Flags, State Seals, Etc.
- Brief History the English Language
- Guide to Pronunciation
- Scholarly Vocabulary of English
- Dictionary of Fiction
- Gazetteer of the World
- Biographical Dictionary
- Scripture Proper Names
- Greek and Latin
- English Christian
- Foreign Words
- Abbreviations

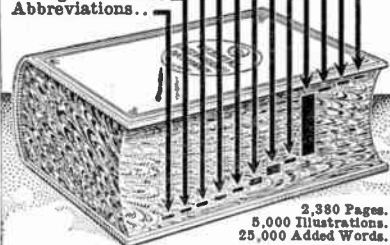

2,380 Pages.  
 5,000 Illustrations.  
 25,000 Added Words.

### Should You Not Own Such a Book?

**WEBSTER'S COLLEGIATE DICTIONARY**, Largest of our abridgments. 1116 Pages. 1400 illusts.

Write for "Dictionary Wrinkles," and Specimen Pages, FREE. Mention in your request *this magazine* and receive a useful set of Colored Maps, pocket size. **G. & C. MERRIAM CO., Springfield, Mass.**

# PHONOGRAPH

**Our 1908  
Model**

*which we  
Positively  
Guarantee*

**FREIGHT PREPAID  
SEVEN DAYS' FREE TRIAL**

We allow seven days' free trial in your own home in which to decide whether you wish to keep it. If the machine does not make good our every claim — volume, quality, saving, satisfaction — just send it back. We'll pay all freight charges both ways.

**\$2** a month buys  
this TALKING  
MACHINE



## FREE TRIAL

**THIS "Dandy" Talking Machine** is absolutely the best value ever offered and the only really high-priced machine ever given on free trial. It is self-running with automatic screw feed, which plays two Standard, Columbia, or Edison records with one winding, and is superior to many high-priced machines, both in appearance and reproduction of tone. All mechanical parts are incased in metal, making them absolutely free from dust, and it is mounted on a beautiful reversible cabinet.

*We guarantee this machine in every way*

## OUR OFFER

**WE** will ship this beautiful Phonograph to any address on seven days' free trial if you will send us your name and three references. You will understand by this that we will not write these people you refer to, but it is merely a form to show your good faith in the dealing. At the end of seven days, if the machine is not exactly as represented, you can return same to us at our expense.

Order this Phonograph to-day, and have the greatest entertainer that has yet been produced, in your own home.

**JOSEPH EWING, President**

125 FRANKLIN STREET



NEW YORK



# Two Splendid Articles



## *Our Wonderful* **GAS LAMP**

We want to show you how you can have this brilliant light in your own home. The ASCO GAS LAMP is simply a generator made in the form of a table lamp. It is so constructed that it will last a lifetime, as it is made entirely of metal, not even glass chimneys being used. With each lamp is supplied a quantity of calcium carbide, which can be bought afterwards at very low cost.

In operating lamp you simply place a portion of carbide in lamp and fill jacket with water, and acetylene gas is instantly generated, giving the most brilliant white light ever discovered.

The ASCO GAS LAMP is absolutely safe and can be upset and rolled on the floor without any danger whatever.

To be brief, the ASCO GAS LAMP is cheaper than Kerosene, safer than Kerosene, gives many times more light, and is much less trouble to use.

Price, \$3.50

## *The "Surety Door Catch* *and Burglar Alarm"*



This is the biggest selling article on the market this year. It is a wedge-shaped alarm which is simply slipped beneath the door; and if any attempt is made to open the door, the wedge tightens and prevents it. At the same time the bell will ring, which would instantly arouse the house and frighten off the intruder. It sells everywhere for one dollar.

*Write for Circulars*

**We Want Agents**

**Write for Special Terms**

## **NEW YORK & LIMA TRADING CO.**

**DEPT. E, 203 WEST BROADWAY, N. Y.**

# This Marvelous Health Vibrator

FOR MAN, WOMAN, AND CHILD

Relieves All Suffering

Cures Disease

## IT IS THE LAMBERT SNYDER VIBRATOR

When you hurt yourself, you instinctively rub the spot. When your head aches, you rub your temples. Why? Because vibration is Nature's own remedy, and rubbing is Nature's crude way of creating vibration and starting the blood to going. Disease is only another name for congestion. Where there is disease or pain, there you will find the blood congested and stagnant. There can be no pain or disease where the red blood flows in a rich and steady stream. Good circulation means good health. Congested circulation means disease and pain.

# STOP THAT PAIN



### The Lambert Snyder Vibrator

is the greatest medical discovery of the Twentieth Century, can be operated by yourself with one hand by moving the steel head over the rigid steel rod, and can be placed in contact with any part of the body, and is capable of giving from 9,000 to 15,000 vibrations per minute—100 times more than is possible with the most expert master of massage. It is Nature's own remedy developed and concentrated, and with one minute's use sends the red blood rushing into the congested parts, removing all disease and pain.

### Endorsed by Physicians

The Lambert Snyder Vibrator is used and endorsed by noted physicians because it is based on scientific principles of health. It cures by removing the cause, forcing the red blood through the congested parts at once. Don't pour

drugs into your stomach for a pain in the knee or back; the trouble is not there.

### What it Does to Disease and Pain

RHEUMATISM, SCIATICA, LUMBAGO, GOUT, ETC., are caused by uric acid in the blood in the form of urate of soda. This acid, through poor circulation at some particular part, gets stopped on its way through the system and, congregating, causes pain. Apply the Vibrator to the spot and you will relieve the congestion and get relief at once.

DEAFNESS, HEAD NOISES, RINGING IN THE EARS, in most cases, are caused by the thickening of the inner membrane through catarrh or colds. To cure this vibration is the only thing, as it is the only way to reach the inner ear drum and loosen up the hard wax or foreign matter so sound may penetrate to the drum.

STOMACH TROUBLE, INDIGESTION, CONSTIPATION, ETC., are caused by the food not properly digesting, it lacks necessary saliva and gastric juices, thus creating congestion in the stomach, forming gases causing pains, bad breath, etc. Apply the Vibrator to the stomach; it settles the food down, releases the gases, regulates the action, and brings about relief instantly.

THE LAMBERT SNYDER VIBRATOR will give marvelous results in the following cases:—

- |                   |               |             |                 |             |
|-------------------|---------------|-------------|-----------------|-------------|
| Locomotor Ataxia, | Neurasthenia, | Toothache,  | Sprains,        | Bronchitis, |
| Paralysis,        | Goitre,       | Catarrh,    | Lameness,       | Hay Fever,  |
| Writer's Cramp,   | Weak Eyes,    | Headaches,  | Pleurisy,       | Piles,      |
| Nervous Debility, | Asthma,       | Insomnia,   | Varicose Veins, | Anemia,     |
| Neuralgia,        | Earache,      | Weak Heart, | Varicocele,     |             |

and early stages of Bright's Disease, and a large number too numerous to mention.

### Development of the Bust

An undeveloped bust is brought about by poor nourishment, tight lacing, or run down health. Apply the Vibrator a few minutes each day, and your breast, neck, and arms soon fill out and become firm, round, and healthy. It forces the blood through the famished parts.

### A Few of Our Many Testimonials

No matter what town or city in the United States you live in, we can send you the names of satisfied customers who are using the Vibrator.

I suffered from severe Rheumatism which made my hands and arms swell and caused me pain beyond description. I bought your Vibrator, and the first application of it reduced the swelling and conquered the pain so much that I was able to get a good night's sleep. Since then I have stopped all medicines and use only the Vibrator.

Lambert Snyder Co.

C. C. WARREN, 68 Virginia Avenue, Jersey City, N. J.

October 20, 1906

Gentlemen—I received your Vibrator and my hearing was so bad I could not hear a watch tick. I can now hear a watch tick holding it at a distance from the ear and can hear sounds that I have not heard in years. I have spent a good deal of money for ear drums and other things, but your Vibrator has done me more good than them all.

ROBERT IRVING, 122 Gooding Street, Lockport, N. Y.

### Read Our Generous Offer

We, the makers and owners of the Lambert Snyder Health Vibrator, assure you that it has cured tens of thousands of people in the United States and in many foreign countries. We tell you that it has given relief and eventual cures in cases where the patient has suffered for years and had been unable to obtain even temporary relief by other means. We are so absolutely certain that our Health Vibrator can help and heal you that we say to you to-day:—Try our Vibrator for seven days—*if it brings relief, if it cures you, if it does what we claim for it—keep it.* If not, send it back and we will refund your money.

**FOR A LIMITED TIME.** By mentioning "Electrician and Mechanic" in sending us your order we will sell our \$5.00 Vibrator at \$2.00, delivered at our store, or mailed on receipt of \$2.35, post-paid.

**FREE**

To readers of ELECTRICIAN AND MECHANIC magazine. Our new book on Vibration, fully illustrated. It tells you what has and is being done by vibration. Our book is a plain, common-sense argument. Send for it to-day; it costs you nothing.

Electric Vibrators—All Kinds

Don't Wait

Don't Suffer

LAMBERT SNYDER CO., - - Dept. E, 41 West 24th Street, NEW YORK

# BE A STAR SALESMAN!

Get in touch with an alert, successful sales organization—the most powerful in the world.

Develop within yourself every attribute that will enable you to meet and master everyday selling problems.

Learn the infinite power of initiative—learn how to apply it to your own creative ability and more than double your earning power.

## This is Your Opportunity! Put Yourself to the Test.

The great sales organization of the Oliver Typewriter wants more salesmen.

This company offers to any accepted, energetic, ambitious man—absolutely free—all expenses paid—a scholarship in the Oliver School of practical salesmanship—and a chance to act as local agent.

The position offers a world of opportunities—the field is unlimited.

The Oliver Typewriter is a mechanical marvel—a vital power in the commercial world.

Business houses, great and small, are discarding antiquated machines and installing Oliver's.

Keen, conservative men—"captains of industry"—have awakened to the Oliver's indisputable efficiency and recognize the Oliver Typewriter as essential equipment of every good office system.

The superiority of the Oliver Typewriter emphasizes it as the standard by which all other typewriters are judged. Its supremacy is absolute.

The New Oliver No. 5 has taken the country by storm.

It meets the demand for durability. Its visible writing saves strain on the eyes. Disappearing Indicator shows exact printing point. The Double Release doubles convenience. Non-Vibrating Base insures stability.

Our untiring efforts to seek and produce "typewriter perfection" have been fulfilled beyond our boldest expectations in the New Oliver No. 5.

Requests for demonstration are pouring in from everywhere. Our large force of thousands is unable to meet such a tremendous demand and we must have more men at once to assist in the great task.

The positions we offer to the men who can qualify are permanent—the compensation is liberal—and the chances of advancement are excellent.

This announcement should kindle the spark of ambition in every one who chances to read it. It will appeal to every man who has it in him to "do things"—but has heretofore been handicapped. It means emancipation from drudgery and halted progress.

Send at once for a copy of the Oliver's remarkable book, "**The Rise of the Local Agent.**" It tells true stories of real life—how ambitious men started at the bottom of the Oliver's ladder of opportunity and now have reached the topmost rungs.

Write for a copy of the book—to-day—now—before you lay aside this magazine.

## The **OLIVER** Typewriter

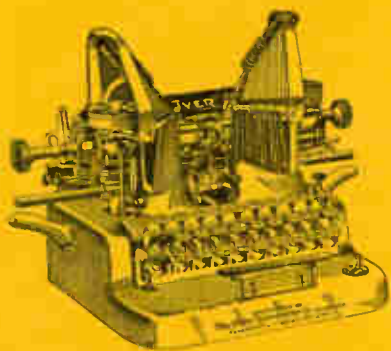

**THE OLIVER TYPEWRITER CO.**  
69-71 FEDERAL ST., BOSTON, MASS.

