

Nov.

RADIO PHONE  
**WRNY**  
STATION

25 Cent

# Science and Invention

IN PICTURES

**40**  
NON-TECHNICAL  
**RADIO**  
ARTICLES

HELICOPTER  
HELPS BUILD  
SKYSCRAPERS

See Page 606

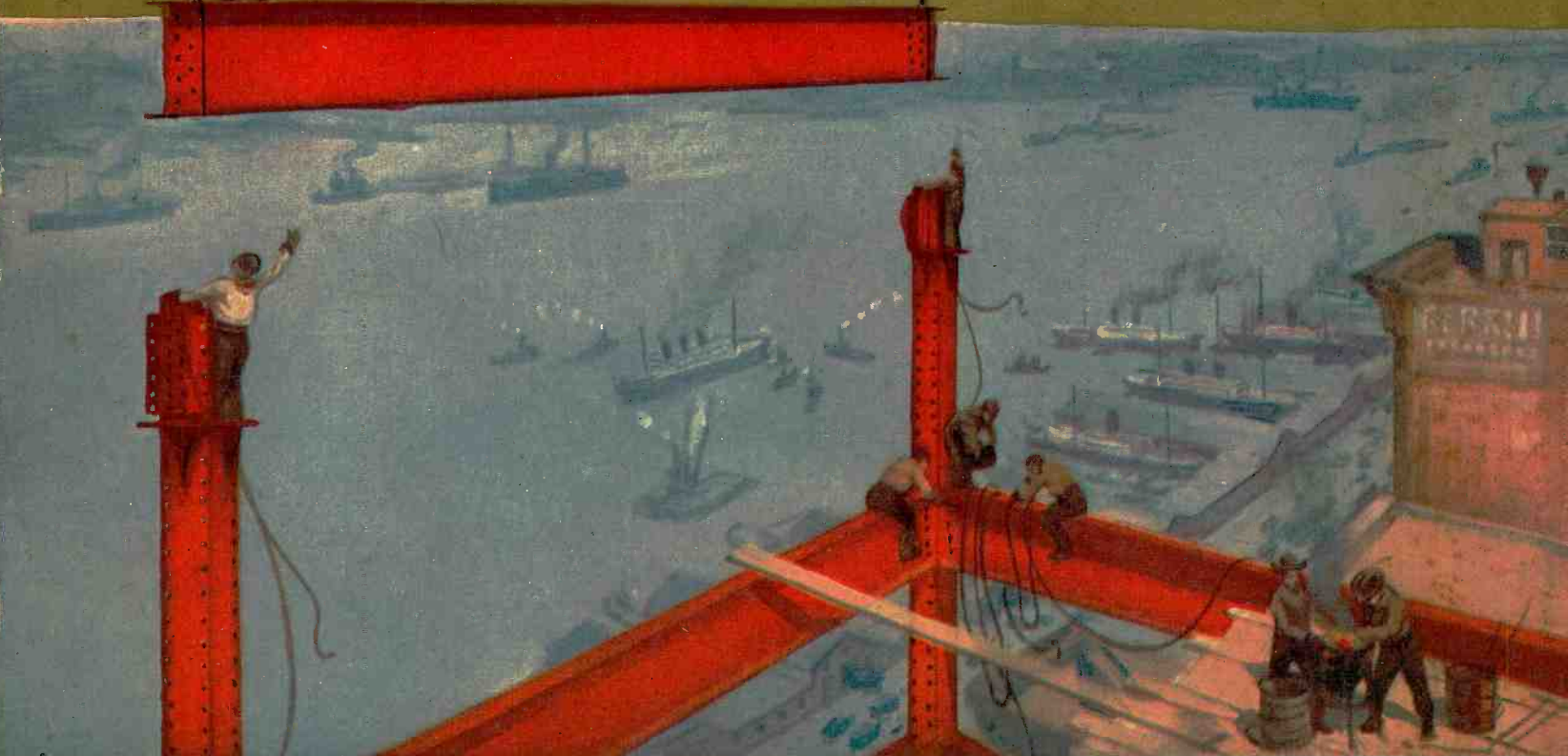

EXPERIMENTER PUBLISHING COMPANY, NEW YORK, PUBLISHERS OF  
RADIO NEWS - SCIENCE & INVENTION - THE EXPERIMENTER - MOTOR CAMPER & TOURIST



*Electrical Experts are in Big Demand!*  
—L.L. Cooke!



# I Will Train You at Home to fill a Big-Pay Job!

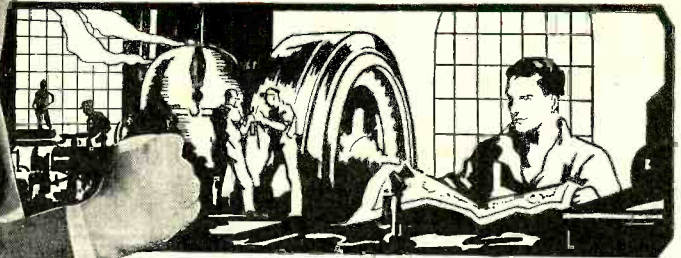

## Look What These Cooke Trained Men Are Earning



### Makes \$700 in 24 Days in Radio

"Thanks to your interesting Course I made over \$700 in 24 days in Radio. Of course, this is a little above the average but I run from \$10 to \$40 clear profit every day, so you can see what your training has done for me."

FRED G. McNABB, 848 Spring St., Atlanta, Georgia



### \$70 to \$80 a week for Jacquot

"Now I am specializing in Auto Electricity and battery work and make from \$70 to \$80 a week and am just getting started. I don't believe there is another school in the world like yours. Your lessons are a real joy to study."

ROBERT JACQUOT, 2005 W. Colorado Ave., Colorado Springs, Colo.



### \$20 a Day for Schreck

"Use my name as a reference and depend on me as a booster. The biggest thing I ever did was answer your advertisement. I am averaging better than \$500 a month from my own business now. I used to make \$18.00 a week."

A. SCHRECK, Phoenix, Arizona



### Plant Engineer—Pay raised 150%

"I was a dumbbell in electricity until I got in touch with you Mr. Cooke, but now I have charge of a big plant including 600 motors and direct a force of 34 men—electricians, helpers, etc. My salary has gone up more than 150%."

GEORGE ILLINGWORTH, 63 Calumet Road, Holyoke, Mass.

It's a shame for you to earn \$15 or \$20 or \$30 a week, when in the same six days as an Electrical Expert you could make \$70 to \$200—and do it easier—not work half so hard. Why then remain in the small-pay game, in a line of work that offers no chance, no big promotion, no big income? Fit yourself for a real job in the great electrical industry. I'll show you how.

## Be an Electrical Expert Earn \$3,500 to \$10,000 a Year

Today even the ordinary Electrician—the "screw driver" kind—is making money—big money. But it's the trained man—the man who knows the whys and wherefores of Electricity—the Electrical Expert—who is picked out to "boss" the ordinary Electricians—to boss the Big Jobs—the jobs that pay \$3,500 to \$10,000 a Year. Get in line for one of these "Big Jobs." Start by enrolling now for my easily learned, quickly grasped, right-up-to-the-minute, Spare-Time Home-Study Course in Practical Electricity.

### Age or Lack of Experience No Drawback

You don't have to be a College Man; you don't have to be a High School Graduate. As Chief Engineer of the Chicago Engineering Works, I know exactly the kind of training you need, and I will give you that training. My Course in Electricity is simple, thorough and complete and offers every man, regardless of age, education and previous experience, the chance to become, in a very short time, an "Electrical Expert," able to make from \$70 to \$200 a week.

### No Extra Charge for Electrical Working Outfit

With me, you do practical work—at home. You start right in after your first few lessons to work at your profession in the regular way and make extra money in your spare time. For this you need tools, and I give them to you—5 big complete working outfits, with tools, measuring instruments, and a real electric motor—5 outfits in all.

### Your Satisfaction Guaranteed

So sure am I that you can learn Electricity—so sure am I that after studying with me, you, too, can get into the "big money" class in electrical work, that I will guarantee under bond to return every single penny paid me in tuition, if, when you have finished my Course, you are not satisfied it was the best investment you ever made. And back of me in my guarantee, stands the Chicago Engineering Works, Inc., a two million dollar institution, thus assuring to every student enrolled, not only a wonderful training in Electricity, but an unsurpassed Student Service as well.

### Get Started Now—Mail Coupon

I want to send you my Electrical Book and Proof Lessons, both Free. These cost you nothing and you'll enjoy them. Make them start today for a bright future in Electricity. Send in Coupon—NOW.

L. L. COOKE, Chief Engineer  
**Chicago Engineering Works**  
2150 Lawrence Ave., Dept. 28  
Chicago



L. L. COOKE, The Man Who Makes "Big-Pay" Men  
Dept. 28  
2150 Lawrence Ave., Chicago

Send me at once without obligation your big illustrated book and complete details of your Home Study Course in Electricity, including your outfit and employment service offers.

**5 big outfits given to you — no extra charge**

**MAIL COUPON FOR MY FREE BOOK**

Name.....

Address.....

Occupation.....

**The "Cooke" Trained Man is the "Big Pay" Man**



# Own a Typewriter!

A Bargain You Can't Ignore! Every Member of the Family Will Use and Enjoy it! Try it Free, and See!

## \$300 and it's yours!

A generous free trial offer and the most liberal terms if you buy

GET YOUR typewriter now. A genuine Shipman-Ward rebuilt Underwood is the one you want—"the machine you will eventually buy!" Everyone needs it; now anyone can afford it. Don't send a cent—but do get our big special offer—our valuable book on typewriters and typewriting—free.

You can learn to write on this standard-keyboard machine in one day. A week after the expressman has brought it, you'd feel *lost* without it. A trial will *prove* it—and doesn't cost you a penny!

Our rebuilt plan gives you the best machine, and saves you a lot of money.

Save on the price, and get a FIVE year guarantee. — All tools, cover, etc., included

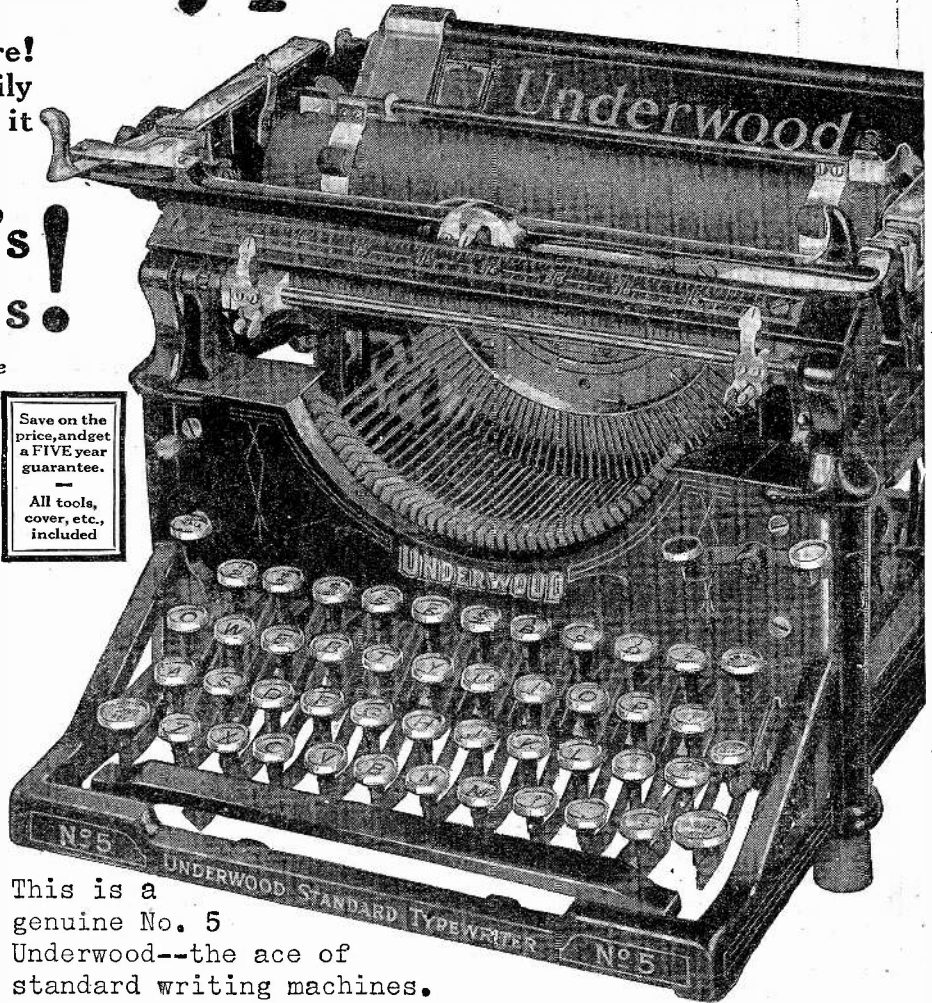

This is a genuine No. 5 Underwood--the ace of standard writing machines.

\*\*\*\*\*  
**\* Act NOW If Ever ! \***  
\*\*\*\*\*

The Underwood is so famous a make, and No. 5 so popular a model, you'll have to speak up if you want one of the lot we are just completing now!

We rebuild from top to bottom; *replace every single worn part*; each machine is in *sparkling* condition. New typewriters are commonly guaranteed for a year; we guarantee these completely rebuilt Underwoods *five years*. That's our Better-Than-New Guarantee! And we guarantee a big saving in money!

### Pay Like Rent

We don't ask for a cent now. Nor any money at all, unless you are completely won by the wonderful writing machine we ship you for an unrestricted 10-day free trial. When you do buy, take advantage of our very liberal scale of monthly payments. A host of our patrons have paid for their typewriters out of money made typing work for others. (One woman made a thousand dollars



at home last year with her Underwood.) If you know typewriters, you know the perfect work and the ease and speed of an Underwood. If you have never owned a typewriter, start with the finest! One that will last you all your life! But, the time to act is NOW. Don't miss out on this present bargain offer. Don't do longer without the convenience of a typewriter. Our modern method of rebuilding, and our economical resale plan remove the last reason for not owning this time-saving, money-making, educational device.

### Free Trial Plan

Our plan gives you the opportunity of a *thorough trial* before you buy. You run no risk whatever. You start to pay for your typewriter *after* you have found it the one and only machine for you! But get the facts before this lot of machines is all in use. Clip the infor-

mation coupon before you turn the page. It will pay you! Note the very useful book you will receive free! Write for full particulars at once.

### Valuable Typist's Manual FREE!

Get our catalog that tells how we rebuild these wonderful Underwood typewriters in the largest factory of its kind in the world, and lowest prices and terms in existence. We will also include free, the new Type Writing Manual—it gives many examples and samples of uses for your typewriter: in business accounts, social correspondence, recipes, shopping lists, household accounts, etc.; school-work; literary work, etc. *This is a typewriting age; no home is complete without a typewriter.* Clip coupon now!



**MAIL to** SHIPMAN-WARD MFG. Co. 2168 Shipman Bldg. Chicago

Please send full offer, with FREE, prices, terms, etc., and full information about your FREE course in Touch Typewriting. All without obligation; this is NOT an order!



Name .....  
St. or R. F. D. ....  
P. O. .... State .....

Vol. XIII.  
Whole No. 151

November, 1925  
No. 7

# Science and Invention

FORMERLY  
ELECTRICAL EXPERIMENTER

Member Audit Bureau of Circulations

EDITORIAL & GENERAL OFFICES: 53 Park Place, New York City  
GENERAL ADVERTISING DEPT.: 53 Park Place, New York City

Published by Experimenter Publishing Company, Inc.  
(H. Gernsback, Pres.; S. Gernsback, Treas.; R. W. DeMott, Sec'y.)

Publishers of SCIENCE & INVENTION, RADIO NEWS, THE EXPERIMENTER  
and MOTOR CAMPER & TOURIST.

## EDITORIAL STAFF

HUGO GERNSBACK, *Editor-in-Chief.*  
H. WINFIELD SECOR, E. E.,  
*Managing Editor.*  
DR. T. O'CONNOR SLOANE, Ph.D., M. A.,  
*Associate Editor.*  
JOSEPH H. KRAUS, *Field Editor.*  
A. P. PECK, Assoc. I. R. E.,  
*Radio Editor.*  
S. GERNSBACK, *Wrinkles Editor.*  
J. KELLY BURLEIGH, *Art Director.*

## CONTRIBUTING EDITORS

Dr. Ernest Bade, Ph.D.  
*Radio—*  
Sylvan Harris.  
Leon L. Adelman.  
*Magic and Psychic Phenomena—*  
Joseph Dunninger.  
Joseph F. Rinn.  
Edward Merlin.  
*Foreign Correspondents—*  
Dr. Alfred Gradenwitz, Germany.  
Dr. H. Becher, Germany.  
C. A. Oldroyd, England.  
S. Leonard Bastin, England.  
A. N. Mirzaoff, France.  
Hubert Slouka, Czechoslovakia.  
P. C. van Petegem, Holland.  
Richard Neumann, Austria.

*Astronomy—*  
Dr. Donald H. Menzel, Ph.D., University of Iowa.  
Isabel M. Lewis, M.A., of the U. S. Naval Observatory.  
*Entomology and Allied Subjects—*  
Dr. Ernest Bade, Ph.D.  
*Physics—*  
Dr. Harold F. Richards, Ph.D.  
Ernest K. Chapin, M. A.  
Dr. Donald H. Menzel, Ph.D., University of Iowa.  
*Automotive Subjects—*  
Tom C. Plumridge.  
George A. Luers.  
*Chemistry—*  
Raymond B. Wailes.

## IN OUR NEXT ISSUE

### Do You Want Part of \$5000?

If you do, see the next issue of this magazine for the announcement of a new contest that will outshine all others in magnitude.

### "Electric Eye" Grades Cigars

A novel application of photo-electric cell makes possible the construction of a machine that automatically selects 30 varieties of cigars.

### Do You Like to Build Radio Sets?

We will describe a novel type of audio frequency amplifier that can be made from spare low-priced parts, but which will give excellent results.

### Scientific Prison Escapes!

The facts of many escapes from large prisons form a story far more interesting because of its authenticity than any detective fiction.

\* \* \*

Due to lack of space when this issue was made up, the article dealing with the cooling of theatres that was announced for this issue had to be left out but will appear in a near future number.

## Contents for November

Editorial .....	603	Is the Earth Solid? .....	632
By Hugo Gernsback.		By Gene Deachen.	
The "Shenandoah" Versus the Elements .....	605	Awards in "Cut Flower" Contest .....	633
By William P. Sullivan.		Entertaining with Chemistry .....	634
Helicopter Helps Build Skyscrapers. ....	606	Chemical Tricks .....	635
By H. Winfield Secor, E.E.		By Dr. Ernest Bade.	
Fire, Smoke and Explosions on Stage .....	607	Etching Glass .....	636
By George Wall.		Leaf Records in Permanent Form .....	637
Solomon's Temple Model Reproduced .....	609	Lamp Chimney Experimental Apparatus .....	638
By A. N. Mirzaoff.		By Raymond B. Wailes.	
Movie Thrills on Skyscrapers .....	610	Testing Bread Value .....	639
By Edwin Schallert.		How-To-Make-It Dept. ....	640
Orchestra Volume From Phonograph .....	612	Readers Forum .....	641
Checker-Board .....	613	Wrinkles, Recipes and Formulas .....	642
Radio-Acoustic Range Finder .....	614	Edited by S. Gernsback.	
By C. A. Oldroyd.		A Continuous Time and News Broadcast Service .....	643
Two New Elements Discovered .....	615	By C. A. Oldroyd.	
By Prof. Donald H. Menzel, Ph.D.		"WRNY" .....	644
Marvelous Mechanism Does Switchman's Work .....	617	Radio Hazards .....	646
By Charles Frederick Carter.		Removing Insulation from Wire .....	647
Science Oddities .....	618	By Herbert E. Hayden.	
New Building Material .....	619	A Novel Six-In-One Receiver .....	648
London Camouflaged .....	620	By L. Ringer.	
By F. Fizzi.		An Efficient Two Tube Reflex Circuit .....	650
Mysterious Japanese Mirror .....	620	By C. Howard Schopfer.	
Deciphering Charred Records .....	621	Hints to the Radio Builder—Part 3 .....	651
Amateur Railroadng .....	623	By Leon L. Adelman, Assoc. I.R.E.	
By G. H. Dacy.		Five Tubes with Simple Tuning Control .....	652
Machine Makes Paper Cups .....	624	By A. P. Peck, Assoc. I. R. E.	
Meteors Photographed .....	625	Radio Oracle .....	653
"Old Film" Contest .....	626	Non-Sci(ence) .....	655
Tarrano, The Conqueror .....	628	Latest Patents .....	656
By Ray Cummings.		Scientific Humor .....	657
Oddities in the News .....	630	The Oracle .....	658
Magic by Dunninger .....	631	Awards in Our \$1000.00 Monthly Contest .....	660
		Radio Wrinkles .....	683

HOW TO SUBSCRIBE FOR "SCIENCE AND INVENTION." Send your name, address and remittance to Experimenter Publishing Co., 53 Park Place, New York City. Checks and money orders should be made payable to Experimenter Publishing Co., Inc. Mention the name of the magazine you are ordering inasmuch as we also publish RADIO NEWS, THE EXPERIMENTER and MOTOR

CAMPER & TOURIST. Subscriptions may be made in combination with the other publications just mentioned at special reduced club rates. Send postal for club rate card. Subscriptions start with the current issue unless otherwise ordered. ON EXPIRATION of your subscription, we enclose a renewal blank in our last number to you, and notify you by mail. Then unless we receive your

order and remittance for a renewal, delivery of the magazine is stopped. CHANGE OF ADDRESS: Notify us as far in advance as possible, giving your old address as well as the new one to which future magazines are to go. It takes several weeks to make an address change on our records.

SCIENCE AND INVENTION is published on the 10th of each month. There are 12 numbers per year. Subscription price is \$2.50 a year in U. S. and possessions. Canada and foreign countries \$3.00 a year. U. S. coin as well as U. S. stamps accepted (no foreign coin or stamps). Single copies, 25 cents each. A sample copy will be sent gratis on request. All communications and contributions to this journal should be addressed to Editor, SCIENCE AND

INVENTION, 53 Park Place, New York City, N. Y. Unaccepted contributions cannot be returned unless full postage has been included. ALL accepted contributions are paid for on publication.

SCIENCE AND INVENTION, Monthly. Entered as second class matter May 10, 1924, at the Post Office at New York, N. Y., under the act of March 3, 1879. Additional entry at Long Island City, N. Y., and

San Francisco, Calif. Title Registered at the Patent Office. Copyright, 1925, by E. P. Co., Inc., New York. The Contents of this Magazine are copyrighted and must not be reproduced without giving full credit to the publication. SCIENCE AND INVENTION is for sale at all newsstands in the United States and Canada. European Agents, S. J. Wise Et Cie, 40 Place Verte, Antwerp, Belgium.

New England Advertising Representative Western Advertising Representatives Pacific Coast Advertising Representatives Kansas City Advertising Representatives  
T. F. Magrane Finucan & McClure A. J. Norris Hill Co. Davies & Dillon  
Park Square Bldg., Boston, Mass. 720 Cass St., Chicago, Ill. Hearst Bldg., San Francisco, Cal. 15 W. 10th St., Kansas City, Mo.



**EVEREADY HOUR**  
**EVERY TUESDAY AT 9 P. M.**  
*Eastern Standard Time*  
 For real radio enjoyment, tune in the  
 "Eveready Group." Broadcast through  
 stations—

WEAF	New York	WSAI	Cincinnati
WJAR	Providence	WWJ	Detroit
WEEL	Boston	WCCO	Minneapolis
WFI	Philadelphia	WOC	St. Paul
WGR	Buffalo	WOC	Liverport
WCAE	Pittsburgh	WCTS	Worcester

# ALWAYS RELIABLE

EVEREADY Radio Batteries are always uniform and reliable! Evereadys perform the same, everywhere, for everybody, needing no skill, calling for no experimentation, wasting no time, saving you money. Trouble-proof, wonderful Evereadys. There is an Eveready dealer nearby.

*Manufactured and guaranteed by*  
**NATIONAL CARBON COMPANY, Inc.**  
 New York San Francisco  
 Canadian National Carbon Co., Limited, Toronto, Ontario

## EVEREADY Radio Batteries

*-they last longer*

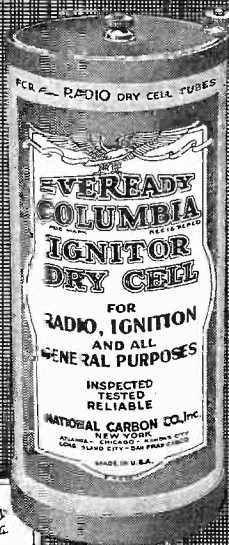

Eveready Columbia Ignitor "A" Battery, the proven dry cell for all radio dry cell tube. 1½ volts

No. 766  
 22½-volt  
 Large  
 Horizontal  
 Price  
 \$2.00

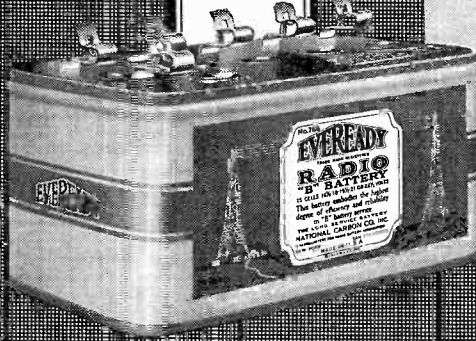

No. 770  
 45-volt  
 Extra  
 Large  
 Vertical  
 Price  
 \$4.75



# SCIENCE and INVENTION READERS' BUREAU

## Time and Postage Saver

**I**N every issue of SCIENCE and INVENTION you undoubtedly see numerous articles advertised about which you would like to have further information.

To sit down and write an individual letter to each of these respective concerns, regarding the article on which you desire information, would be quite a task.

As a special service to our readers, we will write the letters for you, thus saving your time and money.

Just write the names of the products about which you want information, and to avoid error the addresses of the manufacturers, on the coupon below and mail it to us.

If the advertiser requires any money or stamps to be sent to pay the mailing charges on his catalogue or descriptive literature, please be sure to enclose the correct amount with the coupon.

We will transmit to the various advertisers your request for information on their products.

This service will appear regularly every month on this same page in SCIENCE and INVENTION.

If there is any Manufacturer not advertising in this month's issue of SCIENCE and INVENTION from whom you would like to receive literature, write his name, address and the product in the special section of the coupon below.

TEAR ALONG THIS LINE

**READERS' SERVICE BUREAU,**  
**Experimenter Publishing Co., Inc., 53 Park Place, New York, N. Y.**

S. & I. 11-25

Please advise the firms listed below that I would like to receive detailed information on their product as advertised in the ..... issue of SCIENCE and INVENTION.

 THIS FORM SHOULD NOT BE USED FOR TECHNICAL QUESTIONS

NAME	ADDRESS (Street—City—State)	List here specific article on which you wish literature.	If Catalogue of complete line is wanted, check in this column.
.....	.....	.....	.....
.....	.....	.....	.....
.....	.....	.....	.....
.....	.....	.....	.....
.....	.....	.....	.....

 THIS FORM SHOULD NOT BE USED FOR TECHNICAL QUESTIONS

Use this space if you desire information from a manufacturer whose advertisement does not appear in this month's issue.

NAME	ADDRESS (Street — City — State)
.....	.....
.....	.....
.....	.....

Your name..... Dealer's name.....

Your address..... His address.....

If you are dealer check here. City..... State..... City..... State.....





The only school advertising in this magazine that is authorized to confer the degree of Bachelor of Science upon graduates of its Electrical Engineering College.

# WIN WEALTH & HONOR

## Come to Milwaukee

**I** NVESTIGATE—compare—write to any big business concern in Milwaukee for information about us—or to any of the big electrical organizations in the United States—and you will surely decide to come to Milwaukee, on beautiful Lake Michigan, for your training, at America's Greatest Institution of Practical Electrical Education.

Built on the Cornerstone of Personal, Individual Service to every student.

# SCHOOL of ENGINEERING of Milwaukee

## Short-Cut Your Training for Big Pay and High Position

Our equipment is the most elaborate, complete and up-to-date of any electrical school in America, and includes Wiring, Testing, D.C. and A.C. Motor Generator, Armature Winding and Transformer, Starting, Lighting and Ignition, Storage Battery and Chemical Laboratories, Drafting and Designing Rooms and fully equipped Radiocast station right on the grounds of the school. Unique laboratory equipment originally designed and patented by us, housed in concrete four-story building. Our complete facilities afford to every student ample opportunities for actual practice.

No matter how young or old you are, no matter how little or how much general schooling you have had, no matter whether you want to master every branch of electricity and become an Electrical Engineer or want to become a highly skilled and well-paid specialist at one particular kind of

electrical work—there is a place at S. O. E. for YOU. In one of our many classes of students you can learn to be an Electrical Engineer, Commercial Electrical Engineer, Electrotechnician, Junior Electrical Engineer, Practical Electrician, Motor Generator Repairman, Electrical Draftsman, Automotive Electrician, Radio Salesman and Service-man.

We do not use our students to make secret profits for ourselves by selling the work they do and the things they produce in the shops.

Don't even think of enrolling with any other school until you have written direct to S. O. E. Headquarters for full information about the particular kind of training you are interested in. Choose from the list below. Then mark and mail the coupon TODAY.

S. O. E. graduates make *Big Salaries* everywhere in the great electrical field. Our Employment Department will help you secure profitable employment with opportunities for advancement.

**WSOE**  
RADIOCAST STATION  
owned and operated by the SCHOOL OF ENGINEERING OF MILWAUKEE

### Our Special Three Months Practical Vocational Courses

These courses are intensely practical and are easily learned by any man who can read and understand common English and simple arithmetic.

### Electrical Drafting—Learn in 9 to 12 Months

Easy, interesting, pleasant work that is earning big salaries for our graduates all over the world.

### Earn While You Learn

We provide for a limited number of worthy men, half-time jobs at good wages, and permanent positions with unlimited prospects to all duly qualified graduates.

### Electrical Engineering—B. S. Degree in 3 Years

Bachelor of Science degree conferred on graduates. Full provision is made for making up deficient high school credits. It is the Electrical Engineers who have given to the world the thousands of fortune making inventions in the electrical field. No man with this training can fail to realize his highest ambitions in life.

### Home Electrical Laboratory Training

For those who do not see their way clear to come to Milwaukee now, we offer a very thorough and complete Home Laboratory Course. Ask for details on how you can begin your electrical training at home under our patented Home Laboratory Plan with full size commercial electrical power and equipment valued at \$500—LOANED without extra charge.

### Every Instructor a Specialist

These are some of the experts whose teaching has supplied thousands of high-salaried men to the electrical industry through this school—many of whom in overalls and jumpers stand at your elbow teaching and explaining while you learn by doing. The only way you can fail to learn is to refuse to learn: O. Werwath, E.E. Francis A. Vaughn, B.S. Willard C. Hartman, A.B., A.M. Chester C. Aiken, B.S. Asher C. Ball, B.S., LL.B. W. H. Bierk, B.S. W. E. Boren, A.B. Ben. A. Bovee, B.S. E. L. Consover, M.E. J. T. Baker, I. C. Fisher, B.S. George B. Haverson, A.B. Elmer A. Ihke, B.S. Arthur A. Koch, M.S., Ph.D. Fred W. Krotzer, A.B. Charles Nyberg, A.B. C. E. Pettinill, B.S. Charles M. Ploetz, F. C. Raeth, B.S. H. A. Rickeman, A.B. Chas. G. Simpson, M.A., Ph.D. V. M. Murray, B.S. J. W. Smith. A. L. Sudduth. E. L. Wiedner.

New Class Starts November Ninth. Enroll today and tomorrow you will be doing actual electrical work in our big shops and laboratories.

- Course 1: Learn in **THREE Months**: Complete practical course in Electric Light, Heat and Power Wiring and Testing.
- Course 2: Learn in **THREE Months**: Complete practical course in D.C. and A.C. Motors and Generators, Armature Winding.
- Course 3: Learn in **THREE Months**: Complete practical course in Automotive Electricity—Starting, Lighting, and Ignition, and Storage Batteries.
- Course 4: Learn in **THREE Months**: Complete practical course in Radio Sales, Service and Broadcasting.

### Junior Electrical Engineering Learn in 12 to 30 Months

This elaborate course prepares the student for entrance to our College Course for Electrical Engineers. Junior Electrical Engineers are a special type of electrical experts qualified to fit electricity to the demands of modern industry and for such positions as superintendent of maintenance, director of construction, superintendent of installation and testing, electrical equipment salesman and automotive electrician and radio sales and service work.

### Electrotechnician—Learn in 1 Year

This course is especially adapted to meet the needs of those young men who wish to become a Commercial Electrical Engineer but do not possess the necessary entrance requirements. In addition to the Practical Commercial Electrical Engineering studies, you will receive academic subjects.

### Commercial Electrical Engineering—Learn in 1 Year

This new profession demands young men with combined electrotechnical and commercial training. Course unexcelled—most complete, practical electrical training.

### Practical and Theoretical Electricity—Learn in 6 Months

For the man or youth who cannot spare the time or money to enroll for more intensive and higher training, this course is ideal. We positively guarantee that as a student of one of these classes you will learn Practical Electricity in the shortest possible time—no matter how much you pay for your instruction. This course teaches you everything you need to know to go into business for yourself either as the owner of an electrical shop or as an electrical contractor.

LECTURES ON Electricity GIVEN WEEKLY FROM **WSOE** RADIOCAST STATION Ask for FREE SCHOLARSHIP Contest Information.



Mail the coupon today for our Free Illustrated Catalog just off the press. Tell us what course interests you most and we will send you special information. Find out about the great opportunity in Electricity today. Learn how we can help you short-cut your training for **RANK, HONOR and WEALTH**. Don't put it off! **MAIL THE COUPON NOW!**

Men or Action

# SCHOOL of ENGINEERING of Milwaukee

Dept. S. I.-1125, 415 Marshall Street, Milwaukee, Wisconsin

SCHOOL OF ENGINEERING OF MILWAUKEE, S.I.-1125, 415 Marshall St., Milwaukee, Wis.

Please send me, without cost or obligation, your free illustrated book just off the press, and details of the course I have indicated below. (Be sure to mention age, education and course of interest.)

Course \_\_\_\_\_  
 Name \_\_\_\_\_  
 Address \_\_\_\_\_  
 City \_\_\_\_\_ State \_\_\_\_\_  
 Age \_\_\_\_\_ Education \_\_\_\_\_



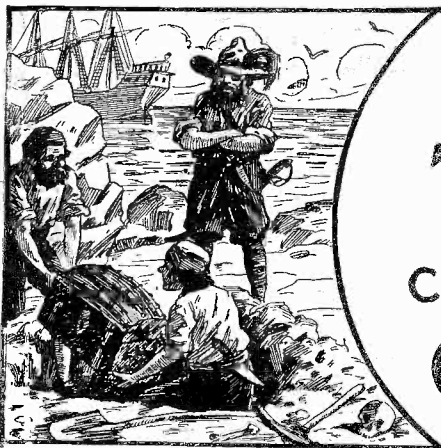

# BURIED TREASURE

can still be found in

# CHEMISTRY



## Good Chemists Command High Salaries

and you can make yourself independent for life by unearthing one of chemistry's yet undiscovered secrets.

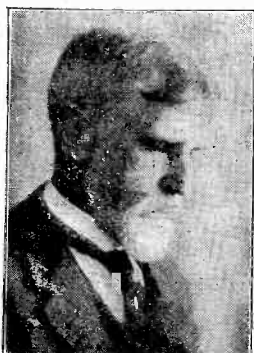

**T. O'CONOR SLOANE,**  
A.B., A.M., LL.D., Ph.D.  
Noted Instructor, Lecturer and Author. Formerly Treasurer American Chemical Society and a practical chemist with many well known achievements to his credit. Not only has Dr. Sloane taught chemistry for years but he was for many years engaged in commercial chemistry work.

Do you remember how the tales of pirate gold used to fire your imagination and make you want to sail the uncharted seas in search of treasure and adventure? And then you would regret that such things were no longer done. But that is a mistake. They *are* done—today and everyday—not on desert islands, but in the chemical laboratories throughout your own country. Quietly, systematically, the chemist works. His work is difficult, but more adventurous than the blood-curdling deeds of the Spanish Main. Instead of meeting an early and violent death on some forgotten shore, he gathers wealth and honor through his invaluable contributions to humanity. Alfred Nobel, the Swedish chemist who invented dynamite, made so many millions that the income alone from his bequests provides five \$40,000 prizes every year for the advancement of science and peace. C. M. Hall, the chemist who discovered how to manufacture aluminum made millions through this discovery. F. G. Cottrell, who devised a valuable process for recovering the waste from flue gases, James Gayley, who showed how to save enormous losses in steel manufacture, L. H. Baekeland, who invented Bakelite—these are only a few of the men to whom fortunes have come through their chemical achievements.

### What Some of Our Students Say of This Course:

I have not written since I received the big set. I can still say that it far exceeded my anticipations. Since I have been studying with your school I have been appointed chemist for the Scranton Coal Co. testing all the coal and ash by proximate analysis. The lessons are helping me wonderfully, and the interesting way in which they are written makes me wait patiently for each lesson.—**MORLAIS COUZENS.**

I wish to express my appreciation of your prompt reply to my letter and to the recommendation to the General Electric Co. I intend to start the student engineering course at the works. This is somewhat along electrical lines, but the fact that I had a recommendation from a reliable school no doubt had considerable influence in helping me to secure the job.—**IL. VAN BENTHOUSEN.**

So far I've been more than pleased with your course and am still doing nicely. I hope to be your honor graduate this year.—**J. M. NORKUS, JR.**

I find your course excellent and your instruction, truthfully, the clearest and best assembled I have ever taken, and yours is the fifth one I've studied.—**JAMES J. KELLY.**

From the time I was having Chemistry it has never been thus explained to me as it is now. I am recommending you highly to my friends, and urging them to become members of such an organization.—**CHARLES BENJAMIN.**

I shall always recommend your school to my friends and let them know how simple your lessons are.—**C. J. AMDAHL.**

I am more than pleased. You dig right in from the start. I am going to get somewhere with this course. I am so glad that I found you.—**A. A. CAMERON.**

I use your lessons constantly as I find it more thorough than most text books I can secure.—**WM. H. TIBBS.**

Thanking you for your lessons, which I find not only clear and concise, but wonderfully interesting. I am.—**ROBT. H. TRAYLOR.**

I received employment in the Consolidated Gas. Co. I appreciate very much the good service of the school when a recommendation was asked for.—**JOS. DECKER.**

## Now Is the Time to Study Chemistry

Not only are there boundless opportunities for amassing wealth in Chemistry, but the profession affords congenial employment at good salaries to hundreds of thousands who merely follow out its present applications. These applications are innumerable, touching intimately every business and every product in the world. The work of the chemist can hardly be called work at all. It is the keenest and most enjoyable kind of pleasure. The days in a chemical laboratory are filled with thrilling and delightful experimentation, with the alluring prospect of a discovery that may spell Fortune always at hand to spur your enthusiasm.

### You Can Learn at Home

To qualify for this remarkable calling requires elaborate specialized training. Formerly it was necessary to attend a university for several years to acquire that training, but thanks to our highly perfected and thorough system of instruction, you can now stay at home, keep your position, and let us educate you in Chemistry during your spare time. Even with only common schooling you can take our course and equip yourself for immediate practical work in a chemical laboratory. Dr. Sloane gives every one of his students the same careful, personal supervision that made him celebrated throughout his long career as a college professor. Your instruction from the very beginning is made interesting and practical, and we supply you with apparatus and chemicals for performing the fascinating analyses and experimental work that plays such a large part in our method of teaching, and you are awarded the Institute's official diploma after you have satisfactorily completed the course.

### Easy Monthly Payments

You don't have to have even the small price of the course to start. You can pay for it in small monthly amounts—so small that you won't feel them. The cost of our course is very low, and includes everything, even the chemistry outfit—there are no extras to buy with our course. Our plan of monthly payments places a chemical education within the reach of everyone. Write us and let us explain our plan in full—give us the opportunity of showing you how you can qualify for a highly trained technical position without even giving up your present employment.

### Special 30 Day Offer

Besides furnishing the student with his Experimental Equipment, we are making an additional special offer for a short while only. You owe it to yourself to find out about it. Write today for full information and free book "Opportunities for Chemists." Send the coupon right now while it is fresh in your mind. Or just write your name and address on a postal and mail it to us. But whatever you do, act today before this offer is withdrawn.

**DON'T WAIT—MAIL COUPON NOW!**



### Experimental Equipment Furnished to Every Student

We give to every student without additional charge this chemical equipment, including forty-nine pieces of laboratory apparatus and supplies, and forty different chemicals and reagents. These comprise the apparatus and chemicals used for the experimental work of the course. The fitted heavy wooden box serves not only as a case for the outfit but also as a useful laboratory accessory for performing countless experiments.

## CHEMICAL INSTITUTE OF NEW YORK, Inc.

Home Extension Division II

66-S—WEST BROADWAY

NEW YORK CITY

**CHEMICAL INSTITUTE OF NEW YORK**  
Home Extension Division II  
66-S—West Broadway  
New York City

Please send me at once, without any obligation on my part, your free Book "Opportunities for Chemists," and full particulars about the Experimental Equipment given to every student. Also please tell me about your plan of payment and your special 30 day offer.

NAME .....

ADDRESS .....

CITY..... STATE.....  
S.I., Nov. '25

# How a Strange Accident Saved Me From Baldness-

*Sixty days ago it made me boiling mad. Today I look back and laugh at the incident for it brought me a marvelous new growth of hair*

I'M willing to bet that I've wasted more money trying to end my baldness than any other man in the world. So naturally I laughed at any ad that sounded like a baldness remedy. And the oftener I laughed, the more bald I became.

When my wife began to look sorrowfully at my thinning hair I smiled regretfully. When my friends began to call me "baldy" I felt somewhat annoyed. But when my private secretary began to look strangely at my glistening scalp and snicker—well it made me mad!

But the worst was yet to come. About sixty days ago I saw a toothpaste advertisement that offered to send a free booklet. It sounded interesting so I clipped the coupon and gave it to my secretary to fill in and mail.

Well, a few days later, to my utter surprise I found on my desk—not a booklet on toothpaste—but a booklet and a letter telling how to end baldness in 30 days!

I glanced from the booklet to my secretary. I felt my blood boiling.

"Miss Harris," I said to her, "I can't say that I appreciate your sense of humor. Just what is your idea? Is it . . ."

She paled. "Why, Mr. Burns—what's wrong—what have I done?"

"Done?" I shouted, "aren't you content with laughing at my bald head—must you make matters worse by sending me this hint. If it pains you to look at my head you are always at liberty to resign!"

Tears came into her eyes. And between sobs she explained why it wasn't really her fault.

She said that the coupon which I asked her to mail had another coupon printed on the back—and the other coupon offered to send a free book about baldness. Well, she simply used her own judgment!

"Hm," was all I could say. And during the entire day not a word passed between us.

But that night on my way home I read the book about baldness. And I have to admit that a more interesting, more helpful, more honest book I've never read in my life. It described an entirely new method of making hair grow—a method perfected by Alois Merke, founder of the Merke Institute, Fifth Avenue, New York. It is the only treatment I had ever heard of that actually reached right down to the hair roots and awakened them to new, vigorous activity.

As I read on I felt myself weakening in my resolve not to try another hair treatment. And then when I read that Merke actually guaranteed a new growth of hair in 30 days or no cost to me—well, I completely weakened and sent for the treatment.



The first two or three times I used the treatment I began to notice that my hair didn't fall out as much as it used to. But a week or so later when I looked in the mirror I saw something that almost bowled me over. For there, just breaking through, was a fine downy fuzz all over my head.

Every night I spent 15 minutes taking the treatment at home. And every day this young hair kept getting stronger and thicker. At the end of a month you could hardly see a bald spot on my head. And at the end of sixty days—well, my worries about baldness were ended. For I had regained an entirely new head of healthy hair. Can you blame me for laughing now at the strange incident of 60 days ago?

ments. Yet now these very same results may be secured in any home in which there is electricity—at a cost of only a few cents a day.

The thing I like most about Merke is that he very frankly admits that his treatment will not grow hair in every case. There are some cases of baldness that nothing in the world can help. But so many others have regained hair this new way, that he absolutely guarantees it to produce an entirely new hair growth in 30 days or the trial is free. In other words, no matter how thin your hair may be, he invites you to try the treatment 30 days at his risk, and if it fails to grow hair then he's the loser—not you. And you are the sole judge of whether his method works or not.

## Coupon Brings You Full Details

This story is typical of the results that great numbers of people are securing with the Merke Treatment.

"The New Way to Make Hair Grow," which explains the Merke Treatment in detail, is the title of the vitally interesting 34-page book, which will be sent you entirely free, if you simply mail the coupon below.

This little book tells all about the amazing new treatment, shows what it has already done for countless others, and in addition contains much valuable information on the care of the hair and scalp. Remember, this book is yours free—to keep. And if you decide to take the treatment, you can do so without risking a penny. So mail the coupon now and get the surprise of your life! Address Allied Merke Institute, Inc., Dept. 4611, 512 Fifth Avenue, New York. Get this Free Book.



## Here's the Secret

According to Alois Merke, in most cases of baldness the hair roots are not dead, but merely dormant—temporarily asleep. Now to make a sickly tree grow you would not think of rubbing "growing fluid" on the leaves. Yet that is just what I had been doing, when I used to douse my head with common ordinary tonics, salves, etc. To make a tree grow you must nourish the roots. And it's exactly the same with hair.

This new treatment, which Merke perfected after 17 years' experience in treating baldness, is the first and only practical method of getting right down to the hair roots and nourishing them.

At the Merke Institute many have paid as high as \$500 for the results secured thru personal treat-

### Read This!

"Results are wonderful. My hair has stopped falling out and I can see lots of new hair coming in. I preach your system to everyone."—F. D. R., Washington, D. C.

"My hair was coming out at an alarming rate, but after four or five treatments I noticed this was checked. My hair is coming in thicker and looks and feels full of life and vigor."—W. C., Great Neck, N. Y.

"I have used your system for eight weeks and although the top of my head has been entirely bald for six years, the results up to the present are gratifying. In fact, the entire bald spot is covered with a fine growth of hair."—W. B., Kenmore, Ohio.

(Original of above letters on file at the Institute.)

Allied Merke Institute, Inc.  
Dept. 4611, 512 Fifth Avenue, N. Y. C.

Please send me—without cost or obligation, in a plain wrapper, a copy of your book describing the Merke System.

Name .....

(State whether Mr., Mrs. or Miss)

Address .....

City ..... State .....



---

# A Lacault Development

---

**T**O the radio-wise, the mere fact that the designer of this new kind of receiver is R. E. LACAULT is a sufficient recommendation. This famous technician has frequently lead the forward march of radio. His popularity is founded on the recognition of his intense practicality. He is no mere theorist! He never misleads, never entangles with useless technicalities. He perceives the requirements of the average radio user and designs in strict accordance with these practical requirements. The result is always complete satisfaction. This new type receiver is the realization of Lacault's fondest ideals of radio reception.

## Specifications

*Circuit*—The new ULTRADYNE Model L-3 employs six vacuum tubes of the six volt, one-quarter ampere type. The first three function as radio frequency amplifiers, the fourth as detector and the last two as audio frequency amplifiers. Operation has been simplified by using automatic filament controls in place of rheostats. The first two stages of radio frequency amplification are tuned while the third stage is fixed.

*Selectivity*—A special resistance system of stabilization prevents these circuits from oscillating at resonance points. More than this, the system actually increases the selectivity of the set without any loss in efficiency. Though the set is so highly selective, there are none of the "critical tuning characteristics" common to so many receivers, due to the use of straight-line wave length condensers. The lever system of control provides a vernier action of a new order.

*Matched Loud Speaker and Amplifier Units*—Distortion has been eliminated by striking an equality in the impedance of the loud speaker unit and the plate to filament impedance of the tubes. The two work in perfect harmony with each other. The new ULTRADYNE is designed to use either an indoor or an outdoor aerial. For most purposes an indoor wire is sufficient. A section of lamp cord run around the moulding of a room is very satisfactory.

*Cabinet*—The cabinet is 24 inches long, 14 inches high and 14 inches deep. Space is provided for the "B" batteries on the inside. Binding posts on the rear of the vacuum tube socket sub-base take the aerial, ground and "A" battery connections which are run through holes in the back of the cabinet. The wood is a rich, brown color, made up of five-ply mahogany veneer and decorated with two-tone line cuttings. DUCO finished to guarantee the permanency of color, grain and lustre. The grill in the center, which conceals the loud speaker horn, is a statuary bronze color and is backed by a meshing of dull gold.

### Guaranteed

To protect the public, Mr. Lacault's personal monogram seal (R.E.L.) is placed on the assembly lock-bolts of all genuine ULTRADYNE Model L-3 Receivers. All Receivers are GUARANTEED so long as these seals remain unbroken. No equivocation about this GUARANTEE. This seal is as positive in its protection as a bank note. As long as you refrain from tampering with it, the ULTRADYNE, Model L-3, will be maintained in perfect condition by its makers.



# ULTRADYNE

## MODEL L-3

PHENIX RADIO CORPORATION

114G EAST 25th ST., NEW YORK

---

## No Dials—No Panel—Built-in Loudspeaker

---

# A New Conception of Radio

*A  
New Kind of Receiver  
No Dials - No Panel  
Built-in Loudspeaker*

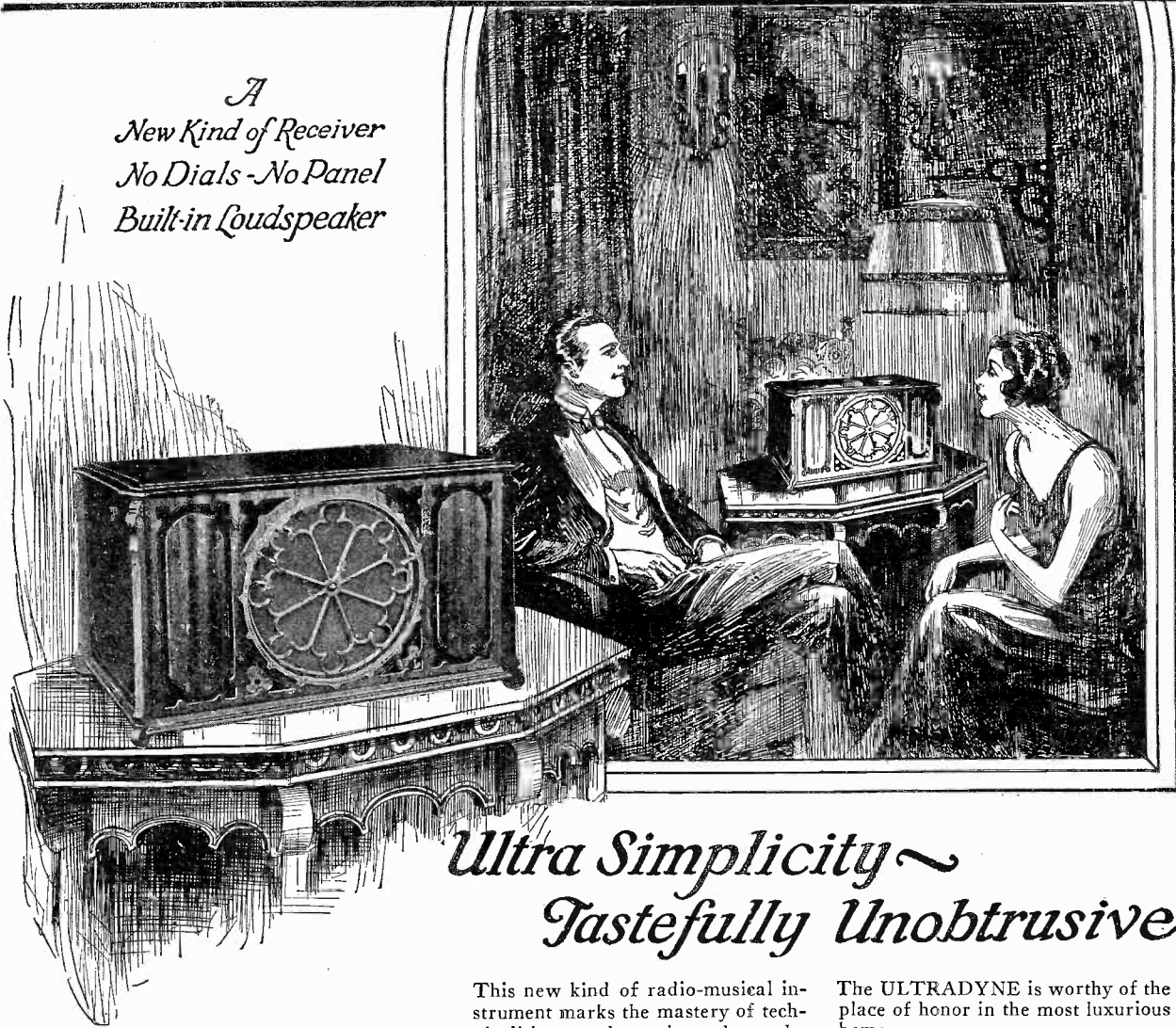

*Ultra Simplicity ~  
Tastefully Unobtrusive*

This new kind of radio-musical instrument marks the mastery of technicalities to the point where the whole range of radio's resources are literally at your instant command.

The ULTRADYNE, Model L-3, supplants the usual "laboratory machine." It is a new artistic table-piece that makes the entrance of radio into the well-appointed home *unobtrusive, inconspicuous*. It represents the triumph of art over mere mechanics.

The ULTRADYNE is worthy of the place of honor in the most luxurious home.

The ULTRADYNE, Model L-3, fulfills everything that the critically-minded have demanded of radio. Why wait any longer, why deny yourself the infinite treasures of radio? The ideal has at last been attained.

Skepticism will vanish if you will allow your local dealer to demonstrate this new modern radio receiver.

*Illustrated Folder on Request.*

**\$135<sup>00</sup>**

# ULTRADYNE

MODEL L-3

PHENIX RADIO CORPORATION

114G EAST 25th ST., NEW YORK

*Beauty in Tone - Beauty in Design*





# Master Electricity By Actual Practice

The only way you can become an expert is by doing the very work under competent instructors, which you will be called upon to do later on. In other words, *learn by doing*. That is the method of the New York Electrical School.

Five minutes of actual practice properly directed is worth more to a man than years and years of book study. Indeed, Actual Practice is the only training of value, and graduates of New York Electrical School have proved themselves to be the only men that are fully qualified to satisfy EVERY demand of the Electrical Profession.

## The Only Institution of the Kind in America

At this "Learn by Doing" School a man acquires the art of Electrical Drafting; the best business methods and experience in Electrical Contracting, together with the skill to install, operate and maintain all systems for producing, transmitting and using electricity. A school for Old and Young. Individual instruction.

### Over 9,500 Graduates are Successful Men in the Electrical World

No previous knowledge of electricity, mechanics or mathematics is necessary to take this electrical course. You can begin the course now and by steady application prepare yourself in a short time. You will be taught by practical electrical experts with actual apparatus, under actual conditions.

The N. Y. E. S. gives a special Automobile Ignition Course as an advanced training for Auto Mechanics, Garage Men and Car Owners. The course covers completely all Systems of Ignition, Starters, Lighting and other electrical equipment on automobiles, motor boats, airplanes, etc.

*Let us explain our complete courses to you in person. If you can't call, send now for 64-page book—it's FREE to you.*

New York Electrical School  
29 W. 17th St., New York, N. Y.

Please send FREE and without obligation to me your 64-page book.

..... NAME  
 ..... STREET  
 ..... CITY ..... STATE

# New York Electrical School

29 West 17th Street, New York

# Science and Invention

Editorial and General Offices, - - - 53 Park Place, New York

*"Those Who Refuse to Go Beyond Fact Rarely Get As Far As Fact" - - - HUXLEY*

## The Mentality of Inventors

By HUGO GERNSBACK

**I**NVENTORS have always been considered as a separate sort of humanity from the rest of us, and indeed they are. Inventors—and we may say this of fully ninety per cent. of them—live in an entirely different world from other people, and have a totally different mentality all the way through. As a rule, we are prone to call every inventor a “crank” or a “nut,” which, to our way of thinking, should be a high compliment to the inventor. As a matter of fact, the average inventor is proud of being a different sort of person from the rest of the mortals, and shows this in unmistakable actions at all times.

### I BELIEVE THAT:

inventors get more real thrills from their work than any other humans.

When I use the word “inventor” I do so advisedly. By this term I mean a man who has at least a few worthwhile inventions to his credit. An inventor is an individual who rarely makes any discoveries himself. Rather, he takes up something that

some discoverer has worked on before, and then makes it practical, which is something which the discoverer never does.

For instance, Heinrich Hertz, the inventor of wireless, who was the first to demonstrate what we now term “radio waves,” was a discoverer. And while he knew, perhaps, more about radio than most of us do today, he did not find or try to find a practical use for it, until Marconi, the inventor, came along, and not only put Hertz’s discovery to practical use, but commercialized it as well. Here you see the distinction between the discoverer and the inventor.

Edison, also, is in the same class as an inventor, having discovered but very few important things, but having invented over a thousand practical things which have been commercialized by himself.

The mentality of the average inventor is, first of all, one of great keenness and perception. It is also one of great originality. The inventor refuses to go along the beaten path, and, as a rule, finds great pleasure in doing exactly the opposite to the conventional.

He also looks at the world with an entirely different eye than the average individual. He sees things that the average man never sees, because they have become too familiar to him. The mentality of the inventor continually asks questions and wants to know why this or that is so. The inventor finds inspiration and thoughtfulness in the most humdrum of things, always with an idea to improve or to better, if possible, present conditions, present appliances, etc.

The inventor is never long satisfied with existing things, and he of all people is quick to see their deficiencies and immediately starts thinking about how they can be improved upon.

It may be said to be an axiom that the great majority of inventors are poor business men. I know many inventors personally, but I have found only two in my

whole experience who were keen business men as well. All the others, if they had been successful at all, could not honestly have claimed success from a monetary standpoint themselves. They usually had business partners or business managers who handled the monetary and organizing end for them, the inventors themselves never bothering about money matters, as such details are always distasteful to the real inventor.

If the inventor has luck and picks the right associates, he may make a fortune for himself and his business partners, but unfortunately he usually gets the worst end of it, because he has no interest in or grasp for financial matters and wants to be left alone in his workshop, his laboratory, or whatnot, in order to pursue his work; which to him is very much more important than mere dollars and cents.

Right here we notice a different slant in the mentality of the inventor—he is, in other words, an idealist. You might go as far as to call him a philanthropist, because, taking the inventors all told, they certainly have done more for humanity in improving our material world than all the so-called philanthropists put together. At least a philanthropist has the money and enjoys a good living while he gives away large sums of money, which, on account of the great total that he already has, mean nothing to him. The inventor, on the other hand, is a much greater philanthropist because he gives away his all, practically, during his entire life, receiving, often, not even a decent living from his endeavors and no thanks in the end.

Another angle of the inventor’s mentality, the least pleasant one, is his great suspiciousness. As a tribe, inventors have found, through many generations, that as a rule they get the worst end of every financial deal, due to their inexperience in business matters. For this reason, most of them are suspicious of everyone, even of the Patent Office itself. And when it comes to trusting anyone with their so-called “secrets,” they will always be found to be a most distrustful lot of individuals. They try to surround themselves with every safeguard imaginable, and I have seen many such queer safeguards in my experience. But evidently all such protections are not of much use, because in the end the inventor usually does not come out on top anyway. The reason is—and this is another paradox of his mentality—the inventor, despite his keenness, has never as yet found it possible to study

human psychology, when it comes to the financing of his invention. Nine times out of ten he insists on receiving from 75 to 90 per cent. of the profits, while the financial and business associate must be satisfied with ten per cent. Naturally, agreements made under such conditions are never lived up to long, and as usual the inventor gets the worst of it.

### I BELIEVE THAT:

every important invention becomes the forerunner of hundreds of others.

### I BELIEVE THAT:

the average type of “nut” inventor is one of the greatest assets of our civilization.

### THE GOLDEN AGE OF SCIENCE

is symbolized by the golden cover OF SCIENCE & INVENTION, LOOK FOR THE GOLD COVER every month!



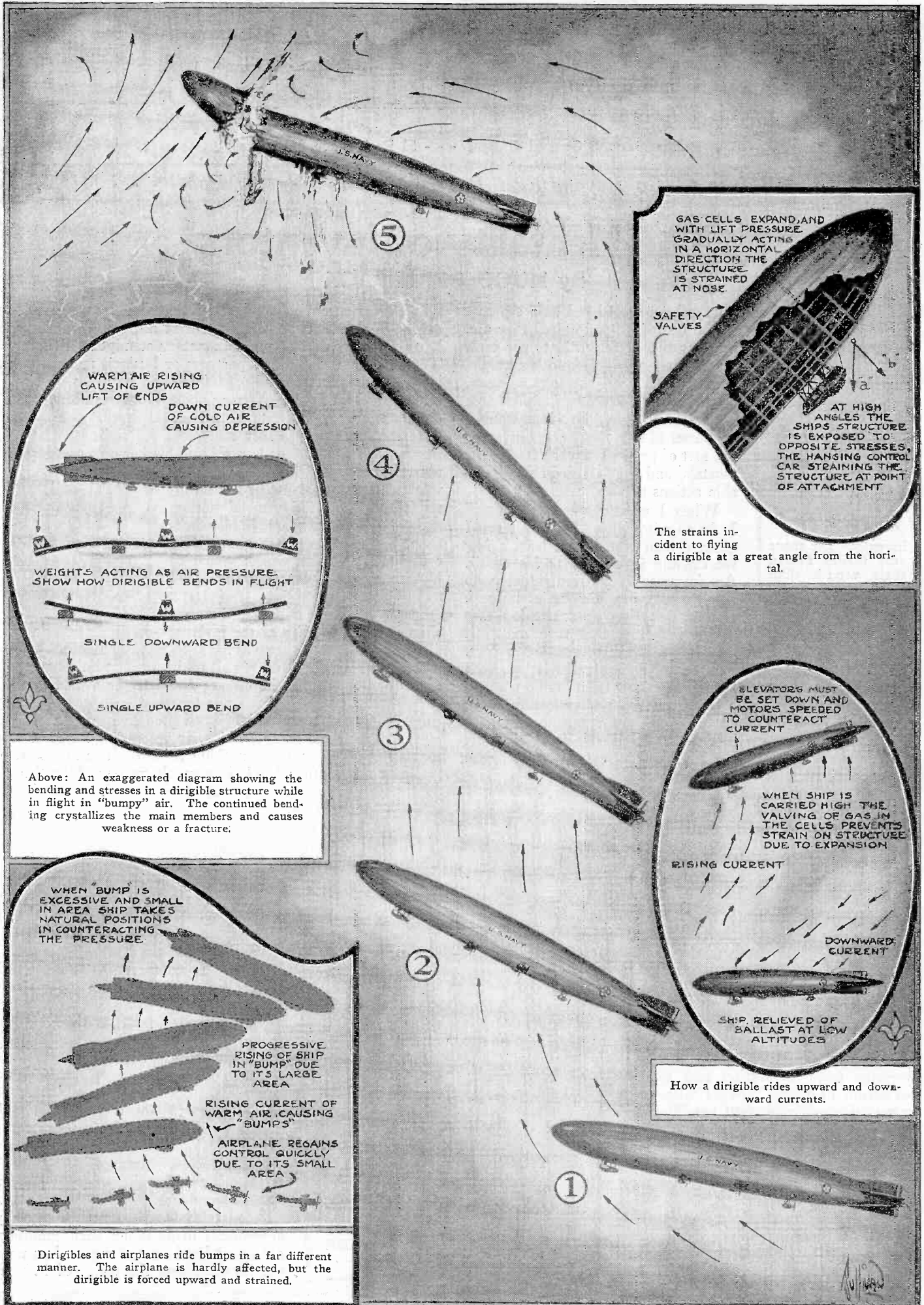

5

GAS CELLS EXPAND, AND WITH LIFT PRESSURE, GRADUALLY ACTING IN A HORIZONTAL DIRECTION THE STRUCTURE IS STRAINED AT NOSE.

SAFETY VALVES

AT HIGH ANGLES THE SHIP'S STRUCTURE IS EXPOSED TO OPPOSITE STRESSES, THE HANGING CONTROL CAR STRAINING THE STRUCTURE AT POINT OF ATTACHMENT.

The strains incident to flying a dirigible at a great angle from the horizontal.

WARM AIR RISING CAUSING UPWARD LIFT OF ENDS

DOWN CURRENT OF COLD AIR CAUSING DEPRESSION

WEIGHTS ACTING AS AIR PRESSURE. SHOW HOW DIRIGIBLE BENDS IN FLIGHT

SINGLE DOWNWARD BEND

SINGLE UPWARD BEND

Above: An exaggerated diagram showing the bending and stresses in a dirigible structure while in flight in "bumpy" air. The continued bending crystallizes the main members and causes weakness or a fracture.

ELEVATORS MUST BE SET DOWN AND MOTORS SPEEDED TO COUNTERACT CURRENT

WHEN SHIP IS CARRIED HIGH THE VALVING OF GAS IN THE CELLS PREVENTS STRAIN ON STRUCTURE DUE TO EXPANSION

RISING CURRENT

DOWNWARD CURRENT

SHIP RELIEVED OF BALLAST AT LOW ALTITUDES

How a dirigible rides upward and downward currents.

WHEN BUMP IS EXCESSIVE AND SMALL IN AREA SHIP TAKES NATURAL POSITIONS IN COUNTERACTING THE PRESSURE

PROGRESSIVE RISING OF SHIP IN "BUMP" DUE TO ITS LARGE AREA

RISING CURRENT OF WARM AIR, CAUSING "BUMPS"

AIRPLANE REGAINS CONTROL QUICKLY DUE TO ITS SMALL AREA

Dirigibles and airplanes ride bumps in a far different manner. The airplane is hardly affected, but the dirigible is forced upward and strained.

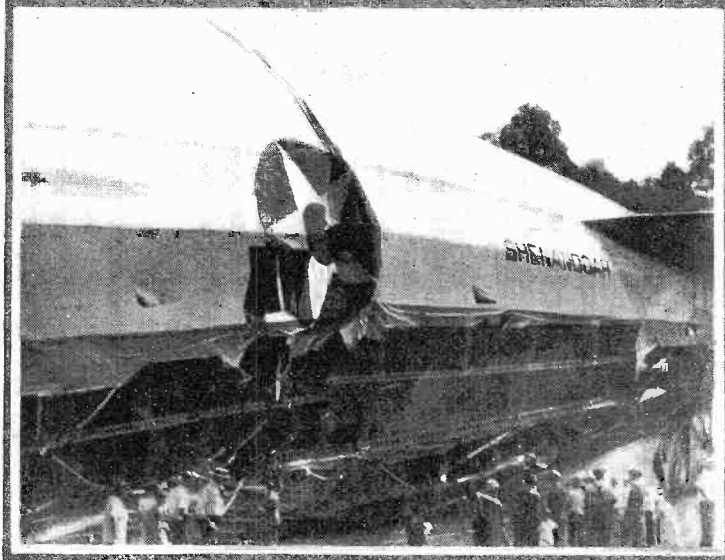
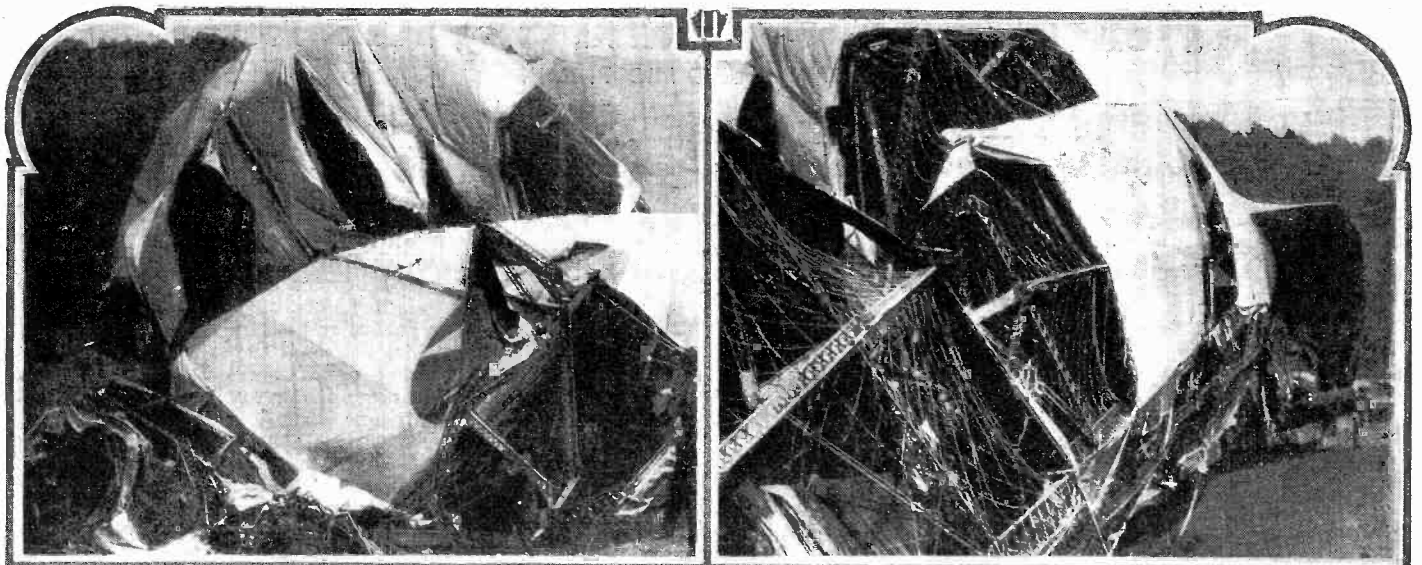

SCIENCE AND INVENTION Magazine has always maintained that the present type of rigid airship is a failure. Note the horrible wreckage of the "Shenandoah" shown in the photographs and our prediction in the reproduc-

**Science and Invention**

FORMERLY  
**ELECTRICAL EXPERIMENTER**  
233 FULTON STREET-NEW YORK

Vol. IX  
Whole No. 102

October 1925  
No. 8

---

**ZR-2**

**N**EXT to the sinking of the ill-fated "Titanic" the disaster that befell the ZR-2 dirigible late last August will probably rank for a long time as the greatest in all transportation. It is almost certain that the disaster will not stop the future building of dirigibles of the ZR-2 type, although the present rigid type are a scientific impossibility.

The principle is wrong all the way thru. For the most part, the dirigible was built as a rigid structure. The weight of the framework was not taken into account. The dirigible must of necessity be extremely light. It is therefore made of an aluminum alloy. If we increase the weight of the framework only 10%, to make it stronger, the lifting capacity of the ship is reduced at once. On the other hand the framework cannot go beyond a certain weight, because the gas cannot breathe life in any longer. It should always be borne in mind that a rigid dirigible is not a balloon. It is not a balloon or a blimp. It is a rigid structure. It is not a balloon or a blimp. It is a rigid structure. It is not a balloon or a blimp. It is a rigid structure.

H. GERNSBACH

tion of an editorial published in 1921. Also note the mention of an all metal dirigible. Plans have recently been submitted to the United States Government for the construction of an all metal lighter-than-air ship.

## The "Shenandoah" Versus the Elements

By WILLIAM P. SULLIVAN, Aeronautical Engineer.

**S**INCE man first began to sail the skies in rigid lighter-than-air craft, the problem of construction and control with regard to the elements has always been a matter of vast importance. Due to its enormous surface it is exposed to many and varying air currents that strain the rigid structure to its limits. These currents sometimes produce pressures totaling many tons and the structure must be designed not only to take these stresses in one direction but to distribute the many opposite and diagonal stresses throughout the entire length of the ship, much the same as an ocean liner distributes the buoyancy stresses of large waves.

The problems concerning the design of such a structure represent a vast amount of engineering analysis, theory and experience. First of all a dirigible to be efficient must be of large dimensions as the strength-weight ratio of the structure varies in proportion to its size. If one were to build a small dirigible, say of 250,000 cubic feet capacity, its efficiency as regards useful load carried would be considerably less than half

the useful load of a dirigible of 500,000 cubic feet capacity. The buoyancy or lift of the confined gas would be exactly double that of the smaller one while on the other hand the structure would be considerably less than twice the weight. To offset this efficiency of useful load carried, the larger ship exposes considerably more area along a greater length to the various air currents and due to its greater weight and area, the stresses become enormous in all directions.

For example in flying a rigid airship in "rough" air the structure tends to bend with the air current and as it travels forward, it follows a snake-like course. It is a known fact that in some instances the keel corridor which is normally a straight pathway, has been completely hidden from view at distances ranging from fifty to seventy-five feet, in much the same manner as one might view the aisles of a railroad train while traveling over a winding section of rail.

It is this constant twisting and bending of the metal lattice and wire structure that bring about fatigue and crystallization, re-

sulting in the failure of important members. This can be overcome only with proper design by experienced engineers on metal construction, especially in the uses of the modern alloys.

The metal which is used mostly in the construction of frames and girders of dirigibles is called duralumin, an aluminum alloy. This metal is very peculiar and today it still has its unknown qualities. It is highly favored in aeronautical construction because of its high tensile strength and low weight, comparing favorably in tensile strength to that of low carbon steel and weighing slightly more than aluminum. It is used mostly where rigidity and lightness is desired, but is seldom used in structural parts that require bending in manufacture, or take severe bending loads in use. This is avoided because of the fact that the metal is not ductile, crystallizes very rapidly and cannot be welded or heat-treated with the degree of safety and cost required in this type of construction.

(Continued on page 674)



# Helicopter Helps Build Skyscrapers

By H. WINFIELD SECOR, E. E.

IN a recent issue of a German publication, Dr. Rudolf Wagner of Hamburg proposed a novel scheme that would enable sufferers from various diseases to obtain the benefits of high altitudes, quickly, easily and comparatively cheaply. The idea in main was to utilize a newly developed type of steam-driven helicopter that would be capable of sustained flights of many hours' duration. His particular type of vertical rising flying machine that is at the same time capable of hovering or of horizontal flight presents many novel features which he explained to the writer.

A much more novel application and one that seems to be very practical is suggested herewith and illustrated at the immediate left. The helicopter, equipped with its regular power system and with its pneumatic landing devices, can be equipped with steel cables and hooks for handling long heavy girders used in the construction of skyscrapers. Thus, cranes and their attendant supports would be eliminated and the work could be carried forward much faster. This newly designed machine, it is said, can be very easily manipulated and steered into any desired position. Its altitude can be maintained with little or no trouble and these faculties make it most adaptable to building work of this nature.

If, instead of girders, it is desired to handle smaller iron or steel parts, electro-magnets could be hung from the hooks on the ends of the cables and used to pick up the parts. The helicopter could then rise and fly to its destination and there deposit the material. It is quite possible that with proper designing, these electro-magnets could also be used for handling the steel girders, doing away with the necessity of suspending the beams by cables.

Right: A girder is being manipulated into place on the top of a skyscraper by means of this new helicopter. Here the steel cables and hooks are being used but the electro-magnets suggested below could be substituted if desired. The mechanism of this steam-driven helicopter is detailed below. The four perpendicular sides C, prevent the body of the device from turning.

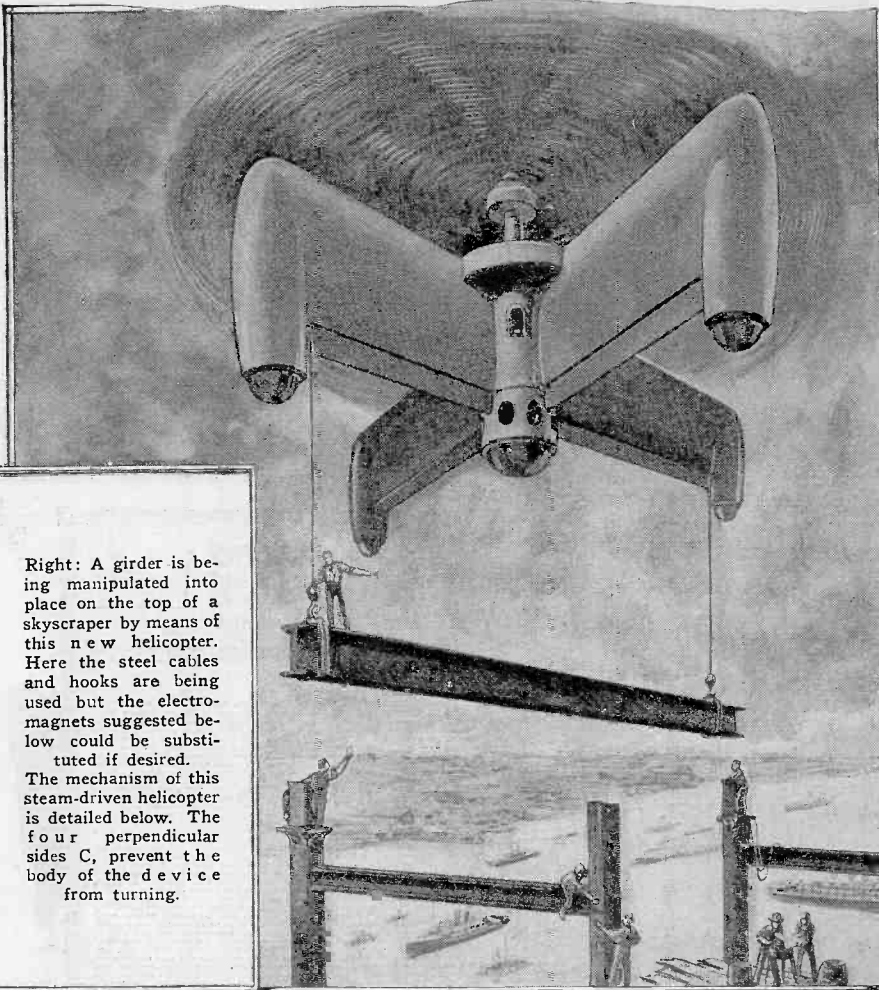

VARIABLE PITCH PROPELLER

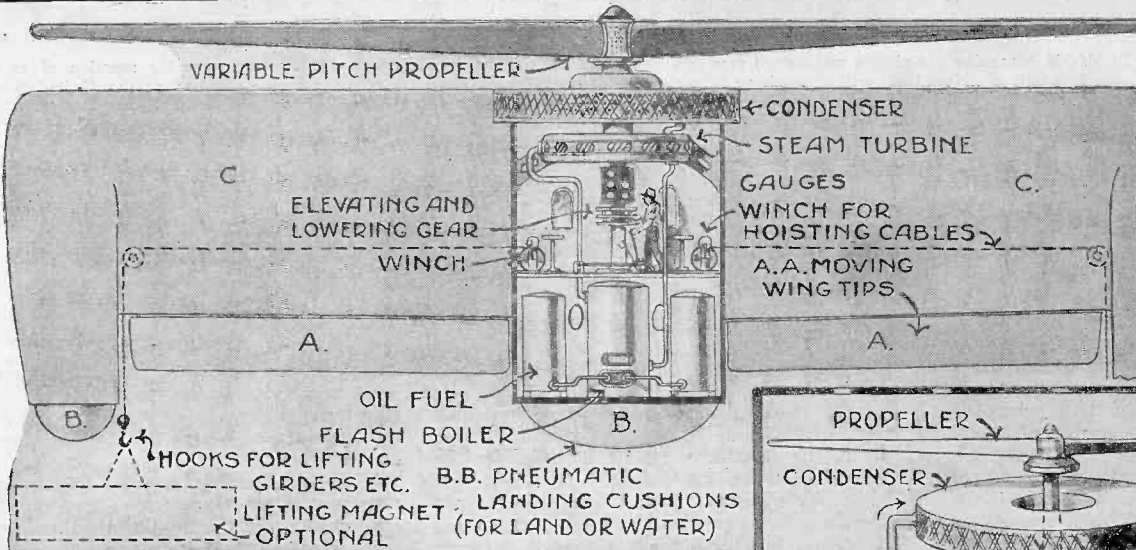

The helicopter's power plant is located in the central portion and consists of a steam turbine equipped with a condenser for saving the water after it has been used as steam. The device is manipulated in horizontal flight by the movable ailerons A. A variable pitch propeller gives different speeds.

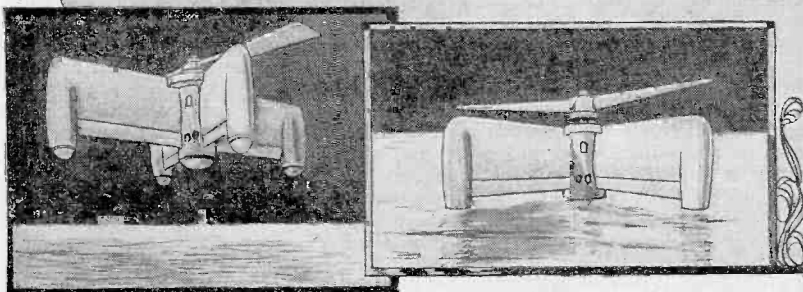

As shown in the two illustrations directly above, this new helicopter can alight in water when necessary, as the pneumatic landing cushions support it on water or land. Right: Details of power plant simplified.

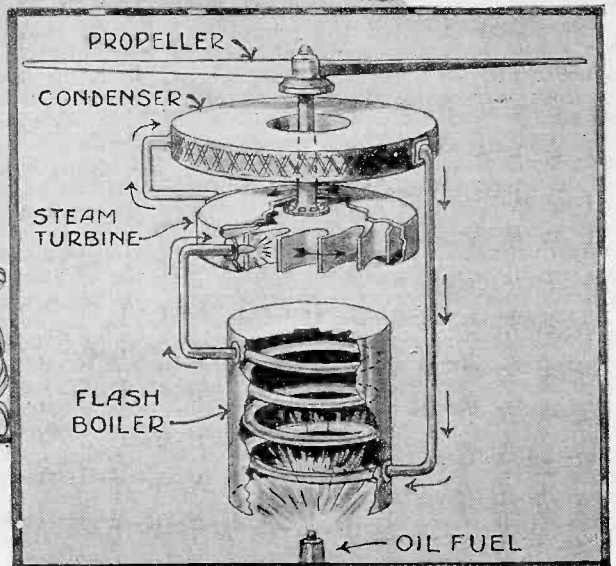

# Fire, Smoke and Explosions on the Stage

By GEORGE WALL (Illustrations by Author)

So realistic is the fire scene in "The Sea Woman", a new melodrama, that the program carries a note to the audience telling them not to become frightened at the effects produced. The various illustrations on this page show how these startling effects were produced without any danger whatsoever to the actors or the audience. The upper part of this page shows the scene as the audience sees it.

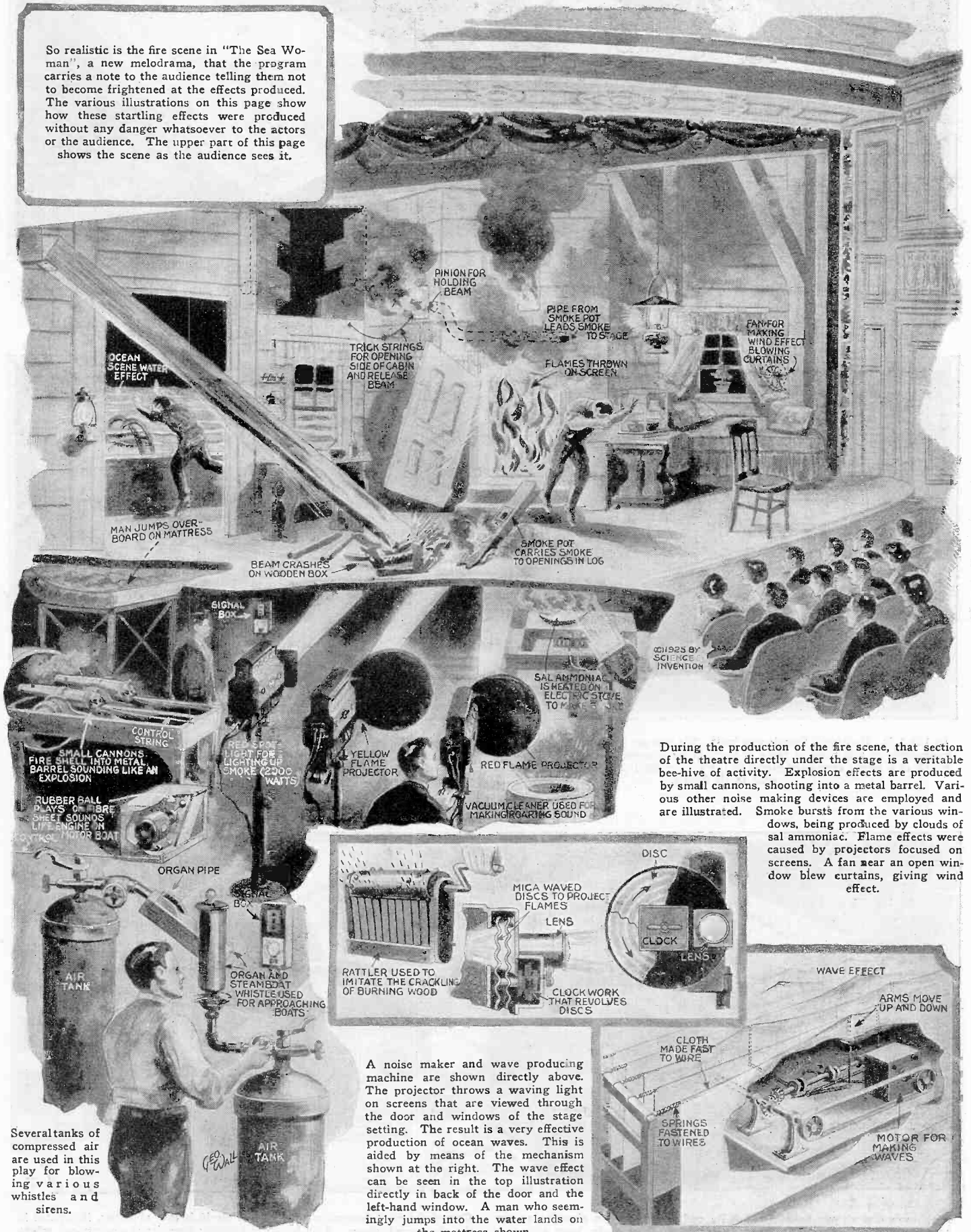

During the production of the fire scene, that section of the theatre directly under the stage is a veritable bee-hive of activity. Explosion effects are produced by small cannons, shooting into a metal barrel. Various other noise making devices are employed and are illustrated. Smoke bursts from the various windows, being produced by clouds of sal ammoniac. Flame effects were caused by projectors focused on screens. A fan near an open window blew curtains, giving wind effect.

Several tanks of compressed air are used in this play for blowing various whistles and sirens.

A noise maker and wave producing machine are shown directly above. The projector throws a waving light on screens that are viewed through the door and windows of the stage setting. The result is a very effective production of ocean waves. This is aided by means of the mechanism shown at the right. The wave effect can be seen in the top illustration directly in back of the door and the left-hand window. A man who seemingly jumps into the water lands on the mattress shown.



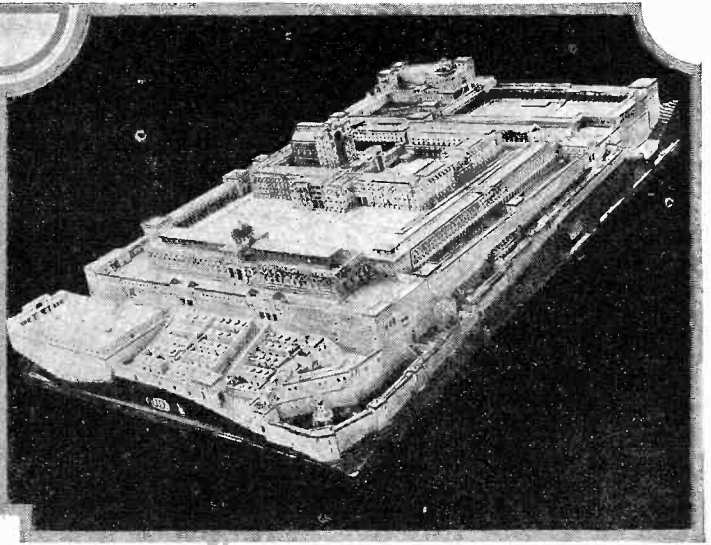
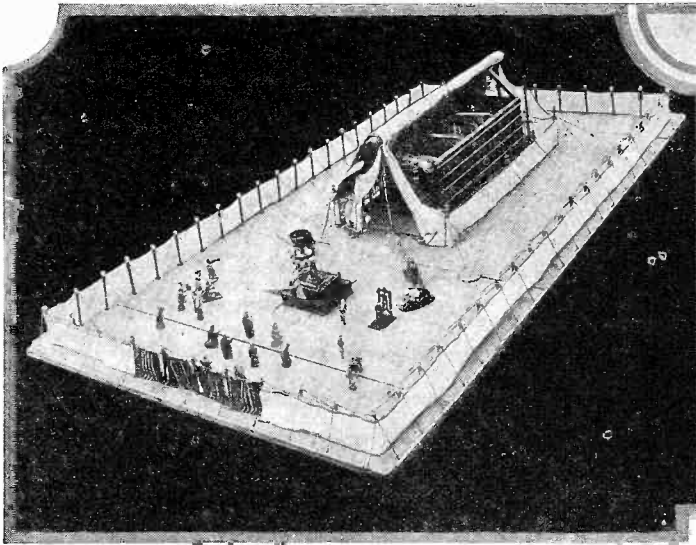

A model of the original tabernacle built in 1487 B.C. is illustrated above. Note the elaborate detail of the various parts and the way in which the side of the tent can be opened to view the interior construction.

Herod's Temple was a most elaborate and complicated affair. A complete model of the various buildings, terraces and walls is illustrated directly above. Careful attention was paid to the exact placement of each part.

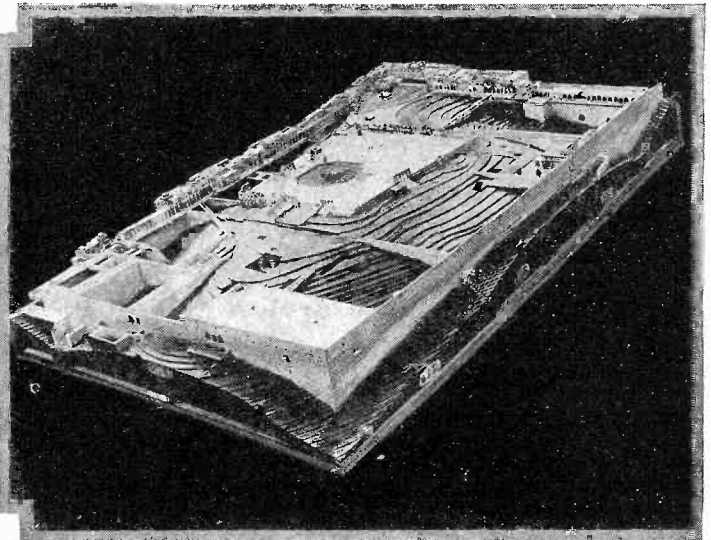
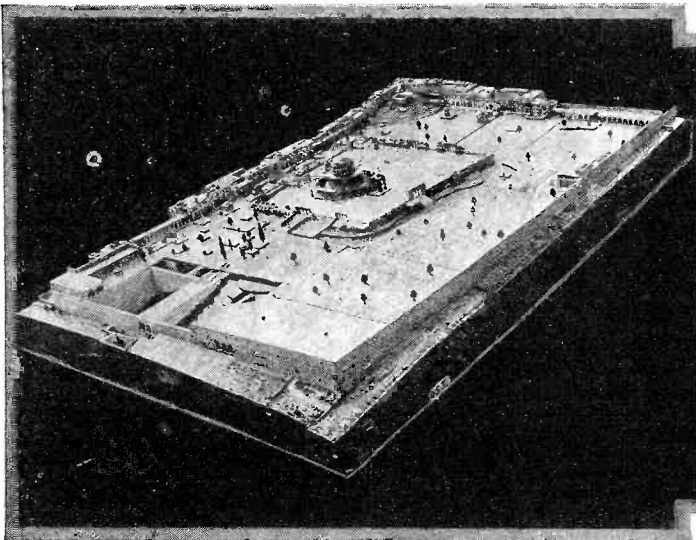

In 135 A.D., Hadrian's Temple was built. We can get a very good idea of the appearance of this original place of worship by reference to the above photograph of a newly completed model in the construction of which attention was paid to all details.

The original contour of Mt. Moriah has been reproduced in model form and a photograph of the completed reproduction is shown directly above. Note the gracefully curved terraces gradually leading up to the summit of the hill.

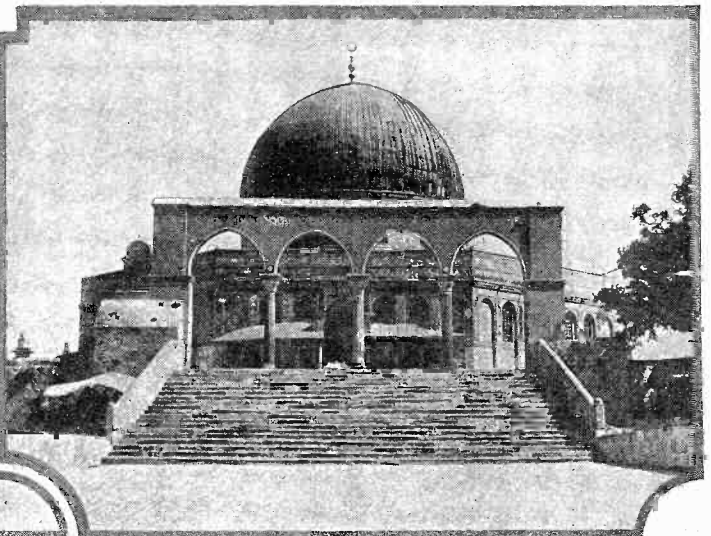
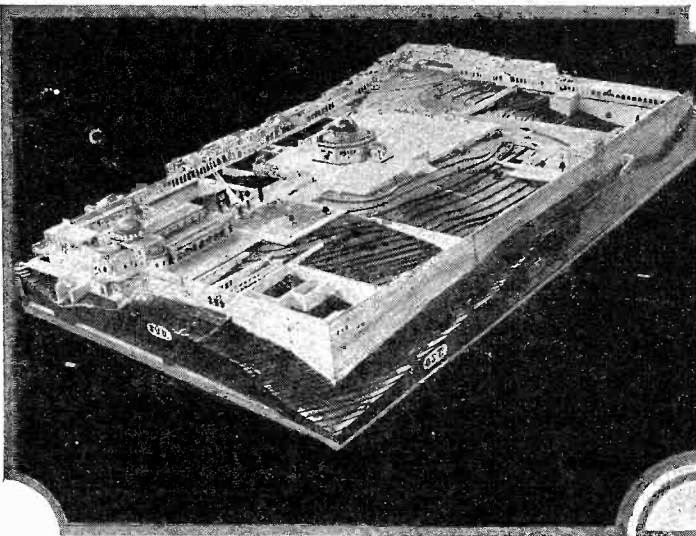

Justinian's Church was built in 530 A.D., and surmounted an elevation as can be seen in the photograph of the model above. Here again, most elaborate workmanship was carried out in fashioning the various buildings and slopes.

One of the most famous mosques in the world is that of Omar, illustrated in the photograph above. This beautiful building occupies the exact spot where the Temple of Solomon stood 3000 years ago. See story on opposite page.



# Solomon's Temple Model Reproduced

By A. N. MIRZAOFF

## Models of the Seven Temples that Stood on Mt. Moriah Brought to this Country Brings Back Romance of Bible Days

**T**HE romance and reality of the Bible, the most wonderful book in the world, are recalled by models of the seven temples that stood on the summit of Mt. Moriah, Jerusalem, beginning with the Tabernacle B. C. 1487, and ending with Justinian's Church A. D. 530. They have been brought to the United States by Mr. N. Lind of the American Colony in Jerusalem, now at 130 West 42nd Street, New York, and are the life's work of the famous Dr. Schick, the noted archaeologist.

The first of the models, therefore, to be considered is the *Tabernacle*, which was erected 1487 B. C. It stood within an extensive court, whose walls were draped with a snow-white curtain carried by 60 pillars whose tops were of silver and whose sockets were of brass. The court was approximately 225 feet in length and 75 feet in width, as described in Exodus. The entrance faced the East.

Dr. Schick's model shows the people in various acts of worship; on the left are the musicians who played accompaniments to the chanting of psalms and hymns by the priests. Before the entrance is a small mound of ashes which each morning were taken by the priests from the altar of burnt offering and then after they had changed their holy garments were carried to a clean spot outside the camp. Next we behold the altar of burnt offering itself. It was made of acacia wood overlaid with brass and was five cubits square and three cubits high.

Jerusalem had been inhabited long before the building of the Tabernacle. Its first mention in history is in the days of Abraham, about 1900 B. C. Melchizedek, who refreshed Abraham with bread and wine after his victory over Chedorlaomer, was, as we learn in Genesis, the "Priest of the Most High God" and King of Salem. This name is from an ancient Semitic root identical with that of the last part of the Caananite Urusalim, or the present Jerusalem, which means Peace. Melchizedek met Abraham at Shaveh, the "King's Dale," which is the Valley of Kedron, just outside Jerusalem, and "came forth" thither, with presents, evidently from a place nearby.

Mt. Moriah is first mentioned in the Book of Genesis when Abraham is directed to go up to the "land of Moriah" to "one of the mountains" which God should point out and there offer up his sacrifice.

Flint implements dating back to the Stone Age, which have been found in the debris of the ancient city and plentifully all around it, testify that the site of Jerusalem must have been inhabited in remote prehistoric times.

The beautiful Tabernacle was, approximately, 45 feet in length by 10 in width and 10 in height. It was divided into two parts, of which the front portion was called the Holy Place and the back division the Holy of Holies. In the photograph of Dr. Schick's model the covering of the Tabernacle is thrown back so this division can be quite plainly seen.

The Tabernacle was composed of 46 boards of acacia wood, for it was the kind of tabernacle that was carried about from place to place throughout the wanderings in the Wilderness. There were 20 boards on each side and six at the Western end, besides the two corner pieces. The Eastern end facing the entrance was left open, only covered with a curtain.

The boards were overlaid with gold, having rings of gold through which ran five bars of acacia wood overlaid with gold; each board had two sockets of silver with

two tenons of brass that were spear-shaped which went down deep into the ground, binding the whole as a solid structure.

The next of Dr. Schick's models is that of the *Temple of Solomon*, built approximately 1,000 years B. C.

David had intended to build the Temple, and to that end had made extensive preparations, but God objected that he was "a man of war" and directed him to leave the erection of it to his son, Solomon, who was "a man of peace." So upon his accession Solomon commenced the great labor. He completed the Temple in seven years, and his magnificent palace, south of it, in thirteen. He also built a second palace for his wife, the daughter of Pharaoh, opposite to his own, and the famous "House of the

of all, 90 years after their return with authority, and succeeded in finishing the building of the city wall in 52 days.

Herod the Great began his Temple in 30 B. C. Though it was never completed in the grand style in which it was begun, it was, nevertheless, the finest of all the temples. To make room for it the temple built by Zerubbabel (Temple of Ezra) had to be demolished. Herod also erected a strong fort north of the Temple, on the site of the Maccabean fort, Baris. This site is now occupied as a barracks.

The magnificent structure built by Herod stood in the time of Christ. It will be recalled that Herod, through the influence of Mark Anthony, was made King of the Jews by Caesar. Returning to Jerusalem, he married Mariamne after having begun the siege of Jerusalem, and with the help of Roman legions he fought against the Jews. The siege, which lasted five months, was bitterly contested on both sides. Finally the Romans were able to make a breach in the wall of the city and forced a way in. A massacre of the population ensued.

Herod removed the cloister toward the south and built a much larger, wider porch, called the Porch of Solomon. This is the porch of which we read in the New Testament, in which Christ walked.

After the Emperor Hadrian had crushed the second revolt of the Jews, A. D. 135, he entirely stamped out Jerusalem as a Jewish city, suppressing its very name, which he changed to Aelia Capitolina. He erected a Temple to Jupiter on the site of the Jewish Temple and put up an equestrian statue of himself on the east of the Rock Moriah. A temple to Isis is said to have been built on the site of the present Church of the Holy Sepulchre. On the south wall of the city, you can see today the inscription that stood at the base of the Hadrian equestrian statue.

But the pendulum of time swung to Christianity. In 530 A. D., after great Rome became Christianized, the Emperor Justinian built a church on the ruins of the site and also built the Basilica in honor of the Virgin Mary over the place where the Porch of Solomon stood. This was in the form of a cross. The head of the cross projected beyond the wall in which were the double and triple gates, necessitating a foundation which covered the view of the double gate from outside.

In 691 A. D. the Ammiad Caliph of Damascus, 'Abd el Melek ibn Merwan, jealous of the fact that the Kalaba in Mecca, the Holy City, was under the authority of his Mohammedan rival, built the beautiful Mosque of Omar on the temple site. Jerusalem is frequently mentioned in the Koran, and the Sacred Rock is the point from which Mohammed is said to have ascended to heaven on his famous charger, Al Borak.

A sum equivalent to the whole revenue of Egypt for seven years was appropriated for the work, and the sovereign himself designed and superintended the erection of the small "Dome of the Chain" in which to deposit this immense treasure, and when it was completed, he liked it so well that he decided on making the sanctuary itself an exact copy of it.

In 813 A. D. the Kalif el Ma'mun repaired the Mosque and put his own name on the face of an outer colonnade as the builder, but neglected to change the date, so his name was laid bare. The present dome was built by Hakim in 1022.

Again the pendulum swung to Christianity and when the Crusaders captured Jerusalem,

(Continued on page 679)

**NEXT MONTH**  
**A Brand New**  
**Craze**

More Interesting Than  
 Crossword Puzzles

A craze that will fascinate and entertain you during your spare time—a new thing that will tax your ingenuity and keep the hands of young and old busy during the coming fall and winter months.

**\$5,000.00**  
**In Prizes**

will be awarded in a new contest, centering about this craze, originated and first presented by SCIENCE AND INVENTION. Be sure to reserve your December issue, in which this new contest will appear.

Forest of Lebanon," which was used as an armory and a royal reception hall. About the middle of the royal court stood the Court of Justice, which contained the splendid Ivory Throne, surrounded by ten golden lions. Cloisters surrounded the whole of the Temple area, as they today enclose the Mosque of Omar on the North and West sides.

Solomon doubled the size of the original Tabernacle in his new temple. In the Tabernacle there was only one candlestick and one table of shew bread, but in the Temple, Solomon placed ten candlesticks and ten tables, some on one side and some on the other; he made a second altar of incense; he placed one altar on each side of the entrance to the Holy of Holies. The Ark of the Covenant occupied the same place.

The next of Dr. Schick's models shows the *Temple of Ezra*, 579 B. C. About 42,360 Jews returned under Zerubbabel from the second captivity. They first built the altar and began their usual sacrifices; then afterwards they laid the foundation of the Temple according to the plan given them by the Persian monarch. Nehemiah came here last

# Movie Thrills On Skyscrapers

By EDWIN SCHALLERT

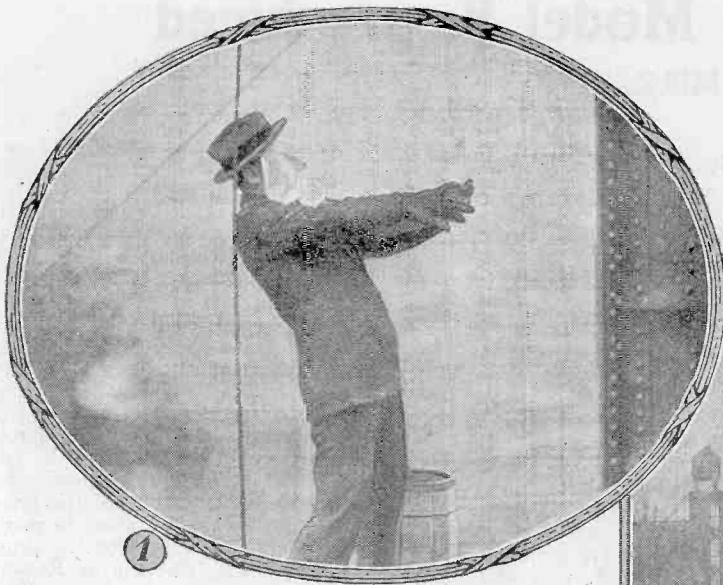

1 While the hero is balanced precariously on a girder, a paper napkin blows into his face. He gyrates back and forth on the beam and the audience, seeing the streets far below and in the background, gasps with horror as he falls, grasping a rope.

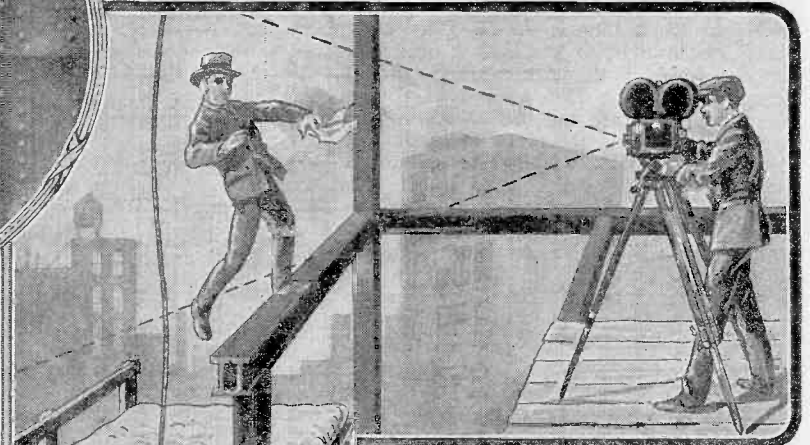

2

In this particular scene on the girder, the camera is focused so that it only includes that part of the scene shown between the dotted lines in Fig. 2 above. The rope which the actor grasps is shown directly in back of him.



3

In reality, the actor is protected by a platform upon which he can land as in Figs. 2 and 3. When he falls from the girder, he is seen to grasp a rope as in Fig. 3, but the camera does not show the platform upon which he lands.

As at the right, in Fig. 4, the rope upon which the hero dangles and with which he falls several stories is paid out from a winch. All this time he is in perfect safety because of the landing net directly below him and out of the lines of the camera.

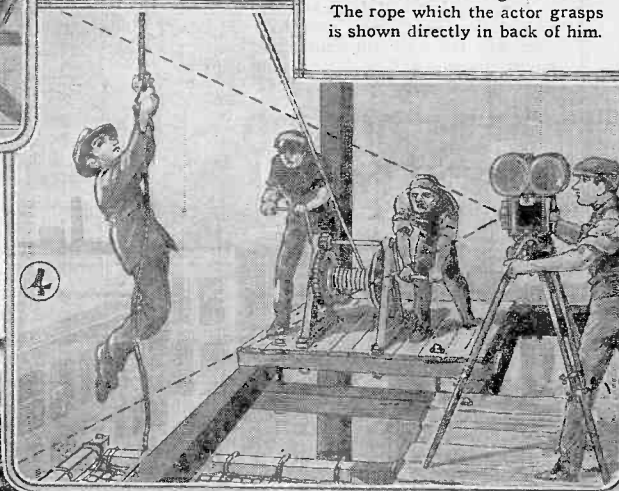

4

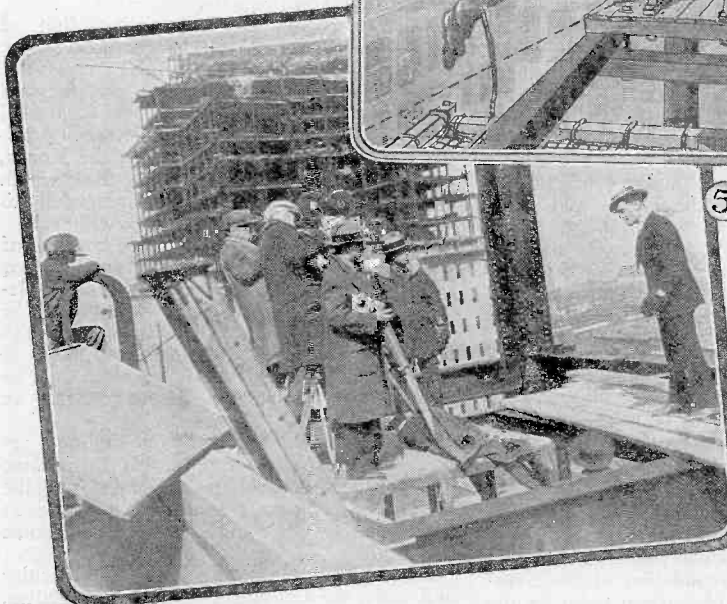

5

The photograph at the left, Fig. 5, shows that many of the scenes were actually taken at great heights. Of course, throughout the entire picture, all of the actors were protected by safety platforms. In some cases a "stunt" man doubled for the hero. The picture at the left was taken from an uncompleted building near that of the New York Telephone Co., and shows the latter in the background.

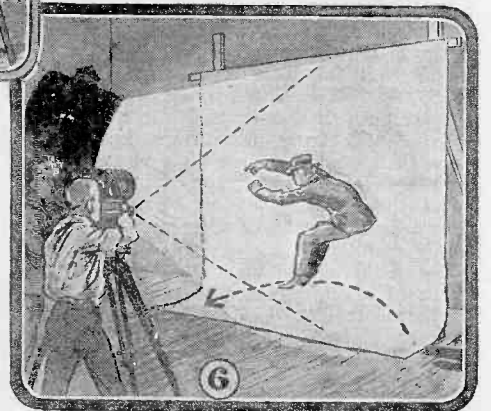

6

Double printing was used in portions of this film, particularly where actors were shown jumping from one girder to another. The actor was taken in action as above in Fig. 6, whereupon this film was printed in conjunction with another one which shows the girders.

NEW YORK skyscrapers supplied the settings for "The Shock Punch," Paramount's latest thriller. The hero of the film goes to work for a steel contractor in order to please the contractor with whose daughter he is in love. His first job is to carry a keg of rivets to the top of the building which he does, running all sorts of apparent risks while climbing around the girders. A paper napkin flies into his face and in trying to get rid of it he loses his balance and is saved by a loose rope after falling several stories. He learns of a plot to cause the last girder to crash down through the structure, wrecking it and causing his sweetheart's father, the contractor, to lose a fortune. He determines to see that the last girder goes into place, and to do this he gets on the girder as it is to be hoisted to the top floor. The cable has been cut almost through, but at the climax of the picture the villain confesses and the girder is swung to safety. The hero leaps from the girder and fights with the foreman. They wrestle on platforms at high altitudes, falling from one to another until the hero finally administers his famous "shock punch" and knocks the villain out.

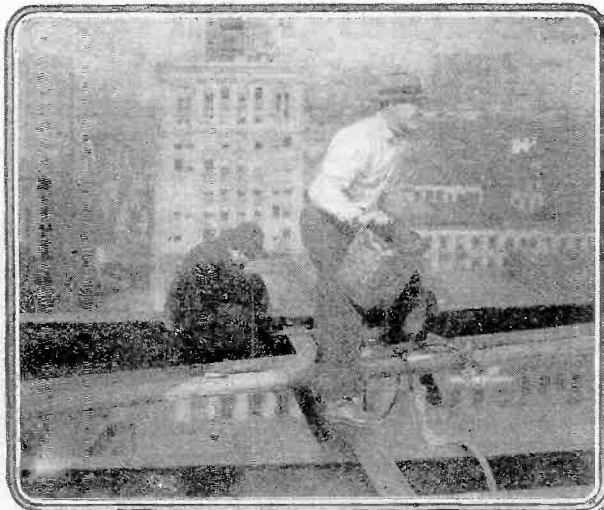

7

An interesting break in the film was had by showing riveters in action on the building as at the left. The photo at the right, Fig. 8, shows the hero on the girder traveling up to the top of the building to see that it gets into place without accident. This view, taken in the studio, was superimposed upon one of the building and the background as in Fig. 12.

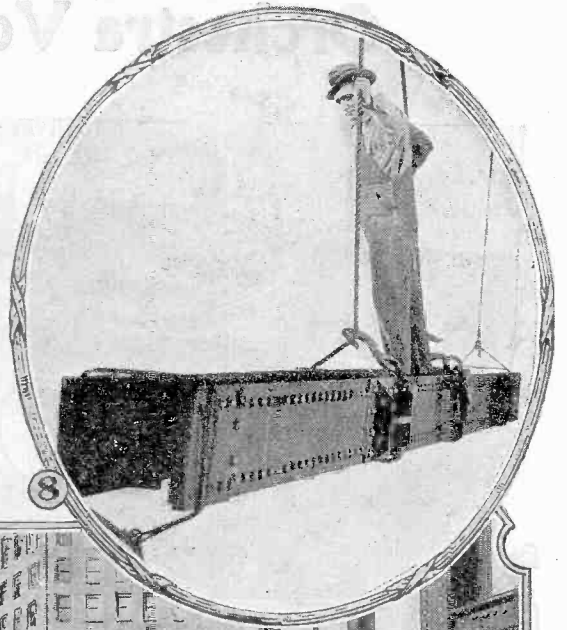

8

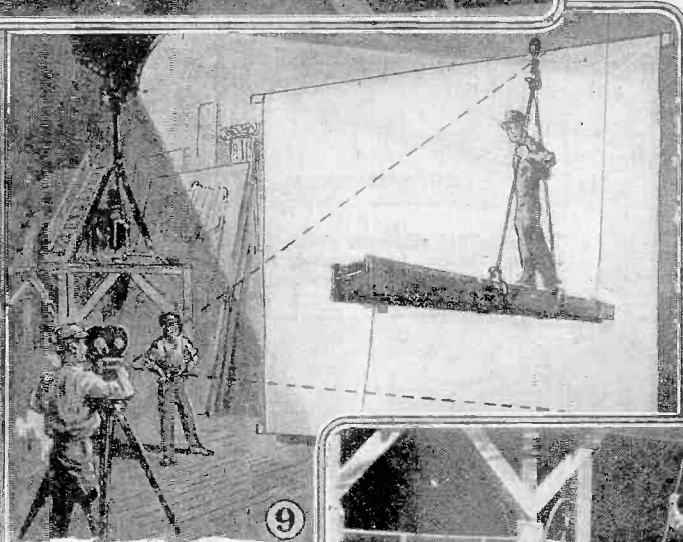

9

A "prop" girder was used to photograph several of the scenes in the studio as above in Fig. 9. These were then superimposed upon other films giving most startling and thrill inspiring effects.

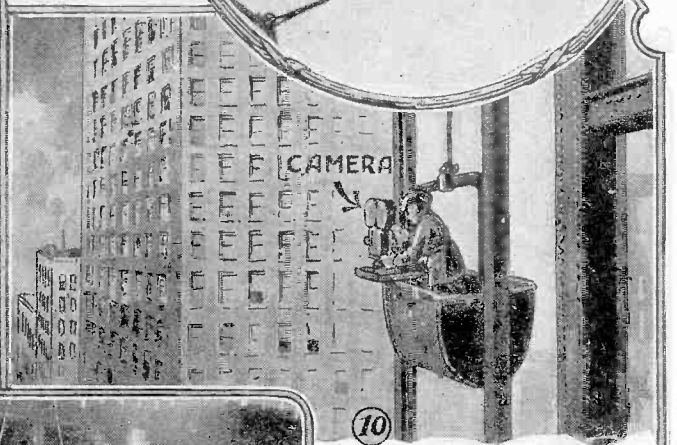

10

Several views of tall buildings were cut into the film at various points to give local color. These were taken by a camera-man riding in a supply bucket as above in Fig. 10.

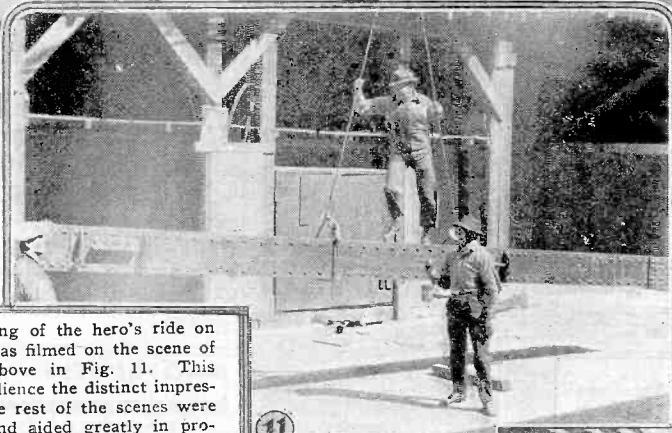

11

The beginning of the hero's ride on the girder was filmed on the scene of action as above in Fig. 11. This gave the audience the distinct impression that the rest of the scenes were not faked and aided greatly in producing the realistic results.

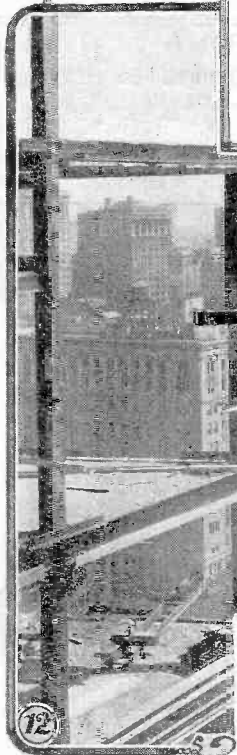

12

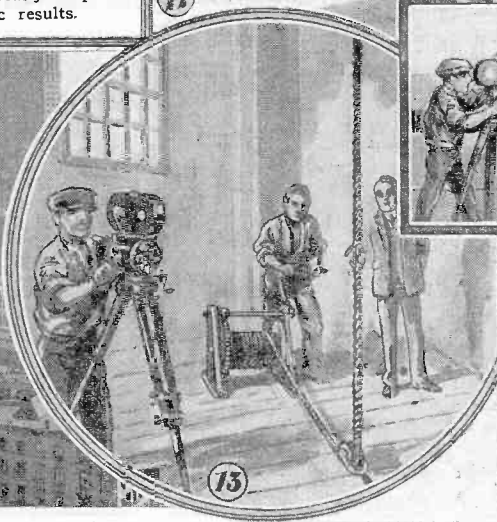

13

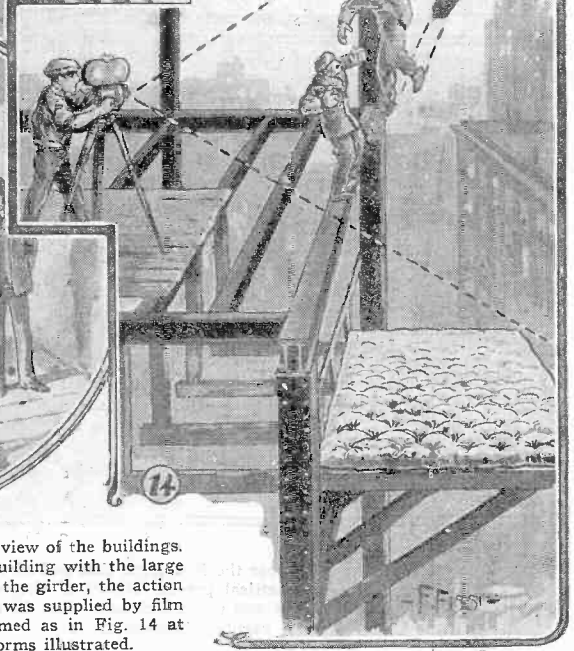

14

Fig. 12 shows a scene such as results from Fig. 8 superimposed on a view of the buildings. The home of SCIENCE AND INVENTION Magazine is in the building with the large water tank on top of it in the left background. During the scene on the girder, the action was frequently cut back to the frayed cable. This added suspense was supplied by film taken as in Fig. 13. The hero's jump from the girder was performed as in Fig. 14 at the right. The actors were protected by the usual safety platforms illustrated.



# Orchestra Volume from Phonograph

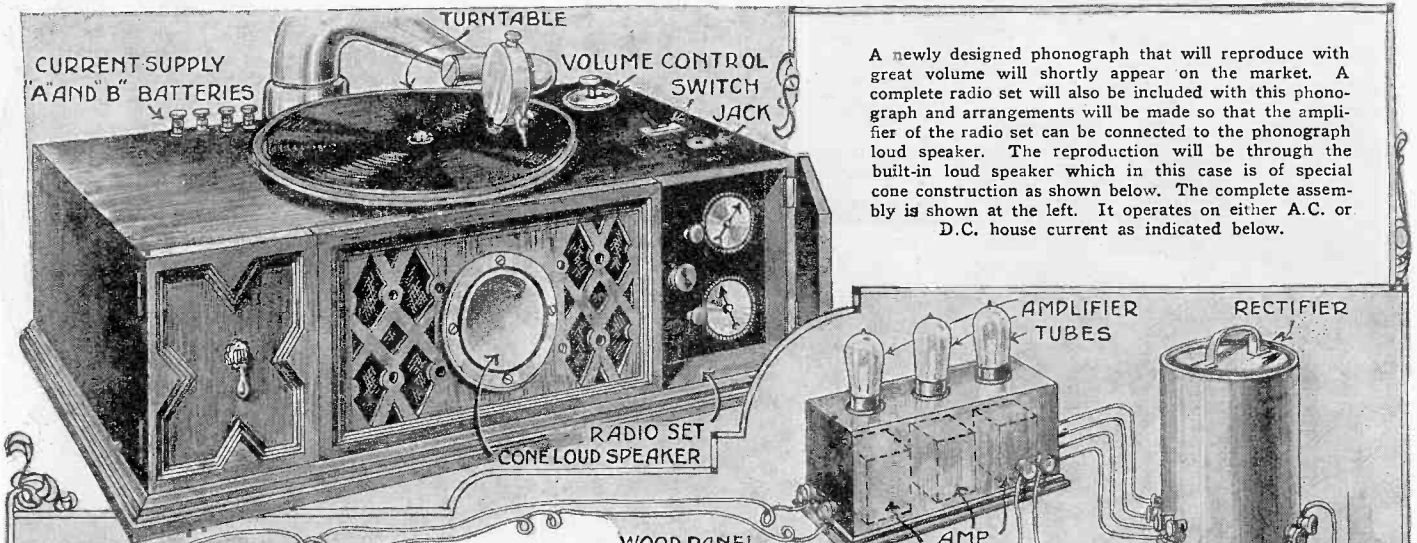

A newly designed phonograph that will reproduce with great volume will shortly appear on the market. A complete radio set will also be included with this phonograph and arrangements will be made so that the amplifier of the radio set can be connected to the phonograph loud speaker. The reproduction will be through the built-in loud speaker which in this case is of special cone construction as shown below. The complete assembly is shown at the left. It operates on either A.C. or D.C. house current as indicated below.

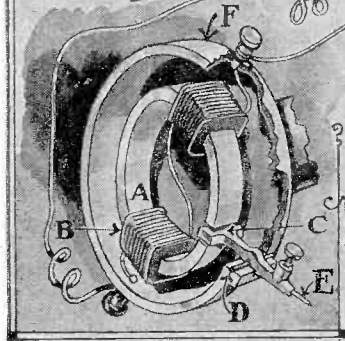

Left: Details of reproducer. A is permanent magnet; B, electro-magnet; C, armature; D, pivot; E, needle, and F, casing. The movement of the armature, C, between the pole-pieces of the magnet, A, sets up fluctuating currents in the magnet coils, B. These fluctuations are in exact accordance with the vibrations impressed on the record.

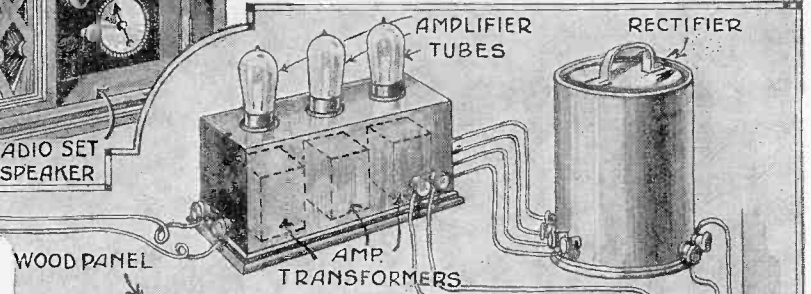

The simplified schematic circuit shows how the lighting current, loud speaker, rectifier, amplifier and reproducer are connected together.

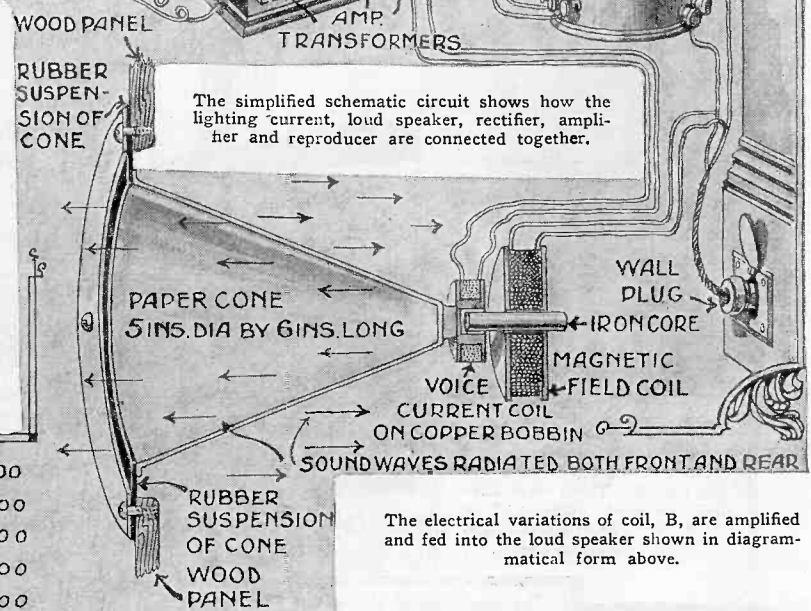

The electrical variations of coil, B, are amplified and fed into the loud speaker shown in diagrammatical form above.

## PANATROPE

The name for this new instrument is Panatrope; a rough idea of its volume compared to that of an ordinary phonograph is given at left.

### PHONOGRAPH OF PANATROPE

Sound ranges of Panatrope and phonograph compared.

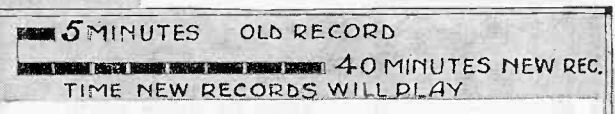
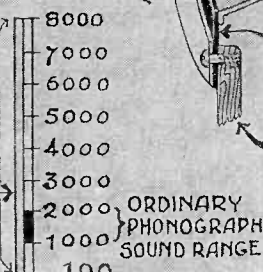

By a new process Panatrope records will play eight times as long as an ordinary phonograph record.

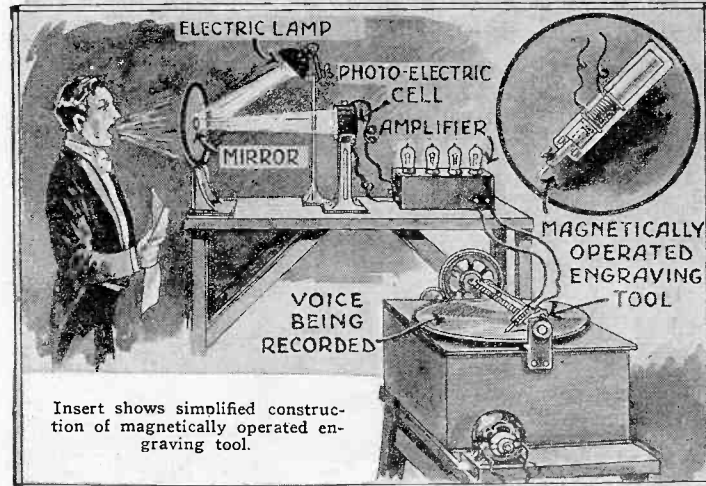

Insert shows simplified construction of magnetically operated engraving tool.

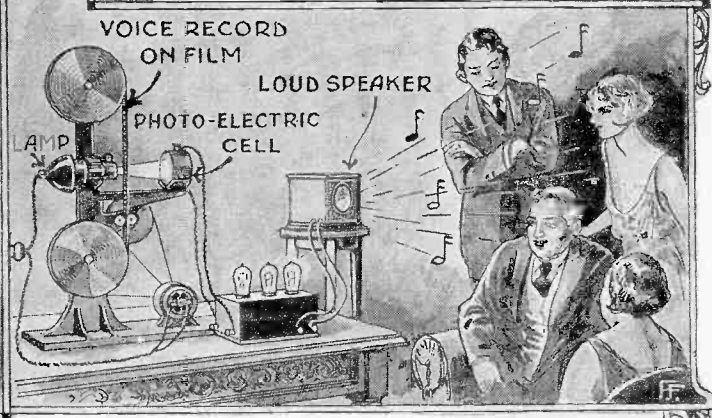

The master record for the Panatrope that will play for 40 minutes is made by an electrical process illustrated above. In this way, grooves can be cut 500 to an inch as against 80 to the inch in a regular phonograph record.

Another system developed by the designers of the Panatrope makes use of a voice or sound record impressed on a flexible film that can be reproduced after the manner shown above. The system is said to differ from the DeForest Phonofilm.

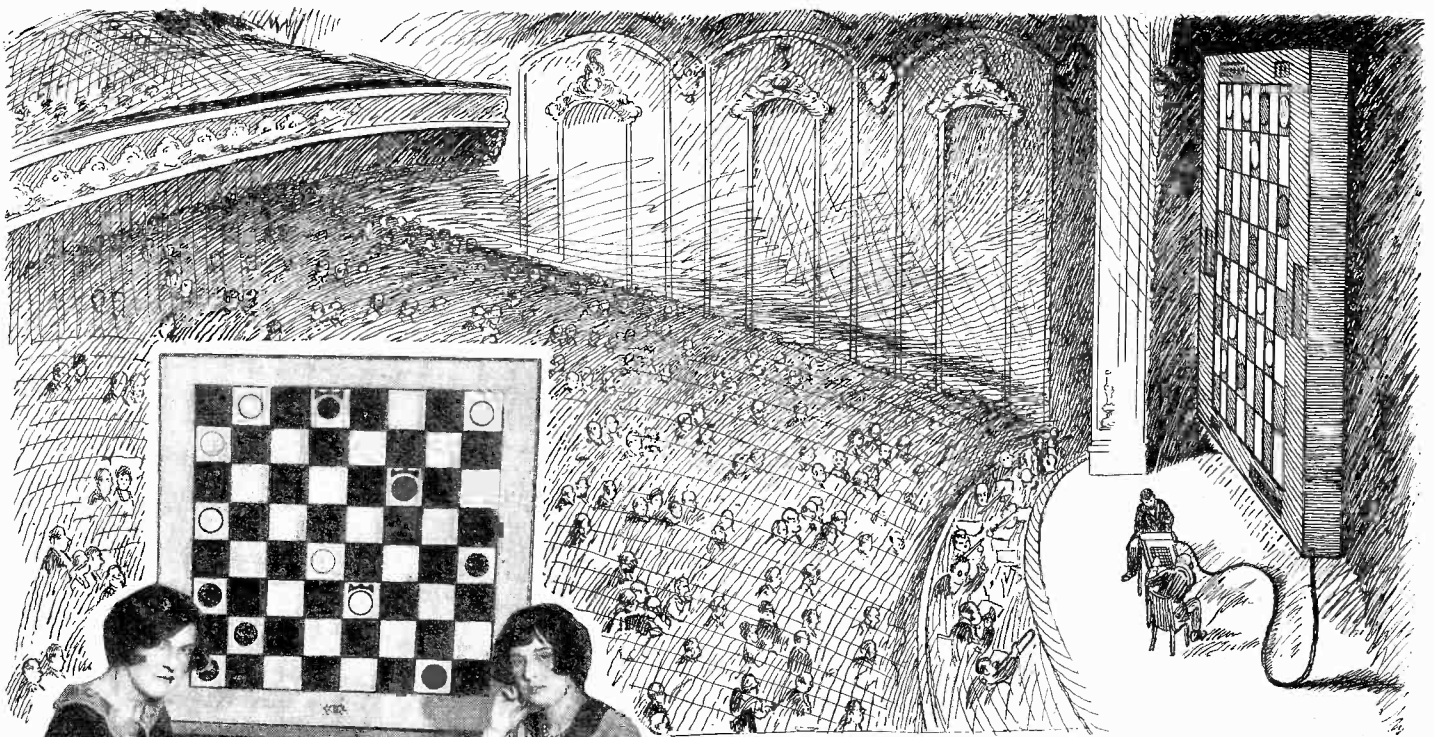

## Giant Checkerboard

THE invention illustrated on this page is an automatic checkerboard of monster proportions intended for use on the stage and which automatically duplicates the moves made by the players during a contest game. The players sit on the stage in full view of the audience and play their defensive or offensive game. Each move is automatically reproduced on the great vertical board, which instantaneously records the progress of the game enabling a large audience of people to experience all the suspense and thrill of the contest felt by those few who have heretofore been able to crowd about the players. As will be seen by the illustration, a small control board is so arranged that each square upon which the checkers are played has a group of concentric contacts. This control board is connected by cable with the monster board placed on the stage platform. When a red checker is moved it will be seen that the circuit is closed across the inner group of contacts, inasmuch as the outer contacts do not touch the metal checker playing piece. When a white checker is played, the outer group of contacts are closed by the checker, but the inner group does not touch the checker. If a red or white king is played, a dual circuit is operated as indicated below, contact being made between the center and the outer groups. Whenever the circuit is closed, a red light or a white light shows for the respective red and white checker, but if either checker should happen to be a king piece, a yellow crown around that checker will appear on the large board. The inventors are W. W. Douglas and H. F. Lenz.

The photo above shows a small model of the electric checker board.

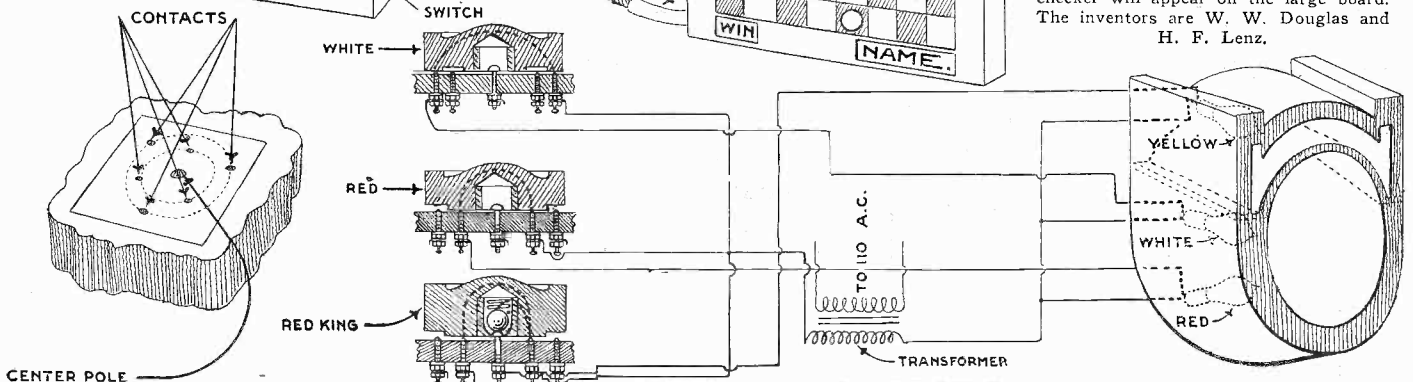
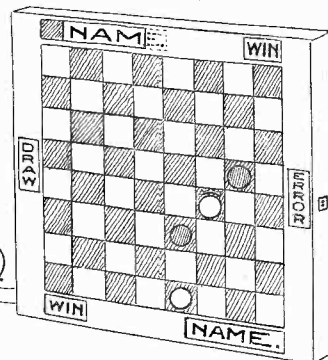
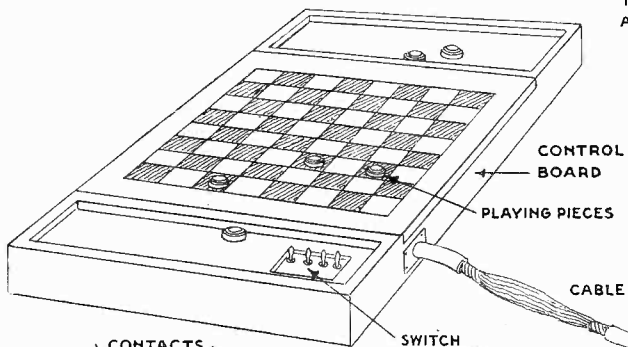
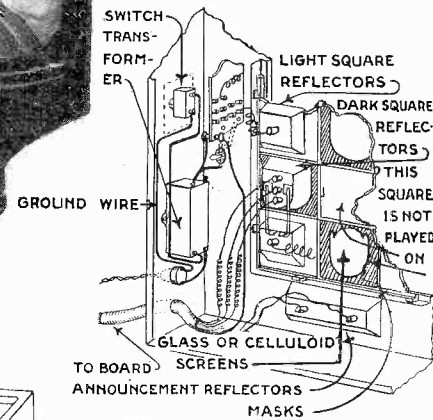



# Radio Acoustic Range Finder

By C. A. OLDROYD, Reporter No. 4433

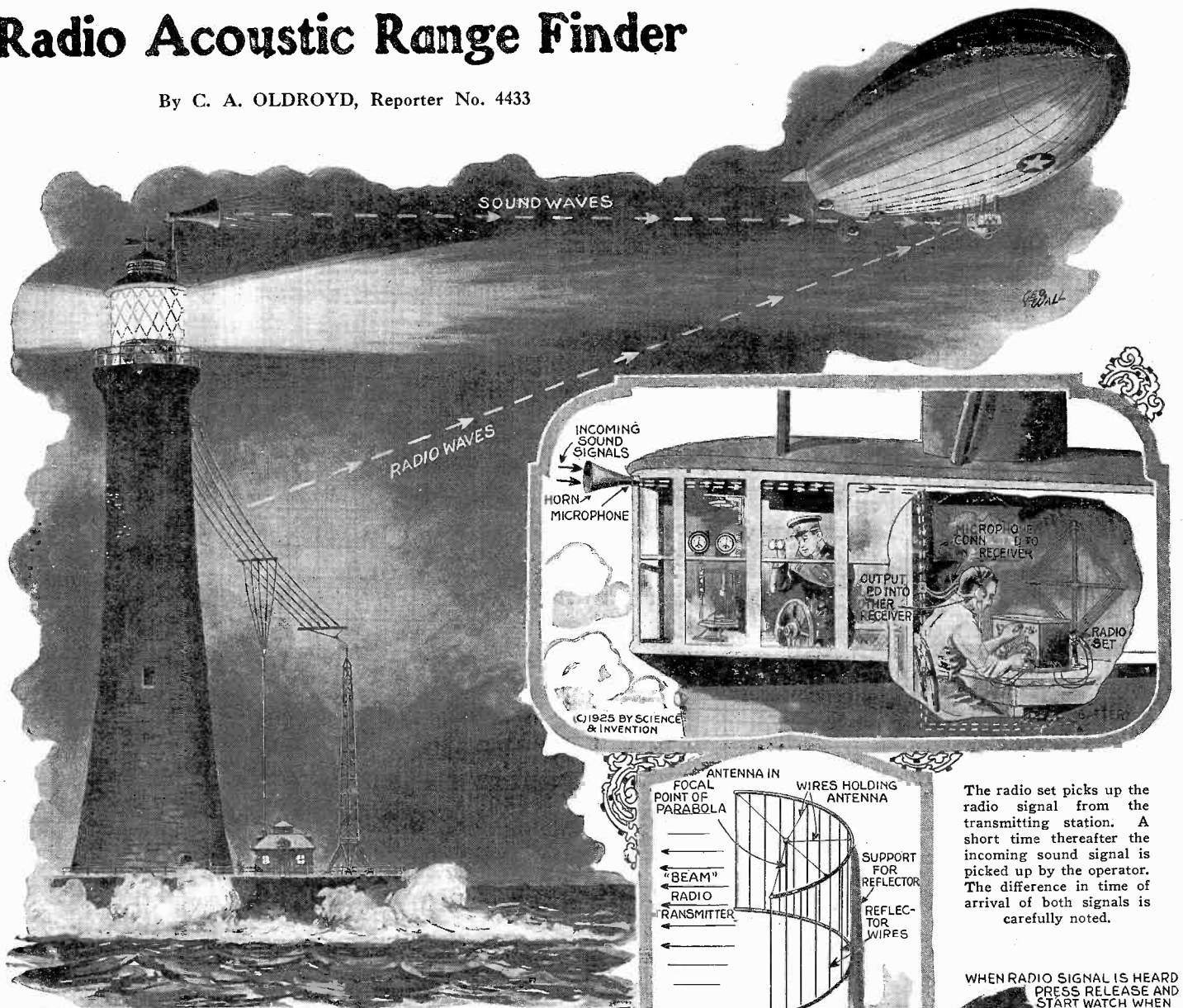

The radio set picks up the radio signal from the transmitting station. A short time thereafter the incoming sound signal is picked up by the operator. The difference in time of arrival of both signals is carefully noted.

WHEN RADIO SIGNAL IS HEARD PRESS RELEASE AND START WATCH WHEN SOUND SIGNAL IS HEARD WATCH IS STOPPED

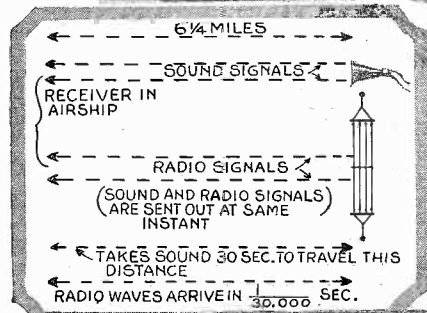
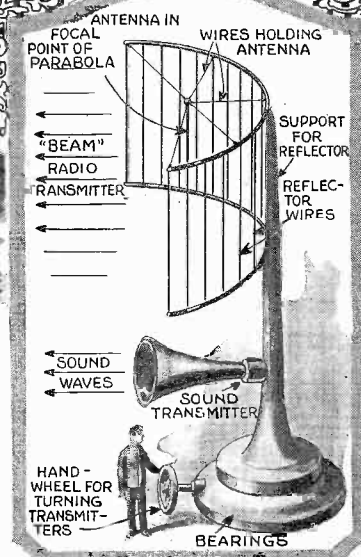
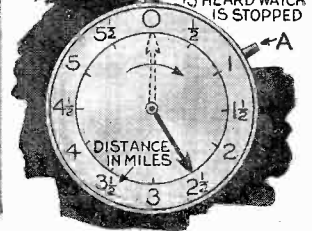

On this page is shown a new system of range-finding, using a combination of radio waves and sound waves. The two impulses are sent out from the shore station or from the lighthouse simultaneously. These radio and sound signals occur every two minutes. A stop watch graduated in miles tells the pilot how far away from the shore he is.

It takes sound 30 seconds to travel a distance of approximately 6 1/4 miles. In air, sound travels 333 meters per second or about one-nine hundred thousandths as fast as radio waves.

RECEIVERS		LONG-DISTANCE (10 KILOMETERS - ABOUT 6 1/4 MILES)				TRANSMITTERS	
B	30 SEC.	G	22.5 SEC. (RELATIVE SPEEDS OF SOUND AND RADIO SIGNALS)	F	15 SEC.	A	7.5 SEC.
D	30,000 SEC.	K	40,000 SEC.	J	60,000 SEC.	C	120,000 SEC.
	1/4		1/4		1/4		1/4

The device at the left shows directive transmission of radio and sound waves. Above at the right is a stop watch especially graduated for miles. When the incoming radio signal is heard, the watch is started. When the sound is heard the watch is stopped.

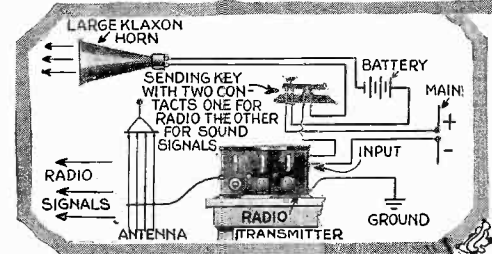

This system eliminates the personal factor because a fraction of a second will elapse before the operator presses the release of the stop watch but this same factor is again added when the sound signal is heard. The above table shows the relative speed of sound and radio signals, and the diagram to the left illustrates the transmitting mechanism.

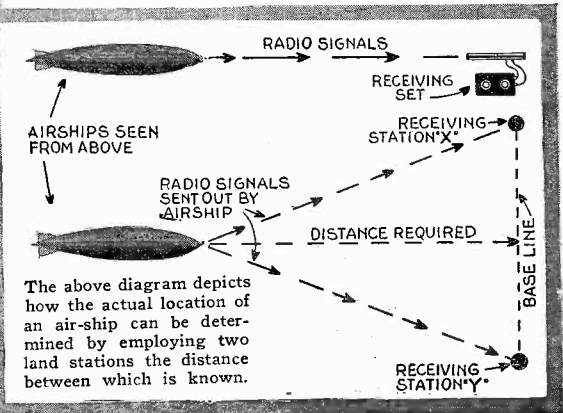

The above diagram depicts how the actual location of an air-ship can be determined by employing two land stations the distance between which is known.



# Two New Elements Discovered

By PROF. DONALD H. MENZEL, Ph.D.

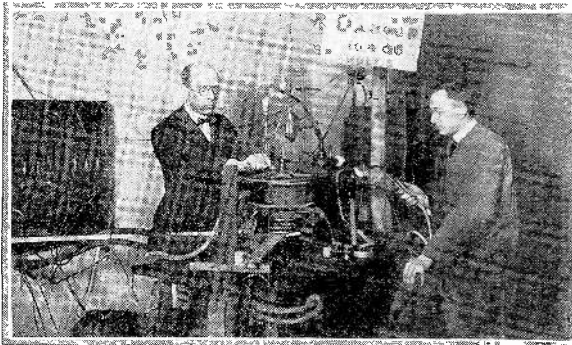

NUMBER	ELEMENT
40	ZIRCONIUM
41	NIوبيUM
42	MOLYBDENUM
43	MASURIUM
44	RUTHENIUM
45	RHODIUM
46	PALLADIUM

The photograph at the left above shows the apparatus that is used for searching for new elements. We know that there are certain gaps in the

list of elements and therefore these can be looked for by special means. The chart at right above shows position of Masurium in scale.

THE news comes to us that Dr. Walter Noddack, of the University of Berlin, reports the discovery of two new elements, to which he has assigned the names Masurium and Rhenium—after the Masurian and Rhine provinces lost to Germany after the war. Both of the elements are heavy metals resembling manganese more than any other, and were found in the minerals gadolinite and columbite. As a rough estimate, about one part in a million of the substance which makes up the earth crust is of these new elements.

The method used in the search is interesting since it is physical instead of chemical. It has been known for many years that, when the various elements are excited by electricity, they will emit certain characteristic kinds of light. Small electrical power will disturb only the outer electrons which

surround the nucleus, and the light emitted will be visible to the eye. With high excitation, however, the innermost electrons are the ones which vibrate and the much greater energies will give light of so short a wavelength that it is invisible to the eye. These are called by the well-known name of X-rays.

For more than fifty years we have known that the elements fall into a regular sequence of increasing atomic weight, from hydrogen (element No. 1) to uranium (element No. 92). The famous physicist, Moseley, found that the "color" of the X-rays (stretching the significance of the word *color* to apply to the position of the emitted light in the spectrum) depended upon the element alone.

Each substance is known to radiate two particular colors of X-rays, very close together in the spectrum. Figure shows a

diagram of the X-ray spectra of elements from Nos. 40-46. It will be noticed that No. 43 is missing. Professor Noddack, after a painstaking search, now reports that he has discovered not only these lines, but also those due to element No. 75—finally proving their existence.

There are three gaps remaining—elements 61, 85 and 87. The first of these three elements is being diligently sought. The University of Iowa has several samples which should contain it if it exists anywhere, but it has not yet been isolated. Neither is it certain that the other two elements exist in actuality. It is known that they would be built much like radium—element No. 88—which is so notably unstable. The search, however, is interesting and, if successful, promises fame to the fortunate discoverer.

## Airplane Toy

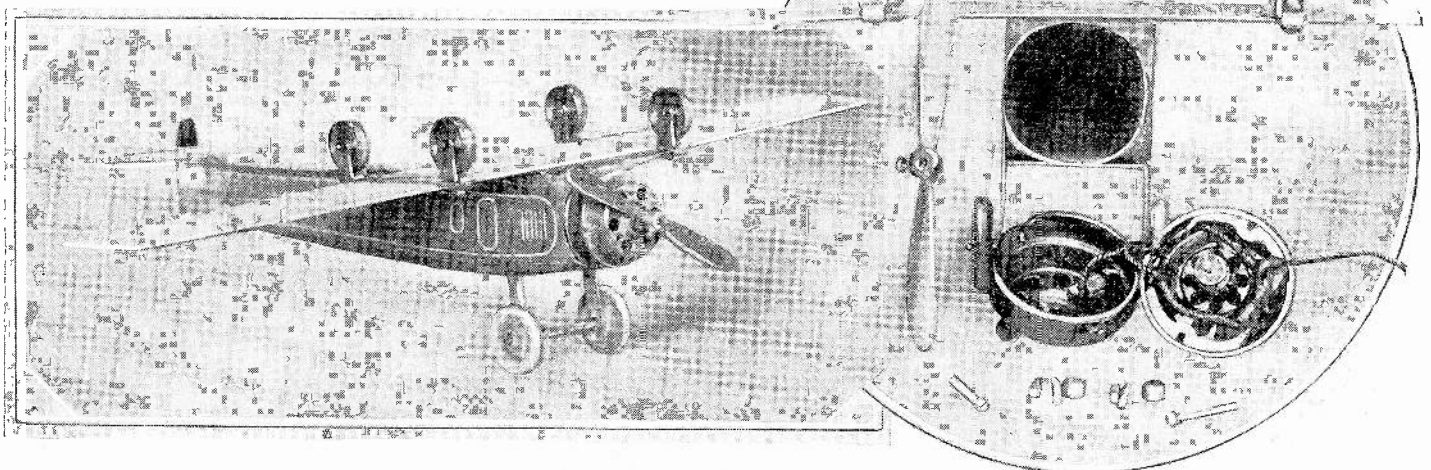

An electrically operated airplane toy that will provide much amusement to children is illustrated herewith. The photograph directly above shows the completely assembled unit and the one at the right above shows the type of motor used and its location in the nose of the fuselage. This motor will run on either A.C. or D.C. at a pressure of 110 volts. The method of operating the plane is shown at the right. Two wires are stretched over a distance such as shown, with one end higher than the other. The current is conducted along these wires and is fed to the motor through the wheels on the top of the wing. The propeller draws the plane up the incline whereupon the current is shut off and the toy coasts back.

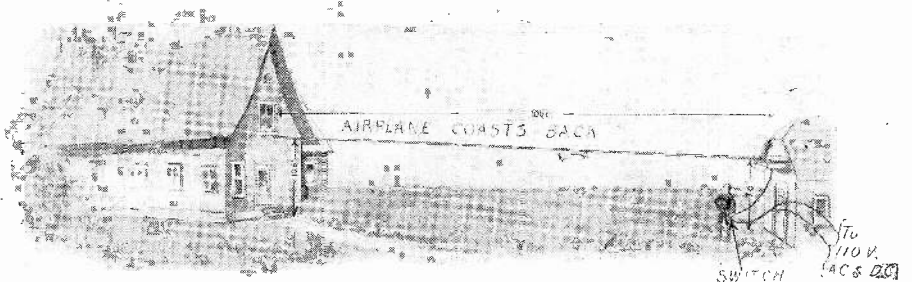

# Automatic Car Control



1 Above: View of control tower which also shows a train of freight cars proceeding down the hill toward the switches and car retarder.

2 Right: A general view of the yards showing the car retarders and in the background, one of the observer's towers. No human beings are near the freight cars, yet they are accurately switched.

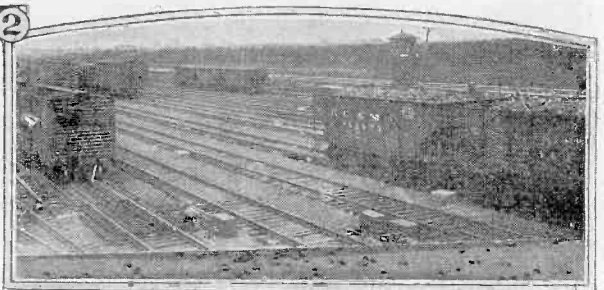

3 Fig. 3 above shows a general plan view of this entire automatic car control system. From the observer's tower the cars are switched and are stopped at any desired point.

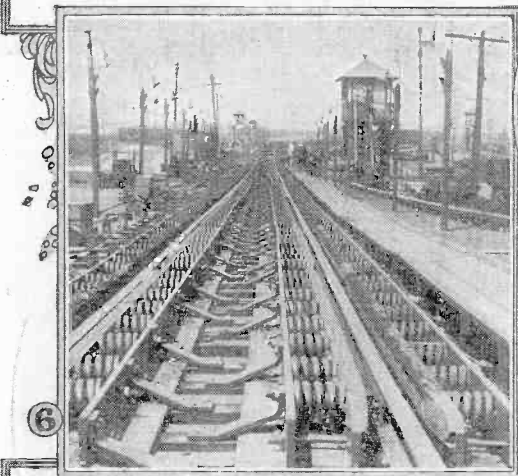

6 Above: Fig. 6 shows a close-up view of the electro-pneumatic car retarders that make this system practical.

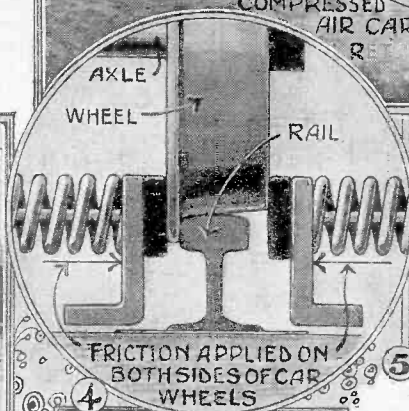

4 Above: Fig. 4 shows how the car retarders operate by pressing friction surfaces against both sides of the car wheels, thus bringing the car to a complete stop in a short space.

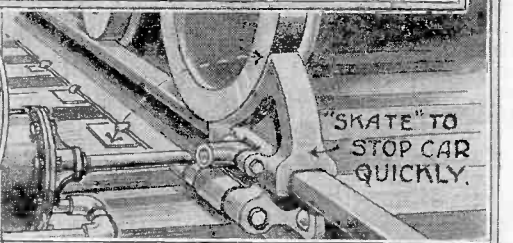

5 Fig. 5 above shows how a "skate" may be applied to the wheels of a car that has run wild. These skates are distributed throughout the yards and are automatically released. The portion on top of the rail is pushed ahead of the car, stopping it.

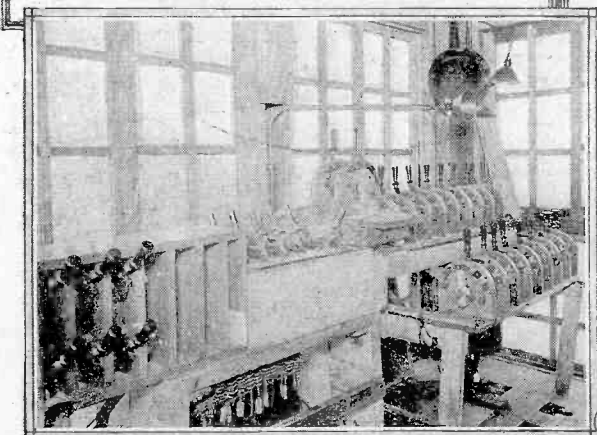

7 At the extreme left of Fig. 7 the controls are shown which enable the operator to apply the skates illustrated in detail in Fig. 5. Some of the other controls serve to manipulate the switches for selecting the track upon which the car is to be placed while the remainder actuate the retarders.

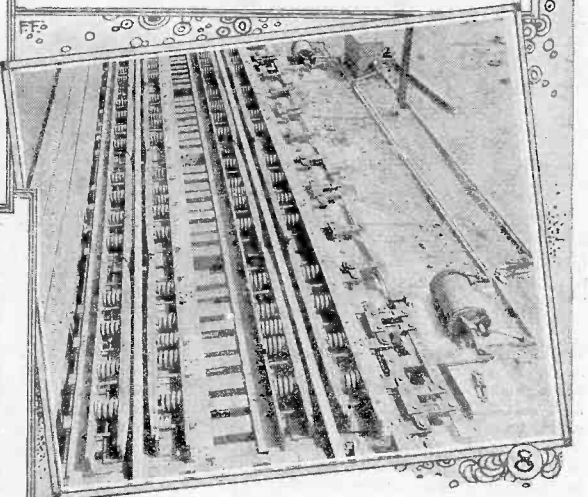

8 In the general view of one of the car retarder sections of this switching system that is shown directly above, the electro-pneumatic release and applicator can be seen to the right of the track. The heavy springs and friction bars of the retarder are also plainly shown.

# Marvelous Mechanism Does Switchman's Work

By Charles Frederick Carter

WITH switch lists for sheet music and rows of diminutive levers in lieu of piano keys five men at Gibson, Ind., daily render silent symphonies in transportation which bring joy to railroad stockholders and despair to the undertakers of America.

These virtuosi operate the Hannauer car retarders, an unbelievably efficient system of mechanism scattered for several hundred yards over the group of tracks constituting the west-bound classification yard by means of which the speed of cars rolling down the hump is perfectly controlled, and numerous switches are thrown to guide the cars to any one of thirty destinations. Through the mediums of compressed air and electricity the car retarders do all the work formerly performed by a young army of switch tenders and car riders, thus speeding up railroad operation, reducing the cost thereof, and totally abolishing one of the most dangerous jobs in connection with present day railroading.

Not a man is to be seen save a solitary figure at the crest of the hump, who, between yawns, languidly lifts a lever to uncouple the next cut or, perhaps, a yardmaster wandering disconsolately through the deserted yard, once so full of life.

Yet bustle is not necessarily efficiency. For instance, on December 1, 1923 it required 77 men to put 1,411 cars over the hump in 24 hours, employing old methods. That was an average of a car each 61 seconds, or 18½ cars per man. After the car retarder system had been fully installed and was working smoothly 10 men put 1,042 cars over the hump in eight hours which was an average of a car each 27 seconds or 104 cars per man and this in the eight hours as stated above. On another occasion 152 cars of merchandise were classified over the hump in 52 minutes an average of a car each 20½ seconds. On still another occasion 70 cars of coal were classified in 16 minutes, an average of a car each 13.7 seconds. No wonder the car retarder can show a saving of 30 cents or better for each car put over the hump.

As for safety, in the year before car retarders were installed three car riders were killed at Gibson not to mention a number of non-fatal accidents. In the year and a half that the car retarders have been in use not a single accident of any kind to an operative has occurred.

Since car retarders have been installed Gibson not only handles all traffic offered but the few employes needed to operate the system sigh for more work to do, even during peak traffic periods to dispel ennui.

"Hump switching" is the most approved method of assembling cars for given destinations and particular trains. A hump is an artificial hill 20 or 30 feet high. Trains to be classified are pushed up an easy grade to the crest of the hump where each car or group of cars coupled together going to one

destination is uncoupled from the rest of the train and allowed to run by gravity down a short steep grade which gives it sufficient momentum to carry it to the farther end of the yard. If uncontrolled the "car cut" as the group or single detached car is called, would run too fast, collide with standing cars in the yard and smash things up.

So each cut of one or more cars as soon as it is uncoupled must be mounted by a rider who regulates the speed with the hand brakes, so that it will neither run too fast nor too far nor stop too soon, a task requiring both judgment and muscle, particularly the latter. In fact, no switchman can set hand brakes by muscle alone hard enough to hold a heavy car carrying a load of 50 to 70 tons. Each car rider carries a club which is a wooden lever that resembles a short pick handle which he inserts in the brake wheel to give the necessary purchase. If the brake is not in good order or if the rail is frosty the rider may lose control of his cut, allowing a couple of 70-ton coal cars at eight or ten miles an hour to collide with a carload of eggs or fancy glassware, and thus help swell the total of damage

Machinery and mechanism of various kinds have come into different industries to such a great extent and have been so far improved that today many machines take the place of human beings. Such is the case with the mechanical switching arrangement described here.

claims for the company to pay. When cars are coated with snow and ice as they often are in winter the car rider's work is extremely dangerous as well as difficult. Sometimes it is necessary to detail men with clubs to break the ice from car ladders so the riders can climb up to the roof where the brake wheels are. In any case the capacity of the "hump" is always limited by the number of riders it is possible to return to it.

The first experiments with power track brakes were made in 1907. Then in 1920 after railroads were returned to private operation the fancy of George Hannauer, Vice President of the Indiana Harbor Belt Railroad, turned to thoughts of a device which would do the work of switchmen. With the co-operation of E. M. Wilcox, master car builder, and R. A. Feldes, chief engineer, a model of something they called a track brake was produced which looked so promising that they installed a life-sized unit in the yard. It didn't work but it came so near working that they were encouraged to persevere.

In three years the processes of evolution

had produced something which they felt justified in rechristening a car retarder. When installed it proved so simple to operate that they added electro-pneumatic switches for the retarder men to work from the same cabins. All that remained was to locate five elevated cabins so that a car moving anywhere in the yard would be under the direct observation of one of the operators, would connect up the apparatus, raise the wages of the operators, find other jobs for the retired car riders and switch tenders and begin business.

The car retarder consists of movable bars 8 to 10 feet long, assembled in units of 32 to 40 feet in pairs on either side of each rail. By means of a compressed air cylinder and a system of levers these pairs of bars can be closed like a vise on both sides of all wheels passing between them. In fact the car retarder is nothing more or less than the familiar air brake operated from the rail instead of the car. The pneumatic brake valves are controlled by electricity. Any pressure from 20 to 110 pounds can be applied at the will of the operator. The retarder is so powerful that a car can be stopped and held on the steepest part of the incline.

Two hundred and forty feet of retarders arranged in seven units with space between them, give the first operator control of movements down the incline. Forty-four other units distributed around the yards are operated by four other men. The control cabins are connected by loud-speaking telephones.

An ingenious auxiliary of the retarders is the skate throwing machine. Mistakes are made and accidents will happen in the best managed yards. As a result a heavy cut may run amuck and threaten serious damage. To guard against this the railroads have for years distributed around the hump yards, heavy cast iron wedges with one face to fit the rail and another curved to fit the tread of a car wheel. When a cut got beyond control the nearest switchman was expected to throw a skate ahead of the front wheel. The friction caused by pushing this wedge of iron along the rail would bring the unruly car to a sudden stop. It was a dangerous feat to throw a skate in attempting which men were sometimes killed. Now the movement of a lever in a control cabin operates an electro-pneumatic device, which sets the skate on the rail without danger to any one.

Indications are that savings in operation alone will pay the total cost of the installation at Gibson in about a year and a half. Aside from this there is a substantial saving in loss and damage claims to be expected from the surer handling of cars and yet another important saving due to the total elimination of personal injuries. There can be no personal injuries where no men are employed.

## Earth Round Says 13th Century Book

Had Christopher Columbus known as much of English theological literature as he knew of navigation he might have saved himself a deal of pains in his effort to prove the world was round. He might have consulted a musty tome recently dug out of the dust of Oxford's hoary libraries, a "Metrical Lives of Saints," written by a monk at the end of the thirteenth century, in which it is set forth that:

As an appel the urthe is round, so that evermo

Half the urthe the sonne by-schyneth, hou so hit evere go.

Moreover, he might have learned many other scientific facts of which his own and succeeding ages seem to have been ignorant.

He would have been told, for instance, that the moon itself gives no light, but

reflects that of the sun like a mirror; that the earth is bigger than the moon, and the sun 165 times bigger still than the earth.

The sun is so far away, wrote this savant of 600-odd years ago, that a man could go more than forty miles a day for 8,000 years before he reached it, and if Adam had set out on the day of creation he would still have a thousand years' journey to perform.



# Science Oddities

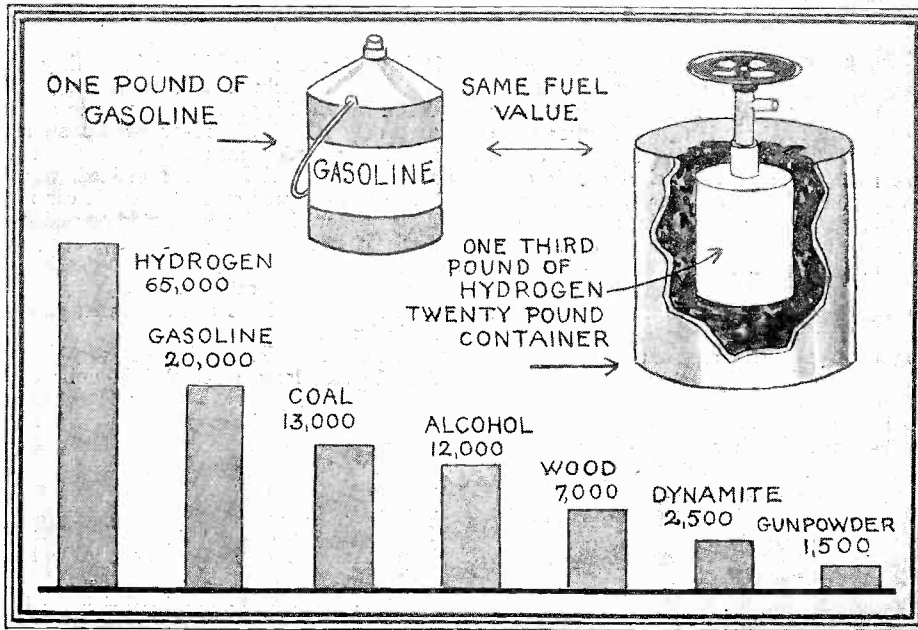

## Is Gasoline the Best Fuel

IS gasoline the best fuel to use in internal combustion engines or do we use it merely because it is comparatively cheap and always available? Of course, modern machinists could construct engines that would run on practically any fuel but still gasoline would be the best to use. The diagram at the left shows the comparative heat values which can be obtained from a pound of each substance listed by mixing with air, and burning or exploding it. Notice that hydrogen heads the list whereas gasoline is second best. One gallon of gasoline has the same fuel value as one-third of a pound of hydrogen, but the difficulty with using the latter is that it cannot be kept in the liquid form indefinitely, but only under pressure. A container for one-third of a pound of hydrogen might then weigh 20 pounds and obviously this material would be impractical for use in automobile and other internal combustion engines. Dynamite, often suggested as a fuel, has a comparatively low value as shown in the illustration. —Dr. Russell G. Harris, Harvard University.

## Cementless Reinforced Concrete

A NEW type of concrete block which is said to save 35% over the cost of standard materials, which is considerably lighter and which saves over 41% in the total cost of manufacture and installation has recently appeared on the market. The Tabatchnic method of making and assembling building blocks, as this system is called, does not utilize cement but the blocks are set and clamped together by means of steel rods as shown in the insert at the right. This material is used for flooring or for roofs as illustrated and when the blocks are made of the same size as is used in other methods, the load bearing capacity is found to be much greater. In an installation such as that illustrated, a light temporary framework is erected to hold the blocks in position until one row is assembled. This truss is then removed and placed for the next row. An ingenious coupling system is used. The reinforcing rod, molded directly in the block, is exposed at the end and the concrete undercut so that the threaded tube can be screwed onto it and to the projecting rod of the next block. In this way, all blocks are in perfect alignment and the stresses are equally distributed.

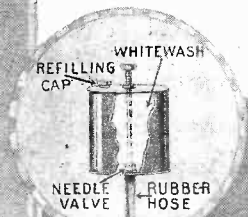
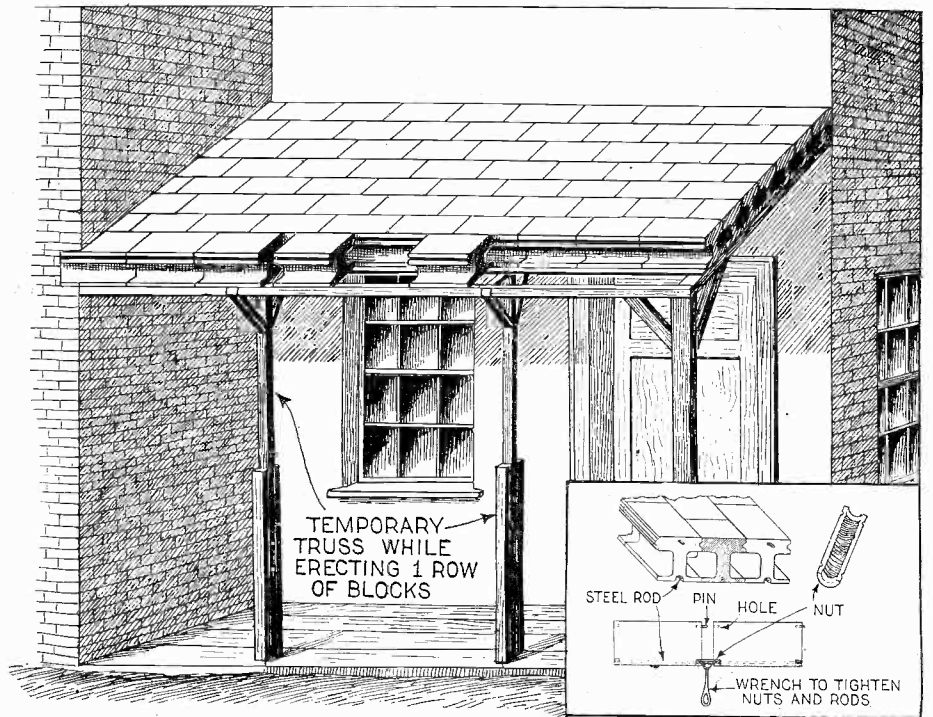

*Figure Skate Writing*



## Novel Skate Writing

A NOVEL method of advertising which consists of what is called "skate writing" is illustrated at the left. The principle which is intended to be used by a roller skater depends upon the flow of a small quantity of white-wash from a portable container through a rubber hose and out onto the skating surface. As the operator performs evolutions and various figures, a trail of white-wash is left, giving the effect shown. This system might be used for advertising purposes in various ways. It would be of particular interest to owners of skating rinks who could settle prize skating contest disputes with it.

**COLD PROOF**

**HEAT PROOF**

**FIRE PROOF**

**SOUND PROOF**

**DAMP PROOF**

**EXPANDS 3 TO 7 TIMES**

**DEAD AIR CELLS FORMED**

## New Building Material

A NEW building material that is said to be far superior to any heretofore placed on the market has recently made its appearance. Known as Insulex, it is a form of aerated gypsum that expands when mixed with water, forming a series of tiny dead air cells as illustrated at the right. This material, when used in building walls, is fire, cold, heat, sound and damp-proof. The production of this material depends upon the introduction of a so-called mineral yeast into the gypsum mixture. There are, however, no soluble salts present in the material which would cause slow decay or weakening of the structure. A two-inch thick layer of the material may be applied at half the cost of one inch of ordinary insulating material.

## Man Weighs

IT is a well-known fact that, due to the buoyant effect of a liquid, any body weighs less when immersed in water than when weighed in the air. When a human being enters water, the amount of liquid displaced is just about equal to the weight of the person, and therefore the weight on a spring balance as at the right is nearly or exactly zero.

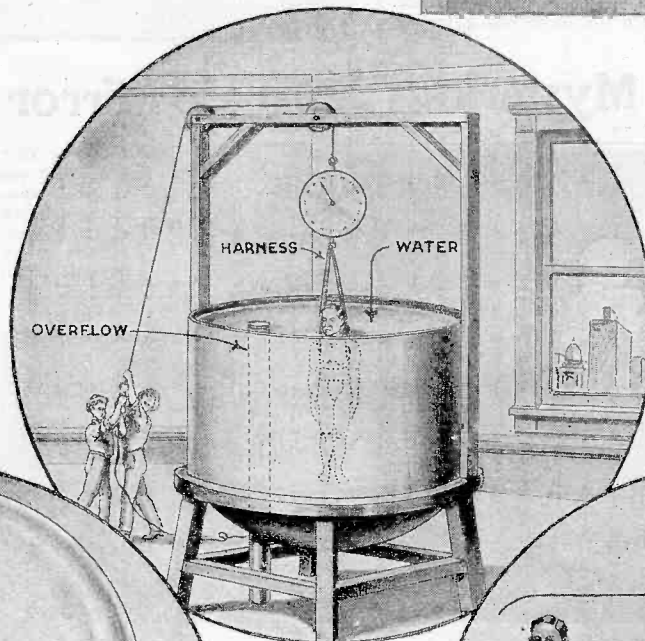

## More In Vacuum

IF a man could be placed in an air-tight jar and his weight measured both with and without the surrounding air, it would be more in the vacuum because the quarter of a pound of air that a man displaces exerts the same buoyant effect upon the body and the subsequent weight in a vacuum would be greater by just that amount.

—Donald H. Menzel, Ph.D.

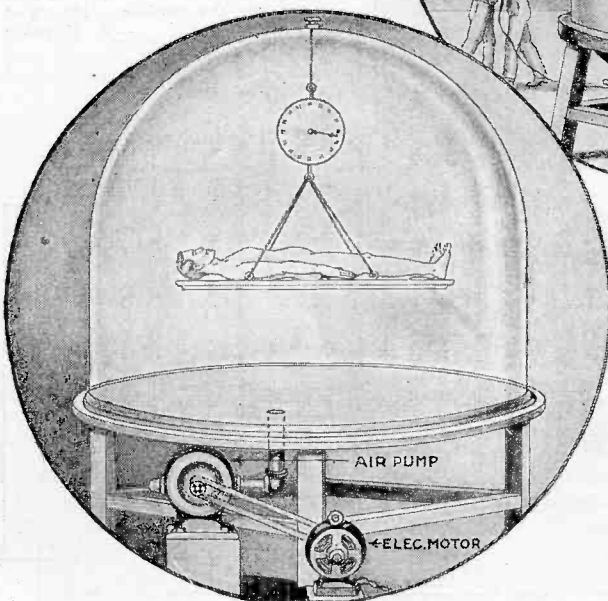

A body of a normal man who weighs 165 pounds will displace approximately that same weight in water, but only one-quarter of a pound in air. If, therefore, the buoyant effect of the latter is removed, as in a vacuum, the man's body will apparently weigh more.

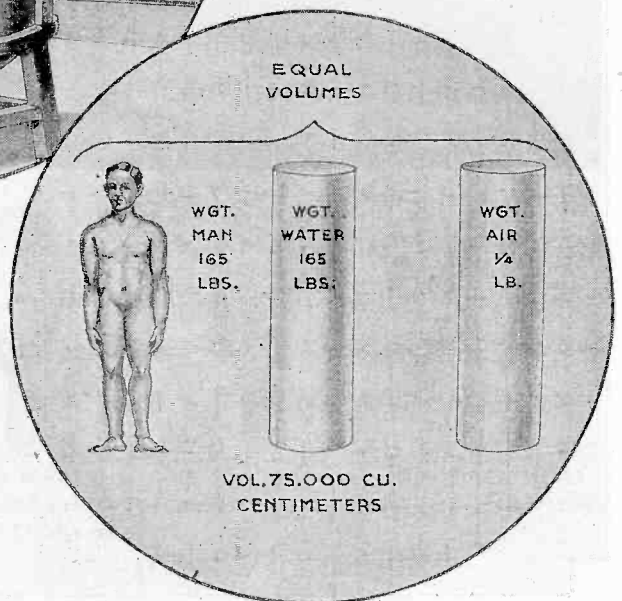



# London Camouflaged

By A. FIZZI

**D**URING the late World War, many schemes were put into practice which would make it more difficult for enemy aircraft to locate positions of certain objects. One ruse which was little known at the time was the disguising of Buckingham Palace, the London residence of the King. It was known to the enemy that the palace was in close proximity to a small lake in a nearby park. Therefore, this lake was secretly drained and on top of the palace an artificial lake one-half inch deep was constructed as will be apparent from the illustration.

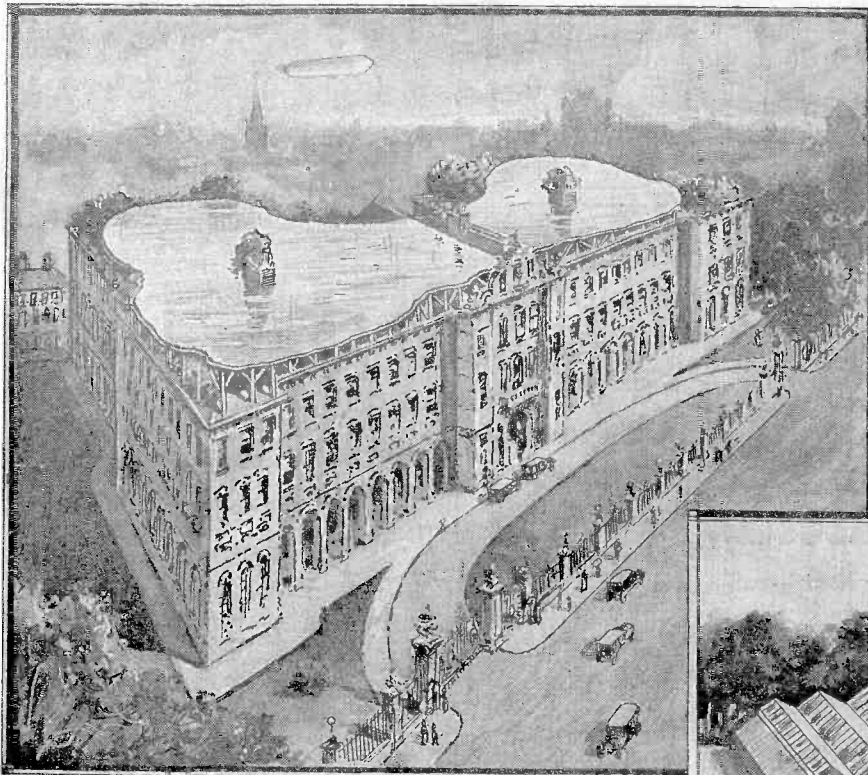

**A**FTER the lake had been drained, the spot was further disguised by building a group of houses in the lake bed. The draw bridge which has been reproduced on the roof of the palace was left in position and was hardly noticeable from the air. Although to a person on the ground the effectiveness of this camouflage is not at all apparent, still to the aircraft gunner flying sometimes miles high to avoid anti-aircraft defenses, the deception was almost complete and undoubtedly saved the palace. The buildings in the old lake bed were not occupied at night when raids were imminent.

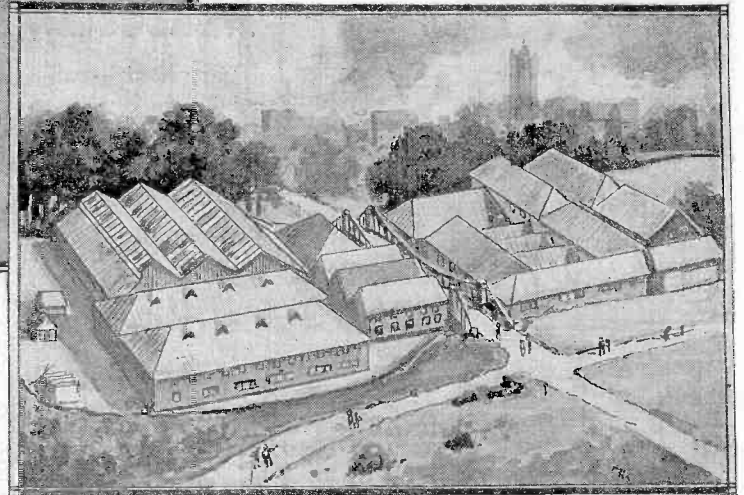

## Mysterious Japanese Mirror

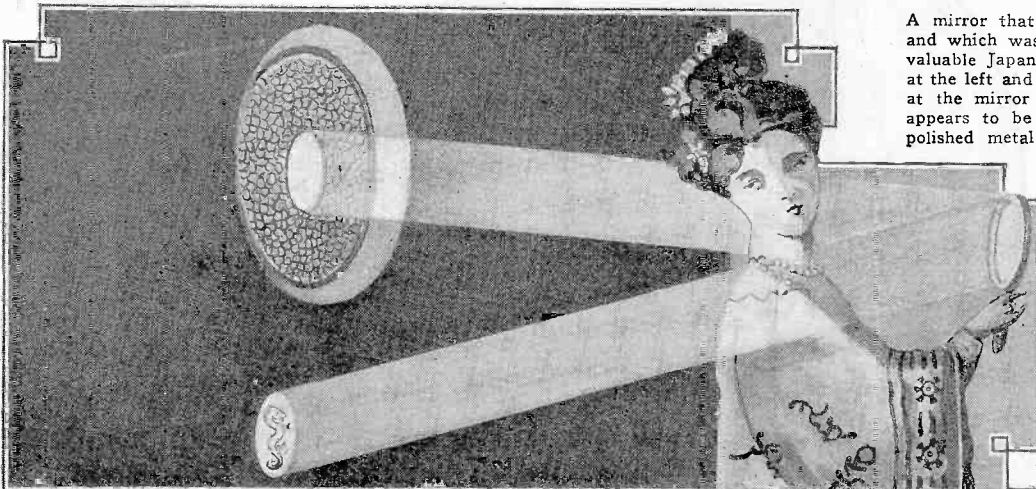

A mirror that produces a most interesting phenomenon and which was recently discovered among some old and valuable Japanese works of art is illustrated in operation at the left and in detail below. When one looks straight at the mirror as when viewing one's own reflection, it appears to be perfectly plain. The mirror is of highly polished metal and a weird dragon is engraved on the back. If the mirror is allowed to reflect a beam of light upon a wall or curtain as shown, the outline of the dragon will be seen on that surface. The secret lies in the fact that in making the mirror a dragon was engraved on the front and then polished off. The fine lines remaining are invisible to the eye, but show up under the conditions illustrated.

—V. Volynkin.

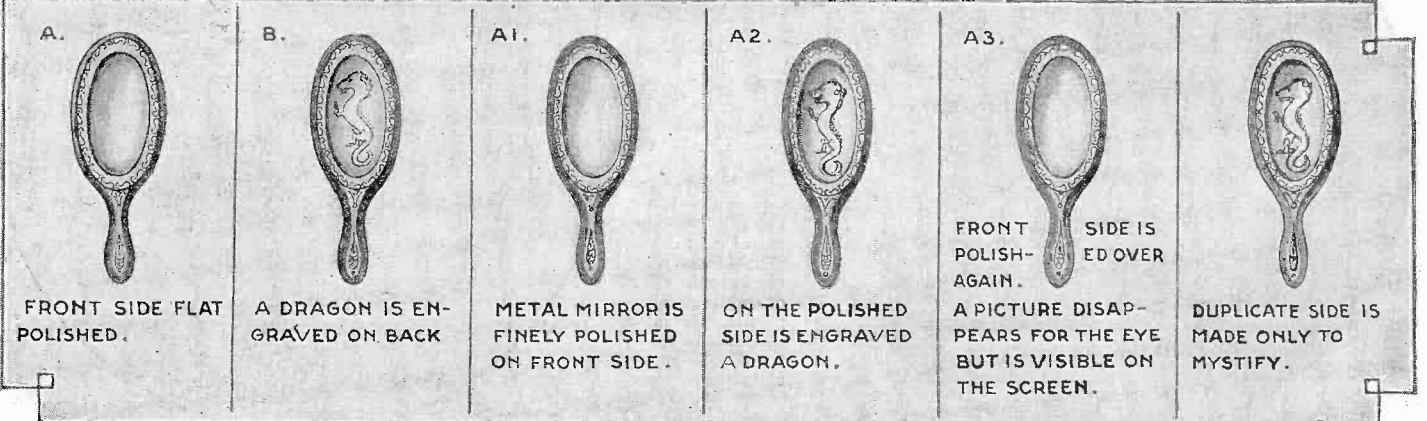



# Deciphering Charred Records

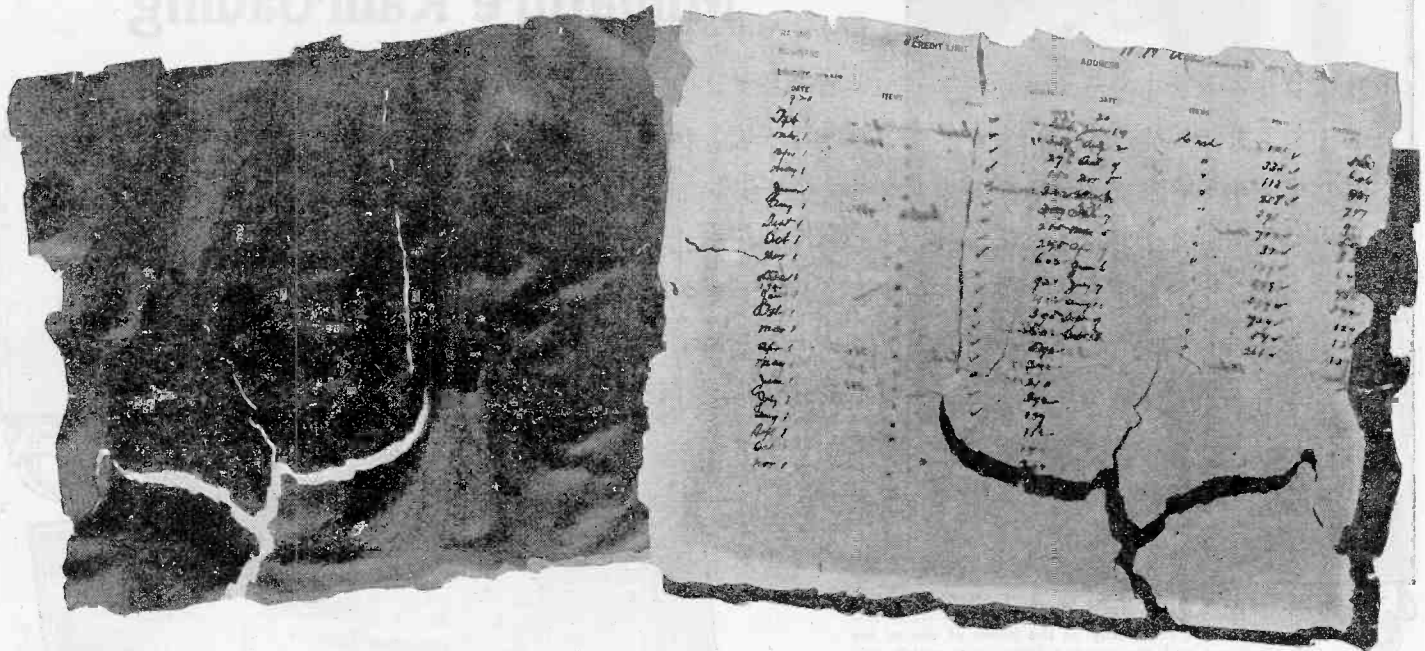

The Federal Bureau of Standards has shown that charred records may be deciphered when photographic plates are used as indicated here. The charred papers are placed in contact with the emulsion of fast or medium speed photographic glass plates; they are kept in this condition in total darkness for from one to two weeks and then developed in the usual manner. It is presumed that the gases contained in the charred papers have the power to fog the photographic plates. The ink acting as a screen, hinders the escape of the gas. On development it is found that the photographic plate has been blackened where it has been in contact with the charred paper except in those places covered by ink. The writing on both sides of the charred paper appears in the print, that from the back of the page being fainter than that from the face. Films do not work very well. The above photographs show a charred record and a photo print therefrom. —Allen P. Child

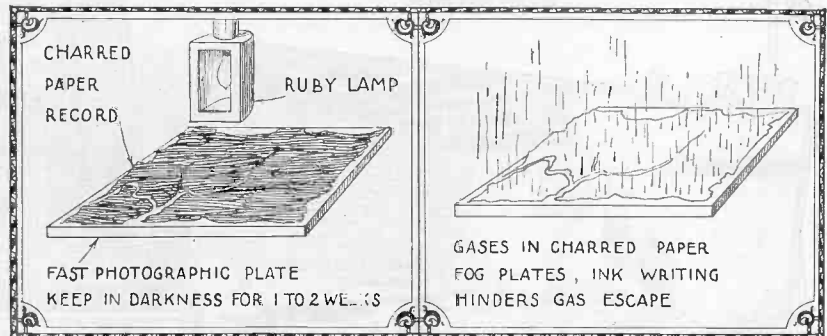

## Rotor Yachting

Ever since Herr Flettner designed his rotor-ship, attempts have been made to improve upon the vessel. In the photographs below we see two types of Flettner Rotor Yachts. The spinning cylinder causes the wind to go around with the cylinder. Decreased air friction on one side of the cylinder produces a partial vacuum and increased air friction on the other side produces pressure. These two forces move the boat.

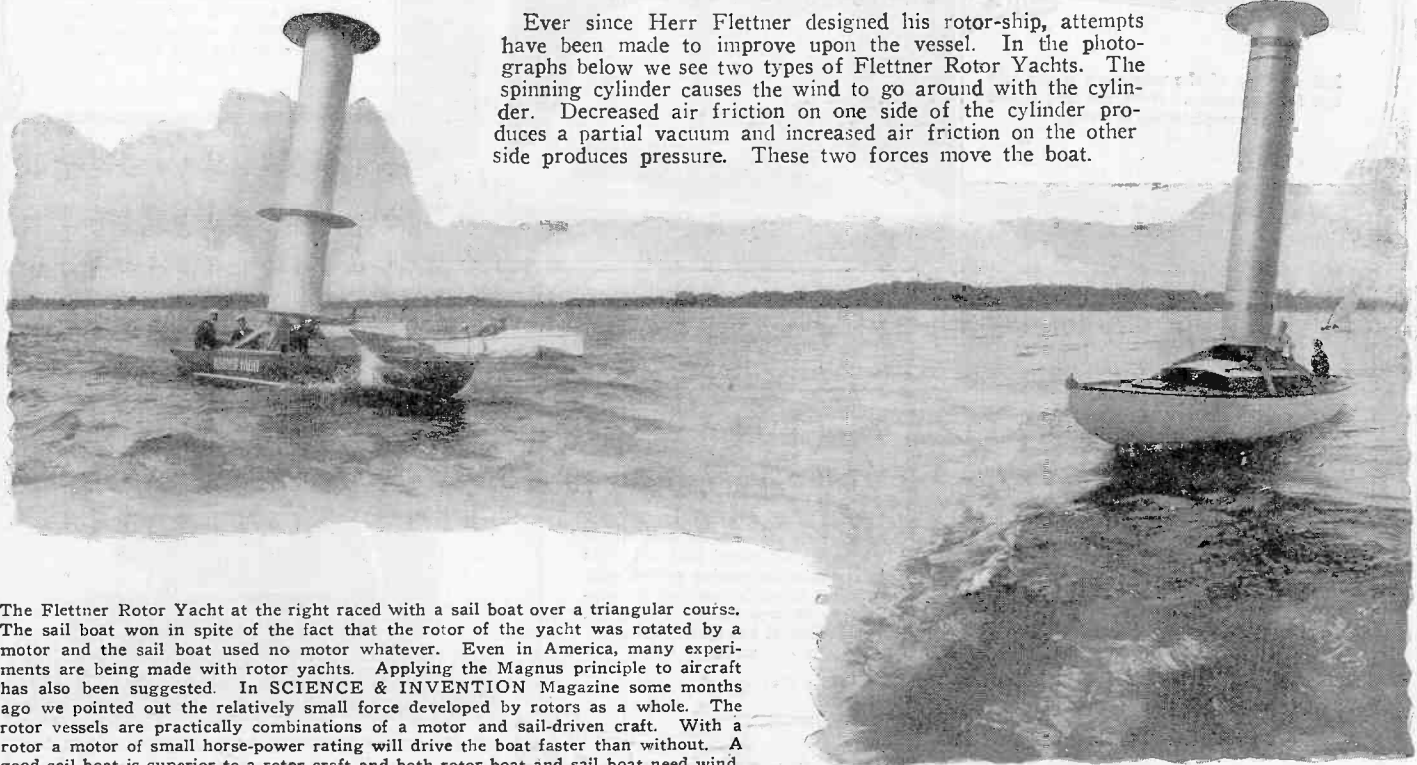

The Flettner Rotor Yacht at the right raced with a sail boat over a triangular course. The sail boat won in spite of the fact that the rotor of the yacht was rotated by a motor and the sail boat used no motor whatever. Even in America, many experiments are being made with rotor yachts. Applying the Magnus principle to aircraft has also been suggested. In SCIENCE & INVENTION Magazine some months ago we pointed out the relatively small force developed by rotors as a whole. The rotor vessels are practically combinations of a motor and sail-driven craft. With a rotor a motor of small horse-power rating will drive the boat faster than without. A good sail boat is superior to a rotor craft and both rotor boat and sail boat need wind.

# Miniature Railroading



Right: One of the miniature locomotives complete in every detail and which accompanied by its tender makes regular trips over the "cellar railroad" located in the basement of J. L. Swartzel's home in Washington, D. C. The models are entirely home-made and are run by electricity.

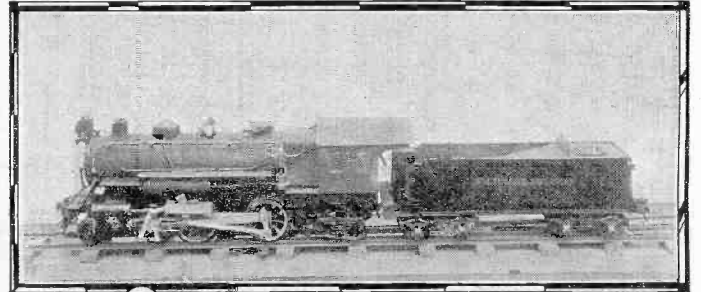

Above: Mr. Swartzel holding one of the rough castings that will eventually be the boiler of one of his locomotives and the wooden form from which this casting was made.

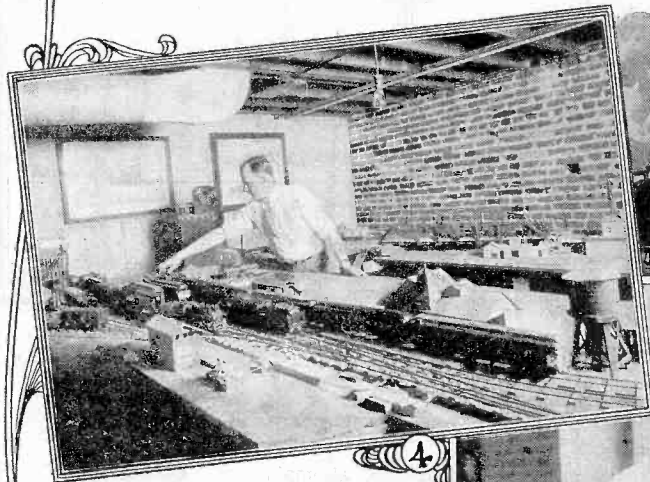
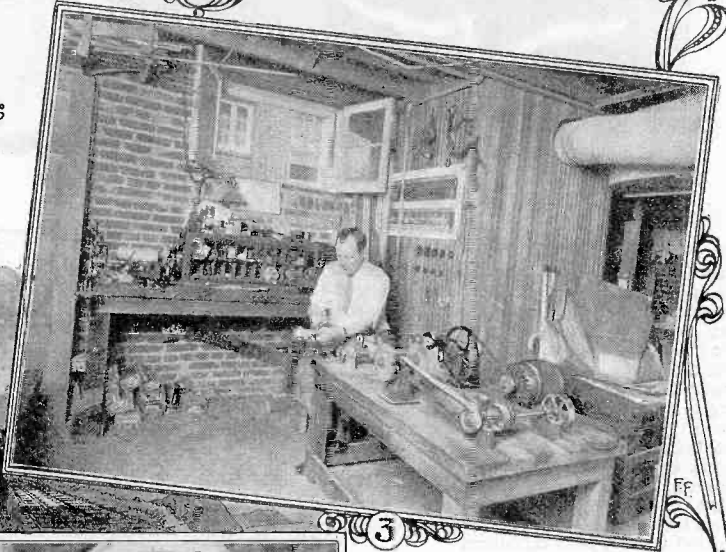

Below: One of the miniature trains laid out for inspection. Note the length and the completeness of design.



Above: A corner of the workshop in which these models were produced. Note the complete layout of tools and machinery that are available. Left, Fig. 4: Another part of the basement where the trains are run. Note the complete miniature equipment including stations, switches, water towers and bridges.

Above: Another model engine complete in every detail even to the tender.



Another model maker is Reginald H. Cladius of New York City who is shown at the right with a replica of one of the Class T types of electric locomotives used on the New York Central Railroad. This miniature locomotive moves over 25 feet of track and can automatically reverse itself. Placed on exhibition, it has excited much interest.



# Amateur Railroading

Thrills, Knowledge and Pleasure Come to the Toy Railroad Operator.

By G. H. DACY

**A** PROMINENT real estate operator of Washington, D. C., is also a railroad president in pantomime. Fate's shuffle shunted this gentleman who started to study railroad engineering and who aspired to build great transcontinental transportation system into the mechanic-less enterprise of selling homes and office buildings, apartment houses and hotels. His interest in railroading, however, has never waned. One of the most interesting collections of miniature locomotives, railroad trains and rolling stock in any private home now enables this genius to satisfy his craving for active participation in the profession which has always been his favorite.

A curious hobby you will probably call it. With John L. Swartzell it is a hobby which is old enough to vote. It began when he as a boy, he was presented one Christmas morning with his first train of toy cars. It has been intensified and expanded by systematic study, experimentation and research from that day to this.

Mr. Swartzell maintains that a man without a hobby is almost as much as a derelict as a man without a country. He says that his railroad building hobby has afforded him greater pleasure than any which money could buy. For 22 years, he has been devoting his spare time, particularly the long winter evenings to his basement shop and his locomotive building operations. The shop is equipped with a small bench lathe adapted for model making which is suitable for either wood or metal turning. A one-fourth horse-power electrical motor provides the power. It drives a counter-shaft so that a set of emery wheels used for sharpening chisels and other tools is actuated mechanically. Then there are drill presses, bench vises, metal-and wood-working tools and the accessory equipment essential in such a home workshop.

The railroad system which Mr. Swartzell has constructed occupies another large basement room. It is mounted on a mammoth table so that contour conditions—geographical bumps and dents—may be provided by the use of special scenery and stage set-ups. More than 450 feet of track have been installed. A complete railroad yard with a multiplicity of switches, a coaling station, water tower, gas tank, water cranes, round house, repair shops, block towers, an icing station, and allied accessories is featured. A metal truss bridge four feet long is interesting. It is an accurate replica of a similar commercial bridge. The maximum load is carried on the upper span. When you lift the bridge from its underside, it appears light and fragile. Yet this same span when set in place on its abutments will easily sustain the weight of a 200 pound man.

The train styles and engine fashions are as diverse as those which you will find in the commercial yards of any great American system. Everything is designed and made to accurate scale. Mr. Swartzell will not countenance guess-work or makeshifts. Seated at his drafting board, he first designs and draws the sketch of the piece of rolling

stock which he plans to make. Then he makes and moulds, shapes and sizes this equipment so that when the model is completed it is a perfect facsimile of the commercial article. It is mechanically and scientifically a true reproduction.

Each locomotive boiler or body is made from an aluminum casting moulded expressly for that purpose at an aggregate cost of \$1.00. Aluminum is ideal for this purpose. It is light in weight and easy to work. One disadvantage obtains because you can not solder other parts to an aluminum base. Brass is too heavy and costly for use in such castings. Even where the aluminum is used, the weight of one of the seventeen-inch locomotives when completed is about  $3\frac{3}{4}$  pounds. This weight is sufficient to enable the amateur toy to ride a curve and draw a train of six cars without derailment.

Mr. Swartzell makes steam style locomotives but provides electricity as the operating power. He purchases the small electric motors and revises or modifies them to meet

## AN INSTRUCTIVE HOBBY

Miniature railroading is a hobby that can be pursued by anyone and it furnishes not only amusement, but also instruction in the mechanics of railroad constructional work. The article on this page shows what can be done by anyone who will take a real interest in this subject.

his needs. One of these motors is fitted to a locomotive truck made of brass which in turn links comfortably in the aluminum casting. The pilot or cowcatcher of the locomotive is made of 14 small pieces of brass dove-tailed securely together. The completed work is really an example of amateur art. It but shows the great detail and thoroughness which Mr. Swartzell devotes to his prize hobby.

The locomotive cab is even equipped with windows made of celluloid and set firmly in tiny copper frames. The usual bell, whistle, headlight and other customary adjuncts are also provided. One of the four model locomotives which Mr. Swartzell has made is provided with outside valve motion or gear. The tenders in each case are as accurate in design and detail as the engines themselves. One type of tender is patterned after the Vanderbilt style. Its fire deck is on the same level as the floor of the locomotive cab. Its boiler and coal pocket are mounted at the forward end of the tender and are accessible from the ground by a series of ladders. Even the coupling device is a true model of the one in commercial use.

The passenger coaches, Pullmans and freight cars are made of white pine with

brass wheels. This wood is easy to work, light in weight and does not split easily. Potentially, Mr. Swartzell plans to replace these wooden cars with metal reproductions to more closely accord with those now in engineering use. One of the dining cars is a model of the latest popular design for North and South travel. It even contains a concealed box underneath the floor of the car where the mattresses for the crew are carried. The observation Pullmans are equipped with hinged gates and a hinged section of the vestibule floor which can be elevated so that a passenger can use the steps to descend to the ground.

The railroad system is wired in three separate units which are controlled from a central switch box by seven individual switches. The arrangement is such that east-bound traffic is functioned in one unit, west-bound travel in another, while the switching activities within the yard are controlled by a third. This means that two trains can be operated in opposite directions at the same time while other locomotives are switching freight cars about the yards and shops. A one quarter horsepower motor and generator are used to provide the direct current for running the trains. All the models are made for use with a direct current system as it is most efficient for such purposes.

The veteran locomotive of the Swartzell railroad system is the original toy which this gentleman has preserved from his earliest boyhood. It is of the type which winds up with a key and is operated by means of a long coiled flat steel spring. This venerable locomotive now 22 years of age is the mascot of the system. Other toys and early models which are historical examples of Mr. Swartzell's self-tutored education in railroad construction and model making are also interesting. The railroad track is made of brass rails fastened securely to white pine ties which are anchored to a firm wooden base. The track is of similar design to standard gauge 120 to 150 pounds rail. Even the frogs are ideal specimens of careful workmanship while the points are painstakingly soldered together.

Mr. J. L. Swartzell is president, chief engineer, expert designer, model-maker, superintendent and mechanic of his private railroad system. He tests out all the vicissitudes and hazards of railroading with his "Tom Thumb" system. He can stage and study the cause and effect of railroad wrecks, derailments, grade crossing smashups and other accidents. He can duplicate in miniature all the emergencies of railroading which may arise and then can iron out the puzzles by ascertaining the correct and efficient solutions. Briefly, this homespun railroad is an educational proving grounds where transportation executives might well serve an apprenticeship. Mr. Swartzell, a graduate of his self-coached school, although he has never had any professional experience in railroading, would qualify admirably for a responsible position as a result of his private study, search and research, quest and conquest.

## "Science and Invention" Leads Again!

**I**N our October number we suggested and described a new airplane landing scheme, utilizing a huge platform erected on top of the New York City Postoffice and the Pennsylvania Railroad station. Here is a despatch from Chicago, dated September 10th, which shows SCIENCE AND INVENTION to be ahead once more.

CHICAGO, Sept. 10 (A.P.)—A landing platform for mail planes on the roof is included in plans for a new \$15,000,000 Chicago postoffice which Congress will be asked to approve at its forthcoming session, Postmaster Arthur C. Lueder has disclosed.

The platform would be two city blocks in length and provide space sufficient for

De Haviland planes. Its use would trim the air mail time between Chicago and Eastern points by nearly an hour, which is required now to transfer mail from the field at Maywood.

Thus we lead again in predicting the advance of science and engineering. Looking ahead invariably pays.



# Machine Makes Paper Cups

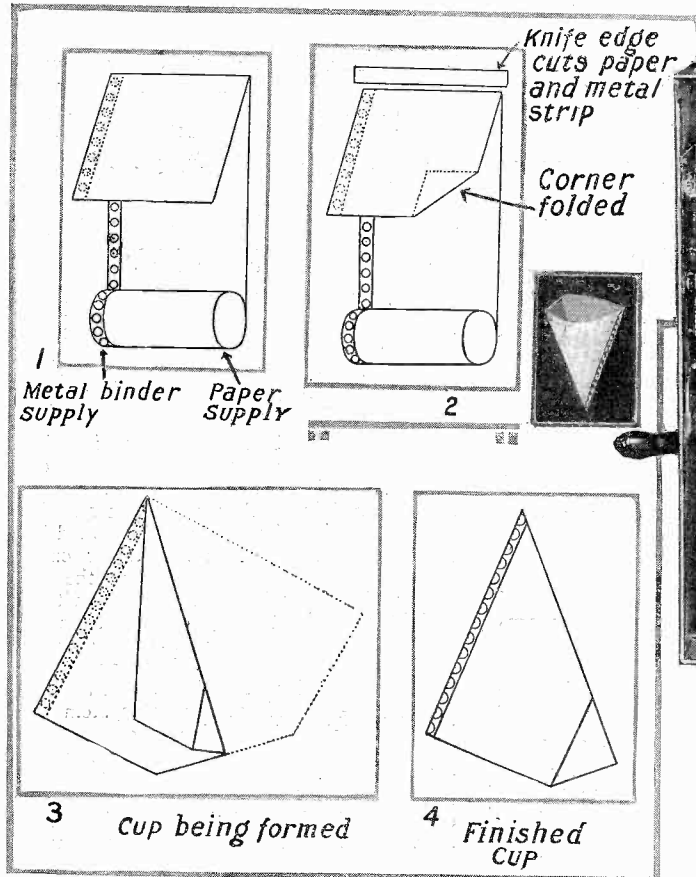

The four main steps in the forming of a paper cup are shown above and the shape of the finished product may be seen in the insert. The paper roll and metal binder supply are side by side and are fed up through slots to the position shown in 1. The paper is then cut and one corner folded over so that the edge will not cut the mouth of the user. An arm carries the paper over as at 3 and a crimping part produces the result as at 4.

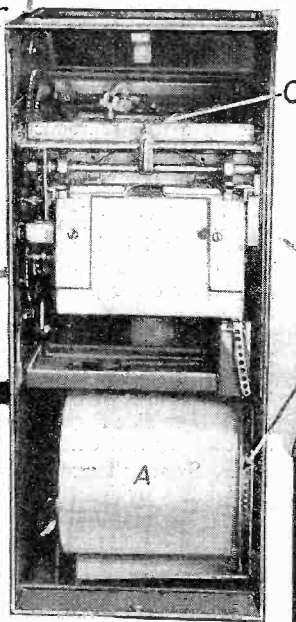

A new device for office use that makes paper cups individually as needed, has recently been placed on the market. No manipulation on the part of the operator is necessary other than the pressing of a button and the turning of a crank. The complete operation is otherwise automatic.



The center photograph above shows a back view of this ingenious machine with the strip of paper removed from the guides, so as to show the mechanism clearly. The roll of paper is indicated by A, the metal binding strip that holds the edge of the cup together by B, and the knife that cuts both paper and metal strip by C. In the photograph at the right above the process of obtaining a cup from this machine can be seen. The button D is first pressed so as to place the mechanism in operating position where-upon the crank, E, is turned three times and a cup is delivered from the chute, F. The entire process can be watched through a glass in the top of the machine. The device can be placed on a specially designed tripod stand or can be clamped to a water cooler as may be desired.

# Musical Novelties



The photograph at the extreme left shows a new one-man orchestra in which the operator plays one instrument with his mouth, does two things with each hand and operates one device with each foot. A rack of instruments, each of which can be played with one hand, is shown in the center photograph. Even the wow-wow mute on the cornet is operated by the same hand that manipulates the keys. The wire shown makes this possible, as it is engaged by the thumb.—Roy R. Harper and H. Bernard.

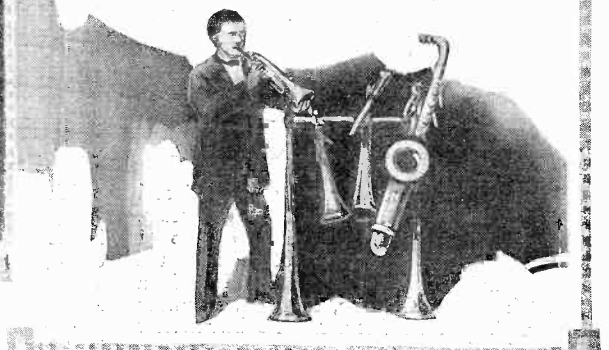

# Meteors Photographed

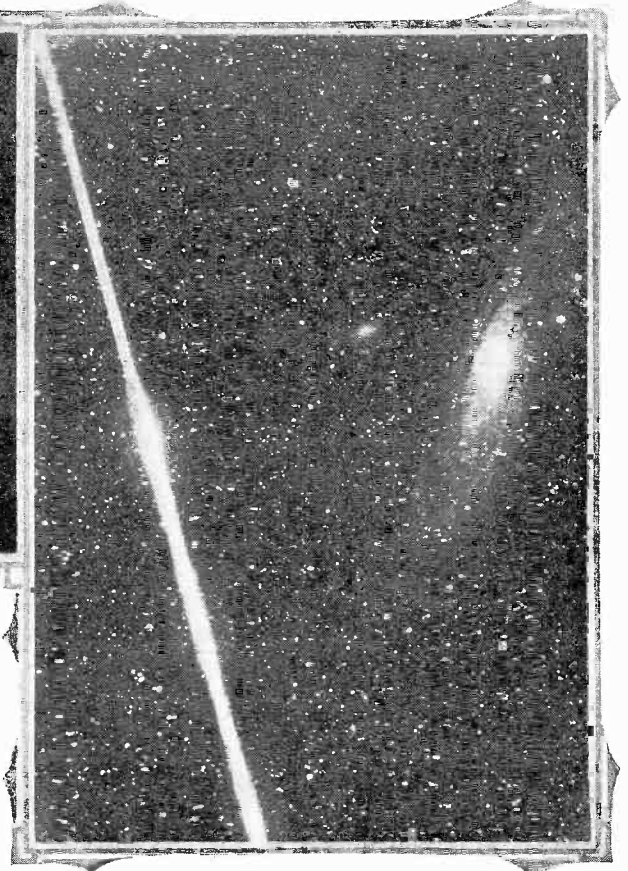

It is rather infrequent that good photographs of the paths of meteors can be obtained, but occasionally a camera shutter is open and pointed toward that section of the sky where a meteor falls. This happened in Oklahoma and the result was the photograph shown directly above. A very well defined reflection of the flash is seen to the immediate right of the vivid streak of light. —H. E. Zimmerman.

At an observatory in Czecho-Slovakia an astronomer was photographing the nebulae of Andromeda through one of the telescopes and was elated to find, upon developing the photograph, that he had caught the flight of a meteor. The result is shown at the right. —Hubert Slouka, Rep. 7110.

# New Water Turbine

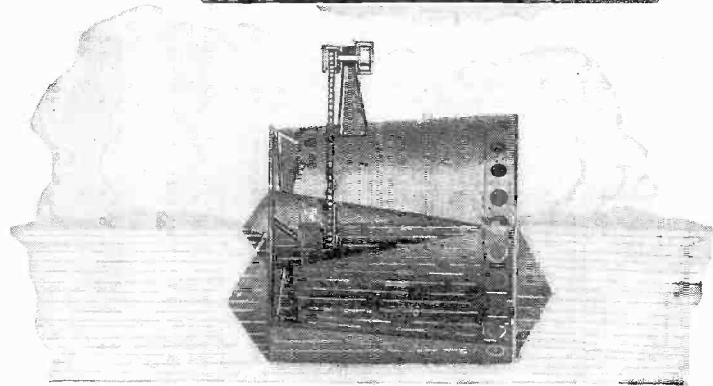
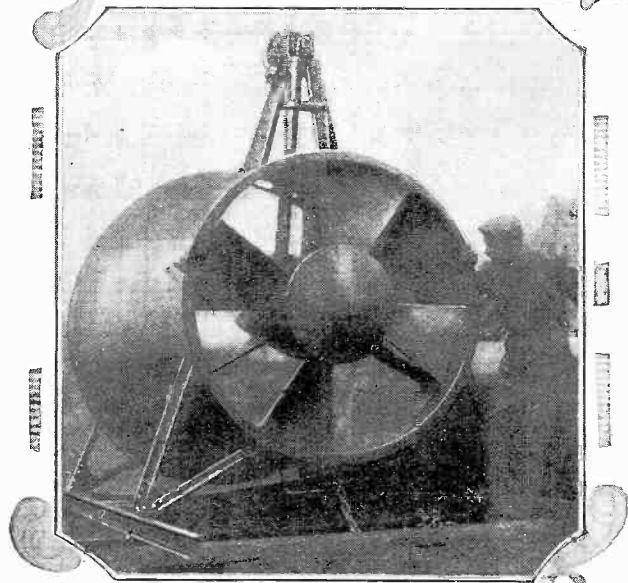
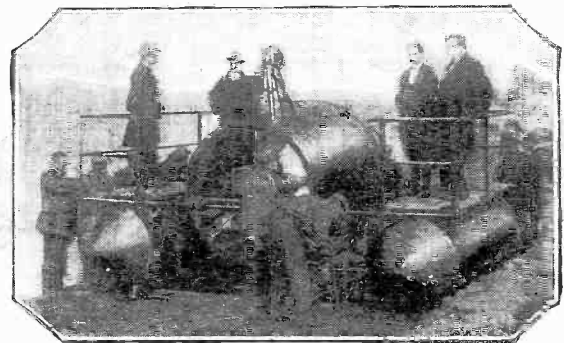
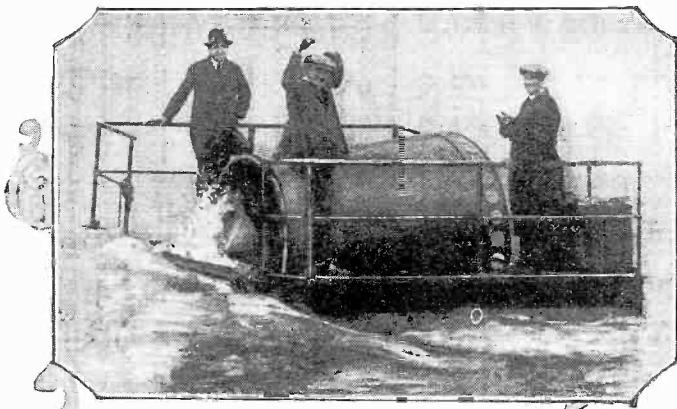

A new turbine has recently been designed and tested in the Danube River, near Vienna, that gathers power directly from flowing streams without necessitating the use of fixed structures. In other words, the entire unit is designed to be placed in a river or stream and to obtain power from the flow of water through the turbine blades. The photographs and drawing on this page illustrate the turbine in detail.

# Old Film

\$100.00 In Prizes—What Can

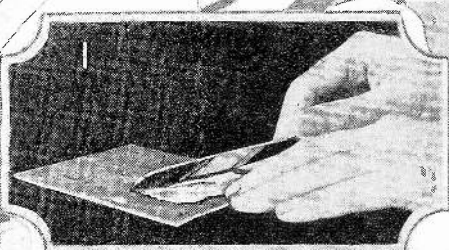

↑ The emulsion from an old photographic film may be removed by soaking the film in hot water and scraping the emulsion off with a knife.

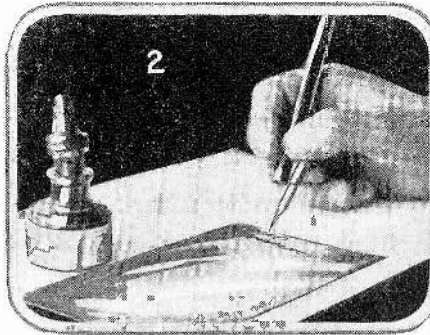

↑ One can easily draw on a film with India ink. This negative may then be used in a regular printing frame and the amateur artist may make dozens of photographic post-cards of his handiwork.

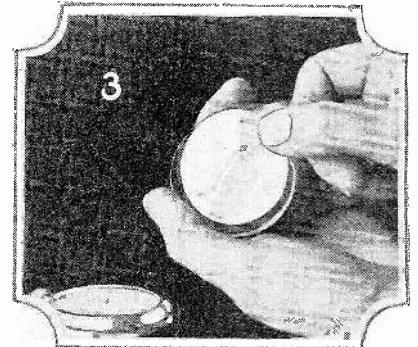

↑ A circular disk of celluloid makes an admirable substitute for a watch crystal. It is not easily broken. The disk can be cut from an old film.

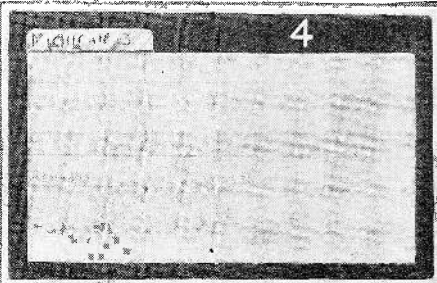

↑ Strips of celluloid are ideal in making indexes for card files. They may be cemented on top of the lettering.

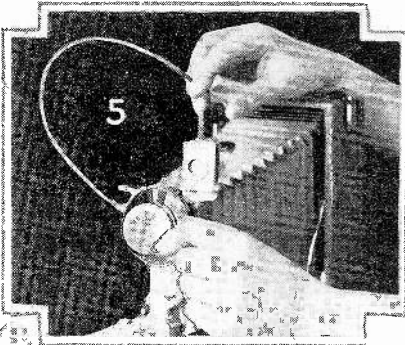

↑ Tinted celluloid disks make good ray filters for cameras. The color is deposited between two disks.

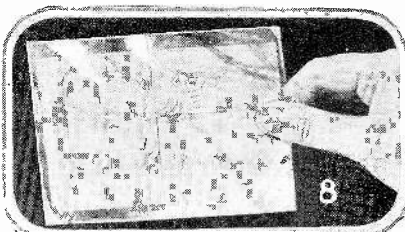

↑ The above illustrates how old films are used for protecting identification cards and the like. Such covering prevents soiling.

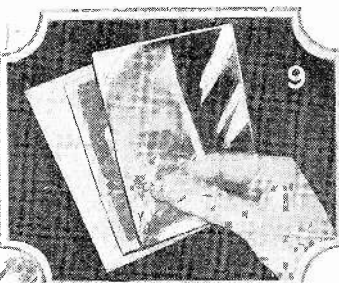

← An old film from which the emulsion has been washed can be used as a substitute for glass as a covering for mounted photographs.

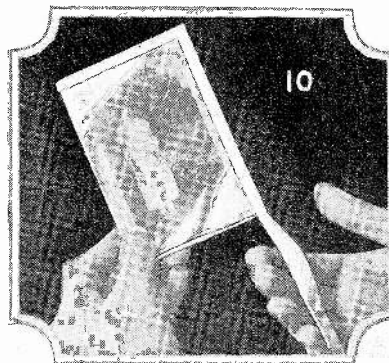

↑ The photograph and its cardboard mount after being joined with the celluloid cover are taped together with paper tape as illustrated in the photo.

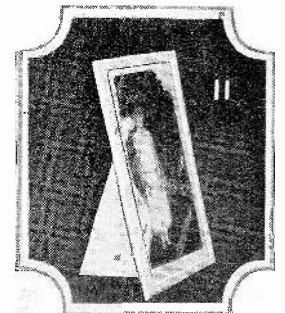

↑ A piece of cardboard glued to the back as illustrated, serves as a stand for the finished product.

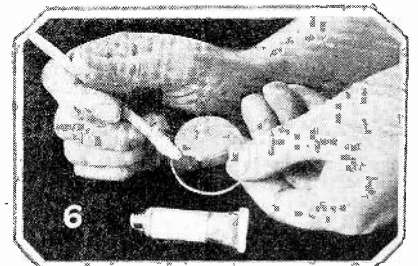

↑ Two circular disks cut from old films are cemented together for the ray filter. The water color tint between the disks is thus protected.



↑ The photo above illustrates how two old films are cemented together for making the card case illustrated in photo 8.

ON these two pages we show a number of articles made from old celluloid photographic films. There are a great many more devices that our readers can build. For suggestions for the best uses of old films we are awarding \$100.00 in prizes. The prize list follows:

**\$100.00 IN PRIZES**

First Prize .....	\$25.00
Second Prize .....	15.00
Third Prize .....	10.00
Four Prizes of \$5.00 each .....	20.00
Six Prizes of \$3.00 each .....	18.00
Six Prizes of \$2.00 each .....	12.00
	<b>\$100.00</b>

For further conditions of this prize contest see the accompanying page.

On this page are shown a number of photographs of uses for old films. Nearly everyone has some old photographic negatives from which no prints can be made. Photos 1 to 11 inclusive show what one of our readers has done with old films. Now what can you do?



# Contest

You Do With Old Films?



CELLULOID DISSOLVED IN ACETONE OR AMYL ACETATE AS CEMENT FOR GLASS, WOOD, CROCKERY OR FILMS ETC.

FILMS MAY BE CUT-BENT BY STEAM OR CEMENTED TOGETHER

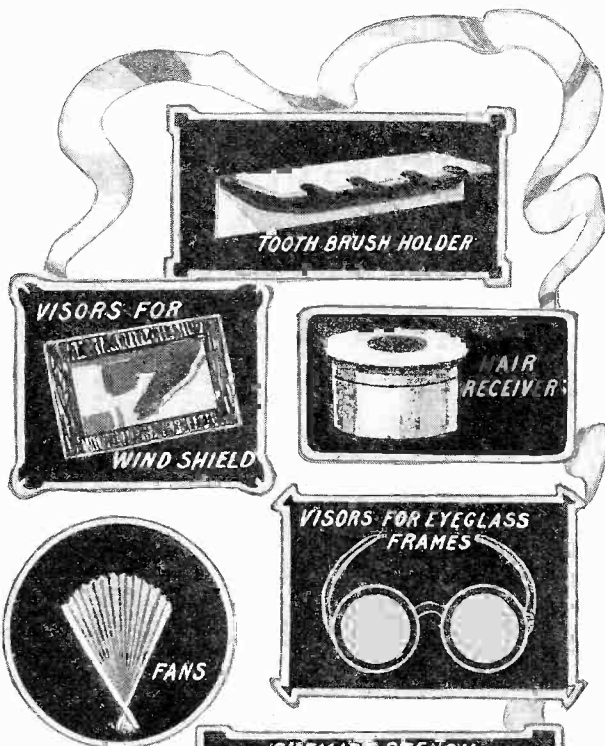



TOOTH BRUSH HOLDER

VISORS FOR WIND SHIELD

HAIR RECEIVER

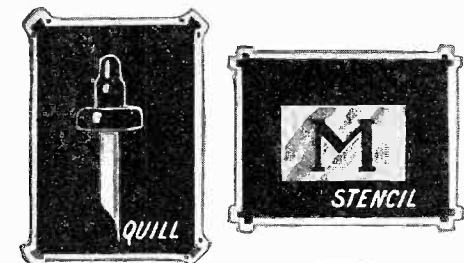
VISORS FOR EYEGLASS FRAMES



QUILL

STENCIL



FANS

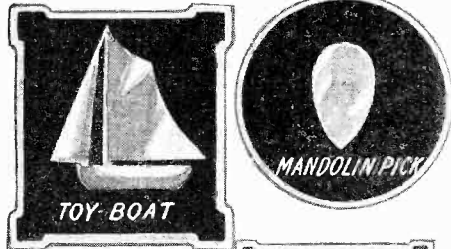

TOY BOAT

MANDOLIN PICK

**CONTEST CONDITIONS**

- 1—The article must be made from old photographic films of any size or similar celluloid sheets.
- 2—The number of entries per contestant is not limited.
- 3—In event of ties the full amount of the prize tied for will be awarded to each tying contestant.
- 4—Films may be cemented, cut, steamed or pressed to form objects.
- 5—No prizes will be awarded for articles described on these pages.
- 6—A rough sketch and a description of fifty words or less per object are required. Models are not required but may be entered. (CAUTION: Do not send inflammable celluloid articles through the mails).
- 7—Contest closes in New York on Wednesday, Dec. 30th at noon. All contributions must be in our hands at that time. Address entries to Editor, Old Film Contest, c/o SCIENCE & INVENTION, 53 Park Place, New York City.

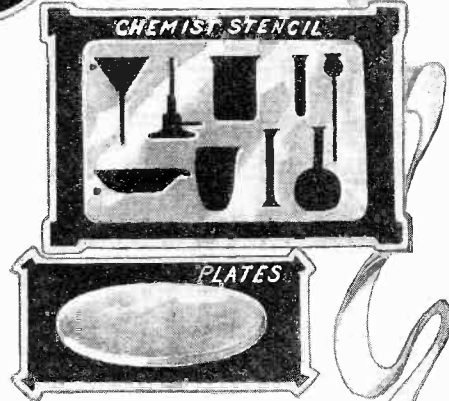

CHEMIST STENCIL

PLATES



TOY PIN-WHEELS

ARTIFICIAL FLOWERS



NAPKIN RING

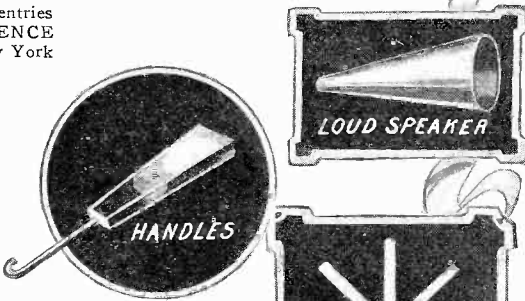

LOUD SPEAKER

HANDLES

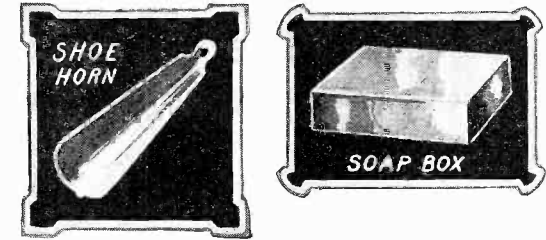

SHOE HORN

SOAP BOX

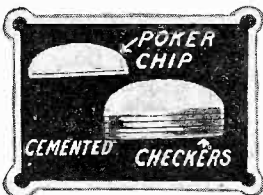

POKER CHIP

CEMENTED CHECKERS



SUBSTITUTE FOR WINDOW

COIL MOUNTING

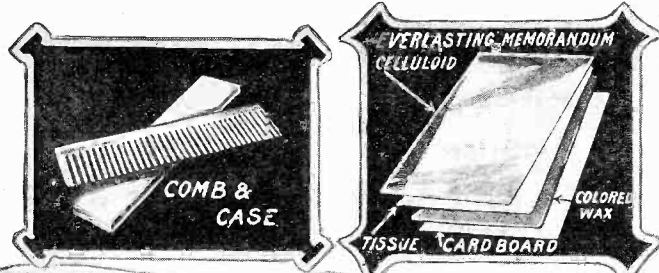

COMB & CASE

EVERLASTING MEMORANDUM CELLULOID

TISSUE CARDBOARD

COLORED WAX



PHONOGRAPH RECORDS



145

HOUSE NUMERALS



BOOK MARK

Before him was the sending disc; it glowed red as they turned the current into it. Then they illumined the mirrors; a circle of them, each with its image of Georg upon the platform.

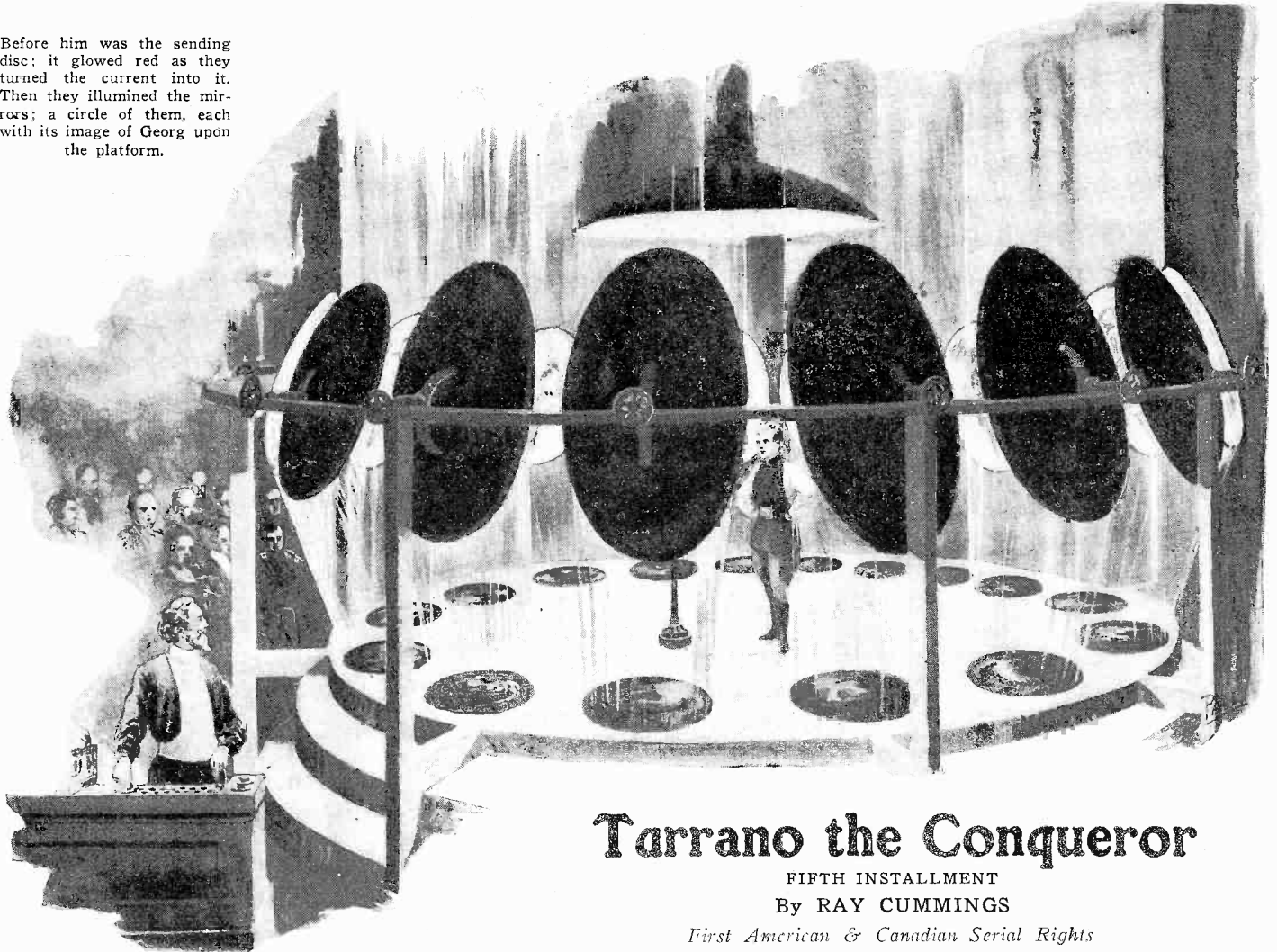

## Tarrano the Conqueror

FIFTH INSTALLMENT

By RAY CUMMINGS

First American & Canadian Serial Rights

### SYNOPSIS

THE story opens in the year 2325 and is related by Jac, a writer of that time, employed by a large news organization of Great New York. On the afternoon of May 12 of that year, the President of the Anglo-Saxon republic is murdered in the midst of a speech. This happened at 5:10 P.M. At 6:15 of the same day the ruler of Allied Mongolia is murdered. Ten minutes later the leader of the negroes of Africa is killed while asleep. This leaves the earth without leadership. Jac and Grayson, a co-worker of his, suspect that the murders are the result of a plot on the part of the inhabitants of Venus. At 8:26 the mail from Venus lands. At 8:44 a message by helio from that planet announces the murder of the ruler of the Venus Central State. A warning comes with the same message and reads in part, "City being attacked . . . Tarrano, beware you are in danger of . . ." The message stops at this point and further communication is impossible.

At 9 P.M. Jac is summoned to Northeast Island, off the coast of Maine, by a Dr. Brende. He goes and is welcomed by the Doctor and informed that the Martian ruler of the Little People had also been assassinated and at the same time communication had become impossible with Mars.

Tarrano, the Doctor states, was at one time a lower official of the Cold Country of Venus. The doctor then announces that he, Brende, has perfected a medical method whereby human beings may be kept from growing old.

Unable to communicate with the Doctor's laboratory in northern Siberia, they set out for that point in Brende's aero. Arriving there they find no one outside and upon entering the laboratory building, are set upon by a group of "Venus-men."

In the ensuing battle, the Doctor is killed and Jac, Elza, the Doctor's daughter, and Georg, the Doctor's son, are taken from the laboratory by Argo, a Venus-man. They are transported in an aero to Venia, a city on the earth inhabited by people of Venus. Here they meet Tarrano, who orders Jac and Georg imprisoned, keeping Elza in his presence. He starts to make love to Elza.

Jac and Georg are imprisoned and held captive by walls of electrical charges that effectively prevent their escape. They are soon joined by Elza and hear that the earth governments have issued an ultimatum to Tarrano. Tarrano joins them and offers Georg complete safety if he will build duplicate models of those that Dr. Brende had completed. Georg refuses.

Tarrano sends a note to the earth governments refusing to come to terms and stating that if war is declared upon him, he will destroy all of Dr. Brende's records and will kill Georg.

By signals the little party of earth people have communicated with a Princess Maida of Venus who is also Tarrano's prisoner. The Princess sends a friend to rescue Jac, Georg and Elza, and the friend, Wolfgar, throws an isolation barrage around them. Suddenly interference is encountered and the barrage broken down.

I heard; but only phrases, for in those few seconds I stood dumbly confused, fascinated by watching the blackness in which we had enveloped ourselves now breaking into lurid, angry sparks.

A distant corner of the room became visible; outlines of the wall-beams; the growing glare of a wall-light in a tube over there. And through the brightening gloom—the figure of a lone man standing. Tarrano!

I heard Georg mutter: "Jac! Make a

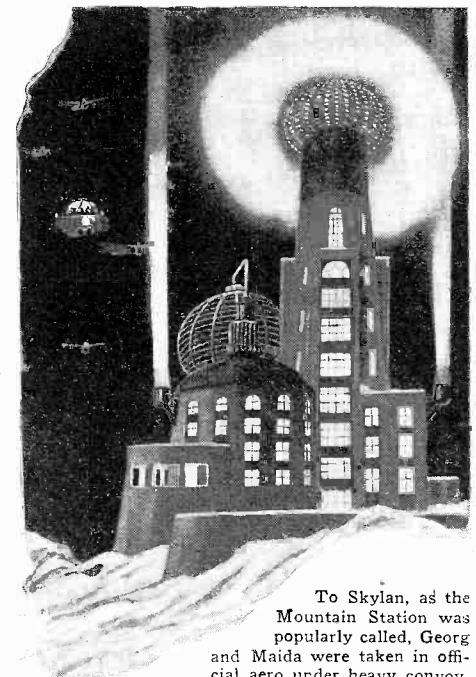

To Skylan, as the Mountain Station was popularly called, Georg and Maida were taken in official aero under heavy convoy.

### Chapter IX

THE isolation barrage which Wolfgar had flung around us was dissolving. Someone—something—was in the room, breaking down the barrage, struggling to get at us. We stood huddled together; Elza clinging to me, Georg beside us. And Wolfgar, gripping the small cylinder which with interference heat was glowing red in his hand.

Georg muttered something; the snapping

sparks of the barrage blurred his words. But I heard Wolfgar say swiftly:

"We're trapped! You, of all of us—you Georg Brende, must escape."

The rest of his words to Georg I did not catch. He was thrusting a weapon into Georg's hands; and giving hurried advice and explanations.

"Princess Maida . . . she . . . in that other tower . . . you, so much more important than the rest of us . . ." Phrases

show of fight! Hold him! But careful—careful of Elza!”

Behind me there came an electrical flash; the pungent smell of burning cloth. Georg was no longer beside us!

Elza was still clinging to me in fright. I shook her off. Wolfgar flung his smoking, useless cylinder to the floor. The blackness at once sprang into light; the sparks died. Tarrano was standing in the room, quietly, before us. Standing with a grim, cynical smile, regarding us.

But only for an instant did he stand quiet. Across the room, creeping for the balcony doorway, I was aware of the figure of Georg. Tarrano saw him also; and with a swift gesture snapped back to his belt the interference cylinder with which he had uncovered us; then plucked at another weapon, gripped it to turn it upon Georg.

Everything was happening too swiftly for coherent thought. I leaped toward Tarrano, with Wolfgar rushing beside me. Elza screamed. Tarrano's hand was leaving his belt. I reached him; flung out my fist for his face.

But in that instant the weapon in Tarrano's hand was brought upon me. My paralyzed muscles made my arm and fist go wide. My blow missed him; he stepped aside; and like a man drunk with baro-wine, I stumbled past him, halted, swayed and struggled to keep my footing.

Wolfgar had felt it also; he was reeling near me, holding himself from falling with difficulty. I was unarmed; but there were weapons hanging from Wolfgar's belt. His numbed fingers were groping for them. But the effort was too great. The blood, driven back from his arms, left them powerless; they fell dangling to his sides.

A few seconds; but we had occupied Tarrano during them. Georg was through the balcony doorway and beyond our sight. Elza was standing motionless, too frightened to move. I felt myself growing numb, weighted to the floor as though my feet had taken root. My arms were hanging like wood; fingers tingling, then growing cold, dead to sensation. And a numbness creeping up my legs; and spreading inward from my arms and shoulders. In a few moments more, I knew the numbness would reach my heart.

Tarrano had not moved, save that single step sidewise to avoid my onslaught. As I stood there now with my face like fire and my brain whirling with the blood congested in it, I heard his quiet voice:

“Do not fear, Lady Elza. This Jac Hallen—as I promised you—is quite safe with me.”

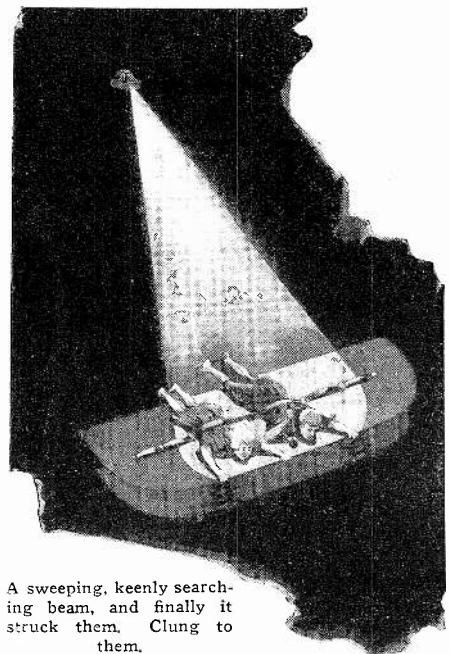

A sweeping, keenly searching beam, and finally it struck them. Clung to them.

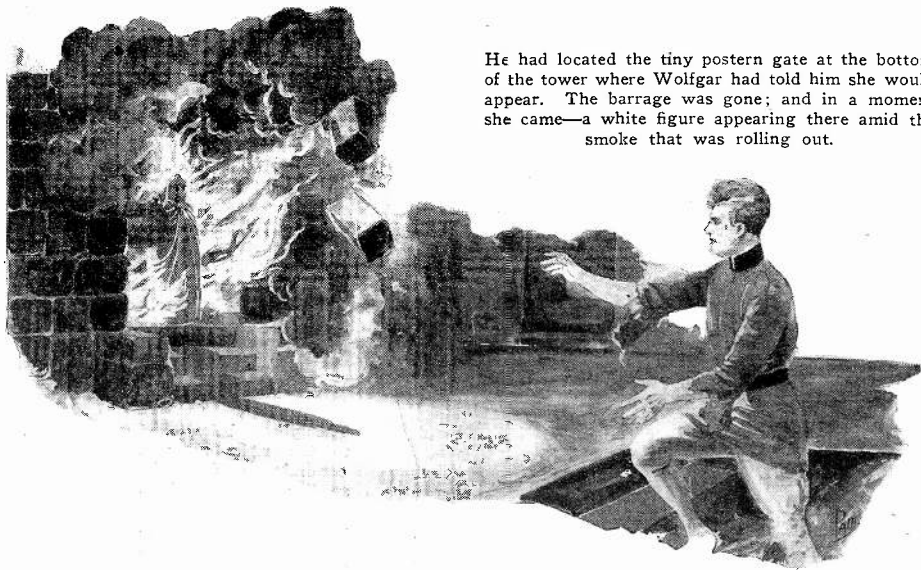

He had located the tiny postern gate at the bottom of the tower where Wolfgar had told him she would appear. The barrage was gone; and in a moment she came—a white figure appearing there amid the smoke that was rolling out.

His gesture waved her aside, that she should not come within those deadly vibrations he was flinging at us. And I saw his other hand lift a tiny mouthpiece from his belt; heard his voice say into it: “Argo? Argo! That Georg Brende—”

He stopped; a look of annoyance came over his face. Argo did not answer! Dimly to my fading senses came the triumphant thought, the realization that Argo outside, upon whom Tarrano depended to seize Georg—had failed.

Action had come to Tarrano. He snapped off his weapon. Released from it, Wolfgar and I wilted to the floor—lay inert. The returning blood in my limbs made them prick as with a million needles. To my sight and hearing, the room was whirling and roaring. I felt Tarrano bending swiftly over me; felt the forcible insertion of a branched metal tube in my nostrils; a hand over my mouth. I struggled to hold my breath—failed. Then inhaled with a gasp, a pungent, sickening-sweet gas. Roaring, clanging gongs sounded in my ears—roaring and clattering louder, then fading into silence. A wild, tumbling phantasmagoria of dreams. Then complete unconsciousness.

CHAPTER X

I come now to recount events at which I was not present, and the details of which I did not learn until later. Fronted by Tarrano in those few seconds of confusion, Georg made his decision to escape even at the cost of leaving Elza and me. He murmured his hurried good-bye. The moment had arrived. He could see Tarrano dimly through the sparks. He leaped backward, through that wall of electrical disturbance which surrounded us. The sparks tore at him; burned his clothing and flesh; the shock of it gripped his heart. But he went through; crept for the balcony. It was dark out there. He would have rushed for Tarrano instead of the balcony, but as he came through the sparks he had seen that the barrier surrounding our tower was momentarily lifted. Argo had cut it off to admit Tarrano a few moments before. He had not yet replaced it—absorbed, doubtless, in watching in his finder what Tarrano was doing with us. He must have seen Georg reach the balcony; and jumped then to replace the barrier. But too late. Georg was over the balcony rail with a leap. The insulated tubes were there—upright gleaming tubes of metal extending downward to the platform below. Tubes smooth, and as thick as a woman's waist.

Georg slid down them. The barrage, above him on the balcony, had been replaced. He saw below him the figure of Argo come running out. A weapon in each hand. The burning pencil-ray swung at Georg, but

missed him as he came down. Had it struck, it would have drilled him clean with its tiny hole of fire. Then Argo must have realized that Georg should be taken alive. He ran forward, swung up at Georg the paralyzing vibrations which Tarrano at that instant was using upon Wolfgar and me.

Georg felt them. He was ten feet, perhaps, above the lower platform; and as he felt the numbness strike him, he lost his hold upon the tube-pipe. But he had presence of mind enough to kick himself outward with a last effort. His body fell upon the onrushing Argo. They went down together.

Argo lay inert. The impact had knocked him senseless, and had struck his weapon from his hand. Georg sat up, and for a moment chafed his tingling, prickling arms and legs. He was bruised and shaken by the fall, but uninjured.

Within our tower, Tarrano was still occupied with us. Georg leaped to his feet. He left Argo lying there—ran over the spider-bridge; down a spiral metal stairway, across another bridge, and came upon the small park-like platform which stood at the bottom of the other tower. He had passed within sight of a few pedestrians. One of them shouted at him; another had tried mildly to stop him. A crowd on a distant terrace saw him. A few of their personal flashes were turned his way. Murmurs arose. Someone at the head of one of the escalators, in a panic pulled an alarm-switch. It flared green into the sky, and buzzed and spat its warning.

The interior-guards—seated at their instrument tables in the lower rooms of the official buildings—had seen Georg in their finders. The alarm was spreading. Lights were appearing everywhere . . . The murmurs of gathering people . . . excited crowds . . . an absurd woman leaning down over a far-away parapet and screaming . . . an ignorant, flustered street-guard on a nearby upper terrace swinging his pencil-ray down at Georg . . . Fortunately it fell short.

For a moment Georg stood there, with the gathering tumult around him—stood there gazing up at that small tower. The tower wherein the Princess Maida was confined. It was dark and silent. Black rectangles of doors and casements, all open—but barred by the glow of the electrical barrage surrounding it.

Georg jerked from his belt the cylinder Wolfgar had given him. Metallic. Short, squat and ugly, with a thick, insulated handle. He feared to use it. Yet Wolfgar had assured him the Princess Maida was prepared. He hesitated, with his finger upon the switch-button of the weapon. But he knew that in a moment he would be too late.

(Continued on page 662)



# Oddities in the News

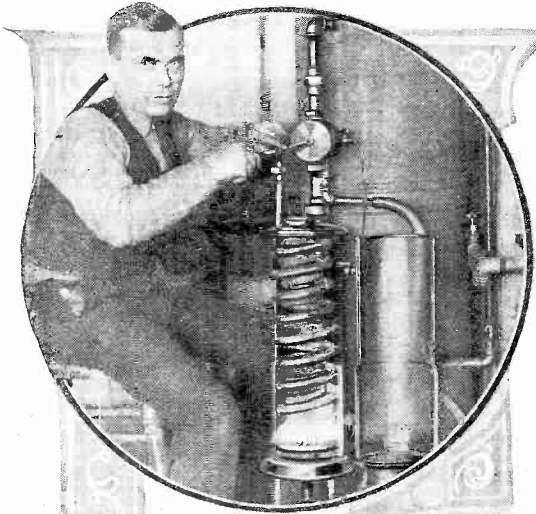

The photo at the left shows Mr. John K. Spencer, who conceived the idea of a thermostat based on an observation made at the age of fifteen, that now has brought him a million dollars. The latest developments of this thermostat are in the fields of gas, steam and hot water control. The thermostat acts directly and positively on the thermals or valves regulating the supply of electricity or gas. Westinghouse Company has been licensed to produce Mr. Spencer's thermostat. The photo shows Mr. Spencer at work on one of his thermostats for regulating the gas supply for the home hot water heaters.



The photo below and to the right show a convenience for the small apartment. This is a combination table and bed. Below it is shown when used as a table, and to the right, when used as a bed by its fair occupants.

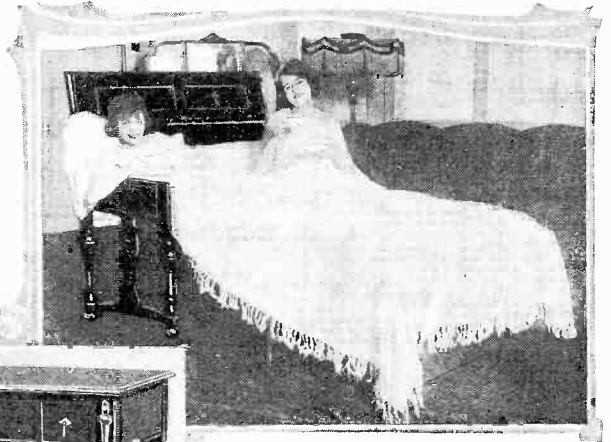

John E. Seaberg of Pittsburgh is seen demonstrating his girder climbing shoes, by means of which he can rapidly climb up any sort of structural steel. Insert shows detail of device.

Below—for the first time in history moving pictures were exhibited in the salon of an Imperial Airways plane. Photo shows passengers in plane and movie screen.

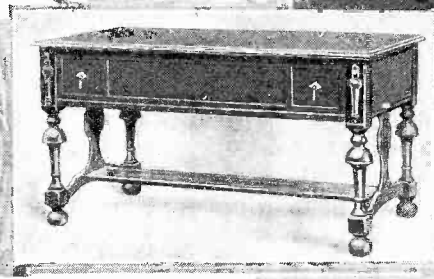
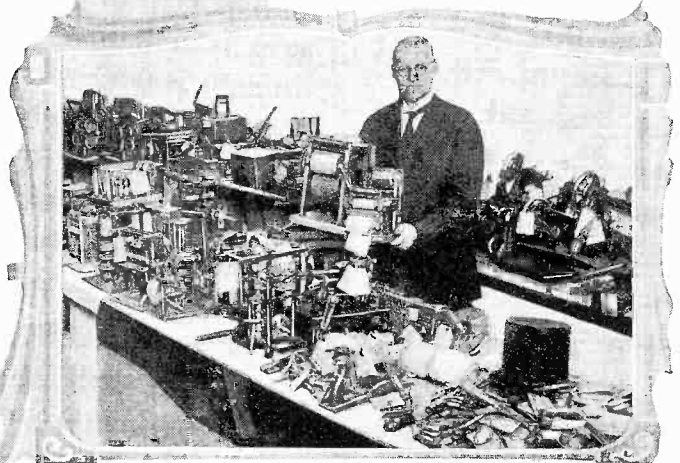
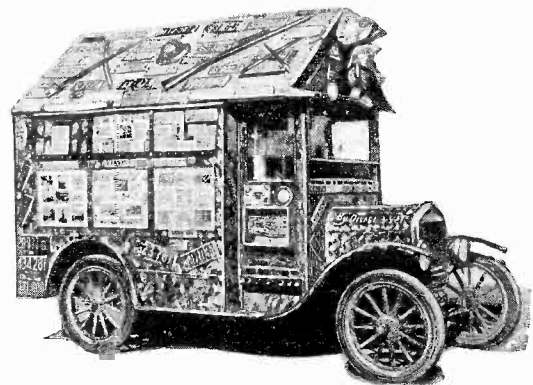
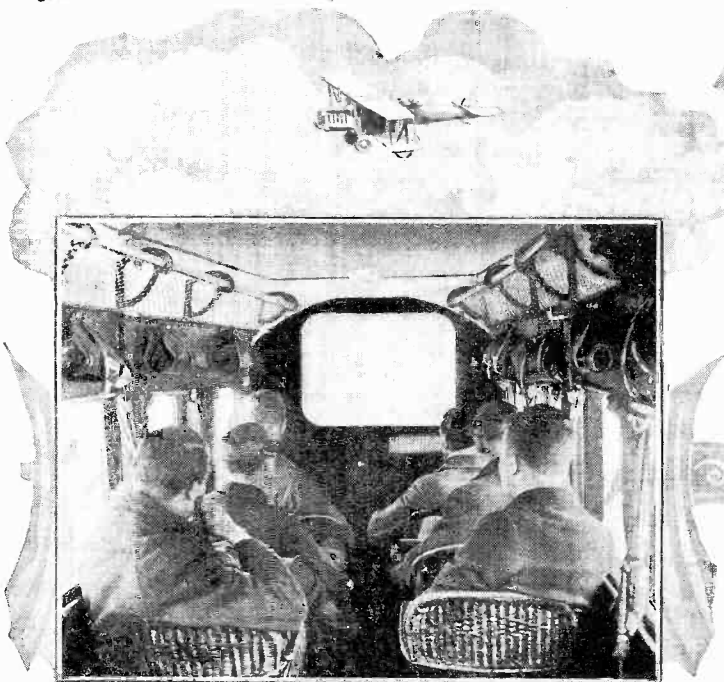

Photo below shows Thomas E. Robertson, Commissioner of Patents, inspecting a part of the collection of over one hundred and fifty-five thousand models of patents which are to be thrown out.



The automobile below used by four ex-service men is to be placed in the Smithsonian Institute for two years. The coins, license plates, stamps and souvenirs fixed to the machine were picked up on the 130,000 miles journey to every civilized country in the world.





# MAGIC "DUNNINGER"

**THE MAN WHO MYSTIFIED**  
 Prince of Wales, Ex-President Harding, Taft, Roosevelt, Pres. Coolidge and other celebrities  
 Writes Exclusively for **SCIENCE AND INVENTION**

**THE MAN WHO MYSTIFIED**  
 Prince of Wales, Ex-President Harding, Taft, Roosevelt, Pres. Coolidge and other celebrities  
 Writes Exclusively for **SCIENCE AND INVENTION**

Folks Are Mystified Yet Delighted by This Man!  
 DUNNINGER AMAZES THIRING EMPLOYEES IN DEMONSTRATION  
 DUNNINGER AS DUNNIGER'S COMMITTEE IN LIBRARY TEST OF MIND READING  
 Really You! The Mind Reader  
 DUNNINGER DRAWS MORE BIG CROWDS  
 Dunninger Will Attempt To Hypnotize Patient, 10 Miles Away, by Radio

NO. 32 OF A SERIES

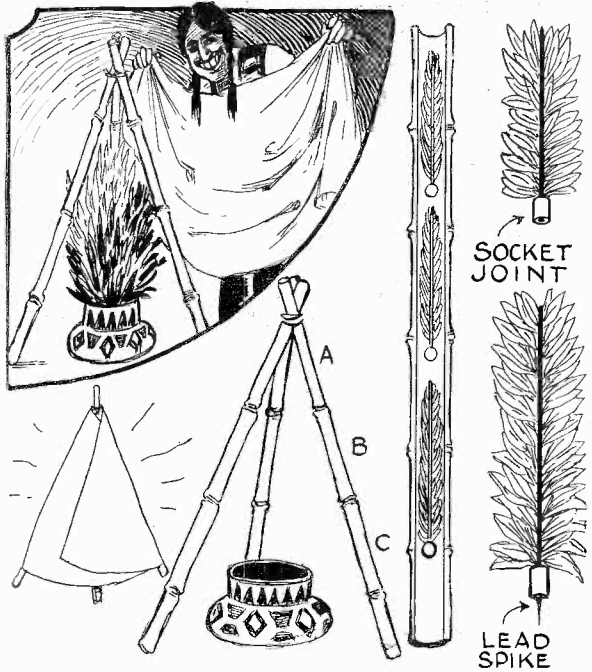

The illustrations at the left show an interesting stage effect easily produced. The Indian makes a tent of three bamboo rods and a cloth. The cloth has previously been passed around for examination. A flower pot is pushed into the tent, and when the cloth is removed, the pot will be found full of flowers. The secret lies in the fact that the bamboos which support the cloth, have holes drilled in them to accommodate feathered artificial flowers. A bottom flower section is equipped with a spike, and others are provided with sockets to make the bush seem large.

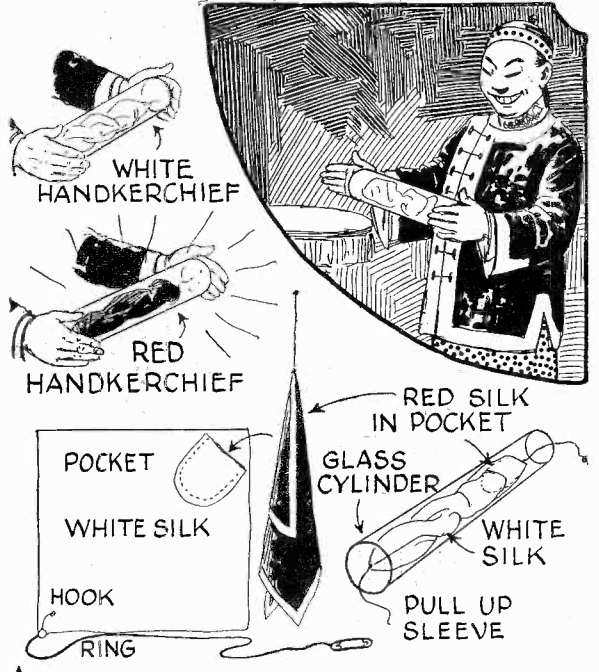

The above illustration shows a unique color change. A white silk handkerchief is placed inside of a glass cylinder. The hand is moved up quickly as if making a pass and a red silk handkerchief will be found in place of the vanished white one. The cylinder and handkerchief are then passed for examination. The secret lies in the fact that the white handkerchief has a pocket sewed on it as illustrated. In this pocket a red silk handkerchief is concealed. Under cover of a movement of the hands, the white piece vanishes up the sleeve being attached to an elastic band. The red kerchief is left behind.

The illustration below shows the vanishing wine bottle. The wine bottle is covered with a cloth. Another bottle top palmed in the hand is then pushed over the cloth, making it appear as if the wine bottle actually passed through the cloth. Meanwhile the bottom portion of the bottle slides onto the performer's arm under his coat sleeve. The finger of the performer's hand inserted into the neck of the bottle wiggles the top around. The inside top is palmed off: the outer top likewise, and the cloth passed for examination.



A number of messages written on paper which are then folded and placed in heavy manila envelopes, are handed to the performer. The envelopes are very well sealed before he gets them. He retires to his cabinet and while there answers the questions asked in the messages, or gives the council desired. A few minutes later he emerges with the envelopes in his hand and permits the seals to be examined. They have not been tampered with. Nevertheless the messages have been removed. The tiny tool illustrated is slipped into the envelope, the message slip is curled upon it, removed, read and again reinserted.

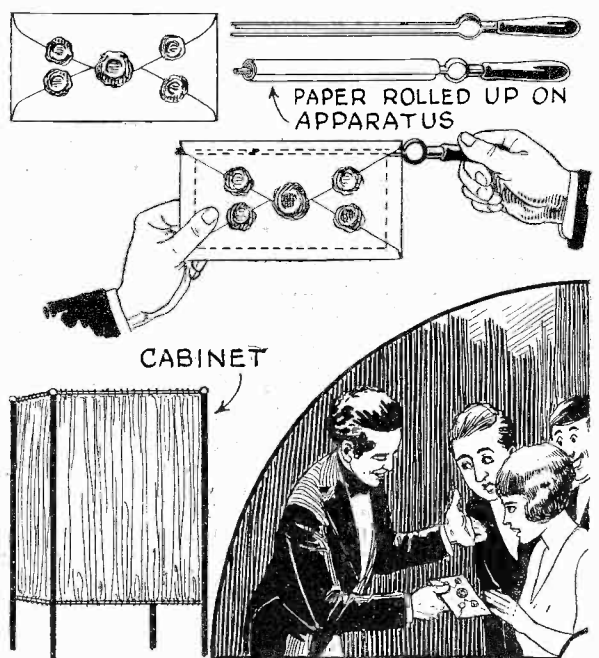

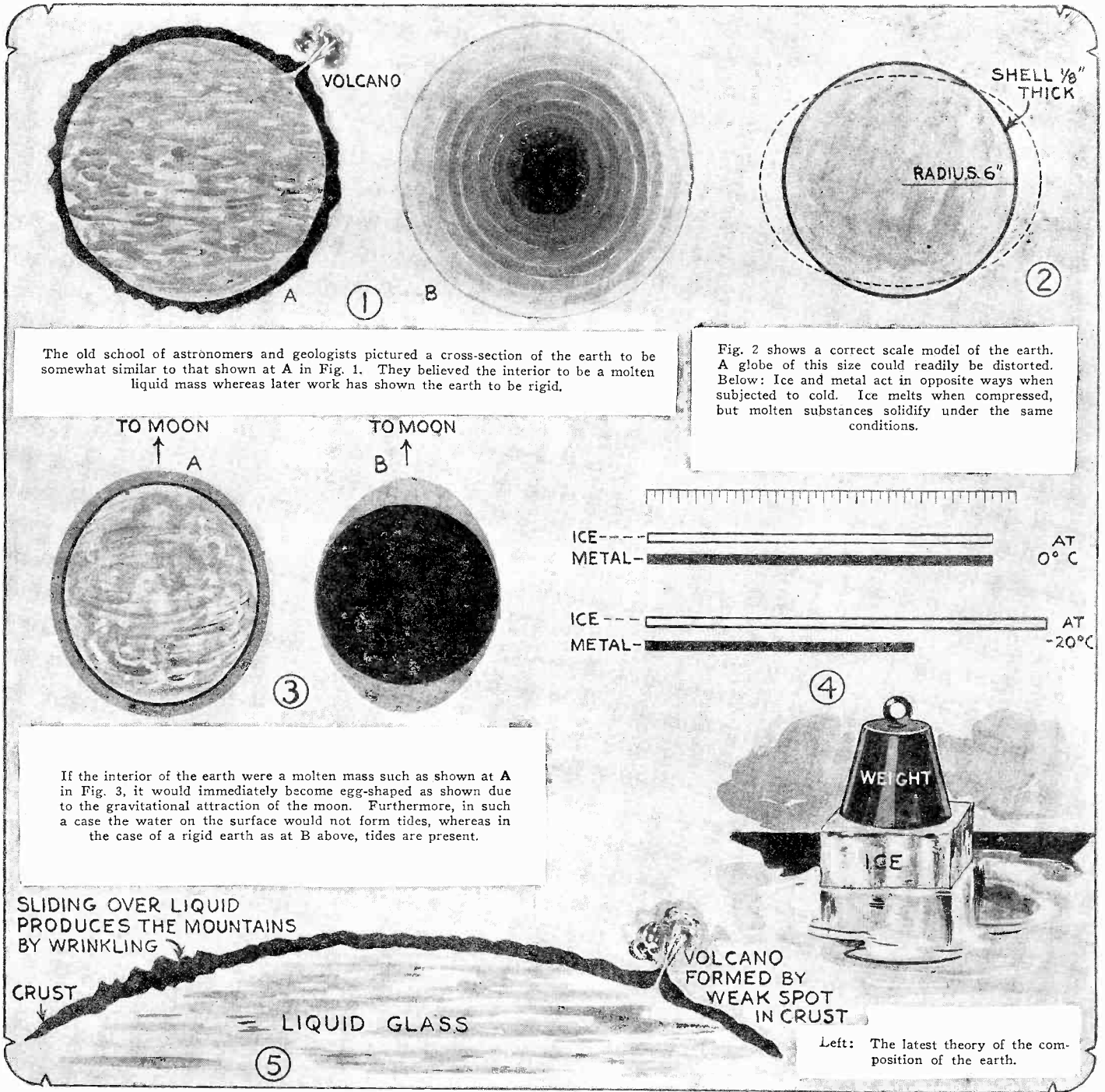

The old school of astronomers and geologists pictured a cross-section of the earth to be somewhat similar to that shown at A in Fig. 1. They believed the interior to be a molten liquid mass whereas later work has shown the earth to be rigid.

Fig. 2 shows a correct scale model of the earth. A globe of this size could readily be distorted. Below: Ice and metal act in opposite ways when subjected to cold. Ice melts when compressed, but molten substances solidify under the same conditions.

If the interior of the earth were a molten mass such as shown at A in Fig. 3, it would immediately become egg-shaped as shown due to the gravitational attraction of the moon. Furthermore, in such a case the water on the surface would not form tides, whereas in the case of a rigid earth as at B above, tides are present.

SLIDING OVER LIQUID PRODUCES THE MOUNTAINS BY WRINKLING

CRUST

LIQUID GLASS

VOLCANO FORMED BY WEAK SPOT IN CRUST

Left: The latest theory of the composition of the earth.

## Is the Earth Solid?

By GENE DEACHEM

THE older astronomers and geologists believed that the earth was a molten mass, encrusted for some fifty miles on the surface where the lava, as we may term it, had cooled. They thought that the interior was still liquid, as shown in A, Fig. 1, for did not the phenomena of volcanoes prove that the interior was still fluid? As further evidence they cited the fact that the temperature increases rapidly in the deeper mines, averaging 1° C. (1.8° F.) for every 360 feet descended. Thus, at a depth of only 100 miles the temperature would be about 1500° C. (2700° F.) sufficient to melt cast iron. Since the deepest mine in the world, in Brazil, reaches only a depth of 6,426 feet, we cannot judge very accurately from the phenomena in this small

part a little more than 1/4,000 of the whole distance, the conditions in the center of the earth.

The work of modern astronomy has necessarily altered this conception of the molten interior. The astronomer has proved it to be rigid throughout (as shown in B, Fig. 1) and this view was immediately challenged by the geologists. The astronomical argument may be briefly presented as follows: Fig. 2 represents the model of the geologists on the correct scale—a sphere twelve inches in diameter, with walls one-eighth of an inch thick. It is filled with water to take the place of the molten interior. Even if the walls were composed of the most rigid material available, it would not take much force to deform it into the elliptical shape

indicated by the dotted line in the figure.

If the earth were plastic, the great forces of the moon's gravitation would raise tides within it, causing it to become egg-shaped as in A, (Fig. 3). If a layer of water covered the earth, there would be no perceptible increase in its depth for the first case, but for a rigid earth the water would be pulled away from it, shown in B. By measuring the height of tides on the earth, astronomers have shown that it is more rigid than steel but not quite as rigid as glass.

It remained for physicists to reconcile the rigidity with the high temperature in the center. The answer is found in the weight of the overlaying layers, which cause a tremendous pressure in the earth's interior. It

(Continued on page 680)



# Cut Flower Contest Awards

## Twenty Pen-Pencils as Prizes

**A**FTER trying out the various methods of preserving cut flowers submitted by our many readers, the judges have finally decided upon those most meritorious. Flowers budding on the same day and, as nearly as the same hour were secured, and the methods given a trial. The selections are not given in order as to their efficacy, but are reproduced here for what they are worth.

### SUGAR SOLUTION—TIES FOR AWARDS

1.—One of the simplest systems is to use sugar to prolong the freshness of the flowers. Chrysanthemums and roses as well as sweet peas when treated with the sugar solution lasted half as long again as the same kinds of flowers placed in salted water and the latter was more efficient than ordinary unsweetened water. It is not necessary that the sweetened water be changed after the flowers have once been placed therein.

For this method three prizes have been awarded. One goes to Mrs. H. D. Jepson, 3736 Colfax Ave. So., Minneapolis, Minn. A duplicate prize is awarded to Mr. Charles Jennerjahn, Box 116, East Northport, L. I., and a triplicate to Chas. W. Klein, 86 Warburton Ave., Yonkers, N. Y., because of ties for the award.

2.—The second prize is awarded to Herbert H. Van Keuren, 518 Jackson St., Amherst, Ohio, for the following method. This method depends upon evaporation to cause a reduction of temperature, which aids to maintain as nearly a natural condition as practical by artificial means. The stems of the flowers are wrapped with loosely woven cloths or cotton. If cotton it is wrapped with a piece of wicking or a very soft cloth. The flowers are then supported in the vase, so that the stems will not reach the water in the bottom of the vessel, but the wicking dips into the water. The water feeds up to the stems through the wick. Due to natural evaporation the temperature of the water reaching the stems is colder than the water in the bottom of the vessel, and this cold water prevents the flowers from wilting as rapidly as they do in warmer water. The wick should be not less than two inches wide, and one wick may serve for a bunch of flowers.

3.—A third prize is awarded to Wm. Lelsam, 716 North Capitol, Indianapolis, Ind., for the following formula. In 740 cubic centimeters of distilled water the following salts are dissolved. Thirty grams of potassium acetate, 10 grams of potassium nitrate, 3 grams of sodium carbonate, and 2 grams of sodium chloride. Then 50 cubic centimeters of 10% formalin solution are added to the whole.

4.—The fourth prize is awarded to Miss Alice Cook, 1312 V Avenue, La Grande, Oregon, who uses a Bromo-Quinine pill in a quart of water.

### MAKES IT GROW

5.—The fifth prize goes to Leo Bloom, 253 Barrion Ave., Johnstown, Penn. Mr. Bloom takes the stem of the flower and splits it. Into the split he inserts an oat seed which he binds in place. The flower is then placed in soil wet with water daily. The tendency of this system is to cause the stem to sprout roots. Nevertheless the method is quite effective.

6.—The sixth award was won by a Lexington, Tennessee man, by the name of

Henry B. Davenport, who adds an ounce of powdered alum to the water in which the flowers are kept.

7.—Corresponding reporter No. 7297, Mr. Philippe A. Judd, 668 McAllister Ave., Columbus, Ohio, well known to the readers of SCIENCE AND INVENTION Magazine wins seventh prize by adding commercial peroxide of hydrogen to a quart of water. Approximately three fluid drams are added to each quart of water.



The handsome combination pen-pencil awarded to each of the successful contestants in our "cut flower" preservation contest.



8.—Mr. George F. Mendenhall, 5115 Iazard St., Omaha, Neb., receives eighth prize for adding glycerine to the water in which the flowers are kept. Half water and half glycerine is used, although for more delicate blossoms a thinner solution is employed. He has found that the .50% solution is best for the average type of flowers.

9.—The ninth award goes to Mannie Stroh, 56 First St., New York City. He uses two grains of tannic acid in every quart of water, and then adds one grain of sodium bicarbonate as an extra inducement for preserving the flowers. The method is quite effective.

### HOW TO PRESERVE FLOWERS—THE BEST COMBINATION

For those desiring to preserve cut flowers we advise that they combine three of the methods outlined by our contestants, namely, the stems of flowers should be cut off while they are held under water. Sugar may be added to the water to increase the life of the blooms and the flowers should be placed in a refrigerator or in a cool place over night. Applying these three systems to every bouquet of flowers you may get, will cause those flowers to last considerably longer than when they are watered daily with ordinary tap water.

10.—Mr. Henry H. Sweets, Jr., 1633 Beechwood Ave., Louisville, Ky., dips lower ends of the stems of the flowers in boiling water immediately after the flowers are cut. This boiling hot water drives out the air bubbles in the stem. Thereupon the flowers are placed in ice water. He is the winner of the tenth prize.

11.—The eleventh prize goes to J. Samachson, 108 Center St., Trenton, N. J., for using the liquid strained from boiled peas as the solution in which the stems of the flowers are immersed.

### HOUSEHOLD AMMONIA USED

12.—The twelfth award goes to John Hamilton, Reporter No. 19937, Milton Heights, Ontario, Canada, for adding a small amount of household ammonia to the water in the vase. The water is changed daily and the household ammonia added every other day.

13.—Mr. Reginald Gross, of 404-9th St. S. W., Puyallup, Wash., suggests that from fifteen to twenty grains of gum camphor be added to the water in which the flowers are to be put. This method is quite effective. He is the winner of the thirteenth prize.

14.—Lilacs, sweet peas and lilies are greatly improved by a twelve per cent. solution of manganese sulphate. In this solution they will keep longer than in water. Carnations last twice as long with a fifteen per cent. solution of manganese sulphate, and roses last longer with a seven per cent. solution of the same chemical. The flowers are clipped just before they are put into the solution. For these suggestions Mr. Paul

Nicewarner, 404 Virginia Ave., South Cumberland, Md., Reporter No. 21913, receives the fourteenth award, which is the sixteenth fountain pen by reason of the fact that three people tied for one of the suggestions.

15.—A rather unique system for preserving cut flowers is the one submitted by Joe Cleveland, Peru, Kansas, who with it wins the fifteenth prize. He first soaks the flowers in water over night and the following morning dips the ends of the stems in hot sealing wax. The flowers need not necessarily be left in water after the sealing wax dipping process.

### USES SODA WATER

16.—Mr. Raymond Hadley, Moundsville, West Va., preserves his flowers by using common carbonated water obtainable at any soda fountain as the solution in which the flowers are kept. Carbonated water is better than ordinary water for this purpose. He is the winner of the sixteenth prize.

17.—Mr. Burton L. Goddard, West Concord, Minn., also employs ammonia, but uses ammonia in conjunction with the system of dipping the flowers in boiling hot water just before they are placed into this solution. A few drops of spirits of ammonia are added to the water in the vase. The stems of the flowers are kept trimmed with a pair of sharp scissors, immediately dipped into boiling water for a moment, and then placed into the water containing spirits of ammonia in the vase. For this suggestion he wins the seventeenth prize.

18.—Mr. John P. Stoddart, Salinas Chaculluta, Arica, Chile, South America, uses ten minims of formalin to every pint of water in which the cut flowers are to be kept. When the flowers are not required for display purposes or other decoration, the flowers should be placed in a cool dark cupboard or in a refrigerator. The blooms are cut dry and never cut immediately after a rain. Contrary to the general belief, the flowers are more fragrant when cut in the morning while there is no moisture upon the blossoms. It might be well to advise that in the home flowers should be placed in the ice box or refrigerator over night. They will last twice as long and sometimes three times as long if they are treated in this manner, as if they are left in-doors in warm rooms. This method is very effective and easily accomplished. He is the winner of the eighteenth prize.

19.—If plenty of leaves of the peppermint plant are thrown into the flask containing the flowers, they will increase the life of cut flowers, particularly of the rose and peony type. For this suggestion William M. Goldber, 711 Dayton Ave., St. Paul, Minn., Reporter No. 516 receives the nineteenth award.

### CUTS STEMS UNDER WATER—TIES AGAIN

20.—Two contestants tie for the twentieth award, and a duplicate prize is accordingly given each. One winner is Mrs. Edith McPherson, 1746-3rd St., San Diego, Calif., and the other W. H. Kinney, 972 Magnolia Ave., Los Angeles, Calif. Their suggestion is very good and will be found to give practical results. It follows:

Flowers wither because they do not get sufficient moisture to sustain life in the various cells. When cut flowers are placed in  
(Continued on page 674)

# Chemical Tricks

By DR. ERNEST BADE

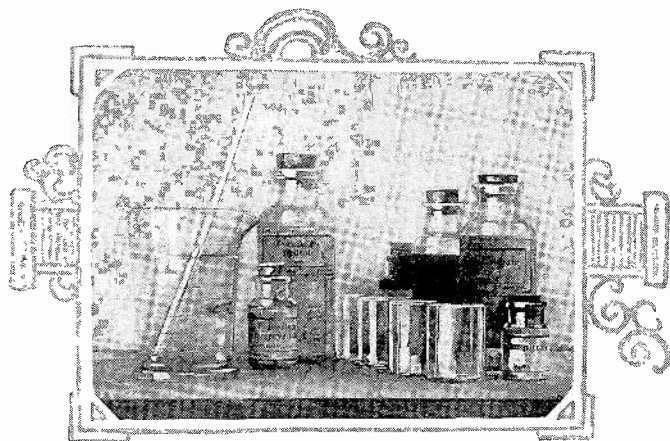

For a mystifying liquid "color changing" trick, the following chemicals are used: potassium hydroxide, potassium ferrocyanide, silver nitrate, ferrous sulphate, copper sulphate, phenolphthaleine. This completes the group of chemicals and the array is by no means formidable. Into a half pint of water, place three drops of concentrated potassium hydroxide solution and twelve drops of a concentrated potassium ferrocyanide solution. The liquid thus formed changes its colors when it is poured into the previously prepared glasses. The glasses are prepared by putting into them one drop of a concentrated solution of the various chemicals mentioned.

The chemicals that can be used for entertaining visitors to your laboratory do not always have to be rare and expensive. The more common types of chemicals can be frequently employed with just as much effect, provided that care is taken in the selection of the proper kind. Under these conditions it is quite natural that the tricks shown must be of a simpler order, and peculiar as it may seem, the simpler the trick, the more mystifying the effect. On the accompanying two pages, several chemical tricks are explained.

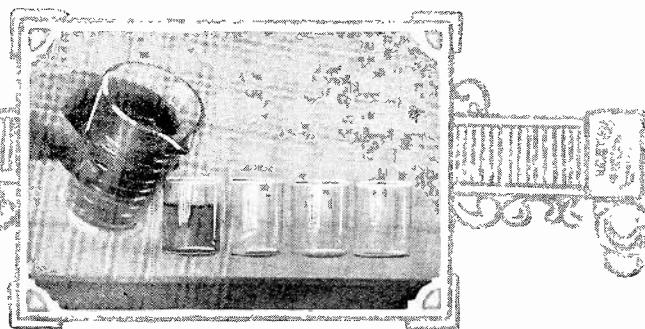

The first glass contains a drop of phenolphthaleine. As the liquid is poured into the presumably empty though moist glass, the water changes into a deep red scarlet color. The glass being only moistened, can be first turned upside down to show that it is empty.

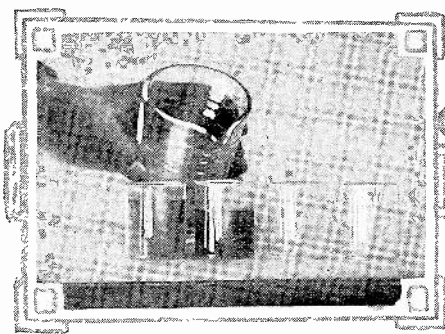

The second glass is then filled with the same water. Of course the water has been previously prepared, as indicated above. This glass contains a trace of copper sulphate, the resulting solution is of a deep red brown color.

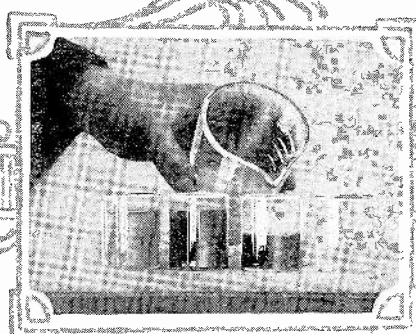

The performer now proceeds to fill the third glass. This has been prepared with a trace of ferrous sulphate. When filled with water, the water changes to a dark green color. The change is instantaneous.

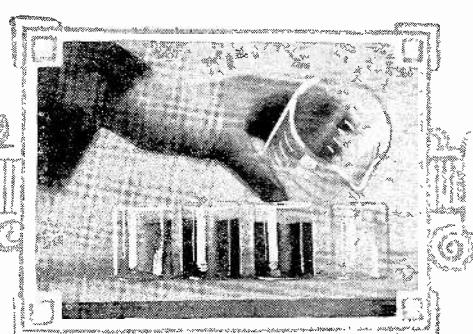

The last glass contains a drop of silver nitrate. This changes the water solution into milk. The last three color changes are produced by precipitates. Consequently, the glasses should be removed at the completion of the trick.

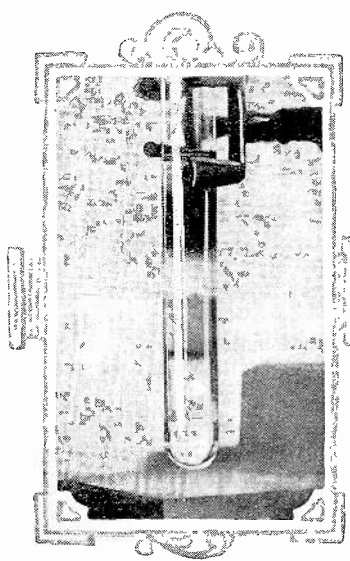

Other chemicals may be used in the trick above. A greenish white color is obtained by using a drop of nickel nitrate. Mercuric nitrate gives a light yellow color, while pyrogallic acid produces a light brown.

Left: Six differently colored liquids, placed one on top of the other, forms another interesting chemical diversion.

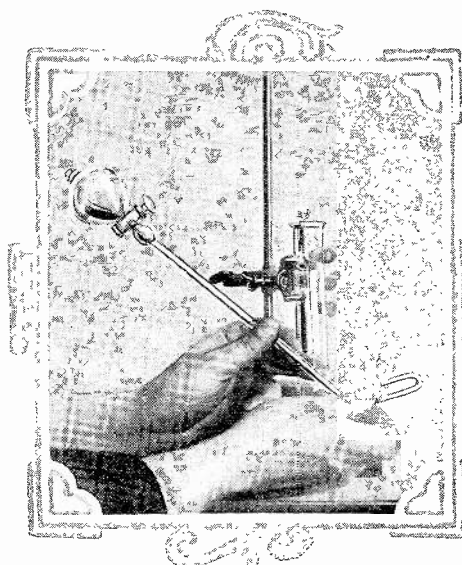

The process for making a set of colored liquids, one liquid layer being supported by the layer immediately beneath, is rather simple. A dropping funnel, a piece of rubber tubing and a small U-shaped piece of glass tubing are required. The glass tubing is fastened to the bottom of the dropping funnel by means of the piece of rubber tubing; and the funnel is clamped in a ring stand. The lower end of the "U" is permitted to rest in the bottom of a rather large test tube. The bottom of the test tube should first be filled to a depth of one inch with water glass (sodium silicate).

# The Magic of Chemistry Helps to Entertain on Dreary Nights

The effects on the accompanying two pages are very easily accomplished. The average experimenter's home laboratory contains all of the material required to produce the mystifying color changes or other effects described on these pages. If the experimenter does not happen to have the chemicals here outlined, he surely should make it his

duty to secure them as soon as possible, as his laboratory is far from complete without them. Most of the substances may be obtained at the local drug store and rarely will the amateur chemist have to send to a supply house for the material. Chemical clubs in high-schools can be entertained with these simple tricks.

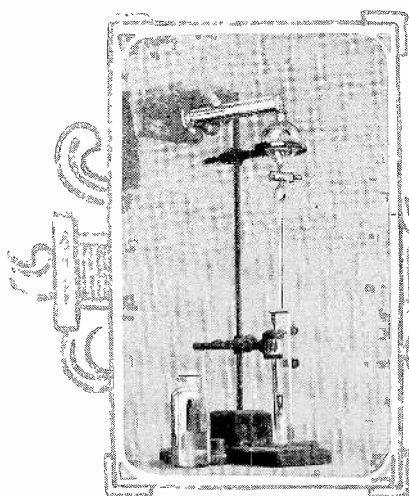

Continuing from the previous page after the test tube has been filled to a half inch depth with water glass, the funnel with the U-shaped tube is inserted into it.

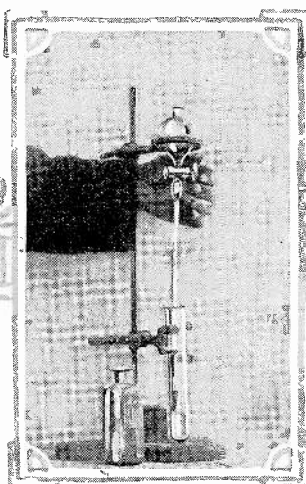

Gently raise the funnel until the open end of the upward bent glass tube is about one-sixteenth of an inch above the liquid. Add glycerine which has been colored with a drop of copper sulphate and a little ammonia. Open the pet cock and allow the solution to gently flow out of the funnel. Again raise the funnel and now add a saturated solution of any salt or even of sugar colored red by means of phenolphthalein and a drop of ammonia. Raise the glass funnel again.

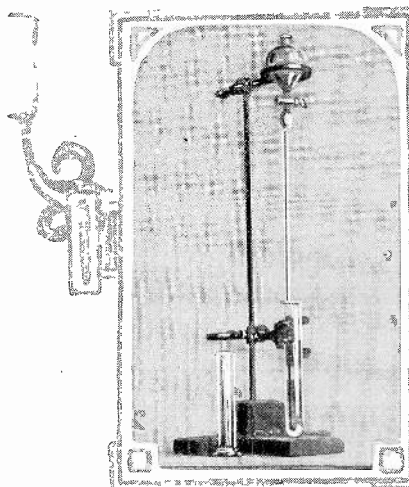

The next layer is produced by a fifty per cent. solution of water and denatured alcohol producing a milky color, and the last by means of ether. The formation will last for a few days.

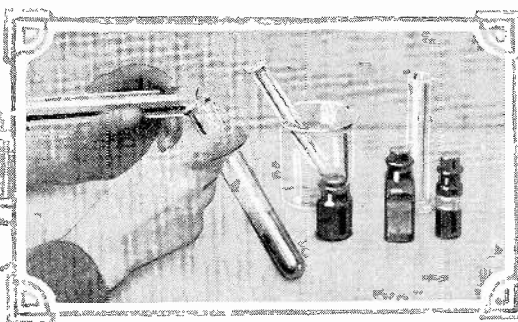

Another very effective trick in the laboratory shows a color change through heat. A yellow piece of paper when slightly warmed changes to a deep red color. The red color disappears again and the original color reappears. The change may be repeated time and time again. Prepare in one test tube a solution of 3.3 grams of potassium iodide in 23 c.c. of water, in a second 1.3 grams of mercuric chloride in 25 c.c. of water, and in the third 1.7 grams of silver nitrate in 10 c.c. of water.

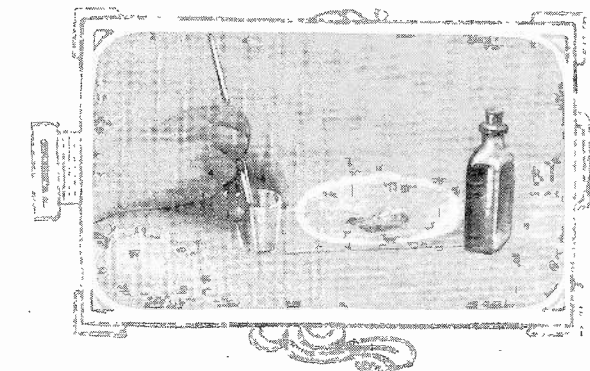

The filtrate should be washed with a little water which may be simply poured upon the filter paper. The moist precipitate is now mixed with a little gum solution. Only a little of the gum should be used, so that a thick paint-like solution results. Filter paper is then painted with this yellow substance, and after it has dried it will show its ability to change color even when but slightly heated.

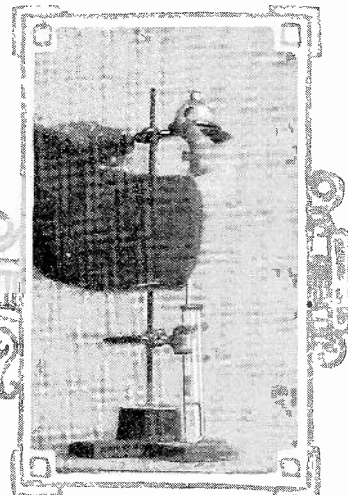

Now place pure water in the separatory funnel. Make sure that the upward bent U-tube is about one-sixteenth of an inch above the top of the liquid as before, and again open the pet cock gradually, so that another inch or so of the water floats on top of the sugar or salt solution immediately beneath it.

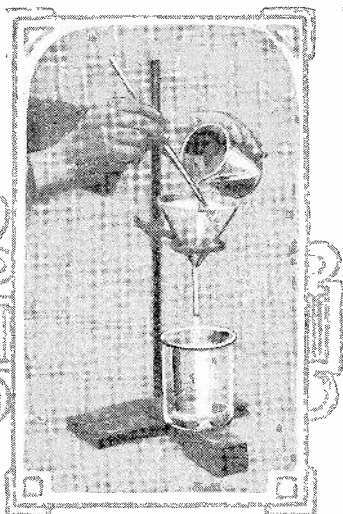

Mix the contents of the first two with the second, shake thoroughly and then add contents of third tube, stir vigorously and filter.

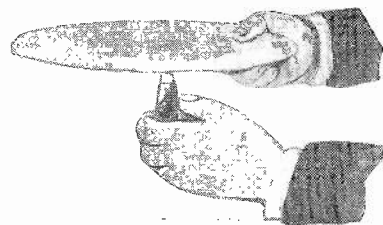

The heat from an ordinary cigar or cigarette held as shown produces a beautiful deep red ring, which disappears when the paper becomes cold.





# THE CONSTRUCTOR



## Etching Glass

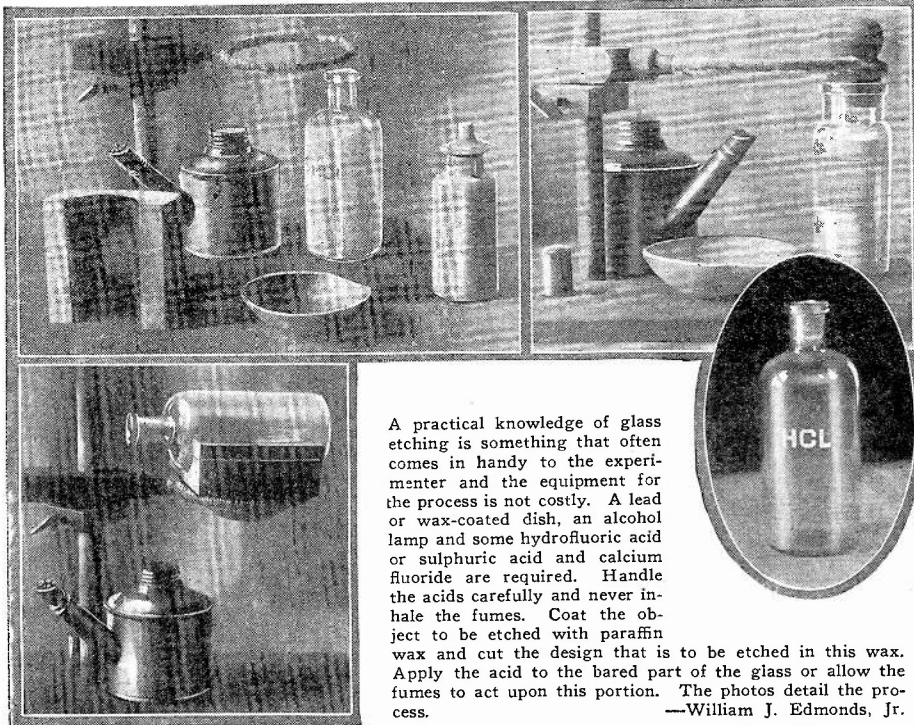

A practical knowledge of glass etching is something that often comes in handy to the experimenter and the equipment for the process is not costly. A lead or wax-coated dish, an alcohol lamp and some hydrofluoric acid or sulphuric acid and calcium fluoride are required. Handle the acids carefully and never inhale the fumes. Coat the object to be etched with paraffin wax and cut the design that is to be etched in this wax. Apply the acid to the bared part of the glass or allow the fumes to act upon this portion. The photos detail the process.

—William J. Edmonds, Jr.

## Barometers

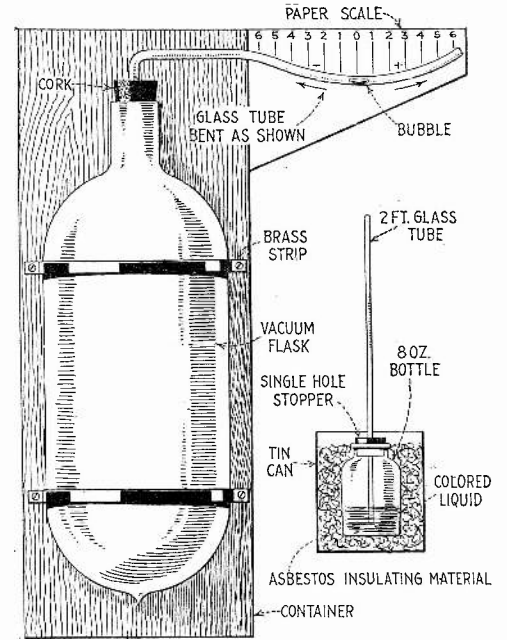

Two barometers are shown in the above illustration. The details are obvious. In each case the pressure flasks should be insulated from heat changes. Movement of bubble or liquid in tubes show changes in atmospheric pressure.

—C. A. Oldroyd and Earl R. Caley.

## A Mechanical Creeper

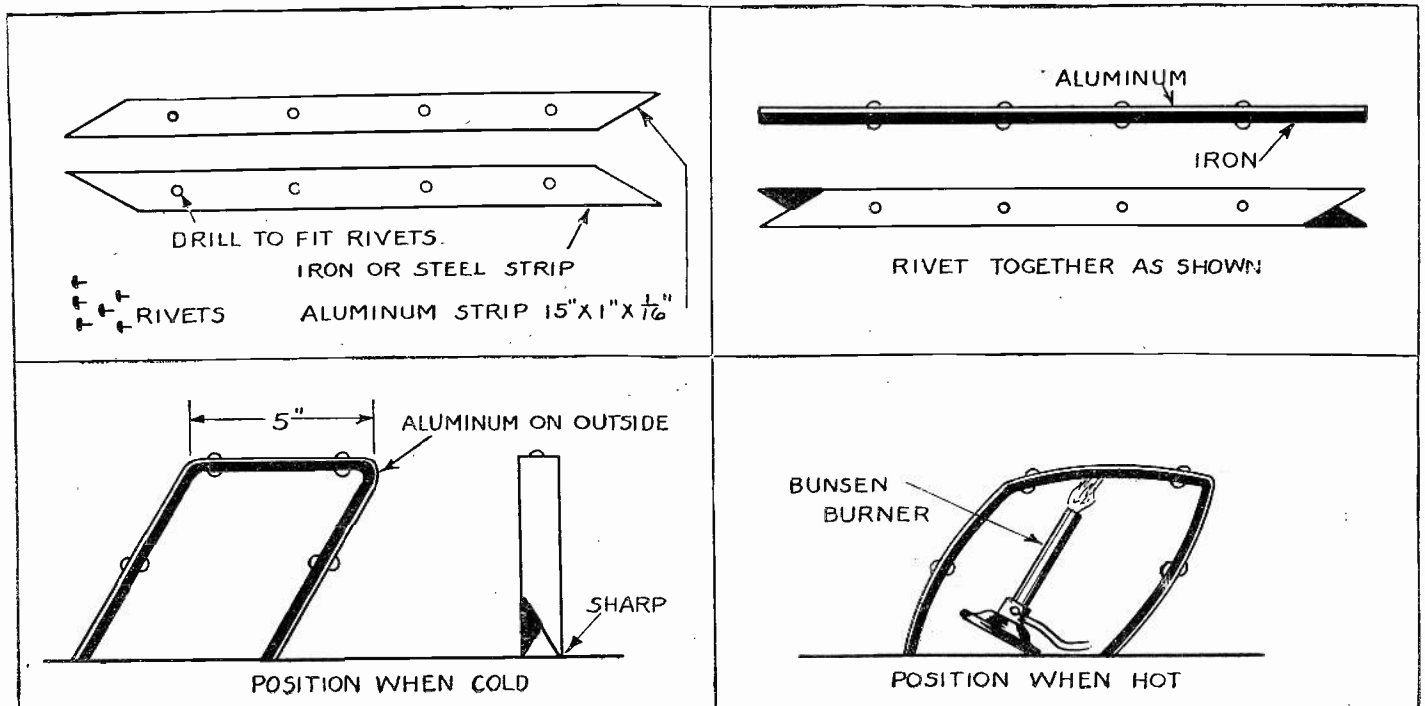

An interesting toy that depends upon the uneven expansion of metals under the influence of heat can be made as shown above. Rivet together two strips of metal, one aluminum and the other iron or steel. Bend to position shown in lower left-hand corner. To operate this little device, place it on a soft

pine board and heat the center of the horizontal portion quickly with a Bunsen burner. It will buckle as shown but if cooled quickly will straighten out, the rear leg will dig into the board and push the toy ahead.

—Harry Lubcke, Rep. No. 1015.

# Leaf Records in Permanent Form

By DR. ERNEST BADE

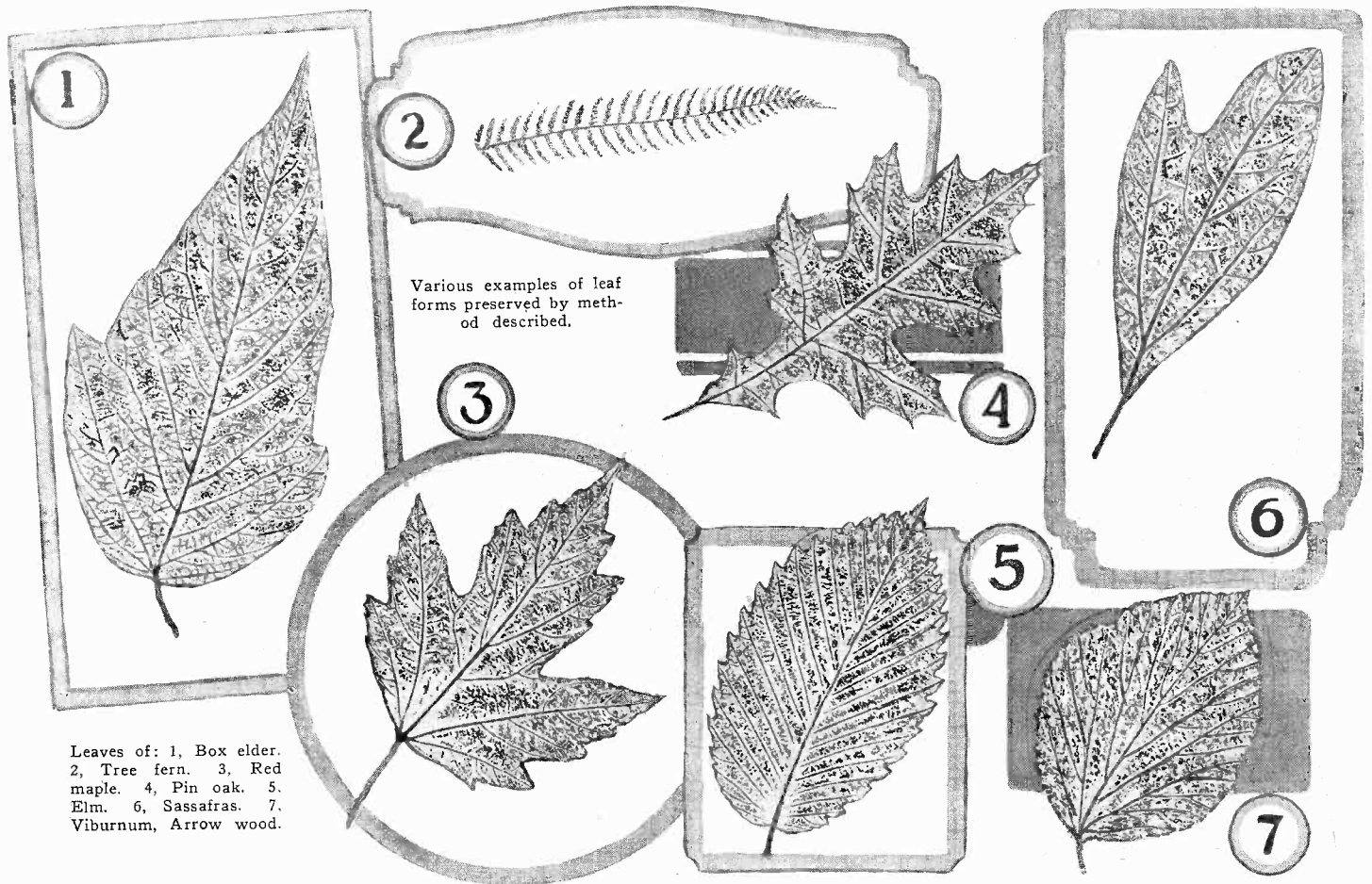

Leaves of: 1, Box elder. 2, Tree fern. 3, Red maple. 4, Pin oak. 5, Elm. 6, Sassafras. 7, Viburnum, Arrow wood.

Various examples of leaf forms preserved by method described.

Records of leaves such as above can be made on sheets of paper that will fit a loose-leaf notebook.

A compilation of leaf imprints properly indexed will afford a source of satisfaction and information.

NO elaborate apparatus is necessary to make accurate and detailed impressions or prints of leaves such as those illustrated herewith. Carbon paper, white paper and a warm iron are the only things required. Perfect leaves should first be selected for making the prints. Place the leaf on a soft surface such as a magazine as at 2 below, after covering the surface of the magazine

with a soft cloth. Over the leaf place the carbon paper with the coated side down and a protective sheet of plain paper over all. Gently press the entire surface of the assembly with a warm flat iron. In a few moments sufficient carbon will have been transferred to the leaf. Carefully remove the carbon paper from the leaf, handling the latter by means of the stalk. Place on a

clean white piece of paper, preferably notebook paper for future filing, the inked side of the leaf in contact with the clean surface. Cover with another sheet and with a warm iron, press the ink into the lower paper. Remove the leaf and a clean-cut positive print or impression of the entire leaf structure will be found on the lower sheet, rivaling photography in effect.

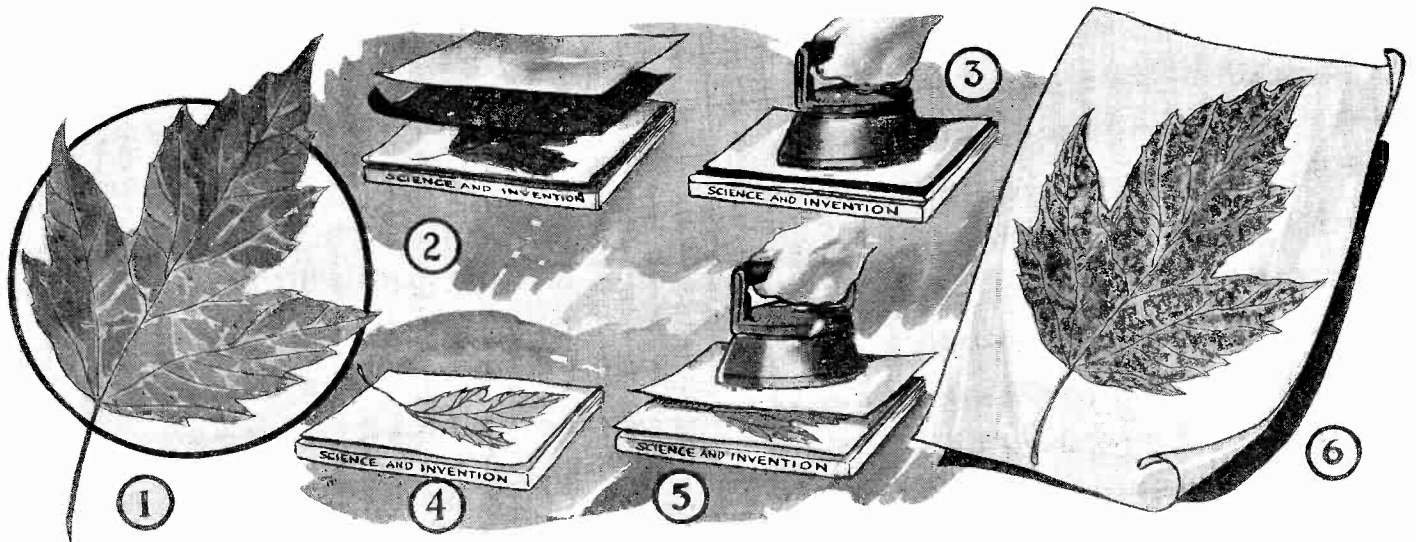

To the student of botany, the process outlined above will prove a valuable aid in the composing of a reference book covering the results of work in the field.

Another version of this process is to coat the surface of the leaf with carbon from the smoke of a candle and to transfer this material to clean paper as in Fig. 5.

# Lamp Chimney Experimental Apparatus

By RAYMOND B. WAILES

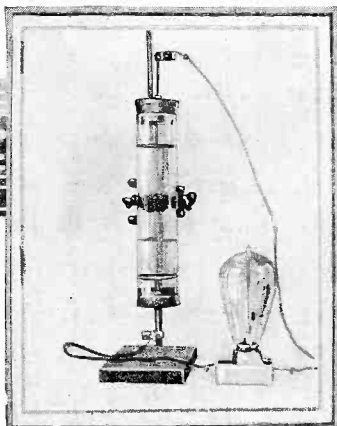

ting electrodes to corks placed in the end of a glass lamp chimney. The upper electrode is moved up and down for current adjustment. A weak solution of salt is A serviceable rheostat can be made by fit-

contained in the chimney.

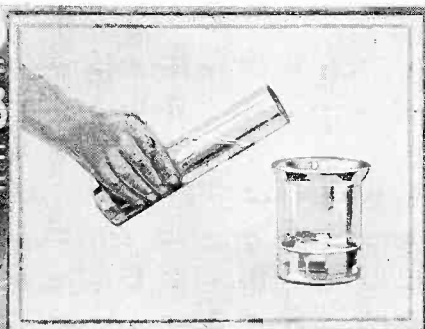

An improvised graduate can be made by stoppering a lamp chimney at one end, and then marking on the glass with a wax pencil the divisions in ounces or cubic centimeters. A strip of marked paper may be pasted to the glass if desired.

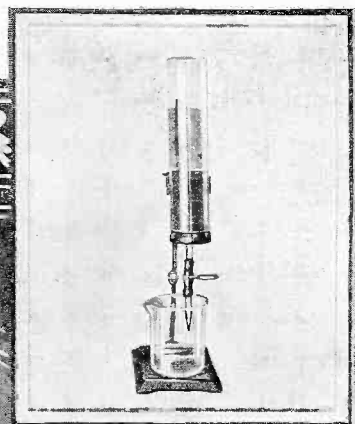

A separatory funnel can be quickly constructed from a glass chimney, a one-hole stopper, and a few pieces of glass tubing, a clamp and a short length of rubber tubing. This is used for separating liquids of different specific gravities, such as oil and water or for dissolving substances in two liquids, and then separating the two liquids for analytical purposes.

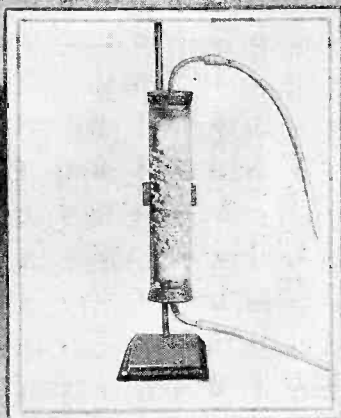

A drying tube for gases is made by filling the interior of a lamp chimney with dry calcium chloride. Wads of cotton are placed at both ends and stoppers and their respective connections are then added.

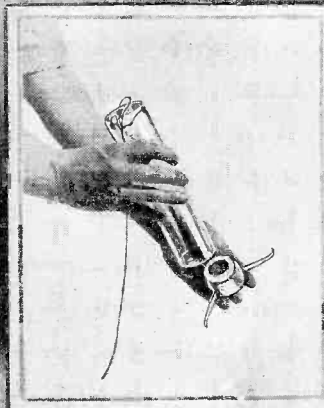

The children will like this water whirligig, which incidentally demonstrates the principle of the reaction turbine. A cork is fitted with three curved medicine droppers; the knurled ends if necessary are previously removed with a file.

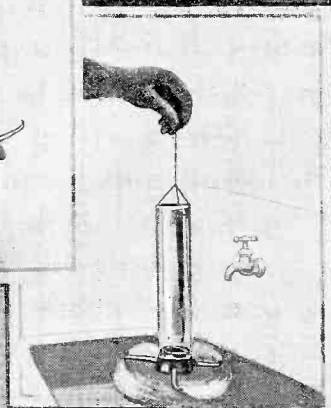

The cork is hollowed so the ends of the droppers protrude inside. Fit the cork to the chimney, fasten a string to the top, fill with water and watch it go.

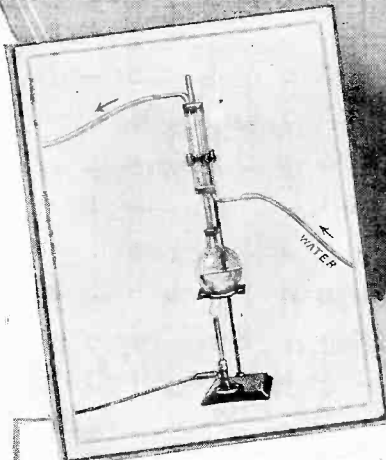

The chemical experimenter can construct his own extractor condenser from a chimney and two two-holed stoppers. A glass tube passes through the center and the water supply is as shown.

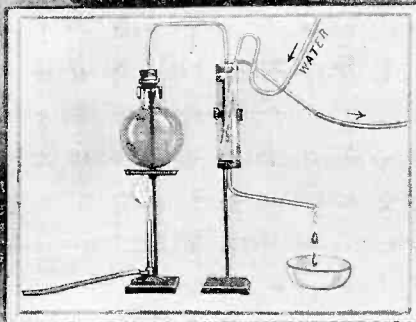

Distillation apparatus is also possible. A bent U-tube passes through a one-holed stopper in the bottom of the chimney, and is connected to the retort as shown. The inflowing water goes to the bottom of the glass chimney and the outflowing water is led away from the top by a tube. The top stopper may be dispensed with and a siphon used.

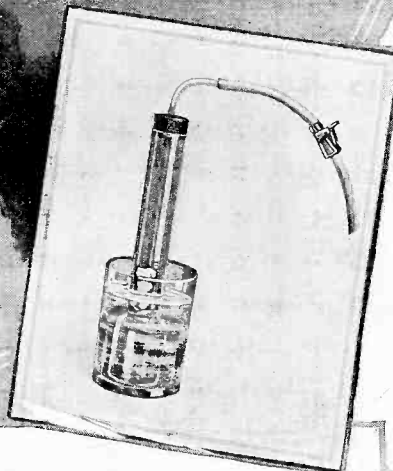

In student's lamp chimney a coil of wire-solder is placed inside or above the constriction and marble or zinc next. Dilute acid is placed in the jar; as gas evolves, acid recedes.



## Drill Guide for Pipe

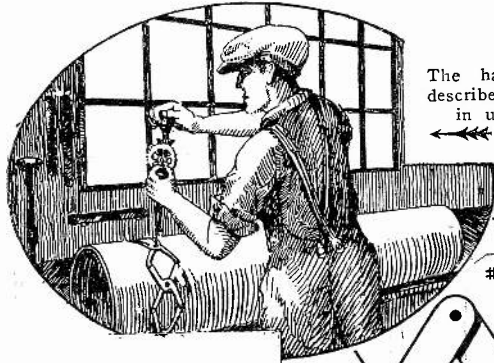

The handy drill guide described below is shown in use at the left.

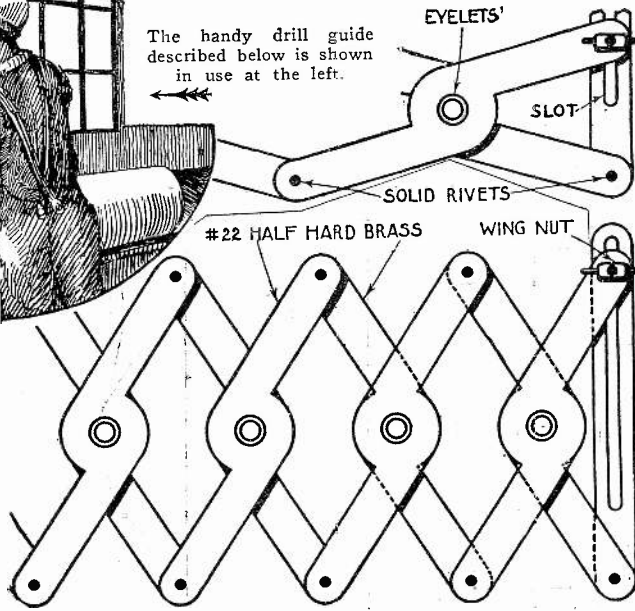

The material used in this lazy tongs arrangement should be 22 gauge brass. This material will be found flexible enough for all ordinary usage on large pipes. A clip can be easily made for holding the ends in position.

When a series of holes have to be drilled in a comparatively large pipe, the task of spacing them and also of centering the drill becomes tedious. Here an ordinary lazy tongs made of comparatively thin strip brass and riveted with solid and eyelet rivets, comes in handy. The constructional details and use of such an accessory are shown above.

—Chris Scott.

## Socket Wrench

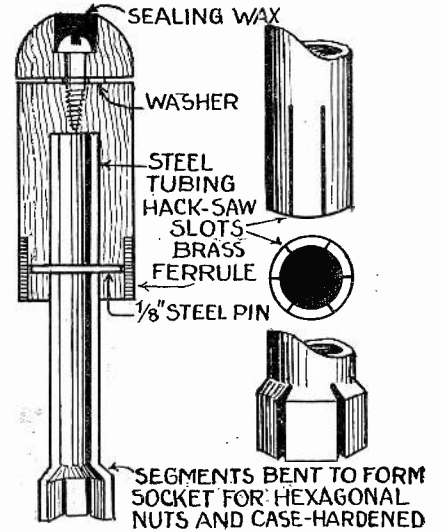

For use on small nuts in out of the way places, socket wrenches may be quickly made by following the constructional details shown above. Several of them should be made up for various sizes of nuts. After the slots are cut in the steel tubing, the end is formed around a nut and then case hardened. The revolving top shown is of great assistance in quick work. It presses against the palm while the fingers turn the handle.

—P. A. Judd.

## Testing Bread Value

Some bakers add too much water to bread in order to increase weight. A good test for this is as follows and is illustrated at the right. Cut two samples of equal weight from different loaves and weighing or balancing them on letter scales. Bake the samples for an hour in an oven and then dry. That which weighs the heavier is the better value as it contains the largest amount of solid matter after the moisture has been driven away. In order to give the bread manufacturers a fair deal in this test, great care should be taken in selecting the slices of bread to be used. They must be carefully cut to the same sizes and should have been made by different bakers at very nearly the same time.

—S. Leonard Bastin.

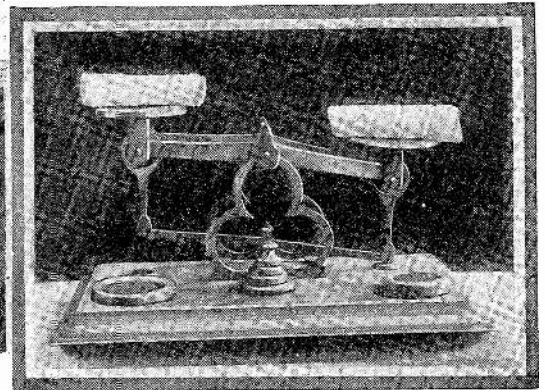
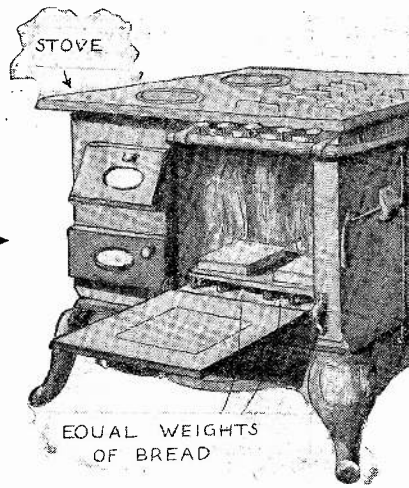

Above: Weighing slices of bread preparatory to conducting the test for the amount of moisture contained therein.

## Restoring Old Books

THE restoring of old books is not too difficult for the amateur if ordinary care is exercised in the process. The book must be first unbound, glue and paste soaked off the back and the pages removed. They are then placed in the intervals between the wooden slips as illustrated and described at the left and held in position by small wooden wedges. After all of the spaces have been filled with pages, the entire unit is submerged in a sufficiently large vessel containing a bleaching agent such as a solution of chloride of lime. This will whiten the paper which is then washed in repeated baths of cold water, the first containing a little "hypo", to remove all traces of the chlorine. Subsequent treatment in the same manner with a weak solution of potash will remove all grease. After the pages are again thoroughly washed, they are dried, pressed together and rebound. Rebinding processes have been described in this magazine in the past.

—J. T. Garver.

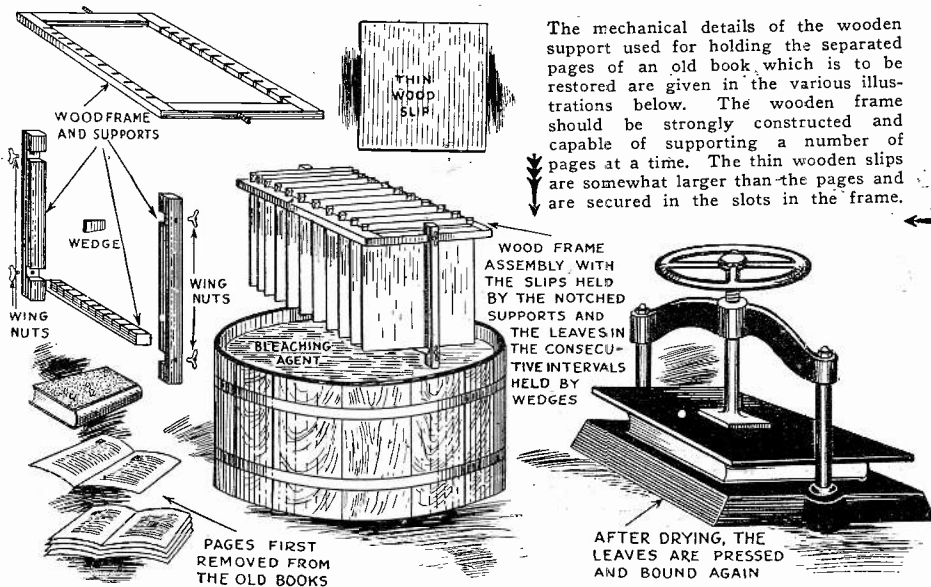



# HOW TO MAKE IT



## Color Changed

A bit of Sodium Carbonate in balloon or in mouth

glass tube

rubber balloon taken in mouth

Colorless solution of Phenolphthalein sucked into mouth or balloon may be expelled as red liquid

or + Water, gives Phenolphthalein Phenolax.

A clever little effect may be had by the amateur magician if he will follow the directions illustrated above. Seemingly all he does is to draw some clear solution from a glass into his mouth and when it is expelled, it is red. The secret lies in the fact that the mouth contains a bit of sodium carbonate whereas the colorless solution in the glass contains phenolphthalein. The mixture produces a red color. If taste is objectionable, use rubber balloon as shown.

—Alton C. Kurtz.

## Hookah

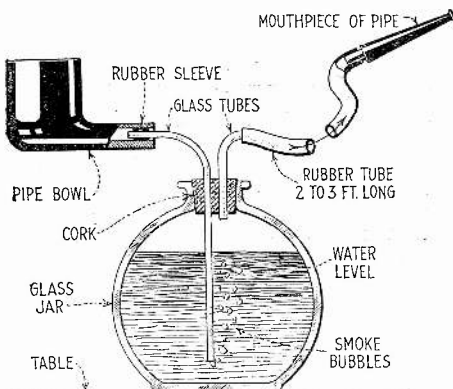

A smoker's pipe that is free from nicotine can be easily made as shown above. The bowl and stem of an ordinary pipe are separated and used as illustrated. When tobacco is smoked in this way, the fumes are drawn through water and most of the nicotine removed. The result is a cool, sweet smoke that cannot be obtained in any other way. Some addicts of this type of pipe say that a very minute quantity of perfume placed in the water is desirable.

—C. A. Oldroyd, Rep. 4433.

## Weight Combinations

EFFE-CTIVE WEIGHT ON LEFT HAND SIDE	WEIGHT PLACED ON LEFT HAND	EFFE-CTIVE WEIGHT ON RIGHT HAND	WEIGHT PLACED ON RIGHT HAND
1	1	0	21 27 3 9
2	3	1	22 27 3 9
3	3	0	23 27 3 9
4	3 1	0	24 27 3
5	9	3 1	25 27 3
6	9	3	26 27 1
7	9 1	3	27 27 0
8	9	1	28 27 1 0
9	9	0	29 27 3 1
10	9 1	0	30 27 3 0
11	9 3	1	31 27 3 0
12	9 3	0	32 27 3 3 1
13	9 3 1	0	33 27 3 3
14	27	9 3 1	34 27 3 3
15	27	9 3	35 27 3 1
16	27 1	9 3	36 27 3 0
17	27	9 1	37 27 3 0
18	27	9	38 27 3 1
19	27 1	9	39 27 3 0
20	27 3 9 1	4 0	40 3 3 1 0

It is possible to obtain a great number of different combinations if we have on hand a set of weights such as those shown above, namely one, three, nine and twenty-seven grams, ounces or pounds as the case may be. Any weight from one to forty pounds can be determined with these four standards. They are variously arranged on opposite pans of the balance as shown in the illustration, following the chart given at the right above. Obviously in the illustration, six ounces of material on the scale will bring about a balance.

—A. A. Blumenfeld.

## Parachute Golf Ball

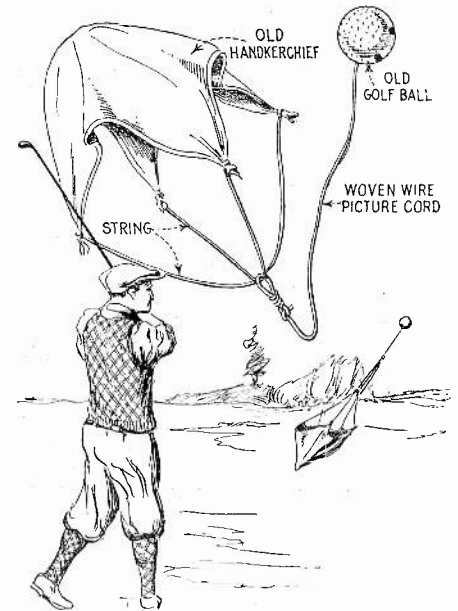

A captive golf ball such as the one shown above enables one to practice in a much smaller space than would be possible if a regular ball were used. Drill a hole through an old golf ball, pass several feet of picture cord through the hole and fasten a home-made parachute to the other end as shown. A knot in the cord next to the ball prevents the latter from coming off.

—F. S. Root.

## Auto Spring Wedge

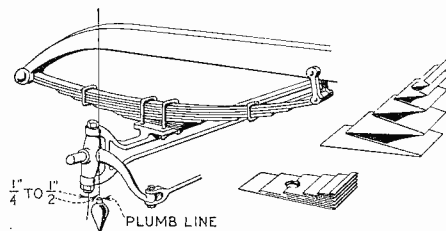

When an automobile spring has to be wedged upward as shown in the above diagram in order to restore caster or in other words keep the axle at the required angle, a solid metal wedge is not always obtainable. In lieu of this, a wedge can be built up of thin sheets of iron cut and bent as shown. The edges are then hammered together, whereupon the finished product will give just as good results as will a solid wedge.

## Unique Violin

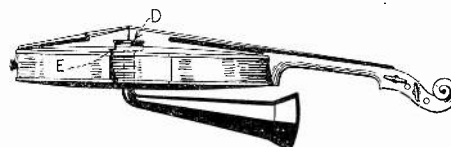

A violin that will produce quite a great amount of volume and with which the sound can be sent in any desired direction is illustrated above. A standard violin neck is used while the body is a block of wood through which a hole is drilled to the end of the horn. A metallic bridge is soldered to the metal diaphragm, D. The diaphragm is soldered to the horn, E. If carefully made, this instrument will be very satisfactory.

—K. A. Sugh, Rep. No. 13,229.

## Toy Submarine

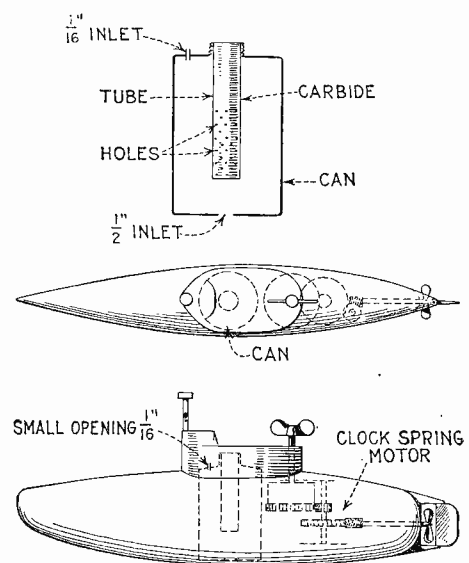

A submarine that will really submerge can be made from a few pieces of scrap tin and wire and a clock spring motor as shown above. The can illustrated must be rather strong so as to withstand pressure. Fill tube with calcium carbide or two parts of citric acid and one part sodium bicarbonate. Fit a dry, soft pine plug loosely into the small hole in the top of the can, place the boat in the water and it will sink only to rise soon to the top again.

—Fred C. Jones.

TELEPATHY

Editor, SCIENCE AND INVENTION:

In the May issue of SCIENCE AND INVENTION Magazine I read that you were offering rewards for evidence of telepathy, clairvoyance, etc. I am a former member of the S. P. R. (Society for Psychical Research) and have had some experience in investigating such things. My most satisfactory work was done with telepathy and I can assure you that telepathy really happens. I am not going to try for the telepathy prize because I cannot afford the time and expense necessary to get up a demonstration, and for other reasons that will appear presently. Here is a summary of one of my reports to the Society for Psychical Research.

The experiments to be described did not start as telepathy experiments, but as investigations along an entirely different line. Mining engineers often meet with a common belief or superstition that it is possible to find gold and other valuable things with a divining rod or the same thing under a different name. Since there is no basis in physics and chemistry for such a belief, I had always scoffed at it and wondered that so many people persisted in it.

Finally I ran across a prospector who asked me to make him a divining rod using a secret formula that he had. To humor him I did so and then told him what I thought of it. He offered to demonstrate and I made a small package of gold dust and hid it. Much to my surprise and confusion he found it—not only once but several times. Disconcerted but unwilling to admit that such a thing could be done, I made an appointment with him for a series of experiments under more test conditions on another day. When the day arrived I made 36 consecutive tests, using great care that the man using the instrument should not learn the location of the gold in any way except by means of his divining rod. He was successful at the first trial in thirty of these tests, and after that in some three trials in the other six. This is altogether too much for the coincidence theory. In five or six of the tests the man was blindfolded and in all of them he had no chance to learn the direction to the gold through any of his senses. I then produced a dummy divining rod made to look and feel like the other one but without a secret formula. Five experiments with this were all successful. The man thought it was the same as the one he had been using.

In all the above tests someone present knew the location of the hidden gold. There were two possible explanations of the phenomena. One was



SCIENCE AND INVENTION desires to hear from its readers. It solicits comments of general scientific interest, and will appreciate opinions on science subjects. The arguments pro and con will be aired on this page. This magazine also relishes criticisms, and will present them in both palatable and unpalatable forms. So if you have anything to say, this is the place to say it. Please limit your letters to 500 words and address your letters to Editor—The Readers Forum, c/o Science and Invention Magazine, 53 Park Place, New York City.

that the divining rod theory was right and that there was some sort of mysterious attraction or influence that moved the divining rod (or the man who held it) toward the gold.

The other was that the divining rod wielder received a direction impulse by telepathy from someone knowing the place of concealment. The last explanation is plausible, because all divining rods are made in such a way as to be very sensitive to very slight, even unconscious, movements of the user's body.

In order to settle the matter I arranged another series of experiments with the same man. I was camped in a mountain cabin miles from any settlement. In this cabin I built a machine for hiding a ball containing gold in any one of a series of padded boxes arranged all around the room near the wall. The ball could be released by pulling a long string. It would roll against a series of spouts leading to the boxes. A pull on another string from the same position—out in the woods one hundred yards from the cabin—removed the spouts and closed all the boxes. Thus the ball would be hidden in a small box at one side or the other of a rather large room and no person living could possibly know which box held it. I adjusted the apparatus until it worked perfectly and never hid the ball twice in succession in the same box.

I then looked up my prospector friend and had him bring his divining rod to my cabin and make a series of experiments. The procedure followed was for both of us to go to the ends of the strings, I would pull them, and we would return to the

house and he would try his divining rod. I kept always behind him no matter which way he turned. No other person was present. He was very confident that his instrument would work under these conditions but it did not. He was unable to find the gold in any case when it was hidden by the machine, even after several trials. He complained that the "conditions" were not right so to test this we made a number of experiments without the hiding machine. In these he walked out in the woods to a point where I could see him from a window and stood with his back to the house while I placed the ball by hand in one of the boxes. He then returned and found the ball at once and was successful every time that the ball was concealed in this way. I kept behind him while the test was being made as before, so that no movement of mine could give him an inkling of the right direction. A return to the hiding machine broke the spell—he was unable to find the ball unless I knew the hiding place.

In all the above experiments no word was said about telepathy. The prospector understood only that I was testing the efficiency of his gold finding instrument.

There is no rational explanation of that prospector's ability to find hidden gold except telepathy. My experiments proved that he was uniformly successful when some person present knew the hiding place and just as uniformly unsuccessful when no person knew the hiding place. All other conditions were the same in both cases.

I have had a number of experiences with real telepathy under various forms, but the above will suffice for an example of it and an indication of its nature. The transmitted thought is a vague mental "feeling." It may be a sense of direction like the above or it may be a feeling of fear or other emotion. If it seems to take the form of a definite thought transfer in the form of definite words or pictures or other sense impressions, the definite thought is formed by the receiving mind. Thus the mind of the receiver will cause a vague feeling of fear to develop into words of warning or it will see a mental picture in a general way like the one transmitted, but not exactly the same except by a chance. If the sending and receiving minds are so exactly alike that the same feelings will lead to exactly the same thoughts, real mind reading is possible. Such cases are extremely rare. On the other hand, the transmission of vague feelings from one mind to another is quite common.

Now you understand some more of the reasons why I do not care to attempt to demonstrate telepathy in order to win a prize. All mental phenomena are difficult to control with laboratory exactness and when we attempt to control a mental "feeling," well, it is like shoveling smoke.

JOHN B. PLATTS, Mining Engineer, Boise, Idaho.

(The great error you made was in being in the same room with the prospector. Had you been out of the room the object would not have been located. If one hides an object it is difficult for them to conceal a slight facial change or to prevent a slight gasp of breath, or even to stop a twitch of the eyes, which would immediately give away the presence of the concealed object. Inasmuch as you were standing behind the prospector, there was very little possibility that he could see the movement of your eyes, but it is simple for him to notice a change in your walk, to hear a slight change in your breathing, or to note any other seemingly trivial effect.—EDITOR.)

To Our Readers

THE publishers of SCIENCE AND INVENTION have decided to put the contents of this magazine to a popular vote by its readers. This magazine is published and edited solely for our readers; and we are more than anxious to give them exactly what they desire. For that reason, we thought it best to put the matter to a popular vote, and let the majority decide. You will readily understand that it makes no difference to the editors and publishers what matter is printed as we can have no preferences in the matter. The readers must be satisfied first!

We hope every reader will see it as his duty to fill in the adjoining voting blank, and send it to the editor. One cent is the total cost, as the blank can be cut out and pasted on the back of a postal card. In case you do not wish to mutilate the magazine, just copy the blank on a postal card and mail.

The editors pledge themselves to abide by the result, which will be published as soon as a sufficient number of votes are in.—EDITOR.

Voting Blank

My vote as to the contents of SCIENCE AND INVENTION appears in this ballot. I have placed a cross in the blank spaces showing either my preference or dislike of the various subjects enumerated.

Name .....

Address .....

- |                               |                               |                                      |
|-------------------------------|-------------------------------|--------------------------------------|
| More <input type="checkbox"/> | Less <input type="checkbox"/> | Scientific Fiction                   |
| More <input type="checkbox"/> | Less <input type="checkbox"/> | Movie Exposés                        |
| More <input type="checkbox"/> | Less <input type="checkbox"/> | Everyday Chemistry                   |
| More <input type="checkbox"/> | Less <input type="checkbox"/> | Astronomy                            |
| More <input type="checkbox"/> | Less <input type="checkbox"/> | Scientific Problems and Puzzles      |
| More <input type="checkbox"/> | Less <input type="checkbox"/> | Mathematical Cross-Number Puzzles    |
| More <input type="checkbox"/> | Less <input type="checkbox"/> | Magic                                |
| More <input type="checkbox"/> | Less <input type="checkbox"/> | The Constructor                      |
| More <input type="checkbox"/> | Less <input type="checkbox"/> | How-to-Make-it Dept.                 |
| More <input type="checkbox"/> | Less <input type="checkbox"/> | Readers' Forum                       |
| More <input type="checkbox"/> | Less <input type="checkbox"/> | Wrinkles, Recipes and Formulas       |
| More <input type="checkbox"/> | Less <input type="checkbox"/> | Radio, General or Constructor—which? |
| More <input type="checkbox"/> | Less <input type="checkbox"/> | Scientific Humor                     |
| More <input type="checkbox"/> | Less <input type="checkbox"/> | Oracle                               |
| More <input type="checkbox"/> | Less <input type="checkbox"/> | Latest Patents                       |
| More <input type="checkbox"/> | Less <input type="checkbox"/> | Patent Advice                        |
| More <input type="checkbox"/> | Less <input type="checkbox"/> | Motor Hints                          |
| More <input type="checkbox"/> | Less <input type="checkbox"/> | Non-Science                          |
| More <input type="checkbox"/> | Less <input type="checkbox"/> | Medical Page                         |

I would like to see additional departments as follows:

**Station**  
**WRNY**  
NEW YORK  
**258.5 Meters - 1160 Kilocycles**  
*is owned and operated by the publishers of this magazine*  
*Our editors will talk to you on -*  
*Monday 9:00 P.M. - Tuesday 8:30 P.M.*  
*Wednesday 9:00 P.M. - Friday 8:30 P.M.*  
*of each week.*  
**TUNE IN ON**  
**WRNY**





# WRINKLES

## RECIPES & FORMULAS



Edited by S. Gernsback

### Vacuum Still

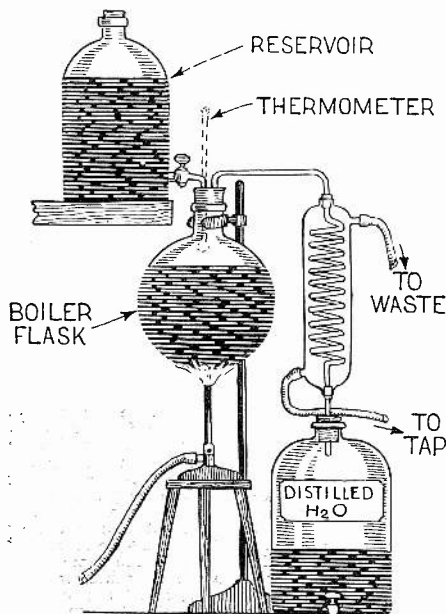

A still, very rapid in action, for producing distilled water is shown directly above. The reservoir is merely a convenience for refilling the boiler. The stop-cock at the bottom of the receptacle is opened until all the air has been driven from the apparatus by live steam. Then close the stop-cock and turn on the tap water through the condenser. Due to the partial vacuum in the boiler flask, the water will boil furiously even with a low flame under it.

—Chris. Henriksen.

### Etching Pencil

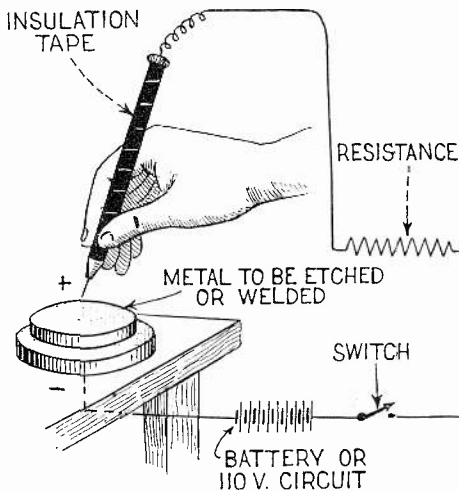

For making an electrical etching pencil, one of the ordinary types of clutch pencils with a metallic barrel is pressed into service. A wire is soldered to the head of the pencil and the barrel covered with tape as shown. One terminal of the current supply source is connected to the pencil through a resistance while the other terminal is connected to the metal to be etched or welded. Use regular pencil leads and for etching, write slowly over the surface. For welding or light soldering, hold the point at the place where the heat is desired. —Frank R. Moore.

### Battery Filler

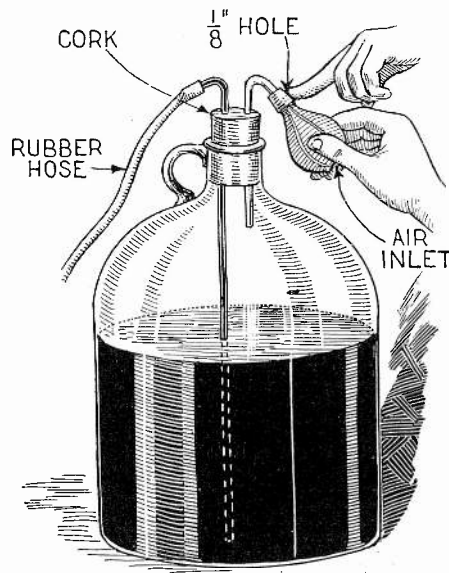

A large glass bottle, equipped with a long glass tube and a short one to which a rubber bulb is fastened makes a good filler for storage batteries. Fill the bottle with distilled water and connect a long rubber hose to the bent glass tube. Place the other end of the hose in the filler hole of a cell and press on the rubber bulb. A hole placed as shown will enable the operator to control the flow of water. If the device illustrated above is lower than the battery, close the hole and pump. Opening the hole stops the flow of water immediately.

—D. L. Campbell.

### Funnel

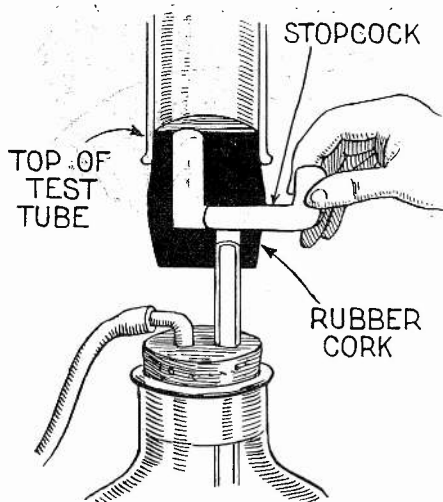

A simple funnel may be made from the top of a broken test tube and it can be equipped with a stop-cock by drilling a rubber cork as shown above. A piece of solid glass rod cuts off the flow from the funnel when it is pressed in and allows the liquid to pass on when pulled out.

—A. A. Blumenfeld.

### Wheel Repair

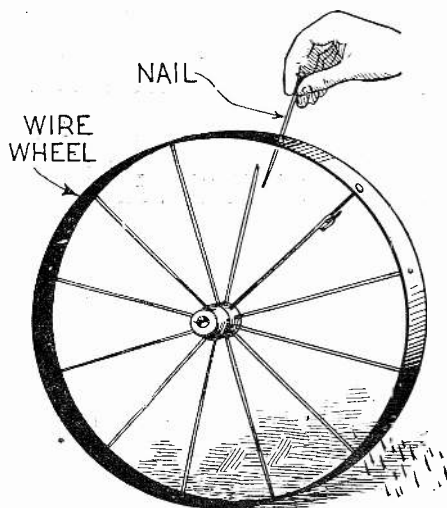

For repairing a spoke in a wire wheel such as used on garden plows or small wagons, wire nails of about the size of the spoke may be used. Remove the broken end and pass the nail through the hole that will be found in the rim as illustrated above. With a pair of pliers, turn hooks in the end of the nail and in the end of the broken spoke. Engage these hooks and with the pliers draw them up as tight as possible and the repair will be found to be very serviceable. A completed repair and one being made are shown above.

—R. Q. Hufford.

### Egg Shell Funnel

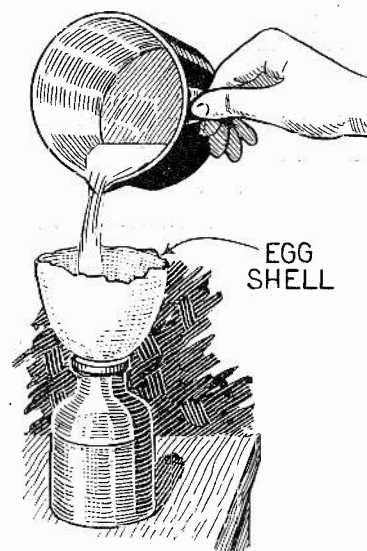

When in need of a small funnel, use half of an egg shell in the end of which a small hole has been made. The funnel will be found to rest quite solidly on the top of a bottle and will be a very satisfactory substitute for the more expensive thistle tube or small glass funnel.

—C. M. Wilcox.

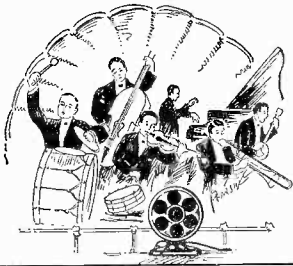

# RADIO

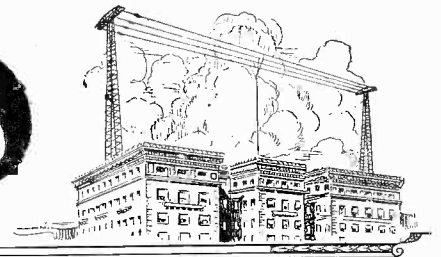

## Continuous News and Time Broadcast Service

A suggestion for a new radio service which would fill an existing want

By C. A. Oldroyd

English Correspondent. Reporter No. 4433

**R**ADIO has found its way into countless homes and offices, and has entertained millions at their own fireside. But radio would become still more useful and almost indispensable if a continuous time service combined with a regular news service would be started.

At the present time signals are sent out only once a day, and that at a time when

from the cable room of a large newspaper organization; in front of him would be a clock fitted with a special alarm, preferably operated by electricity. Some twenty seconds or so, before a time signal is to be sent, a buzzer would warn him, and he would interrupt this news transmission by saying: "Now listen for time"—a few seconds' silence—"Three-fifteen"—only to con-

business men who wish to be informed of the latest happenings, as well as to have correct time, housewives who steal a few minutes from their work to hear how the latest divorce case is getting on and who, incidentally, are warned to compare their clocks and watches with the time transmitted, yachtsmen many miles from the coast, airmen and passengers in airplanes

A continuous broadcasting service of the nature described by our English correspondent would be of great value to the public. Note the wide diversity of material that could be broadcast.

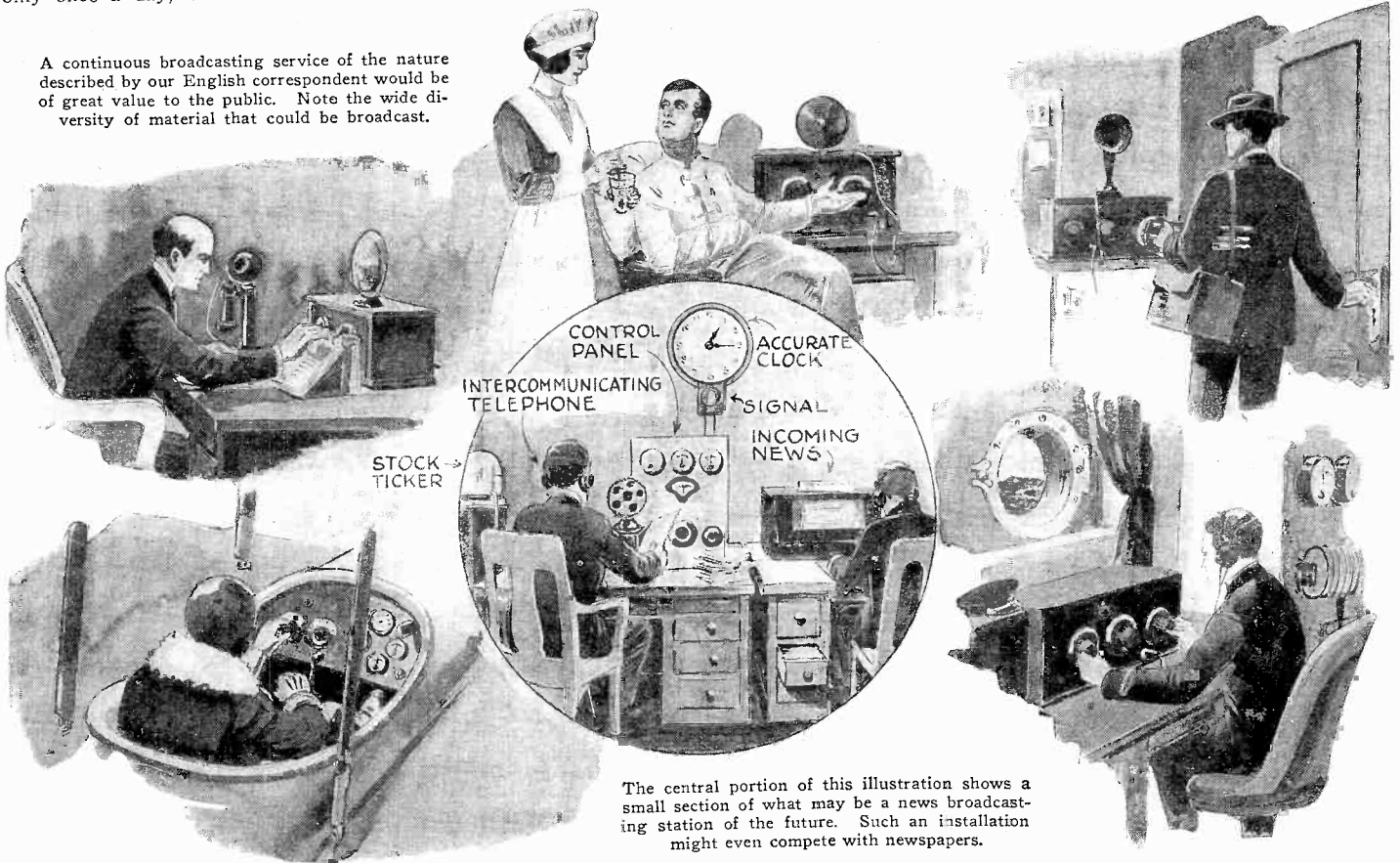

The central portion of this illustration shows a small section of what may be a news broadcasting station of the future. Such an installation might even compete with newspapers.

most people are at work or in their offices where receivers may not be available. A far better system would be the following:

Every five minutes, a time signal might be sent out by radio telephony, so that any listener-in can regulate his or her watch by it. A voice announces, for instance, "FIVE-FIFTEEN." Again at five-twenty, five-twenty-five, etc., a signal is sent, and at the most, a listener would have to wait five minutes before the correct time is transmitted to him.

To make the feature more attractive, the four odd minutes between the time signals would be filled in by transmitting the latest news to the listeners. An announcer would be supplied with special news-sheets fresh

continue reading out the news when the time signal has been sent.

While waiting for the correct instant for giving out the time, the operator's eyes would be focussed on a large, carefully regulated clock, so that the accuracy obtained would be far greater than needed for ordinary purposes. In offices, the loud speaker of a powerful set could be switched on just before the lunch interval, for instance, and all members of the staff could set their watches to the correct time.

Dwellers in a small town or farmers in isolated districts would enjoy a continuous and perfect time service at present denied to them. But most of all, such a service would win countless new recruits for radio;

or airships, in short, all sections of the community would benefit by such a service and would become habitual users of radio. Instead of being a hobby or recreation, radio would become a necessity to everybody, and a few years should see a set in every home.

As to the news service: this need not be red-hot news alone, as there are many applications that have not been touched yet. A few instances are given below:

1. For the photographer:

For a certain district, a standard exposure for a certain stop could be sent out at fixed intervals every day, this would hold good for every district within many miles. For instance:

(Continued on page 679)

# Broadcasting Enters a New Sphere with WRNY as Guide

By CHARLES D. ISAACSON, Program Director WRNY



(EDITORIAL NOTE: *The new Program Director is known all over the world as organizer of concerts for the masses having reached more than 5,000,000 people face to face and in their homes—as lecturer, author and newspaper man.*

**I**T IS going to be the greatest fun of all the things I have ever tried to do, working out this new plan of broadcasting.

Yesterday, you might say, I went for the first time to an improved microphone and could scarcely believe myself as to what was happening. Yesterday, you might say, when I first told my friends that a man only thirty miles away had heard me, they said to me: "Dream on, dream on."

First, there is broadcasting, and then there must come system in broadcasting. To me radio is a combination of theatre, concert hall, opera house, university, town hall and field of sport. Eventually, there is no question but that certain stations will be known for certain things, just as magazines are known in certain fields.

But, in the meantime, it will be the plan of WRNY to get away from the haphazardness of broadcasting and to so organize our time on the air that our listeners will know now, and tomorrow and in months to come, what they will find by tuning in on WRNY at any moment.

In order to do this, WRNY has divided its program into music, the other arts, the theatre, literature and various educational subjects. These departments have been subdivided so that in music we find grand opera, light opera, chanting, song literature, chamber music, violin courses, etc., and, of course, the best of the popular music.

In literature, we have fiction, poetry and serious writings, old and new.

There is a sculpture department, courses in history, geography and science, and so on. The plans will work out something like this: If you tune in on WRNY Monday, you will always find popular dance music, folk songs and national music of the world. Always on Monday there will be poetry and painting and history and geography and travel, but Tuesday, on the other hand, will be a night for light opera and orchestral concerts, and just a word or so on architecture.

If you are of a studious turn of mind, you will soon learn that always on Tuesday you can find lectures on law and history—and so it will go on all through the week. Wednesday will be dedicated to songs, fiction, history and sculpture, and Thursday, the more popular music with certain concert features.

Friday will always be known as grand opera and band concert night, and the night of unusual novelties. I do not want to tell the whole story here. *Radio News* has already published a little booklet that gives a plan and outline, which will be mailed to you upon request. The staff of WRNY is now at work on a big broadcast book that you will want to have in your possession, because it will be the first advance prospectus of broadcasting of any station in history. It will tell you at least six months in ad-

vance how to follow everything you want to know.

In order to carry out this tremendously ambitious program, WRNY is gathering about itself an excellent company.

In the grand opera department there will be associated regularly such noted conductors as Clementi De Macchi, Salvatore Avitabile, Louis Aschenfelder, E. D. d'Avigneau. Both Mr. De Macchi and Mr. Avitabile have conducted throughout Europe and America and Mr. Aschenfelder has turned out some of the greatest singers. D'Avigneau conducted the California grand opera company and brought Leoncavallo, the composer of "Pagliacci," to America. One organization that is now being prepared for WRNY is a complete chorus and orchestra.

The light opera department will give such performances as "Patience," "The Mikado," "Tales of Hoffman," etc. An organization  
(Continued on page 675)

Above: Dr. Chas. D. Isaacson.

On Monday evenings at 8:30 P. M. you will hear all about famous painters as told by Mlle. Dugas.



Mlle. Céleonor Dugas.

The literary, theatrical and fiction departments of WRNY will be directed by Miss Brown.



Miss Anita Brown.

The great music of the world will be presented via radio by Mr. Cooper and the Volga Trio.



J. van Cleft Cooper.

Miss Lee, known as "The Love Song Girl," will undoubtedly be one of WRNY's most popular singers.



Miss Lorna Lee.

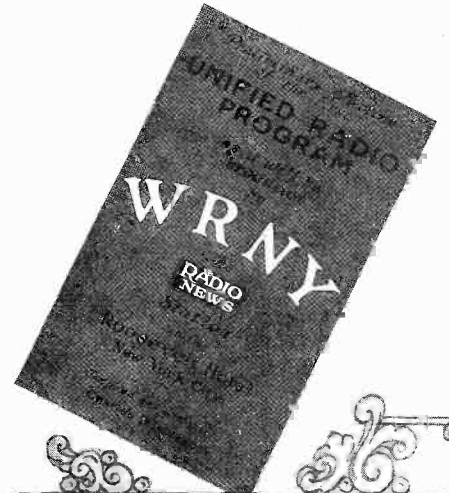

Alexandre Zeitlin will broadcast a series of talks on sculptors Tuesdays at 9.40 P. M.



# WRNY—Radio News, New York

More Details in Regard to the Sharpest Tuned Station  
Operating in the United States Today

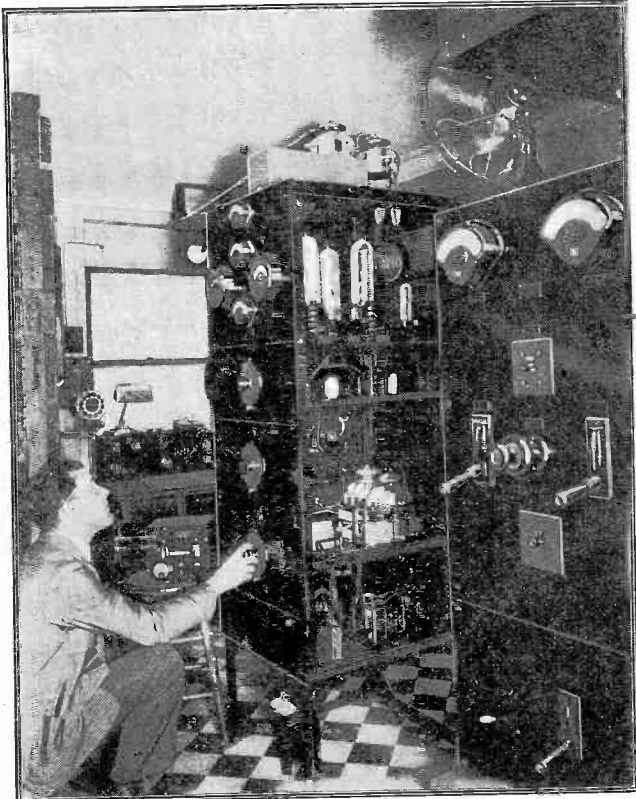

The photograph above shows Gilson V. Willets, manager of station WRNY, tuning the transmitter of that station preparatory to going on the air. The screens are removed from the sides of the transmitter frame in order to show the enormous tubes used. A wave-meter is at Mr. Willets' side.



One of the popular feature artists at WRNY, the Novelty Station in New York, is Jerome Lama, who is here shown playing a solo on his favorite instrument, the Musical Saw. This versatile and original young man draws music from unheard of sources, one of which is nothing less (or more) than an ordinary toy balloon. WRNY is owned and operated by the Experimenter Publishing Co., publishers of this magazine.

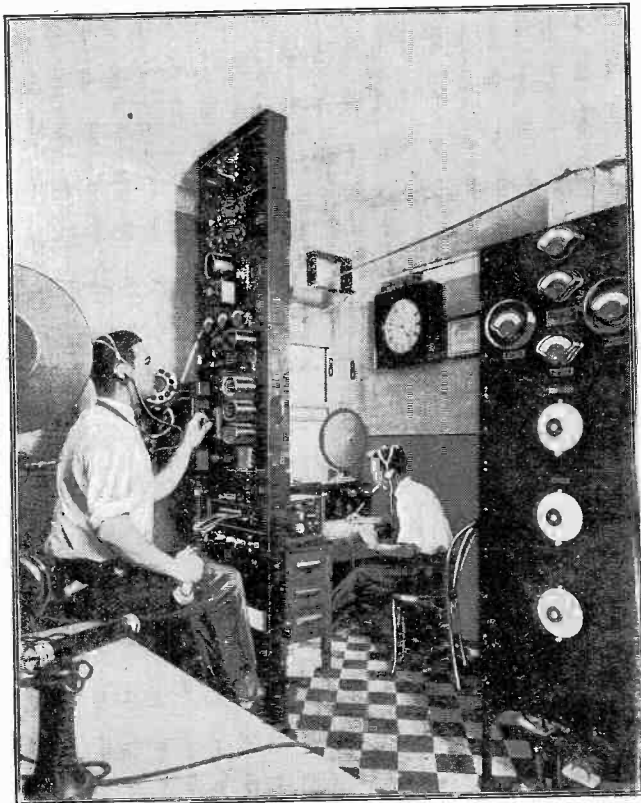

Above we see James Maresca, chief engineer of station WRNY at the control panel. The operator at this position is in touch with all remote control points and with the main studio. He also operates a volume control which keeps audibility constant. At the right of the panel is the 600 meter operator listening for an SOS.

Station WRNY has attained the reputation of being one of the sharpest tuned stations on the air in this country. At all times it is most difficult for anyone listening in to find any deviation from the assigned wave-length. Even the most delicate of apparatus cannot do this, inasmuch as the station is so well operated and the instruments are under such a constant check that it is almost impossible for such a change to take place.

A standard frequency wave-meter is used at this station and it is the one instrument that is seldom if ever idle. It is in frequent demand, and during the time that the station is on the air it is in constant use. Located at the elbow of one of the operators in charge and set at the wave-length upon which WRNY operates, this meter immediately shows any discrepancy in the emitted wave.

Another reputation that WRNY has always lived up to is that which has accorded it the title of the "Novelty Station." Many of the programs are most unique in character. For instance, the "Toonerville Trolley" broadcast once a week at midnight has been pronounced as one of the most novel features ever sent out. "Amateur Night," another feature of this station, has brought in an enormous flood of letters from listeners-in.

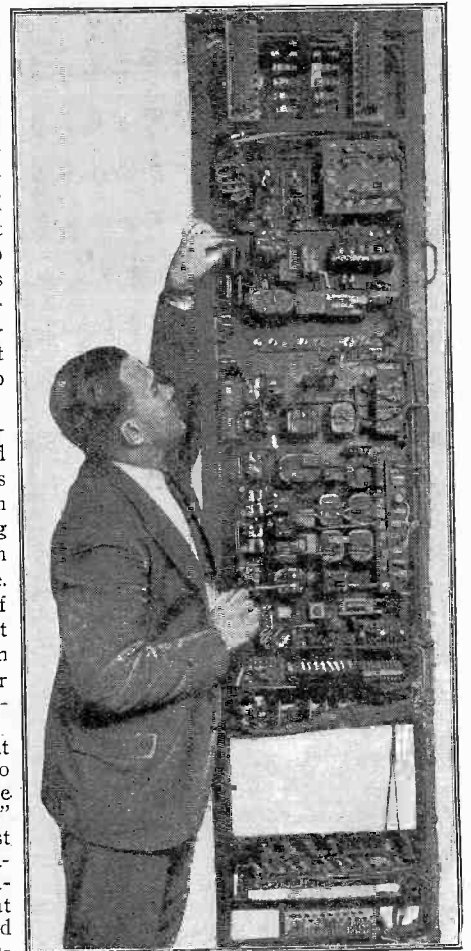

A rear view of the control panel with its various metallic shields removed is shown directly above. This is the same panel that Mr. Maresca is shown in front of in the photograph on the extreme left-hand side of this page.

# Radio Hazards

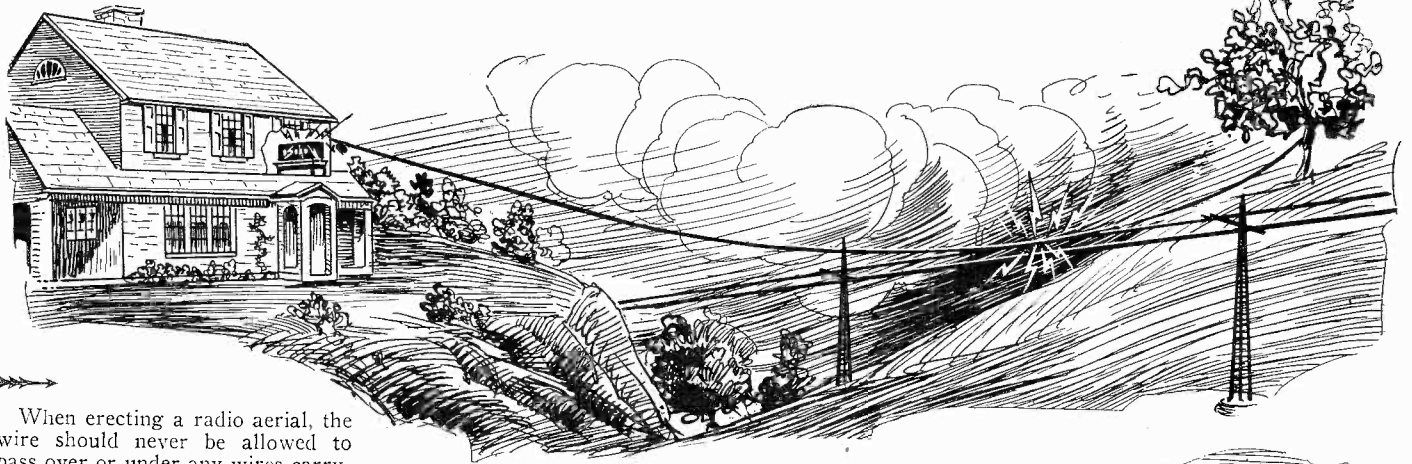

When erecting a radio aerial, the wire should never be allowed to pass over or under any wires carrying current. This holds true regardless of whether the wires are of high potential or are ordinary service wires or telephone lines. Breakage of the aerial or even a stretching of the wire might cause a contact between the aerial and the live wire, whereupon there is a possibility of damage being done to the set as well as the line.

In the installation of a radio set there are many things that the builder should watch if he will avoid trouble of all kinds. We have outlined the most important precautions that must be taken on this page. Directly below we show the user of a portable set attempting to raise his aerial by means of a kite. The wire attached to the kite is very close to a high tension line. There is a possibility that this wire may touch this line with consequent disastrous results to the holder of the other end. When you must use a kite for this purpose, keep away from all nearby wires.

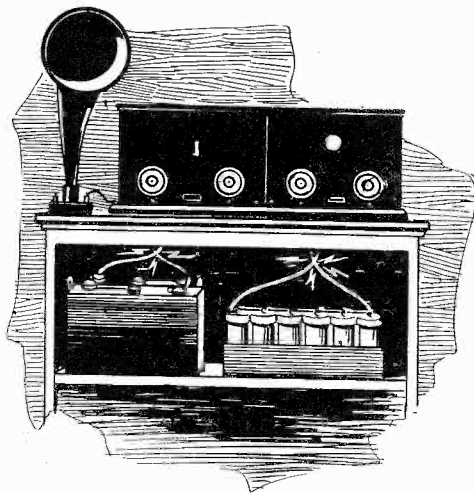
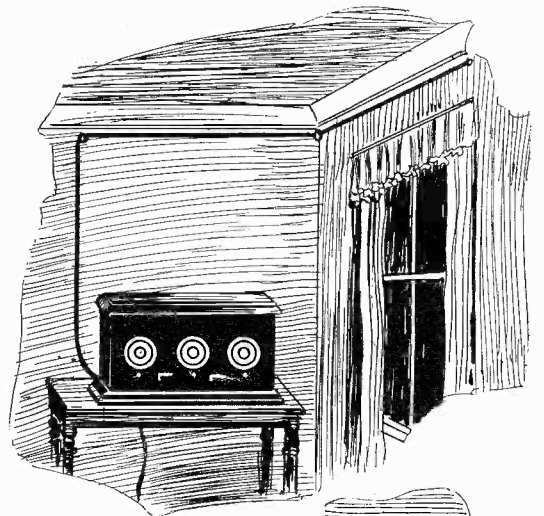

In connecting up both your "A" and "B" batteries to the set, do not fail to use wire covered with heavy insulation, preferably rubber. A short circuit here can do considerable damage not only to the batteries, but there is a possibility that a fire may be started through the heating to incandescence of the wires composing the short-circuit.

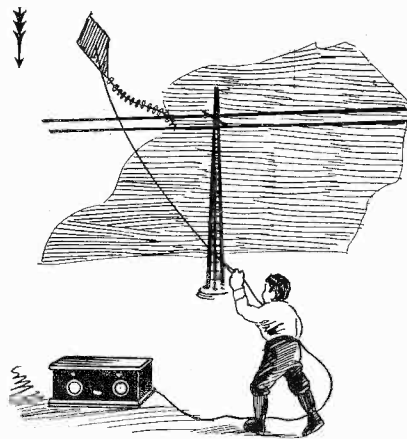

An indoor aerial is good, but keep it away from surrounding chandeliers and electric light wires. Do not tap on to your neighbor's aerial. It is bad business and never satisfactory.

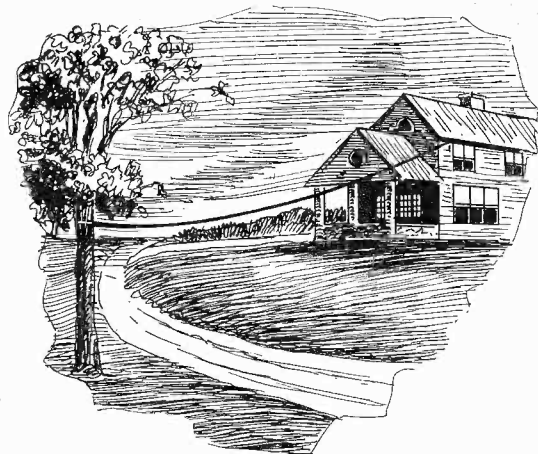

Do not run a radio aerial across a public highway, particularly if that aerial is low. Stretching of the wire due to temperate change or other causes may make the wire so low that it will interfere with the progress of vehicles. Furthermore, if the wire breaks, it may cause trouble with passers-by.

Do not attach your antenna to any electric light line, telephone or telegraph pole, unless you can obtain specific permission from the company owning the poles. To do this unauthorized is to invite trouble in the future.

Do not forget to properly protect your aerial with an approved lightning arrester.

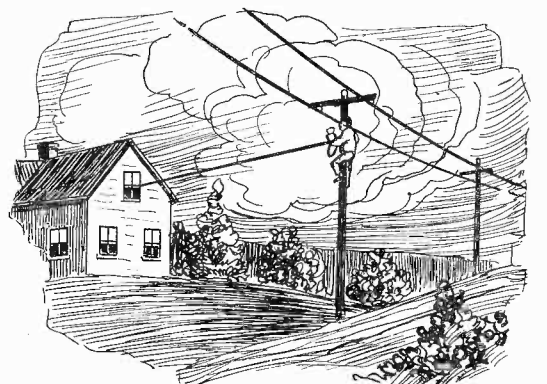

# Removing Insulation from Wire

By HERBERT E. HAYDEN

HERE is one thing that often receives all too little attention from the amateur radio set builder. The writer has seen different people working on radio sets who will take a pair of scissors, a pocket-knife, or even a table knife to remove an inch or so of the insulation from a wire. This is all wrong, for no one of these ways should be followed if you would avoid trouble. If, for instance, you are to try to strip the insulation from a wire using a pocket-knife as shown in the accompanying photograph, there are two things that may happen. First, if the wire is comparatively

nick in it that will weaken it mechanically so that at some future time it may break just when it is most needed. Any sharp edge of this nature must always be avoided when you want to strip a wire.

edge. This space is found to be particularly well adapted to stripping insulation in a pair of pliers of the type illustrated. Open the pliers slightly and place the wire between the two flat surfaces found at the point mentioned. Then squeeze and it will be found that the insulation will be cut on both sides but that the wire will be undamaged. Remove the wire from this position and strip the insulation from it with the other part of the pliers as shown in the photograph. Perfect results will be obtained.

In passing, we might also mention the fact that there are certain types of what are

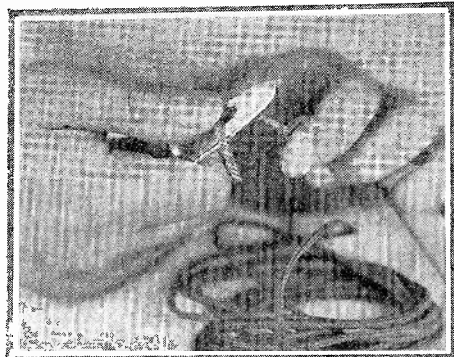

Do not use a knife for stripping the insulation from wire unless a notch is ground in the blade as described in the text.

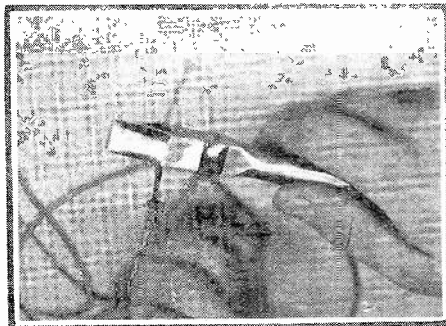

After the insulation is broken, it can be quickly removed from the wire with a pair of pliers held as shown above.

One good kink in connection with this work is to grind or file a small semi-circle in the edge of the knife near the handle. This will not affect its cutting properties, but by placing a wire in the notch, the insulation can be cut and stripped without any fear of harming the wire. Even with this method, however, there is a chance that if the tool is incorrectly manipulated, the wire may be nicked slightly with the possible result mentioned above.

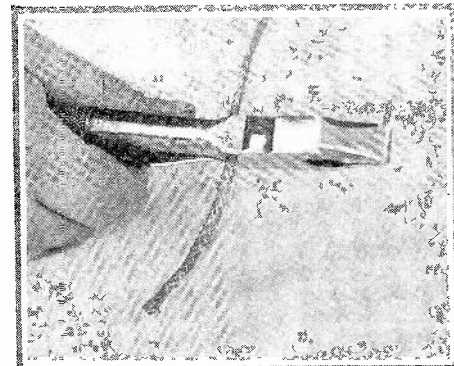

The insulation can be broken preparatory to removal from the wire with that part of the pliers illustrated in use above.

small, you may cut all the way through it and then, if your wire has formerly been measured to fit a certain connection, it will be too short and a new piece must be taken. On the other hand, even if you do not cut the wire completely through, you may put a

The best method that the writer has found for the operations under discussion is to use that little portion of the pliers directly back of the joint or in other words, on the opposite side of the joint from the cutting

known as long-nose pliers that will perform the same operation as that described above if the wire is placed between the jaws close to the joint. Press and then release slightly and you can strip the insulation off the wire with the jaws.

## New Radio Loud Speaker

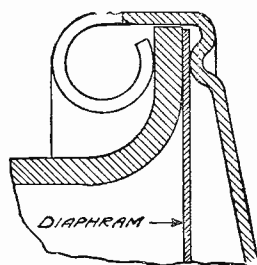
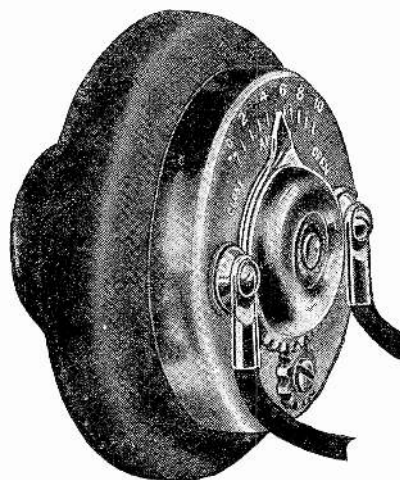

Loud speakers with adjustable diaphragms are most valuable because of their adaptability to various and changeable conditions. Illustrations at left and above show one type to be attached to a phonograph.

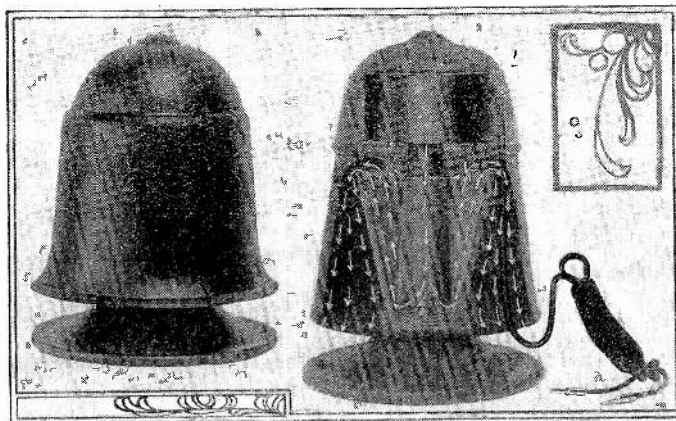

THE weakest point of many radio sets is the reproducer, particularly when any great volume is desired. In order to compensate for variations in the amount of power delivered to the speaker, it is quite desirable to have the air gap between the diaphragm and the pole-pieces adjustable. Often loud speakers and even headphones have appeared on the market having adjustable features, but practically all of them have drawbacks. The photographs directly above show the best of them. Directly back of the unit is a large pointer and a self-locking adjustment. A scale shows the proportional distance between the poles and the diaphragm. This unit can be used either on a phonograph tone-arm or on a horn. The type shown above is equipped with a soft rubber phonograph adapter. This unit gave excellent tone quality and volume on test by the editors. As many of the latest cabinets contain built-in horns, this type of speaker unit is very much in demand.

WE have become so used to loud speakers employing conventional horns or cones that something on a different style is always interesting. Therefore, we illustrate the complete loud speaker shown above which is but 8½ inches high by 6 inches wide at its widest point, but which will give sufficient volume for all purposes and at the same time will reproduce with great fidelity. As shown in the cross-sectional diagram, the actual reproducing unit is located in the top of the bell. From it the sound is projected downward, reflected up, and then down again and out into the atmosphere. In this way, a comparatively long passage-way for the sound is provided in a small space. The unit is so characteristic in construction and so compact that we are sure all of our readers will be interested in it. This novel speaker responded very well to weak signals yet does not rattle when it is required to reproduce with great volume, as tests by editors proved.



# A Novel Six-In

By L.

**T**HIS receiving set is really six sets in one. It can be operated with one, two, three, four or five tubes, and as a long or short wave receiver on any or all of the tubes. The limitation of wave-length range, common to most receivers built on the principle of the Neutrodyne, is overcome to a great extent in this instrument by a tapping arrangement, which allows equal volume on all wave-lengths.

I attribute the success of this set to the coils which I have used. They are made in the following manner:

Drill fifteen radial holes in the edge of the flange of a wooden magnet wire spool (around the circumference of the flange, toward the center) with a No. 29 drill, at such distance apart that the space between them is equal. Some spools differ slightly in diameter, but the holes will usually be about  $\frac{3}{8}$  inch apart. Be sure to drill the holes in a true circle around the spool. Insert fourteen eight-penny nails in the holes and a wooden dowel, or preferably a piece of celluloid knitting needle, in the fifteenth hole. Do not drive nails or dowel into the spool, because they must be taken out again after the coil is wound. The coils are wound with No. 24 double silk-covered wire through-

To wind the coils, first wrap two turns of ordinary wrapping cord next to the spool, winding over one nail and under one. This is to prevent the coil from sticking after being completed. Coils L3, L5 and L7 start at the dowel. Wrap the wire around it once and twist to hold it in place. Then wind on 35 turns, winding over two nails and under two, and again twist around the dowel. This coil is wound to the right with preferably green covered wire. Then let the spool of wire you are using lay in your lap or on the bench without cutting the wire, until the primary coil is wound.

Before winding the primary, wind on four turns of ordinary wrapping cord, over one and under one. Red or blue will make good looking coils when finished. Wind the primary coils, L2, L4 and L6, with No. 24 D.S.C. wire (white) winding over two and under two, as with the secondary, but to the left instead of the right. Wind on fifteen turns, then twist around the dowel and cut off, leaving about six inches of wire for leads. Four turns of red cord are then wound on as before.

Then take the spool of wire you started with, and bridging the primary coil with a small loop, wind on 10 turns to the right, and make a loop for a tap, then wind on 15 turns, twist around the dowel and cut off.

This will give you 60 turns on the secondary.

Cement the coils along the nails only. Do not cement at the dowel, or between the nails. Then withdraw the dowel until it just clears the spool at the inside of the coil. Then take out all the nails and slip the coil off the spool. Then push the dowel through the coil until it extends about  $\frac{1}{8}$  inch beyond the inside winding, and cement all leads to it. Use collodion for cementing.

You will then have a low loss coil with the primary in the center of the secondary, the two coils being wound in opposite directions, and separated from each other by the wrapping cord. The dowel is the mounting.

When connecting the coils in the set, the

soldered together, in both stator and rotor.

The dials will very seldom read the same, after the instrument is assembled. To remedy this, tune in a station around 500 meters, then remove wire from inside of secondary coils, one turn at a time, on those coils connected to condensers which read lowest, until the readings are the same. After condensers are balanced, tap each coil 30 turns from the inside end of winding. This connection is for the short wave side of the switch, as shown in diagram.

The "A" battery is connected to the switch. It will be seen in the diagram that these condensers are switched to shunt either the long or short wave connection. Do not connect rotors to the grids.

The 1 M. F. condenser bypasses both "A" and "B" batteries, and adds volume and clarity to the results.

Any standard tube will work in this set, but UV201-A tubes are recommended. Note well that each tube has its own rheostat. After you have used this set for a while, you will find great advantage in having the rheostats at hand for tuning.

When less than five tubes are in use, the filaments are turned off in those not used. The rheostats all have 30 ohms resistance.

This receiver has several advantages. There is no necessity for using five tubes to bring in a station which is located only a few miles away. The plug, with the antenna and ground connected to it, is inserted in the detector aerial jack, and the station is received on three tubes with the loud speaker and one or two tubes with the phones as desired. Stations between 325 meters and 600 meters are received with the switch thrown to long, and between 200 and 325 with the switch thrown to short.

There is no difficulty tuning through local broadcasting with this receiver.

(Editors Note: This receiver is particularly adapted to receiving WRNY, as it tunes very low. It is especially recommended to our readers as many stations are now operating below 250 meters, the usual low tuning point of the average set.)

We are all particularly interested in short-wave reception at the present time because there are more than 100 stations operating on the lower wave-lengths just above 200 meters that a good many sets, particularly of the home-made variety, cannot bring in. If our readers have other uniquely designed sets that they have made themselves which will really separate stations between the wave-lengths of 200 and 275 meters, we would be glad to receive articles detailing the construction of them for consideration for publication in this magazine.)

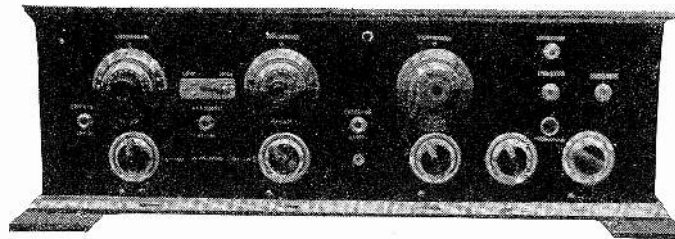

A front view of this rather simple yet very efficient and flexible five-tube receiver is shown in the photograph directly above. Note the wave-length change switch that is located between the first and second dials. A plug and jack arrangement makes it possible to use from one to five tubes on any desired wave-length between 200 and 600 meters.

inside winding is the long wave-length connection, and a tap is taken 30 turns from the inside winding, after the condensers are balanced (as described later) for the short wave-length connection. The tap near the outside of the coil is connected to the neutralizing condenser, leaving the outside connection for the grid. The primary lead nearest the inside of the coil is connected to the "B" battery, except on the first coil, which connects to the ground.

These coils are mounted, by means of the dowel, on a piece of hard rubber 14 inches long and 2 inches wide. Bore three holes 6 inches apart, the size of the dowel, and shellac the dowels into them, placing the coils at an angle of about 30 degrees from the line of rubber base (see photos). Put rubber supports one inch high under the rubber base, and screw to the base of set. It is advisable to drill six holes near each coil for No. 6 screws, for connections from coils to other parts of the instrument.

The condensers, 8, 9 and 10, are 19-plate condensers, with verniers, preferably of the same make. It is better to get 23-plate condensers and rebuild them to 19 plates, with 10 plates on the rotor and 9 plates in the stator, so that the end plates will be rotary. Selectivity and volume are added to the set by assembling them in this manner. After assembly, the plates and washers should be

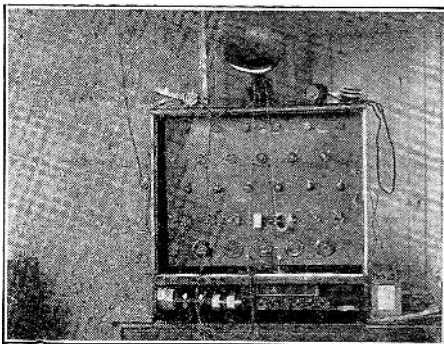

Note honeycomb coils used in this set.

## Foreign Receiver

**R**ECEIVING sets that originate in foreign lands are so different in design from those that we have in this country that they are always interesting to us. The photographs at the left and right show front and back views of a highly efficient, but not very compact receiving set, which is in use by one of our correspondents in India and with which he is able to receive English broadcasting stations and has received KDKA, located in Pittsburgh, Pa., U. S. Three stages of radio frequency amplification and two stages of audio frequency amplification are employed.

—D. R. D. Wadia.

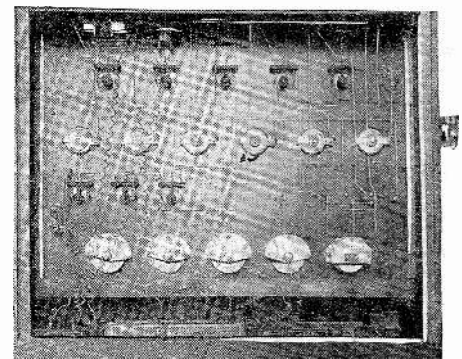

# -One Receiver

RINGER

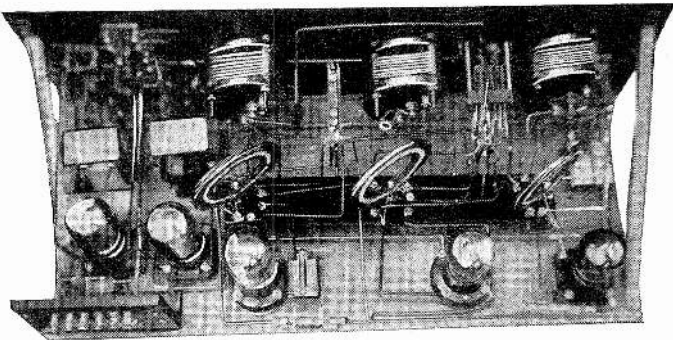

Reference to the photograph above will give the reader an excellent idea of the complete layout of this rather unique receiving set. Note the method of mounting the special coils used. Connections are brought out to a terminal block at the rear of the baseboard.

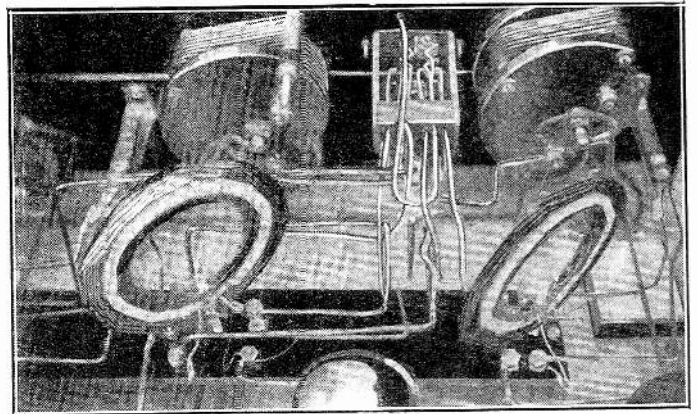

The close-up photograph above shows the details of the anti-capacity switch that is used for changing from the low to the high wave-length band. All of the connections for this switch are shown in the diagram directly below. You will probably have to get a four-pole double-throw switch of the type shown and use only three of the movable poles and six of the stationary contacts. You can easily determine this for yourself when you go to buy the instrument. Note the angles at which the coils are mounted. This helps in keeping the set quiet in operation.

The illustration at the immediate right shows in detail the construction of the specially wound tuned radio frequency transformers that are employed in this multi-wave receiver. Note that the tap which goes to the change-over switch is not made until the receiver has been balanced so that the dial readings are all the same for a given wave-length. The directions for the locating of this tap are given in the text on opposite page. A second tap is made for the neutralizing condenser connection. Make this when winding the second half of the secondary coil.

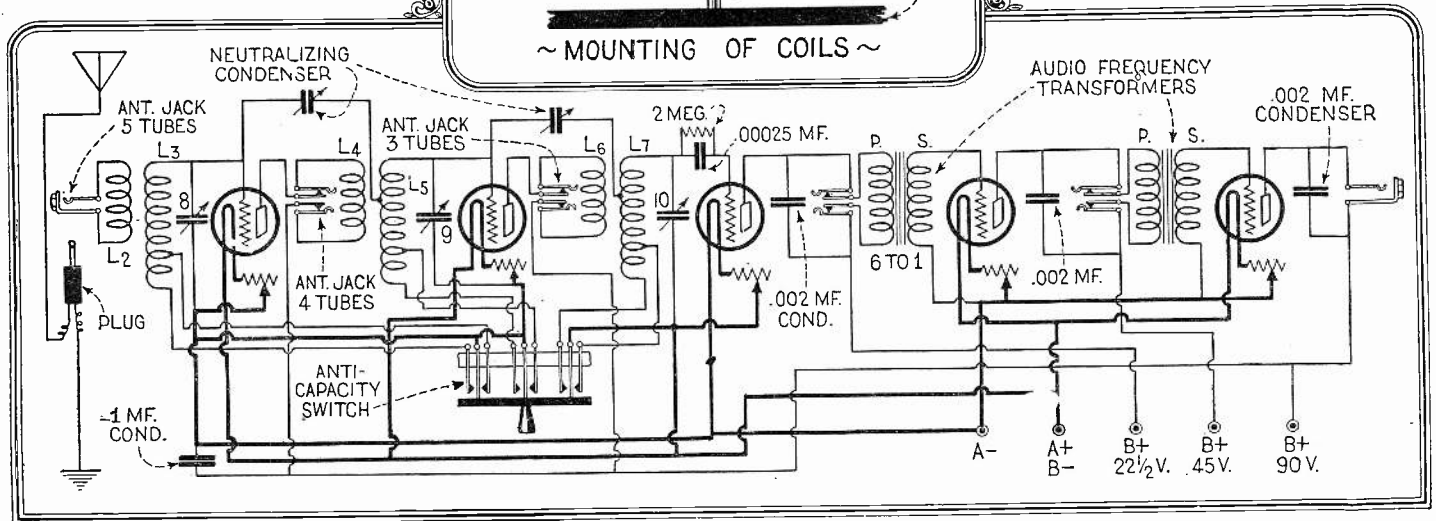
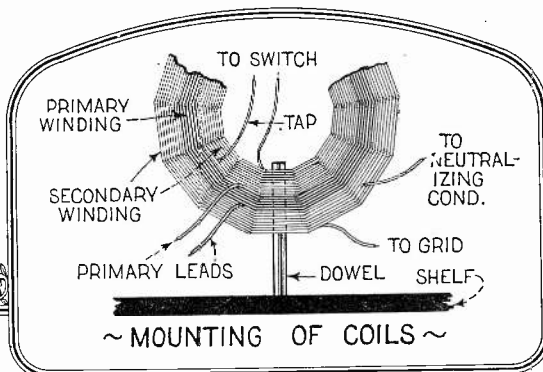

The complete circuit diagram shown above illustrates all of the connections for this six-in-one receiver; the antenna and ground are connected to a plug

which is placed in any one of the three first jacks according to the number of tubes that it is desired to use. Turn off tubes not in use.

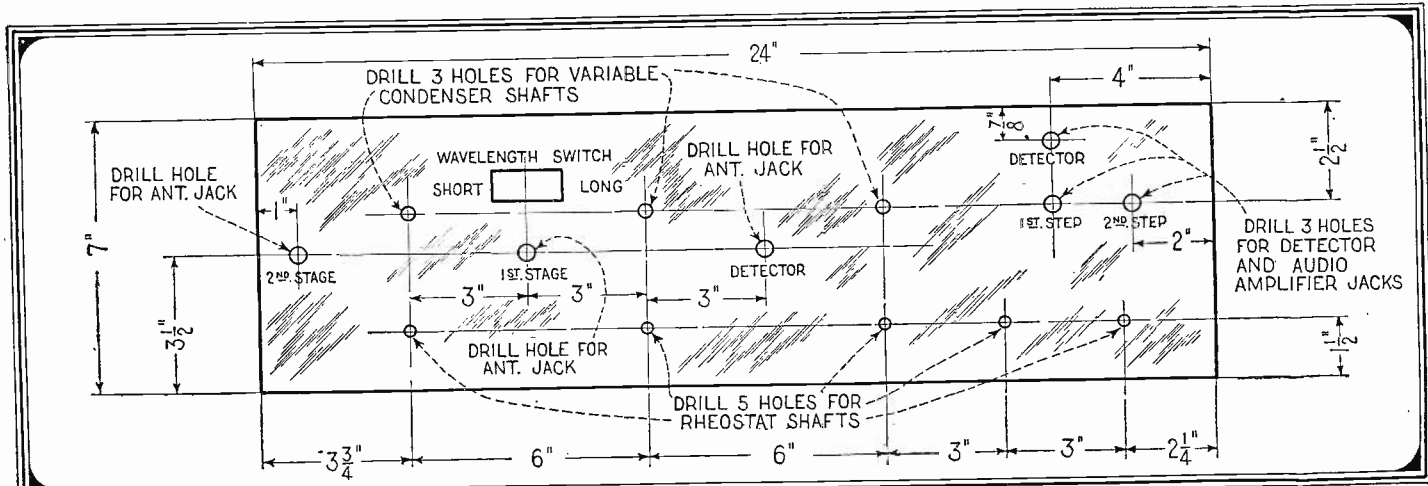

From the panel layout given above, you can readily make up your own panel and lay it out in the best possible manner. The panel that the author used

was 24 inches long by 7 inches wide. Any suitable insulating material may be used but fibre or substances that absorb moisture should be avoided.

# An Efficient Two-Tube Reflex Circuit

Two Tubes Give as Good Results as Three

By C. HOWARD SCHOPOFER

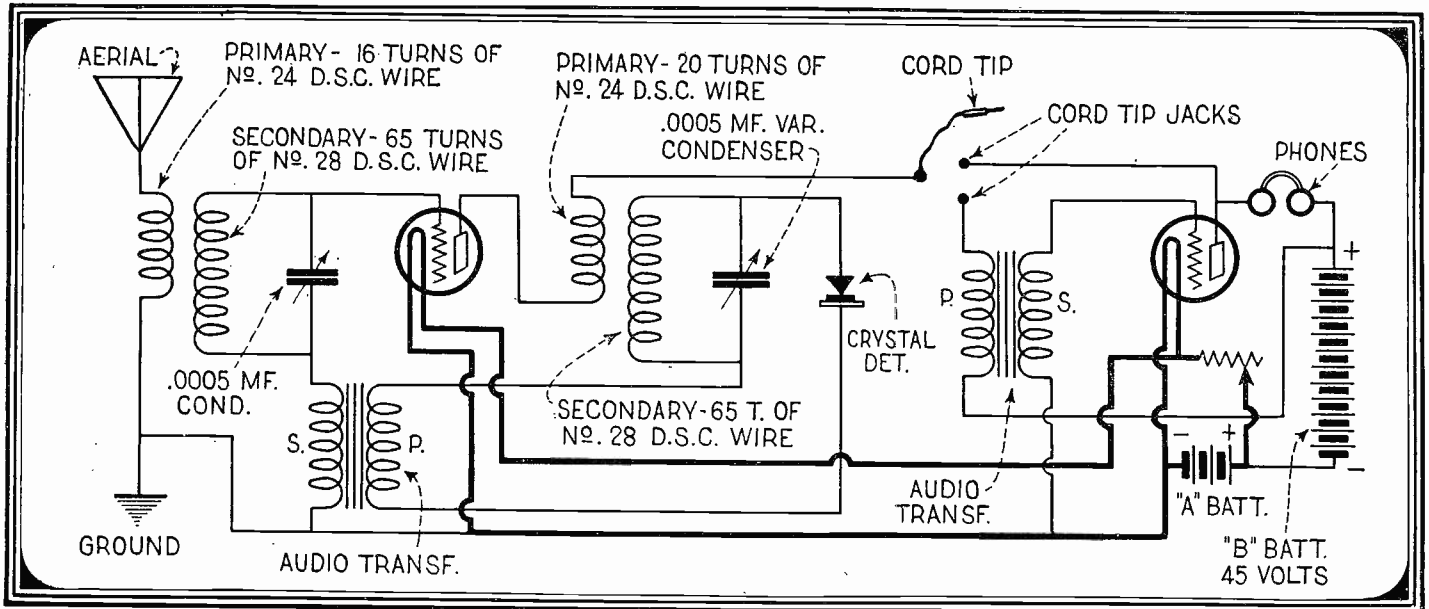

The circuit diagram of this highly efficient reflex circuit which, without any fixed by-pass condensers, gives excellent results, is shown directly above.

The two radio frequency amplifying transformers are wound on spider-web forms, that can easily be made by anyone. Note the plug and jack system.

UNDOUBTEDLY the reflex circuit has found its own place in the annals of radio and is with us to stay. It offers a most interesting field for experimental work and frequently unusual results are obtained from even an ordinary array of apparatus. Particularly are reflex circuits adaptable to use in portable receivers. Many experimenters have turned toward these efficient circuits for sets that they can take with them on trips, but which can be used in the home also under practically all conditions. The set that the writer has designed has given some very good results. The entire unit is even more interesting when it is learned that it can be assembled on a panel only eight inches long by six inches wide. A really workable two-tube set in such a small space is a novelty. The one big space-saver that the writer came across and that makes this set possible is the use of a special variable condenser that takes up no more room than an ordinary

dial. It does not project back of the panel at all. These condensers can be plainly seen in the photograph below and to the right.

When using this receiver as a portable set, two ordinary "C" batteries in parallel furnish the "A" supply for two UV199 tubes. In this way much weight and space are saved. Despite their small size, these batteries will give quite long life because of the small current resumption of the tubes.

The constructional details are, in essence, as follows:

Two standard type sockets are mounted on round-head machine screws three inches long. These support the sockets away from the panel as shown in the photograph. Small audio frequency transformers of the type shown help further to economize space. A semi-fixed crystal detector is mounted in the center of the panel. Select a good one so that you will not have trouble on this score. Variable condensers of the type illustrated

are recommended if the set is to be made very compact. The radio frequency transformers are wound on spider-web forms three inches in diameter and the details for the number of turns are given on the circuit diagram above. Two forms are used for each transformer, separated about 1/4". Note that the units are mounted at right angles to each other. They should also be placed as far apart as the size of the panel will permit. Oscillation should take place when the crystal circuit is open. If it does not do this, try reversing the leads to the primary coil of the second radio frequency transformer. Connections to the crystal should also be reversed to determine the best operating connections.

Forty-five volts of "B" battery will usually be found sufficient for operating UV199's. Local stations can usually be received with loud speaker volume. Be sure to connect the "A" battery terminals as shown in the diagram.

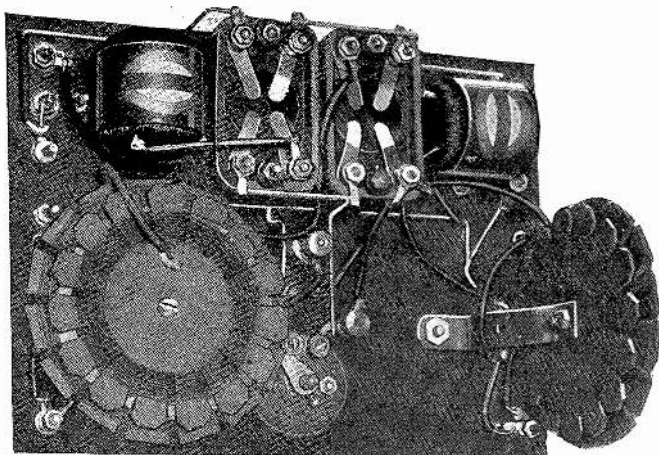

Note the very compact arrangement of the instruments used in this two-tube portable receiver. The writer has had wonderful success with this set and you can duplicate it by following instructions.

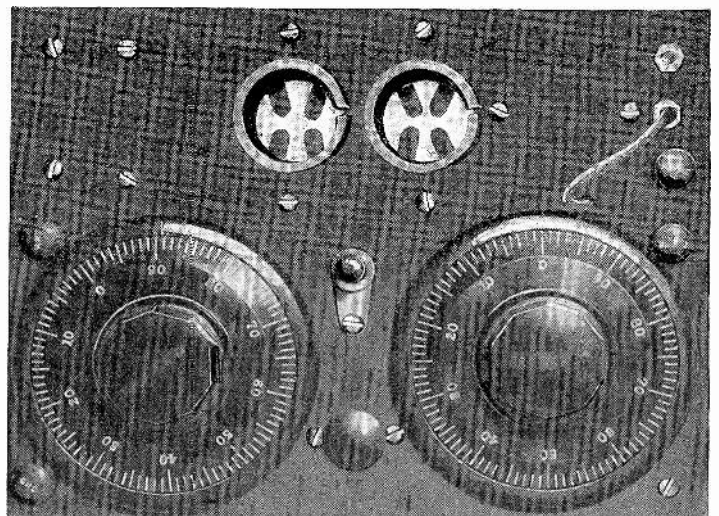

The front panel view of this set shows the plug and jack arrangement enabling the last tube to be cut out when not desired. Note the socket mounting and the position of the crystal detector.



# Hints for Radio Builders

## Part III

By LEON L. ADELMAN, Assoc. I.R.E.

**M**ANY crystal set owners will welcome the decided improvement which is shown by Fig. 1. Here we have an arrangement which allows full wave rectification with resultant increased tonal beauty and volume. Two similar crystal detectors are used, connected in such a way that their output is additive and that one of the headphones receives one

originated by Mr. Hugo Gernsback, editor of this publication. It is called by him the Interflex Circuit. As can be seen, it comprises a crystal in the grid circuit of the detector tube which allows dispensing with the grid condenser and grid leak. A potentiometer is also included in the circuit and the correct manner of wiring it so as to afford grid bias control is shown. Except-

by simply throwing the switch. Deaf persons will find the device to be very helpful. Those who have several straight-line capacity condensers and who, after having read so much lately about straight-line frequency and straight-line wave-length condensers may wish to change, will save money by converting the condensers they have on hand. The straight-line frequency

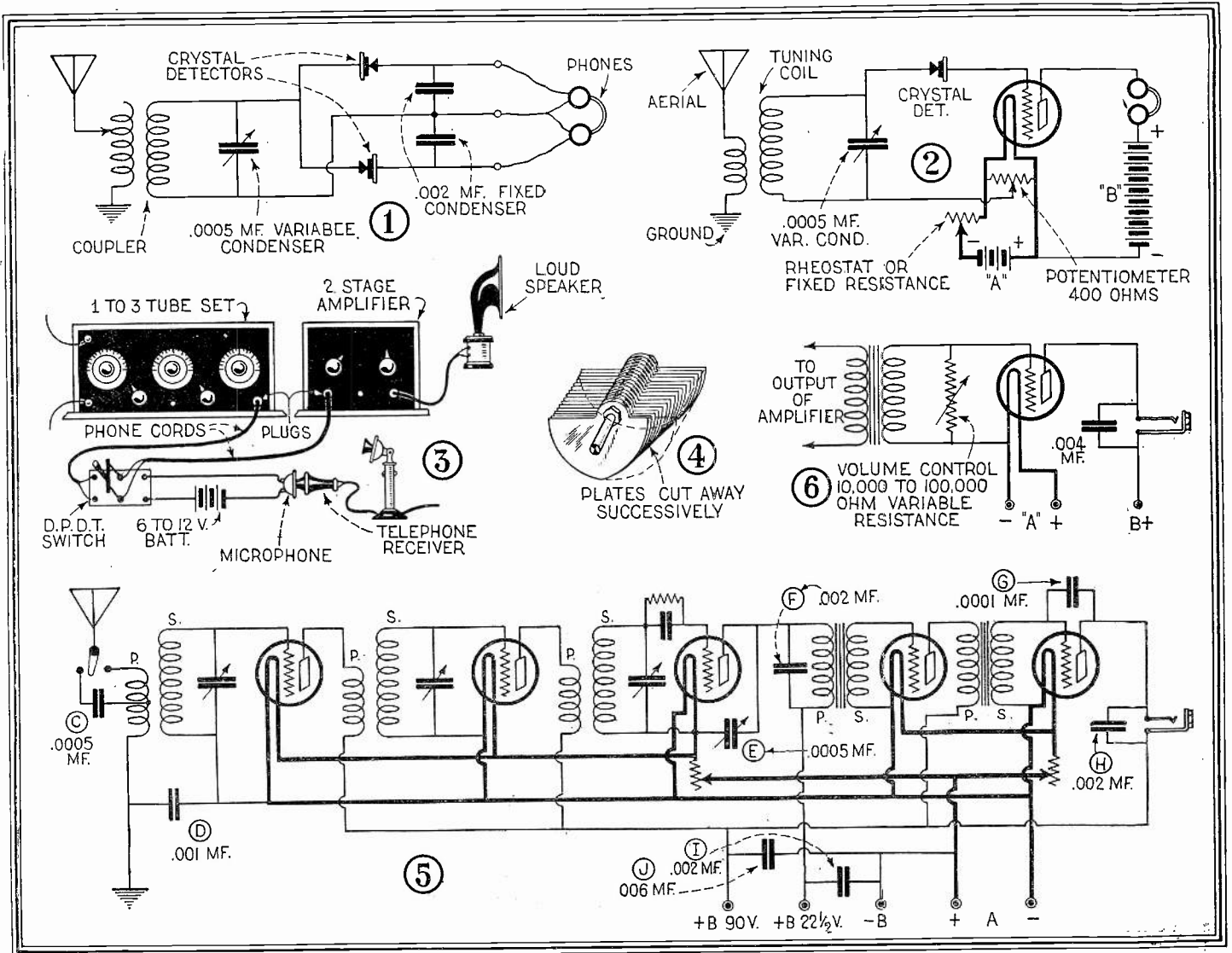

Several valuable hints of interest to the radio experimenter and constructor are illustrated above and described in detail in the accompanying text. A

most interesting circuit and one that we would like to have reports upon is shown in Fig. 1. Try different crystals until the best results are had.

half of the incoming waves, while the other one gets the remaining half. The circuit shows the midpoint or series connection between the phones utilized, and each of the receivers shunted by a .002 fixed condenser. Sometimes, if the signals in one of the receivers are louder than in the other, it is apparent that a bad contact exists in one of the detectors and the condition should be remedied at once. One cannot escape remarking the wonderful quality of the music or speech which such a circuit affords. Experiments with the arrangement show that even static is somewhat suppressed, and when used in conjunction with a resistance-coupled amplifier, perfect reproduction is obtained.

In Fig. 2 is shown a new development as

tional clarity is vouched for the set and the experimenter is advised to try it.

Sometimes, it is desirable to allow several persons to listen-in to a telephone conversation, simultaneously. The amplifier unit of the radio receiver will be found to be quite handy for this use. All that is necessary is to have a double-pole double-throw switch and a separate battery of 6 to 12 volts for the modulating current. The telephone receiver is placed in front of a microphone and the switch thrown over to the correct position. With the relatively high potential of 135 volts on the plates of the amplifier tubes, it is possible to reproduce the telephone conversation with great volume. At an instant's notice, the amplifier unit can be connected to the radio set

condenser is THE thing with which to tune in the various low wave stations. Its use greatly facilitates tuning and will aid in bringing in many stations never heard before. By a simple process of cutting down the plates successively, such as is illustrated in Fig. 4, the desired results can nearly be achieved.

When one compares the functioning of condensers of this type in a short wave set, with that of the other types, he will want to equip all his receivers (if he has several) with them.

The fixed condenser has been used with more or less success by set-builders. Generally, they are used as by-pass condensers, but there are several other uses which great-

(Continued on page 680)

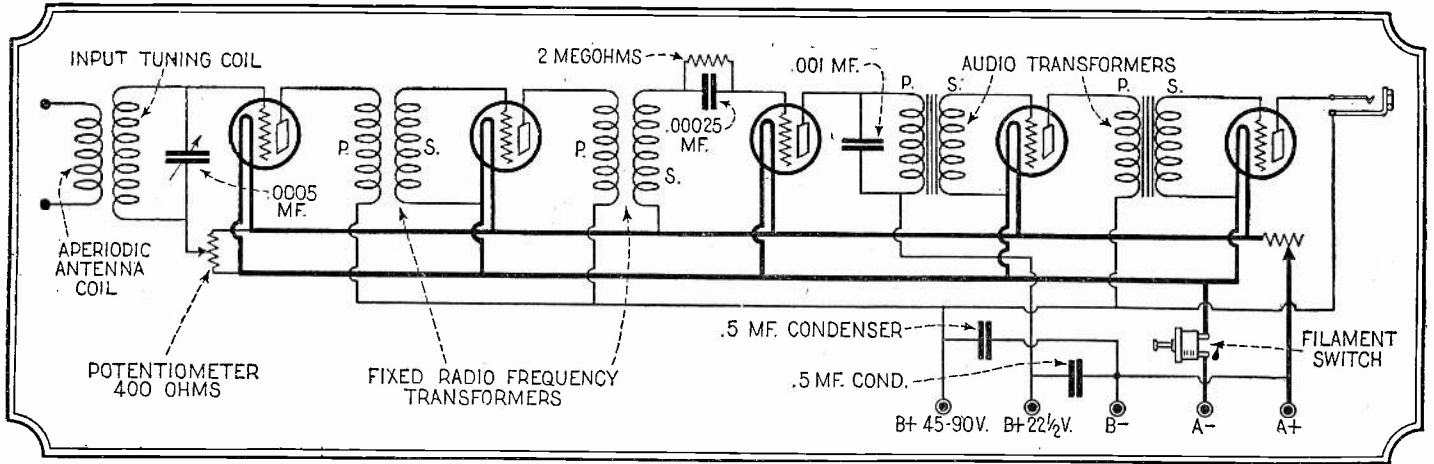

The circuit diagram of this extremely simple five-tube set is shown directly above. Only the input to the radio frequency amplifier is tuned as the two

other R.F. transformers are of the fixed type. By-pass condensers across the "B" battery aid in stabilizing the set. The one dial set is here at last.

## Five Tubes With Simple Tuning Control

By A. P. PECK, Assoc. I. R. E.

SINCE radio broadcasting has been developed to a point where it is entirely practical and since hundreds of thousands of uninitiated persons have started to take an interest in the science of radio reception, manufacturers have turned their attentions toward the production of broadcast reception sets that can be used by almost anyone, even though they do not have any technical knowledge of radio. We have presented sets of this nature from time to time and here illustrate another one for the benefit of our readers. This particular set does not make use of multi-unit variable condensers or of complicated systems of gearing in order to operate more than one instrument with a single control, because in this particular case there is only one variable tuning unit in the whole set and that is the variable condenser in parallel with the input tuning coil. The other two small dials on the front of the slanting panel control a potentiometer and a rheostat.

Although this set contains five tubes, the cabinet that encases the entire unit is quite small in size. The outfit is attractively made and the panel is placed in a slanting position

as can be seen from the two photographs. This not only improves the appearance but at the same time it makes tuning somewhat easier. The photograph in the center of the page shows the large tuning dial equipped

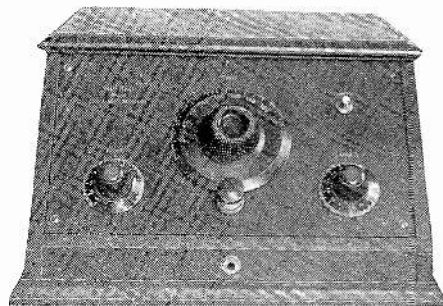

Above: A front panel view of this new single tuning control broadcast receiver.

with a vernier. This latter device aids considerably in tuning, inasmuch as the transformers used in the set are well designed and the consequence is quite sharp tuning.

Stabilization in this set is not accomplished by any of the usual neutralizing methods, but, instead, a 400-ohm potentiometer is shunted across the "A" battery and is used to control the first radio frequency amplifying tube. Even though it is often said that potentiometers introduce losses in receiving sets, still it is true that the same is found when any other method of preventing oscillation is employed. Since the potentiometer system is always under the control of the operator, it is often a favorite with many who are familiar with all types of receiving sets.

As can be seen in the photograph at the lower center of this page, the interior layout of this receiving set is simple in the extreme. The circular instruments located between the three tubes on the center sub-panel are the fixed radio frequency amplifying transformers. If the reader wishes to make a set of this nature for himself, he can employ any transformers in this part of the circuit that will cover the broadcast band. The input tuning coil may be a standard tuned radio frequency transformer.

FOR the radio constructor who desires to attempt to duplicate the results obtainable with this receiver on one that he makes himself, we give the following data. The aperiodic antenna coil shown in the schematic diagram at the top of this page should be wound on a tube of insulating material 2½ inches in diameter. This coil comprises 6 to 10 turns of No. 20 D.C.C. wire, wound at the end of the tube. On the same form and ¼ of an inch from the antenna coil, the input tuning coil is wound. This should have 60 turns of the same sized wire as is used in the antenna coil. Do not paint the surface of the winding with any material as this tends to cause losses in the circuit that are not desirable. If you use a rigid tube and wind the wire tightly, it should not slip out of place. If, however, the latter is found to be the case, paint 4 strips of collodion lengthwise of the coil and spaced at equal distances around it.

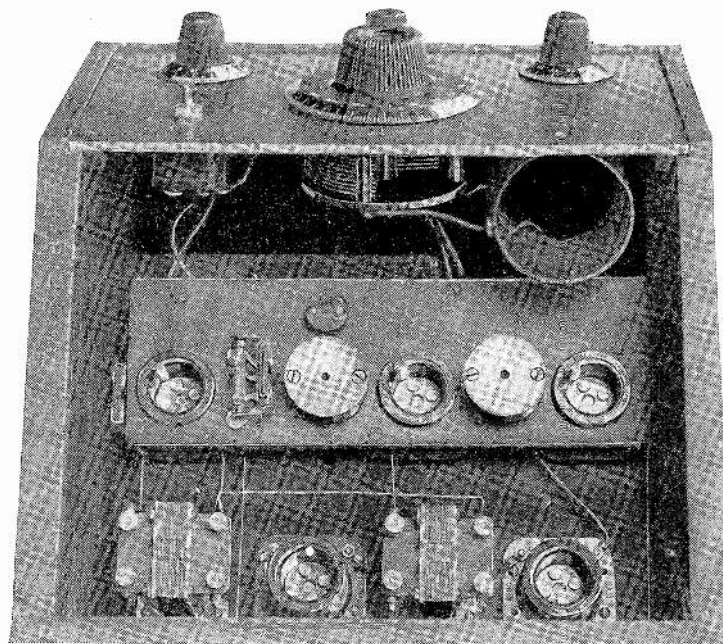

THE audio frequency amplifier used with this set is extremely simple and is laid out on the baseboard directly in back of the panel that supports the radio frequency transformers and the first three sockets. Any constructor can easily duplicate this layout if he desires.

With a set of this nature, practically any types of tubes can be used and even in the radio frequency amplifier not much difference will be noticed with different tubes. This is just the opposite with the case of a neutralized R.F. receiver for in the latter it is necessary to rebalance the radio frequency end of the receiver when new tubes are used. Here, however, because of the potentiometer balancing system, any change necessary is quickly effected. In the photograph at the left, adapters are placed in all the sockets so that UV-199 dry cell tubes can be employed. As mentioned above, however, others can be used with excellent success.

# RADIO ORACLE

In this Department we publish questions and answers which we feel are of interest to the novice and amateur. Letters addressed to this Department cannot be answered free. A charge of 50c. is made for all questions where a personal answer is desired.

## ANTENNA ADAPTER

(399) Q. 1. Samuel Vasquez, Mexico, asks whether he can make up an adapter so that he can use his Super-Heterodyne receiver, which is designed for use with a loop only, with an outside aerial.

A. 1. An antenna adapter may be made with a standard three-circuit coupler but the rotor need not be used. The primary connects to aerial and ground in the usual

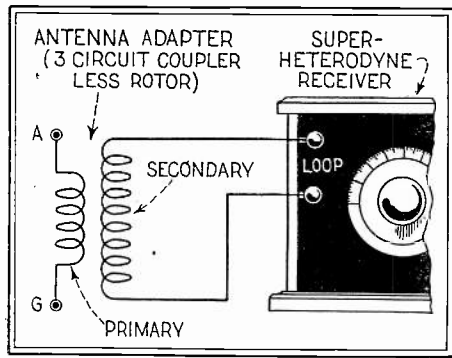

Q. 399. An antenna adapter for use with super-heterodynes is simple to hook up as shown in the above illustration.

manner. The secondary connects to the set in place of the loop. The loop variable condenser will then tune the secondary of the variocoupler instead of the loop.

## INPUT TRANSFORMER

(400) Q. 1. L. M. Whaley, Augusta, Ga., wants some information for the assembling of an input transformer of the tuned type which will match intermediate frequency transformers that he has on hand. This is for use in a Super-Heterodyne.

A. 1. We would suggest that you use two honeycomb coils. They may be of 600 turns and 1,000 turns for the primary and secondary, respectively. The primary is shunted by a variable condenser of .0005 mf. capacity. The secondary is shunted by a very small condenser of less than .00025 mf. capacity. We would suggest a capacity of .00015 mf. This condenser may be fixed.

## FIXED CONDENSER

(401) Q. 1. George A. White, Pawtucket, R. I., says that he cannot obtain .04 mf. by-pass condensers and asks if a smaller type can be used in place of them.

A. 1. Two .02 mf. condensers or four .01 mf. condensers, connected in parallel will be satisfactory.

## NEUTRODYNE VS. TUNED R. F.

(402) Q. 1. Leonard Appel, Washington, D. C., asks us to compare the Neutrodyne type of receiver with the ordinary type of tuned radio frequency set that is not neutralized.

A. 1. There are good and bad points to be spoken of in connection with these two types of multi-tube sets. The average Neutrodyne when properly neutralized is very quiet in operation, whereas the average tuned R.F. type of unneutralized receiver is

noisy and gives vent to the usual squeals and howls that all operators of regenerative sets are familiar with. On the other hand, however, a properly built tuned radio frequency receiver will give much greater volume and usually is better for "DX" reception than a Neutrodyne. The choice between a Neutrodyne and an unneutralized receiver lies in your own desires. If you want a quiet set and do not care for extreme "DX" reception, a Neutrodyne will give excellent results. On the other hand, a tuned radio frequency receiver with the same number of tubes is somewhat cheaper to buy than a Neutrodyne and will as mentioned above give louder signals and more "DX" reception.

## GRID LEAK ADJUSTMENT

(403) Q. 1. Wm. H. Bleschke, Chicago, Ill., says that a continuous whistle is produced in his receiving set which cannot be eliminated unless he reduces his grid leak to about 1/2 megohm. He asks how this trouble can be eliminated.

A. 1. We do not see any reason why you should desire to get at the trouble with your receiving set, since you have already found it to lie in the grid leak. You say that the whistle will be eliminated by reducing the leak to 1/2 megohm. We would say that you should leave the leak set at this point, as it is undoubtedly the correct operating point for the particular tube you are using.

## STORAGE "A" BATTERIES

(404) Q. 1. Orlan Brown, Niagara Falls, N. Y., refers to an article describing the construction of a storage "A" battery published some time ago in the pages of this magazine. He asks whether or not the holes punched in the plate go all the way through.

A. 1. The holes punched in the plates of the "A" battery you mention are to go all the way through the metal. A 10-penny nail may be used for this purpose. We would suggest that you follow the directions given in the article you mention and use plates of the size advised therein. A completed battery of the size described will have an ampere-hour capacity of approximately 12.

Q. 2. In the storage battery charger, described in the same issue of the magazine as the "A" battery, what use is the 100-watt lamp put to?

A. 2. In this simple battery charger, a 100-watt lamp is used to reduce the amount of current passing through the rectifier. If you place a 40-watt lamp in the circuit in place of the 100-watt lamp, the charging rate would be lowered to about two-fifths of an ampere.

## REFLEX DETECTOR

(405) Q. 1. Herman Heibner, Pipestone, Minn., asks why a crystal detector is usually used in reflex sets and whether or not he should substitute a vacuum tube detector for the crystal type shown in a diagram which he sent us.

A. 1. Oscillations are easily started when vacuum tubes are used as detectors in reflex sets. It is for that reason that

your circuit is shown with a crystal detector. It will not be advisable to change over to a tube detector. The set may become more noisy and erratic in operation.

## BABY COUPLER

(406) Q. 1. Henry F. Rosen, Nashville, Tenn., asks how to build a very small coupler to be incorporated in a compact set but which will tune over the entire broadcast range.

A. 1. We give the details below for a coupler of this nature and illustrate the constructional details in these columns. This coupler may be used in a standard tuned radio frequency circuit, but since the coupling between the two coils is variable, no variable condenser need be used across the secondary. The rotor is to be connected in the plate circuit and the stator in the filament circuit. This instrument can also be used for tuning the antenna and first secondary circuit or may be used as a plate variometer for producing regeneration. In the case of using it in the antenna circuit, a series condenser should be used. Also in this instance, it could be connected as a variometer whereupon the series condenser will not be found necessary.

The stator winding consists of a total of 120 double turns of No. 36 S.C.C. wire. The rotor, wound in two slots in a wooden disk 1 inch in radius, consists of 60 double turns of No. 36 S.C.C. wire wound in each slot or a total of 120 turns. In winding these coils, two spools of wire are necessary and the wires for each spool are wound in parallel. One of these wires on the stator coil is connected in series with one of the wires on the rotor coil and the other stator wire is also connected to one end of the other rotor wire. This leaves four wires to be connected to terminals and the prim-

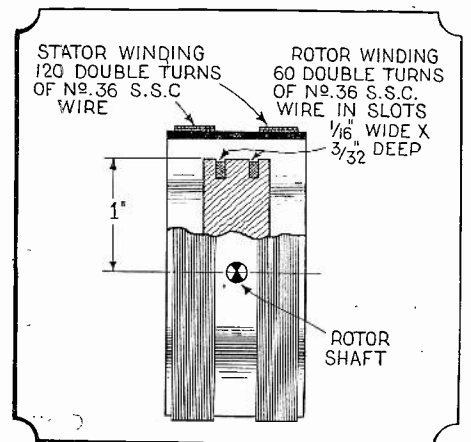

Q. 406. A baby coupler particularly adapted to compact sets is illustrated in detail above. Additional data is given in the text.

ary and secondary coils consist of one stator and one rotor coil each. Instruments of this type will give quite good results when the small space which they occupy is considered. However, for ordinary use, instruments of a larger size wound with larger wire are to be recommended.

## WANTED!!! RADIO ARTICLES

WE want descriptions of new radio ideas which you have worked out in practice. Take photographs of the important parts and make pencil or pen and ink sketches of the hook-ups or mechanical details, et cetera. We are particularly desirous of obtaining new hook-ups and descriptions of single tube sets, reflex and other types which have proven satisfactory. We like articles on new single tube receptors. We will pay good prices for your ideas.

—Editor.



### A. C. TUBES

(407) Q. 1. Eugene Davis, Minneapolis, Minn., asks several questions regarding vacuum tubes which operate on alternating current.

A. 1. We will answer all of your queries compositely. Our illustration in these columns shows in schematic form the disposition of the elements of one type of tube designed to operate on alternating current at a pressure of 6 volts, this current being supplied by a small step-down transformer. The current at a pressure of 6 volts heats the small heater coil indicated, whereupon the heat radiated through the insulating material imparts its warmth to the cathode or metal sleeve enclosing the insulating rod.

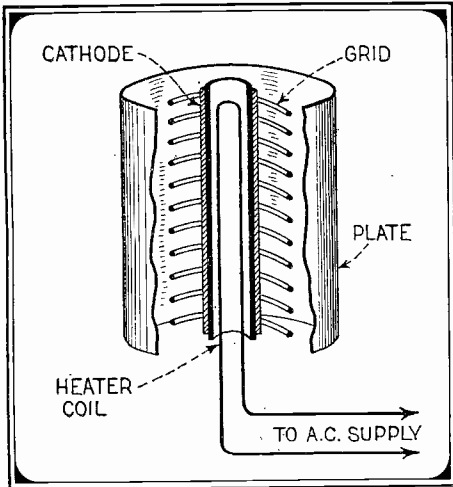

Q. 407. This diagram shows in simplified form the internal construction of a new vacuum tube that operates on alternating current.

This cathode gives off an electronic stream and the operation of the tube from this point onward is similar to that of any other type of tube. A grid and plate of usual design are included as shown. The one great advantage found in the use of a tube of this type is that the wiring in a receiving set using these tubes need not be passed by the Board of Fire Underwriters inasmuch as low voltage is employed. However, other tubes are beginning to appear which are designed to operate directly from the 110-volt line without any intervening transformer. We fear that trouble will arise from the use of these tubes inasmuch as every radio set manufactured to use these tubes will have to be made according to specifications laid down by the Board of Fire Underwriters and the incorporation of tubes of this nature in home-made sets will be a rather hazardous proposition unless great care is taken with the insulation of the 110-volt leads.

### POOR CONDENSERS

(408) Q. 1. E. J. Anderson, Chattanooga, Tenn., says that when he turns the rotor plates of his variable condenser a crackling noise is heard. It is very annoying and gives much trouble when trying to tune in stations. He asks us to diagnose his trouble.

A. 1. Undoubtedly the trouble you experience from a crackling noise when your condensers are varied is due to poorly constructed condensers. They undoubtedly short circuit at certain points or the connection between the rotor plates and the rest of the circuit is poor. Try tightening the bearings and clean out dust from between the plates.

### REGENERATION

(409) Q. 1. Ivon Shepard, Temple, Okla., asks for a simplified review of the theory of regeneration.

A. 1. The general theory of regeneration is that the current in the plate circuit will produce a current in the grid circuit of the same tube, when the plate circuit is coupled to the grid circuit. This induced current causes the grid potential to vary, in phase with the fluctuations of the plate circuit. This results in amplification of the original current in the grid circuit. By balancing the losses of the circuit against the oscillation abilities of the tube, it is possible to produce the maximum amount of regeneration, which is the maximum amplifying characteristic of the tube, just before oscillation takes place. Oscillation of the tube circuit is usually undesirable in radiophone receiving circuits. Very nearly maximum regeneration is the most desired condition of the circuit but not so much should be used as to cause distortion.

### FRYING NOISE

(410) Q. 1. Howard Limbacher, Dover, Ohio, says that he has trouble with a frying noise in the loud speaker of his receiving set and asks if a "C" battery will be of any assistance. He also states that a loud hum is often heard in the phones.

A. 1. A "C" battery would not eliminate the trouble you mention. You may have a noisy tube, or the local electric line may be causing the trouble you mention. We are of the opinion that you have a poor connection in your set. Possibly the tubes do not fit very well in the sockets. There might be an open grid circuit. It is possible that the secondary of one of the audio frequency transformers is burned out. This may be readily determined by a battery and a pair of headphones. Connecting a transformer winding, the dry cell, and the headphones in series should result in a click if the circuit is complete. If there is an open circuit, no click will be heard.

### TUBES

(411) Q. 1. Charles Reiss, Ont., Canada, asks: What is the best type of detector tube for use in a three-tube receiving set?

A. 1. Any of the standard tubes on the market today will usually operate as detectors. It is best, however, to pick out one that operates well on a plate voltage of between 22½ to 45 volts. A tube that requires higher voltage than this for detection is usually not a good detector. A WD-11, WD-12, UV-199 or UV-201A that fulfills the above requirements will usually give good results.

Q. 2. What are the requirements for an amplifier tube?

A. 2. An amplifier tube should be capable of standing quite a high plate voltage without paralyzing. It should operate on voltages up to at least 90 but also should give good amplification at 67½ volts. For second stages of audio frequency amplification, power tubes can be obtained that use up to 250 volts on the plate. These tubes are only employed when very great volume is required. A new tube has appeared on the market which with a plate voltage of 135 volts is said to give double the amplification of the usual UV-201A amplifier with 90 volts on the plate.

### COUPLING

(412) Q. 1. Frank J. Holly, Jr., Ogdensburg, N. Y., asks: What is the advantage of varying the coupling between the coils in a radio receiving tuner?

A. 1. Coils coupled too closely tune broad and produce high frequency resistance. Coils coupled too loosely do not induce very much current to one another, although the high frequency losses are reduced. It is necessary to strike a happy

medium of best coupling. The above is true of ordinary coupled circuits. Where the coupling controls regeneration, it is necessary to vary the coupling in proportion to the amount of current it is desired to feed back from the plate circuits. Here again it is desired to find the point of best feed-back.

### VARIABLE CONDENSERS

(413) Q. 1. Russell L. Plautz, Fowler, Indiana, asks if a spark should ensue when one terminal of an "A" battery is connected to one terminal of a variable condenser and the other terminal of the battery to the remaining post of the condenser.

A. 1. There should be no spark when one terminal of an "A" battery is connected to the rotary plates and the other terminal is connected to the fixed plates. A spark under these conditions would denote a short-circuit. Examination of the plates will probably show where the rotor and stator plates touch.

### NEUTRODYNE

(414) Q. 1. Edward Rumazza, Rochester, N. H., says that he has built a five-tube Neurodyne receiver and that the adjustment of the neutralizing condensers does not seem to have any appreciable effect on the operation of the set. He asks: Is this usually found to be the case?

A. 1. Neurodyne sets will sometimes neutralize without requiring the regular neutralizing capacity. That is the situation you have in your set.

### AMPLIFIER TROUBLE

(415) Q. 1. Aaron L. Abel, New London, Wis., says that his radio receiving set works very nicely on the detector alone, but that his amplifier will not work at all. He says that his circuit is hooked up correctly and that all wiring is perfect. He asks our opinion as to his trouble.

A. 1. If your circuit is hooked up exactly right and your tube lights, we would say that one of your transformers is burned

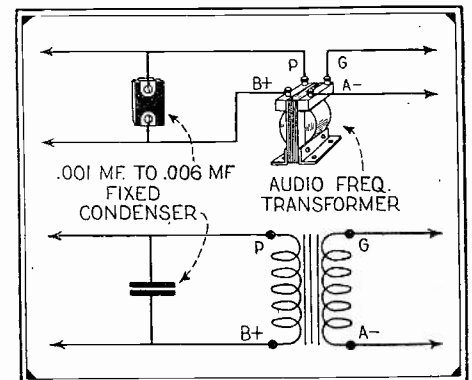

Q. 415. Amplifier troubles are many and varied, but some of them can be alleviated by the addition shown above.

out, or that a connection is broken inside the same. We would suggest that you test all the transformer windings for continuity by means of a dry cell and a pair of phones, after removing the exterior connections to the transformer. Also look over your wiring again and test each instrument in the circuit. It may be that loose contacts are present in the bases of your tubes or that good contact is not being made between your prongs and the springs of your sockets. Look in all these places for the trouble and we are sure that you will locate it. In some cases a bypass condenser of .001 to .006 mf. connected across the primary of the first audio frequency transformer will spell success instead of failure.

# Non-Science

## DOUBLE JOINTED



In the June issue of SCIENCE & INVENTION, I notice an error in one of your drawings. The drawing is reproduced herewith. A man must evidently be more than double-

jointed in order to place his thumb and forefinger into a pair of scissors as indicated by the artist. No wonder I couldn't do the trick. I am going to supply myself with a pair of soft rubber scissors, so that I can dexteriously manipulate them.—*John Wolf-skill.*

## MAGNETIC MAGNATES

The May 14th issue of the *Nashville Tennessean* referring to Mr. Ford's bid to U. S. Shipping Board, advises that, "Boats Will Be Used for Pioneering, Motor Magnet Says."



The "motor magnet" is evidently giving them an "attractive" bid. A couple of them installed along our automobile highways might serve as speeding preventatives. They might draw the motors right out of the automobiles.—*Thos. E. Miller.*

## WE'LL ELECTROCUTE HIM



On page 193 of the June issue of SCIENCE & INVENTION, the Darche Mfg. Co., of Chicago, say: "Live wires wanted capable of making big money."

Here is a chance for the young inventor to scatter his yard full of live wires. This may be done to better advantage if the inventor were to cut a nearby 22,000-volt transmission line. Such advice does not, however, conform with the code of the National Safety Council. The experience is liable to be quite shocking.—*Charles A. N. Hall.*

## NO BAD EGGS HERE

No doubt the Iowa chickens are virtuous. Cold weather has been a decided handicap to Satan and his cohorts of the incandescent pitch fork this spring. Iowa statistics show that there is less evil in cold weather than in warm. Referring to the *Riverside (Iowa) Reader* "due to the cold weather this spring the morality rate among young chickens has been very high."



Why cannot some of this super-abundant morality be transplanted to the flapper element of the more cosmopolitan areas—New York for example.—*erman Schnoebelen.*

## Money for Science Mistakes

The newspapers throughout the country, as well as the magazines, occasionally err. Sometimes these errors are misprints. At other times they are pure scientific misstatements. If you happen to see any of these humorous mistakes in the press, we will be glad to have you clip them out and send them to us. Give the name of the newspaper or magazine in which the error appeared and accompany the inclosure with a few humorous lines. The most humorous ones will be printed in this department, and for each one accepted and printed we will pay \$1.00. No NON-SC(i)ENCE entry will be accepted, unless the printed original accompanies the same. All NON-SC(i)ENCE entries must be scientific and addressed to:

Editor, NON-SC(i)ENCE Dept.,  
c/o Science & Invention Magazine,  
53 Park Place, New York City.

## THE MASTER



In the June 27th issue of the *Lebanon (Pa.) Daily News* we find.

"Distributor wanted to handle lightning. Patented 1920 manufactured 20 countries local or exclusive contract, will instantly charge lead plate car or radio batteries in 20 minutes. Now 2½ year guaranteed lightning batteries will soon be on market, \$30 to \$350 capital needed by applicant. Address Lightning Co."

Well now isn't that a gem? Of course rubber gloves are unnecessary. In 20 minutes your battery is instantly charged. Now we know how long an instant is—20 minutes of course. Wonder if the lightning batteries will shoot a bolt of lightning at the enemy . . . all well trained antagonistic distributors could handle the bolt very easily. Do you call such a man light (ning) of hand?—*Felix Mockell.*

## FRUIT FROM THE TREE OF KNOWLEDGE

In the May, 1922, bulletin of the Marquette University School of Medicine, page 44, appears the following:

"No effort is made in the regular four years' course to equip a man to become a specialist. That takes additional years; but the institution's explicit policy is to carry a student through a carefully graded, correlated, thoroughly comprehensive course of study, so that after graduating and serving at least one year as interne in a good hospital he should be fitted to practice medicine and to take human life in his hands."

"By the fruit of the tree, ye shall know them"; if it's a pear, patients, beware!—*Leone Abel.*

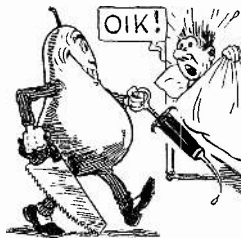

## A PERSONALLY CONDUCTED TOUR

You are now requested to focus your thoughts on the world's largest telescope. A clipping from the *Sunset* magazine of July, 1925, in an article by William Campbell, astronomer, we find "his duties took him to every part of the world, but atop that old mountain near San José, he found time on Saturday evenings (visitors' night) to show thousands of people through the great telescope."

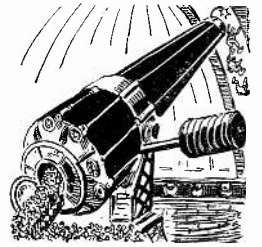

That must be the world's largest telescope. Imagine thousands of people being conducted through it. This is the first time I thought such a thing could happen.—*J. E. Hickey.*

## SILENT AS NOISE

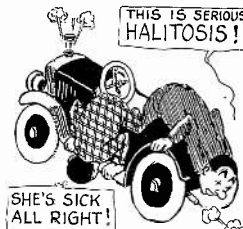

Harold F. Blanchard giving motor hints in the *New York American* June 21st, advises in a statement "if your engine refuses to run . . . listen to the exhaust

from the muffler."

Or in other words when you go in swimming be sure not to get wet. A motor that has an audible exhaust when it is not running would be quite a valuable asset. It could be used to drown out that tinny player-piano that the next door neighbor insists on keeping in action night and day and it would not cost a cent for gas or oil either.

As the famous philosopher F. F. Webb once so aptly put it. "All was quiet: Suddenly the silent noise of an inaudible sound was heard."—*H. S. Koenig.*

## THE EARTH SPREADS

In the October, 1925, issue of *Popular Science Monthly* we find an article on "American Establishes Figures for Earth's Diameters." In this article we are told that "an American scientist has determined the earth's diameters so accurately that his figures have been adopted by all countries."

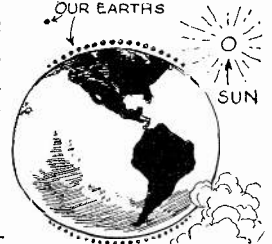

"THE DIAMETER IS 7,926,678 miles at the Equator, while THE DIAMETER FROM POLE TO POLE IS 7,899,964 miles, proving the earth to be a sphere flattened at the poles. Director Hayford's figures will be the basis of every boundary survey in the world in the future."

Now isn't that remarkable? Just imagine after all these years we discover that our earth has a diameter almost ten times that of the sun and thousands of our own earths could easily fit in the space between the *Popular Science* earth and the space representing the perfect sphere. Too bad the meteorological society has not been informed of these figures. Lest you forget, the mean diameter of the earth is 7,917.6 miles.—*A. P. P.*



# LATEST PATENTS

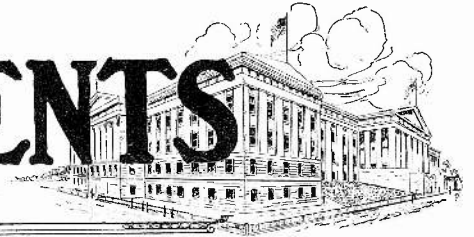

**Cord Untwister**

**Flexible Magnet**

**Receiver Bracket**

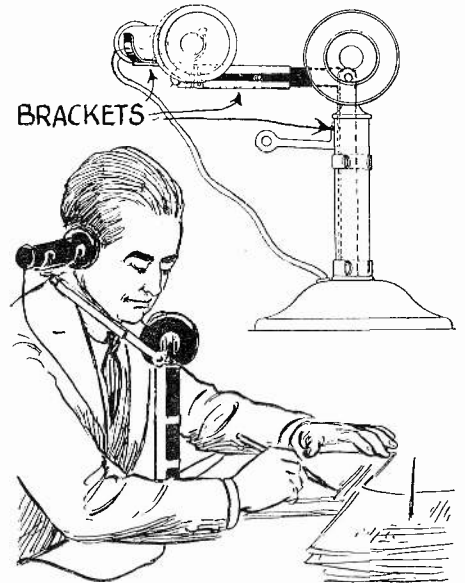
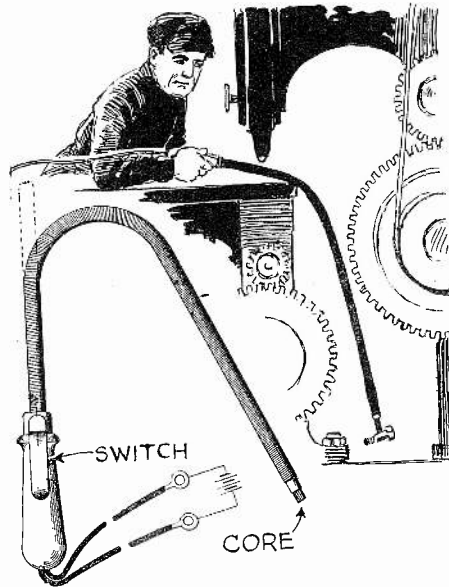
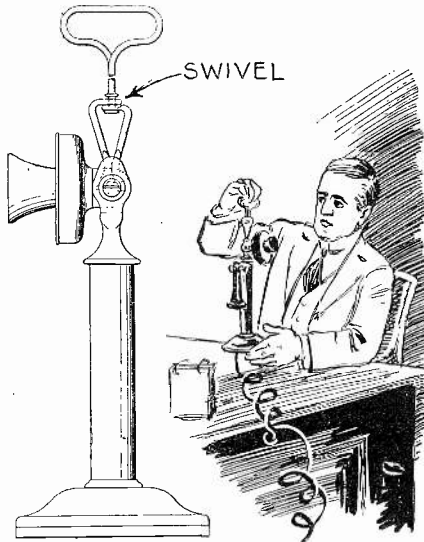

No. 1,536,266, issued to William E. Putnam protects a rather novel attachment for telephones that is illustrated above. We all know the vexatious habit that telephone cords have of twisting into kinks and finally breaking. By means of this device the cord can be quickly untwisted by holding the telephone up by the handle and spinning it around several times. Time, trouble and delays for repairs are thus saved.

No. 1,535,618, issued to Edward C. Mayer describes a flexible electro-magnet that can be made to operate with various kinds of current and on different voltages and which has many advantages when working around machinery. With it, steel nuts, bolts and other small parts can be removed from obscure places with little if any trouble. The shaft of the magnet is flexible so that it can be used in small cramped positions.

This new device that is illustrated in detail and in use above should appeal to all who use the telephone for long periods of time. Two arms, one of which is clamped to the telephone stand as shown are used to support the receiver at the listener's ear. The brackets are adjustable so that the receiver can be placed in any desired convenient position. In this way, the use of the hands is not hindered.

**Saw Guide**

**Auto Signal**

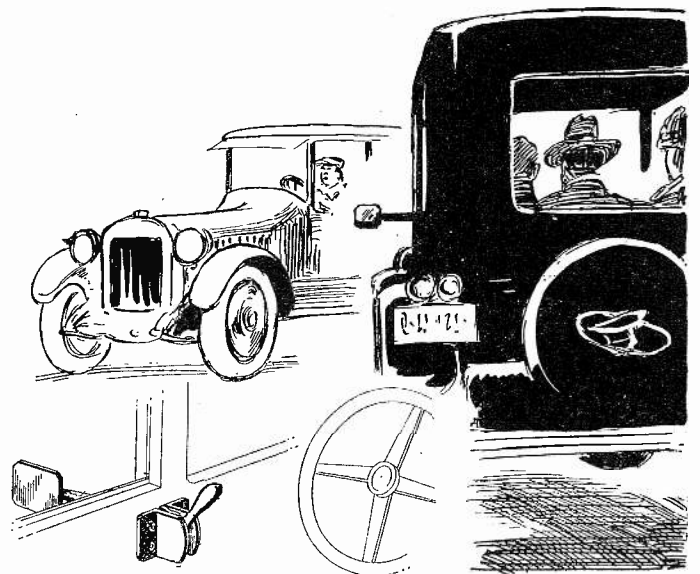
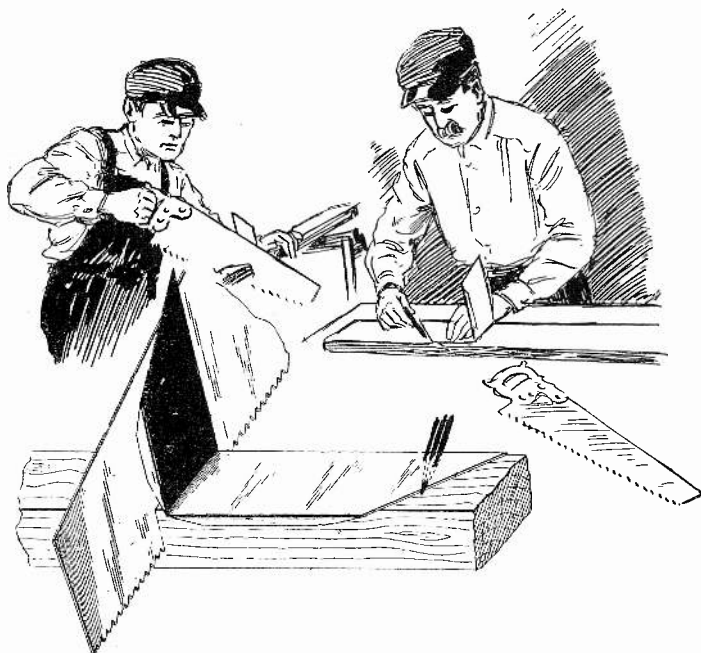

No. 1,535,661, issued to John J. Garrity and John F. Bradley is based upon a simple device made of sheet steel that can be put to many uses by wood workers. It can be used as a square or to guide a saw straight across a timber without the necessity of drawing a line. Turned over edges serve to keep the device straight and square and prevent it from slipping.

No. 1,535,265, issued to Sidney A. Stoetzel covers a rather novel type of manually operated signal for automobiles, particularly for those of the closed type. Thus, in stormy weather when the side curtains or glasses are up, the driver cannot extend his hand to signal, this device proves its worth. It is operated entirely from the interior of the car as can be seen in the above illustration.



# Scientific Humor

## A BLOCKING CONDENSER

FIRST RADIO FAN (looking at parts for set): "Is this that old condenser you were telling me about? I thought you said it wouldn't work."

SECOND FAN: "It wouldn't then, but I've overhauled it and now it's a fixed condenser."—Chas. W. Cannon, Reporter No. 22,273.

## NO CABLE NEEDED



Young Stailate painfully picked himself up from the spot on the hard pavement where he had landed when her father kicked him out.

"Motorically speaking," he remarked, "That is being toed home all right."—M. Bercovitch, Rep. No. 21358.

## OR A-SH-SALOON!

DUB: "I hear Jones has opened up a filling station."

BER: "I thought it was a restaurant!"

DUB: "Well?"—Grace Levine.

## S'OK. WITH US

"You can't drive a nail with a sponge no matter how hard you soak it."—Joseph Allison.

## DROPPING OUT

CRAWFORD: "Every four persons out of five are said to have pyorrhea."

CRABSHAW: "That's what must be the matter with those so-called laws with teeth in them."—Jas J. O'Connell.

## "HELL (N) O"

GARAGE OWNER (answering phone): "Hello, White Front Garage."

VOICE ON THE WIRE: "Hello, is my driver there?"

GARAGE OWNER: "What? Whose driver?"

VOICE ON THE WIRE: "Screw Driver."—Glen F. Stillwell.

## THE FILA-ME(N)T THEM

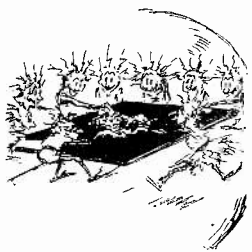

FILAMENT: "What did those electrons do after playing football on the grid?"

VACUUM: "They got hungry, so they went over to the plate to eat."—Charles E. Freeland.

## WE WON'T EVEN SMILE NOW

PROF (at quiz): "What causes laughing?"

FRESHIE: "A laugh is a peculiar contortion of the human countenance, voluntary or involuntary, super-induced by a concatenation of external circumstances, seen or heard, of a ridiculous, ludicrous, jocose, mirthful, funny, facetious or fanciful nature and accompanied by a cackle, chuckle, chortle, cachinnation, giggle, gurgle, guffaw or roar."—A. Schwartz.

## WATSON! THE INSECT POWDER

PROFESSOR OF BIOLOGY: "Where do bugs go in winter?"

ABSENT-MINDED STUDENT: "Search me."—Lester Kapala, Reporter No. 14632.

## FIRST PRIZE \$3.00

### A CHIROPRACTOR NEEDED



"Pa, what is a radio kink?"  
"A radio kink son, is what you get in your back as the result of bending over while you are trying to find out what's wrong with the family radio."

—Emil Guidici.

## PAGE GALILEO

A man went into a clock store and handed out the pendulum of a clock, which he wished to leave for repairs. The watchmaker asked him why he didn't bring the whole clock.

"The clock is all right," was the reply. "It is the pendulum that won't go." As soon as I pulled that out . . . the rest went like the very dickens."—Samuel Bernard.

**W**E receive daily from one to two hundred contributions to this department. Of these only one or two are available. We desire to publish only scientific humor and all contributions should be original if possible. Do not copy jokes from old books or other publications as they have little or no chance here. By scientific humor we mean only such jokes as contain something of a scientific nature. Note our prize winners. Write each joke on a separate sheet and sign your name and address to it. Write only on one side of sheet. We cannot return unaccepted jokes. Please do not enclose return postage. All jokes published here are paid for at the rate of one dollar each, besides the first prize of three dollars for the best jokes submitted each month. In the event that two people send in the same joke so as to tie for the prize, then the sum of three dollars in cash will be paid to each one.

## PERPETUAL MOTION

Doors are made out of trees, trees grow out of doors.—Joseph F. Connolly, Rep. No. 26807.

## A PERFECT SHORT

JOE: "You know, Jack, last night I felt two electrodes."

JACK: "How was that?"

JOE: "I had a positive (+) appetite and a negative (-) bank roll."—E. C. Joyner.

## EVEN THE METER IS RED

PROFESSOR: "What colors are most generally found around electrical machinery?"

STUDENT: "Voltage rose finished in fuse blue."—H. G. Pack.



## A CURRENT EVENT

She was only an electrician's daughter, but oh, what a shock she was to me.—Wm. A. Heitler, Rep. No. 11783.

## SOMETHING FOR THEIR NECK

CHEM. TEACHER (to class of boys): "The subject for today is 'sodium stearate.' How many of you boys have ever heard of it?"

There was no response.

CHEM. TEACHER: "I kind of thought so. Well, the common name for sodium stearate is soap."—William A. Heitler, Reporter No. 11,783.

## AN IRON CONSTITUTION

BILL: "What is an optimist?"

BEL: "An optimist is a man that drinks 'Beef Iron and Wine,' and then drinks 'rust remover' for a chaser."—Leslie F. Carpenter.



## EVIDENTLY

WILLIE: "I'd like to be an aviator when I grow up. Is it hard, dad?"

CRABSHAW: "Sure. You have to learn it from the ground up."—J. J. O'Connell.

## A HOT-AIR BATTLE

CRAWFORD: "How do you stand on the question of the next great war?"

CRABSHAW: "Looks as if it might be between the aviators and the radio broadcasters for the freedom of the air."—J. J. O'Connell.

## SOME JOKES LIVE THAT LONG

The geologist was lecturing on the ways in which rocks are made. "We have here," he declared, "a picture of an enormously thick limestone deposit, which is miles in extent, and it was all made by microscopic animals, called bryozoa."

"How long did it take them to do it?" demanded an incredulous auditor.

"Hundreds of thousands of years, perhaps millions," was the immediate reply.

The man sneered. "I don't believe it," he asserted. "No animal could live that long."—J. Samachson.

## ALARMING

"Which of these clocks is right?"

"I don't know. We have five clocks . . .

When we want to know the time, we add them together and divide by five—and even then we are not certain."—Samuel Bernard.



## UNSOPHISTICATED!

Little Mary must have her picture taken. The modern little girl was greatly bored by the photographer's slowness, and as he caught the bulb in his hand and said, "Now, Mary, watch this little hole and a birdie will come out!" remarked, "Oh, go ahead and expose your plate man and cut out the apple-sauce."—Arthur Sperry.

## NOT AS BLACK AS PAINTED

1ST NEIGHBOR: "What on earth are you wearing all those coats for?"

2ND NEIGHBOR: "Well, I am going to paint my barn, and the directions says 'to get the best results, put on three coats.'"—Carl Carlsen.



# THE ORACLE



The "Oracle" is for the sole benefit of all scientific students. Questions will be answered here for the benefit of all but only matter of sufficient interest will be published. Rules under which questions will be answered:

1. Only three questions can be submitted to be answered.
2. Only one side of sheet to be written on; matter must be typewritten or else written in ink; no penciled matter considered.

3. Sketches, diagrams, etc., must be on separate sheets. Questions addressed to this department cannot be answered by mail free of charge.
4. If a quick answer is desired by mail, a nominal charge of 50 cents is made for each question. If the questions entail considerable research work or intricate calculations, a special rate will be charged. Correspondents will be informed as to the fee before such questions are answered.

## PURPOSE OF CONDENSERS

(1932) Q. 1. Raymond Williams, Calumet, Mich., asks why a condenser is used in a spark coil such as used for ignition purposes in an automobile.

A. 1. There are two main reasons for this little instrument and they are in general as follows: First, the condenser tends to absorb the self-induced current of the primary which is set up by the battery and by doing this, the condenser allows the magnetic field to collapse with the greatest possible speed, completely demagnetizing the iron core and preparing it for the next impulse of current sent through via the vibrator. Remember that all of these actions take place many times per second. The condenser also aids in eliminating the spark at the contact point by this absorption of current.

## PRINCE RUPERT'S DROPS

(1933) Q. 1. Lewis Tucker, Nashville, Tenn., asks what is meant by the term, Prince Rupert's drops, and how they are formed.

A. 1. Prince Rupert's drops are occasionally called Dutch tears and are peculiarly formed pieces of glass made by dropping molten glass into water. Some of the forms which these drops take are shown herewith. These forms are due to the internal strain set up in the material by the sud-

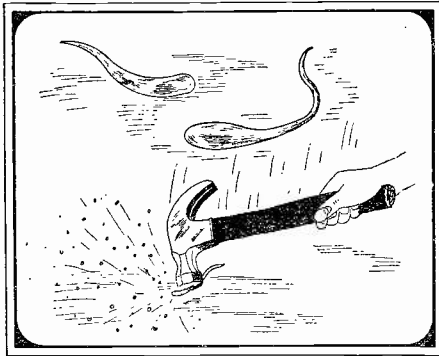

Illustrating the form and action of Prince Rupert drops.

den contraction of the outside. If the end of a drop of this nature is broken off, thus relieving the strain at one point, the rest of the drop will instantly fly into pieces because of the internal stress which is always tending to expand due to the high pressure set up by the sudden compression.

## CARBON DEPOSITS

(1934) Q. 1. Howard Bront, Pasadena, Calif., asks what causes carbon deposits to form in automobile engines.

A. 1. There are several reasons for this formation, among them being the use of the wrong grade of oil, an improper mixture (too much gasoline) from the carburetor and excessive heat. If the oil is used is too light, it will work up past the pistons and enter the firing chamber. Here it will be burned, forming carbon. A rich mixture of gasoline will cause carbon deposits because of the fact that it will not be entirely consumed. Low grade oils contain impurities which when burned form more carbon than would result from the burning of a good grade of oil. Overheating the motor will cause the oil in the crankcase to vaporize more freely and therefore to pass up into the combustion chamber in greater quantities than otherwise would be found. The consequent burning as explained above will form carbon.

## AIRPLANE CLIMBING SPEED

(1935) Q. 1. A. Wade, Rochester, N. Y., asks if the climbing speed of an airplane can be calculated mathematically, and if so, how?

A. 1. This can be done quite readily when several factors are known. The equation is as

follows:  $C = 33,000$  multiplied by  $(H$  divided by  $W)$ . In this equation,  $W$  = the total weight of the airplane,  $C$  = the climbing speed and  $H$  = the horsepower reserve for climbing. For the last figure, let us assume that the motor of the plane can actually deliver 70 horsepower to the propeller. Let us assume that the plane is traveling at a speed of 70 miles an hour and is utilizing 50 horsepower. Therefore, the reserve for climbing is the difference of these two figures or 20 horsepower. This formula holds under ideal conditions where all of the figures are constant. The velocity obtained by solving the calculation is at the beginning of the climb and after a long climb, the rate falls off somewhat.

## PERMANENT MAGNETS

(1936) Q. 1. Richard Schlossberg, Kingston, N. Y., asks: In the large production of small permanent magnets, how are they magnetized?

A. 1. The usual procedure is to magnetize the permanent magnet by placing it in contact with an electro-magnet as shown in the illustration herewith. The pole of the permanent magnet that is in contact with the north pole of the electro-magnet will become a south pole and vice versa.

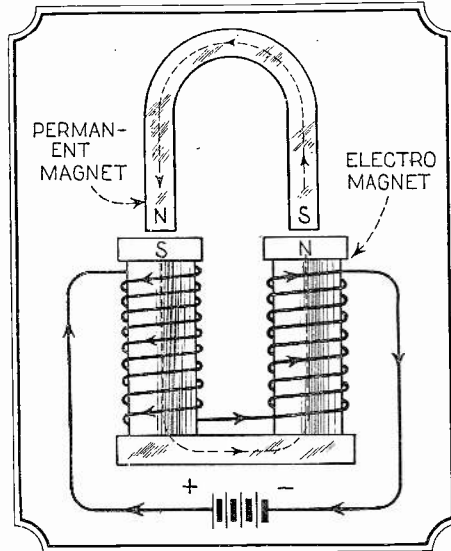

Permanent magnets are made by magnetization by a large electro-magnet as above.

versa. Permanent magnets are made of hardened steel and will retain the magnetism thus induced very well.

## SUN DRAWING WATER

(1937) Q. 1. Stewart Powell, Norwood, N. Y., asks: Is the old saying that "The sun is drawing water" when a series of streaks of light are visible in the sky, based on facts?

A. 1. There is no scientific truth in the statement that the sun is drawing water. This fact is purely an optical one caused by the sun shining through clouds. The effect is never seen on cloudless days.

## FALLING BODIES

(1938) Q. 1. Wm. A. Halderman, Fort Fort, Pa., says that in the study of physics he learned that the force of gravity acts upon a body whether it is in a horizontal motion or at rest and that a body will fall at a constantly increasing velocity, neglecting friction of the air. He says that he has also seen a demonstration of an apparatus that projects a ball horizontally and simultaneously releases a ball so that it falls vertically, proving that both will land at the same instant. He holds that this is true only on a small scale and would not hold true with a projectile fired from a high velocity gun in comparison with a projectile of the same size dropped vertically to the ground from the same

height as the muzzle of the gun. He asks our opinion on this subject.

A. 1. All other things being equal, both of the projectiles will reach the ground at the same instant, regardless of the distance traveled by the one fired in a horizontal direction. Of course, in the average rifle or gun, the bullet rises slightly from the horizontal. The physics law you mention depends upon the fact that after it leaves the muzzle of the gun, it does not rise above a horizontal line drawn from the muzzle. Of course, the faster the projectile is traveling when it leaves the muzzle, the further it will travel, but it will reach the ground at the same time as another object of the same size and weight dropped from the same height in a perpendicular direction. Of course, the objects must both be of exactly the same weight, size and shape, and if a pointed bullet is fired from the gun, a pointed bullet must be dropped in a perpendicular direction in the same position, so that the air friction will not be greater on the latter than on the one fired from the gun. The physics law is only accurate in a vacuum.

## ATOMIZING BURNER

(1939) Q. 1. John J. Blake, Clatskanie, Ore., asks how a heating torch using alcohol and air pressure operates.

A. 1. In this device, a simple type of which is illustrated herewith, the air projected through the small chamber at high velocity carries some

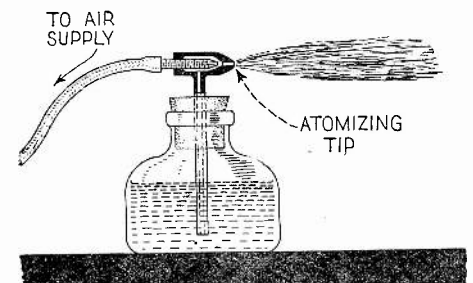

An atomizing burner is shown in cross-section above. See text for description.

of the air in the chamber with it and creates a partial vacuum. Atmospheric pressure then forces part of the liquid in the chamber up through the tube, whereupon it is carried out in a fine spray with the air under pressure. Lighting this spray produces a hot flame. Some other types of torches merely work on the principle of the application of a greater amount of oxygen to the flame by means of compressed air.

## ALUMINUM OXIDE

(1940) Q. 1. William O'Neil, Rosedale, Okla., asks: What oxides of aluminum are known and are they found in a natural state?

A. 1. The only known oxide of aluminum is alumina, the formula for it being  $Al_2O_3$ , and it is found in a native state. It occurs in a very nearly pure form and is crystalline in structure such as is the case in corundum, ruby, sapphire, and in a less pure state, emery. This oxide of aluminum can be prepared in the laboratory by mixing a solution of alum with ammonia, whereupon a white precipitate of the hydroxide is formed. Upon heating this precipitate, pure alumina in the form of a white amorphous powder results.

## THE MOON

(1941) Q. 1. J. K. Martin, Cleveland, Ohio, asks several queries in regard to the moon which can best be answered compositely.

A. 1. The earth's moon is 2,162 miles in diameter and circles around our terrestrial body at a distance of 239,000 miles. It is our nearest heavenly body. One complete revolution of the moon around the earth consumes a little over 27 days. The moon always keeps its same side toward the earth. It has been quite positively ascertained that the moon is a nearly, if not absolutely, dead world. It is devoid of water and has little atmosphere of its own.

**TUNGAR RECTIFIER**

(1942) Q. 1. Maurice Levin, Hartford, Conn., asks us to outline the principle of the operation of a tungar rectifier bulb and also show how it is hooked up.

A. 1. A diagram given in these columns shows the simple connections of a tungar rectifier that does not utilize a transformer for supplying the plate voltage and also shows the important com-

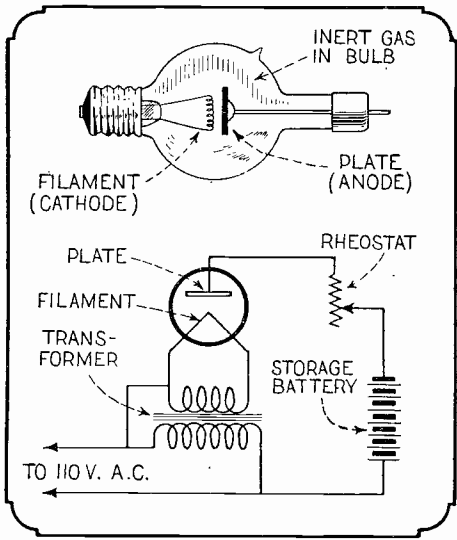

A view of a rectifier bulb and the circuit used with the same are shown.

ponent parts of one of the rectifier bulbs. This type of rectifier is filled with argon gas and provided with a cathode or tungsten filament and an anode, usually coated with graphite. This instrument makes use of the unilateral conductivity of electricity over an electronic stream. Referring to the connections, it can be seen that when one side is positive, current will flow through the battery and the tube and along the circuit to line. When the current reverses, none will flow through the bulb and therefore there will be no current in the battery. In this way the battery receives a charging impulse on every half cycle of the alternating current.

**SPARK COIL**

(1943) Q. 1. E. J. Haudenschield, Ft. Wayne, Ind., asks how an automobile ignition spark coil can be rewound to give a voltage of 110 volts on the secondary from the regular starting battery.

A. 1. Not knowing the primary winding of your spark coil, we cannot give you the specific data for winding the secondary. However, if you will determine the number of turns on the primary and multiply it by 18, you will have approximately the number of turns to wind for obtaining 110 volts from the secondary.

Q. 2. If I run an automobile starting motor which requires 65 to 100 amperes to start an engine, as a generator would it give the above mentioned output?

A. 2. If you ran a starting motor as a generator, you would get approximately 6 volts output but the amperage would be considerably lower than what you mention. In fact, it would probably be on the order of 20 to 30 amperes, depending on the speed at which the motor was driven. The output will be by no means as high as the current consumed by the motor. When the motor is consuming 100 amperes, it is under excessive momentary load and if the current were left turned on for any period of time the motor would become so overheated that it would undoubtedly burn itself out.

**SOLENOID CONTROL**

(1944) Q. 1. J. A. Fontenot, Wilmer, La., in tends to make up a moving doll to be actuated by a solenoid and asks for some details for constructing the latter.

A. 1. The exact dimension for the solenoid for use in the toy doll that you mention will, of course, depend to a very great extent upon the size of the doll and the amount of space available. In general, we would suggest that the glass tube should be about 2 inches long and should be wound for its entire length with No. 24 S.C.C. wire. At least six layers of wire should be wound.

Q. 2. How may a solenoid be made to be used in a reciprocating type of electric engine?

A. 2. The solenoid used in the electric engine you mention should be about 1½ inches long and the winding should consist of at least 10 layers of No. 22 D.C.C. wire, wound the entire length of the core. The connections are so made that the brush automatically makes and breaks the circuit through the solenoid. The reverse lever is so connected as to enable the operator to throw either one brush or the other into the circuit.

**SOLDERING ALUMINUM**

(1945) Q. 1. J. B. Holland, Maupin, Ore., asks us to give some detailed directions for the soldering of aluminum.

A. 1. In actual practice, the soldering of aluminum depends more upon the one who is doing the work than upon the solder used. The chief difficulties lie in the facts that aluminum dissipates heat rapidly and oxidizes almost instantly when heated in the air. The thin film of oxide prevents the formation of a perfect union.

The best process that we know of is to coat the surface with melted solder. Keep the solder molten, hold the aluminum under the surface, at the same time scratching the surface of the aluminum with a wire brush. This removes the oxide film and allows the aluminum to be tinned. When the parts to be soldered together are well tinned, they can be soldered in the usual manner.

An excellent solder for use on aluminum is made as follows:

Tin .....	10 parts
Cadmium .....	10 parts
Zinc .....	10 parts
Lead .....	1 part

The work should be prepared by dipping it into a solution of nitric acid in three times its bulk of hot water, the solution also containing 5 per cent. of commercial hydrofluoric acid. Rinse the metal after removing from the acid bath and dry before soldering.

Another aluminum solder with which no flux is to be used is made up as follows:

Silver .....	2%
Aluminum Phosphorous .....	9%
Tin .....	34%
Zinc .....	50%

**BENDING CASE HARDENED STEEL**

(1946) Q. 1. Guy Reindel, Waseca, Minn., asks how a rod of case hardened steel that has warped out of shape can be bent straight.

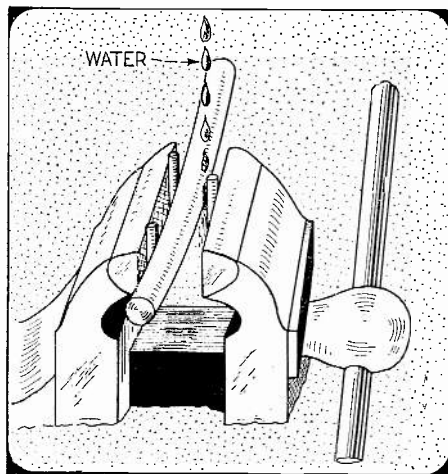

Showing how a rod of case hardened steel may be bent or straightened.

A. 1. This cannot be done by pressure alone or by pounding as this procedure will tend to crack the metal. We illustrate herewith the best method of proceeding with this work. Locate the highest part of the bend and mark it. Heat the bar slightly, but not to a red heat and place it in a vise with three blocks as shown. Direct a stream of water from a sponge against the marked part of the bar and at the same time tighten the vise. The uneven contraction due to the sudden cooling on one side will cause the bar to straighten. Several trials may be necessary before the complete straightening is accomplished.

**SUNLIGHT VS. MOONLIGHT**

(1947) Q. 1. Robert Bront, Astoria, L. I., asks: How does the maximum sunlight intensity compare with moonlight?

A. 1. In answering this query, an average must be taken. Generally stated, the intensity of daylight at midday on a clear day is about one million times greater than the light furnished by the full moon on a cloudless night at zenith.

**RADIOMETER**

(1948) Q. 1. Winfield Scanlon, Liberty, N. Y., says that he has noticed a little piece of apparatus in the window of a jewelry store which consists of a glass bulb in the center of which four little vanes are placed which constantly rotate. He asks: What is this device and how does it operate?

A. 1. The little instrument which you have seen is known as the Crookes radiometer and is sometimes used to approximately measure light radiation when the source is of sufficient intensity. However, it is also extensively used as a window attraction. The vanes or paddle wheel consist of squares of mica blackened on one side and polished on the other. This paddle wheel is

placed on small bearings and inclosed in a bulb exhausted to a low pressure. The rotation of this wheel is caused by the unequal bombardment of the two sides of the vane by the molecules of the rarefied gas. The blackened sides of the vanes absorb more heat than the other side and become warmer. Therefore, the molecules of gas in contact with the blackened side have a greater kinetic energy imparted to them than those near the polished side. The pressure thus imparted causes the paddles to rotate.

**ARTIFICIAL MARBLE AND PAPIERMACHÉ**

(1949) Q. 1. Ira Edwards, Neodesha, Kan., asks for a formula for the making of artificial marble.

A. 1. Artificial marble may be made by mixing together 100 parts of alum, 1 to 10 parts of heavy spar and 10 parts of water. The amount of spar is governed by the degree of translucence desired. The alum is to be dissolved in the water by the use of heat. As the solution is boiling, the heavy spar is mixed in and boiled for some time. Allow to cool with constant stirring until the solution becomes semi-liquid. Then pour into molds.

Q. 2. How may papiermaché be made?

A. 2. Papiermaché may be made as follows: Melt 8 ounces of glue and add about 3 tablepoonsful of the same to 1 ounce of wet paper pulp, stirring the mass thoroughly. Add 4 ounces of dry plaster of paris and mix together thoroughly. It will be found that the mass can hardly be worked and it is necessary to add the remainder of the glue. By working thoroughly, the mixture can be freed from lumps and worked into such a condition that it can be used. Some variation of the above formula may be necessary to obtain the desired results.

**ABSORPTION OF GASES**

(1950) Q. 1. Francis Merlo, Rockbridge, Ill., asks how much gas a piece of charcoal will absorb in comparison with its bulk.

A. 1. If a piece of charcoal is heated and placed in a vessel containing carbonic acid gas, it will absorb about 35 times its bulk of the gas. In the case of ammonia gas, about 90 times the bulk of the charcoal will be absorbed.

**TEST CIRCUITS**

(1951) Q. 1. Herman Glass, New Bedford, Mass., asks us to outline a simple method of testing various electrical instruments for continuity of circuit.

A. 1. In these columns we illustrate two very simple test sets. One is designed to operate on the ordinary lighting current and the other is for use with a storage battery. They both operate on the same principle. All that they consist of is a small lamp in series with two metallic points, the points being provided with insulated handles so as to prevent short-circuiting through the body of the operator. When the points are touched to opposite terminals of any instrument, the lamp will light if there is a continuous circuit through that instrument, and if that instrument is designed to carry enough current to actuate the lamp. If there is not a continuous

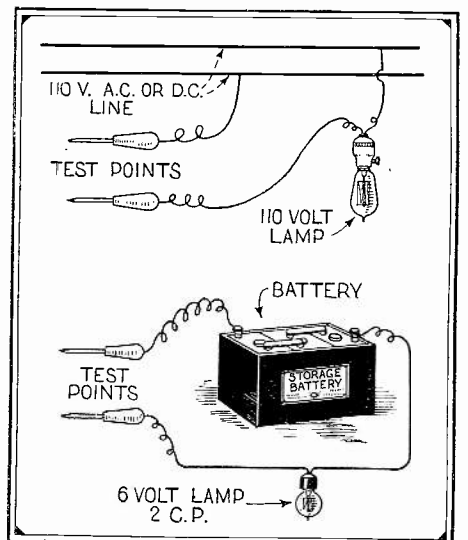

Two simple yet handy test circuits are shown in the illustration directly above.

circuit, the lamp will not light. These systems are only applicable to the testing of instruments which will carry a comparatively heavy current. If a 25-watt lamp is used in the lighting circuit system, about ¼ of an ampere will have to pass through the instrument under test. In the case of the 6-volt system with the two candle-power bulb, about 1/3 of an ampere will have to pass. Using smaller bulbs will reduce the required current.



# \$28,000.00

OFFERED BY

## SCIENCE and INVENTION Magazine

### \$11,000.00 in Prizes for Psychical Phenomena

We suppose there is no need of further challenging the General Assembly of Spiritualists of the State of New York to exhibit those spiritualistic phenomena which they claimed they were capable of producing. The General Assembly published a small pamphlet containing a number of supposedly spiritualistic effects which some of the Assembly could produce without the aid of trickery.

Upon reading the pamphlet we publicly challenged them to produce those effects in our presence. Up to the present time not one single member of the General Assembly of Spiritualists has replied to our challenge.

When any organization of Spiritualists or when any medium claims to be able to produce writing on the inside of sealed slates, when claims are made that ponderable bodies can be levitated without the application of physical or mechanical force, when they claim they can produce independent voices, we want to be shown, and SCIENCE AND INVENTION and Joseph F. Rinn are willing to pay \$11,000.00 for a private exhibition.

### \$5,000.00 in Prizes for Perpetual Motion

Where are all those inventors who have promised to send models of perpetual motion machines to SCIENCE AND INVENTION Magazine? Where are all the models that were to be sent?

This publication has received more than five hundred letters from inventors who have promised to send perpetual motion machine models to be entered in our \$5000.00 prize contest. Up to the present time not one single working model has been forwarded.

The editors of this publication do not believe that perpetual motion is possible and they are desirous of looking at a working model of a perpetual motion machine. For the mere privilege of examining such a machine they are willing to pay \$5000.00. They do not desire the rights to the invention.

Of course, machines working by evaporation, tides, winds or waterfalls are not perpetual motion devices and cannot be entered in the contest. This award is made for the protection of our readers and we advise them not to invest in any perpetual motion proposition.

## \$1000.00 Monthly Contest Awards

### FIRST PRIZE \$100.00

Shenandoah Versus the Elements, by William P. Sullivan.....604-605

### SECOND PRIZE \$75.00

Solomon's Temple Model Reproduced, by A. N. Mirzaoff.....608-609

### TWO PRIZES OF \$50.00 EACH

Chemical Tricks, by Dr. Ernest Bade.....634-635  
A Novel Six-in-One Receiver, by L. Ringer.....648-649

### THREE PRIZES OF \$35.00 EACH

Movie Thrills on Skyscrapers, by Edwin Schallert.....610-611  
Marvelous Mechanism Does Switchman's Work, by Charles Frederick Carter.....616-617  
Amateur Railroadng, by G. H. Dacy.....622-623

### FIVE PRIZES OF \$25.00 EACH

Radio Acoustic Range Finder, by C. A. Oldroyd, Rep. No. 4433.....614  
Old Film Uses (author please send address).....626  
Is the Earth Solid? by Gene Deachem.....632  
Lamp Chimney Experimental Apparatus, by Raymond B. Wailes.....638  
A Continuous Time and News Broadcast Service, by C. A. Oldroyd, Rep. No. 4433.....643

### FIVE PRIZES OF \$20.00 EACH

Checkerboard, by W. W. Douglas.....613  
London Camouflaged, by F. Fizzi.....620  
Leaf Records, by Dr. Ernest Bade.....637  
An Efficient Two-Tube Reflex Circuit, by C. Howard Schopfer.....650  
Hints to the Radio Builder, by Leon L. Adelman.....651

### TEN PRIZES OF \$15.00 EACH

Two New Elements Discovered, by Prof. Donald H. Menzel.....615  
Is Gasoline Best Fuel? by Dr. Russell G. Harris.....618  
Man Weighs More in Vacuum, by Prof. Donald H. Menzel.....619  
Mysterious Japanese Mirror, by V. Volynkin.....620  
Deciphering Charred Records, by Allen P. Child.....621  
New Water Turbine, by Herr Redacteur-Friedman.....625  
Etching Glass, by William J. Edmonds.....636

A Mechanical Creeper, by Harry Lubcke.....636  
Vacuum Still, by Chris Henricksen.....642  
Removing Insulation From Wire, by Herbert E. Hayden.....647

### FIFTEEN PRIZES OF \$10.00 EACH

Musical Novelties, by Roy R. Harper.....624  
Musical Novelties, by H. Bernard.....625  
Meteors Photographed, by H. E. Zimmerman.....625  
Meteors Photographed, by Hubert Slouka, Rep. No. 7110.....625  
Barometer, by C. A. Oldroyd, Rep. No. 4433.....636  
Drill Guide for Pipe, by Chris Scott.....639  
Testing Bread Value, by S. Leonard Bastian.....639  
Restoring Old Books, by J. T. Garver.....639  
Color Change, by Alton C. Kurtz.....640  
Weight Combinations, by A. A. Blumenfeld.....640  
Hookah, by C. A. Oldroyd, Rep. No. 4433.....640  
Unique Violin, by K. A. Sugh, Rep. No. 13,229.....640  
Toy Submarine, by Fred C. Jones.....640  
Foreign Set, by D. R. D. Wadia.....648  
Detector, by David S. Jenkins.....684

### TEN PRIZES OF \$5.00 EACH

Barometer, by Earl R. Caley.....636  
Socket Wrench, by P. A. Judd.....636  
Parachute Golf Ball, by F. S. Root.....640  
Auto Spring Wedge, by O. Justiss.....640  
Battery Filler, by D. L. Campbell.....642  
Funnel, by A. A. Blumenfeld.....642  
Battery Charger, by Fred Ebel.....683  
Coil Form, by Evermont Fiesel.....684  
Lightning Arrester, by J. Bront.....684  
Vernier Condenser, by W. E. Tobin, Jr.....685

### FIFTEEN PRIZES OF \$2.00 EACH

Etching Pencil, by Frank R. Moore.....642  
Wheel Repair, by R. O. Hufford.....642  
Egg Shell Funnel, by C. M. Wilcox.....642  
Shaft Extension, by W. C. Patch.....683  
Spider-Web Form, by J. C. Scales.....685  
(No further entries)

## \$5,000.00 In Prizes—See December Issue

A new craze which will out-do cross-word puzzles!  
SCIENCE AND INVENTION will sponsor this new idea which will appeal to men, women and children. An instructive amusement which will

require no dictionaries, text-books or deep study. If you possess genius and an inquiring mind and we know you do, be sure to order your December issue of SCIENCE AND INVENTION early from your newsdealer.

\$100.00 in prizes awarded for uses of old films. A contest is announced in this issue and closes December 30, 1925.

## \$12,000.00 in Prizes for Articles

82 monthly prizes will be given as follows:

FIRST PRIZE \$100.00  
SECOND PRIZE \$75.00

2 PRIZES OF \$50.00 each

3 " " 35.00 "  
5 " " 25.00 "  
5 " " 20.00 "  
10 " " 15.00 "  
15 " " 10.00 "  
10 " " 5.00 "  
15 " " 2.00 "  
15 " " 1.00 "

Last year SCIENCE AND INVENTION Magazine paid for articles \$13,320.00 to 1,112 prize winners. Hundreds of SCIENCE AND INVENTION reporters won prizes, and up to the time of going to press there were more than 27,000 reporters in the field.

Every month this publication pays \$1,000.00 or more in prizes, exclusive of money paid to those authors who are on contract, and who receive their own rates. At the left the list of prizes issued monthly is itemized, and above are the names of the prize winners for this issue. In order to assist our reporter correspondents in securing available material for publication, we issue without charge the reporter's card, a sample of which is illustrated at the right. Send a postal card for one. It will act as an open sesame in securing news. Address Field Editor, SCIENCE AND INVENTION, 53 Park Place, New York City.

(Note—Unavailable material not accompanied by postage will not be returned.)

REPORTER



NO. 10000

*L. H. Shackner*

CORRESPONDENT  
REPORTER'S  
IDENTIFICATION

THE BEARER OF THIS CARD IS AN AUTHORIZED CORRESPONDENT-REPORTER OF SCIENCE AND INVENTION MAGAZINE. THE PUBLISHERS OF SCIENCE AND INVENTION WILL APPRECIATE ANY COURTESY EXTENDED THEIR REPRESENTATIVE.

EXPERIMENTER PUBLISHING CO.  
*Heard Ball*  
PRESIDENT

(over)

*This Catalogue  
represents the  
world's greatest  
radio store*

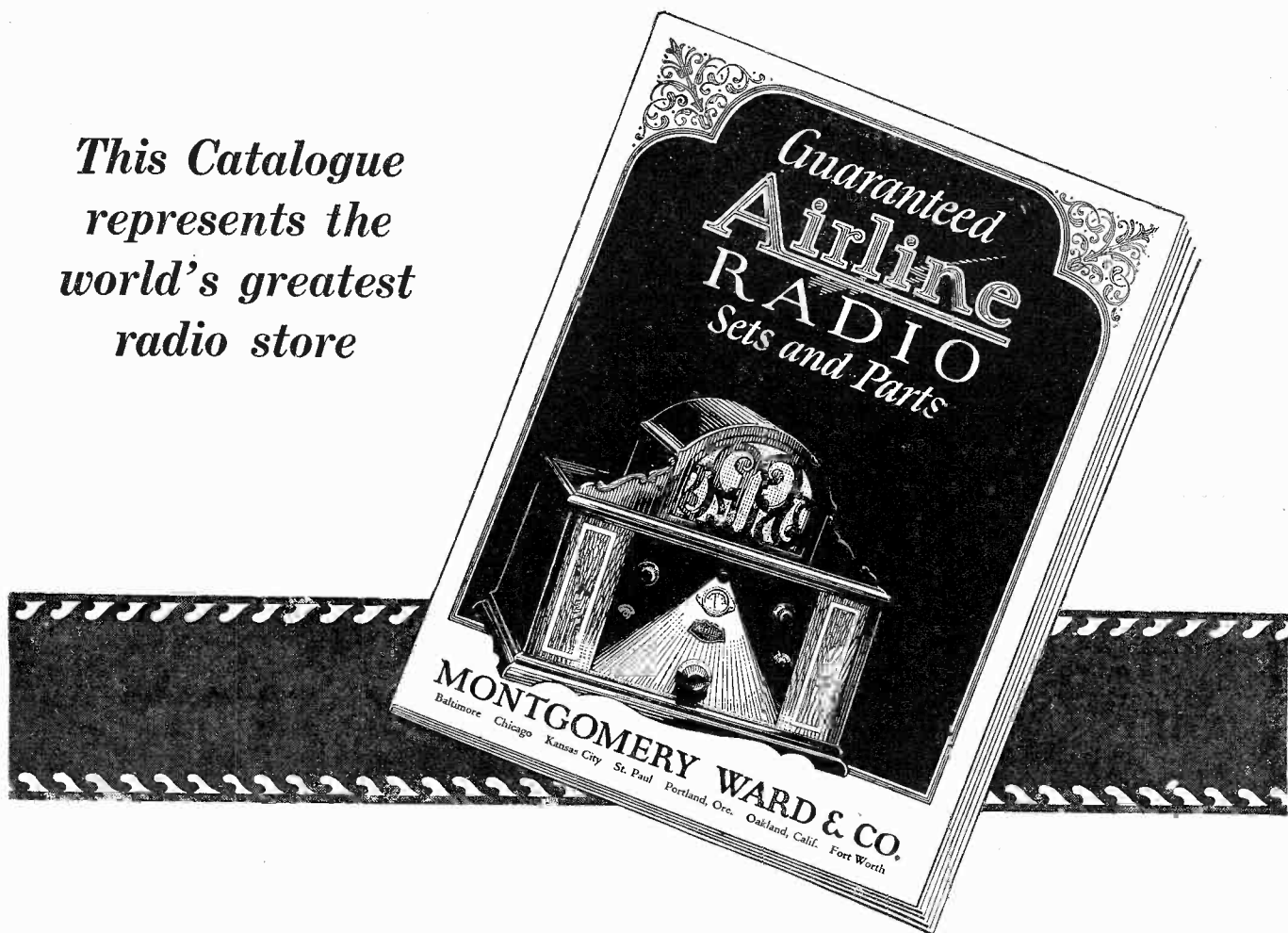

## Ward's New Radio Catalogue Is Yours Free

Where you buy Radio is equally as important as the set you buy.

Send to Radio Headquarters for the most complete Catalogue of the season. See for yourself what is new in Radio and what has been actually tested and approved.

See for yourself what low prices can be made on Radio when it is sold without the usual "Radio profits."

### A Complete Radio Manual

This new 52 page Radio Catalogue shows everything in parts, batteries, cabinets, contains a list of stations, a radio log for recording stations. It shows the best of the new sets. One tube sets that give amazing results. Five tube sets with a single dial to turn. Think of tuning in

one station after another by turning a single dial!

Every price quoted means a big saving to you. Everything offered is tested by our own Radio Experts; in fact, the best experts compiled this Catalogue for you.

Write for this free 52 Page Book. It is yours Free.

### Our 53 Year Old Policy

For 53 years we have sold only quality merchandise under a Golden Rule Policy. You can rely absolutely upon the quality of everything shown in this Radio Catalogue.

To Montgomery Ward & Co. Dept. 40-R  
Baltimore Chicago Kansas City St. Paul  
Portland, Ore. Oakland, Calif. Fort Worth  
(Mail this coupon to our house nearest you.)  
Please mail my free copy of Montgomery  
Ward's New Radio Catalogue.

Name.....

Local address.....

Post Office.....

State.....

ESTABLISHED 1872  
**Montgomery Ward & Co.**

*The Oldest Mail Order House is Today the Most Progressive*

Baltimore Chicago Kansas City St. Paul Portland, Ore. Oakland, Calif. Ft. Worth

# Follow that Hunch!



You've felt that urge to play the Saxophone. You've had a hunch you could do it easy. Follow that hunch. If you want to be popular, if you want to be admired—favored, get this wonderful instrument. Young folks are enamored by its syncopated music. Play jazz in 10 days on your

## BUESCHER True Tone SAXOPHONE

See how easy it is. Everybody has a perfectly normal desire to produce music, yet most people have not the time nor patience to become a musician. But a Buescher Saxophone is different. It looks complicated, but is really very easy to play. With the aid of three free lessons, the scale can be mastered in an hour; in a few days you can be playing jazz tunes. Practice is a pleasure because you learn so quickly.

### Six Days Free Trial, Easy Payments

Send for a Buescher Saxophone or a Cornet, Trumpet or Trombone for six days free trial in your own home. Send no money. If you like the instrument pay a little each month. Clip the coupon now for your free copy of the beautiful Saxophone Book or catalog of any instrument. No obligation whatever. Do it today. Now.

BUESCHER BAND INSTRUMENT CO.  
Everything in Band and Orchestra Instruments  
993 Buescher Block Elkhart, Indiana



**Free!**

This 64 page book tells about the various models, with pictures of professionals using them. Send coupon or postal for your free copy. 278

### Clip the Coupon NOW!

Mail BUESCHER BAND INSTRUMENT CO.  
993 Buescher Block, Elkhart, Indiana  
Without obligation to me, send "The Story of the Saxophone." Check here   
If you prefer other literature describing other band or orchestra instruments check below.  
Cornet  Trumpet  Trombone  Tuba   
Mention any other \_\_\_\_\_  
Write plainly, Name, Address, Town and State in Margin Below

## Tarrano the Conqueror

By RAY CUMMINGS  
(Continued from page 629)

A searchlight from an aerial mast high overhead swung down upon him, bathing him in its glare of white.

His finger pressed the trigger. A soundless flash of purple enveloped the tower. Sparks mounted into the air—a cloud of vivid electrical sparks; but mingled with them in a moment were sparks also of burning wood and fibre. Smoke began to roll upward; the purple flash was gone, and dull red took its place. The hum and angry buzz of outraged electricity was stilled. Flames appeared at all the tower casements—red flames, then yellow with their greater heat.

The trim and interior of the tower was burning. The protons Georg had flung at it with his weapon had broken the electrical barrage. The interference heat had burned out the connections and fired everything combustible within the tower. A terrific heat. It began to melt and burn the *blennie*\*. The upper portion of the tower walls began to crumble. Huge blocks of stone were shifting, tottering; and they began to fall through the glare of mounting flames and the thick black smoke.

Georg had tossed away his now useless weapon—emptied of its charge. He was crouching in the shadow of a parapet. The city was now in turmoil. Alarm lights everywhere. The shrilling of sirens; roaring of megaphoned commands... women screaming hysterically...

A chaos, out of which, for a few moments, Georg knew no order could come. But his heart was in his mouth. The Princess Maida, within that burning building...

He had located the tiny postern gate at the bottom of the tower where Wolfgar had told him she would appear. The barrage was gone; and in a moment she came—a white figure appearing there amid the smoke that was rolling out.

He rushed to her. A figure wholly encased in white *itan*\*\* fabric with head-mask, and tubes from its generator to supply her with air. Wolfgar had smuggled the equipment in to her for just this emergency. She stood awkwardly beside Georg—a grotesque figure hampered by the heavy costume. Its crescent panes of *itanoid* begoggled her.

Behind him, Georg could hear people advancing. A guard picked them out with a white flash. The mounting flames of the tower bathed everything in red. A block of stone fell near at hand, crashing through the metallic platform upon which they were standing. Broken, it sagged beneath their feet.

(Continued on page 664)

\*A cement or mortar used in stone constructions—evidently partially combustible.  
\*\*A universal insulating fabric, as rubber insulates electricity and asbestos bars heat.

## WANTED

ARTICLES pertaining to automobiles such as handy kinks, roadside repairs and anything of interest to the man who drives a car. \$50.00 in prizes every month are offered by MOTOR CAMPER AND TOURIST for such articles. Get a copy at your newsstand and see what is wanted. If your newsdealer cannot supply you send for free sample copy to:

MOTOR CAMPER & TOURIST  
53 Park Place,  
New York City.

Train At Home  
for a fine  
**ELECTRICAL**  
**JOB and**  
a big **RAISE**  
**IN**  
**PAY!**



**If you are now earning less than \$40 a week**

Chief Engineer DUNLAP  
—if you want to be an ELECTRICAL EXPERT —if you want to step quickly into the class of men earning from \$60 to \$250 a week—write me at once! This million dollar school offers ambitious fellows their big opportunity to learn every branch of Electricity at home in spare time by a new, practical JOB-METHOD.

### Go into ELECTRICITY!

—the Business of a Million Opportunities

Be an Electrical Expert. Go into the one great industry where it's easy to get to the top, to make money, to make a real success. You don't need money in the bank or "pull" to get ahead in Electricity—all you need is training, honest, complete training, such as I guarantee.

Learn Electricity Quick by Dunlap "Job-Method"

Rapid progress is made by my students because I train them on actual Electrical jobs, with standard-size tools and materials which I supply them without extra charge.

The first half of my training is Applied Electricity—a complete course in itself. In the second half I give you Electrical Engineering subjects. I give you Electrical, Drafting, Radio, Automobile Electric, and many other valuable subjects all for one small price—on easy terms.

Get My PAY-DOUBLING OFFER

Before you put your time and money into home-training, you want to know if it will lead to a better job and bigger pay. I'll answer that in plain English. Get my catalog, my wonderful, new offers—quick.

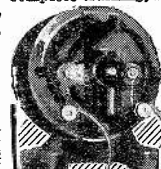

**\$10 MOTOR** used in 4 outfits which I give to every student. A big, man-size motor, same type as used in the great power plants. It is shipped knocked down so you get actual practice in armature winding and assembling. Runs on D. C. or A. C. current or 32v farm electric system.

Training Built by 23 Noted Engineers

This is not a one-man, one-idea school. 22 famous Engineers from Westinghouse, Western Electric, Massachusetts Inst. of Technology, and many other great corporations and universities helped me make this course complete.

Free Job-Service for Students and Graduates

We have supplied thousands of jobs Free both to Students and graduates. This Job-Service keeps in touch with great electrical employers in America.

The AMERICAN SCHOOL

is chartered under the laws of Massachusetts, as an educational institution not for profit. Est. 20 years. Over 200 Executives, Engineers and Educators have prepared the texts used in these wonderful American School home-study courses in Electricity.

CHIEF ENGINEER DUNLAP, Electrical Division  
**AMERICAN SCHOOL** Dept. E826, Drexel Ave. & 58th St., CHICAGO

Mail coupon to Dept. E826, CHICAGO

Chief Engineer Dunlap  I want to be an Electrical Expert. Please rush guarantee, job-service facts, complete information, money-saving offers.

Name.....  
Address.....

## WANTED-MEN TO LEARN RADIO

**\$75 to \$200 a Week**  
Right now, everywhere, big, easy money is being made in Radio. Field unlimited. You can master radio quickly at home in spare time. No previous experience necessary. Now is the time to enter this new, uncrowded field.

**1,000 MILE RECEIVING SET Given to Every Student**  
Our new home-study methods make everything about radio amazingly simple. No other course like it. Makes you expert on radio operation, repairs and installations of all kinds. Send for literature telling all about opportunities and how we give you a 1,000 mile receiving set. Don't miss this big offer—ACT. Write now for big free book.  
RADIO ASSOCIATION OF AMERICA  
4513 Ravenswood Ave., Dept. 611 Chicago

Insure your copy reaching you each month. Subscribe to RADIO NEWS—\$2.50 a year. Experimenter Publishing Co., 53 Park Pl., N.Y.C.



**Send for this  
RADIO  
BOOK  
FREE**



**1926 Catalog of  
RADIO  
BARGAINS  
Save 1/3 to 1/2**

**The World's  
Largest Exclusive  
Radio Mail Order House  
Will Send You This Wonderful Book FREE**

64 illustrated pages containing thousands of bargains in radio sets, semi-finished sets and radio kits of all styles, sizes and approved circuits. **5 tube complete sets as low as \$29.50.** Beautiful models of the very latest designs and types. Elaborate console models with **loud speakers built right into cabinets** of genuine mahogany and walnut. **ALL SETS GUARANTEED.** Coast to coast receiving range. Catalogue also contains everything in radio supplies, including batteries, chargers, loud speakers, transformers, condensers, rheostats and any other parts you may want for improving your set or building a new one. **Guaranteed saving to you of 1/3 to 1/2.**

**AMERICAN  
RADYNOLA  
5 TUBE SET**

**\$29.50**

**The Biggest 5-Tube Value on the Market**

Positively the world's greatest 5 tube radio bargain. **REGULAR \$75.00 VALUE.** Our large quantity production enables us to sell this set for **ONLY \$29.50**, fully built and wired in beautiful mahogany cabinet of latest design with sloping Bakelite panel of Satin finish, handsomely etched and engraved as illustrated. Constructed of the finest low-loss condensers, coils and sockets, bakelite baseboard, panel and dials. **PRICE FOR SET ONLY. \$29.50**  
Transportation charges extra, shipping weight 25 pounds.

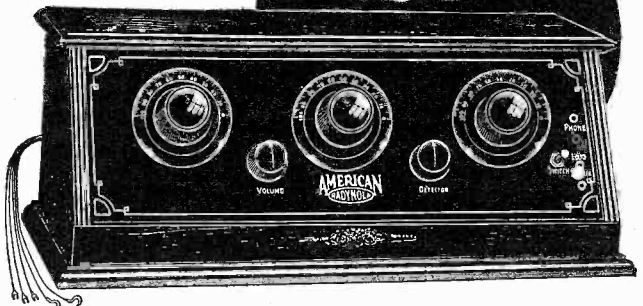

**This Set with All Accessories, Including  
The Famous American Bell Loud Speaker**

with adjustable unit, 2.45 volt "B" batteries, one guaranteed 100 Ampere Hour storage "A" battery, cable for battery connection, 5-201A tubes, Aerial and ground equipment, and everything complete ready to set up and operate. Nothing else to buy. **PRICE \$59.75**  
Transportation charges extra. Shipping weight 100 pounds. Complete instructions with set.

**Order Direct From This Page!** Save 1/3 to 1/2. Our guarantee protects you. Money cheerfully refunded if you are not draft for full amount to insure safety. Refer to any bank or commercial agency regarding our reliability. Write your order and prices plainly. Send post office money order or bank

**Semi-Finished 5-Tube RADIO FREQUENCY RECEIVING SET**

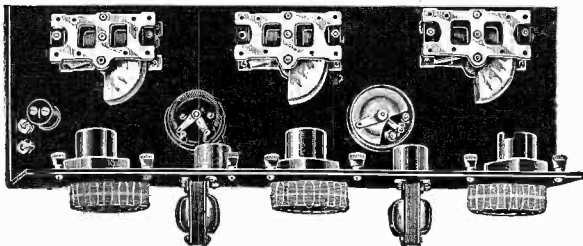

This special offer is astounding the radio world. Coast to coast reception on loud speaker. Low-loss condensers and sockets. Highest quality transformers. Bakelite rheostats. All wiring concealed under Bakelite baseboard. 7 x 18 panel fits into any standard 7 x 18 cabinet. Complete instructions for operating. **GUARANTEED SAVING TO YOU OF \$60.00.** Price of set all mounted. Not wired. **Cabinet of same model as American Radynola pictured above \$5.65 extra. \$18.75**

You must have our catalog no matter what set or kit you want. Our line is complete and includes all popular sets, such as **Superheterodyne, Neutrodyne, Ultra-dyne, Reinartz, Regenerative, Radio Frequency, Browning-Drake, Reflex** and all other latest circuits. Kits, sets and parts manufactured by all well known manufacturers such as **Frost, Howard, Baldwin, Brandes, Western Electric, Columbia** and others.

Our semi-finished sets come with all parts mounted on panel and baseboard ready for wiring. Do not fail to send for our catalog. Remember—we are the largest exclusive radio mail order dealers in the world and carry the best of everything in radio. We save you 1-3 to 1-2 on the following kits. Detailed description appearing in our catalog.

**Semi-Finished 8-Tube Super-Heterodyne**

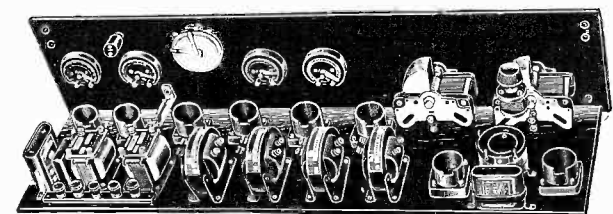

**World's famous 8-tube Super-Heterodyne**

Fully mounted on panel and baseboard. These pictures show interior set and how it looks when enclosed in cabinet. Comes completely assembled ready to wire and operate. We have testimonials from thousands of builders of this set. **Some Have Received Foreign Stations on Loop Aerial.** Unsurpassed in volume and tone quality. Low-loss straight line frequency condensers, vernier dials, finest quality rheostats. Matched Retzner or Columbia long wave transformers. Requires only three screws for attaching panel and baseboard and set is ready to operate. 7x30 panel. Price of set only.

Requires following accessories to complete this set, 7x30 cabinet, 8-201A tubes for storage battery operation or 199 tubes for dry cell operation. 100 Ampere hour storage battery, 2-45 volts v. "B" batteries, loud speaker, center tapped loop aerial. All these items are listed in our catalog at a tremendous saving. **\$43.75**

**NEUTRODYNE**  
Genuine Licensed Neutrodyne kit of parts come fully assembled on the panel and baseboard with complete instructions ready to wire  
**\$29.75**

**COCKADAY**  
3-tube Cockaday kit of parts, fully assembled on panel and baseboard, ready to wire  
**\$15.85**

**REFLEX**  
4-tube Reflex does the work of 7. Fully assembled on panel and baseboard, ready to wire  
**\$38.65**

**ULTRA-AUDION**  
One-tube Ultra-Audion. Wizard of radio. Fully assembled and ready to wire, with instructions  
**\$6.35**

**ALL SETS & KITS**  
described on this page shipped prepaid east of the Rockies, not including Canada. American Radynola 5-tube radio frequency receiver shipped charges collect.

**OUR CATALOG**

includes complete list of broadcasting stations and general information and facts about our free service division. Our radio engineers will help you solve all your radio problems. Send your name and address on a card or in a letter. We will send catalog FREE.

**OUR GUARANTEE**  
Every article exactly as represented. Every article is tested before shipping. Complete satisfaction or money cheerfully refunded.

**RANDOLPH RADIO CORPORATION**  
159 N. Union Ave. Dept. 96 Chicago, Illinois



## This man is sure of his job

HE SAW the handwriting on the wall. Men around him were being dropped right and left. He might have been the next to go but for a familiar coupon which he saw in a magazine. He tore it out and mailed it to Scranton.

Then one day his employer called him in. "Young man," he said, "I have just received a letter from the International Correspondence Schools telling me you have enrolled and have received a mark of 93 for your first lesson."

"I don't mind saying that this letter has saved your job. I had you on the list of men to be dropped. But I'm going to keep you now. And there are bigger things ahead for you. The man who thinks enough of his future to study his job is the kind of a man we want."

HOW about you? Are you sitting on the anxious bench wondering if you will be the next to go? Or are you training yourself so that you will not only be sure of your present job, but will be ready for the job ahead?

This is all we ask: Without cost or obligation, put it up to us to prove how we can help you. Just mark and mail this coupon.

### INTERNATIONAL CORRESPONDENCE SCHOOLS

Box 6223-D, Scranton, Penna.  
 Oldest and largest correspondence schools in the world  
 Without cost, please tell me how your quality for the position or in the subject before which I have marked an X:

- | BUSINESS TRAINING COURSES                               |  |
|---|--|
| <input type="checkbox"/> Business Management            | <input type="checkbox"/> Salesmanship            |
| <input type="checkbox"/> Industrial Management          | <input type="checkbox"/> Advertising             |
| <input type="checkbox"/> Personnel Organization         | <input type="checkbox"/> Better Letters          |
| <input type="checkbox"/> Traffic Management             | <input type="checkbox"/> Show Card Lettering     |
| <input type="checkbox"/> Business Law                   | <input type="checkbox"/> Stenography and Typing  |
| <input type="checkbox"/> Banking and Banking Law        | <input type="checkbox"/> Business English        |
| <input type="checkbox"/> Accountancy (Including C.P.A.) | <input type="checkbox"/> Civil Service           |
| <input type="checkbox"/> Nicholson Cost Accounting      | <input type="checkbox"/> Railway Mail Clerk      |
| <input type="checkbox"/> Bookkeeping                    | <input type="checkbox"/> Common School Subjects  |
| <input type="checkbox"/> Private Secretary              | <input type="checkbox"/> High School Subjects    |
| <input type="checkbox"/> Spanish                        | <input type="checkbox"/> French                  |
| <input type="checkbox"/> Illustrating                   |  |
| TECHNICAL AND INDUSTRIAL COURSES                        |  |
| <input type="checkbox"/> Electrical Engineering         | <input type="checkbox"/> Architect               |
| <input type="checkbox"/> Electric Lighting              | <input type="checkbox"/> Architects' Blueprints  |
| <input type="checkbox"/> Mechanical Engineer            | <input type="checkbox"/> Contractor and Builder  |
| <input type="checkbox"/> Mechanical Draftsman           | <input type="checkbox"/> Architectural Draftsman |
| <input type="checkbox"/> Machine Shop Practice          | <input type="checkbox"/> Concrete Builder        |
| <input type="checkbox"/> Railroad Positions             | <input type="checkbox"/> Structural Engineer     |
| <input type="checkbox"/> Gas Engine Operating           | <input type="checkbox"/> Chemistry               |
| <input type="checkbox"/> Civil Engineer                 | <input type="checkbox"/> Automobile Work         |
| <input type="checkbox"/> Surveying and Mapping          | <input type="checkbox"/> Airplane Engines        |
| <input type="checkbox"/> Metallurgy                     | <input type="checkbox"/> Agriculture and Poultry |
| <input type="checkbox"/> Steam Engineering              | <input type="checkbox"/> Mathematics             |

Name..... 6-26-25  
 Street.....  
 Address.....  
 City..... State.....

Occupation.....  
 If you reside in Canada, send this coupon to the International Correspondence Schools Canadian Limited, Montreal

## Play the HAWAIIAN GUITAR

Just as the Natives Do

**FREE** when you enroll

**\$15 HAWAIIAN GUITAR and Case**

Only 4 Motions used in playing this fascinating instrument. Our native Hawaiian instructors teach you to master them quickly. Pictures show how. Everything explained clearly.

**Easy Lessons**

After you get the four easy motions you play harmonious chords with very little practice. No previous musical knowledge necessary.

**Free Guitar** and outfit in Genuine Seal Grain Fabrikoid Case as soon as you enroll. Nothing to buy—everything furnished. No delay.

**First HAWAIIAN CONSERVATORY OF MUSIC, Inc.**  
 9th Floor, Woolworth Bldg., Dept. 140, New York, N. Y.  
*Approved as a Correspondence School Under the Laws of the State of New York*

Write at Once

You'll never be lonesome with this beautiful Hawaiian Guitar, the 62 printed lessons and the clear pictures make it easy to learn quickly.

A postcard will do. ACT!

## Tarrano the Conqueror

(Continued from page 662)

Georg tore at the girl's headpiece, lifted it off. Her face was pale, frightened, yet she seemed calm. Her glorious white hair tumbled down in waves over her shoulders.

"Wolfgar—he—" She choked a little in the smoke that swirled around them. Georg cut in: "He sent me—Georg Brende. Don't talk now—get this off."

He pulled the heavy costume from her. She emerged from it—slim and beautiful in the shimmering blue kirtle, with long grey stockings beneath.

A spider incline was nearby. But a dozen guards were coming up it at a run. With the girl's hand in his, Georg turned the other way. People were closing in all around them—an excited crowd held back by the heat of the burning tower, the smoke and the falling blocks of stone. Someone swung a pencil-ray wildly. It seared Georg like a branding-iron on the flesh of his arm as it swung past. He pulled Maida toward the head of an escalator a dozen feet away. Its steps were coming upward from the plaza at the ground level. Half-way up, the first of an up-coming throng were mounting it.

### Important Articles to Appear In Nov. Issue of "The Experimenter"

How to Make the Electro Mystic Crystal Globe By Philippe A. Judd

Electrified Butterfly Lives 25 Years By B. Vincent, Southampton, England

Evolution of the Vacuum Tube By Leon L. Adelman, A.M.I.R.E.

The Luludyne By Simon Kahn, 2CGX

Testing Insulating Materials

Liquid Hydrogen

Transmitting Photographs by Cable

But Georg again turned aside. He found Maida quick of wit to catch his plans; and agile of body to follow him. They climbed down the metal frame-work of the escalator sides; down under it to where the inverted steps were passing downward on the endless belts. Maida slid into one of them, with Georg after her, his arms holding her in place.

They huddled there. No one had seen them enter. Smoothly the escalator drew them downward. Above them in a moment the tramp of feet sounded close above their heads as the crowd rushed upward.

They approached the bottom, slid out upon a swinging bridge which chanced at the moment to be empty of people. Down it at a run; into the palm-lined plaza at the bottom of the city.

Down here it was comparatively dim and silent. The alarm lights of the plaza section had not yet come on; the excitement was concentrated upon the burning tower above. The crowd, rushing up there, left the plaza momentarily deserted. Georg and Maida crossed it at a run, scurried like frightened rabbits through a tunnel arcade, down a lower cross-street, and came at last unmolested to the outskirts of the city.

The buildings here were almost all at the ground level. Georg and Maida ran onward, hardly noticed, for everyone was gazing upward at the distant, burning tower. Georg was heading for where Wolfgar had an aero secreted. A mile or more. They

(Continued on page 666)

## ONE EASY PAYMENT

Puts this 15"x6' Quick Change Gear SOUTH BEND LATHE In Your Shop

We ship any size Lathe you need upon receipt of first payment—then you pay balance in convenient monthly installments which the Lathe itself will save and earn for you.

9"x3' Lathe...\$241	15"x 7' Lathe...\$447
11"x4' Lathe... 288	16"x 8' Lathe... 498
13"x6' Lathe... 366	18"x10' Lathe... 721

**33,000 NOW IN USE**

In U. S. and In 64 Foreign Countries. Free Catalog shows 96 styles, all sizes. Select just the Lathe you want.

Write for Free Catalog today

**SOUTH BEND LATHE WORKS**  
 504 E. Madison St. South Bend, Ind.

## NEW VEST POCKET ADDING MACHINE

**ADDS · SUBTRACTS MULTIPLIES · DIVIDES**

**\$2.95**

Does all the work of a \$300.00 machine, yet fits the vest pocket. Easy to operate—does any kind of figuring in a jiffy. The neatest and best constructed portable adding machine made. **Counts Clear Up to 999,999,999.** Total visible at all times. A pull of the finger clears it. Invaluable to anyone who uses figures. Saves many times its cost by preventing mistakes.

**10 Days' Trial** Send no money. Just name and address and we will send machine post-paid. Pay postman on delivery \$2.95. Use it 10 days to prove it does all we claim. Your money back if not perfectly satisfied. Don't be fooled by cheap imitations. Order your Vest-Pocket now from this ad.

Reliable Adding Machine Corp., Dept. 169  
 124 W. Washington St., Chicago, Ill.

**AGENTS** Here's a money maker. Everybody wants one. Splendid profit. Write for special offer.

## LOOK! "Boys," We Have It!

### The "DE-LUX" Automatic Paper-Tape Printer.

Sells for \$15.00

over 100% profit  
 \$50.00 Per day Easy

Just pull the tape—the DE-LUX will do the rest. The modern method used in place of twine by progressive merchants. Saves time and makes packages neater.

We want men financially responsible to act as our distributors in exclusive territory. Wire or write

**METAL PRODUCTS COMPANY**  
 Dept. M, 124 W. 4th St., Los Angeles, Calif.

## NEW BIG POWERFUL MIRACO ultra 5 TUBE RADIO

now only \$59.95 retail

**GET SPECIAL OFFER.** Factory prices save you 1-3 to 1-2. Users everywhere report Miraco Ultra 5 gets programs coast to coast, Canada to San, loud and clear on speaker; outperforms \$100 to \$250 sets. Many hear Europe. Marvellous value—let testimony of users convince you. Smaller sets \$13.75 up. Write.

**MIRACO RADIO GETS 'EM COAST TO COAST**

**AGENTS DEALERS** Write! **MIDWEST RADIO CORPORATION**  
 Pioneer Builders of Sets  
 409 E. 6th St., Cincinnati, Ohio

# "Build Your Own"—Special Inducement

To get you started dealing with us, we offer special prices on these most popular two kits. But your order will have to be sent by November 30 when our regular catalog prices will again be in effect.

Your chance to get the best kit at a big saving! Take it!

All of our Kits contain complete parts for receiver, including drilled and engraved Bakelite-Dilecto panel, finest, roomy mahogany finish cabinet, simple new-style blueprint and instructions, everything—nothing more to buy. All parts highest grade—advertised, well-known, reliable, dependable—fully guaranteed by manufacturers and ourselves. Look at these brands. You cannot get better kits!

## Our New Method of Wiring—Perfectly Simple—No Radio Knowledge Needed

No solder—No bare wires—No poor connections—No dissatisfaction.  
No tools needed except a common screw-driver and common pliers.



All connections are made by the use of our flexible, insulated eyeletted connecting wire in place of bus bar or wire, and solder. And in a fraction of the time usually required when using the old fashioned way. And when the job is done it is neat and your connections are tight.

### 4-Tube Roberts Knock-Out

Superior to most other sets REGARDLESS OF NUMBER OF TUBES!

Spl. \$43<sup>55</sup> Postpaid  
Kit KR, 9215  
Range 3500 Miles

Combines principles of Reflex, Neutralization, Tuned Radio Frequency, Regeneration (without blooping), and Push-Pull Amplification. Smooth-working—easily tuned—non-howling—non-squealing—non-reradiative. Guaranteed absolutely to give entire satisfaction.

See what Doubleday, Page & Co., through Mr. Arthur H. Lynch, Editor of their magazine, "Radio Broadcast," say about the Radio Broadcast's sensational 4-Tube Knock-Out Set developed by Walter Van B. Roberts:  
"Tube for tube, dollar for dollar, result for result, we will stack it up against any receiver for home construction ever described by any radio publication and gamble that it comes out winner."

#### MR. LYNCH ADDS—READ IT!

"It is the best we have ever seen—and we have seen and operated almost every type made and used during the past twelve years. It has pulled in forty-six stations on a loud speaker with two tubes, using an indoor antenna. Its signals have been heard through the air more than a quarter mile. It is not merely the best four-tube receiver, but the best by a very good margin."

#### CUSTOMERS PRAISE IT!

##### Receives Calif. from N. Y. on Two Tubes!

"I have followed the development of the Roberts circuit with results far beyond all expectations. I find it to be EXACTLY as efficient as described, although I was skeptical as to the unusual operation that it was said to have accomplished. I no longer have any doubts, for in the last week of August and to date in September, I have received KGO at least four times. On one of these occasions I received it on my Dictograph loud speaker, using only two tubes! I have consistently received long distance, such as Dallas, Fort Worth, Auburn, La., Hastings, and Kansas City, in all about 65 stations, while just "fishing" locals, such as Pittsburgh,

Schenectady, New York City, Chicago, Boston, etc., it need not be mentioned, are perfect, even on occasions when I have used neither aerial nor ground. I am sure it was a lucky day when this set came to my attention." L. L. Clifford, 190 Second Street, Fulton, NEW YORK.

##### Selectivity Better than Eight tube Heterodyne

"Last week I constructed the four-tube Roberts Knock-Out set. I am more than pleased by its operation, its selectivity being better than my eight-tube super-heterodyne. On a poor night I was able to bring in WOS, WGN, WOC, WSAI, WRZ, and all at loud speaker intensity." Louis R. Jeffrey, 51 Newark Street, Hoboken, NEW JERSEY.

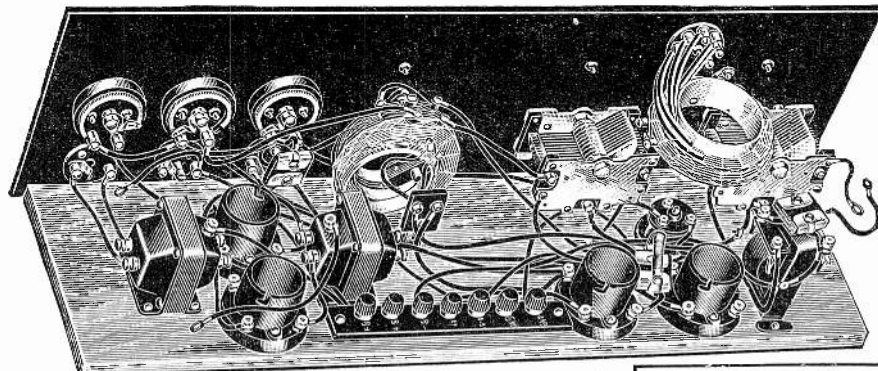

## See What You Get—Best Quality

Fine 7x18x8 mahogany finish cabinet, drilled and engraved Bakelite-Dilecto panel, extra good, non-warping baseboard, Sickies' Roberts' coils, 2 Hammarlund low loss variable condensers, 3 E-Z Toon vernier dials, Thordarson transformer, pair Modern push-pull transformers, 3 Pacont rheostats, 4 Bell Bakelite low loss sockets, Improved single-circuit jack, Improved double-circuit jack, Cutler-Hammer inductance switch, Smilcar filament switch, Pacont grid leak, Hileco grid condenser and mounting, 2 Hileco fixed condensers, Amplex grid-denser, 7 Aristocrat binding posts, binding post strip, complete set "No-Sod-er" connecting wires, hardware, blueprint and instruction sheet. You can assemble in only three hours or so.

List price, \$64.69; our regular catalog price, \$48.56—Special price to October 31, only \$43.51.

### Special Features

Great volume.  
Utmost clearness.  
Sweetness of tone.  
Highly selective.  
Cheap to build.  
Easy to operate.  
Receives great distance.  
Does not radiate or cause squealing in your neighbors' receivers.  
Low cost of upkeep.  
It offers a better combination of sensitivity, selectivity and quality for the total cost than any other circuit we have ever known.  
The best 4-Tube set for home construction ever produced.

## 3-Tube LoLos \$26<sup>51</sup> Postpaid—Kit KR6996 Explorer—Spl. Range 1000 Miles on Loud Speaker

Stations Logged in 2 hours at New York City  
All on Loud Speaker

By one of the editors of "Radio News"

WJZ	72	65	N. Y. City
WEAF	86	77	N. Y. City
WFBH	65	21	N. Y. City
WFAX	55	18	St. Cloud, Minn.
WQAO	73	40	N. Y. City
WBHH	75	43	Chicago
WJY	72	52	N. Y. City
KDKA	70	32	Pittsburgh, Pa.
WTAS	67	25	Elgin, Ill.
WGBS	67	30	N. Y. City
WHN	72	39	N. Y. City
WJAX	88	48	Cleveland
WIT	75	83	Philadelphia, Pa.
KYW	78	93	Chicago
WOC	83	74	Davenport, Iowa

Positively a "hammer!" We have never tested an outfit at anywhere near our price more suitable for long distance broadcast reception. (Contains a low loss 3-circuit tuner, a low loss condenser, low loss sockets, etc.) Special Features: Sensitive—Selective—Clear reception—Simple to construct—Simple to operate—Dependable—Low loss design—Receives long distances—Great volume.

### We Give You High-Class Parts

Fine 7x18x8 mahogany finish cabinet, drilled and engraved Bakelite-Dilecto panel, extra good, non-warping baseboard, Gen-Win low loss coupler, Hammarlund low loss variable condenser, 2 Bell Bakelite dials, 2 Rasco verniers, 2 Pacont A. F. transformers, 2 Pacont rheostats, 3 Bell Bakelite low loss sockets, Improved single circuit jack, 2 Improved double circuit jacks, Smilcar A battery filament switch, Hileco fixed grid condenser and mounting, Pacont grid leak, 7 Aristocrat moulded binding posts, binding post strip, complete set "No-Sod-er" connecting wires, hardware, blueprint and instruction sheet. You can assemble in only a couple of hours. List price for parts \$37.84. Our catalog price, \$29.95. Special Price to October 31st, only \$26.51.

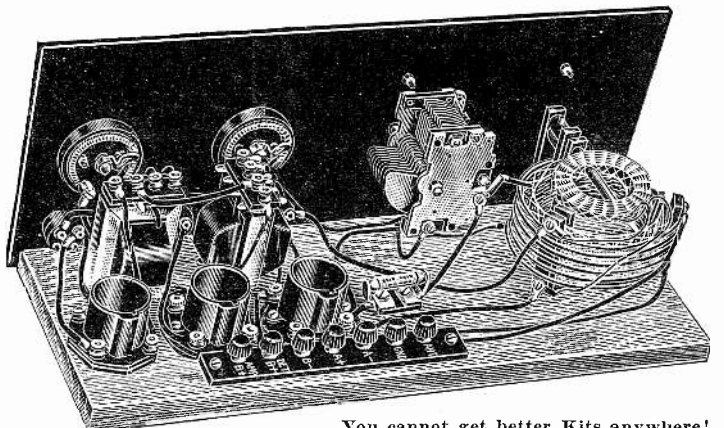

You cannot get better Kits anywhere!

This is a dandy! Order it!

OLDEST RADIO MAIL ORDER FIRM IN AMERICA

ORDER DIRECT FROM THIS AD—ON APPROVAL—NO MONEY IN ADVANCE—SHIPPED SUBJECT TO EXAMINATION WHEN REQUESTED—WE PAY TRANSPORTATION—24-HOUR SHIPMENT—SATISFACTION OR MONEY BACK  
(Foreign customers will please remit with order and include enough for transportation and insurance which we do not pay.)

Send for BIG CATALOG---36 pages, Filled with big bargains in Kits, Parts and Accessories. Send today!

WE SHIP IN 24 HOURS Satisfaction Guaranteed

RADIO SPECIALTY CO., Kit Div. 165Y, 245N, Greenwich St., N.Y.



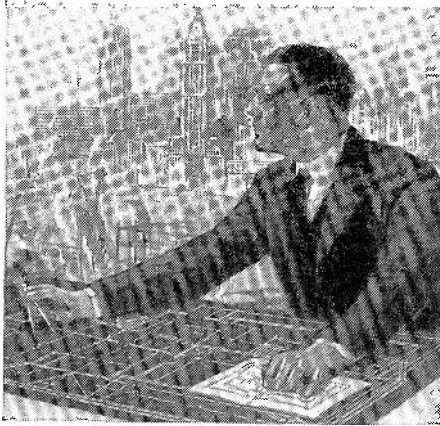

## Former Bricklayer Now Earning \$12,000 a Year

"When I enrolled with the International Correspondence Schools, I was a bricklayer and I didn't know a thing about blueprints. Today I have my own contracting business and I am able to figure the most difficult jobs and execute them to the satisfaction of everyone concerned. My income is between \$12,000 and \$15,000 a year. It certainly was a lucky day for me when I sent in that I. C. S. coupon."

That's a true story of what just one student of the International Correspondence Schools has done. There are thousands of others. Every mail brings letters from men and women telling of increases in income and salary due directly to spare-time study.

One hour a day spent with the I. C. S., in the quiet of your own home, will prepare you for success in the work you like best.

Mail the coupon for Free Booklet

TEAR OUT HERE  
INTERNATIONAL CORRESPONDENCE SCHOOLS  
Box 6222-D, Scranton, Penna.

Oldest and largest correspondence schools in the world

Explain, without obligating me, how I can qualify for the position, or in the subject, before which I mark X.

- |   |  |
|---|--|
| <input type="checkbox"/> ARCHITECT                  | <input type="checkbox"/> Navigation                  |
| <input type="checkbox"/> Architectural Draftsman    | <input type="checkbox"/> SALESMANSHIP                |
| <input type="checkbox"/> Architects' Blue Prints    | <input type="checkbox"/> ADVERTISING                 |
| <input type="checkbox"/> Contractor and Builder     | <input type="checkbox"/> Window Trimmer              |
| <input type="checkbox"/> Building Foreman           | <input type="checkbox"/> Show Card and Sign Painting |
| <input type="checkbox"/> Concrete Builder           | <input type="checkbox"/> BUSINESS MANAGEMENT         |
| <input type="checkbox"/> Structural Engineer        | <input type="checkbox"/> Private Secretary           |
| <input type="checkbox"/> Structural Draftsman       | <input type="checkbox"/> Business Correspondent      |
| <input type="checkbox"/> Plumber and Steam Fitter   | <input type="checkbox"/> BOOKKEEPER                  |
| <input type="checkbox"/> Heating and Ventilation    | <input type="checkbox"/> Stenographer and Typist     |
| <input type="checkbox"/> Plumbing Inspector         | <input type="checkbox"/> Higher Accounting           |
| <input type="checkbox"/> Foreman Plumber            | <input type="checkbox"/> COMMERCIAL LAW              |
| <input type="checkbox"/> Sheet Metal Worker         | <input type="checkbox"/> Mathematics                 |
| <input type="checkbox"/> CIVIL ENGINEER             | <input type="checkbox"/> GOOD ENGLISH                |
| <input type="checkbox"/> Surveying and Mapping      | <input type="checkbox"/> ILLUSTRATING                |
| <input type="checkbox"/> ELECTRICAL ENGINEER        | <input type="checkbox"/> Railway Mail Clerk          |
| <input type="checkbox"/> Electric Lighting and Rys. | <input type="checkbox"/> CIVIL SERVICE               |
| <input type="checkbox"/> Electric Wiring            | <input type="checkbox"/> Mining Engineer             |
| <input type="checkbox"/> Telegraph Engineer         | <input type="checkbox"/> Gas Engine Operating        |
| <input type="checkbox"/> Telephone Work             | <input type="checkbox"/> STATIONARY ENGINEER         |
| <input type="checkbox"/> MECHANICAL ENGINEER        | <input type="checkbox"/> Textile Overseer or Supt.   |
| <input type="checkbox"/> Mechanical Draftsman       | <input type="checkbox"/> TRAFFIC MANAGER             |
| <input type="checkbox"/> Toolmaker                  | <input type="checkbox"/> AUTOMOBILES                 |
| <input type="checkbox"/> Machine Shop Practice      | <input type="checkbox"/> AGRICULTURE                 |
| <input type="checkbox"/> CHEMIST                    | <input type="checkbox"/> Poultry Raising             |
| <input type="checkbox"/> Pharmacy                   | <input type="checkbox"/> RADIO                       |

Name \_\_\_\_\_  
Occupation & Employer \_\_\_\_\_ Business Address \_\_\_\_\_ 3-6-24  
Street and No. \_\_\_\_\_  
City \_\_\_\_\_ State \_\_\_\_\_

Canadians may send this coupon to International Correspondence Schools Canadian, Limited, Montreal, Canada

## Save 20 to 50% FREE RADIO CATALOG

**LATEST IN  
HOOK-UPS  
AND  
RADIO**

Get the lowest rock-bottom prices on radio parts, sets, kits. New free Radio Catalog and Guide brimful of standard, reliable, guaranteed goods. Over 100 latest hook-ups and illustrations. Be sure to get this thrifty book before you buy. It puts money in your pocket. Saves you as much as half on a set. Also please include name of radio fan. Send letter or postal NOW.

**THE BARAWIK COMPANY**  
103-136 S. Canal St., Chicago, U. S. A.

Insure your copy reaching you each month. Subscribe to SCIENCE AND INVENTION—\$2.50 a year. Experimenter Publishing Co., 53 Park Place, New York City.

## Tarrano the Conqueror

(Continued from page 664)

reached the spot—but the aero was not there. They were in the open country now—Venia is small. Plantations—an agricultural region. Most of the houses were deserted, the occupants having fled into the city as refugees when threats and orders came from Washington the day before.

Georg and Maida came upon a little conical house; it lay silent, heavy-shadowed in the starlight with the glow of the city edging its side and circular roof. Beside it was an incline with a helicopter standing up there on a private landing stage . . . Georg and Maida rushed up the incline.

A small helicopter; its dangling basket was barely large enough for two—a basket with a tiny safety 'plane fastened to its out-rigger.

In a moment Georg and the girl had boarded the helicopter. She was silent; she had hardly said a word throughout it all . . . The helicopter mounted straight up; its whirling propellers above sent a rush of air downward.

"These batteries," said Georg. "The guards in Venia can't stop us. An aero—even if

## Feature Articles in November "Radio News"

- Prediction and Fulfillment—Grand Opera by Wireless. By Hugo Gernsback.
- Radio With the Rice Expedition. By T. S. McCaleb.
- Radio-Controlled Automobile. By Herndon Green.
- Hot Cathode Metal Vapor Tubes. By Dr. Bazzoni.
- New Ideas In Radio Receivers. By G. C. B. Rowe.
- New Two-Range Receiver. By Sylvan Harris.

we had it—I doubt if we could get power for it. They've shut off general power by now, I'm sure."

She nodded. "Yes—no doubt."

As they mounted upward, the city dwindled beneath them—dwindled to an area of red and green and purple lights. It was silent up here in the starlight; a calm, windless night—cloudless, save for a gray bank which obscured the moon.

Ten thousand feet up. Then fifteen. The city was a tiny patch of blended colors. Light rockets occasionally mounted now. But their glare fell short. Georg's mind was busy with his plans. Had the helicopter been seen? It seemed not. No rocket-light had reached it; and there was no sign of pursuit from below.

Maida crouched beside him. He felt her hand timidly upon his arm; felt her shy, sidelong glance upon him. And suddenly he was conscious of her beauty. His heart leaped, and as he turned to her, she smiled—a smile of eager trust which lighted her face like a torch of faith in the spire of a House of Worship.

"You are planning?" she said. "You know what it is we must do?"

He said: "I think so. The *volan*\* out there is large enough for two. You'll trust yourself to it with me? You're not afraid, are you?"

\*A small winged board without power, used for emergency descents by volplaning down from disabled aeras.

(Continued on page 668)



# Elto

(Designed and built by Ole Evinrude)  
**Quick Detachable  
Rowboat Motor**

Powerful, Light Weight, Speedy, Quiet Running, Practically Vibrationless. Starts on a quarter turn. Easily carried with you anywhere you go. No rowing, no work, no bother. Just ride and enjoy the greatest of water sports. Slow down for fishing. Speed up for racing. Great power.

**Write for FREE Catalog** describing all the new features, especially the famous Propello Pump. Only Elto has it. Write today.

ELTO OUTBOARD MOTOR CO. Dept. 48  
The Lincoln Bldg., First  
Manfrers Home Bldg., Milwaukee, Wis.



## Make Money Taking PICTURES



Tremendous, big-paying opportunities are open for ambitious men in Modern Photography. This is the picture age. Magazine and newspaper publishers buy thousands of photographs each year. Every manufacturer sends out high priced pictures of his products. Every home wants portraits. Photography is a business running into millions of dollars each year. And there is a great shortage of trained photographers.

### Earn \$3,000 to \$10,000 a Year

Hundreds of men are earning big money and establishing their own businesses. Even during spare time, while training, you can make \$75 a week easily—no matter where you live!

### Amazing New Easy Method

I show you at home, how to do the kind of work turned out by the big studios in New York and Chicago! I show you how to make big money within 30 days! C. M. Cole bought a home with money he had made when only half way through his training. So well do I know what I can do for you that I guarantee

under bond to return every cent of your tuition if you are not thoroughly satisfied.

### Professional View Camera FREE!



Write at once for Free Camera Offer—I give you, free, a splendid professional view camera. You will be astonished and delighted. This offer open for short time only—so act quick! No obligation.

INTERNATIONAL STUDIOS, Inc.  
Dept. 1428  
3601 Michigan Ave., Chicago, U.S.A.

## Seal Rupture With a Quarter

Now you can throw away forever steel bands, chafing leg straps and other heavy makeshift devices. For a well known American scientist has found a new easy way to support ruptured legs, assisted by means of a wonderful little invention weighing less than 1-26 of an ounce. Not only do you do away with the objectionable pressure and tight strapping, but you eliminate the "coming down" of rupture—when running, straining, exercising, sneezing, etc.—which too frequently leads to strangulation. So great has been the success of this wonderful device that it is being offered to ruptured people on an absolute guarantee of instant satisfaction or no cost. Simply drop a postcard or letter requesting free literature to **NEW SCIENCE INSTITUTE**, 4516 Clay St., Steubenville, Ohio.

Insure your copy reaching you each month. Subscribe to SCIENCE AND INVENTION—\$2.50 a year. Experimenter Publishing Co., 53 Park Place, New York City.

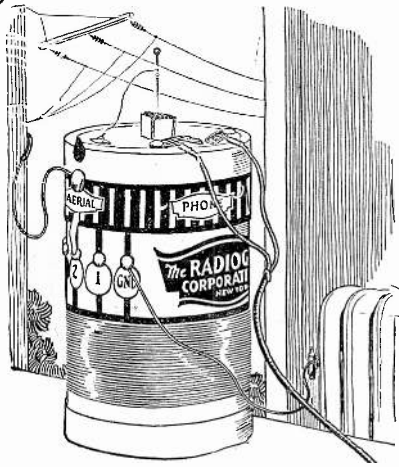

The Simplest Practical Radio Set Made

\$ 1<sup>00</sup>

The **RADIOGEM**

The simplest radio outfit made—yet as practical as the most expensive. A crystal receiving set that you can operate and enjoy even though you know absolutely nothing about radio. You receive the RADIOGEM unassembled, together with a clearly written instruction book, which shows you how to quickly and easily construct the set, using only your hands and a scissors. The outfit comprises all the necessary wire, contact points, detector mineral, tube on which to wind the coil, etc., etc. The instruction book explains simply and completely the principles of radio and its graphic illustrations make the assembling of the RADIOGEM real fun.

**AERIAL OUTFIT**

Complete aerial outfit for the RADIOGEM, consisting of 100 ft. of standard copper aerial wire and two special porcelain insulators. Price .....50c.

- Radiogem - - - \$1.00
- Aerial Outfit - - - .50
- Radiogem and Aerial Outfit - - - 1.50

**RAGEMCO**

Radio Headquarters for the Finest and BEST Radio Tools

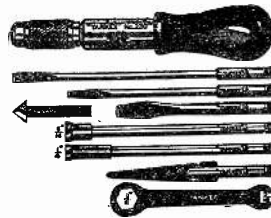

**RADIO TOOL SET**

This is the handiest set of tools ever made for Radio Work by the makers of the famous "YANKEE" Tools. It contains the following: 1 Ratchet Screw-driver, 3/4 in. long holding all attachments; 1 Blade, 3/2 x 3-16; 1 Blade, 3/2 x 1/4; 1 Countersink; 2 Socket Wrenches for all small nuts; 1 Reamer to enlarge holes in panel from 1/4 x 3/8; 1 Wrench, one end 5-16" square or hex. for jack, other 1/2" hex., etc.  
PRICE per set—No. 701 .....\$3.00

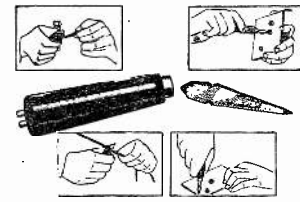

**RADIO HANDI-TOOL**

Bends Bus Bar or wire strips and scrapes wire, bores and reams holes, etc. Tool consists of 4 in. black spanned handle, to which is attached wire bending device, with nicked ferrule and 3 in. long two sided reamer.  
PRICE—No. 702 .....50c



**HAND DRILL**

The hardwood handle is hollow to store drills. Iron frame, nickel-plated parts, ball bearing three jawed chuck holding and centering accurately round shank drills from 0 to 3-16. Length of drill, 12 inches.  
PRICE—No. 303 .....\$2.25



**TOOL CHEST**

Set consists of "LOCK-GRIP" master handle, 5" long, black Rubberoid finish with steel chuck, nickel plated, buffed and with the following 9 tools: Saw, bradawl, large screwdriver, file, scratch awl, gimlet, reamer, chisel, small screwdriver. Each tool of fine steel, drop forged tempered, hardened, and nicely finished. Set comes in leatheroid box with tray.  
PRICE—No. 703 .....\$1.85

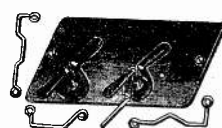

**WIREBENDING TOOL**

For making eyes, loops, bends, and offsets on Bus Bar wire. With this device any Radio Constructor can wire his set to compare favorably with any factory made set. Easier to use and more accurate than pliers. Full directions in box. Made of heavy steel, blued and finished.  
PRICE—No. 263 .....\$1.00

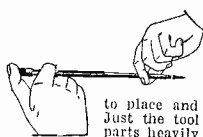

**SCREW STARTER and DRIVER**

Holds any screw by its slot with a firm grip, makes it easy to place and start screws in difficult places. Just the tool for the Radio Constructor. All parts heavily nicked and polished.  
PRICE—No. 304 .....\$1.00



**CIRCLE CUTTER**

Especially designed for the Radio Constructor. Made of the finest material and equipped with the highest grade high steel cutting bits. It does three things at once. It drills its own pilot, cuts out plug and nuts bead or scroll around the hole in one operation. Cuts holes 3/4 to 4 in. in diam.  
PRICE—No. 402 .....\$3.00  
401. Same tool but smaller and not fitted with bead or scroll in one operation.  
PRICE—No. 401 .....\$2.00

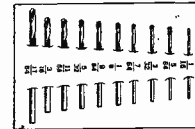

**RADIO DRILL SET**

Composed of 10 straight shank twist drills, fitting all hand and breast drills. The selection of these drills has been especially made for Radio Constructors and consists of the following sizes: 1-16, 5-64, 3-32, 7-64, 1/8, 9-64, 5-32, 11-64, 3-16, 17-64. Drills are mounted on white Holland Linen with sizes clearly marked.  
PRICE—No. 305 .....\$1.25



**HAND DRILL**

Especially designed for Radio Work by the makers of the famous "Yankee" Tools. A beautiful balanced, small, powerful drill with 4 to 1 ratio of gears for speed. Special chuck 9-32" capacity, to take largest drill, mostly furnished with drill or tool sets. Length over all, 9 1/2 in. Weight 1 1/2 lbs.  
PRICE—No. 302 .....\$2.75

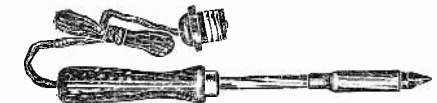

**ELECTRIC SOLDERING IRON**

A perfect tool for Radio Work. Operates either on 110-volt A.C. or D.C. The heat element is of Nichrome, which prevents overheating and assures the desired even temperature. Size of Iron, 10 1/2 in. long. A 4-ft. cord and plug is furnished.  
PRICE—No. 800 .....\$2.00



Three-in-One Nut Wrench. Consists of handle with hollow stem 6 inches in length and three interchangeable sockets fitting popular sizes of nuts. The hexagon sockets grip the nut solidly.  
PRICE per set—No. 301 .....65c



Combination Plier, Wire Cutter, Wire Former and Wrench. Drop forged, slender but exceptionally strong, 6 in. long.  
PRICE—No. 202 .....75c



Side Cutting Nipper, Lap Joint. For cutting all kinds of wire. Jaws hardened and oil tempered. Natural steel finish with polished jaws. Length 6 inches.  
PRICE—No. 201 .....75c

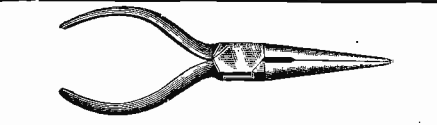

Long Sharp Nose, Side Cutting Pliers. Just the pliers for the radio constructor. Bends and cuts all kinds of soft wire. Nose 1 1/2 inches long, black body, polished jaws. Length 5 1/2 inches.  
PRICE—No. 200 .....75c

Order all tools by order number. All goods are shipped free of transportation charges to all parts of the United States and possessions the same day as the order is received.

**MONEY REFUND GUARANTEE**

If you are not satisfied money will be refunded on return of goods.

The **RADIOGEM** CORP., 66-E W. Broadway, New York

**KNOCK HIS BLOCK OFF**

You would be a better and happier man—if you were only able to “knock the block off” of the man or the thing that stands in your way. **AND YOU CAN!** It's all just a matter of having **PHYSICAL VIGOR AND FITNESS.**

My unusual System of Muscle Building and Promoting Physical Fitness is giving men new bodies for old. I am taking run-down, pep-



less, forlorn men and women under my wing, studying their condition, and instructing them by mail, at their own homes, all over the world, how to get the pink of physical per-

**BENNY LEONARD'S**

HOME COURSE OF MUSCLE AND BODY BUILDING (AND BOXING)

fection they are after. Most of them are young or middle-aged men who were getting prematurely old until I took them in hand. Many are studying my course to learn the **MANLY ART OF BOXING AND SELF DEFENSE.**

Many are getting **BIGGER MUSCLES**—huskier bodies—larger limbs—heavier necks, arms, chests—as a result of the scientific steps of development which I am pointing out to them. And many are forging ahead in business as a result of renewed pep and vitality, the singing, tingling body, which my physical culture course has given them.

Remember—that I didn't always have the perfect body. I now have—once I was skinny and weak. I achieved the **Lightweight Championship of the World** as a result of first **BUILDING BODILY PERFECTION** for myself. What I did for myself I can do for YOU.

It is impossible to tell you all about my methods, here. If you'll just send me your name and address on the little slip printed below, I will send you, free of charge, my wonderful booklet, “Now I Can Tell You,” which tells you just why you should enroll under my personal instruction. Let me send you this free booklet—write for it **NOW—THIS MINUTE**—there's no obligation.

**BENNY LEONARD, Undefeated Lightweight Champion of the World**

123 W. 31st St., Dept. 34-N, New York, N. Y. Send this coupon **NOW**—for my **FREE BOOKLET**—no obligation.

**BENNY LEONARD, 123 W. 31st St., New York City, Dept. 34-N.**

Please send me your free booklet, “Now I Can Tell You,” without placing me under any obligation. I enclose 10c (in stamps or coin) to cover cost.

Name ..... Age .....  
Address .....

**GERMAN ARMY OFFICERS' FIELD GLASSES FREE TRIAL**

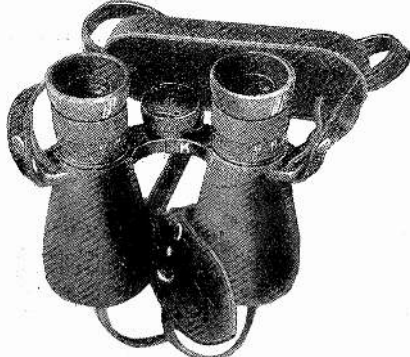

8 power **\$9.85** If you wish to keep them

Free trial coupon will bring you these genuine German War Glasses purchased at exceptionally advantageous rates of exchange.

Manufactured by most prominent of German optical factories. Many were received direct from the Allied Reparations Commission. Conservative \$29.00 value.

Finest achromatic day and night lenses. 40 m.m. objective. Dust and moisture proof. Pupillary adjustment. Built for service, regardless of cost, according to strictest military standards. All glasses guaranteed in perfect condition. We have sold 70,000 pairs of this model to date.

Shipped promptly on receipt of attached coupon on 5 days' free trial. If satisfied send check or money order for \$9.85. Order your field glasses today.

**HENDERSON BROTHERS**

Largest importers of field glasses in America  
97 E. Federal Street Boston, Mass.

**FREE TRIAL COUPON**

Gentlemen:  
Please send me on 5 days' free trial one pair German Army Officers' war glasses. After 5 days' trial I will either return glasses or remit \$9.85.  
Name .....  
Address .....  
State .....  
S. I. 1.

**Tarrano the Conqueror**

(Continued from page 666)

“Oh, no,” she said. “What you say we must do, we will do.”

“We must go higher, Maida. Then, you see . . .”

He told her his plans. And mounting up there into the silent canopy of stars, his fingers wound themselves into the soft strands of her hair which lay upon him; and his heart beat fast with the nearness of her. . . . Told her his plans, and she acquiesced.

Twenty thousand feet. The cold was upon them. Shivering himself, he wrapped her in a fur which the basket contained. At 25,000, they took to the *volplan*. It was a padded board a dozen feet long and half as wide. Released, it shot downward; a hundred feet or more, with the heavens whirling soundlessly. Then Georg got the wings open; the descent was checked; the stars righted themselves above, and once again the earth was beneath.

**The Experimenter**

has come back! If you are one of the one hundred thousand readers of the old **ELECTRICAL EXPERIMENTER**, you will no doubt be glad to hear that the **EXPERIMENTER** is coming back **BIGGER AND BETTER THAN EVER.** **PRACTICAL ELECTRICS** has been changed into an entirely new kind of magazine entitled

**The Experimenter**

In this magazine which has been greatly enlarged in point of contents, illustrations and circulation, you will find the following new departments:

- Experimental Radio
- Experimental Chemistry

There is an entirely new treatment of radio containing experiments only. *90% of the magazine contains pure experiments* written by the foremost authorities in their respective fields, also a monthly editorial by the writer.

A fine roto-gravure section is now added to brighten up the magazine. *If you want experiments, this is your magazine.*

Be sure to reserve a copy from your news-dealer before the issue is sold out. The next issue of **THE EXPERIMENTER** will be on sale at all newsstands beginning October 20th, 1925.

**Hugo Gernsback**  
Editor

They had strapped themselves to the board, and now Georg undid the thongs. Together they lay prone, side by side, with the narrow, double-banked wings beneath the line of their shoulders, and the rudder-tail behind them. Flexible 'planes and tail, responding to Georg's grip on the controls.

Fluttering, uncertain at first, like a huge bird of quivering wings, they began their incline descent. A spiral, then Georg opened it to a straight glide northward—rushing downward and onward through the starlight, in a wind of their own making which fluttered the light fabric of Maida's robe and tossed her waves of hair about her.

A long, silent glide, with only the rush of wind. It seemed hours, while the girl did not speak and Georg anxiously searched the sky ahead. Underneath them, the dark forests were slipping past; but inexorably coming upward. They were down to 5,000 feet; then Georg saw at last what he had hoped, prayed for, but almost despaired of. A beam of light to the northward—the spreading beam of an oncoming patrol. It was high overhead; but it came forward fast. A sweeping, keenly searching beam, and finally it struck them. Clung to them.

(Continued on page 670)

**Here's Work That is Almost ROMANCE!**



**EARN \$50. to \$250. a Week in RADIO**

Get into the great new **BIG-Pay Industry—Radio.** If you're earning a penny less than \$50 a week, *clip coupon now.*

Send for **AMAZING FREE BOOK.** Be a Radio Expert, and drawn down big money for the easiest and most fascinating work in the world. Positions everywhere. Need for Radio Experts in every community. Short hours. **BIG PAY.** Free book gives all the facts.

**Learn Quickly and Easily At Home**

Master Radio Engineers will show you how to qualify, quickly and easily at home, for Radio's fine jobs. We guarantee to train you successfully. Every day **N. R. I.**-trained men are taking good places in the Radio field. Thousands of openings now awaiting the trained man. **FREE EMPLOYMENT SERVICE.** Many other big features. Get the facts—**CLIP COUPON.**

“My charges for consultation \$2.50 per hour. All success due to you.” **R. W. Blackhill, Brooklyn.**

“Radio a gold mine—your course worth thousands.” **A. R. Horke, Winnipeg.**

**Get This Free Book!**

Send coupon below for **FREE BOOK**—“Rich Rewards in Radio.” Read for yourself. No previous experience needed. Common schooling enough. **WRITE NOW.**

**You get all these sets**

Receiving sets, from simplest kind to thousand mile receiver, included to help you learn. An **UNEQUALLED OFFER.** Other special features for limited time only, so **ACT QUICK!**

**NATIONAL RADIO INSTITUTE**  
Dept. 14NB, Washington, D. C.

**MAIL COUPON**

**National Radio Institute, Dept. 14NB, Washington, D. C.**

Without obligating me in any way, please send me your free book, “Rich Rewards in Radio,” also complete information on your practical, home-study Radio course.

Name .....  
Address .....  
Town ..... State .....



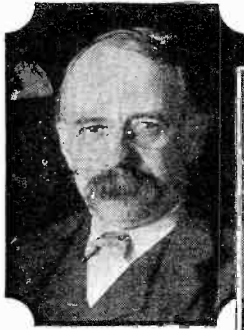

**E. H. HARRIMAN**  
America's Master Rail-  
road Organizer  
Wide-awake boys,  
operating their  
Lionel Model Rail-  
road Systems to-  
day, are preparing  
to be the railroad  
leaders of the  
future.

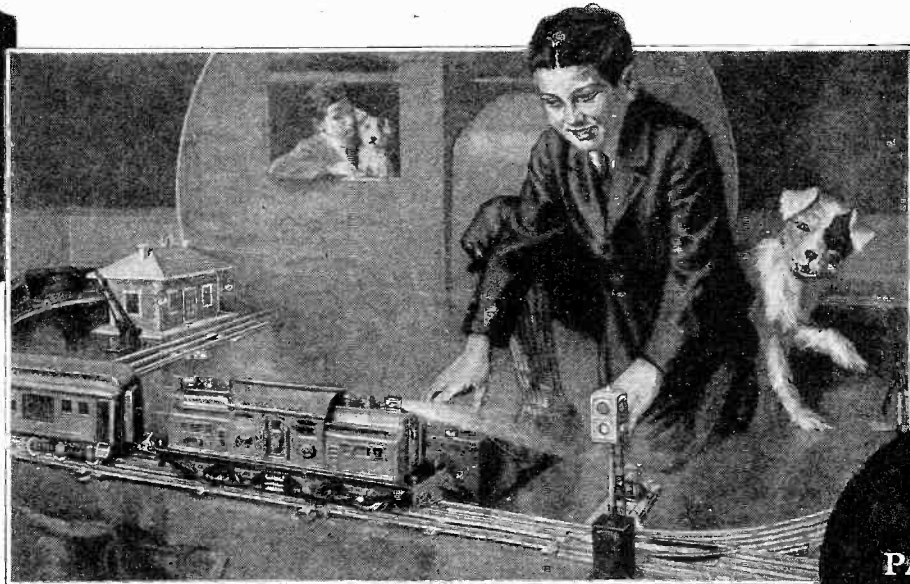

**LOOK  
FOR THE  
PATENTED  
LIONEL  
FEATURES**

## "Why, It Looks Real!"

**O**F course a Lionel Railroad looks real.

It is real. The only difference between Lionel and real trains is the size.

Lionel Engineers take care of that. They design and build Lionel Railroads electrically and mechanically perfect, so that they run like real railroads. They work from the engineers' drawings and blueprints of real railroad locomotives, coaches, freight cars, signals, crossing gates and the many other railroad accessories.

Lionel Model Railroads are way beyond ordinary "toy railroads." They are valuable educators. They are helping American boys to learn how real railroads are run, how the passengers and freight of the nation are transported.

Running a Lionel Model Railroad is exactly like running a real railroad.

This wonderful realism can be found only in Lionel Model Railroads and Accessories.



*Lionel Automatic Train Control. The greatest achievement in model railroad engineering. Starts and stops trains automatically. Just one of the many wonderful realistic railroad devices in the Lionel line of Accessories.*

That's why American boys buy more Lionel Trains than any other make. That's why Lionel has been "Standard of the World" since 1900.

Lionel Model Railroads and Accessories are displayed at all of the best stores. Take father and mother with you to see them and remember: Lionel trains are lowest in price consistent with high quality—complete outfits from \$5.75 up.

Write today for your copy of the beautiful new 44-page Lionel catalog illustrated in actual colors. It shows the complete Lionel line. Sent free on request.

**The LIONEL CORPORATION**  
Dept. 1-G 48-52 E. 21st STREET  
NEW YORK CITY



Be sure to send a post card today for this wonderful 44-page catalog, beautifully illustrated in 4 colors. It is FREE.

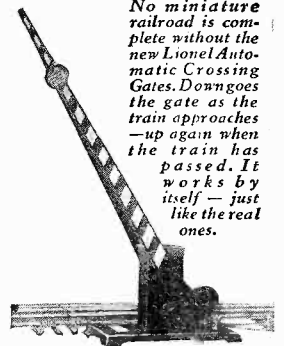

*No miniature railroad is complete without the new Lionel Automatic Crossing Gates. Downgoes the gate as the train approaches — up again when the train has passed. It works by itself — just like the real ones.*

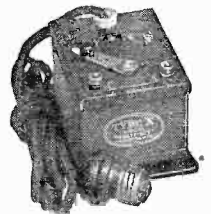

*Lionel "Multivolt" Transformers—Ever-reliable power plants. Run all trains best. A type for every size train.*

"STANDARD OF THE WORLD SINCE 1900"

# LIONEL ELECTRIC TRAINS

MODEL RAILROAD ACCESSORIES

## "MULTIVOLT" TRANSFORMERS

# A new Parks!



**Cabinet Shop Special**  
No. 7  
**\$250**

**Make a real shop in your basement!**  
This handy Parks woodworker is complete shop equipment in itself. With it you can do all sorts of cabinet work. Make toys, furniture, radio cabinets—anything. Built for close, accurate work, yet small enough to fit in a corner of your basement. Operates from light socket. Has motor, rip and cut-off circular saw, jointer and bandsaw. Add lathe and shaper at slight extra cost. A real machine ideal for home use. Send for circular.

**The Parks Ball Bearing Machine Co.**  
1553 Knowlton St., Cincinnati, Ohio  
Canadian Fac.: 200 Notre Dame East, Montreal, Can.

# PARKS

WOODWORKING MACHINES

# COFFEE

By  
**RALPH HOLT CHENEY, Sc.D.**  
Assistant Professor of Biology,  
New York University

While clearly a scientific work, and consequently primarily interesting to the student concerned with the botanical and chemical structure of the coffee tree and its fruit, it nevertheless contains much information of practical value to the trade, and of more than passing interest to the lay reader. The chronological table which just precedes the author's economic discussion of his subject is in itself an amazing amount of historical data presented in concrete form for ready reference. For exhaustive scientific research, for wealth of bibliographical reference to a species of plant life that has become a great economic factor, it is likely to be accepted as an authoritative and standard work.

—CHASE & SANBORN.

Octavo, xviii x 244 pages; 77 half-tone illustrations; bound in blue cloth, gold lettered. Price \$4.50

**THE NEW YORK UNIVERSITY PRESS**  
30 Washington Place New York City

**13 WEEKS FOR 15 CENTS**



**The Pathfinder**  
SHOWS THE WAY THROUGH THE JUNGLE OF EVENTS

You've heard your neighbor praise the old reliable Pathfinder, the wonderful national weekly home magazine that 3 million people read. You can try this unbiased digest of domestic and world affairs for a trifle. The Pathfinder is in a class by itself—nothing else to equal it; time-tested, wholesome. Chuck full of the choicest reading the cream of everything. Science, politics, travel, fun, question box, health, radio etc.; real stories, pictures—instruction, entertainment for all. Send 15c (coin or stamps) for this big paper on trial 13 weeks, or \$1 for full year (52 issues). **Pathfinder, Washington, D. C.**

**Free Mailing Lists**

Will help you increase sales  
Send for FREE catalog giving counts  
names of your best prospective customers—National, State and Local—Individuals, Professors, Business Concerns.

**99% Guaranteed 5¢ each**  
by refund of

**ROSS-Gould Co.** 315 N. 10th St. St. Louis

**Print Your Own**

Cards, Stationery, Circulars, Paper, etc. Save money. Print for others, big profit. Complete outfits \$8.85. Job press \$12.85, Rotary \$19. All easy, rules sent. Write for catalog presses type etc. **THE PRESS CO., Y 47, Meriden, Conn.**

# Tarrano the Conqueror

(Continued from page 668)

And presently the big patrol vessel was almost above them. It hung there, a dark winged shape dotted with colored lights. A signal flash—a sharp command to Georg, but, of course, he could not answer. Then the Director's finder picked him out. The *volan* was fluttering, spiralling slowly as Georg struggled to hold his place.

And then the patrol launched its tender. It came darting down like a wasp. A moment more, and Georg and Maida were taken aboard it. The *volan* fluttered to the forest unguided and was lost in the black treetops, now no more than a thousand feet below.

Surrounded by amazed officials, Maida and Georg entered the patrol vessel. Georg Brende, escaped safely from Tarrano! The Brende secret released from Tarrano's control! The Director flashed the news to Washington and to Great-London. Orders came back. A score of other vessels of this Patrol-Division came dashing up—a convoy

### IMPORTANT TO NEWSSTAND READERS

IN order to eliminate all waste and unsold copies it has become necessary to supply newsstand dealers only with the actual number of copies for which they have orders. This makes it advisable to place an order with your newsdealer, asking him to reserve a copy for you every month. Otherwise he will not be able to supply your copy. For your convenience, we are appending herewith a blank which we ask you to be good enough to fill in and hand to your newsdealer. He will then be in a position to supply copies to you regularly every month. If you are interested in receiving your copy every month, do not fail to sign this blank. It costs you nothing to do so.

To ..... Newsdealer  
Address .....

Please reserve for me ..... copies of **SCIENCE & INVENTION** every month until I notify you otherwise, and greatly oblige,

Name .....

Address .....

which soon was speeding northward to Washington with its precious messenger.

### CHAPTER XI

In Washington during those next few days, events of the Earth, Venus and Mars swirled and raged around Georg as though he were engulfed in the Iguazu or Niagara. Passive himself at first—a spectator merely; yet he was the keystone of the Earth-Council's strength. The Brende secret was desired by the publics of all three worlds. Even greater than its real value as a medical discovery, it swayed the popular mind.

Tarrano possessed the Brende secret. The only model, and Dr. Brende's notes were in his hands. Washington had ordered him to give them up, and he had refused. But now the status was changed. Georg held the secret also—and Georg was in Washington. It left the Earth-Council free to deal with Tarrano.

During those days Georg was housed in official apartments, with Maida very often near him. Inactive, they were much together, discussing their respective worlds. The Princess Maida was hereditary ruler of the Venus Central State—the only living heir to the throne. When Tarrano's forces



## Battery Prices SMASHED!

**To Consumers Only**  
Here is a real battery quality, guaranteed to you at prices that will astound the entire battery-buying public. **Order Direct From Factory.** Put the Dealer's Profit in your own pocket. You actually save much more than half, and so that you can be convinced of true quality and performance, we give a **Written 2-Year Guarantee.** Here is your protection! No need to take a chance. Our battery is right—and the price is lowest ever made. Convince yourself. Read the prices!

Auto Batteries	Radio Batteries
6 Volt, 11 Plate, \$9.50	6 Volt, 100 Amp, \$9.50
6 Volt, 13 Plate, 11.50	6 Volt, 120 Amp, 11.50
12 Volt, 7 Plate, 13.00	6 Volt, 140 Amp, 13.00

**Buy Direct—Send No Money**  
We ask no deposit. Simply send name and address and style wanted. Battery will be shipped same day we receive your order Express C.O.D. subject to your examination on arrival. Our guarantee accompanies each battery. We allow 6% discount for cash in full with order. You cannot lose! Send your order today **NOW!**

**ARROW BATTERY CO.**  
Dept. 9 1215 So. Wabash Ave., Chicago

# 1/2 SAVED on all Standard Typewriters



**AT LAST—World's best Typewriters with every modern writing feature at positively lowest prices and on easiest terms offered.**

**10 DAYS FREE TRIAL**  
A Year to Pay  
**5 YEARS GUARANTEE**

Standard Machines so perfectly Re-Manufactured by the exclusive **Young Process** that they look and write like brand new. Our exclusive, distinctive process makes possible better typewriters at lower prices.

**FREE BIG ILLUSTRATED TYPEWRITER BOOK**  
Write now. See our amazing typewriter bargains. Read what users say and the unusual service we will give you. Don't wait—write today.

**Young Typewriter Co., Dept. 116B, Chicago, Ill.**

## I POSITIVELY GUARANTEE that you can produce wonderful, sweet music in three days and quickly play popular and classical selections.



**Complete Outfit Sent on Trial**

No notes to read. No dreary practice. Just three short, simple lessons revealing every secret of my 12 years' success as a professional saw musician. Amaze your friends with this sensation of radio, vaudeville, orchestra and lodge entertainment. Send 10c for phonograph record of two beautiful Musical Saw solos which also entitles you to complete information about my special introductory offer of Saw Bow Hammer, and Resin, FREE with Course of Instruction.

**MUSSEHL & WESTPHAL**  
881 West Water St. Fort Atkinson, Wis.

# LAW STUDY AT HOME

Become a lawyer. Legally trained men win high positions and big success in business and public life. Be independent. Greater opportunities now than ever before. Big corporations are headed by men with legal training. Earn **\$5,000 to \$10,000 Annually**. We guide you step by step. You can train at home during spare time. Degree of LL.B. conferred. LaSalle students found among practicing attorneys of every state. We furnish all text material, including fourteen-volume Law Library. Low cost, easy terms. Get our valuable 108-page "Law Guide" and "Evidence" books free. Send for them NOW.

**LaSalle Extension University, Dept. 11384-L, Chicago**  
The World's Largest Business Training Institution

You can be quickly cured, if you

# STAMMER

Send 10 cents for 288-page book on Stammering and Stuttering, "Its Cause and Cure." It tells how I cured myself after stammering 20 yrs. B. N. Bogue, 8122 Bogue Bldg., 1147 N. 111. St., Indianapolis

threatened revolution from the Cold Country she had been seized by spies, brought to Earth, to Tarrano in Venia, and imprisoned in the tower from which Georg had so lately rescued her. Wolfgar for years had been her friend and loyal retainer, though he had pretended service to Tarrano.

In the Central State, Maida, too young to rule, had been represented by a Council. The public loved her—but a majority of it had gone astray when she disappeared—had fallen to the lure of Tarrano's promises.

Maida told Georg all this with a sweet, gentle sadness that was pathetic. And with an earnest, patriotic fervor—the love of her country and her people for whom she would give her life.

She added: "If only I could get back there, Georg—I could make them realize the right course. I could win them again. Tarrano will play them false—you know it, and so do I."

Pathetic earnestness in this girl still no more than seventeen! And Georg, sitting beside her, gazing into her solemn, beautiful face, felt that indeed she could win them, with those limpid blue eyes and her words which rang with sincerity and truth.

They sat generally in an unofficial instrument room adjoining the government offices. A room high in a spire above the upper levels of the city. And around them rolled the momentous events of which they were the center.

The time limit of the Earth Council's ultimatum to Tarrano expired. Already Tarrano had answered it with defiance. But on the stroke of its expiration, came another note from him. Georg read it from the tape to Elza:

*"To the Earth-Council from Tarrano, its loyal subject—"*

A grimly ironical note, yet so worded that the ignorant masses would not see its irony. It stated that Tarrano could not comply with the demand that he deliver himself and the Brende model to Washington because he did not have the model. It was on its way to Venus. He now proposed to recall it. He had already recalled it, in fact. He assured the Council that it was now on its way back, direct to Washington. He had done this because he felt that the Earth leaders were making a mistake—a grave mistake in the interests of their own people. Georg Brende was in Washington—that was true. But Georg Brende was a silly, conceited young man, flattered by his prominence in the public eye, his head turned by his own importance. Dr. Brende had been a genius. The son was a mere upstart, pretending to a scientific knowledge he did not have.

"Trickery!" exclaimed Georg. "But he knows the people may believe it. Some of them undoubtedly will."

"And you cannot thwart your public," Maida said. "Even your Earth-Council, secure in its power, cannot do that."

"Exactly," Georg rejoined. He was indignant, as well he might have been. "Tarrano is trying to avoid being attacked. Time—any delay—is what he wants."

The note went on. Tarrano—seeking only the welfare of the people—could not stand by and see the Earth-Council wreck its public. Tarrano had reconsidered his former note. The Brende model was vital, and since the Earth-Council demanded the model (for the benefit of its people) the people should have it. In a few days it would be in Washington. Tarrano himself would not come to Washington. His doing that could not help the public welfare, and he was but human. The Earth-Council had made itself his enemy; he could not be expected to trust his life in enemy hands.

The note closed with the suggestion that the Council withdraw its patrol from Venia. This talk of war was childish. Withdraw



## Service cannot stop

The telephone, like the human heart, must repair itself while it works. The telephone system never rests, yet the ramifications of its wires, the reach of its cables and the terminals on its switchboards must ever increase. Like an airplane that has started on a journey across the sea, the telephone must repair and extend itself while work is going on.

To cut communication for a single moment would interrupt the endless stream of calls and jeopardize the well-being and safety of the community. The doctor or police must be called. Fire may break out. Numberless important business and social arrangements must be made.

Even when a new exchange is built and put into use, service is not interrupted. Conversations started through the old are cut over and finished through the new, the talkers unconscious that growth has taken place while the service continues.

Since 1880 the Bell System has grown from 31 thousand to 16 million stations, while talking was going on. In the last five years, additions costing a billion dollars have been made to the system, without interrupting the service.



AMERICAN TELEPHONE AND TELEGRAPH COMPANY  
AND ASSOCIATED COMPANIES

BELL SYSTEM

One Policy, One System, Universal Service

# PIMPLES

## Blackheads—Acne Eruptions

Now Are Easily Removed at Home at a Small Cost!

Banish those unsightly blemishes easily and quickly by using "CLEAR-TONE"—a simple home treatment that has cured chronic cases of long years standing. Use like toilet water. Leaves the skin clear, smooth and without a blemish. Has made many friends with men, women and children. Elegant for men after shaving. If you have

Pimples, Blackheads, Acne Eruptions on the face or body, Barbers Itch, Eczema, Enlarged Pores, Oily or Shiny Skin—never mind how bad—"CLEAR-TONE" has cured the worst cases I ever saw. Endorsed by druggists, physicians, skin specialists, barbers and over 100,000 Men and Women test cases, who succeeded with "CLEAR-TONE" after failing with everything else.

**FREE!**

Send name today for FREE Booklet, "A CLEAR-TONE SKIN," telling how I cured myself after being afflicted for 15 years. And I know every embarrassment one has to endure with a bad complexion. \$1,000 COLD CASH SAYS I CAN CLEAR YOUR SKIN OF THE ABOVE BLEMISHES.

E. S. GIVENS 168 Chemical Building KANSAS CITY, MO.

Insure your copy reaching you each month. Subscribe to Science and Invention—\$2.50 a year. Experimenter Publishing Co., 53 Park Place, N. Y. C.



# New Self-Massaging Belt REDUCES WAIST -Easily!

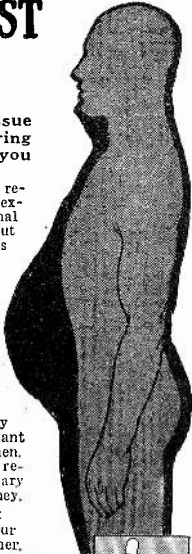

Substitutes good, solid tissue for bulky, useless, disfiguring fat, yet does it so gently you hardly know it is there.

Formerly those who wished to reduce without dieting or strenuous exercise had to go to a professional masseur. His method brought about the desired reduction. But it was expensive and time-consuming, and few could take advantage of it.

### Remarkable New Invention

At last a wonderful new invention brings this same effective method within the reach of all. The Weill Scientific Reducing Belt by means of specially prepared and scientifically fitted rubber is so constructed that as you wear it every breath you take and every movement you make imparts a constant massage to every inch of the abdomen. Working for you every second, it reduces much more rapidly than ordinary massage, saving both time and money.

### Actually Removes Fat

It does not merely draw in your waist and make you appear thinner. It actually takes off the fat. Within a few weeks you find 4 to 6 inches gone from your waistline. You look and feel 10 to 15 years younger.

The Weill Method of reduction is used by athletes and jockeys because it reduces quickly and preserves their strength. Highly endorsed by physicians. Satisfaction guaranteed or your money back.

### SPECIAL TRIAL OFFER

Write today for full description and Special 10-Day Trial Offer. The Weill Company, 7011 Hill Street, New Haven, Conn.

THE WEILL COMPANY, 7011 Hill St., New Haven, Conn.  
Gentlemen: Please send me, without obligation, complete description of the Weill Scientific Reducing Belt and your special 10-Day Trial Offer.

Name.....  
Address.....  
City..... State.....

## WORLD'S HANDIEST CALCULATOR

NEW - POCKET SIZE

Does work of large \$100 machine and very simple to operate.

ADDS  
SUBTRACTS  
MULTIPLIES  
DIVIDES

TOTAL COST \$2.50

Is GUARANTEED for 5 years. Made of steel. No upkeep. No repairs. Everybody who figures needs one.

A SPEED MARVEL. Positively the LOWEST Priced practical calculator on market. New Trial Offer, price \$2.50, send money order or pay postman when machine is delivered (\$3.50 outside U. S.). Supply limited. ORDER TODAY. AGE IS WANTED.

BABY CALCULATOR SALES COMPANY  
P.O. Box 1118, Dept. 40 Chicago, Ill.

## PERSONAL STATIONERY

200 SHEETS and 100 ENVELOPES \$1.00

Printed with your Name and Address

Clear, white bond paper, with envelopes to match. Your name and address printed in beautiful, rich blue ink, on both paper and envelopes, and sent to you postpaid for only \$1.00. (West of Mississippi river and outside of U. S. \$1.10.) If inconvenient to send the money, we will ship C.O.D. Money returned if you are not more than satisfied. Order today. Write name and address plainly.

AGENTS MAKE BIG MONEY taking orders for us. Write us today for our agent's proposition.

ELITE STATIONERY COMPANY  
5030 Main Street Smethport, Pa.

## LEARN DRAFTING

AT HOME IN SPARE TIME

Become an expert Machine Designer—\$50 to \$200 per week. Complete course personal instruction. Easy monthly payments. We furnish complete set of drawing instruments. FREE BOOK explains all—write for it.

THE PRACTICAL MECHANIC  
Dept. 105, South Haven, Mich.

the patrol, and Tarrano himself might go back to Venus. He would wait a day for answer to this request; and if it were not granted—if the patrol were not entirely removed—then the Brende model would be destroyed. And if the publics of three worlds wished to depend upon a conceited, ignorant young man like Georg Brende for the everlasting life, they were welcome to do so.

A clever piece of trickery, and it was awkward to deal with. One had only to watch its effect upon the public to realize how insidious it was. Tarrano had told us—in the tower in Venia: "I shall have to bargain with them." And chuckled as he said it.

A series of notes from the Earth-Council and back again, followed during the next few days. But the patrol was not withdrawn; nor was war declared. The Earth-Council knew that Tarrano had not ordered the model back—nor would he destroy it. Yet if the Earth forces were to overwhelm Tarrano, and the model were lost, a revolution upon Earth could easily take place before Georg could convince the people that he was able to build them another model.

This delay—while Tarrano was held virtually a prisoner in Venia—was decided upon at the instigation of Georg himself. He—Georg—would address the publics of the three worlds. With Maida beside him to influence her own public in Venus, they would convince everyone that Georg had the secret—and that he alone would use it for the public good.

Youthful plans! Youthful enthusiasm! The belief that they could win confidence to their cause by the very truthfulness in their hearts! The belief that right makes might—which Tarrano would have told them was untrue!

Yet it was a good plan, and the Earth-Council approved it, since it could do no harm to try. And it perhaps would have been successful but for one thing, of which even at that moment I—in Venia—was aware. Tarrano's trickery was not all on the surface. He had written into that note—a secret message to his own spies in Washington. Commands for them to obey. A dozen of his spies were in the Earth-government's most trusted, highest service—and some of them were there in Washington, close around Georg and Maida as they made their altruistic plan.

The attempt was to be made from the high-power sending station in the mountains of West North America.\* Our observatory was there; and the only one of its kind on the Earth. It was equipped to send a radio voice audibly to every part of the Earth; and by helio, also to Mars and Venus, there to be re-transformed from light to sound and heard throughout those other worlds. And moving images of the speakers, seen on the finders all over the Earth. Venus and Mars simultaneously. The power, the generating equipment was at this station; and no matter where in the sky Venus or Mars might be, from the Mountain Station the vibrations of mingled light and sound were relayed elsewhere on Earth to other stations from which the helios could be flashed direct.

To Skylan, as the Mountain Station was popularly called, Georg and Maida were taken in official aréo under heavy convoy. Yet, even then, at their very elbows, spies of Tarrano must have been lurking.

The official flyer landed them on the broad stage amid deep, soft snow. It was night—a brief trip from the late afternoon, through dinner and they were there. A night of clear shining stars—brilliant gems in deep purple. Clear, crisp, rarefied air; a tumbling expanse of white, with the stars stretched over it like a close-hung canopy.

They were ushered into the low, rambling

\*The Rocky Mountains, in the United States or possibly Alberta.

## World's Greatest Thought Discovery

There is something cosmic in Man, Beast and Nature—One VIBRATION in Nature makes the whole world kin! Flying Ebony and Captain Hal were checked to win Kentucky Derby, May 16th, in order named. They did.

Psychology — on — mathematical — basis  
Two and two are FOUR around the world, Mathematics is TRUTH!

### FORETELL BY SCALE

The psychological color scheme, the styles, the advertising leads, the winning letters in names day after day and year after year.

The Alpha-Matho Scale made the forty-one consecutive tests of 1921-'22-'23-'24 World's Baseball Series and 1923-'24 Dixie Series inclusive—it tells the psychological result in advance!

Tune-in your conscious Intellectual Energy with subconscious urge, or Solar Energy and win! Be sure you are in Vibration and then go ahead. A "Good Name" in vibration with the public's subconscious mind is worth \$50,000,000.

Mass Intellectual-Pressure and the Alpha-Matho Vibratory Scale—48-page booklet containing the greatest thought Discovery of this or any other age, with Brain-Wave or Alpha-Matho Calendar—Price \$1.00.

### Eleventh Edition; Sold Around the World

(The Yorkshire Institute of England placed order for 500 copies and Books and Authors, New York, June issue, "challenge the scientists.")

MACK STAUFFER, 918 West Terrell Avenue, Fort Worth, Texas, U. S. A.

Credentials: Author of the World's Greatest Prophetic and Psychological novel, "Humanity and the Mysterious Knight," which foretold the broadcasting of "human voice," Marconi's now invention, the "reflector," "color music," "World War," the election of President "H." and over one hundred other world events.

Money back and 10 per cent in five days, if desired



# Stamp out Tuberculosis with these Christmas Seals



The National, State, and Local Tuberculosis Associations of the United States

Insure your copy reaching you each month. Subscribe to SCIENCE & INVENTION—\$2.50 a year. Experimenter Publishing Co., 53 Park Pl., N. Y. C.

building. The attempt was to be made at once. Mars was mounting the Eastern sky; and to the West, Venus was setting. Both visible from direct helios at that moment—Red Mars, from this mountain top, glowing like the tip of an arrant-cylinder up there.

In the brief time since the party had left Washington, the worlds had been notified. The eyes and ears of the millions of three planets were waiting to see and hear this Georg Brende and this Princess Maida.

The sending room was small, circular, and crowded with apparatus. And above its dome, opened to the sky, wherein the intensified helios shaded so that no ray of them might blind the operators, were sputtering as though eager to be away with their messages.

With a dozen officials around him, Georg prepared to enter the sending room. He had parted from Maida a few moments before, when she had left him to be shown to her apartment by the women attendants.

As she moved away, on impulse he had stopped her. "We shall succeed, Maida."

Her hand touched his arm. A brave smile, a nod, and she had passed on, leaving him standing there gazing after her with pounding heart. Pounding, not with excitement at the task before him in that sending room; pounding with the sudden knowledge that the welfare of this frail little woman meant more to him than the safety of all these worlds.

At last Georg stood in the sending room. The officials sat grouped around him. Maida had not yet arrived from her apartment. There was a small platform, upon which she and Georg were to stand together. He took his place upon it, waiting for her.

Before him was the sending disc; it glowed red as they turned the current into it. Then they illumined the mirrors; a circle of them, each with its image of Georg upon the platform. The white lights above him flashed on, beating down upon him with their hot, dazzling glare. The reflected beams from the mirrors, struck upward into the dome overhead. The helios up there were humming and sputtering loudly.

Beyond the circle of intense white light in which Georg was standing, the spectators sat in gloom behind the mirrors. Maida had not come. The Skylan Director, from his seat in the gloom, ordered a woman to go for her.

Then, suddenly, Georg said to this Director:

"I—these lights—this heat. It makes me feel faint—standing here."

Georg had stumbled from the platform. Between two of the mirrors, shaded from the glare, the perturbed Director met him. Moisture beaded Georg's forehead, he was trembling, he seemed confused and passed a hand across his eyes.

"I'll—be quite all right in a moment. I'm going over there." He smiled weakly. A dozen feet away there was an opened outer casement. It looked down twenty feet, perhaps, to the deep snow that covered the station's grounds. The Director started with Georg; but Georg pushed him violently away.

"No! No! You let me alone!" His accents were those of a spoiled child. The Director hesitated, and Georg, with a hand to his forehead, wavered toward the casement. The Director saw him standing there; saw him sway, then fall or jump forward, and disappear.

They rushed outside. The snow was trampled all about with heavy footprints, but Georg had vanished. From the women's apartment, the attendant came back. The Princess Maida could not be found!

And in those moments of confusion, from outside across the starlit snow, an aero was rising. Silent, black—and no one saw it as it winged away into the night.

(End of Part V—To Be Continued)

All the light of the G-E Novalux Highway Unit which otherwise would be diffused skyward or upon adjacent fields is concentrated upon the road. The lamp is a MAZDA gas-filled bulb, of 250 candle-power.

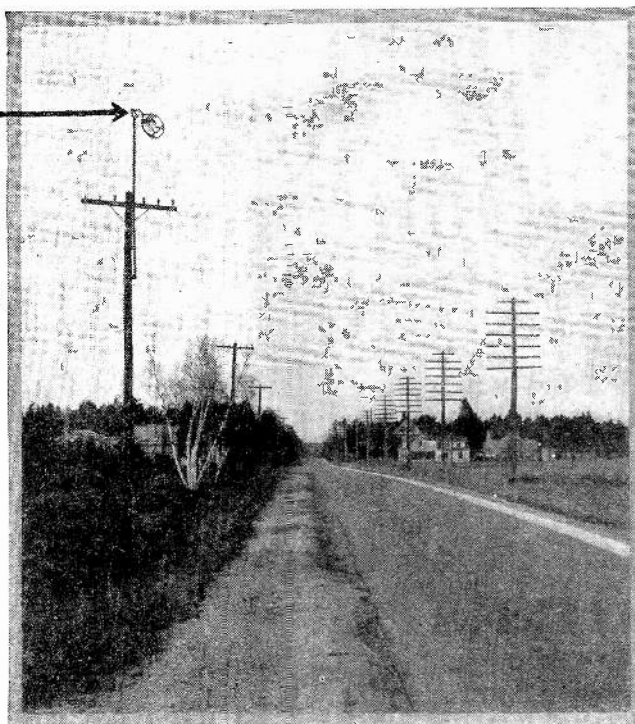

## High lights and Headlights

New Hampshire now uses both. Here is a view of the beautiful Daniel Webster Highway, near Nashua.



In the past two years, 35 States have put in one or more installations of G-E Highway Lighting Units—and every installation is a magnet for tourists and a safeguard for residents. General Electric Company engineers submit plans and estimates, without obligation.

The G-E Highway Lighting Units, placed on top-masts, 40 feet above the road, furnish plenty of light without glare. You can motor with comfort or walk with safety at night on roads like this.

# GENERAL ELECTRIC

**HB ONE DAY BATTERY CHARGING EASILY \$150 to \$300 MONTHLY PROFITS**

Get in the money-making One Day Battery Charging business now. Big demand for One Day Charging Service for auto and radio batteries. Big profits. Only \$35 cash puts money-making HB One Day Charging outfit in your shop. Easy terms on balance; let your big monthly profits pay for outfit. No experience needed. Complete operating instructions free with each outfit. 30 days' free trial in your shop on money-back guarantee. Write for free bulletin 98.

**HOBART BROS. CO. Box S-11 TROY, OHIO**

**NOW \$35 PUTS THIS MONEY MAKING SERVICE IN YOUR SHOP**

**20 SHOT**

**MILITARY AUTOMATIC 32 Cal.**

**\$35 Value**

Extra Magazine FREE. 20 quick, hard and straight shots. Accurate lightning action; reloads automatically. Blue steel, checkered grip.—Greatest Bargain. **SEND NO MONEY.** Pay postman our low price plus postage. On money with orders WB may postage. Satisfaction or money back.

**U. S. IMPORT COMPANY**

Dept. A30, 124 University Place New York

\$8.75

**Makes Pumping Up Tires Unnecessary**

O. M. Hughes of 2514 Monroe, Chicago, Ill., has perfected a new air-tight valve cap that enables auto owners to pump up their tires once and never touch them again until punctured or worn out. Leading tire manufacturers, after thorough tests, have approved Mr. Hughes' invention and banished the old theory that air escapes thru rubber. One inflation lasts the life of a tire, and tire mileage is doubled. These caps retail for \$1.25 for set of five. The inventor wants agents and will send proof and samples Free. Write him today.

Insure your copy reaching you each month. Subscribe to Science and Invention—\$2.50 a year. Experimenter Publishing Co., 53 Park Place, N. Y. C.



## A Few Quick Lines -Thats Me!

A Short Line Here. Another There. Now a Little Curve—a Splash of Shading—a Slight Bit of Exaggeration. That's How Easy it is for Cartoonists to Make Pictures That Sell.

# \$50 to \$250 PER WEEK in Cartoons!

Never before have the opportunities in Cartooning been so great, the field so varied, and the pay so big as RIGHT NOW. Good cartoonists are constantly in demand by newspapers, magazines and Commercial Art Houses. Some earn as high as \$250 a week and many even considerably higher. And yet, through an amazingly simple method you, too, can enter this fascinating big-pay profession. No talent necessary. No hours of drudgery. For by a remarkably easy method that's just like play you learn cartooning right in your own home in spare time. And almost before you realize it you are actually drawing cartoons that sell.

### SEND FOR FREE BOOKLET

A wonderfully interesting free booklet, describing this easy method in detail, and giving you the highly profitable experiences of many students, will be sent to you absolutely free. Simply sign and mail the coupon NOW. Washington School of Cartooning, Room 2611-C, 1113 15th St., N. W., Washington, D. C.

Washington School of Cartooning, Room 2611-C 1113 15th St., N.W., Washington, D. C.

Please send me, without obligation, your Free Booklet on Cartooning and full details on your new easy home-study method of teaching Cartooning. (Please Write Plainly).

Name .....  
(State whether Mr., Miss or Mrs.)

Address .....

City ..... State .....

(If under 16, please give age.....)



Wonderful, new device, guides your hand; corrects your writing in few days. Big improvement in three hours. No failures. Complete outline FREE. Write C. J. Ozmert, Dept. 44 St. Louis, Mo.

### Start a Movie Show

SMALL CAPITAL STARTS YOU  
Big opportunity to become independent. No experience needed. We show you how. Our easy payment plan makes it easy to start. We equip you complete. Our machines used and endorsed by government institutions. Write today for free catalog.  
ATLAS MOVING PICTURE CO.  
636 S. Dearborn St., Dept. 80, Chicago

### BECOME A LIGHTNING TRICK CARTOONIST

Make money chalk drawing. Send \$1 for snappy program of trick drawings, with instructions by a professional cartoonist. Satisfaction guaranteed. Circular free. Balda Art Service, Dept. 4, Oshkosh, Wis.

## The "Shenandoah" Versus the Elements

By WILLIAM P. SULLIVAN  
(Continued from page 605)

In the case of a dirigible such as the late *Shenandoah* where the structure has experienced severe strains, it is difficult even under the closest inspection to determine a slight fracture or weakness, not only because of the thousands of parts that may be affected but to the peculiarities of the metal itself. In a continued high, rough wind, or storm a dirigible can become weakened after a period of time, through fatigue and crystallization, and a severe strain at a weakened point may cause a sudden fracture. The real danger therefore lies in the turbulent air streams which cause the bending and twisting of the frail metal structure.

The most dangerous meteorological manifestation that can occur with regard to a dirigible airship comes when warm and cold air occur side by side. The former climbs the latter, forming a great roll of cloud in an unbroken front, a dreaded formation known as the "line squall."

The large illustration on the title page shows the progressive stages of the *Shenandoah* in the recent disaster. At the lower right the dirigible enters an enormous volume of warm air rising at high velocity and is carried upward. The elevators are immediately set down and all motors speeded up in an attempt to "ride down" the rapidly rising current. To assist in this maneuver the buoyancy of the ship is reduced quickly by allowing the gas to escape through the safety valves situated at the top of each cell. The ship continues to rise, however, due to its great area, until the warm current is suddenly cooled in the higher altitudes. This causes the cool air to descend, forcing the ship down at terrific speed aided by the loss of buoyancy, with its nose directly in the path of another rapidly rising current of warm air that forms the "line squall."

The result is practically the shearing off of the forward portion at the already weakened point of attachment of the control car by the tremendous opposite forces acting suddenly upon a single station or point of the structure. The impact is so sudden that the inertia stored up by the compact weights or masses of the control car and gas tanks causes them to be torn from their fastenings and hurled through space.

The dirigible, due to its enormous area and slowness of control, is carried with the current and it is doubtful under such severe atmospheric conditions, such as a "line squall," that any similarly large rigid structure, no matter how strong, using present-day materials and built light enough to float, could withstand the colossal forces of the elements that caused this recent aerial catastrophe.

## Cut Flower Contest Awards

(Continued from page 633)

a vase of water, the capillary action of the minute tubes running the length of the stems would tend to draw the water up through the stems if there were no air bubbles in the stems. However, when a flower is cut, there is always about one-fourth inch at the end of the stem which immediately absorbs air. This can only be eliminated by placing the stems of the flowers in a vase of water and then cutting off about one inch of stem under water. Do not take flowers from water after cutting the stems.

## Diamond Bargains!

Our Diamonds are noted for their dazzling brilliance and beautiful blue white color. We handle only the best grades.

New IMPORTATION Direct from EUROPE

Don't buy Diamonds from unreliable sources! Know the quality you are getting! You are sure of satisfaction when dealing with us.

### Diamonds for Christmas!

Beautiful Diamond Rings that make ideal Christmas gifts—latest style mountings—priced far below the market. Pay a few dollars down and get your ring at once. Be guided by these facts when you buy Diamonds: Loftis Bros. & Co. import Diamonds direct from Europe and sell direct to you—you save middlemen's profits. Save big money by buying your Christmas presents from us. You always get the best terms and biggest values from Loftis. Order direct from this ad or from our catalog.

**Diamond Book Free**  
You can get all facts before you buy! This book is complete authority on Diamond values. Over 2,000 illustrations and descriptions. Absolutely free. Write today!

No. 28 \$37.50. Blue white Diamond. 15-k white gold. \$100 a week

No. 27. \$100. Blue white Diamond. 18-k white gold. \$250 a week

No. 59 \$50. Blue white Diamond. 18-k white gold. \$125 a week

No. 30 \$100. Blue white Diamond. 18-k white gold. \$250 a week

## LOFTIS

BROS. & CO. F.S.B. Jewelers  
108 N. State Street  
Stores in Leading Cities  
Chicago, Ill.

RADIO FANS—Listen in on WHT every Monday night from 7 to 7:30, every Friday night from 9:30 to 10, central standard time. Loftis Bros. & Co.'s hour of music

## BOYS! BOYS! BOYS!

### THROW YOUR VOICE

Into a trunk, under the bed or anywhere. Lots of Fun fooling the Teacher, Policeman or Friends.

### THE VENTRILO,

a little instrument, fits in the mouth of of fish, used with above for Bird Calls, etc. Anyone can use it.

NEVER FAILS. Also a 32 PAGE BOOK which gives full instructions on Ventriloquism. Formulas for Secret Writing (Invisible Ink), 12 Money Making Secrets and 10 BIG TRICKS ON MAGIC all for 10¢

ROY. NOV. CO., Dept. 308 Norwalk, Conn.  
LARGEST and OLDEST Mail Order House in Connecticut.

### The Famous KON-VER-TER Slide Rule

Instantly adds, subtracts, divides, multiplies, converts fractions or decimals of an inch. Gives sines, co-sines, versed sines, co-versed sines, tangents, co-tangents, secants co-secants of angles directly. Gives square roots, squares, cube roots, cubes and fifth roots and powers of all numbers. Logarithms, co-logarithms, anti-logarithms. Instructions with rule. DeLuxe Model \$3. Cash or C.O.D. New England Novelty Company Wakefield, Mass.

### SEND FOR THE INTERNATIONAL CATALOG

Our net price list. Full line of auto bodies and accessories for Fords at Wholesale Prices. Save big money on bodies by buying Direct from Factory.

FOR FORD—Prices from \$27.85 up. Factory to consumer Direct—Pay only One Profit.

International Body Wks, 914 W. Ohio St., Dept. 4, Chicago, Ill.

## Learn Advertising at HOME

Some of the highest paid men in the world are advertising men. You can learn easily and quickly at home during your spare time. Bigger opportunities now in advertising than ever before. Constant demand for our graduates at big pay.

Send for FREE Book. Giving interesting information and vital facts—just what you want to know about advertising. Write for FREE PAGE-DAVIS SCHOOL OF ADVERTISING Dept. 1428 3601 Michigan Ave., Chicago, U. S. A.

### 1.25¢ By MAIL QUESTIONS and ANSWERS

AIDS TO ELECTRICAL EXAMINATIONS QUESTIONS and ANSWERS

Electricians' Examinations Diagrams, symbols, tables, notes and formulas for preparation for license. New book—House Wiring and Bell Work, \$2.00. Reade Pub. Co., 296 B'way., N. Y. C.

### LEARN AVIATION

Take a W.A.C. Course in Applied Airplane Engineering. Many men earn \$2,000 to \$10,000 a year. Big free outline of airplane parts. Write for Free Catalog.

WESTERN AIRPLANE CORPORATION  
Dept. S-11 Menadreck Bldg. Chicago, Ill.



**Broadcasting Enters a New Sphere With WRNY as Guide**

By CHARLES D. ISAACSON  
(Continued from page 644)

is now going forward under the guidance of Mr. Pierre Remington.

Among song directors are Gennaro Mario Curci, brother-in-law and coach of the famous Amelita Galli Curci. Every other week Mr. Curci and a group of singers will put on a song recital.

Chevalier de Lancellotti, who holds medals from several European organizations, will head one of the leading song recital groups.

Meta Christensen leads a group which will be heard regularly in quartette music. The Bernstein Trio will also be heard in chamber music. Dr. Sigmund Spaeth, author, composer and lecturer, heads a twice-a-month appearance of noted artists who have appeared in Ampico concerts.

We shall be taken around the world in music by the Volga Trio and by J. Van Cleft Cooper, lecturer and singer.

Orlando's Concert Orchestra will offer high-class orchestral programs three times a week.

There will be a Classique Ensemble, headed by Thomas Alonji, which will be heard in Sunday night twilight concerts.

The Sadrian Trio will present old musical comedies.

In the popular music department, Ferrucci's Orchestra will delight listeners-in.

Rita Maginot will play all of the piano classics from A to Z—in just that order.

Mathilda Sper will give one of the piano concerts—a series of dances arranged for the piano.

Others in the piano department are Alexander Chigrinsky and Samuel Schwartzman.

Louis Stillman, one of the most eminent pianists of today, will be in charge of a series of talks on the epic of the piano.

Xavier Cugat, Samuel Polonsky, Giuseppe Adami are among the leaders of the violin department. Cugat has just returned from a tour of Europe, where he was received by the King and Queen of Spain.

In the 'cello department are names like Vladimir Dublinsky and Anna Drittel.

Mme. Clara Novello Davies will organize a twice-a-month oratorical concert on Sundays. Also in the music department must be mentioned such names as Harriet Seymour, noted as a reader in musical education, and James Gordon Beaver, who will handle all the English ballads, and Inez Barbour, who will handle the American composers. John Adam Hugo is now at work on an opera especially written for WRNY.

Kathryn Behnke, known as "The Lullaby Lady," and Lorna Lee, "The Love Song Girl," will be two popular singers.

In the arts department we are proud to have the name of Alexandre Zeitlin, who will lecture on sculpture, and Celcanor Dugas, who will discuss painting.

Anita Browne, who is head of the Allied Broadcasters, will have the direction of the literary, theatre and fiction departments.

Mrs. Brock Pemberton will talk on the costumes of the theatre.

Resta Crowell will cover all of the old plays. In a series on the Kings of Sport, leaders in all fields will appear.

The Society for the Promotion of American Aviation will send men well known in the profession to lecture at WRNY weekly.

The new régime was introduced at the Roosevelt Hotel, where its opening was attended by many prominent New Yorkers. Among those present were Otto H. Kahn, Hugo Reisenfeld, Dr. Herbert Goldstein, Ben Bernie, Hon. Bird S. Coler, Hugh Kent, J. Andrew White, Father Finn and Dr. Sigmund Spaeth.

**FREE WITH THE BIG 3 FT. TELESCOPE**

See people and objects miles away, on land or sea, as if they were close. Wonder Telescope gives new pleasures to home, farm, camp, travel, sport. See moon and stars as never before. Opens out over 3 feet long, in 5 sections; measures 12 inches closed. Brass bound; has powerful lenses. Thousands pleased—'Could tell color of aeroplane 4 miles away.'—Mrs. Yarbrough. 'Saw Provincetown Light, 23 miles away, as clear as if in front of me.'—P. H. Hennington. 'I have been watching submarines 3 miles off the coast.'—P. Grish. 'Can see children playing in school yard 6 miles away.'—A. C. Ealmer. 'Read the numbers on freight cars mile away, see mountains on moon.'—A. C. Ealmer.

**FREE** handsome, sturdy 12 in. leatherette carrying case sent **FRED** with Wonder Telescope for short time.

**Send No Money**

Because of fortunate purchase from large European maker we can give you a big bargain. Be first in your neighborhood; entertain your friends. **Send no money; send only name and address for telescope and case by parcel post.** On arrival deposit with Postman only \$1.25 plus a few pennies postage. Satisfaction guaranteed or money refunded. Order today while supply lasts.

**FERRY & CO., 3224 N. Halsted St., Dept. 1258 Chicago, Ill.**

**Electrical Engineering** Course for men of ambition and limited time. Over 4000 men trained. Condensed course in Theoretical and Practical Electrical Engineering including the close-related subjects of Mathematics and Mechanical Drawing taught by experts. Students construct motors, install wiring, test electrical machinery. Course complete **In One Year**

Prepare for your profession in the most interesting city in the world. Established in 1893. Free catalog.

**BLISS ELECTRICAL SCHOOL**  
251 Takoma Ave., Washington, D. C.

**Amaze Your Friends With Chemical Tricks**

The Boy's Hand Book of Chemistry

Write secret letters with invisible ink; pour blue, brown and black liquid from a glass of water; make a magic pitcher of bluing; make your own magic writing paper, your own ink and dyes. It's all easy if you have Chemcraft Junior—the pocket Chemical outfit. Get yours now. Order right away and get a FREE Copy of The Boy's Handbook of Chemistry; 150 pages of experiments, formulae, interesting chemical information, money-making suggestions and catalog of supplies.

**BOTH 25¢**

**CHEM-CRAFT JUNIOR CHEMICAL OUTFIT**

PORTER CHEMICAL CO. 107 Washington Hagerstown, Md. **POSTPAID**

Insure your copy reaching you each month. Subscribe to Science & Invention—\$2.50 a year. Experimenter Publishing Co., 53 Park Pl., N.Y.C.

# U.S. PATENTS



**SEND FOR THIS FORM**

## Don't Lose Your Rights

Before disclosing your invention to anyone send for blank form "Evidence of Conception" to be signed and witnessed. A sample form together with printed instructions will show you just how to work up your evidence and establish your rights before filing application for patent. As registered patent attorneys we represent hundreds of inventors all over the U. S. and Canada in the advancement of inventions. Our schedule of fees will be found reasonable. The form "Evidence of Conception" sample, instructions relating to obtaining of patent and schedule of fees sent upon request. Ask for them,—a post card will do.



Registered Patent Attorneys in U.S. and Canada  
255 Ouray Bldg., Washington, D. C.  
"Originators of form Evidence of Conception"

# PATENTS

TRADE MARKS · DESIGNS  
FOREIGN PATENTS

## MUNN & Co.

PATENT ATTORNEYS

Associated since 1846 with the Scientific American  
618 Woolworth Building, New York City  
325 Scientific American Bldg., Washington, D. C.  
414 Tower Building, Chicago, Ill.  
367 Hobart Building, San Francisco, Cal.  
222 Van Nuys Building, Los Angeles, Cal.  
Books and Information on Patents and Trade Marks  
by Request.



If your invention is new and useful it is patentable—send me your sketch. Inventions developed, patented. Trade marks and copyrights obtained in the U. S. and Foreign countries.

### Z. H. POLACHEK

Reg. Patent Attorney  
Professional Engineer

70 Wall Street New York

# PATENTS

BOOKLET FREE HIGHEST REFERENCES  
PROMPTNESS ASSURED BEST RESULTS  
Send drawing or model for examination  
and report as to patentability

WATSON E. COLEMAN, Patent Lawyer  
644 G Street, N. W., Washington, D. C.

# Patent Advice

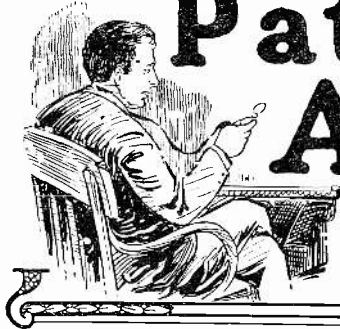

Edited By  
**A. P. PECK**

In this Department we publish such matter as is of interest to inventors and particularly to those who are in doubt as to certain patent phases. Regular inquiries addressed to "Patent Advice" cannot be answered by mail free of charge. Such inquiries are published here for the benefit of all readers. If the idea is thought to be of importance, we make it a rule not to divulge all details, in order to protect the inventor as far as it is possible to do so.

Should advice be desired by mail a nominal charge of \$1.00 is made for each question. Sketches and descriptions must be clear and explicit. Only one side of sheet should be written on.

NOTE:—Before mailing your letter to this department, see to it that your name and address are upon the letter and envelope as well. Many letters are returned to us because either the name of the inquirer or his address is incorrectly given.

### SHOE FASTENER

(912) Rudolph Wilestein, Proctor, Colo., has designed a shoe fastener which consists of a series of metal clips taking the place of ordinary shoe laces. He desires us to advise him regarding this device.

A. 1. With reference to your shoe fastener we would like to know whether or not you ever wore a shoe with this fastener in place, and whether or not you ever felt the pressure of these fasteners against the arch of your foot, and whether or not you ever stooped down when your laces were a little loose to find that the whole shoe suddenly opened. If not, we would advise you to give the device a thorough trial and see it do this. Then again it has not the elasticity of the ordinary shoe laces, and at no time will the shoe feel secure on the wearer's foot.

make for you. The main difficulty with your suggestion is as follows:

In an effort to make these milk bottle tops, at least two or even three operations are necessary. This would materially increase the cost of the top. Also, in capping the bottles, the ordinary machines could not be employed, and they would have to be changed. The surfaces of the cap would have to be printed in two sections, or printed flat and then folded. This printing is likewise more costly. You see, therefore, that in an effort to place your milk bottle tops upon the market, you would have to do so by communicating with small dairies or small dispensers. The larger concerns which already have machines for the cutting, printing and bottling of milk, would not look with favor upon your system, because of its greater cost, and cost is a great item in the transacting of milk sales.

### SNOW REMOVER

(914) John Mayer, Cleveland, Ohio, proposes the use of a steel compartment through which steam is to be directed and which is to be used in congested traffic districts where snow has to be removed quickly. He asks our advice on the idea.

A. 1. We doubt very much if you could take out a patent on your snow removing device, as the system is very old. With regard to efficiency, the device is extremely poor. So much heat must be generated in order to dispose of the snow, that all methods of this nature have met with no success whatever.

If we could concentrate the sun's heat and use this for removing the snow, we would be accomplishing something, but if we have to spend eight or ten times as much for removing snow by means of artificially produced heat, as we would do to have snow shovellers remove it, it will be seen that from the standpoint of economy, the suggestion is worthless.

### GASOLINE TURBINE

(915) J. Wenger, Bryn Mawr, Penna., has designed a rotary gasoline turbine upon which he wishes our advice. He also asks what horsepower such a machine could be expected to deliver.

A. 1. With reference to your gasoline turbine, we would advise that the best you can do is to forget about such a turbine entirely. There are today some two or three hundred patents on gasoline turbines, and the public does not look upon them with any degree of favor. There is no reason why you should spend money on a gasoline turbine which may be shelved the way all other devices are at the present time.

Due to the fact that the gas must be compressed before it is exploded, the power which the machine develops will not be extremely great. Likewise you are making use of the exhaust gases after the explosion and although the energy developed is nearly the same, there will be some tendency to lose efficiency owing to this fact. The angle of the blades will have to be determined by experiment; the greater the angle the higher the speed, and the smaller the power, and vice versa. The horsepower rating of the machine will be practically the same at any angle greater than that between the tip of one blade and the base of the adjacent blade. In other words, there must be no straight line passage in this channel. It would be extremely difficult to calculate the horsepower rating when the area, size of blades, angle of blades, type of blades, compressive and explosive power of the gas is not known. It is only after you build the device and make a Pony brake test, that this rating for a larger machine could be determined.

(Continued on page 678)



Proposed new form of shoe fastener. Our advice in regard to patenting this device is given above.

### MILK BOTTLE TOP

(913) B. J. MacEwan, Oakland, Calif., submits a device for a milk bottle cap wherein the cap is so folded that a handle is provided for removing it from the bottle. He asks our advice.

A. 1. Your idea of a milk bottle top is very interesting. We cannot inform you with regard to its patentability, as this would necessitate a patent research which any reliable attorney can

# INVENTORS PROTECT YOUR IDEAS

Send for our Guide Book, HOW TO GET A PATENT, and Evidence of Invention Blank, sent Free on request. Tells our terms, methods, etc. Send model or sketch and description of your invention for INSPECTION and INSTRUCTIONS FREE. TERMS REASONABLE. BEST REFERENCES.

Name .....

Street .....

City .....

**RANDOLPH & CO.**  
Dept. 172, WASHINGTON, D. C.

**MY PATENT  
LAW OFFICES**

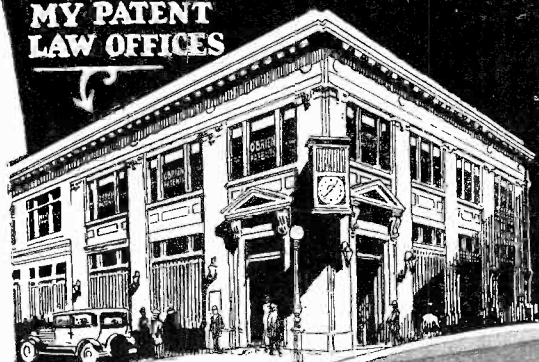

**JUST ACROSS  
STREET FROM  
U.S. PAT. OFF.**



# PATENTS

## INVENTORS Write for these FREE BOOKS!

At the left is a view of my drafting and specification offices where a large staff of experienced experts are in my constant employ. All drawings and specifications are prepared under my personal supervision.

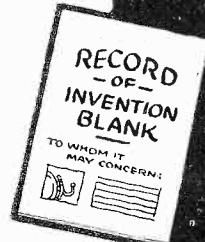

## PROTECT YOUR IDEAS

**Take the First Step Today—ACTION COUNTS**

If you have a useful, practical, novel idea for any new article or for an improvement on an old one, you should communicate with a competent Registered Patent Attorney AT ONCE. Every year thousands of applications for patents are filed in the U. S. Patent Office. Frequently two or more applications are made for the same or substantially the same idea (even though the inventors may live in different sections of the country and be entirely unknown to one another). In such a case, the burden of proof rests upon the last application filed. Delays of even a few days in filing the application sometimes mean the loss of a patent. So lose no time. Get in touch with me at once by mailing the coupon below.

### No Charge for Information on How to Proceed

The books shown here contain valuable information relating to patent procedure that every inventor should have. And with them I will also send you my "Record of Invention" form, on which you can sketch your idea and establish its date before a witness. Such evidence may later prove valuable to you. Simply mail the coupon and I will send you the books, and the "Record of Invention" form, together with detailed information on how to proceed and the costs involved. Do this NOW. No need to lose a minute's time. The coupon will bring you complete information entirely without charge or obligation.

### Prompt—Careful Efficient Service

This large, experienced organization devotes its entire time and attention to patent and trademark cases. Our offices are directly across the street from the U. S. Patent Office. We understand the technicalities of patent law. We know the rules and requirements of the Patent Office. We can proceed in the quickest, safest and best ways in preparing an application for a patent covering your idea. Our success has been built on the strength of careful, efficient, satisfactory service to inventors and trademark owners located in every state in the Union.

## Clarence A. O'Brien

Registered Patent Attorney

Member of Bar of: Supreme Court of the United States; Court of Appeals, District of Columbia; Supreme Court, District of Columbia; United States Court of Claims

Practice confined exclusively to Patents, Trademarks and Copyrights

### Strict Secrecy Preserved Write Me in Confidence

All communications, sketches, drawings, etc., are held in strictest confidence in strong, steel, fireproof files, which are accessible only to authorized members of my staff. Feel free to write me fully and frankly. Your case will have my personal attention. It is probable that I can help you. Highest references. But FIRST—clip the coupon and get my free books. Do THAT right now.

## Mail this Coupon NOW.

**CLARENCE A. O'BRIEN,**  
Registered Patent Attorney,  
9297 Security Savings & Commercial Bank Bldg.,  
Washington, D. C.

Please send me your free books, "How to Obtain a Patent," and "Invention and Industry," together with your "Record of Invention" form without any cost or obligation on my part.

Name.....

Address.....

(Important: Write or Print name clearly)



# PATENTS

**TO THE MAN WITH AN IDEA**

I offer a comprehensive, experienced, efficient service for his prompt, legal protection and the development of his proposition.

Send sketch, or model and description, for advice as to cost, search through prior United States patents, etc. Preliminary advice gladly furnished without charge.

My experience and familiarity with various arts frequently enable me to accurately advise clients as to probable patentability before they go to any expense.

Booklet of valuable information and form for properly disclosing your idea, free on request. Write today.

**RICHARD B. OWEN, Patent Lawyer**  
164 Owen Building, Washington, D. C.  
41V Park Row, New York City

**TRADE-MARKS REGISTERED**

## 1000 NEEDED INVENTIONS!

Here is the most remarkable book ever offered to inventors. One Thousand needed inventions listed and described. Arranged as follows: General Problems; Automotive; Mechanical; Electrical; Chemical; Radio; Marine. Separate chapter on the Ten Most Needed Inventions. This book may give you one idea that can win you a fortune. Nothing else like it has ever been published. Compiled at enormous expense. Edited by Raymond Francis Yates, formerly Managing Editor of a leading scientific magazine. Over 100 pages, durably bound. Send no money. Pay postman only \$1.00 plus postage on arrival. Money back after 10 days' examination if desired. Limited edition. Write NOW.

**BUREAU OF INVENTIVE SCIENCE**  
DEPT. 710 ROCHESTER, NEW YORK

**C. L. PARKER**  
Ex-Member Examining Corps, U. S. Patent Office  
**Attorney-at-Law and Solicitor of Patents**

American and Foreign Patents secured. Searches made to determine patentability, validity and infringement. Pamphlet of Instructions sent upon request

MCGILL BUILDING WASHINGTON, D. C.

**PATENTS** As one of the oldest patent firms in America we give inventors at lowest consistent charge, a service noted for results, evidenced by many well known Patents of extraordinary value. *Book, Patent-Sense, free.* Lacey & Lacey, 644 F St., Wash., D. C. Estab. 1869.

**INVENTIONS Commercialized**  
ON A CASH OR ROYALTY BASIS  
PATENTED or UNPATENTED

*In Business 25 Years - Complete Facilities - References.*

Write **ADAM FISHER MFG. CO.**  
205D Enright Ave. St. Louis, Mo.

**LAW** Personal Instruction  
By Mail Be a lawyer or law trained business man. Quality to earn \$2,500.00 to \$15,000.00 a year.

University methods. TUITION LOW. EASY TERMS. Text books furnished. Practical and authoritative non-resident course. Endorsed by bench and bar. Prepares for bar or business. Over 50,000 students. PERSONAL INSTRUCTION. Guarantee to coach free any graduate failing to pass bar exams. SPECIAL REDUCED TUITION OFFER now in force. Write today for particulars and book on law FREE.

**AMERICAN CORRESPONDENCE SCHOOL OF LAW**  
Dept. 1428 3601 Michigan Avenue, CHICAGO

**AGENTS WANTED SALESMEN DISTRIBUTORS**

To sell Blanche Thermostatic Carburetor Control. Makes Ford's run on 94% air. Doubles gas mileage. Sells on sight. Cadillac now uses Thermostatic control under Blanche license. No experience needed. \$250. to \$2,000. a month profit. Write today. A. C. BLANCHE & CO., Dept. 863-0 602 W. Lake St., CHICAGO

## Patent Advice

(Continued from page 676)

### TOOTH PASTE TUBE

(916) Walter J. Moore, Cambridge, Mass., submits a design of a tooth paste tube in which is placed a sanitary container for a tooth brush. The tooth brush container is placed directly in the center of the usual collapsible tube holding the paste. He asks our advice.

A. 1. We presume that in order to have a tooth paste tube of the nature you have described, you are going to use some secret method of causing the contents of this tube to exude through the orifice. In other words, you do not contemplate using ordinary pressure or the ordinary method of expelling the contents by pinching the tube at the end and rolling it up, so to speak.

But you must employ some other means. Otherwise how would you ever get all of the contents out of the tube? Assuming now that you intend to compress the tube all around the inner container for the tooth brush, it is evident that you will lose 25 per cent, or more of the paste, because it becomes quite impossible to cause the collapsible tube to adhere to the hard tube housing the tooth brush. If the tube housing the tooth brush is not hard, the instant that both units are either compressed or bent, one will be unable to remove the tooth brush; and last but not least, special sizes of tooth brushes would have to be employed in these tooth paste tubes in order to fit within the containers. Consequently the cost of your device would make it prohibitive when it comes to placing it on the market, and the relative usefulness being so limited, we would strongly advise against applying for a patent on the same.

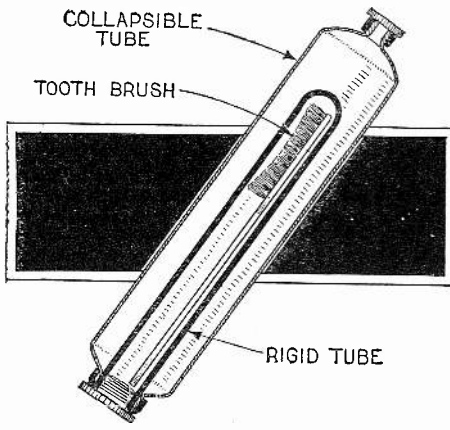

Novel idea for design of tooth paste tube in which is placed a sanitary container for a tooth brush.

### ANTENNA CONNECTOR

(917) R. Geo. Schultz, Holyoke, Mass., asks if after finding a new use for a patented article for which it was not primarily intended, the new device being of entirely different shape, but using the same mechanical principle, he could get protection in the form of a patent on such a device. The system is the double clasp similar to the "hold-on" clutch and is to be used for splicing wires together, or as a binding post.

A. The general principle in patent law is that if a patent is granted for a device, it covers all possible uses and applications thereof. There are many ways of changing the "hold-on" clutch, so that it will conform with your suggestions. We doubt, however, that a patent upon this device will prove of financial value. A great deal depends upon your initiative ability and the funds you have available, for forcing this device into the market. For instance, you could use a simple spring clutch device, which upon pressure would be released. This is just as effective as the clutch spoken of in your communication. These could be arranged in two half sections of tubing or similar to a turn buckle having the center open or hollow. In this manner the aerial wire can be tightened or loosened as desired, without the necessity of having relatively short pieces of wire, as would be the case in your particular construction.

For binding posts the suggestion is not very applicable, unless a simple method for removal of the wire would be employed. Spring binding posts now upon the market are just as effective, however. The only practical utility your device has is as an antenna connector, where its use would be limited. For guy wire locks it could be employed if made sturdy enough. Nevertheless, you can see that the market is limited.

# DON'T OVERLOOK THIS in NEW YORK

**VISIT the Hotel Martinique—look the inviting, comfortable rooms over—note the genuine convenience of location, where you are right in the heart of the busy shopping district and within easy distance of all business centres.**

In fact, you can go direct from the Martinique to any place in New York without stepping out of doors (via enclosed subway from basement).

You will be surprised at the unusual rates of this popular New York Hotel. You can enjoy all the comfort and convenience of the Hotel Martinique at rates as low as \$2.50 per day.

Club breakfast at 45c—table d'hote dinner at \$1.25—also a la carte at unusually moderate prices.

A. E. SINGLETON, Res. Mgr.

*The BEST without extravagance!*

## Hotel Martinique

Affiliated with Hotel M. Alpin  
Broadway-32<sup>nd</sup> to 33<sup>rd</sup> Sts.  
NEW YORK

*Learn Write*



Begin Today—Write for My FREE BOOK can make a good penman of you at home during spare time. Write for my FREE BOOK, "How To Become a Good Penman." It contains specimens and tells how others mastered penmanship by the Tambllyn System. Your name will be elegantly written on a card if you enclose stamp to pay postage. Write today for book.

F. W. TAMBLYN, 424 Ridge Bldg., Kansas City, U.S.A.

# CONN

BAND INSTRUMENTS  
WORLD'S LARGEST MANUFACTURERS

Play for pleasure and profit  
—Conn gives you both in the shortest time. Easy playing is the outstanding feature of Conns, as the world's greatest artists will tell you. Beautiful tone, perfect scale, reliable mechanism. With all their exclusive features Conns cost no more. FREE TRIAL. EASY PAYMENTS on any band or orchestra instrument. Write for details, mentioning instrument.



R. O. Sweeten is one of the hundreds of famous stars who use and endorse Conn instruments.

**C. G. CONN, Ltd.**  
1157 Conn Bldg., Elkhart, Ind.

**CULTIVATE YOUR MUSICAL BUMP**

**INVENTORS** Patent your invention. Costs reasonable. Pay as you earn. Quality service. Patent booklet free.

**AMBROSE T. BUCKLEY**—Patent Attorney  
30 Church St. New York City

**Solomon's Temple Model  
Reproduced**  
By A. N. MIRZAOFF  
(Continued from page 609)

they took the Mohammedan to be the original temple built by Solomon and taken over by the infidels. Churches on this model, therefore, were built throughout Europe by the Templars. Thus a Mohammedan type of architecture became incorporated into the Christian architecture. The mosque was converted into a church and a high altar erected on the sacred rock. Almost 200 years later Saladin moved the altar and repaired the whole building, which was again restored by Mohammed ibn Kalaun in 1327 and by Suleiman the Magnificent in the 16th century. In a lesser degree it has undergone repairs by the later Sultans of Turkey.

Omar's Mosque is of magnificent proportions, but it is so symmetrical that no one would suspect its size when seeing it at a distance. Its dome is 108 feet high and 87 feet in diameter.

It was in December, 1917, that the site of the ancient Tabernacle and Jerusalem, which for 13 centuries, with few intermissions, had been under the rule of the Crescent, returned to the rule of the Cross when the British troops under General Allenby entered the city.

**Continuous Time and  
News Broadcast Service**  
By C. A. OLDROYD  
(Continued from page 643)

"Photographers, please note: Fine sunshine today, experts advise exposure of 1/100th second today, from ten A. M. to two P. M., using standard roll film and stop 4. For super-speed and similar films and plates, use one-half."

With one stroke, all uncertainties in photography would be wiped out, and numerous photographers would become radio enthusiasts.

2. Weather forecasts, transmitted several times per day. As these would only apply to a district of say 100 miles square, forecasts could be more accurate and amended in later transmissions.

3. Shipping data: The incoming trans-Atlantic liners could be announced several hours in advance. Listeners would then be informed of delays in arrival or of unexpectedly fast passages. Mail closing times for far-away countries could be transmitted at fixed times.

Such a service would benefit everybody, and the cost involved need not be very high. The news service would be carried out by day, say during business hours or from about eight A. M. to eight P. M.

During the night, the time service could be carried on by using automatic transmission devices, such as a dictaphone with a specially made record. Electric contacts on the clock dial could start the dictaphone cylinder for a few turns, to send the time signal. After every transmission, the cylinder could be stopped and the reproducer shifted to a new position by a small electric motor.

On the other hand, the time service could be limited to the daytime only.

A special wave-length would have to be reserved for this combined time and news service, preferably very short waves, say ten to fifteen meters might be used.

**PATENTS TRADE-MARKS  
AND  
COPYRIGHTS**

**OUR OFFER: FOR THE PROTECTION  
OF YOUR INVENTION**

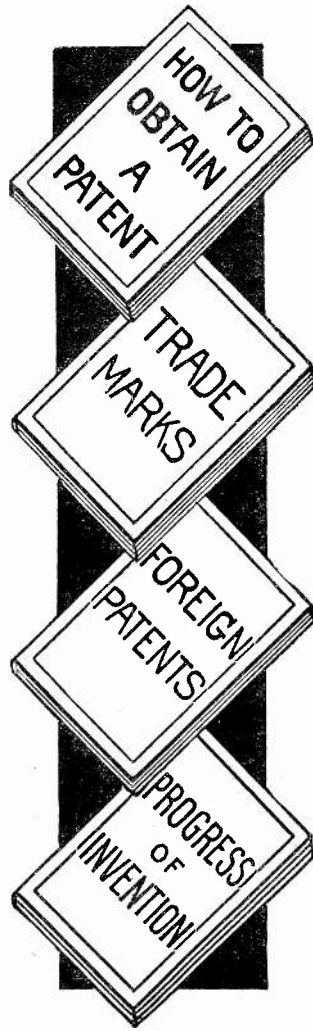

*YOUR FIRST STEP* before disclosing an invention. The inventor should write for our blank form—

**"Record of Invention"**

This should be signed and witnessed and returned to us together with model or sketch and description of the invention for **INSPECTION and INSTRUCTIONS.**

NO CHARGE FOR THE ABOVE INFORMATION

**Our Four Books Mailed  
Free to Inventors**

*Our Illustrated Guide Book*

**HOW TO OBTAIN A PATENT**

Full instructions regarding U. S. Patents. Our Methods, Terms, and 100 Mechanical Movements illustrated and described.

**OUR TRADE MARK BOOK**

Shows value and necessity of Trade Mark Protection. Information regarding *Trade Marks and unfair competition in trade.*

**OUR FOREIGN BOOK**

We have Direct Agencies in Foreign Countries, and secure Foreign Patents in shortest time and at lowest cost.

**Progress of Invention**

Description of World's Most Pressing Problems by Leading Scientists and Inventors.

**IMPORTANT**

Do not submit your invention to anyone before you furnish proof that the invention is patentable or application has been filed. **IN ORDER TO HAVE YOUR CASE MADE SPECIAL TO AVOID DELAY YOU SHOULD TAKE THE PRECAUTION OF HAVING YOUR CASE MADE SPECIAL IN OUR OFFICE** to secure protection, save correspondence and secure early filing date in Patent Office. To secure special preparation of your case send \$25.00 on account with model, sketch and description.

All communications and Data Strictly Confidential. Interference and Infringement Suits Prosecuted. Our Organization offers **PERSONAL SERVICE** by Experienced Patent Solicitors and Draftsmen.

*We Regard a Satisfied Client* as our best advertisement, and furnish anyone, upon request, lists of clients in any state for whom we have secured patents.

*Highest References—Prompt Attention—Reasonable Terms*

**WRITE TODAY**

**FREE  
COUPON**

**VICTOR J. EVANS & CO., Patent Attorneys**

New York Offices Philadelphia Offices Pittsburgh Offices  
1007 Woolworth Bldg. 714-715 Liberty Bldg. 514 Empire Bldg.  
Chicago Offices, 1114 Tacoma Bldg. San Francisco Offices, Hobart Bldg.  
**Main Offices, 779 Ninth Street, Washington, D. C.**

Gentlemen: Please send me **FREE OF CHARGE** your books as described above.

Name..... Address.....



**\$3.25 (C.O.D.)**  
**RADIO Storage "B" Battery**  
 32 Cells  
**Lasts Indefinitely—Pays for Itself**  
 Economy and performance unheard of before. Recharged at a negligible cost. Approved and listed as Standard by leading Radio Authorities, including Pop. Radio Laboratories, Pop. Sci. Inst. Standards, Radio News Lab., Letax, Inc., and other important institutions. Equipped with Solid Rubber Case, an insurance against acid and leakage. Extra heavy glass jars. Heavy, rugged plates. Order yours today!

**SEND NO MONEY** Just state number of batteries wanted and we will ship day order is received. **Extra Offer:** 4 batteries in series (96 volts), \$12.75. Pay expressman after examining batteries. 5 per cent discount for cash with order. Mail your order now!

**WORLD BATTERY COMPANY**  
 1219 So. Wabash Ave., Dept. 23 Chicago, Ill.  
 Makers of the Famous World Radio "A" Storage Battery  
 Prices: 6-volt, 100 Amp. \$11.25; 120 Amp. \$12.25; 140 Amp. \$14.00.  
 All equipped with Solid Rubber Case.

**World STORAGE BATTERIES**  
 Set your Radio Dials at 210 meters for the new 1000 watt World Storage Battery Station, Chicago. Watch for announcements.  
 WDKA • WEA • WGN • WJS • KHJ • KGO • KFAP • WJY • KOP

World Champion  
 .32 - 20  
 or .38  
 or .38  
 Cal.  
 6-Shot  
 Special



Double action SWING OUT CYLINDER, a reliable accurate powerful gun sold elsewhere for \$25.00. **REMOVABLE PLATE**, double safety rifled barrel. TESTED AND APPROVED BY OFFICIAL EXPERTS. Satisfaction or money back. **SEND NO MONEY.** PAY postman \$12.50 plus postage. On Money With Order We Pay Shipping Charges. U. S. IMPORT CO., Dept. S-89, 124 University Place, New York

**"LIGHTING FIXTURES"**  
 READY TO HANG  
 Direct from the manufacturer. Completely wired including glassware. Send for new Catalogue No. 27 (Just reduced prices)  
 Special Proposition to Dealers  
**ERIE FIXTURE SUPPLY CO.**  
 Desk B Erie, Pa.

**FREE 10 DAYS TRIAL**  
 You can have this ball-bearing, long-wearing L. C. Smith Typewriter for 10 days Free Trial with absolutely no obligation whatsoever. After 10 days, if you are not satisfied it is the greatest bargain you ever saw just send it back. If you keep it, pay only \$2.00 down, then small monthly payments. **LOWEST PRICES** ever made on the genuine Ball-Bearing, Silent L. C. Smith—late style—up-to-date, full size—every convenience—highest quality rebuilt, perfect machines—5 Year Guarantee. **FREE TO YOU NOW**—Complete Course in Touch Typing; Tools; Waterproof Cover; Instruction Book—All free now. Send today for New Special Price offer and free valuable typewriter information. **Smith Typewriter Sales Corp.** 303-360 E. Grand Av., Chicago  
**FAMOUS L.C. SMITH**

**LATEST WHOLESALE RADIO CATALOG**  
**FREE** Simply send name **TODAY** for big 48-page catalog of latest radio goods at Wholesale. Live dealers and agents wanted.  
**STANDARD RADIO CO., 112 East 13th, Kansas City, Mo.**

**WADE BENCH LATHE**  
 Cap. 4" dia. x 12" travel. Slidest has length entire length of bed. Lead screw inside head. Hollow spindle. Drilling, re-driving, thread cutting. No. 1 Lathe, pl. headstock, \$28.00. No. 2 Lathe, back-gear headstock \$58.00. Complete line of accessories at equally low prices. Write for interesting free catalog—just out. **THE GEROLD COMPANY**  
 Dent. S-9, 120 Liberty Street, New York

**Great New Invention**  
 For Seekers of Health—Power—Beauty  
**Elco Electric Health Generator**  
 Generates High Frequency Violet Ray, Mechanical Vibration Medical Electricity and Ozone. Four of Nature's Greatest Curative Agents. For Home Treatments at less than 50 cents per year.  
**FREE BOOK** describing this Great New Invention. Re-vitalize yourself. Bring back energy. Be wholly alive. **WRITE TODAY.**  
**Lindstrom & Co., 30 W. Lake St., Dept. 14-28, Chicago**

**Is the Earth Solid?**  
 By GENE DEACHEM  
 (Continued from page 632)

is well known that ice behaves opposite to the actions of most solids. In Fig. 4 it is shown that while ice expands with lowered temperature, iron and metallic substance would contract. The expansion on solidifying of some metals and alloys is distinctly a crystallization phenomenon. A heavy weight placed upon ice causes it to melt even though the temperature be far below its melting point. The effect of pressure on other solids is, of course, exactly opposite—increasing it on the melted substance causes it to solidify. The enormous compression, therefore, makes the earth behave as if it were entirely solid.

Professor Reginald A. Daly, of Harvard University, is a little more specific. At a depth of some sixty miles, he claims in a recent paper presented before the American Philosophical Society, is a layer of liquid glass, rigid because of the enormous pressure. The continents actually float upon this, the sliding about causing the wrinkling of the earth's crust known as mountains. In the past ages, a slight shift of America toward the west caused the Rocky Mountains. Similar migrations, like that of Europe to the south forming the Alps, can be traced to account for the main series of mountains which seem to lie in approximately straight lines.

Volcanoes are also accounted for on this theory; when the crust of the earth is a little too thin, the lowered pressure permits the *solid liquid* to melt—pouring forth its lava in an eruption. For diagram of this and the preceding phenomenon, see Fig. 5.

**Hints for the Radio Builder**  
 By LEON L. ADELMAN  
 (Continued from page 651)

ly improve the results which may be obtained from a radio receiver. Several are shown in Fig. 5. The very first concern is the antenna circuit. If the antenna is too long, a series fixed condenser, (C), should be incorporated to bring down the wavelength. A .0005 will, as a rule, be found effective.

To transfer more energy into the secondary circuit will result in louder signal strength, hence the coupling condenser, (D) between primary and secondary circuits. At the same time, we have a conductively and an inductively coupled receiver which is bound to give better satisfaction.

A variable condenser to provide capacitative feed-back in the detector circuit (F) will improve sensitivity and volume and sharpness of tuning.

A by-pass condenser across the primary of the first audio frequency transformer (F) will allow the remaining radio frequency component to return freely to ground and thus will aid stability.

If the last tube cannot stand the strain of too much volume, a small condenser shunted across it, (G), will give a bit less volume but greater clarity.

A condenser across the phones or loud-speaker, (H), will also tend to clarify the music. If the "B" batteries are shunted with by-pass condensers, (I and J), the radio frequency current will have a lower impedance to traverse, and hence the grids of the tubes will receive higher potentials, resulting in greater volume.

**30 DAYS FREE TRIAL**  
**CUT TO \$49.50**  
**GENUINE MASTER MODEL ROYAL No 10**

You cannot buy a better machine anywhere or at any price than this latest "Master Model" Royal, No. 10. It is, we honestly believe, the best typewriter made. You Save \$53!

**Like New in Looks and Service**  
 Literally like new. Guaranteed for 5 years. Will give splendid service for many more. An all-around machine for letters, cards and billing. Has all late improvements, high-speed type bars, forced alignment, 2-color ribbon, with automatic reverse, tabulator, etc. Standard keyboard; 84 characters.

**Satisfaction Guaranteed or Money Back**  
 Try it 30 days. If it does not please you in every way, send it back at our expense and we will refund every dollar you have paid. Write for full details at once. A postcard will do.

**Cut Prices On All Standard Makes**  
**LINCOLN TYPEWRITER COMPANY**  
 INCORPORATED  
 America's Leading Independent Typewriter House  
 Dept. 57-A 298 Broadway, New York City

**BIG VALUE for 10 Cts.**

6 Stories, Girls and music; 25 Pictures Pretty words; 40 Ways to Make Money; 1 Joke Book; 1 Book on Love; 1 Magic Book; 1 Book Letter Writing; 1 Dream Book and Fortune Teller; 1 Cook Book; 1 Base Ball Book, gives rules for games; 1 Toy Maker Book; Language of Flowers; 1 Morse Telegraph Alphabet; 12 Chemical Experiments; Magic Age Table; Great North Pole Game; 100 Conundrums; 3 Puzzles; 12 Games; 30 Verses for Autograph Albums. All the above by mail for 10 cts. and 2 cts. postage.  
**ROYAL SALES CO., Desk 118 Norwalk, Conn.**

**2650 MILES ON ONE TUBE**  
 Why not enjoy real distance like our thousands of customers the world over. We send complete understandable instructions for 25c or Big Booklet Free.  
**VESCO RADIO CO.**  
 Box DSI-117 Oakland, Calif.

**Straightens Shoulders—Increases Pep**  
**THE NATURAL BODY BRACE**—Corrects stooping shoulders, straightens the back, gives the lungs chance for normal expansion, induces proper breathing. Brings restful relief, comfort, energy, and pep. For men and women.  
**Costs nothing to try it**  
 Write for 30 days free trial offer and free book.  
**NATURAL BODY BRACE CO.**  
 Howard C. Rash, Rt. 286 Rash Bldg., Salina, Kansas

**Study AT Home**  
**Become More Efficient**  
 Courses in Mathematics, Chemistry, Psychology, Education, Business, and 40 other subjects command either High School or College Credit. Start any time.  
**The University of Chicago**  
 27 Ellis Hall CHICAGO, ILL.

**CALCULATIONS**  
 In the Store, Office, Shop, Etc., can be instantly made with the Midget Slide Rule. If you have any figuring to do, order one on trial. It is the most versatile calculator ever invented.  
 The Engine-Divided Scales are on white celluloid, mounted on aluminum, grease- and waterproof. Size 4".  
 Price, with Instruction Book. (Patented 1-17-22) \$1.50. Leather Case 50c extra.  
 Sent C. O. D., if desired. Catalog free.  
 Your money back if you are not satisfied.  
**GILSON SLIDE RULE CO., Niles, Mich.**



In Fig. 6, we have a simple device for allowing the use of a three-stage audio amplifier to give great volume and at the same time preserve a semblance of clarity in reproduction. A volume control in the shape of a variable resistance of from 10,000 to 100,000 ohms is placed in parallel with the secondary of the third amplifying transformer and gives excellent control of volume and clarity. Such an arrangement is ideal where it is necessary to address large audiences, the three stages of amplification giving very good volume. A by-pass condenser of .004 mfd. is shunted across the output.

**CORRECTION NOTICE**

We recently published a review of a book entitled Photographic Facts and Formulas and credited the Alpine Press, of Boston, as the publishers. The publisher of this book is the American Photographic Publishing Co., of Boston. We are glad to make this correction.

**Book Review**

**THE EARTH SPEAKS TO BRYAN.**  
By Henry Fairfield Osborn. Cloth covers. Chas. Scribner's Sons, New York City, N. Y. \$1.00.

This book contains 91 pages. Its style seems somewhat hurried, yet it is remarkably original and suggestive. Dr. Osborn seems to entertain no doubt in his mind that the trial at Dayton, Tenn., will do much good on the side of spreading truth. He does not fear the outcome. He says: "Irrefutable witnesses of our past positively demonstrate two new and somewhat unexpected truths: first, that man has not descended from any known kind of monkey or ape, fossil or recent; with this truth, established not by Bryan, but by the testimony of the earth, one of the chief sentimental objections to the creative evolution of man disappears forever; second, man has a long, independent, superior line of ascent of his own" (page 10). He gives an interesting survey of the arguments in substantiation of the evolutionary hypothesis, which he denies as being in conflict with religion, since the theme of the Bible is religion and morals there can be no serious conflict here either. Professor Osborn does not deny a Creator in this book. He says that evolution by no means takes God out of the universe, but on the other hand makes God imminent in the universe. The real question is, "Did God use evolution as his plan?" The book argues the affirmative of the query. The book covers in a dashing fashion a fascinating field of study.—Rev. J. F. Atkins.

**RETOUCHING NOT DIFFICULT**, by Corydon G. Snyder. Paper covers, 5" x 7½", illustrated, 23 pages. Published by Corydon G. Snyder, Oak Park, Ill. \$2.50.

In its twenty-three pages, this little book is supposed to tell about retouching negatives. It gives some history of the photo sketch and an explanation of the film-etching and negative-etching processes. The latter it seems is a process. There is not much more to be said about the little treatise except that it is attractively made up in nice binding and is illustrated.

**LIGHT AND COLOUR**, by R. A. Houston, M.A., Ph.D., D.Sc. Hard covers 5½" x 8¾", illustrated, 179 pages. Published by Longmans, Green & Co., New York City. \$2.50.

Some things quite familiar to readers of this country appear in this most interesting book. Thus we find an illustration of the Michelson Interferometer in the Mt. Wilson Observatory, and the Optophone to enable the blind to hear ordinary printed matter by the use of selenium. These we merely cite as meeting our eyes while turning over the pages. The book in a sense comes from Glasgow University in Scotland. It is very practical and goes into such things as color blindness, color photography and stereoscopy. The light of the future is treated in a section. Here the author goes into the cost quite elaborately and treats of all kinds of light. Photo chemistry, the effect of sunlight as a curative agency, which has several dreadful titles such as heliotherapy, (helio meaning sun not healing) form an interesting section. Finally we come to the psychology of color. It treats of this rather obscure subject most interestingly and we warmly commend it to our readers.



**LAST CHANCE**  
on this great Bargain Offer

This is the last chance you will ever have to get Croft's LIBRARY OF PRACTICAL ELECTRICITY with Taylor's TRANSFORMER PRACTICE FREE. This big book bargain is offered just for one month more. It will never be offered again. Don't hesitate a minute. Act right away! —order now for Taylor's TRANSFORMER PRACTICE—free.

**The Sure Way TO Big Pay**

**B**IG salaries are paid in the electrical field for expert knowledge. The man who knows electricity in all its many phases—the man who has completely mastered the subject from A to Z—can pick his own job and name his own salary. The only way you can earn more is to learn more. Small knowledge means small pay. Learn the way to bigger pay. Become an expert. Croft will show you how. And the Croft way is the sure way to the big-pay job.

**Croft Library of Practical Electricity**

8 volumes—3000 pages—2100 illustrations—flexible keratol

In the eight books that make up the Croft Library will be found the essentials of a complete electrical education.

Volume One, by Palmer, contains a complete, practical course in mathematics. Volumes Two and Three present the fundamental facts and theories of electricity and its present-day applications.

Volume Four is a practical working manual covering the basic principles, operation and management of commonly used electrical machinery. Volume Five thoroughly covers modern central-station practice.

Volume Six tells how to install wiring and apparatus for practically all services under practically all conditions. Volume Seven covers the wiring of finished buildings and Volume Eight deals with the problems of electric illumination. The man who masters the information contained in these eight standard handbooks has his future success in the electrical field definitely assured.

**Know electricity as experts know it and earn an expert's pay**

No course, no set of books offer a quicker, surer method of mastering electricity than the Croft Library. It is founded on practice—on work as it is actually done. It is jammed from cover to cover with the kind of hard-headed, pay-raising facts you want. Written so that the beginner can easily understand it, yet so sound, so thorough that it is the daily guide of thousands of highly paid electrical workers and engineers. Croft shows you how to master the finer points of electrical practice. He teaches you electricity as experts know it and puts you in line for an expert's pay.

**Examine the books for 10 days free**

We want you to test our statements—we want you to compare the Croft books with others. Fill in and mail the coupon attached and we will send you the entire set of eight volumes for ten days' Free Examination. We take all the risk—pay all charges. You assume no obligation—you pay nothing unless you decide to keep the books. Then \$1.50 in ten days and the balance at the rate of \$2.00 a month. Send the coupon NOW and see the books for yourself.

When your first payment of \$1.50 is received we will send you your free copy of Taylor's Transformer Practice.

But act now—this offer will soon be withdrawn—and will never be made again. Don't miss it!

No money down—small monthly payments—7c a day.

**ACT NOW**  
This is the last time this offer will be made!

**LAST CHANCE COUPON**

Name .....

Address .....

Position .....

Company .....

McGraw-Hill Book Co., Inc.  
370 Seventh Avenue, New York

Gentlemen—  
Please send me the Croft Library of Practical Electricity (shipping charges prepaid) for 10 days' free examination. If satisfactory, I will send \$1.50 in 10 days and \$2 per month until \$19.50 has been paid. If not wanted, I will write you for return shipping instructions. Upon receipt of my first payment of \$1.50 I am to receive a copy of Taylor's Transformer Practice without additional charge. (Write plainly, fill in all lines.)

Mail this coupon

# Just Seven Simple Tools



## —and you can build the finest Radio Receivers Quickly and Easily

It takes but one or two evenings, using only the simplest tools to construct, at home, any one of the big, popular receivers shown on this page.

All you need is the well known CONSRAD Pattern that covers this particular receiver. CONSRAD Patterns are marvelously simple. You don't have to measure the spacing on the panel board or the placing of the parts. It is all drawn for you on the Blueprints the same as indications are given on a lady's dress pattern.

And you don't have to use 100 different tools to complete the job—just six or seven ordinary tools found in every household. A screwdriver, a pen-knife, a pair of pliers, etc., and you are ready to go ahead.

Visit your nearest Radio Dealer, ask him to let you look at some CONSRAD Patterns, select the one you want. Pay the Dealer 50c and you have complete instructions and blueprints for the construction of the Receiver.

IF YOUR DEALER CANNOT SUPPLY YOU, WRITE DIRECT, MENTIONING THE RECEIVER YOU WISH TO BUILD AND ENCLOSING FULL PRICE.

REMEMBER: CONSRAD Patterns—only 50c—give complete full sized blueprints and instruction booklet. Everything ready to build.

The CONSRAD COMPANY, 233 Fulton St., New York

# Consrad

EVERYTHING IN RADIO BOOKS, PATTERNS AND DIAGRAMS

SUPER-HETERODYNE



THE TROPADYNE



THE NEUTRODYNE

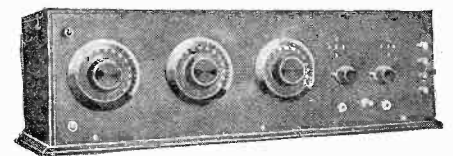

5-TUBE COCKADAY



THE REFLEX

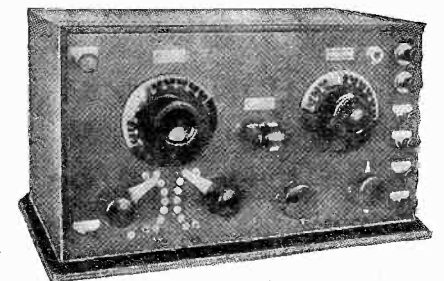

THE PORTABLE

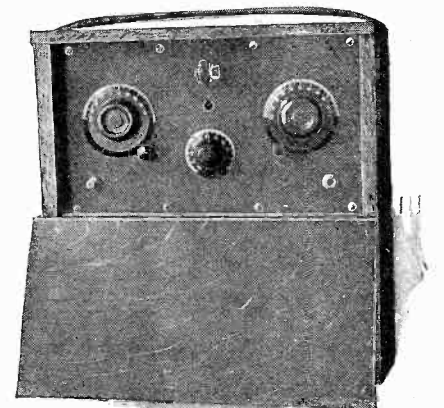

## RADIO WRINKLES

UNDER this heading we are going to publish items of interest to everyone who likes to build radio instruments. In order to continue this department it is necessary for our readers to tell us about their latest experiments. Write us a short description of some time- or money-saving kink you have discovered and send it to us along with a few sketches. Our regular prizes will be paid for this material. Be brief and try to put everything in the drawing. Don't be too elaborate. Address "RADIO WRINKLES" editor, care of Science and Invention.

### Shaft Extension

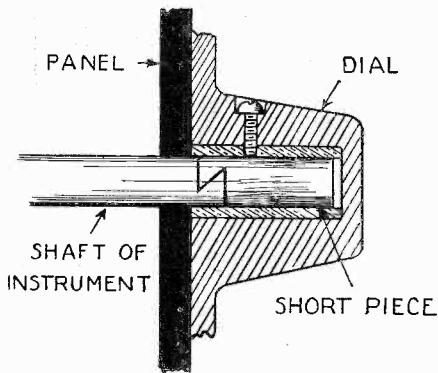

Often it happens that the shaft of an instrument is not quite long enough to place a dial on it. By filing it so as to form a joint as shown above and fitting a short length of brass rod to it, the problem is solved.—W. C. Patch.

### Battery Charger

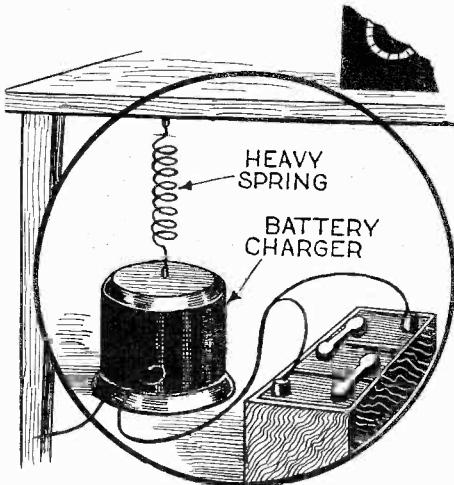

If a battery charger that is too noisy in operation is suspended from a heavy spring as shown in the illustration above, much of the annoyance will be eliminated. Be sure that the spring you employ is strong enough to hold the battery charger off the floor. If the spring cannot be conveniently fastened to the top of the charger, a sling can be made of heavy cord or thin rope in much the same manner as barrels are arranged for hoisting. The spring is then attached to the same point of the sling that the hook would be attached if the sling were around a barrel to be hoisted. By suspending the charger under the table near the storage battery and wiring up a switching arrangement for the two, a compact unit will result. —Fred Ebel.

Washington Jewelry Co., Boston, Mass.

# Amplifies! Beautifies! Clarifies!

The New Burns "MEL-O-TONE" Loud Speaker



10 Days  
FREE  
Trial

Great  
Acoustic  
Achievement

Super-sensitive  
Unit

Send  
NO  
Money

75c Plug  
Included  
FREE

MARVELOUS Super-sensitive Unit; concentric electro-magneto coil construction with PRECISION adjuster to regulate reception from faintest whisper to thunderous VOLUME to fill an auditorium. Stands 22 inches high. Bell is 14 inches and made of lustrous jet black Pyralin, in graceful flower petal design. What a beauty it is! Worthy of the finest homes! The sound conduit is polished aluminum, non-vibrating, non-resonating—eliminates harsh raspy sounds. Mounted on swivel—swings smoothly in all directions. A \$50 Speaker in construction and appearance. OUR PRICE

\$22.50

Send No Money! Pay Nothing to Postman! 10-Days Trial FREE!

We want you to SEE! to HEAR! to ENJOY it!—before paying a cent. If satisfied after 10-Days' trial, you may pay cash, or on our Nationally Famous Charge Account Payment Plan:—\$1 WEEKLY or \$4 MONTHLY.

\$4 a Month

2 Generations of Honorable Dealings



Importers and National Mail Order House  
Largest Distributors of "MEL-O-TONE"  
Loud Speakers.

365 Washington Street, Boston, Mass.  
For prompt attention address RADIO DEPT. 107

Gentlemen: Please send me \$22.50 Burns "MEL-O-TONE" Loud Speaker with 75c Plug included FREE. I enclose NO money, and pay NOTHING to Postman. If I am satisfied, after 10 DAYS' TRIAL, I have the privilege of paying cash or at the rate of \$4.00 monthly. Otherwise, I shall return it.

NAME .....  
ADDRESS .....

Please write PLAINLY! Tear this coupon out NOW! If you wish to tell us something about yourself, it will be appreciated. S111-25

TO own the Burns "MEL-O-TONE" Loud Speaker is to give friends and family real ENJOYMENT when listening to broadcasts. Makes good concerts—BETTER. It amplifies CLEARLY, FAITHFULLY, SWEETLY the beautiful strains of the violin; stirring airs of bands; snap and pep of jazz music; thrilling notes of opera singers; natural inflections of the orator; delightful richness of concert music. We have sold hundreds to "fussiest" Radio Fans—and they are Delighted with the Burns "MEL-O-TONE" Speaker!

ORDER YOURS TODAY! Send NO Money. This Amazingly Liberal Offer for Limited time only! Send coupon now!

NOTE! Eminent Radio Scientists endorse the Horn type Loud Speaker. The curved throat and wide mouth produce concentrated volume, directional volume, greater volume than the Non-horn type which diffuses volume. Try the Burns and test the truth of this FACT yourself.

# WANTED

Railway Postal Clerks  
\$1900 to \$2700 Year

(Postal Salaries Just Raised)

TRAVEL—See Your Country

MEN—BOYS, 18 UP SHOULD MAIL COUPON IMMEDIATELY

Steady work. No layoffs. Paid Vacations



FRANKLIN INSTITUTE,  
Dept. J182, Rochester, N. Y.

Sirs: Send me without charge: (1) Specimen Railway Postal Clerk Examination questions; (2) Schedule showing places of coming U. S. Government examinations; (3) Free sample coaching.

COUPON  
Name.....  
Address.....

**LEARN TO DRAW!**  
Remarkable book—"COMMERCIAL ART AND CARTOONING." Explains how to make illustrations for books, advertisements, etc. Also how to become a Cartoonist. NO CORRESPONDENCE COURSE—Book tells all—14 chapters—125 illustrations. Explains Elementary Drawing; Still Life; Pen, Ink, Charcoal and Gray Work; Cartooning, etc. Bound Flexible. Im. Leather. Postpaid for \$2.00 (C.O.D. 75c extra). OGLIVIE PUB. CO., 57 Rose Street, New York. Dept. 139

POST \$2.00 PAID

## CLASS RINGS & PINS

Largest Catalog Issued—FREE

Samples loaned class officers. Prices \$ .20 to \$3.00 each. No order for class, society, club emblems too large or too small. Special designs made on request.

METAL ARTS CO., Inc., 7723 South Ave., Rochester, N. Y.





# I Fit You for Big Electrical Jobs Like These



From common laborers to ownership of the U. & F. Electrical Company is what these boys did.

## S. & H. Fits You for Jobs Like These

**A**FTER many years' study and experimental work there has been developed this remarkable way of teaching electricity right in your own home. This shop type home training is an exclusive copyrighted feature. You can get it nowhere else. And you receive a diploma actually certified and endorsed by the Lincoln Institute of Technology. You get theoretical knowledge as well as experience of doing practical work. That's why this amazing training is the quickest and the simplest ever devised. Electricity needs you. Right now hundreds of big pay jobs want men. The experts of this great institution know exactly what you need to fit you for these jobs. You can soon be equipped to demand and get the high salaries this profession pays.

### Send for Big Book FREE

If you want to be an electrical expert, send the coupon at once. All who send immediately will receive an amazing

## You Can Be Ready in 20 WEEKS

In just 20 weeks you can receive the amazing training of the S. & H. Engineering Company and Lincoln Institute of Technology and be ready to step into big jobs like Unholz and Farina, or G. Melrose, or G. Fields and hundreds of others. No matter what your experience or education, this is an amazing opportunity.



G. Melrose is earning \$400.00 a month now because he was wise enough to take this electrical training of the famous S. & H. Engineering School.



Free offer of a complete outfit of electrical apparatus, instruments and appliances. Our big Free catalog gives you full information. Find out what S. & H. will do for you. Also about our big Free Employment Bureau. Do not delay. Mail the coupon now.

**S. & H. ENGINEERING CO.**  
In Affiliation with Lincoln "Tech" Dept. L-2, 1422 W. Monroe St., Chicago, Ill.

**CHIEF ENGINEER, S. & H. ENGINEERING CO.**  
1422 W. Monroe St., Dept. L-2, Chicago, Illinois  
Please send me catalog and full information about S. & H. Training, your Free Outfit, your Employment Bureau, etc. No obligation.

Name .....  
Address .....  
City ..... State .....

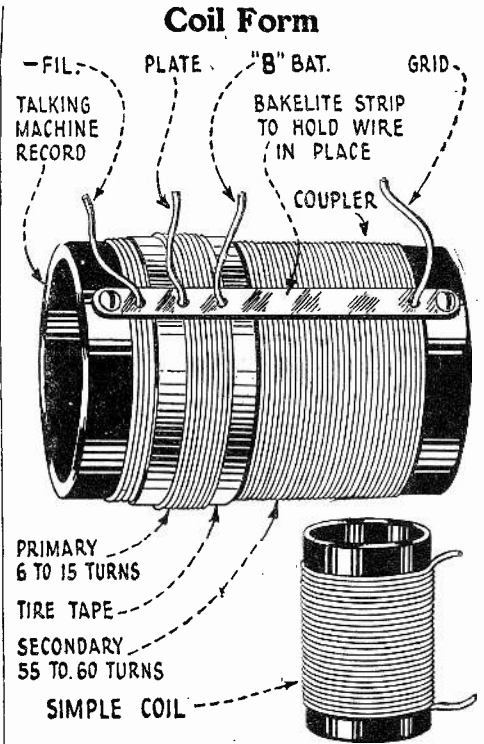

An old style cylindrical phonograph record makes an excellent form for winding coils. Two different types and a method of holding the ends of the wire are shown above.

—Evermont Fisel.

## Detector

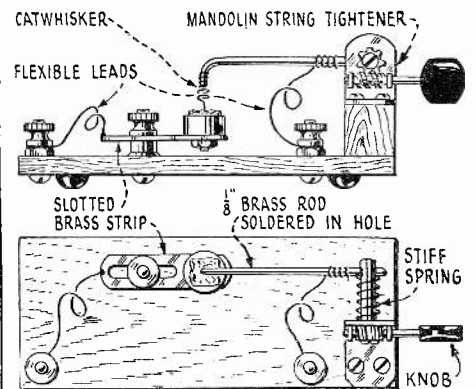

A crystal detector adjuster universal in application can be made by employing a mandolin string tightener for the regulating element of the unit. The other features of this instrument are detailed above.

## Lightning Arrester

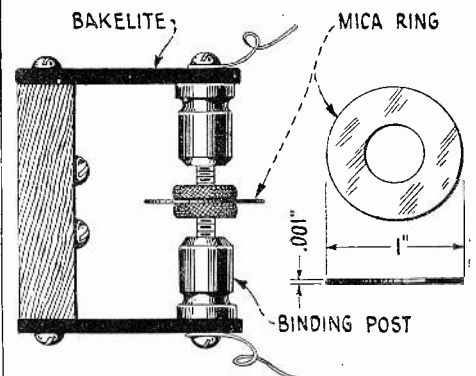

A simple lightning arrester can be made from two binding posts and two strips of insulating material used in connection with a thin disk of mica in the center of which a hole has been cut. The assembly is shown above.

—J. Bront.

# At Last! A Practical and Sensitive Photo-Electric Tube

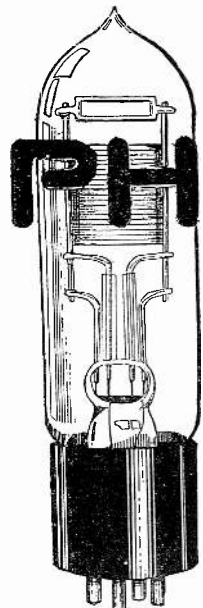

# THE PHOTOTRON

An alkali-metal tube for use in radio movies, picture telegraphy, talking movies, and other light actuated devices. Write for interesting list of uses.

Just the thing for the experimenter! A strong, permanent tube fitting the ordinary radio socket.

PRICE **\$20 each**

## PHOTON ELECTRIC CORPORATION

1623 S. Vermont Ave., Los Angeles

247 Park Ave., New York City

## BLANK CARTRIDGE PISTOL

Protection against Burglars, Tramps, & Dogs



Well made and effective revolver modeled on latest type of Revolver: appearance alone is enough to scare a burglar. When loaded it may be as effective as a real revolver without danger to life. It takes standard .22 Cal. Blank Cartridges obtainable everywhere. Price 50c. Superior quality \$1.00 post-paid. Blank Cartridges, by express, 50c per 100. JOHNSON SMITH & CO. Dept. 434 Racine, Wis.



## WANTED

METAL CAST PRODUCTS CO.  
1696 Boston Rd., New York City



Insure your copy reaching you each month. Subscribe to SCIENCE AND INVENTION—\$2.50 a year. EXPERIENT Publishing Co., 53 Park Place, New York City.

**Vernier Condenser**

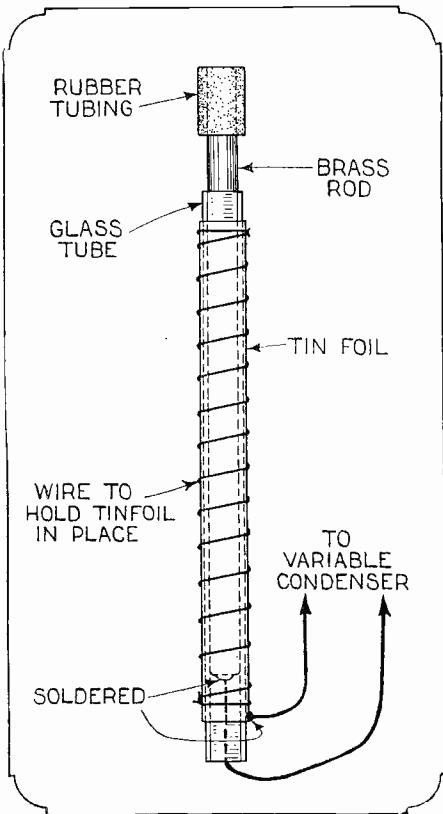

A short length of glass tubing when covered with tin foil and having a brass slider rod, makes a very efficient vernier to be attached to the variable condensers on one's receiving set. —W. E. Tobin, Jr.

**Spider-Web Form**

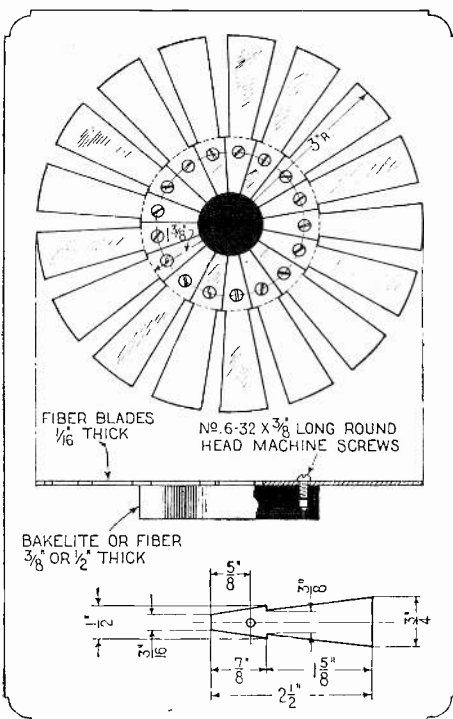

A low-loss spider-web form which readily finds itself adaptable in many cases can be made from a circular sheet of fiber cut into the dimensions given in the above sketch. It must be remembered that a successful coil has an uneven number of spokes, seventeen in this case. —J. C. Scoles.

**22 YEARS OF SUCCESS**

CHICAGO TECHNICAL COLLEGE

FROM THIS RECOGNIZED COLLEGE OF ENGINEERING  
*a Home-Study Course in*  
**DRAFTING**

Everything today is built from drawings made by Draftsmen. Industry calls for 50,000 new men yearly. Draftsmen work hand in hand with the architect, the engineer, the designer, the builder. And thus many men rise from such positions to be heads of great contractors' organizations, directors of railroads, chief engineers—responsible positions commanding very attractive salaries.

**FREE TRIAL LESSON**

Prove your fitness and liking for one of industry's highest paid professions. We want you to know what Drafting is like . . . how readily you can progress . . . how we train and teach you by mail. So, before you enroll . . . FREE . . . without cost or obligation . . . we send you a trial lesson to study in your own home.



Mr. Bjarne C. Dahl

**DRAFTING HALL OF FAME**

Mr. Bjarne C. Dahl says: "Your training has sure been valuable to me. At 26 years of age I was earning \$300.00 a month. And now, at 28, I am Architectural Engineer for J. Morgan, Architect, in California. The Chicago Technical College gives the finest technical training one can get, being the most thoro and practical. Am going to Honolulu in September to inspect a big building project there for my firm."

NOTICE—A well established Placement Bureau assists both graduates and undergraduates to find positions.

**Within Ten Months Increase Your Income**

No special training or talent is required. In 10 months' time or less . . . we can train you . . . at home, in your spare hours . . . to be an expert Draftsman.

And remember this: In Drafting, a big income is open to every properly trained man. Thousands today are earning \$35 to \$100 per week. The reason is simple: Good Draftsmen are in constant demand.

**Book of Facts FREE**

We will send you a 40-page Book. It tells you all about Drafting . . . and our courses. What prominent men say . . . where Draftsmen are employed . . . their salaries . . . their opportunities . . . what our students have done and are doing . . . how many have increased their salaries even before finishing their courses . . . how many hold high-salaried executive positions today. Tells how 34 instructors give you from this recognized 22-year-old college a practical, short, home-study course.

**The Coupon Below Means Money to You**

Find out what Drafting may mean to you . . . mail that coupon. Here is a field in which you can work and win.

We make the test easy, for, with no obligation, we send you a trial lesson FREE. Note the fairness of this offer, the absence of exaggerated promises.

**\$25 Outfit Included**

When you enroll, you will need drafting instruments; so included in the cost of the course, is a \$25 "lifetime" set. If you have instruments, credit will be allowed. Note that we do not claim to give you these instruments "free". Tuition is low, payments easy.

**—In Chicago—Earn While You Learn—**

Those who can come to Chicago will find opportunity to earn living expenses in part-time positions, outside of school hours, while attending day or evening classes at the College.

Chicago Technical College, founded 1904, is known as one of America's oldest and largest schools of specialized engineering. Over 1000 men enroll in resident day and evening courses yearly.

Diplomas in Civil, Mechanical and Electrical Engineering and Architecture granted after two years. Degree of B. S. conferred after three years in the day course. Short courses offered in Drafting, Plan Reading, Estimating, etc. Evening classes for day workers.

If interested in attending Day or Evening Classes at the College in Chicago write for 72-page "Blue Book"—mailed free.

**Send Today for FREE Trial Lesson**  
Fill Out the Attached Coupon NOW

**Chicago TECHNICAL College**

Drafting—Engineering—Electricity—Architecture . . . all branches

Chicago Technical College,  
Dept. 1145, 118 E. 26th St., Chicago, Ill. Name .....

Send me, without cost or obligation, your FREE Trial Lesson and your 40-page Book of Facts about Drafting. Address .....

City and State .....

## Opportunity Ad-lets

YOU will find many remarkable opportunities and real bargains in these columns. It will pay you to read and investigate the offerings made every month by reliable firms, dealers and amateurs from all over the country. No matter what you may be seeking, whether supplies, automobile accessories, the opportunity to make money, or anything else, you will find listed here the best and most attractive specials of the month.

Advertisements in this section twelve cents a word for each insertion. Name and address must be included at the above rate. Cash should accompany all classified advertisements unless placed by an accredited advertising agency. No advertisement for less than 10 words accepted. Ten per cent. discount for 6 issues, 20 per cent. discount for 12 issues. Objectionable or misleading advertisements not accepted. Advertisements for the January issue must reach us not later than November 10th.

**The Circulation of Science and Invention is over 175,000 and climbing every month**

EXPERIMENTER PUBLISHING CO., INC., 53 Park Place, New York City, N. Y.

### Advertising Agents

Advertising in all magazines and newspapers at publishers' lowest rates. Rate Book free. Taylor's Advertising Service, Dept. 6, Freeport, Ill.

### Agents Wanted

Succeed with Your Own Products—Make them yourself. Formulas. Processes by experts. Trade-Secrets. Modern master methods. Catalog free. D. Thaxly Co., Washington, D. C.

Earn big money, fast applying gold initials to autos. Every owner buys—\$1.35 profit on \$1.50 sale—particulars and samples free. Write quick. Lithogram Co., Dept. 19, East Orange, N. J.

Agents Wanted—Full or Part Time to Sell on liberal commission new Thermostat. Automatic Carburetor control Attachment for Ford cars. Increases mileage 100%. No holes to drill. Attached in 2 minutes. Does automatically exactly what Ford Manual instructs driver do by hand. Cadillac now using Thermostat Carburetor Control under Blanche license. Write at once. A. C. Blanche & Co., Dept. 863PX, 602 W. Lake St., Chicago.

Robt. H. Ingersoll of \$1 Watch fame wants good men to sell his Dollar Stropping outfit, an ingenious invention for sharpening all makes of safety razor blades. Great Economic value. Meeting with nationwide approval. Easy to sell. Big repeat business. Agents having remarkable success. Full particulars. Robt. H. Ingersoll, 476H Broadway, New York City.

Agents—Best seller; Jem Rubber Repair for tires and tubes; supersedes vulcanization at a saving of over 800 per cent; put it on cold. It vulcanizes itself in two minutes and is guaranteed to last the life of the tire or tube; sells to every auto owner and accessory dealer. For particulars how to make big money and free sample, address Amazon Rubber Co., Dept. 601, Philadelphia, Pa.

Agents—Write for Free Samples. Sell Madison "Better-Made" Shirts for large manufacturers direct to wearer. No capital or experience required. Many earn \$100 weekly and bonus. Madison Mfgs., 511 Broadway, New York.

Big money and fast sales. Every owner buys gold initials for his auto. You charge \$1.50; make \$1.35. Ten orders daily easy. Write for particulars and free samples. American Monogram Co. Dept. 71, East Orange, N. J.

Earn \$10 daily silvering mirrors, plating and refinishing metalware, chandeliers, bedsteads, headlights. Outfits furnished. N. Decie Laboratories, 1133 Broadway, New York.

\$60—\$200 a week. Genuine Gold Letters for store windows. Easily applied. Free samples. Liberal offer to general agents. Metallic Letter Co., 441 B., North Clark, Chicago.

\$10 daily silvering mirrors, plating and refinishing lamps, reflectors, autos, beds, chandeliers by new method. Outfits furnished. Write Gunmetal Co., Ave. D, Deatur, Ill.

Wonderful Invention eliminates needles for phonographs. Preserves records. Abolishes scratching. Day's supply in pocket. \$20 daily. Sample on approval if requested. Everplay, Desk Hill, McClurg Bldg., Chicago.

Big money—fast sales; everyone buys gold initials for their auto; sell \$1.50 profit \$1.41. Ten orders daily easy. Samples, auto; information free. World Monogram, Dept. 32, Newark, N. J.

Easy Money Applying Gold Initials, Monograms on automobiles. Anyone can do it. Simply transferred from paper; takes 5 minutes. Make \$1.50, cost 5c. Samples free. "Ralco," 1049 Washington, Boston, Mass.

Only one sale a day means \$200 per month! Marvelous new adding machine. Retail \$15.00. Work equals \$30 machine. Adds, subtracts, multiplies, divides, automatically. Computes feet and inches. Speedy, accurate, durable, handsome. Five year guarantee. Offices, stores, factories, garages, lumbermen buy one to dozen. A fortune for live agents. Write quick for protected territory and free trial. Lightning Calculator Co., Dept. W, Grand Rapids, Michigan.

A Business of your own. Make and sell chipped glass name and house number plates, checkboards, signs. Booklet Free. E. Palmer, Dept. 527, Wooster, Ohio.

Why work for others? Make and sell your own goods. We show you how. Free book explains everything. National Scientific Laboratories, 1900A Broad, Richmond, Va.

Greatest tempo saving device! Takes slack and kinks from telephone and electric iron cords. \$25 daily. Samples on approval if requested. Neverknot, Dept. 117 McClurg Bldg., Chicago.

No Dull Times Selling Food. People must eat. Federal distributors make big money; \$3,000 yearly and up. No capital or experience needed; guaranteed sales; unsold goods may be returned. We furnish you with license. Handsome \$15.00 sample case sent on trust. Free Samples to customers. Repeat orders sure. Exclusive territory. Ask now! Federal Pure Food Co., SS2311 Archer, Chicago.

Agents—Signs for stores and offices. Entirely new. Liberal inducement to workers. World Signs T., 166-W Washington Chicago.

Mirrors Re-Silvered at Home. Costs Less 5 cents per square foot; you charge 75 cents. Immense profits, plating auto parts, reflectors, tableware, stoves. Refinishing metalware, etc. Outfits furnished. Write for information. Sprinkle, Plater 955, Marion, Indiana.

Build splendid business making chipped glass number and name plates. Particulars free. Simplex Co., Dept. 93, 1133 Broadway, New York.

At Last! Diamond Rival Discovered! Amazing blue-white Rajah Gem astounds jewelry world and deceives experts. Beautiful sample case free! \$100 weekly! Write quick! Rajah Diamond Co., Dept. F11, Salisbury, N. C.

### Agents Wanted (Continued)

Make \$15.00 daily selling "FIXIT" Rubber Repair (Liquid Rubber) for tires and tubes. Sensation of 1925. Fastest seller. Big money maker. Sample free. Marquette Rubber Co., 2225 N. Wolfram St., Chicago.

Agents: \$11.80 daily cash (send for sworn proof). Introducing New Insured Hosiery, 37 styles, 40 colors, guaranteed seven months. No capital or experience required. You simply take orders. We deliver and collect (or you can deliver, suit yourself). Credit given. Pay You Daily, monthly bonus besides. Winter line now ready. We furnish samples. Spare time will do. Macebec Textile Company, Station 67011, Cincinnati, Ohio.

Marvelous New Invention 400% Profit Liquid quick mend for hosiery and fabrics. Tremendous demand. Over hundred other fast sellers. Local and General Agents, J. E. Johnson Co., Dept. 835, 69 E. South Water St., Chicago.

Agents—Good, steady income. Exceptionally useful household article. The Handycap Company, Newark, N. J.

\$12 An Hour actually earned selling the new Double-Wear Work Shoe. \$5 value selling at only \$2.95. A world-beater. Liberal commission. Write quick. The Double-Wear Shoe Company, East Lake St., Dept. C, Minneapolis, Minn.

Bankrupt and Rummage Sales. Make \$50.00 daily. We start you, furnishing everything. Distributors, Dept. 171, 609 Division, Chicago.

Agents: Enter your own business. Make \$15.00 to \$30.00 daily profit manufacturing and distributing your own products at home. For free particulars, address R. Chase, 5616 No. Market, St. Louis, Mo.

Agents Wanted to advertise our goods and distribute to consumer; 90c an hour; write for samples. American Products Co., 4209 American Bldg., Cincinnati, O.

### Battle Photos and War Relics

For Dens: Relics Collected from Europe's Battlefields. Firearms, medals, helmets, etc. Illustrated catalogue and sample War photographs 25c. Lieut. Welch, 1889 Albany Ave., Brooklyn, N. Y.

### Books

Free—Upon request will send you my literature illustrating the following books: Astrology, Character, Clairvoyance, Concentration, Healing, Hypnotism, Magnetism, Mediumship, Personal Magnetism, Personality, Physiology, Salesmanship, Seership, Success, Sex, Will, Yogi Philosophy, Gazing Crystals, etc. A. W. Martens, E. E. 6, Burlington, Iowa.

25 "Easy" Lessons in Hypnotism "Complete Course" only 25c. Henry S. Collins Co., 197 Fulton St., Brooklyn, N. Y.

\$125.00 set encyclopedia, guaranteed new and unused. Perfect condition. Wonderful bargain \$45.00. Also set Harvard Classics, absolutely new for \$50.00. Clarke, 511 Chapel, New Haven, Conn.

"Master Key" (Success Wonderful) 410 Pages, Cloth \$2.50. Bargain lists New—used (All Subjects) 10c. Phipps Library, 1014 Belmont, Chicago.

### Business Opportunities

Free Book. Start little Mail Order business. Pier, 906 Cortland Street, New York.

You can have a business-profession of your own and earn big income in service fees. A new system of foot correction; readily learned by anyone at home in a few weeks. Easy terms for training, openings everywhere with all the trade you can attend to. No capital required or goods to buy, no agency or selling. Address Stephenson Laboratory, 18 Back Bay, Boston, Mass.

Stop Plodding! Be Successful. Operate a Tire Repair Shop. Make big profits in any locality. We teach you and furnish complete equipments \$100 up. Book of Opportunity free. Haywood's, 1312 South Oakley Avenue, Chicago.

Get Money in Your Mail. "Lambert's Mail Order Secrets" contains successful methods never before published. \$1.00 postpaid. Particulars free. Leon Lambert, Wichita, Kansas.

\$50 a Week Evenings. Mail Order Business. Booklet Tells How. Sample and plan 25c. Free—9 articles worth \$30.00. S. Bradford Co., Shawnee, Okla.

### Chemistry

Develop latent finger prints with non-radiating powders. With directions 35 cents prepaid. The Rogers Laboratory, Rib Lake, Wis.

### Correspondence Courses

Used correspondence school courses. All kinds. Sold on repurchase basis. Big saving. Money back guarantee. Lists free. (Courses bought). Lee Mountain, Pisgah, Alabama.

### Educational

Correspondence courses. All schools. Lowest prices. Terms. Catalog Free. Mention Subject. Economy Educator, 440-H Sansome, San Francisco.

### Farms and Orchards

Pecan-Orange-Fig Groves "On the Gulf". Guaranteed cash. Monthly payments. Big, quick returns. Suburban Orchards, Dept. 1, Biloxi, Miss.

### Female Help Wanted

Women—We can put you in touch with good paying clean work, in any city or town. Full time or spare time. No charge for service. Betty Buck's Employment Service, Box 240, c/o Science & Invention, New York, N. Y.

### For Advertisers

Your 25 word advertisement in 56 Rural Newspapers \$2.60. List FREE. Shaw, 221A, Northeast, Washington, D. C.

I write letters, folders, booklets, complete followup for manufacturers, mail order dealers. Long experience. Write for details. L. Taylor, Box 444, Freeport, Ill.

Alaska Pathfinder, illustrated magazine, three issues with years privilege Alaska information bureau, One dollar. Pathfinder of Alaska Anchorage, Alaska.

### For Inventors

We Develop Your Ideas into commercial shape for presentation to purchasers, making working models, drawings, experiments or tests. Courtesy, efficiency, secrecy and ample equipment; 30 years' experience. Ducorron-Rich Engineering Co., 504 Pacific Mutual Bldg., Los Angeles, Cal.

Unpatented Ideas Can Be Sold. I tell you how and help you make the sale. Free particulars (Copyrighted). Write W. T. Greene, 803 Jenner Bldg., Washington, D. C.

Your Chemical problems solved and working process furnished for Five Dollars. Write me, W. Stedman Richards, Consulting Chemist, Box 2402, Boston, Mass.

Get Cash for your patent or invention under our new plan. Write at once to Inventors' Syndicate, 22 Palladium Bldg., St. Louis, Missouri.

### For Sale

Science & Invention magazines from Jan. 1916 to date for sale or exchange for bench lathe. John Gasko, 1443—3rd Ave., New York.

### For the Photographer

Have you a Camera? Write for free sample of our big magazine, showing how to make better pictures and earn money. American Photography, 118 Camera House, Boston, 17, Mass.

### Games and Entertainment

Free with \$25 order our large die box. Send 20c for our large catalogue of tricks, puzzles, wigs, sensational escapades, Oaks Magial Co., Dept. 549, Oshkosh, Wis.

### Health

Tobacco Habit Banished. No matter how long you have been a victim, no matter how strong your craving, no matter in what form you use tobacco, there is help for you. Just send postcard or letter for our Free Book. It explains everything. Newell Pharmaceutical Co., Dept. 788, Clayton Station, St. Louis, Mo.

### Help Wanted

Silvering Mirrors, French plate. Easily learned, immense profits. Plans free. Wear Mirror Works, Dept. 36, Excelsior Springs, Mo.

All men-women, 18 to 60, wanting to qualify for Government Position, \$140-\$225 monthly, local or traveling, write, Mr. Ozment, 293, St. Louis, Mo., immediately.

Men to Build Radio Sets in spare time. Leon Lambert, 670-H Kaufman Bldg., Wichita, Kansas.

Detectives Earn Big Money. Travel. Excellent opportunity. Great demand everywhere. Experience unnecessary. Particulars free. Write, American Detective System, 1974 Broadway, N. Y.

Detectives Needed Everywhere. Work home or travel. Experience unnecessary. Write, George Wagner, former Government Detective, 1968 Broadway, N. Y.

Earn \$25 weekly, spare time, writing for newspapers, magazines. Experience unnecessary. Copyright book free. Press Syndicate, 936, St. Louis, Mo.

Fireman, Brakemen, Baggage-men, Sleeping car, train porters, (colored) \$140-\$200. Experience unnecessary. 397 Railway Bureau, East St. Louis, Ill.

Railway Mail Clerks—City Carriers. \$1700-\$2700 Year. Men, 18-45. Steady. Common education. Sample examination coaching. Free. Write today. Franklin Institute, Dept. J20, Rochester, N. Y.

### How To Entertain

Plays, musical comedies and reviews, minstrel music, blackface acts, vaudeville acts, monologs, dialog, recitations, entertainments, musical readings, stage handbooks, make-up goods. Big catalogue free. T. S. Denison & Co., 623 So. Wabash, Dept. 99, Chicago.



**Hunting Hounds**

Hundred Hunting Hounds Cheap. Fur liners. Catalogue. Kaskas Kennels, P135, Herrick, Ill.

**Incorporations**

Delaware Incorporator. Charters; Fees Small; forms. Chas. G. Guyer, 901 Orange St., Wilmington, Del.

**Instruction**

Correspondence Courses sold complete; one-third usual prices because slightly used; easy terms; money back guarantee. All schools and subjects. Write for special Free catalog. Courses bought for cash. Economy Educator Service, H202, West 49th St., New York.

**Machinery and Tools**

Concrete Building Block Machines and Molds. Catalogue free. Concrete Machine Co., 305 South Third St., St. Louis, Mo.

**Mailing Lists**

Names—cuts—postcards. Ben Meyer, 35 West 81st, New York.

**Male Help Wanted**

Men—We can put you in touch with good paying clean work, in any city or town. Full time or spare time. No charge for service. Betty Buck's Employment Service, Box 240, c/o Science & Invention, New York, N. Y.

**Manufacturing**

Mechanical Work: all branches. Perfect models. Articles manufactured to order. Reliable. Parma Engineering Works, Brooklyn Station, Cleveland, Ohio.

**Miscellaneous**

Beautiful registered bull pups cheap. Bulldogs, 501 Rockwood, Dallas, Texas.

Agents Names neatly typewritten from our one day old inquiry letters. Price right. H. World 166-W Washington, Chicago.

Wanted articles to manufacture, either on royalty basis or outright purchase. H. L. Cook, Aurora, Ill.

Gummed Labels. Name and Address, 509, 2 lines 30c, 3 lines 50c. Catalogue. Eastern Label Co., W. Clintonville, Conn.

Formulas for Beverages, Syrups, Extracts, flavors, etc. Other good manufacturing specialties. Free information. The Formula Co., 1813 Queen Anne Ave., Seattle, Wash.

At last—a perfect duplicator at low price. Send for detail. Iiten Sales, 406S, Whittier, Calif.

Learn watch, clock and jewelry repairing at home. My three-book course, complete, \$3.00. James Koch, Watchmaker and Jeweler, 1015 Market St., Marcus Hook, Pa.

**Motorcycles—Bicycles**

Don't buy a Bicycle Motor Attachment until you get our catalogue and prices. Shaw Mfg. Co., Dept. 6, Galesburg, Kansas.

**Musical**

Play piano by Ear. A sound system. Postal brings full particulars and Free Booklet. No obligation. Boucher's Harmony Studio, 127 Metcalf St., Ottawa, Can.

**Musical Instruments**

Violins—Deep, Mellow, Soulful—on easy credit terms. High grade, wonderful instruments of my own make. Development of many years' experience. Write for book. Gustav A. Henning, 2124 Gaylord St., Denver, Colo.

**Novelties**

Magic goods, cards, books, novelties, tricks. Catalog free. Clifford Fenner, 2401 Jefferson, Louisville, Ky.

**Old Money Wanted**

\$2 to \$500 Each paid for hundreds of Old or Odd Coins. Keep all old money, it may be very valuable. Send 10c for new illustrated Coin Value Book, 4x6. Guaranteed Prices. Get Postal, We pay Cash. Clarke Coin Company, 14 Street, LeRoy, N. Y.

**Patents**

Inventions commercialized. Patented or unpatented. Write Adam Fisher Mfg. Co., 205 Enright, St. Louis, Mo.

**Patent Attorneys**

Millions spent annually for ideas! Hundreds now wanted! Patent yours and profit! Write today for free book—tells how to protect yourself, how to invent, ideas wanted, how we help you sell, etc. American Industries, Inc., 212 Kresge Bldg., Washington, D. C.

Inventors—Send for Form "Evidence of Conception" to be signed and witnessed, form, fee schedule, information free. Lancaster and Alvine, Registered Patent Attorneys in United States and Canada, 242 Ouray Bldg., Washington, D. C.

Monroe Miller, Ouray Bldg., Washington, D. C. Patent Attorney; Mechanical, Electrical Expert. Free Blue Book gives candid advice.

Patents Procured; Trade Marks Registered—A comprehensive, experienced, prompt service for the protection and development of your ideas. Preliminary advice gladly furnished without charge. Booklet of information and form for disclosing idea free on request. Richard B. Owen, 130 Owen Bldg., Washington, D. C., or 41-T Park Row, New York.

**Patent Attorneys (Continued)**

Patents. Send for free booklet. Highest references. Best results. Promptness assured. Send model or drawing for examination and opinion. Watson E. Coleman, Patent Attorney, 844 G Street, N. W., Washington, D. C.

Inventors write me about patents. My fees payable monthly. Booklet free. Frank Fuller, Washington, D. C.

Unpatented Ideas Can Be Sold. I tell you how and help you make the sale. Free particulars (Copyrighted 1923). Write W. T. Greene, 800 Jenifer Bldg., Washington, D. C.

Lacey Patent-Sense. "The book the inventor keeps." Free. See page 678.

"Inventor's Advisor," the valuable Patentbook with 139 Mechanical movements and illustrations, sent free upon request. M. I. Labiner, Patent Attorney, 3 Park Row, New York.

Herbert Jenner, Patent Attorney and Mechanical Expert, 606 F Street, Washington, D. C. I report if patent obtainable and exact cost. Send for circular.

Get your own patents. Application blanks, complete instructions \$1. Cutting Bros., Campbell, Calif.

Patents. Time counts in applying for patents. Don't risk delay in protecting your ideas. Send sketch or model for instructions or write for Free book, "How to Obtain a Patent" and "Record of Invention" form. No charge for information on how to proceed. Communications strictly confidential. Prompt, careful, efficient service. Clarence A. O'Brien, Registered Patent Attorney, 9297 Security Bank Building (directly across street from patent office), Washington, D. C. See page 677.

Patents: My fee in installments. Free personal advice. Frank T. Fuller, Washington, D. C.

"Stronger Patents for less money." Drawings, specifications, claims \$20. Send half fee with sketch and description. Prompt, efficient action. American Patents Corporation, Barrister Building, Washington, D. C.

**Personal**

Get acquainted. Make new friends. Exchange Letters. Enclose stamped envelope for plan. The Lilly Club, Station H, Cleveland, Ohio.

Your Handwriting Reveals your Character. Send 25c (silver) and ink sample of own or friend's writing for expert analysis and astounding demonstration of dominant characteristics. Real guide to success. R. Pencerat, Hamburg, N. Y.

Radiumact Removes Warts, Moles, Superfluous Hair, Coal, Powder and Tattoo Marks. Particulars sent free. Radiumact Co., 1416 Cadwalader St., Philadelphia, Pa.

**Printing Outfits and Supplies**

Print your own cards, stationery, circulars, paper, etc. Complete outfits \$8.85; Job Presses \$12, \$35; Rotary \$150. Print for others, big profit. All easy, rules sent. Write for catalog presses, type, paper, etc. Press Company, A-6 Meriden, Conn.

**Radio**

200,000 satisfied customers hear distant stations on Lambert Crystal Sets. Copyrighted plans \$1.00. Complete kit and plans \$5.00. Leon Lambert, 670, Wichita, Kansas.

**Salesmen Wanted**

Take orders for coffee, sugar, flour, meats, canned goods, staple groceries, also paints, radio sets, tires, auto and tractor oils. No capital or bond required. We deliver and collect. Permanent business. Big pay. Write at once. Hitchcock-Hill Co., Dept. 83, Chicago.

Sell at Sight. Improved Models. Print merchants' ad on wrapping paper, boxes, bags, etc. Good commission. Automatic Ad-Stamp, Joplin, Mo.

Envelope Sealer selling \$1.50 seals 3500 envelopes hour! Tremendous Demand. Exclusive Territory. Big Repeats. Write today. Free particulars. Red-E, 2025 Nottingham Bldg., Boston.

Distributors:—Wonderful Pricing System all stores. Absolute protection! Exclusive Territory. Immediate repeat sales. Possibilities \$10,000 yearly! Write Millen Mfg., 5504 Nottingham Bldg., Boston.

\$20.00 daily. New patented auto radiator shutter. Real winter proposition. Fastest seller ever invented. Quantity price 49c, retails \$1.50. Jones, 800 N. Clark, Chicago.

California Gold, quarter size, 27c; half-dollar size, 53c. Columbian nickel and catalogue, 10c. Norman Shultz, Box 146, Colorado Springs, Colo.

Stamps 100 All Different 3 cents. S. I. Quaker Stamp Company, Toledo, O.

**Stories or Manuscripts Wanted**

Stories, poems, descriptive articles, plays, etc., are wanted for publication. Submit Miss or write Literary Bureau, 165, Hannibal, Mo.

**Technical School**

Chicago Technical College offers short, intensely practical courses in Drafting and Engineering—civil, mechanical, electrical, structural—Architecture, Building, Construction, Plan Reading, etc. Courses fitted to your needs. No time wasted. Instructors are experts. Graduates in demand at big salaries. Opportunities for part-time work while studying. Day and evening classes. 22nd year. Enter any time. No special preliminary training required. Low tuition—easy terms. Write for 52-page illustrated Blue Book, describing opportunities open to our graduates. Chicago Technical College, 24 Chicago Tech. Building, Chicago.

**Wanted**

Detectives Earn big Money. Work home or travel. Experience unnecessary. Write George Wagner, former Government Detective, 1968 Broadway, N. Y.



**Couldn't Play a Note — Now Makes \$100<sup>00</sup> a Week**

"When I sent for your catalog, I didn't know a note of music. A few months after I bought my Wurlitzer instrument, I had taken my place in a professional orchestra. Now I am making \$100 a week, three times what I made as a clerk. I wish everybody knew how easy it is — anyone who can whistle a tune can play a musical instrument."—Bill Carola.

**Free Trial—Easy Payments**

You may now have any Wurlitzer instrument for a week's free trial in your own home. Examine the instrument, note the fine workmanship, the full, rich tone value and especially how easy it is to play. No obligation to buy—no expense for the trial. We make this liberal offer because we want you to try for yourself a genuine Wurlitzer instrument, the result of 200 years' experience in musical instrument building.

Easy payments are arranged to suit your convenience. This is your opportunity to try a famous Wurlitzer instrument in your own home.



**Send this Coupon**

The Rudolph Wurlitzer Co., Dept. 1258  
 117 E. 4th St. Cincinnati 329 S. Wabash Ave. Chicago  
 120 W. 42nd St. New York 250 Stockton St. San Francisco

Send me your Free Book on musical instruments. Also your Free Trial, Easy Payment Plan. No obligation.

Name \_\_\_\_\_  
 Address \_\_\_\_\_  
 City \_\_\_\_\_ State \_\_\_\_\_  
 Instrument \_\_\_\_\_

**WURLITZER**  
 Copyright 1925, The Rudolph Wurlitzer Co.



**Satisfies Every Owner—**

**Unlike Some Music  
OZARKA SERVICE**

**I**N radio, when one selection does not please, you simply tune it out and pick up another broadcasting station. If it is a matter of unsatisfactory volume or tone in your instrument then it becomes an entirely different matter.

You have certain very definite ideas in mind as to what you want your radio to do. Will you allow us to make a few suggestions regarding a plan whereby you can settle the radio question?

Select the instruments which you think might answer. Have a demonstrating instrument brought to your home. Let each salesman, in turn, make the necessary battery connections. Let him tell you how to operate it but do all the tuning yourself.

You'll buy the instrument then, based on your own operation. You'll size up each one for

- ease of tuning
- distance received
- volume
- tone
- selectivity
- price.

There still remains one very important question to settle—the matter of service. No matter what anyone tells

you sometimes little things may go wrong. The best radio salesman often knows nothing of correcting radio troubles—satisfy yourself.

Our Ozarka representative in your community will gladly put an Ozarka in your home for such a test. More than this, you will find that he is a thoroughly trained mechanic on our instrument. He has gone through a complete course of study under Ozarka Engineers, the men who designed and perfected the Ozarka.

3187 such men today can correct any trouble which may ever occur on any Ozarka instrument—more men are being factory trained daily. You wouldn't buy an instrument blindly—then don't buy service the same way. Any radio instrument is only as satisfactory as the quality of service behind it.

Our Book No. 200 shows the full Ozarka line from \$75.00 to \$197.50, complete with all accessories.

**A Few More  
Men are Needed**

In a great many counties we have the man we want. He is rapidly building up a permanent and profitable business of his own because he has an instrument that will more than meet all competition. More than this, he is trained to back up his sales with the kind of service that counts.

Many well established Ozarka representatives started by giving us only their spare time—their evenings. If your county is open you can do the same.

The investment in cash is very small. The investment in time necessary for study is considerable. It requires patience, but the results have enabled many men to get out of the salary and time clock class.

Any previous sales experience is helpful but not necessary. We can and will teach you how to sell.

**Send for 64 Page Book—  
"The Ozarka Plan"**



This book is entirely too expensive to be sent out on postal card requests. It will be sent FREE to any man who mails the coupon below and who is really anxious to improve his condition. Tell us about yourself—ask for Ozarka Plan No. 100 and don't fail to give the name of your county.

**OZARKA**

122 Austin Avenue K  
Chicago, Illinois



Ask the Man Who  
Wears this Button

**INCORPORATED**

122 Austin Avenue K  
Chicago, Illinois

Gentlemen: Without obligation send book "Ozarka Instruments No. 200" and name of Ozarka representative.

Name.....  
Address..... City.....  
County..... State.....

Gentlemen: I am greatly interested in the FREE book "The Ozarka Plan" No. 100, whereby I can sell your radio instruments.

Name.....  
Address..... City.....  
County..... State.....



Let These Guides

Solve Your Problems

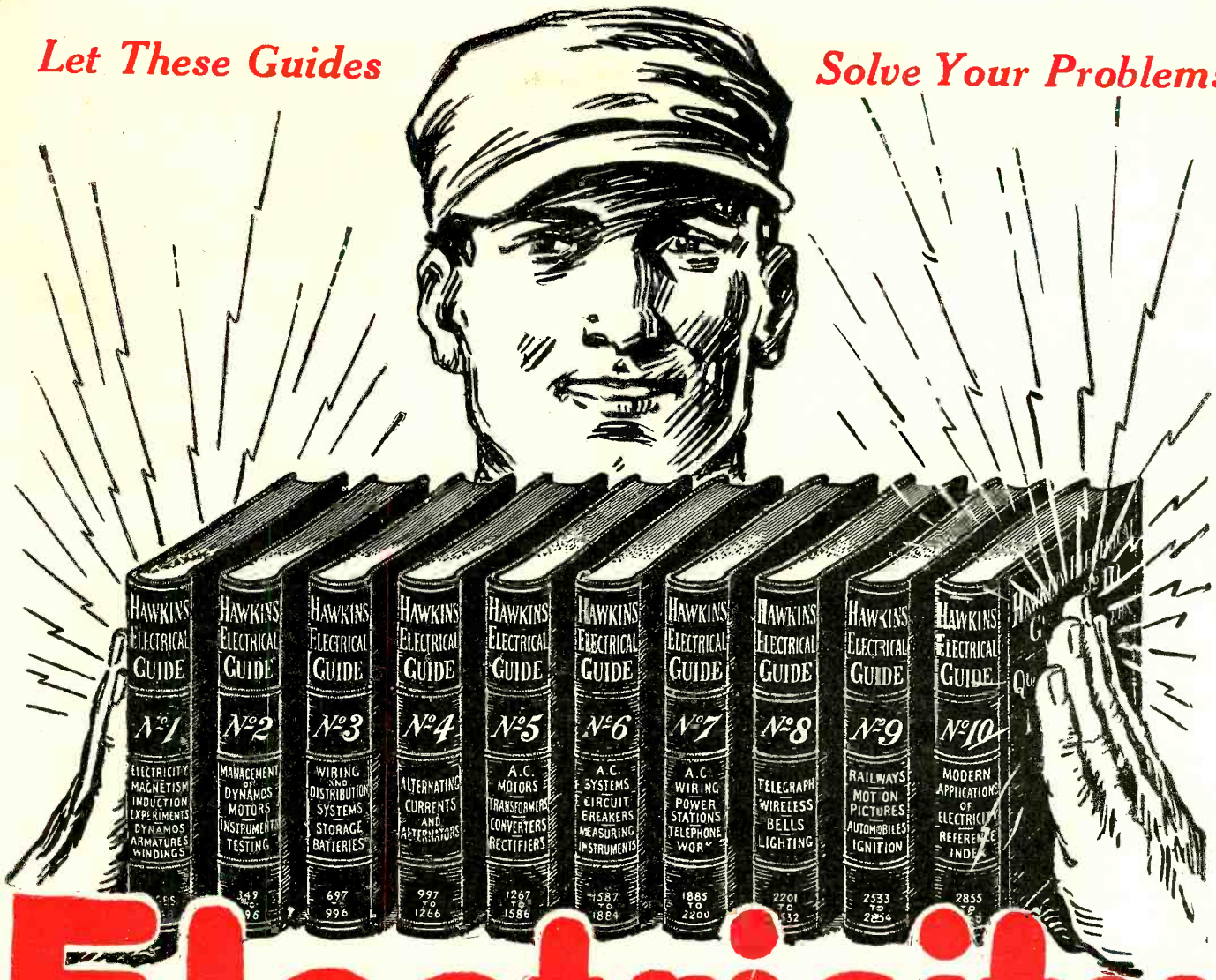

# Electricity at your finger ends

## HAWKINS ELECTRICAL GUIDES IN TEN VOLUMES

**3500 PAGES**  
**4700 PICTURES**

**\$1 A VOLUME**  
**\$1 A MONTH**

**SEND NO MONEY—SEND ONLY THIS COUPON**

Know the facts in Electricity. They mean more money and better position for you. Hawkins Guides tell you all you need to know about Electricity. Every important electrical subject covered so you can understand it. Easy to study and apply. A complete, practical working course, in 10 volumes. Books are pocket size; flexible covers. Order a set today to look over.

**LEARN ALL ABOUT**

Magnetism—Induction—Experiments—Dynamoes—Electric Machinery—Motors—Armatures—Armature Windings—Installing of Dynamoes—Electrical Instrument Testing—Practical Management of Dynamoes and Motors—Distribution Systems—Wiring—Wiring Diagrams—Sign Flashers—Storage Batteries—Principles of Alternating Currents and Alternators—Alternating Current Motors—Transformers—Converters—Rectifiers—Alternating Current Systems—Circuit Breakers—Measuring Instruments—Switchboards—Wiring—Power Stations—Installing—Telephone—Telegraph—Wireless—Bells—Lighting—Railways. Also many Modern Practical Applications of Electricity and Ready Reference Index of the ten numbers.

**SHIPPED FREE**

Not a cent to pay until you see the books. No obligation to buy unless you are satisfied. Send Coupon now—today—and get this great help library and see if it is not worth \$100 to you—you pay \$1.00 a month for ten months or return it.

**THEO. AUDEL & CO.**

65 West 23rd Street, New York City

Please submit me for free examination, HAWKINS ELECTRICAL GUIDE (Price \$1 a number). Ship at once prepaid, the 10 numbers. If satisfactory, I agree to send you \$1 within seven days and to further mail you \$1 each month until paid.

Name .....

Occupation .....

Employed by .....

Home Address .....

Reference .....



# Rouse Your Bigger and Better Self to Action!

I'll help you prove to the world that you CAN succeed!



# ELECTRICITY

Will Fascinate You, Will Thrill You, Will REWARD You!

Remember, there is no substitute for personal training in great shops, on COMPLETE electrical apparatus

Read My Big SPECIAL OFFER

WHY LEAD AN INFERIOR EXISTENCE? No need to drag through life with little or nothing of this world's goods in return for your hard, earnest labor! The chances are 100 to 1 you've got the right stuff in you! You've simply got to apply it in the right direction, like successful folks do. EVERY HONEST, SINCERE, WORTHY, AMBITIOUS FELLOW is entitled to an even break in life. Others are getting theirs! Why not YOU? Right now is the time to solemnly promise yourself to get rid of the jinx that's chasing you through life!

**Hundreds of Coyne-Trained Men Earn \$60 to \$200 a Week**

I have started thousands of men, young and old, on the road to permanent success; have guided them to true happiness and independence. I have evidence to back up my claims—thousands of letters from men who never knew what it was to earn more than a few dollars a week or month until they took my splendid course in Electricity.

## You Don't Need Higher Education or Experience

You learn at COYNE, whether or not you possess advanced education, knowledge of higher mathematics, or experience. My course is not something that you merely study from books and letters. It is a practical LEARN-BY-DOING course.

## Earn While You Learn

My Employment Department helps you get a job if you earn part or all of your expenses and assists you to a good job upon graduation. Many COYNE graduates are now firmly established in their own electrical businesses, and are earning thousands of dollars per year.



## YOUR RAILROAD FARE TO CHICAGO

from any point in the U. S. is included, also special courses in Radio Electricity and Auto, Truck and Tractor Electricity WITHOUT EXTRA COST if you act promptly. Remember, Chicago is a wonderful city to see at any time of the year. It's a city of opportunities and the great electrical center of the world. Clip the Happiness Coupon below at once.

## COMPLETE ELECTRICAL TRAINING IN 12 HAPPY WEEKS AT COYNE

I have perfected an unusual course of instruction in Electricity, a course that is absolutely thorough, that is easy to master, that covers every single phase and factor of the subject, that fits men for the BIG electrical jobs—the HIGH-SALARIED thrilling jobs. COYNE does not teach by correspondence, but by practical, personal training

in the wonderfully-equipped COYNE Shops, located in Chicago, the electrical center of the world. At COYNE your training is really PERSONAL and PRACTICAL, on the most MODERN and COMPLETE electrical apparatus, under guidance of thoroughly-qualified instructors. You also visit great industrial organizations and power plants.

Send for My Big FREE Book and Details of R. R. Fare and 2 Courses without Extra Cost

Be sure to send at once for my big FREE BOOK containing 151 actual photos of electrical operations and methods; also my special offer of Railroad Fare to Chicago and 2 Big Courses without extra cost. Write today, sure, before this offer is withdrawn.

Tune in on COYNE Radio Station WGES

Tune in tonight or any night on our own Radio Broadcasting Station, WGES (World's Great, Best Electrical School), Wave length 260 meters. The famous Coyne Student Broadcasting Synchrotors are on the air every Friday night. Students may join the orchestra, also take part in the athletic and entertainment activities at COYNE, FREE.

H. C. LEWIS  
President

# COYNE

Established  
1899

## ELECTRICAL SCHOOL

1300-10 West Harrison St., Dept. 5338 Chicago, Ill.

## ABSOLUTELY FREE

### A RAFT OF INFORMATION ABOUT ELECTRICAL SUBJECTS

No other book like my great big Electrical Book which costs you nothing—now or later. 151 actual photos. Dynamos, radios, autos, airplanes, farm lighting and power, etc. Send for your copy *this minute*.



H. C. LEWIS, President  
COYNE ELECTRICAL SCHOOL  
1300-10 W. Harrison Street  
Dept. 5338, Chicago, Illinois

Dear H. C.—I'll tell the world I want one of those whopping big, handsome 2-color, 12x15 FREE BOOKS containing a raft of information about Electrical subjects and 151 actual photos of scenes and operations in big shops and power plants. Be sure to tell me about Special Offer of Railroad Fare and Two Extra Courses.

Name \_\_\_\_\_  
Address \_\_\_\_\_

**SEND THIS COUPON NOW!**