

# Bigger Pay for YOU

*"See them first--pay afterwards"*

*Small Monthly Payments if you're satisfied*



## You Can Now Know **ELECTRICITY**

**As Experts Know It**

When we observe the ever-increasing applications and usages of electricity, we wonder if all the present openings and the newly created positions in the electrical world can ever be filled.

The ending of the war lends a new and mighty impetus to the electrical end of American industries. Salaries are soaring. There is practically no limit to the earning power of the man who educates himself in the finer points of electrical work.

### *Actual working facts*

With the advent of the new Library of Practical Electricity, by Terrell Croft, a new era is marked in the production of self educational electrical literature. This library satisfies a demand never heretofore met—the demand for a home study course which would bring out in detail the actual working facts. This great undertaking has been accomplished. It is a seven-year task completed.

### *No previous electrical training necessary*

Three thousand pages, with twenty-one hundred of the clearest illustrations ever put into book form. Each of the eight volumes is indexed so that everything you want to know about electricity is at the finger's end. And when you find what you want, there is not merely a short question and a short answer. You are told everything you want to know. The explanation is clear to you, regardless of whether you have had a previous knowledge of electricity or not.

### *Know electricity as the highest paid engineers know it*

When you are studying the Croft Library of Practical Electricity, you are studying electricity as experts know it. You are acquainting yourself with the methods employed by the highest paid electrical workers and engineers in America.

### *This Library of eight volumes sent to you FREE for 10 days' trial*

So positive are we that you will be pleased with the Croft Library of Practical Electricity that we offer to send the entire ten volumes for ten days' free use. All you need do in order to have the books sent, charges prepaid, is to fill out the attached coupon and return to us. Keep the books ten full days. Then if you are not satisfied, return them at our expense. On the other hand, if you find that they will help you, as they are helping thousands of others, send us the small sum of \$2 per month for eight months.

**ACT NOW**

**FREE EXAMINATION COUPON**

McGraw-Hill Book Co., Inc.  
239 W. 39th St.  
NEW YORK

Gentlemen: Please send me the Library of Practical Electricity (shipping charges prepaid) for 10 days' free examination. If satisfactory, I will send \$2 in ten days and \$2 per month until \$16 has been paid. If not wanted I will write you for return shipping instructions.

Name.....  
Home Address.....  
City and State.....  
Name of Employer.....  
His Address.....  
Your Position..... Ex. 8-19

- 8 Vols.
- Flexible binding
- Pocket size
- 3000 pages
- 2100 illustrations

*A letter that means something to every man in America who is interested in electricity*

McGraw-Hill Book Company, Inc.  
239 West 39th Street, New York, N. Y.  
Gentlemen: In an attempt to express myself about CROFT'S NEW LIBRARY OF PRACTICAL ELECTRICITY, I have never seen and do not believe there was ever printed in the English language, a more comprehensive set of books. It is a library that is just as valuable to the novice as to the expert, because it is all practice.  
Respectfully,  
GUY H. PEIFER,  
Chief, Doplan Silk Corporation, Hazleton, Pa.

**McGraw-Hill Book Co., Inc.**  
239 West 39th Street, New York, N. Y.

# Electrical Experimenter

233 FULTON STREET, NEW YORK

Published by Experimenter Publishing Company, Inc. (H. Gernsback, President; S. Gernsback, Treasurer; R. W. DeMott, Sec'y;) 233 Fulton Street, New York.

Vol. VII. Whole No. 76

Contents for AUGUST, 1919

No. 4

WHEEL-LESS TRAINS GLIDE ON WATER FILM.....Front Cover	POPULAR ASTRONOMY—THE NATURE OF COMETS..... 312
From a painting by George Wall	By Isabel M. Lewis, of the U. S. Naval Observatory
RADIOPLANES WATCH FORESTS AND RANCHES..... 295	STEINMETZ'S OWN SHORTHAND..... 314
BOMB EXPERT EAGAN, SPECIAL INTERVIEW TO ELECTRICAL EXPERIMENTER..... 296	EXPERIMENTS IN PHYSICS, NO. 1—PERPETUAL MOTION... 315
PEACETIME USES FOR WAR INVENTIONS..... 298	By John J. Furia, M.A., Dept. of Physics, New York University
By H. Winfield Secor, E.E.	FIFTY DOLLAR PRIZE CONTEST—USES FOR OLD PHONOGRAPH RECORDS..... 316
CHANGING NATURE'S FACE..... 300	HOW TO MAKE PHOTO-MICROGRAPHS, by G. D. Lauder milk... 317
MAN'S GREATEST CURSE—INFECTED TEETH..... 301	FARADIC CURRENTS—HOW TO APPLY THEM—SEQUEL TO "BUILDING A MEDICAL COIL SET"..... 318
The work of Henry A. Cotton, M.D., How X-Rays of Teeth may Prevent Disease and Insanity.	X-RAY EXPERIMENTS, by Ivan Crawford..... 319
SOLVING THE TRANSPORTATION PROBLEM.—A WHEEL-LESS ELECTRIC RAILWAY PROPELLED BY MAGNETS ON A FILM OF WATER, by H. Gernsback..... 302	HEAT ENGINES—GASOLINE, STEAM, HOT AIR..... 320
THE "TORPEDOPLANE" AND "SUB" SPOTTER..... 306	By John J. Furia, M.A.
By George Holmes	EXPERIMENTAL MECHANICS, LESSON 13, REGARDING REAMERS, by Samuel D. Cohen..... 321
THUNDERSTORM ELECTRICITY..... 307	HOW I INVENTED THE CRYSTAL DETECTOR, SPECIAL ARTICLE, by Dr. Greenleaf Whittier Pickard..... 325
By Rogers D. Rusk, M.A., Late of the Meteorological Section, U. S. Army Signal Corps.	CONCENTRATED OR LOOP AERIALS..... 328
ELECTRIC HAIR BRUSH CONTAINS DYNAMO..... 308	By Prof. Lloyd Knoll, A.M.
INSIDE OF A U-BOAT—DETAILS OF MACHINERY FOUND IN SURRENDERED U-BOATS..... 309	TO WAR ON AN AMERICAN DESTROYER, by A. H. WHEDON... 329
LOCATING AIRPLANES IN NIGHT FIGHTING..... 310	HOW TO DEVELOP YOUR INVENTIVE ABILITY..... 330
	By Jay G. Hobson
	SCIENCE IN SLANG—WHAT MAKES THE STORAGE BATTERY STORE? By Emerson Easterling..... 333



## EDITORIAL

# Speeds

**I**F you had read twenty years ago that it was considered probable and very possible that in 1919 some one would fly across the Atlantic Ocean on canvas wings, propelled by a gas engine, at a speed of 100 miles an hour, you naturally would have turned away impatiently at such childish nonsense. Moreover, you probably would have doubted the sanity of the writer; but even Jules Verne with his most prolific and prophetic mind never prophesied the 1919 trans-Atlantic flight in a heavier-than-air machine.

This naturally brings us face to face with the future. Tho prophesying, as a rule, is bad business, there are certain scientific subjects that can be predicted safely, basing the prediction on mathematical as well as purely scientific grounds.

The question before us is: How fast is it possible for man to travel thru the air? Theoretically at least, there is no limit to the speed at which a human being can travel.

Airplanes already have covered over 200 miles an hour without discomfort to the aviator. At this point we venture to say that should the speed be increased over 300 miles per hour, the aviator will probably be very uncomfortable, due to the terrific rush of air. Even at 100 miles per hour the air lashes the face of an aviator badly. Therefore, flying above 300 miles per hour, he will have to sit in a cabin surrounded by glass, where the rush of the air cannot be felt. Suppose we increase the speed to 500 miles. What happens? Nothing. This speed is so probable that it will no doubt be reached before 1925; possibly much sooner. But we think such speeds will not be reached near the surface of the earth

where the density of the air, and consequently the greater resistance to an airplane, is too high. In order to travel at 500 miles per hour, the future airplane must offer as little surface to the air as possible. It should have no struts, wires, or stays. It probably will fly at a height of 5,000 feet or more, decreasing its speed as it approaches the earth. 1,000 miles an hour? Yes, man will do it. It is not only possible, but very probable. It will be accomplished in a machine which bears but little resemblance to our present-day airplane. Moreover, it will be absolutely necessary to rise at least to 25,000 feet above the earth, as otherwise the dense air will tear the machine apart, unless it were constructed entirely of metal. But because very much less power is required at the level of 25,000 feet, future express airplanes will prefer the high altitudes.

We might mention, *en passant*, that if you were in a machine flying at a steady speed of 1,039 miles per hour, also supposing you had enough fuel to stay up 24 hours, the following historical event would take place. Starting at noon and flying due West along the equator, with the sun above your head, the sun will not set for you on that memorable day. It will be directly overhead, as long as you keep on going, for you will now be flying at the rotational speed of the earth, which is 1,039 miles an hour. Looking down you will see the earth make one complete revolution; you will have seen every point and every continent along the equator. But 1,000 miles per hour is very tame. The earth in its orbital motion around the sun rushes thru space at the terrific rate of 65,533 miles an hour; Venus at 77,054 and Mercury at 105,325 miles per hour. So let us be hopeful!

H. GERNSBACK.

The ELECTRICAL EXPERIMENTER is published on the 15th of each month at 233 Fulton Street, New York. There are 12 numbers per year. Subscription price is \$2.00 a year in U. S. and possessions, Canada and foreign countries, \$2.50 a year. U. S. coin as well as U. S. stamps accepted (no foreign coins or stamps). Single copies, 20 cents each. A sample copy will be sent gratis on request. Checks and money orders should be drawn to order of EXPERIMENTER PUBLISHING CO., INC. If you change your address notify us promptly, in order that copies are not misdirected or lost. A green wrapper indicates expiration. No copies sent after expiration.

All communications and contributions to this journal should be addressed to: Editor, ELECTRICAL EXPERIMENTER, 233 Fulton Street, New York. Unaccepted contributions cannot be returned unless full postage has been included. ALL accepted contributions are paid for on publication. A special rate is paid for novel experiments; good photographs accompanying them are highly desirable.

ELECTRICAL EXPERIMENTER, Monthly. Entered as second-class matter at the New York Post Office under Act of Congress of March 3, 1879. Title registered U. S. Patent Office. Copyright, 1919, by E. P. Co., Inc., New York. The Contents of this magazine are copyrighted and must not be reproduced without giving full credit to the publication.

The ELECTRICAL EXPERIMENTER is for sale at all newsstands in the United States and Canada; also at Brentano's, 37 Avenue de l'Opera, Paris. Member of the Audit Bureau of Circulation.

Sent 40 PAGES RICH CLOTH BINDING

To Any Address

**WITHOUT COST**

or Obligation  
of any kind



you pay  
**NOTHING**  
you return  
Nothing

"THE MASTER KEY IS TOO MODEST A TITLE FOR SUCH A STUPENDOUS REVELATION"

**S**OME men and women seem to attract success, power, wealth, health and attainment with very little conscious effort; others conquer with great difficulty, still others fail altogether to reach their ambitions, desires and ideals. Why is this so?

"The Master Key" will tell you why. No one can read it and not be a changed man or woman. None but who will emerge from its magic pages with a firmer grasp of the future—a sure understanding of what he can do.

"The Master Key" is a key with which many are converting loss into gain, fear into courage, despair into joy, hope into fruition.

A MASTER-KEY will be sent to you, without cost or obligation of any kind if you address

**Charles F. Haanel, 423 Granite Bldg., St. Louis, Mo.**

**This advertisement**

*contains a message of such transcendental importance that every reader of Electrical Experimenter, whether man, woman, or child, should answer it immediately.*

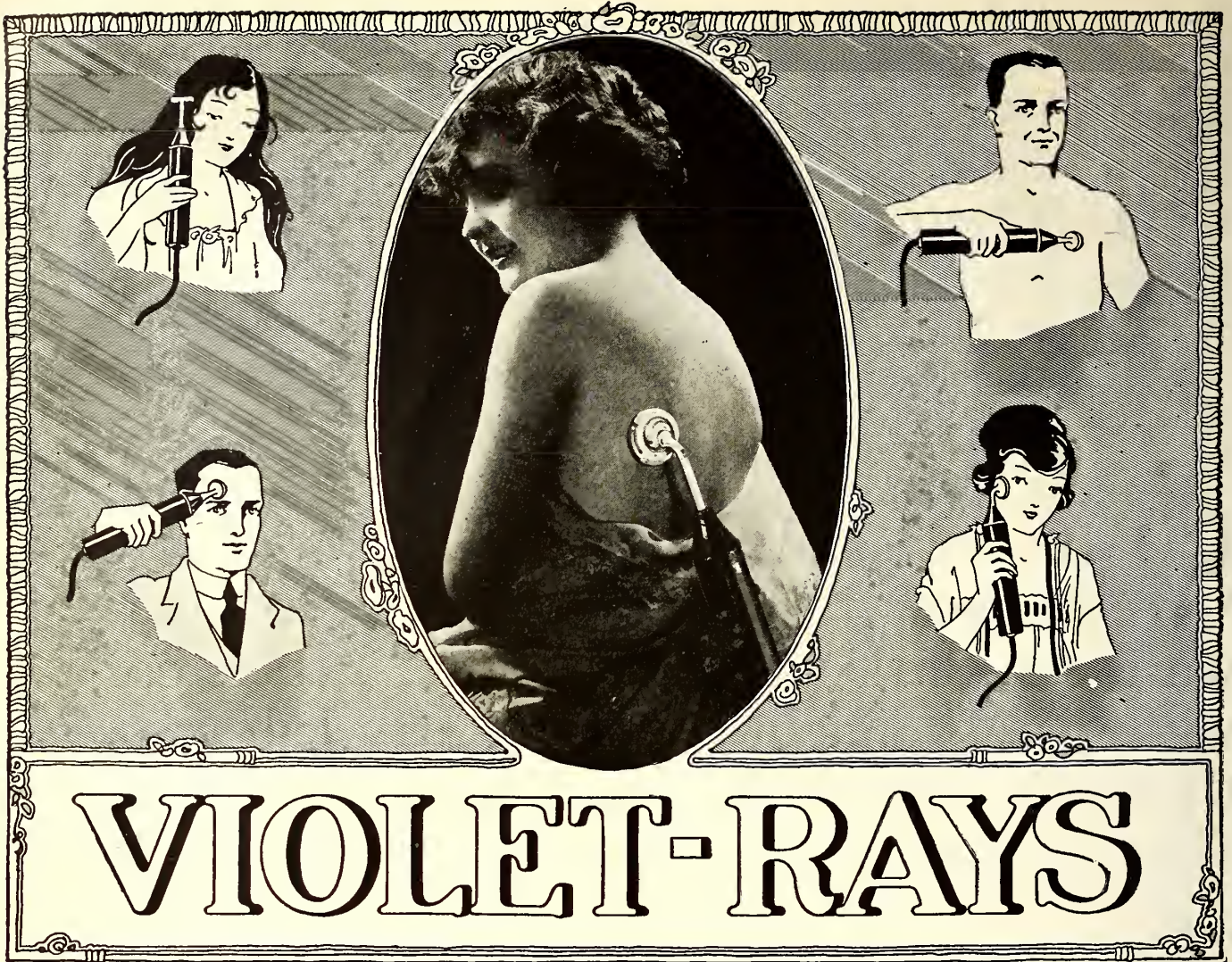

# VIOLET-RAYS

The Magic-like Reliever of Pain. The Marvel of the Age for Rheumatism, Neuralgia, Neuritis, Arteriosclerosis, Hemorrhoids, and Practically Every Other Ailment to Which Flesh is Heir. A Wonderful Beautifier Too! Amazing in the Treatment of Eczema, Blackheads, Wrinkles, Falling Hair, Dandruff, and Every Other Faulty Condition of the Skin and Scalp!

## 10 DAYS FREE IN YOUR OWN HOME

See for yourself the miraculous results of Violet-Rays. Get the wonderful Violetta Violet-Ray Machine for 10 days' free use in your own home. Give yourself exactly the same Violet-Ray treatments for which eminent physicians and beauty specialists charge big fees. Note the marvelous relief that comes even with the first treatment. See how you can virtually feel the Violet-Rays reaching to the very root and cause of any ailment with the great curative forces of Heat, Light, Electric Energy, and Ozone. See too how Violet-Rays youthifies the skin, purifies the scalp and stimulates hair-growth. Note above all how refreshing the effect of Violet-Rays to mind and body—how invigorating and vitalizing—how much better you work, eat and sleep. Prove all these benefits to yourself without obligation. Try the Violetta for 10 days free, and if you are not more than amazed and delighted, simply send it back.

BLEADON-DUN CO., Dept. 2G,  
326 W. Madison St., Chicago, Ill.

Please send me your free book and 10 days' free trial offer on the Violet-Ray Machine. Also full information as to treatment for ailments marked below.

- |               |              |                 |
|---------------|--------------|-----------------|
| Asthma        | Earache      | Piles           |
| Barbers' Itch | Eczema       | Paralysis       |
| Boils         | Eye Diseases | Pimples         |
| Blackheads    | Headache     | Pyorrhea        |
| Bunions       | Hay Fever    | Rheumatism      |
| Callous       | Goitre       | Skin Diseases   |
| Chilblains    | Insomnia     | Sore Throat     |
| Colds         | Lumbago      | Sprains         |
| Corns         | Nervousness  | Tonsillitis     |
| Constipation  | Neuralgia    | Whooping Cough  |
| Dandruff      | Neuritis     | Warts and Moles |
| Deafness      | Obesity      |                 |

Name .....

Address .....

City..... State

### BOOK FREE

Write today without fail. Mail coupon or just a postcard. Let us send you our beautifully illustrated free book, describing the Violetta in detail. Read the amazing phenomena produced by Violet-Ray High frequency current. Why it produces stimulation and sedation. How to give spinal treatments with the Violetta, how to treat various ailments, including nervous troubles, rheumatism, obesity, hay-fever, skin treatments, facial treatments. With the free book we will also send you particulars of our special free trial offer. Mail coupon or postcard now.

**BLEADON - DUN CO.**  
Dept. 2G 326 W. Madison St., Chicago, Ill.

Electrical, Drug and other Jobbers and Dealers: Write us today for our Co-operative Selling Plan.



Not a Vibrator

The Violetta is not a machine that contracts the muscles—it does not shock, it does not pound the muscles—it is absolutely painless. Violet Rays administered by the Violetta are wonderful even for infants!

This advertisement copyright 1919, by Bleadon-Dun Co.

# CHEMISTRY



"The Joy of Father and Boy."

## "ELECTRO"

# Chemical Laboratory

It contains the following 44 chemicals:

Alum  $Al_2(SO_4)_3 \cdot (NH_4)_2SO_4$   
 Antimony (powdered) (Sb)  
 Ammonium Aqua  
 $(NH_3 + H_2O)$   
 Ammonium Carbonate  
 $(NH_4)_2CO_3$   
 Ammonium Chloride  $(NH_4Cl)$   
 Ammonium Sulphate  
 $(NH_4)_2SO_4$   
 Barium Chloride  $(BaCl_2)$   
 Boric Acid  $(H_3BO_3)$   
 Brimstone (Sulphur) (S)  
 Calcium Chloride  $(CaCl_2)$   
 Calcium Oxide (CaO)  
 Calcium Sulphate  
 $(CaSO_4 \cdot 2H_2O)$   
 Charcoal (Carbon) (C)  
 Chloride of Zinc  $(ZnCl_2)$   
 Copper Sulphate  $(CuSO_4)$   
 Ferrous Sulphate  $(FeSO_4)$   
 Ferrous Sulphide  $(FeS)$   
 Glycerol (Glycerine)  
 $C_3H_5(OH)_3$   
 Hydrochloric Acid (HCl)  
 Iodine (I)  
 Iron Chloride  $(FeCl_2)$   
 Iron Oxide  $(Fe_2O_3)$   
 Lead Acetate Pb  $(C_2H_3O_2)_2$   
 Litmus Paper  
 Magnesium Carbonate  
 $(MgCO_3)$   
 Manganese Dioxide  $(MnO_2)$   
 Mercury (Quicksilver) (Hg)  
 Nickel Chloride  $(NiCl_2)$   
 Oxalic Acid  $(H_2C_2O_4)$   
 Sodium Bicarbonate  
 $(NaHCO_3)$   
 Sodium Borate  $(NaBO_2)$   
 Sodium Carbonate  $(Na_2CO_3)$   
 Sodium Chloride (NaCl)  
 Sodium Nitrate  $(NaNO_3)$   
 Sodium Phosphate  
 $(Na_2HPO_4)$   
 Sodium Sulphate  $(Na_2SO_4)$   
 Sodium Sulphite  $(Na_2SO_3)$   
 Stannous Chloride  $(SnCl_2)$   
 Sulphate of Nickel  $(NiSO_4)$   
 Sulphate of Zinc  $(ZnSO_4)$   
 Sulphuric Acid  $(H_2SO_4)$   
 Tin (Granulated) (Sn)  
 Zinc (Metal) (Zn)  
 Zinc Carbonate  $(ZnCO_3)$

The following apparatus are furnished:

One Standard Washbottle  
 One Alcohol Lamp  
 One Conical Glass Measure  
 One Erlenmeyer Flask  
 One Glass Funnel  
 One Delivery Tube  
 Six Assorted Test-Tubes  
 One Test-Tube Holder  
 Ten Sheets of Filter Paper  
 One Glass Dropper  
 One Spoon Measure  
 Glass Tubing  
 One book containing Treatise on Elementary Chemistry and 100 Chemical Experiments to be performed with this outfit.

We present herewith to our friends our new E. I. Co. Chemical Laboratory which contains real chemicals and apparatus to perform real chemical experiments. This outfit is not a toy, put up merely to amuse, but a practical laboratory set, with all the chemicals, apparatus and reagents necessary to perform real work and to teach the beginner all the secrets of inorganic chemistry. With this outfit we give free a book containing a Treatise in Elementary Chemistry, useful data and recipes, and 100 instructive and amusing experiments.

### DESCRIPTION OF THE OUTFIT:

The outfit consists of forty-four (44) Chemicals all C. P. (chemical pure) put up in appropriate wooden boxes, glass bottles, and hermetically closed jars. The acids are put up in glass bottles, with ground-in glass stoppers and there is a sufficient quantity of chemicals supplied (mostly one to two ounces) enough to make dozens of experiments with each. See list of Chemicals herewith.

The apparatus furnished are all of the best obtainable make and of standard laboratory size and shape. A list of the 17 pieces of apparatus furnished with this outfit is printed also herewith.

The instruction book is a real Chemistry Course for the Beginner. Some of the Contents are: Division of Matter: This is a Treatise on Elementary Chemistry and deals with the theory of the Elements, Molecules and Atoms, etc. Chemical Nomenclature. This explains in simple language the derivation of the chemical names of the Elements and their compounds. There is a chapter on Laboratory Operations; Glass Working; First Aid; Fire Extinguishers; Experimenters' Aphorisms, etc.

A good part of the book is devoted to Weights and Measures. The Metric System, the English system and the U. S. System are fully explained.

The following tables are furnished: Symbols and Atomic weights of the Elements; Measures of Weights, Volume, Capacity and Length; Per Cent solutions; Conversion of Measure expressed in parts; Poisons and their antidotes; Technical and common name of chemical substances; Formulas for Cleaning various substances, etc., etc.

Among the 100 Experiments are:

How to make chemical tricks; How to make invisible and magic inks; How to test flour; How to test soil; How to Make Chlorine Gas and smoke (German War Gas); How to bleach cloth and flowers. How to produce Oxygen and Hydrogen; How to make chemical colors; How to test Acids and Alkalies and hundreds of interesting hints and formulas.

The price is still \$5.00

Shipping Weight 10 lbs.

(Can be shipped by Express only.) Send your order today to:



**THE ELECTRO IMPORTING CO., Mfrs.**  
 231 FULTON STREET NEW YORK CITY



See our full page Ad, on page 346 for Free Cyclopedic

You benefit by mentioning the "Electrical Experimenter" when writing to advertisers.



# Master Electricity By Actual Practice

The only way you can become an expert is by doing the very work under competent instructors, which you will be called upon to do later on. In other words, *learn by doing*. That is the method of the New York Electrical School.

Five minutes of actual practice properly directed is worth more to a man than years and years of book study. Indeed, Actual Practice is the only training of value, and graduates of New York Electrical School have proved themselves to be the only men that are fully qualified to satisfy EVERY demand of the Electrical Profession.

## The Only Institution of the Kind in America

At this "Learn by Doing" School a man acquires the art of Electrical Drafting; the best business method and experience in Electrical Contracting, together with the skill to install, operate and maintain all systems for producing, transmitting and using electricity. A school for Old and Young. Individual instruction.

## Over 5,500 Graduates are Successful Men in the Electrical World

No previous knowledge of electricity, mechanics or mathematics is necessary to take this electrical course. You can begin the course now and by steady application prepare yourself in a short time. You will be taught by practical electrical experts with actual apparatus, under actual conditions.

### Special Automobile Ignition Course

We have just installed a special automobile ignition course for auto mechanics, garage men and owners. The course covers completely ignition, starting, lighting and other electrical equipment in connection with automobiles, motor boats, etc.

*Let us explain our complete courses to you in person. If you can't call, send now for 64-page book—it's FREE to you.*

# New York Electrical School

29 West 17th Street, New York

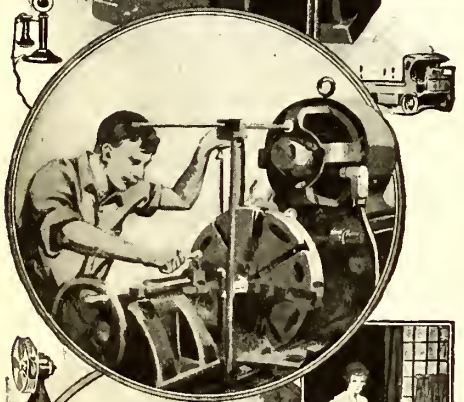

New York Electrical School  
29 W. 17th St., New York, N. Y.

Please send FREE and without obligation to me your 64-page book.

.....(NAME)

.....(ADDRESS)

*You benefit by mentioning the "Electrical Experimenter" when writing to advertisers.*

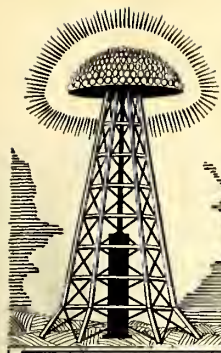

# ELECTRICAL EXPERIMENTER

H. GERNSBACK - EDITOR  
H. W. SECOR - ASSOCIATE EDITOR



Vol. VII. Whole No. 76

AUGUST, 1919

No. 4

## Radio-Planes Watch Forests and Ranches

**A**IRPLANES, plus radio-telephone equipment, have found a brand-new peace-time utility—watching for forest fires in the vast government timber preserves, and also for supervising the operation of large ranches, such as those embracing thousands of acres and found frequently in the great Western farming regions. Some of these farms and ranches are so large that it takes a superintendent all day to make an inspection trip across the ranch, even with a high-powered automobile.

### How the Airplane Plus Radio Is Used to Watch Great Forests and Ranches

The airplane as part of a farm equipment is now a reality. It makes its appearance at Hardin, Mont., on the wheat ranch owned and controlled by John Pierpont Morgan and other New York capitalists. Erhardt Schmitt, former American army

aviator, has been employed to operate the machine. His duties are to carry the ranch manager from one part of the 250-mile, 100,000-acre wheat ranch to other fields. A wireless telephone in the airplane enables the manager to keep in constant communication with the ranch headquarters.

Not only can the manager or superintendent immediately report back to the ranch headquarters, by radio-telephone, but he can give local orders to gang or section foremen by means of small radio receiving (Continued on page 364)

#### SPOTTING FOREST FIRES BY AIRPLANES



WATCH TOWER AND RADIO PHONE STATION

#### AIRPLANE IN ACTUAL USE FOR MANAGING RANCH



AIRPLANE CARRYING RANCH MANAGER ON INSPECTION TRIP OVER MILLION ACRE RANCH

FARM "TANKS" PLOWING ETC.

RANCH HEADQUARTERS AND RADIO-PHONE STATION

RADIO-PHONE ON "TANK"

FIELD SECTION FOREMAN'S SHACK. INCLUDING RADIO-PHONE STATION

Two New and Important Peace-time Uses for Radio-equipt Airplanes—Watching for Forest Fires and Inspecting Large Farms and Ranches.

# Bomb Expert Eagan

SPECIAL INTERVIEW TO THE ELECTRICAL EXPERIMENTER

## Types of Bombs and How to Handle Them

**O**WEN EAGAN! At the mention of his name, the thought of bombs, anarchistic plots and explosives flood the mind. Seated at his desk, I found a man of sixty years, of medium height and massive proportions; head covered with curly gray locks. His

Section of a Film Story of Mr. Owen Eagan's Exploits in "Bombland." For Years Inspector Eagan Has Inspected Infernal Machines by the Hundred and Still Lives to Tell the Tale.

eyes are of piercing steel gray and he has an ever-ready smiling countenance. A firm hand clasp told of a man of power, youthful in spirit, a believer in the great out-doors, a staunch American who cherishes a long and lasting friendship with that Great American, Theodore Roosevelt.

### Mr. Eagan Classifies the Bombs.

We will now let Mr. Eagan tell of his bombs. Among other things, Mr. Eagan said:—

Bombs may be classified into four types, according to the explosives used: Nitro-cellulose, Nitro-glycerin, Nitro-benzol, Alkaline metallic nitrate mixtures.

These explosives permit of many combinations and varied means of igniting them. Bombs may be further classified according to the method of ignition used: Manual, Mechanical, Electrical, Chemical.

The container or envelope of a bomb may be anything from a newspaper wrapt around the explosives to iron pipes, ice cream freezers, violin cases, cigar boxes, bottles filled with concrete and all imaginable kinds of wrappers.

### RULES FOR HANDLING BOMBS

By INSPECTOR OWEN EAGAN,  
Bureau of Combustibles,  
NEW YORK FIRE DEPARTMENT.

If you should receive what you believe to be a bomb or infernal machine thru the mails or by messenger

1. LEAVE IT ALONE.
2. DO NOT PLACE IT IN WATER, CALL THE FIRE DEPARTMENT, OR IF IT IS NOT CONVENIENT, CALL THE NEAREST POLICE OFFICER, WHO WILL AT ONCE NOTIFY THE FIRE DEPARTMENT, AND HAVE THE EXPERT COME TO INSPECT THE SUSPICIOUS PACKAGE IMMEDIATELY.

It is a common but fallacious rule among the general public, that in order to be safe with a bomb or infernal machine, it should at once be placed in a pail of water. If the bomb or infernal machine has a fuse attached to it, and the fuse may be seen burning or sputtering, then drop the bomb in water, which method usually is efficacious in making it harmless, as the lighted fuse is at once extinguished, but the best advice is to leave the house.

However, when this lighted fuse is NOT PLAINLY EVIDENT on the bomb or infernal machine, IT SHOULD NOT BE PLACED IN WATER, as many of these hellish devices are chemically or electrically operated. Another possibility likely to occur, if the suspected bomb or package is placed in water, is that some of them are made up in part of certain chemicals which will explode as soon as the water reaches them. There is an added probability that if the package or bomb is immersed in water, the reaction between the water and the chemical may give rise to a violent and persistent combustion, the flames of which will set fire to the house. In some of these contrivances there is a second compartment containing a high explosive, which can be ignited by heat, and where such a condition as outlined may occur, it is at once apparent that the heat due to the combustion of the initial chemical may generate sufficient heat to detonate the explosive, with possibly fatal results.

Every bomb presents a new problem as regards its envelope, contents and construction, and the best means of opening it without causing it to explode and send me "West." Everything is filled with uncertainty at this stage. The task requires ingenuity, nerve, precision and firmness of hand, which is essential to a surgeon in performing a very delicate operation. In both cases, a life is in the balance. These qualities cannot be gained by study, but must be secured by experience covering many years.

We now enter the second phase of the work. It is now necessary for me to classify and analyze the layout, materials, methods and plan of the bomb maker. What's in the vial? Why the wire? Where is it attached? What's this powder? Is it a mixture of several chemical substances? Why this and why that? Two, four, seven compartments, everything interlocking! Can't see the battery, detonating cap! Can't pull its "teeth"!

The scene is set in someone's home or office, sometimes it is my laboratory; every one has gone; the windows have been raised, doors opened to relieve the compression in the event of an explosion.

There are two opponents, a bomb and Eagan, but Dame Experience is always with me.

The hellish combination has been broken down and then the "guests" are called and there on the table before them in various groups are explosives, timing devices, detonators, ignition mixtures, acids, vials, batteries, wires, fuses and the "bomb-maker's camouflage". Now the wheels of Justice are set in motion and the search for the bomb-maker begins.

Since the discovery and use of gunpowder, bombs of various types have been used.

### The First New York Bomb Outrages.

The first series of bomb outrages in New York, from 1902 to 1910, known as the "Blackhand Bombs," occurred in the Italian section, and these were chiefly of the nitro-glycerin group, manually ignited. Dynamite was placed in olive oil cans and ignited by a time fuse which the "dynamiter" lighted and walked away to await developments.

A large number of bombs of the alkaline metallic nitrate group were made dur-

Another view of the "Animated Weekly" Film Story of Inspector Eagan's Great Work—that of Official Bomb Opener to the City of New York. His is the Only Job that "Has no "Waiting List" of Future Aspirants.

ing this period. These consisted of various nitrates and chlorates and were exploded by time fuses manually ignited. Some were of the grenade type and were hurled at the victims.

Most of the bombs of this period were of a crude design and were made from articles of every day (Cont. on page 341)

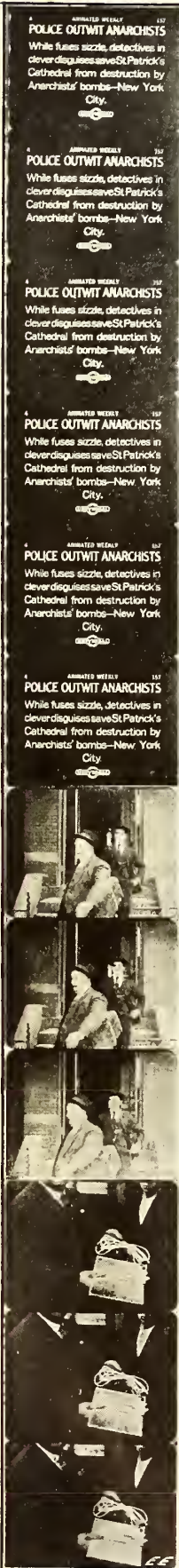



# A Few "Samples" of Eagan's Bombs



## EXPLOSIVES.

F. D. N.

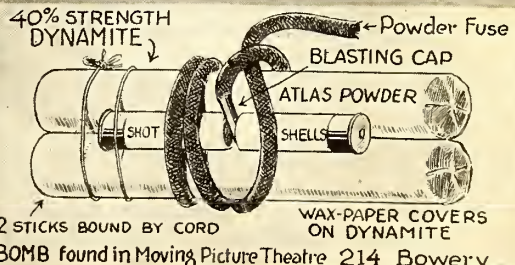
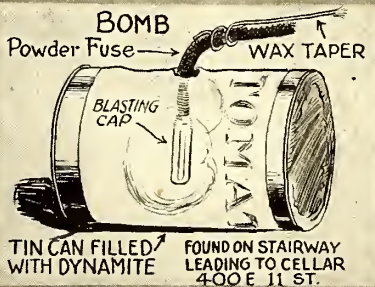

**GIMBEL BROTHERS**

BROADWAY 34th St. N.Y.C.

(Exclusive Story of Mr. Eagan's Bomb Exploits on Opposite Page.)

# Peacetime Uses for War Inventions

By H. Winfield Secor

"SCIENCE moves in mysterious ways, her wonders to perform"—to paraphrase the well-known biblical passage, and never was this demonstrated more pertinently than at the present time, when we find many of the great World War's deadly inventions being converted to peacetime uses. Everybody is being benefited by the industrial application of some of the greatest inventions yet perfected by man, and many thousands more will live to reap the benefits accruing from the as yet undreamt-of applications for both business and pleasure, of airplanes, tanks, wireless devices, submarines, and a thousand and one other attainments of the world's master scientific minds.

A semi-humorous application of the Meissner *airfone*, described elsewhere in this number, is shown in Fig. 1. This device, which is very simple in construction, resembles a speaking tube in form, but incorporates several novel and distinct improvements, among others, an acoustic amplifier, making the device very efficacious for carrying on conversation between the pilot and observer in an airplane, where it is extremely difficult to hear under ordinary conditions, due to the great noise of the engine. A new application of this device is here suggested, namely, to muffle the ever-present and detestable "movie pest." Not only do we find these miserable atoms of humanity in the dark quiet of the movie theater, but also in all of the regular theaters. These brilliant insects must have seen some of the shows which we happened to frequent, about 999 times,—so replete is their knowledge of the "star" and "stares" and all the lesser satellites appearing in the play. They will tell you loudly the climax half an hour before it comes off and so on. So, thanks to the Meissner *airfone*, it should not be so very long before "us ordinary mortals" shall be able to go to the theater and enjoy a performance without having one of these human dramatic compendiums racing along two knots ahead of us, all the way thru the play and telling his sweetheart every move just before it happens. Some of you may like your entertainments served up that way—as for us, we object!

A very good use for the Boche's famed *Poison Gas* is shown in Fig. 2. What better application than to annihilate the rats by asphyxiation—"sauce for the goose is sauce for the gander." The Germans thought they had something brand new in strictly war inventions when they tried poison gas on the Allies, but among other recent applications of this invention to peacetime utilities and requirements was that of killing rats. Of course it goes without saying that before injecting a few dozen cubic feet of mustard or chlorin gas into a rat hole, that you had best provide yourself with a guaranteed gas mask and also buy a few dozen corks with which to plug up the other openings in the walls or floor boards. Give it a trial, ladies and gentlemen—it's the "kaiser" of all rat killers.

Embryonic Tanks were already in use for agricultural and other purposes long before the World War, and in fact the first tanks used by the British Army on the battlefields of France were reconstructed agricultural tractors, built in the United States. These tractors were armed with steel plates and fitted with rapid-firing guns. The illustration, Fig. 3, shows another application besides that of the usual plowing and cultivating operations—that of hauling large logs in the lumbering districts of the great West. In these locali-

ties it is difficult to build even small railroads, and it doesn't pay to build any extensive trackage for such log railroads, as they are not apt to be used for any great length of time. Therefore, the tank tractors should prove very useful, as they can travel over practically any kind of ground, including ditches and even over logs. It will be remembered that during operations in the World War the tanks could crawl over great shell holes, trenches and brooks. This application should provide some fine chances for those of our Tanks Corps soldiers who are aching for army life and the ups and downs met with in the everyday career of a "tank rider." These tanks can haul tremendously heavy loads and resemble in their operating characteristics the work of the famous elephants of India, who pick up with their trunks giant timbers 30 to 40 feet long and measuring 8 to 10 inches square.

Airplanes—oodles of them—will soon be flying over our heads every day all over

dise as by multiplying its everyday utilities, the practical development of aircraft is bound to result. This country, as well as every other power, is keen, of course, to develop aircraft to the highest pinnacle of practicability. The U. S. Army, as well as the Navy Department, has only recently put up a stiff fight for many millions of dollars with which to carry on much-needed airplane developments. One of the best ways to train fliers, especially in this country, where a large standing army or navy personnel is never maintained, will be without a doubt to encourage in every way possible the commercial application of flying machines of all types. Already in England a piano has been transported across the English Channel by airplane, and airplanes are at present available which can lift very heavy loads, and, moreover, they are daily becoming more reliable and less liable to accident, should any part of the machinery fail while in the air. Hundreds of people of course take one look at an airplane, especially when it is ascending or descending in flight, and are satisfied to keep both feet on old *terra firma*. However, some of the latest types of airplanes are guaranteed to right themselves and land safely, even if the engine stops in mid air and the control cables become tied or ruptured. See Fig. 4.

*Liquid Fire*, as shown in Fig. 5, should prove efficacious for several industrial uses, such as burning off paint from iron and steel structures, vessels, etc., and, according to H. Gernsback, also for blazing a path or hole thru ice jams, which frequently prove extremely dangerous during the American winters, when they clog rivers and streams, as well as dams. Under certain conditions it might also be used to blaze paths thru jungle brush.

The *Geophone* is a remarkable physical instrument greatly improved and perfected during the war by the engineers connected with the Allied technical staffs, and used with great success for the purpose of locating enemy artillery and other military operations. Now it has found a distinct peacetime use. See Fig. 6. The saving of many miners' lives has been made possible, thanks to the Geophone, which can detect sound vibrations thru the earth at surprisingly long distances. It has been used successfully in some Government mine tests to pick up the sound of a pick-axe at a distance of about one-quarter mile. There is nothing electrical about the Geophone. It is purely mechanical and acoustic in its function. It operates on the principle that the inertia of a small lead weight within the instrument, and which is secured to a set of diaphragms, will tend to hold its initial position whenever an earth-borne sound vibration, for instance, happens to affect it. The other part of the instrument moves and the lead weight tends to remain stationary in the same manner as your body sways forward due to its inertia when a car suddenly stops. The relative movement of the diaphragm to which the weight is attached with respect to the movement of the casing sets up an air wave, and this is transmitted to the ears thru a rubber tube, in the same way as a physician's stethoscope works. By means of this wonderful instrument, therefore, it is now possible to actually locate entombed miners at considerable distances. Communication with them is also possible by this means. Knowing the location of the entrapped men, it becomes much more expeditious to carry on rescuing and excavating operations in order to save them.

(Continued on page 365)

## September Number of the Electrical Experimenter

*Sir William Crookes' Psychological Researches*, by Hereward Carrington, Ph.D., *Scientific Proof of the Existence of Psychic Force*, as investigated by one of the world's foremost scientists.

*Paris Letter—the Latest Electrical and Scientific News from French Scientific Laboratories*, by Jacques Boyer.

*Practical Experiments in Chemistry*, by Albert W. Wildson—*An everyday plain English talk on the cleansing of clothes*.

*Thermo-Electricity*, by Thomas W. Benson.

*The Mystery of Atmospheric Electricity*, by Rogers D. Rusk, M.A.

*How to Make a Machine for Telegraphing Pictures*, written especially for our young readers by America's greatest tele-photographic expert, Leroy J. Leishman.

*Experiments in Physics—Illusions*, by John J. Furia, M.A.

*New American Salvage Device for Raising Sunken Ships—A most timely and important article*, by Joseph H. Kraus.

*Latest Amateur Radio Receiving Apparatus*, by Charles W. Noller.

*Light Houses—How They Signal*, by A. H. Whedon.

*Electrical Detective to Register Your Chauffeur's Joy Rides*, by Thomas Reed.

*Latest Developments in Flying*.

America. Many people have an idea that the airplane is a peacetime luxury, not to mention a wartime necessity. But such is not the case. If for no other reason the airplane has come to stay in its everyday application to the transportation of mail and the lighter classes of merchant-

# Peacetime Uses for War Inventions

THE MEISSNER "AIRPHONE" SETTLES THE MOVIE-PEST WHO KNOWS EVERY "FILM" BY HEART.



Nº1

AIRPLANES NOW IN USE FOR CARRYING FREIGHT & MAIL.

Nº4

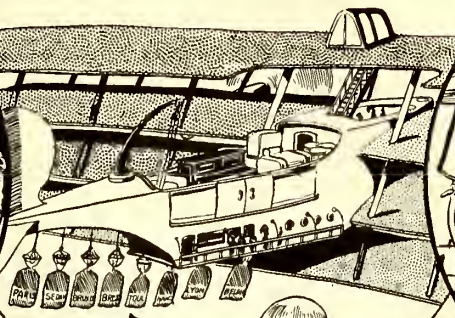

MAIL BAGS

MUSTARD GAS FOR KILLING INSECTS & ANIMALS

Nº2



TO KILL INSECTS. -ACTUALLY USED-

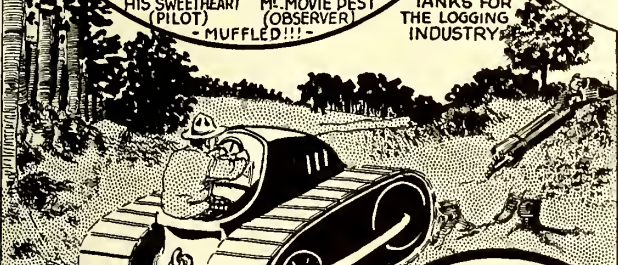

TANKS FOR THE LOGGING INDUSTRY!

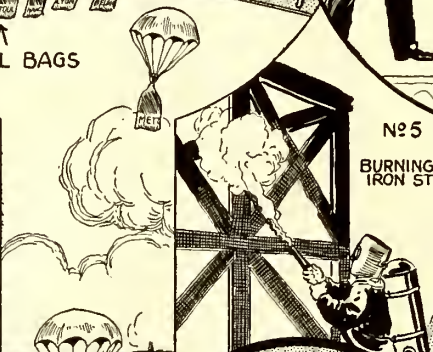

LIQUID FIRE BURNING PAINT OFF IRON STRUCTURES.

MELTING ICE JAMS IN RIVER GORGES.

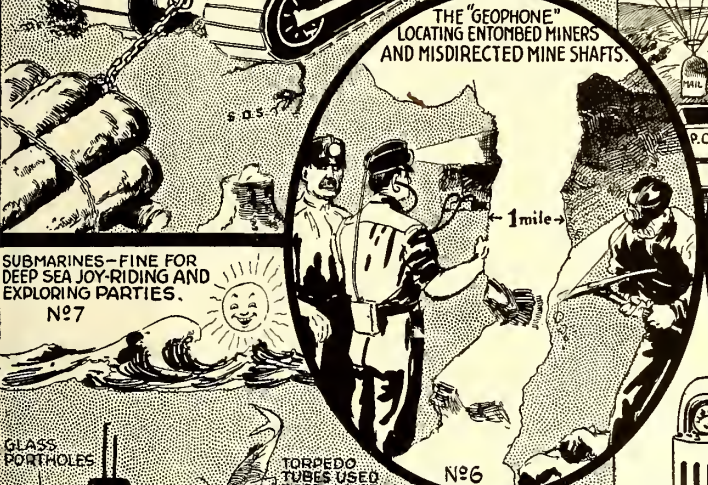

THE "GEOPHONE" LOCATING ENTOMBED MINERS AND MISDIRECTED MINE SHAFTS.

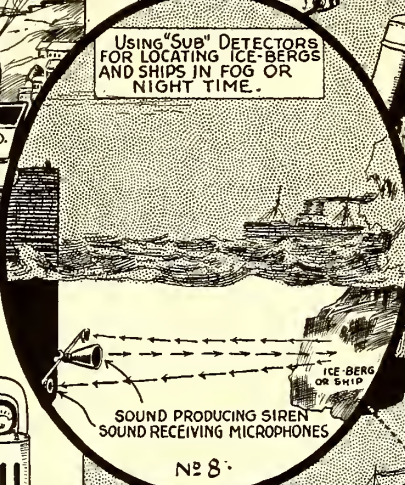

Using "Sub" Detectors FOR LOCATING ICE-BERGS AND SHIPS IN FOG OR NIGHT TIME.

SOUND PRODUCING SIREN SOUND RECEIVING MICROPHONES



SUBMARINES - FINE FOR DEEP SEA JOY-RIDING AND EXPLORING PARTIES. Nº7

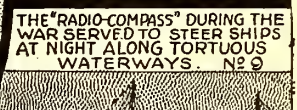

THE "RADIO-COMPASS" DURING THE WAR SERVED TO STEER SHIPS AT NIGHT ALONG TORTUOUS WATERWAYS Nº9

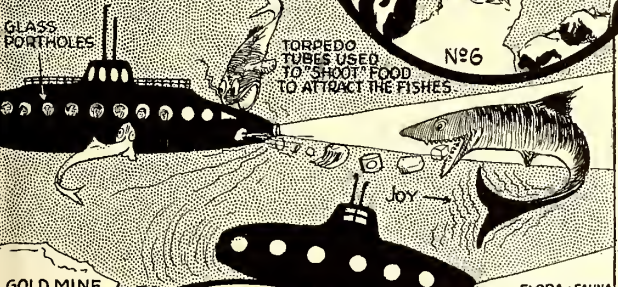

TORPEDO TUBES USED TO "SHOOT" FOOD TO ATTRACT THE FISHES.

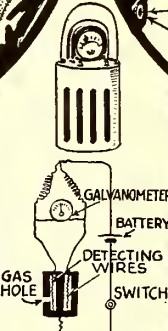

ELECTRIC GAS DETECTORS USED IN WAR; FOR DETECTING MINE GAS, ETC.

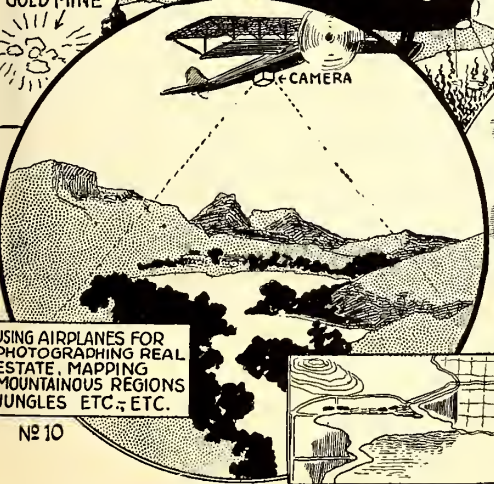

USING AIRPLANES FOR PHOTOGRAPHING REAL ESTATE, MAPPING MOUNTAINOUS REGIONS, JUNGLES, ETC., ETC. Nº10

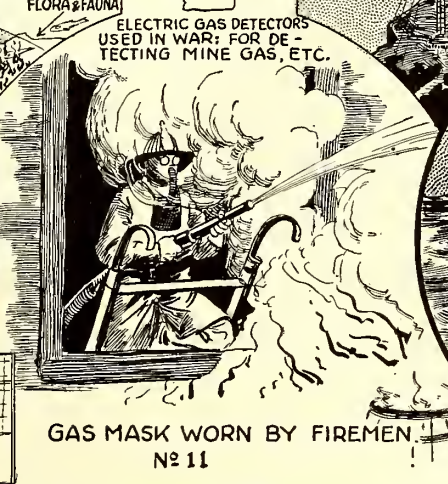

GAS MASK WORN BY FIREMEN. Nº11



DEPTH BOMBS TO BREAK UP ICE-JAMS, KILLING FISH OR BLOWING UP DERELICTS

Full description on opposite page.

Copyright, 1919, by E. P. Co.

# Changing Nature's Face

**T**HE World War has, if nothing else, brought to light the great flexibility and usefulness of explosives such as dynamite, not for the purpose of annihilating men and cities, but for the more human, utilitarian purpose of leveling uneven and rocky ground, blasting out stumps from previously wooded ground,

## How Electricity Plus Dynamite Makes Brooks, Removes Stumps and Breaks Up Rock

ated by a hand-operated dynamo of the magneto type. The dynamo is placed in a substantial cabinet to stand hard usage such as is encountered in blasting work, with a handle protruding from the top of the box containing it. This handle is attached to a gear rack and pinion, the pinion being secured to the shaft of the dynamo, so that

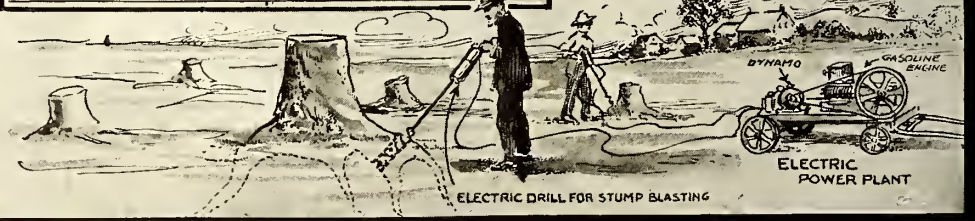
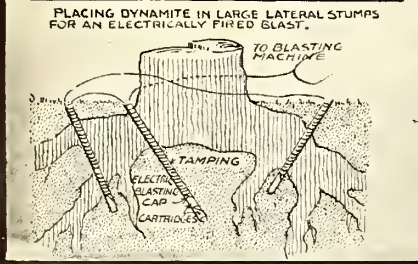
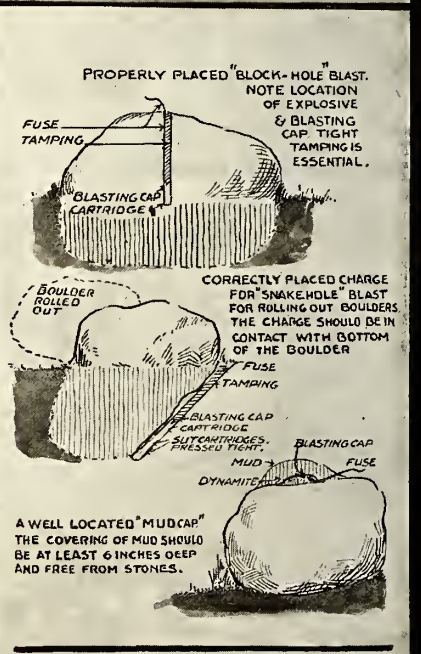
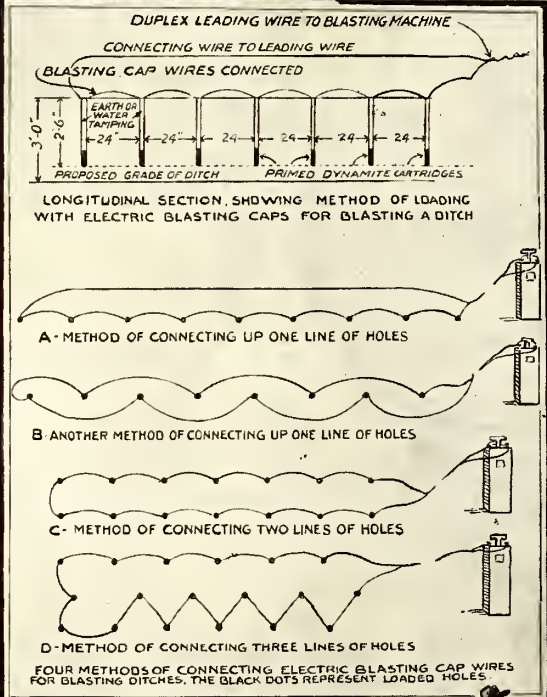
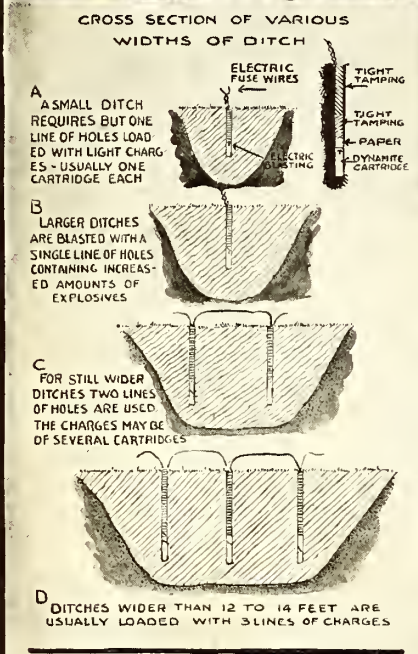

Illustrating a Few of the Wonders Which Dynamite Plus Electricity Accomplish Every Day All Over America. Stumps Are Cleared Out—Boulders Shattered—Ditches Constructed and Even the Courses of Rivers and Streams Altered. Verily the Face of Nature is Changed By Man.

and breaking up rock. Again, brooks and irrigating streams are rapidly "dug" in a single day by the use of dynamite plus electricity, under the highly developed methods now available for applying explosives, and even the course of a river has been changed in the twinkling of an eye. What we are interested in, in the present

discussion, is the practical application of explosives to the everyday requirements of the tiller of the soil and those who are interested in improving wooded or rock strewn property. **The Electrical Detonator.** In "blasting by electricity," use is made of a slight electric current usually gener-

ated by a hand-operated dynamo of the magneto type. The dynamo is placed in a substantial cabinet to stand hard usage such as is encountered in blasting work, with a handle protruding from the top of the box containing it. This handle is attached to a gear rack and pinion, the pinion being secured to the shaft of the dynamo, so that

# Man's Greatest Curse--Infected Teeth

## The Work of HENRY A. COTTON, M. D.

MEDICAL DIRECTOR NEW JERSEY STATE HOSPITAL, TRENTON, N. J.

### How X-Rays of Teeth May Prevent Disease and Insanity

**I**NVESTIGATIONS in the last few years, by both dentists and physicians, have shown conclusively that the greatest menace to the health of the human race today is to be found in the bad condition of the teeth of a large majority of the populace. The instinct of the individual is directed toward saving the teeth, and, unfortunately, a large proportion of the dentists foster this instinct, and in consequence, teeth are capt and otherwise repaired by expensive *bridge work* in order to save the teeth, when from the standpoint of the patient's subsequent ill-health, these teeth should be extracted. Happily,

**M**AN'S greatest danger, the biggest curse of humanity today, are infected teeth. Millions of people are dying of all sorts of diseases, caused directly by infected teeth. Inflammatory rheumatism, insanity, chronic stomach diseases, Bright's disease, nervous diseases, all these are now attributed to infected teeth. The work of Henry A. Cotton, Medical Director of the State Hospital of Trenton, N. J., is of such epoch-making and tremendous importance that every human being ought to know of it.

the best dentists have realized for some years that serious results frequently follow such procedures and have warned the profession against this danger. This subject has received special attention by Dr. Henry A. Cotton, Medical Director New Jersey State Hospital, Trenton, N. J., who in a recent statement on the importance of X-raying the teeth, has the following to say:

"Unfortunately for the patient, infected teeth may not and often do not cause any symptoms which would lead one to believe that anything is wrong with his teeth. This type of infection is what is known as *chronic* in contradistinction to an *acute* infection, and does not cause pain, pus or swelling, and frequently no rise in temperature. Hence, there are no symptoms which direct the patient's attention to this condition, and often they are amazed when they are told that they have infected teeth and that they must have a certain number extracted if they wish to recover from their particular illness. The question is often asked, 'How are we to know that teeth which give no evidence to the patient of serious and often dangerous infection, and externally give no evidence to the dentist of such condition, are infected?' The answer to this is the X-ray, and a more general use of this very simple and harmless procedure will reveal to the dentist as well as to the patient the existence of

infected roots, when to casual inspection the teeth may seem to be healthy and wor-

thy of saving! Naturally, these should immediately be extracted.

"Each individual should know whether or not he is harboring dangerous infection, which may not only undermine his general health but may endanger his life if it be not eradicated. With this knowledge of the danger of infected teeth, all persons should insist upon a thoro examination of their teeth by means of the X-ray and not take the word of a dentist who merely inspects the teeth and pronounces them all right. The failure of the dentist to recognize the existence of root infection and the practise of putting in pivots, gold crowns and

Dr. Cotton proves to us that it is wrong to cap or crown devitalized teeth as they will positively make serious trouble sooner or later. Such teeth should all be extracted immediately; they are the seat of nine-tenths of all our modern diseases.

This article is one of the most important we have published for a very long time, and we urge every reader not only to carefully read it, but to spread its gospel among friends. It will save thousands upon thousands of lives.

—EDITOR.

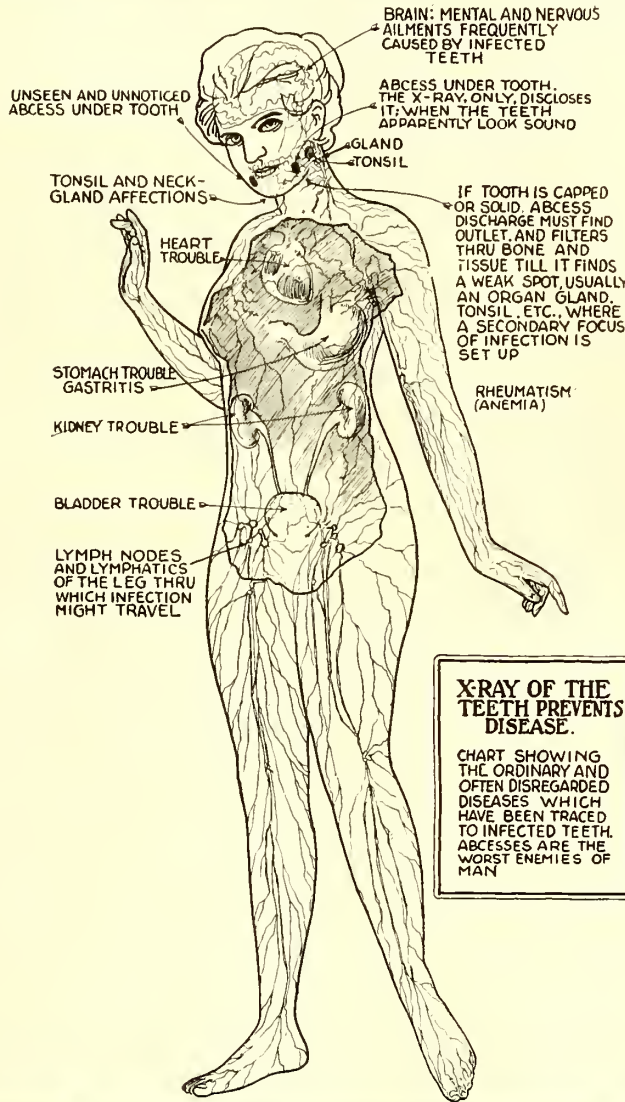

**XRAY OF THE TEETH PREVENTS DISEASE.**  
 CHART SHOWING THE ORDINARY AND OFTEN DISREGARDED DISEASES WHICH HAVE BEEN TRACED TO INFECTED TEETH. ABSCESS ARE THE WORST ENEMIES OF MAN

bridge work, without first taking radiographs of these teeth to be sure that there are no infected roots, has sounded the death knell of many people, for when the infection has invaded other organs it is often too late for extraction of the teeth to be of any benefit. No matter if the teeth give no trouble or if one feels perfectly healthy at the present time, if he has had any dental work done at any time, he should insist upon his dentist radiographing his teeth so that he will not be the victim of a false security and finally succumb to a fatal disease, which might have been prevented if he had taken the precaution mentioned.

#### The Cause of Infected Teeth

"The public naturally inquires: 'Why do we have such bad teeth today when our parents and grandparents did not have these conditions, or, at least, did not have these fatal diseases?' There are several reasons for this. In the first place, our forefathers did not bother with dentists except to have an offending tooth extracted. In the second place, modern dentistry had not developed to the point of expensive repair and preservation of the teeth as we know it today. It has been estimated that 80 per cent. of the people who have had repair work done, even in the most expensive and latest manner, have infected teeth which may become a menace to their health at any time.

(Continued on page 345)

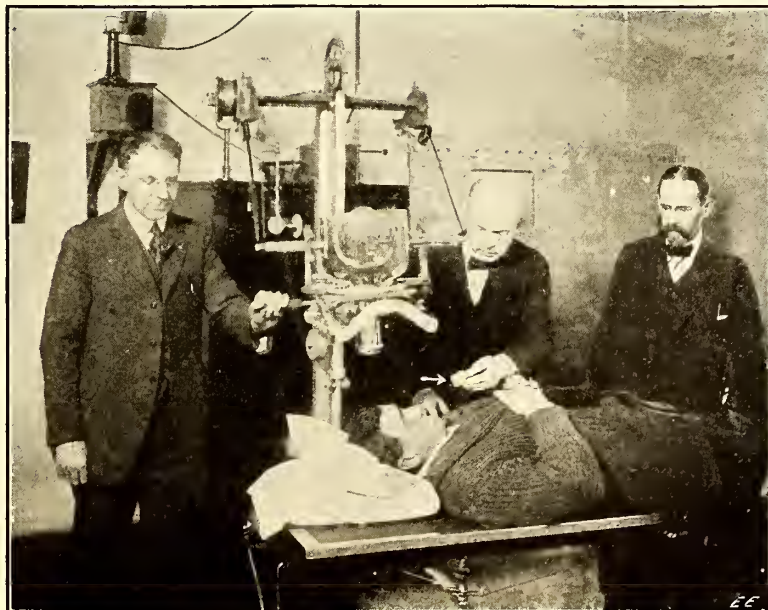

Taking X-Ray Photos of the Teeth at New Jersey State Hospital Laboratory. Arrow Indicates the Small Plate Holder About to Be Placed in the Mouth.

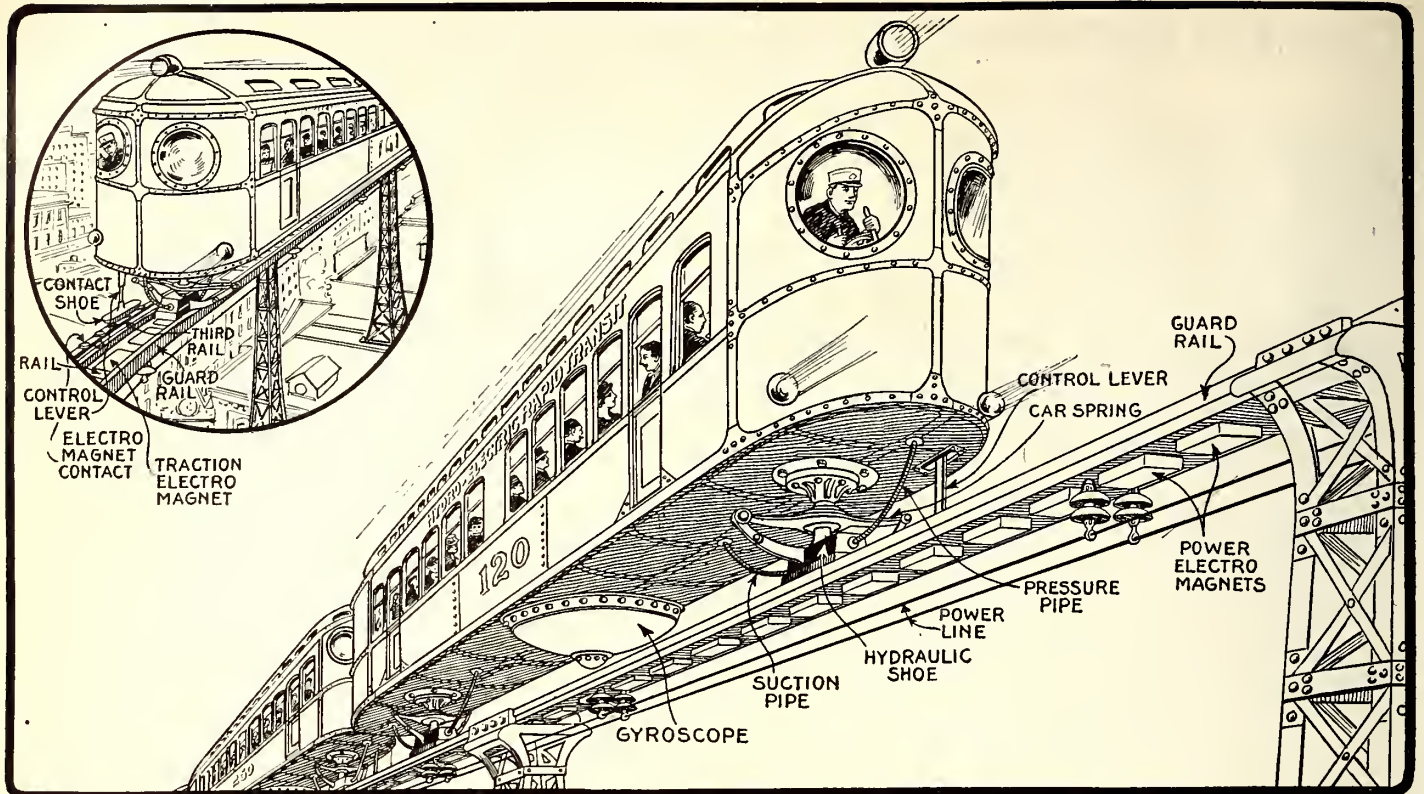

Fig. 5. This illustrates the Propulsion of the Wheelless Gliding Train. The Two Hydraulic Shoes Glide On a Film of Compress Water Squirted from Underneath the Shoes. The water is Recovered by Suction from the Same Shoe so None is Lost. (See Fig. 3.) The Train itself is Kept Upright On a Single Track by Means of a Gyroscope, While the Cars are Propelled by Powerful Electro-magnets, the Contacts of Which are Closed Automatically by the Train as it Moves Along. These Gliding Railroads, Having No Friction, Work so Easily that a Child can Push Along a Car with its Passengers.

## Solving the Transportation Problem

By H. GERNSBACK

### A Railway Which Actually Existed In France

SINCE the advent of the steam locomotive in the early 50's of the last Century, no progress whatsoever has been made as far as speed of our railways is concerned. We are today not riding faster either in our electric or steam railways than our grandfathers did 60 years ago. It is true that we have greatly improved everything else as far as comfort, safety, etc. is concerned, but the speed has not been increased whatsoever. Sixty miles an hour was an everyday occurrence sixty years ago, and was attained by many trains. Today, the average speed of the steam or electrical railways does not approach more than 50 miles.

#### Present Disgraceful Conditions.

What are we to do? In our big cities we are running street-cars on the surface, trains on elevated railroads and down in the subways. The more roads we build, the more acute becomes the shortage of transportation as far as passengers are concerned, and in any big city transportation facilities are always woefully behind the actual demand. In the morning everyone goes to business about the same time and in the evening everyone must ride home—our so-called rush-hours. The density of travel thus become enormous, particularly in cities like New York or Chicago, where conditions, as is well known, are intolerable, and in many cities, disgraceful. If it were possible to operate our railroads with safety only two or three times as fast as they are running now, it stands to reason that everybody would have a seat, an impossible condition now.

We cannot run our trains faster than

they run now without encouraging accidents such as collisions, derailments, etc. As far as the present day railroad is concerned, it is not possible to increase its

**THIS** is the story of a most extraordinary railway which at one time existed in France. Its inventor was killed by the invading Germans in 1870. A railroad that is practical and which has demonstrated its successful operation. It is practically frictionless and can move SAFELY with a speed of one hundred miles an hour. It will be in use thruout the world.

speed at all. There is, however, one solution, an invention which dates back to 1852. we refer to the *Gliding Railroad* which actually had been tried in France, and had



Fig. 1. The Principle of the Gliding Railway. Two Glass Plates are Dipped into Water. The Upper Plate Will Glide with Astonishing Ease. The Two Plates Do Not Touch. A Thin Water Film Separates Them.

been perfected in a small way. At that time, however, many technical obstacles made the project impossible, but all of these objections have now been overcome by new inventions and methods which we will discuss more fully.

#### Principle of Gliding Railroads.

Let us turn to Fig. 1 which gives us the principle of the gliding railroad. Take two smooth pieces of glass, such as are used for photographic plates. Boil them in water, until the gelatin comes off and clean thoroly. Use one large plate and one small plate as shown in illustration. Dip the two plates into water, and place the small plate on top of the larger. It will be seen that the small plate will glide with remarkable ease over the large plate. The important thing to note is that the two plates do not touch. They are supported by a thin film of water, hence the top plate glides on an exceedingly thin water film. As we move the plates back and forth we squeeze out the water little by little, and as soon as the plates touch, the free movement will stop. Were we to drill a hole in the top plate and attach a small tube to it containing water under pressure, we could then for a long time move the plate back and forward with very considerable ease; we would then always maintain a good water film on which our top plate could glide.

Exactly this is the principle of the gliding railroads, first invented by L. D. Girard, a great French engineer. Already in 1852 M. Girard proposed to replace the ordinary railways by means of hydraulic propulsion. He was quite successful with

his first models and in 1854 he conceived the idea to replace the wheels by means of hydraulic skates gliding over flat rails. By means of this method, he did away entirely with all friction for the reason that he interposed between the skate and the track a film of water under pressure. At first M. Girard was using compressed air, but he found that it was necessary to use water under pressure because air did not give satisfactory results.

**Railroad was Actually in Use.**

He actually constructed on his property de la Jonchère, near Paris, such a wheelless railroad which had no locomotive, the cars of the train gliding on a film of water. The propulsion of the train itself was affected by a sort of turbine arrangement whereby a stationary water jet was hurled against stationary vanes mounted under the cars. In other words, the train acted as the stationary part of a turbine, while water jets placed alongside the road, and operating automatically, pushed the train along. This railroad worked very well and actually transported passengers in a limited degree. In 1869 M. Girard obtained a concession from the French Government to run a wheelless railroad line from Paris to Argenteuil. Unfortunately, the Franco-Prussian War in 1870 then broke out and his experimental railroad at de la Jonchère was ruined by the Germans and Girard himself was killed. Nevertheless, the principle had been proven sound by actual practise. There is no reason why with modern methods and improvements it cannot be made a huge success.

In our Fig. 2 is shown one of Girard's hydraulic skates or shoes and its operation. M. Girard's train had two flat rails, and each car had four hydraulic skates or shoes which replaced the usual wheels. Fig. 2 shows three views of the shoe. It will be noted that water pressure is supplied to the shoe which fills the interior fully. As soon as the pressure becomes high enough, it is obvious that the water must escape by raising the shoe clear from the rail, providing enough pressure is used. While the water escapes, it will be readily understood that the shoe itself can nowhere touch the rail proper. In other words, the shoe floats on a thin film of water. If no other means were provided, it can be seen that an enormous quantity of

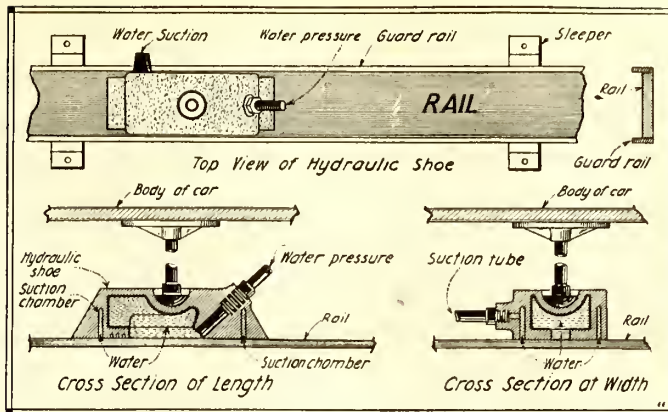

Fig. 2. Showing the Construction of the Hydraulic Shoe in Several Views. The Water is Pumped Into the Shoe Under High Pressure. As the Water Leaves the Shoe, It is Sucked Back Thru the Suction Chambers. The Hydraulic Shoe Cannot Leave the Track On Account of the Guard Rails. (See Upper Right Hand Detail Sketch.)

**No Water Is Lost.**

However, another French engineer, M. Barre had the happy idea to recover nearly all the water, and this arrangement is also

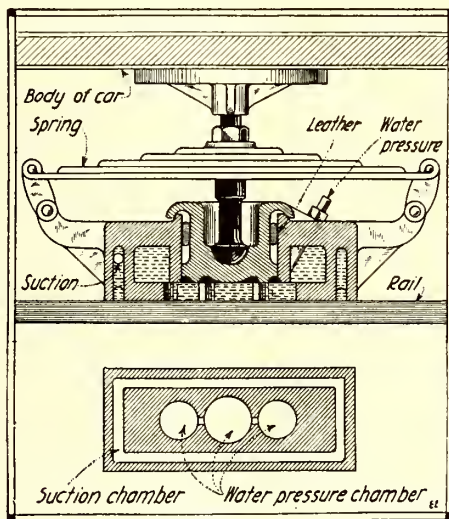

Fig. 3. A Modified Form of the Hydraulic Shoe. It Works Similarly to the One in Fig. 2. Note the Piston Arrangement Which Gives the Train a Feathering, Cushion Effect.

shown in Fig. 2. Running near the edge of the hydraulic shoe will be found an annular suction chamber which is connected to a suction tube. It will be realized that as quickly as the water is prest out from under the shoe, it must pass the suction chamber, and here it is sucked back to the water reservoir of the train to be used all over again. With this ingenious arrangement, it will be readily seen that practically no water is lost except a minute quantity used in wetting the rail, and this loss per train amounts to only a gallon or two per mile, even for a heavy train.

A very important, and as a matter of fact, the most important part of this railway is, that as the cars glide on water they can be made to run with marvelous ease.

**Child Can Pull Train.**

M. Girard already demonstrated that a six year old child could move a standard railway car rapidly over a track, so easily does such a railway operate. The reason is of course that no metal of the train touches the track, therefore nearly all friction is suppress. By actual experiments it has been shown that M. Girard's cars could be moved with a weight one half of one thousandth of the weight of the car. In other words, a railroad car weighing several tons can be pushed along rapidly with an expenditure of a few pounds of energy. The water film itself is of course exceedingly thin, measuring only from one-half to three-quarters of a millimeter. In other words, not much thicker than six sheets of paper on which this story is printed. Nor was the water pressure as high as one might think at first:—10 lbs. per square centimeter.

M. Girard found his greatest trouble in two points. First, he had trouble with his rails at the point where the latter connected. It is of course necessary that a railway of this kind should have an exceedingly smooth metal rail which must not have any unevenness whatsoever. Also where the rails join, it was found necessary to interpose pieces of leather or soft rubber, otherwise the water would squirt out between the rails. Of course, we

would not have this difficulty today because we would simply weld the rails together, making them a uniform piece of metal. This source of trouble, and it was M. Girard's greatest one, would be unknown today. The other great difficulty was to propel the train. **How to Propel Wheelless Trains.**

There was used in Paris at one time an arrangement as shown in Fig. 4. Inasmuch as no wheels are used, and because the hydraulic shoes have no tractive effect themselves, entirely new means must be provided to move the train. The old French idea is shown in this illustration where a rail rack was run all along between the (Cont. on page 336)

Fig. 4. Showing the Propulsion Used in the early French Gliding Wheelless Trains. A revolving Pinion Engages with a Rail Rack, Thus Pushing the Train Along. Illustration Also Shows the Method of Hydraulic Shoe with Comprest Water, and How the Lost Water is Sucked Back.

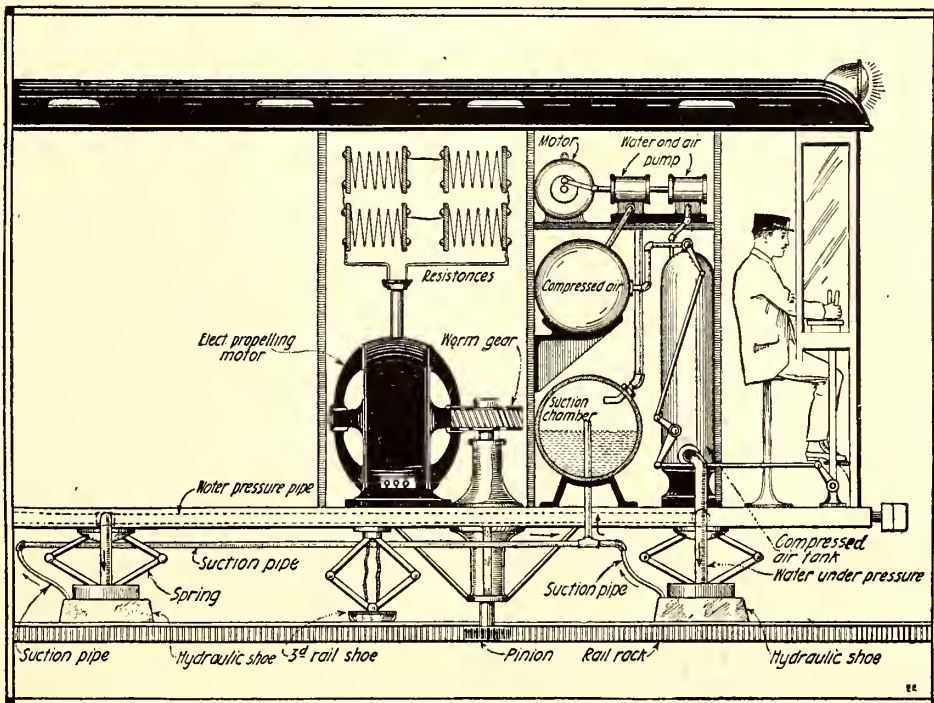

water would be needed to supply the hydraulic shoes, while the train was moving, or even standing still. The water would squirt out incessantly.

# Measuring 1-5,000,000 of An Inch

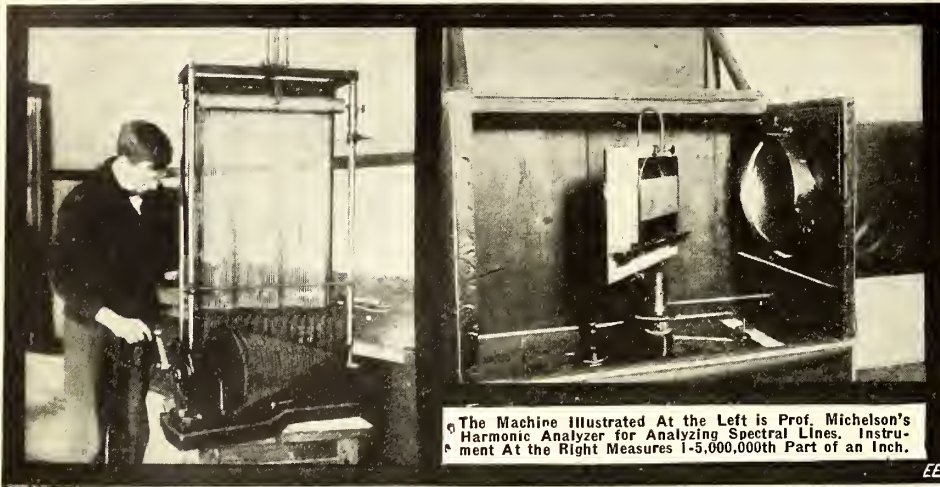

The Machine Illustrated At the Left is Prof. Michelson's Harmonic Analyzer for Analyzing Spectral Lines. Instrument At the Right Measures 1-5,000,000th Part of an Inch.

The wonderfully precise measuring machine here illustrated measures down to 1-5,000,000 of an inch. It was invented by Prof. G. Michelson. Prof. Michelson's grating (on the stand to the left) contains 50,000 parallel, equally spaced lines to the inch.

Precision to the 1/1,000,000th part of an inch has until recently seemed only to be within the realm of ultra-science, as we might say. However, during the war, mechanical precision instruments were improved so markedly that it was quite common, especially in Government ordnance specifications and requirements which called for an accuracy of 1/1,000,000th of an inch.

The photo at left shows Prof. Michelson's Harmonic Analyzer, for analyzing spectral lines into their constituent parts. By means of this device an assistant can do in a few minutes what would require many weeks for a skilled computer.

# Farmers Drive Machinery from Automobile

Herewith is illustrated the latest in automobile power transmitters for driving farm or other machinery. A recent invention of the proprietor of a Colorado machine shop promises to become very popular with farmers who own autos. The invention is an apparatus for transmitting power from an automobile to run the machinery of the farm, but unlike most contrivances of its kind, nothing is removed from the auto, and the auto can be driven off within a minute of the time it is used on this new invention.

The device consists of two four-inch rollers set parallel to each other in a frame and long enough to run the automobile onto them. These rollers are connected by a chain belt, and on one of them is a pulley to run a belt to the machinery. The rollers are locked against turning while placing the auto on the machine, by putting an iron pin thru the links of the drive chain. When the rear wheels of the auto are resting squarely on the rollers, pin is removed and the engine started. This turns the rollers as the wheels revolve, and the belt runs the machinery, the same as any other power would do.

The inventor claims to develop half the rated horsepower of any automobile en-

Here's How to Put Your Henry Ford to Work and Make It Drive Farm or Other Machinery—even Down to Cutting Up Fire Wood. The Inventor of the Automobile Power Transmission Scheme Here Illustrated, Claims to Develop Half the Rated Horsepower of an Automobile Engine on the Belt of the Machine, Which is a Very Good Efficiency Indeed, Considering That the Power is Transmitted by Friction With a Consequent Considerable Loss, Due to Slippage. The Device Comprises Two Four-inch Diameter Rollers, Set Parallel to Each Other, in a Frame Long Enough to Permit the Rear Wheels of the Automobile to Rotate in Contact With Them.

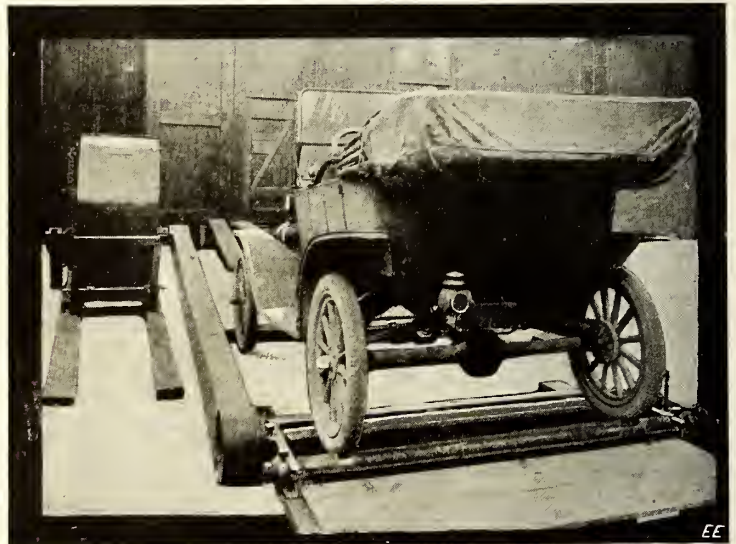

gine on the belt of the machine, which is very good indeed, considering that the power is transmitted by friction only, with

a consequent loss by slippage. The device should find wide favor among farmers everywhere.

# "Movie" Sign Works by Colored Lights



This Picture is not Quite so "Infantile" as it Might Seem At First Glance. Altho the Subject Illustrated Happens to Be, By Painting Two Objects Such as a Hobby-Horse as Here Shown, in Two Different Colors, Say Red and Green, a San Antonio, Texas, Inventor, Richard M. Craig, Has Found That When a Set of Red Lights Are Flashed on the Sign by a Special Electric Flasher Switch, the Red Image Stands Out Plainly; and When the Green Lights Are Lighted and the Red Extinguished, the Green Image Stands Out. By Rapidly Switching the Lights On and Off a "Movie" Effect is Obtained.

One of the latest and cleverest advertising devices is that covered in a patent recently granted to Richard M. Craig of San Antonio, Texas. The inventor arranges two figure positions on the sign, one position of the figure for illumination by red lights and the other by green lights. Next he arranges red and green lights for illuminating the display with a device for alternately switching the current from one set of lamps to the other, the switching device being motor-driven. In the present illustration, we at once perceive that the subject is painted twice in two extreme positions, each position being painted in a different color, such as red for the extreme position and green for the second extreme position. These two positions in red and green under ordinary daylight conditions show plainly, but when they are lighted alternately with red and green lights, then the sign becomes alive and animated, giving a very near approach to a moving object.





Two Views in Paris, Showing the Famous "Camelots" or Street Fakirs, Who Have Here Elected to Tell the Good French People Their "Past, Present and Future" by Wireless. Only it Isn't Wireless!

# Paris Letter

By JACQUES BOYER

**T**HE Parisian "camelot" is more than a street peddler, he is a business man and an actor, sometimes even an acrobat, but always he is a marvelous talker and a humorous entertainer.

A good "camelot" will sell anything on the asphalt of the good town of Paris, be it an old sponge, a pocket-book, a collar button, or ice-cream. We have no intention to give in the following, a history of this so interesting specimen of human being, but we will show, with the help of the photographs here-with, that the renown of the "camelots" is by no means exaggerated and that they keep abreast with the developments of science and are not at all indifferent to the particular trend of public attractions.

These peculiar peddlers, instead of meddling with ordinary merchandise have put the fairy Electricity at work to attract their clients.

Here for instance, one of them detects your thoughts by means of the "Tele-radio"; the other one uses the "Radiograph" to discover the past, present and future.

Of course we don't need to tell you that the instruments which they exhibit have only a very vague resemblance to the ones attributed to Tesla, Marconi or Branly.

Most of the time these apparatus consist solely of a bell connected to a few dry batteries and other formidable appearing scientific apparatus. The answer to the question concerning the past, etc., of the victim, is printed in advance, of course, and glides out of a box by means of a clockwork.

The rest is *camouflage*. *Scientific camouflage*. But some one always falls for the fakes. P. T. Barnum was right. The public wants to be fooled—and gladly pays for it.

**New Electrical Apparatus to Count the Microbes.**

*The Opacimeter.*

This new instrument invented by Messrs. Lambert, Vles, and de Watteville, who have

given it the name of *Opacimeter*, makes it easy to count rapidly the microbes in an emulsion prepared for vaccination purposes. It is composed principally of a photom-

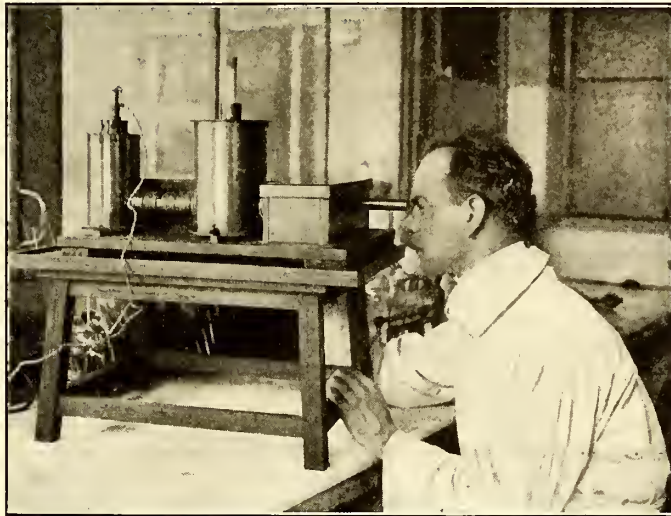

New French Instrument for Rapidly Counting the Microbes in an Emulsion. It is Called an "Opacimeter."

eter made up of two parallel light circuits, coming from one source, the one traversing the phial containing the emulsion, the other subject to a system of dimmers, capable of modifying the intensity of light, after a determined law. The two circuits produce, in the field of an eye piece, two light-spots opposite each other and the other realizes their equal value by adjusting the dimmer system.

A very ingenious system of gauges, lenses and microscopes, the detailed description of which it is not possible to give in this limited space permits the observer to establish with the aid of Spectrophotometric Measures the actual number of microbes contained in the emulsion. The laboratories of the French Army are using the Opacimeter to determinate rapidly and accurately the dose of bacteria to be contained in a vaccinating emulsion.

The Fields of France Are Strawn with "Dud" Shells. To locate them Before Blowing, the Electrical Instrument Here Illustrated Has Been Perfected to Detect Their Presence, Even When Buried Several Feet.

## SHELL LOCATER FOR FRENCH FARMERS.

The shell locating apparatus here illustrated was invented by M. Gutton, Professor of Physics at Nancy, and is akin to one used by surgeons for locating bullets in the body. It consists of two wooden rings each fitted with a pair of electric coils, one traversed by a variable current and the other connected with a telephone. If there is a metal object under the soil in fairly close proximity to the apparatus, the telephone signals the fact; if not, it remains silent. Unexploded hand-grenades are more dangerous than shells, as they are nearer the surface, and liable to burst at the least touch. This apparatus operates on the principle of the Hughes Induction Balance.

The Hughes induction balance is composed of four coils, two in the primary and two in the secondary circuit. When the relative positions of the coils are adjusted correctly, the inductances neutralize each other and no current flows in the secondary circuit. If, however, the slightest change is made in any of the coils, such as by the insertion of any metal object, the mutual induction is unbalanced and a sound is made in the telephone receiver. A detailed description of this device appeared in the February, 1918, issue of this Journal, where a diagram is given of the coil connections.

The secondary coils may be connected in series with a galvanometer or 'phones. An experimenter who has no galvanometer can purchase an inexpensive Weston ammeter. When the shunt has been removed, this will serve as an excellent galvanometer. Some form of interrupted primary circuit is necessary to induce currents in the secondary. An interrupter, mounted on the armature of a buzzer, serves the purpose.



# The "Torpedoplane" and "Sub" Spotter

By GEORGE HOLMES

**T**WO important and novel war inventions are here illustrated and described—the torpedo-carrying seaplane or dirigible, and the microphonic submarine locator, both of these naval warfare improvements being the inventions of an American naval officer, Rear Admiral Bradley A. Fiske.

## Two Revolutionizing Naval Inventions of Rear Admiral Fiske

150 to 200 miles an hour, levels out at 50 feet above the surface, discharges a torpedo directly at the enemy ship at the right

operation is so swift that the enemy has little if any chance of training a gun on the assailant. The "smoke cloud" produced by modern war planes is excellent for this purpose. In one of these attacks a British airman torpedoed and sank a Turkish troopship containing 3,000 troops.

When the idea was first conceived of having an airplane to carry an ordinary torpedo such as is used on the submarine, technical difficulties almost defeated the project, until an American designing firm got hard at work in conjunction with the Air Ministry. The difficulty was not so much of lifting a torpedo as of ensuring that the action of discharging the torpedo be carried out with accuracy of aim and with safety to the pilot. Experiments were carried out in the face of great difficulties and perils.

On the occasion when the initial experiment of discharging a torpedo from an airplane was made, the lightening of the airplane had such a serious effect on the latter that the wings collapsed and the pilot was hurled to sudden death. In another case when the torpedo had been discharged, it hit the water at an awkward angle, and ricocheting over the surface, rose and demolished the airplane, which had not risen out of the way. This discharging of a torpedo was no light risk when the torpedo was of full size, weighing anything up to a ton—three times the weight of the machine in which Blériot first crossed the English Channel.

These wonderful planes can ascend from land or from the deck of a ship, and can descend on the sea and float until help is brought by wireless. When the German fleet surrendered, a seaplane "mothership" with 20 of these machines in its bosom met the Germans 50 miles out at sea, and had any tricks been tried, it would have been simple work for a score of "mystery airplanes" to have leapt into the air and torpedoed the major part of the enemy fleet. This mystery or "cuckoo" airplane—so  
*(Continued on page 348)*

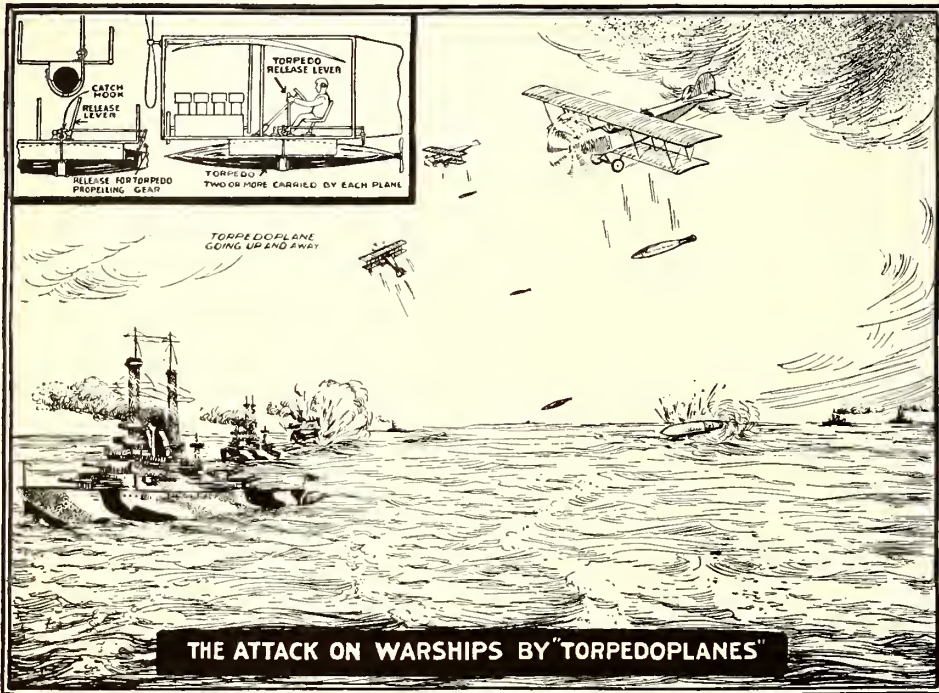

The Naval Engagement of the Future as Rear Admiral Fiske, U. S. N., Sees It. His Powerful "Torpedoplanes" Will Provide New Ways to Repulse Landing Parties and Attack Warships That Are Worrying Naval Experts of Foreign Powers.

The torpedo-airplane or "torpedoplane" as it is called, is a development of the torpedo-carriers, which were first successfully employed in action by the R. N. A. S. at the Dardanelles in 1915, and were subsequently used against us by the Germans in 1917, when they were thus enabled to sink three of our merchant ships off the Southeast Coast. The torpedo carried by the torpedoplanes is of a small size as modern torpedoes go, and weighs about half a ton.

### The Mystery Plane or "Torpedoplane"

The "mystery airplane" was designed to perform from the air more effectively and more swiftly the work formerly allotted to our torpedo-boats. The enemy had devised such successful protection of harbors and ships against our torpedo-boats and submarines that it was only with the gravest risk that we could approach within 30 miles of Kiel and other German fortified ports. But for the newest peril, the torpedoplane, the enemy had no reply.

The news of our discovery of a means of attack that was immune from mine dangers and too swift in its operation to be held off by gunfire reached the ears of the enemy, and is believed, in one quarter at least, to have hastened the Germans in their decision to accept the surrender terms.

Had not hostilities ceased so suddenly these machines would have operated effectively against Kiel harbor and the German warships in their very lair. The efficacy of the weapons will be realized when their operation is explained. One of these mystery airplanes, spying its target, makes a sudden dive from the clouds, at a speed of

moment, after which the pilot pulls back his control stick and disappears into the clouds as suddenly as he appeared. The

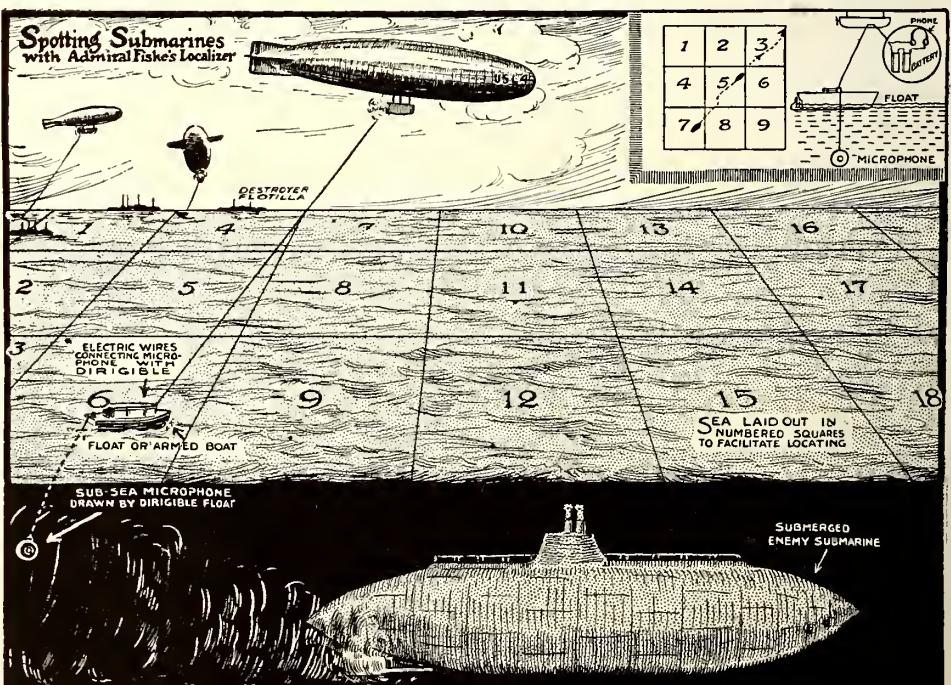

The "Fiske" Submarine Spotter. The "Sub," Once It Is Picked Up by Sound Waves Impinging on a Microphone, Is Trailed Along From Square to Square. The Aircraft Can Attack It With Depth Charges or Signal Instructions to Destroyers.

# Thunderstorm Electricity

By ROGERS D. RUSK, M. A.

Late of the Meteorological Section, U. S. Army Signal Corps.

ONE hundred and fifty years ago the famous Voltaire said: "There are some great lords whom we should always approach with extreme precaution, and lightning is one of them." This is perhaps one rea-

## The Physics of Thunder and Lightning Simply Explained

### How Thunder-Clouds Form.

In a thunder-cloud the almost inconceivably large charges of electricity are often generated in a very short space of time, and sometimes a complete reversal of sign from positive to negative, or vice versa, may occur in a thousandth of a sec-

but this is not necessarily the case. Quite frequently discharges as long as a mile in length will take place in the interior of a single cloud itself. For these reasons it must be explained just what a thunder-cloud is, and how it differs from other

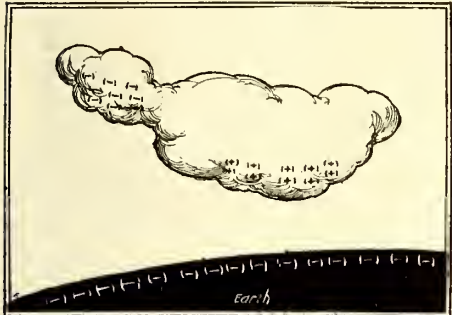

Fig. 1. Showing How a Cloud Is Charged by Electro-Static Induction. The Negative Charge on the Earth Induces an Opposite Charge in the Cloud.

son why we know so little about lightning at the present time, for it certainly is not a very safe subject for close laboratory investigation. For a long time after the electrical nature of lightning was demonstrated by Benjamin Franklin, very little more of any scientific importance was discovered about it, and only today are we learning how the great charges of atmospheric electricity are generated in a thunder-storm. It is a significant fact when we think that a thunder-cloud is the most stupendous and powerful generator of electricity of which we know. A single lightning flash may carry twenty thousand or more amperes at a pressure of millions of volts. Moreover it is Nature's own method, the simplicity of which makes it the more wonderful, for it involves no intricate and complicated machinery. It is not too much to think that the future will sometime see Man harnessing and making use of this tremendous source of energy and bidding it do his will instead of holding it in awe, as he so long has done in the past.

During the war lightning and thunderstorms proved a serious menace to balloonists and aviators, and on this account they were made the subject of special study by the Meteorological Section of the Signal Corps. Their results, in connection with the latest discoveries of scientists in general, are now beginning to throw light on the long hidden mysteries of thunder-storm electricity.

In recent years many theories have been advanced to explain the cause and nature of lightning, but all of them have been more or less vague and indefinite and for the most part they have been unsatisfactory one way or another. Electricity is now recognized as being one of the important factors in the determination of weather conditions, and conversely, weather conditions are very definitely known to determine the electrical state of the atmosphere at any particular time. Sometimes rain produces electricity, and sometimes electrical phenomena cause rain. The place where the two, rain and electricity, are most closely related is in the thunder-storm. Here the rain drops condense primarily about small electrically charged particles called ions, and then again the motions of these particles cause the growth of the lightning charges in a manner to be explained more in detail.

### WHAT TO DO IN A THUNDER-STORM

If you are out of doors in a very severe electrical storm, it is well to observe the following rules for your own protection:

1. Keep away from wire fences. They may carry a dangerous electrical charge long distances. Cattle in pastures are frequently killed thru the neglect of farmers to ground the wire of the fence.
  2. Keep away from hedges, ponds and streams.
  3. Keep away from isolated trees. Oak trees are frequently struck; beech are seldom struck. It is safe in a dense forest.
  4. Keep away from herds of cattle and crowds of people.
  5. Do not hold an umbrella over you.
  6. It is safer to sit or lie down in an open field than to stand.
  7. Drivers should dismount and not stay close to their horses.
  8. Do not work with any large metal tool or implement.
- If you are indoors:—
1. Keep away from the stove and chimney. The hot gases from the chimney may conduct the lightning to and down the chimney.
  2. Do not take a position between two bodies of metal, as the stove and waterpipe, for example. An exception to being near metals is the case of an iron bed. One of the safest places is on a mattress in an iron bed, provided you do NOT touch the metal. The metal surrounding you makes a safe cage, which will prevent the lightning from reaching a person inside.
  3. Do not stand on a wet floor nor draw water from the well or faucet.
  4. Do not stand directly under a chandelier, near a radiator, nor on a register.
  5. Do not use the telephone in suburban districts. In cities there is practically no danger, as the wires are placed underground.

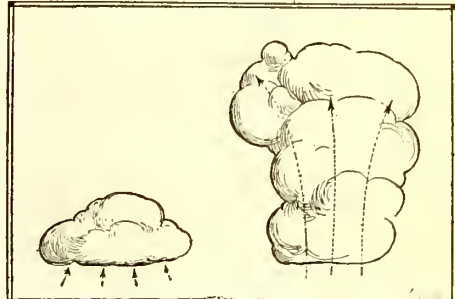

Fig. 2. How a Thunder-Cloud Grows. The Larger Cloud Is the Result of Intense Local Heating and a Strong Up-Rushing Current of Air. Its Height May Be a Mile or More from Base to Top. The Smaller Cloud May Measure Only a Few Hundred Feet in Height.

clouds which seldom carry charges of electricity of any great magnitude, or act in the capacity of electric generators.

Everyone is familiar with the huge rolling, billowy clouds (cumulis) so common on a warm day, but not everyone knows how they are formed. In reality each cloud represents a column of heated air which has risen by convection from the earth's surface, due to the heating effect of the sun, and has carried moisture up with it. When the top of this column has risen to such a height that it begins to cool, and the moisture to condense, the cloud is formed. This may seem unimportant but in reality it is the beginning from which a thunder-storm may develop, if conditions are just right. As moisture in the air does not condense in the form of drops unless there are dust particles or electrically charged particles (ions) in the air to act as centers of condensation, the cloud may already have received a charge from these ions, providing there was a majority of ions of one sign present.

### How Clouds Receive Charge.

A cloud may also become charged by induction. If a cloud which has approached the earth as shown in Fig. 1, is of a form which may divide into two parts, the charge of the opposite sign which has been attracted to that portion nearest the earth may be carried away by it at the time of division, and the other portion of the cloud may carry away a charge of the same sign as the earth. Neither of these two ways in which a cloud may become charged, explains however the production of the enormous charges which are present in a thunder-cloud. These are produced in another way, due to the forces at work when a thunder-cloud is formed.

If the heating is intense and there is much moisture present, when the billowy clouds mentioned above are formed, the result is a thunder-cloud. The process is shown in Fig. 2, where the smaller cloud is the common type visible on most any warm summer day. The larger cloud is the result of intense local heating and a strong up-rushing current of air, and its height may be a mile or more from base to top, while the smaller type may be only a few hundred feet in height. The bulging tops of the larger clouds are the common-

(Continued on page 376)

ond or less. It is usually thought that lightning discharges occur from one cloud to another or from a cloud to the earth,

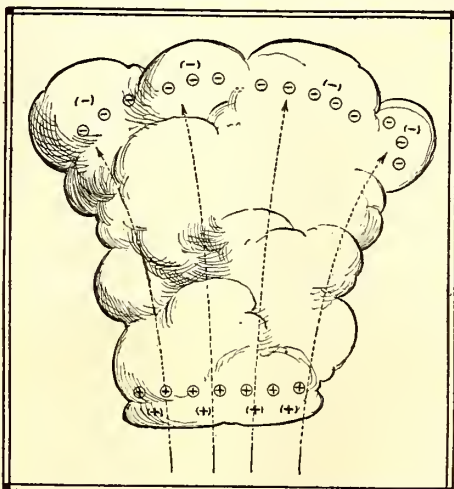
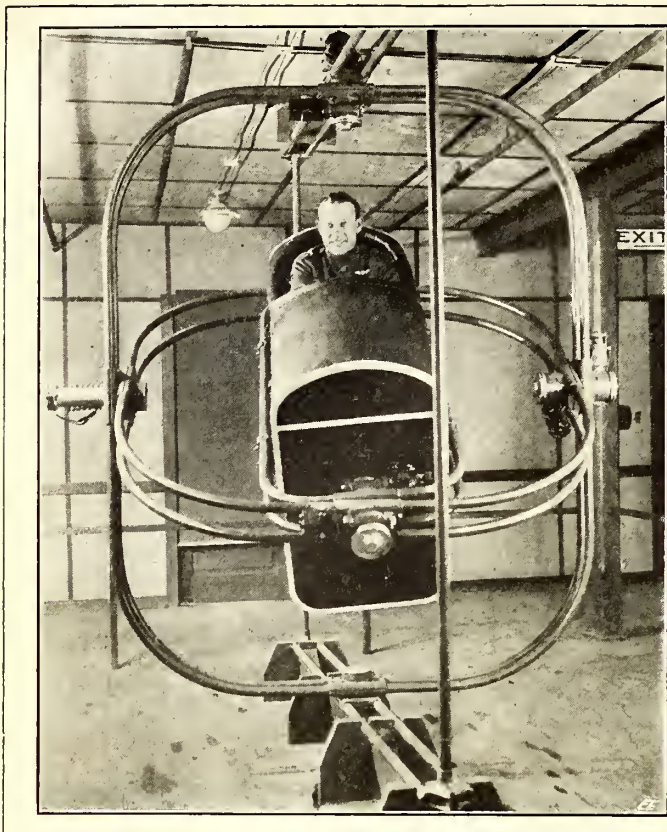

Fig. 3. How a Large Highly Charged Thunder-Cloud Forms by a Continual Shifting of the Oppositely Charged Particles Composing It. The Negative Charges Tend to Move Toward the Top, and the Positive Charges Toward the Bottom of the Cloud.



Above:—The Meissner "Airfone" for Talking Between Pilot and Observer. It Amplifies as Well as Localizes the Speech Waves. At Left:—The Ruggles "Orientator". It is Electrically Operated and Gives All the Thrills of Real Flying.

### "Ground Flying" for Aviators

This machine is used to familiarize the student aviator with the various loops, turns, cuts and dives that every flier must know. One can loop the loop, take a nose dive, make a tail spin and execute the "falling leaf" by simply operating the various electric controls. The invention is now being used with greatest success by the young army officers learning the elements of the flying art at the Army's flying school at Washington, D. C. The Orientator may be controlled by a switch-board at the side but on the floor, so that when desired the instructor may put the student thru various flying maneuvers at unexpected moments.

### How Pilot and Observer Talk

The airfone is a form of speaking tube designed especially for service as inter-communication device between pilot and observer, instructor and student, or any airplane occupants, during full power flight. It consists essentially of a flexible speaking tube provided with a mouthpiece and a neck band, and of a helmet to which two earpieces are attached, suitable connections between the speaking tube and the earpieces being provided. For two-way conversation, two such head gears and tubes are used. Its present design is based on a very close and detailed study of aircraft noise conditions and in the application of acoustics.

## Electric Brush Contains Dynamo

We are all more or less familiar with the various faradic electric appliances such as massage rollers, brushes, et cetera, which can be used in connection with medical coils and the like, but one of the most interesting and withal extremely efficient electric devices recently brought out is the Electrodynamo Brush shown in the accompanying illustrations. It is claimed for this brush that it will rejuvenate the hair, and the makers cite the testimony of experts that it will in many instances help the scalp and also aid in the treatment of a great many ailments. In treating other parts of the body than the scalp, use is made of a flexible conductor and various electrodes which can be quickly attached to the brush. No batteries are required and a powerful current is generated as soon as the projecting finger lever is gently prest. This brush was tested by one of the leading New York electrical testing laboratories, and their report states that it develops an average potential of about 50 volts, and a peak value of from 100 to 200 volts. It is therefore impossible to receive an injuri-



Young Lady Using the Newest Electric Hair Brush. On the Back of This Brush is Mounted a Tiny Dynamo Operated by Pushing the Trigger.

ous shock from this unique device.

A New York physician, Dr. H. J. Lowbringer, expresses his opinion on the electric brush as follows: "This little dynamo is therefore more than a scientific curiosity, because it generates currents of very high voltage with an amperage of infinitesimally low strength; consequently the results of application are similar to one of high frequency current, and thoroly superior to the ordinary faradic battery or the galvanic current, in instances where either diathermic or catalytic results are intended." With this electric brush and the attachments furnished with it, it is possible to give an excellent face massage, the current passing thru the hand of the massager. Also electric foot baths may be taken, or the current, in fact, past thru any part of the body, such as in the treatment of rheumatism, nerve disorders, etc. There is nothing in the device to wear out. The strength of the current may be varied by a regulator on the back of the brush, and it is also controlled by the rapidity with which the finger lever is prest and released. The device is well built.

Application to the Scalp With This Electric Hair Brush is Said to Revitalize the Hair Roots and Tone up the System.

# Inside of a U-Boat

**O**WING to the extent and the manner in which it was used by the Germans to attack commerce, the submarine emerged from the war a rather discredited weapon. This is not to say that it was discounted as a legitimate fighting instrument, and the question is being discust in Allied naval circles as to whether, and to what degree, the type will be included in the plans of naval constructors for the fleets of the future.

An answer to the question has its importance because of the possibility of the peace conference being asked to consider

## Details of Machinery Found in the Surrendered U-Boats

Allies during the war. Altho this was not known until information had been obtained from German sources after the surrender. He also says that the grand fleet, when cruising in the North Sea, was surrounded by a screen of destroyers so intimately placed that it would have been suicidal for any submarine to attempt to penetrate it.

tain a regular submarine patrol off the Horn reef (Denmark), by two or three submarines. By that time, the range of wireless equipment in the British submarines had been increased from 50 miles to 300-400 miles. "It was a vital matter," says the commander-in-chief, "to install efficient wireless apparatus in the only class of vessel that could carry out a watching patrol in the vicinity of German bases."

While, therefore, there are many strong reasons for desiring the abandonment of submarines as they were used by the Germans, yet equally strong is the professional opinion that under-water craft have not

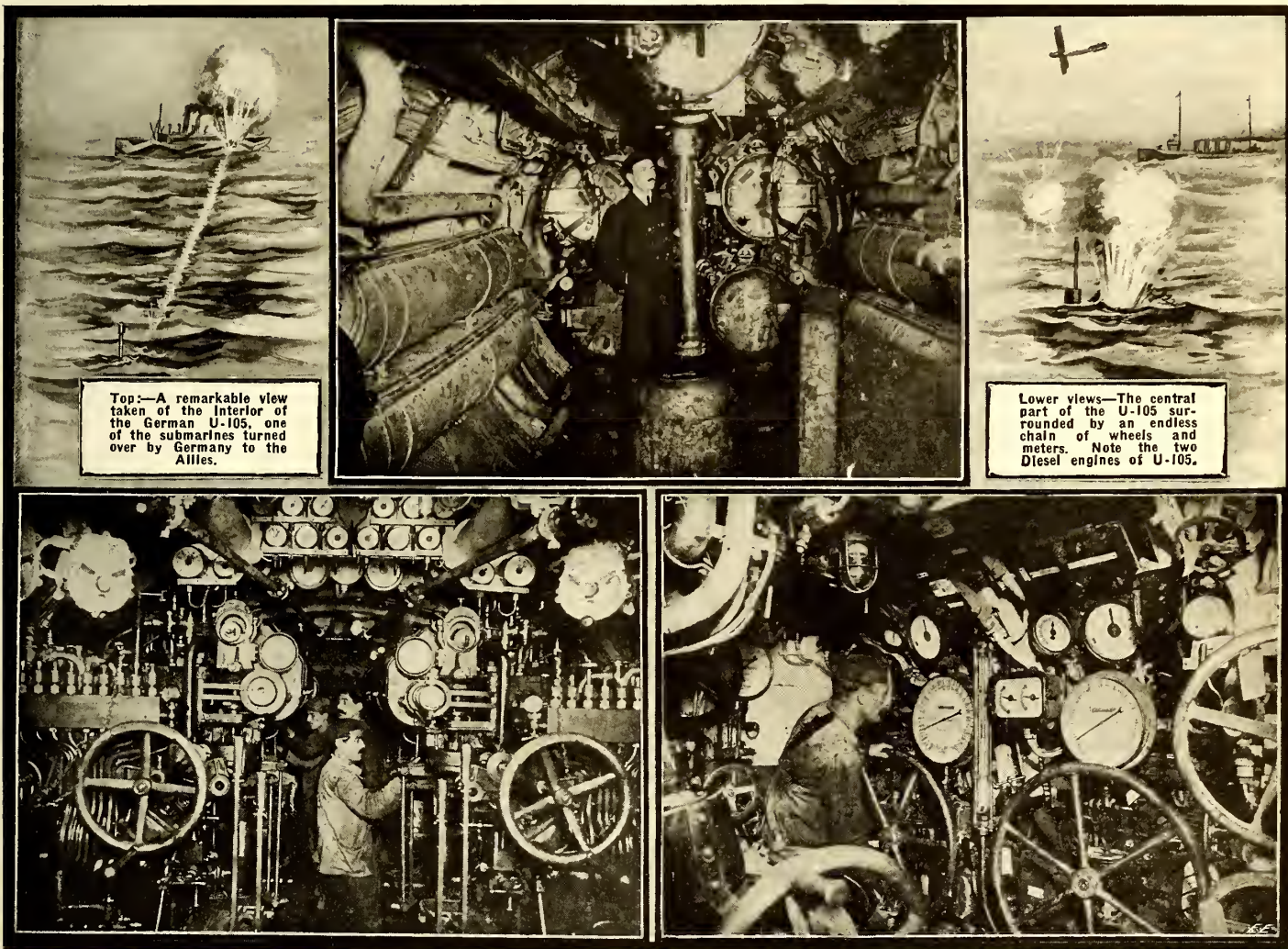

Top.—A remarkable view taken of the interior of the German U-105, one of the submarines turned over by Germany to the Allies.

Lower views.—The central part of the U-105 surrounded by an endless chain of wheels and meters. Note the two Diesel engines of U-105.

Photos © by Underwood & Underwood

the desirability of abolishing submarines altogether. Even if the conference did not touch the matter, it was expected to be one of the first plans for the general reduction of armaments which, in accordance with schedule 111 of the League of Nations covenant, the council would suggest to the member states concerned.

Professional opinion, in all the nations engaged in the war on the side of the Allies, so far as it is confined to the men concerned in the actual fighting, inclines to the view that the submarine was beaten. There have been clear expressions on this point in Britain, America, France, Italy and Japan. Admiral Sims, for instance, declares that 205 U-boats were sunk by the

When such a screen was out, a submarine had to go down and stay down on penalty of being "depth-charged."

Altho the German high command to the end profest faith in the submarine war on merchantmen, Captain Persius has declared since the armistice that this faith was built up on "lies" spread about by the naval chiefs, as to the powers of the U-boats.

### Submarines Have Advantages, Say Naval Experts.

On the other hand a significant indication of the utility of submarines for scouting duty has been afforded by Lord Jellicoe's recent book. He shows therein that not until June, 1916, was it possible to main-

been rendered entirely useless by the inventions directed against them in the war, and that in any case they form a necessary adjunct to any complete naval organization of the future.

What the inside of a German U-boat looked like was a complete mystery to the layman until quite recently when several of the Ex-Kaiser's *unterseeboote* "visited" this country under the guidance of American crews. These sub-sea craft were piloted 3,000 miles across the Atlantic to aid in putting over the Fifth Liberty Loan. The first captured U-boat to reach these waters, flying the American flag, was the U-111. A few days later the mother ship "Bushnell" arrived at New York with several other  
(Continued on page 359)

# Locating Airplanes in Night Fighting

THE photograph herewith of the large Paraboloid reflector with two soldiers standing at either side, and equipt with special head phones, which are connected with the sound detecting apparatus mounted in the central focus of the reflector, is em-

guns, dynamos, motors, gasoline engines, et cetera. The searchlight is mounted on light wheels, similar to small auto wheels, fitted with rubber tires. It can be hauled to any desired spot in a short time.

During the period of the war, many

alone. This new form of locator—the Paraboloid—has several novel improvements over previous apparatus of this type, one of the best features being that it can readily detect the hostile aircraft at great distances, especially valuable when the enemy tries to make a surprise attack at night.

## Spotting the Enemy.

Imagine a peaceful village, such as are numerous in the sparsely settled sections on the coast of England, seemingly defenseless. Yet there seems to be an air of mystery about some of these places—and there is, for thru underhand means, the enemy "spies" learn that secret research work is being carried on in this unassuming little hamlet. It would be suicide upon the part of these "spies" to personally attempt to carry out any large exploitation or even to think of attempting to blow up the place with any hope of success. The nearest recourse that they could have would be to get in touch with a squadron of enemy planes, and notify them where these operations are taking place. On a dark night, these enemy planes issue forth and swoop down, like a nest of hornets, upon this defenseless little village. But one thing they have overlooked. Altho they have come unheralded, it is true, the watchful *electrical eyes and ears* of the engineer corps are prepared for any such surprise, thanks to the fact that they have this marvelous invention on hand, whereby it is possible, no matter how dark the night, to quickly and positively locate the approach of enemy aircraft. To their sensitive ears comes the hum of the engines. Word is flashed to every little town, fort and hamlet within the vicinity, and especially planned advance action is arranged. Ere the fliers have reached their destination, the heavens are being explored by gigantic searchlights for the enemy marauders. Trained gunners, using the very latest types of anti-aircraft guns, are soon popping away at the enemy, and what was hoped to be a great surprise and success on the part of the enemy, turns out to be one grand fizzle, much to his discomfiture.

These powerful searchlights, besides being available for enemy spotting, are also much used as a means of signaling. This is one branch of the signal corps work which has proven one of the big factors in helping to win the war. Searchlights of this type mounted on warships helped to protect the American sea coasts.

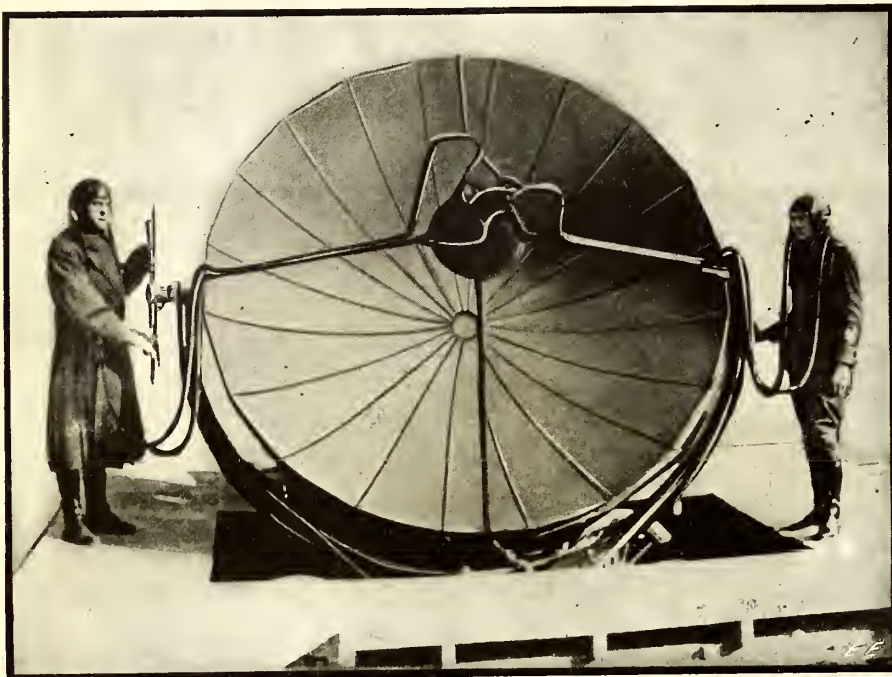

Here is the "Paraboloid"—the Clever Sound Focusing and Detecting Device Used by the Allied Armies in Locating Enemy Aircraft While They Were Yet Several Miles Away. The Sound of the Airplane Engine Carried Far, and by Carefully Focusing the Collected Sounds and Concentrating Them onto a Sensitive Microphone, the Trick was Done.

ployed for locating the direction of approaching hostile aircraft at night. The reflector is balanced and pivoted so that it can be rapidly swung to any angle desired. When the approximate location of the approaching aircraft is determined by means of this sound wave catcher, then powerful searchlights are suddenly flashed on, and their beams pointed in the direction previously indicated by the sound detector. The range of this sound detector, owing to its efficient design, is said to be about  $3\frac{1}{2}$  times that of the unaided ear. It is extremely light and portable, and can be rapidly transported to any place desired.

## Five-Foot Searchlight Added to Terror of Night Fighting.

The accompanying photograph illustrates one of the remarkably light, yet extremely powerful, electric searchlights developed for use in the war. Searchlights of this type were built by the thousand by all of the leading powers, and both sides used them for various purposes, including night battles, the discovery of hostile aircraft, trailing the movements of enemy troops and freight trains, and automobile freight lines.

The searchlight here shown requires about 15 K. W. or 20 H. P. to light it to full brilliancy, and its powerful light will carry from 10 to 15 miles easily. The searchlights that we are usually accustomed to seeing on vessels and in the neighborhood of forts are usually cumbersome affairs, but the exigencies of wartime, where such vast amounts of paraphernalia had to be hauled over by train, horse, or auto-truck, called for the very lightest weight in all such apparatus as these, where there was no real necessity for making such an apparatus of great weight, as is the case with many pieces of machinery, such as

novel and startling inventions have come to the fore, especially means for locating hostile airplanes and dirigibles. The majority of these operate on the simple sound wave principle, the waves being transmitted thru the medium of the air from the propellers of the hostile aircraft. Some of these devices have been made in the form of large tubes, provided with a simple microphone method of detection, but they were rather unwieldy, and to a certain extent never gave full satisfaction, due to the fact that too great a dependence was placed on the amplifying of the hum of the airplane engine by means of microphones

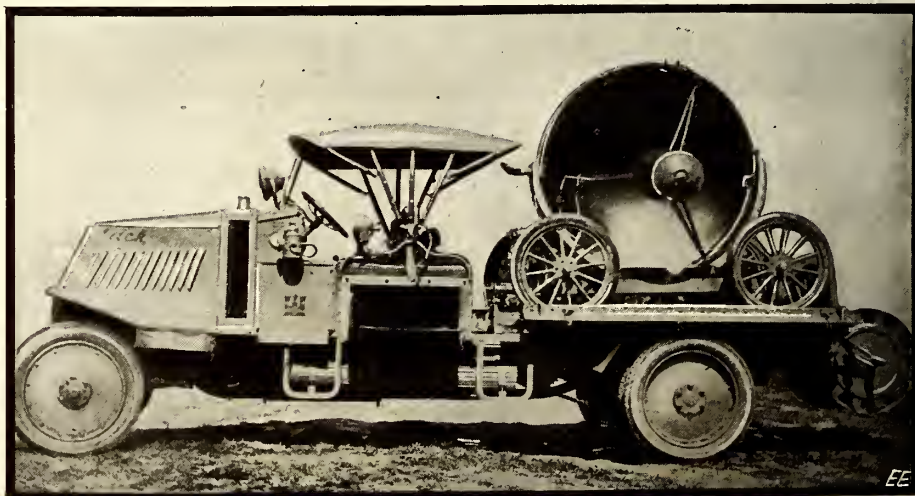

Gigantic Electric Searchlights of the Portable Type Were Used to Expose the Enemy Flier as Soon as the "Paraboloid" Had Succeeded in Spotting Him. The Anti-Aircraft Guns Then "Saluted" Him—and the Allied Planes Finished the Rest.

# Jeweled Portal Welcomes N. Y. Fighters

**N**EW YORKERS, who openly boast "there is nothing new under the sun," had an agreeable surprise in the "jeweled portal" of electric lights erected in Fifth Avenue at Sixtieth Street, on the occasion of the grand review of the Twenty-seventh Division returning warriors. It was designed and erected under the direction of Walter D'A. Ryan, lighting expert.

So magnificent was the illuminated arch that it drew forth the unstinted praise and commendation of everyone who saw it. Frank L. Dowling, President of the Borough of Manhattan, when he first saw the beautiful spectacle, exclaimed: "Like the entrance to Heaven!" And no better description could be given of this handsome testimonial to the bravery, sacrifices and triumph of the sons of the Empire state. The details of the "portal" were worked out by Captain J. W. Gosling, under the direction of Mr. Ryan, who was chief of the department of illumination of the Panama-Pacific International Exposition which took place in San Francisco in 1915, and the success of which became one of the wonders of the world.

Mr. Ryan carried the same style of decoration here as was used at the Panama-Pacific Exposition. The same jewels, to the number of 31,000, were used in this jeweled portal as were used at the Panama exposition. This is really the first time the people of New York had an opportunity to see something that was really new, and it was the second time these jewels were used, the same ones that hung on the tower at San Francisco for one year.

The "Jeweled Portal" is really a gigantic curtain of jewels draped between two obelisk forms, and spans the street at a height of twenty-five feet at its lowest point, and fifty feet at its highest.

The architecture is simple, bold Roman, and is the kind of thing which might have been built on a street in Rome on the return of their victorious legions, but instead of

painted and embroidered banners the modern jewels have been substituted and the whole portal has been given a most modern

dawn or sunset, by illuminating it with arc projectors.

The obelisks stand at either side of the



One of the Most Handsome and Bewitching Electrical Decorations New York Presented to Its Home-Coming Troops. The "Jeweled Portal"—a Mass of Shimmering Cut-Glass Jewels, Illumined by Reflected Spot Lights.

touch by bringing out upon it the delicate flashings of thousands of points of true light, not the color of pigment but the pure colors of the spectrum, the colors only seen in the rainbow, a bubble or in the sky at

roadway and arc flanked by Roman altars, each of which is twenty-six feet high. The jeweled curtain is draped from altar to obelisk across the avenue and down to the  
*(Continued on page 377)*

## Reviving Plants With Electricity

The accompanying illustration shows a clever scheme devised by a Connecticut flower grower for reviving almost lifeless plants, by the application of low-voltage direct current, such as that supplied from a dry or other battery. One of the experiments was tried on a small cactus plant

which had been sent from Mexico, and which seemed to pine away rapidly. The cactus was about dead when the experiment of applying electric current - it was first tried. Two cells of dry battery were connected up with some fine copper wire, the positive pole being connected to a nail

placed in the soil of the flower pot, while the negative pole was secured delicately around the upper branch. The cactus brightened up very sprightly after one week of this treatment, and in two weeks it was plump, green, and growing nicely. Further experiments were tried on a rose bush and a fuchsia with good results, care being taken to see that the positive wire from the battery is applied to the root of the plant and the negative pole to the foliage, so as to promote the flow of sap upward.

It may be thought at first that the battery would soon be exhausted, but the resistance of the plant is of considerable value, so that the flow of current is but a small fraction of the ampere, and the cells will thus give quite a lengthy treatment before being entirely exhausted. Those having access to a storage battery will find it very useful for the purpose. The current in this case should be regulated by means of a small rheostat, such as the rotary, porcelain base 10-ohm rheostats available on the market. Several other interesting experiments were tried by the Connecticut florist, notably on a small plum tree, which was electrically treated with 6 cells, with the result that it blossomed out fully, several days ahead of the other adjacent trees. Another experiment was that conducted on an ever-bearing strawberry plant, which was treated with 2 dry cells. This plant was left in the same row with other berry plants, and its increased size and fruit production was very striking.

Reviving Weak or Stunted Plants with the Small Current from a Few Cells of Battery is the Latest in Science. Anyone Can Do It. The Apparatus is Simple, and the Only Thing Necessary to Watch Closely is That the Polarity is Correct. The Positive Pole of the Battery is Always to Be Connected to the Root of the Plant and the Negative to the Foliage.

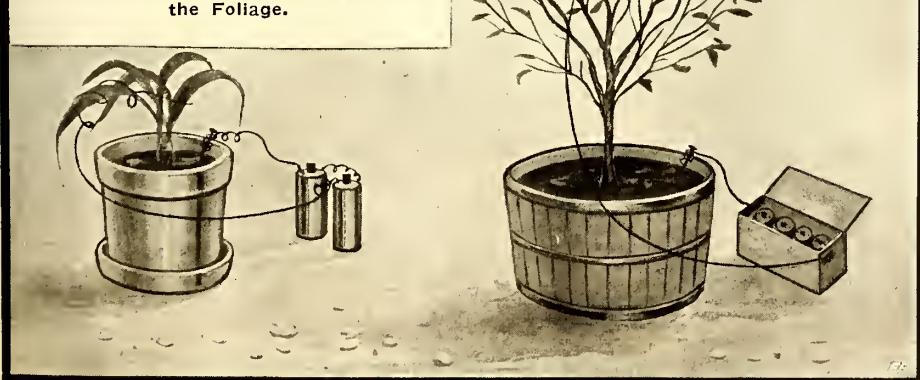

# Popular Astronomy

By ISABEL M. LEWIS

Of the U. S. Naval Observatory

## The Nature of Comets

COMETS, along with shooting stars and meteors, are to be classed as part of the debris of the solar system. According to prevailing theories they may have been originally tenuous outer portions of the primitive solar nebula that escaped being swept up by the nuclei of the planets and their moons owing to the fact that they did not share in the general rotation of the system, or they may, possibly, have been the lighter gases ejected from one or the other of two closely approaching suns that furnished, by the disintegration resulting from their close approach, the material wherefrom our present solar system was formed.

The orbits of comets are inclined at all angles to each other and to the orbits of the planets which, on the other hand, lie very nearly in the same plane.

The larger members of the sun's family, the planets and their satellites, revolve from west to east around the sun. Comets on the contrary frequently *retrograde* or back around the sun in the opposite direction, from east to west.

The paths that these erratic visitors follow in their journeys around the sun bear not the slightest resemblance to the paths of the planets, which are almost perfect circles. The cometary orbits are ellipses of such high eccentricity that it is customary in computing a preliminary orbit of a comet to assume that its eccentricity is unity, *i. e.*, that it is travelling in a parabola. If the eccentricity is less than unity the orbit is a closed curve or ellipse, and if it is greater than unity the orbit is an hyperbola. In the latter case the comet would make one and only one visit to the sun, coming from interstellar space and returning thereto after a brief sojourn within our solar system. Since no cometary orbit has ever been found to be hyperbolic in form it has been assumed that the eccentricity of the orbit is less than unity in all cases and that the comets are all travelling in elliptical orbits and therefore are permanent members of the solar system. The nearer the eccentricity of the orbit of a comet approaches to unity the greater is the path described and the less frequent the comets return to the sun. Since it is very unlikely that the eccentricity of an orbit is exactly unity there are probably no comets that have parabolic orbits tho, for the preliminary computation of the orbit of a newly discovered comet the unknown eccentricity is assumed to be unity. This is generally a safe assumption for the majority of all comets travel in ellipses whose eccentricities approach closely to unity and their periods of revolution around the sun consequently run into the hundreds or thousands or even hundreds of thou-



Giacobini's Comet, December 29, 1915, Photographed with 10" Bruce Telescope, Yerkes Observatory, by E. E. Barnard. Note the Unique Sharply Defined Tail With Convex Edges. The White Dashes Are Stars Leaving a White Trail on the Photographic Plate as the Telescope Followed the Comet During Its Exposure of Several Hours.

sands of years. A wonderful study, indeed.

Donati's comet of 1858, one of the greatest comets of the nineteenth century, had a period of more than two thousand years and its aphelion (the point in its orbit farthest away from the sun) was five times more distant than the orbit of Neptune.

There is, however, a class of comets known as *periodic* comets that are characterized by extremely short periods of revolution around the sun. To this class belongs Halley's comet whose period of seventy-five years exceeds that of any other periodic comet. Encke's comet, on the other hand, has a period of three and a third years which is the shortest cometary period known. Most of the periodic comets are inconspicuous and only visible tele-



Halley's Comet, June 6, 1910, Photographed at the Yerkes Observatory by E. E. Barnard, Taken With 10" Bruce Telescope, Exposure Two Hours. The Most Remarkable Part About This Comet Is That It Disintegrated. Photograph Shows Upper Part Leaving Main Section

scopically even when comparatively near to the earth. Halley's comet is the only one of this class that lays any pretensions to remarkable size or brilliancy and it also is showing the effects of disintegration resulting from too frequent visits to the sun.

Comets are bodies of *great bulk* or volume and *small total mass*. Their tails, which only develop in the vicinity of the sun, are formed of the rarest gases and the best vacuum that man can produce would not be in as tenuous a state as the material existing in the tails of comets. There are many proofs of the extreme tenuity of comets. The earth has on a number of occasions past directly thru the tails of comets without experiencing the slightest visible effects. Stars shine undimmed in lustre even thru the heads of comets. If the earth should encounter a comet "head on" it is doubtful if it would experience anything more serious than a shower of meteors which would be consumed by friction with the earth's atmosphere. It is possible, however, that matter in the nucleus, the star-like condensation in the head of a comet, may consist of individual particles weighing in some instances a number of tons surrounded by a gaseous envelope and held together by the loose bonds of their mutual attraction.

Since the total mass of a comet is so small a close approach to one of the planets, especially Jupiter, produces great changes in the form of the comet's orbit tho the motion of the planet is not disturbed in the slightest degree by the encounter.

The majority of all the periodic comets have been "captured" by Jupiter, that is, the original orbits have been so changed by the perturbations produced by close approaches to the giant planet that their aphelia lie in the vicinity of Jupiter's orbit. Several of the other planets have also "captured" comets in this sense, and the fact that the aphelia of a number of comets are grouped at certain definite intervals beyond the orbit of Neptune has been considered by some astronomers to be an indication that there are two or more additional planets in the solar system revolving around the sun at these distances.

The most interesting feature of a comet is its characteristic tail which develops and increases in size and brilliancy as the comet approaches the sun. As the tail is always turned away from the sun it follows the comet as it draws near the sun and precedes as it departs. Its origin is due, it is believed, both to electrical repulsion and *light pressure* acting upon minute particles of matter in the coma or head of the comet.

It is believed that the curvature of the tail depends upon



the nature of the gases of which it is composed.

Long, straight tails consist chiefly of hydrogen, it has been found, curved tails of hydrocarbons and short, bushy tails of mixtures of iron, sodium and other metallic vapors. At times the same comet will have two or more tails of different types.

Since the material driven off from the nucleus or head of a comet by electrical repulsion and light pressure is never recovered, it is evident that comets are continually disintegrating. Also, comets that have past close to the sun at perihelion passage have frequently been so disrupted by tidal forces that one nucleus has separated

into several parts and the newly formed nuclei have pursued paths parallel to the original orbit, each nucleus developing a tail of its own.

Many periodic comets, it is now known, have gradually been broken up and dissipated into periodic swarms of meteors as a result of the disruptive effect produced by too frequent returns to the vicinity of the sun.

The luminosity of comets is due not only to reflected sunlight, but to certain unknown causes that produce sudden and erratic increases or decreases of brilliancy. The causes of these sudden changes in luminosity are unknown, possibly electrical discharges or chance collisions between fragments of considerable size may account for some of these sudden flashes of brilliancy.

The peculiar behavior of the tails of comets at certain times has frequently been noted and suggests the existence of quantities of finely-divided meteoric or gaseous matter within the solar system that have no appreciable effect upon the huge plan-

etary masses, but offer sensible resistance to the passage of the tenuous gases of which the tails of comets are composed. The fact that the earth daily encounters meteoric dust, meteorites and fire balls also

seen with the naked eye.

Since comets as well as planets obey Kepler's first law, known as the law of areas, and sweep over equal areas in equal times it is evident that when a comet is at perihelion or nearest to the sun it is moving at maximum speed and when it is at aphelion or farthest from the sun it is moving at minimum speed. Moreover, its speed at these two points in its orbit varies tremendously since the orbits of comets are ellipses of very high eccentricity. The speed with which the planets are travelling is, on the other hand, remarkably uniform since their orbits are nearly circular.

The leisurely speed with which a comet travels thru the frigid outer regions of the solar system is gradually accelerated as the comet draws nearer and nearer to the sun until it has acquired near the time of perihelion passage a velocity that occasionally exceeds two hundred miles a second. Here, also, the great increase in light and heat and the strong magnetic field of the sun produce complex changes in the gaseous and meteoric substances of which the comet is composed until the character-

(Continued on page 350)



Daniel's Comet, August 6, 1907, Photograph Yerkes Observatory by E. E. Barnard. This Photograph Shows the Full Length of Tail About 12°, Taken With 3" Lens.

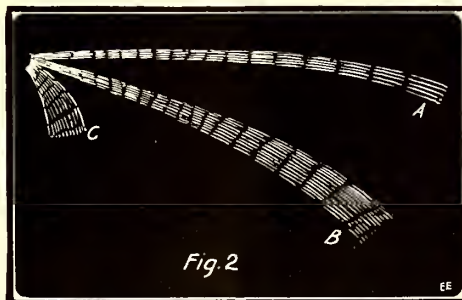

Different Types of Tails of Comets. A—Hydrogen; B—Hydrocarbon Gas; C—Iron and Other Metallic Vapors. The Majority of the Tails of Comets Belong to Type B and Are Therefore Chiefly Composed of Hydrocarbons.

indicates that meteoric matter exists in considerable quantities within our solar system. Tails of comets appear at times to be twisted or brushed aside as if they had encountered some unknown force or some resisting medium.

Up to the present time several hundred comets have been discovered. Nearly three-fourths of this number travel in orbits that are sensibly parabolic with eccentricities approaching closely to unity. Of the remaining number there are about forty that have been "captured" by the major planets, Jupiter, Saturn, Uranus and Neptune, tho Jupiter possesses the lion's share of these captured comets. Scarcely a year passes by that several comets are not discovered. Most of these are telescopic, however, even when they are near the sun and at their greatest brilliancy. Naked-eye comets of great splendor and brilliancy are comparatively rare and there has been a particular dearth of such unusual comets during the past thirty years or so.

The last spectacular comet, unless we make an exception of Halley's comet, which made its return according to prediction in 1910, was the great comet of 1882 which was visible in broad daylight close to the sun and at its perihelion passage swept thru the solar corona with a velocity that exceeded two hundred and fifty miles a

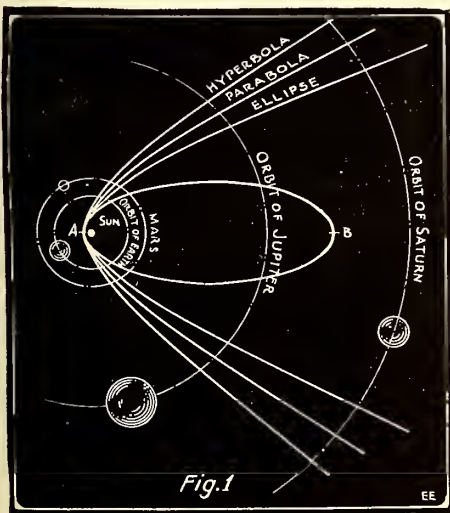

This Diagram Shows a Typical Cometary Orbit of Short Period. A Marks the Perihelion, or Closest Approach to the Sun, and B the Aphelion, or Point Most Distant From the Sun. The Great Difficulty of Determining Whether a Comet of Long Period Is Moving in an Ellipse, Parabola or Hyperbola Is Evident When One Considers How Closely the Three Curves Coincide in the Vicinity of the Sun.

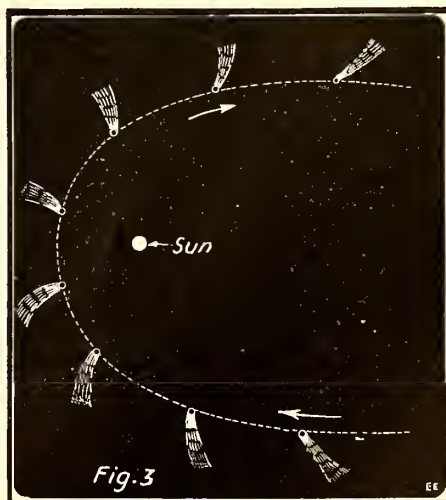

How a Comet Behaves at Perihelion (Closest Approach to Sun). The Tail of a Comet Is Invariably Directed Away From the Sun, No Matter What Its Position in the Heavens.



# Experiments in Physics

By JOHN J. FURIA  
DEPARTMENT OF PHYSICS, N. Y. UNIVERSITY

## 1--Perpetual Motion

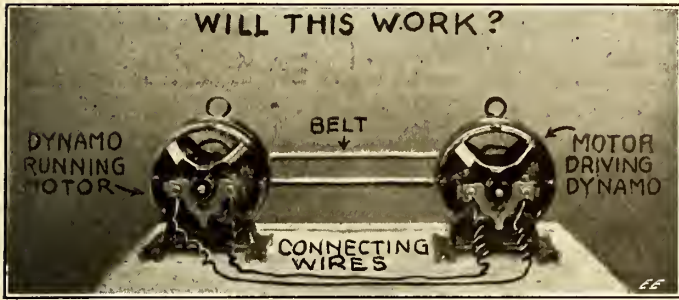
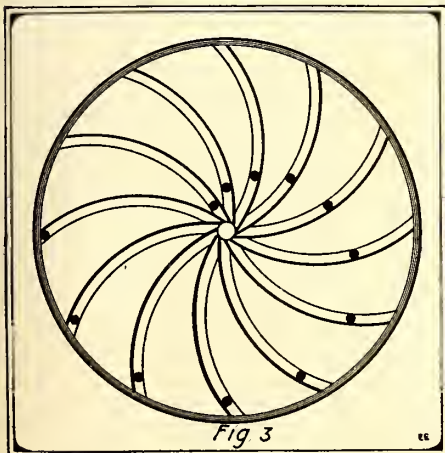

Fig. 5. The Electrical Student's Dream: Belt a Dynamo and a Motor Together. Connect Their Windings Electrically and—Presto! You Have Perpetual Motion! But Do You? Read On, Macbeth, Read On!!

IT is a well known fact that more Time, Energy and Money have been spent and wasted in searches for a machine capable of producing *Perpetual Motion* than for all other scientific pursuits combined. The impossibility of perpetual motion can be demonstrated by the simple elementary laws of Mathematics and Mechanics, and consequently the *truly* scientific mind wastes no time in such a search. Perpetual motion is a direct violation of that fundamental law of Physics, the law of *conservation of energy*; hence in order not to waste time in argument with a perpetual motion inventor, to show him the fallacy in his reasoning (?) one has but to say "it contradicts the law of conservation of energy." The U. S. Patent Office has a sure-fire means of disposing of these would-be inventors—it asks them to produce a working model! That settles it, for if the inventor cannot make the proposed scheme work, who can?

Perpetual motion and perpetual motion machines are defined in many ways, all the definitions conveying the idea of *getting something for nothing, indefinitely*. The getting something for nothing idea, of course, will appeal to the general public ignorant of science, and the natural consequence is "swindling schemes." One definition is—a perpetual motion machine is one which will go on moving without assistance from any external force, except possibly gravity, until the parts of which it is made wear out! The inventor usually



See the Little Balls in the Hollow Spokes of This Wheel? Their Constantly Changing Center of Gravity Was Supposed to Keep the Wheel Revolving—Only It Didn't!

being backed up by publicity specialists). A glowing account of the operation of the machine before a distinguished audience from "Podunk" would appear, together with front page photographs of the machine and of the handsome and distinguished looking inventor—who always spent a life-time and several fortunes in

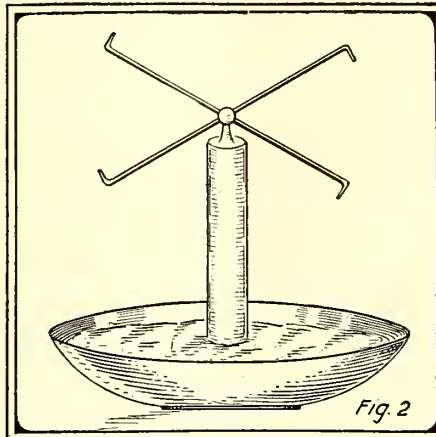

It Should Go on Forever, They Say—This Hydrostatic Marvel. The Atmospheric Pressure of 15 lbs. per sq. Inch on the Water in Bowl Forces it UP Thru the Revolving Arms. The Water Shoots from the Nozzles Back Into the Bowl—Ad Nauseam.

perfecting the ninth wonder. The inventor having spent all his money and all he could borrow would therefore be willing to *sacrifice* a major share in his invention for a few thousand dollars, and some fortunate young heir or widow would perchance acquire an expensive education. Nowadays, if an account of a perpetual motion machine should appear in the papers, some secret service men would keep in touch with the "benefactor to mankind" and in a short time, or as soon as his "gilt edge stock" began to sell, said benefactor would shortly rest behind prison bars.

The first class of machines is of considerable interest. Most of us have at some time or other spent much time in thinking up perpetual

adds that his machine will evolve more power than is required to run it. The efficiency of such a machine would therefore be *greater than 100 per cent.*! Perpetual motion machines fall naturally into two classes—the *absurd class* and the *frauds*. The second of these classes hold no interest for us scientifically. In general a perpetual motion machine would be invented (the inventor being backed up by publicity specialists). A glowing account of the operation of the machine before a distinguished audience from "Podunk" would appear, together with front page photographs of the machine and of the handsome and distinguished looking inventor—who always spent a life-time and several fortunes in

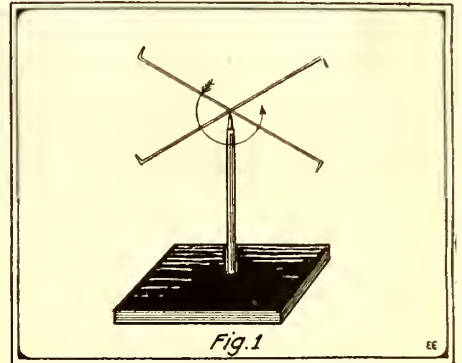

The Static Electric Motor. A Metal Wire Cross with Pointed Ends Pivoted on an Insulated Upright. Connect It to a Static Machine, Fig. 6, and You Have Perpetual Motion—Perhaps?

motion machines and still more time in trying to fathom the reason why our schemes *would not work*. Which one of us has not at some time or other hooked up a small toy dynamo and motor with the intention of causing the dynamo to supply current to run the motor and some lights, bells, trains, etc.—while the motor in turn, belted to the dynamo, drives the latter machine. See Fig. 5. What a great disappointment it was to find that the scheme wouldn't work. To be sure, on connecting the hand drive to the dynamo, we get enough "juice" from it to run our motor and our lights and other things. Also we can run our motor from some cells and by belting cause the dynamo to run. Why then does our perpetual motion machine fail us? The answer is simple—the *law of conservation of energy*. Let us assume that our motor and dynamo were identically made and practically frictionless. The machines of Fig. 5 are of this type. A current of 1/10 ampere is used by each when acting as a motor, at a potential of 10 volts; therefore, 1 watt of power is consumed. Since the efficiency would have to be less than 100 per cent., due to friction and eddy current losses, etc., then when acting as a dynamo *less* than one watt power is given off. Hence one of the machines *can never be made to run the other, let alone do other work besides!*

Another electrical type of perpetual motion machine familiar to most of us depends for its operation (or rather for its failure to operate) on the action of points.

(Continued on page 377)

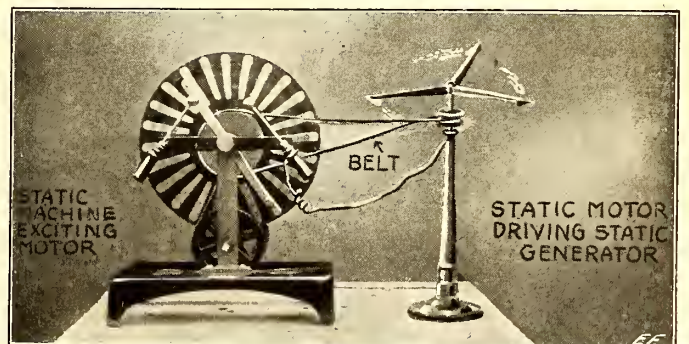

Fig. 6. An Electro-Static Nightmare! The Static Machine Charges the Motor—the Motor, Thru Its Belt, Drives the Generator! Quick, Watson, the Needle.

# \$50.00 Prize Contest

## Uses for Old Phonograph Records

**N**OT so long ago we ran a "Burnt-out Lamp Contest" giving prizes for the best ideas what to do with the old burnt-out lamp globes. Thousands of suggestions were received from every part of the world, and we all had a lot of fun. We publish the best ideas and we know that many of them are now actually being used daily.

Your average experimenter is happy only when he can take a lot of antiquated old "junk" and put it to a new use—he'd take an Egyptian mummy and convert it into a rotary spark plug, if it were possible!

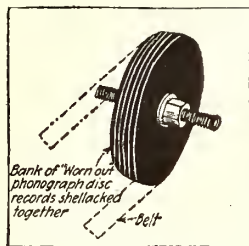

Want a Small Belt Pulley? Procure a Few Old Phonograph Records, Shellac Them, Place in a Vise Until Set, and You Have a Fine Pulley.

So the other evening when we stumbled over a lot of old phonograph records that had been played so long that they would "phono" no longer, we said—Ah, what can we do with them? Too good to throw away! So we think awhile and ended by making a fine Wimshurst static machine, using two plates to generate the juice. Of course that's old stuff, every "bug" knows that trick.

But we felt we had stumbled into a veritable gold mine. Now we admit that our editorial think-tank becomes clogged up once in a while, so we thought we'd put it up to EXPERIMENTER readers—they have us beat forty different ways as a rule. True, in our younger days ye Editor once made a very serviceable pulley by shellacking eight, old, cracked 7" disks together which made a pulley about one inch thick, and which did gallant work. True, that he also once made a rotary variable condenser from a dozen 10 cent records (tin foil shellacked to one side of the records). True, also, that he once constructed an emergency rotary



spark gap using two 7" records shellacked together with zinc plugs screwed to the face of the records—but really all such stunts are commonplace.

Of course you can do much better than this. Somewhere there is a "bug" who will turn in a really good idea. And we're out to find that "bug." Yes it will cost us \$25.00 for that prize idea, but we think it will be cheap at that.

Now, then, boys, let's see how much ingenuity there is around. I promise you lots of fun and your fellow-bugs will bless you for generations, because your ideas will be of tremendous value to them.

Now listen!

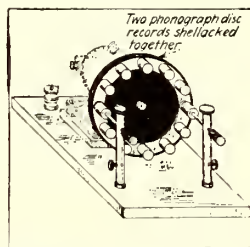

Rotary Spark Gaps Are Quickly Made From Old Phonograph Record Discs.

### OLD PHONOGRAPH RECORD CONTEST.

This contest is open to every reader whether subscriber or not.

These prizes will be paid by the publishers of the ELECTRICAL EXPERIMENTER for the best useful ideas what to do with old phonograph records.

The two important conditions are that the idea must be a useful and original one. It is not necessary that the record or records be used with electrical devices, any use is satisfactory as long as the resulting device is useful and, of course, therefore practical.

Any amount of records, and any and all sizes can be used. Records can be sand-



Two Old Phonograph Records Make a Good Static Machine, When Drest Up a Little With Some Tinfoil Sectors, and Then Rotated in Opposite Directions.

papered, turned down, bent in hot water, etc., it matters not, as long as they are actually used. The final shape does not matter.

We shall try and award the prizes to those who actually have built or made the device which they describe. Therefore those contestants sending actual photographs of the ideas stand a better chance to win a prize.

Description is limited to 200 words. Use one side of paper only. Use ink or typewriter. No pencilled matter considered. Sketches must be on separate sheets of paper.

Contest closes in New York, September 15th. Prize winners will be announced in our November issue.

Address all letters, photographs, etc., to: Editor: "Old Phonograph Record Contest."

## Airplane Parachute a Success

Lieutenant Jean Ors, of the French Army, demonstrated the usefulness of his "aerial life preserver" recently at Atlantic City. This device is an adaptation of the parachute to airplane use, and toward the end of the war was widely employed by the Allied armies, greatly reducing the mortality when machines were shot or caught fire. The test of the device was before a committee of American and foreign experts, and after Lieutenant Ors had proved the worth of the life preserver, he received a special prize of \$500.

The aerial device, contained in an oil-cloth packet, is only fifty inches in diameter and four inches thick. It weighs about fourteen pounds. For the test it was affixed to the underbody of the airplane with a rope running into the cowl, so that the lieutenant could make the release at the proper moment. When it was in place "Eddie" Stinson, America's leading fancy flier, tuned up his craft and he and the Frenchman hopped in.

Stinson and his passenger rose well

above 1,000 feet, and swinging in a giant circle made two trips around the airport. Then, dipping down to about 500 feet, Stinson ran his machine southeast, directly into the wind, so that the parachutist could gage his distance. As Stinson shot in a 200-yard spurt at eighty-mile speed, the watchers saw the lieutenant crawl cautiously over the cowl of the machine, poise there a second, and raise an arm as he ript the fastenings of the parachute, and then plunged earthward from the streaking airplane.

For the fraction of a second he was enveloped in the smoke of the exhaust. Then he came hurtling at the field. Quick as a flash the life preserver opened, the fall of the Frenchman being checked without perceptible shock within fifty feet after he made the jump. Slowly the widespread white silk umbrella, with the army officer dangling at the end of the ropes, swung to earth, the landing being as gentle as the arrival of a raindrop. The descent was made in forty-six seconds.

### In August "Radio Amateur News"

Radio-telephoning from Your Auto  
By A. H. Grebe

A 15,000 Cycle Radio Frequency Alternator for Radio-Telephone Work  
Construction of An Audion Control Panel

Multiple Conical Loose Coupler  
By John G. Merne

Loop Antenna and Direction Finders for Amateur Use  
By David S. Brown

Low Potential Radio Frequency Arc  
By Charles W. Noller

Is the Antenna Doomed?  
By E. T. Jones

Developments in Wireless Telephony  
By Dr. F. B. Jewett

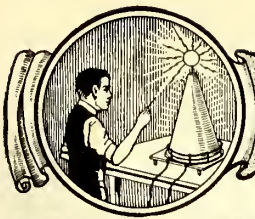

# THE CONSTRUCTOR

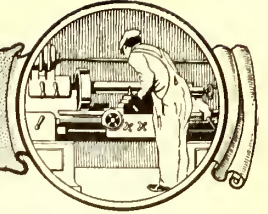

## How to Make Photo-Micrographs

By G. D. LAUDERMILK

**B**IOLGY being one of the subjects in which I became interested, and having fitted up a small laboratory, I found that I required a photographic attachment which could be used in connection with a small microscope. So I

finally evolved one made in the following manner:

The camera was made in two parts; "A," the plate holder, is a shallow box 6" long, 4" wide and 1" deep. The top of the box is hinged and the interior of the plate holder has a depression of a size to take a No. 320 Premo film-pack. It is modeled after the plate holder of a Premo camera. The camera box is 5" deep, 3" wide and 4 3/8" from front to back. The camera has a strip 1/2" wide around it, 1/4" from the top, forming a shoulder upon which the plate holder rests when in place; both the edges of the plate holder opening and the rim above the shoulder are covered with black velvet, forming a light-proof joint.

In the center of the opposite end is an opening 3/4" in diameter closed by a simple sliding shutter made of sheet metal. Both the plate holder and the camera box are covered with imitation leather and are constructed of light wood. The hood "C" is of black cloth and serves merely to confine the draw-tube and prevent leakage of light between the eye-piece and the opening in "B." At the base of the upright is a wooden form exactly of the same shape as the foot of the microscope. This form is so placed that it acts as a guide to keep the microscope in position with the eye-piece.

When photographing, the slide is placed on the stage in the usual way and focust so that all details are brought out sharp.

The microscope is then placed in position, the hood drawn around the eye-piece and fastened with a hook and eye. The shutter is now opened and the exposure made. The length of exposure will vary with the degree of transparency of the object and the depth of staining. Thin clear objects or objects stained with methyl-violet or blue

(Continued on page 356)

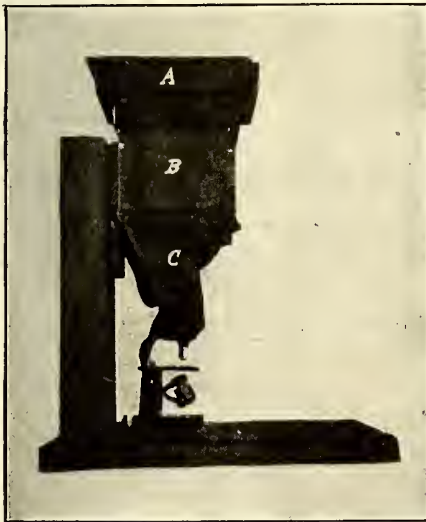

The Apparatus Used in Making Photo-Micrographs, Comprising a Home-made Camera for Holding Plate Holder or Film Pack in Proximity to Microscope Eye-piece

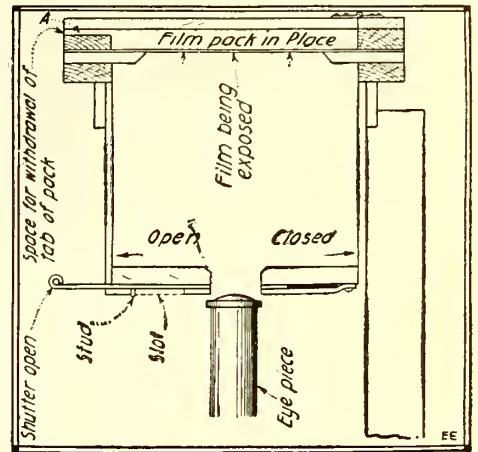

Drawing Showing Sectional View Thru Camera and the Arrangement for Holding the Film Pack or Plate Holder, in Position Over the Microscope Eye-piece

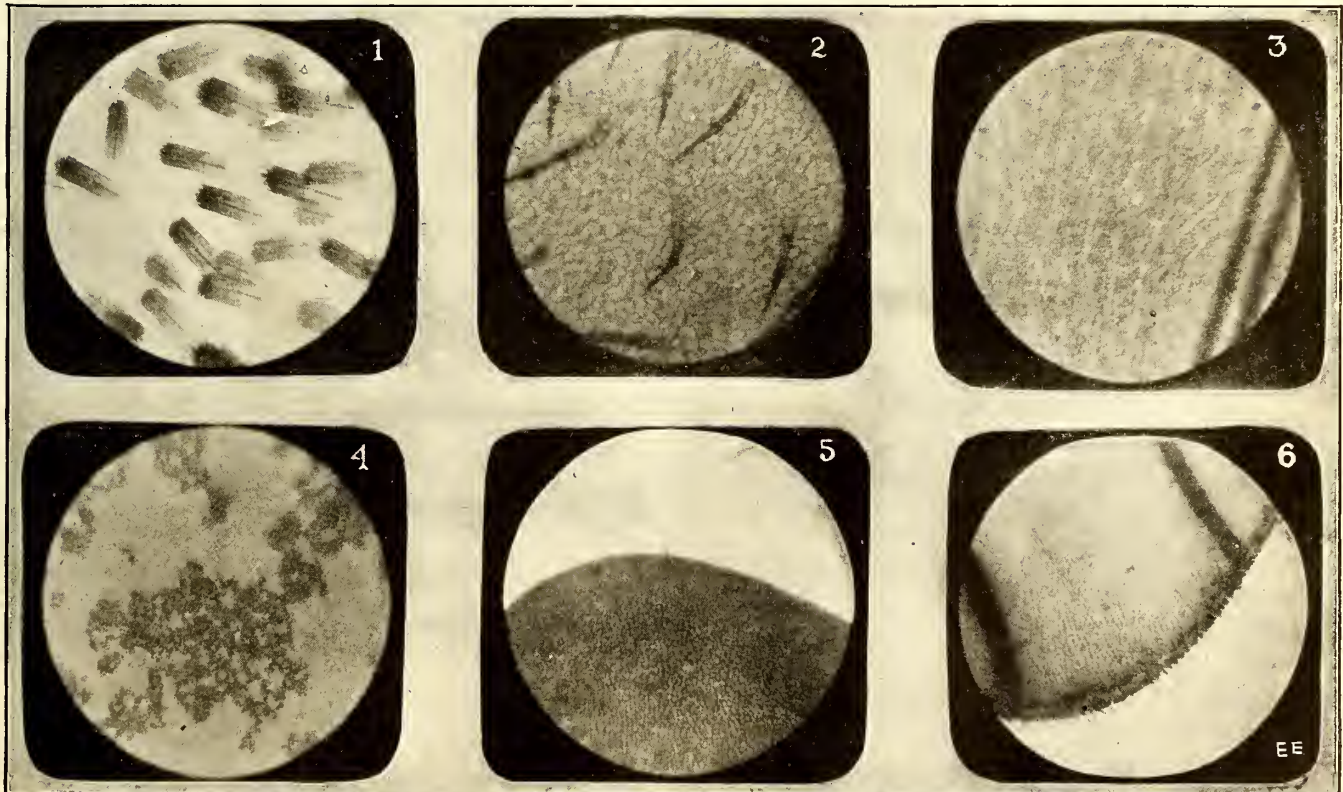

Fig. 1, Microphotograph Showing the Wonderful Wing Structure of the Moth from the Grape-vine Cut-Worm. 2—Parenchyma of Sun Flower Leaf. This Specimen Was Obtained by Stripping a Small Piece of the Epidermis from the Upper Part of the Leaf. The Large Pointed Objects Are Hairs. 3—The Magnified Surface of the Underwing of the Squash Bug; the Dark Line Is Part of the Vein. 4—Nitrogen Fixing Organisms from a Nodule on the Root of a Pea, Which Possesses the Property of Fixing Nitrogen from the Air. 5—Tip of Antenna of a May Beetle. The Short Sharp Bristles Are the Sensory Organs of Smell. 6—Micrograph of a Wing Tip from a Crane Fly, Showing Covering of the Wings.

# Faradic Currents--How to Apply Them

Sequel to "Building a Medical Coil Set."

**A**N extensive article accompanied by working drawings and photographs appeared in the June issue of this journal, covering the construction of a high grade electro-medical or faradic coil. Methods were there explained

of an unsymmetrical alternating current.\* Where much of this work is being done, it is always best to invest in a sensitive milli-ampere meter which can be connected in series with one of the handle cords, so that the current strength in milli-amperes

growths and enlarged glands. In this treatment arrange the poles, if possible, the positive above the negative: while in debility, numbness, inaction, tendency to decomposition, treatment is given with the negative pole. The rule of the positive

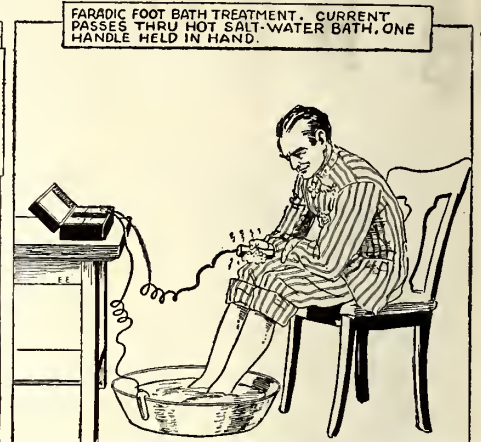

Illustrating Several Interesting Applications of the Faradic Current. The Apparatus for Producing This Current Was Described in Complete Detail in the June Issue of This Journal.

for testing out the polarity of the coil, and thus it becomes easy for even the novice to properly apply the positive and negative electrodes as required in the following directions for the treatment of various ordinary ills, such as, headache, nervousness, rheumatism, etc.

The accompanying illustrations show how several people may join hands so as to form a series connection to the medical or shocking coil, and as many as eight or ten people—or more, may thus join hands in a circle, evolving a great deal of amusement at parties and social gatherings. One of the illustrations shows how a second person may apply the faradic current for facial or other massage with the hand. There are two ways of giving this massage, and one of the accompanying diagrams shows the second method, whereby the person applying the currents forms a shunt circuit to

being administered, can be regulated. The proper current strengths for different ailments is given in any of the works on Electro-therapeutics, which may be consulted at almost every library.

### General Considerations.

In treating diseases of an inflammatory nature and fevers the positive pole is generally utilized. This includes such ailments as swellings, bruises, sprains, extraneous

above the negative cannot always be followed in this treatment.

The primary current starts at the dry cell, passes thru one coil of wire (primary coil) thence thru the circuit-breaker thru the patient. The secondary is the induced current in the finer wire of the coil and is of much greater tension (voltage) than the primary, but not of so much volume (amperage). The primary current is used particularly in the treatment of scrofula ulcers, cancers, extraneous growths, enlarged tonsils, enlarged joints, granulated eyelids, enlarged glands, strictures, etc.\*

The secondary current is applied in the cure of nervous and inflammatory diseases and acts as a tonic upon the system. There are two methods of applying electrical currents to the body viz: 1. General Electrization; 2. Localized Electrization.

By the first method the current is past thru the entire body or part of it. By the second method, the object is to influence special nerves, muscles or organs, limiting the action of currents to these parts, or, instead of trying to influence a muscle, we may stimulate the nerve supplying it, thus reaching the same indirectly. When the refreshing effects of the current are desired to relieve fatigue or ward off approaching paralysis some suitable exercise of the muscles should be combined with the galvanic current. Short sittings are better than long ones. In ordinary cases from two to

the patient. Where a mild current is desired, the shunt method is preferable, while the series connection gives a harsher or stronger current. For the purpose of giving massage treatments, there is available on the market special wrist electrodes, which have a binding-post terminal on them, to which one of the secondary wires from the apparatus may be connected. Many other forms of electrodes, including foot-plates, sponge electrodes, hair brushes, massage rollers, et cetera, are shown in one of the accompanying illustrations. The faradic secondary current produced by medical induction coils is, as explained in textbooks, in the form

\* For further details on the action of induction coils, including the wave form of the secondary or induced current, as well as the primary current, reference may be made to several works on induction coils including the following: "How To Make Induction Coils and Transformers," by H. W. Secor, and a later revised edition by J. S. Curtis, "Induction Coils in Theory and Practice," by Prof. F. E. Austin, "Induction Coils," by H. S. Norrie, "Induction Coils," by Armagnat, also several other works including those by A. Frederick Collins, Allsop, and Trevert.

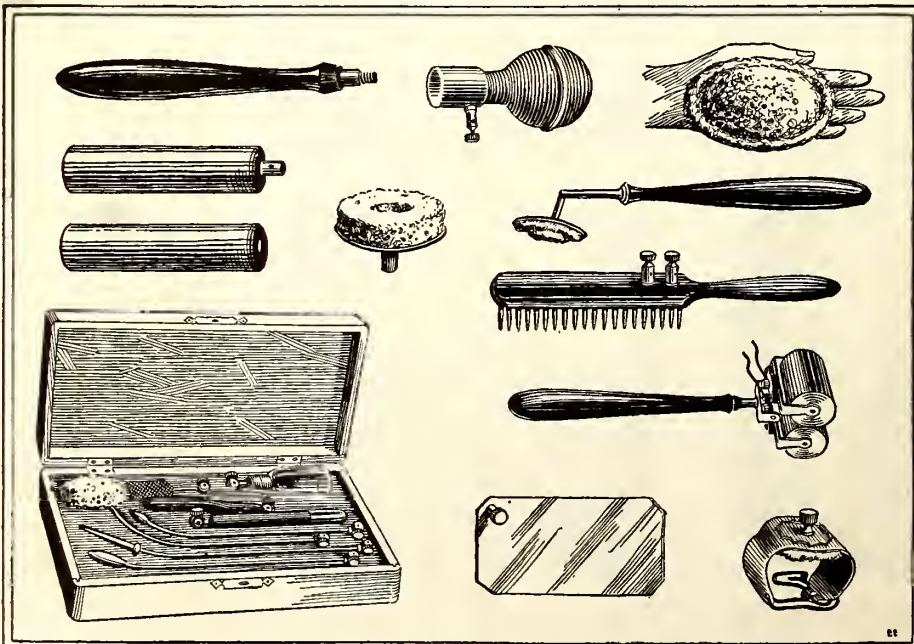

Apparatus Used in Faradic Current Treatment, Including Sponge Electrodes, Massage Roller, Wrist Electrode, Foot Plate, Hair-brush, Bust Copper, Et Cetera.

\*See Electro-Therapeutics Handbook, by Trevert. Also Handbook of Electrotherapeutics by Dr. Strong.

(Cont. on page 366)

# X-Ray Experiments

By Ivan Crawford

THE average electrical reader is not ignorant as to the general nature of X-rays, or more properly Röntgen rays, but he usually knows comparatively little about them. Considering the ever broadening field of usefulness of

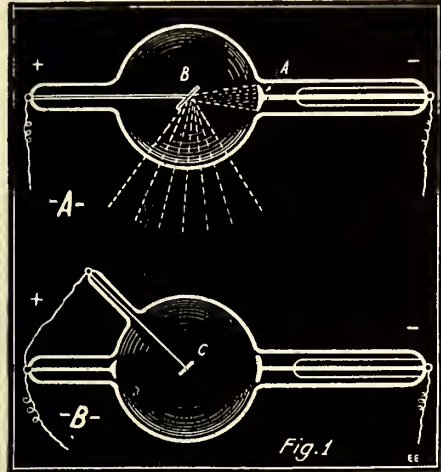

Simple Form of Vacuum Bulb for the Production of X-Rays. When the Cathode Particles Strike the Target, B, They Set Up Etheric Vibrations—X-Rays—Radiating in the Direction Shown by the Dotted Lines.

these remarkable rays, it behooves the experimenter who wishes to keep abreast of the times to make himself better acquainted with them and their properties. It is the author's intention in the following article to briefly outline the latest advances in this branch of science and to give some experiments, using apparatus within the reach of every experimenter.

Röntgen, while experimenting with a vacuum tube, noticed that the sides of the tube exposed to the discharge were brightly phosphorescent, and that if a screen of some phosphorescent substance such as potassium platinocyanid was brought into its vicinity it would become luminous. He also noticed that if a thick piece of metal were interposed a shadow was cast, while a piece

of wood or a thin sheet of aluminum cast only a partial shadow, showing that the rays producing the phosphorescence could penetrate more or less easily objects opaque to ordinary light, but that the amount of penetration varied *inversely* as the density. This may be further illustrated by interposing the hand between the tube and the screen. The flesh being less dense than the bones cast only a light shadow while the latter are distinctly outlined. The rays were also found to possess the property of affecting a photographic plate.

Of course, an ordinary vacuum tube such as the one with which Röntgen first remarked the phenomena, does not produce X-rays in any great quantity. Many different forms of bulbs have been evolved but they may be divided into two general classes, namely, those operated on spark coils and those operated on high frequency currents such as those from a Tesla coil. As the spark coil exciter is more within the reach of the average experimenter, it has been selected for description in this article. Those who are interested, however, in the operation of high frequency X-ray tubes are referred to a most complete article on

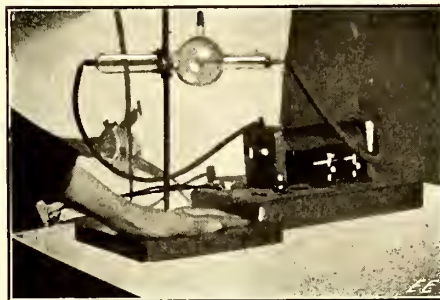

Fig. 4. How the X-Ray Tube, Hand to Be Radiographed, and Covered Photographic Plate Are Arranged.

the subject by Dr. Frederick F. Strong, in the September, 1917, issue of this magazine.

A simple tube for the production of Röntgen rays is shown in Fig. 1A. The cathode A is generally of aluminum and made in the form of a reflector. The anode B is faced with platinum or tungsten and inclined at an angle of 45 deg. to the cathode. Sometimes a third electrode (C, Fig. 1B) is added. This, however, is not necessary in small tubes. The pressure in the bulb must be extremely low. After extended use this tends to become even lower. This, altho producing more penetrating rays, decreases the supply of electrons, making it difficult for the discharge to pass. To remedy this some bulbs are equipt with a small platinum tube fused into the glass. When this is heated it allows the hydrogen to pass. If the bulb is not provided with any means of increasing the pressure it may be done by gently heating it in an oven. When the vacuum is high the bulb is said to be "hard"; as the pressure increases it is said to become "soft." For general work the bulb should be rather "hard."

The nature and properties of the rays will now be discust. When the cathode particles strike the target they set up etheric vibrations which radiate in the direction of the dotted lines in Fig. 1A. The nature of these vibrations has been the field of considerable discussion but has now been practically settled. It is the general belief that

they consist of *extremely short ether waves*, similar in many ways to light. The chief points of difference lie in the facts that the objects which reflect or at least refract ordinary light are transparent to X-rays, neither are they subject to polarization. This evidence is, however, not so conclu-

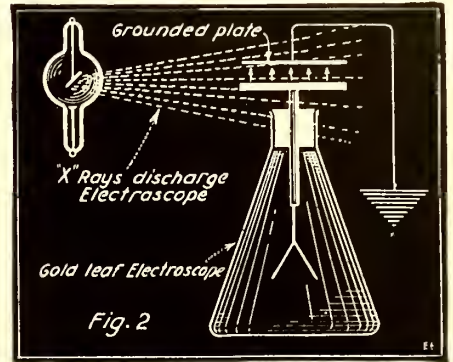

Experiment Demonstrating the Ionizing Property of X-Rays. A Charged Electroscope Is Quickly Discharged When X-Rays are Past Across the Gap Between the Electroscope and a Grounded Metal Plate.

sive as it might seem at first sight. It has been known for some time that X-rays consist of vibrations about  $10^{-8}$  cm. in length. It is impossible to conceive of a defraction grating of suitable spacing to intercept these waves. On the other hand, they have many similar characteristics. They move in straight lines, cast definite shadows, affect a photographic plate, and Brandes and Dorn have shown that they even produce a slight but sensible effect on the retina. Prof. Marx, by a series of complicated experiments showed that they traveled at the speed of light. His results, however, have not been generally accepted and his methods severely criticized. I have stated above that Röntgen rays are not subject to polari-

(Continued on page 375)



Fig. 5. Skilgraph Taken by the Author, Showing Bones of the Hand and Finger-Ring. X-Ray Tube Excited on Two-inch Spark Coil.

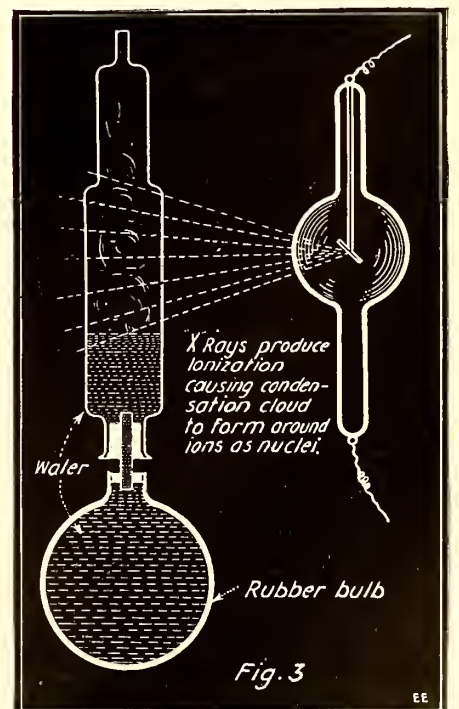

An Intensely Interesting X-Ray Experiment, Showing How Rain (Aqueous Vapor) is Formed by Condensation Set Up on Nuclei Created by X-Ray Ionization.

# Heat Engines

By JOHN J. FURIA, M. A.

Dept. of Physics, New York University.

**T**HE question often arises, "why is the hot air engine not used?" Air certainly is cheaper than gasoline. It takes less fuel to heat air than to convert water into steam. However, it does not follow that the hot air engine

## Gasoline—Steam—Hot Air

the moving fly-wheel causes the piston to move inward (cycle 2). The inlet and exhaust valves are both closed during this cycle, and the explosive mixture is compressed, rendering it capable of delivering greater power when it is exploded. As dead center is again reached, and the mixture is compressed to a maximum, the mixture is ignited by means of an electric spark properly timed. The mixture disintegrates as a result of combustion and forms a gas of tremendous pressure, this pressure causing the piston to move outward. This is the third cycle or power cycle. (Both valves are closed.) On again reaching dead center, the inertia of the fly-wheel causes the piston to move inward; the exhaust valve is automatically opened and the spent gases are expelled. (The inlet valve is, of course, closed during this cycle.) The four cycles are then repeated over and over again.

It is to be noted that during the whole four cycles, only one power stroke is secured; and that this power stroke is secured as a result of chemical action due to the combustion of the fuel mixture. The four cycles occur during two revolutions of the fly-wheel. It is therefore necessary to have a fly-wheel with a large moment of inertia in order to cause a steady running of the engine. Smoothness is obtained by using several cylinders instead of one, thus securing more power strokes per revolution of the fly-wheel. The high price of gasoline together with the complications arising in the devices for securing the proper mixture and the right kind of spark at the right time are points against the gasoline engine. Because of the high temperatures developed as a result of the chemical action, the cylinders must be cooled by some means, usually water circulation (another complication).

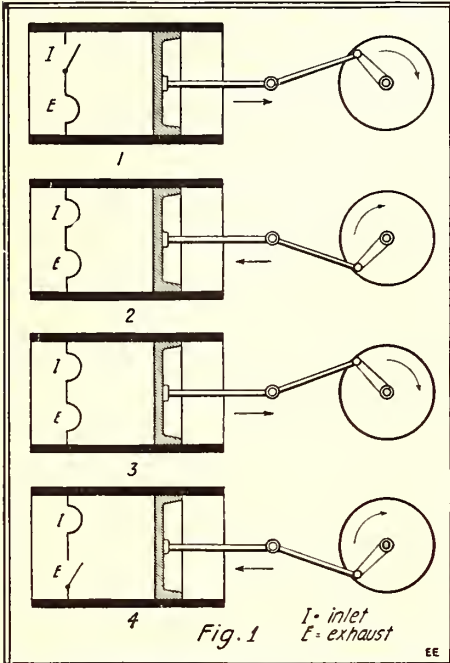
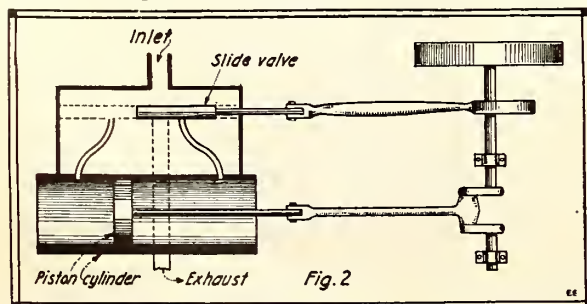

Illustration of Four Cycle Operation in the Gasoline Engine. First the Gas Mixture is Drawn In. Second, Compression Takes Place. Third Comes the Explosion; and Fourth, the Expulsion of the Burnt Gases Takes Place.

is the cheapest to run and at the same time obtain the necessary power. A little review of the gasoline and steam engines together with the principles of operation of the hot air engine will answer our question, why this type of engine is not used.

### The Gasoline Engine.

The gasoline engine (internal combustion) has attained great popularity by its use in the automobile industry. It is flexible, capable of delivering a large amount of power, it develops high speed and power almost instantaneously. It also has an efficiency of about 25 per cent. The engine and the fuel used are light in weight compared with other kinds of engines of similar power. The four cycle engine is typical. Figure 1 is a sketch showing the conditions at each of the four cycles. The first cycle is started by turning over the flywheel (cranking the engine). This causes a suction in the cylinder. The inlet valve is either opened automatically or by the suction. The properly mixed fuel (gasoline and air) enters thru the inlet. (During this cycle the exhaust valve remains closed.) After passing dead center, the inertia of



Right:—Ideal "Hot Air" Engine, Comprising a Cylinder, Piston, Connecting Rod and Flywheel. Heat is Applied to Bottom of Cylinder, Driving Piston Upward.

Left:—Principle of Simple Steam Engine, Showing Slide Valve Actuated by Cam Shaft from Flywheel Shaft. The Steam is Successively Admitted and Exhausted from Alternate Sides of the Piston, Causing Rotation of the Flywheel.

boiler (any kind of fuel can be used). The steam is led into the cylinder thru the inlet valve. In the type illustrated below there are two inlets to the cylinder, one on each side. A slide valve operated by the fly-

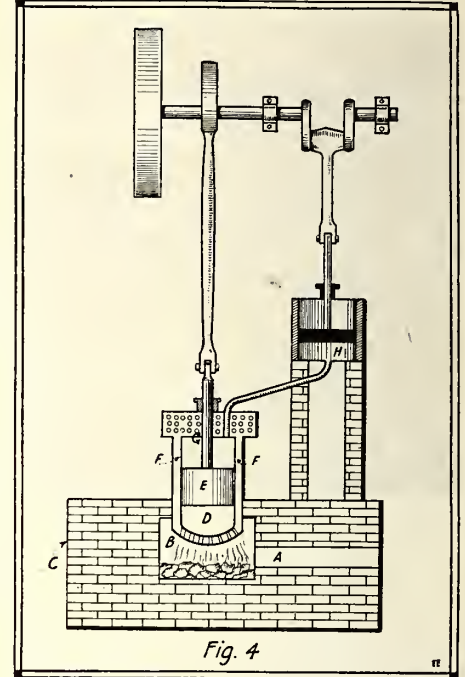

The Stirling "Hot Air" Engine. It Only Consumes 2 lb. Coal per H.P. Hour, Being Therefore More Efficient Than the Steam Engine. These Engines Have Been Built to Develop Several Horsepower.

wheel moves in opposition to the piston, alternately admitting steam to the left and to the right of the piston, thus causing it to move back and forth. It is therefore apparent that there are two power strokes for each revolution of the fly-wheel or four times as many as in the four cycle gasoline engine. The spent steam is usually exhausted into the atmosphere. In the more modern steam engine the spent steam is condensed and brought back to the boiler, thereby requiring water to be added to the boiler much less frequently besides saving fuel. Because of the high price of gasoline, several automobile concerns have expended a great deal of time and money in research and development on automobile steam engines, and their "selling points" are extremely good ones. Getting up steam is reduced to a matter of only a few min-

(Continued on page 373)

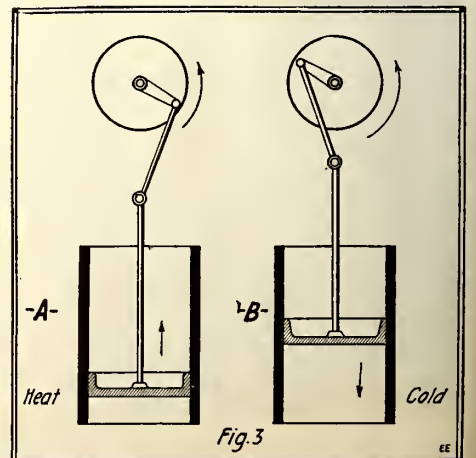



# Experimental Mechanics

By SAMUEL D. COHEN

## LESSON XIII

### REGARDING REAMERS.

**I**N the last lesson we completed the discussion on the subject of "Twist Drills." The reader is undoubtedly aware by this time that it is quite impossible to drill any size hole he desires with rigid accuracy thru the use of drills in commercial

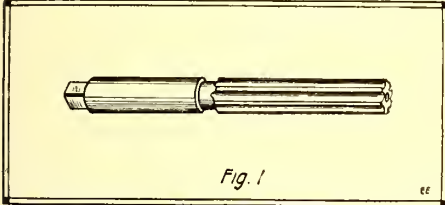

Standard Form of Hand Reamer. The Reamer Is Used to Accurately Clean Out Drilled or Cast Holes, Especially Journal Boxes and Shaft Bearings of All Types.

practise. For example, it is desired to place a pin into a drilled hole to have a *driving* or a *sliding fit*. The reader will find that nine times out of ten he will be unable to obtain the proper size drill to do the work. In this instance another form of tool is at hand, namely, the *reamer*. This tool is used whenever a hole is to be enlarged just a few thousandths more than the original. Sometimes the reamer is used when a smooth hole is required, in which case the hole being first drilled is made *smaller*, in order to obtain the finally required size after reaming.

As in the case of twist drills, there are a large variety of reamers, varying in size, and each is suited for a definite purpose. Properly speaking, the reamer may be defined as a tool for perfecting holes previously drilled or bored. Fig. 1 shows a standard *hand reamer*. The reamer should never be used to remove any considerable quantity of stock, but merely to eliminate minute imperfections left by other tools. In some cases the hole may be made to within .001 inch before the reamer is applied, but generally the allowance of .002 inch to .010, according to the diameter of the hole, may be left for the standard reamer to cut. If given too much material to remove, the cutting edges of the reamer will wear too fast, and its reliability as a *sizer* will be quickly destroyed.

Reamers may be divided into two general classes: the *side-cutting* or *fluted* and the *end-cutting* or *bits*. Each of these classes are subdivided into *solid* and *adjustable* reamers.

The first well-known reamer is called the *solid fluted* reamer, and is made with slight modifications to suit two different cases, namely, hand and machine use. Fig. 2 illustrates a hand reamer which belongs to the *short set*. Reamers of the same general design are also made longer in regular sets. The cutting edges of fluted reamers taper in diameter for about one-fourth their length, from E to D being about .01 inch smaller at E than at D.

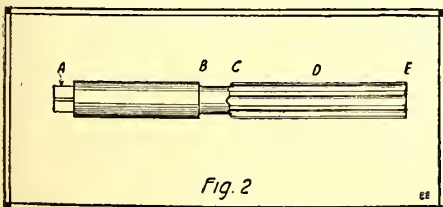

Illustration Showing a Hand Reamer of the Solid Fluted Type for Hand Use. The Letters Refer to Different Tapered Sections Described in the Text.

From D to C the taper is reversed, the diameter decreasing about .0002 inch per inch of length towards C. The part between A and B is usually made about .001 inch smaller than the largest diameter at D. When the cutting edges are worn to such an extent that the blank part, when free from bruises, will not pass thru the reamed hole, the reamer is too small for standard use.

As will be seen, the hand reamer has a square end, upon which a wrench is used to turn it. This is the main distinguishing feature between the above mentioned and the machine reamer of the fluted type. The latter is made with taper and parallel shanks the same as a drill. It may also have a shank of any special shape to fit a certain holder. The machine reamer is generally, tho not always, made straight or parallel, from E to D, Fig. 2.

A reamer having a flute parallel with its axis has a slight tendency to draw in. To overcome this, some mechanics prefer the flutes of both hand and machine reamers, made in the form of a left-hand spiral. The angle of the spiral or helix may be from 4 to 8 degrees.

Another form is the so-called *rose* reamer. Its name is derived from the fact that its cutting end resembles a rose. It is essentially an end-cutting tool and is rarely used for other than machine work. The rose reamer has chip and oil grooves on the sides and is made with any shank required in machine work. This reamer has the larger diameter at its cutting end, and tapers back at about the same rate as the hand-fluted reamer, viz.: .0002 inch per inch of length.

The object of the taper on the fluted reamer is to counteract the tendency of all such reamers to produce a hole larger at the outer end. The rose reamer as well as the twist drill have the taper for the same reason, viz: for clearance.

As compared with the fluted reamer, the rose reamer has one advantage, in that when new it will make holes more uniform in size and shape, but has the disadvantage that when the cutting lips are worn, it will bind on the sides and roughen the hole. If the fluted reamer becomes slightly worn at the end, it will still cut on the sides, but because of its cutting on the sides, it is more likely to be deflected by imperfections of the hole, or to cut larger than its fixt size.

As above stated, the standard fluted reamer should be used for *finishing cuts* only. However, the rose reamer can be utilized for roughing or finishing cuts. When the same reamer is used for both purposes, it becomes unreliable as a standard finishing tool. A good illustration of the rose reamer is shown in Fig. 3.

Another type is the *shell* reamer, which is identical in construction to the fluted and rose reamers, with regard to cutting edges, but differs in that the reamer proper is placed upon an arbor, thus saving in cost of material. It will be seen, however, that when the reamer becomes worn to such an extent that its accuracy is destroyed, it should be replaced by a new one, which occupies the same position on the arbor. Fig. 4 illustrates a typical shell reamer. The arbor drives the shell thru the engagement of its key with a rectangular slot cut across the rectangular shell. These reamers are made with either straight or spiral flutes.

The *shells* as ordinarily made are rather short for hand reaming. They are de-

signed mainly for machine work. The taper begins at the cutting end, and the diameter decreases toward the opposite end in about the same ratio as the reamers previously described.

When these reamers wear .0003 inch to .001 inch below standard size, it is necessary to reset or regrind them to a smaller

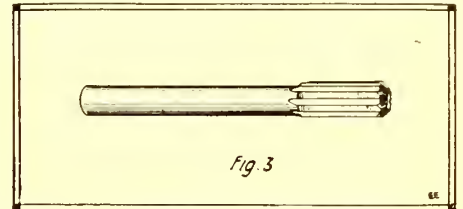

Typical Rose Reamer. This Is Used Considerably for Roughing and Finishing Work, but One Reamer Should Not Be Utilized for Both Purposes, as Inaccuracy Is Bound to Result.

size. Resetting consists in enlarging the diameter of the reamer by hammer blows in connection with a form of *set* or *calking* tool. The latter, which may be made by grinding a common chisel flat on the end, is held against the front of the cutting edges for this purpose. It is necessary to anneal the reamer for resetting, and each cutting edge must be treated until the diameter is about 1/64 inch larger than the standard. Having completed this work, the reamer is now retempered and brought to final size by *grinding*. This is usually accomplished by placing the reamer in a Universal precision grinding machine.

Before grinding the reamer, its center should be carefully cleaned of any dirt or other foreign matter that may have adhered to it. A point scraper made from a three-cornered file answers well for this purpose. After scraping the centers it is usually necessary to lap them. For this process we *chuck* a short brass rod in the lathe and turn the end to the shape of the lathe centers. Having smeared this conical end with fine emery and oil, the reamer is placed on the center of the lathe and started at the greatest speed attainable. The reamer center is lapt by alternately forcing it against and releasing it from the revolving brass. This is done by light pressure with the tail spindle, and for each time that the reamer is prest against the brass it should be revolved slightly. By thus revolving it, we distribute the emery and counteract the tendency of the lap to scratch rings in the center. It is sometimes necessary to return the lap before finishing one reamer; but a skillful workman can do this in ten minutes or less. Instead of having to chuck the lap each time it is used, it would be better to make one to fit the hole in the lathe spindle directly.

[In the next installment the subject of adjustable reamers and grinding of reamers will be discussed—Editor.]

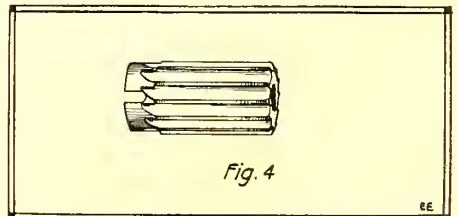

A Shell Reamer. An Arbor or Shaft Supports the Reamer When in Use. They Are Held by a Key on the Shaft and Are Made With Straight or Spiral Flutes.

# HOW-TO-MAKE-IT

This department will award the following monthly prizes: First Prize, \$3.00; Second Prize, \$2.00; Third Prize, \$1.00. The purpose of this department is to stimulate experimenters towards accomplishing new things with old apparatus or old material, and for the most useful, practical and original idea submitted to the Editors of this department, a monthly series of prizes will be awarded. For the best idea submitted a prize of \$3.00 is awarded; for the second best idea a \$2.00 prize, and for the third best prize of \$1.00. The article need not be very elaborate, and rough sketches are sufficient. We will make the mechanical drawings. Use only one side of sheet. Make sketches on separate sheets.

## Automatic Electrolytic Interrupter

FIRST PRIZE, \$3.00

After having experienced considerable trouble in devising a satisfactory electrolytic

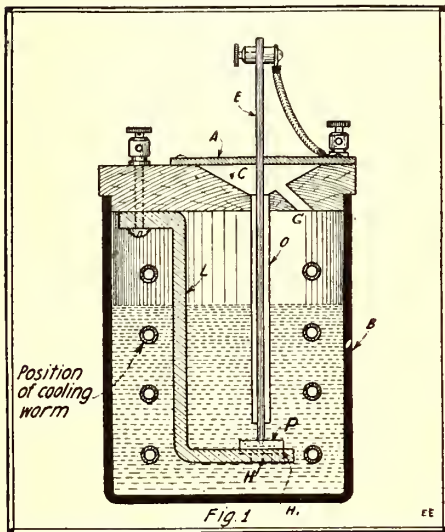

A Really Good Design of Home-made Electrolytic Interrupter.

interrupter, I succeeded in constructing the one described herewith in which most of the faults of its predecessors are eliminated. The greatest of these faults was the dropping of the rod electrode, thus short-

circuiting the device. The materials required outside of the battery jar and wooden top, which must be boiled in paraffin to render it impervious to moisture, are: One-half pound of lead, about five inches of glass tubing, having an internal diameter of one-sixteenth inch, three binding posts, a small strip of brass and a small porcelain cup (used for mixing water colors).

The lead electrode is cast in the shape shown in Fig. 2. A hole somewhat smaller than the cup is bored in the large end. A rabbet, H', is cut around the edge of this hole so that the cup will fit into it. The lead electrode is now completed and fastened to the top with a machine screw and binding post. The top has a cup-shaped cavity reamed out as shown at C, Fig. 1, which is as deep as one-half the thickness of the top. A hole is bored in the center to receive the end of the glass tube, which should fit tight. The bottom of the tube is about three-sixteenths of an inch above the porcelain cup. The cavity also has a small hole G, Fig. 1, in one side to furnish an outlet for the solution which rises in the tube. A brass strip about one-quarter of an inch wide is fastened across the top of the cavity with a wood screw, binding post and a small screw. This strip has a small hole in the center for the rod electrode to pass thru. The rod is best made of phosphor bronze, and should fit the tube loosely. It has a binding post on top to serve as a weight and for connections. The interrupter is now complete, and should be filled to within an inch and a half of the top

with a 10 per cent. solution of sulfuric acid.

The action of this interrupter is as follows: As the rod is worn away by the action of the solution, it is impelled downward by the weight on top, the porcelain cup preventing it from going too far. In case it

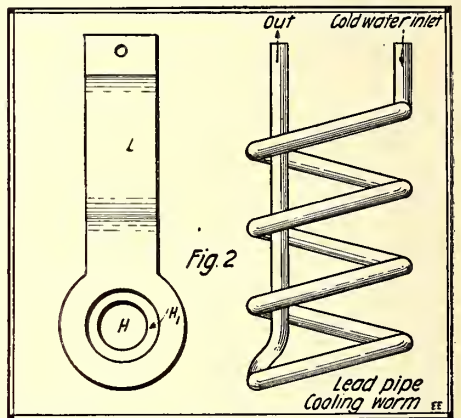

Detail of Lead Electrode and Lead Cooling Worm for Home-made Electrolytic Interrupter.

is desired to operate this interrupter continually for any length of time, it may be cooled by immersing in a large jar of water, or else by inserting a cold water cooling worm in the solution, after the design here pictured.

Contributed by SCOTT E. VANCE.

## Clever Multiple Switch

SECOND PRIZE, \$2.00

I submit herewith an idea for using a motor commutator as a rotary multiple point switch. This sort of switch is useful where it is desirable to economize on space, as on the secondary of a loose coupler.

This switch is, moreover, thoroly dust proof, as it is always on the inside of the cabinet.

Contributed by R. C. SMOLLEN.

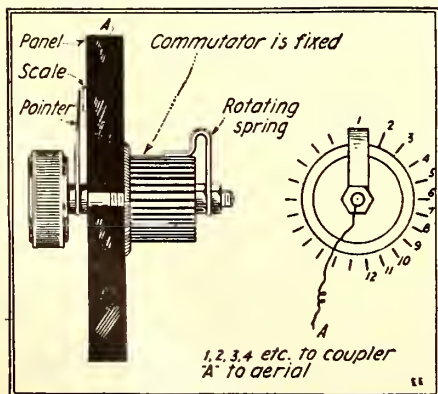

This Classy Multiple Point Coupler and Battery Switch is Constructed From a Small Commutator.

Send us some of your good ideas. We pay for all articles published. Address the Editor How-To-Make-It Dept.

## THE PHONOGRAPH AS A TEACHER.

Many amateurs object to the use of a phonograph for learning wireless telegraphy because of the fact that the sound coming from the phonograph is in no way similar to the actual wireless message.

Close the doors of the machine and place a telephone transmitter on the inside. Or, better still, place the transmitter directly on the end of the tone arm. This latter method can be used with any make of phonograph. Then connect a telephone receiver (or a number of telephone receivers in parallel) in series with the transmitter and a few batteries.

This method overcomes all objections to the phonograph method and is much better than the omnigraph method since the phonograph records can be made to represent two stations of a different pitch sending at the same time, interference, etc. When you tire of listening to radio signals put on an ordinary record and have a "wireless" concert. What?

Contributed by PAUL G. EDWARDS

## "Collar Button" Push Button

THIRD PRIZE, \$1.00

Here is a push button designed to use up all your waste material and make you buy more collar buttons. Bore the holes as shown in a two by one-half inch block of wood, screw on the metal plate D, with the brass spring C insulated from it by the wood or fiber E, slip in your collar button B, glue on the thin piece of wood F, and Eureka! there you have it!

I know my friends will surely bless me for this valuable contribution to Science in the Home. Pa can rest his mind hereafter — when the shirt button drops, he will know it's gone to help the cause of true Science.

Contributed by RAY BILLINGTON.

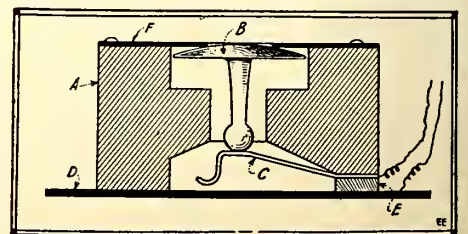

At Last! The "Collar Button" Push Button. Papa Will Never Find His Collar Buttons Now, When They Roll Away Under the Bed. Little "Willie" Will See to That!



EDITED BY S. GERNSBACK

**TELL-TALE FOR REFRIGERATOR DRIP PAN.**

This tell-tale for an ice box drip-pan consists of a piece of hard wood or fiber cut into the form (A). A piece of No. 14 copper wire is bent into the form (C). This form is allowed to turn on pivot (E), which is a current carrying part of the circuit. When the pan is full of water, the form (C) floats up by means of a piece of wood (cork is good) attached to the end. The copper wire makes contact with (D), and the bell rings, indicating that the pan is full. The notch (B) makes it possible to take the device off when emptying the pan. Contributed by EDWARD KENNEDY.

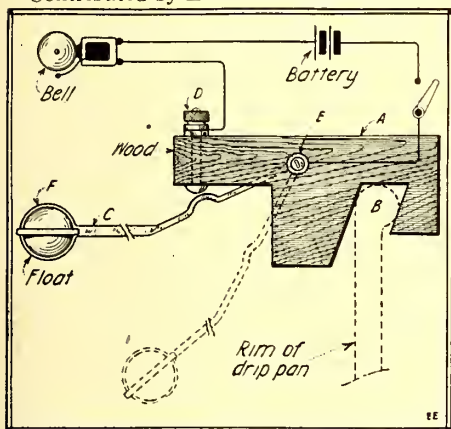

Simplicity Is Stamped All Over This Home-made Refrigerator Drip-pan Alarm. It Costs But a Few Cents to Make and Will Save Your Carpets and Hard-wood Floors.

**HINTS ON LABORATORY APPARATUS.**

By Eugene McGowan

To most experimenters chemistry undoubtedly proves a most interesting study. However the chief fault lies in the fact that things mess up so easily. The following is intended to overcome this difficulty.

First of all the laboratory should be arranged so that the one who uses the room may be able to find everything he wants.

A gross of empty wooden boxes, 12 inches x 8 inches x 4 inches, will be found convenient for keeping dry reagents in.

Labels should be used freely, and all unlabelled bottles washed out. Paper labels on bottles may be protected by a coating of paraffin wax varnish or shellac. But most bottles should have some label in the substance of the glass. These are made in two forms. Enamel labels are melted on the glass. They last well, but white enamel is not always distinct when white crystals are in the bottle. Sand-blast labels are made by roughening the surface of the glass with a jet of sand driven by a blast of air. They are apt to be indistinct when wet, if not made with a really rough surface. They can be made more distinct by rubbing over with crayon or chalk. Sand blast labels cost only about half as much as enamel labels.

Retort stands should be firm and substantial. The sliding collars for the rings should be slotted at the sides, so as to move easily; and a good clamp should be chosen with well-made screw threads.

Deflagrating spoons can be cleaned by holding the cup in the Bunsen flame for a few seconds.

Bunsen burners occasionally get blocked by some molten substance falling into the inner tube. They may be cleaned by washing with water. After washing blow thru the burner to remove any drop of water which may clog the exit. The revolving tube or ring should be frequently turned, so as to keep it in order; otherwise they get jammed and it is impossible to change quickly from a yellow to a blue flame.

Balances should turn with much less than a centigram. Balances with steel knife-edges, if protected from the air of the laboratory, will remain serviceable for years. Those with agate edges set in steel are more durable, but are more expensive. Weights less than a centigram are needless, and cause trouble to beginners. More exact weighing can always be done by watching the pointer, if the weights are accurate.

Management of mercury. Mercury is difficult to manage, on account of its weight and the ease with which it picks up impurities. Stone-ware mortars are better for holding mercury than glass beakers, which easily crack when set down. All operations with mercury should be conducted over a tray or on a table with a groove around the edge.

Dust on the surface of mercury may be removed by allowing the mercury to run thru a dry filter paper in which a few pin holes have been made. Or the mercury may be washed in a current of water, and then past thru a separating funnel. The little moisture on the surface may be removed with a blotting paper. Many metals easily dissolve in mercury; and a very little tin or zinc will spoil its fluidity. They are best removed by shaking the mercury in a bottle with a little nitric acid; the tin or zinc will then dissolve, leaving the mercury pure.

A few words of caution concerning the care of reagent bottles are in place here. A good reagent bottle must have its stopper ground to fit it, and this stopper will not fit any other bottle you may have. Consequently the stoppers should never be interchanged. Again, the stoppers of all reagent bottles, excepting sulfuric acid, should be paraffined, otherwise they are apt to stick.

Do not lay down the cork of a reagent bottle while pouring out a solution, as the stoppers may become changed. Again, no solution but the one corresponding to the name on the bottle should ever be placed in the bottle.

Another important item is that each bottle shall have its own particular place on the shelf, and always be put in its place; thus the amateur chemist will know exactly where to find the proper reagent, just as a printer knows where to find the letters in his case, by prearrangement.

**USE FOR AN ATOMIZER.**

An atomizer is a handy appliance to furnish a draft of air when drying precipitates or evaporating solvents like ether or chloroform. The drying of precipitates and crystals can best be carried out when same is placed on a blotter to help absorb the liquid.

**"SPIRIT" SLATE-WRITING.**

Two thin slates are brought forth and offered for examination by the audience. The operator then places in between the two plates a small piece of chalk and hands

the two slates to some-one (it does not matter whom) to tie with a string or seal all around with sealing-wax. After a few minutes or so, the slates are taken apart and Presto! there is found a message from the "spirit world" written with the chalk, which was placed in there by the "Medium."

The way it's done is this:

The chalk is of special formation; it is made of chalk dust mixed with iron-filings and a little glue. A strong (need not be very big) magnet is used to make the chalk move and write the message. The "Medium" located the chalk by tipping the slates to one corner and placing the magnet under it.

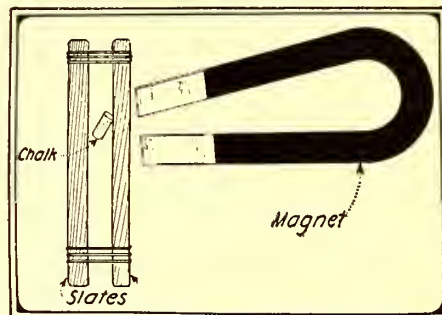

"Spirit" Slate Writing May Be Performed With This Simple Apparatus. The Chalk Container Could Very Well Be a Small Perforated Ball Filled With Powdered Chalk. The Slates Should Be Held Horizontally.

This works better in the dark for the simple reason that the people will not notice the magnet and its use. The darker the better.

Contributed by GEORGE PASTO.

**MAKING THE MOST OF A LITTLE SPACE.**

It is most discouraging to have to spend half-an-hour finding tools and impedimenta before starting an hour's work in the evening. The remedy is to have a place for everything, and keep everything in its place. Also, keep them as compactly as possible. A good deal of extra room can be got out of an ordinary cupboard by the exercise of a little ingenuity. Things not often required should be kept on the top shelf. Perhaps there is still some space to spare. Then tack a piece of cloth or a large handkerchief inside the top of the cupboard, and screw in a couple of brass "crew" hooks a few inches from the ends. Sew a brass ring to each of the free corners of the cloth and you have a sort of cradle in which many odd things may be suspended by slipping the rings over the hooks.

A dozen wooden soap or sugar boxes, stood one above another in a corner of the room, preferably in a recess, will do duty for a cupboard. Capital shelves can be made inside the boxes, using wood from the lids, while the whole structure can be effectually disguised during the daytime by covering it with a piece of dark colored material. Extra room can be made by fixing hooks to the outside edges of the boxes for things that can be hung up, while other odds and ends can be dropt into cocoa tins and the like tacked to the sides of the boxes.

Contributed by H. J. GRAY.

# RADIO DEPARTMENT

## Airplane Antenna Reels

By LESTER F. RYAN

ONE of the most important parts of the antenna system in connection with airplane radio work is the *antenna reel*. Electrically, the antenna system of a radio transmitter consists of a single trailing wire and a counterpoise. The antenna wire is lowered from the airplane during flight by a hand reel and trails out to a distance of about 300 feet, at an angle of 20 degrees to the fuselage.

The antenna reel, as illustrated in Fig. 1, is so designed in order to stand all mechanical and electrical stresses under difficult service conditions.

It is constructed entirely of the highest grade insulating material and will therefore stand the high antenna voltages which are developed by the high power of the transmitter without leakage and danger to the operator.

The drum of the reel will hold 600 feet of stranded phosphor bronze or other antenna cable, i.e., if one antenna of 300 feet of wire is lost, an additional antenna of 300 feet is still available. It is provided with a revolution counter as shown in figure which indicates the number of turns or feet of antenna wire in use.

It is also fitted with a *brake* or locking device, which is used to lock the drum when the reel is not in use. This brake may also be used to control the speed of the unwinding. The antenna wire is of tinned copper, and has a breaking strength of 400 pounds.

To prevent chafing and breakage of the antenna wire near the weight when the antenna is reeled in, due to the swinging of the weight, a stiff phosphor bronze wire is connected between the antenna wire and the swivel hook. A swivel hook is placed at the end of the tail wire to prevent spin-

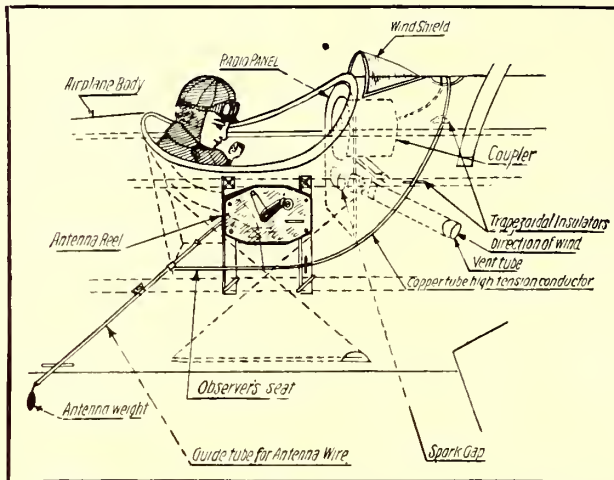

Arrangement of Airplane Antenna Reel On Outside of Cockpit. The Reel Is Self-locking and Also Indicates At a Glance How Many Feet of Aerial Cable the Aviator Has Let Out. The Cable Runs Thru a Guide Tube As Shown. Thousands of Sets Like Those Shown Were Used During the War.

ning of the weight during flight. The weight is of lead, and weighs  $1\frac{3}{4}$  pounds. It is of stream-line form to reduce wind resistance to a minimum.

The insulators used are of trapezoidal shape and serve the purpose of insulating the guide tube from the airplane. The flattened end of the trapezoid is made fast to the copper tube; the opposite base is made fast to the airplane fuselage.

To prevent *sparking* or *grounding* of the antenna to the cowl a *cowl insulator* is used. It is made of bakelized canvas, six inches in diameter, with holes near its periphery for lashing to the cowl.

When installing the antenna system on a plane, great care must be taken to provide sufficient insulation against the high voltages developed by the transmitter. As a rule, the antenna reel is mounted outside

of the fuselage on the right-hand side of the plane, as here shown. It is attached to two vertical pieces of wood which are lashed to the upper main and seat longerons. These pieces contain holes corresponding to the four attachment legs of the reels, and thru which these legs extend to the inside of the fuselage. The circular bakelite nuts, as shown in figure, secure the reel posts to these uprights. The copper guide tube thru which the antenna cable slides after leaving the reel is supported beneath and rearward from the antenna reel at an angle of about 20 degrees to the fuselage. It extends 6 inches beneath the fuselage, and is separated by insulators.

The connection between the antenna helix on the set and the antenna guide tube is as follows: The antenna helix is connected to the lower end of the cowl insulator as shown in figure by rubber-covered cable. The cowl insulator is connected with the antenna guide tube by means of a six-foot length of 0.180-inch copper tubing. The antenna wire is connected to the antenna reel by means of a hole thru the bakelite shaft on which the handle is fastened.

When properly installed, the antenna system should cause no trouble. The antenna reel may safely be operated while sending and is without doubt one of the most ingenious and novel features developed in airplane radio transmitters. This type of antenna reel is used in conjunction with the airplane transmitter described in the July issue of the *Radio Amateur News*.

The modern practise in airplane radiotelegraphy and telephony calls for the use of two antenna cables, let out from either side of the airplane. These cables have weights as usual.

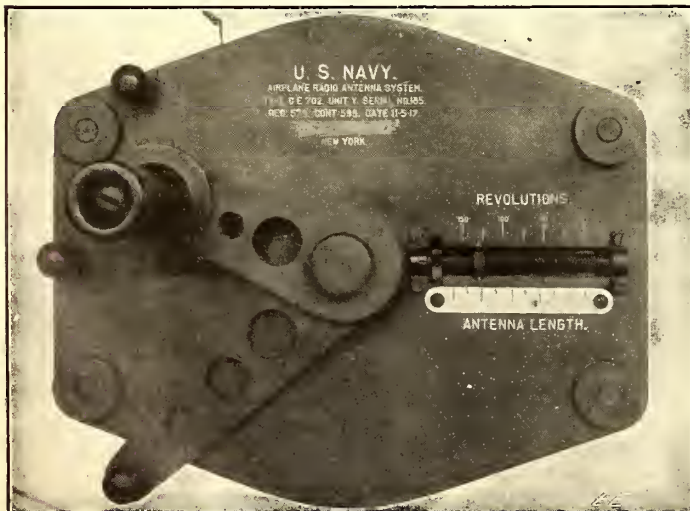

View of Indicator Panel of Antenna Reel Device Fitted On Airplanes. The Length of Aerial Let Out Is Read Off Directly.

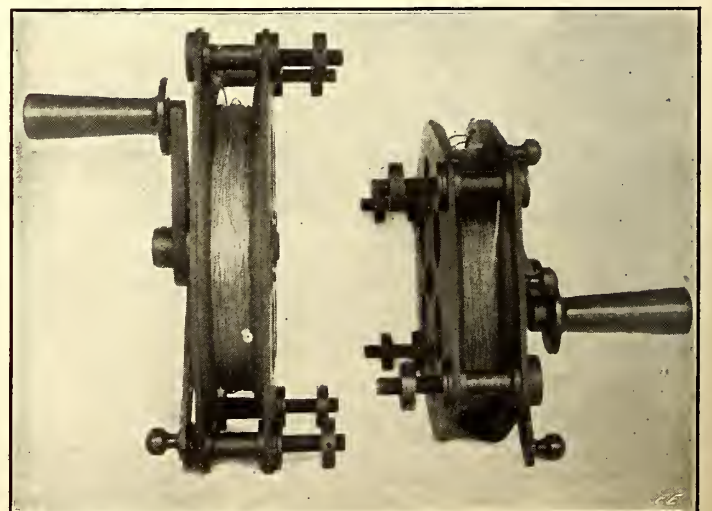

Two Sizes of Airplane Antenna Reels Are Here Illustrated. Note the Heavy Insulating Support Studs by Which the Device Is Supported.

# How I Invented the Crystal Detector

By GREENLEAF WHITTIER PICKARD

SPECIALY WRITTEN FOR THE "ELECTRICAL EXPERIMENTER"

**I**N 1874 Prof. Ferdinand Braun discovered *unilateral conductivity* in a number of the natural metallic sulfids, such as pyrite, galena and chalcopyrite. His observations were limited to the application of battery current to metallic contacts on the minerals, and he noted that a materially larger current would flow in one direction than in the other. Five years later, in 1879, Prof. D. E. Hughes, while experimenting with a carbon microphone, discovered that it was affected by a distant spark discharge, altho there was no wire connection between the circuits. Altho Prof. Hughes did not publish an account of his experiments until 1899, he exhibited his apparatus in operation, over distances as great as 1,500 feet, to many of the prominent English physicists, including Preece, Crookes, Stokes and Dewar. A glance at the circuit employed by Prof. Hughes in 1879 will show that he had the principal elements of the

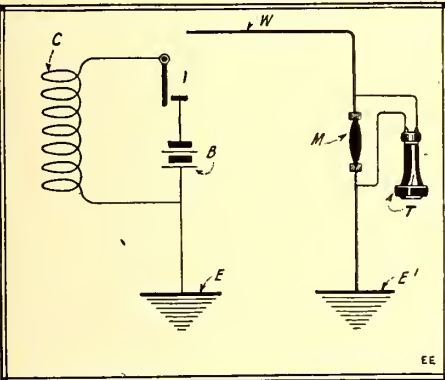

Hughes 1879 Detector System. B is the Transmitting Battery, C an Inductance Coil, I a Mechanically Operated Interrupter and E a Ground Connection. W is the Receiving Aerial, M a Carbon Microphone, T a Telephone Receiver and E' a Ground Connection. Hughes Discovered that the Carbon Microphone Was Affected by a Distant Spark Discharge. Fig. 1.

system re-discovered by Marconi in 1895. Undoubtedly, if Prof. Hughes had had proper encouragement at the time, he would not only have anticipated Hertz in the discovery of electric waves, but also Marconi, in their wonderful application to Radio-telegraphy, and so have altered considerably the course of scientific history. Our immediate interest in Prof. Hughes' work is, however, his detector. As my illustration shows, it consists of a microphonic contact, directly connected to a tele-

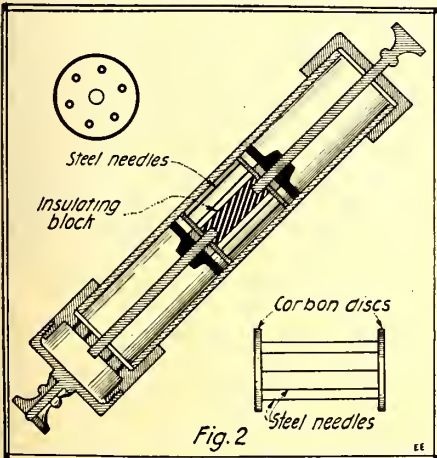

Early "Carbon-Steel" Microphone Detector Used by the Author in 1902 at the Cape May, N. J., Wireless Station.



Dr. Greenleaf Whittier Pickard, Inventor of the Crystal Rectifying Detector. He is Well-known as an Electrical, Telephone, and Radio Engineer and Has Taken Out Numerous Wireless and Other Patents. He Has Tested 31,250 Crystal Detector Combinations.

phone receiver, and without local battery. It is the germ of the crystal detector.

### The Coherer

In 1898, when my work in Radio-communication began, there was but one detector—the coherer. To the early workers in this field, the coherer was the *bête noir* of radio-telegraphy; the principal obstacle to

*F*EW inventions in radio have been made which proved of such tremendous importance to the young art than the Crystal Detector, invented by Dr. Greenleaf Whittier Pickard. In the olden days of the coherer, when we were still groping in the dark, only comparatively small distances could be bridged. The invention of the Crystal Detector may be said to have opened up an entirely new era in radio, for with the coming of this detector great distances were easily bridged and almost perfect communication was possible at all times. "Wireless" had arrived.

But you will want to read the story of how Dr. Pickard invented the Crystal Detector yourself. It is a historical classic. We promise you twenty minutes of most unusual as well as instructive reading.—EDITOR.

assured and speedy communication without wires. Despite its unpleasant idiosyncrasies, the coherer had our deep respect, first because it was the only thing then known which worked, and second because of its supposed extreme sensitiveness to electrical oscillations. In the absence of any quantitative measurements, it was generally assumed that the received energy in radio-communication was so infinitesimal as to absolutely preclude its measurement or even detection by ordinary means, such as galvanometers or telephones, even if by some means it could be converted into a form suitable for these instruments. Altho in some of the early laboratory work with electrical waves various forms of thermo-couples and bolometers were used, the practical workers never considered these as possibilities in actual radio-telegraphy, because of the supposed extremely minute character of the received currents,

to which such a device as the coherer could alone respond. In common with the other workers at that time, I held the same view of radio reception, and spent much time in attempts to improve the coherer as to regularity of action.

### The Microphone Detector.

Much of the trouble in coherer working arose from the adjustments of the coherer adjuncts, the relay-tapper-recorder trio. Realizing this, in the latter part of 1899 I began experiments with a *single contact coherer*, in series with a battery and telephone receiver. I soon found, as several others did at about the same time, that a simple carbon steel microphone consisting of a sewing needle resting lightly against a carbon block, in series with a cell or two of dry battery and a telephone receiver, formed a most effective detector, exceeding the coherer in sensitiveness, speed of working and reliability. And, best of all, I found that this combination permitted a

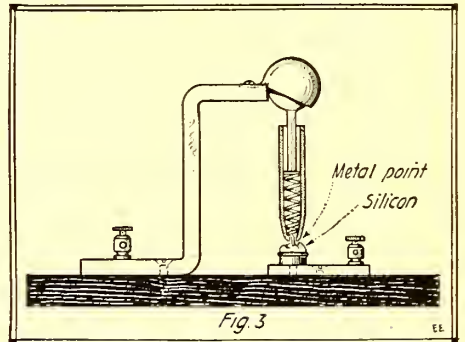

The "Silicon" Detector—A Good Old Stand-by of All Radio Operators. Invented by Dr. Pickard at an Early Date. It Involved a Sharp Metal Point in Spring Contact With a Piece of Fused Silicon.

considerable degree of discrimination between Morse signals and static, which was not possesed at all by the coherer-relay-tapper-recorder combination. All was fish that came to the coherer net, and the recorder wrote down dot and dash combinations quite impartially for legitimate signals, static disturbances, a slipping trolley several blocks away and even the turning on and off of electric lights in the building. Translation of the tape frequently required a brilliant "imagination!"

Altho the microphone detector was a (Continued on page 360)

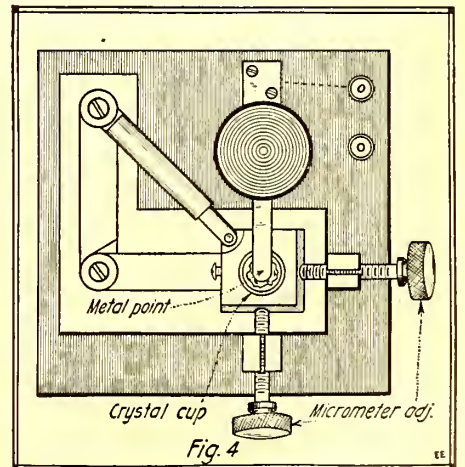

Dr. Pickard's "Micrometer Adjustment" Detector. Can be Used With Any Crystal and the Cup Adjusted With Precision in Any Direction While in Use.

# A Review of Radio-Telephony

**R**ADIO-TELEPHONY has been before the public so frequently of late that an article describing the modern scientific apparatus that has made it possible would not go amiss, it is believed. No one man can claim the credit for discovering "radio-telephony," but electromagnetic waves of so-called "radio" frequency were first intentionally produced and studied by Hertz who was guided by the electromagnetic equations deduced by Maxwell, constructed some twenty years earlier. The first radio

set installed on a battleship was placed on the U. S. S. *New Hampshire*. This set differed from the one in Arlington only in size. The set was installed on the lower bridge deck, and the telephone transmitter and receiver were mounted on the bridge itself. This allowed the captain, while on the bridge, to converse without leaving his post.

After many successful trials, it was decided to install two experimental sets on other battleships and give the operating staff an opportunity to investigate and criticize them. These sets were installed on the battleships *Arkansas* and *Florida* at Guantanamo, Cuba, the first part of February, 1916. It was found entirely practicable to hold a two-way conversation between vessels over 30 miles apart. There is no reason to think that this was the limit of communication as some of these conversations were overheard in Jamaica, a distance of 175 miles. No attempt was made for range as that was not the object in building these sets.

Each set consisted of a transmitting and receiving set complete with motor-generators. An extension circuit was provided so as to allow placing a hand set in the captain's cabin. The normal position of the antennae was connected to the receiving set in order to hear incoming signals. When it was desired to talk, a push button operated a solenoid switch which connected the antennae to the transmitting set and started the motor-generator. This operation consumed only a fraction of a second. The wave length range of this set was from 600 to 1,200 meters. The complete circuit is shown in Fig. 3.

The greatest success with radio-telephony has been accomplished in connection with military work in the air. On May 22, 1917, Major General Squier, Chief Signal Officer of the Army, called a conference at Washington to consider the feasibility of intercommunication between airplanes while in flight by means of radio-telephony. There were present at this conference, besides General Squier, Colonel Rees, of the Royal Flying Corps of Great Britain, Captain, now Colonel, C. C. Culver, of the Signal Corps, and Major, later Lieut. Colonel, F. B. Jewett, and Captain, later Major, E. B. Craft, who had been assigned

(Continued on page 369)

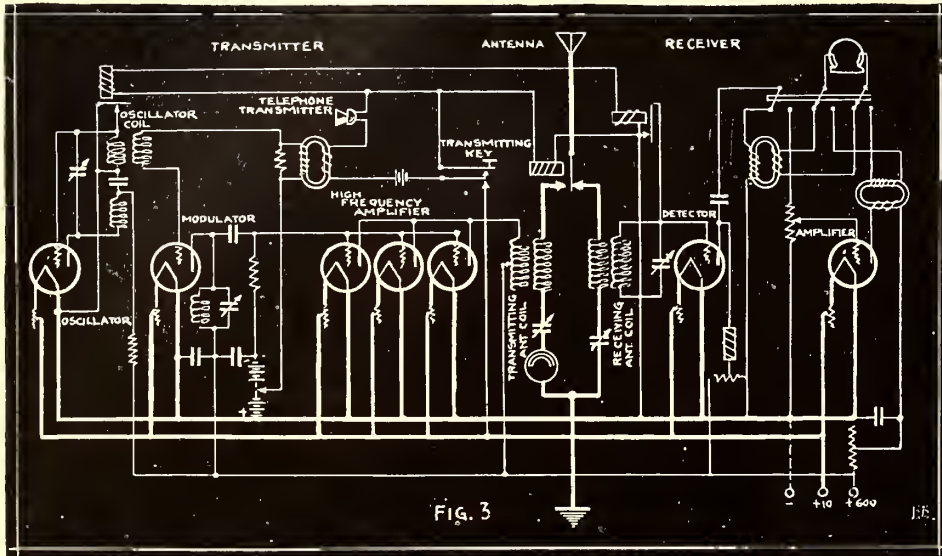

Fig. 3

Battleship Radio-telephone Set.—Schematic Circuit Diagram. Showing Microphone Modulator Circuit, Talking Key, etc. Note How the Vacuum Bulbs are Connected on Parallel.

telegraphic outfit was produced by Hertz, and improved by the discovery of the coherer by Brown, and of the invention of the present form of antennae first by Tesla, followed by Marconi, which allows the radiation of large power by long waves.

At an early date it was realized that a crystal detector in combination with a telephone would produce in the telephone, currents whose amplitudes varied approximately as the amplitudes of the received high frequency wave, and consequently if the amplitude of this wave could be varied at the transmitting station in accordance with speech, radio telephony would be possible.

The receiving apparatus was therefore in existence and all that was necessary was a means of varying the amplitude of the transmitting wave. In regular wire telephony, the amplitude is so varied by microphones, and of course this device was at once applied to radio-telephony. The great trouble lay, however, in the fact that microphones, even when especially designed, cannot easily be made to carry large currents and still function properly. Because of this handicap, numerous voice-operated resistance-varying devices appeared. Using methods of this kind, considerable success was obtained, and in 1912 Vanni succeeded in telephoning 1,000 kilometers.

During the years of 1912 to 1914, a great deal of research work was carried on in connection with the use of the audion in radio-telephony, and in 1914 it was decided that the apparatus was sufficiently developed to warrant an attempt at long range wireless telephony. These tests were so successful, that the Navy Department erected an experimental station at Arlington, Va. The type of power bulb used is shown in Fig. 1. The current, by which the filaments were heated, was supplied by

then transmitting to Darien and other remote points.

The immense racks containing the power tubes are shown in Fig. 2. At the left in this figure is the remote control for operating the motor generator set in the main Navy radio station at Arlington, and also for metering the currents used for lighting the plant and other such auxiliary purposes.

The first opportunity to demonstrate the use of wireless telephony in war was presented early in 1916. After several trials and experiments, the first radio telephone

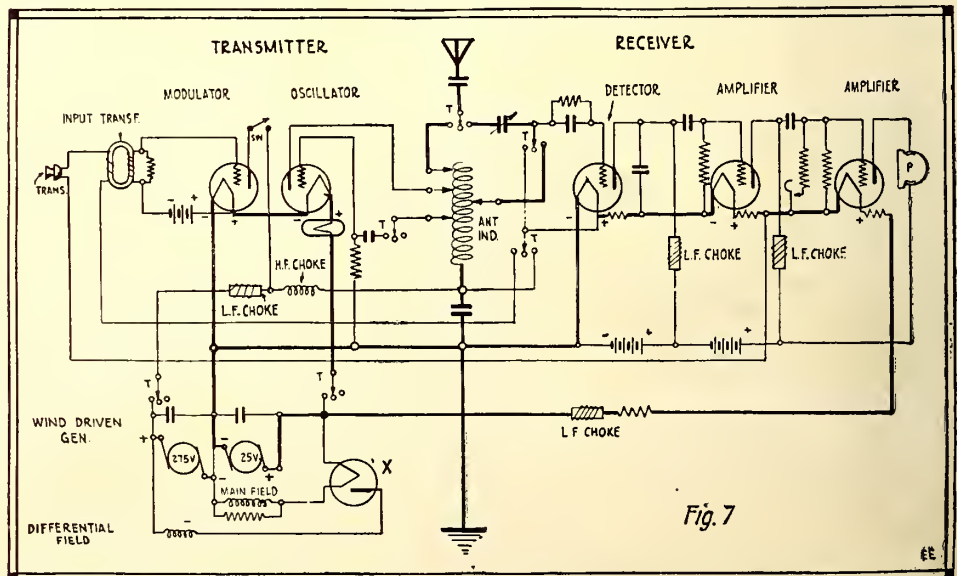
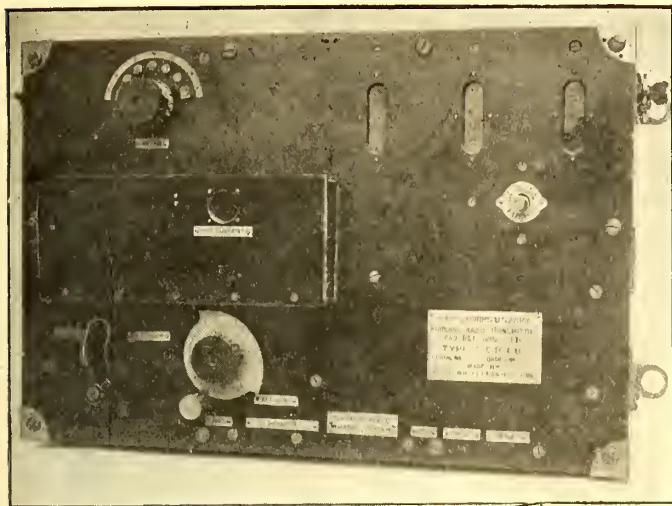

Fig. 7

Schematic Circuit—Airplane Wireless Telephone Set, U. S. Signal Corps—Type SCR-68. Transmitting and Receiving Circuits Are Shown. "X" Indicates the Clever Vacuum Bulb Regulator for Maintaining the Dynamo Voltage Constant.

# American Radio-Telephone Apparatus



4

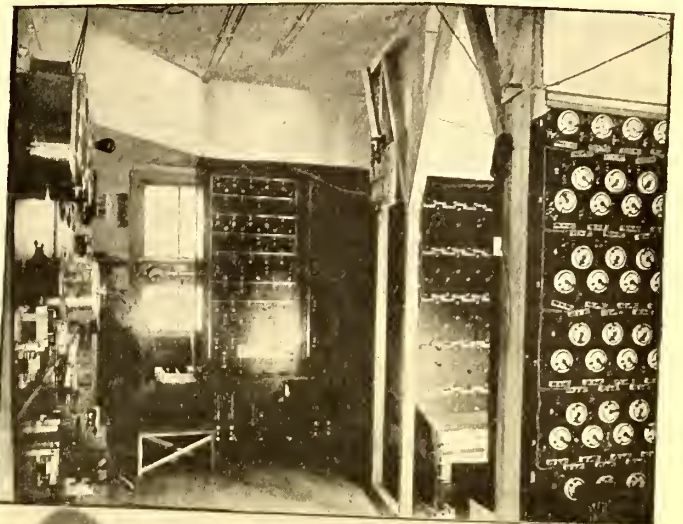

2

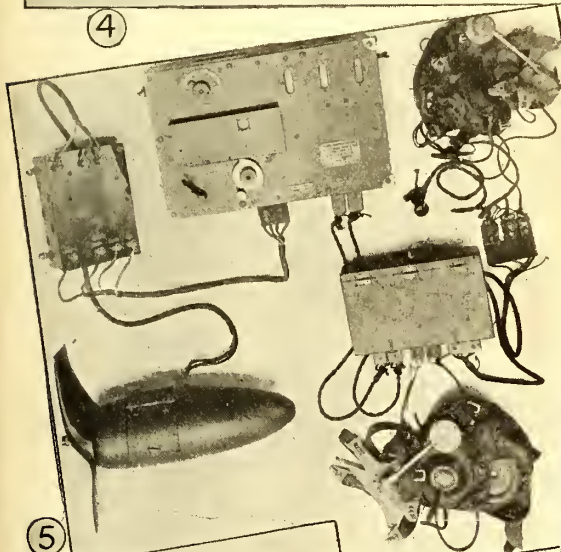

5

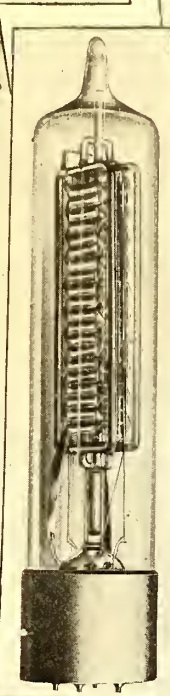

1

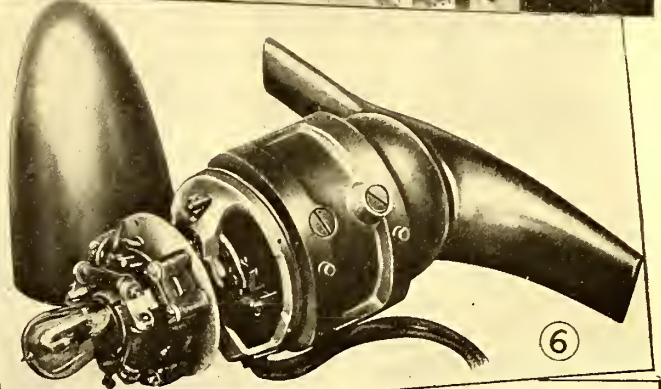

6

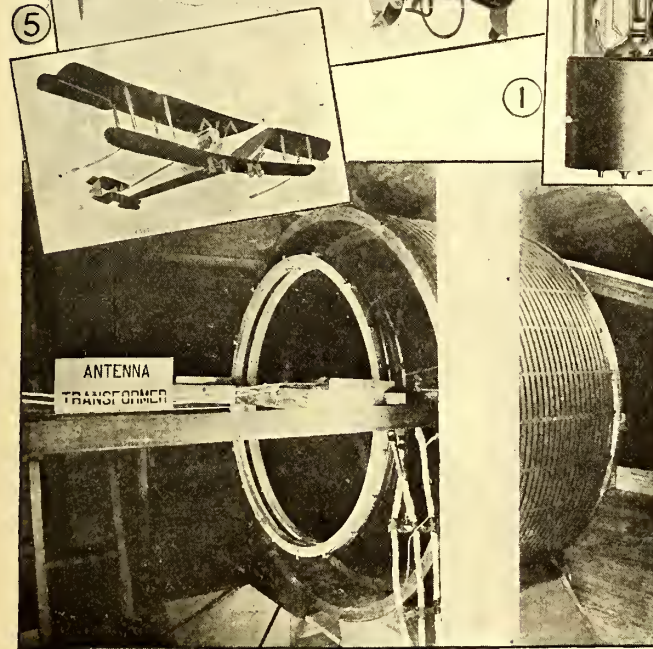

10

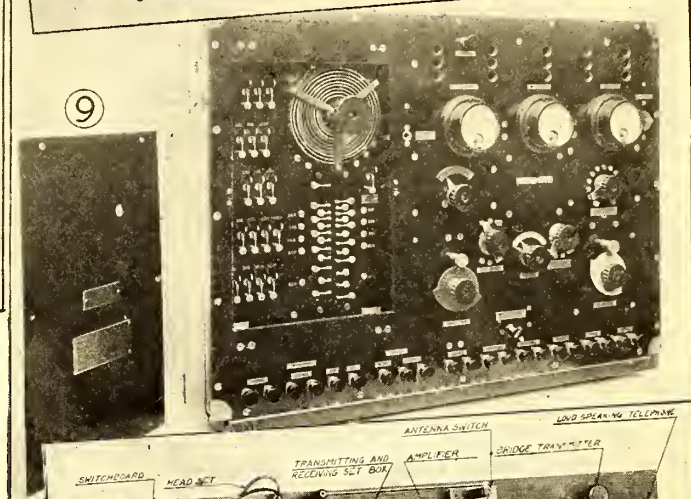

9

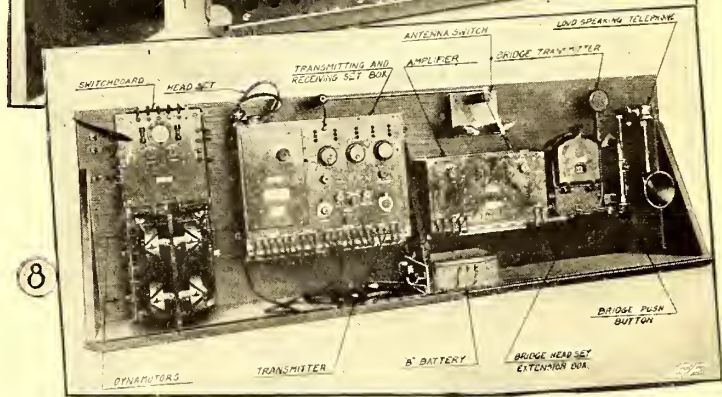

8

## AMERICAN WIRELESS TELEPHONE APPARATUS DEVELOPED AND USED DURING THE WAR.

Fig. 1—Type of Vacuum Tube Oscillator Used in Long Distance Radio Telephone Work. Fig. 2—Remarkable View Showing the Vacuum Tube Rack in the Radio Experimental Station at Arlington, Va. Note the Large Number of Rheostat Regulators for Controlling the Filament Currents of the Various Tubes. Several Hundred Tubes Were Available in This Laboratory, Any One or All of Which Could Be Used at One Time. Fig. 4—Front View of Transmitting and Receiving Set Used for Wireless Telephony by the U. S. Signal Corps. The Vacuum Tubes Are Safely Enclosed Within the Cabinet, and Their Degree of Luminosity Is Visible Thru the Oval Glass Windows in the Upper Right Hand Corner in the Panel. Fig. 5—This Shows the Complete Radio Telephone Equipment for Two-Place Airplane Service. Note the Two Helmets Fitted With Wireless Receivers and the Breast-Plate Transmitters, Specially Designed to Shut Out Noises From the Engine. The Wind-Driven Generator Is Shown at the Left. Fig. 6—View of Wind-Driven Radio-Telephone Generator With Stream-line Cover Removed, Showing Vacuum Tube Which Regulates the Voltage and Keeps It Constant at All Speeds,—an Extremely Clever Invention Due to an American Engineer. Fig. 8—An Assembled View of Various Apparata That Go to Make Up a Standard "Submarine Chaser" Radiophone Equipment. A Loud-Speaking Receiver Is Connected to a Three-Stage Vacuum Tube Amplifier. Fig. 9—This View Shows the "Submarine Chaser" Type of Transmitting and Receiving Set for Radiophony. Fig. 10—Shows One of the Gigantic Antenna Tuning Transformers at the Radio Experimental Station, Arlington, Va. The Secondary of the Tuning Transformer Is Moved In and Out of the Primary, by Means of Cables Which Run to Control Wheels in the Apparata Room. Some of the Most Important Radio-Telephone and Telegraph Researches Carried Out During the War Were Performed at This High Power Government Wireless Station.

# Concentrated or Loop Aerials

By Prof. Lloyd M. Knoll, A. M.

SEVERAL freaks and dreams of radio experimenters before the war have been realized in a device developed by the writer, in connection with the 4th Naval District. Not only does the device eliminate a large amount of interference from other stations of the same wave length, but like the Rogers underground system, eliminates

to contend with. It is no longer necessary to put poles on some high building, string aerials over large areas of ground nor even to tap an old 'phone line. The dream of the experimenter that some day he might put a nail in a flower pot for a ground and run a wire to a nail on the wall of his room is eclipsed and now the camper or tourist can pack a grip and be sure of always being in radio touch with the world.

Many operators will recall how it was easier to get certain stations when the aerial was disconnected from the set. This freak (?) set the writer and his friend, Mr. T. Appleby, to work to solve the problem of receiving regularly without an aerial and their results were put at the disposal of the government with the declaration of hostilities, and is only now being made public. Mr. (now Lieut.) Appleby discovered that the device had a strong *directional effect*. Later the writer concentrated the apparatus and discovered the way to eliminate static as well.

The extreme simplicity of the outfit is one of its most striking features. In fact the amateur has all the parts needed and early systems employed very much the same features but on a large scale. A loop of wire of proper proportions, a detector (a vacuum tube is most sensitive but not necessary), a pair of 'phones, the proper connections, and there you are. In the photograph may be seen a set in operation receiving on 2,500 meters wave length. Fig. 2 shows the receiving hook-up employed. As stated before there is a decided *directional effect* and if the loop is mounted in a vertical plane and rotated around a vertical axis, a remarkable fact is noticed. For example, suppose Fig. 5 to be taken as the circle described by the loop. Now if the signal is coming from a

point along a line 210° from North, then if the end of the loop connected to the



The Author and One of His Loop Aerial Radio Receiving Sets.

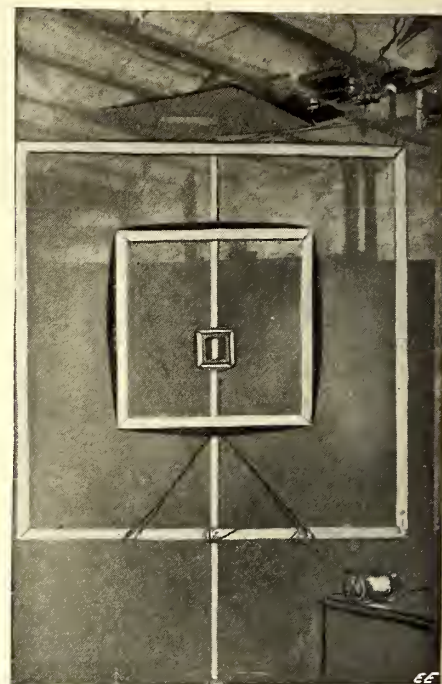

Some of the Author's Loop Antennae. A Small Aerial of This Type Has Picked Up Messages From Stations 200 Miles Away.

static as well, and being in a highly concentrated form it brings the outfit within the reach of the Radio Amateur. It is specially useful for the city wireless "Bug" who has limited space or a fussy landlord

grid of the audion or v. t. moves from A to B, there will be an increase and then a decrease in the intensity of the signal;

(Continued on page 362)

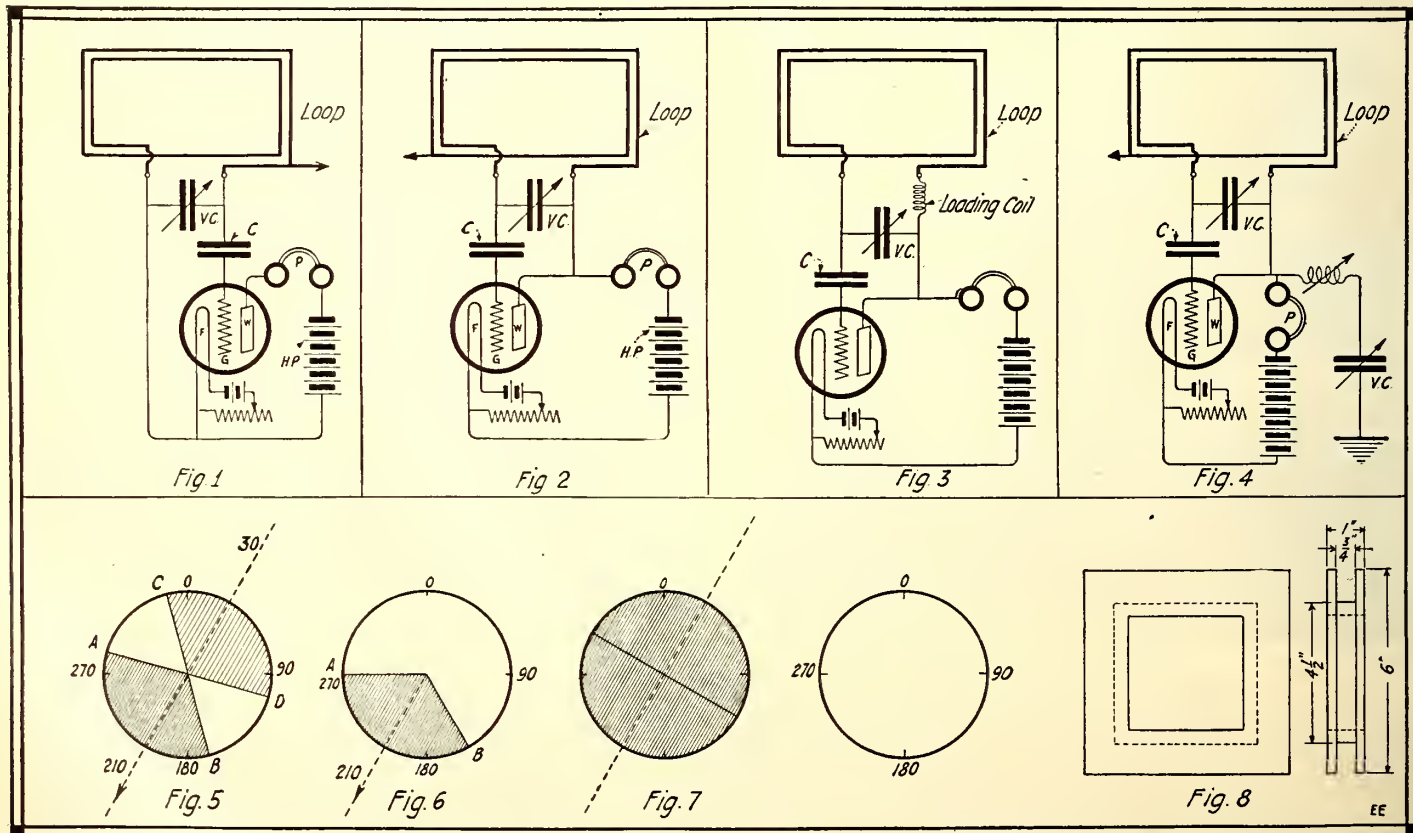

Various Hook-ups of Prof. Knoll's Radio Receiving Apparatus Involving Loop Antennae. The Lower Circle Diagrams Show the Relative Activities of the Loop Antennae.



# To War on an American Destroyer

By A. H. WHEDON

## A Radio Operator's Experience Chasing the U-Boats

**T**O begin with, let it be known that the author spent sixteen long, weary months with the United States Destroyer flotilla based in Queenstown, Ireland, and therefore feels competent to write the following few remarks.

The American destroyers arrived in Queenstown, Ireland, on the fourth day of May, 1917, after a ten-day trip across the Atlantic, during which time our radio transmitting apparatus was not used more than three or four times. You see, when we left the States we had no idea of what we were going into. Our idea of the German submarine question had been entirely derived from reading the newspapers. Consequently, we imagined that we would see a dozen or so a day, and that when a mer-

varied from twenty-seven to thirty-four, and to come down to sweet sixteen, once again meant hard work!

But gradually, as we operated with them, their receiving speed increased, and likewise did their transmitting speed, and again our troubles were increased. Very few of you, probably, have ever heard a "Limy" spark in action, but most of you are fairly familiar with the sound of a low frequency buzz-saw, and believe one who knows, there is not enough difference between them to be happy about. And then, when they

The English are not renowned for their quick perception. We found that fact out to our sorrow. Altho "playing flats" (unauthorized conversation) is not permitted in either Navy, there are times when it is necessary to talk to the other fellow about a message, or on similar subjects. Of course, such conversation must necessarily be as short as possible. In the U. S. Navy every word is abbreviated in this unofficial conversation. For instance, one operator wants to ask another "What is the check on message number one?" It would be transmitted: "Wht ck msg one." After the answer would come "Tks" for "Thanks."

There was an occasion when my ship, the U. S. S. *Conyngham* was in company with the H. M. S. *Snowdrop*, a boat of the "sloop" type, developed during the war.



A "Lime-juicer" (English Sailor) Radio Operator Trying to Decipher What the Blanky-Blank the Yank's Code Message Means.



Don't Look at this Scene too Long or You'll Get Seasick. It Represents What the Radio Room on a "Destroyer" Looks Like in a Heavy Sea.



The Radio Room on the "Destroyer" Had a Leaky Ventilator in the Roof. What Didn't Happen in Those Two Awful Days Off Brest, France,—COULDN'T.

chantship used her radio, several submarines got her position by a direction-finder, and sallied forth to attack her. Naturally, we were very quiet with our own radio instruments, and were terribly disappointed when we reached port without seeing a single "sub."

When we reached Queenstown, the British Admiralty Authorities came aboard to look us over and to hold a conference with our officers. One of the results of the conference was the determination to use the British method of radio-communication. They called it W/T (Wireless Telegraph). Of course, the code was the same, but there the resemblance between the two systems ended. And perhaps you think it was easy to forget, after years of thoro training, the things that came as second nature to us and to substitute absolutely new stuff—it was not very simple.

And when it came to working with the "Limy" (British) ships and stations—my, my! They sent at the terrific speed of sixteen to twenty words per minute. Twenty words was their high speed limit. The American operators who first went over there were all picked men, and their speed

started to speed up on a spark like that—can you imagine it?

Another trifling (?) detail (?) that bothered us was the fact that everybody and everything dashed off on the one wave length—600 meters. And altho there was an order out to the effect that radio work was to be reduced to a minimum, very few people ever took any notice of it. Consequently, in the Irish Sea there was an awful mixup, for on the English coast there are Liverpool, Fishguard and Land's End. Opposite them, a few miles away on the Irish coast, there are Belfast, Dublin and Queenstown, and when all of these stations are trying to work on the same wave length, to say nothing of all the ships in the Irish Sea, there is, to say the least, a little interference. But as the English boats are not equipt with an efficient wave changer, as are all our boats, nothing was ever done about it. Gradually the problem resolved itself into the equation: "The guy with the most power wins," for nobody would ever keep quiet long enough to let the other fellow work. There was a time when I, personally, had a message to send to Liverpool. It took 5 K. W. for 100 miles.

My sending set wasn't working any too well, but as I had a long message to send him, I decided to make a try at it. So I opened up and started. Very shortly I began to miss sparks, so I signalled over "ST BI 5 TRANS BRKN DWN," meaning "Stand by for five minutes. My transmitter is broken down." There was complete silence for a few seconds, while he tried to puzzle it out. Then he came back with a great big question mark. I thought it possible that I had been a trifle speedy for him, so I made a hasty connection and sent it again, more slowly. More silence. Then more question marks. By that time I had fixt my set up, and was just about to start in on friend "lime-juicer" with the message, when he came across with the conventional signal for "Your Morse is unreadable. Put a competent W/T operator on watch." That was all the thanks I got for trying to tell him to wait a minute.

There may be some of you who think that radio in the Navy is a soft job. Well, it is—on a decent sized ship that knows enough not to roll and pitch all the time.

(Continued on page 367)

# How to Develop Your Inventive Ability

By JAY G. HOBSON

(Author of "How to Finance and Manufacture a Patent")

**A**FTER many years of careful research into the mysteries of the human mind psychologists have concluded that every normal person is an inventor by nature, having inventive faculties to a certain degree.



The Automatic Restaurant Is a Clean Place To Eat, Isn't It? But Why Must We Allow People With Dirty Hands To Fumble Around in the Spoon, Knife and Fork Receptacle? Why Not Invent a "Dispenser" for the "Eating Tools?"

Many have developed these talents further than others, but the fact that we are all inventors naturally is of great importance to every one aspiring to create something of value to mankind and themselves. While we are assured that each individual is capable of creating, improving and originating new and useful things, yet most of us find considerable difficulty in deciding upon the best and surest course to pursue in order to develop our inventive qualities to a point of efficiency necessary to cash our ideas for their full worth.

Inventive ability is simply the power of close observation, scrutiny, imagination and analysis of material things as they exist with the way they might be made to exist, if constructed in a different form. All things have at some time or other been the result of some dreamer's or some thinker's imagination and—observation crystallized into a mental picture, then developed until it has merged into actual form, a complete, improved article of practical worth.

The practise of observation, imagination,

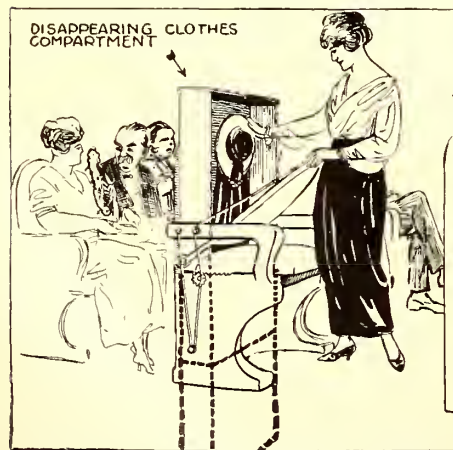

Why Can't We Go to the Theatre and Find a Clothes Compartment in the Back of the Seat That Disappears into the Basement When You Sit Down? Nobody Ever Thought of It!

constructive investigation and analysis will develop this inventive ability and in time make it both perfect and prolific. But there are certain proven ways that help this development more than others. Idle curiosity over things will not promote the inventive training and is not constructive observation or investigation. Investigation, observation and analysis must be done systematically and with a sincere aim in view. There must be a serious desire for betterment and improvement in mind to find that improvement or invention worth while.

The great revolutionary inventions are few and far between, but when they do appear it is evident that some sincere mind has striven to create a working device of his mental picture which was undoubtedly conceived by a fervent desire to produce an improvement over unsatisfactory conditions as they were in the time of the conception. Or probably it was the aspiration to give the world a device that would save unnecessary labor, prolong life, or improve commercial intercourse for big business. However, it is established that to originate or create improvements of value, one must train his mind and imagination to picture things as they should be and then stick to his mental idea until it successfully matures into a practical device of certain operation.

There are numerous examples of inventive development but for illustration we will consider only a few. Elias Howe first observed the pressing need for a machine to do the tedious labor of sewing that in his day was entirely done by hand. After observation came investigation of his idea, then a mental picture or imagination of a machine capable of producing the desired result, then came analysis of mechanical movements necessary to replace the human hand, and finally after years of discouraging effort he succeeded in designing and perfecting a model that not only did what the human hand would do but did it in one-fifth the time. It took Howe years to perfect his first machine mainly because in those days the art of mechanics was only in its infancy, which necessitated his working out of every mechanical detail. Today it is far easier for the inventor. He can conceive the idea, sketch plain plans and drawings and secure assistance to perfect the mechanical details. There are more and greater opportunities to become inventors today than ever. There is more money to be made and quicker. Elias Howe did not labor in vain as his invention made nearly two million dollars in royalties.

The incident of the hair pin and how its inventor observed his wife bending a straight hair pin to prevent it from coming out of the hair is a much hackneyed experience. But only recently an alert young man in Chicago conceived the idea of placing a hump in the neck of the old-fashioned hair pin to prevent it from coming out of the hair. A patent was obtained upon this extremely simple idea, they were offered to the feminine public in attractive packages and now sell by the millions. To date the inventor has made hundreds of thousands out of his simple little improvement, which only goes to prove that nothing is too small or too simple for our consideration and observation, if we would become successful inventors.

The simple ideas are, as a rule, more prolific and prevent infringement to a greater degree. After an idea is received the inventor should strive to picture it in

the simplest possible form. *Simplicity in invention is the secret of patent success.*

There are five distinct ways in which the mind receives inventive ideas, namely thru the five human or physical senses; sight, taste, smell, feeling and hearing. A

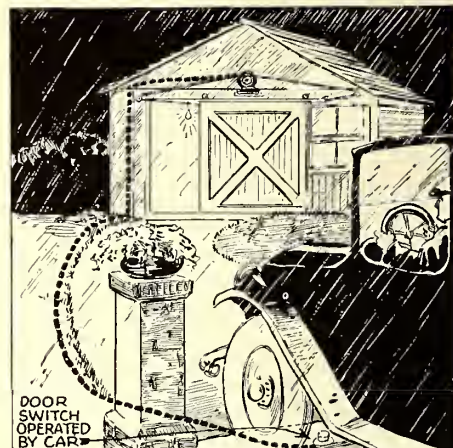

Why Not Invent a Simple and Reliable Garage Door Opener? Thousands of Auto-ists Everywhere Will Not Only Bless You for It, But Will Buy Them by the Hundred. But It Must Be Cheap in First Cost and Maintenance.

person may see an improvement and patent it, or taste a flavor and create a better one, or smell an odor and design a device to eradicate it, or hear a situation and replace it with a different one.

All inventions have entered the inventor's mind thru one or more of these five ideas-carrying channels before materializing into completed form. The mind is the oven or incubator for hatching these inventive germs and forming them into practical articles for earthly use. Therefore to develop one's inventive faculties it is necessary to develop both the five human senses and also the mind that controls them.

For the purpose of suggesting an effective method of development I will now ask the reader to join me on a little inventive expedition up among the clouds of creation.

Our first imaginative stop will be in the office of a modern business man who is branch manager for a large eastern corporation. It is noon time and our friend decides to go out to lunch. We follow him down the avenue to a cafeteria. He en-

(Continued on page 338)



Can You Identify Yourself In a Strange City? You Could Do So With the Simple Pocket Case Here Shown, Containing Your Photo, Signature and a Cancelled Check Endorsed By You.

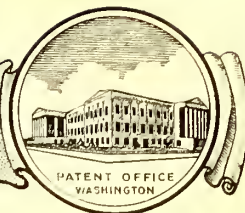
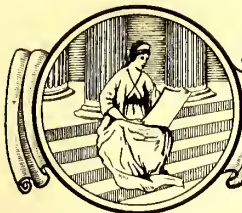

# LATEST PATENTS

### Magnetic Razor.

(No. 1,299,096, issued to Butler Ames.)  
A very ingenious idea is this magnetic razor, which makes the cleaning of safety razors a very simple

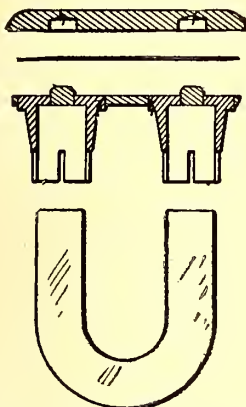

process, as the retaining cap over the razor blade may be instantly removed by pulling it off the magnet cores. The cap and blade members of the razor are adapted to be held in position by a guard member, by magnetic flux passing from one pole of the bi-polar magnet to the other pole, thru the blade and cap, which members are made of steel or other magnetic material.

### Tidal-Power Motor.

No. 1,304,238, issued to Judson E. Wright.)  
In this tide-motor the inventor makes use of one or more floats,

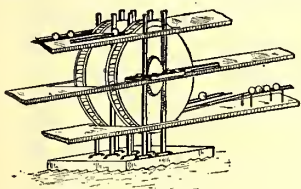

which rise and fall with the tide. The alternate up-and-down movements are made use of thru a pair of gear racks, acting alternately on a pinion or gear wheel as shown. One of the racks acts on the "upward" motion and the other on the "downward" motion, thus preserving a continuous rotary motion in the power wheel. When the action of the tide is low or nil, the power is maintained by a series of spherical weights acting on a bucket wheel connected with an auxiliary power member. These weights are carried to a higher level by the regular tidal motor thru a bucket conveyor.

### Electric Soldering Device.

(No. 1,304,545, issued to Frederick A. Costello.)  
This soldering device comprises a tubular holder resembling a pencil or pen holder, thru which the wire or strip solder is applied to the work to be united. This holder also carries a circuit-closing switch for the primary of a step-down transformer, as shown, and also

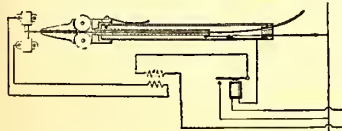

knurled "solder feeding" wheels. The electricity is used only in actually heating the solder when the

same is placed in contact with the work to be united by this clever arrangement. A relay serves to open and close the primary circuit of the transformer in the manner evident.

### Raising Submarine Vessels.

(No. 1,303,912, issued to Hideo Katayama.)  
A clever idea for raising sunken

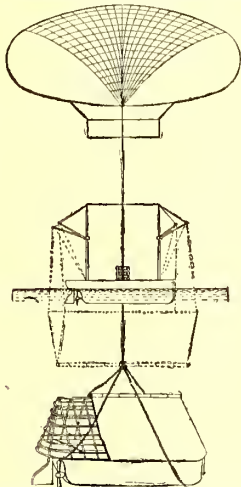

vessels by means of aircraft of the balloon or other type. In the first place, the surface of the upper deck portion of the sunken vessel is covered with a wedge of special pyramidal structure, so that when the balloon or other aircraft is connected with the wreck, as by means of slings, the buoyancy of the balloon may be utilized to greatest advantage. The slanting roof structure reduces the resistance of the body as it is lifted up thru the water.

### Electric Semaphore for Autos.

(No. 1,299,361, issued to Hyman Lieberman.)  
An electromagnetically operated semaphore for automobile signaling, two of which may be used on the car, one on the right and left, respectively. The device works by

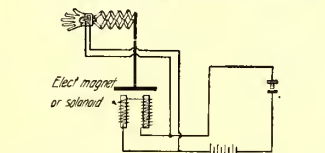
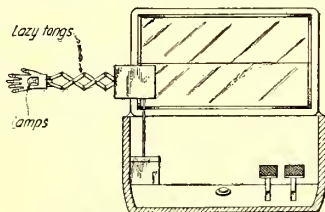

means of a lazy-tongs arrangement connected up to an electromagnet or solenoid. The driver has simply to close the electromagnet circuit with a foot-controlled push-button, when the electromagnet, becoming excited, causes the lazy-tongs to act, thus projecting the hand about two feet. At night the hand may be illuminated by an electric lamp in the palm, which can be seen from either front or rear, and also the fingers can be illuminated by a small electric light placed on each finger.

### Electric Whistle for Toy Railroads.

(No. 1,303,117, issued to William C. Roe.)

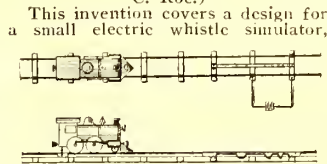

This invention covers a design for a small electric whistle simulator, for electric toy railroads. A special circuit controller in the form of an auxiliary track member is provided, in the design here illustrated and described, so that as the locomotive and train pass over this auxiliary contact placed between the rails the whistle simulator circuit will be closed and the device actuated. The instrument is constructed in the form of a buzzer so as to give a high, shrill note, similar to a whistle.

### Electric Gas Detector.

(No. 1,304,208, issued to Gilbert A. Shakespear.)  
The definite rate of loss of heat from a body exposed to the gaseous mixture is employed as the detecting and measuring agency. A Wheatstone bridge circuit is utilized, including a pair of electrically heated

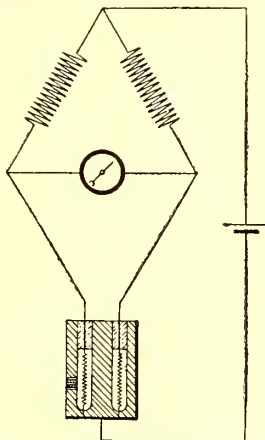

wires, one of which is surrounded by the gas to be tested, while the other is surrounded either by air or by any other gas, which can serve as a "standard" for comparison. A galvanometer is used to adjust the Wheatstone circuits to a state of balance.

### Zigzag Carbon Resister.

(No. 1,298,421, issued to John Thomson.)

The present resister device renders the carbon element of the resister immune to oxidization, thus restoring the slotted member so as to maintain its original resistance at all times. To do this the slots of the resister are filled with a material having coefficient of expansion and contraction nearly identical to that of the carbon forming the resister. Fuzed aluminum oxid and silicon carbid in its crystalline form have proven useful for the purpose.

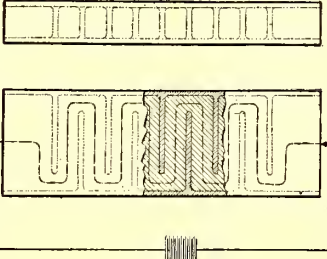

### Telephone Call Recorder.

(No. 1,299,154, issued to Arthur Engelberg.)

This invention relates to an electromechanical device comprising a spring motor which will unroll a paper tape, and at the same time, by means of an electromagnet, cause to be recorded on the tape any telephone numbers of parties which may have called while the owner was absent. This device would seem to

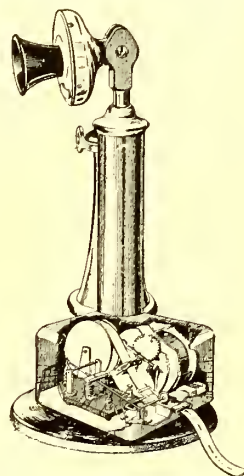

have considerable promise, and if taken up by the telephone companies should prove of great value as a time saver. The spring motor and electromagnet recording device is controlled from the telephone exchange by "Central." Many times people call a party, only to find "that the line is busy", or else that "they do not answer," all of which wastes a good deal of time in the busy man's day. If the number calling was recorded in the office of the absent party, then upon their return they could call back the number in question.

### Magneto Pocket Lamp.

(No. 1,301,595, issued to Marc A. Pattay and Eugene Jaquemont.)

This is a clever idea in magneto electric pocket lamps, and represents several improvements over those heretofore proposed. Not only is it provided with a mechanism for spinning the armature of a small magneto generator, which develops the necessary current for lighting the lamp, by means of a reciprocating rocker arm, but it is also provided with a continuous circular movement crank operated independently and whenever desired by means of a change-over attachment. The device is ingeniously worked out, so that for ordinary lighting purposes it is but necessary to squeeze on the flexible casing of the pocket lamp, which causes the armature of the dynamo to be spun rapidly. No batteries are necessary, and by the arrangement of the mechanism in this lamp it would appear that the light should be practically continuous.

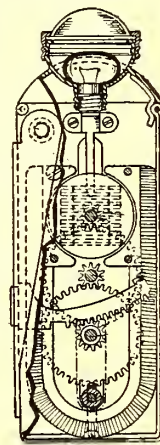



# WITH THE AMATEURS



Our Amateur Laboratory Contest is open to all readers, whether subscribers or not. The photos are judged for best arrangement and efficiency of the apparatus. To increase the interest of this department we make it a rule not to publish photos of apparatus unaccompanied by that of the owner. Dark photos preferred to light-toned ones. We pay \$3.00 each month for the best photos. Address the Editor, "With the Amateurs" Dept.

## "Amateur Electrical Laboratory" Contest

THIS MONTH'S \$3.00 PRIZE WINNER—H. C. SMITH

I PRESENT herewith two photos of my laboratory and one of myself. My chemical laboratory has over 150 solid chemicals and about 100 different solutions. The glassware consists of beakers, Erhlemeyer flasks, funnels, condensers, burettes, hydrometers, evaporating dishes, crucibles, graduates and retorts. It also includes a "French" microscope, a balance, and many other apparatus too numerous to mention here. My "Electrical Laboratory" consists of various motors, generators, condensers, wireless transmitting and receiving apparatus now in construction, also a switchboard under construction, 1/2 K.W. transformer coil and a two-inch spark coil. Unfortunately all of my "Electrical Laboratory" did not get into the picture.—H. C. Smith, 3816 S. Honore St., Chicago, Ill.

HONORABLE MENTION (One Year's Subscription to the ELECTRICAL EXPERIMENTER)—ROBERT NIESSNER and ROBERT BOHATY

HEREWITH are several flash-light photographs of the electrical laboratory and experimental machine shop of Robert Niessner and myself. In this laboratory we do all kinds of experi-

mental and research work in chemistry, electricity, high frequency and wireless. This laboratory was started in 1917, and it is still growing very rapidly.

One of the photos (left) shows Robert Niessner, and the other (right) shows myself. Another shows a corner of our "office," where we do all the figuring and correspondence. One of the views illustrates our electrical testing bench and switchboard, and part of our chemical bench. We possess a large screw-cutting lathe on which we do all kinds of machine work. We have had this lathe only a short time and it has turned out quite a few dollars worth of work for us.

These photographs show only a small part of our equipment. We have all kinds of electrical motors, dynamos, generators, gasoline engines, steam engines, electrical testing apparatus and a complete set of wood and metal working tools.

Among the magazines that we have in our "office" there is the ELECTRICAL EXPERIMENTER, which is of great value to us in our work. We also have many books pertaining to chemistry, electricity, steam and gasoline engines, et cetera.—Robert Bohaty, 434 East 77th St., New York City, N. Y.



# Science in Slang

By EMERSON EASTERLING

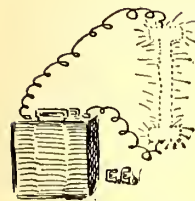

Stokes and party, we, sat in the tonneau while the driver fingered and swore and smoked Turkish cigarettes.

"The name 'storage battery' is a misnomer," commented Jazz. "The juice is not stored as commonly conceded, but is generated or caused to circulate by the chemical action set up in the plates of the cell."

"How did the storage battery or secondary

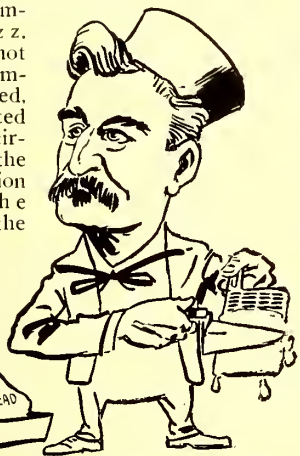

Camille Alphonse Faure, Who Pasted Us a Hot One When He Handed Us the First and Original Pasted Gridplate.

cell come about?" asked "Rat" Morehouse, the bow-legged boy from Berkeley, California.

"Volta and Galvani started the ball in that direction when they got to monkeying around in the dynamic field, but the original storage cell was developed by a bird by the name of Planté. Gautherot got to shooting juice thru platinum wires in water and other electrolytes and observed that the little contraption was capable of kicking back a light current when the juice was cut off. The fact of the case was that he stumbled onto the accumulator idea when he was only trying to jerk the H<sub>2</sub>O into O and a couple of packages of H. Electrolysis, that was his game. You remember, a lot of the scientists thought that ions was as far down as matter could be boiled—electrolysis did that. Like a lot of other things, the secondary cell was a secondary discovery—the inventor was not fishing for the cell.

"Two years after Gautherot's stunt, in 1803, Ritter constructed a secondary pile much like Volta's. By charging for a few moments with a strong galvanic current the pile would give quite a kick. The plates were copper disks separated by cloths moistened in sal ammoniac.

"Count Volta, Bequerel and a stack of other researchers became aware of the fact that gold, silver and platinum and some other nice metals would give secondary currents when subjected to electrolytic action in certain solutions.

"In 1842 Grove slipt us his celebrated gas (no, not mustard) battery. The big idea was the difference in polarity in the two gases, oxygen and hydrogen.

"Mike Faraday had the idea in his hand but did not close up on it when he found that peroxide of lead at the negative pole had a relative high conductivity. The old boy makes note of the fact in his *Researches*.

## What Makes the Storage Battery Store?

"Until 1860, when Gaston (without the assistance of dear Alfonso) Planté threw a bunch of coiled lead plates together into a jar of solution, the old-timers never had the pleasure of seeing a *real* secondary cell. Gaston, with his plates of lead, lead peroxide and spongy lead, and finally lead sulphate in the sulphuric acid electrolyte, was able to run his battery down to where she took the count and then give her a shot of electric hop and watch her hump again. Metzger, Brush and some of the other highbrows boosted the Planté idea along until they had a fairly decent battery out of it."

"What do you mean by lead, lead peroxide and spongy lead, and finally lead sulphate?" inquired Fred Cochran.

"To begin with, the plates are lead, unless the makers build up the plates from lead oxide and sulphates. The charging current turns the positive plate to peroxide of lead. The negative plate of lead sulphate is converted to spongy lead. The electrolyte is about 23 per cent. sulphuric acid in water. When I said that 'finally lead sulphate,' I was referring to the state that means curtains for the cell. A sulphated cell is like a car without gas or a ship on the rocks. Get the idea?"

"What chemical action goes on in the cell during charge and discharge?" asked Velt.

"It is like this," returned Stokes. "When the juice is sent through the cell, entering at the positive plate, the water is changed to its components, hydrogen and oxygen. The oxygen combines with the positive plate, forming lead oxide or peroxide. The hydrogen forms at the negative plate.

"On disconnecting the source and again closing the circuit, the water is again decomposed. The oxygen uniting with the

hydrogen collected at the negative plate and with the plate itself, and the hydrogen uniting with the oxygen of the oxide of lead at the positive plate, causes a current to flow in the circuit that is closed. That is the simple explanation of the operation. There are minor and subsequent actions and reactions that take place, but the only one that makes any difference is the white insoluble sulphate formed by the red or yellow sulphates with the litharge. This formation is a non-conductor and otherwise bothersome and harmful. It is the root of 'sulphation.'

"Generally speaking, the cells are divided into two classes: those in which the active mate-

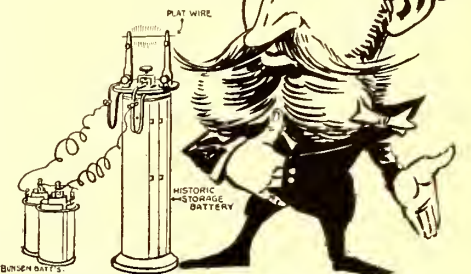

Monsieur Gaston Planté, the Original Goodness-to-Honest Storage Battery Kid.

rial is formed by chemical or electrochemical action, and those in which some easily reducible salt of lead is applied mechanically. Planté types are examples of the former and Faure types of the latter. The Gould batteries are made from the slow former process. The Willard batteries are also of the Planté type, while the Exide cells are of the Faure. The Faure type has a little better output for the weight, but the other has it over on them in sturdiness.

"Tommy Edison stept off the lead and sulphuric solution train of thought and handed us a new one with nickel and steel and iron plates and a twenty per cent. solution of caustic potash (omiting Perlmutter) for the electrolyte. The electromotive force is not as great as the lead type, but the ampere hours per pound is about half—the bulk being the same, practically, as the old line of cells. Upon discharging, the Edison cell shoves as high as three volts and higher onto the line, but decreases after the load sits on her. You are aware of the fact that the old lead accumulator gives out about two and four-tenths volts at the beginning of the discharge—if you did not know of it before, you do now. The old heavy type has it over on the Edison for constancy of current, but the selling point for the Edison is the lightness and mechanical robustness.

"There are other secondary cells that employ plates of bimetallic composition. The most satisfactory are the zinc-lead, copper-lead, and the copper-zinc, besides the Edison nickel-iron cell.

"Sacramento! Puerco! Blankety Blanko!!" And a string of other stuff ending up with the statement that the "automobile no bono" and "a inferno con todos!" The wop broke in on our discussion—of Jazz's.

"I guess I will see what is the matter with the motor," said Stokes as he walked around the hood. "I've got a date with a blind man for a game of craps to-night."

In less than five minutes the Italian was saying "gracias, signor" and we were leaving a cloud of dust behind us.



Tommy Edison Stept Off the Lead and Sulphuric Trail and Handed Us the Nickel-Iron Storage Battery.

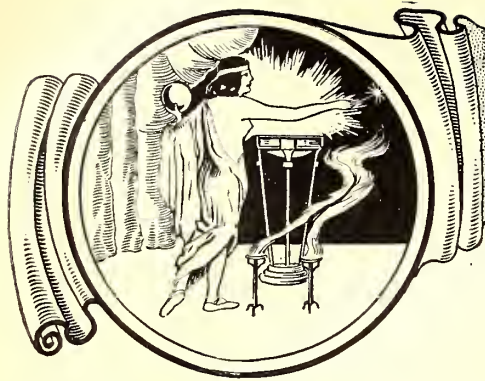

# THE ORACLE

The "Oracle" is for the sole benefit of all electrical experimenters. Questions will be answered here for the benefit of all, but only matter of sufficient interest will be published. Rules under which questions will be answered:

1. Only three questions can be submitted to be answered.
2. Only one side of sheet to be written on; matter must be typewritten or else written in ink, no penciled matter considered.
3. Sketches, diagrams, etc., must be on separate sheets. Questions address to this department cannot be answered by mail free of charge.

4. If a quick answer is desired by mail, a research work or intricate calculations a special rate will be charged. Correspondents will be informed as to the fee before such questions are answered.

## MAKING HIGH TENSION MAGNETO FROM LOW TENSION TYPE.

(1016) J. G. Whitfield, Goldsboro, N. C., inquires:

Q. 1. How can I change a low tension magneto into a high tension type?

A. 1. It is rather difficult to change a low tension magneto of the ordinary type into a high tension magneto unless you are quite familiar with the make-up and appa-

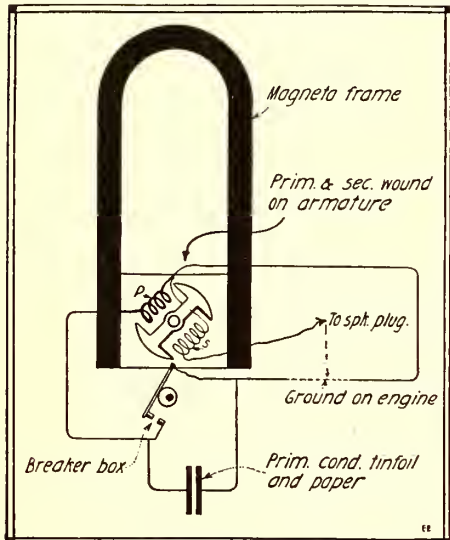

How a "Low Tension" Magneto May Be Converted into a "High Tension" Type.

ratus of the latest type machine. We are pleased to give you herewith diagram showing how most of these high tension magnetos operate.

In one of the modern high tension magnetos there are no revolving coils or commutators of any kind, but simply a rotating mass of iron, which is so formed as to cut the magnetic flux in the field many times per second. In this machine the primary and secondary windings are stationary, and undoubtedly you can obtain some information on this machine, as well as other high tension types, which may be of interest to you, by communicating with the various high tension magneto manufacturers.

## RADIO ANTENNA QUERY.

(1017) Rolf Carbo, Minneapolis, Minn., asks:

Q. 1. For data on a radio antenna for amateur requirements.

A. 1. Regarding the type of receiving aerial which would be best, should be about 125 feet long, 75 feet high, and at least 4 to 6 wires spaced about three feet apart, which will prove very satisfactory for average long-distance reception and commercial wave lengths.

If you intend receiving amateur wave lengths it will be necessary for you to in-

## To Our "Oracle" Friends

Do you realize that not one day passes when we do not receive from 150 to 250 letters address to "The Oracle"? If we were to publish all the questions and their answers we would require a monthly magazine five or six times the size of the ELECTRICAL EXPERIMENTER, with no other matter but questions and answers. Of late the influx of letters has become so heavy that several of our associates have been forced to discontinue important editorial work, in order to answer the mail. This we are certain you do not wish. You do not want your magazine to lower its present high standard. You want the best, the very best, and you know we never have failed you yet.

Moreover the multitude of letters are wholly unnecessary. Most of the questions Readers ask every day have been answered before in "The Oracle." Therefore, ere you sit down to write us, look over your back numbers, and nine times out of ten you will find the answer.

We strive hard to publish only such matter as has not appeared before in our columns, and for that reason, only a small fraction of the queries received by us are actually published.

Your magazine is steadily coming to the fore as the greatest publication in the scientific world. To keep up its present high standard and to make it a better and bigger magazine requires a tremendous amount of untiring effort on the part of the Editors. Therefore, in the future, we CANNOT in your own interest, answer questions by mail, free of charge.

For questions requiring an immediate answer our fee is 25 cents for the first three ordinary questions, and 25 cents for each additional question. We will gladly advise fee for special questions entailing considerable research work or calculations.

Stamped and address envelope should be enclosed with the queries, and moreover, any sketches accompanying them should be drawn in ink on separate sheets. Write plain and, PLEASE, PLEASE BE BRIEF.

Editor of "The Oracle."

terpose a variable condenser in your ground circuit.

About the best thing for an all-around set, we advise a small coupler and audion, adapted to a great many ranges of wave lengths. Unless you intend to build a set to receive only undamped wave stations, we would suggest a very large loose coupler.

We refer to our September, 1915, issue of the ELECTRICAL EXPERIMENTER for excellent data on loose couplers.

## STORAGE BATTERY QUERY.

(1018) B. W. Dresser, Homedale, Idaho, asks:-

Q. 1. Several queries on storage batteries, etc.

A. 1. Answering your first question,

would advise that water for storage batteries should be distilled and kept in glass containers, as no matter what form of metal you might use, it is only natural that minute particles of the container will mix with the water. It is absolutely necessary for storage batteries, to secure perfect satisfaction from the same, to use pure distilled water absolutely free from any elements which might contain iron or any other metals.

The difference between the current and voltage for static machines and high-tension transformers does not vary very greatly, the designs of the machines and transformers having much to do with their outputs, tho the currents are about practically the same.

It is unnecessary to insulate the conductors of a rotor in a squirrel cage induction rotor. In the usual cases bare solid conductors are merely wedged in the slots of the rotor.

## RINGING ALARM BELL FROM TELEPHONE CIRCUIT.

(1019) Theodore Mucha, Terlingua, Tex., writes:

Q. 1. How can I hook up an alarm bell to a regular telephone circuit?

A. 1. With reference to an alarm device for waking up a sleeping person, and to be connected to a telephone circuit, would say that several years ago the Editor installed a very successful form of alarm which will wake the dead.

In order to work this alarm, as the accompanying diagram shows, you will require a telephone relay. This can be pro-

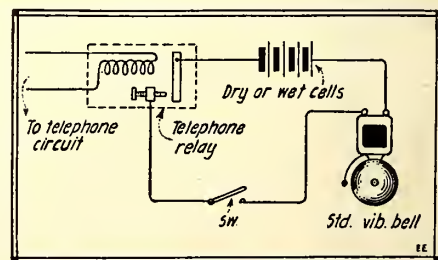

Scheme for Ringing Extension Call Bell from Telephone Station by Means of a Telephone Relay. The Latter Instrument Can Be Obtained from Your Local Telephone Exchange or Supply House.

cured from any supply house at a cost of about \$1.00.

The telephone relay is connected directly across the telephone line so that when the current is sent over the circuit, the relay will close the secondary circuit, in which you can connect batteries, electric horn or alarm bell, etc. You can also obtain, if you so desire, a large 6- to 8-inch telephone extension bell, which may be connected across the telephone line.



Copyright 1919  
by R. J. Reynolds  
Tobacco Co.

**S**AY, what a trick you'll turn for your tongue and taste and temper when you finally get down to bed-rock smokes and let some of that topjoy Prince Albert float into your system! Just will put the quiz into your thinktank as to how much pipe or cigarette-rolling fun you've gone shy on—and, you'll work in a lot of double headers for quite a spell to get all-square!

What's the idea kidding yourself when you know what P. A. will do for your smokespot; when you know what it is doing for men all over the civilized world! You can't hit a happier job than to stock a supply of Prince Albert, jam that joy'us jimmy pipe chuck-full and blaze away! Why, it's like falling into feathers when you've been batting-it-out-on-a-board!

Prince Albert just can't help doing you a clever turn because it won't bite

your tongue at any stage! Bite and parch are cut out by our patented process. Want you to know right here, and now, that Prince Albert will be as gentle with your tongue as a toy purr-kitty is with a stuffed mouse! You can rip champeen-smokespeed-records right up the back with P. A. for packing!

You don't need a percentage table to figure out what Prince Albert's quality and flavor and fragrance will do for your happiness every time the clock ticks! You'll get the answer quick! And, now it's your draw! Prince Albert is sold in tippy red bags, tidy red tins, handsome pound and half pound tin humidors, and, in that classy, practical pound crystal glass humidor with sponge-moistener top that keeps the tobacco in such perfect condition!

**R. J. REYNOLDS TOBACCO CO.**  
Winston-Salem, N. C.

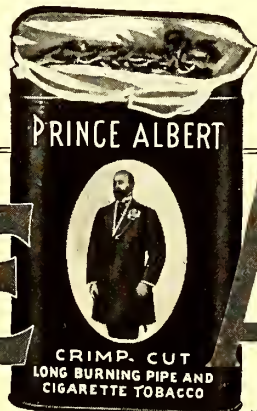

# PRINCE ALBERT

*the national joy smoke*

*you benefit by mentioning the "Electrical Experimenter" when writing to advertisers.*

# Solving the Transportation Problem

(Continued from page 303)

New Ideas by Mr. Gernsback.

two main tracks, while a revolving pinion engaged with this rail rack. The train derived its energy from an electric third rail and shoe which operated the electric motor; this in turn worked the pinion.

In Fig. 3 is shown a later type of hydraulic shoe also operated under the water pressure and water suction plan. With this shoe very little water is lost.

### 100 Miles Per Hour—Safely.

From what has appeared, it will be seen that being that there is no friction, enormous speeds can be obtained with such railways. As a matter of fact one hundred miles an hour is a conservative figure. Nor is it dangerous to run such wheelless gliding trains at such speeds for two reasons. One is that there is no friction. There is no wear and tear of material, and if the flat rail with its guard rails (see Fig. 2) is constructed right, it will be impossible for the shoes to jump the track. And now we come to the most important point as far as the speed is concerned.

These trains it was found could be stopt

We have today a means for propelling the gliding railroad, which is as simple as it is efficient. Our cover illustration as well as Fig. 5 show the means proposed. Fig. 6 also depicts the various methods used. The writer proposes the use of a single track, each car having two hydraulic shoes of the kind shown in Fig. 3. The car is held upright by means of the gyroscope shown. This gyroscope is to be driven by an electric motor and the energy is to be taken from a third rail running alongside the track. This also furnishes the power for the electric lighting system of the train and for the motors which drive the compressors as well as supply the power for the suction pipes. The propulsion of the train is accomplished as follows:

### Electro-Magnets Pull Trains.

The entire track must be supplied with power (tractive) electro-magnets sunk or led into the rail which latter should be of some non-magnetic material such as brass or bronze. The power electro-magnets are



**Increase the life of your phonograph records!**

Having parallel sides (not tapered) these new Sonora Needles always fit the record groove perfectly. They play 50 to 100 times and are for use on ALL MAKES of steel needle records.

**Sonora**  
CLEAR AS A BELL

Semi-Permanent Silvered  
**NEEDLES**

are more convenient and economical and save constant needle changing. They mellow the tone, add to the life of your records and give a maximum of service and satisfaction.

30c Per Card of Five  
40c in Canada

**FREE!** To demonstrate the extraordinary advantages of the Sonora Needle we are glad to mail you a sample free.

**Sonora Phonograph Sales Company Inc.**  
GEORGE E. BRIGHTSON, PRESIDENT  
279 Broadway, Dept. G. N. Y.  
Toronto: Ryrie Building

**CAUTION!** Beware of similarly constructed needles of inferior quality

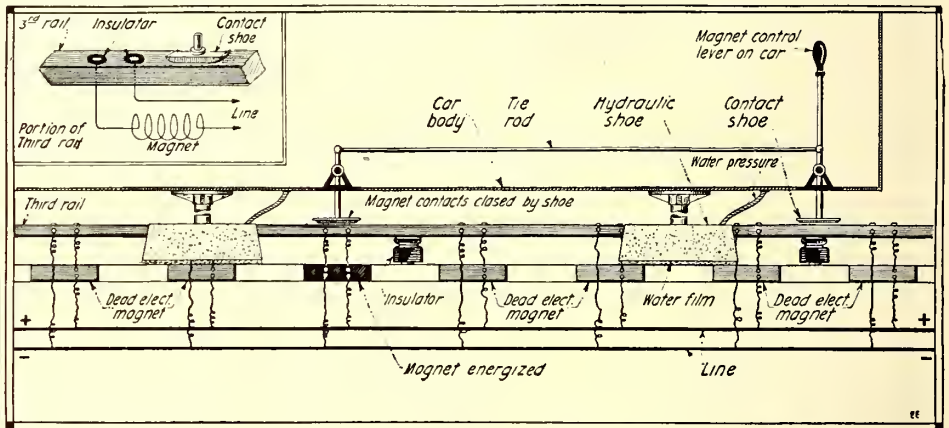

Fig. 6. Showing Mr. Gernsback's Arrangement for Propelling the Train by Means of Electro-Magnets. As the Train Moves One Electro-Magnet is Energized at a Time, Which Exerts Its Traction on One of the Shoes, Thus Pulling the Train Along. Insert Shows Method of Making Contact with Power-Magnets.

almost instantly, and very simply by cutting off the water pressure. This maneuver brings the hydraulic shoe in direct contact with the rail and an enormous friction sets in. No brakes are needed to stop such a train. The train is its own brake. Nor is that all. Such trains can be stopt where the rails dip at an incline of 40%, a thing unheard of on regular railways with wheels. You see in a train of this kind there is nothing to roll and the minute the water pressure is taken off, the train must stop at once even at the worst incline. Inversely if the right tractive method is used to propel the train, it will run up almost impossible inclines at angles no regular railroad would ever think of attaining. Furthermore, in view of what has appeared, it will be realized that the cars do not have to be of such ponderous weight as are the present day ones. They can be constructed of aluminum alloy and could weigh one-quarter of the weight of the ordinary car and still be safe.

### Former Disadvantages.

There was only one real disadvantage on a railway of this sort. During the winter the formation of ice and snow on the rails tended to put the entire road out of business because no means could be found to do away with the forming ice and its consequent unevenness or roughness of the track. This, however, would not worry our present day engineers for the simple reason that our trains would probably carry some electric heater in front of it, each train thus melting the ice as fast as it formed.

placed about six inches or so apart and run thru the entire length of the track. Normally these electro-magnets are not energized as will be seen by referring to Fig. 6. When it is desired to start the train, the conductor moves his magnet-control lever inside of the car. This lever at the lower end has a contact shoe, which when sliding over the contacts as shown, energizes its particular electro-magnet. In Fig. 6 it will be seen that two of these contact shoes are used. This is done so as not to have any dead points, as otherwise the train could not start. In this figure it will be seen that the rear magnet contact shoe has just closed its contacts, and the rear hydraulic shoe comes now under the influence of the energized magnet. This will tend to pull the rear shoe over the energized magnet. But the instant the pull starts, the train moves along as well and the contact is broken.

The momentum of the train, however, is sufficient to carry it along, and by this time the forward contact shoe will have energized the electro-magnet at the extreme right, shown at Fig. 6. The forward hydraulic shoe now comes under the influence of the energized electro-magnet and the train is pulled forward again. This play is repeated constantly and of course very quickly; within a few seconds the train has obtained a terrific speed. This speed increase can be regulated simply by an arrangement which lifts the electric contact shoe away from the contact rail, and by this means the speed of the train can be

(Continued on page 338)

## Send Only 12c

(Stamps or Coin)

And I will send you a copy of my valuable booklet.

### "Hints to Music Loving Owners of Talking Machines"

Tells you how to take care of your machine and records, preserve the life of both, and gives many pointers to improve the tone of your instrument and increase your enjoyment of it. Instructs on the care of the motor, cleaning, speed adjustment, care of the needles—in fact every thing you should know. Send 12c today and the booklet will come by return mail.

J. H. ELLIS, Box 882, Milwaukee, Wis.  
Patentee & Manufacturer. Ellis Harmonious Reproducer

**FREE**

**\$20**



Violin, Hawaiian Guitar  
Ukulele, Guitar, Mandolin, Cornet or Banjo

Wonderful new system of teaching note music by mail. To first pupils in each locality, we'll give a \$20 superb Violin, Mandolin, Ukulele, Guitar, Hawaiian Guitar, Cornet or Banjo absolutely free. Very small charge for lessons only expense. We guarantee success or no charge. Complete outfit free. Write at once—no obligation.

**SLINGERLAND SCHOOL OF MUSIC, Dept. 422, CHICAGO, ILL.**

**BE A CPA ACCOUNTANCY**

The Highest Paid Profession taught thoroughly in a few months of home study by new system.

**FREE BOOK** International Accountants Society  
Dept. 39H, 2826 S. Mich. Ave., Chicago





Pres.  
Alonzo S. Thomas,  
Santa Fe Watch  
Co.

# LISTEN MEN!

Listen  
to  
Me

I HAVE determined to make 1919 the banner year in the Watch Sales of my Company. To do this I must distribute 5,000 "Santa Fe Specials" to 5,000 men in different communities this year. I must do this REGARDLESS OF PRICE OR PROFIT. Therefore, I have Cut the Price of these 5,000 Watches to ABSOLUTELY ROCK BOTTOM. This means that if you act at once you can get one of these Guaranteed Watches on this CUT-PROFIT PLAN, and pay for it in small monthly installments. MY OBJECT:—I know that every Watch sold on this Cut-Profit Plan will sell at least one more at the regular price, so I make this STARTLING, UNHEARD OF OFFER to men who will tell their friends of this remarkable Watch Value, if they find the Watches all and more than I claim for them.

Signed,

*Alonzo Thomas*

Pres. Santa Fe Watch Co.

## I SAY

Unless you already own a Watch that you are sure is just as good as they make them, this is a money-saving opportunity you positively cannot afford to miss. It is a Bargain such as you do not meet every day. For that reason you will have to act promptly or this allotment of 5,000 Watches may all be gone before you get yours. To make sure you get one, suppose you write me personally, care Santa Fe Watch Co., right NOW before you forget it. I want you to join my "5,000 Watch Club" and carry one of these beautiful Standard "Santa Fe Special" watches.

For the  
Man  
Who  
Acts  
Quickly

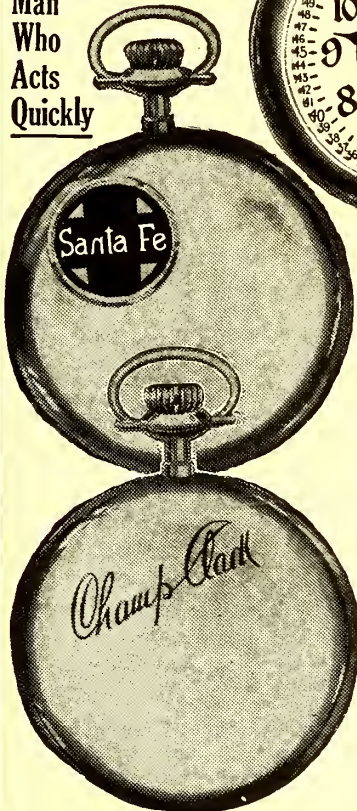
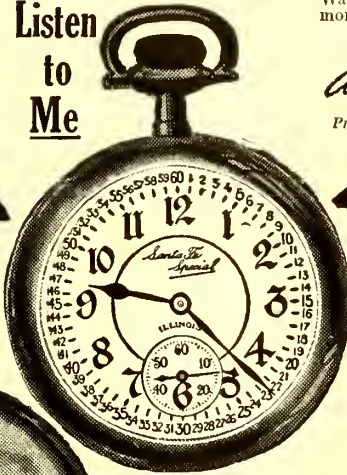

21 Perfect Jewels  
Adjusted to Positions  
Adjusted to  
Temperature  
Adjusted to  
Isochronism  
Adjusted to  
the Second  
Thin Model  
All Sizes

The ILLINOIS Famous \$  
**Santa Fe Special** **250**  
**21 JEWEL RAILROAD WATCH** **A MONTH**

"Santa Fe Specials" are Standard Railroad Watches, Guaranteed to Last a Lifetime and Give Satisfactory Service. Are found in the pockets of men in service on the important railroads of this country. Senators, Congressmen and Governors keep their official appointments by "Santa Fe Special" time. Army Officers and Privates carried them all through the Greatest War in history—thousands of these splendid Watches are in use all over the World. If you want one on my liberal CUT-PROFIT PLAN you had better write for my Free Watch Book today and make your selection without delay. I will send the Watch for you to see WITHOUT ONE PENNY DOWN—I will even allow you to wear the Watch 30 days FREE—then sell it to you on a binding money-back guarantee.

### THINK OF IT!

A Standard Watch at a Saving of 1/3 to 1/2 of Your Money. That is exactly what this wonderful offer means, and it is exactly what you get, if you are so fortunate as to

### NEW CASE DESIGNS

I want you to see the newest designs in Cases used on these "Santa Fe Special" Watches, so that you will fully realize their beauty and up-to-dateness, as well as the value of the Bargain I am offering you. I want you to see the 3-color inlay work—nothing more refined. Then think how distinctive and personal your Watch would be with your own name, monogram or some appropriate emblem engraved in the Case, just to suit your own ideas. You will also want to see the new French Art designs in engraved Cases—all shown in My New Watch Book, printed in beautiful colors. Write for it today, it will be sent FREE.

get your order in time to get one of these 5,000 "Santa Fe Specials" on my Special Distribution Cut-Profit Plan. The coupon, a letter or your name and address on a postal will bring my Free Watch Book right back to you. Don't delay—write today.

## SANTA FE WATCH CO.

880 Thomas Building Topeka, Kansas  
(The Home of the Great Santa Fe Railway)

A letter, post card or this coupon will bring you my Free Watch Book

SANTA FE WATCH CO., 880 Thomas Building, Topeka, Kan.

Please send me your New Watch Book with the understanding that this request does not obligate me in any way.

Name .....

Address .....State .....

### Tropical Climates Make No Difference with the "Santa Fe Special" —Four Seconds in Five Months.

I feel it my duty to let you know how my "Santa Fe Special" is standing the tropics. It is the best watch I have ever carried, with no exception. It has not lost over four seconds since I received it, about six months ago, comparing it with Naval time. I wouldn't sell it for \$50.00 and take chances of buying another make half as good.

B. H. GABBARD, Tutuila, Samoa.

I received the watch and think it is one of the finest pieces of work I have ever had. I am pleased very much with it.

A. RATHOFF,  
U. S. S. Jupiter, Atlantic Squadron.

### Likes It Better Than a Watch that Costs \$85.00.

I find my watch to be the best timepiece I ever owned. I owned an \$85 watch before, which was stolen from me, and to tell you the truth, I can see no difference, so far as keeping good time is concerned, between it and my "Santa Fe Special." The "Santa Fe Special" comes up to the mark of efficiency in every respect. I put her through some severe tests this winter, and she hasn't lost or gained a second yet, as far as I know. If anyone knows the value of a good time-keeper, it is we people here in the Coast Artillery Service. The watch is worth more than you ask for it in my estimation.

FRANCOIS L. WALLON,  
Cpl. First Company, C. A. C.,  
Fort McKinley, Maine.

### A Watch to be Proud of.

Received the "Santa Fe Special" watch today, and am more than pleased with it. I must say that the engraving is the best workmanship I ever saw, and I know I have a watch now that I can be proud of.

J. C. FAHNING, U. S. S. Washington.

### Says It's Worth Sixty Dollars.

I want to say that the watch which you sent me is far above what I expected for the money. A friend of mine with a \$50.00 Hamilton, almost new, offered me his watch and \$10.00 for my "Santa Fe Special." A local jeweler tells me that my watch ought to have cost me \$60.00.

T. E. DAVIS, Hurlburt, N. Mex.

# Solving the Transportation Problem

By H. Gernsback

(Continued from page 336)

regulated to a nicety. In order to overcome the difficulty of starting the train with a bad jerk, it is in the power of the conductor to move the contact shoe forward or back, for a few inches. Thus the hydraulic shoes can be brought under the gradual pull of the electro-magnets by being a greater distance away from the energized magnets as shown in Fig. 6. For, the further the hydraulic shoe is away from the electro-magnet, the less the tractive effect will be.

In the writer's system, the train is stopt the same as by the French method, simply by withdrawing the water pressure. The hydraulic shoe then comes into contact with the track and the train stops almost immediately.

### System Not Expensive

It will be argued that this magnet arrangement is a very expensive method, but this is not the case. These railroads are not intended for great distances, but will be mostly used in cities where first cost is of no consequence. Witness for instance the truly enormous cost of subway construction where the cost per mile frequently runs into millions of dollars. In the electro-magnet tractive scheme, like in all other railroads, it is only the first cost that counts, and it is very much doubted if the idea advanced here will make this railroad cost even one-quarter as much per mile as an ordinary elevated railway.

Another important plan which the writer advances, and which is shown impressively on our cover illustration, is that this railway is not intended to run thru the streets, but rather over the house tops. This is

quite practical with such a railroad for the following reasons: Firstly, the single track will take away practically no light where it crosses over the streets. The track can be very light because the cars themselves are light. Also, there is but a single track, and consequently the structure that carries it can be exceedingly light. Secondly, there is no noise whatsoever. You cannot hear the coming or going of the gliding wheelless trains. They make absolutely no noise and there is moreover no vibration. The pillars supporting the track can be placed on two adjoining house walls as shown in our cover illustration; therefore no foundations are required. Stations can be located on the roof tops if desired, where they will not be as unsightly as at present. Elevators will take the passengers up and down.

Being that these railroads can be run safely at a speed double or triple the present day ones, it should be possible to provide a seat for everyone, no matter what the increase of the population will be. We cannot transport in the future many more people than our present day transportation facilities provide. Airplanes are out of the question for obvious reasons and so are airships for the reason that they cannot be operated quickly enough, and also they cannot carry enough passengers no matter what their size. Take for instance a New York Subway car when packed full will accommodate often as many as two hundred passengers, while a ten car train carries two thousand souls. From this it can be seen that neither the airplanes nor the airship can ever hope to compete with the wheelless trains as outlined above.



*For Perfect Health, Strength, Unlimited Vitality & Improved Personal Appearance*

The  
**STERLING HIGH FREQUENCY VIOLET RAY**

The Sterling Violet Ray is invaluable in the treatment of diseases of the skin, mouth, throat and lungs, derangements of the liver, kidneys, stomach and intestines—soreness in muscles and joints—tired or "sick" brains or lack of "nerve tone." It strengthens heart action—cleanses the blood—brings the flush of youth to the skin—enlivens the hair—puts a "spring in your step" and creates a clear eye and brain.

Specially designed for home use—fitted to work from the ordinary lamp socket—easy to manipulate—under control at all times.

**VALUABLE BOOK FREE**

Read how you can treat innumerable diseases and ailments, improve your personal charm, add strength and vitality and help yourself in hundreds of ways. Just mail the coupon or drop a postal. Do it now, this minute, before you forget it.

The Sterling Electrical Corporation  
1278 West 3rd St. Cleveland, Ohio

MAIL THIS COUPON

FOR FREE BOOK.

THE STERLING ELECTRICAL CORPORATION

1278 West 3rd Street Cleveland, Ohio

Gentlemen:—As per your offer in Electrical Experimenter, please mail me at once, free and postpaid, your book and full information about the Sterling Violet Ray Generators.

NAME .....

ADDRESS .....

CITY ..... STATE .....



## Skinderviken Transmitter Buttons

Nothing like it on the market. Will make an old transmitter better than new. Adjusted in a jiffy. Supersensitive. Talks at all angles.

**Price \$1.00 each.** Discount in quantities

Send us One Dollar, for which we will mail one button prepaid under our money-back guarantee.

**Booklet No. 3 free for the asking**

**SPECIAL NOTICE**

To clear up any misunderstandings that might arise in connection with our offer of last month to pay for suggestions as to uses to which the Skinderviken Button may be put (see our July ad), we wish to announce the following rules:

1. The offer extends only until August 30 and will close on that date.
2. The first prize of \$10 will remain as announced. But instead of paying for all accepted suggestions in proportion to their value, we will pay \$1 for every suggestion we accept.
3. By the words "best idea" we mean the most practical and the one having the most commercial value.
4. Anyone can compete whether you have purchased a button or not. Borrow your friend's—try it out—and send in your suggestion.

Skinderviken Telephone Equipment Co.  
For your convenience in writing us, address  
STECO, 2134 N. Clark Street, CHICAGO, ILL.  
335 Broadway, NEW YORK CITY

# How to Develop Your Inventive Ability

By Jay G. Hobson

(Continued from page 330)

ters, steps in line, picks up his tray and proceeds to obtain his knife, fork, spoon and paper napkin. Directly ahead of him is a man with dirty face and hands who also fumbles around among the silverware probably touching our friend's knife and fork as well as his own. Our friend notices this and frowns, but sees nothing of importance about it other than the unsanitary annoyance for the time being.

At five-thirty P. M. we return to our friend's office and find him all prepared to drive home in his eight cylinder flyer; so feeling the need of fresh air we invite ourselves to go along. We haven't gone far until it begins to rain in torrents, but we don't bother as the top is up. Arriving home our friend turns into the driveway and as he nears the garage observes both doors tightly closed which means that he must get out into the wet to open them and that's no joke. He simply jumps out, gets wet and mutters things we can't record here.

Our friend's wife meets him at the door with the usual welcome and he feels greatly relieved amid the comforts of his cozy little home. Supper is served with our friend enjoying a good meal. During dessert his wife expresses her great desire to see a certain good play at the opera. Husband frowns inwardly for it is his preference to keep within the shelter of his home this wet evening. But observing his wife's earnest desire for additional amusement he strives to show some enthusiasm over

the suggestion. They leave for the show about seven-thirty.

Arriving at the theater thirty minutes later they enter, taking their wraps with them to their seats. Past experience with the check room service has convinced them of this wisdom. The theater is crowded, every seat is occupied. There is no empty seat near them to lay their hot wraps on. Our friend must hold the collection upon his lap which doesn't add to his comfort. Along about the third act when the exciting part of the play makes everyone sit rigid with expectation, our friend is simply sweltering under the many woolen garments over his knees but he just sits there and suffers without one idea concerning the uncomfortable situation.

Returning home after the show our friend finds a telegram waiting for him. It is from headquarters instructing him to make a special business trip up-state to a city that he has never visited before. He prepares for the trip and leaves the following morning. But before leaving he acknowledges the company's wire and at the same time requests them to send him an expense check.

While en route to his destination he takes the hotel directory from the Pullman Library and selects what appears to be the best hotel in the city. He proceeds to this hotel and registers as usual. The following day the company's check arrives

(Continued on page 340)

You can be quickly cured, if you

# STAMMER

Send 10 cents coin or stamps for 70-page book on Stammering and Stuttering, "Its Cause and Cure." It tells how I cured myself after stammering for 20 years.

Benjamin N. Bogue, 757 Bogue Building, Indianapolis



Cigarettes  
made to meet  
your taste!

18c a package

**C**AMELS are offered you as a cigarette entirely out of the ordinary—a flavor and smoothness never before attained. To best realize their quality *compare Camels with any cigarette in the world at any price!*

Camels flavor is so refreshing, so enticing, it will win you at once—it is so new and unusual. That's what Camels expert blend of choice Turkish and choice Domestic tobacco gives you! You'll prefer this blend to either kind of tobacco smoked straight!

As you smoke Camels, you'll note absence of any unpleasant cigaretty aftertaste or any un-

pleasant cigaretty odor. And, you'll be delighted to discover that you can smoke Camels liberally *without tiring your taste!*

Take Camels at any angle—they surely supply cigarette contentment beyond anything you ever experienced. *They're a cigarette revelation!* You do not miss coupons, premiums or gifts. *You'll prefer Camels quality!*

*Camels are sold everywhere in scientifically sealed packages of 20 cigarettes or ten packages (200 cigarettes) in a glassine-paper-covered carton. We strongly recommend this carton for the home or office supply or when you travel.*

R. J. REYNOLDS TOBACCO CO., Winston-Salem, N. C.

# Camel

## CIGARETTES

# \$1.00 INEXPENSIVE ELECTRIC POWER \$1.00

The wonder of the twentieth century inexpensive electric power, this is possible with our new electric power system, a new idea in electricity. With the aid of our instruction and chemicals you can make and install a power battery as shown in the illustration, absolutely safe and simple. Stop wasting money on buying batteries, install the new electric power battery. It is not an acid or dry battery, it is a new combination of wet and dry elements which produce electricity. These batteries are powerful and cheap to operate, they produce a direct current of more than 10 volts, cheaper than any other form of battery. They are wonderful for operating all kinds of experimental work, for lighting purposes and for many other uses where electric current is needed. Any user of batteries knows the value of an inexpensive high voltage electric current. These batteries should be in every home, office, shop and factory, no matter how small a current is needed; to reduce or raise the current of the battery, simply move the volt regulator on the switch board. The beauty of these power batteries is, that they do not evaporate or lose current when not in use, therefore, with every day use recharging the battery is necessary about every month or so, it can be recharged at home in a few minutes, no electricity or machinery is required for this operation, recharging material can usually be obtained around your home or can be bought for a few cents. These batteries when charged weigh about 34 pounds and if properly installed will last for years. Each battery making outfit consists of a completely wired switch board, battery connectors, wire, instructions and plan for making, installing and recharging the battery and complete chemicals. Special introductory price, \$1.00, prepaid. Outside the U. S., \$1.25.

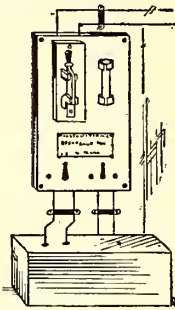

# NEW MODEL TELEPHONES \$2.00



The most useful and inexpensive wall telephones yet developed. Good use can be found for a set of these telephones in many homes, and in office, store or shop, indoors and outdoors; they save many steps and much time. You can easily install these new model telephones and have your own private line with no operators to bother or listen to your conversation. They are thoroughly practical and serviceable all around telephones. Their construction is simple and neat, nothing to break or to get out of order, a child can operate them with ease, they will give satisfactory service at any distance up to 1500 feet, and even at that distance the voice will be perfectly plain and understandable as with the regular commercial telephone. These new model telephones are electrically operated, two batteries will operate a set of phones for a long time, the cabinets are made of polished oak and finished with a durable varnish and fitted with excellent receivers and transmitters, fine workmanship and construction throughout, guaranteed to operate under all conditions. We are offering the New Model Telephones at an exceptionally low price. Each telephone set consists of two New Model Telephones, calling system, wire, instructions and diagram for installing. Special price to introduce \$2.00, prepaid. Outside the U. S. \$2.25. FREE—We want every reader to own a New Model Telephone set, so we are going to give away a 2-cell battery FREE to every purchaser of a New Model Telephone Set.



# ELECTRIC LIGHT IN YOUR HOME \$1.00

The latest electric light, no batteries to buy or electric bills to pay. Anyone can install and maintain this midjet electric light. Safe, simple and smell, no wicks or oil, no chimneys to clean barn, garage and clothes closet as in any open day or night. A touch on the switch and electric light. No matter where you live this light can be installed. It is not affected by heat or cold. Many homes have installed this electric light in their halls, closets, pantries, barns, sheds, cellars, garages, etc., with good results. It is an extremely useful light which no household should be without. The reason for this bright electric light is that the lighting bulb is fitted with a drawn Tungsten filament wire which is much more efficient and durable, besides giving a 300% increase in light as compared with the ordinary carbon lamp. The power system furnished with this lighting outfit is somewhat similar to the electric power battery described above. Each electric light outfit includes the following: Complete directions and plans, copper wire, insulated wire holders, knife switch, drop light fixture with socket, friction tape, battery protector, maroon shade, national mazda globe. Our dry battery compound, which assists in renewing and supplying the current and our current renewing system with which you can renew the current at home without expense. With every day use one recharge usually lasts two to three weeks. This electric lighting outfit is undoubtedly the most practical and durable electric light of low cost and long service ever devised. Special price to introduce these electric lighting outfits \$1.00, prepaid. Outside the U. S. \$1.25.



**Our Guarantee**—It is our intention that every article described above will reach you exactly as described, that it will satisfy you perfectly, that it represents full value for the money you paid or we will refund your money. Just to introduce our new line of goods we are offering them at these greatly reduced prices. We only have a limited number of the above described goods at these prices. Order now, direct from this ad. We guarantee safe delivery anywhere for additional 10 cents on each item.

**A. B. C. PRODUCTS CO. JOHNSON & 13th STS. CHICAGO RETAIL DEPT.**

## YOU HAVE A BEAUTIFUL FACE

### BUT YOUR NOSE?

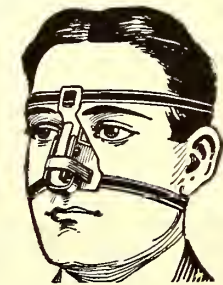

BEFORE

AFTER

IN THIS DAY AND AGE attention to your appearance is an absolute necessity if you expect to make the most out of life. Not only should you wish to appear as attractive as possible, for your own self-satisfaction, which is alone well worth your efforts, but you will find the world in general judging you greatly, if not wholly, by your "looks," therefore it pays to "look your best" all times. Write today for free booklet, which tells you how to correct ill-shaped noses without cost if not satisfactory.

Permit no one to see you looking otherwise; it will injure your welfare! Upon the impression you constantly make rests the failure or success of your life. Which is to be your ultimate destiny? My new *Nose-Shaper*, "TRADOS" (Model 24) corrects now ill-shaped noses without operation, quickly, safely and permanently. Is pleasant and does not interfere with one's daily occupation, being worn at night.

**M. TRILETY, Face Specialist**

**1162 Ackerman Bldg., Binghamton, N. Y.**

**Be an Artist**

Comics, Cartoons, Commercial, Newspaper and Magazine Illustrating, Pastel, Crayon, Portraits, Poster and Fashions. Earn Big Money. Taught by Mail or Local Classes. Write for illustrated booklet, terms and list of successful pupils.

ASSOCIATED ART STUDIOS, 13A Flatiron Bldg., N. Y.

**HEAD ACHES FLU NEURALGIA WOMEN'S ACHES ASK FOR A-K TABLETS**

## How to Develop Your Inventive Ability

By Jay G. Hobson  
(Continued from page 338)

as requested. Being a total stranger in the city he asks the hotel manager to kindly cash said check, explaining who he is and the integrity of his superiors.

The manager very diplomatically explains that he has often heard of his fine company and would be pleased to accommodate him if he will just have some one identify him so that he can be sure our friend is the proper person. For it is possible, from the manager's point of view, that our friend could have found the check—that had happened before! Of course, the hotel does not mean to doubt our friend's honesty for one moment!

Turning around he rams the check deep into his pocket with a vow, to himself, that he will get that check cashed by the first bank he comes to.

Walking slowly down the main business street he runs into a friendly looking bank and he decides to try his luck in there. Approaching the cashier's window deliberately he shoves the check for a hundred toward the cashier with the remark that he would appreciate the favor. The cashier excuses himself for a minute and retires to one of the financial reference books for information about the company.

Promptly returning to his money cage the cashier politely informs our friend that he would be pleased to favor him if he will obtain additional identifications. Our friend is almost desperate by this time and requests the cashier to take him to the president of the bank. The president is courteous but assumes the same stand about further identification as the others. Our friend's spirits dropt very low from this last retort. But glancing down on the expensive mahogany desk of the president he accidentally observed the national emblem of an organization to which both he and the president belong and quickly makes this known. The president's face softened and after a few hand shakes the cashier is summoned with instructions to honor our friend's check which was accomplished among expressions of appreciation.

Now shifting our minds into reverse we will return to our friend's first experience in the cafeteria and see what, if any, improvement was suggested by things that transpired. This simple little test of observation will help to show how far your inventive abilities have been developed. The more observing mind would have received an idea of value after seeing that man with dirty hands musing over the silverware. A mental picture of a sanitary dispensing machine for knives, forks and spoons would have appeared. A machine with levers to operate the dispensing of the silverware so that only one pair of hands would touch the silverware to be used by them. This would be an improvement of worth.

The incident at the garage should have suggested a device to automatically open the doors as soon as the automobile came near enough to put it into motion. Possibly a small electric motor attached to the doors with a bumper switch to come into contact with the front tires of the auto. After the small motor had propelled the doors sufficiently to allow the auto to enter, there would be a cut-off switch on the end of the door that would stop the motor.

Then at the theater our friend's discomfort should have suggested an improvement in seats. One with a clothes compartment in the back that would open when the seat was bent forward and close and disappear thru the floor when the seat was pushed backward.

Being check-bound away from home in a strange city without anyone to identify you is no joke, for I speak from experience.

The trained observer's mind would have pictured a device in the form of a small pocket case with his picture in one side and across the picture would be signed his official signature. In the other side would be secured a cancelled company's check bearing his signature, the stamps of the different banks and clearing houses it has past thru on its way back to the company; and on its face it is marked PAID. This old check would be compared to the new one. The signature on the picture and on the old check and on the hotel register would be compared together, which would be all the identity necessary to obtain the money needed.

A few months ago I was visiting friends in the evening. They owned a popular phonograph that they played for hours each evening and fully enjoyed every moment of it. This particular evening that I called they refrained from playing even as much as one short record, and I could not quite understand the unusual situation. Being by nature somewhat nosy about unusual conditions I inquired of the cause for their abstinence. The husband frankly confest that he had neglected to stop by the music store for a very important accessory necessary for proper playing of their instrument. This explained, I express my regret but immediately an idea flashed thru my mind that there was a great need for a small device to make this important accessory.

For weeks I kept turning that spark of an idea over in my mind trying to picture a machine that would be satisfactory for the purpose desired. Finally I pictured it in detail and soon constructed a working model that proved efficient. Then I applied for broad patents both in the U. S. A. and foreign countries. It is about ready for the market now, but in justice to the manufacturers it isn't possible to explain definitely all about the construction and origination until ready for public announcement. However in a later article I shall show several drawings and give a complete explanation of the invention.

Copyrighted 1919 by Jay G. Hobson

**Bomb Expert Eagan**

(Continued from page 296)

use among the Italians. These bombs were made by Italians who had been employed in fireworks factories in Italy and in America. The cause for the placing of the bombs was feuds among the Italians. A section of the city became known as the "bomb centre."

While walking in a section of the east-side on a fair May day, in the neighborhood of East 11th and 12th Streets, I was stopped by a policeman from the East 5th Street Police Station House. "I was just up to the station house and sent a call for you," he said. "Why?" I queried. He answered, "We have located a big package down in 11th Street, which looks like a bomb, and the people in the house have left their apartments, fearing it will explode."

Upon arriving, I ordered all the children away from the place, and then started to operate upon the bundle. To my great surprise I came upon two fulminate of mercury caps attached to two fuses, and twelve sticks of 40 per cent. dynamite put up in two separate packages! To each six sticks of dynamite, a fulminate cap was attached. The bundle was surrounded on all sides with heavy pieces of iron, bolts and small pieces of slugs. It was then covered with burlap, which in turn was covered with newspaper and bound with

# Why Not Earn \$35.00 to \$100 A Week As A Mechanical Draftsman?

"Get into the profession of big pay and Rapid Advancement with the help of the school that has started hundreds on the Road to Success. I am ready to help you." Roy C. Claffin, President, Columbia School of Drafting.



### Learn At Home In Spare Time

You don't have to stop work or leave home in order to become a trained Draftsman. Through our practical home study Training we will teach you Right in Your Own Home so that you will soon be able to qualify for a good position at Big Pay. We will continue to instruct and help you until we know you have the knowledge necessary to succeed.

### We Will Help You Secure a Position

as soon as you complete our course. We have already placed hundreds of our graduates in good paying positions and are constantly in touch with vacancies for which Draftsmen are Urgently Needed. Government Departments and Private Concerns are continually calling upon us for our graduates because they know that our instruction produces draftsmen of the caliber they need.

### No Previous Training Necessary

Right now—TODAY—there are openings for thousands of Draftsmen in the Government Departments, industrial concerns, and the big engineering offices. One department alone recently called for 1,800 draftsmen. With this tremendous demand has come a big increase in salaries.

### Draftsmen Are Getting \$35 to \$100 a Week

with big chances for even better pay as the demand grows. By enrolling NOW for our practical Home Study Course in Drafting you can quickly qualify for a position as Draftsman and by properly applying the principles we teach.

### Thousands of Men Wanted Right Now

**Drawing Outfit FREE** As soon as you enroll you will be sent our special drawing outfit FREE so that you will be sure to have it to work with while taking the course. This set will be yours to keep. You are not asked to return it after completing the course.

### You Have a Chance to Become a Chief Draftsman

and get to the very top in this fascinating profession. Our course will give you just the knowledge you need to make good as chief draftsman when your chance comes.

### Illustrated Book of Particulars Sent Free

Fill in the coupon below—send it to us and we will send you FREE a copy of our illustrated book telling all about our practical Home Study Course and how you may secure our instruction at once on Easy Terms so as to quickly qualify for one of the Big Positions Now Open.

### Peace Calls For More Draftsmen

With the problems of reconstruction facing the nation the demand for draftsmen is even Greater Than During the War. All big engineering, construction and manufacturing projects must first go through the drafting room before the workmen can commence. You can help in the work of reconstruction and secure a Big Salary with excellent opportunities for advancement. Prepare now and be ready when the demand reaches its height.

### Mail This Coupon To-day

Columbia School of Drafting  
Dept. 1050, 14th and T Sts., N. W.  
Washington, D. C.

Without obligation to me, please send me your illustrated book telling how I can secure your complete Home Study Course, the FREE DRAWING OUTFIT, and your help in securing a position as Draftsman.

Name .....  
Address .....  
City ..... State .....

You benefit by mentioning the "Electrical Experimenter" when writing to advertisers.

# AVON INN

## AVON-BY-THE-SEA, N. J.

**L**OCATED directly on the beach, 50 miles from New York and 2 miles from Asbury Park.

Surrounded by spacious piazzas and extensive grounds, its accessibility to the beach makes it particularly desirable for families with children.

**DANCING BATHING BOATING  
TENNIS GOLF FISHING**

*Write for Booklet and Information*

**AVON INN HOTEL COMPANY**

PROPRIETORS

S. THOMAS PENNA, Manager

a heavy wire. In all, the bomb weighed about thirty pounds.

With the development and common knowledge of explosives of the nitro-cellulose group, chlorat and nitrat mixtures disappeared and the number of composite nitro-cellulose and nitro-glycerin bombs has increased and many ingenious combinations of the above mentioned methods of ignition have been devised, showing that much keener minds and men well trained in chemistry and the use of explosives have made these later type bombs.

### Speaking of Large Bombs.

The first bomb of this type, the "Cunard Bomb," discovered in 1902, was the largest bomb I ever handled. This type was very rare then, but it is now "the usual garden variety." The Cunard bomb was of the nitro-glycerin class mechanically detonated. The bomb consisted of 100 lbs. of 60 per cent, dynamite, placed in two boxes, each containing 50 pounds. These boxes were set inside a larger box within which was set a *timing device* which would set off the fulminating caps and detonate the explosives. The timing device was set to explode when the ship had proceeded two hundred miles from the coast. The man who made the bomb was discovered in a tenement and was found to be insane.

The O. K. Bottling Works Bomb was of the nitro-cellulose type, mechanically and electrically operated, as was evident from the circumstances, weight and size of container, the express charge and the debris. On the morning of December 12th, 1913, a small pasteboard box was delivered by the Adams Express Company and was received by the stenographer, Miss Anna Amusewitz, who laid it aside until she had opened the mail. The bookkeeper who was in the office when the bomb exploded and who survived his injuries, stated that Miss Amusewitz cut the string, thereupon an explosion occurred. The office was wrecked, Miss Amusewitz was hurled into the corner and died within ten minutes. The perpetrator was never discovered.

The Herrara Bomb was of the nitro-glycerin group, chemically ignited. The circumstances were similar to those of the O. K. Bottling Works Bomb, which killed Miss Amusewitz. Mrs. Herrara was killed outright and her husband was totally blinded.

The Taylor Bomb, the second manufactured by Klotz, was of the same type and made by the same person. This bomb killed Mrs. Taylor under the same attendant circumstances as noted above.

My own fingers were blown off by a bomb of the same description and manufactured by the same man who sent it to a prominent man in New York City, (Judge Rosalsky), related Inspector Eagan.

Shortly after the third bomb, Herman Klotz, a draftsman and former employee of the City of New York, was mortally injured by a bomb he was making. Klotz confest to these outrages before his death in the Fordham Hospital.

Since the beginning of the European War, bombs have been of an improved type and are modelled along the lines of munitions used by the European Belligerents.

The Fay Bomb manufactured by Lieutenant Commander Fay, of the German Imperial Navy, was of the alkaline metallic nitrat and chlorat type, mechanically detonated. The bomb case was of steel plates welded together by 100 rivets, and a riveted cover with a water-tight gasket. The interior was filled with a chlorat, nitrat, sulfur and antimony mixture. There were two detonating devices, one within the steel case and the other one the exterior. The exterior mechanism was attached to the propeller shaft of the steamship and the rotation of the shaft tightened the spring on the interior me-

DEPENDABLE  
**KNAPP**  
ELECTRIC SPECIALTIES

## Motors and Electrical Specialties Are Best

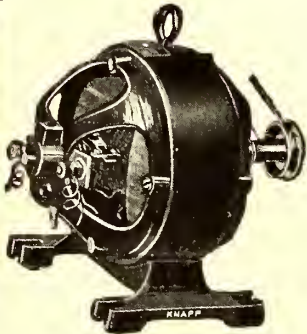

KNAPP DYNAMO MOTOR

Will electroplate, charge storage batteries, run lamps, motors, train of cars, induction coils.—in fact, the number of experiments it can be used for is unlimited. Runs on 4 to 6 Volts or can be connected to run on 110 Volts through a transformer.

Price, Complete, \$7.00

Order to-day. Or your dealer can secure them for you. DESCRIPTIVE CIRCULAR and CATALOG of celebrated **KNAPP MOTORS** and Electrical Specialties from 10c up mailed FREE on request.

KNAPP ELECTRIC & NOVELTY CO., 523 West 51st Street, New York City

Knapp Goods have stood the test for 29 years. No detail in construction has been spared to make them the best that money can buy. The complete Knapp line includes Toy and Power Motors, Generators and Dynamos. Specialties and Novelties that amuse and instruct. Fans, Rheostats, Compasses, etc. And Knapp prices are always lowest. Always insist on Knapp Goods.

### KNAPP "LEARNELECTRICS"

A complete Electrical Laboratory, including a very valuable instruction book by H. P. Gorman, A.I.E.E. Covers all subjects clearly and concisely.



Price, Complete, \$3.50

**S**TAMPS

50 diff. Belgium (large bi-color), China, Jamaica, Portugal, Venezuela, etc., 10c; 100 diff. nice packet, 20c; 1,000 well mixed, 40c; 100 var. U. S., 50c; 1,000 hinges, 10c; Agts. wanted, 50%. List free, 1 buy stamps. L. B. Dover, Overland, Mo.



**TYPE WRITERS**

\$10 AND UP. ALL MAKES. SAVE \$25 TO \$50 on rebuilt at the factory by the well-known "Young Process." Sold for low cash—installment or rented. Rental applies on purchase price. Write for full details and guarantee. Free trial. YOUNG TYPEWRITER CO., Dept. 821, Chicago

chanism so that when the spring automatically released, it tripped the firing pin which exploded the percussion cap, thus detonating the chemical mixture.

**The Recent "Gimbel Bros." Bomb.**

The late nation-wide, Post-Office Bombs were composite bombs of the nitro-glycerin, alkaline, metallic, chlorate type, manually, mechanically and chemically ignited, and were the work of a trained, experienced expert, who knew chemistry, explosives and the psychology of his victims. These nineteen bombs were similar in composition, but not in operation, to the bomb which killed Governor Steunenberg of Idaho. See photo of bomb.

The latest bomb outrages known as the "Anarchist Fighter's Bombs" were of the high explosive type. The details cannot be divulged at this time, but the destruction surrounding the residences where the bombs were set off tells the tale all too well.

There are many foolish bomb scares—from diamond studded wrist watches, sent without notice, to one of the Four Hundred's latest debutantes, to a piece of copper ore sent to a mining engineer or a new kind of cheese sent to a prominent patron of the Waldorf-Astoria, who is a connoisseur of famous cheeses, or it may

**INSPECTOR OWEN EAGAN** holds perhaps one of the most unique positions in the world. Mr. Eagan is the official bomb opener in New York City, where during the last decade more bomb outrages have been perpetrated than in any other community in the world. Mr. Eagan has consented to publish some of his experiences in the columns of the **ELECTRICAL EXPERIMENTER**, and we feel certain that every reader will be intensely interested in Mr. Eagan's experiences. Inspector Eagan has opened thousands of bombs in his past career, only once being injured, when he lost a finger of his left hand due to the premature explosion of a bomb.

be a box of coals containing a ticking alarm clock which has been sent to the Italian barber in the corner barber shop. These jokes cause much worry and excitement and should never be perpetrated. In one case I found a woman in a serious condition, due to the receipt by messenger of a package the inner wrapper of which was decorated by skull and bones and a warning of death. Arriving there and removing this cover, I extracted a bottle of plain "Pluto Water"!

The latest bombs were not the only ones sent to prominent persons.

Carnegie Mansion at Ninety-first Street and 5th Avenue was the scene of a bomb discovery. Another bomb was discovered outside the offices of the Italian Consul at 212 Lafayette Street. These were of the nitro-glycerin class, manually ignited by the application of a match to the fuse.

The late Honorable Mayor Gaynor was the recipient of a similar bomb which was discovered outside his office window with three burnt matches, and a piece of Chinese lighting punk which showed evidence of having been ignited.

The wealthy and prominent persons of our city are not the only victims to have these unreliable and unexpected packages sent to them. Two bombs were placed in churches in this city. Two bombs were placed in moving picture houses on the East Side. One bomb tore away the stairway and gallery. Even tenements suffer as much as mansions and private residences.

**Bomb-Making An Unhealthy Vocation.**

The "bomb maker" is not particular where he manufactures his infernal ma-

# Try This Interesting Experiment

It is something *everybody* can do.

It is something you *must* do, if you would ever be more than a drudge.

It will bring you freedom from worry.

It will make you happy, and independent.

It is wonderful insurance.

It puts you where you can grasp opportunity when it comes along.

It gives you a vacation when you need it.

It means more advantages for your children.

It denotes character and stability.

It puts you out of debt.

It is the beginning of Success.

Try it.

It is—**SAVING!**

It is now made easy by a new system, and interesting.

Almost as fascinating as a game.

It is the Budget System of Saving and Making Money.

You have read about it in the magazine and newspapers.

All authorities endorse it.

It stops you from slipshod spending.

It saves the money that now slips through your fingers—puts it where it will do you some good when you need it.

Thousands of happy, successful families use it today.

It is fast becoming universal among worth-while people.

A business principle applied to the home—that's what the Budget System is.

It shows you in advance the minimum amount you can save.

A Chicago family beat their Budget by \$65.00 last January.

That's getting ahead.

You can do the same.

You have always *intended* to save more.

You have worried about the high cost of living.

You have wondered where all your money went to.

Take that last \$50.00 you spent.

What have you got to show for it?

How much of it can you account for?

Can't you account for *all* of it?

No?

Then you are a reckless spender.

Just such methods keep millions poor.

They cause hand-to-mouth living—and destitute old age.

The Budget System corrects this evil.

But learn the Budget System correctly at the start.

It's so simple.

An accountant named Palmer devised a wonderful Budget Book—

based on seven years' actual experience in the home.

It tells you all about starting a Budget—and how to keep it up.

Then there are pages to last you two years.

By Palmer's System it only takes you a few moments each day.

A grammar school child can do it.

It is all in one handy volume—well bound,

convenient, handsome.

You'll be proud to show it to your friends.

But prouder still to enjoy the advantages it brings to you and those dear to you.

You won't be without this wealth-creating book if you see it.

We want to send it to you *at our expense*.

You don't even need to send postage.

Merely mail the coupon.

We send the book—all charges prepaid.

You keep it five days.

Quickly you will see that it will pay for itself several hundred times.

You will see why users are so enthusiastic about it.

You will want to keep it.

No matter whether your income is steady or variable.

No matter what season of the year.

You will never be without Palmer's Household Money Maker if you see it.

That's why we make such a liberal offer.

Keep it five days.

Then send us the purchase price—

only three dollars.

Think what a trifling sum this is.

It is less than half a cent a day, as the book lasts two years.

Read the letters in this ad.

They are pouring into our office every day.

You, yourself, are likely to write us a letter that will appear on this very page.

But the first step is to send the coupon.

**DO IT TODAY!**

The quicker you get Palmer's book the quicker it begins to save you money.

**ACT NOW!**

KRIEBEL & CO., 643 Home Insurance Bldg., Chicago.

**Users Are Enthusiastic**

I am wild about this book, the one I should have had long ago.  
T. B., Watertown, Fla.

I kept tab on house expense for 6 years, when I told my folks it averaged \$40.00 a week they just laughed at me. We are 10 in the family. Taking the book home I told one of my daughters to put everything down from January 1st to date, when we closed the month of January it amounted to \$174.79. It surprised them all. I am sure I can save what I paid for the book in a week; don't need to wait two years as it is an eye-opener to the folks at home. Be sure and send me another book in December, 1920.  
R. K., Odebolt, Ia.

I am very much pleased with same. Enclosed please find money order to pay for two copies of this great book, kindly send me another copy by parcel post as I desire to turn same over to a close friend.  
D. O. R., Frankfort, Ky.

Will you please accept this check and forward one copy of this book? I have seen a copy of this book and it is just the article I've been looking for for the past year or so.  
W. L. F., Alexandria, La.

I gave the book to a friend of mine for a wedding present and if I am not mistaken it will prove the most valuable present I could have given him. Kindly send me another of these books for my own use.  
W. G. V., Kansas City, Mo.

Attached herewith you will find check in payment of your account against me, and for the balance request that you mail your Household Money Saver to the following four parties.  
A. E. K., Cleveland, O.

**KRIEBEL & CO., 643 Home Insurance Bldg., Chicago.**

You may send me Mr. Palmer's book, prepaid. Within five days after receiving it I will send you \$3, or mail the book back to you.

NAME .....

ADDRESS .....

For the convenience of those who wish to remit cash with order, we allow a cash discount of 25 cents, making the price of the book \$2.75. If you remit cash with order you may keep the book five days, then return it if you do not want it, and we will refund your money.

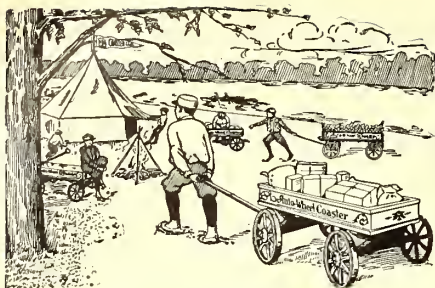

Adventures of the Auto-Wheel Coaster Club

HOW THE AUTO-WHEEL HELPS AT CAMP.

—First the long hike, with the Auto-Wheels carrying the heavy loads—tents, and crows, and fishing tackle, and all the rest.

—And when we pitched camp the Auto-Wheels did a man-sized job hauling away rubbish from the camp area, and bringing up firewood. Jim, the Club Captain, bossed the job, and camp was ready in forty minutes.

—We all wore our Club caps—the kind all Auto-Wheel Club members get free by writing to the Buffalo Sled Company for details.

BOYS: If you want to share the fun of the Auto-Wheel Coaster Club, write for booklet showing Auto-Wheel Coaster and Auto-Wheel Convertible Roadster. A Free Felt Pennant goes with this handsome booklet.

THE BUFFALO SLED CO., 163 Schenck Street, In Canada: Preston, Ont. N. Tonawanda, N. Y.

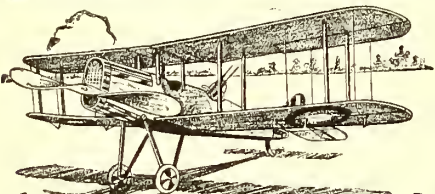

Build And Fly This Model of the Famous DE HAVILLAND DeH-4 BATTLE PLANE

Here's a new IDEAL Model Aeroplane—a faithful duplicate of the war-famous Battle Plane that downed the enemy over the battlefields of France. This new IDEAL Model is in every detail a practical, 3-ft. copy of the original. Has oval aluminum radiator, veneer cockpit and fuselage, aluminum top and bottom engine cowling, hand carved propeller, ball-bearing propeller shaft and rubber-tired disc wheels. Guaranteed to fly from the ground. Miniature gun mount and guns can be made and mounted on the rear cockpit. Build one; it's easy! IDEAL Accurate Scale Drawings, including building and flying instructions, show any bright boy how to do it.

PLANS AND INSTRUCTIONS

- for any of these "planes sent postpaid"
DE HAVILLAND BATTLE PLANE. 35c
Curtiss Military Tractor. 25c
Bleriot Monoplane. 25c
Nieuport Monoplane. 25c
Taube Monoplane. 25c
Cecil Peoli Racer. 25c
NC-4 (ready August 15th). 50c
Advance Orders now booked for NC-4 Plans
IDEAL Model Aeroplane Construction Outfits containing all parts and materials needed to build these Model Aeroplanes are sold by Leading Toy, Sporting Goods and Department Stores. Ask for them at your store.
IDEAL Model Aeroplane Catalog, 48 pages, 5c Postpaid
IDEAL AIRPLANE & SUPPLY COMPANY
159-161 Wooster St., cor. W. Houston St., N. Y. City



FUN Noiseless Target Practice

Fit your .22 with a Maxim Silencer and get no end of fun this summer practicing in your back yard and on your vacation.

MAXIM SILENCER MAKES YOU A BETTER MARKSMAN

It eliminates recoil and all noise of the report, and steadies your aim. Direct from Dealer or Factory \$5.00. Write for Free Book of Stories.

MAXIM SILENCER CO. 89 Homestead Ave., Hartford, Conn.

ALL THE PARTS & PLANS 50 CENTS PREPAID. Don't Send Stamps. Put together in a 'JIFFY' flies 100 feet. Next contest Model Aero-Fleet, next Sept. NIFTY NOVELTY & TOY CO., Newark, N. J.

chine. A cellar in an East Side tenement, the laboratory of a prominent hospital, an abandoned shack in the marshy sections of the suburbs, the servant's room of the mansion, a suite in the most modern apartment house, perhaps in the next apartment wherever you may be living. Bombs, strange as it may seem, have been made by many types of men, in all degrees of education, wealth and state of life.

In the bomb factory in the rear of a quiet and prosperous barber shop, the proprietor was killed by an explosion and upon the examination of his body, a little carelessness in placing a too highly reactive chemical in his pocket was found to have caused the end of his career. This rear room contained enough chemicals to stock a small drug store, sufficient dynamite to clear Long Island of tree stumps and enough modern fire arms and ammunition to make envious a "would-be" Jesse James.

The making or setting of bombs is not a safe and lucrative occupation or hobby, as many of these men meet destruction by their own bombs. The greatest death toll paid by bomb makers occurred in the top floor of a six-story apartment house on Lexington Avenue, between 102nd and 103rd Street. Three anarchists, Hansen, Carron and Berg were killed. A brother of Louis Berger, who used a fictitious name "Murphy," escaped death with severe injuries. The force of the explosion destroyed the three upper stories of this building.

During the war I was kept busy with the routine work of the Fire Department cooperating with the Police, Federal authorities, Defense authorities and in the instruction of agents who were assigned to the investigation of various enemy activities. The signing of the armistice brought its train of trouble with shells, rifle and hand grenades, fuses and every imaginable war relic which contained explosives. Many fingers were torn off by grenades exploding in the hands of children.

Mr. Eagan Only "Official Bomb Opener."

At this point we ventured the question: "How many men are engaged in this kind of work, Mr. Eagan?"

Mr. Eagan's answer is illuminating: "The only official bomb opener other than my own unique position, was the Imperial Chief Inspector of the late Czar of Russia, who held an exalted place in court circles and received a fabulous salary. I am one of the hard working, loyal American citizens in the Civil Service of this City, accepting a humble salary and have secured my position by long and trying experience, constant study and research."

To the question: "How did you engage in this mysterious and dangerous work?" Eagan's answer is to be found in the indomitable spirit of his race.

"As a boy, my Mother would relate to me the mysteries of Cleena, the Fairy Queen of County Cork, Ireland, whose invisible palace was on my great grandfather's estate near Fermoy. The spirit of delving into the occult and mysterious was early developed and not lacking the necessary nerve and grit, I went to it."

The telephone bell rang. "Another bomb," laconically said the inspector. "Here's my card. Ring, if you get a package," were his last words as he dived into the express elevator. I looked at his card. This is what it says:

OWEN EAGAN. BOMB EXPERT. Fire Headquarters. Worth 4100.

FLIES 500 FEET Lightning Racer Experimental Model. This is not a toy. It is a practical, scientific flying model, guaranteed to fly hundreds of feet; designed and built from the finest selected materials, by Model Experts. This machine and our famous "Montauk Flyer" are the only Complete Model Aeroplanes guaranteed to fly 500 ft. selling for less than \$5.00. This model, shipped with monoplane detached, ready and guaranteed to fly \$3.75 prepaid. Send stamps for circular describing this wonderful model. Blueprints of the following models 1-2 actual size 50 cents postpaid in U. S. Bleriot Racer, flies 600 ft. Manhattan Racer, flies 2000 ft. Montauk Flyer, flies 500 ft. 3 ft. Curtiss or De Haviland Biplane, 75 cents each, postpaid. HEC Flying Boat guaranteed to rise from the water and fly 500 ft. Two sheets blueprint \$1.00 postpaid U. S. HEC AEROPLANE CO., 300 E. 49th St., N. Y. C.

30 DAYS FREE TRIAL and freight prepaid on any "RANGER" bicycle. Write at once for our big catalog and special offers. Select from 44 styles, colors and sizes in the "RANGER" line. EASY PAYMENTS if desired, at a small advance over our Regular Factory-to-Rider cash prices. You cannot afford to buy without getting our latest propositions and Factory-to-Rider prices. Boys, be a "Rider Agent" and make big money taking orders for bicycles and supplies. Get our liberal terms on a sample to introduce the new "RANGER". Tire equipment, sundries and everything in the bicycle line at half usual prices. Write today. MEAD CYCLE COMPANY Dept. F.107, Chicago

Chemical Tricks for BOYS. Puzzle your friends with mysterious, harmless Chemical tricks. Four red, white and blue from a glass of water, write secret letters with invisible ink, write with water and have it turn blue, make your own blue ink or ink powder. You can have lots of real fun doing these tricks with "CHEMCRAFT JUNIOR" complete outfit shown at left. Send for your right away and get a Free copy of "The Chemcraft Chemist", an interesting magazine for boys. Amateur Chemist's Catalogue and Hand Book. Publishing valuable Chemical information for Boy Chemists and treating many useful, chemical and scientific facts and stories for the lay. None free. Regular \$1.00. CHEMCRAFT JUNIOR Outfit, at \$1.50, \$2.00 and \$3.00. The Porter Chemical Co., Arcade Bldg., Hagerstown, Md. CHEMCRAFT JUNIOR 25c POSTPAID

ZIP-ZIP Patented Sept. 3rd, 1918. The Greatest 60 Ct. Article on the Market. Shipped right from the factory the same day we receive your order. The Frog is made of beautiful metal; never break or wear out; scientifically made and best workmanship. The rubbers are elastic and lasting, with plenty of pep and force. Zip-Zip, complete, only 50c prepaid. Be sure the name Zip-Zip and your address appear on the article you buy. Order from us or any Sporting Goods Store in your city. Send Stamps, Coin or Money Order. AUTOMATIC RUBBER CO. COLUMBIA, S. C.

35 Miles per hour Is Record of this Car. Boys, Build This Car. This nifty little car driven by gasoline motor, can be built by any boy. Parts are furnished by us and are very cheap. Send 25c for building plans and price list of parts showing how to build this lad's car. SYPHER MFG. CO. 155 Warren Street TOLEDO, OHIO.

UMAKEM Airplane Workchest, containing aircraft work table with mitre cutting board and length gauge, steel drill, steel hammer, Model Maker's steel square, screwdriver, sandpaper block, 10" scroll saw, together with finest quality red and bass wood, aluminum, silk, para rubber, full set of blueprints, directions, and all fittings for building one 36" Bleriot Model flying Monoplane. Price \$10.00. Other Umakem Outfits 50c to \$50. W. R. PRICE, Inc. No. 2 Umakem Building, 127 Fifth Avenue, New York

STAMMERER Send 10 cents for my remarkable book, "How To Stop Stammering. Kill the fear of stammering. Re education the key. The Hatfield Institute, 109 N. Dearborn St., Chicago, Ill.

You benefit by mentioning the "Electrical Experimenter" when writing to advertisers.



U. S. S. TENNESSEE ELECTRIC DRIVEN.

The U. S. super-dreadnaught Tennessee is a sister ship of the California, now being built at the navy yard, Mare Island, Cal., and which is to be launched in the fall. The Tennessee is 624 feet long, 97 feet 5 3/4 inches in width, and has a draft of 30 feet 6 inches. She displaces 32,600 tons and has a speed of 21 knots. She has eight water tube boilers and a fuel capacity of 1,900 tons. Her armament will consist of twelve 14-inch guns, fourteen 5-inch guns, four 6-pounders, four anti-aircraft guns, and two torpedo tubes. She will be manned by a crew of 58 officers and 1,024 men. She will burn oil exclusively and will be equipped with electric drive.

Man's Greatest Curse-- Infected Teeth

(Continued from page 301)

"Tooth infection is undoubtedly transmitted from person to person in the same family, from parents to children, by means of kissing, the use of common drinking and eating utensils, and many other ways. So, if one has infected teeth, he is not only dangerous to himself, but may transmit this infection to other members of his family, especially his children, and produce serious conditions which are difficult to explain. One is appalled at the condition of the first teeth of children, many of whom have to have their first teeth filled. Often the second teeth become infected from the first set and the child carries thru life the result of the neglect of the teeth, on the one hand, and the transmission of the parent's infection, in addition.

"Consequently, we feel justified in advocating radical measures in eliminating the infection from children as well as adults, and that means extracting all infected teeth, whether in children or adults, as soon as there is evidence of infection.

Conditions Resulting from Infected Teeth.

"As we give further attention to the subject of chronic infection of the teeth, we are finding more and more conditions resulting therefrom. At first, the relation of infected teeth to rheumatism was demonstrated by Hastings in 1914. This was a very important discovery, for this disease had baffled physicians who could find no definite cause for it and many fanciful theories were put forward to explain the cause. Not only can rheumatism be prevented by intelligent care of the teeth, as outlined above, but in many cases it can be cured by the simple method of extracting infected teeth. Possibly the most common ailment of people in general today is summed up in the general term 'stomach trouble,' and often this condition resists all attempts at eradication by the ordinary methods and may persist for years, causing the patient to drag out a miserable existence. In the majority of cases, infected teeth are at the root of the trouble, and if the condition has not progressed too far, extraction of those teeth, so fondly cherished for years, may clear up the chronic stomach trouble.

"We have proven conclusively that the infection of the teeth, after years, may spread to other organs of the body and cause disease in these remote regions, which disease has apparently no relation to the teeth, but, nevertheless, the infected teeth are directly responsible for the condition. The bacteria which grow and propagate

(Continued on page 347)

Make a Bigger Income Learn Draftsmanship

Great demand for draftsmen now. Still greater demand in prospect. War over, building is to be resumed and manufacturing to expand to meet home and foreign needs--which means plenty of good positions for draftsmen. Take up this paying profession. The Chicago "Tech" method is the quickest, easiest way to become a draftsman in spare time while you hold your present position. That proved before you pay a penny. (See free lesson offer below.) Send coupon. Learn how to earn \$25 to \$100 a Week or More at interesting work with opportunities to rise to superintendent, manager, or other executive positions. Let the Chicago "Tech" engineers train you At least get the free lesson and information.

Drawing Outfit



(No Extra Charge)

Every student of the Chicago "Tech" Home Study Course

in Draftsmanship receives this drawing outfit--set of instruments in case, drawing board, T-square, triangles, scale, curve, drawing paper, pencils, etc., or a cash credit in case he already has an outfit. You use them while learning--then take them right into your practical work.

NOTE: Enrolled with Chicago "Tech" you have the personal direction of practical engineers, builders and architects who teach you the methods they use in their own work. No useless theories, no time wasted. You are prepared to stand beside old, experienced men. Big advantage to learn from a staff like this--every man a specialist.

Come To the College or TRAIN at HOME

Wherever you are you can have this Chicago "Tech" training. Complete instruction by mail. Exercises, lessons, personal direction of our experts right in your own home if you cannot come to the college for a resident course. Send the coupon and get the facts.

Auto and Gas Engine Course

All about automobile mechanism--its construction, operation and REPAIR--taught by mail. You train directly under the Chicago "Tech" automobile experts. Splendid opportunities open now.

Learn All This in Spare Time

- All about the Principles of the Automobile. All about Gasoline Engines. All about Power Plants and Transmissions. All about Carburetors and Fuel Supply Systems. All about Lubrication and Cooling. All about Batteries. All about Magneto Ignition. All about Starting and Lighting Systems.

Know How To Fix Troubles

Most complete instruction in auto repair work. Equips you for high pay or to start a business. Big demand for trained repair men.

Write Send the coupon and get catalog and all information now.

Easy Payments

The fees for Chicago "Tech" courses are very moderate--and you can pay on easy terms. And also--you can obtain in a few months what it would take several years to acquire by ordinary methods. You can get an early start. You are soon ready to take a paying position and to quickly get back the cost of your course.

FREE TEST LESSON

Other institutions ask you to pay first--and then to find out later how well qualified you are for this profession. We send the free lesson first and place you under no obligation at all. Discover your qualifications before you pay anything. And see for yourself just what Chicago "Tech" offers you in training which will bring a ready market for your services and open opportunities which are closed to the untrained man. The coupon will bring all the facts about the course, the small fee, and the easy terms.

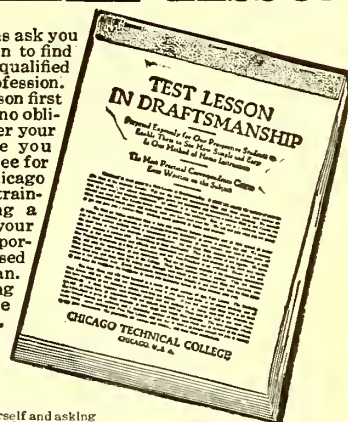

Mark with X the branch you are interested in--or if in doubt about which course to take, write a letter stating facts about yourself and asking our advice which will be freely given. Mail either the coupon or the letter today.

CHICAGO TECHNICAL COLLEGE, 845 Chicago "Tech" Building, Chicago

Without obligation upon me, send your Catalog on subject indicated below. Also FREE Lesson if inquiry is on Drafting or Plan Reading. Mark X opposite work in which you are especially interested.

- Architectural Drafting Plan-Reading--Buildings
Machine Drafting Plan-Reading--Shop Men
Electrical Drafting Estimating
Structural Drafting Surveying
Sheet Metal Drafting Map Drafting
Builders' Course Autos and Gas Engines

Name.....

Address.....

City..... State.....

College or Home Study? State which.....

# FOR EXPERIMENTERS ONLY!!

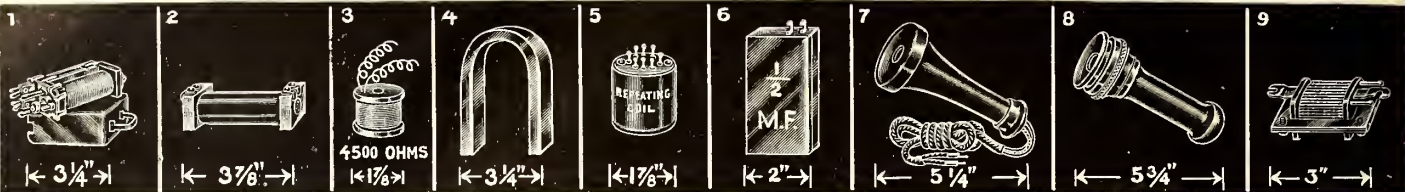

WE have in the past held many extraordinary sales, but we believe that the present one eclipses all by the wonderful values we are offering. The goods which we offer on this page are all standard telephone apparatus. Every piece we are offering is equipment that for one reason or another was discontinued by the telephone companies. If you wanted to buy any of the pieces which we offer herewith, from the manufacturers, the price would at least be ten times what we are asking for it. You can readily ascertain this for yourself by looking over our wonderful prices.

**RUSH**  
Cut out and attach to your order. It will leave us within 24 Hours.

We have bought a large block of these goods and have a large quantity of every item on hand. Immediate shipment can be made on all of the goods in practically any quantity within reason. Shipment within twenty-four hours will be made if you use the adjoining coupon. This coupon saves you several days and your order will then be considered a rush order. We guarantee every piece to be as represented, and we will refund the money if goods are not exactly as claimed by us.

**No. 1 TELEPHONE RELAY**, 1500 ohms—has two oiler-contact springs and is very sensitive. Can be used wherever a sensitive relay is needed. It is adjustable and can be used for a variety of purposes. No. 1 Relay—shipping weight, 2 lbs. Price..... **\$1.50**

**No. 2 STANDARD TELEPHONE Induction Coil**, primary 1 ohm, secondary 55 ohms. Use wherever you need a good induction coil. Has primary and secondary and iron wire core, fibre heads. No. 2 Induction Coil as described—shipping weight, 2 lbs. Price..... **\$0.50**

**No. 3 STANDARD RESISTANCE** wound with German silver wire—4,500 ohms, can be used as a choke or plain resistance, and has many other uses that readily suggest themselves to the experimenter. No. 3 Standard Resistance as described—shipping weight, 4 oz. Price..... **\$0.40**

**No. 4 HORSESHOE MAGNET**, size 3/4 inches wide x 5 inches high. Wul lift about 1 lb. Quality such as user of magnets, which means the best. No. 4 Horseshoe Magnet—shipping weight, 2 lbs. Price..... **\$0.30**

**No. 5 REPEATING COIL (Transformer)**. This is a standard small repeating coil and is used by all telephone companies. It has 4 different windings and eight contacts. Entirely enclosed in iron. The resistance being respectively 72 and 120 ohms, and 90 and 100 ohms. Diagram is furnished. Can be used for wireless, for boosting signals, etc. No. 5 Repeating Coil—shipping weight, 2 lbs. Price..... **\$0.50**

**No. 6 1/2 M.F. CONDENSER**. This is a standard telephone condenser and has 1/2 microfarads. Condenser comes in neat metal casing. This condenser is used in connection with spark coils to absorb the vibrator spark. Invaluable for test buzzers to absorb spark and make the sound of bell more steady. Is also used by every experimenter in connection with wireless where a fixed capacitor is needed. Several of these condensers should be in every experimenter's laboratory. No. 6 Condenser, 1/2 M.F.—shipping weight, 1 lb. Price..... **\$0.50**

**No. 7 DOUBLE POLE BELL TELEPHONE RECEIVER**—hard rubber casing with 2 ft. cord and tips. Standard 75 ohm—very powerful magnets. This receiver can be used in connection with any ordinary telephone work, and you will even find it sensitive enough for short distance wireless work. No. 7 Bell Telephone Receiver—shipping weight, 3 lbs. Price..... **\$0.80**

**No. 8 STANDARD TELEPHONE RECEIVER** with Metal Head. This receiver is made by Stromberg Carlson Co., with genuine hard rubber handle and ear cap. A very good fool-proof as well as sensitive receiver that cannot be put out of order if you try. Used for the same purpose as No. 7 Telephone Receiver. No. 8 Standard Telephone Receiver—shipping weight, 3 lbs. Price..... **\$0.75**

**No. 9 IMPEDANCE COIL (Close Core Transformer)**. This is a very fine little transformer and is used extensively in connection with telephone work. It is in reality an A.C. transformer for which you would pay \$5.00 if you had it made to order. The primary has 0.15 ohms, secondary 2000 ohms. It can be used for a variety of purposes that will suggest themselves to every experimenter. Can be used successfully to boost wireless signals. Also in connection with audions, etc. An A-1 instrument. Size 3 x 3 inches. No. 9 Impedance Coil—shipping weight, 2 lbs. Price..... **\$0.65**

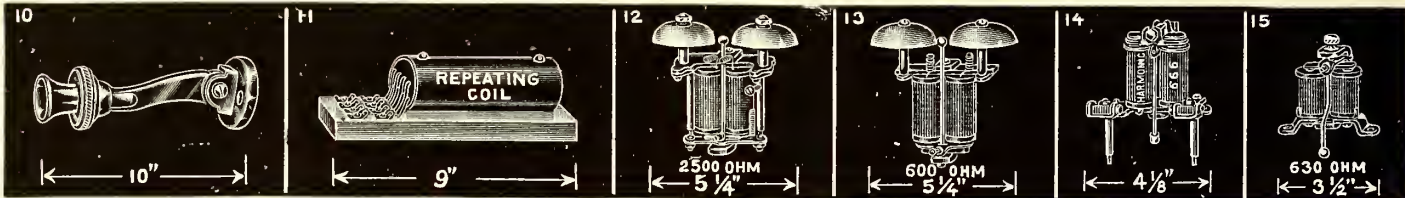

**No. 10 MICROPHONE AND BRACKET**. An A-1 sensitive microphone of the carbon grain type. Has hard rubber mouthpiece and enamel steel bracket, the instrument being 10 inches long. This microphone, in connection with our No. 7 or 8 Receiver, will constitute a complete telephone outfit, good to speak 50 miles or more, at a remarkably low price. No. 10 Microphone and Bracket—shipping weight, 5 lbs. Price..... **\$1.00**

**No. 11 REPEATING COIL (Transformer)**. A standard repeating coil used for telephonic work. The coil windings are encased in an iron tube 2 1/2 inches in diameter. There are eight terminals for the four windings to connect to and the instrument is invaluable in connection with radio work to boost up signals, audion work, etc. Many interesting uses will be found for this coil. Resistances are: 100, 120, 145, 175 ohms. No. 11 Repeating Coil—shipping weight, 8 lbs. Price..... **\$2.00**

**No. 12 POLARIZED RINGER with Bells**. The resistance of the two coils is 1250 ohms each. The armature is perfectly adjustable. Bell will work on any magneto. We also furnish blue print with ringer showing how a first class polarized relay can be made by anyone using only a few pieces of metal and screws. No. 12 Polarized Ringer with Bells—shipping weight, 2 lbs. Price..... **\$1.50**

**No. 13 POLARIZED RINGER with Bells**. This is the same kind of ringer as the No. 12, except that it is not adjustable and that the resistance is less. First class in all respects. Blue print furnished with this to make polarized relay same as with No. 12. Solenoids on this ringer are worth more than the price we ask for the entire ringer, and do not forget a powerful magnet that goes with it. No. 13 Polarized Ringer with Bells—shipping weight, 2 lbs. Price..... **\$1.00**

**No. 14 HARMONIC RINGER**—shipping weight, 4 lbs. Price..... **\$1.60**

**No. 15 RINGER without Bells**—630 ohms. This also is a polarized ringer and has an adjustable armature. The adjustment is done by means of the top screw. A beautiful little instrument. With this instrument, too, we furnish a blue print showing how a polarized relay can be built. You should have several of these beautiful little instruments. They are worth their weight in gold; the powerful magnet alone being worth more than the price we ask for the entire instrument. No. 15 Ringer—shipping weight, 2 lbs. Price..... **\$0.80**

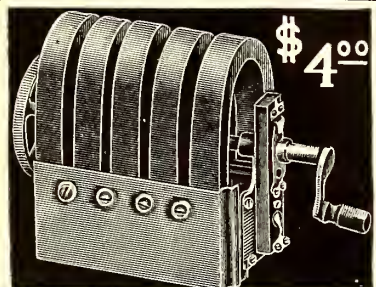

## No. 55 5-bar magneto, 110 Volt A. C. Generator

This is one of the most powerful magnetos ever built, when manufacturers could afford to put good stuff into them; equip with transmission, make and break, etc. Transmission wheels and all brass, crank handle furnished. This magneto, as well as the other ones listed below, will light a 110-volt lamp merely by turning the crank handle slowly. While this magneto gives alternating current only, it can be rewound so it will light up a number of four, six and 10-volt lamps, all depending upon the thickness of the wire you wind on the armature. As we furnish these magnetos, they will give a powerful alternating current and you will not be able to stand the current when grasping hold of the terminals. This makes an ideal shaking machine. All our generators can be transformed into a direct current machine by equipping it with a home-made commutator. Machines are A-1 in all respects and every experimenter should have one of them in his shop. Many other experiments which can be performed with this machine will readily suggest themselves to any experimenter. The magnetos furnished with these generators are very powerful, each one being able to lift one pound easily.

**No. 55 5-BAR MAGNETO GENERATOR** as described—shipping weight, 25 lbs. Price..... **\$4.00**  
**No. 33 3-BAR GENERATOR**, same as described above except that it has only 3 bars, and is somewhat smaller. No. 33 3-bar Generator—shipping weight, 10 lbs. Price..... **\$2.00**  
**No. 44 4-BAR GENERATOR**, same as No. 55 except that it has 4 bars, and is somewhat smaller. No. 44 4-bar Generator—shipping weight, 15 lbs. Price..... **\$3.00**  
**No. 66 6-BAR GENERATOR**, same as No. 55 except that it has one more magnet and the armature is somewhat larger and more powerful. This is the biggest type made and is extremely powerful. No. 66 6-bar Generator—shipping weight, 30 lbs. Price..... **\$4.50**

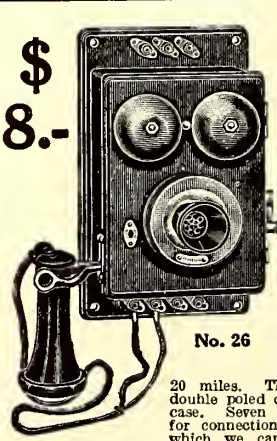

## Complete Wall Set

This is a complete commercial telephone station. The cabinet is of polished oak, piano finish, within which is contained the powerful magneto, the 300 Ohm polarized ringer, and induction coil. The magneto is exceptionally efficient, being of the two bar type with brass gear transmission. The extra sensitive microphone, mouthpiece and two gongs are mounted on the front of the cabinet, giving the entire instrument that desirable appearance of compactness and efficiency. Guaranteed to work over 20 miles. The telephone receiver is a double pole one, and has a hard rubber case. Seven binding posts are provided for connections. The instrument is one which we can offer with pride to our patrons at a ridiculously low price. It is unobtainable anywhere else at less than \$15.00 and is an instrument unequaled in value for the price we ask. Size over all 11" x 10" x 8". Shipping weight, 15 lbs. Price..... **\$8.00**

**No. 26 Long Distance Telephone Set**..... **\$8.00**

**CARBON GRAIN TRANSMITTER**

A special design of transmitter for long distance work. Is used on wireless telephone sets where a steady current of 3/4 to 1 ampere is constantly required. Sizes over all 3 1/4 x 2 1/2 inches. Shipping weight, 3 lbs. No. 6080 Carbon Grain Transmitter as described..... **\$1.00**

"The Livest Catalog in America"

Our big, new electrical cyclopedia No. 20 is waiting for you. Positively the most complete wireless and electrical catalog in print today. 176 Big Pages, 400 illustrations, 300 instruments and apparatus, etc. Big "Treatise on Wireless Telegraphy." 20 FREE coupons for our 160-page FREE Wireless Course in 20 lessons. FREE Cyclopedia No. 20 measure 7x5 1/4". Weight 1/2 lb. Beautiful stiff covers.

**ELECTRO IMPORTING CO., 231 Fulton Street, NEW YORK**

**ELECTRO IMPORTING COMPANY**  
 231 Fulton St., New York City

I enclose herewith 6 cents in stamps or coin, to cover postage, for which please send me your latest Cyclopedia Catalog No. 20 as described.

NAME .....

ADDRESS .....

STATE.....E. E. 8-19

# Man's Greatest Curse--Infected Teeth

(Continued from page 345)

at the roots of infected teeth must have an outlet, especially if the tooth has been crowned and all means of drainage from the upper part of the tooth is thereby cut off. *Then the bacteria filter thru the bone in which the teeth are embedded, which bone is microscopically porous, and from the organisms or bacteria gain access to the lymphatic system and migrate to other organs and set up a secondary focus of infection.* When this condition occurs, it is easy to understand that the mere extraction of the offending tooth will not clear up the condition but the infection must then be eradicated from this new focus.

"We have various methods of locating these secondary foci of infection. If the tonsils are infected as a result of infected teeth, *the teeth should first be extracted and then the tonsils removed.* If the stomach is infected, an examination of the contents will show the presence of this infection and it can be treated by means of vaccines, but always *after* the infected teeth are extracted. In the more serious conditions the *intestinal tract* may be the seat of the *secondary infection* and, by

effect in lowering the vitality and allowing a latent infection to become active.

"By recognizing the fact that mental diseases may be the result of infection and the toxemia or poisoning due to this infection, we have been able to restore many patients, who with our former methods of treatment, became chronic patients and remained in the hospital until the time of their death. *Thus we have been able to discharge 87 per cent. of the patients admitted to the hospital in the last nine months, whereas for a period of ten years, the proportion of discharges to admissions was only 43 per cent.* In other words, we have *doubled* the number of patients who leave the hospital as a direct result of our researches.

"As a prevention of mental diseases, then, it would seem that the proper care of the teeth is of the utmost importance, and we would emphasize the fact that the proper care is entirely different from what the usual dental examination reveals, *and that only by refusing to have devitalized teeth (teeth in which the nerve has been destroyed), crowned, or otherwise preserved,*

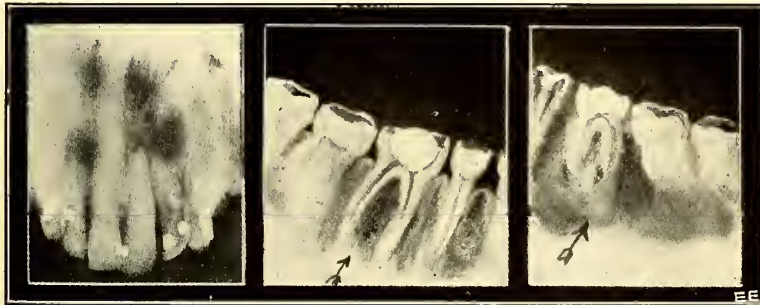

Three X-Ray Views of Infected Teeth. The Two Right-hand Radiographs Show Abscesses Indicated by Arrows: The Dark Patches in the Left-hand Radiograph Indicate Abscesses. This Photo Was Taken Down Thru the Top of the Mouth, the Patient Holding the Plate in the Mouth Between the Teeth.

means of the X-ray certain things relating to the function of the intestines may be found and intelligent surgical aid may have to be invoked.

"There can be no doubt that many unexplained diseases have their origin in infected teeth. Thus Barker, at the Johns Hopkins Hospital, has shown that many cases of *pernicious anemia* have recovered when the infected teeth are extracted. It has also been shown that *serious heart conditions, diseases of the kidneys*—commonly known as 'Bright's Disease'—*diseases of the gall bladder* and many other diseases may be the result, directly or indirectly, of a *focus of infection originating in the teeth.*

### Nervous and Mental Diseases Due to Infection

"Finally, the most serious result of infected teeth is to be found in the relation of this infection to *nervous and mental conditions.* We have been for years groping in the dark, trying to find a cause for these unexplainable conditions. We have considered mental diseases as something apart from general diseases where such things as worry, grief, fear, overwork, and many other elements are usually given as the cause of disease of the mind. Since we have found at the State Hospital at Trenton that *many of the patients suffering from mental disease had also very serious chronic infections of the teeth, tonsils, and gastro-intestinal tract,* and that by *eliminating these infections our patients recovered,* we are justified in concluding that *these chronic infections play a very important role in the causation of the mental condition.* Of course, other factors, such as we have mentioned, have a profound

*and insisting upon having these teeth extracted, can we hope for better teeth and prevent infection, which later will have serious consequences.* This is a matter which can be controlled by the individual and it is the public in general who can bring about a better state of affairs by insisting upon good dentistry, in the sense we have explained, and by not allowing the kind of dental work which preserves the teeth to the detriment of the patient's health. Such results as we are trying to obtain can only be brought about by educating the public in these matters, as well as the medical and dental profession. For this reason we believe that the widest publicity should be given to these facts and their importance emphasized both from the standpoint of prevention and cure.

### CONCLUSIONS.

"We feel justified in summing up the results of modern scientific medical and dental investigations as follows:

1. That bad or infected teeth are extremely prevalent and because they cause no symptoms to the patient are often unrecognized.
2. That these same infected teeth may be the source of many serious and often fatal diseases, including nervous and mental diseases.
3. That the only known prevention of the effects of this infection is to have all devitalized teeth removed as well as the teeth known to be infected.
4. That one should not allow devitalized teeth to be capped or crowned nor pivot teeth to be placed on old roots but insist that these teeth be extracted.
5. That all persons should keep in mind the danger of transmitting this infection to other members of their families, especially children, and thus prevent serious trouble in after years.
6. That while the infection may originate in the teeth, in the course of years this infection will travel thru the lymphatic system and invade other organs, and eventually set up secondary foci of infection, which become more dangerous than the original focus in the teeth."

You benefit by mentioning the "Electrical Experimenter" when writing to advertisers.

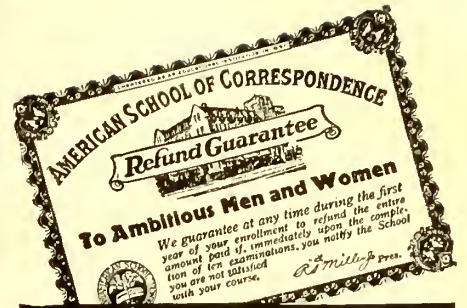

## Find Out What TRAINING Means to YOU

**What it Intensive training Has Done** ing men like YOU for the positions they wanted—given them steady employment—made them sought after by employers—multiplied their earning power—made them leaders in their chosen lines. For thousands, it has changed the drudgery of "getting by" into the joy of GETTING ON. Do you realize that the same intensive training can do the same for you?

Doing things better **Why it** than the other fellow— **Does it** thinking and acting for yourself—having a grip on your task—the expert touch—the trick of KNOWING HOW—that is why you succeed after intensive training. *That is what it does for you.* Training clears away the cobwebs, throws the spotlight on the things you don't know about your work, and makes you the master of any emergency.

## Don't Fool Yourself

Don't be fooled into thinking that "luck" or "pull" will make you a winner. The man without training just scrambles through life—never a money-maker—never sure of his job—never holding a responsible position. As long as you refuse to train you must pass up opportunities and make way for the man who does. Face the facts and then let the American School help you into a better position—the one you want—as it has helped its thousands of students.

## You Take No Risk

The American School's guarantee above means that you can test what training will do for you without risking one cent of your money. We've got to make good with you, so check and mail the Coupon—NOW—for Free Bulletin.

AMERICAN SCHOOL of Correspondence Dept. CG26 CHICAGO



TRAINING THE KEY TO SUCCESS Please send me booklet and tell me how I can fit myself for position marked X

- |  |   |
|--|---|
| ..... Western Union Course             | ..... Accountant and Auditor                  |
| ..... Telephone Engineer               | ..... Steam Engineer                          |
| ..... Draftsman and Designer           | ..... Lawyer                                  |
| ..... Automobile Engineer              | ..... Business Manager                        |
| ..... Automobile Repairman             | ..... Certified Pub. Accountant               |
| ..... Airplane Mechanic                | ..... Bookkeeper                              |
| ..... High School Course               | ..... Stenographer                            |
| ..... Fire Insur. Adjuster             | ..... General Education Course                |
| ..... Sanitary Engineer                | ..... Com. School Branches                    |
| ..... Heating and Ventilating Engineer | ..... Electrical Engineer                     |
| ..... Master Plumber                   | ..... Electric Light and Power Superintendent |
| ..... Civil Engineer                   | ..... Hydroelectric Engineer                  |
| ..... Structural Engineer              | ..... Wireless Operator                       |
| ..... Mechanical Engineer              | ..... Architect                               |
| ..... Shop Superintendent              | ..... Building Contractor                     |

Name .....

Address .....

# Save

## TIRES LIKE THESE



**I Earned \$2200 In Four Months**

**This is Richard A. Oldham**

Mr. Oldham was tel graph operator for the Illinois Central Railroad for twenty years. He is fifty-eight years old. One day he read one of my advertisements and the possibilities of making money in Auto Tire Surgery business. In a few weeks he had purchased and installed a Haywood outfit. A short time afterward he wrote us that his income in four months was as much as it had been in two and one-half years as Telegraph Operator.

**Be a TIRE SURGEON**

Make \$2,500 to \$4,000 Per Year Giving New Life to Old Tires

A Haywood Tire Surgeon can do more with old tires than was even dreamed before the war. By the Haywood Method a Haywood Tire Surgeon can give 4,000 to 5,000 more miles of new life to a tire that two years ago would have been thrown on the junk pile. And it's easy to learn.

### HAYWOOD'S TIRE SURGERY

**20,000,000 tires wearing down every day.** By Tire Surgery you can quickly repair, rebuild and give new life to tires seemingly all worn out. Cuts, gashes, tears, bruises, broken fabric, every kind of an accident that can happen to any tire, inside or out, you can repair and save for long service. **The chance to make money is simply wonderful.**

**\$2,500 to \$4,000 a Year is Possible**

If we told you all the truth you wouldn't believe it. You would say, "it is too good to be true." But you can see what a great field there is for Haywood Tire Surgery Stations—for this better way.

**Send Today for My Free Book**

I have ready to mail you the day I get your request, a fascinating book—all about tires—how to repair them by the Haywood Method—how to start in business—how to build up trade—what to charge. In 48 to 72 hours you can have the whole proposition right in front of you. Use coupon at the left.

**M. Haywood, Pres.**  
**Haywood Tire & Equipment Co.**  
 1210 Capitol Ave.  
 Indianapolis  
 Indiana

**WRITE TODAY**

**M. HAYWOOD, President**  
**HAYWOOD TIRE & EQUIPMENT CO.**  
 1210 Capitol Ave. Indianapolis, Ind.

DEAR SIR: Please send me by return mail your free book on the new Haywood Tire Surgery Method and the details of your free school of tire repairing.

Name \_\_\_\_\_  
 Address \_\_\_\_\_

WITH THIS HAYWOOD OUTFIT



## The "Torpedoplane" and "Sub" Spotter

By George Holmes

(Continued from page 306)

called because of its weakness for laying eggs in other people's nests—is one further testimony to British engineering ability and the resourcefulness of our navy.

Rear Admiral Bradley A. Fiske, U. S. N., conceived the idea of a torpedo-carrying airplane in the winter of 1910-1911 as a means of defending the Philippine Islands, and discuss the idea with the General Board of the Navy. In April, 1912, he applied for patent on the torpedoplane, which was granted in July, 1912, by the U. S. Patent Office.

The Italians were the first to make experiments in dropping weights from an airplane, with a view to evolving a method of launching torpedoes. Captain Alessandro Guidoni, Royal Italian Navy, using a 1910 Farman biplane equip with floats, made a number of experiments at an Italian naval base in 1912-1915.

Captain M. F. Sueter, who was then director of the air department of the British Admiralty, appreciated the value of the idea and in conformity with the practise of the British Navy, which provides that the name of the commanding officer shall appear on a patent application with the name of the author of the invention, a patent application was made in the joint names of Captain Sueter and Lieutenant Hyde Thomson, in March, 1914.

The sinking of a Turkish troopship while at anchor in the Sea of Marmora, in 1915, by a British torpedoplane, created a little more interest in the experiment, but no greater support was given to the work and the experiments were superficial in nature and dragged on slowly, due to lack of official interest.

In May, 1917, those who believed in the potentiality of the torpedoplane and hoped that the Allies would put this device into effect against the German Navy before Germany could build torpedoplanes, were made heartsick by the report that the British steamship *Gena* had been torpedoed by a German torpedoplane.

In connection with the above, it is stated by the Admiralty that this method of attack was first practised successfully in August, 1915, by R. N. A. S. pilots, who sank several ships in the Dardanelles by torpedoes from seaplanes.

### How the Torpedoes Are Carried.

A sketch of one of the German seaplanes that participated in the attack against the *Gena*, showing the pontoon arrangement for holding the torpedo in the German seaplane, is exactly like the arrangement on Admiral Fiske's torpedoplane. The torpedo is held between the two pontoons of the seaplane with a bracing to keep the torpedo from moving while the seaplane is flying.

Some years ago I had occasion to discuss, first with Admiral Fiske and then with Allied officers, the advisability of using automatic brakes to check the velocity or fall of the torpedo. This discussion led to considering a number of methods, such as lowering the torpedo by means of a cable. But it was realized that while it would be feasible to lower the torpedo several hundred feet by means of a cable, and its direction could be maintained by means of vanes, and the possible swerving of the torpedo might also be checked by means of vanes, which would hold the torpedo steady excepting in case of sudden turns, the advantages to be gained were not readily apparent. The giant naval seaplane NC-4, which cross the Atlantic, could easily carry two foot-size torpedoes.

## HOME BATTERY CHARGING

means vitality and long life to your battery and anyone can do it with the **NEW F-F BANTAM BATTERY BOOSTER**

which will fully charge any 6 volt storage battery eF-Ficiently from 100 to 130 volt 60 cycle alternating current lamp socket.

This is a new size of F-F Rectifier and similar to our standard F-F Magnetic Rectifier which has been on the market for over 3 years. Thousands in use giving satisfactory service. Simple, safe, sure acting. Copper and carbon electrodes rectify the current. Capacity 6 volts 8 amperes. Shipping weight 10 pounds. Price complete with Ammeter and Battery Clips \$15.

Send check for prompt shipment via express or if via parcel post add sufficient for postage and insurance. Bulletin 12 on request.

**THE FRANCE MANUFACTURING CO., Cleveland, Ohio**

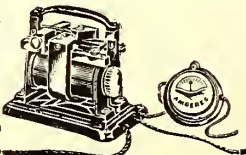

Says the Master Mechanic. The Greb Automatic Grip Puller is a One-Man Puller—Quick-acting, strong and simple in the extreme. May be locked in any desired position. A combination of two or three arms. Heavy Duty Size capacity 1" to 1 1/2"—Junior size capacity 1" to 7/8". Two sets of jaws furnished with each size.

**Ten Days' Trial** If your jobber does not have them we will send you one. Try it ten days. If not satisfactory, return to us and we will refund your money. We also make the GREB RIM TROWEL.

**THE GREB CO., 230 State Street, BOSTON**

## MARKO STORAGE BATTERIES ARE GOOD—TRY ONE

**Paul M. Marko & Co., Inc.**  
 1402-1412 Atlantic Ave.  
 Brooklyn, N. Y.

One Hundred Miles an Hour Torpedo Boat!

Some of the transatlantic planes being designed at present are capable of covering 3,000 miles without stopping. These machines can be converted into torpedo-planes by merely attaching the torpedoes under their planes or at some other convenient place. And then they become flying torpedo boats, capable of cruising at a speed of 100 to 125 miles an hour or more. A crew of half a dozen men will be sufficient to operate such a torpedoplane. Imagine this marvellous combination of speed, potentiality and mobility! What better weapon can we find for the defense of our coasts and island possessions? An enemy fleet bent on attack or carrying an invading force would have to contend with large torpedoplanes before it could come within 1,000 miles of our shores and with smaller torpedoplanes launched from aerodrome ships, such as are recommended by Admiral Rodman.

Admiral Fiske's "Sub" Spotter.

A patent was recently issued to Admiral Fiske on a clever submarine localizer.

As the illustration shows the aircraft, plane or dirigible tows a super-sensitive sub-sea microphone thru the water by means of a float or else an armed boat, which may serve to give battle to the enemy, should he arise to the surface. Suspended from the boat is a sound-detecting microphone connected by circuit wires carried by a cable to a battery and telephone receiver in the car of the airship.

The operation is as follows: When a submarine is under water, power is supplied from her storage battery to an electric motor, whereby the submarine is driven. The continuous whirring sound made by the motor while in operation transmitted thru the water affects the microphone so that this sound is heard and recognized in the telephone receiver by an observer in the airship car, listening thereat.

Being thus apprised of the location of the submarine, the observer may transmit that information to a station ashore, or to a vessel afloat, by any known means—as, for example, by visible signals or by radio-telegraphy.

In order to enable the observer to convey information as to the speed and direction of the submarine, the sea area to be protected may be mapt in divisions of predetermined area, as 1, 2, 3, etc., of the detail drawing reproduced herewith. The observer knowing, for example, that he is over division 7 and hearing the submarine noise in his telephone, signals that fact to an observer at some central station. Afterward, being over division 5, if he still hears the sound, he communicates that further fact. The central station observer thus becomes informed that the position of the submarine is first in division 7, for example, and that its course is to a second position as in division 5, and, therefore, northeasterly, while the time elapsing between the signals will show approximately the speed of the submarine in going from the first to the second position.

The boat may be simply a float in boat shape, or it may be an armed motor-boat with crew on board. In the latter case, as soon as the observer in the airship signals the crew of the detection of a submarine sound, the cable may be detached from the boat, leaving the microphone suspended from the cable, and the boat free to watch for and attack the submarine, or to give warning to other vessels in the vicinity. Any suitable means of release may be provided.

By noting where the sounds in the telephone become louder or fainter, and by steering in such a direction that the sounds become louder or remain in the same intensity, the observer in the airship can move in a direction and at a speed approximately that of the submarine.

# The Worst Crime of Civilization

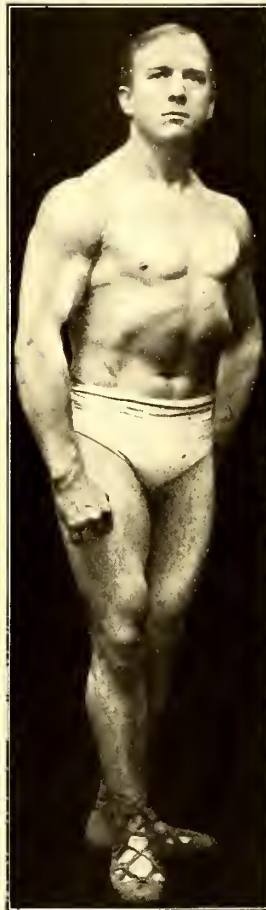

LIONEL STRONGFORT  
"Dr. Sargent, of Harvard, declared that Strongfort is unquestionably the finest specimen of physical development ever seen."

AMONG all our laws for the protection of women and children there is not one to prevent a weak, sickly, anemic man—a creature who is a man in name only—from marrying some pure, wholesome girl and making her the mother of children destined before their birth to be a source of grief and anguish to her as long as she lives.

Men of America, what are you going to do about it? How are you going to protect your sisters and your daughters? How are YOU, who read this, going to protect your future wife and do your part to breed a race of strong, sturdy children that will be a credit to America, instead of poor, sickly, watery-blooded little creatures who have no chance in life, and who, when they grow up, will inevitably help to fill our insane asylums and our jails?

## Men of America, Wake Up!

It's up to YOU, to every individual one of you, to make YOURSELF fit, first of all. It's a living condition that confronts you, not an academic theory. It's a condition based on the immutable laws of heredity, which have operated ever since the world began. It's a condition recognized by every breeder of live stock, and taken advantage of to improve the qualities of the cattle, horses or dogs he raises. It's the great inexorable Law of Nature that Like Breeds Like; that the progeny will inherit the qualities of the sire in an intensified degree.

Read those last two words again, and think—think hard. What will YOUR children be? If YOU are weak and sickly; poisoned by constipation, green with biliousness, tortured by indigestion, wrecked by nervous headaches, with vitality barely sufficient to carry you through your daily work—what kind of children can you beget?

## Fit Yourself to Be a Father

You don't want to deceive the girl who loves and trusts you and wreck her life by making her the mother of children who will cause her to curse the day she married you. You want her to bear happy, healthy, laughing children, who will grow up into strong, virile men and women, a source of joy and comfort to you both in your old age.

FIT YOURSELF to beget such little ones, and at the same time to take the place among men in the world to which you are rightfully entitled. YOU CAN DO IT—there isn't any question about it—IF YOU MAKE UP YOUR MIND TO DO IT. You can get rid of the hampering ailments that are preventing you from being quick, efficient in your work and keeping you from getting a better job or higher position at bigger pay; you can break off any evil habits that are giving you a hang-dog feeling and making you ashamed to look your fellow men and women in the face; you can build up your flabby muscles, strengthen all your vital organs, make your blood rich and red and fill yourself with the punch and power of a REAL MAN, if you will stop "putting it off until tomorrow," take hold of yourself and go about it the right way.

## Strongfortism Will Enable You to Do It

Strongfortism has lifted thousands of weak, ailing, impotent, discouraged men out of the bog of hopelessness and despair and placed them on the broad, straight road to health, happiness and prosperity. Strongfortism has restored the manhood they had destroyed and thought they had lost forever and given them renewed vitality, ambition and the power to DO THINGS in the world. Strongfortism has enabled them to beget children who will make Americans of whom both they and their country will be proud.

Strongfortism will do for YOU what it has done for them. It is simply Nature's way of living life; the way that has no drugs or medicines about it; the way that makes for health and power and potency; the way that gets the most enjoyment out of life. I KNOW whereof I speak. My lifetime has been spent in studying the human organism; in learning Nature's way of building up and strengthening the tissues of the muscles, the vital organs and the brain. I GUARANTEE results; I guarantee to improve you 100 per cent, physically and mentally, if you will follow my directions, and it makes no difference where you live, what your present condition is or whether your youthful follies brought you to it. You can follow out my course without interfering in any way with your present occupation, in the privacy of your own bed-chamber if you like.

DON'T DELAY—tomorrow never comes to those who put things off. Take the first step NOW. Send for my FREE BOOK, "Promotion and Conservation of Health, Strength and Mental Energy." It will show you how to make a MAN of yourself. There's no charge for it; I ask you only to enclose 3-2c stamps to pay for packing and postage. Fill out the coupon and send it in TODAY. You'll hear from me by return mail with something you wouldn't miss for any money.

**LIONEL STRONGFORT**  
Physical and Health Specialist  
1011 Strongfort Institute Newark, N. J.

### FREE CONSULTATION COUPON

Mr. Lionel Strongfort, Newark, N. J.—Please send me your book "PROMOTION AND CONSERVATION OF HEALTH, STRENGTH AND MENTAL ENERGY," for postage of which I enclose three 2-cent stamps. I have marked (X) before the subject in which I am interested. (1011)

- Colds
- Catarrh
- Asthma
- Obesity
- Headache
- Thinness
- Rupture
- Lumbago
- Neuritis
- Neuralgia
- Flat Chest
- Deformity (describe)
- Insomnia
- Short Wind
- Flat Feet
- Stomach Disorders
- Constipation
- Biliousness
- Torpid Liver
- Indigestion
- Nervousness
- Poor Memory
- Rheumatism
- Youthful Errors
- Vital Losses
- Impotency
- Gastritis
- Heartweakness
- Poor Circulation
- Skin Disorders
- Despondency
- Round Shoulders
- Lung Troubles
- Increased Height
- Stoop Shoulders
- Muscular Development

Name.....  
Age..... Occupation.....  
Street.....  
City..... State.....  
Write Plainly



### Be An ELECTROTECHNICIAN

Study to enter the field of electricity as a high-salaried Industrial Specialist. Qualify as a Power Plant Superintendent, City Technician, Salesman of Electrical Equipment, Supervisor of Electrical Equipment Maintenance.

WITH OR WITHOUT A HIGH SCHOOL EDUCATION you can take up this study at this school ONLY. Better your previous education sooner you finish. That's all. Combination of work-shop, laboratory, drafting room and recitation room instruction quickly and thoroughly prepares you as an Electro-technician.

"Earn While You Learn" if you like.

There is no time for delay if you wish a place reserved for you. Next term opens September 2. Clip and mail the coupon today. It may mean a life-time of success for you. DO IT.

School of Engineering of Milwaukee 104-373 Broadway Milwaukee, Wis.

CLIP HERE

School of Engineering of Milwaukee 104-373 Broadway, Milwaukee, Wis.

Gentlemen:—Without obligation, send me catalog, Photo-Story and full particulars regarding the Electrotechnician Course.

Name ..... Address ..... City ..... State ..... Age ..... Education .....

School of Engineering of Milwaukee Institute of Electrotechnics 104-373 Broadway Milwaukee, Wis.

### Be a Mining Engineer

A great profession, not overcrowded, offers the diligent and ambitious student assured and exceptional rewards. Located in the heart of one of the greatest copper mining districts in the world, the College offers a unique combination of theoretical instruction with practical experience in all phases of mine development and operation. Four year course can be completed in three. Vast mines, mills, smelters, electrolytic and power plants of the most modern type, are practically a part of the College equipment and constitute a factor of enormous value in the courses of instruction. Every opportunity for specialization. A state supported college not conducted for profit. Established 1886. "M. C. M. Men Make Good." For descriptive book address Administrative Officer, Houghton, Michigan.

### Michigan College of Mines

MEN will be surprised at what we have ready for our special Summer Hosiery Showing.



CLOCKED Seamless socks of pure thread silk with reinforced heel and toe.

Exceptional value at 89c per pair. Postpaid.

Black—Navy—Grey—Cordovan with white clocks.

Write today for Catalog No. 100X and get acquainted with our other special numbers.

The Bertex Distributing Co. 124 W. 18th St., N. Y. City

### NATIONAL TRADE DENTAL SCHOOL

506 S. Wabash Ave., Chicago, Ill. LEARN MECHANICAL DENTISTRY—DEMAND UNLIMITED A paying professional trade. You will be a trained dental mechanic and receive our diploma when competent. Students given advantage of thoroughly up to date laboratory, and services of graduated Dental Surgeons on practical cases. No effort spared to place graduates advantageously. No age limit. Day or Evening. Individual instruction. No educational requirements. No book or home study. Easy terms. Highest references. Especially attractive proposition to those who write at once for catalog H.

### Popular Astronomy THE NATURE OF COMETS By Isabel M. Lewis (Continued from page 313)

istic tail and peculiar cometary features are fully developed. As the comet again recedes from the sun after perihelion passage its speed slackens once more. It soon parts with all its spectacular features and fades rapidly away into oblivion.

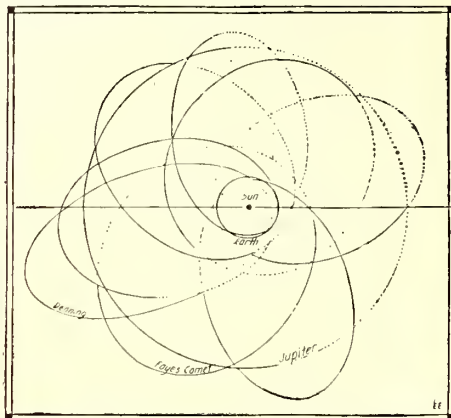

This Diagram Shows How the Planet Jupiter Captures the Large Majority of the Comets. It Will Be Noted That Most of the Comets Are Grouped Around Jupiter's Orbit.

### THE DISTINCTION BETWEEN STARS AND PLANETS.

THE chance enquirer into the mysteries of space usually is puzzled by the distinction that is to be drawn between stars and planets. All celestial objects except the sun, moon and a few chance comets he is apt to group together vaguely under the head of "stars" even to the "shooting stars."

The planets shine only by the reflected light from the sun around which they revolve, as does also the earth, which is one of the smaller planets. This light from the sun may be reflected from a rocky surface, as in the case of the moon, which is not a planet, to be sure, but a satellite of a planet,—the earth,—or it may be reflected by a cloudy atmosphere as in the case of Venus or from surface snow and clouds as in the case of Mars. The outer and larger planets Jupiter, Saturn, Uranus and Neptune, being chiefly in a gaseous condition, reflect sunlight from the gaseous vapors that envelope their central molten or gaseous cores.

Stars, on the contrary, are suns composed of intensely hot incandescent vapors of many chemical elements emitting light and heat of their own. The heat of the stars is inappreciable to us simply because they are so far away.

In size, the planets are conspicuously inferior to the sun and to the average star tho it is now known that there are some dwarf stars in existence that are as small as planets. The sharp distinction remains, however, that planets revolve around a central body that supplies them with the light and heat that they do not possess themselves, while the stars, however small they chance to be, shine by their own light and move thru space as independent bodies.

Not only is the distinction between stars and planets one of physical condition and, generally speaking, size. It is also one of relative distances.

The planets are all comparatively close to the earth. All are companion satellites of the same sun. The nearest Venus comes at times within twenty-six million miles of us and the farthest Neptune within twenty-seven hundred million, but the very nearest

(Continued on page 357)

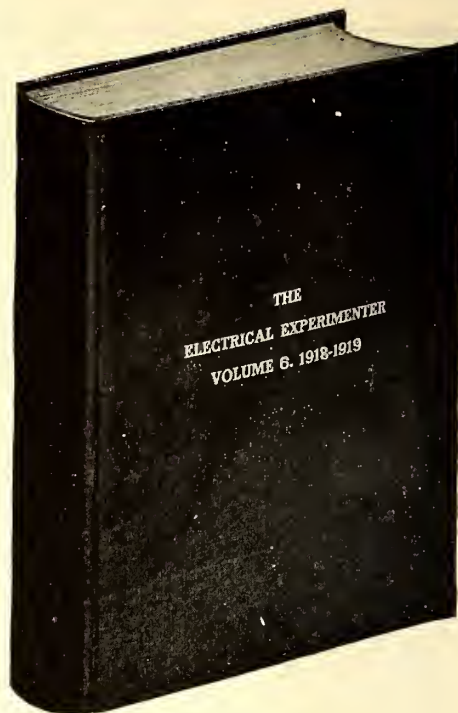

### This Book Cost \$34,000

1200 Authors Contributed

Our Bound Volume No. 6 contains a goldmine of electrical and scientific information. No such value has ever been offered before for so low a price. A marvelous cyclopedia of electricity. A reference book of authentic information not found in any other book in print.

Volume contains twelve numbers of the "Electrical Experimenter" magazine—May, 1918 to April, 1919, inclusive. There are 984 pages, 2,110 complete articles, 1,908 illustrations, 369 questions and answers. Sizes, 12" high; 9" wide; 2" thick.

A world of electrical information; the entire electrical Progress for one year; the greatest reference book on current "Wireless"—all at a price within reach of everybody. Mind you, the book is durably bound in attractive green linen with heavy covers. Letters stamped in gold. You will be proud to have it in your library. We have only 600 copies, therefore be sure and order to-day. Shipping weight 8 lbs. Add a sufficient amount for postage, otherwise we must ship by express.

\$3.00 add postage for 8 lbs.

Positively the Greatest Electrical book bargain in the World. We ship AT ONCE. Order today to avoid delay.

EXPERIMENTER PUBLISHING COMPANY, Inc. Book Department

233 Fulton Street - New York, N. Y. 8-19 Fill in—Tear out—and Mail

Gentlemen: Please send at once your Volume No. 6 as advertised, for which I enclose herewith \$..... I also enclose \$.....extra for postage. Name Address

You benefit by mentioning the "Electrical Experimenter" when writing to advertisers.

**1/2 SAVED**  
GET OUR  
**BIG BOOK**



**DO Your Own PLUMBING AND HEATING at low cost**

Send for our big instructive 256 page well-bound Handy-Man Book Catalog. Every Home Owner, Contractor, Electrician, Farmer, Factory Manager, etc., needs it. Shows over 10,000 Fixtures and Supplies in plumbing and heating at wholesale. Shows how to save skillful labor, hard work and unnecessary material by

**OUR NEW Cut-to-fit-Method**

This wonderful book helps you select and install the proper Plumbing, Water Supply System, Hot Air, Water or Steam Plant. Besides being our Wholesale Catalog it has many practical plans, diagrams, sketches, elevations, etc., showing how to do the work this newer, cut-to-fit way. Any handy man with a few tools can easily do his own installing with the aid of this

**Big Handy-Man Book**

We have spared no effort and have gone to a great expense to compile this valuable book. With economy still a national necessity, it would be unpatriotic to send this expensive book broadcast to non-interested parties. Therefore, we request a temporary deposit for each copy of 25c which we refund on first order, or we send our Bargain Bulletin Free. Address Today



**HARDIN-LAVIN COMPANY**  
40 Years At  
4510-20 Cottage Grove Ave., Chicago  
\$500,000 plants behind our guarantee

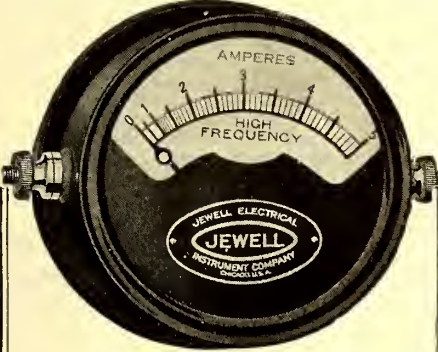

**RADIO FREQUENCY AMMETER**  
4 inch Face  
0 to 3, 0 to 5 or 0 to 10 Amperes.  
Specify Reading Required.  
**\$11.00 Net**

The Jewell Electrical Instrument Co. is prepared to fill the instrument needs of the amateur experimenter in radio and general electrical work, as well as those who desire more precise and accurate measurements of electrical quantities.

We show above our high frequency ammeter, of the thermo couple type, especially desirable for medium sized installations.

For receiving panels, we are supplying small D. C. instruments for plate voltage and filament current, at a very reasonable price.

Write for our special radio instrument bulletin.

**JEWELL ELECTRICAL INSTRUMENT CO.**  
1640 Walnut St. Chicago

READ THE CLASSIFIED ADS. ON PAGES 380-382

**CARUSO CONCERTS TO AMATEURS BY WIRELESS 'PHONE.**

Cleveland, Ohio, or that portion equipt with wireless receiving instruments, heard its first wireless telephone concert on the night of April 17th. And it is to become a permanent institution.

Every Thursday night between 8 and 10 o'clock the radio amateur or professional who "tunes" his instrument to receive wave lengths of 375 meters will be able to listen to strains from Caruso and Sousa's band interspersed with baseball scores and the latest news bulletins.

The concert will come from the plant of the Martin Company, air plant manufacturers and will be audible to wireless operators within 200 miles. It is estimated that 400 radio amateurs "listened in" on the first concert.

The wireless transmission of music is accomplished by use of the wireless telephones as developed by F. S. McCullough, wireless expert for the Martin Company. The same apparatus as is used in airplanes is employed and the music produced by a phonograph. The transmitting apparatus of the telephone replaces the phonograph horn. The baseball news and bulletins were announced by voice, so that no knowledge of "codes" were required to receive them.

**Changing Nature's Face**  
(Continued from page 300)

copper wires extend from the blasting machine to one or more of the detonators. The ends of the two insulated wires inside the cap of the detonator are bridged by a very fine wire, which is soldered to the ends of the feed wires, and it is the heating of this fine bridge wire in the midst of the explosive charge, due to the passage thru it of the electric current transmitted from the dynamo, which ignites the cap explosive and in turn the main dynamite blasting charge. Electric blasting caps are made practically air-tight and water-tight, and are therefore safer to handle than the ordinary open-end blasting cap. It requires about 1 1/2 to 2 amperes to melt the fine platinum bridge wire in the cap.

**Connecting Wires**

Owing to the small amount of current required, about 2 amperes, to melt the fuses in the electric detonators, and as these are invariably connected in series, a fairly small wire can be used to carry the current from its source to the location of the blast, as well as between the various charges, as shown in the accompanying diagram. No. 20 insulated copper wire is usually employed for connection between the dynamite charges in the holes. For the feed wires between the charges and the dynamo, a larger wire, such as No. 14 rubber covered copper conductor, is used. Several ways of connecting the charges in a group, as for instance in blasting a "ditch" or "brook," are illustrated in the accompanying diagrams, A, B, C, D. As will be seen, the various charges are connected in series. However, under some conditions the charges are connected in parallel. The series connection here shown is invariably used when a hand-operated blasting machine is employed to explode the charges. Parallel or series-parallel arrangements are used with dry or storage cells, or else an electric generator driven by a gasoline engine is used as the source of electricity for firing the blast. The standard blasting machines, fitted with magneto generators are designed in different sizes to fire from 1 to 200 charges, depending upon the type and size. The amount of current produced is about 3 amperes with this machine, while

**Mechanical Engineering**



**Learn at Home!**

Employers everywhere are looking for men with mechanical ability. Splendid salaries and rapid advancement are offered.

There is an easy, delightful way in which you can learn right at home in spare time. For 23 years the International Correspondence Schools have been giving men and women just the training they need for success in mechanical engineering and more than 200 other subjects. Hundreds of thousands have stepped into good positions through I. C. S. help, but never were opportunities so great as now.

Let the I. C. S. help you. Choose the work you like best in the coupon below, then mark and mail it today. This doesn't obligate you in the least and it will bring you information that will start you on a successful career. This is your chance. Don't let it slip by. Mark and mail this coupon now.

TEAR OUT HERE

**INTERNATIONAL CORRESPONDENCE SCHOOLS**  
BOX 6197, SCRANTON, PA.

Explain, without obligating me, how I can qualify for the position, or in the subject, before which I mark X.

- |  |  |
|--|--|
| <input type="checkbox"/> ELECTRICAL ENGINEER       | <input type="checkbox"/> CHEMICAL ENGINEER         |
| <input type="checkbox"/> Electrician               | <input type="checkbox"/> SALESMANSHIP              |
| <input type="checkbox"/> Electric Wiring           | <input type="checkbox"/> ADVERTISING MAN           |
| <input type="checkbox"/> Electric Lighting         | <input type="checkbox"/> Window Trimmer            |
| <input type="checkbox"/> Electric Car Running      | <input type="checkbox"/> Show Card Writer          |
| <input type="checkbox"/> Heavy Electric Fraction   | <input type="checkbox"/> Outdoor Sign Painter      |
| <input type="checkbox"/> Electrical Draftsman      | <input type="checkbox"/> RAILROADER                |
| <input type="checkbox"/> Electric Machine Designer | <input type="checkbox"/> ILLUSTRATOR               |
| <input type="checkbox"/> Telegraph Expert          | <input type="checkbox"/> DESIGNER                  |
| <input type="checkbox"/> Practical Telephony       | <input type="checkbox"/> BOOKKEEPER                |
| <input type="checkbox"/> MECHANICAL ENGINEER       | <input type="checkbox"/> Stenographer and Typist   |
| <input type="checkbox"/> Mechanical Draftsman      | <input type="checkbox"/> Cert. Pub. Accountant     |
| <input type="checkbox"/> Ship Draftsman            | <input type="checkbox"/> Traffic Management        |
| <input type="checkbox"/> Machine Shop Practice     | <input type="checkbox"/> Commercial Law            |
| <input type="checkbox"/> Toolmaker                 | <input type="checkbox"/> GOOD ENGLISH              |
| <input type="checkbox"/> Gas Engineer              | <input type="checkbox"/> STATIONARY ENGINEER       |
| <input type="checkbox"/> CIVIL ENGINEER            | <input type="checkbox"/> CIVIL SERVICE             |
| <input type="checkbox"/> Surveying and Mapping     | <input type="checkbox"/> Railway Mail Clerk        |
| <input type="checkbox"/> MINE FOREMAN OR ENG'R     | <input type="checkbox"/> Textile Overseer or Supt. |
| <input type="checkbox"/> ARCHITECT                 | <input type="checkbox"/> AGRICULTURE               |
| <input type="checkbox"/> Architectural Draftsman   | <input type="checkbox"/> Navigator                 |
| <input type="checkbox"/> PLUMBING AND HEATING      | <input type="checkbox"/> Poultry Raising           |
| <input type="checkbox"/> Sheet Metal Worker        | <input type="checkbox"/> Automobiles               |
|  | <input type="checkbox"/> Spanish                   |
|  | <input type="checkbox"/> Italian                   |

Name \_\_\_\_\_  
Present Occupation \_\_\_\_\_  
Street and No. \_\_\_\_\_  
City \_\_\_\_\_ State \_\_\_\_\_

**ELECTRICAL ENGINEERING**

training again open to civilians. Over 3000 men trained for electrical industries in experience of more than a quarter of a century. For men of ambition and limited time. Condensed course in Electrical Engineering enables graduates to secure good positions and promotions. Theoretical and Practical Electricity, Mathematics, Steam and Gas Engines, Mechanical Drawing. Students construct dynamos, install wiring and test electrical machinery. Course with diploma, complete.

**IN ONE YEAR**

Thoroughly equipped fireproof dormitories, dining hall, laboratories, shops. Write for catalog. 27th year opens October 1, 1919.

**BLISS ELECTRICAL SCHOOL**  
260 TAKOMA AVENUE, WASHINGTON, D. C.

DO YOU KNOW WHAT TO DO?  
TO HAVE YOUR WISHES COME TRUE?  
TO BE HAPPY AND SUCCESSFUL?  
TO FEEL THE THRILL OF NEW POWERS?  
TO HAVE A WINNING PERSONALITY?

Our system of Personal Development has shown thousands. It can show YOU. First lesson in SUCCESS, and your Personality Sketch for 10c and birthdate.

**THOMSON-HEYWOOD CO.**  
Dept. 350. Chronicle Bldg., San Francisco, Cal.

# I Can Make You STRONG

I can show you how to develop every bit of strength that a real man should have. I can give you an abundance of vitality and a highly developed body and mind.

The Man who wishes to succeed in business must be endowed with an unusual amount of strength, endurance and vitality. I have found the way to develop these qualities in the shortest possible time. I have done it myself, with my own body, and I have done it for many other of the world's strongest men.

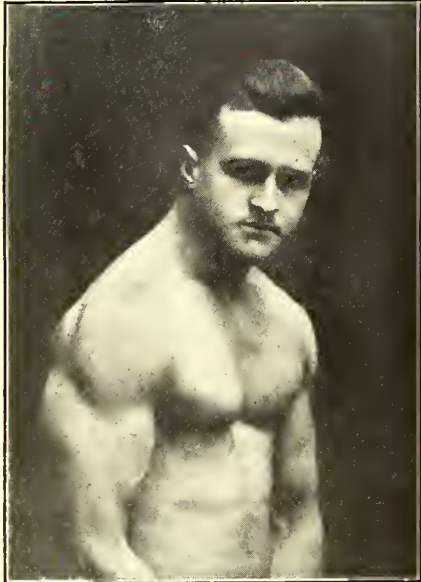

## EARLE LIEDERMAN

The Acme of Physical Perfection

Let me take you in hand and make a real man of you. You will always bless the day that first you sent for my book. I can put pep into your actions, vigor into your step, and make your mind so clear and alert that you simply must go ahead in business and social life. There is no reason why you should go on through life all fagged out, more dead than alive. Let me change all this—let me make life worth living. Give me a chance to show you what I can do for you.

## Send To-day for MY NEW BOOK "Muscular Development"

It tells how I can help you. I will send this valuable book to you by return mail on receipt of only 10c to cover cost of mailing and wrapping. Use the coupon below. The book contains full particulars of my splendid offer, and is profusely illustrated with pictures of many of the world's strongest men whom I have trained. Don't pass this by. Sit right down and fill in the coupon. Do it now, this minute, while it is on your mind.

**EARLE E. LIEDERMAN**  
Dept. 211, 203 Broadway, New York

Earle E. Liederman  
Dept. 211, 203 B'way, N. Y. C.

Enclosed find 10c for which you are to send me at once your new, illustrated book, "Muscular Development."

Name.....  
Address.....  
City.....

the larger machines develop several hundred volts.

In some cases electric light or power circuits are tapt in order to furnish the necessary current for firing the charges. For example: if a circuit is supplying 250 volts and 10 amperes to a light or motor load beyond the point where the line is tapt, then this can be safely short-circuited and relied upon to fire 125 detonators in one series or five series of 25 detonators each. Such use of this current will not interfere with the operation of the motor or the lights, as connection is made for too short a time. Dry cells can be used for exploding electric blasting caps, but their rapid deterioration makes them unreliable. A storage battery will prove much more trustworthy.

### How to Prepare the Blasting Charge.

The preparation of the load is accomplished in several different ways and depends upon natural conditions where the blasting is to take place. Where ordinary wet ground such as in meadows or near a brook is to be blasted, in order to form another ditch or stream, it frequently happens that the necessary blasting holes may be drilled with a crow-bar. After the dynamite cartridge has been placed in the bottom of this hole with the electric detonating wires attached, the hole will in most cases fill with water, and this provides a satisfactory substitute for tamping, and will give very high efficiency when the blast takes place. It is interesting to mention in this particular instance, that in actual coal mining operations the drill hole is commonly filled with water instead of being tamped with coal dust, etc. Water being practically incompressible and possessing considerable inertia under the sudden bursting pressure of the charge, results in very high efficiency of the blast. Where a hole has been drilled in rock, or wherever it has been tamped or filled up with loam, the following proceeding is to be noted: To guard against danger of a prematurely detonating charge, the first five to eight inches of tamping over the dynamite cartridge should be gently packed by means of a tamping stick. When this amount of lightly tamped material has been placed, the rest of the tamping should be made as hard as possible, using a wooden tamping stick for the purpose. Moist clay free from gravel and clods makes good tamping material. Free running sand or moist loam is also effective. As pointed out in instruction books on the handling of explosives, it is not necessary to use any loam to tamp the drill holes, where the blasting is done in watery ground, or wherever the water will fill the hole to a depth of a foot or more. It is good practise, especially where heavy charges are used, to place two inches of paper or dried leaves immediately over the priming charge, so that they can be used as a safety marker, if the tamping has to be removed for any cause.

### Purposes of Blasting.

The accompanying illustration shows three distinct purposes for the blasting operations carried on by agriculturists, and those desirous of cleaning up stump-strewn and rock-covered property. The method of using one, two or three lines of holes for blasting various widths of ditches is shown in the left-hand illustration. It is indeed surprising to learn that these ditches, in actual tests carried on before Government experts, have been blasted out with dynamite in the manner here shown. The bottom level of the ditch, when finished, was so nearly perfect that not a shovel had to be touched to it. In some cases, where specially deep ditches are desired, it sometimes becomes necessary to place another row of holes along the bottom of the first ditch blasted out, and then to blast this out.

The experts in charge of the blasting

**NORMA TALMADGE** says:

"It is one of my favorite magazines. I enjoy reading it every month."



"JUST to get acquainted" send a dollar and receive the next four numbers of

## The PHOTO-PLAY WORLD

Contributions by leading authors  
Beautifully illustrated, handsomely printed  
By the year \$3.50—35 cents a copy

**Trial Offer: 4 numbers for \$1**  
(Foreign postage 50 cents extra)

THE DOWNS PUB. CO., Bulletin Bldg., Phila., Pa.



The Electric Safety razor makes shaving a pleasure. Blade vibrating 7,200 times a minute cuts the beard smoothly and without slightest pull or irritation—feels like a gentle massage. Can be used with or without electric current.

All users of the **Lek-Tro-Shav** speak well of it

A barber says—"Have shaved for years and have never used any shaving device near its equal."

A home user says—"The most pleasing shave I've ever had in my life. Shaves my face closer than I used to shave, but there is no after irritation or ill effects as I usually get from another razor."

No. 1 Made for use from Light Socket.  
No. 2 Made for use from Dry Battery.  
Write for illustrated circular describing Lek-Tro-Shav Safety Razor fully.

**VIBRATING ELECTRIC RAZOR CO.**  
Dept. 122, Omaha, Nebr.

## USE HB BALL BEARING ELECTRIC MOTORS

Big Saving in Power Bills Every Month—HB Ball-Bearing Motors furnish ideal power at lowest cost for factory, machine shop or garage. All power waste eliminated. Amply designed, absolutely trouble proof, economical and reliable. Highest efficiency in daily service. Bearings need refilling only once in three months, require almost no attention.



\$20 Brings You Any HB Motor. Balance on Easy Terms. Sizes 1 to 15 H.P.—Choose to Suit Your Needs. If in doubt about requirements, write our service department. Get their expert advice—FREE. Simply state what machinery to be run and type of current available. We plan your power system for best results at least cost. Pin this ad to your letterhead and mail TODAY for full information. Ask also about HB Battery Chargers, Generators, etc.  
**HOBART BROTHERS COMPANY**  
1505 E. 12th St., Troy, Ohio  
Successful Manufacturers Since 1893

## Telegraph Pictures

BY ELECTRICITY

Complete sets of two machines of this marvelous equipment at ridiculously low prices. Instructive, mystifying and useful. This picture of President Wilson was telegraphed by these machines. Will transmit pictures, maps, drawings and hand writing. Picture telegraphing is the coming science. Write today.



J. LEISHMAN CO., Dept. T Ogden, Utah

## How to Get Rid of Moles



A simple, safe home treatment—15 years' success in my practice. Moles (also BIG growths) Dry Up.

Ask for Free Booklet of Full Particulars

**WM. DAVIS, M. D.**  
4140 State Street Perth Amboy, N.J.

You benefit by mentioning the "Electrical Experimenter" when writing to advertisers.



usually drill a few holes and try several trial shots to ascertain the best depth and spacing for the holes. For ditches of three or three and one-half feet width, the depth of the holes will usually be 24 to 30 inches, and the spacing between the holes from 18 to 24 inches, altho it may be necessary to increase the depth and decrease the spacing in some cases. The test is usually begun with holes two feet deep and 18 inches apart. These are placed in lines and about 10 of them loaded with one dynamite cartridge each.

This loading, say the experts, should lift the soil at least 200 feet into the air and scatter it over the adjoining swamp for a distance of 150 feet, leaving a clean ditch. If such is not the case, then a different loading layout should be tried.

**Blasting Stumps.**

One of the principal uses of dynamite as utilized by agriculturists and by engineers in clearing up large areas containing obstructions is that of blasting out stumps. The lower illustration in the accompanying view shows how a large lateral stump is drilled, and how the electric blasting caps and dynamite cartridges are placed. The terminals of the blasting caps are connected in series, and the two wires run to the blasting machine which should be situated 250 to 300 feet away from the stump at least.

A new innovation in drilling the holes for stump blasting is the use of a portable electric drill or auger. One or more of these electric drills, as may be required, can be operated from a portable gasoline engine and dynamo outfit, or else from electric feed wires supplied by the local light and power company. Compress air drills have also been used to some extent for this work and have proved very satisfactory. In all stump blasting it should be noted that the depth of the holes should reach to the sub-soil, not close up to or in contact with the wood. The best tools for making the holes are the crow-bar and the sub-soil punch.

**Breaking Boulders.**

There are three general forms of blasting applied to rocks, particularly those of the boulder class. *Blockholing* requires the smallest amount of explosives, altho more labor is involved with the drilling of a hole or series of holes directly into the boulder, as shown at the top of the right-hand illustration herewith.

*Mudcapping*, as depicted at the bottom of the right-hand illustration, requires the smallest amount of labor, but a considerably larger amount of explosives, while *snakeholing* is intermediate with respect to both labor and amount of explosives required. Each method has its own particular and special use.

*Blockholing* consists of drilling a hole into the boulder and charging it with a small amount of dynamite. It is the best and simplest method for breaking very hard or very large boulders, especially those of the "niggerhead" type, which are very difficult to break by other methods.

*Snakeholing* consists of punching a hole underneath but immediately against the bottom of the boulder, and placing a charge of explosives in as compact shape as the size of the boulder will permit. A boulder which has been snakeholed out of its resting place is shown in the accompanying right-hand illustration. As will be seen, the explosive, being confined on the under side of the boulder by the earth, can exert a powerful blow on the boulder and will force it out of its position or roll it out. If a sufficient charge is used, the boulder will be broken into fragments. The boulders should always be either pried out or snakeholed out of their resting places to the top of the ground, before attempting to break them by blockholing or a shattering blast of the type described above.

Thousands of Electrical experts are needed now. Come to the great shops of Coyne and let us train you quickly by our sure practical way backed by 20 years of success.

**Earn \$125 to \$300 a Month**

Come to Coyne where experts train you on the actual apparatus. You work on everything from the simple bell to the mighty Generators, Electrical Locomotives and Power Plants. Everything to make you a Master Electrician. Look at the picture taken from life in our shops.

**Become an Expert in 3 1/2 Months**

No need of taking 1 to 4 years to become an expert. We have proved this in thousands of cases. We are the only school teaching by the original Coyne methods, which means no books, no classes—all practical training.

**Earn Your Way.** Our employment department will help every ambitious man to earn a part or all his expenses—without charge.

Bennett W. Cooke, Director  
**COYNE TRADE AND ENGINEERING SCHOOLS**  
 Dept. 28, 39-51 E. Illinois Street  
 CHICAGO, ILL.

**LEARN DRAFTING**

The country needs hundreds of skilled Draftsmen in all lines at big salaries.

Coyne is the only school in the country that gives you the advantages of big shops full of construction and machinery. This makes our drafting courses practical, just like the job you'll have when you graduate. You can't get this in any other school.

**WE TEACH ELECTRICITY, DRAFTING, MOTION PICTURE OPERATING AND PLUMBING**

We teach all these professions in such a thorough, practical way that when you finish you can step right into a position of responsibility and big pay.

Fill out the coupon now and send it for our big free book of information. It tells what others are doing and have done, what you can do.

Be sure and check the trade that interests you. Do it now.

**COYNE SCHOOLS**  
 Dept. 28, 39-51 E. Illinois St.  
 CHICAGO, ILL.

Please send me that big free book. I'm interested in:

- Electricity
- Drafting
- Plumbing
- Motion Picture Operating.

Name .....

Address .....

**"THERE'S MONEY IN IT!"**

**AT HOME LEARN TELEGRAPHY AT HOME**

**MORSE AND WIRELESS**

**TEACH YOURSELF**

In half the usual time, at trifling cost, with the wonderful Automatic Transmitter, **THE OMNIGRAPH**. Sends unlimited Morse or Continental messages, at any speed, just as an expert operator would.

Adopted by U. S. Gov't. 4 styles. Catalogue free.

**OMNIGRAPH MFG. CO.**  
 39L Cortlandt St. New York

**MODEL AIRPLANE SUPPLIES**

Build and fly Model Airplanes ~

Send 5¢ for catalog of complete and knocked-down scale models of new machines, parts, fittings, and supplies.

**Wading River Mfg. Co. 612 Broadway, Brooklyn, N.Y.**

You benefit by mentioning the "Electrical Experimenter" when writing to advertisers.

# How to Sell Your Real Estate



## Any Kind Anywhere

I got cash for my property in less than two weeks. Made sale myself so had no commission to pay. You can do the same with The Simplex Plans for Selling Real Estate. No matter where located, these practical, scientific plans will show you how to sell your property—quickly and for cash—without employing agents or paying commissions. Investigate at once. Learn how easily you can use The Simplex Plans, just as I did, to sell your real estate. Write today (a postal will do) to

**THE SIMPLEX CO.**  
Dept. 62, 1123 B'way, New York  
They will send you full particulars without cost or obligation.

### Quick Results

"Sold for cash in 10 days. Recommend your methods."—Wm. H. Carland, Mass.  
"Your method sold my farm for cash."—Mrs. L. A. Childs, Minn.  
"Sold my property. Your plan quickest I ever saw."—Johnson String, N.J.  
"Sold my hotel for \$5,375."—G. F. Stewart, Ill.

**THE MIDGET SLIDE RULE** will solve any problem in addition, subtraction, multiplication, division and proportion. A Log-Log Scale gives any root or power of any quantity. Gives Logarithms, Sines, Tangents, Cosines, Cotangents and the decimal equivalents of fractions to six figures. It is grease and water proof and will give years of service. This rule is not to be compared with the paper utility rules which sell for \$1.00 and are put together with paper fasteners. It is accurate, simple to operate and comparison shows that it is undoubtedly the fastest and most complete rule made. Our refund guarantee protects you from loss or disappointment. An instruction book 16 pages, 12 illustrations, is sent with each instrument. Diameter of rule 4 in. Made in two models: Metal (white coated steel), \$1.00; Wood, \$1.25. Leather Case 50c extra. Send for catalogue of Slide Rules. Your money back if you are not satisfied.

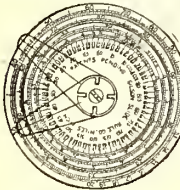

Gilson Slide Rule Co., Niles, Mich.

## Build Your Own Phonograph, Save Over Half

**It's Easy With Our Help**  
A few hours interesting work saves many dollars and gives you a machine exactly to suit your ideals. We furnish motors, tone arms, case material, blue prints and full instructions. Plays any record. You can make fine profit building phonographs for your friends.



Write Today for Our Free Blue Print Offer. Agents wanted for our ready built Choraleons.

**Choraleon Phonograph Co.**  
708 Wmger Bldg., Elkhart, Ind.



## Springfield-Remington

\$711

Single shot rifle altered and refinished. Shoots cal. 30, model 1906 army cartridge. Weight 7 1/2 lbs., total length 39 inches, U. S. Barrel 23 1/2 inches Remington breech action, blued finish U. S. graduated sight. Price \$7.77 plus war tax 78 cents. Cartridges \$3.50 per 100 war tax 35 cents, packing charge 45 cents.

**FRANCIS BANNERMAN SONS** 501 BROADWAY, N.Y.

**Free Book!** Write today for the book about the greatest of all industries—AVIATION. Big demand for trained men. Passenger and mail service soon to all cities. Write for this FREE book, which tells ambitious young men how to get a start and win. Don't delay. Write TODAY. Address: NATIONAL AERO INSTITUTE, Dept. 744Y, 916 So. Michigan Ave., Chicago, Ill.

## LEARN WATCH REPAIRING

You can learn by our modern and original system of instruction every part of the Watch Repairing Trade at home as good or better than at a shop. You can earn money while learning and secure a well paying position or start in business after completing our course of instruction. Good watch repairers are always in demand and earn from \$20 to \$35 per week. For particulars apply to the

Milwaukee School of Watchmaking 166 Mason St., Milwaukee, Wis.

Two Sizes—4 1/4 and 5 1/2 inches. Extra Size—8 inches (black only) \$1.50. Your name in gold inlay—\$3.35. FREE—Liberal supply of ink with retail orders. Agents wanted. Big profits. **J. R. ULLRICH & CO., 27 Thames St. New York**

Mudcapping is known by a variety of fantastic and expressive names, such as "Bulldozing", "Blistering", "Poulticing" and "Adobe Shooting", and is made possible by the fast, shattering action of the higher grades of dynamite. In practise it consists of removing the dynamite from the shell and packing it in a compact conical heap on the boulder, and after inserting a cap and fuse covering it with several inches of thick, heavy mud.

The explosive should be placed on the boulder at the place where it would be struck with a hammer were it small enough to break in that way. This may be on the top or side. If the boulder is embedded in the ground, a snakehole shot to roll it out on the surface should first be made, because the confining dirt makes it much harder to break with a mudcap shot. The mudcovering should be as thick and heavy as it is convenient to make it, not less than 5 or 6 inches, and should be free from stones, as the blast will throw them as tho they were bullets. Never lay a stone on top of the mud for the same reason.

The explosives used are 40 per cent dynamite for easily broken rock and 50 per cent strength for hard "niggerhead" boulders. **Seam Blasting:**—Frequently ledges and boulders have seams from which the mud or stone chips can be removed to a considerable depth. When such a seam is as much as one-half inch wide, successful blasts can be made by packing a reasonable amount of 40 per cent or stronger dynamite into the crack and tamping it securely with moist clay. This method will require about the same amount of dynamite as snakeholing, but is more satisfactory for badly-seamed boulders or ledges. The greatest care must be exercised in placing and tamping the charge to prevent the expanding gases from escaping thru the cracks.

Diameter of Boulder in Feet	No. of Cartridges Required		
	Mud-capping	Snake-holing	Block-holing
1 1/2	2	1	1/4
2	3	1	1/4
3	4	1 1/2	1/2
4	Don't attempt	4	3/4
5	Don't attempt	6	1

This is based on the use of dynamite of 50 per cent strength. If 40 per cent dynamite is used, increase the amounts by half, and if Red Cross Farm Powder is used for snakeholing or blockholing, the amounts should be doubled.

### Scrapping Old Machinery.

Breaking up old machinery, such as heavy castings or steam boilers, can be readily done with dynamite.

For scrapping a boiler use only 40 per cent or stronger explosives. Remove the dynamite from the shell and distribute in a continuous cord about half an inch in diameter all the way around the boiler, and secure it with a heavy mudcap. This can be placed along one of the seams more easily than on the smooth plates. When detonated such a charge will cut the plates almost as neatly as a shearing machine, and will reduce the cumbersome boiler to a size that can be handled.

For breaking heavy castings mudcapping is practised the same as on boulders. Sometimes a hole in the casting can be used for a block hole and loaded as described previously.

Large vessels and even boilers can be broken up by first filling them with water, and, if possible, closing all openings. The dynamite is primed and suspended in the water near the bottom or the thickest metal, but must not be in actual contact with the metal. The explosion of such a charge transmits a powerful blow to all sides and shatters them.

**Brilliant Electric Lights and Big Profits in Battery Charging with this HB Lighting & Charging Set**

With this sturdy, dependable HB outfit, you can make your own electric light at lowest cost, and charge auto batteries at the same time. You SAVE MONEY and make BIG PROFITS. Outfit runs from line shaft or engine. No wear out, trouble proof, economical.

**Small Payment Puts This Money-Maker In Your Shop**

Balance on easy terms. Profits pay for outfit. Absolute Money-Back Guarantee. Ask our Service Department about proper size for your needs. Pin this ad to your letterhead and mail today for information.

**HOBBART BROTHERS CO.**  
Box 83E, Troy, Ohio.  
Successful Mfrs. since 1893.

## 110 V. A. C. GENERATORS

Only \$5.00

Holtzer-Cabot hand generators, while they last, \$5.00

Order from this ad.

House - Lighting Plants

\$225.00 to \$2,100.00. Battery chargers and Motor-Generator Sets, \$25.00 to \$120.00. Dynamos, Motors, all sizes.

**WATSON ELECTRIC CO., Dept. 18 Gas Building, Chicago**



**AMATEURS — INVENTORS**  
ELECTRICAL APPARATUS MADE TO ORDER  
COSTS NO MORE THAN READY MADE

and allows you to

**WORK UP YOUR OWN IDEAS**

**KAUFMAN MACHINE COMPANY**  
1357 Odell St. New York City  
Engineers Expert Instrument-Makers Designers

## EXPERIMENTS

In—Science, Electricity and Invention  
256 Pp., by P. Edelman, \$1.50 Ppd.  
**Here is the big illustrated**  
how to make and do it book you want. Full of stunts, home laboratory wonders, models, etc.

**Edelman Publishers, 1802 Hague Ave., St. Paul, Minn.**

## Fun, Magic and Mystery!

56 Feats in Magic, 250 New Jokes, 21 Puzzles, 1 Fortune Telling Tablet, 52 Money-Making Secrets, 15 Card Tricks, 71 Toasts, 58 Verses in Comic Poetry, 10 Funny Readings, 41 Epitaphs, and 11 Parlor Pastimes. You get all the above-mentioned and our big illustrated Catalog of 125 Magic Tricks for only 10 cents. Write today.

**MYSTIC MFG. CO.,**  
909 Springwells Ave., Detroit, Mich.

**"POPULARITY FOLLOWS THE UKULELE"**

If you play quaint, dreamy Hawaiian music or interest songs on the Ukulele you will be wanted everywhere. We teach by mail simple lessons; give you free a genuine Hawaiian Ukulele, music, everything—no extras. Ask us to send the story of Hawaiian music. You will love it. No obligation—absolutely free.

**The Hawaiian Institute of Music**  
1400 Broadway, Suite 1108, New York

**LEARN TO PAINT SIGNS and SHOW CARDS**

I teach you personally, by mail, in a short time. Oldest and largest School. Big field, work interesting. You can

**EARN \$18 TO \$45 A WEEK**

Fritzner, Minn., wrote: "Did job after first lesson, got \$10, profit \$7.05." Crawford, B. C. says: "Earned \$200.00 while taking course." Get literature, sample, guarantee all FREE.

**DETROIT SCHOOL OF LETTERING**  
Established 1899. 688 D. S. of L. Bldg., DETROIT, MICH.

**PHOTO CRAFT**  
THE NEW PHOTOGRAPHIC JOURNAL  
Devoted to the Art of Picture Taking and Nature Work with the Camera.  
Four Competitions with Valuable Cash Prizes Leading to a Fifth.  
Send 10c for three months' trial subscription.

**Photo Craft Magazine, Ann Arbor, Mich.**

**EARN MONEY**  
Stamping Names on Key Tags. \$50  
Either sex. Spare time. Some make \$25 a week. Send 25c for Tag with your name on and instructions. Returned if required. Exp. Key Tag Co., Cohoes, N. Y.



# PATENT ADVICE

Edited by  
**H. Gernsback**

In this Department we publish such matter as is of interest to inventors and particularly to those who are in doubt as to certain Patent Phases. Regular inquiries address to "Patent Advice" cannot be answered by mail free of charge. Such inquiries are published here for the benefit of all readers. If the idea is thought to be of importance, we make it a rule not to divulge all details, in order to protect the inventor as far as it is possible to do so.

Should advice be desired by mail a nominal charge of \$1.00 is made for each question. Sketches and descriptions must be clear and explicit. Only one side of sheet should be written on.

### Automatic Cut-Out Switch.

(334) Ben Waigand, Nampa, Idaho, states: "I am enclosing a print of a patent my brother and I took out some time ago. I would very much like to hear from you as to its worth in the electrical field. Also what we shall do with the patent."

A. The invention relates to an automobile cut-out switch which is to produce a mechanically operated means, whereby, when a fuse in a three-phase circuit is blown, the switch connecting the circuits will be automatically thrown out of operation from the circuit. In three-phase circuits, one of the fuses may be blown, but this does not entirely break the circuit since it will continue to operate on a one-phase circuit, tending to over-heat the motor or diminish the lights. By means of this invention, however, upon any of the fuses being blown, the switch is thrown open automatically. This seems to be a very good idea except for the fact that the fuse links which work this switch are exposed all around, which we believe is against the Fire Underwriter's ruling. Some device should be attachable whereby this objection is overcome. Otherwise, we think the patent is a good one. How successful it will be from a commercial standpoint we have no means of knowing. It all depends upon the owners of the patent who wish to exploit it.

### Mechanical Converter.

(335) Herbert M. Hubs, Indianapolis, Ind., wishes to know if he could obtain a patent on a mechanical current converter which he designed. He claims that it will work with an efficiency of 80%.

A. It is impossible to say off-hand if a patent can be obtained on the idea as we do not know what it is about. We do not know the technical details; for that reason we cannot give any intelligent advice.

### Electric Typewriter.

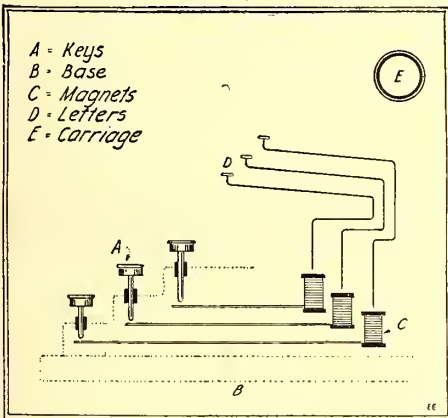

(336) Lucius M. Turner, Royston, Ga., writes as follows: "I have an idea which I think is entirely original concerning a typewriter that will work with electromagnets. My idea is as follows: Have each key used as a switch or, in other words, used like a telegraph key. As you are aware, each arm on which the letter is attached is shaped somewhat as shown in diagram. When the key is pressed the circuit of that particular magnet is closed. For instance, take the letter 'K'. Press the letter K and that closes the circuit of that certain magnet and the letter K is made. Magnets are located under each letter, as shown in illustration. IN THIS WAY ALL LETTERS WILL BE HIT WITH EQUAL FORCE. In reading letters and typewritten matter you often see some letters less plain or dimmer than others. This would be absolutely avoided. The magnets would be very small and therefore consume very little current. The current could be supplied with a few batteries located under the table or in the drawer, or in any other convenient place that is not needed. Please advise me as to whether it could be patented, and if it would be practicable. Also if it could be manufactured at

a reasonable price (please give me some idea as to the price) and if I could find a ready market for same."

A. A very clever idea, and it seems it has the germ of a possible great future. Our present typewriters are operated on a very antiquated plan, and have not been improved since Remington built his first machine. What we refer to is the muscular energy it takes in operating a typewriter. It is rank foolishness in this age of invention and electricity to ask people to wear themselves out by pounding the keys. Electricity should be the mover. Mr. Turner in his invention has shown a very simple way of doing it. He uses the keys to establish the contact. Even the slightest touch will close the circuit. Then electricity, plus electromagnets, will do the rest. Each electromagnet will pull down its key. It thus should be possible to operate a typewriter with the very slightest touch, and each typewriter could be plugged into a light socket or otherwise, a battery or storage battery without any trouble whatever. Of course, the details will have to be worked out to make the device practical, but we certainly think that it is a coming thing. We believe also that such a typewriter could be marketed at a cost only slightly higher than the present-day machine.

We think a patent can be obtained on this invention without much trouble, and we would advise our correspondent to get in touch with a patent attorney at once.

### Auto Tail Lamp.

(337) G. R. Smathers, Charlotte, N. C., says: "I have invented a combination auto tail lamp. It is a combination affair of two lamps in one, one being red, the other white. Either red or white bulbs can be used, or instead use red or white lens. It is electrically operated and is provided with extra "push" for white light, which is to be used in backing out of garage or "turning around" at night, in order to avoid "backing" into obstacles such as fences, ditches, etc. The white light, which is larger and brighter than the red one, serves the same purpose as do the front headlights. This device is also provided with the well-known license-plate bracket. The red light throws a white light on plate from under side."

A. From the description and drawings which we have inspected, we do not see anything fundamentally new in the device, and we doubt very much that a patent can be obtained on the combination. There are many similar devices on the market now.

### Adjustable Book-Mark.

(338) N. Alpert, Sedalia, Mo., submits description and model of a new article of manufacture. In part he says: "Please advise me whether I can obtain a patent on an adjustable book-mark. It is to

**U.S. PATENTS**

SEND FOR THIS FORM

**Don't Lose Your Rights**

Before disclosing your invention to anyone send for blank form "Evidence of Conception" to be signed and witnessed. A sample form together with printed instructions will show you just how to work up your evidence and establish your rights before filing application for patent. As registered patent attorneys we represent hundreds of inventors all over the U. S. and Canada in the advancement of inventions. Our schedule of fees will be found reasonable. The form "Evidence of Conception" sample, instructions relating to obtaining of patent and schedule of fees sent upon request. Ask for them,—a post card will do.

**LANCASTER & ALLWINE**

255 OURAY BLDG.,  
WASHINGTON, D. C.

**PATENTS COPYRIGHTS TRADE MARKS DESIGNS**

**U.S. PATENTS**

Our facilities for securing patents enable us to give prompt and reliable service at reasonable rates. Inventors are invited to write to us regarding questions appertaining to securing patent protection. All matters receive prompt attention. Send sketch for preliminary examination.

*Books free on request*

**A. M. BUCK & CO.**

Patent Attorneys

205 Second National Bank Bldg.,  
Washington, D. C.

**PROTECT YOUR RIGHTS TO INVENTION**

Write today for "Record of Invention," which contains forms to establish evidence of conception. Prompt personal service. Preliminary advice without charge.

**J. REANEY KELLY**

732-P Woodward Bldg. Washington, D. C.

**PATENTS TRADE-MARKS AND COPYRIGHTS**

Before disclosing an invention, the inventor should write for our blank form "EVIDENCE ON CONCEPTION." This should be signed and witnessed and if returned to us together with model or sketch and description of the invention we will give our opinion as to its patentable nature.

Our illustrated Guide Book, "HOW TO OBTAIN A PATENT," sent Free on request.

Electrical Cases a Specialty Highest References Prompt Attention Reasonable Terms

**FREE COUPON VICTOR J. EVANS & CO., Patent Attorneys**

New York Offices: 1001 to 1007 Woolworth Bldg.  
Pittsburgh Offices: 514 Empire Bldg.  
Philadelphia Offices: 135 S. Broad St.

Main Offices: 779 Ninth Street, N. W., Washington, D. C.

Name \_\_\_\_\_ Address \_\_\_\_\_

You benefit by mentioning the "Electrical Experimenter" when writing to advertisers.

# PATENTS

## TO THE MAN WITH AN IDEA

I offer a comprehensive, experienced, efficient service for his prompt, legal protection and the development of his proposition.

Send sketch, or model and description, for advice as to cost, search through prior United States patents, etc. Preliminary advice gladly furnished without charge.

My experience and familiarity with various arts frequently enable me to accurately advise clients as to probable patentability before they go to any expense.

Booklet of valuable information and form for properly disclosing your idea, free on request. Write today.

**RICHARD B. OWEN, Patent Lawyer**  
164 Owen Building, Washington, D. C.  
2276-8 Woolworth Bldg., New York City

# PATENTS

## LACEY & LACEY

Attorneys-at-Law—Patent Practice Exclusively  
Solicitors of

**U. S. and Foreign Patents**  
Trade-Marks, Copyrights

659 F St., N. W., Washington, D. C.

Write Us for Our Free Inventors' Book

**PATENT-SENSE**  
Established 1869

# PATENTS

**INVENTORS:** Send us sketches or a model of your invention and a description of the device for advice in regard to the best way of obtaining patent protection. Our practical experience covers a period of twenty years. Our hand-book on patents is sent free on request. All communications strictly confidential. Write us today.

**TALBERT & TALBERT**  
Patent Lawyers

4287 Talbert Bldg. Washington, D. C.

# PATENTS

Hand Books on Patents, Trade Marks, etc., sent free. Our 70 years of experience, efficient service, and fair dealing, assure fullest value and protection to the applicant. The Scientific American should be read by all inventors.

**MUNN & CO., 622 Woolworth Bldg., N. Y.**  
Washington Office, 622 F St., Washington, D. C.

## Patents Promptly Procured

Send sketch or model for actual search of U. S. Patents. Highest references. Personal service. Moderate fees. Write for Free Patent Book.

**GEORGE P. KIMMEL, Patent Lawyer**  
99-W Loan & Trust Bldg. Washington, D. C.

# PATENTS

If you have an invention and desire to secure a patent, send for our Free Guide Book, **HOW TO GET YOUR PATENT.** Tells our Terms, Methods, etc. Send model or sketch and description for our opinion of its patentable nature.

**RANDOLPH & CO.**  
Dept. 172 Washington, D. C.

be made of two strips of steel. The adjustable strip is so fastened that it is able to slide up and down or sideways. The stationary strip can move sideways in either direction. Near the end of this strip and on the underside, a clip is attached, by which the whole thing may be fastened to a page. I am sending a rough model with this letter. It will give you an idea of how the device will work.

A. This is a very clever idea, and we think there ought to be a market for it. It could possibly retail for five or ten cents, and for this reason five-and-ten-cent stores would probably be a good market to exploit the idea. We think a patent could be obtained.

### Improved Fuse Plug.

(339) Thomas Sheehan, Duluth, Minn., wishes to have our opinion on an improved fuse-plug which works on the thermo-electric principle, similar to the *blinker contact* arrangements, that blink electric lights. This fuse is made similar to the regular fuse, except that in the interior it has a steel wire, which has a tendency to contract when a certain number of volts and amperes pass thru it. Naturally the wire must be of the gage that will not contract unless the voltage is over 110 volts. Our advice is asked on this invention.

A. While this is a very clever idea, and while no doubt it works and perhaps a patent can be obtained upon it, we doubt very much whether it would prove a success from a practical standpoint. We think the Fire Underwriters would not allow such a fuse plug to be put in use, for the reason that there probably would be bad arcing at times, and the heating effect therefrom would endanger fixtures, etc.

A gold palladium alloy which makes an acceptable substitute for the more expensive platinum iridium alloy used in chemists' utensils has been developed by metallurgists in California.

### CREDIT CORRECTION NOTICE.

The story entitled "The Autograph of an Oyster," published in the July issue of the *ELECTRICAL EXPERIMENTER*, should have been credited to the courtesy of the "New York Sunday American" instead of the Star Company, who are the publishers.

## How to Make Photo-Micrographs

(Continued from page 317)

will require a shorter exposure than dense objects or objects stained with carmine or picric acid. The experimenter should use his own judgment in regard to the length of exposure; some idea of the length of exposure may be obtained by examination of the photo-micrographs here shown.

No. 1. Scales from the wing of the moth of the grape-vine cut-worm, and are a good example of the scales which cover the wings of all moths and butterflies. This is the "dust" which comes off on the fingers when holding a butterfly or moth by the wings. Different shaped scales will be found on the same insect by taking scales from the various parts of it.

No. 2. Parenchyma of sunflower leaf; the specimen was obtained by stripping a small piece of the epidermis from the upper part of the leaf. The large pointed objects are hairs, the thin jagged lines mark the cell walls; the small objects shaped somewhat like coffee grains are the stomata by means of which the plant takes in CO<sub>2</sub>, its principal food, from the air.

No. 3. Part of the surface of the under wing of the squash bug. The photo shows cells and the opening of glands which exude moisture, keeping the wing from becoming brittle. The dark line is part of a vein.

No. 4. Is a micro-photograph of the nitrogen fixing organisms from a nodule on the root of a pea. These micro-organisms have the property of fixing nitrogen from the air.

No. 5. Tip of antenna of May beetle; the short sharp bristles are the sensory organs, probably the sense of smell.

No. 6. Tip of the wing of the crane fly, showing covering of fine hairs.

For the average experimenter a microscope having a magnification from 15 to 250 times is sufficient, and with it photographs of pollen, mould, mildew, et cetera, can readily be made.

## Competent Patent Service

By a Former Examining Officer  
of the U. S. Patent Office

# NORMAN T. WHITAKER

Lawyer and Engineer

480 Whitaker Bldg. Washington, D. C.  
Branch Office, 87 Nassau St., New York City.

**INQUIRIES INVITED**

# PATENTS

Inventors Invited to Write for Information  
and Particulars  
Highest References. Best Results.  
Promptness Assured.

## WATSON E. COLEMAN

Patent Lawyer  
624 F Street N. W. Washington, D. C.

# PATENTS

C. L. PARKER  
Formerly Member Ex-  
amining Corps, U. S.  
Patent Office.

## PATENT LAWYER

McGill Bldg.  
Washington, D. C.

Patents, Trade Marks, Copyrights, Patent Litigation

Handbook for Inventors, "Protecting, Exploiting  
and Selling Inventions," sent upon request.



Swing 4 in., 11 in., between centers, 17 in.  
total length. Shipping weight 13 lbs. Bed  
of lathe is machined. Workmanship first-  
class. Equipped with wood turning chuck.  
Can be fitted with 3 in. face plate and grill chuck as  
special equipment. Order one today. Price \$5.00 cash  
with order. **SYFHER MFG. CO., DEPT. C TOLEDO, OHIO**

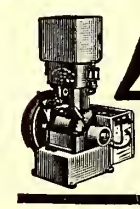

### SMALL ENGINES

Perfect Gasoline Engines—  
1/2, 1 and 1 1/2 h. p. for Farm  
and Shop use. Price, \$27.50  
and up. Also,  
**WASHING MACHINES**  
We ship on trial. Send for  
Booklet and Special Offer.  
**SIEVERKROPP ENGINE CO.**  
1401-19th St., Racine, Wis.

**STARTER for FORD CARS**



### BUILD A \$100 PHONOGRAPH

Assemble your own Phonograph  
Do it yourself in a day.  
Have the finest machine.  
Astounding saving. We  
give you the phonograph  
secrets. Complete instruc-  
tions 10 cents.

**ELECTRO MECHANICAL PARTS CO.**  
160 N. Wella St. CHICAGO

## DOLLAR ADDING MACHINE #1

Adds and multi-  
plies with  
speed of expen-  
sive machines.  
Seven columns capacity. Re-  
markably simple in con-  
struction. Nothing to get  
out of order. Weight one  
ounce. Made  
of metal and  
celluloid. The  
ideal pocket  
desk or home  
machine. Order  
today. The best  
way not to forget is to do  
it now.

**L. J. LEISHMAN CO., Dept. 142, Ogden, Utah**



## \$3 AND \$4 WILL BUY A Beautifully Reconstructed TYPEWRITER

With Every Modern Writing  
Convenience

WRITE TODAY FOR ILLUSTRATED CIRCULAR  
Explaining Try-Before-You-Buy Plan

**HARRY A. SMITH, 738-218 North Wells St., Chicago, Ill.**



### Learn in 6 Evenings

## SHORTHAND Simplified Learn Easily at Home

Practical *K. I. Shorthand*; quickly  
learned. You attain speed easily.  
Great saving in time and expense.  
Guarantee and 30 days' trial given.  
Home study. Modern equipment.  
Used in Government service, in cor-  
porations, schools, professional and  
business offices, private use, etc.  
Brochure and specimen lesson FREE.

**KING INSTITUTE, ED-300,  
Station F, New York, N. Y.**

"Talk as fast as you like,  
I am taking it down in  
K. I. Shorthand."

**Popular Astronomy**

By Isabel M. Lewis

(Continued from page 350)

of the stars is twenty-six trillion miles away. An inconceivable great abyss separates the sun and his planet family from the stars.

It is because they are so near that planets appear disk-like in the telescope, just as the sun and moon appear disk-like without the telescope. Even in the most powerful telescope in existence the stars appear as points of light simply because they are so distant.

Since the planets are so near, they appear to wander thru the sky from day to day and from year to year, the result of the earth's motion around the sun as well as their own motion. As a result of these two motions their apparent motion thru the sky is very complicated and the nearer the planet is to the earth the greater the rate at which it appears to move thru the sky from day to day. The stars, on the contrary, are apparently immovable for many hundreds of years, tho in reality they are in rapid motion thru space.

The continual change of position of the planets is confusing to the beginner who desires to learn to know the grouping of the stars into constellations. It is quite disconcerting to find an unknown bright star where none is indicated on the map. Perchance the observer may think he has discovered a brilliant *Nova*, but *Novae*, especially brilliant ones, are extremely rare. Gradually the fact is brought home that the unknown object is simply one of the five planets visible to the naked eye.

Uranus at the limit of visibility and Neptune far beyond it we need not consider.

Venus and Jupiter one soon learns to recognize by their unusual brilliancy which far surpasses that of the brightest stars. They are distinguished from each other by their distinctive colors and relative brightness. Venus is always a clear sparkling white and considerably brighter than Jupiter who glows unflinchingly with a slightly yellowish tinge.

Mercury, "The Elusive One," as the ancients called him, is rarely seen as he is always so near the sun. When it is possible to catch a glimpse of him in spring or fall when the ecliptic rises most sharply from the horizon, one marvels at his beauty and brilliancy as he twinkles in the twilight with the splendor of a first magnitude star.

Mars, "The Ruddy One," always glows with a deep red tinge but changes very greatly in brightness. When far away from us Mars is very like Antares, the deep red star glowing in the heart of the Scorpion low in the southern, summer sky. When comparatively near to the earth, however, Mars is one of the most strikingly beautiful objects in the sky and surpasses all stars in brilliancy.

Saturn, never particularly interesting without the telescope, is dull leaden colored and, in brightness, resembles a number of first magnitude stars. It is, therefore, more easily mistaken for a star than any of the other planets. It is easy to keep track of this planet when it is once found, however, as it takes nearly thirty years to make one trip around the sun and therefore moves eastward among the stars about twelve degrees a year.

During July and August the splendor of Venus will attract the attention of even chance observers of the heavens. It will be "Evening Star" during these months, as it has been during the spring and early summer and will reach its greatest brilliancy on August seventh. After that date it will draw rapidly nearer the sun.

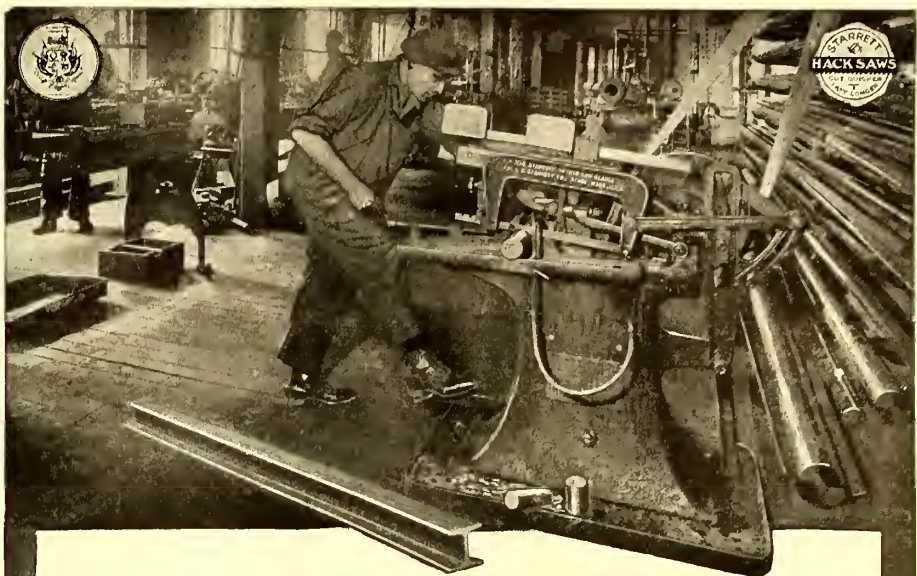

**Choose Your Blade to Fit Your Work**

If you've been cutting 3" round machine steel with a heavy gage, coarse blade and find your next job is on structural beams—7" I beams, for instance—it's cheaper to change to a blade designed for that class of work than to keep on with the coarse blade you used on round stock.

The smaller the cross-sectional area to be cut, means fewer teeth engaged at any single instant and a corresponding increase in wear on the blade at that point. Also, the fewer teeth used the sooner they will dull and the greater likelihood of stripping.

That's one reason why the Starrett Hack Saw Chart recommends different blades for different kinds and shapes of metal. In this case, our tests show that a blade with more teeth to the inch should be used on structural steel than on round stock.

MATERIAL TO BE CUT	40-50 POUNDS		50-75 POUNDS		75-100 POUNDS	
	ALL PURPOSE	HEAVY DUTY	ALL PURPOSE	HEAVY DUTY	ALL PURPOSE	HEAVY DUTY
Light Machine Steel (3" dia)	100	110	110	120	120	130
Medium Machine Steel (3" dia)	110	120	120	130	130	140
Heavy Machine Steel (3" dia)	120	130	130	140	140	150
Light Structural (3" dia)	110	120	120	130	130	140
Medium Structural (3" dia)	120	130	130	140	140	150
Heavy Structural (3" dia)	130	140	140	150	150	160
Cast Iron (3" dia)	110	120	120	130	130	140
Steel Pipe (3" dia)	110	120	120	130	130	140
Cast Iron Pipe (3" dia)	110	120	120	130	130	140
Structural Steel (3" dia)	110	120	120	130	130	140
Cast Iron (3" dia)	110	120	120	130	130	140
Steel Pipe (3" dia)	110	120	120	130	130	140
Cast Iron Pipe (3" dia)	110	120	120	130	130	140
Structural Steel (3" dia)	110	120	120	130	130	140
Cast Iron (3" dia)	110	120	120	130	130	140
Steel Pipe (3" dia)	110	120	120	130	130	140
Cast Iron Pipe (3" dia)	110	120	120	130	130	140
Structural Steel (3" dia)	110	120	120	130	130	140

Write for Starrett Hack Saw Chart No. LE.

**THE L. S. STARRETT CO., Athol, Mass.**

The World's Greatest Toolmakers.  
Manufacturers of Hack Saws Unexcelled. 42-933

**Starrett Hack Saws**

**YOUR OPPORTUNITY**

**Canceled Government Contracts**

We have secured a large quantity of Small Motors, Generators and Charging Outfits. This material is new, still in original cases and carries the full factory guarantee.

**This is Your Opportunity to buy new, guaranteed Electrical Apparatus of Standard Manufacture**

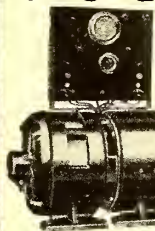

**Battery Charging Outfits**

- For use on 110 volt, A. C., 60 cycle, single phase current only.
- 80 watts, 8 volts, 10 amperes. **\$48.50**
- 130 watts, 80 volts, 5 amperes. **\$68.50**
- 150 watts, 15 volts, 10 amperes. **\$68.50**
- 800 watts, 90 volts, 10 amperes. **\$94.50**

All outfits complete with switch-board as cut shown.

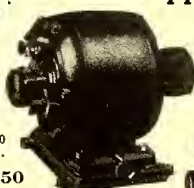

**1/2 H.P. INDUCTION MOTOR**  
110 or 220 volts, A. C.  
60 cycle, single phase,  
1750 R. P. M. **\$32.50**

ALL MOTORS COMPLETE AS CUT

**1/4 H.P. 110 volts**  
cycle, single phase  
1750 R. P. M.

**WASHING MACHINE MOTOR**  
Suitable for operating Small Compressors, Coffee Grinders, Bottle Washers, Lathes, Drill Presses, etc. **\$18.50**

Mail \$5.00 cash or Money Order. We will send C. O. D. subject to full examination.  
**MONEY BACK GUARANTEE**

WRITE FOR CATALOGUE. BARGAINS IN MOTORS AND GENERATORS. SPECIAL QUANTITY PRICES

220 volt **POLYPHASE MOTORS** 1750 RPM.  
60 cycle, 2 or 3 phase. Complete, pulley and base  
1 H.P. \$59.50 3 H.P. \$ 84.50  
2 H.P. \$72.50 5 H.P. \$102.50

110-220 volt **REPULSION MOTORS** 1800 RPM.  
60 cycle, single phase. Complete with pulley.  
1/2 Hp. \$44.50 1 Hp. \$67.50

MANUFACTURERS' DISTRIBUTER

**CHAS. H. JOHNSTON - West End - PITTSBURGH, PA.**

# FREE TO YOU!

## Read this Remarkable Offer!



**OFFER No. 1**

**Wireless Course**

The most comprehensive Wireless Course ever printed. Contains 160 pages, 350 illustrations. Size of book 6 3/4" x 10". Very fine flexible cloth cover.

FREE with a year's subscription.  
Add 5c for postage

**OFFER No. 2**

**Experimental Electricity Course**

This masterpiece contains 160 pages, 400 illustrations. Size of book 5" x 9". Printed on extra thin paper, so book can be slipped into pocket. Handsome flexible cloth cover.

FREE with a year's subscription. Add 5c postage

**OFFER No. 3**

**How to Make Wireless Sending Apparatus**  
By 20 Radio Experts  
**How to Make Wireless Receiving Apparatus**  
By 20 Radio Constructors

These books are by far the most successful wireless books on the market. Size of each book 5" x 7", well bound on good book paper. Covers in two colors. We really cannot praise these books too highly. Each book contains 100 pages and from 88 to 90 illustrations. **BOTH** books FREE with a year's subscription. Add 5c for postage

This is a very limited offer. It may be withdrawn at any time, due to the tremendous cost of paper, which IS JUST DOUBLE WHAT IT WAS ONE YEAR AGO. We have only a limited supply of these fine books on hand; after they are gone we cannot reprint the books until conditions become normal again. Now is your chance.

The publishers of this journal have earned an enviable reputation of giving more than 100 cents' worth for each dollar spent with them. Profit by this liberal opportunity NOW; it may never be made again.

## HERE'S THE OFFER

Subscribe to the ELECTRICAL EXPERIMENTER for one year, at the regular subscription price of \$2.00 per year (Canada, foreign and N. Y. C. \$2.50) and we will send you either books shown in one of the above offers. If you subscribe for two years, two offers will be given, etc.

If you are a subscriber at present take advantage of this wonderful opportunity anyway. If you do, we will extend your present subscription.

**This Offer Limited.**

**Act Now.**

**EXPERIMENTER PUB. CO.**  
233 FULTON STREET  
NEW YORK CITY

**FILL IN — TEAR OUT — AND MAIL**

8-19

Gentlemen: Please enter my subscription to the ELECTRICAL EXPERIMENTER for the term of . . . . . year, for which I enclose herewith \$ . . . . . You will also send me at once FREE your book . . . . . as per offer No. . . . .

.....

Name .....

Address .....

You benefit by mentioning the "Electrical Experimenter" when writing to advertisers.

# Inside a 'U-Boat

(Continued from page 309)

captured enemy craft, the U-117, U-140, UB-148, UB-88 and the UC-97. The views here reproduced were taken on board the surrendered submarine U-105, and the machinery shown is typical of the other German craft of this type.

### Under a U-boat's Deck.

The submarine UC-97 was a smaller craft than some of the others, but proved to be one of the most troublesome craft possess by the enemy during the war. This boat was designed to serve as a mine layer, as well as being fitted for carrying torpedoes, and provided with a 4.1 inch deck gun. She was propelled by oil-burning Diesel engines, each rated at 300 h.p. for travel on the surface. Propulsion when submerged was accomplished by means of four compound-wound interpole generator-motors, mounted in pairs on the same shaft and coupled to the engine by means of a clutch. Each generator-motor unit developed 100 kilowatts capacity, or 130 h.p., when running as a motor at full load. These machines were artificially cooled. When these units are driven by the Diesel engines, while cruising on the surface, they operate as dynamos and charge the storage batteries. When submerged the engine clutches are thrown over, and the generators are now operated as motors by the electric current supplied from the storage batteries. A motor-driven air compressor supplied the necessary compressed air for discharging the torpedoes, emptying submerging tanks, et cetera. The electrical control and switchboard rooms on the UC-97 are situated forward of the engine room, from which all electrical apparatus is controlled. The hull is divided off into water-tight compartments which can be sealed off individually by close-fitting doors. The control room is directly below the conning tower. In this control room we find apparatus for steering the vessel, firing the torpedoes, planting the mines, also for filling or emptying the submerging tanks. Much of this part of the control equipment is installed in duplicate, so that if one set is disarranged the other set may be instantly put into service. The U-boat is steered by electric motors, provided in duplicate. One motor is placed aft and one forward, thus reducing the chances of becoming totally disabled to a minimum. It is possible to maintain the U-boat within two feet of any specified depth below the surface by discharging from or letting in water to the submerging tanks. There are provided elaborate and carefully calibrated depth gages on all submarines which indicate at any instant the exact depth at which the submarine is submerged. One of the accompanying photographs shows these depth gages.

### Collapsible Motor-Operated Periscope.

The periscope is a collapsible affair which can be quickly elevated, thanks to the ubiquitous electric motor, for the purpose of taking a "sighting" and then quickly lowered. Two periscopes are invariably provided, in the event that one should become fouled or shot away. The periscope measures approximately four inches at the base and two inches at the top, thus re-

ducing the visible portion and its accompanying "wake" to the smallest possible dimensions. This is highly important as the "wake", if very broad, can be easily seen by a sharp enemy look-out. Aiming at the head of this wake, the eagle-eyed gunner can make things highly unpleasant for the submersible.

In the forward part of the submersible are located the officers' quarters and the radio operating room, as well as the sub-sea telephone apparatus, by means of which the sounds of the propellers and engines of ships can be heard several miles away.

### The Under-water "Ears" of the U-boat.

No wonder the surreptitious U-boats popt up in the least suspected places, for they could detect an enemy merchantman one to two hours' sail away. By carefully listening to the sounds picked up by the microphones mounted in the shell of the vessel, a steamer or warship could be trailed or maneuvered around for miles. U-boats have been known to dodge the Allied destroyers for periods of three and four hours; "blind-man's buff" you might call it, but he who laughs last laughs best, for the destroyers carried a better under-water sound detector than the "Heinies" and every move along his tortuous course was closely checked up. Periodically, depth charges were "let go" and many times, more than the Germans care to admit, the final crunching sound of a vanquished U-boat, as the depth bomb spelled its doom, came to the ears of the destroyers' officers via the sensitive hydrophone. The U-boats could be trailed just as accurately finally, as if they had been maneuvering on the surface of the sea.

Life on these craft was not to be craved for, especially when a U-boat got cornered and had to lay on the bed of some sound or harbor, for 10 to 15 hours. Electric cooking utensils were supplied, the same as on all of the Allied submarines.

The larger U-boats measured 300 feet and more in length, and had a capacity of 20 or more torpedoes and 45 mines. Craft of this type are propelled by two powerful Diesel engines, developing 1,200 h.p. each, for cruising awash, charging the storage batteries, etc., and when submerged propulsion is effected by a set of four 500 h.p. electric motors. The motors are operated as generators while awash, when it becomes necessary to charge the batteries. These large sub-sea craft often had a cruising range as great as 7,000 miles. The speed of this type of craft on the surface is about 19 knots and submerged about 10 knots. They carry two disappearing deck guns of 4 to 6 inch caliber. The torpedo tubes are four in number at the bow, while two are provided at the stern. At the bow of the U-boat the Germans mounted a cleverly contrived saw for cutting thru sub-aqueous nets. Even so, the nets placed in the waters about the English coasts enmeshed many of them, from which they endeavored to struggle loose in vain, as the official Admiralty reports prove. It may be said in closing that, contrary to the usual expectations, inspection showed the workmanship on the machinery of these U-boats to be very plain and ordinary.

# Go to Church by Telephone

Holding church services by telephone was one result of the influenza epidemic. This was done by one church in Muncie, Ind., which arranged that at 10:30 o'clock, thru the coöperation of the local telephone com-

pany management, the telephones of all subscribers who wished should be connected with the telephone in the church, to which a special microphone was attached. The church organist also played a few numbers, which were thoroly enjoyed by the listeners.

You benefit by mentioning the "Electrical Experimenter" when writing to advertisers.

# Fit Yourself for the Big Job

Don't hesitate any longer. There is a greater demand for trained men now than ever before—greater opportunities—bigger pay—more rapid advancement. It's training that counts now—accurate knowledge—a complete grasp of your trade.

## Drake's Practical Mechanical Books

For Home Study

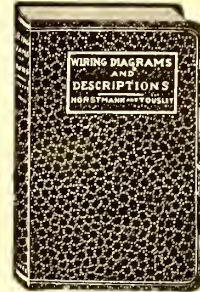

Pave the way to the fat pay envelope. Written in non-technical language that any man can grasp. Send the price of any book listed below. We will send the books postpaid—you keep them five days—if not entirely satisfied return the books and your money will be refunded in full. Order direct from this page. Use the Coupon.

### Electrical Books

- Electric Motor Control Systems and Methods. Leatherette.....\$1.50
- Electrical Tables and Engineering Data. Leatherette.....1.50
- Motion Picture Operation. Leatherette.. 1.50
- Alternating Current. Leatherette..... 1.50
- Wiring Diagrams and Descriptions. Leatherette..... 1.50
- Armature and Magnet Winding. Leatherette..... 1.50
- Modern Electric Illumination. Leatherette 1.50
- Modern Electrical Construction. Leatherette..... 1.50
- Electricians' Operating and Testing Manual. Leatherette..... 1.50
- Drake's Electrical Dictionary. Leatherette 1.50
- Electric Motors, D and A. Leatherette.. 1.50
- Electrical Measurements and Meter Testing. Leatherette..... 1.50
- Drake's Telephone Handbook. Leatherette 1.50

### Automobile Books

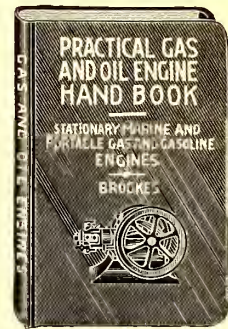

- Automobile Ignition. Leatherette, \$2.00
- Brookes' Automobile Handbook. Leatherette ..\$2.00
- Automobile Starting and Lighting. Leatherette ..\$1.50
- Ford Motor Car, Truck and Tractor Attachments. Cloth, \$1.00
- Ford Motor Car, Truck and Tractor Attachments. Leatherette ..\$1.50
- Automobile Catechism and Repair Manual. Leatherette.....\$1.25
- Gas and Oil Engine Handbook. Cloth..... 1.00
- Gas and Oil Engine Handbook. Leatherette..... 1.50

### Modern Language Courses

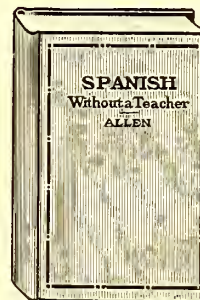

French Without a Teacher, Spanish Without a Teacher, German Without a Teacher. By Professor Philip Schuyler Allen, University of Chicago. An entirely new home series of modern foreign languages. Simplest, easiest-to-master language method ever devised. French, Spanish or German. Pocket size. Each.....\$1.25

### Mail the Coupon NOW

Order on our five day money back plan.

FREDERICK J. DRAKE & CO.,  
1009 Michigan Ave., Chicago, Ill.

Enclosed find (\$.....), for which please send me prepaid the books checked in this adv. (or list attached). It is agreed that I may return same in 5 days if not entirely satisfied, and money will be refunded in full.

Name .....

Address .....

# MURDOCK No. 55



## IT CAN BE PROVED

that our 'phones are good enough for ANY radio service. Order a set NOW. Use them. Test them. Compare them. DECIDE. If after a thorough trial you find that they do not PROVE as good as you want, send them back and get the money. WE WANT YOU TO PROVE OUR POINT—FOR EVERY SATISFIED USER "BOOSTS" MURDOCK 'PHONES.

3,000 Ohm Double Set	2,000 Ohm Double Set
<b>\$400</b>	<b>\$500</b>

INTERESTED IN GOOD RADIO APPARATUS? ASK FOR BULLETIN No. 19

## WM. J. MURDOCK CO.

55 Carter St.  
Chelsea, Mass.

Pacific Coast Representatives  
KEELER WHITE CO.  
221 Second St., San Francisco.

## CORE WIRE

We have been fortunate in securing thru auction several tons of guaranteed pure, double annealed Norway Iron Core Wire and are selling this wire to "Experimenter" readers

At Pre-war Prices, 20cts. lb.

This wire is just the thing for spark coils, transformers, etc., and it is, of course, a very much more superior product than the usual iron wire.

We have only one size left:  
24 INCHES LONG.  
Thickness about No. 21 B and S

If this size should be too long we advise cutting the wire down yourself by means of shears. As long as the supply lasts we offer this wire as described above to our customers at the very low price of 20c a pound. Add postage or we will ship express collect. Order at once.  
Electro Importing Co., 231 Fulton St., N.Y.C.

# How I Invented the Crystal Detector

By Dr. G. W. PICKARD

(Continued from page 325)

great improvement over the coherer, I soon found that it, also, had defects. Severe static or nearby sending would usually cause a partial or complete paralysis of the contact, curable only by the hit-or-miss process of repeatedly jarring the detector so that new contact points were formed, or the old ones unwelded. Even in the absence of severe electrical disturbances, the contacts gradually became, as it were, fatigued, and the signals weakened toward inaudibility, unless periodically restored by jars. Then, also, the microphone detector lived up to its name by acting as a microphone, picking up any slight sound or vibration in a most annoying way. Finally, even if the detector was screened from sounds and jars, it was prone to develop a hissing or frying sound, which overlaid faint signals to their obliteration.

### The Contact Detector Is Invented.

In the first part of the year 1902, the American Wireless Telegraph and Telephone Company erected stations at Atlantic City and Cape May, N. J., about 40 miles apart, and also equip the schooner *Pleiades* as a floating experimental station. On May 29, 1902, I was in the Cape May station, experimenting with a new system of tuning, and receiving signals from the *Pleiades*, then about two miles off Cape May. The detector I was using consisted of several fine sewing needles, laid lightly across a pair of carbon blocks, and in series with three cells of dry battery and a telephone receiver. Becoming annoyed at the microphonic "fry" of my detector, I attempted to check this by, as I thought, cutting out of circuit two of the three dry cells. The frying ceased, and the signals, tho much weakened, became materially clearer thru being freed of their former background of microphonic noise. Glancing over the circuit, I discovered to my great surprise that instead of cutting out two of the three cells, I had cut out all three, so, therefore, the telephone diafram was being operated solely by the energy of the receiver signals. A contact detector, operating without local battery, seemed to me so extraordinary, so contrary to all my previous experience, that altho I did not then know the reasons for its operation, I appreciated its possible great value to the art, and resolved at once to thoroly investigate the phenomenon at the earliest possible moment. This entirely accidental discovery was the foundation of my invention of the crystal detector.

### Silicon and Other Detectors Invented.

During the summer of 1902, I was concerned with the development of a system of radio-telephony, conducting this work in the Boston laboratory of the American (Bell) Telephone and Telegraph Company. As one of the essential elements of this system was a detector which would respond quantitatively to telephonically modulated electrical waves, I at once began a series of tests, first with the form of the carbon-steel microphone I had used at Cape May, and then with other contact materials. Discovering that such detectors responded quantitatively to musical spark signals up to at least 2000 sparks per second, and were therefore capable of receiving speech, I devoted my energies for the time to the transmitting end of the system, finally discovering, in the fall of 1902, an effective means of telephonically modulating a stream of electrical waves. Returning to the detector development, I found that the Telephone Company had in their laboratory

a large quantity of magnetite ( $\text{FeO} \cdot \text{Fe}_2\text{O}_3$ ) crystals, which had been procured as a possible material for loading coil cores. I broke one of these crystals apart, exposing a fresh fracture face, made a small area contact thereon with a brass point, and found that this crystal, like the carbon steel detector, operated well without local battery, but, unlike the carbon-steel contact, did not require a light or microphonic contact for best operation. In the period 1902 to 1906, I tested many different minerals and combinations, including magnetite, pyrite, galena, molybdenite, silicon and zincite. Much development was also required on holders for these minerals. Perhaps one of the greatest early stumbling blocks in such development was the old coherer idea that extremely light pressure contacts were necessary. With the carbon-steel microphone, this was still true, but I can remember my surprise when I found that many of the minerals worked best with quite high pressure contacts.

### 31,250 Crystal Detectors Invented.

A list of the several thousand materials I have tested would make dry reading. Suffice it to say that I have found some two hundred and fifty minerals and furnace products which make operative detectors, either against metallic contacts, or in combination with other minerals. The possible combinations of these two hundred and fifty substances, amounting to some 31,250 pairs, have all been tested by me, or by my assistants, and many hundred useful pairs have been found.

### Oscillating Crystal Detectors.

The last word on crystal detectors and their uses has yet to be written. For example, it may be of interest to know that they can be made to OSCILLATE, under proper circuit conditions, and I have found it possible to receive intelligible signals from UNDAMPED wave stations across the Atlantic, on a simple contact between a fragment of galena and a fine wire.

### MOTHER SHIPTON TOLD OF AVIATION IN 1488.

The following, which is known as "Mother Shipton's Prophecy," was first published in 1488, republished in 1641 and again in 1875. It will be noticed that all the events predicted in it except the last two lines have come to pass:

Carriages without horses shall go;  
And accidents fill the world with woe.  
Around the world thoughts shall fly,  
In the twinkling of an eye;  
Water shall yet more wonders do;  
How strange, yet shall be true.  
The world upside down shall be,  
And gold be found at root of tree.  
Through hills men shall ride,  
And no horse or ass be at his side.  
Under water men shall walk,  
Shall ride, shall sleep, shall talk.  
In the air men shall be seen,  
In white, in black, in green.  
Iron in water shall float  
As easy as a wooden boat.  
Gold shall be found, and shown  
In a land that is not known.  
Fire and water shall wonders do,  
England shall at last admit a Jew.  
The world to an end shall come  
In eighteen hundred and eighty-one.

(It is curious to note that only the last two lines—WHICH DO NOT RHYME—have failed to come true. All the others that do rhyme did come about as prophesied!—Editor.)



# THE ONLY VACUUM TUBE WHICH AMATEURS CAN USE



Fleming Pat. No. 803684  
De Forest Pat. Nos. 841387-879532

Agreements recently effected have made vacuum tubes available for experimental use. The Marconi V. T. is the only vacuum tube, or audion, which may be sold to amateurs, laboratories, schools of instruction and experimenters.

## MARCONI V. T.

### \$7.00 each

Standardized base \$1.50 additional

A highly developed, all-around tube for use as a detector and amplifier in wireless communication. It has practically the same electrical constants as the tube used by the Allied armies and navies throughout the war in continuous wave transmission and reception. The terminals of the elements of the tube are brought out to a 4-prong standardized base, fitting into the standard four-contact bayonet sockets.

Filament current, 0.7 ampere. Filament potential, 4 to 6 volts.  
Plate potential, 20 to 60 volts for reception.

For lighting filaments a *lead* storage battery is preferable because of its constancy of voltage. Ordinary dry cells or flashlight batteries may be used to provide the plate voltage.

The approximate operating life of the MARCONI V. T. is 1,500 hours.

*Delivered postpaid in special container insured against breakage to any address upon receipt of purchase price.*

COMMERCIAL DEPARTMENT

## Marconi Wireless Telegraph Company of America

*Sole distributors for De Forest Radio Telephone & Telegraph Co.*

**Woolworth Building, 235 Broadway, New York**

## HALCUN BAKELITE AUDION PANEL

A die molded panel. 5" by 9"  $\frac{3}{8}$ " thick. A beautiful permanent glossy black. Wires and all connections molded right into the panel, entirely concealed, impossible to corrode or become loosened. Switches all of the bearing type, large shafts to prevent wear.

All metal parts nicked. Connections arranged for damped spark, undamped arc, regenerative and ultra connections. There is nothing like this panel on the market. It is a quality article thruout. Other manufacturers ask more for wood and thin sheet panels.

The Halcun panel is  $\frac{3}{8}$ " thick with a beveled edge provided with supporting brackets. Price, less bulb, prepaid \$12.50

Our big full-line catalogue 6c.

**HALCUN RADIO CO.** 437 Market St. San Francisco, Cal.

### THE BARR MERCURY-CUP WIRELESS DETECTOR

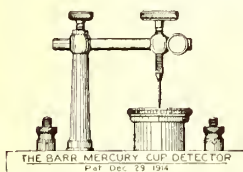

The most efficient Detector on the market. Tested by the United States Government and Marconi Wireless Telegraph Co.

Increases the efficiency of every wireless receiving set by making the signals clear, sharp and distinct.

Instantly adjustable at a constant pressure. For full information and price—write

**THE BARR MERCURY-CUP DETECTOR** 169 Columbia Heights Brooklyn, N. Y.

## Arnold Loose Couplers

Combination Loose Coupler Parts and accessories.

Send 3c stamp for literature which is sure to interest you.

J. F. ARNOLD

2082 Lexington Av. N.Y. Established 1910



ONLY \$10.50

"I am highly pleased with my Colby tuner. Richard F. Morse, 818 Julia St., Jacksonville, Fla." Send 3-cent stamp for bulletin.

COLBY'S TELEGRAPH SCHOOL, AUBURN, N. Y.

### VACUUM TUBES

#### In Wireless Communication

The only book on the subject. Written by E. E. Bucher, author of "Practical Wireless Telegraphy". Price \$1.75.

Wireless Press, Inc. 233 B'way, N. Y.



**AMERICAN ELECTRO TECHNICAL APPL. CO.** 235 Fulton St., N. Y. City Cort. 3153

#### Batteries, -special type for Audions

Switch Points—Binding Posts, Knobs—Levers—Rods—Sliders, Etc.

All parts for the Amateur to make his own Apparatus.

### AMATEURS! DO NOT OPEN TRANSMITTING STATIONS

without first learning to send and receive radio MESSAGES.

#### WILCOX WIRELESS PRACTICE SET

The first need of every amateur. Hightone buzzer and key for learning code. Also for test buzzer and four other purposes. With code, wiring diagrams and instructions. Our new cat. "E" of electrical and wireless apparatus and code chart sent for 3c stamp.

**THE WILCOX LABORATORIES** LANSING, MICHIGAN

## E. F. W. Alexanderson Wins "I. R. E." Gold Medal

At the May meeting of the Institute of Radio Engineers held in New York City, May 7th, E. F. W. Alexanderson, consulting engineer of the General Electric Company, was awarded the gold medal of the institute in recognition of his original research and inventions in the radio field.

In accepting the gold medal, Mr. Alexanderson said:

Such great strides have been made in all fields of science and engineering during the emergency of our late war that I feel it a specially high honor to receive the Radio institute medal at this time.

"The radio art has drawn its talents from almost every profession. Broadly speaking, radio men may be classified as radio physicists, radio engineers and radio amateurs. In a sense we are all amateurs and we shall never know who was the first amateur. We do know, however, that the first radio physicist was Hertz who discovered and determined in his laboratory the laws of electromagnetic radiation. We also know that the first radio engineer was Marconi, who made the first use of electromagnetic waves for practical communication and developed the wonderful system which for the last 20 years has made the high seas safe for navigation.

"Fessenden conceived the possibility of bringing radio engineering within the realm of power engineering, and it was my privilege, due to connection with the General Electric Company, to develop the first radio frequency alternator. Indeed it was thru the work which this Company was requested to do for Fessenden that my interest in radio communication was first excited, and this has resulted in the contributions which I have had the opportunity to make to the radio communication of today.

"Radio telephony is a by-product of the development of sustained radio waves as a method of alternating current power transmission. With the previous system of spark telegraphy it was no more possible to transmit the modulation of the human voice

than it would in land telegraphy to reproduce speech from the dots and dashes of the Morse code. But with the sustained energy of the continuous wave, it has become possible to put a dynamo electric machine behind the wave and vary the flow of power in correspondence with the modulations of the human voice, thus mak-

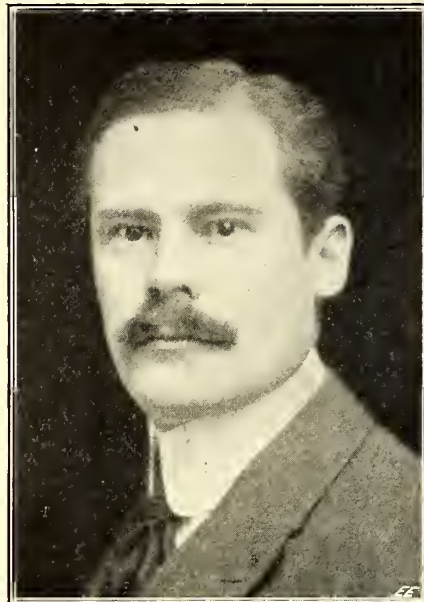

E. F. W. Alexanderson, Well-known Radio and Electrical Engineer, Awarded the "I. R. E." Gold Medal.

ing long distance radio telephony possible.

"Mr. President and members of the institute, it has been a privilege to be connected with the great development in radio in the last years and I wish to express my deeply felt appreciation of the recognition represented by this beautiful medal. I thank you."

## Concentrated or Loop Aerials

(Continued from page 328)

from B to D no sound, and then from D to C another rise and fall of intensity, the maximum in each case occurring when the plane of the loop is along 30-210° line but the signals in A B sector are about twice as loud as in C D sector; this gives the direction of signal in direction of arrow. If however the connections of Fig. 4, are used then the result will be as shown in Fig. 6. The signals will be much louder and will be heard only in the A B sector, thus making it strictly *unidirectional*. If the loop be grounded on the grid side, then Fig. 7 shows the result, i. e., *loud signals but NO directional effect whatever*.

Fig. 3 shows the connections when it is desired to receive on other than the wave length of the loop. In practice it will be found to be simpler to have several loops of proper wave lengths rather than be bothered with a tuner.

As many navy and army operators know, the loop eliminates a lot of interference and also static. However, if it is desired to eliminate static more effectively, then it is necessary to take the loop and outfit into the cellar or under ground. Signals will be found to come in just as loud as tho an elevated aerial were used, but the static will be absent, *even in the midst of a thunder-storm* when an ordinary aerial "spits fire."

The loop shown in the photo and diagram Fig. 8, consists of 240 turns of No.

22 S. C. C. and with a 43 plate variable condenser has a range of from 2,000 to over 3,000 meters. Larger loops can be made if it is remembered that the same length of wire is required. The inductance is determined by the area turns, and hence a small loop will act about as well as a large one. If several loops are operated simultaneously from known points, but separated some distance, the exact location of the sending station can quickly be determined. And further if the circuit of Fig. 4, is used a very large amount of interference on the same wave length can be eliminated, since only such stations as lie in the region from 150° to 270° will be heard at all, while receiving from 210° and as the outfit tunes sharp much of this is cut out. By carefully adjusting the apparatus as good receiving can be done on the loop as with the ordinary aerial, and all other features will be additional. *Stations 200 miles away can be located to a pin point on the map.* Thus the Radio Amateur has opened to him a wide field that will make possible better work with less bother.

### RADIO TELEPHONE BETWEEN ROME AND TRIPOLI.

Wireless telephone communication is maintained between Rome and Tripoli, 600 miles apart, mainly over water.

# Wireless Operators Wanted - At once

**Calls Coming In Steadily, For National Radio Institute Graduates, From All Parts of the Country.**

Commercial Radio has arrived and thousands of positions are now opening up in the Merchant Marine, Aerial Mail and Land Station Service, Railroad Companies, Lake and Ocean Steamship Lines. We are now receiving requests for more National Radio Institute Graduates than we can furnish.

**Salaries Up to \$250 A Month**

With exceptional opportunity for promotion to Radio Mechanic, Electrician, or Engineer. No previous experience or training is necessary. You can learn Wireless the National Radio Institute way, in Ten Weeks, by mail, right in your own home. With our help you can quickly qualify for a good position at big pay. Many of our students secure positions before completing the course, because it is based on actual practice and teaches what is needed to make a big success of Wireless work.

**Get Your Instructions from the Nation's Capital**

(Our Course is Endorsed by the U.S. Government Officials)  
The National Radio Institute headed by authorities who have been closely allied with government training of students, was established in 1914 and is the first school in America to successfully teach Wireless by Mail. The work is under the direction of J. E. Smith, E.E., director of the Radio Department Howard University, and E. R. Haas, formerly of the Radio Division of Yale University.

We now have students throughout the world. Our location in the Nation's Capital together with the standing of our officers and their wide acquaintance among government officials connected with Wireless activities place us in position to give our students the best instruction obtainable and to be of the utmost help in assisting them to secure good paying positions.

**Travel and See the World**

If you want to travel and see the world—go to foreign countries, and increase your knowledge of world affairs Wireless offers you the chance of a lifetime.

However, you are not obliged to travel, but may secure a permanent position at one of the big Land Stations, Railroad, Telegraph, or Steamship Companies if preferred.

**Pay As You Learn**

Our plans of payment bring a wireless education within the reach of anyone who desires to learn. A small payment down on our convenient payment plan, and small following payments, often enables our students to earn the cost of their tuition while actually learning to be a wireless operator.

**Free Instruments to Every Student**

In addition to 5 text books—35 Special Lessons, and 18 Personal Examinations we send you, while taking our course a Standard Automatic Wireless Transmitting and Receiving Set for sending and receiving messages. These fine instruments are Free only to National Radio Institute Students.

**Oldest Wireless School in America**

In addition to being the oldest and largest Wireless School in America our location in the Nation's Capital enables our Students Employment Department to keep in close touch with the best openings for our graduates. A Post Graduate Course is given Free to every graduate. Special discounts are allowed to discharged soldiers, sailors, and marines with former wireless experience and to Radio amateurs.

**FREE**

Our booklet "Wireless the Opportunity of Today," gives you complete information in regard to our course, the quick and easy methods by which you can master wireless, and other important facts you should know. It is free. Just mail the coupon. No obligation whatever on your part.

*Mail This Coupon Today*

National Radio Institute  
Department 90  
Washington, D. C.

Send me free of charge, your booklet, "Wireless the Opportunity of Today," with full particulars regarding your famous 10 weeks Home Study Course, and your Special FREE INSTRUMENT OFFER.

Name .....

Address .....

Town..... State.....

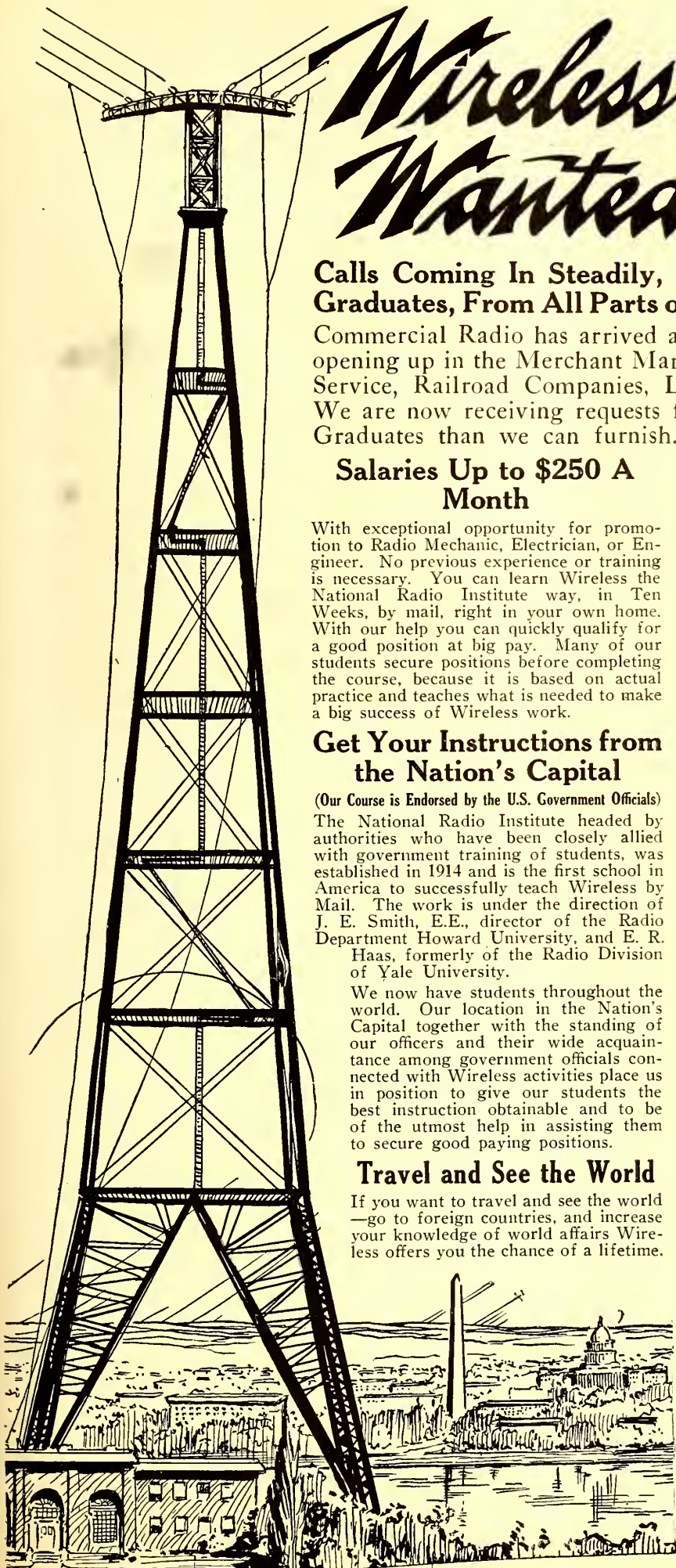

# Wireless Receiving Ban Raised

## MESCO WIRELESS PRACTICE SET

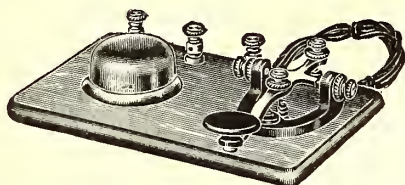

The Practice Set comprises a regular telegraph key, without circuit breaker, a special high pitch buzzer, one cell Red Seal Dry Battery, and four feet of green silk covered flexible cord.

The key and buzzer are mounted on a highly finished wood base, and three nickel plated binding posts are so connected that the set may be used for five different purposes.

List No. 342—Telegraph Practice Set, with Battery and Cord .....\$3.24  
 Weighs 4 lbs. packed.  
 Price does not include postage.

## MESCO Combination Practice Set for Learning the Morse and Continental Visual and Audible Codes

This outfit is the only reliable instrument which will enable students to become proficient operators in the U. S. Naval Service, because it is equipped with a buzzer and miniature lamp enabling the user to master both the visual and audible signals quickly.

List No. 52—Practice Set with Red Seal Battery and Cord .....\$4.05

Weighs 4 lbs. packed. Price does not include postage.

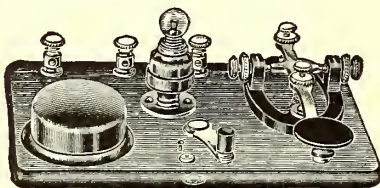

## MESCO RADIO BUZZER

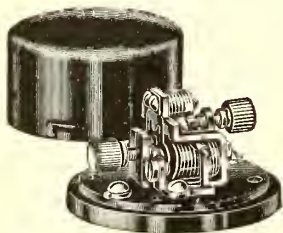

This buzzer maintains a constant note and is recommended as an exciter for checking wavemeters where pure note and ample energy are required.

It consists of practically a closed circuit field of low reluctance, having a steel armature to which is riveted a strap supporting a movable contact. The armature tension is adjustable by means of a screw with a milled head large enough to be easily and permanently adjusted with the fingers. The stationary contact is adjusted by means of a similar screw. The magnet coils are connected in series with a total D. C. resistance of 3.9 ohms. Shunted across these coils is a resistance having a D. C. value of 3 ohms. This shunt eliminates all sparking such as occurs at the break on ordinary radio buzzers and the energy saved thereby is transferred into any oscillating circuit connected to it, the result being that this buzzer as constructed

radiates five times more energy than any other existing type. All connecting wires liable to be broken are eliminated. Contacts are of genuine platinum, which is essential in order to maintain a constant note. The parts are mounted on a Condensate base to insure constancy in operation.

Diameter 2 in., height 1 1/4 in. The cap is attached to the base by a bayonet joint.  
 List No. 55 Mesco Radio Buzzer .....\$2.05

**We carry a Large and Complete Line of Standard Wireless Material Recognized by Experts as such with Competent Experienced Wireless Attendants in Charge**

### Send for the New Edition of Our Catalog W28

It is pocket size, contains 264 pages, with over 1,000 illustrations, and describes in plain, clear language all about Bells, Push Buttons, Batteries, Telephone and Wireless Telegraph Material, Electric Toys, Burglar and Fire Alarm Contrivances, Electric Call Bells, Electric Alarm Clocks, Medical Batteries, Motor Boat Horns, Electrically Heated Apparatus, Battery Connectors, Switches, Battery Gauges, Wireless Telegraph Instruments, Ignition Supplies, etc.

## Manhattan Electrical Supply Co., Inc.

17 Park Place, New York, N. Y.

CHICAGO  
 114 S. Wells St.

ST. LOUIS  
 1106 Pine St.

SAN FRANCISCO OFFICE: 604 Mission St.

## INSTALL A NEW GREBE REGENERATIVE RECEIVER In Your Radio Station

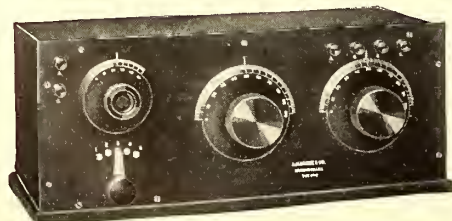

Short-Wave Regenerative Receiver Type CR-2

This Receiver is intended for long distance relay work on wave-lengths between 170 and 580 meters and embodies a highly developed circuit employing continuously variable inductances of the variometer type as well as a number of new mechanical features.

Various models designed to operate on wave length ranges from 170 to

20,000 meters are described in our bulletin sent free upon request.

**A. H. GREBE & CO., Richmond Hill, New York**

## Radio-Planes Watch Forests and Ranches

(Continued from page 295)

stations erected about the ranch. The installation and maintenance cost of these stations is relatively small in any case. They have also been so greatly simplified during the war that practically anyone can be instructed in handling the talking and receiving apparatus in a short time. Some of these sets work as simply as the ordinary telephone.

### Airplanes and Radio Serve to Protect Nation's Forests.

Recently the use of airplanes to patrol the forests and watch for incipient forest fires was extended by the Government and now the wireless telephone has been installed for an experimental trial. If found to be practicable the wireless will be extended to cover the great woods with an invisible net of communication.

The wireless is expected to be an improvement upon wires or cables for one very important reason. In the past great difficulty has been experienced in maintaining wire communication in the forests because of the interruption to the service caused by falling timber, especially in the stormy season. Snowslides have been another source of destruction to the wires. The use of wireless, of course, obviates all such difficulties.

For the purposes of the present experiment the Signal Corps of the Army has lent to the Forest Service four combination sets of transmitting and receiving apparatus. One set of the equipment is to be installed on Mount Hood at an elevation of about 13,000 feet, and another at the nearest forest ranger station, about twelve miles away. Two other sets are to be placed in the Clearwater Forest region of Idaho, which is a very heavy wilderness country.

All of the wireless stations will be established at look-out points, where watch is kept for forest fires, and will supplement the regular service, which not so long ago was augmented by the addition of airplanes for patrol. Now two additional airplane routes for that purpose have been mapped out, both operated from Mather Field, near Sacramento, Cal. The other two routes of the airplane service are operated from March Field, near Riverside, Cal.

The first route from Mather Field will cover the northern parts of the Eldorado and Tahoe forests on the valley side of the Sierras. The planes will start from Mather Field each morning and proceed to Oroville by way of Placerville, Colfax, Nevada City and Strawberry Valley. A landing will be made at Oroville, where a suitable field has been provided. The return trip will be made in the afternoon.

The second route from Mather Field will cover the southern parts of the Eldorado and Stanislaus forests. Starting from Mather Field, the route runs to Placerville, Grizzly Flat, Big Trees, and to a landing near Sonora or Tuolumne. In this case also the return trip will be made in the afternoon. Each of the Mather Field routes has a round-trip length of about 150 miles.

Forest Service reports tell of a successful trial patrol undertaken recently under test conditions. No difficulty was experienced in detecting fires in heavy timber at elevations of from 6,000 to 10,000 feet.

Peculiar interest attaches to the movement for conservation as affecting North Carolina, Tennessee and Kentucky because of the potentialities involved.

**NEW SUBSTITUTE FOR PLATINUM.**

The question of substitutes for platinum has received almost world-wide attention, many nations having been obliged to devise something. Most of the platinum came from Russia before the war. Germany was no exception. Some of the recent substitutes are enumerated in a German paper. The most important seems to be that suggested by Gotthold Fuchs, of Berlin, consisting of a wolfram-gold-nickel alloy which can be cast, forged and rolled, is of light color and polishes brightly, which platinum does not. Another substitute is an alloy of silver, wolfram and nickel. Both these alloys are stated to be acid resisting. A nickel-iron alloy, known as platinite, is said to be serviceable as a substitute for platinum in glow lamps, its coefficient of extension being similar to that of glass. For laboratory purposes an alloy of nickel and chromium affords a platinum substitute for wire and sheets, but cobalt alloys, such as cobalt-iron and cobalt-chromium are as serviceable, especially for acid-resisting purposes.

**Peacetime Uses for War Inventions**

By H. Winfield Secor

(Continued from page 298)

The illustration in Fig. 7 shows two applications out of many for the once busy U-boats. America and the other Allied countries can make use of all the superfluous U-boats without a doubt. For exploring the flora and fauna of the undersea regions they are ideal. They can be fitted with powerful electric projectors, observations lenses and windows, when not only can visual observations of the deep sea life be studied, but even motion pictures can be taken. And for pleasure trips at the seaside resorts—I would hate to have the job of figuring up how many five dollar bills one could rake in, in a single Saturday afternoon, with one of these pleasure submarines at Coney Island, not to mention the Beach at Coronado, Calif., and who would not like to explore the secrets of the Great Lakes? We have heard of the chap who endeavored to dash over Niagara Falls in a rowboat, and no doubt we shall soon hear of the enterprising fun-promoter, who will, for a consideration of \$25.00 or so, invite you for a trip over Niagara in one of the former Kaiser's plush upholstered U-boats. Plush upholstered is right, and we would like to have it about nine feet thick.

In order to attract the sea and lake fishes for the edification of the passengers aboard, we can imagine that some genius will roll up his sleeves and get busy developing a "food gun" which can be attached to the torpedo tube. Presto! Push the button and out flies a perfect barrage of fishsome dainties for our piscatorial neighbors, when they will come bounding forward in great flocks, much to the delight of the submarine's guests, snapping their teeth gladly and otherwise showing how delighted they are.

The *Submarine Detector*, which is shown in Fig. 8, and which was wonderfully perfected during the World War, should find many peacetime applications, particularly on all ocean-going and inland lake vessels for the purpose of locating other vessels in a fog or at night, and also for accurately locating the presence of icebergs and reefs. The submarine detector, of which several different types were developed during the war, operates on one general principle, that of *sound wave transmission thru the water*. The sound produced by the propeller and driving motors or en-

(Continued on page 378)

**BRANDES WIRELESS HEADSETS**



Score 100% efficiency in actual use

"Superior" Set \$6.

CLEAR IN TONE      LIGHT IN WEIGHT      DEPENDABLE IN SERVICE

Sharp, unblurred, readable signals

assured by

"BRANDES MATCHED TONE"

We achieve this by perfectly matching the tone of both receivers in each set. This eliminates all confusion to the ear due to unmatched harmonics.

**YOUR RECEIVER IS RIGHT IF IT'S A "BRANDES".**

Used by many U. S. Gov't experts, and experts abroad, by colleges and technical schools, and by professionals and amateurs everywhere.

**TRIAL OFFER**—Brandes Wireless Headset sent to you on trial for 10 days. Test it; compare it with others, for sensitiveness, clearness, distance. Prove for yourself the fine quality, the "matched tone". The two diaphragms, toned exactly alike, strengthen the signals and prevent blurring. If, for any reason, you are dissatisfied, your money back without a question.

Send 4c for catalogue E

**C. BRANDES, Inc.**

Room 814

32 Union Square

New York City

**UNIVERSAL RADIO APPARATUS**

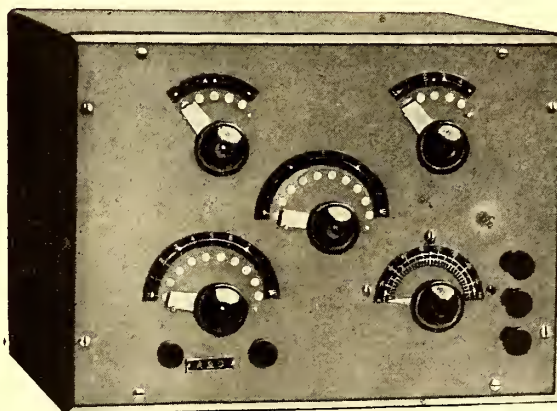

Type UL-5 Receiver

interested in radio apparatus of the highest grade at fair prices, enclose a 2-cent stamp for our catalogue.

**Type UL-5 Receiver.**

This is a complete receiver for undamped waves up to 17,000 meters. No external coils, couplers or condensers are needed, since it is entirely self-contained. Sizes 8" x 12" x 7" approximately.

We control the patent rights for the Mignon System and can supply these instruments.

It is the policy of this company never to consider a sale completed until the customer is thoroughly satisfied. Incidentally our instruments seldom fail to satisfy, because they are scientifically designed and built on honor. If you are

**UNIVERSAL RADIO MANUFACTURING CORP.**

Dept. W

Elmira, N. Y.

## ANY YOUNG MAN

earning less than \$200 per month will find it to his interest to enter the wireless field as a vocation.

We prepare you in 20 weeks, through our correspondence course, for splendid positions and obtain same for you immediately on graduation.

We also pay back a considerable portion of the tuition fee after the student has completed the course.

*Write for Booklet and Details*

### SERVICE RADIO SCHOOL

*Largest Radio School in the World*

Dept. E., 900-2 Pa. Ave. Washington, D. C.

## PROGRESSIVE RADIO APPARATUS

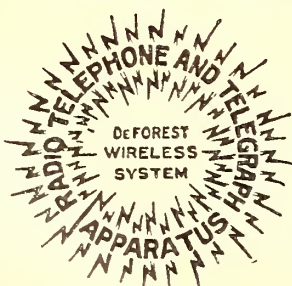

To what reasons can the popularity of De Forest Radio Apparatus be attributed?

Is it because of its consistent performance, excellent workmanship, materials, low prices?

These would account for it partly. The real reason must lie in the fact that we have always been in the van. Design and system employed have been so far in advance of others as to overshadow our rivals.

The De Forest Company is one of the recognized successes in the radio field. Our success has been progressive—more than merely financial, because we give better service—more for your dollars—most modern apparatus—than you can obtain elsewhere.

We do not aim to sell the most radio apparatus—only the best. Quantity is a secondary consideration.

We were the first to produce the audion amplifier and the oscillation undamped wave transmitter, and its popularity is attested by its wide use.

Our latest productions, the Honey Comb Coils, Unit Set, Coil Mountings, Two Step Amplifier and Audion Control Box have been greeted with enthusiastic demand far exceeding our expectations.

The Unit Receiver fills the demand for a really efficient receiver for any and all wave lengths of any preferred circuit and design without the usual costly cabinet and expensive assembly.

By placing your order now you will avoid the greater congestion in our factory when the purchasers of this meritorious apparatus of novel design begin enthusiastically recommending it to their friends.

We have been literally swamped with orders, so do not feel surprised when your dealer tells you it will be necessary to wait a few weeks before you can get delivery.

DE FOREST RADIO TEL. & TEL. CO., 1415 Sedgwick Ave., New York City

## Faradic Currents— How To Apply Them

(Continued from page 318)

eight minutes or at the outside fifteen minutes is long enough for a treatment. The exceptions to this rule are in the treatment of some chronic diseases, as chronic articular rheumatism, etc., and in general electrizations, where a little longer time might be allowed.

No definite rule holds as to the frequency of sitting, as much depends upon the nature of the disease, the sex, age and habits of the patient. Some acute cases require daily sittings, seldom more than that. In chronic cases from two to four times a week may be enough.

### Constipation

Connect the rectum electrode to the *negative* pole of the battery and place it in the anus. At the same time the *positive* over the stomach, liver and bowels. Use the *secondary* current. A small internal dose of cascara sagrada will sometimes prove beneficial. However, the use of cathartics, as a rule, is not advisable, and the above treatment is much better without them. Eat good plain digestible food. A dish of oatmeal and milk eaten in the morning will help to regulate the bowels.

### Corns.

Place the foot upon the foot plate, it being attached to the *negative* pole of the battery and apply the *positive* pole directly to the corn, using a small piece of sponge fastened to the ear electrode. Treatment should last about ten minutes daily. Use the *primary* current.

### Canker.

This is caused by indigestion. Let the patient live upon a light milk diet for a few days. Thoroughly wash the mouth and throat frequently with borax or boracic acid diluted with water. Electrical treatment: Place the *positive* at the nape of the neck on the spine and apply the *negative* to the stomach. This treatment should last about ten minutes. Use *secondary* current. Another treatment is to place the tongue electrode in the mouth having previously attached it to the *positive* pole of the battery and apply the *negative* to the neck and throat. Use *primary* current. A general tonic treatment two or three times a week will be beneficial.

### Diabetes.

Diabetes seems to be a nervous disease, and for that reason we recommend what is called *Central Faradization*. The object is to bring the whole central nervous system under the influence of the primary current. Place the *negative* pole at the pit of the stomach and pass the *positive* over the head and forehead, down the back of the neck and along the whole length of the spine. Use a very light current about the head and increase gradually. Do not apply the current to the head more than one or two minutes at a time. The spine will stand a much stronger current than the head. The back may be treated about five or six minutes. After this give tonic or general treatment for ten minutes, with the *secondary* current.

### Death—Apparent.

People who have to all appearances been dead, have been restored to life by electricity. The test is as follows: Place the sponge electrode (*positive* pole) to the back of the neck, and apply the *negative* to the body over the lungs and heart. A mild *secondary* current is first used, gradually increasing it until the patient shows signs of life. Keep this treatment up for about five minutes, also apply the *negative* electrode to the arms, wrists and hands. Now sponge the whole body with the *negative*.

(Continued on page 371)

**DESTROYER FLOTILLA NAVI-GATED 1,100 MILES BY DIRECTIONAL WIRELESS.**

Seven links in the chain of naval destroyers stretched across the Atlantic by the United States Navy for its transoceanic flight reached their Newfoundland base after traveling from New York enveloped in fog from Fire Island to Trepassey Bay, thus navigating 1,100 miles entirely by directional wireless, with which the Transatlantic seaplanes were equipt. The trip was said by Captain Arthur Crenshaw, base commander, to have been one of the severest tests this means of navigation ever had. The destroyer Philip became separated from the flotilla in the fog, but she entered the harbor soon after her companions.

**To War On An  
American Destroyer**  
By A. H. Whedon  
(Continued from page 329)

Of course, a certain amount of roll and pitch is to be expected—but a destroyer of a very nervous disposition just can't be still at all!

The largest roll that we made while I was on the *Conyngham* was seventy-two degrees to starboard and sixty-eight to port. That is in the ship's log, and signed by the Captain. And, friends and fellow citizens, I maintain that *that* was sure *some* roll. Try it once and see. A destroyer is always rolling at sea, and in a storm she is one great "dance artist."

The *radio shack* is mounted either way forward or way aft, in the place most calculated to get the benefit of the rolling and pitching. Of course, it is superfluous to mention the fact that everybody from the oldest salt down to the newest rookie gets sea-sick on the first trip to sea on a destroyer. The rookies come aboard expecting to be sick. But when a "gob" wise in the ways of ships (big ones) comes aboard, he proclaims for all to hear that he has been going to sea too long to get sea-sick. The day comes when we go to sea. The next day friend "gob" fails to rise for breakfast—not that he is sea-sick or anything like that, y' understand, but simply that last night's chow must have disagreed with him. By noon time he joins the rest of the gang at the lee rail, actively engaged in the sport technically known as "feeding the fishes." Yea, verily, 'tis a great life until you get used to it. And nine-tenths of the sailors get so that the more she rolls, the better they like it.

But now consider the case of the poor radio man, who is forced to sit for at least four hours before his set, never getting up from his chair and never taking his receivers off. Every time the ship takes a big roll he rolls with it, unless his chair is screwed to the deck—but they never are—and there is a wild scramble to hold on to pencils, pads, code books, and other loose articles that have a tendency to hide under power transformers, switchboards, or any other place where it is deuced hard to recover them.

At the first calm spot, the "op" nervously attempts to readjust his detector, and succeeds in making things worse. So he shifts over to the audion and thinks his troubles are over. So they are until he discovers that the filament battery is run down and needs recharging. Then follows a choicc line of briny "cuss" words. About this time the boat decides to take another roll, and the show starts all over again.

In between times, the "op," if he is new on a destroyer, realizes that he really isn't feeling well. Then he begins to wonder why he ever joined the Navy anyway. Of course, he can't leave his post to join

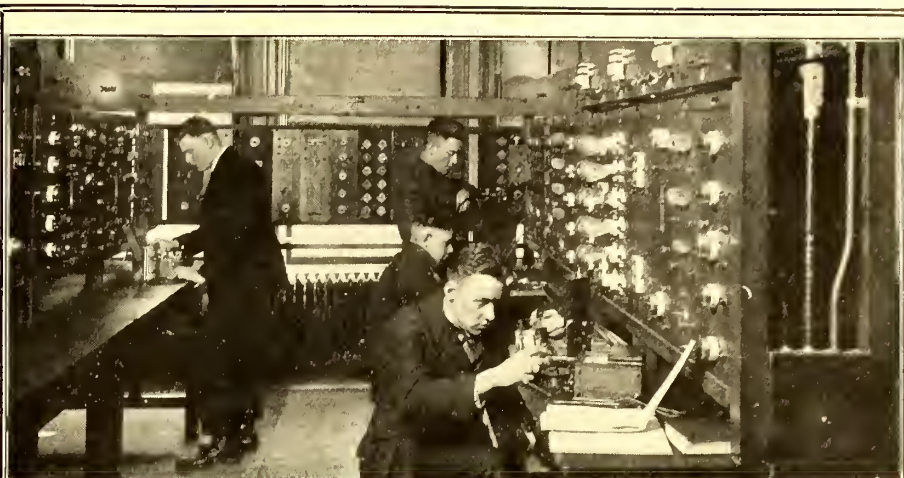

ONE OF THE SEVEN LABORATORIES  
AT THE SCHOOL OF ENGINEERING OF MILWAUKEE  
Where ELECTRICITY Is Taught Quickly And Thoroughly

**Become an Electrician in One Year**

or learn an electrical trade in six months. Greatest of all professions open to you. "Forty billions will be invested in Electricity in next five years," says Edison. Salaries are high. Demand for TRAINED electricians ENORMOUS. Think of electric lighting, electric street cars, electric railway trains, electric telephone and telegraph, electric motors, electric automobiles, electric cooking and heating. Electricity in the air and under the sea. Is it not dazzling?

**Field Limitless—New—Uncrowded**  
Our forty professors of the three departments teach the laws and principles of electricity. Actual training in laboratories; lectures and problems. No special schooling required to enter our practical electrical, electrotechnician and trade courses.

"Earn While You Learn" if you wish. We arrange part-time employment that will help you defray expenses. Athletics, Glee Club, Lakeside Advantages. Board and Room at Students' Fraternity House at cost.

Catalog explains in full. Send for it.  
**SCHOOL of ENGINEERING  
of MILWAUKEE**  
102-373 Broadway, Milwaukee, Wis.

Clip Here

**MAIL THIS COUPON TODAY—RIGHT NOW**

**SCHOOL OF ENGINEERING OF MILWAUKEE**  
102-373 Broadway, Milwaukee, Wis.

Without obligating me, please furnish details of course (or courses) marked below.

<b>Electrician, 1 year</b>	<b>One Year Drafting Course</b>
<b>Electrotechnician, 1 to 3 years</b>	<b>Six Months Trade Courses</b>
<b>Electrical Engineer (3 years) B.S. Degree</b>	<b>Extension or Home Study Courses</b>

Name .....  
Address .....  
City ..... State .....  
Age ..... Education .....

**TRACO QUALITY  
RECEIVING TRANSFORMERS**

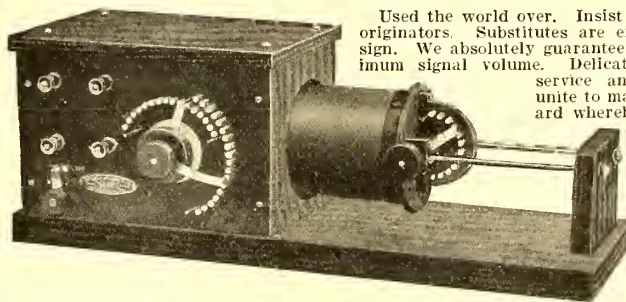

Used the world over. Insist on the genuine, built by its originators. Substitutes are expensive, irrespective of design. We absolutely guarantee our tuners to give the maximum signal volume. Delicate refinement, uninterrupted service and high class workmanship unite to make TRACO tuners the standard whereby all others are judged. If your Dealer does not handle them, order direct from us.

**LIBERTY DETECTOR VALVES, RADIO AMPLIFYING PHONES,** type used by the UNITED STATES, BRITISH and FRENCH GOVERNMENTS, now in stock, for sale.

The Famous 5A and 5C Models  
**THE RADIO APPARATUS CO., Pottstown, Penna., U. S. A.**

Send stamps for bulletins.

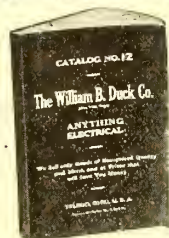

**DUCK'S BIG 300 PP.  
Wireless & Electrical**

Catalog is now as it always has been, the largest and most complete and dependable Wireless Catalog published. Mailed for 12c in stamps or coin which may be deducted on first order of one dollar. Catalog not sent otherwise. This catalog costs us twice the price of other catalogs.

Everything in wireless *worth while* is listed in this catalog. The experienced amateur will tell you to see our catalog before buying. You are thereby insured against an unwise purchase. It is the *Beacon Light* to guide you right in the selection of your wireless apparatus. No bigger or better values are obtainable elsewhere. Send for revised price list. It is yours for the asking.

**THE WILLIAM B. DUCK CO., 230-232 Superior St., Toledo, Ohio**

# AMPLIFY YOUR RADIO SIGNALS

With the new DETECTAGRAPH-TRANSMITTER, the amateur can amplify radio signals to such an intensity that he can hear the signals about his station without the need of the telephone head set.

By the addition of a loud talking telephone he is able to hear the messages many feet away from the instrument.

The super-sensitive DETECTAGRAPH-TRANSMITTER herewith shown is two and three-eighths inches in diameter, five-eighths of an inch thick and weighs less than three ounces. It is the most sensitive sound detecting device ever brought before the public.

The manner in which

the amplifying process is attained is by attaching with tape the DETECTAGRAPH-TRANSMITTER to the regular wireless receiver.

Not only is this instrument applicable for amplifying radio signals, but it can be used with equal satisfaction for magnifying other sounds. Phonograph music can be transmitted from one place to another by means of this instrument, and those who are afflicted with deafness will find enormous benefit by using this transmitter. It is the greatest device for building your own loud talking telephone, detecting and other devices. Can be used for any purpose where a sensitive detecting instrument is required.



Our Super-Sensitive Detectagraph Transmitter. Price, \$7.00 Complete

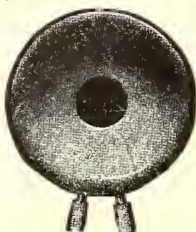

Our Special No. 25 Loud Talking Receiver. Price, \$4.00 Complete



Detectagraph Rheostat, especially made for amplifying circuits. Price, \$2.00 Complete



Super-Sensitive No. 40 Receivers to be used in connection with Detectagraph-transmitters, \$10.00



The Detectagraph Junior Deaf-Phone \$15

Equal to any \$35 instrument made. Outfit consists of Super-Sensitive Transmitter with cord connector; Super-Sensitive Ear Piece with small black cord; Black Single Headband; Black Case and Two Batteries.



Model "B" Horn with Loud Talking Receiver, Cord Plugs and Desk Stand Base. Price, \$10.00 Complete



Model "C" Horn with loud talking Receiver, Cord Plugs and Wall Base. Price, \$10.00 Complete



Detectagraph \$15 This detecting instrument of marvelous sensitivity can be used for detecting secret conversations. Outfit consists of Sensitive Transmitter, 25-ft. Black Cord, Receiver, Headband, Case and Battery.

Order direct from ad.

Or write for free descriptive circular.

## G. BOISSONNAULT COMPANY

26 CORTLANDT STREET

NEW YORK CITY

Makers of Super-Sensitive Microphone Devices

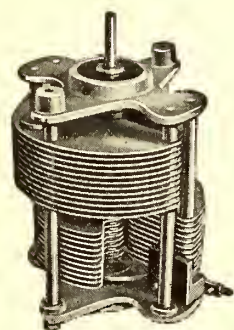

Type 800

Balanced Variable Cond. Supplied in three sizes. Unmounted or mounted in nicked brass case for use with oil or other liquid dielectrics

## Radio Electrical Apparatus

Our new Bulletin Y offers a distinctive line of Radio and Laboratory apparatus including Transformers, Spark Gaps, Oscillation Transformers, Variometers, Variable Condensers, etc., in fact, the most complete line built by any single manufacturer in America.

Bulletin R describes the Cambridge alternating Current Rectifier for

### STORAGE BATTERY CHARGING

Send 3c stamp for both bulletins

## CLAPP-EASTHAM CO.

131 Main Street

Cambridge, Mass.

## You Need These Remarkable Books

### No. 5. Wireless Construction and Installation for Beginners

Describes in detail with working drawings how any handy boy can make his own apparatus at lowest possible cost. Describes simpler and cheaper apparatus than No. 6 Book. 73 pages—67 illustrations.

### No. 6. Experimental Wireless Construction

Explains in detail with working

drawings how to build wireless apparatus, how to erect the aerial, connect and operate. 86 pages—93 illustrations.

### No. 3. Lessons in Wireless Telegraphy

Explains in detail the principles and apparatus for wireless from aerials to end losses and Audions.

Price, 25 cents each, Postpaid, Anywhere

COLE & MORGAN, Inc., Publishers, P. O. Box 473 C. H. Sta., New York City



his friends at the lee rail, but he must do something—quickly!! Ah—he grabs somebody's tin pail that is lying around, which is used to wash in. But friend "op" is not standing on ceremony, he wants action, and quick action—and he gets it!

The radio shack on the *Conyngham* was an inside room, and had no port-holes or other openings on deck. In order to provide for good ventilation, a small air vent was installed in the overhead of the radio room, leading out on deck. It was put in hastily, and was far from being watertight. When we hit a storm and the waves broke over the deck, lo! much "moisture" used to descend into the radio shack. In vain I pleaded with the ship's carpenter, and with tears in my eyes I begged him to fix that "gadget." But he was always doing something else. So I tried to see what I could do to it. When I got thru, it didn't leak, it poured! I had completely broken it. But I was triumphant. Now it would have to be fixed.

But we put to sea with the blame thing still busted. It was the middle of December, 1917, and, for a change, the sea was unusually calm. Everything was all ski for two days, till we met the U. S. S. *George Washington* and the U. S. S. *Huron* to be convoyed into Brest. (This was before the *George Washington* became the Presidential ferryboat. Then, suddenly, all the furies of the sea and heavens turned loose. Everyone who was at sea in that part of the ocean will remember that storm to their dying day. For two days and nights we headed into it and gained but forty miles! Ordinarily the destroyers would have ridden it out with the storm instead of against it. But we had fifteen thousand U. S. soldiers to guard, and we stuck—! At last, even the troop-ships could stand it no longer, and we got a signal from the *George Washington* to "counter-march." That is, turn around and go with the storm. All that night we just drifted, taking things easy, and the next morning the storm had subsided enough for us to try to make port. There were times during those awful two days and nights when even the captain on the bridge remarked that we would never live thru it. And in the face of his belief, he refused to leave the troop-ships to the tender mercies of a stray submarine, for while no "sub" could work during the storm, there was bound to be a calm spell afterward when we would be needed. So we stuck—!

We finally reached port, but what a mess our division was! Of course, everything was absolutely swept clear of the decks. One destroyer even had a smoke-stack carried away, and another one had her main mast broken off. The *George Washington* had lost most of her life boats, and eight men had been washed overboard. The *Conyngham* escaped with very little damage. All our compartments were flooded, and of course there was nothing left on our deck in the way of sea chests, the carpenter's bench, etc. AND the radio shack! Just drift back a few lines to where I mentioned the broken ventilator and then on down further where I mentioned the storm. Two and two never made six—so you can imagine what our radio shack looked like. I had a young Atlantic Ocean in there—six inches of water rushing all over the deck and having a fine time playing with the power transformers and the Leyden jars, with ye scribe perched up on the desk, soaking wet and wondering who started this war.

And so it goes—as someone once remarked—"If we had some ham, we'd have some ham and eggs—if we had the eggs, etc." For those that like it the Navy is sure a fine playground, but personally I am better satisfied to sit here writing this short reminiscence in order to win a few extra pennies for a new pair of shoes for the baby!





# COMMERCIAL WIRELESS

Splendid opportunities now in the **MERCHANT MARINE** for Wireless Operators. Salaries now being paid—Junior Operators, \$85 per month; Chief Operators, \$110; food and quarters included. Equivalent ashore from \$35 to \$40 per week. Interesting and fascinating work. Our graduates in all parts of the world as operators, instructors, inspectors, etc., etc. Students from all over the country. If you are interested in Commercial Radio let the **EASTERN RADIO INSTITUTE** train you. Endorsed by Marconi and Government officials.

**SUMMER COURSES.** Day or evening start any Monday. Send for prospectus.

**EASTERN RADIO INSTITUTE**  
899B Boylston St. Boston, Mass.



# WIRELESS!

**KNOB AND SWITCH LEVER**—Mounted on brass bearing and shaft, threaded 6-32, two inches long. Lever securely fastened to knob. Each 40 cents, postage 4 cents.

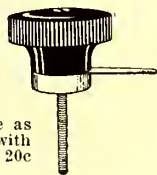

**KNOBS** as illustrated above as used on Switch  $1\frac{1}{4} \times \frac{3}{4}$  with hole for mounting, each 20c postpaid.

**CONTACT POINTS**  $7/32 \times 7/32$  Brass with screw for mounting. Postpaid 25c per doz.

**Bakelite-Dilecto panels, about**

$9\frac{1}{2} \times 19 \times \frac{1}{4}$	Black XX.....	\$4.00
$19 \times 19 \times \frac{1}{4}$	Black XX.....	8.00
$9\frac{1}{2} \times 19 \times 3/16$	Black XX.....	3.00
$19 \times 19 \times 3/16$	Black XX.....	6.00

**A. H. CORWIN & CO.**  
924 Kinney Building Newark, N. J.

# GET OUR PRICES

on the Wireless Apparatus you need. We handle New and Second-Hand instruments on which we can save you money.

All Second-Hand instruments guaranteed to be in perfect working order. What do U need?  
Send us your list now

## RADIO EQUIPMENT COMPANY

630 Wash'n St. Boston, Mass.

# TELEGRAPHY

Both wire and wireless, and Station Agency taught thoroughly and quickly, **BIG WAGES NOW PAID**, some of our recent graduates procuring \$138.00 per month to start. Great opportunities for advancement. Our school the oldest and largest—annual enrollment 600 students. Endorsed by railway, telegraph, wireless and government officials. Expenses low—chance to earn part. Catalog free. Write, **DODGE INSTITUTE, 22nd St., Valparaiso, Ind.**

## A Review of Radio-Telephony

(Continued from page 326)

from the Western Electric Company Engineering Organization to engage in this work. At this time plans were in the making for the tremendous aircraft program which was later undertaken by the Army, and it was clear to all that a successful means of communication between battle planes when flying in squadrons would be of incalculable value and would greatly increase the efficiency with which these squadrons could be maneuvered. The early work had shown such promise that there was justification for assuring the Signal Corps that this means of communication could be worked out successfully and applied to aircraft of various types. As a result of this conference, orders were issued by the Signal Corps for the Western Electric Company to undertake the development of a wireless telephone system for the purpose.

The problem now was to produce sets of minimum size and weight, physical structures which would withstand the extreme vibrations and jars encountered in flying, especially in landing, the most convenient disposition of control elements, suitable sources of power for both high and low voltage, and a form of antenna which would not interfere with the evolutions of a plane in squadron formation.

It was realized that the solution of the last mentioned problem would consume more time than was at our disposal, and while work was immediately started in the field on antenna measurements and study, the design of the sets proceeded on the basis of using a trailing wire antenna.

The working out of a practical helmet design proved to be more difficult than the success of the earlier experiments indicated. It was found that the degree of interference experienced changed very rapidly with slight imperfections in fit. The problem was also complicated by the necessity of providing means for using oxygen at high altitudes, and of providing for the comfort of the wearer over a period of several hours. It was found that a very slight amount of pressure on certain portions of the ear caused excessive pains and headaches after a very short period, and the final design was a compromise between comfort and efficiency as to sound insulation.

The problem of power supply was an interesting one. It was required that the weight should be reduced to a minimum, which precluded the possibility of employing storage batteries. There are obvious objections, also, to attaching any form of generating device to the propelling engine. Consideration of all the factors led to the adoption of a wind-driven generator for the purpose. This generator of about 100 watts direct current output was required to produce a potential of 300 volts for the plate circuits of the vacuum tubes, and a potential of 25 volts for the filament circuits. It is necessary, to insure most efficient operation, that the filament current be kept constant, and the fact that the specifications called for operation with airplane speeds varying from 40 to 160 miles per hour made the problem of voltage regulation loom large. Ordinary forms of electro-mechanical regulating devices did not prove to be successful, and while it was probable that something of this type would eventually have been developed, the problem was solved by a very ingenious arrangement proposed by Mr. H. M. Stoller, in which the vacuum tube is the essential element. The voltage of the generator is held approximately constant by means of a vacuum tube regulator, which controls the field flux. Two field windings are pro-

# RADIO MATERIALS

**Terminated War Contracts**  
Enable Us to Offer at Less Than Cost a Large Stock of Fabricated Parts and Raw Materials.

**SHEET ALUMINUM, COPPER, BRASS and TRANSFORMER STEEL**

**FIBRE, BAKELITE, DILECTO MICANITE, CELLULAK IN SHEET, TUBES and ROD**

**WIRE and LITZ IN ASSORTED SIZES**

**Also Completed CONDENSERS TRANSFORMERS SPARK GAP UNITS REACTANCES**

Call At Our Stock Rooms  
57 New Chambers St., N. Y.

**EMIL J. SIMON**  
217 BROADWAY, NEW YORK

# Q. S. T.

"All men having commercial licenses should report for jobs at once."

Big shortage of operators!

Every student completing the course secures a berth immediately paying \$85—\$130 per month and keep.

Short thoro course—excellent laboratories.

Dormitories—swimming pools.

Call or write for illustrated booklet.

# Y. M. C. A.

## RADIO SCHOOL

NEW YORK CITY

Manhattan Branch: 154 East 86th St. Tel. Lenox 6051  
Brooklyn Branch: Marcy Ave. Near B'way Tel. W'msburg 3800

**WIRELESS** apparatus, Raw Materials, Magnet wires, motors, experimenters' needs, novelties listed in our Catalogue C-3. Assure yourself of prompt service and right prices by buying from this world famed, reliable, experimenters' Supply House.

**The Newman-Stern Co., Cleveland, O.**

# AUDIOTRON VACUUM TUBE PANELS PARTS AND ACCESSORIES

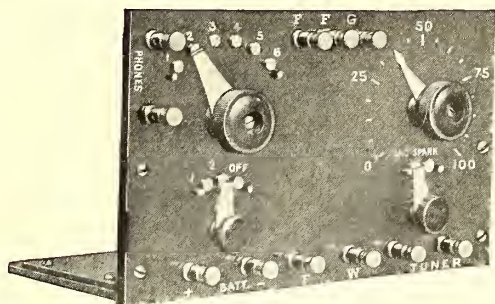

Panel full XX Grade Continental Bakelite Dielecto Steel cut and whitened engraving. All metal parts heavily nickled. Switches for double filament tubes and arc or spark reception. New type Back mounted smooth running rheostat. Panel also furnished in maple with imitation black bakelite finish.

- No. 8B. Full Bakelite panel assembled.....\$15.00
- No. 8BP. Complete set of parts..... 12.00
- No. 8W. Wood panel complete ..... 12.50
- No. 8WP. Complete set of parts..... 10.00

Send for free bulletins on panels, couplers, detectors, parts, etc.

Send cash with order and save all delivery charges. Dealers: write for proposition.

**AUDIOTRON SALES CO., 311 Lick Bldg., San Francisco**

vided, the main field, which is in series with the filament of the regulator tube, and a differential field which is in series with the plate circuit. At minimum speed the differential field is inactive and the generator behaves like an ordinary shunt machine, except that the main field has a small resistance in series due to the regulator tube filament. This filament is so designed that the main field current heats it to a temperature which gives a small electron current. This current flows thru the differential field and reduces the resultant flux. At minimum speed, the differential current is small, but as the speed increases, the main field current tends to rise (as in any shunt generator) and this increases the temperature of the regulator tube filament. The electron current is, therefore, considerably increased, which current, flowing thru the differential field, reduces the generator flux and thus restricts the rise in voltage. Due to the fact that the electron current of the regulator tube increases very rapidly with increase in filament current, the voltage is held practically constant between 4,000 and 12,000 revolutions per minute. The 1.5-ohm resistance units are provided so that the regulator may be set to give different voltages by cutting them in or out of the main field. The 100 ohms shunt resistance is used to prevent hunting.

Upon the completion of the next set of models, field tests were resumed and on August 20th the first two-way telephone conversation between two planes in the air was successfully accomplished. After this first trial, Major Bartholf and Lieutenant Stevens, of the Signal Corps, held two-way conversation between planes with very satisfactory results.

Late in 1917, the type of airplane set shown in Figs. 4 and 5 was installed on our airplanes. The various parts are arranged so that they can be mounted in any available space in the machine. The switch box shown in the diagram is to provide for communication between pilot and observer by means of the same microphones and helmets used in radio-telegraphy. The transmitting and receiving set proper is shown in Fig. 4. This set is 17x10x7 inches and weighs but twenty-one pounds. The generator is of the wind-driven type, and is shown in Fig. 6 with the tail cover removed giving a view of the vacuum tube regulating device. The complete weight of the entire outfit is about fifty-eight pounds. Fig. 7 shows a simplified form of the circuits.

The last distinctive type of radio-telephone outfit is the short wave set installed on submarine chasers and destroyers during the war. These sets are shown in Figs. 9 and 10. The circuits of these sets are practically the same as for the airplane sets, except that the power for them is obtained from small dynamotors run on a 30-volt storage battery. The complete transmitter and receiver, together with the amplifier and extension set, are shown in Fig. 8 and the transmitter receiver itself is shown in Fig. 9.

The set is installed in the radio room with the amplifier for the loud-talker. An extension set consisting of a telephone transmitter and receiver, together with the loud speaker, is mounted in the pilot house. By means of a switch in the radio room, the operator can cut in the extension set while the conversation is being carried on by the captain. It is also possible to use either the head receivers or the loud-speaker for receiving.

This equipment has an effective range of from 5 to 10 miles and can be used in four wave lengths ranging from 250 to 600 meters.—From a paper by E. B. Craft and E. H. Colpitts, entitled "Radio-Telephony," read before the American Institute of Electrical Engineers, Feb. 21, 1919. Photos courtesy Western Electric Co.

## Consolidated Radio Call Book

The "Telephone Directory" of the Sea

This book contains a list of high power Radio Stations of the world with wave lengths they transmit on—a list of stations sending press—time—Q signals—tables for finding charges on radiograms—data on American, British, Canadian, and French Radio Compass Stations, in addition to the

### Wireless Calls of Over 9000 Ships and Shore Stations

In fact this publication is so complete and up to date that large radio companies have contracted for copies for their ships. Since our advertisement in the last issue we have received and tabulated so many additional Radio calls that it has been necessary to raise the price of the book. Price, \$1.00.

Orders postmarked prior to August 1st will be accepted at the old price of 75c.

Published by the

**CONSOLIDATED RADIO CALL BOOK COMPANY, INC.**

41 Park Row, New York City

Send your order to the above address if you are unable to obtain it from your local dealer in Radio Supplies. Orders have already been received from the following dealers:

Haller-Cunningham Electric Co., San Francisco, Cal.

L. Bamberger & Co., Newark, New Jersey.

Smith Novotoy Electric, Inc., Charlotte, N. C.

Radio Equipment Co., Boston, Mass.

Electro Importing Co., New York City.

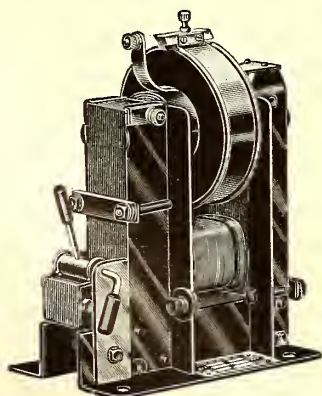

## THORDARSON'S 25,000 Volt WIRELESS TRANSFORMERS

For further information write

**Thordarson Electric Mfg. Co.**  
501 S. Jefferson St. Chicago, Ill.

## Faradic Currents— How To Apply Them

(Continued from page 366)

tive while the positive electrode is at the base of the spine. The room should be well aired, and the patient's feet and hands should be kept warm with hot water and bags.

### Headache.

The treatment of headaches depends upon the cause. If caused by disordered stomach or bowels, what is called a sick headache, place the positive electrode at the base of the brain and apply the negative over the stomach, liver and bowels, using a mild secondary current. General tonic treatment of the whole body with secondary current will cure or help some patients, while central faradization (as described in treatment of diabetes) will help others.

### Indigestion.

Place the positive at the back of the neck and sponge the region of the stomach and bowels with the negative. Another method is to place the positive electrode on the tongue and the negative at the pit of the stomach. Use secondary current. If the patient is debilitated give general tonic treatment of the whole body.

### Neuralgia.

If properly treated, neuralgia is one of the diseases that yield most readily to electrification. There is one difficulty in the treatment of neuralgia by electricity and that is the intensity of the pain. Often the first few treatments aggravate the pain, especially if the current is too strong or the treatment is continued too long. Not over one treatment a day should be given. Give a general tonic treatment of the whole body every other day. For local treatment, where there is no swelling, apply the negative to the painful parts, and the positive at the hands or feet. If there is swelling apply the positive to the disease, and the negative at the hands or feet, using a secondary current.

### Rheumatism—Inflammatory and Acute.

Either of the above kinds of rheumatism may be treated with the positive electrode. If the trouble is about the head, neck, arms or shoulders, hold the negative in the hands and apply the positive to the painful parts. If the pain is below the arms, apply the negative electrode to the feet and the positive to the affected parts. Drink freely of lemonade. Avoid alcoholic liquors, meats and fatty food. A rigid diet for a few days is to be recommended.

### Rheumatism—Chronic.

Chronic rheumatism is much more obstinate and resists a cure more than the acute kind. Very often the general tonic treatment will give relief. For local treatment, treat with the negative electrode instead of the positive as in the acute form. Also use the primary and secondary currents alternately. If the joints are enlarged treat with the positive electrode, using the primary current. Keep the body warm and the feet warm and dry. Do not allow the patient to expose himself to any dampness. The electric bath is to be recommended.

### Sunstroke.

In most cases of sunstroke, electricity is a valuable agent in restoring persons who have been overcome with the heat. General tonic treatment should be given, also central galvanization as described in the treatment of diabetes. Local treatment to the head may be given and a very light secondary current should be used, positive electrode at the head and negative at the base of the spine. In all cases have the attention of a good physician.

# DETROIT

The Auto Center is the Logical Place To

## LEARN AUTO AND TRACTOR BUSINESS

Trained men are needed everywhere to test, repair and give expert advice on care and handling of automobiles, trucks and tractors. Big money for M. S. A. S. Detroit trained men. Good jobs or independent businesses await our graduates. Opportunities unlimited.

**Earn \$100 to \$400 Monthly**

Our Course will teach you how in a few short weeks. Most complete, comprehensive and up-to-date Course known. Wholly practical. No job too hard for our graduates. Every phase of work covered. Actual experience given on dozens of different cars. Entire equipment best obtainable. Instruction includes complete Tractor Course, Brazing, Welding and Tire Repairing taught separately.

**Learn in Detroit—Start Any Time—Our Graduates in Demand**

Here you get the benefit of finest co-operation of biggest factories. They know the thoroughness of our Course and gladly help our students in every way possible. Almost daily we have calls for graduates to fill responsible positions. School open all year. Enter classes any time. No need to waste or lose a moment.

**Money-Back Guarantee**

We guarantee to qualify you for a position as chauffeur, repair man, tester, demonstrator, auto electrician, garage man, automobile dealer, or tractor mechanic and operator, paying from \$100 to \$400 monthly, or refund your money.

**Big Factories Endorse Our School**

They know what we do—how we teach, and the type of graduates we turn out and give our students unusual assistance. Every instructor an experienced man—one who knows and is able to teach others.

**Get Free Catalog**

Tells all about "The Old Reliable School" located in "The Heart of the Auto Industry." Or, better still, jump on the train and come to Detroit as hundreds do. Your fare refunded if everything not as represented.

**MICHIGAN STATE AUTO SCHOOL**

A. G. ZELLER, Pres.  
668 Auto Bldg., Woodward Ave.  
DETROIT, MICH., U. S. A.

**KING MOTOR CAR COMPANY**

DETROIT, U.S.A.

REPLYING TO A RECENT LETTER ADDRESSED TO MR. ARTEMAS WARD MAKING INQUIRY AS TO THE REPUTATION OF THE MICHIGAN STATE AUTO SCHOOL, WILL SAY THAT AS FAR AS I KNOW ALL DETROIT AUTOMOBILE MANUFACTURERS ENDORSE THE WORK THEY ARE DOING. IT IS MANAGED VERY EFFICIENTLY AND THEY HAVE BEEN TURNING OUT SOME VERY GOOD MEN FOR THE AUTOMOBILE INDUSTRY AND CANNOT SEE ANY REASON WHY YOU SHOULD HESITATE ABOUT TAKING A COURSE WITH THIS INSTITUTION.

Yours very truly,  
KING MOTOR CAR COMPANY.

**DETROIT**  
THE HEART OF THE AUTO INDUSTRY

THE AUTOMOBILE CENTER OF THE U.S.A.

## County Agents Here's Your Chance

The 1919 Models are **BIG VALUES**

# THE BUSH

**5-Pass. 4-cyl. Touring**  
**5-Pass. 6-cyl. Touring**

For nearly five years the Bush Car has been doing heavy duty all over this country. It's sold through County Agents only—we do not have distributors.

**County Agent's Proposition is liberal beyond your expectations.**

Get all the information quick. Write at once to J. H. Bush, Pres., Dept. H-15  
**BUSH MOTOR CO.**  
© Bush Temple, Chicago

4-cyl. Lycoming Motor—37 H.P.  
6-cyl. Red Seal Motor—40 H.P.

The Bush Car for 1919, both in the Light Four and Light Six, are unequalled in value anywhere this year. Think of a car with all the modern refinements which includes in its equipment the Boyce Motor Meter at prices modest in the extreme. The Bush method of marketing the Bush Car not only gives the County Agent a better profit than he usually gets but the Bush method of sales gives the user the benefit of high quality at low price. We list below some of the big things—the high grade features—that go into the Bush Car for 1919. These are the things that make a real car.

<ul style="list-style-type: none"> <li>Full Floating Rear Axle</li> <li>Two Universal Joint Drive</li> <li>16-inch Wheel Base</li> <li>Copper Radiator</li> <li>Electric Lighting and Starting (2 unit)</li> <li>Willard Batteries</li> <li>Timken Bearings Throughout</li> </ul>	<ul style="list-style-type: none"> <li>37 H.P. 4-cyl. Lycoming Motor</li> <li>40 H.P. 6-cyl. Red Seal Continents</li> <li>Refinement in Body Finish</li> <li>Plate Glass Rear Windows in Top</li> <li>Deep French Pleat Upholstering</li> <li>Extra Leg Room in Body</li> <li>Light Weight—2450 lbs.</li> </ul>
---	---

The Bush Car is not a twelve months or less proposition. It's not ready for the scrap heap after a year's use. The best material obtainable—the very highest quality construction coupled with what every one knows to be good equipment, such as Willard Batteries and Timken Bearings, insures a long life to the Bush Car even under unusually hard service.

There is a Money Back Guarantee Goes with Every Bush Automobile to show you we mean just what we say about the quality of this car and to prove to you that your confidence in us will not be abused. Our Guarantee is in writing.

Whatever is worth doing,  
Is worth doing well

## Use Bunnell Parts

Sold by all Dealers

Catalog No. 40 E now ready

**J. H. BUNNELL & CO.**  
32 Park Place New York City, N. Y.

9016

9014

9020

9021

## What 15c will bring You from the Nation's Capital

Washington, the home of the Pathfinder, is the nerve center of civilization; history is being made at this world capital. The Pathfinder's illustrated weekly review gives you a clear, impartial and correct diagnosis of public affairs during these strenuous, epoch-making days.

The little matter of 15c in stamps or coin will bring you the Pathfinder 13 weeks on trial. The Pathfinder is an illustrated weekly, published at the Nation's center, for the Nation; a paper that prints all the news of the world and tells the truth and only the truth; now in its 26th year. This paper fills the bill without emptying the purse; it costs but \$1 a year. If you want to keep posted on what is going on in the world, at the least expense of time or money, this is your means. If you want a paper in your home which is sincere, reliable, entertaining, wholesome, the Pathfinder is yours. If you would appreciate a paper which puts everything clearly, fairly, briefly—here it is. Send 15c to show that you might like such a paper, and we will send the Pathfinder on probation 13 weeks. The 15c does not repay us, but we are glad to invest in new friends. **The Pathfinder, Box 57c, Washington, D.C.**

You benefit by mentioning the "Electrical Experimenter" when writing to advertisers.

**Not Toys But Real Apparatus**

the same as used by all operating companies. You had better send us your order immediately to insure prompt delivery, as this equipment will not last long at these prices.

- 110 Volt Hand Generators.... 3 bars, each \$3.00
- 4 bars, each 4.00
- 5 or 6 bars, each 5.00
- Telephone transmitters with arms, each... .75
- Good ringers complete with bells, each.... .50
- Telephone receivers, each..... .75
- Condensers, 1/2 to 2 M.F., each..... .50
- Induction coils, each..... .50
- Relays, each..... 1.50
- Repeating coils, each..... 2.00
- Real complete C.B. wall type telephone... 4.50
- Skinderviken Transmitter Button..... 1.00

Please send money-order or cash with your order  
**ELECTRICAL SPECIALTY COMPANY**  
 Dept. E, 48-50 So. Front St., Columbus, Ohio  
 Dept. E, 128 So. 11th St., Philadelphia, Pa.

**"The Livest Catalog in America"**

Our big, new electrical cyclopedia No. 20 is waiting for you. Positively the most complete Wireless and electrical catalog in print today. 180 Big Pages, 500 illustrations, 300 instruments and apparatus, etc. Big "Treatise on Wireless Telegraphy," 20 FREE coupons for our 160-page FREE Wireless

Course in 20 lessons, FREE Cyclopedic No. 20 measures 7x5 1/4". Weight 1/2 lb. Beautiful stiff covers.

Send 6 cents in stamps or coin for which we will send our latest Cyclopedia Catalog No. 20 as described.

**ELECTRO IMPORTING COMPANY**  
 231 Fulton St., New York City

**110 V. TRANSFORMERS** 6-12-18 Volts Output

Consumes so little current will not move ordinary meter. **\$1.50** Postpaid  
 Ideal for experimental work—NO MOVING parts. (Cannot get out of order; with cord and plug \$2.00. Transformer No. 12—Heavier Output, 6, 12, 18 Volts—\$2.50 with cord and plug. Order from this ad.  
**NATIONAL TRANSFORMER CO.**  
 Dept. 17, 3124 North California Ave., Chicago, Ill.

**WIRELESS CONTROL IN THE PEACE TREATY.**

Wireless: During a period of three months after the peace German high power wireless stations at Nauen, Hanover, and Berlin will not be permitted to send any messages except for commercial purposes, and under supervision of the allied and associated Governments, nor may any more be constructed.

Cables: Germany renounces all title to specified cables, the value of such as were privately owned being credited to her against reparation indebtedness.

Germany will be allowed to repair German submarine cables which have been cut, but are not being utilized by the allied powers, and also portions of cables which, after having been cut, have been removed, or are at any rate not being utilized by anyone of the allied and associated powers. In such cases the cables, or portions of cables, removed or utilized remain the property of the allied and associated powers, and accordingly fourteen cables, or parts of cables, are specified which will not be restored to Germany.

Air: The armed forces of Germany must not include any military or naval air forces except for not over 100 unarmed seaplanes to be retained till Oct. 1 to search for submarine mines. No dirigible shall be kept. The entire air personnel is to be demobilized within two months, except for 1,000 officers and men retained till October. No aviation grounds or dirigible sheds are to be allowed within 150 kilometers of the Rhine, or the eastern or southern frontiers, existing installations within these limits to be destroyed. The manufacture of aircraft and parts of aircraft is forbidden for six months. All military and naval aeronautical material under a most exhaustive definition must be surrendered within three months, except for the 100 seaplanes already specified.

**POCKET WIRELESS SOON, PREDICTS MARCONI OFFICIAL.**

Godfrey Issacs says the English Marconi company, of which he is managing director, expects to have a commercial service of wireless telephones in operation in New York and London early next year.

The company hopes to make arrangements with New York and London telephone companies so that eventually the British and American wireless 'phone subscribers will be able to sit at their desks and "Hello, London" or "Hello, New York."

Isaacs foresees the day, not far distant, when pocket wireless telephones will be in wide use. A business man's secretary, walking along the street, Isaacs says, will hear a bell ring in his pocket, will put a receiver to his ear and hear "his master's voice" give him instructions, probably from an airplane hundreds of miles away.

The Daily Mail says that the British government probably will compel all commercial airplanes and airships to carry wireless telephone or telegraph equipment. Larger machines of both types may be compelled to carry both.

**BULLARD ONCE AGAIN RADIO DIRECTOR.**

Navy orders were issued April 9th, re-appointing Rear Admiral William H. G. Bullard as Director of Naval Communications, a position he held at the time the United States entered the world war, but from which he was detached for service overseas.

Rear Admiral Bullard is an honorary member in the Radio League of America, as our readers will remember.

**AMAZING AUDION DETECTOR**

**VALUES—\$9.50 \$11.75 \$18.85 \$22.00**

Remarkably efficient and handsome audion control panels within the price limit of EVERY AMATEUR, BUILT AND DESIGNED FOR THE AUDION, AS ONLY THE MAKERS OF THE AUDION CAN BUILD IT. IN THE PAST, INSTRUMENTS OF THIS CALIBRE HAVE NEVER BEEN OFFERED AT TWICE THESE PRICES.

GENERAL SPECIFICATIONS, ALL MODELS: Beautifully engraved and grained genuine bakelite panels; 4 prong heavy nickeled tube receptacles; smooth running, positive acting, adjustable rheostats; impregnated efficient mica stopping condensers; adjustable or fixed grid leaks with polished nickel covers; bakelite covered binding posts with new slotted positive connecting feature; positive segmentally connected nickel plated switches; 40 volt B battery of two 20 volt type units cast en block with operating life of 6 to 12 months—a remarkable advance in B batteries; handsome quartered oak cabinets, round corners, standard de Forest "Early English" finish; perfect workmanship and expensive design throughout.

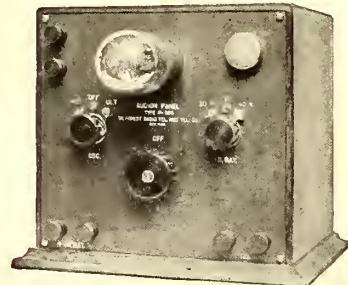

TYPE P500—\$22.00



TYPE P401—\$11.75

Type P-400 Audion Panel—Consists of tube receptacle, grid leak and condenser, rheostat and binding post for connection to tuner, A and B batteries on bakelite panel 7 1/2" x 7 1/2" without cabinet and B batteries..... \$9.50  
 Type P-401 Audion Panel—Same as above with cabinet, \$11.75  
 Type P-402 Audion Panel—Larger panel with 40 volt B battery in cabinet..... \$18.85  
 Type P-500 Audion—Ultraudion Panel—Type P-402, Panel with two switches for audion-ultraudion connection and either 20 or 40 volt B battery in cabinet..... \$22.00

NOTE: All de Forest audion apparatus is sold without the tubes. Audion detector oscillator or amplifier tubes, \$7.00 each additional. Catalog sent on receipt of 10c in stamps to cover postage.

**DE FOREST RADIO TEL. & TEL. CO., 1415 Sedgwick Avenue, New York City**

You benefit by mentioning the "Electrical Experimenter" when writing to advertisers.

# Heat Engines By John J. Furia

(Continued from page 320)

utes at the beginning of the day and the steam pressure is controlled automatically. Kerosene is used as the fuel which is considerably less expensive than gasoline. No shifting of gears is necessary. A turn of the throttle will give enough steam to climb any hill or to slow down to a crawl. No fussing with carburetor or ignition systems. The spent steam is condensed and led back to the boiler so that a much smaller water supply tank is used. No cooling system is necessary. A pilot light using up a negligible amount of fuel keeps enough steam pressure all day, so that one can make an immediate start. All gages operating on the fuel and steam are automatic, thus eliminating all danger. Why is it then that we do not see many of these steam cars. Two reasons—it takes a long time to educate the public—steam cars cannot be kept in the present public garages, since the open flame of the pilot light is liable to ignite the gasoline vapors present in all garages and cause fire. No doubt the steam car has a great future (provided the oil companies do not boost the price of kerosene).

## The Hot Air Engine.

The hot air engine uses neither gasoline nor steam but plain ordinary air and that is pretty cheap. Let us examine the principles of its operation. Figure 3 shows an ideal engine consisting of a cylinder, piston, connecting rod, and fly-wheel. Heat is applied to the lower end of the cylinder as in A, the cylinder being composed of non-conducting material, except the bottom which is a good conductor. The heat will cause the air in the cylinder under the piston to expand great pressure and eventually to expand, forcing the piston upward. If the heat is suddenly removed and replaced by cold, when the piston reaches the top of its upward motion, then the air under the piston will contract and the piston will move downward, due to two causes: (1) the suction under the piston and (2) the pressure from above the piston, since the air above the piston was compressed when the piston moved up. This then would constitute the complete cycle and if repeated indefinitely our engine would continue to run. Let us look at Fig. 2 again. If the inlet were connected to a tank of air and the air heated, the air would expand, enter the cylinder and move the piston; if then new air were admitted and heated, this on expanding and entering the cylinder from the other side, because of the action of the slide valve, would cause the piston to move back again, giving us a motion similar to that of the steam engine.

The ideal hot air engine described above and this steam engine operated as a hot air engine, illustrate the two types of hot air engines in existence. The first typifies the closed cycle engine which operates continuously with the same mass of air (a

fresh charge being occasionally admitted to compensate for leakage). The second typifies the open cycle in which a new charge of air is admitted and exhausted at each stroke. The closed cycle engine is analogous to the new type of steam engine employing a condenser for the spent steam, while the open cycle is analogous to the old type non-condensing steam engine. Therefore it is readily seen that the closed cycle engine is more efficient than the open cycle, none of the fuel being wasted on the exhausted air. In all types of hot air engines, the power is secured by the pressure of the air produced by heat transferred by a separating metal wall. The air is admitted to the cylinder at a high temperature and pressure, it is allowed to do mechanical work on the piston as a result of which the pressure and temperature fall off.

There are two heating systems employed in hot air engines—the regenerative and the non-regenerative. A regenerative system is one which uses a device for absorbing the heat from the air as it passes in one direction and supplying it again on passing in the opposite direction. A non-regenerative system does not employ such a device. One of the best of the hot air engines is the Stirling engine which has been actually used commercially, tho without much success. It is of the closed cycle type working with a constant volume of air, and requires about 2 lbs. of coal per hour horsepower (i. e., more efficient than the steam engine). Its chief objection was that the heating plate, which takes the place of the boiler of the steam engine, burned out rapidly. Figure 4 is a sketch of the essential parts of the Stirling engine. C is the brick foundation of the engine, B the fire box, A the draft, H is the working cylinder, E the displacer acting in opposition to the working piston, D the air-box, F metal gauze, and G coils of pipe thru which cold water flows. The total volume of the air contained in the air-box, the working cylinder and the connecting pipe remains constant. The lower end of D is a plate pierced with holes, thru which the air flows when the displacer E moves downward. The upper part of D, thru which the coils G pass, is known as the refrigerator. The fire heats the air in the air box D. As the engine is started the displacer E moves downward, forcing the hot air thru the regenerator gauze F. Heat is absorbed by F and the air cooled. It is further cooled by the refrigerating pipes G. The pressure in H is therefore diminished and the piston moves downward. This forces the air back thru F into D, gaining heat from F and forcing the displacer upward. The heat gained from F, in addition to that gained from the fire, causes the air to expand, raising the piston in H. This completes the cycle. The inertia of the fly-wheel causes the fly-wheel to push down the displacer E and the cycle is repeated.

# Steinmetz's Own Shorthand

(Continued from page 314)

"It is my opinion that every college student should learn some good accurate system of shorthand, so that he can follow the lectures and make notes without effort."

The system of shorthand that Dr. Steinmetz has evolved as the best adapted for writing on electrical subjects is based upon the "Arends" system of stenography as taught in Europe. Words are written as they are pronounced without regard to their spelling; that is, they are written phonetically. The word "height" is written h-i-t, but in this case the long "I" is used.

One of the most interesting features in connection with this system of shorthand is the fact that French and even Latin and

Greek words and names can be perfectly written and read without the slightest hesitation.

With his own hand, Dr. Steinmetz has written down the rules, or it might be said, the "code" of his system, so as to assist those persons with whom he is working in a translation of his reports and various articles.

With a view of affording every reader of this article, especially those attending college, some knowledge of Dr. Steinmetz's system, a reproduction is given of the alphabet, written out by the famous electrical wizard himself.

## Become An Electrical Engineer



Bachelor of Science Degree in 3 Years

Study Here. Receive a good training. Our degree equals the University but is given for three years of intensive work twelve months of the year.

There is unlimited demand for well-trained ELECTRICAL ENGINEERS. A great industry is using them in vast numbers here and abroad.

Our forty professors are experts. Men of standing in the profession. They will guide you surely and carefully to certain SUCCESS.

Shop practice, laboratory, drafting room and recitation room prepare you fully to enter the Electrical Engineering profession.

Full provision for making up deficient high school credits.

"Earn While You Learn" if you wish. Clip the coupon. Do it TODAY.

School of Engineering of Milwaukee  
College of Electrical Engineering  
103-373 Broadway Milwaukee, Wis.

CLIP HERE

School of Engineering of Milwaukee  
Milwaukee, Wis.

Gentlemen:—Without obligation, send me catalog, Photo-Story book and particulars concerning your 3-Year Electrical Engineering Course with B.S. Degree.

Name .....

Address .....

City ..... State .....

Age ..... Education .....

SCHOOL OF ENGINEERING OF MILWAUKEE  
103-373 Broadway Milwaukee, Wis.

## \$427 BUYS "PRESTO-UP" Bolt-Together House



### The Wonder Buildings of the Age GUARANTEED

Purchased after most rigid inspection by some of the largest Steel, Coal and Industrial Corporations in the United States. You are not experimenting. "PRESTO-UP" Bolt-Together Houses are patented, manufactured exclusively by us and sold at money saving prices. Seven different types of walls to choose from. Wind and weather proof. Invisible joints inside and out. Extremely simple to bolt together. Wonderful strength. Better construction than regularly constructed houses. Exceptionally good lumber. Cement coated nails. Fifteen Year Guaranteed Slate Coated Roofing. Well painted, and best of all, neat in appearance and so simple to bolt together that it is a pleasure to do the work.

Send for CATALOG FX-412 TODAY  
Houses—Garages—Barns—Out Buildings, etc. Also Harris Fresh Air Canvas Houses  
HARRIS BROTHERS CO., Chicago

## ARTIST

Earn \$25 to \$100 per week. Cartooning, Illustrating, Designing successfully taught by mail through new instruction method. Entire outfit free to new students. Write today for beautiful new book "HOW TO BECOME AN ARTIST" and special free offer. Washington School of Art, Inc. 1430 H St., N.W. Washington, D. C.



**RADIO  
AMATEUR  
NEWS**  
REG. U.S. PAT. OFF.

**15 Cents  
AUGUST  
1919**  
OVER 100  
ILLUSTRATIONS  
Edited by  
*H. Gernsback*



**“THE 100% WIRELESS MAGAZINE”**

**What “Radio Amateur News” Is:**

It is destined to become the greatest Radio magazine in the world. Indeed its first issue, the July number, had a circulation of 15,000 copies. It was necessary to print a second edition of 10,000 copies—so great was the demand. The August issue, of which 20,000 copies are printed, with its 48 pages and cover in two colors, its 125 wonderful illustrations, make it the *greatest and biggest Radio Magazine in print today.*

RADIO AMATEUR NEWS is the only INDEPENDENT monthly wireless magazine in existence. It caters to no commercial interests—it has no boss save its readers. It is “different”—it has the latest radio news. It is a scientific magazine but it caters largely to the RADIO AMATEUR—it is by and for the Amateur. It is published by the publishers of the ELECTRICAL EXPERIMENTER, but there will be no duplication of articles in the two magazines. Both are entirely different—but both together will give you ALL the radio news of all the world. Whether you are a Professor or an Amateur, get a sample copy or order it from your News-dealer today.

Page size is the same as Electrical Experimenter

For Sale at All News-stands

**\$100.00 RADIO CONTEST**

“An Ideal Sending Outfit”

is announced in the Aug. issue of RADIO AMATEUR NEWS.

is the subject of the contest. \$100.00 in cash prizes for the best manuscripts submitted.

**JUDGES OF THE CONTEST ARE:**

- |  |   |
|--|---|
| Dr. Lee de Forest, Inventor of the Audion                  | Samuel D. Cohen, Amateur Radio expert                                 |
| Dr. Greenleaf W. Pickard, Inventor of the Crystal Detector | H. W. Secor, Assoc. I.R.E., Associate Editor, Electrical Experimenter |
| Dr. Louis Cohen, Ph.D., Radio expert and inventor          | H. Gernsback, Editor, Electrical Experimenter & Radio Amateur News    |
| Fritz Lowenstein, Radio expert                             |   |

**48 Pages 125 Illust's**

**SPECIAL OFFER**

By request we will accept till August 25th the following special charter subscription rates: 1 year \$1.25; 2 years \$2.20; 3 years \$3.00; 5 years \$4.75. (Add 50c a year for Canada & Foreign.) Cut along dotted line and write your name and address on white margin below. Send along with check or money order. We will start subscription with July (Opening issue) or August issue.

**15c  
The Copy  
\$1.50  
A Year]**

Canada and Foreign  
**\$2.00 A Year**

**SEND  
15c FOR  
SAMPLE  
COPY  
TODAY**

**Contents of August Issue:**

- Radio-Telephoning from your Auto. By A. H. Grebe
- A 15,000 cycle radio frequency alternator for radio-telephone work. By Homer Vanderbilt.
- Ingenious Radio stunts used by Manufacturers. By F. H. Sweet.
- Construction of an Audion control panel. By E. T. Jones
- High Spark Frequency in the amateur field. By Roland H. Lamb.
- Radio activities “over there.” By Corporal A. E. Chute.
- Multiple Conical Loose Coupler. By John G. Merne.
- Loop antenna and direction finders for amateur use. By David S. Brown.
- An Exceptional Radio Receiver. By Eugene Dynner.
- Low potential radio frequency arc. By Charles W. Noller.
- Is the antenna doomed? By E. T. Jones.
- Questions and answers.
- Developments in wireless Telephony. By Dr. F. B. Jewett.
- An efficient hot wire meter. By L. M. Lafave.
- New “B” Battery for vacuum tubes. 100 Radio Prize Contest. Radio Digest.
- Latest Radio Patents. Junior Section.

**EXPERIMENTER PUB. CO., 231 Fulton St., N. Y. C.**

# X-Ray Experiments

(Continued from page 319)

zation. This statement is not altogether accurate. Barkla has observed that when a pencil of rays enter an object which scatters them, the scattering is more marked in a direction parallel to the stream of cathode particles. The greatest objection has been advanced by Bragg. He reasons as follows: If a stream of cathode rays striking a target set up some sort of rays which it has been found instigate new cathode particles when they enter some body, it is reasonable to suppose that these rays merely serve as a means of transferring energy from one electron to another. He suggested that they might consist of neutral doublets made up of a *positive* and *negative* charge, which is broken up when the rays strike some object. This theory might explain why only a few and not all of the molecules in a gas are ionized, for as the doublet moved thru the gas only a few of the molecules would come into contact with it and be charged. Later, however, this theory was disproved.

The most important property of the rays is their power of making objects transparent and affecting a photographic plate. Procure about a 5 x 7 plate and carefully wrap it in black paper. Care should be taken that the *film side is placed upward* as the *glass cuts off a good deal of the radiations*. The bulb should be placed about six inches above the plate and the objects to be photographed laid directly upon it. The arrangement is clearly shown in one of the accompanying illustrations, Fig. 4. The bulb may be procured from several leading supply houses. The one shown is not provided with a third electrode. The coil is connected direct to the bulb, no condenser or spark gap being used. When the connections are properly made the *lower half of the bulb will glow a bright green*. If the polarity of the current is wrong, only a *ring of light* will show. The polarity may be corrected by a pole-changer in the primary circuit of the coil.

Radiographs, while once a comparative novelty, are now fairly common—especially since the war. Many interesting skiagrams have been returned from the front showing the invaluable work X-rays have accomplished. The Customs House has made a novel use of their penetrating power. In order to see if anything such as bombs were concealed in bales of cotton or other apparently innocent objects, the bale would be placed before a powerful X-ray bulb and a man standing on the other side would examine it with a fluoroscope. Of course a small bulb operating on about a 2-inch coil does not possess very great pen-

etrating power, but the reader should experience no difficulty in seeing thru the thick part of the arm. An X-ray picture taken with such apparatus is reproduced herewith. See figure. As was said above, the amount of penetration is proportional to the density, decreasing as the density increases. Use has been made of this fact in determining the atomic weight of unknown elements by measuring their transparency to X-rays. Benoist determined the atomic weight of indium by this process.

Another important property, and the one which gives us the readiest means of measuring their intensity, is their *ionizing* power. This may be easily illustrated by hanging a grounded plate above an electro-scope of the ordinary flask type. The arrangement is shown in Fig. 2. *If the intervening air is exposed to x-rays the electro-scope will be discharged.*

Another interesting experiment is to take an ordinary hydrometer and remove the float. Fill the bulb and about a third of the tube with water. Put your finger over the end to prevent the air from escaping and squeeze the bulb. It will be noticed that a cloud is formed. This is due to the moisture condensing around the dust particles in the air. After this has been repeated several times all the dust particles will be drawn down into the water and *no cloud will form*. Now, if when this condition has been reached, the apparatus is exposed to X-rays, a dense cloud will be formed. *This is caused by the moisture condensing around the ions, due to the X-rays.* This phenomenon forms the basis of the rain-making apparatus described in the February, 1919, issue of this journal as developed and patented by the Australian inventor and engineer, Balsillie.

Röntgen rays also possess the remarkable property of exciting *secondary rays* in substances which they strike. As this is a rather complicated phenomenon and as there are no experiments in connection with it which the average reader may repeat, it will not be discussed here, except to mention that the secondary rays resemble the original cathode rays, only they travel at a slightly slower speed, which is dependent on the hardness of the primary rays. Recently X-rays have found a new application in the analysis of *crystal structure*. It was found that X-rays might be deflected by the cleavage surface of crystals. Using X-rays, it has not only been possible to determine the exact shapes of crystals, but also to actually show the arrangement of the atoms as well as the distance between them.

## “Christmas Bullet” Plane to Fly the Atlantic

Another attempt to cross the Atlantic was announced recently by the Cantilever Aero Company, makers of the “Christmas Bullet” airplane.

In the company's plant at Amityville, L. I., assembling has begun on a huge airplane which is expected to start from New York and land within thirty-five hours at Queens-town, London or Brest.

It will have a wing measurement from tip to tip of 180 feet and will be equipt with four 800-horse power motors, giving a speed of 115 miles per hour. These motors are connected in such a way that should one be put out of commission the operation of the machine will not be affected. The engineer will also be able, if necessary, to overhaul any of the motors, clean the spark plugs and make adjustments while the plane is in flight.

The body of the machine will be 14 feet

in diameter, insuring comfort and proper housing for the crew, who will not at any time be exposed to the elements.

There will be two three-bladed propellers in front of the machine. Each will be 21 feet in diameter, capable of making 600 revolutions per minute. The weight of the machine with full flying rig is 30 tons. It will be controlled thruout by electricity.

Two pilots will be seated in separate compartments, working alternately, each taking the machine for a certain length of time.

The construction and design of this airplane has been under consideration by the Cantilever Aero. experts for six years and every detail has been tested and approved by the designer and inventor, Dr. William Whitney Christmas, it is stated by the builders.



## HIGH SCHOOL COURSE IN TWO YEARS

**YOU ARE BADLY HANDICAPPED** if you lack High School training. You cannot attain business or social prominence. You are barred from a successful business career, from the leading professions, from well-paid civil service jobs, from teaching and college entrance. In fact, employers of practically all worth-while positions demand High School training. You can't hope to succeed in the face of this handicap. But you can remove it. Let the American School help you.

**FIT YOURSELF FOR A BIG FUTURE** This Course, which has been prepared by some of America's leading professors, will broaden your mind, and make you keen, alert and capable. It is complete, simplified and up-to-date. It covers all subjects given in a resident school and meets all requirements of a High School training. From the first lesson to the last you are carefully examined and coached.

### USE SPARE TIME ONLY

Most people *idle* away fifty hours a week. Probably you do. Use only one-fifth of your wasted hours for study and you can remove your present handicap within *two years*. You will enjoy the lessons and the knowledge you will gain will well repay the time spent in study.

### TAKE 10 LESSONS FREE

So that you may see for yourself how thorough and complete our training is. We invite you to take *ten lessons* in the High School Course—or any Course of specialized training in the Coupon below—before deciding whether you wish to continue. If you are not then satisfied you are not out one cent. *We absolutely guarantee satisfaction.* On that basis you owe it to yourself to make this test. Check and mail the coupon NOW for full particulars and Free Bulletin.

**AMERICAN SCHOOL OF CORRESPONDENCE**  
Dept. C H 26 Chicago, Illinois



TRAINING—THE KEY TO SUCCESS

Please explain how I can qualify for the position marked X



- |                                |                                 |
|--------------------------------|---------------------------------|
| .....High School Graduate      | .....Lawyer                     |
| .....Electrical Engineer       | .....Business Manager           |
| .....Elec. Light & Power Supt. | .....Certified Pub. Accountant  |
| .....Hydroelectric Engineer    | .....Accountant and Auditor     |
| .....Telephone Engineer        | .....Bookkeeper                 |
| .....Telegraph Engineer        | .....Stenographer               |
| .....Wireless Operator         | .....Fire Insurance Expert      |
| .....Architect                 | .....Sanitary Engineer          |
| .....Building Contractor       | .....Master Plumber             |
| .....Civil Engineer            | .....Heating and Vent. Engineer |
| .....Structural Engineer       | .....Automobile Engineer        |
| .....Mechanical Engineer       | .....Automobile Repairman       |
| .....Shop Superintendent       | .....Airplane Mechanic          |
| .....Steam Engineer            | .....General Education Course   |
| .....Draftsman and Designer    | .....Common School Branches     |

Name.....

Address.....

You benefit by mentioning the "Electrical Experimenter" when writing to advertisers.

# 4 Famous Books EACH ONE

## A BIG SUCCESS!

THE BOOKS YOU MUST HAVE



### Wireless Course in 20 Lessons

By S. Gernsback, A. Lescarboursa and H. W. Secor, E. E.

A course that tells you everything you can possibly want to know about "Wireless" starting off in lesson No. 1 by explaining the Principles of Electricity. The second and third lessons are devoted to magnetism, motors, generators and wiring. And then, by simple, easy stages, this wonderful Course takes you into "Wireless". The mysteries of "Wireless" are unfolded to you by the use of such simple language so skillfully used that of necessity you must understand every word. The subject is not treated superficially, however, for there is a whole lesson devoted to the Theory and Mathematics of this epoch marking subject. To lend charm to the Course, the last lesson (No. 20) is devoted to a history of Wireless and the men who developed it.

Size of book is 7 x 10 1/4 in. 160 pages, 350 illustrations, 30 tables. Postpaid

Flexible cloth cover..... per copy \$ 50  
Stiff cloth cover..... per copy 1.00

### Experimental Electricity Course in 20 Lessons

By S. Gernsback and H. W. Secor, E. E.

A Course of the theory and practice of Electricity for the Experimenters. This is undoubtedly one of the most complete and comprehensive treatises of this special subject ever published. The book is written by the same authors as the famous "Wireless Course in 20 Lessons".

Every phase of experimental electricity is treated comprehensively in plain English. It is a book not only for the beginner but for every experimenter and student of Electricity. New Experiments are described and explained and nearly every application of Electricity in modern life is given in simple language.

The book contains 160 pages and more than 400 illustrations. Flexible cloth cover..... per copy \$ 50  
Stiff cloth cover..... per copy 1.00

### No. 1. How to Make Wireless Sending Apparatus No. 2. How to Make Wireless Receiving Apparatus

By 20 Radio Experts. Two Remarkable Books

Book No. 1 contains 100 pages, size 7 x 5 in. and 88 illustrations, paper bound.

Book No. 2 contains 100 pages, size 7 x 5 in. and 90 illustrations, paper bound.

These two books have been written and published entirely for the wireless enthusiast who wants to make his own radio apparatus. They contain more information on how to make it than any other books we know of. Only strictly modern radio apparatus are described in these books and the illustrations and descriptions are so clear and simple that no trouble will be experienced in making the instruments.

Book No. 1—How to make Wireless Sending Apparatus.....25c

Book No. 2—How to make Wireless Receiving Apparatus.....25c

THE EXPERIMENTER PUBL. CO. Book Dept., 233 Fulton St., New York

## Thunderstorm Electricity

By Rogers D. Rusk, M. A.

(Continued from page 307)

ly called *thunder-caps*, or *thunder-heads*, and often the clouds will grow so thickly together that to an observer on the earth they appear as a huge dark rolling-cloud extending across the sky, the tops being obscured except to aerial observers several thousand feet in the air. It is while such clouds as these are forming that the electrical forces are at work which build up enormous charges in a manner which will now be described.

### How Rain-Drops Form.

Experiments show that *ions* are nearly always present in the air. Sometimes these are *charged dust particles*, sometimes they are *charged atoms of the gases* of which the air is composed. Experiment further shows that rain-drops condense about *negative ions* much more quickly and easily than about *positive ions*. The earth itself is a very highly charged *negative* body, its charge being estimated at 600,000,000 volts, but the rain that falls is *positively* charged almost as often as it is *negatively*, which may be accounted for by the fact that the *positive* drops, forming more slowly, are larger and heavier and are not retarded so much at times by upward currents of air. It is these upward currents of air in the clouds themselves that produce the charges within the clouds. The *negatively* charged drops being smaller and lighter are carried to the top of the cloud, very often forming a heavy *negative* charge. In a similar manner the heavier *positively* charged drops will fall to the bottom of the cloud forming a strong *positive* charge. In addition the wind may break up the drops into smaller droplets and when this is the case, it is found that the smaller droplets are nearly always *negatively* charged. By these processes of division and formation of charged drops and their separation in the cloud, enormous charges are generated, and the thunder-cloud is seen to be really a huge electrical generator as shown in Fig. 3. And when the charges become sufficiently great the lightning discharge results. This may take place from top to base of cloud which is usually a distance of about a mile, or it frequently takes place between the base of the cloud and the earth which is often a much shorter distance. From cloud to cloud the lightning may flash a distance of *ten or twenty miles*, and at such a time the discharge exercises a powerful *inductive* effect on all nearby clouds, which may cause flashes to occur in rapid succession.

When a *negatively* charged cloud approaches the earth, the *inductive* effect of the earth's charge may cause it to suddenly reverse its charge to *positive*, and the potential become so great that a discharge to the earth follows. Sixty per cent of these discharges to the earth carry *negative* electricity to the earth, while the remaining forty per cent carry *positive* electricity. This shows that sixty per cent of the discharges were from clouds which had built up a higher *negative* charge than the earth itself.

The phenomena of thunder-storm electricity cannot be said to be the product of any one particular cause, or of always exactly the same combination of causes. One thing, however, is certain. All of the above mentioned factors act together and atmospheric conditions are so variable and in such a continual state of change that a definite formula for their operation would be beyond the limits of possibility. The theories of thirty years ago which tried to explain lightning by means of atmospheric friction and other such causes have sunk into oblivion.

## CARNOTITE

(Radium Mineral.) The American Pitchblende found in Colorado, from which *Radium* is extracted.

A generous piece, enough to conduct experiments, such as affecting photographic plates thru opaque material (similar to X-Ray pictures), first made by Sir W. Crookes and Mme. Curie, is furnished in neat, wooden box.

### URANIUM ORE (Radio-Active)

Containing about 35% of pure Uranium; also Radium and Vanadium. One of the most rare and interesting minerals. Twenty milligrams are furnished in glass vial protected by lead cover.

One box of *Carnotite* and one vial of *Uranium Ore* as described above 50c sent prepaid.

FORMULAS  
Luminous Paint—Silver Plating Powder—Liquid Court  
Plaster—Soap Bubble Liquid—Straw Hat Bleach—  
Collapsible Tube Tooth Paste—Resilvering Mirror

Liquid—Polish for Tan Shoes—Dressing for Tan  
Shoes—Paint to make Oil Cloth.  
These Ten Recipes in sealed envelope for 50c.  
Sent prepaid.

SIDNEY SPECIALTY CO., 233 Fulton Street New York City

You benefit by mentioning the "Electrical Experimenter" when writing to advertisers.



# Experiments in Physics PERPETUAL MOTION

By John J. Furia

(Continued from page 315)

See Fig. 6. In Electrostatics we learn that the sharper the point of a conductor, the greater the density of the charge present. Because of the great density, the charge leaves the conductor at the sharp points. If by some means we continually charge a conductor having a shape like that in Fig. 1, then the reaction will cause it to move as indicated by the arrows. The source of the charging can be a static machine (Whimshurst or other type). Why not belt the conductor so as to run our static machine; and sidetrack some of the electricity from the machine to be used for other purposes? One has but to look at the small weight of the conductor and the slow speed

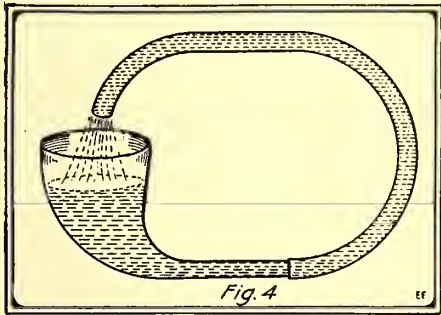

"Perpetual Motion" de Luxe. The Atmospheric Pressure on the Water in the Bowl Will (Theoretically) Force the Water Up Thru the Circular Pipe and Out of Its Open End. Thus the Water Will Circulate Around and Around—Yes It Will—NOT!!!

at which it runs and compare it with the large heavy static machine and the large force required to cause it to give a spark, in order to perceive at once the folly of such an absurd scheme.

Another idea along somewhat similar lines is the following: A screw fits tightly in a cylinder at the top of which is an ordinary rotary lawn sprinkler. As the screw is turned the right way, the water rises in the cylinder. When the water reaches the level of the sprinkler, it comes out from the nozzles and the reaction causes the sprinkler to turn. Once this machine is started it should operate forever, for as it turns, water rises to the sprinkler—while as the sprinkler operates, it turns and causes water to rise in the cylinder. It takes considerable force to cause the sprinkler to ro-

tate due to the reaction; it would require still more force if the sprinkler had to in addition do the work of lifting the water up the cylinder. The reaction due to the water coming out from the level of the sprinkler with no force behind it is very small, and not ever sufficient to cause the sprinkler to budge. See Fig. 2.

Fig. 3 represents the cross-section of a cylinder containing grooved curved spokes. Marbles or lead balls rest in the grooves. It will be seen that the marbles at the left are further from the center than those at the right. Consequently because the rotational moment on the left is greater than that on the right (the marble being of the same size and weight) not only will the machine move perpetually and do work, but it will even start itself? By putting a belt around the cylinder, machinery can be driven continually, perhaps?!X! It is true that the moment on the left is greater than that on the right and therefore there is apparently a tendency to cause rotation opposite to the rotation of the hands of a clock, but if rotation is to take place the top marbles near the center vertical axis will have to be raised over the bend in the spoke, and the machine having no means of doing this, the scheme fails miserably.

The following is a good example of perpetual motion proposed by one ignorant of the simplest fundamentals of hydrostatics. If a pipe having a very large bowl is connected to a piece of tubing of small diameter, and curled in the shape shown in Fig. 4, when water is placed in the bowl, it should come out from the end of the tubing, thus filling the pipe bowl again and the passage of water from the pipe bowl out thru the stem and tubing back to the pipe again will be continuous? This will operate as long as the amount of water in the bowl is large compared with that in the stem and tubing, for then the weight in the bowl will be greater than that in the stem and tubing, and the weight in the bowl will force the water thru the stem and tubing, said early philosophers. This explanation, of course, ignores the fact that it is the pressure in the liquid that counts and not its weight, and since both ends (the bowl and the tubing) are exposed to the atmosphere, they are at atmospheric pressure and hence the liquid will stay at the same level in both.

(NEXT ARTICLE—STAGE TRICKS AND ILLUSIONS)

## Jeweled Portal Welcomes N. Y. Fighters

(Continued from page 311)

altar on the farther side, making a total width of 110 feet. The bejeweled obelisks rise to a height of eighty feet and are surrounded by great jeweled forms in the shape of sunbursts which are each twelve feet wide and twenty feet in length.

Lighting of the portal was effected by two banks of twelve 18-inch searchlights at Fifty-eighth Street and Sixty-second Street, respectively, which threw shafts both up and down town. This effect of more than a million candlepower reflected by the 31,000 jewels, defies description, and New York held its breath and watched the fairy spectacle.

Cut glass jewels, cut scientifically to imitate diamonds, rubies, emeralds and sapphires, are mounted in such a manner as to be kept in motion by the breeze. All the colors of the spectrum gleam from these jewels as the screened lights search out

the portal and the tower tops sparkle in veritable glory above.

While the Victory Arch, and the Court of Heroic Dead attracted many thousands of persons, the dazzling effect of the "Jeweled Portal" set the vast crowds astirring, backward and forward in order to obtain a better or different view of the wonderful illumination.

The "Jeweled Portal" cost \$40,000 to erect, and after being lighted for the first time was acclaimed the greatest thing New York had ever seen.

Architecturally, the portal is an achievement and an innovation praised without stint by the architects of New York, and reflecting great credit upon Mr. Ryan and Captain Gosling, in whose minds the entire scheme was born.—Photo Courtesy General Electric Co.



## Be a Doctor of Chiropractic

Build a successful career in this great profession—Chiropractic, the advanced science of treating disease through spinal adjustment. The demand for Chiropractors is constantly increasing. In larger numbers than ever before intelligent, thinking people are becoming convinced that it is the common sense and really scientific way to relieve pain and disease.

Learn At Home Instruction under the personal direction of a faculty of competent, practical Chiropractors. You can master this good paying profession and graduate with the degree of Doctor of Chiropractic holding your present position. No special preliminary study and no more than a common school education are required. The cost is small—terms easy.

**\$3000 to \$5000 a Year**

The success of many Chiropractors has come so quickly as to be almost startling. Incomes of from \$3000 to \$5000 are not rare—some, upwards of \$10,000 a year. Dr. M. D. Moore, of Kentucky reports \$9000 a year; Dr. L. H. Roche, New Jersey, \$5000; Dr. Hanna, of Florida, over \$5000. You will receive the same kind of instruction which these Chiropractors received. Your prospects will be as bright as theirs. There is no reason why you should not do as well or better.

**22 FREE Charts** Lithographed and printed in colors. Actual value, \$31.50. On this offer you get them all free. Send coupon for facts about free offer—also 72-page Free Book which tells all about Chiropractic and its wonderful possibilities. This is your big opportunity to enter a dignified profession, be your own boss, be occupied in pleasant, profitable work and become independent. Mail coupon today.

### AMERICAN UNIVERSITY

Manierre Bldg., Dept. 523 Chicago, Ill. Without cost or obligation send me by mail, your new illustrated 72-page book and your Free Charts Offer.

Name.....  
Address.....  
City..... State.....

## WANTED



**\$1100 first year**

Examinations everywhere Aug. 23, 1919  
Common education sufficient  
Life Job.  
Franklin Institute, Dept. H-101, Rochester, N. Y.  
Sirs:—Send me at once, free of charge, sample of Aug. 23 Railway Mail Examination questions, list of other U. S. Government positions now open and free book describing them.  
Name.....  
Address.....

## Send To-day for the "Electrical Worker's Friend"

An electrical book of 66 motor drawings with complete instructions for rewinding and reconnecting A.C. motors. Special at \$3.50  
Or write for full particulars of this valuable book.  
SMITH & SMITH PUBLISHING CO.  
1524 LOWRIE ST., N.S., PITTSBURGH, PA.

You benefit by mentioning the "Electrical Experimenter" when writing to advertisers.

**Earn \$35. to \$100. WEEKLY**

**ALL OR SPARE TIME**



You can make \$35.00 to \$100.00 a week. I want busy, energetic, money-makers, to work with me, to advertise, sell and appoint agents. Biggest thing in years. City conveniences without plumbing. Used in any room. Seals on sight. Demonstrating tub furnished. Folds small, self-emptying, non-leakable. Guaranteed 10 years.

**AGENTS MAKE SALES EASILY**

Two sales daily means \$80.00 a week. Leggett, Ohio. "Worked two hours, took two orders, profit \$10.00." Hayhurst, Nebr. "Took 11 orders in 4 1/2 days—profit \$55.00, ordered 12 more tubs." Manning, Iowa, "Sold 10 tubs in one day—profit \$50.00." DeHut, Nebr. "Sold 12 tubs in three days—profit \$60.00." And hundreds of others making big money. 70 percent of homes have no bath tub. Experience and capital unnecessary. Credit given to the right man. Get full particulars and "special plan" all free.

H. S. Robinson, Pres., THE ROBINSON CABINET MFG. CO.  
5013 Factoris Building TOLEDO, OHIO

**Peacetime Uses for War Inventions**  
By H. Winfield Secor  
(Continued from page 365)

gines of the distant vessel is picked up by a sound-sensitive electrical instrument, known as a *microphone*. By turning the microphone in different directions, and noting carefully the position where the maximum sound is heard in the receivers, the spot from which the sound originally emanated can readily be determined even to within a fraction of a degree, it is claimed. For locating icebergs or other obstructions, which of course do not produce any sound themselves, there is required a *sound producer* such as an under-water electric bell or siren. The sound waves radiate from this device, mounted between two microphones on a rotatable arm secured to the vessel, as the illustration shows, travel outward until they impinge against the iceberg or other impediment, when they are *reflected* as the arrows show. These reflections, or the "echoes," are listened for by the aid of microphones and sensitive telephone receivers connected with them. By swinging the bar supporting the microphones and siren in different directions, the position of the obstruction is at once determined. Its distance can also be ascertained with some of the more highly developed apparatus of this class, by direct reading instruments, or else by the relative strength of the sound heard in the receivers.

The *Radio Compass*, as it is called, has come greatly to the fore in the past three years. Prior to the World War it existed mostly in the laboratorial stage. But at the close of the war radio compass stations were to be found not only in the principal coastal regions in the vicinity of shipping activities, but they were also to be found on the great battlefields of Europe, where they were used for the purpose of accurately locating "enemy" radio stations. The radio compass should, we might almost say, find even a greater field of useful application in peacetime than it did during the war. It promises to become one of the most important scientific developments in wireless telegraphy, particularly for the navigation of aircraft. We were recently informed by a naval radio expert that the English Navy had the radio compass scheme worked out to wonderful perfection, and that during the war they were actually able to steer vessels up the entrance to the Liverpool Harbor, one of the most treacherous harbor entrances in the world, on the darkest and most foggy nights, without ever having a collision. See Fig. 9. To do this, a series of radio compass stations were situated on either shore at short intervals, and these stations sent out predetermined radio signals at successive intervals. This expert also mentioned that it was very easy for any Allied war vessel to instantly obtain her location and bearings if she was anywhere about the coast of England or Ireland, utilizing the service of the radio compass stations which dot these coasts. If the vessel wished to know her location, the radio code signal for interrogative "L" was sent out twenty times. This was the official notice to nearby radio compass stations that the ship calling wished to know her location. At least two land compass stations then took readings of her signals, and by triangulation and by means of wire or wireless communication between the two stations which had a fixed base line, the triangle was solved in a few minutes, and the exact location of the ship was transmitted to her radio officer from one of the land stations. The ship received her location figures in latitude and longitude about five minutes after sending out the call letter aforementioned.



**SPECIAL KON-VER-TER SLIDE RULE**

The Hamilton KON-VER-TER slide rule has over 8000 graduations and over 1800 characters on it, will handle anything in Arithmetic, Algebra, Geometry or Trig. This slide rule is in use in all parts of the world and is much simpler to operate than others of similar lines. Does not require a wizard to use it.

Eventually you will get this rule, get it now and save \$100 extra both in time and expense. Utility rules \$1.00, Special De Luxe, white ivory celluloid \$2.50, instructions free. Leatherette case 60c extra.

J. C. HAMILTON & Co.  
Dept. B 7 Water St., Boston, U.S.A.

**MATHEMATICS MADE EASY**

The Arcascope—the Combination Triangle with a Brain—will multiply, divide, figure percentage and proportion, solve all problems in trigonometry and geometry, draw symmetrical figures, plot arcs, etc. Superior to any slide rule. Simple to operate. Also includes a TRANSPARENT TRIANGLE, PROTRACTOR and THREE RULES. Used at Columbia University, West Point, U. S. Aeronautic Schools, etc. Only 85 cents Postpaid. Order today before you forget.

Dept. J. L. J. LEISHMAN CO., Ogden, Utah

**SLIGHTLY USED STANDARD MAKE TIRES**

Size	New Tube	Price	Size	New Tube	Price
30x3 1/2	.. \$1.85	\$ 4.50	35x4 1/2	.. \$3.00	\$10.25
30x3 3/4	.. 2.00	.. 5.00	36x4 1/2	.. 3.50	.. 10.50
31x3 1/2	.. ..	.. 5.50	35x5	.. 3.75	.. 11.00
32x3 1/2	.. 2.25	.. 6.00	36x5	.. ..	.. 11.50
31x4	.. 2.75	.. 6.50	37x5	.. 4.00	.. 12.00
32x4	.. 2.40	.. 7.50			
34x4	.. 2.70	.. 8.50			
34x4 1/2	.. 2.85	.. 10.00			

Special—Brand New 34x4 1/2, Cord, \$12.25

Order now. Shipment made the same day. \$1 deposit required with each tire order, balance C. O. D., subject to your examination. Specify whether you desire to have clincher or straight side tire.

Special cash discount of 5 per cent if full amount accompanies order.

**CENTRAL TIRE & VULCANIZING CO.,**  
2309 S. STATE ST., Dept. E. E. CHICAGO

**The Seneca Motor Car** Built for the Owner \$990.00

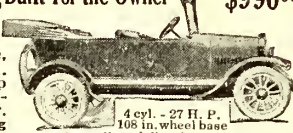

Simple, sturdy construction. Low cost of up-keep and operation. Cantilever springs in rear. Comfortable E-Z riding.

**Dealers Wanted**

Immediate deliveries. Fifth successful year. Increased output. Liberal newspaper advertising in dealers' territory. Wonderful opportunities. Write or Wire NOW.

THE SENECA MOTORCAR CO., 48 Seneca Factory, FOSTORIA, OHIO

**Learn Autos and Tractors**



Wonderful opportunities constantly offered trained men; we train you thoroughly to start your own business or make good money as motor expert, driver, shop foreman, etc.

**15000 Graduates making good. Catalog Free.**

Cleveland Automobile School, 1807 E. 24th St., Cleveland, O.

**DEMINGER WILL SAVE**

**\$40 BIG MONEY SAVINGS FOR YOU**

Used and rebuilt motorcycles, single and twins, \$25 to \$100. Used bicycles, \$5.00; tandems, \$10. All machines guaranteed in good working order. New bicycles and motorcycles at Factory prices. You save dealers' profits. Motorcycle and automobile tires too, \$3.00. Complete line of parts and supplies.

Send for catalog

**YOU 25 TO 50 DOLLARS**

Deminger Cycle Co., Rochester, N.Y.

**SECURE A MOTOR-CYCLE AT LOW COST**



by putting a RELIABLE STEFFEY MOTOR on your wheel. Easy to attach. Costs less to run than an expensive motorcycle. Write at once and secure low factory prices.

**STEFFEY MFG. CO.**  
Dept. E, 5025 Brown St., Philadelphia, Pa.

**CLEARTONE PHONOGRAPHS**

\$4.00 to \$200.00 Retail

Needles 45¢ per thousand in lots of 500,000 Motors \$1.25 to \$14.75 each. Tone Arms and Reproducers \$1.30 to \$5.75 per set. Main Springs 20¢ to 90¢ each. Records, Needles, Sapphire Points and Parts at reasonable prices.

Write for our \$4 page catalogue, the only one of its kind in America, illustrating 33 different styles of Talking Machines and over 500 different Phonographic Parts.

**LUCKY 13 PHONOGRAPH COMPANY**  
Export Dept. 46B E. 12th St., N. Y., U.S.A.

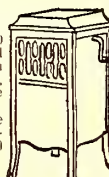

**Learn Watchwork, Jewelrywork and Engraving**

A fine trade commanding a good salary, and your services are always in demand. Address HOROLOGICAL Department, Bradley Institute, Peoria, Ill., for our latest catalog.

**"Hang Your Own Lighting Fixtures"**

One Light Bracket \$1.05—4 Light Shower \$6.15  
Semi-Bowls \$5.85—Plate & Ball 85¢, complete with glassware, Wired, Fine finishes. Send for Photos complete line.

**ERIE FIXTURE SUPPLY CO.**  
Sta. C., Erie, Pa.

**MUSIC TAUGHT FREE**



**You can read Music like this quickly**

In Your Home. Write today for our booklet. It tells how to learn to play Piano, Organ, Violin, Mandolin, Guitar, Banjo, etc. Beginners or advanced pupils.

**American School of Music, 57 Lakeside Bldg., Chicago**

**SAVE 25% to 60%**  
on slightly used **GRAFLEX-KODAKS**

Cameras and Lenses of every description. Equal to new. Save money. Write now for **Free Bargain Book and Catalog** listing hundreds of money-saving bargains in slightly used and new cameras and supplies. All goods sold on 10 days' Free Trial. Money back if not satisfied. You take no chances dealing with us. We have been in the photographic business over 16 years. Write now.

**CENTRAL CAMERA CO., Dept. 178 124 S. Wabash Ave., Chicago**

**A NEW AND EASY WAY TO PAINT SIGNS and SHOW CARDS**

**OUR PATTERNS DO THE WORK**

No experience required. Anyone can paint all kinds of signs, banners, cards, etc., on any surface with our new and easy system of lettering. Complete outfit containing eight alphabets of letters, assorted styles and sizes from two to twelve inches high, also four sets of figures, etc., not printed but life size patterns cut out of durable tag board which can be used over and over again for years, also brushes, colors and book of instructions.

Satisfaction guaranteed. **PREPAID \$7.50**

**ACME SALES CO., Empire Bldg., Denver, Colo.**

**Be FREE From STAMMERING**

Home Exercise Course. Results **GUARANTEED** or **NO PAY**. Write for full particulars.

**SUTHERLAND CURSE, Educational Bldg., 70 Fifth Ave., New York.**

**Want to Make Money?** Send for our big Sale by Mail. You'll save many dollars on your summer purchases of Cameras, Jewelry, Auto Supplies and Traveling Goods.

**DAVID STERN COMPANY**  
1027K Madison St., CHICAGO, U. S. A.

**DO YOU NEED MONEY**

Out of work? Got a lot of spare time? We want men or women in every city to do special local advertising. No experience necessary. Will not interfere with your regular work or household duties. Hundreds are now making \$15 to \$35 weekly. Write me for particulars.

**ALBERT MILLS, Mgr. 118 1/2 American Bldg., Cincinnati, O.**

**158 Genuine Foreign Stamps—Mexican War**

Issues, Venezuela, Salvador and In-10c dia Service, Guatemala, China, etc., only 10c. 100 all diff. fine, 15c; 200 all diff. 25c. FINEST APPROVAL! SUBJECTS 60% to 80% AGENTS WANTED. Big 72-page LISTS FREE! We Buy Stamps. Est. 25 years. **C. E. HUSSMAN STAMP CO. Dept. 67 ST. LOUIS, MO.**

**Handy Binder**

**FOR THE ELECTRICAL EXPERIMENTER**

Holds and preserves 12 issues, each of which can be inserted or removed at will, without tools. Will keep your magazines perfectly for all time or just preserve them permanently. Made of heavy material, extra strongly reinforced at the back and covered with handsome green cloth, suitably lettered in gold.

**65c**

Add postage for 2 lbs.

Experimenter Pub. Co., Inc. Book Department 233 Fulton St., N. Y.



### MAKE UR OWN BATTERIES

NOW you can have a FRESH FLASHLIGHT BATTERY when you need it. Make it yourself in a few minutes. So simple a child can make it! With the MAKE-UR-OWN Flashlight Service Outfit you can now have A YEAR'S SUPPLY OF BATTERIES FOR ONLY \$1.00

ready to use as soon as made. Never fails. Better light. Lasts longer. 25% cheaper, and your flashlight always ready when you want it. ABSOLUTELY GUARANTEED, OR MONEY BACK 40¢ per cent more flashlight service for less money. Get outfit now for your outing, use around house, garage, car, anywhere. Batteries will fit any standard flashlight case of corresponding size. Send coupon with remittance. Amount enclosed will tell you which outfit you want. Sent prepaid, securely packed on receipt of price.



#### DESCRIPTION and PRICES

**Stuart Flashlight Service Outfit** consisting of flashlight case, 1 1/2 X 6 1/2, fibre, heavily nickled brass parts, equipped with Mazda 2.7 volt lamp, parts to make 6 cells, or three MAKE-UR-OWN 2-cell or two 3-cell batteries. No. 240 Complete Outfit . . . \$2.35

**Make-Ur-Own Battery Outfit** consisting of parts to make six cells, or three 2-cell or two 3-cell batteries. Absolutely harmless. Every boy will want one. No. 6404 Renewal Battery Outfit. \$1

#### AGENTS WANTED.

**Serviceable Battery Co.**  
2415 Indiana Ave.,  
Dept. E,  
Chicago, Ill.

#### MAIL COUPON NOW

**SERVICEABLE BATTERY CO.**  
2415 Indiana Ave., Dept. E, Chicago, Ill.  
Please send me Complete Outfit No. 240, for which I enclose \$2.35. Renewal Battery Outfit No. 6404, \$1.00.  
(Cross out the one you don't want)  
It is understood you guarantee these goods and will refund money if not satisfactory.  
Name .....  
Address .....  
City ..... St. to .....  
State make of battery you now use .....

### BIG PROFITS for YOU in HB BATTERY CHARGING

NEW LOWER PRICES NOW IN EFFECT Make \$100 to \$200 Clear Profit Each Month Lower cost—smaller cash payment—BIGGER PROFITS. Start NOW to build big money-making business charging auto batteries. No experience or electrical knowledge necessary. This HB 500 watt Charger recharges 1 to 12 6-volt batteries at once for 10c to 15c each. Owner pays 75c to \$1.50; figure those profits. Small Payment at New Lower Price Puts this Charger in Your Shop Balance on easy monthly terms. Pro-fits will easily pay for outfit. No burn-outs, no expensive renewals—steady 24 hours a day service with BIG PROFITS. Absolute Money Back Guarantee. Tear out this ad and mail TODAY for information.  
**HOBBART BROTHERS COMPANY**  
Box 81E Troy, Ohio  
Successful Manufacturers Since 1898



### TIRES at WHOLESALE

Not Seconds—Fully Guaranteed Genuine "Capitol" or the new Rib-Skid Beacon Tires \$13.60 up. "Inlets Arms" \$2.90 up. Write at once for full description, samples of material, and "Direct-To-You" wholesale prices on these absolutely first quality Fully Guaranteed 5000 mile Tires, Tubes, Armor, etc. Avoid tire trouble, and save one-third your Tire expense by sending size of your tires and name of car today.  
**MODERN TIRE CO.**  
659 7th St., Racine, Wis.

### Electricians

Get up-to-date in HOUSE WIRING! Save TIME, MONEY. LABOR AND STEPS by using our 98 GENUINE BLUE PRINT DRAWINGS, containing all the latest diagrams and connections known in house wiring—every diagram and connection up-to-the-minute as used by first class electricians for wiring BELLS, BURGALAR ALARMS, LIGHTS, ANNUNCIATORS, FIRE ALARMS and ELECTRIC GAS LIGHTS. These drawings are bound in the form of a flexible book (9 x 12) for convenience in using on the job. Send for them, and if they don't make you more efficient as a wireman and save you many times the cost as a contractor, return them and money will be refunded—we can't afford to be without them. ONE DOLLAR postpaid. Send for circulars on other sets of drawings.  
**PATENT SPECIALTY COMPANY**  
P. O. Box No. 583, San Francisco, Cal.

**INSYDE TYRES Inner Armor** for Auto Tires. Double miling, prevent blow-outs and punctures. Easily applied in any tire. Thousands sold. Details free. Agents wanted. Amer. Accessories Co., Dept. 53, Cincinnati

Airplane Photography was pre-eminently one of the most highly developed sciences brought out by conditions imposed by the World War. Complete sections of the battlefield often had to be photographed in a single day's time, and by means of camera guns, and other extremely rapid photographic devices, thousands of pictures could be taken within a few hours in such a manner that when the films were developed and prints made, which took a short time with the perfected apparatus used by the Army in the field, these prints could be matched up by map experts so as to give a true composite photograph of an entire region. The work done by the Photographic Department of the Army in this respect was nothing short of miraculous. At a recent exhibit of this Department's work, one of the composite aerial photographs showed the entire city of Washington, D. C., and environs. The airplane flew over Washington in a certain prescribed course and took all of the photographs which composed the composite view in a little over two hours! The individual prints making up the composite view usually measured about three inches square. Imagine how easy it now becomes to obtain actual physical maps of such regions as the Rocky Mountains and other inaccessible and treacherous localities so that our geographies of tomorrow may indeed prove a marvelous revelation to the school students of today. Airplane photography in its modern aspect and with the high speed available should lend itself well to the requirements of mapping real estate, large farms, railroad sites and hundreds of other localities for many kindred purposes. See Fig. 10.

Gas Masks, as well as Gas Detectors, find many uses in our everyday life. The gas masks are useful to firemen and rescue squads and prove particularly efficacious for use in entering gas-filled mines and other subterranean passages. Gas detectors are not so well known to the general public, as these proved one of the extremely valuable keys to the success of the Allied soldiers. One ingenious form of electrical gas detector is illustrated in Fig. 11. This detector, which also permits of the measurement of the amount and strength of the gas present, comprises a pair of sensitive detecting wires, also a pair of resistance coils and a galvanometer, forming a Wheatstone bridge system, as the diagram shows. At the bottom of the apparatus is shown a metal block in which there are two cavities, each containing a gas detecting wire, and the gas reaches one of these wires thru a series of perforations placed in the external wall of the block. This clever patent has been granted to Gilbert A. Shakespear of Birmingham, England (U. S. patent number 1,304,208).

Depth Bombs apparently seem to be one of those peculiar inventions which follow the old adage—"killing two birds with one stone." Not only did they prove the undoing of the career of many U-boats, but they likewise show great promise of performing many useful peacetime tricks as well. Among other things, the depth bomb should prove uniquely successful in blasting ice jams in river gorges, etc. And as one of our naval officer friends recently told us, thousands of fish are stunned and killed every time a depth bomb is detonated on the water. See Fig. 12. Therefore, why fish with nets in the ocean, when by means of a few depth bombs detonated thirty to forty feet below the water you can stun or kill thousands of fish? Then by a simple suction arrangement pull them into the fishing smack so fast that it would take seventeen bookkeepers and three adding machines to keep account of the catch. Another practical use for depth bombs is the clearing away of derelicts or other obstructions in harbors, lakes or the ocean.

# BOYS



## Learn Drafting

Employers everywhere are looking for skilled draftsmen. They are offering good salaries to start with splendid chances for advancement. Drafting offers exceptional opportunities to a young man because drafting itself not only commands good pay, but it is the first step toward success in Mechanical or Structural Engineering or Architecture. And drafting is just the kind of work a boy likes to do. There is an easy delightful way in which you can learn right at home in spare time. For 28 years the International Correspondence Schools have been giving boys just the training they need for success in Drafting and more than 200 other subjects. Thousands of boys have stepped into good positions through I. C. S. help, but never were opportunities so great as now.

Let the I. C. S. help you. Choose the work you like best in the coupon, then mark and mail it. This doesn't obligate you in the least and will bring you information that may start you on a successful career. This is your chance. Don't let it slip by. Mark and mail this coupon now.

### TEAR OUT HERE INTERNATIONAL CORRESPONDENCE SCHOOLS BOX 6196, SCRANTON, PA.

Explain, without obligating me, how I can qualify for the position, or in the subject, before which I mark X.

- |   |  |
|---|--|
| <input type="checkbox"/> MECHANICAL DRAFTING            | <input type="checkbox"/> SALESMANSHIP              |
| <input type="checkbox"/> STRUCTURAL DRAFTING            | <input type="checkbox"/> ADVERTISING               |
| <input type="checkbox"/> SHIP DRAFTING                  | <input type="checkbox"/> Show Card Writer          |
| <input type="checkbox"/> ARCHITECTURAL DRAFTING         | <input type="checkbox"/> Sign Painter              |
| <input type="checkbox"/> SHEET METAL DRAFTING           | <input type="checkbox"/> ILLUSTRATING              |
| <input type="checkbox"/> BOILERMAKER DRAFTING           | <input type="checkbox"/> Cartooning                |
| <input type="checkbox"/> BRIDGE DRAFTING                | <input type="checkbox"/> BOOKKEEPER                |
| <input type="checkbox"/> MACHINE DESIGN                 | <input type="checkbox"/> Stenographer and Typist   |
| <input type="checkbox"/> ELECTRICAL ENGINEER            | <input type="checkbox"/> Cert. Public Accountant   |
| <input type="checkbox"/> Electric Lighting and Railways | <input type="checkbox"/> TRAFFIC MANAGER           |
| <input type="checkbox"/> Electric Wiring                | <input type="checkbox"/> Railway Accountant        |
| <input type="checkbox"/> Telephone Engineer             | <input type="checkbox"/> GOOD ENGLISH              |
| <input type="checkbox"/> MECHANICAL ENGINEER            | <input type="checkbox"/> Teacher                   |
| <input type="checkbox"/> Machine Shop Practice          | <input type="checkbox"/> Common School Subjects    |
| <input type="checkbox"/> Gas Engine Operating           | <input type="checkbox"/> MATHEMATICS               |
| <input type="checkbox"/> CIVIL ENGINEER                 | <input type="checkbox"/> CIVIL SERVICE             |
| <input type="checkbox"/> Surveying and Mapping          | <input type="checkbox"/> Railway Mail Clerk        |
| <input type="checkbox"/> STATIONARY ENGINEER            | <input type="checkbox"/> AUTOMOBILE OPERATING      |
| <input type="checkbox"/> Marine Engineer                | <input type="checkbox"/> Auto Repairing            |
| <input type="checkbox"/> ARCHITECT                      | <input type="checkbox"/> PLUMBING AND HEATING      |
| <input type="checkbox"/> Contractor and Builder         | <input type="checkbox"/> Textile Overseer or Supt. |
| <input type="checkbox"/> Concrete Builder               | <input type="checkbox"/> CHEMIST                   |
| <input type="checkbox"/> Structural Engineer            | <input type="checkbox"/> Navigation                |
|   | <input type="checkbox"/> AGRICULTURE               |
|   | <input type="checkbox"/> Spanish                   |
|   | <input type="checkbox"/> French                    |
|   | <input type="checkbox"/> Foultry Raising           |
|   | <input type="checkbox"/> Italian                   |

Name .....  
Present Occupation .....  
Street .....  
and No. ....  
City ..... State .....

## AN EASY WAY TO MAKE MONEY

Don't be content to plod along on a small salary. Be independent. Go in the tire repairing business. One man says "I made \$50.00 the first day." Others average \$200 to \$500 a month. Very little capital needed. Jobs plentiful. Every motorist a possible customer. No experience needed. We teach you.

### SHALER Tire Repair Outfit

Improved Wrapped Tread Method Used by Tire Manufacturers  
Does as good work as the big high priced vulcanizing outfits. A boy can use it. It's the only vulcanizer that has Automatic Heat Control, and can't undercure or overcure a tire. Requires no watching or regulating.



**FREE Book**  
"How to Open a Tire Repair Shop."  
It tells how to make big money. Don't delay. Write quick.  
**C. A. SHALER CO.**  
2207 Fourth St. Waupun, Wisconsin

## Opportunity Ad-lets

YOU will find many remarkable opportunities and real bargains in these columns. It will pay you to read and investigate the offerings made every month by reliable firms, dealers and amateurs from all over the country. No matter what you may be seeking, whether supplies, automobile accessories, the opportunity to make money, or anything else, you will find listed here the best and most attractive specials of the month.

Advertisements in this section seven cents a word for each insertion. No advertisement for less than 50c accepted. Name and address must be included at the above rate. Cash should accompany all classified advertisements unless placed by an accredited advertising agency. Ten per cent discount for 6 issues, 20 per cent discount for 12 issues. Objectionable or misleading advertisements not accepted. Advertisements for the September issue must reach us not later than July 22.

### The Circulation of the Experimenter is over 115,000 and climbing every month

EXPERIMENTER PUBLISHING CO., INC., 233 Fulton Street, New York, N. Y.

#### Automobile Accessories.

**Battery Charging Pays Big Profits.** City current or gas engine operates. Easy terms. Hobart Brothers, Troy, Ohio.

**Lubricant Carbon Remover.** Cleans your engine and keeps it clean. Results guaranteed, \$1. Circular. Lewis Gilbert, Skaneateles, N. Y.

**Fords run 34 miles per gallon** with our 1910 carburetors. Use cheapest gasoline or half kerosene. Start easy any weather. Increased power. Styles for all motors. Runs slow high gear. Attach yourself. Big profits for agents. Money back guarantee, 30 days' trial. Air-Friction Carburetor Co., 270 Madison St., Dayton, O.

**Auto Motors and Supplies.** Buick, Hupp, Franklin, Michigan, Everett, Hudson, Chalmers. Both water and air cooled motors, \$40 each and up. Bosch Magnets, \$15 each and up. Presto Tanks, \$5. Coils, Carburetors, Head Lamps, Horns, Air Compressors, Generators, Starters. Write for bargain bulletin second-hand auto accessories. Johnston, West End, Pittsburgh, Pa.

**Power Increased; Carbon Eliminated;** results guaranteed; write for booklet. No-Leak-O Piston Ring Co., Baltimore, Md.

#### Agents Wanted.

**Beginners.** Complete "Mail Order System." C, Box 1005, Atlantic City.

**Agents Wanted** to sell these rubbush washing bars. Save soap and money. Agents making good. Le Hunt, 756 23rd St., Newport News, Va.

**Big Money Made** every day selling our automobile accessories. Every autoist a customer. Most remarkable inventions in the accessory line. Demonstration proves every claim. Particulars free. Exclusive territory if you act quick. The Embee Co., Wilkesburg, Pa.

**\$10 Daily** refinishing chandeliers, brass beds, automobiles by new method, without capital or experience. Free particulars and proofs. Write today. Gunmetal Co., Ave. D, Decatur, Ill.

**Signs for store** and office windows. \$50 a week easily made. Chicago Sign System, G 326 River St., Chicago.

**Wonderful Chance**—Men's shirts and furnishings at wholesale rates, or make \$10 daily starting real business. Goodell Co., Duratex Bldg., New York.

**10 to \$25 a day profit.** Biggest summer seller. Concentrated fruit drinks. Just add water. Delicious drink in a jiffy. Six popular flavors. Bestever Products Co., 2426-SE-8 Polk St., Chicago.

**Agents.** Big returns, fast office sellers; particulars and samples free. One Dip Pen Co., 12 Daily Record Bldg., Baltimore, Md.

**Insyde Tyres,** inner armor for automobile tires, double mileage and prevent punctures and blow-out. Quickly applied. Costs little. Demand tremendous. Profits unlimited. Details free. American Automobile Accessories Co., Dept. 54, Cincinnati, O.

#### Help Wanted.

**Auto Experts Wanted.** \$35 week. Learn easily while earning. Write immediately. Franklin Institute, Dept. H 806, Rochester, N. Y.

**Detectives** make big money. Travel; be your own boss. Either sex. We instruct, small cost. Write Johnson's Detective School, 232 Sheldon Ave., Grand Rapids, Mich., Dept. A.

**U. S. Government** wants Railway Mail Clerks. Hundreds needed. \$1,100-\$1,600 year. Examinations everywhere, Aug. 23. Sample questions free. Write immediately. Franklin Institute, Dept. H 26, Rochester, N. Y.

**Agents 200% Profit.** Wonderful little article. Something new; sells like wildfire. Carry right in pocket. Write at once for free sample. Albert Mills, Mgr., 1287 American Bldg., Cincinnati, Ohio.

#### Fishing.

**Julian's Liquid Fishing Lure.** Doubles your catch. By mail One Dollar. Circular for stamp. George Julian, Albany Bldg., Boston, Mass.

#### Postcards.

**Five Prettiest Women Cards,** hand colored, 25c. Chas. Durso, Dept. 41, 25 Mulberry St., New York City.

#### Stammering.

**St-Stu-t-t-tering** and Stammering cured at home. Instructive booklet free. Walter McDonnell, 105 Potomac Bank Bldg., Washington, D. C.

#### BUFFALO SHOE COMPANY OUTDOOR FOOTWEAR

Seneca and Ellicott Streets  
BUFFALO, NEW YORK, U. S. A.  
142 Oxford Ave., Buffalo, N. Y.

The Experimenter Pub. Co.,  
233 Fulton St., New York City.

Dear Sirs:

Find inclosed a bill for 98c and also money for same. Kindly send receipt. Please pardon me for not sending it sooner.

It was the best ad I ever had and if I ever have any other instrument to dispose of I will advertise in your columns. I received 24 answers inside of 4 days.

Yours for success,  
(Address) J. Rife Barbusser,

#### Exchange Ads.

**For Sale**—Electro Importing Co. Loose Coupler \$6. Never used. James Walker, Pontiac, Mich.

**Sacrifice:** Large Camera, large Scientific book. Want: Wireless Apparatus. Stamp for list. Weniger, Brownsdale, Minn.

**Exchange, Buy, Sell.** Wireless, electrical goods, etc. Large list 6c. State what you have and want. Zehrbach, Box 600, Hiram, O.

**Boys' Books** for chemical or electrical apparatus. Stamp for list. Homer Votaw, Raymond, Wash.

**For Sale**—One new bicycle motor. Makes your bicycle a motorcycle. Walter Van Schaick, Lake Benton, Minn.

**For Sale**—One pair Murdock phones with cord, "Regular" Headband, two thousand ohms. Second-hand, but very sensitive. Twelve "Electro-se" Ball insulators. New Six "Electro-se" strain insulators. New one six hundred volt ground switch, 6 lbs., new. Thirty feet high tension cable 7/16 inch diameter, twenty thousand volts discharge. New six lbs. Copper Clad Wire, 510 feet. Best and latest Wire, new. Cash. Twenty Dollars, or make offer on part of equipment. H. K. Tryon, Berlin, New York.

**\$5 Electrical Water Purifier;** want Film camera. Prints—or offers. Clarence Skinner, Topeka, Kansas.

**For Sale**—Wireless and electrical apparatus, also other articles. Cheap. List free. Write quick. Atley Maurek, Box 157, Austin, Minn.

**Cheap**—Twenty-three dollar Omnigraph. Arnold and Murdock Couplers. Load Detectors. Meeker, 1632 University Ave., N. Y.

**Exchange** pair 1,500 receivers, headband, 100 Amp. switch, 9-4" insulators, fixed condenser, 2 lbs. aluminum wire No. 14, spark gap, 15 ft. ground wire; for folding camera like Kodak, value \$10 (2 1/4 x 3 1/4). Maron, 390 Highland Ave., Malden, Mass.

**For Sale**—Complete unused analytical and industrial I. C. S. Chemistry Course. First \$20 takes it. Nicholas Michel, 217 South 4th St., St. Charles, Mo.

**5 H.P. 2 cycle single cylinder air cooled engine.** Coil ignition. New piston rings and spark plug, good carburetor. Guaranteed A-1. \$25. Money with letter. James E. Walker, Box 63, Marfa, Tex.

**For Sale**—"Ranger Arch-Frame" bicycle; 22-inch, three-speed, clincher tires, nearly new, \$43. Stamp for answer. Gerald Willard, Heron Lake, Minn.

#### Exchange Ads—Cont'd

**For Sale**—2 K.W., D.C. 110 V. Dynamo. Marble slab with 0-150 V. Meter field rheostat and switch attached. Price \$100. Or part in wireless receiving apparatus. S. R. McClure, Helm, Ky.

**Wanted**—Everything. Motor-wheels, cycle-cars, anything. R. Place, Sprague, Fall River, Mass.

**Attention, Experimenter**—Brand new books, "Radio Telephony," by Alfred Goldsmith, \$1.25 (sells for \$2.00). "Practical Wireless Telegraphy," by E. E. Bucher, \$1.25. Arthur E. Reider, 348 E. 15th St., N. Y. C.

**Your Opportunity to Save Money.** I have Printing Outfit; cost \$150; is almost new; will sell for \$100 cash. Have lots of Electrical Wiring Supplies; will sell at my cost (wholesale prices). Paid \$80 for Smith Motor Wheel; very good condition; will sell for \$45 cash. Above statements and your complete satisfaction fully guaranteed. Privilege to return within 10 days. H. L. Baer, Van Wert, Ohio.

**Bargain**—1,200-mile Receiving set, includes loose coupler, loading coil, condenser, silicon detector, buzzer code. Mounted; for \$7. Money Order. Merle Doan, Vera, Oklahoma.

**For Sale or Exchange:** Six copies of Hawkin's Guides, \$3.90; 1 400-day clock in first class condition, \$5; 1 1 K.W. Thordarson Transformer, \$18.90; 1 1/4" Spark Coil, \$1; 1 1-K.W. Tesla Coil, \$15; 1 Crystaloi Detector, Type AA, \$5; 1 E. I. Co. loose coupler, \$2; 1 Navy Type loose coupler, \$4. All in first class condition. Address Walter Franseen, Woodhull, Ill.

**For Sale**—\$40 Cabinet Set. Receives any 1 K.W. set in States. Uses bulb detector. Two loading coils free. \$20. \$35 Rotosped Duplicator and equipment, \$20. No. 3 Box Brownie, \$2. Any article C. O. D. upon 25% payment. No trades. J. C. Gilliland, Munnhall, Pa.

**For Sale**—1/2 K.W. Wireless Transformer complete with rotary motor gap and one battery charging outfit; will charge 3 six-volt batteries at once. Will sell all of above for \$75. A good bargain for someone. E. L. Forslund, Madrid, Iowa.

**Sell**—3 1-r.t. size Wet batteries, 75c each; 2-plunge batteries, 75c; telephone outfit, \$1.00; Selenium cell outfit, \$1.00; loose coupler, \$3.00; 6 bar magneto 110 volt generator, \$4.00; telephone set, \$3.00; Structo Auto Builder, \$4.50. Raymond Fiedler, 70 Sargent Street, Lawrence, Mass.

**Sale**—"1" coil, \$2.50; O. K. motor, \$1.00; step-down Thordarson, \$3.50; 1/4 K.W. transformer, \$5.00. Also wire, silicon steel, etc. R. P. Hanger, Sherwood Ave., Staunton, Va.

**Motor Winders.** See ad under "Blueprints." Charles Chittenden.

**Motor Generator** for Sale. 220 volt, 60 cycle, single phase motor, 30 ampere, 36 volt generator. Specially wound for battery charging; 1 to 24 batteries charged at one time. Used very short time; good as new. Price, including switchboard and 4 charging rheostats, \$230. Earl Hotchkiss, Forestville, Conn.

**For Sale**—High grade regenerative receiver with phones. Will sell parts separately. Also have key, large oil condenser, half-inch coil, motor, etc. Write for prices and description. E. H. Hartnell, Salem, Wis.

**For Sale**—\$8 Loose Coupler, \$6; 2,000 Ohm receivers, \$4; \$4.50 Variable Condenser, \$3.50; \$3.50 Variable Condenser, \$3; \$1 Fixed Condenser, 60c; \$4.50 Detector, \$3; \$2.25 Transformer Key, \$1.50. All Murdock goods. 2" Spark Coil, \$6; Gernsback Interrupter, \$1.85; 2 1/2-pt. Leyden Jars, \$2; \$5 Vacuum Bulb, \$3; 6 Volts 6 Amp. Dynamo, \$1. Guaranteed all new. Send money order. K. Jennings, 106 Blue Hill Ave., Mattapan, Mass.

**For Sale**—One I. C. S. Heavy Electric Fraction Course without bound volumes. Highest cash price takes. Elwood Little, Decatur, Ill.

**Wanted**—Wireless goods for 3 1/4 x 4 1/4 Premo Camera. G. Kostka, 2215 St. Louis Ave., Chicago.

**Will trade** I. C. S. Mechanical Engineering Course for Chemical Laboratory. Herbert Langlois, 2414 Cleveland Ave., Everett, Wash.

**For Sale**—Steel Radio Tower, 115 ft. high. A bargain. W. Turnor Lewis, Racine, Wis.

**Sell.** Set of Ford Spark Coils, \$7.50. Extension Desk Phone, \$6. 2000 Ohm Receivers, \$2. Phillip Stout, 1621 Riverside Drive, Knoxville, Tenn.

You benefit by mentioning the "Electrical Experimenter" when writing to advertisers.

*Business Opportunities.*

**Start a Profitable Business** manufacturing "Puffed Crisp." Delicious confection. Whirlwind money-maker. Machine, Instructions complete \$6.50. Samples 10c. Bestever Products Co., 2426-PE-8 Polk St., Chicago.

**\$30 a Week.** Evenings I made it with a small Mail Order Business; continued my regular job daytime. Free Booklet Tells How, 2c postage. Albert W. Scott, Cohoes, N. Y.

**Enter a New Business.** Earn \$3,000 to \$6,000 yearly in professional fees making and fitting a foot specialty, openings everywhere with all the trade you can attend to; easily learned by anyone at home in a few weeks at small expense; no further capital required; no goods to buy; job hunting, soliciting or agency. Address Stephenson Laboratory, 18 Back Bay, Boston, Mass.

**Anyone Interested** in making \$100.00 month in spare time at home? Send 25c. (coin). L. Stutz, Middletown, Md.

**\$1 Does It.** Bank references furnished. Investigate us thoroughly, that's all we ask. Results count. Our plan \$1 down, \$2 monthly few months gives you Warranty Deed to land. May pay profits \$200 or more monthly. Maps, reports, established facts free. Address Sourlake Texas Oil Co., 867 De Menil, St. Louis, Mo.

**Build Up an Income in Oil.** Others are doing it—Why not you? Today is the opportunity. Join our easy monthly payment plan now—it may mean hundreds in profits. Write for information. National Oil Drilling Co., Dept. K, Houston, Texas.

**Dollars Yearly in Your Back Yard.** No gin-seng, mushroom dope. New ideas. Investigate. Particulars free. Metz, 313 East 89, New York.

**Manufacturers of Electric Vibrators and Hair-dryers** are requested to send us price lists at once and conditions of payment and delivery. I. Calvete, Ltd., 46, Newman Street, Oxford Street, London, W. I. England.

**We Write Ads.** that pull. Send outline for advice. Sales Letter \$2. Jacobus Advertising Service, 1073 Sanford Ave., Irvington, N. J.

**Victory.** Mechanical Toy Soldier window attraction. 30 inches high. Salutes, turns head, points with finger, etc., as set. Well made, nicely dressed officers, privates, Uncle Sam, etc. Electrically operated. Does some stunt every half minute or oftener as set and will salute soldier and pay no attention to other if desired. Representative wanted in each city and town. Write for prices. The John M. Biggs Co., Box 324, Chattanooga, Tenn.

**We will start you** in the cleaning and dyeing business; little capital needed; big profits. Write for booklet. The Ben-Vonde System, Dept. H, Charlotte, N. C.

**Open for proposition.** R. A. Holmes, 1934 Edmondson Avenue, Baltimore, Maryland.

**Break into the Newspaper Game** as correspondent or city reporter. Our correspondence course endorsed by leading editors. We give instruction and actual experience in gathering and writing news. Write for details. American Institute of Journalism. "A Newspaper School Run by Newspapermen." Dept. E, 22 Hawley St., Boston.

**Your Money Back** within ten days if not satisfied. Only one dollar per share for undivided interest in Sinking Ship Saver Patent. Two full pages illustrated description on second and third pages, news section, in 1918 June issue Illustrated World and first full page July, 1918, Popular Mechanics Magazine. Send \$10, \$25, \$50, \$100, or \$1000 for as many shares and copy of patent. Inspect them and if not satisfied return to me within ten days and get your money back. C. Stewart Henslee, Inventor and Patentee, Chattanooga, Tenn.

**Money-Making Farms.** 19 States. \$10 to \$100 acre. Stock, tools, crops, often included to settle quickly. Write for big illustrated catalog. E. A. Strout Farm Agency, 150 E C Nassau St., New York.

**The Enricht Chemical Technical Laboratories** at Farmingdale, N. Y., offer their services to Manufacturers in Research work to improve and cheapen their output. Terms moderate. Correspondence solicited. Results guaranteed or no charge.

**"Quick-Action Advertising—How It Is Building Business for the Progressive Advertisers of America";** A little story of results told by the advertisers themselves—not the publishers. You will be interested in reading this little booklet which we have prepared for prospective advertisers, a copy of which will be gladly mailed to you upon request. It tells you how to talk business with 1,000,000 intelligent, interested and responsive Americans every month—men who know what they want and who have the money to buy it. Write for particulars and rates today. Douglas Wakefield Cutlee, 225 W. 30th St., New York.

*Blue Prints*

**236 A. C. Motor Connections,** 2 to 12 poles, contains 54 single, 42 two phase, 50 three phase Star, 40 Delta, 12 Star-Delta. Appendix 38, changes of voltage, phases, speed, cycles, etc. Particulars and sample free. Charles L. Chittenden, 811 West 18th Street, Kansas City, Missouri.

*Motors, Engines & Dynamos.*

**Gas Engines.** Marine, stationary and cycle motors for bicycle attachment, rebuilt and guaranteed. Don't fail to get our price list before buying. Prices 50% lower than others. Write. United Motor Repair & Supply Company, 305-309 Broadway, New York.

**Small Motors and Generators** from bankruptcy and receivers' sales. Motors for all phases of current. Immediate delivery. Less than one-half regular prices. See display ad on page 239. Johnston, West End, Pittsburgh, Pa.

**Gasoline Engine,** marine or stationary, 3/4 horse. Castings, \$8. Speed Lathe complete, \$2.75. Send 12c for blueprints. M. & J. Specialty Co., 252 Parke St., Pontiac, Mich.

*Miscellaneous*

**For Sale.** Choice Silver Black breeding foxes. Reid Bros., Bothwell, Ont., Canada.

**Wanted.** Small gasoline and steam engines, small lathes, drill presses and other light machinery. Will pay high cash prices for good material. Johnston, West End, Pittsburgh, Pa.

**Here, Boys!** Jersey Skeeter, flies 100 feet; see our ad page 344. Nifty Novelty & Toy Co., Newark, N. J.

**Mansfield's Automatic water and oil finder** a proved success, silver medal awarded. Particulars from Edwin A. Mansfield & Co., 94 Victoria Road, New Brighton, England.

**Let me send you a harmless and agreeable recipe** to stop the odor and relieve your sore feet for one dollar. Guaranteed or money refunded. Louis Burchard, 119 East Vermijo St., Colorado Springs, Colo.

**Breed Canaries.** Profitable pastime. Particulars free. Bird Farm, Lynnhaven, Virginia.

*Motion Pictures.*

**Electric Arc Generator** halves expense. Your engine operates. Easy terms. Hobart Brothers, Troy, Ohio.

**Photoplays Wanted.** Big prices paid. You can write them. We show you how. Free particulars. Rex Publishers, Box 175, E14, Chicago.

*News Correspondents.*

**Earn \$25 Weekly,** spare time, writing for newspapers, magazines. Experience unnecessary; details free. Press Syndicate, 566 St. Louis, Mo.

*Song Poems Wanted.*

**Write the Words for a Song.** We write music and guarantee publisher's acceptance. Submit poems on war, love or any subject. Chester Music Co., 920 So. Michigan Ave., Room 265, Chicago, Ill.

**Write the Words for a Song.** We revise poems, write music and guarantee to secure publication. Submit poems on any subject. Broadway Studios, 107C Fitzgerald Bldg., New York.

*Stamps & Coins.*

**Stamps—12 different from warring nations,** 10c; 10 different foreign coins, 15c; 10 Uruguay stamps, 10c. Lists free. Toledo Stamp Co., Toledo, O.

**California Gold.** Quarter size, 27c; Half dollar size, 53c; dollar size, \$1.10; large cent, 1820, and catalogue, 10c. Norman Shultz, Kings City, Mo.

**1844 cent, 10c.** 7-7 McClellan Ave., Detroit, Mich.

**Stamps—61 All Different Free.** Postage, 3c. Mention paper. Quaker Stamp Co., Toledo, O.

**100 Different Stamps 12c.; 200, 27c.** Michaels, 5600 Prairie, Chicago.

**Lusitania Medals.** Exact duplicates of German medal celebrating murder of innocents. Everlasting proof of Hun's damnable duplicity. 50c each; three for \$1.00; \$3.00 per dozen. C. E. Mahood, Warren, Pa.

**Best One Cent Approvals in America.** F. P. Hand, 1117 So. 60th St., Philadelphia, Pa.

**Rare Coin Over 100 Years Old,** 12c. Bohn, Crafton, Pa.

**Approval Applicants,** 65 different stamps Free. Reference—5 cents. Harland Burgett, 419 Spring St., Lima, Ohio.

*Old Money Wanted.*

**We Buy and Sell Old Coins.** \$2 to \$500 each paid. Keep All Old Money; you may have valuable coins. Send 10c. for New Illustrated Coin Value Book, 4 x 6. Guaranteed prices. Get posted. Clarke Coin Co., Box 110, Le Roy, N. Y.

*Telegraphy.*

**Telegraphy** (both Morse and wireless) and Railway Accounting taught thoroughly and quickly. Big salaries now paid. Great opportunities. Oldest and Largest School—est. 45 years. Catalog free. Dodges Institute, 7th St., Valparaiso, Ind.

*Cameras, Supplies—Photo Developing.*

**Clean, Neat, Perfect Kodak Finishing** at the lowest prices. Work returned the same day received. Send film for sample print and copy of catalogue on developing, printing, enlarging and hand coloring, also copy of Photo Craft Magazine, which will help you make better pictures. Photo Craft Co., Box 69, Ann Arbor, Mich

**For 15c** we will develop and furnish prints from one, six or eight exposure film or enlargement 8x10, your favorite negative, 20c to show quality and service. Associated Photo Company, Sta. A 12, Cincinnati, Ohio.

**Mail us 15c** with any size film for development and six velvet prints. Or send six negatives, any size, and 15c for six prints. Or send 35c for one 8 x 10 mounted enlargement. Prompt, perfect service. Roanoke Photo Finishing Co., 255 Bell Ave., Roanoke, Va.

*Health.*

**Cigarette, pipe or chewing habit conquered.** Nature's method. Guaranteed. Write for free brochure. Edw. J. Woods, TA-300, Station F, New York.

**Tobacco or Snuff Habit Cured** or no pay; \$1 if cured. Remedy sent on trial. Superba Co., SA, Baltimore, Md.

**Tobacco, Cigarette Habit Quickly Overcome.** Eniram Remedy Co., Anderson, Ind.

**Pyorrhea.** H. E. Kelty, D.D.S., M.D., pyorrhea specialist for 15 years, has developed a successful home treatment for pyorrhea. Purifying, healing, preventative. Full month's treatment and booklet \$1. Circular free. Dr. H. E. Kelty, 106 Gladwin Ave., Leonia, N. J.

*Chemicals.*

**Chemicals in Sets, \$13.50 to \$54.25.** Apparatus in sets, \$11.75 to \$55. Write for particulars. Ziegler Experimental Laboratory, Rochester, N.Y.

**Chemicals.** Special, 35 different chemicals, one ounce of each, including mercury, acids, etc. Sent express prepaid \$2.50. Jos. Simpson, 3880 Windsor Place, St. Louis, Mo.

**Amateurs and Experimenters—**We can supply you with any chemicals and apparatus at the lowest prices. Write for our price list. Jos. Simpson, 3880 Windsor Pl., St. Louis, Mo.

**Chemists.** Send 75c for a complete set of 150 labels for your chemicals. Reginald Pitts, 103 Third St., Hanover, Pa.

**Standard Chemicals and laboratory apparatus,** cheap and reliable. July list and 10 formulae 6c. Frane, Eureka, Ill.

**Potassium Sulphocyanide C. P.** at 50c per oz., postpaid. Ziegler Experimental Laboratory, Rochester, N. Y.

*Electrical Supplies & Appliances.*

**Castings, Blueprints, Engines—**Gas and Steam, 1/2 H.P. up. Gears, Pulleys, Pumps, Fittings, Small Boilers. Complete circulars for stamp. Latest models. Universal Gas Motor Co., 364 Monadnock Block, Chicago.

**Obtain a Vial of Radium** to complete your outfit. Used for illuminating light bulbs, keyholes, watch dials, etc. Price 1.00. Address G. Raymond Laboratories, 298 Broadway, N. Y. C.

**Motor Connections.** See ad under "Blueprints." Charles Chittenden.

**Magnets:** Large Horseshoe Magnets. Will lift 12 lbs. Mail \$1, stamps or Money Order. Parcel Post Prepaid to all parts of U. S. or Canada. West Side Novelty Co., Drawer No. 8 Wabash P. O., Pittsburgh, Pa.

**Battery Charging** pays big profits with HB Equipment. Electric Light Generators and Motors can also be furnished on easy payments. Full information free. Hobart Brothers, Troy, Ohio.

**Storage Batteries** charged by alternating current. Inexpensive, Simple and Efficient; Instructions and Print \$1. K. & S. Engineering, Box 124, Sewickley, Pa.

**Electrical Workers** and all others who are interested in Electrical Work in the Reconstruction that is taking place. To send us their name and receive descriptive literature of our Modern Blue Print Chart Method of Electrical Wiring. Souvenir information card included. Electrical Wiring Diagram Co., Box C. 173, Altoona, Pa.

**"Danditoy" Transformers,** 2 1/2-27 1/2 volts, \$2.98. Description sent. Eagleco, Darien, Conn.

**For Sale—2,000 Standard Signal Corps Audion B. Batteries,** Type BA-2, each 22 volts, 50c each while they last, postage extra, 1 lb. Herman Silber, 164 Ross St., Brooklyn, N. Y.

**Lava Insulation** is not molded but individually sawn, lathe turned, milled, drilled, threaded. No limitation on form, only on size. Killed at two thousand degrees. Hard, strong, accurate, fire, acid proof. Ask for hook. American Lava Insulator Company, Chattanooga, Tenn.

For Inventors.

Inventors join National Institute of Inventors, 118 Fulton St., New York City; membership society 1,900 strong; will help protect, develop, finance and market your invention. Absolutely no charge. Write for booklet.

"Sell or Finance Inventions." Read Money Talks Magazine. Send for free sample copy. 70-B Park Place, Newark, New Jersey.

Inventors write me about patents. My fees payable monthly. Booklet free. Frank Fuller, Washington, D. C.

Inventors. Protect yourselves. Record your idea before exposing it to anyone, even to me. Paul Klein, M.E., Consulting Engineer, Registered Patent Attorney, 21 Park Row, New York.

We manufacture Patents, Stampings, Armature Discs. Write us. C. C. Elsener Mfg. Co., Harvey, Ill.

600 Mechanical Movements, also illustrations and explanations of 50 perpetual motions. My book, Inventors' Universal Educator, 4th edition, tells how to procure and sell a patent for your new invention. Government and other costs. Covers the matter from A to Z. 140 pages elegantly bound. Contains noted Court decisions on Patent cases. Mechanical Movements greatly assist inventors—suggest new ideas that might prove of great aid in perfecting inventions. Tells how to select an attorney. Has valuable information regarding Patent Sharks, Selling Agents and Brokers. Price \$1. Postage free. Fred G. Dieterich, 603 Ouray Bldg., Washington, D. C.

Patent Drawings \$2.00 the sheet. Applications \$10.00. 12-16 inch tracings \$3.00. Edw. F. Dowis, Huntington, W. Va.

Patent Attorneys.

Inventors. Send sketch of your invention for advice regarding patent protection. Twenty years' experience. Handbook on patents sent free. Talbert & Talbert, Patent Lawyers, 4822 Talbert Bldg., Washington, D. C.

Patents Procured, Trade Marks Registered. A comprehensive, experienced, prompt service for the protection and development of your ideas. Preliminary advice gladly furnished without charge. Booklet of information and form for disclosing idea free on request. Richard B. Owen, 130 Owen Bldg., Washington, D. C., or 227-8 T Woolworth Bldg., New York.

John M. McLachlen, Atty. at Law, Patents, Trade Marks, Copyrights, 410 McLachlen Bldg., Washington, D. C.

M. F. Miller, Ouray Building, Washington, D. C., Patent Attorney, Mechanical and Electrical Expert. Best quality of work and results. Moderate charges. Advice free.

Patents promptly procured by personal expert service. Information on request. James D. Lyles, Washington, D. C.

Patent Attorney. Electrical engineer, mechanical expert; thorough personal service. Frank Ledermann, 21 Park Row, New York.

Patent Your Own Inventions. Save attorney's fees; we prepare applications; furnish full instructions and give satisfaction. Free information. Carl Larsen Co., Park Row Bldg., New York City.

Patents—My fee payable in monthly installments. Send sketch for advice. Booklet free. Frank Fuller, Washington, D. C.

Inventors' Adviser. Sent free on request. Wm. C. Linton, 918 F St., N.W., Washington, D. C., 363 University St, Montreal, Canada.

Millions Spent Annually for Ideas! Hundreds now wanted! Patent yours and profit! Write today for free books—tell how to protect yourself, how to invent, ideas wanted, how we help you sell, etc. 212 Patent Dept., American Industries, Inc., Washington, D. C.

Printing.

Printing? We do it right and at reasonable prices. Write for quotation and samples. Parcel Post Printery, Dept. A, Kinmundy, Ill.

100 Bond Letterheads and Envelopes, \$1.25 Postpaid. Garland Miller, Trimble, Ohio.

100 Engraved style visiting cards, 50c.; 100 emblem cards, 70c. H. Gregory, Warwick, N. Y.

Phonographs and Supplies.

Don't destroy worn Phonograph records. Send \$1 for bottle of Record Renewer. Treats 50 records. Reduces scratching, revives tone. Cleans polishes and preserves record. Record Chemical Co., West Mansfield, Ohio.

Build Your Phonograph. "Perfection" high-quality spring and electric motors, tone arms, reproducers. Wonderful results. Big saving. New catalog and building instructions mailed for ten cents. Indiana Phonograph Supply Co., Indianapolis, Ind.

Make Your Own Phonograph. Particulars free. DeSelio-PhonE, P. O. Box 720, Attica, Indiana.

Build Your Own Phonograph and manufacture them for profit. Drawing instructions, parts, price list, blueprints, etc., complete, sent free upon request. Write today. Associated Phonograph Co., Dept. E-1, Cincinnati, Ohio.

Patents for Sale.

My Patent, Window-Shades-Operating-Levers, for sale outright. Operates window shades electrically. William Lee, 337 Ave. L, Galveston, Texas.

Personal.

Get Vital Strength. Retain youthful vigor. Wonderful results. Intensely interesting booklet free. Winslow H. Chase, Washington, D. C.

Tricks, Puzzles and Games.

Tricks, Puzzles, Jokes, toys, games, novelties, doll and cane racks, plays, wigs, stage supplies, escapes and illusions. Large 1917 catalogue free. Oakes Magical Co. Dept. 549, Oshkosh, Wis.

Magic. Entertain at home. Tricks, puzzles, novelties. Big Catalogue A, 25c. Martinka & Co., Inc., Harry Houdini, President, 493 Sixth Avenue, New York City.

Black Art Hindoo experiments, 1919 edition, 25c. Invisible ink. Free trick. Catalogue each order. Lindhorst Magic X Shop, St. Louis.

Magic—Card Tricks. Sensational escapes, jokes, novelties. Everything in the amusement line. Large illustrated catalogue of a thousand tricks free. Write today. Largest amusement goods manufacturers in the world. Heaney Magic Co., Desk 204, Berlin, Wis.

Stage Tricks with 500 Illustrations. Catalog 15c. Small catalog free. Hornmann Magic Company, 304 West 34th St., New York.

All Magicians are reading the leading magical magazine. You'll like it, too! Send 25c. for three months' trial. Sample copy, 10c; one year \$1. The Eagle Magician, Dept. EE, Minneapolis, Minn.

Instruction

Wellington Laboratories announce Radio Service Department. All Wireless questions thoroughly considered and answered; 25 cents and postage each. Radio formulas and diagrams; 50 cents upward. 194 Verona Avenue, Newark, New Jersey.

Make Patent Drawings. Big demand; big pay. Complete instruction book only \$1. Patent Drafting Syndicate, Post Box 858, Schenectady, N. Y.

Make Dry Batteries. Simple, practical instructions, with blue print, 25c. Derigo Sales Company, Bath, Maine.

Stuck? What is it? A question, problem or experiment in physics, chemistry, biology, electricity, mathematics, radio, X-Ray, etc. Prompt and accurate information furnished by us. Enclose 25c to cover expenses. Address Association Amateur Scientists Bureau of Technical Information, 225 Lynch Street, Brooklyn, N. Y.

Attention! Improve your handwriting! Easy mail lessons. Write today. C. G. Prince, 130 W. 104th St., New York.

Wireless.

Wireless Coils—Transformer and Spark Coil Secondaries, Induction, Tuning and Loose Coupler Coils wound to order by machinery. Also Model Building for inventors. R. D. Wylie, No. 7 Oregon Yacht Club, Milwaukie, Oregon.

Amateurs! Receiving instruments made to order. Loading Inductances, Loose Couplers and Tuners a specialty. Southern Wireless Co., 801 Silver Ave., Greensboro, N. C.

Radio Apparatus of Quality. Manufactured to your own specifications. Radio Engineering Company, Baltimore, Md.

Primarys and Secondaries for loose complers \$2.50 per set. Complete instrument \$4.50. Coil for tuner \$1.50. Complete \$2.50. Goods prepaid. Leon Pennell, 75 Ellsworth St., Brockton, Mass.

Men—Learn Wireless in Ten Weeks. Thousands of positions now opening for men and boys qualified as radio operators, electricians, mechanics, inspectors and draftsmen. Beginner operators now averaging \$150 per month; no previous experience or wireless education necessary to enter. Opportunity to travel and see the world. Oldest and largest radio school in America; established 1914. We train you through our correspondence course or at our local school to qualify for official license and help you secure a position on land, sea or aerial mail. Wireless outfit free for home practice. Free catalogue on request. National Radio Institute, Dept. 89, 14th and You Sts., Washington, D. C.

Experimenters—Special gray seamless cardboard tubing, 5" and 5 3/4" diameter, 25c per foot. Postage extra. Send stamp for complete price list. Maier & Co., 335 East 93rd St., New York.

Sale of Multi-Audi-Fone radio telephone transmitters. 3 ampere, \$6.00; 2 ampere, \$4.00. Limited quantity. Order now. Satisfaction guaranteed. Modern Radio Equipment Company, Elizabeth, N. J.

Switch Points. Binding posts, switch levers, and small parts, send 2c. for catalogue describing these and other goods. A. W. Bowman & Co., 23 Church St. (Harvard Square), Cambridge, Mass.

Books.

Twelve Easy Wireless Lessons, \$5.00. Order yours Now. Stratton Electric, 215 Federal Greenfield, Mass.

Books. Osteopathic, Chiropractic, Sex, etc. For practitioners. Circulars sent. Murray Publishers, Elgin, Ill.

Dear Reader. If Occult, New-Thought and Scientific books appeal to you, send for my catalogue, it's free. I have books on Personal Magnetism, Concentration, Spiritualism, Clairvoyance, Seer-ship, Will, Mind, Hypnotism, Mesmerism, Character Reading, Healing, Mysticism Success, Salesmanship, Mechanics, Entertainment, etc. A. W. Martens, J-49, Burlington, Iowa.

Crucified Anne Cath. Emmerich and visions, nativity, Egypt, Cana; 4 books, 20c. Klein Co., Brandon, Minn.

World-Romic System. Masterkey to all languages. Six textbooks, \$1.44; French chart, 37c.; Spanish, 37c.; aviation dictionary, \$1.50; French-English aviation dictionary, 61c. Languages, 143 W. 47th St., New York.

"Chicago Mysteries" Illustrated Book, 25c. Catalogue, 2c. Paul Duff, 2713 Mozart, Chicago, Ill.

Nature Laws every married and engaged person should know. Two volumes complete, 50c. (No stamps.) Central Company, 599 Ninth Ave., New York.

To Get Better Pictures. Read the amateur photographers' weekly; illustrated; weekly prize competitions; print criticisms; many unique features; \$1.50 per year; three months' trial subscription 25c. Abel Publishing Company, 401 Caxton Bldg., Cleveland, O.

Old E. E. Back Numbers. We have some valuable old E. E. back numbers on hand as follows: 1915—Jan., Feb., March, April, May, June, July, Aug., Sept., Oct., Nov., Dec., price each 35c. 1916—Jan., Feb., March, May, June, Nov., Dec., price each 35c. 1917—Jan., April, May, June, Aug., Nov., Dec., each 35c. 1918—March, May, June, July, Aug., 35c; Sept., Oct., Dec., each 20c. 1919—Jan., Feb., Mar., Apr., May, June, July, 20c. We can fill orders at once upon receipt of your remittance and if you have not these numbers already, now is your chance to get them, as they probably will be snapped up very quickly. Experimental Publishing Co., 233 Fulton St., New York City.

Formulas.

Worth-while Formulas—Egg Substitute, Orangeade Powder, Mechanics' Soap. Entire collection 10c. Norman M. Ovri, Dept. 3, Hemet, California.

500 Formulas—Resilvering Mirrors, Renewing Dry Batteries, Luminous Paint, Mechanics' Soap, 25c. Catalogue 2c. Ideal, 5501-E North Robcy, Chicago.

Money Making Secrets, 5c each. Book of twenty, price reduced to 25c. E. Forrest, 302 Millman St., Peoria, Ill.

500 Successful money-making formulas and trade secrets. Postpaid 25c. Charles Dynes, Winchester, Ind.

For Men.

Detectives Earn Big Money. Travel. Great demand. Experience unnecessary. We train you. Write for free particulars. American Detective System, 1968 Broadway, N. Y.

Send us your dull razor blades. We re-edge them Good as New, any kind, 2 1/2c each. Prompt service and satisfaction guaranteed. Dealers wanted. Kenedge Company, Inc., 184 Washington St., Chicago, Ill.

Dredge's Necktie Valet removes wrinkles (without ironing) from neckties. Sample 25c. Dept. E, 190 Pilgrim, Highland Park, Mich.

For the Hair.

I Was Bald. Obtained hair growth by an Indian's ointment containing genuine bear oil and rare plant juices. Many others have good hair-growing results. Will send box, postpaid, with recipe, 10c. John Hart Brittain, 150 E. 32nd St., BA-300, New York.

For Advertisers.

We Write Ads. that pull. Send outline for advice. Sales letters \$2. Jacobus Advertising Service, 1073 Sanford Ave., Irvington, N. J.

Free Advertising. Send dime for sample copy of The Trading Post, and details of free advertising. Trading Post, Box 24, Hiram, Ohio.

Quick-Action Advertising—How it is Building Business for the Progressive Advertisers of America; A little story of results told by the advertisers themselves—not the publisher. You will be interested in reading this little booklet which we have prepared for prospective advertisers, a copy of which will be gladly mailed to you upon request. It tells you how to talk business with 1,000,000 intelligent, interested and responsive Americans every month—men who know what they want and who have the money to buy it. Write for particulars and rates today. Douglas Wakefield Coutlee, 225 West 39th St., New York.

You benefit by mentioning the "Electrical Experimenter" when writing to advertisers.

### GREATEST TOY SENSATION OF THE DAY! FIGHTING DREADNAUGHT

**SENSATIONALLY REALISTIC!!!**

Here is a model of Uncle Sam's fighting monsters. Eight big guns, each of which fires at correct intervals, from twelve to twenty times. Extra ammunition always obtainable. Absolutely harmless. Can be operated indoors or out. Now the best of it is you can OWN the ship and command the frin yourself! By having two or three Battleships, you can arrange EXCITING NAVAL BATTLES in your own home. Price complete with Ammunition, 15c, three for 40c, or a fleet of 1 ships for \$1.50 postpaid. Extra Ammunition, 5 cents per box.

### TOOTH-ACHE STOP

**EASY TO USE**

Stops the Pain Stops the Tooth

Space a little bit below the tooth. The Anest. acts instantly on the paste, forming an anesthetic filling. Absolutely harmless. Have it ready for the next bad attack. 20c per tube, postpaid.

### "SAFETY 1st" PINS

A clever novelty. The Safety First Pins are made of the finest steel, and are very durable. They are made in all colors and are very popular. They are made in all colors and are very popular. They are made in all colors and are very popular.

### Mysterious Ghost

This is not a pretty object, but the people who practice the occult arts are much interested in it. It is a ghost which is said to be seen in a room full of people who are sleeping. It is a ghost which is said to be seen in a room full of people who are sleeping.

### INKLESS PEN

**WRITES WITH WATER**

600 words you dip. Makes its own ink every time. It is a pen which writes with water. It is a pen which writes with water.

### SIMPLEX TYPEWRITER

**ONLY \$2.50**

Cheap But Good. So Simple a Child Can Use It. We Guarantee the Writing.

Though so marvellously cheap, this machine is a thoroughly practical typewriter. It is a thoroughly practical typewriter. It is a thoroughly practical typewriter.

### SQUIRT RING

**Wonderful X-Ray Tube**

You may have a lot of fun with this Squirt Ring. It is a ring which squirts. It is a ring which squirts.

### STAGE MONEY

A wonderful little invention producing optical illusions both surprising and amusing. It is a little invention which produces optical illusions.

### SNEEZING POWDER

Place a very small amount of this powder in the nostrils. It is a powder which causes sneezing. It is a powder which causes sneezing.

### NEW BOOK ON ROPE SPLICING

**USEFUL KNOTS, HITCHES, SPICES, ETC.**

How to Make and What They Are Used For. Knobs to Use and Knobs to Avoid.

### LUMINOUS PAINT

**Make Your Watches, Clocks, Etc., Visible by Night**

The very latest discovery in the world. It is a paint which makes things visible by night.

### MUSICAL KAZOO MAGIC FLUTE

Wonderfully Sweet Toned Musical Instrument. A marvelous musical instrument which is easy to play.

### ALL THE LATEST SURPRISES AND JOKE NOVELTIES

- Pharo's Serpents Eggs, Box \$1.00
- Eight Kings (very lifelike), \$1.00
- Five Ninjas (very lifelike), \$1.00
- Ford Auto Puzzle (Largest), \$1.00
- Five Kings Chess (very lifelike), \$1.00
- Five Kings Chess (very lifelike), \$1.00
- Five Kings Chess (very lifelike), \$1.00
- Five Kings Chess (very lifelike), \$1.00

### Boys, you can have Movies at your own home with this latest model MOVING PICTURE MACHINE

Use Standard Films same as the larger machines. Very easily managed. Simply turn the handle. **PRICE Complete \$2.65** Postage 15c, extra including Film. Extra Films, 15c each postpaid



THIS IS A GENUINE MOVING PICTURE MACHINE and the motion pictures are clear, sharp and distinct. The Motion Pictures are first constructed, and carefully put together by skilled workmen. It is made of Russian Metal, has a beautiful finish, and is operated by a finely constructed mechanism. The projecting lenses are carefully ground and adjusted, triple polished, standard double extra reflector, throwing a ray of light many feet, and enlarging the picture on the screen up to three or four feet in area. The light is produced by a standard double extra reflector, throwing a ray of light many feet, and enlarging the picture on the screen up to three or four feet in area.

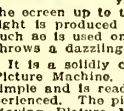

It is a solidly constructed and durable Moving Picture Machine. The mechanism is exceedingly simple and is readily operated by the most inexperienced. The pictures shown by this marvelous Moving Picture Machine are not the common, ordinary and inferior Magic Lantern variety, but are life-like photographic reproductions of actual scenes, places, and people which never tire the audience. This Moving Picture Machine has caused a rousing enthusiasm wherever it was used.

### JOHNSON SMITH & CO.

Dept. E 10 3224 N. HALSTED ST., CHICAGO

### ANARCHIST BOMBS

Consists of a little glass vial, containing a liquid form of chemical which produces a most horrible odor. One dropped in a room full of people will cause a most horrible odor. One dropped in a room full of people will cause a most horrible odor.

### ITCHING POWDER

This is another good practical joke; the intense discomfort of the victim is soon over; but themselves thoroughly enjoyed. All that is necessary is to rub the powder on the place where the itching is desired. It is a powder which causes itching.

### INVISIBLE INK

Writing written with this remarkable ink vanishes entirely in a few seconds if desired, leaving the paper quite blank. 15c per bottle. It is an ink which is invisible.

### LOVE LETTER INK

Writing written with this remarkable ink vanishes entirely in a few seconds if desired, leaving the paper quite blank. 15c per bottle. It is an ink which is invisible.

### LUMINOUS INK

Writing written with this remarkable ink glows in the dark. It is an ink which glows in the dark.

### GOOD LUCK RING

A very striking and successful ring, made of genuine metal. It is a ring which is very striking and successful.

### MULTIPLYING BILLIARD BALLS

This trick is so effective as to amaze the most experienced hands. It is a trick which is so effective as to amaze the most experienced hands.

### THE "LITTLE GIANT" TYPEWRITER

A First Class Writing Machine for \$12.50. It is a machine which is a first class writing machine.

### LOADED CIGARETTES

Just like ordinary cigarettes, but loaded with a surprise. It is a cigarette which is loaded with a surprise.

### SERPENT'S EGGS MYSTIC SKELETON

A jointed figure of a skeleton which can be made to move. It is a skeleton which can be made to move.

### CIGARETTE ROLLER

A very neat and useful device for rolling cigarettes. It is a device for rolling cigarettes.

### MIDGET ILLUSTRATED BIBLE

A Great Curiosity. The Smallest Bible in the World. It is a bible which is the smallest in the world.

### THE CONJURER'S CASKET

Apparatus and Directions for a Number of Mysterious Tricks. Enough for an Entire Evening's Entertainment! 50c

### SHARPEN-M-ALL SAFETY RAZOR

SHARPENS EVERY KIND OF SAFETY RAZOR BLADE. Sharpens the Gillette and Durham Duplex both edges at one time. It is a razor which sharpens every kind of safety razor blade.

### "The Baby" Double Action Hammerless Revolver

A HANDSOME AND MOST EFFECTIVE WEAPON \$6.50 Measures but 4 1/4 inches long



Take regular 22 calibre cartridges. The new Baby Double Action Hammerless Revolver has been produced to meet the ever increasing demand for a revolver that would combine accuracy, ease of use and light weight with the essential features of Efficiency and Practicality. It is small in size, yet is just as effective and accurate as the most powerful weapon you can buy. Every lady should have a revolver and should know how to use it. It is a revolver which is small in size, yet is just as effective and accurate as the most powerful weapon you can buy.

### THE WATCH CAMERA

The most wonderful and ingenious Camera made. It is but little larger than a watch. It is a camera which is but little larger than a watch.

One Cent a Picture. This camera is so simple and so easy to use that even a child can use it. It is a camera which is so simple and so easy to use that even a child can use it.

### QUICK AS A FLASH

Time and Instantaneous shutters. Weighs but 2 ounces; picture perfect. It is a camera which is quick as a flash.

Endorsed by amateurs and professionals alike. It is a camera which is endorsed by amateurs and professionals alike.

### JOHNSON SMITH & CO.

Dept. E 10, 3224 N. Halsted St., Chicago

### WOULD YOU LIKE TO EARN ONE OF THESE MAGNIFICENT BICYCLES ABSOLUTELY WITHOUT COSTING YOU ONE CENT?

HUNDREDS OF OTHER EXPENSIVE PRESENTS ALSO GIVEN

We have secured an enormous quantity of very beautiful colored gifts, consisting of art, floral, landscape, religious, patriotic, etc. and are going to sell them at a very low price. It is a gift which is very beautiful and colorful.

Now all you have to do is to send your name and we will send you 25 of these beautiful pictures, without any charge whatsoever. It is a gift which is very beautiful and colorful.

Remember, you get these goods as a premium for selling the pictures and sending us the money. You don't have to pay a cent for them. It is a gift which is very beautiful and colorful.

By continuing the sale of our pictures you can earn the magnificent Bicycle Illustrated. It is a gift which is very beautiful and colorful.

### New Vamping Card

PIANO PLAYING MADE EASY. No Teacher Needed. It is a card which makes piano playing easy.

Persons having neglected their Musical Education need not despair. It is a card which makes piano playing easy.

### SHARPEN-M-ALL SAFETY RAZOR

SHARPENS EVERY KIND OF SAFETY RAZOR BLADE. Sharpens the Gillette and Durham Duplex both edges at one time. It is a razor which sharpens every kind of safety razor blade.

Also sharpens the Gem Junior, Ever Ready, KeenKutter, Mark Cross, Clark, Autogrip, Star, Crustell, and ALL OTHERS. It is a razor which sharpens every kind of safety razor blade.

### Potmend

Stops a leak in a minute. The finest repairer for ironware, Agnewware, Cast-iron, brass, tin, etc. It is a product which stops a leak in a minute.

# Regain Your Health Thru

# RenuLife VIOLET RAY

## Treatments at Home



Unequaled for neuritis and rheumatism

More Than 25,000 Volts  
No pain, shock or muscular contraction. Entirely harmless — powerfully effective.

There is no "quackery" or uncertainty about *RenuLife Violet Ray*. It is not claimed to be a "Cure All," but it has proved in thousands of cases a practical health-producing, revitalizing agent—powerful in restoring normal physical conditions—yet gentle, soothing and perfectly safe. You can treat yourself. Get full information regarding uses shown on coupon below.

### Users Get Wonderful Results

#### (Voluntary Testimonials)

"The RenuLife Violet Ray High Frequency Generator is superior in efficiency because of its perfect character and control of current, compactness and perfect insulation. The smallness and lightness of Electrode holder is also a great advantage." "The doctor told me that the trouble was hardening of the arteries. I wish I had got it a year ago. I would not be without it for all the money in the world." "I cannot recommend it too highly." "I have been using mine now for a week for Sciatica and I am highly pleased with results." "I think it is one of the best little machines that was ever invented." "I have used it with excellent results for the restoration of hair and stiff and sore rheumatic finger joints." "I am well pleased with the Generator, and the kind treatment received from your Company." "My Generator has stopped my neuritis." "Every house should have a RenuLife Violet Ray High Frequency Generator, for the treatment of Neuralgia, Neuritis, Sore Throat, Kernels in Neck, Cramps, Headache, Stiff Neck, Muscular Soreness, Rheumatism, Paralysis—in short, pains of all kinds."—M. D. "I have been much relieved by the use of your Violet Ray Generator." "It is fine for Insomnia." "I find it such a help in nervousness." "I would not part with it for five times the price. It is sure a little wonder." "I am more than pleased with the Generator; the whole family are using it." "A neighbor lady was suffering from lumbago and could not move, and my wife brought over the Generator and in less than ten minutes the lady was greatly relieved." "Your Generator is just the thing for me. That tired feeling has left me and I feel like myself again." "It has relieved me of the nervousness and also it has helped me a great deal in using it for the treatment of rheumatism."

This type Violet Ray Instrument is designed with light handle, easily manipulated; the most of the apparatus is contained in a case giving ample space for electric units of efficient size.

### How RenuLife Benefits

Science has demonstrated a strange relation between electricity and life cells. This instrument harnesses a tremendous current of electricity and applies in the form of Violet Rays so that the body welcomes and responds to it in a marvelous manner—no pain—shock or the slightest harmful effects. A few seconds of RenuLife Violet Ray gives more benefit than hours of the old time battery methods—because a thousand times as much voltage is made use of.

The irresistible revitalizing powers of *RenuLife Violet Ray* reach every nerve cell, fibre and part of body. Blood is enriched and purified by a flood of oxygen, giving added vitality and strength. Assimilation and digestion improved—functions restored to normal—extra supply of fresh blood quickly brought to area treated, removing congestion and supplying nourishment. While relieving pains and aches, the manifest results of disorders, it removes the deep seated cause, combines the benefits of electricity, vibration, exercise, stimulation and oxidation.

### Get Book "Health via Violet Ray"

Learn the whole marvelous story of the Violet Ray—this method that works with nature to restore and build up. Learn how you, at home, can now use these great curative forces of Violet Ray—heretofore only available at big expense from physicians or beauty doctors. Send coupon or postal card now and receive free book describing uses, quoting low prices (within the reach of all) and explaining liberal *Trial Plan*.

#### RenuLife Electric Co., Inc.

1208 Marquette Bldg., Detroit, Mich.  
Canadian RenuLife Electric Co., Ltd., 1208 Netting Bldg., Windsor, Ont.  
Toronto office, 614 C. P. Building.

Live Sales Representatives write for proposition



Increases energy and vitality



Treatment for nervousness and general debility



Ozone most beneficial for catarrh, throat and lungs. Also anemia



Stops falling hair — promotes hair growth. Wonderful beauty aid

## BOOK FREE

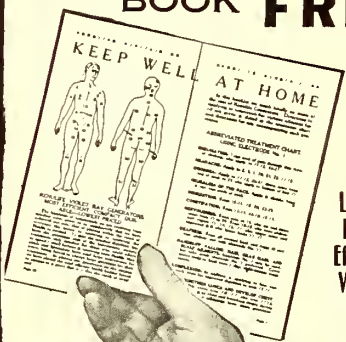

Lowest Prices Efficient VIOLET RAYS

3 Models for Home Use



## COUPON FOR BOOK and Special Information

RENU LIFE ELECTRIC CO., 1208 Marquette Bldg., Detroit, Mich.  
Please send without obligation, your book "Health," explaining Violet Ray treatments with RenuLife Generators; also give full particulars as to its application for ailments checked below.

#### TREATS SUCCESSFULLY

- |                      |                        |                    |
|----------------------|------------------------|--------------------|
| .. Abscesses         | .. Facial Neuralgia    | .. Piles           |
| .. Anemia            | .. Falling Hair        | .. Pimples         |
| .. Asthma            | .. Gout                | .. Pyorrhea        |
| .. Arteriosclerosis  | .. Hay Fever           | .. Rheumatism      |
| .. Baldness          | .. Infantile Paralysis | .. Scars           |
| .. Blackheads        | .. Insomnia            | .. Sciatica        |
| .. Brain Fog         | .. Lameness            | .. Skin Diseases   |
| .. Catarrh           | .. Locomotor Ataxia    | .. Throat Diseases |
| .. Colds             | .. Lumbago             | .. Sprains         |
| .. Chills/blains     | .. Nervous Affections  | .. Toothache       |
| .. Dandruff          | .. Neuralgia           | .. Weak Eyes       |
| .. Deafness          | .. Neuritis            | .. Wrinkles        |
| .. Eczema            | .. Paralysis           | .. Warts and Moles |
| .. Enlarged Prostate |                        |                    |

Write your name and address in margin below and cut out with coupon